

AT MICROFICHE REFERENCE LIBRARY

A project of Volunteers in Asia

Compost, Fertilizer, and Biogas Production from
Human and Farm Wastes in the People's Republic of
China

Edited by: Michael G. McGarry and Jill Stainforth

Published by:

International Development Research Centre
60 Queen Street
P.O. Box 8500
Ottawa, Canada K1G 3H9

Paper copies are \$ 6.00; free to local groups in
developing countries.

Available from:

International Development Research Centre
60 Queen Street
P.O. Box 8500
Ottawa, Canada K1G 3H9

Reproduced by permission of the Communications
Division, International Development Research
Centre.

Reproduction of this microfiche document in any
form is subject to the same restrictions as those
of the original document.

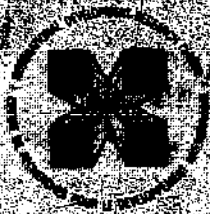

IDRC-TS8e

©1978 International Development Research Centre
Postal Address: Box 8500, Ottawa, Canada K1G 3H9
Head Office: 60 Queen Street, Ottawa

McGarry, M. G.
Stainforth, J.

IDRC

IDRC-TS8e

Compost, fertilizer, and biogas production from human and farm wastes in the People's Republic of China. Ottawa, IDRC, 1978. 94p.

/ IDRC pub CRDI / . Report on the use of human and / agricultural waste / s for compost, / fertilizer / , and bio / gas / production in / China / - discusses various methods of / hygiene / ic / waste disposal / , composting, / parasite / elimination; / building material / s and / construction technique / s for / village / / sanitation / / equipment / and / fuel / - producing biogas plants. Includes an / evaluation / of results.

UDC: 628.3 (510)

ISBN: 0-88936-140-1

Microfiche Edition \$1

**Compost, Fertilizer, and Biogas Production
from Human and Farm Wastes
in the People's Republic of China**

Editors: Michael G. McGarry and Jill Stainforth

Translated by Lee Thim Loi from *A Compilation of Data on the Experience and Sanitary Management of Excreta and Urine in the Village*, published by The People's Hygiene Publisher, People's Republic of China.

Contents

Foreword Michael G. McGarry	3
The Practices and Management of Excreta and Farm Waste Composting	5
Treatment of Livestock Manure and Human Waste for Reuse	15
The Two-Partition-Three-Tank Hygienic Toilet	35
Construction of the Fixed Top Fully Enclosed Biogas Plant	51
Research Results on the Effectiveness of Excreta Treatment in Biogas Plants	71
Biogas Production and Reuse from Farm and Human Wastes	85

Foreword

The need to conserve resources and to find alternative sources of energy are becoming major concerns of most governments. As well, international assistance programs are increasingly emphasizing the need to employ technology in rural areas that is within the technical, social, and economic capacities of the people for whom it is intended.

One way of bringing together both of these needs is through a renewed look at the use of "wastes" — both human and animal. In most so-called developed countries, human wastes are regarded as unwanted by-products and discharged as pollutants into the surrounding environment. However, in the People's Republic of China, such wastes are looked upon as out-of-place resources and valued as low-cost sources of energy to be treated and recycled into the production process.

This collection of papers describes the design, construction, maintenance, and operation of Chinese technologies that enable the Chinese to treat human excreta, livestock manure, and farm wastes to produce liquid fertilizer, compost, and methane gas.

These papers have been translated from the Chinese and are published in response to an increasing number of questions on Chinese practices and experiences in biogas production, excreta use, and composting. This report represents one of the very few reports from China giving empirical data on these processes.

The reader will likely notice some duplication between the various chapters. This is because each was written by investigators and practitioners from various parts of China and we wished to translate and present the documents as close to their original form as possible.

The People's Republic of China is gratefully acknowledged for sharing their experiences and for having published the original manuscript. Thanks are due especially to Lee Thim Loi who undertook the enormous task of translating the original material and to the Regional Office for Southeast Asia of the World Health Organization for their cooperation and assistance.

Michael G. McGarry

Associate Director

Health Sciences Division

International Development Research Centre



The Good Daughter-in-law

by Hsieh Chang-yi

"Early in the morning, the magpies cry,
 The newly-wed daughter-in-law is carrying excreta on a pole
 Liquid from the excreta stains her new trousers
 The hot sweat soaks into her embroidered jacket
 The commune members praise her and mother is pleased
 All tell her she has got a good daughter-in-law."

The Practices and Management of Excreta and Farm Waste Composting*

Since 1964 we have standardized the management and hygienic disposal of excreta and urine, expanded the sources and raised the efficiency of fertilizer, and collected and created a high-quality fertilizer by destroying the bacteria and parasitic eggs that existed in the human and domestic animal excreta and urine. As well, we lowered the morbidity of enteric pathogens, reduced the breeding areas of flies and mosquitoes, improved environmental health, promoted and increased food production, and increased the health standards of all the committee members. Between 1963 and 1971 food production per acre increased by 74%, enteric pathogen morbidity decreased by 80%, and the morbidity of pigs' disease dropped from 5 to 0.3%. Basically, the health profile of the villages was reformed.

Three Selections

Selecting the Management Team

The person in charge of agriculture in the district revolution committee is responsible for sanitary works and fertilizer collection and he is helped by a vice-principal appointed from the committee. Together they must encourage other related departments to cooperate and support the organizers of sanitary works and fertilizer collection. The public society is supervised by a deputy manager, and a management team is formed of comrades from the ministries of agriculture and forestry, veterinary medicine, commerce, and health, and both this team and the production team have members to assume the responsibilities. This arrangement ensures close coordination of all levels. In addition, sanitation and fertilizer collection are included in everyone's daily routines along with agricultural production, and are therefore planned, inspected, and supervised by the management team.

Selecting the Professional Fertilizer-Collecting Team

The choice of fertilizer-collecting personnel is crucial to the efficient and hygienic collection of fecal material. The number of people chosen to be sanitary personnel depends on the number of families in each production team. Between one and three are usually selected and are responsible for fertilizer collection throughout the year.

* This report was prepared by the hygiene section of the district of Chien Ann revolution committee, Province of Hopei.

Locating the Excreta Treatment Field

The dimensions of the excreta treatment field for storing compost depend on the size of the production team. Generally, the excreta field is built in (1) an area 100 m downwind from a village; (2) a sheltered area facing the sun (to promote fermentation) and located on high ground; (3) an area 100 m from water sources to prevent their contamination by wind, runoff, or seepage; and (4) an area convenient for the preparation of materials and the delivery of fertilizer.

Five Standardizations

Standardization of Alterations to Connected Toilets and Piggins

Previously, toilets connected to piggins tended to result in lost fertilizer, to be unhygienic, and to expose both humans and pigs to pigs' disease. Therefore, the production teams decided to modify the committee members' waste stations and create favourable conditions for mass composting (Fig. 1).

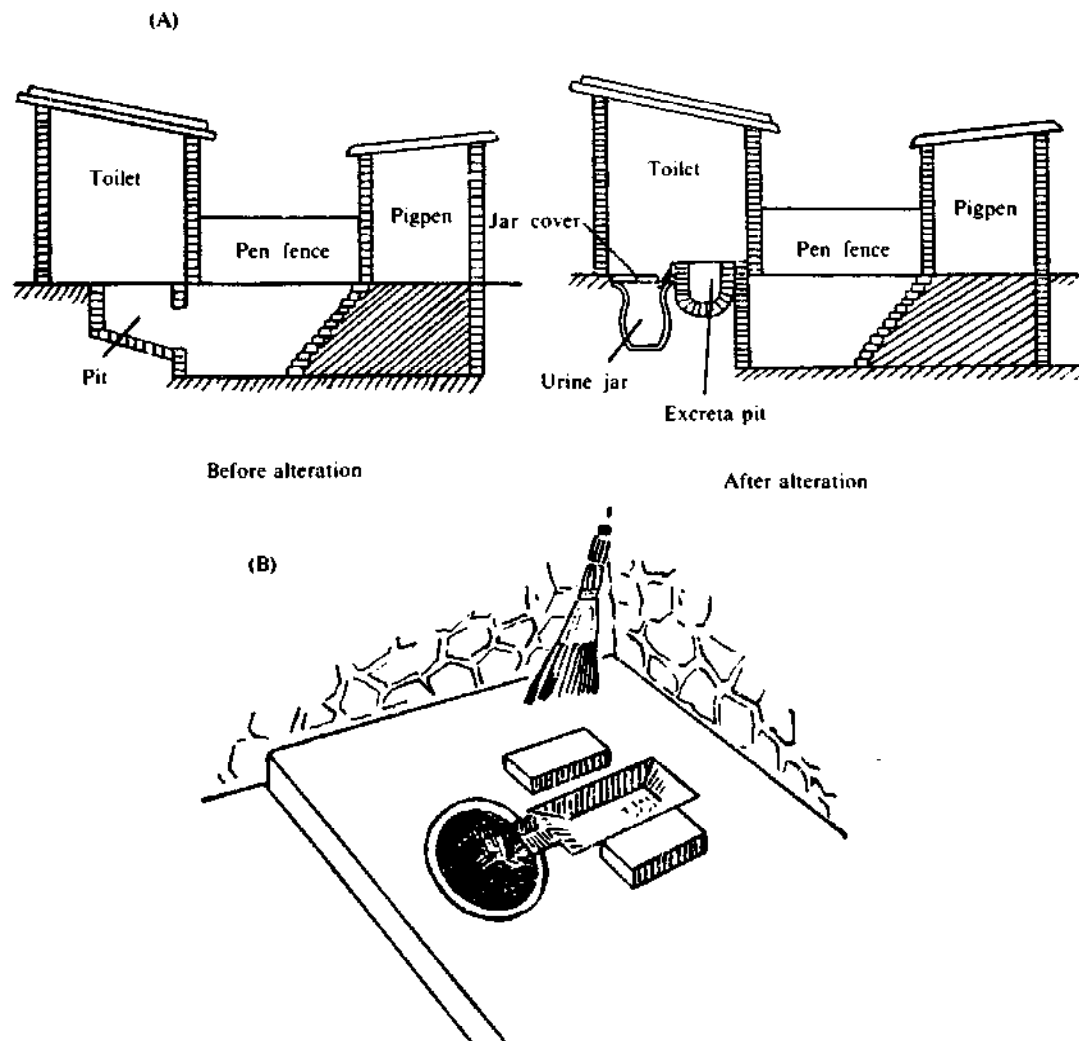

Fig. 1. (A) Connected toilets and piggins before and after alteration. (B) Shallow pit toilet after alteration.

Standardization of Prices for the Supply of Fertilizer

The supplies of human excrement and urine, rubbish, wastewater, and polluted soil by the committee members should be paid for according to their quality, to motivate the committee members to collect and supply these materials.

Standardization of Rewards for Sanitary Personnel

Payment is based on the nature of work done. Work merit points are awarded to the sanitary personnel and equal pay is given to both men and women.

Standardization of the Amount of Fertilizer a Farmer Can Keep

Based on different conditions, those who want to use pig fertilizer can keep it for their own composting but their work merit points will be deducted. The quantity retained should equal the amount of fertilizer used by the production team per acre of cultivated land.

Standardization of the Management System

Under the unified leadership of the party, an effective management system has been set up. It organizes street sweeping and clearing of poultry and domestic animal pens to meet daily production levels, and collects and delivers wastes daily to the fertilizer treatment field.

“Four-Combined-into-One”* High-Temperature Composting Methods

Ground-Surface Continuous Aerobic Composting

This method involves completely mixing the four types of raw materials, regulating the moisture content, and then piling the mixture up to a height of 15 cm (to prevent drafts from getting in, and waterlogging), and placing four 8-cm diameter timbers horizontally on top to form a “#” shape with a distance of 1 m between timbers. Where the timbers cross, four vertical timbers are erected and waste is piled up to a height of 1 m and then covered with earth and the timbers are withdrawn when the earth cover has dried slightly. Generally, it takes 20 days in summer and 1 month in winter for the compost to ferment and mature (Fig. 2).

This method has the following advantages: (1) it is not affected by the daily production of raw materials nor does it involve daily preparation, clearing, manufacturing, or covering; (2) it saves both materials and labour, and conserves the full richness of the fertilizer; (3) its temperature rises faster and lasts longer, and more efficiently kills bacteria and destroys parasitic eggs; (4) a uniform temperature can be maintained within the compost, and heat conducted, causing a faster rate of decomposition and higher fertilizer efficiency; (5) it can satisfy the immediate demand for fertilizer for agricultural

* “Four-combined-into-one” refers to the four sources of organic material combined to produce fertilizer: human feces and urine, animal feces and urine, waste plant matter, and soil.

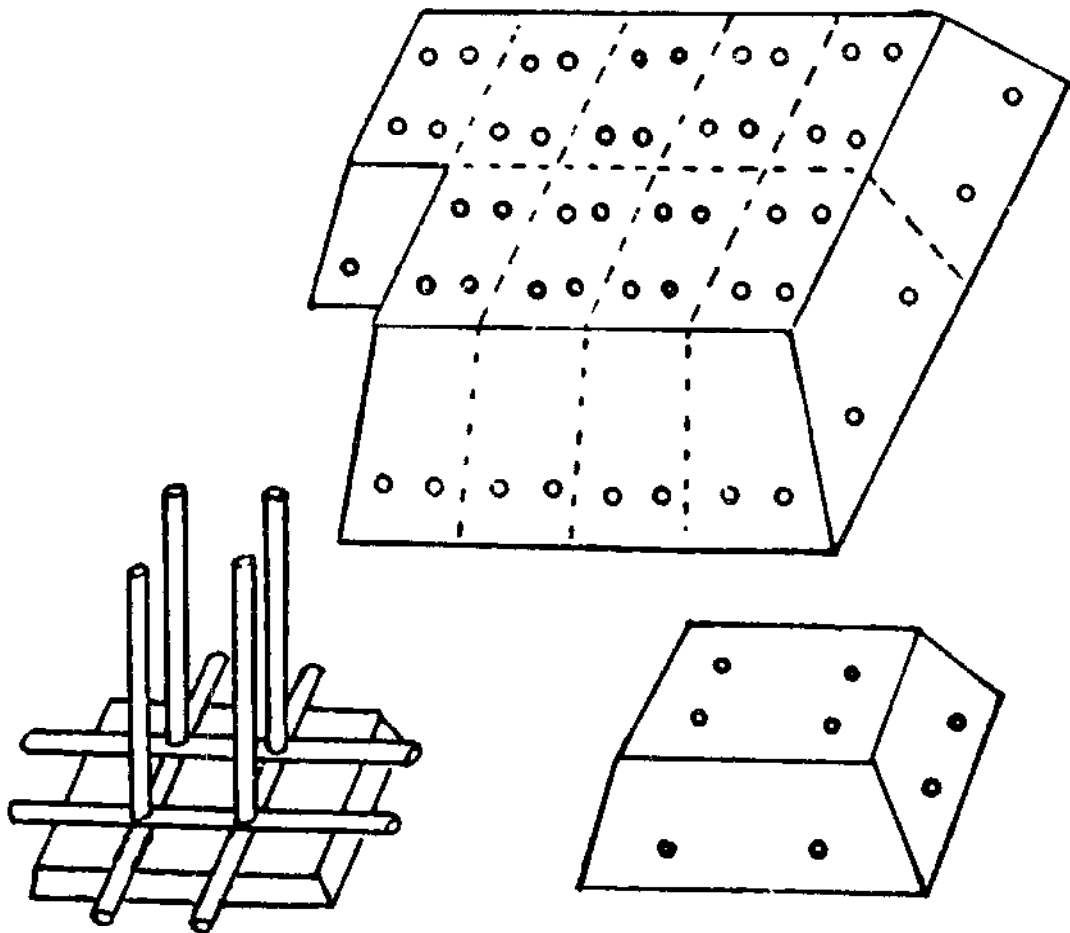

Fig. 2. Ground-surface continuous aerobic composting pile.

use; and (6) it is simple to operate, any team can use it, and the method can be used in spring, summer, and autumn. Its only drawback is that the high temperature is not easily attained in winter. However, if the excreta field is sheltered, and the person in charge very efficient, the temperature could still be made to reach 50 °C and higher.

Large-Pit, Fully Aerobic Composting

To build the required pit, a trapezoid rectangular area must be excavated to a depth of 150 cm, a width of 120 cm, and unlimited length. With these dimensions the sidewalls will not collapse and the construction will be simplified. A ventilating channel of about 75 cm² is excavated along the middle of the pit floor. This channel should be intersected by others excavated at 90-cm intervals along the length of the pit. A layer of millet stalks should be placed on top of the ventilating channels, and 8-cm diameter bundles of millet stalks (or timbers) should be erected at the four ends of the channels and at the intersections. The pit can then be filled to ground level with composting materials and covered with earth. The next day more waste can be added and covered with a layer of grass to keep in the heat. In 1 month the compost can be removed for use (Fig. 3).

This method's advantages are that after the winter freeze, the internal temperature rises faster and can be conserved more effectively, which aids in

the killing of bacteria and destruction of parasitic eggs. The disadvantages are the intensity of labour and the great amount of material required; also the efficiency of the fertilizer can be easily lost after it is removed from the pit. This method has been used in winter only by some of the district teams.

Compost Mixture Proportions

Experiments using different proportions of organic materials have been carried out in our district. The best combination of raw materials was found to be one-quarter each by weight of the following: human excrement and urine; domestic animal and poultry feces (these were mainly mule, horse, donkey, and a small amount of ox feces); rubbish (earth obtained from sweeping streets, brushwood and grass ashes, weeds, and leaves); and soil (sand cannot be used). A variation of this "four-combined-into-one" combination based on volume and not weight has also been successful. High production rates were obtained with these same raw materials by the production teams of our district, and therefore we extended their use throughout the district.

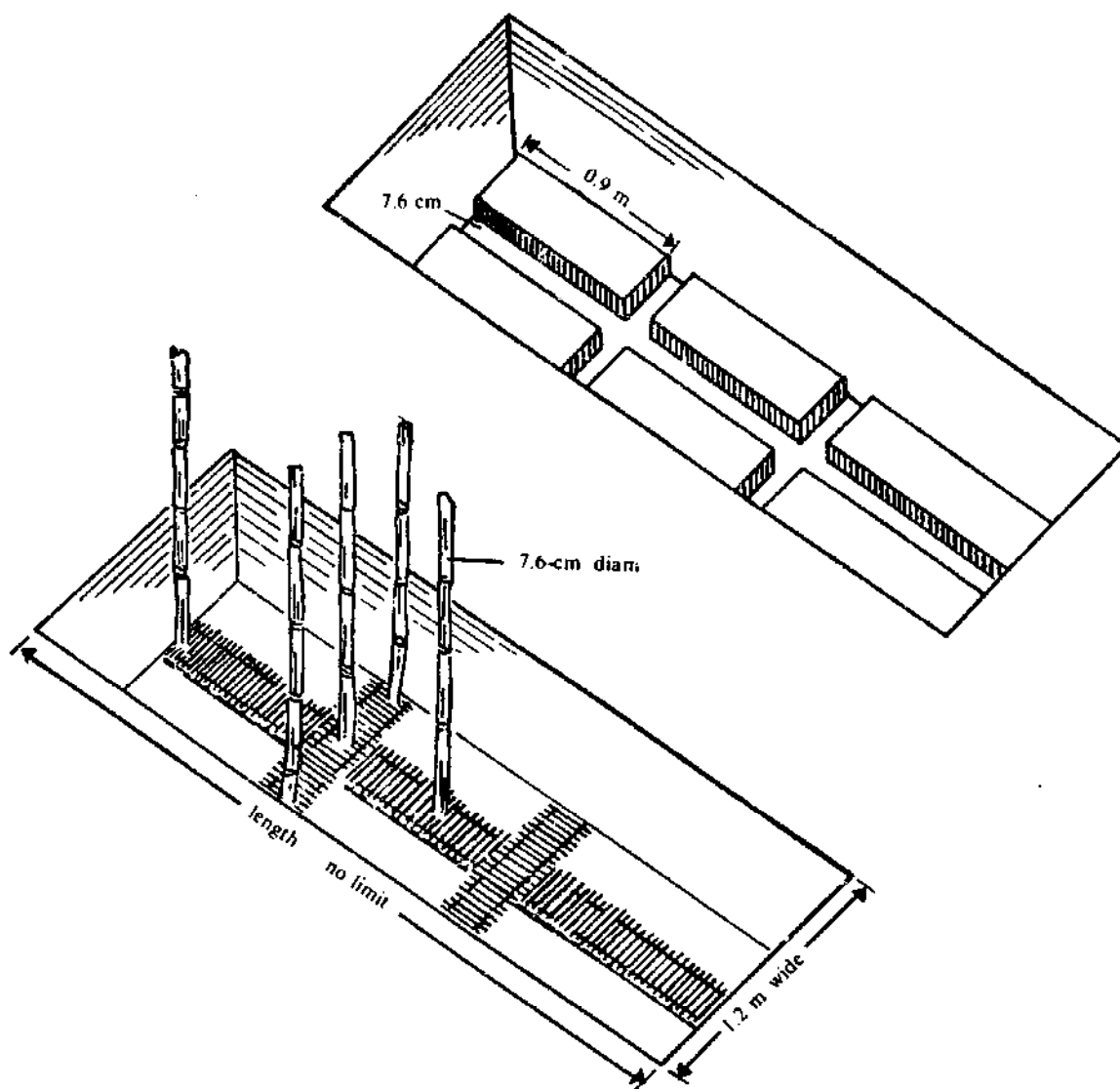

Fig. 3. Fully aerobic composting pit.

Although the mixture is known as "four-combined-into-one," the soil content actually exceeds 25%. According to one analysis of the compost, the soil from the bottom of the pen was about 50% domestic animal feces and 25% rubbish, so that although the soil constituted 25% of the mixture, the actual quantity of soil amounted to 50-60%. With this amount of soil, it is possible to preserve the fertilizer's quality. However, if extra soil is added it may lower the fermentation rate and the temperature of the compost. Extra soil can only increase the weight of the fertilizer but not improve it. In a low temperature season, addition of extra domestic animal excreta could probably help fermentation.

Preparation of Materials

The human excrement and urine should be poured into a mixing tank (or bucket) and mixed well to form a dense fecal liquid; the dry soil and the domestic animal or poultry feces should be pounded to fragments (to ensure that the central part of the feces will be fermented) and then the mixture should be piled up. The method of composting is given on page 7.

Covering the Compost with Earth

If earth is not used to cover the compost, a large temperature difference will occur between the surface and the centre of the compost. This will not only retard the fermentation and the maturing of the compost but will also make the goal of harmless disposal impossible. If earth is used to cover the surface of the compost, the temperature of the compost will be uniform throughout and its surface temperature will rise, aiding the destruction of the human and poultry enteric pathogens, parasitic eggs, and crop disease bacteria; the rate of evaporation inside the compost will be reduced and fermentation aided; the loss of nitrogen will be avoided; the breeding of flies inside the compost will be prevented; and the spread of foul odours will be avoided. Based on their composting experience, the sanitary personnel of the Chiao village management team developed a covering method using 1 part of crushed horse feces mixed with 2 parts of soil. This method prevents cracking of the soil layer and as the horse feces contain a lot of thermophilic fermentation bacteria, fermentation in the compost is assured. Generally, a 5-cm covering of earth will be adequate. In summer, to prevent rainwater accumulating on the compost surface, the earth covering should be properly sloped.

Technical Problems of Composting

Air

As aerobic composting is based on the aerobic fermentation bacteria decomposing organic matter, proper ventilation must be provided inside the compost to accelerate the fermentation and the maturing of the compost. As excess ventilation will increase the rate of water evaporation and heat dissipation and retard the decomposition of organic matter as well as the destruction of human and poultry enteric pathogens, parasite eggs, and crop diseases, the ventilation must be properly controlled.

The material should not be piled too compactly or too high, and the holes for ventilation must be kept clear. According to the compost conditions in our district, the ventilating holes should have a diameter of not less than 8 cm. When temperatures are low, the ventilating holes can be blocked to prevent the loss of nitrogen.

Humidity

A suitable water content should be maintained inside the compost to ensure the proper activity of the fermentation bacteria. If the water content is too high, the air space in the compost will be reduced and the activities of the aerobic fermentation bacteria will be retarded. According to the composting materials available in our district in winter (organic matter and small amounts of rubbish or crop stalks), the temperature and water evaporation rate are low and the compost humidity should be kept at about 30% and increased with increasing temperature. In the late spring and early autumn it should be around 40%, and in summer, with high temperatures and water evaporation rates, the humidity should be raised to about 50%.

To test the adequacy of humidity or water content, when one beats the compost with a shovel it should remain compact, but when turned over it should break up into small pieces. These characteristics indicate a humidity level of about 30%. Otherwise, after the materials have been piled up, a bundle of millet stalks can be inserted into the compost and left there for 5 minutes: if the millet stalk is still dry when it is pulled out, the water content is low; if there are water droplets on the stalks, the water content is high; if just damp, the humidity is adequate, about 50%.

Temperature

Temperature is an important condition of fermentation and the hygienic efficiency of the compost. The pathogens, parasitic eggs, flies, and larvae are killed by the heat generated in the fermentation process of the fecal fertilizer. Most of the pathogens multiply at temperatures of 20-40 °C and cannot survive at temperatures above 50-60 °C, the temperature most suitable for the activity of fermentation bacteria. Hence the temperature of the compost should be maintained at 50-60 °C, preferably over a 5-7 day period.

Composting Efficiency

In March 1965, to determine the efficiency of composting, we carried out two sets of random sampling observations in several composting pits in the village of Chiao. The results were as follows.

Internal Temperature

By the 4th day after the aerobic compost had been covered with a layer of earth, its temperature climbed to 40 °C and higher and the highest temperature reached was 59 °C, which lasted for 16 days. During the entire composting, the average internal temperature was 40.3 °C. On the other hand, after the anaerobic compost had been covered, its temperature rose to 40 °C and higher only on the 7th day, reaching a high temperature of 52 °C, which

lasted for 4.5 days. During the composting, the average temperature was 29 °C. These results suggest that aerobic composting is more efficient than anaerobic (Table 1).

Table 1. Composting temperature statistics (°C).

	Expt	Compost temp			No. days temp above 40 °C	Avg external temp
		Low	High	Avg		
Aerobic	1st	14	59	38.6	15	20
	2nd	23	55	41.99	17.3	23.6
Anaerobic	1st	13	52	29	6	20
	2nd	22	39	29.1	0	23.6

***Escherichia coli* Levels**

Before composting, the *E. coli* counts in the nine pits were 0.000004 gram of material per bacterium and after the composting, the average count was 0.011 gram, except in one ground-surface aerobic and two anaerobic pits where it was 0.0043 gram.

Ascarid Egg Mortality

The average mortalities before and after the aerobic composting were 31.5 and 98%, respectively, and 36 and 97% before and after the anaerobic composting (Table 2).

Table 2. Ascarid egg mortality (%) before and after composting.

	Expt	Before composting		At highest comp temp		After composting	
		Alive	Dead	Alive	Dead	Alive	Dead
Aerobic	1st	69	31	29	71	4	96
	2nd	68	32	7	93	0	100
Anaerobic	1st	64	36	37	63	6	94
	2nd	64	36	2	98	0	100

Nitrogen and Water Content

The fertilizers lost no efficiency when the fermentation and maturing processes occurred at high temperatures. The composting increased the level of active ammoniacal nitrogen indicating that the fertilizer's efficiency is increased and its nutrients can be more easily utilized by plants. Also, a reduced water content would facilitate the transportation and application of the fertilizer (Table 3).

Decomposition

Before composting, the compost was grayish-yellow, the rubbish, weeds, and other organic matter were hard, and the excreta smelly; after composting

Table 3. Fertilizer efficiency and water content before and after composting.

	Expt	Active nitrogen (%)		Water content (%)	
		Before	After	Before	After
Aerobic	1st	0.06385	0.09942	31.5	24.5
	2nd	0.08931	0.1638	25.6	26 ^a
Anaerobic	1st	0.07471	0.11600	32	28
	2nd	0.09515	0.1021	25	26 ^a

^aDuring the second experiment, the water content increased after the composting because rain got into the pit.

the compost had become blackish-brown, all the raw materials were well mixed, loose, and scattered, the rubbish, weeds, earth fragments, and fecal lumps were soft, and there was no excreta odour.

Although we have had some success in the collection of fertilizer and in sanitation, there are still many unsolved problems. Some production teams did not finish the project for a number of reasons — the technical guidance lagged behind the working requirements; the coordination between the collection of fertilizer and sanitation was poor and made harmless transformation and disposal impossible; or scientific research on composting was lacking. Further research is therefore required to find solutions.

Treatment of Livestock Manure and Human Waste for Reuse*

Improving the village's hygienic composting is an important step in increasing agricultural production and reducing disease, and an important element in the basic development of village hygiene.

We began composting with the intention of eradicating the "four evils" and cleaning the environment in the public patriotic and hygienic campaign, to ensure that crop and animal production and the health of the whole district undergo major changes including an increase in fertilizer and food production, a reduction in disease, and the creation of a very wholesome environment. After repeated trials, further improvements have been made in the hygienic way of composting that include the "four reformation," "five construction," and "six unity" campaigns.

Some reforms to be made in the "four reformation" program include the redesign of toilets into the front basin and rear-pot type, building chicken coops with two or three levels, and building cattle pens with sieved bottoms. The five elements of the "five construction" campaign include the construction of a fertilizer storehouse, urine storehouse, dry-ash storehouse, cattle-urine storage pool, and a fertilizer-collecting pool. The six elements to be collected and mixed in the "six unity" campaign are human excrement and urine, domestic animal feces, pigpen waste, chicken excreta, dry ashes, and soil. These campaigns are to be managed and applied collectively.

The Kao Chia village management team and the revolution committee in the district of Chu Fu, after carefully studying the "four reformation" and "six unity" phases (in the hygienic composting experience of the Jih Chao district) have combined the production of compost and the sanitation works in the hygienic composting campaign. After 8 years of practice, very successful results in increasing the annual food production were achieved while the capital costs were reduced. The experience of the Kao Chia village management team has proved the importance of large-volume composting in achieving higher agricultural production. A village's sanitation and its basic construction works can be improved if its hygiene is closely integrated with the composting and environmental health improvements.

A brief description on the methods of hygienic composting used by the Province of Chilin and the district of Jih Chao are presented here.

Construction Methods

Toilets

The excreta pit must be strong, long lasting, and leakproof; the excrement and urine should be collected separately, and the fresh excreta covered with

* This report was prepared by the patriotic and hygienic campaign committee office of the Province of Shantung.

earth; the pit must be easy to clean; it must be separate from the pigpen (Fig. 1A); it should have a surrounding wall and cover, and would be better constructed as a house, if possible; and it should be made of local building materials.

Household and public toilets can be made either of earthen jars or of brick-lined pits. The pits can be shallow or deep; the shallow pits are built in the winnowing-basket or ridged style, and the deep pit is flat-bottomed.

The foundation of the toilet should be either of compacted clay or concrete. If necessary, a layer of bricks or rock should be used and the surface rendered with cement slurry. The shed should be made of either grass or tiles.

When constructing a toilet using earthen jars, a suitable site must be chosen and then two pits excavated the size of jars (about 25 cm in diameter), and then the jars must be placed in the pits. The front jar should be 1-2 cm lower than the rear jar and the top of the rear jar about 1 cm above ground level. The area around the jars must slope outward to prevent water from getting in. Stepping-stones or bricks should be placed on both sides of the excreta jar. In some toilets the urine pot has been placed off to one side at the end of a urine drain rather than immediately in front of the other jar (Fig. 4). This type of toilet is suitable for the plain and areas where there are kiins.

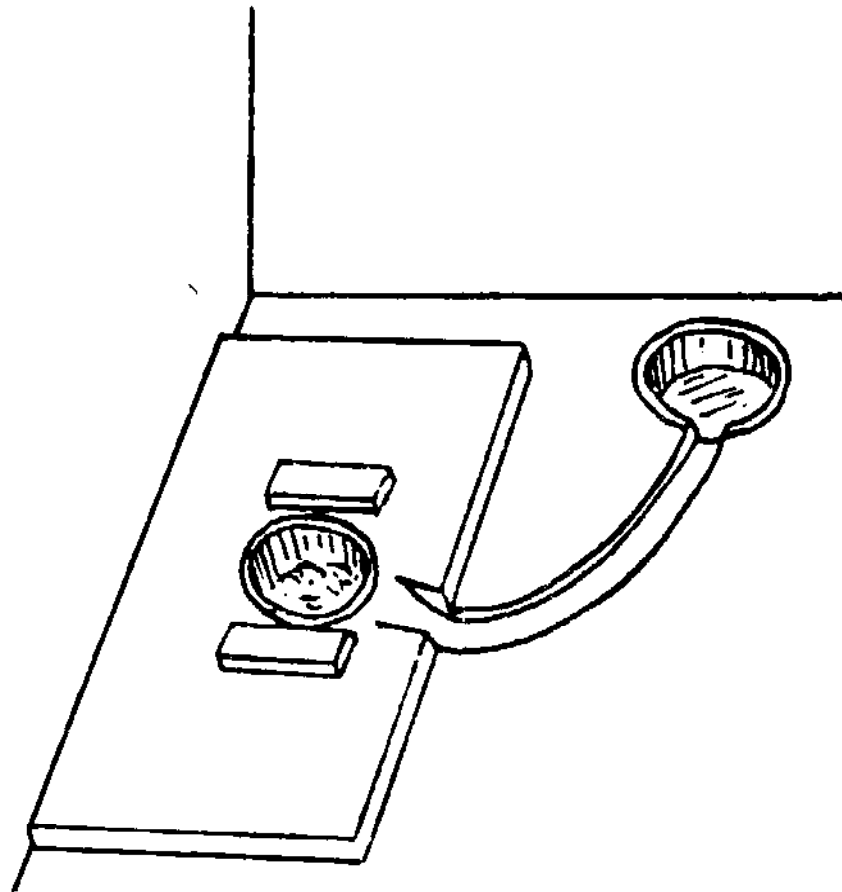
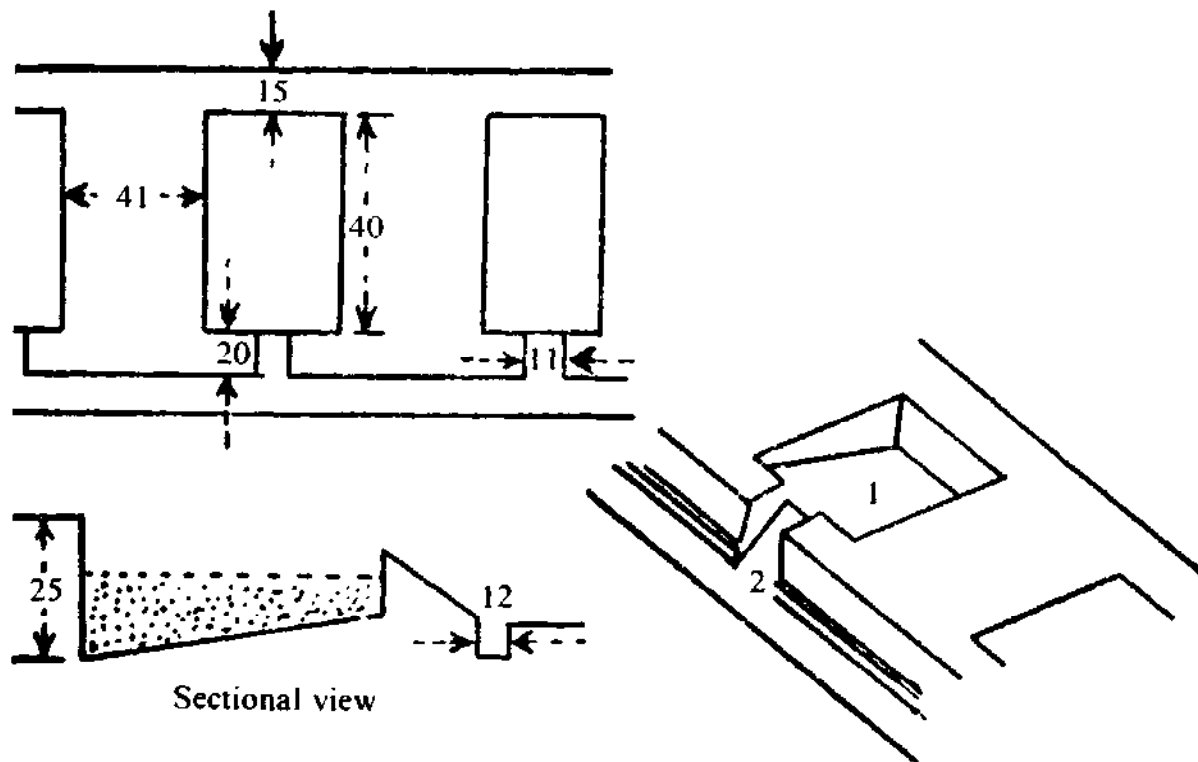

Fig. 4. Jar toilet.

Shallow pit toilets are usually 40-50 cm long and 25 cm wide and deep, and deep pit toilets are 40-60 cm deep. The shallow winnowing-basket and ridged pits have a gradient of about 1 in 10 (Fig. 5 and 6).



Sectional view

Fig. 5. "Winnowing basket" toilet: 1, excreta pit; 2, urine drain.

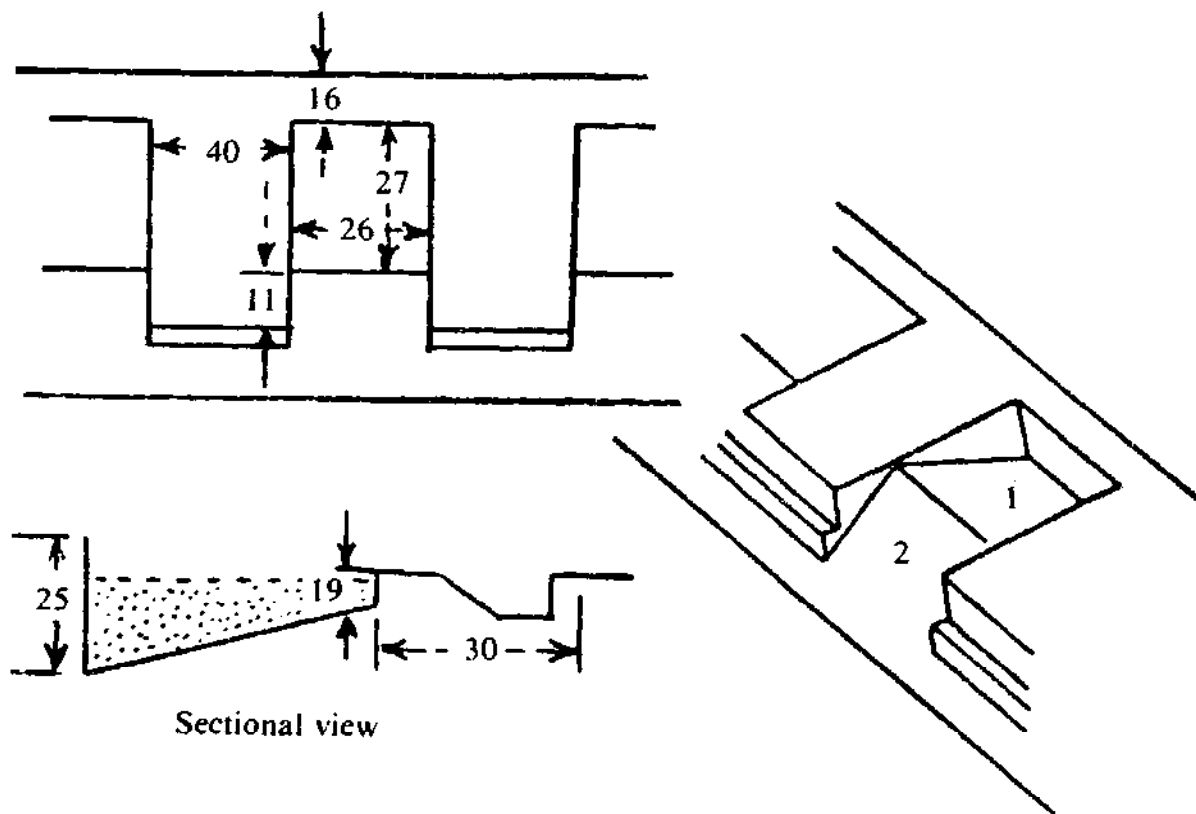

Sectional view

Fig. 6. Ridge toilet (1): 1, excreta pit; 2, urine drain.

The pits are usually built with bricks or stones and rendered with cement mortar. About 25-45 bricks are needed for each pit. Another simple pit uses only 16 bricks (Fig. 7). Pit toilets are practical in both mountainous areas and in the plains.

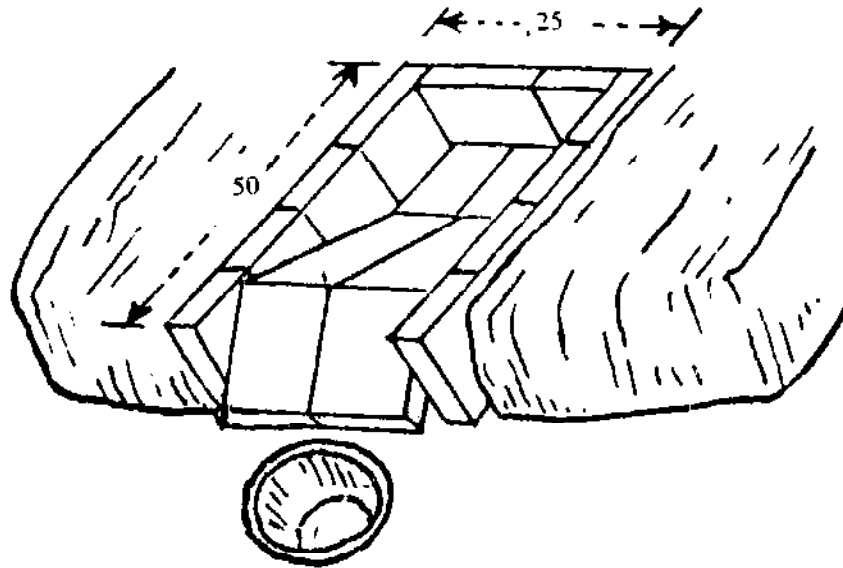

Fig. 7. Ridge toilet (2).

Earthen-jar toilets are economical and widely used although the jars are fragile, inconvenient to clean, and unable to withstand cold weather. The pit toilets are strong and lasting. Shallow pit toilets can be cleaned easily but deep pit toilets are difficult to clean and also require more material in their construction.

Pigpens

The pigpen should be located in a north-south direction, fully ventilated, and facing the sun; the excreta pit and the ground must be firm and without leakage to permit fertilizers to be collected; it should be separate from the household toilet; and it should be convenient to the public, easy to manage, and hygienic. The common pigpen should be constructed in front of the village or in the rice fields and private pig raising should be confined to a smaller area.

Flat-Bottomed Pigpen

The total length of the pen is 4-5.5 m and its width about 3 m. The ground should be of compacted clay or concrete and should slope from north down to south for drainage and exposure to the sun. A shed occupying about one-third of the north end of the pen should be constructed as a pigsty, with a door near the feeding troughs. In the centre of the pen the pigs can move around and at the lower end can defecate and urinate. There is a 10-cm² opening at the bottom of the southern wall to drain the wastewater. The opening is connected to a sewer that drains the wastewater into the fertilizer collecting pit. The size of the fertilizer collecting pit depends on the number of pigs. Generally, it is

4-5 m long, 2-3 m wide, and 0.8-1 m deep. The surrounding wall is about 1 m high and the pen is suitable for group pig farming (Fig. 8).

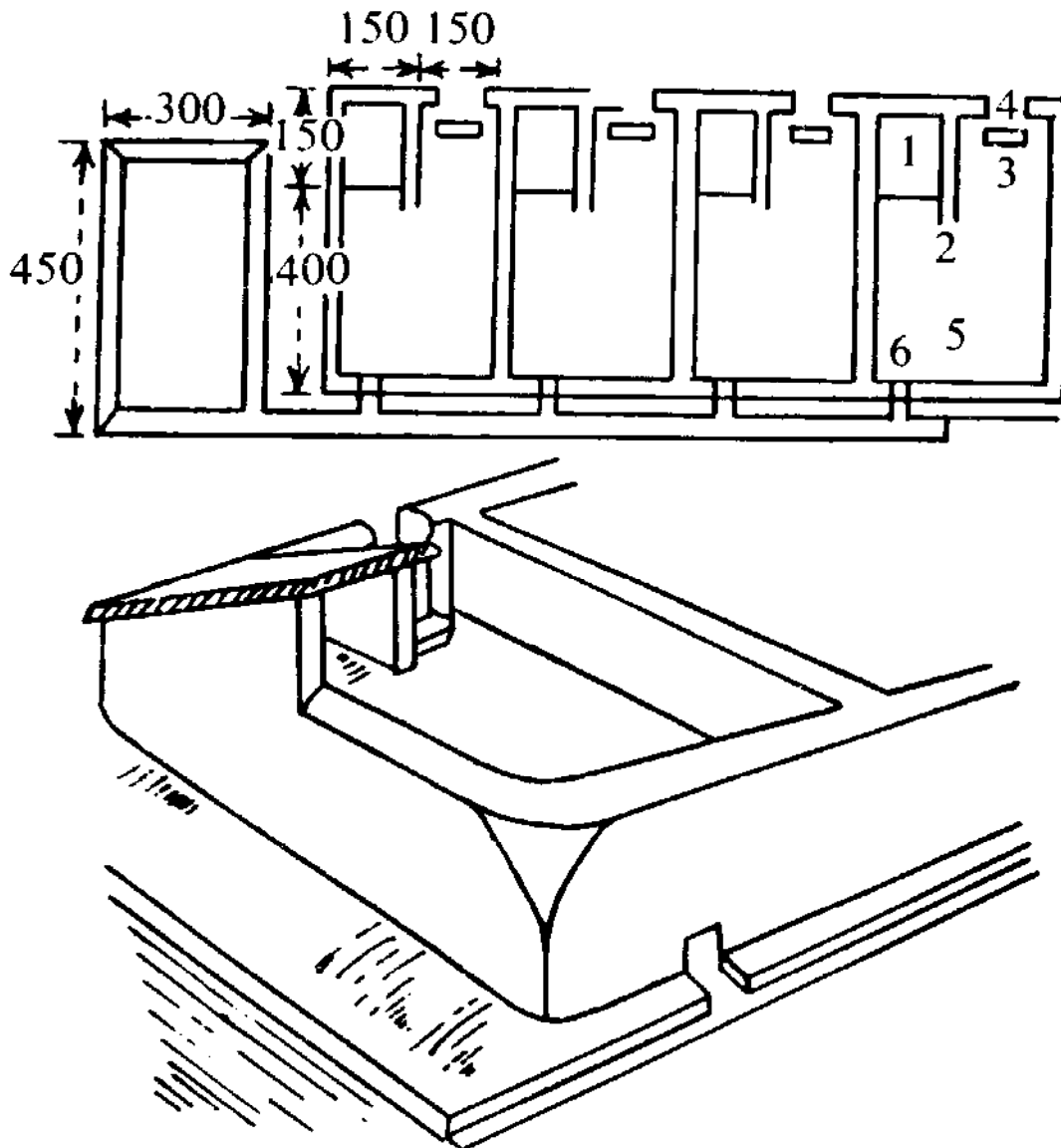

Fig. 8. Flat-bottomed pigpen suitable for group pig raising: 1, pigsty; 2, partition; 3, feeding trough; 4, pen door; 5, excreta area; 6, wastewater drain.

Split-Level Pignens

This pen's total length is the same as that of the flat-bottomed pen, and is divided into upper and lower areas. The upper pen occupies one-third of the total pen area and the lower pen the rest. A shed is constructed as a pigsty at one end and the feeding troughs are placed opposite it. The excreta pit in the lower pen can be either deep or shallow; the deep one is more than 1 m deep and the shallow one is 40-80 cm deep, and is connected to the pigsty by steps.

There are two common types of split-level pens. In one, a partition between the pigsty and the feeding troughs extends to the edge of the lower pen. This arrangement forces the pigs to pass through the lower pen before

feeding or resting, which increases the trampling of the excreta, and fermentation (Fig. 9). In the second, the partition wall between the pigsty and the feeding trough extends to 70-80 cm short of the edge of the lower pen, leaving a passage. The excreta pit in the lower pen is also shallower, making this type of pen suitable for raising sows (Fig. 10).

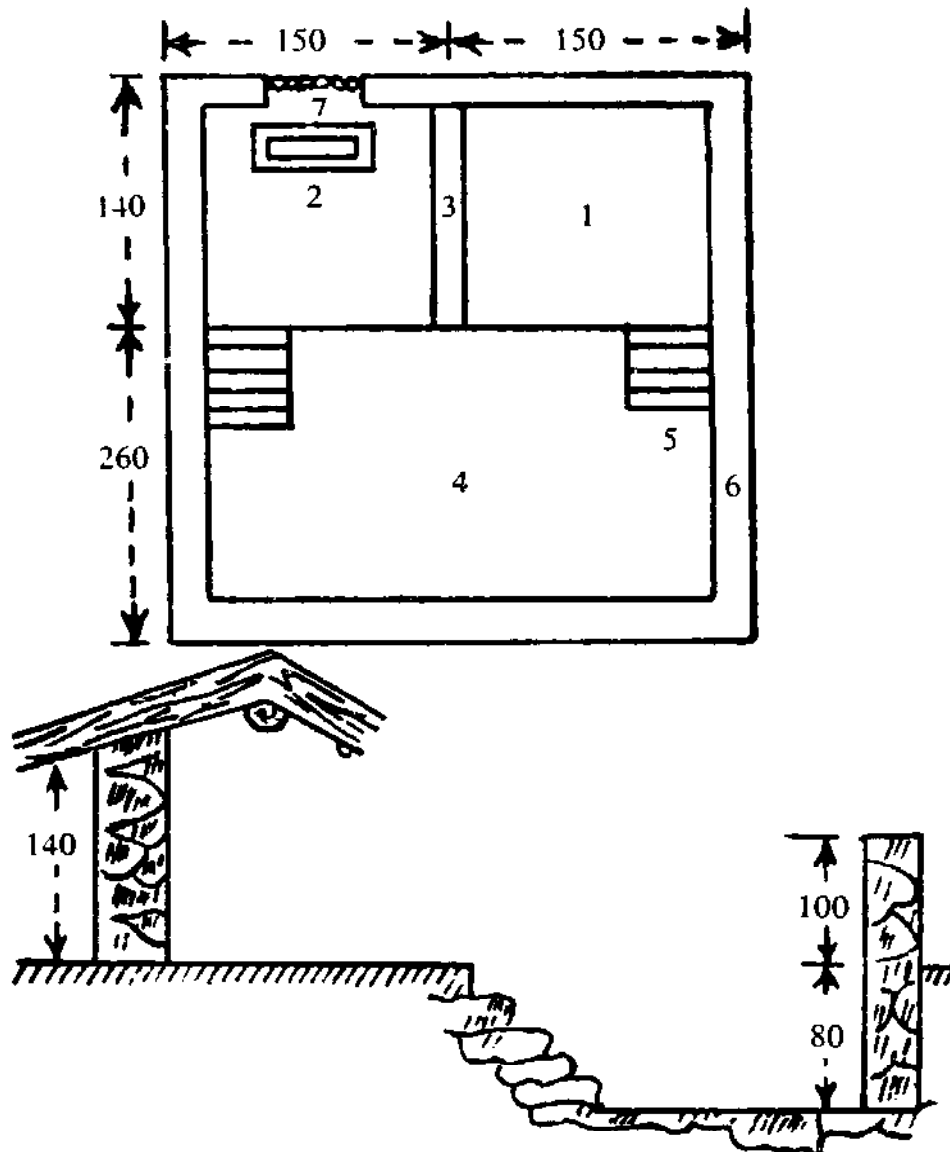

Fig. 9. Deep split-level pigpen: 1, pigsty; 2, feeding trough; 3, partition; 4, excreta pit; 5, steps; 6, wall; 7, pen door.

Fertilizer Pit Pigpen

The size is the same as for the pens just described. The pigsty and the feeding trough are separated by a wall that extends to the edge of the excreta pit. The excreta pit has a length, width, and depth of 2 m, 1.8 m, and 40 cm respectively, and is surrounded by a passage about 60 cm wide. Both ends of the passage are connected with the pigpen and the feeding troughs, which forces the pigs to travel this way to eat, excrete, and urinate, and trample in the excreta. Every few days, the excreta are removed and put into the fertilizer collecting pit for composting (Fig. 11 and 12).

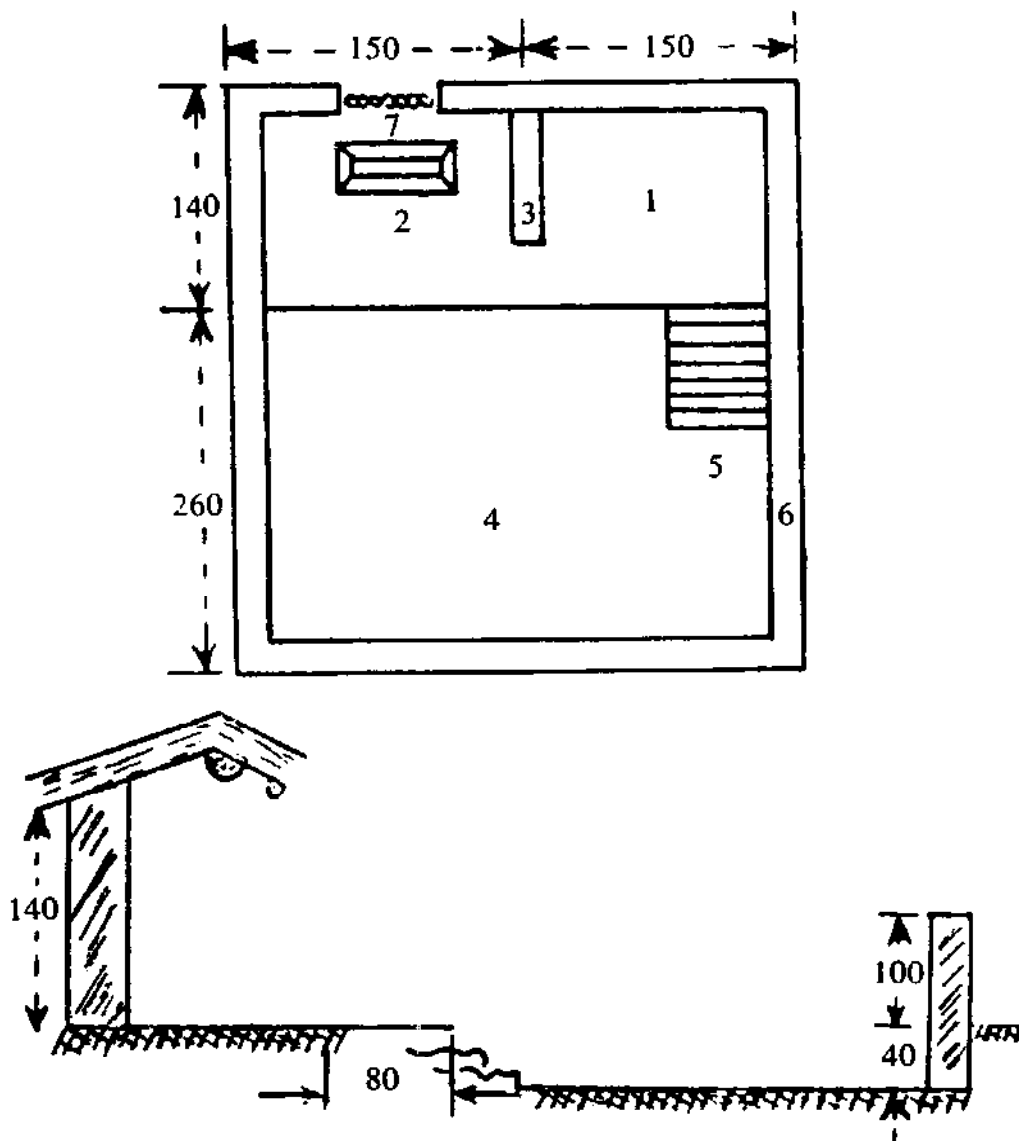

Fig. 10. Shallow split-level pigpen: 1, pigsty; 2, feeding trough; 3, partition; 4, excreta pit; 5, steps; 6, wall; 7, pen door.

Comparison of the Piggens

The flat-bottomed pen is very easy to clean. Although there is no water accumulation or breeding of mosquitoes, the feces have to be removed frequently and a layer of earth needs to be laid on the floor of the pen, which is labour-intensive and a bit troublesome.

The split-level pen is convenient to the public and can hold more fertilizer than other pens. The pit can also act as a wastewater pool. However, mosquitoes breed easily in summer and the pen is difficult to clean.

The fertilizer pit pigpen is convenient to the public and favourable to the fermentation of the feces. However, much work is required to remove the feces and to cover the floor of the pen with layers of earth to keep it clean.

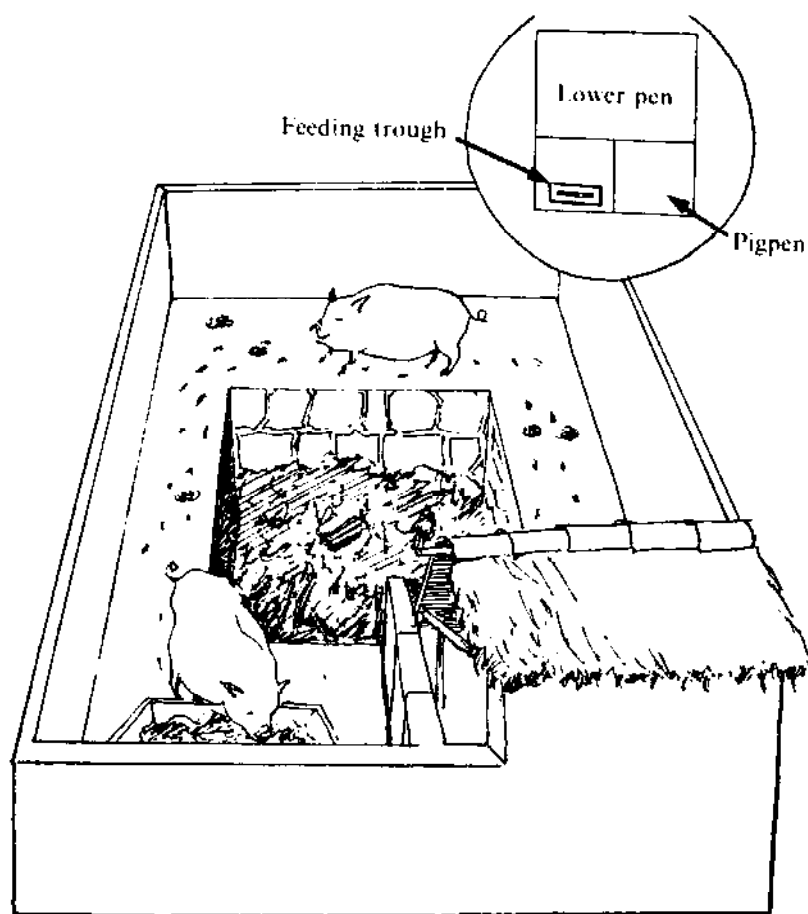

Fig. 11. Fertilizer pit pigpen.

Domestic Animal Pens

The pens must be spacious, well-ventilated, facing the sun, and able to withstand winter wind and cold, and they must be separate from human dwellings and constructed at the edge of the village.

Most of the domestic animal pens are like houses where a layer of earth is put in the pen after the excreta is removed. Therefore, the floor of the pen must be compacted with concrete and the feeding trough must be above ground level. The upper and lower portions of the feeding trough must be 70 cm and 25 cm above the ground level, respectively, and its depth about 30 cm. The trough can be made of local materials and it must be strong and lasting.

Some trees may be planted in front of the rearing field to indicate the nature of the compound, and a simple shed can also be constructed in the summer. An elevated feeding trough will guarantee the hygiene of the animal feed.

In some of the mountain areas group rearing of domestic animals is practical and pig and goat pens are constructed right in the rice fields. The pens are constructed for rearing and the fertilizer is collected and composted on the spot. Moving the animals to the rice fields is appropriate in mountain and plain areas that are too far from the production team. The size of the pen depends on the land distribution. If the land is concentrated on one mountain

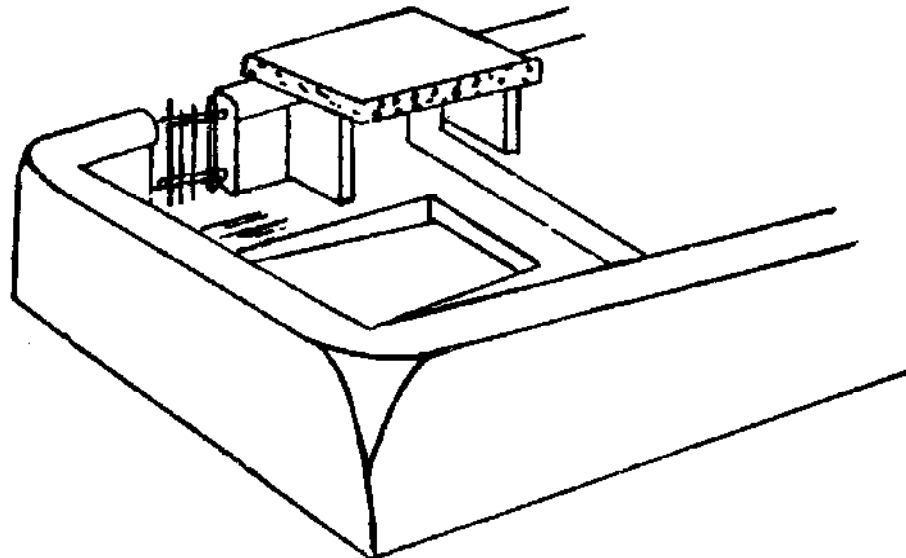
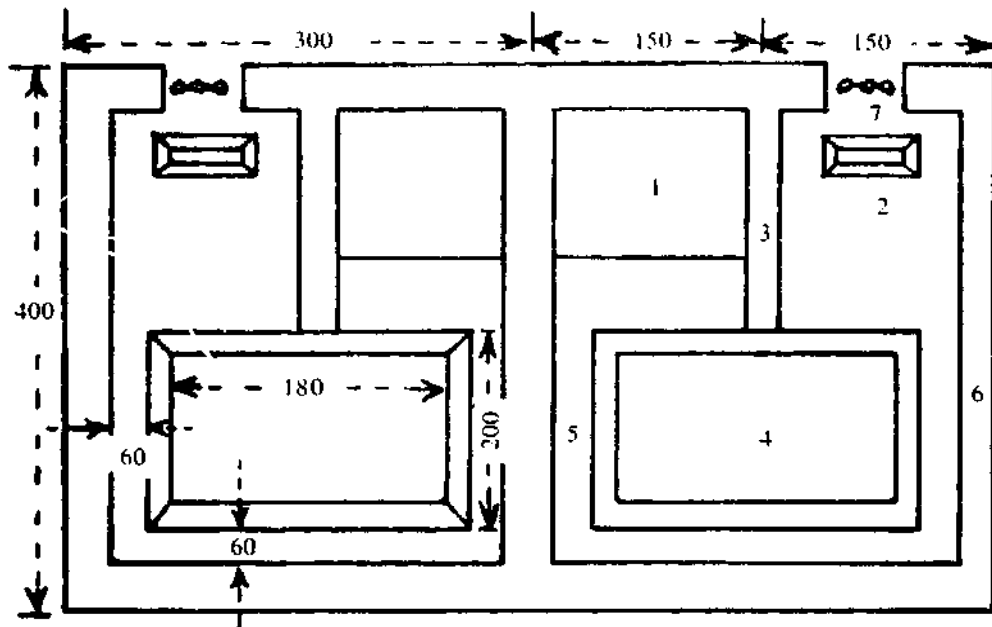

Fig. 12. Fertilizer pit pigpen: 1, pigsty; 2, feeding trough; 3, partition; 4, excreta pit; 5, passage; 6, wall; 7, pen door.

the pen can be built there. If the fields are widely scattered the pen can be built and managed separately depending on the number of production team units, although this must be arranged properly in terms of demand. The advantages of moving the domestic animals to the rice field include saving the time and labour of transporting the earth and delivering the fertilizer; it is convenient to the cultivated land for the application of fertilizer, and also improves the sanitation in the village.

Chicken Coops

The coops must be strong and long lasting, well ventilated, and facing the sun; they must be safe and hygienic and constructed for easy removal of excreta. The most common coop is the three-level type with a lower level for the collection of excreta, a middle level for perching, and an upper level for

laying eggs. The size of the coop depends on the number of chickens being reared. Normally, it is about 1.2 m high, the lower level is slightly smaller than the middle one, which is high enough for a chicken to stand in, and the upper level can accommodate two hens laying eggs. Some horizontal sticks are placed in between the middle and the lower levels for the chickens to perch on (iron bars, wooden sticks, or bamboo sticks can be used). The stick should have a diameter of not less than 2-3 cm and the distance between sticks should not be less than 5-6 cm. The floor of the nest must be above ground level to prevent rainwater from getting in. The door of the coop should be either of timber or bamboo and have an opening on it, or else a plank, brick, or vitrified tile can be used (Fig. 13).

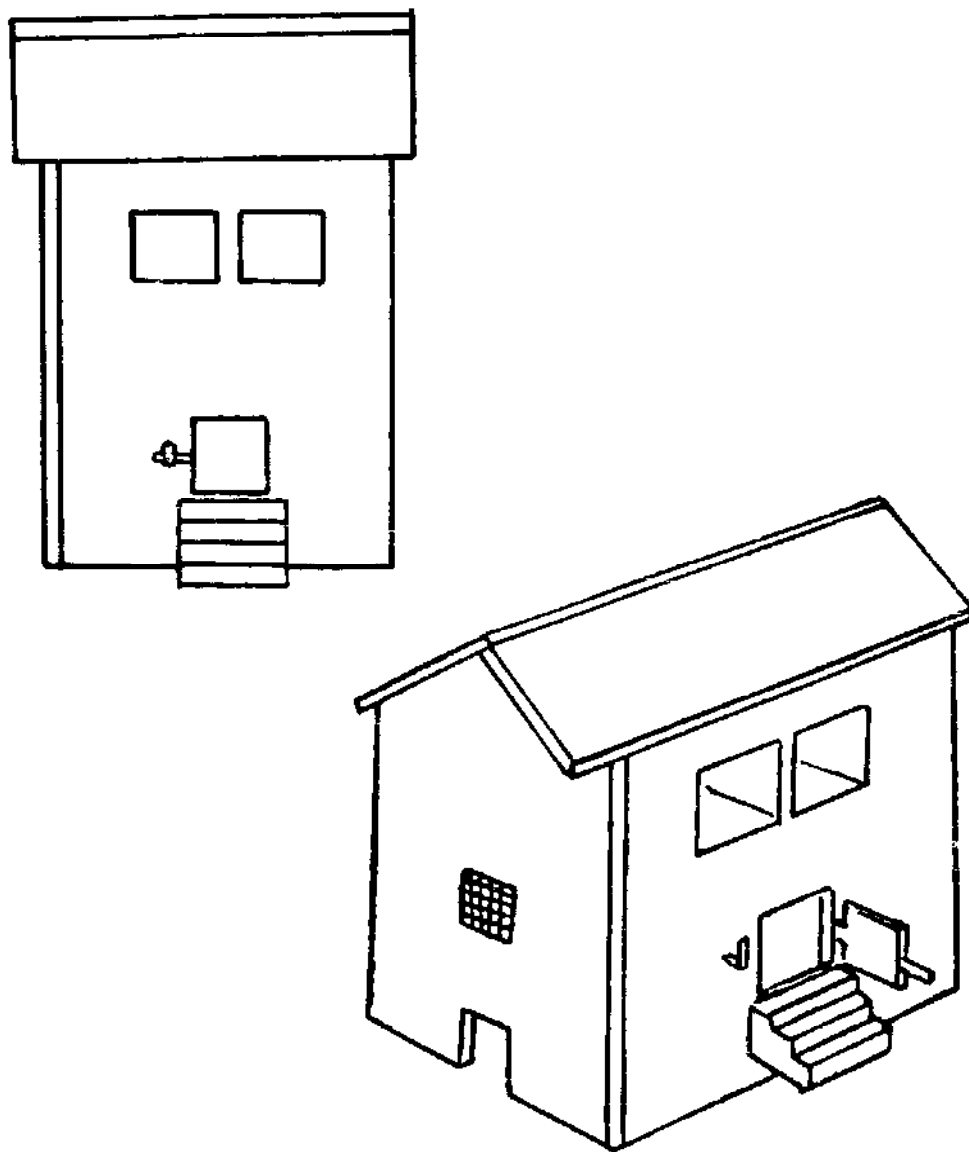

Fig. 13. Three-level chicken nest.

The advantages of the three-level chicken coop are that excreta can be collected easily and it is hygienic and can aid in the prevention of epidemics of chicken diseases.

Excreta Treatment Field

The field must be built outside the village, preferably near the animal-raising farm; it must be located on high ground with a properly compacted and flat floor with a gentle slope to facilitate drainage; it should be used only as an excreta treatment field and not for any other purpose; and it must be situated at least 30 m from any water sources.

Fertilizer Collecting Pit and Urine Storage Pond

The fertilizer collecting pit walls and the pond bed are constructed of rubble or bricks with cement mortar. Some of the pond beds are built with concrete and have proper compaction. The size, according to the experience of the Kao Chia village, for mass collection and composting should be large with a length, width, and depth of 10-15 m, 5-6 m, and 1-1.5 m respectively. The edge of the pit should be 2-3 cm higher than ground level to prevent rainwater from flowing in. The production team might construct two or three pits and use them in rotation (Fig. 14).

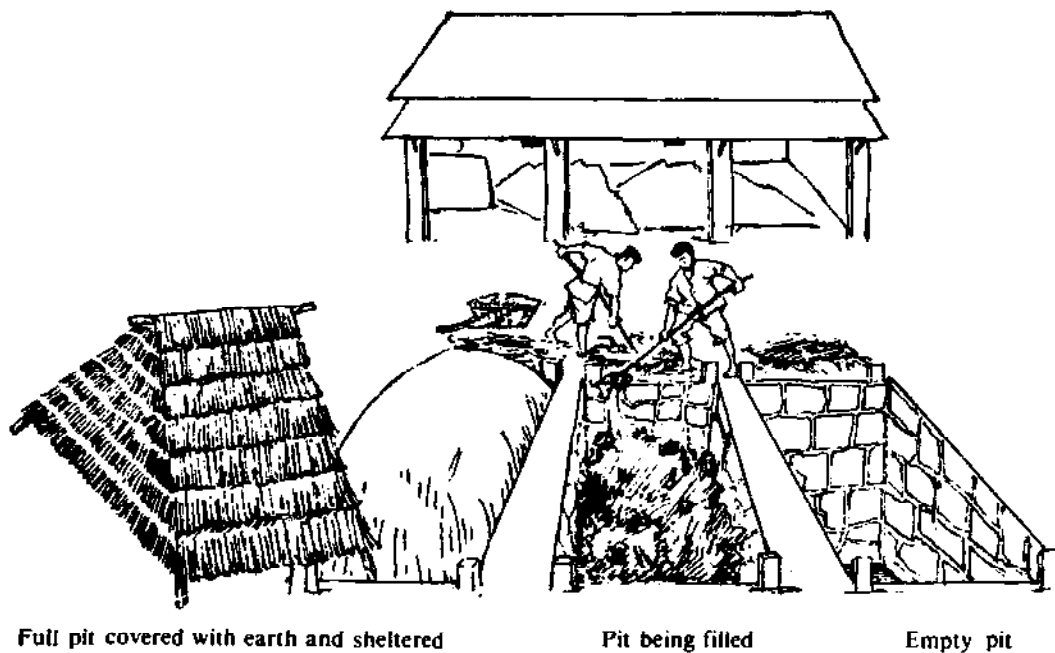

Fig. 14. Fertilizer collecting pits being used in rotation.

Two or three urine storage ponds with the same dimensions as the fertilizer collecting pits can be built by a production team. Square ponds are about 2-3 m² and circular ponds about 1.5 m in diameter. The surface of the pond must be totally covered (Fig. 15).

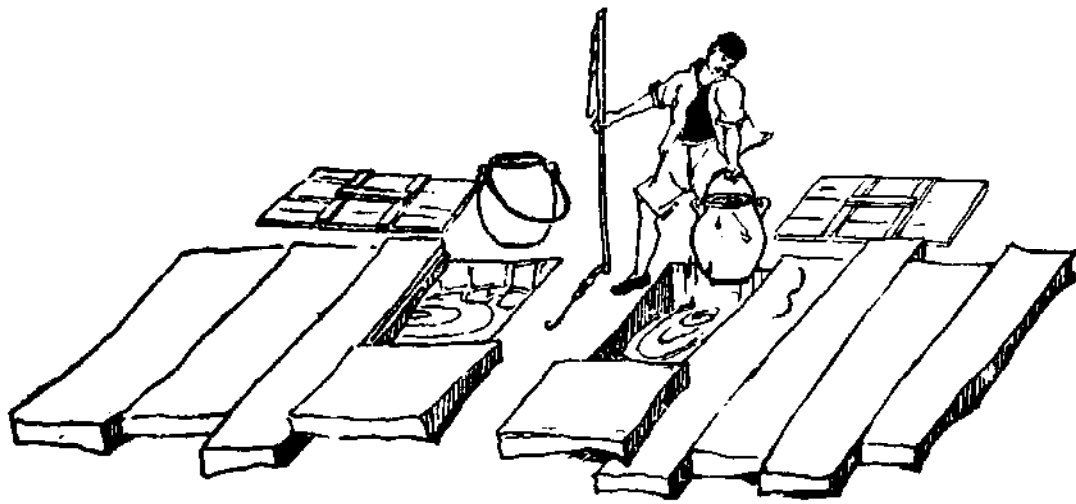

Fig. 15. Urine storage ponds.

Storehouses for Fertilizer, Dry Earth, and Dry Ashes

The fertilizer storehouse is suitable for composting a mixture of excreta and earth. Each production team should construct two or three units with dimensions larger than a house, 5 m long and 4 m high and wide. It should have no front wall and should look like a horse stable. Ventilating holes should be made in the roof and there should be one or two windows on the side walls (Fig. 16).

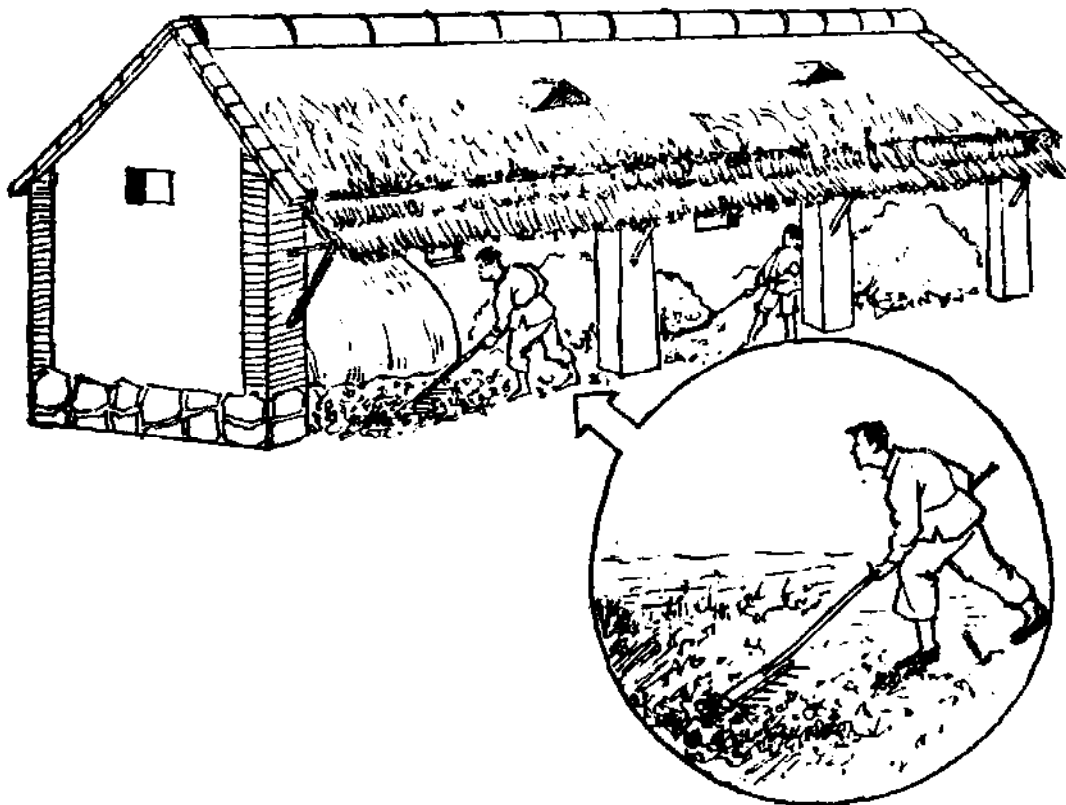

Fig. 16. Fertilizer storehouse.

The dry-earth storehouse is a place where fine dry earth can be stored for composting use. Depending on the method of composting, the dry-earth storehouse can be built either separately or combined with the fertilizer storehouse. Each production team should construct one or two units with the dimensions given above.

The dry-ash storehouse is for the collection of both grass and tree ashes. Each production team should construct one or two dry-ash storehouses with dimensions the same as a house, or in a circular form with a height of 2 m and a diameter of 2.5 m and with an opening at the top where ashes can be dumped in and an opening at the bottom from which they can be removed.

Collecting and composting the fertilizer in the storehouse will protect it from the wind, sun, and rain, thereby conserving the efficiency of the fertilizer without any loss.

Organization and Management of Hygienic Composting

In many areas, a hygienic composting committee has been formed under the unified leadership of the production team and the revolution committee, or the composting and fertilizer collecting is done by the organizing team hygiene subcommittee. A small composting-management committee can be formed in the production team. The number of members on the committee depends on the organization of the production team itself. If a committee does not establish any system then the vice-secretary or vice-commander of the main team will be left responsible for the whole team's collecting, composting, and use of fertilizers and any other jobs involved. Fertilizer collecting and composting must be included in the daily meeting agenda.

Annual Selection of the Professional Composting Team

The selection of a team is necessary annually to provide unified management of composting for the farmers and also to ensure that better fertilizer can be composted and production thereby increased. To do this, a professional composting team must be established so that there are some specialists responsible for the work.

The requirements of the professional team are not only to reform the fertilizer management system and alter the methods of composting, but also to follow the relevant policies and be responsible for the operation of integrated composting. Therefore, the selection of members for the professional team must be taken seriously.

The size of the professional team depends on the size of the production team and the amount of fertilizer available. At present, a professional composting team is selected from every organization team, and a professional committee is chosen from every production team.

Altering Management Methods

To develop the concept of "group production" the old methods of collecting and composting fertilizer must be reformed; the various small-scale methods must be combined to form an integrated system managed centrally.

The collection and composting of a combination of human and domestic animal excreta, pig and goat feces, chicken excreta, dry ashes, and polluted earth and fertilizer should be centrally managed (using the "Six Unity" management system) by the production team. A professional team responsible for collecting and composting fertilizer is also needed. The human excrement and urine, chicken feces, and dry ashes can be collected and stored separately by the committee members and the production team can mix them. As for the committee members' pig raising and fertilizer collecting, "the household feeds the pigs, and the team takes care of the pen," i.e., the committee member feeds the pigs, and the team assigns people to transport the earth, spread a layer of earth in the pen, add water, remove the excreta, and clean the pen.

The rules need to be established and encouraged by rewards. To develop the professional composting personnel's abilities to reform the farmers' fertilizer sanitation, and to ensure that composting is hygienic, rules must be implemented and encouraged by rewards, and a campaign of comparing, learning, helping, and overtaking should be launched. The rules should involve personnel, duties, quality standards, schedules, and sanitation.

The selection and number of composting personnel depends on the size of the production team and the jobs involved. Generally, in the plains two or three members per production team might be enough, whereas in the mountains more may be needed as the committee members are living in a more widespread area.

There are six principal duties for the composting personnel: (1) to clean the committee members' household toilets and chicken coops, and the public toilets and streets; (2) to select a composting team to deliver earth and spread it in the pens and to remove the fertilizer and clean the pen; (3) to do the bookkeeping and to balance and promulgate the accounts related to the collection of human excreta and urine, domestic animal feces, and rubbish (generally, the balancing and promulgation of accounts should be done every 10 days and every month, respectively); (4) to collect all available fertilizer, then compost and transport it; (5) to assist the people responsible for feeding the animals to improve their methods of removal and management of feces in the domestic animal sheds; and (6) to report to the people responsible for hygiene any cases of illness found when visiting homes.

Fertilizer quality standards can only be raised if the composting personnel carry out their duties responsibly. Each kind of fertilizer must be composted in fixed proportions, and above all, no extra earth or water must be added to the fertilizer to increase its quantity as this would lower its quality. Once the human and domestic animal excreta and urine are delivered to the excreta treatment field, they must be composted immediately and protected from dogs, chickens, wind, sun, and rain.

Regular schedules must be set by the composting personnel for cleaning and washing both the toilets and domestic animal pens. Especially in the summer and autumn, toilets must be cleaned and the fertilizer composted and covered daily. In winter and spring they need be cleaned only every 2 or 3 days. A layer of earth should be spread in the pigpens immediately after the excreta is removed, and flat-bottomed pens must be cleaned and have earth spread in them daily.

To prevent epidemics, sanitation standards must be respected when compost is being prepared. Composters must be responsible for the sanitary management of toilets, pigpens, streets, and excreta treatment fields; and they

should eliminate flies and larvae. In addition, each individual should protect his own health while collecting and composting fertilizer, and should wash his hands before meals.

A domestic-animal management system should be established so that the feeding personnel of each production team feed the domestic animals well, in addition to so-called "four industry" and "six cleanlinesses" methods of management. The "four industry" method encourages people to be industrious in sweeping and composting and the "six cleanlinesses" approach promotes clean animal feed, clean troughs, clean bodies, clean sheds, and clean raising fields.

Disposal of Animal Wastes

It is possible to increase the amount of compost available to stimulate agriculture by proper management and disposal of animal wastes. Correct handling of wastes is also fundamental to the eradication of pathogens. The requirements for effective disposal of animal wastes are that it stimulate fermentation of the fertilizer and preserve and increase its efficiency; that it destroy and kill the pathogens of human beings, domestic animals, and also render the compost harmless; and that it be simple to carry out.

Altering Unscientific Composting Methods

The methods of collecting, composting, and spreading fertilizer commonly used in towns and villages include drying it, irrigating crops with fresh excreta, and connecting the household pit privy to the pigpen. These methods improve neither production nor sanitation and must be totally reformed.

Drying has been the most common method of treating human excrement and urine for years, but the method has a number of shortcomings. Analysis shows that more than 50% of the nitrogen content in the excrement and most of the nitrogen in the urine is lost. In addition, when the excreta is being spread and mixed in, it attracts flies and pollutes the air, especially when the weather is windy and rainy, and this in turn has an adverse effect on water sources and soil, which may lead to the spread of disease. For these reasons excreta drying is considered a bad practice and should be abandoned.

Irrigating crops with fresh excreta is done by some production teams who apply raw human excrement and urine mixed with water directly to vegetable and rice fields. The disadvantages of this method are that unfermented nitrogen in the excrement and urine is not easily absorbed by plants. If too much is used, the solution concentration will be too high for the soil, increasing its osmotic pressure and preventing the plants from absorbing water and nutrients, and thus injuring the sprouts. In terms of sanitation, the situation is even worse: spreading the fresh excreta on the ground not only encourages flies to breed but also spreads around enteric pathogens and parasites in the excreta, which can have an adverse effect on public health. Therefore, watering with fresh excreta is more harmful than beneficial and should also be abandoned.

Connecting toilets to pigpens is a method that has been used for centuries. The toilet is connected directly to the pigpen and it is quite common that the human excreta are consumed by the pigs. The disadvantages are not only that a large amount of human excrement and urine is lost, but also that perfect

conditions for the spread of disease are created. Therefore, toilets and pigpens must be separated for the proper collection of human excrement and urine and prevention of disease.

Composting Granular Fertilizer in the Fertilizer Storehouse Scientifically

After the human excreta is transported to the excreta treatment field, a layer of fine, dry earth should be spread on the ground, the excreta poured on top and spread out, and enough dry earth added for a thorough mix (3 parts soil to 1 part excrement is recommended), and then it should be raked and rolled into fine soybean-size particles. These granules must form an aggregate when compacted in someone's hand, but should spread out once they are thrown down. The water content should not exceed 20%. The mixture should then be piled in the fertilizer storehouse to ferment. New material should be added daily to increase the quantity of fertilizer. The height of the pile should not exceed 2 m for ease of handling.

Earth is added to conserve the fertile elements of the fertilizer. Too much should not be added as this only increases the weight making transportation more difficult, wastes the labour required to dig up and transport the earth and deliver the fertilizer, and also retards the fermentation of the compost and lowers its quality. To guarantee that the granular fertilizer can be composted annually, sufficient dry earth must be stored in the spring, prior to the arrival of the winter rainy season. The use of earth should be organized by the production team, and it is wise to practice this method of composting on a flat piece of land.

This method's advantages are that the fertilizer's richness is absorbed and retained by the addition of the fine dry earth; fermentation occurs in the storehouse and is not affected by wind or rain so no fertilizer is lost; and its full efficiency can be conserved.

According to the preliminary experiment carried out in the district of Jih Chao, "the average temperature inside the compost ranged from 36.92 °C to 40.93 °C. An internal temperature of 42 °C and above could be maintained for 5 to 6 days with 92-94% destruction of the ascarid eggs while external temperatures ranged from 19.2 °C to 35 °C for 25-38 days. Average preservation of nitrogen in the fertilizer was 94.43%. Moreover, weather did not affect the composting and it could be carried out even on rainy days, and the method, being simple, required less labour than other methods.

Pit Composting Method

After the human excrement and urine, rubbish, and the polluted soil are transported to the excreta field, they are mixed in a suitable proportion (generally 40% human excrement and urine to 60% rubbish and polluted soil). The human excrement and urine are spread on top of the rubbish, and soil is added; these are all mixed thoroughly to form a soft clay-like material (with a water content around 30%) that is then placed in the composting pit, covered with a layer of earth, and left to ferment.

An evaluation of this method shows that the temperature inside the pit is more uniform, the evaporation of the nitrogen in the fertilizer is lower as water is added and earth is used as a cover during fermentation, and the content of decomposed matter is higher. However, as the ventilation is poor, the water

content high, and the temperature low, fermentation takes longer and the hygienic effect is poor.

Mixed Compost Fermentation

The human and domestic animal excreta and urine, polluted soil, and weeds are thoroughly mixed to become the "three-combined-into-one" or "four-combined-into-one" fertilizer. It is stored using the ground-surface or pit method, covered with a layer of earth, and left to ferment.

Ground-surface composting method — The ground should be properly compacted prior to composting. A mixture of the fertilizers mentioned above is used in a ratio of 40% human and domestic animal excreta and urine to 60% polluted soil, with a water content of about 20-30%. These are placed on the ground to ferment. The stack of compost is generally 2-3 m wide, 1-1.5 m high, and of unlimited length. Depending on the amount of excreta available, the pile can have either a rectangular or circular shape, and is covered with earth immediately after the compost has been piled up.

Pit composting method — A pit 1 m deep, 3-4 m long, and 2-3 m wide is dug and the bottom of the pit is compacted with either clay or concrete, and the well-mixed raw materials are placed inside to ferment. The compost should be piled to 20-30 cm above ground level and then covered with a layer of earth.

As these methods use many types of waste and polluted materials, the quantity of available compost has increased and environmental health has improved. The temperature of the compost normally reaches 40-50 °C during fermentation, which kills many kinds of disease, parasitic eggs, and larvae in the excreta, and is therefore beneficial to the health both of human beings and of domestic animals. At present, this is a better method for using all sources of fertilizers and for the disposal of excreta and urine.

Technicalities of Fertilizer Collecting and Composting

The fermentation process that human and domestic animal excreta and urine undergo in composting relies on the function of microorganisms. They cause changes to occur in all sorts of raw materials, simple and complex, and transform material that cannot be absorbed by growing crops into nutrients that can be. The high and low internal temperatures of the compost are important indicators of the level of fermentation activity and multiplication of the microorganisms. Generally, the temperature should be kept in the 40-50 °C range for about 5 days, as this will be more effective in terms of sanitation, and to achieve this the composting personnel should have a good command of the following techniques.

Compost Mix Proportions and Local Conditions

The purpose of composting is to make good use of the fecal fertilizer. The proportions mixed should be based on the number of fertilizer sources in the area, the types of crops, the demand for fertilizer, and the composting method. In some areas it is not possible to collect all sources of fertilizers in the recommended proportions because the availability of some raw materials, such as weeds, varies from season to season. Full use should be made of the human and domestic animal excreta and urine, rubbish, and polluted soil as they are

available year-round. Agricultural by-products such as weeds and leaves may be used by teams that are short of domestic animals and their waste products. The purpose of adding earth is to conserve the nitrogen in the fertilizer but too much should not be added, and clay or topsoil are better than sand or sandy clay, which retard fermentation; besides, the fertilizer's quality can be damaged by the addition of too much soil, and labour is wasted transporting first the soil and then the heavy fertilizer. Generally, it is adequate to combine 40-50% of excreta and urine with 50-60% of polluted soil and weeds.

Improving the Method

Humidity is a key factor in the fermentation of compost. Microorganisms need a certain amount of water to function; excess water fills spaces in the compost reducing the oxygen level, and a lack of water leaves the organic matter too hard. Too high or low a water level reduces the microorganisms' activity, which in turn slows fermentation. Therefore, the water content must be controlled according to the location, the raw materials available, and circumstances. Before the materials are composted, the proper water content can be indicated by a simple test: when a handful of the mixture is compressed it should cohere, but when dropped it should separate. In winter and early spring, less water can be added as the temperatures are low and water evaporates slowly, but in summer and autumn when the temperatures and evaporation rates are high, more water can be added.

To increase fermentation the ventilated composting method can be used with good results. There are two methods. One involves digging cross-ventilating channels on the ground or on the bottom of the pit and in the side walls, about 10 cm wide and deep. Millet stalks are placed on top of the channels before composting to prevent their getting clogged. A stick about 10 cm in diameter is inserted every 1-1.5 m while the composting materials are being piled up and then withdrawn immediately, leaving holes for ventilation. As the external temperature strongly affects the internal temperature, the ventilating holes must be blocked at night in the early spring and the late summer when temperatures are low to conserve the heat, and opened on warmer days. In summer, when the external temperature is consistently higher and the internal temperature of the compost reaches 50 °C, the holes may be blocked to reduce evaporation and preserve the fertilizer, water, and temperature.

The other method, known as loose composting, involves piling the composting materials loosely to increase the ventilation. In hot weather the compost may be compacted. As the external temperature in winter is low, the anaerobic composting method (compacted composting) without any ventilation is more efficient at conserving the temperature and the fertilizer's quality.

The volume of the compost varies seasonally depending on the amount of fertilizer available. In winter, when the volume is small and the temperature is difficult to raise, the pit-composting method favours the conservation of heat for fermentation. In spring, summer, and autumn, ground-surface composting is commonly used and the preparation, composting, and covering can all be done in 1 day to reduce the loss of the fertilizer's richness and to meet the sanitation standards. The time required for complete decomposition varies with the seasons and the materials available, but generally takes about 20 days in the summer, 25-30 days in the spring and autumn, and 45-60 days in the

winter. The time required is shorter if only human excrement and dry soil are used than if human and domestic animal excreta, weeds, and dry soil are mixed together.

The Effect of Geographical Location

Different composting methods are used in different areas. In low-lying river basins, where high water table areas exist, the compost is wet and its temperature difficult to raise, and the decomposition and maturation of fertilizer can be slow and wasteful. In these areas, the composting site should be on high ground, and the ground-surface rather than the pit method should be used. As there is limited land available in mountainous areas, the pit composting method is recommended as it uses less land. In the plains where land is plentiful, the ground-surface and pit methods of composting may be combined. Whatever method is adopted, small-scale composting is recommended so that (except in winter) the preparation, clearing, composting, and covering can be done daily.

The Importance of Covering the Compost

If the compost is not properly covered, nitrogen and water will be lost as the compost temperature rises. If the compost is too loose and dry inside, its temperature will drop quickly, retarding or even halting the biochemical activity of fermentation and flies will breed easily. Therefore the earth covering is very important. Earth can be mixed with horse excreta, wheat bran, or rice straw and should be applied over the compost in a 3-4 cm layer to prevent cracking, to conserve the fertilizer, water, and temperature, and to keep flies from breeding.

The Two-Partition-Three-Tank Hygienic Toilet*

In view of the remarkable results achieved by the district of Chiong in curing illness and killing spirobacteria, the public has been encouraged to practice excreta management. The two-partition-three-tank hygienic toilets have been developed in which the excreta and urine are collected and treated till they are harmless. The method very successfully destroyed larvae and eggs and protected the water sources from contamination by the excreta, and thereby destroyed the media of schistosomiasis and other enteric pathogens. Our tests showed that both the *E. coli* value and the index of parasite eggs dropped within the permissible level and the efficiency of the fertilizer increased remarkably. Schistosomiasis and other enteric infections were prevented, health standards of all the committee members were raised, hygiene was improved, and the health of the village was altered.

Building the Tanks

All the enteric pathogens (paratyphoid and shigella) and the parasite eggs (schistosome, hookworm, and ascarid) are destroyed in a two-partition-three-tank toilet because of the long time that the feces spend in storage and fermenting, the function of the ammonia, and the settling of the larvae and eggs. The advantages of this type of toilet are that the larvae, eggs, and the pathogenic microorganisms in the excreta and urine are destroyed; flies are prevented from multiplying, and both flies and larvae are eliminated; the release of harmful gases resulting from the decomposition of organic matters is prevented, and excreta and urine are kept from polluting the environment; and the amount of fertilizer collected and its efficiency are increased.

The structure of the two-partition-three-tank toilet includes squat or bucket toilets and three excreta tanks: the first for fresh excreta and urine, the second for fermentation, and the third for storing treated excreta. The sectional views of the toilet are shown in Fig. 17 and 18.

To prevent their contamination, no water sources or reservoirs should be within 10-15 m of the toilets. The toilets should be located on high ground away from any low-lying area with heavy infiltration and the site should be convenient to the public.

Excreta Tank Volumes

The volumes of both the first and second tanks are the same, and not less than the amount of excreta produced in 10 days. The third tank's volume is not

* This report was prepared by the prevention of epidemics stations of the districts of Chinkiang and Chiong, Province of Kiangsu.

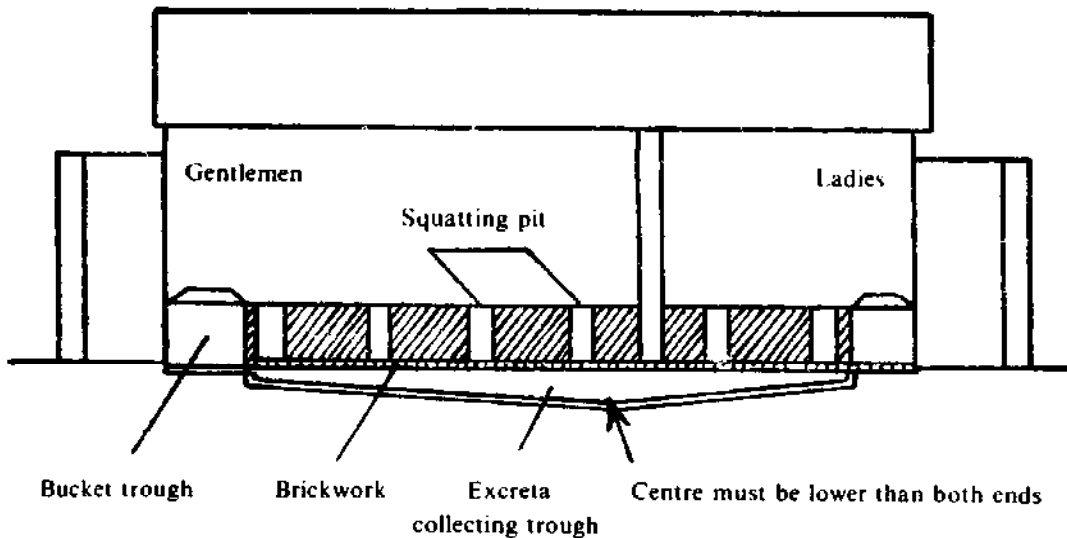

Fig. 17. Side view of toilet.

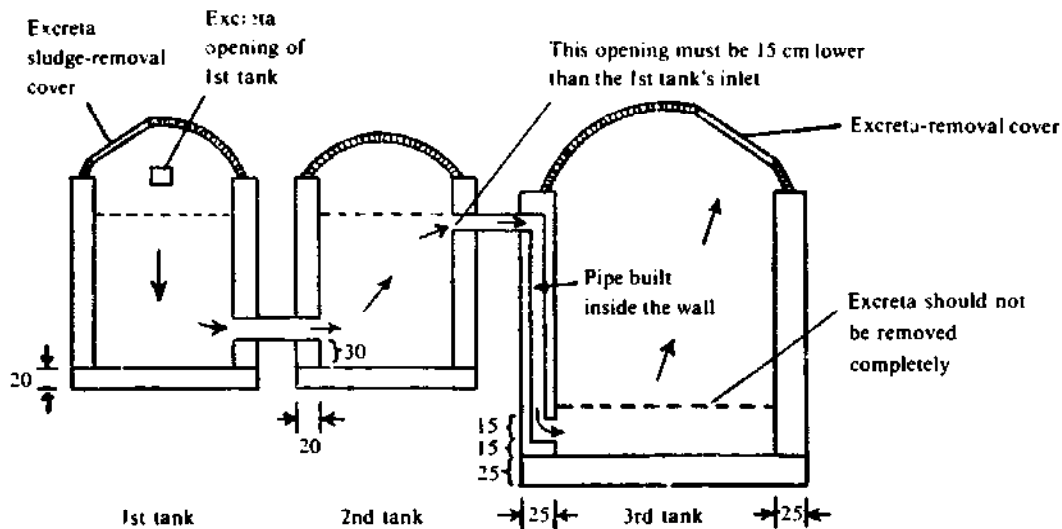

Fig. 18. Sectional view of tanks.

less than the amount of excreta produced in 30 days, to facilitate the excreta storage. Calculation of the volume of the excreta tanks is based on an average excreta production of 2 litres per person per day (including the excrement, urine, and the water used to wash the bucket), multiplied by the number of persons using the facility and the number of days, and divided by 1000, i.e.,

$$\frac{2 \text{ litres} \times \text{no. of persons}}{1000} \times \text{no. of days} = \text{volume of the excreta tank (m}^3\text{)}.$$

For example, if a production team had to construct a hygienic toilet to be used by 100 persons, the volume of each of the first and second tanks would be found using the following equation:

$$\frac{2 \text{ litres} \times 100 \text{ persons} \times 10 \text{ days}}{1000} = 2 \text{ m}^3,$$

and this volume can hold 2400 kg of excreta. The third tank is three times larger than the first tank, or 6 m³, and can hold 7200 kg of excreta.

In areas where the production teams are making bricks, the three excreta tanks can be built of brick, and the covers of the tanks can be built of broken bricks or concrete.

Construction Methods

For a community of 100 people, the structure will require about 300 kg of caustic lime, two bags of cement, and broken bricks or tiles to build the covers of the three excreta tanks. Local materials should be used to build the superstructure.

With reference to the number of people using the facility and to the data provided in Table 4, two circular pits should be excavated with the same diameters. During the excavation, the upper 1 m of topsoil should be carted away and the clay retained (which has been cleaned of brick, grass, roots, sand, and gravel) and piled next to the pit for later use. The newly bought lime should be left to weather but should not be boiled in water. If there is an immediate need, the caustic lime can be spread out and sprinkled with some water to expedite its weathering but it should not be totally weathered. A fine sieve can be used to separate the weathered lime from the lumpy caustic lime. Later, this will prevent cracks from forming in the walls of the excreta tanks in which the lime was used. The treated lime and clay fragments should be mixed in a ratio of 1:4 (i.e., 1 kg of lime to 4 kg of clay), and a small amount of water should be sprinkled in during the mixing so that the lime and clay can form an aggregate. The mixture can then be poured into the circular framework made of "25"-type bricks or slabs of soil (the distance between the bricks and the tank's wall in the first and second tanks should be about 20 cm, and 25 cm in the third tank). When it is poured to a height of half a brick, a stick can be used to compact it. Then the bricks or soil slabs can be used to build the next layer of the circular framework, and then the lime-clay mixture can be poured in and compacted again. The same procedure is repeated until the walls reach their full height. When the foundation of the first tank reaches the third layer of bricks (i.e., is 50 cm thick), a horizontal passage can be made between the first and second tanks. This passage can be built using the "25"-type bricks to a height and width of 10 cm, or a 16-cm diameter concrete pipe can be used instead. When the first tank is 30 cm above ground level, a 10-cm² opening should be made as an excreta inlet leading to the excreta collecting trough. This

Table 4. Diameters and depths of the two-partition-three-tank hygienic toilets.

	Tank depth	No. of persons													
		50		60		70		80		90		100		150	
		Ø ^a	D ^a	Ø	D	Ø	D	Ø	D	Ø	D	Ø	D	Ø	D
1st and	Excavated	1.3 ^a	1.7	1.4	1.7	1.5	1.7	1.6	1.7	1.7	1.7	1.8	1.7	2.0	1.7
2nd tanks	Completed	0.9	1.5	1.0	1.5	1.1	1.5	1.2	1.5	1.3	1.5	1.4	1.5	1.6	1.5
3rd tank	Excavated	1.86	2.2	2.0	2.2	2.1	2.2	2.25	2.2	2.35	2.2	2.46	2.2	2.9	2.2
	Completed	1.36	2.0	1.50	2.0	1.6	2.0	1.75	2.0	1.85	2.0	1.96	2.0	2.4	2.0

^aØ, diameter of tank; D, depth of tank; unit, m.

Note: The calculations are based on the amount of excreta produced in 10 days for the first and second tanks, and in 30 days for the third tank.

passage should have a 30° slope to prevent the excreta from remaining in the passage. When the second tank is 15 cm below the opening of the first tank's excreta inlet, a 10-cm² passageway should be made that connects with the vertical drop pipe of the third tank. This vertical pipe should be constructed inside the wall of the third tank, starting from the second layer of bricks, and should open out 30 cm above the bottom of the tank.

The bricks or slabs of soil in the circular framework of the tanks can be removed once the tanks have been built. All the loose clay in the walls of the tanks can be cleared away with a shovel, and then "green ash" (lime mixed with rice straw ash) can be used to render them. A 20-cm layer of 1:4 lime-clay should be spread on the bottom of the tanks and compacted, or, if the infiltration rate is high, a mixture of gravel, fine sand, and cement slurry should be used instead). Once the base of the tank has been completed, the top of the tank should be covered immediately with bricks or tiles to keep sunlight off the tank wall, which could crack.

For the removal of the fecal sludge an opening with a top width of 25 cm, bottom width of 45 cm, and a height of 45 cm should be made in the first tank and an airtight cover should be provided for it. The second tank cover should have no opening, but there should be one in the third tank, 30 cm wide at the top, 50 cm wide at the bottom, and 55 cm high.

The excreta collecting trough should be built outside the house with a slope of not less than 30° to keep chickens and dogs from eating the excreta and to facilitate cleaning.

Valves made of movable boards should be installed where excreta is discharged and in the channel between the excreta collecting trough and the first tank to prevent the foul gases in the first tank from backing into the toilet.

The three tanks should be arranged in a triangle (they can also be in a line). The first tank (excreta intake tank) should be 30 cm from the excreta collecting trough, and the distance between the tanks should be about 30 cm.

The excreta slip trough must have a slope of 45° (i.e., a 1:1 slope) to allow the excreta to slip into the tank without collecting in the trough and creating an unsanitary situation. The three excreta tanks should be built before the excreta collecting trough, superstructure, or squatting pits are built. The passage from where the excreta is dumped into the collecting trough must be well sloped and include a right-angle bend so that the collecting area is kept dark to keep flies out.

After the toilet is completed, and before it is used, the first tank should be filled with water up to the opening leading to the second tank. This will keep papers, weeds, and other debris from clogging the passage as these materials normally float on the surface of the first tank.

The fecal liquid in the second and third tanks must always be deep enough to cover the pipe opening between them to prevent air getting into the second tank from the third and affecting the fermentation there. This detail should be made known to the people who remove the excreta.

Efficiency of the Two-Partition-Three-Tank Hygienic Toilet

The two-partition-three-tank hygienic toilets constructed in the district of Chiong represent a very important step in the improvement of the environment

and health of the village, where schistosomiasis and other epidemics have been eliminated and the health of the committee members and labour force has been protected. Strict management of the excreta and urine and a harmless transformation of wastes has been effected. The harmless transformation process of the two-partition-three-tank hygienic toilet occurs mainly in the first and second tanks, in which the excreta ferment for about 20 days. To see if the excreta and urine have been rendered harmless, we investigated the efficiency of the two-partition-three-tank hygienic toilets. The items studied were the *E. coli* index, the ascarid egg count and mortality, total nitrogen, active nitrogen, pH value, specific gravity, fertilizer temperature, and other factors. An evaluation of sanitation was made based on the results of the examination.

Sampling and Methods of Examination

Hygienic toilets were sampled in the two areas: Lin Chiao and Shih Chiao of the Ta Cho public society. Fresh samples of excreta and urine were taken from each toilet in the squatting area and in the first, second, and third tanks. Samples were also taken from the upper, middle, lower, and bottom layers of the hygienic toilets of Shih Chiao, to observe the settling conditions and mortality of the ascarid eggs. The *E. coli* value was determined using the three-step fermentation method, the ascarid egg count by the flotation method, ascarid egg mortality by morphologic observations, and total nitrogen and active nitrogen by the colorimetric method.

In the first tank of the two-partition-three-tank hygienic toilet, excreta and urine are collected. It has an aerobic decomposition function and the excreta and urine inside the tank undergo primary fermentation. The second tank is the important part of the hygienic toilet; it is a fully enclosed fermentation tank in which the excreta and urine change from a solid to a liquid state. The third tank is the excreta storage tank and has both storage and fermentation functions. The fermentation conditions of each tank are given in Table 5.

Table 5. Fermentation conditions of the hygienic toilet tanks.

	1st tank	2nd tank	3rd tank
Upper layer	Lumpy, foamy, grass-green excreta, smelly and with a thickness of about 0.5 m	Yellowish fecal liquid, smelly, and dense	Light green, slightly smelly, clean water-like liquid
Middle and lower layers	Dark, pasty, and turbid liquid, smelly	Dark green, water-like liquid, smelly	
Bottom layer			Black, dense, pasty fecal sludge

In addition to fermentation conditions, the fertilizer temperature, pH value, and specific gravity in each tank were also recorded and are presented in Table 6. Table 6 also shows that the tanks' temperatures in both Liu Chiao and Shih Chiao were higher than the same day's external temperature of 1.8 °C and 4.5 °C, respectively.

The second and third tanks' temperatures were higher than that of the first tank. Therefore, it is evident that the amount of fermentation increased from tank to tank. The pH value range was 7.6-8.2 with few exceptions, and it was slightly alkaline. The specific gravity decreased from tank to tank; the

contents of the first tank were semisolid and of the second were liquid with a specific gravity of 1.010. This is evidence that harmless transformation by fermentation was increasing, the amount of organic matter diminishing, and the excreta becoming more dilute.

Table 6. Temperature, pH, and specific gravity of fertilizer in the hygienic toilet tanks.^a

	Location of toilets	1st tank	2nd tank	3rd tank
Temp (°C)	Liu Chiao	3.8	4.5	6.0
	Shih Chiao	5.2	7.0	6.0
pH value	Liu Chiao	8.2	7.7	8.0
	Shih Chiao	7.6	7.7	8.0
Specific gravity	Liu Chiao	Semisolid	1.012	1.010
	Shih Chiao	Semisolid	1.012	1.010

^aSamples in Liu Chiao were taken on the morning of 29 February, and in Shih Chiao on the afternoon of 29 February.

E. coli Counts

According to Table 7, the *E. coli* values of the fresh excreta and urine in the squatting areas of the hygienic toilets of Liu Chiao and Shih Chiao were 10^{-7} and 10^{-8} , respectively. In the second tank the values increased to 10^{-5} , and in the third tank to 10^{-3} , which met the sanitation requirement. This clearly shows that from tank to tank the excreta-urine mixture was being rendered increasingly harmless.

Table 7. *E. coli* counts in the hygienic toilet tanks.

	Health reqmt	Squatting area (fresh excreta & urine)	1st tank	2nd tank	3rd tank
Liu Chiao	10^{-2}	10^{-7}	10^{-6}	10^{-5}	10^{-3}
Shih Chiao	10^{-3}	10^{-8}	10^{-7}	10^{-5}	10^{-3}

Ascarid Egg Mortality

A comparison was made between the mortality of the ascarid eggs in the hygienic toilets of the two areas, Liu Chiao and Shih Chiao; the rate of ascarid egg death was observed; and in the hygienic toilets of Shih Chiao the number of ascarid eggs in each layer was counted and their settling characteristics observed. The results appear in Tables 8 and 9.

Table 8. Ascarid egg mortality (%) in the hygienic toilet tanks.

	Health reqmt	Squatting area	1st tank	2nd tank	3rd tank
Liu Chiao	> 95	11	74	88	100
Shih Chiao		19	82	88	100

Table 9. Ascarid egg count (in no./g) in the hygienic toilet tanks in Shih Chiao.

Layer	1st tank	2nd tank	3rd tank
Upper	2337	3100	0
Middle/lower	668	9	0
Bottom	NA	NA	2263

Table 8 shows that the mortality of the ascarid eggs in the fresh excreta and urine of the squatting areas of both Liu Chiao and Shih Chiao were 11% and 19%, respectively, whereas the mortality in the first tank increased to 74% and 82%, respectively, in the second to 88%, and in the third to 100%. (The sanitation requirement is above 95%.) This shows clearly that the hygienic toilet very effectively renders the mixture harmless.

To investigate the ascarid egg distribution and transfer within each tank further, examinations were made of the separate layers in each tank in Shih Chiao. In the upper layer of the first tank were the solid excreta containing many ascarid eggs — 2337 per gram of excreta (Table 5). The middle and lower layers were pasty and semisolid but there were only 668 ascarid eggs per gram. The upper layer of the second tank contained pasty and lumpy semisolid excreta comprising as many as 3100 ascarid eggs per gram. However, a remarkable reduction in the number occurred in the middle and lower layers of the second tank where only 9 eggs per gram were found.

What caused this dramatic reduction? It can be explained by the difference in specific gravity between layers as the middle and lower layers of the second tank contain a watery liquid with a specific gravity (1.012) lower than the specific gravity of ascarid eggs (1.14). Therefore, most of the ascarid eggs settled to the bottom. In the third tank where the upper, middle, and lower layers contained a clean watery liquid having an even lower specific gravity (1.010) the eggs were even more scarce. To verify our explanation, we examined the fecal sludge on the bottom of the third tank and it contained as many as 2263 eggs per gram and 98% of them were dead. These results indicate that the settling effects in both the second and third tanks are high.

Fertilizer Efficiency

Measurements of both the total nitrogen and active nitrogen (nitrogen that can be directly absorbed by plants) were made in the hygienic toilets of both Shih Chiao and Lu Ben before and after harmless transformation.

Table 10 shows that following harmless transformation the active nitrogen content of the hygienic toilets in both Shih Chiao and Lu Ben were 0.23% and 0.35%, respectively, both higher than the 0.02% minimum requirement reported in Shanghai. In Shih Chiao, the active nitrogen levels before and after harmless transformation were 0.08% and 0.23%, respectively, showing a 2.8 times increase. And in Lu Ben, the active nitrogen measurements before and after the harmless transformation were 0.08% and 0.35%, respectively, an increase of 4.3 times.

It is evident from Table 10 that the efficiency of the fertilizer in the hygienic toilet has been increased considerably. The total nitrogen measurements before and after the harmless transformation in Shih Chiao were 0.39% and 0.25%, respectively, and in Lu Ben, 0.51% and 0.40%. The total nitrogen loss ranged from 21.57% to 35.90%, which was less than the total nitrogen loss of the conventional nonhygienic toilets. According to a report, the nitrogen loss was 40.1% in an open-air toilet that had a retention time of 85 days.

Conclusions

The results show that the temperature of the fertilizer, specific gravity, *E. coli* values, and ascarid egg mortality all increased as fermentation

Table 10. Total nitrogen and active nitrogen in the hygienic toilet.

		Total nitrogen		Active nitrogen	
		Content (%)	Total N loss (%) after treatment	Content (%)	Active N loss (%) after treatment
Shih	Before treatment	0.39	-	0.08	-
Chiao	After treatment	0.25	35.90	0.23	2.8
Lu	Before treatment	0.51	-	0.08	-
Ben	After treatment	0.40	21.57	0.35	4.3

increased. The foul smell of the excreta disappeared, the excreta gradually turned black, the fecal liquid became clear, the specific gravity dropped, organic matter was reduced, the *E. coli* value was 10^{-3} , and the ascarid egg mortality was 100% in the third tank, and all of these factors met the sanitation requirements (*E. coli* values should be between 10^{-2} and 10^{-3} and ascarid egg mortality should be 95% or higher).

A remarkable increase occurred in the efficiency of the fertilizer with the active nitrogen increasing to 0.2% and above, and a comparison of the active nitrogen before and after the harmless transformation showed an increase of 2.8-4.3 times. The total nitrogen loss was from 21.57 to 35.90%, which was less than the loss in ordinary nonhygienic toilets.

As the excreta in the first tank was in massive form, worms and eggs were difficult to separate from the lumpy excreta without agitation, and therefore the natural settling rate of the worms and eggs was not high. In the middle and lower layers of the second tank, the excreta changed from a solid to a liquid state through fermentation, and the worms and eggs that had been in the lumpy excreta were left in the fecal liquid where they settled to the bottom layer of the tank. In the third tank, as the fecal liquid was more dilute, the settling function was even better.

It is likely that the ascarid eggs died earlier than the *E. coli* as there were no ascarid eggs in the third tank, but the *E. coli* count there was 10^{-3} . To improve the harmless transformation of bacteria the second tank should be enlarged to increase the retention time for fermentation.

Ascarid Egg Viability Testing

Here, one factor in the harmless transformation of village excreta and urine will be evaluated: the viability of the ascarid eggs. We hope that this will provide some useful data on the management of excreta in the village, reconstruction of toilets, and on the efficiency of the harmless transformation of excreta.

There are a variety of enteric pathogens, viruses, and parasite eggs in the excreta and urine that can infect human beings through various media (such as water, food, or hands), and are therefore serious threats to public health. Hence it is necessary to have the village excreta properly managed and to carry out the harmless transformation to control and reduce infectious diseases. To know when the excreta and urine have been rendered entirely harmless, they should be evaluated bacteriologically, and tests on the survival levels of the ascarid eggs and on the efficiency of the fertilizer should be carried out.

The ascarid egg mortality level is a direct indicator of factors of infection (unlike *E. coli*, which only shows a possibility of disease transmission) as the ascarid eggs are more resistant and their death would mean that other larvae and eggs would also die. Ascarid egg mortality should be above 95%, an epidemiologically safe level. Experiments have shown that under normal circumstances the ascarid eggs die in 10 min at a temperature above 55 °C, they survive for 4 yr at 0 °C, they neither grow nor die at 27 °C for 40 days, and they die at -30 °C in 24 h. Based on the available data in other areas, the time and the temperature required for some of the larvae and eggs to die off are shown in Table 11.

Table 11. Time and temperature required for eggs to die.

Eggs	Temp (°C)	Time required to die
Schistosome	53.5	1 min
Hookworm	55.0	1 min
Ascarid	55.0	10 min
Ascarid	60.0	5 s
Flagellate	56.0	10 s

Table 11 shows that it takes higher temperatures and longer periods for the ascarid eggs to die off than it takes for other larvae and eggs. Ascarid eggs die in 10 min at 55 °C or in 5 s at 60 °C, which was both hotter and longer than required for the schistosome eggs, which died in 1 min at 53.5 °C. In terms of the settling velocity, the schistosome eggs settled completely within 2 h whereas only 98% of the ascarid eggs had settled in the same time, and after 24 h only 99.92% had settled. Therefore, the mortality of the ascarid eggs is a very significant indicator in the prevention of schistosomiasis. Formerly, the staining method was used to detect the survival or death of the ascarid eggs. Generally, dead eggs would stain and living eggs wouldn't, but in our observations we discovered that some dead eggs did not stain, which greatly affected the accuracy of the tests. A comparison with statistical analysis was made for both the staining method and the culturing method, and the results are shown in Table 12.

Table 12. Comparison of the staining and culturing methods.

Exam. no.	Staining method			Culturing method			Chi-square value of the staining method and the culturing method	
	No. of eggs examined		Mortality (%)	No. of eggs examined		Mortality (%)	χ^2 value	P value ^a
	Alive	Dead		Alive	Dead			
1	77	23	23	40	60	60	28.20	0.01
2	76	24	24	50	50	50	16.70	0.01
3	80	20	20	56	44	44	9.94	0.01
4	61	39	39	51	49	49	2.03	0.05

^aDegree of freedom $n = 1$.

The accuracy using the staining method to count the living and dead eggs would be too low for practical purposes. Although the culturing method gives more reliable results, the incubation is time-consuming and therefore

unsuitable for testing purposes. Considering this, we researched the methods of examination of the viability of the ascarid eggs.

We deemed that the important characteristics of the ascarid eggs were their outer appearance; that is we could determine the viability of the ascarid eggs through the characteristics of their external morphological appearances. Experimental research was then carried out based on this idea; we overcame the difficulties in operating under a microscope, and took pictures with the microcamera. Finally, we systematized and analyzed the results, and arrived at a scientific basis for the detection of the viability of the ascarid eggs. The resultant method is not only fast and simple to do, but it is also very accurate and therefore suitable for use even in the village. Repeated experiments showed that it is only necessary to observe 100 eggs carefully for 30 min. The most important morphological characteristics of the ascarid eggs that we found in our experiments are described below.

Unicellular Period

The fertile egg is oval-shaped. Its size varies from 45 to 75 microns X from 35 to 55 microns, averaging 60 X 45 microns; its outer layer is shell-like and has a rippled membrane outside the shell. Originally it has a grey-white colour but is affected by bile, which turns it yellow-green or yellow-brown. The membrane comes off through external physical effects during treatment, but this does not affect the egg's ability to live. After losing the membrane, the egg can still grow (Fig. 19). The shell of the ascarid egg is formed of two or three oval-shaped rings. If the outer layer cracks, the egg dies (Fig. 20). Within the egg there is a circular egg cell enclosed by a yoke membrane in the centre of the shell. There are crescent-shaped transparent spaces at each end that appear to shrink or grow as the egg cell sometimes moves. Sometimes the space appears as a very thin line, but the egg is still alive (Fig. 19).

The egg is dead if both sides of the egg cell are closely connected to the eggshell and there is no visible space, and one side is dilapidated and forms a crack (Fig. 21). Also, if there is a vacuole in the crescent-shaped space, irrespective of its number or size, the egg is dead (Fig. 22). Normally, both crescent-shaped spaces can be seen clearly, the only difference being their size. If only one crescent-shaped space is visible and the other disappears, the egg is dead (Fig. 23). If both crescent-shaped spaces are filled with a lot of granular cells, it is called granulated cell, and the egg is dead (Fig. 24).

If, on the other hand, the ascarid egg is observed in a standing position under a microscope it appears circular in shape and the crescent-shaped spaces are invisible, but the egg is still alive. It is also important to distinguish the granulated cell from the living egg in the gastrula stage. In the gastrula stage, half of the granules of the egg are very dense and the other half loose, and there is a space inside the shell, whereas the granules of a granulated cell are distributed evenly and there is no space inside the shell.

When the eggshell is intact and both crescent-shaped spaces are visible, circular vacuoles appear inside the egg cell. These vacuoles stand out clearly having a strong diaphaneity. Our tests have shown that the vacuoles always appear on the edge of the egg cell first, in indefinite numbers (Fig. 25), and thereafter, they gradually develop toward the centre and finally the whole egg cell including the crescent-shaped spaces is full of vacuoles (Fig. 26). Whenever vacuoles appear inside an egg shell, irrespective of their number or size, the egg is dead.

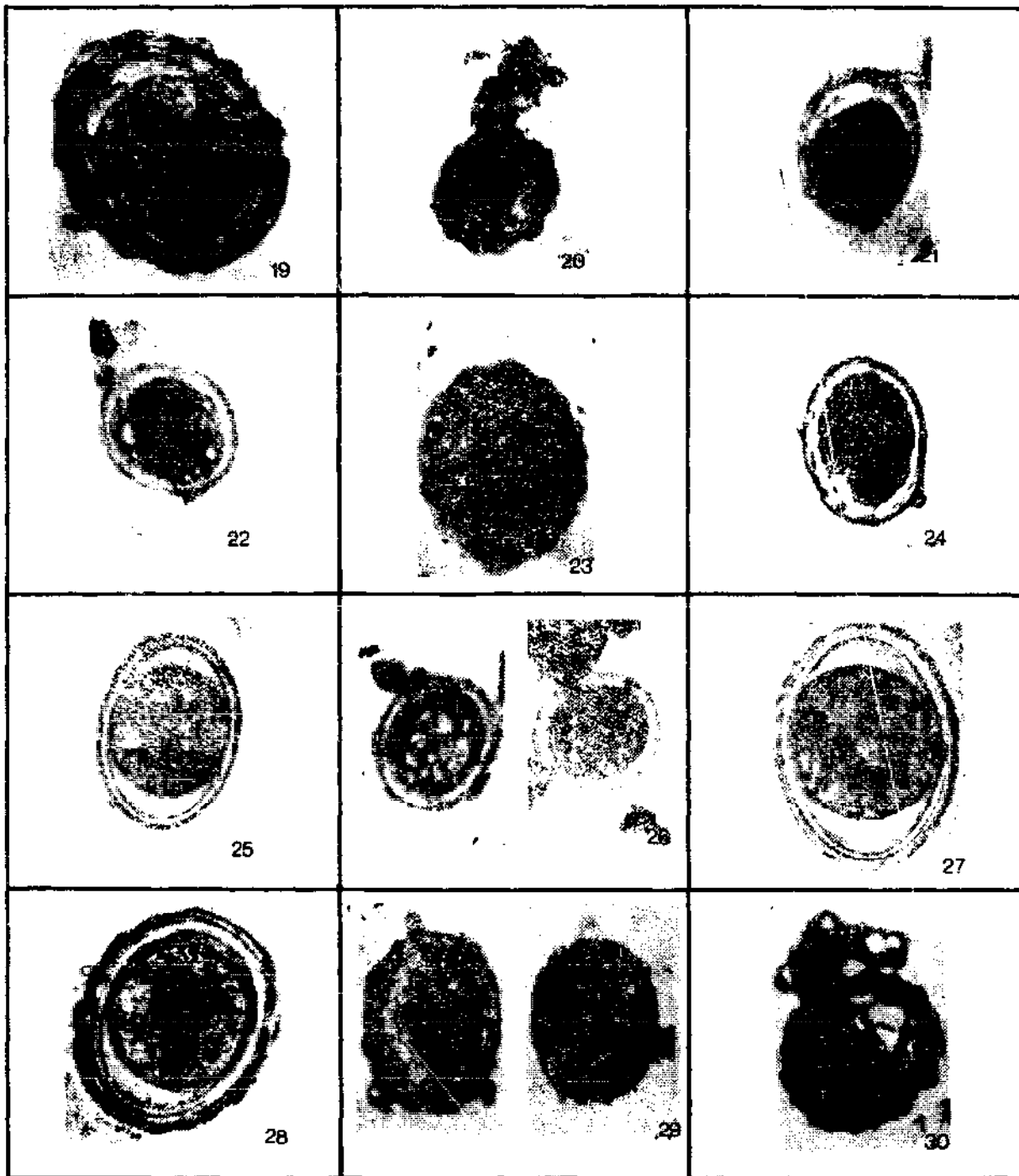

Fig. 19. Living egg with membrane. **Fig. 20.** Cracked eggshell with contents forced out. **Fig. 21.** Left side of egg cell separated from eggshell. **Fig. 22.** Vacuole in the crescent-shaped space. **Fig. 23.** Only one crescent-shaped space visible. **Fig. 24.** Granulated cell. **Fig. 25.** Several vacuoles at the edge of the egg cell. **Fig. 26.** Egg cell filled with vacuoles. **Fig. 27.** Uneven distribution of granules inside egg cell. **Fig. 28.** More granules in the centre of the egg cell than at its edge. **Fig. 29.** Cell granules and cell fluid mixed together giving turbid and coagulated appearance. **Fig. 30.** Dissolution of the egg cell's contents.

Under normal circumstances, the egg cell is full of granules but the size and distribution of the granules may not be uniform (Fig. 27). Sometimes there will be more granules in the centre of the egg cell than at its edge (Fig. 28) and in the area where there are fewer granules a nonuniform transparent area will appear. The uneven distribution of the granules and the differences in the egg's diaphaneity do not affect its ability to live; it can still survive. If the spotted granules inside an egg cell are not clear, are mixed with the cell fluid, look turbid and coagulated, and fill up the whole eggshell, the egg is dead (Fig. 29). The egg is dead when its contents dissolve and the egg looks empty and translucent (Fig. 30).

Contraction commonly occurs in the egg cell of a dead egg in varying degrees; in some it is slight but in others it is very obvious (Fig. 31 and 32). The contraction of an egg cell normally occurs simultaneously with its deformation (Fig. 33). Some egg cells lose their original shape completely and become all kinds of odd shapes including elongated (Fig. 34) and lumpy (Fig. 35). The contraction of an egg cell also commonly occurs simultaneously with the cell's transmutation and changing of position (Fig. 36). If the egg cell remains inside the eggshell after it has ruptured (Fig. 37) the egg is dead.

According to the ascarid egg characteristics given above, dead eggs are indicated by vacuole transmutation, granulated cells, disappearance of one crescent-shaped area, congelation and vitreous transmutation, contraction of the egg cell, transmutation and shifting of position, rupture of the egg cell, and broken eggshell.

We cultured eggs with characteristics of dead eggs together with living eggs. We found that those showing one or two of the characteristics mentioned above would not grow through culturing, whereas the living eggs grew and became larvae after 2-3 wk. The morphological characteristics of the larvae and eggs in each stage are presented below to help in the detection of dead and living eggs.

Twin-Cellular Stage

Normally the larva and egg are as described above during the unicellular stage prior to growth (Fig. 38). In the twin-cellular stage (first cleavage stage), the egg becomes two to three egg cells connected in series. The size of each cell varies little and they overlap one another. At this stage, the granules inside the cells are bigger and looser than at the unicellular stage, and there is a fixed space between the egg cell and the eggshell (Fig. 39).

Multicellular Stage

When the egg has more than four cells, the distribution of the granules is the same as in the twin-cellular stage, and there is a clear division between the egg cell and the eggshell (Fig. 40). However, if different sizes of cells appear at the multicellular stage, the egg is dead.

"Mulberry" Stage

Here, the egg cell has segmented into numerous small cells similar to a mulberry. There is a clear division between the egg cell and the eggshell. Each small cell is about the same size and they overlap one another creating a cubic effect (Fig. 41).

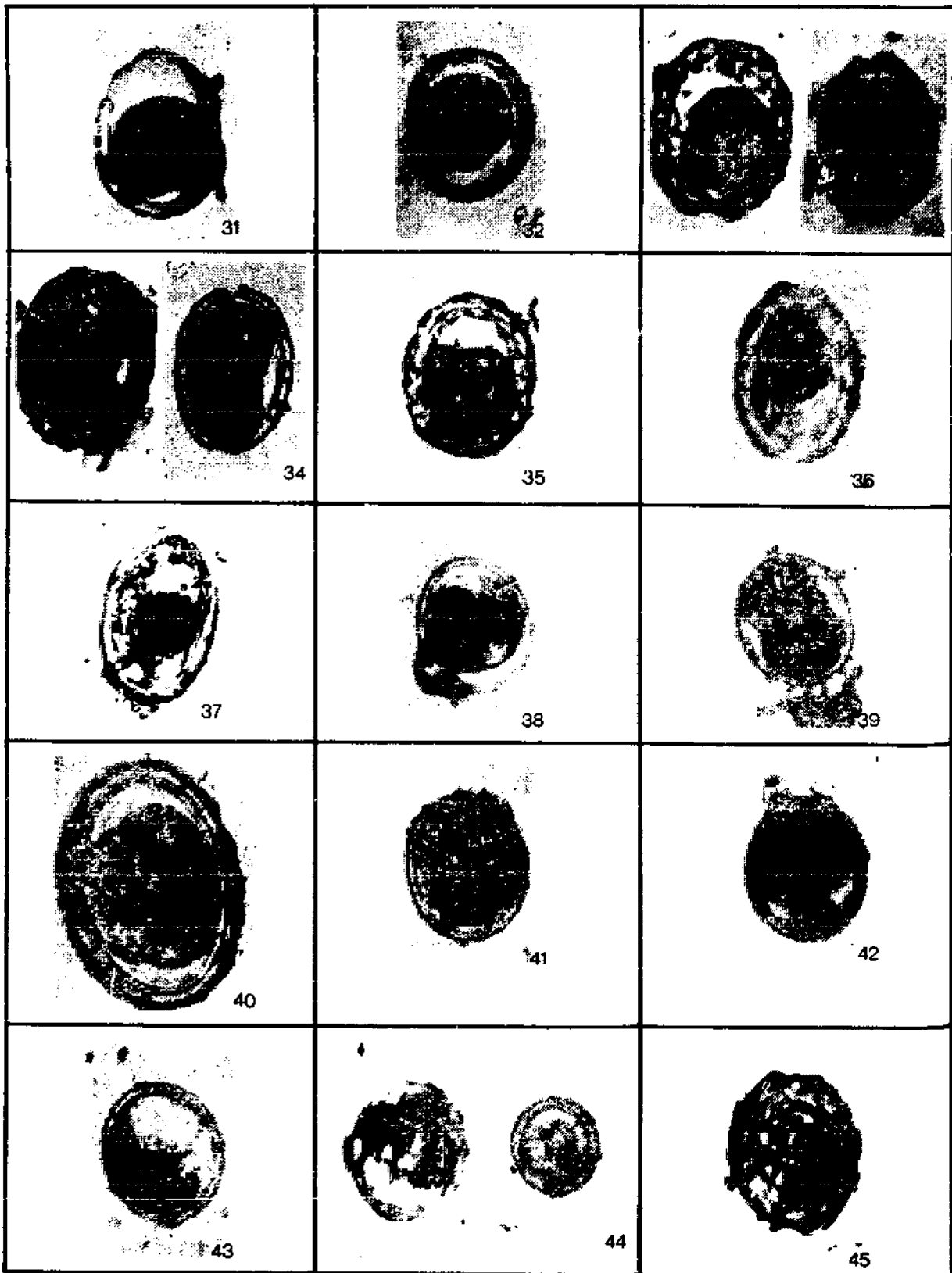

Fig. 31. Contraction of the egg cell. Fig. 32. Shrinkage of the egg cell. Fig. 33. Transmutation of egg cell. Fig. 34. Elongated egg cell. Fig. 35. Lumpy egg cell. Fig. 36. Contraction, transmutation, and shifting of position of egg cell. Fig. 37. Egg cell remnant. Fig. 38. Normal unicellular living egg. Fig. 39. Twin-cellular stage. Fig. 40. Multicellular stage. Fig. 41. Mulberry stage. Fig. 42. Gastrula stage. Fig. 43. Blastula stage. Fig. 44. Larval stage. Fig. 45. Dead egg after high temperature treatment.

Gastrula Stage

Here, the egg cell mixes together to form an aggregate; half of the granules inside the aggregate are more densely compacted than the other half (Fig. 42). Under microscopic observation the cell resembles the granulated cell during the unicellular stage and is frequently mistaken for a dead egg. However, with familiarization they are easily differentiated.

Blastula Stage

The egg cell grows into a kidney-shaped blastula. It has a clear depression in the middle of its side and it is easy to differentiate under a microscope. The granules are similar to those in the gastrula stage, half of them larger and half looser (Fig. 43).

Larval Stage

The egg cell becomes a larva with different shapes such as "S," "8," "6," and "2" that rotate inside the eggshell. The granules inside the larva are unevenly distributed, and the portions with and without granules can be seen under a microscope. The cells are yellowish and generally sticky (Fig. 44). At this stage it is not always easy to differentiate the head from the tail, but after 2-3 days the skin of the larva will slough off and then the larva appears smaller. The sloughed off skin normally stays to one side of the eggshell, and if the larva is filled with granules throughout its body, the egg is dead. The skin that is sloughed off by the larva is not easy to see clearly under a microscope. It is easily mistaken for the dead egg cell that has been exposed to high temperatures (Fig. 45). However, it can be seen clearly by increasing the magnification of the object lens. Normally the larva will not leave the eggshell by itself. It can be discharged by pressing a needle lightly against the eggshell. Once discharged, both its head and tail can be seen clearly. There are no granules in its head or in the lower portion of its tail; they only appear at its centre. Living larvae can be seen moving around inside the eggshell.

To further prove the reliability of the morphological observation method in the detection of dead and living eggs and larvae, we have analyzed both this and the culturing method statistically, and the results are presented in Table 13.

Table 13. Comparison of morphological observation and culturing methods.

Exam. no.	Morphological observation			Culturing method			Chi-square value of the morphological observation and the culturing methods	
	No. of eggs examined		Mortality (%)	No. of eggs examined		Mortality (%)	χ^2 value	P value ^a
	Alive	Dead		Alive	Dead			
1	51	44	46.32	40	60	60.00	3.51	0.05
2	67	45	40.18	50	50	50.00	2.06	0.05
3	49	51	51.00	56	44	44.00	0.98	0.05
4	21	17	44.74	46	54	54.00	0.94	0.05
5	52	44	45.83	51	49	49.00	0.19	0.05
6	54	46	46.00	54	46	46.00	0.00	0.05
7	57	43	43.00	50	50	50.00	0.98	0.05

^aDegree of freedom $n = 1$.

According to seven sets of tests on the chi-squared value, all the P values are less than 5%. Therefore, the method of morphological observation for determining the viability of ascarid eggs can be used.

Construction of the Fixed Top Fully Enclosed Biogas Plant*

Characteristics of Biogas

Biogas is a combustible gas that all organic matter (such as human excreta, animal feces, and crop stalks) produce when they ferment and are decomposed by anaerobic bacteria under conditions of uniform humidity, constant temperature, and full enclosure in a tank. The chemical properties of biogas are that it is very stable, does not dissolve in water, and is lighter than air. Biogas is a mixture of gases comprising 60-70% methane, 30-40% a combination of carbon dioxide and a small amount of hydrogen sulfide, and others. Pure methane is a colourless, tasteless, and odourless gas, but as the biogas consists of a small amount of hydrogen sulfide, it smells very slightly of eggs. When the methane and air mixture burns, a blue flame is emitted, and it produces a large amount of heat energy. It is known that 1 cubic meter (1 m³) of biogas will generate 5200-5900 kcal of heat energy (1 kcal is defined as the heat required to raise the temperature of 1 kg of water by 1 C°). This is sufficient to bring 130 kg of water from 20 °C to a boil, or light a biogas lamp with a brightness equivalent to 60-100 W for 5-6 h.

Advantages of Using Biogas

Improvements in the living standards of committee members and a solution to the problem of fuel shortage have been two results of using biogas. It is a very good quality fuel; a fermentation tank with a capacity of 1 m³ is normally sufficient to supply fuel for cooking and lighting for a family of five. With the increased biogas production in the warmth of summer and autumn, biogas can also be used for cooking part of the animal feed. Its advantage is not only in reducing the fuel costs and improving living standards, but also in relieving a portion of the labour force from having to collect brushwood and transport coal, and freeing them for other productive chores; some of the housekeeping chores women do can also be avoided.

Environmental Improvements

Parasite eggs in excreta can be reduced to less than 2%. In field tests schistosome flukes were eliminated, and hookworms were reduced by 99% in the treated excreta. Schistosome eggs survived in the biogas plant for 14, 22, and 37 days in summer, autumn, and winter, respectively. Ninety percent of the hookworm eggs died within a month and more than 99% died off in 70 days in the winter. These results have provided the basis for an effective tank desludging schedule.

* This report was prepared by the revolution committee of the district of Mien Chu, Province of Szechuan.

The biogas plant is very effective at destroying some pathogens. The *E. coli* index in the intake chamber of the plant was 1218 billion, and it dropped to 0.78 billion at the outlet chamber, showing a remarkable decrease. The *E. coli* that were in the middle and upper layers of the fecal liquid had more or less lost their ability to ferment lactose after fermentation had taken place in the plant. According to our observations, dysentery-causing bacilli died out within 30 h of being placed in an anaerobic biogas-producing environment, whereas the control group died out in 17 days and survived in clean water for 93 days. Spirochetes died within 30 h of being introduced into the biogas, and the control group survived for 17 days. There was no evidence of the growth of fly larvae in more than a full year of observation except at the entry to the intake chamber of the biogas plant.

The biogas plant is able to kill bacteria and destroy parasite eggs because the tank is fully enclosed and thus unfavourable to their growth; the removal of excreta from the middle layer of the tank facilitates the settling of the worms and eggs in the excreta; the retention time for the excreta in the plant is at least half a year; and the ammonia concentration caused by the fermentation of the excreta is high.

Biogas is formed by fermentation when green grass and other wastes are fed into the plant, and a good quality fertilizer is produced simultaneously. The ammonia nitrogen concentrations of human excreta, poultry feces, urine, crop stalks, green grass, and the other wastes used are increased by about 10% by fermentation. The crop stalks (e.g., rape pod and corn) originally used as fuel can be used instead as animal feed, which will stimulate pig farming.

In addition, biogas can be used to forecast caterpillars, as a fuel for the production of bacterial fertilizer, and to drive various kinds of steam engines.

Requirements for Biogas Production

Having the raw materials required for the production of biogas is not enough. Microorganisms are similar to other organisms in that they can only grow under certain conditions. These conditions therefore must be created to produce biogas properly.

Enclosure

Biogas is an organic matter formed by decomposition by anaerobic bacteria. To ensure that the anaerobic bacteria decompose organic matters properly, the fermentation tank must be fully enclosed, waterproof, and leakproof. If the fermentation tank is not fully gastight it will neither function normally nor be able to retain the biogas stored there.

Water

The production of biogas is inefficient if the fermentation materials are too dilute or too concentrated. With too little water, the activities of the microorganisms will be affected and the quantity of biogas produced will be reduced; on the other hand, if the water content is too high, the fermentation tank cannot be fully utilized. If the raw materials for fermentation are excreta and urine from human beings and poultry, and manure (organic fertilizer), the water should be added in a ratio of 1:1, in other words, to 100 kg of feces and urine 100 kg of water must be added; if the raw material for fermentation

is crop stalks, it is better to add more water as the water content of stalks is difficult to estimate.

Temperature

Whether the fermentation and decomposition processes in a fermentation tank can proceed properly or not depends mainly on the tank's temperature. After operating for more than a year, it was found that normal production can be achieved by keeping the temperature at 20 °C. During the summer and autumn the tank's temperature averages about 23 °C and plenty of biogas is produced; in winter when temperatures range from 0 to 7 °C, the tank's temperature stays at about 10 °C, and biogas is still produced.

pH Level

To ensure normal growth of microorganisms, the environment provided must be kept either at a neutral pH or be slightly alkaline. The degree of acidity or alkalinity is indicated by a pH value that must be kept between 7 and 8 (a litmus paper can be used to determine the pH). Organic matter will continue to produce organic acids during the fermentation process. If the fermentation liquid becomes too acidic, alkaline material (such as lime or ashes) can be added to neutralize it.

Nutrients

Fermentation materials can be divided into two groups: nitrogen-poor materials (e.g., green grass and crop stalks) and nitrogen-rich materials (e.g., human feces and urine, and small animals' corpses). The nitrogen-poor materials contain a lot of cellulose, which promotes biogas production, whereas the nitrogen-rich materials provide nutrients for microorganisms, which promote the growth and multiplication of anaerobic bacteria. Experiments have shown that biogas production can be increased if the various raw materials can be fed into the tank in suitably mixed proportions.

Enclosed Three-Stage Biogas Plant

The general arrangement of the enclosed biogas plant is shown in Fig. 46. It consists of six main sections: the intake chamber, the fermentation tank, the gas storage tank, the outlet chamber, the liquid pressure tank, and the gas pipe. Their functions and interrelationships are briefly described below.

Intake Chamber

This is the area through which the fermentation materials are fed into the fermentation tank. It should be a suitable size and is normally built as an inclined "bell-mouth," so that the fermentation materials can be easily fed in.

Fermentation and Gas Storage Tank

The biogas is produced and stored in this area. The tank is either rectangular or circular and is connected to both the intake and outlet chambers of the tank. The organic materials ferment in the tank and the biogas is produced and rises to the top of the fermentation tank where it is stored.

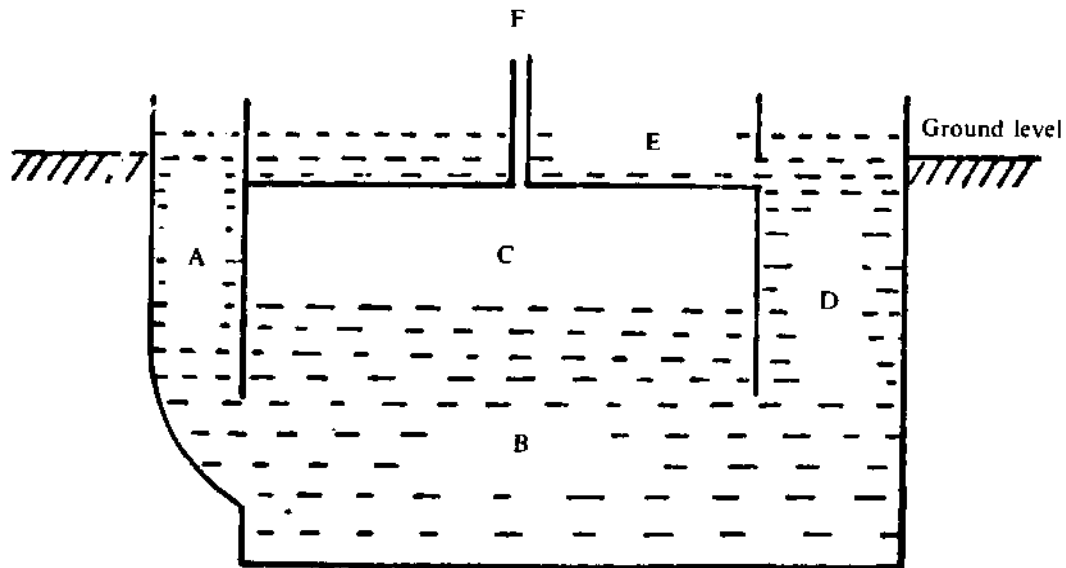

Fig. 46. General arrangement of the enclosed biogas plant: A, intake chamber; B, fermentation tank; C, gas storage tank; D, outlet chamber; E, liquid pressure tank; F, gas pipe.

Outlet Chamber

This is the section from which the fertilizer will be taken out after fermentation.

Middle-Layer Removal of Treated Excreta

There is a door between the fermentation tank and the outlet chamber half as wide as the fermentation tank and half as high as the tank: a removable drop-board is fixed to the door (Fig. 47) or an applied excreta tank can be constructed adjacent to the outlet chamber (Fig. 48). The bottom of the applied excreta tank is slightly higher than the top of the door to the outlet chamber and there is a small excreta overflow hole at the bottom of the partition between the applied excreta tank and the outlet chamber. The middle and upper layers of the fecal liquids in the outlet chamber will flow into the applied excreta tank via the excreta overflow hole, and will thus be separated from the parasite-egg-containing excreta in lower layers. The separated liquid will also be protected from the parasite eggs that rise when the bottom sludge is stirred up.

In terms of killing bacteria and eggs, the excreta storage tank with the applied excreta storage area is considered to be superior. Experimental results indicate that the number of parasite eggs in the inlet chamber is 24 066 per 100 ml of fecal liquid, whereas in the applied excreta tank the number was 416 per 100 ml, indicating a reduction there in parasitic eggs of 98.23%.

Liquid-Pressure Tank

An opening at the bottom of the liquid-pressure tank connects it to the outlet chamber. As can be seen in Fig. 46, when the pressure inside the gas storage tank is greater than the atmospheric pressure, the fecal liquid in the fermentation tank will be forced into the outlet chamber and then into the liquid pressure tank; when the pressure inside the gas storage tank is less than

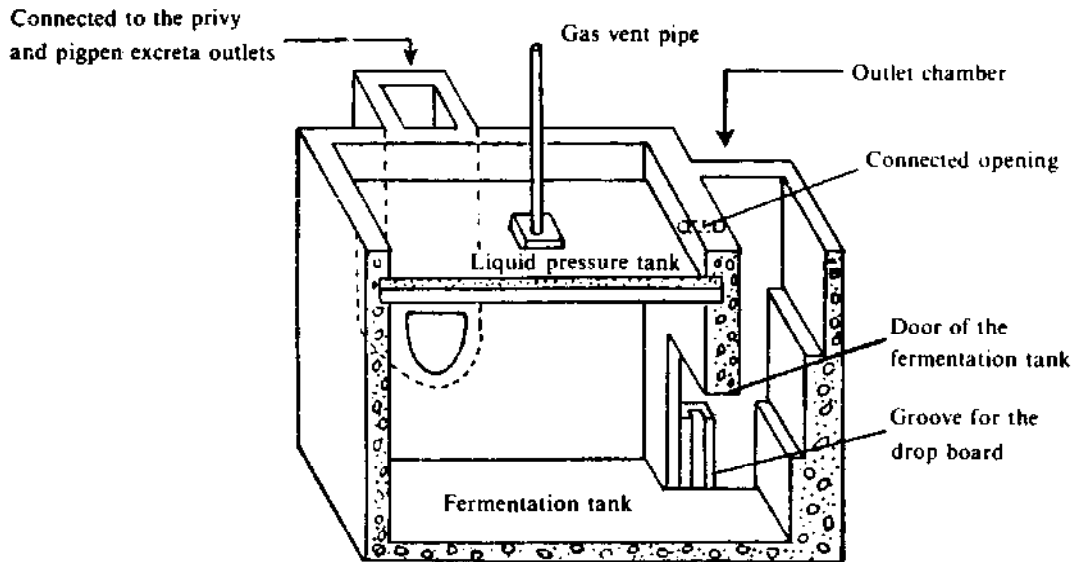

Fig. 47. Enclosed three-stage biogas plant with drop board.

atmospheric pressure, the fecal liquid will flow back into the fermentation tank; and when the pressure inside the gas storage tank is equivalent to the atmospheric pressure, the fluid levels of the fermentation tank and intake and outlet chambers will be the same. Thus the pressure of the biogas inside the gas storage tank will be kept constant by the automatic adjustment of the liquid pressure. The biogas inside the gas storage tank is supplied for use via the gas pipe located on top of the cover.

Construction of the Biogas Plant

Construction Guidelines

First, each layer of concrete must be laid firmly, and the various joints must be cross-linked. Sticks and reinforcing bamboo strips can be used to form the core of the partition wall between the fermentation tank and the outlet

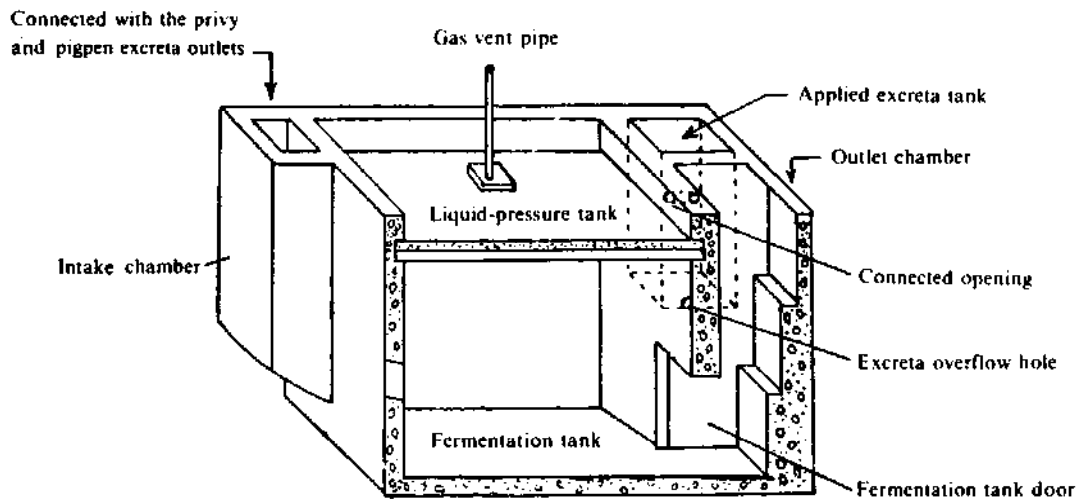

Fig. 48. Enclosed three-stage biogas plant with applied excreta tank.

chamber, with both ends of the stick or bamboo strip stuck in the earth to withstand high pressures. It has been found that the pressure inside the fermentation and the gas storage tanks is about 140-280 kg/cm².

Second, all components of the concrete must be mixed in proper proportions and thoroughly, lime must be sifted, sand must be washed, and whenever cement is used, water must be sprinkled on it while it cures.

Third, each layer of the cement mortar rendering must be firmly adhered to the next, and there should be no air bubbles in the mortar.

Finally, the foundation of both the wall and the tank must be stable to avoid any settling.

Choice of Site

The site must be on high dry ground and have a low water table; it should face the sun and not have the sunlight blocked by trees. The top portion of the intake chamber of the plant must be connected to the excreta outlets of both the privies and pigpens (Fig. 49), and the plant must be situated near where the biogas is to be used.

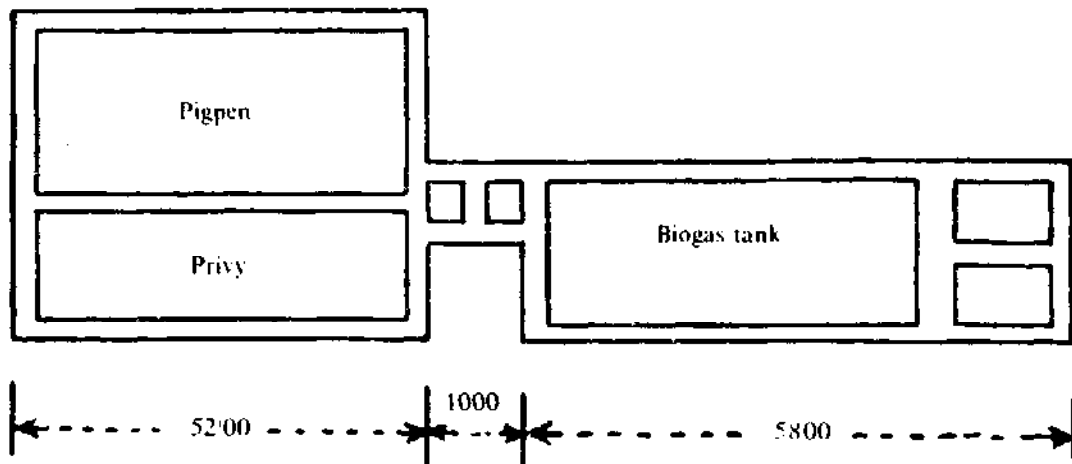

Fig. 49. General arrangement of the biogas plant.

Size of Fermentation Tank

The size of the tank will depend on the biogas' intended use. The calculation of the fermentation tank's volume is normally based on 2 m³ per person to provide sufficient biogas for cooking and lighting. The whole tank should be underground and have a depth of about 3 m and a width of 1.2-1.5 m, and the side wall should slope toward the base (the upper portion will be wider than the base by 10-20 cm) so that the fermentation tank is a rectangular trapezoid. The formula for calculating the volume of the fermentation tank is given below:

$$[\text{width of the upper portion of the tank (m)} = \text{width of the tank's base(m)}] \\ \times \text{height (m)} \times \text{length (m)} = \text{volume of the fermentation tank in m}^3.$$

Building Materials

The following materials are required to construct a biogas plant with a capacity of 10 m³: about 100 kg of lime, 100-200 kg of cement, 1 m of pipe for

the gas outlet (steel or PVC), and several plastic or bamboo tubes for biogas delivery.

As the district of Mien Chu is situated in the Chuan-Si plain, no rock is available. Local materials such as pebbles and concrete are generally used to construct the tanks. (For the construction and the structure refer to Fig. 50 and 51.) The procedures are given below.

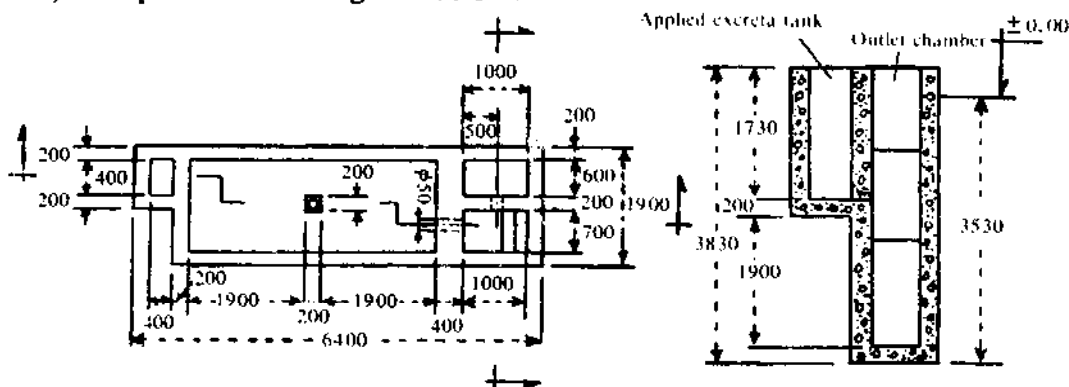

Fig. 50. Ground plan and cross section of biogas plant: units, mm; volume of fermentation tank, $4 \times 1.5 \times 3 = 18 \text{ m}^3$; \emptyset , diameter.

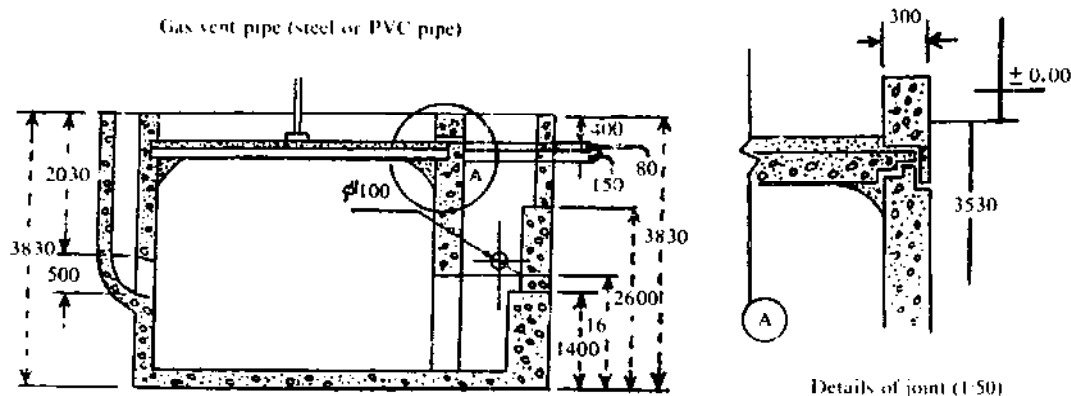

Fig. 51. Sectional view.

Excavation

Excavation should follow the plan provided (Fig. 50). Depending on the soil characteristics, adequate slope must be provided when excavating to prevent landslides. If the water table is high and water infiltrates into the sump, groundwater should either be blocked at its source or another site chosen.

Concrete Mixture

The raw materials used in concrete are lime, sand (gravel), and soil. They are in the ratio of 1:1.5:1.5. The mixture should be very thoroughly mixed after water is added. The moisture content in the concrete is correct when the concrete forms an aggregate when kneaded and spreads out when released. The concrete must be mixed prior to use, and the lumps of lime that are not completely burnt discarded to prevent them from "flowering" once built into the wall and damaging the structure.

Wall Erection

Prior to the construction of the concrete wall, the foundation must be properly compacted and wooden piles driven into it. Planks can then be erected vertically in the sump as wall forms about 30 cm away from the wall of the sump (depending on the desired thickness of the tank wall). Concrete is then poured into the form in layers and properly compacted (particularly at the joints, which must be very tight). A 10-cm layer of pebbles can be added between layers of concrete but they must be thoroughly mixed into other layers of concrete to avoid the leakage of water or gas. The addition of pebbles will not only reduce the construction cost but will also increase the ability of the wall to withstand pressure. The fermentation tank wall can also be constructed using pebbles, feldspar, slate, or brick with cement mortar. The height of the wall should reach to about 50 cm below ground level leaving room for the fermentation tank cover, the privy, and the pigpens. A key joint should be built at the top of the concrete wall as shown in Fig. 51 so that the cover and the side walls interlock tightly.

Intake Chamber

The top of the opening of the intake chamber is 40 cm or more across and the bottom is about 50-60 cm across and opens at the centre of the fermentation tank on the same level as the fermentation tank door. The depth of the inlet chamber is about 1.5-1.8 m and has a "bell-mouth" shape to facilitate the introduction of fermentation material. The intake chamber should not be in line with the door of the fermentation tank but to one side to prevent excreta from getting into the outlet chamber while being fed in. The top opening of the intake chamber is connected to the excreta outlets of both the privy and the pigpen to minimize the growth of fly larvae. The intake chamber can also be built with pebbles, vitrified clay pipe, or brick, and cement mortar. The construction of the intake chamber and the wall of the fermentation tank must be done simultaneously, making sure that all the joints are properly made and no leakage is possible.

Installation of the Mixer

The purpose of installing a mixer inside the fermentation tank is to break the scum on the upper layer and to agitate the settled sludge at the bottom of the tank so that the biogas can rise into the gas storage tank. However, the fermentation tanks constructed in our district have capacities of only 10-20 m³ and the sludge is removed annually. After using them for more than a year, we found that the installation of a mixer was not necessary.

Partition and Fermentation Tank Door

The partition between the fermentation tank and the outlet chamber is constructed of concrete to a thickness of about 40 cm. This wall is reinforced either with sticks or bamboo and both ends (of the stick / bamboo) must be inserted into the earth to withstand the high pressure inside the tank (if slate is used, it must also be put into the walls of the fermentation tank and the outlet chamber). A door should be built at the bottom of the partition wall between the fermentation tank and the outlet chamber. The height of the door is about 1.3-1.4 m (about half the depth of the tank), and its width is 70-80 cm, to facilitate the removal of sludge.

Liquid-Pressure Tank

The wall of the liquid-pressure tank built on the perimeter of the fermentation tank's cover is also of concrete (or pebbles or slate) and is about 30 cm thick and 30-50 cm high. Half the wall of the liquid-pressure tank sits right on top of the fermentation tank's cover and half is outside (Fig. 51). Gravel is not used in the concrete for the lower portion of the liquid-pressure tank wall. The joints between the fermentation tank and the cover must be totally surrounded both to increase the weight of the tank's cover and to minimize the space between the fermentation tank and its cover. In addition, in the construction of the wall next to the outlet chamber, a 5-6-cm opening must be made at the bottom connecting it with the outlet chamber (or applied excreta tank). During the construction of the liquid-pressure tank's wall, the walls of both the outlet chamber and the applied excreta tank should be made the same height as the liquid-pressure tank.

Tank Floor

After completing the concrete wall, a layer of concrete about 15 cm thick should be placed on the base of the tank, compacted properly, and another layer of diluted concrete laid down. If water percolates through the base of the tank, first a layer of pebbles should be spread and then cement slurry (or diluted concrete) poured into the gaps between the pebbles and then finally a layer of concrete should be poured on top (cement, sand, gravel; 1:2:4). The floor of the tank must be constructed in such a way that it will not sink, that no water will percolate through it, and that it will protect the foundation of the wall.

Rendering the Inside of the Tank with Cement

Internal rendering is the key to preventing any water or gas leakage and must therefore be done carefully. Internal rendering (known in other areas as plastering or masonry) is done in the three steps described below.

Cement Plastering

During the construction of the concrete wall, fine concrete sifted and mixed well with 10% lime should be spread on the wall with a trowel, particularly over uneven and pocketed areas.

Rendering the Base Layer

After the wall has been plastered flat a trowel can be used to spread on a 0.3-0.5-cm layer of 3:7 sand mortar (fine sand and lime in the ratio of 3:7). The surface can be rough to better adhere to the next layers of cement mortar. The fermentation tank cover can be built after the floor has been rendered.

Final Rendering

This step is done after the dome's formwork is removed. To check that the walls are solid, use a finger or small stick to knock against various parts of the wall for any empty sound indicating a hollow. If any is found, the wall should be opened and rerendered there. This step is particularly important in the gas storage tank, at the joints between the side walls and the fermentation tank

cover, and on those portions damaged by the removal of the dome's formwork. Repeated plastering should be done at all the joints to form a fillet (as shown in Fig. 51), and any minute hollow space on the cover should be smoothed over with cement mortar. Cement mortar rendering can be done once or twice on the fermentation tank and its cover using cement, lime, and some fine sand in the mortar. Tiny holes form if mortar containing only cement and fine sand is used and the addition of lime can increase its density and prevent the leakage of gas or water (ratio of 1:2:1 of cement, lime, and fine sand is recommended). After completing these three steps, one or two layers of pure cement slurry should be applied with a brush. Cement can be omitted by using a 1:1 lime-sand slurry to render a 0.2-0.3-cm thickness.

Drop Board

The drop-board (Fig. 47) acts like a small dam in a drain, and is made by installing a removable board outside the door of the fermentation tank, about 5-10 cm lower than the top of the door. Another way it can be made is by placing the lower part of the drop board horizontally across the outlet chamber from the step opposite the door to the top of the door, blocking the fecal sludge inside the fermentation tank. This method will also remove the excreta from the middle layer and reduce the number of parasitic eggs there. Removable concrete slabs should be provided as covers for both the outlet chamber and the applied excreta tank.

Dome Cover

The cover of the fermentation tank is the critical part in the construction of the biogas plant. In the absence of slate and the shortage of steel and cement, pebbles and "four concrete" can be used to construct the cover. The materials required for this are three planks 2-3 cm shorter than the width of the fermentation tank, six timbers 50 cm shorter than the depth of the tank, 12 big wedges, and sundries including bricks, small bamboo sticks, bamboo splints, and iron nails. A plank should be nailed to the tops of two vertical timbers to form a frame, rocks and wedges should be placed underneath the timbers, and three parallel frames erected inside the tank. The fermentation tank's partition wall and its opposite wall serve as the dome's frames on both ends, and the tops of both walls are bow-shaped to form the structure of the dome. As the width of the fermentation tank is only 1.2-1.5 m, the dome can be only 15-20 cm high. Bricks should be placed on top of the three frames following the contour of the dome. The arches on the five frames must be the same height. Finally the small bamboo sticks must be placed across the top of the five frames, and two bamboo splints placed 2-3 cm lower than the tops of the side walls of the fermentation tank so that the cover and the fermentation tank's side walls can be tightly joined.

Stone Cover

Flat, long, and wedge-shaped stones about 20 cm in diameter should be selected and washed. They should be placed upward on the dome's frame from the side walls working toward the centre, using small pebbles or stones to fill the gaps, and then cement mortar or concrete slurry (lime, cement, and fine sand in the ratio of 1:1:2) should be poured into the gaps. (Cement mortar can be used to fill the gaps between pebbles while laying

them.) If smooth stones are not available, slate or bricks can also be used to build the dome, but if bricks are used, they must first be immersed in water.

“Four Concrete” Cover

A cover can also be made using cement, lime, medium sand, and gravel or pebbles in the ratio of 1:1:2:4. The lime must be finely sifted, and the sand and gravel must be washed and clean of earth and grass. The lime, cement, and sand should be mixed completely first, and then the gravel added and mixed in gradually while water is added. Before pouring a 20-25-cm thickness of the “four concrete” on the dome’s frame, it can be compacted immediately with an iron bar. The cement slurry must be spread evenly. When the “four concrete” has dried slightly, it should be covered with a damp grass carpet, sprinkled frequently with water, and left to cure for 6-7 days. A cover can also be built using lime, sand, and gravel, without the cement.

Concrete slabs were used for the cover before we used the pebble and “four concrete” combination. The ratio of cement, sand, and gravel in the concrete can be 1:2:4 (labelled as #140 temporary), and one part of lime can be added to increase the density of the concrete. A framework must be prepared prior to the casting of the concrete slab that is 30 cm longer than the width of the fermentation tank, 60 cm wide, and 15 cm thick. The framework is trapezoidal, about 1 cm wider on top than at the bottom. Bamboo strips can be used inside the framework as reinforcement instead of steel. The bamboo strips should be spaced about 15-20 cm apart and be strongly tied. They can be painted with pitch to last longer. The bamboo strips should be 4-5 cm shorter than the framework. Before casting the concrete slab, an “ox-paper” covered with soap bubbles should be placed on a piece of flat land and the framework placed on top of the “ox-paper” with small stones used to hold the reinforcing bamboo strips in position inside the framework. The clean sand should be mixed with the cement and then with clean gravel while water is gradually added till the mixture is uniform. The concrete should then be poured into the framework, and compacted properly with an iron bar, to make a slab about 12-15 cm thick. To prevent the concrete slab from drying too fast or being damaged by rain, a wet grass carpet should be placed over the slab when it has dried slightly. If the weather is dry, water should be sprinkled on the grass mat 5 or 6 times a day to keep in the moisture. After curing for 6-7 days, the concrete slab should be fully set and the framework can be dismantled and the concrete slab used about 10 days after its casting.

The following five points should be kept in mind when erecting the fermentation tank’s concrete slab cover: (1) earth and grass should be removed completely from the top of the already smoothed peripheral walls of the fermentation tank, and then a layer of cement mortar (cement and fine sand in the ratio of 1:2) should be spread over them; (2) two arched sticks should be put on either side of the fermentation tank’s side walls and the concrete slab placed on top of them and then the concrete set into position before removing the circular sticks to prevent the concrete wall from cracking under the slab’s weight; (3) the “ox-paper” on the concrete slab must be torn off and all the dirt stuck on the slab cleaned off; (4) it may be noted that the slab’s surface is very smooth after casting as the cement slurry appears to be heavier in this part. This smooth surface must be placed downward, facing the interior of the fermentation tank to allow as smooth a join as possible between the fermentation tank’s side walls and the cover; and (5) after making two

concrete slabs this way, a V-shaped gap is left between them, and a 1:2 cement mortar can be used to fill it (Fig. 52). A simple frame can be erected inside the tank with its horizontal surface 2-3 cm lower than the top of the side walls and the concrete poured directly on top to form a one-piece concrete slab to cover the fermentation tank. (If a thick piece of slate is used for the cover, it must have a smooth base and be clean of earth before use.)

After the erection of the fermentation tank's cover by one of the three methods mentioned above, an 8-cm layer of well-compacted concrete must be applied to the cover, which may be followed by a further layer of 1:2 cement mortar. This is to increase the weight of the cover and minimize the leakage of gas from the gas storage tank. A hole 3 cm in diameter must be provided on top of the cover for the gas pipe.

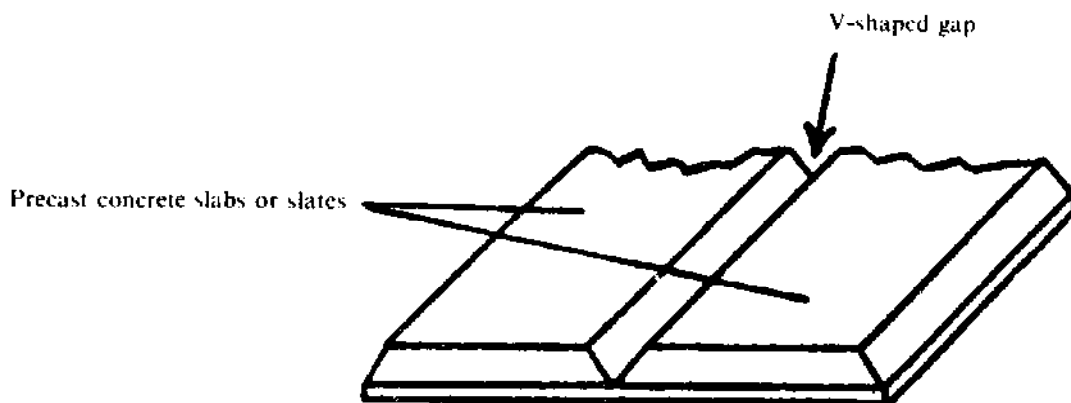

Fig. 52. Gap between precast concrete slabs.

Dismantling the Dome Frame

After the liquid-pressure tank is completed and the space outside the walls is backfilled with the spoils, it is possible to dismantle the dome frame from inside the fermentation tank. After removing the wedges, the frame, timbers, and bamboo sticks can all be dismantled and removed. Safety measures should be taken prior to the removal of the dome's framework to avoid any accident.

Gas Pipe

Either steel or PVC pipe can be used as the gas outlet pipe. It should be about 1 cm in diameter and 1 m long. It should be set in the hole in the fermentation tank cover and its base covered with a cement mortar curb 10 cm high and 20 cm in diameter to prevent any gas from leaking.

Privy and Pigpen

The foundation of both the privy and the pigpen must be higher than the biogas plant's liquid-pressure tank. The intake chamber of the biogas plant is connected to the excreta outlets of the privy and the pig- or ox pen, and these outlets slope at 45° so that the excreta can flow directly into the biogas plant. If the privy and the pigpen are to be constructed above the liquid-pressure tank, the biogas plant must first be operating normally, otherwise the tests for the quality of the biogas plant will be affected (the methods of examination for water and gas leakage will be given later). If the privy and pigpen are built this

way, the applied excreta tank must be expanded to replace the function of the liquid-pressure tank.

Safety Valve

The safety valve (also known as the pressure gauge) (Fig. 53) is a simple device made of two glass tubes and a hose in a U-shaped tube filled with coloured water. Tube A is connected to the gas outlet of the biogas plant via a Y-shaped tube, and tube B is open to the atmosphere. The heights of the water columns of the pressure gauge vary when pressure is created by the production of biogas inside the biogas plant.

The safety valve has three functions: first, to determine whether there is any gas leaking in the biogas plant; second, to estimate the quantity of the biogas in the gas storage tank by reading the difference in levels of the water columns in the pressure gauge; and third, to protect the tank from cracking. If too high a pressure is created as a result of an excess production of biogas within the plant, the coloured water in the safety valve will be forced out through tube B and the pressure will drop automatically.

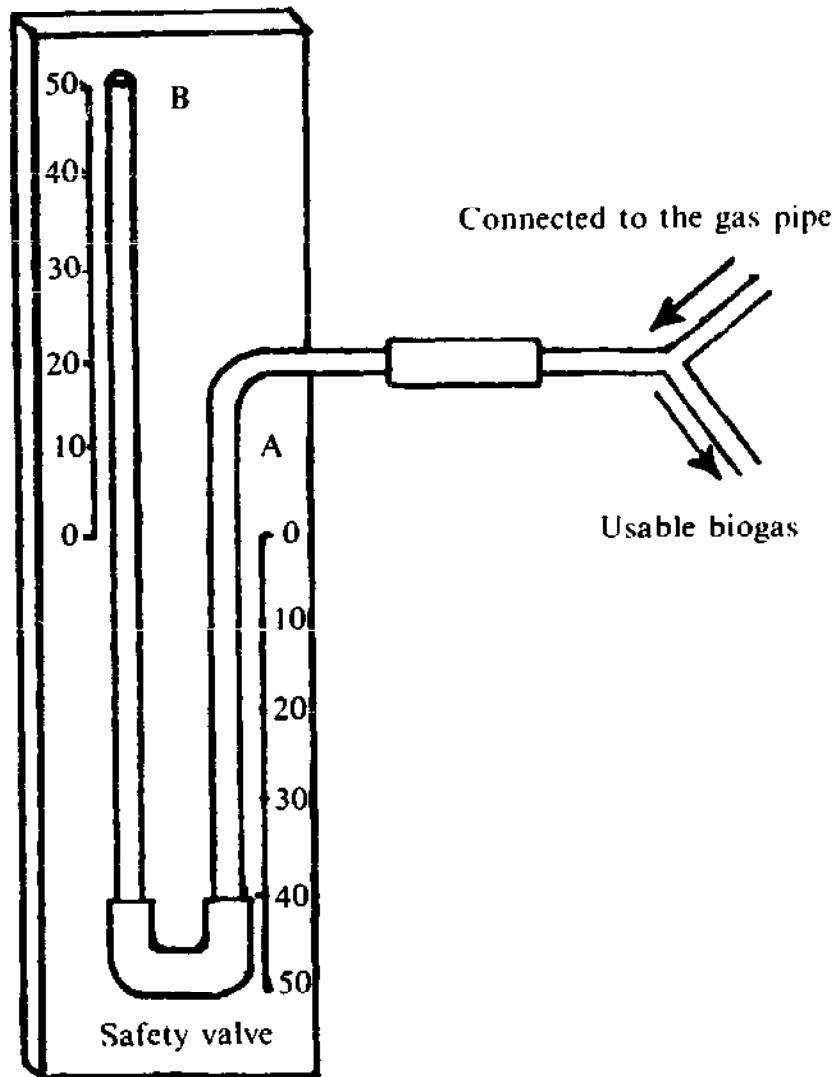

Fig. 53. Safety valve (pressure gauge) (glass tube I.D. = 1 cm).

If the coloured water in the safety valve is forced out, the biogas will also escape, thereby reducing the quantity of biogas inside the gas storage tank. (Afterwards, the U-shaped tube will have to be refilled with coloured water.) To overcome these two shortcomings an automatic safety valve is now used. Its installation is relatively simple (Fig. 54): a stopper drilled with two holes is inserted in the mouth of a 100-ml bottle and one long and one short glass tube (or syringe) are placed into these two holes; the short glass tube is connected by hose to tube B of the U-shaped safety valve, then this bottle is inverted and attached near the safety valve. When the plant pressure exceeds atmospheric pressure, the coloured water will be forced into the inverted bottle through the tubes B and C, any biogas that gets into the bottle will be released through tube D, and the coloured water in the bottle will return to the "U" tube through tube C when the plant pressure drops. This will keep the pressure inside the plant at a constant water column height. In addition to this, a class automatic pressure control device, in the shape of a gourd has been invented (Fig. 54).

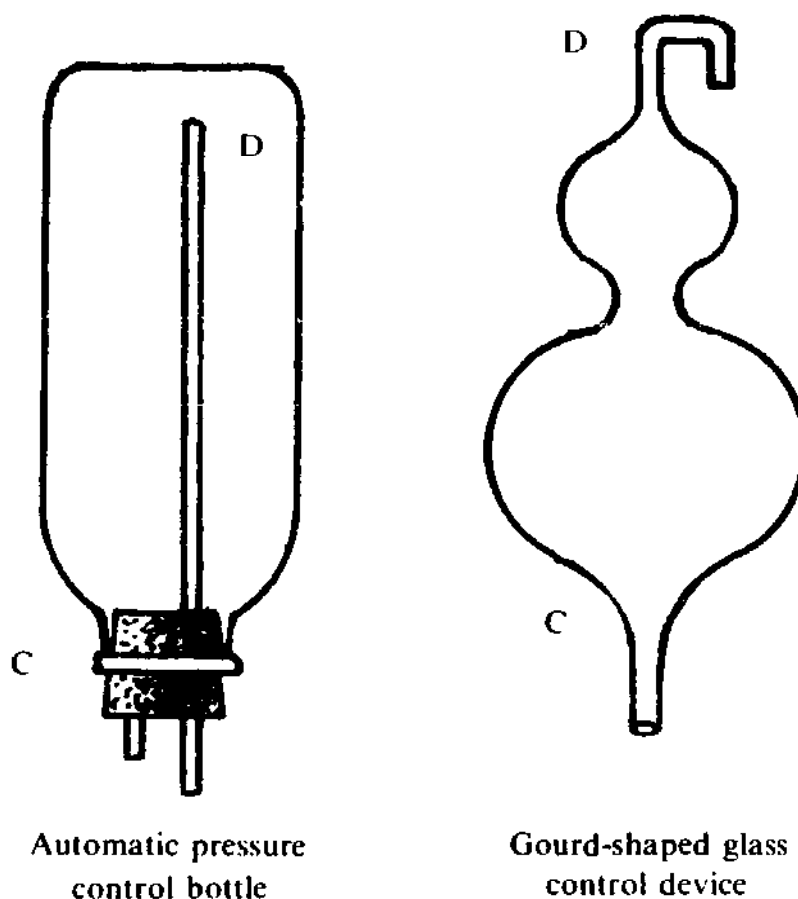

Fig. 54. Automatic pressure control devices.

Safety Precautions

Good workmanship includes taking precautions against any collapse during construction. Direct sunshine, rain, and flooding during the summer, and construction of the plant in the rainy season should all be avoided, and precautionary measures should be taken against freezing.

The plant should not be filled with or emptied of water or organic material too quickly (this means that a water pump cannot be used) as the sudden increase or decrease in pressure inside the tank could cause the structure to crack.

As biogas is very combustible, brushwood and grass should not be placed near the tank; igniting anything inside the tank should also be forbidden. The tube transporting gas should not leak and should be kept away from fire. These measures will help prevent fire and explosions.

A 30% concentration of biogas can anesthetize a person, and a 70% concentration can asphyxiate a person or cause him to choke to death. Therefore the tank must be well ventilated when someone is inside desludging it and before he enters the tank to clear out the biogas. The best way is to put one end of a hose in the tank through which a person can breathe fresh air if he begins to feel ill.

Before any repairing is done inside the tank, the sludge must be completely removed to avoid any accident.

Examination of the Biogas Plant for Water and Gas Leaks

A very strict examination must be carried out on the biogas plant following its construction. The biogas plant cannot be used until it has been proven waterproof and gastight. The gas storage efficiency increases with effective enclosure as any minute holes in the gas storage tank will destroy the storage capacity and the pressurization. If water leaks from the fermentation tank, or from the intake or outlet chambers, the fecal liquid will seep out, and the gas production will be reduced.

Therefore, prior to introducing organic materials into the plant, a thorough examination should be made to find where water and gas leaks occur, and the whole situation must be analyzed before any corrective measures are taken. The methods of checking for water and gas leaks are given below.

Examination of the Tank's Walls

A finger or small stick can be used to tap all over the wall to listen for any hollow sound indicating unfilled space in the wall, which would have to be opened and repaired.

Examination of the Liquid-Pressure Tank

The liquid-pressure tank should be filled with clean water and checked after 2 days for any water seepage or leakage around the tank's cover. The water should be left in the liquid-pressure tank so that any gas leakage can be observed at a later stage.

Examination of the Structure of the Tank

The tank should be half-filled with clean water and observed over a 3-4 day period. The water level should drop no more than 4-5 cm under normal circumstances.

Examination of the Gas Storage Tank

The U-shaped safety valve should be assembled and connected to the gas vent. The tank is then filled with water or inflated with air using a gas cylinder to make the column of water in the safety valve rise to a given level. After 24 h the water column should be checked to see if it has dropped or not. Under normal circumstances it should drop about 2-3 cm. This pressure test (known as the positive pressure method) should be done two or three times at 20-, 40-, and 60-cm levels in the safety valve, and the estimated maximum pressure that the cover can stand should never be exceeded. If gas escapes, the leak must be located and repaired.

Other parts of the tank should also be carefully observed when the positive pressure method is being used. The tank's cover and the curb at the bottom of the gas pipe should be checked for any air bubbles developing. The water levels in both the intake and outlet chambers should rise as a result of the increased pressure in the gas storage tank, and this will enable testers to check for water leaks in the upper parts of both chambers.

Examination of the Join Between the Tank Cover and the Side Walls

The earth surrounding the cover-wall seam should be removed and the space filled with clean water. When the positive pressure method is being used, someone should check along the join for any evidence of bubbles of escaping gas.

Examination of the Gas Outlet and Gas Pipe

The conventional method involves submerging these items in water and forcing air from a gas cylinder through them. If bubbles form on the walls of the tubes there is a leak.

Repairing Water and Gas Leaks in the Biogas Plant

Gas leaks occur most commonly where the tank walls meet the cover, and where the gas pipe is connected to the tank's cover. Water leaks usually occur in the intake and outlet chambers and in the floor of the tank. There are five ways that poor wall construction can cause water and gas leaks: (1) incompletely burned limestone that gets built into the concrete wall can "bloom"; (2) the concrete may not be properly compacted; (3) air may get caught between layers of the cement mortar as a result of careless rendering; (4) the various joints may not be well fitted; and (5) the plant may settle as a result of a poorly made wall or an unsuitable foundation.

Normally it is easy to deal with gas and water leaks. For instance, if gas leaks around the curb of the gas pipe, the size of the cement curb should be increased; if air spaces are found in the wall then the wall should be filled and rendered at those spots. If cracks appear, they should be widened and deepened and filled with cement mortar. However, several special situations are outlined below.

Unlocated Leaks

The upper portion of the fermentation tank and its cover should be washed and brushed and rendered again with cement mortar and the area should be brushed several times with cement slurry.

Gas Leaks that Appear Once the Plant is in Use

After organic material has been put into the plant and a small gas leak is found, the leak can be repaired on the outside surface of the tank to avoid having to empty out the fecal liquid. Before the leak is repaired the tube transporting gas from the gas pipe to the safety valve should first be removed so that the internal pressure of the tank equals atmospheric pressure, then cement mortar or concrete can be used to patch the leaking area, and after the cement or concrete has dried, the tube can be reconnected to the gas pipe. With this sort of repair, a small amount of biogas can still be produced. A proper repair job can only be done when the tank is desludged and the inside of the tank can be thoroughly rerendered with cement mortar.

Water Leaks

Groundwater will filter into the tank and the fecal liquid will seep out if there is any crack in the wall or in the floor of the tank. If the floor leaks, it can be reinforced by pouring pebbles and concrete or cement on top; if water leaks through the wall, the crack should be found and patched several times with cement mortar. Sodium silicate may be mixed with cement for patching. The sodium silicate solution and cement will congeal within 2-3 min. To seal the entire area a suitable amount of water should be added to the sodium silicate solution before use.

Filling the Biogas Plant

The necessary raw materials for biogas production are human, pig, and ox excreta, crop stalks, grass, and other plant material. Generally the proportions are human excreta 10%, animal feces 30%, crop stalks 10%, and water 50%. If the intake chamber of the biogas plant is connected directly with the night soil and feces outlets so that they flow directly into the tank, no special management is required. The water content will decrease as fecal liquid is removed from the applied excreta tank for use as fertilizer and a large quantity of sediment will remain in the fermentation tank, but gas production will return to normal after water is added.

Before plant matter is put into the tank, it should be composted for more than 10 days so that its decomposition will already have begun, and biogas production will begin immediately. If the material is largely agricultural, such as crop stalks or green grass, high levels of organic acids are released by microorganic action into the fermenting fluid. To maintain the pH inside the tank at 7 or 8, a suitable amount of lime solution or grass ash should be added regularly to the tank.

Disposal of Sludge and Sediment

The plant should be desludged once a year to prevent too much sludge building up. Some parasitic eggs will survive in the sludge removed from the tank, and therefore chemicals should be used to disinfect it before it is used, in the ways described below.

- Liquid Ammonia — 12 kg of 20% liquid ammonia should be added to each cubic metre of sludge and mixed thoroughly. The sludge can be used after 2 days.
- Lime — 100 g of lime mixed well with each kilogram of sludge will destroy schistosome eggs.
- Ti Pai Chung — To every 400 kg of sludge, 50 g of 50% Ti Pai Chung can be added and mixed thoroughly to destroy the schistosome eggs.
- “6% 666” — 3.5 kg of 6% 666 powder mixed well with each cubic metre of sludge will kill up to 90% of bacilli and hookworms.

The Biogas Stove and Lamp

Biogas is a very high quality fuel, and it requires a good burning vessel to have complete combustion. The basic structures of both the biogas stove and lamp are similar, and common elements include a nozzle, an air inlet, and a mixing chamber. The biogas stove is made by adding the fire sieve plate (Fig. 55), and the lamp, by adding a “rootstock of lotus” and a mantle (Fig. 56).

The nozzle is a hollow tube made of bamboo, glass, or plastic. The nozzle hole is the size of a needle point (0.5 mm diameter) and the other end of the nozzle is connected to the gas supply hose from the plant. After biogas enters the lamp through the air inlet it will spray out from the nozzle at very high speed and the air surrounding this gas stream becomes a low pressure area. The air will be drawn into the mixing chamber to mix with the biogas as it passes through the nozzle. Due to the fixed direction of gas flow in the mixing chamber, the biogas will rush only to the openings of the fire sieve plate of the biogas stove or to the “rootstock of lotus” of the biogas lamp for combustion.

The brightness and force of combustion of the biogas stove and biogas lamp depend mainly on the biogas pressure, the mixing ratio of biogas with air (approx 1:10), and the conditions of mixing between the biogas and the air. Based on the above conditions, the magnitude of the force of combustion is greatest when the flame of the stove appears to be slightly yellow and a bit bright and burnished and makes a “sha-sha” sound. At present, there are various kinds of biogas stoves and lamps made of a soil and carbon ash mixture for a variety of uses.

The mantle of the biogas lamp is made of a Ramie fibre (the same fibre from which grass cloth and linen is made) net immersed in a thorium nitrate solution. The Ramie fibre turns to ashes when burned and forms a layer of thorium dioxide, which emits a dazzling white light at high temperature. As biogas is almost half as light as air and as hot air flows upward, the brightness of the standing biogas lamp is greater than that of the hanging lamp.

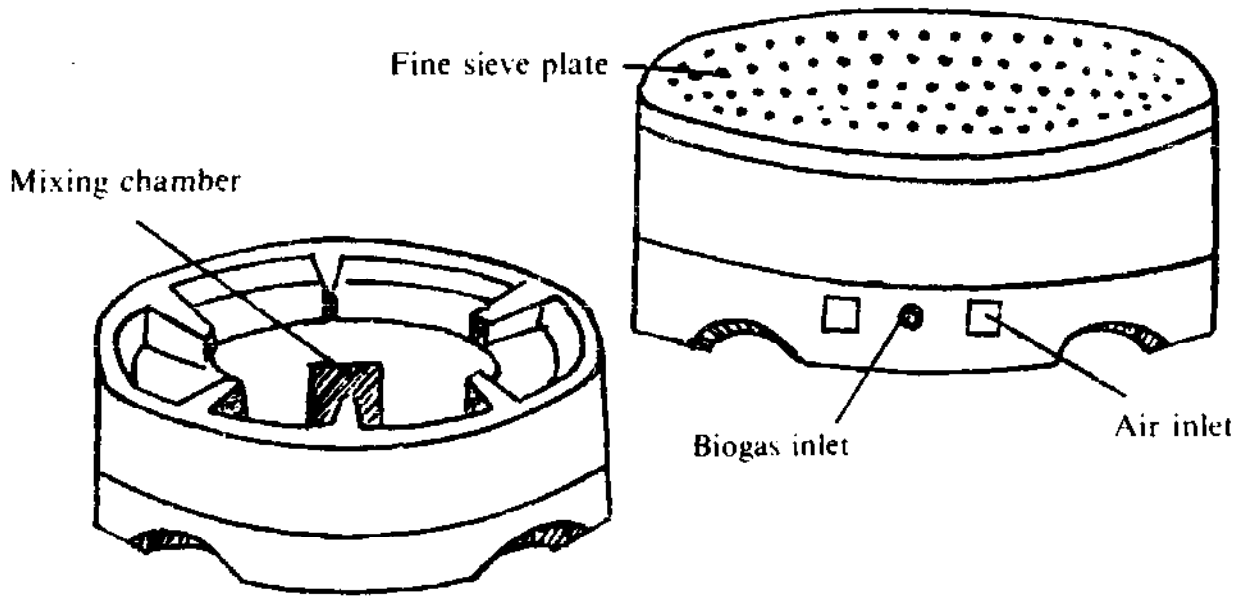

Fig. 55. Earthen biogas stove.

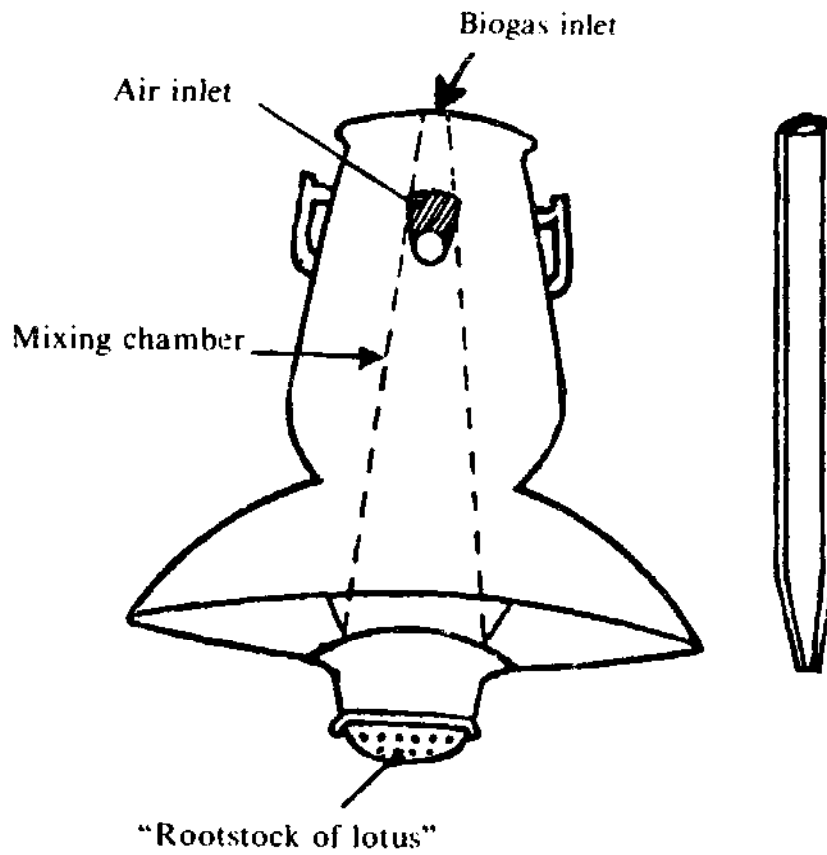

Fig. 56. Earthen biogas lamp.

Research Results on the Effectiveness of Excreta Treatment in Biogas Plants*

Some of the society teams in the district of Mien Chu and other districts in our province have combined the local methods of biogas production with the management and disposal of excreta. To investigate the changes caused in the parasitic eggs and pathogens, and in the efficiency of fertilizer by the fermentation of the fecal liquid in the biogas plant, a year-long investigation was carried out on 19 biogas plants in the districts of Mien Chu, Chung Chiang, and Ann Hsien, and the details are given below.

Parasite Egg Count and Distribution in Fecal Liquid

Samples were taken from the intake chamber, the bottom layer of the fermentation tank, the fecal liquid in the bottom layer of the outlet chamber, and the applied fecal liquid in the upper layer of the outlet chamber in each of the fermentation tanks under investigation. The samples were then examined using the methods described below.

A fixed amount of fecal liquid at a given water concentration should be prepared and the number of parasitic eggs in every 10 ml of the fecal liquid should then be counted. A similar method can be used to determine the number of parasitic eggs in the top, middle, and lower layers of the fecal liquid in the outlet chamber.

There were more parasite eggs in the fecal liquid in the intake chamber than in the tank bottom or outlet bottom, and there were fewest in the applied fecal liquid. The number of parasite eggs in the applied fecal liquid was 93.6% lower than in the intake chamber (Table 14).

The number of parasite eggs in the outlet chamber was the highest in the lower layer (79.7%), followed by the middle layer (17.6%), and lowest in the upper layer (2.7%) (Table 15).

The Drop Board's Effect on Parasite Egg Distribution

The percentage reduction of the parasite eggs in the applied fecal liquid was 80% before and 98.23% after installing the drop board, showing an increase of 18.23% (Table 16).

Parasite Egg Viability in Winter and Summer

Biogas production can be affected both in the summer (air temperature 28 °C and tank temperature 23 °C) and the winter (air temperature 0 °C and

* This preliminary report was prepared by the prevention of communicable disease office of the district of Mien Chu revolution committee, Province of Szechuan.

Table 14. Distribution of parasitic eggs in the fecal liquid.^a

Area sample taken	No. of exam.	Avg no. of eggs (no./100 ml)
Intake chamber	45	23852
Tank bottom	35	17363
Outlet bottom	45	15132
Applied fecal liquid	45	1505

(%) Reduction of parasitic eggs in the applied fecal liquid compared to number in intake chamber: 93.6%

^aNo. of biogas plants tested: 19. Dates tested: January-June 1972.

Table 15. Number of parasite eggs in various layers of the outlet chamber.

Layer sample taken	No. of exam.	Avg no. of eggs (no./100 ml)	%
Upper	13	403	2.7
Middle	13	2817	17.6
Lower	13	12704	79.7
Total		15924	100

tank temperature 10 °C). Night soil containing schistosome, hookworm, and ascarid eggs was collected in January and June and thoroughly mixed. These samples (of about 120 g each) were placed in several porous plastic bags with four to six openings per cm², and put into the biogas fermentation tank and then removed at fixed time intervals. After incubation the schistosome eggs were examined. The soil and sand incubation method with isolation was used to determine the number of hookworms. The ascarid eggs were collected, incubated, and observed in terms of their viability. Each time samples were taken, the temperature, pH value, and the ammonia concentration of the fecal liquid were measured and recorded.

The longevity of each type of parasitic egg in winter was determined. Schistosome eggs survived for 37 days. (They survived only 14 days in the summer.) Ninety percent of the hookworm eggs died within 30 days and more than 99% died off in 70-100 days. Between 10 and 90 days after placing the fecal bags in the tanks, the viability of the ascarid eggs ranged from 63 to 79%, which decreased to 47.1% after 100 days. At this stage, the death rate reached 52.9%, showing a remarkable drop in viability (Table 17).

Schistosome Egg Count and Distribution

Six litres of fecal liquid should be taken from the intake area, tank floor, and outlet chamber, along with 48 kg of applied fecal liquid, and these should be left to settle for 1 h. The four samples should be washed and left to settle separately several times before being poured into 4- or 10-litre flasks, incubated at 28 °C, and observed for schistosome flukes after a given time.

Twenty-two samples were taken for examination from each of eight biogas plants in areas reported to have endemic schistosomiasis. Schistosome flukes were found only twice in the intake fecal liquid, and none were found in the applied fecal liquid.

Several experiments have shown that as the ammonia concentration increases, the schistosome egg survival decreases.

Table 16. Number of parasitic eggs in various parts of the fecal liquids before and after using the drop board.

Area sample taken	Without drop board		With drop board	
	No. of exam.	Avg no. of eggs (no./100 ml)	No. of exam.	Avg no. of eggs (no./100 ml)
Intake	4	64999	31	24066
Tank bottom	2	40500	29	17545
Outlet bottom	4	39666	31	13644
Applied fecal liquid	4	12963	31	416
(%) Reduction of parasitic eggs in the applied fecal liquid compared with the intake fluid:		80.0		98.23

Table 17. Longevity of parasitic eggs inside the biogas plant in winter.^a

No. of days after commencement of expt	No. of schistosome eggs in night soil	Hookworm isolation		Ascarid eggs	
		No. in each 10-g sample	Reduction (%)	Alive (%)	Dead (%)
Before expt:	20+	789		96.5	3.5
10	5+	276	65.1	67.8	32.2
20	5+	184	76.7		
30	5+	8			
37	5+				
40	(no discovery from 40-43 days)	52	93.4	65	35
50		12		70	30
60		44	94.4	79.3	20.7
70		3	99.6	63	37
75		0	100	65	35
80		4	99.5	69	31
85		0	100	72	28
90		3	99.6	68	32
95		4	99.5	66	34
100		0	100	47.1	52.9

^aDates of experiment: 25 January to 4 May 1972. Temperature: air, 1-20 °C; tank, 9-18 °C. Average concentration of ammonia: 0.19 g/100 ml.

Table 18. The concentrations of ammonia and the longevity of schistosome eggs resulting from different proportions of organic materials in the fecal liquids.^a

% of feces, urine, & grass in the fecal liquid	No. of expt	Avg ammonia conc. (g/100 ml)	Avg life span of the schistosome eggs (days)
30	1	0.09	13
50	2	0.13	13.5
70	3	0.14	11.6
80	1	0.15	10
90	1	0.16	7
100	3	0.17	5

^aThe proportions of night soil, pig feces, urine, and grass (all taken from the village pit privies) were pig feces and urine 90%, human excreta and urine 5%, and grass 5%. Room temperature during the experiment ranged from 23 to 28 °C.

The Drop Board's Effect on Schistosome Egg Distribution

Before and after placing the removable drop board in a 10.22 m³-capacity biogas plant at the Mien Chu Ching Tao public society, 360 kg of night soil were collected every 5 days from the public village privy (which proved to contain schistosome eggs) and were put into the intake chamber. The next day the fecal liquid was withdrawn from the inlet and the applied fecal liquid from its tank for examination of the schistosome eggs. Experimental results before the drop board was used revealed the presence of schistosome flukes in the fecal liquid of the inlet four times out of six. After the drop board was installed, three sets of examinations were carried out in both the intake and applied fecal liquids, and flukes were found each time in the intake chamber and not once in the applied fecal liquid.

Ammonia Concentration and the Longevity of Schistosome Eggs

Into several 10-litre filter flasks glass tubes should be inserted through the centre of the stopper right to the bottom of the flask. The tube should be connected at the neck of the flask to a gelatine capsule for biogas collection. The proportions of night soil, animal feces, urine, and crop stalks in the fecal liquid should range from 30 to 100%, the rest being water. Seven litres should be put into each flask and left fully enclosed to ferment and produce biogas. After biogas production begins, 2-3 litres of night soil sediment containing the schistosome eggs should be added through the sampling tube. Then the fecal liquid should be withdrawn from the bottom of the flask at fixed time intervals so that the schistosome flukes, the ammonia concentrations, and the conditions of biogas production can be observed. The percentage of feces, urine, and grass in the fecal liquid, the ammonia concentration changes (g / 100 ml), and the dying-off time of the schistosome eggs during several experiments are given in Table 18.

Hookworm Egg Count and Distribution

A 200-ml sample should be taken from each of the intake, tank bottom, and outlet bottom, together with 1000 ml of applied fecal liquid (calculated as settled for 1 h and concentrated about 10 times fecal liquid sediments). Each sample is then mixed with sand and soil, incubated, and isolated for a count of hookworms.

The hookworm incubation and isolation rates were the highest (87.09%) in the intake fecal liquid where the average number of hookworms was also high (168.8 / 200 ml); the rates and numbers were lower in the tank bottom and outlet bottom and lowest in the applied fecal liquid (isolation rate 22.58% and number of hookworms 0.8 / 200 ml) (Table 19).

Ascarid Egg Count and Distribution

The ascarid eggs should be collected in the fecal liquids from different parts of the biogas plant, placed in a test tube filled with 1 ml of water, and

incubated at 25-28 °C. They should then be examined under a microscope and the number of eggs that have survived or died should be counted to determine their growth rate and mortality.

The number of viable ascarid eggs was highest in the fecal liquid of the intake chambers; viability was reduced in the fecal liquids of the tank bottom and the outlet bottom, and reduced remarkably in the applied fecal liquid (Table 20).

Table 19. Hookworm isolation in various areas in the fecal liquid.^a

Area sample taken	No. of exam.	No. of hookworm isolations (%)	Total no. of hookworms	Avg no. of hookworms
Intake chamber	31	27 (87.09)	4568	168.8
Tank bottom	22	13 (59.09)	810	70
Outlet bottom	30	16 (53.33)	448	28
Applied fecal liquid	31	7 (22.58)	6	0.8

^aVolume of sample: 200 ml. The sample of the applied fecal liquid was 1000 ml during the examination but only 200 ml were used in the calculations to facilitate the comparisons.

Table 20. The growth rate of ascarid eggs in various areas in the fecal liquids.

Area sample taken	No. of exam.	Total no. of ascarid eggs under observation	Alive		Dead	
			No. of eggs	(%)	No. of eggs	(%)
Intake	22	1596	1086	68.04	510	31.96
Tank bottom	16	957	632	66.06	325	33.94
Outlet bottom	22	1137	732	64.3	405	35.7
Applied fecal liquid	18	1173	710	60.5	463	39.5

Bacteria Viability

E. coli

Samples should be taken from both the intake fecal liquid and the applied fecal liquid of the biogas plant, and after a series of dilutions, the MacCorkey liquid media can be used for incubation and then the *E. coli* index can be determined.

Three biogas plants were investigated twice each. The average *E. coli* index in the intake fecal liquid was 1218 billion, and in the applied fecal liquid was 0.7 billion; a remarkable decrease in the applied fecal liquid was evident (Table 21).

Enteric Pathogens

In a 1-litre filter flask, 1 ml of bacterial seed containing 10 billion shigella dysenteric or paratyphoid B pathogens should be mixed with different proportions of the filtered fecal liquid (7.5 openings / cm² filter) from the biogas plant to a total volume of about 300 or 400 ml and then the flask should be sealed tightly with a stopper. Two glass tubes should then be put through the stopper, one right into the fecal liquid for sampling and the other into the

Table 21. *E. coli* counts.^a

Plant	No. of exam.	<i>E. coli</i> count (avg no./litre)	
		Intake fecal liquid	Applied fecal liquid
		<i>billion</i>	<i>million</i>
Lee x x	2	5.76	25.0
Pong x x	2	127.94	137.5
Sixth of the Seven Teams	2	231.95	68.16
Avg of three plants		121.88	76.85

^aDate of examination: March 1972. Temperature: air, 13-17 °C; tank, 12-16 °C. Ammonia concentration: 0.12-0.17 g/100 ml.

top of the flask for withdrawing the biogas. The short tube of the filter flask should be connected to the gas transporting hose of the biogas plant. Then the filter flask should be set in a bamboo basket and sunk with weights to the bottom of the outlet chamber of the biogas plant. Samples should be taken at fixed time intervals after the bacterial seed is mixed with the fecal liquid and introduced into the biogas plant. The pathogens should be isolated after enrichment and distinguished by primary biochemical reaction and conglomeration experiments. The pathogens are considered dead if no pathogens are isolated in three tests. To the same bacterial seed either the filtered fecal liquid from the biogas plant or cool boiled water can be added, and the flask can be placed inside a room for comparison, and be sampled at fixed time intervals with the same methods described above to test the viability of the pathogens.

Shigella

The shigella bacillary dysentery pathogens survived 93 days in the cool boiled water and 17 days in the ordinary fecal liquid but could not be isolated after being placed in an environment similar to that of the biogas plant for 30 h (Table 22).

Bacillus Paratyphoid B

This survived for 98 days in cool boiled water, 41 days in ordinary fecal liquids, and 44 days in an environment similar to that of the biogas plant (Table 23).

Spirochetes

The spirochetes such as tularemia, hemorrhagic jaundice (*Leptospira icterohaemorrhagica*), autumn fever, and seven-day fever should be mixed with the Koch medium cultures of about 20-30 ml, and placed in small 100-ml flasks with tight-fitting stoppers and connected to the top portion of the flask with the tube transporting gas from the biogas plant, keeping the biogas pressure between 20 and 40 cm of water in the pressure gauge column. Samples should be taken at fixed time intervals after the introduction of the biogas, and a microscope used to examine the condition of the spirochetes. A sample of the same bacterial seed should then be placed in a test tube and left in a room for comparison, and the same method used to study the spirochetes at fixed time intervals.

After four experiments, the microscopic observation showed that the spirochetes died out within 29.5-31 h after the introduction of biogas, whereas the spirochetes in the comparison group only died out after 101-308 h (Table 24).

Table 22. Viability of bacillary dysentery pathogens.^a

Ratio of bacterial liquid (seed) to fecal liquid	Results of isolation after enrichment
<i>Experimental group</i>	
1:18.4	Immediate: negative
1:17.5	Immediate: negative
1:1	Immediate: positive; 24 h: negative
Purely seed	Immediate, 6 h: positive; 30 h: negative
<i>Control group</i>	
1:7	17 days: positive
(Seed: cool boiled water)	18 days: negative
1:7	93 days: positive
	95 days: negative

^aDate of experiment: 5 April-12 July 1972. Temperature: air, 15.5-28 °C; room, 11.5-28 °C; tank, 14-24 °C. pH values: seed and excreta mixture, 7-8; seed and cool boiled water mixture, 6.8-7.5.

Table 23. Life span of bacillus paratyphoid B.^a

Mix ratio of bacterial liquid (seed) and fecal liquid	Results of isolation after enrichment (no. of days)
<i>Experimental group</i>	
1:10	44: positive
	47: negative
1:1	44: positive
	47: negative
<i>Control group</i>	
1:10	41: positive
(Seed: cool boiled water)	43: negative
1:16.6	98: positive
	103: negative

^aDate of experiment: 27 April-10 August 1972. Temperature: air, 20.5-28 °C; room, 17-27.5 °C; tank, 19-23 °C. pH value: liquid mixture of seed and feces: 7.8-8; liquid mixture of seed and cool boiled water: 7-7.5.

Summary of Research Results

More than 40 investigations have been conducted in 19 operating biogas plants. A comparison of the applied fecal liquid with the intake fecal liquid showed that the total number of parasite eggs was reduced by 93.6%, the average number of hookworms was reduced by 99%, no schistosome flukes were found, and the number of dead ascarid eggs was high; in the applied fecal liquid both the total number of parasite eggs and of surviving parasite eggs was considerably lower than in the intake liquid. Tests showed that the parasite eggs in the biogas plant could survive for 14 and 37 days in autumn and winter,

respectively. In winter 90% of hookworm eggs died off in 30 days, and the mortality of the ascarid eggs increased remarkably in 100 days. Experiments on the viability of the bacteria have proved that the *E. coli* index was much lower in the applied fecal liquid than in the intake fecal liquid; in an environment similar to the biogas fermentation tank the shigella bacillus died out in 30 h, the spirochetes within 29.5-31 h, and the bacillus paratyphoid B in 44 days. After fermenting in the biogas plant the fecal liquid containing half night soil, animal (mostly pig) feces, urine, grass, and half water, had an ammonia nitrogen concentration higher in the applied fecal liquid than in the intake area by 7.7%, and by 40% over the level in the untreated pig feces and urine.

Table 24. Viability of spirochetes.

	Results of microscopic observation (alive (A) or dead (D)/no. of hours following introduction of biogas)					
	1st test	2nd test	3rd test	4th test	5th test	6th test
1st sample	A/4.5	A/21.5	D/29.5	D/46		
2nd sample	A/4.5	A/21.5	D/29.5	D/46		
Control	A/4.5	A/21.5	A/29.5	A/46	A/51	
3rd sample	A/4	A/24	D/31	D/54	D/101	
Control	A/4	A/24	A/31	A/54	D/101	
4th sample	A/4	A/24	D/31	D/54	D/101	
Control	A/4	A/24	A/31	A/54	A/101	D/408

Note: In the 1st, 2nd, and comparison tests, tularemia, autumn fever, seven-day fever, *Spirochaetosis icterohaemorrhagica*, and Koch medium mixed cultures were used. In the 3rd, 4th, and comparison tests *Spirochaetosis icterohaemorrhagica* and Koch medium culture were used. Room temperatures during experiments were in the 23-28 °C range, and the pH value was 7.0-7.5. The 1st and 2nd tests were begun at 12:20 p.m. on 27 June 1972, and the 3rd and 4th tests at 10:30 a.m. on 25 June 1972.

Settling Out of Worms and Eggs

For several reasons the settling rate of parasite eggs is high in the biogas plant. It is relatively deep (about 3 m), the fecal liquid is more dilute than human and animal feces and urine (specific gravity: 1.005), and the fecal lumps decompose after fermenting in the biogas plant. As a result, 79.7% of the parasite eggs were able to settle down to the bottom of the tank, 17.6% remained in the middle layer, and only 2.7% were left in the top metre of fecal liquid.

Mortality of Parasite Eggs

All the parasite eggs settled on the tank floor were dead by the time the tank was desludged. Although many parasite eggs were present there, it was generally only the upper layer of fecal liquid in the outlet chamber that was removed for use as fertilizer. Normally, replacement of the input materials or reparation of the tank is carried out annually, and all the fecal liquid and sludge or sediments should be removed then. According to our experiments and previous reports, all the schistosome and hookworm parasitic eggs died out within 3 months in both summer and winter. In addition, when chemicals such as caustic lime, "666" powder, ammonia water, urea, and lime were used in the desludging, those parasitic eggs that had settled recently and were still alive were all killed.

The anaerobic environment does not favour the growth of aerobic bacteria. As large amounts of organic matter decompose in a fermentation tank, they consume large quantities of oxygen, and the tank fills up with biogas very quickly. According to the analysis done by the chemistry department of the Chungking University the biogas produced by local methods contained 72-76% methane (CH₄), 22-24% carbon dioxide (CO₂), and only 1-3% of oxygen (O₂). Basically, the environment is anaerobic and therefore aerobic bacteria such as shigella and spirochetes quickly die off.

Increased Ammonia Concentration

To determine the ammonia nitrogen level, samples from four parts of the biogas plant should be collected. The simple method of ammonia determination can be used to find the concentration of the ammonia nitrogen in the pit privies where night soil and pig feces and urine are collected for comparison.

Results have shown that after the feces, urine, and grass have fermented in the biogas plant, the concentrations of ammonia nitrogen of the fecal liquids in the tank bottom, outlet bottom, and the applied fecal liquid are higher than in the intake chamber (Table 25). The level is also higher in the applied fecal liquid than in the intake area by 7.7%, and by 40% over the level in untreated pig feces and urine. The concentration of ammonia nitrogen in the night soil and urine was 0.20 g / 100 ml in the fully enclosed three-pit privy.

The ammonia content of the fecal liquid in the biogas plant was 40% higher after fermentation than in the untreated pig feces and urine. This factor would accelerate the death of both the parasite eggs and pathogens.

Table 25. Comparison of the ammonia nitrogen (NH₃-N) concentrations in various parts of the plant and in the fecal liquid in the privies and pigpens.

Area sample taken	Fecal liquid from the biogas plant		Fecal liquid from the pigpen		Night soil and urine from the enclosed privy	
	No. of exam.	Avg NH ₃ -N conc. (g/100 ml)	No. of exam.	Avg NH ₃ -N conc. (g/100 ml)	No. of exam.	Avg NH ₃ -N conc. (g/100 ml)
Intake	39	0.13				
Tank bottom	31	0.14	10	0.10	10	0.20
Outlet bottom	39	0.14				
Applied fecal liquid	40	0.14				

Factors that Affect the Efficiency of the Biogas Plant in Treating the Excreta

Tank Shape

Most of the biogas plants are fully enclosed with pressure rising and falling automatically as biogas is produced and used. Generally the length, width, and depth of the fermentation tanks are 3-5 m, 1.5-2 m, and 3 m, respectively, with a capacity of 10-20 m³. Most of the doors between the fermentation tank and the outlet chamber are as wide as the fermentation

tank. Some tanks have been modified by connecting the inlet chamber directly to the privies and pig- and ox pens. Most of the doors between the fermentation tanks and the outlet chambers in the biogas plants in the district of Mien Chu are only half as wide as the fermentation tank; in other places applied excreta tanks have been constructed adjacent to the outlet chambers, and removable drop boards have been installed across the doors (as described above).

The problems related to the shape of the tank that affect the efficiency of the biogas plant in treating the excreta are the size of the door connecting the fermentation tank with the outlet chamber and the design and arrangement of the outlet chamber and the intake area. Prior to the modification of the biogas plant, the width of the door was the same as that of the fermentation tank, and the intake chamber was directly opposite the outlet chamber. In this type of tank, when the fecal liquid was flowing or when new materials were fed in, much of the fecal sediment would flow into the outlet chamber and the parasitic eggs floated up with the fecal sludge in the applied fecal liquid, so that parasite eggs in the applied fecal liquid could not be reduced by more than 80%. In the modified biogas plant, the width of the door is only half the width of the fermentation tank and its height half of the depth of the tank.

In some other tanks where fewer parasite eggs were found in the middle and upper layers of the fecal liquid, the applied excreta tank was constructed adjacent to the outlet chamber or a removable 1-m high drop board was installed over the door (Fig. 57) so that only the middle and upper layers of fecal liquid could flow into the applied excreta tank or outlet chamber and then be removed for use. Some even constructed the intake chamber at the side of the biogas plant (Fig. 58) to keep the fecal sludge from flowing into the outlet chamber: there the parasitic eggs in the applied fecal liquid were reduced by a remarkable 98.23%. Experiments on the viability of the schistosome eggs before and after the modification of the plant show that after adding the drop board, the flukes and eggs were even more efficiently removed.

Proportions of Organic Materials Used in the Biogas Plant

About 40-50% of the biogas plants use mostly night soil, animal (mainly pig) feces and urine, and some crop stalks. Others use 10% or less of night soil and animal feces and urine and a higher proportion (15%) of crop stalks. These materials are then mixed with 50-70% of water. In some areas because of a shortage of feces and urine or because of accumulated rainwater, the fecal liquid became very dilute and larval growth increased. The pH value of the fecal liquid ranged between 6 and 8.

Biogas production increases with the proportion of night soil, poultry feces, urine, and grass in the plant's feed material. Therefore, efforts could be directed to reducing the size of the tank, and increasing the night soil, poultry feces, urine, and grass to suitable proportions. Also, work needs to be done to find an easier way to construct tanks at lower capital cost without adversely affecting biogas and fertilizer production while still treating large amounts of excreta.

Green grass, crop stalks, and leaves are among the raw materials fermented to produce biogas. One biogas plant with a 10 m³ capacity in the Chung Chiang area would require 1800-3000 kg of green grass each year. After fermenting in the biogas plant, it produces large amounts of both biogas and fertilizer.

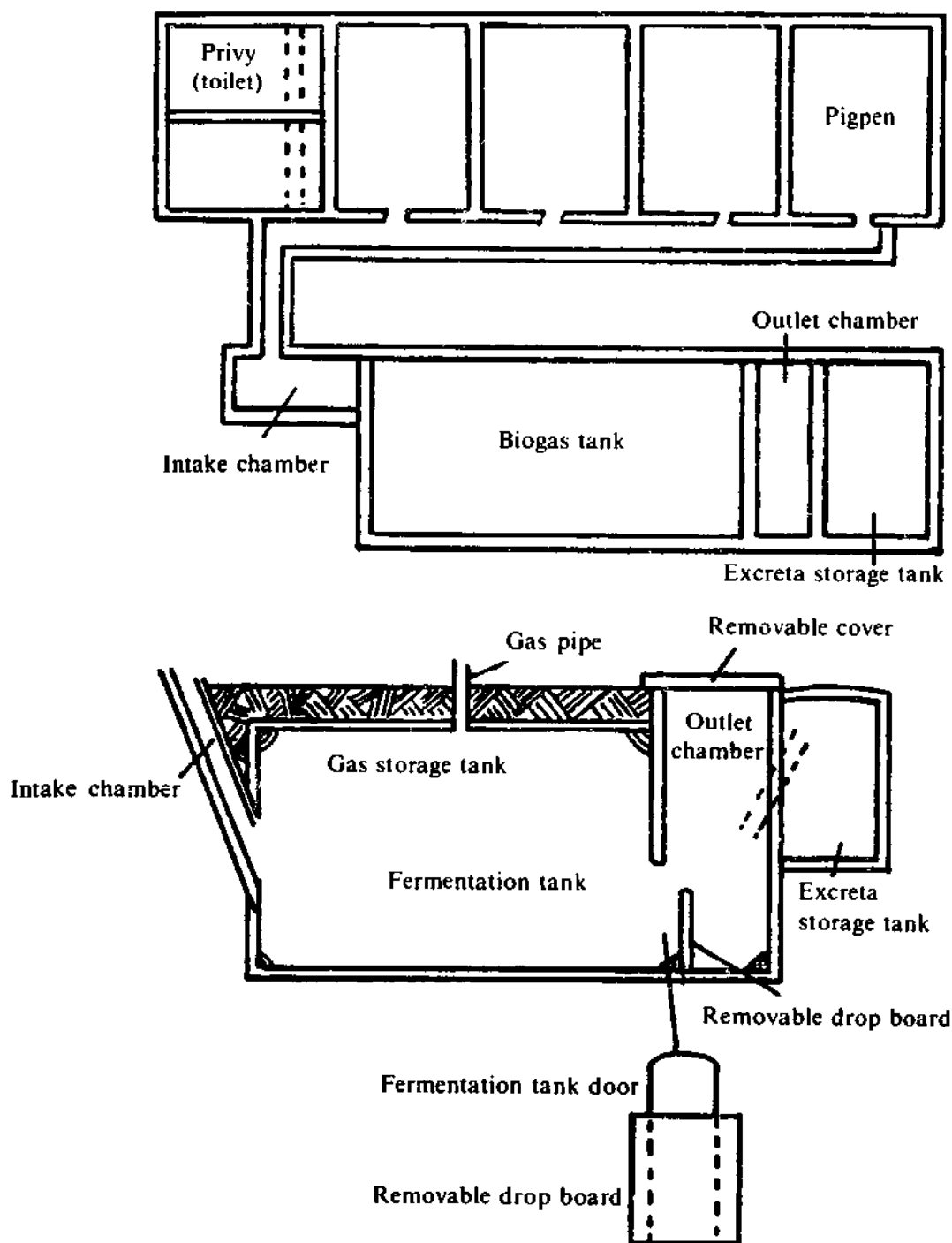

Fig. 57. Pigpen and privy biogas tank (rectangular).

Problems with Excreta Treatment in the Biogas Plant

The ability of the biogas plant to kill the bacteria and destroy parasite eggs must still be increased. The tank's temperature is not high (10-24 °C). Although the ammonia concentration of the fecal liquid is high, it does not yet

reach the concentration that could kill and destroy the worms and eggs quickly, and therefore the parasitic eggs in the biogas plant die off more slowly than in an enclosed tank of night soil and urine. The facultative bacteria such as paratyphoid B and *E. coli* can still survive longer. These are the weaknesses of the biogas plant treatment of excreta, and further research should be carried out on them.

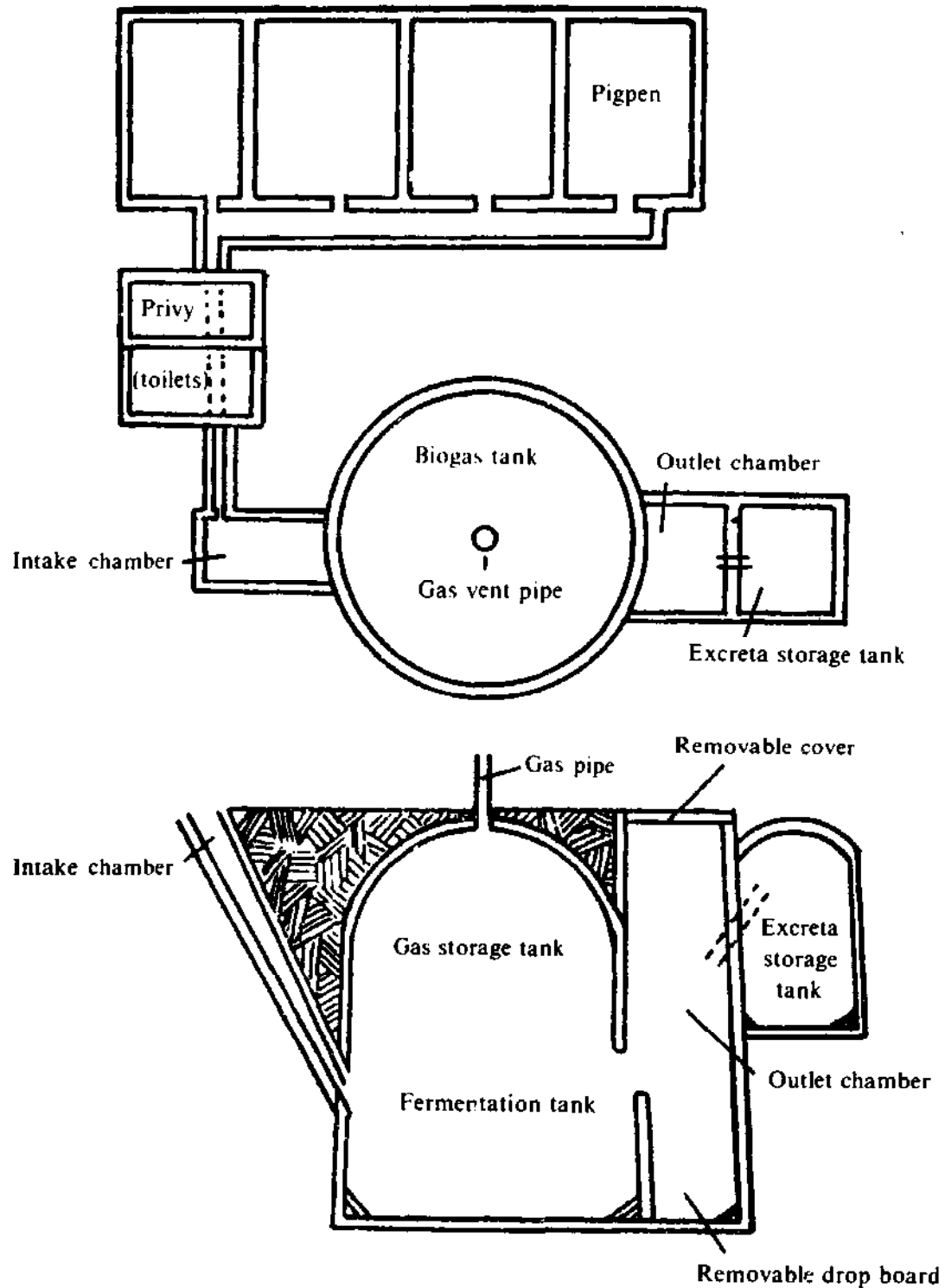

Fig. 58. Connected pigpen and privy biogas tank.

The effects of the flow of the fecal liquid inside the tank on the efficiency of the sedimentation of the parasitic eggs need to be further researched to improve the size of the tank and the efficiency of settling and removing the eggs.

Research on how to increase the biogas production and the efficiency of the fertilizer and on practical problems of biogas production and fertilizer formation is still needed.

Advantages of Excreta Treatment in the Biogas Plant

Worms and eggs are effectively removed by settling and pathogens are effectively destroyed. Advantageous conditions are created for the overall management of excreta disposal. All the night soil and poultry feces and urine can be put into it for treatment, thus reducing the number of open-air human and poultry pit privies. The result has been an improvement in public health standards.

Biogas can be used for cooking rice and animal feed and provides an efficient way to solve the brushwood shortage in the villages, also saving the labour required to collect and transport the brushwood, which can instead be diverted to agricultural production. In addition biogas production provides a large amount of fertilizer for use in agricultural production.

Biogas Production and Reuse from Farm and Human Wastes*

Connected Pigpen and Privy Three-Stage Septic Tank

During construction of pigpens and privies by the production team of T'ang Ngan, slate, lime, and fine sand were used to incorporate slate into the walls of the units. In the cover of the pigpen and privy three-stage septic tank, timbers were used to build the dome mould first, and then 1:6 cement and fine sand slurry was used to build the dome-shaped cover. After 2-3 days the cement-sand slurry dried, and then the dome mould was dismantled. The floor of the pigpen and privy three-stage septic tank was of a 1:6 mixture of cement and gravel.

For the harmless disposal of excreta in the three-stage septic tank the tank is divided into three so that the excreta flows from the first tank to the other two. The retention periods for night soil and pig feces are 20 and 40 days, respectively. Excreta inside this fully enclosed three-stage septic tank create a condition suitable for the anaerobic bacteria to grow, multiply, and ferment, producing a fixed temperature and free ammonia, in which new fecal lumps decompose rapidly and become diluted by the fecal liquid. The specific gravity of the parasitic eggs is relatively high (schistosome eggs 1.14, diluted fecal liquid 1.04), causing them to settle out. Inside the first and second tanks the mass production and multiplication of anaerobic bacteria, the heat and free ammonia created by fermentation, and other factors help kill pathogens and parasitic eggs, all contributing to the harmless disposal of excreta.

Structure of the Three-Stage Septic Tank

The tank's basic requirements are that it be waterproof and allow no leakage. Each tank should have a removable door to facilitate the desludging and repairing. In the first tank one should install a pipe higher than the roof of the privy. A connection should be provided at a suitable height between compartments. Human excreta flows into the tank through a pipe leading from the privy and the connection between the first and second tanks is half way up the partition (the partition is as high as the tank). A baffle 9/10 as high as the partition is constructed next to the intertank connection, 60 cm long and 40 cm wide, to keep the sediments containing more parasitic eggs and scum from the first tank from flowing into the second, and to allow only the middle layer of diluted fecal liquid containing relatively fewer parasitic eggs to flow through the intertank connection into the second tank.

* This preliminary report was prepared by the district of Fu Sui and the area of Lan Ning infectious disease prevention stations, in the "Chuang Tsu" (minority groups) self-government area of the Province of Kwangsi. It describes the experience of the T'ang Ngan production team.

The human excreta is retained in the first tank for 20 days and then flows into the second tank to mix with the pig feces and urine. It is stored there for another 20 days, and then flows into the third tank, where it becomes harmless. The arrangement of the intertank connection between the second and third tanks is similar to that between the first and second except that the height of the baffle is lower to prevent the pig feces and urine inside the second tank from flowing back into the first.

After the construction of the three-stage septic tank is complete, the first tank should be filled with water, and a vitrified clay pipe or precast concrete pipe 60 cm long and 14 cm in diameter should be installed, inclined at 85° to collect the excreta from the squatting area of the privy. The pipe should enter the first tank 2-3 cm below the water level. Excreta should be flushed with water down the pipe and into the first tank to prevent odours and keep mosquitoes and flies from breeding.

Size of the Three-Stage Septic Tank

The size of the first tank is calculated on the number of people using the facility and the assumption that the quantity of human excreta and water needed to flush it averages 1.8 kg per person a day, and the retention time is 20 days. The second tank's size is based on the number of pigs, each one producing about 18 kg of feces and urine per day, a retention time of 20 days, plus the volume of the first tank, as the human excreta is also retained in the second tank for 20 days. The third tank is used to store the treated excreta, and its size is based on the fertilizer requirement.

Location and Construction of the Three-Stage Septic Tank

This facility should be small and decentralized (one per 10 families) near the houses and convenient for feeding the pigs and using the privy. It must be situated at least 30 m from any water sources and must be on high ground above adjacent ponds, storm drains, and the water table so that if they overflow the efficiency of the fertilizer will not be affected.

Three alternative types of pigpen and privy three-stage septic tanks constructed by the production team of T'ang Ngan are where (1) the night soil and the pig feces and urine are mixed together and flow through the first, second, and third tanks; (2) the night soil and the pig feces and urine flow separately through the first tank, mix and ferment in the second tank, and then flow into the third tank; or (3) the night soil and pig feces and urine flow separately through the first and second tanks, and then mix in the third tank.

The second of these systems is the best (Fig. 59). Its advantages are that it transforms the excreta to a harmless state most efficiently; it effectively prevents mosquitoes and flies from breeding; and it keeps rainwater out of the septic tank. Its disadvantages are that a longer drain pipe is required for the pig feces and urine, and is therefore more difficult to clean; and it occupies more space than the others.

Connected Pigpen and Privy Biogas Plant

In the autumn of 1972 the production team of T'ang Ngan assessed the experience of other areas and their own local conditions, and constructed four

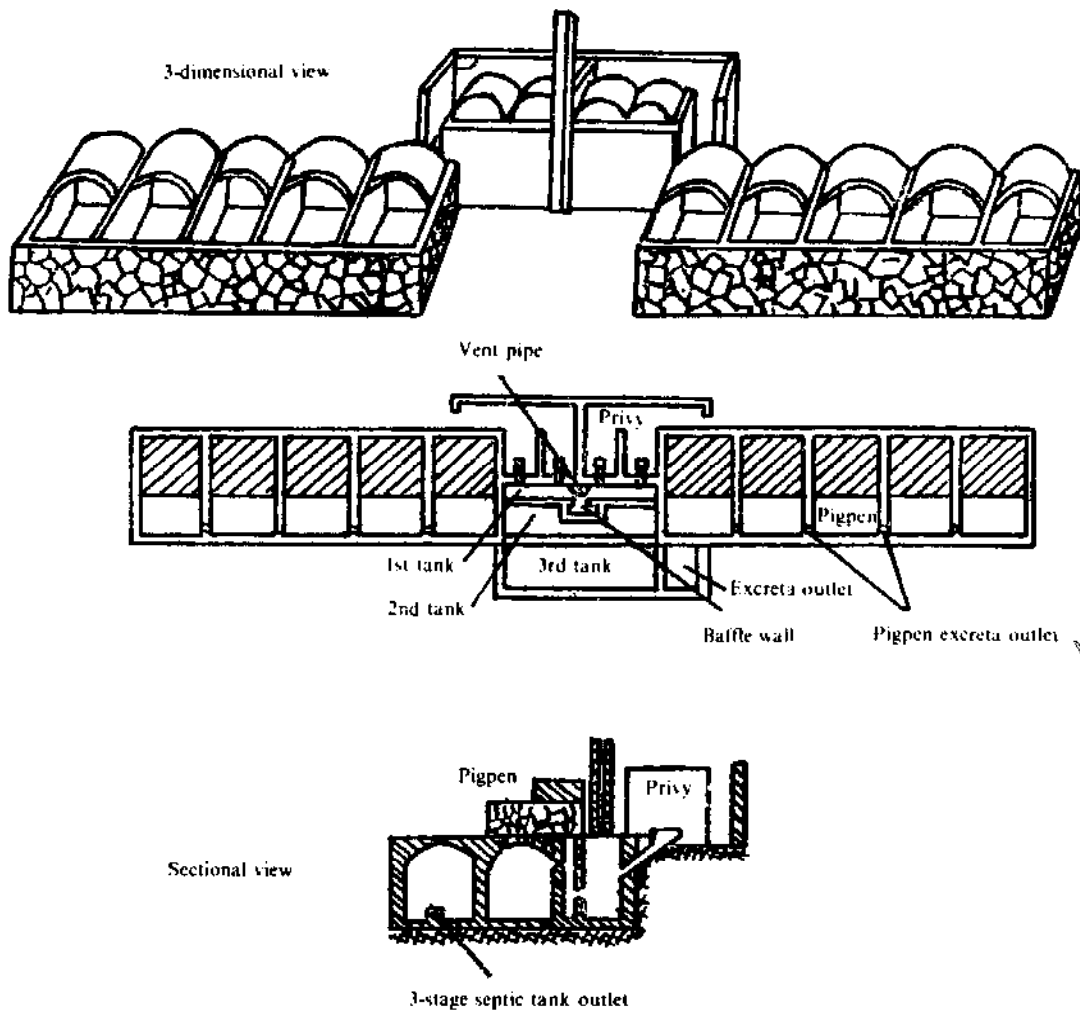

Fig. 59. Pigpen and privy three-stage septic tank.

additional biogas plants. The biogas plant replaced the three-stage septic tank in treating excreta till harmless (the ascarid eggs were reduced by 95%) and was also used to solve fuel and lighting problems.

Structure of the Biogas Plant

There are two types of biogas plant constructed mainly of rock by the production team of T'ang Ngan; one is circular (3 m in diameter and 3 m deep) and one is rectangular (4 m long, 3 m deep, and 1.4 m wide). The general structure of the early pressurized fully enclosed biogas plants built by the production teams of T'ang Ngan and Ta T'ang (public society of Fu Nam, District of Fu Sui) includes an intake chamber, fermentation tank, drop board, gas storage tank, outlet chamber, gas pipe, middle-layer fecal liquid passageway, and an applied excreta tank. Their functions and inter-relationships are described below (Fig. 57 and 58).

Intake Chamber

This is the area from which the fermentation materials are fed into the fermentation tank, and it normally is built as an inclined bell mouth, so that the fermentation materials enter easily.

Fermentation Tank and Gas Storage Tank

In this area biogas is produced and stored, and it is connected with both the intake and outlet chambers. The organic materials ferment here, producing biogas, which rises to the top of the fermentation tank where it collects in the gas storage tank.

Outlet Chamber

When the pressure inside the gas storage tank equals atmospheric pressure, the liquid levels of the fermentation tank and the outlet chamber are the same. When the amount of biogas inside the gas storage tank increases, and its pressure is greater than atmospheric pressure, the biogas pressure will lower the liquid level in the fermentation tank and consequently raise the levels in both the intake and outlet chambers, forming a "U" shape. The fecal materials in both the intake and outlet chambers will in turn put pressure on the biogas maintaining the pressure inside the gas storage tank constant through automatic pressure adjustment, and as a result biogas can be piped to each household.

Applied Fecal Liquid Storage Tank

The applied fecal liquid storage tank is connected to the outlet chamber by the middle-layer fecal liquid hole. When the biogas pressure inside the gas storage tank is higher than atmospheric pressure, the fecal liquid inside the fermentation tank is forced out into the outlet chamber and from there into the applied fecal liquid storage tank. From there it is removed for use.

Removable Drop Board

Based on the principle of middle-layer excreta removal from the three-stage septic tank, a door about 60 cm wide and half as high as the fermentation tank is built between the fermentation tank and the outlet chamber. A removable drop board two-thirds as high as the door is installed at the door. There is an applied excreta storage tank adjacent to the outlet chamber, whose floor is slightly higher than the door of the fermentation tank, and with a partition between it and the outlet chamber. A small inclined opening at the bottom of the partition, known as the middle-layer fecal liquid passageway, is built in. This is where the middle-layer fecal liquid of the outlet chamber flows into the applied excreta storage tank, reducing the number of parasitic eggs in the treated excreta there as compared to the number in the excreta in the outlet chamber.

Fully Enclosed, Pressurized Biogas Tank with Excreta Removal from the Middle Layer

Location

The biogas plant must be sited on high dry ground where the water table is low, facing the sun, and away from trees that would block the sunlight. The plant should also be near the household that is going to use the biogas. The biogas plant must be connected to the privy and pigpen.

Size and Structure of the Tank and the Materials Required

The biogas plant must be constructed underground, and it is better to bury the top of the tank 20-40 cm below ground level. The tank must be well built and strong, waterproof, and have no gas leak. The structure of a rectangular tank should be deep rather than shallow, narrow rather than wide, and long rather than short. It is easier to construct a rectangular than a circular tank, but more material is required. Normally, the tank's depth is 2.5-4 m and the width is 1-1.5 m. Less material is required for a circular tank but it is stronger and more biogas can be produced in it. Normally, a round tank's depth is 2.5-4 m, and the diameter is 2-4 m.

Calculation of the volume of the rectangular tank:

Volume of fermentation tank (m^3) = tank's length X tank's width X tank's depth

Calculation of the volume of the circular tank:

Volume of fermentation tank (m^3) = (radius of the tank)² X 3.14 X tank's depth

How big should the biogas tank be? The size of the fermentation tank of the biogas plant is determined by the amount of gas regularly produced and consumed. Every cubic meter of fecal material in the fermentation tank produces about 0.4-0.5 m^3 of biogas in 24 h. The gas needed for a 200-candlepower biogas lamp is 0.1 m^3 / h, and cooking rice and boiling water take 0.5 m^3 / person per day.

Example: Four people live in a household; they light a 200-candlepower lamp for 4 h per day, and they use biogas to cook rice and boil water. What is the required size of the fermentation tank?

Given: Gas production: 0.4-0.5 m^3 / day

Gas consumption: 0.1 m^3 / 200 candlepower-h
0.5 m^3 / person / day

Gas consumption for lighting per day:

$$0.1 \text{ m}^3 / 200 \text{ candlepower-h} \times 1 \text{ lamp} \times 4 \text{ h} = 0.4 \text{ m}^3$$

Gas consumption for boiling water and cooking rice per day:

$$0.5 \text{ m}^3 / \text{person} / \text{day} \times 4 \text{ persons} = 2 \text{ m}^3$$

Total gas consumption per day:

$$0.4 \text{ m}^3 + 2 \text{ m}^3 = 2.4 \text{ m}^3$$

$$\text{hence } 2.4 \text{ m}^3 / \text{day} \div 0.4 \text{ m}^3 / \text{day} = 6 \text{ m}^3$$

Therefore a 6- m^3 fermentation tank must be constructed to supply sufficient biogas for cooking and lighting for the household.

Construction Method

The excavation should be done following the plan. The footing of the walls must be excavated 30 cm deeper than the base of the tank, and 1:3:6 cement, lime, and fine sand should be used for the wall. When it reaches full height, the wood mould of a dome should be installed, and 1:3:3 cement, lime, and fine sand used to build the dome. The dome's mould can be dismantled

after 3-4 days. Then 1:1:3 cement, lime, and fine sand can be used to render the internal walls first to a thickness of 2 cm, then with a 1:2 cement-fine sand mix they can be rendered a second time to a thickness of 1 cm, and finally with pure cement mixed with lime the walls can be rendered twice more. The floor should then be spread with slate to a thickness of about 20 cm, and then a 1:2 cement-gravel mix poured on top to a thickness of about 15 cm, and finally this can be rendered with cement slurry. The top of the tank should be 30 cm below ground level when complete so that it can be covered with earth and protected.

Tests should be done to find out whether there is any water or gas leakage in the tank after it is completed. After proving that there are no leaks, organic material such as human and poultry excreta and urine, crop stalks, manure, and green grass can be fed into the tank in a mixture of 1 part of organic matter to 1 part of water. Some fecal liquid from the old pit privy should be added initially to the tank as seed to accelerate the growth and multiplication of the bacteria inside the tank. These bacteria continue to decompose the cellulose and produce biogas while growing and multiplying. Generally biogas is produced for 3-4 days after the material is fed in. After the gas pipe, biogas safety pressure gauge, and biogas lamp or stove are all connected, then cooking and lighting are possible. (As the use of local materials is preferred, it may be difficult to find a 1-m long, 1 cm in diameter steel or hard-plastic pipe.)

High-Temperature Composting Plant for Ox Excreta, Solid Wastes, and Grass

The composting plant (Fig. 60) creates a condition favourable to the growth of the aerobic thermophilic cellulose decomposing bacteria. Therefore, in the construction of the high temperature composting plant, a drainage system must be included that provides a through draft. Removable bricks must be placed on top of the drain. These drains are interconnected with vertical through-draft pipes in the columns at the four corners of the bins. This allows air into the compost that will stimulate the growth and multiplication of aerobic bacteria. Each compost bin is 3 m long and high, and 2 m wide. The ox excreta must be dried and crushed, then mixed with solid wastes and grass, placed in the composting bin with pig feces and urine spread over each layer, and finally kept at a fixed moisture level under an earth covering.

The temperature of the compost will increase after several days and reach 50-60 °C. The temperature will drop between 30 and 40 days later, and at this stage the compost will be fully mature. Results of analysis of the efficiency of the fertilizer show that the ammonia nitrogen content of the compost is 0.03%, which is twice as high as the results of the old method that employed drying the ox excreta (0.015%). Its advantages are that a better quality and more fertilizer is produced, excreta can be made harmless, fly multiplication is reduced, and environmental health improved. The high water content of the ox excreta and poor ventilation due to the fine cellulose, which is unable to stimulate the growth and multiplication of aerobic bacteria, make fresh ox excreta unsuitable for placing directly into the composting plant, and necessitates its being dried and crushed before use, which is a bit troublesome.

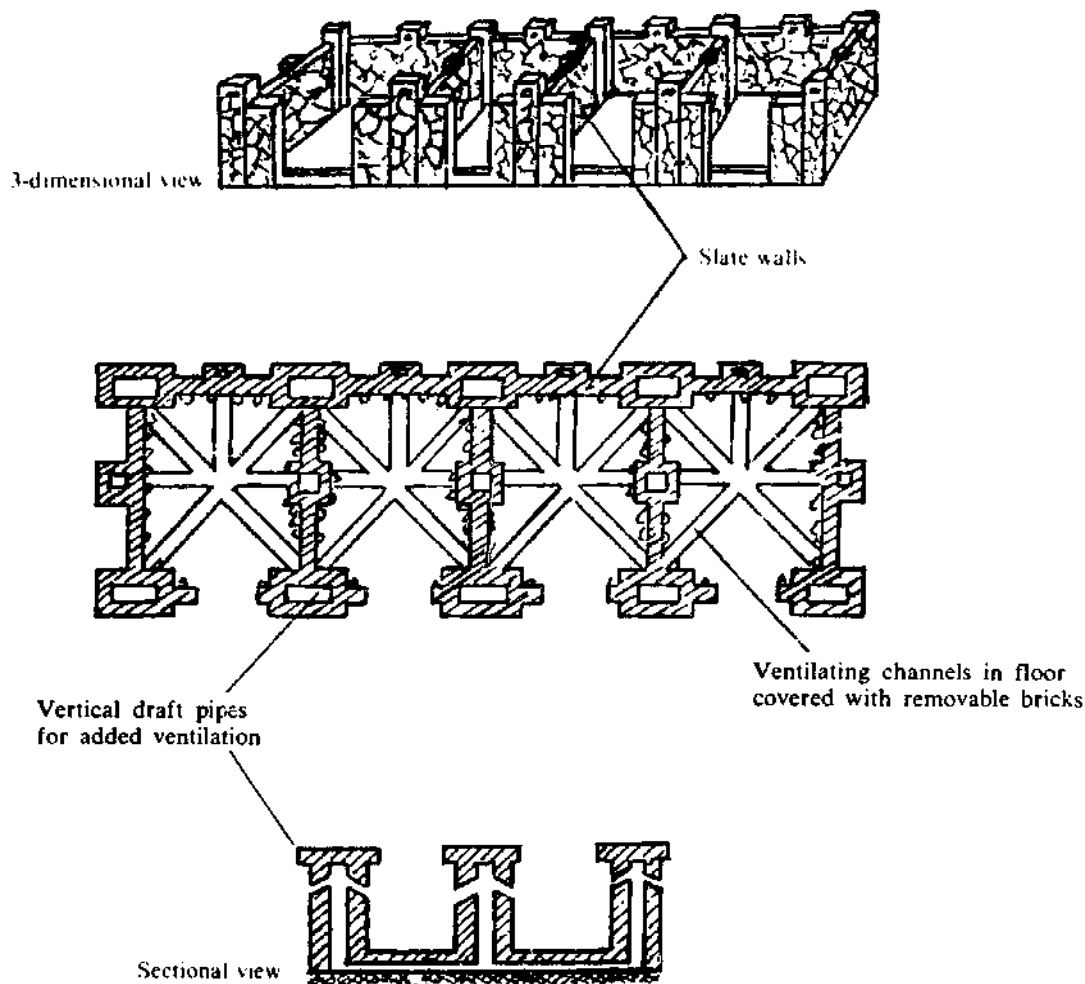

Fig. 60. High-temperature composting plant for ox excreta, solid wastes, and grass.

Safety Pressure Gauge

The gauge is made of two 1-m long glass tubes (internal diameter: 0.5 cm) and one of rubber, in a U-shape, and the glass tubes are filled with coloured water (Fig. 61). Tube A is connected with the gas pipe in the biogas tank through a "Y" tube and tube B is connected to a 100-ml (or larger) bottle.

A two-holed rubber stopper is inserted in the mouth of the bottle, and two glass tubes, one short and one long, are placed through the holes of the stopper; the short tube is connected with tube B of the safety pressure gauge by a rubber hose, and the bottle is inverted and attached near the safety gauge.

When the pressure on the water column is high from the biogas plant, the coloured water will be forced into the bottle through tube C and any extra biogas will be released through tube D. When the pressure inside the tank is reduced, the coloured water in the bottle will flow back into the U-shaped tube through tube C. This mechanism will enable the water in the gauge to adjust automatically to changes in the biogas tank's internal pressure.

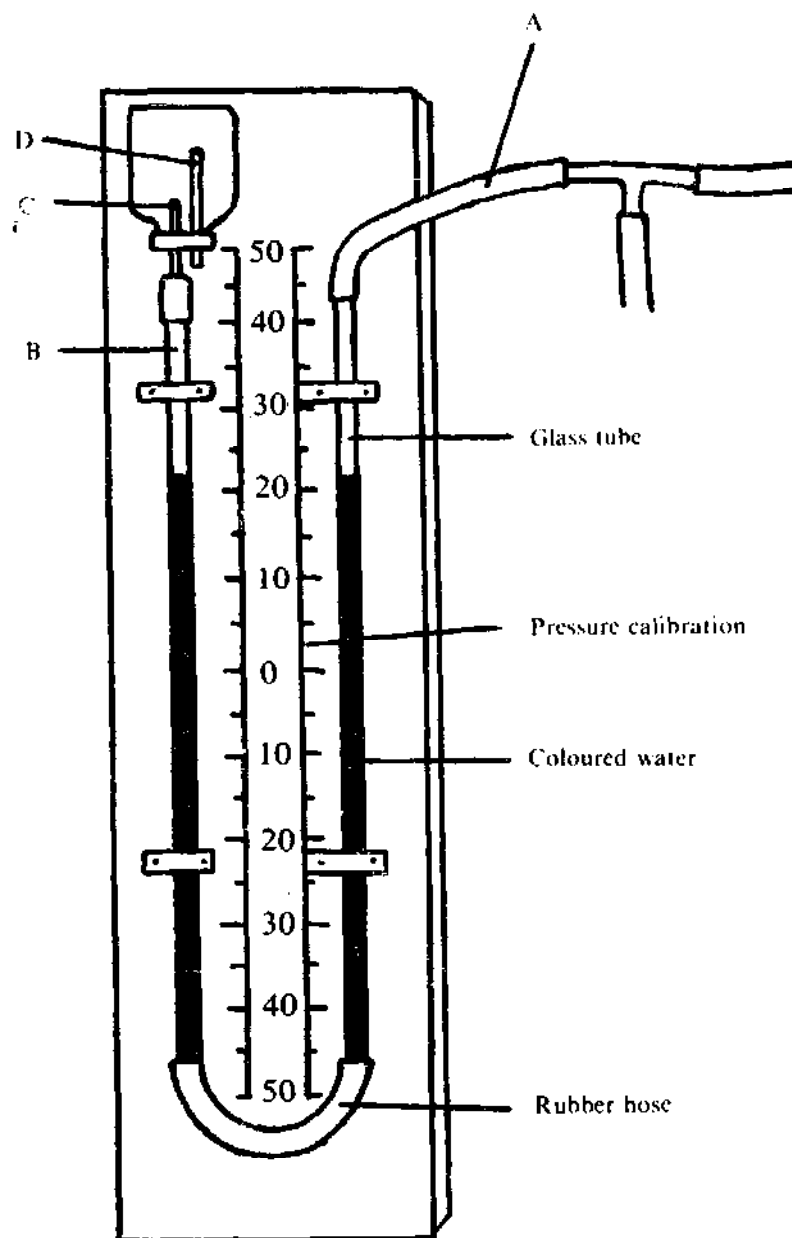

Fig. 61. Safety pressure gauge.

Biogas Earthen Stove

To make the earthen stove one can use yellow soil, red soil, or white clay mixed with a suitable amount of salt water and burnt rice husk, fine coal, or dust. These will help it to withstand heat and prevent cracking.

To reduce the forward resistance of the biogas inside the stove, the biogas-air mixing ditch must be smooth. The biogas fire openings and the biogas spurt holes should not be too big; normally, the size of a needle point should be large enough so that the biogas can spurt out under high pressure. Suitable space should be provided for the biogas to mix inside the burning

vessel, and normally it should be shallow and narrow, so that the biogas will be forced out through the openings under increased pressure. The biogas and air must be mixed in a certain proportion to enable the flame to blaze and produce a greater heat. The normal ratio of biogas to air is 1:8 (in volume). A blue flame indicates that the nozzle is properly adjusted and that the biogas and air are mixing properly (Fig. 62).

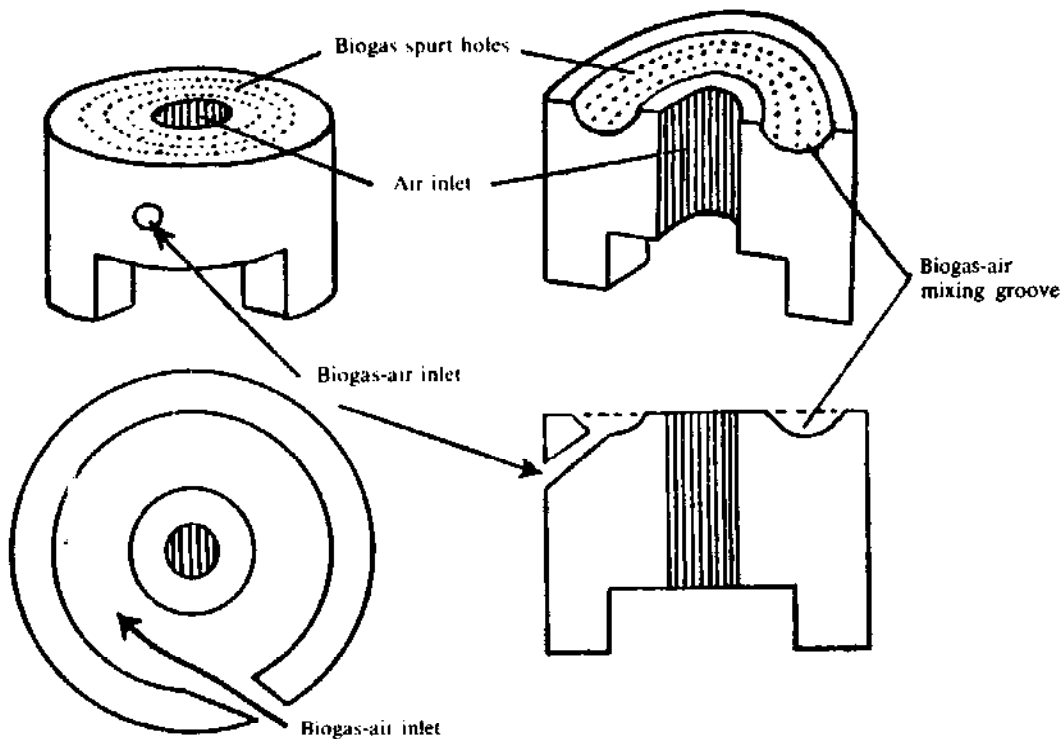

Fig. 62. Earthen stove with mixing groove.

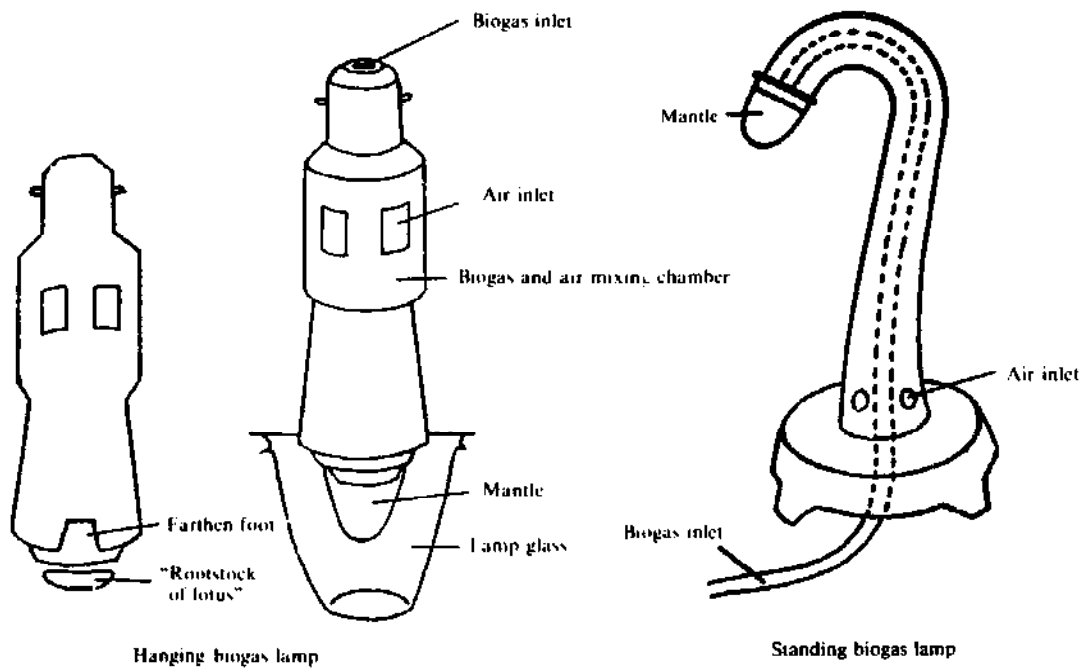

Fig. 63. Biogas lamps.

Biogas Lamps

The lamp is similar to the biogas stove as both its brightness and force of combustion depend on the biogas pressure: the ratio of biogas to air and the mixing area are also similar. The parts of a biogas lamp are the air inlet, the mixing chamber for the biogas and air, the "earthen foot," the "root-stock of lotus," the biogas inlet, the mantle, and the lamp-glass (Fig. 63).

The mantle of the biogas lamp is made of Ramie fibre net immersed in thorium nitrate solution. The Ramie turns to ashes when it burns and forms a layer of thorium dioxide which emits a dazzling white light at high temperature.