

AT MICROFICHE
REFERENCE
LIBRARY

A project of Volunteers in Asia

Rural Mechanics Course 2:
Blacksmithing, Welding, and Soldering

By: John van Winden

Published by: TOOL Foundation
Entreptodok 68A
1018 AD Amsterdam
The Netherlands

Available from: TOOL Foundation
Entreptodok 68A
1018 AD Amsterdam
The Netherlands

Reproduced with permission.

Reproduction of this microfiche document in any form is subject to the same restrictions as those of the original document.

BLACKSMITHING, WELDING AND SOLDERING

RURAL MECHANICS COURSE 2

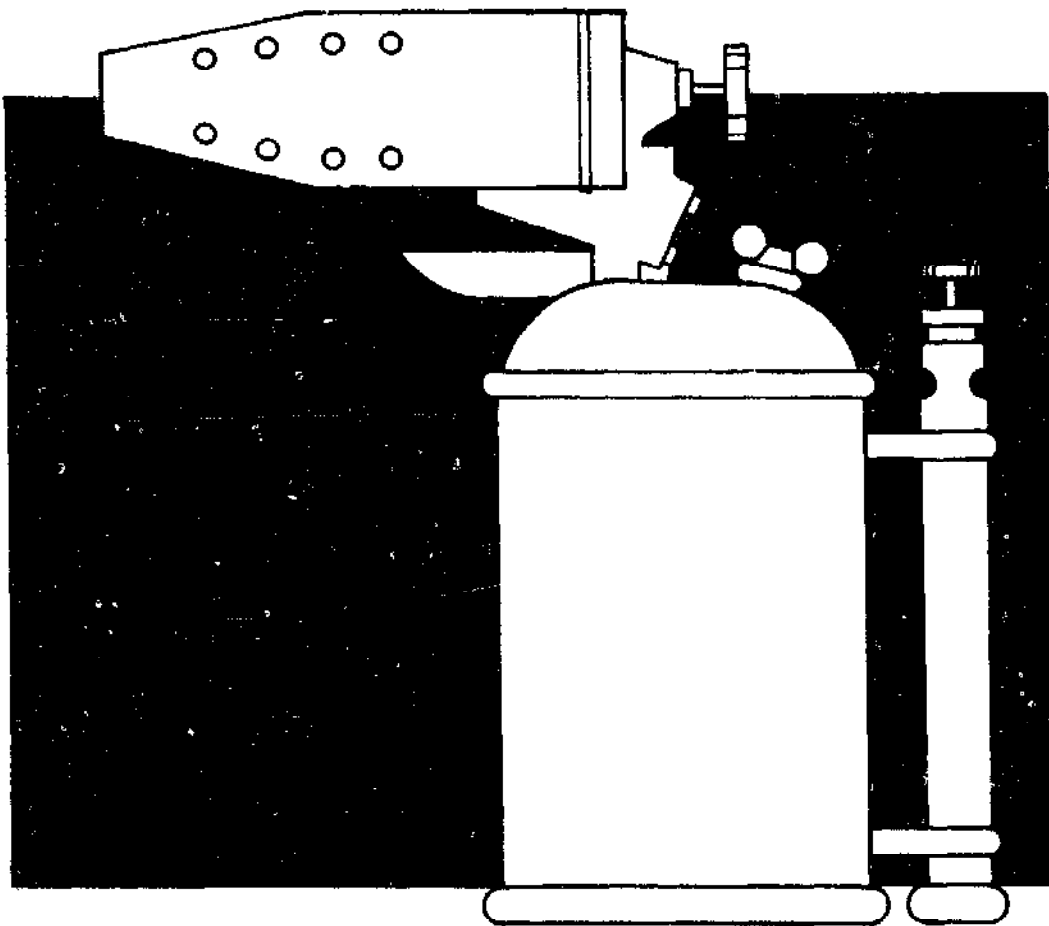

tool 

John van Winden

Blacksmithing, Welding and Soldering

RURAL MECHANICS COURSE 2

tool

First impression 1989

Publisher TOOL foundation
Entrepôtdok 68A
1018 AD Amsterdam
The Netherlands

Author Bro. J. van Winden
Drawings Bro. J. van Winden, J. Hovingh and R.
Crossen

Corrections F. de Jong, F. Grefkens, G. Klaassen
HTO platform, J. Keuper SLO
Enschede, P. Thoonsen, ITP London
UK

Translation Taalwerk textperts bv Soest
Typesetting and lay-out Uitgeverij Jan van Arkel Utrecht
Printer Krips Repro Meppel

© Stichting Kongregatie F.I.C., Maastricht, 1988

All rights reserved. No part of this publication may be reproduced in any form, by print, photography, micro film, or any other means without written permission from the publisher.

Whilst every care has been taken to ensure the accuracy of the information given in the Rural Mechanics Course neither publishers nor author can be held responsible for any damage resulting from the application of the described methods. Any liability in this respect is excluded.

CIP-GEGEVENS KONINKLIJKE BIBLIOTHEEK,
DEN HAAG

Winden, John van

Rural mechanics course / (John van Winden ; draw.
by the author ... et al.] - Amsterdam : Stichting TOOL
2: Blacksmithing, welding and soldering / [transl. by:
Taalwerk textperts bv]. - Ill., tek.
ISBN 90-70857-15-4
SISO 650.2 UDC 621.01 (075.3)
Trefw. leermiddelen ; mechanische techniek

Preface

We have decided to publish this edition of the Rural Mechanics Course in response to the many requests from people involved in training for technical vocations and in general development work.

The main aim of this set of books is to provide technical training information in understandable language and with illustrations suited to the understanding of those involved.

The contents of these books reflect the rural development taking place in the agricultural sector in particular, where many urgent needs have to be looked after and solved in order to achieve sound development at all levels.

This Rural Mechanics Course has been compiled for teaching in Technical Vocation Centres in addition to a Rural Building Course, which deals with skills such as carpentry and masonry.

We are grateful to the Stichting Brothers F.I.C., Stichting TOOL for their technical assistance, Stichting Cebemo for their financial support and the German Volunteer Service for so many volunteers who have contributed in no small way to the compilation of these books.

It is our sincere wish that the contents of these books may be of assistance in stimulating the use of appropriate techniques to aid agriculture and general development.

Bro John van Winden F.I.C.

Introduction

In many situations radical and urgent changes are taking place in rural areas in order to restore land to agriculture, to bring about better living conditions and secure health and educational facilities - the basis for a healthy economy.

Needs arising from these changes are not always dealt with because many technical institutions do not provide appropriate technical training geared to solving problems which have gone unnoticed in the past.

It can also be noted that small co-operative workshops are being started these days in the interests of agriculture and these too may develop as they deal with the upkeep of small mechanized farm implements and diesel engines used for water supply or with making ploughs, handcarts, gardening tools, etc.

Integrated and relevant technical training and grouping young people together into co-operative movements should be emphasized to ensure sound agricultural and general development. That is why an attempt has been made to achieve appropriate technical training for rural mechanics, who will contribute in no small way towards the necessary development.

Since the technical needs in rural areas are many but do not on the whole need highly specialised technicians to solve them, the rural mechanic - because his training covers a broad basis - will often be solving problems arising from the introduction of new implements or tools.

The course lasts four years, almost two years of which are set aside for so-called 'on-the-job training'. This is practical training provided in various workshops under the guidance of qualified technicians as well as a centre instructor who visits the workshop at intervals to see for himself how the trainees are progressing. During 'on-the-job training' the trainee is rewarded for his work which may help him later to buy the set of tools he has used during his training, so he can start working immediately after completing the course successfully.

Rural mechanics course

A set of four books has been compiled to accompany the four-year course for rural mechanics:

- 1 - General metal work, sheetmetal work and handpump maintenance
- 2 - Blacksmithing, welding and soldering
- 3 - Maintenance and repair of stationary diesel engines
- 4 - Technical drawing

While each of these books covers the full material of one course, a lot of additional information needed besides the contents of one particular book will be found in another book. So it is difficult to use just one of these books without consulting the others. The text on the properties of metals, for example, is to be found in the general metal work book. But this information is also needed when you are dealing with other subjects, such as diesel engines, blacksmithing etc.

As mentioned above, this course is made up in such a way that most of the practicals can be carried out with a limited set of tools. You will however notice that extra equipment or tools are needed sometimes and these must be available in the Vocational Centre's workshop.

It is believed and hoped that with the formation of co-operatives these additional tools and equipment will be available in the workshops because, though they are more expensive, they can be owned by the group.

The main aim of this course is that the trainee, besides acquiring a good formative background, will learn to master such skills as:

- working with and maintaining all the tools explained
- blacksmithing to such a degree that he will be able to shape different metals to the required implements, tools, etc.
- repairing, maintaining and installing hand waterpumps
- dismantling, repairing and assembling stationary diesel engines
- sketching or drawing simple items in orthographic, oblique and isometric form; reading engine or machine manuals.

This set of books can be used partly in the classroom but must also be used during workshop practice, where the reality of what can be seen will add greatly to the text and

illustrations in the books. Practical exercises recommended in the books can be varied since the practical nature of this course calls for articles to be made which can be used directly by people who may order them. But care should be taken that, though production may be necessary for one reason or another, all the skills which must be mastered are incorporated in each practical, so as to ensure sound training.

It is very important to study the proposed timetable given in each book to ensure that all skills are given the necessary attention. Apart from the progress made by each trainee, the time recommended for each skill may vary as well. Some skills take more time to master than others.

You will note the absence in this course of the science which may be important in explaining the diesel engine in particular. Providing this background theory is however beyond the scope of the course. But if the need arises, the relevant science should be included during part of the related subject time.

This Rural Mechanics Course is the result of many years' observation and experimentation with different techniques. The contents have frequently been revised to serve all those interested in rural development, and it is hoped this course will be used in many technical vocation centres and communities. It is also the sincere wish of the founders of this course that the trainees should feel on completion of their training that they are able to contribute personally to the development of the rural areas, which is of such importance to any general development.

Rural mechanics course lay-out and timetable

Four year training course

- a - Full Centre training: workshop practicals, trade theory, technical drawing and related subjects. Two years = 80 weeks
- b - Partly Centre training: trade theory, technical drawing, related subjects. Practicals take place outside the Vocational Centre. One year = 40 weeks
- c - On-the-job training: practicals take place outside the Vocational Centre. (Practicals are however controlled by Centre staff and marks are awarded for any progress made.) One year = 40 weeks

Total vocational training time
Four years = 160 weeks

Weekly timetable for related subjects and practicals

a - Trade theory	4	hours
b - Technical drawing	1 1/2	hours
c - Mathematics	2	hours
d - Language	2	hours
e - Other related subjects	2 1/2	hours

Total related subjects	12	hours
Total hours workshop practice	28	hours

Total training time in centre 40 hours

Four-year timetable, workshop practicals.

One full year reserved for Centre workshop practice:

a - General metal work	
b - Blacksmithing	
c - Welding and Soldering	
d - Sheetmetal work	1120 hours

One full year reserved for Centre workshop practice:

a - Stationary diesel engines	
b - Agricultural machinery	1000 hours
c - Water pumps and water supply	120 hours

Two full years reserved for on-the-job training:

a - One year partly practicals	1120 hours
b - One year full on-the-job training outside the Centre. (Care should be taken that the time is evenly divided for practical training in all skills.)	1760 hours

Three-year centre timetable for trade theory

a - General metal work	}	240 hours
b - Welding and soldering		
c - Blacksmithing		
d - Sheetmetal work		
e - Stationary diesel engines		220 hours
f - Waterpumps and supply		20 hours

Total theory time: 480 hours

Blacksmithing

In days gone by blacksmithing was practised and regarded as an art form as well as a skill because many articles were also made for decoration. But for some time the skill of blacksmithing declined because many blacksmiths did not know how to handle modern requirements. Nowadays the introduction of modern methods of agriculture and animal traction means the need for blacksmithing has become urgent again since many implements can be made and repaired locally.

In this part of the Rural Mechanics Course, blacksmithing is explained through text and illustrations and some practical examples. As you will note, most examples shown in this book are in line with requirements in the agricultural sector since most of the needs are at that level.

The explanations in this book make no claim to give a full, specialized training in blacksmithing. The contents should be seen as appropriate techniques to serve the prevailing needs.

As explained elsewhere, blacksmithing should not be taught right at the start of the Rural Mechanics Course. It is advisable to give some training first in general metalwork before any actual blacksmithing is practised, so that the trainee already has some understanding and feeling for metals and handling tools.

At the beginning of the blacksmithing exercises the trainee should be given plenty of time to get acquainted with a hammer action on metal. With each hammer blow, gentle or full force, the metal reacts and bends in one way or another. The observations and feelings during this action should give the trainee the skills required to do all the necessary practicals.

Though this book is for use in the classroom, it should be used frequently in the workshop as well where practical results can be compared with the text and illustrations in the book. It must be realized that blacksmithing is to a large extent a matter of practical experience and the text and illustrations can only aid this process.

Besides the hammer action, the colours appearing during the heat treatment of metals are very important and here again a lot of time should be spent on observation of these colours.

Forge welding can be practised at the end of the course. Although this is a very difficult skill it may be good to let the trainee gain some experience in this field.

Scrap metal is sometimes used for blacksmithing and it is important to test this metal first for its properties - a process which is explained in the general metal work book. Only when the metal used has been identified can the correct treatment be given.

To ensure sound but economical training, many exercises can be carried out on the same piece of metal. So practicals should be set which are not on too large a scale but demand the practise of various skills at an early stage.

Good teamwork should be encouraged during blacksmithing exercises because most of the jobs have to be done with two or more craftsmen. It is therefore advisable to have the trainees working in pairs for some time to foster the spirit of teamwork and also to make it possible for pairs to observe each other during particular exercises.

Although techniques are explained in the text and illustrations, they may sometimes differ which is why trainees should be encouraged to observe and practise different methods and to be inventive where necessary.

At least at the very beginning of this course trainees should be given the opportunity to shape metal freely, without too much stress on dimensions. Only after they have acquired the necessary feeling for hammer actions and heat treatments and how metal reacts should more attention be paid to exact dimensions.

Practical training

As explained before, this course allows for practical training both in the Centre workshop and outside the Centre (on-the-job training). During the Centre training, spending time on serial production of real articles is not encouraged because this will interfere with the schedule, so production should be reserved for the on-the-job training period.

But a good training method may include the making of implements such as ploughs, harrows, carts, etc. Although these implements may be large in size and demand different skills, they can be made in parts. The skills needed to make these parts should coincide with the programme of practicals being taught at that particular time in the workshop. Finished parts can be stored until all the parts of that specific implement have been made and can then be assembled. During practical work in the workshop attention must be paid to cleanness and safety. Tools must have their place on the workbench or in the toolbox and materials must be looked after.

Final marks given for each finished workpiece should incorporate marks for the construction, the use of tools, the tool itself, economy with materials and procedure, cleanness and safety.

Additional information needed to master the skills of blacksmithing can be found in the other books of the Rural Mechanics Course.

Arc welding, gas welding and soldering

It is often necessary to join metals and recondition certain farm tools or implements and this frequently involves welding.

Although the trainee is encouraged during this course to work with a limited number of tools, it should also be noted that, with the formation of co-operative movements, many members may buy and own more expensive equipment such as gas or arc welding sets. Supplementary text and illustrations on these skills are therefore included to ensure fully and widely trained craftsmen.

This book contains text and illustrations on the best common methods of arc welding, gas welding and soldering. Parts of this book can be explained in the classroom but the greater part should be used in the workshop, where actual work is practised and the results obtained can be compared with the text and illustrations offered.

Additional knowledge needed for welding is to be found in other books of the rural mechanics course.

Workshop practicals on welding are often expensive and difficult to carry out to the full extent. But at the beginning of the course much can also be learned from observation and evaluation.

It is advisable to have trainees working in small groups where one does the actual welding and others observe, discuss and evaluate the job done. The first exercises can be done on scrap metal but at a later stage products made during general metalwork or blacksmithing exercises may need to be welded together.

Besides the workshop practicals, trainees receive so-called 'on-the-job' training where welding can be practised. That is why the instructor placing a trainee for on-the-job training must know what the main activities are in the particular workshop so that he can ensure sound practical training.

When a welding job is finished, marks should be awarded not only for the quality of welding but also for such aspects as the time taken, especially if a generator set is used, acetylene or oxygen consumption, welding rods, etc.

Safety first

In this part of the Rural Mechanics Course you will learn how to shape metals so that you will be able to make articles which are useful to our community. Agriculture is the most important activity in our area, so you will spend a lot of time learning the necessary skills and techniques for making and repairing agricultural implements. The various processing techniques in metalworking can cause damage to your health if you don't follow the safety regulations.

Safety

Keep your eyes wide open; "keep a close watch", "judge" and "act". Learn the safety rules which you will be taught during this course.

The first thing you should remember is that the workshop is a place for working, not a playground. Watch the other activities in the workshop and make sure you're alert whenever an accident happens.

Learn these rules

- Watch your step! Don't come too close to anyone who is working with tools, so you won't get hurt by accident.
- Always stand upright! Don't lean against walls or workbenches. If an accident were to happen, you might not be able to act in time.
- Take care that your tools are in good condition! You might be blamed for causing serious injuries to other people if they're not!
- Learn how to help with first aid in case of accidents! You might even save your own life by knowing how to act.
- Keep your head out of the way when you're hammering a piece of metal! The hammer head may slip and hurt you or your helper.
- Always wear safety-goggles when necessary, to protect your eyes against tiny pieces of metal which may fly around when you're forging, cutting or grinding.
- Never swing a hammer towards another person, the hammer head may slip and hurt someone.
- Don't walk barefoot across the workfloor; sharp or hot pieces of metal might hurt your feet.

**BEWARE OF HOT METAL - IT MAY
LOOK AS IF IT'S COOLED DOWN, BUT IT
HASN'T!**

Measuring and marking

Steel rulers

The rural mechanic can use three different types of ruler for blacksmithing.

Fig. 1-A shows a 300 mm steel rule which is used for small work. Fig. 1-B shows a 1000 mm steel folding rule which is used for larger measuring. Fig. 1-C shows a 1000 mm steel measuring tape used for curved measuring.

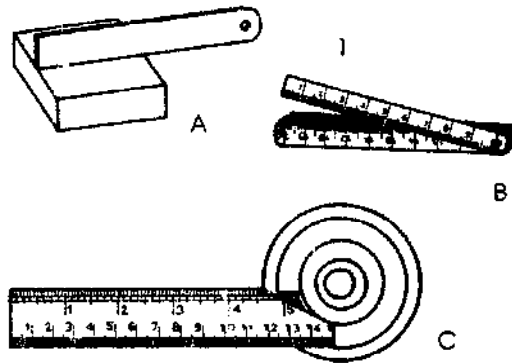

Squares

Two different types of square are used for blacksmithing.

A try square for small work is shown in Fig. 2-A. Fig. 2-B shows a larger square for large work.

Sliding bevel.

The sliding bevel as shown in Fig. 2-C is used to check the different angles.

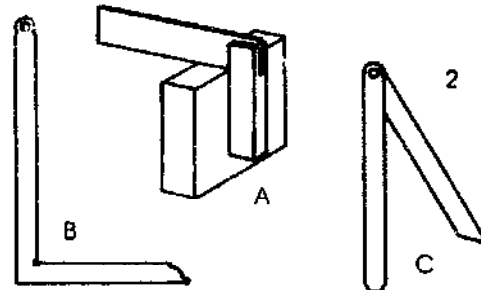

Scriber/Punch.

The scriber is used to mark lines on the metal. These lines are difficult to see on hot metal, so the punch is used to make marks which are still visible when the metal is hot. See Fig. 3.

Dividers

A divider is a two-legged instrument with hardened points, used to mark curves and transfer dimensions from the hot metal to the rule. See Fig. 4-A.

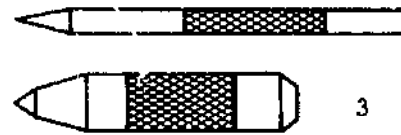

External callipers.

The pair of external callipers shown in Fig. 4-B is also used to measure hot metal, flat or round, and transfer these measurements to the rule.

Blacksmith's gauge.

The blacksmith gauge can be made in the rural workshop from sheet metal. The gauge is used to measure hot metal. It has some openings with different dimensions. See Fig. 5.

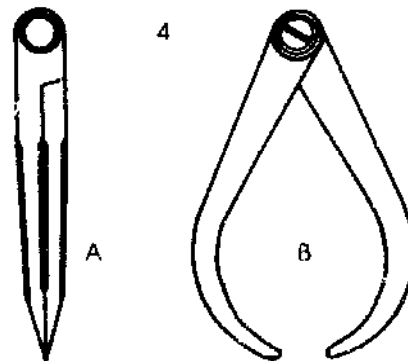

The anvil

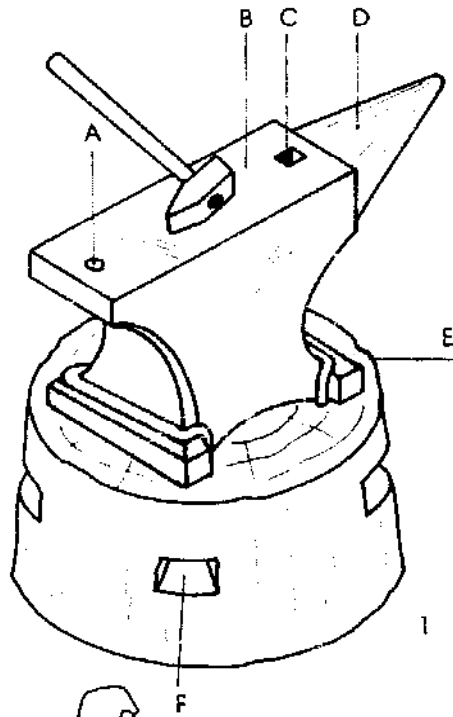

The anvil is the workbench for the blacksmith. It is used for all kinds of blacksmithing operations. The surface of the anvil is made of hardened steel and must be kept clean and free from rust and other dirt. The anvil as shown in Fig. 1 should be mounted on a firm base to resist the vibration caused by hammering.

The anvil base should be made of concrete or (even better) from a log. The grain of the log should be vertical to reduce vibration. A band of steel can be put round the log to prevent the log from splitting. The anvil is held down with four fixings secured to the base. See Fig. 1-F.

The names given to the parts of the anvil are:

A - Punch hole, a round hole to punch through
B - Face, the top of the anvil which is used for drawing down metal, cutting, hammering and other general work

C - Hardie hole, for inserting tools

D - Round beak, used for rounding operations

E - Anvil stand, the wooden or concrete stand on which the anvil is mounted with brackets or bolts

Position of the worker at the anvil

Mount the anvil at such a height that you can reach it with the knuckles of your clenched fist when you're standing upright. See Fig. 2. The correct way of standing at the anvil is with one foot parallel to it and the other one at a straight angle.

The right foot is usually placed directly under the punchhole. See Fig. 3.

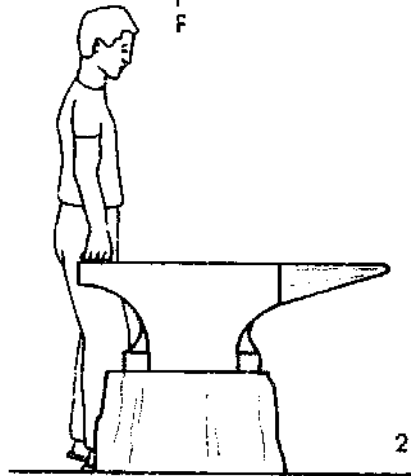

Locally made anvil

A locally made anvil is shown in Fig. 4. It is made from a piece of rail and shaped like an anvil. It is good to make a slot in the top of the base when you mount this type of anvil, to ensure rigid mounting.

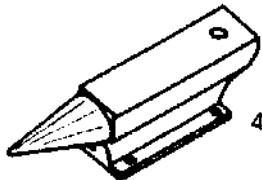
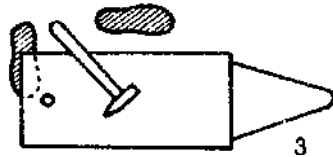

Blocks and vices

Wooden block

Shaping materials with an irregular shape is not always done on the anvil. Other materials, like a wooden block (see Fig. 1) can also be used as an anvil.

This block is used to shape agricultural hoes. Farmers are very particular about the shape of their hoe. Different people like different shaped hoes. So a wooden block can be shaped and the sheet metal can be hammered to this shape.

The shaping should be done very quickly, otherwise the hot metal might burn the wood. Re-shape the top if necessary.

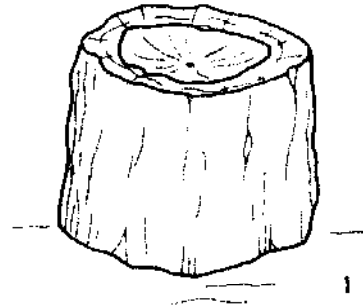

Swage block

A swage block as shown in Fig. 2 is used to forge material with different cross-sections into the required new shape.

The curved sections on the four sides can be used to change the cross-sections of bars from round to semi-circular, etc.

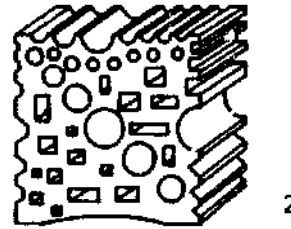

On the flat side of the swage block there are many differently shaped holes which can be used to bend bars, form heads on bolts, etc. The swage block is often mounted on a specially designed table.

Bench vice

A bench vice for blacksmithing should be designed in such a way that it can stand a great deal of force, Fig. 3.

A good bench vice is made of cast steel. The spindle and thread should be of good quality.

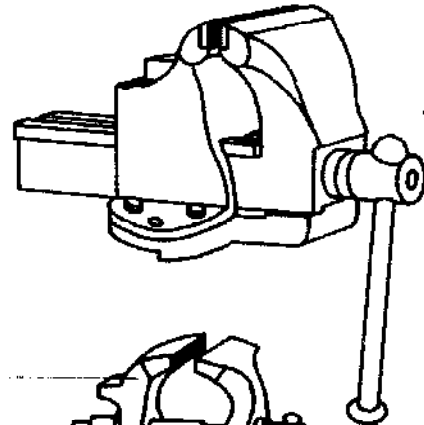

Leg vice

A leg vice as shown in Fig. 4 is designed for really tough blacksmithing work. The leg of the vice is placed in line with the stationary jaw 4A-B. The leg is fixed to the workbench with a clamp, 4-C. The jaw is fixed to the top of the bench with a plate and bolts 4-D.

The movable jaw is guided between two steel plates, 4-E. The jaw pivots on a bolt, 4-F.

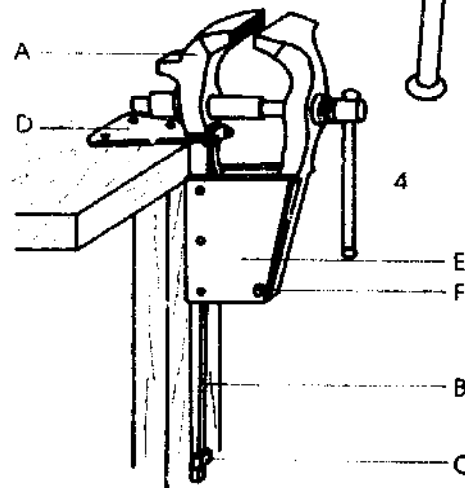

Tongs

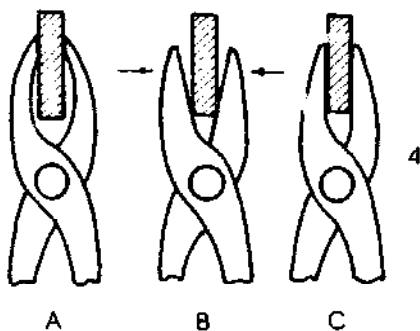
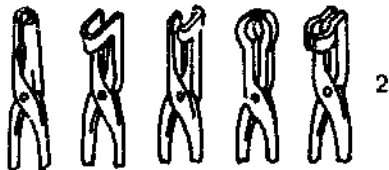
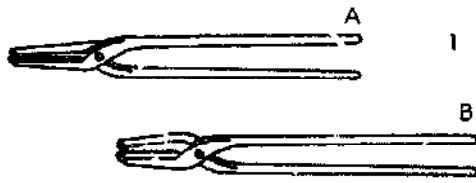

Tongs are used to hold workpieces during forging operations. Great attention should be paid to the design of the tongs and the quality of the steel. Tongs should be able to hold a workpiece firmly in order to make a good workpiece and avoid accidents.

Shape of tongs

The mouths of tongs are shaped differently to ensure the grip on workpieces of different cross-section.

The two pairs of tongs shown in Fig. 1-A and 1-B are the most commonly used tongs. Tongs 1-A are used to pick up hot metal and are therefore called pick-up tongs.

The tongs shown in Fig. 1-B are designed with an open mouth to secure the grip on metal with an larger cross-section. These tongs are called open-mouth tongs.

Other tongs are shown in Fig. 2. They have different shapes to suit the grip on metal of different cross-section.

Universal tongs

When you study the shape of the mouth of the universal tongs, see Fig. 3, you see that these tongs can be used for metal of different kind of shapes. So it's very useful to have these sorts of tongs in the rural workshop.

Correct shape of mouth

When you're checking the different tongs, make sure that the mouth is correctly shaped to ensure a firm grip on the workpiece. The tongs shown in Fig. 4-A have a mouth which is too wide, it grips only with the tips.

In Fig. 4-B you can see that the mouth is too narrow. The metal doesn't fit completely into the mouth of the tongs.

Correctly shaped tongs are shown in Fig. 4-C. The mouth has a good grip on the whole workpiece.

If the mouth of the tongs is too wide or too small it is good practice to insert a piece of metal between the legs and re-shape the mouth on the anvil with the actual workpiece placed in the mouth. See Fig. 4-B.

Hand hammers

You need hammers of various designs for forging operations. The most common hammer is the hand hammer, which is used with one hand. Two types of hand hammers are commonly used in the rural workshop:

- straight pein hammer
- cross pein hammer

Both types of hammers are shown, Fig. 1 shows a straight pein hammer, Fig. 2 shows a cross pein hammer.

The weight of hand hammers varies from 1 to 2 Kg. The length of the handle varies from 150 to 350 mm depending on the work to be done. The cross-section of the handle is shown in Fig. 3; its dimensions are 20 x 30 mm.

Hammer handles

All hand hammers have wooden handles. Handles should be made of straight grained wood, without knots or other defects. The handle should have an appropriate length and a good shape.

Don't use handles made of cross grained wood. Most tropical woods are cross grained, they're no good for this purpose. But in the bush you can find branches from certain trees which can very well be used for handles.

As shown in Fig. 3, all hammer heads have a lightly curved hole which is used to house the handle. The dimensions of the handle should be equal to the dimensions of the hole in the hammer head.

Push the handle into the hole of the hammer head and strike the top of the handle with another hammer. Never strike the hammer head to fix the handle; that method is wrong, the head will not be fixed firmly onto the handle.

Place a wedge in the handle as shown in Fig. 4.

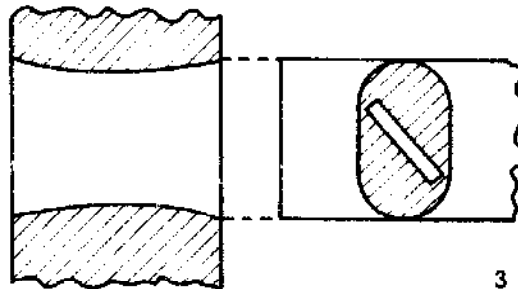
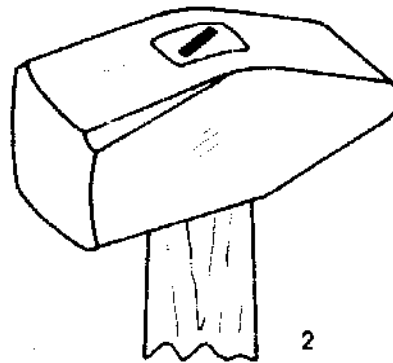
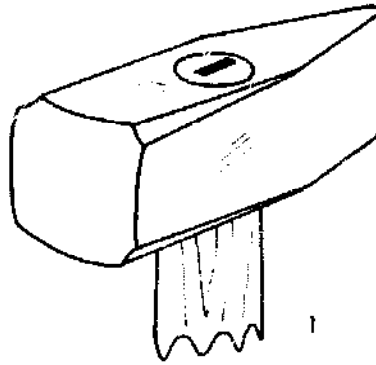

Striking with the hammer

Success in blacksmithing largely depends on the ability to strike the hammer efficiently. Most blacksmithing operations require heavy, well-directed blows. Where they are more suitable, light blows should be used.

Strike **LIGHT** blows with a motion from the **WRIST**. See Fig. 1.

It's important to strike one or two light taps first to find the right direction and grip on the hammer to direct the hammer blows accurately. Follow with quick sharp blows of appropriate force.

Use your **WRIST** and **ELBOW** for medium blows. See Fig. 2.

It's also important to use a hammer of the right size. Using a heavy hammer on light work is awkward, the blows cannot be placed accurately. Using a light hammer on heavy work is a very slow and tedious business.

Use a heavy hammer for heavy blows. Use your **SHOULDER**, your **ELBOW** and your **WRIST** as well. See Fig. 3.

REMEMBER:

- Grip the handle firmly.
- Most of the movement should come from the wrist.
- Never strike a hammer on a hardened surface, the hammer might bounce or get damaged.
- The striking surfaces of the hammer and the anvil should be free of dirt and oil.
- Assure yourself that the hammer head is properly secured.

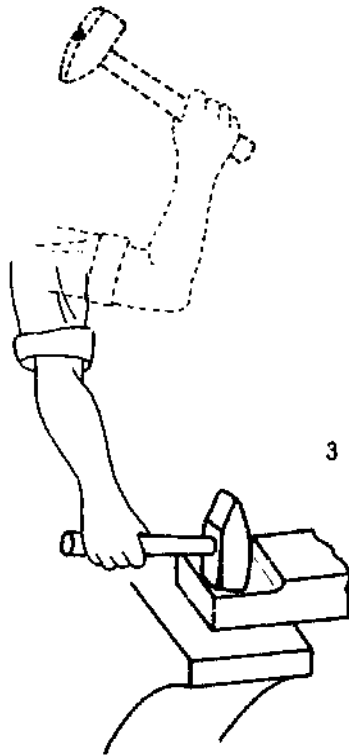
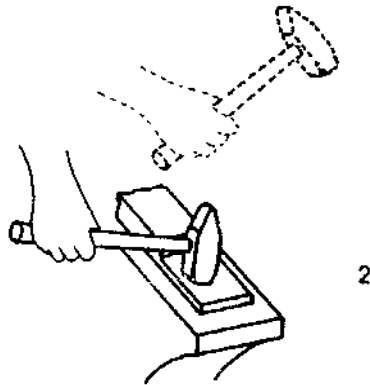
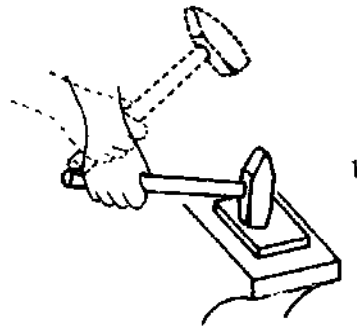

Bench hammers

It's very useful to have bench hammers as well as hand hammers in the rural workshop. These hammers are mostly used to shape sheet metal.

Most of the time we use:

- Cross pein hammer, see Fig. 1.
- Ball pein hammer, see Fig. 2.

The hammer heads are made of tool steel. The ball, pein and face of these hammers are hardened. Hammers are sold at weights from 0.1 to 2 kg.

The heads of the hammers are rounded off slightly. This is done to avoid making any marks on the steel during the shaping, see Fig. 3.

The handles of these hammers are shaped differently than the handles of hand hammers. The handle of the hand hammer is straight, while the bench hammer's handle is slightly curved over the entire length, see Fig. 3.

The hole in the hammer head is different too. It's not curved but conical towards both sides of the hammer head, see Fig. 3.

The shaped hammer handle is forced into the hole and secured with a wedge on the other side (Fig. 4), filling up the gaps 3-A and 3-B.

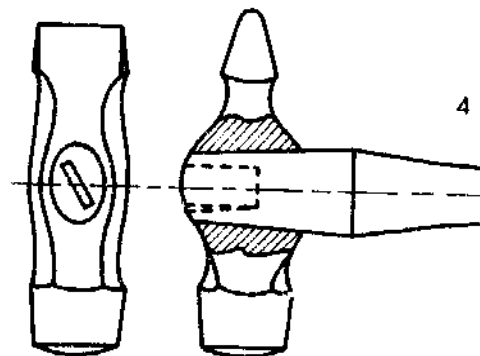
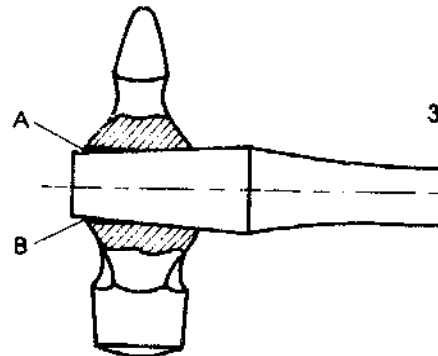
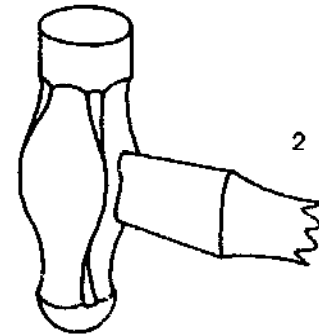
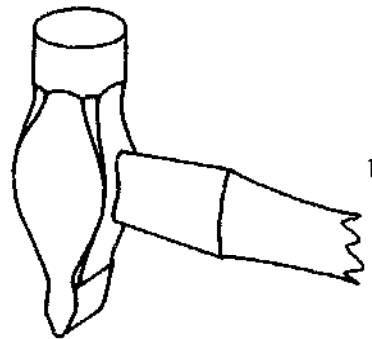

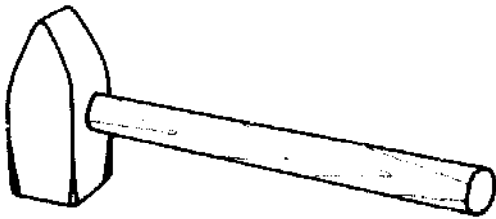

1

Striking with the sledge hammer

A heavy sledge hammer (from 3 to 10 kg) as shown in Fig. 1, is used to speed up the forging of heavy materials. It's economical to do the forging as fast as possible, because then less re-heating is necessary during forging.

In every hammering operation, the body motion should combine maximum precision in direction with the energy put in the hammer blow.

Before striking the workpiece, place the hammer head on top of the workpiece or tool to find the right distance you'll have to take during the forging operation.

It will take a lot of time to master this hammer. Hold the hammer in both hands firmly. The heavy hammer head needs precise guidance to make sure it will land exactly flat and vertically on the workpiece.

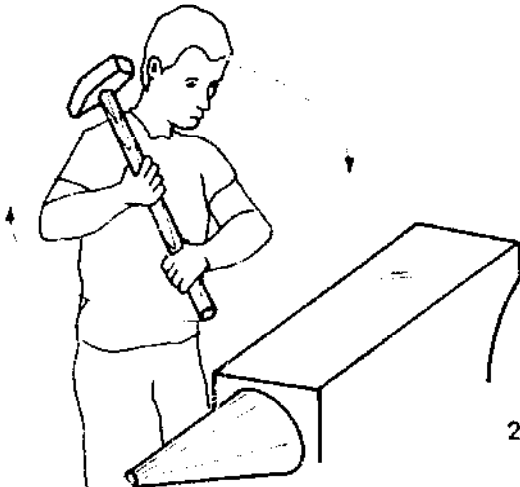

2

As shown in Fig. 2, the sledge hammer is held firmly at the end of the handle with one hand. The right hand is then placed somewhere in the middle. The whole hammer is held over the right shoulder.

Start moving the hammer, while the left hand moves the handle to the right side of the body to give it room to pass, the right hand guides the hammer head, sliding forwards, see Figs. 3 and 4.

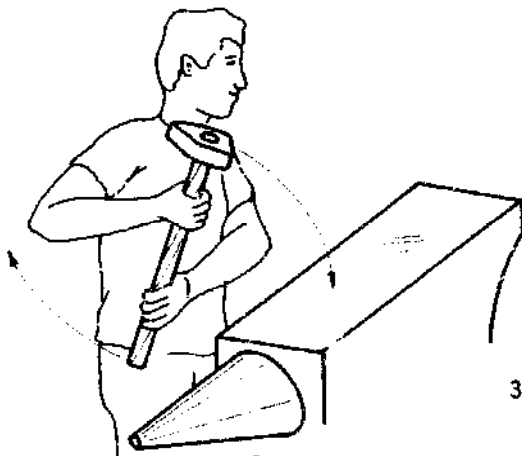

3

Hammering procedure

As mentioned before, good understanding between the blacksmith and his helper is important.

See to it that, when the helper uses the sledge hammer, the blacksmith guides the rhythm of the blows with his hand hammer.

If he finds it necessary to stop, he just touches the anvil lightly with his hand hammer - a sign for the helper to stop immediately.

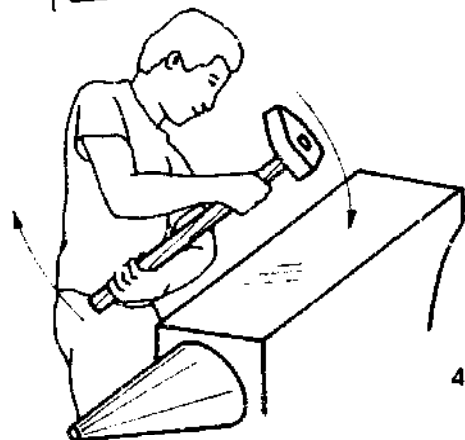

4

Safety precautions

Check that the handle and the wedge are fixed properly before you start to use the sledge hammer. A hammer head that is not fixed properly will easily lose its grip during forging.

Forge

The forge is a very important piece of equipment in the rural workshop. It should be placed in a semi-dark place to ensure correct observation of the colours appearing when the steel is heated. It is advisable therefore to have a movable forge, especially if the workshop is not large and the forge is not in use all the time. Forges can be made of different materials. The size should suit requirements but a square area of 60 x 60 cm is usually enough. The top should be on the same level as the anvil.

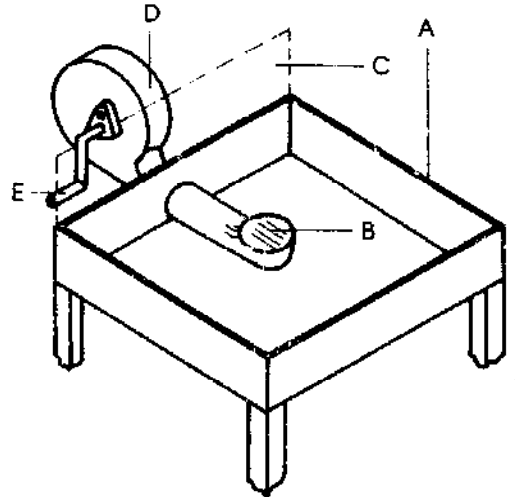

Forge and blower

A forge with hand-cranked blower is shown in Fig. 1. The whole construction is made of steel and angle iron, the top has a wire edge 1-A. The inside top of the forge should be lined with fire clay to form the fire-resistant base for the fire. A hole is left in the centre to allow the air from the air gate to pass through 1-B. A metal shield 1-C can be placed at the end of the forge to protect the helper turning the fan from the heat.

The air needed for the fire is forced from the fan 1-D through the blow pipe to the air gate 1-B. This is done with handle 1-E and with the help of a gear system at the side of the fan.

Any ash entering the blow pipe through the air gate 1-B can be taken out through the ash hole, Fig. 2-A.

Fig. 3-A shows a rake which is used to push charcoal together.

Fig. 3-B shows a water jug which is used to keep the fire under control so that ash is limited.

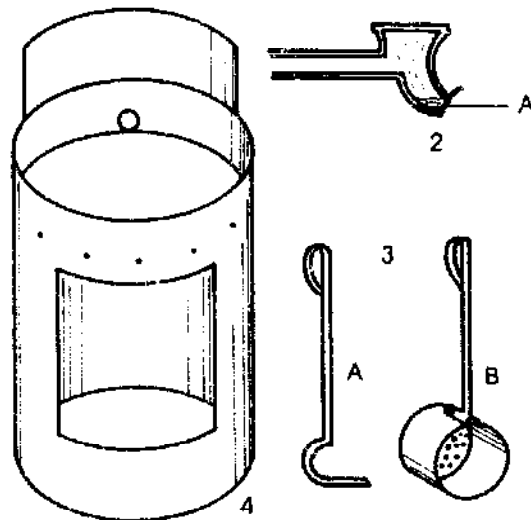

Other types of forge

Another type of forge construction is shown in Fig. 4. It is made from an oil drum. Here again, the lid of the oil drum should be mounted at a lower position for the clay base. A hole can be cut in the front to store charcoal. The blower can be mounted at the back with brackets.

A forge can also be built up from clay, see Fig. 5. It would be advisable to re-inforce the top with a concrete layer. The hole under the forge can be used for storing charcoal.

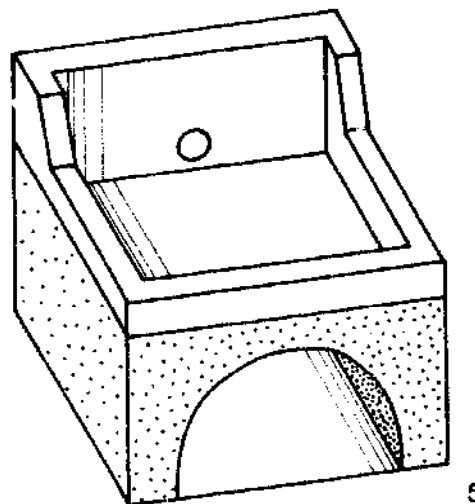

Blowers and bellows

Centrifugal blower

A good centrifugal blower as shown in Fig. 1 can be made in the rural workshop. For construction you need:

- Bicycle wheel and handle, mounted on a steady construction.
- Fan made from sheet metal and shaped as shown in Fig. 1-B.
- Steel axle and bearings.
- Wooden pulley.
- Fan housing, made from wooden sides and covered all round with thin sheet metal.
- Blow pipe to forge.

It should be understood that the larger the bicycle wheel and the smaller the diameter of the wooden pulley, the faster the fan will turn.

Bellows

All kinds of bellows can be made. It is a good idea to visit a local blacksmith and study the type he's using.

A particular type of bellows is shown in Fig. 2. These bellows are mounted behind the forge and ensure a steady flow of air. Part 2-A is used to supply the air to part 2-B, where the air is stored and pressurized by weight 2-C.

Fig. 3 shows a cross-section of these bellows. The whole construction is made of three pieces of thick plywood and covered with leather. The centre board 3-X is stationary - that is, it does not move. If board 3-A is fixed with a long hinge, it can be pushed down. If this is done, air will flow through valve 3-B to the lower chamber. If you lift board 3-A, valve 3-B will close and the air will flow to the top chamber through valve 3-C where the air is pressurized by weight 3-D. The blow pipe 3-E has such a diameter that the required amount of air can easily flow into the forge.

Fig. 4 shows a cross-section of similar bellows but made from old car inner tubes. The tubes are fixed to a wooden box, 4-A, and two movable boards. If weights are placed on board 4-B, the air will be pressurized in chamber 4-C.

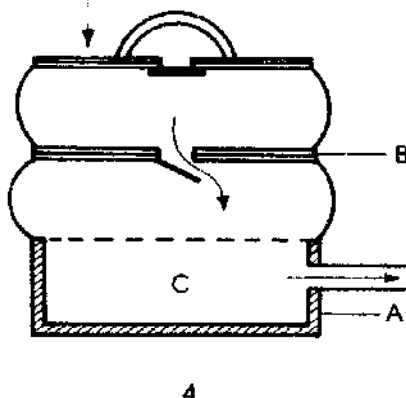
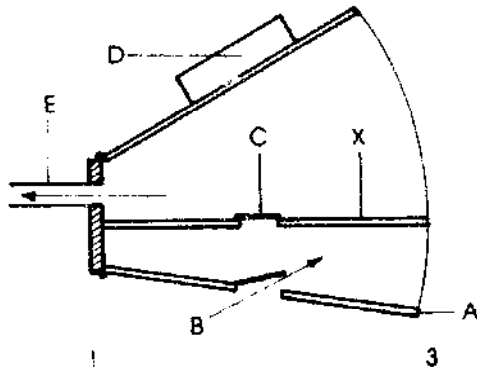
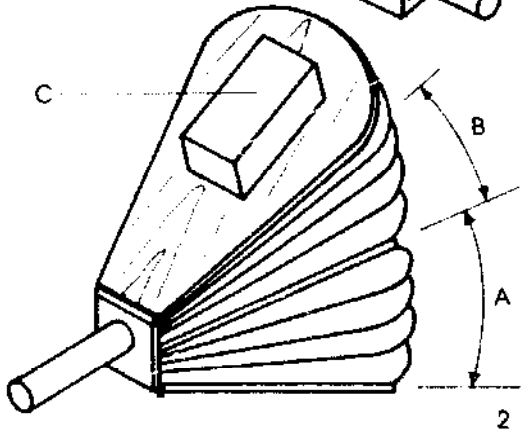
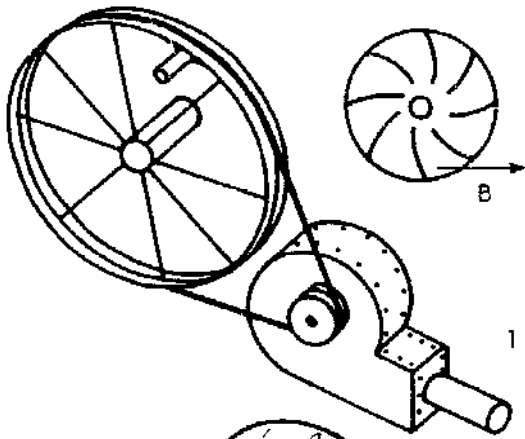

Fuels for forging

There are different fuels for forging. The best known for us is the charcoal made by burning hardwood trees. Other fuels such as palm nut shells or coconut shells are used in different parts of the country.

Charcoal should be stored in a dry place, off the ground, because it easily absorbs moisture and then performs poorly during burning. Charcoal should also be graded well - that is, it should have small and larger pieces so that a good forge fire can build up.

Most of our experience described in forging is based on the use of charcoal. Be careful with other fuels, because every fuel has its own properties and may give other results during forging.

Fire management

The forge in the rural workshop should be located in a semi-dark place to make the forging colours visible. There should be ample space round the forge to allow room for heating large pieces of steel.

To light the fire, put some dry paper or long wood shavings on top of the air gate. Light the paper and blow some air, gently turning the fan or moving the bellows. Add some medium sized dry charcoal while supplying a little more air. Build up the fire by adding the necessary charcoal and blowing air gently. Push the charcoal together with a rake to stop the fire becoming too large. Blow enough air to ensure that no sparks fly off from the fire; the fire should burn with gentle blue flames.

Position of the workpiece

The position of the workpiece in the fire should be such that it cannot be cooled by either the cold air entering through the air gate or the surrounding cold air. Fig. 1 shows incorrect positioning of the workpiece. Fig. 2 shows the correct position of the bar. It will be heated all round.

Long pieces should be positioned as shown in Fig. 3. It is therefore good to build the fire bed as shown, so the bar can be supported on two sides.

Since blacksmithing usually involves two people, the helper should turn the fan or operate the bellows while watching the fire and adding fuel when necessary.

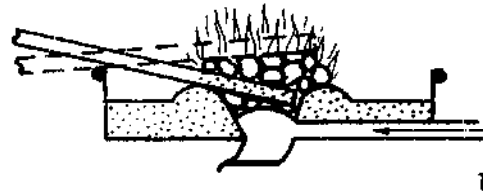

1

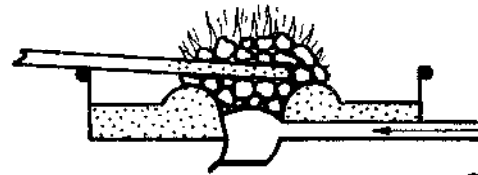

2

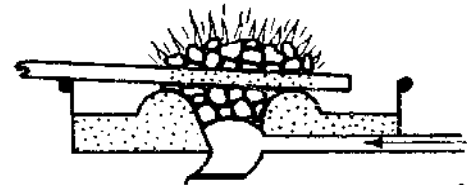

3

Forging temperatures for mild steel

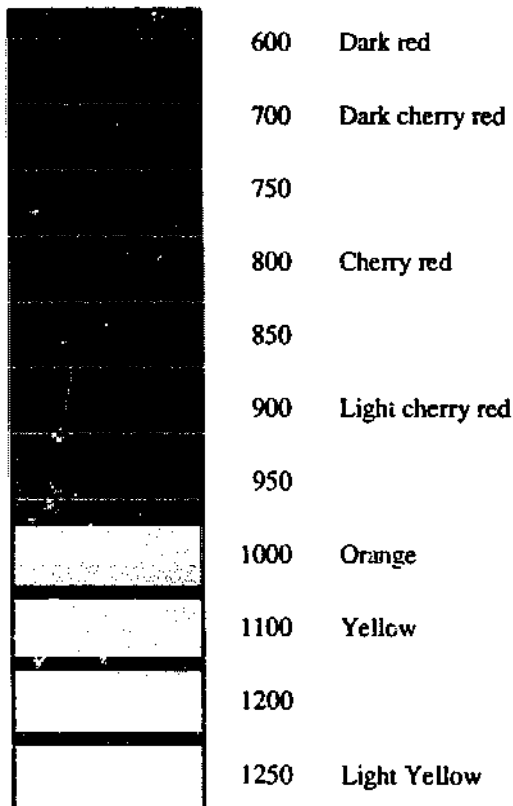

It is very important for the rural mechanic to learn how to judge the forging temperatures of steel because there is a limited temperature range in which forging is possible. When steel is heated, you will see the colour of the steel change. First it glows with dark red colour. When it becomes hotter, the colour changes to orange and then to light yellow.

The hotter the steel, the softer it gets. When forging mild steel, only two temperatures are important for the beginner:

- THE TEMPERATURE AT WHICH TO START FORGING
- THE TEMPERATURE AT WHICH TO STOP FORGING

Forging temperatures

Fig. 1 shows the colours at the different forging temperatures. The temperature at which mild steel is forged is between approximately 950 and 1100° Celcius.

When you have heated the steel to this temperature, it will glow a yellow colour. The workpiece must be taken out of the fire when it reaches this temperature and is this colour. Now it can be forged easily because it is very soft.

The steel cools during forging and its colour turns darker. Stop forging when the steel turns red. The temperature of the mild steel is then approximately 900° Celcius. You will notice that forging becomes more difficult as the steel cools. The lower the temperature of the steel, the harder it becomes.

REMEMBER:

- Never heat mild steel above 1100° because this temperature will make it burn. The steel is burning when you see sparks flying off the workpiece.
- Never forge mild steel below 950° because the steel may crack due to hot brittleness.
- Make sure you observe the colours in semi-dark surroundings. If there is too much light in the workshop, the colours are difficult to recognize.
- Burning steel can no longer be used.

Heating small workpieces

When heating small workpieces, watch the colour of the workpiece very carefully to ensure the right temperature. Since a small workpiece cannot hold much heat, it is best to heat the tongs to be used so they do not reduce the heat of the workpiece.

Sheet metal

Sheet metal up to 3 mm thick and pieces of steel with a small diameter are placed on top of the charcoal fire without being covered. Thin metal and small pieces heat up very quickly and you must watch carefully during heating, otherwise they may overheat and burn. It is impossible to see the colour if there is a layer of charcoal on top of the metal.

Tapered pieces

Very often pieces with a tapered end have to be heated. The tip of the taper heats much faster than the thicker end. To avoid overheating the tip, cover the thicker part with charcoal and leave the thinner part free. If necessary, the thin part of the workpiece may have to be cooled with water to avoid over-heating.

Localized heating

If it is necessary to heat only one particular part of the workpiece, you must use the water jug and regularly spray water round the locally heated part of the workpiece.

Scale

During the manufacture of steel bars and forging operations, scale is formed by either the rolling mill or the hammer. The wheels of the rolling mill and the face of the hammer are cold and when they touch the heated steel they cool the surface of the metal. So scale forms on the surface.

Scale, which is thus thin layers of quickly cooled metal, peels off the metal during forging. If scale is hammered into the material it reduces the quality. Scale should be shaken off the metal by knocking it after heating against the side of the anvil and the anvil can be cleared of scale regularly with the side of the hammer.

Speed and accuracy

Speed and accurate work are essential to produce good forging work. Slow forging and correcting mistakes during forging leads to high consumption of charcoal, wasted time and poor quality in the workpiece produced.

To produce good forging work, remember the following:

- Be clear about how to execute the work, all steps should be known in advance.
- Have all roughly shaped and cut materials on hand as well as the necessary tools.
- Choose a heavy hammer whenever possible, light hammers are not efficient for general forge work.
- Remember, it is very bad practice to take out the heated workpiece and then look for your hammer.
- Build up a good, correct fire.
- Always have as many workpieces as possible in the same fire. Instead of heating one workpiece at a time, several can be heated together; this is economical. A helper who turns the blower can manage the fire at the same time and select the piece which is ready to be forged.
- Heat workpieces to the correct temperature, heat only that part which is to be forged.
- Do not lose any time when transferring the workpiece from the fire to the anvil, small pieces cool down very quickly.
- Do not continue hammering when the workpiece is cold; re-heat it.
- Keep the following in mind: it is necessary to work fairly quickly in order to maintain the correct temperature.

Forging precautions

Certain safety precautions must be taken into account while forging. The most important are:

- If possible, wear a leather apron so that hot pieces of scale flying around during the forging cannot burn your clothes.
- Use the correct tools for forging.
- Check the hammer, chisel heads, wedges and handles regularly.
- Make sure you and your helper communicate well with each other.
- Place all the tools in convenient places before you start forging so you can take them up very easily when you need them.
- Cool the cutting tools in time when they become too hot during forging.
- Place finished hot workpieces out of reach; they are still very hot which cannot be seen from just looking at them.
- Ask visitors to stay far enough away from the forge and anvil to avoid accidents.
- After use, check all the forging tools and re-shape them if necessary before storing them in the tool store.

The flow of grain in steel

The advantage of forging shaping materials with cutting tools is that the forging procedure does not disturb the flow of grain in the steel.

That is why products made by forging are stronger than the same products made with cutting tools.

Examples are shown in Figs. 1, 2 and 3. First, items made by forging are shown. Fig. 1-A shows a spanner made by drop forging. Fig. 2-A shows a forged bolt head and Fig. 3-A shows a hole made by punching. Items cut from the solid are shown in Fig. 1-B (spanner made with cutting tools), Fig. 2-B (machine made bolt head) and Fig. 3-B which shows a hole made by drilling.

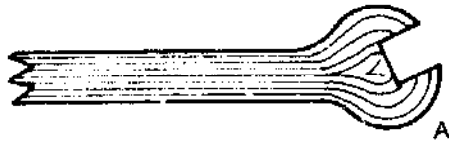

1



B



A

2



B

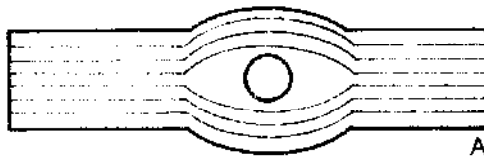

A

3

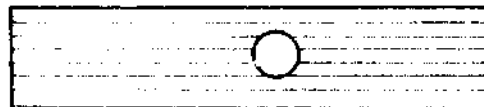

B

Alignment

Re-aligning

Before you attempt to start forging, you have to check the material for straightness. Straightening pieces of metal is called re-aligning.

Re-aligning as shown in the illustrations is forming metal without cutting. It removes unwanted changes in the shape of materials which have been caused during transport.

Straightening bars

If a bar is bent, it can be straightened by short blows over the hardie hole of the anvil. Two people are needed if the bar is long. After every blow the bar should be moved a little. Do not hammer too much in one position. See Fig. 1-A.

Bars can also be straightened over the length of the anvil, see Fig. 1-B. Do not hold the bar too tight. The vibration during hammering can be very painful.

Straightening wide stripes

The straightening of wide stripes is shown in Fig. 2. Place a packing block in the anvil. Place the strip with the hollow side down on top of the anvil and hammer with short blows over that part of the surface which is not supported. Cover the whole length of the bend.

Twisted bars

If bars are twisted, they can be straightened with a torsion tool as shown in Fig. 3. Clamp the bar in the anvil and place the torsion tool at the far end. Twist the tool in the required direction.

Torsion tools have different openings. A wide opening cannot be used for bars with a small diameter.

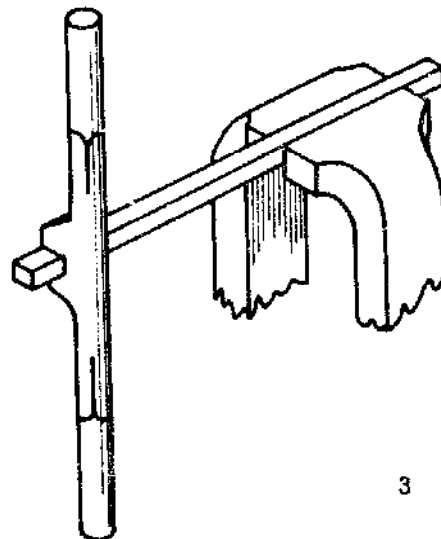
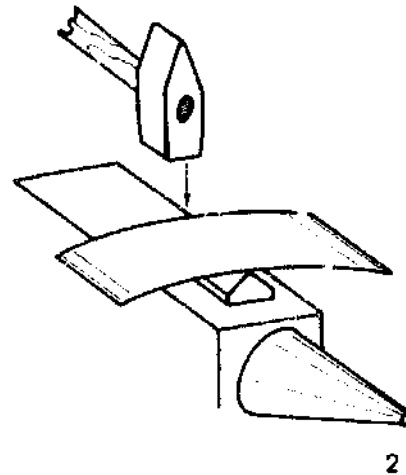
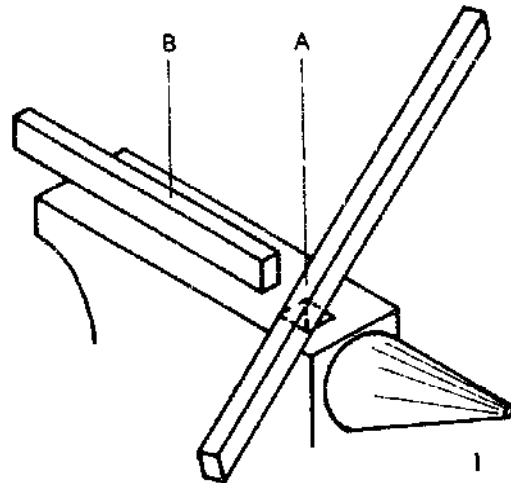

Hammer action

A heavy hammer may be chosen for shaping metal. This hammer is held firmly to ensure the correct action.

The face of the hammer should always hit the workpiece very flat on the surface so that no hammer marks can be seen. Fig. 1-A shows the correct way of hammering out and Fig. 1-B shows the wrong way. Note the marks left behind.

Hammering out

The shape of the workpiece changes during hammering out. It may become longer, wider, thinner or curved.

It makes a difference whether you use the face of the hammer or the pein. If you use the face of the hammer, as shown in Fig. 2-A, the material spreads evenly in all directions.

If you use the pein of the hammer, as shown in Fig. 2-B, the material spreads in only two directions. When hammering with the pein, you can control the way in which the workpiece will extend. If you hammer and pull towards 2-X at the same time, the workpiece will become longer in that direction.

Bending and shaping

A flat strip of metal can be curved sideways by hammering one half of the strip. This is a good way to make a curved knife.

- Scribe a line on the workpiece, as shown in Fig. 3-A.
- Hammer the part 3-B as shown, with the pein of the hammer.
- The hammered part becomes longer and this makes the strip bend.

NOTE:

During hammering the outside of the edge becomes thinner. That is why you must place the workpiece near the edge of the anvil to be able to let the pein of the hammer project over the edge of the workpiece. A piece of metal may also be placed under the workpiece, Fig. 4-A.

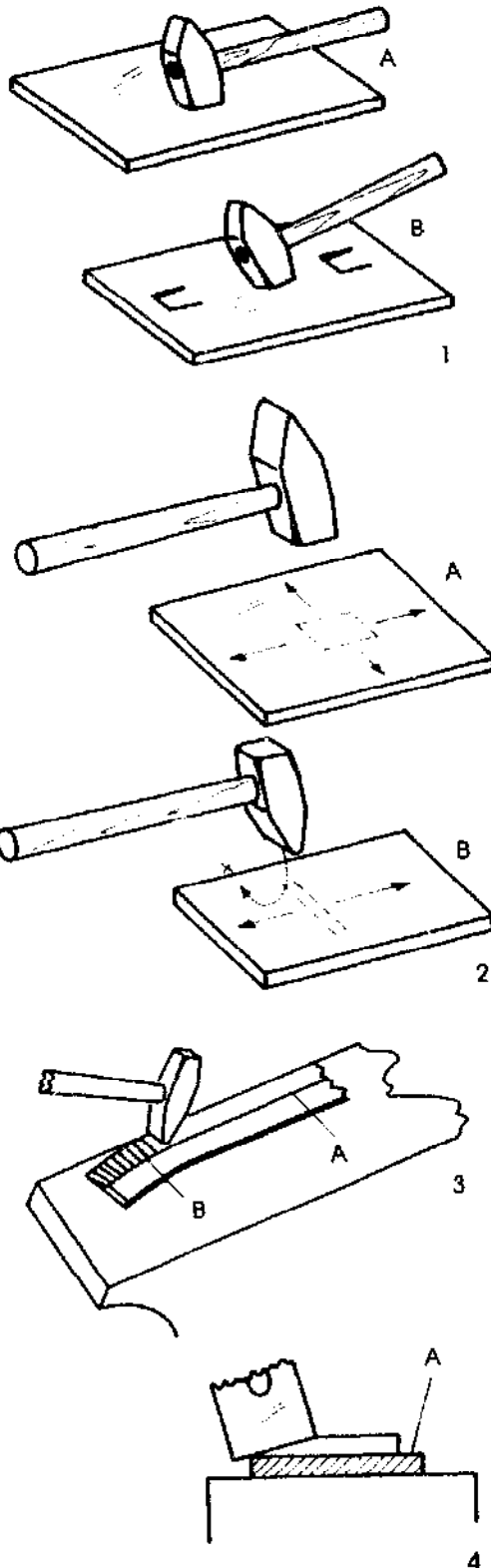

Cutting hot metal

Hot metal can be cut in three different ways:

- Hot chisel and hammer
- Hardie and hammer
- Hot chisel, hardie and hammer

Cutting with these tools is meant only for rough work on hot steel. If several pieces have to be cut from one long piece of steel, it is advisable to cut them one after the other while the steel is still hot. This avoids unnecessary cooling and reheating of the steel. Workpieces with a large cross-section can also be cut hot.

Hot chisel

The hot chisel shown in Fig. 1 has a cutting edge ground to an angle of 30 degrees with a slightly convex edge.

The edge of this chisel is less tempered. This condition is rapidly changed by contact with hot metal.

The heat absorbed by the hot chisel can change the properties of the steel. So cooling the chisel regularly in water is essential to avoid this change in properties.

Hot chisels often have stout wire handles coiled around the head of the hot chisel. Yet a wooden shaft is more satisfactory because it is rigid, so the operator can place the tool in the right place more accurately and quickly.

Hardie

Hot metal can also be cut with the help of the hardie together with a hand hammer. See Fig. 2.

The hardie is placed in a square hole in the anvil. Make sure the cutting edge is ground to an angle of 60°.

Hardie and hot chisel

Metal can be also cut with the aid of a hardie, hot chisel and hand hammer. This method of cutting makes work fast but also takes a lot of skill. See Fig. 3.

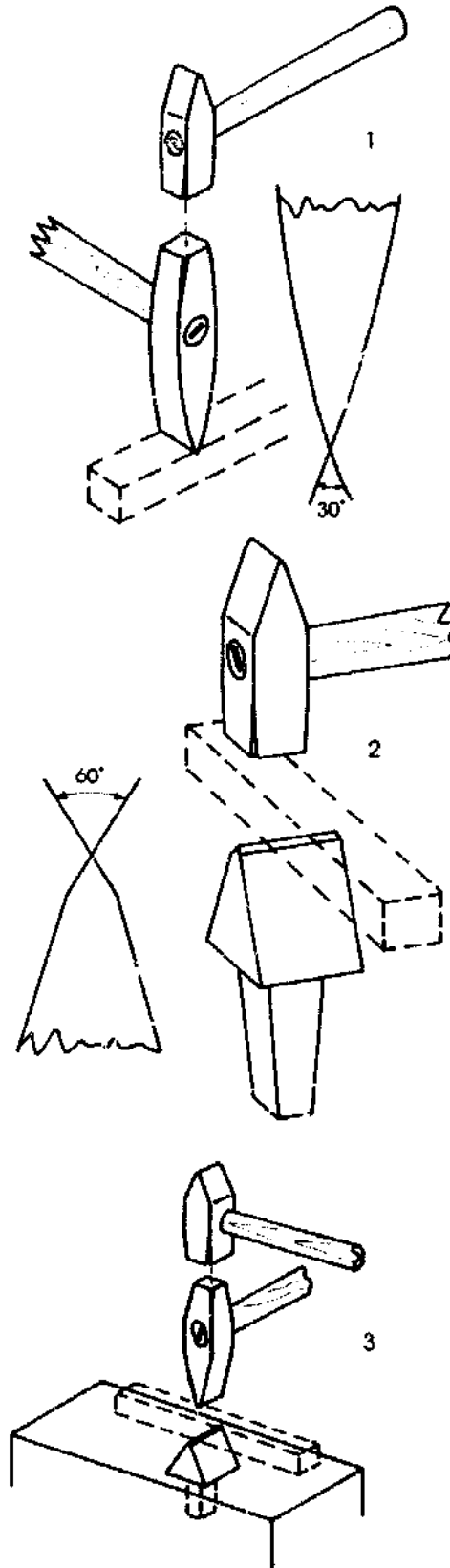

Cutting with a hot chisel

One of the most important skills to master while you're cutting hot metal with a hot chisel is holding the hot chisel exactly straight and square to the workpiece and seeing to it that the workpiece contacts the hot chisel exactly at the centre of the heat.

The method of cutting hot steel with the hot chisel is as follows:

- A - Mark the workpiece all round with the cold chisel, see Fig. 1.
- B - Cutting with a hot chisel is done on a mild steel plate placed on top of the anvil, see Fig. 2-A. This is to protect the cutting edge of the hot chisel against contact with the anvil when it cuts through the material.
- C - Heat the cutting area of the workpiece to at least a cherry red colour.
- D - Place the heated workpiece on top of the anvil and move the hot chisel until it is locked into the groove made by the cold chisel.
- E - Hold the hot chisel, exactly straight and square to the workpiece, with your right hand and the workpiece with your left hand.
- F - Command the striker to hit the hot chisel with the sledge hammer, making sure that he hits the head of the hot chisel exactly at the centre.
- G - Quench the hot chisel in water after every 3 or 4 hammer blows to avoid over-heating the cutting edge.
- H - Turn the workpiece a quarter of a turn after each blow. Nick all sides evenly.
- I - When the metal is nearly cut through, break it off on the edge of the anvil. See Fig. 3.

REMEMBER:

If the hot chisel is held slanted in any direction, the handle may break off or the chisel may jump off the workpiece during the cutting procedure.

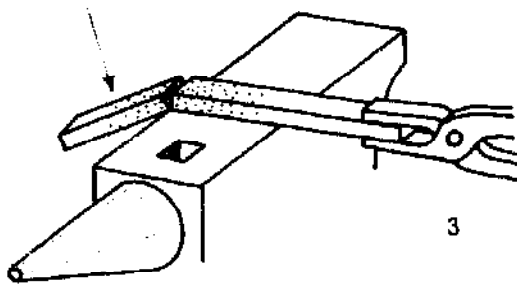
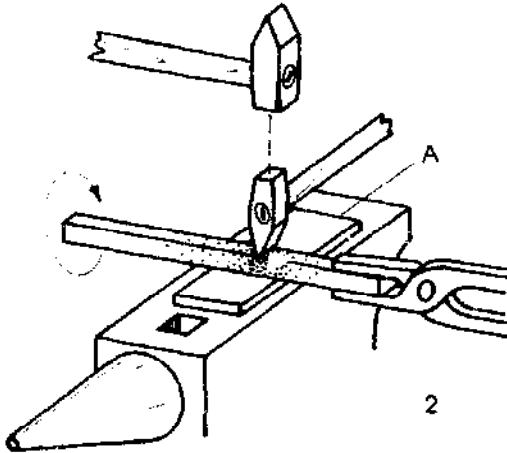
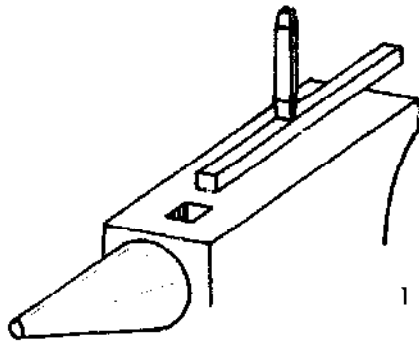

Cutting with a hardie

If there is no helper or the workpiece has a small cross-sectional area, the hardie can be used to cut hot metal. The correct procedure to follow is:

- A - Mark the workpiece all round with a cold chisel. See Fig. 1.
- B - Insert the hardie in the hardie hole of the anvil. make sure the cutting edge is sharp and ground to the correct angle.
- C - Heat the place on the workpiece where cutting is to take place to at least cherry red.
- D - Place the heated workpiece on the hardie and shift it so the cutting edge of the hardie locks into the groove made by the cold chisel. See Fig. 2.
- E - Strike with the hand hammer exactly on top of the bar in the centre above the groove.

Do not apply hammer blows which are too heavy because this can distort the workpiece.

Be particularly careful with round bars. Use light hammer blows and roll the bar a quarter of a turn after each blow.

When cutting square or rectangular bars, turn the bar a quarter of a turn after each blow. See Fig. 2.

- F - Continue cutting until the bar is nearly cut through.

But do not cut right through or you might hit the cutting edge of the hardie with the hammer.

- G - Nick the material on all sides and break it off on the edge of the anvil. See Fig. 3.

Chamfered edges

Cutting with the hardie can save a lot of work especially when chamfered edges are required. During the process of cutting, chamfered edges are formed on all sides because of the shape of the cutting edge of the hardie. See Fig. 4.

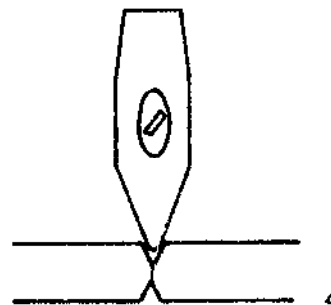
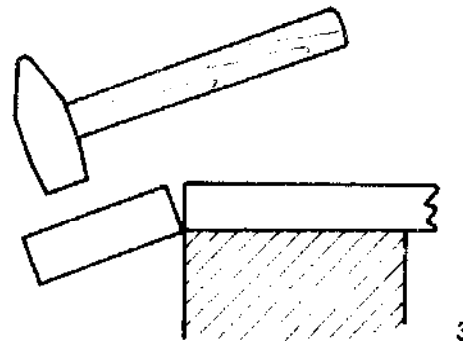
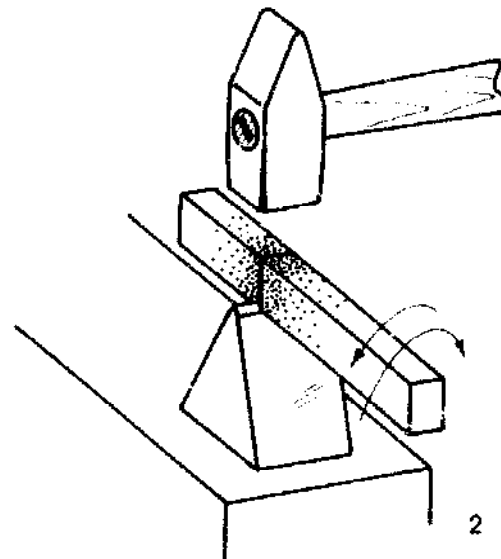
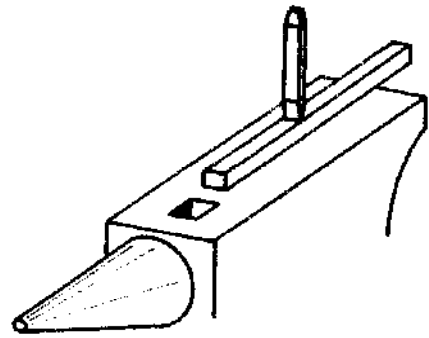

Cutting with the hardie and hot chisel

For workpieces with larger cross-sectional areas, the hardie may be used in combination with the hot chisel.

Accuracy and skill are needed to make sure the hot chisel, the hardie and the sledge hammer are exactly over each other during the cutting process. See Fig. 1-A and 1-B.

Cutting method

- A - Mark the cutting line all round the workpiece with a cold chisel (see also Fig. 1 on page 28).
- B - Insert the hardie in the hardie hole of the anvil. Have the hot chisel on hand and the striker ready.
- C - Heat the workpiece where it is to be cut to the right temperature.
- D - After heating the workpiece, place it on the hardie, making sure the cutting edge of the hardie is locked into the groove made with the cold chisel, see Fig. 2.
- E - Make sure you hold the workpiece exactly horizontal and square to the hardie and the hot chisel vertical and square to the workpiece.
- F - Command the striker to strike with the sledge hammer, which must contact the head of the hot chisel exactly in the centre from directly above.
- G - Nick the workpiece on all four sides evenly and as deeply as possible.

Remember to cool the hot chisel when necessary.

- H - Break the workpiece apart on the edge of the anvil.

REMEMBER:

Check the angle of the hot chisel, which should be 30 degrees.

Check the shafts of the hot chisel and the hammer.

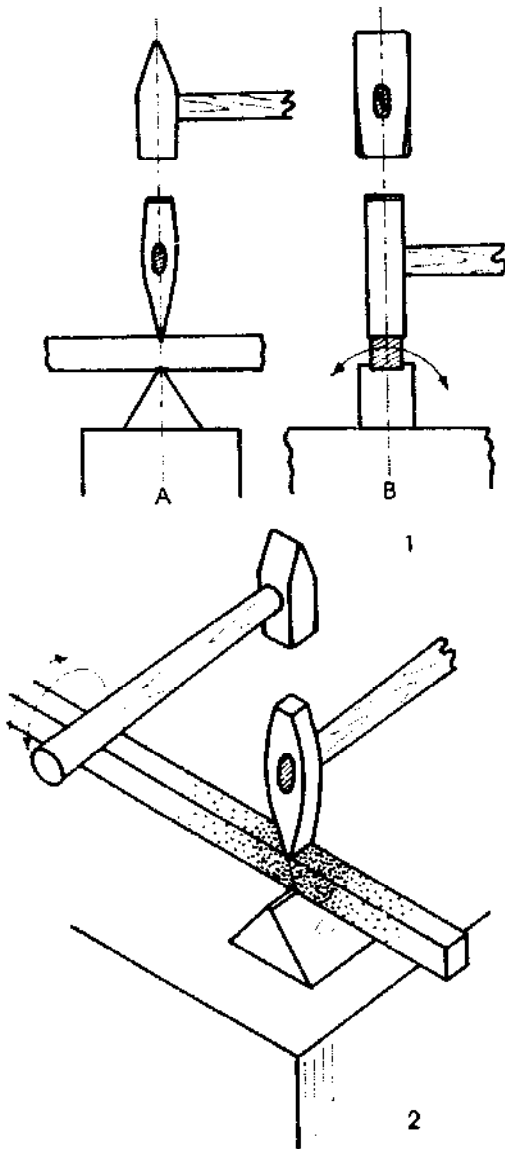

Squaring a round bar

A rotating method as shown in Fig. 1 is used to square a round bar or to reduce the cross-section of a square bar. After striking the hot bar a few times on one side, the bar should be rotated to forge the other side. During forging you will notice that the side in contact with the anvil cools faster. Each time the metal cools beyond a visible heat glow, it should be re-heated. Forging should be done very fast, yet securing a square shape.

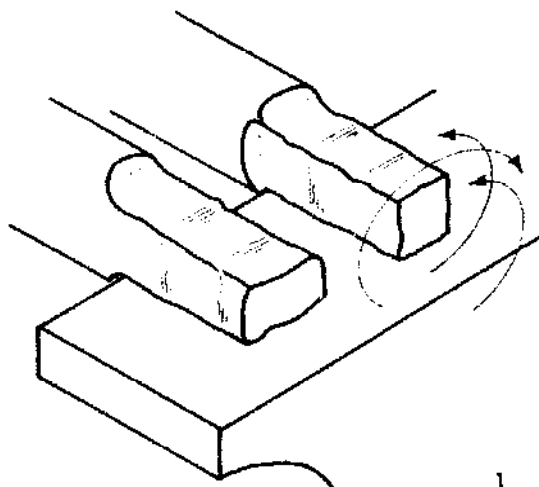

Tumbling 90 degrees

A 90 degrees tumbling method is shown in Fig. 2. Place the heated bar (2-A) on the anvil and forge side X. During the forging of side X the opposite side, marked Y, will become a little flat as well.

Turn the bar through 90 degrees and forge side O as shown in 2-B.

Turn the bar backwards again and forge the bar square as shown in 2-C and 2-D. Sides Q and Y will become flat as a matter of course.

Forge the bar every time over a short distance on all sides.

Reheat the bar when necessary and do not forge cold steel.

Try to work at a high and rhythmical speed for this job has to be done fast.

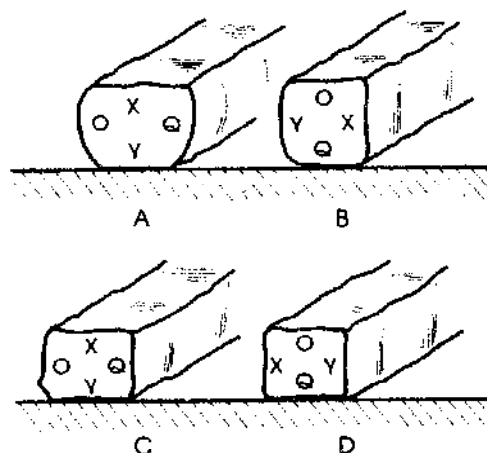

Chamfering the end of a square bar

Heat the very end of the square bar. Place it on the anvil, while holding the bar at a wide angle as shown in Fig. 1-A. With the face of the hand hammer, deliver rapid blows to the edge of the bar, rotating the rod after each blow.

When a large chamfer is needed, reduce the angle of the bar each time, as shown in Fig. 1-B, so that one edge of the chamfer rests correctly on the anvil face.

Tapering a round rod

Forging a taper at the end of a round bar is shown in Figs. 2, 3 and 4.

A - Heat the end of the bar.

B - Place the bar on the anvil, holding it up at the required angle and shape the bar to a square, tumbling it over after each hammer blow. Leave the tip end square, see Fig. 2-A.

C - Turn the bar as shown in 2-B and shape the bar to a hexagon, see Fig. 4-A.

While forging, make sure the metal is hot enough to avoid "piping", as shown in Fig. 3.

D - After forging the hexagon shape, forge the bar to a round shape, rotating the bar and using light hammer blows. See Fig. 4-B. The tip of the bar should cope with the edge of the anvil to allow the hammer enough space without touching the anvil.

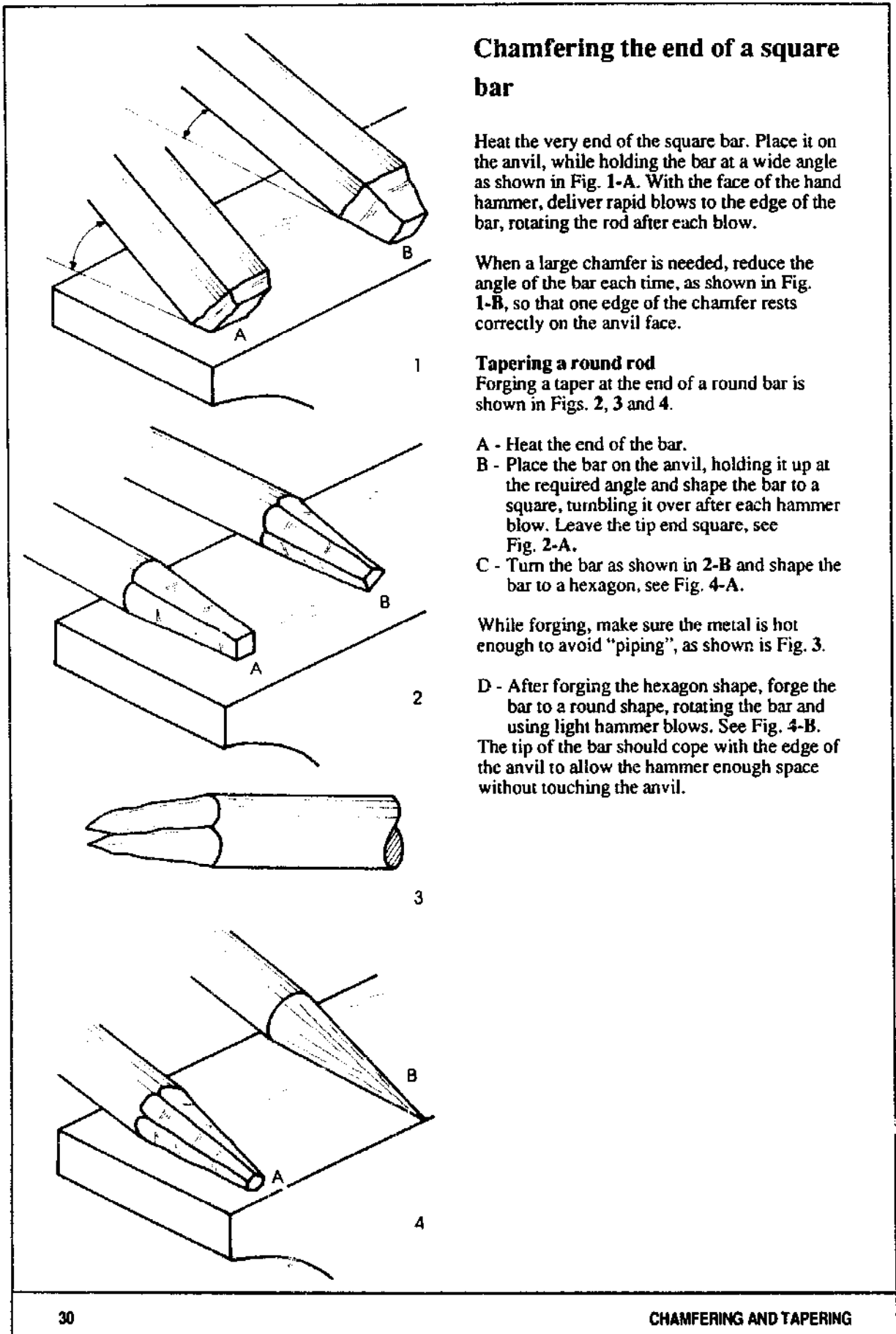

Drawing down round to square

Two methods can be used to draw down a round bar to a square bar. Drawing down is done with the aid of:

- Round beak and hand hammer
- Anvil face and hand hammer

Round beak and hand hammer

This method is a rather rough method of drawing down and to obtain an even surface you have to smooth and straighten the bar regularly on the face of the anvil.

- A - Heat the round bar to the required temperature
- B - Transfer the bar to the anvil round beak, holding the tip of the bar at the centre, at right angles and exactly horizontal. See Fig. 1-A and 1-B.
- C - Strike the hand hammer on top of the end of the round bar, strike with moderate force, especially if the bar is small in diameter. The face of the hammer should land exactly in line with the centre of the round beak. See Fig. 1-B.
- D - After the first blow, turn the bar 90 degrees and strike the other side.
- E - After the second blow, move the bar slightly forward and repeat the process; make sure the blows overlap each other. See Fig. 2-A and 2-B.
- F - When some length has been drawn down, smooth and straighten that part on the face of the anvil, see Fig. 2-C.
- G - Continue until the whole bar has been drawn down.

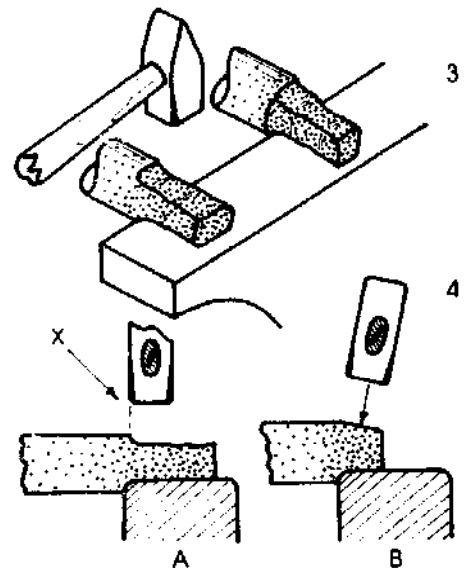
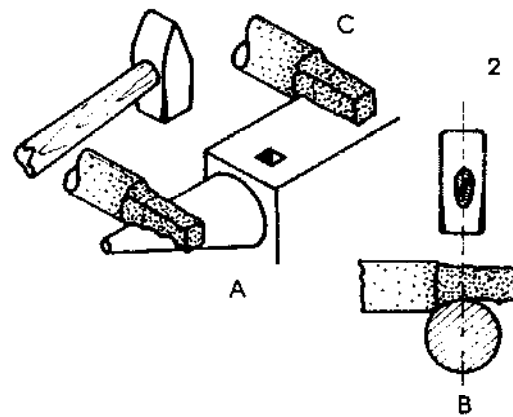
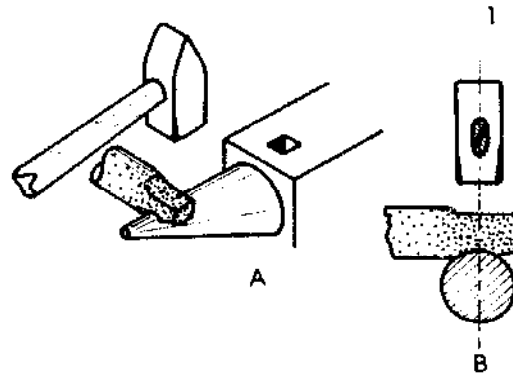

Anvil face and hand hammer

Drawing down on top of the anvil face is shown in Fig. 3. Drawing down this way is similar to drawing down on the round beak. A few hints follow:

- When drawing down, always use the same force along the whole bar on both sides.
- Apply a little more force on the side of the hammer which is in line with the side of the anvil, see x in Fig. 4-A, to avoid the situation shown in Fig. 4-B.
- Always make the hammer blows overlap each other.

Drawing down metal

This chapter explains how metal is drawn down. Drawing down can achieve different shapes. See Figs. 1, 2 and 3.

Drawing down reduces the cross-sectional area of a bar, so the workpiece becomes longer; you must take this into account when marking out the length of a workpiece.

Different methods and tools are used for drawing down metal. It mostly depends on the size of the workpiece, the shape required and the accuracy you want to achieve.

The blacksmith's work allows slight differences in dimensions, which can be corrected if necessary at a later stage by cutting or filing etc.

Drawing down, square to round

To change the shape of a square bar to a round bar, you must first change the square bar into an octagonal bar, see Fig. 2.

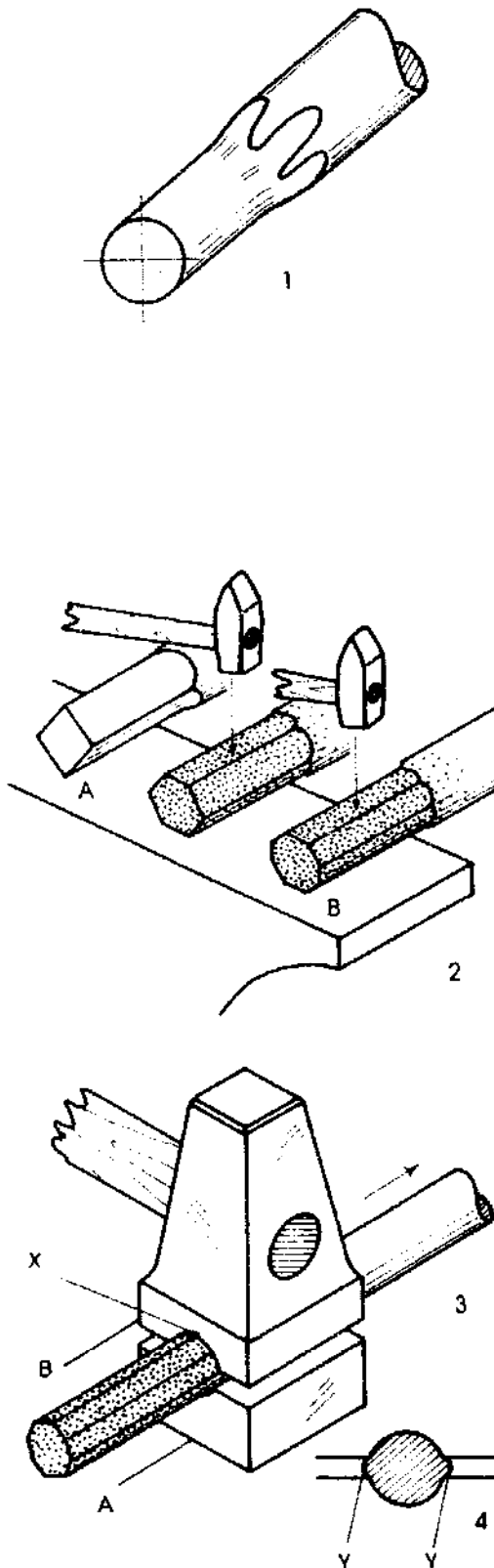

- A - Heat a piece of the bar to the required temperature.
- B - Transfer the bar to the anvil and place it on one edge on top of the anvil face, see Fig. 2-A.
- C - Hammering the top edge means the opposite edge will also be reduced. Use moderate hammer blows.
- D - After each blow, turn the bar onto another edge and draw it down. See Fig. 2-B.
- E - While hammering the edge, move the bar forward at the same time.
- F - Insert the bottom swage, see Fig. 3-A, in the hardie hole of the anvil.
- G - Place the heated octagonal bar in the groove of the bottom swage. Place it in such a way that one edge of the octagon points upwards, see Fig. 3-X.
- H - Place the top swage 3-B straight and square on top of the bar, in line with the bottom swage.
- I - The striker should hit the top swage with moderate blows. As shown in Fig. 4, the hole in the swage is only partly round. If the blows are too heavy, the octagonal bar may be distorted, see Fig. 4-Y.
- J - After each blow, turn the bar 90 degrees, moving it forward at the same time. The swages should overlap the already rounded-off area.

Drawing down with bottom fuller

Drawing down with a bottom fuller is in principle the same procedure as drawing down with the aid of a round beak. The real difference is that, with the bottom fuller, material can be drawn down deeper and at a lower rate. That is why this method can be used if the thickness of the bar is to be greatly reduced.

When drawing down, it is very important that the blows are of the same force to ensure equal thickness over the whole length of the bar.

Make sure the hand hammer strikes exactly above the centre of the bottom fuller, see Fig. 1. If it contacts towards the tip, the bar may bend downwards. If you strike more towards the other side, the bar will bend hollow or jump out of the tongs.

- A - Place the bar with the tip on the bottom fuller, exactly square and horizontal, see Fig. 1.
- B - Move the bar forward after each hammer blow and work along the whole edge of the bar.
- C - Smooth the bar with the hand hammer on the anvil face

The bar is now rectangular, see Fig. 1-B. If the bar must be square, repeat the whole process. See Fig. 1-C and 1-D.

Top and bottom fuller

Drawing down with the top and bottom fuller is the fastest method, but it requires a great deal of skill.

Two points are very important. Hold the top fuller square and horizontal and exactly vertical above the other fuller, see Fig. 2. If this is not done, the bar may bend or the top fuller - if it is not held vertical - may jump out of your hand or the shaft will break.

Select matching top and bottom fullers carefully - they have different sizes. Hold the bar with your left hand and the top fuller with your right hand.

Draw down the bar to a rectangular shape, smooth the surface on the anvil face at regular intervals. See Fig. 3.

If a square shape is needed, repeat the whole process on the other side of the bar. See Fig. 4.

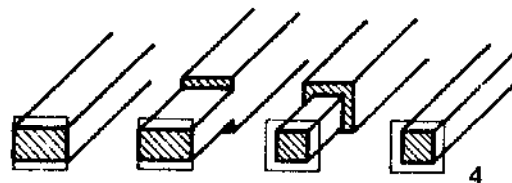
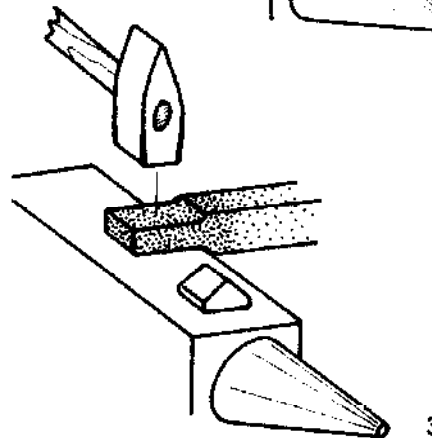
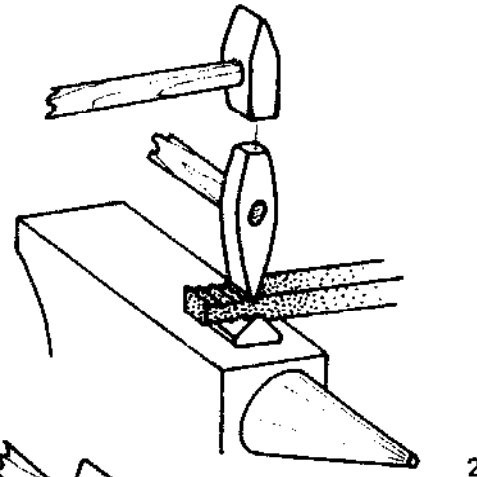
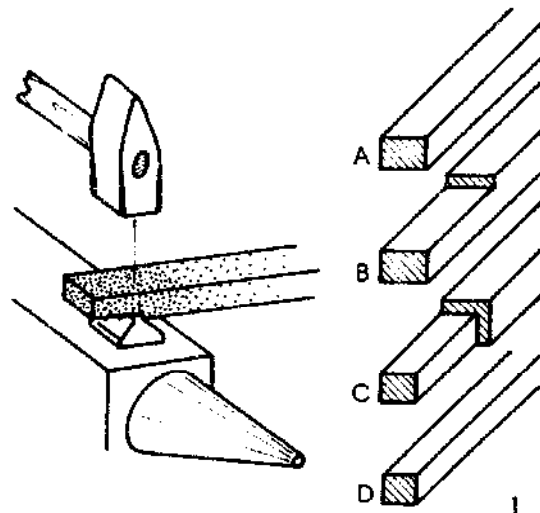

Drawing down a square bar

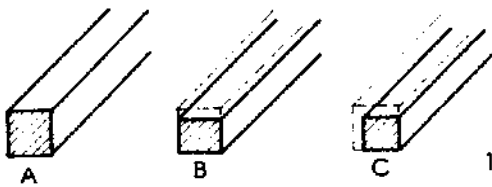

Sometimes the cross-sectional area of a square bar has to be reduced. This can be done in several ways. Fig. 1 shows how a bar is reduced and that the reduction is on only two sides of the bar.

Round beak and hand hammer

One method of drawing down a square bar is shown in Figs. 2 and 3. It must be clear that, if the bar is placed more towards the anvil face, more material has to be drawn down at once. This can be done with heavy hammer blows but it leads to inaccurate work.

A better way is to place the bar more towards the tip of the round beak and thus draw down less material at once - with moderate blows, but leading to more accurate work.

Fig. 1-C shows that only two sides are drawn down, first one side and then the other.

- A - Heat the bar to the required temperature.
- B - Place the bar on top of the round beak, holding the tip of the bar at rightangles to the centre line and exactly horizontal. The tip should not extend beyond the centre line.
- C - Strike with the hand hammer as shown in Fig. 2, turn the bar after each blow as shown in Fig. 3-A and move it forward after this second blow.
- D - Smooth the surface occasionally with the hand hammer as shown in Fig. 3-B.

Anvil and hand hammer

A square bar can also be drawn down with a straight pein hammer on the face of the anvil. See Fig. 4.

- A - Heat the bar to the required temperature.
- B - Place the bar on the anvil and strike it at the end with the hand hammer, which has a straight pein preferably. See Fig. 4-A.
- C - After a few blows, smooth the area with the face of the hand hammer. See Fig. 4-B.
- D - Turn the bar and proceed on the other side as shown in Fig. 5-A.
- E - Smooth the area with the hand hammer as shown in Fig. 5-B.

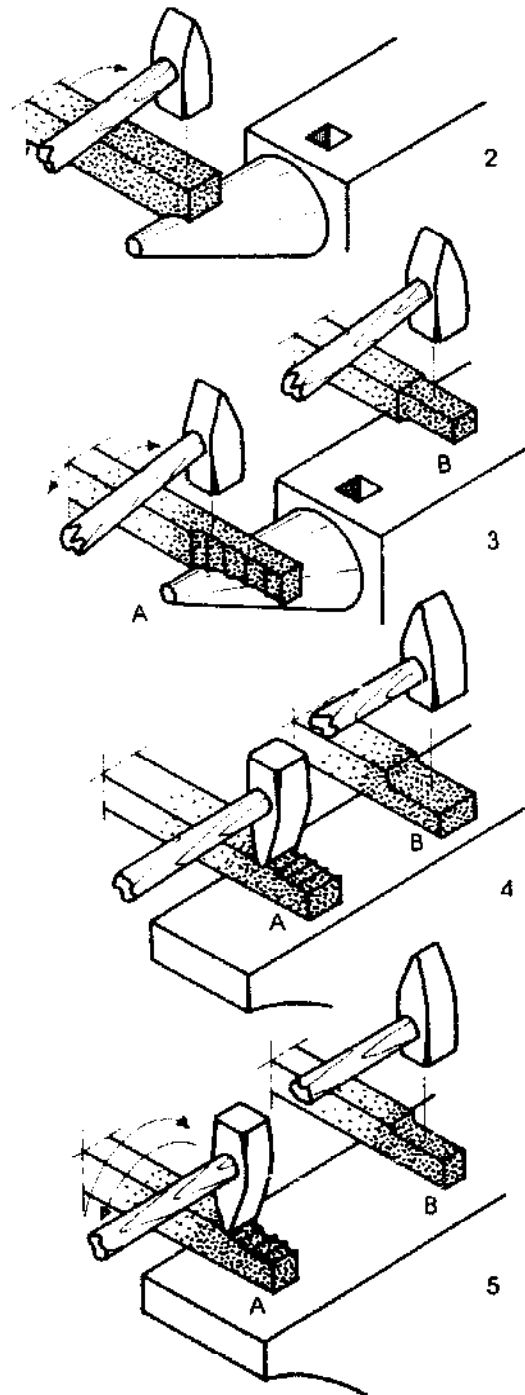

Necking in

To make bolts, axles, shafts etc, you sometimes have to draw down a section of a bar, either round or square. This work is called "necking in". The procedure is as follows (see Fig. 1):

- Drawing down square (1-B)
- Drawing down octagonal (1-C)
- Drawing down round (1-D)

Drawing down

- A - Mark a line with the cold chisel, see Fig. 1-A.
- B - Insert the bottom set into the hardie hole of the anvil.
- C - Place the tip of the heated bar straight, square and horizontal on top of the bottom set.
- D - Place the set hammer exactly on top of the bar above the bottom set, so the four corners are in line with each other, see Fig. 2.
- E - Strike the centre of the set hammer exactly vertically with the sledge hammer.
- F - Turn the bar 90 degrees after the first blow.
- G - Continue the process, working backwards from the front end, making sure the drawing down always overlaps.

NOTE:

At least half the face of the set hammer should always rest on the bar when the striker strikes with the sledge hammer. If this is not done, the set hammer tilts and slips off the bar.

See Fig. 3 - the wrong way.

See Fig. 4 - the correct way.

- H - When you come to the actual "NECK IN" recess of the bar, be sure the bottom set and the set hammer are exactly in line with each other, see arrows in Figs. 6 and 8. Watch the line marked with the cold chisel. See Fig. 5.

- I - Turn the bar so the edges of the drawn down section are on the bottom set and draw down the square to an octagon. See Figs. 5 and 6.

- J - The octagon is then rounded off with the aid of a top and bottom swage of correct diameter. See Figs. 7 and 8.

REMEMBER: One edge of the octagon is always placed on top between the top and bottom swage. See Fig. 8-A.

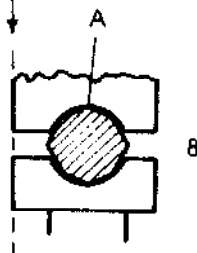
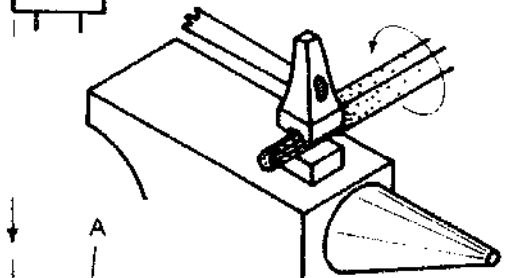
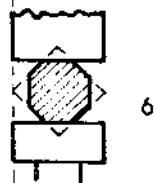
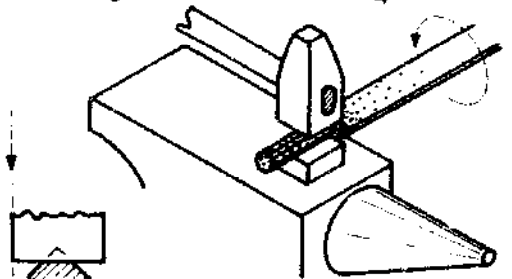
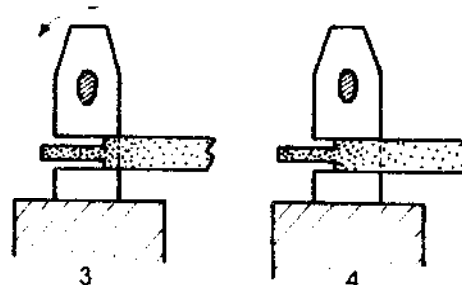
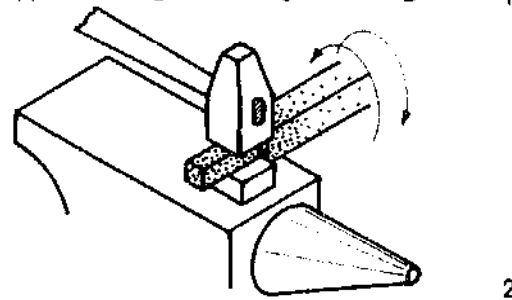
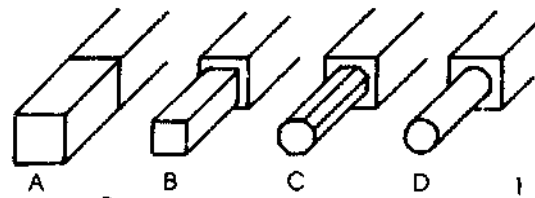

Drawing down on swage block

The shape of the metal bar can also be reduced and changed with the aid of a swage block, see Fig. 1-A.

A swage block has many differently shaped holes and the sides have many differently shaped curves. Fig. 1-B shows some of the ways to change the shape of a bar.

During forging, the heavy swage block absorbs much of the heat. Note too that the length of the workpiece increases during forging.

Upsetting process

The process of upsetting, see Fig. 2-A, is used to increase the cross-section at the end or at any place along a bar. Upsetting makes that part of the bar thicker, with the result that the length of the bar decreases, see Fig. 2-B. Take this into account when you cut material before upsetting is carried out.

Upsetting is mostly done to provide the material needed for shaping the heads of rivets and bolts, but also for operations where larger cross-sectional areas are needed.

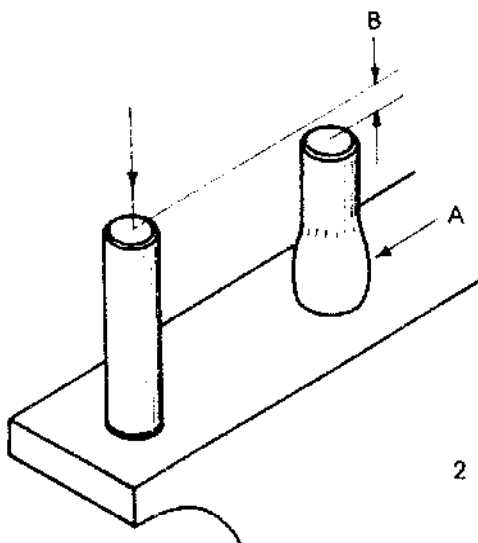
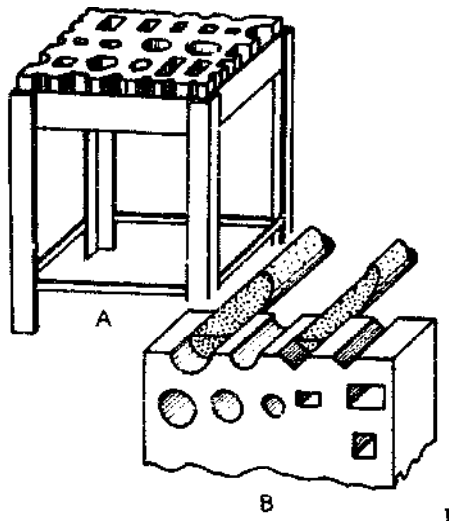

Pre-conditions for upsetting

Important pre-conditions for successful upsetting are:

- The bar should be straight over its whole length.
- Both ends of the bar must be exactly square to the length of the bar.
- The edges of both sides should be a little tapered, see Fig. 1- A, to ensure correct hammer contact at the exact centre of the bar.
- The correct temperature for upsetting is 1250° Celcius, thus white hot.
- After heating, the bar should be cooled over its whole length except the part to be upset.
- To achieve the correct bulging of the material it may be necessary to cool the very tip of the bar as well, to avoid flaring. See Fig. 2.
- Turn the bar each time to ensure even upsetting on all sides, see Fig. 1.
- Keep the bar exactly vertical during upsetting.
- Strike with medium-heavy blows. Hammer rapidly because the anvil absorbs much of the heat.
- While upsetting, watch the shape of the upset part. It must change from A to B and C, see Fig. 3.
- Re-shape the upset part occasionally as shown in Fig. 4 to obtain the correct shape shown in Fig. 3-D.

Incorrect preparation

If the ends of a bar are not exactly square over the length, the heated section inevitably bends out of line during upsetting, see Fig. 5-A, 5-B and 5-C.

It is therefore essential to ensure that cutting is square and the edges of the ends are slightly tapered. Tapered ends will take hammer blows closer to the centre of the rods and thus reduce the danger of buckling. Mistakes must be corrected at once before upsetting is continued.

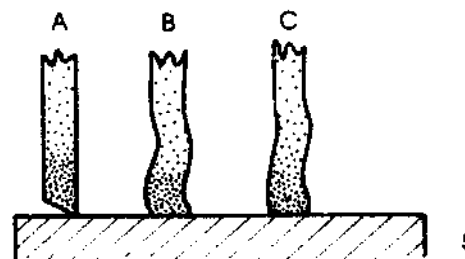
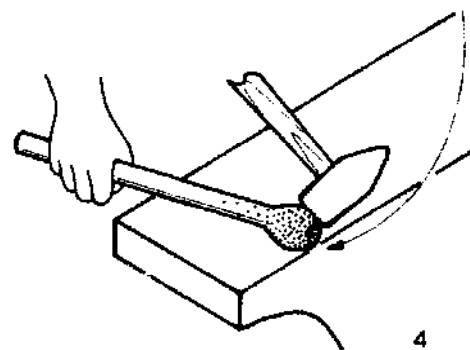
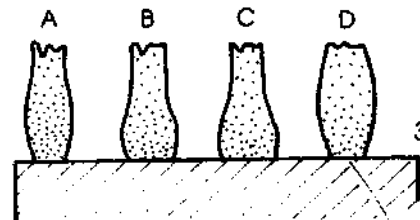
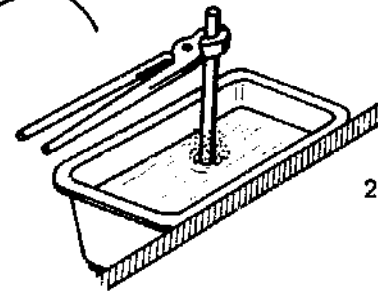
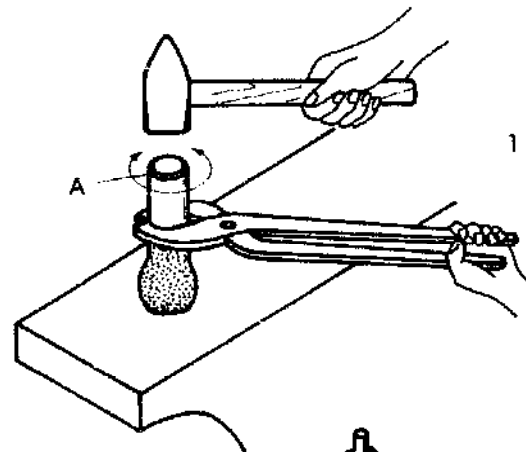

Upsetting in the vice

Round bars up to 12 mm diameter or square bars up to 10 x 10 mm can be upset with care in the bench vice. Always use protective vice caps (see Fig. 1-A), made of mild steel, when you do upsetting in the bench vice. It protects the bar from marks made by the serrations of the vice jaws. The blacksmith's leg vice should be used for bars with a large cross-section.

Clamping bars in the bench vice

There are various ways of clamping bars for upsetting.

- Short pieces can be clamped vertically in the bench vice as shown in Fig. 1. To stop the bar slipping through, it can be supported from below with a piece of mild steel.
- Longer bars can be clamped in the vice as shown in Fig. 2. The disadvantage is that the bar may find no support below and may therefore slip through during the upsetting operation. Wherever possible, support the bar underneath.
- Long bars can be clamped as shown in Fig. 3. This clamping method ensures a firm grip but makes upsetting more difficult. This method must not be used in the leg vice because the jaws are positioned differently.

Upsetting in the vice

Upsetting in the vice is shown in Fig. 4. A lot of practice is needed to master this skill.

- A - Mark the length of the upsetting.
- B - Heat the marked out end of the bar to white heat.
- C - Take the piece out of the fire and cool the workpiece as far as the part to be upset.
- D - Transfer the workpiece to the bench vice and clamp it firmly.
- E - Strike the heated end firmly with the hand hammer, as shown in Fig. 4. Turn the bar round.
- F - Do not continue hammering if the metal is cold; heat it again to avoid flaring.

If the heated end of the bar bends during upsetting, correct the mistake immediately. While hammering, draw the hammer back or push it forward as necessary. See Fig. 5.

QUESTION: Which device has been omitted in Figs. 2-5?

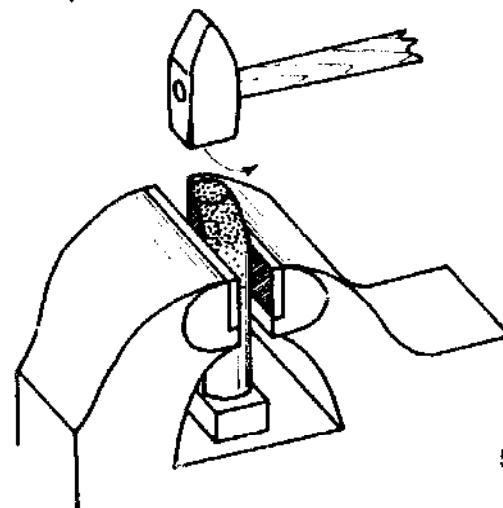
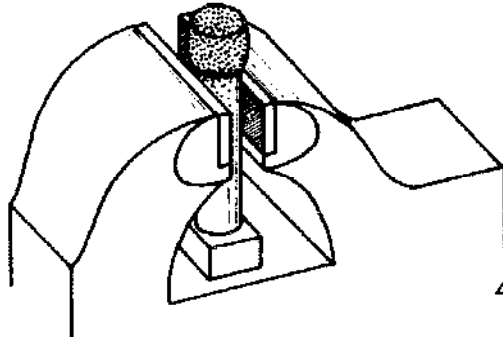
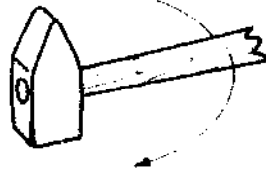
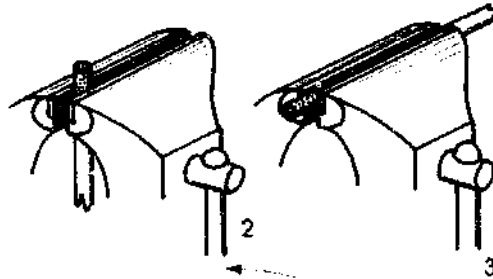
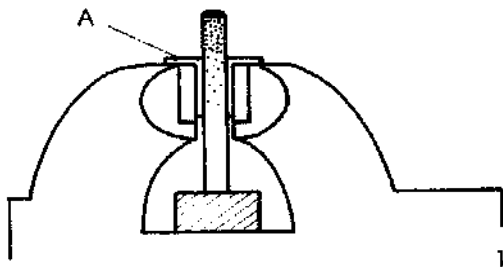

Heading tool

Heading is forging a head for a bolt, rivet, etc. This is done with the aid of a heading tool, see Fig. 1.

The heading tool may have one or more holes with different diameters to suit the different diameters of bars inserted. The surface of the heading tool is hardened to absorb the hammer blows during the heading procedure.

It is good practice to mark round the holes, with a punch, the outer diameter of the heads for the different bolts, see Fig. 2. While heading, you cannot see after a while whether the forging is lopsided. That is why the punch marks can prove helpful.

The length of bar needed for upsetting and heading is approximately 2.5 to 3 times the diameter of the bar.

bar diameter	upset mm	head diameter	thickness mm
6	15-18	10	4
8	20-24	13	5,5
10	25-30	17	7
12	30-36	19	8
16	40-48	24	10

For heading, the upset part must be at least white hot.

Forging a head on a bar

- A - Mark the length for the part to be upset.
- B - Heat that part.
- C - Cool the bar as far as the mark.
- D - Upset the bar as described before.
- E - Heat the bar again to white hot.
- F - Cool the bar again to the upset part.
- G - Slip the bar through the correct hole in the heading tool.
- H - Start heading with rapid hammer blows. A 1 kg hammer is suitable for this work. See Fig. 3.

While heading, watch that the heading is towards all sides - the punch marks show you which way the head is moving.

- 1 - Flatten the head to the correct diameter, at the same time making sure the head is of the correct thickness.

If during heading the head goes out of the centre, you must correct this mistake immediately with "drawing" or "pushing strokes".

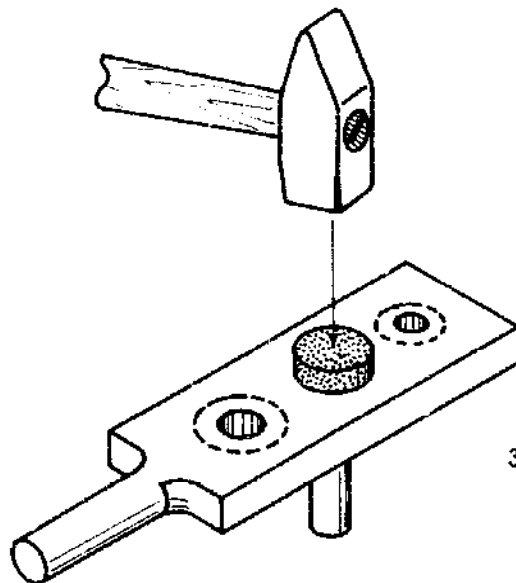
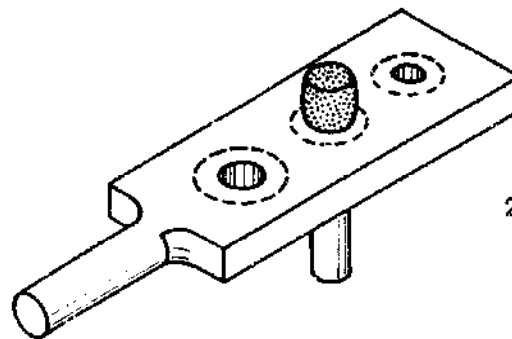
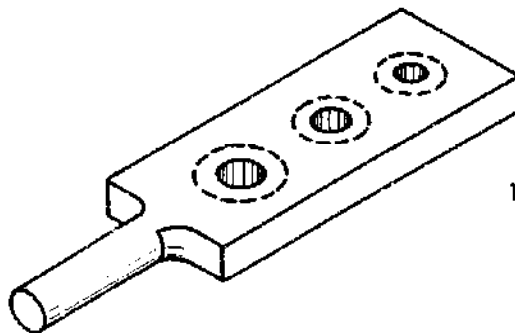

Shaping a square head

The square head for a bolt is made by upsetting a bar and at a later stage forging the head to the correct shape.

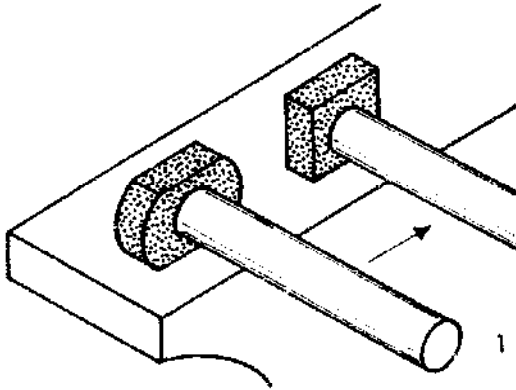

- A - After upsetting, re-heat the workpiece again to white hot, cool the body of the bolt as far as the upsetting.
- B - Place the workpiece on the anvil face and forge the flat sides, turning the bolt at regular intervals as shown in Fig. 1.
- C - Check the dimensions of the head in good time. This can be done with the blacksmith's gauge. See Fig. 2.
- D - When the head has the correct dimensions, heat it again and place the bolt in the heading tool. Chamfer the edges.

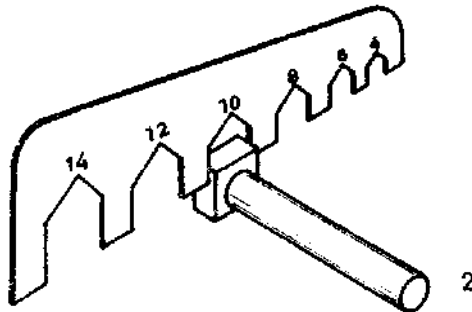

As you chamfer the edges, re-shape the inside of the head to a sharp inner corner.

Shaping a round head

The head of a bolt, like the head of a carriage bolt, should be shaped in a specially made heading tool, as shown in Fig. 3.

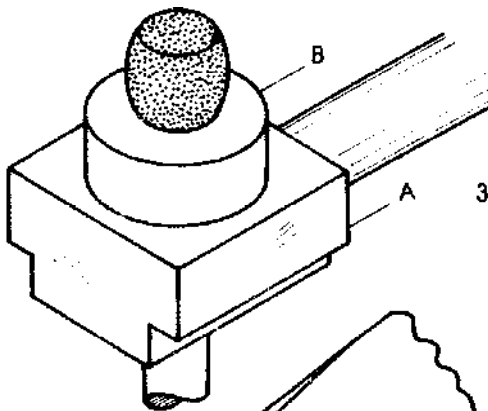

The body (3-A) is made of steel and the ring (3-B) of hardened steel. The ring should be hard enough to absorb hammer blows on the edges.

Two recesses can be made in the body so this tool can be placed in the leg vice. This makes the work easier because the bar can be held underneath the tool and drawn down during the forging process.

It is very important to study Fig. 4. You see the bar placed in the heading tool and the hammer forging the head. At the edge of the head a small part should be left straight to prevent the edge of the head becoming too sharp.

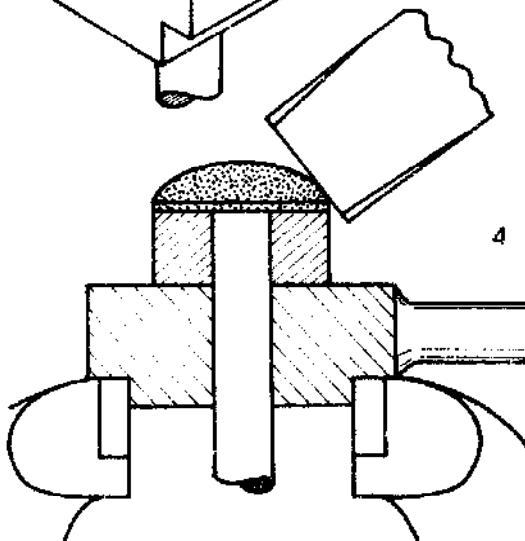

While heading, turn the heading tool round and forge the head from different sides to ensure that the metal is forged down to all the sides and to obtain a correctly shaped bolt head.

Heading is done with heavy hammer blows first. Later on, moderate hammer blows are used for finishing. Re-heat the head in good time. Do not forge when the temperature is too low.

Forging bolt or rivet heads of other shapes is explained at a later stage.

Punching

Punching is another important skill to be mastered by the rural mechanic. Punching is done when holes of different diameter and shape are needed, as shown in Fig. 1.

Because material is lost during punching, it is not advisable to do this on bars with small sections.

Upset that part of the bar where the hole is to be made. The degree of upsetting depends on the material and the hole to be made.

Sequence of operations

- A - Mark the place to be punched with a centre punch, deep and clear.
- B - Heat the material to near yellow heat.
- C - Transfer the workpiece to the anvil, holding it with your left hand in the tongs.
- D - Place a piece of charcoal in the centre punch mark. This makes the hot punch loosen easily after punching.
- E - The hot punch should be placed exactly vertical on top of the workpiece and held firmly.
- F - Command the striker to strike the hot chisel; this should be done very fast.
- G - Stop punching when the underlayer of the hole is hard and cool, approx. $\frac{3}{4}$ of the thickness of the material, see Fig. 2.

The location of the hole is easily seen on the other side of the material. That place looks darker than the rest of the material.

- H - Punch the material over the anvil hole at that spot. See Fig. 3.

Quench the hot punch at regular intervals as shown in Fig. 4. The heat of the workpiece is also absorbed by the hot punch and this may change the property of the steel from which the hot punch is made.

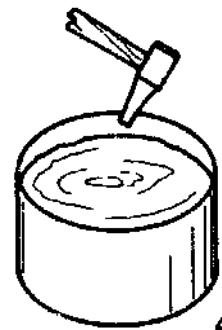
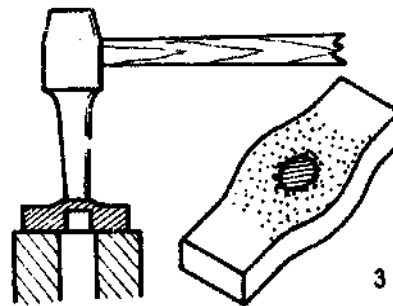
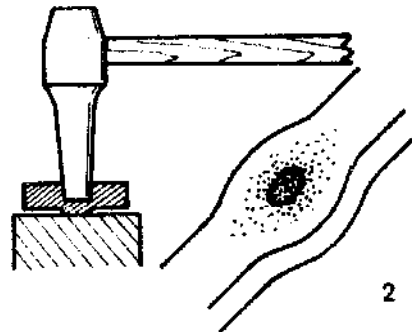
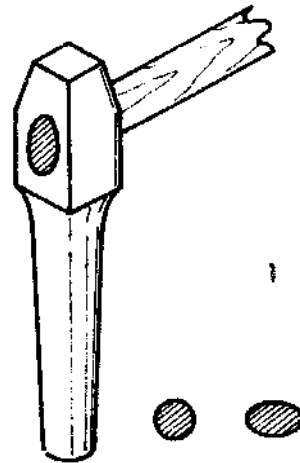

Drifting

Drifting is a method of making holes or widening holes without losing material.

In Fig. 1 you see illustrations of drifts with different sections.

- Round drift (1-A)
- Square tapered drift (1-B)
- Square straight drift (1-C)

You will understand that drifts of many different shapes can be made.

Making a hole with a drift

- A - Mark the hole with a cold chisel, making a slot, see Fig. 2-A.
- B - Mark the ends of the hole with a centre punch, see the dots in Fig. 2-B.
- C - Heat the workpiece to a yellow heat and place it on the anvil. Note that the mark appears darker than the rest of the heated part.
- D - Take the hot chisel and "lock" it into the previous groove made.
- E - Drive the hot chisel halfway through the metal. Turn the workpiece 180° and cut through the material. See Fig. 3-A.
- F - Since the drift is tapered, you have to make a mark on the drift at exactly the correct diameter. See X in Fig. 3-B.
- G - Drive the drift through the material until you reach the mark.

The final result is a slightly tapered hole and the sides of the material bulge, as shown in Fig. 4-B.

Square holes

Round tapered holes can be changed into holes of another shape, such as oblong or square, with drifts as shown in Fig. 5.

In Fig. 5-A you see a square tapered drift driven through a round hole.

In Fig. 5-B the square tapered hole is made straight with the drift shown.

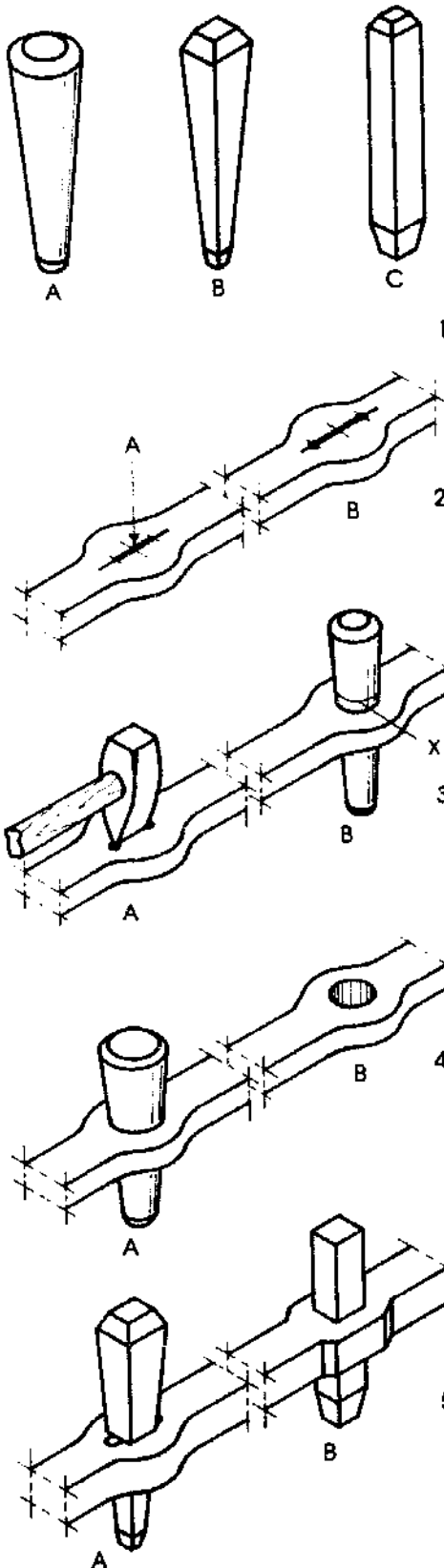

Splitting metal

It may be necessary to split metal if you have to make a product as shown in Fig. 1. The split made is widened on the horn of the anvil. But there is one danger in widening and that is that a crack may occur on the inside because of the widening. To avoid this crack, drill a hole at the end of the split as shown in Fig. 1-B instead of making a mark with the cold chisel, see Fig. 1-A.

Splitting metal with the hot chisel

- A - Mark the cutting line with the cold chisel. Mark the end of the split with an X mark or with a punch.
- B - Drill a hole if necessary.
- C - Heat the workpiece to the correct temperature.
- D - Place the workpiece on a piece of mild steel.
- E - Place the hot chisel in the groove made by the cold chisel, holding it vertically and in line with the marking line.
- F - While the helper strikes the chisel at regular intervals, the blacksmith moves the chisel over the cutting line at the same time, see Fig. 2.
- G - Make sure there is good co-operation with your helper. It takes some time to master this skill. Remember, both the hot chisel and the sledge hammer must be moved.
- H - Quench the hot chisel at regular intervals in water.
- I - When the cut is $\frac{3}{4}$ of the way through the metal, turn the work to the other side and cut through the material from there, see Fig. 3, watching out that you don't touch the mild steel plate with the hot chisel. Cutting through should be done with moderate blows.

Thick material or material which has to be cut edgewise can be handled in the same way. See Fig. 4-A and 4-B.

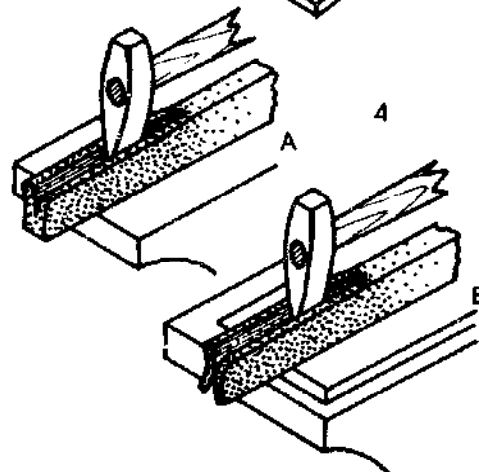
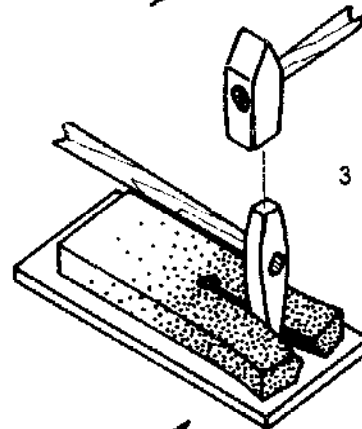
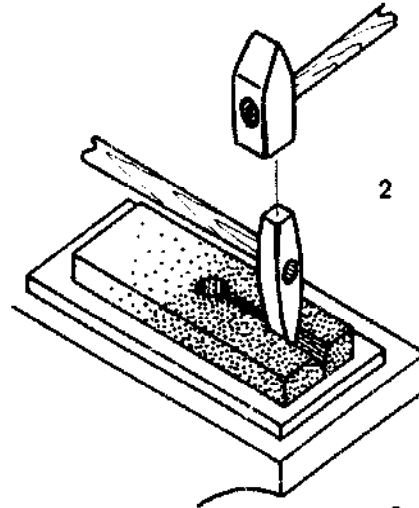
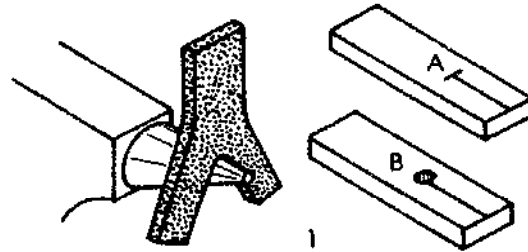

Twisting bars

Twisting is not done often but it is good to master this skill for decorative purposes. Square or flat bars are twisted, possibly at one or more places along the bar.

Twisting should be regular and this depends on the heating of the metal. It should be heated evenly along the whole length, because any part which is hotter will turn more easily. It is advisable not to cut the material before twisting because the bar decreases in length and this is very difficult to calculate.

Twisting is done as shown in Fig. 1. The twisting tool should have two handles to ensure that the bar remains straight. To make sure the twists are regular, a piece of pipe can be used with a cut-away section as shown in Fig. 2.

If more than one part of the bar has to be twisted, the parts should be heated to the same temperature to ensure equal twisting of all the parts.

Bars with a small cross-section up to 6 mm can be twisted cold.

Flaring the end of a bar

Flaring means driving material in a specific direction during forging. It is done with the pein of a hand hammer.

For flaring operations, the material should be heated to white heat and the hammer blows should be fast and firm.

Heavy material is first drawn down on the anvil, see Fig. 3.

Fig. 4-A shows you how the material is driven away towards both sides. At a second stage the material is driven towards one side 4-B.

Draw the hammer in the direction you want to drive the material while hammering.

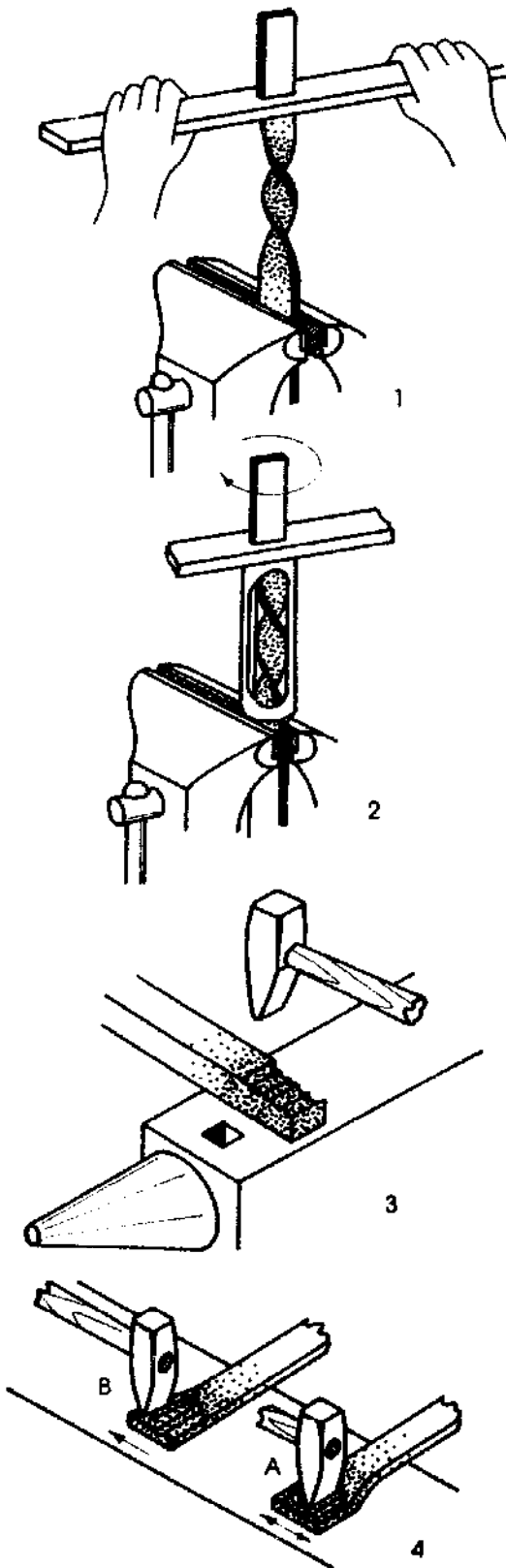

Hot bending metal

The hot-bending of steel has several advantages over cold-bending.

- Sharp bends can be made easily without cracking the material.
- The force needed to make a bend is much lower.
- Materials with a large cross-section can be bent.
- Difficult curves can be made by hand on the anvil or in the vice.

Bending theory

Some theory about the bending of metal should be studied before any actual bending can be done.

During bending, you will observe (see Fig. 1):

- The material compresses on the inside of the bend, see Fig. 1-A.
- The material stretches on the outside of the bend, see Fig. 1-B.
- Where the material neither compresses nor stretches a neutral axis occurs, see Fig. 1-C.

The arrows in Fig. 1 show the area where the material is compressed and stretched and where the neutral axis is.

BENDING ANGLE: is the actual number of degrees over which the whole bar is bent, see Fig. 2-A.

BENDING RADIUS: is the radius of the actual bend, see Fig. 2-B.

BENDING AXIS: is the centre point from which the inner and outer bend take their curves, see Fig. 3-A.

Bending results

The results of bending a piece of metal can be seen in the front view and cross-section in Fig. 4. The outside of the bend becomes slightly hollow due to the stretching force 4-A. The inside of the bend bulges outwards due to the compression of the metal, see Fig. 4-B.

NOTE: Although the bending angle of the bar in Fig. 3 is the same as in Fig. 4, the bending radius and bending axis are different.

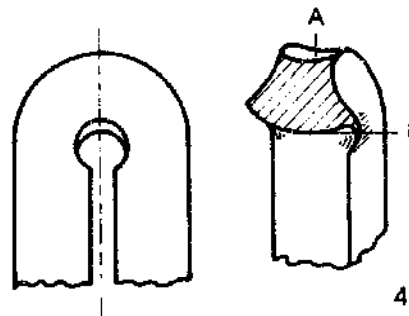
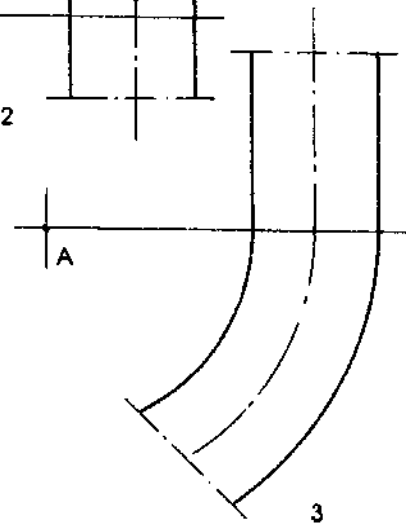
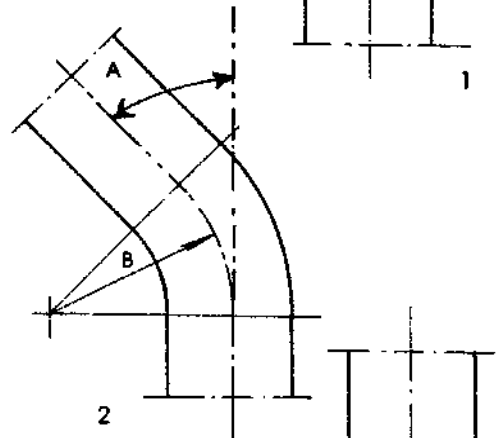
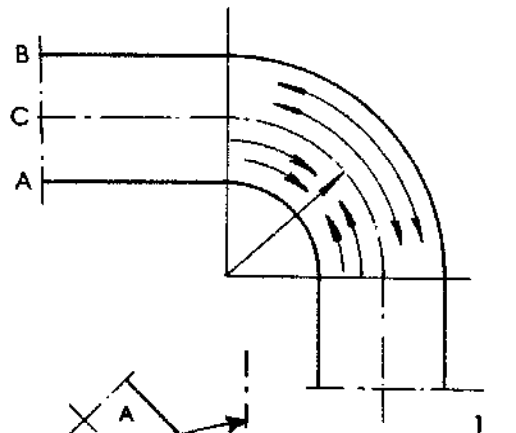

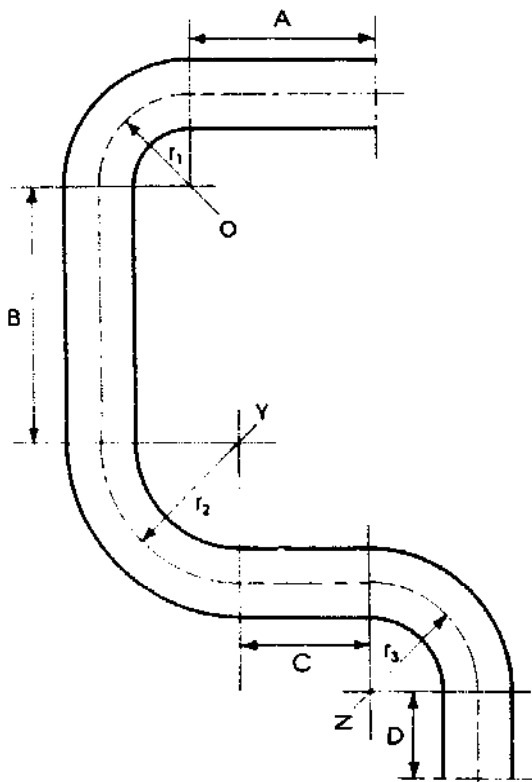

Stretched length

The actual length of the material to be cut for the workpiece shown in Fig. 1-A is the stretched length measured over the neutral axis of the workpiece.

CALCULATION:

Length: $A + B + C + D =$ mm

Bend 'O': $r_1 \times \frac{\pi}{2} =$ mm

Bend 'Y': $r_2 \times \frac{\pi}{2} =$ mm

Bend 'Z': $r_3 \times \frac{\pi}{2} =$ mm

Total length = mm

$\pi = 3.14$

Rolling mill direction

It is important to know the direction the steel follows during bending in the rolling mill, see Fig. 1-B. During the process in the rolling mill, steel is compressed and forged into various shapes. The fibres of the metal are forged in line with the rolling direction, much like fibres in timber.

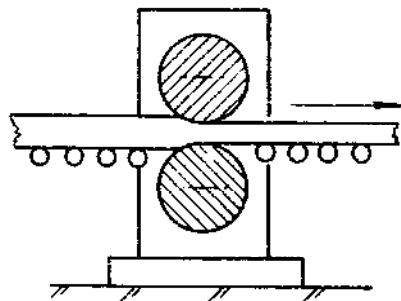

The bending operation is correct if the bend is made in line with the rolling direction. See Fig. 2.

The bending operation is wrong if the bend is made at rightangles to the rolling direction. See Fig. 3.

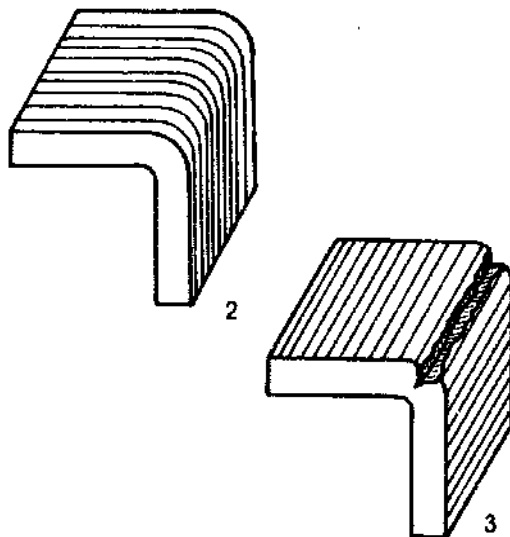

Working temperatures

The temperature range for hot-bending mild steel is from DARK RED to WHITE HEAT. Wide bends can be made at a lower temperature than sharp bends. Steel with a large cross-sectional area is bent at a higher temperature than steel with a small cross-sectional area, because the higher the temperature, the softer the steel gets and the lower the amount of force needed for bending. A difficulty with hot-bending is evenly heating the area to be bent. Uneven heating causes uneven bends. The correct position of the workpiece in the fire is therefore very important.

Bending in the leg vice

Metal can also be hot-bent in the leg vice or bench vice if the metal has a small cross-section. A disadvantage of hot-bending in the vice is that the jaws of the vice absorb much of the heat. Hot-bending should therefore be done very fast.

Round bars should not be bent in the leg vice because the jaws of this vice are not parallel and cut into the material. It therefore cuts the material and weakens it.

Compression and tension

Looking at Fig. 1, you will note that during bending the metal stretches on one side of the axis and is compressed on the other side.

If you clamp a piece of steel in a vice and bend it over the sharp edge of the jaw, the material cannot compress on the inside, so only stretching takes place. This results in a bend shaped as shown in Fig. 2. As the bend is stretched too far, it distorts.

Bending over a vice clamp

To ensure correct clamping, a vice clamp as shown in Fig. 3-A should be made. Vice clamps are made in the workshop with various rounded corners.

Clamp the workpiece with the vice clamp into the vice. See that the mark is in line with the bend of the vice clamp.

Hammer the bar down gradually over the vice clamp, making sure the blows strike ahead of the part which is already bent.

Do not hammer on the bend itself.

Hold the bar with your left hand while forging, use tongs if necessary. Pull the bar down with each hammer blow, to guide it down vertically. Guide the bar. If you pull too much, the bar bends, not the bend itself.

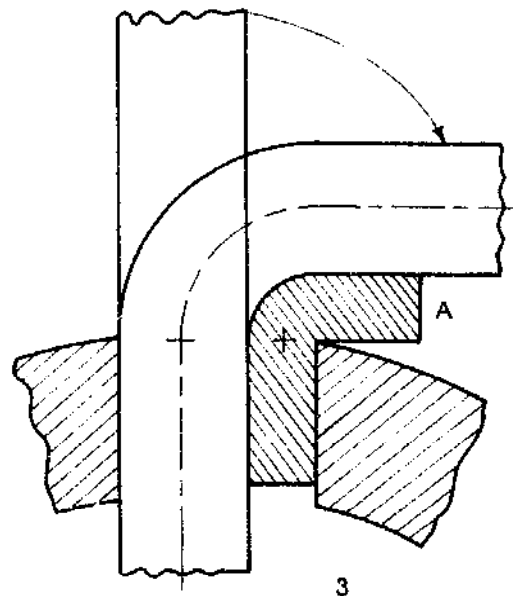
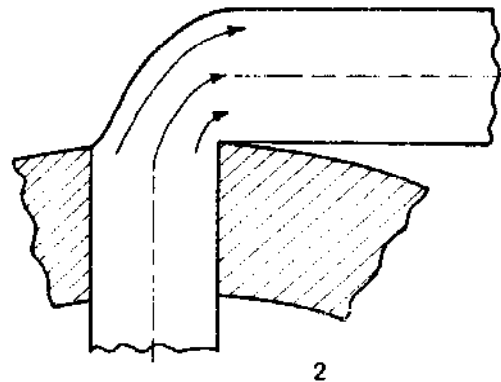
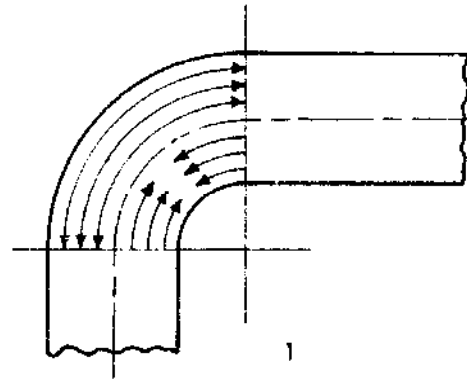

Bending in the bench vice

Flat bars can be bent in the bench vice as shown in Fig 1. To avoid a sharp bend, which may cause cracks, the bar must be bent over a vice clamp with rounded corners.

When shaping the bend, hammering should be at 1-A and not on the actual bend. The bar should be guided at 1-B. This should be done in harmony with the rate of bending to avoid the whole bar being bent as shown in 1-C.

Short bars can be bent with a piece of pipe.

Bending in the swage block

The swage block with its many differently shaped holes and curves can be put to good use for bending round, square and flat bars.

A - Before bending the bar, find the correct hole first and mark it with chalk in order not to lose time looking for it when the metal is hot.

B - Use a centre punch to mark the place where the bend must start.

C - Heat the metal and insert it in the marked hole, exactly in line with the top of the swage block.

D - Pull the bar down to form the bend. See Fig. 2.

It is also possible to make bends with a radius on the inside by clamping a solid round bar over the swage block in line with the desired hole. See Fig. 3.

Make sure the centre punch mark is in line with the centre of the solid round bar. See Fig. 3-X.

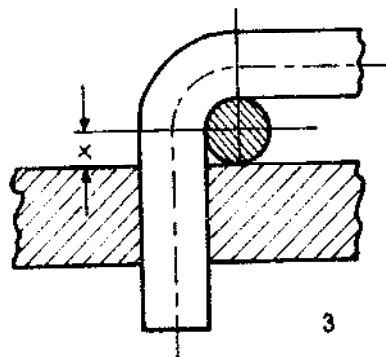
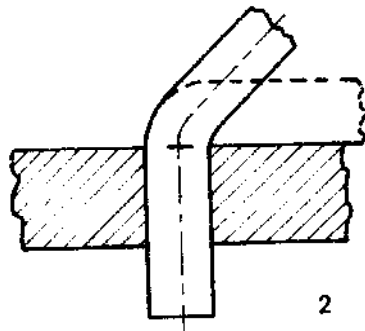
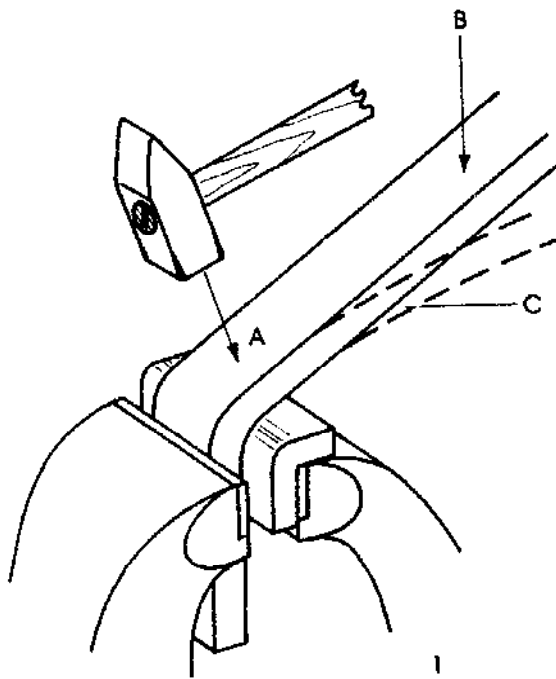

Bending on the anvil face

- A - Before heating the material, use a centre punch to mark the place where the bend is to be. See Fig. 1-A.
- B - Heat the workpiece where the bend is to be made.
- C - Cool the ends of the workpiece, leaving the part to be bent.
- D - Place the workpiece over the anvil face as shown in Fig. 1-B. Place it exactly square to the side of the anvil to ensure a correct bend.
- E - Use moderate hammer blows to bend down one end of the workpiece as shown in Fig. 1-C.

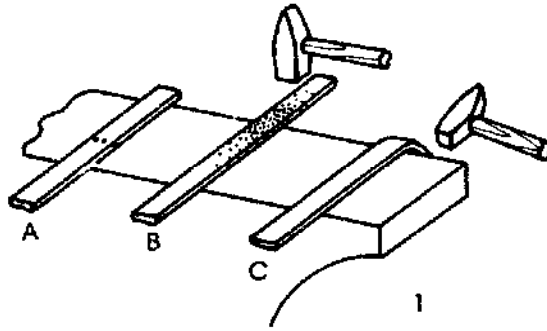

Since the edge of the anvil face is slightly rounded, the inside of the bend will also be slightly rounded. And the outside should be more rounded, depending on the thickness of the material.

- F - The bend should be corrected as shown in Fig. 2-A and 2-B. Hammering should follow the A-B-A-B pattern.

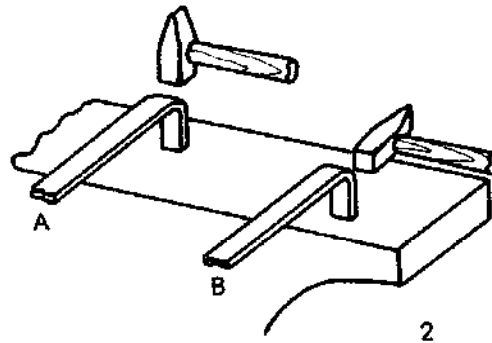

Check both straightness and squareness after the workpiece has cooled. See Fig. 3-A and 3-B.

During bending, the force of hammer blows must be just heavy enough to bend the material but not to damage it by flattening. This is particularly important when bending round material, which is easily distorted by hammer blows.

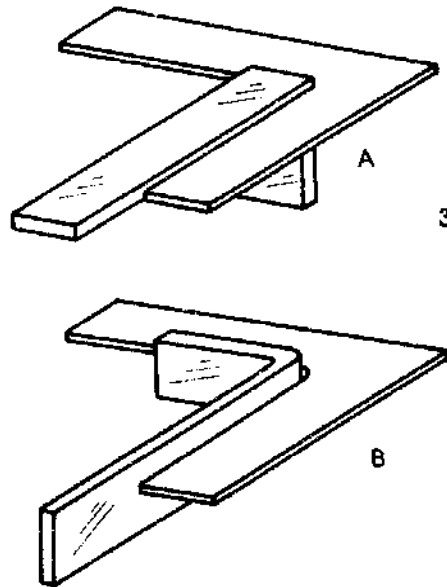

Making a sharp bend

If for one reason or another a workpiece is needed with sharp inside and outside corners, the material for the bend must be upset at the point where the actual bend is to be, see Fig. 1-A.

After upsetting, the workpiece must be forged as shown in Fig. 1-B and bent over the side of the anvil, see Fig. 2-A.

Minor corrections can be made during bending, as shown in Fig. 2-B and 2-C.

After shaping the outside of the bend, the inside can be shaped on the hardie as shown in Fig. 3.

While working, compare the results with the angle drawn on the floor or on a sheet or with the large square.

Making a sharp bend is not easy and you have to work very fast.

Although the sequence of operations is shown in steps, everything must be done in such a way that fast working is ensured.

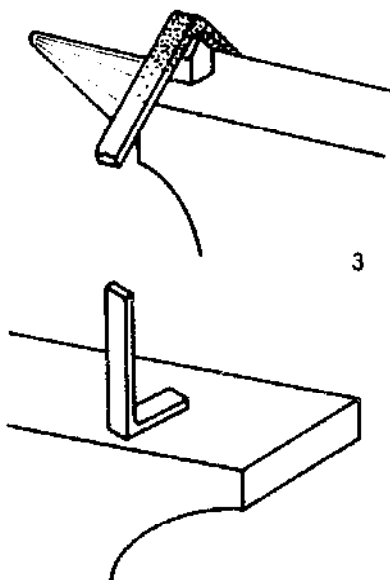
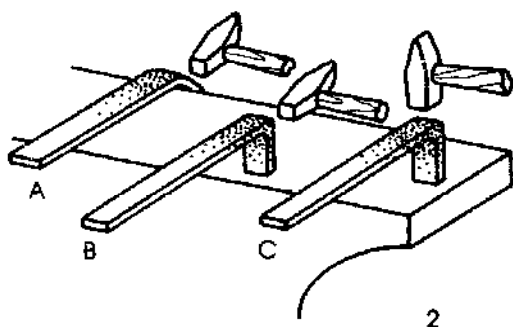
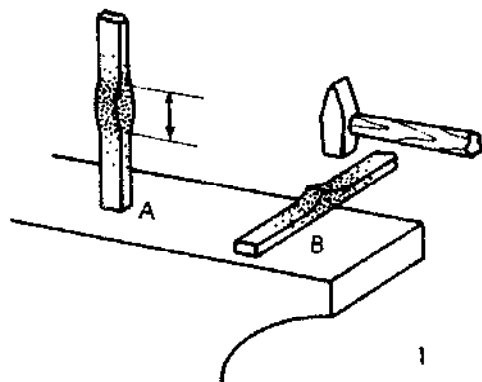

Bending on the round beak

When a bend is forged on the round beak of the anvil, the workpiece must be held at 90 degrees to the surface of the round beak when viewed from above. Bars with small radii should be bent near the top of the round beak, while bars with large radii should be bent near the anvil face.

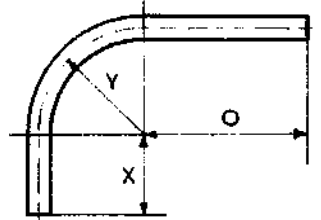

It is very important in bending on the round beak that the workpiece is held in such a way that the first mark on the side of the workpiece is a little distance ahead of the centre line of the round beak. See Fig. 2. The smaller the radius of the bend, the smaller the distance to the centre line.

Sequence for making a bend

- A - Calculate the stretched length of the workpiece and use a centre punch to mark the calculated distances on the side of the workpiece. See Fig. 1.
- B - Heat the metal to a uniform heat, uneven heating causes uneven bends.
- C - Place the workpiece in the correct position on the round beak.
- D - Bend the bar down with punching hammer blows, see Figs. 2 and 3.
- E - While hammering, also punch the bar gradually forwards. Large radii require more 'feed' at a time than small radii.
- F - Frequently compare the bend with the radius drawn on the floor or on a sheet of metal and correct mistakes immediately.
- G - Stop bending when the second mark is directly above the centre line of the round beak. See Fig. 4.
- H - After finishing the bending, check that the measurements and flatness of the bend are correct. This can be done by sighting or by placing the workpiece on top of the anvil face. Corrections should be made with moderate hammer blows.
- I - Check measurements again when the workpiece is cold. Minor corrections can be made when the metal is cold.

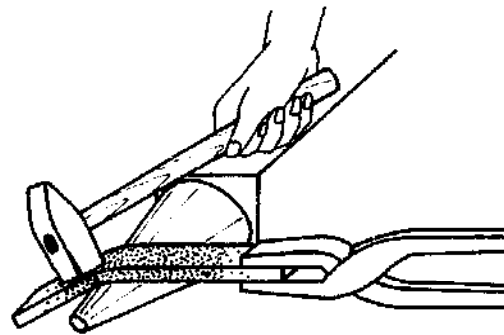

2

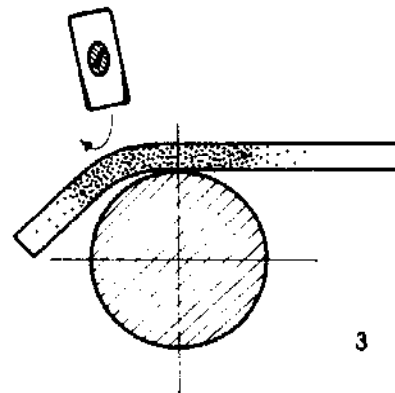

3

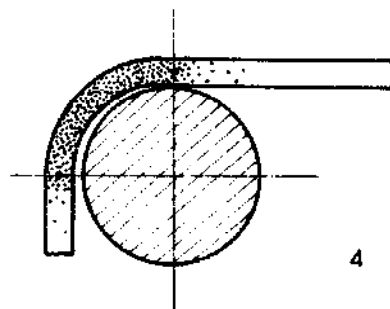

4

Practise this bending and feeding several times with an old piece of metal before you attempt to make an actual bend.

Acute angle bend

When making of this angle too, draw the acute angle with chalk on the concrete floor. Set the sliding bevel as well.

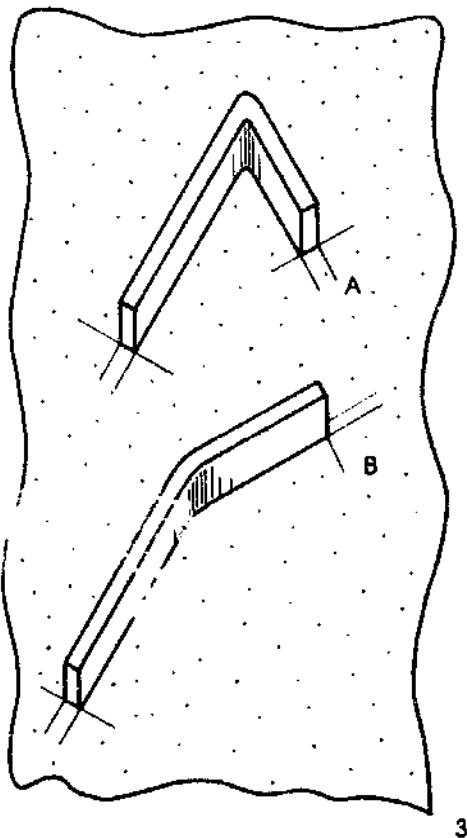
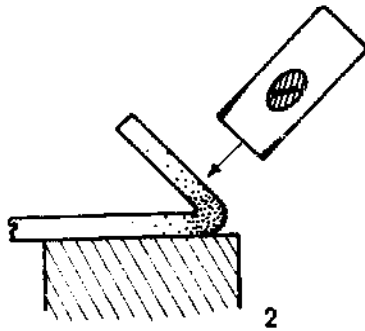
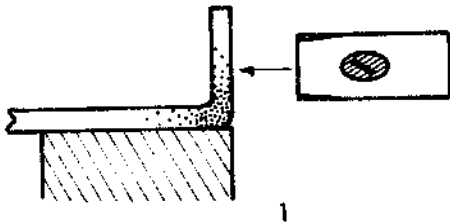

- A - Forge a rightangled bend as described above.
- B - Re-heat the workpiece if necessary.
- C - Place the workpiece on the anvil face with the short end exactly vertical. See Fig. 1.
- D - Hammer down the short end as far as necessary, making sure the hammer face lands flat on the short end. See Fig. 2.
- E - Do not hammer on the actual bend, but a bit higher as shown in Fig. 2.
- F - Compare the angle at regular intervals with the angle on the floor. See Fig. 3-A.
- G - When the angle is bent correctly, quench the workpiece and correct minor mistakes. Corrections can be made when the workpiece is cold.

Bend with an obtuse angle

If you bend material to an obtuse angle (any angle greater than 90 degrees and less than 180 degrees), you must first draw this angle on the floor of the workshop or on a piece of sheet metal. Placing the bend on top of the drawn angle makes it easy to compare the result without cooling the workpiece. See Fig. 3-B.

After quenching the workpiece, the angle can be checked again with the sliding bevel.

Bending offsets

These illustrations show three types of offsets:

Fig. 1 shows a single offset. This can be used for making heavy articles, hasps, staples, etc.

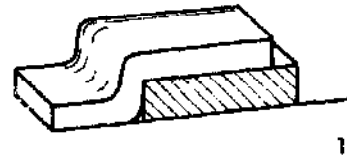

A double offset is shown in Fig. 2. This shape is used for sliding bolts, clamps, etc.

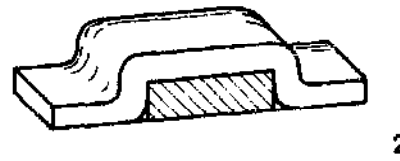
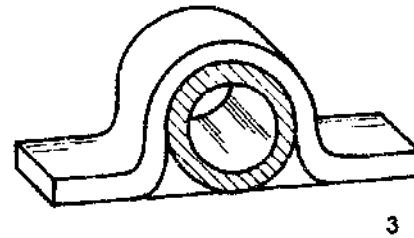

Fig. 3 shows a half round offset. This is used for pipe clamps, sliding bolts or other purposes where a half round clamp may be useful.



Tools to use for offsetting

Offsets on medium heavy metal strips or bars can be made by heating the workpiece and shaping it over a guide piece as shown in Fig. 4-C.

This guidance piece is especially useful when manufacturing large numbers of offsets.

During the work, the actual workpiece is held between guide piece 4-C and 4-B. The last piece is pressed down on the workpiece by a steel clamp 4-A.

The steel clamp is inserted in the hardie hole and after force is applied at 4-A the clamp will be tight on top of the workpiece.

Steel clamps can be made easily. The quality of steel should be such that it is flexible.

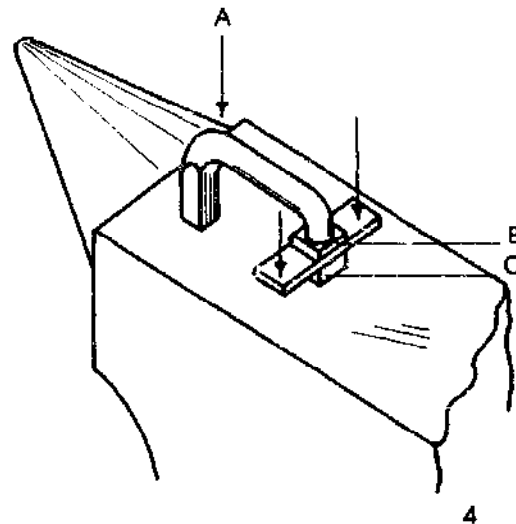

Making offsets

First prepare the correct guide piece (see Fig. 1-B) which should be of a width similar to the width between the offsets and of a thickness equal to the height of the offset. See Fig. 1.

Mark the length of the offset 1-B on the side of the bar with a centre punch, see dot on 1-A.

Heat the spot where the bend is to be made.

Place the hot workpiece on top of the guide piece. Place the second guide piece on which the clamp 1-C is placed.

Place the top fuller 1-D at a distance X from the punched point to allow enough room for the offset.

Tell the helper to strike the top fuller with moderate blows.

While the top fuller is pressed towards the guide piece, it must also be held square to the workpiece. See Fig. 2.

Note the angles at which the top fuller is held during the exercise.

Double offset

As shown in Fig. 3, a double offset consists of two single offsets made on both sides of the workpiece.

It is not advisable to cut the material for a double offset before offsetting. It is easier to shape the whole workpiece first and then cut it off the bar.

If you work fast and accurately, you can make the two single offsets at one time.

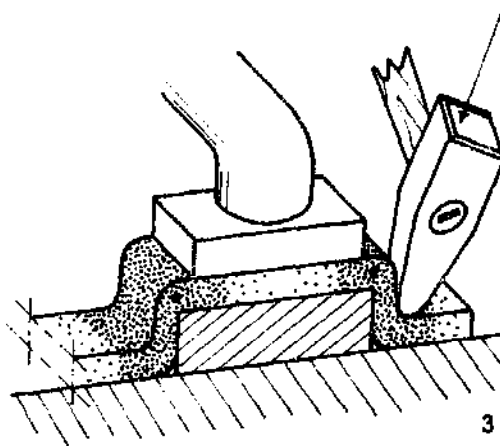
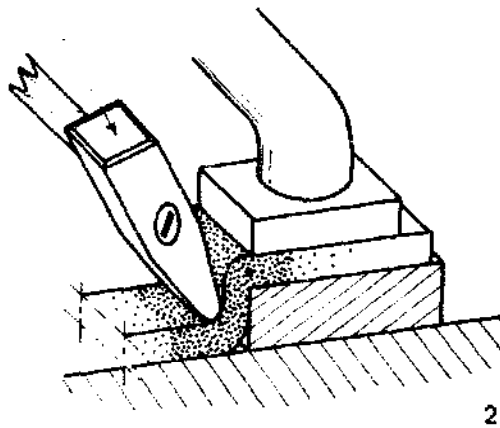
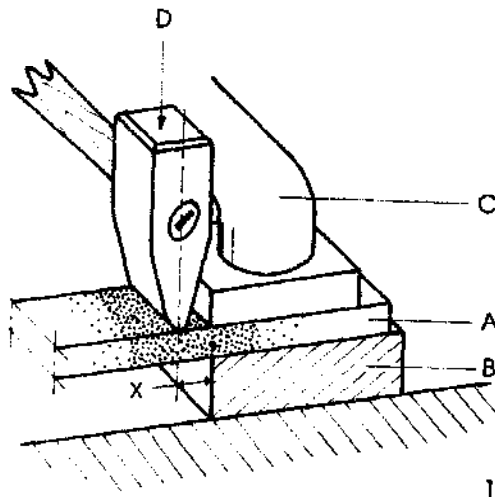

Half round offset

Fig. 1 shows a technical drawing of a half round clamp.

The stretched length is:

$$A + B + C + D = \quad \text{mm}$$

$$E = \frac{2\pi R_1}{2} = \quad \text{mm}$$

$$F = \frac{2\pi R_2}{4} = \quad \text{mm}$$

$$G = \frac{2\pi R_2}{4} = \quad \text{mm}$$

$$\text{Total} = \quad \text{mm}$$

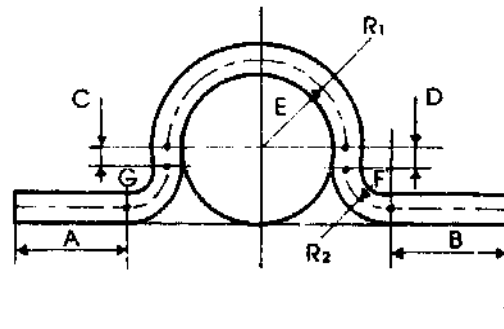

Half round offset procedure

- A - Use the centre punch to mark the points obtained in the technical drawing. Mark them on both sides of the workpiece.
- B - Heat the centre of the workpiece and, using two pairs of tongs, bend the bar over the cylinder as shown in Fig. 2-A.
- C - After cooling the centre, heat the two parts which are to be offset.
- D - Place the bar quickly over the cylinder and hold it tight to the cylinder with a clamp.
- E - Place a top fuller exactly square on the highest mark, see Fig. 2-B.
- F - Tell the helper to strike the top fuller firmly. The fuller slides down during this process. See Fig. 3.
- G - The offsets must be shaped very fast and the two offsets are made at once as shown in Fig. 4.
- H - The final shaping can be done with the hand hammer.

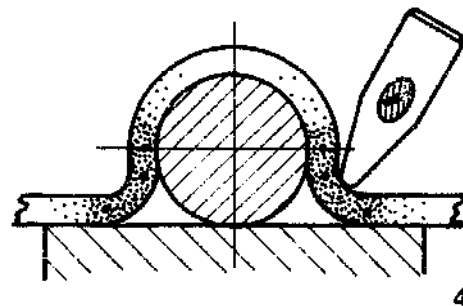
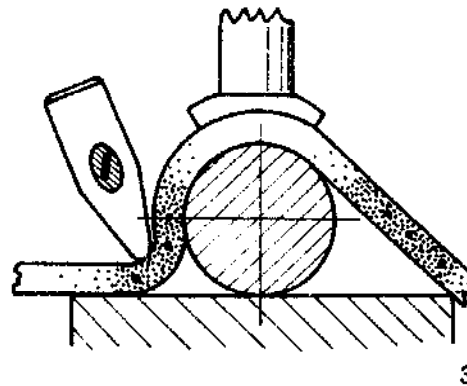
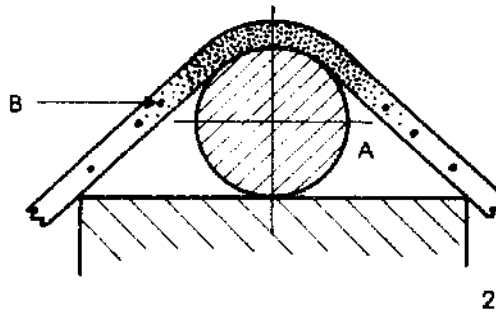

Bending and forging an eye

One of the most common bending jobs in the rural workshop is the shaping of an eye on the end of a rod. You can use the following method:

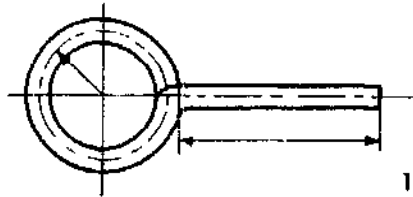

1

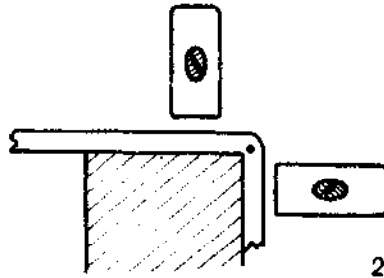

2

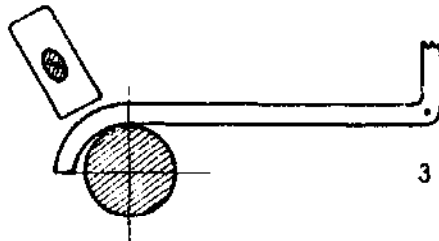

3

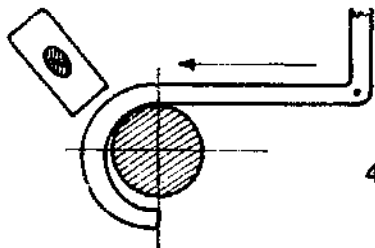

4

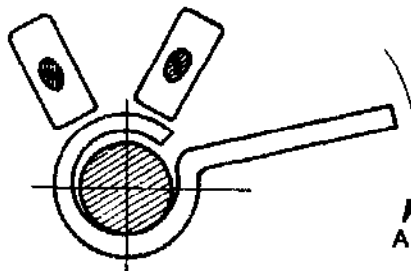

5

- A - Make a drawing of the eye and calculate the stretched length, see Fig. 1.
- B - Mark the stretched length with a centre punch on the side of the bar. Do not cut the bar, it is better to do this when the job is finished.
- C - Place the bar in the forge and heat the place round the square bend to a good red heat.
- D - Bend the bar square over the anvil at the centre punch mark. See Fig. 2.
- E - Heat the stretched length of the bar.
- F - Place the tip of the bar on the round beak of the anvil. Large eyes should be forged towards the anvil face, small eyes more towards the tip of the round beak.
- G - Start forging the eye from the tip, back towards the stem of the eye. Work rapidly and do not allow the metal to become too cold, otherwise the bending is too slow and difficult, the metal does not bend at the places required. See Fig. 3.
- H - Bending and feeding must be co-ordinated, so feed the bar at a regular rate after each blow of the hammer. See Fig. 4.

If the square bend at the junction of the stem and the eye tends to straighten out, it is an indication that the end of the stock is not being kept hot enough during the bending process.

- I - Round the eye by driving it back over the point of the round beak, noting carefully where it does not rest against the round beak and striking the metal down lightly at these points, while moving the stem down. See Fig. 5.
- J - Centre the eye on the stem if necessary by placing the stem on the anvil face, with the eye projecting over the edge, and striking the eye.

For this operation it is essential that you heat the stock well at the junction of the stem and the eye, but leave the eye itself virtually cold. You can achieve such a condition by heating the whole eye and then cooling most of the rounded part quickly by dipping it in water.

Bending a ring

- A - Calculate the stretched length of the ring.
- B - Use a centre punch to mark the centre on the side of the workpiece, see dot in Fig. 2.
- C - Draw the inside of the ring on a piece of sheet metal, so that you can check by comparison during forging.
- D - Heat the first half of the workpiece and bend the first quarter of the ring. Be sure to hold the workpiece horizontal, see Fig. 3.
- E - After bending one quarter of the ring, compare it with the circle on the sheet metal. Correct any mistakes immediately.
- F - Re-heat the workpiece if necessary.
- G - Continue bending to a half circle. Compare the work regularly with the circle drawn on the sheet metal.
- H - Stop forging when the centre mark punch is exactly above the centre of the round beak, see Fig. 5.
- I - Re-heat the workpiece and place the other side on the round beak.
- J - Forge the other half ring. See Figs. 5 and 6.
- K - While it is still hot, place the workpiece on top of the anvil face and check whether the ring is flat at all directions.

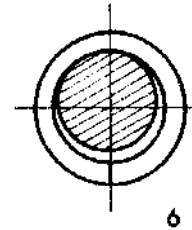
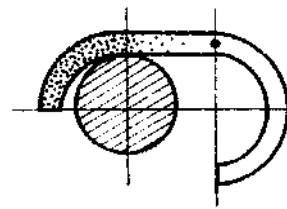
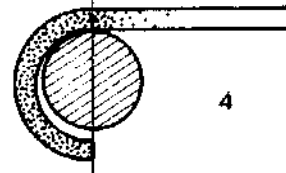
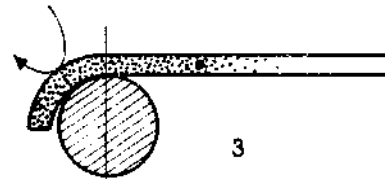
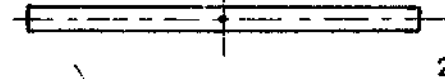
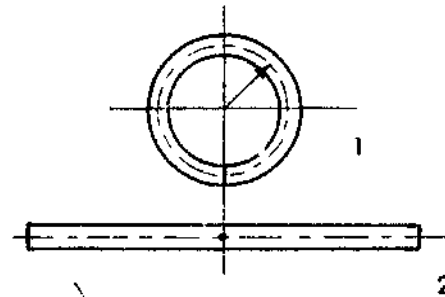

Bending a link

The skill of bending a link is similar to that of bending a ring. The difference is where to start and stop forging.

- A - Calculate the stretched length of the chain, as shown in Fig. 7.
- B - Mark the four points B-C-D-E on the bar as shown in Fig. 7.
- C - Start bending at point 7-B and stop at point 7-C.
- D - Turn the workpiece and bend the other half, point 7-D to 7-E.

After forging, the two bends meet at point 7-X.

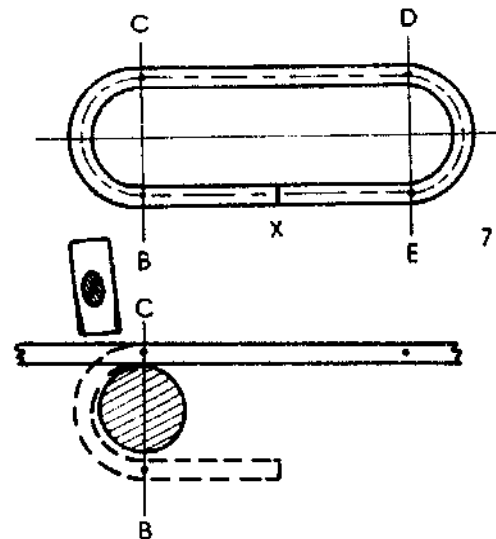

Bending and forging a small eye

If a very small eye must be forged at the end of a flat bar, it is forged on the face of the anvil, using a round bar.

Before you start bending, you must forge the beginning of the eye to an angle of approximately 45 degrees. This is necessary to ensure correct connection between the eye and the bar. See Fig. 1.

Before forging, heat the bar to at least a yellow heat.

After chamfering, heat the bar again. Place the tip over the edge of the anvil as shown in Fig. 2. Forge the eye while feeding the bar gradually over the edge of the anvil, see 2-F. Hammering should be at 2-H.

Continue bending until nearly half the eye is forged.

After heating, place the bar as shown in Fig. 3. Place the piece of round bar in the partly forged eye and forge the eye over the round bar.

Remember that the hammer blows must be horizontal, pointing to the centre of the bend (3-H).

After finishing the forging, hammer out the inserted round bar. See Fig. 4.

Do not hammer again because you will distort the eye.

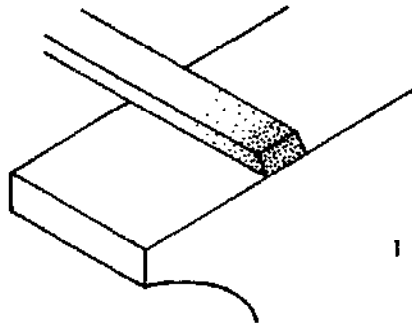

1

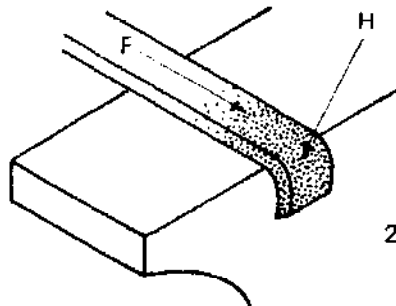

2

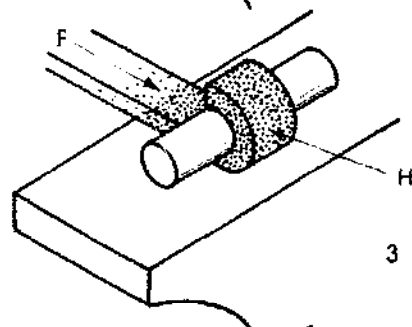

3

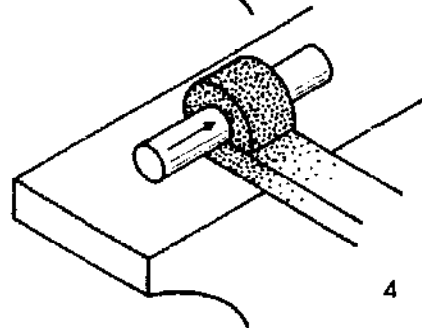

4

Bending a bar edgeways

A lot of skill is required to bend a bar edgeways over the round beak of the anvil. See Fig. 1.

Before bending, mark the bend and heat the metal to at least yellow heat.

Forging should be done very fast with well-aimed heavy blows, as described above.

During forging it is likely that the metal will bulge at the sides of the bar. Correct this occasionally on the face of the anvil. See Fig. 2-A.

During bending, the metal on the outside of the bend becomes smaller than on the inside of the bend. To avoid this, upset the bar before starting the actual bending. See Fig. 2-B.

Bending short bars in the bench vice

When short bars must be bent edgeways, it is better to bend them in the bench vice with a piece of pipe of the same diameter or shape as the bar. Using a pipe makes guiding the bar very easy.

Slip the pipe over the bar, as shown in Fig. 3, very near to the location of the first bending. While bending, pull the pipe backwards as shown by the arrow, so the bar can bend over the vice clamp. Correct any bulging of the material on top of the anvil at regular intervals.

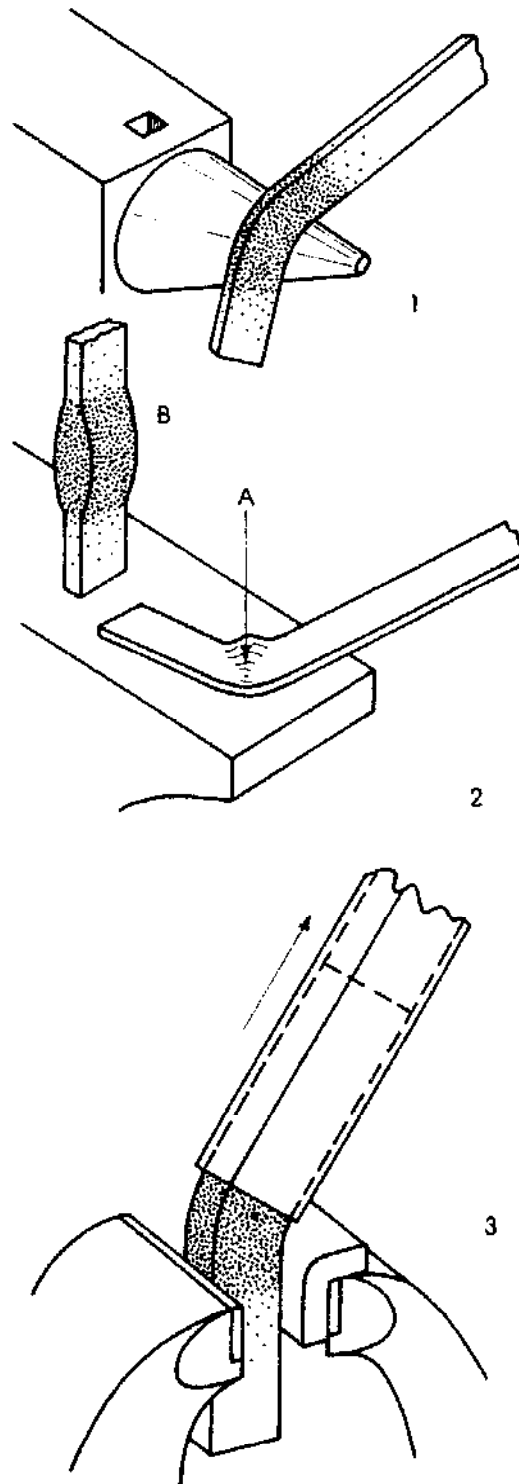

Rightangled bend in angle steel

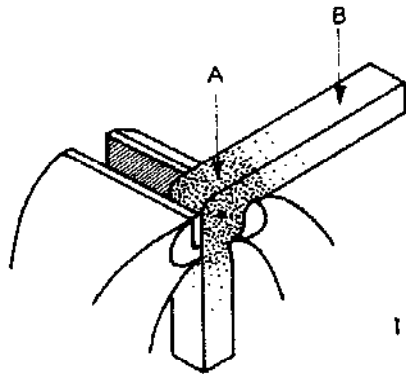

- A - Mark with a centre punch the place where the bend is to be made.
- B - Place the angle iron in the bench vice, clamping it at the centre punch mark.
- C - Bend the angle iron by hammering at point 1-A and pressing one of the legs down at 1-B. See Fig. 1. During bending, the side flange of the angle iron bulges out.
- D - After bending the angle iron, re-heat the bend and immediately cool the straight flange in water. See Fig. 2.

Helpers must be ready for the next stage of the work.

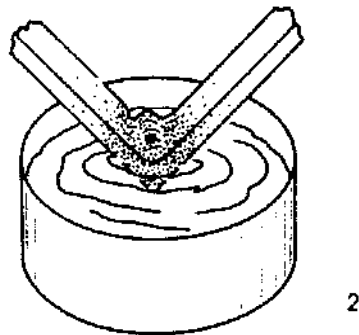

- E - After cooling the straight flange, place the angle iron very fast on top of a corner of the anvil and hammer down the bulge very gently, while pressing the legs towards the anvil, see Fig. 3-A, 3-B and 3-C.

It should be clear that the bulge cannot be flattened out in one move. Re-heat the bend and repeat the procedure described above until the bend is flat. See Fig. 4-A, 4-B and 4-C.

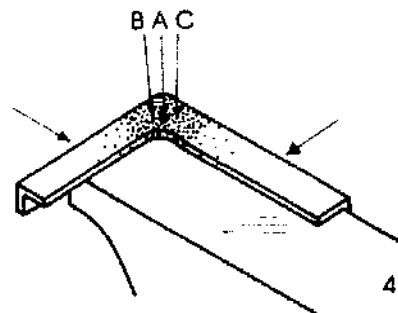
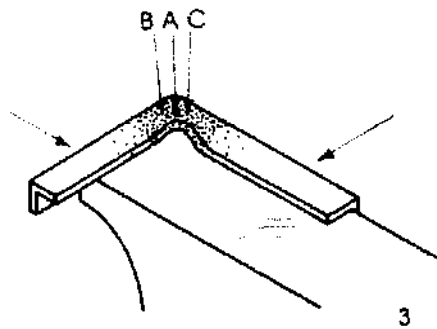

Bending an angle iron ring

Fig. 1 shows the two half bent angle iron rings, with the vertical flange inside.

The stretched length of the angle iron is calculated over the neutral axis shown in 1-A.

Tiny holes in the horizontal flange may help you to understand how the bending procedure is carried out. See Fig. 1-B.

During bending special forces appear in the upright flange 1-C.

If you tried to forge the ring right away, you would find that the angle iron tends to bend in two directions instead of on only one side.

To avoid this, forge the angle iron first in the opposite direction, as shown in Fig. 2 (note the position of the hole). The direction of hammering is indicated by the arrow.

After bending, see Fig. 3-O, place the angle iron on the round beak of the anvil and forge the angle iron down to shape the correct bend desired, see Fig. 3-Y. Again, note the position of the hole 3-B.

Fig. 4 shows a half angle iron ring with the upright flange on the outside. Follow the procedure described above for shaping the angle iron in the opposite direction. See Fig. 5.

This is a very hard job, which requires a lot of experience.

If more than one ring must be made, a solid square bar can be forged into a ring and then fixed on top of a swage block as shown in Fig. 6.

Heat the angle iron and fix it with a clamp to the square bar. Pull the angle iron round the mould.

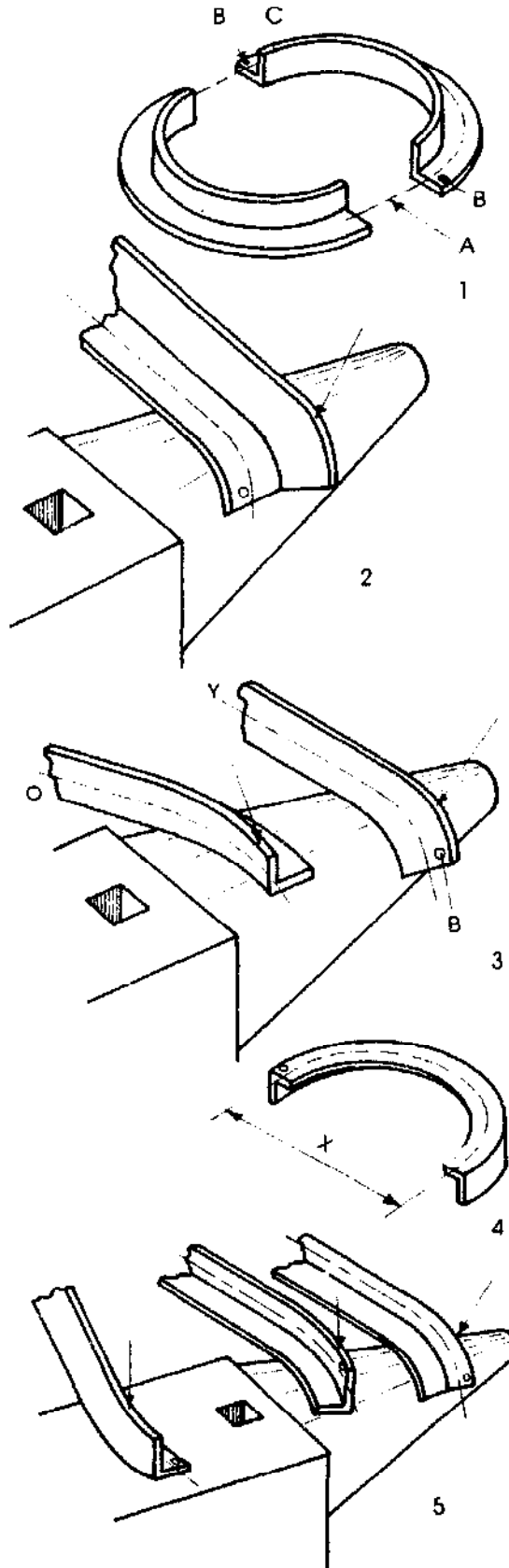
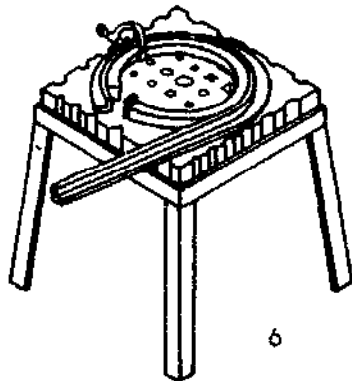

Bending with the bending fork

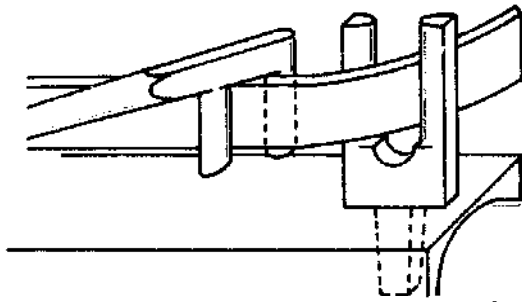

1A

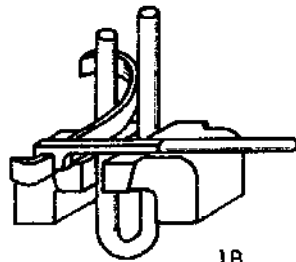

1B

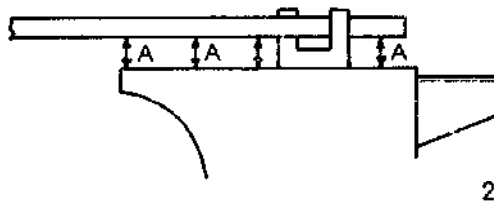

2

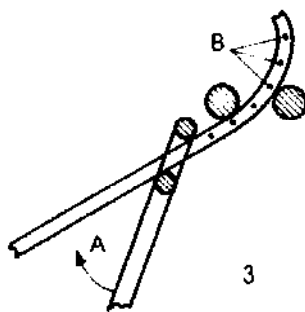

3

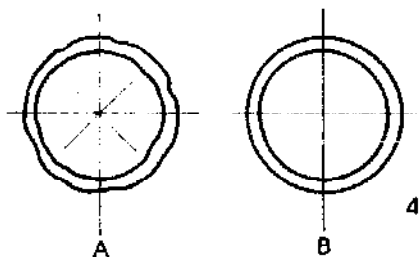

4

Bends with a small radius are made on the anvil or in the bench vice. Large bends in thin bars are made with a bending wrench and bending fork, see Fig. 1-A.

This combination of tools is easy to make in the workshop. The fork can be made from a round bar, see Fig. 1-B. During use, it can be clamped into the bench vice.

IMPORTANT!!

- While bending, hold the material exactly horizontal, as shown in Fig. 2.
- Always "pull" on the handle of the wrench with the same strength and over the same distance, see Fig. 3-A.
- Feed the material through the opening of the fork very evenly in equal amounts, see Fig. 3-B.

The material must be fed in very small amounts to ensure a smooth circle and to avoid buckles. See Fig. 4-A and 4-B.

Bending procedure

- A - Draw the end of the circle on the floor or on a piece of sheet metal.
- B - Calculate the stretched length and cut the metal if necessary.
- C - Heat both ends of the bar if you are making a circle.
- D - Forge both ends over the round beak of the anvil. It is not possible to bend these first parts in the bending fork.
- E - Heat the material again and place the bar in the bending fork, holding it exactly horizontal.
- F - Start bending with the wrench in very small steps, controlling the feed and the pull of the wrench. The smaller the steps, the smoother the bend.

Make allowance for the "spring back" while pulling the wrench.

- G - Compare the results with the drawing on the floor at regular intervals.
- H - Also check frequently that the material remains flat at the sides. If this is not the case, correct this mistake immediately.

Bending with these tools takes a lot of practice.

Forge welding

A very difficult skill to be mastered by the rural mechanic is forge welding. When metals are heated gradually, they soften and become plastic as the temperature increases. It reaches a point where the two pieces can be joined together by means of pressure and hammering. This procedure is called forge welding.

SUCCESSFUL WELDING DEPENDS ON:

- Sound understanding of the process of forge welding.
- Good knowledge of materials.
- Building a correct fire.
- The use of sand or flux.
- Correct preparation of the joints.

Before welding can be done, the parts to be joined must be prepared in such a way that welding becomes relatively easy and a strong connection between the parts is secured.

Forge welding joints

Workpieces with different shapes demand different joints. These are prepared as shown in Figs. 1-2-3 and 4.

Fig. 1 shows three different lengthening joints, 1-A shows a Vee joint, 1-B a scarf and 1-C a butt joint.

Fig. 2 shows a scarfed angle joint.

"T" Joints are shown in Figs. 3 and 4.

Remember that the more surface there is on a joint, the stronger the weld.

Shaping on a joint surface

At a later stage you will learn that sand or a flux is needed for forge welding. This flux or sand is applied between the joint surfaces and must come out during the welding procedure.

To make it possible for the flux to come out of the joint during the first light hammer blows, the inner surfaces of the joints must be a little round in shape, as shown in Fig. 5-A.

In Fig. 5-B you see an example of a joint where the flux is enclosed due to the hollow shape of the parts which must be welded together. During welding, the flux will be hammered inside the steel instead of being able to jump out at the sides of the joint as shown in Fig. 5-A.

Never shape the edges of a joint to a sharp shape. A thin metal edge burns easily. Leave at least about 1.5 mm material. See Fig. 1 and 2.

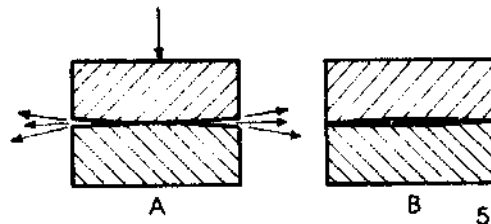
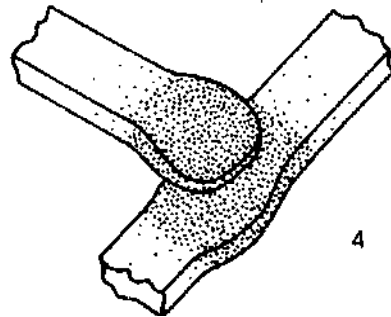
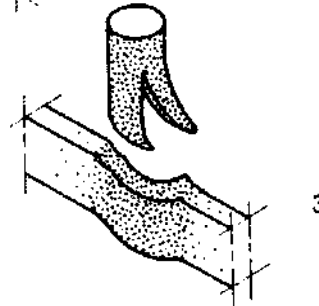
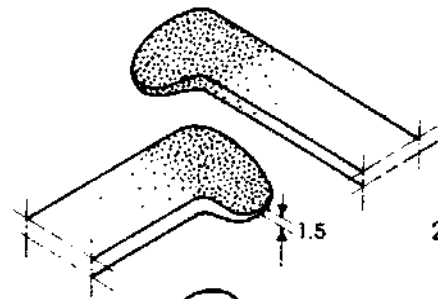
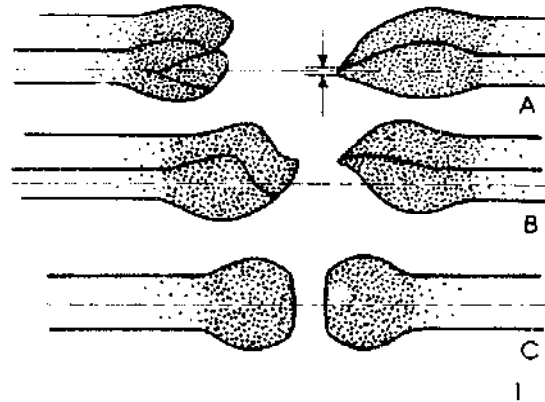

Formation of scale

When metal is heated and exposed to the surrounding air (oxygen), the outer layer is covered with burned material, called scale. Scale must be removed before and during welding and formation of new scale should be avoided.

Sand and fluxes

Clean sand or a flux is used to prevent formation of scale between the surfaces to be welded together. Flux is a combination of chemicals in powder form. The most common flux is called BORAX.

When metal is heated to orange heat, the flux or sand must be applied very fast to the surfaces of the weld, to prevent the metal losing a lot of its heat. As the metal approaches the white welding heat, the flux melts and flows over the whole welding surface to form a glossy smooth layer. Then, when the metal is taken out of the forge, the oxygen can no longer reach the surface of the metal and no scale can form.

Be carefull when using flux.

If you use too much flux, it will cause more scale formation rather than less. Excessive flux cannot be pressed out of the joint during the welding procedure and prevents the correct adhesion of the metal, a weak joint is the result.

Welding temperatures

The correct temperature needed for forge welding is about 1350°. This temperature gives the metal a white heat glow. But welding temperatures may differ according to the alloy elements, especially the carbon content.

If you want to check the temperature of the steel - and thus its colour - during the work, do not take the whole workpiece out of the fire. If possible, push the bar through the fire and check the colour. Pull it back quickly if the correct temperature has not yet been reached.

Another method to check whether steel has reached the welding temperature and is in a pasty condition is to take a steel rod with a diameter of approximately 6 mm. One end of the rod must have a blunt point, which is inserted in the fire near the workpiece.

When the tip of the rod has the same temperature as the workpiece, touch the workpiece with it. If the rod sticks to the workpiece, the metals have reached the welding temperature.

Forge welding procedure

Before you start forge welding, make sure of what you are going to do. Think about the whole procedure and when you are finally ready to do it; DO IT VERY FAST!

Several things must happen at the same time during welding. Hammer force must be used at both ends of the bar to keep the joint together, while the joint itself is hammered through with light hammer blows at first, gradually increasing in force.

Do not hesitate during the work because metal rapidly loses its welding heat.

Success in forge welding

Success in forge welding depends on:

- Having a good knowledge of forge welding
- Having all necessary tools ready near the anvil
- Having a good fire built up
- Heating the workpiece to the required temperature - around 1350 degrees Celsius, giving a white colour
- Not looking at the heated part for too long; the light may blind you for some time
- Knocking all dirt off the workpiece against the side of the anvil before starting to hammer
- Working in harmony with your striker and helper. Each has his own particular work to do
- Striking first with light, rapid hammer blows from the centre towards the outside. This is to make sure all the flux comes out of the joint
- Increasing the hammer force gradually to heavy hammer blows, while turning the workpiece regularly.
- Finishing off the workpiece while hot with the hand hammer or in some cases with the top and bottom swage or flatter.

"WORK VERY FAST, CORRECTLY AND SURELY"

NOTE:

If joints do not hold, examine the weld. If you see dark spots, there was dirt in the weld. If the material is pitted and mottled, it has been burned. In either case, the materials cannot be used again.

Cold-bending metal

Bending metal in a cold state is not easy. You will observe:

- Sharp bends cannot be made easily without cracking the material.
- The amount of force needed to make a bend can be great.
- Materials with a large cross-section cannot be bent.
- Difficult curves are difficult to make.

Some theory about the bending of metal should be studied before actual bending can be done. See pages 45 and 46.

Bending

In general it is advisable to design workpieces with rounded bends instead of sharp bends, to avoid cracks during the bending operation.

Rounded bends can be made with the aid of a bending block, see Fig. 1, or with a bending hook, see Fig. 2.

The advantage of using a bending block instead of a bending hook is that the bending block has various rounded edges over which bends of different radius can be made.

Marking and clamping a workpiece

Before bending, mark the inside length of the bend with a centre point on the side of the workpiece.

Clamp the workpiece in the vice together with the bending tool.

Make sure the mark for the inside bend is in line with the mark on the bending tool, see Figs. 1 and 2.

Clamp the material and bending tool in the bench vice in such a way that the actual bending can be done in the direction of the fixed jaw of the vice. This is to avoid putting too much force on the movable jaw.

Bending a bar

Wide bends can be made at once in the bench vice, using a hammer and a bending hook.

If the bar is too heavy, a pipe slipped over the bar may help to pull it down during hammering, see Fig. 3.

Short bars or bars which are heavy to be bent by hand, can be bent by hammering, as shown in Fig. 4. Hammer with your right hand and pull the bar down with your left hand.

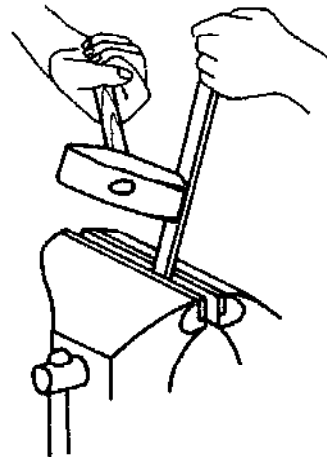
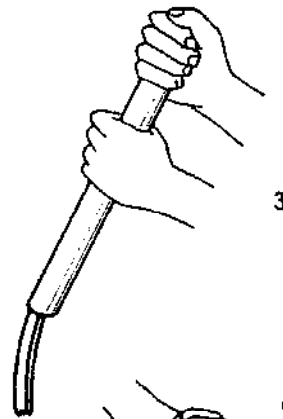
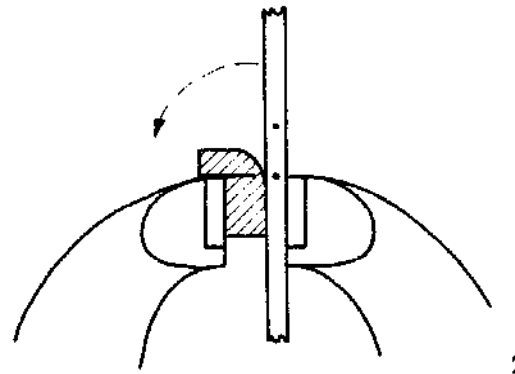
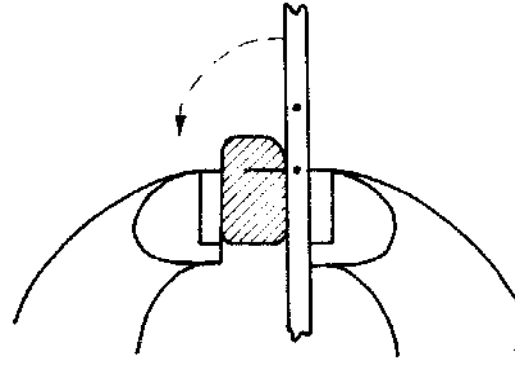

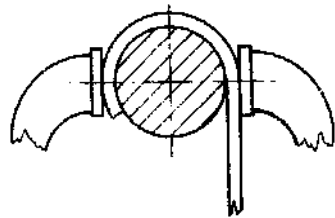
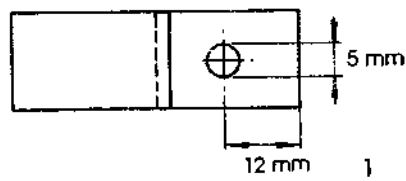
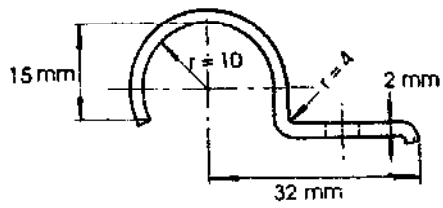

2

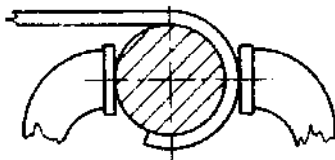

3

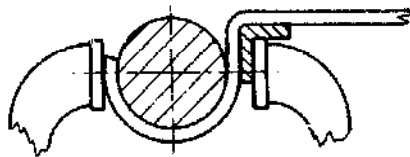

4

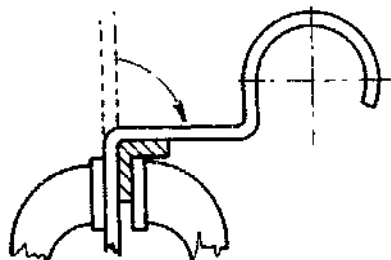

5

Exercises

Fig. 1 presents an exercise. Figs. 2 to 5 give some helpful hints for making this workpiece.

Fig. 6 also shows an exercise. Figs. 7 to 10 show a method of making this workpiece.

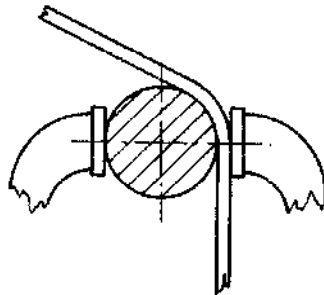
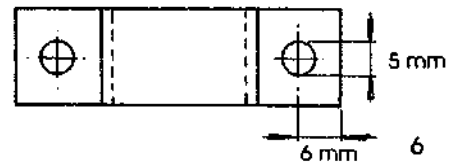
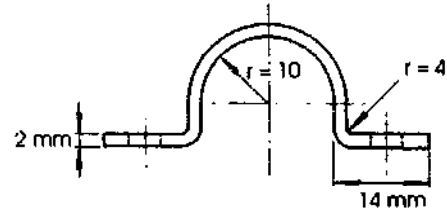

7

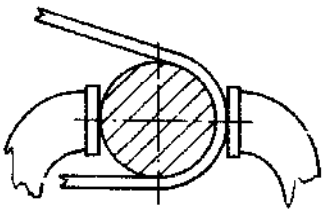

8

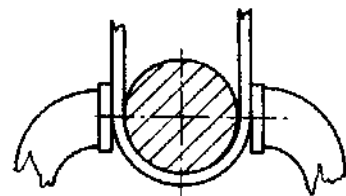

9

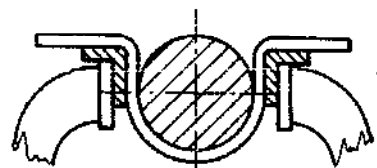

10

Rivet and riveting tools

Riveting is joining two metals together with one or more rivets.

In hot-riveting a heavier rivet set is used than in cold-riveting. A rivet set as shown in Fig. 1-A can be placed in the hardie hole of the anvil or in the vice. The cupping tool is shown in Fig. 1-B. It is shaped in such a way that it can be held with the left hand or with tongs.

Both the rivet set and the cupping tool have a round hole which is slightly less deep than the rivet head shape. This stops the riveting tools touching the metal which is to be joined, see Fig. 5-A.

The actual length of the rivet must be equal to the thickness of the material to be joined, including twice the rivet diameter. See Fig. 2.

The actual length of a rivet to be countersunk on one side must be the thickness of the materials including 1 times the diameter of the actual rivet. See Fig. 3. A mistake has been made in Fig. 3, which one?

Before drilling the hole for the rivet, clamp the material firmly and drill the hole through. Do not loosen the clamp but leave it until the riveting is finished. Countersink the edges of the hole as shown in Fig. 4.

The diameter of the rivet increases when it is heated. The hole for the rivet must therefore be 0.5 mm larger than the diameter of the rivet.

Hot riveting procedure

- A - Mark the hole with a scribe
- B - Clamp the metals together firmly
- C - Drill the hole through
- D - Countersink the edges slightly, do not loosen the clamp
- E - Heat the rivet
- F - Insert the rivet and place the whole combination on top of the rivet set
- G - Shape the rivet as shown in Fig. 5
- H - Finish off the head of the rivet with the cupping tool. See 5-B.

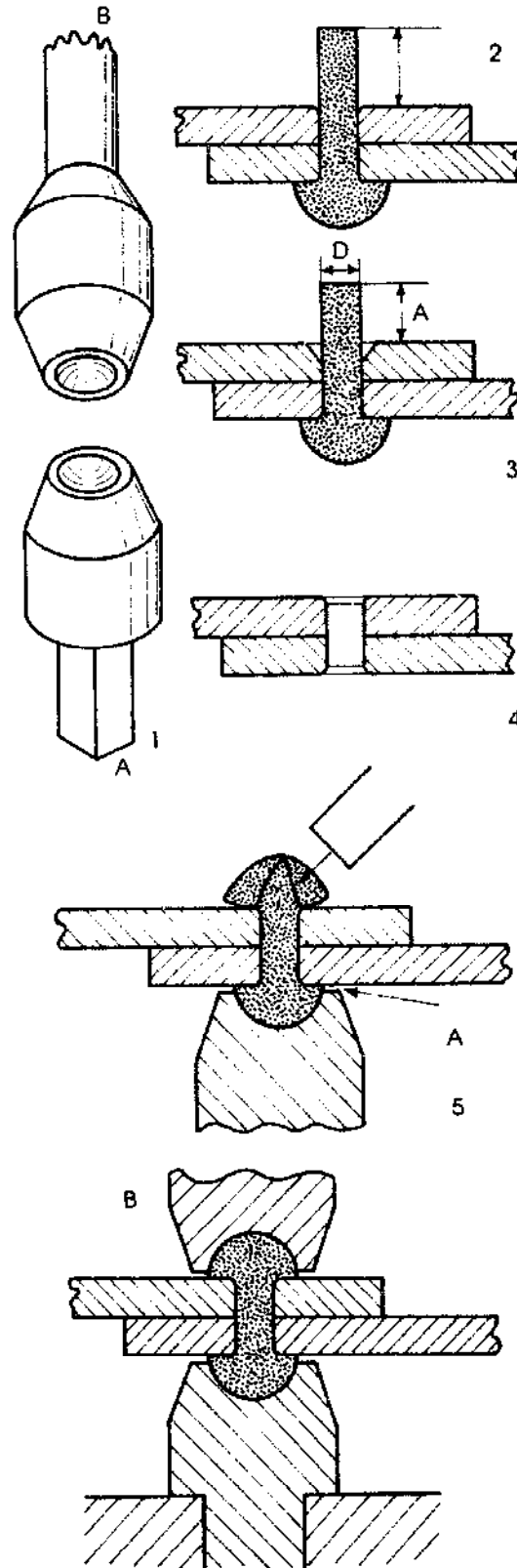

Round head rivet

A round head rivet is shown in Fig. 1.

- A = Radius rivet head
- B = $0.6 \times$ diameter
- C = Equal to (rivet) shaft diameter
- D = Rivet diameter
- E = Total rivet length

Countersunk rivet

Fig. 2 shows a countersunk rivet.

- A = 70 degrees angle
- B = Equal to rivet diameter
- D = Rivet diameter
- E = Total rivet length

Rivets should be placed as shown in Fig. 3-A. The distance from any edge of the material should be at least 1 to 2 times the rivet diameter.

If no allowance is made for the correct distance and the rivet is placed too close to the edge, the metal may bulge or crack during riveting. See Fig. 3-B.

Holes drilled in the metal to receive the rivet should be exactly in line, as shown in Fig. 4-A. The edges should be slightly chamfered.

Fig. 4-B shows a way of lining up holes which is wrong.

While hot-riveting, it is good to use tongs as shown in Fig. 5 to pick up the hot rivets and place them in their holes.

An old piece of sheet metal can be used to hold the rivets in position during heating, see Fig. 5.

Rivets with a diameter larger than 10 mm are fixed hot. Rivets themselves should be made in advance with a heading tool.

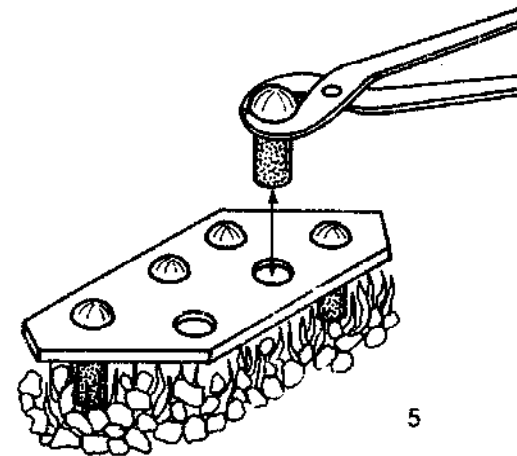
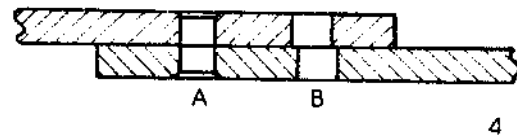
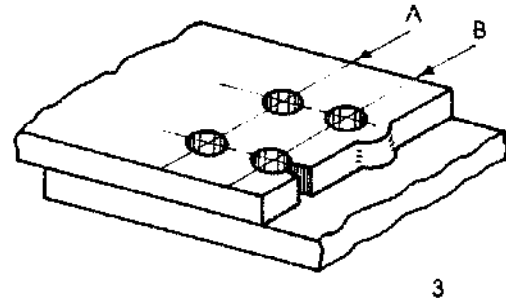
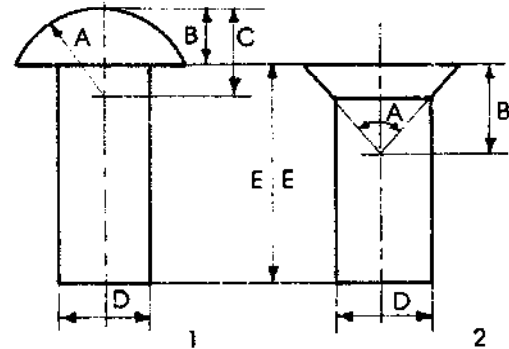

Metallurgy

Metallurgy for blacksmithing

Although you have learnt in previous lessons about the process of melting iron and making steel and its properties, it is good to know more and to repeat the facts occasionally in the context of forging wrought iron and steel and making simple tools.

Basic forging processes are made possible because the iron becomes malleable/plastic and can be forged when it is heated above a cherry red colour. Steel can be welded when it is heated to a white heat. It burns if it is heated above a white heat and cannot be used anymore.

Heat treatment

The blacksmith is also involved in making tools. Some garden tools can be made from mild steel, but the good tools for a craftsman are made from a steel with a carbon content of 0.70 % and above, because steel with such a carbon content responds to heat treatment.

Carbon is a soft black material, called graphite in its natural state. You find graphite in your pencil lead. Charcoal contains a high percentage of carbon, so does coal.

In industrial circumstances the carbon content is given with the steel. If you are going to use a steel of which the carbon content is not known, you can find it by the spark test - see previous lessons in the general metalwork part.

During and after the manufacture of a product made of steel, it may be necessary to change the properties of this steel to be able to work on it and give it a final property with a specific hardness.

Ways of changing properties are:

HARDENING

Steel is hardened by heating it above 720 degrees Celsius followed by a rapid cooling in water.

TEMPERING

After hardening steel one can reduce its brittleness and give the steel any desired hardness by reheating it at a lower temperature.

ANNEALING

Annealing steel consists in heating and subsequent gradual cooling, by which internal stresses are removed and the steel becomes tough and ductile.

Hardening

Hardening is the process of heating a metal uniformly to a temperature slightly higher than a cherry red colour (approximately 800 degrees Celsius) and then quenching it rapidly in water. When you heat metal, heat it slowly and uniformly, turning the workpiece regularly in the fire.

The structure of steel changes during hardening and this must be clearly understood to avoid mistakes and disappointments.

For example: the structure of the steel changes when you heat a piece of steel (with a carbon content of 0.70) to 800 degrees Celsius and plunge this hot piece rapidly into cold water; the outer layer of the piece of steel cools very fast, with the result that the inner part of the steel cannot cool, so the outer layer cracks due to the tension of the shrinking taking place. The faster the cooling, the harder the steel becomes, depending of course on the carbon content.

Cooling should therefore be controlled.

A workpiece which has been hardened must be tempered (see below) as soon as possible because, as mentioned above, the hardened piece is very highly stressed and can develop cracks. For the same reason, do not drop a hardened workpiece or it may break.

Another important factor in the hardening process is that, when a thin workpiece is cooled, it cools very fast. Thick workpieces cool more slowly. So if you have to cool a workpiece of uneven thickness, the thinner parts should be cooled first.

Much can be said about hardening, but first and foremost it is a matter of experience. That is why you should observe the processes critically and make notes about your own experience.

Tempering

Tempering is controlled cooling of steel which has been hardened.

When steel has been hardened, it may have become too hard for the purpose you need it for.

Some of the hardness obtained may have to be taken away to ensure the correct hardness of the steel. A special process called tempering is used for this purpose.

Tempering means heating steel to a certain temperature—which is far below the hardening temperature—and then cooling it, not suddenly, but in a controlled way. The temperature at which the workpiece is tempered is determined by:

- the function of the workpiece
- the desired quality of the workpiece

Since you cannot use a thermometer to measure the temperatures during the tempering process, it is important to observe the colours which appear on the surface of the metal just after heating and before cooling. These are called tempering colours.

Tempering colours

As we learned in previous lessons, iron metal which comes into contact with the surrounding air (oxygen) forms a layer at its surface called rust - or, while it is hot, scale. One property of this layer of rust, even if it is very thin, is that it exhibits certain colours at certain temperatures. When tempering metal, we use this property to control the cooling while observing the colours which appear. Correct colours are observed when the metal has a shiny, clean surface which is only cleaned just before tempering by means of a sharpening stone.

Various temperatures with their colours are shown on the tempering and forging colour chart, see page 20 and the next page. Colours on the chart on page 73 are equal to the temperatures mentioned (in degrees Celsius). Before tempering, large workpieces can be heated in the blacksmith's forge. To avoid burning the steel, small workpieces can be heated by placing the material edge way over a piece of hot steel, from which it will take over the required heat. Tempering is one of the most important, but also very difficult skills in rural mechanics. It will take you a lot of time to master this skill. After tempering, you can use the spark test to find out the correct hardness of steel you have tempered.

Tempering and forging colours chart

Hardness	Temp °C	Colour	Purpose
Very hard	220	Light straw yellow	Razors, scrapers, paper cutting knives.
Very hard	230	Straw yellow	Drills, planing tools, thread cutting tools.
Very hard	240	Dark straw yellow	Penknives, drifts riveting tools, reamers.
Hard	255	Brown yellow	Wood drills.
Hard	265	Red brown	Top and bottom fullers, twist drills.
Medium Hard/tough	275	Purple	Cold chisels, hammers, set hammers, sledges, table knives.
Medium Hard/tough	285	Purple-blue	Wood chisels, cut lasses, axes, centre punches.
Medium Hard/tough	295	Full blue	Cold chisels for steel, knives.
Tough/hard	310	Light blue	Drills, tinsnips, screwdrivers, carsprings, hot chisels.
Tough/hard	330	Steel grey	Wood saws, punches, light springs.
	600	Dark red	Forging.
	700	Dark cherry red	Forging.
	800	Cherry red	Forging.
	900	Light cherry red	Forging.
	1000	Orange	Forging.
	1100	Yellow	Forging.
	1250	Light yellow	Forging.
	1400	White	Forging and welding.

Tempering continued

As mentioned above, tempering colours are created on the surface of the metal after polishing and heating it. As the temperature rises, the colours become deeper and you will also note that a rainbow of colours is created, moving over the surface of the metal. The most difficult part of tempering is observation of the many colours and then deciding when to stop and quench the metal.

Tempering a cold chisel

Good practice in mastering the skill of tempering is to temper a cold chisel.

A very quick method is to heat the chisel tip to a length of roughly 30 mm to a dark cherry red colour. Take the chisel in a pair of tongs and quench the whole chisel in water. You can then test the hardness of the chisel by scraping the tip of a file over the surface of the chisel. You can also try out the hardness on a scrap piece of metal.

Another, more refined method is to heat the cutting edge side of the chisel to about 50 mm length, dark cherry red.

After heating, hold the chisel in a pair of tongs and quench the length of 25 mm in water. In a few seconds you will see the visible heat glow of the unquenched part disappear, so then withdraw it immediately.

Let the chisel rest on the edge of the anvil or bench vice and rub the surface with a sharpening stone until it is clean and shiny. Lay the chisel flat on a cold surface which may absorb much of the heat from the chisel.

During polishing, the remaining heat in the rest of the chisel spreads gradually towards the tip of the chisel. The first tempering colour to appear is faint yellow followed by light yellow, straw yellow, dark straw yellow, dark brown, light purple and finally blue. This colour scheme never varies in the average high carbon steel and indicates a hardness colour. When the correct colour reaches the cutting edge of the chisel, arrest the process by quenching the whole chisel in water, moving it up and down until it has cooled completely.

Do not withdraw the chisel too soon after quenching the first time. There is still too much heat in the tool and the tempering colours run too fast. If you wait too long before withdrawing, there may not be enough heat left to make the full colour range visible and then you have to start all over again.

Annealing

To be able to cut, file or shape steel or change the properties of the steel permanently and relieve the internal stress, it may be necessary to anneal the steel. This is done by:

- A - Heating the steel slowly to a cherry red or a little above
- B - Holding the steel for some time at this temperature to ensure uniform heat
- C - After this, letting the steel cool very slowly. The best method is to stop the forge in which the steel has been heated and leave the steel until its glow has disappeared
- D - Burying the steel in fine sand or ashes to ensure a slow cooling process.

Exercises

Making a knife blade

Have a fairly tough and hard steel ready with 90 to 100 points carbon.

Mark and cut the steel, see Fig. 1.

Heat the steel and shape the tang, making two notches as shown in Fig. 2, and then shape the tang as shown in Fig. 3.

Place the metal edgewise on the anvil face and forge a curve as shown in Fig. 4 on the side which is to be the cutting edge of the knife.

Place the curved workpiece flat on the anvil face and forge a curve as shown in Fig. 5, starting at the tang and moving towards the tip of the knife blade.

As the inside curve is hammered out, the metal gradually straightens, producing the shape shown in Fig. 6.

Tempering the knife blade

A knife blade must be tempered as shown in Fig. 7. Part 7-A should be soft, part 7-B hard and part 7-C the hardest. That is why you have to heat the blade by holding the thick part underneath and moving the blade back and forth over the fire or drawing it over a hot piece of steel as shown in Figs. 8 and 9.

Temper colours for the blade range from yellow to blue, depending on the use of the knife at a later stage. Temper the tang and the top of the knife blade to a light blue.

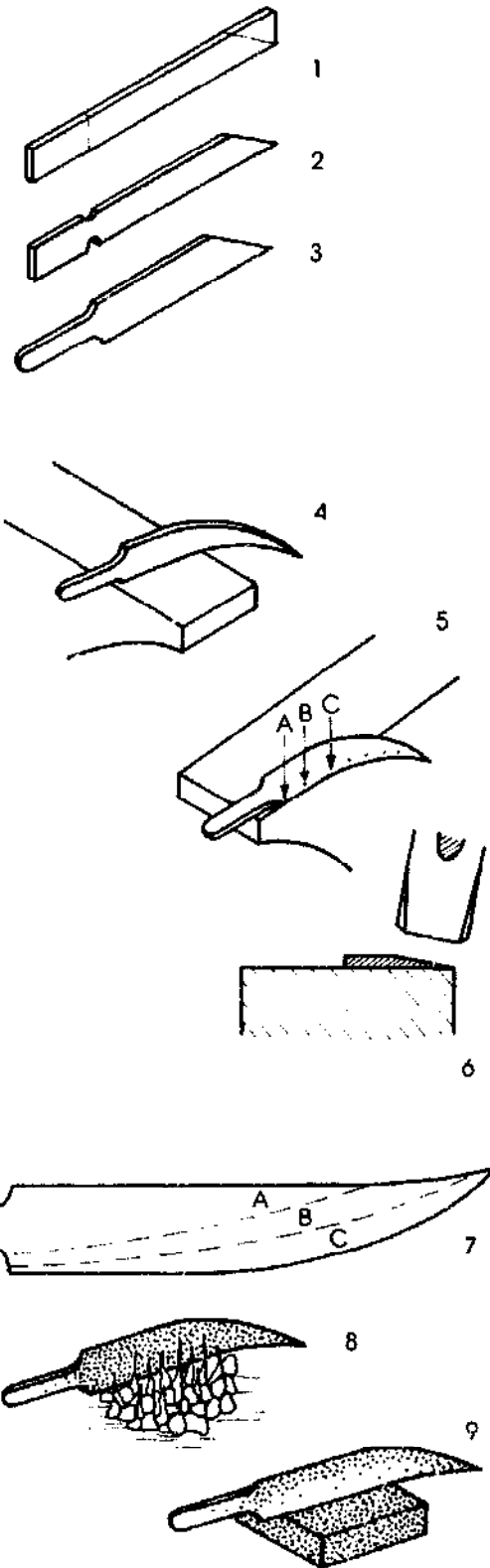

Mason's trowel

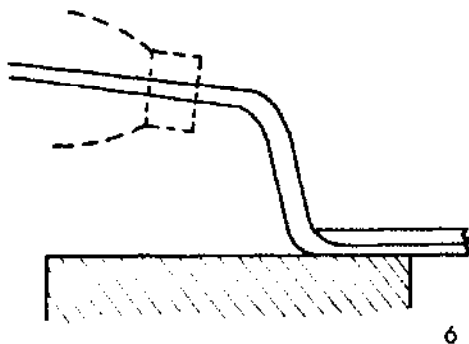
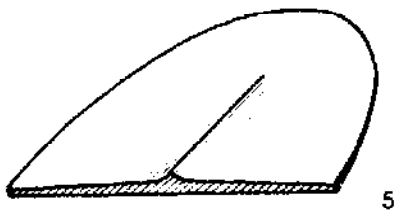
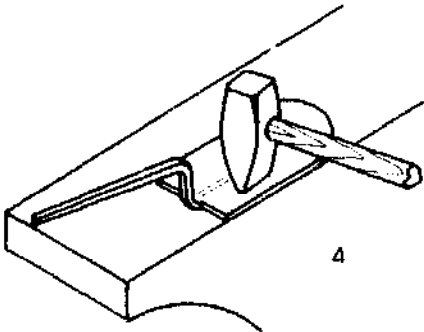
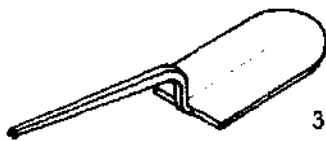
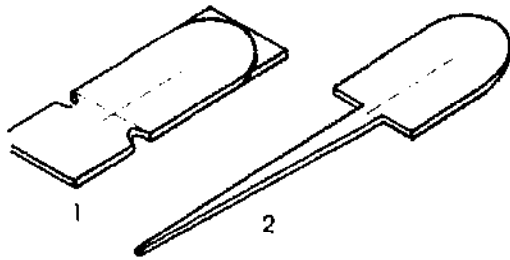

Hammer head

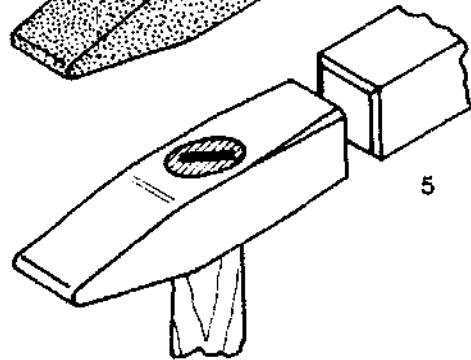
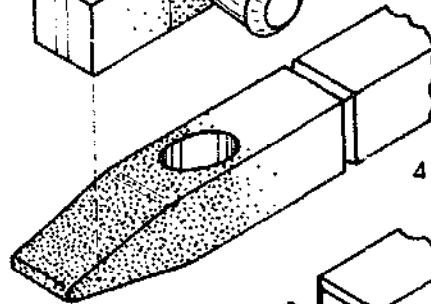
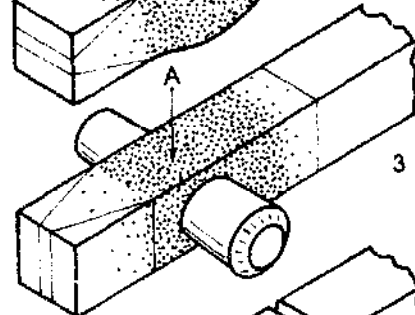
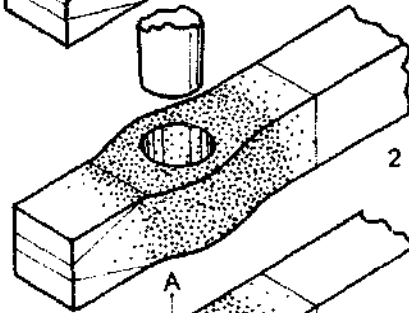
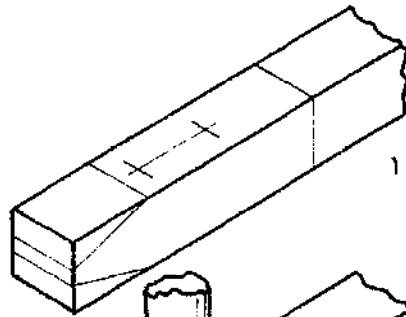

NOTE: Fig. 3-A shows the way to flatten the sides of the hammer head.

STUDY:

- Forging
- Punching
- Cutting
- Drawing down
- Tempering

Spade/shovel

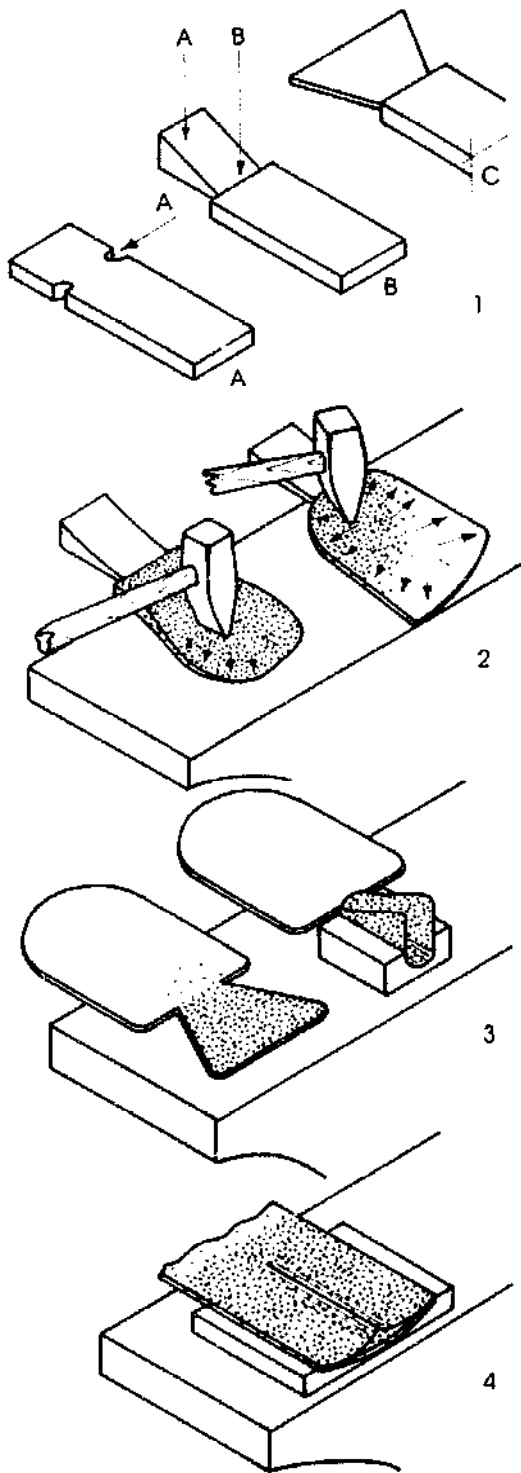

Garden tool

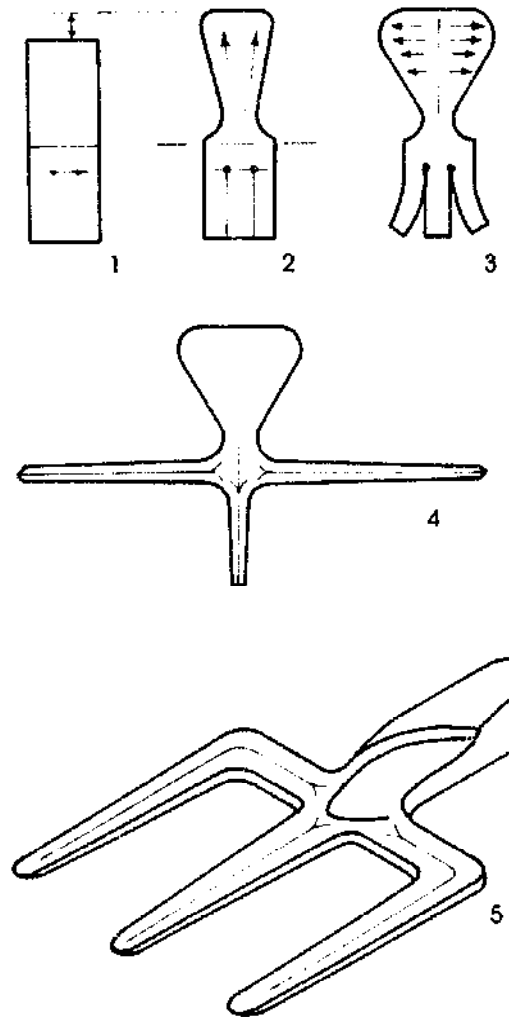

NOTE:

The arrows in Fig. 2 of the shovel as well as in Figs. 2 and 3 of the garden tool indicate the direction of drawing down.

Part A in Fig. 1 of the shovel is thicker than part B due to drawing down the metal.

Fig. 3 shows how to fold the handle holder of the shovel.

A steel jig is shown in Fig. 4 to shape the blade of the spade/shovel.

Mason's hammer

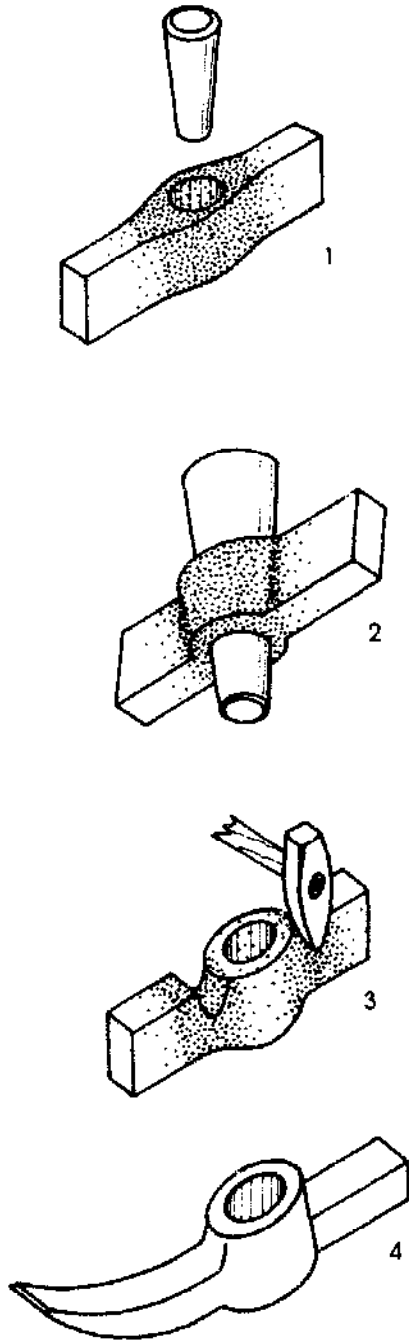

STUDY:

- Forging
- Punching
- Cutting
- Tempering

Pick-axe.

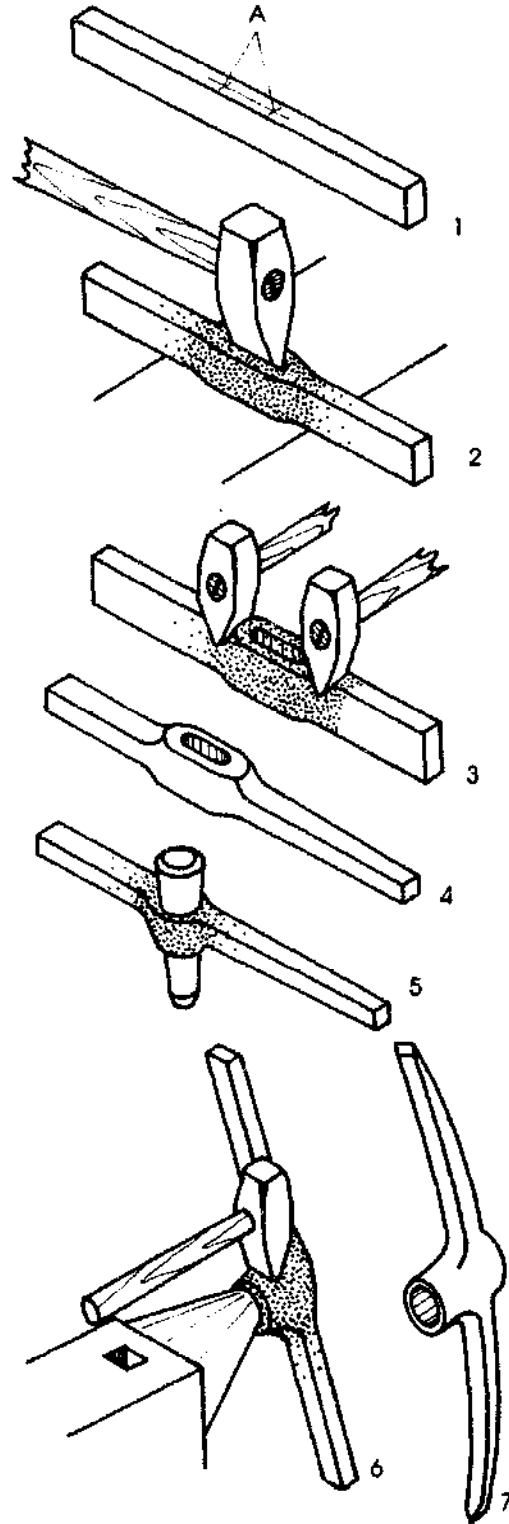

The holes indicated in Fig. 1-A should be drilled.

Blacksmith's tongs

- A - Take two pieces of steel with a length of 400 to 650 mm and approximately 20 x 30 mm. Mark the workpiece.
- B - Shape the recesses with the fuller, as shown in Fig. 1-A.
- C - Forge the mouth of the tongs, see Fig. 1-B and 2.

Note the distance from the centre of the rivet hole to the inside of the mouth.

- D - Draw down the handle from a rectangular shape to an oblong shape.
- E - Punch or drill the hole for the rivet.

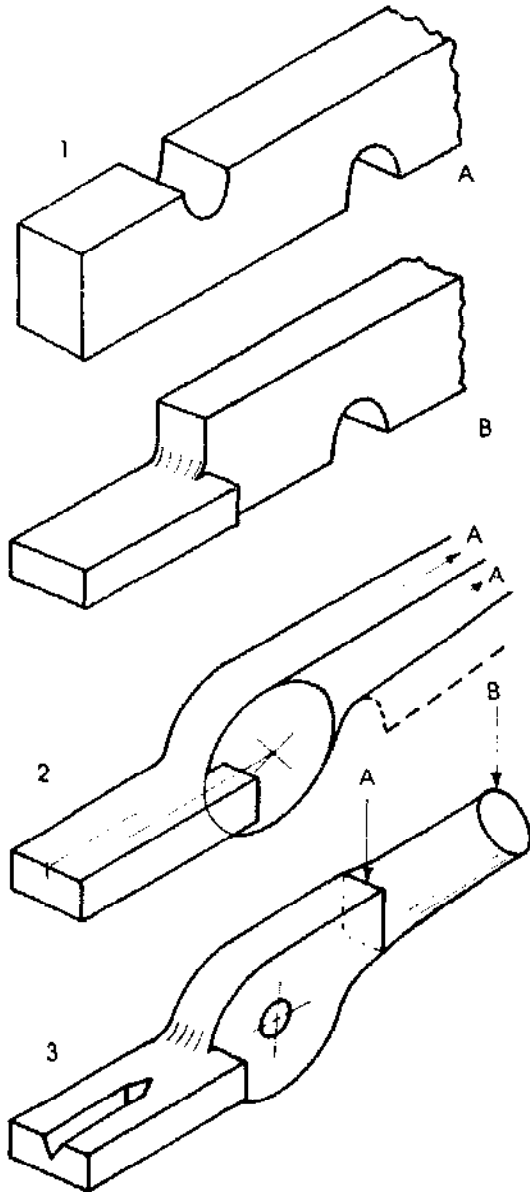

Cold chisel

Forge the cutting edge on the anvil face as shown in Fig 1.

Do NOT start as shown in Fig. 2, because forging like this produces the result shown in Fig. 3.

Fig. 4 shows the correct way. Forge a square and then shape the cutting edge. Grind off the forging excess (4-A).

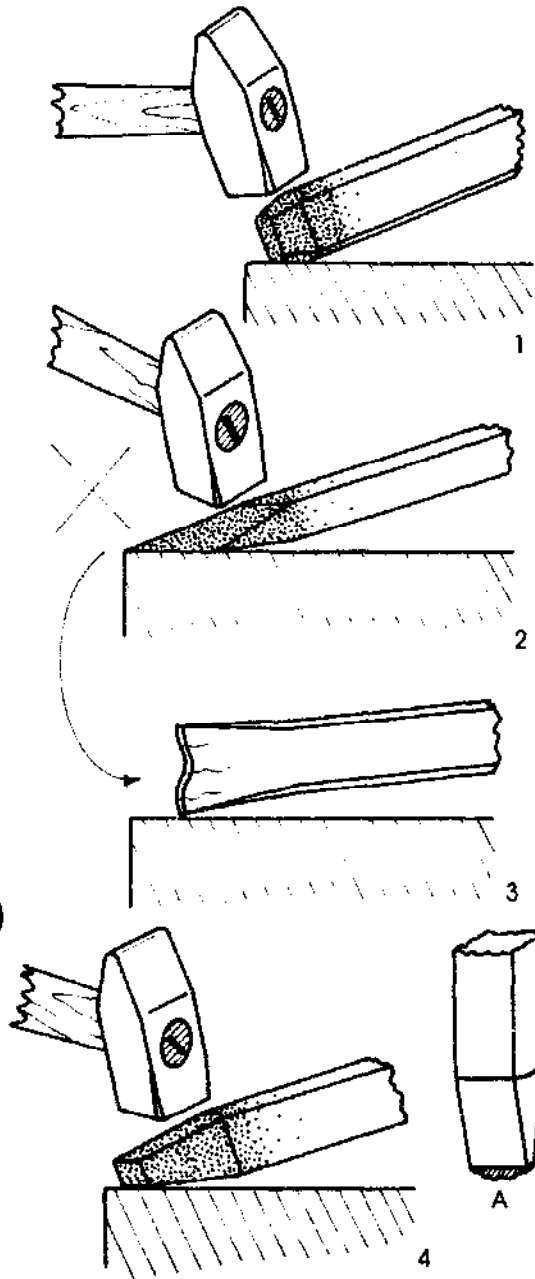

Carriage bolt

A carriage bolt is used to fasten wood to metal or wood to wood. This is often done in making farming implements and it is therefore good to know how to make such a carriage bolt.

The carriage bolt consists of:

- Round flat head
 - Square part, which stops the bolt turning during tightening.
 - Round shaft with a threaded end for a nut.
- See Fig. 1.

Much skill is needed to shape the head of the carriage bolt. It is a good idea to make your own heading tool for it which can be clamped into the leg vice, see Fig. 2.

The material needed to shape the flat round head and the square part is equal to three times the diameter of the shaft.

While upsetting the bar, take care not to upset it too much, because it will be impossible to shape the square part if the bar is too thick. So shape it roughly as shown in Fig. 3. It is good practice during upsetting to support the piece of bar from underneath, so that upsetting occurs only where it should.

Re-heat the bar after upsetting and place it in the special heading tool.

Shape the head with rapid hammer blows directly at the centre of the upset part so the material is forced to spread into the corners of the square hole.

Re-heat the head, insert the bar in the heading tool, taking care that the square part under the head exactly fits into the square hole again.

Shape the round head with rapid hammer blows, while drawing the material to the outside all around. See Fig. 4.

Leave a square part at the edge of the head to prevent the hammer touching the heading tool and at the same time to avoid sharp corners.

It is good practice to warm the heading tool as well - not too much but just enough to ensure that the heat is not drawn out of the bolt head too rapidly.

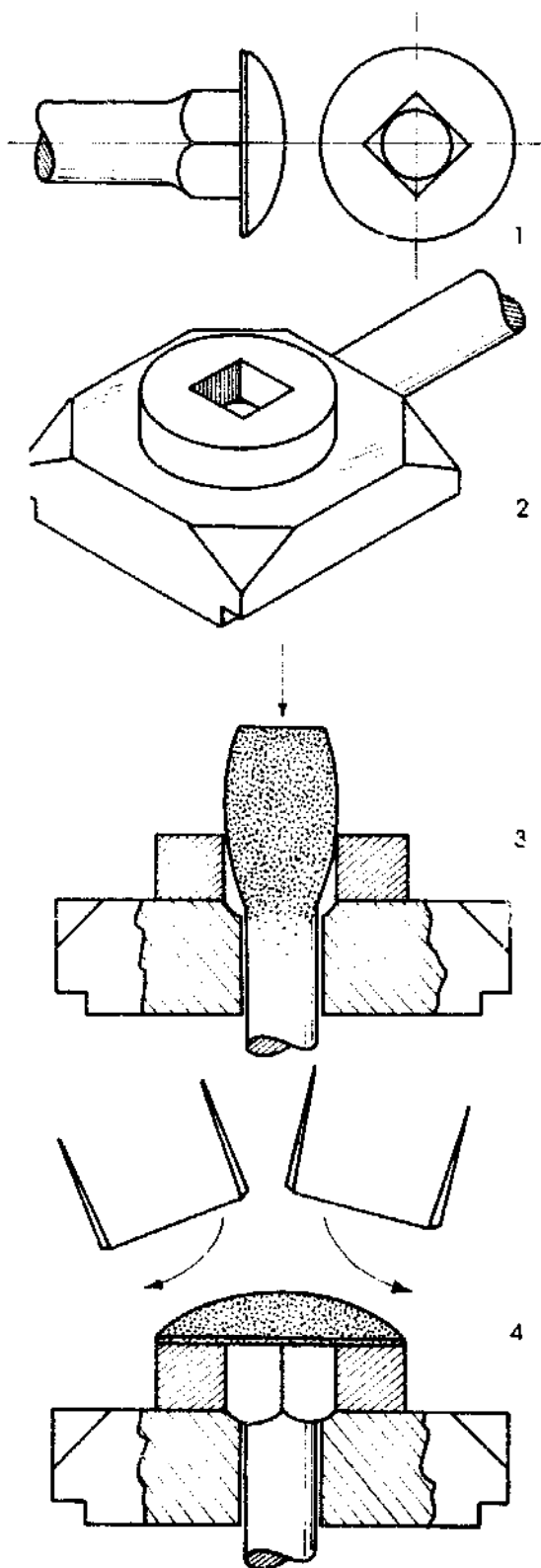

Round bolt head with slot

This bolt consists of a rounded oblong head with a slot in the centre to lodge the tip of the screwdriver. The shaft can be of any length and the end is threaded for a square nut.

This bolt head is easier to make than the head of the carriage bolt. The only different skill is making the slot. See Fig. 1.

A special heading tool is needed and can easily be made in the workshop. Note that the corners are cut off to make room for the hammer while shaping the edges of the head. The ring welded on top of the square part of the heading tool is for the same reason - to make room for the hammer. The ring 2-A is made of tool steel, the square part 2-B of mild steel. Two recesses under the heading tool are for clamping the tool in the vice. See Fig. 2.

A - Use a centre punch to mark the length of the part to be upset.

B - Upset the head as described above.

The length to be upset is equal to 1.5 times the diameter of the bar. Study Fig. 3.

C - Finish the head as shown in Fig. 4.
Hammer with a drawing movement as shown in the illustration.

Leave a small part of the head square to avoid a sharp edge on the bolt head. This also stops you touching the heading tool with the hammer.

D - Cut the slot with a hack saw.

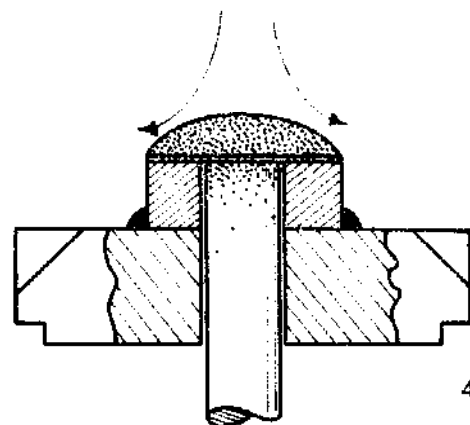
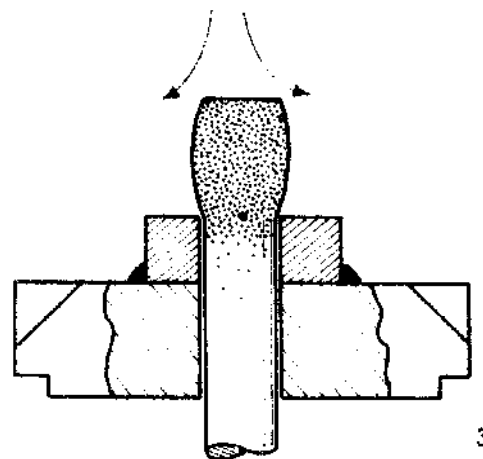
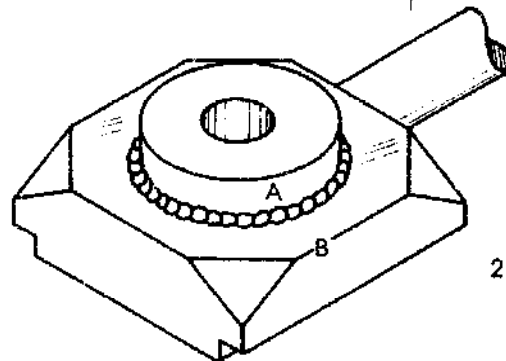
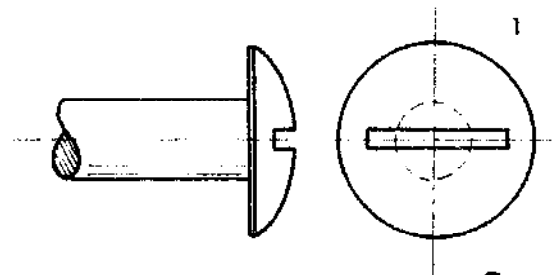

Countersunk bolt

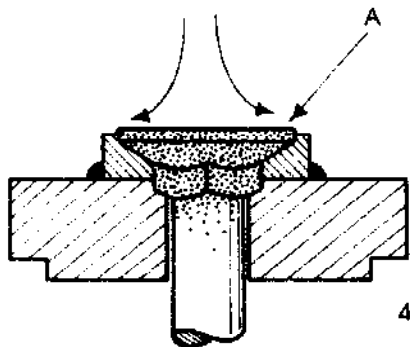
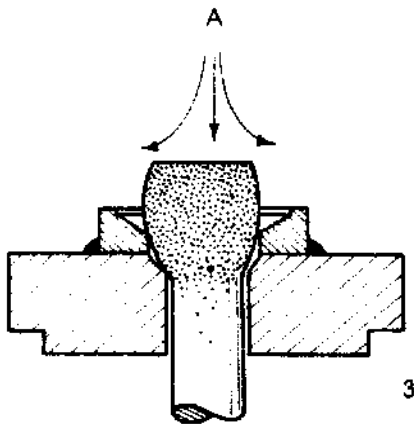
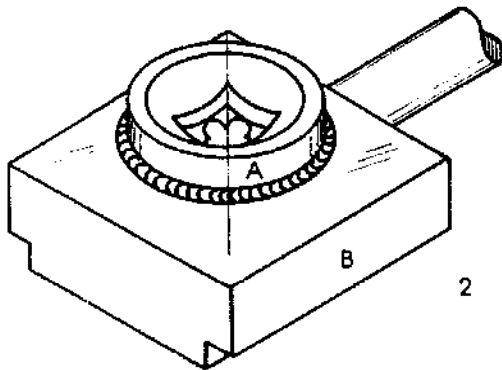
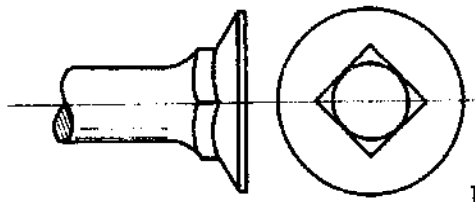

This bolt consists of a countersunk shaped head, a square part to stop the bolt turning when being tightened, a threaded shaft. This bolt is mainly used to fix mouldboards and shares to the frog of the ploughs, see Fig. 1.

A special heading tool should be made as shown in Fig 2. The top ring (2-A) of this heading tool is made of tool steel and can be welded to the heavy part 2-B which is made of mild steel.

The top edge of the ring must be flat and wide enough to resist the hammer blows.

Two grooves made underneath the heading tool make it possible to fix the tool in the vice.

A - The total length to be cut from a bar is the length of the shaft including the part to be upset, which is 1.5 times the diameter of the shaft.

B - Upset the bar as explained before.

C - Re-heat the upset part and place it in the special heading tool, see Fig. 3.

D - Forge the flat head, hammering with a drawing movement, see Fig. 3. Draw the metal to all sides while turning the workpiece round.

E - First hammer exactly vertically as shown in Fig. 3-A to force the metal into the square hole.

When the bar has to be re-heated for one reason or another, make sure you replace the square part correctly in the square hole.

In view of the amount of metal to be upset, the head of the bolt protrudes a little above the heading tool. This is to avoid damaging the heading tool with the hammer. See Fig. 4-A.

Flat bolt head with slot

The bolt you see in Fig. 1 is mainly used in making of farming implements. It consists of a shaft and a flat head with a slot which avoids protruding parts and stops the bolt turning when being tightened.

The surplus you need to shape the flat head is 1.5 times the diameter of the bolt shaft.

- A - Mark the correct length on a bar - that is, the length including 1.5 times the shaft diameter.
- B - Use a centre punch to mark the length to be upset, see Fig. 2.
- C - Upset the end of the bar before you place it in the heading tool.
- D - Re-heat the bar and place it in the special heading tool.
- E - Shape the flat head, using drawing hammer blows. But the face of the hammer must be horizontal when it strikes the flat head.
- F - After shaping the head, take the bar out of the heading tool and quench it.
- G - Mark the slot with a cold chisel on top of the flat head.
- H - Re-heat the head, replace it in the heading tool and punch the slot as shown in Fig. 4.

Make sure the tool to punch the slot has the correct dimensions.

Be careful not to make the slot too deep, it will weaken the head.

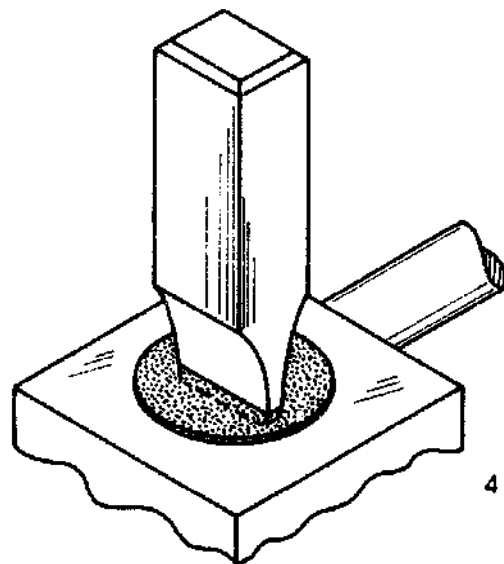
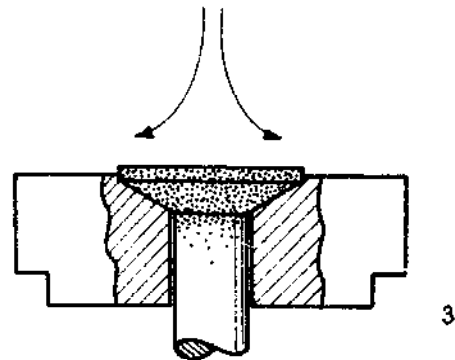
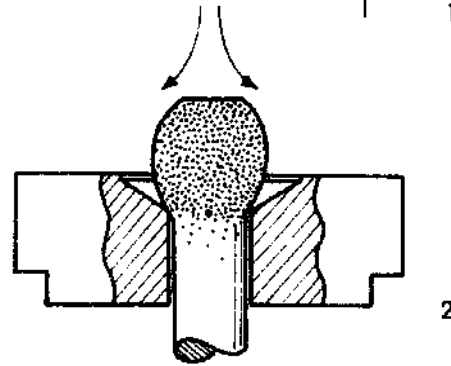
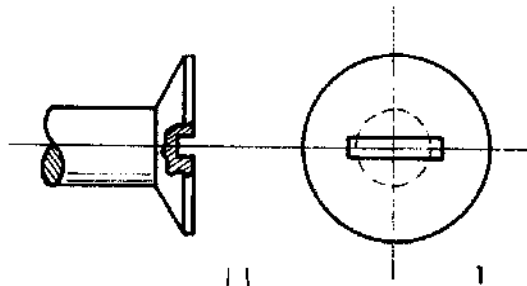

Cramps

It is preferable to use blacksmith's tongs with an appropriate round jaw opening. If tongs such as this are not available, ensure that the closed side of the tongs is upwards, as shown in the side view Fig. 3 and the bottom view Fig. 5.

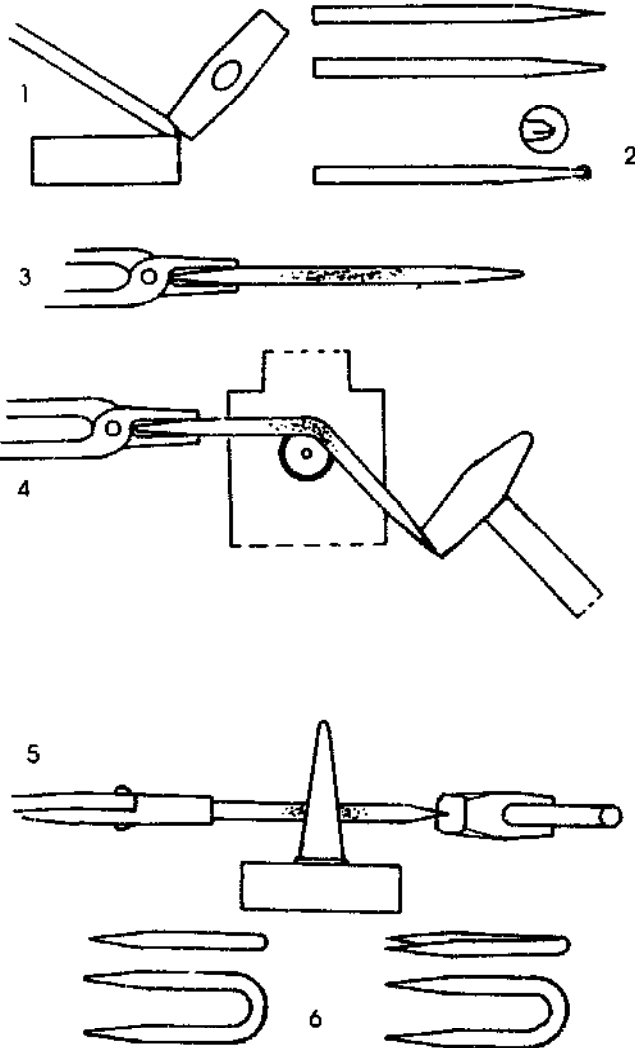

Stormhook

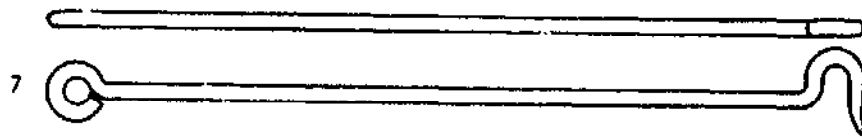
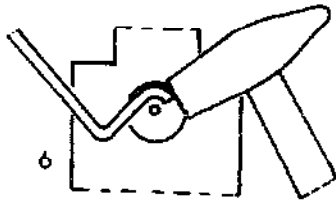
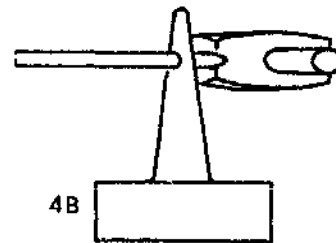
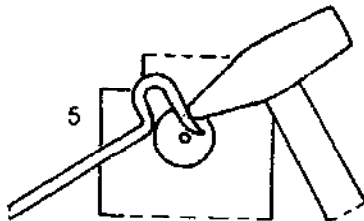
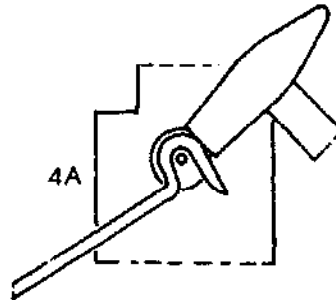
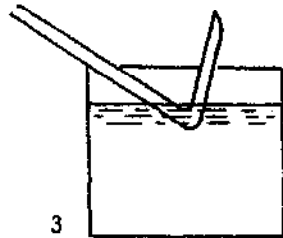
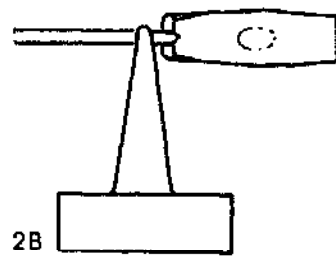
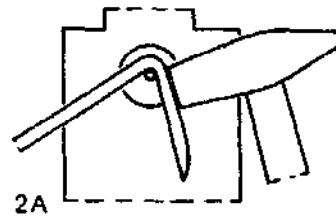
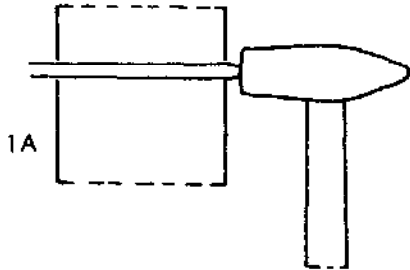

Welding

Electric arc welding

Arc welding is joining two metals together with the aid of a filler rod and heat. In electric arc welding the heat is supplied by electricity from a welding transformer.

A socket shown in Fig. 1-B supplies electricity with a high voltage to the welding transformer. The transformer changes the electricity to a low voltage which is not harmful and can be used for welding. This electricity however has a high current strength which is essential for obtaining a strong flaming arc.

The electricity produces a very bright arc with a temperature of about 4000° C.

REMEMBER:

The electricity from the socket is very dangerous. It can easily kill you if you touch bare connections.

Electric arc welding equipment

- A - ON/OFF switch
- B - Socket
- C - Plug
- D - Welding transformer (AC)
- E - Current control
- F - Earth clamp
- G - Welding table
- H - Workpiece
- I - Electrode
- J - Electrode holder
- K - Apron
- L - Welding shield
- M - Gloves
- N - Chipping hammer
- O - Wire brush

How to connect the welding transformer

- A - Set the main switch in OFF position
- B - Put the plug into the socket
- C - Clamp the earth clamp to the steel welding table
- D - Make sure the electrode holder does not touch the welding table or the transformer
- E - Select the correct current
- F - Set switch in ON position
- G - Clamp the electrode into the holder
- H - Start welding

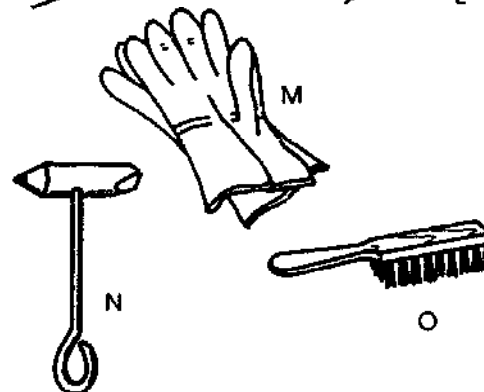
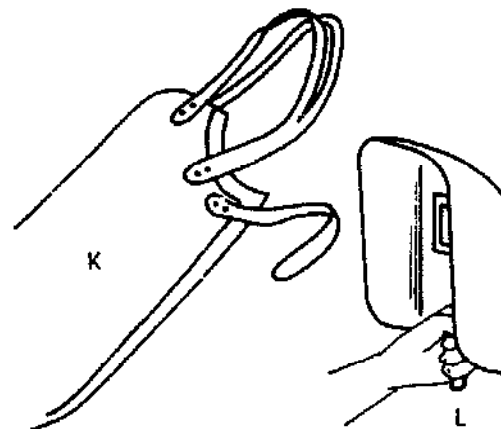
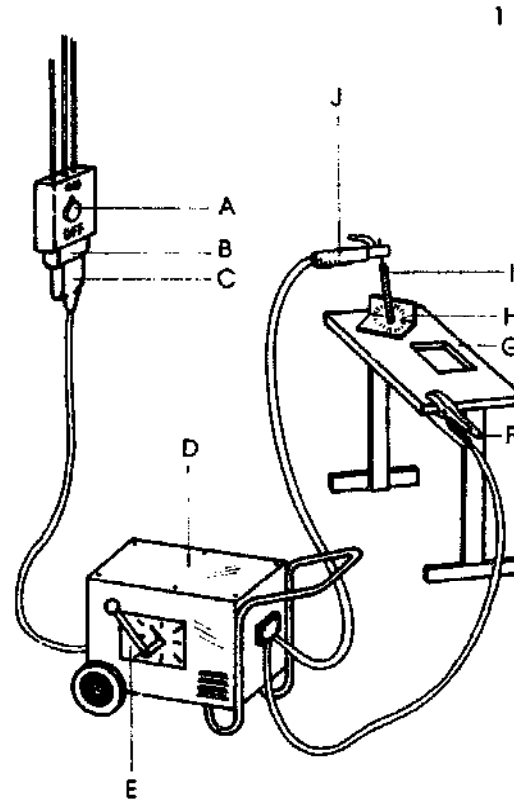

Safety rules

Before starting to weld, you must be aware of the dangers involved:

- The bright light of the arc
- Hot metal and flying sparks
- Electric shocks

Safety precautions

- Use a proper welder's eye shield with dark glass when you look into the arc. Never use regular safety goggles instead. They do not give your eyes and your face enough protection.
- If you do not use the eye shield, your eyes will become very painful. Do not rub your eyes when this happens. If necessary, ask for medical help.
- Always wear safety goggles when you remove slag from a weld with a chipping hammer.
- Keep your skin covered as far as possible. Radiation from the bright light of the arc can cause skin injuries. Protect your skin against flying sparks. Wear leather gloves. A leather apron is also useful. Remove all flammable materials from the welding area. Don't carry matches or a lighter in your pocket.
- Keep electric cables in good condition. Repair the insulation if it is damaged.
- Do not use welding equipment in wet or damp areas, it will increase the danger of electric shocks.
- Shut off the electricity when you stop welding. Do not forget this in case you use your own power unit.
- Never work on the welding transformer unless you have pulled the plug out of the socket.
- Be extremely careful when you weld fuel tanks or containers. Take the necessary precautions.

Electrodes

A welding electrode is a rod made of various materials and of various lengths from 200 to 450 mm and a diameter of 3 mm or upwards. Electrodes are coated with a layer of chemicals or fluxes. The purpose of this coating is to have a steady arc and improve the quality of the weld. The coating of the electrode absorbs moisture. You will notice this because a damp coating has a darker colour than a dry one. As damp electrodes result in poor welds, it is important to store them in a dry place.

Especially in the wet season, it is very difficult to keep electrodes dry. You can dry electrodes by laying them in the sun or near the forge - but not too near!!!

Types of electrodes

Only four different types of electrodes are used in the rural workshop:

- Electrodes for mild steel. This is the most common type because most of the welding is done on mild steel.
- Electrodes for high carbon steel. These electrodes are used to weld car springs.
- Electrodes for cast iron.
- Electrodes for hard surfacing.

Setting the current

The current is set with a handle or a wheel on the welding transformer.

The current and the diameter of the electrode depend on the thickness of the material to be welded together, the length of the cables and the size of the whole workpiece which may take much of the heat away during welding. Thick electrodes need a higher current than thin electrodes.

		PLATE THICKNESS (mm)					
		1	2	3	4.5	6	8 up
ELECTRODE Diameter (mm)	2	20	40				
	2.5	20	40	60			
	3		50	80	105	130	140
	4			90	140	160	170
	5				150	170	180

CURRENT TABLE

NOTE:

The current can be a little higher or lower, depending on the circumstances. After some practice, the trainee soon learns the best current setting to use.

How to start an arc

There are two ways to start an arc:

The **TOUCH AND WITHDRAW** method which is shown in Fig. 1.

- A - Keep the electrode at right angles to the workpiece surface.
- B - Move the electrode down to the surface of the workpiece.
- C - Withdraw the electrode quickly as soon as it touches the workpiece.
- D - Touch and withdraw a few times very quickly.

The **SCRATCHING** method as shown in Fig. 2.

Scratch the electrode tip over the surface of the workpiece.

Do this in the same way as you strike a match. It is easier to strike when the electrode is hot. To heat the electrode, scratch a few times on an old piece of metal.

WARNING:

Keep your eyes protected when you strike an arc.

Freezing the electrode

When a beginner tries to strike an arc, the electrode will often stick to the workpiece. This is called 'FREEZING'.

A very high electric current will flow through the electrode when it freezes. This current may damage the welding transformer and the power unit. You must therefore detach the electrode as quickly as possible.

There are two methods of detaching the electrode:

- Twist the electrode left and right while pulling it loose, see Fig. 3.
- Release the electrode from the holder and cut off the electrode, see Fig. 4.

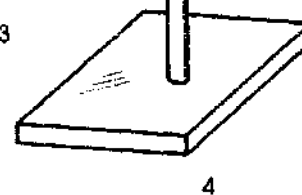
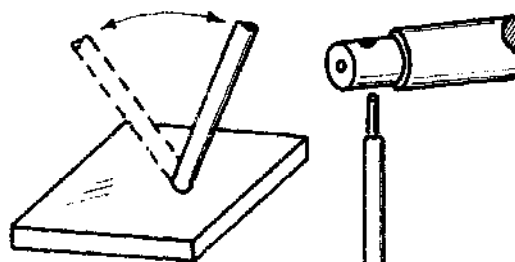
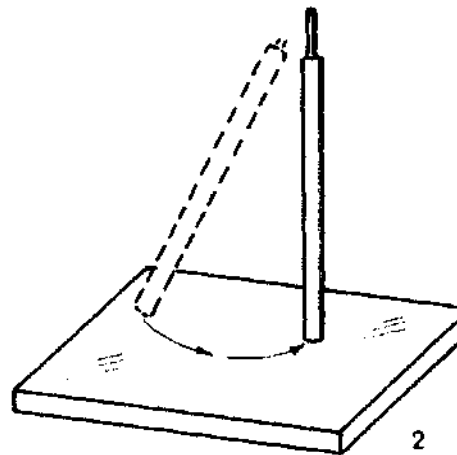
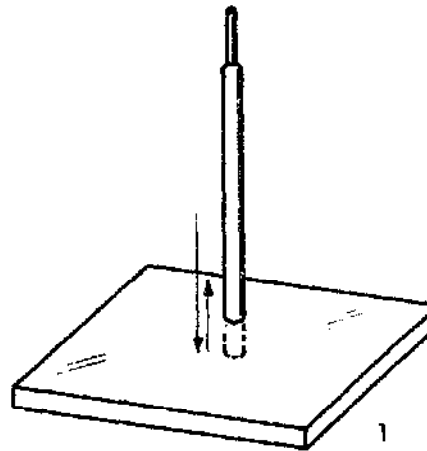

How to run a straight bead

The first welding exercise is to make straight beads on a flat piece of metal, see Fig. 1.

- A - Find in the table (shown on page 92) the correct diameter of welding rod.
- B - Set the welding transformer at the correct current (see table).
- C - If the current is too high, the bead burns deep into the workpiece. If the current is too low, the workpiece barely melts and does not fuse properly with the bead.
- D - Strike the arc, using in turn the two methods described.
- E - Hold the electrode at an angle of 20 degrees in the direction of travel, see Fig. 2.
- F - Start welding.

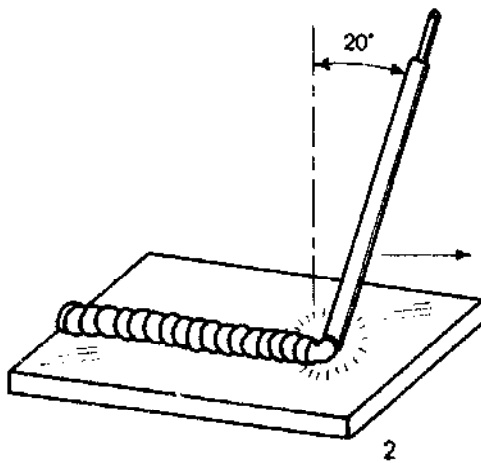
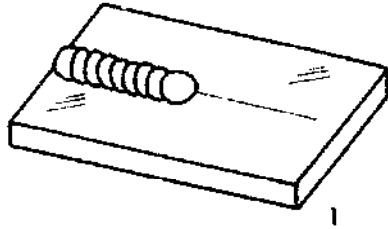

The rate of travel

The rate of travel is the speed with which you move the electrode.

If you move the electrode too slowly, the bead becomes too thick.

If you move the electrode too fast, the bead becomes irregular and thin.

You will find the correct speed by experience and by judging the appearance and width of the bead, which should be approximately three times the diameter of the electrode.

The arc length

The arc length is the distance between the tip of the electrode and the workpiece. The length should be about the same as the diameter of the electrode. When you use an electrode with a diameter of 3 mm, the arc length should also be 3 mm.

It is, however, impossible to measure the arc length while welding; an experienced welder can judge the distance by listening to its sound.

- If the arc length is correct, the arc has a steady flame and makes a sharp cracking or frying sound.
- If the arc is too long, it has an irregular flame and makes a hissing sound.
- The arc should not be so short that the electrode coating touches the workpiece or the electrode freezes.

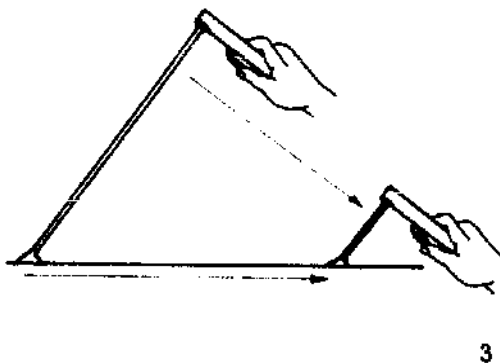

The electrode becomes shorter during welding. The directions in which your hand and the electrode are moving are therefore different. Your hand moves slantingly downwards while the electrode moves along the surface of your workpiece, see Fig. 3.

This requires a lot of practice and a steady hand.

How to inspect a bead

After you have made a bead, it is covered with "slag", the material which is left over from the electrode coating. Slag must be removed with the chipping hammer and the wire brush. After removing the slag you can inspect the quality of the bead. If you cut the workpiece with the hacksaw, you can also inspect the cross section of the bead, see Fig. 1.

When you inspect a bead you must watch the following:

- Penetration of the bead
- Fusion of the bead
- Undercutting

Penetration

Penetration depends on how deep the bead has melted together with the two plates. Deep penetration gives a strong weld, see Fig. 2.

Fusion

Fusion or the melting together of the sides of the bead with the plates. When a part of the bead has not fused with the plate, this is called 'overlap', see Fig. 3.

A good bead has no overlap and is completely fused with the plates.

Undercutting

Undercutting happens when the penetration is too deep and part of the plates has burned away, see Fig. 4.

Undercutting makes the weld very weak.

Effects on the current setting

A correct current setting is shown in Fig. 5-A. There is good penetration, no overlap and no undercutting.

Poor penetration and poor fusion occur when the current is too low, see Fig. 5-B.

When the current is too high, penetration is too deep, undercutting and spatter are the result, see Fig. 5-C.

Spatter also occurs when the arc length is too long.

Effect of travel speed

Correct speed gives a regular, normal bead with good penetration, see Fig. 6-A.

The result of a low speed is a very large, wide bead with overlap, see Fig. 6-B.

When the speed is too high you get a small, narrow and irregular bead with poor penetration, see Fig. 6-C.

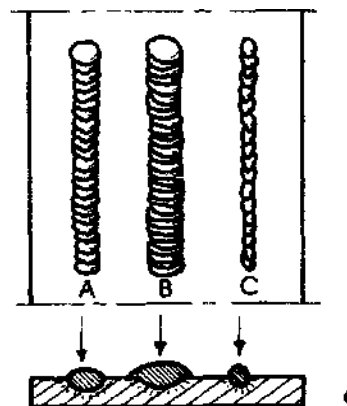
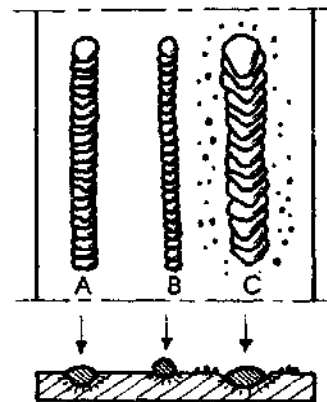
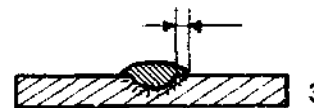
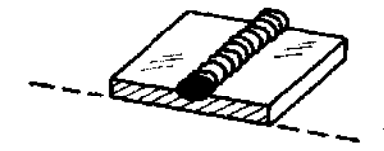

Electric arc

What happens in the electric arc?

Study Fig. 1 in which:

A = Coating	F = Metal drop
B = Electrode	G = Arc
C = Bead	H = Puddle
D = Slag	I = Crater
E = Gas shield	J = Penetration

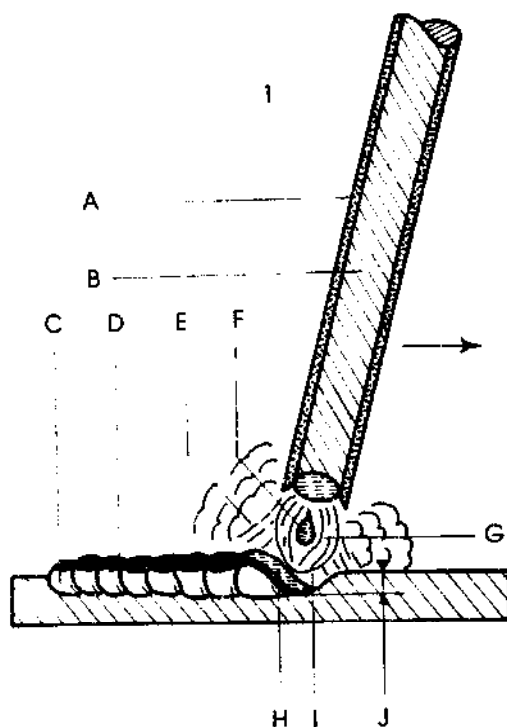

The heat of the arc melts a small puddle of molten metal onto the workpiece. The arc forces this puddle backwards so there is a bare crater in front of the bead.

The heat also melts small drops from the tip of the electrode. These drops pass through the arc and are added to the puddle.

At the same time the coating of the electrode burns and melts. This produces gas which protects the molten metal against the atmosphere. It also produces the slag which covers and protects the bead.

The electrode must move fast enough so that the molten slag and the puddle cannot move in front of the arc, otherwise you get slag inclusions in the weld.

The arc must point partly at the puddle and partly at the crater in front of the puddle. In this way the heat of the arc can reach the bottom of the crater to give good penetration. If the electrode moves too slowly, the arc points only at the puddle and penetration is poor.

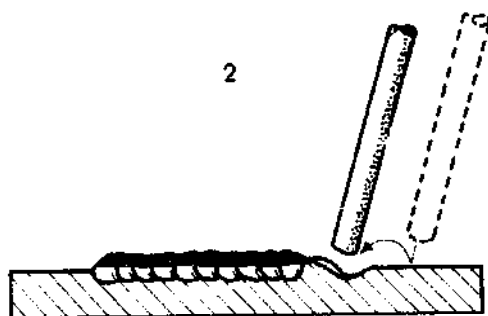

Re-starting a bead

When you finish a bead you will notice the crater at the end of the bead. If you want to continue this bead (see Fig. 2) you must first fill the crater:

- A - Chip away the slag from the crater at the end of the weld.
- B - Strike an arc just ahead of the crater.
- C - Move the arc back into the crater to fill it.
- D - Then resume welding in the forward direction.

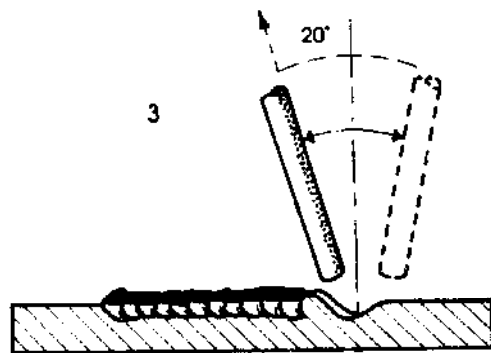

Finishing a bead

If you do not want to have a crater at the end of a bead, you must break the arc as follows, see Fig. 3:

- A - Make a pause at the end of the bead to fill the crater.
- B - Move the electrode back over the weld some 10 mm.
- C - Change the angle of the electrode quickly, about 20 degrees.
- D - Break the arc. The weld crater is now completely filled.

Weaving motion

Weaving is a side-to-side motion of the electrode across the bead during welding, see Fig. 1.

Weaving is done to produce a wider bead than would be possible without weaving.

Weaving also keeps the metal in a molten state a little longer. This allows the gas to escape and the slag to rise to the surface.

If weaving is not carried out correctly, it causes many welding faults instead of improvement.

The weaving motion must not be wider than THREE times the diameter of the electrode, otherwise you run the risk of slag inclusions. To achieve a neat weld, keep the width of the bead constant.

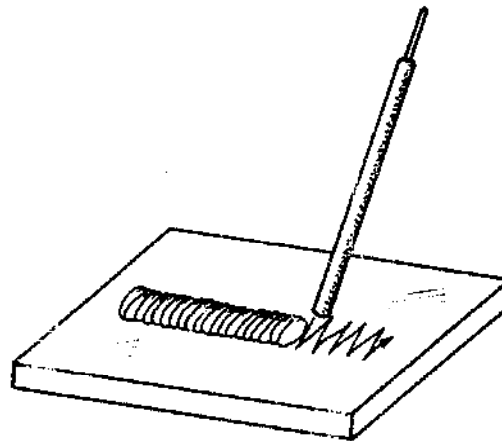

2

Weaving patterns

Several patterns are shown in Fig. 2.

The crescent weaves 2-A and 2-B are the easiest to master.

It is important to stop at each side of the weave, see dots. These stops are necessary to avoid undercutting along the sides of the beads.

If patterns shown in 2-D, 2-E or 2-F are used, the electrode remains at the sides of the weld longer and stops are not necessary.

Pattern 2-C is used for weaving narrow beads. Mastering the skill of weaving takes a long time. The best is to practise on a piece of scrap metal, using different currents and different electrodes.

It is very important to have a steady hand. Do not start welding after you have done a lot of blacksmithing work.

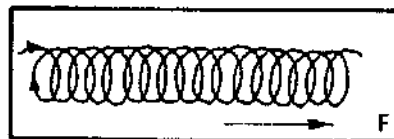
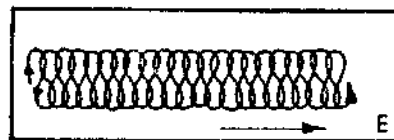
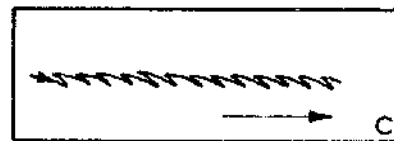

Building up a pad

Building up a pad means covering a workpiece with a layer of welding material, see Fig. 1.

Worn out machine parts can sometimes be repaired by building them up and smoothing them.

How to build a pad

- A - Mark out the area you want to build up, see Fig. 1.
- B - Deposit a straight bead, holding the electrode at a 20 degree slope in the direction of travel, see Fig. 2.
- C - Chip away the slag and make a second bead. The electrode must now slope 20 degrees in the direction of travel and must also slope 20 degrees to the side. This is to make sure the second bead fuses properly to the first one. See Fig. 3.
- D - Continue making beads as before. Chip away the slag each time. The beads must fuse properly and the line of beads must be straight. See Fig. 4.

Building up a pad is faster if you use weaving to deposit the beads.

To build the pad higher, a second layer can be deposited 'across' the first layer. If necessary, deposit more layers till the pad is high enough.

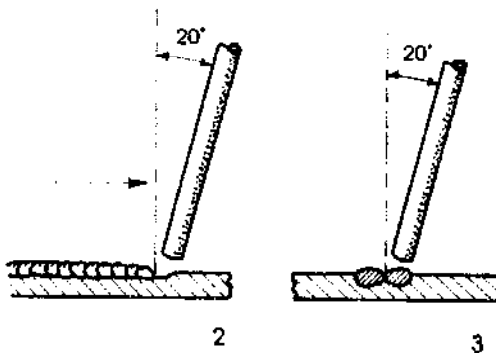
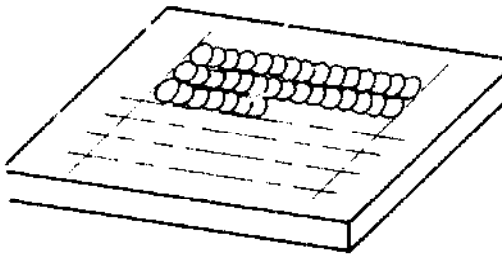

Types of welding joints

When you can make good beads, it is time to learn to weld joints. The names of the different joints (see Fig. 1) are:

- A - Square butt joint
- B - 'V' butt joint
- C - Lap joint
- D - Outside corner joint
- E - Edge joint
- F - 'Tee' joint

The welds on the joints 1-C, 1-D and 1-E are known as 'FILLET' welds.

Welding positions

There are four different positions in which you can make welds:

- Flat position, see Fig. 2
- Horizontal position, see Fig. 3
- Vertical position, see Fig. 4
- Overhead position, see Fig. 5

It is easiest to weld in a flat position, because then gravity helps to pull the molten metal into the joint.

Whenever possible, position the workpiece so that welding can be done in a flat position.

Unfortunately this is not always possible. Horizontal welding can be done from left to right or right to left.

Vertical welding is done from the bottom upwards to support the molten metal on the bead just made.

Using the correct electrode and the correct current makes overhead welding less dangerous.

Use protective clothing in case drops of hot liquid metal fall onto you.

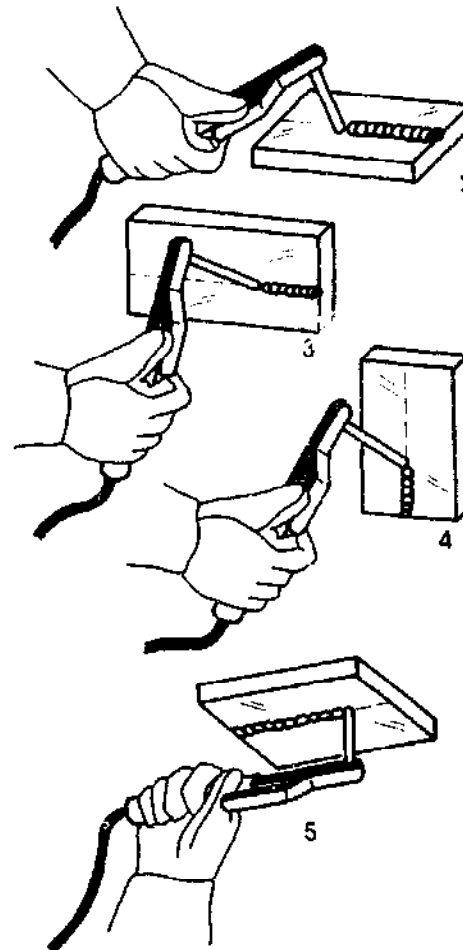
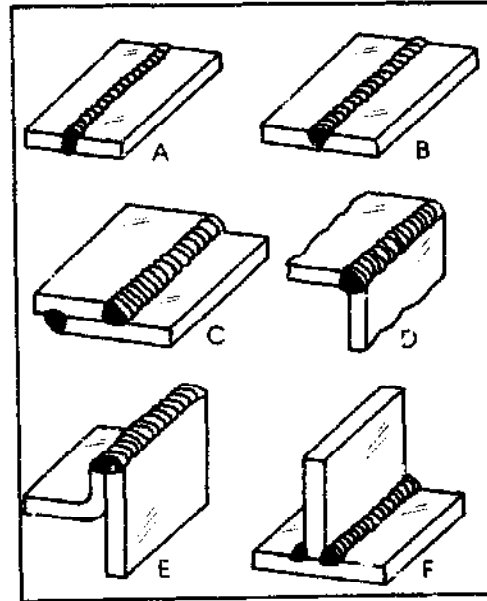

Contraction/expansion

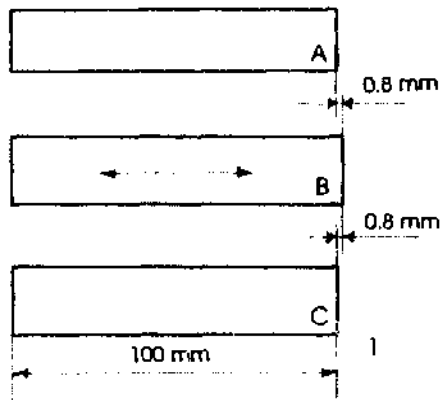

In previous lessons you have learned that metal which is heated up expands. An example of this is illustrated in Fig. 1.

Piece 1-A is 100 mm long. Piece 1-B is heated to a 600° C and thus expands by 0.8 mm. When cooled, the length of the piece (see Fig. 1-C) is exactly 100 mm again.

Expansion

During welding, the metal of the workpiece is heated locally with the result that stress is built up in the workpiece.

The illustration in Fig. 2 shows what happens when two pieces of metal, which are rather wide, are welded together. Both pieces shear over each other when welding is done in the direction of the arrow.

Welding two strips of metal together results in a wide gap between the two pieces, see Fig. 3. A metal frame, welded together at the corners in the direction of the arrows will also tend to bend, see Fig. 4.

If the corners of a frame are welded together in the direction of the arrow, shown in Fig. 5, the members will tend to bend outwards.

To avoid shearing or widening the gap while welding, it is necessary to 'tack-weld' the two pieces together first, as shown in Fig. 6.

Tack the plates together with welds no longer than 5 mm and spaced at 50 to 100 mm.

For thick plates the tacks may be 20 to 30 mm long and spaced at 200 to 300 mm.

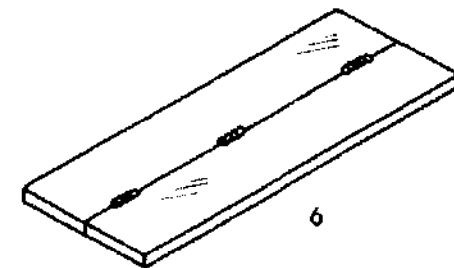
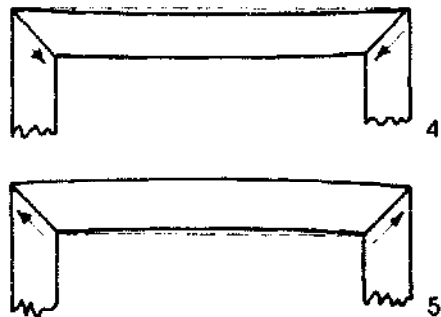
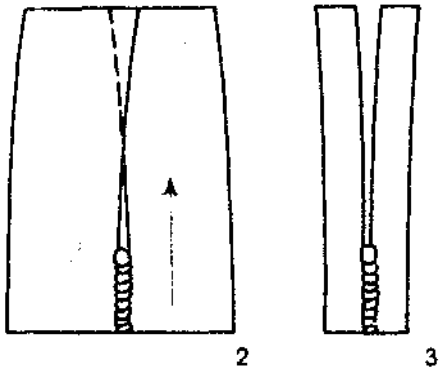

Single pass fillet weld

Fillet welds as shown in Fig. 1 can be made on:

- A - Corner joint (inside)
- B - Lap joint
- C - Corner joint (outside)
- D - Tee joint.

A fillet weld with one bead is called a 'single pass fillet weld'.

A - Clean the work of rust, scale and other foreign matter.

Make sure the edges to be welded fit together reasonably.

B - Tack the workpiece into position with one or more short 'tack welds', see Fig. 2.

C - Remove the slag from the tack welds before you weld the joint.

The electrode must make an angle of 45 degrees to both plates during welding, see Fig. 3.

Also make sure the electrode slopes in the direction of travel, see Fig. 4.

Beginners should tilt the workpiece so welding can be done in a flat position, see Fig. 5. Some pieces of angle iron can be very useful for positioning the work, see Fig. 5-A and 5-B.

An outside corner joint must be welded with a fairly low current, otherwise the electrode burns through the material. Other fillet welds can be made with a fairly high current.

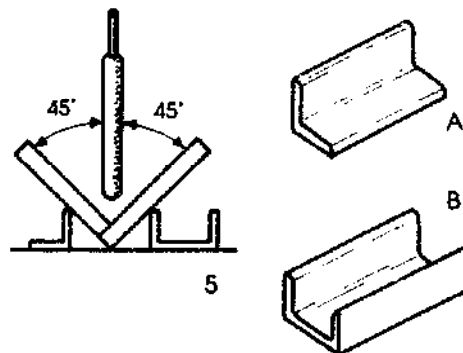
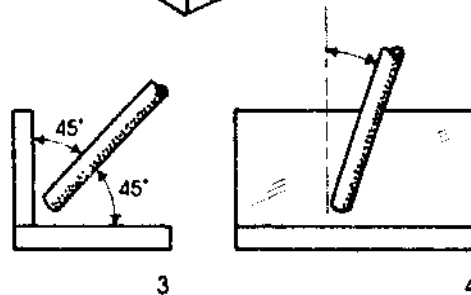
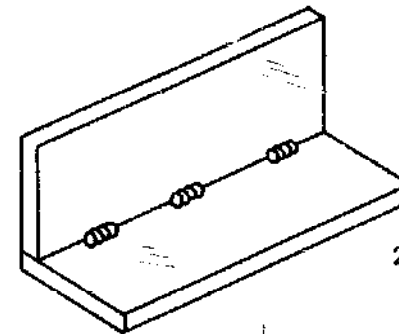
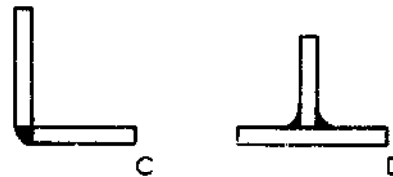
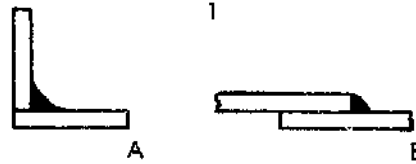

Appearance of fillet welds

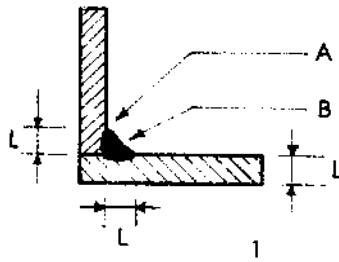

If you study a correct fillet weld, you see the line of fusion, Fig. 1-A, is straight. There is of course no undercutting or overlap and the surface of the weld is flat, see Fig. 1-B. A fillet weld is roughly triangular in shape. Both sides of the triangle must have the same length, see Fig. 1-L. The length must equal the thickness of the plates.

A multiple pass fillet weld

When you make a fillet weld on thick material, it is necessary to make more than one bead. This is known as the 'multiple pass fillet weld', see Fig. 2.

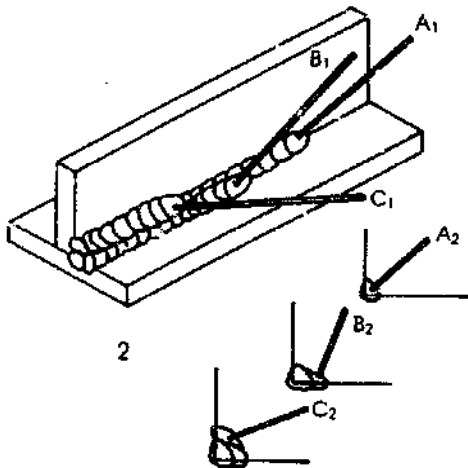

When you make a multiple pass fillet weld you must:

- Remove the slag after every bead
 - Hold the electrode as shown in Fig. 2
- | | | |
|-------------|----------|----------|
| First pass | A1 = 40° | A2 = 40° |
| Second pass | B1 = 60° | B2 = 60° |
| Third pass | C1 = 30° | C2 = 80° |

Heat distribution in a weld

When you run a bead on a thick plate, the heat of the arc can easily flow away as shown in Fig. 3.

If you use the same current to run a bead on a thin plate, the heat cannot flow away so easily. The thin plate becomes hotter and penetration is deeper, see Fig. 4.

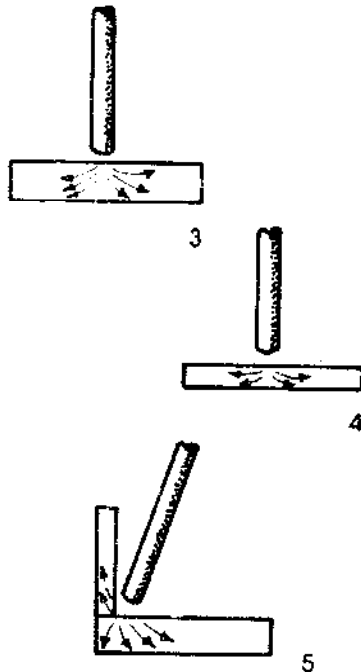

Care must be taken when you weld plates of unequal thickness, see Fig. 5.

You must point the electrode more towards the thick plate while welding. In this way more heat is directed onto the thick plate and both plates heat evenly.

Closed square butt joint

The closed square butt joint is suitable for welding plates together with a thickness of 1 to 2 mm.

Sequence of operation

- A - Prepare the plates so they fit together correctly.
- B - Tack the plates together. Make sure the edges of the plates are in close contact with each other, see Fig. 1.
- C - Make short tacks and place the tacks at short intervals, see Fig. 1.
- D - Weld the plates together with one single bead.

If the plates are very thin or if they fit together poorly, it is better to use a so-called 'backing plate' under the joint. See Fig. 2.

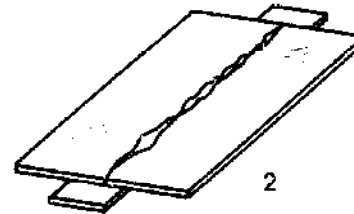
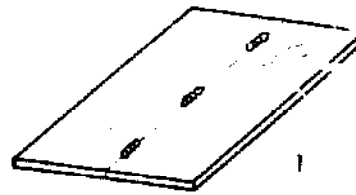

Open square butt joint

This joint, shown in Fig. 3, is suitable for plates with a thickness of 2 to 5 mm.

The distance between the plates should be half the plate thickness. See Fig. 3-o.

After setting the plates correctly, tack them together at regular intervals.

A cross-section of a 1 mm plate is shown in Fig. 4. The joint is a closed square butt joint.

An open square butt joint is shown in Fig. 5 for plates with a thickness of 2 to 3 mm. Tack them together in this position.

Weld them with one single bead.

If the plates are 4 to 5 mm thick, they must be welded from both sides, see Fig. 6.

While welding, use a slight weaving motion to fill the gap between the plates.

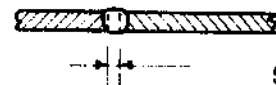
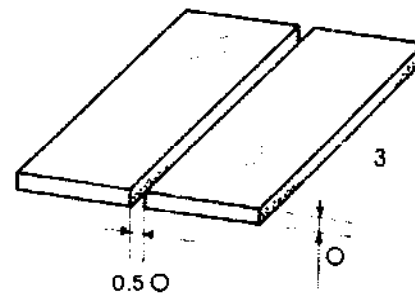

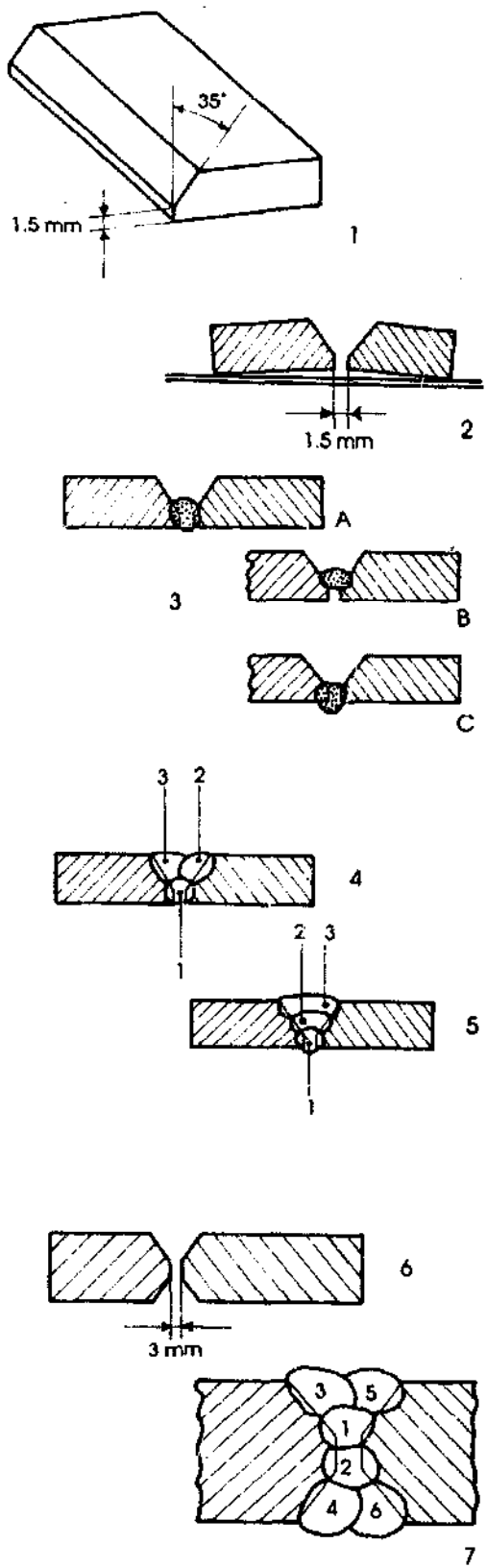

'V' butt joint

If the plates are thicker than 5 mm, they have to be joined with a 'V' butt joint.

The 'V' butt joint is made as follows:

- A - Make a bevel of 35 degrees on the edge of the plates, see Fig. 1. Leave a square face of about 1.5 mm.
- B - Place the plates as shown in Fig. 2, with the centre a little tilted to allow for shrinkage which may distort the plates. The height depends on experience. The root gap should be about 1.5 mm.
- C - Use a fairly low current to deposit the first bead, called the 'root pass', see Fig. 3.
- D - Chip away the slag and check the root bead.
- E - Deposit the next beads in the sequence shown in Fig. 4. Or deposit the beads with a weaving motion as shown in Fig. 5.

Make sure during welding that the bead has good penetration. See Fig. 3-A.

Some wrong root passes are shown in Fig. 3-B and 3-C.

Double 'V' butt joint

When plates are thicker than 12 mm it is better to use a double 'V' joint, see Fig. 6.

The double 'V' butt joint is made as follows:

- A - Make bevels on both sides, see Fig. 6. Leave a square face in the middle about 3 mm wide.
- B - Weld a bead on one side and then on the other side, see Fig. 7. Follow this sequence because then the heat is distributed and you avoid warping the metal.

Broken shafts or axles must be welded with a double 'V' joint.

Overhead welding

When you weld in the overhead position, gravity tends to pull the molten metal out of the weld, see Fig. 1.

To make a correct weld, the puddle must be kept small to keep it under control. If the puddle is too large, the molten metal runs down.

To keep a puddle small you must:

- Use a small electrode (up to 3.25 mm)
- Use a low current
- Do not use weaving

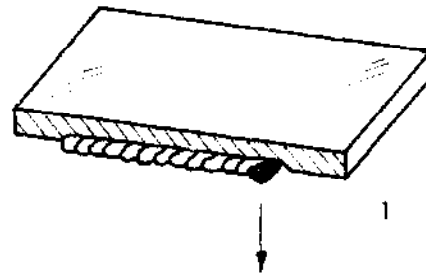

Welding vertically downwards (downhill)

Downhill welding is welding in the vertical position while the electrode moves downwards, see Fig. 2.

This method of welding is used to weld plates up to 5 mm thick.

In downhill welding, the puddle tends to run down and fill the crater, see Fig. 2-A. This running down causes poor penetration.

To secure a good weld, slope the electrode 30 degrees in the direction of travel, see Fig. 2-B.

Use a higher current and higher speed than for welding in a flat position.

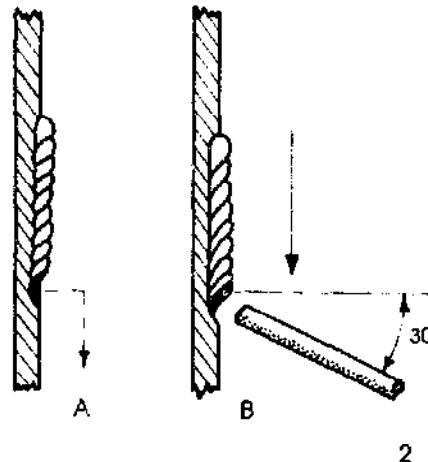

Welding vertically upwards (uphill)

This is welding in the vertical position while the electrode moves upwards, see Fig. 3.

This method of welding is used for plates with a thickness of more than 5 mm.

In uphill welding, the puddle tends to run back onto the weld, leaving a bare crater, see Fig. 3-A.

The puddle can be controlled:

- By sloping the electrode at 5 to 10 degrees away from the direction of travel, see Fig. 3-B.
- By using lower speed and lower current than welding in the flat position.
- By making a wide bead, using a semi-circular or crescent weave, see Fig. 3-C and 3-D.

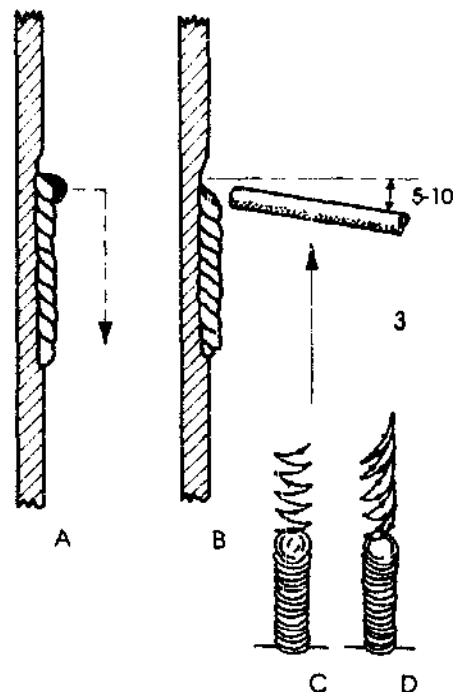

Welding pipes

The difficulty in welding pipe is to keep the correct electrode angle. The electrode must always point 15 degrees to the centre of the pipe, see Fig. 1.

There are two ways of keeping the correct electrode angle:

- The welder can work round the pipe without moving it. In this case it is necessary to break the arc several times, so the welder can change his position, see Fig. 1, start at A.
- Another method is to roll the pipe over the welding table while keeping the electrode above the pipe, see Fig. 2.

Before you can join two pieces of pipe, the pieces must be aligned and tacked together. The pipe must be tacked with three or four tacks.

Straight pieces can easily be aligned by laying them in a piece of angle iron.

Pipes with a wall thickness exceeding 4 mm must be provided with a 'V', see Fig. 3, and welded in stages to make correct welding possible.

An example of this is given in Fig. 4 where you see the build up of the weld and the position of the electrode, which is 70 degrees. Before vertical welding is started, the pieces must be tacked together in such a way that the space between the pieces is equal on all sides.

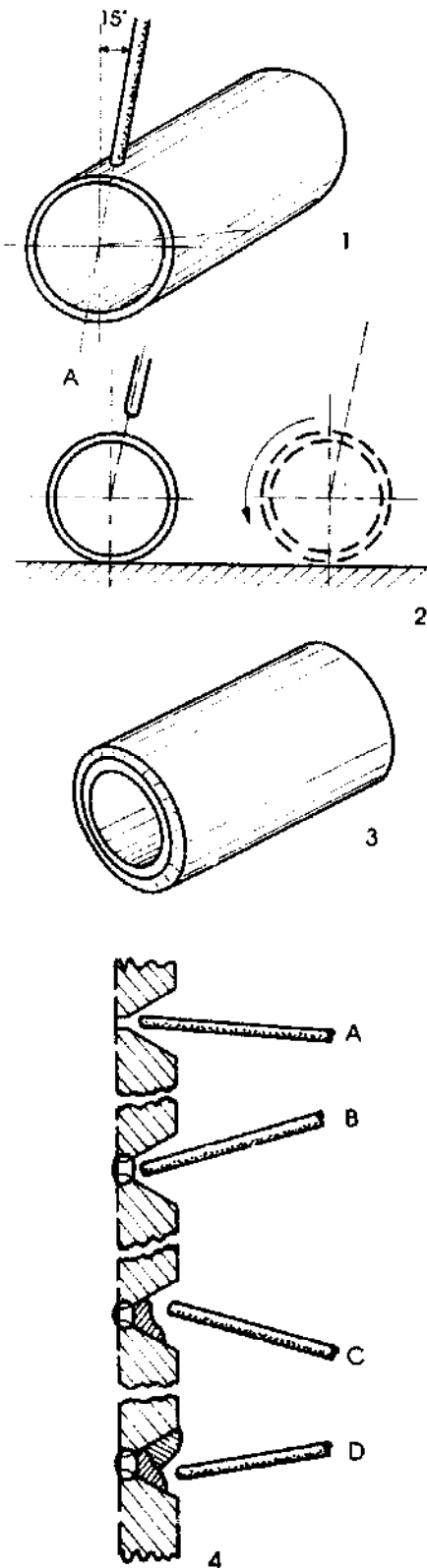

Building up a worn shaft

Many worn machine parts or agricultural implements can be built up by arc welding, see also the section on 'BUILDING UP A PAD'.

Fig. 1 shows the end of a worn shaft. You have to lay the beads lengthwise and in a certain sequence, shown in Fig. 2. When you use this sequence you avoid over-heating and thus warping and bending of the shaft. When enough metal has been built up, you can grind the shaft to the correct size.

Welding cast iron

Cast iron easily cracks when the weld cools. This is caused by expansion and contraction of the metal at different temperatures. You can avoid these cracks as follows:

- Use a thin electrode. Mostly a 3.25 mm electrode will do. Use a low current.
- Make short welds, about 30 mm long. Allow the work to cool before making the next bead.
- Never quench cast iron. This makes it very hard and brittle.
- Place the workpiece in ashes and allow it to cool as slowly as possible.

Take your time when you weld cast iron pieces. It does not pay to do a quick job as the workpiece will soon break again.

Hard surfacing

With hard surfacing electrodes you can make a weld which is very hard and resistant to wear. Many agricultural machines and implements have parts which are subject to much wear. You can repair these parts by building up a pad with hard surfacing electrodes as seen in Fig. 3.

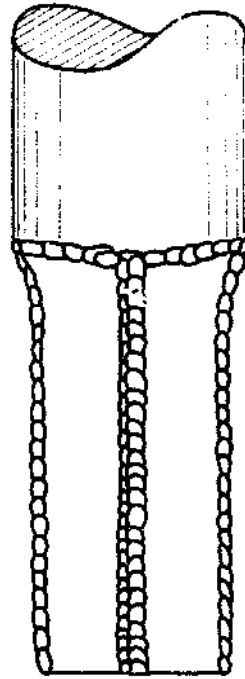

1

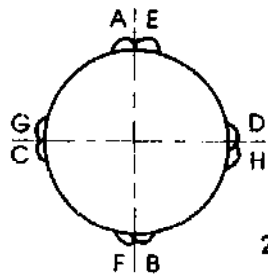

2

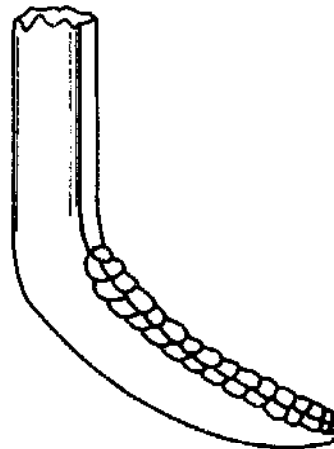

3

Gas welding

Gas welding, also called OXY-ACETYLENE welding, is very valuable in the rural workshop. Various kinds of welding, heating and cutting can be done with gas welding equipment.

In gas welding the metals are heated by an extremely hot flame. A mixture of two gases is burned to produce this flame:

- ACETYLENE, which is the actual fuel
- OXYGEN GAS

When you burn acetylene in the open air, you get a moderately hot flame. But when you burn acetylene mixed with pure oxygen, the flame becomes very hot, up to a temperature of 3200° C.

This flame is called: 'OXY-ACETYLENE FLAME' and can be used to weld metals together.

NOTE:

Gas welding can be very dangerous. Take good care to follow the regulations given in this book. Wrong use of gas welding equipment can result in severe injuries.

Gas welding equipment

Gas welding equipment is shown in Figs. 1-3.

- A - Oxygen cylinder
- B - Acetylene cylinder
- C - Pressure regulators
- D - Safety valve
- E - Rubber hoses
- F - Hose clamp
- G - Torch (also shown in Fig. 2)
- H - Torch tip
- I - Oxygen cylinder valve
- J - Oxygen torch valve
- K - Acetylene cylinder valve
- L - Acetylene torch valve
- M - Safety goggles (see Fig. 3)
- N - Spark lighter
- O - Fire clay bricks.
- P - Steel-top welding table

The cylinders should be placed against a wooden beam which is fixed tightly to the wall. This beam (seize 10 x 10 mm) has two hollows in order to give support to the cylinders. This beam also serves as a shelf for the caps.

NOTE:

In tropical countries make sure you buy the right type of hose, because rubber deteriorates very fast.

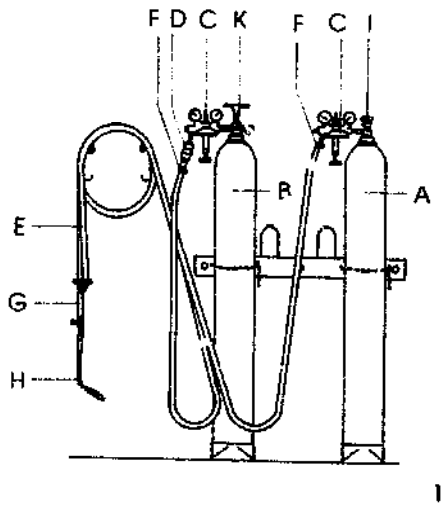

1

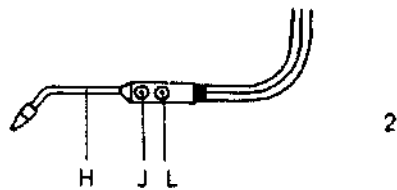

2

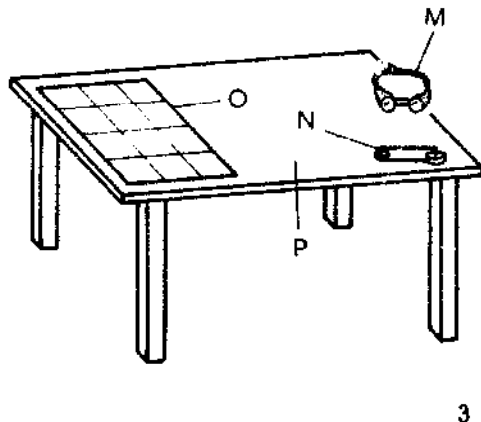

3

Gas welding equipment

Oxygen and acetylene are stored in separate cylinders, both under high pressure. The pressure in the cylinders is too high to work with. So the pressure is reduced in the regulators to obtain the correct working pressure.

The torch is connected to the regulators of the cylinders by hoses, which are fixed together at several places to keep them together during work.

The gases are mixed inside the torch. The mixture can be adjusted with the knobs on the side of the torch; in this way the flame can be regulated.

The cylinder, the pressure gauge, the hose and the torch valve for acetylene are all RED.

The cylinder, the pressure gauge, the hose and the torch valve for oxygen are all BLUE.

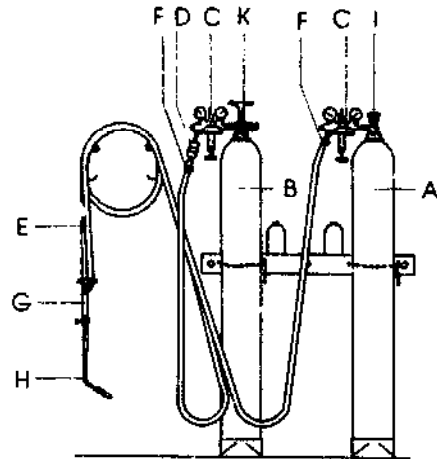

EXERCISE:

Mark at Fig. 1 all the names of the different parts. Use a coloured pencil to colour the cylinders and hoses.

Pressure regulations

As shown on the previous page there are two regulators. One for oxygen and one for acetylene. Fig. 2 shows a regulator. The parts are called:

- A - Cylinder pressure gauge
- B - Working pressure gauge
- C - Regulator screw
- D - Cylinder connection
- E - Hose connection
- F - Safety plug
- G - Safety valve (acetylene only)

The safety valve prevents the acetylene cylinder and the regulator from backfiring. The use of such a valve is vital.

The cylinder pressure gauge gives you the pressure of the gas in the cylinder.

- A full oxygen cylinder has a pressure of 150 to 200 bar.
- A full acetylene cylinder has a pressure of 15 bar.

The working pressure gauge gives you the pressure of the gas that flows to the torch. The maximum safe working pressure

- For oxygen 3 bar
- For acetylene 1½ bar

It is good practice to mark the maximum working pressure on the gauges. With the regulator screw you can adjust the working pressure. When it is completely screwed out, the working pressure is ZERO. As you screw it in, the working pressure rises.

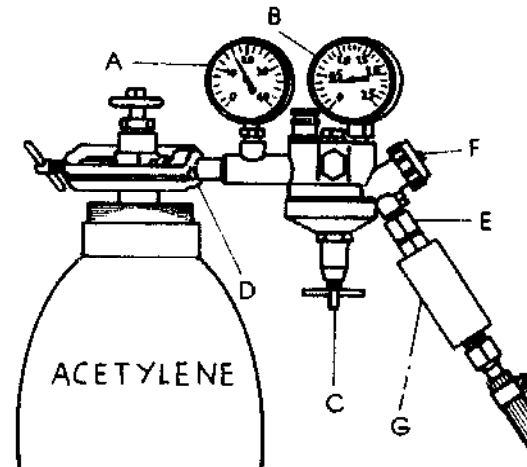

Acetylene generator

Instead of using acetylene from a cylinder, one can also prepare acetylene on the spot by using an acetylene generator.

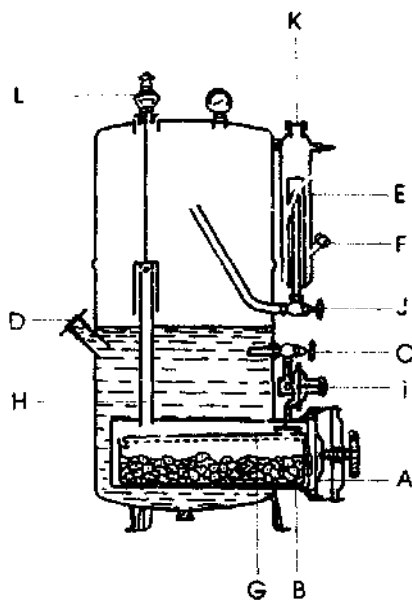

An acetylene generator is shown in Fig. 1 and 2.

- A - Hatchway
- B - Carbide drawer
- C - Water fall tap
- D - Water filling cap
- E - Safety valve
- F - Spout
- G - Water spreader
- H - Pipe
- I - Regulator
- J - Outlet tap
- K - Lead disk
- L - Safety valve

Loading the generator

- A - Make sure the generator is perfectly upright.
- B - Remove hatchway (1-A) and pull out carbide drawer (1-B).
- C - Close water fall tap (1-C).
- D - Open water filling cap (1-D).
- E - Pour water into the generator up to the brim, then close cap (1-D).
- F - Open tap (1-C) for a few seconds to make sure that the water is free to fall on the carbide.
- G - Put water into safety valve (1-E), filling it through spout (1-F) up to the brim of the spout itself, and then close the relative cap.
- H - Spread out carbide uniformly in drawer (1-B); replace water spreader (1-G) and slide drawer (1-B) into the generator and shut hatchway (1-A).

When these last operations are completed, the generator is ready to start operating. Before starting it is good practice to check that hatchway (1-A) and caps (1-F and 1-D) are hermetically sealed.

Operating the generator

Opening tap (1-C) causes water to descend through regulator (1-I) to water spreader (1-G) which distributes it over the carbide contained in drawer (1-B).

The carbide produces gas by chemical reaction. The gas rises through pipe (1-H) and enters into the upper tank, where it creates a pressure that is measured by the relative pressure gauge.

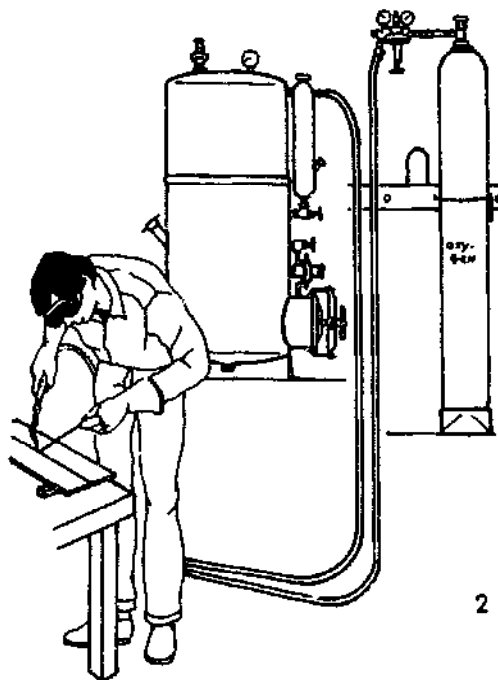

Acetylene generator continued

This pressure acts on regulator (1-I), see Fig. 1 on page 110, which in turn controls the passage, and the resulting fall of water on the carbide.

Variations in pressure caused by the consumption of gas control the opening of regulator (1-I), the fall of water on the carbide, and consequently the replacement of the gas consumed.

During use the gas passes from cut-off tap (1-J) into mechanical-hydraulic safety valve (1-E).

The mechanical-hydraulic safety valve includes lead disk (1-K) which breaks, discharging the gas into the atmosphere, whenever backfire from the torch causes a dangerous pressure or temperature inside the valve itself.

Starting to operate

It is recommended, especially at the beginning of each new load, that water fall tap be opened up only for a quarter of a turn to avoid an excessive initial production of gas which could in turn cause excessive overpressure.

Gas produced by the first load in a new generator is naturally mixed with the air already existing inside the generator. It is therefore necessary to discharge part of the contaminated gas before lighting the torch.

The production of gas will be automatically regulated according to the consumption of the torch used, without adjustments being necessary, until the carbide contained in the generator is exhausted.

Whenever torches are used with delivery rates equal to the maximum delivery rate of the generator, it is good practice to close water fall tap (1-C) before finishing work in order to consume the gas contained in the tank. This will avoid overpressures that might be caused by the residual reaction.

Stopping work and re-loading

Whenever work is stopped for periods longer than a few hours, both the water fall and the gas outlet taps should be closed.

Re-loading can begin when both the carbide and the acetylene inside the generator are

Every flame or spark source must be moved away from the generator. When this is done, slowly open hatchway (1-A), remove carbide drawer (1-B), wash it and dry it.

Add water up to the brim of spout (1-D) and then close it.

Check the water fall by opening tap (1-C) for an instant, then replace drawer (1-B) which has been filled with carbide according to the instruction given under 'loading the generator'

Maintenance

The water in the generator must be replaced at least every six months. It is discharged through the outlet located on the bottom of the generator. At the same time this is done, the inside of the generator should be well cleaned in order to remove deposits - using anti-spark tools (made of bronze, brass, wood etc.).

The water in the hydraulic valve should be inspected at least every 8-10 days.

Safety valve (1-L) can remain unused for a long time, and as a result its membrane can become stuck and prevent correct operation. It is good practice to activate it from time to time by pulling the upper pin while the generator is under pressure.

It may happen after long use that deposits build up in central pipe (1-H) obstructing the passage of gas to the tank. This pipe may be cleaned by unscrewing the cap on which safety valve (1-L) is screwed and by then removing the inner cap that covers the pipe itself.

The water filter in tap (1-C) can, if necessary, be removed for cleaning by unscrewing the coupling on which the tap is fastened.

Water fall regulator (1-I) can also be disassembled for any necessary maintenance. It is set for the normal operating pressure of the generator.

Safety and room regulations

An acetylene generator can be used everywhere. Whenever it is intended for stationary use in closed rooms, make sure that the room is large and well ventilated.

There must be a distance of at least 10 meters between burning systems or flame equipment and the generator. This can be reduced to 5 meters whenever the generator is protected against sparks and heat radiation or used for outside work.

Acetylene generator continued

WARNING:

No work or operation using unshielded flames can take place within 5 meters of an acetylene generator.

Cleaning

All generator cleaning operations must take place outside and by the light of day, artificial lighting can cause accidents.

Backfire

Backfire may be accompanied by the explosion of the mix and the breaking of the lead disk (1-K). In this case immediately close outlet tap (1-J), then remove the disk-holding cap, replace the safety disk and top up the water level in the valve as is explained in the instructions.

Source: Instruction manual of Fabbriche Riunite Ossigeno, Verona, Italy.

Safety rules

Acetylene is a fuel gas and burns easily. Oxygen supports combustion and thus makes oil, grease and other materials burn fiercely.

When you handle gas welding equipment, take every safety precaution to avoid fire or an explosion.

- Carefully follow the instructions for lighting the torch and adjusting the flame.
- Wear gloves and dark goggles when you are welding, see Fig. 1-A.
- Never put down a burning torch. Close the torch valves or use a special support to put the torch down, see Fig. 1-B.
- Do not hang the hoses over the regulators, you may damage them.
- NEVER use an acetylene cylinder when it is lying flat, it may cause a leakage of liquid, use a wooden block as shown in Fig. 1-C.
- Do not carry matches or a lighter in your pocket.
- Remove all flammable materials from the welding table and area.
- Use soapy water to check for leaks. Never use a flame for this.
- Rubber hoses suffer a lot from the tropical climate. Check them regularly. They can also be checked by submerging them in water.
- NEVER weld with leaking equipment.
- Always screw the cover over the cylinder valves when you transport a cylinder, see Fig. 1-D.
- NEVER place a cylinder in the sun or near a forge, see Fig. 1-E.
- Support the cylinders so they cannot fall. The safest way is to chain them to the wall.
- Keep grease and oil away from the oxygen equipment, see Fig. 1-F.
- Never use oxygen to clean or blow out objects.
- Handle the gas cylinders with care. Do not damage them. Never weld on a gas cylinder.
- Use hose clamps to connect hoses to their connecting nipples.
- If there is burning gas near the hoses, the regulator or the valve, close the cylinder valve, extinguish the fire and cool the cylinder with water.

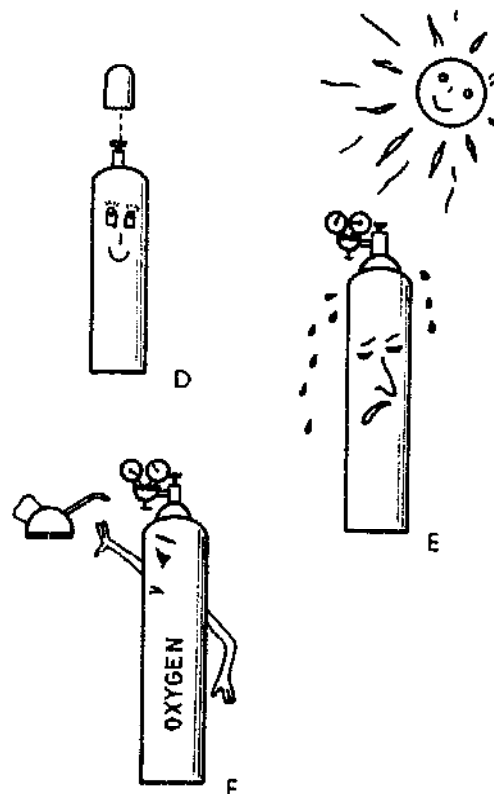
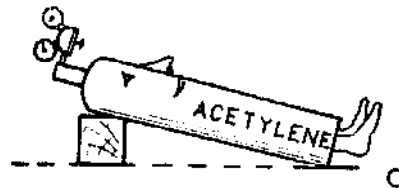
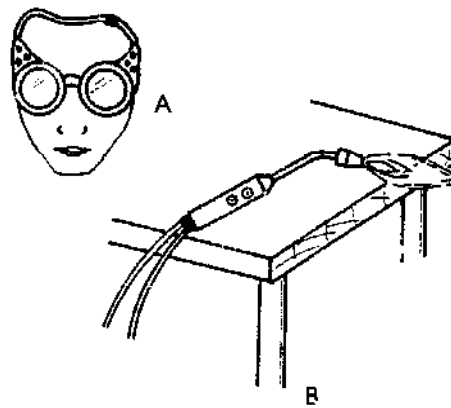

Attaching regulators, hoses and torch

When connecting regulators, hoses and torch it is advisable to use the same sequence of operations each time:

- A - Before you attach the regulators to the cylinders, open the cylinder valve for a second to blow out any dirt and dust which may have entered during transport.
- B - Wipe off the connections and connect the regulators to the cylinders. Tighten the nuts with the correct spanner and never force them.
- C - Connect the hoses and the torch, the RED hose to the ACETYLENE connections, the BLUE hose to the OXYGEN connections.
- D - Before you use the equipment, you must check for leaks. A good way to do this is: Open the cylinder valves and regulators to build up pressure in the hoses. Then close the cylinder valves. The pressure on the gauges should remain the same. If the pressure is reduced, there must be a leak somewhere.

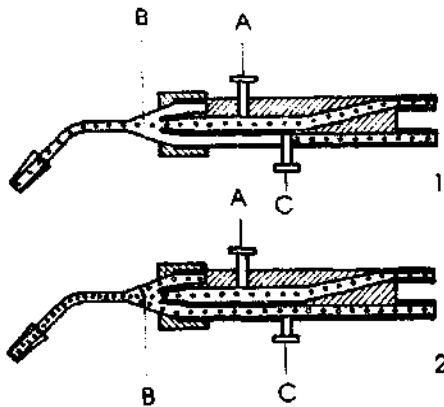

Torch operation

There are two regulating valves on a torch - one for oxygen and one for acetylene, see Fig. 1 and 2.

Because of the high pressure in the oxygen cylinder first the oxygen valve (Fig. 1-A and 2-A) on the torch is opened which results in a high speed outflow of oxygen (o). An underpressure occurs in the mixing chamber (1-B and 2-B). We now open the acetylene valve (1-C and 2-C) on the torch. Because of the underpressure in the mixing chamber the acetylene (o) is sucked in. A mixture of oxygen and acetylene is formed in the mixing chamber. This mixture is the actual welding fuel.

Selecting a torch tip

The connection between torch tip and handle is made with a right-hand type of nut which is first moved over the torch tip and then connected to the handle, see Fig. 1.

You should make sure the torch tip is tightened properly and the safety valve connected correctly to prevent oxygen entering into the acetylene, which may cause an explosion.

NOTE:

The torch tip connecting nut should only be assembled with the use of manual force. Do not use a spanner.

There are several sizes of torch tips which can be connected to the handle, see Fig. 2.

Choose a torch tip of the correct size. Use a small tip for thin metal welding.

- Too large a tip over-heats the workpiece.
- Too small a tip heats too slowly and is inefficient in the use of gas.

Often there are instructions in the torch tip container regarding the size of tip to be used.

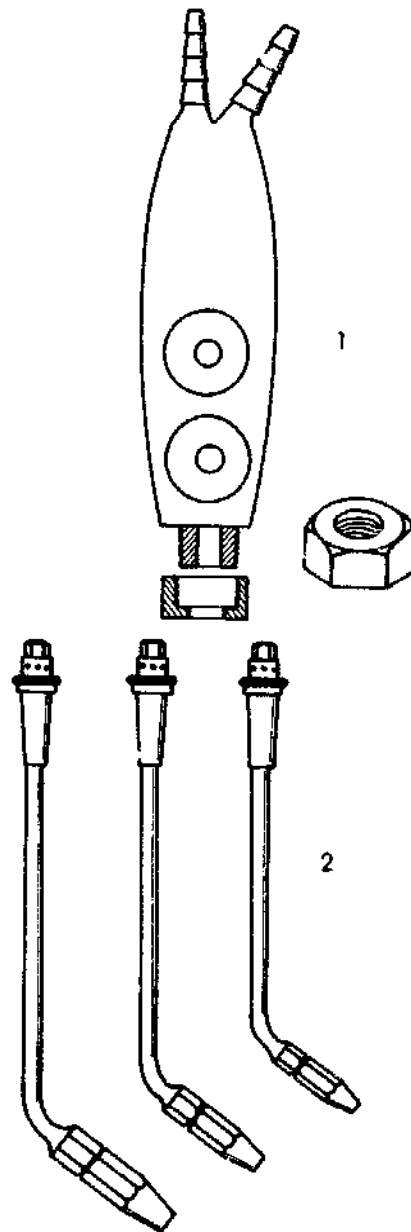

Lighting the torch

The procedure for lighting the torch must be followed exactly as explained below. Take this book to the workshop and follow the instructions step by step.

- A - Inspect the equipment to make sure all parts are in good operating condition.
- B - Close the torch finger tight. Turn the regulator screws all the way out, counter-clockwise.
- C - Open the oxygen cylinder valve SLOWLY. If you open it too quickly, the pressure surge may damage the regulator. Open the oxygen cylinder valve completely and leave it fully open during welding.
- D - Open the acetylene cylinder valve slowly with the correct spanner. Open it only 1/2 turn.
Leave the spanner on the valve to close it quickly in case of an emergency.
- E - Open the oxygen torch 1 1/2 turn. Turn the oxygen regulator screw until the working pressure is indicated. Close the acetylene torch valve finger tight.
- F - Open the acetylene torch valve a 1/2 turn. Then the acetylene regulator screw until the working pressure is 0.2 bar, unless another pressure is recommended. Close the acetylene torch valve finger tight.
- G - To light the tip with a spark lighter, first open the oxygen torch valve fully. Then open the acetylene torch valve a 1/2 turn. Never use a cigarette lighter to light the torch.
- H - Adjust the acetylene torch valve to get the correct flame.

NOTE:

The appearance of the correct flame is explained at a later stage.

Shutting off the torch

If the operator wants to put down the torch for a few moments, he only has to close the torch valves:

- FIRST close the acetylene valve
- THEN close the oxygen valve

If the operator wishes to stop for a longer period or when the work is finished, he must shut off the equipment completely:

- A - Close the torch valves as described above.
- B - Close the cylinder valves tightly.
- C - Open the acetylene torch valve to drain the hose.
- D - Close it again and turn the acetylene regulator screw completely off.
- E - Open the oxygen torch valve to drain the hose. Close it again and turn the oxygen regulator screw completely off.
- F - Hang the hoses and the torch in the correct place, avoiding twists or sharp bends in the hoses.

REMEMBER

**LIGHTING THE TORCH
OXYGEN IS OPENED FIRST**

**SHUTTING OFF THE TORCH
OXYGEN IS CLOSED LAST**

WARNING

The torch valves should be closed only:

FINGER TIGHT

The valves will be damaged if you use force.

Types of flames

Different types of flames can be created by opening or closing the acetylene valve. The oxygen valve should always be fully opened. If the oxygen pressure is too high (e.g. the flame is blown out) the pressure should be regulated with the valve on the oxygen cylinder.

You will find it important to know and be able to adjust the three types of flame described below.

Carburizing flame

This is a flame with an excess amount of acetylene. Acetylene contains a lot of carbon and this is added to the molten metal during welding and the steel becomes very hard and brittle if too much carbon is added.

So a carburizing flame is only used for hard surfacing. It must not be used for normal welding.

A carburizing flame, shown in Fig. 1, has two white cones at the tip of the torch (1-A and 1-B). The outer cone 1-A is called the acetylene feather. If you increase the amount of acetylene, the acetylene feather becomes bigger.

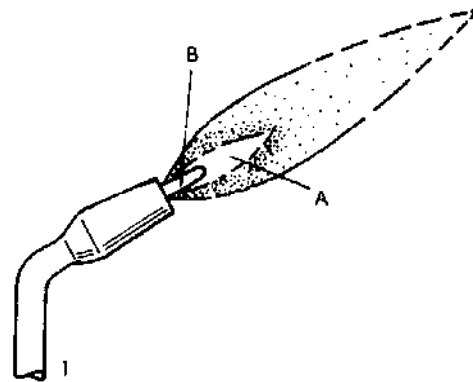

Neutral flame

In this flame an equal amount of oxygen and acetylene is burned. Most welding operations are done with a neutral flame.

A neutral flame as shown in Fig. 2 has only one white corner cone (2-A) and is made as follows:

- Start with a carburizing flame
- Slowly reduce the amount of acetylene

Exactly at the moment the acetylene feather disappears or merges with the inner cone, the flame is neutral

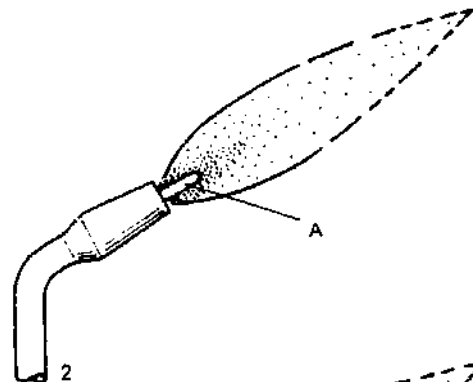

Oxidizing flame

In this flame an excess amount of oxygen is used. The excess oxygen burns or oxidizes the metal.

An oxidizing flame is hardly ever used.

An oxidizing flame (see Fig. 3) looks almost the same as a neutral flame, only the cone (3-A) is a bit shorter and sharper.

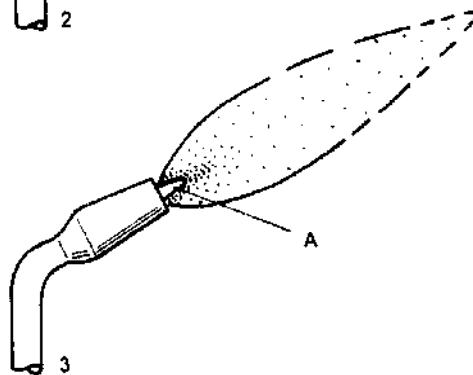

NOTE:

When you weld with a neutral flame you must check it frequently to make sure it stays neutral. This is easily done by opening the acetylene torch valve a little and closing it again until the outer cone just disappears.

Backfires

During welding, it can happen that the torch "backfires" or goes out with a loud snap.

Backfires may be caused as follows:

- The gas flows out too slowly and the working pressure is too low. In this case adjust the valves slightly upwards for both the oxygen and acetylene.
- Overheating of the tip, caused by excessive use, welding in a hot corner or because the tip is too loose. Shut off the gas and allow the tip to cool.
- The inside of the tip may have carbon deposits. These particles act as ignitors. Carefully clean the tip.

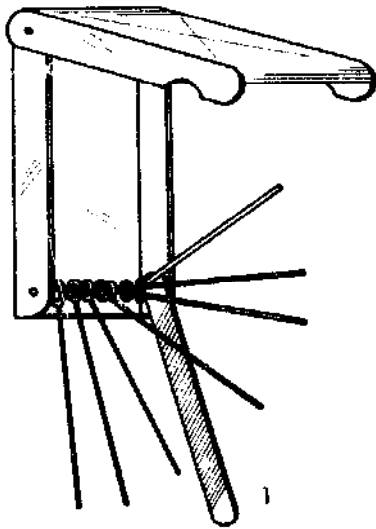

Flashback

A flashback is a condition where the gas burns back into the hose. When a flashback occurs, you hear an explosion followed by a whistling noise. This is a very dangerous situation. So close the cylinder valves immediately, acetylene first, then the oxygen.

A flashback may be caused by a clogged torch or by a leaking connection anywhere. Find the cause and clear it correctly.

Cleaning the tip

All welding torch tips are made of copper. They can be damaged by the slightest rough handling - dropping, tapping or chopping with the tip on the work may damage the tip beyond repair.

Tip cleaner

A special tip cleaner is supplied with the torch container. For each tip there is a kind of drill and a smooth file, see Fig. 1.

Before cleaning the tip, select the correct drill and move it, without turning, up and down through the hole in the tip, see Fig. 2.

The smooth file is then used to clean the surface of the tip, see Fig. 3. While cleaning, leave the oxygen valve partly open to blow out the dust.

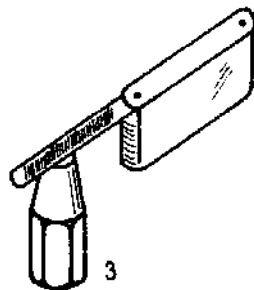
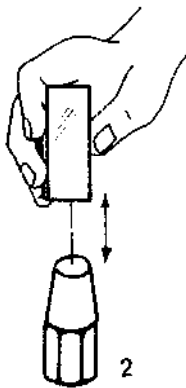

Trouble shooting

If

Then

The torch is hard to light →

- you should check the
- acetylene pressure
- oxygen pressure
- torch nozzle
- functioning of the injector
- disconnect the acetylene hose from the torch, open the oxygen valve and put your finger on the acetylene connecting nipple to check if underpressure occurs.

Slanted flame →

- clean the torch nozzle

Small weak flame →

- open the acetylene valve further
- raise the acetylene pressure
- lower the oxygen pressure

The flame cone is too large →

- close the acetylene valve slightly
- lower the acetylene pressure
- raise the oxygen pressure

Sooting flame →

- open the oxygen valve
- raise the oxygen pressure.

How to weld joints without a filler rod

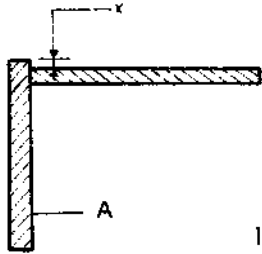

Fig. 1 shows a cross-section of two pieces of metal which have to be welded together without using a filler rod.

Piece 1-A has to protrude in this case as shown at 1-X.

Clamp the pieces into the correct position, exactly square.

Move the torch in the direction of the arrows shown in Fig. 2. Make sure the edge is heated enough to let the surplus metal melt over the corner to ensure a neat and strong weld.

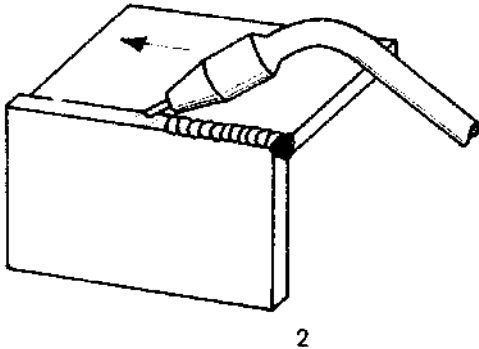
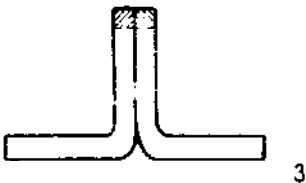
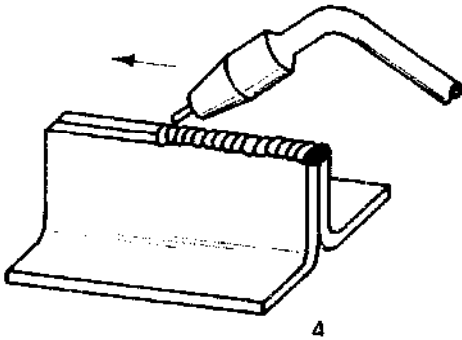

Fig. 3 shows the cross-section of a flange joint. The hatched part on top of the flanges is used as filler material during welding.



Move the torch as shown in Fig. 4. Heat the metal deep enough to prevent the corners melting away.



Carrying a puddle without a filler rod

Now you have the first exercise in gas welding. Have all your equipment ready as explained above and, on a piece of scrap metal, practise controlling the size of a molten puddle and carrying it along as the weld is made.

- A - Select the torch tip. Put on dark goggles.
- B - Light the tip and adjust the flame to neutral.
- C - Hold the tip at an angle of 45° to the surface of the metal piece, see Fig. 1, pointing it in the direction of the weld.
- D - As you know, the hottest part of the flame is just in front of the torch tip cone. This hottest part should come into contact with the metal. But keep the cone about 3 mm above the actual work, see Fig. 3. Do not touch the work with the cone.
- E - Hold the flame in one place until the puddle starts to form. Then move the torch slowly forward with a circular weaving motion, see Fig. 2.
- F - The forward speed is important. If the speed is too slow the puddle becomes too large. If the speed is too fast, the puddle is too small.
- H - Do not move the flame outside of the puddle, indicated by two lines, see Fig. 4-A and 4-B. If the puddle becomes too large, lift the torch for a moment to allow the metal to cool.

Practice carrying a puddle until you can easily produce a uniform ripple. If the torch tip becomes dirty, wipe it on a piece of wood to clean it.

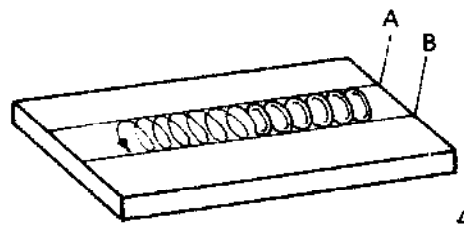
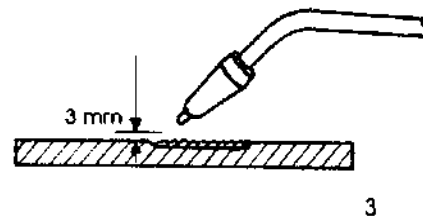
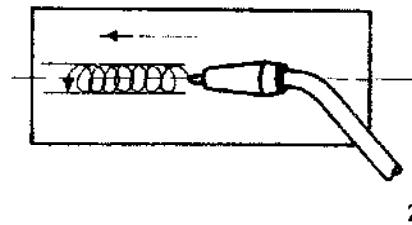
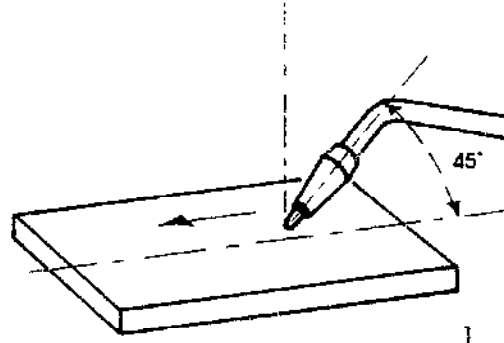

The filler rod

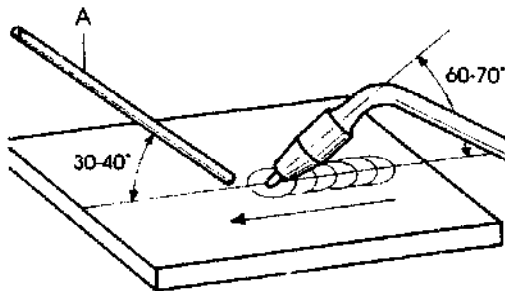

1

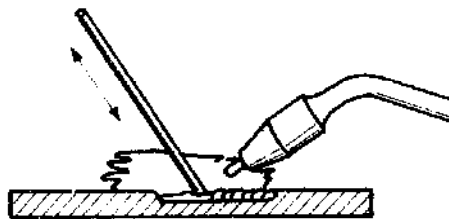

2

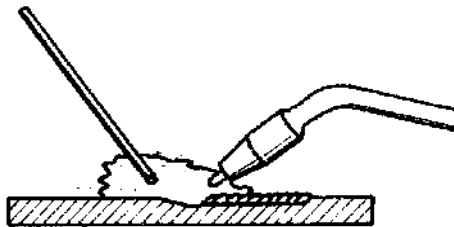

3



4

Filler rods (see Fig. 1-A) are long thin rods used for welding. They are made from the same material as the material which has to be welded.

There are filler rods for steel, cast iron, copper and aluminium.

Filler rods are available in different diameters and the rods for steel and cast iron have a copper coating to protect them against corrosion.

Carrying a puddle with a filler

- A - Hold the torch tip in the same way as described above for a puddle without a filler rod at 60-70°, see Fig. 1. Hold the tip in the direction of travel so the flame pre-heats the metal.
- B - Hold the tip of the filler rod in the outer envelope of the flame, see Fig. 3.
- C - Hold the filler rod at an angle of 30-40 degrees to the direction of travel, see Fig. 1.
- D - When the puddle is formed, dip the end of the filler rod into the puddle and melt off a bit from the filler rod, see Fig. 2, then move the end of the rod back into the outer envelope of the flame, see Fig. 3.
- E - Move the puddle forwards with circular motions as shown in Fig. 4. Add some metal from the filler rod at regular intervals. Do not let the metal drip from the rod.
- F - A uniform width and height of the bead is produced by welding at the correct speed.

Welding with filler rod

Good welding can be learned in part from a book but more from practice under the guidance of a qualified welder.

The actual welding process is shown in Fig. 1:

A - Base metal, workpiece

B - Solidified metal

C - Torch tip

D - Cone

E - Molten metal from filler rod

F - Filler rod

G - Direction of welding

While welding, care must be taken to ensure the metals are thoroughly fused together and not just sticking together at the surface, as shown in Fig. 2.

To ensure complete fusion which penetrates the entire surface to be welded, heat the prepared edges of the two metals deep enough so the filler rod material can penetrate deep enough, see Fig. 3.

Before welding, the edges of thick material must be shaped to a V to be able to penetrate deep enough later, see Fig. 4.

While welding, concentrate the heat of the flame into the V until a molten pool of metal appears and then add metal from the filler rod by dipping the end into the pool so that it melts and makes up the V.

Multiple-pass welds

For very thick plates it may be necessary to fill in the bottom of the V with one pass and then repeat the process with additional passes, see Fig. 5.

Never hold the flame too long in one place, particularly on thin material because you run the risk of burning a hole in the metal.

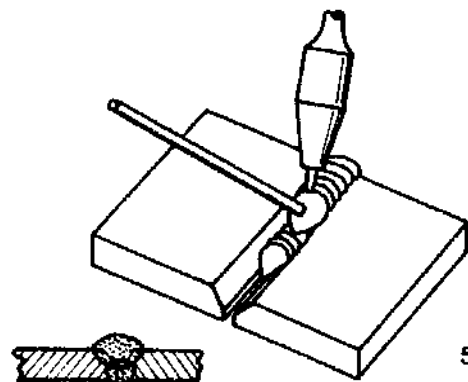
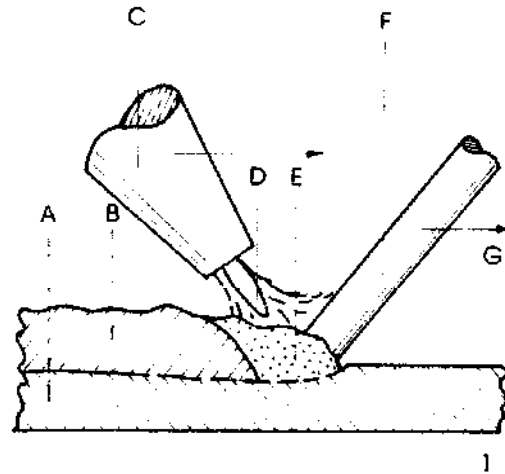

Various types of welds

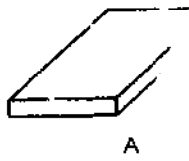

A

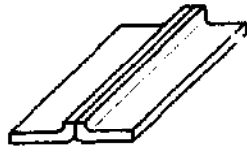

B

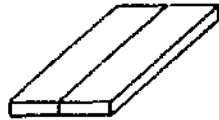

C

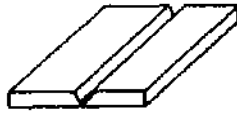

D



E

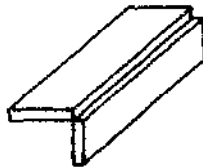

F

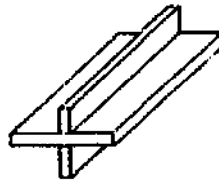

G

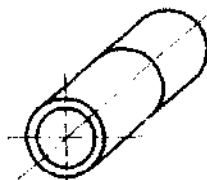

H

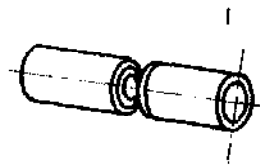

I

- A - Blind weld
- B - Double flanged butt weld
- C - Square butt weld
- D - Single 'V' butt weld
- E - Double 'V' butt weld
- F - Corner weld
- G - Fillet weld
- H - Pipe butt weld
- I - Pipe single 'V' butt weld

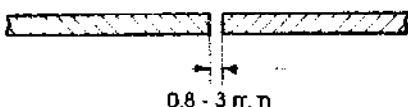
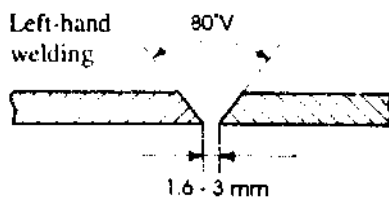
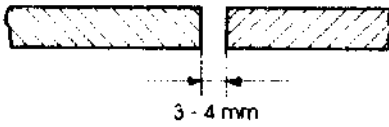
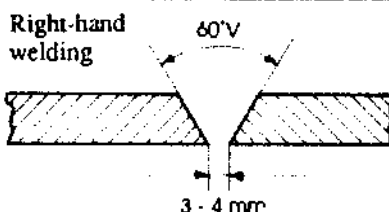
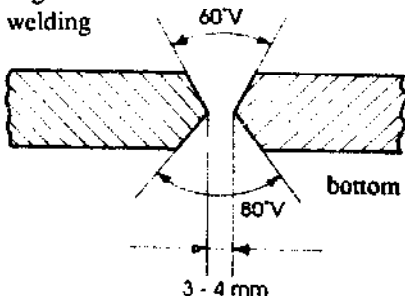
Edge preparation	Thickness of metal	Diameter of welding rod	Speed – mm per minute
Left-hand welding 	0.8 mm	1.5 mm	127 - 152
	1.5 mm		100 - 127
Left-hand welding 	2.5 mm	1.5 - 3 mm	100 - 127
	3 mm		90 - 100
Left-hand welding 	4 mm	3 - 4 mm	75 - 90
	4.8 mm		60 - 75
Right-hand welding 	6.4 mm	3 - 4 mm	50 - 60
	8 mm		35 - 40
Right-hand welding 	9.5 mm	3 - 6.5 mm	30 - 35
	12.5 mm		22 - 25
Right-hand welding 	15 mm	6.5 mm	19 - 22
	19 mm		15 - 16
	25 mm		10 - 12

Welding positions

Fig. 1 shows some of the different positions in welding, called:

- A - Flat or downhand welds
- B - Vertical welds
- C - Inclined welds
- D - Horizontal welds
- E - Overhead welds

Welding procedure

There are five methods of gas welding:

- Left-hand welding
- Right-hand welding
- Vertical welding
- Horizontal welding
- Overhead welding

Left-hand welding

Left-hand welding is shown in Fig. 2-A and 2-B. This weld is made by working from right to left, see arrow Fig. 2-A.

The torch is held in the right hand at an angle of 60 to 70 degrees, see 2-B. The rod is bent to be able to hold it conveniently at a 30 to 40 degree angle to the surface of the workpiece, see Fig. 2-B.

In the case of welding thick metals together, move the torch from side to side as shown in Fig. 2-A.

Right-hand welding

Fig. 3 shows you the method for right-hand welding. This weld is made from left to right, see arrow Fig. 3-A.

During right-hand welding, hold the torch at a 40 to 50 degree angle to the surface of the workpiece, see Fig. 3-B.

If V edges are needed they can be made some 20 degrees less than for left-hand welding. Note the movement of the torch.

Right-hand welding is particularly suitable for materials with a thickness of over 3 mm. It gives a better welding result as the heat is directed more accurately on to the molten pool.

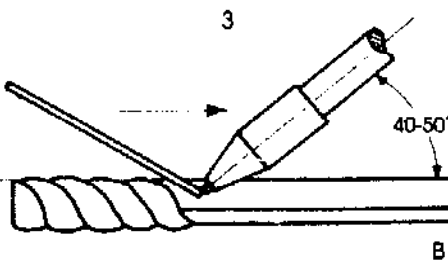
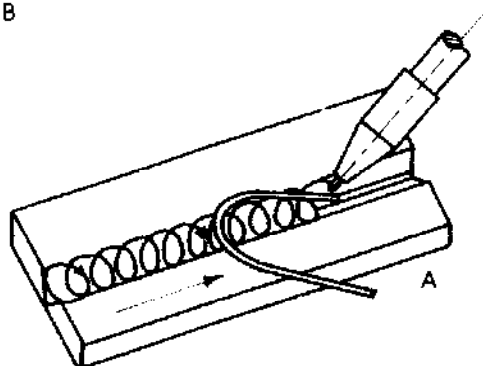
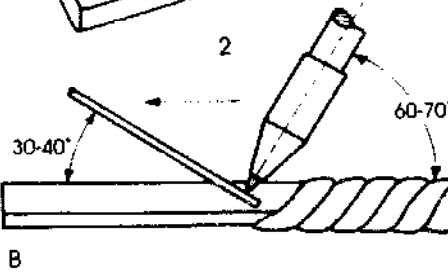
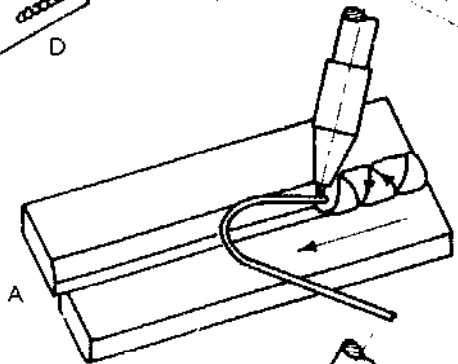
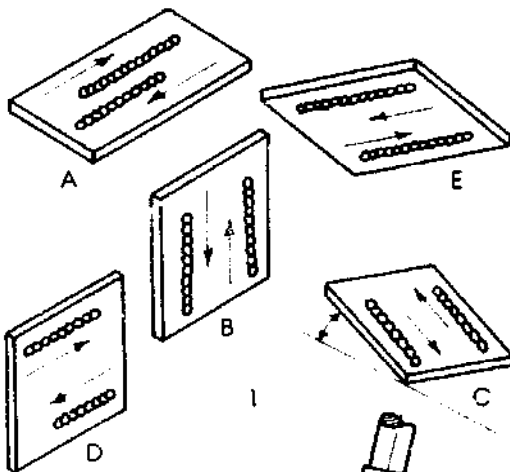

Welding procedure

Vertical welding

Welding in a vertical position is shown in Fig. 1-A and is commonly done from the bottom up. Point the torch upwards to an angle of about 45 degrees, see Fig. 1-B.

Hold the filler rod downwards at about the same angle as the torch, see Fig. 1-B.

While welding, hold the torch at the bottom of the weld until a puddle is formed, then add the metal from the welding rod.

Lift the torch a little at regular intervals to allow the metal in the lower part of the puddle to solidify and to form a small shelf to support the puddle.

Move the torch upwards at a steady speed, keeping the puddle shallow and adding metal to build the weld.

Make sure the weld penetrates to the bottom of the joint.

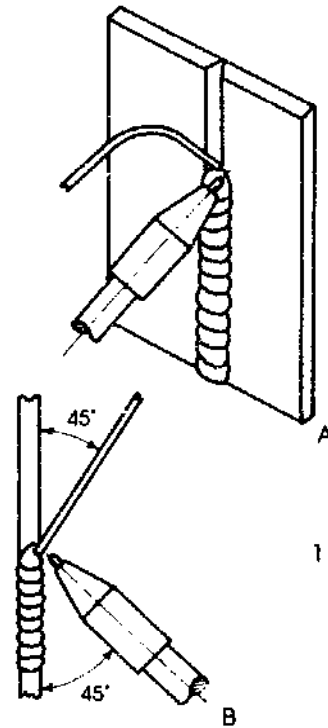

Horizontal welding

When welding in the horizontal position, hold the torch and the filler rod at an angle of approximately 45 degrees to the workpiece, see Fig. 2.

Weave the flame back and forth on the edges of the two pieces, holding it longer on the lower piece than on the top one.

When the edge of the top piece just reaches the welding temperature and becomes plastic, rather than very fluid, add the metal from the rod.

Lift the torch briefly at regular intervals to allow the back edge of the puddle to solidify.

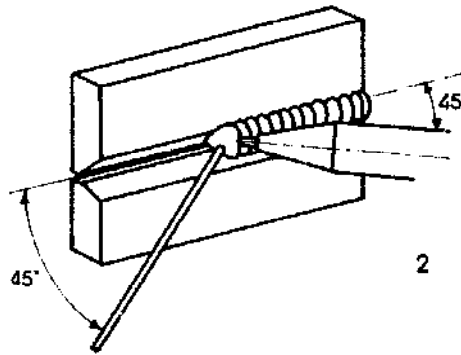

Overhead welding

Welding in the overhead position is done much the same as in the flat position, except that the torch is held at nearly 90 degrees to the surface of the workpiece, see Fig. 3.

Also a little less heat is used and the puddle is kept small and shallow.

Moving the end of the filler rod through the puddle helps to move the puddle along and keeps it shallow.

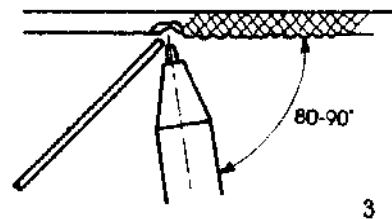

Torch and rod position

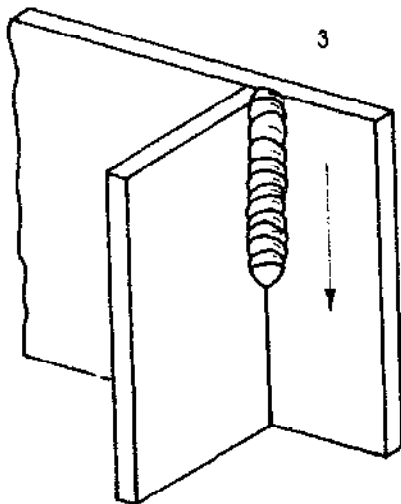
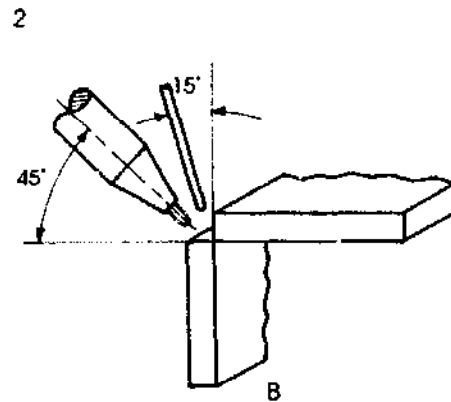
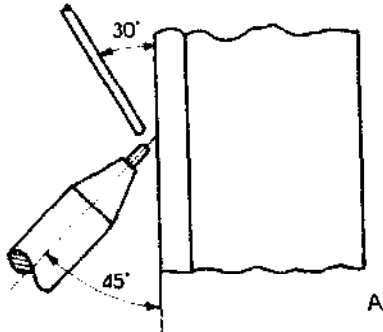
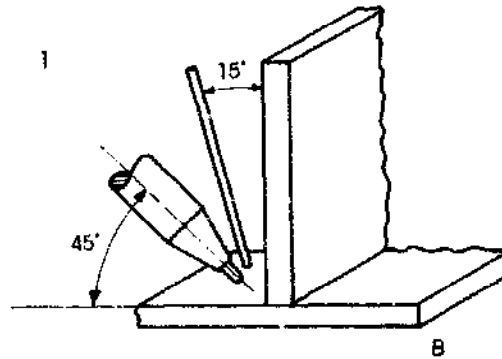
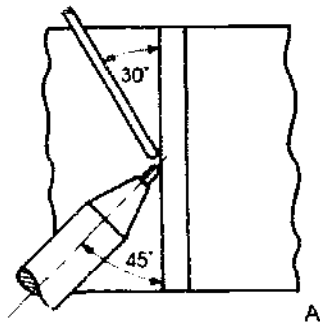

Position of torch and rod in T joints

Fig. 1-A and 1-B show position of torch and filler rod when welding T joints.

Position of torch and rod in corner joints

Fig. 2-A and 2-B show position of torch and filler rod when welding corner joints.

Vertical welding

When welding downhill, use only straight beads, see Fig. 3.

Weaving motion produces a large puddle which cannot be controlled and finally drops down.

Welding a pipe

Welding a pipe demands careful preparation. One of the methods is to prepare a 'V butt joint' as shown in Fig. 1.

Place the two pieces of pipe in a horizontal position and exactly in line, keeping the correct space between them.

Tack the pieces, shown in Fig. 2, together at the spots 2-A, 2-B and 2-C (view from above).

Clamp the pipe in a vertical position and start welding in a horizontal position at point 2-D. Move round the pipe while welding, do not turn the pipe, see arrow in Fig. 4.

Keep the first 10 mm of the weld deposit narrow and flat, but well fused and penetrated into the joint.

While the puddle leaves the bottom part and starts up to the side of the joint, the most difficult part of the weld begins.

To overcome difficulties, keep the torch tip straight in the line of travel and pointing into the weld.

Also keep the rod straight in the line of travel and fairly flat against the pipe, see Fig. 3 and 4.

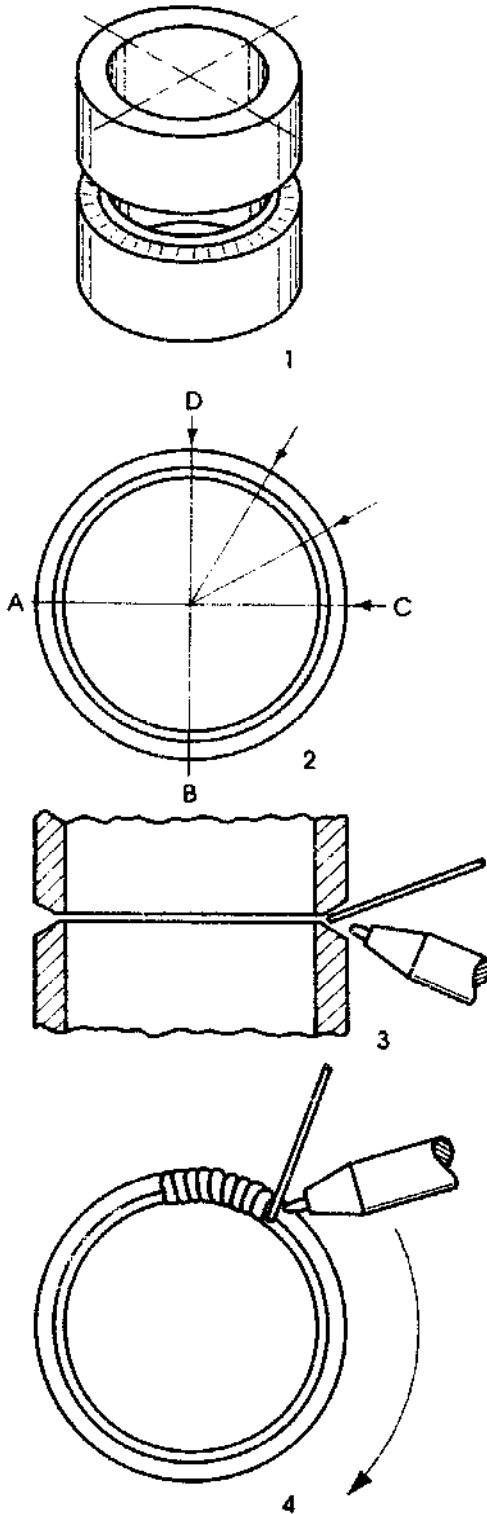

Welding cast iron

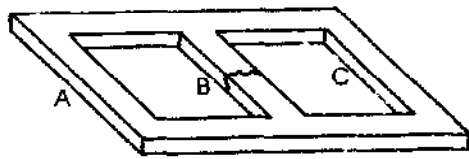

1

Fig. 1 shows a workpiece made of cast iron and cracked at 1-B.

The welding of this crack may present problems, if you do not study the correct sequence of operations.

Before welding cast iron, careful study of the shape of the workpiece should be made to prevent uneven expansion and contraction.

When you heat part 1-B of the workpiece, it expands and there is high stress on the surrounding parts, especially parts 1-A and 1-C.

Since cast iron has a low ductility, it cannot strain and the stress may be sufficient to cause a new crack.

Pre-heating the workpiece to a red heat reduces the risk of cracks.



2

Sequence of operation

- A - Study the shape of the workpiece.
- B - Know where contraction will take place.
- C - Shape the crack with a file or grinding wheel to a V, see Fig. 2-A.
- D - Pre-heat parts 3-A, 3-B and 3-C to a red heat. Heating should be done equally over all three parts, see Fig. 3.
- E - Weld the crack together, using a special cast iron rod, see Fig. 4.
- F - When the metal in the crack starts melting, dip the welding rod in a flux.
- G - Place the rod with the flux in the molten metal and stir it lightly.
- H - After welding, place the workpiece under sand to allow very slow cooling.
- I - Slag should be removed with a scraper or brushed off. Do not use a hammer.

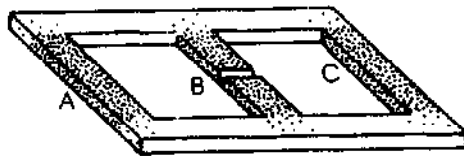

3

NOTE:

The most important part of welding cast iron is the study of the shape of the workpiece and the preparation of the workpiece to allow equal contraction.



4

Soldering

Soldering

Solder is an alloy which melts at a low temperature. Soldering is joining metal parts with solder.

There are two types of soldering:

- Soft soldering, which is done at about 200° C.
- Hard soldering, also called brazing, which is done at about 900° C.

Soft soldering

For soft soldering you need three main things: a soldering iron, solder and flux.

A soft soldered joint is not strong, so it should be used only when strength is not important - for example, on sheet metal work and radio repairs.

Iron, steel, copper, zinc, tin and lead can be soldered. Aluminium cannot be soldered by normal means.

Soldering tools

Soldering is done with a soldering iron which may have a hammer bit shape, see Fig. 1, or a straight bit, see Fig. 2.

A soldering iron has a handle (1-A), a shaft (1-B) and a bit (1-C).

The bit is made of copper because solder easily sticks to it and because it can be heated rapidly. The size of the bit depends on the work. A large bit holds the heat better than a small bit. The bit should be as large as possible without being inconvenient to handle.

A steel wire brush as shown in Fig. 3 is used to clean the bit before soldering starts, see Fig. 4.

A smooth file can also be used for cleaning, see Fig. 5.

A triangular scraper as shown in Fig. 6 or a blade scraper as shown in Fig. 7 is used to scrape all dirt off the surface of the metal to be soldered.

Abrasive paper is sometimes used to clean the surface of the metal.

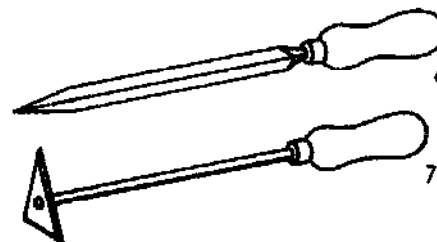
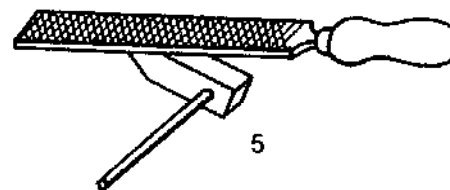
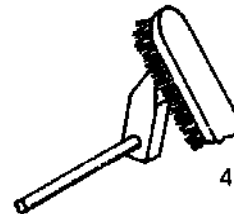
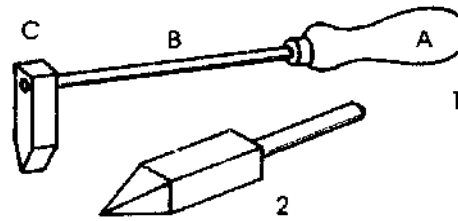

Blow lamp

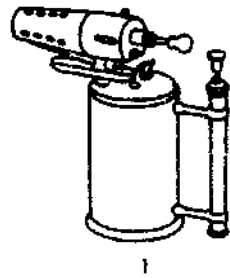

The blow lamp shown in Fig. 1 is a handy instrument for soldering if no gas welding equipment is available.

It can be used for soft soldering on large work, brazing and for heating such things as stubborn nuts in order to get them out. Most blow lamps use petrol but some use paraffin. Make sure you fill the tank with the right fuel.

Parts of the blow lamp

See Fig. 2.

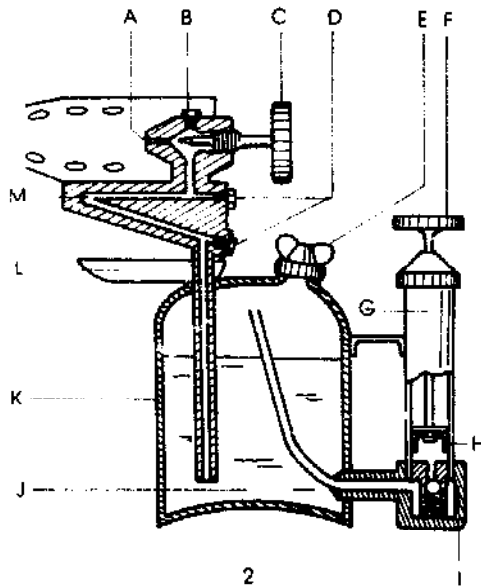

- | | |
|-----------------------|------------------------|
| A - Burner nozzle | H - Seal |
| B - Screws (to clean) | I - Foot valve |
| C - Control valve | J - Fuel |
| D - Screws | K - Tank |
| E - Filler cap | L - Priming cup |
| F - Pump | M - Vaporation passage |
| G - Handle | |

An alternative blow lamp is shown in Fig. 3 using the same references as Fig. 2.

How to light the blow lamp

- A - Fill the tank until it is $\frac{3}{4}$ full with the correct fuel.
- B - Close the control valve.
- C - Pump ten strokes to pressurize the fuel tank.
- D - Prime the filling cup with spirit or with a cloth soaked in paraffin and light the spirit. The spirit has to pre-heat the burner to vaporize the fuel.
- E - Light the torch by opening the control valve just before the spirit is finished. If necessary light the lamp with a match applied to the holes in the side of the burner.
- F - Shut off the lamp, close the control valve just enough to stop the gas. Do not overtighten the valve.

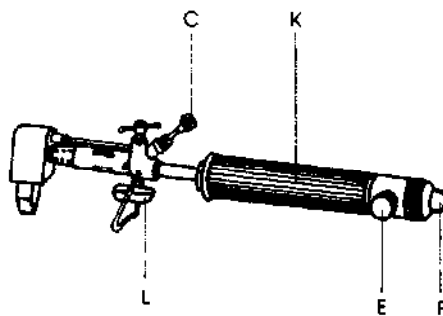

Maintenance

PUMP TROUBLES: Take out the pump rod and apply some oil to the seal. If the seal is worn out, replace it. Another cause of trouble may be the foot valve. Dirt may cause the valve to stick or leak.

FUEL LEAKS: If fuel leaks around threaded joints, unscrew the joint and rub some soap on the thread, tighten the nut.

WEAK FLAME: A weak flame can be caused by a lack of pressure, pump a little more. If pumping does not help, the fuel passage may be clogged. Take the lamp apart carefully. Soak the passage in paraffin and blow through it or use a needle with care.

Solder

Soft solder is an alloy of tin and lead which melts at about 200° C. There are some figures to go with the solder. For example, 50/50 solder is made of 50% tin and 50% lead, see Fig. 1-A and 1-B.

Solder is available in rods (Fig. 1) and wire (Fig. 2). The advantage of soldering wire is that the core is filled with soldering flux in the form of paste, so no separate flux is needed when this wire is used.

Soldering rods contain no flux but they are much cleaner than the wire. For larger work it is better to use soldering rods.

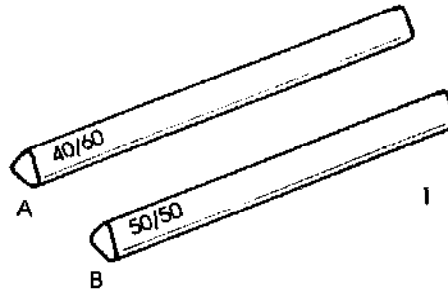

Flux

Before soldering, clean the workpiece. It is very important that the metals to be joined are free of dirt, grease and corrosion. You can remove corrosion by filing, polishing with abrasive cloth or applying car battery acid. But it is very important that, after using the acid, you wash the workpiece thoroughly to make sure all acid is removed.

When the workpiece is clean, you have to apply some flux to it. The flux prevents new oxidation of the workpiece.

Two types of flux can be used:

- Soldering paste, sold in tins, Fig. 3.
- Zinc chloride, as a liquid, Fig. 4.

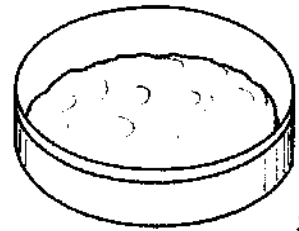
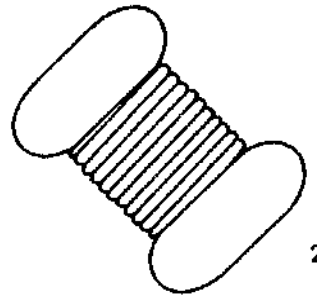

How to make zinc chloride

- A - Dissolve small pieces of zinc in hydrochloric acid.
- B - Stop adding zinc when no more of it dissolves and some zinc is left in the bottle. Now the acid is 'killed'.
- C - Zinc can be obtained from the shells of old dry-cell car batteries. Clean them before using them.

Precautions

Prepare the 'killed' spirits in the open air, away from fire, as explosive gases are produced.

Be careful not to get acid on skin, clothes or tools.

Prepare and store the acid and zinc chloride in glass jars or bottles and close them well, as the fumes will corrode any metal object in the vicinity.

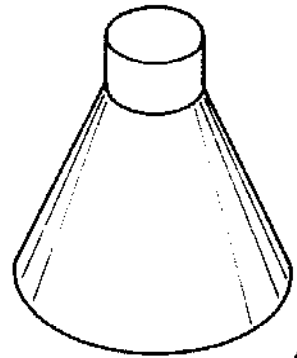

General soldering rules

The most important rule is cleanliness. Good soldering is only possible if the iron and the workpiece are very clean. Use a damp cloth to remove any dirt from the iron and the work after every application of solder.

Be patient. Allow the heat to flow from the iron into the workpiece. The place to be soldered must be so hot that the solder melts. Always use hot iron. The iron must be so hot that it melts the solder immediately.

Be careful not to heat the iron too much. If the solder turns yellow, the iron is too hot. Support the work on a wooden workbench or a piece of wood. If a vice or anvil is used, the metal sheet will not become hot enough, since the metal of the anvil or vice will absorb all the heat.

Do not use more solder than necessary. Big lumps of solder make a weak joint.

Tinning the soldering bit

- A - The tip of the soldering iron must be cleaned and coated with solder before it can be used. This is called tinning. If the bit is very dirty or pitted (holes on the surface), it must be filed first. See Fig. 1.
- B - Heat the bit with the tip upwards, as seen in Fig. 2. Never heat the tip. Heat the bit until it is hot enough but never red hot.
- C - Wipe the bit with a damp rag to remove all dirt, see Fig. 3.
- D - Dip the bit quickly in the flux, see Fig. 4.
- E - Melt some solder on the tip of the bit, see Fig. 5.

Now the bit is tinned and ready for use.

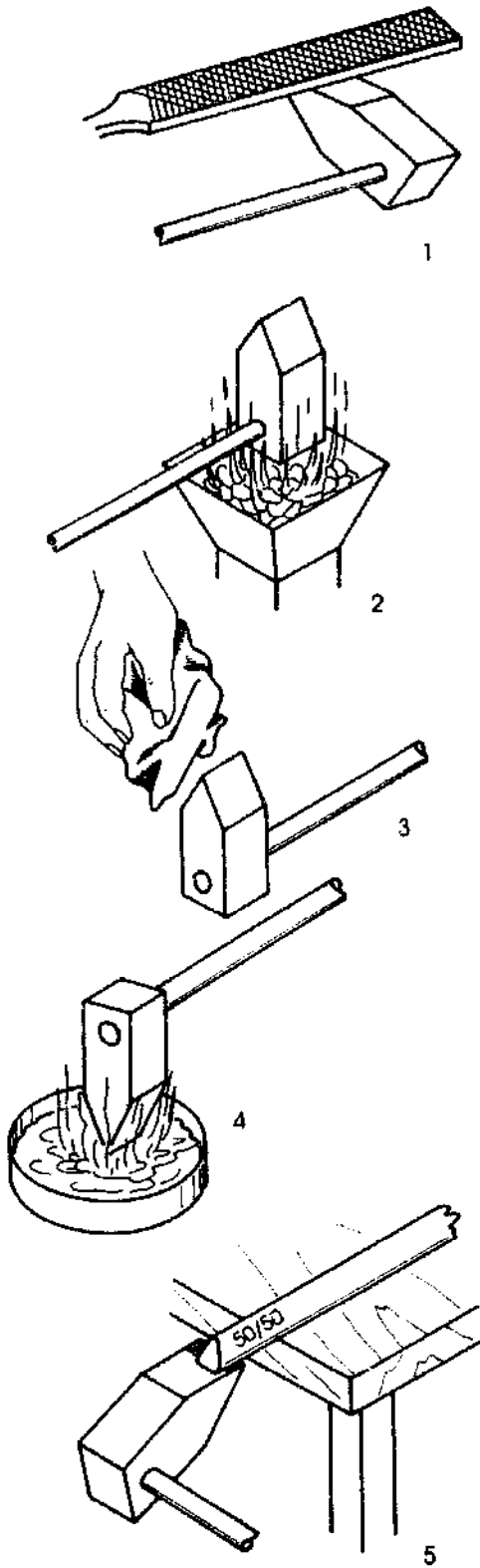

Soldering a lap joint

Apart from sweating a lap joint together, another way of soldering can be applied to join long lap joints together.

After cleaning the edges of the two pieces, apply flux to both sides of the metal pieces.

Line out the two pieces and tack them together, as shown in Fig. 1, at regular intervals.

After being tacked together, the lap joint can be soldered over its whole length.

While working, hold the soldering bit against the edge of the top piece and move it slowly in the direction of the arrow, see Fig. 2.

Hold the soldering rod against the side of the soldering bit. Because of the heat, the solder will become liquid and move down to the metal.

At regular intervals press the top of the joint with the soldering rod to press the sheet metal together. Hold the bar in this position until the solder between the joint is solid.

After finishing soldering, wash off all the dirt and especially the flux, to prevent corrosion, see Fig. 3.

Filling a round joint

Examples of circular joints are: the bottom of a drinking mug, a copper pipe in a fitting, a bushing over an axle, etc.

Such circular joints must be soldered together in such a way that the gap between the parts is filled with solder.

Fig. 4 shows the soldering of the bottom of a drinking mug. After cleaning, polishing and applying flux, assemble the parts.

While heating the metal with the soldering bit, hold the solder against the edge of the joint and it will melt and flow into the gap of the joint, see Fig. 5.

Wash away all flux when the joint is finished.

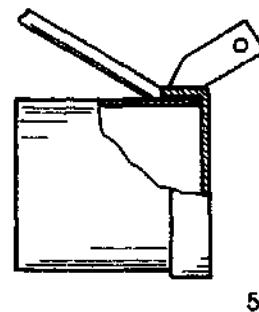
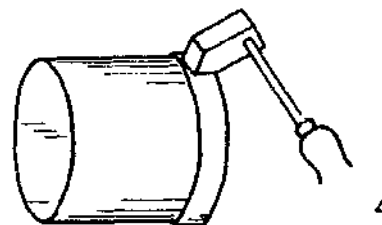
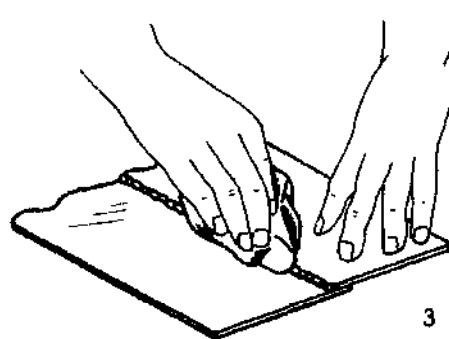
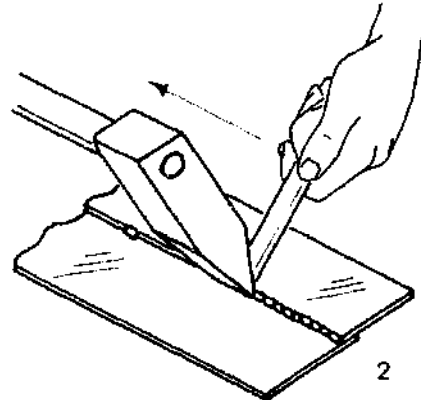
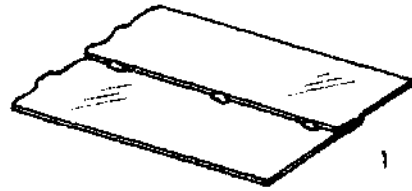

Sweating a lap joint

The best way to make a lap joint of sheet metal is to sweat the parts together with the aid of solder and a soldering bit.

The sequence of operations is:

- A - Clean the surfaces of the joint with a scraper or abrasive paper, see Fig. 1.
- B - With a brush, apply some flux on the surfaces of the joint, see Fig. 2.
- C - Take the soldering bit, which has already been heated and tinned. Melt some drops of solder on the bit, as shown in Fig. 3.
- D - Transfer the solder from the bit to the workpiece.
- E - Move the soldering bit slowly along the edges of the sheet metal and coat it with a thin layer of solder, see Fig. 4. Make sure the layer is very thin and there are no lumps of solder.
- F - Lightly flux the two tinned surfaces again.
- G - Place one tinned surface on the other. Move the hot soldering bit slowly over the joint, see Fig. 5. Make sure the iron is kept flat on the sheet metal while pressing it down.
- H - While soldering, press the two sheets together with a piece of wood until the solder is solid, see Fig. 5.
- I - Wash the workpiece thoroughly after finishing the work. All flux should be removed. Liquid flux in particular is very corrosive, it corrodes the metal and makes it black.

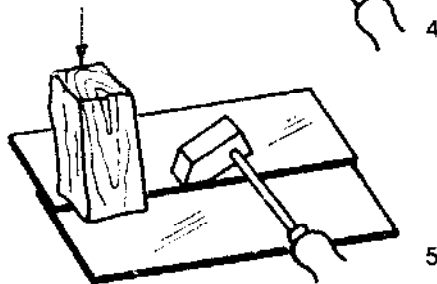
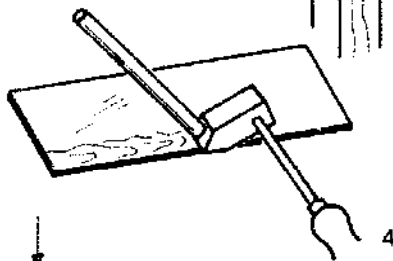
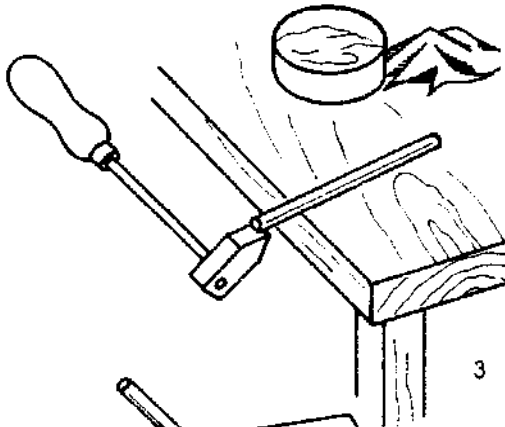
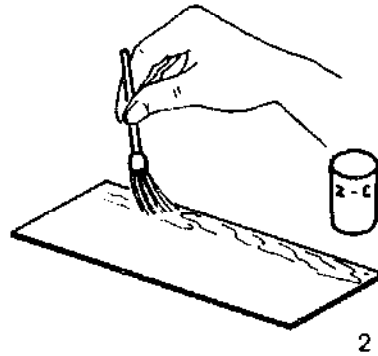
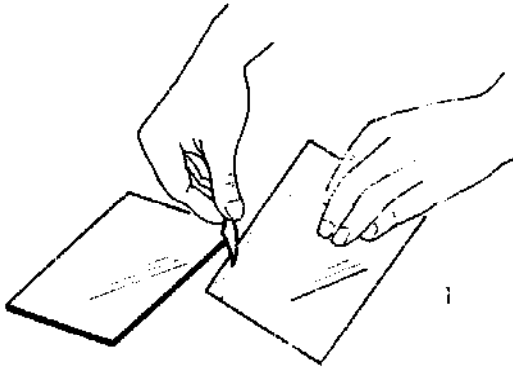

Repairing holes

Small holes can be filled with solder. Clean the metal on both sides of the hole. Apply some flux.

Take a soldering iron, put some solder on the point of the bit and slowly turn the point of the bit round in the hole.

Check whether the solder is spread on both sides of the hole. If not, you need to solder the other side as well.

Larger holes must be drilled out and closed with a rivet. To make it waterproof, some solder should be applied over the rivet on both sides.

Very large holes have to be patched. The patch can be sweated over the hole.

Repairing a cracked tube

A cracked oil or fuel tube can be repaired with a copper wire.

- A - Clean the tube, including the inside.
- B - Polish the outside of the crack.
- C - Apply some flux.
- D - Tin the tube all round where it is cracked.
- E - Put some more flux on the tinned tube.
- F - Apply some flux to the copper wire and solder it. Make sure the tube is hot enough to melt all solder.

WARNING:

When repairing containers, make sure the container is very clean on the inside. To avoid an explosion, fill the container with water before soldering or brazing.

Brazing (hard soldering)

Brazing is done with a blow lamp using gas and air. The brass solder to be used is an alloy of zinc and copper and melts at 800 to 1000° C. If you have no blow lamp but do have a gas welding set, you can use this for brazing. Borax is used as a flux during brazing. Brazing gives much stronger joints than soft soldering, but not as strong as welding. Brazing is especially useful for repairing pans, buckets, fuel tanks and tubes.

How to do brazing

- A - Polish the surface of the workpiece or file it bright.
- B - Make a thick paste of borax powder and water. Apply this flux to the workpiece.
- C - Play the flame over the work to keep it hot. The part to be brazed must be dark red in colour. Be careful not to melt the work or to burn holes in it.
- D - Hold the brass rod in the flame to heat it. Dip the rod quickly in the borax powder and bring it to the workpiece.
- E - On contact, the rod will melt and quickly run over the surface of the joint.

Small holes can be filled with brass. Larger holes have to be patched. If parts have to be joined, you clamp them together with wire to keep them in position during the work.

Silver soldering

Silver soldering is a hard soldering process which may be classified between soft soldering and brazing.

Silver solder is an alloy of silver, copper and zinc and melts at 700 to 800° C.

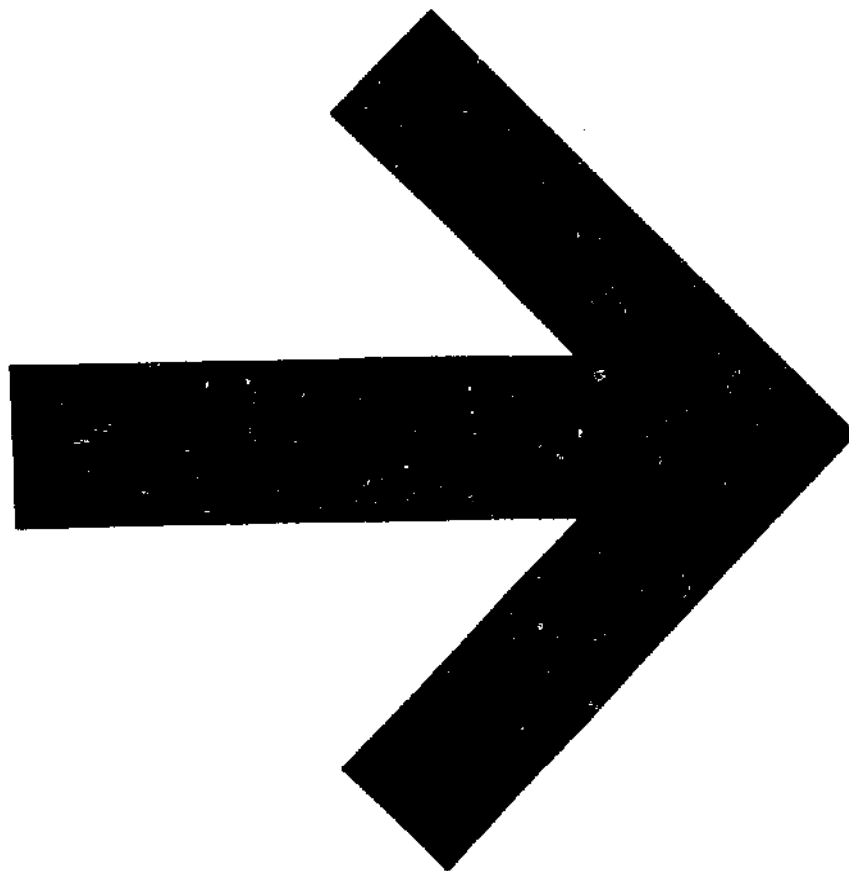

Contents

Rural Mechanics Course	
Preface	3
Introduction	3
Rural Mechanics Course	4
Lay out and timetable	5
Blacksmithing	6
Practical training, welding and soldering	7
Safety first	8
Forging tools	
Measuring and marking	9
The anvil	10
Blocks and vices	11
Tongs	12
Hand hammers	13
Striking with the hammer	14
Bench hammers	15
Striking with the sledge hammer	16
Forge	17
Blowers and bellows	18
Forging temperatures	
Fuels for forging	19
Forging temperatures for mild steel	20
Heating small workpieces	21
Forging and shaping	
Forging precautions	22
Shaping	
Alignment	23
Hammer action	24
Cutting hot metal	
Cutting hot metal	25
Cutting with a hot chisel	26
Cutting with a hardie	27
Cutting with the hardie and hot chisel	28
Squaring	
Squaring a round bar	29
Chamfering and tapering	
Chamfering the end of a square bar	30
Drawing down	
Drawing down round to square	31
Drawing down metal	32
Drawing down with bottom fuller	33
Drawing down a square bar	34
Necking in	35
Drawing down on swage block	36
Upsetting	
Pre-conditions for upsetting	37
Upsetting in the vice	38

Heading		Carriage bolt	82
Heading tool	39	Round bolt head with slot	83
Shaping a square head	40	Countersunk bolt	84
		Flat bolt head with slot	85
Punching		Cramps	86
Punching	41	Stormhook	87
		Electric arc welding	
Drifting		Electric arc welding	91
Drifting	42	Safety rules	92
		How to start an arc	93
Splitting metal		How to run a straight bead	94
Splitting metal	43	How to inspect a bead	95
		Electric arc	96
Twisting		Weaving motion	97
Twisting bars	44	Building up a pad	98
		Types of welding joints	99
Hot bending		Contraction/expansion	100
Hot bending metal	45	Single pass fillet weld	101
Stretched length	46	Appearance of fillet welds	102
Bending in the leg vice	47	Close square butt joint	103
Bending in the bench vice	48	'V' butt joint	104
Bending on the anvil face	49	Overhead welding	105
Making a sharp bend	50	Welding pipes	106
Bending on the round beak	51	Building up a worn shaft	107
Acute angle bend	52		
Bending offsets	53	Gas welding	
Making offsets	54	Gas welding	108
Half round offset	55	Gas welding equipment	109
Bending and forging an eye	56	Acetylene generator	110
Bending a ring	57	Acetylene generator continued	111
Bending and forging a small eye	58	Acetylene generator continued	112
Bending a bar edgewise	59	Safety rules	113
Rightangled bend in angle steel	60	Attaching regulators, hoses and torch	114
Bending an angle iron ring	61	Selecting a torch tip	115
Bending with the bending fork	62	Lighting the torch	116
		Types of flames	117
Forge welding		Backfires	118
Forge welding	63	Trouble shooting	119
Formation of scale	64	How to weld joints without a filler rod	120
		Carrying a puddle without a filler rod	121
Cold bending		The filler rod	122
Cold-bending metal	65	Welding with filler rod	123
Exercises	66	Various types of welds	124
		Welding characteristics	125
Hot riveting		Welding positions	126
Rivet and riveting tools	67	Welding procedure	127
Round head rivet	68	Torch and rod position	128
		Welding a pipe	129
Metallurgy		Welding cast iron	130
Metallurgy for blacksmithing	71		
Tempering	72	Soldering	
Tempering and forging colours chart	73	Soldering	133
Tempering continued	74	Blow lamp	134
		Solder	135
Exercises		General soldering rules	136
Making a knife blade	77	Soldering a lap joint	137
Mason's trowel & Hammer head	78	Sweating a lap joint	138
Spade & Garden tool	79	Repairing holes	139
Mason's hammer & Pick axe	80		
Blacksmith's tongs & Cold chisel	81		