

# **AT** MICROFICHE REFERENCE LIBRARY

A project of Volunteers in Asia

## A Blacksmith's Bellows

by: A. Inversin and D. Sanguine

Published by:

South Pacific Appropriate Technology  
Foundation  
P.O. Box 6937  
Boroko  
National Capital District  
Papua New Guinea

Paper copies are \$ 2.30 in the South Pacific,  
\$ 3.50 in Asia, Africa or Latin America, and \$5.00  
in Australia, Europe or North America.

Available from:

South Pacific Appropriate Technology  
Foundation  
P.O. Box 6937  
Boroko  
National Capital District  
Papua New Guinea

Reproduced by permission of the South Pacific  
Appropriate Technology Foundation.

Reproduction of this microfiche document in any  
form is subject to the same restrictions as those  
of the original document.



# A BLACKSMITH'S BELLOWS

DESIGNED BY  
A.R. INVER SIN

UNIVERSITY OF TECHNOLOGY  
LAE, PAPUA NEW GUINEA

DECEMBER 1977

SOUTH PACIFIC  
APPROPRIATE TECHNOLOGY  
FOUNDATION

THE PRINTING OF THIS BOOKLET WAS FUNDED BY A GRANT FROM THE  
NEW ZEALAND GOVERNMENT.

FOR FURTHER INFORMATION REGARDING THIS AND OTHER S.P.A.T.F. PUBLICATIONS,  
CONTACT:

SOUTH PACIFIC APPROPRIATE TECHNOLOGY FOUNDATION,  
P.O. BOX 6937,  
BOROKO,  
PAPUA NEW GUINEA  
PHONE 212499

S.P.A.T.F. is a project of the Office of Village Development.

# **A BLACKSMITH'S BELLOWS**

**Designed by A.R. INVER SIN**

**UNIVERSITY OF TECHNOLOGY**

**LAE, PAPUA NEW GUINEA**

**Drawings by DAVID SANGWINE**

**Published by the South Pacific Appropriate Technology Foundation**

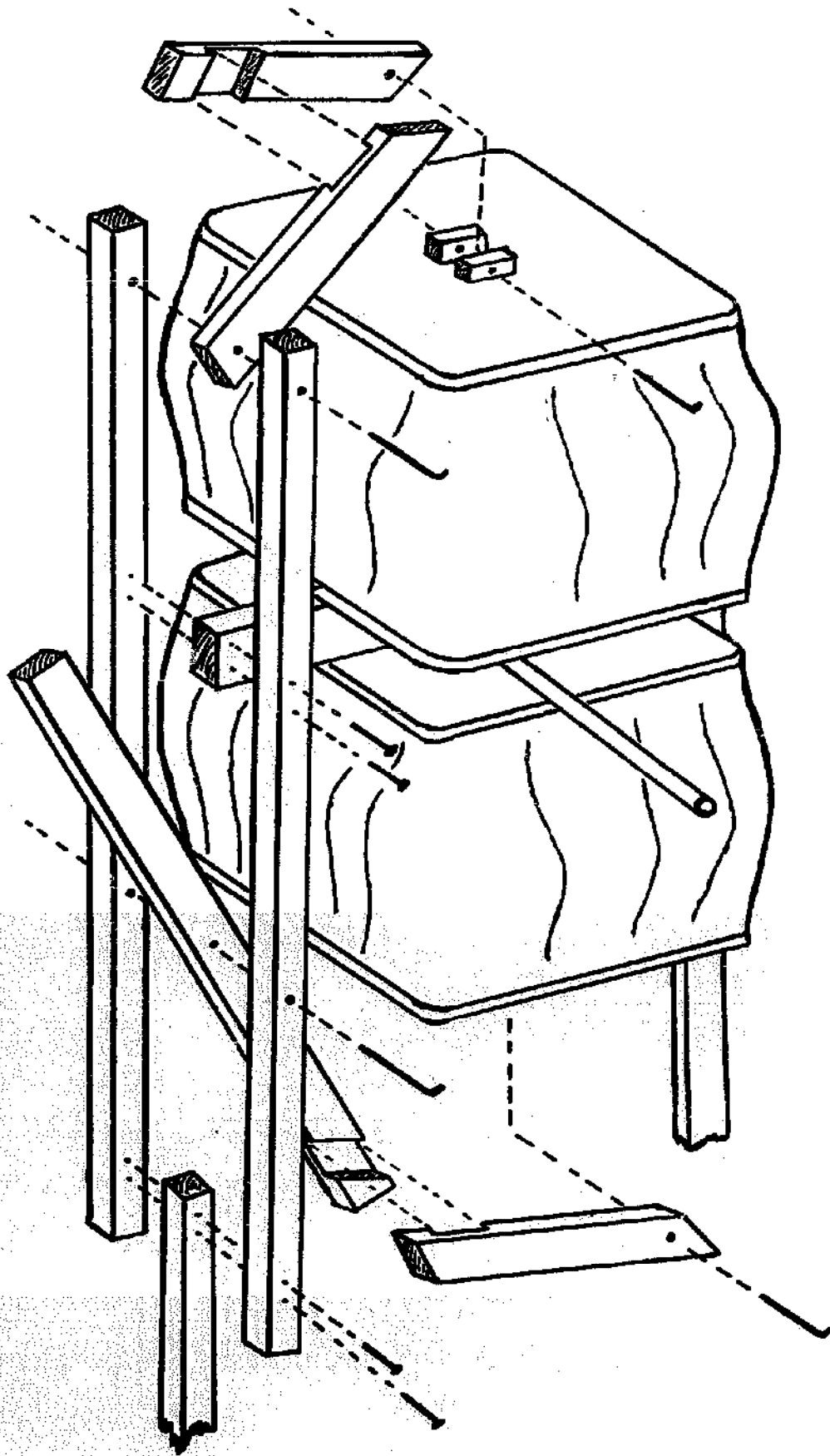

# TOOLS

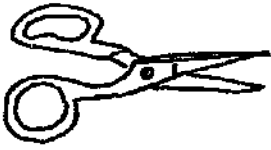

SCISSORS



HAMMER



TAPE MEASURE

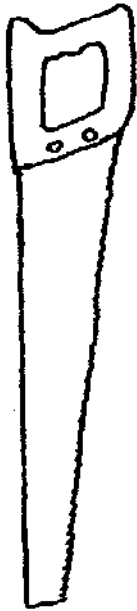

SAW



METAL FILE

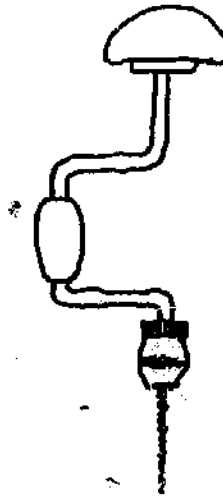

DRILL WITH  
6 mm. (1/4 in.) BIT



TIN SNIPS



CHISEL

# MATERIALS

2 INNER TUBES  
FROM NORMAL SIZE CAR TYRES  
(GOOD CONDITION)

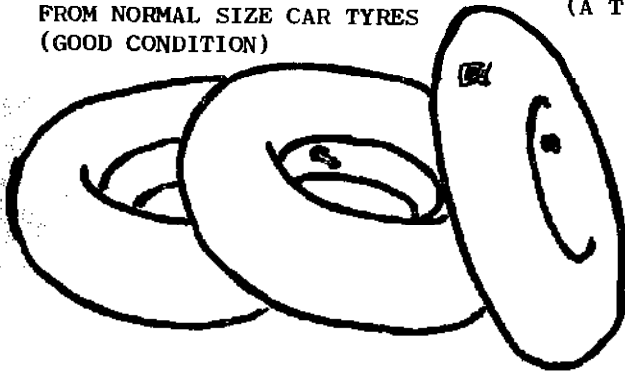

1 INNER TUBE FOR CUTTING  
(A TRUCK TUBE IS GOOD)

PLYWOOD ABOUT 12 mm. (½ in.) THICK  
1 METRE x 1 METRE (4 ft. x 4 ft.)

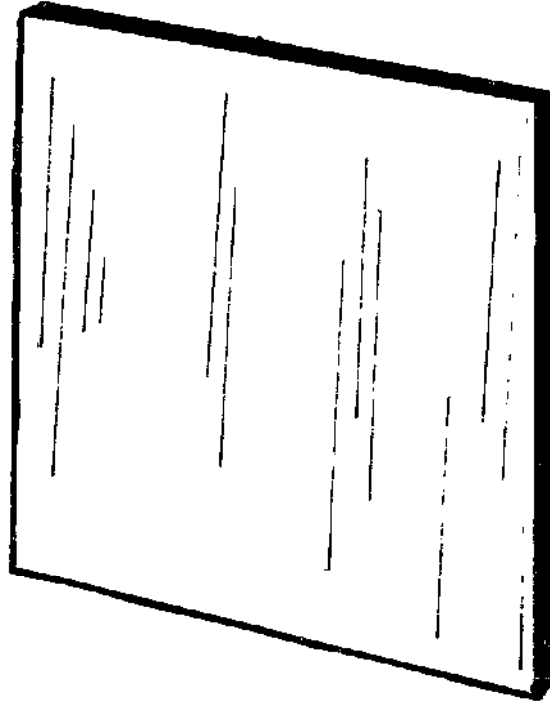

PIECES OF WOOD ABOUT 5 cm. (2 in.) WIDE  
AND 2 cm. (1 in.) THICK  
ENOUGH TO MAKE ABOUT 6 METRES (20 ft.)

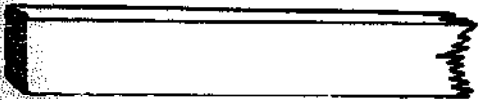

ABOUT 40 4 cm. (1½ in.) NAILS



ABOUT 200 2 cm. (¾ in.) NAILS

2 cm. (¾ in.) STEEL PIPE  
ABOUT 60 cm. (2 ft.) LONG



PIECES OF THIN  
SHEET METAL

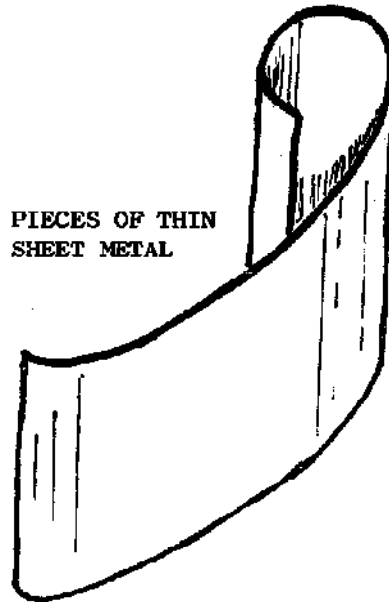

6 mm. (¼ in.) METAL ROD  
4 PIECES EACH ABOUT 10 cm. (4 in.) LONG



# BUILDING THE BELLOWS

1

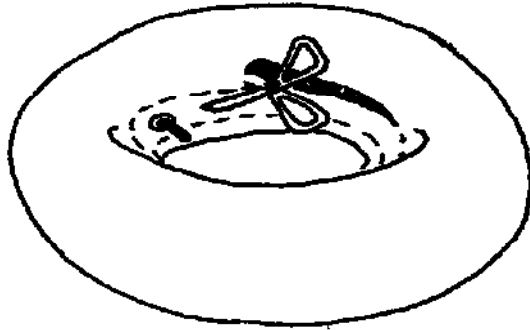

CUT A STRIP FROM  
2 OLD CAR INNER TUBES.

2

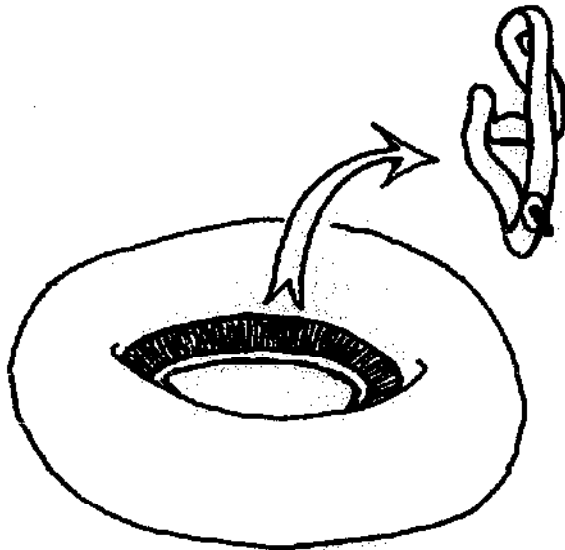

THROW AWAY THE STRIPS.



3

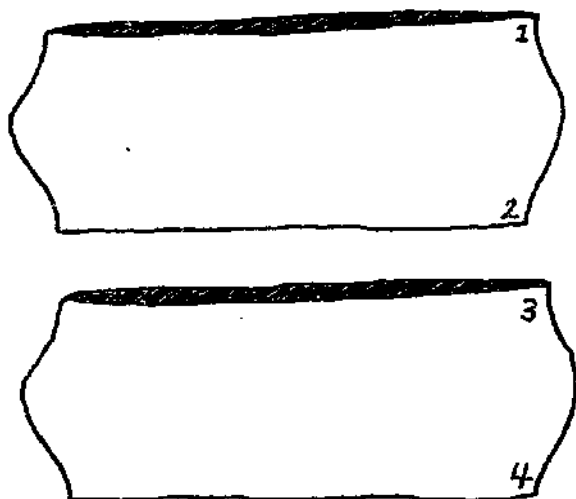

OPEN OUT THE TUBES LIKE THIS.

NUMBER EACH OPENING.

4

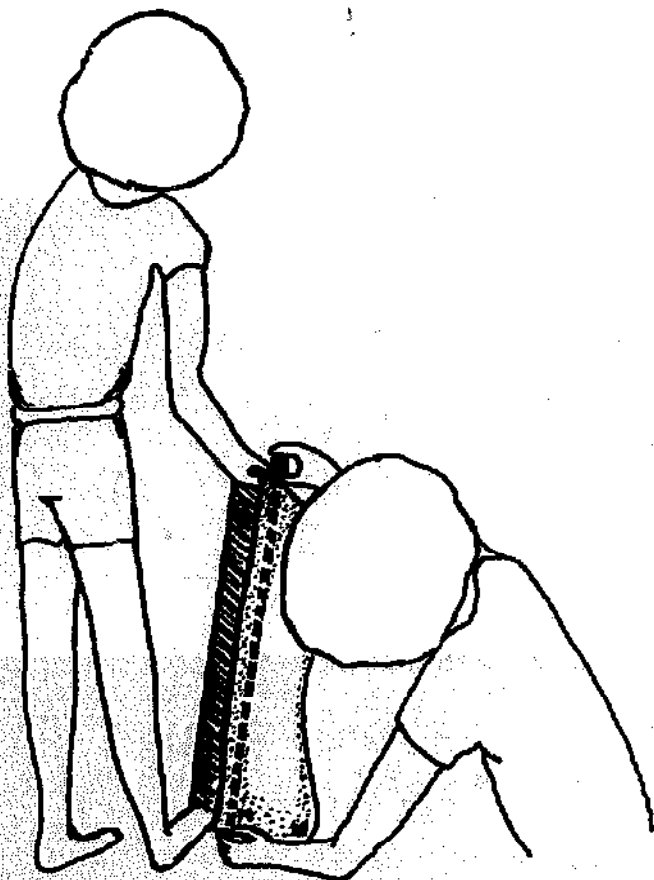

FULL OPENING NUMBER 1 TIGHTLY  
AND MEASURE ONE SIDE.

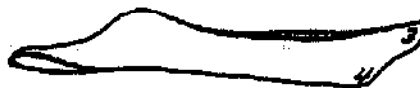

5

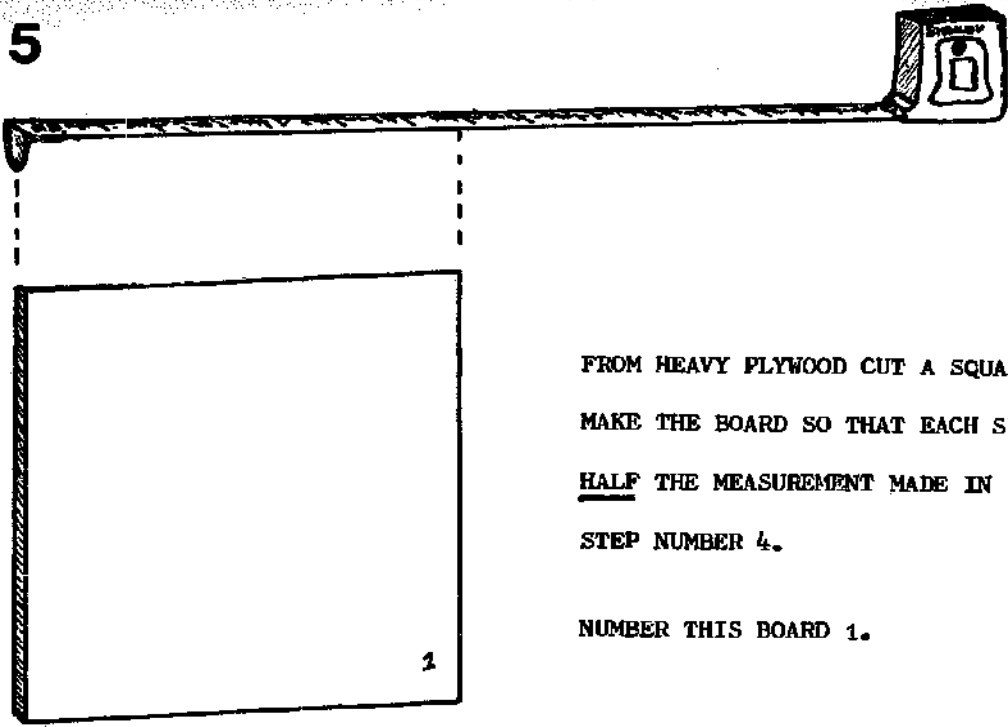

FROM HEAVY PLYWOOD CUT A SQUARE BOARD.  
MAKE THE BOARD SO THAT EACH SIDE IS  
HALF THE MEASUREMENT MADE IN  
STEP NUMBER 4.

NUMBER THIS BOARD 1.

6

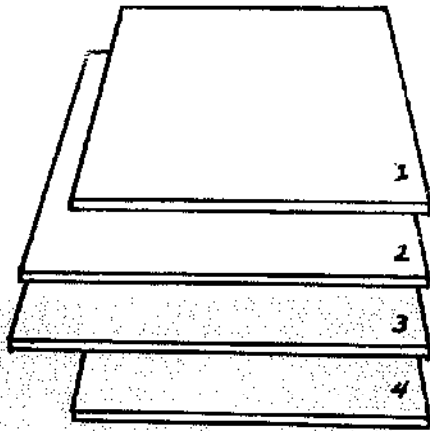

CUT 3 MORE BOARDS IN THE SAME WAY  
FOR OPENINGS NUMBER 2, 3 AND 4.

NUMBER EACH BOARD.

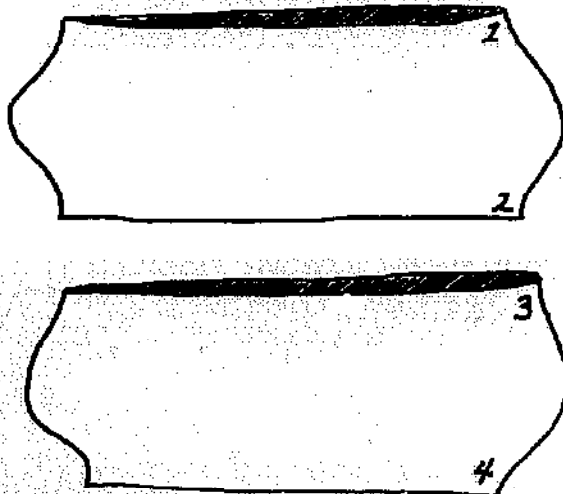

7

MAKE THE CORNERS ROUND.

DON'T CUT OFF TOO MUCH.

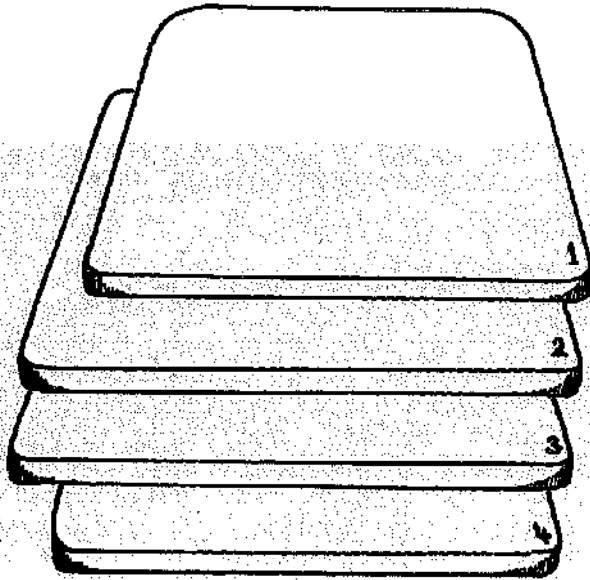
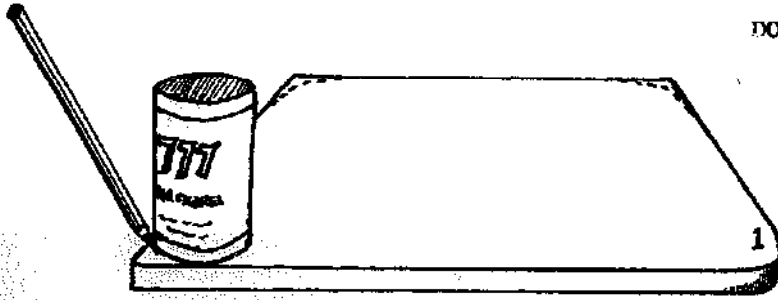

8

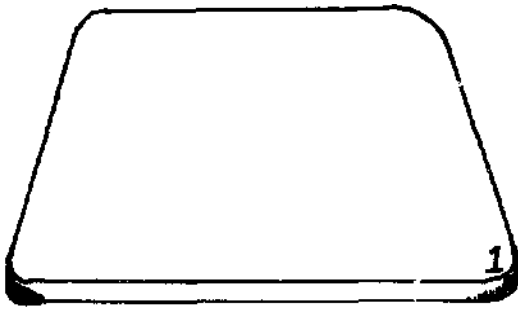

NO HOLES

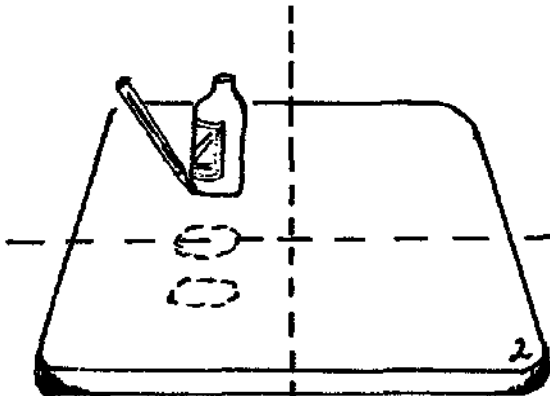

2 OR 3 HOLES

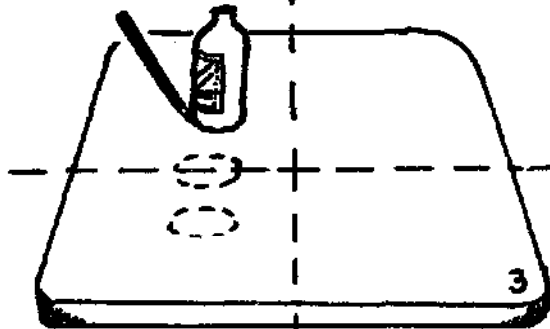

3 HOLES

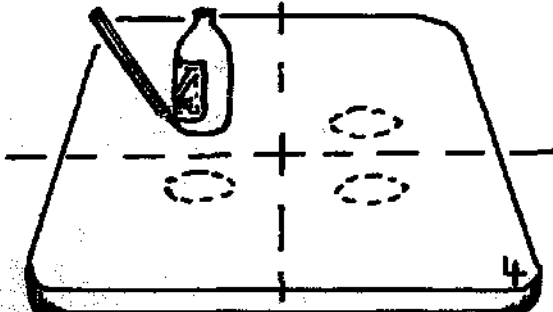

4 HOLES

IN BOARDS NUMBER 2, 3 and 4,  
CUT 5 cm. (2 in.) HOLES  
FOR THE AIR TO PASS THROUGH.

9

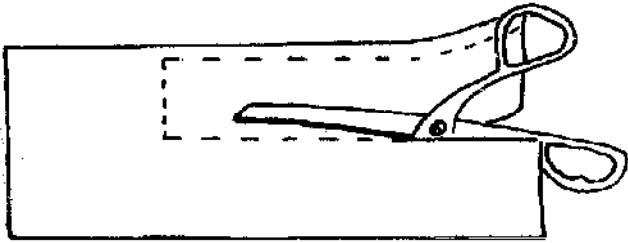

CUT 3 PIECES OF HEAVY RUBBER  
TO MAKE FLAPS.  
MAKE THEM BIG ENOUGH  
TO COVER THE HOLES  
AS SHOWN IN STEP NUMBER 10.

10

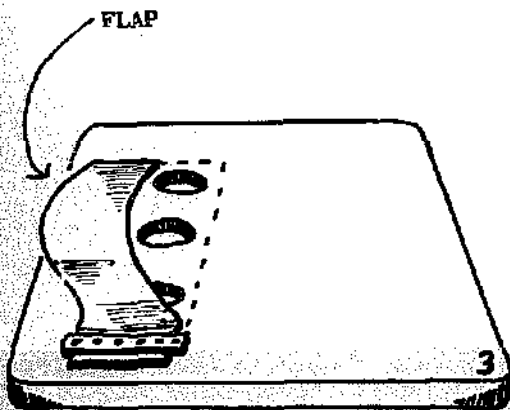

USE A STRIP OF SHEET METAL  
TO NAIL THE RUBBER FLAPS OVER THE HOLES  
IN BOARDS NUMBER 3 AND 4.

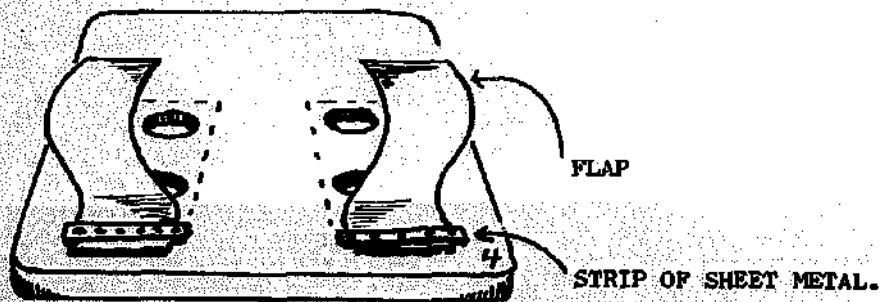

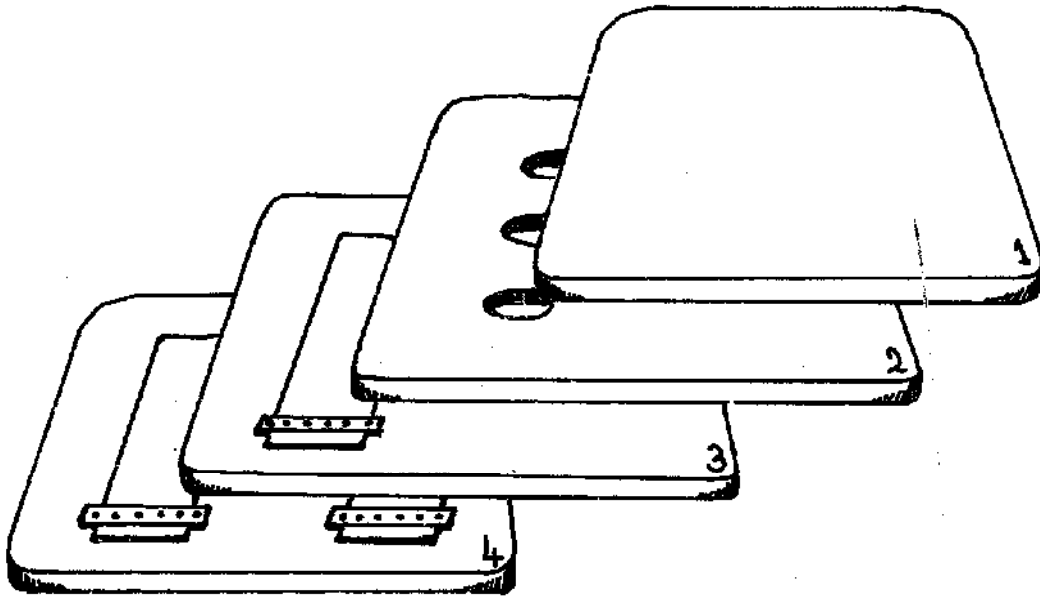

NOW THE BOARDS SHOULD LOOK LIKE THIS.

11

CUT 4 PIECES FROM THE 5 cm. x 2 cm. WOOD.

CUT THEM SO THEY WILL MAKE A BOX  
LIKE THIS TO FIT AROUND THE FLAP  
ON BOARD NUMBER 3.

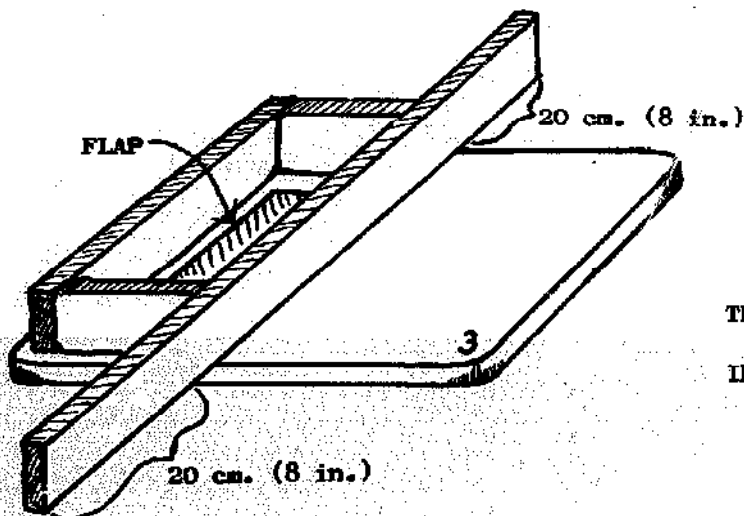

THE LONG PIECE WILL GO  
IN THE MIDDLE OF THIS BOARD.

12

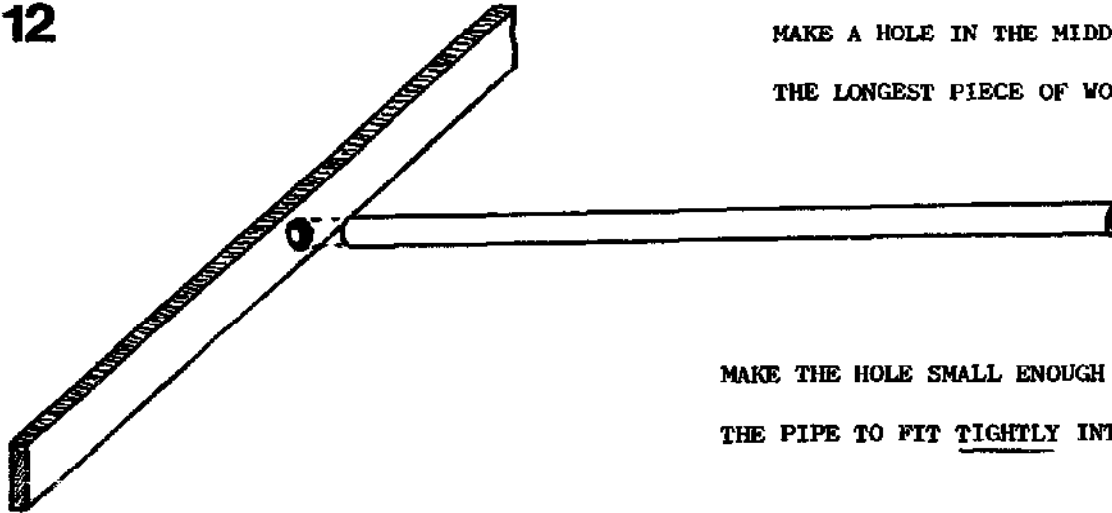

MAKE A HOLE IN THE MIDDLE OF  
THE LONGEST PIECE OF WOOD.

MAKE THE HOLE SMALL ENOUGH FOR  
THE PIPE TO FIT TIGHTLY INTO IT.

13

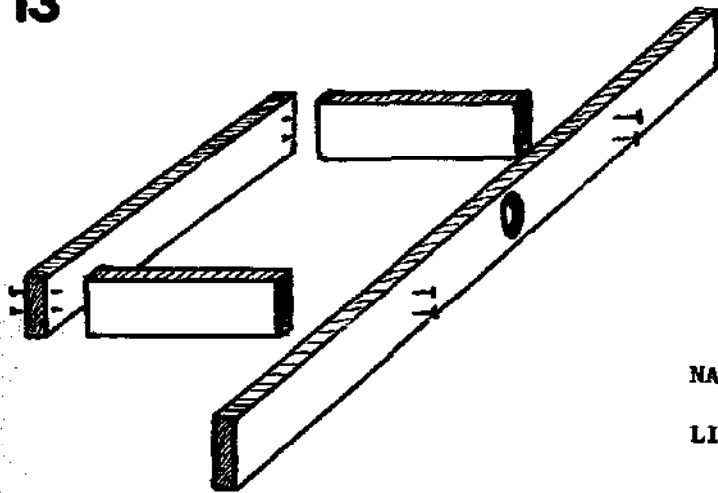

NAIL THE 4 PIECES OF WOOD TOGETHER  
LIKE THIS.

14

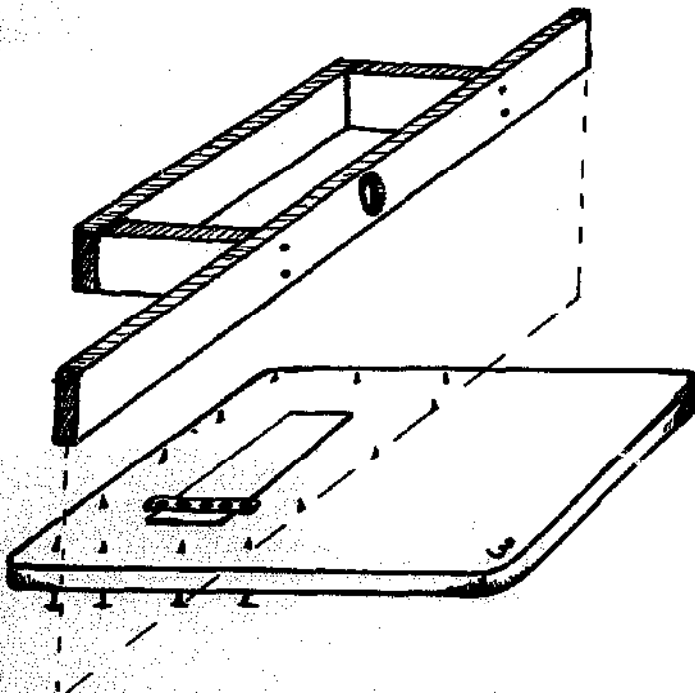

NAIL THE BOX  
TO BOARD NUMBER 3.

15

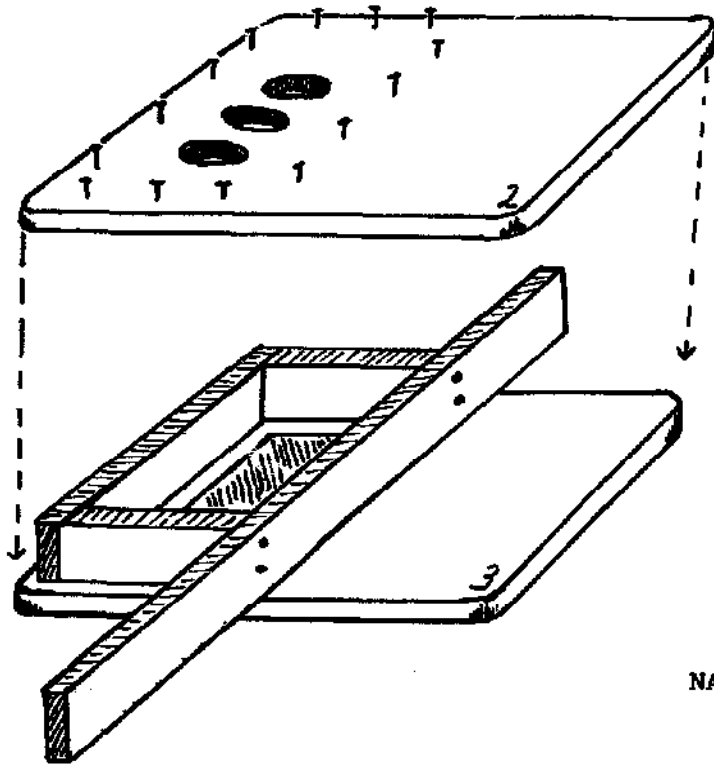

NAIL BOARD NUMBER 2 OVER THE BOX.

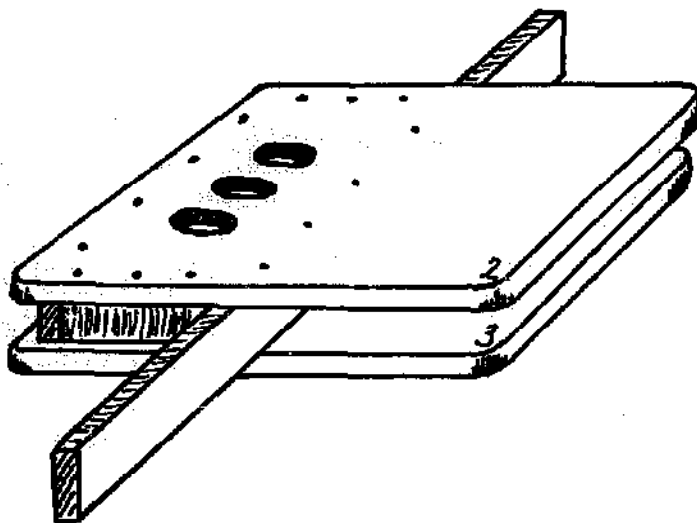

NOW IT LOOKS LIKE THIS.

THIS BOX SHOULD BE WELL MADE  
WITH AIR-TIGHT JOINS.

USE CARPENTER'S GLUE OR  
GUM FROM THE BUSH.



16

CUT 4 SMALL PIECES FROM THE  
5 cm. x 2 cm. WOOD.

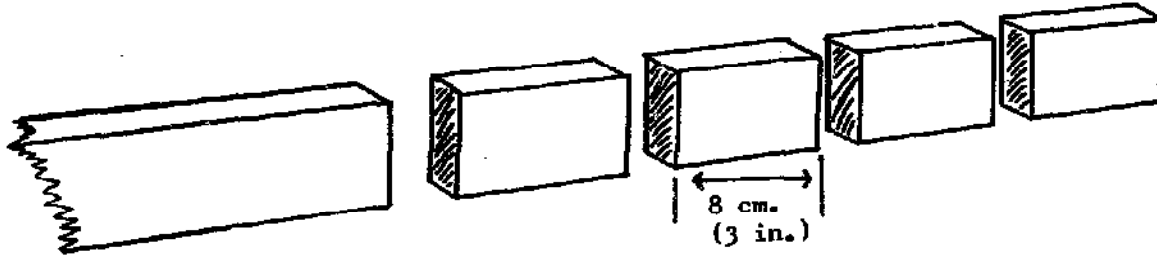

EACH PIECE SHOULD BE ABOUT 8 cm. (3 in.) LONG.

17

DRILL A HOLE THROUGH  
THE CENTRE OF EACH PIECE.

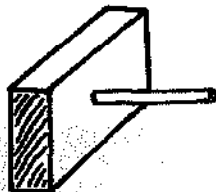
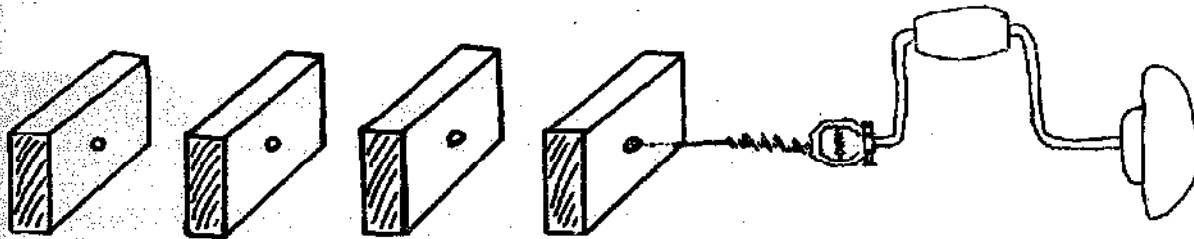

MAKE THE HOLE BIG ENOUGH  
FOR ONE OF THE METAL RODS.

18

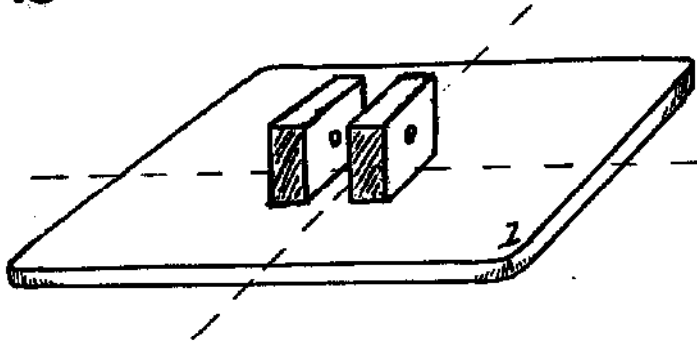

NAIL 2 OF THE PIECES  
TO BOARD NUMBER 1.

PUT THEM IN THE MIDDLE  
OF THE BOARD.

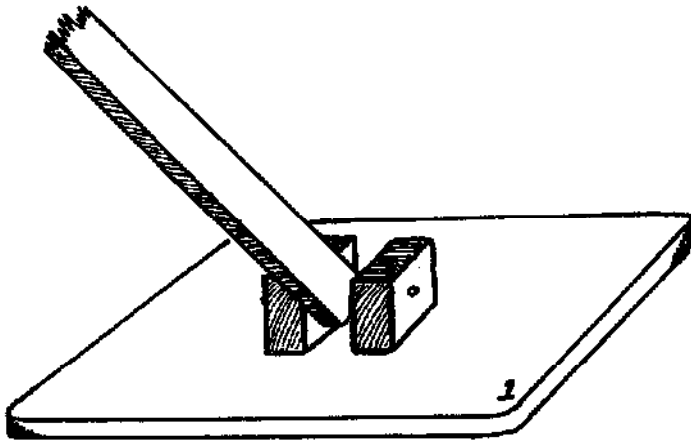

PUT THEM FAR ENOUGH APART  
THAT A PIECE OF  
THE 5 cm. x 2 cm. WOOD  
WILL FIT LOOSELY BETWEEN THEM.

19

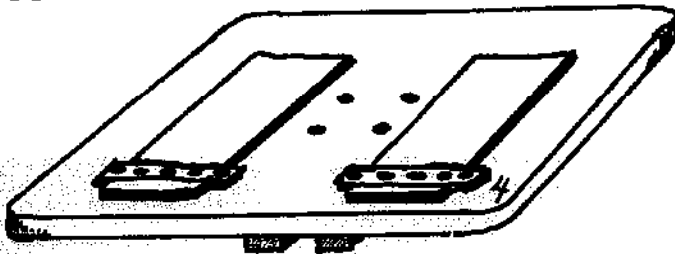

NAIL THE OTHER 2 PIECES TO BOARD  
NUMBER 4 IN THE SAME WAY.

PUT THEM IN THE MIDDLE  
OF THE BOARD,  
ON THE SIDE WITHOUT FLAPS.

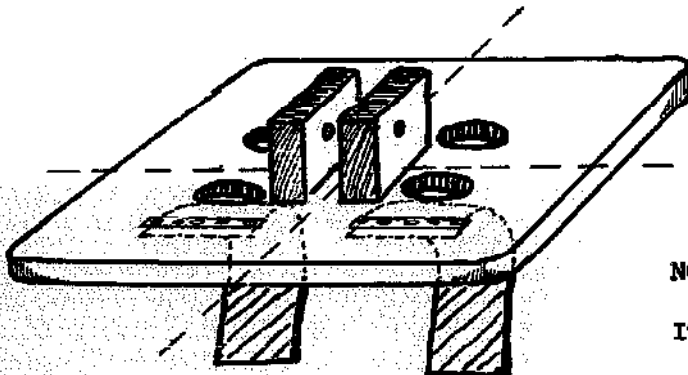

NOW IF YOU TURN OVER BOARD NUMBER 4  
IT WILL LOOK LIKE THIS.

20

CUT THIN STRIPS OF SHEET METAL.

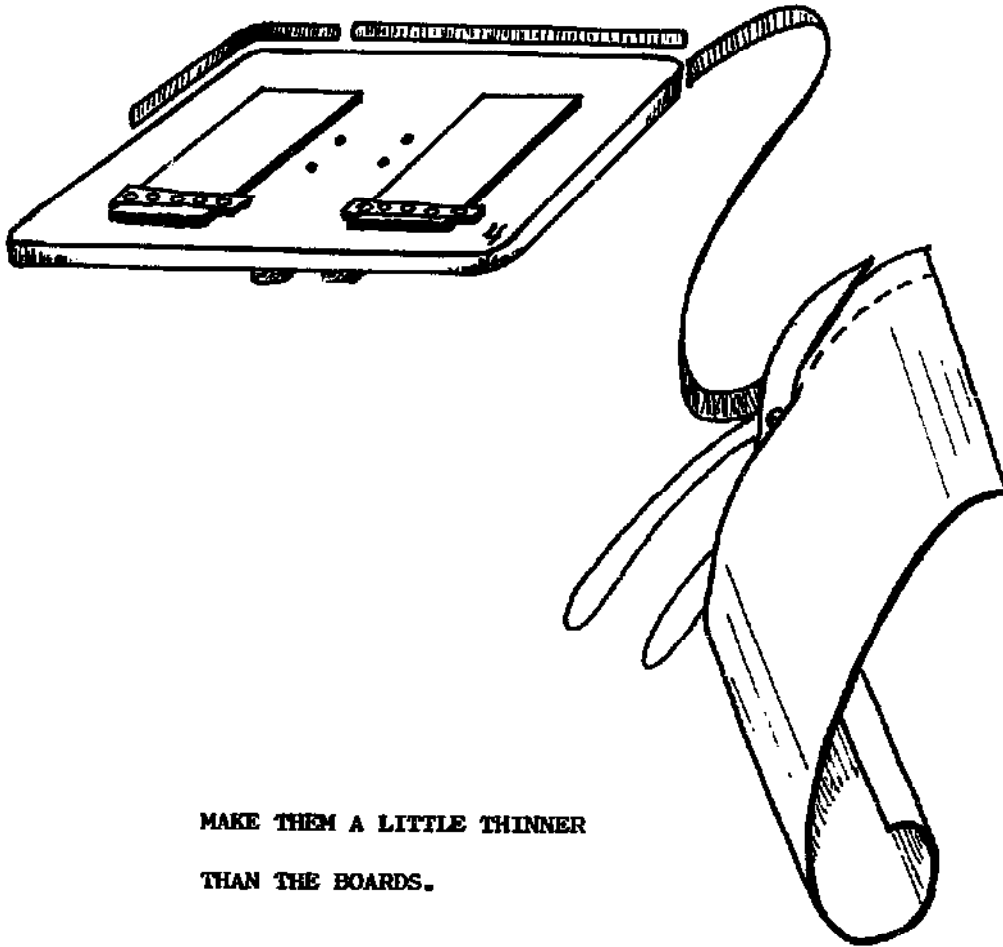

MAKE THEM A LITTLE THINNER  
THAN THE BOARDS.

CUT ENOUGH PIECES TO GO  
ALL AROUND THE BOARDS.

21

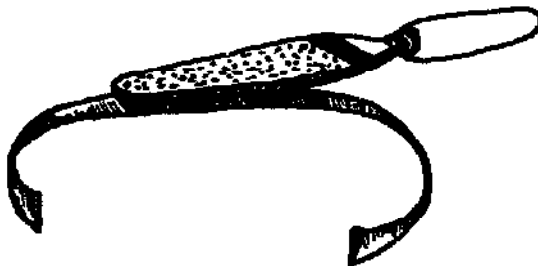

FILE OFF THE SHARP EDGES.

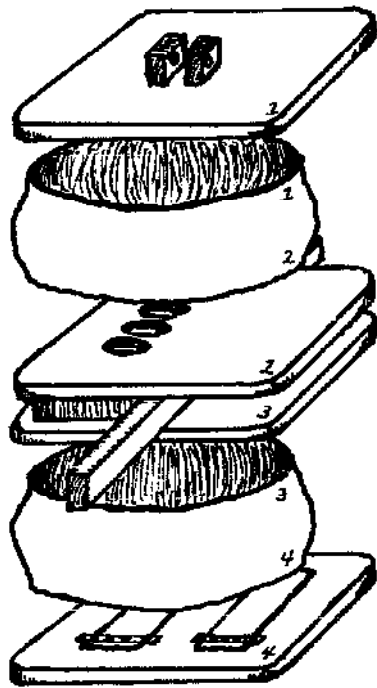

THE PIECES YOU HAVE MADE  
WILL GO TOGETHER LIKE THIS.

22

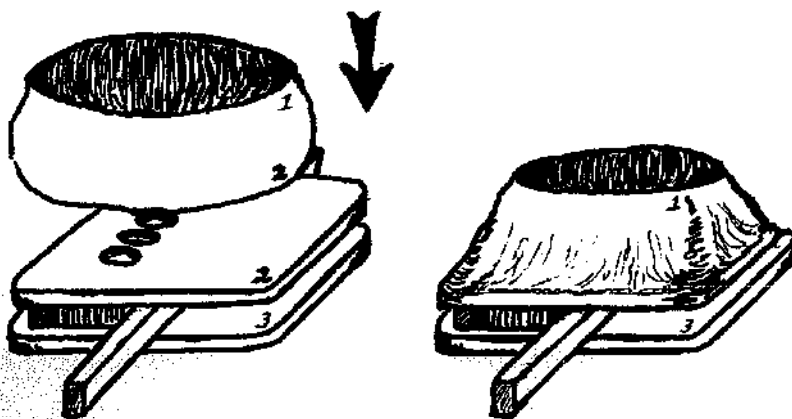

PUT TUBE OPENING NUMBER 2  
OVER BOARD NUMBER 2.

23

USE SHORT NAILS TO NAIL STRIPS OF SHEET METAL  
AND THE TUBE TO THE BOARD.

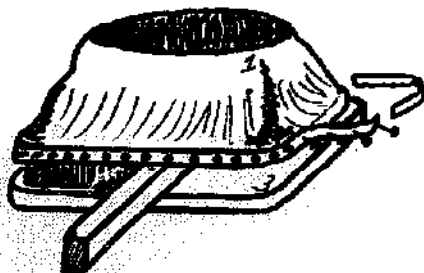

PUT THE NAILS CLOSE TOGETHER --  
3 cm. (1 in.) APART.

THE STRIPS OF METAL MUST NOT  
GO OVER THE EDGES OF THE BOARD  
AND CUT INTO THE TUBE.

24

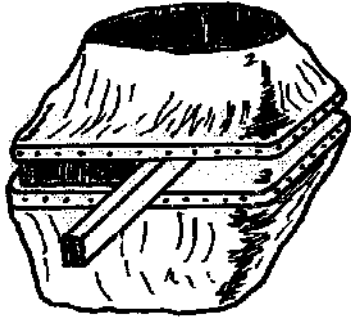

NAIL OPENING NUMBER 3 TO BOARD NUMBER 3  
IN THE SAME WAY.

25

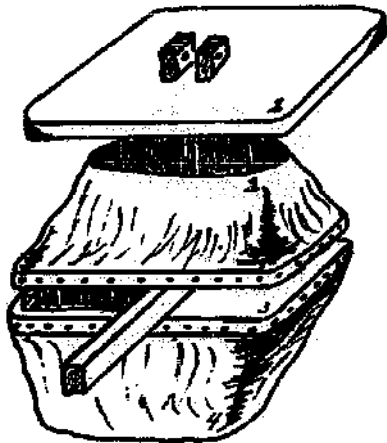

FIT BOARD NUMBER 1  
INTO OPENING NUMBER 1.

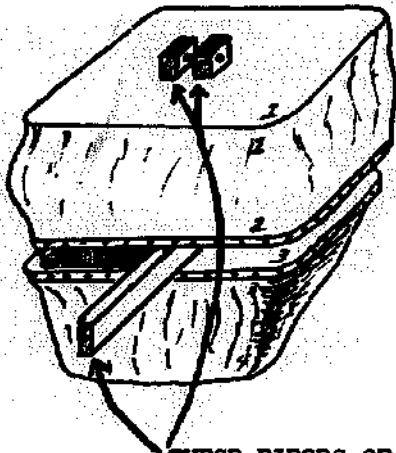

THE SIDES OF BOARD NUMBER 1  
MUST BE PARALLEL TO THE SIDES OF  
BOARDS NUMBER 2 AND 3.

THESE PIECES OF WOOD  
POINT IN THE SAME DIRECTION.

26

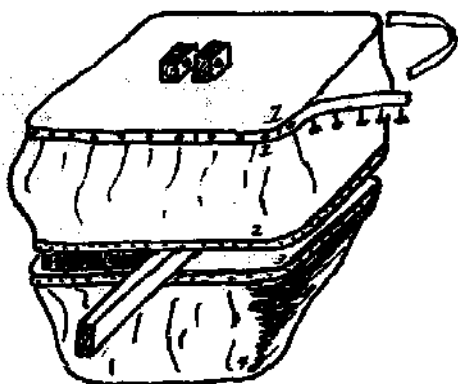

AGAIN USE STRIPS OF METAL  
TO NAIL THE TUBE TO THE BOARD.

27

NAIL OPENING NUMBER 4 TO BOARD NUMBER 4  
IN THE SAME WAY.

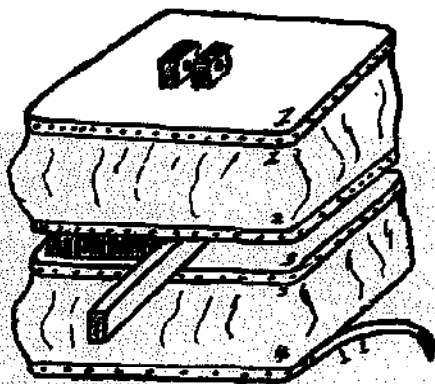

THE SIDES OF BOARD NUMBER 4  
MUST ALSO BE PARALLEL TO THE  
SIDES OF BOARDS NUMBER 2 AND 3.

BE SURE THE FLAPS ARE INSIDE THE TUBE.

28

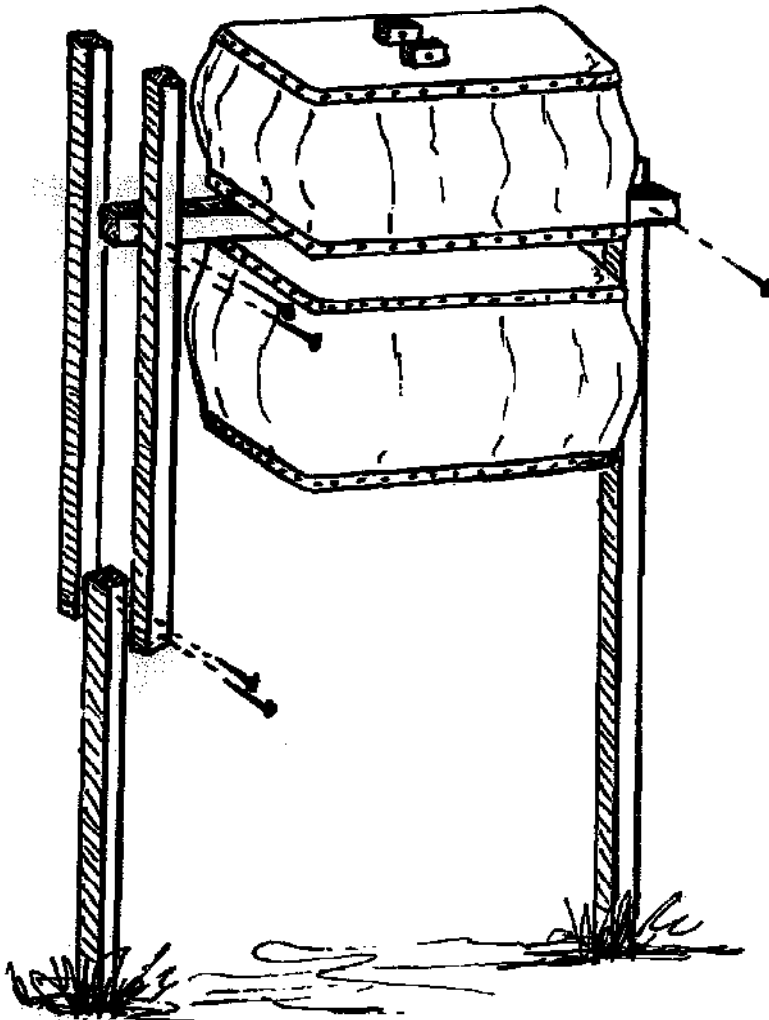

FROM THE REST OF  
THE 5 cm. x 2 cm. WOOD  
CUT PIECES  
TO MAKE SUPPORTS.

29

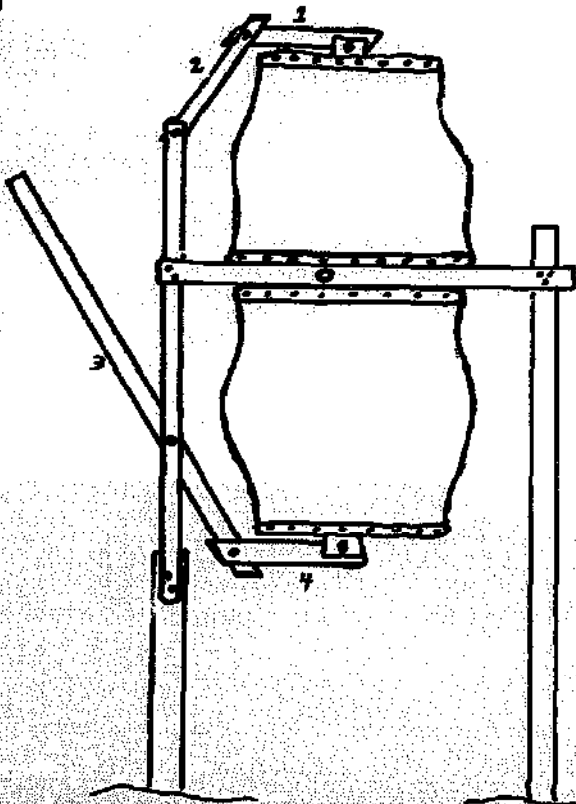

CUT 4 MORE PIECES OF WOOD  
TO MAKE ARMS.  
MAKE THEM LONG ENOUGH SO THEY FIT  
ONTO THE BELLOWS AS SHOWN.

DRILL HOLES IN THE SUPPORTS  
AND ARMS WHERE SHOWN.

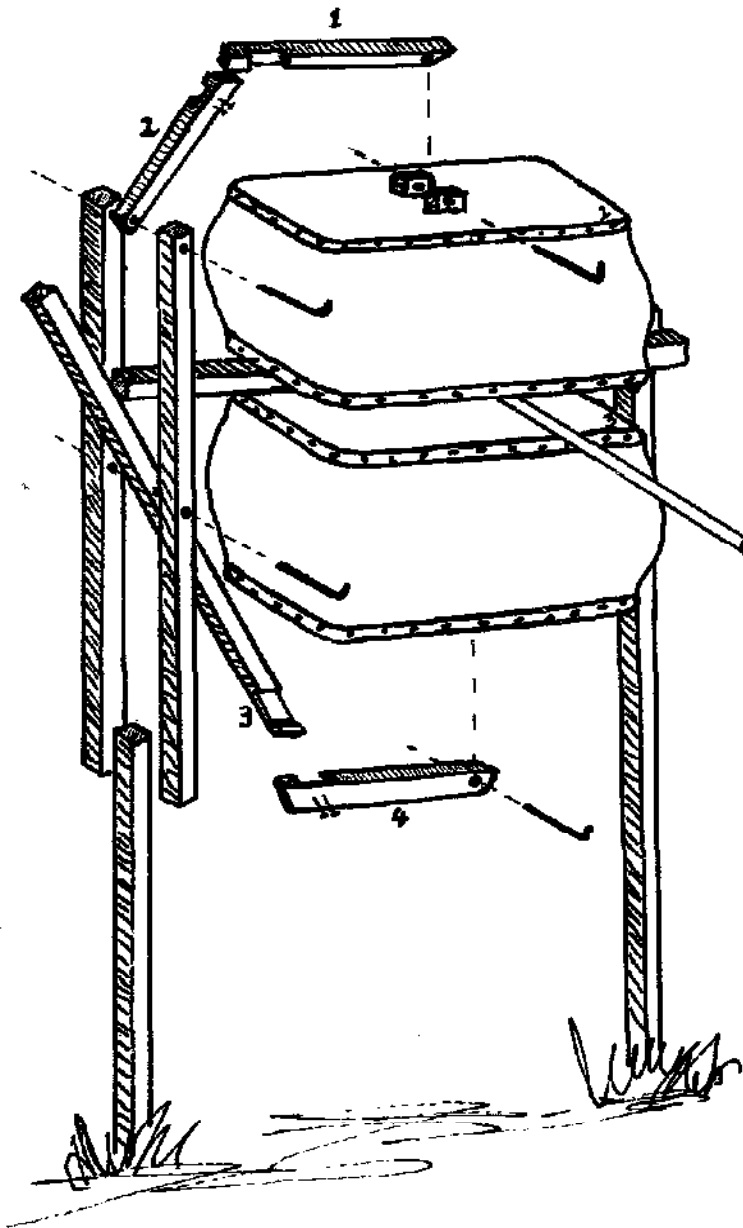

NAIL TOGETHER ARMS 1 AND 2.

NAIL TOGETHER ARMS 3 AND 4.

PUT THE ARMS IN PLACE  
AND PUT THE METAL RODS  
THROUGH THE DRILLED HOLES.

MAKE SURE THE ARMS MOVE FREELY.

FIT THE PIPE INTO THE HOLE  
MADE IN STEP NUMBER 12.



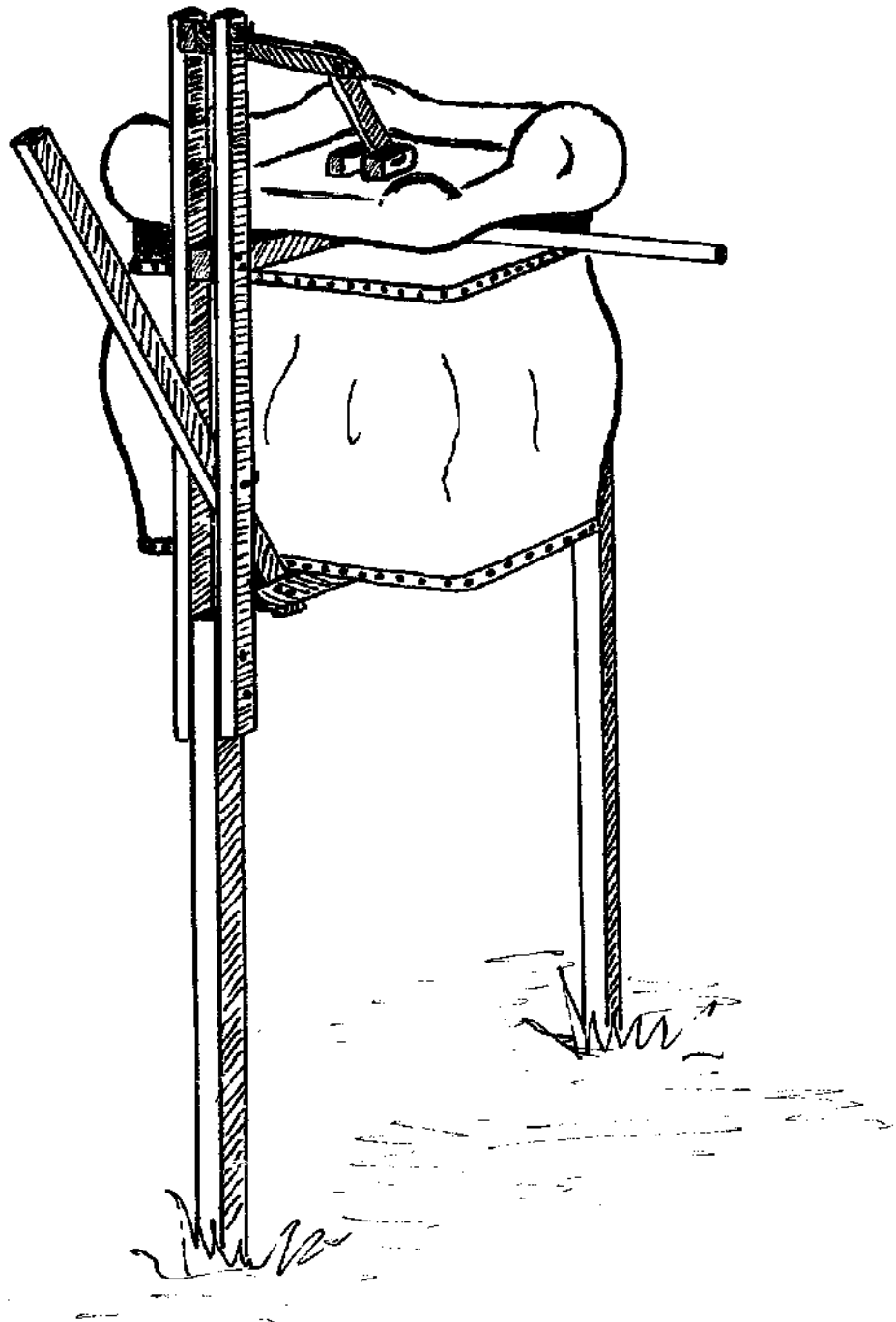

THE FINISHED BELLOWS LOOK LIKE THIS.

# HOW IT WORKS



AIR MOVES THROUGH THE HOLE  
IN ONE DIRECTION.

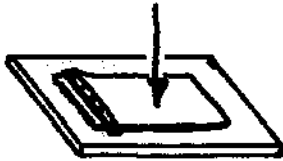

THE FLAP STOPS THE AIR  
FROM MOVING BACK  
IN THE OTHER DIRECTION.

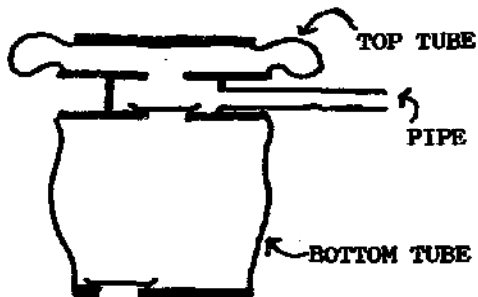

WHEN YOU START TO USE THE BELLOWS,  
THE TOP TUBE HAS NO AIR IN IT.  
THE BOTTOM TUBE IS FULL OF AIR.

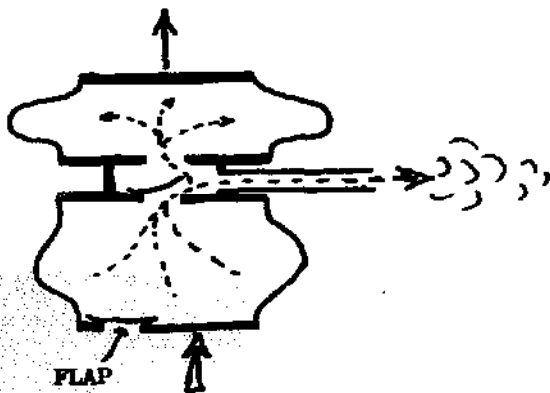

THE HANDLE PUSHES UP THE BOTTOM TUBE.  
THIS FORCES AIR OUT THROUGH THE PIPE,  
AND INTO THE TOP TUBE.  
THE BOTTOM FLAP STOPS THE AIR  
FROM GOING OUT THROUGH THE HOLE  
IN THE BOTTOM BOARD.

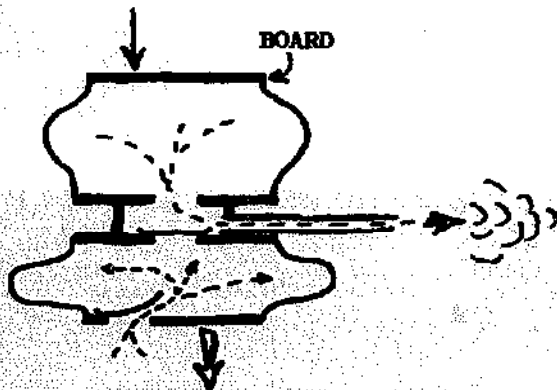

THEN THE BOTTOM TUBE FALLS DOWN AGAIN.  
THIS SUCKS AIR BACK INTO THE  
BOTTOM TUBE THROUGH THE HOLE.  
AT THE SAME TIME, THE AIR  
IN THE TOP TUBE IS BEING FORCED OUT  
THROUGH THE PIPE BY THE WEIGHT OF  
THE BOARD ON TOP.

SO THERE IS ALWAYS AIR  
COMING OUT THROUGH THE PIPE.