

**Compendium In
The Integrated
Farming System**

Compendium In The Integrated Farming System

**Selected & Edited by John Furze 1996/97/98/02
Holme Bygade 12, 8400 Ebeltoft Denmark
Tel/Fax/Voice: + 45 86 10 07 86
E-mail: <furze@post.tele.dk>
Aarhus University Faculty of Political Science,
Law & Economics**

NB:

It should be noted that this Compendium is for the express use of students, workers, research and production engineers and technicians, and for political decision-makers at all levels - concerned with development of production capability.

It does not intend nor imply any infringement of any of the copyrights of any of the authors quoted.

Indeed, this Compendium is intended and presented in grateful thanks, and to perhaps bring these authors to a wider public.

Integrated Farming System: Vol. I: J. Furze [ed.] 1996/97/98.

- Page 11:** Presentation at International Permaculture Conference.
Chan. Copenhagen Denmark August 1993.
- 19:** Dyke Pond Concept.
Korn. DPS - DTU / Asian Institute of Technology - Bangkok. 1996.
- 27:** HaNoi System for Waste Water Treatment. AIT / Viet Nam.
- 33:** Project Proposal for Cuba.
Chan. Biomass Energy Conference, - Havana January 1995.
- 40:** Project Proposal for Brewery in Fiji.
Chan. May 1995.
- 44:** Integrated Farming Project in Viet Nam.
Chan. 1995.
- 56:** Integrated Farming Project in P.R. China.
Zhong, Chan, Furtado, Ruddle. 1986.
- 107:** Energy Efficiency of the Integrated Farming System.
Chan. 1988.
- 136:** Dike Pond System & Case Study in P.R. China.
Chan. 1986.
- 169:** The Mulberry Dike Carp Pond System of Pearl River Delta.
Ruddle, Furtado, Zhong, Deng. 1983.
- 186:** Energy Exchange.
Ruddle, Deng, Liang. 1983.
- 207:** Seminar at Danish Technical University & Danish Agricultural University.
Copenhagen Denmark. June 1992.
- 211:** Lecture Notes from Seminars. - Furze. 1992

Volume 2.

- Appendix pages: 239 - 609.

APPENDIX

Subject, Page nr. and Source.

AQUACULTURE

- 239: Owner-Built Homestead. B. & K. Kern USA 1974/75//77 0-684-14926-5. [A].
250: Other Homes & Garbage. J. Leckie et al. USA 1975 0-87156-141-7. [B].
267: Radical Technology. G. Boyle, P. Harper UK/USA 1976 0-394-73093-3. [C].
269: Energy Primer. Portola Institute USA 1974 0-914774-00-X.
282: The New Alchemy Institute # 3. Woods Hole, Massachusetts USA 1976.
292: Technological Self-Sufficiency. R. Clarke UK 1976 0-571-10835-0. [D].
293: Eco-Tech. R.S.de Ropp Delacorte Press NY. USA 1975 0-440-02233-9.
296: Permaculture. B. Mollison Australia/USA 1990 18-55963-048-5. [E].
348: Freja 1975 - Perspektivplan 3. School of Arch. Cph. DK 1975 87-87555-028. [F].
349: Fish-farm in BanglaDesh. DANIDA DK 1989 87-7265-079-6.
350: Freja 1975 [F]. / Self-Sufficiency. J. & S. Seymour UK 1973 0-571-09954-8.

DUCKS, GEESE & POULTRY

- 351: Ken Kern 1974/75 [A].
352: Liklik Buk. Melanesian Council of Churches, P.N.G. 1977 0-86-935-0244.
354: Peoples's Workbook. EDA Johannesburg South Africa 1981 0-620-05355-0. [G].
356: "Chicken-tractor"- Radical Agriculture. R. Merrill [Ed.] USA 1976 06-090437-6.
357: Cloudburst 1. V.Marks [ed.]. Cloudburst Press Brackendale BC. Canada 1973.
359: Shelter II. distributed by Random House Pub. USA 1978 0-394-73611-7.
360: City People's Book of Raising Food. H. & W. Olkowski. Rodale Press USA 1975
363: Soft Technology Magazine # 27. ATA 247 Flinders Lane Melbourne Australia.
365: Berlingske Tidende # [in Danish] - 13 Oct. 2001 - <http://poultry.kvl.dk/>
367: Urban Permaculture. D.Watkins. Permanent Pub. UK 1993 1-85623-002-3
369: Organic Farming. N.Lampkin. Farming Press UK 1994 0-85236-191-2

HYDROPONICS

- 371: Radical Technology [C].
377: Food. S.Szczelkun Unicorn Bks. Brighton UK/Seattle USA 1972. 0-85659-006-1
378: Technological Self-Sufficiency [D].
379: Complete Veg. Gardener's Sourcebk. D. Newcomb USA 1980. 0-380-75318-9.
380: Other Homes & Garbage [B].
381: Hydroponics - Public Works. W. Szykita. Links Pub. USA/UK 1974 [H].
385: Interview with Shijeo Nozawa. Earth Summit News [Rio-Brazil] 1992.

NB - Also consult:

- Hydroponic Food Production. H.M. Resh USA 1978. 0-912800-54-2.
- Organic Gardening under Glass. G. & K. Abraham USA 1975. 0-87857-104-3.

DIGESTERS AND METHANE

- 387: Other Homes & Garbage [B].**
- 411: Technological Self-Sufficiency [D].**
- 417: Tubular Plastic Bio-Digester. Simalenga, SIDA/FAO-FARMESA, PO-Box 3730 Harare Zimbabwe.**
- 433: Tube-digester [Fry] - The Autonomous House. B. & R. Vale [I].**
- 435: Installation Manual [CD] University of Agriculture. HCM-City Viet Nam / University of Tropical Agriculture - www.hcm.fpt.vn/inet~utaf**
- 440: Fittings etc. from Fulford and from Crook etc. IT Books London UK.**
- 452: Digester Design. Al. Rutan. Home Power Magazine # 27,28. USA. 1992.**
- 454: Biogasgruppe "Bundschuh". Ekkehard Schneider Munich Germany.**
- 458: Anaerobic system for coffee waste water. BTG - NL / AMANCO - Costa Rica.**

WATER PURIFICATION

- 462: Permaculture. B. Mollison [E].**
- 471: Other Homes & Garbage [B].**
- 480: "Ecol-system" - The Auton. House. B. & R. Vale UK 1975. 0-500-93001-5 [I].**
- 481: "Ecol-system" - Energy, Env. Build. P. Steadman UK/USA 1975 0-521-20694-4.**
- 482: The Owner-Built Home. Ken Kern USA 1972/75 0-684-14218-X [J].**
- 485: Sunshine Rev./Integrated Solar-system. H.Røstvik Norway 1991 82-91052-01-8.**
- 486: Flow-Forms.**
- 488: Permaculture. B. Mollison [E].**

WELLS, PONDS, DAMS, TANKS & WATER-PUMPING

- 489: Self-Sufficiency. J. Seymour Faber & Faber UK 1976 0-571-11095-9.**
- 491: Permaculture. B. Mollison [E].**
- 502: The New Alchemy Institute # 3. Woods Hole, Massachusetts USA 1976.**
- 503: The Owner-Built Home. Ken Kern [J]. / Mollison [E].**
- 507: Engineering in Emergencies. J.Davis, R.Lambert. IT Books. London UK 1997/2000 1-85339-222-7.**
- 513: The Autonomous House. B. & R. Vale [I]**
- 515: Glass-fiber tank modules. G. Chan.**
- 516: Wire-power transmission. VITA USA 1963/77 [K].**
- 519: Hand-pump for Irrigation. EDA [G].**
- 523: Trompe device - for compressing air. B. Mollison [E].**

BUILDING CONSTRUCTION

- 524: Central bathing house & compost unit with integrated greenhouse. Ken Kern 1972/75 & 74/75 [A-J].**

- 539: Compost Materials. B. Mollison [E].
- 540: Septic-tank Systems. Ken Kern [A-J].
- 542: Civius-Compost Toilet. Survival Handbook. M. Allaby ed. Macmillan UK 1975 0-330-24813-8.
- 544: Adobe-Dome & Adobe Barn. Ken Kern [A-J].
- 550: Organic Farming. N.Lampkin. Farming Press. UK 1994 0-85236-191-2.
- 551: Greenhouses and IFS for Cold Climates. George Chan.
- 560: Hydroponic-Greenhouse Design. Home Power Magazine # 28. USA. 1992.
- 561: Hydroponic-Greenhouse System. Aproprate Tech. Sourcebook, VITA USA 1976 917704-00-42.
- 562: Greenhouse. Public Works [H].
- 565: Greenhouse. Shelter II. dist. by Random House Pub. USA 1978 0-394-73611-7.
- 566: Greenhouse. - Ken Kern [A].
- 567: Sunpit Greenhouse. H & J Hinds Cloudburst 2. Cloudburst Press Canada 1976.
- 571: Aqua-Dome. Jesper Saxgren People's College Kolding Denmark.
- 577: Simple Dome Greenhouse. Niels Bandholm Hjortshøj Århus Denmark.
- 587: Wood-strip Dome. Domebook 2. dist. by Random House Pub. USA 1971/74.
- 588: Domes. E. Thorsteinn, Box 62 - 121 Reykavik Iceland.

ENERGY POTENTIAL & CONVERSION TABLES

- 594: Remote Area Power-supply. Rainbow Power Ninbin NSW Australia 1991/93.
- 597: Wind-speeds & Descriptions. J. Furze, B. Mollison, P. Gipe, etc.
- 600: Windmill for Water-pumping. Aermotor Windmill Corp. San Angelo Texas USA
Also consult: - FIASA Windmill Co. Argentina.
and Southern Cross Corp. Queensland Australia.
- 601: Water-pumping Capacity of Wind-mills. P. Gipe USA 1993 0-930031-64-4.
- A: Village Technology Handbook. VITA USA [K].
- 602: Estimating Small Stream Water Flow.
- 605: Measuring the Flow of Water in Partially Filled Pipes.
- 607: Probable Water Flow with Known Reservoir Height, & Size & Length of Pipe.
- 609: Estimating Water Flow from Horizontal Pipes.
- 611: Determining Pipe Size or Velocity of Water in Pipes.
- 613: Estimating Flow Resistance of Pipe Fittings.
- 615: Determining Pump Outlet Size & H.P. Requirement.
- 618: Determining Pump Lift Capacity, Transmission, etc.
- B: Matematical Conversions and Tables.
- 620: Biological Paths to Self-Rel. R.E. Anderson Sweden/USA 1979 0-442-20329-2.
- 622: The Power Guide. W.Hulscher, P.Fraenkel UK/Netherlands 1994 1-85339-192-1.
- 631: Triangulation - [H] & Trigonometry tables.

B: ENERGY. #

Solar:

- A: Solenergi. / Sunshine Revolution [book, - video also available]. - Harald N. Røstvik, Stavanger, Norway/USA 1991 82-91052-01-8 / 82-91052-03-04 / Video - 82-91052-02-6
B: Practical Photovoltaics. R.J. Komp, Aatec Pub. Ann Arbor Mich. USA 1981/82 0-937948-02-0
C: Strom aus der Sonne. Bernhard Krieg, Elektor Verlag Aachen Germany 1992 3-928051-05-9
D: Sol.tech.3-7723-7792-0/Sol.anlag.3-7723-4452-6/Sol.energ.3-7723-7932-X B.Hanus, De. 96/97
E: Thermische Solarnergie. Müller, Germany [De.] 1997 3-7723-4622-7
F: Compendium in Solar-cookers & Food-dryers. J. Furze 1996
1: SolEnergiCenter Denmark Tel: +45 43 50 43 50 E-mail - www.solenergi.dk
2: EDRC-Univ. of Cape Town S. Africa E-mails - edrc@engfac.uct.ac.za cha@engfac.uct.ac.za

Wind:

- A: Forsøgsmøllen Rapport 1-4. Poul La Cour, Denmark 1900/1903
B: Wind Power for Home & Business. Paul Gipe, USA 1993 0-930031-64-4
C: Wind Power Plants. Hau, Germany 1997/98 3-540-57064-0
D: Windgeneratoren Technik. Hanus, Germany 1997 3-7723-4712-6
E: Wind-turbine Blade Design and Praxis. J. Furze, 1993/94
F: Compendium in Low-cost Wind-mills. J. Furze, 1993/95

Bio-Mass Energy and Fiber Technology:

- 1: a: Danish Energy Agency. b: Prof. H. Carlsen Danish Technical University .
c: S. Houmøller E-mail - houmoller@dk-teknik.dk d: Bio-Raf, Bornholm Denmark.
2: Prof. H. Stassen, BTG University of Twente Netherlands.
3: Huub J. Gijzen, IHE Delft University Netherlands. [University Cali Columbia]
4: Prof. T. Reed, Bio-Mass Energy Foundation Golden Co. USA. E-m. ReedTB@Compuserve.com
5: Prof. J.R. Moreira, NEGAWATT São Paulo Brazil.
6: Dr. A. Borroto, CEMA University of Cienfuegos Cuba.
7: Dr. P.R. Rogue, CETA University Santa Clara Cuba. E-mail - ceta@ucentral.quantum.inf.cu
8: Prof. R.H. Williams, Center for Energy & Environmental Studies, Princeton University USA.
A: Biological Paths to Self-Reliance. R. E. Anderson, Sweden/USA 1979 0-442-20329-2
B: Energie aus Bio-Mass. Flaig, Mohr. Germany 1994 3-540-57227-9
C: Bioenergy for Development. Woods, Hall. FAO-Rome 1994 92-5-103449-4

Bio-Gas Energy. - [Digesters]:

- For Large Systems: - Danish Energy Agency. Copenhagen DK Fax: + 45 3311 4743
For Medium-size Systems: - "Danish Bio-Energi" Issue nr. 28/1996 p.10. - nr. 30/96 p.12.
& nr. 32/97 p.10. E-mail - biopress@post4.tele.dk
- Prof. H. Stassen, BTG University of Twente Netherlands.
For Small Low-cost Units: - Prof. Zhong, Guangzhou Inst. of Geography China.
[Plastic-bag digesters, - University of Agriculture & Forestry, Thu Duc HCM City Viet Nam,
& Integrated Farming]. <http://ourworld.compuserve.com/homepages/utaf>
<100013.3330@compuserve.com>
- Dr. Bo Göhl FSP: E-mail - fspzim@harare.iafrica.com
- Dr. E. Murgueitio: E-mail - cipav@cali.cetcol.net.co
- Prof. Preston: E-mail - thomas.preston@sarec%ifs.plants@ox.ac.uk
- F. Dolberg: E-mail - frands@po.ia.dk
- Prof. G. Chan: E-mail - 100075.3511@compuserve.com

Wave Power:

- 1: Power from the Waves. D. Ross Oxford University Press UK 1997
2: Erik Skaarup, Wave Plane Int. Cph. Denmark Tel: + 45 3917 9833 / Univ.of Cork Ireland.
See: "Energi & Planlægning" June 1997 page 10. E-mail - sunmedia@dk-online.dk

Water-treatment Water-pumping - etc.:

- 1: Prof. Thomas L. Crisman, University of Florida Gainesville Florida USA
2: Prof. P. D. Jensen, Agricultural University of Norway E-mail - petter.jensen@itf.nlh.no
3: Beth Josephson, Center for Rest. of Waters Falmouth Ma. USA E-mail - bjoeph@mbi.edu
4: Angus Marland, Watershed Systems Ltd. Edinburgh Scotland Fax: +44 [0]31 662 46 78
5: Alexander Gudimov, Murmansk Marine Biological Inst. Russia E-mail - vladimd@fiffo.hsf.no
6: Francois Gigon, NATURA Les Reussilles Switzerland Fax: +41 [0]32 97 42 25
7: Carl Etnier, Stensund Ecological Center Trosa Sweden Fax: +46 15 65 32 22
8: Prof. Ülo Mander, Institute of Geography Univ. of Tartu Estonia E-mail - ylo@math.ut.ee
A: Field Engineering. F. Longland - [P. Stern, ed.], UK 1936/93 0-903031-68-X
B: Mini HydroPower, T. Jiandong et al. UNESCO/John Wiley & Sons UK 1996 0-471-96264-3
C: Compendium in Hydraulic Ram-pumps. J. Furze, 1995

- # NB: It should be noted that a comprehensive multimedia6 program on renewable energy on 3 CD's, is issued by the Danish Technological Institute. E-mail - infove@dti.dk
- The Danish branch organization for heat and ventilation: CD - "Multi-Sol", showing mounting/assembly work processes for solar-collectors. <http://www.vvsu.dk>
- During 1998, a CD on access to wind-energy info. - should be issued under a common EU project, with as the coordinating Danish partner; - Handelshøjskole in Århus DK.
- A CD with a database on Renewable Energy is available from UNESCO-Publishing Paris.
- An energy/development CD-library is available from Belgium. E-mail - humanity@innet.be <http://www.oneworld.org/globalprojects/humcdrom>

Plus:

- Rainbow Power Company Catalogue, Ninbin NSW 2480 Australia. Fax: + 61 66 89 11 09.
- Catalogue from Real Goods Co. Ukiah CA 95482-3471 USA. Fax: + 1 707 468 94 86
E-mail - realgood@well.sf.ca.us
- Home Power Journal, Post-box 520 Ashland OR 97520 USA. Fax: + 1 916 475 3179.

Plus Other Titles:

- 01: Energy & Environmental Cooperation, Furze/MINVEC 91/93.
- 02: Comp. in Wind-turbine Blade Theory & Praxis, Furze 1993.
- 03: Compendium in Low-cost Windmills, Furze 1993.
- 04: Compendium in Hydraulic Ram-pumps, Furze 1995/96.
- 05: Compendium in Solar-cookers & Food-dryers, Furze 1996.
- 06: Ferment, Mollison Australia 1993 0-908228-06-6.
- 07: Sunsh. Revol. Røstvik Norway/USA 92 82-91052-01(3)-8(4).
- 08: Chinese Bio-gas Manual, M. Crook (translator)
P.R. China/UK 1976/85. 0-903031-65-5.
- 09: Running a Bio-gas Program, Fulford UK 1988 0-946688-49-4.
- 10: Proceedings of 1st. Int. Conf. on Ecol. Engineering,
Stensund People's College Sweden 1991.
- 11: Proceedings of 2nd. Int. Conf. on Ecol. Engineering,
Wädenswil Switzerland 1995. 0-87849-741-2.
- 12: Living Houses, F. Miller, A. Reite Technological Institute Pub.
/GAIA-Oslo Norway 1993. 82-567-0659-7.
- 13: Field Engineering, Longland UK 1936///93 0-903031-68-X.
- 14: Making Aquatic Weeds Useful, National Acad. of Science
USA 1976 Lib. of Congress nr. 76-53285.
- 15: Fruit Biology, Kolesnikov Mir Pub. Moscow USSR 1966.
- 16: Sustainable Agri. Systems, Edwards USA 90 0-935734-21-X.
- 17: Organic Farming, Lampkin UK 1990 0-85236-191-2.
- 18: Agricultural and Industrial Machinery Catalogue,
CeCoCo Ibaraki City Japan.
- 19: Book Catalogue, Int.Tech. 105 Southhampton Rd, London UK.



Dyke/Pond System and Permaculture

"The Waste Theory of Development". The Dyke-Pond System in Southern China has practised not only organic farming, which during many centuries has involved the intensive use of its soil and recycling of all its natural resources, but also succeeded in having the highest productivity per unit surface of the land in the world, all without non-renewable input from outside.

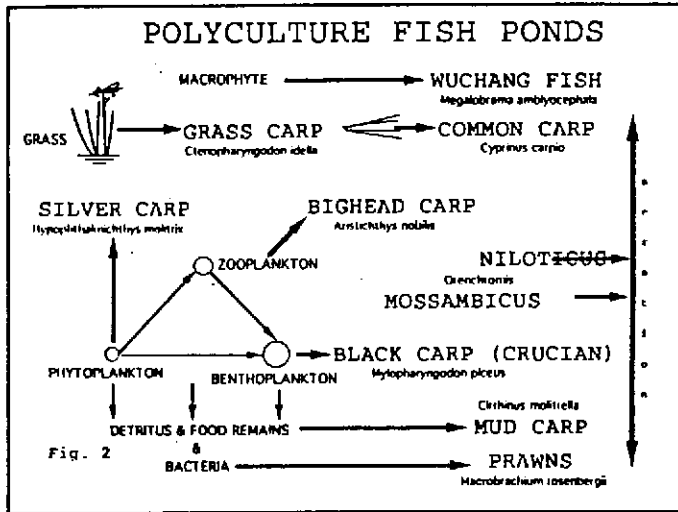

The Dyke-Pond System in Southern China integrates livestock, aquaculture and agroindustry, using the residues of one process as input for the following ones. The main and most important feature is the use of the deep fish pond, which is 2.5-3m deep, for natural treatment of livestock wastes, optimal growth of various plankton, and the use of many kinds of fish feeding at different trophic levels to consume all these plankton (fig.1). The fish in turn produce their own wastes which are naturally treated by the pond water, and the highly mineralized pond water is used to irrigate and fertilize a big variety of crops without having to use any chemical fertilizer or toxic pesticide.

Unfortunately, the so-called modernisation craze is now upsetting the ecologically balanced system with high input of chemical fertilizer and other pollutants which are just left to pollute the whole environment, at a time when the developed world, plagued with these same problems, is looking for viable alternatives which, ironically, China has used for centuries! Why does China have to make these stupid mistakes?

The author has proved that the traditional Dyke-Pond System can be enhanced considerably into an Integrated Farming System, using the appropriate scientific methods and technological innovations, to have optimal productivity that chemical fertilizers cannot do, while

maintaining the same ecological principles. It is now being implemented in Vietnam, which has not yet caught the virus of modern development, but it will come. It is hoped that we still have time to help that country avoid the same disastrous route taken by China now.

A further progress has been made in Brazil, where the Integrated Farming System has been combined with the conventional Stabilization Pond System to make the latter more economic by using all the resources available to produce livestock, fish and plants. It will not make the multibillion waste industry happy, but it will help the poor and needy who have the same human rights to have their wastes treated, and make the whole process pay.

Fig 2. shows why it makes sense to have such integration. Such a concept is now submitted to the Pemaculture movement with the hope that in the search for a truly sustainable system of development, they will adopt the "Waste Theory of Development" which treats all wastes as valuable resources. They should be completely recycled and reutilized instead of polluting and degrading our only globe.

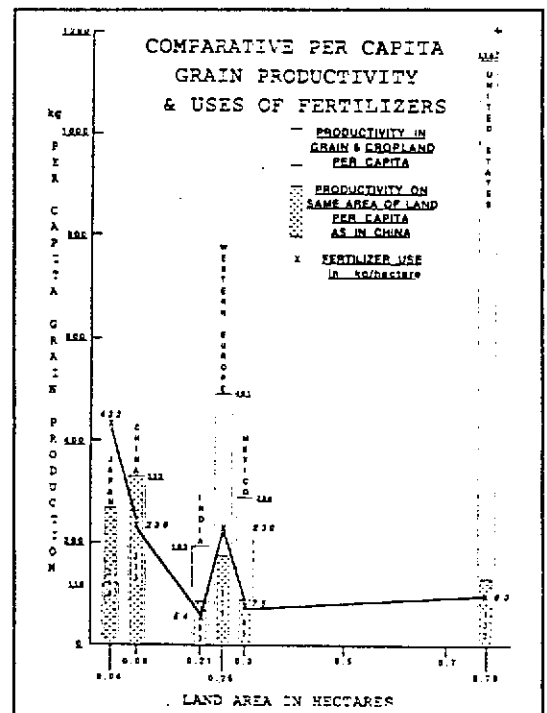

Integrated Stabilization Ponds

"A Lowcost/ Lowenergy Sewage Treatment Plant". The use of stabilization ponds worldwide has reduced sewage treatment costs where cheap land is available, and is more effective than the costly conventional treatment plants that require concret or steel structures and much artificial energy.

Introduction Stabilization Ponds rely on natural growth of algae which through photosynthesis fix carbon dioxide from the atmosphere and release oxygen to mineralize the organic wastes. So the treated effluent contains excess minerals and the original heavy metals which are all pollutants and can cause eutrophication in receiving bodies of water as well as food contamination.

Unfortunately, because of accumulating dead algae which are themselves organic pollution, stabilization ponds require constant cleaning, which is not always done, resulting in nuisances and eventually breaking down. Obviously, control of these dead algae is the quick answer to the problem, but it is not so simple. They are minute and well scattered in a huge volume of water. So filtration is out of the question. Their growth should be strictly regulated or some more practical means should be found to remove them from the system.

By scientifically combining the stabilization ponds with a traditional farming system of livestock, aquaculture and agriculture, which is 5 centuries old in southern China and still going strong, together with some appropriate ancient and modern practices from other countries, the author has come up with a most effective waste treatment system which is also an efficient farming enterprise. It is called the "Integrated Stabilisation Pond (ISP) system.

Strategy and objectives The function of the conventional primary, secondary and tertiary ponds are modified not only to treat the organic wastes more effectively but also produce useful biomass that can be easily harvested. Their efficient operations also provide high-yield and high-quality fertilizer and feed that are then utilized to operate a cost-effective and highly efficient livestock project. The use of a digester to improve the wastewater treatment process also provides a convenient source of renewable energy; biogas.

The same ecological principles behind the traditional integrated farming system, which recycles all wastes and residues completely instead of letting them pollute the environment,

as in most parts of the world, are maintained in the ISP system. So the objectives of the ISP, which can become affordable for all small and isolated communities, more significantly in the tropics, are now aimed at the following:

- Realistic conversion of an expensive municipal utility, handling a huge volume of water with only one percent of organic wastes but still with a very high risk factor, into a paying proposition that can be handled by one farm family for a small to medium sized community.

- Improved effectiveness of all natural processes involved but with minimum external input except for sun, air and living organisms.

- Complete recycling and reutilization of all resources within the system.

- Optimum productivity of biomass per unit of area of land for use as energy, livestock feed, human food and raw material for agroindustry.

Design considerations *Functions.* Its most important function

Primary pond is to settle the organic matter in sewage for digestion by anaerobic organisms at the bottom of the pond, but it also releases objectionable methane into the atmosphere as a long lasting greenhouse gas. This can be greatly reduced by having a shallow (not more than 1m) primary pond and a much larger surface for better photosynthesis while reducing the digestion process (fig. 2). Unused land such as marshes that cover millions of hectares worldwide, can be used for this purpose while converting it into highly productive farms.

If diffused air is supplied, using photovoltaic pumps during the day, windpumps where applicable, and free biogas energy to run a compressor, this greenhouse gas can even be eliminated.

Another important function is to oxidize organic wastes by aerobic organisms using naturally dissolved oxygen from the atmosphere and that produced from atmospheric carbon dioxide through photosynthetic action by natural algae during the day. But at night the algae consume oxygen and can deplete it before the sun rises again. The dead algae accumulate in the pond and consume oxygen all the time.

INTEGRATED STABILIZATION POND SYSTEM

chanpermB

NOT TO SCALE

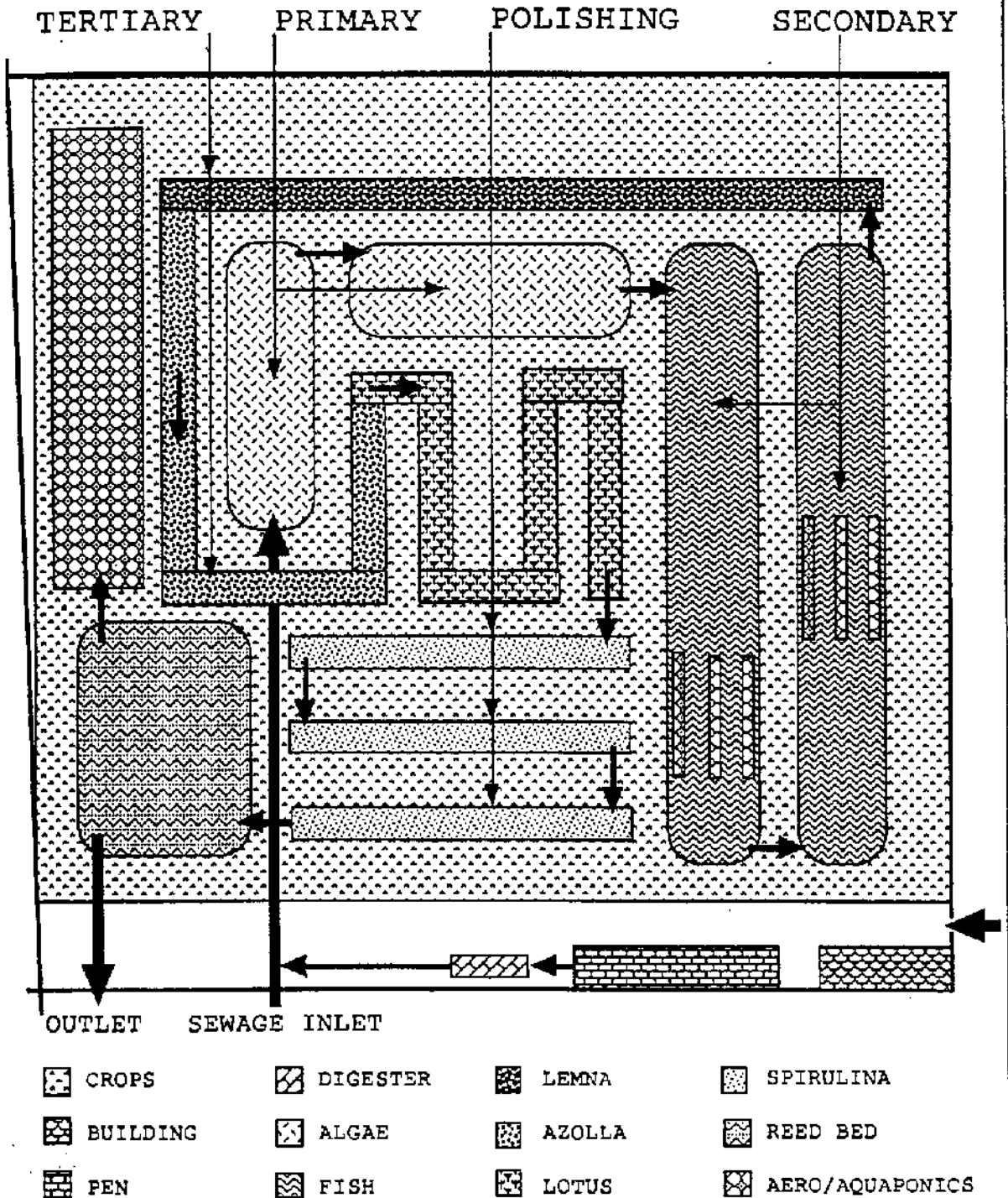

SCHEMATIC PLAN

Fig. 1

As the organic content of sewage, which is the objectionable part, is converted into the more aesthetic minerals, reducing the BOD (biochemical oxygen demand) considerably, new organic algal wastes are produced. So the primary pond has only replaced one pollutant by two others: minerals and dead algae.

Maintenance. There should be adequate oxygen (dissolved or photosynthetic) in the pond at any time. If inadequate, there will be scum formation and odours besides the health hazards because less pathogens are being destroyed. The dead algae must be removed by cleaning the pond regularly in order to improve the performance, but this maintenance is often neglected or blatantly ignored worldwide and it should not be allowed by stricter legislation and its enforcement. It is false to claim that no maintenance is required or the final effluent is of bathing quality, as some government or private institutions do without being challenged.

Efficiency. The efficiency of a primary pond is measured by the reduction of BOD and fecal coliforms at the outlet. This will depend on the algal growth, which is more prolific with adequate sun, warmth and minerals are available. This is a good reason to introduce livestock into the system not only to make use of the big volume of water in the pond, but also to increase the mineral content.

Role of the Digester. The livestock wastes should not go directly into the pond but through a digester which can be as simple as a plastic bag for a small facility or a brick and concrete tank, reducing the BOD by as much as 60% for a hydraulic retention of 5 days. The additional minerals will ensure a prolific algal growth, indicating a good oxygen supply during the day, serving its purpose, but should not reduce it too much at night. The aim should be to flush as much of the algae as possible into the secondary pond.

If there should be stray fish in the pond (fish should not be introduced in the primary pond), they will be under stress in the early hours in the morning because of excess methane and nitrite caused by lack of oxygen. In the extreme cases, they can jump out of the water or simply die in the pond.

Secondary pond *Functions.* While algae are required in adequate quantity in the primary pond for supplying the free oxygen for oxidation of the organic wastes, they are not essential to deal with the residual organic wastes in the secondary pond. The high mineral content discharged in the secondary pond will encourage more algae to grow, and this should not be allowed to happen in order to avoid eutrophication.

Efficiency. The most efficient way of removing the algae as well as the other organisms that grow naturally in the water is to have various kinds of suitable fish to consume them. The fish is then used as high protein feed for pigs and other livestock, or as food where acceptable.

Here we take advantage of an amazing phenomenon that only occur with Chinese polyculture of many kind of fish that feed at different trophic levels. So the secondary pond should be very deep (2.5–3m) in order to accommodate at least 6 kinds of fish, see fig. 3.

Fish Polyculture. The productivity of fish can be increased considerably by good management of the pond water to maintain its high quality, which also means that the waste treatment processes in the secondary pond is functioning well. Besides adequate aeration by some of the fish themselves to reduce the noxious gases such as ammonia and nitrite, the processes involved include the right microorganism growth for nitrification of the organic matter, and for reducing the accumulation of minerals and sludge

Fig.1, Primary pond

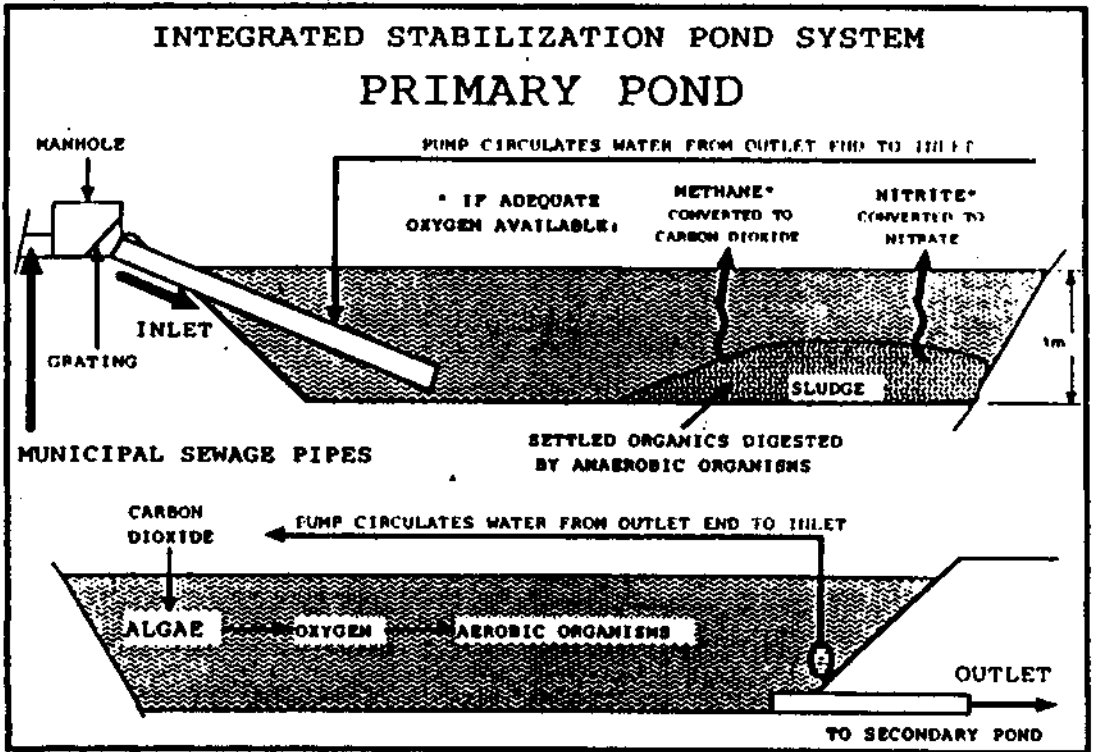

Fig. 2, Secondary pond

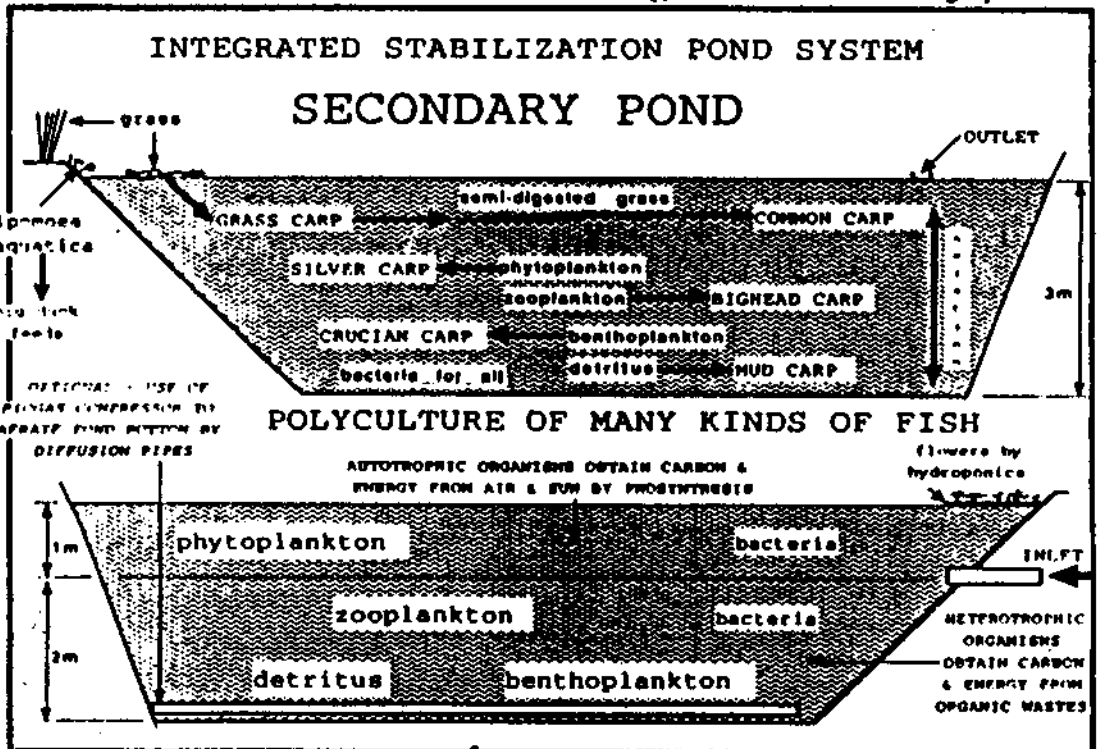
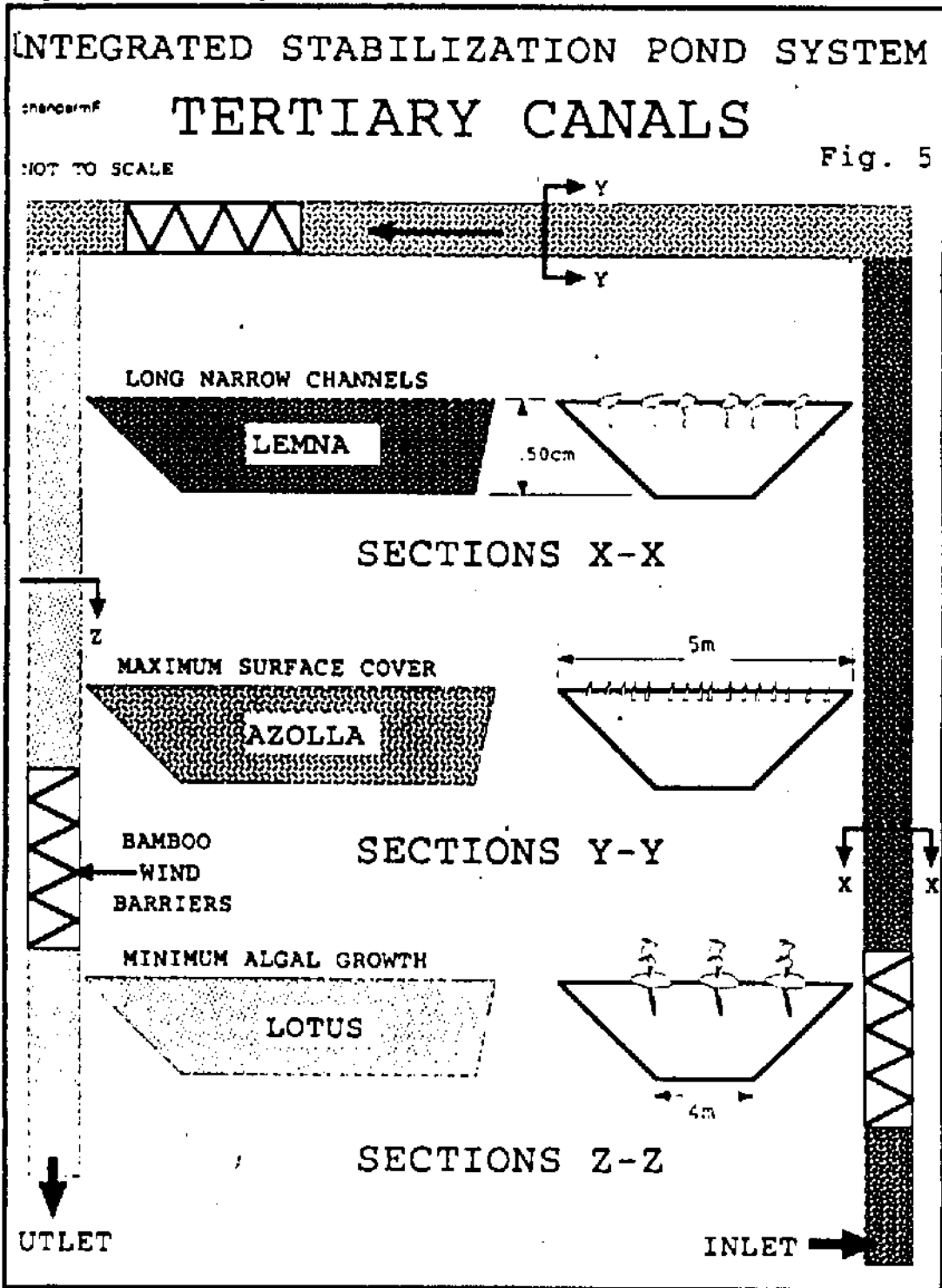

Fig. 3, Tertiary Canals.



of the incoming wastes. Special bacteria can be bought on the market to activate such processes.

The micro-organisms produced daily should best be totally consumed by the fish population because any residue obviously becomes a potential pollutant. Good management depends on the right number and size of each kind of fish to consume its respective feed, and determine how often the pond has to be cleaned. The proof of its success is measured by the yearly fish yield which can be as much as 15 tons/hectar/year, when corresponding yield in conventional fish ponds worldwide (1m average depth) is 3-4 tons. This makes the sewage treatment plant more cost-effective.

In turn the fish also produce their own wastes which must be naturally treated in the pond water and converted into more minerals which must be allowed to go to the tertiary pond.

Role of the deep pond. The bigger volume of water per unit surface area not only increases the hydraulic retention time for better treatment of the wastes from the sewage, pigs and fish, but also capitalizes on the natural aquatic biomass activities which are many times productive than those on land.

Autotrophic organisms grow by photosynthesis at the top of the pond using solar energy and atmospheric carbon dioxide. Heterotrophic organisms grow in the lower part of the pond using organic matter present as source of both energy and carbon. A deep pond provides all the space required for these plankton to grow as much as possible.

Efficiency. The rates at which these plankton are consumed every day by many kinds of compatible fish determines the efficiency of the secondary pond. So far up to 10 kinds of compatible fish and shellfish have been tried in some countries, but more research and development are needed in this neglected field in order to tap this potential.

The effluent from the secondary pond still contains some algae and minerals when it enters the tertiary pond, but not as much as in the pond that has no fish culture and where the algae continue to increase without being consumed, while the oxygen released during the photosynthetic growth of the algae mineralizes more dead algae. It is true that in such a case the secondary pond does not have to be so deep, but it has no tangible benefits from the big capital investment to treat such a huge volume of very diluted sewage. Moreover, a deeper pond only needs an additional excavation of a few more centimeters and the excavated soil used to raise the level of the dykes.

Tertiary pond *Functions.* The minerals (nitrate, phosphate, heavy metals, etc.) entering the tertiary pond should not encourage algae or plankton to grow. This is achieved by having a very shallow (not more than 50 cm) pond with the surface fully covered to prevent algal growth, and with minimum organic matter in the pond to reduce heterotrophic organism growth.

The best and cheapest way to achieve these objectives is to grow suitable macrophytes that are fast growing and can be harvested as easily as possible. So far the most suitable, particularly in the tropics, are Lemna and Azolla which make good livestock feed, with Pistia and Salvinia next because of their extra fibre that makes them more difficult to digest, even if they are bulkier and produce more biomass.

Water Hyacinth is bulkier still, with more ligno-cellulose that requires microbial processing to make it more digestible. Other macrophytes, which have the additional advantage of being suitable for human consumption, are Lotus, Water Chestnut, Water Peanuts, Arrowhead, Ling, etc.

Operation. The aim is to cover the whole pond surface within 2-3 days so that solar penetration is reduced to a minimum. The main problem is the drifting of the plants towards the end of the pond by wind. This is prevented by floating bamboo or wooden barriers to divide the pond-surface into small sections.

The pond should be built like a channel not exceeding 5m wide for easy harvesting with one person on each side dragging the bamboo or wooden barrier with a rope at each end. In the existing bigger ponds, as found in America, the planting is done in a floating barrier matrix and the harvesting by a patented special machine.

Final Polishing *Removal of Residual Elements.*

The effluent from the tertiary pond has very low biochemical oxygen demand and total solids, compared with any other system in the world, but still has a relatively high amount of residual minerals that can be distributed through stone drains or loosely jointed clay pipes in clay beds where they are readily removed by vegetables, fruits and other crops. In order to make more efficient use of the land and of the mineralized water, various planting methods such as multi-cropping, aquaponics, aeroponics, hydroponics, trellis over pond, and rotation of crops are also used. Any residual algae can also be retained in the soil and eventually become nutrients to fertilize crops. The water that finally leaches away into any body of water should be completely demineralized, and not contribute to eutrophication anywhere.

It is ironic that there can still be a case of too much fertilizers in the tertiary pond effluent when in most farming systems worldwide there is a shortage and has to be made good by polluting and relatively expensive chemical fertilizers. This is especially so if it is decided to make optimal use of the big volume of water in the system, as well as making the existing ponds more profitable, by having more livestock and a correspondingly bigger digester. It should be noted that it does not cost so much more to double the volume of a planned digester before it is built, so it is important to make the right decision from the start and provide for the land to use the extra fertilizers in order to produce sufficient biomass to feed the livestock directly, or indirectly by selling the crops to purchase the required feed.

Others Forms of Polishing the Effluent. The tertiary pond effluent can also be used in different ways. One profitable product, for both monetary and nutritional value, is *Spirulina* which is grown in very shallow (20cm) basins lined with plastic sheets or in concrete. Both fresh and sea water can be used, but an extra source of carbon dioxide is necessary for optimum productivity. Presently, sodium bicarbonate is used but a cheaper substitute is now under study. Presently, some other forms of algae with the same or even better characteristics are being investigated. There is no doubt that that more research and development is needed to make use of the vast quantity of plant and animal life still at our disposal.

In areas near the coastline, where the land is too sandy to retain the highly mineralized effluent long enough for plants to make use of the nutrients, the effluent can be mixed with more sea water and then used to irrigate and fertilize salt-tolerant crops like oil-rich *Salicornia* over a much larger surface.

Where tidal flats exist, the tertiary pond effluent can be discharged into corrals where crops like *Spartina* could be grown, making use of the minerals available. In shallow lagoons, *Eucheuma* can replace the *spartina*. All these plants produce much biomass from which agar-agar can be extracted for the icecream and sweet industries, with the residues used as livestock feeds.

Conclusion One big criticism of stabilization ponds all across the world is that they occupy too much land, which is not justified for dealing with dilute wastewater that contains so little pollutants. The fact that they do not work as claimed in almost every country except where they are over-designed to delay the

day of reckoning, because of the lack of maintenance but more often because the ponds are not cleaned when required, is often conveniently ignored. It is the same story with conventional sewage treatment plants, which mostly convert the organic pollutants in the sewage into inorganic ones and shift the problem somewhere else. But the pollution, as we now know too well, just as we have learnt of other pollution problems from the CFC and other noxious gases emitted mostly by the industrialized world, is still there. All this reflects badly on the integrity of the multimillion dollar sewage or waste treatment industry, which is expanding its activities to the developing countries where the poor people cannot afford such defective methods to deal with such a simple act that Mother Nature is performing all the time.

This is what The Integrated Stabilization Pond System is all about: imitating all the natural processes but enhancing them with appropriate science and technology, besides plain common sense from the farmer, the engineer, the agriculturist, the economist, the sociologist, and the honest politician. It has solved the existing problems of organic waste treatment by solving the existing problems of modern farming, which uses chemical fertilizers, toxic pesticides and fossil fuels while putting farm families out of work.

The Integrated Stabilization Pond System transforms an isolated and badly maintained waste treatment facility into an Integrated Farming System of livestock, fish, plants and even agroindustry that can be managed by one or two farm families living a rewarding life on the premises. Because of the tangible benefits, the incentive is there for doing the maintenance and the cleaning when required, while the new system improves the effectiveness of all the natural processes involved; optimizes productivity of various biomass for food, feed and fuel on unit area of land; and recycles all the resources for maximum reward – all without degrading the precious environment or depleting the limited natural resources.

The Dike-Pond Concept: Sustainable Agriculture and Nutrient Recycling in China

Following rapid industrialization in China, traditional integrated-farming techniques are being lost before their potentials have been properly assessed. South of Canton, organic farming and waste recycling have been practiced for centuries in a dike-pond system, which still offers sustainable income opportunities and a multiple-crop yield which is, per area, among the highest in the world. Within the system, leakage of nutrients and the use of chemicals are minimized. A study of the dike-pond concept points at simple ways to reduce unfavorable environmental impacts of food production.

INTRODUCTION

The old Chinese dike-pond concept is one of the most efficient ways of farming a land area, with a production of diversified crops, and a carrying capacity of 20–40 tonnes (t) $\text{ha}^{-1} \text{yr}^{-1}$ (1). The dike-pond system (DPS) evolved over several millenia as an intensive agricultural technology integrating commercial cultivation of vegetables, sugar cane, napier grass, mulberry, sericulture, carp polyculture, and livestock farming.

The integrated-farming concept is remarkable in its adaptation to existing natural conditions and high nutrient recycling, and the methods have spread to other Far Eastern countries. Apart from the production yield, in principle not surpassed outside China, major differences exist in other countries in the exploitation of off-farm wastes, the contribution of benthic fish species, and the dimensions of the ponds.

In the People's Republic of China, the per capita availability of arable land ranks among the lowest in the world, and the DPS concept was almost certainly developed because of the shortage of basic commodities. Today, however, the traditional DPS may be regarded as an economically feasible and extremely high-yielding farming concept which builds on the accumulated knowledge about self-sustainability. Above all, DPS implies balanced exploitation of the environment for the production of food. For three decades after the foundation of the People's Republic of China in 1949, DPS was organized in accordance with socialist collective principles (1). With the introduction of nationwide rural reforms in the late 1980s and household responsibility, the managerial organization of DPS was radically altered (2). The typical DPS farming unit is now on average 0.2–0.5 ha which is managed on a semi-intensive or intensive basis by

Figure 1. The feeding interactions of the most common Chinese carp species in polyculture. From upper left: the Grass carp forages on macrophytes; planktivorous fishes are Silver- and Bighead carp; bottom species are detritivorous and omnivorous Common- and Mud carp. (Box 1).

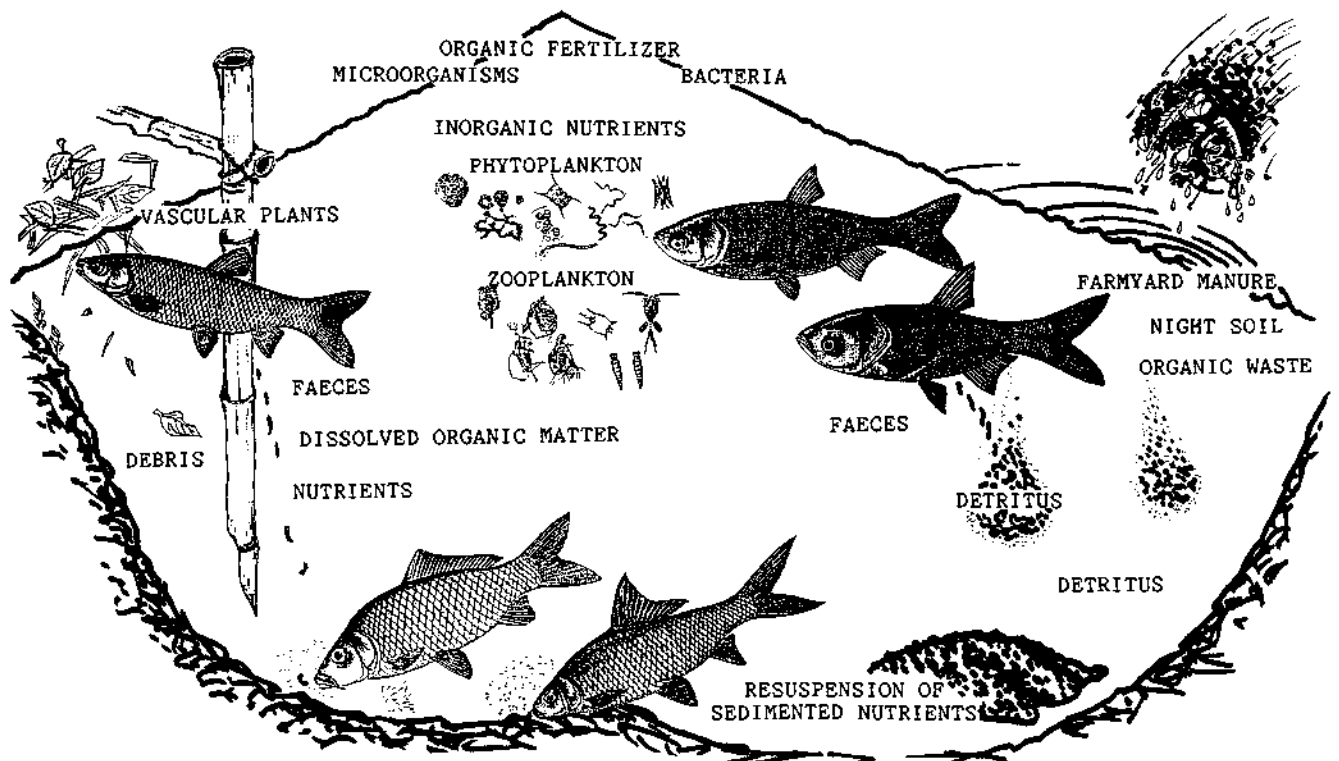

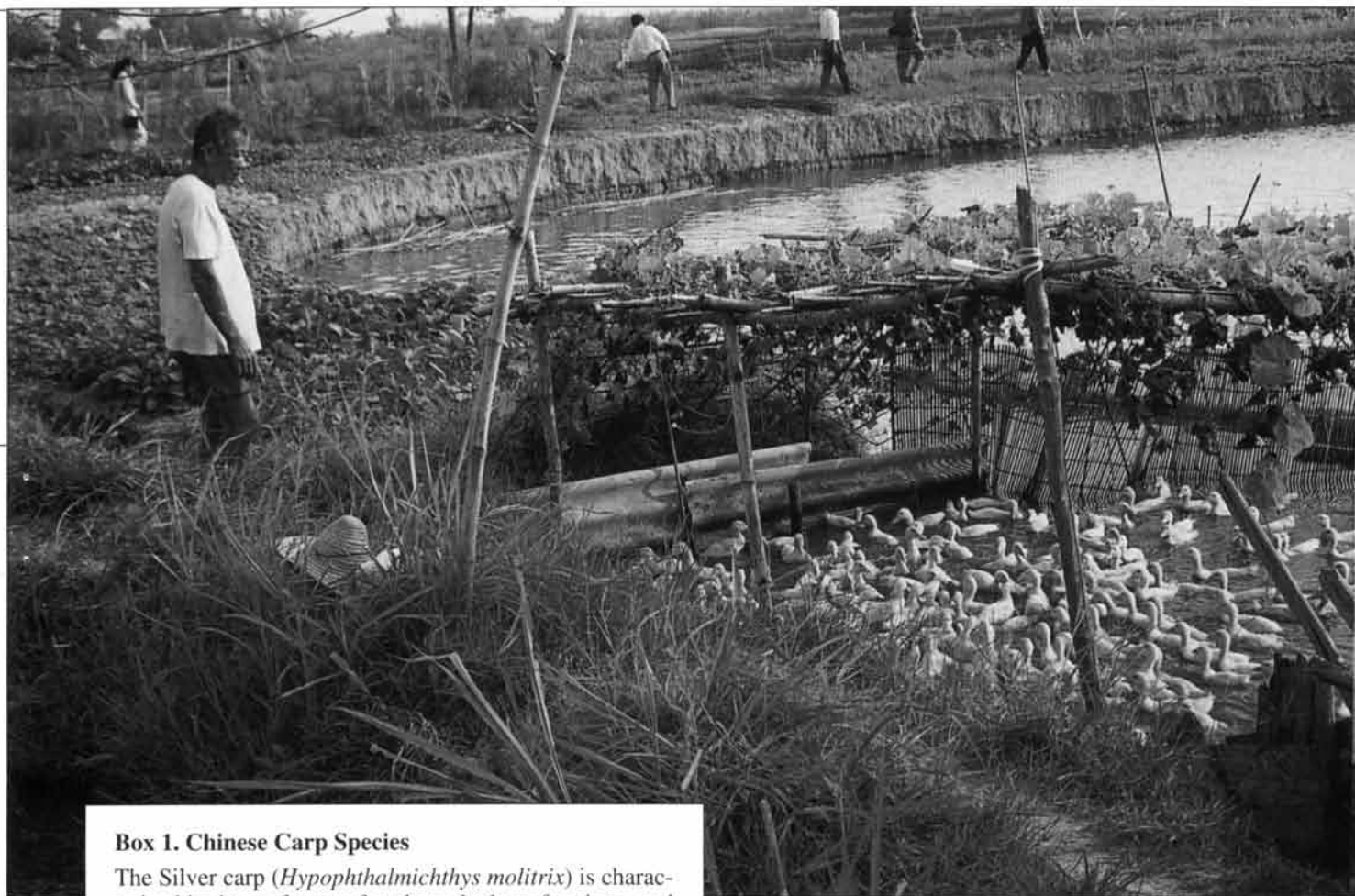

Box 1. Chinese Carp Species

The Silver carp (*Hypophthalmichthys molitrix*) is characterized by its preference for phytoplankton fractions, and the efficient filtration and transformation of such matter to fish proteins. Thus, the Silver carp constitutes a direct linkage between, on the one hand, suspended nutrients and fish growth and, on the other, the growth of the bottom dwelling fish species which exploit its faeces and other organic debris.

The habitat of the Bighead carp (*Aristichthys nobilis*) is the middle water layers, a little below the stratum of the Silver carp. The Bighead carp also filters out plankton, primarily zooplankton.

The Grass carp (*Ctenopharyngodon idella*) is unique in feeding primarily on macrophytes and coarse vascular plants. It uses most common types of farmyard waste, recycling the primary products directly to become valuable fish meat. Consequently, the Grass carp is an ideal component of any integrated agricultural practice. Although the assimilation efficiency of coarse components is not very impressive, faeces constitute a readily available energy source for other carp species, and release inorganic nutrients to the plankton population of the pond.

Through the coexistence of Silver carp and Bighead carps, pond water is continuously purified to sustain a higher density of Grass carp. But such stimulating interactions are complex, as becomes obvious when overall nutrient balance and the microbial and plankton dynamics are considered.

Eventually, detritivore and omnivore benthic fish species (i.e. *Cyprinus carpio* and *Cirrhina molitorella*) are important for the exploitation of farm wastes, since a large amount of matter sooner or later ends up on the bottom of the pond. The bottom feeders also play a significant role in the process of resuspension, from which the coexisting pelagic species benefit.

The farmer inspecting his ducks integrated in the fish pond. A screen of Cucurbitaceae provides some shelter for the ducks. Fertile vegetable beds surround the pond. Photo: M. Korn.

diligent family entrepreneurs. In the southern provinces the system has developed to cover an area of 800 km² in the Pearl River Delta region (Zhujiang Delta, south of Canton), where it supports a population of more than 1.2 million (1, 3–5).

The traditional Chinese farming concept is now threatened as a result of industrial development, urbanization and monocultures that rely on commercial fertilizers, etc. Yet the DPS has not been sufficiently researched. In a global context, the high efficiency and sustainability of traditional DPS-farming renders the concept suitable for wider dissemination.

AQUACULTURE

Aquaculture plays an increasingly important role in the supply of fresh fish products on a worldwide scale. The United Nations Food and Agriculture Organization (FAO) reports the production of farmed fish to have more than doubled since 1984, to a total of 16 million tonnes by 1993 (estimated value USD 35 000 million). The People's Republic of China supplies about half of the total world production (6).

Fish constitute a major source of animal protein throughout the world, and especially so in many subtropical and tropical countries (7). Fish farming is significant in food production because of the high production output and the nutritional value of fish products. The relatively high production capacity is a result of the impressive physiological efficiency of fish in converting nutrients to energy and animal protein. In this respect, fish are unsurpassed by other vertebrates (8, 9).

In China, the pond is always the primary source of profit in

integrated agriculture; the heart of the traditional DPS concept. In the DPS, the best land to water area exploitation is thought to occur at a 2:3 relation; with multi-layered crops, vegetables and livestock on the dikes surrounding a central fish pond. However, due to ageing, erosion and fish being the primary cash crop, some ponds in the Zhujiang Delta appear to have expanded recently and now have a 2:4 (or more) relationship. The depth of a pond is typically 3.5 m from bottom to the level of the crop on the dike (or 1.7–3 m of water) (1, 10).

FISH POLYCULTURE

China is among the oldest nations to cultivate fish and, unlike European enterprises, several different fish species, mainly carp, have been raised together in polycultures (10). Managerial methods may differ from region to region, and the ratio of the different species of carp varies somewhat. The stocking ratio depends on species availability, market prices, the actual growth of the fish and the season of the year, etc. Nevertheless, a form of empirical guideline for the farmer has been accumulated over the years, based on the behavior and feeding strategy of the fishes.

Basically, 4–5 species (or more) of fish are stocked in the same pond to exploit different water levels and feeding niches (11). The varied feeding strategies of the different carp species permit the exploitation of organic matter of different origin and composition; species are able to filter out the water plankton and exploit coarse vascular plants, which are an important nutrient source in integrated farming and pond dynamics (10, 12–15). Each species seems to utilize and generate its own distinctive environment, and the species integrate well in a healthy equilibrium. This is due to synergistic effects at the interspecies level, and productivity is related to the management of the pond. Thus, a Chinese proverb is that "one Grass carp sustains the growth of three Silver carps" (Fig. 1 and Box 1).

In the subtropical monsoon region of the Zhujiang Delta, traditional polycultures allot a high priority to demersal fish species like the Mud carp, Common carp or the Crucian carp. Such benthic species may constitute 85–92% by number of the total carp population. Harvestable yields may typically result in 21, 19, 17, and 43% (by weight), of Grass-, Silver-, Bighead carp, and benthic species, respectively (10, Chen, Y.L., pers.comm.). Many ponds are managed in mixed age and size combinations,

in a rotation of harvesting and stocking, so as to maintain the optimal fish density throughout the cultivation period and at any time adapt to changes in market demands (1, 10). For waste-fed aquaculture it is an advantage that most carp species tolerate extremely low levels of dissolved oxygen (< 1 ppm), particularly occurring during the night (16). The success of any farmer involved in waste-fed fish culture depends on the skillful management of its small, man-made ecosystem. At its best this constitutes a balanced system, which for a reasonable input may return quite an impressive output.

Pond Input

It is also true for DPS that the more you feed the fish the better the harvestable yield. The technology used in the traditional management of the pond and fish feeding, is principally green-water aquaculture. Organic fertilizers (viz. faeces, urine, and household wastes) are transferred to the pond; mineralization takes place in the water to render the inorganic nutrients available to naturally occurring phytoplankton. Due to the predation pressure on zooplankton, which results in relative scarcity, enhanced microalgae populations increase to a high density and constitute a major part of the diet of the pelagic fish species.

Guidelines for the correct administration of different natural fertilizers have evolved. These guidelines are essentially, for nitrogen (N) and phosphorous (P): 1.5–2.2 and 0.2–0.5 t ha⁻¹ yr⁻¹, respectively (17–20). It is not possible to characterize the value of manure on an absolute scale, but some examples from Chinese experiences are presented. On an annual basis, the production of 10 t of fish ha⁻¹, may consume up to 75 t duck manure or 454 t pig manure or 550 t cattle manure ha⁻¹ (wet weight) (10, 19). Ducks are obviously the most efficient contributors and often physically share part of the pond. The recommended contribution through manure from different livestock species and the way this may be integrated is summarized in Table 1. Principally, urine contains higher levels of N and potassium (K) than faeces, whereas the content of P is higher in faeces; with the exception of pig manure (19). However, each pond may in principle be regarded as unique and general guidelines should be observed with caution.

The traditional DPS preserves important knowledge and skills that are currently needed in the management of waste-fed systems. Correct administration of manure is needed to fertilize the pond according to the variations encountered in water dynam-

Table 1. The recommended annual contribution of farm wastes and livestock manure from different species and the expected fish sustainability; primarily through enhancement of plankton growth (data from (10)). Data marked * from Chen, Y.L. and Li, pers. comm., 1992. Data marked ** are extrapolated from a theoretical max production of 200 t ha⁻¹ yr⁻¹ of sugarcane.

Livestock/ farm wastes	Fish sustainability kg ww fish	Manure yr ⁻¹ kg ww(dw)	Value * USD
1 duck (0.18 duck m ⁻²)	5.5	42	0.3
1 pig	44	2000 (938)	3.0
1 cow	272	15 000 (7031)	
1 ha vegetables (10 tonnes)	2400		
1 ha sugarcane (50 tonnes **)	1250**		
1 ha mulberry: 594 kg silk pupae	594		
12 150 kg larval excreta	729		

ics, climatic conditions, stocking density, and agricultural interactions. High phytoplankton densities often show inherent oscillations, leading to periodic anoxia and plankton population crashes, but these may be controlled in advance by actively limiting the nutrient input. A skilled farmer gauges the condition by the color of the pond's water: Should the balance of the system be affected, he takes steps to adjust it, e.g. by exchange of water or liming.

From an environmental point of view it is interesting to note that, since water is costly, a fish pond is normally managed without effluents. Apart from in emergency situations, emission of water is allowed only once or twice a year, in association with fish harvesting, pond excavations, and the exploitation of pond deposits for soil fertilization (21).

When commercial fish feeds are available, a supplement may be added prior to harvesting in order to fatten the fish. When these products are not available, soybean products and ricebran are generally added to the pond. The quantities that are administered are difficult to assess. The amount of commercial fish feed that is added is the amount considered necessary to optimize the output. In

traditional DPS, a typical input of fish feed corresponds to 10%–20% of fish-marketing prices. The commercial fodder supplement, if any, could typically be 3–7 t ha⁻¹ yr⁻¹ (22). In China, a considerable quantity of farmyard waste, garden-plant debris, and harvested vascular plants like napier grass (*Pennisetum purpureum*) and water hyacinth (*Eichhornia crassipes*) is provided as basic fodder: the water hyacinth is primarily regarded as a nuisance in many other countries. In newly started ponds, the water is conditioned by decomposing grass and selected herbaceous plants (Tatsao/Dacao; plants belonging to the Asterales, Laminales, and Scrophulariales) which are put in the pond as a basic fertilizer 5–10 days before stocking. On low-nutrient soils, urban off-farm waste is imported to the farm or, alternatively, small amounts of inorganic fertilizer are applied, at least during the first 3–5 years, to enhance the nutrient status of the farm. As reported by Ruddle and Zhong (1), up to 40% of the excrement, household waste, and vascular plant material that is used may be purchased as off-farm products and transported to the DPS.

In the nutrient budget, it may be difficult to assess the contribution of farm wastes to the actual growth of the fish in a certain pond. This is partly because of the complexity of pond dynamics, which depend on the biological processes involved in the decomposition of organic matter, some of which is directly consumed by the fish, and partly because of the seasonal variations which are reflected in the management procedures. The general inconsistency of the currently available input data may also make assessment difficult. A typical net primary production of pond phytoplankton is 22.4 t (dry weight) ha⁻¹ yr⁻¹ (1, 23); about 3 g C m⁻² day⁻¹. This corresponds to about 1/3 of maxi-

mum primary production, measured in tropical upwelling areas of the world oceans (24).

Concerning the nutrient budget, fish recovery rates are reported to be 6–12% (or less) gross fish efficiency, relative to input of gross primary production and feeds (25, 26); major losses being community respiration (20, 27) and sedimentation. Avnimelech and Lacher (28), for example, found a net sedimentation of 25% carbon, 75% nitrogen, and 80% phosphorous in intensive monoculture; that is without resuspension by benthivorous fish species. The complex energy conversion ratio of 10:1 (between the total energy input and energy of fish production) has been calculated and discussed (1).

Fertilized ponds and eutrophic lake systems attain high densities of plankton populations and support large quantities of microorganisms (pico- and nanoplankton). Recent research has focussed on the microbial processes, where decomposers interact with the herbivorous food chain and constitute a significant energy pool (20, 29–31). Thus, a complex interaction of bacteria, protozoa, fungi, meiofauna, and detritus, is vital in waste-fed aquaculture, but it also immobilizes a proportion of the existing nutrients. Further research into detrital food chains is necessary to elucidate mass-balances and system dynamics with the ultimate goal of improving fish yields.

Pig manure and excreta of mixed origin are quite often fermented together with other organic waste before the substance is added to the pond or applied on the dikes in controlled fertilization. The biogas which is hereby produced is sometimes exploited by Chinese households or in the large collective farming villages, which may rely upon pig manure for the generation of electricity for light, and on methane for cooking. Some villages

Figure 2. Artists view of the complete integrated dike-pond farming concept; comprising multiple cropping on the dikes, ducks, and the central polyculture fish pond.

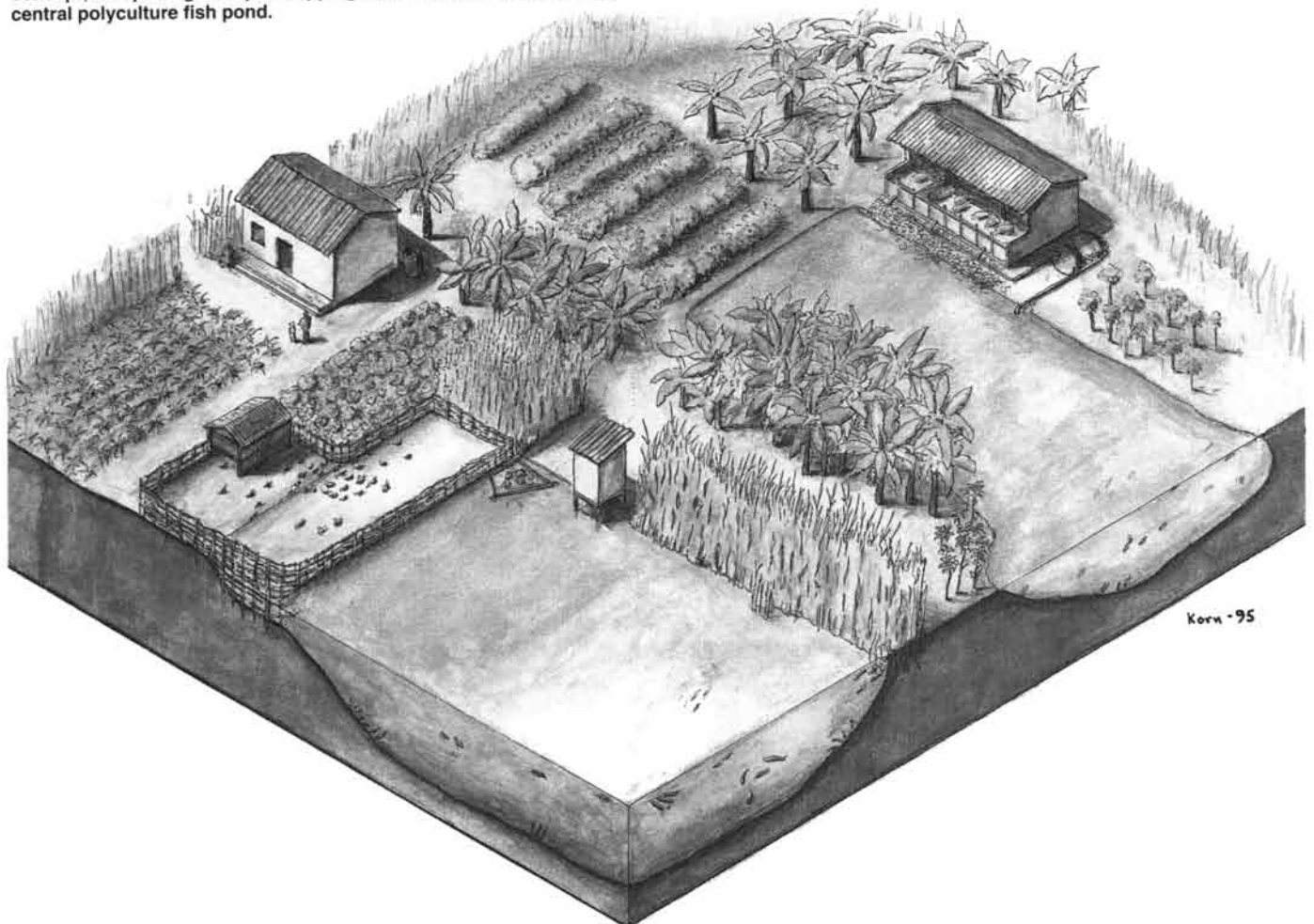

are totally self-reliant as regards energy today, although energy is not their primary production (32).

Pond Output

Statistically, an attainable output from the intensively managed, multi-cropping subsystem is 7–10 t fish (ww) ha⁻¹ yr⁻¹. Higher yields are achieved through supplementary feeding and mechanical surface aeration; practiced during morning hours in midsummer or round noon for agitation purposes. Registered maximum yields for traditional carp polyculture are up to 15–22 t ha⁻¹ (1, 10, 22, Guangzhou Statistic Bureau -1992, Zhang, C. and Ma, K., pers. comm.). These fish yields are extremely good compared with other aquaculture facilities under comparable technological and subtropical conditions (18, 19). For comparison, in Bangladesh the current target is an improvement of the annual output from as little as 0.5 to 3 t ha⁻¹ (33, 34, Danish Foreign Ministry, pers.comm., 1994).

Reported fish-feed coefficients are from 0.75 to more than 2 (10, 22), which implies a consumption of 1 to 2 kg of fodder to grow 1 kg fish (dry feed to live fish weight). By Western standards, an optimized, intensive fish culture may attain conversion rates from 0.8 to 1.2; i.e. trout culture (35, 36, Forsøgsdambruget i Brøns, pers.comm.). However, efficiency data at this level are not directly comparable, because of uncertainties relating to the water content of the fodder and contributions of organic debris and enhanced plankton.

The price of fish in China began to fluctuate after the planned economy system was partly abandoned. In the region of Guangzhou, the 1992 prices for the four most common carps varied between USD 0.6–0.9 to 1.9 kg⁻¹ fresh fish. Fresh eel was USD 7.7 kg⁻¹, Largemouth bass was USD 4.9 and Mandarin fish USD 9 kg⁻¹. Current trials with new aquaculture technology (eel culture in particular) indicate that profits may be around 30% higher than with traditional carp culture (22, statistical data from: Tong, W.F., Li, Z.M., and Liang, S.H., pers.comm., 1992). Therefore, fish polyculture is gradually being replaced by monocultures with exportable outputs. However, the widespread DPS multi-cropping simultaneously offers a large additional output of basic crops from the fertile dikes surrounding the pond.

HARVESTABLE CASH CROPS

In integrated agriculture in the Zhujiang Delta, the year-round crop cultivation on the dikes and associated waters represents complex seasonal rotation and biennial inter-cropping. There is no slack season, and the dikes are continuously cultivated. Composted household waste is applied as the principal fertilizer in a quantity of 35 t ha⁻¹ yr⁻¹ to bananas and 90–180 t ha⁻¹ yr⁻¹ to vegetables, 2–3 times a year depending on the particular crop rotation. As a supplement, in certain lots, some 3000 m⁻³ ha⁻¹ yr⁻¹ of pond mud (approx. 4300 t dry mud) and occasionally, 1.7 to 3.8 t of urea may be applied in nutrient-poor subsystems (1). The typical vegetables of the region are species of cabbage, spinach, cucumbers, beans, peas, and root crops. In addition, many fruit trees are cultivated, such as citrus, lichee, mango, papaya, etc.

An area of dike-ponds of 6 ha may produce a total yield of around 220 t (ww) yr⁻¹. This corresponds to a mean of 37 t ha⁻¹ yr⁻¹ of differentiated vegetable/crop and livestock harvest, or between 10–80 t ha⁻¹ depending on the composition of crops (Table 2.). According to Chinese standards, the income from the integrated cultivation system is enough to feed 143 persons ha⁻¹, as compared with 11 persons ha⁻¹ in paddy field farming. About 3 full-time annual labor inputs of average intensity are needed for the overall cultivation of one ha of dikes and ponds (1; Zhong, G., pers.comm.).

A comparison with cropping results elsewhere can only be indicative, since climate and soil characteristics, crop type, spe-

cies variety, and the harvesting and removal of organic matter from the farm significantly affect available data. The yields of a modern organic farm in the temperate zone may be selected as one reference, e.g. waterfed, good and fertile soil in Denmark. The output here is up to 22 t ha⁻¹ yr⁻¹ (equivalent to 18 t dry weight) of beet which is harvested after a growth period of nine months. On organically manured 'ecological' plots, up to 10 t ha⁻¹ yr⁻¹ of cereals (equivalent to 4.5 t barley and 4.5 t straw, dry weight) and 12 t of clover may be grown. The yields of vegetables in European countries are often much lower partly due to national legislation and the restrictions on organic fertilizer (37, 38, Mikkelsen, G. and Kristensen, E.S., pers.comm.). From Swiss experiences, between 20 and 27 t ha⁻¹ vegetables, 29.9 t ha⁻¹ beetroot, and 31 t ha⁻¹ potatoes may be produced annually from organic farming (39).

Although the average and maximum productivity of plants are highest in the tropics, different physiological adaptations render the net productivity of many climax vegetations comparable throughout the world (40). Thus, biological adaptation seems to compensate to some extent for an unfavorable climatic environment. Different cultural and seasonal inputs impose the major constraints on our comparison.

CONVENTIONAL FARMING

Modern conventional farming is a concept essentially different from organic farming in every respect. In industrial countries, the yields attained in conventional intensive farming are expected to exceed those of organic farming by 10–30%. Data from Danish mixed dairy farms indicate a difference of 20–37% for grain crops and 12–18% for fodder beet (41, 42). Results from some Western countries show a mere surplus of 2% for cereals and 1% for potatoes (39).

However, the largely subsidized overproduction of the European agricultural sector has recently brought about financial strain and political embarrassment, in the form of a growing concern about the environment, and the realization that finite natural resources need to be carefully managed. Recent studies in the USA concluded that the reduced use of agrochemical inputs may markedly lower production costs and lessen agriculture's potential for adverse environmental and health effects, without necessarily decreasing, and in some cases even increasing, crop yields and the productivity of livestock management systems (43).

Modern Western aquaculture relies on fossil fuel, a continuous exchange of water (flow-through facilities), aeration with purified oxygen, automatic feeding, and regular pharmaceutical applications. An intensive Danish fish farm, in 1995, produces from 500 to almost 2000 t ha⁻¹ yr⁻¹ of fresh fish, such as trout or eel (Danish Trout Growers Association, pers. comm., 8). To reach this production level, trout farming in Denmark consumes more than 50% of overall operating expenses in enriched fish feeds.

Table 2. The harvestable yield from one hectare of arable land in the traditional DPS agricultural concept. Data are given as biomass, wet weight (data (1); Zhong, G., pers. comm.).

Annual yield	tonnes ha ⁻¹
Live fish	10
Sugarcane	75
Mulberry	20–30
Silk worms	1.9–2.25
Vegetables	80
Bananas	30

European salmon industry consumes 6 times more energy in feed than that expended in the remaining activities directly involved in conventional cage farming (44). Up to 20–40% of automatically added feeds may be lost through the net meshes and cause severe local eutrophication (45, 46). In terms of weight, 7–31 times more nitrogen and 3–11 times more phosphorous per kg of fish produced is released to the environment, than in waste-fed fish ponds (47).

Since extruded feeds are much more expensive than fertilizer and nutrient conversion efficiency in green-water aquaculture is considered to be only slightly less than in intensive Western facilities, this could have significant implications for reducing expenses in fish-production.

ENVIRONMENTAL CONSIDERATIONS

Water shortage is a matter of global concern, which can put the viability of large urban areas in question. Enormous land areas are affected by recurrent floods due to erosion and silt deposits in major natural reservoirs. The described farming system represents a useful tool for land and water management. The concept is well suited to the exploitation and transformation of wetlands and riparian ecotones under subtropical and tropical monsoon conditions. In these areas, seasonal flooding and erosion constitute major threats to grain and crop production, and yet water may be scarce in the dry season. Alluvial soils can be converted to year-round fertile pasture when ditches are constructed, since basins and channels reduce the negative consequences of occasional flooding. The dams and their associated supply and drainage canals are essential for the irrigation of adjacent farmland, notably paddy fields, and may serve as a water reservoir in dry seasons.

In the People's Republic of China, environmental problems have become more acute during the last decade, and water pollution has increased, even in rural areas, with high concentrations of leached fertilizers, pesticides, and industrial contaminants (48). Dike-pond farming is currently converted into profitable eel and carnivorous fish aquaculture, simultaneously implying the increased use of refined nutrients, antibiotics, pesticides and fuel input.

The chemical impact of the "Green Revolution" has spread unevenly over the world because of the differences in ecosystems and socioeconomic factors in different countries. Thus, the European farmer deposits an annual average of 224 kg mineral fertilizer on each ha farmed; in Asia the figure is 168 kg ha⁻¹ yr⁻¹, and in Africa between 8–11 kg ha⁻¹ yr⁻¹ (49). In the current situation, where surpluses are the Western norm and the cost of maintaining these surpluses is unacceptably high, less intensive production methods with lower levels of output may be preferable to taking large areas of land out of agricultural production altogether. Organic farming methods may generally help to reduce the environmental damage caused by human activities, such as leaching chemicals.

Integrated systems are managed according to the principles of 'modern' organic farming. Often, the fertilization relies exclusively on the natural mineralization of such organic wastes that are locally available; favoring microorganisms and their conversion of energy from decaying plants. One of the most important functions of these microorganisms is the fixation of atmospheric nitrogen and the oxidation of methane. In the DPS, all waste matter is considered a precious product which is recirculated on location or sold to neighboring farmers. Significant quantities of household waste are even channelled from the urban centers to be recycled as fertilizer for the dikes. Since an exchange of the pond water tends to generate unstable internal conditions, water effluents are rarely discharged from the fish ponds. In this regard, the DPS serves as an important buffering sink for large amounts of household waste in the process of being

Box 2. Green-water Technology

The color of the water is one of the basic instruments in the management of Asian aquaculture. The coloration is due to the combined effects of plant and animal plankton, suspended microorganisms, detritus (feed, dissolved matter), and metal ions, etc. In the green-water technique, water is inoculated with organic fertilizer, and the natural growth of planktonic organisms is stimulated to a high density before the water is considered suitable for stocking with fingerlings. Green water is considered a highly valuable resource once the desired pond-water conditions have been established, and the farmer strives to maintain it in a stable and dynamic state. Skilful and flexible management adjusts the visible criteria any time, and this is reflected in harvestable yields. Water exchange is rare and performed with caution.

The successful cultivation of fish relies on the managerial control of the water color. The green matter serves to stabilize and improve the physical and chemical water environment, since potential toxic substances are reduced, the content of dissolved oxygen is increased, fish stress is reduced, and cannibalism and certain diseases are suppressed. It has been shown that autochthonous elements present in microcosmic water may directly induce better shrimp growth than can be obtained in clear water regardless of feeding (54).

recycled. Organic matter from the DPS is degraded and mineralized in the dike soil or in the microbial food web of the pond.

The described agricultural system, with its many sub-units of ditches and stagnant waters, has perhaps not yet been properly appreciated as a waste-management method in communities that cannot afford a sewage system. Recently, pond constructions were suggested as a suitable type of wetland for nitrogen removal, with the ability to retain 0.07–7 t N ha⁻¹ yr⁻¹, depending on the nitrogen load (50). In areas of rapid urbanization, modifications of the existing system would definitely be applicable as a kind of biological filter, comparable with the latest techniques for biological degradation of industrial pollutants, or for retention of leaching fertilizers in artificially flooded meadows and "root-zone" facilities.

In a global effort to minimize dependence on finite sources of energy and to alleviate the prevailing scarcity of fuelwood, biogas has an obvious potential. It has been proposed that a larger amount of the organic waste matter be treated in a methane generating pit to reduce the loss of energy from the pond detritus and to improve the overall energy efficiency. Hence, in some parts of China, biogas fermentors are widely used; the residue which is produced still retains most of the nitrogen and phosphorous of the biomass, and is of considerable value as a fertilizer (1, 32, and Chan, G.L., pers. comm.).

Eventually, combinations of agriculture with waste-fed fish farming and aquaculture development may imply certain health hazards, like the transfer of enteric microorganisms, e.g. salmonella and, depending on the regional distribution, malaria, onchocerciasis (river blindness), schistosomiasis (bilharzia) and leptospiroses (51, 52). Fermentor treatment of excreta and other waste serves to reduce the health hazard associated with such matter, because it neutralizes most bacteria and major pathogens. Infections and parasites in the fish are also reduced by this sanitizing of fecal matter. It might be concluded that waterborne infections, and health hazards imposed by the diseases borne by

water-dependent vectors, will infringe on the net result of the DPS. Simultaneous measures to diminish some DPS-associated health hazards must be encouraged, however, further research is needed to determine exactly how (53). The cultural obstacle to the use of human and animal excrement as a pond fertilizer, unacceptable in a large part of the world, could be solved in this way.

SUMMARY AND CONCLUSIONS

The Chinese dike-pond farming concept is one of the most productive agricultural systems in the world, and is able to sustain a population of more than 140 persons ha^{-1} . In certain regions, this traditional integrated-farming concept is capable of increasing the productivity of arable land area by a factor of almost 100, taking into consideration all its different products from the same plot. Annually, 30–80 t ha^{-1} of crops may be harvested from pond-adjacent land which is fertilized with 35–100 $\text{t ha}^{-1} \text{y}^{-1}$ of domestic waste and large amounts of excavated pond deposits. The hub of the DPS, i.e. cultured carp species, convert most of their energy from detritus and natural plankton and need very little fish feed. The pond plankton reaches high densities from the mineralization of added organic waste and resuspended debris. In DPS, with carp polyculture, 10–15 $\text{t ha}^{-1} \text{y}^{-1}$ of fish or more may be harvested from the addition of manure corresponding to 1–2 $\text{N t ha}^{-1} \text{y}^{-1}$.

Conventional modern farming has been accused of environmental degradation, and of creating potential health hazards in the food as well as decreased food quality. Organic agricultural methods, less costly and less dependent on finite resources and infrastructure, are an alternative. In organic farming systems, including DPS, ecological diversity is preserved, and the investment risk is low compared with monoculture systems. The described traditional Chinese farming concept may be fully competitive with conventional agriculture and in some cases may even increase per area yields. Moreover, DPS offers sustainable income-generation opportunities.

Our world has a population problem, a food problem, an ex-



Traditional DPS plot with mulberry dike and fertile water.
Photo: M. Korn.

cess of manpower, and a shortage of arable land. Sustainable technology and simple managerial methods are needed and in demand. Many countries in warm regions would benefit from adaptation of the Chinese DPS model, if sociocultural conditions and local resource-management methods were adequately considered.

Ditches and dams are an important tool in land and water area management. Retaining water and soils, the dikes and reservoirs serve as an important pool for nutrients. In principle, they are easily modified to a suitable sewage-treatment system for reducing the industrial impact on the environment.

Industrial development in the People's Republic of China in the last decade has shown little respect for the environment and indigenous farming technology. The old dike-pond system may disappear completely before the potential of this traditional and sustainable integrated-farming concept has received the attention it deserves in a global development context.



Buffalo grazing on the banks of the supply channel. Napier grass, shrubs, tatsao species and bananas.
Photo: M. Korn.



Multicropping with napier grass banking the pond and bananas and some citrus on the central dike. Photo: M. Korn.



A concrete ditch distributes pig manure to the fish ponds. Napier grass, small mangoes and scattered bananas are seen bordering the pond. Photo: M. Korn.

References and Notes

- Ruddle, K. and Zhong, G. 1988. *Integrated Agriculture-Aquaculture in South China: the Dike-Pond System of the Zhujiang Delta*. Camb. Univ. Press, 173 pp.
- Bauer, S. and Kesling, M. 1992. Agricultural policy in China: application of planning versus market principles. *J. Int. Agr.* 31, 175-192.
- Zhong, G. 1990. The types, structure and results of the dike-pond system in South China. *Geojournal* 21, 83-89.
- Zhong, G., Chan, G.L., Wang and Yao. 1986. *Case study I-III*. Special Publ.
- Chan, G.L. 1985. *Integrated Farming System*. Elsevier Sci. Publ., Amsterdam.
- FAO. 1995. *The State of World Fisheries and Aquaculture*. FAO Fisheries Dept., Rome.
- FAO. 1992. *Fish and Fishery Products. World Apparent Consumption Statistics based on Food Balance Sheets (1961-1990)*. Compiled by Laureti, E. FID/C 821, 477 p.
- Landau, M. 1992. *Introduction to Aquaculture*. John Wiley & Sons, Inc. NY, 440p.
- Gordon, M.S. 1977. *Animal Physiology: Principles and Adaptations*. Macmillan Publ. Co., Inc., New York, 699 pp.
- Zhong, L. 1991. *Pond Fisheries in China*. International Academic Publishers, 260 p.
- Bardach, J.E., Ryther, J.H., and McLarney, W.O. 1972. *Aquaculture-the Farming and Husbandry of Freshwater and Marine Organisms*. Wiley-Interscience, New York.
- Bitterlich, G. 1985. The nutrition of stomachless phytoplanktivorous fish in comparison with tilapia. *Hydrobiologia*, 121, 173-79.
- Edwards, P. 1980. The production of microalgae on human wastes and their harvest by herbivorous fish. In: *Algae Biomass*. Shelef, G., and Soeder, G.J. (eds). Elsevier, North Holland Biomedical Press, Netherlands.
- Spataru, P. 1977. Gut contents of Silver carp, *H. molitrix*, and some trophic relationships to other fish species in poly-cultural systems. *Aquaculture* 11, 137-46.
- Yashou, A. 1971. Interaction between common carp and silver carp in fish ponds. *Bamidgeh*, 23, 85-92.
- Boyd, C.E. 1982. *Water Quality Management for Pond Fish Culture*. Elsevier Sci. Publ. Comp.
- Hopkins, K.D. and Bowman, J.R. 1993. A Research Methodology for Integrated Agriculture-Aquaculture Farming Systems. In: *Proc. Aquacult. Eng. Confr.* Wang, J.K. (ed.). June. ASAE Pub. 02-93, pp. 89-98.
- Edwards, P., Pullin, R.S.V. and Gartner, J.A., 1988. Research and education for the development of integrated crop-livestock-fish farming systems in the tropics. *ICLARM Cont. No. 470*, 51 pp.
- Little, D. and Muir, J. 1987. *Integrated Warm Water Aquaculture*. Inst. of Aquacult. Publ., Univ. of Stirling, UK, 238 pp.
- Moriarty, D.J.W. and Pullin, R.S.V. (eds). 1987. Detritus and microbial ecology in aquaculture. *ICLARM Conference Proc. 14*. Manila, 420 pp.
- Wu, H. 1986. Water balance of the dike-pond system of the Zhujiang Delta and its ecological function. *Trop. Geogr.* 6, 8 pp (In Chinese).
- Korn, M. 1992. *Integrated Fish Farming*. Spec. rep., Tech. Univ. of Copenhagen, Denmark, 46 pp.
- Wang, Z., Luo, Q. and Wang, G. 1986. On the relationship between productivity of fish and plankton's quality in the dike-pond region. *Trop. Geogr.* 6, 3-12. (In Chinese).
- Raymont, J.E.G. 1980. *Plankton and Productivity in Oceans*. Pergamon Press, Oxford.
- Zur, O. 1981. Primary production in intensive fish ponds and a complete organic carbon balance in the ponds. *Aquaculture* 23, 197-210.
- Ayyappan, S., Rao, N.G.S., Rao, G.R.M., Janakiram, K., Purushathaman, C.S., Saha, P.K., Paul, K.C., Muduli, H.K., Sinha, V.R.P. and Tripathi, S.D. 1990. Production efficiencies of carp culture ponds under different management practices. *J. Aquacult. Trop.* 5, 69-75.
- Teichert-Coddington, D.R. and Green, B.W. 1993. Influences of daylight and incubation interval on water column respiration in tropical fish ponds. *Hydrobiologia* 250, 159-165.
- Avnimelech, Y. and Lacher, H. 1979. A tentative nutrient balance for incentive fish-ponds. *Bamidgeh*, 31, 3-8.
- Riemann, B. and Christoffersen, K. 1993. Microbial trophodynamics in temperate lakes. *Marine Microbial Food Webs* 7, 69-100.
- Takamura, N., Zhu, X-B., Yang, H-Q, Ye, L., Hong, F. and Miura, T. 1992. High biomass and production of picoplankton in a Chinese integrated fish culture pond. *Hydrobiologia* 237, 15-23.
- Schroeder, G.L. 1978. Autotrophic production of microorganisms in intensively manured fish ponds and related fish yields. *Aquaculture* 14, 303-325.
- Chan, G.L. 1987. Waste treatment processes for the integrated farming system. Personal handover.
- Ahmed, M. 1992. Status and potential of aquaculture in small waterbodies in Bangladesh. *ICLARM Tech. Rep.* 37, 36 pp.
- Dolberg, F. 1991. Adding a learning to a blueprint approach, or what a small amount of flexible money can do. *Livestock Res. Rural Develop.* 3, 1-10.
- Danish Trout Growers Association, 1994. Annual report.
- Enell, M. and Ackefors, H. 1991. Nutrient discharges from aquaculture operations in Nordic countries into adjacent sea areas. *ICES, C.M., /F:56 Ref. MEQC*, 17 pp.
- Halberg, N., Kristensen, E.S. and Kristensen, I.S. 1993. Økologisk Kvægbrugsdrift, teknisk-økonomiske Gårdresultater, 1992-93. In: *Studier i Kvæg-Produktionssystemer*. Kristensen, T. (ed.). Statens Husdyr-brugsforsøg, Danish Ministry of Agriculture, Pub. No. 722, 74-111. (In Danish).
- Mikkelsen, G. and Nielsen, L. 1991. Sædeskifte er en mirakelkur; og Stabilit udbytte i økologisk drift. *Landsbladet Kvæg*, 12, 7-10. (In Danish)
- Lampkin, N. 1992. *Organic Farming*. Farming Press Books, UK, 700 p.
- Whittaker, R.H. 1975. *Communities and Ecosystems*. MacMillan Pub. Co. Inc. New York, 385 p.
- Danish Statistical Bureau. 1994. *Landbrug, en Opgørelse over Danmarks Samlede Høstudbytte for 1993*. 10, 22. juni, 4 pp. (In Danish).
- Halberg, N., Kristensen, E.S. and Kristensen, I.S. 1994. *Expected Yield Loss when Converting to Organic Farming in Denmark*. NJF-Sem.: Converting to organic agriculture, Finland, March. Special print, 14 pp.
- National Research Council. 1989. *Alternative Agriculture*. National Academy Press, Washington DC.
- Folke, C. and Kautsky, N. 1989. The role of ecosystems for a sustainable development of aquaculture. *Ambio* 18, 234-243.
- Ackefors, H. and Enell, M. 1994. The release of nutrient and organic matter from aquaculture systems in Nordic countries. *J. Appl. Ichthyol.* 10, 225-241.
- Torpe, J.E., Talbot, C., Miles, M.S., Rawlings, C. and Keay, D.S. 1990. Food consumption in 24 hours by Atlantic salmon (*Salmo salar* L.) in a sea cage. *Aquaculture* 90, 41-47.
- Edwards, P. 1993. Environmental issues in integrated agriculture-aquaculture and wastewater-fed fish culture systems. In: *Environment and Aquaculture in Developing Countries*. Pullin R.S.V., Rosenthal, H., and Maclean, J.L. (eds). ICLARM Conf. Proc. 31, pp. 139-170.
- Smil, V. 1992. China's environment in the 1980's: some critical changes. *Ambio* 6, 431-436.
- Preston, T.R. and Murgueitio, E. 1992. *Strategy for Sustainable Livestock Production in the Tropics*. CIPAV, Colombia, 89 pp.
- Fleischer, S., Gustafson, A., Joëlsson, A., Pansar, J. and Stibe, L. 1994. Nitrogen removal in created ponds. *Ambio* 23, 349-357.
- Manson, P. 1987. *Manson's Tropical Diseases*. Bailliere Tindall, London, 1557 pp.
- Shuval, H.I. 1991. *Health Guidelines and Standards for Wastewater Reuse in Agriculture*. Hist. Persp., Great Britain.
- Caincross, S. 1989. *Guidelines for the Safe use of Wastewater and Excreta in Agriculture and Aquaculture*. Prep. by Mora, D., WHO/UNDP.
- Laber, K.M. and Pruder, G.D. 1988. Using experimental microcosm in shrimp research: the growth enhancing effect of shrimp pond water. *J. World Aquacult. Soc.* 19, 197-203.
- The studies in P.R. China were conducted as part of the Cultural Agreement Programme, with financial support from the Danish Ministry of Education. The author would like to express his sincere gratitude to Prof. Zhong Gongfu of the Guangzhou Academia Sinica, for very important contributions and the generous data supply from the Regional Chinese Water Bureaus. Thanks go also to Dr. Eng. Huang Fuxiang of the Guangzhou Inst. of Geography, for valuable assistance and lingual translations.
- First submitted 21 December 1994. Accepted for publication after revision 17 May 1995.

Mads Korn has an MSc in environment and aquaculture. He has served as a consult to major Danish trout farmers and to various NGO's on tropical fish research. He is a Board Member of the DPS-Danish Committee, CDC, Technical University of Denmark. He has lately been engaged in the field of plankton dynamics in waste-fed fish cultures, attached to the Freshwater Biological Laboratory, University of Copenhagen. His current address: Asian Institute of Technology, GPO Box 2754, Bangkok 10501, Thailand 12120.



WASTEWATER REUSE IN AQUACULTURE :

**socially and environmentally appropriate
wastewater treatment for Vietnam**



THE HANOI SYSTEM

Hanoi, the capital city of the Socialist Republic of Vietnam has a population of more than 1 million people, about 40% of whom live in the old city which is served by a central, combined wastewater : stormwater, drainage system. The wastewater flows southwards by gravity to low lying Thanh Tri district where it is treated by a traditional system : the nutrients in the wastewater are reused to grow fish, rice and land and aquatic vegetables which form a significant part of the diet of the city's people.

HISTORICAL DEVELOPMENT

The system has been developed mainly by the farmers of Thanh Tri district through experience accumulated over the past 30 years. In 1960 this district was a sparsely populated backswamp where rice produced low yields; the crop was also frequently destroyed by flooding. Farmers began to experiment with wastewater-fed fish culture but fish yields were low : there was only wild fish seed from the river to stock the fishponds and the supply of wastewater to, and drainage of water from, the fishponds were inefficient. During the 1970s the canals were deepened and pumps were installed to supply wastewater to fishponds and rice fields, leading to the evolution of the large-scale system in operation today.

SYSTEM OPERATION

WASTEWATER TREATMENT

There are no large, conventional, wastewater treatment plants in Hanoi. The daily discharge of 320,000 m³ of wastewater flows by gravity to Thanh Tri district where it is treated by the agricultural-aquacultural reuse system.



Water gate on Kim Nguu river

The area is dissected by the Kim Nguu and the To Lich rivers which drain the wastewater from the city. The wastewater is pumped from these rivers into concrete channels which distribute it to fishponds and fields. As it flows through these farms it is treated and re-used before being discharged into the Nhue river.



Pumping wastewater from Kim Nguu river



Channelling wastewater to fishponds



Wastewater flowing into a fishpond

Analyses of biological oxygen demand (BOD_5) indicate significant reduction with distance along the Kim Nguu river from which wastewater is repeatedly withdrawn and discharged for reuse. BOD_5 fell from 90 mg/l at Lo Duc Sewer at the head of the system in municipal Hanoi to 8 mg/l at Phap Van near the Nhue river in the dry season in 1994. Visual observations confirm these scientific measurements, demonstrating a high wastewater treatment efficiency of the system.



Raw wastewater



Wastewater after treatment in fishponds

REUSE

Wastewater is reused and treated in four main types of farming:

- Fish culture in 200 ha
- Rotation of rice and fish culture in 400 ha
- Land vegetables
- Aquatic vegetables



Rice-fish culture



Fish harvest



Cultivation of land vegetables



Cultivation of aquatic vegetables

The farmers have learned by experience to regulate the amount of wastewater pumped into their fishponds. The black, deoxygenated wastewater from the rivers mixes with and fertilizes pond water, colouring the water green as it produces plankton upon which the fish feed. Green water is ideal as this indicates a productive and healthy environment for fish. If the pond water clears the farmers pump large volumes of wastewater into their ponds but they avoid pumping too much wastewater which would lower the dissolved oxygen and raise the concentrations of ammonia which would kill the fish. Yields of 5-8 tonnes of fish such as silver carp, rohu and tilapia are harvested annually per hectare.

Farmers rotate rice and fish in shallow ponds located at a distance from the rivers where the supply of wastewater is insufficient to culture fish in the dry season. Fish yields of 4-5 tonnes and rice harvests of about 3 tonnes per hectare per crop are harvested from these sites.

A wide range of land vegetables such as cabbage and kale, and aquatic vegetables such as water spinach, are irrigated and fertilized with wastewater throughout the area.

SYSTEM BENEFITS

- Employment for farmers in Thanh Tri district and for wholesalers and retailers of fish, rice and vegetables in municipal Hanoi
- A supply of relatively cheap food for poor consumers in Hanoi.

About 4,500 tonnes of fish cultured in wastewater-fed fish ponds in Thanh Tri district are sold annually in Hanoi which comprise 40-50% of the total fish supply of municipal Hanoi

- A low-cost system to efficiently treat wastewater
- A healthy environment in the suburbs of Hanoi which acts as a lung for the city



Employment of women in vegetable cultivation



Marketing water spinach in Hanoi



Marketing fish in Hanoi



Silver carp, rohu, tilapia

NEED FOR STUDY

The locally developed, wastewater treatment and reuse system of Hanoi remains to be subject to detailed, interdisciplinary, scientific study. Proposals to introduce Western mechanical systems of wastewater treatment would be premature without proper consideration of the benefits of the current system; although poorly understood, this effectively treats wastewater and provides significant additional social and environmental benefits to the city.

It is proposed that an interdisciplinary study be carried out on the Hanoi wastewater treatment and reuse system, considering:

- its importance and efficiency in wastewater treatment
- its importance and efficiency in wastewater reuse in agriculture and aquaculture
- potential risks to public health, both pathogens and toxins, for farmers and consumers, from fish, rice, and vegetable cultivation and their consumption
- the degree to which the area can resist pressures from urbanization and other alternative land uses
- the possibilities for technical improvements of the system in terms of more efficient wastewater treatment and more efficient wastewater reuse
- a social and environmental analysis of the costs and benefits of the system, with emphasis on their impact on women, children and the poor.

INTERNATIONAL RECOGNITION

The social and environmental value of wastewater-fed fishponds is recognized internationally:

- The International Union for the Conservation of Nature (IUCN) recognizes wastewater-fed fishponds as a special category of man-made wetlands

- The World Health Organization (WHO) recommends that, where possible, reuse of wastewater should be the preferred method of wastewater disposal to minimize treatment costs and to obtain maximum agricultural and aquacultural benefits from the nutrients contained in wastewater
- The World Bank (WB) and the United Nations Development Programme (UNDP) publishes symposia and technical reviews on wastewater reuse
- The International Reference Centre for Waste Disposal (IRCWD) forecasts that wastewater reuse in aquaculture will become an increasingly important form of waste disposal, water pollution control and food production in the future

THE HANOI SEWAGE FISH GROUP

This pamphlet has been produced by the Hanoi Sewage Fish Group, a multidisciplinary group of researchers from:

- Hanoi City Agricultural Service
- Hanoi University, Department of Environmental Engineering
- Hanoi University of Civil Engineering
- Hanoi Medical College
- People's Committee, Thanh Tri District
- Research Institute for Aquaculture No.1, Ha Bac

Support was provided by the Agricultural and Aquatic Systems Program of the Asian Institute of Technology, Bangkok, Thailand.

For further information, please contact either:

Dr Le Thanh Luu,
Research Institute for Aquaculture
No. 1, Dinh BangTien Son, Ha Bac, Vietnam,
Fax: 84 4 273070, Tel: 84-4-271368

or

Professor Peter Edwards,
Agricultural and Aquatic Systems Program,
School of Environment, Resources and Development,
Asian Institute of Technology, G.P.O. Box 2754,
Bangkok, Thailand 10501,
Fax: (66-2) 5246200, Tel: (66-2) 5245477

3. Biochemical Conversion of Biomass for Energy

**INTEGRATED FARMING PROJECTS FOR CUBA
(with Useful Lessons from VIETNAM)**

Prof. George Chan, Environment Consultant
Antenna Technology, Geneva, SWITZERLAND
formerly with Guangdong Academy of Sciences, Guangzhou, CHINA
MAIL : 14 Poivre Street, Beau Bassin, MAURITIUS
TEL : +230 464-2659 **FAX** : +230 211-0297

INTRODUCTION

Cuba is a sugar-producing country which has followed the conventional system of having monoculture of sugarcane, using chemical fertilizers and pesticides, to produce 7 million tons of sugar annually as a commodity for export. The sugar mills are operated by burning the bagasse in boilers to produce steam for generating electricity. The residual molasses are used for making alcohol or exported as raw materials, with some of the new residue of vinassa used on the land and the rest left to pollute various bodies of water. A convenient 'barter' system was made with the old Soviet Union which buys the sugar and alcohol, and then sells foods, chemical fertilizers and fossil fuels to Cuba. This worked very well until the Soviet Union disintegrated, and Cuba's economy has suffered the consequences. The current sugar production is reduced to half the amount, and there is shortage of chemical fertilizers and fossil fuels. Cuba is now forced to produce more of its foods and is doing well.

Cuba is now faced with a big dilemma as it struggles to re-orient its development strategies -- on its own as it cannot depend on any big power in the West, which is a blessing in disguise as it should not repeat the same mistake again. Now that Cuba has to compete with nearly 100 countries to sell its sugar on the world market, it will find that the price is not economic. So Cuba should seize the opportunity to diversify its sugar industry and make it more self-reliant as well. It can benefit by learning at least two useful lessons from Vietnam, where small farmers have stopped selling their cane to the sugarmills and are using it themselves for various purposes, and some have converted their monoculture of sugarcane or rice into integrated farms to earn a much higher income.

For the sugarmills, which require massive funding to renovate their boilers and other equipment, there are also the possibilities of converting their sugar from a cheap commodity into raw materials for other industries to make useful products now being imported or for export to earn foreign exchange. One most important aspect is to stop burning bagasse to generate electricity, and transform it into high-value feeds for livestock by microbial processing, and then use the livestock wastes and fast-growing macrophytes to produce biogas for electricity generation, with the residues as fertilizers in aquaculture and agriculture. This new strategy will allow Cuba to make better use of its biomass. It can also set an example for many other developing countries in similar situations to follow, as the post-GATT era makes it more difficult for them to compete on the open market.

LESSONS FROM VIETNAM

The small farmers have various inputs such as chemical fertilizers and pesticides from the sugarmills to grow their sugarcane, and the costs are deducted when they sell their crops, leaving them a meagre income equivalent to US\$200 per hectare per year when a farm family requires double this amount just to survive. So they must look for odd jobs or cultivate a small food garden and keep a few animals and birds which grow poorly on scraps and vegetation. Some farmers have been encouraged to crush their sugarcane with a handmill and use the juice as energy feed, supplemented with peanut cakes which they have to buy. Some of the bagasse is used as pig feed and the rest as cooking fuel. A few now have a small plastic bag digester, costing about \$20, which gives them biogas fuel from the livestock and human wastes, and save more bagasse to grow mushroom as high-value food and earthworm as high-protein feed. This biological process not only improves the protein content but also breaks down the lignocellulose and makes the bagasse more digestible. The slurry is used as fertilizer in a small fish pond and the pond water is used to irrigate and fertilize crops. So the income from integrating various farming activities has gone up 2-3 times, with the additional saving in time that would otherwise be wasted in collecting firewood for cooking and grass or leaves for the livestock.

A more sophisticated system of integrated farming has been tried by the author during the past 3 years and has shown extremely good results. Part of the family rice field has been converted into a big and deep pond, 3,000m² minimum, for polyculture of fish without using any artificial feed except grass grown on the edges for one fish. Five other kinds of fish feed on various kinds of plankton fertilized with the effluent of a plastic digester fed with wastes from 15-20 pigs, and the yield is at least 3 tons of fish per year which is worth \$2,000. With the profit on the pigs and crops, and the savings in fuel, the income can reach \$2,500, which represents a small fortune for the farm family. This income will increase as the pig feed, which must be purchased during the first year, is gradually replaced with crop and processing residues produced on the farm.

An added bonus on one farm, which is not quite a year old, is the suitability of the soil for brickmaking. So the farmer did not only have his pond of 3,000m² dug at no charge but he also received \$4,000 for the excavated soil from a brickmaker. He built both his integrated farm and a 4-room house, and had the operating funds for 50 pigs. He will make \$1,000 profit on his pigs and \$2,000 on his fish for the first year, and has already sold some vegetables. The local government officials were so impressed that they have put 200 hectares at the disposal of the author for development as eco-farms, and the first phase of 16 farms will be implemented this year -- Fig. 1. This project will be auto-financed, with each farm family receiving \$8,000 for the 2 ponds of 3,000m² each, which will be adequate to build and operate the integrated farm. The income per family will be \$6,000 during the first year, and will increase tremendously as the purchased livestock feed, which represents 2/3 of the production costs, is replaced with the farm residues by the third year. Additional farm activities such as aquaponic culture of cereals and flowers on half the surface of the pond and aeroponic culture of vegetables and crops on the dykes will bring in substantial income to the farm family working full-time.

PROJECTS FOR CUBA

Cuba can use its marshy and low-lying land to develop self-financed and self-sustainable integrated farms for individual families as in Vietnam, and make itself not only self-sufficient in all its basic and essential foods, but with quite a substantial surplus for export as well.

As for its sugar industry, Cuba can combine the same integrated farming system for its small as well as big planters to grow the sugarcane as an organic product. The big advantage in having the sugarcane grown on the dykes between the ponds is that no extra irrigation or fertilization is required as the roots will obtain all their needs from the groundwater by themselves. On half the surface of the ponds, cereals and grass can be grown as livestock feeds or fruits and flowers for extra income. The pond water can be used in shallow basins to grow various kinds of fast-growing macrophytes as feedstock for the digester.

The livestock wastes and the macrophytes will be digested to produce biogas fuel to generate all the energy required for the sugar making, with the effluent oxidized while producing algae as high-protein feed, before the mineralized water is used to fertilize the fish ponds. The fish can be used as feed for the livestock if there should be any qualms about eating it as in Vietnam.

Some of the bagasse will be converted into better-quality feed by growing mushroom and earthworms on it, and the remainder made into pulp, paper, carton, particle board and even fibreglass panels. All the molasses will be used to produce alcohol, with the vinassa treated in the digesters, and the needed energy produced on site. So all the available biomass will be converted into energy, feeds and many useful products, without any of it being burnt -- see Fig. 2.

Finally, the sugar will no longer be used as a cheap commodity but as raw materials for industries such as plastics, detergents, water softeners and other useful products for import replacement and export to other countries -- see Fig. 3.

CONCLUSION

Cuba has the choice between promoting grassroots self-sustaining employment to lift its peasant communities from poverty to spectacular but equitable prosperity, while protecting the total environment in conformity with the sensible guidelines approved by all governments in the world at the 1992 United Nations Conference on Environment and Development in Rio de Janeiro, Brazil, and cheap labour-intensive industrialisation of urban and special zones worldwide while creating increasing environmental problems caused by domestic and industrial wastewaters, household and farm refuse or manure, and toxic or greenhouse gases -- just like the rest of the world. It is hoped that the leaders and people of Cuba will opt for the former and avoid the disaster that many other nations got themselves into by adopting the latter. Cuba should not miss such a unique opportunity to set an example for all those developing countries that are in such a huge and insurmountable financial and environmental mess. All because they chose inappropriate development strategies based on costly external inputs to produce cheap commodities and goods for export, and failed to take advantage of new and appropriate technologies to promote self-sustainable farming systems and avoid the same serious mistakes that the whole world is trying to solve, but in vain.

EXPANSION OF SUGAR INDUSTRY

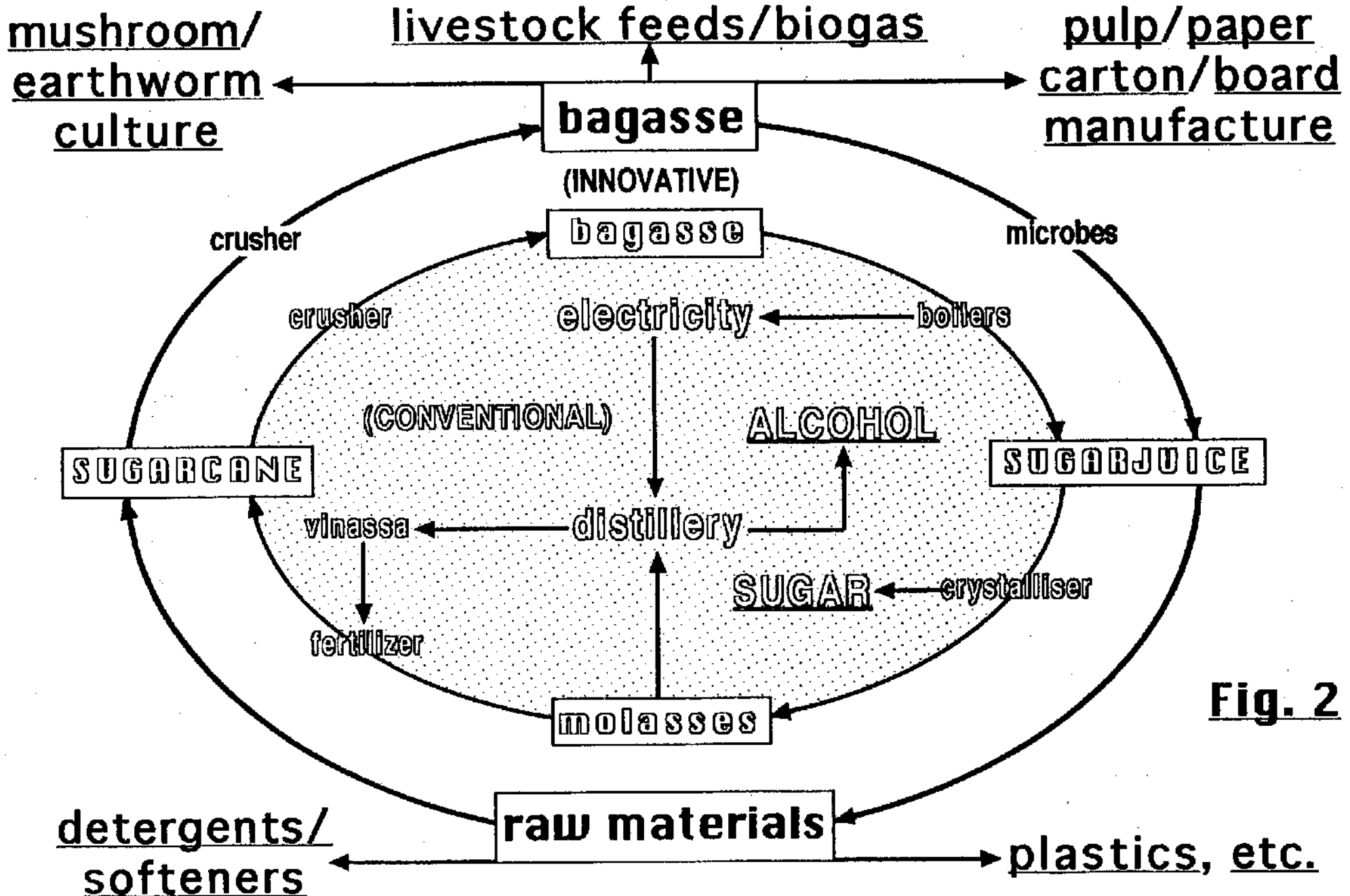

Fig. 2

COMPARATIVE SUGAR INDUSTRY

Fig. 3

<u>CONVENTIONAL</u>	<u>INNOVATIVE</u>
<p>Sugarcane monoculture with chemical fertilizers, pesticides and equipment using fossil fuel</p>	<p>Organic sugarcane is only one of various diversified crops in Integrated Farming Systems</p>
<p>Main product is SUGAR as a cheap commodity for export to a few nations paying subsidies</p>	<p>Sugar is used as raw material to make many useful products to replace expensive imports</p>
<p>Some molasses are used to produce alcohol when power is available at the sugarmill; the rest (85%) is exported to rich nations as cheap raw materials</p>	<p>All molasses are utilised to make not only some alcohol, but also high-quality protein feeds to allow local livestock industries to be more viable</p>
<p>The alcohol process leaves a residue called vinassa which is partially used on the land but the rest pollutes water bodies</p>	<p>Any residue is always treated and recycled in an anaerobic digester, which is mandatory in any kind of integrated farm</p>
<p>The bagasse is burnt in boilers to generate electricity to run a sugarmill and a distillery while sugarcane is being harvested</p>	<p>No bagasse is burnt, but it is either made into many useful products or processed into high-value feeds for livestock</p>
<p>Burning of biomass is not only wasteful but also destroys rich resources and pollutes the air</p>	<p>Livestock wastes and various macrophytes produce biogas fuel for generation of electricity</p>

Prof. George CHAN
14 Poivre Street
Beau Bassin, MAURITIUS
TEL: +230 464-2659
FAX: +230 211-0297

Mr. John Furze

8000 Aarhus
Denmark

Dear John,

It has been a long time since we tried to convince the Cubans that there are viable alternatives to their sad state of post-Soviet development. In fact, the United Nations University has just had the first World Congress on Zero Emission in Tokyo on 6-7 April, and I was lucky to be one of the speakers -- see enclosed paper. Please see enclosed agenda. Dr Mauricio Garcia-Franco, Park Hill C-2, Egota 4-24-12, Nakano-ku, Tokyo 165, Japan (Phone/Fax +81-3-5343 6979), is the Cpprdinator for Latin America. Please ask your Cuban friends to write to him to have more information on the ZERI programme. I am the Coordinator for the Islands and will start implementing the first ZERI project for a brewery in Fiji next July (enclosed), as I am already doing more than what the others at ZERI are trying to do. Maybe, I can work together with Mauricio for a future project in Cuba. As usual, USA is very involved in UNU, and so is Japan which will not favour Cuba because of USA, but we can always try.

On 16 February, I wrote to Dr Hector Perez de Alejo Victoria to ask him to get FAO assistance for my involvement in Cuba, but have not yet heard from him. Perhaps you can pull a few other strings and see how we can help Cuba -- see enclosed paper.

I am still trying to find some funding for my fares and expenses to implement the Vietnam Eco-Farm project, which does not itself require any money from anybody, but I will spend my own money if necessary, as Vietnam is not very far from here. It is incredible that no organisation or rich country is prepared to help such a project. I have asked UNU ZERI to include Vietnam (enclosed) in its programme, as they will get a lot of mileage from it. I have already done all the spade work and is ready for implementation now while the others are still at the conceptual stage.

I am in China doing an Integrated Sewage Farm project for the Hamburg Environmental Institute and will be back in Mauritius by the end of this month. Please wite to me there.

With best personal regards to you and Jorgen.

Sincerely,
George Chan

PROPOSED PILOT PROJECT FOR FIJI BREWERY

Prof. George CHAN
Environmental Engineering Consultant
MAURITIUS

INTRODUCTION

Following the ZERI Expert Meeting held in Beijing, 1-4 April 1995, the ZERI Congress in Tokyo, 5-7 April 1995, and subsequent consultation with Mr. Gunter Pauli, Founder of ZERI at the UN University and the ZERI panel of experts: Prof. Dr. Li Wenhua from China, Prof. Dr. Keto Mshigeni from Tanzania, and Dr. Mauricio Carcia-Franco from Venezuela, and based on my long association with Fiji, I prepared the present pilot project to make maximum use of the residues of a brewery in Fiji. The attached chart shows the various processes to treat and use the different wastes as effectively and efficiently as possible. It is hoped that such a pilot project, benefiting from my 30 years' experience on such work in many countries, will allow worldwide scholars to study without any undue delay and improve the whole concept of Integrated Development with Zero Emission which can bring economic and ecological benefits to island and other isolated situations in the world.

JUSTIFICATION

Beer manufacture and consumption are increasing worldwide and, especially in the developing countries, are a drain on food grains and imported fossil fuels which are very costly while people are short of food and energy, besides producing various kinds of wastes which degrade the environment. The objectives are to utilise all the wastes as useful resources, after full treatment using natural processes and at very low costs, and make beer brewing as well as other similar industrial enterprises more economic without any environmental pollution or depletion of resources.

PROCESSES

The one-hectare pilot plant will be built as near as possible to an existing brewery, preferably on waste land and even marshes. It will use some of the different wastes produced to demonstrate the validity and capacity of 5 main processes dealing with:

- (i) Solid Wastes
- (ii) Liquid Wastes
- (iii) Waste Heat
- (iv) Carbon Dioxide Emission
- (v) Spent Yeast

(i) Solid Wastes

The solid wastes are the residues from grains and additives used in beer making, and have a high protein and fibre content. They are usually fed to

livestock, which find them indigestible because of the ligno-cellulose, so it is broken down naturally by growing straw mushroom (*Volvariella volvacea*) on it with simple means -- a common occupation of farmers in China and Vietnam. It is proposed to try the shitake mushroom (*Lentinus edodes*), which is the most expensive in the world, using a technique developed in Fujian, China, using brewery wastes and straw instead of cutting down oak trees. Another way of using the solid wastes more economically is to grow selected earthworms of high protein content as chicken feeds, instead of using grains.

The livestock produce wastes which are given primary treatment in a digester while producing biogas as fuel for the brewery. The effluent is used to grow algae in shallow basins by photosynthesis while producing oxygen to give the secondary treatment to the remaining wastes, with the algae flushed into deep ponds as fish feed. The highly-mineralized effluent flowing into the deep ponds also encourages growth of various plankton as fish feeds. So fish polyculture, which is widely practised in China, can produce 10-15 tons of fish per hectare per year without having to add artificial feed except for grass grown on the edges of the ponds to feed the grass carp. Five or more other kinds of fish are used to feed on the different plankton produced daily.

The fish in turn produce their own wastes which are treated naturally by the self-purification capacity of the pond water, and the mineralized effluent is then used to irrigate and fertilize all kinds of crops in aquaponic floats made of bamboo or organically-produced plastic sheets on half the pond surface, on in aeroponic towers and greenhouses on land -- all current practices in China.

(ii) Liquid Wastes

Too much water is used in beer making for cleaning purposes -- between 20-30 tons to make one ton of beer in developing countries, and at least 7 tons in the developed ones. The BOD varies between 1,000 and 1,500 mg/l, and the COD is 50% more. Such a huge quantity of water should be recycled, but not in digesters because of the prohibitive costs involved, but in a minimum of two long and narrow primary ponds of 1 metre deep for at least 2 days' retention.

The design should facilitate the individual flushing of these ponds into the deep fish ponds mentioned in (i) above by gravity.

(iii) Waste Heat

The waste heat from the brewing process should be recovered and used to heat water for washing the equipment instead of using caustic soda and other polluting chemicals. The biogas generated from the livestock wastes is a convenient source of fuel for the same purpose in the pilot project. For a full-size treatment plant for the whole brewery, electricity can be generated from the biogas to supply most of the brewery requirements.

(iv) Carbon Dioxide

Much carbon dioxide gas is emitted during the brewing process and can be recovered for use in the brewery or bottled under pressure and used for draught beer. Unfortunately, the equipment is still expensive for the small breweries, and it is hoped that less expensive equipment will be available soon. Another possibility is to use the carbon dioxide in greenhouses or convert it into sodium bicarbonate for use in high-protein spirulina algae production.

(v) Spent Yeast

The technologies are already available for recovery and reuse of yeast, and for manufacture of some pharmaceuticals, with the residues mineralized in bio-oxidation ponds and then used to fertilize fish ponds.

ZERI PILOT PROJECT FOR FIJI BREWERY

(One-Hectare Treatment of Existing Waste Products)

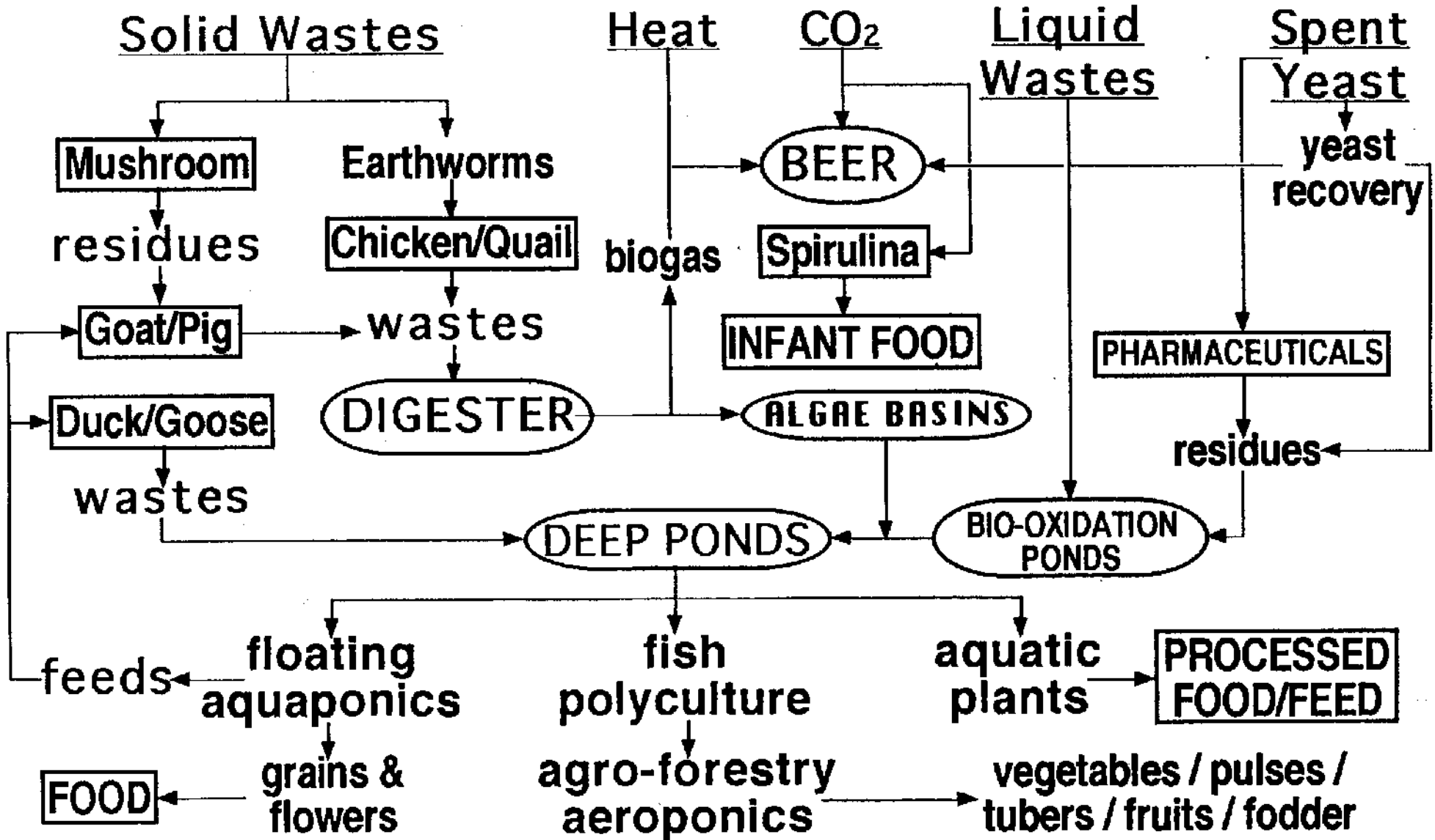

JAKARTA—Late last year, a professor from Mauritius went to Fiji with a plan to use the large amounts of sludge generated by a local brewery to benefit the local people. The pilot project would use the effluents from beer-making to sustain a variety of agricultural businesses. It calls for linking five different farm processes, using each one's waste as input for the others.

Called the Integrated Farming System, it is largely the brainchild of George Chan, a 72-year-old ecologist, engineer and professor. Chan is modest when he describes his idea's prospects, but to the Fijians and other participants involved in the project, it is a model of creative recycling with a dramatic payoff in environmental protection.

At a conference on reducing industry emissions, held here in July, Chan spoke about pilot projects in Namibia and Fiji. Attended by over 250 participants, the Third World Conference on Zero Emissions convened for a three-day meeting to discuss the urgency of pollution control.

In a room full of policy-makers, development consultants, business folk, and a few NGOs it is quite easy to spot Chan. He is usually surrounded by people interested in siphoning new thoughts from him or being enthralled by his calm logic, but what is most noticeable is his appearance—silver hair which he wears like a mane and the large shaded retro-eyeglasses he wears. But despite his appearance, it is his ideas which are attracting all the attention.

"Our system is a way of using all waste," he told *The Earth Times*, "including effluent and excrement, to be funneled in supporting five different types of local industries—which include cultivating fish, mushrooms, vegetables, livestock and producing methane to be used as fuel for electric power."

Chan says his method is one of sound business because it uses all by-products and opens new opportunities for diversification. But at its heart, it is a way to cope with the destructive environmental impact of emissions from a Fiji-based brewery.

That brewery uses from 2.5 to 8 gallons of water to produce one quart of beer. This

leaves large quantities of waste water, which is normally dumped into the surrounding ocean—at the rate of about 400,000 cubic meters per year. The result was an increase in the ocean's alkalinity which caused temperatures to rise in the shallow waters. Chan said the effects of such dumping can severely harm marine life and damage whole ecosystems.

Instead of dumping the waste, Chan decided to transport the brewery's sludge to the site of his experiment—the Montfort Boys' Town, a school for disadvantaged children on the largest island of Fiji. The boys had been cultivating fish, using the money they earned to help support the community. "Now doing work for Chan," said Brother Paul, head of the Boy's Town, "the boys will be gaining many valuable experiences which they can use later in life."

They are still raising fish, but now they have been able to branch out into other pursuits as well.

Brewery waste is rich in chemically-bonded carbohydrates which animals cannot digest, Chan explained, "but mushrooms can use this waste, taking what it needs and leaving a residue which can then be used as feed for livestock." The Montfort boys helped in building damp shacks for growing shiitake, oyster and straw mushrooms, some of which are harvested for sale, some to end up on their own dining tables.

Residues from the mushroom cultivation are collected by the boys and used as slop for pigs.

Excrement and waste from the livestock is then taken to a "digester"—a rectangular contraption made of concrete and metal about the size of a small car—which uses sunlight and algae to convert most of it into methane gas and fertilizer. The average digester costs about \$30 to build, lasts for about three years and can process 12 cubic meters of waste in 48 hours.

The released methane is captured in bottles at the top of the digester, yielding energy equivalent to about three gallons of



Professor George Chan.

gasoline a day, which to a developing country like Fiji is worth its weight in gold. The methane is used to power the Boys' Town electric generator and can be sold commercially as well. Using methane as an energy source also relieves the strain on forests for firewood.

The solid matter that remains in the digester moves through a solution, releasing some of its bacteria and resulting in a fertilizer that can be used for crops—and is safer to use than chemical fertilizers.

"They create surpluses in nitrate contents," said Chan of chemical fertilizers, "and studies have shown the harmful effects of too much nitrates in vegetables on children."

As the solid matter moves out of the digester it falls into a series of small pools filled with plankton, bacteria and other microorganisms which eat away at the waste and chemicals, leaving behind an ideal fish food.

This food goes into a large pond filled with six different species of fish, each performing a role in a complex system of sustaining the others by minimizing the threat of disease. If one species is harmed by an epidemic in any given year, the boys can rely on the other fish to sustain their income.

The nitrogen-rich fish droppings are then recycled as hydroponic nutrients used to grow vegetable crops without soil.

Chan said that his system accounts for about 80 percent of the feed needed for the fish. Ordinarily, he said, the cost of feed makes up about half of the operating costs of fish farming, which yields about \$500 to \$1,000 a year per hectare (2.47 acres). With his system, he said, each hectare yields \$10,000 a year.

"If we produce our own fish using these methods," said President Mara of Fiji, "we can become self-sufficient and even become an exporter."

—KYU-YOUNG LEE

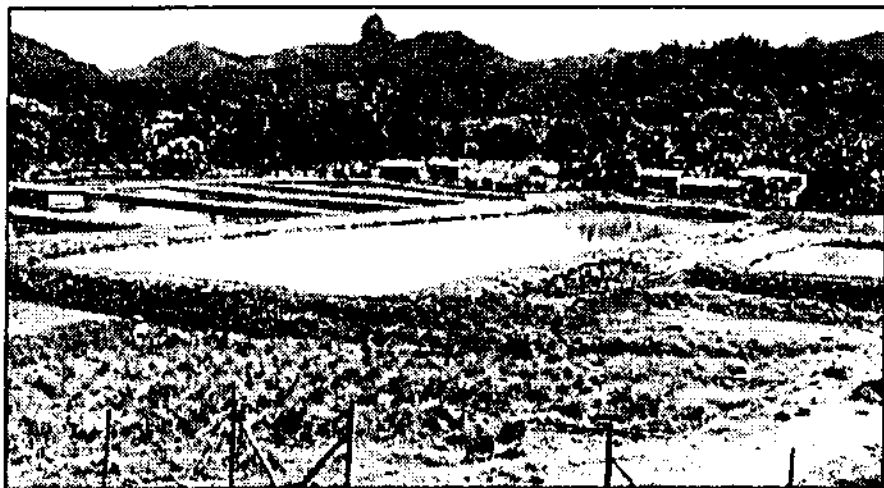

GEORGE CHAN

In Fiji, cultivating fish as in these pools is booming.

WHY THE INTEGRATED FARMING IN VIETNAM ?

**LIKE ALL OTHER
DEVELOPING COUNTRIES
VIETNAM
HAS ADOPTED A SYSTEM
THAT IS NOT APPROPRIATE !**

**THE LINEAR SYSTEM:
INPUTS → PRODUCTS =
FAILURE + WASTES**

**PRODUCTION COSTS ARE HIGH!
THE PRODUCTS ARE EXPENSIVE!
ENTREPRISES GO BANKRUPT!
THE WASTES POLLUTE!**

**THE INTEGRATED SYSTEM:
RECYCLING → PRODUCTS
= PROFITS + RESOURCES**

SONGBEn
chanbioM

**THE INPUTS COST NOTHING !
THE PRODUCTS ARE INEXPENSIVE !
THE FARM FAMILIES PROSPER!
THERE AIN'T ANY WASTES!**

**WE DERIVE THE BEST
AVANTAGES FROM OUR GOOD
CLIMATIC CONDITIONS**

**WE USE OUR ABUNDANT
RESOURCES TO MEET OUR BASIC
AND ESSENTIAL NEEDS BEFORE
PRODUCING FOR OTHERS**

**THE AGROINDUSTRIAL PRODUCTS
FOR EXTERNAL TRADE ONLY
CONTAIN LOCALLY-AVAILABLE
INPUTS AND TECHNOLOGIES**

ECO-FARM IN VIETNAM

(SONGBE PROVINCE)

SUMMARY

**Most Peasants Cannot Develop Integrated Farming
The Biggest Constraint is CAPITAL for Investment**

**Except Where the Soil is Suitable for BRICKMAKING
Much Better Still if the Land is Low-Lying and Marshy**

**A Brick Firm Digs the Fish Ponds FREE OF CHARGE
While Paying for the Excavated Soil for Brickmaking**

**The Money is Adequate to Build the Integrated Farm
& Operate the Various Livestock/Fish/Plant Activities**

**Within One Year the Integrated Farm Family Prospers
Within Three Years It Owns a Self-Reliant ECO-FARM**

ECO-FARM PROJECT

PHASE 1 : TAN MY VILLAGE

TAN UYEN DISTRICT, SONGBE PROVINCE

OBJECTIVES OF PROJECT

- Demonstrate an ECO-FARM project in a low-yield and low-lying rice field in the Songbe Province of Vietnam
 - The demonstration consists of :
 - 8 integrated farms of 1.12 ha each
 - 8 integrated farms of 1.36 ha each
 - one rural centre of 1.82 ha + roads
 - The integrated farm consists of :
 - 6 x 8 pigs monthly (48 at a time)
 - 96 pigs yearly or 10 tons of meat

In Phase 2, poultry will be added:

- 3 x 200 ducks/month (600 at a time)
2,400 ducks or 5 tons of meat/year
- 2 x 400 chicks/month (800 at a time)
4,800 chickens or 5 tons of meat/year

- 2 fish ponds of 3,000m² each
- 30,000 fingerlings at any time
- 9 to 10 tons fish/hectare/year
- Capitalize on natural properties of subsoil suitable for brick making
- Have brick-making firm to dig the fish ponds to required depth and buy excavated soil for brick making
- Payment at the rate of US\$4,000 per pond of 3,000m² x 1m deep or a total of \$8,000 for one farm
- This sum is adequate to build the whole integrated farm with enough operating funds for various livestock/aquaculture/agronomy/agro-industry
- Total Project will be self-financed, except consulting services provided by bilateral arrangement with an NGO

CONCLUSIONS

The Integrated Farming System enables the young farm families in Songbe province, southern Vietnam, to develop the low-lying and even marshy land into high-yielding ponds for fish polyculture and elevated dykes for livestock and crops in an enterprise which is both economically-viable & ecologically-balanced

Presently, farmers have two crops of rice annually with a net income of US\$200-300 per hectare, which is only half of what they require to make ends meet, so they have to supplement their income by fishing in the nearby river and go to the woods to cut down the trees for firewood, which they then sell illegally

The Integrated Farming System allows them to have many LIVESTOCK/FISH/PLANT activities at the same time, but the staggered work programme is planned in such a way that the farm family only has to work half-day but can get a yearly income of \$3,000-4,000

Livestock feed is the only recurrent purchase during the first year, but it is gradually replaced by fodder trees, macrophytes, and crop & processing residues to become self-sufficient during the third year, while the farm produces all the other means of production

ECO-FARM LAYOUT SB

16 UNITS OF 1.12 & 1.36 ha
TOTAL AREA : 22.56 hectares

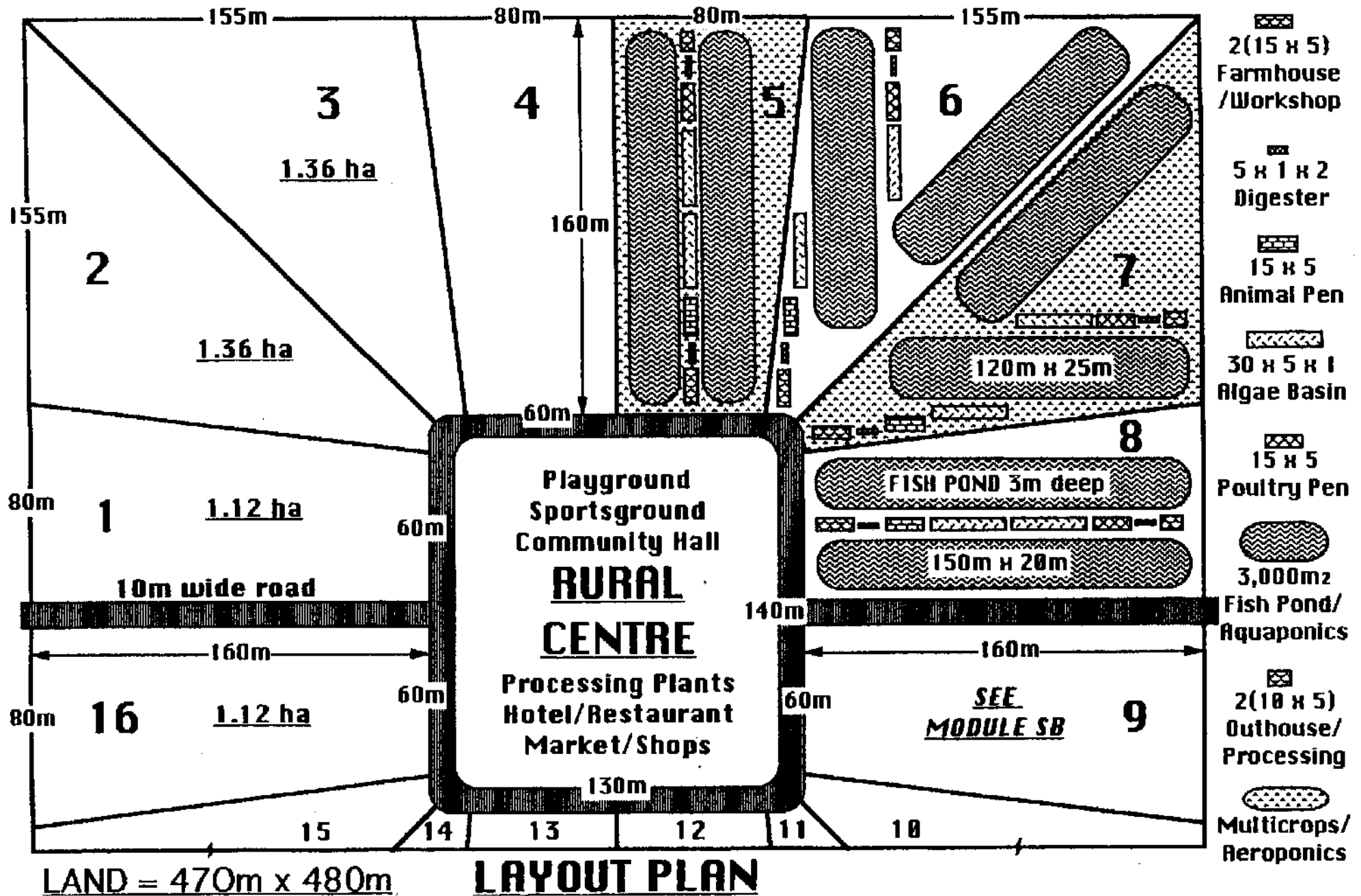

ECO-FARM MODULE SB1

UNIT OF 1.12 HECTARE

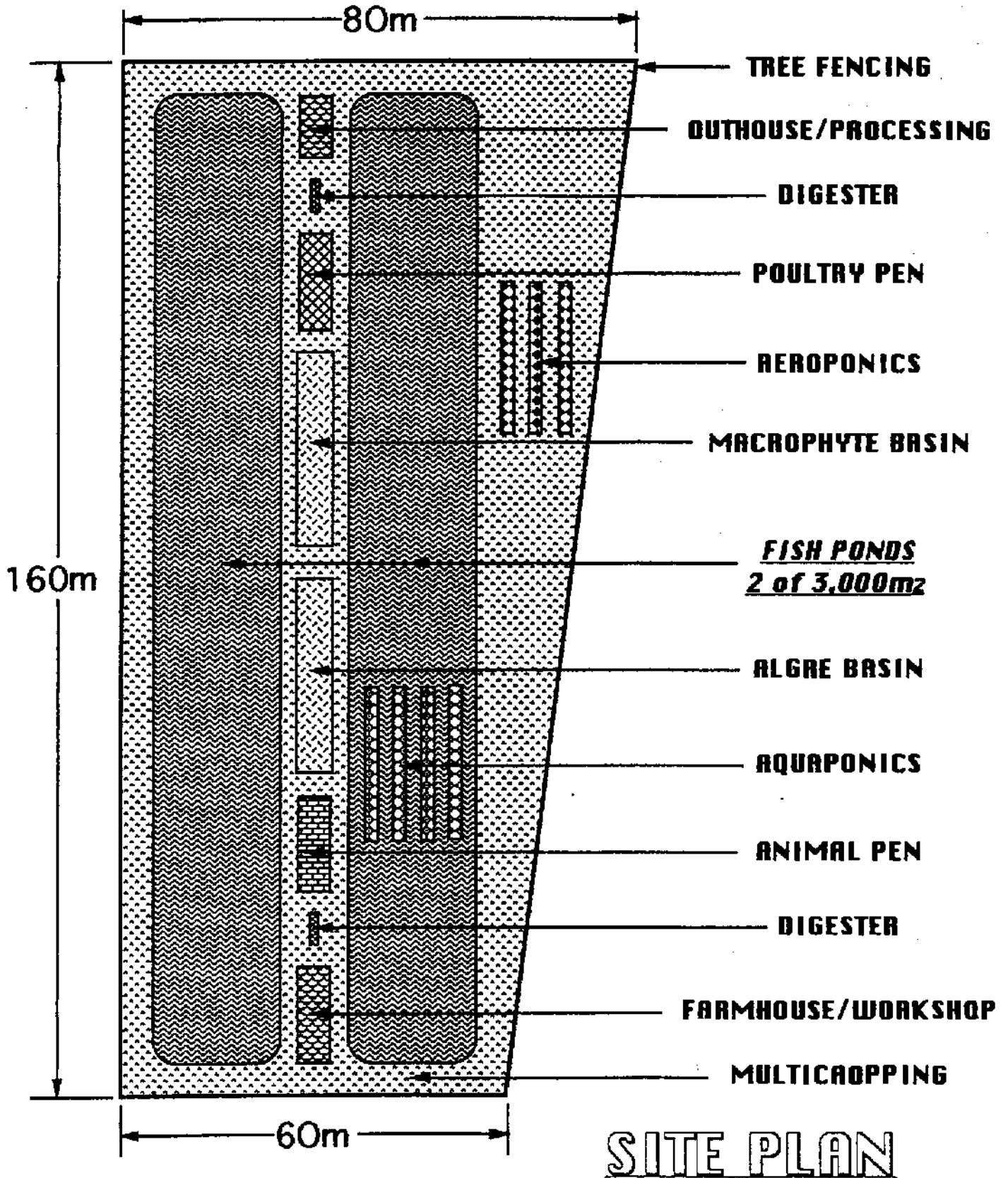

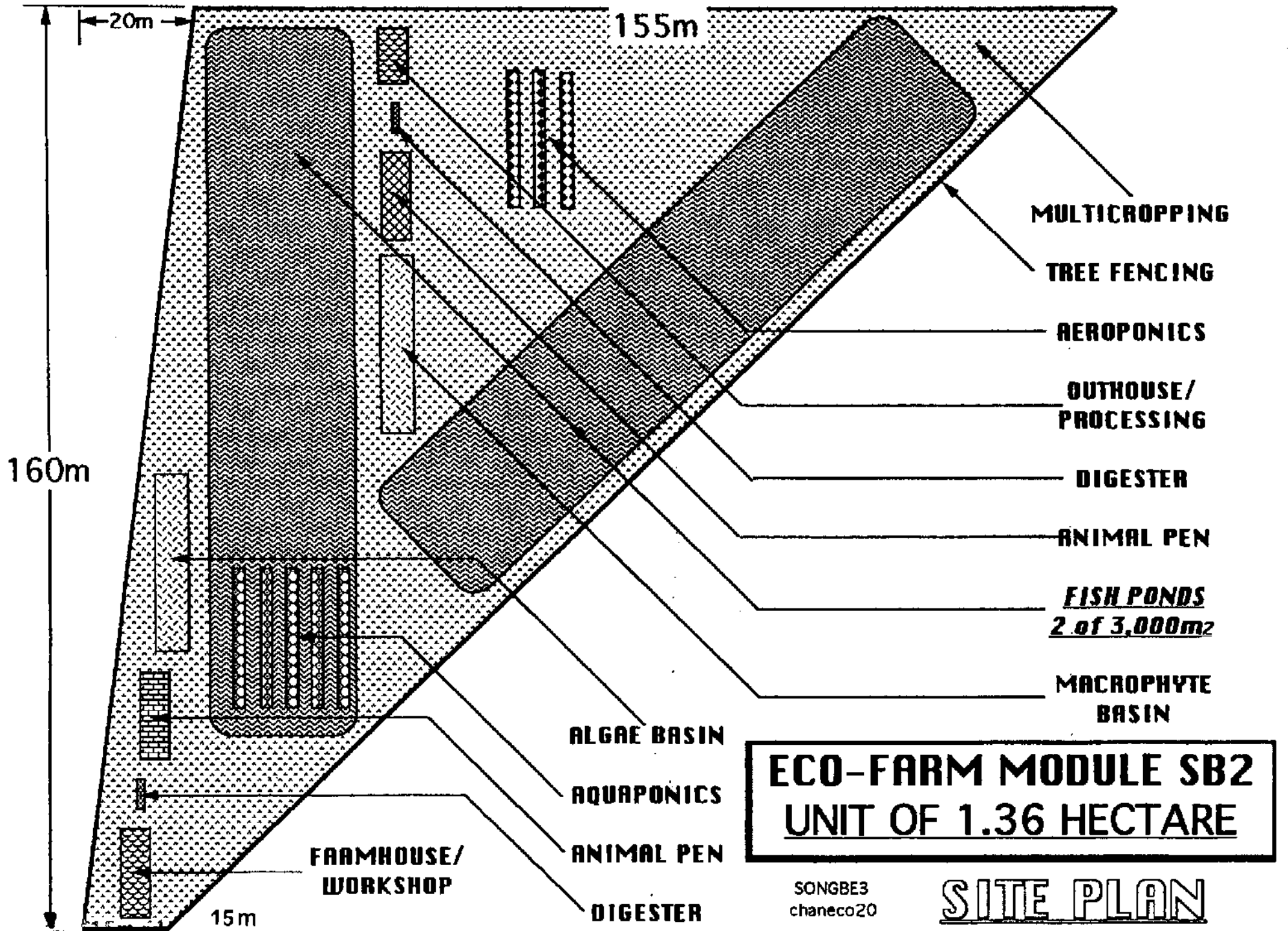

ECO-FARM SECTIONS SB1

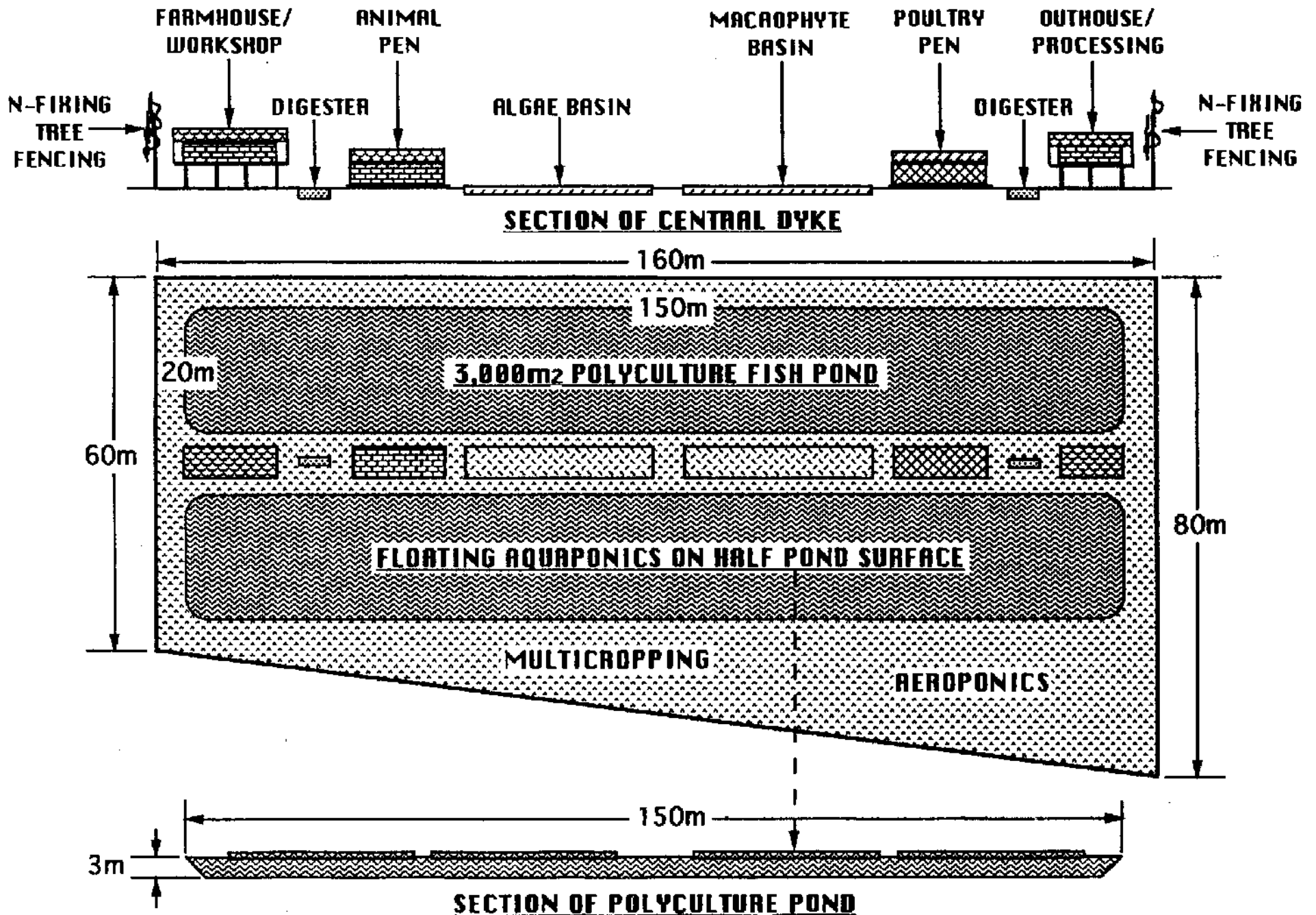

FARM BUDGET

0.7 Hectare Farm (Songbe1, VN)

	<u>US\$</u>
One pond of 3,000m ²	2,000
Animal pen of 50m ² + digester	<u>1,000</u>
<i>TOTAL Capital Expenditure</i>	<u>3,000</u>

30 piglets @ \$50	1,500
* <u>Purchased feeds, etc.</u>	<u>1,500</u>
<i>TOTAL Operating Capital</i>	<u>3,000</u>

NOTE : FARMER REQUIRES CAPITAL OF \$6,000

Sale after 6 months @ \$120	3,600
Profit for one batch of pigs	600

Profit for 2 batches/year	1,200
Sale of 3 tons of fish @ \$600	1,800
Sale of vegetables/year	300
Sale of banana & papaya/year	300
Savings on biogas for fuel/year	<u>100</u>
<u>TOTAL PROFIT for first year : \$3,700</u>	

* Savings on Purchased Feeds are made gradually by substitution with fodder crops, crop and processing residues -- Total Amount Saved : \$3,000/year

Profit for Second Year = \$3,700+\$1,500 = \$5,200

Profit for Third Year = \$3,700+\$3,000 = \$6,700

FARM BUDGET

1.2 Hectare Farm (Songbe2, VN)

US\$

SALE OF EXCAVATED SOIL 8,000

(suitable for brickmaking)

Two ponds of 3,000m² NONE

Animal pen of 50m² + digester 2,000

TOTAL Capital Expenditure 2,000

60 piglets @ \$50 3,000

* Purchased feeds, etc. 3,000

TOTAL Operating Capital 6,000

NOTE : FARMER HAS CAPITAL FROM SALE OF SOIL

Sale after 6 months @ \$120 7,200

Profit for one batch of pigs 1,200

Profit for 2 batches/year 2,400

Sale of 6 tons of fish @ \$600 3,600

Sale of vegetables/year 1,000

Sale of banana & papaya/year 1,000

Savings on biogas for fuel/year 200

TOTAL PROFIT for first year : \$ 8,200

* Total savings on Purchased Feeds : \$6,000/year

Profit for Second Year = \$8,200+\$3,000 = \$11,200

Profit for Third Year = \$8,200+\$6,000 = \$14,200

THE INTEGRATED FARMING SYSTEM

An Ecological Agro-System at
the Service of Farm Family
Units in Developing Countries

Presented

by

**ZHONG Gongfu
George L. CHAN
Jose I. FURTADO
Kenneth RUDDLE**

March 1986

A: Professor ZHONG Gongfu, BS.

A 1941 graduate of the former Zhongshan University in Guangdong, China. He was Director of the Guangzhou Institute of Geography, and has devoted the past 20 years to the expansion of the dike-pond-system in water-logged and low-lying areas. He has now retired, but is still very active in the Geographical Society of China, and other learned institutions. He is a representative in the Guangdong Provincial Assembly.

B: Professor George Lai CHAN, BSc (Eng) DIC.

A 1949 engineering graduate from the University of London, UK, and with a 1961 PhD, in environmental engineering from the same university. After 10 years as a civil engineer in Mauritius, he worked for the South Pacific Commission in his specialized fields of housing sanitation, water supply, and waste-water treatment in most of the islands in the Pacific. He has also taught environmental health at the University of Papua New Guinea. He has now retired. He is mainly concerned with the development of local resources through complete re-cycling of all residues in an integrated farming system in order to control environmental pollution, and at the same time improve public health, nutrition, energy conservation, and traditional farm activities.

C: Jose I. FURTADO, BSc (Hons) PhD.

A 1960 zoology graduate of the University of Western Australia, Perth, and has a 1966 doctorate from the University of Malaysia - KL. He was professor of zoology and also coordinator of the tropical ecology degree program at the University of Malaysia - KL. He is at present scientific advisor with the Commonwealth Secretariat in London UK. His main interests are in aquatic ecology, behaviour, and socio-biology, biogeography and evolution, and human ecology. He is interested in advancing the concepts of behaviour and ecology through their application in natural resource and environmental management, technological innovations and science management and organization.

D: Kenneth RUDDLE. BA (Hons) PhD.

A 1964 geography graduate of the University of Manchester, UK. and with a 1970 doctorate from the University of California - LA. USA. He has held various research and teaching positions in the USA, and done projects for the UN University, and for the US-Aid. He has been consultant to institutions in the Philippines, Indonesia, R. of Korea (South), and Japan. He is now associate professor at the National Museum of Ethnology, Osaka, Japan. His fields of interest include human ecology, traditional use and management of natural resources in coastal zones, water-land inter-active systems, and the Integrated Farming System.

SUMMARY

This *DOCUMENT* describes the INTEGRATED FARMING SYSTEM (IFS) project proposed for Zhujiang (*Pearl River*) Delta, Guangdong Province, CHINA, where such a concept has been established for centuries. Presently, it is based on an *integrated aquaculture/agriculture* concept known as the MULBERRY DIKE--CARP POND--SILKWORM system. It is now proposed to expand it into a *much more integrated* one of LIVESTOCK--AQUACULTURE--AGRICULTURE--FARM INDUSTRY by involving international agencies and universities in its further development through application of modern but appropriate technology and management techniques. A request is made to the international, regional and national organizations to fund the proposed project, which requires a sum of U.S. \$2,451,000, spread over 6 to 7 years, for the scientific, technological, management, and socio-economic investigation and testing of the system, under different environmental conditions in the Zhujiang Delta region. It is hoped that the numerous multi-disciplinary data collected and analysed during this project will enable many other countries to assess the INTEGRATED FARMING SYSTEM as an *environmentally sound and economically viable strategy* for their own development plans, and help them solve some of their urgent problems of poverty and stagnation through mobilization of their human resources and utilization of their own natural resources in sustainable and self-reliant development programs, not only for their immediate benefit but also for future generations.

INTRODUCTION

The INTEGRATED FARMING SYSTEM (IFS) has been tried during the past 20 years by one of the authors (1 & 2) in various experimental farms in a few Pacific islands, and by some individuals in parts of Asia. They have shown that it is possible to integrate LIVESTOCK, AQUACULTURE, AGRICULTURE and FARM INDUSTRY as a viable *ecological development system* through recycling of all the organic wastes to stop propagation of diseases caused by bad sanitation while producing fuel, feed and fertilizer; and utilizing existing scientific and technological innovations in animal husbandry, algae and fish culture, multicropping, and produce processing to increase the economic return. This symbiotic use of local resources did not get much support because of absence of scientific data, insufficient research, lack of positive development in these fields, and lack of knowledge of such possibilities which also go against established practices and are regarded with suspicion.

Moreover, as outlined by Furtado (3), there are many socio-economic and other constraints, besides the application of scientific and technological innovations, inhibiting the further development of such integrated farming systems. One important initiative has already been taken by the United Nations University (UNU) sponsoring a three-year (1980-83) applied research project, in which the other three authors were involved, on the well-established resource recycling system of AGRICULTURE and AQUACULTURE at LELIU in the Shunde District of Guangdong Province, as described by Ruddle, Furtado, Zhong & Deng (4).

With the new scientific data on its physical (energy and nutrient relationships), biological (interactions among all living organisms), and socio-economic (relationship between employment and economic return, and mutual benefits between rural and urban or industrial communities) aspects, and additional input from other appropriate sources, it is hoped that the proposed project will lead to the favorable development of the INTEGRATED FARMING SYSTEM in the project area and its subsequent dissemination, not only to the less developed region of China with similar physical environment, but eventually, with suitable biological, cultural and organization adaptations, to its successful transfer to other parts of the developing world.

THE BASIC AIM OF THE
PROPOSED
INTEGRATED FARMING SYSTEM
PROJECT

IS TO IMPROVE THE
ECONOMIC STATUS & SOCIAL
WELFARE
OF MOST RURAL COMMUNITIES
IN THE DEVELOPING COUNTRIES
THROUGH
PROPER UTILIZATION
OF THEIR
NATURAL & HUMAN RESOURCES
IN AN
AGRO-ECOLOGICAL-HEALTH
SCHEME

In the southeast region of Guangdong Province, China, near the mouth of Zhujiang (Pearl River), the small-scale farmers have been engaged during two millennia in highly productive agriculture and aquaculture projects on the delta, based on generations of empirical practices that have allowed them to remain net exporters of produce and processed goods for such a long period while maintaining the ecological balance.

About four hundred years ago, they reached a complex but properly balanced integrated development strategy, known as the MULBERRY DIKE- CARP POND-SILKWORM ecosystem, where polyculture of various species of fish enriches the pond mud that is then used to fertilize the mulberry trees on the dikes; the mulberry leaves are fed to silkworms to produce silk and their excreta, together with human and other livestock wastes, are dumped into the ponds to feed the fish and fertilize the growth of plankton as fish feed. The mulberry tree is rotated with sugarcane and during the winter months, when it is too cold for the silkworms, vegetables are grown.

This integrated agro-system is the basis of rural development in the southern part of Zhujiang Delta, with an area of 800 square kilometers and where 1.2 million people live. Without any doubt, it has proved to be successful on a very wide geographic and economic scale unmatched elsewhere in the world, as stated by Ruddle et al (5). It has survived every political and social upheaval happening in China during many centuries, so the concept has nothing to do with ideology, but its success is due to the discipline, diligence and receptive nature of the people based on their cultural heritage.

The Chinese farmers will certainly welcome the additional technology and modern management techniques of the proposed IFS project to their already efficient system. It will also provide more employment for their new generation that want more consumer goods, for which they are prepared to work harder. This is what the IFS is all about: **HARD WORK**, but also **GOOD MONEY** through high productivity and substantial savings in production costs. Such incentives can work wonders anywhere -- and more so in China.

Although the IFS has promise for the rest of the developing world, it is subject to the strict discipline of the Chinese peasantry working in cooperation. Perhaps the developed world could also look at the IFS as an effective means of prevention of waste and control of their environmental pollution problems, as no country can now afford to exploit its limited resources without considering the ecological damage.

**IT CAPITALIZES ON THE
WISDOM
OF A
TRADITIONAL AGRO - ECOLOGICAL
SYSTEM
OF
AQUACULTURE & AGRICULTURE
KNOWN AS THE
MULBERRY DIKE-CARP POND-
SILKWORM PROJECT
ESTABLISHED BY THE CHINESE
FOUR CENTURIES AGO
IN THE SOUTHERN PART OF ZHUJIANG DELTA
WITHOUT
DAMAGING THE ENVIRONMENT
OR
UPSETTING THE ECOLOGICAL BALANCE**

The MULBERRY DIKE-CARP POND-SILKWORM system provides the farm family unit with a diversity of occupations and products all year-round, and brings in a wide range of income at various intervals during the year. According to Zhong (6) and Ruddle (7), these farm ecosystems are providing much higher economic returns than do other agrarian practices in the Zhujiang Delta, besides creating employment opportunities in an area under population pressure. The multiple fish harvests (6-7 times/year), mulberry leaf sale or silk filament from the cocoons (8-9 times), sugarcane (once), banana (once), and winter vegetables (twice), together with some processing of the primary produce and employment of many women in the silk factories and some men in the sugar mills, contribute to the wealth of the farm family unit.

There should be no illusion about the hard work required to keep such a system operating at its maximum efficiency. As explained by Ruddle (8), the labor demand in the area of Zhujiang Delta with the most developed integrated systems, covering an area of 800 square kilometers with 1.2 million people, is quite intensive to take care of the ponds, dikes, and silkworms. Still the system can only absorb 40 to 60% of the available labor force, and even with the small-scale mechanization considered desirable to increase output now being implemented, the situation can only become worse. The proposed IFS will include livestock such as pig and poultry, and more aquatic plants and cash crops that will also provide feed and preferably fertilizer, in order to create more employment to keep the people on the farm.

This self-reliant and diversified system is in line with the rural development policies of the Chinese Government, which is now faced with the increasing exodus of farm labor to the urban and industrialized areas, mainly for better pay, and with the increasing costs of continuing to subsidize fertilizers and seeds to farmers for remaining on the land. There is also the problem of higher labor costs for harvesting grains on the big farms, which can result in more mechanization and create more unemployment problems. It makes sense to keep the small farms, but with much more diversity and higher economic returns through helping every farm family unit to take care of itself -- and prosper.

Prosperity among the small farmers is an important factor that should not be ignored. This will allow them to expand their economic activities with modern equipment and appropriate mechanization, and let them participate in a systematic and gradual move toward the modernization goals of their country.

**THE
MULBERRY DIKE - CARP POND -
SILKWORM**

CONCEPT

AIMS AT OPTIMIZING THE

ECONOMIC RETURN

ON THE

FEED & FERTILIZER

WITHIN A

CLOSED SYSTEM

WITH INPUT FROM

NATURAL RESOURCES

SILKWORM EXCRETA

&

PEOPLE ONLY

The proportion of land to water is a critical factor in determining the economic return of a particular system. The land needs the pond mud as fertilizer, supplied by the fish excreta, for the mulberry trees to grow well and supply plenty of healthy leaves to the silkworms; the fish population depend on the silkworm excreta available for fish feed or as fertilizer to grow planktons for fish feed; and the bigger the fish population, now expertly provided through polyculture, the higher will be the fertilizer value of the pond mud.

However, the most important commodity is the fish, which brings in the highest income because of the daily demand for this fresh product in Guangzhou, Hong Kong and Macau. Polyculture of fish is already well developed, and the Guangzhou Institute of Geography already has a substantial collection of scientific data on the variety of feed available in a deep pond and the species of fish that will live at different depths and feed on specific plankton and residues. The aim is to have maximum population of fish in a unit area of pond to utilize all the available feed, whether it is in the form of fish excreta or plankton, but ensuring that there is no organic pollution affecting the oxygen content or causing diseases among the fish. Any additional feed required by the fish must also come from the system, so the dikes are used primarily to meet the feed requirements of the fish, which are closely dependent on the fertilization of the ponds by human, silkworm and other livestock wastes within the system.

The mulberry and sugarcane plantations depend on the domestic and international market demand for silk and sugar, and had created some problems in the past because of fluctuating demand and prices, but there is no such problem with fresh or live fish.

Only minute quantities of chemical fertilizer are occasionally used, and both the land and water have retained their high fertility for four centuries of integrated farming. This should be of significant interest to a few provinces in China and some neighboring countries with *declining soil productivity* because of abuse of chemical fertilizer in sugarcane fields, monoculture of cassava, overgrazing, etc.

ITS

AIM

IS TO UTILIZE

ALL AVAILABLE RESOURCES

IN THE MAN-MADE ENVIRONMENT

BUT RELYING MOSTLY ON

NATURE

LIVESTOCK WASTES

& HUMAN LABOR

THROUGH BALANCING OF THE

FERTILIZER/MULBERRY

TREE/SILKWORM/FISH

FOR

OPTIMUM PRODUCTIVITY

The original purpose of the IFS in the Pacific islands was to find an economical way of treating human excreta in rural communities in order to control communicable diseases transmitted by contaminated soil, water and food. The cheap systems isolated the excreta in pits or discharged it in bodies of water, depriving the soil of useful nutrients that have been taken from it through slash and burn culture of food crops. The villages could not afford the expensive systems such as septic tanks and package treatment plants, so their environment deteriorated through bad sanitation and soil depletion, leading to debilitating diseases and malnutrition that had an adverse impact on their economic and social well-being.

The IFS offers an effective treatment system of isolating the wastes of both humans and animals, and then converting their organic and pathogenic contents through digestion and oxidation into harmless substances that can be used as fuel for domestic and other purposes, and fertilizer to grow algae as high protein feed and a variety of cash crops. After the initial capital costs, the system depends mostly on local natural resources for its operation while controlling the existing environmental health and farming problems. Its further development will enable the villagers of most tropical and subtropical countries to capitalize their untapped assets, and give them new opportunities for the improvement of their environment as well as their quality of life through maximum economy and self-reliance.

Its development by Chan (9) in the U.S. Commonwealth of the Northern Mariana Islands led to a multi-disciplinary project that received one of the highest awards from the U.S. Department of Energy for energy innovation in a national contest in 1984.

**ONE OF THE
OBJECTIVES
OF THE PROPOSED
INTEGRATED FARMING SYSTEM
PROJECT IS TO PROTECT THE PEOPLE FROM THESE
HEALTH HAZARDS
BY DISTANCING THE
DISEASE ORGANISMS
OF BOTH HUMAN AND ANIMAL WASTES
FROM THE COMMUNITY THROUGH AN ELABORATE
TREATMENT SYSTEM
THAT UTILIZES
ALL THE WASTES
TO PRODUCE
FUEL
FEED
&
FERTILIZER**

Human wastes are flushed directly from the toilet bowl, and livestock wastes are washed two or three times a day from the pen floor, into one or more digesters for primary settling and digestion (under anaerobic conditions) of the organic content. This is followed by secondary settling and further digestion, with the organic matter reduced by two-thirds into stable minerals. This process also gives a useful by-product (biogas) containing two-thirds methane for use as fuel.

The digester effluent, still containing one-third of the organic content, is oxidized in shallow basins and tanks aerated by mechanical means to complete the mineralization process, with a high protein by-product (algae) for use as animal feed.

The mineralized effluent then flows into deeper fish ponds to fertilize growth of plankton for fish feed. The pond effluent is then distributed through drip irrigation pipes into the soil for irrigation and fertilization of food and cash crops.

The treatment processes in the IFS follow the same principles as those used in the most modern plants, but the IFS also uses the valuable by-products instead of wasting them:

<u>PROCESSES</u>	<u>BY-PRODUCTS</u>	<u>USES</u>
Isolation		
Primary Settling	Liquefied Effluent	Further Treatment
Digestion	Biogas	Fuel
+		
Secondary Settling	Secondary Effluent	Fertilizer
Digestion	Biogas	Fuel
+		
Extended Aeration in shallow ponds	Algae	Feed
+		
Stabilization in deep ponds	Plankton Fish	Feed Food & Feed
+		
Demineralization (Soil Absorption)	Crops	Food, Feed, Fuel & Fertilizer

UNFORTUNATELY

HUMAN EXCRETA

IS ALSO USED AS

FERTILIZER

WITH ITS INHERENT

PUBLIC HEALTH

AND

OCCUPATIONAL HAZARDS

RESULTING IN

ABSENTEEISM

ON THE FARM

THAT

AFFECTS

RURAL PRODUCTIVITY

AND

REDUCES

FARM FAMILY INCOME

The IFS involves every farm family unit, individually and jointly, in the proper management of the land, air and water resources for sustainable growth of the rural economy, with a view to producing a whole range of livestock, aquatic life, trees, crops, and processed foods and goods through complete recycling of all locally available resources in a scientific, sanitary and environmentally sound manner, and with minimum input from outside. They aim at producing most of the fuel with biogas, biomass and its derivatives such as ethanol, and other local sources of energy, if appropriate, such as solar, wind and hydropower; animal feed such as algae, aquatic plants, and crop and processing residues; and fertilizer through fixation of atmospheric nitrogen with plants and trees, and mineralization of organic wastes after proper digestion to recover the energy content. Some activities will be done as joint ventures or through farmers' associations for economic or logistical reasons.

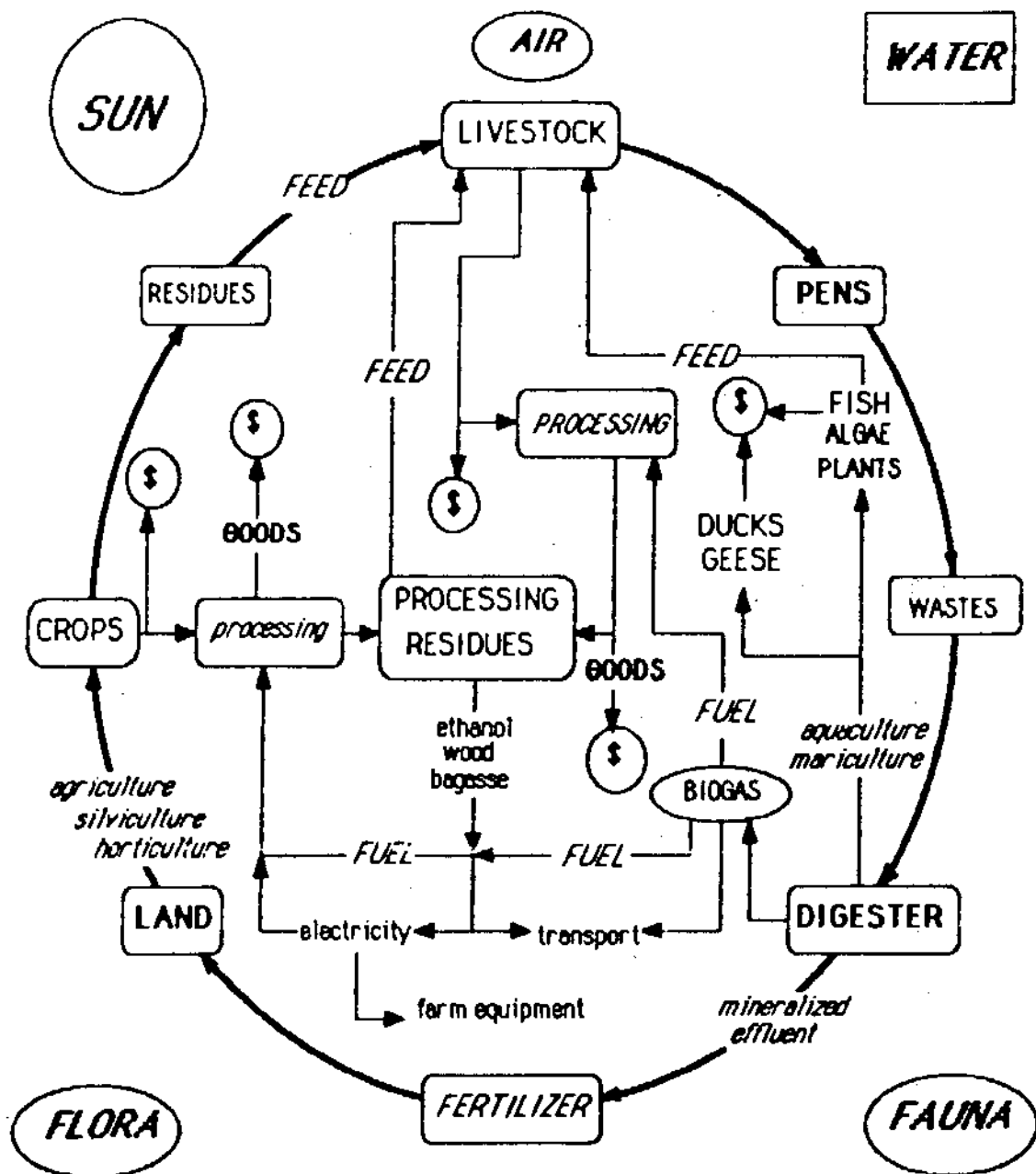

FOOD - ENERGY - WASTE CYCLE

A SECOND OBJECTIVE
IS TO OPTIMIZE THE
TRADITIONAL
INTEGRATED
AQUACULTURE-AGRICULTURE
SYSTEM.

THROUGH ITS FURTHER
EXPANSION

INTO A MUCH MORE INTEGRATED SYSTEM OF
LIVESTOCK-AQUACULTURE
AGRICULTURE-INDUSTRY

BY INVOLVING CONCERNED
INTERNATIONAL SPECIALISTS
IN FURTHER DEVELOPMENT OF THE CONCEPT
THROUGH UTILIZATION OF MODERN
SCIENTIFIC KNOWLEDGE

&

APPROPRIATE TECHNOLOGY

The project will be operated by selected staff of the Guangzhou Institute of Geography, under the leadership of Professor ZHONG Gongfu, who has been involved in the MULBERRY DIKE-CARP POND-SILKWORM system for over 20 years. He will have *overall supervision* of all the activities in the IFS project, and will be responsible for all dealings with the Central, Provincial and District Government. Besides the Director of GIOG, who will act as Chairman during the meetings of the IFS Coordinating Committee, four other members of the Institute staff will be directly involved in the project -- see *Appendix A*.

The Institute has both the personnel and the equipment to carry out all the tests required to determine the composition of all the products and residues in the above operations. So it can very well contribute a considerable amount in manpower and in services to help the IFS project. *Appendix B* gives a brief description of the Guangzhou Institute of Geography and the tasks it can perform.

The Institute will have the collaboration of Mr. George Lai CHAN, a Visiting Research Scholar who has advocated the integration of LIVESTOCK- AQUACULTURE-AGRICULTURE-FARM INDUSTRY in every farm family unit for rural eco-development in the Asia/Pacific Region during the past 20 years. He will act as Liaison Officer with the *external* organizations involved in the project, whether financially or academically. He now lives in Shenzhen, not too far from the project area, and will be available for an aggregate period of six months every year to work on the project.

The project will also have two other Research Scholars, Professor Jose I. FURTADO and Associate Professor Kenneth RUDDLE, who were involved in the United Nations University applied research project in LELIU. They will provide the *scientific, ecological, social and economic* expertise based on many years of work on the international scene, and will stress the importance of the socio-economic impact of science and technology on the different strata of the community. The Chinese social fabric has been strong enough to maintain a closely knit society that has survived all kinds of adversity, and is mainly responsible for the success of present day economic revolution on such a gigantic scale. It is also worth looking into all the negative consequences, particularly in relation to future marketing problems and income maldistribution, which will undoubtedly disrupt the traditional balance with possible, but **not inevitable**, social and economic woes so familiar in many developing as well as developed countries.

THE DURATION OF THE PROPOSED IFS PROJECT IS

6 TO 7 YEARS

AND INVOLVES

SCIENTIFIC & TECHNOLOGICAL
DEVELOPMENT

SOCIO-ECONOMIC FIELD STUDY

AND

DATA COLLECTION & ANALYSIS

IN

THREE REGIONS OF ZHUJIANG DELTA

WITH DIFFERENT PHYSICAL

ENVIRONMENTS :

SOUTHERN

CENTRAL

WESTERN

In the existing MULBERRY-CARP-SILKWORM system, the cycle is generally as follows:

OPERATIONS	REQUIREMENTS	PRODUCTS
- Mulberry trees grow on dykes	Healthy trees	Leaves (\$)
- Leaves of mulberry tree fed to silkworms	Healthy silkworms	Cocoons/silk filaments (\$)
- Silkworm excreta put into fish ponds	Plentiful excreta as fish feed and fertilizer	Planktons as fish feed (S) (S - savings)
- Polyculture of various species of fish, mainly carps	Appropriate species in optimum numbers	6-7 harvests yearly (\$)
- Transfer of pond mud to dykes	Rich in minerals and compost	Fertilizer for mulberry (S)
- Intercropping with banana & winter vegetables, or rotation of mulberry with sugarcane	Fertilizer and water	Marketable produce/raw material (\$)

One very important factor to remember is that this agro-system produces silk and sugarcane as raw materials for the existing factories employing many local men and women. This situation should not be disrupted by the proposed changes, and the market study should ascertain that the raw material demand will be adequately met before the land use pattern is changed. The LIVESTOCK-AQUACULTURE-AGRICULTURE-FARM INDUSTRY system will complement the above cycle, providing additional fuel, feed and fertilizer on the spot to create more farm activities and increase the economic returns for the farm family unit.

While hoping that further research and positive development by the Institute staff and visiting graduate students and academics will lead to expansion of our activities during Phase II of this IFS project, the proposed expanded cycle for Phase I will be as follows:

OPERATIONS	REQUIREMENTS	PRODUCTS
- Silkworm culture (as above) but excreta discharged into digesters instead of being put directly into fish ponds	Improved sericulture technology & disease control	Longer silk filament in shorter time -- more (\$)
- Pigs and chickens raised in pens and cages	Proper animal husbandry	Meat and poultry (\$)
- All wastes washed into some digesters and settling tanks	No leakage or corrosion	Biogas fuel (S)
- Digester effluent pumped to pitched clear plastic cover over shallow reservoir on flat roof of pen and then into the reservoir for algae culture	Wind or solar pump with biogas pump as standby. Liquid flows over roof cover as a thin film	Increased algal growth (S). Extra aeration for mineralization
- Roof effluent discharged into algae basins or tanks, and kept in motion by paddle wheel or compressed air	Clear effluent for good solar penetration. Avoid eutrophication	Algae used as animal feed, fertilizer or digester feed stock (S)
- Basin effluent flows through hydroponics troughs & aeroponics pots to grow crops	Proper hydroponics and aeroponics technology	Various plants as food (\$) and feed (S)
- Trough effluent discharged into fish tanks and ponds	Polyculture technology	Multiple fish harvests (\$)
- Pond effluent pumped to overhead tank, then flows into drip irrigation pipes on dykes to irrigate and fertilize crops	Same pumps as for digester effluent	Trees, fruits, vegetables, and livestock feed (\$)
- Pond mud on dykes (as above, but not sole source of fertilizer)	More and better fertilizer	Higher output and better crops (\$)
- Processing of livestock and crops (pickling, fermenting, drying, smoking, sugaring, salting, etc.)	Small equipment & machinery, and new & appropriate technology	Processed foods/goods, and livestock feed (\$) & (S)

The proposed IFS project will be done in three phases as follows:

- Phase I - Testing and further development of the MULBERRY DYKE-CARP POND-SILKWORM system *integrated* with the LIVESTOCK-AQUACULTURE-AGRICULTURE-FARM INDUSTRY system at the experimental station and two selected farms in the vicinity of LELIU, where the *land to water* ratio is only 1:4, with a view to optimization of the proposed IFS.
- Phase II - Application of the IFS to three farms each in the central and western parts of the Delta, where the ratio of *land to water* is between 1:1 and 4:1, in order to diversify the farming activities, create local employment opportunities, and optimize utilization of all available resources.
- Phase III - Relationship of the IFS in the whole Zhujiang Delta, with an area of 12,000 square kilometers and 10 million people, to the *urban and industrial* areas of Guangzhou, the provincial capital, Shenzhen and two other special economic zones, Hong Kong, and other fast developing areas along the coast of Guangzhou Province, concerning supply and demand, production, marketing, income structure and distribution, and the social implications.

Each *phase* will be for a duration of 2 to 3 years, but there will certainly be much overlapping which will enable the *whole* project to be completed in six to seven years. The distinction between the three phases only serves to highlight the areas where the emphasis should be put in order to achieve our objectives, but we have no intention of separating the technological and scientific aspects from the socio-economic ones at any stage.

During Phase I, there will be a construction period of 6 months, followed by 6 months of trials and experiments with livestock breeds and various species of plants available in the tropical world, and then 12 to 18 months of data collection on an agreed list of operations. Meanwhile, research and development will continue at LELIU Experimental Station and at the Institute by the staff and overseas scholars. The teaching during Phase I will be limited to the local farmers and extension officers in seminars and group discussions. Phases II & III will concentrate on training of both local and overseas technicians and trainers, and will be described in another document at a later stage.

THE WORK WILL BE DONE IN

THREE PHASES

EACH PHASE

WILL BE FOR A DURATION OF

2 TO 3 YEARS

PHASE I

**IS DESCRIBED IN COMPREHENSIVE
DETAILS**

IN THE PRESENT PAPER

It is obvious that such a critical *fertilizer-livestock-feed* relationship can work better in the southern part of the Delta, where there is much more water and less land. The water needs much less fertilizer to produce more biomass than the land, particularly with polyculture that has reached a stage of near perfection in that area. The big fish population per unit area can provide more fertilizer for the land, which has a much lower area than the ponds. Together with the abundance of water, we can expect all kinds of plants (from vines to trees) to grow extremely well in that part.

As we move away from the rivers, the proportion of land increases until we reach the part where water can become a problem. Water is the most important element in the IFS, where it is recycled throughout the whole system from flushing the wastes of the animal pen into the digester to the irrigation of plants on the dykes. It overflows from one operation to the next, except where it has to be pumped to the pen roof and overhead tank, and allows one person to operate the whole system with a water hose at the animal pen. Its shortage will restrict the fish pond area where evaporation losses have to be constantly replaced, and will reduce both the aquatic biomass and the pond mud fertilizer. To make up for such deficiencies, we need more livestock and algae basins or hydroponics troughs, which require much more capital expenditure than fish ponds. We will certainly have problems with extra feed for the livestock and with fertilization of the additional land from products within the system.

Much work in the present IFS project will be involved with this critical assessment of the *fertilizer-livestock-feed* balance in order to optimize productivity in specific cases of land to water ratios of 1:4, 1:1 and 4:1 in the southern, central and western parts respectively of the Zhujiang Delta and beyond. We will need a lot of help in technological innovations, introduction of suitable crops, and availability of water on the farms.

So in Phase II the Integrated Farms will consist of many small-scale combinations to assess the productivity based on the land-water ratio and interaction.

PHASE I

IS IN *LOW-LYING* AREAS

WHERE THE MULBERRY/SUGARCANE
DYKE-FISH POND SYSTEM

AND

THE FLOWER-FISH POND SYSTEM

VARY FROM

WELL ESTABLISHED

TO

RECENTLY INTRODUCED

PHASE II

IS ON *DRYER* LAND





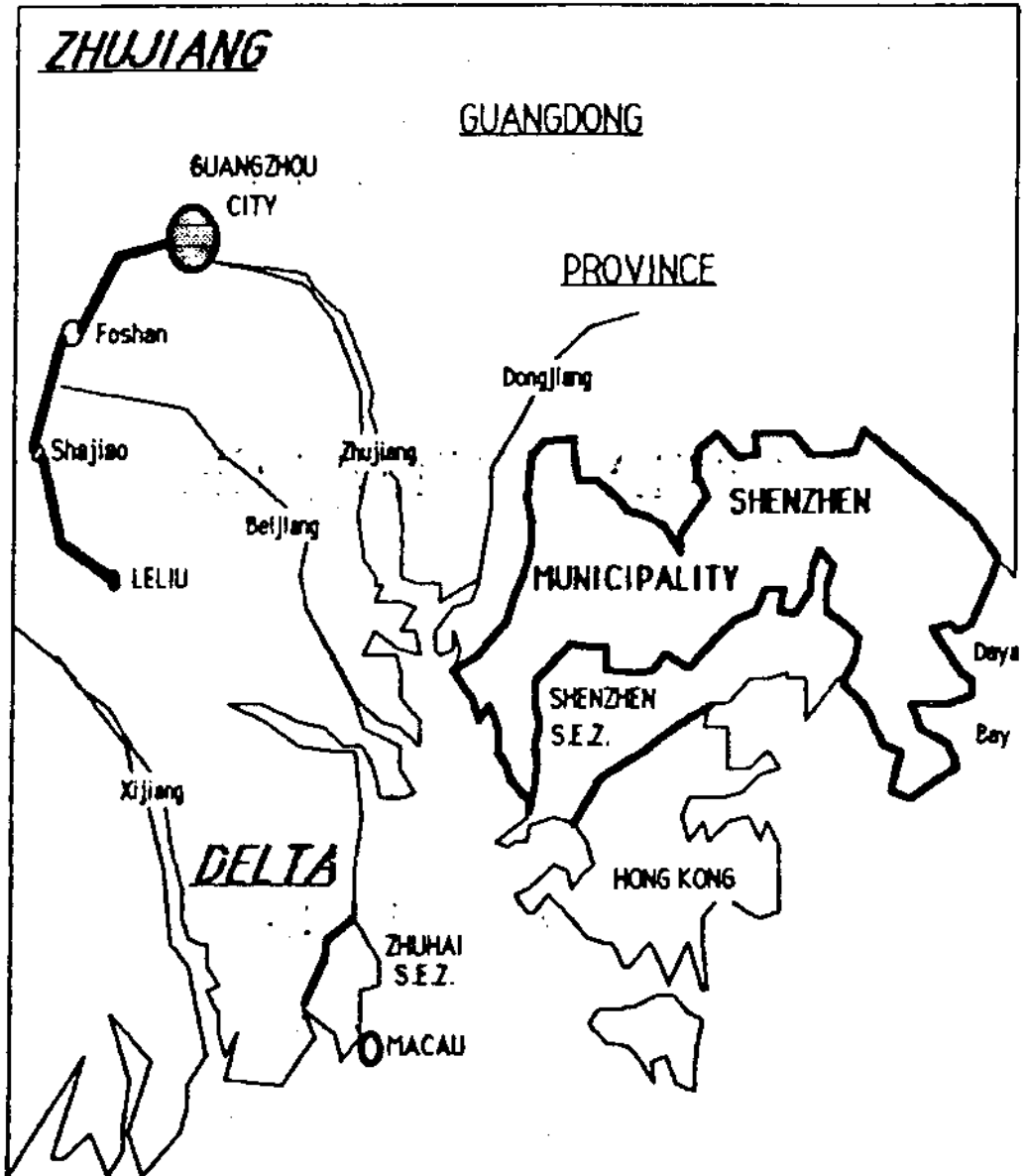

AND WILL HAVE MANY

SMALL EXPERIMENTAL FARMS

FOR THE LAND-WATER INTERACTION STUDIES

This map of South-West Guangdong shows part of the project area of Zhujiang Delta for the proposed IFS project, and its proximity to the urban and industrial areas of Guangzhou, Foshan, Hong Kong & Macau, and to the special economic zones of Shenzhen and Zuhai. The Zhujiang Delta project area extends to the West and North, and covers an area of 12,000 square kilometers and has a population of 10 million.



LEGEND		A Algae Basins/Ponds		F Animal Pens/Workshop
		B Existing Farmhouse		H Hydroponics/Aeroponics
		C Vegetables/Fruits		P Potted Flowers & Trees

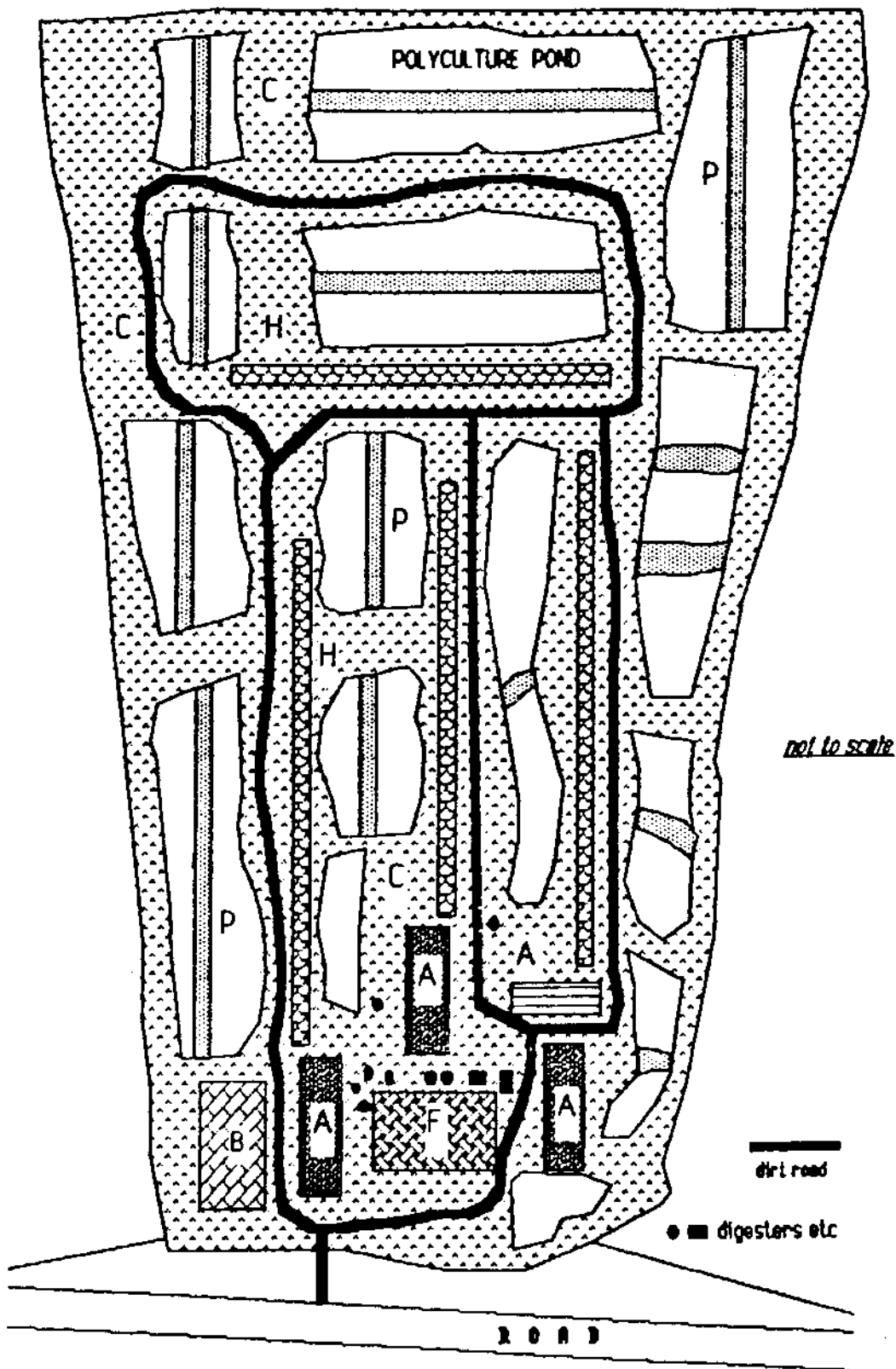

This map shows a typical integrated farm for a farm family unit. It can be modified to suit the number and size of households in the farm family unit.

The three project farms already have the dike-pond system in place, all with good access roads. They will all be further integrated with pig, chicken, duck and goose farming; algae and other aquatic life culture; intercropping and multicropping of various crops; and crop and livestock processing. The pigs and chickens will produce extra excreta, which will pollute the ponds because of the enormous quantities and kill the fish unless we provide the treatment described above. Ducks and geese will also be raised in the ponds, thus producing extra fertilizer.

The most important criterion for the *increased integration* is not the size of any new livestock herd added to the system, but the *quantity of wastes* that the livestock produce. Dr. Donald L. Day, University of Illinois, Urbana, U.S.A., has shown in the table below that the products from various livestock are only a fraction of the quantity of wastes produced. The new wastes must generate enough fuel, fertilizer and feed to justify the addition of the livestock.

LIVESTOCK	BODY WEIGHT	EXCRETA/YEAR	PRODUCTS/YEAR
Cow	455 Kg	13,270 Kg	1,820 Kg milk & 135 Kg calf
Yearling*	255	7,465	225 Kg meat
Sow	90	1,660	35 Kg piglets
Pig**	45	995	180 Kg produce
Layer Chicken	1.8	33.2	13.5 Kg eggs
Broiler Chicken**	0.9	23.2	12.2 Kg poultry

* Average weight from 1 to 2 years old, slaughtered at the end of the second year

** Average weight from birth to market size; 2 pigs/year and 5 broilers/year

The pigs, chickens, ducks and geese will require additional feed, which will be provided by algae and aquatic plants, crop remains as well as processing residues, and leaves and pods from trees such as *leucaena leucocephala*, which can also fix nitrogen from the air into the soil.

At a later stage, other livestock such as goat, cattle, rabbit and pigeon will be added to the system, provided that there is a need for their extra wastes and the system also produces the extra feed. Another very important factor is the improvement of animal husbandry, particularly breeding techniques such as artificial insemination, nutrition quality through scientific formulation, and disease prevention and control -- all for maximum reproduction, survival rate, and growth. The traditional pattern of keeping a few animals and birds in order to dispose of food remains, and at the same time fatten them up for the festive seasons, does not have a place in the IFS. We want to produce as much meat as we can to sell for maximum profit, but still at competitive prices.

THE WORK IN PHASE I WILL BE DONE IN

THREE SEPARATE LOCATIONS

UNDER DIFFERENT CONDITIONS :

1. MODEL FARM AT

LELIU EXPERIMENTAL STATION

2. PRIVATE FARM OF

POLYCULTURE PONDS/FLOWER

CULTURE AT CHENCUN

3. EXISTING FARM NOT

DOING TOO WELL IN A

POOR AREA AT DEQING

The important aspect of the animal pen is the *floor*, which must be in brick, concrete or stone, where available, in order to facilitate the flushing of animal wastes into the digester two or three times a day. We must also use some of the space inside the pen by having the chickens in cages above the piggery area, with a proper drain under the cages for complete containment and easy flushing of the droppings. The flat concrete *roof* of the pen and the *top part* of the digesters and gas storage tanks are also used to grow algae or flowers, using aeroponics. It is worth investing some money in the pen for these economic as well as sanitary reasons. Using the three kinds of material for the floor, which is subjected to very harsh treatment from constant pounding by the pigs and the acid in the wastes, will allow us to compare the price, performance and eventually the durability of each of these materials.

The digesters will be built with three different materials : clay brick, reinforced concrete, and prefabricated fiberglass. Since the digester is the *heart* of the whole INTEGRATED FARMING SYSTEM, it will not be worth saving any money on it at the expense of workmanship, durability and air tightness. It can only function, as intended, if the anaerobic conditions are maintained and the useful biogas does not escape. There are already too many digesters that have leakage and/or corrosion problems, and can only be rehabilitated at great expense in areas where they can least afford it. One gas storage tank will be built with a fiberglass or ferrocement holder floating in a brick container filled with water, one with a reinforced plastic bag supported on an aluminum frame, and another in fiberglass. Each digester and each gas storage tank will have a manometer and a gas meter for monitoring purposes.

Two sets of algae basins will be shallow: one with concrete floor and brick baffle walls or with brick baffle walls on a bed of sand and covered with reinforced plastic, and the other in fiberglass channels. Each set will have a paddle wheel to keep the liquid in motion during working hours. A third set will have deep fiberglass tanks also with paddle wheel or compressed air outlets for the same purpose. Trials will be made with the liquid containing the algae to discharge directly into a fish pond, to feed directly to ducks and geese, to mix with pig and chicken feed, to harvest with micro-fine filter sheets or a small centrifugal skimmer and dry for future use, to apply directly on land as fertilizer, and to feed into the digester to increase biogas production.

**THE
CONSTRUCTION PROGRAM**

FOR

EACH FARM

CONSISTS OF

ANIMAL PEN

DIGESTERS

GAS STORAGE TANKS

ALGAE BASINS & TANKS

HYDROPONICS TROUGHS

AEROPONICS POTS

The effluent from the algae basins or tanks flows through a series of **aeroponics** pots and then into shallow **hydroponics** troughs, made of fiberglass or lined with plastic sheet and containing gravel, for culture of vegetables and flowers, using most of the residual algae and some of the minerals as fertilizer, and finally into the fiberglass fish tanks and existing fish ponds.

Highly developed **polyculture** of at least *six* species of fish at *three* different levels is already taking place on a wide scale. With strict disease control, the pond productivity can probably be optimized now. Experimental culture of prawns and other shellfish, eel, and other aquatic and semi-aquatic plants (besides the already established lotus, water chestnut, watercress, ipomoea aquatica, duckweed, and water hyacinth) in marginal ponds to compare their economic returns as well as providing more diversity in the pond products. Feed trials will also be made with different kinds of primary produce, crop remains and processing residues on various species of fish and other aquatic life.

Besides the land taken by the above activities and the farmhouse, workshop and silkworm shed on the **dikes**, all the rest is used for agriculture, horticulture and silviculture, incorporating multicropping, intercropping, rotation of crops, and their preservation or conversion into stable products. What is essential is the availability of fertilizer, water and fuel on tap, and this is what the IFS will provide to the farm unit on its existing dykes at the cheapest possible cost. The mineralized water is pumped into overhead tanks to provide pressure for drip irrigation, which will ensure that the nutrients go to the plant roots only.

The **workshop** is best located on the ground floor of the farmhouse, with the residential quarters above, but in the present project the workshop will be located at the animal pen. The workshop is used for food processing activities that can be done at farm level and, if space is available, silkworm culture. As much as possible, natural methods will be used, but these traditional techniques will be improved with appropriate equipment and machinery, developed by some United Nations agencies and a few commercial firms, which will be run on biogas or other locally produced fuel. The capital and running costs will be compared with the same operations using imported fuel.

**THE EXISTING
FISH PONDS
&
DIKES
WILL BE FITTED WITH
MECHANICAL PUMPS
OVERHEAD TANK
DRIP IRRIGATION SYSTEM
AND A
WORKSHOP
EQUIPPED WITH VARIOUS PIECES OF
SMALL MACHINERY
&
LIGHT EQUIPMENT**

Processing activities requiring bigger machinery or operation will be left to joint ventures owned by the local farm family units. These will include a dairy for milk and milk products; slaughter house and related industries such as cannery and tannery; mill for flour, sugar or oil, and making of soap, confectionery, and stock feed; factory for juice, syrup, sauce, wine, vinegar, and condiments; distillery for liquor, methylated spirits as fuel, and ethanol for running vehicles; factory for spinning silk, cotton, and plant fibres; and other factories for pulp, paper, cardboard, wax, and a broad range of consumer goods using local raw materials. The *present* project does *not* consider such issues, as they have already been documented *elsewhere*.

The project will not build a farmhouse, and each farm family unit will use its existing one. However, it is worth looking at its design to suit the IFS in order to make it functional as well as economical to build. One possibility is to have a *courtyard* design that will provide an enclosed unit with the pen, workshop, silkworm shed and storeroom on its four sides, and the central space used for open air activities such as drying grain. On one side the residential quarters can be built as an upper floor, preferably opposite the pen and on the windward side. All the concrete roofs will be used for growing algae and potted flowers. It is hoped that the family of one of the eight project sites will agree to build a model farmhouse during the project period, and we will be happy to offer advice and professional help to make it a success.

Much can be done by the farm family unit itself in order to reduce costs, such as the reinforced concrete structure for the animal pen, but some items can be more economically produced in a central factory. The aim is to build a *permanent* system that will not only benefit the present generation, but also many others to come.

The expensive items are the digester/gasholder units, algae basins and tanks, hydroponics troughs, aeroponics pots, overhead tanks, and irrigation pipes. The pressurized items are made in fiberglass, which is corrosion and rot free, and the others in thinner fiberglass or reinforced plastic sheets. They are all prefabricated in standard modules or rolls, so that they can be easily added at any time to make any combination to accommodate the particular requirements of any integrated farm. *Appendix C* shows the versatility of such a system.

**THE
COST
OF ESTABLISHING AN
INTEGRATED FARM
IS
NOT CHEAP
BUT IT SHOULD BE
CONSIDERED
AS A
BUSINESS INVESTMENT
WHICH WILL BRING IN
HIGHER ECONOMIC RETURN
THAT WOULD OTHERWISE BE
IMPOSSIBLE TO OBTAIN**

FLOW CHART

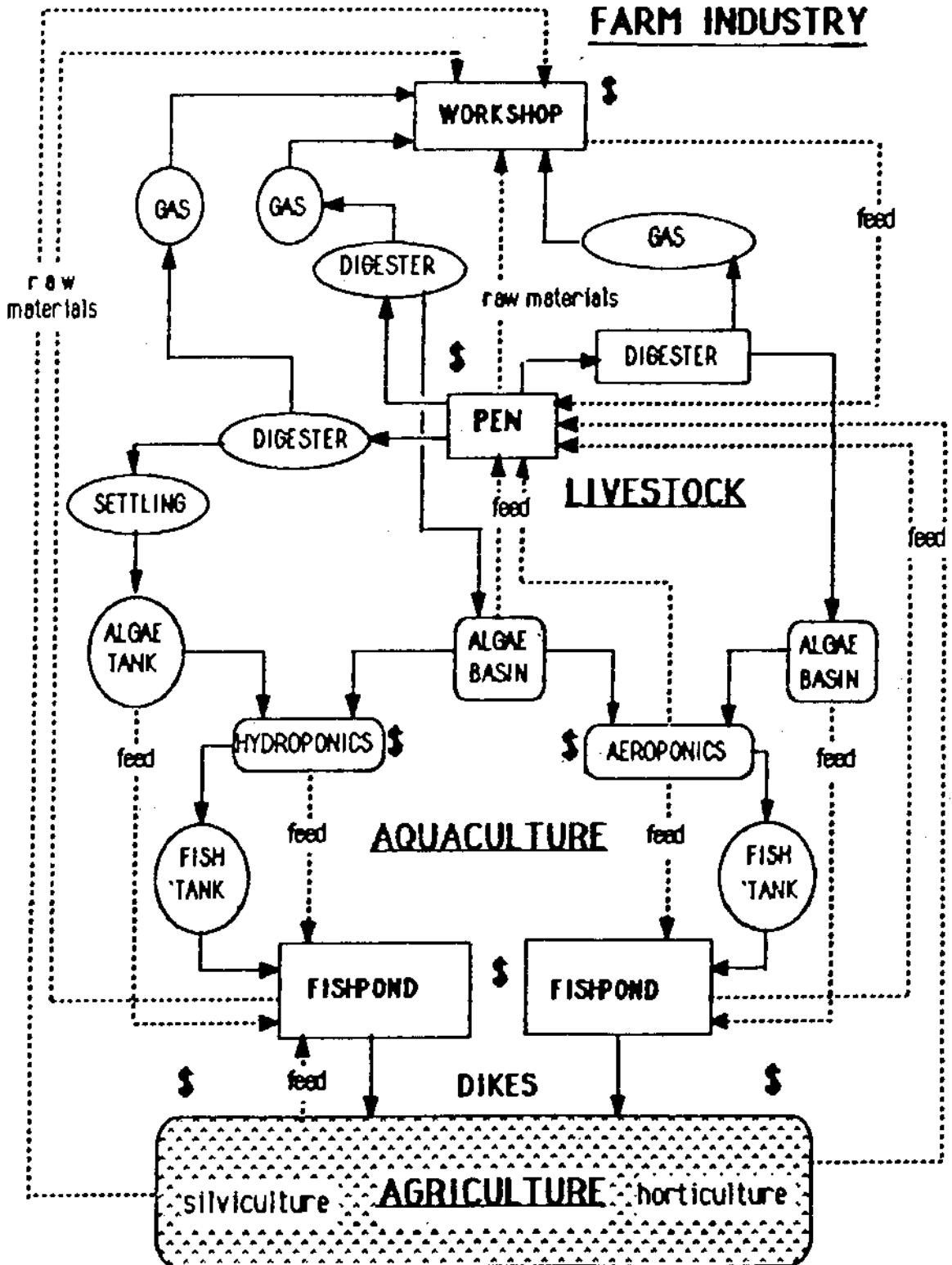

THE IDEA IS TO MAKE

PROFITS

FROM THE SAVINGS IN

FUEL

FEED

FERTILIZER

AS WELL AS FROM THE

SALE

OF

FARM PRODUCTS

AND

PROCESSED FOODS & GOODS

**FOR
EACH
OF THE THREE FARMS IN
PHASE I
THE STANDARD COSTS
ARE GIVEN IN**

**LIST (A) FOR
MATERIALS & CONSTRUCTION**

**LIST (B) FOR
EQUIPMENT & MACHINERY**

**LIST (C) FOR
PERSONNEL & ADMINISTRATION**

The standard costs of **materials and construction** are as follows :

<u>LIST (A)</u>	<u>RMB</u>
Animal pen & Workshop in reinforced concrete (2 floors x 100 square meters)	30,000
Digester in clay bricks (50 cubic meters)	5,000
Digester in reinforced concrete (20 c.m.)	5,000
Digester in fiberglass (4 x 6 c.m.)	5,000
Gasholder in bricks and fiberglass or ferrocement holder (2 x 6 c.m.)	3,000
Gasholder in plastic bag (25 c.m.) & aluminum frame	3,000
Gasholder in fiberglass (2 x 6 c.m.)	3,000
Algae basin in concrete & brick, and brick & plastic sheet (2 x 100 s.m.)	4,000
Algae basin in fiberglass channels (100 s.m.)	4,000
Algae tanks in fiberglass (2 x 3 c.m.)	4,500
Fish tanks in fiberglass (2 x 3 c.m.)	4,500
Hydroponics troughs in fiberglass (25 x 0.6 m x 4 m)	4,000
Hydroponics troughs with reinforced plastic sheets (4 m x 100 m) -- to suit size of roll	4,000
Aeroponics pots and aluminum threstles	2,000
Overhead tank (6 c.m.) with 20 m steel stand	3,000
Drip irrigation pipes (2,000 m)	<u>4,000</u>
	COSTS 88,000
	CONTINGENCY 10% <u>9,000</u>
	<u>97,000</u>
TOTAL (for materials & construction) - U.S. \$	<u>32,000</u>

The estimated costs for equipment and machinery are as follows :

LIST (B) R.M.B

6 gas meters for digesters and gas storage tanks	300
1 biogas generator (10 HP)	2,000
1 biogas generator (30 HP)	3,000
1 two-stage compressor for biogas bottling (3 HP)	1,000
6 gas bottles (25 & 50 kilograms)	700
3 gas rings (2", 3" and 5")	300
2 gas lamps (single & double mantles)	200
1 gas instant water heater (1 c.m.)	400
1 electric water heater (4 c.m.)	400
2 sets of paddle wheels for algae basins	600
2 air compressors of 3 HP for algae tanks (one standby)	1,400
300 metres of 1/2" plastic aeration pipes & fittings	300
25 metres corrugated plastic sheets (2 x 3 m) for pen roof	1,000
10 s.m. of clear plastic cover & frame for algae tanks	1,000
1 photovoltaic water pump (3 HP)	2,000
1 wind pump (3 HP)	1,000
1 electric pump (3 HP)	1,500
1 centrifugal skimming pump (5 HP)	2,000
1 set hand micro filters	500
2 aerators for fish ponds (5 & 10 HP)	1,000
1 tractor (10 HP) with bucket & 3 trailers	20,000
5 implements (plough, harvest, pump, compressor, spare)	8,000
1 electric hammer mill (3 HP)	3,000
1 electric grinder (3 HP)	1,000
1 foot operated chipper	400
1 electric oil press (3 HP)	6,000
1 electric blender (3 HP)	1,000
1 centrifugal dryer (3 HP)	3,000
1 electric mixer (3 HP)	1,000
1 solar dryer (4 c.m.)	1,000
1 gas dryer (4 c.m.)	2,000
1 electric dryer (4 c.m.)	2,000
Sundry containers	400
Sundry tools	600
Sundry materials	<u>1,000</u>
	COSTS
	71,000
	CONTINGENCY 10%
	<u>7,000</u>
	<u>78,000</u>

TOTAL (for equipment & machinery) = U.S. \$26,000

The estimated costs for **personnel & administration** are as follows :

LIST (C)

R M B

Project Director	25,000
GIOG staff (Allowances for 4 Field Coordinators)	40,000
GIOG field workers at Leliu	15,000
Visiting Research Scholar (Travel & Fees)	95,000
Research Scholar - Technology (Travel & Fees)	50,000
Research Scholar - Socio-Economic (Travel & Fees)	45,000
Expert Services (Travel & Subsistence Only)	40,000
Graduate Students (Fares Subsidy & Allowances)	40,000
Local Travel (Meetings outside Guangzhou)	10,000
Overseas Travel (International Meetings on IFS)	30,000
Subsistence Allowances (Local & Overseas Travel)	20,000
Transport -- one 4-Wheel Drive and one Pickup	40,000
Running & Maintenance Expenses (driver)	20,000
Bi-lingual Secretary	10,000
Office Equipment	30,000
Office Expenses	10,000
Printing & Publications	10,000
Training (Seminars/Group Discussions)	25,000
Meeting Expenses (including Fares & Per Diem)	15,000
Scientific & Field Instruments (if N.A. at GIOG)	60,000
<i>(Funding added to Training in Phases II & III)</i>	
Sundry Items for GIOG Laboratories	20,000
Sundry Items for Leliu & Other Stations	20,000
Compensation for use of farms for project (average)	40,000
	<hr/>
COSTS	710,000
CONTINGENCY 10%	<u>70,000</u>
	<u>780,000</u>

TOTAL (for personnel & administration) = U.S. \$ 260,000

Funding is requested from international, regional and national agencies for the whole project, spread over *6 to 7 years*, and will be made up of the three categories (A, B & C) detailed in **COSTING** above. In **Phase I**, the funding required is for construction and furnishing of the three farms, as listed in (A) and (B), and for personnel and administration, as listed in (C), amounting to a total of RMB 955,000 for Year 1, which is equivalent to U.S. *318,300* (based on \$1 = RMB3). For Year 2, there is no construction but some materials will be required for minor additions and modifications to improve performance. For Year 3, some innovative equipment and machinery will be tested for the same reason. The **total** funding required for **Phase I** is U.S. *\$894,000*.

The same procedure is followed for **Phase II**, which starts at Year 3 when three more farms will be constructed in the central part of the Delta. In Year 4, three other farms will be built in the western part. There will be no more farm construction in **Phase III**, except for some modifications as and when necessary, and there will be testing of a few pieces of equipment or machinery to optimize productivity. The personnel and administration costs are quite substantial throughout the whole project, but they are absolutely necessary in order to deal with all the scientific, technological, managerial, social and economic aspects involved.

The *SCHEDULE OF FUNDING* is given below for the whole project, and the details for all three categories are similar to those of Year One. For subsequent years, a 5% inflation rate is provided, with the figures rounded off. However, the **total** cost of the project is much **higher**, and the **balance** is provided by the Guangzhou Institute of Geography as the local contribution for cost sharing.

The Institute will provide the services of its staff and all its appropriate equipment and facilities for all data collection, laboratory testing and analysis required by the project, estimated at more than US\$400,000. However, all sundry items used on the project, travel expenses and per diem for field work will be paid by the project. The Institute will also provide office space for the project free of charge, but the project will have one full-time bi-lingual secretary who will be responsible to the Project Director. She will do the liaison work between him and the Institute, the appropriate government authorities, and the external officers concerned. She will also be responsible to the Visiting Research Scholar for all communications between him and the external officers and agencies connected with the project.

FUNDING
IS REQUESTED FOR THE
WHOLE PROJECT
COSTING

U.S. \$2,451,000

SPREAD OVER

6 TO 7 YEARS :

PHASE I

(2 TO 3 YEARS)

U.S. \$894,000

PHASE II

(2 TO 3 YEARS)

U.S. \$803,000

PHASE III

(2 TO 3 YEARS)

U.S. \$754,000

The *SCHEDULE OF FUNDING* (U.S. \$) for the **WHOLE PROJECT** is as follows:

<u>PARTICULARS</u>	<u>YEAR</u>	<u>A</u>	<u>B</u>	<u>C</u>	<u>TOTAL</u>
<u>PHASE I</u>					
South Zhujiang/Leliu:					
Construction of 3 IFS,	1	32,000	26,000	260,000	318,000
Operation & Testing, and					
Collection of Data; and	2	6,000		275,000	281,000
Socio-Economic Study of					
<i>South & Central Zhujiang</i>	3		5,000	290,000	295,000
<u>PHASE II</u>					
Central & North Zhujiang:					
Construction of 6 IFS,	3	35,000	28,000	50,000	113,000
Operation & Testing, and					
Collection of Data; and	4	38,000	34,000	300,000	372,000
Socio-Economic Study of					
<i>Central & North Zhujiang</i>	5	8,000		310,000	318,000
<u>PHASE III</u>					
WHOLE Zhujiang Delta:					
Operation & Testing of all	5		8,000	60,000	68,000
9 IFS, & Collection of Data;					
and Socio-Economic Study	6	3,000	3,000	380,000	386,000
of Zhujiang's relationship					
to nearby urban areas	7			300,000	300,000
<u>TOTAL FUNDING:</u>		122,000	104,000	2,225,000	2,451,000

THE EXTERNAL FUNDING OF THIS
INTEGRATED FARMING PROJECT

WILL BE LESS THAN
U.S. \$400,000 A YEAR

BUT THE POTENTIAL
OF SUCH A SYSTEM
FOR THE DEVELOPING WORLD
CANNOT BE ESTIMATED
IN MONETARY TERMS ONLY
BECAUSE

THE BENEFITS
WILL BE FELT IN SO MANY
PROBLEM AREAS :

HEALTH	NUTRITION & FAMINE
EMPLOYMENT	INCOME DISTRIBUTION
ECOLOGY	ENVIRONMENTAL PROTECTION
LAND USE	RESOURCES MANAGEMENT

CONCLUSION

The INTEGRATED FARMING SYSTEM aims at gradual improvement of the economic status of rural communities, representing 80% of the population in China and most of the Third World, with emphasis on self-employment and self-reliance. The Chinese leaders were wise in prohibiting the employment of workers by individuals, because of past exploitation practices which is still rampant today in many developing countries. With the Responsibility System, recently adopted by China under the Four Modernization Programs, which has brought spectacular changes in the economic status of some sections of the rural population, the hiring and firing of workers are now permitted, though still subject to some limitation. Already this has led to some polarization which, if allowed to expand, will have the same disastrous socio-economic consequences as those plaguing the developing world today. It is ironical that in this highly technological age there are still millions of human beings without the basic requirements of nutrition, housing, public health, and economic pursuits to promote individual and social-well being.

China can still have her modernization programs, and avoid the problem of one section of the population becoming prosperous at the expense of the others, by giving the means and opportunities to the least aggressive peasants through the IFS. This system concentrates on a much more intensified and rational utilization of locally available resources such as energy, fertilizer, feed and raw materials, through application of modern technology based on optimum biological, chemical and physical changes, and use of improved management practices. It allows the individual rural family to have a variety of farming and industrial activities to increase production of food and consumer goods, and improve the overall income. Hopefully, this will retain people on the land and encourage them to work for themselves, and also convince the new generation that the future of farming remains bright for them and for generations to come.

The INTEGRATED FARMING SYSTEM can only succeed if there is the political commitment to provide the financial and technical resources to help the farmers participate in the national development programs. China has the unique advantage of public ownership of these means of production and development, as well as a population that is traditionally hard-working. China can put such resources at their disposal -- she has already done so by contracting out some of the state rural enterprises to the highest bidders or providing soft loans for new ventures -- and give special consideration to the needs of the individual farm units wanting to benefit from the IFS. Besides the more equitable and economic use of limited as well as renewable resources, we can considerably reduce the social disruptions and tensions that are so evident with all the other systems worldwide.

In conclusion, the INTEGRATED FARMING SYSTEM is more likely to succeed in China, not only because of long traditional practices that will ensure widespread involvement of the farming community but, most importantly, because of the political commitment to the modernization programs and willingness to experiment with various promising systems aimed at higher economic results. China can then become a universal case study for the rest of the developing world to assess all the scientific, technological, environmental, economic, social and cultural aspects of the IFS, and adapt it to their own needs and circumstances. It is the *first* step the people of a developing country must take -- no other nation can do it on their behalf -- because it is only when they can feed themselves properly in a dignified and rewarding manner that their mind can develop rationally, irrespective of ideology, and they can then take an active part in their country's development plans.

ORGANIZATION CHART

(*... INTER-ACTION)

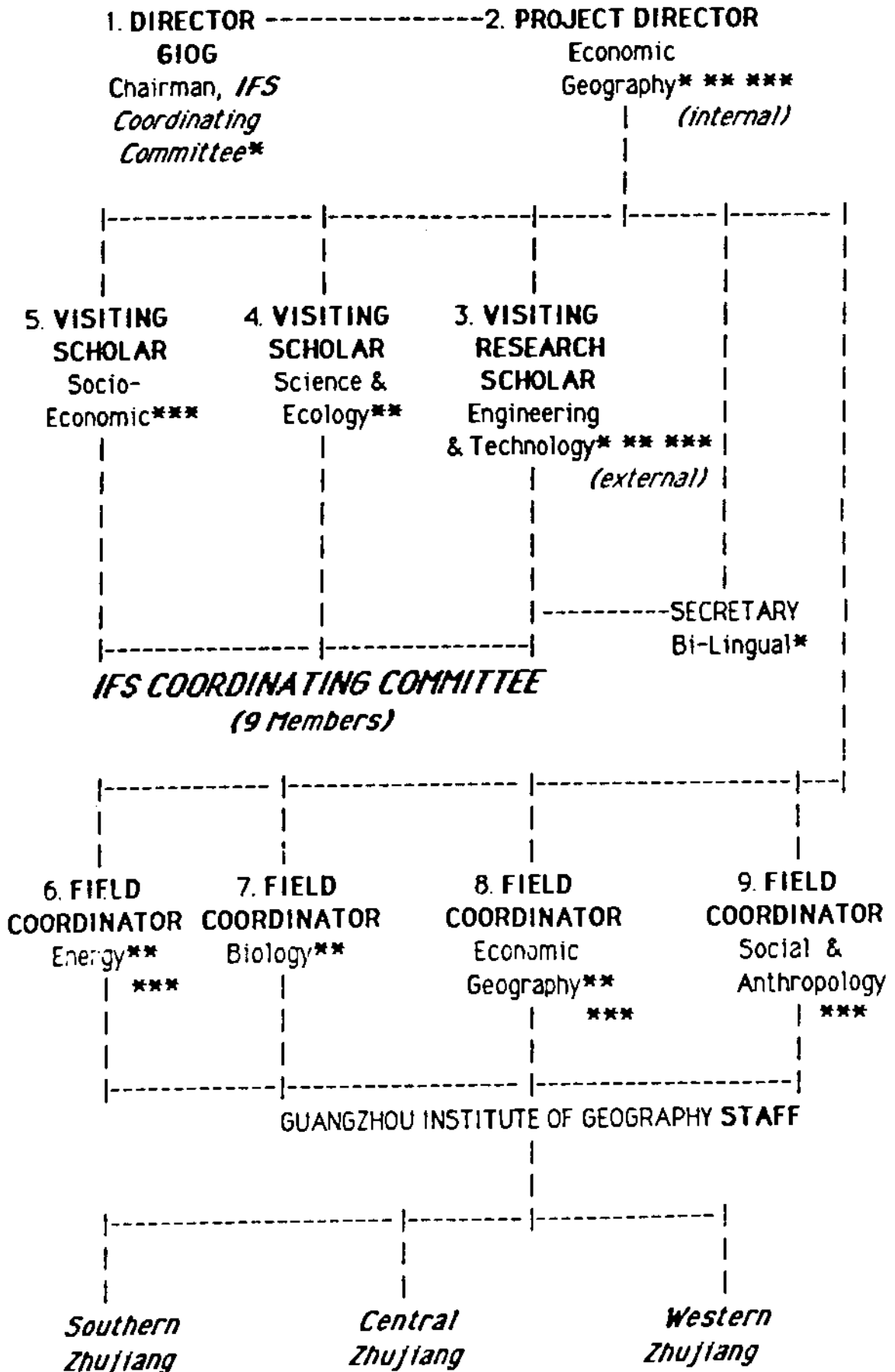

REFERENCES

1. Chan, G.L. Regional Symposium on Conservation of Nature, Noumea
An Integrated Sanitation Programme for Atolls & Low Lying Islands
Paper presented at Meeting of International Union for Conservation of
Nature & Natural Resources (IUCN) & South Pacific Commission, 1970
2. Chan, G.L., Reddy, H.G., & Haeri, M. United Nations ESCAP, Thailand
Biogas Technology & Utilization -- State of the Art
Survey of Thailand, Korea, Japan, Philippines, India & Pakistan, 1975
3. Furtado, J.I. In R.S.V. Pullin & Z.H. Shehadeh (eds.) *Integrated
Agriculture-Aquaculture Farming Systems*, Manila, Philippines
*Research & Information Requirements for Integrated
Agriculture-Aquaculture Farming Systems*
ICLARM, 251-256
4. Ruddle, K., Furtado, J.I., Zhong, G.F., & Deng, H.Z.
*The Mulberry Dike-Carp Pond Resource System of the Zhujiang Delta,
People's Republic of China: Environmental Context & System Overview*
Applied Geography (1983), 3, 45-62
5. Ruddle, K., Zhong, G.F., Deng, H.Z., Liang, G.Z., Wang, Z.Q., & Wu, H.S.
*Large-Scale Integrated Agriculture-Aquaculture in South China:
The Dike Pond System of the Zhujiang Delta*
Cambridge University Press (1986)
6. Zhong, G.F. Guangzhou Institute of Geography, China
*The Mulberry Dike-Fish Pond Complex: A Chinese Ecosystem of
Land-Water Interaction on the Pearl River Delta*
Human Ecology (1982), 10, 2, 191-202, Plenum Press
7. Ruddle, K. National Museum of Ethnology (NMOE), Osaka, Japan
*Rural Reforms and Household Economies in the Dike-Pond Area
of the Zhujiang Delta, China*
Bulletin of NMOE (1986) 10, 4
8. Ruddle, K. National Museum of Ethnology, Osaka, Japan
*Labor Supply and Demand in a Complex System:
Integrated Agriculture-Aquaculture in the Zhujiang Delta, China*
Bulletin of NMOE (1985) 10, 3, 773-819
9. Chan, G.L. U.S. Commonwealth of the Northern Mariana Islands
The Integrated Farming System Paper presented at the IUCN Planning
Commission Meeting, April 1984, Montreal, Canada
Landscape Planning (1985), 12, 257-266, Elsevier Science Publications

ENERGY EFFICIENCY
OF THE
INTEGRATED FARMING SYSTEM

George L. CHAN, DIC BSc(Eng)
Environment Consultant

Visiting Professor
GUANGDONG ACADEMY OF SCIENCES
Guangzhou Institute of Geography

*B4-5 NANYANG MANSION
SHENZHEN SEZ 518001
Guangdong Province, CHINA*

1988

THE INTEGRATED FARMING SYSTEM

A COMPLEX SOLAR-BASED ECOSYSTEM MADE UP OF VARIOUS COMPONENTS:

- CHEMICAL ELEMENTS SUCH AS:

C	H	O	N	
P	K	Na	S	
Ca	Mg	Fe	Si	etc.

- FREE NATURAL RESOURCES SUCH AS:

SOIL (humus/organisms)

WATER (aquatic life)

AIR (Carbon Dioxide/Oxygen/Nitrogen)

- COMPOUNDS SUCH AS:

PROTEINS

LIPIDS

CARBOHYDRATES

FIBRES

- BIOMASS PRODUCTION SUCH AS:

LIVESTOCK

AQUACULTURE

AGRICULTURE

AGRO-INDUSTRY

* They all play important roles in the Integrated Farming System (IFS).

* They are interdependent, integrated in an ecological whole, some with symbiotic or synergetic relationships.

* Their changes can affect all organisms in the ecosystem, including humans and nutrients, fauna and flora.

THE HUMANS SHOULD MANAGE PROPERLY & RESPONSIBLY THE ECOSYSTEM WITH THE SELF-PURIFYING PROCESSES OF ECO-TECHNOLOGY -- NOT BY THE POLLUTING EFFECTS OF PETRO-TECHNOLOGY -- THAT MAKE MULTI-DIMENSIONAL USES OF THE NUTRIENTS TO PRODUCE OPTIMUM FAUNA AND FLORA TO FEED, SHELTER, CLOTHE AND DEVELOP MANKIND AT THE LOWEST POSSIBLE COSTS AND WITHOUT DEGRADING THE ENVIRONMENT.

C O N T E N T

1. INTRODUCTION	...	1	
2. TRADITIONAL DIKE-POND SYSTEM	...	2	
2.1. Construction	...	2	
2.2. Energy Budget	...	3	
2.3. Energy Exchange	...	4	
2.3.(i) Mulberry Dike-Silkworm-Fish Pond Model	...	4	
2.3.(ii) Fish Ponds at GIOG Leliu Model & Four Typical DPS Households	...	5	
2.3.(iii) Dike-Pond Model at Eco-Farm outside Beijing	...	6	
2.4. Energy Evaluation	...	7	
2.4.(i) Photosynthetic Losses	...	8	
2.4.(ii) Photosynthetic Return	...	8	
2.4.(iii) Net Socio-Economic Balance	...	9	
2.5. Future of the DPS	...	11	
3. INTEGRATED FARMING SYSTEM	...	12	
3.1. Construction	...	12	
3.1.(i) Digester Unit	...	12	
3.1.(ii) Algae Unit	...	14	
3.1.(iii) Special Growing Media	...	15	
3.2. Energy Budget	...	16	
3.3. Energy Exchange	...	17	
3.3.(i) Livestock	...	17	
Animal Production per hectare of Integrated Farm	...	18	
3.3.(ii) Aquaculture	...	20	
3.3.(iii) Agriculture	...	21	
3.3.(iv) Industry	...	21	
Artificial Energy Input-Output & Conversion Rate	...	22	
Comparative Benefits & Economic Returns	...	23	
3.4. Energy Evaluation	...	24	
3.5. Future of the IFS	...	24	
References	...	25	
Appendix I-A	Calculations of Input & Output (Dike-Pond System)	...	26
Appendix I-B	Calculations of Input & Output (Modernized Dike-Pond System)	...	28
Appendix I-C	Calculations of Input & Output (Integrated Farming System)	...	30

ENERGY EFFICIENCY OF THE INTEGRATED FARMING SYSTEM

George L. Chan

1. INTRODUCTION

The Integrated Farming System (IFS) is a timely expansion of the traditional Dike-Pond System (DPS), an ecological and sustainable form of integrated polycultural aquaculture and multicropped agriculture that has been operating continuously in the Pearl River Delta of South China for over four centuries. The DPS is now being 'modernized' with indiscriminate introduction of chemical fertilizers, toxic pesticides and artificial feeds to increase productivity, without considering the disastrous impact of the newly-created pollutants on the environment. The IFS is the ecological and economic alternative to this environmental degradation, and it involves highly-intensive culture of livestock, aquatic life and terrestrial crops through ecological interactions of land and water resources aimed at complete recovery and recycling of all wastes and residues in a controlled environment, utilizing worldwide scientific knowledge and technological innovations. This paper analyses the energy exchanges in the traditional biological and physical processes of the DPS, and demonstrates how modern science and technology can improve these energy exchanges considerably by removing the constraints or other limiting factors in order to have a much higher overall efficiency, without any recourse to chemicals and toxic materials, or costly feeds, while protecting the environment.

The figures for this paper are obtained from work performed on the DPS by the Guangzhou Institute of Geography (GIOG), in collaboration with the United Nations University from 1980 to 1983, at the Agricultural Experiment Station in Leliu Commune, Shunde County 1/, and at an eco-farm outside Beijing by the Municipal Research Institute of Environmental Protection (BMRI) 2/. After 1983, the Guangzhou Institute of Geography continued with the work, and was joined by the author in 1985 to expand the DPS into the IFS. Unfortunately, many attempts at obtaining further funding from local and overseas sources for this work have so far proved unsuccessful. Finally, two joint-venture commercial piggeries in Bao'an and Shunde counties, Guangdong Province, faced with insurmountable problems of pollution and escalating costs of artificial feeds, agreed to have a pilot farm based on the IFS 3/. Without establishing these pilot farms, there is no way to convince the conservative farmers that the IFS actually works before they will invest further in their DPS farms. We also require the production figures to show how much superior the energy efficiency of the IFS really is, when compared with the DPS or any other system, in order to convince the lending institutions that the IFS can bring such high economic returns that are beyond the wildest dream!

abandoned when the possibility arose for DANIDA to fund a pilot project in China.

2. TRADITIONAL DIKE-POND SYSTEM

The Dike-Pond System (DPS) in the Pearl River Delta of Guangdong Province in South China is a system of intensive aquaculture, dating back to three millenia, that had been integrated four centuries ago with multicropped agriculture in a closed cycle that uses the residues of one operation as the input for the following ones. Despite its empirical limitations, the DPS is undoubtedly the most energy-efficient agrosystem in China, and even the whole world. Unfortunately, the present craze about modernization at all costs is threatening this ecologically-balanced and pollution-free system, with a growing number of farmers using artificial feeds, chemical fertilizers and toxic pesticides to increase productivity, totally disregarding the pollution problems. Some are also abandoning their farms to start small industries that are irresponsibly releasing toxic and even dangerous pollutants into our water, air or soil. It is indeed sad to see such a unique ecological agrosystem being replaced by so-called modern farming that has done untold damage to the environment in many parts of the world, because of ignorance of these facts by the Chinese farmers gullible enough to accept 'modern' ideas from outside as 'gospel'. It is, of course, too much to ask those unscrupulous merchants of 'death' to tell the Chinese leaders the whole truth about chemical and toxic agriculture!

2.1. Construction

Today, it is difficult to imagine that over 800 km² of low-lying land have been converted into deep ponds and elevated dikes by hand, starting thousands of years ago; or that centuries ago the simple farmers had 5 to 6 compatible species of carp in the same pond feeding on natural plankton at different trophic levels. Only grass was fed to one species in order to start a whole complex food chain to meet the needs of the other species of fish in that traditional polyculture system. With the empirical knowledge passed on from father to son, the farmers have been able to sustain this ecologically-balanced system for centuries, and there is every good sign that it can continue for ever unless, of course, the decision makers let the present chemical farming degenerate into the same dangerous situation as in the 'modern' world. It would be a real disaster indeed!

As with most traditional systems, the DPS did not expand to other regions outside its place of origin, or get the attention of administrators and academics, at home or abroad, until recently. The first scientific study done at international level only started in this decade when the United Nations University (UNU) decided to provide funding for three years, and no longer, for two outside consultants to work with the Guangzhou Institute of Geography 4/. The situation was not much better in China as recent scientific papers have shown: relationship between productivity of fish and plankton 5/; quantification of energy exchange on both ponds and dikes 6/; and evaluation of the extra benefits obtained from treating the livestock wastes before using the effluent in the ponds 7/.

2.2. Energy Budget

From the energy aspect, the DPS has everything going for it. Today, the ponds are dug with a bulldozer or excavator, and it is faster and more energy efficient. This is where heavy equipment is appropriate and really economic. Once set up, it does not require any recurrent expenditure to maintain it, as in the "drain and develop" method which often requires pumping at the lowest level to dispose of the water -- we have a few of these white elephants in the province to remind us of such stupidity, and we keep on paying more for it as energy costs escalate. The DPS also allows the farmer to have a variety of products: livestock, aquatic life and terrestrial crops, with higher yields because of on-site irrigation and fertilization year-round, and at the lowest production costs because of minimum input from outside the system.

Solar radiation is the main energy source, as in all agrosystems, but only 0.1 - 0.2% of this huge amount of natural energy absorbed by the dikes and ponds within the system is stored chemically in the economic products, as determined at Leliu 8/. This is due to over half the global radiation not being available for photosynthesis, and of the remainder that is photosynthetically active radiation (PAR) there are huge natural losses: 28% in reflected radiation and 71% in heat, metabolism and decomposition, leaving only 1% which is stored chemically in the nutrients (wastes, fertilizers, micro-organisms) and detritus (stems, roots, left-over feeds, humus) of the soil and of the pond water and mud, and in the economic products (representing only 0.1 - 0.2%).

In the DPS, there is not much we can do about the 99% biological and environmental losses. The dissipated heat from metabolism and reflected radiation from the dikes are practically non-recoverable, but can be slightly reduced from the water surface if it is covered with floating aquatic plants such as water hyacinth or duckweed, at the expense of plankton growth. Since the carps need the plankton for their own growth, the surplus aquatic plants will be wasted because the few livestock kept for family consumption can only consume some of them. As for the remaining 1%, 0.8% is in the soil and pond mud. The nutrients in the pond mud are not used directly, as the latter has to be spread on the dikes before the fertilizer is available to plants, and in the meantime decomposition of the organic content releases gases that escape into the atmosphere. The only way the 0.2% for the economic products can be increased is to grow more fast-growing crops on the dikes in order to use the PAR and the excess nutrients in both soil and water more effectively, as we shall see later.

The productivity of the DPS can also be increased by having external energy (electricity, coal, firewood, gas, oil, gasoline) or energy-related (feeds, fertilizers, pesticides, equipment or machinery) input. This is referred to as "artificial" energy, which does not only cost money but often pollutes as well, and the DPS is going through such a 'crisis' at the moment.

2.3. Energy Exchange

We can analyse the energy budget and look at the various components of the ecosystem to see what we can do to improve the natural as well as artificial energy efficiency, so as to increase the economic products as well as the net socio-economic balance. The net socio-economic balance is the difference between the value of the economic products and the socio-ecological costs to the community (environmental pollution, depletion of natural resources, unemployment, etc). These are not easily quantified, but it will be up to the decision makers, from top government to the lowest household levels, to make their judgement after considering all the facts, if not figures.

2.3.(i) - Mulberry Dike - Silkworm - Fish Pond Model

In the DPS model of GIOG at Leliu, both the natural and artificial energy inputs are considered for a mulberry/winter vegetable (90%) and grass (10%) dike, a fish pond of the same surface area, and fertilization of pond with excreta from silkworms (fed on mulberry leaves) and wastes from a few pigs (consuming the food scraps and crop residues). The fish are raised on grass and commercial feeds. The solar radiation is measured with quantum sensors from Japan and processed with integrators from USA. The input and output, given as 10⁹ MJ/hectare/year, are as follows:

I T E M S	I N P U T		O U T P U T		
	natural	artificial	losses	stored	economic
<u>Radiation (PAR)</u>					
Fish Pond	13,558				
Mulberry	6,436				
Vegetables	1,560				
Grass	1,560				
<u>Wastes</u>	11				
<u>Commercial Feeds</u>		55			

<u>Losses</u>					
Reflection			6,526		
Metabolism			16,274		
Decomposition			133		
<u>Stored in dike/pond</u>					
Roots & Stems				54	
Leftover feeds				20	
Pond Mud				142	
<u>Economic Products</u>					
Silk cocoons					9
Fish					20
Vegetables					2
TOTALS	23,125	55	22,933	216	31
<u>PERCENTAGES</u>	99.76	0.24	98.93	0.93	0.13

2.3.(ii) - Fish Ponds at GIOG Lellu Model & Four Typical DPS Households

An analysis is also made of the artificial energy input for the fish ponds of the Lellu model and four typical DPS households surveyed during the UNU/CHINA project in the Nanshui Brigade. PAR input per unit area is assumed to be the same for all ponds. We are concerned here with the kinds of input, and their quantities supplied to every pond, the energy values extrapolated in rate/hectare, their percentages, and the conversion rates. We want to discuss (i) their impact, good and bad, on the ecology of the ponds; and (ii) their economic implications for the farmers. These details will help us in our evaluation of present practices and in our recommendations for steps to be taken at the farm level in order to improve the energy efficiency and the economic return. In the following table, the input figures are in tons supplied to every pond, the extrapolated energy values of input and output in 10⁹ MJ/hectare, and the conversion rate measured as output/input.

K I N D S	LELIU STATION			HOUSEHOLD I			HOUSEHOLD II			HOUSEHOLD III			HOUSEHOLD IV		
	INPUT	VALUE	o/o	INPUT	VALUE	o/o	INPUT	VALUE	o/o	INPUT	VALUE	o/o	INPUT	VALUE	o/o
WASTES															
Silkworm	47.24	99.34	29.8	-	-	-	1.66	20.80	2.7	-	-	-	-	-	-
Animal	10.14	21.32	6.4	50.00	317.97	36.1	22.50	281.92	37.1	22.72	497.25	60.2	4.50	91.65	30.5
Human	-	-	-	3.50	22.26	2.5	5.07	63.53	8.4	2.98	65.22	7.9	4.60	93.69	31.2
Total Wastes	57.38	120.66	36.2	53.50	340.23	38.6	29.23	366.25	48.2	25.70	562.47	68.1	9.10	185.34	61.7
GREENS															
Elephant grass	17.72	106.32	31.9	2.50	49.62	5.6	2.50	84.45	11.1	2.50	102.10	12.4	3.75	114.83	38.3
Sugarcane wastes	-	-	-	20.00	397.01	45.1	5.00	168.90	22.2	-	-	-	-	-	-
Food/crop remains	-	-	-	4.50	89.32	10.2	-	-	-	-	-	-	-	-	-
Total Greens	17.72	106.32	31.9	27.00	535.95	60.9	7.50	253.35	33.3	2.50	102.10	12.4	3.75	114.83	38.3
COMMERCIAL FEEDS															
Concentrates	6.68	106.32	31.9	0.09	4.29	0.5	1.75	140.41	18.5	1.00	160.60	19.5	-	-	-
Total Com. Feeds	6.68	106.32	31.9	0.09	4.29	0.5	1.75	140.41	18.5	1.00	160.60	19.5	-	-	-
TOTAL ENERGY INPUT		333.30			880.47			760.01			825.17			300.17	
ENERGY OUTPUT/FISH		40.83			41.22			41.22			38.39			28.86	
CONVERSION RATE		0.12	12		0.04	4		0.05	5		0.04	4		0.09	9

2.2.(iii) - Dike - Pond Model at Eco-Farm outside Beijing

In the DPS model of BMRI, only the artificial energy inputs are considered for a grain/vegetable dike, a fish pond, and fertilization of pond with excreta of the fish (fed on grass and commercial feeds) and digested wastes of livestock (fed with greens and commercial feeds). It realized the importance of the solar energy aspects, but did not consider it worthwhile to quantify them. Instead it measured the artificial energy using a calorimeter made in China 9/. The conversion rate is given as output/input.

AGRICULTURE

COMPONENTS X 10 ³ MJ	I N P U T			OUTPUT	RATE
	organic	inorgan.	TOTAL		
Rice	8344	3982	12326	29640	<u>2.40</u>
Wheat	5792	1173	6965	8320	<u>1.20</u>
Feed crops	94	8	101	110	<u>1.09</u>
Barley	1875	462	2337	1889	<u>0.81</u>
Rape	1213	266	1479	777	<u>0.53</u>
Cotton	228	91	319	118	<u>0.40</u>
Fruits	91	45	136	55	<u>0.40</u>
Vegetables	1078	1185	2295	824	<u>0.40</u>

LIVESTOCK (including FISH)

COMPONENTS X 10 ³ MJ	INPUT	O U T P U T			RATE
		PRODUCTS	WASTES	TOTAL	
Mule	1373	880	327	1206	<u>0.88</u>
Pig	1090	293	574	866	<u>0.79</u>
Lean pig	2934	1690	500	2190	<u>0.75</u>
Duck	1516	21	1033	1061	<u>0.70</u>
Other livestock	1944	766	385	1151	<u>0.59</u>
Chicken	2817	431	1214	1645	<u>0.58</u>
Milk cow	2640	233	928	1181	<u>0.45</u>
Goat	1141	17	249	265	<u>0.23</u>
Fish	126	9	101	110	<u>0.17</u>
Beef cattle	3923	184	228	410	<u>0.11</u>

2.4. Energy Evaluation

The input-output energy balance enables us to evaluate the efficiency of every component of the model. The most striking feature is that the potential of solar energy is huge, but so is the wastage, leaving only a minute amount for us to use. It also makes us realize that a slight reduction in the losses can make a significant contribution to the economic balance of the whole system. Even with the minute amount stored chemically within the system, the economic products represent only one-fifth, so there is much room for improvement if we can transform some of the stored energy into useful products.

We should thoroughly explore these two important areas instead of introducing external energy and energy-related inputs into the DPS. This is what the expansion of the DPS into the IFS is set out to do, because there is enough scientific innovations to do so. The learned institutions in the rich countries are littered with reports containing most useful knowledge that is not applied because they are not 'culturally' or 'socially' ready to use them. However, most of the reports are quite appropriate for the developing world, where there is a lack of personnel and funding to do research in similar fields. It would save much time and money if our graduates would spend their time perusing all the available reports for technology that is immediately useful to our people, instead of pursuing studies on useless subjects that are only of academic interest to a few of us. Otherwise, we just waste our few capable people because they either return home and find that they cannot use their newly acquired knowledge, and their frustration leads them to metamorphose into useless politicians; or they migrate to the rich countries where they get a huge salary to work in their new fields. We should stem this brain drain, and stop wasting our limited human and financial resources on such practices!

Fortunately, there are a few people in China, India and certainly a few other developing countries who are devoting their time, sometimes on a voluntary basis, to capitalize on this 'free and readily available' source of technology and try to apply it to their local situations, but many more 'volunteers' are needed. So it is unfortunate that not enough attention is paid to such appropriate development in the Third World because it is not spectacular or big business, and most scientists and technologists prefer the glamor and money of high technology to the lowly task of putting some wastes, that nobody wants, to good use. So we let these wastes pollute the environment of the poor and even desperate people, who have to worry about basic needs like food and health . . .

From the figures, which can be considerably improved if computers are used -- another case of high technology at the service of the grass roots communities -- and more trained personnel are available in China, we can make intelligent decisions on how to utilize our available resources for maximum efficiency and how to optimize productivity.

2.4. (i) - Photosynthetic Losses

In the DPS, the plankton in the ponds and the plants on the dikes make use of the photosynthetically active radiation through natural biological and physical means, which also set the limits for their growth, while the remaining PAR is lost. Moving the big volume of pond water, using windmill, electric or photovoltaic aerators, can improve phytoplankton growth by bringing the whole biomass to the surface in order to use more PAR. Higher yields of fish are also obtained, but so are the costs in both capital and operation. It may be cheaper if we can have inexpensive and shallow containers floating on the pond surface to grow the phytoplankton, and then feed the fish with it, but meanwhile terrestrial algae basins will do.

Much more use can also be made of the available PAR by selecting fast-growing and high-yielding phytoplankton and plants. For example, the natural phytoplankton in Leliu produce about 20 tons dry/ha/year. By inoculating the pond with selective algae such as spirulina, which grows very fast and has a protein content of up to 75% compared with the common ones that only have 30-40%, there is no doubt that the both the phytoplankton and fish yields will increase. Floating aquatic plants such as water hyacinth produce annually 900 tons/ha, azolla 400, and Lemna 300. As for terrestrial plants, the yield for elephant grass is 225 tons/ha, and hybrid Napier grass over 300. This abundant biomass can be used as substrate for microbial processing into high-protein feeds.

2.4.(ii) - Photosynthetic Return

There are three main aspects of any agrosystem that influence its productivity: structure, management, and technology. The structure in the DPS is very simple — just a deep pond and an elevated dike — but it has made a world of difference, not only when compared with the original waterlogged or flood-prone low-lying land but even with the best farmland in any other country. The whole surface within the boundary of the structure can be utilized, with the pond even offering two-dimensional culture: fish and plants in water and plants on the surface.

However, the direct use of livestock wastes in the pond increases the turbidity and limits the solar radiation entering the water, besides consuming dissolved oxygen. At best, photosynthesis by phytoplankton is limited to the top 30-40 cm, so it greatly reduces growth of the minute plants that some fish eat, restricting the food chain complex and fish yield. Similarly, only a part of the pond surface can be used for floating aquatic plants, or phytoplankton growth will again suffer. More important still, the quantity of livestock wastes is limited to the natural capacity of the pond water mineralizing the organic content without depleting the dissolved oxygen, or the fish will simply die. From practical experience, the farmers in the dike-pond region limit their growing pigs to 45 per hectare. Again, aeration can increase this number but the big volume of air required to oxidize the additional wastes can be prohibitive in capital and energy costs.

With better management of the system, more use can be made of the stored energy in the livestock wastes, and pond nutrients and detritus, to reduce the production costs and also control pollution at no extra cost, instead of adding costly chemical fertilizers to the system and increasing the chemical oxygen demand (COD). As can be seen later in the IFS, the wastes can first be treated with appropriate technology to (i) convert the organics in the wastes into soluble minerals to reduce turbidity and avoid consumption of dissolved oxygen in the pond; and (ii) recover most of the stored energy as biogas fuel, and by having three-dimensional culture of plants on both ponds and dikes to use up the nutrients as fertilizers. Multicropping and rotation of crops are used for pest and disease control, instead of toxic pesticides and chemical prophylactics that can end up in the food chain and create health hazards that affect the consumers.

2.4.(iii) - Net Socio-Economic Balance

The figures for the artificial energy input show that for the Leliu Station the inputs of Wastes : Greens : Concentrates are 36 : 32 : 32 in the fish ponds, and the conversion rate of input-output is 0.12. For the four households, it varies between 0.04 and 0.09. The inference is that utilization of sufficient quantities of concentrates (containing adequate proteins, essential amino-acids and trace elements besides lipids and carbohydrates) at Leliu gives the best energy conversion efficiency, but not necessarily the best economic return which is influenced by the price of the concentrates. For example, in 1983 the price per ton was US\$152; in 1988, it is already \$300 and will undoubtedly continue to rise.

Among the four households, the one that is as energy efficient as Leliu is Household IV which does not use any concentrate. The other three are much less efficient, even with the use of some concentrates, but they also use much more wastes and greens than are necessary, wasting energy that does not contribute to the output. The greens are only consumed by the herbivorous carps and are not palatable to the others that are protozoa, benthos, invertebrate and bacteria eaters. Also the nutrients in the raw wastes are not readily available to the phytoplankton, besides consuming dissolved oxygen and releasing gases that inhibit fish growth.

The lesson to be learnt is that too much of anything can be harmful, and the best conditions in any pond are to have sufficient greens that can be consumed by the herbivorous fish at feeding time, and enough organic matter in the wastes to enhance growth of zooplankton, benthoplankton, invertebrates and bacteria in the complex food chain to feed the other species of fish. Household IV is the example to study in order to increase its efficiency. Not only does it not use costly concentrates, but it also has less wastes, and the conversion rate is still the best among the four typical households. There is no doubt that if the wastes can be converted into nutrients that are immediately available to the plankton or other aquatic plants eaten by fish, the overall yield will improve.

10 The figures at the eco-farm outside Beijing show the conversion rates of various crops and livestock (including fish). Rice is the most energy efficient, followed by wheat but, unfortunately, they both yield less monetary benefits than the other crops. So energy efficiency alone cannot be the deciding factor for the farmers to choose the crops they want to grow, because economic efficiency is more important to them. They should, however, be aware that some energy-related inputs can be cheap or even 'free' while others are relatively expensive. Of course, they should go for the 'free' ones, but only if these are readily available without any hidden costs, and they should be told the whole truth by the authorities.

Although often ignored, the farmers should also consider the ecological efficiency, which can be an important factor when evaluating the net socio-economic balance. We should evaluate the socio-economic costs of environmental pollution caused by wastes that cannot be taken care of naturally or that degrade the environment and prevent natural regeneration of resources; depletion of non-renewable resources that deprive future generations of their fair share; unemployment caused by big farm equipment that is energy-intensive; and other sociological ills that cannot be given a monetary value, but can be very costly. The net socio-economic balance depends on how ^e decision makers view these factors -- not a comfortable thought, judging by what is happening worldwide.

Taking rice as an example in 'modern' farming, many farmers are now using chemical fertilizers instead of traditional organic manure or co-planting with azolla/anabaena that fix nitrogen from the air as fertilizer for the rice plants and at the same time produce fast-growing biomass as livestock feed 10/. Even in rich USA, the farmers have small lobsters in the rice fields feeding on the phytoplankton growth in the shallow water, not only to supply their wastes as fertilizer for the rice but also for converting the stubbles, after harvesting the rice, into succulent and high-value protein food, thus increasing the economic return per unit area 11/. Another big advantage is that the lobsters also 'cultivate' the fields by their burrowing and have the fields ready for replanting, without the present chore that the poor Chinese farmer has to do, walking slowly behind his water buffalo to plow the soil and bury the stubbles.

It is irresponsible and even insane to use chemical fertilizers, with their high costs and adverse environmental effects, when the time-honored azolla or innovative rice-lobster combination can bring much more return to the rice farmer. Outside the DPS area, the situation is worse as two crops of rice per year can only bring a surplus income of ¥50-100 (US\$13-25) per mu (15 mu = 1 ha) after meeting the needs of the farm family. During winter, the farmers want to grow vegetables, but often they don't have water for irrigation, so many of them do not even bother about it. No wonder many farmers are leaving the land to get a paid job elsewhere, and very little is being done to retain them on the farm.

2.5. Future of the DPS

On the initiative of the political leaders and various departments of Guangdong Province, with backing from their State counterparts, 3,000 hectares of waterlogged and low-lying land in the counties of Gaoyao, Sihui and Huiyang are being transformed into dikes and ponds in the optimum proportion of 1 : 2 of surface area, with a loan of US\$12 million from the International Fund for Agricultural Development (IFAD) and a matching fund of \$19 million from the State Government. The money is used to excavate deep ponds and build the dikes above flood level with heavy equipment by the County Government. Then every family chooses its lot, and applies to the designated state bank for the appropriate loan which includes the total cost of the reclamation work and the money for all the materials required to start the farming operations. The family members then put in all the labor they can supply to build the farmhouse, workshop, and other facilities to make the farm operational. The project includes the setting-up by the government of fish hatcheries, plant nurseries and livestock breeding stations, in order to guarantee the supply of all the basic requirements for the farms.

So the future of the DPS in Guangdong Province is fairly bright, and both the political and administrative commitments are strong enough for its expansion to the whole province. It is gratifying to see that an international agency like IFAD has capitalized on a traditional and ecological form of development, and committed such a substantial funding not only to popularize it in the less fortunate sections of the population, but is also transforming vast areas of wasteland to productive use. The authorities concerned are confident that the new DPS farmers will be able to repay their loans without any difficulty, and that this IFAD/CHINA project will have a snowballing effect all over the province. It is hoped that both IFAD and the Chinese Government will allow the provincial government to use the loan repayments to establish a revolving fund for this purpose.

The question of whether the transfer of such technology to other parts of China is possible or not does not arise, as some provinces have already tried the DPS. The major limitation, besides a bank loan, is the cold weather in winter but various greenhouses are being tried. Fig. 3 shows one that has given encouraging results as far north as Beijing. The simplest one has a bamboo frame and PVC cover, but the one with plastic section frame and special polyethylene cover is the one recommended. As for technology transfer to other developing countries, each case should be dealt with on an individual basis, starting with a visit to China followed by a pilot project at a government station for demonstration and training.

However, the ultimate aim, as the farmers become well established with their DPS farms, is to encourage them to apply for further loans to expand into the IFS, and avoid the irresponsible expansion that some traditional DPS farmers have done.

3. INTEGRATED FARMING SYSTEM

The Integrated Farming System is the economic and ecological solution to the new problems created by the present changes to the DPS. From the economic aspects, the IFS makes sense because it is only logical that we should optimize the utilization of resources already present in our system before introducing fertilizer and feed from outside. It is all the more desirable to do so when the cost of optimization is so much lower than what we pay for these additional products, more often with foreign exchange that is badly needed for other more essential imports. From the ecological aspects, the IFS becomes more dramatic because we are converting pollutants into useful resources, not only at no recurrent cost because we rely on free micro-organisms to do the work under optimum environmental conditions, but also with big savings for the system in fertilizer and feed. Moreover, there is abundant biogas fuel in the bargain.

3.1. Construction

The IFS requires three additions to the structure of the DPS: (i) a digester unit and (ii) an algae unit between the livestock and the fish ponds, and (iii) special growing media for aquaponics, hydroponics and aeroponics. Such investments must be made not only to increase productivity, as in any enterprise, but with the added bonus of converting all the wastes into useful products. What is more important is that the investments are within the means of the farm family and are good for more than 10 years.

3.1.(i) - Digester Unit

The digester can be a cheap item when a small fixed-domed one is built in China for a household, using local materials and farm labor, but it has always been a relatively expensive addition to a household in other countries because of the high cost of the steel gasholder. Many attempts have been made to reduce its costs, but in vain. The only one that partially succeeded was a cheap bag made of neoprene rubber or red-mud plastic, but it was subject to puncture caused by rodents, or after constant rubbing against hard objects as the bag continuously expanded and contracted. It was very difficult to repair unless it was totally emptied and dried -- not an easy task. There were also some problems with the materials not being resistant to ultraviolet rays of sunlight and some chemicals, besides being sometimes stretched by the gas pressure beyond their elastic limits.

However, to deal with a sizable herd of livestock like the one we have in the IFS, the cost of the bigger digester which requires a reinforced concrete or steel tank, is prohibitive. So there is a tendency to increase the BOD loading per unit volume, resulting in lower digestion efficiency and build-up of solids. When straw, used as bedding or feed, is also washed into the digester there is frequent blockage that is very difficult to clear. Another major problem is access to the digester, externally because it is usually partly buried, or internally because it is a closed tank with or without a small manhole, when some repairs or alterations have to be made.

The new Chinese digester (Fig. 1) incorporates all recent innovations in design worldwide. It consists of a dug-out channel with naturally sloping sides. In waterlogged land where all our DPS farms are now situated, there is no need to line the channel, and the digestion chamber is dug 2 meters below water table. Above this chamber we have a concrete wall of 1.05 meters high surrounding the channel, and a primary algae tank, 1 meter high, is suspended on hooks in the wall and floats on the water surface. The tank is made of a special polyethylene sheet that is resistant to ultraviolet rays and most chemicals, and can last for up to 20 years with livestock wastes. This tank is connected to the digestion chamber by a pipe of 0.3 meter long at one end, and is filled with water up to the outlet which is just below the 1 meter level. This tank is supported by the water in the digestion chamber, which has an inlet 15 cm above the outlet. The pressure of the water in the tank against the concrete wall, also lined with the special polyethylene sheet and has a neoprene gasket between the two sheets, makes the digestion chamber leak-proof.

When biogas is formed it rises and collects under the algae tank, pushing some water up the connection pipe into the algae tank and through the outlet until the unit is in equilibrium. This equilibrium is maintained as more gas is formed and more water flows out, with the difference in level between the water in the algae tank and the water in the digestion chamber giving a hydraulic pressure to the biogas. This pressure is restricted by the special polyethylene sheet, and is 30 cm water column for nylon-reinforced 30-mil sheet (tensile strength 200 kg/cm²); it cannot exceed 10 cm for non-reinforced 30-mil sheet (66 kg/cm²). Further production of gas depresses the water level below the connection pipe, and gas escapes to maintain the equilibrium. When biogas is used, the water level in the digestion chamber rises, and that in the algae tank goes down, again maintaining the equilibrium, but the hydraulic pressure to the biogas also decreases. We can increase this pressure by flushing the livestock wastes into the digester when biogas is used, and the wash water raises the level in the algae tank up to the outlet.

The algae tank also produces prolific algae as feedstock for the digester to increase biogas production, if required for more industrial purposes. Otherwise, the algae can be used as high-protein feed for the livestock. This digester takes more surface area than the deeper ones, but the output and value of the algae are much higher than if the land is used for any other farming activities. Because the digester unit reduces the BOD by 50% (after 50 days' retention), and the subsequent algae unit described below reduces the BOD by a further 30% (after 60-90 days' retention), we can have 10 times the number of pigs (or equivalent livestock), i.e. 450 per hectare, and still do not pollute the same size of fish pond as in the DPS because the pollutants entering the pond remain the same as the original 45 pigs per hectare.

Now we have an industrial-sized treatment plant for the wastes of 450 pigs (or equivalent in other livestock) per hectare of fish ponds with a relatively small space for the digester and algae units, at very low costs but with substantial amounts of fuel, fertilizer and feed as useful byproducts. More important still, we have solved the usual problems connected with digesters worldwide, as mentioned above. As a bonus, we can easily empty the algae tank and lift the top off to have complete access to every part of the digester, without digging up anything, or to repair the sheet in case there is a tiny hole made by a rodent.

3.1.(ii) - Algae Unit

The effluent from the digester unit flows into a secondary and a tertiary algae basins in series (Fig. 2), where fast-growing and high-yielding algae are grown and harvested daily as protein-rich fish feed. The construction is simple, with a one-meter high brick wall and sandy bottom lined with the special polyethylene sheet. Every algae container is provided with a small windpump and biogas-operated aerator to keep the liquid in motion in order to expose all the phytoplankton to sunlight during the day and keep the dissolved oxygen level as high as possible during the night.

The main purpose of the algae unit is not only to reduce the BOD loading by a further 30% before the effluent enters the fish pond without any fish kill, but to grow selective algae as fish feed in a better controlled environment than the pond. Because we can move the whole biomass to the surface and have more or less saturation of dissolved oxygen and carbon dioxide, besides all the nutrients present, the algal growth can be many times more than the normal phytoplankton growth in the fish pond, where photosynthesis is limited to the top 30-40 cm. So instead of the 20 odd tons/ha of natural phytoplankton, we can grow high-protein algae such as *Spirulina maxima* up to 500 tons/ha, or 25 times more, making more use of the PAR. Therefore, two algae basins of 133 m² each can produce as much feed as in the 6,667 m² ponds to meet the fish phytoplankton requirements on a one-hectare Integrated farm (2/3 ponds). However, we use two algae basins of only 100 m² each to meet 75% of the phytoplankton requirements, and let the fish ponds produce the remaining 25% naturally. The 10% BOD left in the effluent entering the fish ponds is sufficient to enhance the complex feed chain for the non-herbivorous fish.

It means that we can cover up to 75% of the pond surface with aquatic plants (azolla, lemna, water hyacinth, water lettuce, etc) and aquaponic troughs (for tubers and beans), and leave the remaining 25% free for photosynthesis of phytoplankton but can still be used to grow submerged plants. This also supplies the dissolved oxygen during the day for the fish. In addition, we have many small wind and photovoltaic stand-alone pumps, avoiding any electrical wiring over the ponds, to lift the bottom water to the pond surface for natural aeration and to eliminate the harmful gases (H₂S, CH₄, NO₂) that cause fish stress or inhibit their growth.

3.1.(iii) - Special Growing Media

On every fish pond (Fig. 3) there are four rows of floating aquaponic troughs (1 m x 1 m square, and 30 cm high) made of plastic, with the central part (30 cm x 30 cm square, and 1 m high) having small openings on the four sides for planting over the whole height. The empty spaces are filled with special growing media that draw the mineralized pond water by capillary action to irrigate and fertilize crops. Tubers such as sweet potatoes are grown on the flat part and various bean vines on the central part fitted with trellis to prevent the beans from covering the tubers.

On the center of every dike (Fig. 4) there is one row of nitrogen-fixing *leucaena leucocephala* and various fruit trees, with wingbeans planted near the trees and groundnuts in between. On each edge there is one row of plastic aeroponic towers (40 cm x 40 cm, and 3 m high), spaced one meter apart center to center. The towers are filled with special growing media. A windpump and a standby biogas-operated pump lift the highly mineralized pond water to an overhead tank, and the water is then supplied by gravity in an overhead pipe to all the towers for irrigation and fertilization purposes. The towers have small openings on all sides, where various beans are grown horizontally over the whole height and supported on a trelliswork. Between the towers are suspended hydroponic troughs, filled with an inert growing media, and planted with soya or mung beans, with groundnuts grown underneath.

In half of the open spaces, cereals such as rice or corn are grown. In the other half, leafy vegetables are grown using multicropping and rotation of crops. Two compatible seeds are broadcast at the same time, with one crop ready for harvesting after 4 weeks and the other one another 4 weeks later. There is no raised plant bed, transplanting, or tilling of the soil, but the seeds broadcast are different every time. Up to 12 crops a year are obtained, and the vegetables are either sold or transformed into high-quality feed by cheap, but efficient microbial processes. The hydroponic troughs and multicropping fields are also supplied with irrigation and fertilization water from the overhead tank through perforated pipes.

The special growing media for aquaponics, hydroponics and aeroponics enable us to have three-dimensional culture of food and feed, making the maximum of the abundant nutrients in the pond water and using as much as possible of the PAR to fix carbon dioxide and nitrogen from the atmosphere. We have also chosen various kinds of crops aimed at two main objectives: to supply the farm family with nutritious food; and have raw materials for processing mechanically into higher-value goods such as oil and flour for sale, and by micro-organisms into high-quality feed for the livestock. Income from the sales is used to buy cheap feed materials for further microbial processing into high-protein feeds. The livestock eat less of the high-quality feed but grow faster with a higher proportion of lean meat that fetches much better prices.

3.2. Energy Budget

From the energy aspect, the IFS cannot be more efficient. The capital cost is relatively low, with a useful life of 10-20 years and practically no recurrent cost for its maintenance. It is designed so ingeniously that automatic flushing of the livestock wastes sets into motion a series of operations that range from livestock through aquaculture to agriculture. The livestock wastes are automatically flushed by a siphon tank into the digestion chamber at one end, displacing an equal volume of supernatant liquid through the connection pipe at the other end into the primary algae tank, and the same volume overflows from the outlet situated at the other end of this tank. The effluent enters the secondary algae basin at one end and overflows into the tertiary algae basin at the other end. The effluent from the tertiary algae basin overflows into a series of fish ponds, all using the overflow principle, until it discharges into some hydroponic troughs for soya or mung bean culture, and finally into a deep storage tank. A windpump lifts this water to the roof of the farmhouse to supply drinking water to the animals. Another windpump also lifts the mineralized effluent from the last fish pond to an overhead tank to supply the irrigation pipes by gravity, with a standby biogas-operated pump for windless days. A few times a day, a plunger pushes down the floating wastes at the inlet of the digestion chamber with an automatic pulley and rope device. So we have a system that is more or less in perpetual motion, without using any external source of energy.

One relatively expensive item is the provision of plastic containers for aquaponics, hydroponics and aeroponics, but they should pay for themselves within a year or two because of the increase in crop production. The problem is to obtain the loan for the initial capital costs. However, this should be encouraged because it actually expands the area of arable land.

Not only does the IFS recycle all the wastes and residues as fuel, fertilizer and feed many times more than what can happen naturally in the DPS, but it also optimizes production of a much wider range of high-quality products with minimum artificial energy and energy-related input, with the ultimate aim of achieving self-sufficiency.

The IFS also makes more use of the PAR by providing an almost continuous canopy of plant life that increases photosynthetic activities over an area that is effectively larger than the surface of the farm itself, because of three-dimensional cultivation. By selecting fast-growing and high-quality crops, we are also utilizing more of the stored energy in the nutrients. What is now required is a biogas-operated pumping device to remove the mud from the pond bottom daily and spread it over the dikes. It would be more beneficial for the system as a whole to have the organic content of the pond mud decomposing on land and releasing the nutrients to plants than to have this process at the pond bottom, releasing gases that cause fish stress and interfere with their healthy growth.

3.3 Energy Exchange

An analysis of the IFS energy budget shows a positive socio-economic as well as ecological balance, because of almost total absence of non-renewable energy and energy-related input, and total protection of the physical environment from any pollution because of complete recycling of all wastes and residues. The IFS not only creates more employment for the farm family with relatively modest investment and low operation costs, but also removes the drudgery of most routine work through simple automation based on the law of gravity. It still makes good use of the PAR, although more efficiently than the DPS or any other system worldwide, but more important still, the IFS requires very little artificial energy-related input to improve productivity. It just provides optimum conditions to enhance the natural processes so that energy exchanges and material recycling, which we are going to analyse now, can be much more efficient.

The table below shows the production on a one-hectare integrated farm of 2/3 ponds and 1/3 dikes under the four main categories of operations: Livestock, Aquaculture, Agriculture and Industry. We have limited the items to a minimum in each category, with their yields rounded off, to simplify the calculations.

3.3.(i) - Livestock

In China, the pig is used as the standard livestock with the following assumptions that approach average field figures: weight of 100 kg in 6 months, during which time it consumes 250 kg of dry feed and produces 500 kg of wet wastes. The one-hectare integrated farm produces 600 pigs annually, buying 50 piglets every month while selling or processing 50 pigs of 100 kg each. A good program of marketing that the farm family can easily handle is to supply one pig to a butcher and process another one on the farm or at a cooperative every weekday. The livestock provides the farm family with its daily cash flow, amounting to ¥700 (US\$200) @ ¥3.50/kg, or ¥210,000 (US\$60,000) annually — a substantial sum by any standard, especially when the feed cost is so low!

The quantity of wastes produced is 300 tons, representing 18,000 m³ of biogas or 90,000 kWh (or about 250 kWh/day). This amount is normally adequate to meet the energy needs of a one-hectare farm for farming and industrial purposes, but it can be increased by 50% or more, if required, by feeding the algae from the primary algae tank into the digester every day, and keeping the liquid temperature between 35° and 40°C with a solar heater in the tropics. The addition of the algae to the digester increases the carbon content considerably, but also a smaller amount of nitrogen. In any case, the carbon/nitrogen ratio is increased providing better conditions for biogas production and reduction of solids and COD 12/. However, if there is sufficient biogas to meet all the needs on the farm, it is better to use the algae as high-protein livestock feed, instead of letting the excess biogas escape into the atmosphere.

unjust

(a) Underlined items - Available

ANNUAL PRODUCTION PER HECTARE OF INTEGRATED FARM
(2/3 Ponds & 1/3 Dikes)

(b) ? - Quantity as required

OPERATIONS	INPUT	FROM	P. OUTPUT	USES	S. OUTPUT	USES	T. OUTPUT	USES	Q. OUTPUT	USES	TO
LIVESTOCK											
300 pigs	75t feed	INDUSTRY	<u>30t stock</u>	Market \$	150t wastes	Digester	Biogas	Direct	<u>45,000 kWh</u>	Equipment	Industry
300 pigs	75t feed	INDUSTRY	<u>30t stock</u>	Industry	<u>20t goods</u>	Market \$? Buy feed	Micr. Proc.	? Feeds	-	Livestock
	600 piglets	External			10t offals	Processing	Concentrates	Formulation	<u>5t Conc.</u>	-	Livestock
			4t algae	Substrate	150t wastes	Digester	Biogas	Indirect	<u>45,000 kWh</u>	Machinery	Industry
					Add fungi	Micr. Proc.	Concentrates	Formulation	<u>2t Conc.</u>	-	Livestock
AQUACULTURE											
Carp	20t feed	AQUACULTURE	8t fish	Raw Mat.	-	Processing	Concentrates	Formulation	<u>4t Conc.</u>	-	Livestock
	Fish fry	External	40t wastes	Pond bottom	Organic Mat.	Fertilizer	Pond mud	On dikes	Bact. Act.	Nutrients	Agriculture
					Fish wastes	Nutrients	10t Organism	Fish feed	Minerals	Fertilizer	Aquaculture
Prawns	8t feed	AQUACULTURE	<u>1t prawns</u>	Market \$	12t wastes	Pond bottom	Organic Mat.	On dikes	Bact. Act.	Nutrients	Agriculture
	Prawn fry	External	1t prawns	Industry	<u>0.5t Fr. gd.</u>	Market \$	0.5t Resid.	Processing	<u>0.5t Conc.</u>	-	Livestock
Algae Basins	sun/air	P.A.R.	10t algae	Fish feed	Oxygen	Mineralizat.	Nutrients	Fertilizer	-	-	Aquaculture
	Seeds	IN SYSTEM			Nitrogen	Protein					
Phytoplankton	sun/air	P.A.R.	3t plankton	Fish feed	Oxygen	Mineralizat.	Nutrients	Fertilizer	-	-	Aquaculture
	Seeds	IN SYSTEM			Nitrogen	Protein					
Grass/Ipomoea	sun/air	P.A.R.	5t grass	Fish feed	5t wastes	Fish feed	Fish wastes	Pond bottom	Mineralizat.	Nutrients	Agriculture
	Seeds	IN SYSTEM	5t greens	Substrate	Add fungi	Micr. Proc.	Ensilage	Formulation	<u>1t Feeds</u>	-	Livestock
Floating Plants	sun/air	P.A.R.	200t plants	Substrate	Add fungi	Micr. Proc.	Ensilage	Formulation	<u>40t Feeds</u>	-	Livestock
	Seeds	IN SYSTEM			Nitrogen	Protein					
Submerged Plants	sun/air	P.A.R.	10t plants	Substrate	Add fungi	Micr. Proc.	Ensilage	Formulation	<u>2t Feeds</u>	-	Livestock
	Seeds	IN SYSTEM			Oxygen	Mineralizat.					
Aquaponic tubers	Seeds	External	20t tubers	Substrate	Add fungi	Micr. Proc.	Ensilage	Formulation	<u>5t Feeds</u>	-	Livestock
	Irrigation	AQUACULTURE	Deminerliz.								
	Nutrients	AQUACULTURE	Fertilizat.								
Aquaponic beans	Seeds	External	10t beans	Processing	<u>2t Oil</u>	Market \$? Buy Feed	Micr. Proc.	? Feeds	-	Livestock
	Inoculants	External			8t Resid.	Processing	<u>4t Conc.</u>	-	-	-	Livestock
	Irrigation	AQUACULTURE	Deminerliz.								
	Nutrients	AQUACULTURE	Fertilizat.								

Pilot project was to confirm these figures. Not done because of Ormeau, 1988 incident in Seaside.

ANNUAL PRODUCTION PER HECTARE OF INTEGRATED FARM (cont.)

OPERATIONS	INPUT	FROM	P. OUTPUT	USES	S. OUTPUT	USES	T. OUTPUT	USES	Q. OUTPUT	USES	TO
<u>AGRICULTURE</u>											
Leucaena trees	Irrigation Seeds	AQUACULTURE IN SYSTEM	1t feed	Raw Mat.	Add fungi Nitrogen	Micr. Proc. Fertilizer	Ensilage -	Formulation -	<u>0.5t Feeds</u> -	- -	Livestock Fruit Trees
Fruit trees	Irrigation Fertilizer	AQUACULTURE OTHER CROPS	<u>1t fruits</u>	<u>Market \$</u>	? Buy Feed 1t Leaves	Micr. Proc. Micr. Proc.	Ensilage Ensilage	Formulation Formulation	? Feeds <u>0.5t Feeds</u>	- -	Livestock Livestock
(Aeroponic beans Hydroponic beans)	Seeds Seeds Irrigation Nutrients	External External AQUACULTURE AQUACULTURE	5t beans) 1t beans) Deminerliz. Fertilizat.	Processing	<u>1t Oil</u> 5t Resid. Nitrogen	<u>Market \$</u> Processing Protein	? Buy Feed <u>2t Conc.</u>	Micr. Proc. -	? Feeds -	- -	Livestock Livestock
(Wingbeans Groundnuts)	Seeds Seeds Irrigation Nutrients	External External AQUACULTURE AQUACULTURE	1t foods) 5t nuts) Deminerliz. Fertilizat.	Processing	<u>2t Flour</u> 4t Resid. Nitrogen	<u>Market \$</u> Processing Fertilizer	Buy Feed <u>2t Conc.</u> -	Micr. Proc. - -	? Feeds - -	Livestock - -	Livestock Fruit Trees
(Azolla Rice)	Farm stock Seeds Irrigation Nutrients	AQUACULTURE External AQUACULTURE AZOLLA	10t azolla) 3t rice) Deminerliz. Nitrogen	Raw Mat. " Fertilizer	Add fungi " -	Micr. Proc. " -	Ensilage " -	Formulation " -	<u>5t Feeds</u> <u>3t Feeds</u> -	- - -	Livestock Livestock Rice
(Corn Centrosema vine)	Seeds Seeds Irrigation Nutrients	External External AQUACULTURE AQUACULTURE	1t corn) 2t vine) Deminerliz. Fertilizat.	Raw Mat. "	Add fungi "	Micr. Proc. "	Ensilage "	Formulation "	<u>0.5t Feeds</u> <u>0.5t Feeds</u>	- -	Livestock Livestock
Leafy Vegetables	Seeds Irrigation	External AQUACULTURE	<u>8t Veges</u> 8t Resid.	<u>Market \$</u> Substrate	Buy Feed Add fungi	Micr. Proc. Micr. Proc.	Ensilage Ensilage	Formulation Formulation	? Feeds <u>2t Feeds</u>	- -	Livestock Livestock
<u>INDUSTRY (utilizing exclusively BIOGAS energy from the system)</u>											
Small Goods	300 pigs	LIVESTOCK	<u>20t Goods</u>	<u>Market \$</u>	10t offals	SEE ABOVE					
Oil	Beans/Nuts	AGRICULTURE	<u>3t Oil</u>	<u>Market \$</u>	Residues	Concentrates	SEE ABOVE	-	-	-	Livestock
Flour	Beans/tubers	AGRICULTURE	<u>2t Flour</u>	<u>Market \$</u>	Residues	Concentrates	SEE ABOVE				
Micro-organisms	Microbes	IN SYSTEM & External	High-Protein Feeds		Palatable to Livestock		Metabolize Efficiently		Natural Preservation		

The effluent still contains all the original nutrients in the wastes, enhanced by the nitrogen and carbon dioxide fixed by the algae not only in the primary tank, but in the secondary and tertiary basins as well. What is more important is that at least 90% of the nutrients are readily available for use as fertilizer when the effluent enters the fish ponds, without any organic pollution. The nutrients are again increased by the plant and fish life in the ponds through photosynthetic and planktonic activities. Crops are grown in the ponds and on the dikes so that the nutrients are used up in the proportion of 2/3 and 1/3 respectively.

Moreover, because of the long retention period in both the digester and algae units, no pathogenic organisms can survive. This is a very important factor in China because the people make no difference between human and animal wastes -- they all end up in the digester, and receive more effective treatment than in the expensive sewage treatment plants in the rich countries, where the hydraulic retention time is in hours instead of weeks, which is the case with the IFS.

3.3.(ii) - Aquaculture

As already explained, the algae basins do not only treat the wastes aerobically to prevent fish kill in the ponds, but they also produce the phytoplankton for the fish more efficiently -- 4 tons annually in 2 basins of 100 m² each. The great depth of the pond, 3 meters instead of the usual 1 meter, and the small amount of organic matter entering the pond also provide a balanced ecosystem, and the ingenious choice of several compatible species of carps, in sufficient numbers in order to consume nearly all the plankton, invertebrates and bacteria over the whole depth, keeps the pond relatively healthy. The addition of the wind or photovoltaic pumps in the IFS accelerates the sluggish escape of 'toxic' gases from the pond bottom, besides aerating any deoxygenated water, and can only enhance the environment for the fish to grow without stress or disease. It will be almost perfect when we can lift the pond mud with a special pump and spread it over the dikes every day.

Since it takes 20 tons of feed to produce 8 tons of fish, and 8 tons of feed to produce 2 tons of prawns in our IFS ponds every year, and we do not add any artificial feed at all, the system is producing the 28 tons of high-quality feeds: 14 tons of algae in the tank and basins, 3 tons of phytoplankton and 10 tons of various organisms in the ponds, and 5 tons of grass (20% dry) grown at the edges of the ponds. The wastes produced by the fish and prawns amount to 32 tons a year, and are mineralized naturally in the ponds while producing the 10 tons of organisms (protozoa, benthos, invertebrates and bacteria) annually as natural fish feeds. Some of these minerals are used by the aquatic plants (5 tons of greens, 200 tons of floating plants and 10 tons of submerged plants) and the aquaponic culture (20 tons of tubers and 10 tons of beans), and the remainder by the terrestrial plants as described under "Agriculture" below.

Input from outside is limited to fish and prawn fry, seeds and nodule bacteria inoculants, so there are big savings on fertilizers while the yields increase, because we have converted pollutants into useful nutrients for the fish, prawns and plants. The prolific growth of aquatic plants also removes a considerable amount of the minerals from the ponds, preventing them from causing eutrophication problems elsewhere, but they contain about 90% water. As livestock feed, they are not efficient because the high mineral content makes the animals refuse to eat large quantities of them, so they do not contribute much to growth. However, they make a good substrate for microbial processing, using natural micro-organisms such as fungi 13/ to increase the protein content and improve metabolism in the livestock, which then grow well without consuming much, and produce good lean meat.

3.3.(iii) - Agriculture

The dike area is relatively small, but we increase the cultivation surface by growing up to 3 meters high on the special plastic towers and trellisworks. We irrigate and fertilize as often as the plants need for optimum growth, because we always have water and fertilizer available within the system. Input from outside is limited to deficient trace elements, seeds and nodule bacteria inoculants, again making big savings on fertilizers while the yields increase considerably.

The row of leucaena and fruit trees not only act as wind breaker but also provides 2 tons of feeds (leaves for microbial processing and pods) and 1 ton of fruits annually. Next to the trees, wingbeans are grown using the trees as poles to climb up to 4 meters or more, producing 1 ton of beans, tubers and edible leaves. Between the trees, groundnuts are grown. The leucaena trees and the legumes fix nitrogen into the soil for the fruit trees to use. On the edges of the dikes, 5 tons of various bean vines are grown in the aeroponic towers and supported on trellisworks. Between the towers, 1 ton of soya or mung beans are grown in suspended hydroponic troughs, with groundnuts grown below. The total yield of groundnuts is 5 tons.

3.3.(iv) - Industry

The industrial activities are limited to processing of the farm produce to obtain non-perishable and high-value foods and goods, with the residues used as livestock feed, with or without further processing. Half the animals are slaughtered on the farm or at a cooperative and processed into ham, Chinese bacon, Chinese sausage, and other smoked, dried, salted or frozen goods, with the residues processed into concentrates. The fish are totally converted into fish meal. The prawns are either sold live or fresh, after polishing in a separate pond for a few days, or frozen (headless or shelled), and the residues mixed with the fish meal. The beans and nuts are pressed for oil, ground into high-protein flour, and made into snacks or fermented products, with the residues made into concentrates.

Operations	Integrated Farming System			
	Income	Expenses	Recycled	Profit
Aeroponics				
Beans/Nuts	4900	500	-	4400
Biogas power	-	-	800	-800
Equipment/Labour	-	2000	400	-2400
Net Profit/Loss	4900	2500	1200	1200
Paddy Fields				
Azola	800	100	-	700
Rice	900	200	-	700
Biogas power	-	-	300	-300
Equipment/Labour	-	500	600	-1100
Net Profit/Loss	1700	800	900	0
Upland Crops				
Corn/Vine	250	150	-	100
Vegetables	4600	200	-	4400
Biogas power	-	-	200	-200
Equipment/Labour	-	1200	800	-2000
Net Profit/Loss	4850	1550	1000	2300
Industry 1.				
Pig/Animals	40000	1100	30000	8900
Poultry/Other	2500	-	-	2500
Biogas power	-	-	2000	-2000
Equipment/Labour	-	3900	1500	-5400
Net Profit/Loss	42500	5000	33500	4000
Industry 2.				
Beans	7500	300	3600	3600
Biogas power	-	-	900	-900
Equipment/Labour	-	1100	600	-1700
Net Profit/Loss	7500	1400	5100	1000
Industry 3				
Nuts/Beans	4500	300	1500	2700
Biogas power	-	-	900	-900
Equipment/Labour	-	300	500	-800
Net Profit/Loss	4500	600	2900	1000

All figures in \$USD.

24 These high-value goods are sold and the money used to purchase inexpensive whole grains for processing into oil or flour, and feed materials such as bean and nut meals, bran and pollard. The feed materials, together with the crop and processing residues, cereals, tubers, vegetables and aquatic plants are all processed by micro-organisms to increase the protein content and transform them into more palatable and easily digestible feeds for livestock. The main objective is to produce as much high-quality feed as possible for the livestock, which is the mainstay of the IFS economy. Normally the pig feed represents up to 70% of the production costs, and all savings on this item are net profit.

3.4. Energy Evaluation

There is no doubt that with better structure, management and technology, the IFS is making more and better use of the PAR, the stored energy, and the resources recovery than in the DPS or its 'modern' version, because of the negligible artificial energy input. In the following table, we compare the inputs and outputs, and the conversion rates of the DPS, the 'modern' DPS, and the IFS to show the latter's higher energy efficiency besides the fabulous monetary returns from all the integrated farming operations.

It is hoped that the figures will convince all those skeptical academics and research scholars, agriculturists and technologists, economists and sociologists, and farmers from both the developed and developing worlds that we do not need to perpetuate the wasteful development strategies of the so-called modern world that is now heading toward a real disaster. We just cannot afford to waste our resources any longer because their supply is limited on this earth, and more people want a fair share of what Mother Nature has to give to all her children, and not just a 'chosen' few.

3.5. Future of the IFS

The Integrated Farming System offers a whole world of opportunities to our young generation in animal husbandry, now limited to only a few species, often inappropriate, dictated by some countries; aquatic life, in our lakes, rivers, lagoons and coastal waters that are producing practically nothing on such vast areas of our small planet; plant industry, with such a huge variety of high-quality foods that are neglected because of ignorance or they are only found in traditional diets in their indigenous areas; and food processing industry, for preservation and added value instead of the present wastage due to cultural, social or other constraints.

Last but not least, the computer enthusiasts can have a field day with the energy exchanges and materials cycles to improve efficiency and optimize productivity in all the inter-related activities of the IFS.

A Bon Entendeur, Salut!

1: CALCULATION OF INPUT/OUTPUT
Integrated Farming Systems

Appendix 1 c.

I N P U T				O U T P U T			Profit
Item	Quantity	Internal	External	Item	Quantity	Value	Remarks
LIVESTOCK - Pigs							
Piglets	600	-	12,000	Pigs (mkt)	30t	36,000	sale
Materials	...	-	1,800	Pigs (fac)	30t*	36,000	process.
Feeds (int.)	50t	15,000+	-	Wastes (g)	300t#	3,000	biogas#
Feeds (ext.)	100t	-	30,000	Algae Con.	2t+	800	pig feed
Power	8,000W+	800W	-				
Equipment	...	-	4,000				
Labor	1,000h+	1,000	-				
Drugs	...	-	700				
	8,000W+	16,800	48,500				
Sub-total	1,000h+	15,000+	65,300		2t+	75,800	\$10,500p
AQUACULTURE - Fish & Prawns							
Fish fry	30m	-	600	Fish	6t+	3,000	feed
Feeds (phy)	20t	1,000	-	Prawn (mkt)	1t	8,000	sale
Prawn fry	200m	-	2,000				
Feeds (phy)	8t	800	-	Plank. (fi)	10t"+	1,000"+	fish/pr.
Materials	...	-	1,000	Plank. (pr)	3t"+	300"+	feed
Power	6,000W+	600W	-	Algae (p)	10t"+	500"+	fish/pr.
Equipment	...	-	1,000	Phytoplank.	3t"+	150"+	feed
Labor	1,000h+	1,000	-				
Drugs	...	-	450				
	14,000W+	3,400	5,050		26t"+	1,950"+	
Sub-total	2,000h+	15,000+	8,450		8t+	12,950	\$4,500p
Aquatic Plants							
Seeds (aqua)	1t	-	50	Grass (fi)	2t"+	150"+	fi. feed
Materials	...	-	100	Green Con.	1t+	400	pig feed
Power	4,000W+	400W	-	Plant Con.	10t+	1,000	pig feed
Equipment	...	-	200	Fish wastes	4t	200	nutrient
Labor	1,000h+	1,000	-	A. plants	60t#	3,000	biogas#
	18,000W+	1,400	350		28t"+	2,100"+	
Sub-total	3,000h+	15,000+	1,750		19t+	4,750	\$3,000p
Aquaonics							
Seeds (tub)	100k	-	100	Tuber Con.	3t+	1,500	pig feed
Materials	...	-	50				
Power	4,000W+	400W	-				
Equipment	...	-	500				
Labor	400h+	400	-				
Trace elem.	...	-	50				
	22,000W+	800	700				
Sub-total	3,400h+	15,000+	1,500		22t+	1,500	-0-p
Aquaonics (cont)							
Seeds (bean)	100k	-	100	Beans	3t**	1,800	process.
Materials	...	-	200	Crop Con.	2t+	800	pig feed
Power	4,000W+	400W	-				
Equipment	...	-	700				
Labor	1,000h+	1,000	-				
Trace elem.	...	-	200				
	26,000W+	1,400	1,200				
Sub-total	4,400h+	15,000+	2,600		24t+	2,600	-0-p
AGRICULTURE - Trees							
Seedlings l.	5k	-	20	Feeds (l)	0.5t+	100	pig feed
Seedlings f.	100k	-	100	Feeds (f)	0.5t+	100	pig feed
Materials	...	-	50	Fruits	1t	1,000	buy feed
Power	4,000W+	400W	-				
Equipment	...	-	400				
Labor	200h+	200	-				
Trace elem.	...	-	30				
	30,000W+	600	600				
Sub-total	4,600h+	15,000+	1,200		25t+	1,200	-0-p

W+ Cumulative power in kWh from wind energy
h+ Cumulative wages paid by system

+ or " Cumulative feed production in system
* or ** For processing industry

+ Cumulative value of system-resources, excluding wind power

Appendix 1 c.

I N P U T				US \$	O U T P U T			Profit
Item	Quantity	Internal	External		Item	Quantity	Value	Remarks
AGRICULTURE (cont) - Aeroponics								
Seeds (bean)	100k	-	200		Beans	3t**	1,800	process.
Seeds (nut)	100k	-	100		Nuts/beans	3t*	1,500	process.
Materials	...	-	200		Crop Con.	4t+	1,600	pig feed
Biogas power	8,000K+	800+	-					
Equipment	...	-	1,800					
Labor	400h+	400	-					
Trace elem.	...	-	200					
	8,000K+	1,200	2,500					
Sub-total	5,000h+	15,800+	3,700			29t+	4,900	\$1,200p
Paddy								
Azolla	100k	-	50		Feeds (az)	4t+	800	pig feed
Rice	300k	-	150		Feeds (ri)	3t+	900	pig feed
Materials	...	-	100					
Biogas power	3,000K+	300+	-					
Equipment	...	-	400					
Labor	600h+	600	-					
Trace elem.	...	-	100					
	11,000K+	900	800					
Sub-total	5,600h+	16,100+	1,700			36t+	1,700	-0-p
Upland Crops								
Corn	20k	-	30		Feeds (co)	0.5t+	150	pig feed
Vine	20k	-	20		Feeds (vi)	0.5t+	100	pig feed
Vegetables	50k	-	100		Vegetables	8t	4,000	buy feed
Materials	...	-	200		Feeds (va)	2t+	600	pig feed
Biogas power	2,000K+	200+	-					
Equipment	...	-	1,000					
Labor	800h+	800	-					
Trace elem.	...	-	200					
	13,000K+	1,000	1,550					
Sub-total	6,400h+	16,300+	2,550			39t+	4,850	\$2,300p
INDUSTRY*								
Pigs	30t*	30,000	-		Pork goods	20t	40,000	sale
Materials	...	-	1,100		Offal Con.	5t+	2,500	pig feed
Biogas power	20,000K+	2,000+	-					
Equipment	...	-	3,000					
Labor	1,500h+	1,500	-					
Preservat.	...	-	900					
	33,000K+	33,500	5,000					
Sub-total	7,900h+	18,300+	38,500			44t+	42,500	\$4,000p
Beans	6t**	3,600	-		Oil	2t	6,000	sale
Materials	...	-	300		Bean Con.	3t+	1,500	pig feed
Biogas power	9,000K+	900+	-					
Equipment	...	-	1,000					
Labor	600h+	600	-					
Preservat.	...	-	100					
	42,000K+	5,100	1,400					
Sub-total	8,500h+	19,200+	6,500			47t+	7,500	\$1,000p
Nuts/beans	3t*	1,500	-		Flour	2t	3,000	sale
Materials	...	-	300		Bean Conc.	3t+	1,500	pig feed
Biogas power	9,000K+	900+	-					
Equipment	...	-	200					
Labor	500h+	500	-					
Preservat.	...	-	100					
	51,000K+	2,900	600					
Sub-total	9,000h+	20,100+	3,500			50t+	4,500	\$1,000p
HOUSEHOLD								
Biogas power	9,000K+	900+	-		Savings	9,000 kwh	300	domestic
Sub-total	50,000K+	21,000+						

K+ Cumulative power in kwh from biogas

System resources value: \$21,000

Labor wages paid by system (\$1/hr): \$9,000

Value of BIOGAS power:

\$6,000, representing 20% of system resources

* Cumulative feed produced in system = 50t

TOTAL CASH PROFITS: \$27,500

TOTAL SYSTEM RESOURCES: \$30,000

REFERENCES

1. Ruddle K., Deng H.Z. & Liang G.Z., Osaka -- Bult. of N.M.O.Ethn., 11, 1, 323-343, 1986
ENERGY EXCHANGES & ENERGY EFFICIENCY OF HOUSEHOLD PONDS
In the Dike-Pond System of the Zhujiang Delta
2. Bian Y.S., CHINA -- Beijing Municipal Research Institute, 1987
A BRIEF INTRODUCTION TO LIU MING YING ECO-SYSTEM
Experimental Eco-farm for Research & Development
3. Chan G.L., CHINA -- (mimeo) 1988
THE PILOT INTEGRATED FARM FOR SOUTH CHINA
Rural Development for South China & Tropical/Subtropical Countries
4. Ruddle K., Furtado J.I., Zhong G.F. & Deng H.Z., CHINA -- Appl. Geog., 3, 4S-52, 1983
THE MULBERRY DIKE - CARP POND RESOURCE SYSTEM OF ZHUJIANG DELTA :
I. Environmental Context & System Overview
5. Wang Z.Q. et al, CHINA -- Tropical Geography, 6, 1, 1-12, 1986
THE RELATIONSHIP BETWEEN PRODUCTIVITY OF FISH & PLANKTON
In the Dike-Pond System of the Pearl River Delta
6. Deng H.G., Wang Z.Q., Wu H.S. & Liang G.Z., CHINA -- (mimeo) 1984
THE MULBERRY DIKE - CARP POND RESOURCE SYSTEM OF ZHUJIANG DELTA
III. Energy Flow and Substance Cycles
7. Zhong G.F., Chan G.L., Wang Z.Q., Wu H.S. & Yao H.Y., CHINA -- (mimeo) 1987
THE INTEGRATED RURAL DEVELOPMENT IN GUANGDONG PROVINCE
Report to Chairman, Standing Committee, People's Congress, Guangdong Province
8. Zhong G.F., Deng H.Z., Liang G.Z., Wang Z.Q. & Wu H.S., CHINA -- Academia Sinica, 1988
ENERGY FLOW & MATERIAL CYCLES IN THE DIKE-POND SYSTEM OF ZHUJIANG DELTA
Research & Development done at Guangzhou Institute of Geography
9. Bian Y.S., CHINA -- Beijing Municipal Research Institute, 1987
CALCULATION, ANALYSIS & RESEARCH ON INPUT-OUTPUT RATES OF SUPPLEMENTARY ENERGY
Utilization of Livestock Wastes as Biogas Fuel & Fertilizer on an Eco-Farm
10. Food & Agriculture Organization, Rome -- FAO Soils Bulletin 41, 1978
CHINA : AZOLLA PROPAGATION
FAO/UNOP Project on Improving Soil Fertility through Organic Recycling
11. National Academy of Sciences, USA -- BOSTID Report 21, 1976
MAKING AQUATIC WEEOS USEFUL :
Some Perspectives for Developing Countries
12. Biljetina R., Srivastava V., Chynoweth D.P. & Hayes T.D., USA -- Conf. Paper, 1986
ANAEROBIC DIGESTION OF WATER HYACINTH AND SLUDGE
Research & Applications of Aquatic Plants for Water Treatment & Resource Recovery
13. National Academy of Sciences, USA -- BOSTID Report 28, 1979
MICROBIAL PROCESSES :
Promising Technologies for Developing Countries

DIKE - POND SYSTEM

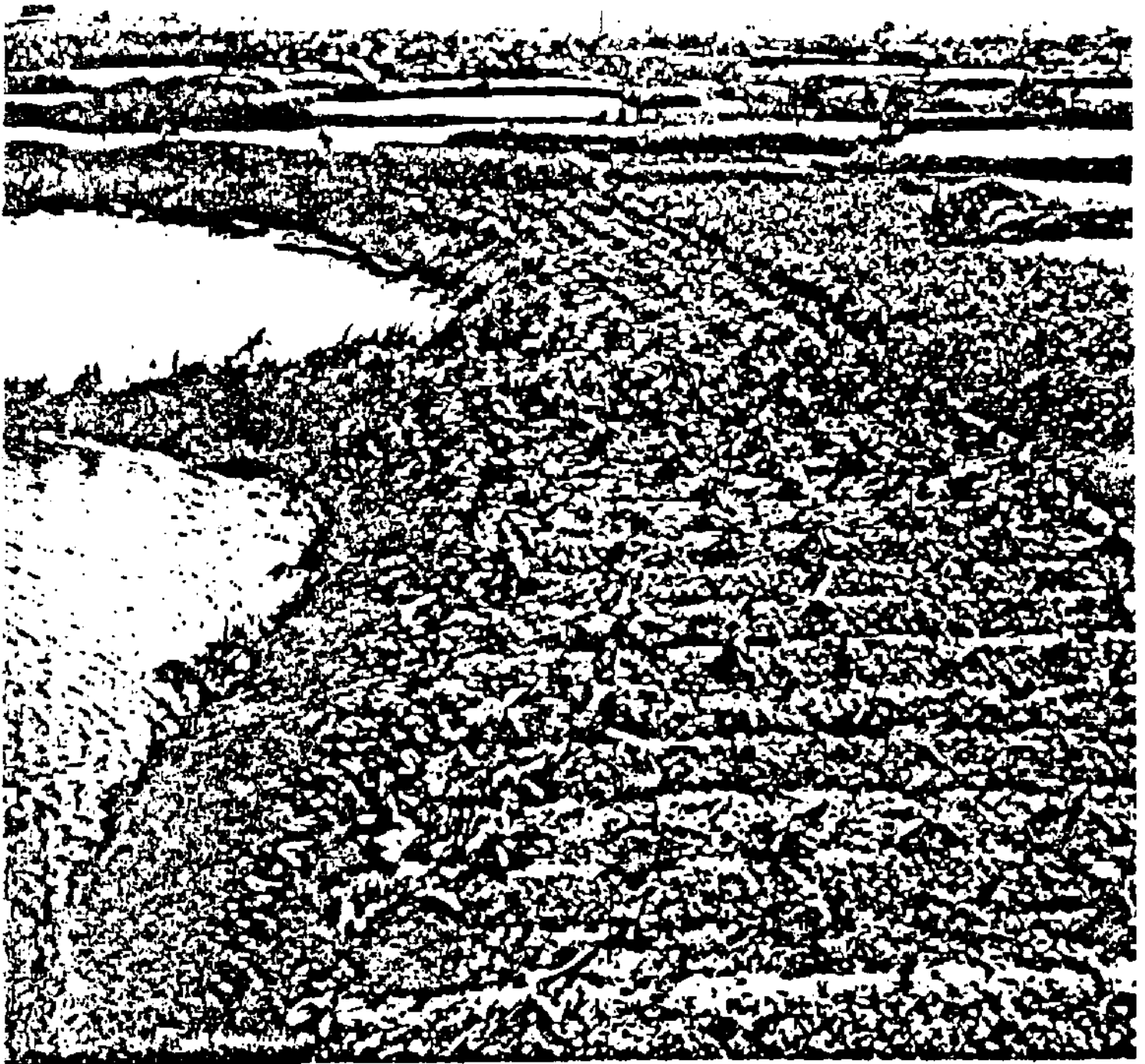

FISH POLY CULTURE - AQUATIC PLANTS

HYBRID GRASS (FISH FEED)

MULTICROPPING / INTERCROPPING
(FRUITS & VEGETABLES)

MULBERRY (SERICULTURE) ROTATED WITH SUGARCANE

II. EXISTING DIKE - POND SYSTEM

The Dike-Pond System is based on every household becoming a self-reliant production unit of fuel, feed and fertilizer relevant to its chosen activities in the community, and relies on a series of symbiotic interactions aimed at a self-sustaining ecosystem using all locally available resources. In addition, it can have agro-industry at household or community level with minimum input from outside. This system has been practised by all farmers during the past four centuries involving 1.2 million people over 800 square kilometres in the Pearl River Delta of Guangdong in South-East China.

1. LIVESTOCK

- Crop and processing residues are fed to livestock, and livestock manure is used as fertilizer in the fish ponds.
- Livestock consists of pigs, goats, water buffaloes, chickens, ducks, geese, pigeons, quails, rabbits, silkworms and bees

2. AQUACULTURE

- Polyculture in deep fish ponds enables various layers of different species of fish to consume specific feeds (phytoplankton, zooplankton, benthos, molluscs, bacteria, detritus, feces) present or growing naturally in the manure-fertilized water.
- Species of fish include mainly silver carp, bighead, common carp, grass carp, black carp and mud carp.
- The only additional feed is elephant grass grown on the banks of the fish ponds. Some small shallow ponds are also used to grow water hyacinth, water lettuce, lake lotus, azolla and various duckweeds as livestock or fish feed.
- Some water chestnut and lotus are grown on the surface of the ponds as gourmet food.

3. AGRICULTURE

- Various vegetables are grown on the dikes between the ponds all the year round, with ample water, fertilizer, sunshine and warmth.
- Mulberry is also a very important crop for the long-established silk industry. It is rotated with sugarcane every five years for pest and disease control.
- The dikes are fertilized with nutrient-rich mud removed from the bottom of fish ponds three times a year. No chemical fertilizer is used in the traditional system.
- There is no expensive drainage, waste disposal or irrigation system, as the ponds act as effective stormwater drains, efficient sewage treatment plants, and more than adequate water storage for irrigation. Both aquatic and land crops remove minerals from the water, controlling eutrophication.
- There is no loss of soil or nutrient, as everything is recycled in a closed system. Water losses are limited to evaporation and transpiration, and recharge is from the aquifer and rain.

- Human labor and water buffalo power, working in harmony with nature in an enhanced environment, have enabled a wide region with past history of flooding and waterlogging to become the world's most efficient farming community in terms of produce diversity, productivity, operation costs and energy balance.

NOTE: The traditional farm with the Dike-Pond System is completely self-reliant and provides the farm family with a balanced diet and a substantial surplus for the market, without spending any money on fuel, feed and fertilizer. However, in the areas adjacent to towns, where no farming is done but there are additional resources in the form of nightsoil, food remains and processing residues, the integrated farms have access to them and recycle them as fertilizer and feed to produce more livestock, fish and crops to meet the food needs of the town people. This is a unique situation where there is interaction and interdependency between the urban center and the surrounding rural areas, thus making a closely knitted community that economically and ecologically solves its food, fuel, fertilizer, and waste disposal problems with minimum input from outside.

III. PROPOSED INTEGRATED SYSTEM

-- The existing Dike-Pond System has relied mainly on farming practices based upon the empirical wisdom of many generations of local farmers until a decade or so ago, when a few dedicated Chinese scientists and technologists started to investigate some of the scientific bases for system integration.

- Moreover, many outside institutions have done research work on similar systems because of increasing concerns about their acute problems of environmental degradation and depletion of non-renewable resources, but their useful results were not applicable to their social or cultural environment and their reports just remained on the shelves. Some of them even became interested in the Chinese integrated systems and have started to apply their research and development findings in China.

- More recently, after the "responsibility system" was introduced in the Chinese farming communities, a UNU survey found out that only 35-50% of the labor force was required in the dike-pond system of the household unit, and many men and women had to look for other work outside the farms. It was recommended that modern science and technology should be used to increase the activities of the existing system and its economic rate of return, so as to make it worth while for the surplus labor to remain on the farms.

- It is now proposed to expand the Dike-Pond System and optimize the productivity through introduction of scientific innovations and sound technology already developed in China and abroad, as China should not waste time or money on pure research that is already available, but still maintaining the vital land-water interactions in accordance with the traditional self-reliant and ecological principles.

- The proposed Integrated Farming System (IFS) converts LIVESTOCK and AGRICULTURE into a three-dimensional operation, which has already been achieved in AQUACULTURE, with at least two kinds of fish living in each of three distinct levels. It also produces the maximum amount of biogas energy within the system for its operation and industrial activities, utilizing renewable energy such as other biomass conversion, hydro, solar and wind, if necessary.

- It should be noted that some mechanization already exists in the farms closer to urban areas, and the tendency is to use some locally-produced feed, chemical fertilizer and even pesticide. This problem can be controlled if emphasis is put on the use of wind and hydro to generate electricity for towns and factories, methane and ethanol for vehicle operation, and plant material for the manufacture of commercial fertilizer and pesticide.

1. LIVESTOCK

- The number of livestock in the existing system is limited by the available feed from crop and processing residues, and the natural capability of the ponds to treat the wastes effectively in order to prevent fish kill caused by oxygen depletion.

- With a more efficient waste treatment system consisting of upflow digesters and deep algae tanks before the effluent is allowed to enter the polyculture ponds, the number of livestock will be increased ten-fold to start with, and more as husbandry and waste treatment improve beyond present levels.

- For the three-dimensional operation, the livestock will be housed on three levels:

- | | |
|------------|---|
| a. Ground | - Pig, Goat, Deer, Buffalo, (Minicattle)
Siikworms |
| b. Window | - Chicken, Rabbit, Snake, (Pangolin)
Duck, Goose |
| c. Ceiling | - Pigeon, Quail, Bee |

Where there is the danger of disease propagation, as in the case of chicken and pig, there should be complete isolation of the two species within the animal house.

- A new livestock will only be introduced if its wastes can provide the fuel and fertilizer required to produce its feed within the system.

- Crop residues containing lignocellulose, such as corn cob and rice or wheat straw, will be made more digestible by treatment with cheap alkalis to provide an abundant and palatable feed for livestock.

2. AQUACULTURE

- Besides the kinds of carps that have been cultured for centuries, new species of fish and shellfish will be introduced, provided that the newcomer is not a predator and does not compete for feed with the others, unless it brings in a higher economic rate of return than the carp it replaces.

- Preference will be given to fish and shellfish that feed at the lowest trophic levels in order to consume all the aquatic life in the ecosystem.

- The three levels of fish and shellfish are as follows:

- | | |
|-----------|--|
| a. Top | - Grass carp (macrophytes, grass)
- Common Carp (feces, benthos)
- Tilapia (omnivore) |
| b. Middle | - Silver Carp (fine algae)
- Bighead (protozoa, coarse algae)
- Tilapia (omnivore)
- Crayfish (macrophytes) |
| c. Bottom | - Black Carp (molluscs)
- Mud Carp (detritus)
- Common Carp (benthos)
- Prawns (benthos, bacteria) |

- Present depth of 3 metres will be increased to provide more space for possible newcomers, with the bottom water brought up to the surface for aeration using windpump, photovoltaic, or submersible pump connected to a biogas-operated generator.

- Various kinds of grass and aquatic plants will be grown as feed for the fish and shellfish -- see AGRICULTURE below. Suitable greenhouses will also be tried for use in colder climates.

3. AGRICULTURE

- Besides present practices of crop rotation, companion planting, intercropping and multicropping for pest control and high productivity, which will be expanded, and the growing of crops over and under water, on the ground, over and under ground, there will be much emphasis on growing of crops in special containers using mineralized water. Hydroponics is already well known, but there is a new technology using containers that allow plants to be grown horizontally along its sides, and can be stacked vertically to the suitable heights. There are two combinations:

i. Aquaponics

- The special containers are in a trough that floats on the pond surface, and are stacked to a height of one metre to grow suitable vegetables, fruits, vines and flowers, using capillary tubes to draw water automatically from the pond to irrigate and fertilize the crops.

ii. Aeroponics

- The special containers are stacked on the ground to a height of 2-3 metres to grow vegetables, fruits, vines and flowers, using windpower or photovoltaic to pump pond water for irrigation and fertilization. Missing trace elements will be added for the plants concerned.

- The various crops are as follows:

a. Over Water

- Water hyacinth, Water lettuce, Water cabbage
- Lake lotus, Azolla, Duckweeds
- Water chestnut, Lotus root & seed
- Watercress, Taro leaves (shallow)
- Ipomoea aquatica (edges)
- Elephant grass (banks)

b. Under Water

- Algae (spirulina)
- Kelps (giant ones)

c. Above Water

- Vegetables, Fruits, Vines, Flowers
(traditional and aquaponics)

d. On the Ground

- Rice, Taro (in shallow water)
- Pumpkin, Melon, Gourd

e. Over Ground

- Leaf, Fruit, Vine
- Grain, Seed, Nut
- Napier grass, Mulberry, Sugarcane
- Bamboo, Leucaena, Fruit trees

f. Above Ground

- Vegetables, Fruits, Vines, Flowers
(drip irrigation, hydroponics & aeroponics)

- The free and adequate supplies of feed and energy on the farm for proper animal husbandry encourages the production unit to increase its livestock for maximum profit, without the pollution problems caused by an enormous amount of wastes because of the most efficient treatment based upon sound and appropriate technology to convert them into useful byproducts of fuel and fertilizer.

- The free and constant sources of water and properly treated wastes at the very spot where they are needed, together with biomass propagating naturally with its checks and balances in an ecologically balanced system, and the efficient utilization of this biomass as feed by various compatible species of edible and popular fish -- all is conducive to optimum productivity at minimum cost and maximum profit from the polyculture system.

- The free and readily available supplies of water and nutrients to grow crops in a warm climate on a year-round basis, and the wisdom of practising polyculture on land to duplicate the success already achieved in water for centuries, provide a big variety of agricultural, horticultural and forestry products for both trade and industry.

- This integrated Dike-Pond system has brought meaningful social and economic development to the rural communities of South-East China. It is rapidly expanding to many other parts of China, and will be improved in the IFS. The only limitation is the weather. In the colder areas, the greenhouse can become a viable and economic proposition for the Integrated farming System.

- The Chinese success in rural development is a miracle, and has nothing to do with ideology, colonization or foreign aid. It evolved long before the 'foreign' Manchu rule and survived foreign occupation, civil war, isolation from the rest of the world, and the present communist government. The most important factor is that the rural communities understood their own problems and their priorities, just like rural populations do all over the world, but the Chinese did not leave the solutions to the urban people in the local or foreign government who were usually ignorant of the rural problems.

- The Chinese farmers had never depended on the government to do much for them. To survive, they had to be concerned with the basic needs of everyday life and the cruel realities of their precarious situation. They wanted quick but effective solutions that could be obtained locally at low costs in every aspect: social, cultural, economic and environmental.

- Above all, they were motivated, and knew that they could only reach their goals through self-reliance and discipline, hardwork and perseverance -- and they did it!

PERSONAL NOTE

I saw the Dike-Pond System for the first time in January 1986, exactly a year ago. I had been to the Pearl River Delta area two and a half years earlier and had been back twice with my eldest son and then my younger brother and his family. Every time, we behaved like a real WOC (Westernised Overseas Chinese) who had come to the ancestral village for a quick look-see, never thinking that the village folks had anything to teach the University of London graduates.

I was very humble when Professor Zhong, Academia Sinica, with whom I am now working on the Integrated Farming Project, showed me the Dike-Pond System in the County of Shunde in the Pearl River Delta, with my ancestral village bang in the middle of it!

- One thing that strikes the visitor to the Dike-Pond System in the Pearl River Delta is the absence of tall trees on the dike itself. To start with, one row of fast-growing *Leucaena leucocephala* will be planted along the centre of every dike. The leaves and pods of this tree will provide high protein feed to both livestock and fish, besides fixing nitrogen into the soil.
- Drip irrigation, using cheap plastic pipes to get the pond water to the roots of trees and other suitable plants, will prevent wastage of valuable mineralized water from the pond.
- A most important feature in the whole IFS design is to have a series of automatic operations that relies on gravity overflow in order to reduce labor and pumping requirements. So we should have the waste water from livestock to flow by gravity into the digester, with the effluent overflowing into the algae tank; and the same overflow system works from algae tank to fish pond. Pumping will only be required to lift the pond water to a small overhead tank to supply water to the drip irrigation and aeroponics systems, and to lift water from the bottom of the fish pond to aerate it, using renewable energy.
- Multicropping, which allows two compatible seeds of leafy vegetables to be broadcast at the same time, with one crop harvested four weeks later and the other after another three or four weeks, can produce up to 10 crops of popular vegetables a year. This will ensure that all nutrients from the pond water will be utilized profitably instead of causing eutrophication in the waterways.

4. AGRO-INDUSTRY

- Produce from the Integrated Farming System will be processed as much as possible for added value and creation of new employment, besides having the valuable processing residues as livestock or fish feed.
- The processes involved will make maximum use of the sun, air, salt, sugar, vinegar, smoke, yeast, and other beneficial organisms.
- The processed goods will include flour, sauce, condiment, and a variety of dried, salted, sugared, pickled, smoked, fermented, bottled and canned vegetables, fruits, grains, meat, poultry and fish products.
- Fuel for the agro-industry will come mainly from biogas, which is produced by anaerobic digestion of all livestock wastes in a properly designed upflow digester unit. The design shown is made of steel, but it can also be made in smaller modules that can be mass produced in fibreglass, and connected in series to the capacity required.
- Additional stockfeed for the digester unit will come from algae and other easily digestible biomass mixed with sludge that will be constantly recycled.

IV. C O M M E N T S

In the IFS, there is a very close and symbiotic relationship between animal husbandry, fish culture and agriculture, which is an ecological and economic balance between the high output but unnatural monoculture system and the low output but natural subsistence farming. Nothing should be introduced in the proposed IFS to upset the ecological system or reduce the economic rate of return, and the main objective should be to optimize productivity through improvement of overall efficiency while protecting the environment for sustainable development. No scientific or technological innovation is worth the disruption of this time-tested eco-development system.

ZHONG G.F., CHAN G.L., WANG Z.Q., & YAO H.Y.

INTRODUCTION

The Integrated Dike-Pond system has been operating for over 400 years in the Pearl River Delta of Guangdong Province, China -- see map -- and has survived all the political and social upheavals in China during that long period. It is also practised over a wide area of over 800 square kilometers, and on a big scale involving 1.2 million people (Photo 1).

In the proposed Integrated Farming System project of Guangzhou Institute of Geography (1), which will involve the expansion of this Dike-Pond system into an Integrated Livestock-Aquaculture-Agriculture-Industry one, the present authors are collecting basic data on the three main field stations chosen for that project. This paper deals with one of them: LU LINXIN farm in Nanhai County. Two subsequent papers will deal with a government farm and a cooperative enterprise in Deqing County of Zhaoqing Prefecture, and another private flower enterprise in Shunde County.

BACKGROUND

China has chosen an alternative model of socio-economic development that combines what the Chinese leaders think to be the best of the two main ideologies prevailing in the world. The State owns most of the land and enterprises, and controls the overall economy to prevent unwanted exploitation of any kind; and the individual households or groups of households have contracts with the State or its local representatives to work the land and/or operate the small and medium enterprises for a fixed price and/or quota, and are free to make as much money as they can with the surplus products. This has resulted in the rural communities earning high incomes and improving their quality of life considerably. It is indeed the first time in world history that rural income is much higher than that of urban or government workers.

Since the Integrated Farming System project is only involved with the Pearl River Delta at present, we will limit our study to the three counties we have chosen for that project: two counties, Nanhai and Shunde, in the delta itself, and Deqing, on the north bank of West River which flows into the same delta.

DIKE-POND SYSTEM

The Dike-Pond system (2) consists of deep fish ponds for polyculture of carps, and elevated dikes mainly for mulberry rotated with sugarcane and intercropped with fruits and vegetables (Photo 2). The mulberry leaves (Photo 3) are fed to silkworms (Photos 4 & 5) to produce silk cocoons (Photo 6) for a long-established silk industry (Photo 7), and the sugarcane supplies the raw material for existing sugar mills. Some pigs are kept (Photo 8) mainly to eat the crop residues and to provide wastes which, together with the silkworm excreta, fertilize the fish ponds, which are in fact the most efficient waste treatment plants in the whole world (3). Sometimes chickens or ducks (Photo

9) and geese are added to the system to increase the economic return and to produce additional wastes. The pond mud, rich in organic and mineral matter, is spread on the dikes two or three times a year to fertilize the crops (Photo 10). The whole system is a balanced one, and can supply all the feed and fertilizer required by the various components of a properly-designed system. However, if there should be some deficiencies in an unbalanced system or in some of the smaller farms, they can be made good either through improvement in the design or operation, or with input from bigger farms, but still within the Dike-Pond system.

LU LINXIN FARM

The farm chosen for the expansion of the Dike-Pond system into a more integrated one in the Guangzhou Institute of Geography project belongs to Lu Linxin and his wife. They have two children, one girl of 15 and a boy of 12, both receiving a good education without having to help on the farm. The couple operates the dike-pond system consisting of 11 mu (15 mu = 1 hectare) of ponds that produced 3,500 kg of fish in 1985, and 6 mu of dikes planted mainly with mulberry, but also have sugarcane, elephant grass for fish feed, fruits and vegetables for their own consumption. In their contract under the responsibility system, they can only have one pond, but they have also leased two other ponds and dikes from two farm families who did not want to farm their land because of other activities. The couple also raises 33 pigs and 2,700 chickens, and look after three large rooms of silkworms (Photo 11) with 7 crops of cocoons a year. So they are kept very busy, and their only entertainment comes from their big color television set. They seem very happy with their lot, pointing out that they have piped water and electricity, and adding that it is from a hydroelectric plant. There is not a single bad word from Lu or his wife about the government or the agricultural officer -- a universal complaint everywhere else in the world.

They have a brickhouse with four rooms on the ground floor and another four on the top floor. They occupy three rooms on the ground floor, with the fourth one for baby chicks. The whole top floor is used to raise chickens. They have a separate building for the pigs and silkworm culture, and another building for fattening more chickens.

All the wastes from the household, silkworms, chickens and pigs are used to fertilize their three fish ponds, and all the crop residues are fed to the pigs. The pond mud is spread on the dikes twice a year to fertilize the mulberry trees for their silkworm operation, and other plants. Fingerlings and some feed concentrates are bought for the fish ponds, and they have to buy feed for their chickens. They also have to pay the annual contracted price to the State and the rental fee to the two farm families for the ponds and dikes.

They expect the ponds to produce a higher yield of 4,500 kg of fish in 1986, with a higher profit because of the higher price at present. Their net total income in 1985 was ¥13,000 (¥3.4 = US\$1), and they are aiming at ¥18,000 this year. Chart I shows the expenditure and income for each of the farm operations, and their corresponding profits. Such a household is obviously doing very well. Its yearly expenses are shown in Chart II, with savings of ¥8,000.

Lu Linxin and his wife are now looking for a piece of prime land to build a new house for their children, who have no intention of working on the land, but are aiming at a college education. It is always good to aim high. It seems to be the general attitude of most people in China, where every child now has the opportunity to go to school, and this is a positive attitude that augurs well for the China of Year 2000, provided that they can maintain their equitable system of government.

SYSTEM EFFICIENCY

There is no doubt at all that the symbiotic interaction of aquaculture-agriculture in the Dike-Pond system is the most efficient method of producing food in an environmentally sound and sustainable manner, and it is worth while expanding this system while maintaining the ecological balance, as proposed in the project of Guangzhou Institute of Geography. This system is already widely practised in many countries of the south-eastern part of the Asian continent, where there has always been sufficient balanced foods to keep the relatively high population healthy and strong, with practically no obesity or destitute poverty, as in other parts of the world. It may be worth while for some of the hundred poor countries to take a serious look at this concept, instead of continuing with systems that do not work or living on charity. In China, this system has done wonders for centuries, and now with the innovative responsibility system in a country which owns all the means of production and development, this system has certainly proved that it can make the farming communities prosperous without utilizing big farm equipment or imported fuel, feed or fertilizer. The farm families can now afford better food, clothing, shelter and amenities, and the substantial savings will enable them to improve their quality of life considerably within one generation, but there is still plenty of room for improvement.

However, a previous study of the economics of the Dike-Pond system (4) has shown that modern external inputs, such as feed concentrates, reduce the rate of economic return. It also showed that a higher input of livestock wastes increases the efficiency of the system. So these are at least two big issues we will have to consider very carefully in our proposed Integrated Farming System project with the Guangzhou Institute of Geography. It is of paramount importance that we produce the required feed within the system itself for any new livestock we want to introduce into the system, or increase the stocking rate of existing livestock; and that all the wastes produced by the additional livestock should be utilized to optimize the productivity of the whole system. A further important factor, of course, will be to ensure that the additional wastes do not pollute the system, causing livestock and plant diseases or deaths, and that the additional feed and fertilizer generated by such wastes are fully utilized within the system in order to maintain the ecological balance.

THE INTEGRATED FARMING SYSTEM (IFS)

The IFS will allow the Dike-Pond system to be expanded by the farm family without upsetting the ecological balance. In accordance with the FOOD & FEED CHART in Appendix I, the following changes are recommended:

1. Livestock

During the first phase, we will not interfere with the costly chicken operation, which depends on commercial feed -- so is outside our terms of reference -- but we can increase the number of pigs which are also more economical to raise. A sow can easily have 2 litters of 8 piglets per year, representing 1 to 1.5 tons of livestock, depending on the breed. There is adequate room in the existing building for up to 100 pigs, and we will increase the number from the present 33 gradually as the feed becomes available within the system.

The wastes will be isolated in a digester unit consisting of two fiberglass tanks of 6 cubic meters each and two settling tanks where algae are grown to provide oxygen for one of the treatment processes, before being used as protein feed for the pigs. We need the digester unit to ensure that the nutrients in the wastes are not lost through production of ammonia and sulphides by converting them into nitrates and sulphates that remain in the system, while producing biogas fuel which will be used in the kitchen and to generate electricity for pumping the digester effluent to the fish ponds that are over 100 meters away, and to operate the submersible pumps and standby compressor for the ponds.

The silkworm operation will be expanded as more mulberry trees are planted on the dikes where vegetables are now grown, and the silkworm excreta will go into the digester unit instead of being dumped into the ponds. There is at present an increasing shortage of silk cocoons for the existing factories in Nanhai because traditional suppliers from other counties are now building their own silk factories. Intercropping of vegetables will still be done when the mulberry trees are young or after the leaves are harvested, but the bulk of vegetable growing will be transferred to the edges and on the surface of the ponds, using aquaponics, aeroponics and hydroponics for uptake of the minerals in the pond water.

2. Aquaculture

The three existing ponds will be converted into primary, secondary, tertiary and polishing ponds. With more nutrients available from the digester unit, the plankton and bacteria growth will be more prolific, and the stocking rate of fish will be increased accordingly. Freshwater prawns will also be introduced in the secondary and tertiary ponds. No supplemental feeding will be required, except for grass and vine grown on the edges of the ponds. Aquatic plants will be grown on the surface of some ponds for food and feed. Small submersible pumps will draw water near the bottom of the ponds and spray it over the surface to maintain a safe dissolved oxygen level.

The pond ecosystem is the most critical part, or the heart, of the whole system, so the ponds should receive the most attention. A complex and numerous population of plankton and bacteria together with many kinds of organic wastes must be consumed by the right kinds of fish and prawn that feed at the lower trophic level, and in adequate numbers so as not to have left-overs that will pollute the pond, when the fish will come up for air and fall sick, and eventually die.

3. Agriculture

Fruit and nitrogen-fixing trees will be grown in the middle part of the dikes, but the remainder will be planted with mulberry, rotated with sugarcane every four or five years, and intercropped with vegetables. More vegetables and flowers will be grown in plastic containers and troughs near the edges of the ponds vertically and horizontally through aeroponics and hydroponics, and also in plastic aquaponics tanks floating on the ponds, with automatic irrigation and fertilization from the pond water drawn by capillary action. We want to make full use of the wasted space above the ponds, and the area utilized will depend on how much the farm family wants to grow. Ducks and geese will be raised to increase the nutrient content in the ponds as much as the farmer wants.

4. Industry

If Lu and his wife are not already exhausted and want to add value to their farm produce through processing, there are many small machines available in Asia for this purpose. It would be a pity to let the excess biogas escape into the atmosphere.

RECOMMENDATION

The scope of the Integrated Farming System of the Guangzhou Institute of Geography is almost unlimited, and it deserves financial and technical support from international and national organizations, as any improvement to this rural development system and the transfer of such concept to the developing as well as developed countries will result in the efficient utilization of the world's natural resources and control the environmental deterioration we are witnessing worldwide.

The solutions to many of our development problems are in our own backyard and . . . backside!

REFERENCES

1. Zhong G.F., Chan G.L., Furtado J.I. and Ruddle K. (mimeo) 1986
THE INTEGRATED FARMING SYSTEM -- An Ecological Agro-System at the Service of Farm Family Units in Developing Countries. Guangzhou Institute of Geography, Guangdong, CHINA
2. Zhong G.F., Guangzhou, CHINA -- Human Ecology, Vol. 10, 2, pp191-202, 1982
THE MULBERRY DIKE-FISH POND COMPLEX: A Chinese Ecosystem of Land-Water Interaction on the Pearl River Delta
3. Chan G.L., Shenzhen, CHINA -- (ms submitted to Mother Earth News) 1986
WASTE TREATMENT FOR PROFIT -- Multiple Benefits of Complete Biological Recycling Plants
4. Ruddle K., Osaka, JAPAN -- National Museum of Ethnology, Vol. 10, 4, pp1145-1174, 1985
RURAL REFORMS & HOUSEHOLD ECONOMIES in the Dike-Pond Area of the Zhujiang Delta, China

CHART I -- FARM OPERATION COSTS
(Rounded Figures in RMB ¥)

	<u>EXPEND.</u>	<u>INCOME</u>	<u>PROFIT</u>
Purchase of FINGERLINGS	900		
Purchase of FISH FEED (grass & concentrates)	500		
Sale of FISH (3,500 kg)		7,000	
PROFIT ON FISH			5,600
Purchase of PLANT MATERIALS	200		
Purchase of FERTILIZER	-0-		
Sale of CROPS (sugarcane)		2,000	
PROFIT ON CROPS			1,800
Purchase of SILKWORM EGGS	500		
Purchase of MULBERRY LEAVES	400		
Sale of Silk COCOONS		3,000	
PROFIT ON SILK COCOONS			2,100
Purchase of PIGLETS	800		
Purchase of PIG FEED	-0-		
Sale of PIGS (27)		3,000	
PROFIT ON PIGS			2,200
Purchase of CHICKS	2,000		
Purchase of CHICKEN FEED	6,000		
Sale of CHICKENS (5,500)		12,000	
PROFIT ON CHICKENS			4,000
CONTRACT PRICE	1,100		(1,100)
RENTAL OF TWO FARMS	1,600		(1,600)
	<hr/>	<hr/>	<hr/>
	14,000	27,000	13,000
	<hr/>	<hr/>	<hr/>

CHART II -- FAMILY EXPENSES
(Rounded Figures in RMB ¥)

SUPPLEMENTARY FOOD	1,500
CLOTHING	600
HOUSEHOLD EXPENSES	400
APPLIANCES	1,000
SCHOOLING	300
FESTIVALS	700
EMERGENCIES	500
	<hr/>
	5,000
	<hr/>

SAVINGS (on INCOME of ¥13,000 in 1985) = ¥8,000

INTEGRATED FARMING SYSTEM
(LU LINXIN Farm -- Nanhai, China)

ITEMS	INPUT	RESIDUES	OUTPUT	PROCESS	RESIDUES	PRODUCT	REMARK
<u>PIGS</u> 2 x 100	Feed & Labour	<u>Wastes</u>	LIVE PIGS (12 - 18 tons)				✓
<u>WASTES</u>	Digester	<u>Slurry</u>	(Biogas)	Generator		(Electricity)	
<u>SLURRY</u>	Basin/Paddle & Tank/Compressor	<u>Primary Effluent</u>	(Algae) (C. Carp)			(Pig Feed)	
<u>PRIMARY EFFLUENT</u>	Primary Pond Aerators in <u>ALL Ponds</u>	(Slurry/Algae) & (Protozoa/Shell & (Bacteria) <u>Secondary Effluent</u>	(C. Carp) & (B. Carp) & (M. Carp)	Hammer Mill To Secondary Pond	Liquid to Secondary Pond	Fish Meal (Pig Feed)	
<u>SECONDARY EFFLUENT</u>	Secondary Pond Water Hyacinth & Duckweed & Lake Lotus & Water Lettuce (Pig Feed)	(Algae) & (Protozoa) & (Benthos) & (Detritus) <u>Tertiary Effluent</u>	S. Carp & H. Carp & C. Carp & Prawn	Polishing Pond with Aquaponics & Grassland Napier Grass To Tertiary Pond	Mineralized Water to Aeroponics & Hydroponics with Crop Residues (Fish Feed)	Food Fish Food Prawn (small) Vegetables/Flowers (Pig Feed) Grass Carp	✓ ✓ ✓ ✓
<u>TERTIARY EFFLUENT</u>	Tertiary Pond Lotus Root/Seed Water Chestnut & Ipomoea Aquatics & Taro Root/Leaf (ALL FOOD)	(Algae) & (Protozoa) & (Benthos) & (Detritus) (Weed) <u>Final Effluent</u>	S. Carp & H. Carp & G. Carp & Prawn Prime Vegetables	Polishing Pond with Aquaponics & Grassland Napier Grass & Centrosema Vine To Garden	Mineralized Water to Aeroponics & Hydroponics with Crop Residues (Fish Feed) (Duck/Goose Feed)	Food Fish Food Prawn (BIG) Vegetables/Flowers (Pig Feed) Grass Carp Duck/Goose	✓ ✓ ✓ ✓ ✓
<u>FINAL EFFLUENT</u>	Garden	Crop Residues (Pig Feed)	Leucaena Trees Vegetables Flowers Fruits	Ground/Cooked Grassland Napier Grass & Centrosema Vine	Leaf & Bean	(Pig Feed) (Pig Feed) (Fish Feed)	✓ ✓ ✓

QIANHOUIE FARM

The construction of this farm caused a split in the Qianhoujie Production Brigade, because three households were for and the others were against the Dike-Pond system. The three 'brave' households agreed to pay a rent to the whole brigade in order to have the Mulberry Dike-Fish Pond system established on 33 mu of ponds and 7 mu of dikes, with five of them planted with mulberry and two with elephant grass. They borrowed ¥50,000 for the project from the bank, with repayment over five years. They must have done well, because their cooperative farm looks very neat (Photo 7) and besides meeting all their cash obligations, all three households have built new houses (Photo 8).

The whole operation seems to put emphasis on fish culture, even though the ponds were only dug to 1.5 m deep due to financial constraints, excluding the possibility of polyculture at the moment. The grass is used as fish feed (Photo 9), and the mulberry leaves provide the input to the silkworm operation, with the silkworm excreta used to fertilize the ponds. They also have a few piggeries with a total of 15 sows, some of them with piglets, to further fertilize the ponds, but the breeding and animal husbandry need to be upgraded. Still they got 400 kg of fish per mu in 1985 and are expecting 500 this year.

SYSTEM IMPROVEMENT

The main objectives of the Deqing Field Project in the IFS proposal of the Guangzhou Institute of Geography are two-fold:

1. To modify the system at the government farm and carry out experiments with various types and numbers of livestock and plants to determine the maximum quantity of wastes that our treatment system can handle, with only renewable input obtained from the system, before the aquatic or plant life start to have problems; and

2. To use the results from the experiments at the government farm to modify, GRADUALLY & VERY CAREFULLY, the cooperative farm at Qianhoujie, in order to establish new farm-based industries that will use its lower-value produce as raw materials to manufacture higher-value foods and goods, while supplying its own energy, fertilizer and feed requirements within the system.

In order to reach these objectives, which will depend on increase in the waste input without polluting the system, and provision of all the requirements for the new industries, it is proposed to make three major changes at the government farm in Deqing, which is typical of all the dike-pond farms in the whole prefecture, as follows:

- (1). The number of pigs will be increased to the equivalent of 7 per mu -- the best experimental figure obtained so far. On the government farm, there will be a total of 49 pigs, with seven piglets added every month and seven market-size pigs (fed for about 6 months) sold. On the cooperative farm, the animal husbandry will be improved for the existing 15 sows before the number is gradually increased to a total of 25. They will be artificially inseminated to produce two litters every year of 8 to 9 piglets each. Their wastes will be washed three times a day into one digester unit of suitable size for each piggery, similar to the Nanhai project mentioned above.

Other livestock such as goat, chicken, pigeon and rabbit will be added at the government farm to replace the equivalent number of pigs or as an addition, provided that they are viable, which means that their wastes must produce within the system all the feed they need. Ducks and geese will automatically be part of the system, as they do not need much in feed or space, besides having a waste that is relatively less polluting. A couple of water buffaloes will be added to help with the harvesting of fish, as shown below.

(ii). The fish ponds at the government farm, and one at Qianhoujie, will be divided into smaller ones of 3.5 mu, with a maximum width of 20 m to have an oblong shape for easier harvesting, and deepened to 3 m or more to enable three levels of fish to feed on the various kinds of feed present in the ponds, as already explained in the Nanhai project. At the government farm, one pond will be deepened to 4 m and another to 5 m, with prawns added to the system, and the plankton and bacteria content from various depths examined to determine their strains and numbers (3). The appropriate species and stocking rates of suitable fish and prawn will be added to the ponds to consume all the feed present, with special attention paid to predatory occurrences.

(iii). The dikes will be widened with the excavated earth to have different dike-pond ratios and compare them with the 4:6 one, which has been found over many years of practical experience to have sufficient nutrients in the polyculture pond mud to fertilize the mulberry/sugarcane dike area with three transfers of pond mud a year.

It is recommended that there should be no monoculture of citrus on the dikes, despite its high and profitable yield, because of disease risks. We should definitely leave the few existing rows of citrus on the dikes, as they can produce fruits for nearly 20 years before replanting is necessary, but we must also have rotation of crops and companion planting to control pests and diseases without use of pesticides. We have already found that rotation of sugarcane with mulberry keeps both plants healthy, and on the new land we should find out more about other such combinations, as well as for companion planting, that have already been done in other parts of the world, in order to save time and money. We must also try nitrogen-fixing trees and shrubs, many of them producing livestock feed as well, and many varieties of grass and vines that are good feeds for fish and livestock. There will also be a lot of work to be done on aquaponics, aeroponics and hydroponics, so as to make use of the space above the ponds.

SYSTEM OPERATION (see FOOD & FEED CHART in Appendix I)

The success of the Integrated Farming System as a whole depends on the effectiveness and efficiency of the Waste Treatment Operation (4). This operation consists of three main units:

1. Digestion Unit, comprising the isolation, settling and digestion processes;
2. Oxidation Unit, which uses a lot of oxygen from various sources, and the processes usually takes place in both shallow and deep ponds; and
3. Demineralization Unit, that involves mostly plants on

The first two units prevent the livestock wastes from polluting the soil and water through conversion of their organic compounds into minerals; while the last unit prevents the minerals from polluting the water and soil through uptake of these minerals by means of plants. All three units must have the best environmental conditions for optimum effectiveness of all the biological processes involved, and all these processes must be made to work at maximum efficiency through chemical and/or mechanical means.

1. Digestion Unit

The livestock wastes are digested and partially mineralized to allow a maximum of 40% of the organic content in the digested effluent discharging into the deep polyculture ponds, because we design the Digester Unit for two-thirds reduction in BOD content of the original wastes. Otherwise, we should redesign the unit, with increased capital cost, or reduce the loading rate, which means reduction or replacement in the number of livestock.

The biogas produced is needed to operate the pumps and compressors of the treatment plant, which should not consume much because the static head is not more than 4 m for one fractional horsepower pump per mu, and the rate of air delivery is quite small, but the bulk of the biogas is used directly for boiling and heating, and to run a generator to produce electricity for the new industries. This is one of the main reasons why we want to increase the livestock population in the 'vicious' circle of "wastes - fuel - fertilizer - feed" in order to produce the best fresh and processed foods at the cheapest price. Another reason is that we also need the fertilizer to increase the feed for the livestock and food for maximum profit.

We should also consider the use of windmill and photovoltaic cells, floating on the pond, for the pumping operation even if they require higher capital cost, because there is no recurrent expenditure on fuel. Besides exploring all the possibilities of processing the farm produce without the use of even renewable energy, such as solar drying with or without addition of sea salt, spices and/or locally-produced condiments, the farm is also connected to the Deqing power grid, which uses hydro-electricity, as a standby supply.

2. Oxidation Unit

The digested effluent is almost completely oxidized in a series of primary, secondary, tertiary, and polishing ponds, which are all strictly controlled. They are sterilized and fertilized prior to stocking with fingerlings from separate nursery ponds where special feeding takes place. We must ensure that adequate numbers of each species of fish and prawn are in the various ponds to consume all the available feed. The most important thing to monitor is the dissolved oxygen content at the bottom of the ponds, particularly in the early hours of the morning. During the day, the natural algae present in the ponds fix nitrogen and carbon dioxide in the air through photosynthesis and release oxygen that oxidizes the organic matter into minerals. This does not happen at night, but the organic content still consumes oxygen, and when morning comes the bottom part of the ponds can be depleted of oxygen when some fish will jump out of the water. The submersible pumps that bring the bottom water to the surface should be operating constantly during night time, and only intermittently during the day depending on the weather, preferably using windpower with biogas as stand-by power supply to prevent oxygen depletion until sunrise.

3. Demineralization Unit

We should also ensure that too much minerals do not pollute the ponds, causing plankton to grow so much as to cause eutrophication. Uptake of these minerals from the water is done by traditional surface plants such as lotus and water chestnut for food, or water hyacinth, duckweed, lake lotus and water lettuce for feed. Some of them have prolific growth, depending on the amount of nutrients in the ponds, and can also be used to produce biogas (5), which gives us a very important option when we are either short of feed or fuel. We are looking for a weed similar to the seawater giant kelp that will grow in fresh water, and use it as fish feed or to produce biogas. Ipomoea aquatica and taro are grown on the edges of the ponds for food, together with grass and vines on the sloping banks for feed. Vegetables and flowers are grown in aquaponic tanks floating on the ponds, and also vertically in aeroponic towers and horizontally in hydroponic troughs along the edges on the shorter sides of the ponds. All these plants are irrigated and fertilized with the pond water drawn by capillary action.

On the widened dikes some more mulberry and citrus trees will be planted, and there will be one row of leucaena leucocephala to act as windbreaker. These trees grow to over 30 feet high in three or four years. They also fix nitrogen into the soil, and their leaves and pods are good protein feed for livestock. The rest of the dikes, except for a footpath along the longer edges of the ponds, have multicropping and intercropping of various vegetables, fruits, herbs, nuts, and edible flowers.

The footpath on a dike is used for harvesting fish or prawn from the adjacent pond. Before harvesting begins, all the aquaponics tanks are drawn to one end of the pond. On each long side of the pond, one person with a water buffalo, holding the end of a net, walk from one end of the pond to the other, dragging the net to catch the size of fish required, without having to empty the pond. If we want to catch the prawns for transfer to the polishing pond, we use a small mesh net to let the prawns through, followed by a smaller mesh one to catch the prawns. More important still, before we harvest the fish from the deep ponds, or the prawns from the polishing pond, we drag a line with strips of bamboo hanging at different depths along the pond two or three times. These strips of bamboo scare the 'wastes' out of the poor creatures, and make them jump up in the air, leaving their wastes behind. We want them to empty their intestines, which are completely flattened, before they are sent to market. The valuable nutrients belong to the ponds.

CONCLUSION

In the Integrated Farming System, we are not looking at the treatment of some inevitable wastes coming from our farming operations where we have an option to treat or not to treat them, or to do the minimum required by laws and regulations. We have actually based our complete farming system and its allied industries on a highly developed waste treatment technology that cannot fail if everything is done properly. It is a similar situation to flying an jet plane or running a nuclear plant. At least in our Integrated Farming System we can always pick up the pieces and start all over again, learning from our mistakes and trying our best not to repeat them.

However, the best lesson comes from Mother Nature herself, and with our advanced science and technology we are confident that what Nature can do we can do better. We just have to make sure that we work with, and not against, her. Mother Nature has been abused since the beginning of time, with the elements mainly responsible for most of the damage, and she has always recovered, sometimes showing the scars. Unfortunately, where the human hand has struck the blow harder than usual, Nature has suffered almost irreparable damage, but there is nothing that Nature cannot repair, given the required time. So our role, while we try to help Nature, is to catch up with time. It means that we should use everything we know in science and technology to speed up every process that Nature does to recover from any abuse. The faster we do what Nature intends to do, the better our reward will be. This is the whole basic philosophy behind the Integrated Farming System, and the tool we have is high-technology Waste Treatment Operation.

Now it's up to us to make up our mind about true and fair development for all, and how much we all want to contribute in helping Nature. If we can fly to the moon, and have enough resources to blow the whole earth to pieces, we must be smart enough to help Nature's army of anaerobic bacteria to destroy more organic matter through faster digestion; Nature's multitude of single cell algae to produce more oxygen for quicker oxidation; the different species in the ponds maintaining the natural pecking order, with plenty to eat for everybody so that they can all play their respective roles fully. So it goes on and on, as long as we keep Mother Nature happy.

The Chinese have shown that, despite being behind the rich countries in what is called modernization, her peasants have succeeded in obtaining sustained and more than adequate growth on their land for centuries, without any external input, by working in harmony with Nature, while others continue to deplete Mother Nature of her resources as if there is no tomorrow. With our advanced science and technology, we want to improve the quality of life for ourselves and our fellow humans on this one and only earth and our future generations, not only by following the same traditional Chinese philosophy but also by improving it.

Can we, really?

November 1986

REFERENCES

1. Ruddle K., Furtado J.I., Zhong G.F. & Deng H.Z. — *Applied Geography* 3, pp45-62, 1983
THE MULBERRY DIKE - CARP POND RESOURCE SYSTEM OF THE ZHUJIANG (Pearl River) DELTA, CHINA :
I. Environmental Context & System Overview
2. Zhong G.F., Chan G.L., Furtado J.I. & Ruddle K. (Mimeo) 1986
THE INTEGRATED FARMING SYSTEM — An Ecological Agro-System at the Service of Farm Family
Units in Developing Countries. Guangzhou Institute of Geography, Guangdong, CHINA
3. Buok H., Malecha S.R. & Baur R.J. — *J. World Mariculture Society* 12 (2), pp203-213, 1981
POLY-CULTURE OF FRESHWATER PRAWNS (*Macrobrachium rosenbergii*)
With Two Combinations of Carps in Manured Ponds
4. Chan G.L., Shenzhen, CHINA — (ms submitted to Mother Earth News) 1986
WASTE TREATMENT FOR PROFIT — Multiple Benefits of Complete Biological Recycling Plants
5. Brijetia R., Brivastava V., Chynoweth D.P. & Hayes T.D. — 1986
ANAEROBIC DIGESTION OF WATER HYACINTH AND SLUDGE — Paper Presented at Conference

FOOD & FEED CHART

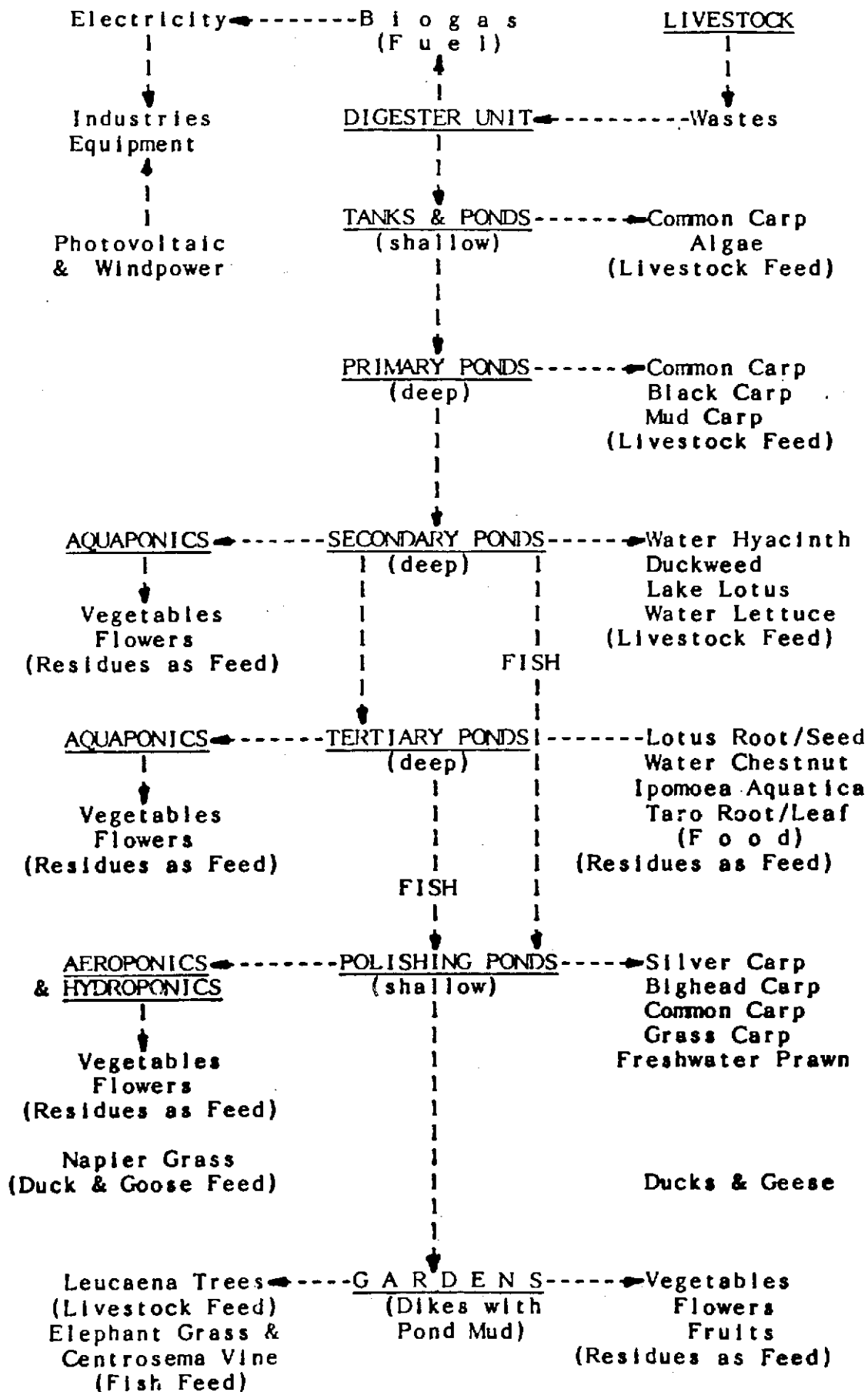

CASE STUDY OF THE INTEGRATED DIKE-POND SYSTEM

(No. 3) IN SHUNDE COUNTY

Zhong G.F., Chan G.L., Wang Z.Q. & Yao H.Y.

INTRODUCTION

Although the Integrated Dike-Pond System (IDPS)* has been in continuous operation for over 400 years, the polyculture fish pond has evolved over two millenia. Carps and other freshwater fish have been cultured by the counties in the Pearl River Delta, which has vast areas of low-lying land crisscrossed with watercourses, for local consumption and the market of Guangzhou, the provincial capital, and subsequently to Hong Kong and Macau. The most famous of them all for big and tasty fish has been Shunde County, a reputation it still enjoys today. It is also the county with the most dike-ponds, as shown in Map 1.

In the proposed Integrated Farming System (IFS)* project of the Guangzhou Institute of Geography (1), we have chosen the Commune of Chencun because of its peculiar situation. It has an increasing number of small farms that are growing plants & flowers in pots on the dikes (Photo 1) or on the terraces of their homes (Photo 2) for sale not only in the local markets of Guangdong as decorative "biblots" for the home (Photos 3 & 4), but also for export to Hong Kong and Macau, where there is a craze for giving potted plants with 'golden' citrus fruits for the Chinese New Year (Photo 5), with most families receiving as many as one dozen. This very lucrative practice has made the farmers more prosperous, putting them into the new 20,000 Yuan Farmer class (1 US\$ = 3.4¥), but it has also disrupted the ecological balance of the traditional agrosystem. The objective of the IFS project is not only to restore this ecological balance, with the number of flower farms continuously increasing, but also to optimize the overall productivity of the whole system itself.

BACKGROUND

The traditional dike-pond system is similar to that already described in Nanhai County*. With a dike-pond ratio of 2:3, and a few pigs, ducks and chickens meant for household consumption at festival time, the whole system is balanced, with no external input of feed or fertilizer. There is no problem when flowers are grown and cut to sell for social or ceremonial occasions (Photo 6), or as a beverage, either on its own such as chrysanthemum, or mixed with tea such as jasmin. Only the flowers are harvested and the plant residues remain on the farm. With potted flowers, the whole plant goes with the pond mud which is the best agricultural soil available, and the pot itself is very often made of the same soil. The pond mud is constantly removed (Photo 7) and made into blocks for future use (Photo 8), instead of spreading it on the dikes two or three times a year for agricultural purposes and is eventually returned to the pond. The ecosystem is also deprived of the plant residues as feed or fertilizer. It seems like a total loss!

*More details of the IDPS and the IFS are given in the previous two CASE STUDIES OF THE INTEGRATED DIKE-POND SYSTEMS (No. 1 & 2), NANHAI & DEQING

There was also no problem in Chencun under the Commune system, with the ratio of rice fields, fish ponds and flower dikes being 4:3:3, and people only worked a fixed number of hours for specified wages. With the new economic reforms under the Responsibility system, the land was subdivided into small plots of 1 to 2 mu (15 mu = 1 hectare), except for the ponds. Each household was allocated one lot of rice field or flower dike, or a fish pond. Water for the rice field comes from the pond, and so does the pond mud for the flower dikes. The ponds are usually fertilized by a few pigs. The households with the ponds only have the fish, but have no control of the water or pond mud, except that only two boats are allowed to take the mud at any one time.

The Dike-Pond system is consequently disrupted: the fish do not get all their feed from the system, and supplementary feed has to be bought on the local market; and there is not enough mud to go around, forcing people to dig it from streams or even from dikes and other places. Organic fertilizer, in the form of processing residues such as peanut or soya cake, is now bought from the market but, sooner or later, chemical fertilizers will be introduced with the associated problems now experienced by many other countries, unless something is done now to stop the rot.

What makes things worse is that with the sudden prosperity, there is a building boom all over the Pearl River Delta, with thousands and thousands of bricks (Photo 9) made from good agricultural soil, thus depriving agriculture of a very important planting media and, of course, it is much worse when the pond mud itself is utilized for this purpose. Unfortunately, these are realities of life, and it is no good trying to stop this trend. The IFS will just have to solve this additional problem -- and fast!

MULTIPLE FARMS AS MAIN FIELD STATION

For our main field station in Chencun, we cannot have one dike-pond farm as in Nanhai or Deqing County, so we have to choose a combination after visiting three farms:

(i). One medium flower farm with direct access to pond mud;

(ii). One very small flower farm without direct access to pond mud; and

(iii). One large flower farm with a fish pond, but not adjacent to one another.

(i). Feng Guorong Farm

This flower farm, which is run by Feng Guorong (Photo 10) and his wife, consists of 1.5 mu of dike they obtained from their production team under the Responsibility system and is a typical size for most households in this part of Shunde County. They also have another 3 mu of dikes rented from two households, now engaged in non-farming activities, for which they pay ¥400 per mu per year. They employ two workers at ¥80 per month plus board and lodging. They sell 50% of their potted plants to local bulk buyers mainly for export to Hong Kong and Macau, 20 - 30% directly to Hong Kong buyers having the export licence, and the remainder in the local flower market during a few days for the Chinese New Year. Their net income is ¥20,000 a year -- see CHART 1.

Feng's father, one of the first farmers to go into the potted plant and flower business, has set a good economic example for other farmers to follow, and it is not likely to stop soon. Many of them are along the Guangzhou-Macau main road going through the county, and the flowers make a really beautiful sight instead of the monotonous rice fields, the days of which are numbered in Chencun. Because of the much higher rice production per mu, thanks to the Responsibility system, and the shortage of pond mud, a plan has already been approved for converting 10,000 mu of rice fields into fish ponds. The ultimate aim is to replace rice planting, which has the lowest cash return of all crops -- see CHART II -- besides being very labor-intensive, with more lucrative plants that also require less back-breaking effort. Nobody can blame the Feng household for wanting to put their time and money, which is plentiful now, into more profitable enterprises, and then purchase the low-cost rice, local as well as imported from Thailand or even U.S.A., at the market.

Unfortunately, the dikes are not functioning as they should be in Chencun. There is no more mulberry to feed the silkworms that produce valuable excreta for the fish pond, and no more crop residues to feed the fish or livestock, but the dikes still receive the fertile pond mud many times a year instead of the traditional two or three times. The pond mud does not remain on the dikes, where it is subsequently washed by rain back into the pond, but is put in earthen pots (they should start using plastic pots) and sold with the potted plants (Photo 11). To make things worse, as far as pond mud is concerned, these potted plants have already invaded the yards (Photo 12), spare rooms, terraces (Photos 13 & 14) and roofs (Photo 15) of the farmhouses. In fact, the farmhouses in Chencun are built with terraces on every story for this purpose.

There is already a plan to have metal shelves for 'high-rise' cultivation. This one-way traffic cannot obviously continue, with mostly infertile soil brought in to replace the fertile pond mud. This is where the IFS comes in . . .

(11). Liu Xiang Farm

Liu Xiang is the manager of an aquaculture production station that markets the fish in Chencun County, and he also treats ponds where there is fish disease. He only has a very small plot of land that every household is entitled to, mainly for keeping a few pigs, chickens and ducks, or growing some vegetables for his own consumption, but he has potted flowers, grown from various seeds imported from overseas, on his small plot (Photo 16). What is more disturbing from the ecological point of view is that he also has the same potted plants on the three terraces of his house (Photos 17 & 18).

With his exotic potted flowers, sold at ¥30 each, he has a net annual income of ¥3,000 from his small plot of land and ¥18,000 from his terraces. Together with his salary and bonuses, he earns ¥30,000 a year. Like the farmers, he too depends on the pond mud for his potted flowers. As other employed officials follow his example, the mud situation can only get worse.

(iii). Li Lun Farm

This is one of the very few households that have both flower dikes and fish pond. The dikes are next to the farmhouse (Photo 19), but the pond is a few kilometres away. Li uses the mud from a nearby fish pond, and other farmers use the mud from his pond. Besides some elephant grass grown on the sloping banks between the pond and the dikes, Li feeds his fish with grain and feed concentrates, which also improve the growth and taste of the fish. He can afford this 'luxury' because he sells his fish at high prices to the restaurants in Guangzhou and even Hong Kong, where the famous Cantonese Steamed Fish is the most expensive dish on the menu. It is steamed to perfection with the right amount of ginger, shallot and subtle condiments, as only the Cantonese chefs can do, and the taste of the white chunky pieces of fish is unforgettable.

The Li family is obviously doing very well (Li Lun's father, Li Tong, is manager of a fish fry farm), and they are building a new 4-story house with terraces for potted plants (Photo 20). Although we have not been able to obtain details of their income, we guess that they must be the richest family in Chencun.

SYSTEM CONCEPT

Before we make changes to the IDPS concept in order to cater for the newly created situation in Shunde County, it is worthwhile recapitulating the ecological principles and design considerations that have brought sustainable growth and economic prosperity to the whole region for such a long time. We can then carefully add to them in the IFS project while making sure that we do not deviate unnecessarily from the natural agrosystems on which we can always rely for sustainability and self-reliance.

We rely on many processes similar to those happening in Nature, but we also use our scientific and technological knowledge to accelerate them as much as possible through all the biological power at our disposal, with additional mechanical power if really necessary. Although all this requires skilful coordination, it is not beyond the capability of the versatile farmers to manage**. We rely on:

- Three main fields -- livestock, aquaculture and agriculture -- to give us the symbiotic system that provides the fuel, feed and fertilizer we need to produce optimum yield of food with practically no fossil fuel based input.

- A relatively small amount of specially-grown plants but mostly on natural organisms and crop and processing residues to provide adequate and balanced feeds for all livestock.

- Animals that have the natural ability of converting simple biomass, such as grass or crop and processing residues, not wanted by humans -- with only natural input from the sun, air, water and soil -- into high-protein and relatively expensive food, and producing much organic wastes that can be properly treated to recover the stored energy and other elements in more desirable forms.

**As an analogy, the motor vehicle is a sophisticated and complex product of science & technology, but the driver does not have to know motor engineering as long as he can coordinate all the movements of his hands and feet, while keeping his eyes on the road.

- Various compatible species of fish and shellfish that feed at the different low trophic levels so as to consume all the existing organisms thriving in a pond receiving a heavy load of organic wastes.
- Many aquatic plants, such as water hyacinth used in China for centuries, that harbor high bacterial growth in their roots to deal with organic matter besides being able to survive in highly mineralized ponds, and also take up high doses of minerals from water to control eutrophication.
- Oxygen to keep our system operating efficiently at all times, and it can be in any useful form and produced in any natural way, directly from photosynthesis or indirectly from biogas and wind or hydro-operated equipment.
- Interactions or linkages between what we have on land and in water that allow all residues to be used as raw materials for subsequent processes, so as not to leave any permanent pollutant in the system.
- Rotation of crops, companion planting, and biological pest control, so as to prevent diseases and destruction by pests that can ruin our system, without the use of chemical pesticides that can also destroy the beneficial organisms present in the system.
- Natural obstacles such as water in channels or ponds, trees, bushes and thorny plants to fence in our livestock and provide day-time shelter for some of them, but all livestock are properly housed not so much for their own comfort as to preserve their valuable wastes, so that they can be promptly and easily flushed into the digester unit.

DESIGN CONSIDERATIONS

In our design we have to keep in mind the goals we are aiming at:

- No handling of excreta, for sanitary and cultural reasons, as they should mechanically or automatically be flushed into digesters where they are isolated, settled and digested before the effluent discharges into a series of ponds.
- No composting of leaves or fibrous matter, as this process is far too slow. They are ground and mixed with livestock feed, and any indigestible part getting into the excreta is dealt with inside the digester.
- Minimum labor through gravity flow by locating the livestock pen at the highest point, or built up to the required height, and the wastes flushed manually with a hose or automatically from a siphon connected to an elevated tank into the digester by gravity. Inside the digester unit the liquid overflows from one tank to the other; the same overflow system exists in the series of primary, secondary, tertiary and polishing ponds.
- Mechanical lifting of water using wind and photovoltaic pumps from tertiary or polishing ponds to overhead tanks for flushing livestock pens and for emergency supply of pond water to the aeroponic troughs or to the drip irrigation piping system on the dikes; and from the bottom of primary, secondary and tertiary ponds to the surface for oxygenation.

- Minimum use of fossil fuel in the system, either directly or indirectly, except for capital expenditure on imported machinery and equipment required for processing of farm produce, and transportation of produce to the local market.

- Direct utilization of biogas for boiling, heating, and running farm equipment and vehicles; and generation of electricity with biogas for other processes in the farm industries, with connection to the public electricity grid as standby.

- No costly irrigation system or competition for use of water on our dikes, as the water is plentiful and is only a few meters away from any livestock or plant. Some plant roots can draw their own water from the water table under the dike itself; otherwise, a relatively cheap drip irrigation piping system, fed from an overhead tank, brings the mineralized pond water to the roots of the plants.

- No wasteful soil erosion on our dikes, with any soil washed by rain going straight into our ponds, and the nutrient-rich pond mud is regularly pumped back on the dikes. Now that there is a special mechanical pump for this purpose, we can do it more often than the traditional two or three times a year; we will do it every two months or so, before we broadcast our two kinds of compatible seeds in our multicropping program that aims at 10 to 12 crops of vegetables a year.

- No flooding of our dikes or unnecessary dilution of our ponds by rainwater coming from hills and sloping land through digging of collection channels at appropriate places. This is a relatively cheap solution to the flooding problems plaguing many places in the world, and it can save a crop that sometimes means a matter of 'life and death' to some poor farm families.

- No public health problem caused by use of toxic pesticides, or by use of pond products as livestock feed. Pond products are ground, sun-dried and/or oven-dried using biogas, directly or indirectly. Fish and shellfish used as food are properly "polished" in separate ponds where they are fed specially grown grass and vine before going to market, and is of much higher quality and hygienic standards than fish obtained near sea outfalls or from lakes polluted by industrial wastes in many parts of the developing as well as developed world.

CHOICE OF DESIGN

A good example on a do-it-yourself design of a self-sustaining farm from the New Alchemy Institute, U.S.A., appeared in Mother Earth News (2). The approach is somewhat different to ours, and should appeal to people who do not think like us that the waste issue is the most important of all in an integrated farming system to achieve sustainable growth, but the development philosophy and ultimate objectives are exactly the same. In both cases, the final design should satisfy the needs of the farmer and meet the requirements of his farm. Their concept is mainly based on conservation of energy, nutrients and other natural resources on the homestead or small farm, but ours goes much further than that and is already on a regional scale.

In our IFS project we aim at the best possible combination of livestock, aquaculture and agriculture, which is reached after assessing all the wastes and residues produced and their usefulness to the whole system in order to optimize productivity. In both cases, we have to consider the biological relationships between the various components, making changes if necessary, in order to maintain the ecological balance. The final products and profits are not as important in our design -- they are all good in any case.

However, once the design is finalized, the farming operations must be functional and labor efficient, with maximum but simple automation such as conveyor belt for feeding, perforated plastic pipe for watering, or siphon tank for automatic flushing or drip irrigation; and reasonable daily attention for routine tasks and maintenance.

In the Chencun farms, the link has been broken at the dike level, where the fertile pond mud is taken away with the potted plants, instead of letting the rain wash it back into the pond. So it has to be replaced with new soil, which is less fertile or can be completely infertile. To make things worse, the flower operation requires more and more fertile pond mud as the business expands, and the present farmers still do not want to buy chemical fertilizers. It is gratifying to see that the old farmers tend to reject the idea of introducing new chemicals into their traditional system, but this will not last long. One fine example is the sterilization of fish ponds prior to stocking, using quicklime and teaseed cake which is produced from the oil-tea camellia seeds. The younger farmers do not hesitate to cut out all the extra work required in the traditional method, and use the chemical prophylactic Dipterex instead (3).

The next trend will be to use chemical pesticides, which are now advertized in the media, ignoring the bad effects obtained in the rest of the world. There should be a more aggressive campaign from the appropriate organizations in the West to inform the Chinese farmers about their disastrous experiences with chemical farming, and they in turn should learn more about what the Chinese have done for centuries on the issues that people in the West are now spending their money and effort to address. This mutual help will save everybody concerned a lot of valuable time looking for solutions to our present and future problems.

The Chencun farmers do not want pigs, which they say do not mix well with flowers. They do not want chickens either, which are worse because they cost so much to feed. In any case, no one wants to sacrifice any land for the livestock. The household with the fish pond only has enough space for a few pigs, so the only acceptable livestock that can thrive on water are ducks and geese, but preferably geese, which produce more meat and eat mostly grass, grown on the banks, and find the rest of their diet in the pond. However, to have enough geese to fertilize the big pond and supply all that fertile pond mud, there should be more grass grown to feed them. The solution is to have a cooperative of either the farmer with the pond adjacent to Feng Guorong's farm and all the other farms surrounding it, or Li Lun's pond and all the farms adjacent to it. We can grow various kinds of hybrid grass, with vines climbing up the grass in some sort of companion planting, on the dikes and put the pots on elevated multi-storied shelves.

So we now end up with an integrated Goose-Fish-Flower farm (see CHART III) with grass and vine to feed both geese and fish, the goose wastes to fertilize the ponds, and the pond mud used as media for the potted flowers. Uptake of minerals from the pond water will be done by the grass, so a watering system using photovoltaic or wind power will be included. If there should still be too much minerals in the ponds, then further uptake of the nutrients will be done through aquaponics -- to grow flowers.

We are still a bit apprehensive about dumping new soil into the fish pond, and agree that we should do so with a big hose to deposit the soil gently all over the bottom of the pond, so as not to have too much suspended soil that can interfere with the growth of the various organisms required as feed for the different species of fish.

ALTERNATIVE DESIGN

With the new program of converting some rice fields into ponds, we would like to recommend that the planning take into consideration the IFS concept. Each pond can have an area of 8 - 9 mu and be oblong in shape. The pond farmer has a small plot of land at one end for his farmhouse and another plot at the other end for his piggery, with a total land area not exceeding 0.5 mu. There are 3 flower farms on each side of the pond, and each farm has an area of 1.5 mu. The six flower farmers and the fish farmer can work as a cooperative, with no other outsider having access to the water or pond mud.

We feel we must have the pigs, which are the most economical livestock to raise. As previously mentioned in the Nanhai proposal, one sow can produce between 1 and 1.5 tons of livestock a year, and can be artificially inseminated instead of being serviced by a boar, which eats one ton of feed a year and sleeps most of the time. Because space is limited on the 0.5-mu farm, we recommend that the pigs be used as raw materials for making the Chinese version of ham, bacon, jerky (uncooked), sausage, cocktail sausage, liver sausage, stuffed head and trotters, corned pork and luncheon meat. They are very tasty, do not require refrigeration, and are very popular with local and overseas Chinese. There are also the sideline industries such as leather, bristles, lard, and blood & bone meal.

More important still, the pigs produce a huge load of wastes to fertilize the new soil brought in to replace the pond mud. We should choose a very clayey soil and dump it in a small pond where we let the adult pigs have a good mud bath a few times a day. Then we clean the pigs under a line of high pressure showers, using the water from the tertiary and polishing ponds that has been pumped to a tall overhead tank, and let the washwater go into the ponds. We can thus have soil mixed with wastes 'transported freely' to our polyculture ponds, and avoid the problem of excess turbidity. We can also add a certain amount of fine sand directly into the deep ponds.

We will include prawns in the polyculture ponds, and grow aquatic plants on the pond surface. We will also grow vegetables and flowers in aquaponic tanks, and aeroponic and hydroponic troughs. A reasonable number of ducks and geese will be raised to fertilize the ponds every day. A small separate pond will be used to 'polish' the fish a few weeks before sale.

On the dikes, there will be the full range of trees and other crops. The flower nursery and potted plants will be on elevated aluminum shelves, which will require a high capital cost but should be a viable investment.

In short, we will have a diversified farm, without any activity receiving excessive attention, in conformity with our design concept. However, there will be more emphasis on the potted flower planting, which is the subject of our special investigation. It would be interesting to compare the financial benefits of the two stations, in relation to capital investment and input in man-hours.

NEW FLOWER TECHNOLOGY

During our survey, we also visited the Chencun Flower Experimental Station, and saw the Dutch Hothouse Project (Photo 21) which cost US\$400,000 just for the imported building materials and equipment. It has its own diesel generator and a series of blowers to control the environment for growing imported flower bulbs (Photo 22) and an elaborate overhead and drip irrigation system (Photo 23). The flowers will be ready for export to Hong Kong and probably Macau for the Chinese New Year. After that, there is practically no market for such expensive flowers in Asia until a year later, and it is hoped that the flowers can be exported to Europe or America, provided that the price is competitive. This is very doubtful at the moment because of the big energy input and the high cost of fuel in a sub-tropical region, besides the extra cost of chemical fertilizers.

There is no doubt at all that such a system works very well in Holland because of its cold climate, and people use flowers all the year round for many occasions. The Hong Kong market is only viable for one week before the Chinese New Year, and during the remaining 51 weeks a handful of flowers are sold for some weddings and funerals.

Such a system has also been proved to be very successful in some Middle Eastern countries with vegetables, which are often imported by plane, but their oil is cheaper than water, and their desert sand is not as fertile as the Pearl River Delta soil, particularly the dikes fertilized by the nutrient-rich fish pond mud that have proved so effective for over 400 years.

We have heard nothing but negative reports from the people concerned in Chencun. They also laugh at the suggestion that vegetables can be grown in the Dutch hothouse if the flowers prove to be too expensive for a restricted market. No other nation in the world can produce vegetables more efficiently and cheaply than the Southern Chinese, with the cheapest ones such as chard or cabbage at ¥0.40 (12 US cents) a kilogram. As for growing more flowers for export, China should have turned toward Singapore, Hawaii or Tahiti, where tropical flowers are grown naturally for the local and tourist trade. Flowers of the bird of paradise and orchid families are of incredible beauty, and are not seen very much in South China.

We recommend that the same amount of money (in Renmenbi and not in US \$) be given for the IFS project of the Guangzhou Institute of Geography, so that we can compare the economic viability of the two projects. This worthwhile exercise will prevent China from making monumental mistakes in the future . . .

CONCLUSION

The Shunde County farms have given us a good opportunity to look at the versatility of our Integrated Farming System, and to remind us of the importance of balancing the input and output of the system. We have also been warned that it is not wise to concentrate on one or two operations, even though they bring the highest monetary return, because we can over-utilize one resource at the expense of another, breaking the Food-Energy-Waste cycle (CHART IV) upon which we depend so much for sustainable growth.

We look forward to the field work and experiments outlined in the IFS project of the Guangzhou Institute of Geography, as we will be involved with the improvement of a truly sustainable farming system that is not just conceptual or experimental, but has been in operation continuously over more than 400 years on a geographic and economic scale unmatched elsewhere on this earth. We hope the national, regional and international organizations will soon give more attention to this viable development concept and provide the necessary funding for its improvement and eventual transfer, with appropriate modifications, to other developing countries. Somehow it has been overlooked by most experts of these organizations in their development strategies and plans to solve the fuel, feed and fertilizer problems of a poor and hungry Third World. What is more incredible is that even China itself is guilty of this same neglect, as many national and provincial institutions are turning to the outside world for solutions to their rural development problems, or are starting from scratch to develop some 'bright' concepts based on what has already existed for centuries in their own backyards . . . !

Will we ever learn?

CHART I -- FENG GUORONG'S FARM OPERATION COSTS
(Rounded Figures in RMB ¥)

	<u>EXPEND.</u>	<u>INCOME</u>	<u>PROFIT</u>
Purchase of PLANT SEEDS	500		
Purchase of CLAY POTS	2,000		
Pond Mud/Organic fertilizer	500		
Labor (wages)	2,000		
Board & Lodging/Extras	2,000		
Utilities/Maintenance	500		
Transport/communications	500		
Rental & Contract Fees	2,000		
Sale of POTTED PLANTS/FLOWERS		30,000	
PROFIT ON PLANTS/FLOWERS			20,000
	<hr/>	<hr/>	<hr/>
	10,000	30,000	20,000
	<hr/>	<hr/>	<hr/>

CHART II -- COMPARATIVE RETURNS ON FARM ACTIVITIES
 (Zhong Gongfu - Guangzhou Institute of Geography)

<u>FARM ACTIVITIES</u> with I.D.P.S.*	<u>RETURNS WITH</u> <u>MULBERRY = 100</u>	<u>TYPICAL INCOME</u> <u>RMB ¥/YEAR/MU</u>
Mulberry	100	750
Paddy Rice	41	305
Sugarcane	44	330
Fruits (banana/papaya)	90	675
Fish	134	1,000
Fruits (citrus)	270	2,000
Flowers	410	3,075

* Returns are less than half without the Integrated Dike-Pond System.

CHART III -- CHENCUN MAIN FIELD STATION (SHUNDE COUNTY)

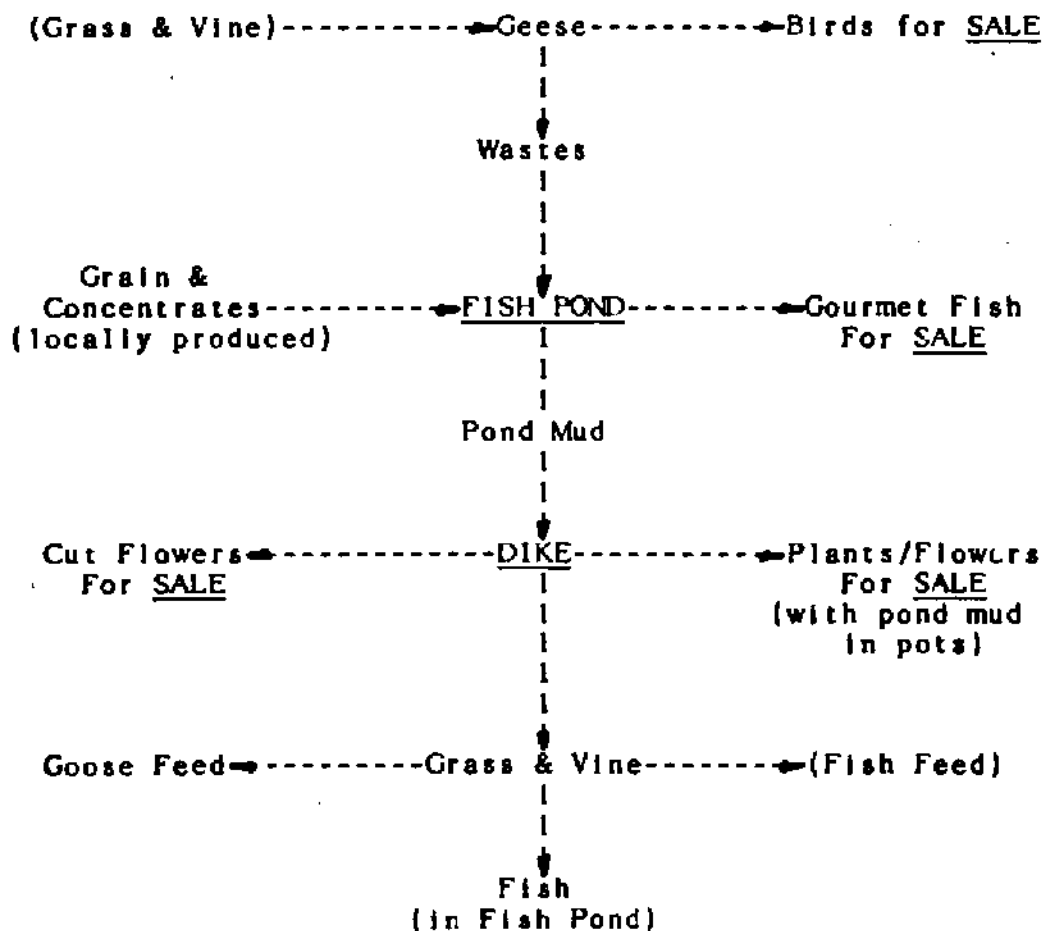

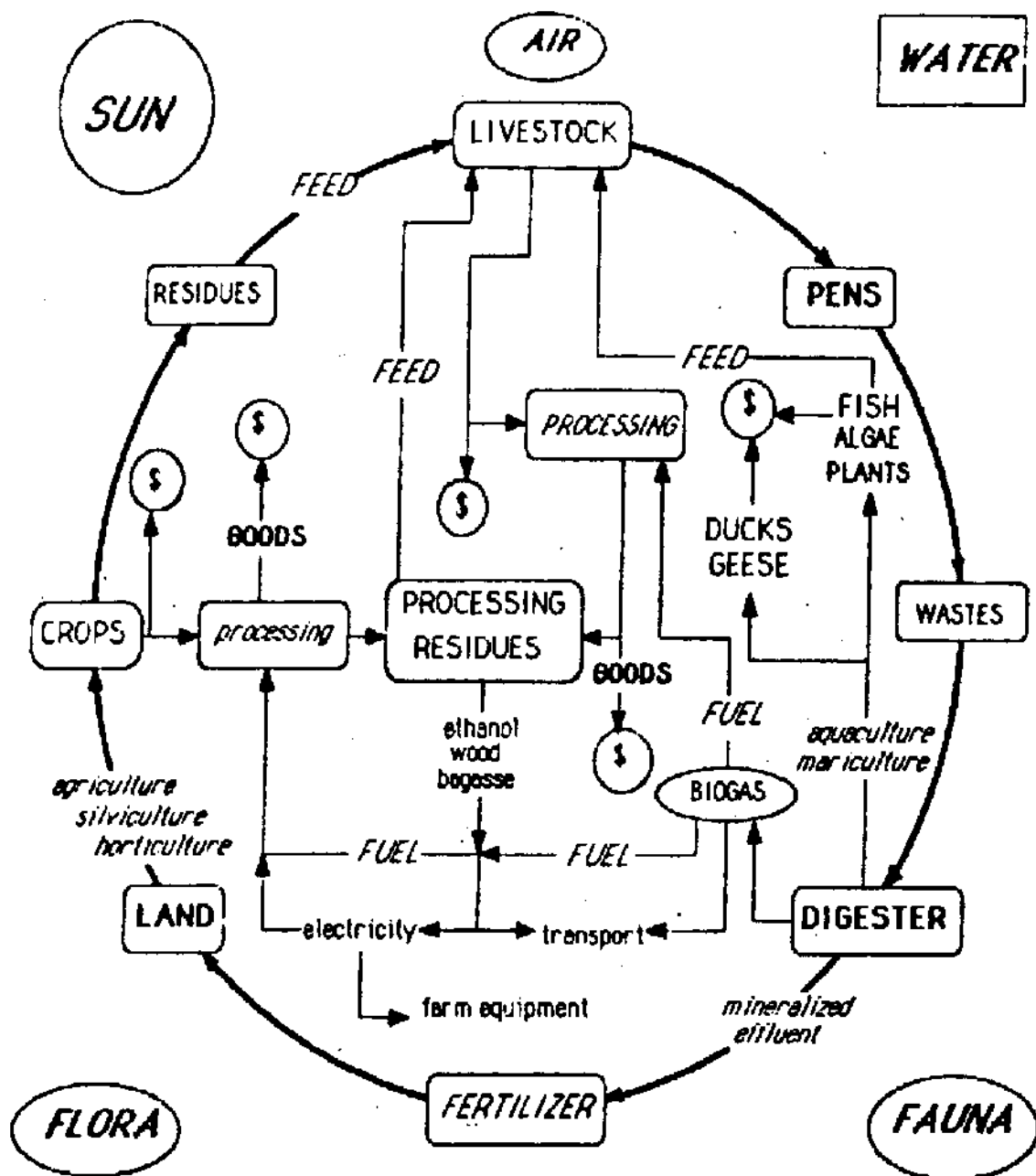

FOOD - ENERGY - WASTE CYCLE

November 1986

REFERENCES

1. Zhong G.F., Chan G.L., Furtado J.I. & Ruddle K. (mine) 1986
THE INTEGRATED FARMING SYSTEM -- An Ecological Agro-System at the Service of Farm Family Units in Developing Countries. Guangzhou Institute of Geography, Guangdong, CHINA
2. Quinney J., New Alchemy Institute, USA -- Mother Earth News, July/August, pp54-65, 1984
DESIGNING SUSTAINABLE SMALL FARMS & HOMESTEADS: Design Guidelines & Design Process
3. Ruddle K., Osaka, JAPAN -- National Museum of Ethnology, Vol. 10, 4, pp1145-1174, 1985
RURAL REFORMS & HOUSEHOLD ECONOMIES in the Dike-Pond Area of the Zhujiang Delta, China

The mulberry dike-carp pond resource system of the Zhujiang (Pearl River) Delta, People's Republic of China:

I. Environmental context and system overview

K. Ruddle

National Museum of Ethnology, Senri Expo Park, Suita, Osaka 565, Japan

J. I. Furtado

Department of Zoology, University of Malaya, Kuala Lumpur, Malaysia

G. F. Zhong

Institute of Geography, Academia Sinica, Guangzhou, PRC

and H. Z. Deng

Institute of Geography, Academia Sinica, Guangzhou, PRC

Abstract

Although not well understood scientifically, integrated and diversified aquaculture-agriculture systems have a history of some two millennia in parts of South and Southeast Asia. With the extremely limited farm area and scanty resources available to the typical small-scale farmer of these regions, integrated agro-ecosystems, based on generations of empirical knowledge, provide a balanced diet and often a small marketable surplus for poor rural households, while continuously recycling nutrients and energy through the system, producing little waste, and maintaining a local ecological balance. Despite the few scientific data available on such systems, they are being widely advocated for use in developing countries with no prior experience of integrated farming.

This paper (paper I) describes the environmental context and provides an overview of the mulberry dike polycultural carp pond resource system of Leliu Commune, in the Zhujiang Delta of the People's Republic of China, where complex and highly productive integrated farming systems are operated on a geographical and economic scale unmatched elsewhere. Subsequent papers will focus on the human ecology of the dike-pond system, the ecological basis for system integration, and the results and implications of experiments and trials for increasing the productivity of and the economic rate of return from the system.

Introduction

The integration of aquaculture and agriculture is an ancient, widespread and enduring practice in South and Southeast Asia. Nevertheless, the structure, functions and management of such systems have been little appreciated outside those regions until relatively recently. The systems are based on livestock, fowl and fish husbandry in

combination with a range of seasonally rotated crops. Small numbers of pigs and ducks, together with the fish, provide the household with animal protein and often a small cash income, while aquatic macrophytes, crop residues and kitchen leftovers feed the livestock, whose manure, together with systematically collected human excrement, fertilizes the fishpond and eventually the cultivated field. Such diversified and integrated systems have sustained small-scale farm households for centuries. In the more sophisticated variants of such systems, nutrients and energy are continuously cycled, little waste results, and an ecological balance is preserved.

Almost without exception, such traditional and sophisticated resource systems have been overlooked by development planners, perhaps because they have been regarded as small-scale subsistence operations, ill suited to fulfilling the urgent food and raw material needs of developing nations.* As a consequence, few data are available to refute this reasoning, virtually nothing is known of the techniques and technologies used, and data on levels of productivity and farm economy are seriously deficient, if available at all.

Traditional Asian integrated systems of aquaculture and agriculture, particularly those in the People's Republic of China where such systems have been best developed and applied on the widest geographic and economic scale, have recently aroused major interest among Western scientists and development planners. While this trend is to be applauded, a note of caution is in order. Chinese integrated farming systems remain in large measure based upon the empirical wisdom of many generations of local farmers. Although Chinese scientists, such as those engaged in the artificial propagation of carps, have recently brought a more analytical approach to bear on the subject, for the most part the scientific bases for system integration remain to be properly ascertained. This, in turn, has led to the acceptance as proven of many assumptions about integrated agro-ecosystems, a dangerous situation since much basic work remains to be done before integrated resource systems can be transferred with a reasonable assurance of success to other parts of the developing world. Further, virtually all attempts to improve the scientific understanding of traditional, integrated agro-ecosystems have concentrated on extremely detailed micro-studies of various biological, physical, technological and economic aspects—such as the nature of the animal waste linkage between livestock and fish from the perspective of fertilizing the pond and feeding the fish—particularly as they concern polycultural pond systems. There has been little attempt to relate these detailed studies to the larger-scale relationships such as those between the pond and the dike, or those between the pond-dike system and the general environment within which the integrated resource system functions.

As Furtado (1979) has demonstrated, the constraints inhibiting a fuller scientific understanding of integrated agro-ecosystems, and thus their improvement, development and wider dissemination, lie as much in the social as in the natural sciences. The major factors that affect the performance of integrated agro-ecosystems—energy, materials, spatio-temporal considerations and information diversity—are not, as a whole, well-known, and the socio-economic aspects of such systems, which are complex and little understood, are in particularly urgent need of detailed analysis.

In an attempt to remedy some of these deficiencies, a three-year (1980–83) applied

* A resource system is a combination of human, biotic and abiotic elements that provides for the flow of human utilities. It consists of the entire chain of events via which a component of the general environment is perceived as a resource and passes from its source through procurement, processing and technological transformation to the creation and delivery of an end-product that satisfies a perceived human need (for an elaboration see Ruddle and Grandstaff 1978; Grandstaff *et al.* 1980).

research project is being undertaken in Leliu Commune in the Zhujiang Delta, south of the city of Guangzhou, by the Academia Sinica (Guangzhou Institute of Geography). In the Zhujiang Delta an old-established and very elaborate integrated system of intensive agriculture and the polyculture of carps and other fresh-water fish, which has evolved progressively over 2000 years, is operated on a geographic and economic scale unmatched elsewhere in the world.

This paper presents a descriptive overview of the resource system and the environmental context in which it functions. Later papers will be devoted to the human ecology of the dike-pond system, the ecological bases for system integration, and the results and implications of experiments and trials for increasing the productivity and economic rate of return of the system. Since a broader study of the principal energy and nutrient pathways represents an essential first step in the organization of systemic information for planners and resource managers, particularly for those concerned with the wider adoption of integrated systems, the authors believe that the kind of synthesis they attempt to provide in these papers is basic to an understanding of the conceptual context of highly detailed micro-studies. In this way, the now-familiar problems that arise from *ad hoc* interventions within large, complex systems, based on the detailed study of subsystems alone, can be avoided or at least mitigated.

The biophysical environment

The Zhujiang (Pearl River) Delta, a densely populated region of some 12 000 km² focusing on the city of Guangzhou (Canton), is the economic and cultural core of southeast China. This delta has been built up by several large rivers that converge in the region, principally the Xijiang, Beijiang and the Zhujiang (Fig. 1). An intricate maze of

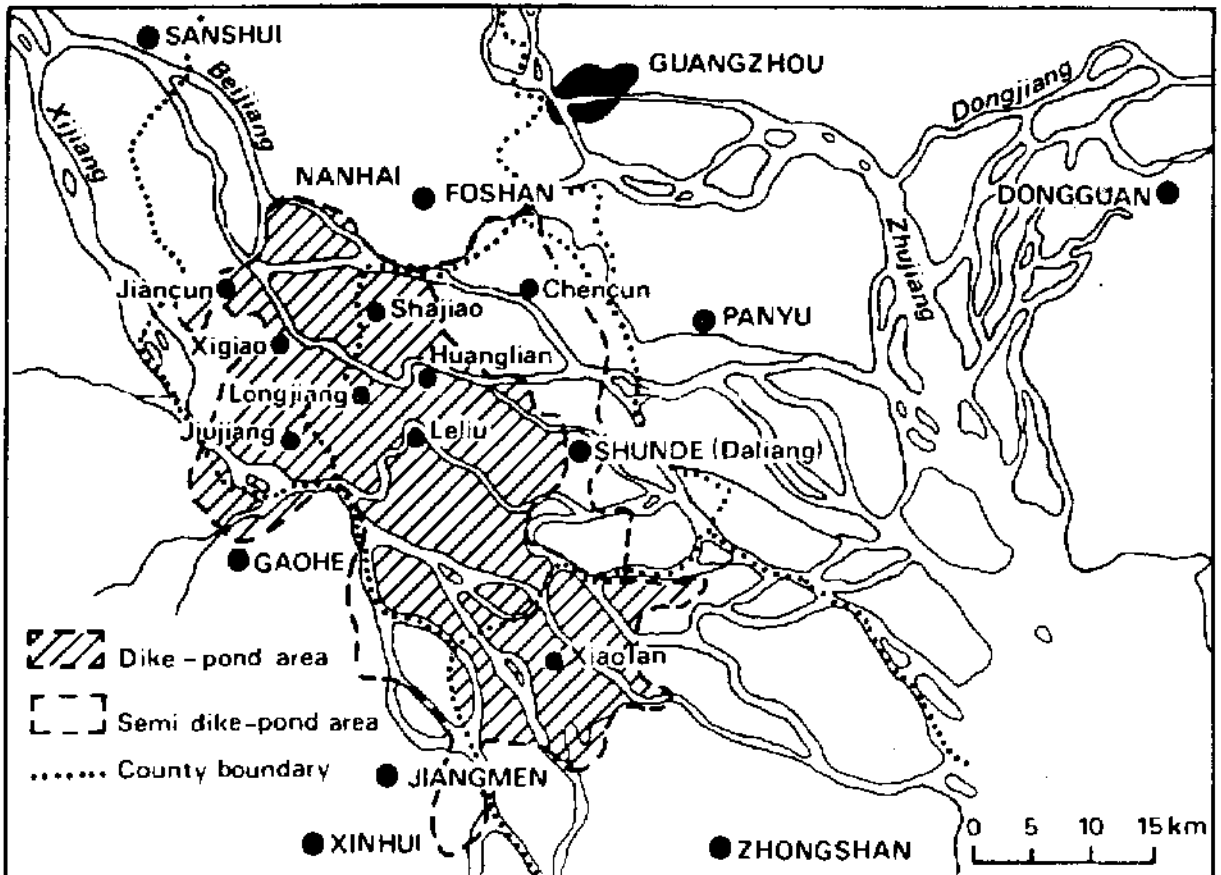

Figure 1. Location of research area in the Zhujiang Delta.

smaller natural and man-made watercourses traverses the delta and provides the main transport arteries. The soils of the Zhujiang Delta, developed from recent alluvium, are rich in organic matter and are only slightly porous. Those in Shunde County, for example, were primarily paddy soils with some tracts of meadow-boggy soils prior to the development of the dike-pond system. But after centuries of intense cultivation and irrigation under this system, distinctive classes of silty soils have emerged.

Numerous low, scattered hills, rising some 50 m above the plain, emerge from this low-lying delta. They are composed of soft sandstones, clays and conglomerates. In sharp contrast with the alluvial areas, lateritic soils have developed on the hills, which have served principally as cemeteries, pastures and as a source of fuelwood. Formerly stripped of trees and heavily eroded, since 1949 the hills have been reafforested with both timber and fruit trees.

The climate of the Zhujiang Delta is warm temperate, and rainy (*Cfa* of the Köppen classification), and is affected by the monsoonal circulation. It is characterized by an annual mean temperature at Shunde of 22°C, and an annual average range of 15°C, with mean temperatures in the warmest months of 28.7°C (July) and 28.4°C (August), and in the coldest months of 13.0°C (January) and 14.7°C (February). Summers are hot and rainy, with maximum recorded temperatures of 37°C and some 1700 mm of rain, 84 per cent of the average annual total. Mean annual relative humidity is 82 per cent, with a high in June of 85 per cent and a low in January of 76.9 per cent. Although generally mild, under the influence of the Mongolian high pressure system winter air temperatures occasionally fall to 1–2°C, with an average of 2–3 days of frost per annum. Hours of sunshine average 2000–2250 p.a. Southern China is subject to a variety of damaging climatic hazards, principal among which are spring drought, flooding from monsoon rains, and the passage of two to five typhoons during the summer and early autumn (Luo *et al.* 1980). Since 1949, however, the impact of these hazards has been greatly mitigated by flood control and water supply projects.

The modern policy context

After the Cultural Revolution (1966–73) a new policy for rural development was adopted, some elements of which are clearly based on traditional strategies of using resources and providing cooperative labour. This modern policy is characterized by priority being given to agriculture over industry (PRC 1975), the integration of traditional and modern technology, and a centrally directed but locally administered, two-directional approach to development planning and programme implementation. In the agricultural sector its main aspects are: national self-reliance and food security; top priority in resource use being given to the satisfaction of basic needs, the creation of jobs, and the promotion of agricultural growth; integrated rural development; resource conservation; integrated agricultural systems and waste recycling; a de-emphasis of animal husbandry (except for fisheries); the close integration of research with production; and popular participation in the planning process.

The social organization of production

By the late 1960s, the local-level formal administrative structure of China had assumed its present three-tier form of 'people's commune', 'production brigade', and 'production team'. Nevertheless, the household remains the smallest single unit of Chinese social organization and the one in which the *de facto* use and management of privately owned resources such as small garden plots and domestic animals is vested.

The production team, the basic agricultural production and accounting unit in most

communes, generally consists of 20–30 households. In it is vested the ownership of all agricultural implements other than those privately owned. Since basic local production decisions are made at this level the production team is also the smallest unit in the national planning process. Intermediate is the production brigade, which serves largely as a planning and administrative unit. It undertakes productive activities too large for the production team, such as constructing and managing drainage and irrigation systems, or land reclamation and improvement schemes. Brigades also operate agro-industries, farm machinery repair shops, and the like, as well as schools and health stations. The highest unit in the local organization is the people's commune. It undertakes activities too large for the other levels and also performs higher-order administrative, economic, social and political functions.

In the Zhujiang Delta, Leliu Commune, with 5044 ha of cultivated land and a population of about 87 000 persons organized into some 19 000 households, typifies those parts of Shunde County in which fishponds comprise the largest single category of land use. No rice is produced in this commune and land use is dominated by fishponds (2420 ha) and dikes (1330 ha in sugarcane, and 752 ha under mulberry). Land privately cultivated for foodstuffs, mainly for household consumption or sale in local markets, amounts to 103 ha. Fruits, vegetables and oil seeds are also intercropped and rotated with the principal crops. Chickens, ducks, geese, pigs, the occasional water buffalo (used mostly for tillage) and eels are raised in addition to fish. Agriculture and aquaculture are mechanized to a very small extent only. The commune also includes two small urban centres, Leliu and Huanglian.

The labour force of approximately 36 000 persons is organized into 29 brigades and 257 production teams. The latter range in size from 150 to 500 members and, although basically comprehensive in organization, have specialized groups among them, such as those for fishpond operations, mulberry cultivation, and the like. The farm labour force is supported by various other specialized teams including, *inter alia*, those for physical construction, transport, and machine repair and maintenance. Other teams work in the complementary small-scale manufacturing sector of the commune economy, producing goods both for use within the commune and for sale elsewhere. Special teams composed of children and old people watch for signs of pest infestation in the fields, and implement appropriate control measures.

Agricultural production within the commune is closely integrated with, and supported by, various levels of locally conducted, practical problem-solving research: an Institute of Agricultural Sciences and an Institute of Aquaculture at the county level; an Agricultural Extension Station at the commune level; an 'agricultural group' at the brigade level; and specialized personnel at the production team level. Organization and coordination of research work throughout the county is undertaken by the Scientific and Technological Committee, a department of the County People's Government.

Historical evolution of the Zhujiang Delta pond–dike systems

About 1000 years BP the coastline in the Zhujiang Delta met the Xijiang in the present-day counties of Nanhai and Gaohe (Li 1657). At that time the lowlands were neither widely nor continuously cultivated, owing to continual flooding and the presence of acid sulphate soils, and village economies in the region were based mostly on the capture and collection of marine resources. At higher elevations, however, fruit cultivation, especially of litchi (*Litchi chinensis*) and longan (*Euphoria longana*), had developed rapidly since its beginning during the Han Dynasty, some 2000 years BP.

Meanwhile, during the mid-14th century, water control measures were started in the lower-lying areas around Jiujiang, near the Xijiang. Smaller watercourses were

dammed and diked to make fishponds. Ponds were dug to drain marshes and natural ponds in order to create agricultural land, and the excavated soil was used to construct dikes. Historically, the middle and lower reaches of the Xijiang were China's main source of naturally occurring carp fry, and the early artificial ponds were devoted mainly to fry breeding and rearing on a commercial basis.

The first commercial crops grown on the dikes were fruits, particularly litchi and longan, as a consequence of the region's long experience with, and fame for, fruit cultivation, together with the large market demand throughout China. However, it is also probable that fruit cultivation was partly a response to declining local water-tables that resulted from the rapid seaward progression of the delta, and which, when added to the impossibility of retaining water on the dikes, ruled out rice growing. At that time, however, there was apparently little or no conscious organization of an integrated fruit dike-fishpond system in terms of the linked input and output of materials and energy, although both activities might have been undertaken on the same farm unit. Fruit cultivation was simply the most profitable way of utilizing the dryland areas created by the excavation of fishponds.

Mulberry cultivation, silkworm breeding, and silk weaving have a history of about 2000 years in the Zhujiang Delta, and were initiated in order to produce goods for home consumption or to pay taxes. But by the early part of the Tang Dynasty (seventh century AD) these activities had already developed into a substantial industry to satisfy the trade that developed rapidly when Guangzhou was opened to international commerce, 1200 years ago. Mulberry growing and silkworm rearing remained separated both geographically and conceptually from fish cultivation, since even by the 13th century few dikes were planted to mulberry. By the 1620s, however, mulberry was being widely cultivated on the dikes between the fishponds, experience having shown that the economic returns from integrated mulberry dike-fishpond systems were greater than those obtained from cultivating fruit trees on the dikes. Moreover, pond mud, enriched with silkworm excrement and other wastes that had been first used to fertilize the pond and feed the fish, was found to be a superior fertilizer for mulberry bushes than was the raw silkworm excrement applied hitherto, which when applied to excess damaged the mulberry leaves. With this discovery an integrated dike-pond system was found to be beneficial to both mulberry and fish, and far better than growing rice (Zou 1894). Thus by the 1650s farmers in the area around Jiujiang and Xigiao began to replace old fruit trees with mulberry and hemp over some 70-80 per cent of the dike area (Li 1657). This process continued until around 1800, by which time most parts of Shunde County were devoted exclusively to the integrated dike-pond system.

Added impetus was given to the widespread adoption of this system in the 1750s when the Qing government closed all ports except Guangzhou to foreign trade, and at the same time limited the export of Hu (Taihu) silk. Thus the demand for Yue (Guangdong) silk increased abruptly and prices soared. Conversion of paddy fields to dike-pond systems continued apace and was extended beyond the areas of low-lying marshlands, the eradication of which was the main objective of the system.

A further boost to silk production in the region, and which led to a 30 per cent rise in prices consequent upon quality improvement, occurred after the mechanization of the reeling process. With the opening of the first modern filature, in 1866, at Jiancun village in Nanhai County, the integration of mulberry and fish entered a new phase. Not uncommonly, rice cultivation was abandoned as an increasingly larger area was converted to ponds and dikes. Centrally located in the Delta, and thus at the hub of rural water transport, Shunde County emerged as the locality with the largest area devoted to mulberry-aquaculture systems. The County's leadership was firmly

established with the opening of the Yi Chang Mechanized Filature, at Daliang, late in the last century. Shunde, which now accounts for 75 per cent of the Delta's silk production and has the most fishponds (Zhong 1979), had converted 6700 ha of paddy fields into integrated mulberry dike-fishpond farms by the end of the 19th century. By the end of the Qing Dynasty (1911) the Zhujiang Delta had some 66 700 ha devoted to this kind of agro-ecosystem, and by 1925, the apogee of Guangdong silk production, 93 000 ha of dikes was planted to mulberry.* But a massive decline was soon to set in with the worldwide 'Great Depression'.

Sugarcane has been cultivated in the Zhujiang Delta for about 2000 years, mostly on the higher and drier slopes of the uplands, and utilizing mainly two local varieties, *zhuzhe* (lit. 'bamboo-sugarcane', *Saccharum sinense*) and *muzhe* (lit. 'wood-sugarcane', species not identified). Since the Song Dynasty (12th century AD) Panyu County has been one of China's important sugar-producing areas. But a relatively poor-quality product with fluctuating yields, Guangdong sugar was grown mostly to satisfy local demand. Profits were therefore slight, and so the industry was slow to develop. During the 'Great Depression' silk prices fell dramatically, large areas of mulberry dikes were left uncultivated, and about one million silk workers were unemployed. Seeking a profitable replacement for mulberry, entrepreneurs introduced in 1932 several varieties of sugarcane from Java, and from 1934 onwards other varieties were brought from the Philippines, including POJ 2727, 2878 and 2883, and 'Yellow Galedonia'. Many of the abandoned mulberry dikes were planted to sugarcane, and the region's first sugar refinery was established in Shunde County in 1936. Thus the focus of Guangdong's sugar industry shifted from the uplands to the dike-pond region. Despite the widespread adoption of sugarcane cultivation, many former mulberry dikes were converted to mixed vegetable production or paddy rice, or were left derelict. This may be inferred since the area under mulberry declined from 93 000 ha (1925) to 35 000 ha (1935), and no more than 6700 ha were planted to sugarcane in Shunde, Zhongshan, and Nanhai Counties combined (Li *et al.* 1976).

The Japanese Occupation (1938-45) dealt another severe blow to local silk production, because prices declined precipitously in the face of competition from both silk and artificial fibres produced in Japan. At the same time, rice prices increased dramatically nationwide, and because relatively little food grain was cultivated in the Zhujiang Delta, expensive rice had to be imported from elsewhere in China and from abroad. Unable to purchase expensive rice with the now meagre earnings from their silk, farmers in the Zhujiang Delta rapidly abandoned the dike-pond system and the cultivation of rice and other foodstuffs became both more extensive and intensive.

Although excavation of fishponds and dike construction was historically considered to be the best way of transforming nature to make an area that was formerly marginal economically and subject to a range of natural hazards more productive in economic terms, until 1949 cropping patterns on the dikes were dictated by market prices rather than by the ecological considerations that are the essence of traditional integrated farming systems. But since 1949, while market demand in the guise of fixed production quotas has remained an undeniable force in determining patterns of resource use in the dike-pond region, the integrated utilization of resources based on fundamental ecological principles has evolved hand-in-hand with the exigencies of economic dictates. As a consequence, the components and processes of the dike-pond system have become progressively more tightly integrated in terms of complementary inputs and outputs; the system has become more elaborate in terms of the crops and animals

* All area data have been converted from *mu* (1 *mu* = 0.066 ha) and extrapolated.

raised and in terms of the spatial and temporal patterns of intercropping, interplanting and rotation; overall system productivity has been raised, and energy losses, resulting from unutilized waste or by-products or niches not exploited, minimized. However, further refinements and improvements that demand a more rigid linking of the various components of the system are still forthcoming, such as the integration of biogas digesters for energy and fertilizer production, as has recently taken place in the Xinbu Brigade of Leliu Commune (Mai *et al.* 1980).

Components of the dike-pond resource system

Components within the fishpond

Much of the success of fresh-water aquaculture in Southeast Asia, and particularly the high productivity of Chinese ponds, is the result of polyculture, the raising of several different compatible fish species, and often other aquatic organisms, in the same body of water. This is the most efficient technique for using a limited pond area since the complementarities among the species, particularly in feeding habits, permit the harmonious exploitation of available ecological niches and the optimum use of the foods available at the various trophic levels of the complex aquatic food chain.

Apart from a few specialized instances of eel culture and initial experiments with Indian carps, together with the inclusion of Bream (*Megalobrama amblycephala*) and Tilapia (*T. nilotica*) in the fishpond, all the fishponds in Shunde County are devoted to the culture of Cyprinids, the so-called Major or Chinese carps: the Grass carp (*Ctenopharyngodon idellus*), the Silver carp (*Hypophthalmichthys molitrix*), the Bighead carp (*Aristichthys nobilis*), the Black or Snail carp (*Mylopharyngodon piceus*), the Mud carp (*Cirrhinus molitorella*), and the Common carp (*Cyprinus carpio*). Each species has distinct feeding habits and each occupies a different level within the pond.

Traditionally, from April to July of each year, the fishponds of Shunde County were stocked with larvae and fry obtained from the lower and middle reaches of the Sikiang. Fry, caught near the banks in broad and relatively straight sections of the river where the current is slow, were carefully sorted, and raised in nursery ponds prior to their transfer as fingerlings to the culture pond. But, since 1949, pollution in the major rivers has drastically reduced the natural supply of fry and larvae and has made hatchery production a necessity, although larvae and fry are still caught, particularly to provide brood stock and thereby to help mitigate the genetic effects of in-breeding among artificially propagated fish. In China, the artificial propagation of the major species of Chinese carp has made great strides since 1958, and in particular it has been simplified to the extent that it can be easily undertaken at the level of the production team (Chung 1980).

Fry are usually raised under monoculture to fingerling size in nursery ponds with an area of 0.13–0.2 ha. Prior to stocking, ponds are treated with quicklime, to remove predators and unwanted species and to control infections among the fish, at a rate of 900–1125 kg ha⁻¹ for dry ponds and at 1875–2350 kg ha⁻¹ in ponds containing water 1 m deep. Tea-seed cake is then applied to the ponds at a rate of 325–365 kg ha⁻¹ m⁻¹. This alternate application of lime and tea-seed cake maintains the normal pH balance of the water. Two or three applications of compost or organic fertilizer such as *dacao* (a traditional fertilizer made by combining various herbaceous plants, soy-bean meal or curd, and either rice bran or peanut cake powder), totalling 11 250–18 750 kg ha⁻¹ m⁻¹ are given to the pond 10–15 days before stocking to stimulate the growth of plankton on which the fry feed.

Fry are stocked in the nursery ponds 3–5 days after hatching. Stocking rates

vary, but are high initially, at 1–1 500 000 ha⁻¹ being reduced after 7–10 days to 75 000–150 000 ha⁻¹. Reported survival rates are relatively low, at 30–40 per cent (FAO 1979). Nursery ponds containing fry are fertilized carefully so as not to deplete dissolved oxygen levels. *Dacao*, at a rate of 19 500 kg to 150 000 fry per hectare is applied 2–3 weeks after stocking Silver carp or Bighead carp. Ponds containing weak fry of these species receive additional fertilization with peanut cake powder, at a rate of 4.5–18 kg to 150 000 fry per hectare divided equally into 2–4 applications per day. Ponds with Mud carp or Grass carp require less fertilization, 1250–3000 kg to 150 000 fry per hectare of *dacao* being applied every three days and 22.5–37.5 kg to 150 000 fry per hectare of either peanut-cake powder or rice bran is supplied daily. Under such management fry attain fingerling size in 3–4 weeks.

Ponds for rearing fingerlings are prepared in the same way as those for fry. Robust fry, a uniform 3–3.5 cm in length, are used for stocking under either monoculture or, more commonly, under polycultural conditions, the stocking rates varying according to the system used. Fingerlings are usually reared in two stages, using separate ponds at each stage. In the first stage, which lasts for a month, they are reared to a length of 6 cm, and in the second to 12 cm. Feeding is almost the same as for fry, but more feeds like rice bran, soy-bean cake, peanut cake, silkworm pupae, crushed snails and fishmeal, with chopped duckweed, soft grass and vegetable tops added for the Grass carp fingerlings, are provided. With proper management, especially of water quality and quantity, cleaning and sterilization of the ponds, and the elimination or scaring-off of predators, fingerling survival rates of 70–90 per cent are reported.

Most production ponds in Shunde County are rectangular or square in shape, permitting more efficient natural or mechanical aeration of the water and facilitating mechanization of pond operations. They range in size from 0.2 ha to more than 0.5 ha, although the majority are less than 0.5 ha. An area of 0.26–0.33 ha is regarded as ideal, but in zones of porous soils production ponds of 0.66 ha are not uncommon. Rectangular ponds are preferred, aligned east to west to maximize the available hours of sunshine, and with a length to width ratio of 6:4 to minimize dike erosion by wave action and to optimize fish and crop production. Apart from public sewage ponds used to collect faecal matter, ponds are not constructed in the lee of tall buildings or trees, thus minimizing the interception of solar radiation and wind.

Pond-water depth ranges from 2 m to more than 3 m, with a preferred depth of 2.5–3 m. If the water is too shallow its strata are not deep enough to optimize polyculture nor to rear large numbers of fish, and overheating and eutrophication problems can arise. Conversely, when the water is too deep temperatures and light in the bottom layers are low, bottom waters may become deoxygenated, and plankton production reduced. Maintenance of these relatively deep ponds is not problematical since draining and filling operations are increasingly mechanized and the need for sluices and other water control devices is reduced. Pond bottoms are almost horizontal, sometimes with a slope of 1/220–1/300 from the water inlet to the outlet side. In localities with sandy or porous soil, dikes are lined with bricks or concrete.

In the Zhujiang Delta the main fish species raised is the Grass carp, combined as environmental conditions and the availability of inputs permit with Bighead, Silver, Black, Mud and Common carp, and sometimes with Bream and Tilapia. In the production ponds of this region fish cultivation continues to be based on the traditional mixed-age or size polyculture, in which fish of varying sizes and of different species are reared from fingerling to marketable size in the same pond. The larger fish are selectively harvested in quantity every 3–4 months, with 3–4, and in some places 5–6, harvests per year during the rearing period, and the pond is selectively restocked with younger individuals. Thus in any given pond there are fish at various stages of growth.

Although densities and species composition vary from place to place within the region, stocking densities of 15 000 ha⁻¹ are not uncommon.

Because stocking densities are high, extremely heavy fertilization of ponds and feeding of fish is practised in the Zhujiang Delta, but since the integration of the resource system is so tight, this presents few if any logistical problems. Only organic fertilizers are applied to both ponds and crops. Of these the most important is pig manure, which is applied at the rate of 562 t ha⁻¹ yr⁻¹. Commonly, pigsties (as well as the latrines for humans) are built adjacent to the pond, on the dike, so that the manure can either fall or be flushed directly into the pond; but increasingly, pig manure and human excrement are fermented and also used to produce biogas prior to its application to dike or pond in more precisely controlled fertilization (ISF 1980). When available, chicken manure (and that of the few water buffaloes) is used as fertilizer, at the rate of 15 t ha⁻¹ yr⁻¹. 'Fertilized water', which consists of 77 per cent residues of soy-bean curd and 23 per cent other fermented wastes from food-processing factories, is applied to ponds at the rate of 200 kg to 1 kg Silver carp per year. Additional pond fertilization is provided by the decomposition of fish excrement and of digested or partly digested fish food.

Fish are fed with organic materials produced on the associated dikes, in some cases after these products have been processed in nearby agro-industrial plants. Fish do not normally receive any supplementary high protein food of animal origin. Grass carp is the principal species raised, and this is fed mainly with grasses, sugarcane husks, leafy vegetables and aquatic macrophytes grown on the dikes or in proximate water bodies. In general, such rough plant material constitutes 99.6 per cent of fish feed, the balance being made up by fine food consisting of the fermented residues of soy-bean curd, soy-bean cake, peanut cake and rice bran. The natural fertility of the pond water, enhanced by manuring, promotes the growth of plankton, the principal food of the Bighead and Silver carp. Common and Mud carp are detritus feeders, whereas the Black carp feeds on snails. On this basis, Chinese farmers have determined empirically that the crops from 1 ha of dike can provide the feed for fish in 1 ha of associated ponds. The climate of the Zhujiang Delta is well suited to the raising of the major Chinese carps. On the coldest days in winter, pond temperatures usually remain above 1–3°C, the critical lower limit for the main species cultivated, apart from the Mud carp, which suffers mortality at temperatures below 5°C (Aquaculture Department 1960). The lethal lower temperature for *T. nilotica* is 11°C (Bardach *et al.* 1972), but hybrids with *T. mossambica* are more cold resistant. Pond-water temperatures in summer rarely approach 35°C, the upper limit for the growth of the species.

The principal environmental problems of concern to Shunde County fish farmers occur in the pond micro-environment as a result of the extremely high organic loading of the water. Pond fertilization and fish feeding are therefore carefully controlled, and water quality is strictly monitored, especially to assess dissolved oxygen (DO) levels in the hours just prior to sunrise. This is particularly critical in these ponds, which are relatively deep by the usual standards of aquaculture. DO levels are monitored by observing fish behaviour. Optimum levels for ponds in this region are 5 mg l⁻¹; when they decline to 1 mg l⁻¹ fish start to surface, and when the DO falls below 0.2 mg l⁻¹ large-scale fish mortality results (Zhong *et al.* 1965). Serious oxygen depletion is indicated when the bottom-dwelling species come to the surface, a rare occurrence in the Zhujiang Delta, where good pond management is the norm.

Components of the dike

While not diminishing the overall policy of achieving self-reliance and the satisfaction

of basic needs from locally available renewable natural resources, the single most important commodity produced by the dike-pond system of Shunde County is fish. Hence the agricultural use of the dikes is geared basically to the feed requirements of the fish and the fertilization needs of the pond. The relative emphasis placed on mulberry and sugarcane, the main commercial crops cultivated on the dikes, is also a response to both the domestic and international market demand for silk and sugar. Balancing market demand and pond input requirements, and thus the main crop grown on the dikes, results in a fluctuating ratio of pond to dike area.

On the basis of dominant crop grown, four principal types of dike are recognized: mulberry dikes, sugarcane dikes, fruit dikes, and miscellaneous crop dikes. Compared with those in other regions of well-integrated farming systems, dikes in the Zhujiang Delta are exceptionally large and varied, both in morphology and function. For the integrated system practised in this region, level-top dikes 6–10 m in width and 0.5–0.7 m in height above the level of the pond surface are considered ideal. In the Zhujiang Delta dikes range in width from 6 m to 20 m. Narrow dikes have a small surface area that renders cultivation inefficient, and on the widest dikes it is difficult to provide enough pond mud as fertilizer. Dikes of medium height (0.5–0.7 m) above the pond surface absorb enough water from the pond to maintain a soil-water content ideal for most crops cultivated. Low dikes (<0.5 m above the pond surface) suffer from waterlogging in the plant root zone and are liable to inundation during the flood season, whereas high dikes (>1.0 m) are unable to absorb enough pond water.

In the Zhujiang Delta year-round crop cultivation on the dikes and in the associated waterways presents a complex picture of seasonal and biennial rotation and of intercropping. There is no slack season in agriculture and the dikes are under continuous cultivation. Cropping is closely connected with the husbandry of mammals, fish, and silkworms. The principal commercial crops cultivated are mulberry (*Morus atropurpurea*), sugarcane (*Saccharum officinarum*), various fruits (especially litchi, longan, and bananas and plantains [*Musa* spp.]), together with a wide range of other plants for domestic use, livestock and fish feed, and for marketing.

In the Delta, 9400 ha of dike are devoted to the cultivation of mulberry, the leaves of which are fed to silkworms (*Bombyx mori*). Mulberry leaves are harvested 8–9 times per year, between March and late November. In this region 1 ha of dike yields an average of 22 500–30 000 kg yr⁻¹ of mulberry leaves, which results in a yield of 1875–2250 kg of silkworm cocoons. Shunde County accounts for 90 per cent of the cocoons produced by Guangdong Province (unpublished local statistics).

Climatically, this region is well suited to both mulberry cultivation and silkworm rearing. Mulberry grows best at temperatures of 25–30°C, whereas its growth is hindered below 12°C and it cannot survive drought at temperatures greater than 30°C. Thus in this area the mulberry shrubs are pruned in late November and the dike intercropped with various vegetables until February of the next year. The period December–February is too cold for leaf production. Mulberry is a heliophilous plant, which at 30°C on a sunny day produces 2 mg (dry matter) 100 cm⁻² hr⁻¹ of leaf surface. This is reduced by 50 per cent on cloudy days and by 70 per cent on rainy days, hence mulberry leaf production is somewhat inhibited during the rainy seasons. Rainfall is sufficient for mulberry growth and, without irrigation, dikes of medium height absorb enough pond water to maintain adequate moisture at an average depth of 35 cm, the root zone of the mulberry plant. In drought periods the dikes can be irrigated easily from the nearby ponds.

Temperature and humidity are important factors in sericulture. Silkworms grow only at temperatures between 15°C and 32°C, and die in drought periods at temperatures above 40°C. They require a relative humidity of 70–80 per cent for

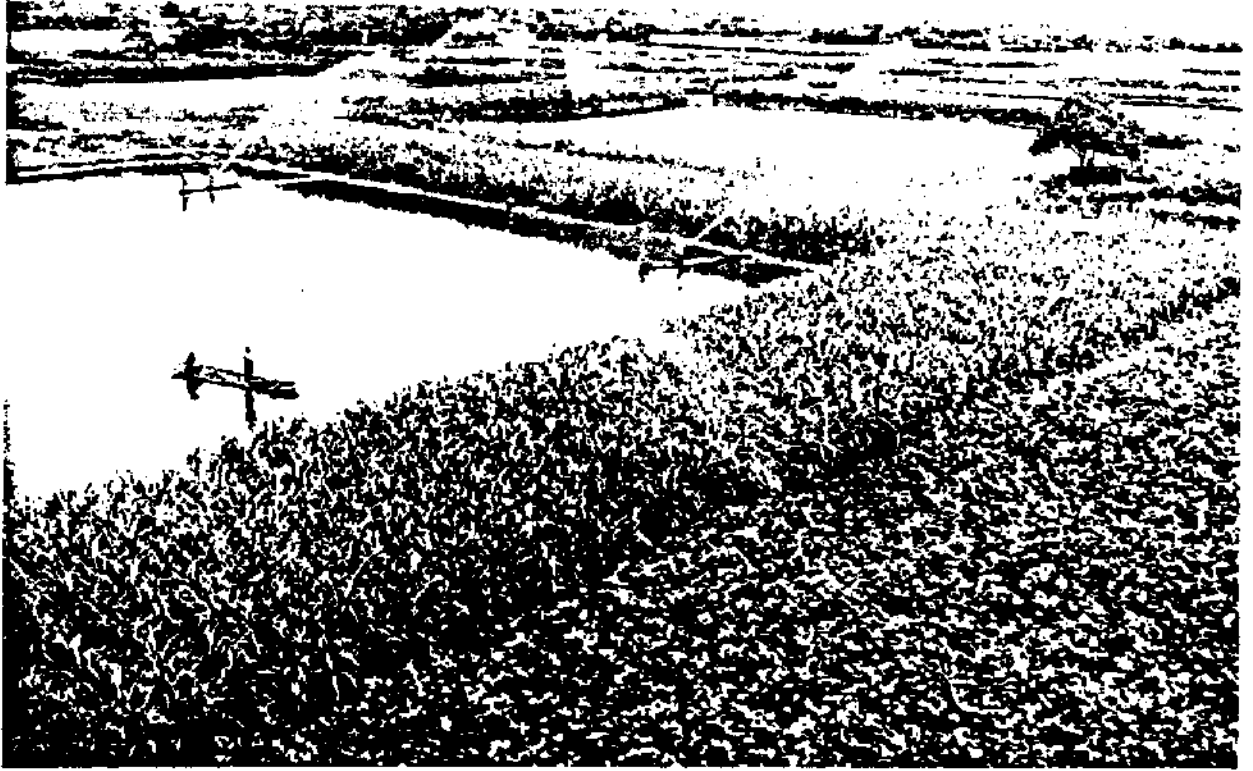

Plate I. Irrigating sugarcane and mulberry with pond water.

optimal growth. Except in winter, when dry Mongolian air occasionally intrudes, relative humidity in the Zhujiang Delta is always high. From May to September, high temperatures and high relative humidity are detrimental to silkworm growth, but are mitigated by using bamboo frames constructed for the silkworms in the rearing sheds.

In the Zhujiang Delta mulberry shrubs are pruned after the last harvest of leaves and the dikes are interplanted with an assortment of vegetable crops. This has the additional effect of improving mulberry yields. And to reduce plant diseases and insect pests the dike is planted alternately with mulberry and sugarcane, which also has been demonstrated locally to increase the yields of both crops as well as to improve soil quality.

With 15 300 ha of dike area under sugarcane and an average yield of 75 t ha^{-1} , the Delta produces 12.5 per cent of Guangdong Province's sugar and is one of China's leading sugar-producing regions. Sugarcane is well adapted to the annual temperature and rainfall regimes of the region. The plant's greatest water demand occurs during the period June–September, coinciding with the months of highest precipitation, and the second period of high water demand occurs in January–April, when again the rainfall is sufficient. Mean monthly temperatures normally satisfy the requirements of sugarcane, the growth of which is retarded below 20°C and which stops altogether at temperatures of less than 10°C . Frost damage is rare in the Zhujiang Delta. Dikes are planted to sugar in the autumn, the crop requiring up to 16 months to reach maturity.

In early spring, before the mulberry shrubs come into leaf, mulberry dikes are interplanted with soy-bean (*Glycine Max*), mung bean (*Phaseolus aureus*), taro (*Colocasia antiquorum*), peanut (*Arachis hypogea*), and other vegetable crops, which

are harvested in May and June, and bananas, plantains, and fruit trees are cultivated along the edge of the dike. In summer and autumn, at the very edge of the dike, melons and gourds are planted and trained on bamboo trellises that hang over the pond, thereby shading the water and preventing excessively high temperatures that would endanger the fish. Each November, after the last harvest of mulberry leaves, the dikes are interplanted with Chinese cabbage (*Brassica pekinensis*), cabbage (*B. oleracea*), leaf mustard (*B. juncea*), carrot (*Daucus Carota*), and radish (*Raphanus sativus*), which provide two harvests, the last being in February. For feeding fish, Elephant grass (*Pennisetum purpureum*), maize (*Zea Mays*), sorghum (*Sorghum spp.*), and sweet potato (*Ipomoea batatas*) are planted on all available spare land, including the dike slopes, roadsides, around the settlements, and along the watercourses. To feed fish and pigs, aquatic plants such as duckweed, water lettuce (*Pistia Stratiotes*) and water hyacinth (*Eichhornia crassipes*) are cultivated in canals, rivulets, and associated bodies of water.

Energy and matter linkages in the dike-pond system

Integrated farming is an ancient practice in China and one that has become more refined as a consequence of the agricultural and rural development policies implemented since 1949. Although based on solid economic and ecological principles, in the Chinese case the fundamental motives for the further development of integrated systems appear to be the need to maximize productivity per unit of land; the national policy of diversified self-reliance in food and basic raw materials production; and that the by-product (waste) from one resource use must, wherever possible, become an input into another use of resources. The mulberry dike-carp pond resource system of the Zhujiang Delta contains at first sight an extremely complex range of matter and energy linkages among pond, dike, and the general environment (Fig. 2), but in reality the components of the system are amenable to relatively easy integration.

At the heart of the system is the pond. To produce or maintain a fishpond, soil is excavated and used to build or repair the dikes that delimit the pond and produce the essential inputs for it. Prior to being filled with water, the pond is prepared for fish cultivation by clearing, sanitizing, and fertilization (see above), the required inputs being lime and tea-seed cake, which derive from the general environment, and organic manure, which is procured from the animal husbandry and subsystem on the dike.* Under natural conditions, soil and organic materials gradually refill the pond through the processes of dike erosion, but this is interrupted two to three times a year when organically enriched pond mud is dug from the pond and used to fertilize and build up the upper surface of the dike. Pond mud is also used to make mud-beds for mushroom cultivation on the floor of the silkworm shed in winter, when silkworms cannot be raised.

The pond is then filled, through the inlet channel, with river water, which bears nutrients, pollutants, fauna, flora and disease organisms. Water also enters directly as rain as well as through run-off from the dike. Water, enriched with additional nutrients and bearing pollutants, fauna, flora and disease organisms, leaves the pond in controlled discharges via the pond drainage outlet. Water is also lost through evaporation and transpiration, and via seepage into the dike, as well as being removed at regular intervals for the irrigation of the crops planted on the dike.

Fish, in addition to the fry and fingerlings that enter with the river water, are stocked

* Capital, labour, organization, technology, and other such inputs are assumed as given throughout this section.

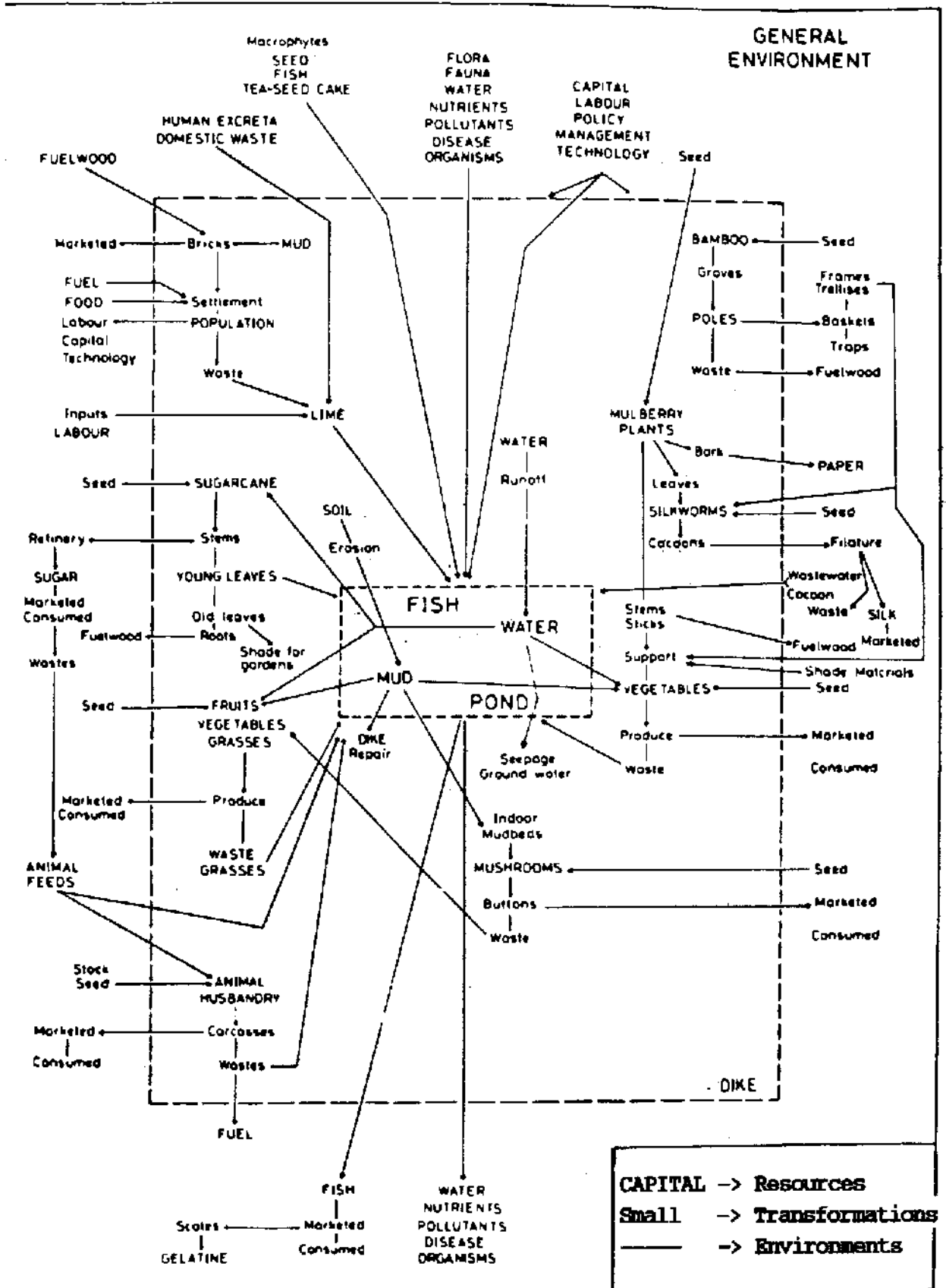

Figure 2. Energy and matter linkages in the mulberry dike-carp pond resource system of the Zhujiang Delta.

in the pond (see above). Some fish of marketable size are consumed locally but most enter the market; 70 per cent of the fish produced in Shunde County, for example, are sold live, mostly to Guangzhou, Hong Kong and Macao. Fish sales contribute the largest source of income to the region's agricultural sector, the Zhujiang Delta yielding 90 000 t yr⁻¹ of fish (1979), or 50 per cent of the total production of Guangdong Province, and 80 per cent of the nation's live fish exports (unpublished statistics of Foshan Prefecture). Fish waste is used as pond fertilizer, and fish scales are used to produce gelatine.

A range of linked subsystems functions on the dike. Mulberry and sugarcane, planted in alternate years, are the main cropping subsystems. Mulberry cuttings, obtained from the general environment (i.e. off any given dike) are planted on the dikes fertilized with pond mud and irrigated by hand with nutrient-rich pond water. The principal objective of mulberry cultivation is to produce leaves used as forage for silkworms. Mulberry bark is also harvested for making paper and, after pruning, the branches are used as sticks to support climbing vegetables, or as fuelwood.

Inextricably bound up with the mulberry subsystem is silkworm raising. Silkworms are raised in special rearing sheds in the settlement and the cocoons sent to the filature in the nearby urban centre for yarn production, most of which enters international commerce. Waste water, together with cocoon waste and dead larvae, is returned from the filature and used to enrich the fishpond and feed the fish. Silkworm excrement is removed from the rearing sheds and used in the pond as fish feed.

During the off-season for silkworm production mushrooms are cultivated on mud-beds, prepared from pond mud, on the floor of the silkworm rearing sheds, using spores obtained from the general environment. Mushroom 'buttons' are both consumed locally and marketed fresh, bottled or canned. The nutrient-rich mud-bed on which the mushrooms are raised is used to fertilize those sections of the dike on which vegetables, fruit trees and grasses are cultivated, after the final crop of mushrooms has been harvested.

Vegetable and grass production is a fundamental component of the dike-pond system, providing both essential food for the fish and vegetables for home consumption and marketing. These crops are also fertilized with pond mud and used mushroom mud-beds, and irrigated manually with pond water. Gourds and melons, trained on trellises over the pond, provide shade, and when necessary the vegetable gardens themselves are shaded using old sugarcane leaves. Small groves of bamboo are also a fundamental part of the system and provide construction materials and poles that are used to fabricate baskets, traps, screens, and trellises and frames which are basic tools in other subsystems, as well as providing waste used as fuelwood.

Sugarcane, some of which is either annually or biennially rotated with mulberry, is also an essential subsystem in the dike-pond complex. The principal product is of course refined sugar, but ancillary products used as inputs to the dike-pond system are young leaves fed to the fish and to pigs; old leaves that provide screens to shade crops, roofing thatch and fuel, and roots used as fuel. Refinery wastes are returned to the dike-pond in the form of animal and fish feed.

Pigs, raised mainly to provide manure but also for meat and ancillary products, are kept in styes constructed on the dike. Young stock is either obtained from the external environment or bred locally. External inputs to the subsystem consist principally of feedstuffs from the sugar refinery as well as occasional medicines and other similar requirements. The concentrated feed requirements of pigs are met by feeding weaned piglets a diet of greens, particularly aquatic macrophytes such as water hyacinth, which are assiduously cultivated under a separate subsystem, sugarcane tops, and other vegetable waste. Pigs are regarded as 'walking fertilizer factories' and their faeces and

urine are the essential fertilizer of the fishpond. Animal dung, mixed with coal dust and dried, is also used as fuel.

The basic food (apart from rice) and shelter needs of the human settlements in the dike-pond district are met from the system itself. Basic local food sufficiency assures a balanced diet; fuel needs are met largely from waste products; and bamboo and dike mud (used to manufacture unglazed bricks and tiles) provide the basic materials for housing and furnishings. Other basic social and physical needs are satisfied within the commune. In addition to providing fundamental inputs into the dike-pond system in the form of capital, labour and technology (in conjunction with the higher-order organized social units) human settlements provide excrement, urine, and other household wastes that form basic organic inputs into the fishpond.

Conclusion

The mulberry dike-carp pond represents a highly intensive, integrated aquaculture/agriculture system in which many outputs of subsystems constitute the inputs for other subsystems. In this way not only is the medium for the growth of fish and crops provided, but so too is the environment in which their food and fertilizer requirements are produced. The system thus results in high yields of all commodities produced, a wider range of products per unit area of land than could otherwise be obtained, and lower costs for inputs, which, in the absence of integration, would be imported from outside the system, usually at considerable expense in terms of capital, time and labour. In conventional, semi-intensive fish farming, for example, under systems not integrated with either crop production or animal husbandry, supplementary feed usually accounts for 50 per cent of the total farm operating budget (Schroeder 1979), and pond fertilizers and other inputs for the field crops comprise a large item of the budget of a non-integrated farm. In addition to the economic benefits afforded by integrated systems, integration is also beneficial to the environment in that it solves the problems of organic waste disposal in a sanitary manner and obviates the *in situ* toxicity and downstream residue problems that arise from the incorrect use of organic fertilizers. In the dike-pond system of the Zhujiang Delta, integration exists exogenously between the pond, the dike and the general environment (see above), and endogenously within each of these elements.

Integrated systems of aquaculture and agriculture, such as that of the Zhujiang Delta, have many obvious advantages over those that are not integrated. Principal among them are that pond fertilizers and fish feeds are produced locally and at low cost, thereby almost eliminating the uncertainties of supply and greatly reducing the costs commonly associated with the use of compounded feeds and inorganic fertilizers. Hence profits from the cultivation of fish are increased by as much as 30–40 per cent in the People's Republic of China (FAO 1979). By using pond mud as fertilizer for the crops, soil fertility and crop yields are raised without the expense of inorganic fertilizers. In national terms these savings are considerable when it is realized that an estimated 30 per cent of all agricultural fertilizers used in the PRC are derived from fishponds (FAO 1979); and, as a consequence of integration, the human consumer is assured a regular and balanced diet as well as a high degree of self-reliance in a wide range of foodstuffs and raw materials.

The different types of agricultural activity involved in complex integrated agroecosystems call for a diverse range of skills, and, on the scale practised in the Zhujiang Delta, also require a large, well-organized labour force. Moreover, integrated systems of such complexity can only be operated on a large scale. Under such systems the

economic results from any one component are not viewed as important; instead, maximizing the returns from the whole is the objective.

Thus the dike-pond system is ideally suited to the densely populated Zhujiang Delta and to the social and political organization of the PRC. Further, in biological and physical terms, the region is well suited to the assemblage of animals and crops that together form the mulberry dike-carp pond system. These topics will be analysed in detail in later papers.

Acknowledgements

The field research on which this article is based was funded by the Water-Land Interactive Systems Project of the United Nations University's Programme in the Use and Management of Natural Resources.

References

- Aquaculture Department, People's Government of Guangdong Province (1960) *Guangdong chitang yangyu (Fish farming in ponds in Guangdong)*, 2nd ed. Guangzhou: Guangdong People's Publishing House (in Chinese).
- Bardach, J. E., Ryther, J. H. and McLarney, W. O. (1972) *Aquaculture: the farming and husbandry of freshwater and marine organisms*. New York: Wiley-Interscience.
- Chung, L. (1980) *The biology and artificial propagation of farm fishes*. Ottawa: International Development Research Centre (mimeo).
- FAO (1979) *Aquaculture development in China*. Rome: FAO.
- Furtado, J. I. (1979) Research and information requirements for integrated agriculture-aquaculture farming systems. Paper presented at the ICLARM-SEARCA conference on integrated agriculture-aquaculture farming systems, Manila 6-9 August.
- Grandstaff, T. B., Ruddle, K., Hawkins, J. N., Foin, T. C. and Davis, W. G. (1980) Implementing the resource systems approach to transformational development. *Resource Management and Optimization* 1(2), 145-160.
- Institute of Soils and Fertilizers (ISF) Academy of Agricultural Science Research, Sichuan, PRC (1980) *The utilization of biogas fermentation residue-sludge and effluent*. Vienna: UNIDO (mimeo).
- Li, C. X. (1657) *Jiujiang xiang-zhi (Village annals of Jiujiang)*. Nanhai: publisher not indicated (in Chinese).
- Li, H. Z. et al. (1976) *Zhujiang sanjiaozhou nongyezhi (Agriculture in the Zhujiang Delta)*. Foshan: publisher not indicated (in Chinese).
- Luo, K. F., Zhong, G. F., Deng, H. Z., Wu, H. S., Deng, Y. Y. and Chen, D. J. (1980) *Background to the utilization of the dyke-pond area of the Zhujiang (Pearl River) Delta, China*. Guangzhou: Guangzhou Institute of Geography (mimeo).
- Mai, X., Chen, R., Li, N-G., Hu, C. and Shearer, W. (1980) Xinbu system. *Development Forum* 8(9), 8-9.
- People's Republic of China (1975) The Constitution of the People's Republic of China. In *Documents of the First Session of the Fourth National People's Congress of the Republic of China*, article 10, p. 15. Beijing: Foreign Language Press.
- Ruddle, K. and Grandstaff, T. B. (1978) The international potential of traditional resource systems in marginal areas. *Technological Forecasting and Social Change* 11, 119-131.
- Schroeder, G. L. (1979) Fish farming in manure-loaded ponds. Paper presented at the ICLARM-SEARCA conference on integrated agriculture-aquaculture farming systems, Manila 6-9 August.
- Zhong, G. F. (1979) Mulberry-dyke-pond on the Pearl River Delta (sic). Guangzhou: Guangzhou Institute of Geography (mimeo).
- Zhong, L. et al. (1965) *Jiayu de shengwuxue he rengong fanzhi (The biology and artificial propagation of domestic fishes)*. Beijing: Science Press (in Chinese).

Energy Exchanges and the Energy Efficiency of Household Ponds in the Dike-Pond System of the Zhujiang Delta, China

Kenneth RUDDLE*, DENG Hanzeng** and LIANG Guozhao***

INTRODUCTION

In the Zhujiang Delta of South China an integrated system of intensive agriculture and polycultural aquaculture has evolved during the past two millenia. In the central delta, south of the city of Guangzhou, and centering on Shunde and adjacent counties, this system now covers an estimated 800 km² and supports some 1.2 million persons. The system is composed of three essential components: fish ponds, mulberry dikes and sugar cane dikes. The individual components of the dike-pond system are tightly linked together by energy and materials cycles: plant and animal wastes feed the fish and fertilize the pond; organically rich mud is dug from the pond bottom and spread three times a year as a fertilizer over the dikes; and throughout the year run-off from the dikes gradually returns the mud to the pond bottom, where its nutrients are restored. Apart from natural processes of dissipation, energy and materials are removed from the system only in such economically useful forms as the fish, silkworm cocoons, sugar cane, vegetables and pigs sent to market [RUDDLE *et al.* 1983; RUDDLE *et al.* n.d.].

The fundamental concept underlying highly intensive, integrated aquaculture-agriculture farming systems is that many outputs of sub-systems become inputs for other sub-systems. Thus in the dike-pond system of the Zhujiang Delta not only are the media for the growth of fish and crops provided but so too is the environment in which their food and fertilizer requirements are produced. This results in higher yields for all commodities produced and a wider range of products than could otherwise be obtained. It also results in lower costs for inputs, which, in the absence of such integration would have to be imported from outside the system.

Gradually, however, this traditional tight recycling within the dike-pond system is being supplemented by an import of energy and materials from outside sources. This is particularly evident in the pond component, where chemical

* 5th Research Department, National Museum of Ethnology

** Guangzhou Institute of Geography, Chinese Academy of Sciences

*** Guangzhou Institute of Geography, Chinese Academy of Sciences

prophylactics are replacing those traditionally used, and factory-produced concentrated fish feeds are supplanting sugar refinery waste.

In previous articles the evolution and structure [RUDDLE *et al.* 1983], labor supply and demand [RUDDLE 1985a] and household economics [RUDDLE 1985b] of the dike-pond system of the Zhujiang Delta have been examined. This article offers a preliminary analysis of energy exchange as one of the ecological bases for system integration. Analysis of the energetics also permits evaluation of the efficiency with which individual households utilize the material resources available to them. Such an evaluation is of major importance in understanding the rationality of household decision-making under the independent management introduced by the "household responsibility system" of farming.

To understand how those fundamental processes operate in the dike-pond system of the Zhujiang Delta field experiments were conducted on energy exchange and materials flow. In terms of these processes the dike-pond system is inherently extremely complex, thus for experimental purposes a simplified model was employed. In this model the system was divided into the fish pond and mulberry dike sub-systems, linked by the silkworm sub-system.¹⁾ The inputs and outputs of each sub-system were the focus of the field research.

METHODOLOGY

Biological and physical research concentrated on the quantitative analysis of energy exchange, for which the following parameters were measured from April, 1981 until September, 1983, using standard field techniques:

- (1) Solar radiation, net radiation on the dike and over the pond, reflex radiation and photosynthetically active radiation (PAR) on the dike and beneath the pond surface;
- (2) Air temperature gradients, humidity and wind speed over the dike and pond, pond water temperature at selected levels, dike soil temperature and moisture content at selected levels, and the dike soil heat flux;
- (3) Evaporation from the pond surface, precipitation, interception of rainfall by the mulberry canopy and mulberry stem flow;
- (4) Pond water levels; and
- (5) Primary productivity of the pond, fish production, productivity of mulberry, mulberry detritus fall, and silkworm productivity.

Samples of soil, pond water, pond mud, mulberry parts and silkworm excrement were analysed and their nitrogen and carbon contents measured.

For solar radiation an MS-42 pyranometer (EKO Instruments, Japan) was used to measure global radiation, a LI-190SB quantum sensor (LI-COR, USA)

1) Other types of dikes, such as those planted to sugar cane or vegetables, lack the linking silkworm component.

was used to measure the PAR, and a LI-193SB (LI-COR) underwater spherical quantum sensor was mounted 30 cm below the pond surface to measure underwater PAR. Output of the MS-42 was integrated using an MP-060 integrator (EKO Instruments) and those of the LI-190SB and LI-193SB with two LI-550B integrators (LI-COR), for a period of one hour.

Analysis of the biological and physical characteristics of the system required that a semi-permanent field laboratory be established and that sophisticated instruments be placed on dikes and ponds for three years. Given the nature of dike-pond operations together with a lack of space, inadequacy of electricity supply, relatively poor access and other physical difficulties, it was impractical to build a laboratory in a "typical" village. Further, since the social organization of resource use was undergoing major changes during the time of research there was a risk that particular ponds and dikes could not be monitored continuously for a three-year period.

A permanent two-storey building equipped with a laboratory, instrument recording room, dormitories and living facilities was therefore constructed adjacent to the ponds and dikes to be monitored, in the grounds of the Agricultural Experiment Station of Leliu Commune, Shunde County. This decision had no negative impact on research results since the production dikes and ponds monitored for the project were typical of the area, being used by the Station personnel both for their own sustenance and as a baseline against which to compare experimental results.

Household data are based on interviews conducted with 7 percent of those comprising the First Production Team of the Nanshui Brigade of Leliu Commune, Shunde County. In a previous article dike-pond capitalization and management was analyzed, as was the rate of economic return on labor and emerging differences among households as a consequence of the rural reforms recently implemented in China [RUDDLE 1985b]. As in that article so in this analysis of household energy efficiency emphasis is placed on the fish pond, since this element constitutes the ecological core of the entire dike-pond system. To facilitate comparison with the earlier economic analysis, the parameters of the four household ponds used here are the same as used previously [RUDDLE 1985b].

Annual excrement and urine production rates used to calculate household pond annual loading rates and therefore energy transfers were, for humans, 0-7 yrs, 175 kg; 8-15 yrs, 350 kg; 16+ yrs, 700 kg. The average annual production of excrement and urine per pig was taken as 2.7 t [Unpub. data, Biogas Research Unit, Xinbu Brigade, Leliu Commune].

EMPIRICAL MEASUREMENT OF ENERGY SUPPLY TO THE SYSTEM

Energy passes through the complex food-web of the dike-pond system and undergoes a series of exchanges as it flows among the sub-systems. It forms a

complex flow which is exported in various forms and via various pathways of the system. Some energy exports, such as those stored in silkworm cocoons or in the fish, are of economic value. Others, like losses in the form of radiation, have no economic worth.

As with all ecological systems, solar radiation is the energy source that drives the dike-pond system. This energy enters the system via three pathways:

- (1) Absorption by the dike crops, which convert solar energy into chemical energy during photosynthesis;
- (2) Absorption by phytoplankton in the pond, and conversion to chemical energy via photosynthesis; and
- (3) Direct inputs into the pond of chemical energy stored in plant materials and waste products, used, respectively, as fish feed and pond fertilizer.

The annual global radiation in Leliu Commune is 4.85×10^3 MJ/m².²⁾ The maximum monthly global radiation occurs in August and the minimum in February. The annual PAR is 2.31×10^3 MJ/m², or about 48 percent of the global radiation.³⁾ The annual PAR cycle is almost the same as that of the global radiation (Fig. 1).

(1) ENERGY ABSORPTION BY DIKE CROPS

The annual solar radiation reaching the crop canopy is about 48.5×10^6 MJ/ha, of which the PAR accounts for 48 percent (*i.e.*, 23.1×10^6 MJ/ha). During the growing period the PAR intercepted and absorbed by the mulberry canopy is 16.2×10^6 MJ/ha, or about 70 percent of the annual PAR. Thus when mulberry dikes yield leaves at a rate of 30 t/ha/yr, the energy stored in the actual net photosynthesis products is 283.2×10^3 MJ/ha/yr, or 1.75 percent of the PAR absorbed by the canopy during its growth period.

Other crops cultivated are more efficient utilizers of PAR. On sugar cane dikes yielding at 90 t/ha/yr the radiation converted into chemical energy stored in the actual net products is 628.14×10^3 MJ/ha, or 2.7 percent of PAR; and on dikes yielding Elephant grass at a rate of 187.5 t/ha/yr, the energy stored is about 948×10^3 MJ/ha, or 4.1 percent of PAR.⁴⁾

2) MJ= Million Joules.

3) Of the three main regions into which solar radiation is usually divided, the visible spectrum, from 400-700 nm, plays a fundamental role in photosynthesis. It is therefore designated as Photosynthetically Active Radiation (PAR).

4) The energy utilization efficiency of sugar cane and Elephant grass is higher than that of mulberry, since they are C-4 plants, whereas mulberry is a C-3 plant. The former has a much lower CO₂ compensation point and much lower light saturation than the latter, hence it has a much higher productivity. C-4 plants apparently lack photorespiration when photosynthesizing under optimum conditions, thus they have very high rates of CO₂ assimilation compared with most C-3 plants [ETHERINGTON 1982]. The maximum recorded annual yield is 85 t/ha dry matter from Elephant grass in El Salvador and Puerto Rico, where the efficiencies of solar energy utilization were 5.4 and 4.9 percent, respectively [COOPER 1975]. In our case from the Zhujiang Delta the dry matter yield of Elephant grass is about 43 t/ha (*i.e.*, in the middle rank).

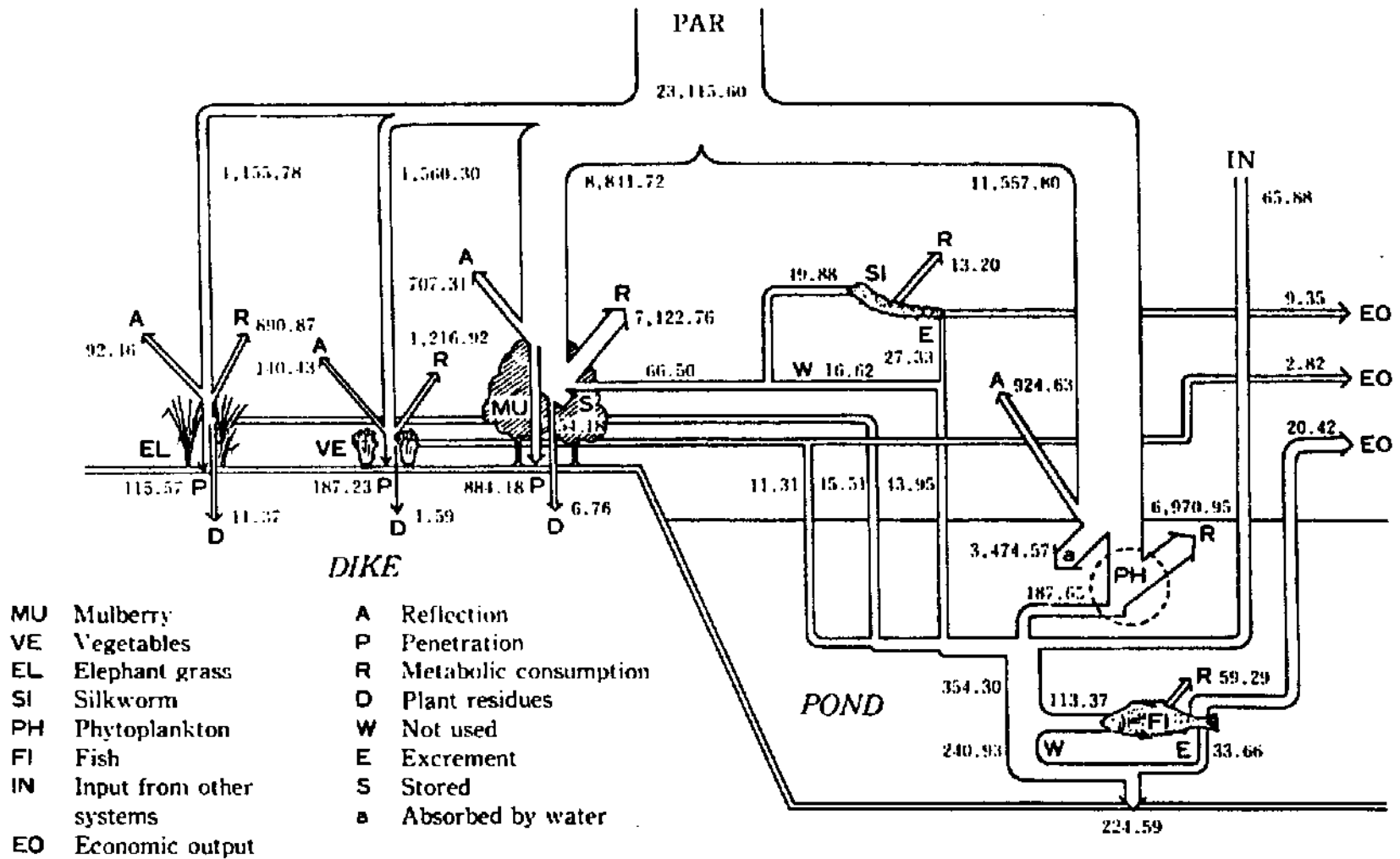

After Deng *et al.* [n. d.] and Ruddle *et al.* [n. d.]

Figure 1. Energy Flow in the (Mulberry) Dike-Pond System (10^3 MJ/ha/yr)

(2) ENERGY ABSORPTION BY PHYTOPLANKTON

Phytoplankton is the main producer in the pond, and therefore plays a fundamental role in fish cultivation. It comprises the food for Silver carp, and sustains the zooplankton consumed by other fish, such as the Bighead carp.

The average albedo of the pond is about 8 percent. Thus the annual PAR penetrating the water surface is 21.3×10^6 MJ/ha, of which approximately 67 percent is absorbed by phytoplankton. The net primary production of phytoplankton is about 22.4 t dry matter/ha/yr, in which the energy stored is 375.3×10^3 MJ/ha. The efficiency of PAR utilization is approximately 1.6 percent.

Owing to an abundance of plankton and suspended matter water transparency is only 30–40 cm, therefore the incident irradiance is attenuated rapidly and 30 cm below the water surface PAR is only 0.25×10^3 MJ/m², or 11 percent of that received at the surface. As a result primary productivity is low, because photosynthesis by phytoplankton is restricted to the first 50 cm of the water column.

(3) CHEMICAL ENERGY INPUTS TO THE POND

The silkworm sub-system provides the energy linkage between the mulberry and pond sub-systems. It absorbs energy stored in harvested mulberry leaves, and, since most outputs of silkworm rearing enter the fish pond as a mixture of mulberry leaf waste and silkworm excrement (*cansha*), transmits the energy to the pond. In general, some 75 percent of the mulberry leaves supplied is consumed by the silkworms. Together with silkworm excrement the remaining 25 percent of unconsumed leaf debris is dumped into the pond. When 30 t/ha/yr of mulberry leaves is fed to silkworms 16.2 t of *cansha* is produced, in which the energy stored is 97.65×10^3 MJ, or 66 percent of that supplied to the silkworms.

The fish pond is the most complex component of the entire dike-pond system, since it has the most ramified structure and complex food-web. This is mirrored in a complex pattern of energy flow.

Energy enters the pond along four principal pathways: —

- (1) Via solar energy converted and stored by phytoplankton;
- (2) Via energy stored in the *cansha*;
- (3) Via energy stored in crops used as fish feed; and
- (4) Via energy contained in other feedstuffs and manures.

Total energy input in the control pond is 333.3×10^3 MJ/ha/yr, 106.3×10^3 (31.9 percent) of which is stored in concentrated feeds, 21.3×10^3 (6.4 percent) in pig manure, 99.3×10^3 (29.8 percent) in *cansha* and 106.3×10^3 (31.9 percent) in the green fish feeds. Energy stored in the annual net primary production is another main energy source for fish. The total energy input to the fish is therefore 708.6×10^3 MJ/ha/yr. Of this, 375.6×10^3 (53 percent) is derived from phytoplankton, 106.2×10^3 (15 percent) from green feeds, 99.2×10^3 (14 percent) from *cansha*, 21.3×10^3 (3 percent) from pig manure, and

106.2×10^3 (15 percent) from concentrated feeds.

The energy intake by the fish accounts for only 32 percent of the total energy input to the pond. Some 72 percent of this intake energy is absorbed, and the remainder output with fish excrement and in the process of respiration. The energy stored in an annual total fish yield of 7.5 t/ha is 40.83×10^3 MJ/ha, only about 5.8 percent of the total input.

MODELLING ENERGY FLOW

Based on those observed rates of energy exchange in the control pond a simplified system of energy exchange in the dike-pond system can be modelled. In this model two energy inputs exist, solar energy and that contained in the various feeds which input to the pond energy from other sub-systems. There are two main energy outputs; the aggregate economic output of products and natural losses.

A two-way energy exchange system exists between the dike and the pond. Energy enters the pond via materials grown on the dikes and then fed to the fish, and, in the case of the mulberry dike, via silkworm excrement. This is then returned to the dike in the form of pond mud. However, the energy contained in the mud cannot be utilized directly by the crops.

In this model a 1 ha mulberry dike-pond system is assumed in which 50 percent of the area is dike and 50 percent pond. Of the former, 0.45 ha is planted to mulberry and 10 percent, or 0.05 ha, under Elephant grass. During the winter rest period vegetables are interplanted with the mulberry. The following crop yields are assumed: mulberry leaves 30 t/ha, silkworm cocoons 2.1 t/ha, Elephant grass 225 t/ha and vegetables 3.75 t/ha. It is further assumed that 80 percent of the vegetive matter harvested is used as fish feed and 20 percent consumed by humans. Approximately 16 t of waste is produced per ha of mulberry. It is assumed that all is put into the pond. Finally, the net primary production of phytoplankton is taken as 22 t/ha (dry weight). Thus from these sources the total energy supplied to the pond to produce fish is 288.42×10^3 MJ.

Based on the energy conversion rate of fish (*vide supra*), an additional 65.88×10^3 MJ of energy must be added to the pond in order to harvest 3.75 t of fish from 0.5 ha of ponds. This can be done by adding externally-produced concentrated feeds, and pig excrement from within the system.

The total energy input of 354.3×10^3 MJ required to attain a fish production of 7.5 t/ha/yr is composed of 187.8×10^3 (53.0 percent) from phytoplankton, 43.9×10^3 (12.4 percent) from *cansha*, 56.7×10^3 (16.0 percent) from green feed, 10.9×10^3 (3.1 percent) from pig excrement, and 54.9×10^3 (15.5 percent) from concentrated feeds (Fig. 1). These modelled estimates align closely with those derived from the field analyses (Table 1).

Table 3. Energy Budget of Primary Production in the (Mulberry) Dike-Pond System (10^3 /MJ/ha/yr)

Input		Output
PAR INPUT		
Fish pond	13,557.80	
Mulberry	8,841.72	
Vegetables	1,560.30	
Elephant Grass	1,560.30	
NET PRIMARY PRODUCTION		
Phytoplankton		184.65
Mulberry		127.44
Vegetables		15.72
Elephant Grass		56.88
ENERGY LOSS		
Radiation		6,526.41
Heat		16,204.5
TOTALS	23,115.60	23,115.60

derived from other sub-systems accounts for only 0.28 percent of the total.

The annual total PAR is $23,115.60 \times 10^3$ MJ/ha, 50 percent of which reaches the pond surface, 38.25 percent the top of the mulberry canopy, and 6.75 percent and 5.0 percent the vegetable and Elephant grass canopies, respectively (Table 2). As a result of reflectance from the pond water surface and from crop canopies, of penetration through the canopies, and of absorption by both the pond water and the particles suspended within it, the PAR absorbed by the main producers on the dike and in the pond (*i.e.*, mulberry, vegetables, Elephant grass and phytoplankton) amounts to $16,589.20 \times 10^3$ MJ/ha.

Owing to biological and environmental limiting factors, as well as to the physiological requirements of the producers, nearly 98 percent of the PAR is dissipated as heat. Energy converted in the photosynthesis process and fixed in the net primary products is 387.69×10^3 MJ/ha. Of this, 48.4 percent is produced by phytoplankton, 32.87 percent by mulberry, 4.06 percent by vegetables and 14.67 percent by Elephant grass (Table 3). The efficiency of solar energy (PAR) utilization is therefore only 1.86 percent.

Of that net primary energy production, 0.73 percent is output for direct human use, 80.2 percent is supplied to the main consumers within the system, 13.98 percent is stored in the living parts of the mulberry, and 5.09 percent enters the soil via detritus fall and stubble.

When silkworm and fish, the two main consumers of the system, are combined the total energy input for secondary production amounts to 376.85×10^3 MJ/ha, of which 17.65 percent is supplied to silkworms and 82.35 percent

Table 4. Energy Budget of Secondary Production in the (Mulberry) Dike-Pond System (10^9 MJ/ha/yr)

Input		Output	Stored
INTAKE ENERGY			
Mulberry Leaves	66.50		
Fish Feed and Manures	310.35		
ECONOMIC ENERGY			
Silkworm Cocoons		9.35	
Fish		20.42	
LOST ENERGY			
Metabolism		72.49	
Decomposition		132.90	
STORED ENERGY			
Pond Mud			141.69
TOTALS	376.85	235.16	141.69

to fish. Most is derived from within the system itself (i.e., from net primary production), but 17.5 percent is input from outside (Table 4).

Energy contained in silkworm waste is not included within the energy supply, since it flows only between the consumers. The total energy stored in the second-

Table 5. Total Energy Budget of the Mulberry Dike-Pond System (10^9 MJ/ha/yr)

Input		Output	Stored
ENERGY INPUT			
PAR	23,115.60		
Feeds and Manures	65.88		
ECONOMIC ENERGY			
Silkworm Cocoons		9.35	
Fish		20.42	
Vegetables		2.82	
LOST ENERGY			
Radiation		6,526.41	
Metabolism		16,273.99	
Decomposition		132.90	
STORED ENERGY			
Mulberry root and stem			54.18
Detritus Fall			19.72
Pond mud			141.69
TOTALS	23,181.48	22,965.89	215.59

dary economic products equals 29.77×10^3 MJ/ha, of which 31.4 percent is from cocoons and 68.6 percent from fish (Table 4). Thus the total secondary economic energy utilization efficiency is 7.9 percent, a much higher figure than for primary production.

The energy contained in silkworm waste is not dissipated because it is re-used by the fish. Unconsumed fish feed and fish excrement reach the pond bottom and combine with the sediments. There, through a series of biochemical and chemical processes, part of the energy contained in the sediments is released with various gases, and the remainder stored in the mud, which is then periodically returned to the dikes as fertilizer. This feedback accounts for 37.6 percent of the total secondary energy input. But it cannot be utilized by plants directly. The energy dissipated as heat during the metabolic processes of the consumers accounts for 54.5 percent.

Thus of the total energy input to the dike-pond system 28.15 percent is lost as radiation together with 70.78 as heat and with gases, and 0.93 percent is retained in the living parts of the crops, dike soil and pond mud. Only 0.14 percent is output in the form of economically useful products (Table 5). The economic energy output is 32.58×10^3 MJ/ha/yr, of which fish accounts for 62.66 percent, cocoons for 28.68 percent and vegetables for 8.66 percent.

THE ENERGY EFFICIENCY OF HOUSEHOLD PONDS

The efficiency with which pond inputs and phytoplankton are converted to fish in ponds contracted by individual households can be compared in energy terms (Table 6). For this purpose the research station pond in which field observations of energy exchanges were made is used as a control that represents standard pond management practises employed in the region under the former collectivist system of resource management. Variations from this standard level manifested by the ponds of the individual households, which are now free

Table 6. Energy Conversions in Fish Ponds for the Four Households and the Control Pond

	A		B		C		D Total A+B+C	E Output	Conversion Rate			
	Excrements		Green Feeds		Concentrates				10 ³ MJ/ha	10 ³ MJ/ha	D:E	A:E
	10 ³ MJ/ha	A/D %	10 ³ MJ/ha	B/D %	10 ³ MJ/ha	C/D %						
HH 1	340.23	38.6	535.95	60.9	4.29	0.5	880.47	41.22	21.4:1	8.3:1	13.0:1	0.1:1
HH 2	366.25	48.2	253.35	33.3	140.41	18.5	760.01	41.22	18.4:1	8.9:1	6.2:1	3.4:1
HH 3	562.47	68.1	102.10	12.4	160.60	19.5	825.17	38.39	21.5:1	14.7:1	2.7:1	4.2:1
HH 4	185.34	61.7	114.83	38.3	—	—	300.17	28.86	10.4:1	6.4:1	4.0:1	—
CP	120.66	36.2	106.32	31.9	106.32	31.9	333.30	40.83	8.2:1	3.0:1	2.6:1	2.6:1

Note: HH=Household; CP=Control Pond.

Table 7. Supply of Inputs to Household Fish Ponds

Input	Extrapolated Application Rate (t/ha/yr)	Actual Application Rates						Recommended Rates	
		Produced by Household			Supplied Externally			t/ha/yr	Actual
		(t)	(\$)	(%)	(t)	(\$)	(%)		
HOUSEHOLD 1									
A: EXCREMENTS									
Pig	151.50	42.00	127.92	84.0	8.00	24.36	16.0	65.0	21.4
Human	10.60	1.84	24.24	52.5	1.66	21.94	47.5		
B: GREEN FEEDS									
Elephant grass	7.58	2.50	50.76	100.0	0.00	0.00	0.0	52.5	17.3
Kitchen and field waste	13.60	2.25	0.76	50.0	2.25	0.76	50.0		
Sugar cane waste	60.60	0.00	0.00	0.0	20.00	253.80	100.0		
C: CONCENTRATES									
Concentrates	0.27	0.00	0.00	0.0	0.09	13.70	100.0	6.3	2.1
HOUSEHOLD 2									
A: EXCREMENTS									
Pig	113.60	22.50	101.52	100.0	0.00	0.00	0.0	51.6	10.2
Human	25.60	5.07	66.98	100.0	0.00	0.00	0.0		
Silkworm	8.30	1.66	42.26	100.0	0.00	0.00	0.0		
B: GREEN FEEDS									
Elephant grass	12.60	2.50	50.76	100.0	0.00	0.00	0.0	12.6	2.4
Sugar cane waste	25.20	0.00	0.00	0.0	5.00	50.76	100.0	4.2	0.8
C: CONCENTRATES									
Concentrates	8.83	0.00	0.00	0.0	1.75	507.61	100.0	6.7	1.3

		HOUSEHOLD 3								
A: EXCREMENTS										
Pig	229.50	22.72	45.68	100.0	0.00	0.00	0.0	}	59.6	5.9
Human	30.10	2.98	39.26	100.0	0.00	0.60	0.0			
B: GREEN FEEDS										
Elephant grass	25.25	2.50	50.76	100.0	0.00	0.00	0.0		25.2	2.4
C: CONCENTRATES										
Concentrates	10.10	0.00	0.00	0.0	1.00	152.28	100.0		6.7	0.6
		HOUSEHOLD 4								
A: EXCREMENTS										
Pig	34.09	4.50	13.71	100.0	0.00	0.00	0.0	}	45.6	6.0
Human	34.84	4.60	61.04	100.0	0.00	0.00	0.0			
B: GREEN FEEDS										
Elephant grass	28.40	3.75	76.14	100.0	0.00	0.00	0.0		28.4	3.7
C: CONCENTRATES										
Concentrates	0.0	0.0	0.0	0.0	0.00	0.00	0.0		6.8	0.9

to select rates and types of inputs [RUDDLE 1985 a and b], are thus a reflection of the individual household's perception of the relative value of different pond inputs in fish production, or of the inputs available to the household or that can be afforded by it.

In this analysis the same four households (HHs 1-4) examined in previous articles [RUDDLE 1985 a and b] are again used. Each household pond is of a different size (0.33, 0.198, 0.099 and 0.132 ha for HHs 1-4, respectively), thus all measurements of inputs and outputs have been extrapolated to t/ha.

For this analysis pond inputs have been simplified [*cf.* RUDDLE 1985b] (Table 7) and household pond energy efficiency is measured by the equation: Fish Yield (FY) = Phytoplankton (P) + Excrements (E) + Green Feed (GF) + Concentrated Feed (CF), in which the energy values are: $P = 9.4 \times 10^3$ MJ/t, $E = 2.1 \times 10^3$ MJ/t, $GF = 6.0 \times 10^3$ MJ/t, $CF = 15.9 \times 10^3$ MJ/t. For simplification "excrements" includes human, pig and silkworm waste (*cansha*); "green feeds" includes Elephant grass, kitchen and field waste, and sugar cane waste.

The ponds of all four households are less efficient energy converters than is the control pond. In the latter a total of 333.3×10^3 MJ/ha/yr of a balanced mixture of inputs (36.2 percent excrements, 31.9 percent green feeds and 31.9 percent concentrated feed) yielded 40.83×10^3 MJ/ha of fish. This represents an energy conversion ratio of 8.2 : 1.

The best household pond energy conversion ratio was attained by that of HH 4, at 10.4 : 1, which compares well with the control pond figure. With a total energy input of 300.17×10^3 MJ/ha/yr, this pond yielded 28.86×10^3 MJ/ha of fish. It is noteworthy that this is the most traditionally managed of the four ponds examined, in that the inputs are excrements and green feeds only. No concentrated feed is applied.

In contrast all three remaining ponds achieved poor energy conversion ratios, at 18.4, 21.4 and 21.5 for HHs 1-3, respectively. Whereas in the control pond 1 t/ha of fish can be produced with a total energy input of 44.4×10^3 MJ/ha, and in that of HH 4 56.6×10^3 MJ/ha are needed, the three remaining ponds perform poorly. In the ponds of HHs 1-3, 116.3, 100.4 and $117.0 (\times 10^3$ MJ/ha) are required, respectively, to produce 1 t/ha of fish.

Thus a considerable amount of the energy input to the householders' ponds is not required for fish production. In addition to being wasted, this unnecessarily excessive input of material may, by raising BOD levels, inhibit fish production by reducing levels of dissolved oxygen.

In the ponds of all four households in excess of 80 percent of the energy input is derived from the traditionally used excrements and green feeds. However, the relative percentages of these components vary among households from 38.6 to 68.1 percent for excrements and from 12.4 to 60.9 percent for green feeds. On the other hand, reflecting its recent availability, expense, and

general lack of familiarity to local farmers, is the relatively little use still made of concentrated feeds. None is used by HH4, it constitutes only 0.5 percent of the energy input to the pond of HH1, and slightly under 20 percent in the two others. In no household pond does the rate of concentrate use approach that of the control pond, in which it comprises 31.9 percent of the total energy input.

IMPROVING THE ENERGY EFFICIENCY OF HOUSEHOLD PONDS

In the pond operated by HH1, for example, present input rates create an excess energy loading of 547.1×10^3 MJ/ha over the rate required to produce fish at 1 t/ha in the control pond. By a reduction of that portion of the excrement and green feed loading accounted for by purchased inputs (Table 7), excrement loading could be lowered by 18 percent and green feed loading by 83 percent. This would reduce energy loading of excrement origin to 278.99×10^3 MJ/ha (*i.e.*, by 61.24×10^3 MJ/ha) and that from green feed sources to 91.11×10^3 MJ/ha (*i.e.*, by 444.84×10^3 MJ/ha). This would give a total energy reduction of 506.08×10^3 MJ/ha, for a total input of 374.39×10^3 MJ/ha. This loading is still 41.09×10^3 MJ/ha in excess of that in the control pond.

By this simple remedial action alone a total of 97.1 t/ha (29.2 of excrements and 67.9 of green feeds) of inputs could be eliminated, as could a total cash expenditure of 911 \$(U.S.)/ha (Table 8). However, excrement loading would remain excessive in this pond. This could be further reduced by introducing household supplied excrements to the pond at a rate of 65 t/ha, and selling the remainder (about the same rate) to other users. This would then give an energy loading of excrement origin of approximately 136.5×10^3 MJ/ha.

Were this action to be taken an energy deficit of 101.4×10^3 MJ/ha would

Table 8. Purchase Price of Pond Inputs, Shunde County (Aug., 1983)

Input	Price (\$ [U.S.]/t)
A: EXCREMENTS	
Pig	3.05
Human	13.02
Silkworm	41.00
B: GREEN FEEDS	
Elephant grass	20.30
Sugar cane waste	12.69
Household waste ⁽¹⁾	2.00
C: CONCENTRATES⁽²⁾	152.28 (284.26)

Table Notes;

⁽¹⁾ Category includes kitchen and field vegetable waste.

⁽²⁾ Prices for blended concentrate produced by the factory in Leliu Town. Free market price given in parentheses.

be created. This could be compensated for by the supply of 6.37 t/ha of concentrated feed (which supplies energy at the rate of 15.9×10^3 MJ/ha/t) for a public price of 970 \$ or a "private" price of 1810.73 \$.

Assuming that this additional input of concentrated feed could be obtained at the public price of 152.28 \$/t (Aug., 1983) then the switch in pond energy sources could be made with virtually no difference to the household economy. Further, given the dramatic improvements in pond water quality that would result from this change in inputs, fish yields would increase, thereby providing a greater return on labor and operating capital than is experienced at present.

At 760.01×10^3 MJ/ha, the energy loading of the pond operated by HH 2 exceeds that of the control pond by 426.71×10^3 MJ/ha. Levels of all categories are greater than those of the control pond. Apart from concentrates and the sugar cane waste component of green feeds, all inputs are generated within the family holding.

The rate of excrement loading can be reduced to 35 percent of its present level, *i.e.*, from 147.5 t/ha to 51.6 t/ha. This would reduce energy loading from excrements to 128.19×10^3 MJ/ha from the present 366.25×10^3 MJ/ha. Assuming that the less expensive pig excrement were used to satisfy household pond requirements, the sale of 25.6 t of human excrement, 62 t of pig excrement and 8.3 t of *cansha* would yield an extra cash income of 862.7 \$(U.S.). Green feed loading could be reduced by 55 percent by the elimination of almost 21 t/ha of sugar cane waste. This would reduce the energy loading from this source to 114.01×10^3 MJ/ha, and would reduce the cash outlay on green feeds by almost 256 \$ (*i.e.*, from 319.78 \$ to 63.45 \$).

Concentrates are being loaded at a rate of 8.83 t/ha, giving an energy loading about 34×10^3 MJ/ha above that of the control pond. Concentrate input could therefore be reduced by some 24 percent to give an energy loading of 106.72×10^3 MJ/ha. In other words, the rate of concentrate loading can be reduced by 2.11 t/ha to 6.72 t/ha. This would result in a saving on present cash outlays of 321.3 \$, if the concentrates were purchased at the controlled public price, or \$600 if they were bought on the free market.

In that way, and using the same inputs, an energy loading of 348.92×10^3 MJ/ha - still slightly above that of the control pond - can be achieved. This will result in three major benefits for HH 2: -

- (i) Bring in a cash income of 862.7 \$/ha on the sale of excrements hitherto put into the pond;
- (ii) Reduce the actual cash outlay for purchased inputs by 577.3-856 \$/ha, depending on the purchase price of the concentrates; and
- (iii) By reducing BOD loading, enhancing DO levels and improving water transparency (and hence phytoplankton productivity) will increase fish yields, thus producing a greater cash income on fish sales.

The pond operated by HH 3 receives an energy loading 491.87×10^3 MJ/ha

in excess of that of the control pond. This overloading is largely the result of the excessive input of excrements; the pond operated by HH 3 being loaded with 4.66 times more excrement than the control pond. The excrement loading in this pond can be reduced by a rate of 200 t/ha (to 59.6 t/ha). This would reduce the energy loading by 432×10^3 MJ/ha, to 130.47×10^3 MJ/ha.

Were the excrement loading of the pond satisfied from pig excrement produced on the farm unit, all the human excrement of the household could be sold to other users, instead of being input to the household pond. This would produce a cash income of 391.9 \$/ha, and the 169.9 t/ha of surplus pig excrement would yield a further 518.2 \$/ha. Thus an additional cash income at the rate of 910.1 \$/ha could be generated by a reduction of excrement loading.

Fifty percent more concentrated feed than is necessary is also loaded into this pond. Loadings could be reduced to 6.74 t/ha, thereby lowering energy inputs by 53.42×10^3 MJ/ha, to 107.18×10^3 MJ/ha, or almost equal to that of the control pond. This would result in savings on cash outlays of 511.6–955.1 \$/ha, at no loss in fish productivity. Green feeds are input to this pond (just Elephant grass) at a rate marginally below that of the control pond.

Were those modifications to be made to the input rates for this pond, total energy input would fall to 339.75×10^3 MJ/ha, or slightly in excess of that of the control pond. In addition, a cash income of 910.1 \$/ha that is now foregone would be generated by the sale of excess excrements, and 511.6–955.1 \$/ha would be saved on present cash outlays for concentrates. By modifying its pond energy loading thus, this household could reap an additional profit of 1421.7–1865.2 \$/ha, without considering the further profit that would accrue from increased fish yields.

In complete contrast to the ponds operated by the other three households, the inputs made into the pond operated by HH 4 load less energy than do those made to the control pond. This slight deficit, of 33.13×10^3 MJ/ha below the control pond, occurs because no concentrated feeds are used in the pond of HH 4. All inputs (two excrements and Elephant grass) are generated on the farm unit. Excrements are loaded at a rate some 33 percent greater than in the control pond. Excrement loadings could be reduced by one third, and 23 t/ha of human excrement sold at 13.02 \$/t to raise 299.46 \$ for the purchase of almost 2 t of concentrates at the public sale price.

The input of 2 t of concentrated feed would provide 31.8×10^3 MJ/ha to the pond. This would reduce the energy input to 256.83×10^3 MJ/ha, a deficit of 76.47×10^3 MJ/ha, or just over double the existing deficit. This could be made up by the purchase of a further 4.8 t/ha of concentrates, to provide a total of 108.27×10^3 MJ/ha (which aligns closely with the control pond) of energy derived from this source. However, the purchase price of an extra 4.8 t/ha of concentrates would be 730.9 \$/ha at the controlled public price and 1364.4 \$/ha at the free market price.

Thus in the case of the pond operated by HH 4 it is difficult to suggest that the energy sources be better balanced and brought into closer alignment with those of the control pond. Such a modification could only be justified if improvements to water quality caused by the addition of concentrates would raise the fish yield sufficiently to cover the cost of the additional 4.8 t/ha of concentrates.

Since this pond has the most efficient energy conversion rate of all four household ponds examined, and because all inputs made to it are generated from within the farm unit, at only an opportunity cost, it is tempting to recommend that this operation not be tampered with. There is, after all, far less justification for doing so than in the case of the other three households' ponds.

THE IMPACT OF MODIFIED ENERGY INPUTS ON HOUSEHOLD ECONOMIES

An analysis of the impact of modified pond energy inputs on household economies can be made by converting the extrapolated rates of recommended changes to actual rates, by the factor of pond area (*vide supra*).

Thus in HH 1 if the cash expenditures of \$300.8 for the purchase of excrements and green feeds is eliminated, and \$65.3 generated by the sale of excess household supplied excrements, an additional working capital of \$366.1 will become available for the purchase of concentrates. This new purchase would require the outlay of \$320. Were the recommended changes made in the management of this pond a direct benefit would be the addition of \$46.1 to the household income. Total income would increase marginally by 3 percent [*cf.* RUDDLE 1985b]. Although only a marginal increase in income can be predicted from the changes made in energy inputs, income should be further boosted by increased fish yields resulting from improved pond water quality as a consequence of the change in inputs.

Similarly, in HH 2 if excessive energy loading is reduced cash outlays for purchased inputs could be reduced by \$50.7 for green feeds and to either \$63.6 or to \$118.8 (depending on the purchase price) for concentrates. In addition, \$170.8 could be raised by the sale of excrements produced by the household. This would add \$285–340 to the household income, an increase of some 10 percent [*cf.* RUDDLE 1985b].

In HH3 the sale of surplus excrements generated by the household would yield an additional income of \$90, and a reduction in the amount of concentrates purchased would reduce that expense by \$50.6–94.5. In this way there would be an addition of \$140.6–184.5, or 9–12 percent, to this household's income of \$1519.5 [*cf.* RUDDLE 1985b].

HH4 could generate \$39.5 by the sale of surplus excrements. It would then have to spend \$136.7–255.15 on the purchase of concentrates, *i.e.*, a loss of \$97.2–215.6 on the switch in inputs. In the case of this household were the

proposed modifications made to pond inputs, income would actually decrease by 4–9 percent [*cf.* RUDDLE 1985b], depending on the price at which concentrates could be purchased. If they could be obtained at the lower, public price then the slight reduction in income could easily be compensated by the sale of increased fish yields. At the higher, private price, however, that would not be so certain easily assured.

CONCLUSION

There remain, however, several limitations to the scenario analyzed here. In summary, these are the regular and sufficient supply of concentrated feed to local pond operators from the newly opened factory in Leliu Commune; the adoption of concentrated feeds as a consequence of repeated and successful demonstration effects; a continued market for household produced and surplus excrements that would absorb these surpluses as they continued to increase with the wider adoption of concentrates; the ability to divert sugar cane waste to other productive industrial uses (*e.g.*, pelletized feeds); and the industrial use of *cansha*, among others.

The ripple effects of inducing thousands of pond contracting households to modify energy inputs to the dike-pond system are not without solution at the higher spatial levels. However, persuading the Cantonese peasant to forego the time-honored use of easily and locally available and assured pond inputs, and to replace them with those from a less certain and externally widely dependent source will be far less simple.

ACKNOWLEDGEMENTS

The field research on which this article is based forms part of a much broader study of the human ecology of the dike-pond system of the Zhujiang Delta undertaken from January, 1980 until December, 1983. The entire research project was conducted under the joint financial sponsorship of the United Nations University, Tokyo, and the Chinese Academy of Sciences, through the Guangzhou Institute of Geography. It constituted one component of the project on water-land interactive systems conducted by the former Programme on the Use and Management of Natural Resources of the U. N. University, and co-ordinated by the first author.

For the research on energy exchanges we are particularly indebted to the kindness of Mr. Pan Zhenbiao, Head of the Leliu Commune Agricultural Experiment Station, for permitting us to construct a large, permanent research facility in his station, and to set up instruments and lay electrical cables throughout the station. We are also grateful to those householders of the First Production Team of the Nanshui Brigade who provided detailed data on inputs made to their own ponds.

Bibliography

- COOPER, J. P.
1975 *Photosynthesis and Productivity in Different Environments*. Cambridge: Cambridge University Press.
- DENG, H. Z., Z. Q. WANG, H. S. WU & G. H. LIANG
n.d. The Mulberry Dike—Carp Pond Resource System of the Zhujiang (Pearl River) Delta, People's Republic of China: III Energy Flow and Substance Cycles. Guangzhou: Guangzhou Institute of Geography (mimeo.).
- ETHERINGTON, J. R.
1982 *Environment and Plant Ecology*. New York: John Wiley.
- MONTEITH, J. L.
1972 Solar Radiation and Productivity in Tropical Ecosystems. *Journal of Applied Ecology* 9: 747-766.
- RUDDLE, K.
1985a Labor Supply and Demand in a Complex System: Integrated Agriculture-Aquaculture in the Zhujiang Delta, China. 『国立民族学博物館研究報告』 (*Bulletin of the National Museum of Ethnology*) 10(3): 773-819.
1985b Rural Reforms and Household Economics in the Dike-Pond Area of the Zhujiang Delta, China. 『国立民族学博物館研究報告』 (*Bulletin of the National Museum of Ethnology*) 10 (4): 1145-1174.
- RUDDLE, K., J. I. FURTADO, G. F. ZHONG & H. Z. DENG
1983 The Mulberry Dike—Carp Pond Resource System of the Zhujiang (Pearl River) Delta, People's Republic of China: I, Environmental Context and System Overview. *Applied Geography* 3: 45-62.
- RUDDLE, K., G. F. ZHONG, H. Z. DENG, G. H. LIANG, Z. Q. WANG & H. S. WU
n.d. *Large-scale Integrated Agriculture-Aquaculture in South China: The Dike-Pond System of the Zhujiang Delta*. Cambridge: Cambridge University Press (in press).

中国，珠江デルタの家族経営養魚池における
エネルギー循環とエネルギー効率

ラドル・ケネス，鄧 漢 增，梁 国 昭

本論文は華南，珠江デルタにおける養魚システムでのエネルギー利用効率を，個人管理で家事労働によって経営されている養魚池と，実験的にコントロールした養魚池とで比較，検討したものである。すなわち，1981年4月から1983年9月にわたって実験養魚池において実施した太陽エネルギー，光合成 (PAR)，その他のパラメーターの測定にもとづき，養魚システムでのエネルギー循環とそれに関する労力および資本投下についての分析をおこなったものである。

調査のおこなわれた，すべての家族経営の養魚池において，実験養魚池に比較するとエネルギー利用効率において劣る，という結論が導かれた。実験養魚池においては排世物，植物性飼料，濃縮飼料のインプットが年間， $333.3 \cdot 10^3$ MJ/ha で， 40.83×10^3 の漁獲が得られ，

エネルギー転換率は 8.2 : 1 である。最も効率のよい家族経営養魚池においても、1 t/ha の漁獲にたいして、 56.6×10^3 MJ/ha のインプットを必要とし、エネルギー転換率は 10.4 : 1 である。他の養魚池においては、1 t/ha の漁獲のために、おのおの 116.3, 100.4, 117.0 ($\times 10^3$) のインプットがなされている。

この結果にもとづき、家族経営養魚池におけるエネルギー効率の改善勧告を関係当局におこなった。養魚池にたいするエネルギーのインプット率を変えるだけで世帯あたりの現金収入が 4-12% 増加するばかりではなく、そのことにより養魚池内の有機分の減少にとまらなう水質改善がおこなわれ、漁獲の増加が見こまれるからである。

ABSTRACT

This article examines the use of energy within the dike-pond system of the Zhujiang Delta, South China, and compares the efficiency of a control fish pond with that of a sample of individual, household fish ponds. Based on the measurement of solar radiation, photosynthetically active radiation (PAR) and other relevant parameters over a control dike-pond system, from April, 1981 to September, 1983, the energy budget of the dike-pond system and energy exchanges within it were analyzed. A simplified model of the energy paths within the system was then constructed from those empirical observations. The energy inputs to four typical household ponds were then evaluated against the control pond and the model.

All household ponds examined were less efficient energy converters than the control pond. In the latter a total of 333.3×10^3 MJ/ha/yr of inputs (excrements, green feeds and concentrated feed) yield 40.83×10^3 of fish; i.e., a conversion ratio of 8.2 : 1. In comparison, the best household energy conversion ratio is 10.4 : 1, in which 56.6×10^3 MJ/ha are needed to produce 1 t/ha of fish. In the other ponds analyzed 116.3, 100.4 and 117.0 ($\times 10^3$) are required to produce 1 t/ha of fish.

Recommendations are made for the improvement of the energy conversion efficiency of household ponds. If implemented, this would immediately increase household cash incomes by 4-12 percent, as a result of changed rates of energy inputs. An additional benefit, not measured here, is the increased fish yield from improved pond water quality with a reduced organic loading.

Invitation

(Everybody is welcome)

Three-day Seminar on Dike/Pond-System

June 22nd, 23rd and 24th, 1992

Location:

DIA, Akademivej, Building 381, 2800 Lyngby, Denmark

Topic:

Introducing experiences from the Dike/Pond-System in China in a sustainable ecological Development

The Chinese Dike/Pond-System is a unique integrated farming system based on 400 years of experience. The system consists of fish ponds and dikes. The very high efficiency of this system is caused by the use of sediment in the ponds as fertilizer for the crop at the dikes, and wastes from the crop production at the dikes are thrown into the ponds as fodder for the fishes.

Main lecturer at the seminar is George L. Chan, who has a life-time's experience within environmental engineering and who has been working with DPS in China in collaboration with Academia Sinica, Beijing.

The seminar will discuss the use of Dike/Pond-System (DPS) in China and the global environmental concepts and potential use of DPS outside China. Moreover it will illuminate the traditional practices and the modern trends of DPS.

Danish students and supervisors working at the project "Multidisciplinary Investigations of the Chinese Dike/Pond-System" are expected to take part in the seminar in order to gain understanding of available knowledge and to identify and formulate the different investigations.

Seminar on Dike/Pond-System

DIA, Building 381, Akademivej, 2800 Lyngby

Programme

<u>TIME</u>	<u>THEME</u>	<u>LECTURER</u>
<i>Monday 1992.06.22</i> <i>Chairman: Eli Dahi, CDC, DTH.</i>		
09.00 - 10.00	Dike/Pond-System: Definition, History, Type, Perspective.	GC
10.00 - 11.00	China: Historical Background, Travel, Language.	HT
11.00 - 11.30	<i>Tea/Coffee Break</i>	
11.30 - 12.30	Socioeconomical Environment of DPS	GC
12.30 - 13.30	<i>Lunch</i>	
13.30 -	Students Group Discussion and Field Work Planning.	
<i>Tuesday 1992.06.23</i> <i>Chairman: Berit Pettersen, DIA-K.</i>		
09.00 - 10.00	Integrated Farming, Geographical Survey.	OS
10.00 - 11.00	Selection of Components: Plant, Animal, Biogas.	GC
11.00 - 11.30	<i>Tea/Coffee Break</i>	
11.30 - 12.30	Selection of Components: Fish, Waste Handling.	GC
12.30 - 13.30	<i>Lunch</i>	
13.30 -	Students Group Discussion and Field Work Planning.	
<i>Wednesday 1992.06.24</i> <i>Chairman: Mads Korn, Danish Aquarium Fishes and Research.</i>		
09.00 - 10.00	Energy Budget in Dikes and Ponds incl. Biogas.	GC
10.00 - 11.00	Nutrition Cycle (N,P,K), Mass Balance.	JJ
11.00 - 11.30	<i>Tea/Coffee Break</i>	
11.30 - 12.30	Design, Criteria and Tradition.	GC
12.30 - 13.20	<i>Lunch</i>	
13.30 -	Students Group Discussion and Field Work Planning.	

Co-ordinator

Karl Allesø, DPS Danish Committee.

Lecturers

- GC Dr.Eng. George L. Chan, Env. Eng. Consultant. Antenna Technology, Geneva.
HT Hatla Thelle, MA in Sinology, Centre for East and Southeast Asian Studies.
OS Prof. Olav Stølen, Royal Danish Veterinary and Agricultural University.
JJ Johannes Janssen, Association of Danish Fish Meal Producers.

FISKEOPDRÆT PÅ LANDSBYNIVEAU I UDVIKLINGSLANDE

Dansk Akvakultur Forenings U-landsgruppe (DAF-U) afholder i samarbejde med CARE Danmark et seminar om ovenstående emne. Seminaret finder sted:

Mandag d. 22. juni 1992, kl. 19.00-22.00

**På Landbohøjskolen i København
Bülowsvej 13, Auditorium 2.02
1870 Frederiksberg C**

INDLEDERE:

Dr.Eng. George L. Chan, Antenna Technology, Genève:
Fish and carp polyculture in the traditional Chinese ponds and environmental management.

Seniorkonsulent John Stellwagen, DIFTA:
Biologi og teknik i enkle tropiske dambrug, med Bangladesh som et eksempel.

International konsulent Frands Dolberg:
Training og extension modeller i udviklingslande, med udgangspunkt i erfaringer fra akvakulturprojekter i Bangladesh.

Videnskabelig medarbejder Kim Carstensen, WWF, Verdensnaturfonden:
Projektetik, med erfaringer fra akvakulturprojekter.

ORDSTYRER:

Biolog Thormund Schmidt, generalsekretær for CARE Danmark

Seminarets baggrund:

DAF-U er i færd med at undersøge mulighederne for at igangsætte små og enkle akvakulturprojekter i udviklingslande. I den forbindelse er der etableret et samarbejde med blandt andet CARE Danmark. Seminaret er et led i dette samarbejde.

Deltagelse i seminaret er gratis. Der søges om støtte til at publicere indlæg og kommentarer.

Tilmelding senest 9. juni 1992 til:
CARE Danmark, Borgergade 14, 1300 København K, tlf. 33 15 00 07.

Med venlig hilsen

Knud Elverskov
Dansk Akvakultur Forenings
U-landsgruppe

Thormund Schmidt
CARE Danmark

DELTAGERLISTE TIL SEMINAR

"FISKEOPDRÆT PÅ LANDSBYNIVEAU I UDVIKLINGSLANDE"

mandag d. 22. juni 1992, kl. 19.00-22.00

DTH U-landscenter 4593 1002-5921
Halgøsevej 4, 474 2000 Hørsholm 3296278

Karl Allesen, DTH U-Landscenter
Torben Bindelev, CIC Marine
Thorkil Boisen
Jacob Bregnballe, Asnæs Værkets Fiskeopdræt
Charlotte Bunck
Lone Christensen
Jens Christian Eriksen
Finn Colmorn
Henning Cornelius Price, CIC Marine
Inger Dalsgaard
Lars G. Olsen
Rasmus Gether Sørensen
Martin Grossell, Danmarks Akvarium
Henrik Jarlbæk
Gorm Jeppesen, CIC Marine
Kis Kapel
Nabil Karas
Elsebeth Knudsen
Lars Linned, CIC Marine
Henrik Mahler
Inge Marie Jegstrup
Adam Nørregaard
Finn Ramsøe Jensen
Charlotte Ringbæk
Nanna Roos
Martin Rossell
Hanne Skaarup, Landbohøjskolen
Bo Skaarup
Berit W. Petersen, Danmarks Ingeniør Akademi

John Furze.
Eli Dahl.

32 96 2278

Fra Dansk Akvakultur Forenings U-landsgruppe:

Anders Dalsgaard
Knud Elverskov
Lars Haumann
Eric Støttrup Thomsen

Fra CARE Danmark:

Helle Johansen
Thormund Schmidt

LECTURE NOTES

John Stellwagen.

PROBLEM - of how to transfer technology.

1: Type of technology.

In Bangladesh entrepreneurs have started fish-farms. With the help of Danish Aid Agency are now able to increase their income.

Production of fish benefits the middle class.

Duckweed produced in starter ponds, then transferred to fish ponds. Protein composition is 30 - 40%.

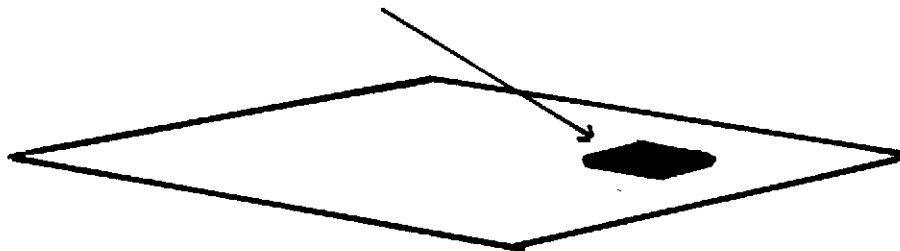

10 kg. duckweed => 1 kg. fish.

Household waste can produce the duckweed.

A Hospital will produce pr. day waste-equivalent app.

=> 3000 people => 800 kg. duckweed pr. day.

Bamboo poles in the water,
- this worries the fish,
so they jump into the
air, and thereby empty
their intestines.
This keeps wastes
in the pond.

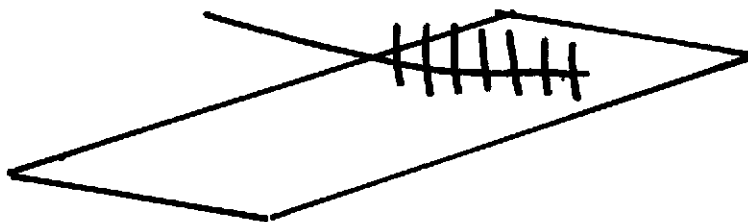

Waste was food, -
before being eaten
by the fish.

PROBLEM: - farmers are substituting fish for local consumption, with eels for export markets.

Chinese plastic-bag bio-gas units being introduced in Bangladesh. Cost app. \$ 50 USD. pr. unit.

Algae basins: - water hyacinth and duck weed.

DPS (Dyke-pond-system) / Integrated Farm System.
Area required, - 0.5 - 1.0 hectare pr. family-unit.

Innovation comes from multiple sources (" conflict and fight ") and not from harmony.

" Farmer first and last " - model.

How to develop a process, that will lead to the "process" that one wants.

Move the scientist out to the farmer, make joint decisions - test the technology out on the farm.

Production with integration.

Prof. George Chan.

Wuchan fish feed on water hyacinth.

Common carp, and Tilapia, by swimming up and down will aerate the pond.

Prawns can replace Common Carp, they will eat bacteria, etc.

Frands Dolberg.

The Danish Aquaculture Group for Developing Countries (DAF-U), cooperate with the NGO - CARE.

The World Wildlife Fund - WWF, has as it's aim to ensure biological diversity, and a sustainable development.

- 1: Prevent pollution.
- 2: Preserve the ecological environment.
- 3: Survival of different species.
- 4: Utilization of resources in a sustainable way.

=> High planetary life-quality for the individual.
" Think globally - trade locally ".

7% of global fishery is under production forms. This figure could be 3 times as high.

PROBLEM;- with the introduction of new species in an environment.
Water hyacinth problem; - great precaution necessary with aquaculture in existing wetland areas.

Prof.George Chan.

Example of the DPS in South Guangdong, China.
Socio-Economic-Aspect:

China at village level - decentralized, but must follow main policy.

At present no funds come from the government to the villages. Farmers do not deal individually with the " bureaucracy ".

The village often have a selected group who negotiates on their behalf, and who obtain permits etc.

Urban residents must have a ration card; - allowing purchases at controlled prices.

In S. China a growing problem with increased crime by unemployed minority groups immigrating from N. China.

There is a problem with villages who are unable to help themselves with their own resources.

PROBLEM; - with village development in mountain areas.

DEVELOPMENT IS IMPOSSIBLE WITHOUT WATER.

The Dyke System => Respect for water.

Bio-gas Airship for transport in mountain areas.

Pearl River Delta in S. China.

Development on west-bank of river has been more intensive.

The type of development depends on the available waste.
In suburban areas, - deliver food and return the waste back to the farm.

Sewers carry effluent into rivers, - removing the nutrients and polluting the river water, => resulting in a lack of fertilizer for agriculture.

ELEMENTS	MICROBES	WASTE
Sun	Yeast	Humus
Air	Bacteria	Birds
Water	Organisms	Animal
Soil	Macrophytes	Human

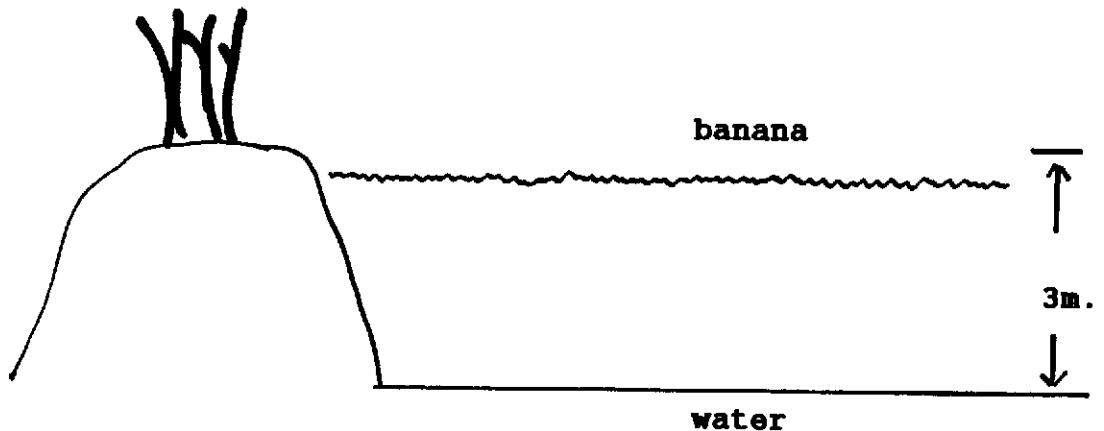

PROBLEM; of clay / acid soil: -

=> Mix sugar cane leaves with soil giving good humus.

Stream / canal for communication - transport.

Elephant grass.

Pond gives 8 - 15 tons fish/year.

Ducks, -> but only in enclosed areas of ponds.

Farmers cut the grass, and throw into the pond. - The Grass Carp has teeth in throat. Common Carp eats the pre-chewed grass.

Silver Carp eats the algae.

Other Carp types eat other organisms. [layer feeding in pond]

Ecological Town.

Integrated Farm Systems.

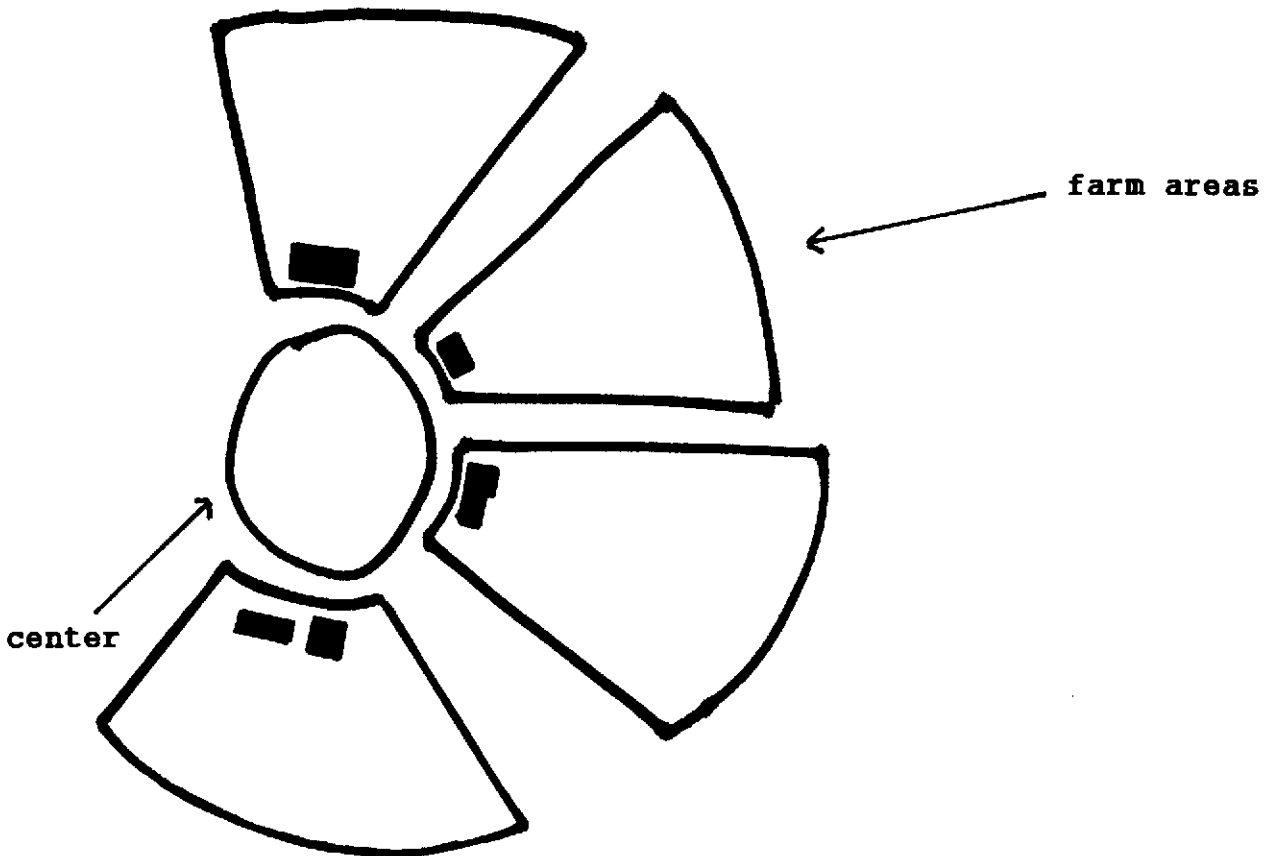

Fish ponds must be 66% of the total area and 33% for crops.

Thesis a Swiss engineer at MIT in 1890's - production in water is 100 times larger production, than production on land.

If the pond depth is 3 meters instead of 1 meter; => increases the pond's capacity to treat waste.

CHINAMPA System in S. America / Mexico: - System still in use on the high plateau of Venezuela.

Archaeology Dept. of Cornell Univ. USA: - Investigating former agricultural systems in Mexico.

1: Forest. Self-sufficient system, low population - stagnation.

2: Prairie. USA -> Population leave former inhabited mountain areas. This requires re-generation projects for mountain areas, using organic principles.

For ex. in S. France no-tillage methods => no erosion.

PROBLEM of sheep.

Organic farming does not produce enough fertilizer / but lots of waste material, - must use waste to save use of ammonia.

3: Slash and Burn. In Pacific islands, -> trees are slashed and burnt, - after a few years the soil is depleted, resulting in wild grass.

4: Irrigated Farms. Wastes or fertilizer used; giving fair to good yield.

5: Terraced Farms. Prevents rain water from washing away soil. Allows the water to penetrate the ground. => Ecological system.

Sophisticated Systems.

1: Chinampa.



Small drains, no waste, - but low yield. System lasted for 1000 years.

2: Viet Nam.

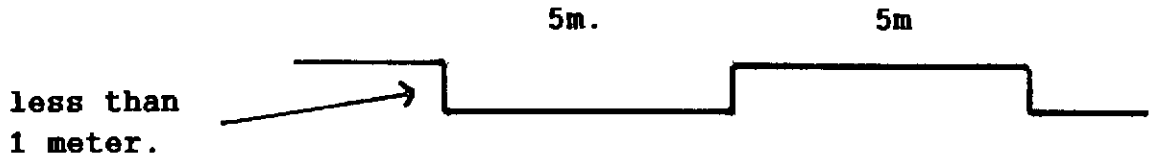

20 kms from Ho Chi Minh City; - drain dyke, no waste. Plant material growing on dykes. System abandoned, due to organic material not being put into the dykes.

3: Thailand.

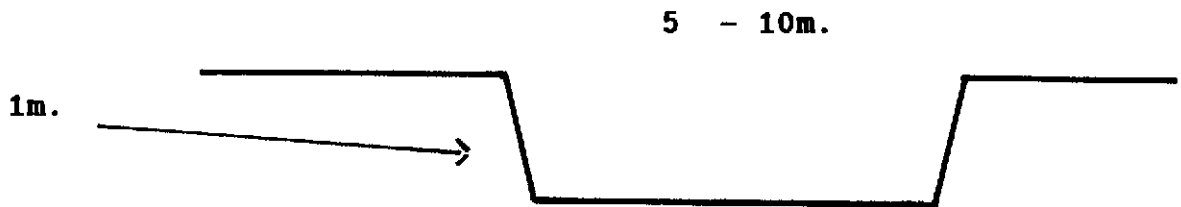

Channel dyke, with utilization of wastes.

4: S.China.



- 50% of surface area is water. Utilization of wastes.

=> High yield.

Pr. unit of surface area: => Highest yield in the world.

5: Integrated Farm.

Instead of putting waste directly into the pond: -

A: The waste goes into a digester.

B: Then into algae system (high protein animal feed), reducing the organic content by 90%

Livestock / Aquaculture / Agriculture / Industry.

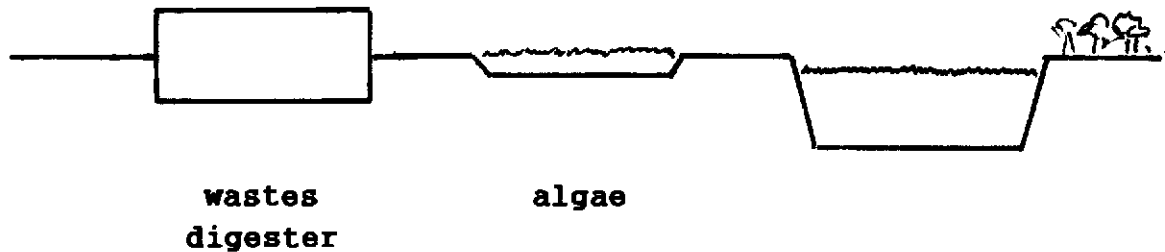

Lowland Plain. Azola, fixes nitrogen thereby giving a higher yield.

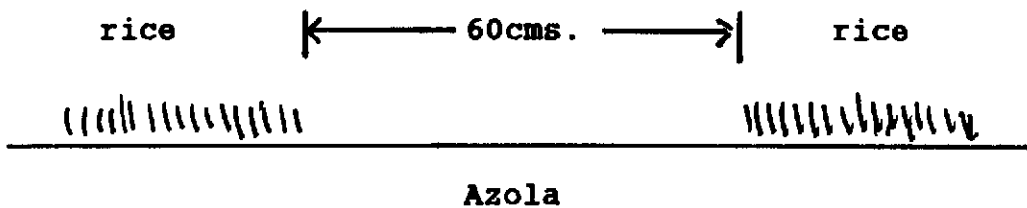

Acid Plain. Sugarcane / Bagasse etc.

Marshlands. Mulberry, fruit etc.

Hill areas. PROBLEM: - Lack of water, => citrus fruits.

Physical Chemical Process. Rapid growth of bacteria - plankton in water.

Biological Processes. Necessary bacteria for breakdown of organic matter.

Environmental Processes. Natural purification of wastes, removal of mud from pond bottom, -> put on banks/dykes.

Market Economy. Capitalism => Consumerism => Pollution.
Eg. S. Korea, \$ 8.8 billion deficit. - \$ 70 billion export.

Colonial Economy. Heavy colonial subsidy, which keeps the system from collapsing. Great potential disaster.

Independent Economy. Potential corruption.

Local Economy. De-centralization - cooperation. Production depends on local conditions.

Integrated Eco-Development. F.ex. at village level $\frac{1}{2}$ day el supply from hydro unit. $\frac{1}{2}$ day el supply from other generator sources.

Prof. Chan involved with development of bio-gas powered airship together with a German group. Such a transport machine can refuel anywhere. This enables otherwise un-attainable resources to be reached.

Eco-Development.

Air
Soil Water
Fossils
Minerals
Forests
Flora
Fauna
Organisms

Sustainability => Eco-Development.

Integrated farming 1 => 10
Industrial farming (USA) 10 => 1

Total energy: input / output.
Total costs.
Selling prices.

Producer is responsible for total costs.
" Polluter - payer - policy "
Reduction of product costs through re-cycling.

Sustainability prevents indiscriminate consumerism and gives fair shares to all.

With any farming system: - Livestock need a digester, => effluent for algae. Need to cover 50% of area with water.

Crops can grow on water.

Macrophytes.

Multi-cropping systems / Aeroponic towers and hydroponic troughs.

With Integrated Permaculture Systems, - need for large land area.

With bio-gas systems: Fuel is only 20% of benefit, 80% is fertilizer.

It is necessary to have systems that give high productivity with smaller land use. With better use of animal waste. - instead of (as is usual practice), leaving wastes/manure on the land.

6 Case Studies.

3000 year old Dyke Pond System.

450 year old polyculture.

1: Rice Dyke Ponds.

a: Traditional

b: Modified

c: Modern

d: Innovative with use of fertilizer, - (methane).

2: Mulberry Dyke Ponds.

Elephant grass for carp feed. Mulberry for silk worms. Fruits and vegetables.

3: Banana Dyke Ponds.

a: Traditional

b: Modified

c: Modern

d: Innovative with fertilizer.

4: Fruit trees on the Dykes.

Lychees and Logans, - perhaps cattle - grass cut for cattle feed.
- A new type of grass from Taiwan, - soft at bottom.

5: Citrus Dyke Ponds.

Fruits obtain higher prices, no need of special watering.

6: Flower Dyke.

Flowers remove organic material from the pond-bottom. With selling of plants => the mud is removed (and sold), as well.

NOTE: that in this type of pond, an aerator is needed.

=> However the usual type of aerators will only aerate the surface of the water, when there is a real need of aeration at the bottom of the pond.

All systems must be examined in light of factors: a -> d.

There is a great problem when carp is replaced by eel for export markets.

Re-cycling of resources.

1: Livestock re-cycling.

- a: ruminant - cattle, sheep, goat
- b: monogastric - pig, rabbit, reptile.
- c. poultry - chicken, duck, squab / pigeon.

with -- a: methane problems

b: overcrowded batteries

c: difficult to collect duck waste, so these should go direct into the pond. The ducks must be therefore confined to an enclosed/fenced area of the pond.

With cattle; - cut grass is brought direct to them.

Circular
Piggery

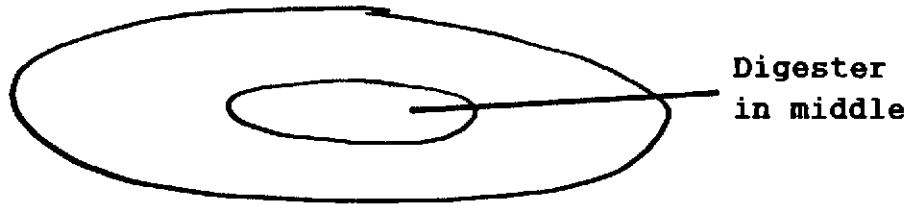

Waste cycle.

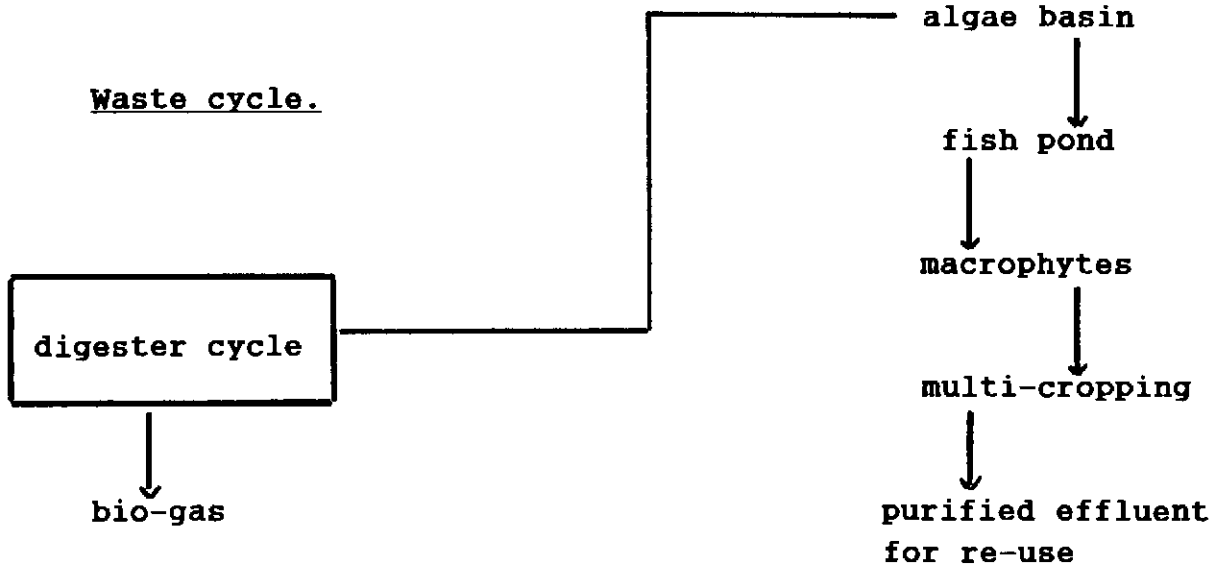

Waste Treatment.

- 1: Traditional
- 2: Re-cycling
- 3: Conventional (Expensive and inefficient).

There is a problem of prejudice against food/waste.

Conventional water treatment plants:

- a: First stage - settling
- b: Secondary settling and aeration.
- c: Third stage, - filtration, etc, final disposal.

NB: All work in conventional systems is done by natural organisms and large amounts of water.

Waste Development.

Resources Treatment Utilization

Ecological Treatment.

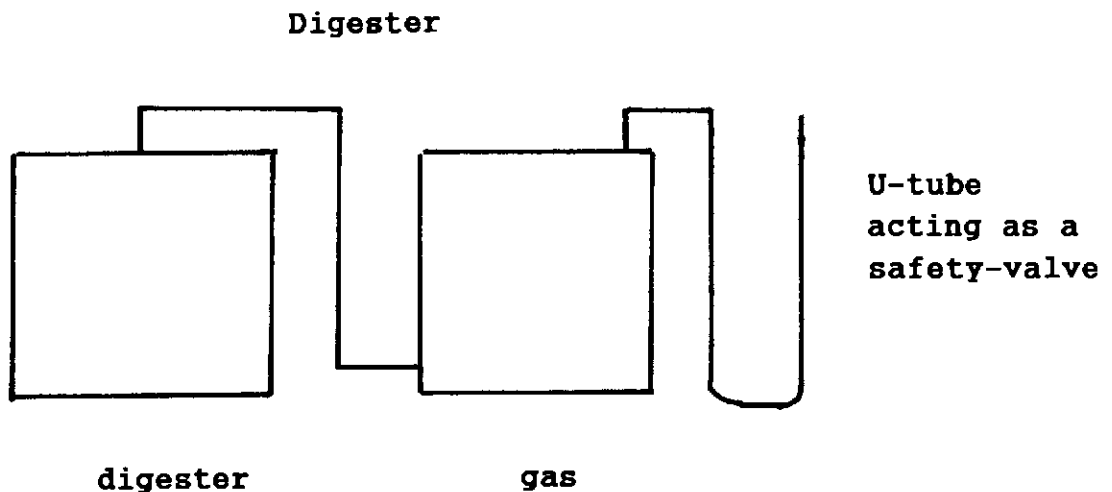

Digesters have always been expensive because of gas-holders made of steel. Indian digesters are more expensive. New Chinese type, uses water moving up and down instead of bag moving up and down.

A mixture of 50% cow manure + 50% poultry manure gives a production twice as high, as either type of manure used alone.

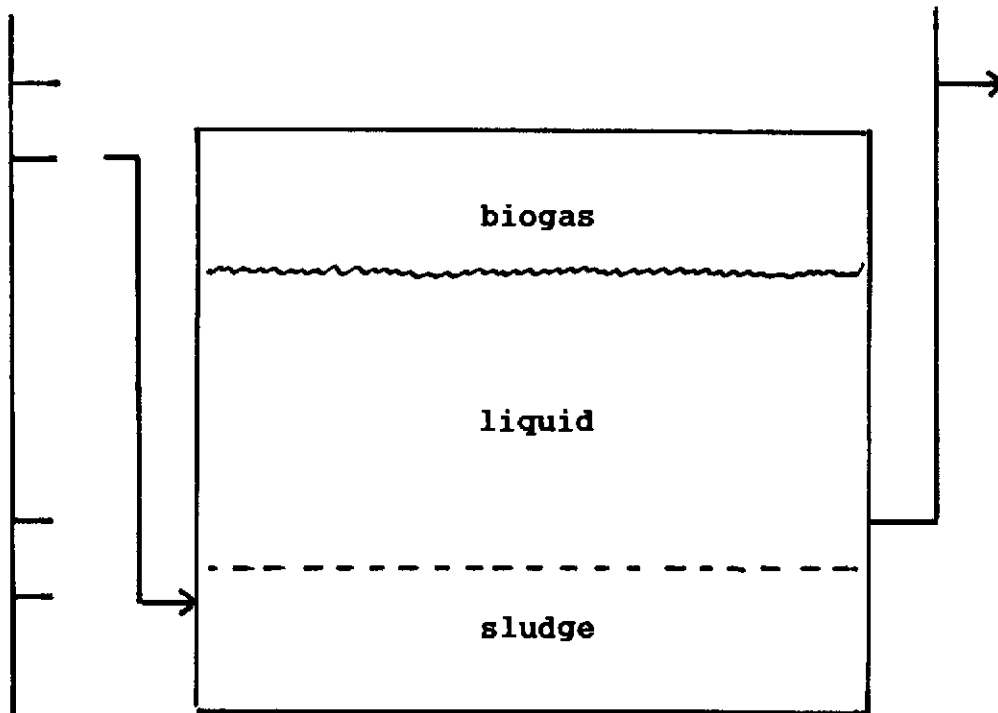

input/output
height ranges

simple container to retain waste-water between 5 - 10 days for anaerobic digestion.

There is no problem with the use of thin bags for digesters. Neoprene plastic from Du Pont Plastics.

Red-mud from aluminum production mixed with plastic, this gives a digester cost of \$ 1 USD pr. cubic meter.

Livestock efficiency.

Preference should be given to monogastric animals.

=> Not necessary to clean out the digester.

=> In cold climates (Korea), greenhouses have been built on top of digesters.

A 1.5 MW bio-gas power station in operation.

The use of bio-gas gives many advantages: Reduction of tree-felling for firewood, treatment of waste material, etc.

Energy - Mass balance - Design.

Fishery.

- 1: Rivers / lagoons
- 2: Mariculture
- 3: Fishing fleet

Aquaculture - re-cycling

Fish ponds

Macrophytes ----- water lettuce etc.

Sea bed => Spartina
Eucheuma
Kelp
Nori
Caged fish

Polyculture => DPS / IFS

Fish ponds: ---- Prawns can replace Common Carp.

50% of the pond area can be covered with plants.

" Aquaponic-Tower " ---- floating tower construction, plants grow on outside of tower, water being drawn up by plant roots or textile materials.

Algae basin: ---- [deeper basins => necessary to aerate by compressed air-blower],

Algae => feed to geese.

Urban-area sewage treatment plant: ---- use of water hyacinth.

Positive Action

Fossil Fuel

Wastes

Landfills

Socio-Economic and Eco-

Cultural Order

Natural Resources.

Self-Sustainable Systems.

Energy Bio-Mass Socio-Economic Benefits

Components

Energy ecology

Production process

Digesters: ---- It is preferable to have many small inexpensive digesters, than one big unit.

(1% of solar energy converted by the photosynthesis process).

Always use renewable energy transfer systems: -> wind energy - solar and bio-mass systems.

Energy available from digester: => 20% - However, 80% from the resulting fertilizer. Too much emphasis has been placed on the " Energy " / (fuel equivalent).

Solar-Based Eco-System.

Chemical elements,

Soil Water Air

Compounds: (Proteins, Carbohydrates, Lipids, Fibers)

Bio-Mass Production: (Livestock; Aquaculture, Agriculture; Agro-Industry).

TO DEVELOP: => need of livestock, -- cattle, goats, mini cattle.
(Mini cattle: - Acad. of Sciences in USA -- cross-breeding with a Mexican type).

Without a good source of fertilizer , cannot increase production.
=> Development means a good source of fuel and fertilizer sludge from digester.

2300 years ago the Chinese writer Fang Hei wrote the textbook on aquaculture.

Aquaculture is concerned with farming and rearing of fry and fingerlings to marketable size.

Aquaculture can give a local pollution problem.

Lone Dybkjær, Member of European Parliament.

Careful attention should be paid to bio-diversity (there are only 125 aquaculture-species in world).

Prof. George Chan.

Integrated farming is a semi-intensive farming system in which natural resources are efficiently utilized to maintain and increase production.

=> Optimum use of organic resources.

=> Jobs => labour-intensive => high-productive-operation.

It is important to pay great attention to the condition of the mud on the pond bottom: --- The " taste ", - The smell.

It is useful to draw detailed/comprehensive flow diagrams for the system.

-- animal manure is immediately utilized by the fish.

Feed Utilization.

= $\frac{\text{Food (Kg.)}}{\text{Growth (Kg.)}}$

= $\frac{\text{Fertilizer (Kg.)}}{\text{Growth (Kg.)}}$

FCR: (Food Conversation Ratio) => Feed Quotient

FQ - (Fishmeal)	=	1.0
FQ - (Fish-flour) Pigs	=	2.5
FQ - Pig manure	=	25.0
FQ - Cow manure	=	40.0
FQ - Herbaceous Fish, filter-feeding fish	=	2.0

(2 Kg. fish faeces => 1 kg. fish).

Protein.

Fish: 1000 Kg. Tobis => 180 Kg. = 18%

220 Kg. Fish-flour => 159 Kg. = 72%

396 Kg. Animal feedstuff => 159 Kg. = 40%

Figs. --- protein utilization - 27.7%

1000 Kg. Feedstuff => 260 Kg. = 26%

Oxygen Concentration.

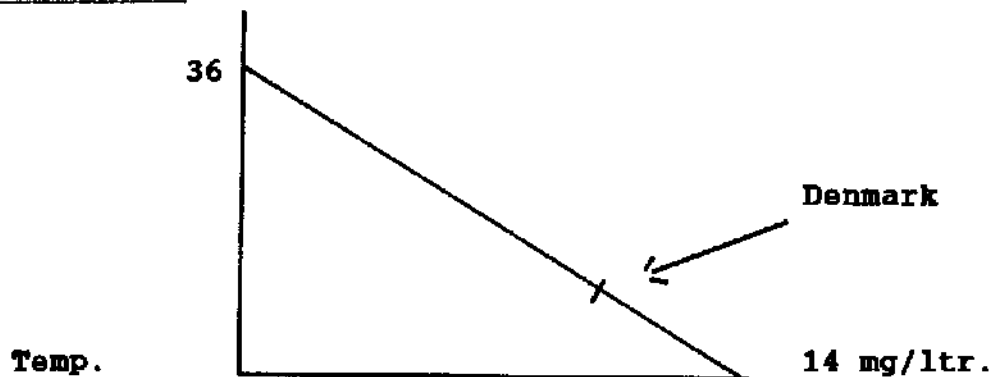

In Chinese pond:

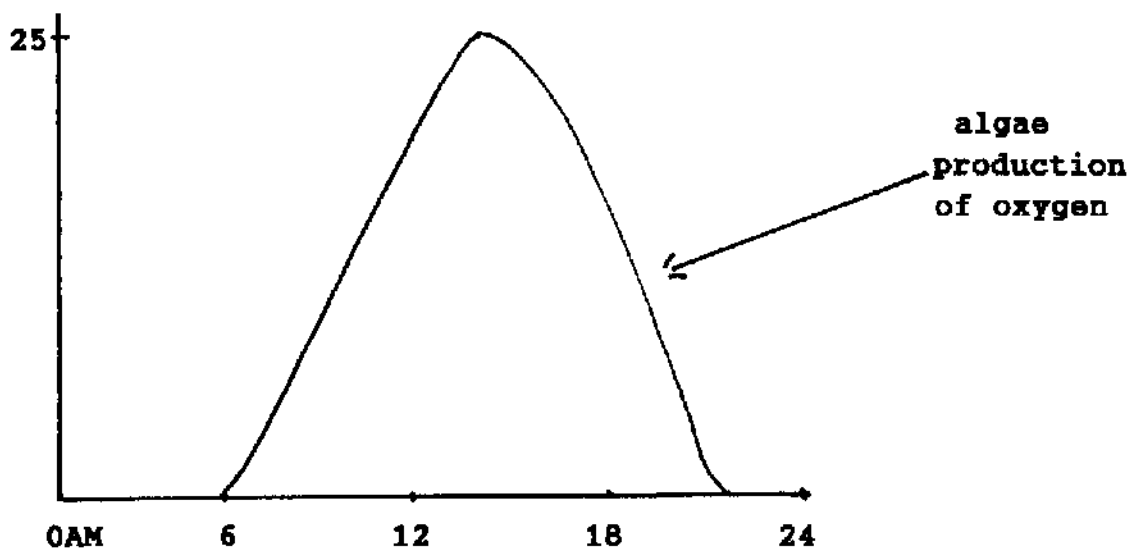

With too high algae concentration the fish will die for lack of oxygen at night.

[Visibility for algae concentration app. 30 cms.]

Dirty water-material will stick to the gills of the fish.

BOD -- Biological Oxygen Demand.

Water Hyacinth	----	1.74
Cow manure	----	20.6
Pig manure	----	30.0
Integrated Fish pond	----	0.1 / ltr.

Research is still needed to cut costs in tropical areas.

There is a large difference between Aquaculture and Integrated Systems / Dyke pond.

Systems are not balanced with too large growth of algae.

It is necessary to have a balanced eco-system.

All Photoplankton and Zooplankton must be consumed in the system.

- All food not consumed will pollute the system.

Bio-gas gives not only energy but also treatment of organic waste. => (reduction of pollutants by 90%)

1: Digesters

2: Algae pond

Manure must go into the pond, as fertilizer for the plankton.

OPTIMIZE

MAXIMIZE

RE-CYCLING

Understand the necessity for the provision of the right kinds of bacteria, => correct conversion of material.

Instead of using raw sewage => treated waste material can now be used as fertilizer or as feed for algae.

Ecological Benefits => other benefits (socio-economic.).

Input ==== > Output

No chemicals, no artificial fertilizer, no pollution.

With mix of 2 different types of seed => crops can be harvested at different times.

plants can be grown in 3 meter high towers, with top irrigation.

-> bio-gas units save trees, and solve many sanitary problems.

100000 workers and a technical staff of over 1000 in different bio-gas programs in P.R. China.

Bio-gas Air-Ship.

Can be used for transport in mountain / coastal areas, at a fraction of the cost of a helicopter. Made of plastic.

Helium is a by-product of natural gas.

3 Models: 8 meter, 30 meter, 60 meter length.

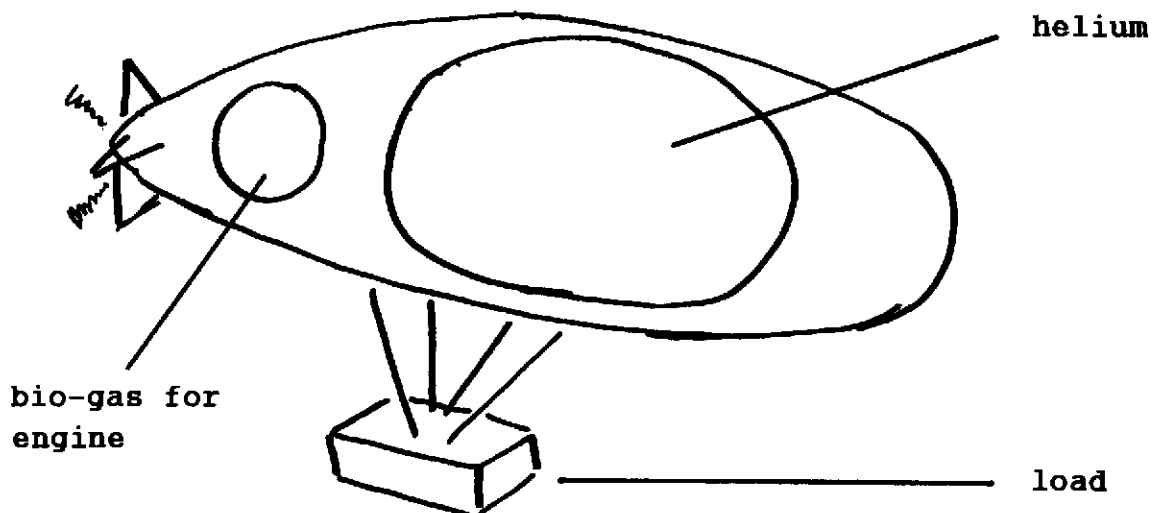

Digester for household use. - 6-10 cubic meter capacity.

Digester: - 2 times 50 cubic meters; minimum cost app. \$ 50 USD.

The following formula can be used to obtain an idea about the amount of manure that is needed for a certain fish production:

$$M = (Y1 - Y2) \times C$$

M = quantity manure required (kg)

Y1 = target yield of non-filter feeding fish (kg)

Y2 = yield of (filter-feeding) fish that can be raised on the excrements of the herbivorous fish in the pond (kg)

C = conversion rate of the manure

Target yield is 500 kg of each fishtype.

Production period 6 month

C pig = 25

What is the M pigs ?

In case only 12.000 kg of pig manure is available , how much cow dung is required ?

The number of fingerlings (Y) required can be calculated with the formula :

$$a \times y \times b = c$$

where a = survival rate ; b = size at harvest ; c = yield at harvesting.

How much fingerlings are required if the next factors are assumed. death rate 10% , average harvest weight 750 gram and yield 5000 per hectare.

Explain the difference of availability of phosphorous for carp and trout in different feed ingredients.

ingredient	% Phosphorous	% availability of phosphorous	
		carp	trout
fishmeal	0.99	26	60
rice bran	0.79	25	19
wheat germ	0.58	57	58

Suppose we want to give the fish some extra feed because the primary production has gone down for some reason . We have two ingredients easily available . They are wheat with a protein percentage of 10 and semi dry silkpupae with a protein content of 44 . We require a feed with 30 % protein. What would the right mixture be to obtain the protein level we are aiming at ?

**Compendium In
The Integrated
Farming System
Appendix**

Compendium In The Integrated Farming System Appendix

**Selected & Edited by John Furze 1996/97/98/02
Holme Bygade 12, 8400 Ebeltoft Denmark
Tel/Fax/Voice: + 45 86 10 07 86
E-mail: <furze@post.tele.dk>
Aarhus University Faculty of Political Science,
Law & Economics**

NB:

It should be noted that this Compendium is for the express use of students, workers, research and production engineers and technicians, and for political decision-makers at all levels - concerned with development of production capability.

It does not intend nor imply any infringement of any of the copyrights of any of the authors quoted.

Indeed, this Compendium is intended and presented in grateful thanks, and to perhaps bring these authors to a wider public.

APPENDIX

Subject, Page nr. and Source.

AQUACULTURE

- 02: Owner-Built Homestead. Barbara & K. Kern USA 1974/75/77 0-694-14926-5. [A].
- 13: Other Homes & Garbage. J. Lockie et al. USA 1975 0-87156-141-7. [B].
- 30: Radical Technology. G. Boyle, P. Harper UK/USA 1976 0-394-73093-3. [C].
- 32: Energy Primer. Portola Institute USA 1974 0-914774-00-X.
- 45: Technological Self-Sufficiency. R. Clarke UK 1976 0-571-10835-0. [D].
- 46: Eco-Tech. R.S.de Rapp Delacorte Press NY. USA 1975 0-440-02233-9.
- 49: Permaculture. B. Mollison Australia/USA 1990 18-55963-048-5. [E].
- 101: Freja 1975 - Perspektivplan 3. School of Architecture Cph. DK 1975 87-87555-028. [F].
- 102: Fish-farm in BanglaDeah. DANIDA DK 1969 87-7265-079-6.
- 103: Freja 1975 [F]. / Self-Sufficiency. J. & S. Seymour UK 1973 0-571-09934-8.

DUCKS AND GEESE

- 104: Ken Kern 1974/75 [A].
- 105: Liklik Buk. Melanesian Council of Churches, Papua New Guinea 1977 0-86-935-0244.
- 107: Peoples's Workbook. EDA Johannesburg South Africa 1981 0-620-05355-0. [G].
- 109: "Chicken-tractor" - Radical Agriculture. R. Merrill [Ed.] USA 1976 06-090437-6.

HYDROPONICS

- 110: Radical Technology [C].
- 115: Food. Stefan Szczelkna Unicorn Bookshop Brighton UK/Seattle USA 1972. 0-85659-006-1.
- 116: Technological Self-Sufficiency [D].
- 117: Complete Vegetable Gardener's Sourcebook. D. Newcomb USA 1980. 0-380-75318-9.
- 118: Other Homes & Garbage [B].
- 118a: Hydroponics as a Hobby. Public Works W. Szykita ed. Linka Publishing NY-USA/London-UK 1974 [H].
- 119: Interview with Shigeo Nozawa. Earth Summit News [Rio-Brazil] 1992.

NB - Also consult:

- Hydroponic Food Production. H.M. Resh USA 1978. 0-912800-54-2.
- Organic Gardening under Glass. G. & K. Abraham USA 1975. 0-87857-104-3.

DIGESTERS AND METHANE

- 120: Other Homes & Garbage [B].
- 144: Technological Self-Sufficiency [D].

WATER PURIFICATION

- 146: Permaculture. B. Mollison [E].
- 155: Other Homes & Garbage [B].
- 164: "Ecol-system" - The Autonomous House. R. & R. Vale UK 1975. 0-500-93001-5 [I].
- 164a: "Ecol-system" - Energy, Environment, Building. P. Steadman UK/USA 1975 0-521-20694-4.
- 164b: Sunshine Rev./Integrated Solar-system. H.Rosvik Stavanger Norway 1991 82-91052-01-8.
- 165: Flow-Ferms.
- 166: Permaculture. B. Mollison [E].

WELLS, PONDS, DAMS, TANKS & WATER-PUMPING

- 168: Self-Sufficiency. J. Seymour Faber & Faber UK 1976 0-571-11095-9.
- 170: Permaculture. B. Mollison [E].
- 181: The Owner-Built Home. Ken Kern USA 1972/75 0-684-14218-X [J]. / Mollison [E].
- 185: The Autonomous House. B. & R. Vale [I]
- 186: Glass-fiber tank modules.
- 187: Wire-power transmission. VITA USA 1963/77 [K].
- 190: Hand-pump for Irrigation. EDA [G].
- 194: Trompe device - for compressing air. B. Mollison [E].

BUILDING CONSTRUCTION

- 195: Compost-Toilet Unit. Ken Kern 1972/75 & 74/75 [A-J].
- 204: Compost Materials. B. Mollison [E].
- 205: Septic-tank Systems. Ken Kern [A-J].
- 205a: Civic-Compost Toilet System. Survival Handbook. M. Allaby ed. Macmillan UK 1975 0-330-24813-8.
- 206: Tubular Plastic Bio-Digester Design. Simalunga, SIDA/FAO-FARMESA, PO-Box 3730 Harare Zimbabwe.
- 222: Tube-digester [Fry] - The Autonomous House. B. & R. Vale [I].
- 223: Half-Dome Greenhouse. Ken Kern [A-J].
- 224: Adobe-Dome. _____
- 226: Adobe-Barn. _____
- 228: Greenhouses and IFS for Cold Climates. George Chan.
- 237: Hydroponic-Greenhouse System. Appropriate Technology Sourcebook, VITA USA 1976 917704-00-42.
- 237a: Greenhouse. Public Works [H].
- 238: Aqua-Dome. J. Saxgren, People's College Kolding Denmark.
- 242: Simple Dome Greenhouse. Niels Bandholm Hjørtshøj Århus Denmark.
- 244: Domes. E. Thorstein, Box 62 - 121 Reykjavik Iceland.

ENERGY POTENTIAL & CONVERSION TABLES

- 253: Remote Area Power-supply. Rainbow Power Nimbin NSW Australia 1991/93.
- 256: Wind-speeds & Descriptions. J. Furze, B. Mollison, P. Gipe, etc.
- 259: Choosing a Windmill for Water-pumping. Acramotor Windmill Corp. San Angelo Texas USA.
Also consult: - FIASA Windmill Co. Argentina & Southern Cross Corp. Queensland Aus.
- 260: Water-pumping Capacity of Wind-mills. P. Gipe USA 1993 0-930031-64-4.

A: Village Technology Handbook. VITA USA [K].

- 261: Estimating Small Stream Water Flow.
- 264: Measuring the Flow of Water in Partially Filled Pipes.
- 266: Determining Probable Water Flow with Known Reservoir Height, & Size & Length of Pipe.
- 268: Estimating Water Flow from Horizontal Pipes.
- 270: Determining Pipe Size or Velocity of Water in Pipes.
- 272: Estimating Flow Resistance of Pipe Fittings.
- 274: Determining Pump Outlet Size & H.P. Requirement.
- 277: Determining Pump Lift Capacity, Transmission, etc.

B: Mathematical Conversions and Tables.

- 278: Biological Paths to Self-Reliance. R.E. Anderson Sweden/USA 1979 0-442-20329-2.
- 280: The Power Guide. W. Hulscher, P. Fraenkel UK/Netherlands 1994 1-85339-192-1.

C:

- 285: Triangulation - [H] & Trigonometry tables.

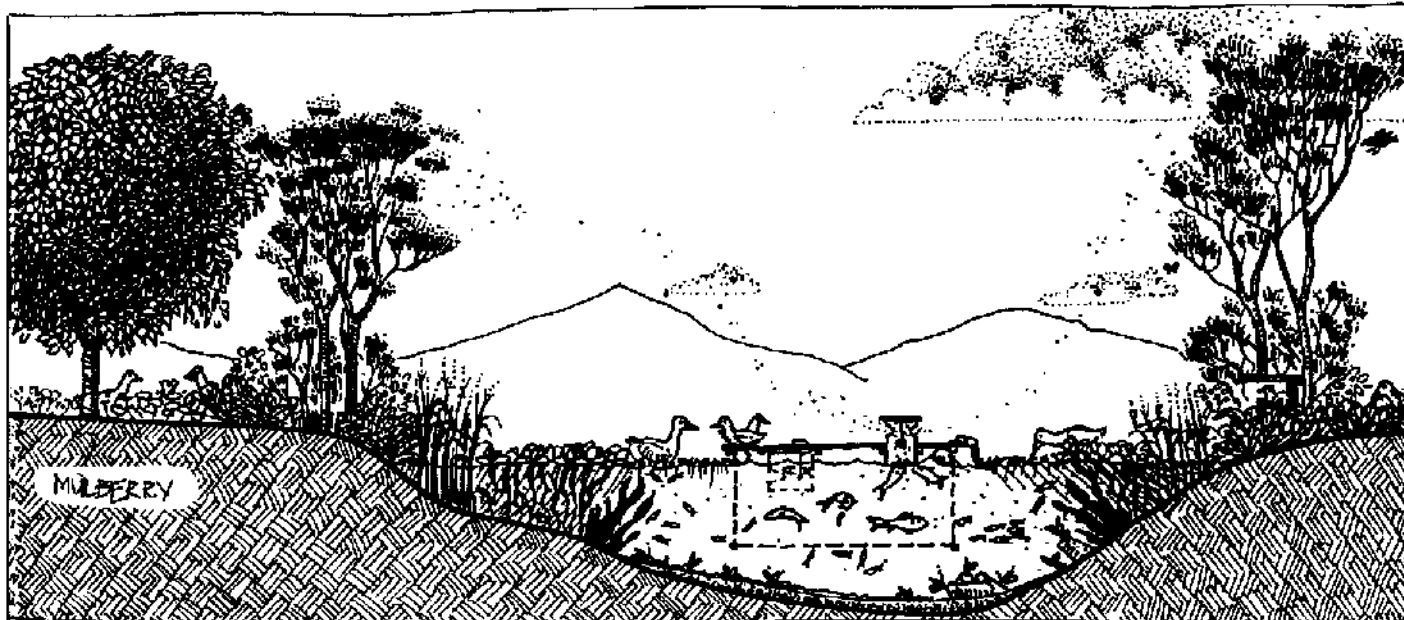
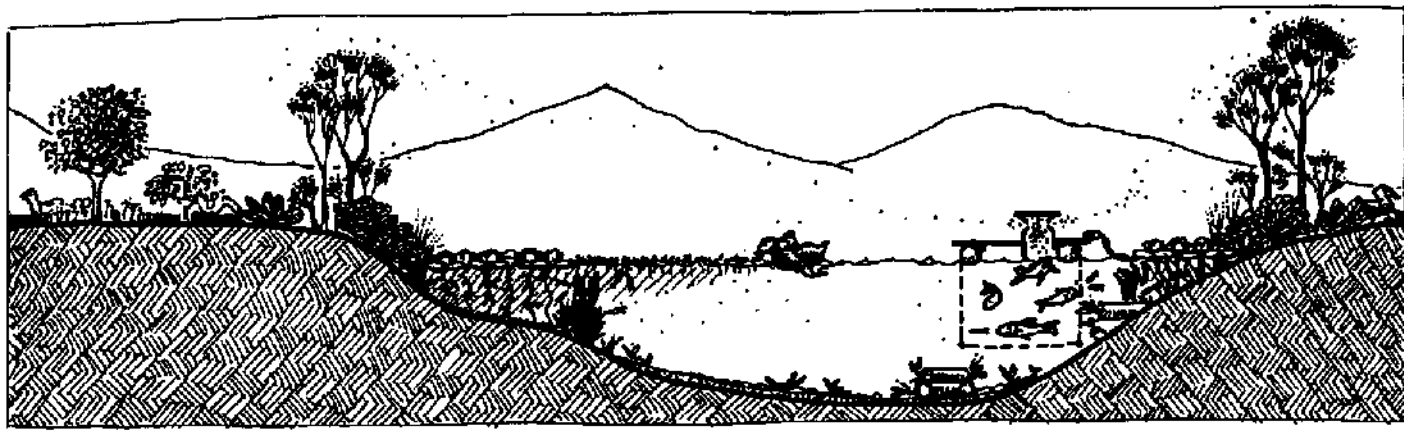
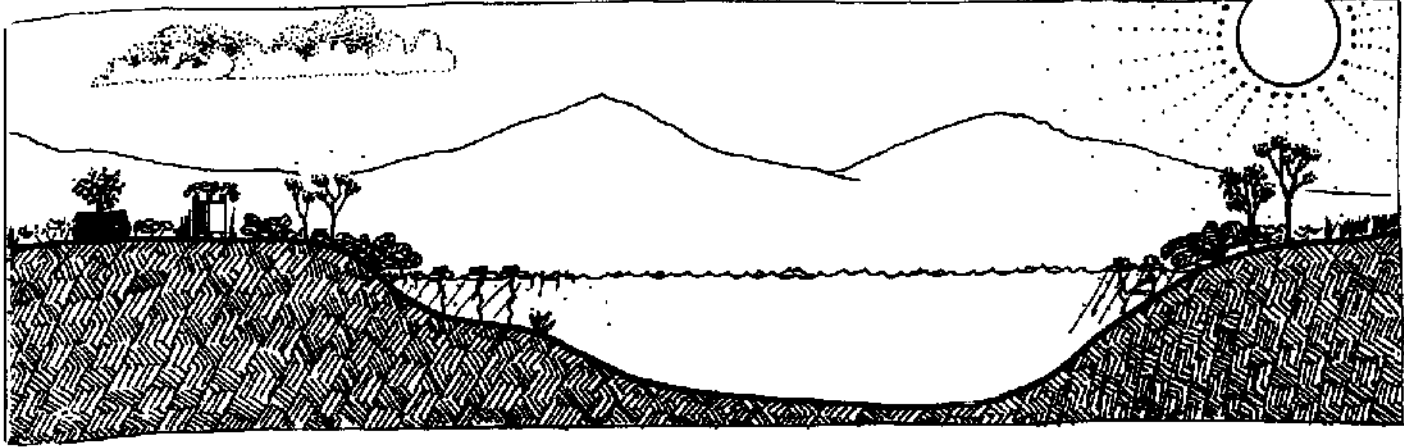

Fish Culture



The old saw that goes, "There are more fish in the sea than ever came out of it," is rapidly becoming questionable: witness the endangered survival of some fish species, like the salmon. For at least one good reason, therefore, a thoughtful fish management program is one of the really exciting prospects for homestead food production. Yet, it never ceases to amaze me how few North American homesteaders get into a fish management program. Practically all the ancient civilizations — Mesopotamia, Egypt, China, Peru — maintained fish farms in their gardens. Fish farms in Europe date back to the stone-lined Roman-style ponds. During the Dark Ages monks perpetuated farming practices to supply fish for Lenten and Friday sacramental observances.

Fish culture continues to interest European farmers, and in Asia practically every small homestead includes a series of ponds where intensive fish production is maintained. With the North American farmer's regard for livestock as having prestige value the unseen fish offers no commensurate status symbol. What the land-animal farmer doesn't appreciate is that fish cultivation can produce twenty-times as much protein as can animal production. On good permanent pasture young cattle may gain 300-pounds per acre per year; on poor land the gain is about one-tenth this amount. But average fish production under intensive management is in excess of 6,000-pounds per acre per year. To be exact, fish increase in weight two-times more than cattle do in terms of increase per unit weight of animal per unit weight of food consumed. And fish protein is superior to meat in quality: it contains no carbohydrates and only one-tenth of one percent fat. Being lower on the food chain, much less energy is consumed by a fish in its life activity. An important part of the energy that a land animal obtains from food is required just to maintain its body temperature and to support its weight. Being cold-blooded and being supported by water, fish become a far more economical (efficient) meat producer.

The American-style conservation pond will, therefore, be differentiated from Asiatic-European pond management practices which will be discussed later in this chapter. Fish in a conservation pond perpetuate by annual reproduction and are harvested by hook-and-line, a method invented in late Paleolithic times. A well-managed conservation pond will yield to a patient hook and line as much as 500-pounds of fish per acre per year. From an uncared-for pond one would be lucky to land 100-pounds of fish per year.

Proper pond management starts with a properly engineered pond. Consider, first, the water shed area. In the eastern U.S., where well-distributed rainfall averages 40-inches a year, the water shed should not be more than 20-times the surface acreage of the pond. Here in the West a considerably larger water shed area is required due to dry summers and high evaporative rates. Excessive water flow and flooding should be avoided by building diversion terraces. There is really no good method of screening fish from an overflow. A wide spillway, however, saves more fish than a deep one. Pond depth is related to climate: a 3-to-12 foot depth is ideal except in northern states where WINTER-KILL is avoided by deepening the pond to 16-feet. Winter ice creates a seal over a pond, preventing an adequate exchange of gases between air and water.

Sufficient oxygen content of pond water is insured when the depth is kept shallow. Fish culturists have found that oxygen content and fish stress are related, leading to disease when undue stress activates a latent virus in the fish. Disease outbreaks occur following low-oxygen periods. When the water temperature is the same from surface to bottom, as in early spring, the evenly distributed weight or density of the water makes for an equal circulation and an evenly distributed oxygen content. But in the summer there is a danger of oxygen deficiency in a pond, called SUMMER-KILL. The combination of cloudy skies, calm winds and high temperatures in a shallow, weed-laden pond can wipe out a fish population overnight. In the summer shallow water often becomes choked with aquatic vegetation, such as cattail and bulrush. Under such conditions the organic decay and respiration demands are high on the available oxygen supply of the water. Basic forms of plankton and algae die off, and in the process of dying they, too, use up valuable oxygen.

Even a small-but-constant flow of water into a pond will raise the oxygen level. Water from the bottom of the pond should be replaced with fresh water, especially in deeper ponds where temperature differences cause a stratification or layering of water levels. To insure adequate circulation of lower and upper water levels some sort of releasing device must be installed on the bottom of the pond. Details of one such conservation pond bottom-water overflow is illustrated below.

Asiatic-European pond management practices are far more sensible about the maintenance of fish oxygen and food requirements. In these

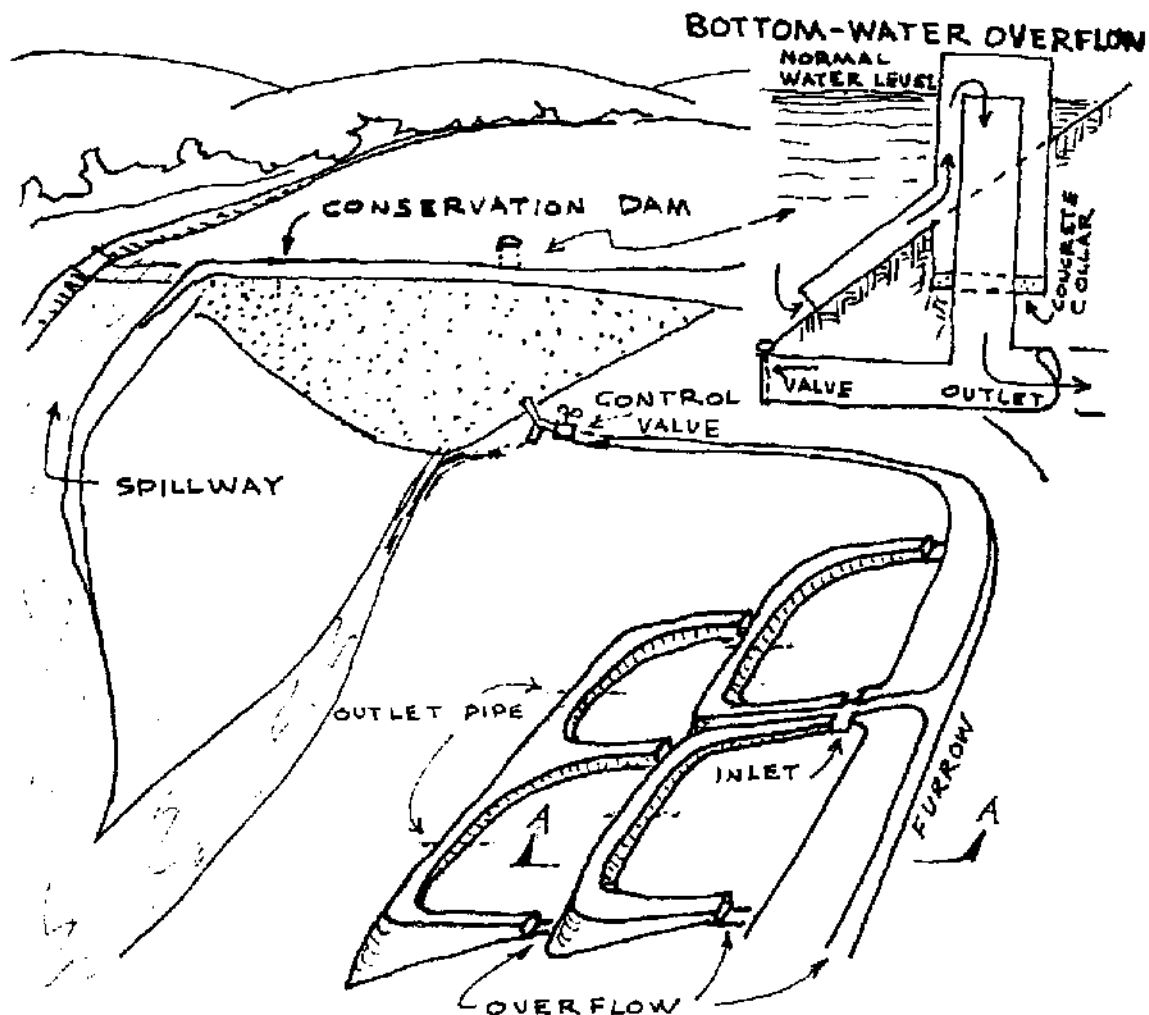

CONTOUR PONDS BELOW CONSERVATION DAM

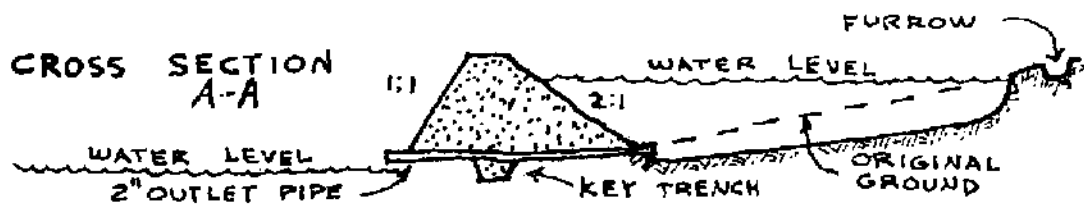

countries it is a common practice to stock ponds with a wide variety of fish species and sizes to best utilize the available food supply. Too little available food in a pond may cause predacity among its population. On the other hand, too much food causes oxygen deficiencies along with the formation of toxic gases. Some fish, like grass carp, are stocked for the primary purpose of devouring grass and underwater weeds. Furthermore, it has been found that faeces from the grass carp contain massive amounts of half-digested vegetable matter which is fed upon by other fish. And, of course, the manural value of fish wastes stimulate plankton growth. Grass carp do well in colder climates, and their vegetive-eating nature permits a more extensive shoreline area. Shoreline creatures (such as water insects, tadpoles

and crawfish) should be encouraged. Some forward-thinking pond builders even suggest the use of interior tree-planted islands to further increase the shoreline perimeter.

In China fish ponds are drained every few years. Aquatic vegetation and surplus muck are removed to fertilize gardens and orchards, and the pond bottoms are exposed for a period to the sun and the air. The pond bottoms are then planted to soybeans, rice or alfalfa — with far less fish disease and parasitic incidence when the pond bottoms are harvested and later re-stocked with fish.

Correct STOCKING practices constitute another important feature of pond management. It is the water temperature that influences fish spawning, and so, obviously, the species chosen should be attuned to its water-environment. Large mouth bass, bluegill and catfish thrive in warm water ponds; trout, in cold water. Small mouth bass, pike, and yellow perch do well in water of intermediate temperature. In general, trout are a poor choice. They live high on the food chain, requiring generous quantities of protein food themselves.

Bass live relatively high on the food chain, too, but stocking practices have been formulated to make bass one of the best choices for conservation ponds. That is, bass are stocked with bluegill at the ratio of 1-to-10. Bass feed on the bluegill during the summer and fall months, thereby controlling the bluegill population whose prodigious reproduction constantly threatens their own survival. This mutual association works in other ways, too. Bass, like all fish, are caught when they are hungry — in the spring — when their food supply is scarce. In the winter, the cold water temperature de-activates their digestive process, and the fish feel no hunger. So, at the time of the year when bass are least available (summer), the bluegill are most prevalent. A well-managed pond will yield 5-pounds of bluegill for each pound of bass.

Fish yield can be tripled by fertilizing the pond, clear water denoting poor production. If one can see a white object a foot beneath the surface of the water it is not adequately fertilized. Organic fertilizer provides food for a heavy growth of microscopic algae. Worms and larva live on this algae, and, of course, fish live on the worms and larva. Fertilization also indirectly reduces weed growth since the microscopic plants (which it supports) supply shade, thereby reducing weeds. Water weeds and shallow-water plants should be discouraged, for, as I already pointed out, they cause excessive stagnation and oxygen depletion.

Conservation pond management can prove to be an enjoyable past-time for the time-affluent sports-minded homesteader. But the best use for the conservation pond of the serious-minded fish producer is as a water supply for real, honest-to-goodness fish CULTURE PONDS. Culture ponds are different from conservation ponds in four important respects: they are shallow; they can be drained, they can be kept dry or under water alternately; and they are managed in conjunction with

two-or-more, adjacent, gravity-fed ponds. Also, there should be no through flow of water in a culture pond. Seepage from one pond may be used to keep the next in the series full.

An ideal culture pond arrangement consists of three, $\frac{1}{8}$ th-acre ponds, adjacent to each other but terraced to allow for gravity drainage. The 3-foot depth may be increased to 5-feet at the deep end in less water reliable areas or where winter frosts occur.

Three-hundred-and-fifty million years of life on this planet have enabled fish to develop a high reproductive potential that enables them to outlive their predators. Even so, fish mortality in a natural environment is considered to be 80 per cent. Under artificial (culture pond) conditions the mortality is reduced to 10 per cent. As background for the understanding of a dynamic fish culture program, consider for a moment the most basic mutual exchange relationship; a fish, a snail, and a water plant are placed outside in a bowl of water. The plant uses fish and snail waste, prepared and made available to the plant by the snail. And, with a little help from the sun, the plant releases the necessary oxygen to purify the water and keep the snail and the fish from suffocating. The fish, in turn, lives off the plant. This ecology may be over-simplified, but it does demonstrate the basic relationship that takes place. In a real life situation one finds bacteria and algae at the base of this food chain. Bacteria utilize complex waste materials in the water, and algae utilize inorganic salts, carbon dioxide and water in the presence of sunlight to produce protein and carbohydrate. One form of plankton (phytoplankton) feed from these basic food forms; another plankton (zooplankton) eat the phytoplankton; minnows eat the zooplankton; and larger fish eat the minnows.

A balanced environment of this sort can be reproduced on an economic scale by any homesteader. Farmers in the Rhine Valley have been doing it for a hundred years. After a few years of grain crops these farmers flood their fields and stock them with carp. The carp thrive on vegetive residue, mature rapidly, and are then harvested by draining the field. The fish-manured fields once more are sown to grain and the cycle is repeated.

Of course, the Chinese perfected pond culture two thousand years ago. They developed complex water-control and dam-construction techniques, and they knew almost everything we know today about fish stocking and reproduction, pond fertilization and weed control. One of the greatest contributions that the Chinese made was the breeding of fish varieties to live on the wide variety of food found in a balanced pond situation. Their multi-species stocking includes an herbivorous-eating, a plankton-eating, and a bottom-feeding fish. Even single species of fish, like carp, were bred to a specific regimen. Mainland China today produces more fish than any other nation in the world — over a million-and-a-half tons in 1965!

Modern homesteaders could do no better than to pattern their pond culture program after that of the Chinese. We know it works! First

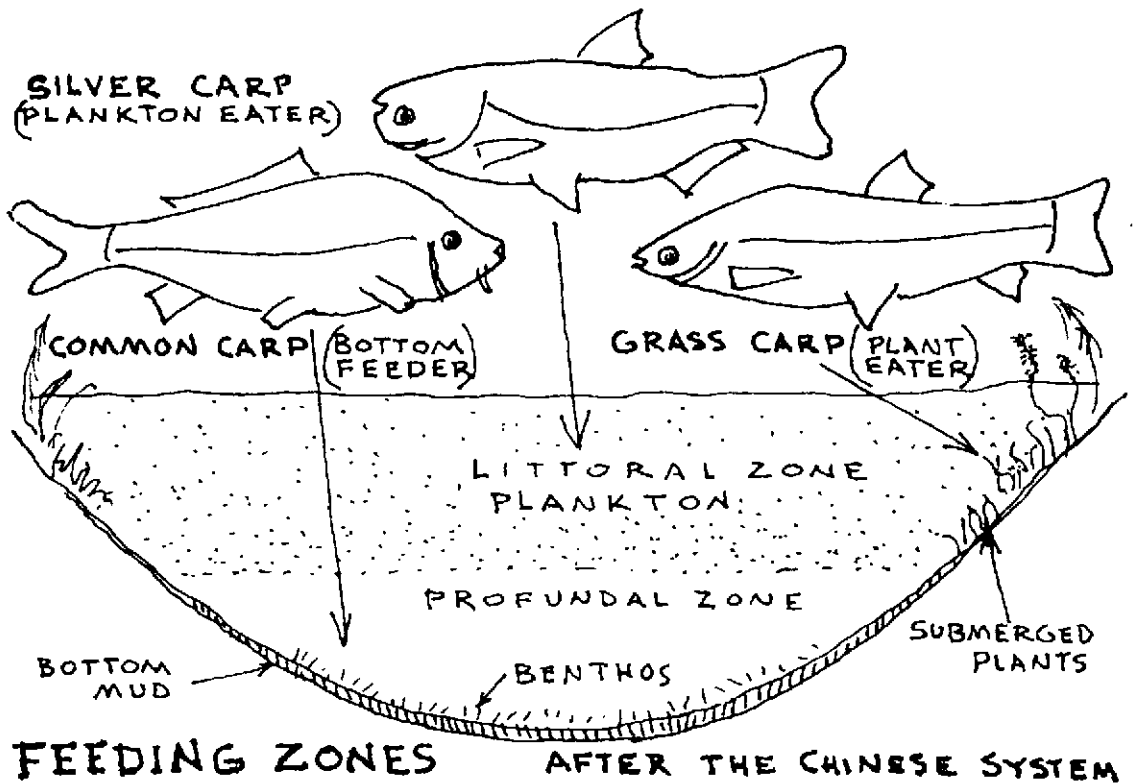

of all, the multi-pond arrangement is employed, especially to separate the breeding and growing stages. Under Chinese management, fish culture is a small scale activity that includes the orchard, garden, pig, duck and chicken in its cycle of production. Wherever possible this polyculture program is set up on a slope to take advantage of gravity flow. Here's how it works: nutrients leached from garden and orchard drain into the fish pond.. Fertilizer from pig and poultry is also washed into the pond, pig dung containing 70 per cent digestible food for fish. When the fish are harvested their offal and the undersized are fed to pig and poultry. Muck from the pond is then scraped out and placed on garden and orchard terraces. Or a field crop, such as rice, is planted in the harvested pond. Nutrient-rich water from the fish-manured pond is also used to irrigate orchard and garden crops. In China, it is the plant that is manured, not the field.

Centuries ago the Chinese discovered the importance which ducks have in this mutual exchange. Ducks are allowed on the pond to help control weeds and snails. The Muscovy breed seem to be hardiest and easiest to raise. It has been found that carp, grown in ponds to which ducks have access, grow from 2-to-5 times as fast as those grown without duck populations.

Ducks, in China, also function — along with frogs, chickens and pigs — as natural pesticides. The Asian principal of pest control creates good food for farmyard inhabitants through thoughtful husbandry of insects and weeds. The old adage, "If you can't beat 'em,

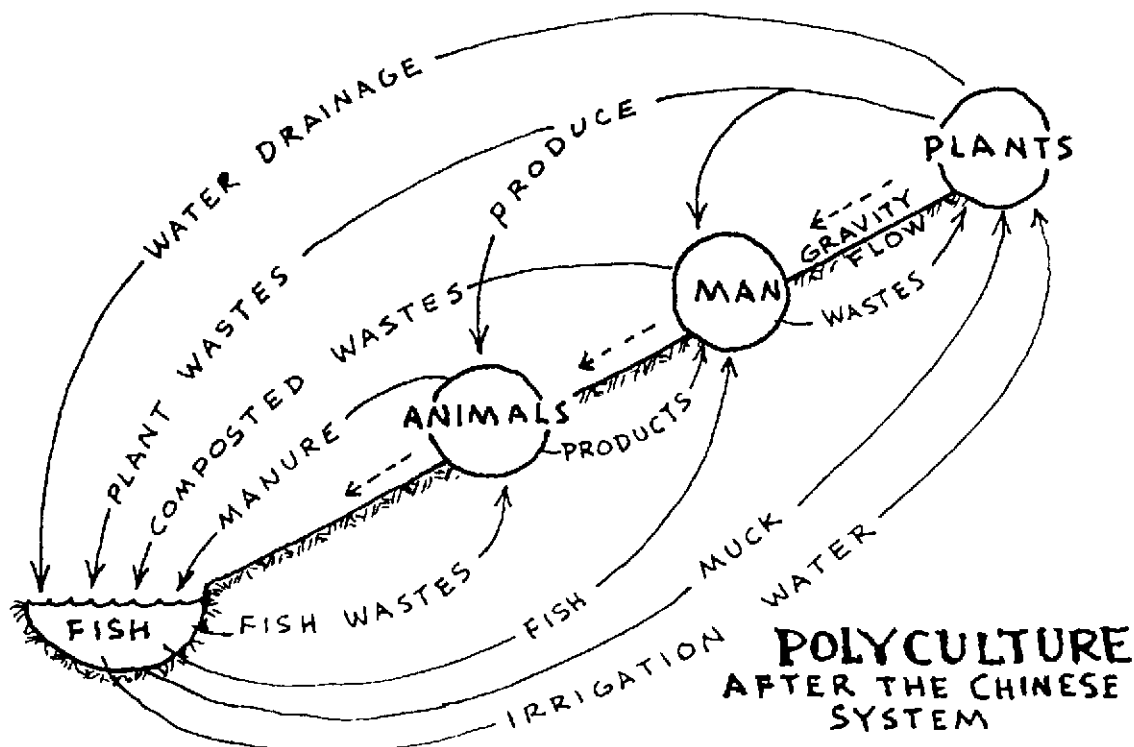

join 'em," may be rewritten in Chinese usage, "If one cannot eradicate them, use them." One other thing: it is a custom in China for the fish farmer to establish field privies over his ponds to encourage the passer-by to stop to rest.

In recent years the Food and Agricultural Organization of the United Nations has done extensive research in fish culture. This organization has, in fact, made a science of intensive fish production, called aquaculture (the growing of aquatic food organisms). Polyculture, the management of a variety of crops in a single production area, is now being promoted and recommended by an impressively qualified scientific community. Much work has been accomplished in developing improved fish strains. One of the most promising of these is a species originally raised in Africa — the Tilapia. Tilapia are easy to breed. A pair raised under favorable conditions will reproduce their numbers to 1½-million in one year! Besides being generally free from parasites under crowded conditions, Tilapia are herbivorous and convert waste foodstuffs efficiently. They live low on the food chain, but do require warm water growing conditions.

Along with other phases of aquaculture, original research work raising Tilapia in North America is being done by a privately-funded group who call themselves the New Alchemists (Woods Hole, MA 02543). Currently, "backyard fish farms" are being managed experimentally as the aquaculture aspect of homesteading gains popularity. New Alchemists can provide an essential coordination service to these novice aquaculturists. As more and more people become turned on to fish culture and their own experiences become coordinated and related to others', a re-birth of this valuable homestead activity will, hopefully, occur.

One member of the New Alchemists recently collaborated on the issuance of a massive book, **AQUACULTURE — THE FARMING AND HUSBANDRY OF FRESHWATER AND MARINE ORGANISMS**, (John Wiley, N. Y., 1972). I would urge that seriously interested homesteaders read this book — if it can be borrowed from some university or research library. The printing price (\$37.50) in no way warrants the small amount of **USABLE** information for homesteaders contained therein. Far too many of its 868 pages are devoted to such scary, but commercially viable topics as induced breeding, artificial propagation, or hormonally-induced spawning through intra-muscular injection of

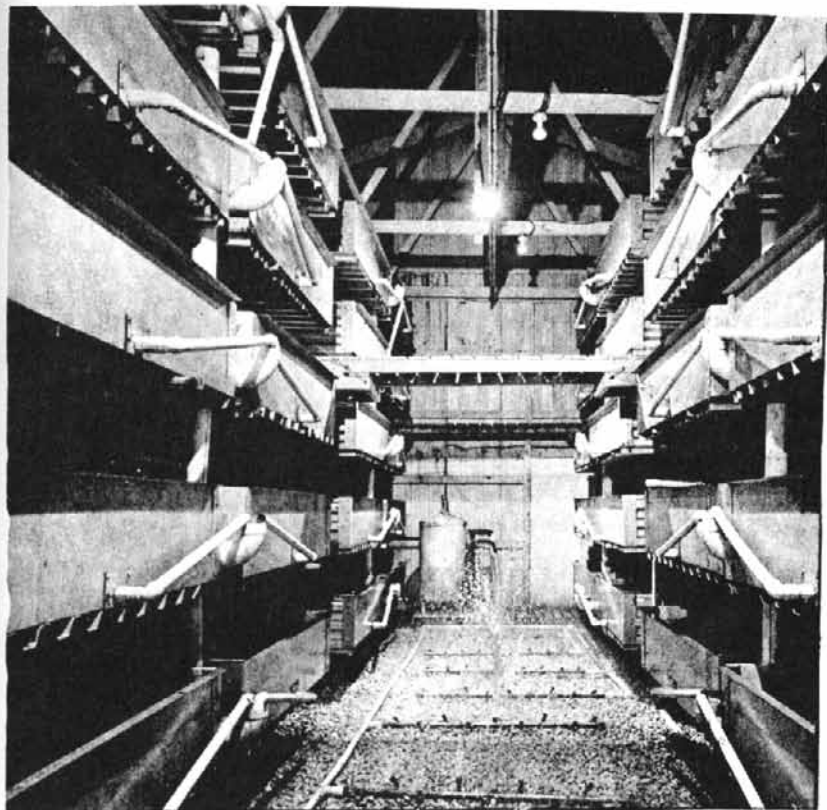

FEATURES OF CONTROLLED ENVIRONMENT AQUATIC PRODUCTION:
1) WATER TEMPERATURE MAINTAINED AT CONSTANT 78° WITH THERMOSTATICALLY CONTROLLED HEATERS.
2) AERATOR IN EACH TANK ALLOWS HEAVY STOCKING, PRODUCTION CAPACITY 10 LB/CU. FT. FEED CONVERSION 2.5:1 HIGH PROTEIN FEED
3) 40 UNIT TRAY (PICTURED) EQUIVALENT TO 30 ACRES SURFACE WATER
4) 40,000 LBS CATFISH PER YEAR AT 35¢ LB LIVE WEIGHT.

pituitary extract. The current state and future direction of commercial fish production in this country is not unlike any other of our ridiculous, monoculture farming practices — like chicken and rabbit production, for instance. Similar closed-system, indoor-cage, food-rationed, controlled-environment practices prevail. One company even offers “controlled marketing” features: “There is no need to market immediately when fish reach 1¼-pounds. If prices are unfavorable, it is possible to reduce the water temperature and withhold feed. Fish will hold their weight until market conditions are more favorable.”

In contrast to the American-style agribusiness approach to fish production, some agencies like the United Nations Food and Agricultural Organization offer valuable research and development for third world countries. In 1966, the U. N. held a world symposium on warm water pond fish culture and subsequently published a 5-volume proceedings.

Since 1934, extensive fish pond research has been carried on by H. S. Swingle at Auburn University in Alabama. At one time over one hundred ponds were drained and refilled in order to develop simple pond management techniques which could be used by farmers to increase their fish yields.

I have reserved a description of today’s most significant fish production research for last. It summarizes the very best thinking in poly-culture subsistence where fish are but a small, integral part of a homestead ecosystem. Mr. George Chan, currently teaching at the University of Papua, New Guinea, has built a working demonstration of a full-cycle waste digester. Here’s how it works: homestead wastes — excrement from humans, pigs and poultry — are washed into a simply-constructed, 300-gallon, concrete digester tank. Anaerobic decomposi-

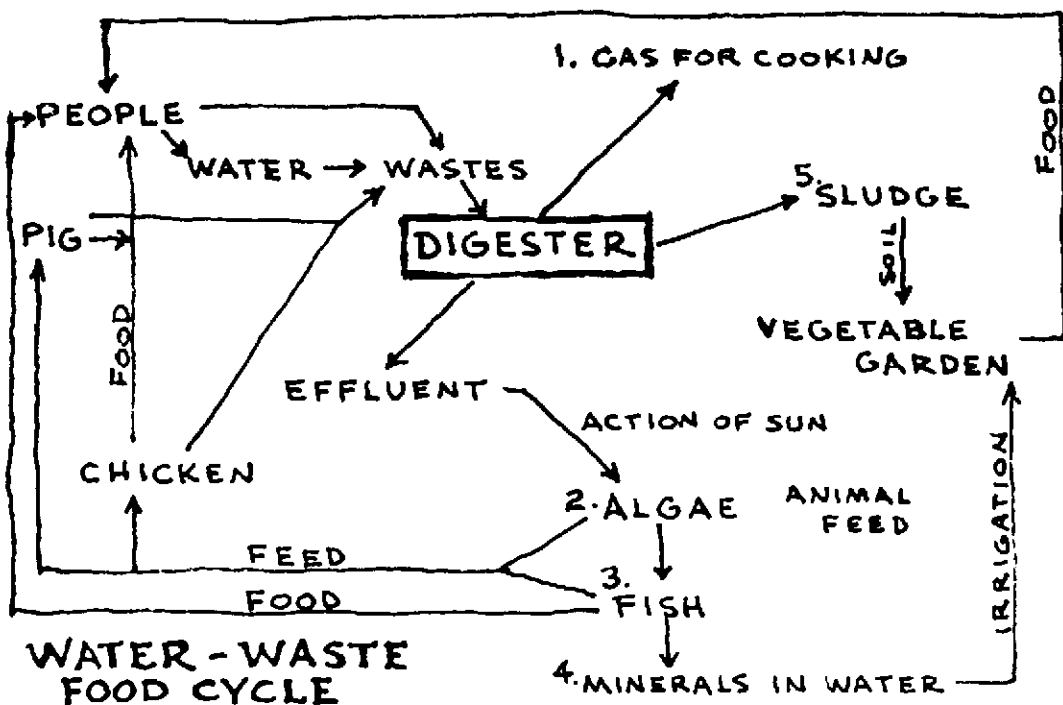

tion takes place, producing methane gas which is piped into the home-
stead for cooking and refrigeration. Effluent wastes from the digester
are then discharged into a small pond where sunlight and warmth
cause a high-protein algae to grow. The algae is harvested, fed back
to the pigs and poultry, and the algae-purified effluent is then chan-
neled into a small fish pond. Tilapia, carp and other varieties of fresh
water fish readily fatten on the algae. The fish are harvested for
human consumption and are also cooked and mixed with dried algae
for a highly nutritious animal feed. The final stabilized sludge from
the digester waste is drained into a garden plot where mineral-rich
vegetables are grown for human and animal consumption. Pond water
is also used for irrigation.

The Taiwan government has sponsored these digester units in an
effort to advance rural development and to prevent the drift of young
people to already over-crowded cities. George Chan points out that
there are now over 5,000 such digester units in operation in Taiwan
alone. This is quite amazing in view of the fact that American
methane-freaks have for years been playing around the periphery of
the idea with hardly a single WORKING digester to show for their
efforts.

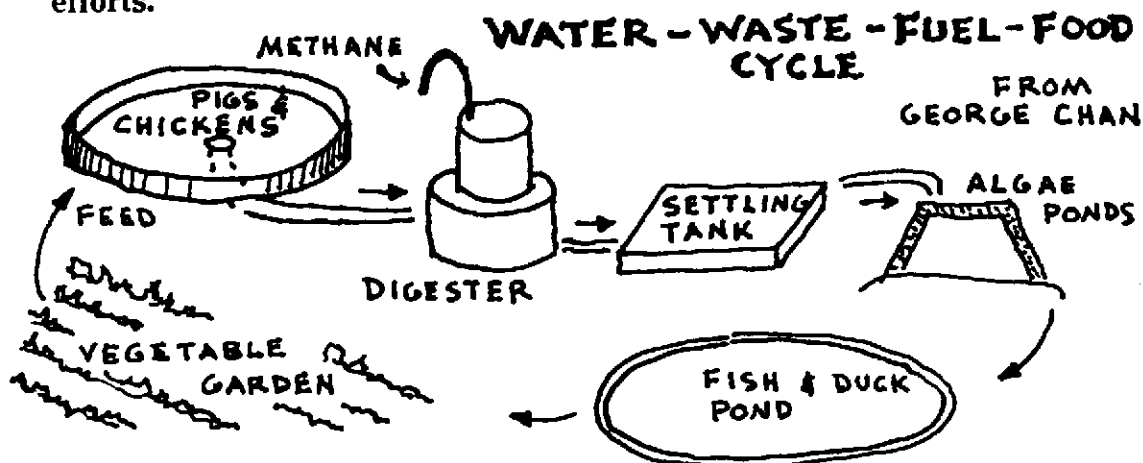

Animal Waste

Pig and Chicken manure is ideal. Circular barn has concrete floor sloping into central digester.

Digester

Capacity 300 gallons for 30 pigs and 24-hours of effluent flow. Fresh waste should be discharged into the digester each day.

Settling Tank

Capacity 24-hours of effluent flow. Bacteria complete digestion of organic matter and destruction of harmful organisms.

Algae Basin

Concrete floor and walls one-foot high. Surface area about 600 square feet with two longitudinal baffles to prevent short circuiting. Shallow depth insures maximum sunlight penetration.

Algae Ponds

Pond size about 60x15x3 feet deep. Several ponds may be installed for larger operations. Pond is formed in the earth into a truncated "V" shape, lined with puddled clay and covered with 3-4 inches of sand to prevent colloidal suspension of clay. Algae is removed daily and mixed with animal feeds or is sun-dried for future use.

Fish Ponds

Pond size about 100x15x5 feet deep, built like an algae pond, but without the sand cover. Growth rate is about one-pound each month. Fish may be processed into meals for animals or eaten by humans. They feed on algae and water microbes and not on excreta. Several ponds may be installed.

Ducks

Ducks do not compete with fish for food. Together they keep the pond clean, controlling mosquito larvae and weeds.

Vegetable Garden

Watered and fertilized with rich effluent and humus (sun-dried sludge). Vegetables provide the bulk of animal feed.

(Adapted from George L. Chan, senior lecturer in environmental Health, University of Papua, Port Moresby, New Guinea--as reported in EARTH GARDEN No. 8)

AQUACULTURE

A good percentage of the food for your household can come from aquaculture, the art of applying agricultural principles to control the raising of aquatic organisms; it includes the cultivation of fish, shellfish, and algae. This art has been practiced worldwide for thousands of years, most extensively in the Far East. Aquaculture *does* exist in the United States—primarily in the form of catfish farms and trout hatcheries—but terrestrial agriculture still accounts for most of our food production. We don't mean to insult agriculture, which is a perfectly respectable way to grow food, but aquaculture is generally *more productive* than agriculture and *more efficient* than raising livestock. (Figures for chicken production are comparable to some aquaculture figures, but aquaculture is more efficient at converting feed into biomass.) Any person who is trying to get the maximum food yield out of his land would be wise to consider using part or all of it for an aquaculture operation.

Aquaculture's superior productivity is due to three characteristics of its medium. First, water absorbs and retains the sun's energy better than land; a pond thus will have more energy available for organisms to use than a comparable land area. Second, water can diffuse material throughout itself, an ability dry land lacks. This ability to mix materials within itself results in a much more even distribution of nutrients than that of soil; on land, one spot might be deficient in a vital nutrient that is at toxic concentration in a spot but a few feet away. The third (and main) advantageous characteristic of water is that it occupies a three-dimensional space: different organisms can live at different depths under the same area of surface. Land is virtually two-dimensional, with life only on, and a short distance above and below, the surface. Thus, an area of water is more productive than an equal area of land because there is more habitable volume. The ancient Chinese found that using all three dimensions of

water made a very productive system. Realizing that different species of fish live at different levels in the water column and eat different food ("occupy different niches" in biological terms; see Figure 7.11), they deduced that it might be possible to culture many different species of fish in the same pond; the fish would not only not interfere with each other, but would even complement each other. For example, an algae-feeding species near the surface and a bottom feeder, both with high reproductive rates, can harmoniously coexist; their young are controlled by a predator species, and the waste products of all three species could in turn fertilize the water, thus supporting the growth of algae for the herbivorous species. This culturing of more than one species is called *polyculture*. Obviously, different types of fish must be chosen with care, as two random species do not necessarily complement each other.

In spite of the greater efficiency of polyculture, often economic and social factors confine only one type of fish to a pond. This practice (called *monoculture*) is less efficient with both food and space, and consequently less productive than polyculture.

Already we've mentioned twice that aquaculture is "more efficient" than agriculture, but we haven't really explained what we mean. Efficiency, in this case, is the number of pounds of food an animal must be fed for it to grow one pound heavier. It takes more than one pound of food to grow one pound of animal because some food is burned up as the energy the animal uses to live. Aquatic animals need less of this energy than land animals because water supports their bodies. In addition, most aquatic animals are cold-blooded, and less energy is expended by cold-blooded animals than warm-blooded animals. Since our domestic land animals are warm-blooded, it follows that aquatic animals burn less food into energy than land animals, and can convert more of this food into meat. Thus, in principle, aquaculture is more efficient than culturing land animals.

Another theoretical concept sheds light on this question of efficiency: the food chain. In a generalized ecological system, production occurs when tiny one-celled plants, phytoplankton, use energy from the sun and nutrients from the water to grow and produce more biomass. They are eaten by microscopic animals, zooplankton, which are in turn eaten by bigger and bigger animals until the final consumer is a large fish or land predator. You will remember that organisms at each level use up some (indeed, most) of the energy they absorb to carry on their own life functions; thus less energy is available to other consumers higher up the chain. Consequently, the most efficient theoretical way of utilizing the original solar energy input into a system is to cultivate the lower-order consumers: herbivores or zooplankton feeders. But there is a limit to how low you can go before dining becomes unpalatable, or inefficient, or both. Most

human societies prefer fish to chironomid larvae and steak to grass; even if you were so inclined, it would take hours to catch a mouthful of copepods. In such circumstances, it's better to let a higher-order consumer convert food to an edible state. A good discussion on energy needs and fish yields for various types of aquaculture practices can be found in the *Energy Primer* (see Bibliography, under Merrill, et al.).

The amount of biomass produced is limited by the concentrations of nutrients and vital molecules present in the system, some of the most important being nitrogen, phosphates, carbon dioxide, and oxygen. In a given situation, nitrogen and phosphate concentrations may be too low to permit further production of biomass. When organic waste is added to this limited-nutrient system, bacteria decompose it, releasing nitrogen compounds, phosphates, and other nutrients. Thus, adding *garbage* will add nutrients to a pond, which may stimulate plant growth, which stimulates zooplankton blooms, which in turn increase the food supply and therefore the growth of the organism which the culturist is attempting to raise! (For further information, see "Oxidation Ponds" in Chapter 5.) However, caution must be exercised when applying any such "fertilizer"; the decomposition that produces these nutrients also uses up vital oxygen and makes the water more turbid. It is possible that the end result may be the death of a fish crop, rather than its enhanced growth. Inorganic fertilizers like superphos-

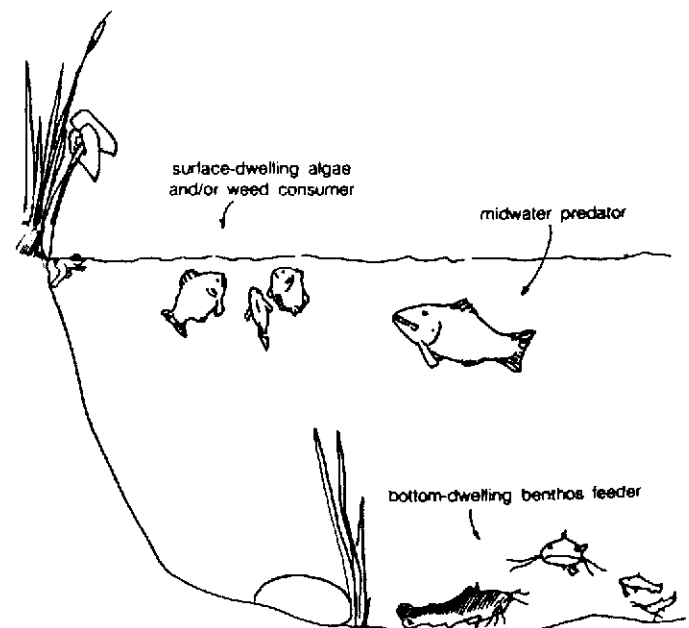

Figure 7.11 Polyculture in a fish pond: efficient utilization of the three-dimensional pond environment can be promoted by culturing compatible, noncompetitive species which have differing feeding niches and habitat niches.

phates can also stimulate growth and, since bacterial decomposition isn't needed, avert any danger of an induced oxygen shortage. But inorganic fertilizers cost money, while garbage is cheap and plentiful.

Before going any further, we must differentiate intensive from nonintensive aquaculture. *Intensive aquaculture*, as the name implies, involves feeding the fish, controlling their breeding, and much more; in general, you spend a good deal of your time and labor shaping the environment and life patterns of fish. *Nonintensive culture* is a minimal-labor operation; the fish are not controlled except for an occasional cleanup of debris in the pond, fertilization of the pond, and the harvest itself of the fish. As you might imagine, nonintensive culture is generally less productive, but it is also less expensive and time-consuming.

Production figures which follow in our discussion are given in kilograms per hectare per year (kg/ha-yr). A kilogram (kg) is 2.2 pounds, and a hectare (ha) is 10,000 square meters or 2.47 acres. Thus, a kg/ha-yr is a little less than a pound/acre-yr.

Please realize that all we can do is summarize some of the information applicable to the question of aquaculture. For a more detailed look at specific problems, you are encouraged to consult other references and sources, many of which are listed in the Bibliography.

Some Fundamental Considerations

One cannot, so to speak, just plunge into an aquaculture operation. There are several important questions which must be faced beforehand. Hopefully, those preceding pages where we described the superiority of aquaculture haven't made you excessively optimistic. Success still requires a great deal of work and the first job is to forget anything you've heard about how easy aquaculture is. A few success stories have led to books being rushed into print, describing the ease with which fish can be raised and their riches reaped. These stories should be filed in the same place as the early-1929 stories of how anyone and everyone could get rich in the stock market. If aquaculture was such a sure bet, everyone would be doing it. Although it has great potential, aquaculture requires as much care and maintenance as gardening, and, like gardening, not every site is equally suitable. The weeds still must be pulled, the water checked, and the fish fed. And as an added bonus, fish, too, are menaced by a great variety of predators and diseases just itching to get at them.

The central questions you must answer concern the physical features of your site. If a body of water can't exist on a site, obviously aquaculture is impossible. The soil and subsoil must be tested for water-retaining qualities and fertility. Existing topographical features should allow

complete pond drainage, and the legalities of draining into existing streams must be investigated. Other important factors include the accessibility of the pond and nearby insecticide concentrations. Of *critical* importance are adequate primary and emergency sources of water, the temperature and quality of this water, the organisms present in it, the likelihood of floods, and the need for water permits.

The next level of questioning is related to the specific organism you want to culture and where to get it. Obviously, the question of species must be resolved first. Then you must decide whether to initiate the stock with mature breeders or with a younger stage (fry or fingerlings, in the case of fish). Remember that, in many cases, it's better to buy fish that are already hatched than to try to hatch them yourself, even if it means you can't be self-sufficient. Breeding and caring for eggs and fry is an art—an extremely difficult art for some species—and it can require additional expensive equipment. If you want to breed the fish yourself, there must be a supplier from whom you can purchase breeders. Then the age, size, and number of breeders of each sex all need to be determined. Furthermore, the culturist should know at what temperature spawning occurs and how long the breeders must be in breeding surroundings before they spawn, so that you don't harvest them too early and wipe out your stock. And with fingerlings, the culturist must know what size and number to stock and how to stock them without causing thermal shock. The aquaculturist must also do all the necessary preparatory work on the pond water before stocking.

And yet there is more: you must determine and stock the proper food for the fish. The culturist should determine the fertility of the pond, the type and amount of fertilizer that will induce the desired plankton population, the feasibility of artificial feed, and what is needed for the winter.

Answers to these questions are beyond the scope of this chapter, but we refer you to some sources of information. For general reference information, the best English-language encyclopedia is *Aquaculture: the Farming and Husbandry of Freshwater and Marine Organisms* by John Bardach, John Ryther, and William McLarney. It contains a great deal of information on practices throughout the world and information on fish not commonly cultured in the United States. A very good book on trout culture and fish diseases is *Culture and Diseases of Game Fish* by H.S. Davis. These and other books on fish culture are listed at the end of this chapter, in the Bibliography.

For more specific questions, help can be obtained from federal and state agencies—fish and game commissions, the Fish and Wildlife Service of the Department of the Interior, and conservation agencies. Other sources might be nearby universities and colleges, especially

those involved in Sea Grant programs. Still other sources are those people actively involved in existent commercial ventures: fish farmers, fish-farming associations, and distributors or researchers for fish-food companies. Helpful publications are put out by federal and state governments, universities, and the United Nations Food and Agriculture Organization (FAO). Information is also supplied by such periodicals as *The American Fish Farmer*, *Farm Pond Harvest*, and *The Progressive Fish-Culturist*, as well as in research reports in scientific and industrial journals. However, one note of caution is necessary. If you have a problem, understand that advice and solutions can vary from one source to another. As a case in point, a fish breeder once had a disease problem he couldn't solve. He asked the state fish and game agency for advice and sent them some diseased fish. Evidently they didn't examine the fish too carefully because, each week for several successive weeks, they told the breeder to try different solutions, all of which were expensive and none of which worked; the breeder lost most of his fish. He later learned that his problem was due to flukes, a parasite easily controlled by one application of the right chemical. The moral of the story is that aquaculture is an inexact science; don't expect anyone to know all the answers.

Living Quarters for Fish

Don't forget! Fish live in water. This means that successful aquaculture requires an adequate water supply and a container to hold the water. Obvious though this may seem, it is sometimes forgotten, and the results are both costly and embarrassing.

An adequate water supply is one that furnishes water during the driest part of the season, which is usually when it's needed the most. For freshwater aquaculture, this water can come from either wells, surface runoff, streams, or springs. Well water has the advantage of being a fairly reliable, relatively pollution-free source, and is also free of undesirable aquatic organisms; however, it needs to be pumped and is low in oxygen. Surface water may not have to be pumped, but it usually contains undesirable fish which are extremely adept at crawling through filters and infesting your pond. Springs are clean water sources that don't need to be pumped and are preferred when available.

Whatever the source, this water must be contained in some manner, in either ponds, troughs, raceways, circular ponds, or silos. Fish also can be isolated in larger water-bodies by means of floating nets or cages. The type of container you select depends upon local geology, your aesthetic taste, the type of fish you're raising, the amount you want to produce, and your pocketbook. If you want to raise fish in a sylvan setting reminiscent of Walden Pond, concrete circular ponds will never do; you should

opt for a farm pond (and lower production). Or, if you live downtown and your backyard only has room for garbage cans and a clothesline, then a farm pond is not practical; you should look into fiberglass silos.

Ponds: Ponds are used mostly for warm-water fish, but they can also be used for trout. For a dirt-bottom pond, the soil must retain water. The Soil Conservation Service of the Department of Agriculture can check the moisture-retaining properties of your soil. If the earth doesn't retain water, a sealant such as bentonite can be used, or a vinyl sheet can be laid between water and ground; but both these methods add considerably to your cost. As we mentioned earlier, be sure that the pond is constructed so that it can be drained completely. Details of construction and illustrations are presented in our discussion of farm pond programs. If there is already a pond present which you wish to use, care must be taken to insure that no undesirable fish are in it. This "care" usually means draining your pond and starting from scratch.

Raceways and Circular Ponds: Pond water, because it is stationary, can be enriched with fertilizer; the pond is thus applicable for warm-water fish which usually live in "productive" water (turbid with phytoplankton, for example). However, salmonid fish (trout and salmon) prefer clear, nonproductive water. Because running water carries away the growth-inhibiting waste products of these fish, the best production of salmonids occurs in either raceways or circular ponds. Expenses can mount up for these types, since they usually need to be constructed and maintained with pumps and filters.

Raceways are long troughs which are slanted or stepped downhill. Water enters through the uphill end and leaves from the downhill end (see Figure 7.12). Since water is continuously flowing through the raceway, great quantities are needed to operate it. American raceways are usually built with concrete, and this material is not cheap. Earth raceways are less expensive and provide natural food for the fish. The soil must retain water, however, and the probability of disease is increased. If you happen to have a clear, cold-water stream on your property, you have a natural raceway and may need only to dam it up a little or build several small pools.

In a circular pond, water is shot out of a pipe on the rim of the pond and the water flows around the pond in a spiral, finally exiting by a drain in the center (see Figure 7.12). This approach uses much less water than a raceway, but it still consumes a considerable amount. Because there must be a permanent slope down to the drain, concrete must be used for the bottom and sides, a sacrifice of both natural beauty and many dollars. Construction of a pond 2.5 feet deep and 20 feet in diameter would cost between \$1500 and \$2000.

If you don't have enough room, water, or money for raceways or circular ponds, high production also has

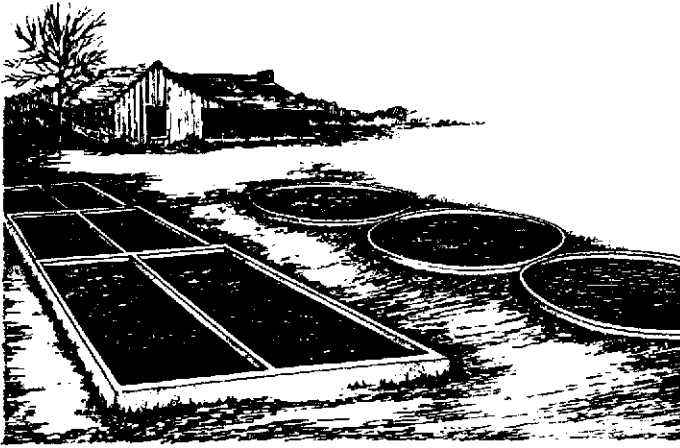

Figure 7.12 Most frequently found in hatcheries, raceways and circular ponds both require large quantities of water and also pumping equipment.

been attained in barrels. In *Aquaculture* (Bardach, et al., 1972), it is reported that Pennsylvania Fish Commission biologists at Bellefonte, Pennsylvania, once raised 2720 kilograms of trout in a fiberglass silo 5 meters high and 2.3 meters in diameter. It was merely an experimental approach, but you might look into it.

Cages and Nets: Fish are grown inside cages and nets when they are cultured in the ocean, in powerplant effluents, or in large streams. This kind of isolation makes harvesting easy, yet provides a constant supply of circulating water to the fish. The fish, however, must be hatched and raised through early youth in another type of container or else young fry must be collected from some other source. In addition, any use of structures on public waterways first must be cleared with legal authorities.

Freshwater Aquaculture

Now that we've surveyed the promise, problems, and structures used in aquaculture, we finally can get down to discussing the fish. Much of the data which follows has been drawn from *Aquaculture* by J. Bardach, et al. Bear in mind that great climatic differences occur within the expanse of the United States; some forms of aquaculture which are applicable to one area are wholly inappropriate in another. Most aquaculture activity in this country is carried out in the Southeast, where the warm climate makes possible a long growing season and rapid growth during this season. In the northern part of the United States, the temperature during the summer can be every bit as warm as in the South; but the warm season is shorter, resulting in less annual growth for fish, and the winters are extremely cold, often resulting in no growth. Tropical breeds like *Tilapia*, which are very successful in

warm climates, cannot survive in the North without special care. And such eurythermic breeds (tolerant of wide temperature ranges) as channel catfish and bass can be cultivated in both the North and South, but grow more slowly in the colder climate.

Do not, however, be misled: aquaculture is still (and equally) feasible in the northern United States. It has been carried on for centuries with great success in the extreme climates of Japan, the north of China, and Eastern Europe. Species native to these regions can survive the local extremes of temperature; years of experience have taught the people which species grow and taste the best, and are the most amenable to aquacultural techniques.

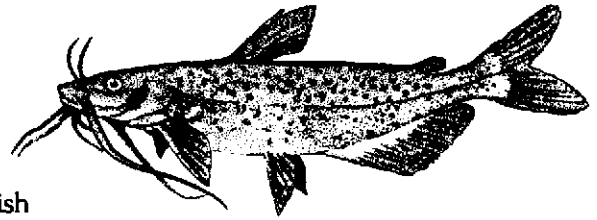

Catfish

There is a great deal of data on commercial catfish farming and so it is a good first species to take under consideration. Catfish do well under intensive culture because they adapt well to crowded conditions and have an excellent feed-conversion ratio (usually about 2 pounds of feed for every pound of fish, but often as low as 1.3:1). Large fish farms often spawn catfish in aquariums or tanks. The small fish are placed in ponds at concentrations of anywhere between 20,000 and 100,000 per acre. After the first season, when the fish are between three and eight inches long, they are restocked at reduced concentration levels—usually between 1500 and 2000 fish per acre. They are ready for market in another seven or eight months, weighing about a pound each. An average yield is about 1700 kilograms per hectare.

Optimum water temperature for catfish is about 85°F. Below 60°F and above 90°F, feeding and growth drop off sharply. The growing period, however, lasts as long as the temperature is within this range.

The dissolved-oxygen content of the water is of vital importance. Greater quantities of fish per acre make heavier demands on available food and oxygen, so management becomes more difficult. A large part of the oxygen in a pond is produced by algae; it is sometimes necessary to use fertilizer to encourage algal growth if you start a new pond. Later, the problem becomes one of controlling excess algae, since at night the algae become oxygen consumers and compete with the fish for the available oxygen. Overfeeding, too, can lead to serious problems in this area, since uneaten food can stimulate algal growth and also consumes oxygen as it decays. Oxygen content is highest late in the afternoon and lowest just before dawn. It is not unusual for the entire population of a pond to die in one night due to oxygen

Table 7.8 Catfish Diet Guidelines^a

Diet Element	Percent of Total Feed
Crude protein, more than	30
Digestible protein, more than	25
Animal protein, more than	14
Fish meal protein, more than	5
Crude fat, more than	6
Crude fiber, less than	20

Notes: a. Taken from F. Meyer, *Second Report to the Fish Farmer*.

depletion. In the summer, oxygen levels should be measured every day early in the morning and should be kept well above 3 parts per million (consult fish and game agencies for measurement techniques). A serious shortage can be alleviated temporarily by partially draining the pond from the bottom, where there is less oxygen, and then adding more water. The best way to add this water is by spraying it through the air where it picks up a great deal of oxygen. In the long run, however, the problem must be solved by careful pond maintenance and control.

Catfish are fed about 3 to 5 percent of their body weight each day. During a seven-month growing period, the cost of feed is between \$100 and \$150 per acre for a pond with 2000 fish per acre. During the winter, only about one-third as much food is consumed per day; the cost is proportionally less.

The amount your fish will grow is directly related to proper diet. The ingredients, of course, can be varied. Catfish have been raised using soybean as the only source of protein, although its utilization is very poor at lower temperatures. Table 7.8 presents a set of diet guidelines, and Table 7.9 illustrates a suggested feed formula. Balance in the feed content is stressed.

If you want to avoid commercial fish food, you can raise soybeans as a protein source; but processing to make them acceptable to the fish must be tried out experimentally. Worms and insect larvae also can be raised in a compost pile. Alternate sources of protein are minnows or other herbivorous fish raised in the same pond. But with these diets, don't expect the same growth rates as from commercial feed.

Catfish have been raised in densities of up to 600 per cubic yard in cages and raceways. Cages anchored in lakes and rivers rely on natural wind and water currents to carry out wastes and to carry in an adequate oxygen supply, while raceways require continuous circulation of fresh water to provide the same two maintenance tasks. However, because extremely well balanced diets and highly skilled management are necessary, these high-density culture methods are still largely in the experimental stage.

Production is directly related to management capabilities. The more a catfish is fed, the faster it will grow. On a commercial fish farm, a catfish is brought to marketable size (about a pound) in two growing seasons. Since fish are stocked at a rate of between 1500 and 2000 per acre, an average commercial yield is between 1500 and 2000 pounds. The total cost for rearing a one-pound catfish on a commercial basis is about 35 cents, of which 10 or 15 cents is spent for feed.

The problems of intensive culturing are many, some of which cannot be handled adequately in a small living unit or backyard. If, for example, you have only a limited supply of electricity, it might be impossible to harvest and preserve the fish all at once. This limitation would mean feeding a large population of nongrowing fish through the winter. There is also the matter of reproduction. Most small-scale catfish farmers find it more economical to buy fingerlings directly from hatcheries than to attempt the difficult task of raising their own. Large numbers of small fish do not compete well in the same pond with significant numbers of larger fish. And diseases can wipe out the farmer overnight. If you're still interested in catfish, it is best to start with a small pond and then expand as you learn more about it. This, in fact, is a good rule for any aquaculture operation you try. (For more information, see the listing under F. Meyer in the Bibliography; polyculture of catfish is discussed in the next section.)

Tilapia

Tilapia is a species of small tropical fish which is omnivorous, feeding happily on algae, plants, or insects. The New Alchemy Institute conducted an experiment where several individuals in different parts of the country attempted to raise *Tilapia* in small ponds; details are described in the *Backyard Fish Farm Workbook for 1973* (see listing under W.O. McLamey in the Bibliography), and a brief summary is presented here.

Tilapia require a water temperature above 60°F to survive; for breeding and maximum growth, the best temperature is in the mid-eighties. Consequently, most of

Table 7.9 A Suggested Feed Formula^a

Ingredients	Percent
Fish meal (menhaden)	12.0
Soybean meal	20.0
Blood meal	10.0
Distillers solubles	8.0
Rice bran	35.0
Rice by-products	10.0
Alfalfa meal	4.5
Vitamin premix	0.5
	100.0

Notes: a. Taken from F. Meyer, *Second Report to the Fish Farmer*.

the ponds used a plastic dome to retain heat and extend the growing season. The plans for making the dome are available for \$5 from *Popular Science Magazine* (355 Lexington Avenue, New York 10017). The ponds described in the experiment were approximately twenty feet in diameter. (Commercial swimming pools can be used if it is not possible to dig a pond.) The earthen ponds were lined with heavy plastic sheets to prevent water leakage. Ordinary tap water can be used but, prior to the addition of fish, it must stand for a day or two to permit dissipation of the chlorine residue.

The ponds were fertilized with manure to induce algal growth. The manure was not added directly to the pond, since this direct application would have made the water too turbid. Instead, it was placed in a burlap bag which then was placed into the pond. Another method of fertilizing involved the preparation of enriched "manure tea"; this stew was separated from the pond proper by a partition which only allowed the passage of liquids.

A pump and filter for recirculating the water is desirable because fish produce growth-inhibiting *metabolites* as waste products. These metabolites stunt the size of other fish of the same species. Commercial filters for small ponds are available, but they are expensive and use a lot of electricity. The New Alchemy report describes a filter in which the water was pumped first into a settling tank, next over broken oyster or clam shells (which removed the metabolites), and finally back into the pond.

The chief source of food for the experimental *Tilapia* was algae. The experimenters also fed them greens, soybeans, earthworms, insects attracted by ultraviolet light, and mosquito larvae. No attempt, it seemed, was made to be particularly quantitative about the amounts.

None of the participants in the New Alchemy project spent over \$200. As an example of their results, one pond stocked 119 fish in May and then added 168 later in the season. Total weight of the fish stocked was 1319 grams or 2.85 pounds. In November, 316 fish were harvested, weighing a total of 6140 grams or 13.5 pounds, a total weight increase of about 360 percent. Only twenty-five of the fish harvested, however, were large enough to eat. There are plans for a repeat experiment and better results are expected.

It would be feasible for a small group with limited space to attempt to raise *Tilapia*, but, as of this writing, it is illegal to import *Tilapia* into California except by special permit for exhibition purposes. You should check with your own state fish and game agencies about local regulations. They might possibly make an exception for a research project.

One promising polyculture procedure is the combination of catfish with *Tilapia*. One discouraging result of the New Alchemy *Tilapia* experiment was the large number of small fish in their harvest. The catfish could use these small fish as a food source and, at the same

time, control their population. The *Tilapia*, in turn, could control pond fertility by consuming excess algae and waste matter. In an experiment at Auburn University, 500 *Tilapia* and 1800 catfish were stocked per acre. The result was 400 pounds more catfish per acre than from a pond stocked with catfish alone. On many fish farms, catfish and minnows are raised together. One drawback, however, is that catfish do not become active predators until they weigh a pound or more.

Carp

Carp (*Cyprinus carpio* and other species) are the most heavily cultivated fish in the world. They have a bad reputation in the United States, but it's not entirely the carps' fault. They were transplanted here during the last century by someone who wanted to culture carp in a country that was then up to its gills in wild fish and had no demand for cultured carp. Ultimately, the unwanted carp were released into the wild, where in a few short years they reverted to their wild state and erased the tasty characteristics that had been established by centuries of careful breeding. However, their descendants still have many traits which make them desirable for culture; it also might be possible to get some of the untainted foreign species if reverted "natives" displease you.

Carp are tough fish, highly tolerant of temperature and water conditions; they spawn easily in captivity and can be cultured over most of the United States. Breeding carp spawn in the spring, when water temperature warms up to about 60°F. In the Far East, fiber mats are anchored just below the surface of the water and carp lay their eggs against the bottom side of these mats. In intensive-culture procedures, the eggs then are removed from the pond to be hatched and raised past the fry stage in separate containers. They feed on zooplankton, algae, and detritus, and do especially well in cages in sewage effluents.

In some parts of the world, subsistence (nonintensive) culture of carp is carried out; breeders and eggs are left alone in the pond and the new fry survive on naturally produced food. Here, as elsewhere, nonintensive yields are less than those of intensive culturing. Polyculture with a predator fish (trout, pike, perch, bass) to control the number of young carp can increase the growth of the survivors. In China, polyculture has produced incredible yields in small ponds. Different species of carp have been bred so that one species feeds on macroalgae, a second feeds on phytoplankton, another on zooplankton, and yet another on bottom detritus. In this highly efficient system, each species complements the others and none are competing. Yields can reach 7500 kg/ha-yr.

On the other hand, subsistence farming in Haiti produced 550 kg/ha-yr. Fingerlings were stocked which took from seven to nine months to reach maturity. With intensive culture in sewage effluent in Java, up to 1,000,000 kg/ha-yr have been produced, a very impres-

sive production figure.

Raising carp, however, does present a few problems. For example, because the temperature fluctuates in the temperate zone, it's possible that carp can be induced to spawn too early and a late cold spell will kill the fry. Competing species usually make survival difficult for young carp. Also, carp eggs are particularly susceptible to fungus outbreaks, and the grown fish easily fall victim to diseases. As with *Tilapia*, metabolites produced by carp limit their own growth (these wastes can be eliminated by similar filtering systems, as well). In spite of any problems, carp culture, particularly a Chinese polyculture arrangement, is well worth considering.

Pike

The pike is a carnivorous, large game fish, highly prized by sport fishermen. Pike are cultivated commercially in the United States, to be released into the wild and then hooked by the fortunate angler.

Intensive culture is accomplished by catching breeders in the spring when the water reaches 50°F, stripping out and then mixing together the eggs and sperm. Fertilized eggs are hatched in jars, and these fry must be fed intensively with zooplankton and small fish.

In nonintensive culture, a number of fingerlings can be planted in a pond in spring and left to their own devices until you fish the survivors out in the fall or the next year (only 2 to 5 percent of the fry actually last until fall).

Common problems of pike culturing are the difficulty of producing fry, their high mortality, and (because they are further along in the food chain) their low production. Pike have a low conversion efficiency and produce only about 10 kg/ha-yr. In a polyculture arrangement, pike are suggested for use in controlling an out-of-hand carp population; they may or may not prove effective in this role.

Perch and Walleye

Perch and walleye are carnivorous fish of the same family. The former is commonly cultivated in Europe and the latter in the United States. Techniques are similar and both can be cultured in any region of the United States.

In intensive culture, the farmer builds a nest and induces spawning in the breeders by pituitary hormone injection. Eggs are hatched in jars and, after the fry consume their yolk sacs, they are fed zooplankton. While still in the fry stage, they can be stocked in a pond with carp.

Fertilizing the ponds of perch and walleye with garbage may present some problems. For example, a Minnesota walleye pond was fertilized with barnyard manure in the spring and a desirable cladoceran (a crustacean) bloom resulted. However, summer fertiliza-

tion resulted only in algal scum growth and no cladocerans; the fish ran out of food. Other growers found that sheep manure and brewer's yeast applied together kept the cladocerans blooming through the summer. Yeast is expensive, however, and its role is not exactly clear. There also have been reports of perch grown in sewage effluent.

In nonintensive culture, a few males and females can be stocked together and left unattended; young fingerlings should appear by fall. Some growers remove the fish from the pond over the winter; it takes these growers about 150 kilograms of fish to feed 100 kilograms of perch. Another solution to the over-wintering problem is to dig the pond deep enough for them to survive by themselves (twelve to fifteen feet in at least one-quarter of the pond).

Production of perch and walleye is higher than that of pike. They are, however, more difficult to handle and the questions of maintaining a carnivorous food supply and over-wintering must be dealt with. These fish also are suggested for polyculture with carp, even though their effectiveness as predators is not clear.

The Air-breathing Labyrinth Fish

Labyrinth fish (family Anabantidae) are air-breathing fish which can crawl over land when their pond dries up. They have been cultivated successfully (both intensively and nonintensively) in Southeast Asia, usually in a polyculture system with carp. Labyrinth fish are omnivorous, feeding on zooplankton, insects, and plants. They also flourish in water which has a low oxygen concentration, and thus avert a major headache for growers who use small stagnant ponds. Production depends on the species, but usually averages a few hundred kg/ha-yr.

The difficulty with applying labyrinth fish culture to our local situation is that the fish are not native to the United States, which raises certain problems. An ecological objection is that introducing a foreign fish which could escape might upset the balance of our local ecosystems. There's also a likelihood that its introduction is illegal. Finally, breeders would be very difficult to find. Even if these obstacles could be overcome, the utilization of labyrinth fish is still in experimental stages. Culture of the gourami (a labyrinth variety) was attempted in France unsuccessfully, and thus doubt remains as to whether this tropical fish can survive in more temperate zones.

Eels

Eels are catadromous fishes; that is, they spawn at sea but the young mature inland in freshwater. They are cultivated primarily in Japan and Taiwan, where they are considered a delicacy.

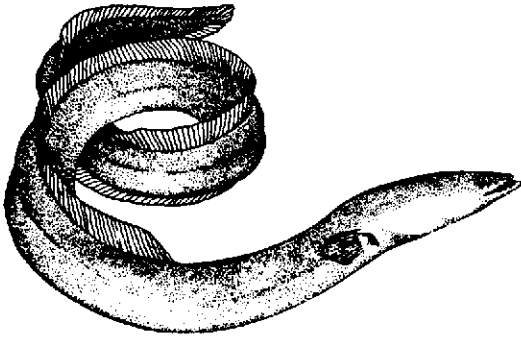

Eels have never spawned in captivity; the stock, therefore, must be replenished each year. Elvers (newly hatched eels) are caught with nets when they migrate to the mouth of a river and these captives are stocked in small ponds at a concentration of 600,000 per hectare for three months, after which they are thinned and then transferred to bigger ponds.

Eels are sloppy and inefficient feeders; they swim into cages filled with worms, minced fish, crushed mollusks, and animal guts, and thrash about in this food until a sufficient amount manages to get into their mouths. The food which they thrash out of the cage need not be wasted. Different species of carp can be stocked which feed on this "excess" and yet another species can be planted to feed on the plankton and algae which bloom after the excess food decomposes. With natural food, the protein conversion efficiency for eels is 6:1, which is very low; artificial food can raise this ratio to 2:1.

The best production is obtained in running water or in aerated and recirculated ponds. Optimum temperature is from 68 to 82°F. When polycultured with carp, total production averages 8000 kg/ha-yr. In well-developed running-water systems, production averages 26,000 kg/ha-yr (Japan). The European eel proves more difficult to culture because it is susceptible to diseases to which the Japanese species is resistant.

Drawbacks to the culture of eels include their inefficient protein conversion rate and the extremely high cost and quantity of their food. And, since they don't spawn in captivity, you must replenish your stock on a yearly basis. To make matters worse, elvers in America are only common on the Atlantic coast, and methods of capture have not been well developed.

Trout

These fish are among the most popular game fish in the world. A large proportion of the fish culture in the United States is devoted to trout, which are usually raised for the purpose of stocking fishing grounds.

Intensive culture is a laborious and difficult process. Trout are unusual in that they grow best in cold, sterile water and are more efficient in monoculture than polyculture. Trout won't spawn in captivity without help; they must be artificially fertilized by stripping eggs and sperm. Eggs are hatched in trays, and the fry are raised in

shallow raceways and then moved to larger raceways as they grow; circular ponds and silos can also be used. In any case, great quantities of clean water must be available. Water temperatures are normally maintained between 50 and 65°F, and oxygen concentrations must be no less than 5 ppm (parts per million). Trout feed on invertebrates or artificial food. One-year-old trout can be polycultured as predators with carp, although they prefer cleaner water. Intensive culture can produce up to 60,000 kg/ha-yr under the best conditions.

It is also possible to raise trout nonintensively, in cold-water ponds. In general, such ponds exist only in the northern tier of states, in Canada, and on the Pacific Coast. To supply your family, a pond should be between one-half to one acre in area, with a degree of both inflow and outflow; at least a quarter of the pond should be from twelve to fifteen feet deep if it freezes in winter. Water temperature during summer *must* be between 50 and 70°F and culture should not be attempted where the water is warmer. The top six inches or so can exceed this limit of 70°F, but if the warm zone delves much deeper, there may not be enough oxygen to sustain the fish.

Trout rarely spawn in these ponds. Consequently, fingerlings (two to four inches) must be stocked at least every other year. Depending on the fertility of the pond, the stocking rate should be 300 to 600 fingerlings per acre; the cost would be only about \$20 per acre. Restocking should take place in the fall or late summer, after most large fish have been harvested, to avoid any cannibalism. The pond should be able to produce enough food to sustain the trout; in cold or infertile ponds, supplementary feeding or fertilizing might be required. The danger of fertilization is that the decomposing organic matter uses up oxygen, a very critical factor for trout.

Fishing can begin as soon as the fish reach six or eight inches in length and must be done regularly or the pond will never reach its full carrying capacity. Production averages 50 kg/ha-yr without supplementary feeding.

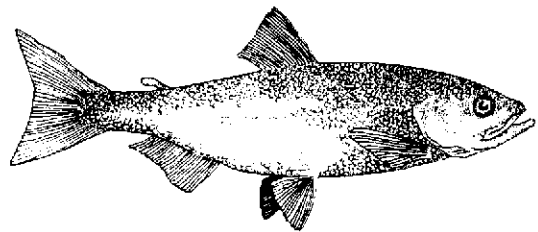

Salmon

Salmon belong to the same family as trout and, like them, are anadromous (they spawn in freshwater and mature at sea). Although trout can grow in freshwater, salmon *must* mature in brine.

Salmon are cultured intensively, if at all. Like trout, spawning is achieved by stripping; unlike trout, the Pacific salmon die after spawning. The fry are raised in

raceways until they reach the smolt stage (about two years), after which they must be put out to sea. Fingerlings which have been grown experimentally in cages floating in the ocean are fed on pellet food for six to nine months and then harvested. Growth is rapid and this method shows some promise, but obviously it can be used only in selected areas.

Sturgeon

Sturgeon are huge anadromous fish which are highly prized in Russia for food and caviar (their eggs). They were once plentiful in the Great Lakes but were needlessly and unjustly destroyed for preying on "more desirable" species; today, they are cultured for the most part by fish and game agencies for the purpose of replenishing depleted sturgeon fisheries.

Sturgeon are difficult to spawn; they, too, require a pituitary hormone injection and are stripped by incision. The fry are kept in troughs, fed on cladocerans for ten days, and then put into ponds. Here they are fed *Daphnia* and oligochaetes for several weeks, and finally are released into brackish water. Up to 30 percent of the eggs survive through this stage.

A freshwater sturgeon is called a sterlet. These, of course, are not released into brackish water and can be cultured with carp. The laborious spawning process limits their use for food production. They also don't grow very rapidly; some sturgeon in your pond might make great conversation pieces, but don't count on them for food.

Crayfish

Crayfish are freshwater decapod crustaceans which are cultured mostly in Louisiana and France, but they have also been grown as far north as Wisconsin and Washington. Necessary for their culture is a flat-bottomed, shallow pond with some plant cover along the edges. This is flooded in May or June and two weeks later, adult crayfish are added. The crayfish pair up and dig burrows into the sides of the pond, where they mate. Two weeks after adding the crayfish, the pond is drained at a rate calculated to take about thirty days. During this period, the crayfish live in their burrows and forage for their young. The pond is reflooded in September. The young mature in six months, and harvesting can begin in November.

It is possible to integrate crayfish culture with a rice crop in a two-year cycle. Rice is planted in the spring and the field is flooded in May, stocked with crayfish, and then drained from July to August. The rice is harvested from December to June. The field then can be drained again and tamed into pasture until the following spring. Crayfish production is from 400 to 700 kg/ha-yr in rice fields and less under other circumstances. American crayfish, fortunately, have no major disease problems.

However, there may be a difficulty with deoxygenation in the burrows.

Clams

Cultivation of marine clams in the Far East takes place by collecting larvae at sea and planting them in clam beds, where they set in and grow. There is little available material on freshwater clam culture, although it is known that some clam species require a fish host at one stage in their larval development. At Auburn University, a few clams of the species *Lampsilis claibomensis* were stocked in the polyculture with bluegill, redear sunfish, and bass, and then ignored until the annual harvest. The average yield for clams over six years was 1010 kg/ha-yr (318 kilograms without the shells); the fish contributed 464 kg/ha-yr. In a control pond without clams, only 317 kilograms of fish were harvested; clams may promote additional growth in a fish culture by their water-filtering capability. If freshwater clams are native to your area, there doesn't seem to be any harm in adding a few adult clams to a fish pond, and there may be a great deal to gain.

Sunfish and Largemouth Bass

Sunfish, primarily the bluegill (genus *Lepomis*), are excellent food and game fish which can tolerate a wide temperature range. While in some fish cultures adults are reluctant to breed, the major problem with sunfish is that they breed too easily. These mad propagators eat invertebrates and some algae, and their high reproductive rate, if unchecked, causes competition and depletion of food sources; the culturist will end up with many small fish, no one of which can make up a meal.

Reproductive excesses of sunfish can be attacked in various ways. It is possible to breed hybrids which, when crossed, will produce sterile offspring or offspring of only one sex. Another technique is to raise fish in floating cages so that the eggs fall through the mesh; the parents are unable to care for the young, which then die. These methods seem to be both wasteful of life and nonproductive; they also don't encourage a self-sustaining fish population. A better way to control reproduction is to polyculture sunfish with a predator such as the largemouth bass, which eats enough young sunfish to control their numbers and which itself can be harvested for food.

The largemouth bass is an excellent game fish of large size, rated as one of the most intelligent fish in the country. Culturists cannot force it to spawn at different times of the year, even with hormone injections; but when left alone in a pond during the spring, a pair of bass is only too anxious to be accommodating. They are solely piscivorous (fish-eating) and are used to control populations of catfish, buffalofish, bluegill, redear sunfish, and

carp. Largemouth bass are, in fact, ideal for nonintensive polyculture with a prolific breeder like bluegill.

The Farm Pond Program

The nonintensive polyculture systems mentioned above are often used in ponds developed under the farm pond program, a scheme initiated by the government to conserve water and wildlife, which reached its peak popularity in the 1950s, but which is still widely used. Under this program, federal or state agencies supply and stock noncommercial ponds one time with bass and bluegill fingerlings, *free of charge*. Sunfish or catfish are legal substitutes. Maintenance and labor is minimal; after a few months, you merely face the challenge of catching your own pan-sized fish!

These ponds are considered “recreational” and, while they can’t produce enough for commercial purposes, they can contribute significantly to the food supply for a family living unit. For the purposes of a small self-sufficient living group in temperate climates, a bass-bluegill farm pond culture is considered the best combination. Production figures of 250 to 450 kilograms per hectare have appeared, but it has not been made clear whether or not this is a sustained yield.

Maintenance is minimal once stocking is completed, but there are several problems. A pond of this nature has to be fished regularly or it will become overstocked. Poor pond design has often resulted in too rapid a flow rate or floods which wash out the fish. Weeds, while not too difficult to control, may require some attention.

Constructing the Farm Pond

A farm pond is not a backyard undertaking; an area larger than a quarter of an acre is necessary to produce sufficient fish biomass. Details of pond construction outlined here are also applicable to any other type of aquaculture that uses ponds.

The best type of site is a small valley or depression with steep sides and gradually sloping floors. The steep sides help to assure fairly deep water at the edge of the pond, which is useful in weed control. One mistake often

made is selecting a site through which *too much* water flows. This surplus flow carries silt into and fish out of the pond. Depth should be from two to eight feet. Wells or springs are excellent water sources.

The pond can be either excavated or else constructed by building levees or dams around a natural depression. Construction is preferable since drainage can be accomplished without pumping. In general, the dam should be designed with a 2:1 slope on both sides. The width of the base should be about four times the height (plus the width of the top). The top of the dam can be about seven to twelve feet wide. Soil for this purpose should contain a large percentage of clay. In addition, to prevent water seepage, a clay core wall should be built beneath the dam. This is done by digging a trench four to ten feet wide down to “watertight” soil and then refilling it with a clay soil (see Figures 7.13 and 7.14). Of course, soil for the dam itself can be taken from the pond bed. If your dam is more than twelve feet high, you had better consult a civil engineer. In addition, don’t forget to include a drain and maybe even a spillway. After construction, the dam tends to settle several inches. You also might check in Chapter 3 for further discussion of dams in terms of electricity. For visual attractiveness and for erosion control, plant your vegetation as soon as possible. Don’t limit yourself to grass; consider all the possibilities—fruit or nut trees, vegetables, berries. . . .

The cost of a dam varies. Soil can be moved with a dragpan pulled by a team or tractor, or be pushed with bulldozers, or be hauled in trucks. If you own your own equipment, you can construct a pond fairly cheaply. Otherwise, a bulldozer operator will cost approximately \$20 an hour to hire. See chapter 3 for more details.

Weed Control

Weeds should be kept to a minimum; one suggested figure is 25 percent or less of the surface area. Since young bluegill can escape from bass by hiding in the weeds, excess vegetation tends to slow down the growth of bass and contributes to an overpopulation of competing small bluegill, few of which can grow to edible size. Shallow-water weeds such as cattails and marsh grass

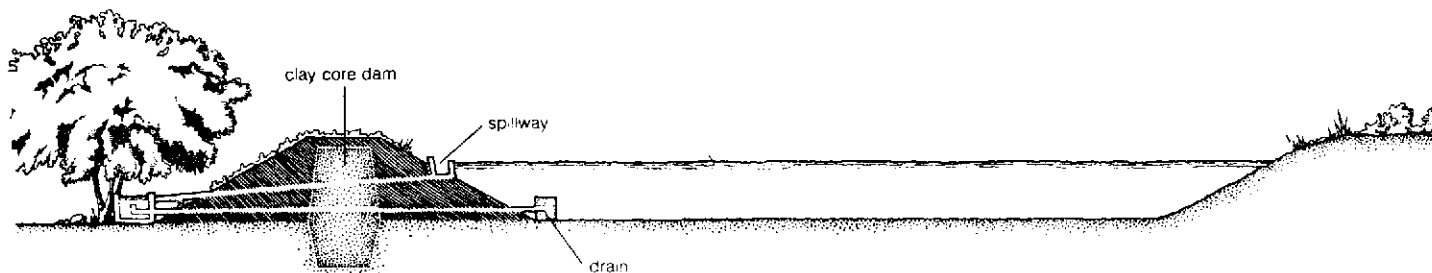

Figure 7.13 A side view of a pond.

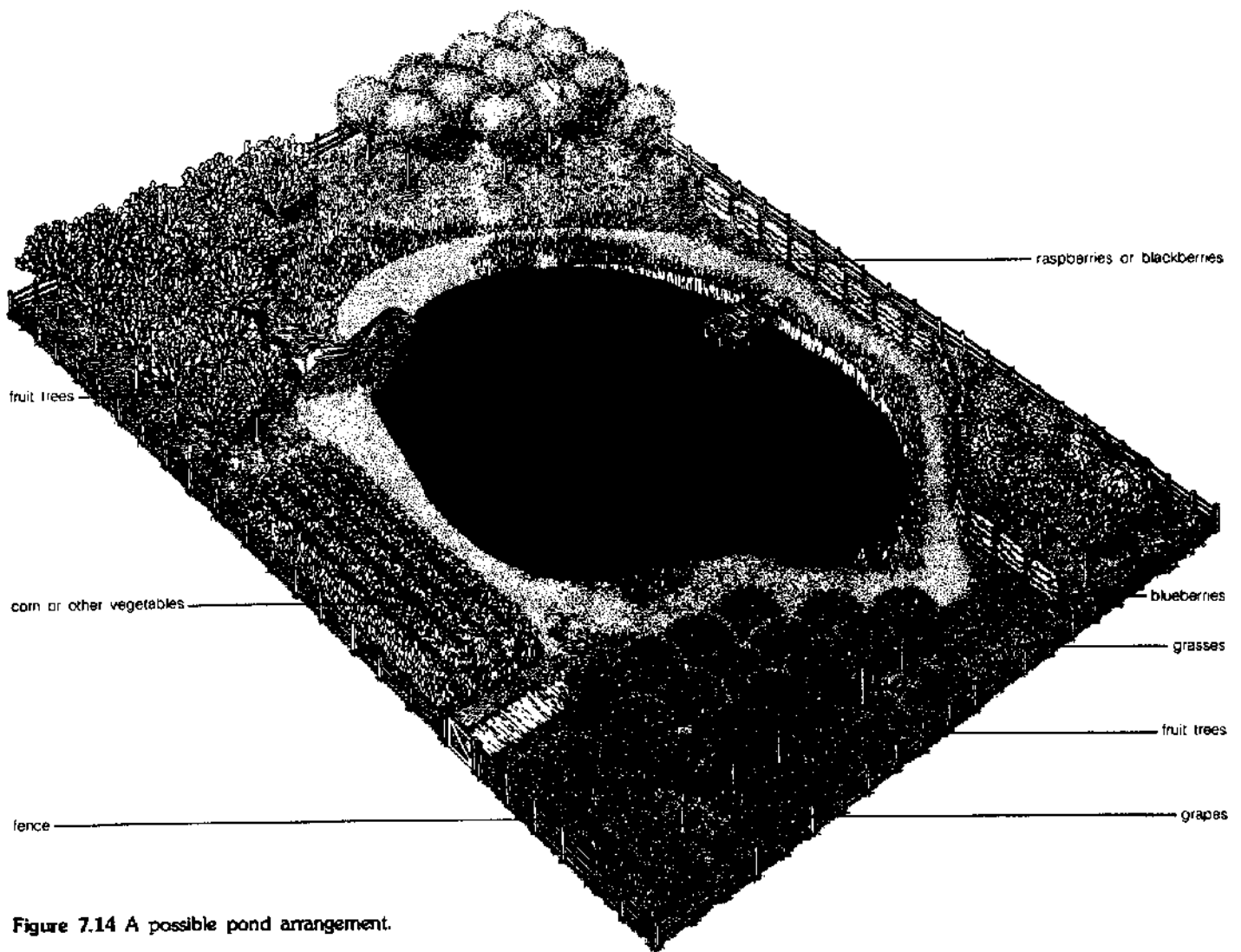

Figure 7.14 A possible pond arrangement.

must be pulled out by hand. Lily pods, which root in deep water but have leaves that rest on the surface, are best controlled by cutting the leaves; some plants also have leaves beneath the surface of the water, which, too, need to be cut. Floating plants such as duckweed must be raked out. Filamentous algae can be minimized by successfully controlling the other weeds. And any harvest of unwanted water weeds is an excellent addition to your compost pile.

Stocking and Fishing

In California, the Department of Fish and Game will provide free first-time stocking for any noncommercial pond (check your own state agency for local regulations). The fish should spawn soon after they are stocked. A sand and gravel bottom is best for spawning. If your pond has a mud bottom, good spawning grounds can be created by adding a few bushels of gravel at ten-foot intervals around the margin of the pond.

Stocking must be done correctly the first time around or the pond will never reach its maximum carrying capacity. Largemouth bass should be stocked at a rate of 50 to 100 fingerlings per acre, depending on the pond's

fertility; bluegill fingerlings should be stocked at a rate of at least ten times that of the bass. Pond fertility for ponds which are not to be fertilized is based on the soil type. For example, forest soils support the least fertile ponds, light-colored soils are intermediate, and black-colored soils support the most fertile ponds. Table 7.10 summarizes the guidelines for stocking.

Stocking is done in the spring and, as we have mentioned, can be done free of charge by a federal or state agency. It is best not to fish for the first year, and only bluegill should be taken the second year. Bass do not reproduce until they are two years old; they should not be fished until June of the third year—that is, after their spawning season. Only bass over twelve inches long should be taken because overfishing small bass will result in a high concentration of small bluegill. Table 7.11 provides a guide for harvesting. It is important that fishing be done regularly; in spite of the greater attraction that larger bass have for fishermen, four pounds of bluegill should be taken for every pound of bass, or the population will fluctuate (see Figure 7.15).

The stability of the pond population can be measured either by seining and counting or by recording the

progress of your fish catch. A desirable population has catches of both bluegill (at least six inches) and bass (one to two pounds). Any other yield indicates that one of the species is overcrowded. If you start to catch crappies, bullheads, carp, buffalofish, suckers, or green sunfish, then potential problems may develop since these fish compete with bass and sunfish for food and may also prey on their young. Carp are excellent fish for culture, but they don't contribute to a bass-bluegill system. They can be used, however, as substitutes for bluegill to form a bass-carp polyculture system.

Pond Fertility

To increase the carrying capacity of your pond,

Table 7.10 Fish Stocking for Unfertilized Ponds^a

Fish Species	Black-colored Soils	Light-colored Soils	Forest Soils
Largemouth Bass	100	75	50
Bluegill	1000	750	500
Bluegill	700	500	350
Redear	300	250	150
Channel Catfish	100	75	50

Notes: a. Numbers indicate populations of fingerlings to be stocked per acre, from A.C. Lopinot, *Pond Fish and Fishing in Illinois*.

Table 7.11 Recommended Maximum Angling Harvests^a

Carrying Capacity of Pond (pounds per acre)	Species of Fish					
	Largemouth Bass			Bluegill and/or Redear Sunfish		
	25	50	100	75	200	400
1st Year harvest						
Total number or Total pounds	None	None	None	None	None	None
2nd Year harvest						
Total number or Total pounds	None	None	None	120 ^b	320 ^b	640 ^b
3rd Year harvest						
Total number or Total pounds	10	20	40	120 ^b	320 ^b	640 ^b
Each succeeding Year harvest						
Total number or Total pounds	10 ^c	20 ^c	40 ^c	120 ^b	320 ^b	640 ^b

Notes: a. Based on pond size of 1 acre, from A.C. Lopinot, *Pond Fish and Fishing in Illinois*.
 b. 6 inches and larger.
 c. After quota is reached, all bass over 18 inches can be harvested.

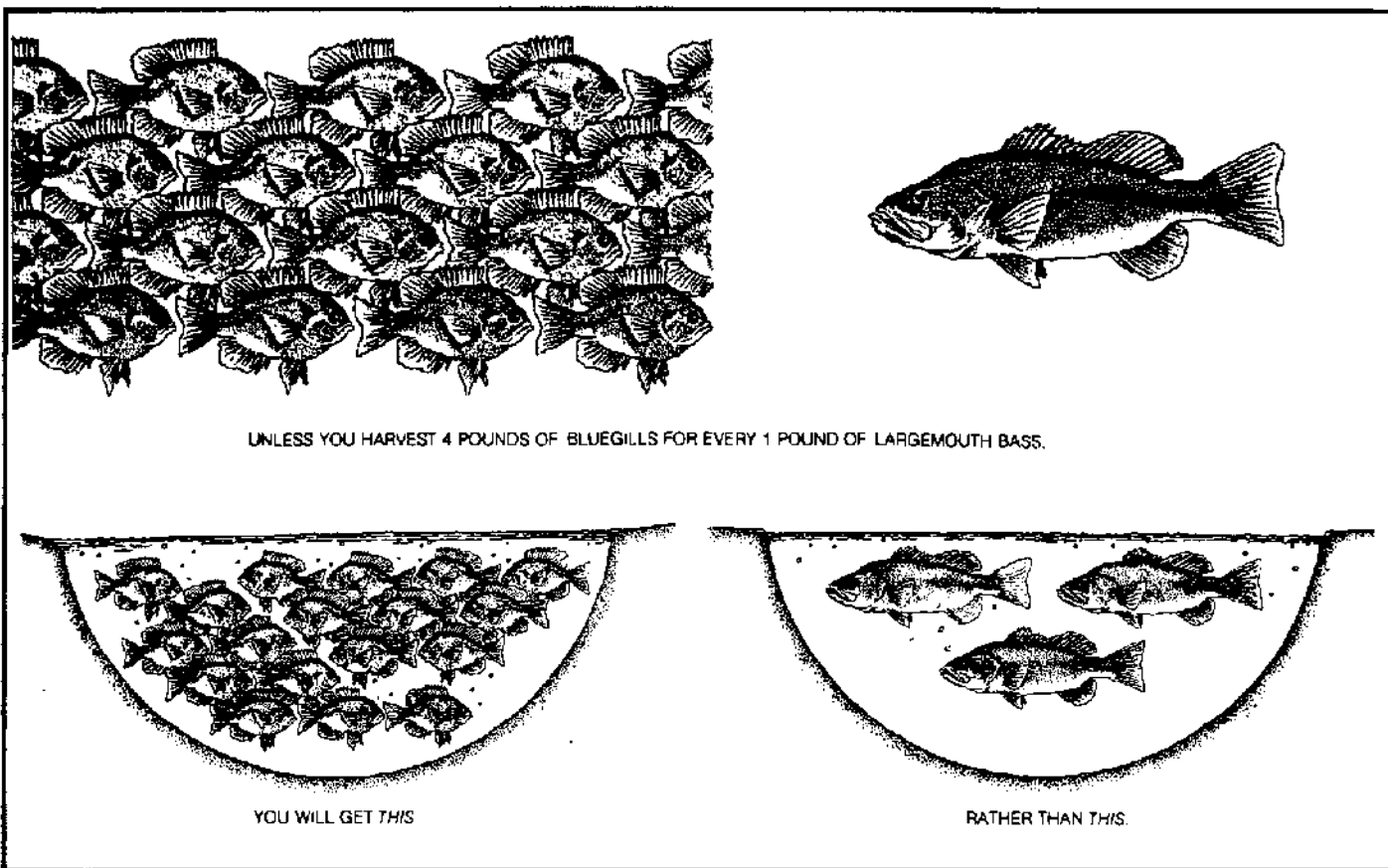

Figure 7.15 A harvesting pointer.

fertilizers for algal growth can be used. Since algae form the base of this aquatic food chain, in theory, more algae will yield more and larger fish. Fertilizing is a difficult technique to control, however, whether it be in the form of organic wastes or inorganic compounds. To repeat a few points made earlier, decomposition of organic waste (including organic fertilizer) uses up oxygen and this oxygen depletion may kill fish. Or fertilizing can overstimulate algae and aquatic plants; their subsequent decomposition also causes oxygen depletion and kills fish. Sometimes only a green algal scum (rather than a zooplankton bloom) results. An important point to remember is that carp are much more tolerant of both low oxygen concentration and high turbidity than bass or bluegill; consequently, fertilizer can be used with carp more successfully than with the latter two species.

Using a pump or some similar device to add oxygen to fertilized water would eliminate the problem of oxygen depletion, or so it would seem. Then an unlimited amount of fertilizer could be added safely and fish production would be correspondingly greater; but, in fact, such success does not follow automatically. As fish become overcrowded, they display a greater susceptibility to disease.

One safe and (potentially) highly productive way of fertilizing your pond is to add in a few native adult clams. If they flourish, they will be a significant source of food for the fish. Furthermore, their filter-feeding capabilities may improve your water quality. If the clams don't live, very little will have been lost. Further information on the farm pond program can be found in two publications listed in the Bibliography, by the California Department of Fish and Game and the U.S. Department of Agriculture, from which much of the above material was drawn.

Mariculture

The prospect of farming the oceans for food has been widely discussed for many years. Mariculture is best carried out in protected salt water, in a salt-water pond, slough, or protected bay. Tidal flow would be the most likely source of circulation, although pumps could be used in some cases. If circulation is adequate, a pond of only one-quarter of an acre is fine for most mariculture operations, some of which are so productive that we wonder why there isn't more research in this field. In the United States, there are legal restrictions on the use of public waters; this limitation may explain the lagging research, to some degree. By and large, mariculture practices require a combined sense of art, science, and experimentation, and the harvests should be considered useful food supplements rather than staples. Explore the possibilities if you live near the ocean.

Invertebrates

In the United States, more is known about culturing invertebrates than vertebrates. A difficulty with all mariculture, and particularly invertebrate culture, is that the animals undergo a sequence of different larval stages before maturity; each stage requires special (often unknown) environmental conditions. Nonetheless, we can discuss a few of the more prominent crops.

Crustaceans: Crustaceous animals grow by molting (shedding their exoskeleton), a process which wastes a lot of energy; thus their food conversion efficiency is low. In most countries, shrimp culture consists of opening a sluice gate at high tide and letting the water (which hopefully contains shrimp) flow into a pond. The gate is then closed and any shrimp present are trapped. Captured shrimp grow in the pond until they are harvested. Yields of 300 to 800 kg/ha-yr are reported, but these yields can fluctuate dramatically. Only the kuruma shrimp of Japan is cultured intensively, and this culture involves very close attention to the water quality and the feeding at each stage of the shrimp's life cycle.

Malaysian prawns are often mentioned as a promising food source for culturing since they are durable and live in everything from brackish concentrations to fresh-water. Unlike many invertebrates, they can be raised in captivity from egg to adulthood. For food, larval prawns require brine shrimp and fish eggs; older prawns eat small pieces of meat. Control of the temperature and salinity of the water is necessary for all life stages. As we will discuss later, Malaysian prawns can be polycultured with numerous types of herbivorous fish.

Bivalve Mollusks: Bivalves are filter feeders and require no additional feeding. They also are adept at concentrating pollutants in their biomass at toxic levels, so know the quality of your water. The two most popularly cultured bivalves are oysters and mussels. Site selection is vital in bivalve culture; they like areas with high algal productivity, strong tidal currents, and few violent waves.

Free-swimming oyster larvae metamorphose and settle on a solid surface. The young, settled oysters ("spat") then grow to maturity. The trick in oyster farming is to catch the spat, which requires that you be in the right place at the right time; your local government biologist can advise you on improving your chances. Spat are caught by putting out the shells of other bivalves as tempting solid surfaces on which the spat hopefully will settle. These shells are either piled on the bottom or suspended from rafts. Maintenance consists of checking for predators and cleaning off silt. Estimated yields are around 50,000 kg/ha-yr for rafts and 500 kg/ha-yr for bottom culture.

Mussel culture is similar to that of oysters, but the larvae are caught using rope rather than shells. This rope

is spiraled around a stake driven into the bottom. Mussels sometimes get so heavy and crowded along it that they fall off; thinning is necessary periodically. Environmental requirements are the same as for oysters. Production in the Galician bays of Spain, where conditions are evidently perfect, reaches the astonishing figure of 600,000 kg/ha-yr. Unless conditions in your neighborhood are really perfect, don't expect yields like that; many other places, in fact, get very low yields.

Fish

Several different species of marine fish have been cultured commercially as a food source. Among these are yellowtail, Pacific mackerel, sardines, anchovies, milkfish, and mullet. The two major species are mullet and yellowtail, and a description of the practices by which they are currently raised adequately illustrates the status of the art. Neither species is native to America (and can't be cultured here), but the techniques used in their culture can be applied to native fish if you're enterprising.

Mullet: Mullet are brackish-water fish which also can survive in freshwater. Spawning can be induced only by injections of carp pituitary, and even if spawning is achieved, the fry seldom last a week. Culturing is still experimental and utterly dependent on getting advanced fry from fishermen. In Israel, these fry are planted in fertilized ponds with carp and *Tilapia*. The best yield from these ponds was 1155 kg/ha-yr, 44 percent of which were mullet. Culture in other countries is less complicated and consists of blocking off bays, letting the fish grow, and then harvesting.

Yellowtail: Yellowtail are pelagic fish of the Western Pacific which also cannot spawn in captivity. Larvae are picked up at sea and sold to fry specialists, who sell the fry in turn to culturists. In Japan, yellowtail are kept in floating nets and are fed reject shrimp and fish. Reported production is incredible, reaching 500,000 kg/ha-yr. The major obstacle to yellowtail culture in the United States is that they aren't available here; consequently, fry cannot be obtained. There are other likely pelagic species off American waters, but it's still an unresolved question whether or not these other crops can be grown in captivity.

Algae

Culturing algae (freshwater or marine) in an enclosure—for example, a small blocked bay or a backyard tank—can add another layer to the recycling operations of a small community. Algae can grow on the soluble nutrients in wastewater from your anaerobic digester. Not only can algae be used to remove certain pollutants from your water, but, when harvested, they can be used as either compost, fertilizer, animal feed, or fuel to cycle back into the digester. Such a scheme has

been proposed by Golueke and Oswald in Berkeley (see Bibliography). Using algae as a tertiary treatment for secondary effluent of domestic wastewaters has also been proposed by J.H. Ryther and his coworkers. Details of the characteristics of the effluent from the digester, its use in algae production, factors affecting algal yields, and the biochemical characteristics of algae can be found in "Oxidation Ponds" (Chapter 5).

Experimental Aquaculture Systems

Several fairly complex experiments on recycling waste in an aquaculture system are now in progress. The goals are twofold: the elimination of potential pollutants from the environment and the generation of useful products. They are described here more as an illustration of possible future developments than as projects for you to tackle.

Tertiary Biological Treatment

A research group headed by John Ryther at Woods Hole Oceanographic Institution, Woods Hole, Massachusetts, is investigating the effectiveness of growing marine organisms on secondary effluent from domestic wastes. Planktonic algae have been found to remove all available nitrogen from mixtures of wastewater to seawater in the range of 1:5 to 1:20. The algae are then fed to shellfish in a second tank; under optimal operating conditions, 85 percent of the algae are removed by the oysters. The water from the oyster tank then flows into a third system containing macroalgae such as *Chondrus* and *Ulva*, which remove the nitrogenous wastes generated by the oysters. Ryther's group is also experimenting with macroalgae as food for abalone. The actual usefulness of such a system is going to depend upon further research to determine whether hazardous levels of viruses, microorganisms, heavy metals, and trace contaminants accumulate in the food products. Figure 7.16 schematically summarizes the proposed system.

The Ark

The New Alchemy Institute is experimenting with a greenhouse-enclosed, recirculating aquaculture system applicable for use by a small living group. Water flows by gravity through three ponds in sequence. The uppermost pond filters the water through crushed shells on which grows a slime layer of microorganisms. Here wastes are filtered by the shell and detoxified by the microorganisms. Ammonia is oxidized to nitrites and nitrates which are used by algae growing in a separate area of the first pond. The algae are fed to *Daphnia*, a crustacean growing in the second pond. Both *Daphnia* and algae are fed into the third pond in which *Tilapia* and catfish are grown in polyculture. The water is then recirculated to the first pond by means of a wind-driven pump; it also passes through a solar heater which restores optimum tempera-

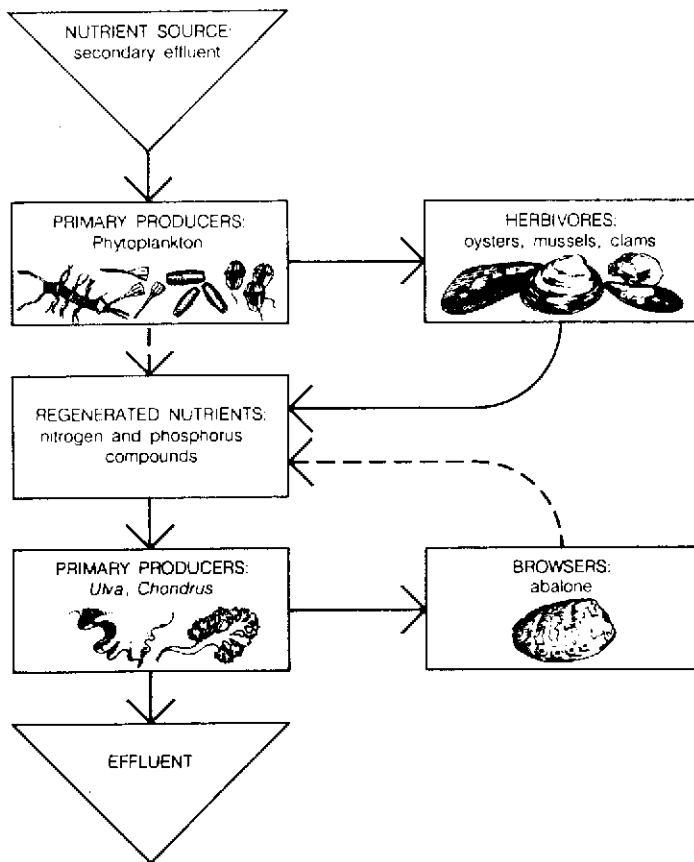

Figure 7.16 A tertiary biological treatment scheme.

tures. Costs have been estimated to be about \$2300 for materials. Several modifications of the basic three-pond ecosystem are possible. One proposal is to grow vegetables in gravel hydroponic tanks fed by water from the fish pond. Another suggestion is a horizontal division of the fish tank by screens, to permit the layered culture of the great Malaysian prawn in the top section and carp in the bottom. Further information can be found in the *Energy Primer* (Merrill, et al.) and in an article by N. Wade, both listed in the Bibliography.

And so this chapter, like the whole book, is a beginning. Food, with all of its processes, possibilities, delightful mysteries, and ramifications, is a vast subject. You now have some basic information which you can expand through further reading and through the process of "growing your own." There are new avenues to be explored, avenues which will not unbalance any more of this earth than has already been thrown awry, which will not lead to consumption of any more resources than have already been depleted, which will not waste any more "waste." And what is considered "experimental" today may be common practice in a few years. So grow, harvest, and enjoy the fruits of your labor; "double dig" it!

Bibliography

Agriculture

- Angier, B. 1972. *One Acre and Security*. New York: Vintage Books.
- Bell, R.G. 1973. "The Role of Compost and Composting in Modern Agriculture." *Compost Science*, November-December 1973.
- Bridwell, R. 1974. *Hydroponic Gardening*. Santa Barbara, Calif.: Woodbridge Press.
- Cienciala, M. 1966. "Factors in the Maturing Process of Some Swiss Refuse Composts." International Research Group on Refuse Disposal, Bulletin no. 28. Washington, D.C.: U.S. Dept. of HEW.
- Colby, B. 1972. *Dairy Goats: Breeding/Feeding/Management*. Amherst, Mass.: American Dairy Goat Association.
- Commoner, B. 1971. *The Closing Circle*. New York: Alfred A. Knopf.
- Edinger, P., ed. 1971. *Sunset Guide to Organic Gardening*. Menlo Park, Calif.: Lane Books.
- Golueke, C.G. 1973. "Latest Methods in Composting and Recycling." *Compost Science*, July-August 1973.
- Heck, A.F. 1931. "The Availability of the Nitrogen in Farm Manure under Field Conditions." *Soil Science* 31:467-81.
- Heck, A.F. 1931. "Conservation and Availability of the Nitrogen in Farm Manure." *Soil Science* 31:335-63.
- Howard, L.E. 1947. *Earth's Green Carpet*. Emmaus, Pa.: Rodale Press.
- Jeavons, J. 1973. *The Lifegiving Biodynamic/French Intensive Method of Agriculture*. Palo Alto, Calif.: Ecology Action of the Midpeninsula.
- . 1974. *How to Grow More Vegetables*. Palo Alto, Calif.: Ecology Action of the Midpeninsula.
- Jeris, J.S., and Regan, R.W. 1973. "Controlling Environmental Parameters for Optimum Composting." *Compost Science*, January-February 1973.
- Jull, M. 1961. *Producing Eggs and Chickens with the Minimum of Purchased Feed*. Bulletin no. 16. Charlotte, Vermont: Garden Way Publishing.
- Kaysing, B. 1971. *First-Time Farmer's Guide*. San Francisco: Straight Arrow Books.
- Klein, G. 1947. *Starting Right with Poultry*. Charlotte, Vermont: Garden Way Publishing.
- Merrill, R.; Misser, G.C.; Gage, T.; and Bukey, J. 1975. *Energy Primer*. Menlo Park, Calif.: Portola Institute.
- Morse, R.A. 1972. *The Complete Guide to Beekeeping*. New York: Dutton Press.
- Obrist, W. 1967. "Experiments with Window Composting of Comminuted Domestic Refuse." International Research Group on Refuse Disposal, Bulletin no. 29. Washington, D.C.: U.S. Dept. of HEW.
- Odum, E.P. 1971. *Fundamentals of Ecology*. 2nd ed. Philadelphia: W.B. Saunders Company.
- Philbrick, J., and Philbrick, H. 1971. *Gardening for Health and Nutrition*. New York: Rudolph Steiner Publications.
- Poincelot, R.R. 1972. *The Biochemistry and Methodology of Composting*. New Haven, Conn.: Connecticut Agricultural Experiment Station.
- Richardson, H.L., and Wang, Y. 1942. "Nitrogen Conservation of Night Soil in Central China." *Soil Science* 54:381-89.
- Ried, G. 1948. *Practical Sanitation*. New York: C. Griffin.
- Rodale, J.I. 1961. *How to Grow Vegetables and Fruits by the Organic Method*. Emmaus, Pa.: Rodale Press.
- . 1966. *The Complete Book of Composting*. Emmaus, Pa.: Rodale Press.

- . 1973. *The Encyclopedia of Organic Gardening*. Emmaus, Pa.: Rodale Press.
- Rolle, G., and Orsanic, B. 1964. "New Method of Determining Decomposable and Resistant Organic Matter in Refuse and Refuse Compost." International Research Group on Refuse Disposal, Bulletin no. 21. Washington, D.C.: U.S. Dept. of HEW.
- Root, A.I. 1973. *Starting Right with Bees: A Beginners Handbook in Beekeeping*. Medina, Ohio: A.I. Root Company.
- Root, A.I., and Root, E.R. 1966. *The ABC and XYZ of Beekeeping*. Medina, Ohio: A.I. Root Company.
- Rubins, E.J., and Bear, F.E. 1942. "Carbon-Nitrogen Ratios in Organic Fertilizer Materials in Relation to the Availability of Their Nitrogen." *Soil Science* 54:411-23.
- Saunby, T. 1953. *Soilless Culture*. New York: Transatlantic Arts.
- Sunset Magazine. 1972. "Getting Started with the Biodynamic-French Intensive Gardening." *Sunset*, September 1972, p. 168.
- Ticquet, C.E. 1956. *Successful Gardening Without Soil*. New York: Chemical Publishing.
- U.S. Department of Agriculture. 1966. *Raising Livestock on Small Farms*. Farmers Bulletin no. 2224. Washington, D.C.: Soil Conservation Service, U.S. Department of Agriculture.
- . 1971. *Beekeeping for Beginners*. Home and Garden Bulletin no. 158. Washington, D.C.: Soil Conservation Service, U.S. Department of Agriculture.
- Davis, H.S. 1970. *Culture and Disease of Game Fish*. Berkeley, Calif.: University of California Press.
- Dobie, J., et al. 1956. *Raising Bait Fishes*. Circular 35. Washington, D.C.: Fish and Wildlife Service, U.S. Department of Interior.
- Edminister, F.C. 1947. *Fish Ponds for the Farm*. New York: Charles Scribner.
- Golueke, C., and Oswald, W. 1965. "Harvesting and Processing Sewage Grown Plankton Algae." *Journal of Water Pollution Control Federation* 37:471-98.
- Jones, W. 1972. "How to Get Started." *American Fish Farmer*, December 1972.
- Lopinot, A.C. 1972. *Pond Fish and Fishing in Illinois*. Fishing Bulletin no. 5. Springfield, Ill.: Illinois Department of Conservation.
- McLarney, W.O. 1971. "Aquaculture on the Organic Farm and Homestead." *Organic Gardening and Farming*, August 1971, pp. 71-77.
- , ed. 1973. *The Backyard Fish Farm Workbook for 1973*. Woods Hole, Mass.: New Alchemy Institute.
- Maloy, C., and Willoughby, H. 1967. *Marketable Channel Catfish in Ponds*. Resources Publication vol. 31, January 1967. Washington, D.C.: U.S. Department of Interior.
- Meyer, F. 1973. *Second Report to the Fish Farmers*. Washington, D.C.: Fish and Wildlife Service, U.S. Department of Interior.
- Ryther, J.H.; Dunstan, W.M.; Tonore, K.R.; and Huguenin, J.E. 1972. "Controlled Eutrophication—Increasing Food Production from the Sea by Recycling Human Wastes." *Bioscience* 22:144-52.
- Ryther, J.H.; Tenore, K.R.; Dunstan, W.M.; Goldman, J.C.; Prince, J.S.; Vreeland, V.; Kerfoot, W.B.; Corwin, N.; Huguenin, J.E.; and Vaughn, J.M. 1972. "The Use of Flowering Biological Systems in Agriculture, Sewage Treatment, Pollution Assay and Food Chain Studies." Progress Report. NSF-RANN GI 32140. Woods Hole, Mass.: Woods Hole Oceanographic Institution.
- U.S. Department of Agriculture. 1948. *Farm Fish Ponds*. Farmers Bulletin no. 1983. Washington, D.C.: Soil Conservation Service, U.S. Department of Agriculture.
- Wade, N. 1975. "New Alchemy Institute: Search for an Alternative Agriculture." *Science* 187:727-29.

Aquaculture

- Bardach, J.E.; Ryther, J.H.; and McLarney, W.O. 1972. *Aquaculture: The Farming and Husbandry of Freshwater and Marine Organisms*. New York: Wiley-Interscience.
- Borrell, A., and Scheffer, P. 1966. *Trout in Farm and Ranch Farms*. Farmers Bulletin no. 2154. Washington, D.C.: Soil Conservation Service, U.S. Department of Agriculture.
- California Department of Fish and Game. 1965. *The Fish Pond—How to Stock and Manage It*. Sacramento, California: California Department of Fish and Game.

Fishfarming in the Solar Greenhouse, USA 1979.

Amity Foundation, PO Box 7066,
Eugene OR 97401 USA.

The Freshwater Aquaculture Book,
McLarney, USA 1984. 0-88179-018-4.

Aquaculture Training Manual,
Swift, UK 1993. 0-85238-194-8.

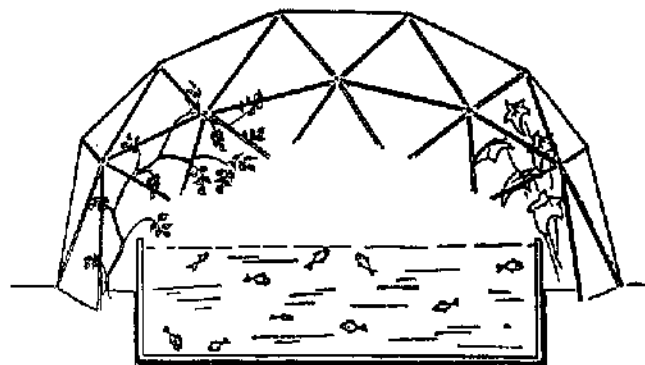

FISH POND AND DOME

AFTER THE GOLDFISH

In the far East, 'back yard' fish ponds are an important source of protein for many families. As a result, one or two varieties of *Tilapia* and Grass Carp fish have been developed for this purpose; they could, perhaps, be bred for conditions in this country. Most *Tilapia* varieties need high day-temperatures in order to achieve maximum growth. One type, namely *Tilapia rendalli*, has been successfully introduced to the river waters of St. Helens, Lancashire. It survives chiefly because of the waste heat dumped into the river by local industrial plant. Perhaps more importantly, *Tilapia* are resistant to high levels of pollution and low levels of oxygen—a combination not uncommon to this part of the world.

Tilapia rendalli, (also known as *Tilapia melanopleura*) and its cousin *Tilapia tholloni* are two varieties which feed exclusively on low-grade vegetable matter. For this reason they can be fed on kitchen waste, such as vegetable peelings and coffee grounds, when they have grown bigger than 4–5 cms in length. In many far Eastern countries, the habit of throwing sewage into the fish ponds is common practice, and enhances the growth of the fish (although exposed, untreated sewage can be hazardous to human health).

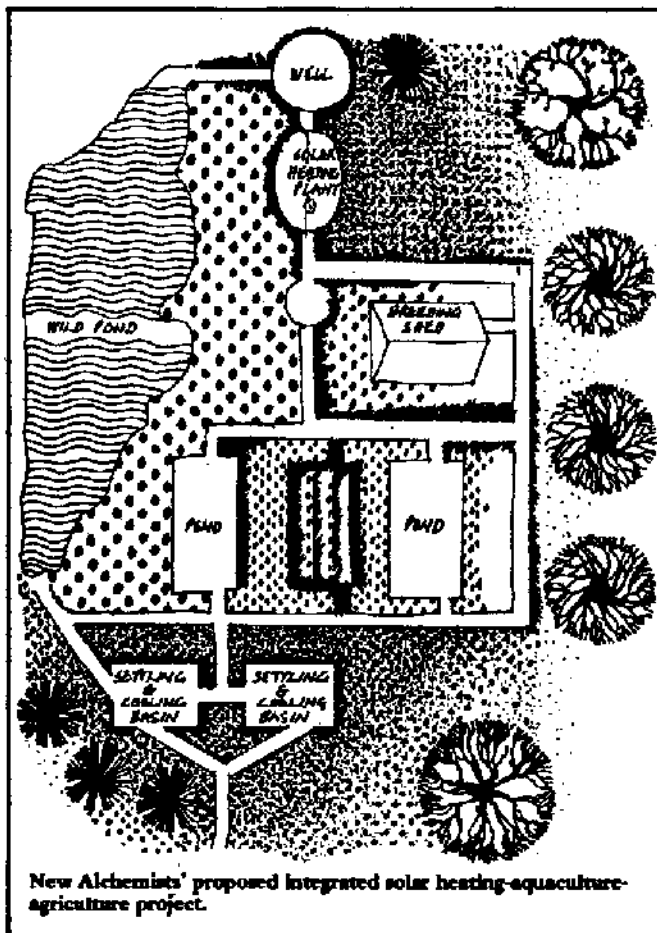

For breeding a suitable variety of *Tilapia* for this climate, it may prove profitable to look firstly at temperature control, since *Tilapia* are inclined to over-reproduction at their optimum temperatures of 20–21°C (68–70°F).

One omnivorous variety with a lower reproductive potential is *Tilapia sparrmani* which will tolerate temperatures as low as 8°C (46–47°F). *Tilapia* grow



New Alchemists' proposed integrated solar heating-aquaculture-agriculture project.

quickly if fed daily:— my pair of *T. mossambica* (omnivores) grew from 1½ inches to 4 inches in their first six months, and to a fat 6 inches length in their second six months. Most fish automatically stop growing when they reach a size related to their pond-dimensions (although I have seen *Tilapia* almost as big as their tanks). By continuously circulating the water in and out of their tanks, it is possible to trick

<i>Tilapia</i>	Ducks	Fresh water 'mussels'	Crayfish	Catfish
<p>Yield: up to 3,000 kg/ hectare of live fish stocked at 3,000 fingerlings 1 hectare</p> <p>Food input: virtually nil as they feed upon phytoplankton. Fertilization necessary (see ducks)</p> <p>Harvesting: <i>Tilapia</i> will be harvested in the fall, and small breeding facilities maintained over winter, at 25°C</p> <p>Breeding: monosex cultures to prevent stunting or overpopulation, hybrid strains 100% male from <i>Tilapia hornorum</i> <i>Tilapia mossambica</i> <i>Tilapia</i> will not survive winter outside of artificially heated ponds, consequently they will not upset natural ecosystems if they accidentally escape</p>	<p>Yield: 200 ducks/ hectare</p> <p>Food input: nourishment mainly from the pond, some duck feed necessary and research into most appropriate source needed</p> <p>Fertilisation: recent research in Czechoslovakia demonstrated duck manure produces more nutritious and digestible varieties of phytoplankton than commercial phosphate fertilizers</p> <p>Pens designed so that duck wastes enter ponds</p>	<p>(<i>Lampsilis clabourneris</i>)</p> <p>Yield: minimum of 200 kg/hectare of shelled mussel meats used as food crop, being eaten fried or in soups and shells for buttons and ornaments</p> <p>Food input: virtually nil, and its filtering action has been shown to increase fish production (bass and bluegills) by 40%</p> <p>Source of soil: their waste products known as 'mussel mud' make superb soil-fertilizers for vegetable production. One pond will be left drained each year, and planted to vegetable crops. Duck wastes and 'mussel mud' will make fertilizer input unnecessary.</p>	<p>There are over 100 species of crayfish in US, all edible. Research will be needed to select most suitable species, although one of <i>Orconectes spp</i> might be best for pond culture</p> <p>Yield: up to 1,000 kg/ hectare</p> <p>Food input: it is not known in this polyculture system if extra crayfish food will be needed to maintain yields in pure crayfish ponds. Culturists often add hay, potatoes, cracked corn, etc</p>	<p>All ponds will drain into either of two cooling/settling basins designed to insure that thermally organically enriched water does not pass out of the system</p> <p>Yellow bullheads (<i>Ictalurus natalis</i>) and 'mussels' which are tolerant of turbidity and enriched waters will be stocked to provide a further source of good quality food and fishing for the community's children</p> <p>After draining the sediment will be added to winter garden or vegetable garden</p>
				
<p>New Alchemy Institute's polyculture system (Adapted from W.O. McLarney, 1970)</p>				

fish into believing themselves to be in roomier surroundings than they are. This has been achieved with *Tilapia* by Bill McLarney of the New Alchemy Institute, and with Rainbow Trout by Frank Mitchell of the Institute for Local Self-Reliance in Washington D.C. Dr. Mitchell's system works in an urban basement containing 500 gallon tank, artificial lighting and pumping equipment. 500 to 1,000 trout are maintained in tap water which is re-circulated every hour by a low-energy electric pump.

In the New Alchemists' system, solar-heated ponds are stocked with young *Tilapia* at densities of 3,000 per hectare and achieve a harvest of up to 3,000 kilogrammes per hectare. Food for the fish is almost totally provided by phytoplankton in the water. These organisms are in turn nourished by the manure of ducks which live on the same pond. The ducks are fed on fairly standard duck feed.

Similar polycultural systems in Malaya make use of several species co-existing on the same area to optimise local conditions. One example comprises a 4.4 hectare pond next to pigsties. Running water passes through the sties to carry their manure into the ponds where *Tilapia* and Chinese Carp are stocked. The fish thrive on fast-growing diatoms and crustacea produced by the pig dung. The ponds are also planted with a fast growing aquatic vegetable called *Ipomea Repens* which is harvested by hand at a rate of several hundred kilogrammes per day. These vegetable plants are fed to the pigs, thus completing the cycle. Overall, the farm produces 30,000 kilogrammes of pig-meat and 3,000 kilogrammes of fish each year.

John Wood

Bill McLarney in NewAlchemy *Tilapia* dome. The temperature of the dome is regulated by opening sections of its skin.

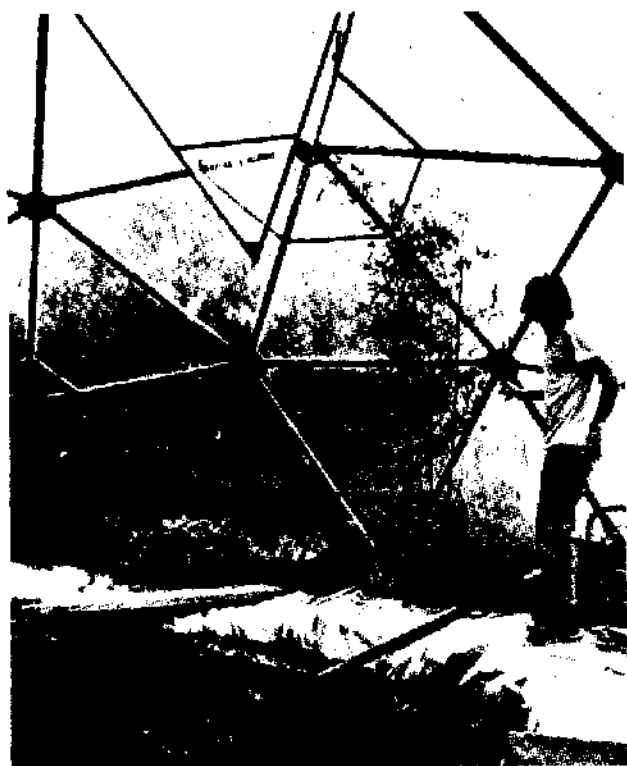

AQUACULTURE

AQUACULTURE: BRINGING IT HOME WITH THE NEW ALCHEMISTS

The art of culturing fish and shellfish for food, has been a flourishing tradition in Asia for centuries. In many "polyculture" ponds several species of edible plants and animals are grown together with a degree of ecological sophistication unrivaled in animal husbandry. In the United States aquaculture has been limited to the growing of single cash crops (e.g., trout, catfish, oysters) in commercial ponds or coastal waters. There never has been much of an interest in an aquaculture that could work for small groups, farmers, or communities using local resources and ecological techniques in temperate North American climates.

However as our beef/oil economy continues to decay, more and more people are beginning to think about producing food at the local level for their families, collectives, neighborhoods, communities, etc. For some the old "Victory garden" will flourish on roof-tops and street corners, in backyards and vacant lots. For others the bounties of vegetables, herbs and fruits can be enhanced with animal protein supplied by a low energy, low cost, ecologically-sound aquaculture. In order to work, such a mini-fish farm must be suited to the needs and local resources of individuals and small groups with little in the way of money or land.

To this end the New Alchemy Institute (Box 432, Woods Hole, Massachusetts 02543) has been experimenting with various "backyard fish farms" for the past few years. So far the New Alchemists have been concentrating on five basic strategies in an attempt to develop a low-cost, indigenous aquaculture adapted to northern climates: (1) the use of ecological models from Asian polyculture ponds, (2) the use of inexpensive greenhouses over fish ponds to keep the waters warm, (3) the use of biological filters for the transformation of toxic substances into useful nutrients, (4) the use of solar/wind power to regulate the internal climate of the pond-greenhouses and to pump filtered water through the system, (5) the use of fertilizers and supplemental fish foods produced in local gardens and insect cultures. The New Alchemists have published numerous useful how-to-do-it pamphlets, books and articles on the philosophy/ecology/hardware of backyard fish farms (see Aquaculture, page 137). Because the following paper is written only as a perspective, we refer the reader to the New Alchemy Institute for the "nuts and bolts" stuff. However, as the New Alchemists themselves are the first to admit, very little is known about small aquaculture operations in temperate climates. We can put together information from esoteric articles, the experiences of a few aquaculturists, the records of perennial fish ponds in the tropics or even the pertinent fallout from commercial set-ups, but perhaps more than any other kind of food/energy system described in the *Primer*, aquaculture is still in our heads . . . it needs participants and the flow of our experiences.

-R. M.

AQUACULTURE

by Dominick Mendola

The purpose of aquaculture is to provide fish and shellfish protein for human diets. The need for a substantial increase in the world's supply of protein is obvious . . . as is the place of fish in human nutrition. What is not so obvious is why aquaculture is a beneficial means of food production, especially protein. The reason is because aquaculture is more akin to agriculture than to ocean fisheries since the means of production (water, landstock and equipment) are accessible to many people and resources can be controlled by individuals, small groups, or even entire communities.¹ Also, since many of the fish populations presently exploited by ocean fisheries have reached their maximum sustainable yields, aquaculture can help supply the additional needs of an increasing demand for fish products.²

There are definite advantages to culturing fish as a food source. For one thing fish are able to produce more protein per pound of food eaten than, say, a cow, chicken, or any other land animal (Fig. 1).

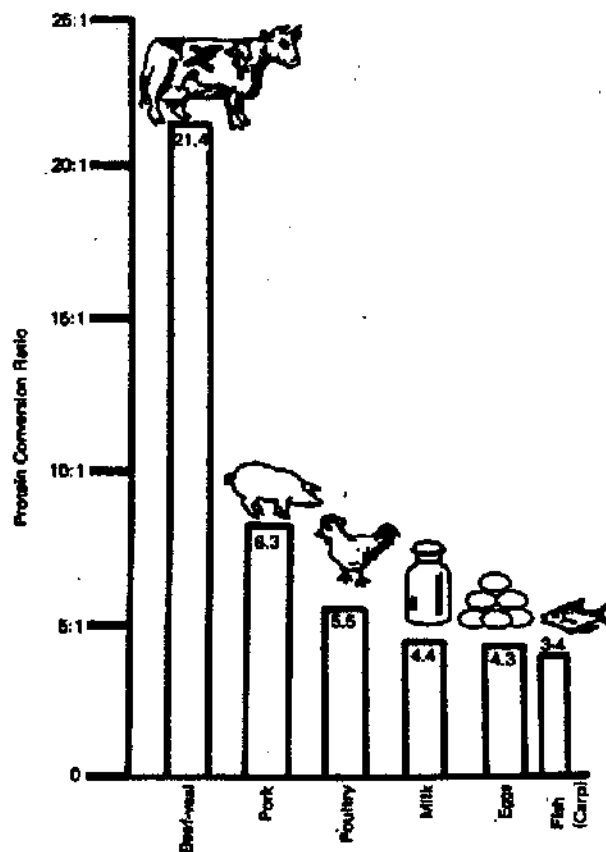

FIG. 1 POUNDS OF PROTEIN GIVEN TO VARIOUS LIVESTOCK TO PRODUCE 1 POUND OF PROTEIN FOR HUMAN CONSUMPTION. REDRAWN FROM FIGURE OF LAPPE (REF. 3) AND DATA OF BARDACH ET AL (REF. 1).

There are two basic reasons for this: (1) Fish and shellfish live in a medium that has about the same density as their bodies and as a result they don't have to spend much energy supporting themselves against gravity. Thus, aquatic animals have a reduced skeleton and a greater ratio of flesh to bones . . . a definite advantage for a food species. (2) Fish and shellfish are cold-blooded, and their body temperatures are essentially that of their surroundings. Because of this they don't have to spend much energy maintaining warm body temperatures as do warm-blooded birds and mammals. This "saved" energy can go into the production of animal protein.

There are other advantages. Fish live in a three dimensional world where nutrients necessary for growth are distributed throughout a volume. So for a given area, aquaculture can yield more food than land-based animal husbandry.⁴ For example, in an area once used for cattle grazing in Tanganyika, beef was produced at a rate of 9.8 pounds per acre per year (lbs/acre/yr). When this was replaced with aquaculture (with artificial feeding) fish production provided meat at the rate of about 2200 lbs/acre/yr.⁵ Table I shows yields of selected aquaculture systems compared to typical land-animal husbandries.

As Table I indicates, there are different kinds of aquacultures: fresh water, brackish and marine. There are also a wide variety of animals (fish and shellfish) and plants (seaweeds, watercress, water lettuce, etc.) that are widely grown. We shall emphasize fresh water pond aquaculture that uses indigenous resources (simple materials, locally-grown fish foods and solar/wind power supplies). There are several reasons for this approach: (1) The methods and materials needed for this form of aquaculture are available to more people than for mariculture (farming the sea) or commercial aquaculture. (2) Costs can be kept low and human labor can provide the energy for construction and maintenance. (3) Many existing bodies of water can be easily converted to this form of aquaculture. (4) With small, self-contained fish operations one can easily control most of the inputs affecting the health, productivity and stability of the system. For example, many of the pollutants (pesticides, heavy metals and petroleum products) increasingly found in fish products can be eliminated or at least reduced

with small aquaculture systems. However, even with local freshwater supplies one must consider the history of the use of toxic chemicals in the area. In fact it is always best to have water checked by a water quality laboratory since many toxins, especially pesticides, are slowly but surely finding their way into almost every supply of surface and ground waters in the U.S.^{9,10,11}

Aquaculture	Place	Culture/Feeding	Annual Yield* (lb/acre/yr)
FISH			
Largemouth bass, bluegill	U.S.	Polyculture/natural	225-400 (average)
Channel catfish	U.S.	Commercial ponds/artificial	2,000-3,000 (maximum)
Channel catfish	U.S.	Experimental, sewage ponds	3,600
Chinese carps	S.E. Asia	Polyculture/heavy fertilizer	6,300-8,000 (maximum)
			2,700-3,600 (average)
Common carp	Poland	Sewage ponds	1,200
Common carp	Japan	Intensive ponds/heavy	4,300
Komarine (Mullet)	U.S.	Tidal ponds/natural	145 (average)
Rainbow trout	U.S.	Flowing water ponds/heavy	60,000 (maximum)
Tilapia	Tropical world	Ponds/fertilization, feeding	2,000-5,500 (large fish)
			18,000 (small fish)
Walking catfish (Clarias)	Thailand	Commercial/heavy feeding	88,000 (maximum)
SHELLFISH			
Sea mussel	Spain	Floating rafts	540,000 (with shell)
			270,000 (meat)
Freshwater mussel	Alabama	Polyculture, experimental ponds	1,131 (with shell)
			413 (meat)
Oyster	U.S.	Bottom culture, mechanical pest control	4,300 (maximum)
Oyster	U.S.	Bottom culture, chemical pest control	45,000 (maximum)
Oyster	Japan	Floating lines, no pest control	50,000 (average)
LAND HUSBANDRY			
Pasture beef	U.S.	Animals range free	50-200
Hogs	Malaysia	Natural forage	2,300-11,000
Chickens	U.S.	Cages/artificial feed	160,000

TABLE 1. YIELDS OF SOME DOMESTIC FISH, SHELLFISH AND LAND ANIMALS. FROM REF. 4, 6, AND 7.

*In terms of energy production fish have a caloric value of about 1 kcal/gram of wet weight; e.g., the "Walking Catfish" produces about 4 million kcal/acre/year. For comparison, beef production yields only about 162,000 kcal/acre/year. (Ref. 10).

tion). In ideal polyculture, large plants provide food for some fish, while microscopic floating plants (phytoplankton) serve as food for others. These plant-eating fish in turn serve as food for flesh-eating fish. All waste products are then eaten as detritus by certain other fish and shellfish. In this way, all available food niches are filled so that energy flow and nutrient recycling can proceed at a maximum rate. There are of course many possible combinations of fish and shellfish that are ecologically impossible as for example when a particularly voracious fish eats everything else in the pond. In other words, a lot of aquatic organisms living together *per se* do not produce ecological diversity. Only certain combinations can do that.

Once a proper polyculture system is found, it usually turns out to be synergistic, that is the growth of each individual species is enhanced beyond the point where it would be if it were raised separately in a monoculture. Put another way, polyculture assures that all food materials added to the system are completely used for growth. And herein lies the great advantage of polyculture over monoculture in aquatic food production systems.

Polyculture and the Sacred Carp.

The polyculture model comes from the Chinese and Asian peoples who have been practicing the art of aquaculture for thousands of years. Today, in China, freshwater aquaculture provides at least 1.5 million tons of protein food every year.¹⁴ As noted above, the Asian polyculture system is based on the belief that the pond is an ecosystem and that it should contain a variety of edible species for the maximum use of food and habitats.

The mainstay of the Asian polyculture pond is the Chinese Carp, of which there are several species (Fig. 2).

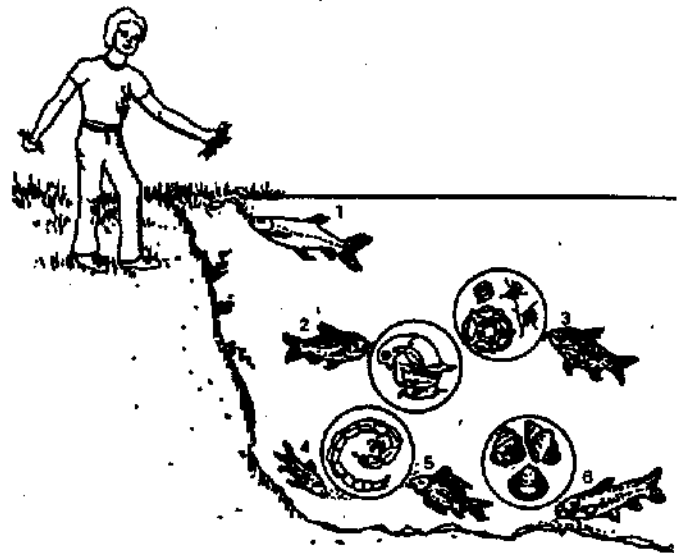

FIG. 2 FEEDING HABITS OF PRINCIPAL CHINESE CARP SPECIES. (1) GRASS CARP (*Ctenopharyngodon idellus*) FEEDING ON LARGE FLOATING PLANTS. (2) BIG HEAD (*Aristichthys nobilis*) FEEDING ON MICROSCOPIC ANIMALS (ZOOPLANKTON) IN MIDWATER. (3) SILVER CARP (*Hypophthalmichthys molitrix*) FEEDING ON MICROSCOPIC PLANTS IN MIDWATER. (4) MUD CARP (*Cirrhinus molitorella*), AND (5) COMMON CARP (*Cyprinus carpio*) FEEDING ON BOTTOM ANIMALS, DETRITUS AND CARP FECES. (6) BLACK CARP (*Mylopharyngodon piceus*) FEEDING ON MOLLUSKS. FIGURE REDRAWN FROM BARDACH ET AL. (REF. 11)

Typical yields from Chinese polyculture ponds average about 2400 lbs/acre/year, with some of the better ponds producing 4800-8400 lbs/acre/year.¹⁵ Yields are increased by feeding manures, vegetable wastes and other organic materials to the ponds. These fertilize the water and increase the primary productivity (yields of plants). This excess food energy is then passed up the food chain to the carp.

Often the Asians situate their fish ponds at the bottom of a hill or sloping farmland, allowing natural drainage to carry the manures and agri-

**1 kilogram/hectare = 2.2 lbs/2.47 acres or about 1 lb/acre (actually 1 kg/ha = .89 lbs/acre).

Many of the aquatic species that can be cultured for food are from tropical countries where aquaculture has been a way of life for centuries. Some of these animals can be imported or bought from distributors on this continent (see Reviews), and will thrive under artificially heated conditions. However, with a few notable exceptions (e.g., *Tilapia*) it is probably best to rely on temperate climate species, especially those found in the local area. (See Aquaculture appendix page 141, for list of some commonly available species together with their general habits)

Ecological Food Production and Aquaculture

In nature it is common to see many kinds of plants and animals living together all with different habits. Generally speaking, in natural communities with a high degree of ecological diversity (i.e. with many kinds of plants and animals exchanging energy among themselves) like tropical rainforests or coral reefs, one usually finds a greater degree of stability than "simple" communities like pine forests or corn fields. With high ecological diversity there is less chance that disease or sudden changes from outside will destroy the integrity of the community or kill off individual species.^{12,13}

In aquaculture, ecological diversity is called *polyculture*, where a variety of plants and animals, picked for their mutually beneficial interactions, are grown together in the same system (pond, tank or combine-

*A few filter materials (e.g. polyurethane foam and activated carbon) have been used successfully to remove toxins from water solutions. However such filters are impractical in all but the smaller or commercial systems since they must be changed often or cleaned with organic solvents. Also, to be effective, the filters require a very slow flow rate.

cultural runoff into the pond (Fig. 3).

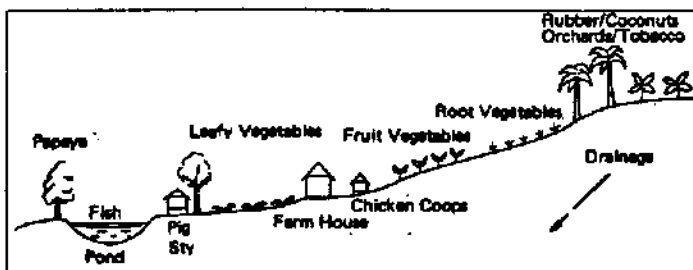

FIG. 3 AN INTEGRATED AQUACULTURE-AGRICULTURE SYSTEM USED IN SINGAPORE. REDRAWN FROM BARDACH ET AL (REF. 1) AND DESCRIPTION OF HO (REF. 8).

The Asians also use the pond water to irrigate (and fertilize) their crops. At regular intervals the ponds are drained and the accumulated bottom sludge is dug out and added to vegetable beds as compost.

Table II has been compiled to show various carp polyculture schemes that have been tried throughout the world. These examples give an idea of optimal conditions for the stocking, management and feeding of carp.

Simple Energy Budgets for Aquaculture

There doesn't seem to be any information or exact accounting of all energy inputs into freshwater fish ponds. (But see the materials list for the 3 backyard fish models built by the New Alchemists, in their Journal No. 2). For now we have to be content with budgets based on labor inputs

for Asian pond operations.

La Mer⁷ described a very efficient 11 acre farm near Penang, Malaya on which a tenant farmer kept pigs and fish, and tended a small diverse garden and some rice fields. The pigs were bred, kept in a nursery, and then fattened in pens. Some pigs were kept in sties on the banks surrounding a series of 8 small ponds (about 2 acres total). Daily the farmer allowed running water to wash through the pig sties and carry the dung and excess pig food into the ponds by a series of drainage ditches.

The ponds were about 3 feet deep and were stocked with various Chinese carp (Common, Silver and Grass), in polyculture with *Tilapia mossambica*. All ponds were planted with "water lettuce" (*Ipomea repens*), a floating aquatic plant suitable for pig food (21% protein—dry weight). Under these conditions the water lettuce grew so rapidly that about 1100 lbs/day (wet weight), in excess of that eaten by the carp, were harvested and added as a supplement to the pig food (broken rice, rolled and ground oats, groundnut cake, copra cake, bran, fish meal, and cod liver oil) in a ration of 1/3 water lettuce to 2/3 feed.

Production of fish during the first year was about 3200 lbs/acre. The farm also produced 700 pigs (about 2700 lbs. of pig meat). The records of production costs showed that the fish gave a higher proportional return than the pigs because little labor and materials were spent tending the fish, whereas a great deal of labor plus additional food was spent on the pigs. In other words, the energy subsidy of the fish culture was lower than for the pigs. Since the only inputs were human labor, we can easily estimate the time (energy) necessary to manage and harvest the 2 acres of ponds from what we know of fish raising. (Table III, next page).

Species, Stocking Ratio	Treatment and Stocking Density	Yield and Survival
1. KWUNGTUNG PROVINCE, CHINA		
TENANT FARM, 1/5 ACRE		
a. Mud Carp (Ref. 13)	Mud Carp—600 fingerlings (30 lbs.)	~ 4000 lbs/acre/year
b. Grass Carp (Ratio not given)	Grass Carp—200 fingerlings (14 lbs.)	
c. Big Head Carp	Big Head Carp—25 fingerlings (9 lbs.)	
d. Silver Carp	Silver Carp—25 fingerlings (9 lbs.)	
e. Black Carp	Black Carp—10 fingerlings (2 lbs.)	
f. Common Carp	Common Carp—25 fingerlings (2 lbs.)	
2. INDIA EXPERIMENTAL PONDS		
a. Grass Carp (Ref. 16)	24,300-36,300 per acre	2590 lbs/acre/year
b. Silver Carp (3:4:3)	Carp fry	80% survival
c. Common Carp	No feeding data	
3. ISRAEL, BRACKISH WATER PONDS		
a. Common Carp (Ref. 17)	Variable stocking rates.	(estimated) 6250-8000 lbs/acre/year
b. Silver Carp	Ponds fertilized.	
c. <i>Tilapia aurea</i> Food habits unknown	Fish fed pelletized diet high in protein.	
d. <i>Tilapia nilotica</i> . Plankton feeder? Omnivore or feeds on high plants (exact habits unknown)		
e. Grey Mullet (<i>Mugil</i> spp.) Plankton, benthic algae		
4. ROMANIA, 300 ACRE POND		
a. Common Carp (Ref. 18)	1700, 570, 40 respectively lbs/acre	1750 lbs/acre/year
b. Silver Carp (3:1:1)	Yearling fish, supplemental feeding	56% Common, 34% Silver, 10% Grass
c. Grass Carp		Food Conversion Ratio 3:1
5. ROMANIA, 300 ACRE POND		
Same as above (Ref. 18) (14:8:1)	2350, 1300, 160 per acre respectively. Supplemental feeding.	2050 lbs/acre/year
6. CHINA, 1 1/2 ACRE POND		
a. Black Carp (Ref. 15)	Black Carp—773 (844 g)	Total weight 11,800 lbs/year
b. Silver Carp	Silver Carp—2000 (23 g)	~ 50% Black
c. Big Head	Big Head—400 (30g)	Net Production 10,000 lbs/year or
d. Bream (<i>Parahramu pckinesia</i>) Feeds on insects, worms, small fish	Bream—1214 (25 g)	6700 lbs/acre/year
e. Common Carp	Grass Carp—110 (191g)	95.6% survival
	Common Carp—1905 (26g)	
	Total 6402 (812 kg)	
	Fish (1800 lbs)	
4. BURMA, 3 REARING PONDS, 0.2 ACRES EACH		
a. Grass Carp (Ref. 19)	1370-2035 2g fingerlings/acre	(After 6 months)
b. Silver Carp (Variable)	Fed with mixture of rice bran, peanut cake, and chopped green vegetation. (Ratio 1:1:2)	Total production 1700, 1520, 1242 lbs/acre
	7-11 lbs/day (quantity doubled after 3 months)	Average production: Silver—868 lbs/acre
		Grass—720 lbs/acre
		Survival: Silver 95%, Grass 97%

TABLE II POND STOCKING DENSITIES, MANAGEMENT TREATMENTS AND YIELDS OF VARIOUS CARP POLYCULTURE SCHEMES

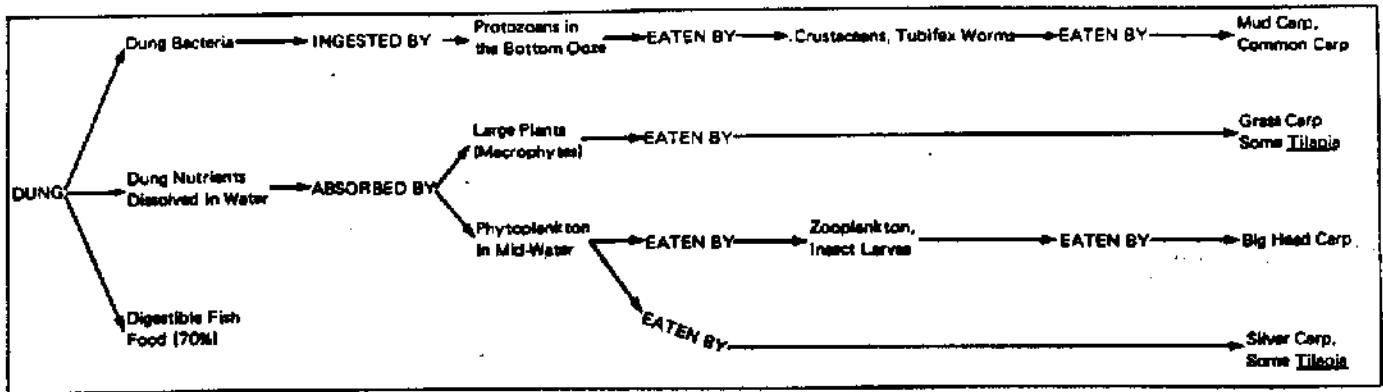

FIG. 4 THE CONTRIBUTION OF DUNG FERTILIZER TO THE DIFFERENT FOOD CHAINS OF A POLYCULTURE FISH POND.

LABOR ENERGY INPUT

- A. Assume that a person doing moderate work consumes about: 170 kcal/hr.
- B. Assume that the farmer must spend about 900 hours per year tending and harvesting the fish from the 3 acres of ponds.
- C. Therefore total labor energy expended is:
 $300 \text{ hrs/year} \times 170 \text{ kcal/hour} \dots\dots\dots E = 85,000 \text{ kcal/year}$

FISH ENERGY OUTPUT (PRODUCTION)

- D. Annual fish production from the 3 acres of ponds is: 3600 kilograms (7900 lbs)
- E. Assume energy value of fish flesh to be:
1 kcal/gram wet weight
- F. Then energy value of total production is:
 $(3600 \text{ Kg}) \times (1 \text{ Kcal/gram}) \dots\dots\dots F = 3,600,000 \text{ Kcal/year}$

ENERGY BUDGET OF MALAYSIAN POLYCULTURE FISH POND
 C/F $\dots\dots\dots 0.02 = 2\%$ i.e. a labor energy subsidy of 2 Kcal is required for every 100 Kcal of fish produced

TABLE III ENERGY BUDGET FOR POLYCULTURE FISH PONDS IN MALAYSIA. NOTE: THE PIG MANURE AND SPILT PIG FOOD THAT FERTILIZE THE PONDS ARE CONSIDERED AS BY-PRODUCTS OF THE PIG PRODUCTION, AND FOR OUR PURPOSES HERE ARE NOT FIGURED IN THE ENERGY BUDGET. BASIC DATA FROM REF. 7

It is interesting to note that the pig dung serves as food for the fish in at least four important ways (Fig. 4). This illustrates the importance of organic fertilizers to the balanced diversity of the fish pond (i.e., more than just one food chain is supplied with food).

Taiwan is another Asian country where fish is an important part of the diet (63% of the animal protein eaten). Aquaculture in Taiwan covers the range from intensive coastal oyster farms to carp and Tilapia polycultures in inland ponds. The results of one study from Taiwan²⁰ are important because they suggest that under comparable conditions freshwater pond aquaculture has a higher return on energy/material investment than either pig farming or ocean fishing (Table IV).

Type of Husbandry	Kg*/Man Year Average High	Kg/Hectare/Year** Average High	U.S. \$/Kg Average Low
Brackish Water (Milk fish)	3,098	11,022	0.37
Freshwater Ponds (carp, Tilapia)	10,453	70,607	0.31
Shallow Sea (oysters)	45,575	1292	0.16
Hog Farming	12,000	(see Table I)	0.43

* 1Kg = 2.2 lbs.
 ** 1 Kg/ha = .89 lbs/acre

TABLE IV PRODUCTIVITY AND PRODUCTION COSTS FOR DIFFERENT TYPES OF WATER AND LAND HUSBANDRY IN TAIWAN. AFTER REF. 20

When compared in terms of protein production, the results stay relative-

ly the same. Shallow sea oyster farming is the most economical, followed by freshwater pond aquaculture (Table V). However, it is worth re-emphasizing the obvious: freshwater pond aquaculture is practical for many more people than is mariculture. And in this sense, it may be the most efficient means of animal protein production.

Product	Production ^a		Cost		
	Kg Protein/Man-Year Average	High	U.S. \$/Kg Average Low	Protein %	Fat %
Brackish Water (Milk fish)	519	1,123	1.63	2.84	20
Freshwater (Carp)	1,148	7,759	2.80	1.81	22
Shallow Sea (Oyster)	4,332	-	1.60	-	10
Hog	757	-	6.81	-	8

TABLE V ESTIMATED COST OF PROTEIN PRODUCTION IN TAIWAN. FROM REF. 20

Using the same logic we did for the Malaysian fish-pig farm we can now estimate the energy budget of the Taiwan polyculture system (Table VI).

LABOR ENERGY INPUT

- A. Assume the labor energy of a man-year to be:
(8 hr/day) (170 kcal/hr) (365 days/yr) $\dots\dots\dots 496,000 \text{ kcal}$
 - FISH ENERGY OUTPUT (PRODUCTION)**
 - B. 23,000 lbs/man year^a $\dots\dots\dots 10.5 \text{ million kcal}$
- ENERGY BUDGET OF TAIWAN FISH FARMING**
 A/B = .05 = 5%

TABLE VI PARTIAL ENERGY BUDGET OF FRESH WATER POND AQUACULTURE IN TAIWAN. AFTER REF. 20. BUDGET INCLUDES MAINTENANCE ENERGY ONLY AND NOT SECONDARY INPUTS LIKE: PRE-PLANNING, SITE CONSTRUCTION, PRODUCTION ENERGY OF MATERIALS USED, FERTILIZERS, ETC.

Although these examples are for tropical countries, they do suggest that an aquaculture which is practiced with ecological techniques is an extremely efficient means of obtaining protein for human nutrition. Also, aquaculture can thrive on waste products and need not depend upon grains which themselves can be used for human food.

As a final point of interest we can compare the energy budgets (protein ratios) of various foods produced in the U.S. (Fig. 5).

This information suggests that fish provide more animal protein per energy input than any other kind of U.S. food (compare to Fig. 1), even though most of the fish produced by the U.S. is from offshore fishing.

The Small Fish Farmer in the U.S.

We have given examples of pond aquaculture systems operated in the tropics. Now what about comparable systems for temperate latitudes... specifically the U.S?

First of all it is important to understand that the single most important

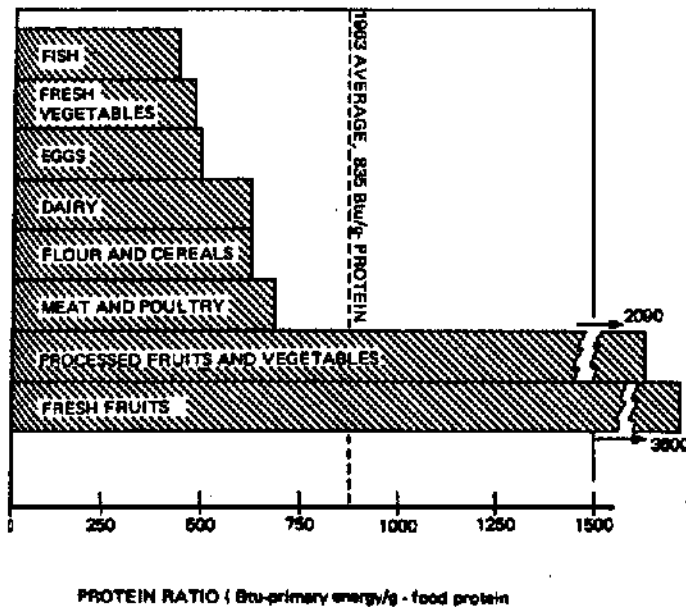

FIG. 5 PROTEIN RATIO OF VARIOUS FOOD GROUPS IN THE U.S. PROTEIN RATIO = RATIO OF ENERGY INPUTS TO ENERGY OUTPUTS (PROTEIN ENERGY). REDRAWN AFTER REF. 21.

factor with regards to fish production is water temperature. Being cold-blooded, fish and shellfish respond immediately to changes in temperature, generally growing better in warmer water. The tropics receive more solar energy and have a warmer average climate than the higher latitudes. Thus aquatic organisms grow faster and for longer periods (year around) in the tropics than they do in temperate climates. Generally speaking, within the temperature range in which a fish can thrive, an increase of about 10°C can cause growth and metabolism to double. This relationship is also reversible. Growth rates can be cut in half for each 10°C drop in average water temperature. Below a critical temperature, of course, growth ceases altogether (e.g., when fish are over-wintering), and if the water temperature continues to fall, a lower *lethal limit* is reached.

As a result of this temperature relationship, natural or managed aquatic systems in most of the U.S. aren't very productive. This is why the majority of commercial aquaculture operations (except trout which thrive in cold waters), are located in the southern Gulf states.

The small farmer not living on the Gulf of Mexico, in the southwestern U.S. or southern California has few choices if he wants to raise fish for food in farm ponds. He is bound to choose an endemic species that can survive over winter, until summer when growth can resume. Since the growing season is so short (3-6 months in most of the U.S.) productivity is low compared to the tropics.

In the U.S. the traditional regime is the Largemouth Bass-Bluegill community. The bass is a predator and feeds only on smaller fish (including their own offspring) and invertebrates it can find in the pond. The bluegill feeds mostly on bottom animals. Because they eat mostly animals and not plants, bass-bluegill cultures rarely produce more than 400 lbs/acre/yr.

The same situation exists for the other traditionally cultured fish in the U.S. (catfish, trout and perch), which are basically flesh eaters growing only during the warm part of the year. When raised in small farm ponds without supplemental feeding, yields are very low. It is only when these fish are raised commercially that the yields increase substantially. Commercial trout and catfish are big business in the U.S., and like the rest of agriculture they have already been locked into the agribusiness syndrome. Monoculture is practiced with heavy overstocking and feeding with high protein trout and "cat chows." The ponds must be artificially aerated to keep the fish from dying. Plants are kept out of the system lest they foul up the "efficient" workings, and if they should happen to become established . . . herbicides are often used!¹⁴

But even with chemical aids and technical "advances," American catfish farmers seldom produce more than 3000 lbs/acre/yr. Trout have yielded up to 80,000 lbs/acre/yr (Idaho trout farms), but the fish are very expensive

due to the high cost of the operation.

There is another point to be made. The bass-bluegill system is traditional primarily because these species are a favorite of sport fishermen, and not because they are a food-species per se. Herein lies the difference between U.S. and Asian pond fish cultures. Whereas the Asians are serious about trying to get as much food out of their ponds as possible, Americans are content with an occasional fish dinner to augment their beef/pork diets. Also Americans are fairly squeamish about the fish they eat; very few seem willing to accept a more productive plant-eating fish like carp. In fact, most herbivorous fish have been dubbed "trash fish" in this country. Possibly these prejudices will give way in time as animal protein becomes more expensive. For example, per capita consumption of fish increased 15% between 1967-1970.² And since there will always be people who want to "grow their own" we just might see an increased interest in rural fish ponds.

According to Bill McLarney,²² a 1 acre farm pond somewhere in rural America, with bass and bluegill, could produce 108 pounds of edible meat per year if the following management practices were followed: (1) Periodic harvesting of larger fish by partial draining and seining. This provides additional food for the remaining smaller fish. (2) Leaving about 25% of the small fish that remain after the last harvest (in mid-late fall), and a small breeding population of adult fish making the pond a perennial source of food. (3) Using proper skill in dressing the fish. McLarney quotes a 40% dressing loss for fish caught in Massachusetts ponds. With these precautions one could get over 100 pounds of edible fish meat per acre per year in a growing season of about 6 months.

Tending a large farm pond is only practical if you happen to live on a farm or other open space; but what about people with just a backyard. Are there fish rearing systems for them?

The Backyard Fish Farm

At the present time a small research group in Massachusetts, the New Alchemy Institute, is experimenting with different kinds of small scale aquaculture systems geared to individuals, families and small groups. The Alchemists have pioneered in methods of raising herbivorous fish in small ponds and tanks enclosed by greenhouses, and fueled with local resources.

The Alchemists' systems are modeled after Asian polyculture farms, but are adapted for northern climates. They have done this by: (1) Incorporating home-built solar heat collectors to add to the warming effect of the greenhouse and raise the water temperature of the ponds to 20°-30°C. At these temperatures Tilapia and carps undergo rapid growth and reach harvestable size in as little as 10 weeks if given proper food. (2) Stocking, fertilizing and feeding with organic wastes and natural foods grown either near or right in the cultures. (3) Using biological filters for removing toxic materials, and wind energy for moving the filtered water. The systems are designed to be ecologically efficient without requiring large sums of money for their construction, or much time for their maintenance.

To date the New Alchemists have tested three basic aquaculture models (Figs. 6, 7, 8). Figure 9 shows their next planned project . . . The Ark. Journal No. 2 of the New Alchemy Institute has a complete description of all four set-ups. We will describe briefly one of their systems (the Mini-Ark). It illustrates the basic strategy behind backyard fish farming: to mimic fish culture after a natural pond ecosystem.

Figure 8 shows the "Mini-Ark." Designed as a precursor to the Ark (Fig. 9), it is a closed recirculating system in three stages. A water pumping windmill made from simple materials (see Wind Section page 95 of *Primer*) circulates the water by pumping it from the lower fish pool to the upper pool where the water then flows back down through the middle and lower pools by gravity.

The upper pool is a purifying filter consisting of three separate compartments: a biological filter, an earth filter and an algae culture. Basically the entire filter pool takes the place of the earth-bottom of a natural pond or lake. The biological filter is a bed of crushed clam (Quahog) shells which provides a large surface substrate for the growth of nitrifying bacteria. These microbes convert the toxic waste materials produced by the fish (mostly ammonia) into nitrates and nitrites (NO₃ and NO₂). If allowed to accumulate, these toxins would either kill the fish directly or stunt their growth. Also the nitrates and nitrites are the form of nitrogen most pre-

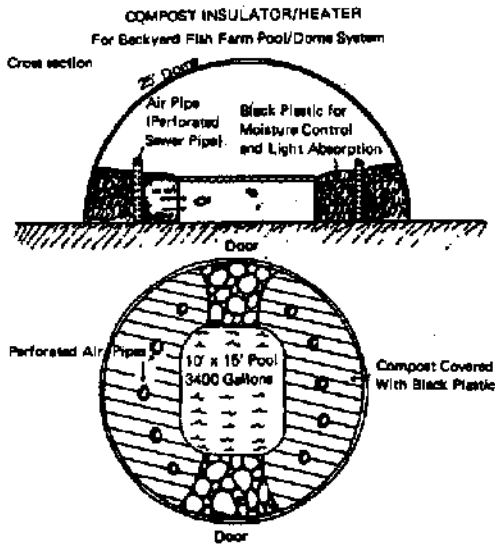

FIG. 6 A DOME-COVERED FISH POND FOR NORTHERN CLIMATES. FROM THE JOURNAL NO. 2 OF THE NEW ALCHEMY INSTITUTE.

ferred and acceptable to plants.** Thus potentially harmful wastes are recycled into useful nutrients for the plants, which in turn feed the fish, etc, etc. The clam-shell filter does two other things: it traps suspended organic matter which tends to use up available oxygen, and it buffers the pH of the culture water.

The earth filter section consists of small water plants growing in dirt. The earth does two things: first, it provides trace elements vital to growing plants and animals; second, it inoculates the system with nitrifying bacteria for the biological filter. The aquatic plants growing in the earth bed contribute oxygen to the filter thus ensuring the life of the (aerobic) nitrifying bacteria even when wind and water circulation are poor.

The third compartment of the upper pool becomes rich with microscopic algae (phytoplankton) as the nutrients from the biological filter flow into this space. This rich "soup" is allowed to flow into the middle pool where tiny crustaceans (*Daphnia*) eat the phytoplankton and increase in numbers. The middle pool is periodically drained into the bottom pool where the *Daphnia* serve as food for juvenile fish growing there.

The bottom pool (8500 gallons) is the main culture pool for the fish. Presently the Alchemists are stocking species of *Tilapia* in polyculture. These fish grow well in the warm water (28°-30°C) made possible by the

**Recent research ²³ has indicated that when raising herbivorous fish like *Tilapia* or *Carp* it may not be wise to include large water plants in the system since they remove large amounts of nutrients (especially nitrates and phosphates) which would otherwise be used by the phytoplankton for primary productivity.

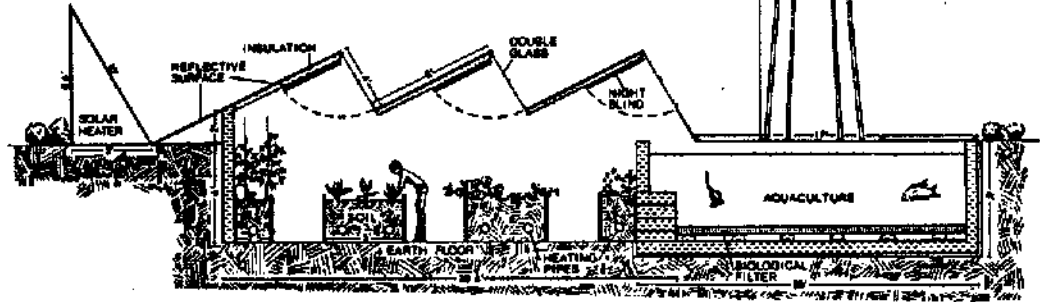

FIG. 9 THE ARK; A PROPOSED ADVANCED MODEL OF THE MINI-ARK. FROM JOURNAL NO. 2 OF THE NEW ALCHEMY INSTITUTE.

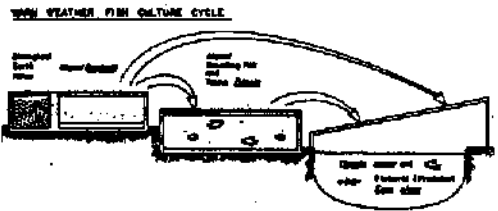

FIG. 7 A THREE-TIERED, FLAT TOP FISH RAISING COMPLEX. FROM THE JOURNAL NO. 2 OF THE NEW ALCHEMY INSTITUTE.

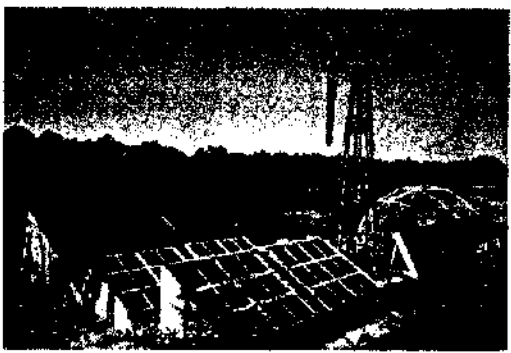

FIG. 8 THE MINIATURE ARK; A WIND-POWERED, SOLAR-HEATED, COMBINED GREENHOUSE AND BACKYARD FISH FARM. FROM THE JOURNAL NO. 2 OF THE NEW ALCHEMY INSTITUTE.

greenhouse cover, good pond insulation and a solar collector. Since the Alchemists have been conducting their experiments as models for others to use, they have not been trying to produce especially high yields. However Bill McLarny feels that they might be able to harvest about 100 lbs/yr of fish from one of their dome ponds (3000 gallons). This is quite an improvement over natural non-managed systems when we consider that this pond is only 0.02 acres (remember the maximum 400 lbs/acre/yr for the best bluegill farm ponds).

There are many techniques used by the New Alchemists to increase fish productivity. They are listed here by way of summary:

1. Increase water temperature by using insulated pools, greenhouse structures with double insulating skins, solar water heaters, insulating night covers for the tanks and reflective panels which bring more heat into the pools.

2. Fertilize with manures to increase the primary productivity of the system.

3. Raise herbivorous fish which feed at the primary consumer level of the food chain and are thus more efficient at converting primary productivity (aquatic plants) to fish meat.

4. Polyculture . . . growing a variety of animal species that feed in different ecological niches and utilize different living habitats of the contained ecosystem (culture tank or pond).

5. Raise natural foods in or near the system for supplemental feeding (see Fig. 10). These foods may include midge fly larvae (*Chironomids*), fly maggots, other insects caught by "bug lights" at night, earthworms, amphipods as well as plants such as garden weeds, vegetable wastes (especially carrot tops), grass clippings, etc. (See the bibliography at the end of this article for further information on the cultivation of natural animal foods for fish.) When animal protein is used as a supplement to the plant diets of herbivorous fish, especially in the early stages of growth, it enables the fish to grow faster and stay in better health than when they are fed strictly on plant materials. The New Alchemists have found that about 10% of the diet of *Tilapia* should be made up of animal foods. Animal protein also has a high conversion efficiency into fish flesh. In other words it takes less animal foods to produce a given amount of fish flesh than it does plant material (Table VII).

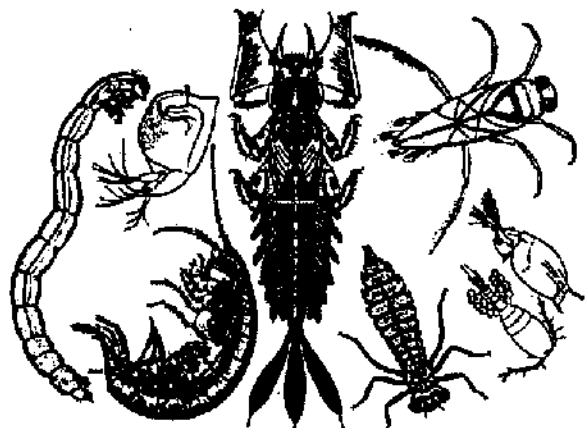

FIG. 10 AQUATIC INVERTEBRATES GROWN AS NATURAL FOODS FOR CULTURED FISH AND PRAWNS. CLOCKWISE FROM UPPER RIGHT: WATER BUG, CLADOCERON AND COPEPOD, DRAGONFLY NYMPH, GAMMARUS, CHIRONOMID MIDGE LARVAE, DAPHNIA, CENTER, MAGFLY NYMPH.

materials that have a long life and low energy cost.

8. Consideration of the cost-effectiveness of the system. Is it economical to build and maintain? The New Alchemists have taken pains to design for the homesteader or small group, but yet have not skipped on design. Their systems are designed to last and provide paybacks in terms of edible products for many years.

The Neighborhood Fish Farm

Another system worth mentioning is one that has been designed to serve the animal protein needs of a larger number of people, say a group of families or a community. It is derived from the greenhouse-polyculture schemes described above. It is a fairly large system and it emphasizes, in addition to fish production, shellfish culture and vegetable hydroponics.

The modular unit is shown in Fig. 12. It is a quonset-type greenhouse 100' by 30' that is equipped with double plastic walls, insulation on the north side and ends, and solar heat collectors alternated with clear double-wall sections on the south side. Inside are three large culture tanks (60' x 6' x 4') built of polyurethane foam, hand layed-up cement and fiberglass (the tradeoffs on tank design haven't been completely explored as yet). Also smaller tanks for rearing natural foods and housing biological filters are included as partitions from the larger culture tanks. An area at one end of the greenhouse is set up for rearing juvenile animals and keeping breeding adults. Finally, associated with each main tank is a hydroponic growing compartment where the culture water from the main tanks (a "soup" of excellent fertilizer) is flushed through gravel beds planted with vegetable crops (Fig. 11).

Nutrient Rich Effluent From Prawn Tanks

Foods of Plant Origin		Household scraps	
Lupine seeds	3-5	Banana leaves	25-0
Soyabeans	3-3	Culms Grass	48-0
Maize	4-6		
Cereals	4-6		
All cereals	5		
Potatoes	20-30		
Maize	3-5		
Cottonseed	2-3		
Cottonseed cake	3-0		
Groundnut cake	2-7		
Ground maize	3-5		
Ground rice	4-5		
Oil palm cakes	6-0		
Mill sweepings	8-0		
Rice flour	8-0		
Manioc leaves	13-3		

Foods of Animal Origin	
Gammarus	3-9-6-6
Chironomids	2-3-4-4
Housefly maggots	7-1
Fresh sea fish	6-9
Fish flour	1-3-3-0
Freshwater fish	2-9-6-0
Fresh meat	5-8
Liver, spleen and abattoir offals	8
Prawns and shrimp	4-6
White cheese	10-15
Dried silkworm pupae	1-8

Mixtures	
Fresh sardine, mackerel head, dried silkworm pupae	3-5
Liver of horse and pig, sardine, silkworm pupae	4-5
Silkworm pupae, silkworm feces, grass, soyabean cake, pig manure, night soil	4-1
Coelund Trout diet No. 6	7-1
Raw silkworm pupae, processed barley, Lems and Gammarus	2-5

TABLE VII CONVERSION RATES OF VARIOUS FOODS INTO FISH. CONVERSION RATE = WEIGHT OF FOOD/INCREASE IN WEIGHT OF FISH. THE LOWER THE NUMBER THE MORE EFFICIENT IS THE FOOD IN PRODUCING FISH FLESH. ADAPTED FROM HICKLING (REF. 15).

8. Periodic harvest of larger fish. This allows the remaining smaller fish to use the available food more efficiently.

7. Use of low-impact technology for building the equipment needed to run the fish farm. These include windmill pumps for circulating water, solar collectors for warming the pond water, wind generators and heating coils for heating the water during periods of cloudy weather, and use of building

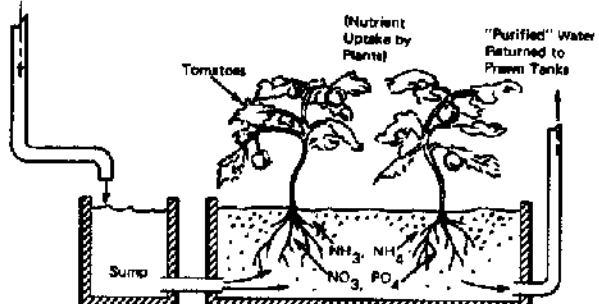

FIG. 11 HYDROPONIC VEGETABLE GROWING TANK. ILLUSTRATES PURIFYING ACTION OF PLANTS ON NUTRIENT LADEN CULTURE WATER.

Among the many kinds of animals grown is the giant Malaysian fresh-

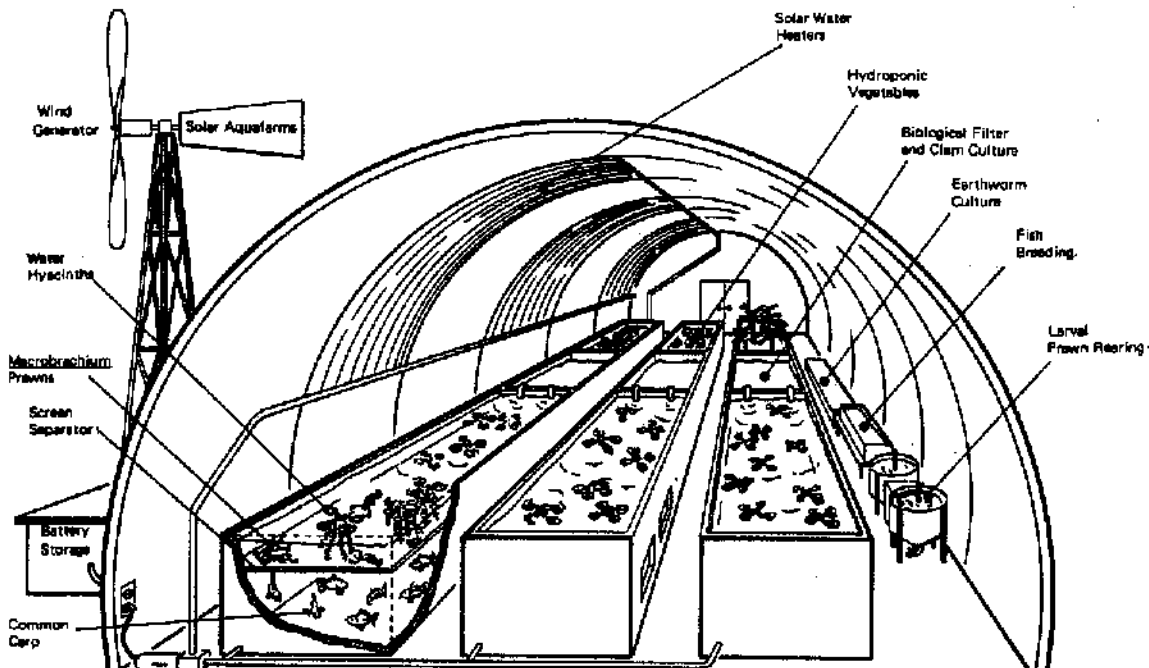

FIG. 12 A 100' x 30' "AQUASOLARIUM" SOLAR-WIND POWERED AQUATIC FOOD PRODUCTION UNIT. AFTER A DESIGN OF D. MENDOLA, NEW ALCHEMY INSTITUTE—WEST AND S.A. SERFLING, SOLAR AQUAFARMS, DAVIS, CA.

water prawn (*Macrobrachium rosenbergi*). A relative of saltwater shrimp, this animal is especially suited to freshwater tank culture. It is fast growing (egg to adult in 7-9 months at 27°C), hardy, omnivorous, disease resistant, easy to breed and tasty. The Western New Alchemists have spent the last 2 years working with this animal and heartily recommend it. It is ideal for culture as human food since it has a high protein content (22% wet weight) and a high yield of edible meat (about 50%).

The females bear from 10,000 to 60,000 eggs (15,000 average). About 60 to 80% of these hatch as planktonic larvae. After spending about 30 days in special rearing vessels, the larvae "settle out" as bottom-crawling, diminutive versions of the adult animal. Survival from eggs to this post-larval stage is usually about 50% with good culture conditions.

The main culture tanks are partitioned horizontally to keep prawns in the top half and common carp in the bottom half. The top half is planted with floating aquatic plants (water hyacinths) whose fibrous roots serve as a habitat for the juvenile prawns. The hyacinths also act as hiding places for the adults, since the males are very aggressive towards each other (i.e. territorial) and tend to fight if allowed to come into contact.

Other methods have also been proposed to house the adult prawns, but these are primarily designed for intensive, high-yield commercial operations.

Common carp are kept beneath the horizontal screen. These feed on the rain of organic wastes coming from above. The carp are bred in the laboratory and stocked as juveniles in the subspace. The fish wastes are taken up by the water plants and the hydroponic vegetables.

After the water is passed through the hydroponic beds it is pumped into the biological filter beds and then back into the main culture tanks. A scheme is also being worked out where a portion of the culture water including organic debris is passed into a bed of fresh water clams (*Corbicula*). The bivalves filter out the detritus and use this food energy for their own growth. They multiply readily without any management, and can be periodically cropped to be fed back to the prawns or used for human food. Still another cycle involves some of the culture water passing into a tank where *Daphnia* are grown as food for the juvenile prawns.

The prawns must eat particulate materials. They will take almost any garden scrape chopped finely and are particularly fond of cooked rice and raw oats. Only supplemental amounts of these foods are needed, since a good portion of their food can be the clams, *Daphnia*, and plants cultured

system.

The energetics of the prawn-carp operation are still being worked out by the west coast New Alchemists who plan on writing a workbook on it next year (Fig. 13, next page). What is known already, however, is that about 600 pounds of prawns (450 pounds of meat) and 400-600 pounds of fish meat per year can be harvested from a system whose initial costs (materials plus maintenance) average \$1000 per year amortized over 10 years. This is a reasonable expenditure for a system that yields over 1000 pounds of edible meat . . . not to mention the unknown quantity of clams and vegetables.

..

We have seen examples of backyard, neighborhood and farm-scale fish farms tailored for the American environment and modeled after natural aquatic ecosystems. Obviously any aquaculture set-up requires a certain amount of biological skill to construct and maintain. However, with time, patience and proper attention, we believe these schemes, or ones like them, can be made practical and serve as integral parts of a local food producing operation.

OBTAINING FISH AND SHELLFISH FOR AQUACULTURE

Some freshwater animals suitable for aquaculture are legally controlled in many states. For example, in California, it is illegal to import grass carp and the freshwater clam *Corbicula* across state lines, or to release these species into natural waters. In closed aquaculture systems (those recirculating the same water) you have control over species escaping into local streams, etc., and possibly upsetting their ecological balance. In open systems (those using water from local sources and releasing culture water into them) there is always a possibility of contamination. Tropical or subtropical species like *Tilapia* or *Macrobrachium* would probably not survive a winter in streams and rivers in most of the United States. Others adapted to cool waters might thrive. In any event it is probably best to check with your local Fish and Game Office. They can tell you the legal implications of growing a particular fish or shellfish for food. As far as obtaining *Tilapia*,

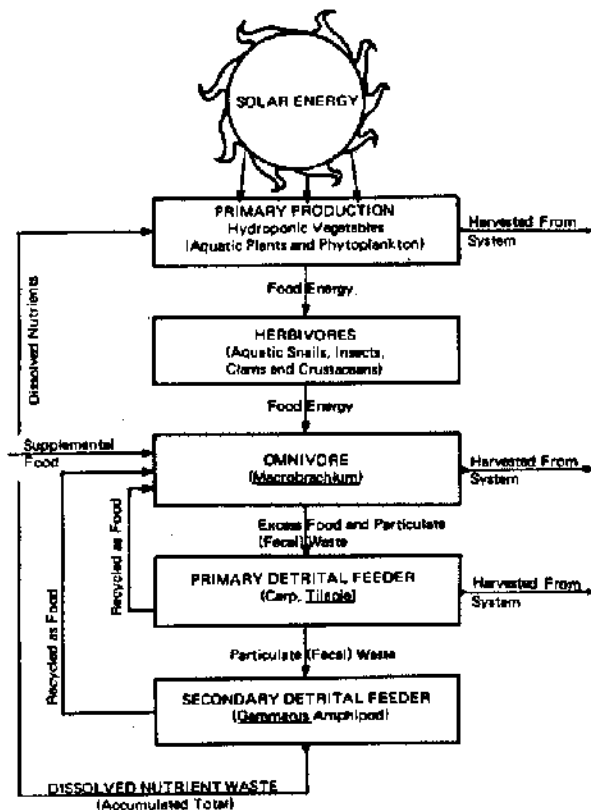

FIG. 13 ENERGY AND NUTRIENT FLOW SCHEME FOR A CLOSED-CYCLE POLY-CULTURE SYSTEM DESIGNED FOR MAXIMIZING PRODUCTION OF FISH AND PRAWNS AND MINIMIZING ENERGY LOSSES

inquiries should be made with local aquarium stores, or by contacting one of the distributors listed below.

Sources for fish stocks:

Perry Minnow Farm
Rt. 1, Box 128-C
Windsor, VA 23467
(Israeli Carp)

J. M. Malone and Son Enterprises
P.O. Box 158
Lanoka, Arkansas 72068
(Grass Carp, Tilapia)

Finally, *Journal No. 2 of the New Alchemist* includes further information on how and where to obtain stocks of *Tilapia*. *Journal No. 2* and other pamphlets on aquaculture (see below) can be obtained from:

New Alchemy Institute
Box 432

Woods Hole, Massachusetts 02543

NEW ALCHEMY AQUACULTURE PUBLICATIONS

1. AQUACULTURE BIBLIOGRAPHY

William O. McLarney. Includes references on polyculture and pond construction. Available from New Alchemy, or Readers' Service, *Organic Gardening and Farming* magazine, Emmaus, Pennsylvania 18049. Price \$1.00

2. THE BACKYARD FISH FARM WORKING MANUAL FOR 1973

W. O. McLarney, ed. This first "how-to-do-it" manual for backyard fish farmers has been updated and much improved in a comparable article in *The Journal of the New Alchemists No. 2*.

3. WALTON H: A COMPLETE GUIDE TO BACKYARD FISH FARMING

W. O. McLarney and J. H. Todd. 1974. It's all we have learned about raising fish under intensive and ecological conditions. An extensive treatment intended to assist those wanting to start raising low-cost, high-quality fishes. Includes sources of fish. *The Journal of the New Alchemists No. 2*. 1974. \$6.00.

4. AQUACULTURE SERIES FOR ORGANIC GARDENING AND FARMING MAGAZINE (EMMAUS, PA 18049).

August 1971. W. McLarney. *Aquaculture on the Organic Farm & Homestead*

November 1971. W. McLarney. *The Fish Pond Revisited*

January 1972. J. Todd and W. McLarney. *The Backyard Fish Farm*

February 1972. W. McLarney. *Why Not Carp?*

5. AQUACULTURE: THE FARMING AND HUSBANDRY OF FRESHWATER AND MARINE ORGANISMS

J. Bardach, J. Ryther and W. O. McLarney. John Wiley and Sons, 1972. 888 pages. \$37.50. This is the definitive English language text in the field. NA's McLarney was the primary contributor to the book. It's very expensive, but if you are going to commit yourself to aquatic farming, you will need to read it. Ask your library to buy it. The cost is largely in the plates and illustrations which add a lot of value to the text. See Reviews.

6. STUDIES OF THE ECOLOGY OF THE CHARACID FISH, BRYCON GUATEMALENSIS, IN THE RIO TIRIMBINA, COSTA RICA, WITH SPECIAL REFERENCE TO ITS SUITABILITY FOR CULTURE AS A FOOD FISH

W. O. McLarney. *The Journal of the New Alchemists No. 1*. \$2.00, 1973. Yep, it's what it says it is!

7. THE ARK: A SOLAR HEATED GREENHOUSE AND AQUACULTURE COMPLEX ADAPTED TO NORTHERN CLIMATES

By several New Alchemists. *The Journal of the New Alchemists No. 2*. 1974. \$6.00. Design and rationale for such a structure. All our aquaculture structures employ a variety of methods for trapping and storing the sun's heat. Discussion of these methods are in articles on aquaculture.

8. AQUACULTURE: TOWARD AN ECOLOGICAL APPROACH

W. O. McLarney. In: "Radical Agriculture," ed. Richard Merrill, Harper & Row (in Press).

REFERENCES CITED

¹Bardach, J. E., J. H. Ryther, and W. O. McLarney. 1972. AQUACULTURE: THE FARMING AND HUSBANDRY OF FRESHWATER AND MARINE ORGANISMS. See reviews.

²Whitaker, Donald R., 1972. AQUACULTURE VERSUS LATENT RESOURCES. 17th Annual Meeting, Atlantic Fisheries Technology Conference, Annapolis, Maryland, October 22-26, 1972.

³Lappé, Frances M., 1971. DIET FOR A SMALL PLANET. Bantam Books, Inc. New York.

⁴McLarney, W. O., 1971. AQUACULTURE ON THE ORGANIC FARM AND HOMESTEAD. *Organic Gardening and Farming Magazine*, August 1971.

⁵Schuster, W. H., G. L. Kesteven, and G. E. D. Collins, 1954. FISH FARMING AND INLAND FISHERIES MANAGEMENT IN RURAL ECONOMY. F.A.O. Fisheries Study No. 3. Rome, Italy.

⁶Ho, R., 1961. MIXED FARMING AND MULTIPLE CROPPING IN MALAYA. In: Proceedings of the Symposium on Land-Use and Mineral Deposits in Hong Kong, Southern China and Southeast Asia. S. G. Davis (ed.), Hong Kong University Press.

⁷Lalane, O. W., 1952. PIG-REARING, FISH-FARMING AND VEGETABLE GROWING. *Malayan Agricultural Journal*, Vol. 35, No. 3, pp 156-166. Kuala Lumpur, Malaya.

⁸McLarney, William O., 1970. PESTICIDES AND AQUACULTURE. *American Fish Farmer* 1(10):6-7, 22-23.

⁹Woodwell, George M., P. P. Craigend, and H. A. Johnson. 1971. DOT IN THE BIOSPHERE: WHERE DOES IT GO? *Science* 174:1101-1107.

¹⁰Manigold, D. B. and J. A. Schultze, 1969. PESTICIDES IN WATER: PESTICIDES IN SELECTED WESTERN STREAMS. A PROGRESS REPORT. *Pesticide Monitor Journal* 3:124-136.

¹¹Riesborough, R. W., 1969. CHLORINATED HYDROCARBONS IN MARINE ECOSYSTEMS. In: *Chemical Fallout* M. W. Miller and G. C. Berg (ed.), Charles C. Thomas, Springfield, Illinois.

¹²Margalef, Ramon, 1968. PROSPECTIVES IN ECOLOGICAL THEORY. University of Chicago Press, Chicago, Illinois.

¹³Odum, Eugene P., 1971. FUNDAMENTALS OF ECOLOGY, 3rd edition, W. B. Saunders Company, Philadelphia, Pennsylvania.

¹⁴McLarney, W. O., 1974. AQUACULTURE: TOWARDS AN ECOLOGICAL APPROACH. In: "Radical Agriculture," R. Merrill (ed.), Harper & Row (in press).

¹⁵Hickling, C. F., 1971. FISH CULTURE. See reviews.

¹⁶Anon. 1968. F.A.O. AQUACULTURE BULLETIN, Vol. 1, No. 1, July 1968. F.A.O., Rome, Italy.

¹⁷Anon. 1971. F.A.O. AQUACULTURE BULLETIN, Vol. 4, No. 1, October 1971. F.A.O., Rome, Italy.

¹⁸Anon. 1967. Indo-Pacific Fisheries Council. *Current Affairs Bulletin* 50:25, 1967. F.A.O. Bangkok, Thailand.

¹⁹Anon. 1971. Indo-Pacific Fisheries Council. *Occasional Paper* 71/5, 1971. F.A.O. Bangkok, Thailand.

²⁰Sheng, Yung C., 1973. COMPARISON OF THE ECONOMIC POTENTIAL OF AQUACULTURE, LAND ANIMAL HUSBANDRY AND OCEAN FISHERIES: THE CASE OF TAIWAN. *Aquaculture* 2:187-195.

²¹Hirst, Eric. 1973. ENERGY USE FOR FOOD IN THE U.S. Oak Ridge National Laboratory Report No. ORNL-NSF-EP-57.

²²McLarney, W. O., 1971. THE FARM POND REVISITED. *Organic Gardening and Farming*, November 1971.

²³Fogers, H. H. and D. E. Davis, 1972. NUTRIENT REMOVAL BY WATER-HYACINTH. *Weed Science* 20(5): 423-428

A GUIDE TO THE STUDY OF FRESH-WATER BIOLOGY

A hip-pocket guide to the identification of fresh-water animals. A recognized classic, the fifth edition adds fish to the algae, protozoans, rotifers, molluscs, and insects (immature ones too) described in earlier editions. Excellent drawings illustrate the key characteristics of each organism, while a key-guide fills in the gaps for identification. Also included: materials for collecting in the field and methods of determining water chemistry. A valuable book for those learning to identify food organisms of cultured fish... and, of course, the fish themselves.

A Guide to the Study of Fresh-Water Biology
James Needham and Paul Needham
1982, 3rd ed. (1st ed., 1938); 108 pp
\$2.95

from:
Holden-Day, Inc.
900 Sansome Street
San Francisco, California 94111

TEXTBOOK OF FISH CULTURE: BREEDING AND CULTIVATION OF FISH

More information is included in this book for the would-be organic fish farmer than any other single book I've read. A major sourcebook for the breeding and cultivation of freshwater food-fish. Packed with drawings, tables and photos of culture hardware and systems presently in use throughout the world. There is also information on pond construction, maintenance and improvements, natural methods of increasing pond production, enemies and diseases of fish, harvesting of fish etc. The high price and lack of an index are drawbacks, but this book is a must for the serious aquaculturist.

Textbook of Fish Culture: Breeding and Cultivation of Fish
Marek Huet
1976; 436 pp
\$27.00 (± 12.50) plus shipping

from:
Fishing News (Books) Ltd.
23 Rosemount Avenue
West Byfleet, Surrey, England
or
110 Fleet Street
London EC4A3JL

FISH CULTURE

One of the finer books on the subject: well organized, full of illustrations and many references (312). Also: aquaculture history, pond construction and management, fertilizers, supplemental feeding and foods, brackish and sea water culture, stocking rates, yields, fish genetics, diseases etc. The photos (96) take you around the world in pond culture. The data on stocking rates are especially valuable. This book is cheaper than Huet or Bardach, et. al., but not as inclusive.

Fish Culture
C. F. Hixling
1973 (2nd ed); 317 pp
£ 4.50 (\$10.85 U.S.)

from:
Faber and Faber
24 Russell Square
London WC1E 3AF

GROWTH AND ECOLOGY OF FISH POPULATIONS

Definitely for the serious practitioner only... not a book for the beginner, but for those who want a deeper understanding of the ecological principles behind rearing fish. Sections include: growth processes in fish, food, competition and niches, growth and maintenance of populations, predator-prey relationships among fish, the trophic environment and fish growth, etc. Contains information not found in other books reviewed here. Well illustrated in textbook fashion, a little heavy on the mathematics.

Growth and Ecology of Fish Populations
A. H. Westerley
1972; 293 pp
\$13.50

from:
Academic Press
111 5th Avenue
New York, N.Y. 10003

AQUACULTURE: THE FARMING AND HUSBANDRY OF FRESHWATER AND MARINE ORGANISMS

Hailed as a "bible" by American aquaculturists, this comprehensive volume covers both freshwater and marine aquacultural practices. There are sections on general principles and economics, plus sections on culture methods and techniques for every major species being cultured throughout the world. These include: Common, Chinese and Indian carp; pike; perch; bass; Tilapia; mullet; sea; salmon and trout; pompano; yellow-tail; marine flatfish; freshwater crayfish; orabi; scallops; mussels; abalone; squid; shrimp, lobster and frogs; seaweeds and edible freshwater plants. There are many references, excellent illustrations and photos showing the systems and apparatus in use for the different culture practices. Although the emphasis is towards commercial aquaculture, there is much information for the organic fish farmer. Recent printing of the paperback edition will bring this valuable sourcebook into the reach of all those interested in aquaculture.

Aquaculture: The Farming and Husbandry of Freshwater and Marine Organisms
John E. Bardach, John H. Ryther and William O. McLarney
1972; 868 pp
\$37.50 hardback

paperback edition late 1974
from:
Wiley-Interscience
605 3rd Avenue
New York, NY 10016

ECOLOGY OF FRESH WATER

A concise guide to life in fresh waters. The author takes you on a field trip to a pond, a quiet canal and a running stream to sample the plants and animals in a manner that unfolds the beauty of the aquatic world. Chapter on aquatic plants has good drawings (usually hard to find), and chapter on energy transfer in aquatic ecosystems tells it like it is... and neatly too. The book introduces the basic concepts and terminology of aquatic ecology without getting esoteric... a real must for the beginner. Very well illustrated and referenced, the book fits in your hip pocket or satchel.

Ecology of Fresh Water
Alicia Linsley Brown
1971; 129 pp
\$4.00

from:
Harvard University Press
79 Garden Street
Cambridge, Massachusetts 02138

FISH AND INVERTEBRATE CULTURE: WATER MANAGEMENT IN CLOSED SYSTEMS

Definitely the first book to buy if you're ready to get started in fish farming. An excellent manual covering the necessities—biological, mechanical and chemical filtration, the carbon dioxide system, respiration, salts and elements, toxic metabolites, disease prevention by environmental control, laboratory tests, etc. A real "nuts and bolts" book for the culturist. Many fine drawings show water management hardware, water circulation and flow schemes, relevant biological and chemical cycles and water treatment procedures. The information is especially directed to the problems encountered in closed-system culture in tanks or small ponds, but the chemistry is also applicable to water management in larger systems.

Fish and Invertebrate Culture: Water Management in Closed Systems
Stephen H. Sporer
1970; 145 pp
\$9.50

from:
John Wiley & Sons, Inc.
1 Wiley Drive
Somersex, N.J. 08873
or 1530 South Redwood Road
Salt Lake City, Utah 84104
or **WHOLE EARTH TRUCK STORE**

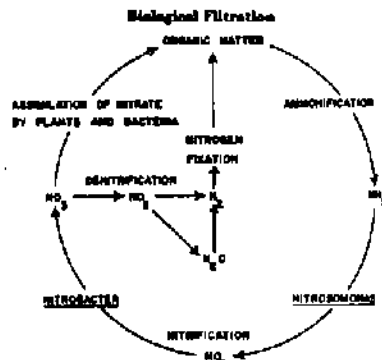
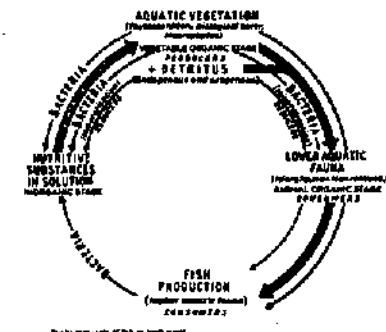

Figure 1. The nitrogen cycle.

BOOKS, SYMPOSIA AND GENERAL ARTICLES

Introductory Note: The literature on aquaculture is scattered among various obscure scientific and popular publications, many of them of rather poor quality. Literature dealing with the broad field of aquaculture is scarcer than writings on specific forms of the art. (Adapted from Aquaculture Bibliography of Bill McLamey, NAU-East).

Bardach, J.E. 1968. AQUACULTURE. Science, 161: 1098-1106. Brief world survey of aquaculture and its future.

Bardach, J. E. and J. H. Ryther. 1968. THE STATUS AND POTENTIAL OF AQUACULTURE. Vol. No. 1, Culture of Invertebrates and Algae, Vol. No. 2, Fish Culture, NTIS.

Borgstrom, G. (ed.) 1961. FISH AS FOOD. Vols. 1 & 2. Academic Press, N.Y.

Eddy, Samuel. 1957. HOW TO KNOW THE FRESH-WATER FISHES. Wm. C. Brown Co., Dubuque, Iowa. Identification of the native fishes of North America.

FAO (Food and Agricultural Organization of the United Nations). 1966. FAO WORLD SYMPOSIUM ON WARM WATER POND FISH CULTURE. Hanoi—FAOWS, 123 papers by top aquaculturists from all over the world. Mostly in English.

Cerking, S. D. (ed.) 1967. THE BIOLOGICAL BASIS OF FRESHWATER FISH PRODUCTION. John Wiley & Sons, N.Y.

Hong, S. L. and T.V.R. Pillay. 1962. HANDBOOK ON FISH CULTURE IN THE INDO-PACIFIC REGION. FAO Fisheries Biology Technical Paper No. 14. 204 pp. Detailed treatment of Asian fish culture. Techniques of pond fertilization, polyculture stocking, etc.

Jones, W. 1970. COMMERCIAL FISH FARMING: HOW TO GET STARTED. American Fish Farmer 1(2):5-8.

Proyer, G. A. 1965. NEGLECTED ASPECTS OF FISH CULTURE. Indo-Pacific Fisheries Council, Current Affairs Bulletin. 36:1-9. Digestibility of algae, effects of different fertilizers on algae, pros and cons of natural aquatic plants as fish food, optimal size of ponds, genetic selection, etc.

Schaeperclaus, W. 1948. TEXTBOOK OF POND CULTURE. Fishery Leaflet No. 311, U.S. Dept. Inver., Fish and Wildlife Series, Wash. D.C.

U.S. Bureau of Sport Fisheries and Wildlife. 1970. REPORT TO THE FISH FARMERS, THE STATUS OF WARM-WATER FISH FARMING AND FISH FARM RESEARCH. Fisheries Research Publ. No. 83, U.S. Dept. Inver., Division of Fisheries Research, Wash. D.C.

MAGAZINES AND JOURNALS

AMERICAN FISH FARMER. P.O. Box 1900, Little Rock, Arkansas 72203 (monthly). Good coverage of aquaculture in this country and throughout the world.

AQUACULTURE. Elsevier Scientific Publishing Co., 52 Vanderbilt Ave., N.Y. Scientific articles on aquaculture... both freshwater and marine. Up to date research.

AUSTRALIAN FISHERIES. Fisheries Division of Australian Government, Public Services. Dept. of Primary Industry Canberra, A.C.T. 2600.

BAMIDGHEH. (Bulletin of Fish Culture in Israel), Niv-David, D.N., Israel. (monthly). Scientific papers on fish culture in Israel and elsewhere (in English). Deals with carp, mullet and Tilapia. Israel has done quite a bit in fish culture in arid climates.

FAO FISH CULTURES BULLETIN. P.A.O. Rome, Italy. (Quarterly). Short reports on aquaculture development worldwide.

FAO PUBLICATIONS—REPRINTS. Available from: Unipub, Box 433, New York, NY 10016. Send for list of available titles under FAO headings.

FARM POND HARVEST. 372 South East Ave., Kankakee, Illinois 60903, (Quarterly). Mostly items on management of American farm ponds for sport and food fish production.

PROGRESSIVE FISH CULTURIST. Gov. Print. Office. (Monthly). Mostly hatchery culture of

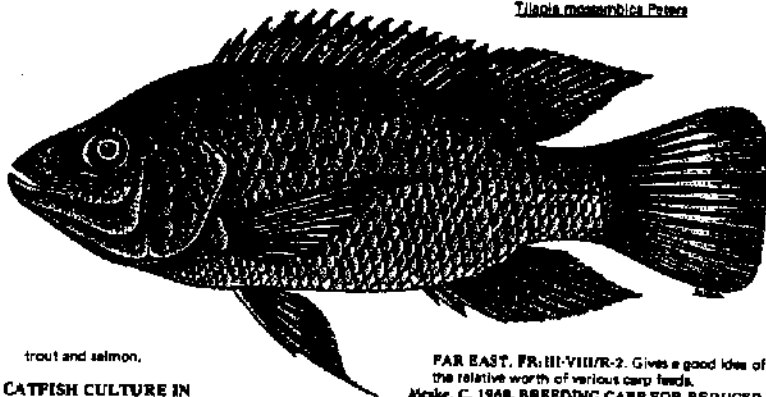

trout and salmon.

CATFISH CULTURE IN THE UNITED STATES

Introductory Note: The channel catfish is the most important aquacultural species in the United States. It may or may not be well suited to the homesteader, but they could conceivably become the first fish to be raised on a commercial scale, using organic methods, in this country. —B.M.

Allen, F. 1971. WEHAW FARM—RICE RAISERS THE RIGHT WAY. Organic Gardening and Farming 18(7):65-72. Contains a brief description of growing catfish in conjunction with rice.

AMERICAN FISH FARMER 2(3). This issue contains three good articles on the economics of catfish farming.

Brown, E. B., M. G. LaPlante, and L. H. Covey. 1969. A SYNOPSIS OF CATFISH FARMING. University of Georgia College of Agriculture Experiment Stations. Bulletin 69, 50 p.

CATFISH FARMERS OF AMERICA. The Catfish Farmer. The monthly official publication of the CFA, \$6.00 per year from: Catfish Farmers of America, Tower Building, Little Rock, Arkansas 72201.

CATFISH FARMING. From Agri-Books, Box 5001-AG, San Angelo, Texas 76901. \$12.00.

Lee, J. S. 1971. CATFISH FARMING. Mississippi State University Curriculum Coordinating Unit for Vocational-Technical Education, State College, Mississippi 39761. 103 p. \$2.00. Excellent detailed treatment of all phases of catfish culture.

Mahan, P. 1973. RAISING CATFISH IN A BARREL. Organic Gardening and Farming, Nov. 73:112-117.

Springe, H. S. 1957. COMMERCIAL PRODUCTION OF RED CATS (SPECKLED BULLHEADS) IN PONDS. Proc. S. E. Am. Game Fish Commissioners, 10:156-160. The only paper on the possibility of culturing bullhead catfish, which might, under some conditions, be more suitable to the homesteader than channel catfish.

Temeyer, O. W. and C. W. Dryon. 1967. PRODUCTION OF CHANNEL CATFISH. Kansas State University of Agricultural Experiment Station. Bulletin 508.

CARP CULTURE

Many good papers on carp culture also appear in Bamidgheh, the Bulletin of Fish Culture in Israel, and the serious reader should consult the annual indices for this journal. —B.M.

Altkuahl, K. H. 1966. SYNOPSIS OF BIOLOGICAL DATA ON COMMON CARP, *Cyprinus carpio*. (Linnæus) 1958, Asia and the Far East, FAO Fisheries Synopses 31.1.

Baekel, T. and K. Stegman. 1966. TEMPERATURE AND YIELD IN CARP PONDS. FAOWS, FR: V/7E-2.

Ehrlich, S. 1964. STUDIES ON THE INFLUENCE OF NUTRIA ON CARP GROWTH. Hydrobiologia 23(4):196-210.

Kirpichnikov, V. S. (ed.). 1970. SELECTIVE BREEDING OF CARP AND INTENSIFICATION OF FISH BREEDING IN PONDS. Bulletin of the State Scientific Research Institute of Lake and River Fisheries. Vol. 61, 249 pp. NTIS.

Lang, S. W. 1966. FEEDS AND FEEDING OF WARM WATER FISHES IN PONDS IN ASIA AND THE

FAR EAST. FR: III-VIII/R-2. Gives a good idea of the relative worth of various carp feeds.

Mesler, C. 1968. BREEDING CARP FOR REDUCED NUMBER OF INTERMUSCULAR BONES, AND GROWTH OF CARP IN AQUARIA. Bamidgheh 20(4):108-119. Describes a highly intensive system of growing carp in a closed recirculating system, with spectacular yields.

Nair, K. K. 1968. A PRELIMINARY BIBLIOGRAPHY OF THE GRASS CARP. FAO Fisheries Circular 302, 155 pp.

Nambiar, K.P.P. 1970. CARP CULTURE IN JAPAN—A GENERAL STUDY OF THE EXISTING PRACTICES. Indo-Pacific Fisheries Council, Occ. Pap. 1970/1, 41 p. Fairly complete treatment of Japanese practices.

Saris, S. 1966. SYNOPSIS OF BIOLOGICAL DATA ON COMMON CARP, *Cyprinus carpio* (Linnaeus) 1783, Near East and Europe, FAO Fisheries Synopses 31.1.

Swenson, J. K. 1965. OBSERVATIONS ON GRASS CARP IN ARKANSAS. Progressive Fish Culturist 27(4):201-206.

TILAPIA CULTURE

Introductory Note: Despite the great importance of Tilapia in fish culture, there is not extensive literature on these fishes. Below are listed a few publications which may be helpful. Many good papers on Tilapia culture also appear in Bamidgheh, the Bulletin of Fish Culture in Israel, and the serious reader should consult the annual indices for this journal. —B.M.

Avrut, J. S., Jr. E. W. Shell, and R. O. Smithersman. 1966. PROCEDURES FOR OVERWINTERING TILAPIA. FAOWS FR: V/8-3.

Chien, P. 1957. THE TILAPIAS AND THEIR CULTURE, A SECOND REVIEW AND BIBLIOGRAPHY. Fisheries Bulletin FAO 10:1-24.

Helding, C. F. 1963. THE CULTIVATION OF TILAPIA. Scientific American, 208:143-152.

Lamber, C. W. 1967. TILAPIA MOSSAMBICA AS A FISH FOR AQUATIC WEED CONTROL. Progressive Fish Culturist 29(1):48-50.

Maer, A., M.A.E. Mortimer and I. Van der Linde. 1966. FISH CULTURE IN CENTRAL EAST AFRICA. FAO, Rome. 158 p. Good, simple description of African methods, many of them involving quite small ponds.

Myer, G. S. 1955. NOTES ON THE FRESHWATER FISH FAUNA OF MIDDLE CENTRAL AMERICA WITH SPECIAL REFERENCE TO POND CULTURE OF TILAPIA. FAO Fisheries Paper No. 2:1-4.

Shell, E. W. 1966. RELATIONSHIP BETWEEN RATE OF FEEDING, RATE OF GROWTH AND RATE OF CONVERSION IN FEEDING TRIALS WITH TWO SPECIES OF TILAPIA, T. MOSSAMBICA AND T. NILOTICA. FAOWS FR: III/7E-9.

Springe, H. S. 1946. BIOLOGICAL MEANS OF INCREASING PRODUCTIVITY IN PONDS. FAOWS, FR: V/R-1. Tilapia-carp combinations for culture in the United States.

Springe, H. S. 1968. COMPARATIVE EVALUATION OF TILAPIAS AS POND-FISHES IN ALABAMA. Transactions of the American Fisheries Society 99(2):142-148.

Uchida, R. N. and J. E. King. 1962. TANK CULTURE OF TILAPIA. Bulletin of United States Fish and Wildlife Service: 199(42):21-52.

BASS AND SUNFISH IN FARM PONDS

Introductory Note: Most state conservation departments and many university agricultural extension services have booklets on farm ponds which may be useful, particularly to neophytes.
—B.M.

- Devision, V. E. and J. A. Johnson. 1943. FISH FOR FOOD FROM FARM PONDS. U.S. Department of Agriculture, Farmers' Bulletin 193B. 27 pp.
- Devision, V. E. 1947. FARM FISH PONDS FOR FOOD AND GOOD LAND USE. U.S. Department of Agriculture, Farmers' Bulletin 193B. 29 pp.
- Ember, D. A. 1971. FOOD OF THREE SPECIES OF SUNFISHES (*Lepomis*) AND THEIR HYBRIDS IN THREE MINNESOTA LAKES. *Transactions of the American Fisheries Society* 100(1):124-128. May be useful to anyone planning polyculture including sunfish.
- Lewis, W. M. and R. Heidinger. 1971. AQUACULTURE POTENTIAL OF HYBRID SUNFISH. *American Fish Farmer* 2(5):14-16.
- Ricker, W. E. 1948. HYBRID SUNFISH FOR STOCKING SMALL PONDS. *Transactions of the American Fisheries Society* 75:84-96.
- Stoeddie, T. M. 1960. FARM POND MANAGEMENT. Agricultural Extension Service, The Ohio State University. 24 pp.

TROUT

- Bassay, G. 1971. HOW TO GROW TROUT IN YOUR BACK YARD (OR OTHER UNLIKELY PLACES). Available for \$3.00 from Life Support Systems, Inc., Box 3296, Albuquerque, New Mexico 87110. Gens Bussay manufactures and sells closed recirculating systems which are claimed to make it possible to grow large numbers of trout—organically. If one wishes—at low cost on any scale from very small for individual use to a large commercial operation.
- Lavrovsky, V. V. 1966. RAISING OF RAINBOW TROUT (*Salmo gairdneri* Rich.) TOGETHER WITH CARP (*Cyprinus carpio* L.) AND OTHER FISHES. FAOWS, FR-VIII/E-3. That's right, they grow trout and carp together in Russia.
- Scheffer, P. M. and L. D. Marriage. 1969. TROUT FARMING. U. S. Soil Conservation Service. Leaflet 332, GPO 510. Should be read by would-be beginners of trout culture.
- Borell, A. E. and P. M. Scheffer. 1966. TROUT IN FARM AND RANCH PONDS. U.S. Department of Agriculture, Farmers' Bulletin, No. 2154. 18 p. GPO 50-10.

AMERICAN CRAYFISH CULTURE

Introductory Note: Most of the available literature on crayfish culture deals with Louisiana species and methods. Techniques should be developed for crayfishes native to other parts of the country. Anyone seeking to do so should explore the purely biological literature on crayfish as well as the culture literature, paying particular attention to size, feeding habits, and reproductive habits of the species which are of interest.

—B.M.

- Anonymous. 1970. CRAWFISH: A LOUISIANA AQUACULTURE CROP. *American Fish Farmer* 1 (9), pp. 12-15.
- Felding, J. R. 1966. NEW SYSTEMS AND NEW FISHES FOR CULTURE IN THE UNITED

- STATES. FAOWS FR. VIII/2.
- Hann, B. Glenn. 1971. CRAWFISH CULTURE TECHNIQUES. *American Fish Farmer* 2 (3), pp. 3-6, 21 and 24.
- Lacasse, Cecil. 1970. CRAWFISH FARMING. *Fisheries Bulletin*, No. 7. Louisiana Wild Life and Fisheries Commission, P.O. Box 44093, Capitol Station, Baton Rouge, Louisiana 70804.

POND POLY-CULTURE

Introductory Note: Although polyculture is one of the oldest and most important methods of increasing fish pond productivity, there is little literature dealing with polyculture per se. What little there is deals mostly with Oriental systems, but it should be read by the serious aquaculturist, for these must serve as the models for analogous systems in North America.

—B.M.

- Buck, D. Homer, Richard J. Bour and C. Russell Rose. 1973. AN EXPERIMENT IN THE MIXED CULTURE OF CHANNEL CATFISH AND LARGE-MOUTH BASS. *The Progressive Fish Culturist* 33 (1):19-21.
- Childers, W. F. and G. W. Bennett. 1967. EXPERIMENTAL VEGETATION CONTROL BY LARGE-MOUTH BASS—TILAPIA COMBINATION. *Journal Wildlife Management* 31:401-407.
- Cocbe, A. G. 1967. FISH CULTURE IN RICE FIELDS, A WORLDWIDE SYNTHESIS. *Hydrobiologia* 50(1):1-44.
- Prewitt, R. 1970. RAMBLING ALONG. *American Fish Farmer* 2(1):23-24. Brief discussion of the beginnings of polyculture in the U.S.
- Sarg, S. 1955. CULTURE OF TILAPIA AS A SECONDARY FISH IN CARP PONDS. *Bamidigh*, 7(3):41-45.
- Tang, Y. A. 1970. EVALUATION OF BALANCE BETWEEN FISHES AND AVAILABLE FISH PONDS IN TAIWAN. *Transactions of the American Fisheries Society* 99(4):708-718. Technical discussion of Chinese carp polyculture in relation to feeding and fertilization.
- Yashou, A. 1969. MIXED FISH CULTURE IN PONDS AND THE ROLE OF TILAPIA IN IT. *Bamidigh* 21(3):75-82.
- Hahouy, A. 1958. ON THE POSSIBILITY OF MIXED CULTIVATION OF VARIOUS TILAPIA WITH CARP. *Bamidigh*, 10(3):21-29.

FERTILIZATION

- Ball, Robert C. 1949. EXPERIMENTAL USE OF FERTILIZER IN THE PRODUCTION OF FISH-FOOD ORGANISMS AND FISH. *Michigan State College Agricultural Experiment Station Technical Bulletin* 210, 28 pp.
- Melndre, C. David and Carl E. Bond. 1962. EFFECTS OF ARTIFICIAL FERTILIZATION ON PLANKTON AND BENTHOS ABUNDANCE IN FOUR EXPERIMENTAL PONDS. *Oregon Agricultural Experiment Station Technical Paper No. 1423*, Corvallis, Oregon.
- Swingle, H. S. and E. G. Smith. 1939. INCREASING FISH PRODUCTION IN PONDS. *Transactions of 4th North American Wildlife Conference*, American Wildlife Institute, Washington, D.C.
- Swingle, H. S. 1947. EXPERIMENTS ON POND FERTILIZATION. *Alabama Agricultural Experiment Station Bulletin* 264, 34 pp. Auburn, Alabama.
- Tanner, Howard A. 1960. SOME CONSEQUENCES

- OF ADDING FERTILIZER TO FIVE MICHIGAN TROUT LAKES. *Transactions American Fishery Society* 89(2):198-205.
- Walby, Pawel. 1966. FERTILIZATION OF WARM-WATER FISH PONDS IN EUROPE. FAOWS, FR-11/R-7.

NATURAL FOODS

- De Witt, John W. and Wendell Candland. 1970. THE WATER FLEA, DAHMLIA, AS A COMMERCIAL FISH-FOOD ORGANISM FROM MUNICIPAL WASTE OXIDATION PONDS. Humboldt State College, Arcata, California.
- McLurey, William O. 1974. AN IMPROVED METHOD FOR CULTURE OF MIDGE LARVAE (*Chironomididae*) FOR USE AS FISH FOOD. *Journal of the New Alchemists* 2:118-119.
- Sorbelson, F. 1973. HIGH DENSITY CULTURING OF THE BRINE SHRIMP, *ARTEMIA SALINA*. *Aquaculture* 1(1):385-391.
- Sporos, Stephen. 1973. MAKING YOUR OWN FISH FOOD AND HOW TO RAISE EARTHWORMS AND BRINE SHRIMP FOR FISH FOOD. Chapter in: *Marine Aquarium Keeping*, Wiley-Interscience, New York.
- U. S. Fish and Wildlife Service. 1962. FISH BAITS: THEIR COLLECTION, CARE, PREPARATION AND PROPAGATION. U.S.D.I., Fish and Wildlife Service, Leaflet FW-28. Includes mealworms, bloodworms, earthworms, Helgrammites and other aquatic forms, among others.
- Yashou, A. 1956. PROPAGATION OF CHIRONOMID LARVAE AS FOOD FOR FISH FRY. *Bamidigh* 22(4):101-105.
- Yount, James L. 1966. A METHOD FOR REARING LARGE NUMBERS OF POND MIDGE LARVAE—WITH ESTIMATES OF PRODUCTIVITY AND STANDING CROP. *The American Midland Naturalist* 76(1):230-238.

NUTRITION, GROWTH AND ENERGETICS

- Dawies, P.M.C. 1967. THE ENERGY RELATIONS OF *CARASSIUS AURATUS* (GOLDFISH)—III. GROWTH AND THE OVERALL BALANCE OF ENERGY. *Comparative Biochemistry and Physiology* 23:59-63.
- Halver, John E. (ed.) 1972. FISH NUTRITION. Academic Press, New York.
- Hastings, W. H. (ed.) 1966. WARMWATER FISHERY NUTRITION. U.S.D.I. Bureau of Sport Fisheries and Wildlife, Fish Farming Experimental Station, Stuttgart, Arkansas.
- Mann, K. H. 1965. FISH IN THE RIVER THAMES. *Journal Animal Ecology* 34:253-75. Deals with metabolism and production of natural and culture fish.
- Mann, Hans. 1961. METABOLISM AND GROWTH OF POND FISH. In: Bergstrom, G. (ed.) *Fish as Food*, Vol. 1:82-89.

POND CONSTRUCTION

- Delmendo, M. N. et al. 1970. CONSTRUCTION OF PONDS FOR AQUACULTURE. Indo-Pacific Fisheries Council. Symposium 18-27 Nov. 1970. Paper No. IPFPC/70/SYM 26. FAO Bangkok 2, Thailand. Deals with larger ponds—as for commercial culture. Some general guidelines, useful to smaller systems.
- Dilloo, O. W., Jr. 1970. POND CONSTRUCTION, WATER QUALITY AND QUANTITY. Paper presented to the California Catfish Conference, Sacramento, California, January 30-31, 1970. Probably available from U.S. Soil Conservation Service, Fort Worth, Texas.
- Mitchell, T. E. and M. J. Uary. 1967. CATFISH FARMING—A PROFIT OPPORTUNITY FOR MISSISSIPPIANS. Mississippi Research and Development Center, 787 Lakeland Drive, Jackson, Mississippi. 83 pp. Deals specifically with catfish farming, but the information on pond construction is among the best available. Probably some charge for this publication.
- Reafso, G. Jr. 1969. SEALING LEAKING PONDS AND RESERVOIRS. U.S. Soil Conservation Service. SCS-TR-150. 6 p.
- Vanicsek, C. David and A. Wendell Miller. 1973. WARMWATER FISH POND MANAGEMENT IN CALIFORNIA. U.S. Department of Agriculture Soil Conservation Service Report No. M7-N-23056. GPO.

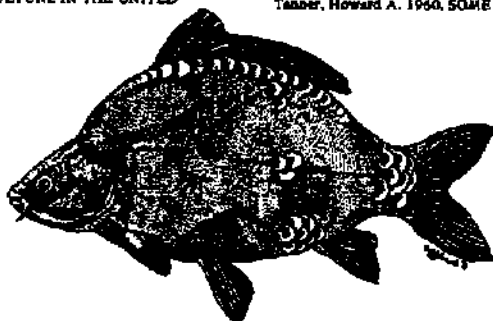

Cultured "Mirror" Carp

POPULAR FISH AND SHELLFISH SPECIES SUITABLE FOR SMALL-SCALE FRESH WATER POND CULTURE IN THE U.S.

Species	Feeding and Habits	Area of Origin/Culture	Temperature Range (°C)		Comment
			Optimum	Minimum	
CYPRINIDS					
Common carp <i>Cyprinus carpio</i>	Eats attached algae, bottom detritus and benthic animals.	China/worldwide	16°-28°	13°	Can be polycultured
Mud carp <i>Cirrhinus molitorilis</i>	Eats attached algae, bottom detritus and benthic animals.	China/worldwide	20°-28°	13°	Can be polycultured
Grass carp <i>Ctenopharyngodon idella</i>	Eats large plants, floating and attached. Also grass clippings, weeds.	Amur river, China	23°-29°	13°	Can be polycultured
Big Head carp <i>Aristichthys nobilis</i>	Eats microscopic animals (Zooplankton) in mid-water.	China	20°-28°	13°	Can be polycultured
Silver carp <i>Hypophthalmichthys molitrix</i>	Eats microscopic plants (phytoplankton) in mid-water.	China	16°-28°	14°	Can be polycultured
Black carp <i>Mylopharyngodon piceus</i>	Eats bottom molluscs (snails, clams, mussels)	China	20°-28°	13°	Can be polycultured
CICHLIDS					
Tilapia banded (or microcephala)	Eats large and maybe microscopic plants. Tolerates brackish water.	Coastal West Africa from Senegal to Congo	20°-30°	12°	All Tilapia will breed in captivity.
Tilapia mossambica (Java Tilapia)	Eats mostly plankton, but also all plant material and some animal feed. Tolerates mild salinity.	East Africa/S.E. Asia, Japan, Latin America, U.S.	15°-30°	16°	Slightly aggressive to other species. Difficult with small carp in polyculture.
Tilapia nilotica (nile Tilapia)	Eats plankton and large plants.	Syria to East Africa/throughout world.	15°-30°	16°	Little known.
Tilapia zillii	Eats only plants, mostly large. Used in weed control.	Equatorial East Africa/throughout world	22°-26°	15°	Aggressive toward other species.
Tilapia sura	Eats a variety; chopped plants, grain and animal foods.	West Africa	25°	13°	
SALMONID					
Rainbow trout <i>Salmo gairdneri</i>	Eats mostly aquatic insects. Needs high protein diet when fed artificially and lots of oxygen.	Pacific coast of North America	13°-20°	12°	Generally monoculture but possible for polyculture.
CENTRARCHIDS					
Bluegill <i>Lepomis macrochirus</i>	Eats mostly bottom animals, possibly algae	U.S. principal species stocked in farm ponds for angling.	20°-25°	10°	Eats young of other species. High reproduction causes stunting.
Redear Sunfish <i>Lepomis microlophus</i>	Eats bottom animals especially snails.	U.S. principal species stocked in farm ponds for angling.	20°-25°	10°	Eats young of other species. High reproduction causes stunting.
Largemouth bass <i>Micropterus salmoides</i>	Eats small fish and bottom animals. Stocked with sunfish in farm ponds, also bluegill (1 bass: 10 bluegill) needs lots of oxygen.	U.S. lakes and ponds	20°-30°	10°	Obligate carnivore—eats other fish and invertebrates.
Crappies and Pomoxis spp.	Eats bottom animals.	U.S. lakes and ponds. Stocked with bass.	20°-30°	10°	Very low reproduction. Used only in fish-out ponds.
MISCELLANEOUS FISH					
Bignmouth Buffalo <i>Ictalurus cyprinellus</i>	Eats plankton, bottom animals and detritus.	Popular in U.S. in early 1900's. Renewed interest in hybrids.	20°-25°	13°	♀ Black X ♂ Bignmouth = fast growing hybrid.
Smallmouth Buffalo <i>Ictalurus nebulosus</i>	Eats plankton, bottom animals and detritus.				Stocked in catfish ponds
Black Buffalo <i>Ictalurus niger</i>	Eats plankton, bottom animals and detritus.				Also used in rice field rotations (900 lbs/acre in 18 months).
Channel catfish <i>Ictalurus punctatus</i>	Eats other fish and bottom animals.	U.S. rivers, lakes and ponds. Widely cultured. Survives freezing.	22°-28°	15°	Mostly grown in commercial monocultures. Not practical for small scale rearing.
Brown bullhead <i>Ictalurus nebulosus</i>	Eats other fish and bottom animals.	U.S. rivers, lakes and ponds	22°-28°	15°	Smaller and handier than Channel catfish, but more susceptible to disease. Reproduce easily without management, but stunting and overpopulation can occur.
Yellow bullhead <i>Ictalurus natalis</i>	Eats other fish and bottom animals.	U.S. rivers, lakes and ponds	22°-28°	15°	
Black bullhead <i>Ictalurus melas</i>	Eats other fish and bottom animals.	U.S. rivers, lakes and ponds	22°-28°	15°	
SHELLFISH					
Red crayfish <i>Procambarus clarkii</i>	Scavenger; table scraps, detritus, etc. but needs some plants for best growth.	Southern U.S. to 35°N, into Southern California. Found in streams, creeks, lakes and flood control channels.	10°-30°	13°	Due to rapid growth, more suitable for growth than <i>Astacus</i> or <i>Pacifastacus</i> . Use in polyculture with carp, bass, bluegill, etc.
Bivalve molluscs <i>Lampyris</i> spp. <i>Corbicula</i> spp.	Live in bottom mud/ooze. Filter out plankton and floating detritus.	<i>Lampyris</i> in Mississippi Valley; <i>Corbicula</i> introduced from Asia, now found in waterways of East and West coasts.	10°-30°	5°	<i>Lampyris</i> needs fish as host for parasitic young—drawback. <i>Corbicula</i> does not. Do poorly in turbid or low O ₂ water. Very susceptible to copper and other heavy metals. Good polyculture animals; improves O ₂ supply for fish.



Midge Culture

Tests of the Effectiveness of *Chironomus* Larvae as a Growth-Promoting Supplement in Fish Diets, and Improvement of *Chironomus* Culture Methods

MIDGE LARVAE PRODUCT

MIDGE COVERED BURLAP HUNG VERTICAL USE AL-
NATURE LARVAE ARE HARVESTED BY MOVING BURL-
LARVAE ABOVE SUPERIOR QUALITY PRO-

Photo by Fritz Goro

INTRODUCTION:

Our work with midge (*Chironomid*) larvae in 1974 concentrated on two areas: further improvement of culture methods and tests of the effectiveness of the larvae as a growth-promoting supplement in fish diets.

For details of the technique used in our low labor midge culture system, as developed in 1973, see McLarney, Henderson and Sherman (1974) and McLarney (1974). A major change in the culture system in 1974 was the adoption of a two stage culture system utilizing nursery ponds and growth ponds. Burlap culture substrates were first laid horizontally in small pools for natural inoculation by wild adult midges. These ponds were fertilized with a mixture of Milorganite (R), soy meal, pond mud and fine sand which settled onto the burlap to provide an optimal substrate for larval attachment and growth. After a culture of early stage larvae had developed, the burlap substrates with attached larvae were transferred to deeper ponds where they were hung vertically until the larvae grew to optimum size for fish food. Using this two stage method it appears that some improvement was made over 1973 yield rates. However, due to circulation problems in the high volume

growth pools and significantly increased labor in the two stage system, we are currently doing further research with simpler methods before publishing details of an optimum cost and labor-effective midge larvae culture technique.

The feeding trials (McLarney, Levine and Sherman, in preparation) were very successful and will be reported here in some detail.

Our research has been predicated on the "hunch" of some aquaculturists that *Chironomid* larvae are not merely good fish food, but have unusual growth-promoting qualities, even when fed in very small quantities. This assumption was tested, on a pilot scale, by Yashouv (1956) and Yashouv and Ben Shachar (1967), but their samples were not large enough to provide definitive information. Our studies represent the first statistically meaningful test of the food value of midge larvae.

We tested our cultured midge larvae (*Chironomus* sp., a member of the *C. tentans* Fabricius group) on *Tilapia aurea* (Steindachner) and Israeli carp (*Cyprinus carpio* var. *specularis* Lacépède), the two major fish varieties cultured at New Alchemy East. Concurrent-

ly, Joseph Levine of the Boston University Marine Program tested our larvae as a food for juvenile American lobsters (*Homarus americanus* Milne-Edwards). *T. aurea* is generally considered to be highly herbivorous, but it has been shown that the young feed extensively on invertebrates (McBay, 1961). Israeli carp are omnivorous at all life stages, while lobsters are largely carnivorous.

FISH FEEDING TRIALS:

Methods: Both species of fish used in the experiments were housed in a series of twelve fifty-five gallon aquaria kept in a plastic greenhouse. The tanks were aerated, but filtration was not provided. Cleaning was effected by siphoning off twenty-five per cent of the water weekly and replacing it with fresh tap water; most fecal matter and other detritus was removed in this process.

Each group of fish received a standard diet composed of seventy-five per cent rolled oats and twenty-five per cent roasted soy meal. The standard diet was fed at the rate of two per cent of the total weight of fish, six days a week. As the tanks all soon developed dense green algae blooms, the fish were able to augment their diet by filter feeding. In four control tanks, the fish received no additional food. In a second group of four tanks, the fish received a supplement of midge larvae (*Chironomus* sp., a member of the *tentans* group) comprising two percent by (wet) weight of the grain diet. The final four tanks received midge larvae at the rate of ten per cent of the grain diet. Each group of fish was weighed three times at the start of the experiment, two weeks later, and four weeks later. All fish were fin-clipped so that individual, as well as group, growth rates could be determined. Data from the full four-week period of the tilapia trials and the first two-week period of the carp trials are presented here.

Test groups of fish were chosen to have approximately the same total weight of fish in each tank at the start of the experiment. In the first experiment

with *T. aurea*, six fish were stocked per tank and weights of individual fish varied from 0.7 to 18.0 g; group weights were 31.1 to 48.0 g. In the second *T. aurea* experiment, only five tilapia were stocked per tank, and these fish were chosen to be more nearly uniform in size than those in the first experiment. Individual weights ranged from 1.0 to 7.3 g; group weights from 16.1 to 23.5 g. The carp trials involved six fish per tank. Total weight of groups ranged from 58.3 to 72.3 g and weight of individuals from 2.3 to 21.2 g.

Water temperatures were 22 to 33°C during the first *T. aurea* experiment, 27 to 33°C during the *T. aurea* experiment and 20 to 32°C during the carp experiment.

Results: In the first *T. aurea* experiment, there was a slight increment in growth rate with the amount of midge larvae fed, but the difference was not significant and certainly would not justify any effort to provide midge larvae for young *T. aurea*. However, if the fish are broken down into two size groups, the differences in growth rate are more striking. Since it is well known that younger fish generally have a greater need for animal food, the data for all fish weighing less than 5 g at the start of the experiment were considered separately. Among these fish, those receiving a two per cent midge larvae supplement increased their weight considerably more than those receiving no midges. Those receiving a ten per cent midge larvae supplement grew faster than those receiving a two per cent supplement, but the difference was not as great as between the fish receiving a two per cent supplement and those receiving no larvae.

It was decided to repeat the experiment using more uniform sized, smaller fish. The results are similar to those obtained with the small fish in the first experiment. Results of all the *T. aurea* trials are shown in Table 1.

For purposes of statistical analysis, growth data from the smaller fish in the first trial were combined with those from the second trial. Each set of three aquaria (those receiving 0, 2% and 10% midge supple-

TABLE 1
Feeding trials with *Tilapia aurea*

	First Trial June 1-28			First Trial June 1-28*			Second Trial July 5 - August 2		
	No Midges	2% Midges	10% Midges	No Midges	2% Midges	10% Midges	No Midges	2% Midges	10% Midges
No. of Fish	24	23	24	11	9	12	20	20	20
Final Weight (grams)	236.1	241.8	235.1	53.1	43.6	69.2	144.8	149.5	151.1
Initial Weight	163.5	162.9	153.9	32.2	21.9	32.2	88.5	80.0	74.2
Gain in Four Weeks	72.6	78.9	81.2	20.9	21.7	37.0	56.3	69.5	76.9
Per Cent Gain	44.4	48.4	52.8	64.9	99.1	114.9	63.6	86.9	103.9

*Fish weighing five grams or more at start of experiment excluded.

TABLE 2

Per cent weight increments of *Tilapia aurea* in eight sets of experimental aquaria and their rank within sets.

Set No.	No Midges		2% Midges		10% Midges	
	% Gain	Rank	% Gain	Rank	% Gain	Rank
1	55.4	3	79.0	2	112.2	1
2	72.0	3	116.4	2	126.0	1
3	51.8	2	43.9	3	57.3	1
4	100.0	3	151.2	2	184.5	1
5	43.5	3	58.0	2	63.6	1
6	69.2	3	73.1	2	107.0	1
7	95.8	2	84.7	3	141.6	1
8	104.6	3	145.2	1	115.2	2
	<i>Sum of Ranks</i>	22		17		9

ments) was considered separately and the total gain in weight of the fish in the three members of the set was ranked (Table 2). Applying the Kendall Coefficient of Concordance (Siegel, 1956) to the ranked data, $s = 86$, $\chi^2 = 10.752$ and the differences in the weight increments of the three experimental lots of fish are significant at the 1% level.

TABLE 3
Feeding trials with Israeli carp, August 12-30

	No Midges	2% Midges	10% Midges
No. of Fish	24	24	23
Final Weight	290.5	292.5	279.9
Initial Weight	260.8	252.5	241.4
Gain in Two Weeks	29.7	40.0	38.5
% Gain	11.4	15.8	15.9

Growth rate of Israeli carp in the experiment was markedly less than that of *T. aurea* (Table 3). This can probably be ascribed to the fact that the carp were very nervous and did not adapt to aquarium life as readily or as well as the tilapia. The mean weight increments for the three experimental lots of carp differed in the same manner as for the tilapia, but the difference was not significant.

The difference in growth rate between carp receiving midge larvae and the controls was greater after two weeks than at the conclusion of the experiment. The decline in growth during the latter half of the experiment may have been due to an infestation of anchor worm during that time. About half the fish were affected, and four individuals lost weight during this period.

LOBSTER TRIALS:

Methods: The lobster trials will not be described in as much detail as the fish trials, on the assumption that lobster culture is of less interest to our readers than culture of fish which are potential staple pro-

tein sources. However, the results further support the hypothesis that midge larvae are an excellent growth-promoting food. Full details of our procedures can be found in McLarney, Levine and Sherman (in preparation).

The test lobsters were juveniles, 6.0 to 6.5 mm in carapace length, and were fed a standard diet of commercially available frozen brine shrimp (*Artemia*) at the rate of 0.018 g dry weight/lobster/day. This constituted the entire diet of the controls; test animals received *Chironomus* larvae in amounts equivalent to two per cent and ten per cent by dry weight of the brine shrimp diet. Experimental feeding was continued until the animals had molted twice, and the growth increment was calculated by comparing intermolt period length, carapace length and total weight measured immediately after each molt.

Results: Lobster results are summarized in Table 4. As expected from previous work, there was no significant difference in the lengths of the intermolt periods due to large sample variance.

Increase in carapace length was noticeably higher in both experimental groups than in the control. The mean increase shows 0.5 mm increments between the experimental groups (Table 4). Weight gain and percentage weight gain, on the other hand, indicate significant differences between both groups given midges and the controls, but not between the midge-fed groups themselves.

DISCUSSION:

The results of these experiments argue for the feasibility of culturing midge larvae, using the hanging substrate method (McLarney, Henderson and Sherman, 1974; McLarney and Sherman, in preparation), as a dietary supplement for food animals. In the fish experiments, not only were *Chironomus* larvae an effective growth promoter, they appeared to be more effective with the smaller fish tested.

TABLE 4

Feeding trials with American lobsters, including significance values determined by T-test for independent samples

	Average Intermolt (days)	Increase in Carapace Length (mm)	Absolute Weight Gain (gms)	Per cent Weight Gain
Control (<i>Artemia</i> only)	18.6±3.2	1.0±0.4	0.05±0.0	27%±4
	NS	.05	.05	.01
<i>Artemia</i> + 2% Larvae	19.3±1.5	1.5±0.3	0.18±0.10	77%±33
	NS	.05	NS	NS
<i>Artemia</i> + 10% Larvae	16.0±7.4	2.0±0.4	0.19±0.06	76%±25

Significance values for comparisons between Control and 2% Larvae: Intermolt (NS), Carapace Length (.01), Absolute Weight Gain (.01), Per cent Weight Gain (.01).
Significance values for comparisons between Control and 10% Larvae: Intermolt (NS), Carapace Length (.05), Absolute Weight Gain (NS), Per cent Weight Gain (NS).

The early life stages are at once the most critical period for the fish culturist, and the time when it is easiest to provide a relatively high percentage portion of larvae.

The difference in growth between fish receiving the ten per cent midge supplement and those receiving the two per cent supplement was in all instances less than the difference between those receiving the smaller supplement and the controls. In interpreting this data, it should be kept in mind that while rolled oats and roasted soy meal are essentially dry, eighty-six per cent of the weight of a live *C. tentans* larva is water. On a dry weight to dry weight basis, then, the rates of dietary supplementation with midge larvae in the fish experiments were 0.28 per cent and 1.40 per cent. Such a pronounced effect on growth rate from such small weights of midges suggests that we are dealing, not with the effect of increased quantity of protein, but with a vitamin or amino acid effect.

In the lobster trials, both absolute and percentage weight gain showed the same effects observed in the tilapia. The carapace length data, however, show significant differences not only between the controls and the experimental groups, but also between the two experimental groups. This apparent discrepancy can be explained by observing that carapace length alone, though a standard measurement in the literature, does not reflect possible differences in claw size and length of abdomen.

While the weights of midge larvae and frozen brine shrimp used in the lobster trials were reckoned on a dry weight - dry weight basis, the differences in growth rates of midge-fed and control lobsters are greater than one might expect. To postulate a protein or amino acid effect here does not seem satisfactory. Chemical analysis of larvae of the midge *Chironomus plumosus* and various other invertebrates cultured for use as fish foods in the U. S. S. R. (Ivleva, 1969) did not indicate that *C. plumosus* larvae differ notably from the rest, except in that *Artemia salina* do not contain

Vitamin A. It should also be noted that Chironomids are unusual among invertebrates in containing large amounts of hemoglobin.

Artemia are a standard component in the diet of many cultured aquatic animals. In some cases, including some lobster cultures, they are the sole food. It has been shown recently that in such cultures, live *Artemia* are superior to frozen (Schleser and Gallagher, in preparation). No technical explanation has been advanced for this phenomenon, but it has historical precedent in the "live food mystique" of aquarists. It is possible that some nutrients are lost in the freezing process. If this were true, the addition of a small amount of live food, e. g., the midge larvae in our experiments, might provide a factor critical to the growth of cultured animals.

In the present instance the picture is further complicated by the results of studies in which lobsters were reared in the same system used in these experiments and fed on one hundred per cent live food diets. Percentage weight increment of our two experimental groups reared on frozen *Artemia* and small amounts of live midges (seventy-seven per cent ± thirty-three; seventy-six per cent ± twenty-five) did not differ significantly from that of lobsters reared on a *Ceramium - Jassa - Mytilus* association (eighty-one per cent ± twenty) (Levine, in preparation) and on high density *Capitella capitata* cultures (seventy-one per cent ± fourteen) (Mencher, in preparation).

From the results of work done to date, we cannot say whether or not there is a unique growth-promoting component or combination of components in midge larvae, or what that component or combination of components might be. We can say that midge larvae added in small quantities to standard fish and lobster diets resulted in significant enhancement of growth and that the ease of their cultivation and utilization renders them desirable for use in many forms of aquaculture.



We do not recommend midge larvae for culture as the principal food for any type of fish. There are many other good foods which can be provided more easily in bulk. As can be seen from our work, the effectiveness per weight of midge larvae is greatest when they constitute only a small proportion of the total diet. We do recommend their inclusion as a supplement in the diets of cultured fresh water and marine animals. If we assume a larval production rate of 100 g/m² of water surface/week (which we have attained in our best pools), then 10 m² of ponds could provide a two per cent supplement continually for eighty thousand young fish averaging 5 g each. If the increment in growth of the fish were comparable to that achieved in our experiments, a midge culture system would certainly be a worthwhile expenditure of time and space.

ACKNOWLEDGMENTS:

As in previous years, the midge work was done under the auspices of the Woods Hole Oceanographic Institution, and both sets of feeding trials were carried out on the Woods Hole Oceanographic Institution's premises. To offer a blanket acknowledgment of that Institution, however, would be to overlook the massive bureaucratic interference and the attitudes of certain scientists and administrators which nearly prevented our 1974 work from being carried out — a fine example of the sort of frustration which added impetus for some of us to leave "establishment" science and join forces in New Alchemy. We do wish to give special thanks to Dr. Derek Spencer of the Department of Chemistry, who was instrumental in overcoming the institutional pettiness which threatened our work. Drs. Jelle Atema and John Ryther provided facilities for the fish and lobster work, respectively. Camas Lott was especially helpful with the tedium of setting up the experiments, maintaining and weighing fish. Dr. Woolcott

Smith made valuable suggestions concerning the analysis of the data.

— William O. McLarney
Joseph S. Levine
Marcus M. Sherman

REFERENCES

- Ivleva, I. V. 1969. Mass cultivation of invertebrates: Biology and methods. Academy of Sciences of the U. S. S. R., All-Union Hydrobiological Society. Published for the National Marine Fisheries Service by the Israel Program for Scientific Translations. 148 pp.
- Levine, J. (Manuscript in preparation for W. H. O. I. Technical Reports). The *Ceramium - Jassa - Mytilus* association as an experimental link in a lobster polyculture system.
- McBay, L. G. 1961. The biology of *Tilapia nilotica* Linnaeus. Proc. 15th Ann. Conf. Southeastern Assn. Game and Fish Commissioners: 208-218.
- McLarney, W. O. 1974. An improved method for culture of midge larva for use as fish food. The Journal of The New Alchemists (2): 118-119.
- McLarney, W. O., S. Henderson and M. M. Sherman. 1974. A new method for culturing *Chironomus tentans* Fabricius larvae using burlap substrate in fertilized pools. Aquaculture. (4): 267-276.
- McLarney, W. O., J. S. Levine and M. M. Sherman. (In preparation). Midge (Chironomid) larvae as a growth-promoting supplement in fish and lobster diets.
- Mencher, F. (Manuscript in preparation for W. H. O. I. Technical Reports). *Capitella capitata* and *Chondrus crispus* as experimental links in a lobster polyculture system.
- Shleser, R. and M. Gallagher. (Manuscript in preparation). Formulations of rations for the American lobster, *Homarus americanus*.
- Siegel, S. 1956. Non-parametric statistics for the behavioral sciences. McGraw-Hill, New York.
- Yashouv, A. 1956. Problems in carp nutrition. Bamidgheh, 79-87.
- Yashouv, A. and R. Ben Shachar. 1967. Breeding and growth of Mugilidae, II. Feeding experiments under laboratory conditions with *Mugil cephalus* L. and *M. capito* (Cuvier). Bamidgheh 19: 50-66.

Cultivo Experimental de Peces en Estanques

PREFACE

While one of the roots of New Alchemy lies in the disenchantment some of us feel with the framework of institutional science, we do not wish to present the attitude that there is little of value in the work being done in universities and research stations of the world. Science and technology do make important contributions and from time to time we shall describe some of the work which seems especially relevant from a New Alchemy point of view.

Such an editorial effort is handicapped by the impossibility of keeping up with all the scientific literature in even one field. We are indebted to Sr. Alberto Donadio, of Medellin, Colombia, for bringing to our attention the work of Prof. Anibal Patiño R. of the Universidad del Valle, Cali, Colombia.

Professor Patiño's work is especially gratifying to me, since he has arrived independently at many ideas similar to my own for the development of tropical aquaculture (McLarney, 1973a), and has demonstrated that they will work – biologically and economically.

The following account, which should be of interest to anyone involved in tropical ecologies or economies, is excerpted and paraphrased, with Professor Patiño's kind permission, from his paper "Cultivo experimental de peces en estanques", which appeared in *Cespedesia*, Vol. II, No. 5, pp. 75-127. For information on obtaining the original paper (in Spanish), write *Cespedesia*, Jardin Botanico del Valle, Apartado aereo 5660, Cali, Colombia.

INTRODUCTION

Professor Patiño's work parallels New Alchemy schemes for tropical aquaculture in four respects:

1. He advocates polyculture of certain species of *Tilapia* and local fish species.
2. The primary foods for the fish, apart from those produced by fertilizing the fish pond, are weeds, agricultural wastes or various plants which can be cultivated with a minimum of effort.
3. Selected fish are grown to market size in cages. The remainder are left, essentially unmanaged, in a pond which serves as a hatchery.
4. Excess small fish are fed to other farm livestock, such as hogs and chickens. The wastes from these animals are used to fertilize the pond.

Professor Patiño has demonstrated the economic feasibility of this approach for the campesino (small farmer). He has also outlined plans for the implementation of this sort of fish culture in the countryside.

We shall discuss these features of Professor Patiño's work in the order listed above. All of the work described

was carried out in four ponds fed by the Rio Tuluá in El Jardin Botanico del Valle, Mateguadua, Colombia. The ponds, each 10 m x 30 m x 1.2 m, were lined with polyethylene and fertilized with cow manure. Professor Patiño and four students from the Universidad del Valle accomplished all of the work from the construction of the ponds with pick and shovel to the conclusion of the experiments in a year and a half.

POLYCULTURE

Four species were chosen for the initial studies: *Tilapia mossambica* Peters, *Tilapia rendalli* Boulanger (= *Tilapia melanopleura*), and two native characins, the bocachico (*Prochilodus reticulatus magdalenae* Steindachner) and the jetudo or patalo (*Ichthyoelephas longirostris* Steindachner). The two tilapia were chosen because of the ease with which they may be cultured, and because of their different feeding habits. As both species are already established in the Rio Cauca drainage, which includes the Rio Tuluá, there are no ecological objections to the use of these exotics. The native species were chosen because both are valuable food fishes currently threatened by environmental change, and because they might fill ecological niches complementary to the tilapia.

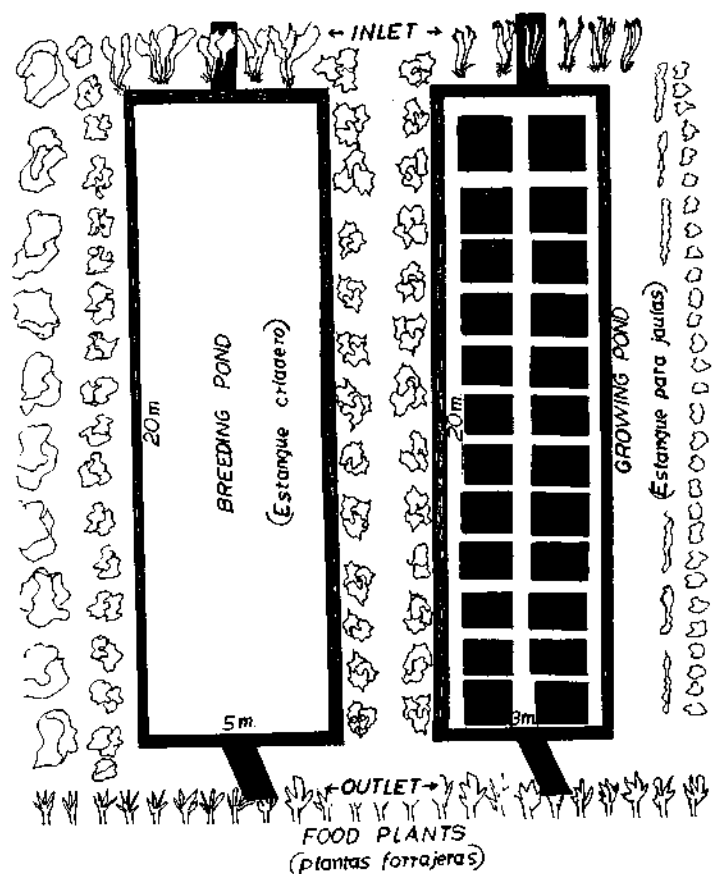

To describe briefly the four species:

T. mossambica is omnivorous, but feeds mostly on phytoplankton and benthos. It is a mouthbreeder and multiplies very rapidly, which leads to overcrowding and sometimes enables it to out-compete valuable, but less prolific or aggressive species. *T. rendalli* is herbivorous by preference. Though not a mouthbreeder, it is, nevertheless, more prolific than either of the characins studied. Both species of tilapia are considered good food fishes.

The bocachico is economically the most important fish in the Cauca valley. It feeds on algae and detritus, obtained by sucking up mud and periphyton. In the Cauca valley, it may compete with *T. mossambica*. The bocachico lives mostly in standing or slow-moving waters, but requires running water to breed.

The jetudo, in nature, is entirely a creature of swiftly flowing waters. It feeds primarily on algae attached to rocks and river bottoms and is described as having a "delicate" flavor.

Professor Patiño has only begun to investigate the possibilities of culturing the two native species, but he has raised two important questions:

1. What is the behavior of the jetudo when confined in standing water?
2. What is the effect on growth of the bocachico in ponds when combined with *T. mossambica* or *T. rendalli*?

With respect to the first question, it was demonstrated that the jetudo will survive and grow in standing water. This is also true of another edible characin, the machaca, *Brycon guatemalensis*, which occurs naturally only in flowing waters (McLarney, 1973b). Sixty-four jetudo, with a mean weight of 69.3 g, were introduced into one of the ponds. Over a period of twelve months they grew to a mean weight of about 115 g. Only four died. Prior to the introduction of the fish the pond was fertilized with commercial 14-14-14 fertilizer and planted densely with *Elodea canadensis* to maintain high levels of dissolved O₂. The lowest concentration recorded during the experiment was 6.8 ppm. This experiment was disrupted somewhat by the accidental introduction of some young *T. mossambica*, which may have competed for food with the jetudo.

Two ponds were used in the tilapia - bocachico experiments. One was stocked with 150 juvenile bocachico with a mean weight of 34.7 g and 100 *T. mossambica* with a mean weight of 6.0 g. The other pond received an identical lot of bocachico plus 80 *T. rendalli* with a mean weight of 47.6 g. (It should be noted here that a possible limiting factor in culture of the bocachico is its delicacy with respect to handling. Mortality of bocachico during capture, transport and stocking was thirty-five per cent, that of tilapia less than five per cent.) Prior to stocking, both ponds were fertilized with 14-14-14 at the rate

of 1 kg/pond; at the time of stocking the water in both was light green. The *T. rendalli* pond was densely planted with *Elodea canadensis*. Three months later, *Elodea* was placed in the *T. mossambica* pond as well, to aid in oxygenation.

Periodic examination of the stomach contents of sample fish showed that there was more overlap between the feeding niches of the bocachico and *T. mossambica* than between bocachico and *T. rendalli*. While the ponds differed in such respects as size and reproductive rate of tilapia, dissolved O₂ concentration, provision of supplementary food (leaves of various plants supplied daily to the *T. rendalli*), and abundance of aquatic plants, the evidence suggests that the combination bocachico - *T. rendalli* is complementary, while the combination bocachico - *T. mossambica* - is not.

This conclusion is more strongly supported by the relative growth rates of the bocachico in the two ponds. After twelve months the bocachico confined with *T. mossambica* had reached a mean weight of about 94 g, while those in the *T. rendalli* pond had reached a mean weight nearly double that - about 175 g.

If bocachico or jetudo are to be used in practical fish culture, they must be bred in captivity. This has not been done to date, but Professor Patiño does not foresee this as a serious problem. He thinks that the process of pituitary injection, which has been successful in inducing many other typically rheophilic South American fishes to spawn in standing water (de Menezes, 1966), is likely to succeed with these species also.

The remainder of the work was carried out solely with the two *Tilapia* spp. Some of this work has further implications for polyculture.

USE OF AGRICULTURAL WASTES OR WEEDS AS FISH FOOD

A variety of terrestrial and aquatic plants were tested for acceptability for food for *T. rendalli*. Fifteen, including the aquatics *Elodea canadensis*, *Potamogeton crispus* and *Chara* sp. were consumed readily. Ramos (1971) and Huet (1970) offer additional lists of plants accepted by herbivorous tilapia. Hickling (1971) states that *T. rendalli* will accept a daily ration of 15% of its weight in yuca leaves (*Manihot esculenta*) or 33% in *Colocasia*. The difference reflects the water content of the leaves.

Of the plants tested, Professor Patiño recommends yuca, bore (*Alocasia macrorrhiza*) and chayamansa (*Cnidocolus chayamansa*), an edible euphorb shrub indigenous to Mexico. He lists four advantages of these plants:

1. Their leaves are high in protein (17.2 per cent, 23.25 per cent and 24.2 per cent, respectively).
2. They are easy to grow and can be propagated vegetatively.
3. They grow rapidly and produce large amounts

of useable vegetation.

4. They are tolerant of poor soils.

Professor Patiño suggests the consumption of aquatic plants by *T. rendalli* might be useful in weed control. I would like to suggest that in some instances they could be "pastured". In general, the provision of vegetable foods for tilapia should be left up to the individual farmer who best knows his local resources. If the leaves of a plant, such as yuca or banana, which can also provide the farmer with food or a cash crop, can be employed, so much the better.

CULTURE OF *T. RENDALLI* IN CAGES

The major problem in tilapia culture is overpopulation resulting in stunting. Three solutions have been applied.

1. Careful selection of only male fish for the culture pond.

2. Production of "monosex" hybrids — one hundred per cent male or nearly so.

3. Careful use of predatory fishes to thin, but not eradicate, the tilapia.

These techniques all require inputs of energy and managerial skill which cannot ordinarily be expected of the Latin American campesino embarking on a completely new food-raising enterprise. Cage culture solves the problem more simply. The eggs of all species of tilapia sink and are initially deposited in a nest dug in the bottom of the pond. When the fish are confined in wire cages suspended off the bottom, the eggs pass through the cage bottom out of reach of parental care. The pond in which the cages are placed or preferably, another pond, can be used as a natural "hatchery" in which tilapia are left to multiply virtually unmanaged. From time to time, stock can be selected from this pond for intensive culture to market size in the cages.

Other advantages of cage culture include:

1. Intensive culture with minimal labor and materials.

2. Technological and economic feasibility for the campesino.

3. Facilitation of feeding, inspection of the stock and harvest.

4. Continual harvest and replenishment of growing stock.

5. Rendering many types of water bodies useable for fish culture.

The first two cages constructed by Professor Patiño and the students were made of galvanized wire mesh and chanu or chano (*Humiriastrum procerum*) a local water-resistant wood. The cages, 2 m x 1 m x 1 m, were situated on legs which raised them 25 cm off the pond bottom. Later cages were constructed more economically by making four of the sides from such indigenous materials as cane. Wire was used for the bottom so that enough light could penetrate to permit the growth of oxygenating plants underneath the cage.

The cages were placed 1 m apart in one of the ponds, over a dense growth of *Elodea*. Each cage was stocked with 50 or 100 three month-old *T. rendalli* with a mean weight of 22.5 g. Each cage received a handful of bore leaves twice daily. Two cages received an additional daily supplement of wheat bran. At the beginning of the experiment each cage was given ½ kg of bran daily. This was gradually increased to 1 kg/day.

The result was excellent growth and low mortality (four per cent). For the first month the young fish, which had been reared previously on commercial pelleted food, refused to eat the bore leaves. Subsequently they accepted the leaves and grew rapidly. After five months in the cages, when the fish were eight months old, the mean weight of the fish not receiving the bran supplement was 165 g. Those receiving the supplement averaged 200 - 250 g. Growth slowed considerably after five months, indicating the logical time to harvest.

After five months, the tilapia which did not receive the bran supplement had increased their weight by a factor of 7.33. The comparable factor for the supplemented fish was 8.89 - 11.11.

For purposes of comparison, Professor Patiño cites Kuronuma (1968) who describes the cage culture of various marine fishes in the fertile Inland Sea of Japan. Kuronuma considered an annual production of 29 kg/m² remarkable. These fish were fed a high quality dry food with a conversion ratio of 1.6. In Professor Patiño's experiments, the unsupplemented *T. rendalli*, stocked at 100 fish/cage, produced 28.5 kg/m² of pond surface in five months. While no attempt was made to determine the conversion ratio of bore leaves, it was undoubtedly much higher than 1.6. At New Alchemy East we have achieved a good conversion rate of 1.5 with *Tilapia aurea* and *Tilapia zillii*, and believe that part of our success is due to small amounts of animal protein (earthworms, insects, etc.) in their diet, particularly when the tilapia are small (McLarney and Todd, 1974).

"One-upmanship" in terms of weight/surface area data is an occupational disease of fish culture. Undoubtedly the production achieved by Professor Patiño could be bettered by using concentrated foods or by technological improvements. What matters is not competition among fish culturists, but the fact that his technique is inexpensive and does not require great sophistication on the part of the farmer, yet can result in the production of hundreds of kg of fish in a short time within a small area.

INTEGRATION OF FISH CULTURE WITH CULTURE OF HOGS AND CHICKENS

Professor Patiño points out that, while Colombian farmers commonly raise chickens and hogs for sale or their own use, growth of these animals is limited by their diet, consisting chiefly of corn, platano peels,

minced sugar cane and table scraps, plus whatever the animal can forage. Such a diet is usually deficient in animal protein. Colombian campesinos cannot afford to make up this deficit by the use of concentrates, as is done in more affluent countries. Professor Patiño suggests that excess small cultured tilapia could fill this gap. For this purpose he recommends *T. mossambica*, which can be maintained without supplemental foods on plankton in fertilized ponds, and multiplies more rapidly than *T. rendalli*. The two species could be grown in polyculture, or a separate small pond could be set aside for *T. mossambica*. The pigs or chickens could be maintained near the fish pond so that the ponds can be fertilized with their manure.

Young *T. mossambica* were tested for acceptability as food for chickens and pigs. The tests on chickens were preliminary and established only that chickens prefer cooked fish. Tests with hogs were more extensive. These animals eagerly accepted whole, raw young *T. mossambica*. They had no difficulty with bones or fin rays.

One quantitative feeding experiment was conducted with hogs. Four one month-old Duroc Jersey hogs were divided into two pairs (one male and one female per pair). The control pair, which had a mean weight of 8.6 kg, was fed twice daily with cooked platanos (including peels) and minced sugar cane, in increasing quantities as the animals grew. The experimental pair, with a mean weight of 7.5 kg, received the same diet, plus a daily ration of whole, raw *T. mossambica* measuring up to 8 cm in total length. The daily tilapia ration was 100 g per hog at the start of the experiment and was increased to 250 g over the experimental period.

After four months, the hogs were weighed again. The mean weight of the control animals was 16.5 kg, that of the test animals 24.5 kg, or 33.1 per cent more, even though they had started the experiment being slightly smaller. The mean weight gain of the controls was thus 7.9 kg, or 48 per cent, while the hogs whose diet was supplemented by tilapia had a mean weight gain of 17.0 kg, or 69.4 per cent.

Professor Patiño does not consider the final weight of either pair of hogs satisfactory, due to irregularities in the feeding regime. Neither can his results be considered statistically significant. Nevertheless, the experiment indicates what might be achieved.

THE "CAMPESSINO FISH CULTURE UNIT" AND ITS ECONOMICS

Based on the results of the experiments described here, Professor Patiño has drawn up a plan for a "Unidad Piscícola Campesina" (Campesino Fish Culture Unit), using *T. rendalli*, with the potential to accommodate additional species. The physical layout of such a system is illustrated in Fig. 1.

His plan for the UPC, as he calls it, includes the following instructions:

1. Select a pond site with the help of an expert. New Alchemy's new method of pond sealing should render site selection easier (McLarney and Hunter, see page 85).

2. Plant the area around the pond site with fish food plants. Professor Patiño suggests one hundred stalks of yuca, one hundred roots of bore, chayamansa and other suitable plants as available locally. These need occupy less than ½ hectare. It is important to plant before beginning pond construction, so that the plants are producing by the time the fish need food.

3. Build two ponds:

- a. A nursery pond ("estanque criadero"), 5 m x 20 m x 1 m, connected by a ditch to a good water source, with another ditch for drainage. When filled, the nursery pond should be fertilized. When the water turns green, add five hundred to one thousand juvenile *T. rendalli*.

- b. A growing pond ("estanque para jaulas") near the nursery pond, also provided with inlet and outlet ditches. The growing pond should be at least 3 m x 20 m, and 1.5 m deep. Plant this pond with aquatic plants and introduce twenty-four cages, each measuring 1 m x 1 m x 1 m, spaced equidistantly. Each cage should be equipped with legs to keep it 30 cm off the bottom.

4. When the tilapia start to grow, select individuals 6-8 cm in total length and stock them at 200 per cage. All the cages can be stocked at once, or stocking can be staggered to suit the culturist.

5. Feed the fish in the cages twice daily, in the morning and late afternoon, with leaves of the food plants. Feed as much as the fish will consume, but no more. If feasible, supplement their diet with wheat or rice bran.

6. Inspect each cage monthly to determine if health and growth of the fish are satisfactory. For this purpose, the cages may be lifted slightly so that the quantity of water in them is reduced. They should not be lifted completely out of the water or held up too long, as the fish will become very excited and subsequent losses due to jumping out may occur.

7. Harvest after five months, or when the fish have reached the desired size.

Using the costs reported by campesinos who have built ponds in the vicinity of Mateguadua, and the results of the experiments reported here, Professor Patiño makes the following economic projection (Table 1).

According to Professor Patiño's projection, in the first year, with only one harvest and all of the initial costs of construction, a profit of \$1,740 Colombian dollars could be realized. In subsequent years, with harvests up and expenses down, the projected profit would be \$10,980 Colombian, with only two harvests per year. To any such evaluation the benefit of in-

TABLE 1: PROJECTED INVESTMENT
IN AND INCOME FROM A CAMPESINO
FISH CULTURE UNIT

Investment (in \$ Colombian):

Pond construction, with pick and shovel	\$ 800
Construction of inlet and drainage ditches	400
Cost of twenty-four cages, at \$40 each	960
Food plants	300
Unforeseen costs	540
Total Investment	\$3,000

Annual Maintenance Cost:

(Including repair of cages)	\$1,500
TOTAL	\$4,500

Income

Net Production per cage, first year..... 26 kg	
Production of twenty-four cages,	
first year	624 kg
Value of harvest, first year (assuming a price	
of \$10/kg of fish).....	\$6,240
Value of the harvest, second year (minimum	
of two harvests).....	\$12,480

As of Summer, 1975, \$28.50 Colombian was the
equivalent of \$1.00, U. S. Funds

creased nourishment provided by the fish to the
campesino family and to their livestock must be added.

DISCUSSION

Professor Patiño envisions that such ponds could be set up not only on campesino farms, but also "in grammar and high schools, in training schools, vocational agricultural institutes, in SENA, and even in the universities" where they would serve educational, scientific and recreational functions, as well as provide food. He suggests that the crop could be used in school cafeterias or shared among the students. "The development of fish culture should be conceived as a great crusade operating throughout the national educational system," he writes, "How much more useful and functional this type of activities and educational experiences would be than the bland and repetitive textbook instruction which is now given in our centers of education."

I can only add that the need for the type of education and action urged by Professor Patiño extends

far beyond Colombia. The lack of effective aquaculture programs in most of Latin America is obvious. Those few which have been proposed or enacted are mostly concerned with taking advantage of long growing seasons and cheap labor supplies to produce a product for export or sale to the relatively affluent, and confer economic benefit only to the entrepreneur and a handful of laborers. A few plans which have taken better aim at the important economic, nutritional and ecological problems have foundered for a variety of reasons — biological bottlenecks, lack of research funds, failure to approach the problem at a level meaningful to the campesino, etc. Professor Patiño has surmounted these problems to design and test a fish culture system that is ecologically and economically sound with great potential to alleviate some of the problems of Latin America.

— Anibal Patiño R.

Précis by William O. McLarney

REFERENCES

- Hickling, C. F. 1971. Fish Culture. Faber and Faber, London. Revised Edition.
- Huet, M. 1970. Traite de Pisciculture. Editions Ch. de Wyngaert, Bruxelles. Fourth Edition.
- Kuronuma, K. 1966. New Systems and New Fishes for Culture in the Far East. World Symposium on Warm Water Pond Fish Culture. Rome, FAO. FR: VIII-IV/R-1.
- McLarney, W. O. 1973a. Possible Latin American Analogs of Oriental Pond Polyculture Using Indigenous Fishes. Paper presented at the 53rd Annual Meeting of The American Society of Ichthyologists and Herpetologists, San Jose, Costa Rica.
- McLarney, W. O. 1973b. Studies of the Ecology of the Characid Fish *Brycon guatemalensis* in the Rio Tirimbina, Heredia Province, Costa Rica, with Special Reference to Its Suitability for Culture as a Food Fish. *The Journal of The New Alchemists* (1): 52-57.
- McLarney, W. O., and J. R. Hunter. 1975. A New Low-Cost Method of Sealing Pond Bottoms. *The Journal of The New Alchemists* (3): 85.
- McLarney, W. O., and J. H. Todd. 1974. Walton Two: A Complete Guide to Backyard Fish Farming. *The Journal of The New Alchemists* (2): 79-117.
- de Menezes, R. S. 1966. Cria y Seleccion de los Peces Cultivados en Aguas Templadas en America del Sur y Central. FAO World Symposium on Warm Water Pond Fish Culture. FR: IV/R-5.
- Ramos, H. A. 1971. Las Tilapias en Colombia. *Revista Esso Agrícola*, No. 6.

Aquaculture

Every medieval monastery used to have its fish pond. From it it drew a fair proportion of protein, mainly in the form of carp. Those monasteries, in fact, have much to tell us that is relevant to contemporary problems. With vows of poverty, the monks set out to become self-sufficient in food. They found, as will anyone who tries hard enough to do that, that they always produced a surplus. In the end, those accumulated surpluses made them embarrassingly rich. Planet Earth, take note.

But not many of us now have half an acre of pond we can devote to carp. Fish-farming is probably the most productive method in existence of using land, giving in the Far East yields equivalent to several thousand pounds of excellent food to the acre. With one exception, no one has yet tackled the problem of scaling fish-farming down to family size, and maintaining similar or better production.

That exception is the New Alchemy Institute-East, on Cape Cod in the United States. Thanks largely to the pioneering efforts of its director John Todd, it has started in on the long road to backyard fish-farming. In 1973 it persuaded Americans all over the country to build small pools, cover them with plastic to keep the heat in, and provided each experimenter with a pair of breeding fish. The object was to raise 500 1½ lb fish in an area no bigger than a small child's swimming pool during the six summer months. There were failures, and there were successes. If you join the New Alchemy Institute as an associate member, you can receive all the information gathered during that experimental period. Even if you don't, you can go quite a long way towards setting up your own fishery for a very small expenditure.

The preferred fish is tilapia, a native to the Near East and Africa which grows extremely fast in warm water, is rich in protein and has a good flavour. And the first thing you need is a pool, approximately 12-14 feet in diameter, and some 3 feet deep. You can buy such a pool from toy shops for a reasonable amount of money. Or you can make one in concrete, or dig one in the ground, lining it first with polythene to stop seepage. If you do the latter, however, you need to put insulation under the bottom and round the sides, otherwise the water will lose heat to the ground too quickly. As your pool will be emptied in the autumn, the insulation need last only six months, and bales of straw will do very well.

Over the pool you need to construct a greenhouse of some kind - or, of course, you can put the pool in an existing greenhouse. If you don't have anything suitable, the easiest, most transportable and lightest structure you can make is a dome. It needs to be between 18 and 25 feet in diameter at ground level, and you can get dome plans from many publications. Specifically, if you write to *Popular Science Magazine*, 355 Lexington Avenue, New York, NY 10017 and enclose \$5 they will send you back their Sun-Dome plans, which are what the New Alchemy Institute recommends. It takes only two to three days to put the wooden structure for the dome together. And then you need to double-glaze it. As always, glass is best if you can afford it. If not, greenhouse quality transparent vinyl sheeting will last a good 5 years. Failing that, polythene will do, but don't count on it lasting for a second season. In the winter, incidentally, you can use your sun dome as a greenhouse for growing winter veg, or as a tank for growing some cold water fish.

Now tilapia will not survive in water cooler than about 60°F (15°C). Even at that temperature they won't grow at all, and will only breed and thrive when the water climbs over 80°F. Temperatures of that order are not so difficult as you might think. A double-glazed greenhouse with no ventilation will hit 90°F any time between April and September when the sun is out. And with such a large body of water in the pond, the temperature will fall only very slowly.

In the United States warm enough temperatures are obtainable simply through solar heating as far north as Cape Cod for most of the six summer months. Elsewhere it's a matter of trial and error. Probably you'll need some additional heat source. You can put a small stove and flue in the dome, and run it off wood or coal. You can use an electric heater, which will be costly. Or you can make a small solar panel, and run the warm water from it in copper pipe through the fish tank itself. That will do the trick easily in the UK, where even very large swimming pools in the open can be solar heated with great ease to temperatures in the 80s.

Next fill your pool to within 6 inches of the top with water. You'll have to use your normal supply, but if it's chlorinated allow it to stand for a couple of days and agitate it occasionally to lower the chlorine level to suit the fish. Any new tank or pond should be filled two or three times and siphoned off to leach away any contaminations. Then leave the water to stand, and get it up to the required temperature somehow or other. You should be doing this in April.

Next find your tilapia - in the US you may be able to get them from the New Alchemy people. Otherwise it's the pet shop, and they may take some tracking down. It doesn't matter greatly what species you have, but it is a good idea to order a breeding pair well in advance because they're not easy to find. Your pair will come in a plastic bag full of water. On no account just let the fish out and into your pool. You must lower the bag, complete with fish, into the pool and leave it there until the water temperature in the bag is the same as in the pool. When it is, release the pair.

By this time your pool will probably have gone deep green. That's fine. It means it's full of the algae which will be the tilapias' main food for the rest of the summer. If it's not, you must visit some local ponds, and scoop out a gallon or so of water from the greenest looking ones. Chuck that in your pond and it should green up in a couple of days. From now on you must keep the water fertilized to feed the algae. Do this by lowering in it a sack of manure, or grass clippings or green waste. But be careful. Too much fertilization will starve the fish of oxygen and they'll die. Best not to use poultry manure which is too rich.

The only other thing to do is siphon out - from the bottom - about 10 per cent of the water every week or so, and top up with fresh water.

If the water temperature is up in the 80s, the pair should start to breed straight away. The eggs will be spawned and fertilized, and the female will then take them into her mouth for hatching out after a day or two. Tilapia are mouth-breeders, and the young will live in mummy's mouth, darting out for occasional forages as they get bigger, and returning there when anything untoward occurs.

At this stage you need to provide some additional feed. Of course, you can buy fish food and throw it in, but that's expensive. You need about half a pound of meat protein per day for a growing stock of 500 fish, and perhaps the easiest way is to make an earth worm factory, and throw the worms to the fish. Any good gardening book will tell you how to grow worms in quantities which will exceed your wildest nightmares. Or you can grow maggots on rotten meat - but you run the risk of fly infestation. A hunk of meat hung over the pond is not a bad idea, for the maggots will grow quickly at that temperature and drop straight into the pond.

You don't want more than 500 fish in your pond. You'll have to gauge that by taking water samples and making rough counts. When you've got enough then hike out the breeding pair and store them in a heated aquarium for next year. A temperature in the mid-60's will be enough to keep them ticking over.

By September or October you'll be having great difficulty in keeping your water temperature up. There's no point in keeping the fish any longer, for they won't be growing much; and if the temperature drops much lower they'll die. So drain most of the water away, using a sieve to prevent the tiniest fish escaping, and then harvest your catch. A smart blow between the eyes will kill the fish, and anything over ¼ lb is well worth eating. You may find you like to eat them smaller than that, but it will depend on how well you've done. Anything too small to eat you can give to the cat or the hens or the compost heap, or simply keep as pets.

I don't know how well you'll do - but I do know that if you get it all right you could easily end up with more than £100 worth of really good food for the deep freeze - or even pickling. And if all the land I owned in the world was a sunny plot 20 feet square, then I'm pretty sure that's what I'd do with it. The rewards are vast. If you get 100 lb of fish from that area, you're producing at the rate of more than 10,000 lb of very good food to the acre. Say 4 tons to the acre. If you grew cereals, one of the most productive means of using land, you'd get no more than 2 tons to the acre, and those tons will have less than half the protein value. If you ran sheep, you'd do well to get more than 300 lb of lamb off each acre every year. In fact, it wouldn't take many people growing fish in their yard to solve the world food problem once and for all.

8. Aquaculture

There are compelling reasons why the true Whole-earther should turn his attention to aquaculture for part of his food. First, 75% of the planet's surface is covered by water. Second, water, if correctly used, will produce more animal protein than an equal area of dry land.

There are two kinds of aquaculture, salt-water and fresh-water. The salt-water variety involves owning or renting some coastal property. Fresh-water aquaculture involves owning a stream or lake or making a pond.

Fresh-water aquaculture. In his book *Fish Culture* (Faber and Faber, London, 1971) C. F. Hickling described some of the reasons why it is worth engaging in this form of aquaculture: "Fish culture can use land too poor to be useful agriculturally, and water with qualities unsuitable for agriculture or irrigation. Swampy land, undrainable for agriculture, makes very good fish pond sites. Land which may be toxic to plants because of a very acid reaction may be suitable for fish ponds. In Israel brackish water with as much as 8,000 to 10,000 parts per million salt are used for fish culture. Major fish farming industries are based on the changing brackish waters of estuaries."

For the true Whole-earther, who is often forced by lack of means to buy land of poor quality, this statement may be of special interest.

Fish culture in fresh water is governed mainly by temperature. Such fish as catfish and tilapia require water between 70 and 80° F for maximum growth. Trout, however, will hardly survive in water above 70° F and do best in water around 56–58° F.

Fish ponds. A number of points should be borne in mind by any Whole-earther who contemplates making a fish pond:

(1) Try to excavate your pond so that it has a flat bottom surrounded by banks. The best average depth of water for fish is 3 feet and the only reason for making the pond deeper is to prevent it from drying out in the dry season.

(2) Always try to locate your pond on a site high enough so that it can be drained by gravity. Draining is desirable not only because it facilitates harvesting the fish but also because it increases the fertility of the pond and improves oxygenation of the water. Ideally, the fish grower should have two or three separate ponds, which should be dried out in rotation every 2 years. A good crop can be grown on the bottom mud.

(3) If possible, ensure a water flow through your pond. This can be done by diverting part of the flow from a small creek to pass through the pond. Catfish, even with intensive feeding, will generate only 1 ton of fish per acre per year in water that is static. If 200 gallons of water per hour can be directed through the pond, production can be raised to 3,500 pounds per year. A still larger flow will enable one to harvest 5,000 pounds per acre.

(4) Quality of the water will determine the success of the fish growing venture just as quality of soil determines the outcome of an agricultural enterprise. The pH (degree of acidity or alkalinity) of the water is important. It can safely range from 6 to 9. At an acid pH of about 4 most fish die and water more alkaline than 9.5 inhibits growth. Calcareous water with high levels of dissolved lime are more productive than non-calcareous. To determine alkaline reserve, take 100 milliliters of water, add three drops of methyl orange indicator. If it turns pink the water is too acid. If it turns pale yellow, add 0.1 normal hydrochloric acid drop by drop until it turns pink. Water of medium productivity requires 8–30 drops. The best alkaline reserve is indicated by 30–75 drops. To correct acidity, scatter powdered limestone on the water.

(5) A spillway must be constructed to enable one to empty the pond and to take off excess water during heavy rain. The most convenient form which will serve both purposes is shown in fig. 7. This spillway must be constructed before the walls of the

dam are raised and must have sufficient diameter to take the runoff from a heavy rain storm. The screen prevents loss of fish when the dam is drained. The boards enable you to regulate the depth of water. Before the season of heavy rain some boards can be removed to lower the water level and accommodate the new inflow.

(6) It is distressing to discover, after much time and effort has been expended on pond construction, that the water leaks out faster than it enters. This frequently happens in newly constructed ponds. It generally indicates that the banks were not poked down firmly enough while they were being built. The leaks often seal themselves after the first heavy rains. It is possible in small ponds to seal them with a sheet of plastic (black polyethylene is best but must be leached for several days before fish are introduced). The plastic can be covered with a layer of mud or sand. Dressings of bentonite (a fine clay) will also help seal the leaks in ponds.

(7) Oxygen level in pond water is very important. Fish depend on the dissolved oxygen (D.O.) in water and its level decides which fish you can grow. The D.O. level in freshly filled ponds may be very low so no pond should be stocked with fish immediately. Allow about 40 days for oxygen levels to build up.

(8) To produce the maximum crop of fish a fish pond must be fertilized. Many fish farms in Java are run in conjunction with pig sties, the manure being transferred directly to the ponds. Poultry manure and human manure are also used but the employment of untreated human sewage is objectionable on account of the danger of spreading disease. In Munich, Germany, sewage effluent is used to support a crop of carp. Organic matter, such as manure, must be added cautiously to the pond, preferably when the temperature of the water is low. The decay of the organic material uses oxygen and may therefore asphyxiate the fish. The warmer the water, the less oxygen it can hold in solution. Phosphate is the most important fish pond fertilizer and can be applied at the rate of 25–30 kilograms of phosphorus pentoxide (P_2O_5) per acre. Potash is rarely deficient in fish ponds.

(9) Draining the pond is the only efficient way of harvesting fish. Seining is much less effective. Using a large seine and dragging it through the pond 10 times, Hickling found that the haul on the tenth pass was not much lower than the haul on the first. Ponds can be completely cleared of fish by the use of derris root, the active principle of which is rotenone. This substance is both a fish poison and an insecticide but it is harmless to humans. A dose calculated to give 6 parts derris per million of water will be sufficient and will not make the water toxic for more than 5 days. The derris should be spread evenly over the surface of the pond. The fish will be stupefied and float to the surface. They can be collected with dip nets. Care must be taken to ensure that the pond is not overflowing when the derris is applied as the fish poison may contaminate other water. Fish stunned with derris can be quickly revived by putting them in fresh water.

A freshly made slurry of quick lime is also a fish poison, and can be used to disinfect a pond after it has been drained. The quick lime (calcium oxide) becomes converted into calcium carbonate, which is beneficial and aids the growth of the fish.

(10) Food for fish in ponds should be placed in definite stations near the bank and marked off with floats. Regular inspection of these feeding stations will show whether fish are eating all the food. Household scraps, spoiled grain, even fresh grass can be fed to fish if the right combination of species is used (for example, grass carp that will eat fresh grass, leaves and vegetable refuse). Maize, wheat and lupin seed should be soaked before feeding to fish.

Fish grow better if the feed is supplied frequently, so mechanical food dispensers are coming into use in fish farming. There are even demand dispensers on which the fish learns to push a button, thereby releasing food whenever the fish needs it. Fish must be watched to see if they are using all the food. In very hot weather care must be taken not to overfeed the fish. The excess food will rot and lower the oxygen content of the water. Hot and windless days will put fish off their feed.

The fish farmer must know approximately how fast his fish are growing as food supply must be proportional to their weight. A sample of fish should be removed from time to time. This can best be done with a small fish trap or cast net. Fish should be disturbed as little as possible as they lose weight when frightened. It is usual to feed 5% of the weight of the fish per day but this applies only to foods of high food value. Less nutritious foods must be supplied in larger amounts.

Raceways. A raceway is a channel through which water flows at a rapid rate. It is particularly suitable for raising fish having a high oxygen need such as trout. The dimensions of the raceway will depend on the amount of water available. Raceways used for high-density catfish culture at the Skidaway Institute of Oceanography in Georgia consist of a series of segments 10 feet wide and 100 feet long containing water 3–4 feet deep. There are 25 of these segments. Water from a 3-acre pond flows by gravity through the first segment and over a 1-foot-drop aeration weir into segment two, and so on. At the end water is pumped back to the pond. A flow rate of 0.05 gallon per minute per cubic foot of raceway makes it possible to raise fish at a density of six fish per cubic foot. The method is thus well suited to high-density fish culture but the layout is expensive compared with the fish pond. It may be necessary to line raceways with plastic or rocks to prevent erosion of banks by the rapidly flowing water.

Trout. These are cold-water fish of the salmon family. Ideal water temperature is around 58° F. Brown trout can stand water up to 70° F and rainbow trout up to 75° F but these high temperatures are bad for the fish. Although raceways with rapid water flow are best for trout the fish can be raised in ponds. A very successful trout growing operation has been started in Denmark using earthen ponds. Rainbow trout have been raised and show very fast growth in ponds fed by sewage effluent at Munich. Rainbow trout do not need as much oxygen as brown trout or brook trout. Trout are carnivorous fish and voracious feeders. In the United States, where a considerable trout-growing operation is located on the Snake River near Buhl, Idaho, the trout are fed specially prepared pellets. In Denmark they are fed on trash fish. The true Whole-earther would probably prefer to set up a more self-contained biosystem by using leaves and manure to grow worms, feeding the worms to the trout, putting the spent compost on the garden. If he runs out of worms he can buy trout chow. The fish are amazingly efficient food converters and, according to J. E. Bardach (*The Status and Potential of Aquaculture*, vol. II, P.B. 177768, from Clearinghouse, Springfield, Va. 22151), can convert 1½ pounds of food into a pound of fish. Special strains of trout with rapid growth rates have been developed by Lauren P. Donaldson of the University of Washington.

Although trout can be raised from eggs the fish farmer would do best to buy fingerlings from a hatchery. They cost here in California about \$30 per 100 (rainbows). They can be raised to a satisfactory size in 2 years or less, depending on the feeding schedule. Details of feeding rate can be obtained from manufacturers of trout chow.

Catfish. These are warm-water fish and their maximum growth occurs in water at 80° F. It is quite possible, if one is willing to take the trouble, to raise one's own fish from eggs. The fish spawn when the water is 80° F. Pairs of selected brood fish are placed in 5 × 10-foot pens of hardware cloth or chicken wire located around the edges of the pond. The fish need sheltered places in which to build their nests. These can be wooden boxes partly filled with gravel, nail kegs or crockery jars. Several inches of water must cover the tops of the nests. Fish weighing 1–4 pounds produce 4,000 eggs per pound body weight. Eggs hatch in 5–10 days at 70–80° F.

It takes a year to bring catfish from egg to fingerling size. A second year is required to bring the fish up to ¾ to 1 pound. Those unwilling to try to raise fish from eggs can buy them as fingerlings of various sizes. The cost here in California (1973) is about \$15 for 50 half-inch fingerlings. Catfish can be raised in raceways at a density of two to six fish per cubic foot of water (see J. W. Andrews, ed., *High Density Fish Culture*, Skidaway Institute of Oceanography, Skidaway Island, Savannah, Ga., 1970). The equipment needed for such intensive rearing is expensive and probably beyond the means of the average Whole-earther. In the rich bottom lands of the Mississippi, which are the center of catfish culture in the United States, ponds are used which are commonly no bigger than 1 acre. Channel, blue and white catfish are raised in these ponds and the yields, if the pond is unfertilized, will be around 200 pounds per acre. If the pond is fertilized or the fish are fed, the yield can be raised to 1,000 pounds per acre. A flow-through of water can increase yields to as much as 5,000 pounds per acre.

Quite good yields can be obtained from unfertilized ponds by using a mixture of fish species. Without much labor one can harvest from an acre of water 200 pounds of catfish, 100–300 pounds of buffalo fish and 50–60 pounds of bass per year.

Carp. This noble fish, famed for its wisdom and longevity, has been cultured in carp ponds for centuries. In old England every monastery had its carp ponds and the monks fed the carp and the carp fed the monks and both grew fat in the process. In favor of these fish are the following qualities: They breed readily, stand low temperatures, do well in stagnant water. Near Munich they are raised in ponds into which the partially treated sewage of the city is led. The sewage promotes growth of algae, the algae are eaten by various worms, the worms are eaten by carp, the carp are eaten by the inhabitants of Munich. A perfect example of recycling. Carp can also be trained to feed themselves on cheap foodstuffs compounded into pellets like those used in trout culture. A carp presses a target plate in the water and a pellet is released. The carp fancier can take his pick of a variety of species, from the highly decorative oriental carp to the silver carp or grass carp. The silver carp from the Amur River is particularly popular in the Soviet Union. It is herbivorous, has delicious tender flesh and few bones. In Israel the carp is grown along with mullet and tilapia and the yield of fish in these mixed cultures increases because the entire volume of the pond is used as a three-dimensional growing space.

Most Whole-earthers will probably prefer the simplest form of aquaculture involving the use of some animal wastes to fertilize the water and raise a mixed culture of bass, bluegills, carp and catfish with a few bullfrogs thrown in to make music at night. In this way the Whole-earther can go fishing whenever he feels like it, catch his supper with rod and reel or use a seine net if his skill as an angler is insufficient. The trouble with most farm ponds is that they are not fished enough and the resultant overcrowding produces masses of fish too small to be worth eating.

Ocean aquaculture. This type of aquaculture can be divided into three parts: (1) culture of sea plants, (2) of invertebrates, and (3) of fish or marine animals (ocean fish culture).

Sea plants. The plants of the sea take two forms: single-celled algae which make up the *phytoplankton* and which float freely in the upper layer of the ocean; and the larger plants (seaweeds) that are usually anchored to rocks and grow in shallow water relatively close to the shore.

The culture of one-celled algae whether in sea water or in fresh is a large subject (for more information, see the letter by Pat Patterson, *Last Whole Earth Catalog*, p. 59). There are those who have suggested that such algae cultures will be humanity's last resort to save it from mass starvation. Probably, when things get that bad, this ill-starred hominid will prefer to become extinct. There is, however, a very practical reason for growing one-celled marine algae. Such algae are the natural food of oysters and abalone and their culture will be described in connection with the growing of these invertebrates. Here we are mainly concerned with the culture of seaweed, particularly the kind called *nori* in Japanese and *laver* in English. Laver culture in Japan is quite technical, for the Japanese are surely the world's leading aquaculturalists. The secret involves gathering special spores

(carpospores) and letting them grow on oyster shells. This is done at the marine laboratory in tanks 6 X 8 X 3 feet holding 250 strings of 10 oyster shell collectors. The carpospores grow on the shells as a dark red incrustation and release monospores in the autumn. At this time the fisherman who grow laver come to the laboratory with special nets which they immerse in the tank, paying the equivalent of \$1 per net. The monospores settle on the net, which is then set out in an estuary. The seaweed grows during the winter and is harvested from January until April.

The seaweed is highly nutritious and digestible, the algae protein constituting 30 to 50% of the dry weight. It is said to have a nutritional value comparable to beef. One acre of intensively cultivated seaweed will bring in \$3,000. Unfortunately, the Japanese, besides being the world's best aquaculturalists, are also the world's worst polluters and are progressively rendering their estuarine waters incapable of growing anything. But a true Whole-earther with a relatively unpolluted estuary within reach might try laver culture (see M. Kuogi, "Recent laver culture in Japan," *Fishing News International*, July-September 1963; or particularly for invertebrate and algae culture, see John H. Ryther et al., *The Status and Potential of Aquaculture*, vol. 1, P.B. 177767, Clearinghouse, Springfield, Va. 22151).

Invertebrates. Oyster culture and abalone culture represent two methods of growing first-class animal protein that might recommend themselves to any Whole-earther with access to open water. It is not very difficult to raise oysters and the project can be combined with sewage purification. Such a scheme has been worked out by John H. Ryther, who runs two "farms" at Woods Hole Oceanographic Institution. In the first farm, treated sewage is used to culture phytoplankton in carboys exposed to light. This operation can be done in a greenhouse or with artificial light. The algae cleanse the sewage by removing much ammonium, nitrate and phosphate, though they will not grow in sewage polluted by toxic industrial wastes. The sewage is mixed with aerated sea water pumped in from the ocean. Water carrying the algae is then pumped into the second farm, consisting of large tanks in which are suspended strings of scallop shells covered in oyster spat. The oysters grow on these shells using the algae as food. Such oysters can be harvested and fed to people. Another example of recycling.

It is also possible to raise oysters in ponds of sea water as is being done on Long Island. The baby oysters can be suspended on strings of scallop shells or on plastic netting called Netron (made by Du Pont).

By suspending his oysters in this way from rafts or buoys the grower saves them from various hazards that threaten oysters grown on the bottom (Fig. 8). This method of culture by suspension is used very successfully in Hiroshima Bay by the Japanese, who harvest the world's largest oyster crops: 58,000 kilograms per hectare as opposed to 10 kilograms per hectare from the public oyster grounds in the United States (see J. E. Bardach, "Aquaculture," *Science*, vol. 161, pp. 1098-1106, 1968).

The Whole-earther can have fun and learn a bit about marine biology if he raises his own seed oysters. Oysters can be forced to spawn by introducing them into warm sea water (about 23° C) and the oyster spat can be collected on strings of scallop shells on wires suspended in the tank from cross pieces or on strips of Netron. Less enterprising Whole-earthers may prefer to buy their baby oysters. They can get them from Japan or from the Lummi Indians of Lummi Island, Wash., who have gone into aquaculture in a big way and are specialists in oyster growing.

The whole process of growing marine invertebrates, including shrimps, lobsters, crabs, clams, mussels and abalone, is in an

embryonic stage in the United States. It is of special interest to Whole-earthers who live in such states as Maine that have ample shore lines. Writing in *The National Fisherman* (February and March 1971) Dr. Robert L. Dow, Marine Research Director, Maine Department of Sea and Shore Fisheries, describes the present state of the art. He sees Maine aquaculture as being worth far more than the state's existing industries. The great threat to this wholesome activity is, as usual, industrial pollution of coastal and estuarine waters.

Ocean fish culture. The chief apostle of ocean fish culture is Dr. Lauren P. Donaldson of the University of Washington. His specialty is the rainbow trout, of which a sea-going variety is known as the steelhead. A trout and salmon breeding program which has been in progress for more than 30 years has resulted in the development of some truly remarkable fish. Whereas a wild rainbow trout in a lake will reach a weight of only 200 grams in 18 months one of the new hybrids may grow to an astonishing 3,000 grams in the same period. Selective breeding can be used to produce similar improvement in salmon (salmon and trout belong to the same family of fish, the Salmonidae).

The idea underlying fish farming in the ocean is to release specially bred fish to forage in the sea ("the big posture") but to keep them under control, just as a rancher keeps his cattle under control. This has been done in places as far apart as Norway and Tasmania. Concerning this method of farming the sea Dr. Donaldson has this to say: "In Tasmania, for instance, the culturists are using estuarial water and farming rainbow trout and brown trout in the type of floating enclosures that are so popular off the coast and along the fjords of Norway. The Tasmanians do not have to go to a great expense, but they do have their animals completely under control at all times. Their food supply is natural food plus other food. The fish are readily available for marketing any day you want them. They simply say that it is much better to keep the fish under control than to hunt all over to find them as you do in the regular commercial fisheries."

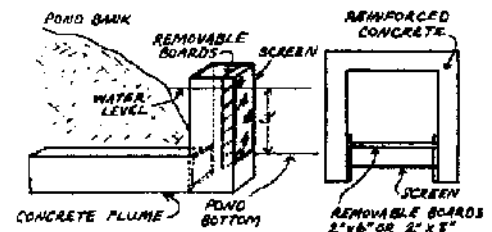

POND CONSTRUCTION

FIGURE 7

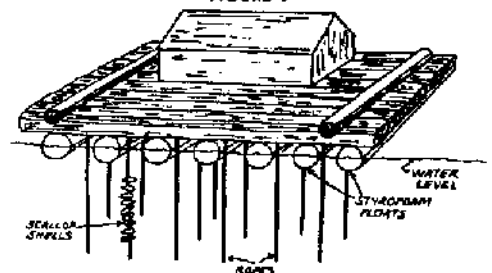

RAFT FOR OYSTER OR MUSSEL CULTURE

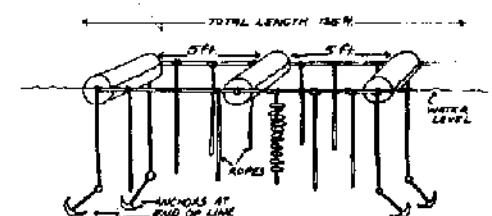

LONG LINE METHOD OF OYSTER CULTURE

METHODS OF OYSTER OR MUSSEL CULTURE

FIGURE 8



AQUACULTURE

Whoever discovers how to cultivate the eel should get a Nobel Prize, don't you think?

(Daijiro Murata, eel chef, Tokyo)

Catfish farming is living; everything before or after is just waiting.

(Don Carr, entrepreneur, Eagle Pass, Texas. Quote in Huke and Sherwin, 1977)

The highest fish production per hectare can only be obtained by using a combination of species of different feeding habits.

(Swingle, 1966)

Water conservation and irrigation is the lifeblood of agriculture. Grain can be taken as the basic crop, and around it developed industry, animal husbandry, forestry, aquaculture, and other integrated occupations.

(Mao Tse Tung)

total landscape, although we are constantly increasing the area of impoundments in an attempt to cope with the energy demands and water supply to cities and industry. In impounded areas, on wet terraces, and in canals and raceways, water ceases to be a merely erosive influence and becomes a very productive medium for plant and animal cultures. Associated with water are those specialised plants and animals which are adapted to or seek out water margins, shallows, and the water meadows (plains) which are inundated in floods.

Of all existing systems, tropical rainforest and shallow-water aquatic environments have the greatest natural yields. Mangrove swamps, marshes, and estuaries produce sometimes prodigious biomass of great complexity. Our attitudes to these systems has historically been ambivalent, and since the invention of the bucket dredge and bulldozer, typically destructive. Many marshes, estuaries, saltflats and ponds have been drained or deeply flooded to suit our private purposes, often in disregard of their total yields and values. Only in recent times have we begun to appreciate that a great many of our other activities, such as salmonid and inshore fisheries, depend on the conservation of the wetland habitat.

For millenia, we have occupied the shorelines and islands of marshes, and developed complex civilisations on the floodplains and deltas of major rivers. Swamps have always yielded a variety of foods for people. One of the bases for the concept of bioregion is that of WATERSHED and this too is an ancient natural division of tribes and languages. Cooperative communities and bioregional democracies have been based on water rights, as have hydraulic tyrannies; both exist today.

There is an intimate and indissoluble link between the health of a river, and the health of the catchment; here we can sense the literal truth of the concept of the "upstream and downstream costs" of our activities;

13.1

INTRODUCTION

The term WETLANDS covers both natural and artificial impoundments of water: lakes, ponds, bogs, swamps, marshes, and the shallow water or intertidal areas of estuaries and marine marshes. The emphasis here is on those areas used by people for foraging and fish-farming. Because of the complexity of the wetlands environment, and of the species within it, an attempt is made to cover some of the design and planning principles and to restrict descriptions to a relatively few systems. The breeding and rearing of any one species is also omitted, as a comprehensive specialised literature exists on this aspect of aquaculture.

Except in very favoured areas, or on recently glaciated shields, water as ponds is a minor part of the

THE CASE FOR AQUACULTURE

Pollution, in all its forms, most rapidly permeates landscapes and societies via water. Wherever we have used biocides in a catchment, we can reap death in the rivers and the seas offshore as far out as the reef areas, and in the sea itself. The death of coral reef areas is closely correlated with the use of 2,4-D and 2,4,5-T inland. Preservation of the cleanliness and variety of water habitats is as critical to the survival of nations as is the conservation of soils. Both are in peril today.

In specialised cultures, water becomes the main medium for life sustenance, and all island cultures neatly combine the water and earth resources, as does the old Hawaiian *ohana* synthesis (Figure 10.28). Elsewhere, as on the Euphrates and on Lake Titicaca in Peru, whole cultures based on reed beds derive forage, boats, housing, bread, and meat from *Typha*, *Phragmites*, *Cyperus* or like reeds, while it is said that the Aztecs at Lake Tenochtitlan in Mexico had what is possibly the most productive system of polyculture yet devised, with chinampa crop, waterfowl, reedbed, and fish culture combined.

The cultures in terraced padi (rice and taro) serve much of Asia and Oceania, with minor subsidiary crops. The deltaic mazes of the Fly, Chao Praha, Mekong, Nile, and Ganges rivers support rich cultures of great variety and resource choice, with marine, estuary, freshwater, mangrove, and land organisms to choose from. Many of these advantages can be fairly cheaply created in most humid and some arid environments, even if in miniature.

Before the 1960's, there was a lively and large global aquarium trade, and plants, molluscs, fish and no doubt disease organisms were widely distributed. Many of these were released into local streams and became naturalised. Even this effect was dwarfed by the government-assisted distribution and protection of salmonid fish as a preserve of the idle and the affluent. A few fish species, notably *Tilapia* and carp, were brought in as a basic farmed food for terrace rice and taro culture in Asia or in famine areas. However, it is still true that the great majority of aquacultures have a predominantly local flavour and species composition, and few introduced species have proved to be as adapted and productive, or as uniquely suited, as indigenous species. Only if there are no local species, or if all trials in using local species are fruitless, do people look to exotic forms.

Aquacultures now range from open-water cage and ring-net systems to highly intensive tank or channel-flow cultures. On islands, atolls, and in deserts, totally innovative systems have evolved—and will in future evolve—where local species were absent or of minor productive capacity. As pelagic fisheries are exploited by the oil-rich western nations, island people have been forced to develop alternative systems, and aquaculture is one of these. Unlike terrestrial cultures, many aquaculture developments have been polycultural from their inception.

Until the last few decades, we have been able to harvest sufficient fish, molluscs, and plants from natural water systems. This is no longer the case, and a new impetus is evident in the creation and culture of organisms in the aquatic habitat. Even though a limited production has existed for millenia in all continents, new species are brought into culture annually, and the problems of breeding and rearing a wide range of organisms are being solved.

There are complex reasons for the sudden revival and expansion of aquacultural systems; some of these are undoubtedly connected with over-fishing of the marine resource, but perhaps as important is the change in food habits resulting from global travel and information, with a consequent change from fatty and red meats to fish and shellfish, and a general widening of the demand for variety in foods that can be eaten raw or lightly cooked.

Water cultures had long-tested and undoubted stability, and many have persisted without external inputs for thousands of years. The stability and productivity of aquaculture systems are superior to the terrestrial culture systems so far developed. Given the same inputs in energy or nutrients, we can expect from 4–20 times the yield from water than that from the adjoining land. To summarise why this is the case, we need only to note that:

- Water supply is constant for plant and animal growth in aquatic and semi-aquatic habitats.
- Plant nutrients in particular are available in soluble and easily assimilable form.
- Water and nutrient flow is a factor not represented in fields but is a critical boost to production in water.
- Water organisms (fish, shellfish) need waste little energy in movement; they are largely free of gravitational effects and weight disadvantages.
- Light, nutrient, and plants occupy a three-dimensional medium. There are complex edges, surfaces, and conditions developed as a result, and a variety of species to occupy these.
- The often rigid (and very recently monocultural) inhibitions of farmers are not as yet evident in water cultures, where the advantages of polyculture have been recognised from the beginning.
- Energies lost in cultivation are eliminated or reduced in aquatic systems, although management may need to be as skilled as it is for land crops.
- Impounded water has a great variety of products other than food; it flows on to energy production, recreation, irrigation systems, and transport.

Although all these reasons for greater yields with less inputs have always been there, dirt farmers generally have been slow to convert to aquacultures, and perhaps rightly so where a supporting infrastructure of storage, transport, and sales is lacking. But as these begin to develop, then it becomes worthwhile to abandon the production of the many surplus commodities now clogging world food markets in the developed

countries for the more stable and specialised products of aquaculture. Another reason to delay action has been to await the development of earthworking equipment, as it has taken some tribal groups thousands of years to develop terrace areas that we can now create in a few weeks or months of earthworking with machines.

There are even more commonsense reasons to develop aquacultures in areas where people are at risk from famine or flood, as ponding, water harvesting, or diversion cannot help but aid food production generally, and reduce the extremes of drought and flood, even in semi-arid areas. Fish production has long been combined with wet terrace crop, and now in many terraced areas the emphasis is changing from starch to protein production. Fish are replacing rice as a yield over large areas of abandoned padi in Indonesia, for a great gain in protein yield and a reduction in the fuels needed for food preparation (Pullin and Shehadeh, 1982).

Aquaculture, in short, is as much a stable future occupation of responsible societies as are forests, and between these two beneficial systems we will see a great reduction of the areas now given over to pastoralism and monocrop. Both these latter occupations are enterprises less and less favoured by society, and their products are an obvious risk from any point of view one cares to take (fiscal, health, social welfare, energy efficiency, or general landscape stability).

Aquaculture is no more valid as a high-energy-use monoculture than its historical predecessors—the large grain or single-crop farms. It is at its most enjoyable, convivial, and socially valuable when encountered as community taro-terrace culture, and at its most depressing as 100 ha intensive prawn or catfish farms. Thus, my attitude throughout is to stress sensible yield and procedure, but to discourage the "maximum yield of one species" outlook.

To design for greatest energy efficiency, we need to look at the whole pond landscape and configuration to aid aeration, heating, nutrient flow, and the numerous accessory benefits we can get from hydraulic technologies such as water wheels or ram pumps. We as designers need to apply the same methodologies to aquaculture as to any designed system. We can perhaps hold one idea (or species) at centre, and see how many of our designed features connect to and from it, and how many other benefits can be nested within the system, supplying as broad a range of needs for ourselves and other species as we can reasonably achieve. Wild duck do not annoy catfish, and pay their way in phosphatic fertilisers; there is no need to deprive them of islands, shallows, or nest boxes. **Figure 13.1** shows some elements of pond polycultures.

A pond can act as a mirror, a heat store, a run-off area, a cleanser of pollutants, a transport system, a fire barrier, a recreation asset, an energy storage, or an irrigation accessory. All this, and it is intrinsically productive as well. It presents a host of opportunities for aesthetic and functional placements of trees and plants; buildings and pond furniture such as jetties,

rafts, boats; and habitat for birds and wildlife, for beavers, water-rats and turtles amongst fringing vegetation, logs, stones, and hummocks.

Thus water (unless treated as a monoculture) has great potential for beneficial design, both in pond configuration and for species mixes. It is an exciting challenge to the innovative farmer, and I will try to give some design parameters with an emphasis on beneficial design for nutrients, plant control, multiple use, and thus higher yields. People rearing specific plant or animal species should spend some time researching the large amount of literature on those cultures.

Skills in pond management, and especially in integrating species and yields, or in judging and regulating water quality are hard-won. To gain in yields and not lose out in costs or disease is a difficult balancing act. We need to start small and build on successes, planning better strategies at each point. For the home-owner a set of tanks or a small pond is pleasurable and probably profitable, as labour is seldom assessed. Nor is such a pond anything but a recreational and relaxing place, but for those who wish to profit from aquaculture, planning and design, and monitoring and research, are essential to success at the intensive level. Those who are able to select and develop an extensive site (20 ha or much larger) can accept lower total yields with less costs and risks. It is a question of options, lifestyle, and preferred approach and aquaculture may well be the accessory enterprise (e.g. medicinal products from algae, or silkworm culture, or cabin fishing licenses) that turns a profit.

13.3

SOME FACTORS AFFECTING TOTAL USEFUL YIELDS

GENERAL CONSIDERATIONS

Figure 13.2.A and **B** illustrate the classical relationship between weight gains in a well-stocked pond, and the reduction in the numbers of fish in one brood or spawning over time.

When we buy an aquarium, fish retailers will tell us to stock 2 cm of fish per gallon, or 4 litres. When we go to a fish nursery for fingerlings, the grower will tell us to stock one 8 cm fish to every square metre of water *or* linear metre of pond edge, as in **Figure 13.3**.

These are approximate measures. What they mean is that a certain VOLUME, AREA, or EDGE of pond will supply so much oxygen and nutrient to the fish. Ponds are said to have a specific "carrying capacity". If we overstock or crowd water, fish cease to grow (or some may die) and the water is then said to be fully stocked. Growth rates of fish approximate **Figure 13.4.A**. We can

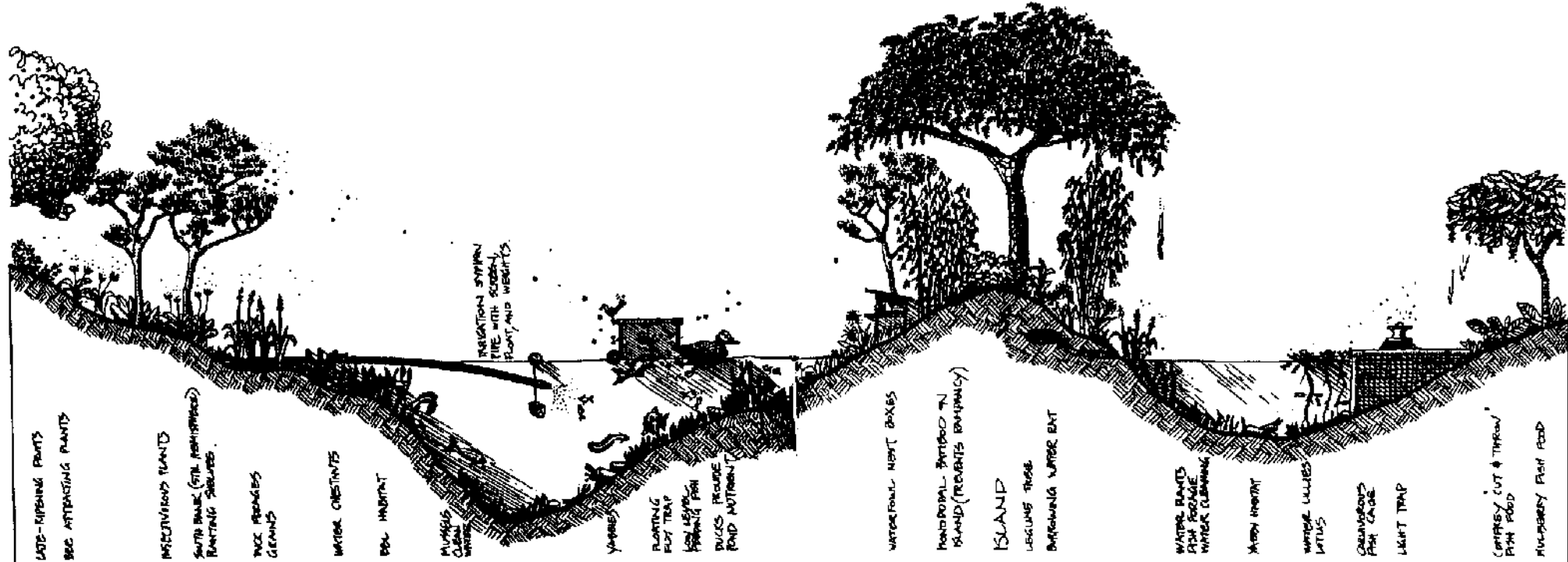

FIGURE 13.1
POND POLY CULTURES.
 Some typical pond elements and furnishings.

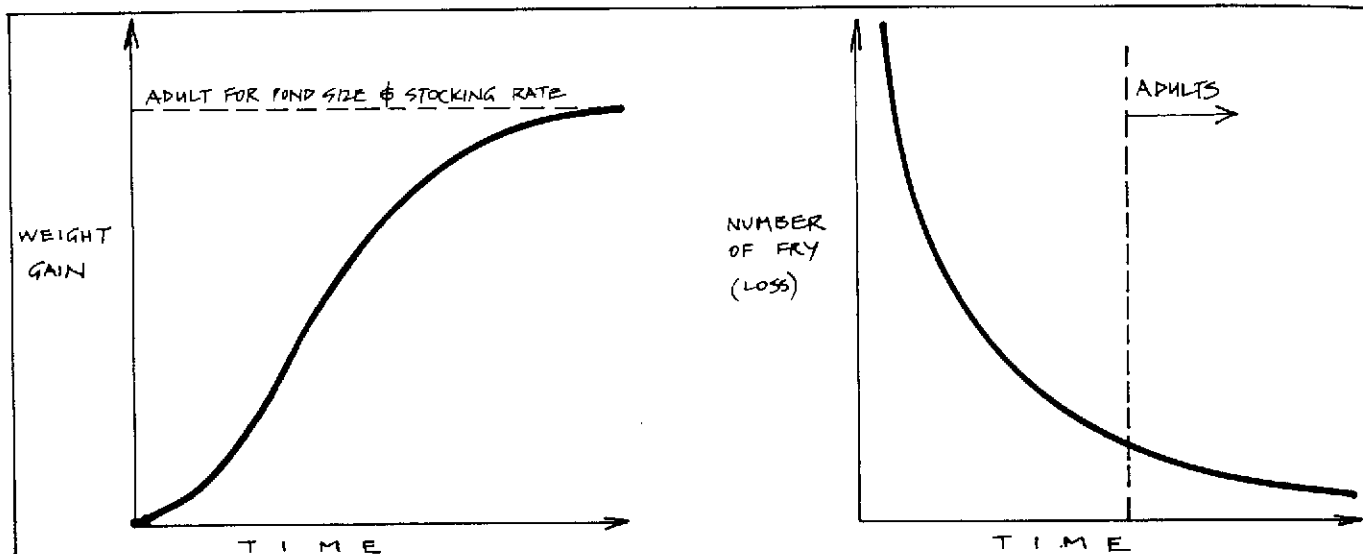

FIGURE 13.2
GENERAL CONSIDERATIONS AFFECTING YIELDS.
 General curves for weight/number relationships in wild fish populations; ponds can also lose 13–20% of fry.

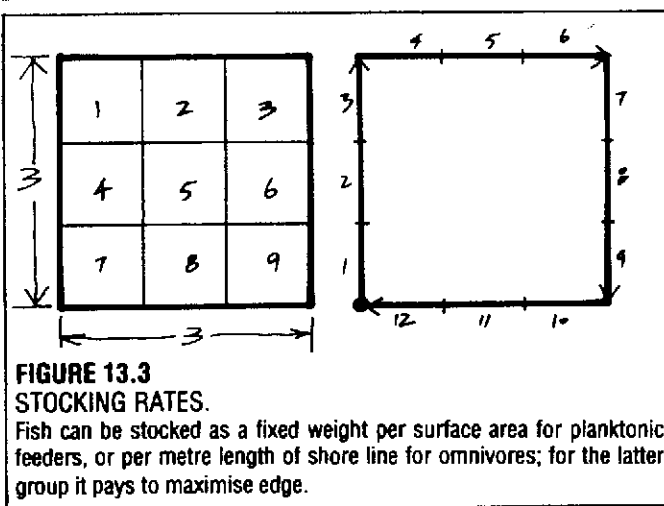

FIGURE 13.3
STOCKING RATES.
 Fish can be stocked as a fixed weight per surface area for planktonic feeders, or per metre length of shore line for omnivores; for the latter group it pays to maximise edge.

do several things to lift the carrying capacity of ponds, such as supplying more oxygen by stirring in air, more nutrient by supplying manures, and more edge by crenellating the edges.

The highest fish production recorded was achieved in a rapid canal flow of mainly sewage. The least productive pond would be a circular, warm, clear, concreted basin in a quiet valley.

We can (after a year of trial) establish the capacity of our own ponds. We will take a figure of 200 kg of fish/ha/year—a modest yield. We can grow this much fish every year as:

- 200 × 1 kg fish;
- 400 × 500 gram fish;
- 800 × 250 gram fish; or
- 1000 × 125 gram fish.

About 300 g is generally accepted as minimum pan-fish size. Below this size fish can be utilised by being dried or made into paste.

This gives as a good guide to stocking procedure, although by liming, manuring, providing high protein food, or aerating, we can lift the base productivity. It is the same as pasture management (except we expect

higher yields/ha). However, if our fish breed in the pond it soon becomes crowded, and we get a lot of little fish. If our fry die off quickly, we get too few fish and harvest a very few larger fish only.

A good way to overcome the breeding problem is to keep a few predatory fish in a cage or netted-off area of the pond. A good way to overcome fry loss is to rear these in small covered ponds, and release them as fingerlings or well-grown fish in order to give them a flying start. All this becomes routine after a while. There are a few other things to watch for: that predators are not too plentiful in the ponds, and that when harvesting we get *all* the fish out if possible, unless we have pond breeders continually culled by screened-off predators, when we can take some fish at all times. This is how natural ponds work.

We could go on to design for two factors:

- The mix of plant and animal species we would like to grow, or know will grow well together—our polyculture GUILD or association.
- The way we will lay out our ponds—CONFIGURATIONS.

EDGES, INTERFACES, AND GRADIENTS IN WATER

The edge effect in water is rather like that of land surfaces, but somewhat more pronounced. Anyone who goes fishing will vouch for the importance of shore-line, channel edge, weed-bed, or reef as productive environments. When stocking rates are estimated for fingerlings, the concepts of surface area or margin length are interchangeable, so that a relatively narrow drain will hold as many fish as a broadwater several times its surface area. Hence the sinuous canal is a rich environment for life forms compared with the circular or square pond, and much cheaper to construct in clay soils.

Maximum edge is assured by either swale, canal, or chinampa systems (Figure 13.33), which themselves

can be sinuous in a flat landscape. Even modest canals make for low-energy transportation, either as barge, flatboat, or float. Harvesting, too, can be simplified by skimming, floating, or trapping products in flow.

Edges occur, or can be produced, in great variety at the land/water interface. Forest, shrubbery, reed-bed, mudflat, gravel, marsh, ice and snow all produce unique habitat beside water surfaces, utilised by very different organisms. Amongst waterfowl, the preferences for a great variety of edge is as marked as it is amongst frogs; some preferring barren spits, and others forest and mulch. Quite small ponds can provide the essential nesting and refuge places for many bird and frog species.

The surface of water itself, because of the molecular tension there, supports striding, floating, and sucking organisms and has caused peculiar adaptations e.g. the fringed legs, buoyant seeds, and suctorial mouthparts of insect, plant, and tadpole respectively. The mud generates and hides a host of rooted, tunnel-making, ciliated, and burrowing or sliding lifeforms from mussels to larval lampreys, tubifex worms to tubers. As the pond surface is critical to gaseous exchange, so the mud surface is to nutrient retention, and it is there that phosphates and nitrogenous products are stored, and humic and faecal products accumulated as mulch. Anaerobic and reducing processes can take place within the close confines of the base mulch, while aeration takes place on the water surface or by the medium of plants, wind, or flow turbulence.

ENERGY CONSIDERATIONS

Our design strategies for aquaculture systems must hinge, as ever, on the energy costs of the system: its sustainability in terms of present and future resource costs. The actual excavation of ponds, if well planned and executed, creates a very durable resource, needing little but minor maintenance. Ponds and terraces hundreds (sometimes thousands) of years old are still in production.

Continuing costs, however, are associated with growing fish (or other aquatic organisms) and getting them to market. While both are to some extent site-dependent, the inputs of high quality food or nutrient as an integral part of planning is very much a design-dependent factor.

J. E. Bardach assesses FOOD, FERTILISER, and FUELS for water pumping as the main recurrent fish culture costs, and choice of species as critical to economic production (large carnivores being most expensive to rear). Well over 90% of the energy or monetary production costs are in the three factors mentioned. Labour and fuel energy are to some extent interchangeable, and while the utilisation of waste food is a saving, other pollutants are a cost (sometimes a terminal cost), as the water environment is very susceptible to biocides (*Proceedings of the 14th Pacific Science Congress, USSR, 1979*).

Water supply itself may become the limiting factor in

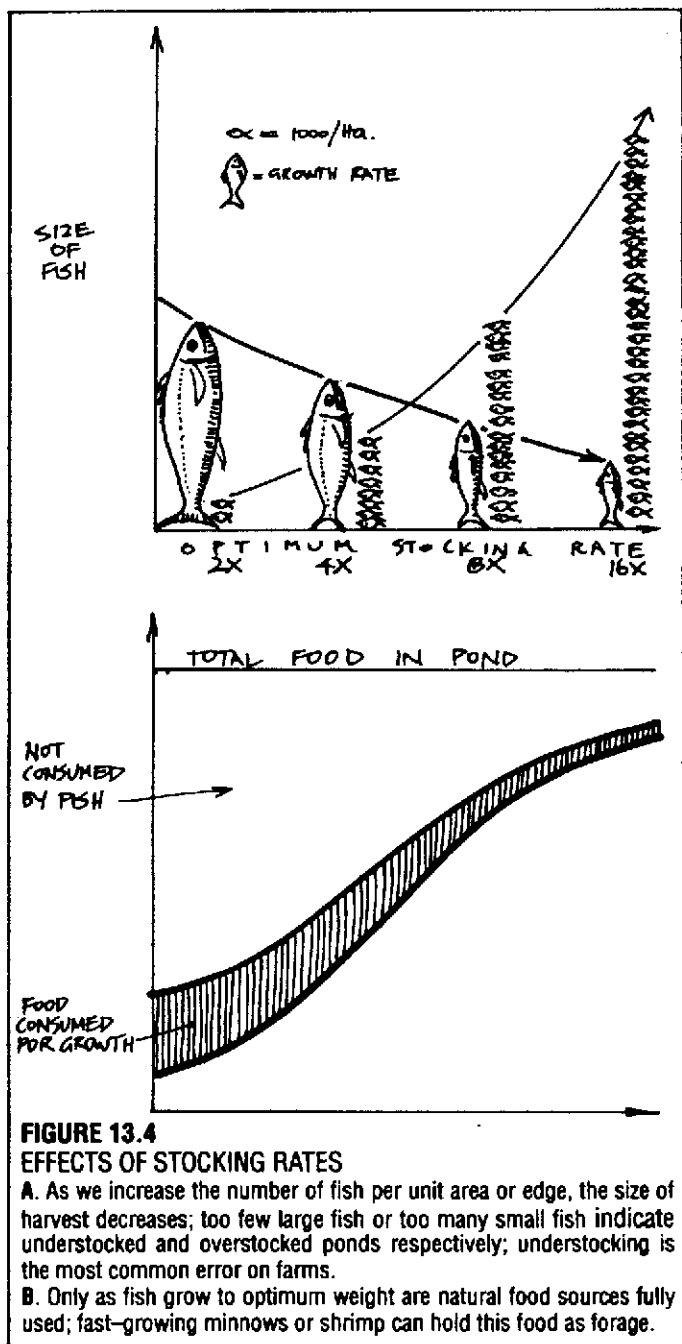

FIGURE 13.4
EFFECTS OF STOCKING RATES

A. As we increase the number of fish per unit area or edge, the size of harvest decreases; too few large fish or too many small fish indicate understocked and overstocked ponds respectively; understocking is the most common error on farms.

B. Only as fish grow to optimum weight are natural food sources fully used; fast-growing minnows or shrimp can hold this food as forage.

many areas, and recycling of wastes, well-selected polycultures, and careful attention to distances and market are seen as strategies needing attention. Bardach gives some current production costs as:

System	Production Costs	
	MJ/g	kcal/oz
Wild-caught lobster	3.22	21,801
Wild-caught shrimp	2.50	16,953
Intensive silo rearing of perch	2.24	15,167
Pond catfish (USA)	0.58	3,941
Pond polyculture of carp, mullet, Tilapia (Israel)	0.027	184
Sewage/stream culture of		

Such analyses show why distant-water fishing is collapsing in all sensible (or oil-conserving) countries, and why aquaculture is also likely to eclipse terrestrial production of protein, especially of intensive or feedlot systems. Today, food preferences are also favouring fish and aquatic products generally in health-conscious people, and when I heard recently of an Australian sugar-cane farmer who had converted his riverside canefields to extensive prawn ponds, I was certain that he would be in business long after the sugar refineries had closed down.

As for inherent conversion efficiency, an average figure for catfish, carp, mullet and so on would be 1.5-2.3 kg of high-value invertebrate food to 1 kg of fish flesh (excluding eels and large fish carnivores). While no terrestrial species reaches this sort of efficiency, chickens and some non-domesticated stock come close, at 3.5 or a ratio of 4:1, but beef, mutton, and pork are produced at double or treble the feed cost of fish. We shall see very close attention paid to these factors in the near future, or see the bankrupting of western agriculture as fossil fuel energy becomes unusable in terms of its pollutants.

In this section on yields, critical to pond management, we will restrict discussion to those ponds built specifically for fish and aquatic plant culture, and thus presume that they are from 0.5-2.6 m deep, with controlled inflow and outlets, which can be drained or pumped dry if necessary.

WATER QUALITY

All life processes, and decomposition in aerated waters, consume oxygen. A general level of 5 parts per million (ppm) is very satisfactory in ponds. At 1 ppm many fish species may die except for a select adapted group of air-breathers used in stagnant and weedy tropical still-ponds. Augusthy (1979) notes that snakeheads (*Ophiocephalus*), Singhi (*Heteropneustes*), the catfish *Clarias*, Mahi (*Notopterus*) and *Anabas* in India all have sacs, labyrinth organs, or special air chambers near the gills from which they can derive oxygen by breathing air. Other fish die in the anaerobic conditions of weedy

tropical shallows where the above species, the adapted lungfishes, and many minor species survive. Even derelict swampy ponds can yield 2,400 kg protein/ha/year if a polyculture of air-breathers is stocked, as three or more of the above species, or equally hardy species.

The fish in tropical still ponds combine well with the crop plant *Euryhale ferox*, a spiny floating plant of the water-lily family whose period of yield and harvest coincide with the maturation of the fish. The ponds used are 1-1.5 m deep, and as the fish help control malarial mosquitoes, there are multiple benefits. Seeds of *Euryhale* are marketed as a "popcorn" in India.

The integration of specialised warm-water aquacultures, or the stocking of oxygen-depleted waters is also dealt with by Pullin and Shehadeh (1982). They describe the modification of rice padi to accept specialised species assemblies. Fish refuges are made in padi either as a peripheral canal or as a sump to contain fish between flooding for crop. Figures 13.5 and 13.6.

Temperatures in rice pond water may reach 34°C, with optimum growth at 22-28°C. In Indonesia, fish are pan size at 10-12 weeks, while in cooler areas (Japan) it may take 2-3 years of summer seasons to produce pan-size fish in padi. Weedy padi is in part cleared by using (in Thailand and Malaysia) such species as *Trichogaster pectoralis*, *Clarias macrocephalus* or *C. batrachus* for weeds, *Ophiocephalus striatus* as a predator, and *Anabas testudineus*. With such combinations, the extra crop of fish in rice reaches 70-400 kg/ha/year (water 10-34°C). Good fish mixtures, e.g. *Helostoma temmincki* (35%),

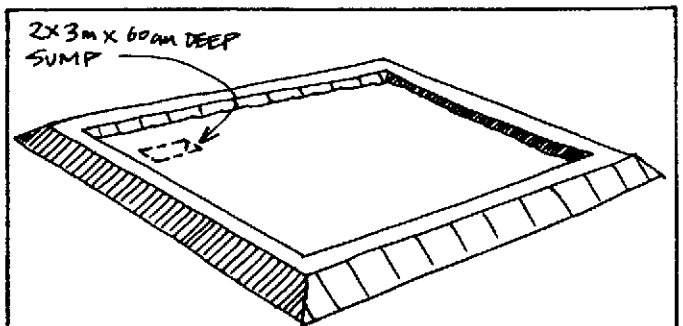
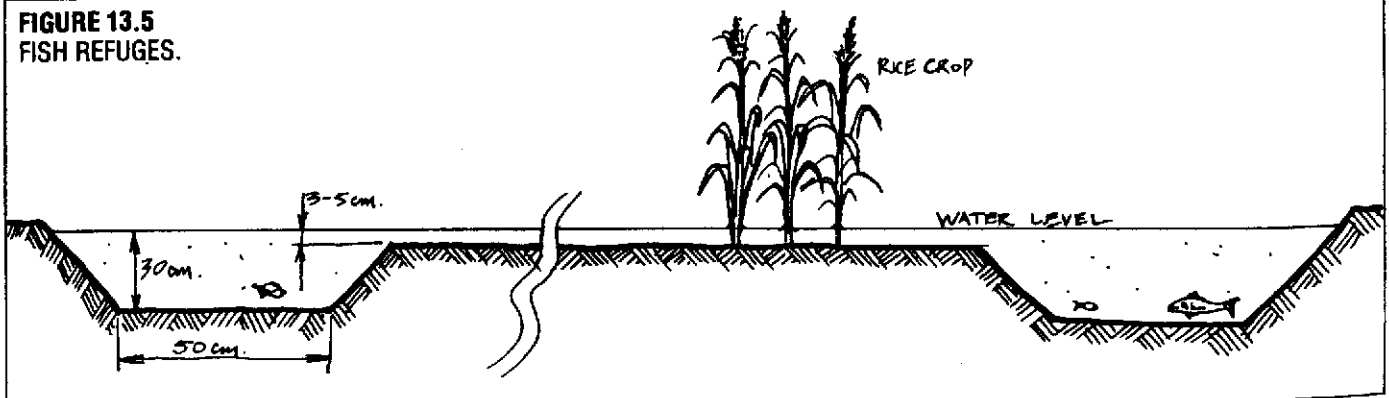

FIGURE 13.6 FISH REFUGES Deep "kettles" in a shallow pond can prevent fish dying in freezes, of excessive heat, or from accidental pond water loss; they also assist capture in draw-down conditions.

FIGURE 13.5 FISH REFUGES.



Osteochilus hasselti (15%), *Cyprinus carpio* (15%) and *Puntias gonionotus* (35%) give best yields. Alternatively, *Sarotherodon mossambicus* (50%), *Helostoma* (20%), *Osteochilus* (15%), *Puntias* (15%), and *Cyprinus carpio* (10%) are satisfactory. (The percentages are those of fry or fingerlings of these species.) Such polycultures are the result of a series of trials in padi, and all use weed-eating species and predators to control small fish. Crayfish (*Cambarus clarkii*) are also stocked in rice padi, a difficult and specialised pond system, but the fish yields there may add a critical element to nutrition.

We generally classify waters (and in particular sewage lagoons) as:

- **AEROBIC:** where oxygen is well-supplied by wind overturn, turbulent flow, aerators, or rapids, and where there is a light load of decaying organic material.

- **FACULATIVE:** (many swamps and weed-clogged ponds, secondary treatment sewage ponds) where the surface may be aerated, but where sediment or sludge collects in cold periods and the pond base becomes anaerobic (sulphur-fixing bacteria then decompose the sediments).

- **ANAEROBIC:** primary sewage ponds and over-fertilised shallows where there is a low (1 ppm or less) oxygen status.

As less oxygen can be dissolved in warm water than in cold water, and as the plants that produce oxygen by day consume it at night, there is a danger that healthy, weed-filled shallow ponds may develop severe oxygen deficiency on warm summer nights. If valuable fish stocks are held there, care should be taken to both reduce the level of wastes in the pond, and to arrange for automatic aeration at critically low levels. Such dangers are less in clearwater, cold, and open or flowing pond systems where this factor can sometimes be ignored. However, oxygen supply becomes a limiting factor in fish stock density at levels above 5000 kg/ha or thereabouts, and then oxygen as air bubbles needs to be supplied (Figure 13.7).

There are several commercial aerators on the market, and many can be solar-powered. But wherever water can be led from a head of 2 m or more, fountains, showers, and "Flowforms" (Figure 4.34) will oxygenate ponds. A considerable energy saving is achieved if only part of the pond is aerated at critical periods; fish will gather (kettle) there in times of need. For eels, this aerated section is built with a narrow pass to the main pond to prevent aerated water escaping.

It is often ideal to combine the feeding station with the oxygenated area so that food wastes are also oxidised and waste control simplified; some such arrangement is illustrated in Figure 13.8.

ACIDITY-ALKALINITY

Ponds in areas of peats, mangroves, cordgrass flats, samphires, and with water derived from heaths and granites, or siliceous soils, can be very acid in reaction (pH 4.0 or less), the acids being humic acids, tannins, and minor organic acids. In such cases, hydrogen

sulphide may also be released by ponded peats or swamps to create sulphuric acid. Peat stripping, mounding, fresh-water or rain leaching, and liming are all used to bring such ponds into production. Below the peats, and especially in basaltic soils, bluish clays produced under reducing conditions may occur (anaerobic or low pH). Fish will thrive in quite acid (natural) waters if calcium is available.

If we drain peats, the organic material dries out, oxidises, and releases carbon dioxide, gradually losing bulk so that some fields in fens slowly sink below drain or even sea level. Fens are derived from alkaline waters, bogs and peats from acidic waters. Marshes, fens, and bogs contain unique plant species and are rich wildlife habitats; hopefully, the era of fen drainage is drawing to a close, as the preservation of wetland habitat is a priority of all enlightened governments and landowners.

As pond pH is ideally 6.0–8.0 or even to 8.5, and only a few fish grow well below these levels (notably salmonids, which are also one of the few satisfactory fish in monocultures), most culture ponds are routinely limed when they are made. They are also regularly checked for pH levels, which are adjusted with unburnt lime after the initial burnt lime dressing. Thus, in the matter of site selection, it is of great advantage to site ponds where run-off from limestone areas can be ponded, or where natural pH levels are already high. Lethal limits for most fish are pH 3.7 (acid) and 10.5 (alkaline).

In practice, we can aim for a pH mosaic in ponds and pond series, as many valuable food organisms prefer soft (acid) water, while fish, molluscs, and freshwater lobsters and prawns prefer hard (alkaline) waters. Crushed dolomite, marble chips, hard limestone gravels, and oyster or mussel shells give a slow release of calcium in tanks, small ponds, intake filter systems, and the upper sections of canal systems.

There is an interaction with pH, respiration, and plant density; pH may rise at night or in clogged coastal waters with *Chara* and other algal forms, or fall as peats form and anaerobic conditions develop.

Not all organisms appreciate hard water (calcium rich), and if accessory ponds are to be developed to breed soft-water fish, forages, or main crop, only organic acids are used, chiefly hydrochloric, humic, or phosphoric acids. The same effect can be sometimes produced by using a peat or dense moss/peat area to filter water, by laying peats on the pond base, and by creating a swampy condition around the culture pond.

MUD, SILT, HUMUS, AND WASTE REMOVAL

Wastes of any nature in ponds reduce water quality if they occur in excess, or if they occur as dead material. We can in some ways distinguish rotting wastes from fertilisers, as the latter need not create excessive growth if herbivorous fish, nutria (a large aquatic rodent), or shrimp are available to eat the detritus or weeds that would otherwise die and create anaerobic conditions.

There is little or no problem in flowing canals or well-aerated ponds, but still ponds need regular monitoring for waste removal. This is most handily achieved by draining and liming the pond and taking off a season of dryland crop (clover, fenugreek) before flooding.

Where ponds cannot be drained, care should be taken

to keep at least one bank clear of trees for dredging or bucket removal of muck, which is traditionally layered with green crop for compost in Asia. In padi and terrace, 2-5 cm of mulch is retained over the clay base for cropping. All terrace can be drained to a dryland cycle.

In deeper non-draining reservoirs, recourse must be

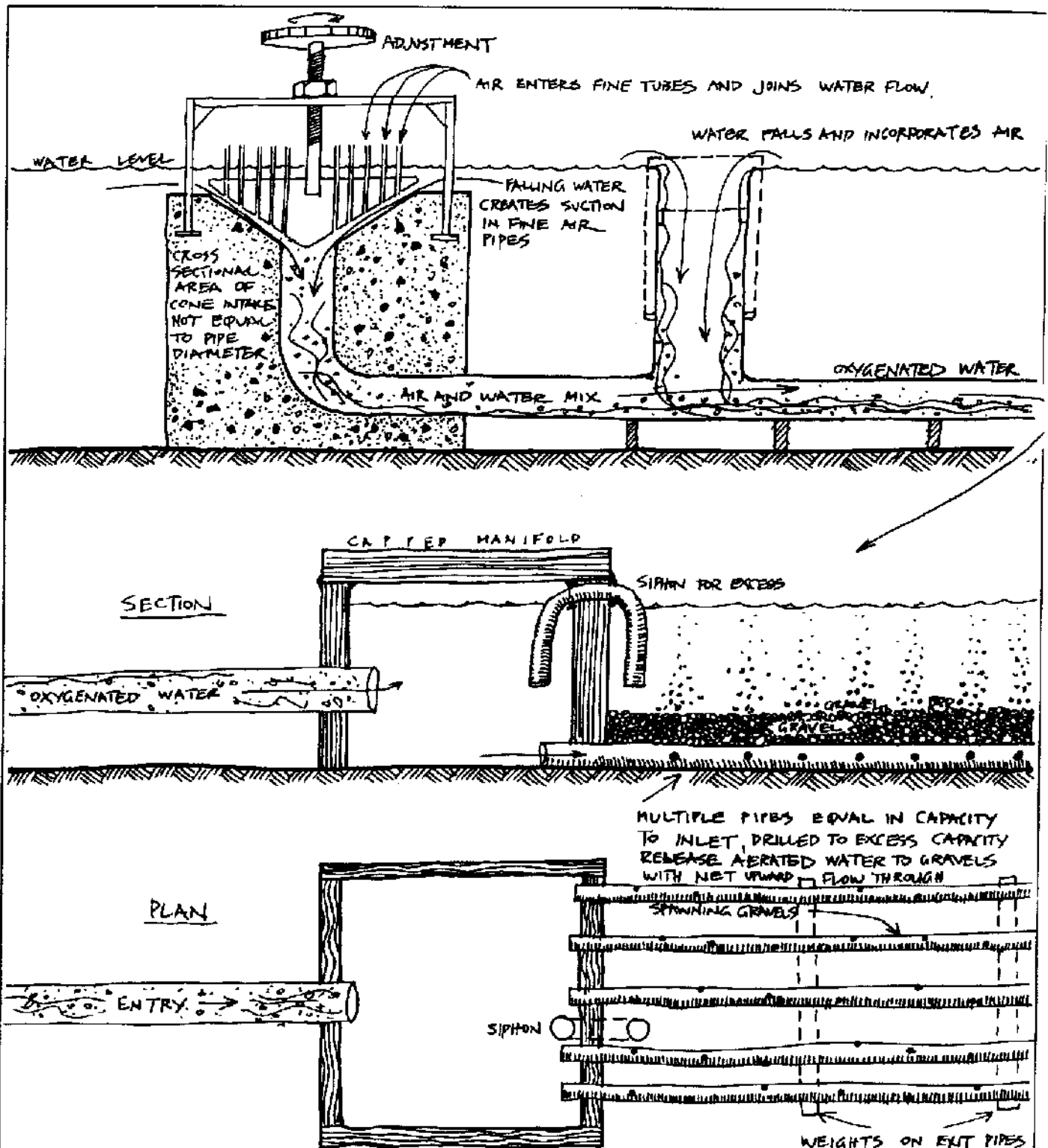

FIGURE 13.7
CONE AERATOR

A simple "trompe" or cone aerator in flow, with oxygenated water piped to refuges in ponds prevents fish losses due to anoxic conditions, or

assists hatching of trout eggs in gravels.

made to a jet pump, which can be used as a vacuum cleaner to pump detritus out of the reservoir (and which will remove soils up to gravel size). This can be deposited near the pond as adjacent retaining walls or as low islands and causeways so that silt settles out, and the water flows back to the pond free of detritus. The pumps are typically raft-mounted and liquid fuel powered (Figure 13.9).

FERTILISERS

After testing waters, it is likely that minor elements and phosphates may be needed. Caution should be observed in adding nitrates to waters where natural manures are used, or in desert basins where water nitrate levels can be high. Be careful also in using boron-containing detergents, or any biocides not recommended for fish. (Salt, copper sulphate, weak formalin and some antibiotics are used to control diseases or parasites without lasting harm.)

Pig, duck, and second-stage sewage are all used in fish ponds, and any bird or animal manures are useful. We can distinguish between heavily fertilised ponds intended for intensive algal growth to feed milkfish or prawns, ponds where higher vegetation is encouraged to feed grass carp or *Tilapia*, and almost clear-water ponds for bass, perch, and salmonids (trout). That is, we adjust fertiliser to fish food preferences, and in any polyculture a larger proportion of fish can be algal or plant feeders (5:1 herbivore: predator is a usual ratio).

Phosphatic rock and granite dust can be used to supply lime once selected nutrient levels have been achieved. The stocking of waterfowl, the erection of perches for gulls, ducks, and land birds, the siting of pigeon lofts, pig pens, or chicken roosts over water, the erection of martin and swift nest sites in water (or bat roosts in Holland) are all devices to bring in complex plant nutrients to ponds (Figure 13.10).

Phosphates, potash, and minor elements are fixed and held in water in a matter of 12-14 hours, or 3-4

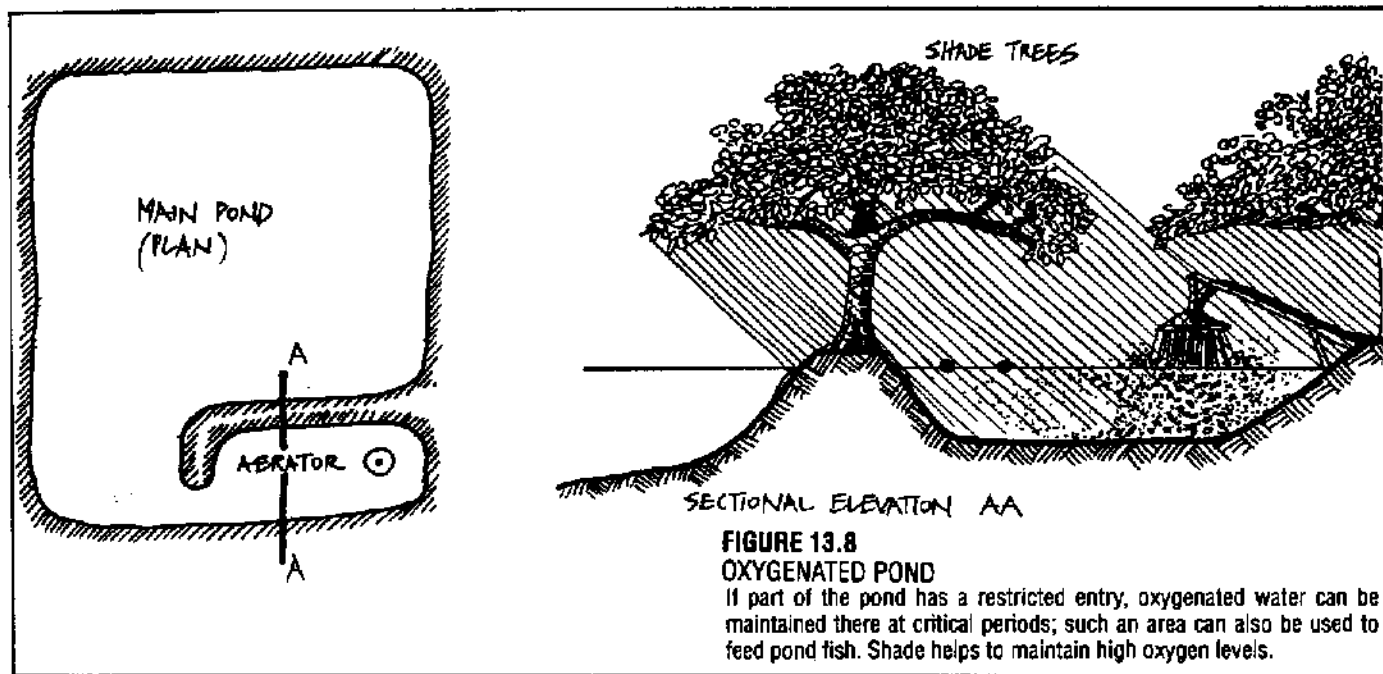

FIGURE 13.8
OXYGENATED POND

If part of the pond has a restricted entry, oxygenated water can be maintained there at critical periods; such an area can also be used to feed pond fish. Shade helps to maintain high oxygen levels.

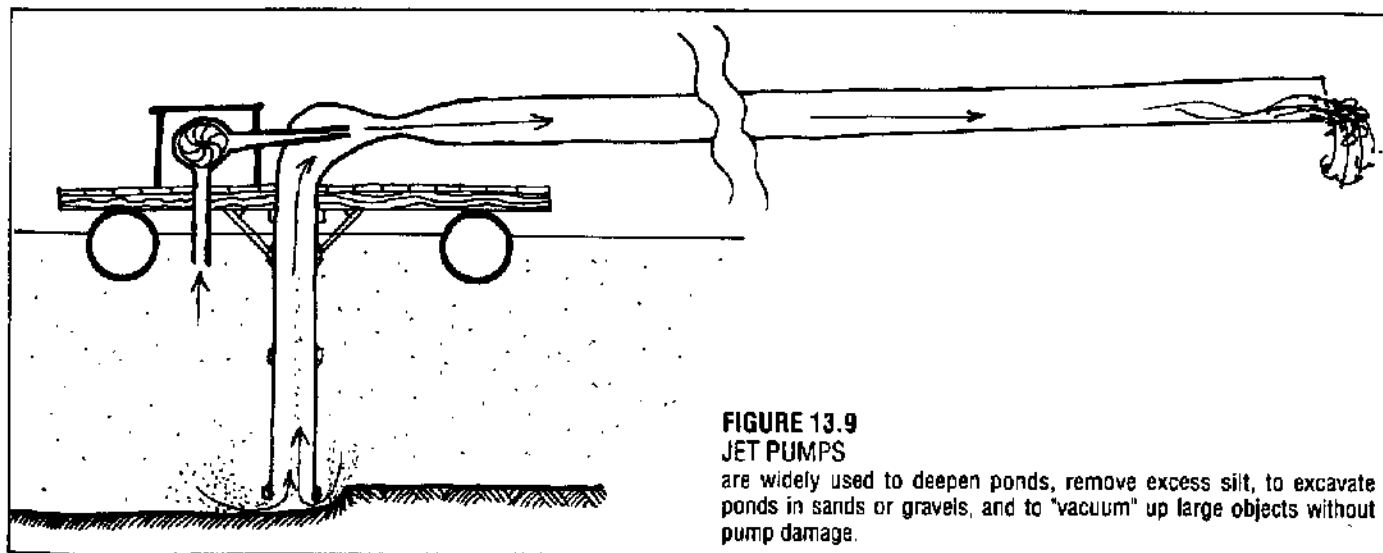

FIGURE 13.9
JET PUMPS

are widely used to deepen ponds, remove excess silt, to excavate ponds in sands or gravels, and to "vacuum" up large objects without pump damage.

days (in oceans), and can be added to quiet marine bays as well as to ponds. Mussels in particular convey phosphates to the mud via their anal siphons, and are the major phosphate reservoir of ponds or rivers. As even modestly fertilised ponds can alter the yield by factors of from 2 to 10 times, attention to nutrient supply is a critical strategy.

As fertiliser uptake is so rapid, we need to stock fertile ponds with shrimp or large numbers of small forage fish while our fingerling pan fish are growing, or we lose yields. Too-high nitrate status can be filtered via a forage food pond of crustaceans, or through reed beds. We rely on land crop downstream to remove excess nutrient from pond overflow. In flow-on ponds, we can usually achieve a doubling in yield of species such as melons, tomatoes, or fuel forests, so that fish ponds are a key feature in raising land-based yields. Swingle (1966) records a difference in yield for mussels (in the same pond) of from 52.8 kg unfertilised to 1,012 kg fertilised (whole weight; meats are 35% of total) so that the fertiliser factor, well-managed, is a critical yield strategy.

SHELTER AND REFUGES

Stacks of pots, pipes, tyres, and bundles of rope, reeds, or brush can have a decisive yield effect on predation losses of young fish, crayfish, and species subject to predation by their fellows. Crab and crayfish culture, in particular, benefits from such refuges. Similarly, forage species in ponds need breeding refuges to persist. Figures are hard to come by, but yield increases of 10–30% are recorded for crustaceans, and 20–100% for forage fish protected by shallows or weedy areas. Mortality of young and fry are always greater in ponds of simple design and without escapements. Cage culture is not only in itself a high-yield system, but enables the strategic separation of predator and prey (or adults and juveniles).

TEMPERATURES

Within water, surfaces and gradients develop from the effects of heat, solutes, particles, or stream flow. These are utilised differently by different species, so that a river or lagoon opening by a shallow bar to the sea may have saltwater fish at depth and freshwater species on the upper section, and either colder forms at depth or (in icy winters), warm refuges at depth for fish to kettle (crowd in until warmer conditions develop).

The interface between cold and hot water is termed a THERMOCLINE and between salt and freshwater a HALOCLINE; such boundaries can be abrupt transitions if no turbulent flow exists. Where no pronounced surface separation occurs between hot and cold or salt and fresh, gradients develop, especially where wind overturn or current flow is a factor. Fish, molluscs, and plants have specific niches in such gradients, and may move with tide or current to adjust to their specific needs.

At or about 21°C (70°F) we make a categorical difference between *coldwater* fish, to which such temperatures are lethal or debilitary; and *tropical* fish, which suffer cold stress or will not breed below this point. A few common fish (*Gambusia*, the mosquito-eating fish) are temperate tolerant or EURYTHERMAL (1–36°C), but optimum feeding and spawning conditions for coldwater fish are around 15–18°C, and for tropicals 20–25°C. Rainbow trout will die if kept for long periods above 14°C, while *Tilapia* die below 12°C.

Higher temperatures certainly stimulate plant growth and algae production, or general turnover, and it is advantageous to be able to keep winter temperatures at optimum for the species mix selected. We may achieve this in any of a number of ways:

- By including a solar pond (heater) in any other pond (Figure 13.10), or as an accessory to a pond.
- Using waste-heated water from industries such as power stations, salt works, or food processing plants.

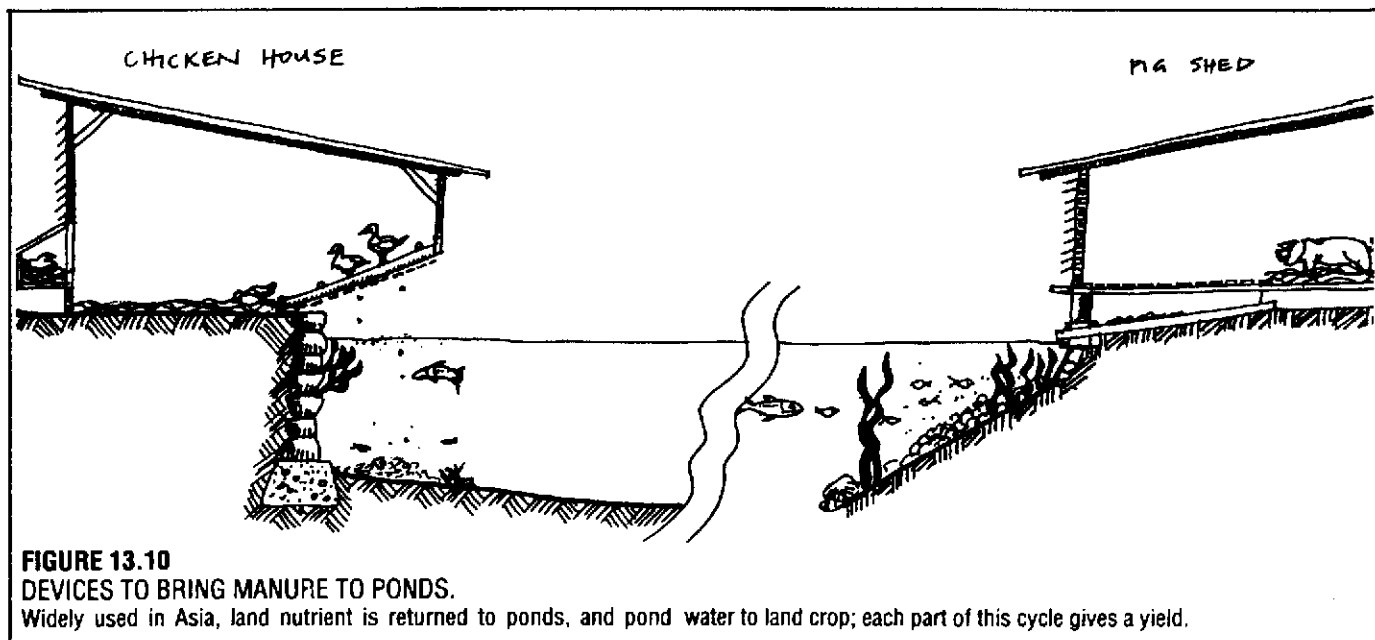

FIGURE 13.10
DEVICES TO BRING MANURE TO PONDS.

Widely used in Asia, land nutrient is returned to ponds, and pond water to land crop; each part of this cycle gives a yield.

- Glazing over canals, refuges, or building raft columns insulated from the earth and colder waters, as heat refuges for cold-tender fish (Figure 13.27).

- Providing heat refuges as earth-covered pipes, shaded canals, or kettles of 5 m or so deep in shallow ponds.

Adapted local fish generally need little assistance to survive, but selected stock or exotic fish can require refuges for a week or more of extreme weather. Where no local heat sources are found, pond water pumped over a dark roof, rocks, or cement areas very efficiently extracts solar heat at close to 100% efficiency. Sections of bitumen road can be used in this way, or can have pipes buried under them at 1–5 cm depth as thermal siphoning systems for pond heating in winter. Glasshouses to hold small ponds, compost heat, collectors and trough reflectors are all strategies to maintain heat for higher production. Gains in yields of from 2 to 5 times are common where ponds are regulated to optimise feeding activity and food growth.

Heating devices can raise water levels 3°C or more (glasshouses), and although this doesn't sound spectacular, it can extend the growing periods of fish by 30–40% (*New Scientist*, 30 June, 1977). Collectors, of course, depend on the area of collection relative to the pond. Heat pumps from canals can deliver heat to ponds in the same way, shortening maturation times of fish or plants to about one-third that of cool, open pond areas. Passive collector systems are ideal, and cheap to run by a system of thermosiphon and non-return valves if heat sources are placed below the pond to be heated, as in Figure 13.11.

SALINITY

Fresh water contains very little salt. Coastal lagoons usually contain 7–9 parts per thousand (ppt); few frogs can breed above this concentration. Seven ppt is the safe upper limit for human consumption. Brackish water is detectably salty at 11–12 ppt, and oysters may be found from this concentration on. These are the salinities of estuaries and brackish waters. At about 27 ppt many shellfish and marine organisms are found,

and the sea itself is at 33–35 ppt.

In areas of high evaporation and restricted tide flow, hyper-saline conditions can develop. Marine organisms seldom spawn above 40–50 ppt, and if fish and crabs do occur there, it is often as one-sex populations, one-age groups, or gigantic forms. Many desert organisms and some desert fish can live to 60 ppt salt.

Fish which live all their lives in freshwater rarely do well above 8 ppt. A great many fish and shrimp, however, migrate fresh to salt and vice versa, some spawning in rivers (trout), some in the sea (eels). Because of their wide range of tolerances, these groups are called *euryhaline*. Many mullet, salmonids, and some oysters and shrimp can be kept in fresh to saline waters. Saltwater fish rarely tolerate salinity below 28 ppt.

Changes in salinity may kill pond fish not adapted to estuaries; salt or freshwater is also used to kill external parasites and disease in fish. Estuaries and brackish waters generally contain more fish species than the river itself, or the sea offshore, although the sea is far richer in molluscs and crustaceans.

In estuaries and lagoons, a halocline (salt-fresh surface) can develop, with the denser salt water at depth, or pushing up under the surface of an estuary as a tidal wedge below the fresh water. Haloclines are common in deep lagoons or rivers with barways. Marine forms live at depth, and freshwater fish at the surface, sometimes for many miles inland. As tides push into and recede from large river estuaries, extreme changes in temperature (especially in winter) and salinity can occur, so that at low tide a mud-living shellfish can be in fresh water at 4°C, and at high tide in seawater at 20°C. Many species in this zone burrow, migrate with the tide, or return to the river at high tide.

Thus, salinity is a species-specific factor rather like temperature, and salinity regulation just as much a matter of concern as temperature regulation. We seldom get sudden increases in salts in ponds, but a hazard of marine pond culture of the inshore tropics is torrential rain. Even with flood diversion drains, the sea itself may become so dilute as to kill lobsters, prawns, or milkfish in marine impoundments.

Very rich brackish-water polycultures of algae, crabs, mullet, sea bass, milkfish, eels, and trout are possible in

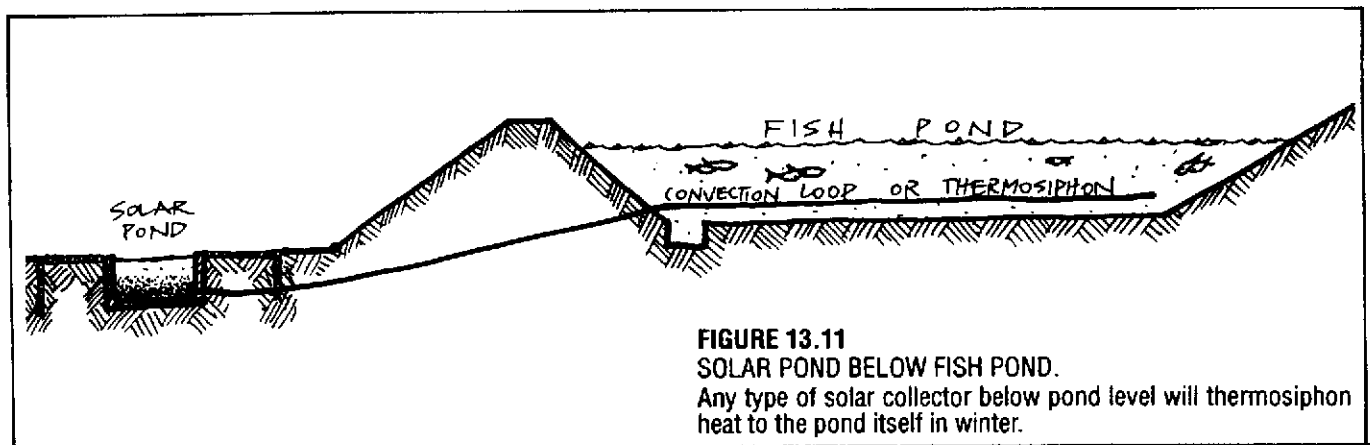

FIGURE 13.11

SOLAR POND BELOW FISH POND.

Any type of solar collector below pond level will thermosiphon heat to the pond itself in winter.

estuarine (and desert or atoll) impoundments. Salinity is controlled by flood by-pass canals and sea weirs or locks. Fish are graded to suit pond conditions, or a salinity mosaic is established to mix species as diverse as carp and mullet. Where tide and streams interact, as in some Hawaiian fish ponds, both freshwater and marine species can be cultivated in one pond series.

Brief immersion in salt water is an old remedy for reducing fungal disease in freshwater fish.

FLOW

Even very modest flow stimulates gaseous exchange, photosynthesis, and therefore growth in plants up to a level where mechanical damage by turbulence can occur. Flow in food-rich waters increases yields far beyond that possible in still ponds, but most streams do not have heavy natural food yields unless they are fertilised or manured, and then a problem of stream clogging with aquatic weeds can occur, necessitating control by nutria, grass carp (White Amur carp) or another efficient herbivore. The other great advantage of flow is in the oxygenation of water, either via a "Flowform", aerator (Figure 13.7), or series of rippled falls or weirs in the stream bed.

The balance we would like to achieve in flow is to maintain sufficient flow for aeration and vigorous plant growth, but to restrict flow to a level where we do not suffer rapid leaching of soluble nutrients and calcium. For this reason we often pipe or channel flow to fish and terrace areas rather than working in the stream itself, where floods can affect us in several obviously deleterious ways ranging from fish losses to physical damage to structures, and a wipe-out of balanced fertiliser in waters. In ponds, we may hold back flow for a few days to allow fertiliser uptake, then resume flow for aeration.

13.4

CHOICE OF FISH SPECIES (VARIETIES, FOOD, HEALTH) AND FACTORS IN YIELD

SELECTION FOR EFFICIENT FOOD CONVERSION

Fish low on the trophic scale, those eating plankton, algae, or vegetation, are produced at higher yields. For example (if ponds used are fertilised) we can reasonably expect a maximum production/ha/year of:

Bass (a predator)	196 kg
Catfish (an omnivore)	370 kg
Bluegill (an insectivore)	560 kg
Java <i>Tilapia</i> (a plankton feeder)....	1,612 kg

(Swingle, 1966)

Obviously, if our choice was for one species, it would be for *Tilapia*. However, real-life tests must be carried out, as some of these neat orders of yield can be reversed if forage is supplied or pelleted food provided. Each trial must be made under the food management schedule proposed, because fish can harvest different

foods more or less efficiently. For example, if we add pelleted food, the yields are:

Catfish.....	2,688 kg
Bluegill.....	896 kg

(Reversing the order found in fertilised ponds only.)

Yields in this case depend on the food type.

Having selected a set of *species* in this way, what can we do about variation within species?

If we stock a high density of fingerlings of one size (5000–10,000/ha), and feed these fish, then we can net out the pond after a few weeks or months and select only the larger fish as brood stock, or as an "efficient" variety. After only one year of selection, bass fingerlings from such fast-growing strains converted food at an efficiency of 3.4:1, whereas unselected fish converted at from 7.3:1 average, and the worst cases at 24.2:1—a range of metabolic efficiency greater than the differences *between* species! (Swingle, 1966).

In ponds, and particularly where we raise fish in hatcheries, or where the water supply is free of fish and their diseases, we can both select and ensure stock free of external parasites and internal pathogens, by close attention to cleansing eggs and fry.

The results in ponds can be to double the number of fish growing to maturity or marketable size. Thus, the three factors above give guidelines to raising fish yields by several orders of magnitude. Eels are usually caught at sea (as elvers) for this reason.

Yield increase of from 40–200% are achieved in a pond by the judicious admixture of species. Some examples from Swingle (1966) are given here, and more will be given as examples of traditional systems later. However, it is a sensible initial approach to try to work out what sort of functions any species in a polyculture should serve. Some of these are:

RAPID UPTAKE OF NUTRIENTS

This serves two purposes: the first to fix any fertilisers we may add, and the second to convert wastes produced by dense stocking of other fish. Ideal species are those that breed in ponds, grow fast, and convert decomposers to food. Better still if they form a group which doesn't fly off (as insects do) or migrate out of the pond (like frogs). They then remain as fish food for the young pan fish which are slowly growing up.

Ideal selections are:

- SHRIMP, especially if provided with vegetation or brush bundles for cover; also small crabs, scuds (amphipods), and molluscs.
- MINNOWS or small free-breeding fish; again, provided with cover and screens as the large fish grow, or with shallow water refuges.

Examples (kg/ha/year) Ponds fertilised:

- Bluegill on their own (at 3,900/ha).186.4 kg
- Bluegill with *Gambusia* fish3,449.4 kg (yield increase of 18 times).

OR

- Bluegill and bass (a polyculture; at 3,750 and 134 fish/ha respectively).....282.6 kg

- Bluegill, bass, and fathead minnows.....470.6 kg (a 66% increase on the above).

Swingle hypothesizes that 50% of a pond devoted to cover or special habitat for small forage species would not reduce the total yield of pan fish, much as 30% tree shelter in fields does not reduce the weight yield of livestock. It is therefore important to plan the shallows of such ponds.

Minnows have increased yields for trout, salmon, *Tilapia*, bass, bluegill, mullet and so on. Our trials should resolve *which* minnows, and how we provide cover or escapement for them. Prawns benefit from brine-shrimp (*Artemia*) mixtures, and most fish benefit from shrimp in ponds. A second reason for adding a pond species is:

WATER QUALITY

This refers mainly to food waste uptake. Species successfully used are fresh or brackish-water mussels, and plants. As plants also add to the daytime oxygenation, and mussels also actively circulate water, both have a dual effect. Their yields are additive to the fish yields, and increase fish yields while they allow higher stocking rates, e.g.

Fish alone316.6 kg

Fish plus mussels.....464.4 kg

(plus 864 kg of mussel meat. We could add 600 kg of water chestnut if plants were also used. Algae activates bacteria and improves the oxygen content of water, as do higher plants).

CULLING OF EXCESS SMALL STOCK (PREDATION)

Small numbers of predators (at any level: fish, turtles, or mammals that eat some of the smaller fish) to prevent over-stocking are essential for a well-maintained growth to market size. Cormorants, otters, or other efficient predators serve this function in large lakes and rivers, but we need better-regulated systems in ponds. Bass, soft-shelled tortoises, snakeheads and pike are just some of the species used to control breeding in carp and bluegill. For example (per ha/year or cycle);

Bluegill alone316.6 kg

Bluegill plus bass.....484.4 kg.

Increase in yields are modest, of the order of 30-50%, but the predators often fetch higher prices than the prey species, so that the fiscal economics of yields are greater than the figures of weight increase may suggest.

UTILISATION OF DIFFERENT FOODS

This is where a greater potential lies. It is not atypical to find carp ponds with any of the above species mixes, plus 3-7 varieties of carp, all chosen for their distinct food preferences. Even a few additional species help. Examples are (yields per hectare):

Common carp alone (2,500/ha)314 kg

Buffalo fish alone (2,500/ha)896 kg

Buffalo fish (2,500) plus 250 carp/ha ...925 kg (300% increase on carp alone)

OR

Channel catfish alone (4,400)1,400 kg/ha

Channel catfish (4,400) plus 1,250 *Tilapia* 1,834 kg/ha

Yields are greater for more species added. In the latter case, the food conversion efficiency of catfish (1.7:1) was unaffected by the *Tilapia*; there was no stunting of one of the species by the addition of another. Similarly, the addition of pangas (*Pangasia*) to ponds rich in molluscs does not affect yields of carp or *Tilapia*, nor their feeding efficiency, but adds to yield. It is important to choose fish of different food preferences for maximum yield from polycultures.

THE CONTROL OF BREEDING IN FISH PONDS

We can only talk about optimum stocking rates if we can count on the number of fish in the pond remaining fairly constant. This is not the case where fast-growing pond fish kept beyond 3-7 months can breed in the pond itself. Fish culturists avoid this sort of overstocking by a variety of methods suited to species, technology, and site. Some of the systems used are:

- by stocking one sex or sterile hybrid fish. Hybridisation in *Tilapia* species give sterile males or one-sex stock fish. "Counts in" are "counts out" less mortality (allow fry losses of 30-40%).

- by crowding fish. Brown bullhead cease to breed above 7,500 fish per hectare (Swingle, 1966). Other species are also inhibited, probably by crowding stress or waste accumulation.

- timing. Fish added and harvested in spring-summer fast-growing conditions can be taken before, or at the point of, breeding, and the pond then restocked.

- predation. Predators with, or screened off from, the breeding fish can reduce their numbers to an optimum level; predator fish yields are a bonus.

- lack of substrate. Ponds lacking the right substrate or niche for breeders will thereby prevent eggs being laid or surviving. Fish will often not spawn if substrate is not provided.

- lack of habitat. Fish that breed in fresh, saline, or seawater will not breed if kept in (or transferred to) a different habitat. This applies to mullet, eels, trout, milkfish, prawns, and shrimp. A lesser effect is that of suitable water temperature. A rise or fall in water level is crucial to carp and mullet species that breed on flooded grasses or reeds.

- hormonal manipulation. Pituitary extract is widely used to induce spawning, and trials of other hormones are being made to inhibit spawning (*Puntius* is a fish used for pituitary extract).

FISH LOSSES FROM OTHER CAUSES

Losses in ponds can occur from theft, very efficient

predation by numerous or large predators, by diseases or parasites carried in by stream water, as a result of extreme heat or cold, and by accidental draining of the pond. There are obvious precautions to take, involving fences, locks, automatic signalling or pumping systems, and predator control. The fish culturist needs to live close to or overlooking the pond area for all these reasons.

Losses due to sudden heavy rains in estuarine ponds may be unavoidable in shrimp culture, but flood by-passes are a normal precaution in freshwater pond culture. As fish density increases, the upper limits to yield may be determined by pond water quality and a set of pathogens encouraged by crowding. This latter factor may be the ultimate barrier to yields, as it is in land livestock.

STOCKING RATES

This is a critical factor. Some of the stocking rates are given in the above examples, and they range from 200–300 fish/ha for a predator to 5,000–10,000 fish/ha for plankton eaters and detritus feeders like *Tilapia* or carp. That is, rates depend on the ability of the fish to stand crowding, find food, and use food efficiently.

Very low stocking rates produce low yields of large fish; thus beware of early trials which show a low yield if fish were stocked (alone) at less than 1000/ha. Too dense a rate will result in a larger proportion of unmarketable small fish. We can tolerate some 5–10% of stunted fish, but no more than that. Examples of such factors are:

RATE/HA	YIELD (KG)	MARKETABLE (%)
TILAPIA (allowing a 200 g fish as marketable)		
5,000	316.2	97.5
10,000	403.2	50.4
BUFFALOFISH (allowing an average of 250 grams as marketable)		
300	152 averaging 636 g /fish.	
600	273.5 averaging 603 g /fish.	
1,080	656.5 averaging 590 g /fish.	

From the above data, we have exceeded the sensible stocking rate for *Tilapia*, and not yet reached the rate that would reduce "marketable size" for buffalofish. Incidentally, *Tilapia* at below market size took 7 months more to reach the limit of 200 g achieved by the fast growers in 6 months! (Swingle, 1966). There is a selection factor involved here, and we can select from the fast growers for future brood fish.

Management helps, in that one heavy stocking can be sold off as they reach market size, or a predator can be added to cull the smaller fish. However, we need a good measure of optimum stocking rate for every species used, and this can only be achieved by experiment. Similarly, we need to decide the rates at which polycultures of fish are stocked by assessing the

proportion of too-small fish in any one species in the polyculture at harvest time.

In Fertilised Ponds

Fish stocked as fingerlings lose a lot of food unless a fast-breeding forage fish utilises it. Fingerling numbers fall off rapidly as they grow (in predatory fish, by cannibalism), but with supplementary food, much larger numbers can be stocked, saved, and therefore can use the natural foods better. Also, they reach market size much faster, e.g. with brown bullhead (all fish fed while water was above 16°C). See Table 13.2.

TABLE 13.2
STOCKING RATES IN FERTILISED PONDS

NO. STOCKED (per hectare)	FISH PRODUCED kilograms
Tilapia alone	
2,500	631.7
5,000	840.1
7,500	1,011.8*
15,000	1,387.0
Tilapia with catfish (all fish fed at 16°C plus)	
560	302
2,500	1,076.7
5,000	1,709.7
7,500	2,646.6

*Above this rate no spawning occurred in the pond

13.5

FISH POND CONFIGURATIONS AND FOOD SUPPLY

POND CONSTRUCTION

Pond or terrace construction on the small scale (to 0.2 ha) can be hand-tuned for drainage, levelling, and spillways, but larger constructions arise either as a result of many years of hand labour, and are then built to suit the landscape, or are built in modern times by survey and machine. Still-ponds have an essential need for a compact clay base, while tidal and diversion ponds can tolerate some losses from seepage.

New ponds need careful assessment and survey for factors of evaporation, seepage, water sources, sealing, and stability. As few fish ponds exceed 2–3 m in depth, earth, clay, and stone-faced earth walls suffice to hold water (Figure 13.12). Many trout ponds and fast-flow channels are concrete-sealed in intensive systems, but by far the most productive, common and economical ponds are clay-based. Ponds can evolve from low-walled padi to deeper permanent or seasonal fish systems, or have a dry cycle in summer seasons.

The chapter on water deals with the essentials of construction of dams. The clay core or seal is effective in miniature in fish ponds. A build-up of organic mulch and algae in ponds assists sealing, so that even ponds

in sandy loams may gradually evolve to reduce water losses. Long uncompacted canals, however, need good clay bases to prevent water loss in transit, although seepages are not necessarily lost to production if land crop and trees can be planted to utilise seepage water.

It is of great value to elucidate the uses of ponds from very small to commercial sizes, as a proportion of very small ponds have valuable uses in home gardens and for domestic food supply in both urban and rural areas. What we are talking about here, in general pattern terms, is the *order of size*, and therefore appropriate use.

Ponds from 1 – 10 square metres

Very small garden ponds of from 2 to 60 cm deep can be made from old baths, stock watering tanks, plastic-lined holes with protective clay or earth covers, and so on. Pre-cast ponds in plastic, fibreglass, and concrete are sold in most areas.

In shallow ponds, Chinese water chestnut (*Eleocharis dulcis*), kangkong (*Ipomoea aquatica*), watercress (*Rorippa (Nasturtium) aquatica*), taro (*Colocasia esculentus*), frogs, and small fish thrive. Frogs are excellent predators in the garden (as are lizards), and *Hylid* (tree) frogs inhabit the leaves of plants, feeding on insects by day and night.

A square metre of taro gives 20–30 kg of starchy food, while deeper ponds will grow Indian water chestnut (*Trapa natans*), lotus (*Nelumbo*), and arrowhead (*Sagittaria*). Boiled taro, cassava, or plantain can be added to fish food. Stocks of small forage fish for larger ponds can be kept in house ponds, together with mussels and useful molluscs, basic plant stocks, and shrimp.

At 10 square metres, and about 2 m deep, clear fibreglass or Kalwall® ponds, as used at the New Alchemy Institute (NAI—Cape Cod, USA), produce fish and products valued at from \$4.50 to \$17 per square foot (1984), and amortise costs in 3–5 years, yielding fish, shrimp, and enriched water for semi-hydroponic crops. These ponds provide useful heat storages for night and winter heating, and can be used in greenhouses, or

outdoors for much of the year. Outdoor ponds at the NAI are placed in front of reflective (white) walls on white gravels to maximise solar input, increase yields, and lengthen seasons of growth. The Rodale organisation in the USA has also made extensive trials on small tank production of fish.

In glasshouses, such ponds give good yields and moderate temperature extremes, while providing algae-rich waters for terrestrial plant beds, so that fish wastes (and nitrates) are reduced in the water and routed to plants.

It has long been clear that there is a business opening for standard-sized ponds, equipment, and fish stocks for domestic pond culture. This is a field in which there are few suppliers (and most of these have concentrated on decorative plants). I expect that we will see productive pond kits for home owners in the near future. Subsidiary uses are as water stores for fire, tank supplies for gardens in dry periods, productive disposal systems for food wastes fed to omnivorous fish, and sources of recreational interest such as aquariums (fish tanks are very peaceful to contemplate and are recommended for workaholics as a relaxing hobby).

Ponds from 10 – 100 square metres

Ponds of this size are very useful to rear fish fry for sale or stocking, breed forage fish, produce large quantities of vegetable crop, supply aquaculture nurseries and aquariums with plant and animal stocks, and to create significant fire-breaks, water reserves, and heat moderation. One special pond of this size can supply house heating and hot water (the solar pond); it can be built just to heat a larger pond.

For a family, an intensively-managed fish pond of 100 square metres comes close to providing a full protein and vegetable resource if carefully designed and stocked, and if a beneficial polyculture is maintained. Aeration via a photovoltaic cell and air pump may be necessary for high yields, but the modest yields of 300–2,000 kg of protein that can be realistically expected are a significant contribution to food

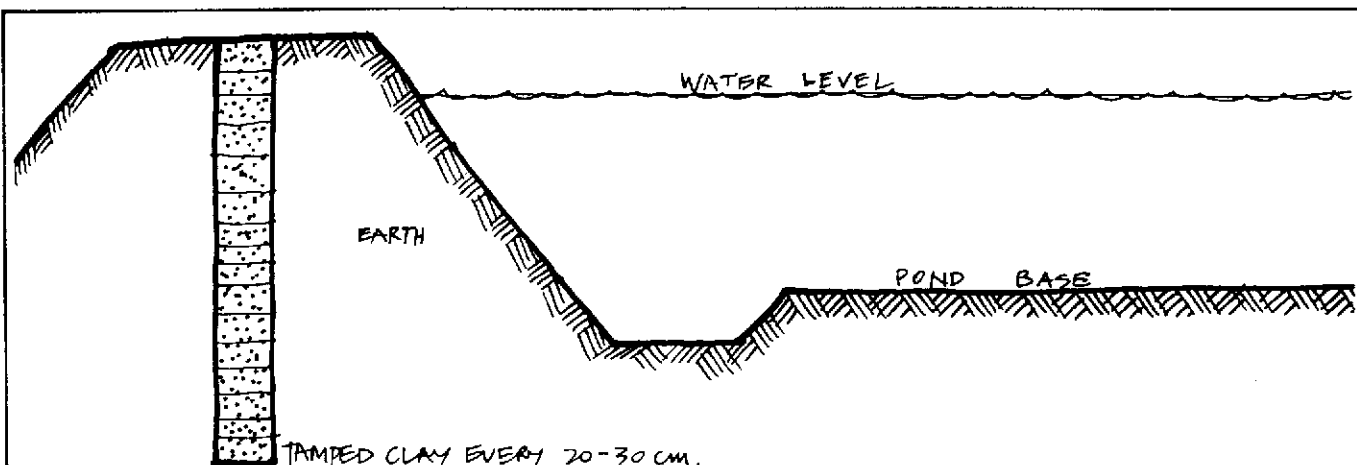

FIGURE 13.12
POND WALLS

Where clay is in short supply, a tamped clay cut-off core is an economical sealer for pond walls.

self-reliance.

In a sense, these are specialty ponds, with a need for very careful planning and subsequent modification (like the home garden, and part of it). Ponds of this size can be an important part of waste food disposal, and can form part of a total wastewater system. In line with a biogas or septic tank unit, they will grow a fairly constant mass of green manures that can be reaped or gathered for garden mulch or biogas recycling.

Ponds 100 - 500 square metres

Chakroff (1982) and others regard ponds of this size (alone or in series) as ideal for fish culture. Easily harvested, netted, or drained, and capable of holding specific age, size, or species assemblies, such ponds

give flexibility in management. Devoted to special crop, even one 500 square metres (or five 100 square metres) pond can provide an income from baitfish, aquarium fish, special plant crops, and intensively managed fish (e.g. prawns) of high value. A nursery of any sort, providing eggs, seeds, fry, or fingerlings to growers need not exceed this size. In 1983, incomes of about \$30,000 were possible from open-air ponds of this size stocked with prawns (Hawaii).

Ponds 500 square metres - 5 hectares

About 5 ha is estimated to provide a full (affluent) family income in high-value product. Ten to twenty prawn ponds (with ducks, mussels, and edge plants) is a full-time job akin to (but more easily managed than) a

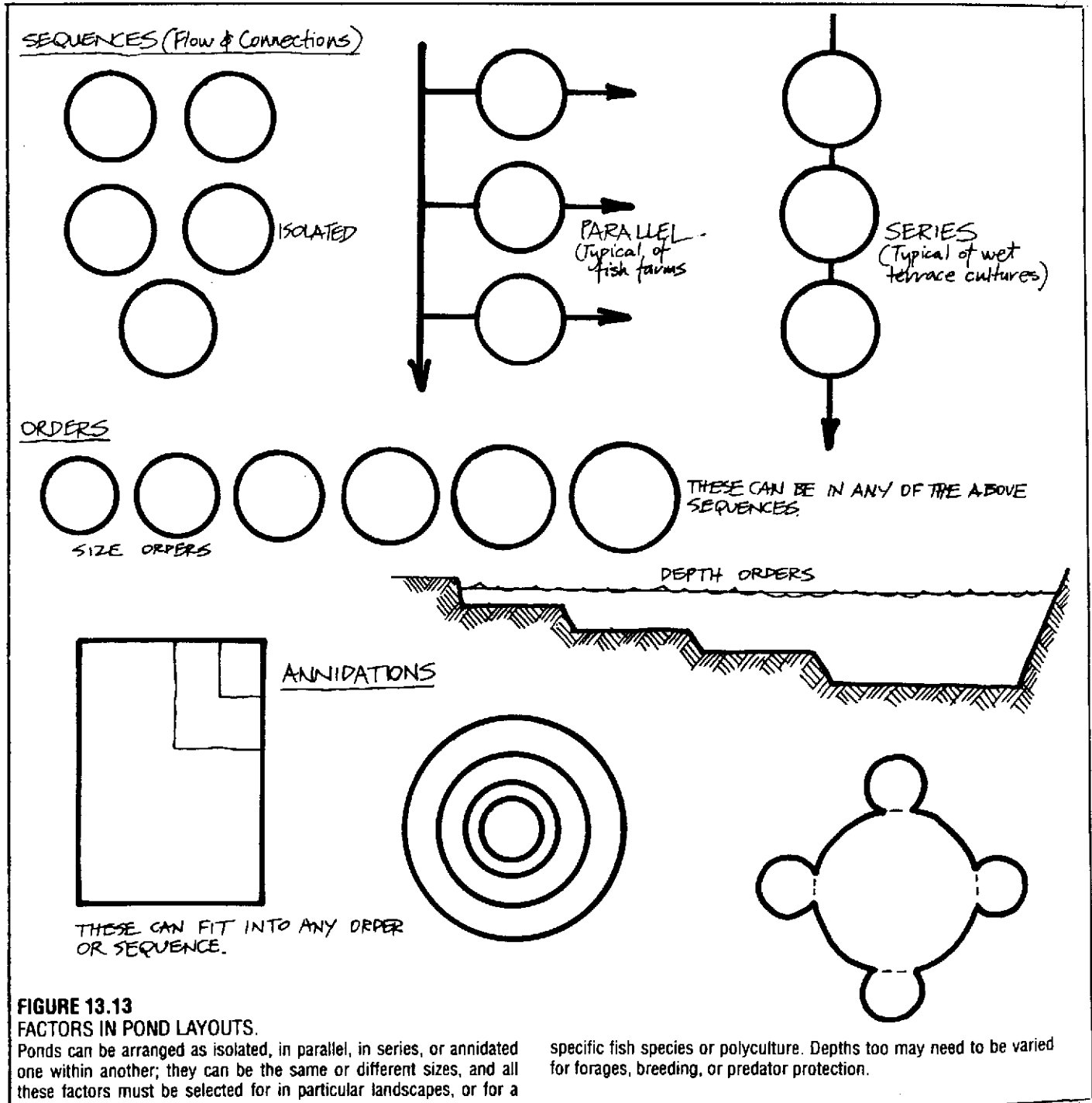

market garden. Many successful enterprises never exceed this size (a family farm). The scale permits multiple use and perhaps leaseholds of other activities, will supply a relatively large area of land crop, and form a complete fire-break for homesteads and fuel forests. We can characterise these as semi-intensive; many eel-rearing establishments operate at about this size. Sewage ponds little in excess of 5 ha will provide safe disposal for small towns.

Ponds greater than 5 hectares

Impoundments of 50-500 hectares are now not uncommon as extensive farms. Even a single impoundment of this size, designed for easy management, gives a living to a family or families. At 10-20 ha, given that the design is fairly adequate, harvest and occasional re-stocking is the main activity. Companies and investors may try to run such systems intensively, and are often limited by cost-benefit, food supply, or disease control ceilings. Innovative leaseholds, recreational fishing, and new scales of planning (including village or shoreline residence development and holiday homes, boating, and sales of water itself) may become feasible.

Every size order can include specialty ponds of the previous order, devoted to specific functions. Some functions may in one or other way serve all orders while themselves remaining small. This is true of an intensive hatchery for trout, carp, or perch.

Given that we have some ideas about the best uses for size or volume of water, what are the best arrangements for series of ponds, and what shapes might ponds take? What order of ponds in total landscape can

we define, and what specific constraints or freedoms are permitted or imposed by site selection?

ORDERS OF DEPTH

Depth, as for surface area and volume, has its orders and effects. Mere films of water, or wet mud patches, suffice to grow most productive green salad and root crop, to allow bees to safely drink, revive frogs, and breed a few mosquitoes. Soil at field capacity is effectively a "pond in hiding". From 2 to 6 cm depth, some of the smaller floating plants take root and form mats, and scuds and small crustaceans flourish. From 10-100 cms depth, true floating and anchored plants can separate out their niches, and we can grow Indian water chestnut or almost any fish species covered by the water. Even in rich algal ponds, some light will penetrate.

The maximum commonly used depth to rear fish in culture is 2 m, and at this depth no unstable thermoclines develop to create sudden overturns of oxygen and temperatures; the ponds are easily wind-aerated and yet deep enough to buffer air temperature changes.

From 2-15 m, lakes of clear water are potentially productive. Below this depth, less biological cycling takes place, and less still in the cold, deep, sometimes anaerobic depths of V-shaped lakes with leaf-fall on the margins. Deeps of 4-5 m do have a limited use to fish escaping high surface temperatures, or ice. Caves under water serve the same purpose, and it is common to find trout huddled in drainage pipes under the dam wall on hot clear days (they are then easy to catch if the drainage valve is suddenly opened!)

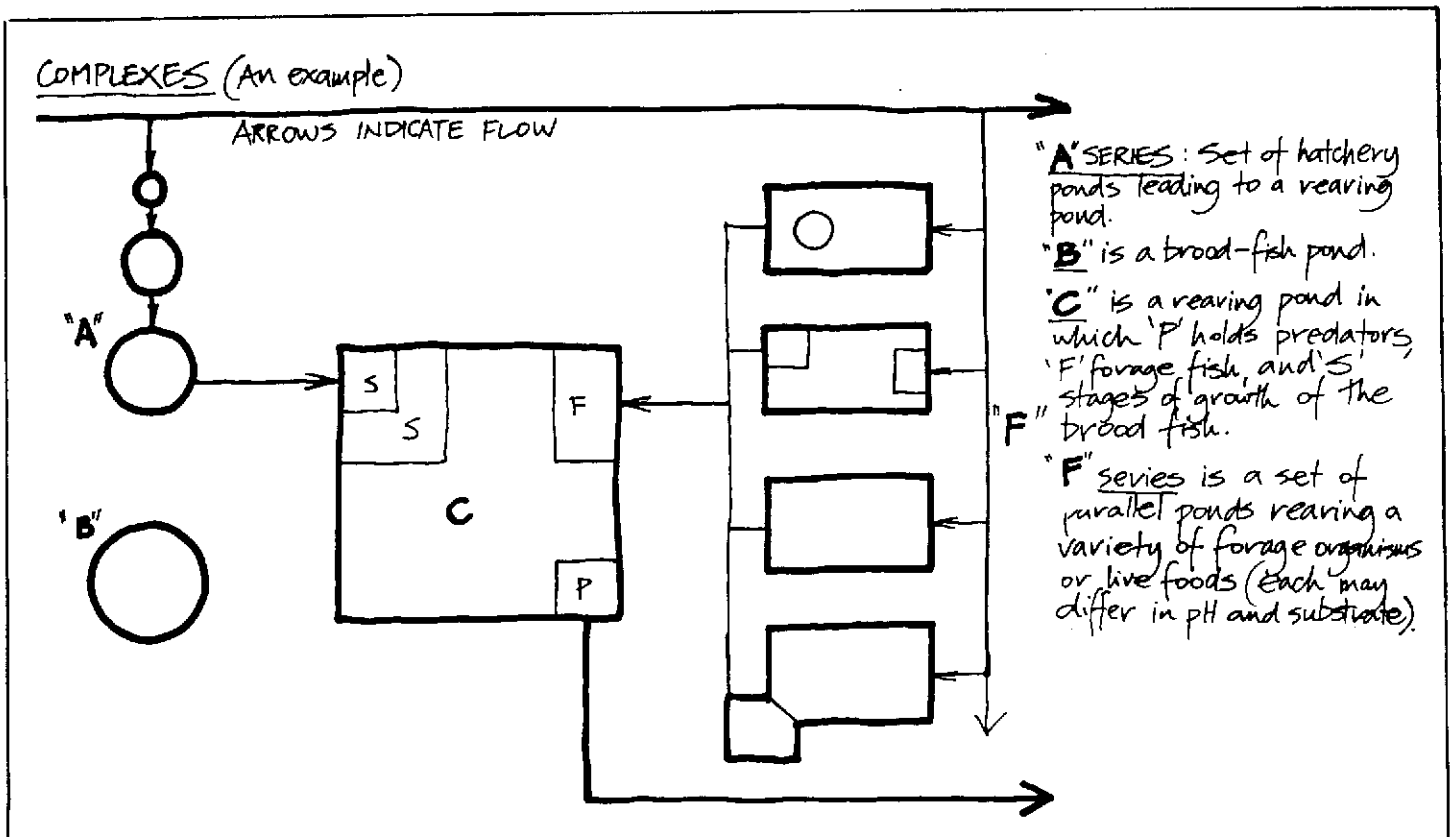

Depth and plants together serve as a set of breeding refuges for the food organisms of omnivores and carnivores. As we will later see, the configuration of levels at different depth may have a profound effect on the total yield or availability of such food organisms.

Thermoclines may develop above 15 m depth, and are fairly typical of lakes subject to sudden seasonal changes in their temperature. Overturns in temperature typically occur in autumn and spring. While in summer the surface waters remain consistently warmer than those at depth, in winter we can get surface ice, then warmer water at depth, and finally ice again deep in the lake, where very cold streams pool up and freeze. Fish may live in a sort of icy sandwich, or tucked away kettled in a modest cave or hollow in shallower water.

PONDS IN SERIES AND FLOW

Ponds can be built isolated from, in parallel with, in consecutive series with, in order sequences with other ponds, or as any combination of these. They can also be annidated (nested) one within each other, and in fact have some features which permit linear arrangements (the pond as canal or waterway).

Isolated Ponds and "Isolation" Ponds are familiar to

every aquarium keeper. New stock, diseased stock, trial polycultures, and an insurance against general loss may dictate a set of still-water ponds in quite separate situations (not sharing any flow of water). A set of tanks above grade, or still-ponds filled one at a time can be effectively isolated. Even if treated the same, they will still manage to be different, which is one of the fascinations of aquaculture. Water systems are more connected within themselves, and convey small differences more rapidly than land systems.

Ponds in parallel are perhaps the common fish-culture system, and are analagous to irrigation bays on land in that they possess a head canal (inflow system), an individual flow-through, and a tail canal (drainage system) which also works for surplus water in rains. They are effectively isolated *unless* a disease, pollutant, or qualitative change occurs in the common water supply, when all may fail together, unless (as is also common) flow regimes are staggered so that some flow, others are still.

The parallel series is ideal for valley floor ponds where water at head has been diverted along contour, for single feeder pipes, and for some narrow tidal benches. There are many advantages, and some basic disadvantages in that one cannot "feed the other". That is, we cannot set up a controlled trophic ladder in

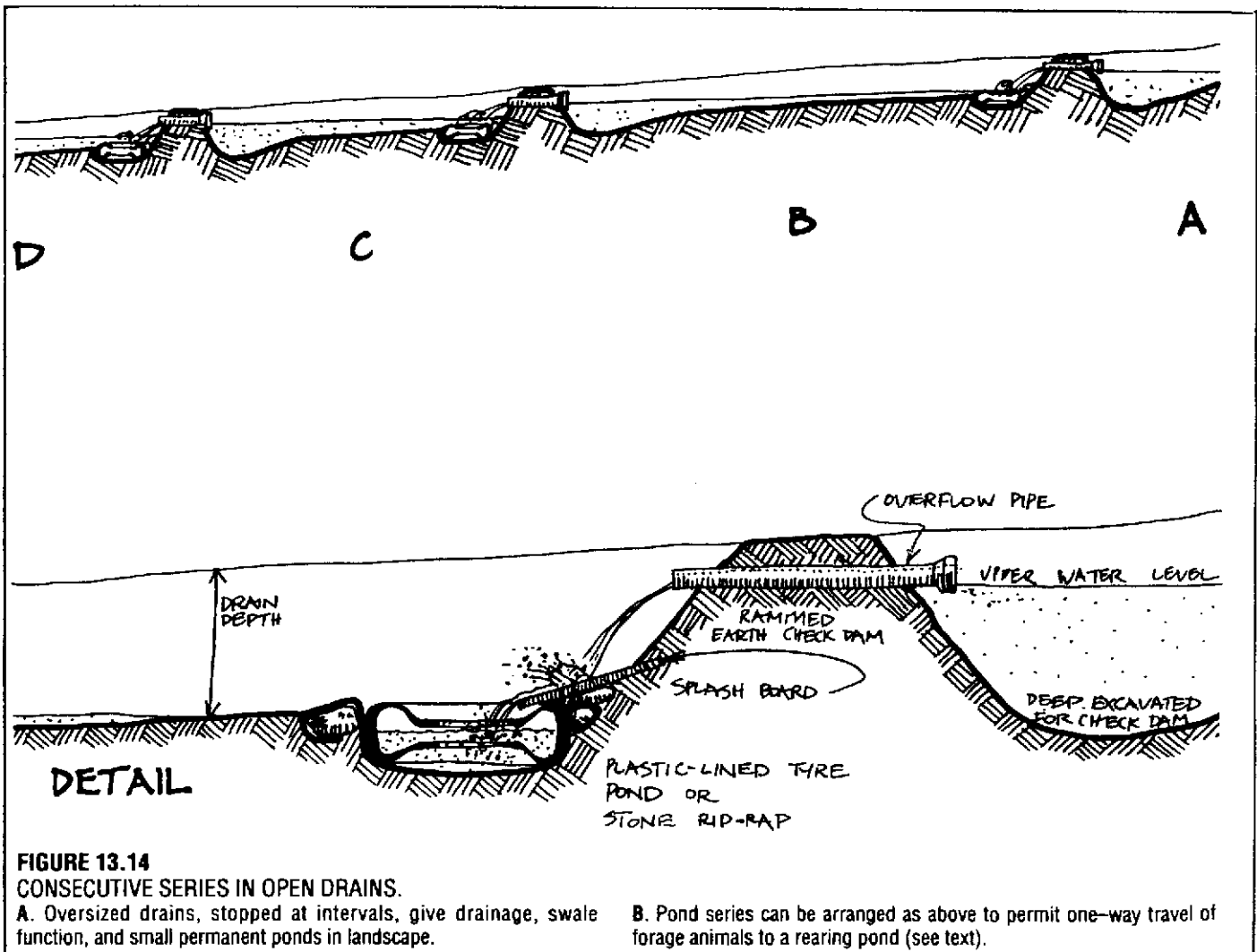

FIGURE 13.14

CONSECUTIVE SERIES IN OPEN DRAINS.

A. Oversized drains, stopped at intervals, give drainage, swale function, and small permanent ponds in landscape.

B. Pond series can be arranged as above to permit one-way travel of forage animals to a rearing pond (see text).

parallel ponds, where food is cultured and allowed to flow down to higher trophic levels (minnows to trout).

Consecutive Series can be arranged in trophic levels, with orders of ponds breeding forage fish or shrimp spilling over to ponds containing carnivorous fish; or with marshy ponds of tadpoles, scuds, and *Daphnia* flowing into ponds of omnivores. Even more handily, primary sewage lagoons (anaerobic) can feed secondary lagoons rich in insect and other arthropod fauna and zooplankton (faculative ponds) which in turn cascade into aerobic ponds of useful fish, mussels, shrimp, or green vegetable crop, which in turn...etc. **Figure 13.14.**

Moreover, as quite small ponds (about one-seventh or one-ninth of the size of the next) deal with the anaerobic phase, and as these are best constructed as tunnels or canals from which gas (methane) can be collected, the order of size in this sort of series can be suited to function.

Similarly, a very small hatchery can supply a larger fry pool, which in turn supplies a fingerling tank, which can now provide stock for large ponds. The orders of size here are more like one-tenth or one-twentieth of the next, and their aeration, structure, and therefore construction will differ. Eels are reared in such increasing size order of ponds, as are trout.

Thus, consecutive series has an essential function in terms of orders, but may make little sense in terms of a set of equal-sized ponds of the same function (such as a consecutive series of 500 square metre ponds all stocked with fingerlings). Consecutive series may also be forced on us by valley configuration or other site limitations, and then the risks of change in water quality compels close monitoring.

Evolutionary Pond Systems

Every evolutionary (old) fish culture system or terrace complex has an intricate set of ponds and flows. Elements are added on as needed, as money and time permit, as new information and needs arise, or as new species are incorporated. Although complex, these systems work well and are comfortable to work with. Successful modifications are preserved, mistakes rectified, and catastrophes remedied. However, many such systems are never intended for easy reading, and a novice inheriting one might spend weeks or months working out how to control and manage the system. All are quite unique, and often subtle in operation, with complex water control.

Ruled-up Pond System

In contrast, the flatland rice farmer who converts to catfish may evolve a simple, standardised, all-pervasive and often monocultural rectilinear farm visible from an airliner as a network of precise regularity imposed on the landscape. Anyone can understand it; the system is probably easy to control, but it costs in food, and tends to be a bit boring. The plan may very well have been drawn up by a Euclidean geometry student determined to force an unnatural

rigidity on nature. All that is needed to manage is power (energy). But then power, as Mr. Kissinger remarked, is the ultimate aphrodisiac, and there may be some murky compensations hidden in the pattern.

While all of the above evolutions have their admirers, there are potentially a set of quite different approaches, only one of which may be to consider the pond complex as a component of total landscape, and others of which refer more directly to energy (or food) supply and have to do with configurations, or the shaping of ponds themselves.

ANNIDATIONS

We can nest any sort of smaller pond in a larger pond in a variety of ways:

Cages and ring nets in large bodies of water allow control of feeding, harvesting, and disease in caged, netted, or fenced-off fish. They are in (and may benefit from) the larger body of water, but are concentrated for management. Similarly, eggs and fry can be separately reared in partitioned ponds or in aquariums. Their survival is much enhanced, as many fish and crustaceans are cannibalistic (or rather non-selective).

Predators may be kept to thin out populations, separated by a mesh which permits any stunted or young fish to pass. Or, shrimp may live out their lives in shallows which nevertheless adjoin a deep area where their predators lurk.

A solar pond, yielding heat, can be nested in or below a frozen pond, and thaw it in winter. A shaded, chilled, or aerated pond may act as a refuge in hot weather. Part of any pond can be glassed over, even insulated (on shore and in the water) for a heat refuge, while remaining open below or via a base slot for fish to use as a refuge in chilly weather.

Floating basins or mini-nets of live food can be placed in larger ponds, as can a single gravid (pregnant) crayfish, whose young fall free into the larger pond to commence growing without predatory adult competition.

All of the above are operating and valid, although some are energy-storage rather than integrated aquaculture annidations intended to aid fish or plant production. Listing them helps us to decide on how we may use such accessory systems in any pond, but there is no doubt that if we plan them to start with, we can make the original pond much more easy to fit than if we tack them on later, or as afterthoughts. As an after-thought, many "ponds in ponds" are made either to hold wild fish trying to enter a cultured pond, or to hold migrating escapees from a cultured pond. Both are illustrated in **Figure 13.15** as one integrated system (upstream and downstream fish traps or sorting cages).

PONDS AS PART OF THE LANDSCAPE MOSAIC

I believe that when creating ponds in barren (or agricultural) landscapes, we must plan for a beneficial

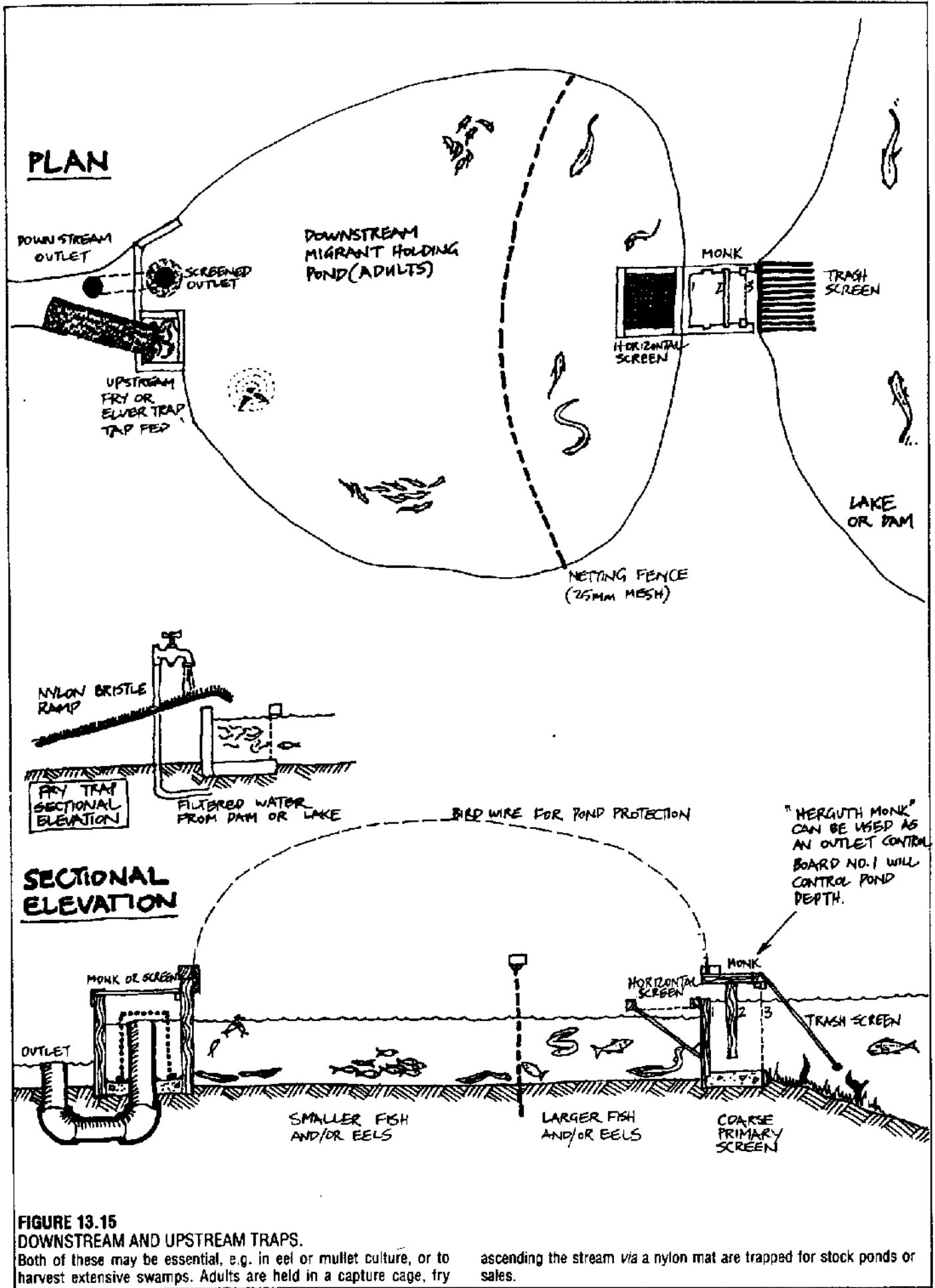

PLAN

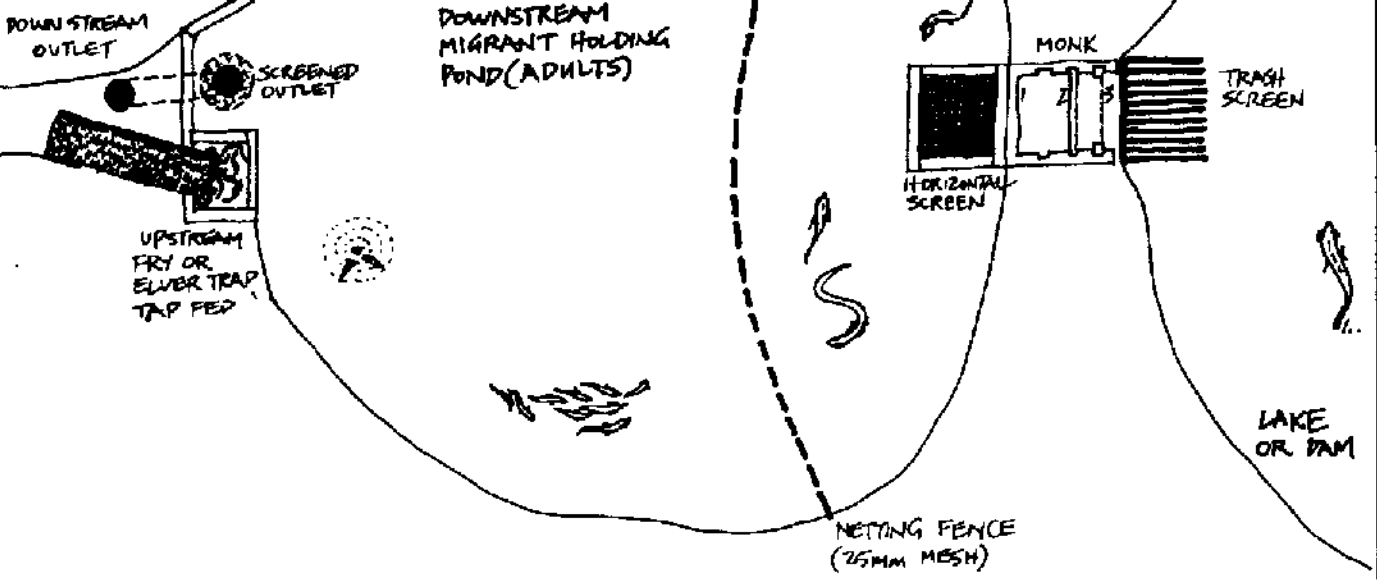

SECTIONAL ELEVATION

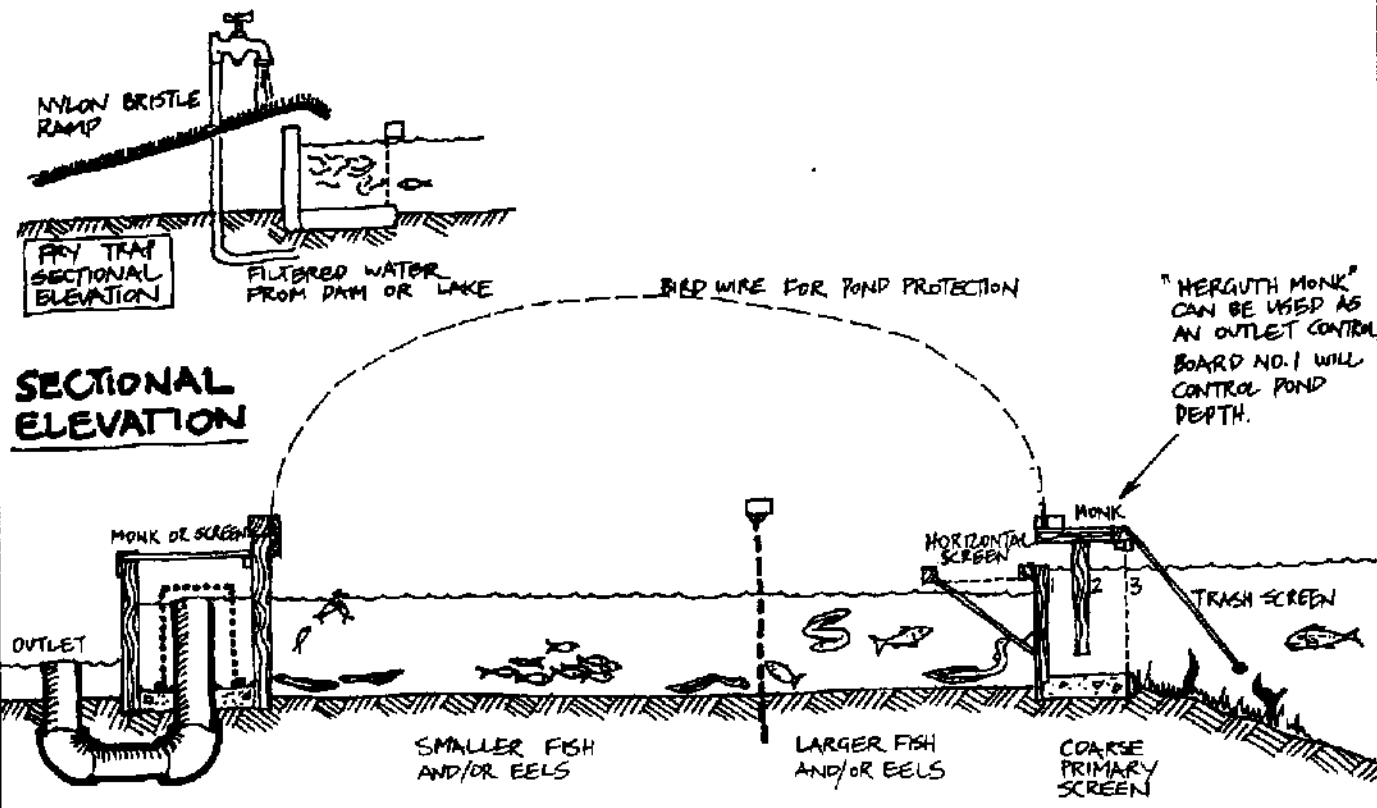

FIGURE 13.15
DOWNSTREAM AND UPSTREAM TRAPS.
 Both of these may be essential, e.g. in eel or mullet culture, or to harvest extensive swamps. Adults are held in a capture cage, fry

ascending the stream via a nylon mat are trapped for stock ponds or sales.

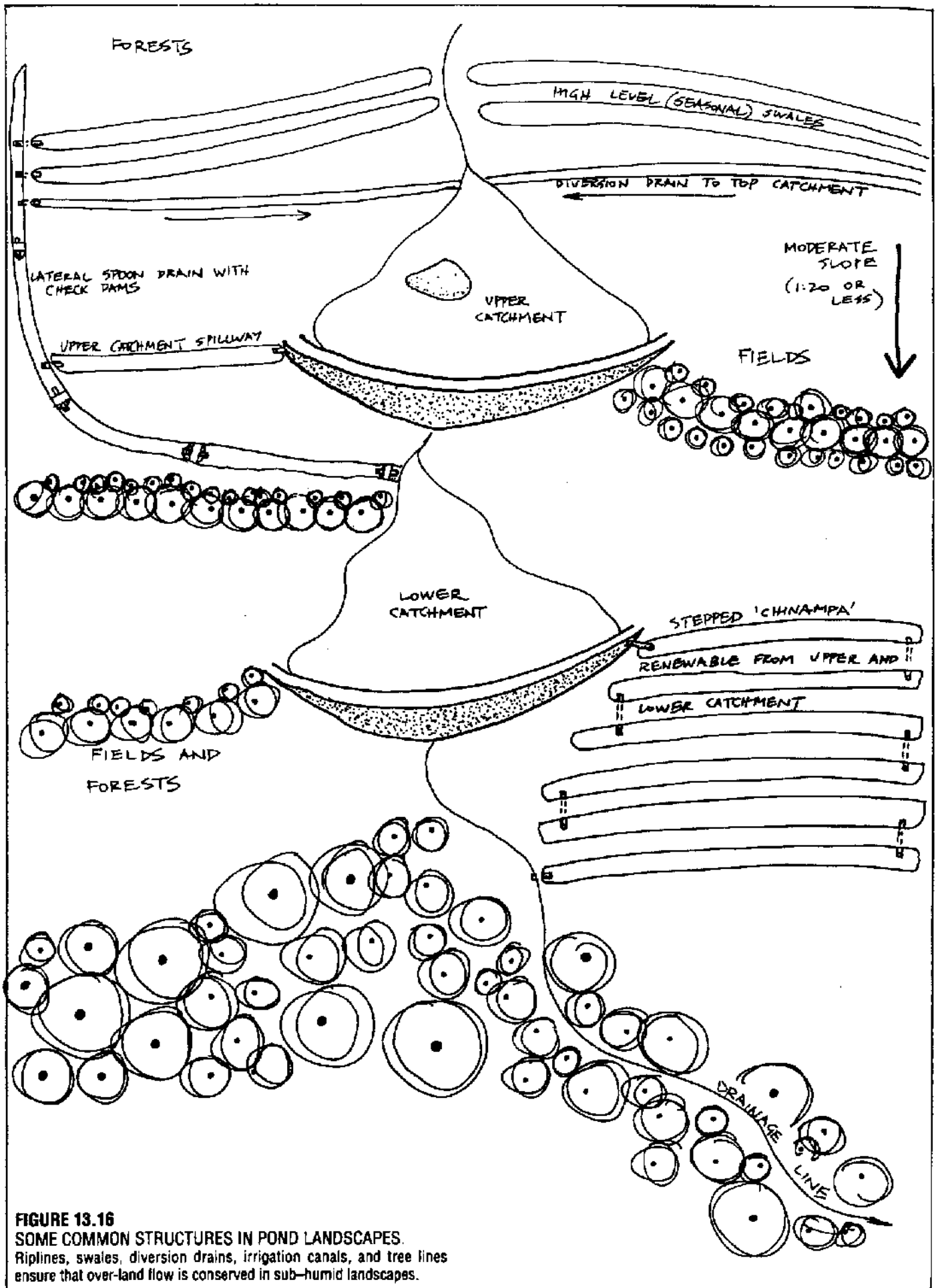

FIGURE 13.16
SOME COMMON STRUCTURES IN POND LANDSCAPES.
 Riplines, swales, diversion drains, irrigation canals, and tree lines ensure that over-land flow is conserved in sub-humid landscapes.

mosaic of forest, pond, marsh, and prairie or rangeland. The role of the forest (correctly chosen) is to produce clean water of good nutrient quality, to absorb wastes from fish and their plant associates, and to provide a variety of foods either directly (as fruit) or indirectly (as insect bodies and frass) to the pond in return.

The role of the marsh is to provide a rich habitat for birds and crustacea so that ponds and the forest collect phosphates, and that of the meadow to provide for some mammals and plants that interact with both forest and water. Given that we distinguish four sections or component assemblies (open water, marsh, prairie, forest) in our mosaic, we can have both simple edge effects and other complex edges involving more than two junctions.

As a round figure for sub-humid or humid areas, perhaps we need something like 15% pond, plus 15% marsh (contiguous), plus 30–60% forest, and a remainder in meadow, crop, or pasture (10–40% of the total). Moreover, we need the forest upstream of, downstream from, and between our ponds, the marshes upstream of and in the ponds, and pasture or prairie as downstream and random patches, where trees are difficult to grow. We could perhaps link the whole with a complex of permanent or intermittent drains, streams, canals, and swales (Figure 13.16).

We can even define some ideal forests, partly in terms of site and climate, and partly in relation to the pond component. River red gums, some other eucalypts, and some leguminous trees provide an enhanced phosphate drip from rain throughfall. They belong close to the waterways and water edges. Many fibrous-rooted willow and *Casuarina* species either need, or "fix", phosphates. They belong in the downstream forests. So do freshwater mussels; they belong in and are confined to the pond.

We can see many opportunities for sensible local design, encouraged by past successes (mulberries, duck, and silkworms in the Chinese carp-pond complex). Having discussed the series, orders, annidations, and layouts of ponds, we can consider how to shape our ponds.

POND CONFIGURATION FOR EDGE EFFECTS

Figure 13.17 shows the plan of some ponds of 75 square metres (surface area). They have equal depth, contain the same volume of water (and the same quality of water), and differ mainly in their configuration or ground plan. Pond A (5 m radius) has about 32 m of edge, or margin. Pond B, which is 37.5 m long and 2 m wide has 81 m of margin, and pond C is 1 m wide and 75 m long with 153 m of margin. All are made below grade, or with wide banks, indicated by the thin lines; this "halo" we will call the ZONE OF EDGE EFFECT. Note that B and C differ profoundly in that this zone occupies only some of the field in which B lies, but all of the field enclosed by the folds of C.

Let us consider that a large proportion of the plants

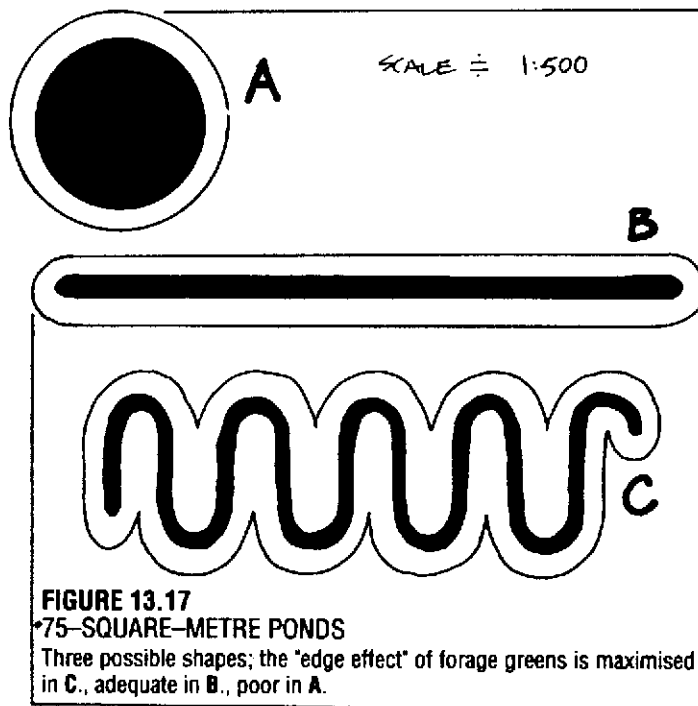

FIGURE 13.17
75-SQUARE-METRE PONDS
 Three possible shapes; the "edge effect" of forage greens is maximised in C., adequate in B., poor in A.

around all these ponds can be either eaten by, or will host organisms that can be eaten by, the omnivorous fish we have placed in the ponds. It is at once obvious that pond B provides 2.6 times, and C provides 5 times the food of pond A to our omnivores, and that the land around pond C will do much better at this than the fields around A or B. Moreover, while pond A is rather self-contained and inflexible, pond B is easily partitioned, and pond C easily compartmentalised for parallel flow. Pond C is indeed a very flexible pond in every way.

Further, if our pondside vegetation grows over the pond edge for a modest 0.5 m, then it affects only some 25 square metres of pond A, but reaches half way across pond B and clear across pond C. Thus, if this is of benefit (and we can design it to be so), pond C benefits by a factor of 3 times more than does pond A.

Again, if we wish to partition any or all of the ponds using a set of two 1 metre square sieves, we get only 1 m of bank in pond A in our new enclosure, but any amount of bank in pond B (with 2 partitions) and the same in pond C (with 3 partitions) depending on our desired ends (see Figure 13.18).

Given modern machinery, or even pick and shovel, all are equally easy to construct. However, as up to 15 or more times the natural food is available in pond C, our decision is a simple one. There is one last consideration: long narrow ponds can fit easily on slopes, and as troughs they can be stepped and stacked. While circular ponds can be stacked, they become more inaccessible, and as slopes steepen, more expensive to build. So why are most fish ponds we see round or square? Probably because we used a compass and ruler to design them, rather than spend a little time on the consideration of some more basic and life-related implications.

There are serious drawbacks to linear ponds on leaky

sites, as they may lose more water than circular ponds. However, on well-sealed and clay sites, this is not a factor and sealing a linear pond with a plastic liner is also simple. Evaporation from both is equal, or less in shaded narrow ponds. Channel-shaped ponds are appropriate for establishing a modest aquaculture on slopes fed by a spring, where clay is present in the soils, or as part of a total canal connector system.

Note that the ponds in Figure 13.19 are (or are intended to be) all of the same area and volume. That is, all ponds lie in a 2 ha field and are 1 ha area themselves. The field is planted to tamarack, which grows very well near water, but poorly away from water. Between the tamaracks and the pond edge, blueberries thrive, arching over the water and reaching a metre or two from the pond edge to the trees. They benefit both from the water and the acid tamarack mulch. Through them and above them, grape hybrids climb in the conifers. At the edge of the lake rainbow trout feed, eating both the blueberries that are knocked down by birds and the insects coming to the plants. In addition, the manure of the blackbirds coming to the blueberries encourages a bloom of phytoplankton much appreciated by rainbow trout. At a glance, which field and pond of the four in Figure 13.19 will produce the best?

There are many potential pond configurations, and many alternative species assemblies to that of trout, grape, blueberry, and tamarack, but wherever we spend a few hours analysing a more efficient or benign configuration before we call in the bucket and dredge, our return may be many times that of the Euclidean or

"straight" designer. The yield goes on for years and years, while the digging of the pond is a single event.

Circular ponds and tanks are most appropriate to intensive fish rearing with a water flow at head, or pumped. The usual arrangement is to set water intake jets at an angle, and by this means contrive both to aerate and to induce current flow in a round tank. Most of these intensive rearing tanks, suited also to fry and any active swimmers, have a central water regulating and drainage system to facilitate harvest.

Heat-welded or rivet-silicone tanks of clear plastic or fibreglass (as used at the NAI) have the multiple advantages of growing dense algal food, storing heat, and as well as rearing fish (*Tilapia* is popular), serving as a hydroponic and eventually a terrestrial nutrient source for plants, whose roots are pruned by fish. These indoor tanks are integrated with glasshouse and crop to give multiple benefits; most are still-ponds (aerated but not in continuous flow).

In the earth, the configuration of a round pond has little benefit, giving the least edge for area. Most existing ponds are rectangular (to aid fish-out by netting), and in large series. They are usually built without shallows or bays for forage, often lack drainage, and (as in tank culture) the majority of food has to be supplied from purchase. It is in these essentially simple or factory systems that pumping, food supply, and maintenance of water quality become the major costs of production.

Figure 13.20 suggests that we can set up a separate but interconnected mini-system, rather like a pond with shallows, or a pond with different sizes of boulders and gravels. How could we stock this pond?

We have some 16 possible environments. Ponds A1

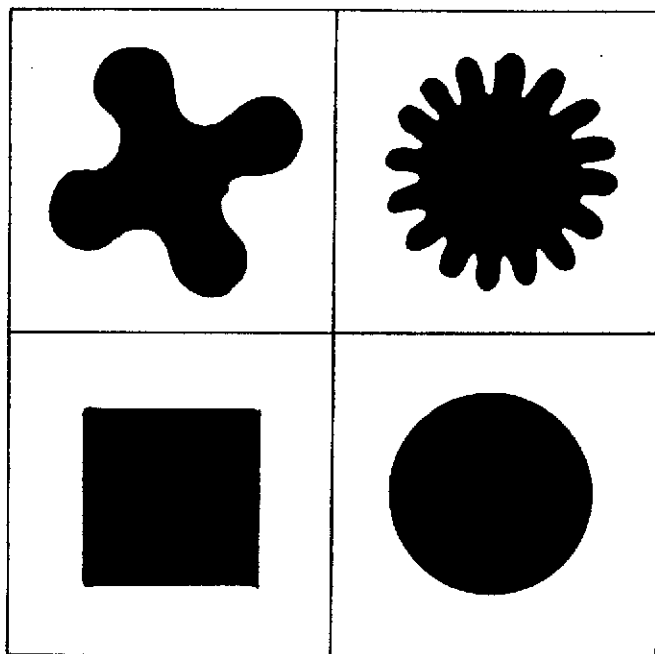
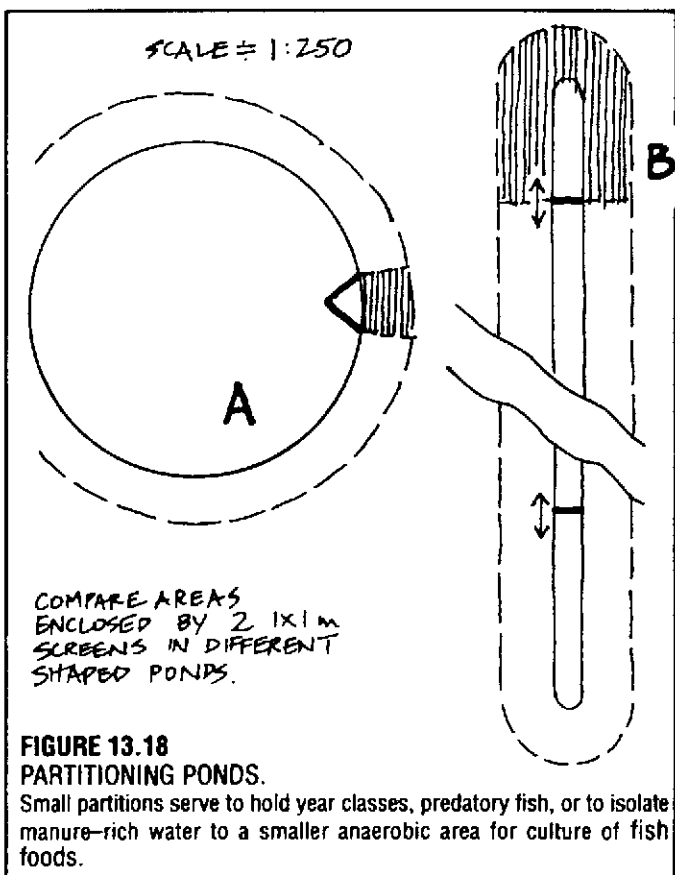

and B1, are for frogs, scuds, marsh plants, and peaty organisms. Ponds A2 and B2 are good bait fish ponds, some needing alkali, some acid, some muddy/humic water. Pond B3 can be our pan fish—or a *predator* species of that pan fish, e.g. A3 can be top minnows, B3 sunfish, and C largemouth bass, so that B3 and C eat A3, and C eats small B3. All these fish species breed in ponds and are carnivores. They (in effect) supply each other with food. All eat tadpoles, frogs, scuds, and water fleas at different life stages. All screens are one way. Even more simply, we could build a single pond and arrange screens as for Figure 13. 21.

Thus, we have several choices of configurations, and a pond series of different volumes, areas, aspects, orientations, perimeters, depths, nutrient states, and even handiness for servicing. Figure 13.21 also gives us good orientation potential, and increases the perimeter of the whole pond. Our "screens" can be as simple as graded gravel or boulder mounds separating the pond into areas. The boulders themselves then become a complex edge and refuge.

When we consider pond margins, we have choices of weedy, woody, mown, or flowering plants. The life forms of woods, flowers, herbage, and lawn can fall in the ponds.

As well, we can attract insects in with light, colour, scent, or sound. Some aquatic invertebrate species may

take up residence in the boulder screens. I have never seen a pond just like this, although I know of some natural ponds with some of each of these characteristics. But I feel as though we would learn a lot from planning and constructing a pond of this nature.

THE CLIMATIC ORIENTATION OF PONDS: COLD, HEAT, AND WIND

When we have the opportunity to orient ponds, as we do in marshes or flatlands, our concerns are to do so for the benefit of the water environment. The criteria are very like those governing house orientation.

Some conditions are:

- climate basically cold: oxygenation less important than heating (Figure 13.22).
- cold winter winds, warm to hot summers: oxygenation in summer, protected in winter (Figure 13.23).
- hot at most seasons: oxygenation a primary need, shade necessary for shallow pond (Figure 13. 24).
- variable (continental) climate: different needs in any of four seasons (Figure 13.25).

POND USES DETERMINED BY SITE

Huet (1975) and some others give a few sensible

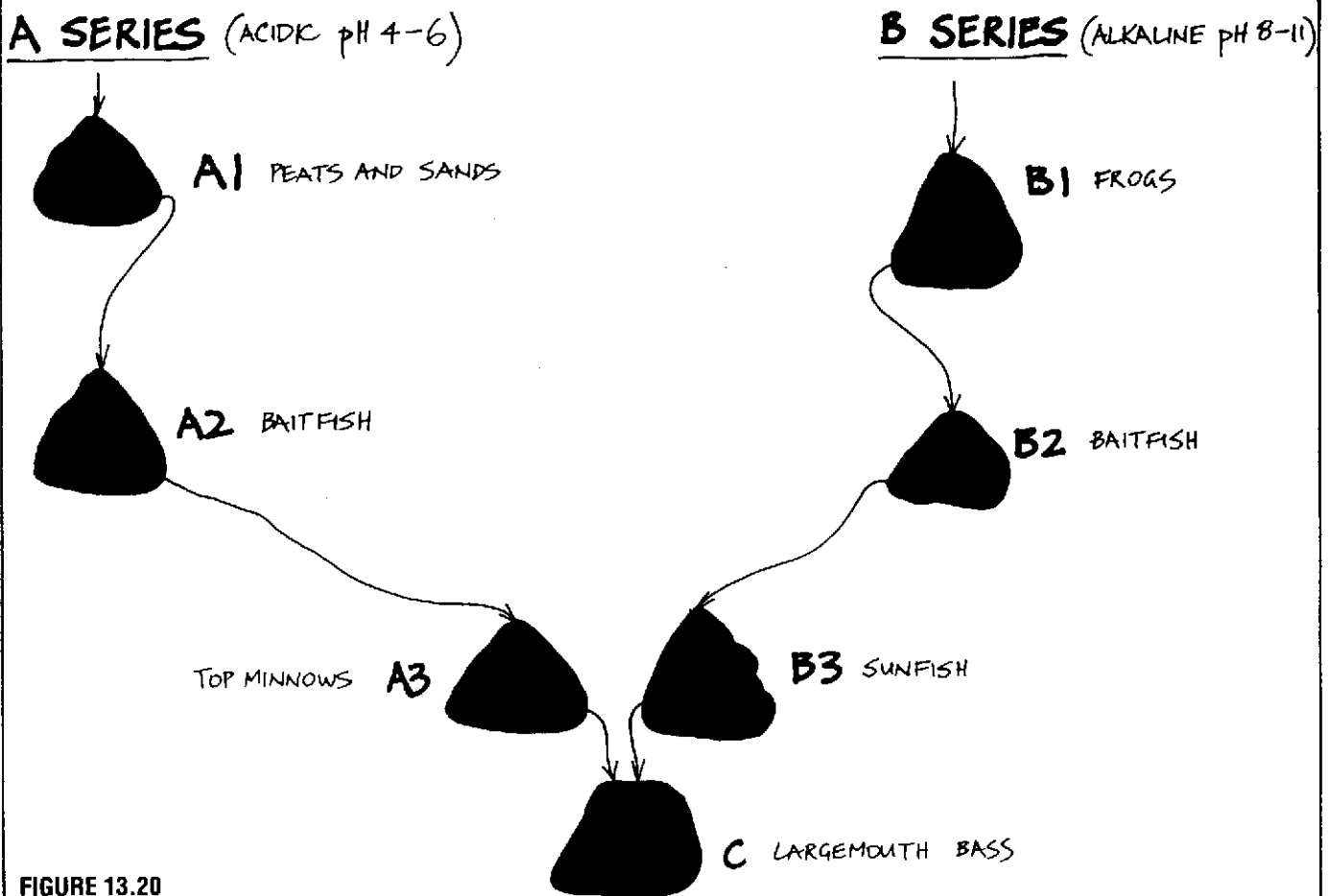

FIGURE 13.20

SEPARATE BUT INTERCONNECTED PONDS.

"Flow down" of food to successive trophic levels; both acid and alkaline waters can feed into rearing ponds in a "self-forage" sequence.

site-related pond arrays for valley sites. While it seems obvious that near-flat sites give greater freedom, these also lack the potential for vigorous through-flow and aeration provided by hill streams directed to valley ponds. It is the width of valleys or estuarine flood plains that may in the end determine a parallel or consecutive flow sequence from river or tide at head.

A second site restriction is that of soil type. Although artificially sealed ponds can be established in any location, stable clay and clay-loam soils are needed for

cheap extensive pond systems. Clay is expensive to dig and transport. There are sites obviously subject to soil slump where no ponds at all should be established, as water from even small refuges lubricates the shear planes of soils in slip-off areas, and can trigger earth or mud slides. District inspection, a soil survey, and some simple tests at a soil laboratory will reveal such delicate sites; some are specifically mapped as soil types, or as unstable slopes on land-use plans.

Reservoirs of great size have very similar effects on

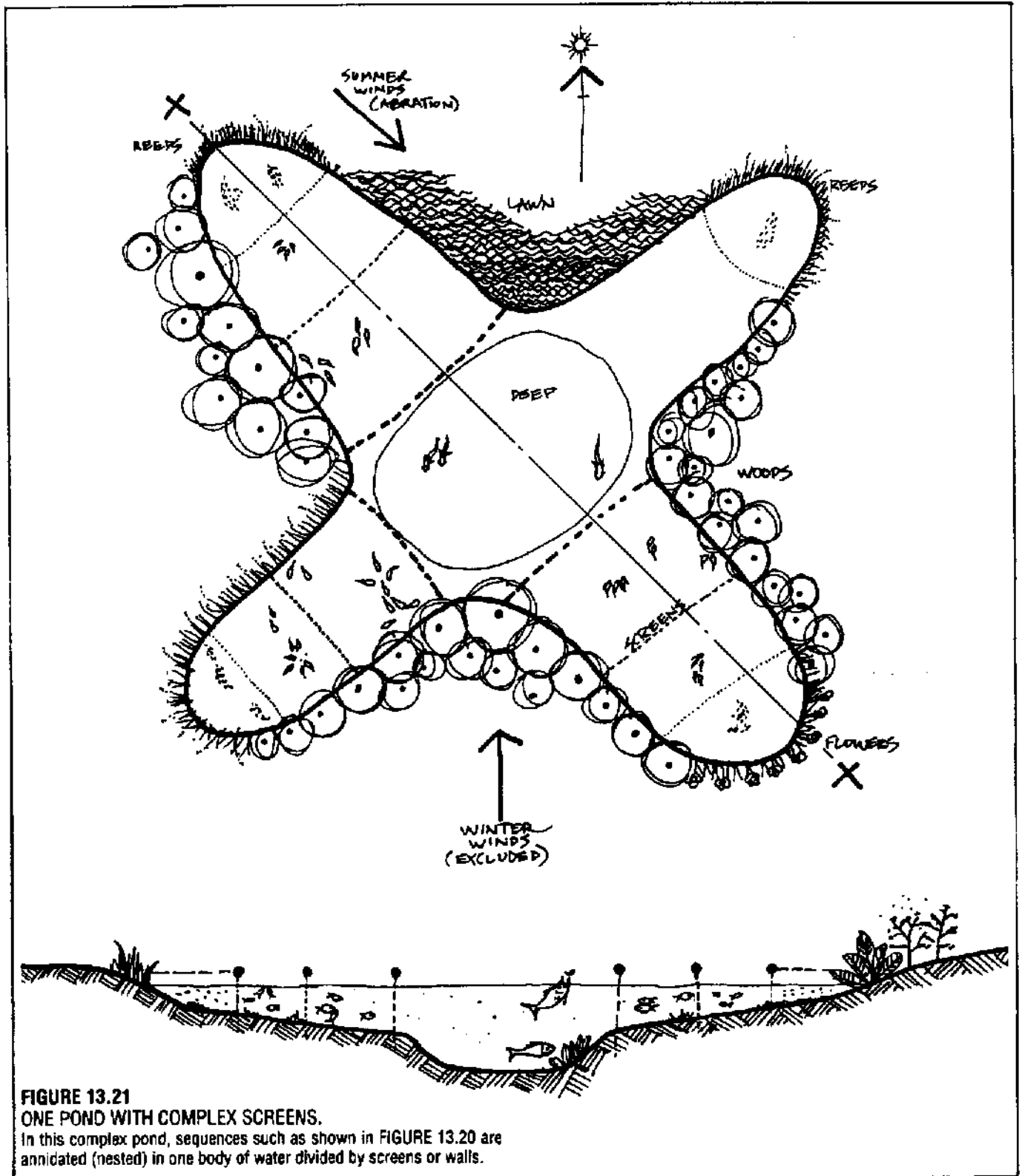

FIGURE 13.21
ONE POND WITH COMPLEX SCREENS.

In this complex pond, sequences such as shown in FIGURE 13.20 are annidated (nested) in one body of water divided by screens or walls.

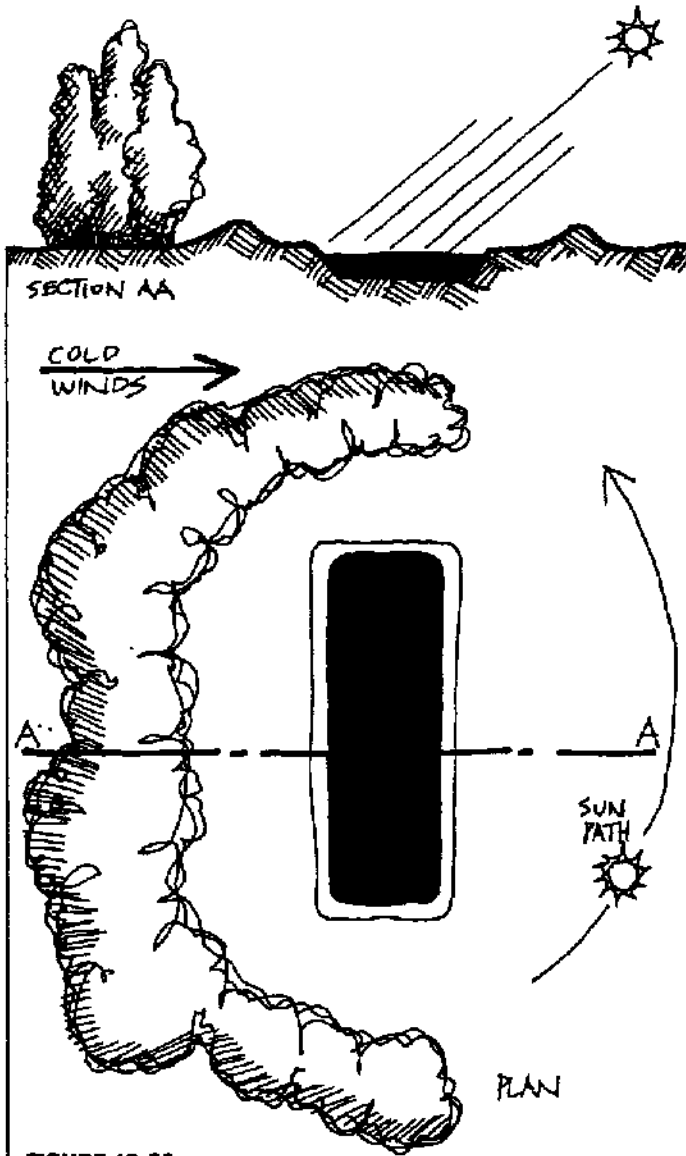

FIGURE 13.22

OXYGEN LESS IMPORTANT THAN HEATING.

In cold climates, pond shelter, orientation, depth, and configuration is critical for extending warmth in cool periods, hence fish and plant growth.

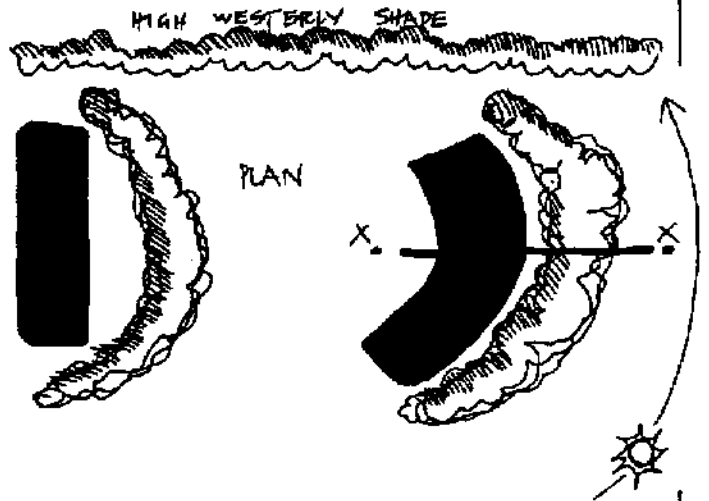
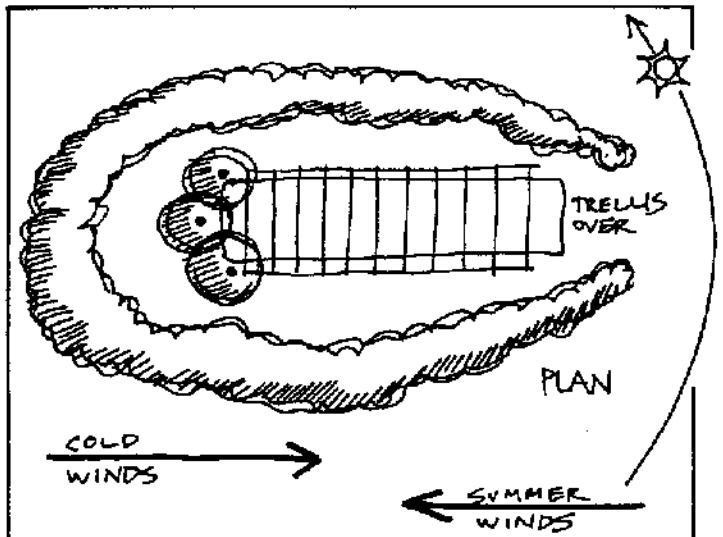

FIGURE 13.24

HOT MOST SEASONS

Overheating of pond is reduced by trellis and high shade hedgerow, wind tunnel below hedges as per section, deeps on shaded edges.

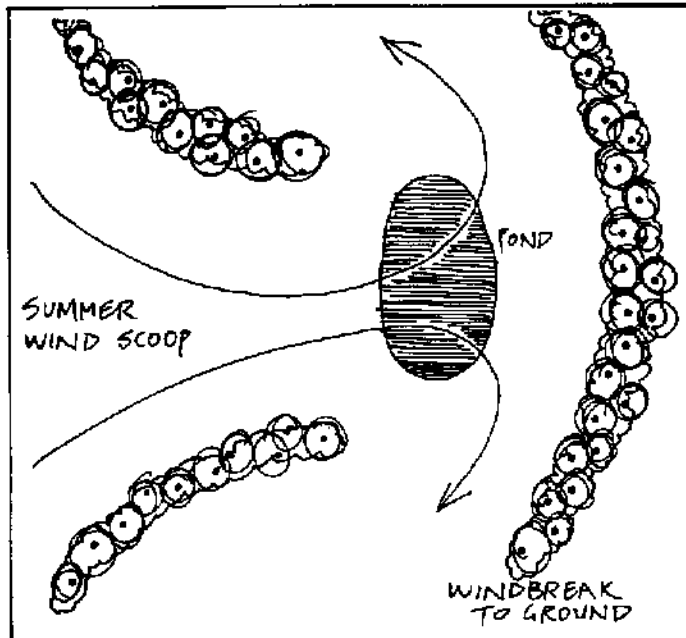

FIGURE 13.23

COLD WINTER WINDS, OXYGEN IN SUMMER.

incipient earthquakes, and water seeping through rock cleavages may either stabilise or destabilise faults, with potentially beneficial or catastrophic effects. For the building of large dams above human settlements, busy roads, or populated valleys, we modest pond-workers need make way for the more heroic aptitude of the civil hydraulics engineer, and even then with a lingering doubt that their structures will, in the end, persist, or that the potential catastrophe will merely be deferred. As a safe limit, ponds in restricted valleys should be limited to one or two metres in height, while those above broad flats can safely disperse a greater volume of water. Fish ponds, however, rarely cause civil catastrophes, and there is almost always good advisory or regulatory services available.

Rarely, we can find a property with a natural constriction between hills that enables us to flood 50-200 ha with one small dam wall. Our capital costs in such a situation can be very small in terms of the total production potential, and a little accessory earth-moving to create peripheral swamps, jetties, or to

create islands is all that is needed apart from the small retaining dam and spillway.

Aquaculture must be as seriously designed as any other important production system. If a system is so planned, yields should exceed terrestrial crop in the same region by factors of 10-20 (more in arid areas), and there is no better use of land than as pond-and-forest systems. Of all endeavours, aquaculture (and its polyculture accessories) show greatest promise for the reduction of land areas in present use, and the repair of damage caused by badly-managed pastoralism and monocrop systems.

THE FURNITURE OF PONDS AND MARSHES

Any wetland habitat can be increased in yield and use by the addition of some basic facilities which provide special habitat. Some of these are configurations or earth structures, others are constructs or technological additions. They cover such areas as:

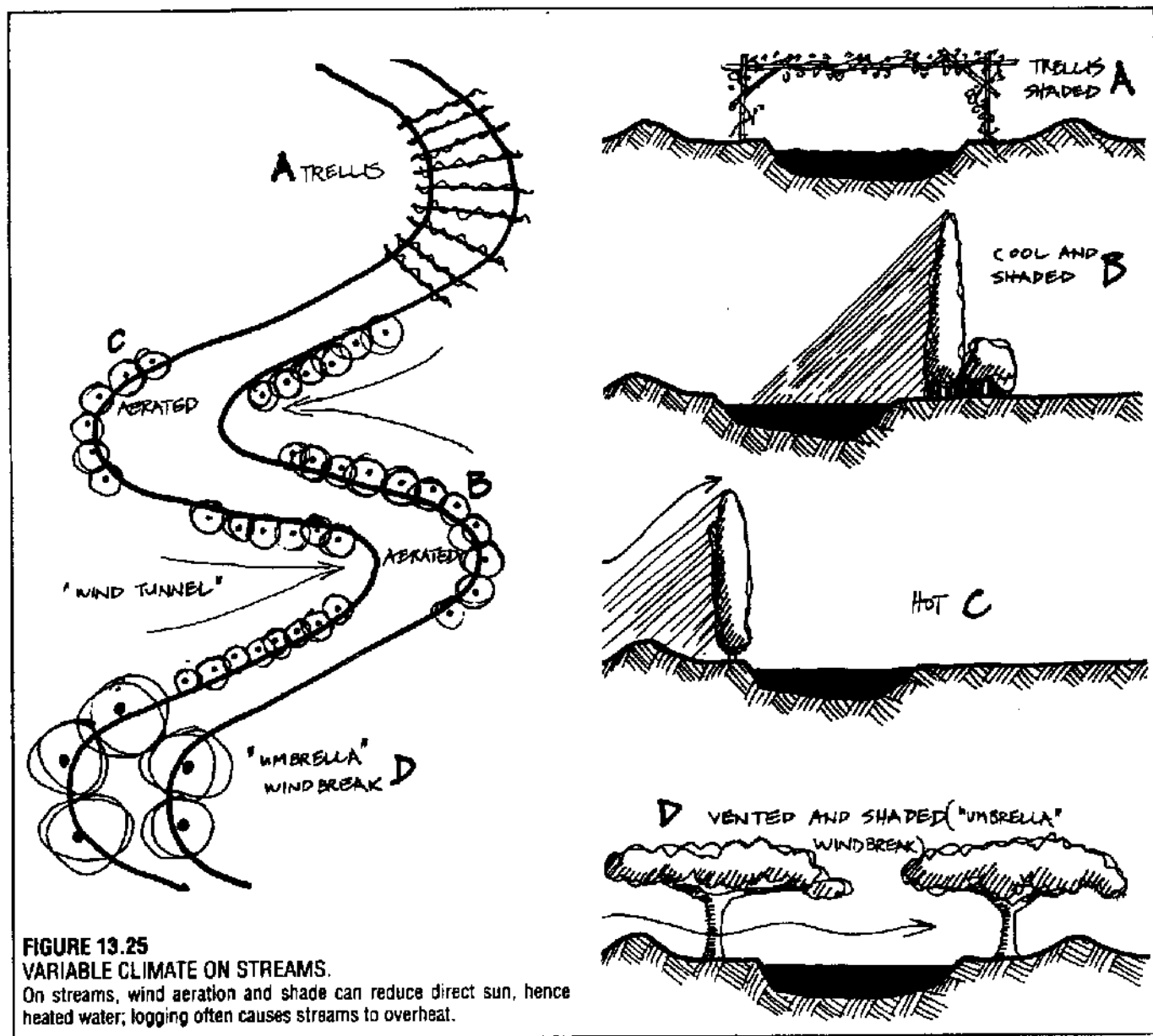

FIGURE 13.25
VARIABLE CLIMATE ON STREAMS.
 On streams, wind aeration and shade can reduce direct sun, hence heated water; logging often causes streams to overheat.

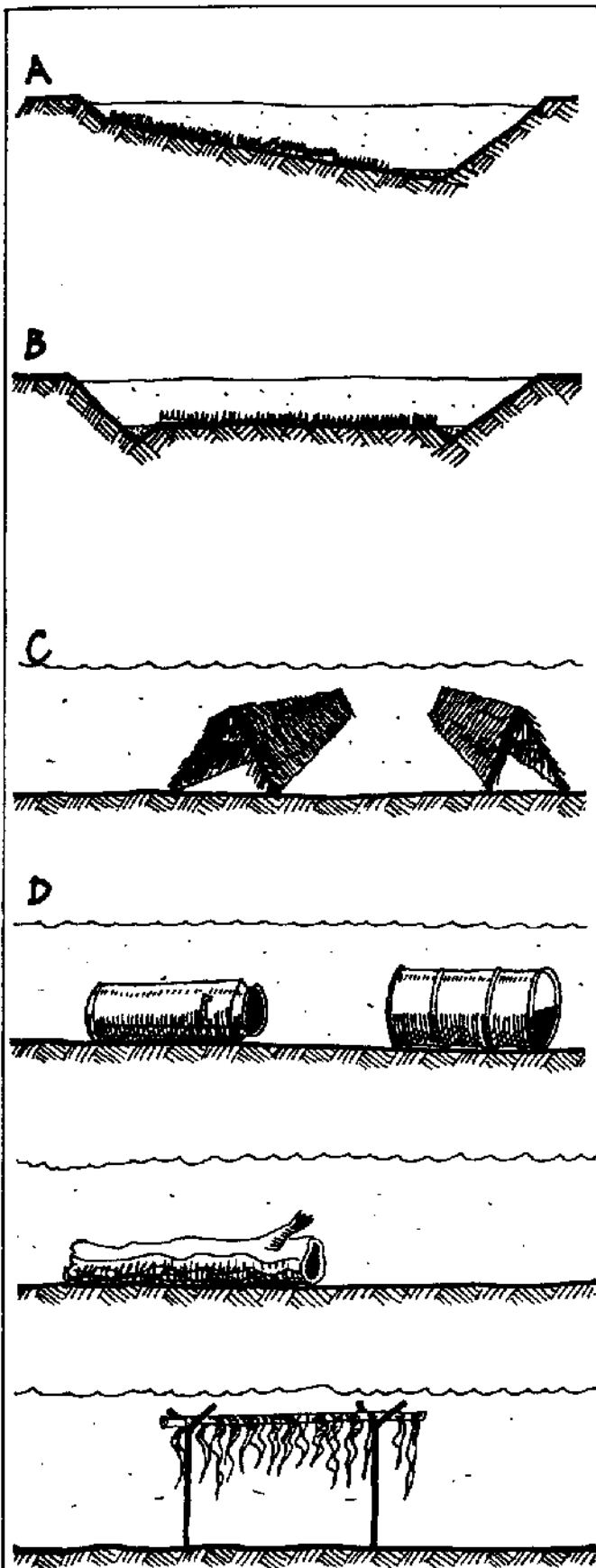

FIGURE 13.26
BREEDING SUBSTRATE.

A. Grassy slopes flooded for carp; B. alternative flood system; C. thatched shelters for "cave breeders"; D. logs or drums for large perch caves (Murray River cod). Gravels, sands, rock piles, mud caves, floating weed, and bundles of reeds or twigs provide other egg sites.

A. Configuration

- *Islands and Hummocks*: Although the construction of quite small islands are excellent wildfowl habitat (quickly occupied by nesting birds), islands have other uses, such as the isolation of useful but invasive plants (runner bamboos), and as a strategy to increase edge for fish. Islands also create sheltered bays in windy areas, or can streamline the winds to better oxygenate water.

Swan and other hummock-nesters may be limited by available (defended) nest sites, and can expand their numbers with small hummocks in shallows. Many territorial waterfowl find these of use for night-roosts, and a good many useful tree species are hummock-dependant. Alligators are the natural hummock architects of Florida swamps.

- *Peninsulas* (islands with narrow causeways) are safe house sites in areas of high fire frequency. They also elaborate the edge effect, increasing the area of shoreline for plants and fishermen.

- *Deeps*. The fish species of shallow waters and marshes may be decided in their composition by the number of deeper refuges in times of extreme cold or heat. Several species occupy such kettles in both tropical and temperate or cold lakes. Figure 13.33, in fact, is a series of continuous or extensive deeps in marsh, which is probably the highest-production water of any natural system.

With several carp, galaxiid, catfish, and perch species, deeps flooding out over mud and grass spawning beds are essential to their natural breeding cycle, and we can arrange a "flood" cycle by water regulation, to induce spawning. Many waterfowl also respond to this stimulus.

B. Structures

- *Breeding Substrates*. Depending on species, we can place a series of substrates on which fish will deposit

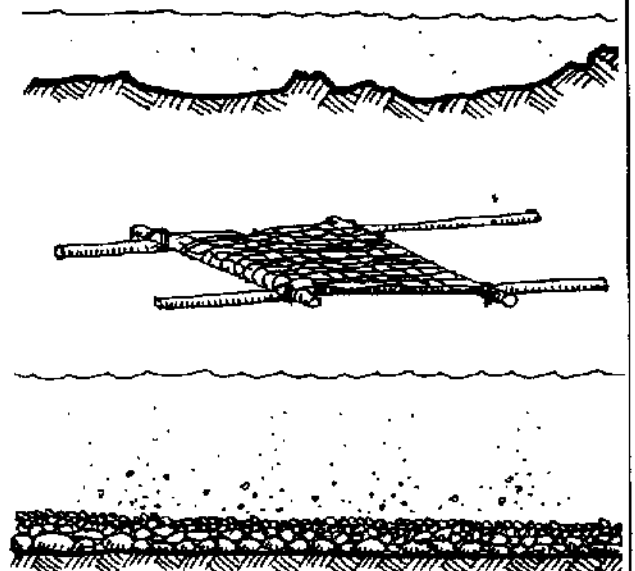

eggs. Some of these are figured (Figure 13.26). Others are in the form of earth material, gravels, subsurface aerators, and hollow breeding refuges such as logs, pipes, milk churns or drums and tanks. Many cannibalistic crayfish and territorial fish species defend such homes, and their population density depends on these refuges. Tyre heaps or piles of broken pipe provide condominiums for such species.

For small species such as shrimp, snail, notonectids,

and some small fish, bundles of brush perform two functions: that of a breeding substrate, and as a refuge from larger predators. All such refuges can be arranged to be hauled out, and then they operate as "traps" for the species (octopus, eels, and crayfish stay in their holes or in old tyres; shrimp and freshwater crab cling to brush piles), or to collect their eggs and fry.

• *Rafts*: Rafts serve as floating docks in tidal waters, as supports for houseboats or pumps, as walkways to

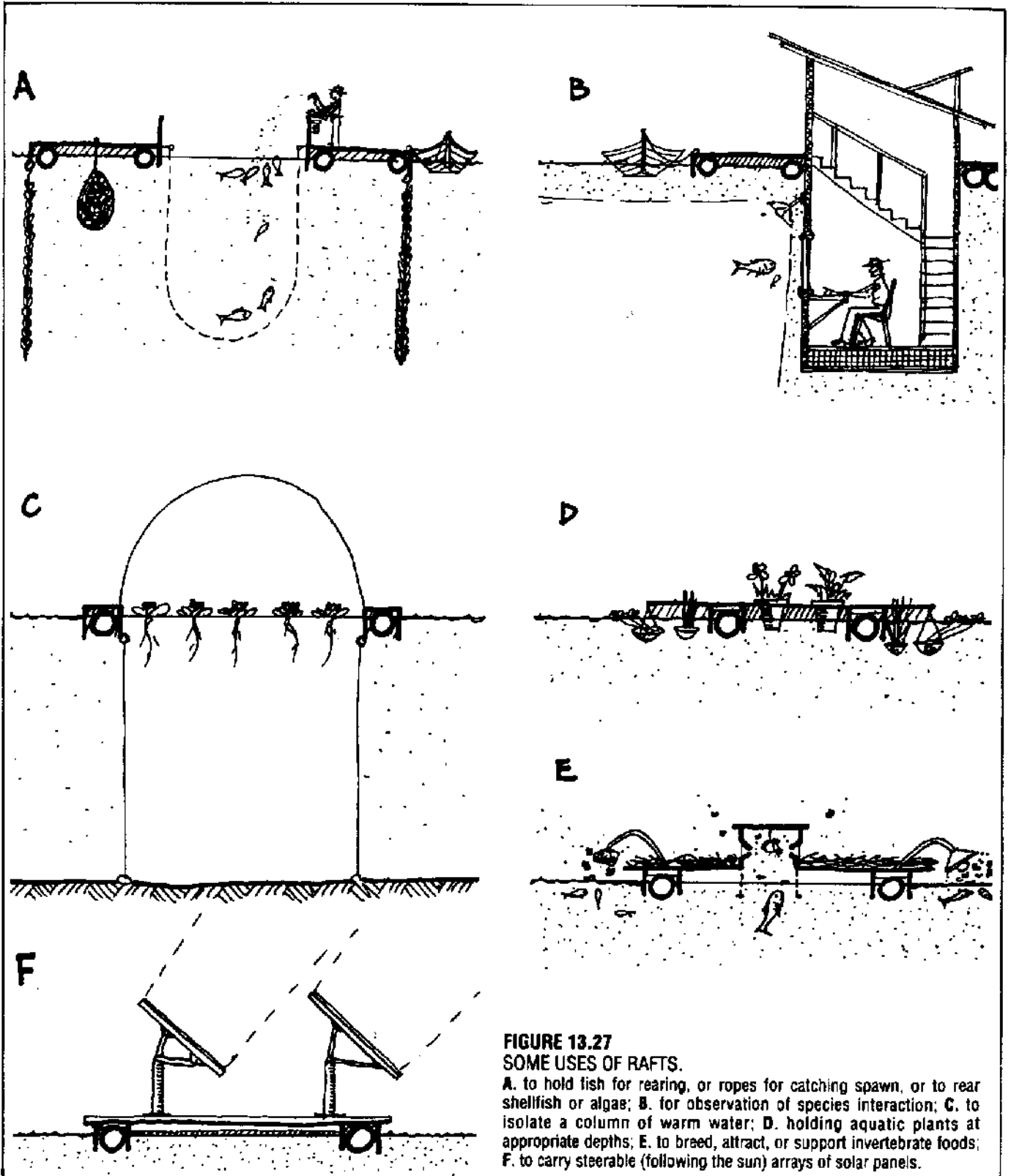

FIGURE 13.27
SOME USES OF RAFTS.

A. to hold fish for rearing, or ropes for catching spawn, or to rear shellfish or algae; B. for observation of species interaction; C. to isolate a column of warm water; D. holding aquatic plants at appropriate depths; E. to breed, attract, or support invertebrate foods; F. to carry steerable (following the sun) arrays of solar panels.

fish cages and ring-nets, as surface floats for organisms cultured on ropes, brush, and in mesh bags, and as observation platforms. Some of these uses are figured (Figure 13.27). With fluctuating surface levels induced by tides or the draw-down of dam storages, only a raft arrangement can cope with the steady level of water needed by certain water plants and nesting birds.

Cultures on rafts range from light and lure traps for insect foods to insect incubators of leaf litter or animal wastes. In many cases, multiple uses of rafts are feasible. Rudolf Doernach, a German architect, has actually built raft houses in cistern ponds, and was in this way able to "follow the sun with the house". Heavy arrays of solar cells and solar collectors are most economically oriented to the sun on raft structures of this type. Rafts also hold self-feeders for fish and waterfowl.

- **Screens and fences.** Shallow-water fences and screens are useful in polycultural stocking to keep predators from cultures of forage fish, or to allow stunted fish to be culled by predators. Outlet and inlet screens either prevent or regulate the migration of species (Figure 13.28).

Screens (Figure 13.29) can be horizontal, sloping, vertical, or as cylinders and cones. The configuration enables, in each case, some degree of self-clearing or deflection of solid particles. Rotating drum screens can be made to be entirely self-cleaning and self-turning, providing a small head of water is available. Drum screens are particularly useful for skimming ponds or collecting floating plants and algae for use as manures or forages.

Fences are a cheap way to screen shallow areas, or to separate the area between deeps. Again, they separate predator-prey or cage populations of carnivorous fish.

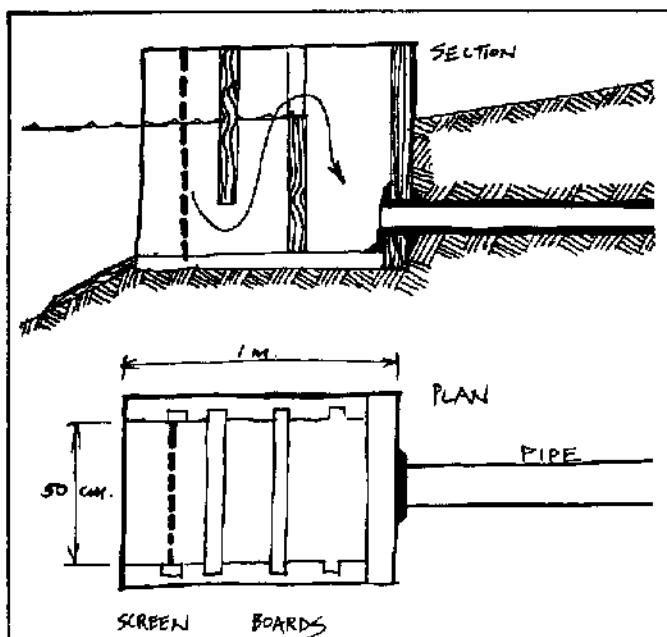

FIGURE 13.28
SCREENS AND BOARDS.

Classical "Herguth monk" outlet incorporates a screen and a level control board.

For a small grower, they enable brood fish to be kept in the same ponds as immatures, and two antagonistic species to be reared in a pond. Screen fences beside deeps in marshes prevent fish escaping from them (extending predation to shallow waters), or permit frogs to breed in shallows without excessive predation

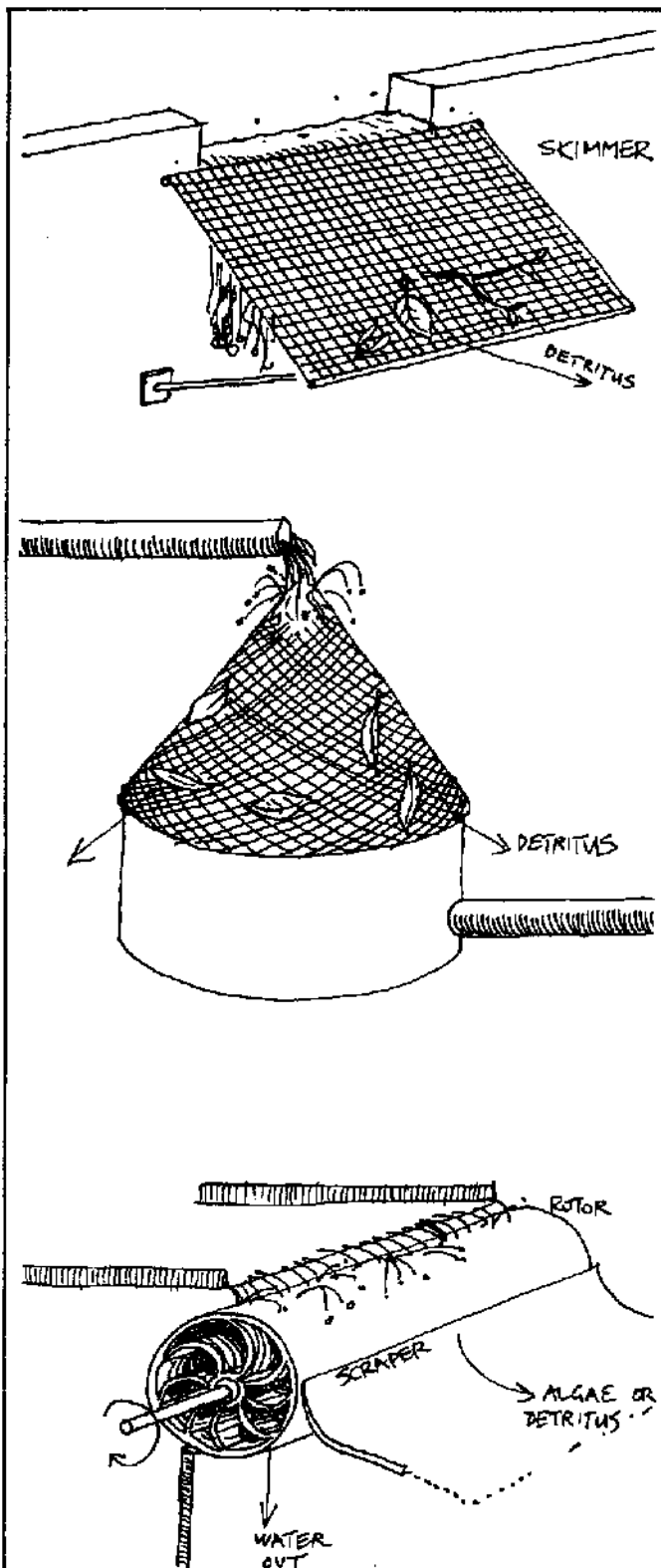

FIGURE 13.29
VARIOUS TYPES OF SCREENS
to remove leaves, algae, or to self-clean.

from trout.

• *Outlets and Inlets.* For ponds, the types of water level controls are a critical factor. Modern production of reliable and flexible pipe has made very simple level control possible, either as an elbow or upturned flexible pipe.

Outlets can also be a harvest system, as baskets into which water falls, or as smaller ponds with screened spillways that gather fish migrating downstream. Both are used to gather eels or trout from complex swamp systems difficult to harvest by nets.

Inlets are likewise regulated and screened, but greater attention must be paid to prevent the entry of silt, weeds, or unwanted organisms into the pond itself. Consequently, inlets can be complex systems of filters and screens where water quality is poor, or very simple pipes where unpolluted and fish-free water is drawn from springs. Some inlet systems are given in Figure 13.30.

CAGE CULTURE

Cages of wood, woven natural materials, metal mesh (and nowadays modern synthetic meshes) have been used since antiquity to trap or harvest fish, and are in current widespread use for intensive fish rearing in both still and flowing waters. Cages can be used to protect eggs and fry, and species such as sturgeon are hatched in cages (Figure 13.31.A). Live fish, crayfish, prawns, molluscs, and eels have been traditionally held in cages or *caufs* (pronounced corfs), floating barges, and wet wells in boats for the fresh fish market. They are also used to hold eels, oysters, crayfish, carp, and weed or algae eaters to reduce algal taints in fish flesh (Figure 13.31.C).

Where flow is rapid, cage mesh large, or wave motion exists, oxygenation in cages is no great problem. There is some advantage, however, in shaping cages subject to rapid tidal flow, or to induce water circulation in the cage, as in Figure 13.31.B.

Normally, however, cages are circular, as in salmon ring-net culture, or plain square to suit slatted wood construction (Figure 13.31.D). Typical rearing cages in which fish are fed, and which float in larger bodies of water, have a water flow maintained by the swimming action of the fish themselves. Such cages produce the largest yields known to aquaculture.

Mooring cages can be effected by individual anchors, as sets of cages attached to floating docks or walkways, or as gangs of cages fastened to lines, and (allowing a boat-width between cage pairs), the gangs can be stretched across bays, or anchored to float-lines in open water not subject to violent wave action (Figure 13.31.E). Old tyres serve well as spacers between cage units. I used caufs for years in sheltered bays to hold shellfish and net fish for market, and rarely suffered losses, but all cages need an annual inspection and watchful maintenance. Predators such as octopus and seals can cause large mortalities in cage fish, whereas pond fish can avoid such losses by evasion. On rare occasions, large shark attack caged fish and destroy cages, a loss not experienced in pond cultures!

NUTRITION AND FOOD SUPPLY

The same care must be paid to the nutrition of fish and shellfish as to that of land species. Vitamin supply from fresh greens, fruits, and algae are essential. High-protein foods, with a modest admixture of starchy foods (and all of these in fresh condition) is a requisite for healthy growth, as fertiliser is for plants. There is no substitute for fresh live food to produce high quality fish. Some strategies for better fish nutrition are given here; they are *the* critical strategies for cost savings (or energy conservation).

Fish maintain growth by eating about 1% of their body-weight daily, and gain most weight (at the least waste of food) when fed at 3% of body-weight daily. Again, trials of feeding are needed for specific species and size groups, but it is a good rule of thumb to feed out as much food as will be completely eaten in 15 minutes, to check on food wasted, and to establish a growth curve from samples taken as the fish grow.

Demand feeding, where the fish themselves trigger a food supply when hungry has its advantages, but may necessitate pelleted foods purchased at some 60–70% of total expense. Sub-samples of netted fish can be weighed and a weighed ration fed at 3% of total, allowing a 10–12% mortality in fingerlings, and 40–60% in fry.

It should be obvious that whatever food we can grow or collect as "wastes" is a critical factor in energy and cost conservation. For some of these strategies we must look to systems within the boundaries of the pond

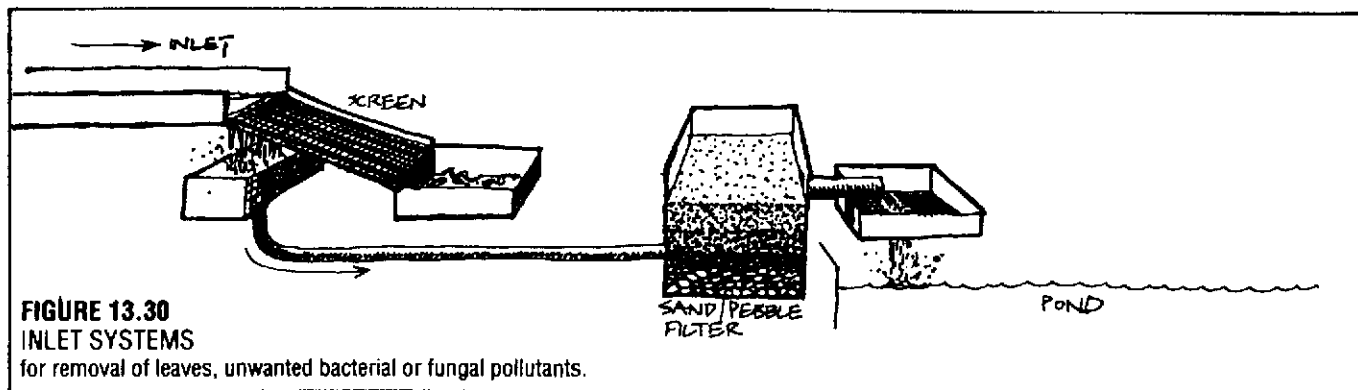

FARMING INVERTEBRATES FOR FISH FOOD

(shrimp, minnows, algae) but for others we must closely design the pond margin and create accessory food systems outside the pond itself. While this section completes a summary of the factors that we can manipulate to increase yields, we will follow with a set of food provision strategies, which I believe will have a profound effect on yields, although it is not a factor identified by others unless with respect to breeding or pond management for harvest.

Dried insects and other invertebrates are high in protein value, thus forming a very important fish food, e.g. if we take the "food quotient" (F.Q.) formula as given in Augusthy (1979):

F.Q. = $\frac{\text{wt. of food given (e.g. 200 kg of minced fish waste)}}{\text{wt. of fish gained (e.g. 100 kg of fish gain)}}$

Then: F.Q. = 2 for fish waste in this example.

In these terms, insect larvae are 1.8, compared with guinea grass at 48. Obviously, we do well to encourage

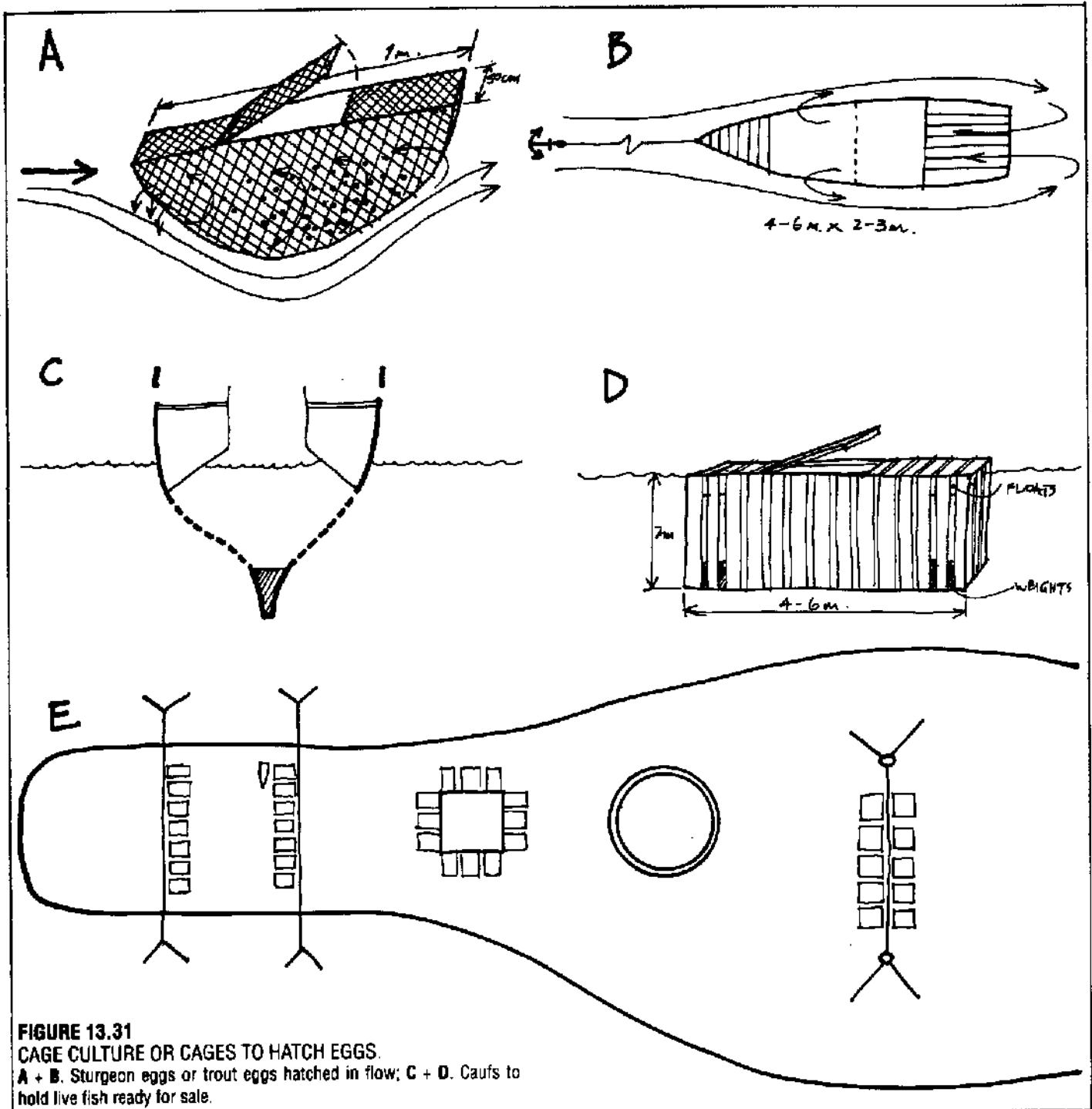

FIGURE 13.31

CAGE CULTURE OR CAGES TO HATCH EGGS.

A + B. Sturgeon eggs or trout eggs hatched in flow; C + D. Causfs to hold live fish ready for sale.

insects. There are several ways to do this, and some are:

Cockroaches, mealworms, and sowbugs:

Scatter food waste or flour, cover with leaves, and "seed" with cockroaches or sowbugs. Add to this pile some leaves and starches from time to time. Millipedes and cockroaches build up in tropical areas, and can be used to feed ducks or fish. Dano Gorsich on Moloka'i Hawaii, has a successful cockroach mulch heap of *Hibiscus* leaves which produces cockroaches for his ducks; if the pile is half-turned every few days, cockroaches are taken by the ducks. The duck manure then stimulates plankton growth in ponds.

Similarly, a "sandwich" mound of boards, paper, leaves, and so on breeds sowbugs (woodlice) and houses earwigs. These can be sieved and shaken out, or the mound demolished and rebuilt with ducks or chickens present. *Zostera* (eel grass) is a good sowbug base.

Termites:

A perforated 200 l drum or loose brick pit, covered can be filled with paper, old wood, cardboard, and straw, and then watered. Termites will invade if they are in the area, or sowbugs can be seeded in cool areas. The pit is periodically dug or sieved out for insects (Figure 13.32).

Plague locusts:

Up to the 4th or 5th instar, these insects form ground swarms (flightless), and can be vacuumed, brushed up, or "trawled" in grasslands using a side-towed bar and net. Frozen or dried, they are ideal protein food (people in many cultures eat the singed or dried bodies). They are largely overlooked as a high protein fish food resource. Fermented and dried they can be dry-stored.

Standard light-and-fan floats are available to attract

night-flying insects and blow them down to the water surface. Yellow floats attract grasshoppers to ponds, where many fall short of their goal and are consumed.

Pasture grubs:

These are the larvae of *Aphodius*, *Phyllophaga* and other beetles or moths. They occur at high densities (10 t/ha is not uncommon) in the top 3 cm of soil. Strips of field can be skimmed, sieved, and the grubs "floated" out of the dust with salt solution, dried, or frozen. At an F.Q. of 2-3, every hectare should grow 2-3 t of trout or other high value fish! Also, the adult beetles will cluster around bright lights and can be trapped in funnel-and-drum systems, and also frozen or dried. This is a good way to raise turkeys, when a daily disc-plough line can turn up 100 kg or so of grubs: all this on pasture carrying less than 0.5 t of sheep/ha.

In general, any dense collection of insects can be cultivated, harvested, and converted to fish food; food wastes can be converted to insect food in many cases.

Snails for fish and duck food:

A well-limed area planted to arum lily, *Nasturtium*, root sets of horseradish, *Brassica* seed, broad beans, and cucurbit vines if "seeded" with a few buckets of snails and watered occasionally, will build up a dense snail population over a few years. These can be "fed off" to ducks or gathered and minced for fish food as needed. Every 10 or so square metres, a clump of arum or *Agapanthus* will form permanent snail harbours; *Nasturtium* and horseradish provide food, as do cucurbits and annual *Brassica* species or globe artichokes. Snails can reach high densities under these conditions.

The large tropical snail *Achatina* likes a mixture of papaya, over a ground cover of cucurbits, *Nasturtium*,

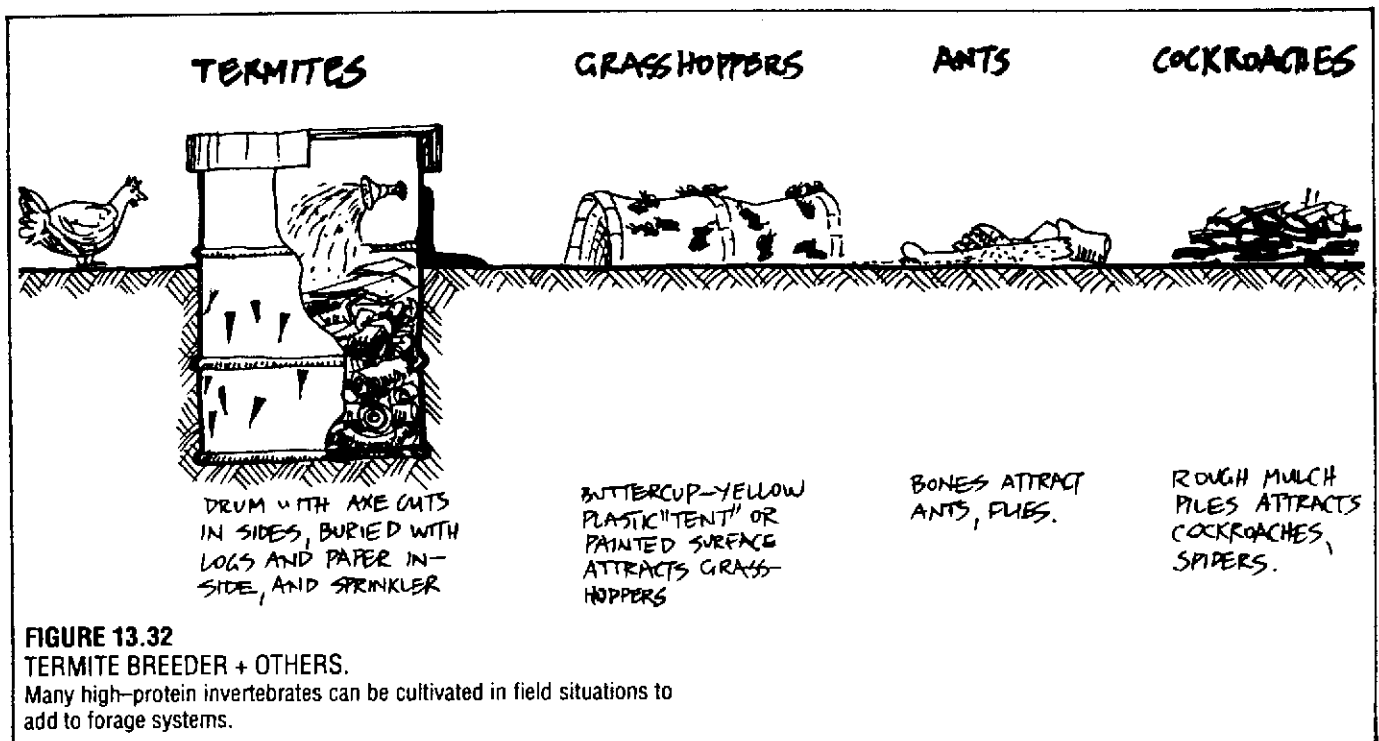

FIGURE 13.32

TERMITE BREEDER + OTHERS.

Many high-protein invertebrates can be cultivated in field situations to add to forage systems.

and fleshy or mucilaginous harbours. Desert snails can be collected from post tops in swales or grasses, where they gather to avoid soil heat.

Zooplankton:

Water fleas, cyclops, ostracods, rotifers, and so on can be cultured in small ponds or tanks supplied with lettuce, potato slices, crushed sugar cane, manioc (cassava) or legume leaves. A shallow bay off the fry ponds can be screened off for this purpose, and the plankton will swim out into the fry ponds. Conditions in the enriched area may not suit fish, but produce ample food.

Midge larvae and tubifex worm cultures in rich, shallow, organic ponds supply essential fry food, as do the brine shrimps (*Artemia*) of salt pans. *Artemia* culture is one of the very few productive uses of saline inland ponds.

Larval flies:

Carrion flies will "blow" waste meats or carcasses suspended over ponds, and near-putrid shallows supplied with kitchen sink water will breed "gentles" (larvae of *Tubifera tenax* flies) in the muddy base (depth of water 1–2 cm).

It is in the development of such high-protein foods as accessory to fish ponds that we save the greatest continuing cost of fish culture—food. In our site planning such areas are as important as the ponds themselves. For herbivorous species, semi-rampageous plants such as *Nasturtium*, *Tradescantia*, *Dolichos*, and comfrey supply hardy and palatable foods to fish such as *Tilapia*. In channel cultures, the banks themselves (when planted to such species) are a complete food supply.

Aquatic molluscs:

Species of the genera *Physa*, *Limnaea*, *Bythnia*, *Vivipara*, *Pisidium*, *Sphaerium* and so on occupy most alkaline waters. They form a large part of the food of fish, and are easily cultivated on vegetation in organic ooze in shallows and on stream banks, or in pools.

Worms:

Small or large-scale worm beds are invaluable sources of food for fish; worms are collected by flooding the beds at intervals. With a source of hay, food scraps, or manure, worm-growing can be a major fish food producer. The hessian (burlap) cover of worm beds can be immersed in or suspended over ponds after flooding the beds.

FODDER POND SEQUENCES

As each small pond falls through a pipe to the next, upstream migration is prevented while downstream migration is possible or even aided. Ponds I have built were organised as per Figure 13.33.

The criteria for upstream species are simple. In plants, it is that they be non-invasive, and in animals,

low on the trophic ladder. If such ponds are arranged along spoon or V-drains, several origins and destinations can be achieved, with forage fish or invertebrates migrating always downstream, and even then a perched pond above the trout or predator system can make a trout-free forage-fish polyculture.

From the intake: Ducks add manure; shrimp eat algae produced by the manure. Some shrimp larvae escape to the next pond where a small fish breeds (*Gambusia* for example). These fall again to trout or perch in the last (outlet) pond. Snails can be part of this downflow if a separate intake is arranged. Species suitable to each stage are:

A. ORIGIN:

Animals. Manurial species such as ducks, freshwater mussels, amphipods and phreatocids (mud shrimp), small freshwater crabs (*Halicarcinus*), snails, shrimp (*Atya*, *Macrobrachium*), frog larvae (*Hyla*, *Rana*, *Crinea*).

Plants. Non-flowering or non-invasive species such as taro, and manurial species such as *Azolla*. Insects and their larvae will also be represented, like it or not.

Structures. Rotted logs, reed beds, brush and small cover. Taro or other useful crop can also be planted in any pond downstream.

Edges. Comfrey, vining legumes, fruit.

B. NEXT POND DOWN:

Animals. Any of the above plus more predatory invertebrates and very small fish working at planktonic level, e.g. surface-feeding fish such as minnows, *Paragalaxids*, *Saxilaga* in the mud.

Plants. Useful edible species (kangkong) on mounds.

Structures. Reed bed, small pipes and logs.

Edges. Mulberry, berry fruit, legumes, comfrey.

C and D follow much the same sequences as given in B. Products or yields can be taken off at any level as shrimp, snail, ducks, frogs, taro, *Tilapia*, perch, or trout. Even pH can be altered in some chains to allow different species to enter the chain, and niches arranged for special plant or animal groups, so that high oxygen and low oxygen demand species are accommodated. Such systems can accept water polluted by phosphates and nitrates as part of their intake, providing plants and organisms can be found to cope with that level of pollutant (Figure 13.33).

There are at least three strategies to increase the diversity of the waters; all apply to relatively small still-ponds, marshes, or perched ponds. We can:

- Locate ponds at headwater and ridge locations, thus creating small ecological islands;
- Salt small ponds for the development of semi-estuarine species; and
- Manure small ponds and marshes with trace elements, animal manures, and phosphatic or nitrogenous fertilisers in order to produce large quantities of forage fish, algae, or crustaceans which will feed trout.

Swingle (1966) proposes that up to 50% of a catfish pond can be in shallows; these are to provide food for the main fish (as shrimp), not at a cost of reducing fish

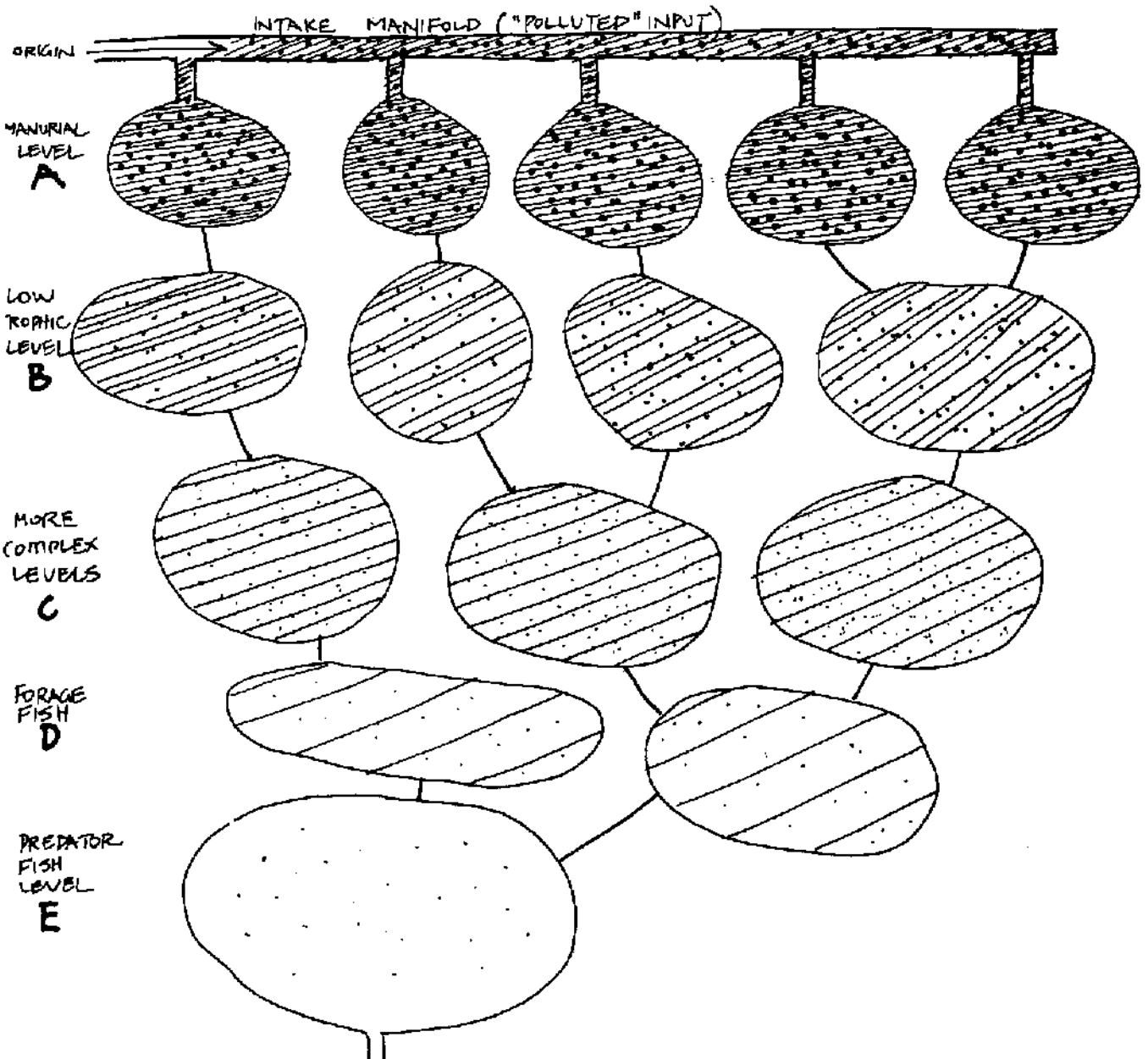
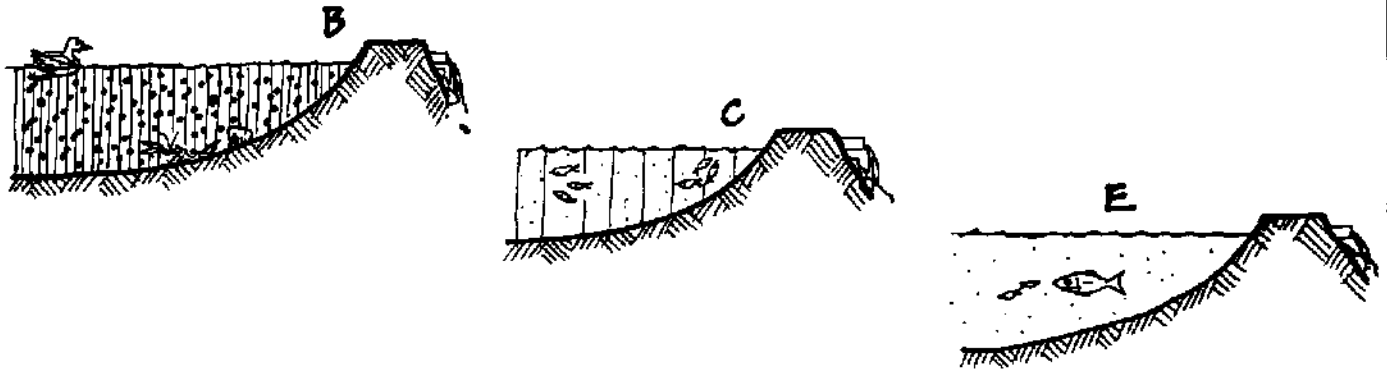

FIGURE 13.33

LEVELS OF POLLUTANTS IN PONDS.

Pollutants, here as manures, are successfully reduced by A. algae and zooplankton; B. invertebrates such as shrimp and shellfish; C. minnows; D. baitfish; and E. a polyculture of predatory fish. Water plants and margin plants greatly assist this process.

TABLE 13.3
ORDERS OF YIELDS GIVEN SPECIFIED CONDITIONS.

kg/ha/year protein	CONDITIONS
10 – 50	Deep, cold; rocks around lakes with few shallows.
30 – 60	Deep artificial resevoirs
60 – 90	Artificial resevoirs modified for fish and forage culture.
80 – 150	Natural shallow lakes, unfertilized, e.g. glacial outwash areas, natural shrimp yields in coastal lagoons of low pH.
200 – 500	Basic "standing crop" of fish in fertile (but not fed) fish ponds, e.g. bass, trout, bluegill; extensive fertilized waters of one to three species.
500 – 1,000	Unfertilized brackish lagoon cultures of milkfish; modified rice padi crop of carp or <i>richoseras</i> ; central padi "plateau" cropped, and plants cut for water manure. This is the upper range of totally natural systems.
1,000 – 2,000	Fertilized, extensive carp, milkfish, and mullet cultures, including a dry cycle. About the limit of extensive systems. <i>Puntius</i> in padi culture; intensive prawn culture. Fertilizer now 25–50% of costs. Well-chosen and unfed ploycultures can also achieve these yields.
2,000 – 5,000	<u>Intensively</u> fertilized and fed pond polycultures of selected species; water quality monitored. Some feeding or crop residues supplied. Optimum conditions. Food is 60+% of total costs.
5,000 – 20,000	Intensive cage and cauf cultures or small aerated ponds of carp, catfish, tilapia; fertilizer and food now 96% of total costs, and waste products may limit production; disease control is critical. land cycle of wastes essential, to reduce nitrates.
20,000 – 150,000+	Cage culture in oxygenated food-rich streams or with accessory foods. Vigorous flow or waste removal essential and achieved by channel flow. Hardy and disease-free fish stocks essential.

numbers, but at a gain in energy needed to feed them.

Fish such as *Tilapia* and carp are commonly fed on starchy foods from adjacent crop (pumpkin, banana, sweet potato, yam, taro, beans and bean flours, grains and doughs), but also eagerly eat the fallen insects, seed, and fruit from fringing vegetation, along with selected water weeds.

Tilapia, in particular, eat many fruits and edible leaves from garden weeds and vines. For this reason, market gardens and fish ponds belong together, but as fish-pond water is also of good nutrient value to gardens, the relationship is enhanced. Crop production from well-fertilised ponds may be as much as twice that from resevoir irrigation.

Grass carp neatly trim fringing vegetation such as *Dolichos* species, and save encroachment of weeds into taro, while not only mixing quite well with *Macrobrachium* prawns but actually increasing prawn yields without feeding them artificial food. Like *Tilapia*, they appreciate garden waste, plants, and fruits. Barry Costa-Pierce (pers. comm.) has a variety of polycultures under test in Hawaii, and the ponds in which he keeps grass carp with prawns have neatly-trimmed edges (bitten by the fish, not lawn

mowers), while the prawns grow as well on grass carp fecal detritus as they do on chicken pellets in nearby monoculture ponds. Even if they grow less, or if we increased pond margins as an edge effect, or planted comfrey and clover, *Dolichos*, *Tradescantia*, and lucerne along the pond edges for fodder, it is preferable to create the conditions for yield at the pond than to import them from elsewhere at great cost in energy.

13.7

CHANNEL, CANAL, AND CHINAMPA

Next to cages (and sometimes integrated with them) channels of 0.5–2.0 m deep are widely used in fish culture; they are the only economic way to develop "ponds" on slopes of more than 8° unless we develop water terraces. Channels maximise edge effects, and natural foods can be substantially more available in channel culture. The chinampa is probably *the* most efficient culture configuration for natural feeding of fish, and many rice padis have now been modified for this effect.

"The chinampas... of the Valley of Mexico... date back

YIELDS OUTSIDE THE POND

more than 2000 years and were the main source of foodstuff for the inhabitants of the entire valley, producing as many as seven different crops in a year, two of which were maize." (Tompkins, P. 1976, *Mysteries of the Mexican Pyramids*, Harper and Row.) Properly maintained, chinampas could remain fertile for centuries without having to lie fallow. Rafts of water vegetation were cut from the surface of the canals and towed to mounded banks where they were built up in layers and covered with rich mud scooped up from the canal bottom.

I have extended the use of the word chinampa to include any system in which a sequence of canals and banks in approximate parallels are developed for growing fish and marginal plants. Given a body of standing water such as a lake or swamp, or a humid landscape with a clay base that will retain water all year, or a water table close to the land surface, it is possible to create a cross-section harmonic of land and water whose uses are bounded only by the limits set by climate, the imagination, and the harvest capacity of the designer. Chinampa systems combine the best of both worlds in soil and water culture, and are in use in deltaic regions of Thailand to grow fish and truck crop, ducks and fruit trees (Figure 13.34).

There is one other strategic benefit of chinampa systems, in that useful but potentially rampant species such as runner bamboo, vine blackberry, hops, horse-radish and like crops can be water-isolated from other land systems. Small moated islands have the same facility, and waterfowl can nest or rest on these without interference from foxes and feral cats.

We can cheaply create chinampa swamps with a few compacted retaining walls where water levels are regulated to back up over chinampa systems. The ratio of channel to dryland culture is normally about 1:1-3, but if we reverse this ratio, herbivorous fish, plankton eaters, and crayfish are self-foraging.

Crayfish and grass carp in channels 2 m wide, ranging over a swamp strip of 5-10 m wide have a rich forage supply, plus land edges. The terrace or swamp can be drained, and in 3-4 weeks harvested or cropped, and the vegetation of terrace and shelf act as fish food and manure. With the right selection of species (ducks, mussels, weed-eating fish, crayfish, or eels) such systems give yields in excess of 1000 kg/ha of water surface, as many food organisms and plants are intimately available to the canal fish.

On slopes, Huet (1964) reports good yields from trout canals in Switzerland (fed or unfed) at 40-60% greater than broad-pond culture. For hill canals, a reliable water intake and clay soils are essential to permanence. The vegetation of the edges, shallows, and margins are a critical factor in nutrient supply.

Flow down

We have dealt with "in pond" yields as factors of water quality and fish selection. This does not take into account upstream, incorporated, or downstream yields not directly related to fish flesh. For instance, if we feed industrial fish food pellets to ducks or pigs, and let the manures of these animals fertilise the ponds, we get about the same yield (or even more) of such plankton and detritus feeders as prawns, carp, *tilapia*, and mullet, plus the duck or pig products. This is a question of the correct routing of the food supplied, and involves land yields.

Further, if we use fertiliser on land crop, feed that to pigs and ducks, and use their manures for fish, we get an even greater yield. Beyond that, we can grow permanent low-fertiliser crop for pigs (banana, papaya, acorns), use sparing fertiliser, and get even greater total yields.

Alcohol recovery and the subsequent biogas digestion of green feed, tubers or starchy food, manures, and wastes produces a flow-on slurry not one whit less fertile than the original substances, so that we are now arriving at an integrated flow-down system of tree forage > animal protein > manures > alcohol > biogas > water crop (plants) > forage-fish. Even within this flow, side cycles to worms, notonectids, or *Daphnia* give better utilisation and a yield at every step. The problem that we begin to strike here is that no one family or person can manage a very complex integrated system. We need a higher order of social organisation in order to manage these maximum yields (Figure 13.35).

Margins

Ponds, depending on their shape, give a new and productive edge in landscape. Trees and vines grow better there, and selected marginal plants drop leaves, insects, insect wastes, fruits, and extend roots into ponds as fish foods. They also shelter ponds or direct winds over them, prevent over-heating and chilling of waters, and provide cover for forage species. Thus, a whole set of yields are available from pond margins.

Ponds

We know that weedy shallows, brush piles, fences, rocks or pipes, and rafts provide additional shelter, escapement, or forage in ponds. There is a rich field here for increasing yields. We could devote 50% of the pond to such cover or forage systems.

Downstream

Water from densely-stocked fish ponds is a rich source of irrigation water for land plants. Yields from sewage or fish-pond water are 2-5 times that from intake water. These land crops, as fuels, food, forage, or structural product, must be integral to pond development if we are to realise the full value of fish ponds, and utilise the

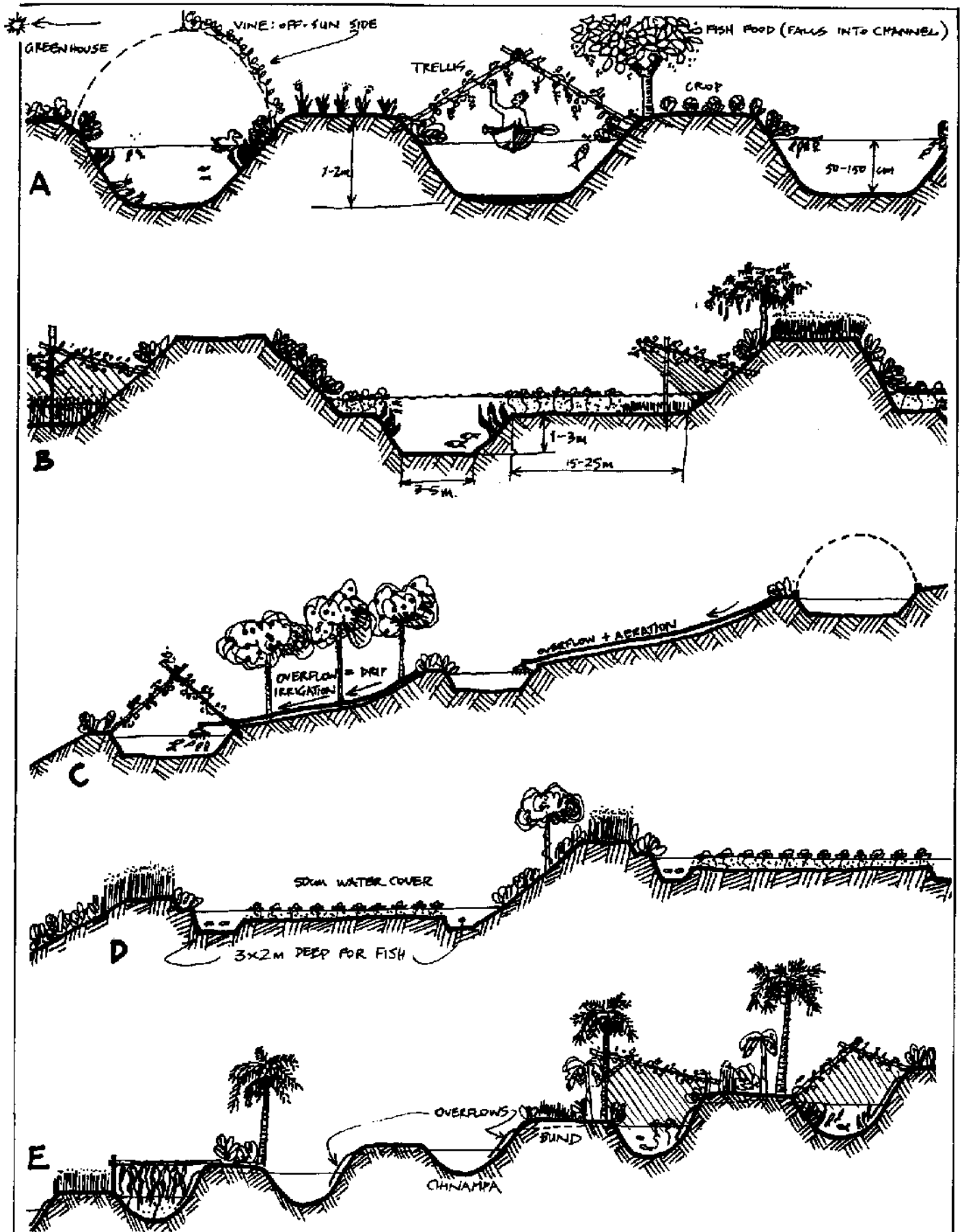

FIGURE 13.34
CHINAMPAS.

Some variations on the earth-water harmonic: A. in flatlands; B. in swamps; C. on hillsides; D. at terrace edges; and E. as canals on

clay-based hillsides with top-up stream water at highest level.

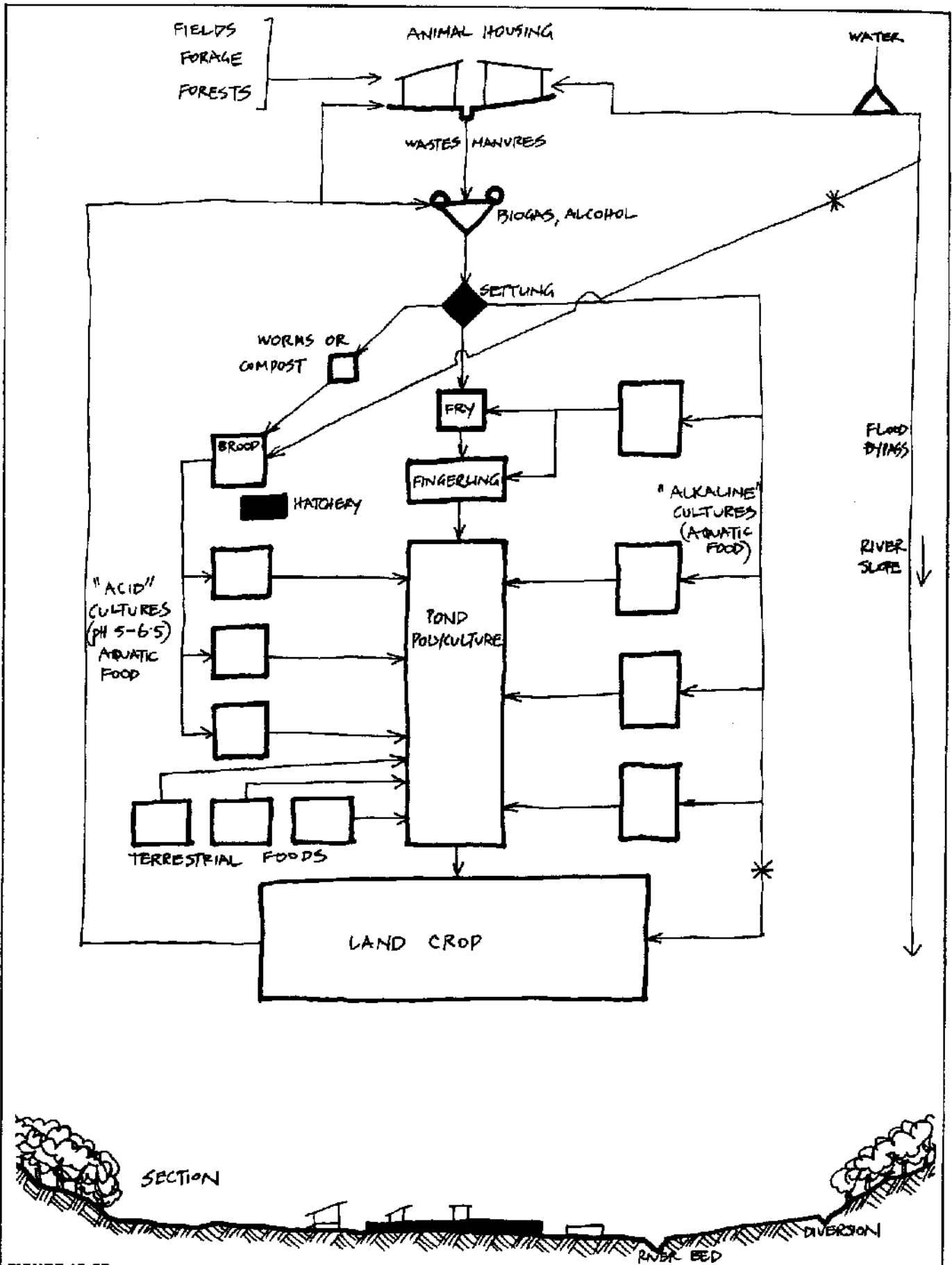

FIGURE 13.35

SCHEMATIC OF INTEGRATED POND SYSTEM.

Intended to self-provide for food and energy; forage for land animals is assumed.

wastes and algae flowing downstream.

PLANTS OF THE MARGINS

There is a curious lack of data on marginal plants in most literature, even if their value is sometimes noted in passing. What can marginal plants achieve?

- Cover for fish, shrimp, waterfowl, and hence predator protection.
- Spawning and nesting sites for fish and waterfowl.
- Fruits and flowers which manure or directly feed organisms in and on the water.
- Leaves, bark, limbs, and detritus for decomposers in the water such as diatoms, phreatocids, algae, sponges.
- Hence a feeding base for fish and low-trophic feeders or browsers such as shrimp, mullet, and molluscs.
- Insects attracted to blossoms, or falling as larval and pupal forms into the pond.
- pH modification from mulch and leaves, buffering of extreme pH levels.
- Materials to control mosquito larvae and snails, to stupify fish, to make traps and screens, and for conduits and pipes.
- Prevention of bank erosion by mat roots and leaf buffering of wave and flow energy.
- Wind, shelter, shade, and hence evaporation and temperature modification.
- Beautiful reflections.... what more could one ask?

Marginal plants live in a milieu of fairly constant moisture and buffered temperature changes, hence tend to be reliable producers of fruit, nectar, and flowers,

tubers and foliage. Many are either very resistant, or very susceptible, to water rot and attack from aquatic organisms, hence making excellent wharf and boat timbers, or rotted mulch in water. Others contain air cells which make them light and buoyant, or conversely are very dense and sink like stones (*lignum vitae*), so that marginal or aquatic timbers have unique values in specific usages.

In crop, those honey-producers of ditches and ponds are very reliable in yield, while tubers are consistently produced, and drought is an unknown restraint on yield (Figure 13.36).

13.9

BRINGING IN THE HARVEST

There are very few areas of the western world where fresh fish is easily available locally (unless we live near a city fish-market). Modest aquacultural ponds can change that, as fish of known quality and species can be locally supplied. Aquaculture brings shellfish and crayfish or shrimp to areas remote from sea resources. At present, affluent nations eat about 10% (6.1 kg) of fish and 90% red meats (60.1 kg). (Figures for the USA in 1979 from *Science* 206, 21 Dec., 1979.) This is all due to change as aquacultures mature.

It helps a great deal if regional growers can establish a "people's market" on the model of organic growers, when even live fish can be offered. Variety can also be built in if growers allot species to specific members, or if complex polycultures are established.

Processing of fish on farm has many advantages. Drying, smoking, freezing, and salting or reducing to pastes and sauces are all small-scale activities. It is

FIGURE 13.36

WETLAND MARGINS AND ENVIRONMENT

Hummock or chinampa systems allow self-irrigated crop, waterfowl nest sites, and special crop at water edges.

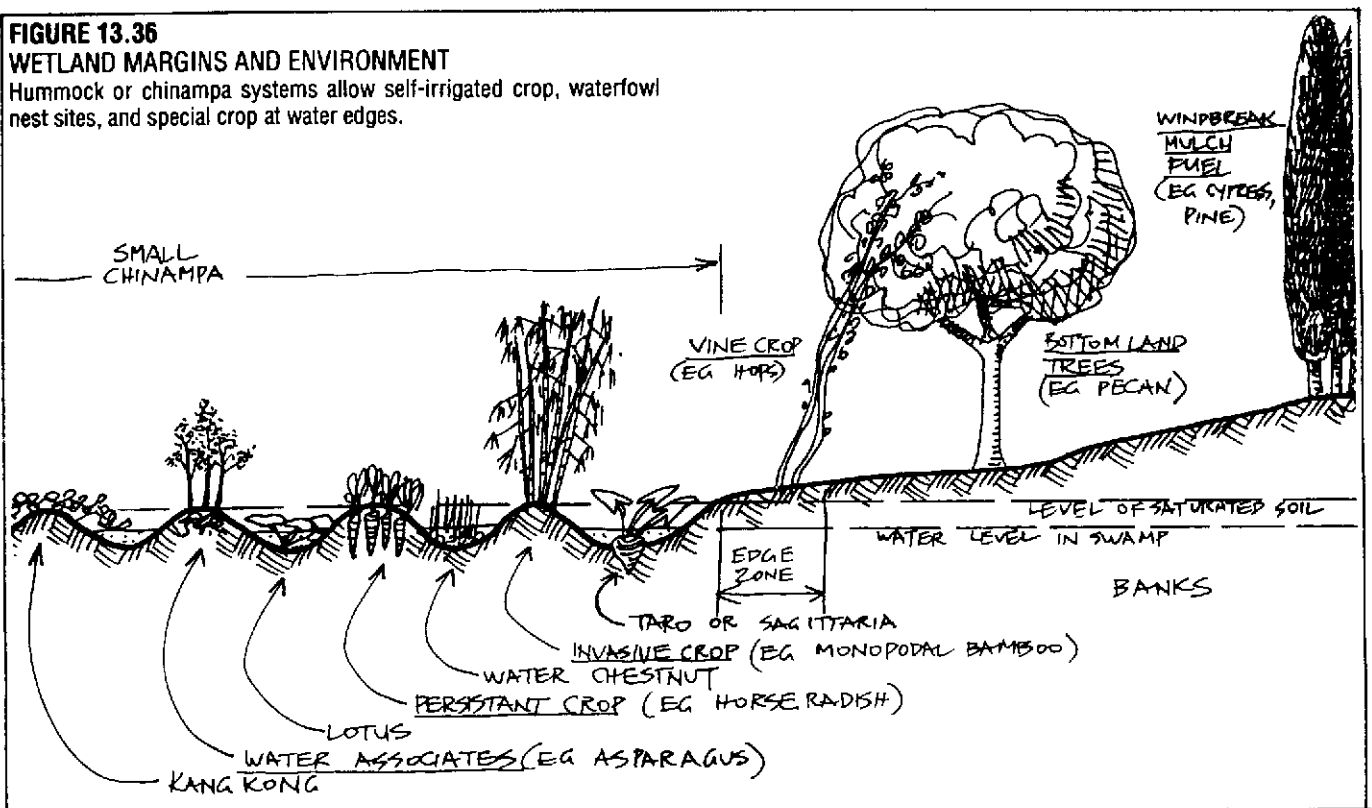

critical to protein production in the tropics that rapid processing of fish is achieved in view of the potential for spoilage. More everyday manufacture of clear plastic drying tents or boxes is needed rather than emphasis on increasing fishing efficiency or production, as up to 40% of a catch can be lost to spoilage and damage by rodents and birds.

Ferment of fish wastes (as practiced in Indonesia) produces a protein-rich, salt-stabilised liquid sauce of great value to people on rice diets, and such techniques are an essential part of salvaging fish wastes for market dispersal. Processing also increases on-farm economics and rural employment potential.

For non-carnivorous species, catch-and-restock systems can greatly increase yields over batch or total removal of the species. Many permanent ponds are run on this basis, or that of natural breeding in the case of crayfish (when a *maximum* size limit is used to return large, fast-growing breeders to the pond or breeding area). It is always wise to consider returning or keeping the largest fish, and eating the slightly smaller grades (unfortunately not a strategy well-applied in sea fisheries).

Although a great emphasis is put on fish, true aquacultural planning should always include diverse plant products, with emphasis on local staples. Fish are then accessory to a broad product base, and to tree crops. The disease problems that build up in aquacultures are due to over-emphasis on one species or class of food and high yields, and also to a neglect of shade, wild foods, and the beneficial effects of plants on water quality.

13.10

TRADITIONAL AND NEW WATER POLY CULTURES

The very antiquity of some terrace and riverside cultures demonstrates their sustainability in human terms. The wet terraces of the Ifugao people of the Philippines have been in use for at least 3,000 years; the flood cultures of the Nile (now sadly but perhaps temporarily ended) is probably 17,000 years old; the chinampa system of Mexico is also antique, as are the flood-plain, lakeside, and river cultures of Asia.

Harold Conklin in "Ethnographic Cities of Ifugao", *Scientific American (Review)* February 1982, calculates that 1000 years of toil created these terrace cultures. He makes a commentary on water cultures that Fox (1977) makes on the Indonesian palm cultures—that these peoples recognise no external authority. Not only is it an inappropriate and interfering concept in self-sustained systems, but the creators of such systems have learned a self-governance never developed by any central authority in history. The construction of common canal systems and shared irrigation necessitates community organisation and self-control. Hydraulic despotism, as found in colonised areas, predisposes societies to exploitation and centralised government. Water is, in all sane or democratic

societies, regarded as a *public* resource.

Growing 0.5 hectares of padi rice, and 0.25 ha of sweet potato as staples, with 1 ha of woodlot and grove crop, domestic pigs and chickens fed from gleanings and crop, the Ifugao family of 5 spend 400 person days of productive labour per year, or 80 days per able individual. Rainfall is an incredible 3 to 6 m/year, necessitating constant terrace maintenance. The terraces have 2 cm of soil, and half the mass of the bunds is in stone. Canal and ditch maintenance necessitate annual earth and stone repairs; the equivalent value or objective cost is one day of rice for one hour of work.

There are a good many useful plant species of the marine and aquatic environment; only some 20–30 species of water plants are in constant culture or have been subject to varietal selection. Many species are still wild-gathered or (if cultured) are derived from unselected wild stock. Yet there is an obvious potential for wetland forestry, craft product, and specialised forage crop assembles for species such as bees, ducks or waterfowl, and fish. Pigs utilise seasonal swamps and water margins for a variety of fodders. Cattle enter lagoons and shallow waters to browse, while species like the Soay sheep, turtles, and the Galapagos iguana browse the large seaweeds of the seashore, and seagrasses. In samphire pastures geese, swan, and fish species browse at varying tide levels. Anyone interested in specific plant assemblies can evolve a fairly complex array of forbs, shrubs, vines, and trees to suit specific or specialised purposes. There is an obvious role for seed, vegetative, and general aquatic nurseries and suppliers, which are undeveloped in most countries.

Rather than enumerate all the cultured species, I have chosen to deal with a few selected polycultures of plants, to briefly treat the marginal plantings, and to suggest plant assemblies for specific sites. I will describe both a cold area and subtropic plant system to illustrate the aquatic potential, selecting wild rice (*Zizania*) for cool areas, and taro (*Colocasia*) for the tropics. Rice (*Oryza*) itself is grown from temperate to tropical areas, and is not dealt with here, but is very well described by Fukuoka^(3,4).

WILD RICE CULTURE

(*Zizania lacustris*) Minnesota, very cold winters and hot summers.

Wild rice is a tall annual grass (to 2.5 m) with several perennial species in the same genus; it has been gathered as a grain for centuries by Amerindian tribes of Canada and the United States, from Minnesota to Florida.

Species or seed collected for culture trials should be gathered from selected plants at the climatic and water provenance suited to the culture site. Some few crops have been grown in the Southern hemisphere, but for the most part the 3 million kg produced are grown in the Minnesotan region. Of the total production, about 50% is still wild-gathered in traditional fashion by Amerindians, who beat out the grains into a canoe, and

the remainder in extensive fields of up to 100 ha created by modern growers, with all the inefficiencies that monocultures entail.

Wild rice has been brought into culture within the last 30 years, and selection is now taking place. It is therefore one of the most recent grains to be developed, but one peculiarly suited to cold swamps and shallows with intense summer heat. The original culture was for duck flyway (wildlife) seed, and wild ducks harvest perhaps 70% of the total production, as the seed ripens slowly over 3–4 weeks. Mechanical harvest gathers only that seed which is ripe at harvest. Thus, while commercial yields are low (only 50–100 kg/ha), prices are high (at \$10 kg in 1984), so that fields of 100 hectares or so give a cash return of up to \$100,000 annually in rice alone.

Wildfowl, in dabbling the fallen seed in fields, help thin out seed which will germinate after a winter stratification; the plants crowd if not so thinned. Ideal spacing is 20 x 35 cm, and for small plots, with selected heads, yield can be 200–500 g/head. Obviously, the problem with yield is not in the plant, but in the need to harvest at one time, mechanically. Home plots, gathered over 3–4 weeks, are in fact very productive, and only 200–800 plants should supply a family if well cared for. A strategy used by Indians to save the grain from predation and shattering is to bundle and tie 10–20 heads together, and to untie them periodically for threshing into canoes.

Seed is saved from selected plants and held over winter in bags under water in the icy lakes, or in water in refrigerators at 40°F. It is sown in spring in fields flooded to about 16–20 cm deep, and harvested from mid–autumn. The fields are dried out for 2–3 weeks before machine harvesting, and must be rested or sown to another crop to clean the ground if a new cultivar is to be introduced, as self-seeding otherwise perpetuates the first-sown variety.

In the large fields and deep margin ditches of Minnesota, a self-generated polyculture of crayfish (*Homarus*), mink, beaver, and thousands of waterfowl has evolved with the wild rice culture. Coyote also range the bunds, and packrats store much of the seed. The crayfish live in ditches and browse 5–10 m into the crop, causing some damage, but as they are themselves a potential crop, or a food for mink, this is tolerated. Duck potato (*Sagittaria*) can become a weed of the system, but this is also a waterfowl food and prefers somewhat deeper water than the rice plant, or can be removed by culture or hand weeding if necessary. There is an obvious potential for coldwater fish-rearing in the canals and ditches of the system (species such as trout and bullheads), not as yet developed. Manuring by *Azolla* is not practiced, and the fields are rested dry in winter.

An intriguing potential is the propensity of the packrats to carry and store large quantities of sound, cleaned grain into artificial shelters (like engine manifolds), insulated and plugged by *Typha* (cumbungi, cattail) seed silk. Narrow fields and a set of such

artificial storage sites may well be the best way to harvest, and breeding packrats could be supplied with alternative food for the winter, or allowed to keep 15% of their stores full. They may well be the most efficient, as well as the cleanest, harvesters for the crop, and can scarcely do worse than the 50–100 kg (or less than 10%) gathered by machines costing \$300,000 or more! Bill Mackently (pers. comm.) uses grey squirrels to collect hickory nuts and acorns in this way, and provides them with buried pipes to store the nuts. He leaves them about 15% of the harvest.

Duck fattening, crayfish harvest, mussel meats, fish production, and vine crop of hops or silverberries (*Actinidia arguta*) are obvious supplementary products to the crop, and could be viable accessory systems, together with restricted fur production, some special forestry, and recreational fishing or tour potential. I have attempted to portray some of this complexity in Figure 13.37, and acknowledge my debt to the pioneer growers Hubert and Leonard Jacobson of Aitken, Minnesota, who kindly supplied me with data (and some wild rice to eat). A small terrace or pond of wild rice should be the aim of every home gardener who can obtain seed and who enjoys a nutritious grain, as most Americans do. For wildlife (especially waterfowl!) refugees, there is no better autumn fodder.

TARO CULTURE

(*Colocasia esculenta*) Hawaii, subtropics to tropics, and cooler frost-free areas.

I admit to a weak spot for taro fields and terraces, especially those of the traditional Hawaiian culture. Taro is an herbaceous perennial to 1 m high with large arrow-like leaves and a swollen stem base or tuber which can reach 10 kg, but is normally marketed at 1 kg or so, after an 8–15 month growing period (there is no "off season" in the subtropics).

There were some 1,100 Hawaiian varieties, and perhaps 100 or so are still preserved. It is a staple food in Hawaii and some other parts of Polynesia and southeast Asia, where rice or breadfruit are also staples. Grown as a monoculture plant for centuries, the recent accidental or deliberate introduction of *Azolla*, *Tilapia*, fish, crayfish, and Chinese edible coiled gastropod snails have diversified the wet terrace cultures, although the Hawaiians traditionally rear local fish and prawn species in the ponds.

Taro is propagated by small side tubers or more commonly by a cutting based on a crown disc of about 1 cm thick, and the lower 18 cm of stalk from the old tuber at harvest. Cuttings have the leaves removed by a slant cut just above the first leaf node.

There are special varieties for boiling, baking, ferment to *poi*, or cooking as green leaf spinach (*luau taro*). All taro must be cooked due to the stinging crystals of oxalic acid in the leaves (which can grossly irritate the bare back of non-Hawaiians like myself, incautiously carrying bags of tubers in this way).

There has always been a fish culture tradition with

taro, of local prawns, shellfish, and freshwater fish. *Tilapia* and introduced prawns have merely extended the potential, as have crayfish (*Homarus spp*). What is missing is a good variety of edible freshwater mussels to fix phosphates in the terrace mud. In older times, nutrient supply was of forest leaves (chiefly *Aleurites* or *Hibiscus*). The stems of kukui trees (*Aleurites*) were stood to rot in the upper terraces where they produced a local edible ear fungus. About 80% of the bulk of a log was in this way converted to fungus, and the remainder broken up as water mulch. Very extensive canal and wet terrace systems were developed for taro culture, and the fermented *poi* used as a staple, as were boiled or baked taro.

Accessory margin crops are ti (*Cordyline*)—the Polynesian "wax paper" and wrapper for baked foods—papaya, banana, coconut, and sugar cane. No vine crop was grown, but as taro appreciates partial shade, there is a potential for marginal or wide-spaced overhead kiwifruit, passionfruit, pole bean, or cucurbit crop. Bunds planted to *Dolichos hosei* or *Phylla nodosa* (was *Lippia nodosa*) would be useful nitrogenous mulch sources, and would remain short and trimmed at the water level by *Tilapia* or grass carp (which are also on Hawaii).

As pigs and latterly ducks are also traditional livestock, construction of their pens over feeder canals or the upper terraces would add substantially to nutrient supply, although the ducks need confinement to a few ponds as they too appreciate the edible Chinese snails (which are a high-priced local delicacy).

Taro is also grown on dryland areas under irrigation, and responds very well to thick mulch and green crop. In these situations intercrop of *Brassica*, melons, ginger, or lettuce is viable. Beds are normally 1.3 m wide at 30 beds/ha, with taro spaced at 40 x 60 cm in diamond pattern. There are 55,500 bulbs/ha, averaging 1 kg or a little more for each bulb, or a yield of 55 t/ha. Drip irrigation is also used on land crop, at 120 lines/ha (4 per bed). Spacing in wet terrace is similar, but the "intercrop" there is more profitably prawns, although kangkong and watercress are spot-planted in many taro terraces for greens, and both are planted as low mound crop in special shallow terrace or canal systems with faster flow than is found in taro systems.

In other climates, or mild coasts of the Atlantic and western Pacific (New Zealand), eel rearing would combine very well with taro culture. Taro is set out in wet mud or shallow water, but at maturity can be kept flooded at mid-thigh, or with 0.5 m of free water above the softer muds of the terrace, where prawns and grass carp (which co-exist very well) can be stocked.

It is obvious from the above information, much of which I owe to the hospitality of friends like Chuck and Tina Busby, Imu and Rachel Naki on Moloka'i, and Richard Waller on Hawaii itself (dry taro culture), that taro is a very productive and flexible plant for a basic starchy food, and that a rich polyculture can be developed in the taro which is itself well protected from browsers by its oxalic acid spicules.

Every tropical garden deserves a patch or so of taro; it is often grown as a mulched patch or groundcover below fruit trees in higher rainfall areas, or as a subsidiary crop in banana, guava, avocado, and macadamia nut orchards. There is no more pleasant environment than a rich taro, comfrey, papaya, guava, and banana polyculture, with chilis, ginger, peppers, ducks, pigs, and fish, a visit to the sea for *limu* (seaweed) and crab, and a good earth oven (*imu*) to cook in.

The foregoing detailed accounts of the traditional and possible aquaculture systems may give designers and farmers some different ideas for productive local land-water integrations.

FIGURE 13.37
WILD RICE CULTURE.

Associated mink, beaver, crayfish, mussels, pack rats, trellis, greenhouse adds to yields; tying of heads prevents seed loss from shattering. [Jörg Schultz].

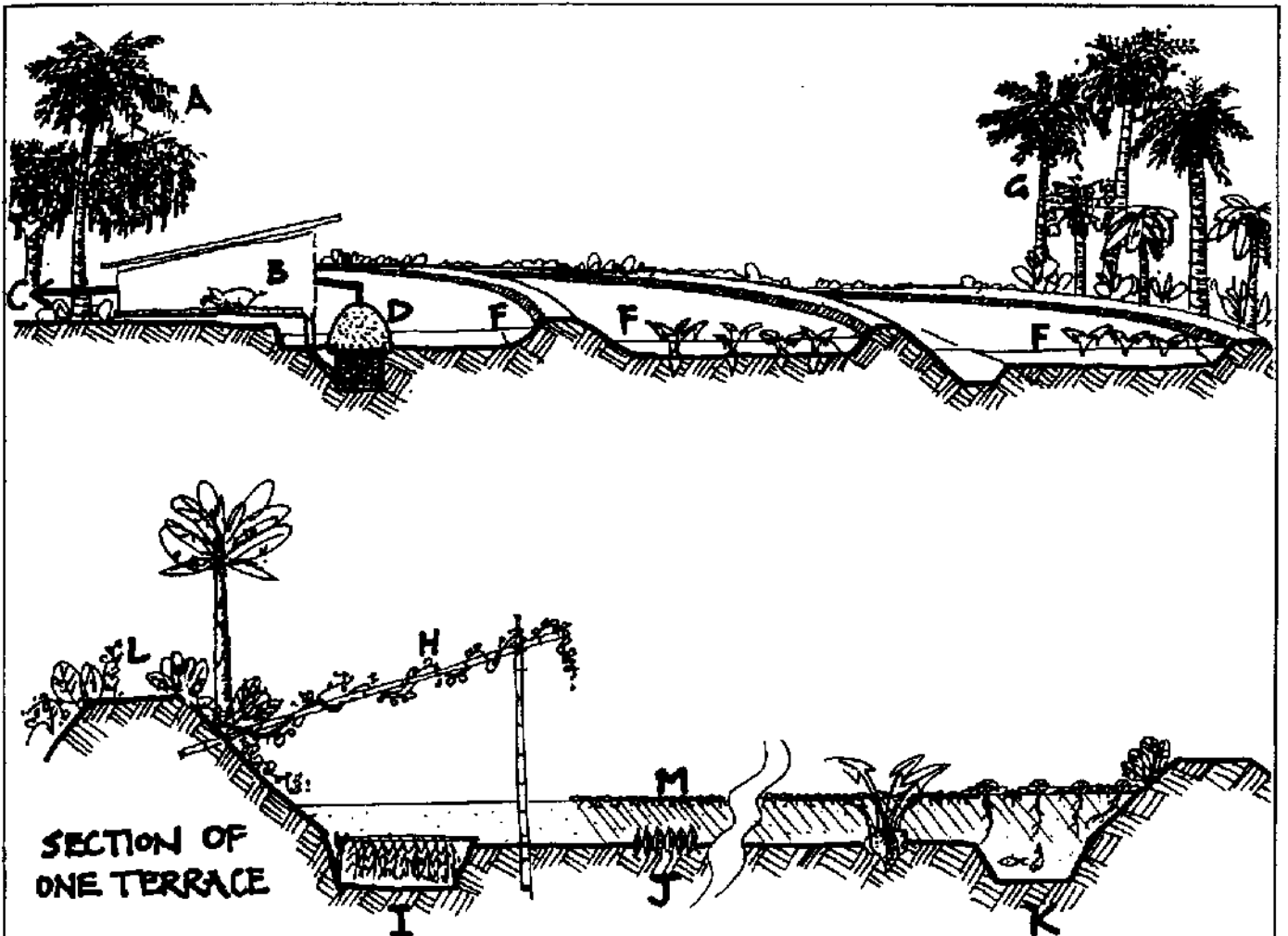
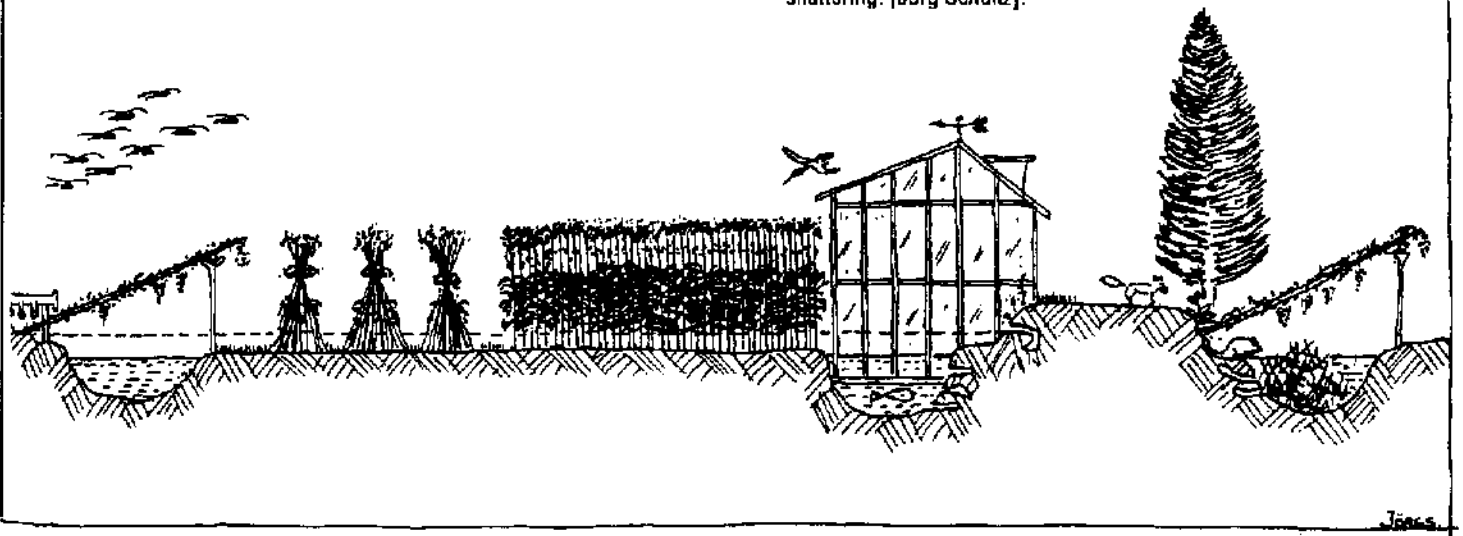

FIGURE 13.38
TARO TERRACES.

Nutrient as an in-pond gas digester (D) is released to all ponds (F-F) in series; pigs (B) bring nutrient from land forages (A), which are also used to clean up discharge water (G). Useful bund crop (G), trellis

over ponds (H), screened deeps for prawns (I) or fish (K), azolla as mulch (M), mussels as phosphate (J) all add to yields of traditional taro terraces, or rice culture.

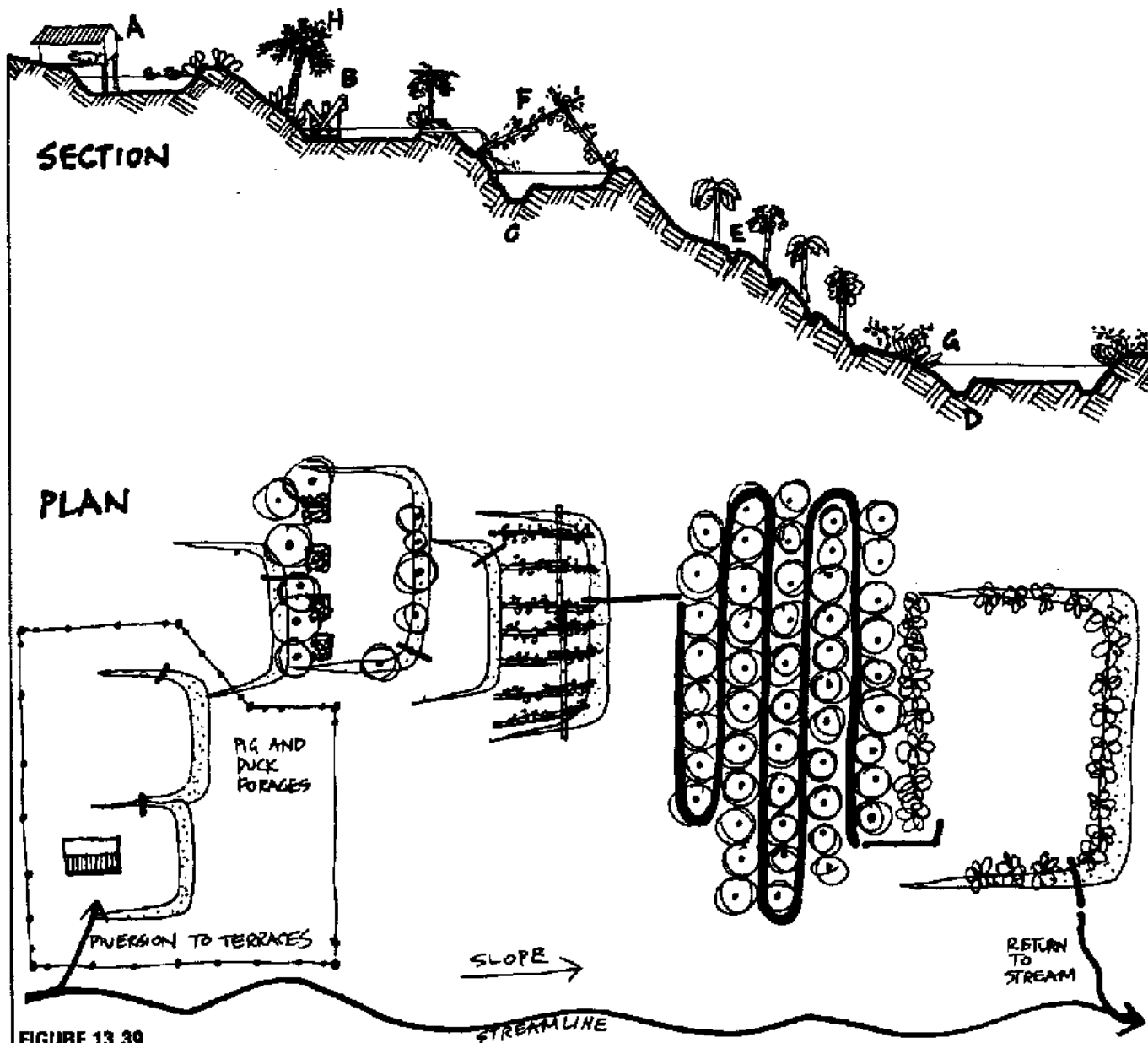

FIGURE 13.39

MODIFICATIONS TO TARO FIELDS.

Water is diverted from stream, fertilised, used in crop, and returned to stream free of pollutants.

A. Animal house; B. logs rotting to produce edible fungi (*Aleurites*); C. deep channel for shrimp, fish; D. fish-taro padi with peripheral

channel; E. series of irrigation channels in papaya crop, bananas; F. cucurbits, beans on trellis; G. margin crops e.g. comfrey, taro, *Tradescantia* for fish food; and H. coconut on margins.

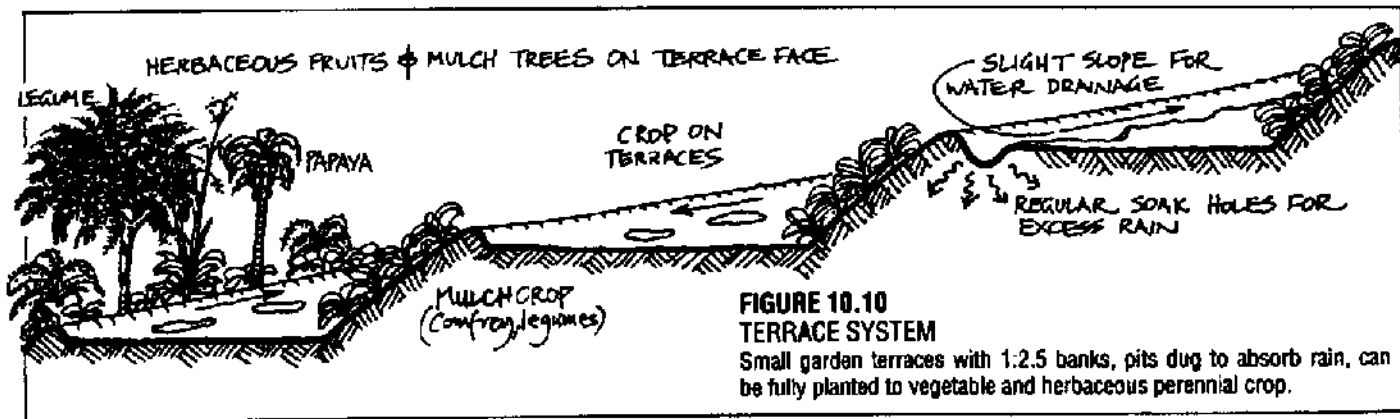

FIGURE 10.11

SETS OF NARROW TERRACES ON STEEP SLOPES;

A series should be limited to 6-8 at one place, forested above and below, and to the sides, for stability; paths slope alternately to spill excess run-off, and are mulched. Twice annually path mulch is lifted to uphill terrace beds.

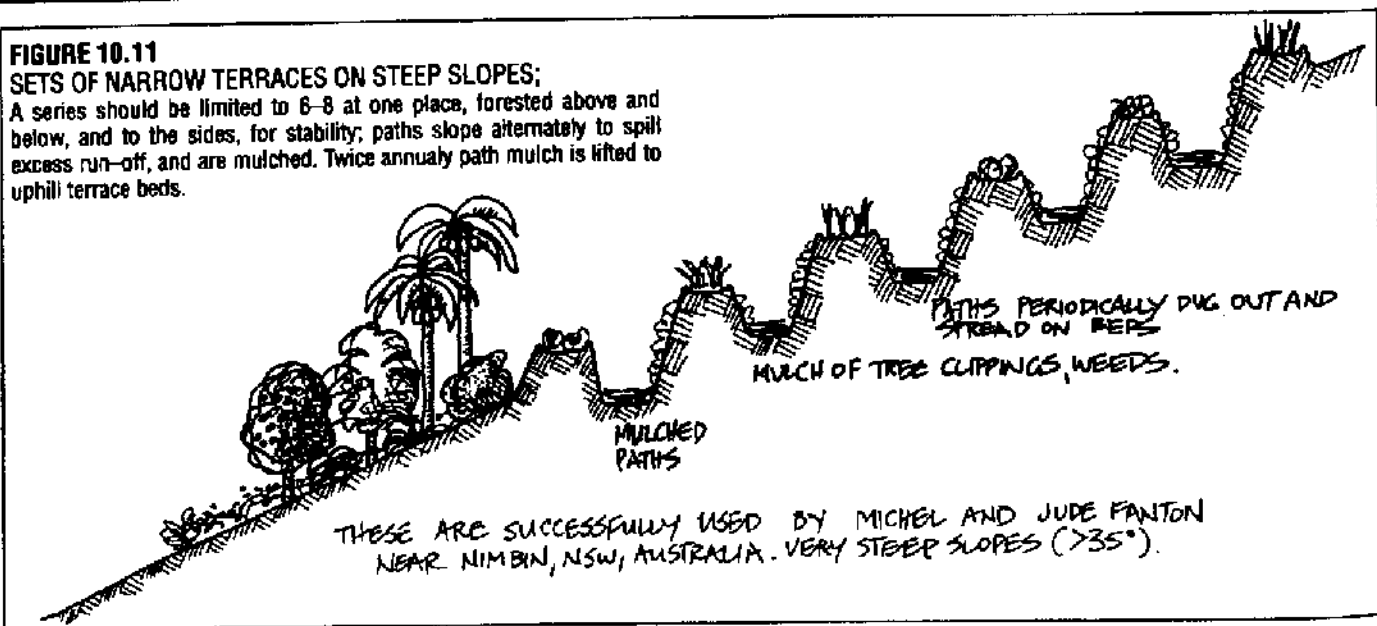
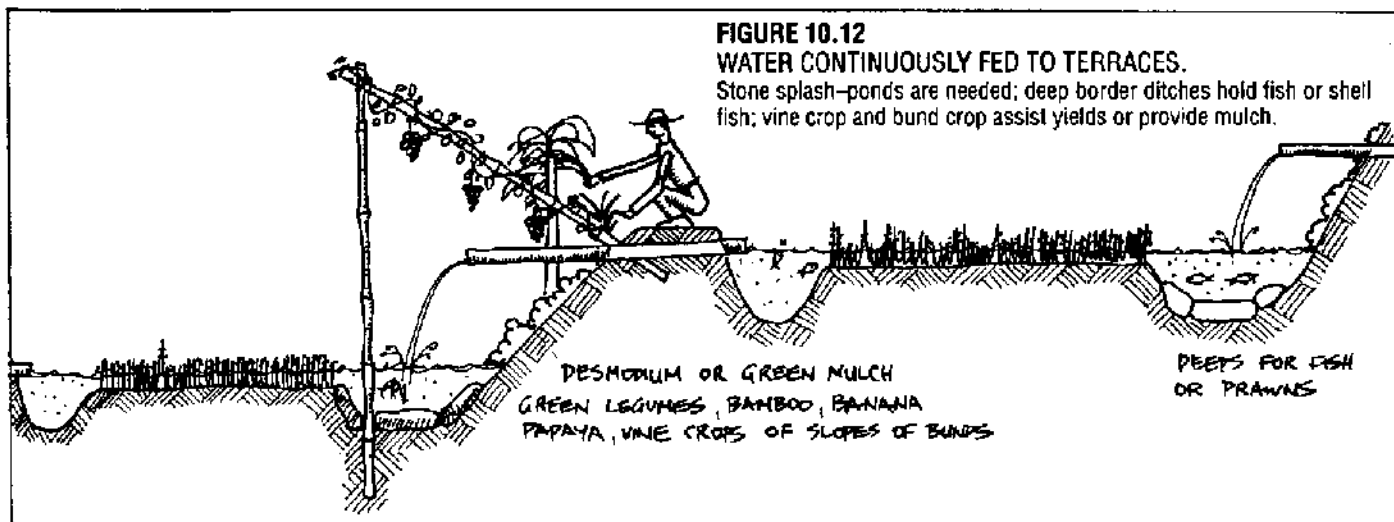

FIGURE 10.12

WATER CONTINUOUSLY FED TO TERRACES.

Stone splash-ponds are needed; deep border ditches hold fish or shell fish; vine crop and bund crop assist yields or provide mulch.



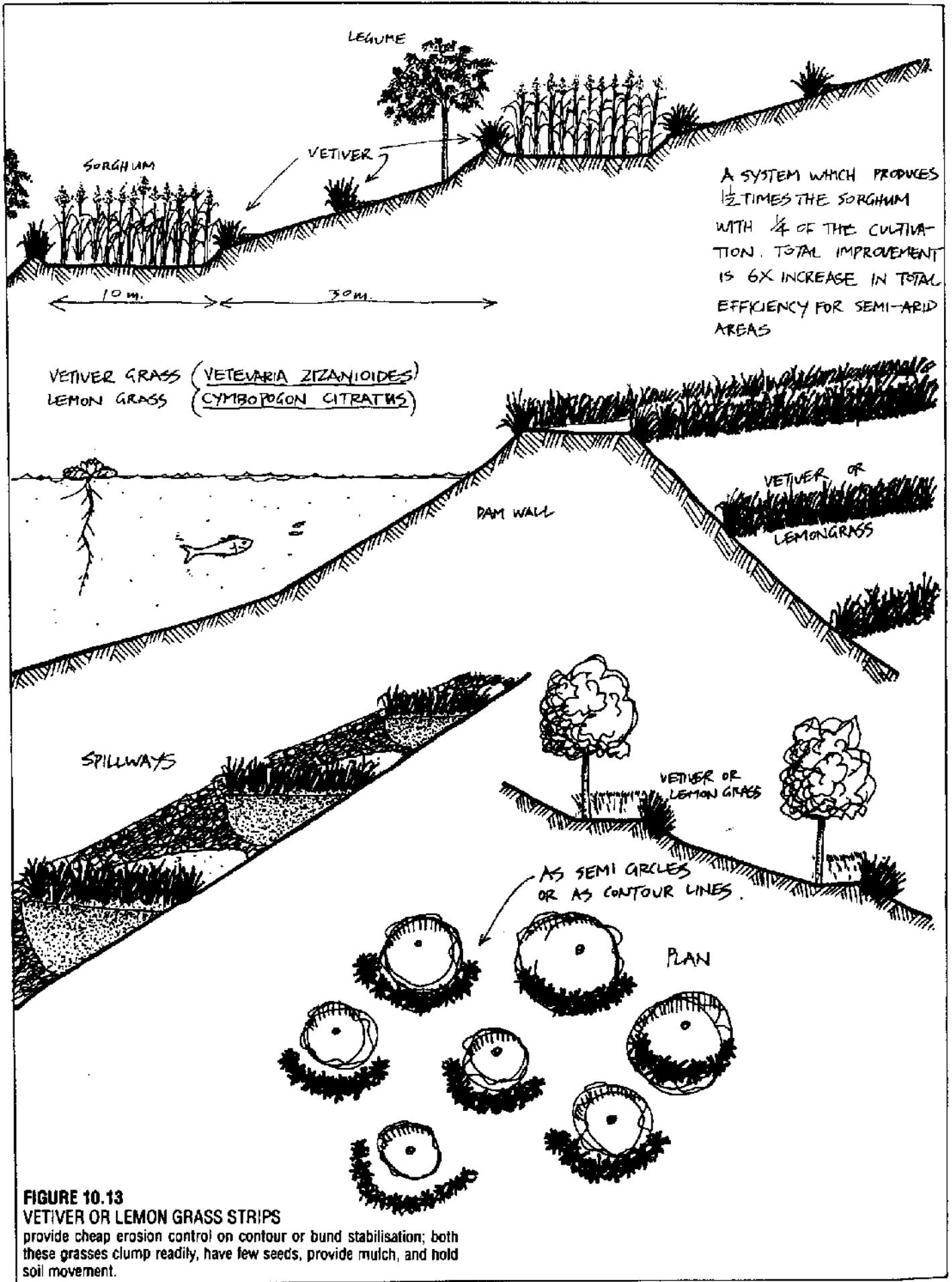

FIGURE 10.13

VETIVER OR LEMON GRASS STRIPS

provide cheap erosion control on contour or bund stabilisation; both these grasses clump readily, have few seeds, provide mulch, and hold soil movement.

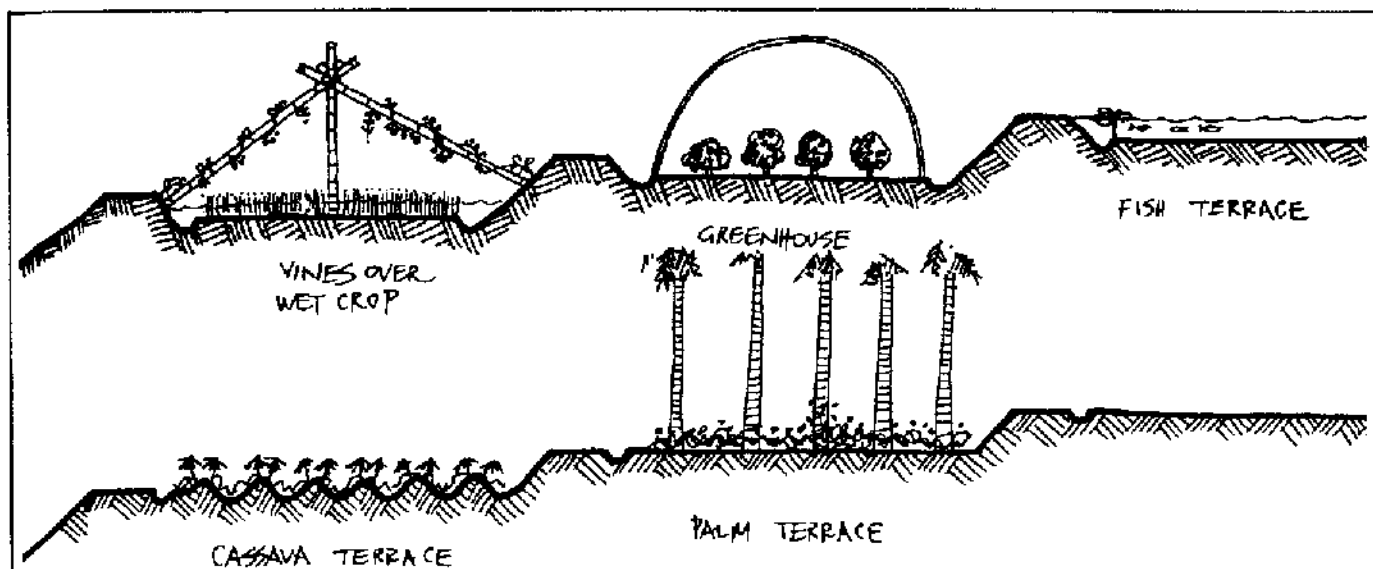

FIGURE 10.14

VARIATIONS ON TERRACE CULTURE.

Wet terrace (padi), fish crop, shadehouse or grow-tunnel, ridge crop,

palm, and grain culture vary production and stabilise terrace cultures; alternate dryland and wet (padi) crop suits summer-wet sub tropics.

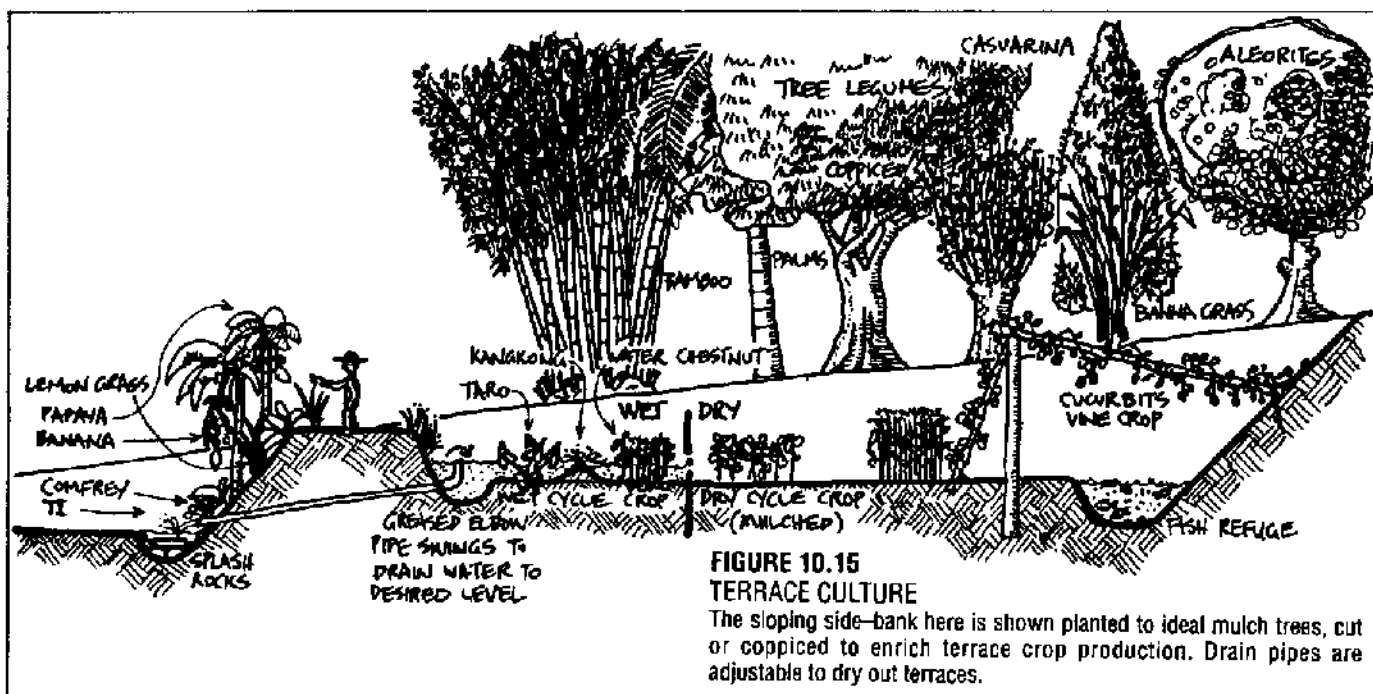

FIGURE 10.15
TERRACE CULTURE

The sloping side-bank here is shown planted to ideal mulch trees, cut or coppiced to enrich terrace crop production. Drain pipes are adjustable to dry out terraces.

AQUACULTURE: DESIGNERS' CHECKLIST

Due to the special susceptibility of water life, minimal to zero biocide use is essential near or in waterways.

With fish:

- Stock rates below, at, and above suspected optimum (plus or minus 2,000/ha).
- Fertilise pond and bring pH to 7+.
- Select diseasefree stock.
- Exclude or guard against predators.
- Maximise edge and natural foods.
- Introduce predator fish at about 1:5 ratio.
- Select fish for no pond aeration, or to suit the aeration method proposed.
- Select fish for good local value, but assess food costs for each species.
- Provide shelter from predators and excess light and heat.
- Select fast-growing brood stock for the particular site, from fry to adults.
- Devise a fish/plant polyculture for the ponds.

Analyse landscape for natural or cultivated food resources.

Vary pond depth, pond size, and pH to suit a set of food species and productive fish for the district.

Carefully analyse pond configurations for specific polycultures, easy management, site, and weather effects.

Pay attention to aquatic and marginal crops, downstream crop, and total landscape balance.

Devise accessory food systems for fish or invertebrates, as vegetation, root crop, invertebrates.

In any design, include some appropriate (small or large) wetlands, even if it is from waste water.

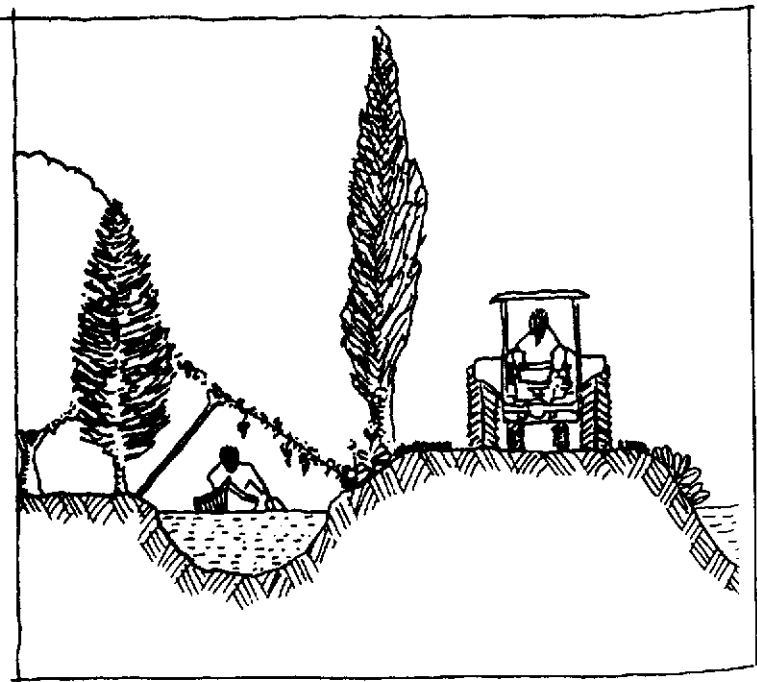

Happy growing.

REFERENCES

- Augusthy, K. T., *Fish Farming in Nepal*, Institute of Agriculture and Science, Tribhuvan University, Nepal, 1979.
- Bardach, J. E., J. H. Ryther and W. O. McLarney, *Aquaculture: the farming and husbandry of freshwater and marine organisms*, Wiley, N.Y. (A basic text.)
- Bryant, P., K. Jauncey, and T. Atack, *Backyard Fish Farming*, Prism Press, Dorset, U.K., 1980.
- Chakroff, Marilyn, 1982, *Freshwater Fish Pond Culture and Management*, Peace Corps/VITA Publications No. 36E, 1982.
- Darlington, P. J. Jr., *Zoogeography: the geographical distribution of animals*, John Wiley & Sons, Inc. London, 1963. (Some good discussions of species groups; for a wider reference.)
- FAO Fisheries Technical Paper No. 130, *A Catalogue of Cultivated Aquatic Organisms*, 1974.
- Hawaii State Center for Science Policy and Technology Assessment, *Aquaculture Development for Hawaii (1978)*.
- Hills, C. and H. Nakamura, *Food from Sunlight*, University of the Trees Press, California. (Algal culture and aquaculture.)
- Huet, Marcel, *Textbook of Fish Culture*, Fishing News Books Ltd. Surrey, U.K., 1975. (Excellent text on breeding and rearing of fish and coldwater species.)
- Huke, R. E. and R. W. Sherwin, *A Fish and Vegetable Grower for All Seasons*, Norwich Publications, Vermont, 1977.
- Iversen, E. S., *Farming the Edge of the Sea*, Fishing News Books, Surrey, U.K., 1968.
- Machado, A. E. de Mafra, *Criacao Pratica de Peixes*, Livraria S/A, Sao Paulo, Brazil, 1980.
- Maclean, J. L., 1975, *The Potential of Aquaculture in Australia*, Aust. Govt. Publishing, Canberra, ACT, 1975.
- Palmer, E. L. and H. S. Fowler, *Fieldbook of Natural History*, McGraw-Hill, N.Y., 1975. (A useful compendium of species and families.)
- Pullin, S. V. and Ziad H. Shehadeh, *Integrated Aquaculture and Aquaculture Farming Systems*, International Centre for Living Aquatic Resources Management (ICLARM), 1982, PO Box 1501, Metro Manila, The Philippines.
- Swingle, H. S., *Biological Means of Increasing Productivity in Ponds*, 1966. F.A.O. Symposium on warm-water pond fish culture 40-181, Rome, 18-25 May 1966. (A key reference on yield strategies in fertilised and supplemented food ponds.)
- Tapiaor, D. D. et. alia, *Freshwater Fisheries and Aquaculture in China*, F.A.O. Fisheries Technical Paper No. 68, Rome, 1976.
- Toews, D. A. A. and M. J. Brownlee, *A Handbook for Fish Habitat Protection on Forest Lands in British Columbia*, Government of Canada (undated).
- United States Academy of Sciences, *Making Aquatic Weeds Useful*, Washington, D.C., 1976.

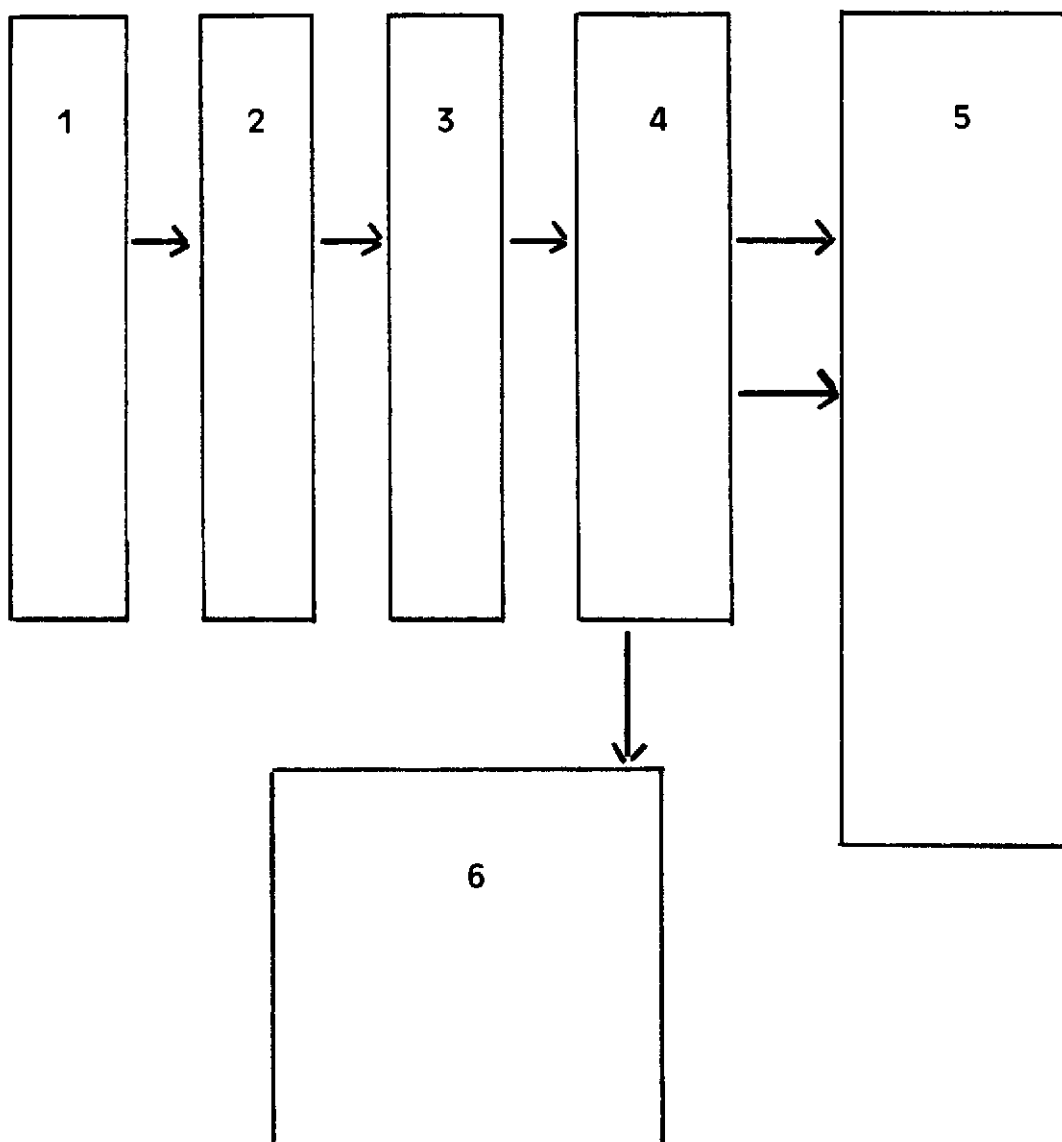

CARP IN FISH PONDS

- 1: Parent Carp => Pond 1.
Small shallow ponds, 5-30 cms. Temperature 14-16 degrees C.
- 2: Eggs are deposited on plant stems.
- 3: Parent fish are removed before the eggs are hatched.
- 4: The young remain in pond app. 1 week.
- 5: Removal to pond 2; remain app. 1 month, attain a length of app. 3 cms. Feed: - Daphniae, water fleas, aquatic molluscs
- 6: When fish reach wt. of app. 30-50 gr. => removal to pond 3.
- 7: Pond nr. 4, flowing water 1-2 m. deep, [necessary in cold season/s].
- 8: Pond 5 => Fish start wt. 30-50 gr. Finish wt. 300-500 gr.
Feed: Insect larvae
- 9: 2 year old fish in pond nr. 6. Depth of pond app. 30-70 mm.
Start wt. app. 300-500 gr.
Market/sales wt. app. 1300-1500 gr.

FISH PRODUCTION IN BANGLADESH

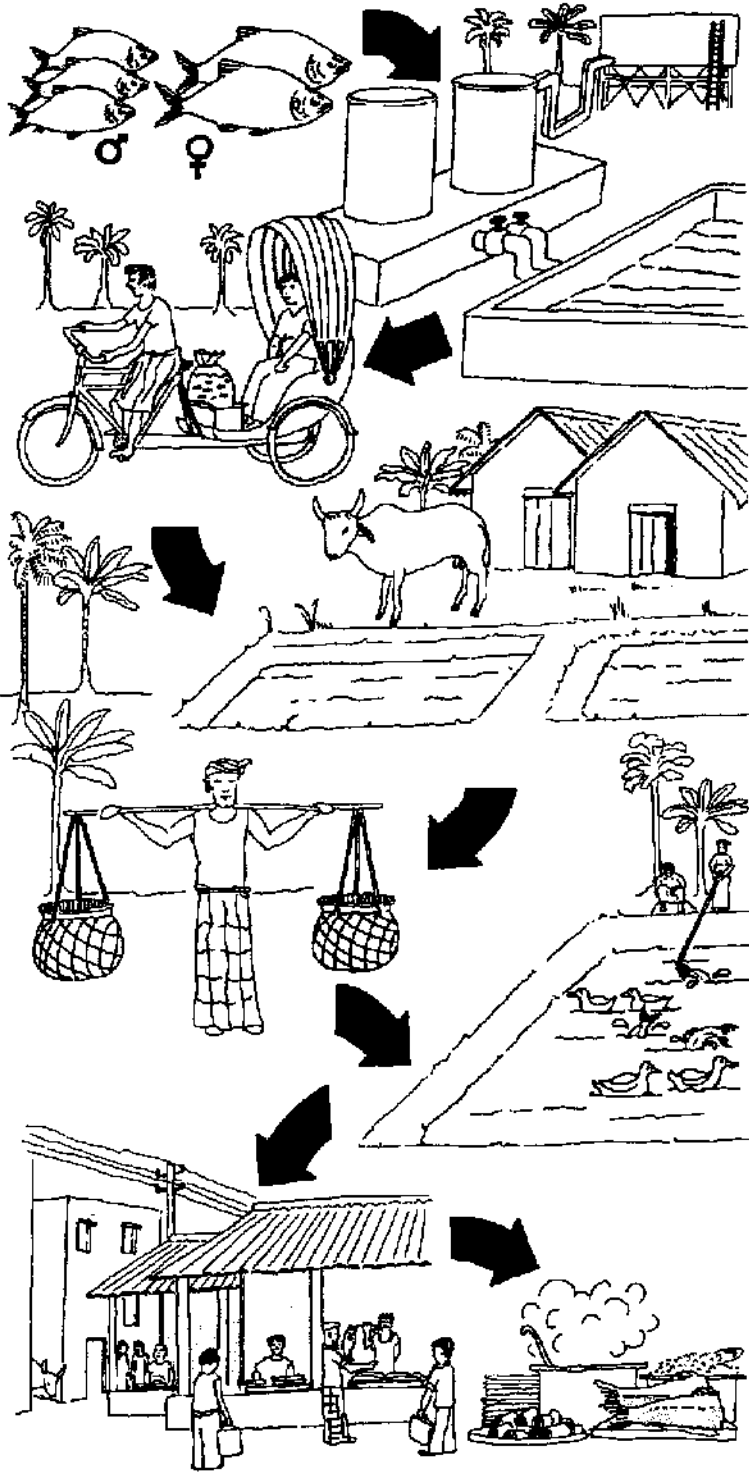

1: 1 kg. fish eggs => (500 000 eggs),
will require 1-2 large females and 3-4 males.
Sales price: 5700 Taka.

2: 100 000 fish fry with wt. of 2 gr. survive.
Sold after 4 - 5 weeks as fingerlings.
Sales price: 33 000 Taka.

3: Sold to merchant, - transport to production
ponds.
Sales price: 47 000 Taka.

4: Production pond, - 17 000 fish survive.
Sales price: 600 000 Taka.

5: 2 500 fish consumed by pond workers, or
used in further production.
14 500 fish sold on market. - market costs
4 taka pr. fish.

500 000 eggs => Unit price => 0.0114 Taka.

100 000 fry => - => 0.33 Taka.

100 000 fry => - => 0.47 Taka.

17 000 fish => - => 35.29 Taka.

14 500 fish => - => 39.29 Taka.

[45.38 Taka]

Taka = Bangladesh money unit.

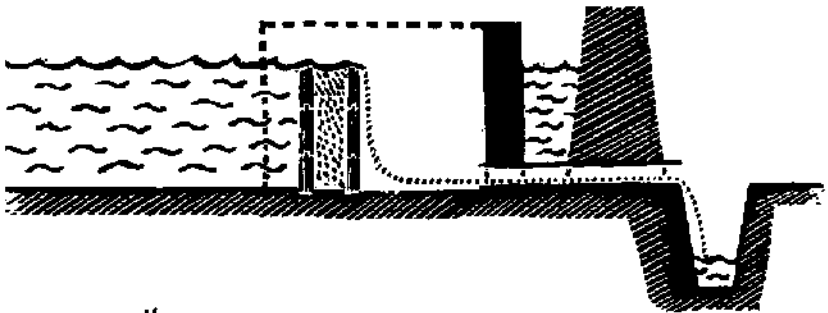
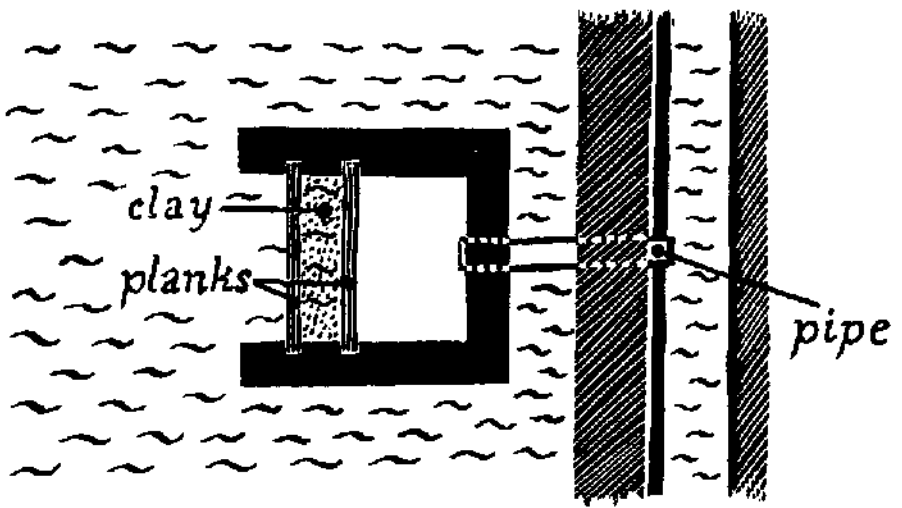
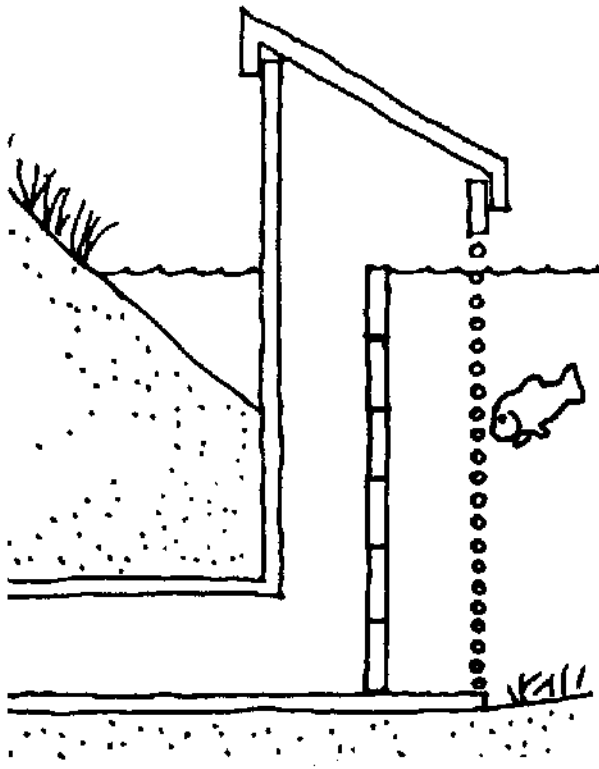

"MONK" device for controlling water level in fishponds

DUCKS

Where a serious fish culture program is initiated one would do well to include a duck and pig population for balanced fertilization.

By living on the water much of the time, ducks naturally balance a fish production program better than chickens. Even the constant action of wings and feet is known to seal a leaky fish pond. Few people are aware of the fact that some duck varieties lay more eggs than chickens (as many as 50 per year). Also, duck eggs are larger; it takes 4 hen eggs to equal the size of 3 duck eggs. A duck's profitable laying life is two-to-three times greater than a chicken's.

Unlike chickens, ducks do all their egg laying at night. Thus, free-ranging is possible during the day without concern for secreted eggs. Ducks are like goats in their resistance to disease — in the same way that chickens and cows are alike in their susceptibility. The death rate among growing ducklings is very low. Like goats, ducks thrive on marginal land.

WHITE PEKIN



WHITE RUNNER



WHITE MOSCOVY



KHAKI CAMPBELL



AYLESBURY

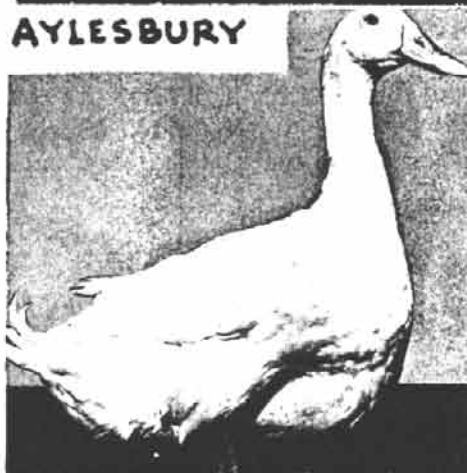

PEKIN - GOOD TABLE 8# 120 EGGS/YR. NERVOUS. POOR SETTERS
MOSCOVY - GOOD GRAZING 7# GOOD SETTERS POOR LAYERS (45)
KHAKI CAMPBELL - BEST LAYERS (300) POOR TABLE 5#
RUNNER - GOOD LAYERS (150) POOR TABLE 5#
AYLESBURY - GOOD TABLE 9# POOR LAYERS (100) POOR SETTERS

DUCKS

Scientific name: Mallard: Anas platyrhynchos
Muscovy: Cairina moschata
Product: Meat, eggs, feathers, down
Size: Males 4 - 5.5kg; females 2 - 4.5kg
Age to breeding: Ducks 6.5 months
Muscovies: 7.5 months
Normal life span: 3 years
Breeds available: for meat - Muscovy, Pekin,
Aylsbury, Rouen. for eggs - Indian
Runner, Khaki Campbell

Description: Ducks are web-footed birds that like to live near water. They can move quickly in water, but their legs make it difficult for them to move on land. They have large heads, slender necks and broad bills with tiny saw-like teeth on the edges, that helps them to pull weeds and grass. They have an oil gland above the tail to waterproof the feathers. Domestic ducks have lost the ability to fly. They are often easier to look after than fowl but they still require good feed and management.

Remarks: When catching ducks or Muscovies hold them by the wings, not by the legs. Muscovies are ready for eating at 14-16 weeks when they should weigh about 4kg. Well managed ducks (not Muscovies) can produce more eggs a year than chickens, but good management is difficult. Muscovies seldom give more than 60-90 eggs depending on their age.

Muscovies are not true ducks, but are probably a cross between a swan and a duck. They are better parents than true ducks and are slightly hardier.

Most ducks in villages are Muscovies. They are easily recognized by the enlarged hairless skin on the face of older birds.

Feeding: Ducks do well eating grasses like paspalum, panicum, setaria or sojeri with legumes, and eat insects, snails, frogs and fish. Some flocks of Muscovies have learned to break the shell of dem-dems on their own. Ducks do well on chicken feed but should also have greens or kaukau. While ducks will grow well without added feed, regular feeding each evening will keep them near the house, and chicken feed will help them to lay many eggs. Ducks are messy feeders and it is necessary to take special care in a duck house.

Breeding: Muscovy eggs take 35 days to hatch. True duck eggs take only 28 days to hatch. Muscovies will breed with true ducks but only a few of the eggs will hatch. Ducks from those eggs can not have offspring. One male (the drake) for each 5 females is enough. Muscovies are very good setters, and will hatch the eggs of other birds that are forgetful. A duck will raise more young if the newly hatched ducklings are raised artificially like baby chickens.

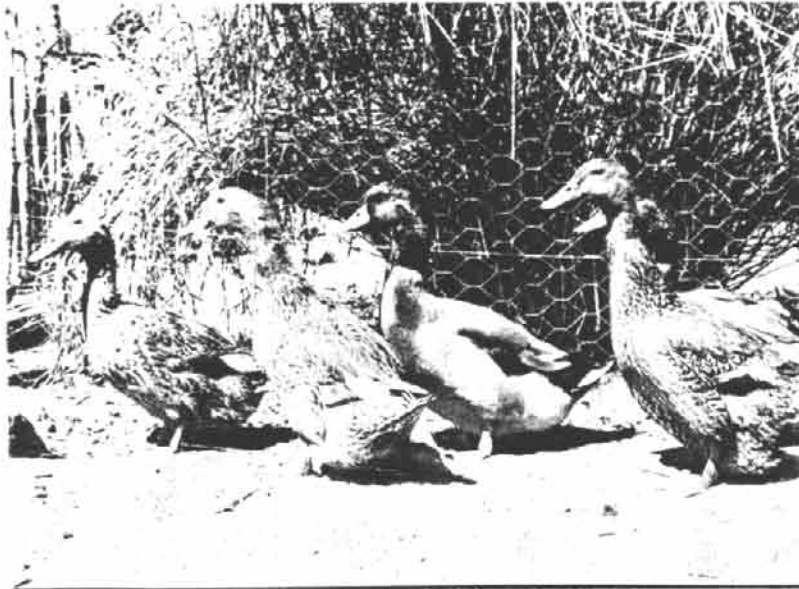

Housing: A simple house like those for chickens is enough, but special care is necessary to see that they cannot spill the water on the litter. Ducks lay their eggs in the morning and should be kept in the house until about 9am. Young ducklings should be kept in the house until they are four weeks old and large enough to avoid being eaten by crows and eagles. Although ducks like water for swimming, they do not need it. They should have water troughs deep enough to put their heads under water since they need to wash their eyes regularly.

Diseases: Ducks are more resistant to coccidiosis than chickens, which is one reason that they are hardier. They can get food poisoning, so special care is needed to keep food and water containers clean.

GEESE

Scientific name: *Anser anser* (except Chinese goose)

Product: Meat, feathers, down

Size: 6-8kg

Age to breeding: 1 year

Normal life span: 20-30 years

Description: Geese are larger than ducks, have longer necks, make a loud honking noise and are good "watch dogs". They have heavy down feathers under the big feathers which can be plucked for soft pillows and mattresses. Like ducks they have oil glands near their tail for oiling the feathers. They are cautious, not "silly". They are very intelligent. They are able to protect themselves very well, with their wings and bill used as weapons. They have lost their ability to fly long distances.

Breeds: Although there are many breeds of domestic goose, the best for the tropics is the Chinese goose since they breed easily in the tropics and lay eggs all year round. Other domestic geese need a cold period before breeding.



Male and female Chinese Geese with their babies (goslings).

Uses: Geese are usually raised for meat. The offspring of a pair of geese will provide 45-70 kilograms of fatty meat a year. The down feathers may be plucked from both the live geese (carefully!) and dead geese to be used for pillows and blankets. Since they eat mostly grass, some farmers use them for weeding crops, if the crop is not attractive to the geese.

Habits: Geese need free access to grass and other edible leaves. They will also eat insects, small water animals, vegetables and grain. The grass eating habit makes them a good lawnmower. They eat little bits all day. Geese like water but do not need it for breeding. The female lays 3-6 eggs at a time, and will raise as many as 6 families a year. One male (called a gander) is needed for every 2 or 3 females. Usually geese mate for life.

Housing: Is not required for geese in small numbers.

References: *Ducks and Geese in the Tropics* by A.G. Wanen, *The Complete Poultry Book*, by W. Powell - Owen, Cassell, London.

Ducks and Geese

Ducks and geese are in some ways better than chickens. Some breeds can produce as many eggs as chickens, are cheaper to house, and eat snails and weeds. They are cheap to keep because they can get up to three quarters of their food from the veld. The only thing you need for ducks and geese that you do not need for chickens is a pond, but this need not be large.

Breeds

Ducks: For egg production, the best breeds are Indian Runners and Khaki Campbells. For meat, the best breeds are Pekins and Mallards. Pekins can be eaten at eight weeks. Their feathers are useful for pillows and they produce eggs when well fed. Mallards are small birds which do not give as much meat as other breeds, but they breed faster.

Muscovy ducks are very good for small farmers because they breed so well. They have four laying seasons a year, and are very fertile. You can eat them at 10 to 12 weeks, when the drake (the male) weighs 4kg. Their feathers can be plucked, but you must be careful not to leave them bare, because this can make them sick during the breeding season. If you are thinking of selling

feathers, it is probably better to get white Muscovies than black because white feathers always get a better price. You can start Muscovies very cheaply, by getting just one male and three females.

Geese are strong birds which can live by eating grass. They are also very good 'watchdogs'. The best breed is the ordinary white hybrid farm goose.

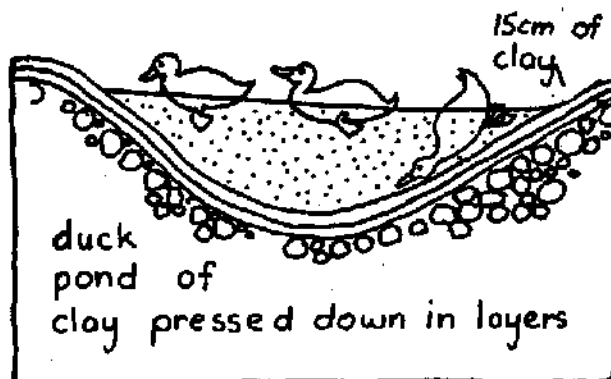

Water

You can keep ducks on streams, dams or ponds, but do not let ducklings into deep water until they are big enough to get out easily. Small concrete ponds are quite easy to make and you can also make a pond by putting an iron bathtub into a hole in the ground.

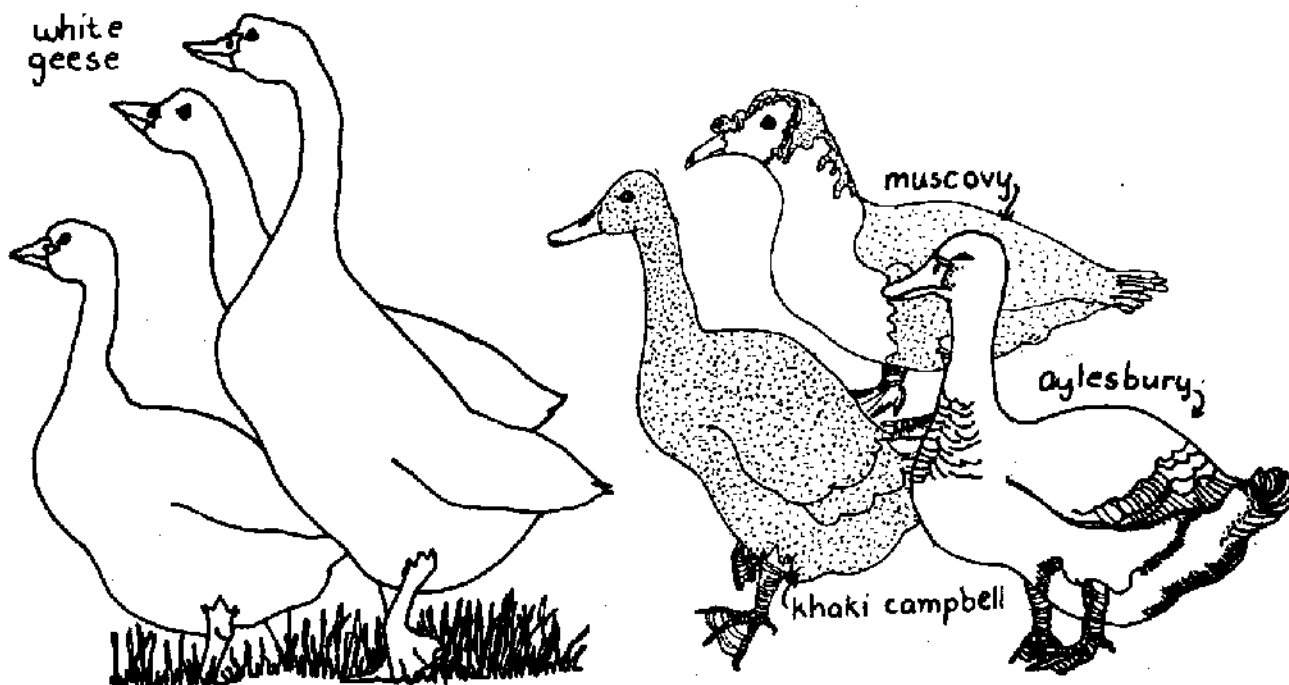

Feeding

Ducks and geese can feed themselves from the veld, but you should also feed them kitchen and vegetable scraps. If birds are laying eggs, they must get better food. You should give each duck 200g per day of ordinary chicken laying mash, about 60g in the morning and 140g in the evening. Laying mash is expensive, but you can make your own feed with 140g bran and $\frac{1}{4}$ cup of fish meal or $\frac{1}{4}$ cup skim milk in the evening for protein. Always give your ducks clean drinking water. Dirty water and dirty feeding dishes cause diarrhoea.

Housing

You must keep your ducks and geese in a shed at night because of attacks by animals. Ducks lay their eggs before 10 in the morning, so locking them up at night makes it easy to collect their eggs in the morning. Housing can be very simple. The important thing is that the ducks are given dry straw. If ducks are kept in damp, cold places at night, they often become lame (unable to walk).

Geese lay eggs for 20 weeks every year. Lock them up in the afternoon when they lay their eggs.

Looking after young birds

The important thing about looking after young geese and ducks is to give them a warm, dry home. They must not be allowed to start swimming as soon as they have been born. In summer, do not let them in the water for at least 4 days, in winter for 3 weeks. Young ducks and geese must have shade at all times.

Breeding Geese

If geese are housed in healthy conditions they can lay eggs for six to eight years. You can get more young geese by taking away the first lot of eggs and giving these to a broody Muscovy duck to sit on. The first 2 eggs are usually infertile and can be used for cooking. The goose will then lay a second lot of eggs, and this time let her sit on them. Geese breed in pairs so you must have the same number of males and females if you want all the females to have babies. You should choose mates at least two months before the breeding season, which starts in August. Once geese have been mated they should not be separated as this could stop them from breeding for the whole of the breeding season.

duck house of
thatch and
scrap
wood

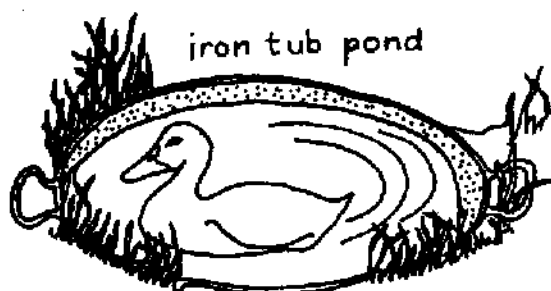

iron tub pond

oil drum
laying
box

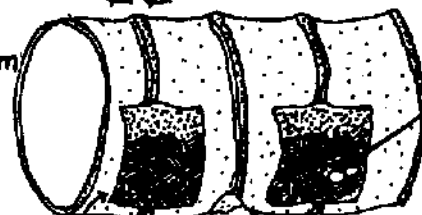

grass
keeps
ducks
warm

cut out
doors for
ducks

stone to stop
drum rolling

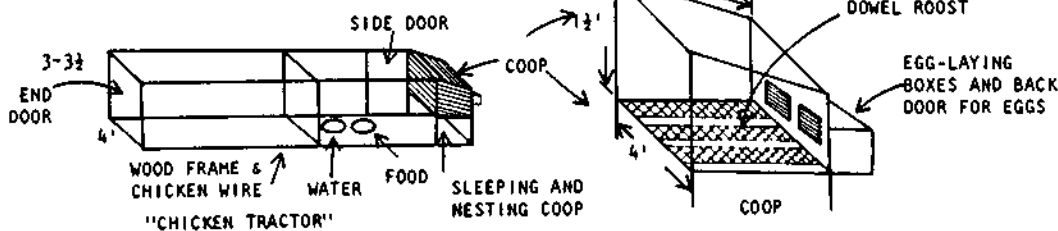
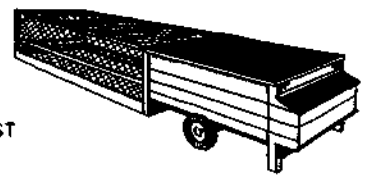
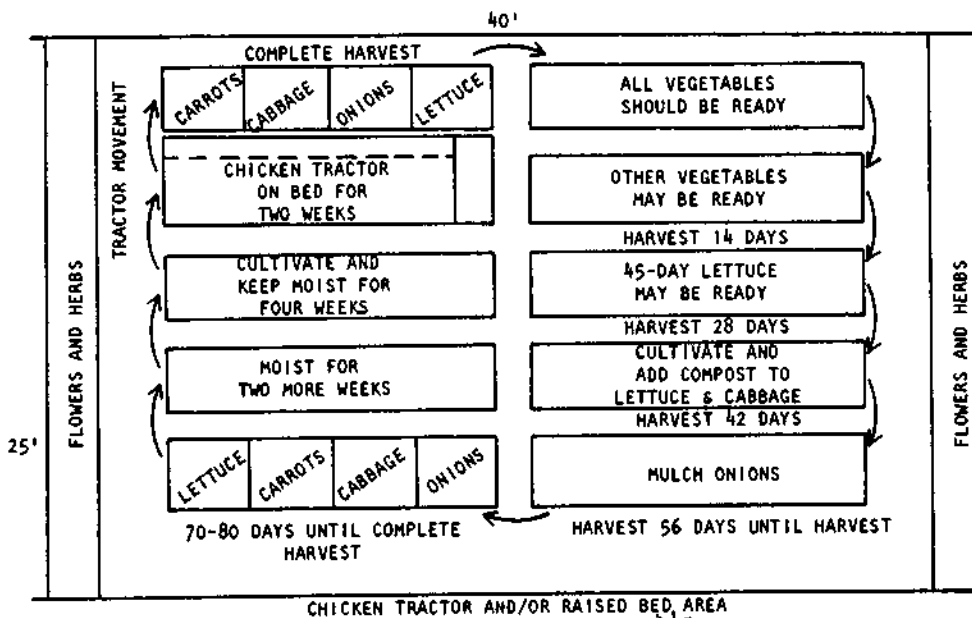

FIGURE 7. Suggested planting and rotation scheme for the "chicken-tractor" mixed-husbandry method of cultivation with ten beds under rotation.

SUGGESTED LIST FOR CHICKEN TRACTOR
(1 of 10 beds illustrated)

BRASSICAS:

Turnips-----35-60 days
Early cabbage-----60-65
Early broccoli-----40-60
Early cauliflower-----50-60
All middle and late brassicas
do a double transplant
2 wks in first flat and
4 wks in second flat.

LETTUCE:

Loose leaf lettuce----40-50 days
Butterhead lettuce-----65-80
Head lettuce, needs a double transplant

ONIONS:

Start seeds in flat and
transplant 4-6 weeks later.
The seed flat may need thinning,
and the bed may have to be
thinned once after transplanting
for small salad onions.

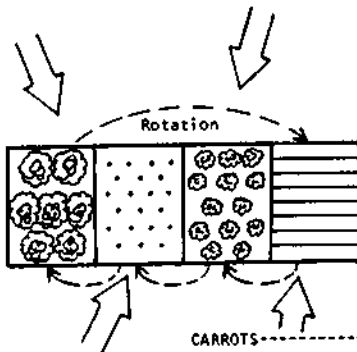

CARROTS-----68-76 days
BEETS-----55-80
DWARF SUGAR PEAS----65

FIGURE 6. Rotation scheme for one raised bed. Vegetables are grown closely together in a carefully cultivated rectangular area 3-4 feet wide and 15-20 feet long.

A surprising amount can be grown on a 40' x 25' plot. This plot can be worked by a simple "chicken-tractor" method (see below and Figure 7), by the two-week or long-term compost method, or by some combination of the two. In the layout, ten raised beds (one of which is shown in Figure 6) are prepared. Beds are divided into four different vegetable-type sections: (1) Carrots, beets, or Chinese peas; (2) one of the brassicas; (3) onions; and (4) lettuce. The four sections are rotated each time a new planting occurs (Figure 7). All footpaths are planted in rye grass and legumes (alfalfa, vetch). These areas will provide extra compost, mulch material, or feed supplement for the chickens (see below). Two or three borders are planted with flowers like borage, sunflower, Jerusalem artichokes, scarlet runner beans, chrysanthemums, or various pinks. The flower "hedges" are places for beneficial insects to live in. Some tomatoes, peppers, or herbs can be mixed with these borders. Some Brussels sprouts make good insectary plants which attract and house pests, especially aphids, which in turn serve as a food source for beneficial insect predators and parasites.

If the "chicken-tractor" mixed-husbandry method is used (Figure 7), chickens six weeks old or older (about eight of them) must be raised for the "tractor." Barelegged brown egg-layers are the best since they get along well with each other, scratch up the earth well, and produce fine eggs. The tractor should be roughly the length of the bed and maybe a foot wider to allow the chickens to forage in one of the paths beside the bed (see Figure 7). If they are fed grains, garbage, grass, and alfalfa, the chickens will give an egg a day in good weather, they will clear out all weeds, slugs, and insects, and they will work their manure and some garbage scraps into the soil fairly uniformly. If sorghum is in the feed they may leave this behind; it will sprout after the chickens have moved on to the next bed. Move the chicken pen to the next plot every two to four weeks, depending on how rich the soil should be. Immediately after the move, the ground should be cultivated. Fluff up the soil with a turning fork, cultivator, and a rake so that it is two to three inches higher than the normal ground level (called "raised beds"), and thus the roots can obtain more oxygen.¹³ Leave the bed open and keep it moist for about four weeks. At the end of this period, add 50 to 100 pounds of compost to the bed. Then carrots may be seeded, or else onions, lettuce, and brassicas transplanted into the bed. Approximately three to four weeks before the chicken tractor is to be moved on to a certain bed, seed that area with oats, wheat, or rye. Then when the chickens are moved to that place they will have the equivalent of spring grass, which is probably the best food of all. Do not expect great results from this method at first, because the timing and bed preparation may have to be adjusted for your area. However, you will learn a great deal from it.

Poultry Housing

Copyright 1973
by Bus Hayden

by bus hayden

Space

The most important principle in the housing of birds is that of space; available space determines the number and variety of fowl which can be kept. The recommended floor and roost space for the three main groups are as follows:

Breeds	Floor Space (per bird)	Roost Space (per bird)
Asiatics	4 sq. ft.	10 in.
Utility (American and English)	3 sq. ft.	8 in.
Mediterranean	2-3 sq. ft.	6-8 in.

Less than these amounts of space creates havoc: it promotes disease, cannibalism, and leaves the weaker birds no place to feed or roost adequately - making them unhappy 'boarders'.

Climate

The next most important item is climate. The climate of a chicken coop should above all be dry, and free from draft. It requires adequate ventilation, but this can be obtained by having only one side of the house open, since a draft can only be created where there is both inlet and outlet for air currents. This open side should be facing away from the prevailing and storm winds: in our case a western exposure is best. Where a western exposure isn't possible, either a roof vent, or vents around the windows (covered with cheesecloth or burlap) should suffice. When part of an existing building is being devoted to poultry, a draft-free roosting area can be achieved by placing the roosts in an adequate-sized box, which would consist of a floor or drop-board, three walls and ceiling: the size of the box is determined by the number of roosts needed.

Temperature

Birds can withstand several degrees of frost, but temperatures over 75 degrees F. can cause problems. Fowl which are confined at higher temperatures or with no shade become irritable and begin to peck at one another, especially during the moulting seasons (of which the chicks have three). The erupting of new pin feathers leads the birds to picking: when blood is drawn it easily leads to cannibalism.

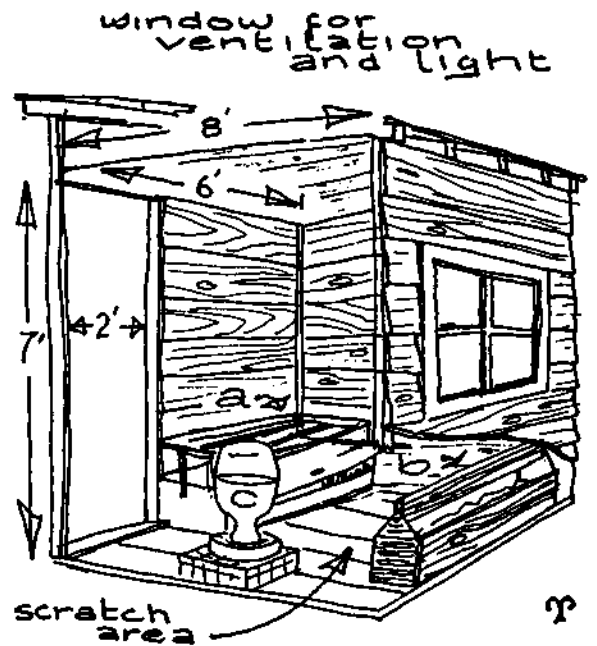

Floor Plan - 12 birds

- (a) roosting area; built over the community nest
- (b) feed - grit, mash and oyster shell
- (c) water - on stand to catch drips

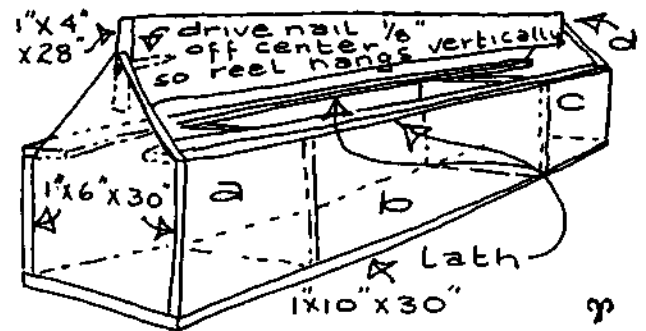

Feed Hopper - floor or stand

- (a) grit box
- (b) mash section
- (c) oyster shell
- (d) floating bar (1" x 4" with nails driven in ends; allows it to rotate)

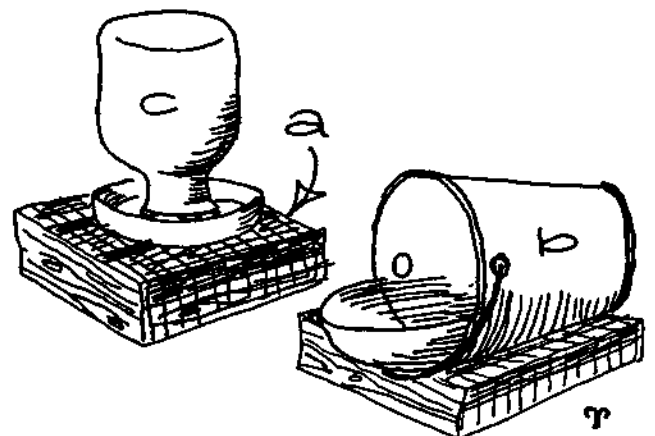

Water Stand

- (a) box 2' square: tomato flat or frame covered with 1/2" mesh wire
- (b) side pail
- (c) glass fountain

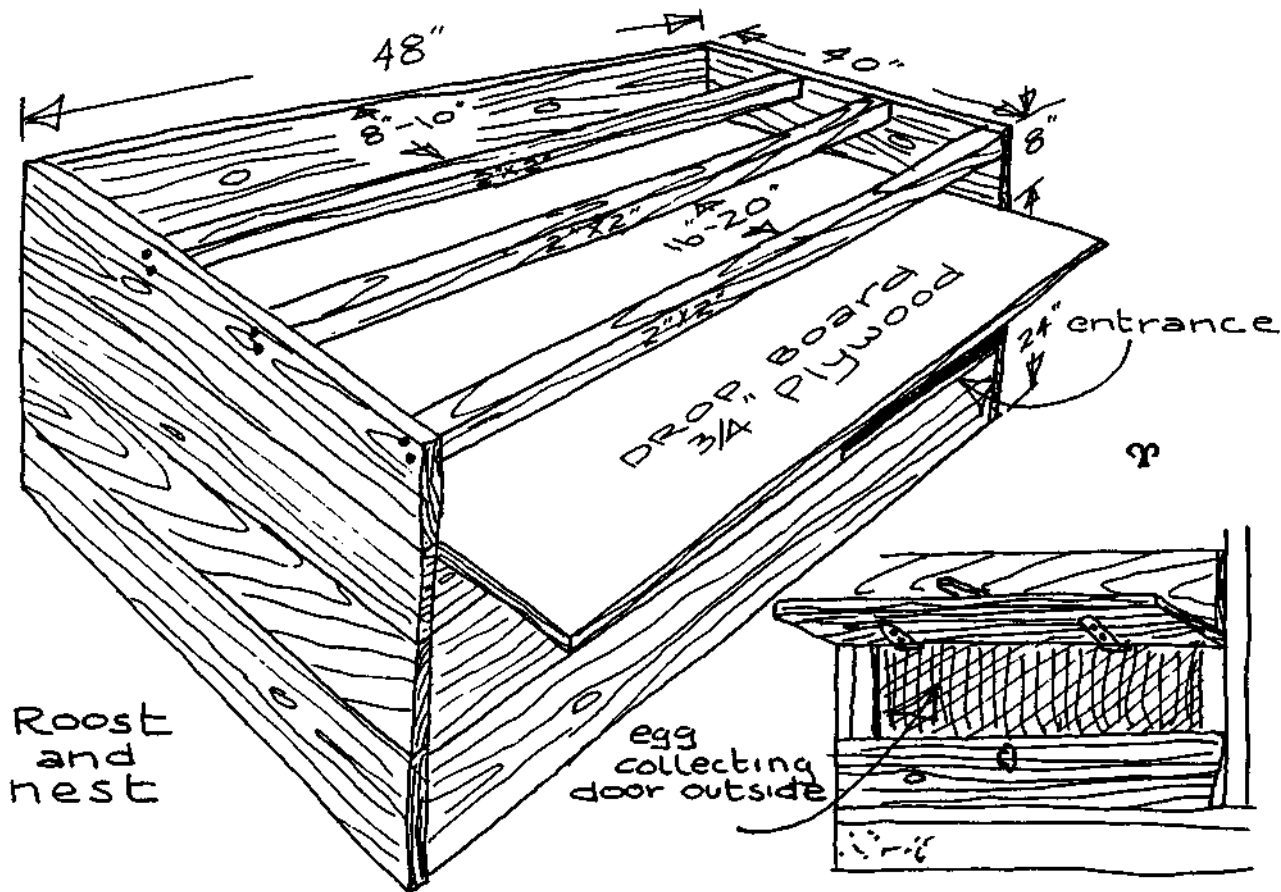

Lighting

Poultry must have adequate light in order to see and feed, for it identifies its food entirely by sight. A dull, gloomy coop leads to lethargic, non-active, non-producing birds. Birds do best in a well-lighted and well-ventilated coop, where there is an abundance of natural light which does not raise the temperature of the coop. In addition, it is highly recommended that all coops be whitewashed inside - this will reflect light so that most of the floor space can be used for activity. Windows can afford to be fairly high where they receive direct light from the cooler winter sun, but not from hot summer sun. For maximum winter productivity, artificial light supplementing the natural daylight to maintain a 12- (or at most, 13-) hour day is preferable. Light in excess of 13 hours can produce a false moult, and hence a cessation of egg production; less than 12 hours reduces egg production, for it takes roughly a 12-hour day to produce an egg. Birds, as all animals, are regular in their habits, and extensive variation in the hours of light will have a detrimental effect on production. Unless one can maintain a very regular artificial light supplement it is preferable to depend on natural light, though production will be somewhat less.

Roosting

These bars on which the birds roost (approximately 2x2 stock is usual) are placed on the horizontal, above and parallel to a platform called a drop board.

The first one is placed 8 to 10 inches out from the back wall, and subsequent ones at 16 to 20 inch intervals. The drop board should extend a further 16 inches in front of the front roost; this allows the birds to alight before seeking a spot on the roost. Drop boards should be a maximum of 30 inches from the floor of the coop. The roosts themselves should be 6 to 8 inches above the drop boards for convenience in cleaning the latter. Fowl deposit over half their droppings at night; the use of the drop board thus helps to maintain a cleaner litter on the floor (bedding). It also makes available straight poultry droppings (manure), which when allowed to dry can be stored in empty feed sacks as an excellent fertilizer for plants requiring high nitrogen content. As for myself, I recommend the area under the drop board be used to house the community nest. As this space is visually dark, and therefore less effective for feeding activity, it makes an ideal nest site. I make a box using 1 x 8 inch stock, three boards deep. This places the drop board at approximately 24 inches from the floor.

Exercise Yards

These are located by preference on the east or west side of the building, unless the south exposure is fairly dense in plantings. Poultry enjoy morning and evening light; in the heat of the day they are inactive and seek shade.

This is an excerpt from a forthcoming book by Bus Hayden.

Backyard Hen House

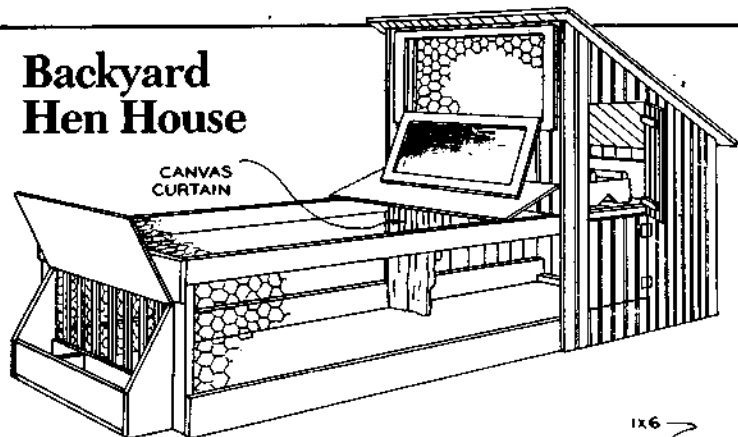

PICTORIAL VIEW

This small hen house will accommodate 12 laying hens, enough to supply an average family. It is portable and can be easily moved. By opening the upper half of the double door, roosts and nests can be removed for cleaning without the hens escaping. The sloping hinged roof serves as a door, providing access to the nests. At damp times of the year, the structure can be placed on an elevated platform and kept there until the soil is dry enough to allow the hens to exercise in the runway.

FRAME OF 1x2 COVERED WITH GLASS SUBSTITUTE

ROOSTS OF 2x2 ON REMOVABLE FRAME

1x8 DRIP BOARD

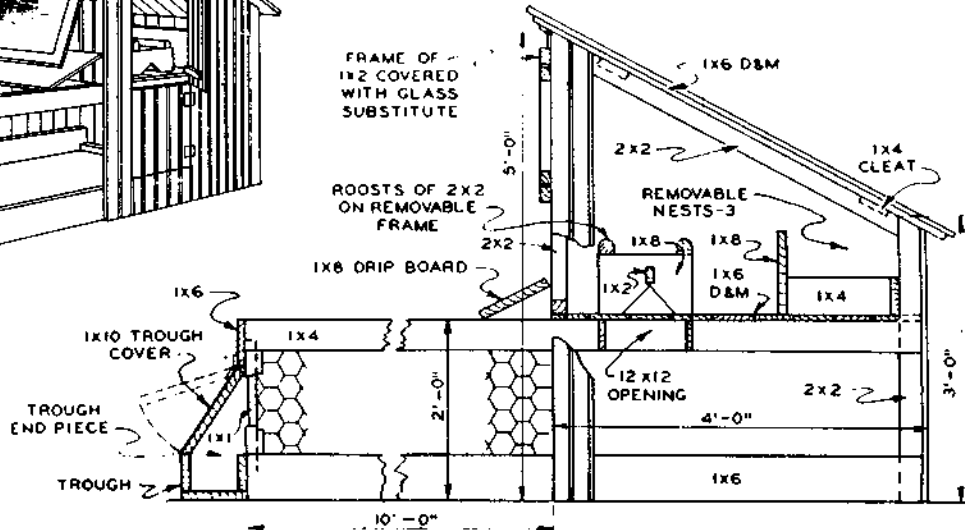

SECTION VIEW

HINGES
ROOF HINGED TO PROVIDE ACCESS TO NESTS

HINGES

2x2

V-JOINT SIDING

1x2 CLEAT

ROOSTS

2x2

1x8

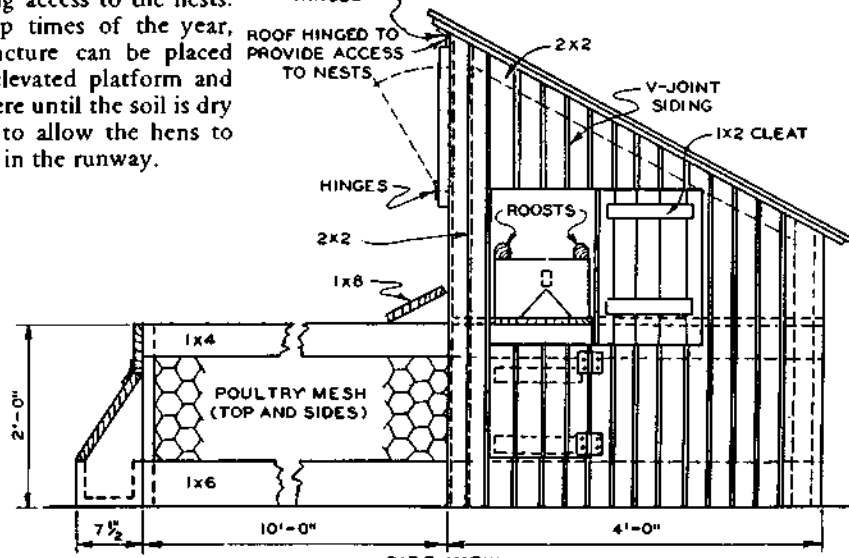

SIDE VIEW

GLASS SUBSTITUTE

1x2

1x8 DRIP BOARD

1x1 SPACED 2" 1x6

1x10 TROUGH COVER

FEED

GRIT BOX

FRONT VIEW

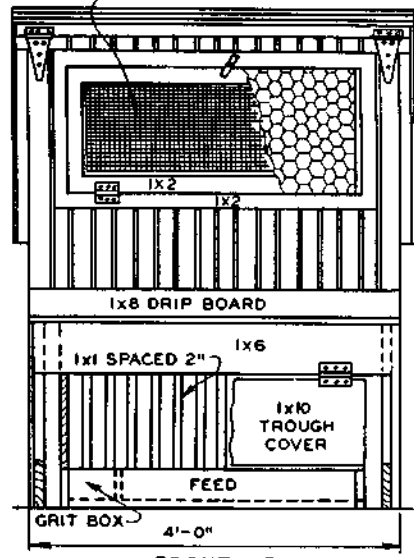

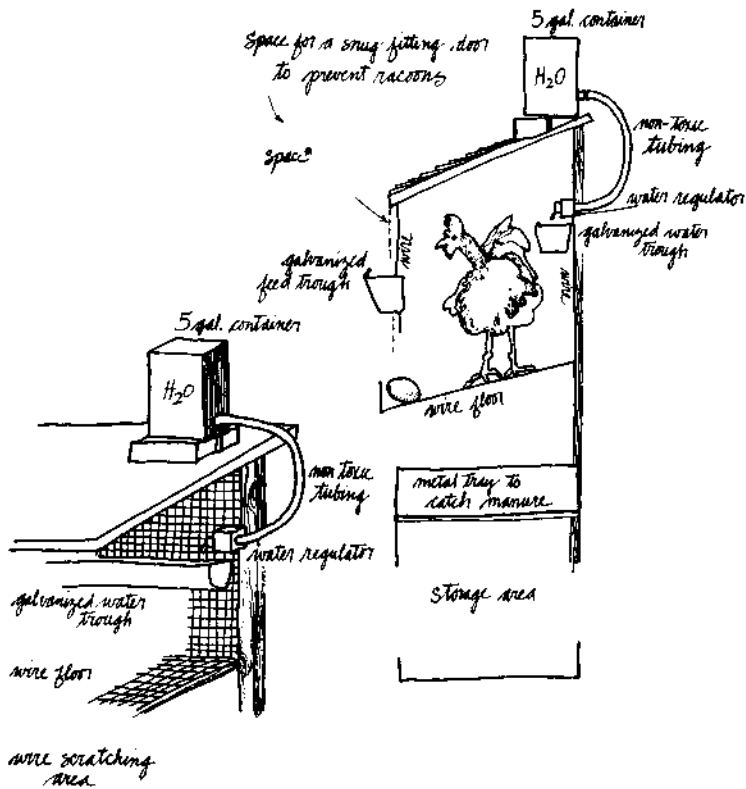

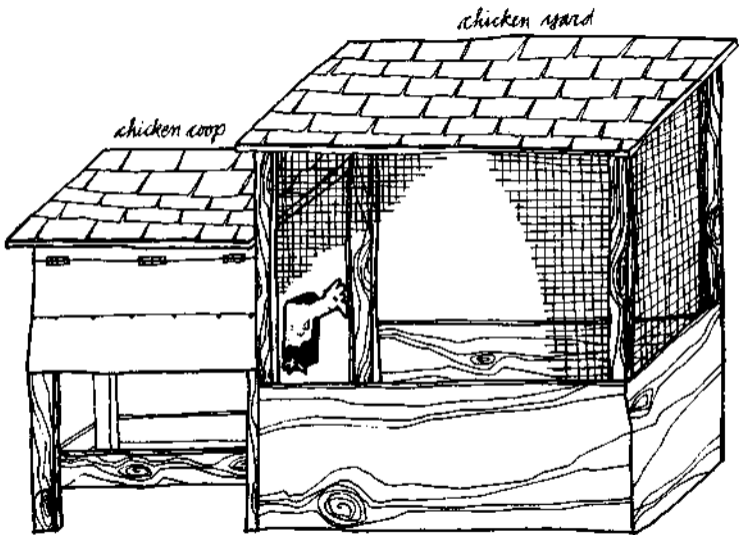

chicken yard

chicken coop

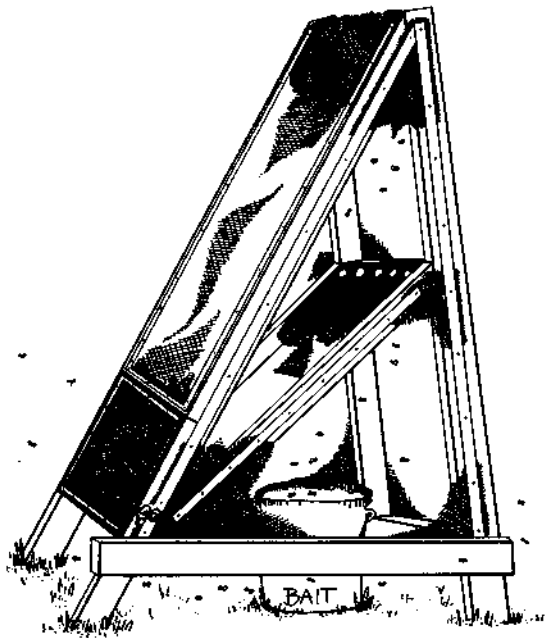

fly trap made from hardware
mesh and scrap lumber

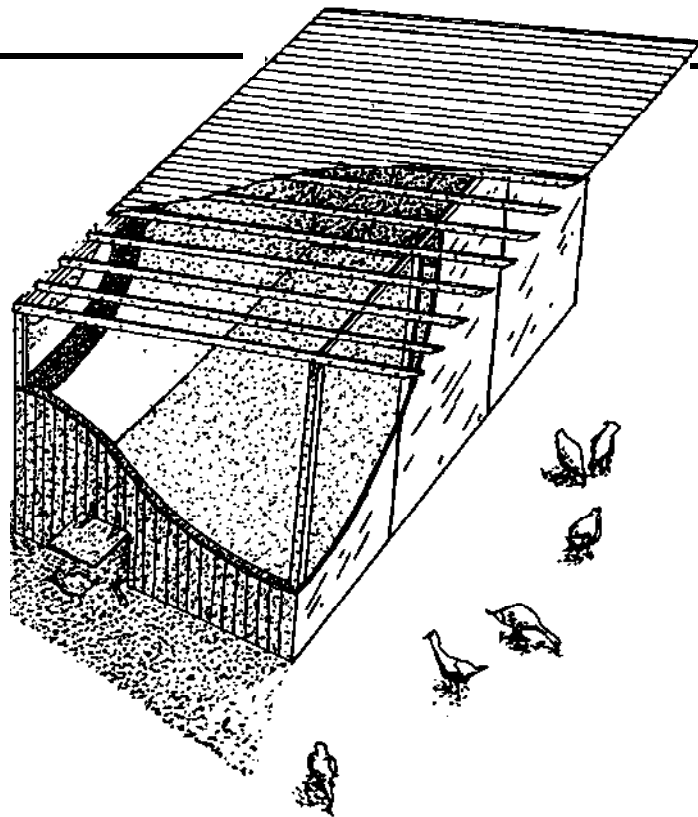

SOLAR CHOOK HOUSE

By Ian Grey

The building has been operating for over seven years in the mountain area north of Buchan in Victoria and is the home for about 15 - 20 hens and 5 - 10 ducks.

The outside of the building is timber (ex car cases) painted with sump oil to preserve it, while the inside on the East and West walls is corrugated roofing iron to permit easy delousing if this should be needed, and to make it hard on the teeth of any rats.

The South wall interior is an eight inch thick (200 mm) mud-brick wall white washed on the inside. The North wall is timber-framed with acrylic sheet windows across the full width and four blade louvre windows top and bottom also across the full width of the wall.

At least some of the windows are open during the day every day as a high air flow is needed to keep the birds healthy, but all the windows are closed at night to retain the heat within the building during winter but they are left open in summer.

Between all the walls except the North wall we packed loose straw in green

garbage bags to provide insulation, this was also used under the roof. The space between the walls was 100 mm and under the roof the gap was 150 mm.

The heat created by the sun, the brooding birds and the decomposing deep litter maintains an even temperature all year. At night the birds cluster near the mud-brick wall and well away from the window and so are less likely to attract foxes and other predators.

The constant air flow through the building removes odours quickly while the steady warmth composts the dropping and the wood shaving deep litter very quickly keeping the garden happy and the birds pest free.

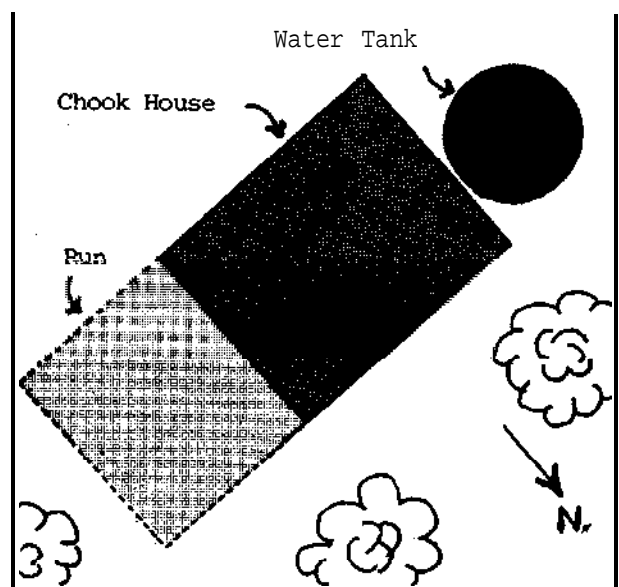

Fig.1. Orientation of Chook House.

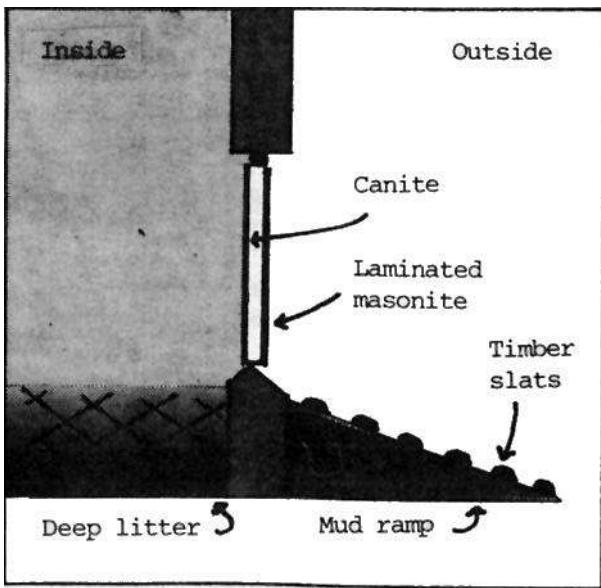

Fig 2. Insulated hen door detail.

The birds have an insulated doorway to the run (as shown on diagram) so as to reduce cold draughts particularly around the ducks.

The open run with trees around it protects the building to the East while a large 40,000 gallon water tank stops the hot west sun.

The chook house has had many satisfied and tasty inhabitants who earn their lodging by a steady flow of eggs. There has never been a pest or an infection problem in the main building although we have lost some birds to feral cats and young chickens to hawks and eagles so I would rate this effort as tried, tested and successful.

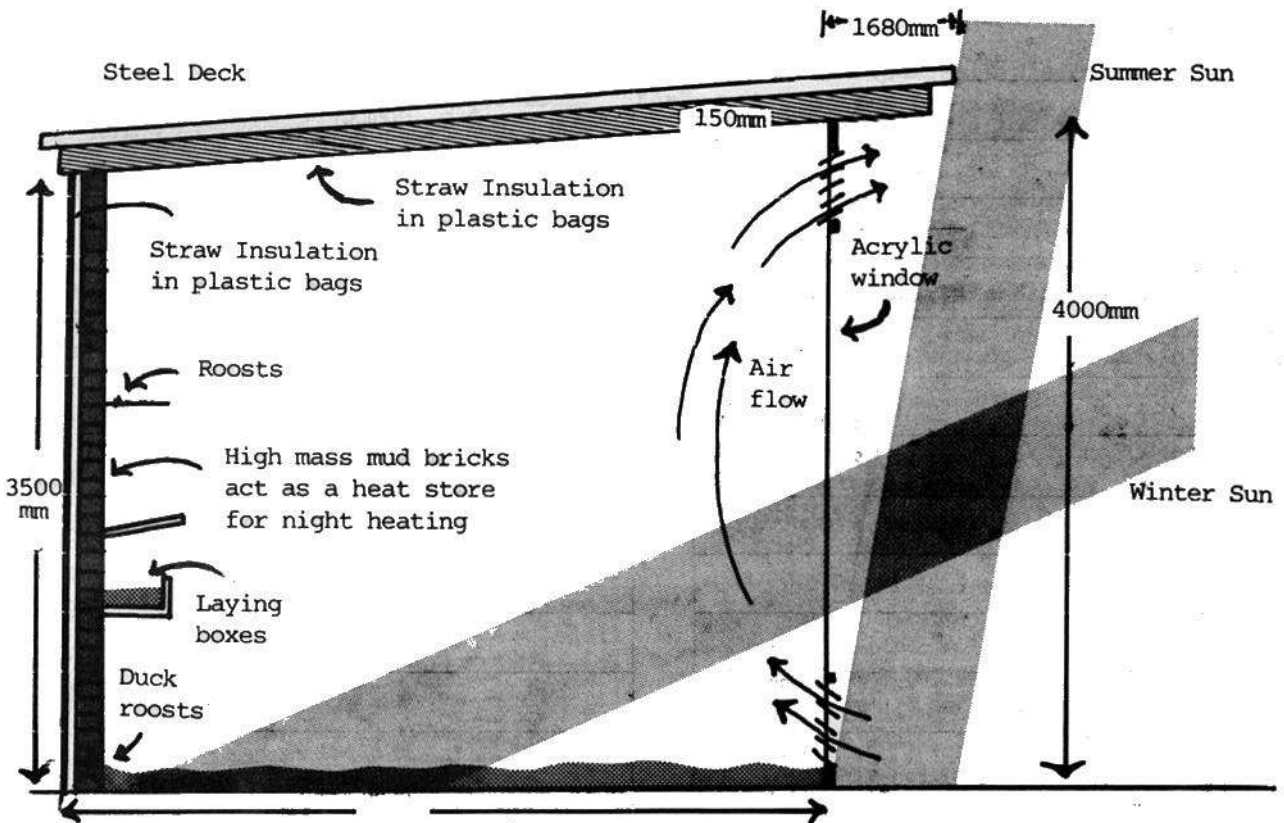

Fig.3. Detailed side view of the Solar Chook House.



Før i tiden gik hønsene i denne landsby i Bangladesh frit rundt med risiko for at blive bytte for rotter og rov-fugle. Nu har de fået bure bygget af lokale materialer.
Foto: Anders Permin

Giv ti kyllinger til en fattig kvinde i et udviklingsland. Efter et år kan hun betale for et tag på sit hus, få børnene i skole og give dem sund kost. Der er tale om forbedringer i levevilkår på mellem 100 og 200 procent. Når det går bedst. Og det gør det oftest. Især når der er taget udgangspunkt i en mangesidet indsats.

Når internationale bistandsorganisationer tidligere overhovedet beskæftigede sig med fjerkræproduktion i tredje verdens lande, fokuserede man typisk på forebyggelse af sygdomme.

»Men det er ikke tilstrækkeligt. Mortaliteten blandt fjerkræ i udviklingslande er på 80-90 procent. Selvom man ved hjælp af vacciner kan redde kræene fra at dø af sygdomme, så dør de bare af sult i stedet. Fjerkræerne skal også trænes i at passe dyrene, der skal ordentligt foder til og ikke mindst et marked at afsætte produkterne på,« siger dyrlæge Anders Permin, Den Kgl. Veterinær- og Landbohøjskole (KVL).

Han er centerleder for det såkaldte fjerkrænetværk, der blev etableret i 1997 og tæller en række nationale såvel som internationale organisationer og institutioner, som arbejder med at forbedre fjerkræproduktionen i den tredje verden.

Netværket med danskerne som primus motor har fremmet opmærksomheden på, at man med ganske få midler kan forbedre levestandarder ganske betydeligt hos tusinder af fattige familier i udviklingslandene.

»Formålet med vores indsats er ikke fjerkræproduktionen i sig selv, men at bruge fjerkræ som et redskab til at bekæmpe fattigdom,« siger Anders Permin.

Ikke blot er der hurtig omsætning ved fjerkræ og lave omkostninger. Det er også en vigtig faktor, at

fjerkræproduktionen i udviklingslandene er kvindernes gebet (det hænger naturligt sammen med, at fjerkræ er lavprestige dyr).

Mange undersøgelser viser, at udviklingsaktiviteter, der har kvinder som målgruppe, har størst effekt. Ikke blot for kvinderne selv, men også for deres familier. Kvinder bruger i langt højere grad end mænd deres midler i den hjemlige husholdning. Desuden er kvinder langt bedre tilbagebetalere af gæld end mænd. Fjerkræprojekterne bygger på mikrolån, og ifølge erfaringerne er tilbagebetalingsprocenten hos kvinder omkring 90 procent, mens den hos mænd kun er cirka 50 procent.

Allerede da Anders Permin i årene 1991-1993 arbejdede som trainee i et FAO-projekt i Zambia (FAO er FN's organisation for fødevarer og landbrug, red.), begyndte han at undre sig over, at ingen syntes at interessere sig for fjerkræ.

»Vi beskæftigede os med kvæg, men vores indsats havde ingen effekt overhovedet. Bønderne fik flere og flere kvæg, men deres levevilkår blev ikke forbedret. Det var meningen, at bønderne skulle producere kød, som de kunne sælge og tjene penge på. Men de beholdt dyrene i stedet for, hvilket indirekte medførte til overgræsning af de fælles marker,« siger han.

Det er en kendt problematik, at mange af tredje verdens fattige småbønder sætter lighedstegn mellem kvæg og status. De slakter nødtigt køerne og opfatter dem som en sikkerhed til de dårligste tider med tørke.

»Hvis man så bare havde haft foder nok. Men tværtimod, både jorde og kvæg blev udsultet. Ydermere er der lang produktionstid på en ko i modsætning til fjerkræ. Det tager tre uger at udklække et æg, og seks-syv uger senere har man en kylling, der kan spises. Desuden er der ingen religiøse hindringer forbundet med kyllinger. Så vidt jeg véd, er kyllinger kun forbudt

spise blandt masaierne i Østafrika,« siger Anders Permin.

Da han i 1993 fortsatte sin traineeperiode i FAOs hovedkvarter i Rom, forhørte han sig om initiativer rettet mod fjerkræproduktion. Han fandt en eneste, der beskæftigede sig med området, men problemet blev hovedsagelig anskuet som veterinært.

»Hvad nytter det med vacciner, hvis der ikke er foder nok, hvis hønsene ikke lægger tilstrækkeligt med æg, bliver taget af rotter, eller hvis der ikke er et marked til at aftage kyllingerne?« spørger han.

Anders Permins ph.d.-afhandling kom naturligvis til at handle om fjerkræproduktion i en tredje verden-kontekst. Ph.d'en var færdig i 1997, og han var selvskreven som en af de forskere, der tog initiativ til det nytænkende fjerkrænetværk.

Fjerkræhold i udviklingslande havde hidtil været et felt, som kun veterinærer og landbrugsforskere beskæftigede sig med, men i fjerkrænetværket inddrager man også antropologer og socioøkonomer ud fra en holdning om, at et fjerkræholds produktivitet ikke kun afhænger af effektiv sygdomsbekæmpelse, men også af den lokale kultur, landsbystruktur og de klimatiske forhold.

De aktuelle vilkår er desuden bestemmende for forskningen og udviklingen af nye højtydende kyllingeracer.

Netværket bliver drevet med midler fra Danida, men Anders Permin synes, det kniber med kommunikationen fra giveren.

»Danida støtter netværket, vi er eksperterne, men man glemmer at informere og bruge os, når der sendes missioner ud for at undersøge, hvor og hvordan man kan gøre en indsats inden for landbrugssektoren. Det er jo tanken, at vi skal samarbejde med Danidas landbrugs-sektorprogrammer,« siger han.

Indtil videre er fjerkrænetværket involveret i eller koordinerer projekter i Bangladesh, Eritrea, Benin, Burkina Faso og Malawi. Endvidere er man i en indledende formuleringsfase for et projekt i Vietnam.

Ideen med at satse på fjerkræ blev udtænkt allerede for mere end 20 år siden af den engagerede bangladesher Nazir Ahamed, der er tidligere veterinærdirektør og nu national projektkoordinator.

Han greb den dengang nyslåede idé, også af bangladeshisk oprindelse, med at give kvinder mikrolån. Ved at låne dem et beløb i størrelsesordenen 50 til 200 kroner og ved at hjælpe dem til at organisere sig i et indbyrdes afhængigt forhold, viste fjerkræproduktion sig hurtigt at være en lukrativ forretning.

Den bangladeshiske model har ifølge Anders Permin udviklet sig til at være temmelig kompliceret. Kreditterne bliver brugt til at holde produktionen i gang. Dvs. til foder, vacciner og udstyr. Men det ville være ineffektivt uden træning af kvinderne. De trænes derfor på ugentlig basis af en lokal NGO, som også står for at sikre indbetalingerne af lånene.

Kvinderne oplyses desuden om ernæring, hygiejne, sundhed osv. Fjerkræet skal ind om hatten, og om dagen skal det have mulighed for at kunne beskytte sig i bure eller under interimistiske skjul af grene og blade. Og så skal der arbejdes på at øge hønsenes æglægning.

»Typisk giver en høne i en landsby i et udviklingsland 40-50 æg om året. I Danmark lægger hønsene op til 320 æg om året. Hvis vi kan komme op på bare 150 i projektbyerne, vil det være en stor succes. For at nå det mål skal de lokale racer krydses med en højtydende race,« siger Anders Permin.

Nogle af kvinderne står for opfostringen af moderdyrene, som så

bliver solgt til de andre kvinder, der sælger deres produkter på markedet, som er fundamentet for, at hele organiseringen af indbyrdes afhængige interessenter bliver succesfuld.

Fjerkrænetværket er netop blevet evalueret af Danida. Det blev positivt vurderet, og for nylig fik centrets indsats endnu et løft. Det var, da KVL i august var vært for den store internationale konference Association of Institutes for Tropical Veterinary Medicine, AITVM.

Arrangørerne havde sat fjerkræproduktion på dagsordenen en hel dag, hvor Anders Permin og hans kolleger præsenterede deres forskning. Det resulterede i mange interesserede spørgsmål og nye kontakter.

Foruden at netværket på konferencen fik sat spot på fordelene ved fjerkræproduktion, er det også lykkedes at påvirke store internationale organisationer som f.eks. FAO til at tænke i mere multifaktorielle baner. Altså ikke kun i vacciner og fjerkræsundhed, men også i bæredygtig produktion med afsætningsmuligheder.

Endelig har fjerkrænetværket i samarbejde med KVL også etableret en mastersuddannelse for både danske og udenlandske studerende. I øjeblikket er tre danskere, 15 bengalere, to malawier og en zimbabwianer i gang med masters-studiet.

Anders Permin håber, at der engang med tiden også kan blive midler til ph.d.-studier med henblik på at lægge grundlaget for at opbygge lokal forskningskapacitet. Her og nu er han dog glad for at være med til at uddanne masters-studerende, der siden kan rejse hjem og sprede det glade budskab om, at en multifaktoriel satsning på fjerkræproduktion kan reducere fattigdommen.

<http://www.poultry.kvl.dk/>

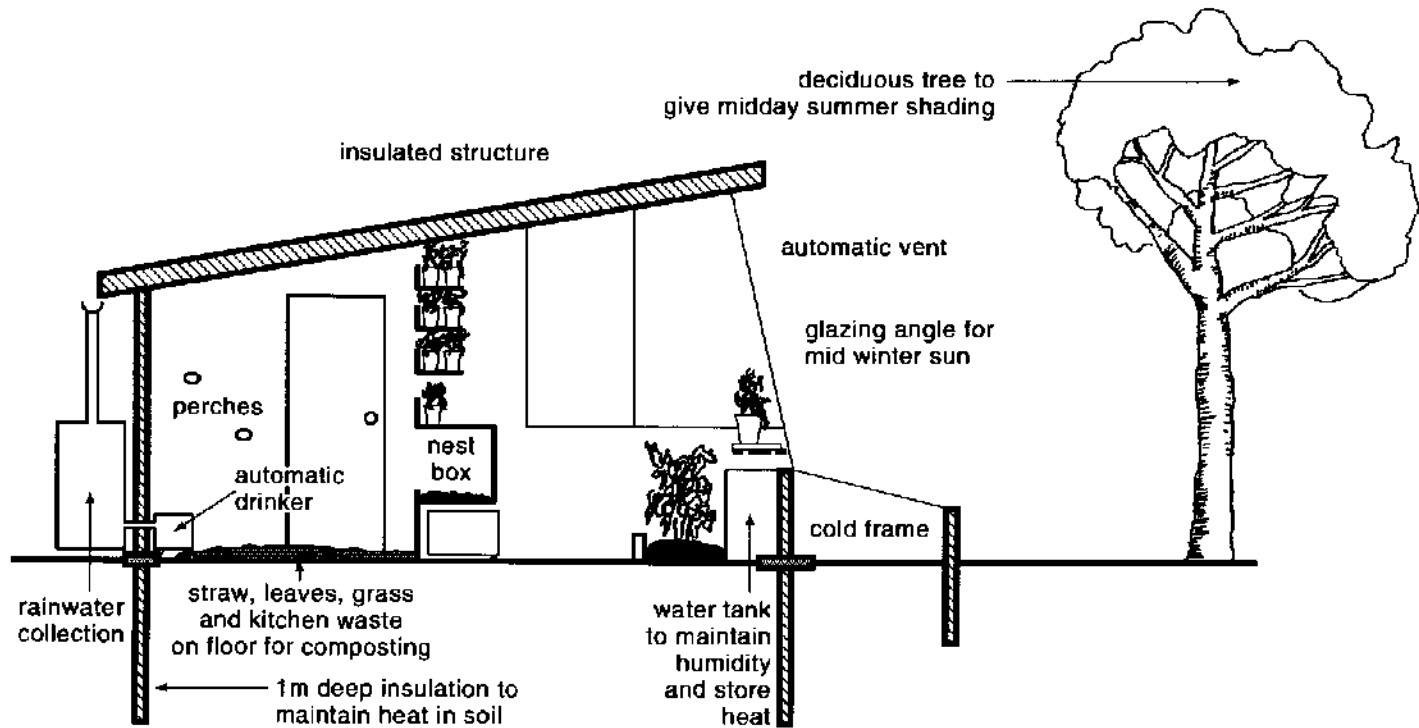

Combined Chicken House/Greenhouse

QUAIL

These lovely little birds are very discrete, giving the occasional cheep or trill and produce about 300 eggs a year.

A good laying variety is the Coturnix, known as European or Japanese quail. You can keep up to 6 females with one male.

Housing

The biggest problem is rats, so any housing needs fine mesh all round it. I keep mine in a small ark on wheels on the lawn in the summer. This has an enclosed area to one end with a small pop hole for the quail and access doors at each end for me. In the winter, keep them undercover and supplement the lighting to give a total of 14 hours a day to maintain egg laying. When they are startled, they fly straight upwards, so line the roof with bubble foam to stop them hurting themselves.

Feed

Quail need a constant supply of water. They require a high protein diet such as pheasant or chick crumbs plus some greenery. Sprouted alfalfa is good in winter. Of course, any flies caught in a fly trap are welcome.

Eggs

Eggs can be eaten fresh having been hard boiled for 1 minute, or then pickled in a vinegar solution or brine. They can also be sold fresh.

Figure 8.11 Aviary housing for poultry.

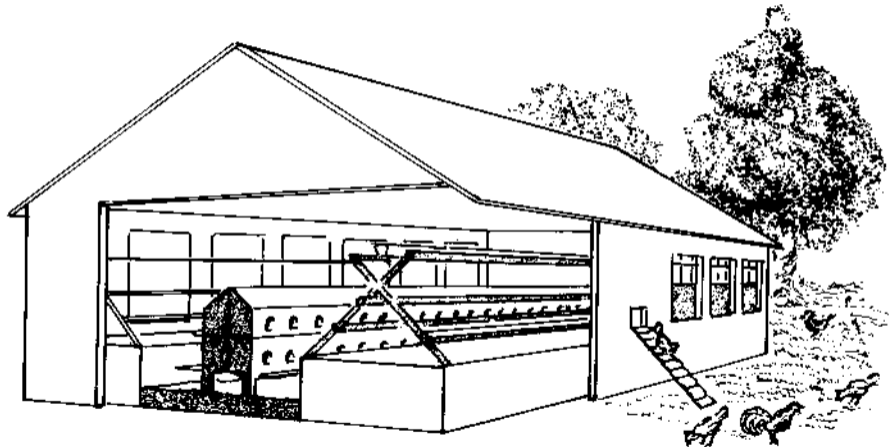

Source: Fölsch (1982).

Table 8.1 Composition of ration for laying birds using organically produced feeds.

<i>Feed component</i>	<i>Source</i>	<i>Per cent of ration</i>
Energy	Maize	25.0
	Wheat	18.0
Crude fibre	Oats	3.0
	Bran	6.0
	Dried grass	3.0
	Field beans	10.0
Protein	Maize gluten	8.5
	Meat meal	7.0
	Dried yeast	9.0
	Field beans	10.0
Minerals	Carbonated feed chalk	5.3
	Chalk grit	3.5
	Monocalcium phosphate	0.7
	Feed salt	0.4
Vitamins etc.	Brown seaweed	0.6
	Cod liver oil	5 litres/ tonne

Source: Züllig (1988).

Table 8.2 Standard poultry feed mixture Neu-Eichenberg.

44.5%	Feed wheat
18 %	Fodder peas
8 %	Field beans
5 %	Green meal
11.5%	Maize gluten
7.5%	Pearled chalk
2 %	Mineral mixture
2 %	Edible oil
1.5%	Molasses

Source: Deerberg (1989).

HYDROPONICS

the answer lies in solution

Hydroponics is the art and science of growing crops without using soil, by feeding them on solutions of water and nutrients which contain all the vital elements necessary for quick and healthy development. At first glance, such a method of cultivation might well strike the average householder or gardener as being directly opposed to traditional systems of tilling the ground, and indeed—following the views of some schools of thought—as unnatural.

Yet, if we will but take time to make just a brief study of the relevant facts we will soon see that although hydroponics is of course very different in practice to conventional farming and gardening, it is actually a completely natural technique, based on accepted ecological principles, and combining high productivity with several important environmental advantages for both plants and human beings.

In modern industrial societies, few persons, even if they are lucky enough to possess a plot of earth, have the opportunity—or the energy after a hard day's toil in factory or office—to dig, manure and weed the soil in order to produce green food for themselves and their families. In addition, the problem of space is fast becoming more serious and there are millions of people who would like to garden at weekends but who have not got any room to do so. Meanwhile, the prices of vegetables and fruits sold in shops and markets increase rapidly and constantly, putting ever greater strains on already hard-pressed household budgets and depriving men, women and children of the benefits of fresh produce, always essential for a balanced and healthy diet.

It is therefore not surprising that today more and more persons are turning towards hydroponics as a means of providing regular supplies of green foods and fruit in their homes. Gardening without soil can be very attractive to flat dwellers, people living in apartments or in tower blocks, in overcrowded cities and suburbs, or in other congested surroundings, whose resources are limited. Because hydroponic methods take up much less space than soil gardening would they are ideal for such situations. Moreover, soilless crop growing demands no hard manual work, and there are no jobs to perform comparable to those of digging, manuring and weeding the earth. Provided a few simple rules are adhered to, anyone can operate a hydroponic unit successfully in conditions where ordinary soil gardening would be impracticable.

The term 'hydroponics' means literally 'water working' and is derived from the Greek words *hudor*, water, and *ponos*, work. It was first used by Dr. William F. Guericke, of the University of California, in the mid-1930's. Since that time, of course, many advances have been made in soilless cultivation, so that we now find hydroponic techniques well established in many areas of the world. Numerous different methods of soilless crop growing have been developed, adapted to contrasting circumstances,

such as climate, geography, finance and levels of technology. Thus there are hydroponic systems for large commercial farms, others for desert or barren regions, and still more for householders, amateur gardeners and those persons interested in self-sufficiency and diverse life-styles.

Plants need certain essential items to grow and produce harvests. These include: light, air, water, a support for their roots, and food. Air is a gift of nature; light may be too but it can also be provided by man in the form of electricity; water similarly can come from rainfall or by pipe and well; a support for the roots can be supplied through different devices; while food may be offered in convenient and ingenious ways, which are completely acceptable and satisfactory to the plants.

In hydroponics, we strive to create the best environmental conditions for crops. Instead of giving plants earth and manure to feed on or anchor their roots in, we provide them with certain types of substrates or growing media and nourish them on solutions of water and fertilizers. Various misleading statements are made from time to time asserting that hydroponic methods of culture are artificial and that the produce from soilless units is lacking in nutritional value. Now although it may well be that food produced in factory farms is tasteless and inferior, this is not the case with hydroponic produce. In fact, the flavour and palatability of fruits and vegetables grown without soil are excellent, because the plants receive maximum feeding with a well balanced range of nutrient elements. Extensive tests and analyses have indicated that the mineral and vitamin contents of hydroponic crops are fully up to highest quality standards. Flours from hydroponically grown wheat have proved better for bread making, while it has been possible to incorporate extra iron and calcium in tomatoes and other vegetables for feeding to babies and invalids. On farms, it is now possible to grow grass without soil in special hydroponic units, for feeding dairy cows and beef stock, which matures in seven days after sowing. This green forage is extremely high in protein and mineral content and greatly increases milk yields and the health and well-being of cattle or other livestock.

Agricultural scientists and farmers know very well that excessive artificial fertilizers, without the use of any humus, destroy the tilth of, and degrade, the land. But they continue to employ them alone or in unbalanced quantities for purely economic reasons to get money as quickly as possible, without thought for the future. This is the chief criticism that can be made of modern farming. Evils such as erosion, disease, and destruction of the environment follow upon this abuse of the good earth. But in hydroponics there is no land to destroy, so any such complaint cannot be made. On the contrary, by creating vegetation where there has been none, hydroponics performs a most valuable ecological function.

The hydroponic method, in practice, means that instead of applying organic or inorganic manures to land, where they have to be, in the first case, broken

down by bacterial action before they can be assimilated by green plants, the fertilizers are given direct as solutions to the crops. Higher plants cannot absorb immediately organic materials. A considerable time must elapse before the necessary changes take place to make the nutrients present in such substances available to crops. What we are doing in hydroponics is simply to shorten this period dramatically, thus providing immediate nutriment in well balanced form to plants. This is why growth is so much more rapid in soilless cultures and the crops thrive so well. The process is perfectly natural and is in fact much safer and ecologically more sound than the current soil farming practice of spreading vast unbalanced quantities of chemicals over the countryside.

GROWING METHODS

Many different systems and methods of hydroponics are in use throughout the world today. Whilst some of these techniques are intended to serve the purposes of large commercial growers, quite a number are ideally suited to the needs of households, communities and families, for self-support and home production. Naturally, it is advisable to consider carefully the standard of education and the general social and technological development or condition of any community—those which exist or those which may be desired—when recommending a hydroponic technique for particular circumstances. It would be useless to introduce certain practices,

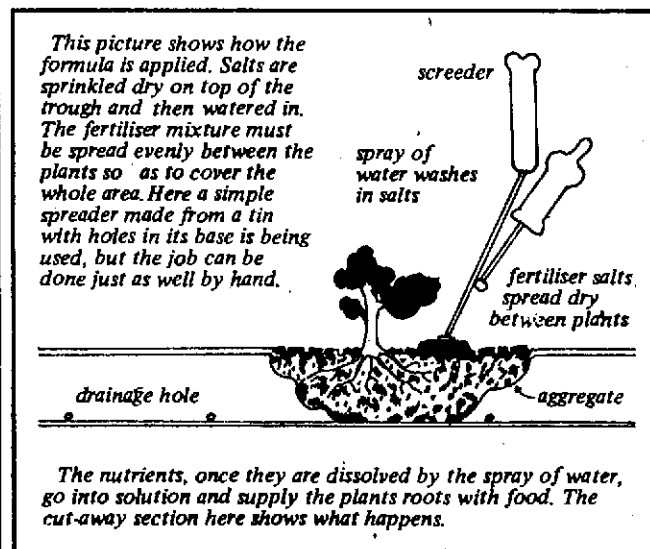
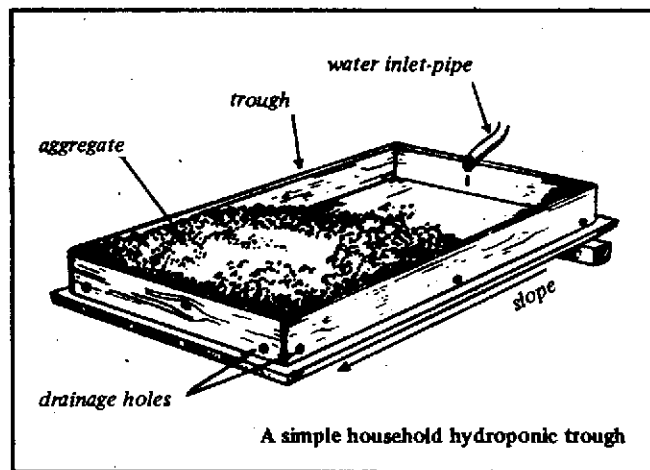

perhaps well suited to a peasant population living in under-developed surroundings, to a more intellectually advanced group in an industrial situation. Quite apart from differences in tastes and habits, there is a need to provide a viable level of operations for each case, or else skills present in the people concerned would be wasted. This is good ecology—to match the system to the subjects concerned, so that a satisfying and balanced life-style is secured.

Let us now consider a few methods of simple hydroponics for food production:

(a) *Sand or aggregate culture.* Very cheap hydroponic units can be made by lining wooden green-grocers' boxes or similar containers with polythene plastic sheeting or by using plant pots and plastic troughs. Normally, such receptacles should not be less than six inches deep and not over two feet wide, though they may be of any convenient length. For larger areas, beds or troughs, some eight inches deep by a yard wide and again of any appropriate longitudinal dimension, can be prepared by stretching the polythene sheeting over the ground or bare surface available, and supporting it at the sides and ends by bricks, stones, boards or other means. It is, however, possible to make almost any shape of trough or container to fit in with the circumstances of a backyard, kitchen, rooftop or other site. Many other good places exist for soilless gardens around the home, such as window sills, verandahs, the sides of pavements, and waste ground.



Applying nutrients in a soilless bed formed of stones and sand.

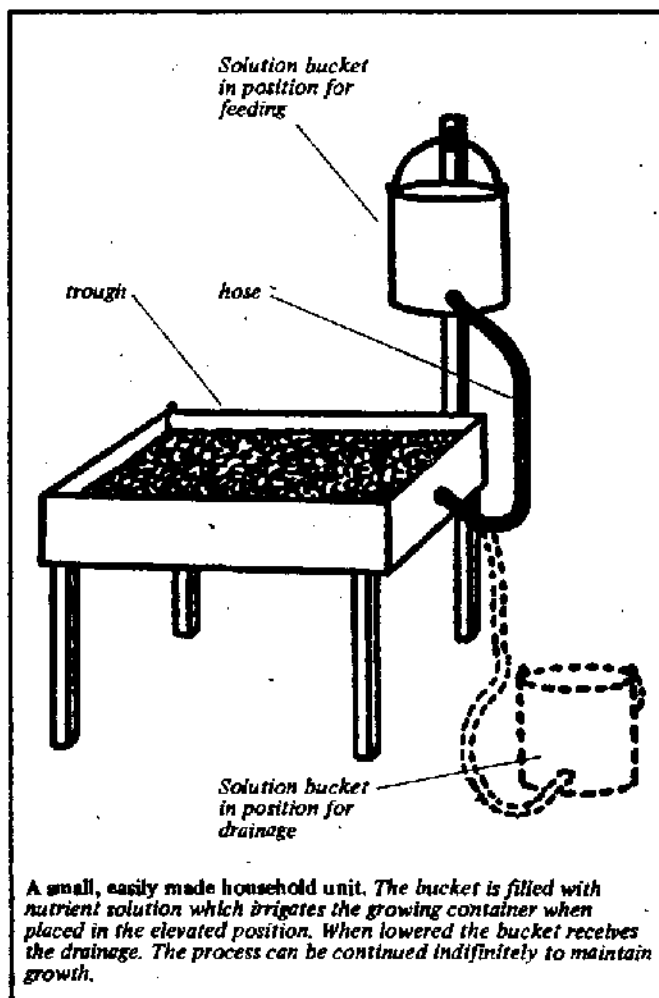

Once the hydroponic container has been chosen and lined with polythene, if necessary, a small drainage hole should be made in the base, or if it is a very large and long trough then several holes must be made. In the case of pots, there will be no need to do this because apertures will already exist in their bottoms. Drainage holes are generally about $\frac{1}{4}$ inch in diameter and can be provided with removable plugs. The purpose of these is to allow excess moisture to seep from the troughs or pots. Gutters may be provided to catch this liquid, or saucers and trays can be placed underneath pots.

The next task is to fill the container with growing medium. This is the substrate which anchors the plants' roots in position and acts as a reservoir for the water and fertilizers. Sand, fine gravel, well-broken bricks, washed cinders and charcoal, vermiculite, and many other materials will make excellent growing media. Allow the substrate to come up to about $\frac{1}{2}$ inch below the top of the sides of the container. Then smooth over the surface carefully. Some hydroponicists like to put an inch or two of pebbles or broken stones of larger size at the bottom of the troughs or pots beneath the main growing medium to ensure better drainage and aeration. Sands for hydroponics should be of medium and coarse grades, while the best sizes for gravels are $\frac{1}{8}$ th to $\frac{1}{4}$ inch.

The hydroponic trough or container will now be ready and should be watered with plain water to make the growing medium about as moist as a damp sponge that has been lightly wrung out. Excessive

watering is bad, the containers should not be kept flooded or water standing in them because this prevents air from reaching the plants' roots. Sow seeds not more than $\frac{1}{4}$ inch deep in the substrate, or plant young seedlings by scooping out small holes in the growing medium and pushing back the material gently around the stems so that they will stand firmly. Spacing may be up to 50 per cent closer than in soil gardening. It is a good plan to raise seedlings at home for hydroponics by sowing the seed first in small boxes of sand and then transplanting the young plants, when they are about three inches in height into the main containers.

After sowing or planting have been completed, feeding or nutrient application must commence. Nutrient mixtures can be made up at home or may be bought ready-made. If the first course is adopted, the mixture shown in table 1 is a good general purpose one for hydroponics. Weigh out these salts on ordinary scales and mix them well together, storing them in a dry sealed container. Larger amounts may be prepared by multiplying all quantities by a constant figure, so that the proportions stay the same.

To apply the formula to the hydroponic garden, mix one-third of an ounce, which is about one standard unheaped teaspoonful, with one gallon of water and spray or pour as many gallons of this solution onto the surface of the growing medium as may be necessary to keep it continually moist, but not flooded or too wet. This should be done as often as necessary. In winter, application of nutrient solution once or twice weekly should suffice, but in

warm, dry summer weather daily additions will probably be needed.

The solution can be applied in small units by watering can, but in larger troughs or beds it is easier to place it in an elevated tank or drum and allow it to run down through a hose pipe onto the growing medium. Whilst application is in progress, and for a short time after, keep the plugs in the drainage holes. Later, these apertures may be opened, to allow excess moisture to escape and air to be drawn into the substrate. The seepage can be collected in a bucket, tray or sump and returned to the tank.

Once weekly, open the drainage holes, to permit surplus liquid to run off, and every two or three months flush through the hydroponic containers with fresh plain water to remove any accumulated residues, and then start again with solution applications.

It is important to keep all hydroponic gardens clean and well cared for. During absences, for instance, on holidays, bowls, buckets or tanks of solution may be placed beside troughs or containers, and strips of cloth or wicks, with one end dipped into the nutrient liquid and the other inserted in the growing medium, to convey water and nutriment to the crops

◆ (b) *Bengal method* This is similar to the simple sand or aggregate culture already described, except that the growing medium or substrate is composed of a mixture of about two parts of coarse sand and three parts by volume of fine gravel, pebbles, broken bricks or other materials, all well blended together. The substrate is kept constantly moist, just like a damp sponge that has been lightly squeezed out. The method was devised in India, where great poverty exists, and because not many persons could afford solution tanks, the technique of dry application is employed. This means that after mixing up the formula the nutrients are scattered evenly over the surface of the growing medium at the rate of between one and two ounces of nutrient per square yard of trough space. Spreading of dry nutrients should be done on average weekly. Immediately after sprinkling the salts, they must be watered with plain water from a can or hosepipe, so that they dissolve and are washed down into the substrate in solution, to become available as plant food to the crops' roots. In between the times of nutrient spreading only plain water is given as irrigation to keep the troughs always damp.

Simple home hydroponics in Bengal.

The Sharder process. Hydroponic rice in Bengal: the method is ideal for providing food for households. It is an organically based technique. (Note the manure shells or pots).



The Sharder process. *Hydroponic rice in Bengal: the method is ideal for providing food for households. It is an organically based technique. (Note the manure shells or pots).*



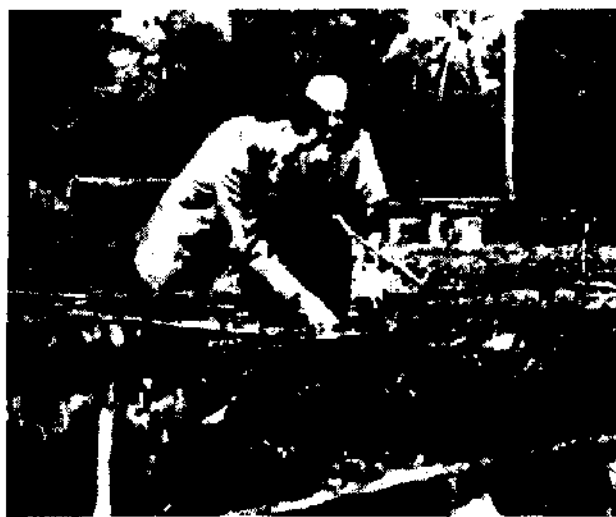

A hydroponic garden. In the first trough are beetroots and cauliflower, one month after sowing. (Take our word for it).

◆ (c) *Sharder process*. In order to help people who dislike using fertilizers, or those living in areas where local conditions make it difficult to obtain adequate supplies of inorganic nutrients, a process called the Sharder technique has been developed, also in Bengal. Normal beds or containers of aggregate are used, but to provide the crops with nourishment, manure shells or pots are placed at intervals along the troughs. These consist of earthenware vessels, lined with some kind of sieve or screen and pierced by a number of tiny holes in the bottom. The pots are filled with a nutrient sludge or semi-liquid manure, a typical formula for which is:

Fresh or dried dung . . . 1 handful
Matured oilcakes . . . 4 teaspoonfuls

Alternatively, such materials as hoof-and-horn meal, bonemeal, shoddy, or similar plant foodstuffs can be utilised. Dried wood ashes are also fairly effective. To mature the oilcake (cotton, castor, groundnut or other feed cake or waste) knead it with a little water, add ground bones together with some potash (fresh wood ashes or saltpetre), then store in a closed container for about two months. This disposes of any odours.

When the manure shells are placed in the hydroponic troughs, and sunk a few inches into the aggregate, with only the upper portions remaining exposed, they slowly release their nutrient contents into the substrate. Covers should be put over the vessels, and from time to time they may be refilled

Hydroponic vegetable garden.



1

Fertilizer	Ounces
Ammonium sulphate	15
Potassium sulphate	3½
Superphosphate	5
Magnesium sulphate	3
Ferrous sulphate—enough to cover the head of a match	

2

Manure	Ounces
Hoof-and-horn meal	15
Bonemeal	8
Ground chalk	6
Ground magnesian limestone	18
Fresh wood ashes	20
Scrapings from a rusty iron nail—enough to cover half a teaspoon	

with nutrient sludge or topped up. Every three months, flush through the beds or containers with plain water to cleanse them. Normal irrigation with water is provided to keep the substrate always moist. It should be noted that this process may be classed as organic feeding.

The formula shown in table 2 may be used in towns or industrial areas. *Mix well together and dilute to a thick sludge with water. Place in pots of about 2 lb capacity each, prepared as already described, and set them at intervals of up to one yard apart in the hydroponic units. The bottoms should be sunk three inches into the substrate. The sludge will slowly percolate into the growing medium, providing plant nutrients. See that it is not too thick and that the liquid strains slowly out of the vessels into the troughs or containers. It should not however run too rapidly. Top up with water and fresh formula monthly. Larger amounts can be made by increasing the total bulk, keeping the relative proportions constant.*

Self-sufficiency, eco-houses and various forms of alternative technology, are today of increasing importance. Several designs have been proposed, and used, which include the hydroponic production of green food based upon the adaptation of domestic waste matter for the nutrition of home grown crops. Waste and excreta, after processing by anaerobic digestion, algae farming, and other treatments, can be employed profitably, thus making for a self-contained life support system. When such organic nutrition is favoured, production of methane gas can be undertaken as well, so providing heat in cold periods.

Ingenuity and inventiveness, together with technological adaptations, have come to make hydroponics an ideal means of producing large amounts of foodstuffs very economically in quite simple ways, thus providing a significant contribution to ecological living. The field is open to further developments and we should see numerous such units in existence in the future.

by James Sholto Douglas

GOODBYE NATURE?

Growing food without natural soil allows a high degree of control and intensity of production. A great deal of good quality plant food may be grown within a small space.

Hydroponic culture replaces the soil or compost with a completely inert material such as sand, gravel, vermiculite or ash to act as a medium of support for the plant structure. Carefully balanced chemical solutions supply all the plants mineral nutritive requirements. Even the sunlight may be replaced with artificial lighting and of course the temperature and humidity may be exactly controlled.

Nutrient Solution: the use of chemical nutrients might be thought of as costly, but in fact, it is more economical than adding fertilisers to soil. The nutrient chemicals consist of the normal cheap commercial fertilisers. It is essential to use correctly balanced nutrient solutions to obtain results as good or better than normal natural soil production.

Any clean nonpoisonous water supply may be used. However the pH or acidity value of the water to be used must be discovered by analysis. The ideal pH value for plants is between pH 5 and pH 7 or slightly acid (pH 7 being neutral.) Most chemists will be able to supply the indicator papers necessary for a pH test. If the water is below pH 5 i.e. too acid, then the alkalinity must be raised by the addition of sodium or potassium hydroxide (caustic soda and caustic potash.) To correct a water which is too alkaline (i.e. above pH 7.) then add small amounts of sulphuric acid.

Elements necessary: ———

Nitrogen. 200 parts per million.
 Potassium. 200 p. p. m.
 Phosphorus. 65 p. p. m.
 Magnesium. 50 p. p. m.
 Calcium. 250 p. p. m.

Iron. 5 p. p. m.
 Boron. 1 p. p. m.
 Manganese. 1 p. p. m.
 Copper. 1/2 p. p. m.
 Zinc. 1/2 p. p. m.

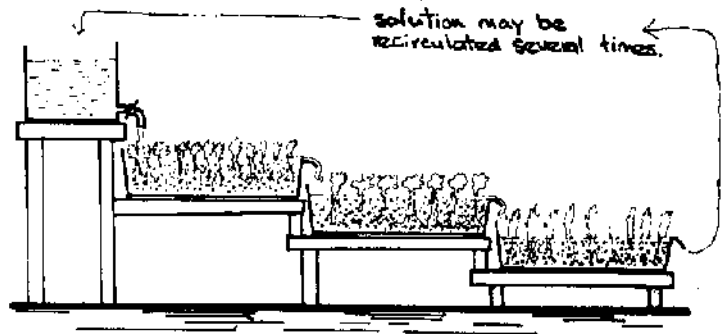

For 50 gallons of water the following compounds supply the necessary major elements in an economical mix. Dissolve in the order given.

Magnesium Sulphate — 4.25 ounces
 Super phosphate (16%) — 7.5 ounces
 Potassium Sulphate — 4.0 ounces
 Ammonium Sulphate — 2.0 ounces
 Sodium Nitrate — 7.75 ounces

Note: the proportion of ammonium sulphate to sodium nitrate could be increased, particularly in the summer, to reduce the sodium content.

Trace elements for 800 gallons (keep as stock solution) mix in order as below.

Boric acid — 0.72 ounces
 Zinc sulphate — 0.28 ounces
 Manganese sulphate — 0.52 ounces
 Copper Sulphate — 0.25 ounces

These are mixed in 4 pints of water to make the stock solution and 5 fluid ounces is added to each 50 gallons of the solution of major elements.

2.8 ounces of ferric ammonium citrate dissolved in 2 pints of water is kept separately to supply the necessary iron. 5 fluid ounces is added to each 50 gallons as above.

If you want to experiment first with small amounts of solution you can buy the trace elements ready mixed dry then to make up 10 gallons of nutrient you need: —

magnesium sulphate — 0.9 ounces
 potassium sulphate — 0.5 ounces
 potassium nitrate — 0.5 ounces
 calcium nitrate — 2.0 ounces

Your water supply may contain sufficient of the trace elements already. Experiment by leaving elements out.

Hydroponics

Wherever you live, even if you've no garden or yard of any kind, you can grow at least some of your own vegetables. Hydroponics is the art of growing plants without soil, either indoors or outdoors, in yields which sometimes reach the equivalent of 600 tons to the acre. A few square yards of space will provide most of your needs – a few square feet will keep you in salads, with a few winter vegetables thrown in for good measure.

Basically, you need containers for the plants, a substrate of some kind for them to grow in, and a mineral solution of exactly the right chemicals with which to nourish them. And the first objection is always that people don't like the idea of chemically-grown vegetables. Nonsense. Use of chemicals in the garden and the field is, I agree, to be deplored – it's an admission of failure, shows an inability to respect the proper laws of crop rotation, and it can turn what was once good soil into a sort of chemical blotting paper. The reason is that if you use chemicals, you don't at first have to bother about soil condition. But after a time, as your loose, crumbly soil gets replaced by panned mud-flats, you realize what you've done. By then, it's too late; you've got soil erosion and impoverishment, and there's not much you can do about it. That's why excessive use of chemicals on agricultural land is such a bad thing.

But hydroponics is quite different. You don't use any soil, there's no humus to preserve and improve, and the plants you grow will taste every bit as good as those from the best organic garden. If you don't believe it, then you must try it for yourself.

The first thing you need is containers. They've got to be waterproof, must be at least 6 inches deep, preferably a bit more, and must not contain chemicals which will either damage the plants or be subject to erosion from the chemical nutrient solution. You can use wooden boxes, and line them with polythene, making a few holes in the bottom and sides to allow for drainage. These holes must be pluggable, with wooden dowel or plasticine, or even screwed up bits of paper. The box itself is usually raised off the working level a few inches and a tray placed underneath to catch the drips. The plugs are removed from underneath when you want to wash the box and its content through with pure water, and to allow aeration of the roots.

Polystyrene window boxes are ideal, if you can get them cheaply. Old kitchen sinks, sections of barrels, big flower pots, and old tin baths are also good. But if your container is metal you must paint it with an asphalt-based paint to protect it. Creosote and similar chemicals must never be used or you'll lose all your plants.

Into this box, whatever it may be, you put the growing medium, whose job is really only to support the plant and anchor the roots. Again you can use many different things, and the one you choose will usually be the cheapest thing you can get locally. Sand will do, for a start. But you do need coarse sand, or the bed will get waterlogged. If you can mix in something slightly larger, like all-in aggregate as used for concrete mixing, that'll be fine. If you've old bricks lying around, break them up with a lump hammer till the largest bits are about $\frac{1}{4}$ an inch across, and use them complete with all the brick dust you make in the process. Vermiculite (used to make lightweight concrete) is probably the best material of all, but it's not the cheapest. You can, in fact, use any inert substance which ranges in particle size from about $\frac{1}{4}$ to $\frac{1}{2}$ an inch across down to dust. You must avoid anything with lime or plaster in it.

You then line your box with pebbles or broken pieces of flower pot to give you good drainage, and fill the box to within an inch of the top with your medium. Remove the plugs from the bottom and wash it all through with clean water to make the medium settle down. Firm it with the hand but don't push it down too much. The biggest problem with hydroponics is making sure the roots get enough air – and that means there must be plenty of air spaces in the medium. The plugs *must* be removed every few days to let excess moisture drain away and air flow up between the roots. Very important.

Next, you need to make up a nutrient solution. This you do either by buying the constituent chemicals from a chemist and mixing them yourself, or buying a proprietary brand mix direct from a supplier, which will be much more expensive. If you want to do that, you can get Phostrogen from Phostrogen Ltd, Tower House, Barmouth, Wales, or Sustanum from Trace Element Fertilizers Ltd, 118 Ewell Road, Surbiton, Surrey. There are others.

If you make your own, the books on hydroponics will give you plenty of examples to choose from. The two most often used are BM1 and BM3.

salt	amount in ounces	
	BM 1	BM 3
Ammonium sulphate	–	10
Sodium nitrate	12½	–
Potassium sulphate	4	3½
Superphosphate	5	5
Magnesium sulphate	3½	3
Iron sulphate	enough to cover a match head	

When you have bought these chemicals, mix them up in an old bowl with a wooden spoon and then store in an air-tight container. When you need to fuel your plants you take one-third of an ounce of the mixed salts – which in practice means one unheaped teaspoonful – and dissolve it in one gallon of water. Almost without exception, the water you use for the house will be satisfactory. There is an easy test. Put some cut flowers in a vase, add the water you intend using, and watch them for two or three days. If they stay healthy, the water is OK.

Before planting, you should wash your containers through with this water. Then plant your seed as you would in a garden, or transplant your seedlings. The only difference is that no seeds, however big, need to go more than half an inch deep. The next day take your gallon mixture, fill a watering can with it, and sprinkle it on the bed. Sprinkle enough to thoroughly moisten the medium, but not so much that any water is left standing about. Your medium must from now on be kept in this moist condition. How often you will need to feed depends on the warmth and humidity of the environment. It's dry and hot once a day may be necessary. If it's not, twice a week will be enough.

And that's all there is to starting off on the road to hydroponics. It's best to start with just two or three containers, and growing just your salad crops, plus perhaps a few tomato plants. If all goes well, you'll certainly want to get into larger-scale hydroponics.

And if you've a large enough cellar or attic, you should be able to grow very nearly all your own vegetables (if you don't have enough daylight, you can buy daylight fluorescent lamps). As far as I know, there's nothing you grow in the garden that can't be

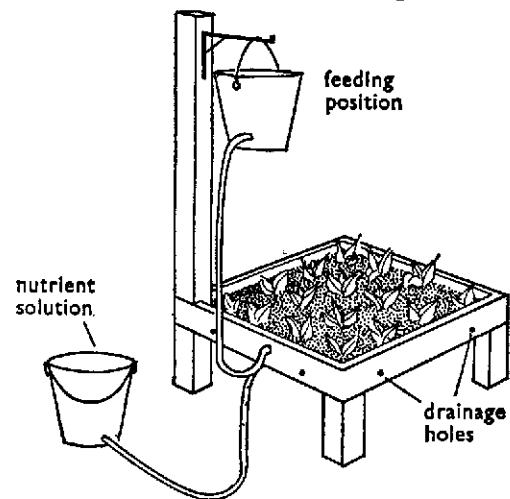

HYDROPONIC BED

grown in the hydroponics box. And there are a great many vegetables, such as peppers and aubergines, that can't be grown in the garden at all, but only in the house or the conservatory. If you've room to put that solar-heating greenhouse I recommended in chapter 7, then it may be a good idea to turn it into a hydroponic-growing area if you've no garden and hence no soil.

It's no good my telling you how much square footage you'll need to grow all your own stuff. It depends on how clever you are in inter-cropping – planting slow and fast growing crops very close so that one is pulled up and over before the next is mature. And of course, as soon as one plant is finished, you pop in the next succession as quickly as you can. That way you can get very intensive production, without exhausting the soil because you haven't got any.

But if you go big-scale, you'll probably end up with more automatic watering systems and possibly heating pipes running through your medium. There are countless ways of doing all that, at very low cost, and any good book on hydroponics will tell you how.

The flooding method

The growing medium is flooded one to three times a day for a period of one half to two hours at a time. The rest of the time the roots have oxygen available through the growing medium. After flooding, the nutrient is allowed to drain back into the solution reservoir. The flooding process can be handled automatically with a pump and timer.

You can make your own flooding system (see drawing) using a plastic dishpan, a bucket, and several feet of plastic tubing. Use epoxy glue to connect the system.

Once a day fill the bucket with solution and lift the bucket so the solution goes down the hose to the growing tray. Leave the bucket on a shelf or table until the entire solution has run into the tray. After about two hours lower the bucket so the solution can drain back into the tray.

To utilize a pump instead of gravity flow, replace the nutrient bucket with some type of plastic air-tight nutrient container (an inexpensive plastic air-tight jug will do). You will also need to purchase a simple aquarium pump (buy this at a pet store). Connect the pump to the container as shown in the drawing. When you turn on the pump, the air pressure forces the solution from the tank into the growing tray. When you turn off the pump, the nutrient drains back into the reservoir. To automate the system, hook the pump to an inexpensive timer and set it to run the pump about two hours a day.

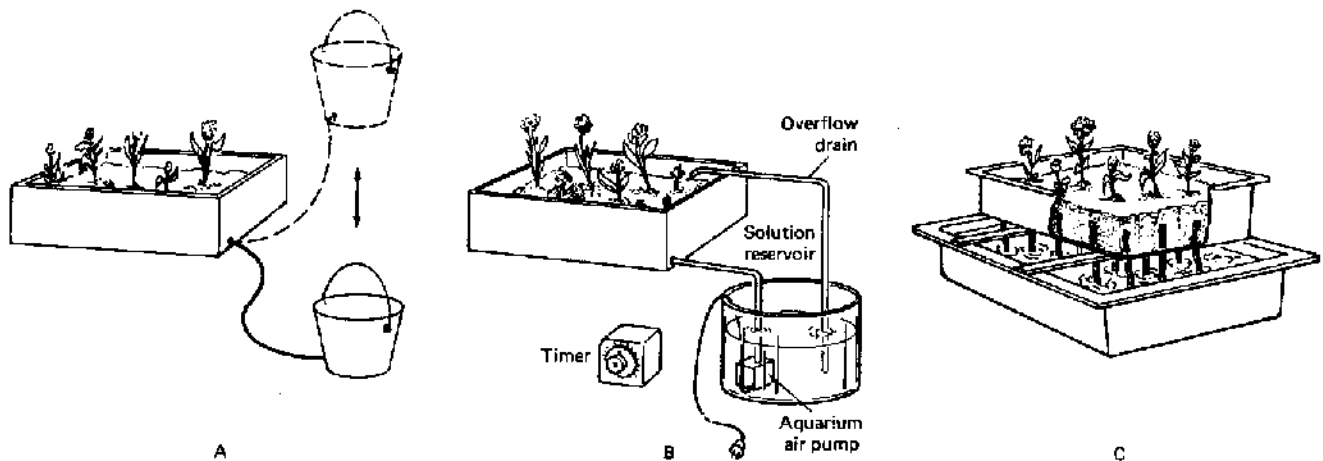

THREE WAYS OF FLOODING

Basic system: Using a bucket with a growing tray, the bucket is raised above the tray once or twice a day and the solution flows into the tray. Then the bucket is placed below the tray, and the solution flows back.

Automatic system: Using a submersible pump and a timer, the solution is automatically pumped into the growing tray as desired; then it flows back through the overflow drain into the reservoir. Using an aquarium pump and a nutrient

The wick method

A synthetic fiber wick draws the water-solution into the growing medium, allowing both moisture and air to feed the plant continuously.

To make your own system place two plastic growing trays (such as a plastic dishpan) one on top of the other. Place the nutrient solution in the top tray and the growing medium (perlite, sand, or other material) in the bottom tray.

Drill small holes about three inches apart in the bottom of the top plant tray and thread pieces of fabric through the holes down into the solution. Make your wicks from synthetic fabric such as nylon, polyester, or rayon. Be sure the fabric you use will draw the moisture the entire length of the wick.

After you have completed your system, fill the bottom tray with nutrient material, and then wet the wick to start the action. After that you will need to replace the solution every two weeks.

Drip method

The plants, grown in a perlite/peat moss medium, are watered slowly with the nutrient solution through drip irrigation tubes—allow just enough solution to run so that all the moisture is absorbed by the growing medium.

solution in an airtight container, the pump can be turned on and off by hand.

Wick system: In this two-tray system the nutrient solution is placed in the bottom tray, the growing medium and plants in the top tray. Wicks made of synthetic fabric are placed in the solution, passed through holes drilled in the top tray, and then embedded in the growing medium. The solution is drawn up into the top tray continuously.

Hydroponics

Now that you've been thoroughly convinced of the benefits of organic farming, and now that you've been told how it's best to let natural biological controls solve all your problems, let's look at another highly productive method of farming which is not natural and, in its pure form, uses nothing but chemicals. Hydroponics may be taken loosely to include all forms of agriculture that do not rely on soil as a planting medium. Sand, gravel, cinders, and other such materials can be included as hydroponic media.

The main advantage of hydroponic agriculture is increased production with low maintenance costs. Production is high because growth can be controlled easily through careful regulation of the nutrients applied to the plants. Disadvantages include the high initial cost of plumbing, the use of processed chemical nutrients, and the great volume of water needed. Water can be conserved if a recycling system is designed, but this feature also adds to the initial plumbing costs.

There are as many ways to apply the nutrients as there are types of media. Nutrient solutions may be prepared and applied by hand or by pump. The solution can be sprayed onto the plants, dripped onto the plants, or supplied to the plant bed by irrigation or subirrigation. The beds may be located either outdoors or in greenhouses. Obviously, building a greenhouse would be a significant expense that would have to be balanced against its higher yield.

In general, the more complicated and mechanized the hydroponic system is, the more expensive the installation costs will be. The simplest setup is a sand or gravel system where the nutrients are applied dry and then watered in by a hand-held hose. If gravity is used, no pump will be needed to drain the nutrients. (Feeding should last about fifteen minutes; after this time, the nutrient must be removed somehow, by some form of drainage.) Moderately coarse silicate sand from the beach is ideal as a medium. The sand can be placed directly into a shallow pit lined with a wooden border. Such a setup can be used to grow virtually all plants that are grown in soil, with root crops doing the best. Your major expense is then only the chemical nutrients; industrial grade salts are recommended since they also supply needed trace elements. A typical mixture is:

Sodium nitrate	13.50 oz.
Potassium sulphate	4.00 oz.
Superphosphate 16% P_2O_5	10.00 oz.
Magnesium sulphate	4.00 oz.
Ferrous sulphate	0.25 oz.
Water	100 gal.

Adequate stock solution can be made up once a week; the amount of time involved depends upon your dexterity. The solution should be applied at least once a day. A significant time-saving feature of hydroponics is that almost no time has to be spent weeding. A hydroponics system that requires no inorganic chemical additives and is used in conjunction with a fish-farming scheme is mentioned at the end of our discussion of aquaculture.

Small-scale hydroponics can be practiced in urban communities and even in apartments to grow beans, tomatoes, and other small vegetables. The easiest procedure is to place three or four inches of clean gravel into several plastic dishpans (see Figure 7.10). A small-diameter plastic hose is fixed into a side hole along the bottom edge of each pan. The other end of the hose connects up with a pail of nutrient solution. Feeding and watering is done by raising and lowering the pail twice a day. When you raise the pail above the level of your pans, the solution percolates into the gravel; after fifteen minutes, when the pail is lowered below the dishpans, the solution percolates back into your pail and drainage is complete. For further information on hydroponic designs, see the listings under R. Bridwell, T. Saunby, and C.E. Ticquet in the Bibliography.

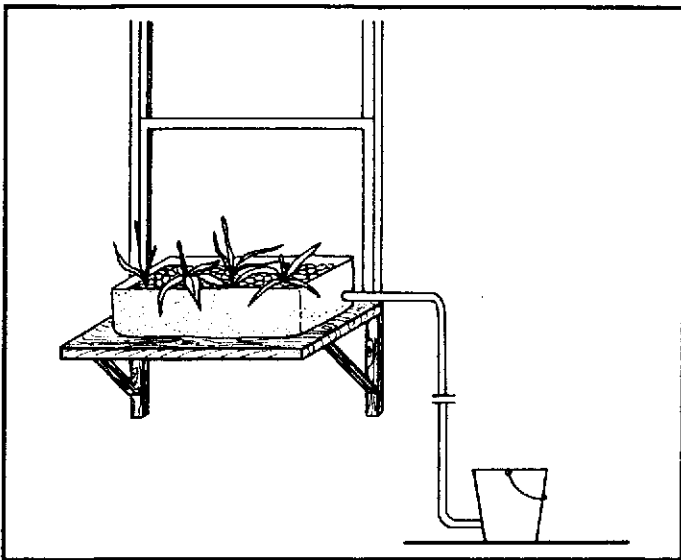

Figure 7.10 A small-scale hydroponics setup: Small indoor gravel beds can support healthy growing vegetables. The bucket containing the feed solution is lifted to water the vegetables, then lowered to allow drainage. This is done twice a day.

SYSTEMS OF SOILLESS CULTURE

Water Culture

In the water-culture method, plants are supplied with mineral nutrients directly from a water solution. The chief advantage of this method over aggregate culture is that a large volume of solution is always in contact with the root system, providing an adequate water and nutrient supply.

The major disadvantages are the difficulties of providing an air supply (oxygen) for the plant roots and proper support and root anchorage for the plants.

Materials and Equipment

The cost of growing plants through hydroponics depends upon the cost of chemicals and water used in the preparation of the nutrient solutions, the size of the operation, and the amount of mechanization. The cost may be quite low if you have a small setup and use available materials.

For a large setup, you will need a tank or trough constructed of concrete or wood. A depth of 6 to 18 inches and a width of 2 to 3 feet are the most common sizes for the larger tanks. If you use wood, be sure that it is free of knots and sealed with asphalt that does not contain creosote or tars. Do not use asphalt that leaves an oil film on the surface of the water. If the system is small, you can use glass jars, earthenware crocks, or metal containers. Metal containers should be well painted on the inside with an asphalt-base paint. Glass jars must be painted on the outside with dark paint to keep out light. A narrow strip should be left unpainted so that the level of the solution can be seen in the glass container.

The seedbed or plant bed should be 3 or more inches deep and large enough to completely cover the trough or tank. To support the litter, cover the bottom of the bed with chicken wire or 1/2-inch-mesh hardware cloth painted with an asphalt-base paint. Fill the bed with litter. The litter may be of wood shavings, excelsior, sphagnum moss, peat, or some other organic material fairly resistant to decay. Germinate the seed in sand or vermiculite and transplant to the water-culture bed. Keep the bed moist until the plants get their roots down into the nutrient solution.

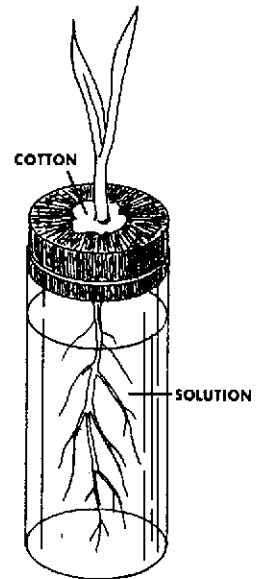

A simple method for growing plants in solution.

DURING THE PAST SEVERAL DECADES, many amateur and commercial gardeners have become interested in growing plants with their roots in an artificial medium instead of soil. This method of growing plants is commonly known as "hydroponics." It is also sometimes referred to as nutrient-solution culture, soilless culture, water culture, gravel culture, and nutriculture.

Soilless culture of plants is not new. One of the first experiments in water culture was made by Woodward in England in 1699. He was trying to determine whether water or the solid portion of the soil was responsible for plant growth. By the mid-nineteenth century, Sachs and Knop, the real pioneers in this field, had developed a method of growing plants without soil.

In the late 1920's and early 1930's, Dr. W. F. Gericke was able to grow plants successfully on a large scale through the laboratory technique of solution culture. Dr. Gericke used the term "hydroponics" to describe this method of growing plants. Today, hydroponics is used in commercial production, but it is employed mostly in those areas where soil is lacking or unsuitable for plant growth. Hydroponics is also a tool in plant research as well as a fascinating hobby.

REQUIREMENTS FOR PLANT GROWTH

The requirements for plant growth in soil culture and nutriculture are the same. The only fundamental difference between the two methods is the manner in which the inorganic nutrients required for growth are supplied to the roots.

Temperature. There is an optimum temperature range for plant growth. Above or below this range, plants will not do well. Warm-season crops usually do well between 60° and 75° or 80° F., with 60° F. the night temperature. Cool-season crops do well between 50° and 70° F., with 50° F. the night temperature. Temperatures for best growth should be maintained whenever possible.

Light. Most cultivated plants need large amounts of sunlight. When plants are grown indoors, additional artificial light is sometimes needed. If plants are grown entirely under artificial light, the intensity of the light must be very high without causing the temperature to rise above the optimum range.

Water. Water should be available in adequate amounts in the soil or in soilless culture for proper growth. Too little or too much water will not give optimum growth.

Oxygen. In soil that is not waterlogged, adequate oxygen should be available. In hydroponic systems for growing plants, there may not be sufficient oxygen in the nutrient medium. To provide enough oxygen, it is often necessary to bubble air through the solution surrounding the roots.

Carbon Dioxide. Carbon dioxide, a gas, is taken up through the surface of the leaf and furnishes carbon and oxygen. These elements are required, along with hydrogen, in the manufacture of carbohydrates. Carbohydrates are used by the plants as food.

Mineral Nutrients. The plant must absorb certain minerals through its roots to survive. The minerals required in relatively large amounts are nitrogen, potassium, phosphorus, calcium, magnesium, and sulfur. Those required in small amounts are iron, manganese, boron, zinc, and copper. Molybdenum and chlorine are also useful to plants, but the quantities required are so minute that they are usually supplied in the water or along with the other mineral nutrients as impurities.

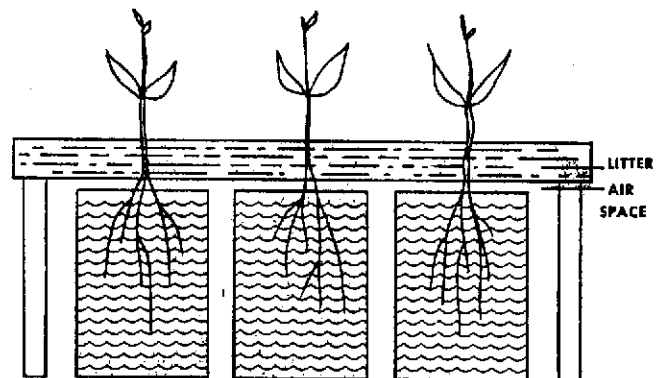

Cross-section of a simple water-culture system.

Aeration

The water-culture method often fails because of inadequate aeration of the solution. The space between the seed bed and the nutrient solution may provide enough air for the roots of certain plants. But

you must make special provision to allow an exchange of air between this space and the air outside. Prop up the seed bed a fraction of an inch or drill holes in the container or tank just above the highest solution level.

If you have trouble aerating the roots, use an aquarium air pump. Do not stir the solution too vigorously. You may damage the tender roots and cause poor plant growth. Pumping the air through an air stone, a perforated pipe, a porous glass tube, or a hose covered with a fine screen will reduce root damage by breaking down the air bubbles.

Water Supply

An adequate supply of pure water is essential for this system of hydroponics. The mineral content of water varies from place to place. In some areas, water is softened by replacing the calcium and magnesium with sodium. Sodium is toxic to certain plants when present at high levels. Boron and copper may be toxic at very low levels in the water, even though these elements are required in minute quantities for plant growth. Usually the minerals in water are not detrimental to plant growth. Calcium and magnesium, which are often present in water, are beneficial to plants.

Applying Nutrient Solution

Nutrient solution may be added by hand, by means of a gravity-feed system, or mechanically.

In a small setup, the nutrient solution can be mixed in small containers and added by hand as needed.

In a large setup, the gravity-feed system can be used effectively. The nutrient solution is mixed in a vat and tapped from the vat as needed. A large earthen jar or barrel will serve as the vat. If you use a metal barrel or container, paint the inside with an asphalt-base paint.

A pump can be used to transfer the material from the mixing vats to the growing tanks. Use a special non-rusting pump, or wash the pump carefully after each use. This precaution is necessary because the chemicals used in the nutrient solution will corrode metal.

The time to add nutrient solution depends upon the temperature and the growth of the plants. When the plants are young, the space between the seedbed and the nutrient solution may be quite small (sometimes one-half inch is sufficient). As the plant roots grow, lower the nutrient level slowly, keeping the level of the solution as constant as possible.

When the temperature is high and evaporation rapid, the plants may need additional solution every day. *Keep the roots at the correct level in the water.* The roots will die if allowed to dry out.

The container or tank should be drained completely every two weeks and the nutrient solution renewed from the mixing vats. This operation should be arranged so that it can be accomplished in a short time. If more than a few minutes elapse between the time of draining the tanks and refilling them, the roots will dry out. To delay the drying of the roots, change the solutions on a cloudy day or after the sun has gone down.

Transplanting seedlings or seeding directly into the seedbed will get the plants growing under the solution-culture system. The litter must be kept moist until the roots become established in the nutrient solution.

Transplant seedlings carefully. Work the roots through the support netting into the nutrient solution; then build up the litter around the plant to support it.

Aggregate Culture

This method is often referred to as "sand culture" or "gravel culture." Aggregates are used much as soil is used in conventional plantings — to provide anchorage and support for the plants.

The aggregate in the tank or container is flooded with a nutrient solution as required. The advantages of this system of hydroponics over the water-culture method are lack of trouble in aerating the roots, ease of transplanting seedlings into the gravel or other aggregate medium, and less expense.

Materials and Equipment

The tank or container should be *watertight* to conserve the nutrient solution. Construction materials will depend upon the size of tank or container. Large tanks can be built of wood, asphalt paper, concrete, or metal. The wood should be free of knots, and cracks should be

sealed against leakage with asphalt. Asphalt paper can be used with wood framing to make a workable tank. A metal tank should be painted on the inside with an asphalt-base paint.

Metal, earthen, and glass containers can be used quite successfully for a small-scale operation. Ground beds, flower pots, baskets, and even bean hampers have been used in aggregate culture. Since they are not watertight, however, some of the solution is lost. Metal containers should be painted on the inside with an asphalt paint, and glass containers should be painted on the outside with a dark-colored paint.

The aggregate material may differ greatly in composition. Well-washed silica sand makes one of the better materials. But any sand,

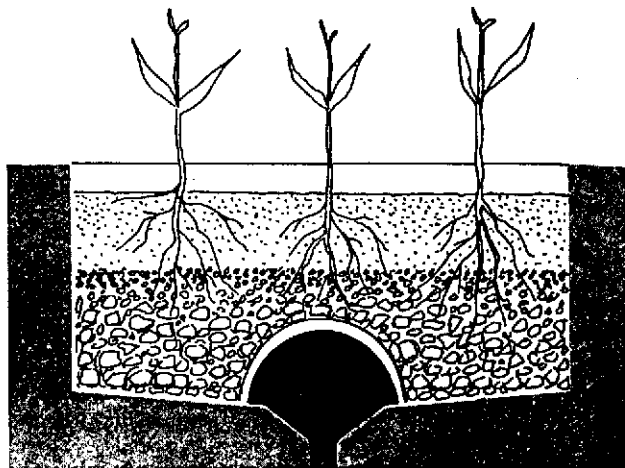

Cross-section of plants growing in aggregate culture.

preferably of coarse texture, that does not contain lime may be used. Sand is a desirable medium because of its ability to hold moisture, and because plants may be easily transplanted to it.

A mixture of sand and gravel makes a very good medium if the sand or gravel does not contain much lime. Well-washed cinders may be used, provided that they are not high in toxic materials. Other materials such as peat moss, vermiculite, wood shavings, etc. are also satisfactory. You can obtain aggregate materials from local lumber yards, garden centers, or garden-supply houses.

Aeration

Aeration is much easier in aggregate culture than in the water-culture system. Draining and refilling the tank with nutrient solution causes air to move in and out of the aggregate material, thus supplying adequate oxygen to the roots.

Water Supply

Water requirements for this system are the same as those for the solution-culture methods. The mineral nutrients and the minerals present in the water as impurities accumulate in the aggregate materials as a result of evaporation. To overcome this accumulation of minerals, flood the aggregate material with water every two weeks. Drain off the water to wash out the minerals.

Applying Nutrient Solution

The "slop" or surface method is the simplest for adding the nutrient solution. In this method, the solution is poured over the aggregates by hand. A manual gravity-feed system with buckets or other vats and small growing containers may be used. The vat is attached to the bottom of the tank or container with a flexible hose, and is raised to flood the tank and lowered to drain it. The vat may be lowered and raised by hand or by means of a mechanical device. The vat should be covered to prevent evaporation and filled with new nutrient solution at least once every two weeks.

The gravity drip-feed system also works satisfactorily, and reduces the amount of labor. The vat is higher than the tank in this system, and the solution drips from the vat just fast enough to keep the aggregate moist.

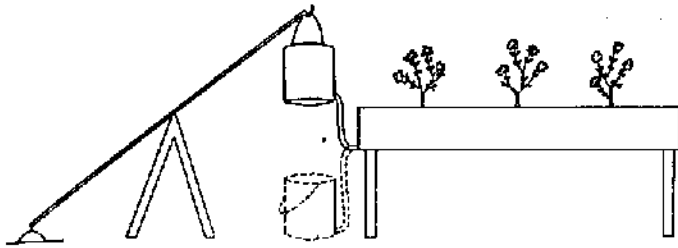

A manual gravity-feed system.

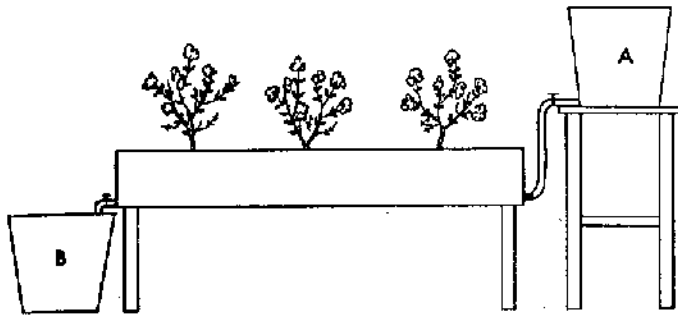

A simple gravity-feed system. The solution flows from vat A into the aggregate material in the growing bed. When the growing bed is flooded, the solution is drained into vat B and then returned to vat A.

A pump can be used to raise the solution to the desired depth for sub-irrigation. Sub-irrigation is a system of supplying the nutrients by raising and lowering the solution level from the bottom. The solution must be raised to a higher level for younger plants than for older plants. A timer may be arranged on the pumping system so that the nutrient solution can be added whenever necessary. If the pump is not a non-rusting pump, it should be washed carefully after each use to prevent rusting. This mechanical system for adding the nutrient solution is practical only for a large setup.

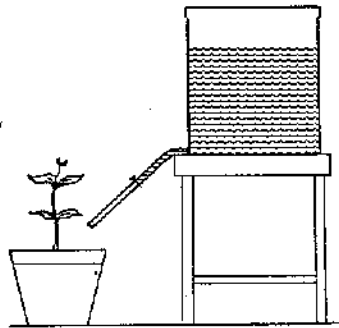

A gravity drip-feed system.

The nutrient material must be added and drained or raised and lowered in the tanks once or twice a day. When the weather is especially hot and dry, the aggregate material may need more than two drenchings. Examine the aggregate material frequently to be sure that it has not dried out around the roots. After a few examinations, you will know about when the nutrient solution should be added. Remember — frequent drenchings will cause little harm, and permanent injury may result if the plant roots dry out.

Do not use the nutrient solution more than two weeks. If the solution is used for longer periods, it will probably build up salts or fertilizer residues that will damage the plants.

Seedlings or rooted cuttings may be used in this system. The aggregate material should be flooded and the solution drained off before planting. This will leave a well-packed, moist seedbed.

Seeds may be planted directly in the aggregate material. Do not plant too deep. Flood or sprinkle the tank with water frequently to prevent the aggregate material from drying out at the surface. If this happens, small seedlings may die. A few days after the seedlings have germinated, start using nutrient solution.

The safest way to get the plants established is by transplanting the seedlings from a germination bed. The seed should be germinated in a medium that is free of soil. Soil on the roots may cause them to rot, and may also cause trouble by getting into the nutrient solution.

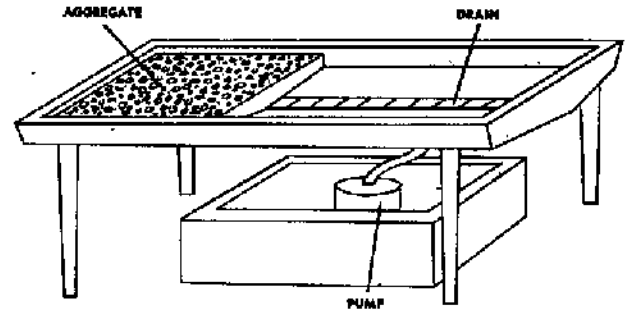

A simple mechanical subirrigation system.

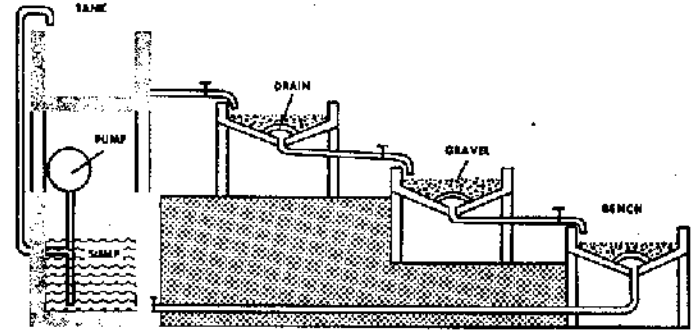

Cross-section of a mechanical gravity-feed system.

PREPARING THE NUTRIENT SOLUTION

For proper growth, plants must be supplied with nitrogen, phosphorus, potassium, calcium, magnesium, sulfur, iron, manganese, boron, zinc, copper, molybdenum, and chlorine. Within certain limits of composition and total concentrations, there can be a rather wide range in the nutrient solutions suitable for plant growth. Usually the small amount of minerals in the water supply can be ignored. When nutrients are deficient or present in excess in the solution, however, the plants will suffer. For this reason, you must be careful in selecting and adding the minerals that go into the nutrient solution.

Purity of the nutrient materials or chemicals is important in preparing a solution. In some cases, the fertilizer grade of a chemical may be used, and in other cases, a technical-grade or food-grade chemical may be needed. The best grades have few impurities; the lower or fertilizer grades may have more. Sometimes the plants may use the impurities. Because of the low price of the fertilizer-grade chemicals, they should be used whenever possible.

Many formulas have been devised for supplying the nutrient requirements for plant growth. Most of these recommendations will give satisfactory results, but they often require less than one gram of chemicals that are not easy to obtain.

Paint the storage vats and containers used for the nutrient solution to prevent exposure to light, and close the vats and containers to prevent contact with the air. Evaporation of the solution, whether through the atmosphere or through plants, reduces the amount of water and increases the proportion of salt in the solution. Too much salt may be detrimental to the plants.

Pre-Mixed Chemicals

The chemicals needed for hydroponic plant growth are now being mixed in the correct proportions. These mixtures may be obtained through catalogs, or from garden-supply stores and reputable fertilizer suppliers. They are relatively inexpensive, and small quantities will go a long way in growing plants. Follow the directions on the container.

Self-Mixed Chemicals

You may want to prepare your own nutrient solution. The nutrient solution given below was worked out by the late Dr. D. R. Hoagland

of the University of California. This solution supplies the major elements required for plant growth. It is easy to prepare, and usually gives satisfactory results.

Salt	Grade	Nutrients	Amount for 25 gallons of solutions	
			ounces	level tablespoons
Potassium phosphate (monobasic)	Technical	Potassium Phosphorus	½	1
Potassium nitrate	Fertilizer	Potassium Nitrogen	2	4 (of powdered salt)
Calcium nitrate	Fertilizer	Calcium Nitrogen	3	7
Magnesium sulfate	Technical	Magnesium Sulfur	1½	4

The table below can be used as a guide for adding nutrients required in very small amounts. You can obtain the chemicals listed from a garden-supply store or drug store. When you buy manganese chloride, zinc sulfate, or copper sulfate, be sure that the formulas for these salts are the same as those shown in the table. The amounts of solution given may be more than you will need. The amounts of chemical salts and water needed may be reduced by one-half or even more.

Salt (all chemical grade)	Nutrients	Amount of water to add to 1 tsp. of salt	Amount to use for 25 gallons of solution
Boric acid, powdered	Boron	½ gallon	½ pint
Manganese chloride (MnCl ₂ ·4H ₂ O)	Manganese Chlorine	1½ gallons	½ pint
Zinc sulfate (ZnSO ₄ ·7H ₂ O)	Zinc Sulfur	2½ quarts	½ teaspoon
Copper sulfate (CuSO ₄ ·5H ₂ O)	Copper Sulfur	1 gallon	½ teaspoon
Iron tartrate	Iron	1 quart	½ cup

Zinc sulfate and copper sulfate usually do not need to be added because of their presence as impurities in the water and in the other chemical compounds used in making up a nutrient solution. If you use the water-culture method of growing plants, it may be necessary to add the iron solution once or twice a week. You may want to use the chelated form of iron, since this form will not readily precipitate out of the solution. Mix 1½ ounces of NaFe EEDTA 13 percent Fe₂O₃ in 5 quarts of water. Use ¼ pint of this solution in 25 gallons of water.

Other sources of nutrients may be substituted for those in the tables as long as they furnish the mineral nutrients needed by the plants. The toxic effects of some chemicals upon plant growth must always be considered when making substitutions.

After all of the chemicals have been mixed into the solution, check the pH (acidity or alkalinity) of the solution on a pH scale. The pH scale runs from 0 to 14. Any solution below 7.0 is acid, and any solution above 7.0 is basic or alkaline. A pH of 7.0 is neutral.

Plants that do well at a low pH (between 4.5 and 5.5) include azaleas, buttercups, gardenias, and roses. Plants that will grow at a pH level between 7.0 and 7.5 include potatoes, zinnias, pumpkins, and myrtle. Usually plants will not grow with any success in solutions below a pH of 4.0 or above a pH of 8.0. For most plants, the solution should be slightly acid within a range of 5.5 to 6.5.

Use an indicator or pH tester to determine the pH of the solution. Indicator papers register pH within different ranges. When dipped into the solution, the paper will change color at different pH levels. There are other devices for determining pH, and testing kits may be obtained from scientific and chemical supply houses.

If the pH is above the desired range, it can be brought down by adding dilute sulfuric acid. Add the acid in very small quantities, stirring the solution at the same time. An eye dropper is useful for this purpose. Count the drops. After a few drops have been added, retest the solution. Continue adding acid and retesting until the solution reaches the desired pH range. If you count the drops of acid, you can put the same number of drops into the solution each time the solution is made up. You will not need to make further pH tests as long as the water and chemicals of the solution remain unchanged.

SYMPTOMS OF PLANT-NUTRIENT DEFICIENCIES

Plants will usually display definite deficiencies if the nutrients are not present in adequate amounts. The following symptoms may occur if the level of one mineral nutrient is not high enough to be within the range needed for best plant growth. There may be several reasons other than a nutrient deficiency why a plant will display a definite symptom. But if one of the deficiency symptoms occurs, a lack of the proper nutrient may be suspected, and the amount of that nutrient increased.

Deficient nutrient	Symptoms
Nitrogen	Leaves are small and light green; lower leaves lighter than upper ones; not much leaf drop; weak stalks.
Phosphorus	Dark-green foliage; lower leaves sometimes yellow between veins; purplish color on leaves or petioles.
Potassium	Lower leaves may be mottled; dead areas near tips and margins of leaves; yellowing at leaf margins continuing toward center.
Calcium	Tip of the shoot dies; tips of young leaves die; tips of leaves are hook-shaped.
Magnesium	Lower leaves are yellow between veins (veins remain green); leaf margins may curl up or down or leaves may pucker; leaves die in later stages.
Sulfur	Tip of the shoot stays alive; light-green upper leaves; leaf veins lighter than surrounding areas.
Iron	Tip of the shoot stays alive; new upper leaves turn yellow between veins (large veins remain green); edges and tips of leaves may die.
Manganese	Tip of the shoot stays alive; new upper leaves have dead spots over surface; leaf may appear netted because of small veins remaining green.
Boron	Tip of the shoot dies; stems and petioles are brittle.

EXPERIMENTS FOR YOU TO TRY

Many interesting experiments can be performed with soilless culture. Two experiments, the first dealing with pH levels, and the second with nutrient materials, are outlined below. You may want to work out variations of these experiments or try others of your own.

Experiment 1: pH Levels

Use the nutrient solution shown in the tables on pages 12 and 13, or a solution prepared from commercial pre-mixed nutrients. Adjust the pH of the solution to between 5.5 and 6.5.

Pour the solution into three containers. Do not change the pH of the solution in the first container. This solution is the "check" or "control." Lower the pH of the solution in the second container to below 4.0 by adding dilute sulfuric acid. Raise the pH of the solution in the third container to 8.0 or above by adding a dilute sodium hydroxide (NaOH) solution. Test the pH of the solutions with an indicator.

The following plants do well at a pH range between 5.5 and 7.0: carrot, coleus, cucumber, geranium, orange, pepper, petunia, strawberry, turnip, and violet. Grow a plant from this list in each of the three solutions. Choose only *one kind* of plant (pepper, for example), and be sure the plants are about the same size. If you use seeds, plant them all at the same time.

Notice the differences in growth between the plants in the three solutions. You may want to set up various pH ranges to find the best pH in which to grow a particular plant.

Experiment 2: Nutrient Levels

You will need to prepare three nutrient solutions for this experiment. The first solution is a pre-mixed nutrient solution or the "standard" solution listed in the tables. Use *twice* the recommended amounts of nutrients in the second solution. For the third solution, use *one-half* the recommended amounts of nutrients. You will probably not want to prepare 25 gallons of each solution. The amounts of salts and water may be reduced by one-half, one-fourth, or even more, as long as you mix the proper proportion of ingredients for each of the three solutions.

Be sure to grow the *same kind* of plant in each container so that you can compare results between the plants. If you transplant into these containers, choose plants that are uniform in size. By varying the nutrient and pH levels and observing the effects of these changes upon the plants, you can determine the proper pH and nutrient levels for a particular plant.

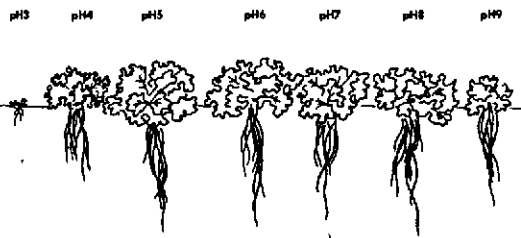

Effect of various pH levels on the growth of lettuce (from D. I. Arnon and C. M. Johnson).



Effect of various nutrient levels on plant growth.

Interview with Shigeo Nozawa, Director of Hiponica Theory Research Institute, Japan. Earth Summit News - 9/12 June 1992.

Q: What triggered your involvement in environmental and development activities ?

A: I became interested in this area of biology because of the threat of a food crisis and the postwar population explosion in Japan. The population began to expand at an exponential rate, whereas the annual agricultural production increase was only about 2 or 3 percent. It was obvious that we would soon face a severe food-shortage. However we have been able to avoid it so far using scientific technology.

Q: It seems that in connection with today's environmental issue, people are too much concerned with and confined by the physical aspects of our world. What do you think about this ?

A: Today's science cannot fully explain what life is and what it means to be alive. Since we recognise that the Earth is alive and it is this life that is in danger, unless we consider the meaning of life as a factor in scientific investigation, I don't think science can come up with solutions. I believe science should evolve to take seriously the power of the spiritual world.

Q: Please tell us about your experiment with tomato plants.

A: I grew a regular tomato plant in a circulating solution of ordinary fertilizer and water. In a very short time, the plant bore over 10 000 tomatoes. I feel this method can be useful in alleviating a food-shortage crisis. One issue would then be irrigation. the initial investment in irrigation in a near-desert area will be worthwhile because as I understand it, re-vegetating a desert has caused a change in the local weather system, which has produced rain.

Q: How do you plan to follow-up on this experiment ?

A: My current research focusses on the issue of the will to grow. I have been able to cut down on the amount of space roots occupy, to 1/8 of the regular bulk, and still have the plant grow to the same size as when the roots were left to grow naturally. In both cases the weight of the roots was the same. In other words, even under adverse conditions, the plant will manage to grow. It's almost as if the plant reacted to these bad conditions and worked harder. This will to grow has to be left to the plant; if people try to control it, its potential will be lost. The new stage in agriculture will be to learn how to let the plants grow to their fullest potential. This technological system can contribute to alleviation of food crisis in countries where they cannot feed themselves. The method I used requires very little investment in terms of equipment and labour.



More than 130,000 tomatoes grow from a single plant using an adaptation of water-culture methods.

Why a Digester?

What is a methane digester anyway? A methane digester is nothing more than a container which holds our organic wastes in a manner which allows natural bacterial degradation of the organic matter to occur in the absence of oxygen. By causing this anaerobic (oxygen-free) process to occur in a container, we control the conditions inside and outside the container to promote the efficiency of the process and capture the bio-gas product. The fact is that the methane digestion process will occur quite naturally without our interference—all we do is try to improve the process somewhat. What else can a digester do for us besides provide some bio-gas? First, it rids us of our organic wastes—horse manure, human excreta, vegetable wastes, and so forth; and second, it converts these wastes into resources. These resources are (in addition to the bio-gas) sludge and effluent, both excellent fertilizing materials.

But bio-gas and sludge are only resources if you both need and are in a position to utilize them. What this means is that digesters basically are only suitable for a rural or semi-rural setting. If this is your situation and you are interested in building a digester, you will want to consider the costs and the potential returns before embarking on a digester trip.

Bio-gas consists of methane mixed with carbon dioxide, approximately two parts methane to one part carbon dioxide by volume, and with very small additional amounts of oxygen, nitrogen, hydrogen, carbon monoxide, and hydrogen sulfide. Any appliance that runs on natural gas, which is primarily methane, runs well on bio-gas pressurized in the proper range (2 to 8 inches of water or 0.07 to 0.3 pounds per square inch [psi]), including gas stoves, refrigerators, hot-water heaters, lamps, incubators, and space heaters. Butane and propane appliances also have been run on bio-gas, and it can be used to operate steam and internal-combustion engines, both of which can operate electrical generators. In *Mother Earth News*, Keith Gilbert reports: "There are currently available from Japan several models of steam engines which can be used for any number of things on the farm or in a small factory. They are quite inexpensive (the starting cost is about \$100 for a small one), and will operate a wide variety of equipment including such things as: Electric generators, hammer mills, shredders, pumps, power saws for producing lumber, compressors, irrigation pumps, combines for threshing grain and beans, and other power machinery. One Japanese steam plant I observed was being used to operate a small saw mill and it did an effective job. It was

a wood burner and cost only \$60. Contact the Japanese Trade Legation for further information."

A small-scale digester will produce relatively small amounts of energy. We must maintain a perspective when we plan how to make use of the methane produced. As a point of reference, per capita consumption of natural gas in the United States is about 350 cubic feet per day. This represents about 30 percent of the total consumption of energy in this country for all purposes. It is clearly unreasonable, at normal consumption levels, to expect to drive a car or to take care of space heating with the output of a small digester, as you can see from the rates at which various appliances use methane (Table 5.1).

If we want to use a methane digester to provide all or some of our gas-related energy needs, we need to know what our present consumption is or is likely to be in the near future. An average family of five, using natural gas for cooking, heating water, drying clothes, and space heating, will consume on the order of 8000 to 10,000 cubic feet per month during the winter in California (mild winters). If space and water heating are handled by solar energy or by a wood-burning stove, and clothes are dried

Table 5.1 Rates of Use of Methane^a

Use	Rate (ft ³)
Lighting, Methane	2.5 per mantle per hour
Cooking, Methane	8–16 per hour per 2- to 4-inch burner
	12–15 per person per day
Incubator, Methane	0.5–0.7 per hour per cubic foot of incubator
Gas Refrigerator, Methane	1.2 per hour per cubic foot of refrigerator
Gasoline Engine (25 percent efficiency)	
Methane	11 per brake horsepower per hour
Bio-Gas	16 per brake horsepower per hour
As Gasoline Alternative	
Methane	135–160 per gallon
Bio-Gas	180–250 per gallon
As Diesel Oil Alternative	
Methane	150–188 per gallon
Bio-Gas	200–278 per gallon

Notes: a. Adapted from *Methane Digester for Fuel Gas and Fertilizer*, by Merrill and Fry

in the sun, the winter monthly consumption can be cut to about 2000 to 4000 cubic feet, easily within the range of a digester of moderate size.

If you presently use natural gas, you can estimate your requirements by looking at your utility bills for the last year (if you can't locate your bills, the utility company will usually provide you with copies). Then you can estimate cubic feet of natural gas used per month over an annual cycle, as well as the maximum monthly use (usually during winter). Once you have this estimate and when you are able to calculate the quantity of methane available from your waste materials, then you can evaluate the level of self-sufficiency you can achieve. Even if you are able only to satisfy half of your estimated needs, you may still consider it worth your while to build a digester as a waste-handling unit and energy supplement.

Natural gas in the United States now costs on the order of 1 to 2 cents per 10 cubic feet (in 1975). If we compare raw gas from a methane digester to natural gas, we find that natural gas has about 1000 Btu/ft³ while bio-gas has about 600 Btu/ft³; thus, it takes roughly one-third more bio-gas to give the same heat value as natural gas. If we consider a small digester producing on the order of 50 cubic feet of bio-gas per day (two-thirds methane), we save about \$12 to \$24 per year at current prices. It becomes obvious that small-scale digesters are not built primarily for savings on gas alone. If we consider other aspects of digesters—the value of the sludge and supernatant as fertilizer—our benefits are somewhat more apparent. If you are located in a remote area, the value of the gas as well as the fertilizer would be significantly increased because of transportation costs or the absence of a steady gas supply.

In quantity, commercial dried-sludge fertilizer costs close to \$1 per 100 pounds. This is equivalent to about 100 gallons of wet sludge effluent from a digester, since a gallon weighs about 10 pounds and the effluent is almost 10 percent solids. Besides this modest return, you then have the added comfort of knowing that sludge from methane digesters operating on concentrated slurries is known to have a superior fertilizer value compared to sludges from municipal sewage-treatment plants (which operate on a very dilute input). Another factor you may consider is that, for many locations, the cost and labor involved in installing a septic tank and leaching field are avoided.

It is very difficult to estimate the cost of building a digester, as expenses vary with the ingenuity of the builder, the good fortune of finding used or surplus equipment, and the amount of labor hired out. Ram Bux Singh suggests a design for a digester capable of producing 100 cubic feet of gas per day, and calculates that it would cost \$400 to build, as the construction is largely of concrete and masonry (in 1971). William Olkowski built a

300-gallon digester for \$150, out of surplus tanks, valves, and hoses. John Fry was able to produce about 8000 cubic feet of methane per day with a digester initially costing \$10,000. With gas at a value of 10 cents per 100 cubic feet, the value of Fry's daily gas production is about \$8, giving an annual value of \$2920. At this rate, he was able to pay for the cost of his digester within three years, giving him "free" gas from then on.

Even though our main concern in this book is not economics, the costs and returns of each potential energy source cannot be ignored and, in fact, must be weighed very carefully before you embark on a given project. If you are thinking seriously about designing a methane digester for a small-scale application, you must ask yourself one basic question: Is a small-scale digester practical? Will the methane digester provide you with enough gas and fertilizer to make it worth your time and money to build and maintain it? The answer to this question depends upon your available wastes and money and your willingness to alter your lifestyle to make the time to maintain the digester properly. The larger the scale of its operation, the more practical and feasible a methane digester becomes. Thus, what might not be practical for a single family may well be practical for a large farm or a small group of families. The ideal, of course, is an integrated energy-resource system. Figure 5.1 depicts such a system, where the methane digester constitutes a focal point for the other energy sources as a waste-to-resource converter.

The present state-of-the-art in methane digesters for small-scale operations is limited to homebuilt and owner-operated units. There are no commercially available units at the present time—you will have to design

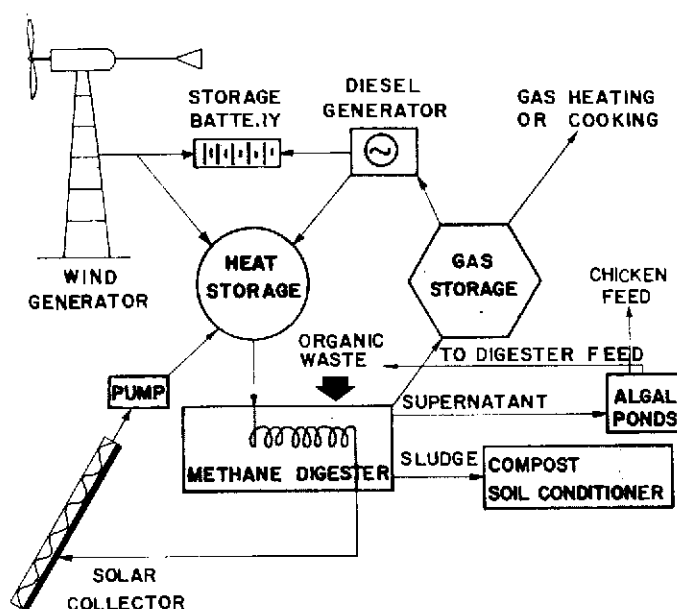

Figure 5.1 An integrated energy and resource system utilizing a digester.

and build your own methane digester if you want one. Your decision to build or not build a digester rests with an evaluation of your basic needs—waste-disposal and energy needs, fertilizer requirements, and any other appropriate considerations related to your particular situation. We can't give you a ready-made guide for evaluating your needs and requirements—you must do that. What we can say, however, is that if you do not own one or two horses or cows, or several hundred chickens, a methane digester is not going to be worth your investment. Beyond this lower limit, you must do some careful estimating. The design considerations in this chapter should help you out and there are several excellent publications on the construction and operation of small digesters for home or farm use. One of the most recent, *Methane Digesters for Fuel Gas and Fertilizer*, was produced in 1973 by the members of the New Alchemy Institute. The NAI work is based in part on an earlier, extremely helpful publication, *Bio-Gas Plant* (1971), produced under the direction of the Indian investigator Ram Bux Singh. A third very practical resource is *Practical Building of Methane Power Plants* by L. John Fry. The New Alchemy Institute Newsletter is available for \$4 from the New Alchemy Institute West, P.O. Box 376, Pescadero, California 94060.

The Digestion Process

Methane digestion is an *anaerobic* process; it occurs in the absence of oxygen. In anaerobic digestion, organic waste is mixed with large populations of microorganisms under conditions where air is excluded. Under these conditions, bacteria grow which are capable of converting the organic waste to carbon dioxide (CO₂) and methane gas (CH₄). The anaerobic conversion to methane gas yields relatively little energy to the microorganisms themselves. Thus, their rate of growth is slow and only a small portion of the degradable waste is converted to new microorganisms; most is converted to methane gas (for animal manures, about 50 percent is converted to methane). Since this gas is insoluble, it escapes from the digester fluid where it can then be collected and burned to carbon dioxide and water for heat. It turns out that as much as 80 to 90 percent of the degradable organic portion of a waste can be stabilized in this manner, even

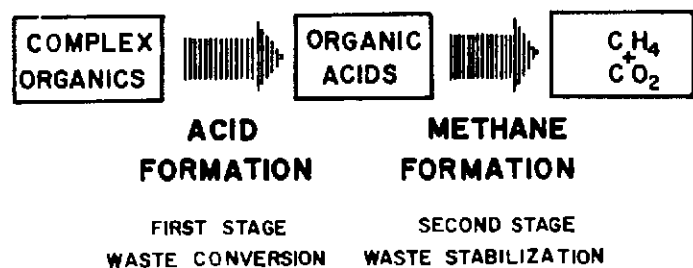

Figure 5.2 The two stages of anaerobic methane digestion.

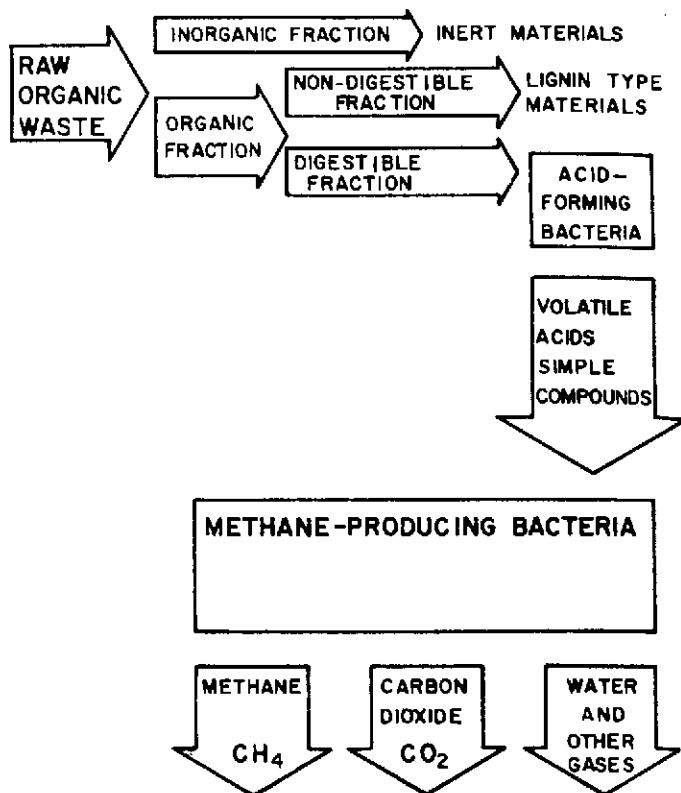

Figure 5.3 The biological breakdown of organic material in a methane digester.

in highly loaded systems.

Anaerobic treatment of complex organic materials is normally considered to be a two-stage process, as indicated in Figure 5.2. In the first stage, there is no methane production. Instead the complex organics are changed in form by a group of bacteria commonly called the "acid formers." Such complex materials as fats, proteins, and carbohydrates are biologically converted to more simple organic materials—for the most part, organic fatty acids. Acid-forming bacteria bring about these initial transformations to obtain small amounts of energy for growth and reproduction. This first phase is required to transform the organic matter to a form suitable for the second stage of the process.

It is in the second stage of anaerobic digestion that methane is produced. During this phase, the organic acids are converted by a special group of bacteria called the "methane formers" into gaseous carbon dioxide and methane. The methane-forming bacteria are strictly anaerobic and even small amounts of oxygen are harmful to them. There are several different types of these bacteria, and each type is characterized by its ability to convert a relatively limited number of organic compounds into methane. Consequently, for complete digestion of the complex organic materials, several different types are needed. The most important variety, which makes its living on acetic and propionic acids, grows quite slowly and hence must be retained in the digester for four

days or longer; its slow rate of growth (and low rate of acid utilization) normally represents one of the limiting steps around which the anaerobic process must be designed.

The methane-forming bacteria have proven to be very difficult to isolate and study, and relatively little is known of their basic biochemistry. The conversion of organic matter into methane no doubt proceeds through a long sequence of complex biochemical steps. These complexities, however, need not concern us here; we can represent the overall process schematically (Figure 5.3) and derive the level of understanding necessary for our purposes. The two major volatile acids formed during the anaerobic treatment, as we implied a moment ago, are acetic acid and propionic acid. The importance of these two acids is indicated in Figure 5.4, which shows the pathways by which mixed complex organic materials are converted to methane gas.

Digester Design Process

There are two basic designs for the anaerobic process. One is the "conventional" process most widely used for the digestion of such concentrated wastes as animal manures and primary and secondary sludges at municipal treatment plants. The other process is one designed to handle more dilute wastes and has been termed the "anaerobic contact" process. These two process designs are depicted schematically in Figure 5.5. We will concentrate our discussion on the conventional process since most of our waste materials will come in concentrated form.

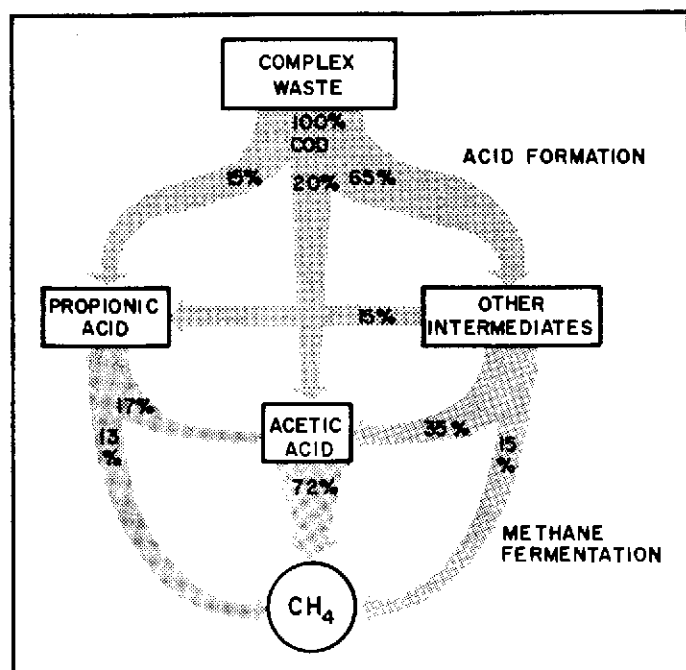

Figure 5.4 Pathways of methane formation from complex organic wastes.

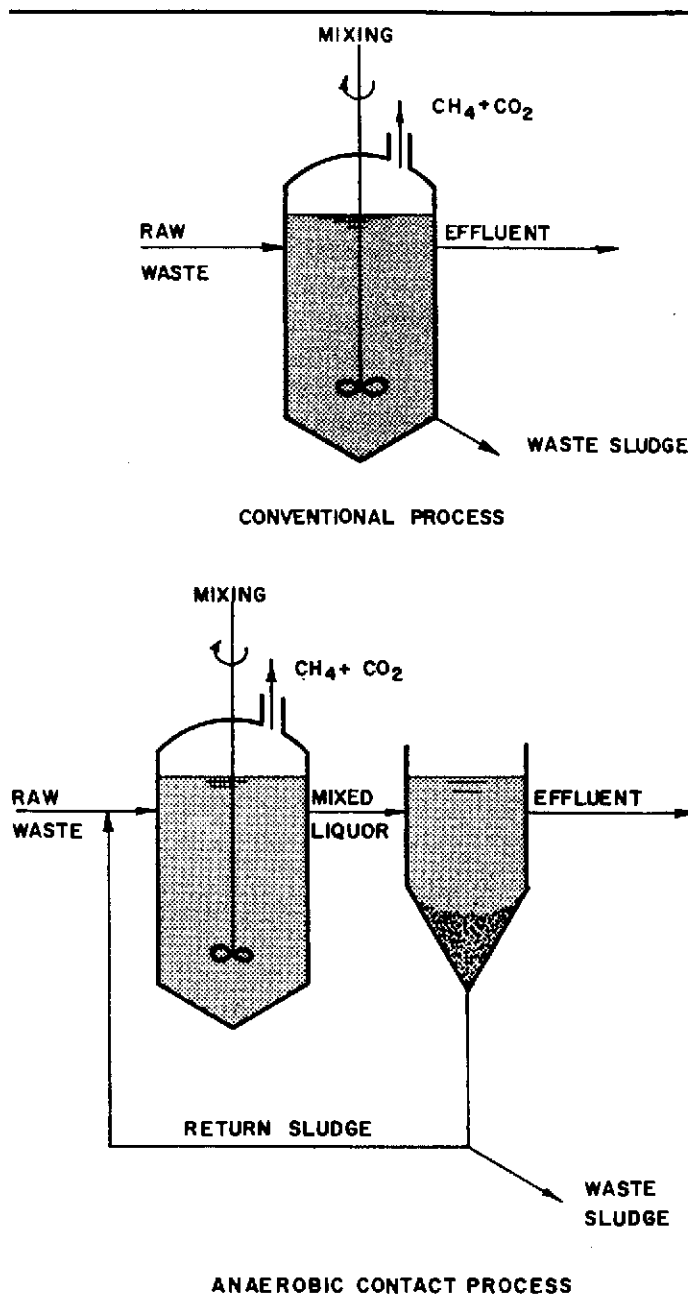

Figure 5.5 The two basic methane digester designs.

The conventional anaerobic treatment setup consists of a digestion tank containing waste and the bacteria responsible for the anaerobic process. Raw waste is introduced either periodically or continuously and is preferably mixed with the digester contents. The treated waste and microorganisms are usually removed together as treated sludge. Sometimes this mixture is introduced into a second tank where the suspended material is allowed to settle and concentrate before the sludge is removed.

There are many variations on a theme possible for methane digesters. A digester can be fed either on a batch basis (the more simple) or on a continuous basis, depending upon the trade-offs between initial cost,

sophistication of design, and the cost of maintenance and operation. Any decision as to feed type also will depend on the projected scale of the operation. Another factor that you will need to consider is heat for the digester (to optimize the rate of methane production) and insulation of the digester tank (to reduce heat loss). These are cost considerations and will require you to do some estimating on your own specific design details once you have arrived at a tank size for your needs. A design decision which you will need to make early in the design process is whether you want a single-stage or a multiple-stage digestion system. This is really a question of how many tanks you want in series and is related to the residence time of the materials in the digestion system—details we will cover. Mixing of the digester contents is desirable since this agitation helps to increase the rate of methane production. The decision to mix mechanically or to allow natural mixing (much slower) depends again on a cost/benefit analysis which you must perform for yourself. A final consideration has to do with the manner in which you add your feed and remove your supernatant effluent (liquid by-product). There are basically only two possibilities: digesters with fixed covers and ones with floating covers.

Like any other design process, there are many interrelated factors involved in the design of a methane digester. Let us assume for purposes of discussion that we want to evaluate the design of a methane digester for a small five-acre farm—say, several cows, horses, and goats, and maybe fifty chickens. What kind of information must we have available before we can sit down and make our calculations? The first and most obvious consideration is the type and quantity of organic waste which can be used as feed for the digester. There will be a number of wastes—cow manure, chicken droppings, goat turds, and maybe the green trimmings from the vegetable garden (in late summer, early fall)—and we will need to know something about the composition of the various waste materials to insure that our friendly bacteria have a well-balanced diet (with special attention paid to nutrients such as nitrogen). Knowing the quantity and quality (composition) of the waste materials available as feed for the digester, we can calculate the mixture and size of our actual input into the digester (slurry feed). Then we can estimate the required size of the digester tank for specified conditions of temperature and residence time of waste in the tank—the average time that the waste is in the digester before leaving as sludge or supernatant liquid.

Once we know the quantity and quality of our organic wastes and the temperature and residence time of wastes in the digester tank, we will be in a position to estimate the amount of gas which will be produced—thus allowing us to pick a size for the gas collection tank. Your gas tank should be of sufficient size (several days' use) to insure that you will have gas available for occasional

high-consumption use.

Notice that our attitude toward the methane digester is slightly different from the design procedures involved with deriving power from wind, water, or sun. We do not start out with design considerations to develop a methane digester to cover *all* your power needs; instead, we concentrate on your available resources in the way of waste products and investigate how much benefit you can derive from them. This is a reasonable attitude not only because here we are concerned with waste-handling, but also because of the economics involved. As we will see later, two cows and a horse can provide around 10 percent of an average individual's methane needs; if we then multiplied by a factor of 10 to accommodate 100 percent of our needs, we have a small ranch! So, all in all, we attempt to provide you with data to analyze what you have available right now; this same data, of course, can be used to calculate a 100 percent self-sufficient household or small community, if you have the requisite time, money, and waste already at hand.

Raw Materials

As we mentioned earlier, anaerobic organisms—bacteria that grow in the complete absence of oxygen—are responsible for converting the various organic raw materials into useful methane gas (CH_4), with carbon dioxide (CO_2) and water (H_2O) as by-products. Chemical analyses of anaerobic bacteria show the presence of carbon, oxygen, hydrogen, nitrogen, phosphorus, potassium, sodium, magnesium, calcium, and sulfur. This formidable list of elements, along with a number of organic and inorganic trace materials usually present in most raw materials used in methane fermentation, is essential for the growth of anaerobic bacteria; the hard-working bacteria must have a well-balanced diet if you expect them to perform at their best. Here, a well-balanced diet means adequate quantities of such nutrients as nitrogen and phosphorus. Nitrogen is generally the most important because it is the nutrient most likely to limit bacterial growth and, therefore, the rate and efficiency of methane production. A well-balanced diet for anaerobic bacteria also requires about thirty times more carbon than nitrogen, so you will need to know something about the carbon and nitrogen composition of the waste materials you are feeding your digester.

Phosphorus is third in importance only because smaller amounts are commonly needed. Although phosphorus and other elements that are found in even smaller percentages are necessary for growth, digesters are rarely inhibited by a lack of any of them because normal waste materials contain sufficient amounts to satisfy the bacteria's needs. (Interestingly enough, most detergents are "polluting" because they contain relatively large amounts of phosphorus compounds and other growth nutrients which stimulate growth of microorganisms and algae in

Table 5.2. Production of Raw Materials^a

Average Adult Animal	Urine Portion ^b	Fecal Portion ^b	Livestock Units
Bovine (1000 lbs)	20.0	52.0	
Bulls			130.0-150.0
Dairy cow			120.0
Under 2 years			50.0
Calves			10.0
Horses (850 lbs)	8.0	36.0	
Heavy			130.0-150.0
Medium			100.0
Pony			50.0-70.0
Swine (160 lbs)	4.0	7.5	
Boar, sow			25.0
Pig, over 160 lbs			20.0
Pig, under 160 lbs			10.0
Weaners			2.0
Sheep (67 lbs)	1.5	3.0	
Ewes, rams			8.0
Lambs			4.0
Humans (150 lbs)			5.0
Urine	2.2		
Feces		0.5	
Poultry			
Geese, turkey (15 lbs)		0.5 ^c	2.0
Ducks (6 lbs)		—	1.5
Layer chicken (3.5 lbs)		0.3 ^c	1.0

Notes: a. Adapted from *Methane Digesters for Fuel Gas and Fertilizer* (Merrill and Fry) and *Anaerobic Digestion of Solid Wastes* (Klein).

b. Pounds of wet manure per animal per day.

c. Total production.

receiving waters, leading to overproduction and stagnation.)

Assuming sufficient food is available in the proper form, other environmental conditions must also be satisfied for bacterial growth. The size and amount of the solid particles feeding the digester, the amount of water present in the feed slurry, how well the contents of the digester are mixed, the temperature range, and the acidity or alkalinity of the digesting mixture must all be favorable. Also, there are several kinds of waste that you must not use or your digester will cease to function properly. Let's start our discussion by looking into the composition of various organic wastes, and then we can talk about how to prepare a nourishing diet for your bacteria.

General Composition of Wastes

Table 5.2 is intended to give you a general idea of what to expect from animals as sources of energy. At least three variables (size of animal, degree of livestock confinement, and portion of manure collected) make this data nothing more than a series of rough approximations, but nevertheless it can be useful. Table 5.3 shows more specifically how the production of wet manure can vary (proportionally, in this case) with the weight of the animal. Manure deposited in open fields is obviously hard to collect and transport to the digester. NAI figures that open grazing during the day with confinement at night will yield about one-half of the total output as collectable raw material.

The portion of manure collected is important because urination is an animal's way of disposing of excess nitrogen and the nitrogen content of the raw material is a primary design consideration. Fecal material collected from cattle, horses, swine, and sheep in confinement may contain some or all of the urine output. You must make some judgment as to about how much urine is contained in the collected raw material. Human wastes are easily combined or separated, while poultry waste is produced in one combined load.

It is difficult to estimate the output of a garbage grinder in the kitchen. When sanitary engineers design treatment facilities for a city in which most people use garbage disposals, they increase the projected per capita output of sewage solids by 60 percent. If you have a garbage grinder, it might be practical to increase your daily output by about one-half (instead of 0.6) of the total sewage output of the household.

NAI uses a useful term called the *Livestock Unit* as a means of comparison of outputs between different kinds of animals (see Table 5.2). Taking the smallest tabulated output (that of a standard 3.5-pound layer chicken) as the unit of comparison, all other outputs are calculated as multiples of the chicken standard. Under this system, a common dairy cow is seen to be as valuable as 120 chickens from the standpoint of manure production. The Livestock Unit system is based on output of digestible solids, a term we must now define.

Wet manure or raw material is composed of both

Table 5.3 Hog Manure Production vs. Weight^a

Hog Weight (lbs)	Feces ^b	Urine ^b	Total Manure ^b
40-80	2.7	2.9	5.6
80-120	5.4	6.1	11.5
120-160	6.5	8.1	14.6
160-200	8.5	9.1	17.6

Notes: a. From "Properties of Farm Animal Excreta" (Tsiganides and Hazen).

b. Pounds per day.

water and solids. We define the solid portion (*total solids*) as the "dry weight" of the raw material, or the portion which would remain if the wet material were dried at a temperature of 212°F until no more weight was lost by drying (sun-dried manure still contains up to 30 percent water). It turns out that, of the total solids (TS), the fraction which would be digested by bacteria in a normal digester is proportional to the portion which would be *burned off* if it (total solids) were again heated, this time to about 1100°F, and kept at that temperature until once again there was no more weight loss. This digestible portion is called *volatile solids* (or VS). The remaining portion (after the water is evaporated and the volatile solids are burned off) is called the *fixed solids*. Figure 5.6 demonstrates these relationships for horse manure.

Table 5.4 gives approximate values for the digestible portions of a variety of raw materials. These figures must be used realizing that the values have been arrived at under specific experimental conditions which may differ from those present in any other case.

The first part of the table (green garbage, kraft paper, newspaper, garden debris, white fir, average refuse, chicken manure, and steer-manure fertilizer) is drawn from an article by S.A. Klein (see Bibliography). Notice that his values for percent moisture are *extremely* low (green garbage has only 1 percent moisture). Except for the steer-manure fertilizer, all of his raw materials were freeze-dried before examination. His percentages of volatile solids are usable directly because volatile solids are taken as a percentage of dry *total solids*, not wet raw material. However, unless you can duplicate Klein's freeze-dried initial conditions (unlikely), his values for total solids should not be applied directly to your wet raw material.

There is a further complication with calculation of

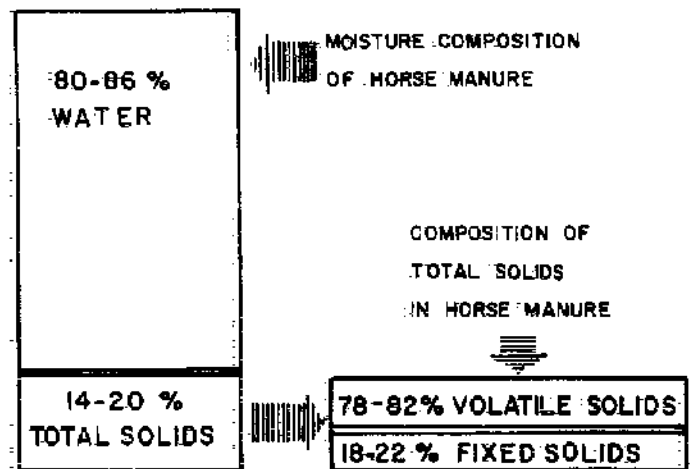

Figure 5.6 Moisture and solids content of horse manure.

total solids of raw materials. If we assume that the raw manure is collected from animal enclosures, it is reasonable to assume that fresh fecal material will contain some urine as liquid. This urine content will raise the percentage of moisture in the manure above the "normal" level if the urine does not evaporate before the manure is used in the digester. A bit later we will detail the chemical significance of this addition of urine. The values in the rest of Table 5.4 are calculated with the assumption that the manure is used as a raw material for the digester *before* the urine component has evaporated significantly. If a rough separation of fecal material and urine is assumed, 20 percent total solids can be used as a good approximation for the fecal material for steers (fresh), horses, swine, and sheep. Separate values are given for human urine and fecal material because separation is more practical, and chicken manure will always contain the animal's urine excreta because, as we mentioned, the two components are deposited in the same load.

Table 5.4 Composition of Raw Materials^a

Material	%Moisture	%Total Solids (TS)	Volatile Solids (% of TS)	%C	%N	C/N Ratio
Green garbage	1.0	99.0	77.8	54.7	3.04	18
Kraft paper	6.0	94.0	99.6	40.6	0	∞
Newspaper	7.0	93.0	97.1	40.6	0.05	813
Garden debris	24.8	75.2	87.0	-	-	-
White fir	9.3	90.7	99.5	46.0	0.06	767
Average refuse	7.3	92.7	63.6	33.4	0.74	45
Chicken manure	9.8	90.2	56.2	23.4	3.2	7
Steer manure (prepared fertilizer)	45.7	54.3	68.5	34.1	1.35	25
Steer manure (fresh) ^b	86.0	14.0	80.0	30.8	1.7	18
Horse manure ^b	84.0	16.0	80.0	57.5	2.3	25
Swine manure ^b	87.0	13.0	85.0	-	3.8	-
Sheep manure ^b	89.0	11.0	80.0	-	3.8	-
Human urine	94.0	6.0	75.0	14.4	18.0	0.8
Human feces	73.0	27.0	92.0	36.0-60.0	6.0	6-10
Chicken manure (fresh)	65.0	35.0	65.0	-	-	-

Notes: a. From "Anaerobic Digestion of Solid Wastes" (Klein) and *Methane Digesters for Fuel Gas and Fertilizer* (Merrill and Fry).

b. Includes urine.

Table 5.5 Gas Production as a Function of Volatile Solids^a

Material	Proportion (%)	Cubic Feet of Gas ^b	Methane Content of Gas
Chicken manure	100	5.0	59.8
Chicken manure & paper pulp	31	7.8	60.0
Chicken manure & newspaper	69	4.1	66.1
Chicken manure & grass clippings	50	5.9	68.1
Steer manure	100	1.4	65.2
Steer manure & grass clippings	50	4.3	51.1
Steer manure & chicken manure	50	3.4	61.9
Steer manure & sewage sludge	50	5.0	63.9
Grass clippings & sewage sludge	50	7.8	69.5
White fir (wood) & sewage sludge	10	9.3	68.9
White fir (wood) & sewage sludge	90	4.3	69.7
Newspaper & sewage sludge	10	9.9	67.1
Newspaper & sewage sludge	90	8.8	69.0
Newspaper & sewage sludge	20	7.5	69.5
Newspaper & sewage sludge	30	7.5	69.5
Newspaper & sewage sludge	70		

Notes: a. From "Anaerobic Digestion of Solid Wastes," by S.A. Klein.
 b. Per pound of volatile solids (VS) added.

If you are an adventuresome experimenter, you can perform your own laboratory analysis for total solids by drying a known weight of wet manure in a kitchen oven at 212°F and measuring the weight lost (evaporated water). This weight loss is divided by the original wet weight and multiplied by 100 to give the percentage of moisture content in the original wet manure:

$$E. 5.1 \quad \% \text{ moisture} + \% \text{ total solids} = 100\%$$

Figure 5.6 demonstrates this point.

We also should note that Klein's value for percentage of volatile solids for steer fertilizer is lower than the value for fresh steer manure (from NAI) because he is using manure which has been partially digested before examination, during the composting/preparation process involved in fertilizer production. His chicken manure (% total solids) is also high in comparison to the fresh manure value (NAI) because his extremely dry starting material will naturally have a higher content of total solids.

Tables 5.5 and 5.6 can be used to get a rough idea of the potential production of bio-gases (60 percent methane, 40 percent carbon dioxide) from typical raw materials if the volatile-solids content of the raw material is known. Equations presented in a later section can be

Table 5.6 Gas Production as a Function of Total Solids^a

Material	Bio-gas (ft ³) ^b
Pig manure	6.0-8.0
Cow manure (India)	3.1-4.7
Chicken manure	6.0-13.2
Conventional sewage	6.0-9.0

Notes: a. From *Methane Digesters for Fuel Gas and Fertilizer* (Merrill and Fry). Note that total solids rather than volatile solids is used as the determinant of produced gas volume.
 b. Per pound of total solids (TS) added.

used to determine the production of methane from other materials, if you know or can determine their volatile-solids content.

Example: Let's calculate the cubic feet of methane per pound of raw chicken manure we can reasonably expect on the basis of information given in Table 5.5.

Solution: First we need information on percent TS and percent VS for fresh chicken manure given in Table 5.4. The cubic feet of methane per pound of fresh chicken manure is given by

$$\frac{\text{Cubic Feet of Methane}}{\text{Pound of Raw Material}} = 1 \times \% \text{ TS} \times \% \text{ VS}$$

$$\times \frac{\text{ft}^3 \text{ Gas}}{\text{lb}} \times \frac{\% \text{ Methane}}{\text{Gas}}$$

E. 5.2

$$= 1 \times 0.35 \times 0.65$$

$$\times \frac{5 \text{ ft}^3}{\text{lb}} \times 0.598$$

$$= 0.68 \text{ ft}^3/\text{lb}$$

This gives us a rough estimate of the quantity of gas we can expect from a pound of fresh chicken manure, but what we eventually want is to be able to calculate the gas production for a mixture of raw wastes in a general way. Knowing specific information on gas production per pound of waste is helpful, but limited to the specific waste material.

Ram Bux Singh has recorded outputs of gas from vegetable matter that were seven times the output from common manures. NAI also found great increases in gas production brought about by the addition of fluids pressed from succulents (cacti). However, because the carbon content of plant material (compared to nitrogen content) is very high, the digestion of plant material releases a far greater percentage of carbon dioxide than the digestion of manures. Since carbon dioxide does not burn, we must view it as an impurity, and plant-generated bio-gas is therefore qualitatively inferior to manure-generated bio-gas.

Substances Inhibiting Digester Operation

Plant material also contains a high percentage of fixed solids, thus leaving a lower fraction of volatile solids. If the material itself is used instead of the pressed juices, scum formation in the digester will be greatly accelerated and can cause problems. McNary and Walford found that citrus peels ruined their digesters, due to the presence in the peels of the chemical inhibitor, d-limonene. Other substances that are known to inhibit the digestion process include heavy metals (zinc, lead, mercury, copper), high amounts of ammonia (above 1500 parts per million, or ppm), and the alkali elements (sodium, potassium, calcium, and magnesium). Another serious problem is the presence of sulfides, observed in many sewage-treatment digesters. Sulfides are easily detectable by their distinctive rotten-egg odor. It is very unlikely that any toxic materials will be present in small digester units utilizing manures and household wastes. If, however, toxicity is suspected, further study in the matter is required. P. McCarty has presented problems of digester toxicity in simple and concise terms and he is recommended for further reading on this aspect (see Bibliography). Later in the chapter, we also consider the digestibility of algae.

Carbon/Nitrogen Ratios

Our bacteria use carbon and nitrogen in the production of new cells and methane, and most people agree that, since carbon and nitrogen are used in the cells in the approximate ratio (C/N) of 30:1, the optimum ratio in the feed slurry also should be 30:1. By altering the composition of the inflow slurry, the digester can be "tuned" for efficient output. And, since the percentage of methane is in some ways determined by the carbon/nitrogen ratio of the feed, the quality of the gas also can be regulated.

The C/N ratio is difficult to establish for a general category of raw material because of the difficulty in testing for the *available* quantities and because the actual content of a material can vary with the maturity of the plants involved or the storage time of the manure. For these reasons, the figures given in our tables must be taken as approximations and guides rather than exact design parameters. It is the best we can do at this time.

Nitrogen is present in waste in many chemical forms, not all of which are equally available to anaerobic bacteria. The nitrogen in ammonia, for example, is more readily available (see Figure 5.7). Also, since urination is an animal's method of eliminating excess nitrogen, the amount of urine present in the manure will strongly affect the C/N ratio. Poultry waste is high in available nitrogen because urine and feces are excreted in the same load. Cattle and other ruminants (cud chewers) produce manure with an especially low nitrogen content since the bacteria essential to their digestion process live in one of their two stomachs and consume much of the nitrogen contained in the animal's diet. Vegetable waste is typi-

cally quite low in nitrogen content, while algae is quite high. Stable manure will usually be higher in nitrogen because it contains more urine than pasture manure (however, the straw included in stable manure can act to offset this increase because of its *low* nitrogen content).

Tables 5.4 and 5.7 give values for percent of *dry weight* (total solids) for nitrogen, since both volatile-solids and fixed-solids sources of nitrogen are available to the bacteria. The carbon percentages are for volatile or nonlignin portions whenever possible, again using dry weight. Using the weights of various raw materials and their C/N ratios, a recipe for a total-inflow C/N ratio of 30:1 can be derived from Tables 5.4 and 5.7. Further qualitative information about the importance of the C/N ratio in determining the quality of the bio-gas produced is provided in Table 5.8. Be sure that you are working with the *digestible* portion of the raw materials in your calculations. Singh recommends that the C/N ratio never exceed 35:1, but NAI notes that a level of 46:1 would be acceptable if it were unavoidable.

Although the addition of plant waste raises the carbon content of the inflow slurry significantly and aggravates the scum problem, it also tends to buffer the system at an alkaline level, protecting against a dangerous drop in pH to the acid level. Since overloading the digester with too much raw material lowers the pH and stops digestion if allowed to continue, the presence of plant material in the digester helps to protect the system from failure due to overloading.

Example: If we have 50 pounds of cow manure and 20 pounds of horse manure, what is the C/N ratio of the mixture?

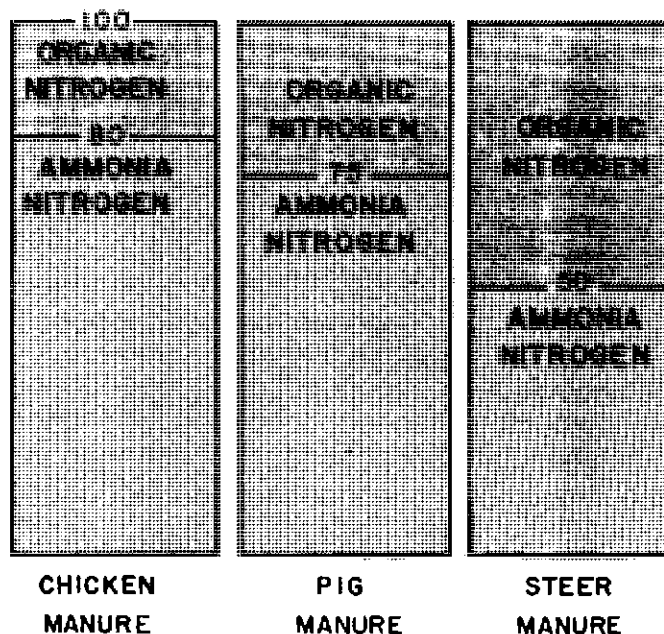

Figure 5.7 Variations in organic and inorganic nitrogen in different manures. The nitrogen of ammonia is more readily available.

Table 5.7 Nitrogen Content and C/N Ratio^a

Material	Total Nitrogen (% dry weight)	C/N Ratio
Animal wastes		
Urine	16.0	0.8
Blood	12.0	3.5
Bone meal	—	3.5
Animal tankage	—	4.1 ^b
Dry fish scraps	—	5.1 ^b
Manure		
Human feces	6.0	6.0–10.0
Human urine	18.0	—
Chicken	6.3	15.0
Sheep	3.8	
Pig	3.8	
Horse	2.3	25.0 ^b
Cow	1.7	18.0 ^b
Steer	1.35	25.3
Sludge		
Milorganite	—	5.4 ^b
Activated sludge	5.0	6.0
Fresh sewage	—	11.0 ^b
Plant meals		
Soybean	—	5.0
Cottonseed	—	5.0 ^b
Peanut hull	—	36.0 ^b
Plant wastes		
Green garbage	3.0	18.0
Hay, young grass	4.0	12.0
Hay, alfalfa	2.8	17.0 ^b
Hay, blue grass	2.5	19.0
Seaweed	1.9	19.0
Nonleguminous vegetables	2.5–4.0	11.0–19.0
Red clover	1.8	27.0
Straw, oat	1.1	48.0
Straw, wheat	0.5	150.0
Sawdust	0.1	200.0–500.0
White fir wood	0.06	767.0
Other wastes		
Newspaper	0.05	812.0
Refuse	0.74	45.0

Notes: a. From "Anaerobic Digestion of Solid Wastes" (Klein) and *Methane Digesters for Fuel Gas and Fertilizer* (Merrill and Fry).
 b. Nitrogen is the percentage of total dry weight while carbon is calculated from either the total carbon percentage of dry weight or the percentage of dry weight of nonlignin carbon.

Solution: Cow manure is 86 percent water and 14 percent solids (Table 5.4). So its dry weight (50×0.14) equals 7 pounds of total solids. These dry solids are 1.7 percent nitrogen (also from Table 5.4) and so the weight of nitrogen (7×0.017) is 0.119 pounds. Cow manure's C/N ratio is 18:1; so, since it contains 18 times as much carbon as nitrogen, it has (0.119×18) 2.14 pounds of carbon, dry weight.

Using the same procedure for horse manure (84 percent water, 16 percent solids, 2.3 percent nitrogen by

Table 5.8 C/N Ratio and Composition of Bio-gas^a

Material	Gas			
	Methane	CO ₂	Hydrogen	Nitrogen
C/N low (high nitrogen)	little	much	little	much
Blood				
Urine				
C/N high (low nitrogen)	little	much	much	little
Sawdust				
Straw				
Sugar and starch				
potatoes				
corn				
sugar beets				
C/N balanced (near 30:1)	much	some	little	little
Manures				
Garbage				

Notes: a. Adapted from *Methane Digesters for Fuel Gas and Fertilizer* (Merrill and Fry).

dry weight, and C/N ratio of 25:1—Tables 5.4 and 5.7), we find that horse manure has a dry weight of 3.2 pounds, and contains 0.074 pounds of nitrogen and 1.85 pounds of carbon, dry weight.

The total carbon content, then, is 2.14 pounds plus 1.85 pounds, or 3.99 pounds, dry weight. The total nitrogen content of the mixture is 0.193 pounds, dry weight. Thus, the total C/N ratio of the mixture is:

$$\frac{3.99 \text{ lbs}}{0.193 \text{ lbs}} = \frac{21}{1}$$

A C/N ratio of 21:1 isn't all that bad, but it's lower than the 30:1 we would like. A little bit of thinking will reveal the fact that we can never do better than a C/N ratio of 25:1, that of horse manure, because each time raw material is added, both the carbon and nitrogen components will be added proportionately. Obviously, the less cow manure we use (18:1), the better our C/N total will be; but we would lose total volume unless we found some horses to replace the cows.

Our hope for improving the C/N total beyond 25:1 lies in adding some raw material with a C/N of greater than 25:1 (or better yet, greater than 30:1)—wheat straw, for example (C/N = 150:1).

Assuming that we want to use all of our cow and horse manure and that we have some wheat straw to spare, take the total dry solids (10.2 pounds) with a total C/N ratio of 21:1 and combine it with some amount of wheat straw (you can guess at a figure for percent moisture; how about 10%?). Then use the above procedures to get the C/N ratio for your new mixture. Run through the calculations more than once to get a feel for the principles and an idea of how much wheat straw would be required to bring the total C/N up to around 30:1. (Try 1.5 pounds of wheat straw; you should get a C/N ratio of just about 30:1.)

Feed Slurry

Moisture Content, Volume, and Weight

For proper digestion, the raw materials must contain a certain amount of water, and experience with operating digesters has shown that a feed slurry containing 7 to 9 percent solids is optimum for digestion. To calculate the amount of water that must be combined with our raw materials to give this consistency, the moisture content of the raw material must be known.

Moisture values for various feed materials often used in digestion appear in Table 5.4. If there is any doubt as to the correctness of these values, or if the raw materials under consideration do not appear in this table, a direct determination of the moisture is usually feasible: we require only a small balance and an oven set at 212°F.

First, a small pan or plate is weighed and filled with a sample of the raw material. Care should be taken that the portion of the material used in this determination is representative of the entire batch to be used in the digestion process. Pan and raw material are then weighed together. After this step, pan and material are placed in the oven and allowed to dry until all the water has evaporated. When drying is completed, the pan and contents are allowed to cool in a dry place and are weighed once more. Percent moisture is given by

$$\text{E. 5.3} \quad \%M = \frac{W_i - W_f}{W_i - W_p} \times 100$$

where $\%M$ equals the percent moisture of the raw material; W_p equals the weight of the pan or plate (lbs); W_i equals the initial weight of the pan and sample, before drying (lbs); and W_f equals the final weight of the pan and sample, after drying (lbs).

Say the weight of your pan is 0.1 pounds, the initial weight is 2.1 pounds, and the final weight is 0.7 pounds. Then the percent moisture is

$$\begin{aligned} \%M &= \frac{W_i - W_f}{W_i - W_p} \times 100 \\ &= \frac{2.1 - 0.7}{2.1 - 0.1} \times 100 \\ &= 70\% \end{aligned}$$

Once the moisture content of the feed material(s) is known, the amount of water that must be added in order to give an 8 percent slurry (midway between 7 and 9 percent) can be calculated.

Let's first deal with the situation when the total weight of raw material we intend to put in the digester is known (by either weighing or estimation). We are going

to introduce a long list of definitions and a very formidable-looking series of equations, but don't worry—we arrive at the other end with a few fairly simple formulas. Here are the definitions:

$\%M$ = moisture content of raw material in percent

M = moisture content of raw material as decimal fraction

$\%TS$ = percent of total solids in raw material

TS = total solids as decimal fraction of weight of raw material

W_r = total weight of raw material

W_s = weight of total solids in raw material

W_w' = weight of water already in raw material

W_w'' = total weight of water in 8 percent slurry

W_w = weight of water to be added to make 8 percent slurry

V_w = volume of water to be added to make 8 percent slurry

W_{st} = total weight of slurry

V_{st} = total volume of slurry

V_r = volume of raw material

D_r = apparent density of raw material

The moisture content of the raw material can be equated with the percentage of total solids in the raw material, either as percentages or as decimal fractions:

$$\text{E. 5.4} \quad \%TS = 100 - \%M$$

$$\text{E. 5.5} \quad M = \frac{\%M}{100}$$

$$\text{E. 5.6} \quad TS = 1 - M$$

The weight of solids in the raw material is given by the following two relationships:

$$\begin{aligned} \text{E. 5.7} \quad W_s &= W_r TS \\ &= W_r \times (1 - M) \end{aligned}$$

To produce an 8 percent slurry, 8 pounds of solids should be mixed with 92 pounds of water, including, of course, the water already present in the raw materials:

$$\text{E. 5.8} \quad W_w = W_r M$$

The total amount of water contained in an 8% slurry is

$$\begin{aligned} \text{E. 5.9} \quad W_w'' &= 92 \frac{W_s}{8} \\ &= 11.5W_s \end{aligned}$$

and the amount of water which you will need to add is the difference between the total moisture needed and the moisture already present:

$$\begin{aligned}
 \text{E. 5.10} \quad W_w &= W_w'' - W_w' \\
 &= 11.5 W_r - W_r M \\
 &= 11.5 W_r \times (1 - M) - W_r M \\
 &= 11.5 W_r - 12.5 W_r M
 \end{aligned}$$

The volume of water to be added is

$$\begin{aligned}
 \text{E. 5.11} \quad V_w &= \frac{W_w}{62.3} \\
 &= 0.1845 W_r - 0.2 W_r M
 \end{aligned}$$

since water weighs 62.3 pounds per cubic foot at 60 to 70°F.

The weight of the 8 percent slurry can be calculated by adding the weight of water added to the original weight of raw material:

$$\begin{aligned}
 \text{E. 5.12} \quad W_{sl} &= W_w + W_r \\
 &= 12.5 W_r \times (1 - M)
 \end{aligned}$$

and this must be equal to the sum of total water and total solids:

$$\text{E. 5.13} \quad W_{sl} = W_w'' + W_s$$

By using 65 pounds per cubic foot as an average density of the 8 percent slurry, the volume of the slurry is

$$\begin{aligned}
 \text{E. 5.14} \quad V_{sl} &= \frac{W_{sl}}{65} \\
 &= 0.192 W_r \times (1 - M)
 \end{aligned}$$

where V_{sl} is in cubic feet (1 gal = 7.5 ft³).

So, using Equations 5.10, 5.11, 5.12, and 5.14, we can figure out the weight and volume of the water to be added and the weight and volume of our 8 percent slurry, once we know the total weight of raw material and the moisture content (don't mix up M with $\%M$):

$$W_w = 11.5 W_r - 12.5 W_r M$$

$$V_w = 0.1845 W_r - 0.2 W_r M = \frac{W_w}{62.3}$$

$$W_{sl} = 12.5 W_r \times (1 - M)$$

$$V_{sl} = 0.192 W_r \times (1 - M)$$

When the volume, density, and moisture content of a raw material are known (instead of the total weight), calculation of the volume of 8 percent slurry can be done in the following manner. The weight of raw material can be estimated by multiplying volume times density:

$$\text{E. 5.15} \quad W_r = V_r D_r$$

where D_r is in pounds per cubic foot. The volume of slurry then becomes

$$\text{E. 5.16} \quad V_{sl} = 0.192 V_r D_r \times (1 - M)$$

The apparent density of the raw material can be estimated by weighing a known volume of material (without compacting the raw material) and dividing the weight by the volume.

When a mixture of, say, three materials ($\%A + \%B + \%C = 100\%$) is to be used in a digester, the moisture content of the mixture can be computed by

$$\begin{aligned}
 \text{E. 5.17} \quad M_{mix} &= \frac{\%A \times \%M_a}{100} + \frac{\%B \times \%M_b}{100} \\
 &\quad + \frac{\%C \times \%M_c}{100}
 \end{aligned}$$

where the subscripts denote the individual components of the mixture, A, B, and C. The weight of the mixture is

$$\text{E. 5.18} \quad W_{mix} = W_a + W_b + W_c$$

and the volume of the mixture is computed in a similar manner:

$$\text{E. 5.19} \quad V_{mix} = V_a + V_b + V_c$$

This same procedure can be followed for any number of mixture components.

Example: From two cows and a horse, you have 50 pounds of cow manure ($\%M = 86\%$) and 20 pounds of horse manure ($\%M = 84\%$). What is the volume of the slurry?

Solution: We must first compute the moisture content of the mixture. Total weight of mixture is

$$W_a + W_b = 50 + 20 = 70 \text{ lbs}$$

Percent cow manure in the mixture is

$$\%A = \frac{50}{70} \times 100 = 71.5\%$$

Percent horse manure in the mixture is

$$\%B = \frac{20}{70} \times 100 = 28.5\%$$

The percent moisture of the mixture is

$$\begin{aligned} \%M_{mix} &= \frac{71.5 \times 86}{100} + \frac{28.5 \times 84}{100} \\ &= 85.5\% \end{aligned}$$

The volume of water to be added (from Equation 5.11) is

$$\begin{aligned} V_w &= 0.1845 \times 70 - (0.2 \times 70 \times 0.855) \\ &= 0.95 \text{ ft}^3 \end{aligned}$$

The weight of water to be added (also from Equation 5.11) is the volume times the density of water:

$$\begin{aligned} W_w &= V_w \times 62.3 \\ &= 59.2 \text{ lbs} \end{aligned}$$

The volume of the 8 percent slurry (from Equation 5.14) is

$$\begin{aligned} V_{sl} &= 0.192 \times 70 \times (1.0 - 0.855) \\ &= 1.95 \text{ ft}^3 \end{aligned}$$

Now we have come to a potentially confusing point. The raw material contains a lot of void spaces and when water is added to make up the slurry, it is "soaked" up by the raw manure—thus, the volume of added water and the volume of raw material cannot simply be added to find the volume of slurry.

Particle Size

The solids in your slurry should be in small particles so that bacterial action can proceed at a maximum rate (the previous calculations of the water needed to produce an 8 percent slurry assume that the solids are of sufficiently small size so that a slurry is produced!). Reducing the particle size also will facilitate transport of the slurry in pumps and pipes if these are used.

Manure does not require much reduction in the size of its solids—thorough mixing with water is sufficient in most cases. But when garbage, garden debris, or other kinds of refuse are to be digested, they should be shredded or chopped up by hand if a shredder is not available.

A good way to judge the proper particle size in a

slurry is to observe how fast the solids settle out or if there are many solids floating on the surface after the water has been added. If there is a fast settling, the solids will accumulate on the bottom of the digester too quickly and make it difficult for the bacteria to do their work. In the case of floating material, the bacteria may never reach the solids to degrade them. With the raw materials normally used in digestion operations, flotation might be more of a problem than rapid settling. If the mixture is viscous enough, flotation can be avoided by proper mixing to entrap the particles. If flotation takes place, scum problems will appear in the working digester. L.J. Fry has studied the scum problem and has offered some useful information on handling the scum in digesters (see Bibliography).

Acid/Base Considerations (pH)

The term pH refers to the amount of acid or base present in solution. Too much of either can kill the methane-producing bacteria. As we described earlier, methane production is a two-stage process. In the first stage, one group of bacteria (the acid formers) utilize the organic matter of the feed solution (slurry) as a food source and produce organic acids. These acids are utilized in the second stage of digestion by another group of bacteria called methane formers. The methane formers utilize organic acids as food and produce methane. A balance of these two groups of bacteria must be maintained inside the digester at all times.

The methane formers multiply much more slowly than the acid formers, and this fact can result in an acidic environment that inhibits the growth of the methane formers. When you first start up your digester, such an imbalance is very likely. To help the situation, artificial means for raising the pH (to make the solution neutral—pH 7.0) of the feed have been successfully employed. Bicarbonate of soda can be used for this purpose at about 0.003 to 0.006 pounds per cubic foot of feed solution. This should be added to the slurry routinely during start-up and only when necessary while the digester is in full operation. Lime also can be used, but it is not as safe as bicarbonate and should be avoided if at all possible.

The pH of the feed slurry or the supernatant liquor can be determined in a number of ways. The most inexpensive ways are *pH paper* and the indicator *bromthymol blue*. Both may be obtained from a chemical supply house. The pH paper is easier to use, but it does not work well in the presence of sulfides, a common substance in anaerobic digesters.

Methane digestion will proceed quite well when the pH lies in the range 6.6–7.6. The optimum range is 7.0–7.2. In this range, a drop of bromthymol blue indicator will be dark blue-green in color (about one drop of indicator to ten drops of solution). If the mixture becomes more green, an acidic environment exists and

bicarbonate of soda should be added. A deep blue color indicates a basic solution. In this case the cure is patience; in time, the digester will return to normal by itself.

Calculating Detention Time

Now that we have calculated the components of our feed slurry, we must find out *how long* the feed will need to remain in the digester to be processed. Temperature considerations play a large factor, so we will need to discuss them a bit. Then we can add in a safety factor and find out exactly how large a tank we will require. In order to find out the digestion time, we must return to a discussion of volatile solids and do a few preliminary calculations.

Chemical Oxygen Demand (COD)

Volatile solids, you will remember, are that portion of the total solids which burn off at a temperature of about 1100°F, and they represent the organic fraction of the total solids. Organics which can be decomposed by bacteria are called biodegradable. This portion is what the bacteria will use as a food source. It is also the portion responsible for methane production during digestion.

To calculate the minimum time required for digestion of certain raw materials, the *chemical oxygen demand* (the *COD*) of the feed slurry is required. This quantity represents the amount of oxygen required to oxidize—that is, to degrade or destroy—the organics by chemical means. In order to make the best use of available data and formulas, it is more convenient to express the *COD* in parts per million (ppm) than in pounds per cubic foot (where 1 lb/ft³ equals 16,000 ppm). We also require the moisture content and percentage of volatile solids of the raw material (both appear in Table 5.4). For mixtures of raw materials, the amount of volatile solids in pounds for each component *A*, is given by

$$E. 5.20 \quad VS_a = W_a \times (1 - M_a) \times \frac{\%VS_a}{100}$$

where VS_a equals the weight of volatile solids of component *A* (lbs); W_a equals the weight of raw *A* used (lbs); M_a equals the moisture content of *A* as a decimal fraction; and $\%VS_a$ equals the percent of total solids that are volatile (from Table 5.4). The total amount of volatile solids then can be found by adding up the amounts of volatile solids of each component.

The concentration of volatile solids in the feed slurry (VS_{con}) is equal to the total amount of volatile solids present in the feed (VS_{total}) divided by the volume of the feed (which we calculated in the previous section):

$$E. 5.21 \quad VS_{con} = \frac{VS_{total}}{V_{sl}}$$

The *COD* concentration of most materials can be approximated as equal to 1.5 times the volatile-solids concentration (or, of any specific sample, the total *COD* equals 1.5 times the volatile-solids total). But we must also account for the fact that only about 50 percent of the volatile solids are biodegradable:

$$E. 5.22 \quad COD = 0.5 \times 1.5 \times VS_{con}$$

If we want to express the *COD* in parts per million (after measuring the VS_{con} in pounds per cubic foot), the conversion equation is

$$E. 5.23 \quad COD = 0.5 \times 1.5 \times 16,000 \times VS_{con} \\ = 12,000 \times VS_{con}$$

These last equations can also give us the *total COD* of a particular batch of feed, which we will need in later calculations.

Example: If 50 pounds of cow manure with 86 percent moisture and 80 percent VS is mixed with 20 pounds of horse manure having 84 percent moisture and 80 percent VS to produce, upon addition of water, an 8 percent slurry, calculate the biodegradable *COD* (in ppm).

Solution: As we calculated previously, the volume of this particular slurry is 1.95 cubic feet. Using Equation 5.20, the volatile solids of cow manure is

$$VS_{cm} = W_{cm} \times (1 - M_{cm}) \times \frac{\%VS_{cm}}{100} \\ = 50 \times (1 - 0.86) \times \left(\frac{80}{100}\right) \\ = 50 \times (0.14) \times (0.80) \\ = 5.6 \text{ lbs}$$

The volatile solids of horse manure, by the same equation, is

$$VS_{hm} = 20 \times (1 - 0.84) \times \left(\frac{80}{100}\right) \\ = 2.56 \text{ lbs}$$

so, the total amount of volatile solids in the mixture is

$$VS_{total} = 5.6 + 2.56 = 8.16 \text{ lbs}$$

The concentration of volatile solids in pounds per cubic foot (from Equation 5.21) is

$$VS_{con} = \frac{VS_{total}}{V_{sl}}$$

$$= \frac{8.16}{1.95} = 4.18 \text{ lbs/ft}^3$$

Then the biodegradable COD of the feed slurry in ppm is

$$COD = 12,000 \times VS_{con}$$

$$= 12,000 \times 4.18$$

$$= 50,300 \text{ ppm}$$

Solids Retention Time

Now that we have the COD of our slurry mixture, we are in a position to figure out how long it must remain in the digester. The solids retention time (SRT) is the average time that the incoming solids stay in the tank. We assume here that the mechanical design of our digester—its inflow and outflow schemes—is such that when new raw materials are introduced into the digester, they will replace old and digested material (a bottom inflow and top outflow arrangement, for example).

The SRT relates the digestion operation to the age and quantity of microorganisms in the system, and it is a sound parameter for design. An SRT of at least 10 days is a good rule-of-thumb value for the conventional digestion process. There also is a *minimum SRT* which reflects the ability of the microorganisms to consume the food source and reproduce themselves. If the SRT is less than the minimum SRT, you will literally wash out the bacteria faster than they can reproduce themselves and the digester will begin to lose efficiency. If the SRT is not increased, eventually the digestion process will stop. The minimum SRT is given by the following equation:

$$E. 5.24 \quad \frac{1}{SRT_m} = \left[a \times k \times \left[1 - \left(\frac{K_c}{K_c + COD} \right)^{1/2} \right] \right] - b$$

where SRT_m equals the minimum solids retention time (days); COD equals the biodegradable chemical oxygen demand (ppm); a equals a constant showing how many bacteria can be produced per amount of food (COD) available (equal to about 0.04); b equals a constant showing how fast the bacteria die (equal to about 0.015); k is a factor for how fast the bacteria will consume food (depending on the temperature of digestion); and K_c equals the minimum amount of food required before bacteria can start multiplying (also dependent upon the

temperature of digestion).

Values of k and K_c for the temperature range 59 to 95°F appear below:

Temperature	k	K_c
59°F	3.37	18,500
68°F	3.97	10,400
77°F	4.73	6,450
86°F	5.60	3,800
95°F	6.67	2,235

You can see from this table that favorable conditions for digestion increase with increasing temperature. If the digestion time is well above the minimum retention time, it has been found experimentally that the efficiency of the process (how much methane is produced) is about the same for digester temperatures ranging from 77 to 86°F. At 68°F it is a little lower and at 59°F it is about one-fourth the efficiency of the range from 77 to 86°F. Below 59°F very little if any methane appears to be produced. For the raw materials in our last example (50 pounds cow manure and 20 pounds horse manure) the COD was calculated as 50,300 ppm. Then, at 68°F for instance, the SRT_m of these raw materials is

$$\frac{1}{SRT_m} = \left[0.04 \times 3.97 \right. \\ \left. \times \left[1 - \left(\frac{10,400}{10,400 + 50,300} \right)^{1/2} \right] \right] - 0.015$$

$$= 0.108$$

and the SRT_m is the inverse of this quantity:

$$SRT_m = \frac{1}{0.108}$$

$$= 9.25 \text{ days}$$

Therefore it will take about 9 days at a minimum to have the digestion of 70 pounds of combined manure going full blast.

Temperature Considerations

We just saw that temperature plays a very significant role in the digestion process. Anaerobic bacteria can operate either in a low or in a high temperature range. Bacteria that grow well in the range of from 77 to 95°F are called *mesophilic*, while bacteria that grow at higher temperatures (120 to 140°F) are called *thermophilic*. The higher temperatures required by thermophilic bacteria

make them economically prohibitive for the small digesters we are considering here. Moreover, digestion within the thermophilic range produces a supernatant effluent much higher in colloidal (hard to settle out) solids, as shown below:

Characteristics of Supernatant from Laboratory Digesters	Thermophilic Range (130°F ± 10)	Normal Range (90°F ± 10)
Total solids (ppm)	0.309	0.231
Volatile solids (%)	67.1	58.5
Settleable solids (cc/1)	17.2	12.0
Suspended solids (ppm)	1490.0	773.0
Nonsettleable solids (ppm)	451.0	107.0

Therefore, only mesophilic bacteria are considered, and you should take the time to get to know your bacteria.

Mesophilic bacteria are very sensitive to temperature and temperature variations. This sensitivity, in turn, has a very noticeable effect on digester design and operation. As an example, consider the minimum solids retention time we just calculated, based on a temperature of digester operation of 68°F. At that temperature, the minimum solids retention time was calculated as approximately 9 days. By keeping all conditions of that example constant except for the temperature, you can calculate that the minimum solids retention time at 95°F is approximately 3 days! In other words, a 27°F increase in the digester operating temperature results in a reduction of the minimum solids retention time by two-thirds. This kind of impact in the minimum solids retention time will have an obvious impact on how fast the process can go and therefore on the size of the digestion and gas storage tanks needed. The higher temperatures result in a decreased detention time while more methane also is produced. So, the digestion tank will be smaller while the gas storage tank is larger. These considerations must be included in the selection of a safety factor, which we will discuss in a moment.

Any increase in temperature increases the rate of gas ebullition (bubbling) and so increases the solids bubbling about in the supernatant. There is not an appreciable change in this solids content over the temperature range of 70 to 95°F, but an unheated tank warming in the summer months may have rapid enough temperature changes and consequent changes in tank activity to show a high overflow of solids and even a complete overturn of the tank! Uniformity of tank temperature through controlled heating and insulation can reduce the possibility of any such unpleasantness.

Remember that, unless the digester is to be located in a tropical climate, temperatures of 95°F (optimum gas production) require artificial heating and/or insulation of the digester tank. The most common method of heating the tank uses methane-burning heaters, and this drain of

methane production should be included in your calculations of total gas output. The heat losses and heat requirements of your digester must be calculated; if, for example, all methane produced has to be used for heating your digester, heating should not be employed. (For detailed calculations, see listings under Metcalf and Eddy, Eckenfelder and O'Connor, and Perry in the Bibliography.) An alternate method might involve the use of solar heating, although we've never seen it done.

Insulating the digester in some fashion will help to reduce extreme temperature variations. A number of digester designs place the digester totally or partially underground, so that the surrounding soil provides some insulation. Housing the digester inside a building also provides some protection against extreme temperature variations. This approach is, however, handicapped by the fact that feed slurry and sludge and supernatant products then have to be transported in and out of some structure, which might interfere with its other uses. Another pitfall of this approach is that the storage tank for the bio-gas should be located *outside* the building, to minimize explosion hazards inside.

Safety Factor

As in most design operations, a minimum is never taken as the basis for final calculations—it is multiplied by a safety factor before it is used to calculate other design parameters. Because it is difficult and time-consuming to get a methane digester operating properly, but it is easy to “kill” the digester operation by overloading, our safety factor is used to prevent accidental overloading.

The magnitude of a safety factor for the digestion process lies in the range of 5 to 100 and depends on the following considerations: 1) expected variations in temperature—the greater the variation, the greater the safety factor; 2) expected variations in raw materials (flow concentration and type of material)—dealt with as temperature variations; 3) other raw-material characteristics (C/N ratio, presence of phosphorus and other nutrients)—increase the safety factor as the C/N ratio moves away from 30 or the nutrient content drops; 4) competence of operators and attendance of the process; and 5) confidence in SRT_m value and the numbers used in calculating it.

We can express the use of the safety factor in the following equation:

$$E. 5.25 \quad DT = SF \times SRT_m$$

where DT equals the digester detention time (days); SF equals the safety factor; and SRT_m equals the minimum solids retention time (days).

Unfortunately, no precise value can be given for the safety factor. Its usefulness rests on the fact that, as the degree of variation and uncertainty increases in factors

important to the design and operation of any digester, the greater the potential for digester failure. We can only make some qualitative recommendations here and suggest that you do some experimentation and observe the results of your own digester. A reasonable rule of thumb for the safety factor is a minimum of 5 for a well-controlled digester with constant feed rate and composition, and a stable temperature of about 90°F. A safety factor of 10 would be advisable for a system with fluctuations in feed rate and composition, but a rather stable temperature at about 90°F. And finally, a safety factor of 20 or more for systems poorly controlled as to feed rate, composition, C/N ratio, or temperature.

Example: For the example considered thus far (50 pounds of cow manure and 20 pounds of horse manure), let us say that it is known that temperature variations will occur, but that the raw materials will not change appreciably as to nature and amounts. Further, let us suppose that methane production is employed only when these raw materials are available and that the digester is not attended extensively.

Solution: Based on these considerations, a reasonable choice of a safety factor will be about 20. Then

$$DT = SF \times SRT_m \\ = 20 \times 9.25 = 185 \text{ days}$$

Digester Characteristics

Calculating Tank Volume

Once the digester detention time is determined for our available raw materials, the volume of the digester tank can be calculated. In the case of a batch-system operation, the volume of the feed slurry (which we calculated previously) is equal to the volume of the digester. But in the case of a continuous or semi-continuous feeding system, the amount of raw materials processed per unit time must be known before we can determine the volume of the digester required. In either case, the following calculations do not include the volume of the methane gas produced. As we speak of it here, the digester volume is the volume that the slurry occupies excluding the gas that is produced during the process. Provisions obviously must be made to take care of this gas volume—a separate gas-collection tank or a floating-top digestion tank, for example—and we will consider these systems a bit later.

We should add that a reduction in liquid volume occurs in the digester once methane is being produced. This reduction will create volume variations inside the digester, but their effect is insignificant.

The equation we use to determine the volume of a

digester tank (slurry feed, supernatant effluent, and sludge) for a continuous-feed operation is

$$E. 5.26 \quad V_t = V_{sl} \times DT$$

where V_t equals the volume of the tank; V_{sl} equals the daily volume of the slurry concocted from the raw materials (from Equation 5.14); and DT equals the detention time (Equation 5.25).

Example: For the case of two cows and a horse we have been using as a sample, it is known that 70 pounds of combined manure is produced daily and that the volume of the 8 percent slurry is 1.95 cubic feet. The required digestion (detention) time also has been estimated as 185 days (with a safety factor of 20). What is the volume of the required digester tank?

Solution: The volume of the digester is

$$V_t = V_{sl} \times DT \\ = 1.95 \times 185 \\ = 360 \text{ ft}^3$$

At 7.5 gallons per cubic foot, the tank should be able to hold 2700 gallons.

Now let's change our safety factor from 20 to 10 (that is, assume we have a much better controlled system). The new detention time is then 92.5 days, and the digester tank volume is then

$$V_t = 1.95 \times 92.5 \\ = 180 \text{ ft}^3 = 1352 \text{ gal}$$

Thus, for the same feed rate, the tank volume is a simple function of the detention time—double the detention time, double the tank volume.

Operation and Types of Digesters

First of all, digesters should be located to minimize the distances for transporting manure and wastes, for piping the gas, and for transporting the sludge and supernatant effluents. Secondly, since the digestion process can continue only under anaerobic conditions and since combinations of 5 to 15 percent methane in air are highly explosive, it is of the utmost importance that no air enter your digester with the incoming slurry. If the outside opening of the inflow pipe is well above the highest possible level of the liquid in the tank and the inside opening of the pipe to the tank is well below the lowest possible level of liquid in the tank and the inflow pipe is open to the atmosphere only during periods of slurry addition, the chances for air/methane mixing are

minimized. Indian experimenters also have found that an 8 percent slurry is more dense than the digesting sludge in the tank. If the slurry is added at the bottom of the tank, its density will keep it below the older sludge until it, in turn, begins to digest and is pushed upward by new additions. This mode of addition affords the digestion process a natural mixing which supplements any mechanical techniques.

A pipe 3 inches in diameter should be sufficient for the inflow of the slurry. The pipe should be straight and without bends or the slurry is apt to cake on the inside and clog it, requiring periodic reaming to allow free flow.

An 8 percent slurry is very similar in consistency to cream. The raw material must be reduced to an adequate particle size and then must be well dispersed in the water medium before it is added to the tank. This mixing process may require a sturdy basin or trough to allow vigorous stirring.

Certain design characteristics determine your control over the quality of the supernatant in your digester. Single-stage (one tank) digesters can incorporate either fixed covers, floating covers, or multiple outflow valves (see Figures 5.8 and 5.9).

Fixed-cover digesters require that supernatant, or perhaps sludge, be removed for the introduction of fresh slurry. If the supernatant is removed simply by overflow through an outflow pipe, then the rate and time of excess liquid removal is obviously identical to the fresh slurry introduced (if no sludge is withdrawn at the same time). And, by the way, since continuous agitation or agitation due to the addition of raw slurry causes an increase in solids in the supernatant (due merely to mechanical action), slurry input should be slow and constant for the highest quality supernatant.

Supernatant preferably should be removed using an outflow valve at a more convenient and advantageous time—for example, before feed addition. Removal flow

rates have to be high to prevent clogging of the valve. Floating-cover tanks offer the best timing control of supernatant removal: the supernatant need not be removed each time slurry is fed into the digester.

Two-stage digesters provide a far superior quality of supernatant. Here, the first tank is agitated and heated and the consequent overflow, full of suspended solids, runs into an unagitated tank for settling. The second tank need not be very large since it only serves the purpose of separating the solids from the mixture. Once the solids have settled, they can be recycled into the first tank to promote biological activity. Obviously, the two-stage digester system is preferred if your resources allow for construction of the second tank. However, problems can arise due to the septic properties of the supernatant. These properties can cause particle suspension in the settling tank if the settled solids are not removed periodically.

Overloading of a digester can cause serious impairment of sludge-supernatant separation. Rudolfs and Fontenelli (see Bibliography) studied the problem of overloading and we can summarize some of their findings here. They found an optimum loading rate for a two-stage digester operating at 82 to 84°F to be about 0.1 pounds of volatile solids per cubic foot of primary (the first tank) digester capacity per day. Doubling this loading rate increased the solids content in the supernatant to a point where sludge-supernatant separation was not easily achieved. For single-stage digesters, it was determined that even at loading rates of only 0.042 pounds of volatile solids per cubic foot per day, the supernatant contained about 3 percent solids. In sanitary-engineering practice, loading rates of 0.03 to 0.1 pounds of volatile solids per cubic foot per day are used for single-stage digesters with detention times on the order of 90 days. These figures will give you an idea of the range of loading rates which have been found experimentally to give reliable perform-

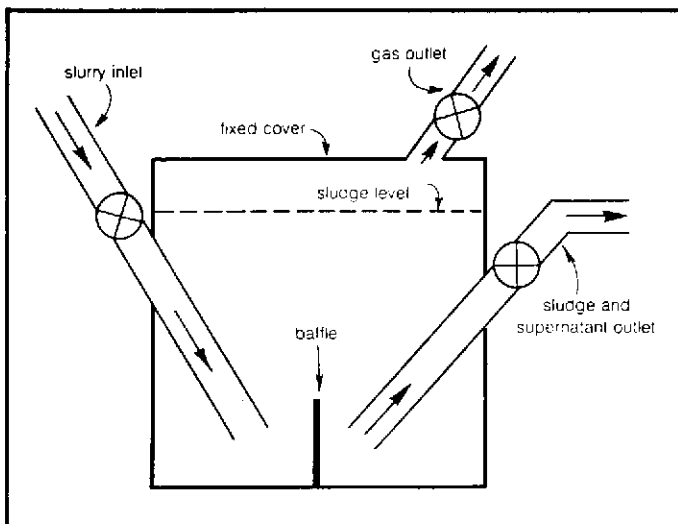

Figure 5.8 A fixed-cover digester with outlet placed at the desired sludge level in the digester.

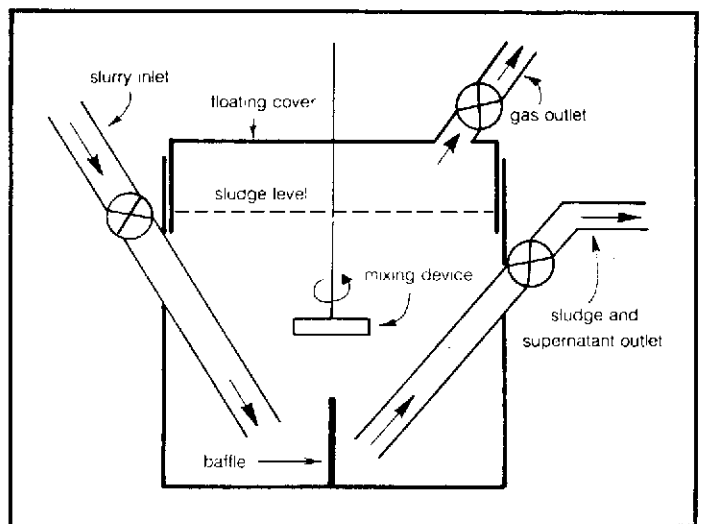

Figure 5.9 A floating-cover digester. For a two-tank system, simply connect two tanks in series. Mixing devices are useful, but optional.

ance from a digester. The engineering book by Metcalf and Eddy has a lot of useful detailed information if you are keen to go into greater depth and L.J. Fry has collected the best set of practical notes and experiences presently available concerning operation and maintenance of small-scale digesters (see Bibliography).

The importance of good sludge-supernatant separation is manifested first in terms of the effective capacity of the digester. With poor separation, solids—particularly fresh undigested solids—are much more likely to escape by overflow in the effluent. Because these solids are then no longer available as a fuel source, there is a decrease in digester efficiency and gas production. These factors, too, should be considered when selecting a safety factor for the digester. Poor separation also results in thinner and larger volumes of sludge. A sludge of 5 percent solids will contain twice as much water as a sludge of 10 percent solids and this excess water can create a handling problem, particularly in drying the digested sludge.

The sludge can be pumped out or, more simply, an outlet pipe 2 to 4 inches in diameter can be fitted as near to the bottom as possible, to allow for the periodic removal of the digested sludge into a dolly or wheelbarrow. Or, given the proper initial elevation, a large-diameter pipe can carry sludge directly into your garden or fields. A sludge outlet is not essential in batch digesters, though it simplifies unloading.

Start-up Considerations

A very important aspect of digester operation is the initial development of a good gas-producing sludge. You cannot overestimate the importance of this phase of digester operation.

It is advantageous to start the digester with a "seed" containing anaerobic bacteria. A sample of digester sludge from a properly operating municipal sewage-treatment facility or sludge from another methane digester would be ideal. Anaerobic muds from swamps or lake bottoms also can serve the purpose. If none of these is available, it would be wise to prepare a tightly sealed container of soil, water, and organic matter. This should sit in a warm place, about 95°F, for a few weeks. When the digester is ready to begin operation, everything but the gritty particles of soil should be decanted into the digester with as little exposure to air as possible.

We also must remind you about pH considerations. During start-up, the digester is often too acidic for the methane-forming bacteria. Review the section on pH for testing and rectifying techniques.

Products of a Digester

A normal unmixed digester will separate into layers as shown in Figure 5.10. Each of these layers can be used as a resource if the proper opportunities are available.

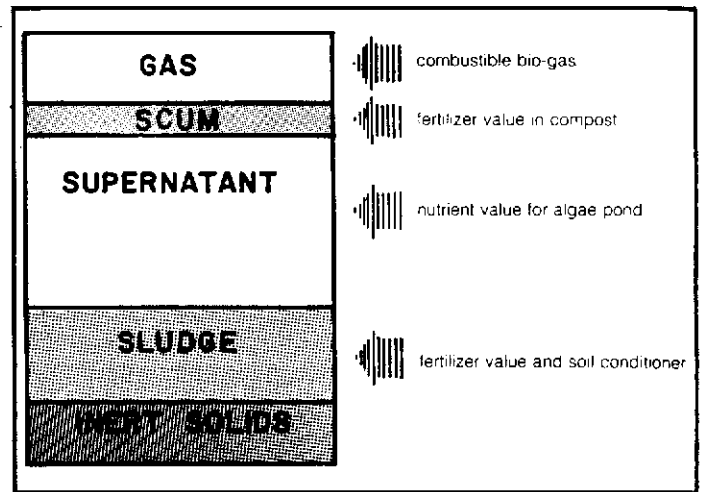

Figure 5.10 Stratification in a methane digester and uses of its products.

Methane gas, supernatant liquor or effluent (the liquid product of the digestion process), and sludge are withdrawn in a continuous or semi-continuous digester setup, at a volume rate equal to that of feed after an initial detention time period has elapsed.

Bio-gas and Gas Storage

Given the *COD* (assuming proper pH, temperature, and *C/N* ratio), an estimate of gas production can be made. We use the formula

$$E. 5.27 \quad C = 5.62 \times [(e \times COD) - 1.42W_2]$$

where *C* equals the cubic feet of methane produced at 32°F and 14.7 psi (lbs/in²) pressure; *e* equals the efficiency of raw-material utilization—how efficient the bacteria are in converting raw material to methane—with 6.0 being a recommended value; *COD* equals the total biodegradable chemical oxygen demand of the raw materials (this time we have a total, not a concentration: in pounds); and *W₂* equals the weight of solids produced due to bacteria (lbs). This last factor we have not spoken of yet and, indeed, we *still* don't have to (see "Sludge"). The reason? For anaerobic decomposition the second term in the equation (*1.42W₂*) is small compared to the first term; and because of this comparative smallness, we can approximate our production using the shortened equation

$$E. 5.28 \quad C = 5.62 \times e \times COD$$

You may recall from Equation 5.22 that the *COD* equals *0.75 VS_{total}*; therefore

$$E. 5.29 \quad C = 5.62 \times 0.6 \times 0.75 VS_{total} \\ = 2.5VS_{total}$$

A nice, neat way to estimate the volume of methane gas!

For our 50 pounds of cow manure and 20 pounds of horse manure, the VS_{total} was 8.16 pounds. The methane produced will be

$$C = 2.5 \times 8.16$$

$$= 20.4 \text{ ft}^3$$

Remember, this is methane produced and bio-gas is only about two-thirds methane. The volume of bio-gas can be obtained by multiplying C by a factor of 1.5. Certain materials and their gas productions were listed in Table 5.6; also remember that the quality of the bio-gas will vary (see Table 5.8).

So, now we know that when the digester continuously is fed 70 pounds of combined manure daily (of a specified 50/20 mix), it will produce about 20 cubic feet of methane per day, after an initial period of time equal to the detention time. (At current prices for natural gas, this total is equivalent to 4 cents a day and would satisfy maybe 10 percent of the needs of an average individual.) The inherent assumption here is that all previously mentioned conditions—size solids, water content of feed slurry, etc.—are met. We also assume that the C/N ratio is favorable and that there are enough nutrients present. If the digester is not producing approximately the above calculated volume of methane, you should try to eliminate any possible malfunctions and insure that all assumed conditions are met. A bit later we will present a trouble-shooting summary. But now let's speak of how to collect and store the gas.

As methane is insoluble in water, it bubbles to the top of the digester tank. In order to maximize methane production and help eliminate oxygen from the system, the digester tank should be kept fairly full. Depending on your digester design, an additional tank for gas storage may be needed. Singh also suggests a few possible designs for gas storage tanks (see Bibliography).

A balance will have to be struck between the daily production of methane and the rate at which the methane is used. Since methane is a very dilute fuel, a compressor will have to be employed if periodic production of methane in considerable excess of the daily capacity to use it is anticipated. However, this seldom is the case. Ideally, the storage tank should be sufficiently large to hold at least several days' worth of optimal daily gas production. This capacity will allow some leeway in your rate of consumption as well as provide sufficient bio-gas for any short-term task that requires a high rate of energy input. Storage capacity certainly should be in excess of the anticipated peak daily demand. In the case of batch digestion, a few digesters with staggered digestion periods should be operated in order to maintain a relatively uniform rate of gas production.

For purposes of keeping oxygen out of the system and for maintaining a slight positive gas pressure, a

floating-tank setup is best (see Figure 5.11). This is a concrete or steel tank filled with water on which the gas-holding tank floats. If concrete is used, the tank should be sunk in the ground to be able to withstand the pressure of the liquid inside. In any case, a below-ground design is desirable in colder climates to prevent freezing of the water; a thin oil layer on top of the water also helps to prevent freezing. The water-holding tank should be taller than the gas-holding tank, so that all the air can be flushed out of the gas-holding tank (by opening the top valve and pushing down on the floating tank until the top of the tank reaches the water level) before methane production begins. If you want, a few cups of lime can be added to the water in order to increase the fuel value of the gas by removing inert carbon dioxide—alkaline water will dissolve a larger quantity of carbon dioxide than water at neutral pH.

A simple apparatus can be set up to monitor the gas pressure in the gas storage tank (see Merrill and Fry). Or, a standard pressure gauge can be mounted on the gas line. The pressure can be controlled within a broad range by adding weight to the cover of the float tank or by using counterweights on pulleys. A compressor may be needed if large quantities of gas are needed at distances too far for piping (perhaps 100 feet, when we use weights on the cover to increase pressure) or to fuel a moving machine such as a car or rototiller. Small quantities of gas also can be made mobile by storing them in inner tubes.

Supernatant

For all practical purposes, the supernatant produced is approximately equal to the amount of water added to produce the 8 percent slurry that feeds the digester (see Equation 5.10). For removal techniques, see "Operation and Types of Digesters."

This supernatant can vary in color from clear,

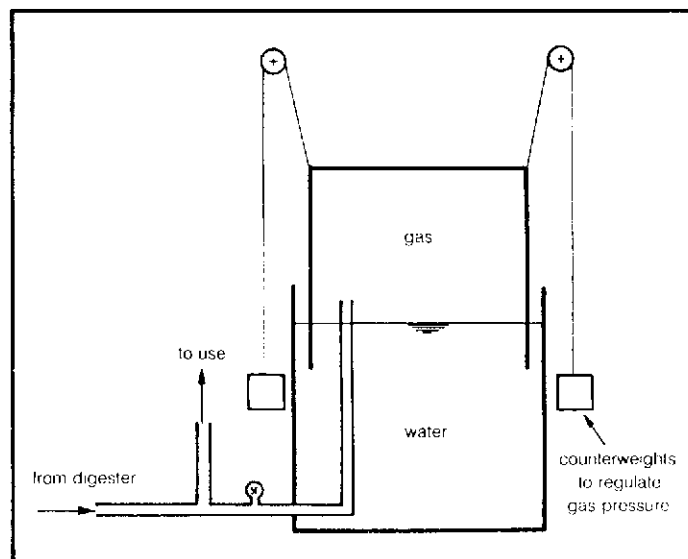
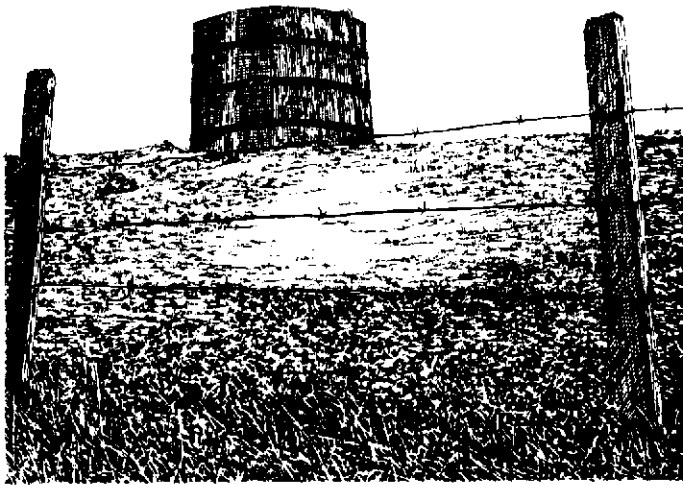

Figure 5.11 Floating-cover gas collection tank.



through various shades of yellow, to a very unsightly black. The odor may be unnoticeable or extremely offensive and nauseating. A properly operating digester has a clear (to slightly yellow) supernatant with few suspended solids and with no offensive odor.

As we discussed earlier in digester operations, various parameters can affect the quality of the supernatant resulting from digestion. As you would suspect, the characteristics of the raw slurry affect the supernatant: solids increase in the supernatant with the fineness of division of the slurry, and they also increase as the volatile-matter content of the slurry increases. This is due to greater activity and agitation in the digestion of these solids. Neither of these two factors is easily controllable. The amount of water in the slurry is, however, a controllable factor. Excessive volumes of slurry water produce excessive volumes of supernatant.

As we also have mentioned, two-stage digesters provide a far superior quality of supernatant. Single-stage, fixed-cover digesters are less expensive, but two-stage digesters offer vast improvements for a minimal extra cost. There are also temperature parameters, which we mentioned in the section "Temperature Considerations."

Supernatant has its uses—fertilizer for your fields, material for your compost pile, feed for your algae (see "Oxidation Ponds" in this chapter and also Chapter 7). But if you have an excess quantity, you must know what to do with it. In the past, supernatant was viewed primarily as a disposal problem rather than as a utilizable resource, and several methods were evolved for the liquor's disposal. For example, the supernatant was disposed of on sand beds. This method is unsatisfactory

because of prohibitive costs due to clogging and odor problems. Centrifugation also has been used, but, on a small-scale basis, this is neither practical nor economical.

In large-scale digesters, the predominant method of disposal is to return the supernatant to the input of the digester. A.J. Fischer reports that this can cause problems in these digesters if the total-solids content exceeds 0.30 to 0.50 percent (see Bibliography), but this still is probably the most practical method for supernatant disposal in a small-scale, manual-fed digester: without perfect separation of the supernatant, the liquors can be recycled into the digester as solvent for making dry waste into a slurry.

Sludge

The sludge produced in a digester is a combination of the nonbiodegradable portion of the solids introduced into the digester and the amount of bacteria produced during the digestion process. After operation has started and the digester is running continuously, the amount of sludge solids produced by nonbiodegradable solids (W_1) is given by

$$\begin{aligned} \text{E. 5.30 } W_1 &= W \times \left[1 - (0.5) \left(\frac{\%VS}{100} \right) \right] \\ &= W_s \times (1 - M) \times \left[1 - (0.5) \left(\frac{\%VS}{100} \right) \right] \end{aligned}$$

where W_s equals the weight of sludge solids produced due to initial solids (lbs); W_r equals the weight of raw material added (lbs); M equals moisture of raw material as a decimal fraction; and %VS equals the percent of volatile solids of the raw material. In case mixtures of raw materials are used, both M and %VS must be those of the mixture, as calculated previously.

The amount of sludge solids produced in the form of bacteria is

$$\text{E. 5.31 } W_2 = \frac{0.04 \times \text{COD}}{1 + (0.015 \times \text{DT})}$$

where W_2 equals the weight of sludge solids of bacterial origin (lbs); COD equals the total biodegradable chemical oxygen demand (lbs); and DT equals the detention time of the digester (days).

The total amount of sludge solids produced is then

$$\text{E. 5.32 } W_{ss} = W_1 + W_2$$

Since the digested sludge is approximately 10 percent solids by weight, the amount of total sludge (10 percent solids + 90 percent water) is

E. 5.33

$$W_{sludge} = 10W_{ss}$$

If we assume an average density of 65 pounds per cubic foot for the digested sludge, its volume is

$$E. 5.34 \quad V_{sludge} = \frac{W_{sludge}}{65}$$

Example: In the example considered thus far (50 pounds of cow manure mixed with 20 pounds of horse manure, with an average moisture of 85.5 percent, a %VS of 80 percent, and a VS_{total} of 8.16 pounds, digested for 185 days), how much sludge will be produced?

Solution: The amount of sludge solids produced due to incoming solids is

$$\begin{aligned} W_1 &= W_r \times (1 - M) \times \left[1 - (0.5) \left(\frac{\%VS}{100} \right) \right] \\ &= 70 \times (1 - 0.855) \times \left[1 - (0.5) \left(\frac{80}{100} \right) \right] \\ &= 70 \times 0.145 \times [1 - (0.5 \times 0.8)] \\ &= 70 \times 0.145 \times 0.6 = 6.09 \text{ lbs} \end{aligned}$$

The biodegradable COD is given by

$$\begin{aligned} COD &= 0.75VS_{total} \\ &= 0.75 \times 8.16 \\ &= 6.12 \text{ lbs} \end{aligned}$$

The sludge solids due to bacteria are

$$\begin{aligned} W_2 &= \frac{(0.04 \times COD)}{[1 + (0.015 \times DT)]} \\ &= \frac{(0.04 \times 6.12)}{[1 + (0.015 \times 185)]} \\ &= \frac{0.245}{3.775} \\ &= 0.065 \text{ lbs} \end{aligned}$$

The total weight of sludge solids is

$$\begin{aligned} W_{ss} &= W_1 + W_2 \\ &= 6.09 + 0.065 \\ &= 6.155 \text{ lbs} \end{aligned}$$

The total weight of sludge is

$$\begin{aligned} W_{sludge} &= 10W_{ss} \\ &= 10 \times 6.155 \\ &= 61.55 \text{ lbs} \end{aligned}$$

The total volume of the sludge is

$$\begin{aligned} V_{sludge} &= \frac{W_{sludge}}{65} \\ &= \frac{61.55}{65} \\ &= 0.947 \text{ ft}^3 = 7.1 \text{ gal} \end{aligned}$$

The above figures are for a single load in one day. If the digester is run continuously with 70 pounds of combined manure a day, the production figures represent production per day (for removal techniques, see "Operation and Types of Digesters"). And depending on the degree of agitation, the digestion period, and other factors, poor separation of the sludge and supernatant may occur. This larger volume of dilute sludge will require more labor to produce usable fertilizer.

Containing nitrogen (principally as ammonium ion NH_4), phosphorus, potassium, and trace elements, the digested sludge is an excellent fertilizer—it has a higher quality than the digested sludge from sewage plants, which use very dilute waste. It is also a very good soil conditioner. Recently, ammonium has been found to be superior to nitrate (an oxidized form of nitrogen and a standard nitrogen fertilizer) since it adsorbs well to soil particles and is therefore not as easily leached away, a serious problem with nitrate fertilizers. When exposed to air, the nitrogen in sludge is lost by the evaporation of ammonia (NH_3). Adsorption to soil particles can prevent this evaporative loss, and so the fresh sludge should be blended or mixed into the soil by shovel, fork, or tilling. If not used promptly, it should be stored in a covered container, or else stored temporarily in a hole in the ground and covered with a thick layer of straw.

The capacity of soils to take up sludge varies considerably. For example, sludge has to be spread more thinly on clay soils than on loamy soils, at least until the soil structure is improved. In any case, the soil should not be allowed to become waterlogged; waterlogging prevents aerobic microorganisms and processes from eliminating any disease-producing organisms which might not have been destroyed in the digester (if human waste was used).

Digested sludges produced from human waste should be used with some caution. Though the area is not well studied and no firm information is available, it is suggested by K. Gilbert (see Bibliography) that when batch digestion is carried out, a digestion period of at least three months is desirable so that adequate destruction of pathogenic organisms and parasites occurs. However, the minimum digestion period required for adequate sanitation has not yet been definitely demonstrated. And since mixing occurs in a continuous-flow digester, there is

no way to insure that all introduced material will undergo a lengthy digestion period.

Incorporation of the sludge into the soil provides a set of conditions unfavorable for pathogenic organisms that thrive in the human body, but common sense dictates that sludge should not be used on soil growing food (excluding orchards) to be eaten raw. The fertilization of these soils with sludge should be done several months before planting and preferably used on land not to be cultivated for at least a year to insure complete exposure to aerobic conditions.

Digestibility of Algae

Because of a growing interest in the subject, we include a few separate remarks about algae. Difficulty has been encountered in the anaerobic digestion of algae. This is due to several factors. Firstly, algal material is highly proteinaceous. As a result, high ammonia concentrations arise in the culture media, pH increases, and bacterial activity decreases. Other problems arise due to the resistance of living algal cells to bacterial attacks. However, if algae is not the only feed source (mix it with manure, for example) for the digester, these problems virtually disappear. Algae also is a good source of carbon for balancing the nutrients of your slurry.

Further promising aspects of algae digestion are that alum-flocculated algae (see "Harvesting and Processing of Algae" in this chapter) digest just as well as algae that do not contain the 4 percent inorganic aluminum. Detention times as short as 11 days are possible, and variation of the detention time from 11 to 30 days has little effect on gas production. Loading rates can be as high as 0.18 pounds of volatile solids per cubic foot of digester capacity per day without deleterious effects. Digesters using algae also are much less affected by variations in loading rates.

For raw sewage sludge, there are 9.2 to 9.9 cubic feet of gas produced per pound of volatile matter introduced. For algae at mesophilic temperatures, only 6.1 to 7.0 cubic feet of gas is produced per pound of volatile solids.

The sludge produced by algae has undesirable characteristics due to the fact that it is not completely digested. There is an odor problem not encountered in sewage sludges. The algal sludge is highly colloidal and gelatinous. As a result, it dewateres poorly and disposal becomes a problem.

The use of algae to capture energy from the digester supernatant and the sun has some future possibilities (see "Oxidation Ponds"). Major problems now involve the conversion of energy stored in algae to usable forms. Digestion seems marginally applicable to such conversions.

Summary of Methodology

So far we have considered the various aspects of digester design separately. Now if we are to pull everything together, we can summarize the design process in a series of steps as follows:

1. Knowing the daily weight of available wastes to be used as digester feed, calculate the characteristics of the waste mixture, W_{mix} , $\%M_{mix}$, VS_{mix} , using Tables 5.4 through 5.7.
2. Calculate the C/N ratio for the mixed waste and make any adjustments which are necessary to achieve a reasonably balanced diet (C/N = 30:1 optimal).
3. Compute the COD, choose a projected digestion temperature, and then compute a minimum solids retention time.
4. Pick a safety factor appropriate to the situation and compute the detention time and then the volume of the digester.
5. Make your design decisions about the nature of your digester (one-tank or two-tank, fixed-cover or floating-cover, etc.).
6. Estimate the daily rate of gas production from VS_{total} , subtract gas necessary to heat tank (if applicable), and size collection or storage tank.

Indications of Poor Performance and How to Avoid It

A good indication of poor performance is the amount and quality of bio-gas your digester produces. If gas production is well below the value calculated using VS_{total} , the digestion is not proceeding at the optimum rate. When the carbon dioxide (CO_2) content of the bio-gas exceeds 50 percent, the digester is performing poorly. In both cases, corrections can be made to improve the digester operation.

The percentage of CO_2 in your bio-gas can be found either by devising a homemade gas analysis unit or by purchasing a commercial kit. A rather simple, easy-to-use manual gas analyzer is made by the Brenton Equipment Company (P.O. Box 34300, San Francisco, California 94134), called the Bacharach Duplex Kit. This analyzer is available in a form for measuring CO_2 in the 0 to 60 percent range, perfect for digester analysis.

If you prefer to devise a system for yourself, you will need some way of measuring the gas volume. Displacement of water inside a container of known volume can be employed if the container is marked at different volume capacities. If a known volume of bio-gas is bubbled through a lime solution, the carbon dioxide of the bio-gas will react with the lime and thus will be removed from the bio-gas mixture. If the volume of the gas remaining after bubbling through the lime solution is measured, the

percentage of carbon dioxide in the bio-gas mixture is given by

$$E. 5.35 \quad \%CO_2 = \frac{(V_{bb} - V_{ab})}{V_{bb}} \times 100$$

where V_{bb} equals the volume of bio-gas before bubbling through lime and V_{ab} equals the volume after bubbling.

Factors that cause poor digester performance or even complete failure include:

1. Sudden change in temperature (either due to climatic changes or failure of the heating system if one is used).
2. Sudden change in the rate of loading (how fast raw materials are introduced into the digester).
3. Sudden change in the nature of raw materials (materials or mixtures of raw materials other than what is routinely added).
4. Presence of toxic materials.
5. Extreme drop in pH (the digester has become acidic).
6. Slow bacterial growth during the start-up (especially important at initial stages of operation).

In case of poor performance or failure, the following steps should be followed:

1. Provide pH control.
2. Determine the cause of the upset: improper environmental conditions (pH, temperature); nutrient insufficiencies (C/N ratio, phosphorus); or toxic materials present (limonene, heavy metals, sulfides).
3. Correct the cause of the imbalance.

Poor operation can cause foul odors in the bio-gas, sludge, and supernatant. With proper and careful operation, such problems are minimized. The case of poor performance and failure is a whole study in itself and hardly enough material can be presented here on the subject. P.L. McCarty (see Bibliography) gives a good review that is concerned mainly with sewage-treatment digesters, but also is applicable in every case.

Safety Considerations

Methane/air mixtures are explosive when methane is present in 5 to 15 percent by volume. In an atmosphere of an inert gas (such as the carbon dioxide in bio-gas), oxygen must be present at least to the extent of about 13 percent before an explosion can occur. Obviously, you must take precautions to prevent explosive mixtures from occurring. Although no accidents have been reported in the literature for small digestion units (they rarely are. . .), it is highly advisable that the entire gas-handling system—piping, valves, storage tank, and so on—be

designed with the utmost care. You should give special consideration to any possible leaks that might develop at any point of gas transport or storage. Needless to say, methane is merely another name for the natural gas commonly used for home cooking and heating. It therefore should be handled and used with the same caution. There are numerous examples of asphyxiation and death due to gas leakage from stoves and other household devices.

How supernatant and sludge are used becomes critical when human excreta are used as raw materials. Very little is known about the fate of pathogenic organisms during an anaerobic digestion process. The direct application of sludge and supernatant as fertilizer material is not recommended on vegetables or any other plants which are consumed by humans. Using them in orchards is quite safe, however. If no human excreta are used, both sludge and supernatant are safe for use anywhere as fertilizer material. In the case of pig manure, the precautions stated for human excreta apply, since certain pathogens common to pigs are transmittable to humans.

In case the water table is near the surface of application, sludge and supernatant should not be used as fertilizer but rather transported where there is no possibility of the sludge and/or supernatant leaching through soils into the groundwater. If this is not possible, provisions should be made for drying these products in impermeable basins and using the resulting dry solids in a manner that avoids groundwater contamination.

Final Thoughts

Your decision to build or not to build a methane digester ultimately will be based upon an analysis of the costs and benefits to you and your willingness to alter your lifestyle sufficiently to be compatible with the day-to-day operation of a digester. If you construct a digester, it should be planned and designed in a manner that takes into consideration the potential impacts—visual, physical, and chemical—on the environment. A digester potentially can free you from total dependence on your local utility company, but it surely will tie you to the routine maintenance and operation of the digester itself. Digesters are not for everyone, but if they fit into your lifestyle, we wish you well and hope that you produce the best gas around!

OTHER WASTE-HANDLING TECHNIQUES

In the first section we considered the use of a methane digester as both a waste-handling technique and as a potential waste-to-resource converter. But a digester does not fit into everyone's plans,

Getting the right mix

When you load a digester there are two things you must watch out for. The first is the size and dilution of the material you put in. The second is the amount of carbon in relation to nitrogen that it contains.

It's no good adding logs of wood or bales of hay to a digester. The bugs simply won't be able to get their teeth into them quick enough. The best rule I know is that anything you put in should be small enough for you to be able to eat (never mind whether you want to or not – I'm talking about size). And the second rule is that you must usually dilute it with water to make a suspension of at add too much water, the solids will settle out and you'll be running what is in effect a septic tank. A septic tank does indeed produce methane, but by no means at the optimum rate. So you can't, for instance, just run all the house waste from the soil pipe into the digester. Most of the water must go somewhere else.

To get the right percentage of solids in the mix is again easy enough. You want a slurry the consistency of moderately thick cream. Usually, you'll add stuff to the digester by mixing the slurry in a small compartment which drains through a plughole into the digester. You mix until the creaminess is right, then pull out the plug, and if you've got it right the stuff will flow down the drain into the digester. If it won't flow, you've made it too thick.

The carbon to nitrogen ratio is just as important, but much more tricky to get right. Methane-producing bugs need the right food, and that means they need food in which the carbon to nitrogen ratio is fixed at between 30 and 35 to 1. There's no easy way to work out the ratio of the stuff you're putting in, except to weigh it and look up the C:N ratios in a good table. I've put just about all the quantitative information that is available on methane production into the table overleaf, but readers should take it with a good deal of caution. The information comes from many different countries and has been accumulated over many years. The only real test of performance is to see what actually comes out of your digester. Such figures as these offer at best a rough guide.

The first two columns of figures can be used to work out the C:N ratio of any mix you need. But you must remember the difference between dry and wet weight. All the % N figures are given for dry weight, and hence the solid content of any batch must be worked out before trying to find out how much nitrogen it contains.

Suppose the digester were being fed with a mix comprising 3 lb human sewage, 5 lb poultry manure, 4 lb vegetable waste and 5 lb oat straw. The first thing to do is work out the solid content or dry weight. As a general rule of thumb you count 20 per cent of the total weight of most animal manure as solids. One-fifth of the wet weight, in other words, is the dry weight. Poultry are a bit different, and you should count one-third. Humans are different again, and you count 28 per cent for shit, and only 6 per cent for pee. For green matter, the amount of water varies enormously, but you can

Methane Production Data

Material	%N*	C:N Ratio	Digestion Time (days)		Daily Amount (lb)	Solid Content (lb)	Gas Production	
			25°C	35°C			ft ³ /lb*	ft ³ /day
cow dung	1.7	18-25	50	25	52	10	3.1-4.7	30-50
horse „	2.3	25			36	7		
pig „	3.8	20	40+	30+	7.5	1.5	6-8	9-12
sheep „	3.8	22			3.0	0.5		
human „	5.5-6.3	6-10	20-45	11-15	0.5	0.14	6-9	0.8-1.3
poultry „	6.5	15-25	30	10	0.3	0.1	6-13	0.6-1.3
urine	15-18	0.8						
blood	10-14	3-4						
meat scraps		5.1						
grass/hay	4.0	12						
cabbage	3.6	12						
tomato	3.3	13						
lucerne	2.8	17						
seaweed	1.9	19						
red clover	1.8	27						
mustard	1.5	26						
potato tops	1.5	25						
average								2 (wet)
greenstuff	2.7	20		40-50		25%		7 (dry)
wheat straw	0.5	150						
oat straw	1.1	48						
sawdust	0.1	200-500						unsuitable

* dry weight

	wet weight (lb)	dry weight (lb)	production/ lb	total
human manure	3	0.84	6 ft ³	5.04 ft ³
poultry manure	5	1.67	6 ft ³	10.00 ft ³
vegetable waste	4	1.00	7 ft ³	7.00 ft ³
oat straw	10	10.00	7 ft ³	70.00 ft ³
		13.51 lb		92.04 ft ³

appliance	specification	gas consumption (ft ³ /hr)
gas cooker	2" diameter burner	11.5
	4" diameter burner	16.5
	6" diameter burner	22.5
gas lighting	1 mantle lamp	2.5 to 3
	2 mantle lamp	5
	3 mantle lamp	6
refrigerator	18" x 18" x 12"	2.5
incubator	18" x 18" x 18"	1.5 to 2
boiling water		10 per gallon
running engines	converted diesel or petrol	16-18/h.p./hr

reckon an average of one-quarter for the dry weight. Straw, of course, is already dry.

From the dry weight you can work out how much nitrogen the original material contained if you know the % N figure (column one of the table). If you also know the C:N ratio (column two) you can then work out how much carbon it contains. If you have 1 lb of nitrogen, and the C:N ratio is 25, you then have 25 lb carbon. The whole calculation goes like this:

	wet weight (lb)	dry weight (lb)	%N	weight N (lb)	weight C (lb)
human manure	3	0.84	6.0	0.050	0.40
poultry manure	5	1.67	6.5	0.108	2.16
vegetable waste	4	1.00	2.7	0.027	0.54
oat straw	5	5.00	1.1	0.055	2.64
				0.240 lb	5.74 lb

hence C:N ratio = $5.74 : 0.24 = 24$

This would be somewhat low for an ideal mix. If a further 5 lb of oat straw were added, the C:N ratio would rise to 28.4, which would be as near perfect as makes no difference.

This does not mean, of course, that an elaborate calculation has to be made every time you add some muck to the digester. In practice you probably end up adding roughly the same mix every time – varying it perhaps between winter and summer, when there will be more greenstuff available. You'll end up being able to adjust the C:N ratio by intuition.

How much?

As with a wind generator, you need to know both how much energy you can expect from your digester and how much you're going to need. The answer to the first question will only really be known when you've run the digester for a few months. There are figures available on what other people have achieved – but the results depend enormously on such things as how well you control the temperature and acidity, what kinds of bug you manage to capture,

what sort of mix you feed in, in what quantities and what amounts, and even on what kinds of food you and your animals eat.

But to get an idea, take the example we used in the last section. From the figures in the table on page 206, we would expect:

	wet weight (lb)	dry weight (lb)	production/ lb	total
human manure	3	0.84	6 ft ³	5.04 ft ³
poultry manure	5	1.67	6 ft ³	10.00 ft ³
vegetable waste	4	1.00	7 ft ³	7.00 ft ³
oat straw	10	10.00	7 ft ³	70.00 ft ³
		13.51 lb		92.04 ft ³

I have of course used the lowest quoted production figures. And to be thoroughly pessimistic, you should count on using, say, one-third of your production for heating the digester. That leaves you with only 60 cubic feet. What can you do with that much gas?

The gas itself will probably be only about 60 per cent methane, and so its calorific value cannot be taken as anything above 600 BTU per cubic foot. In other words, 60 cubic feet is worth 36,000 BTU, or 10.6 kWh. That should produce energy for a family of four to cook for a couple of days. Or you could use it for lighting, running a small refrigerator (gas, not electric), powering an engine or turning an alternator. Probably the greatest world authority on methane generation is the Indian Ram Bux Singh, Director of the Gobar-Gas Research Station, Ajitmal, Etawah (U.P.) India. (If you write to him, Singh will send you two very useful booklets his research centre has prepared on methane.) Singh quotes the figures on page 209 for gas consumption.

So 60 cubic feet of gas will run a single mantle lamp for 20 hours at least, power a small refrigerator for 24 hours, or boil up 6 gallons of water (theoretically, 60 cubic feet of gas is sufficient to boil 22 gallons, but in practice the result depends on how efficient the burner is and how much heat you waste in warming up the surrounding air and not the water). Or you could run a 10 h.p. car for about 20 minutes which, at 30 mph, would take you just 10 miles. That, incidentally, tells you a lot about the economics of motor vehicles. Sixty cubic feet of bio-gas is the equivalent of one-quarter

of a gallon of petrol. See next chapter for methane as a possible alternative to petrol.

appliance	specification	gas consumption (ft ³ /hr)
gas cooker	2" diameter burner	11.5
	4" diameter burner	16.5
	6" diameter burner	22.5
gas lighting	1 mantle lamp	2.5 to 3
	2 mantle lamp	5
	3 mantle lamp	6
refrigerator	18" × 18" × 12"	2.5
incubator	18" × 18" × 18"	1.5 to 2
boiling water		10 per gallon
running engines	converted diesel or petrol	16-18/h.p./hr

If this doesn't seem too encouraging, Robert and Brenda Vale have done a much more elaborate calculation. They assume that a household of 3 people keeps 1 pig and 2 goats. They collect all the human waste, all the pig waste, and half the goat waste because the goats are put out to graze during the day. In addition, all the green waste from a $\frac{3}{4}$ -acre garden is put in the digester, assuming it is worked intensively and provides two crops a year. With the addition of 1 lb of straw a day, used as bedding for the animals, they reckon to collect about 60 cubic feet a day (which would reduce to 40 cubic feet if the gas was used to heat the digester). That would be just enough to provide for all cooking needs for an average family. The gas authorities use a figure of 80 therms a year as the average family cooking requirement. This is equivalent to 8 million BTU a year, which works out at about 37 cubic feet of bio-gas a day.

By far the easiest way to use the gas from a methane digester is with burners designed to run off natural gas (which is almost pure methane). To do this, however, involves removing the carbon dioxide from the bio-gas produced. It's also a good idea to remove hydrogen sulphide and water vapour, both of which will be present and both of which are corrosive. So the gas is bubbled through lime water (which removes both carbon dioxide and any ammonia present) and then passed through beds of calcium chloride, to remove water vapour, and iron filings, to remove hydrogen sulphide. If the calcium chloride is heated after use, the water

vapour will be driven off and it can be used again. If the iron filings are exposed to air, they can be used again as well. Any sensibly designed methane plant will include two of these scrubbing arrangements, with a system of taps to make the gas flow through one or the other. The chemicals in the one not in use can then be regenerated or replaced while the other is being used.

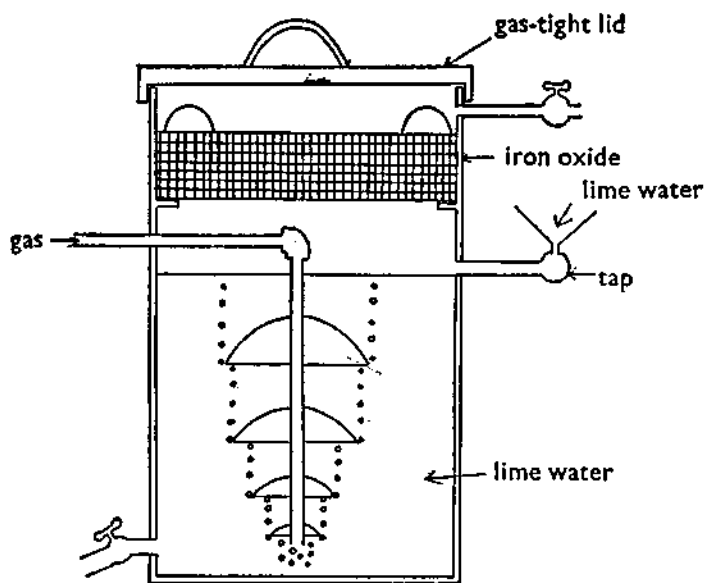

SCRUBBING UNIT

The result will burn well in a normal natural gas burner, providing it is raised to the same pressure as natural gas supplies – which is about 8 inches of water gauge or 0.3 lb per square inch above atmospheric pressure (just over 2 kiloNewtons per square metre, for the metrically minded). Don't be put off by complicated-looking figures. The pressure needed is very small and easily made by adding a weight to the top of the gas holder (see next section). To find out what weight to add, attach the gas supply pipe to a glass tube filled with water and bent in a U-shape. Go on adding weights till the water on one side of the tube is about 8 inches higher than on the other. Then you've got roughly the right pressure. You may find the gas burners work at lower pressures. Don't be deceived, though, because if they do they'll be working very inefficiently.

There is an alternative to the problem of burners, which is to make your own. I don't recommend it. Playing around with methane is quite dangerous enough, without inviting explosions. But if you're ever in India it is possible to buy burners there manufactured specifically for bio-gas.

FOREWORD

Most of rural population in the developing countries depend on wood fuel as a source of energy for cooking, and most of these families have little if any light available in the dark hours. For these reasons, there has been, for the last twenty years or so, an increasing interest in the use of bio-gas systems in rural areas.

The products of bio-gas systems are seen as possible solutions to two serious problems in poor rural areas: As a renewable energy source, it can provide the much-needed cooking and lighting fuel without the need to purchase scarce and expensive kerosene; and the digested sludge is seen as a good source of fertilizer that can improve agricultural productivity.

Large scale bio-gas plants, notably the Chinese and Indian types, have been promoted in the region over the years with varying degree of success. The main constraint to wide adoption of these plants is the high capital cost which makes the technology beyond reach of many small holder farmers.

In early 1980s, a low cost, family size bio-gas digester using plastic sleeves was developed in Colombia to meet the real economic concerns of rural farmers. The technology has been widely adopted in Colombia and Vietnam and efforts to promote these systems in Tanzania, Kenya and Uganda has shown promising results. It is therefore hoped that this guide booklet will assist development workers, extensionists and farmers to be able to build and install the bio-digesters in the rural areas.

INTRODUCTION

Biogas is a gas produced from organic materials such as animal manure, human excreta, kitchen remains, crop straws and leaves after decomposition and fermentation under airtight (i.e. no light, no oxygen) conditions. This is sometimes called "anaerobic" condition. The airtight pit or container is called the "digester", and the process of decomposition and fermentation is referred to as "digestion".



nitrogen, thus it can be used as a fertilizer for field crops. It can also be used as a source of nitrogen in animal feeds.

The digestion process is brought about by bacterial activity whose mode and rate determine the quantity and quality of bio-gas and slurry produced. Bacterial activity in the digester depends on several factors, notably the amount of water used to dilute the substrate (the organic materials), temperature in the digester (optimum temperature is 35°C), and the type of substrate fed.

The main constituents of bio-gas are the methane gas (CH₄) and carbon dioxide (CO₂). The bio-gas burns very well when the methane content is more than 50 percent, and therefore bio-gas can be used as a substitute for kerosene, charcoal, and firewood for cooking and lighting. This saves time and money and above all it conserves the natural resources i.e. from cutting trees to get firewood.

In the fermentation pit, only part of the organic material is converted into bio-gas, leaving behind some liquid slurry. This slurry is very rich source of soluble

Previously, there were two main types of bio-gas systems promoted in the region, the floating-dome type sometimes known as Indian type (Figures 1a and 1b), and the fixed-dome type better known as Chinese digester (Figure 2). Though there have been successful reports on these bio-gas systems in India and China, the uptake in most of developing countries have been minimal mainly due to the high installation costs which are beyond reach for most rural farmers (Silayo, 1992; CAMARTEC, 1990).

In the early 1980s, in an effort to provide its rural population with much needed cooking fuel, a low-cost tubular plastic bio-digester was developed in Colombia (Figure 3). The technology which is now widely used in Vietnam and Colombia has been promoted in Tanzania and Kenya over the last three years by the FAO/SIDA Farming Systems Programme. 40 units have been installed in Tanzania and have stimulated interest among farmers as appropriate technology for use in and promoting women's well-being in rural areas (Lekule, 1996).

Figure 1a: The floating drum plant with cylindrical digester

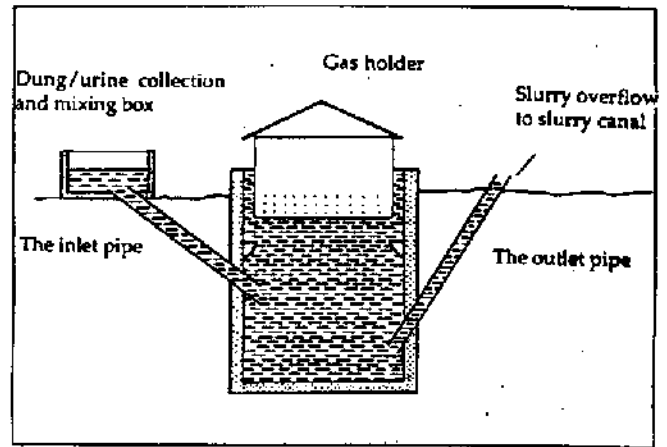

Figure 1b: The floating drum plant with dome bottom and cylindrical top digester

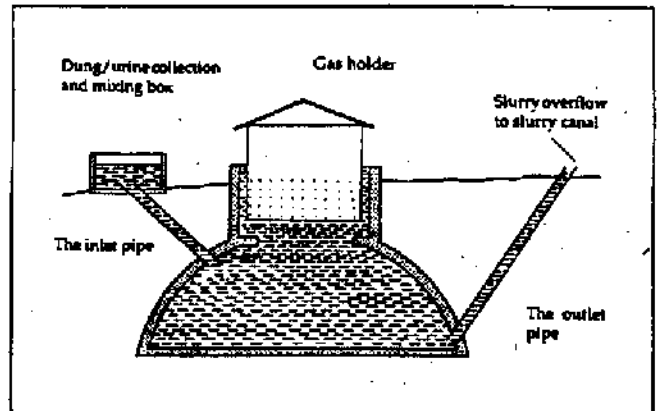

Figure 2: A fixed dome bio-digester with a flat bottom, open top and a cylindrical expansion chamber

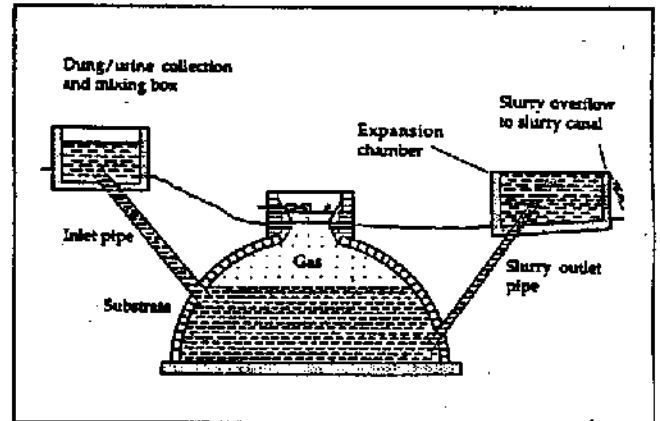
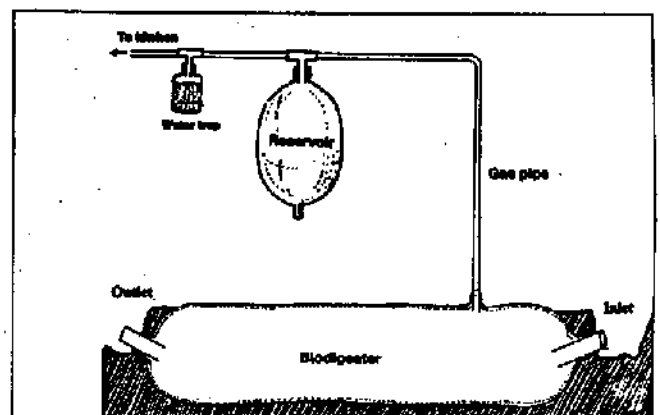

Figure 3: Essential features of a plastic tubular bio-digester



ADVANTAGES OF BIO-DIGESTERS

The bio-gas technology have several advantages under crop-livestock farming system and in protecting the environment in a particular area. Lekule (1996), Brown (1987) and Silayo (1992) have cited the following major advantages:

1. It provides an alternative to firewood and thus reducing the rate of deforestation.
2. Improves crop-livestock farming system through nutrient recycling.
3. Improves women welfare by reducing workload of collecting firewood.
4. It improves the health of women and children (otherwise exposed to harmful smoke and fumes from traditional fuels) and provides non-polluting and smokeless kitchen.
5. It is relatively cheap source of energy compared to other fuel.
6. It promotes cleanliness in a village.
7. It promotes health by the safe treatment of manure-particularly human wastes-to prevent the spread of disease.
8. As a renewable energy, it provides reliable power supply and is environmentally friendly technology.

Apart from getting bio-gas and fertilizer, decomposition and fermentation of organic materials in airtight pits improves sanitation because the gas and slurry obtained does not usually smell, and moreover breeding sites for flies, gnats and mosquitoes which transmit diseases are eliminated.

Bio-gas is an alternative energy source which is not detrimental to the environment

The bio-gas technology may not be acceptable to some communities mainly because firewood and dry cow dung is readily available for cooking.

Effluent (the liquid slurry) from bio-digester is rich in Nitrogen (N), Phosphorous (P) and Potassium (K). It can therefore be used as fertilizer for fish ponds, vegetable gardens, fruit trees and crop plants.

BIO-GAS PRODUCTION SYSTEM

Figure 4 outlines the technical sub-systems for bio-gas production and utilisation (Silayo, 1992). It is comprised of the following:

1. **Procurement of organic materials:** Organic materials and water which are the essential source of bio-gas are gathered together in one place.
2. **Preparation of digester substrate:** The organic materials (the substrate) are mixed with water in adequate proportions.
3. **Feeding the digester:** The prepared substrate is fed to the digester through the inlet opening.
4. **The digestion process: (**)** This takes place when decomposition and fermentation of substrate by bacteria in the digester. This results in the formation of bio-gas and slurry.
5. **Storage of digestion products:** The primary product is bio-gas which can be stored in the digester itself or separate gas holder depending on the design of the digester. Slurry as a secondary product, can be used directly or stored in a pit or converted into compost for future use.
6. **Use of digestion products:** Bio-gas is rich source of energy, therefore it can be used for cooking and lighting. Slurry is mainly used as fertilizer on agricultural crops. It can also be used to enrich animal feeds with nitrogen.

THE DIGESTION PROCESS

In order to appreciate the importance of maintaining the right conditions for bio-digester to function properly, one has to understand the bio-chemical reactions taking place in the bio-digester.

The principle of bio-digester is based on the fermentation of organic effluent and wastes under anaerobic conditions producing an inflammable gas mixture, consisting of 60 - 70 percent methane and about 30 - 40 percent of carbon dioxide. This is achieved through the following stages:

1st Stage

Biopolymers are attacked by hydrolytic and fermentative bacteria which secrete enzymes and ferment hydrolysed compounds into acetate and hydrogen. A small amount of the carbon converted will end as volatile fatty acids (VFA) known as propionic and butyric acids.

2nd Stage

Another group of bacteria, hydrogen producing acetogenic bacteria continue with the process by converting the VFA into acetate and hydrogen.

3rd Stage

Finally, methane producing bacteria convert the hydrogen and acetate into methane. There are different types of bacteria with specialization. Some convert only acetate while others convert only hydrogen. In-order for all these bacteria to work properly and arrive at end product, conditions have to be well balanced. For example, overfeeding can upset this balance as it will lead to accumulation of volatile fatty acids.

Figure 4: Bio-gas production and utilisation system

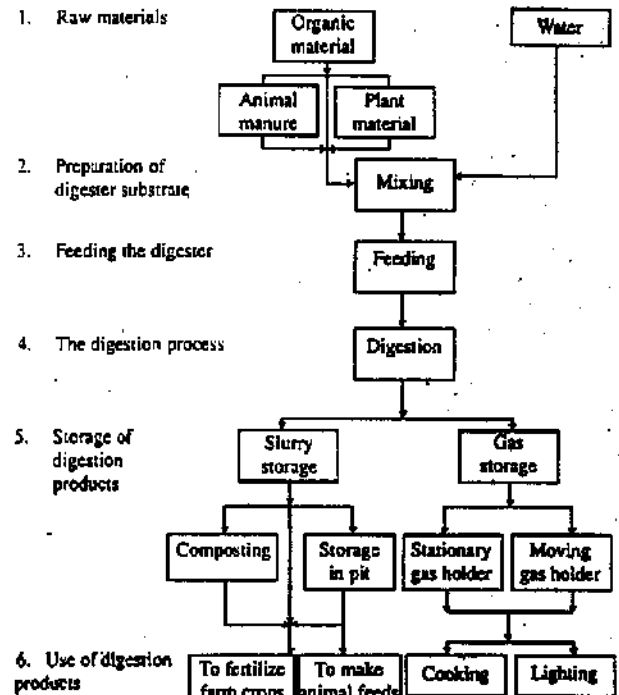

In most developing countries, bio-mass is the main source of energy for domestic use. In Tanzania, for example, it accounts for over 90 percent of total energy consumed in the country, while oil, electricity and coal accounts for less than 10 percent.

Due to their suitable carbon to nitrogen ratio and total solid content, cattle, pig and poultry manure are highly recommended as raw materials for bio-gas production.

Cattle and pig manure can be mixed together or cattle and pig manure can be mixed with plant material.

When leaves and crop straws are used as part of organic materials (sub-strate), they should first be chopped to 1 - 3 cm, then decomposed in a temporary pit for about a week before feeding in the digester.

Two cattle or 8 pigs are enough to produce dung for a 5 m³ bio-digester which can produce enough gas for a family of six people.

In order to optimize the use of this effluent, it should be removed daily and applied directly to the gardens or farms. The application of 10 litres of effluent to 1 m² of soil surface is equivalent to applying 60 kg of Nitrogen fertilizer per hectare.

CARE AND MANAGEMENT OF TUBULAR BIO-DIGESTER

Several factors will decide whether the biogas plant or digester will work properly. These include: Availability of organic materials to feed the plant; daily management of bio-gas plant, temperature and the immediate use of produced slurry. For successful operation and trouble free bio-digester, the following should be observed:

Protection

The digester should be protected from sunlight (ultra-violet radiation). It is therefore advisable to cover the bio-digester using banana leaves, iron sheet or canvas material to avoid direct sun rays.

The plastic is a delicate material and it should be protected by making a hedge or fence around the pit to stop goats, chicken and children from tearing the poly-thene tube. Prevent anything with sharp ends from getting into the bio-digester.

Availability of water

Water is a very important ingredient for the successful operation of bio-gas plants. Without sufficient water it might be difficult to obtain enough gas for daily need from digesters. Water is required for mixing the manure and a ratio of 1 manure : 2 water is recommended, i.e. one bucket of manure and two buckets of water daily.

Where water is scarce, bio-gas technology can not be adopted since water is needed everyday for making the plant feed.

Regular feeding

The digester should be fed regularly everyday. Do not overfeed. The methanogenic bacteria require constant and balanced conditions all the time. (See Appendix I for calculating the loading rate and retention time). A 5m³ digester will require 19 kg of manure and 47 litres of water to produce enough gas for a day.

When the colour of the effluent is green, it indicates that the digester is overloaded, i.e. digestion is incomplete due to short retention time.

Cattle dung as starter

When feeding the digester with cattle manure there is no problem of acidity. However, when other materials (such as garbage and manure from other animals) are used, the acidity might be too high and this will stop the methane producing bacteria from functioning. For best results, cattle dung should initially be used as it contains the right pH (acidity) and bacteria for starting a digester.

Effluent recycling

Recycling part of the digested slurry improves the performance of the bio-gas plant. This plays the same role as stirring of slurry which helps to break the surface scum and the bacteria to reach the foodstuff. Each day about 30 - 40 litres of effluent should be recycled through the digester. This should be done immediately after the bio-digester is changed.

Gas pressure

The volume of tubular plastic bio-digesters is about 5 m³. This will produce a gas which will cook for about 3 hours. During cooking the pressure will normally go down and the fire might be extinguished. Therefore it is important that during cooking, an object weighing 3-5kg is always hung on the reservoir to maintain constant pressure in the collection tank.

Temperature

There is a close relation between bio-gas production and fermentation temperature. Maximum gas production will occur at 35-40°C. Mesophilic methane bacteria can operate between 20°C and 40°C. As the temperature goes down, gas production decreases and will cease at 10°C. Seasonal and diurnal temperature variation are deleterious to methane gas production. Therefore, tubular bio-digesters cannot work effectively in the highlands and should not be installed in cold areas.

BENEFITS AND COST COMPARISON

Although it is difficult to totally quantify the economics of using bio-gas, it offers enormous economic, social and ecological advantages and has an important role to play in providing sustainable energy production.

In order to assess the economic and social benefits of the plastic digester, a study was conducted in Tanzania in the households where bio-digester were installed. Although it is difficult to quantify the deforestation rate, it was found that after adoption of bio-gas digesters, woodfuel consumption can be decreased by 60 percent (Lekule 1996).

Comparing with other energy sources i.e. charcoal and kerosene, a survey conducted in Tanzania showed that 3 bags of charcoal and 121 litres of kerosene were consumed per month in a family of six. If this is amortised it is approximately US\$ for charcoal and US\$49 for kerosene which presents a real saving (direct benefit) when bio-gas is used. As for labour, there was no direct cost associated with handling of the bio-digester. The use of family labour to mix the manure and feed it did not interfere with other activities. On the other hand, 71 percent of the respondents reported that they had reduced the frequency of firewood collection by half.

Construction cost of tubular plastic sleeve bio-digester is less than US\$ 100 as compared to US\$1000 when constructing large scale conventional bio-gas plants (Lekule and Sarwat, 1996).

APPENDIX I

Calculating the loading rate and retention time of bio-digester

The parameters that determine the economics of operating a bio-digester are:

- the rate of gas production (litres/day) and
- the efficiency of gas production (amount of gas generated for every unit of fermentable solids entering the digester measured as litres/kg of organic matter).

- The loading rate (the amount of fermentable solids per unit of active digester volume per day).
- The retention time (the average time the substrate stays in the digester).

The higher the loading rate the more gas is produced but the efficiency of gas production is reduced (Figure 25). The longer the retention time, at a fixed loading rate, the greater the efficiency of gas production but gas production per day is reduced (Figure 26).

Figure 25:

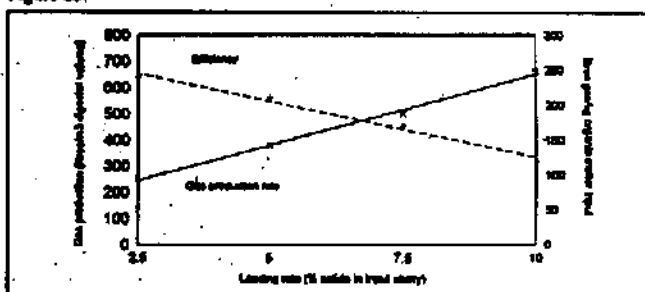
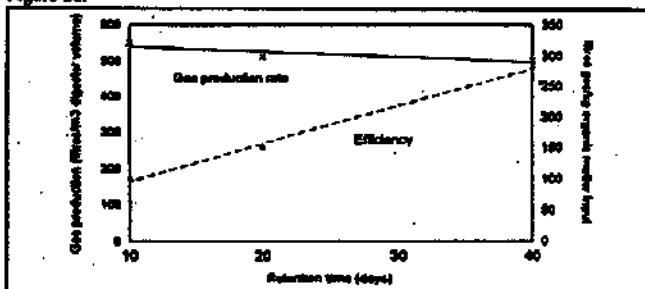

Figure 26:



In practice there are limits on the loading rate since it has been found that when the solids content of the input slurry rises above 5 percent, the flow through the bio-digester is impeded. Retention time generally is determined by the number of animals and hence the amount of manure available. If there are few animals (e.g. only one cow or four pigs) then it is better to have a longer retention time, which will happen anyway if the concentration of the input slurry is maintained at 5 percent.

As a rule of thumb, the amount of gas produced depends on the volume of slurry in the digester which is two-thirds of the digester volume. The digester volume is also related to the retention time measured in days and the feed rate measured in m³ feed/day.

It has been shown that 97.3 percent of total yield of gas from fermenting cattle manure will be produced in 50 days at 35°C. In order to have a retention time of 50 days, daily input in a 4 m³ digester can be calculated as follows:

Volume of slurry:	$2/3 \times 4 = 2.7 \text{ m}^3$
Daily input:	$2.7 \text{ m}^3/50 \text{ days} = 54 \text{ litres/day}$
Total solid content for cattle excrement (theoretical value)	= 17 percent
In order to have solid content of 5 percent in the input, the amount of fresh manure should be:	
$0.05 \times 54 \text{ litres} / 0.17$	= 15.8 kg of fresh manure and
$54 \text{ litres} - 15.8$	= 38.2 litres of added water
(assuming density of feed is 1 000kg/m ³)	

THE TUBULAR PLASTIC BIO-DIGESTERS

The low-cost tubular plastic digesters was developed by CONDRIT (*Consultorias el para el Desarrollo Integrado del Tropico*) located in Cali, Columbia in early 1980s (Figure 5). The digester was based on a design first promoted in Taiwan, known as the "Red Mud PVC" bio-digester (CONDRIT Ltda, 1995).

In East and Southern Africa region, the technology was introduced in 1993 through the technical cooperation programme of FAO executed in Tanzania, which aimed at the transfer and adaptation of technologies that has been validated in other tropical developing countries.

Later, in 1994, a local NGO known as SURUDE (Foundation for Sustainable Rural Development), submitted project proposals to DANCHURCHAID and the FAO/SIDA Farming Systems Programme (FSP) for the widespread promotion of low cost bio-digesters in Tanzania. Currently more than 40 bio-digesters have now been installed in various villages of Tanzania. SURUDE has also made initiatives to popularise the technology in Kenya and Uganda (Lekule, 1996) with support from FSP.

Most of the digesters installed have a volume of 5m^3 with a capacity of providing gas at a rate of $0.354\text{m}^3/\text{m}^3$ per day which is enough for a family of six people.

MATERIALS REQUIRED TO MAKE A TUBULAR PLASTIC BIO-DIGESTER

You can easily make your own bio-gas digester using common and readily available materials. Normally it takes about one day to install the bio-digester. To make a tubular plastic bio-digester you will need the following main components:

1. A polythene tube of 0.2 mm thickness, with a radius of 45 - 80 cm and 8-10 metres long. (This is the main component of the plant.)
2. A PVC pipe of 120 cm long with a radius of 10 cm. (For carrying gas.)
3. A tube (preferably from an old tyre), which will be used to fit the pipe to the polythene tube.
4. Appliances, a burner for cooking and a bio-gas lamp for lighting.

The full list of materials required is shown below:

BIO-DIGESTER MATERIALS.

- Transparent polythene tubular film of 280 cm circumference (89 cm diameter, thickness about 0.2 mm). The thickness can be estimated by the weight of a given length of tube which should normally be 10 kg for 20 m of length.
- 2 ceramic or PVC tubes of 100 cm length and 15 cm internal diameter (id).

Figure 5: A low cost bio-digester (original design with in-built storage tank)

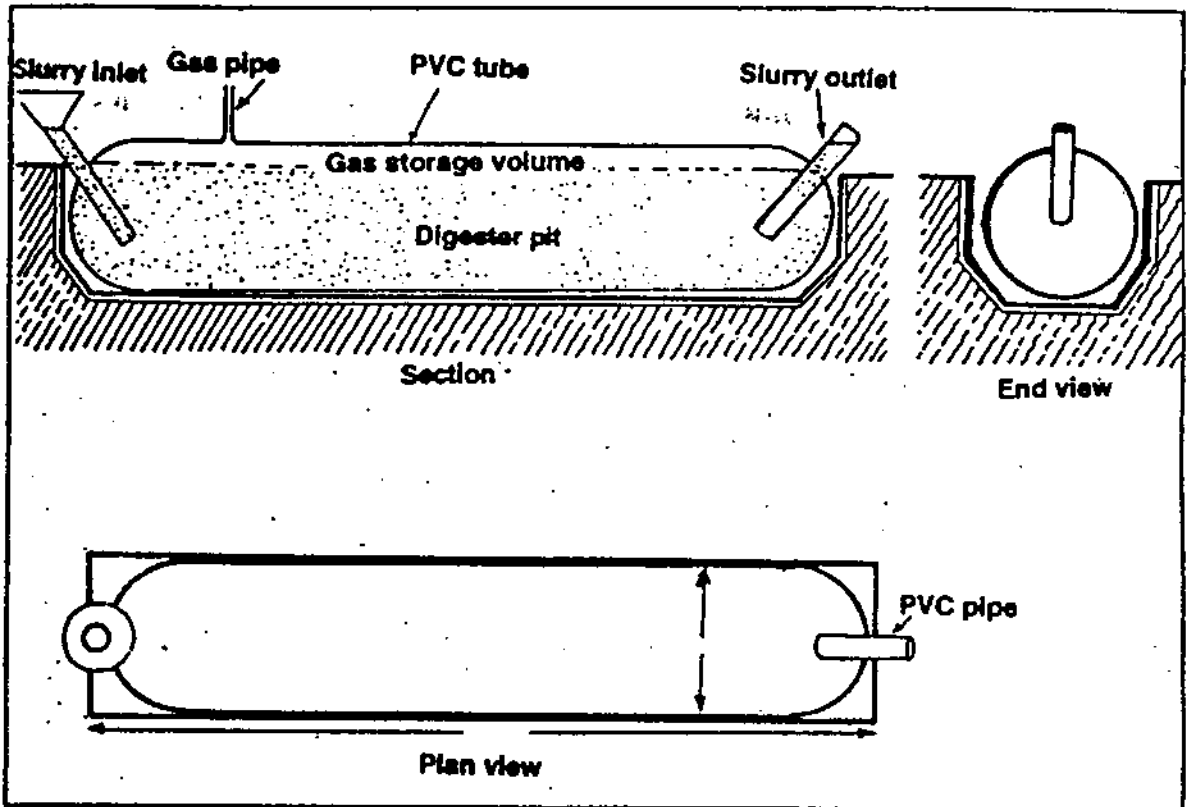

- 2 PVC adapters (male and female) of 21 mm internal diameter (i.d.).
- 2 rubber washers (from car inner tube) of 10 cm diameter and 1 mm thickness with a 21 mm diameter central hole.
- 2 PVC washers of 10 cm diameter and 1 mm thickness with a 21 mm diameter central hole.
- 1.2 m of PVC pipe of 21 mm i.d.
- 5 to 20 m of PVC, 21 mm i.d., rigid tube or flexible plastic hosepipe (the length depends on the distance from digester to the kitchen).
- 4 waste inner car tubes cut into 5 cm bands.
- 1 transparent plastic bottle.
- 3 PVC elbow "L" pieces of 21 mm i.d.
- 3 PVC "T"-pieces of 21 mm i.d.

Single stove for cooking:

- 3 steel tubes of 21 mm i.d., each 10 cm long.
- 1 tap of 21 mm i.d.
- 1 metal elbow of 21 mm i.d.

Methodology for construction (Fig. 6):

A trench is dug to receive the bio-digester. The walls must be firm and the floor must be flat or with only a minimum slope. There must be no sharp stones or protruding roots in the walls or floor. The cross-section of the trench for a tubular film bio-digester of 89 cm diameter has dimensions of 65 cm width at the top, 50 cm width at the bottom and 65 cm depth.

The length depends on the amount of manure available. The average is 10 m which requires manure from at least two cows or eight pigs. Two lengths of the polythene tube are cut, each 11 m long (for 10 m long bio-digester), laid on smooth ground and one inserted into the other (Figure 6).

A small hole is made in the two layers of the plastic tube, approximately 1.5 m from one of the ends. One PVC and one rubber washer are fitted on the flange of the male adapter which are then threaded through the hole from the inside to the outside. A second PVC washer and rubber washer are put on the male adapter from the outside of the tube and secured tightly with the female adapter. The exit of the female adapter is closed temporarily with a small square of plastic film and a rubber band.

A safety valve is made from a transparent plastic bottle, a "T"-piece and three PVC tubes (one of 6 cm and the other two of 30 cm length). Water is poured into the bottle and maintained at 3–5 cm depth (above the mouth of the tube).

The bio-digester is filled with water up to two-thirds of the depth, moving up and down the outlet (as indicator of the water level inside the tube). The air trapped inside the tube escapes from the safety valve as the volume of water increases. The gas pipe leading to the kitchen is then

A ceramic pipe is inserted to two-thirds of its length into one end of the plastic tube. The plastic film is folded around the pipe and secured with 5 cm wide rubber bands (made from the used inner tubes). The bands are wrapped in a continuous layer to cover completely the edges of the plastic film, finishing on the ceramic tube. The inlet tube is then closed temporarily with a square of plastic (or a plastic bag) and a rubber band. From the open end, air is forced into the tube in waves formed by flapping the end of the tube. The tube is then tied with a rubber band about 3 m from the end so that the air does not escape. The procedure for fitting the outlet tube is the same as for the inlet tube. The complete assembly is then carried carefully to the trench and placed inside. The ceramic tubes are laid at 45° inclination and fixed temporarily.

attached (it must not be on the ground and the water trap should be at the lowest point in the gas line).

The gas reservoir is made from a length of polythene tube (3–4 m) and a PVC "T". It can be located horizontally or vertically but should be shaded from the sun and have a weight (half a brick) suspended from the bottom to increase the pressure. It is fitted into the gas line as close as possible to the kitchen to maximise the rate of gas flow to the burner since the system operates at very low pressure (only 3–5 cm water head).

Figure 6: Features of a plastic continuous flow tubular bio-digester

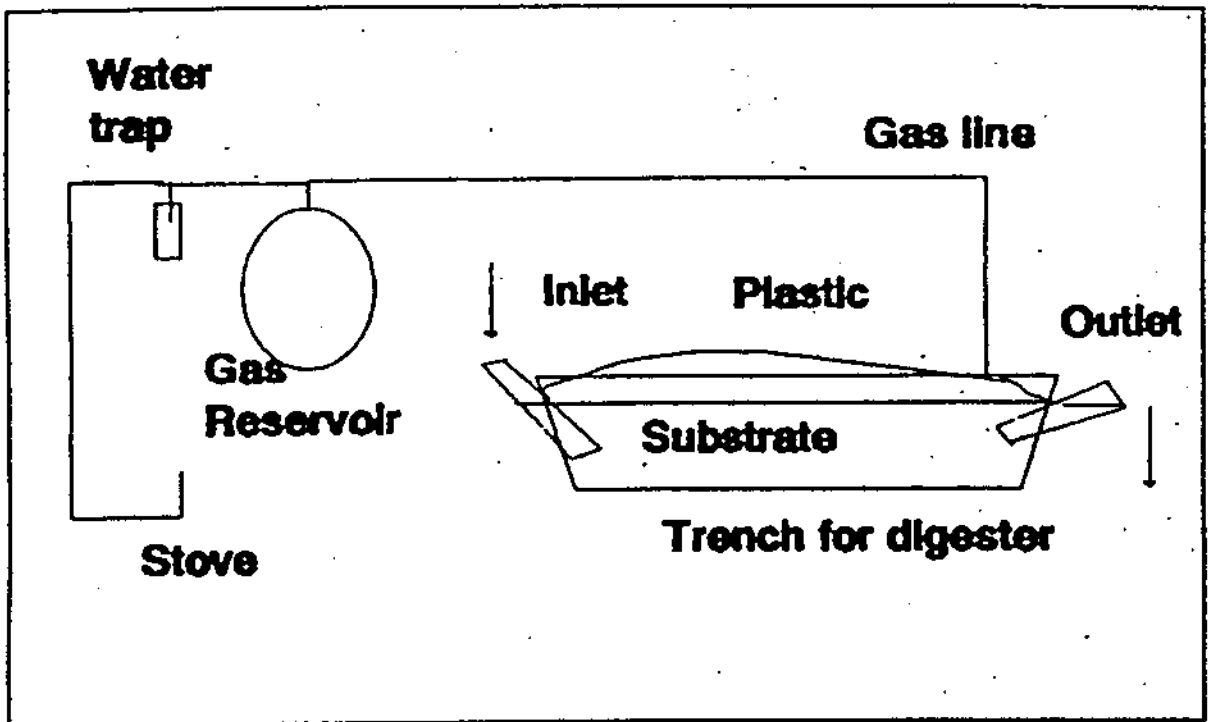

REFERENCES

Brown N. 1987. Biogas Systems in development. *Appropriate Technology Vol. 4* No 3 pp 5-7

CAMARTEC. 1990. Centre for Agricultural Mechanisation and Rural Technology, Tanzania bio-gas extension service, GTZ.

CONDRIT Lda. 1995. Improvement and promotion of tubular bio-gas digesters. Mission report submitted to the FAO/SIOA Farming Systems Programme.

Lekule F. P. 1996. Technologies for Improving the well being of rural women in Tanzania. Final report submitted to FAO/SIDA Farming Systems Programme.

Lekule F. P. and Sarwatt S.V. 1996. Use of Biogas as an alternative source of domestic energy to reduce deforestation Paper presented at the SPW/Environmental course.

Sitayo V.C. 1992. Small bio-gas plants. Design, management and use. Agrotec publication.

Estimated costs of materials for a family size tubular plastic bio-digester (based on the installation cost of bio-digesters in Tanzania)

Item	Quantity	Cost (US)
Polythene sheet (0.2 mm thick)	18 kg	40
Gas pipe (21 mm id)	15 m	9
PVC "T" and "L" pieces	6	3.2
Steel pipe	0.75 m	3
A tap (to control gas flow)	1	3
PVC for inlet and outlet	1.2 m	2.4
PVC, (10mm id)	1	1.2
Inner tube strips	20	0.6
Plastic bottle	1	0.5
TOTAL:		62.9
<i>Source: Lekule (1996)</i>		

PREPARATION FOR THE BIO-DIGESTER SITE

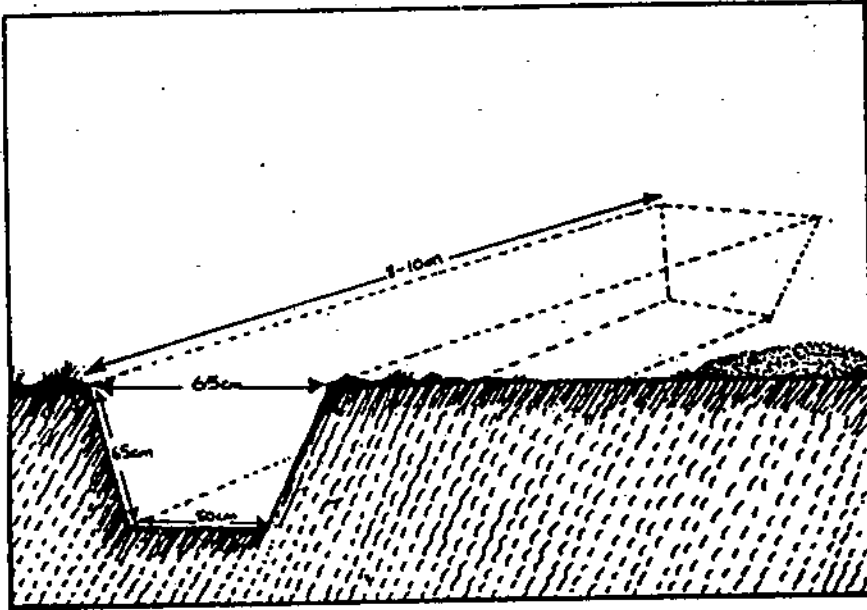

Figure 7:

Select a good site where there is enough source water, e.g. near your house and where you are sure of getting the dung every day. If you have animals, select an area near the animal shed. Mark the pit to required measurements before you start digging.

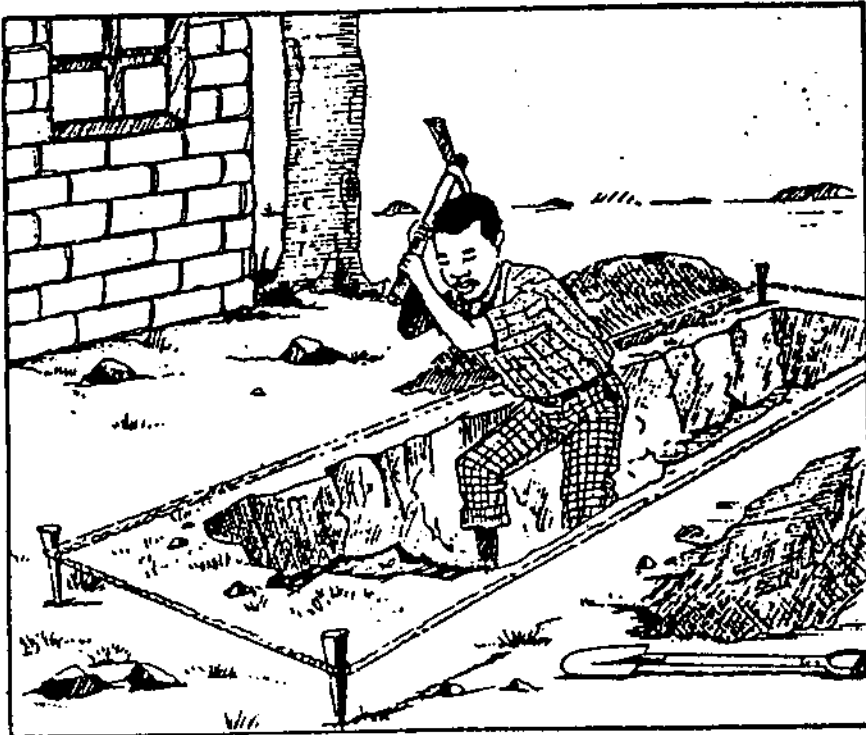

Figure 8:

When digging the pit, the width of the pit at the top should be wider than at the bottom to allow for expansion of the polythene tube as the gas builds up. Make sure the bottom of the pit is level. The length of the pit and the polythene tubing should be the same.

PREPARING AND INSTALLING A TUBULAR PLASTIC BIO-DIGESTER

Figure 9:

First check the polythene tube for any holes especially around the corners and fold both ends to fit the width of the pit.

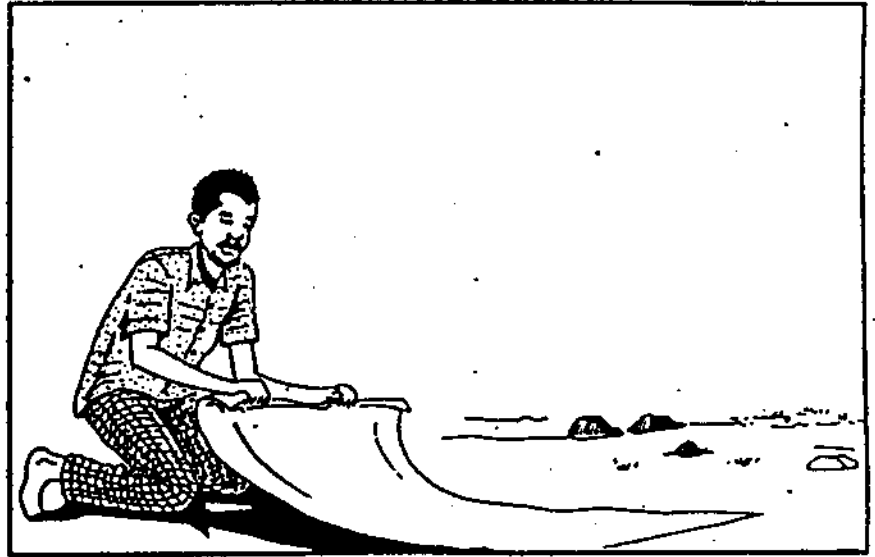

Figure 10:

Take the cylindrical polythene tube and measure 8 metres leaving an allowance of half a metre both ends for fitting the PVC pipe.

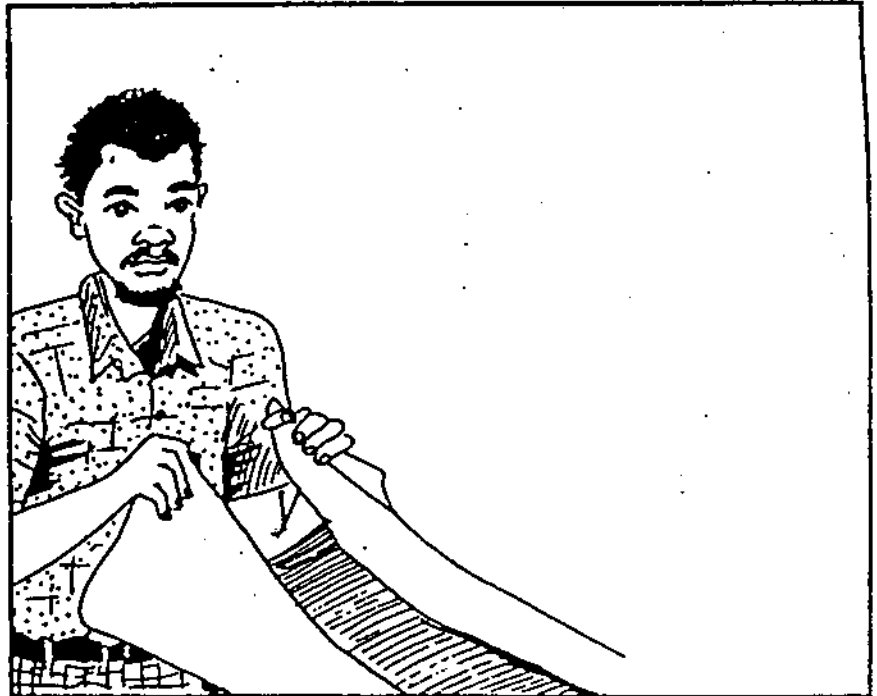



Figure 11:

Cut two 60 cm long pieces of the PVC pipe with a 10 cm radius and insert them into the ends of the poly-thene tube.

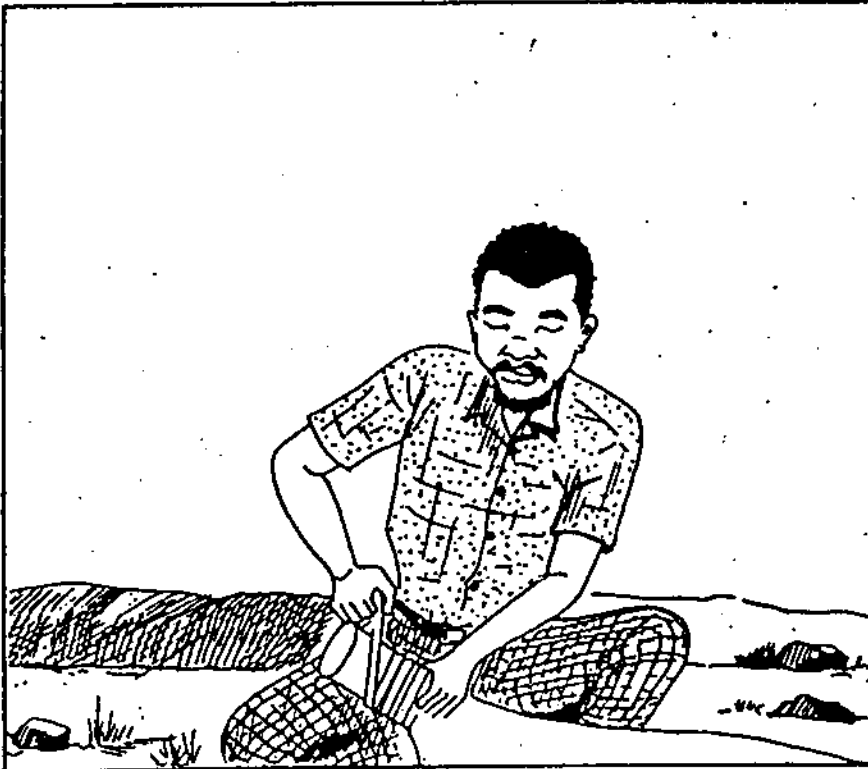

Figure 12:

Using the inner car tube, fasten tightly both ends of the poly-thene tube. Make sure there is no allowance for gas to leak.

Figure 13:

Make a small hole of radius 1 cm at a distance of 1 metre from the beginning of the bio-digester. The hole should be at the top of the polythene when full of gas.

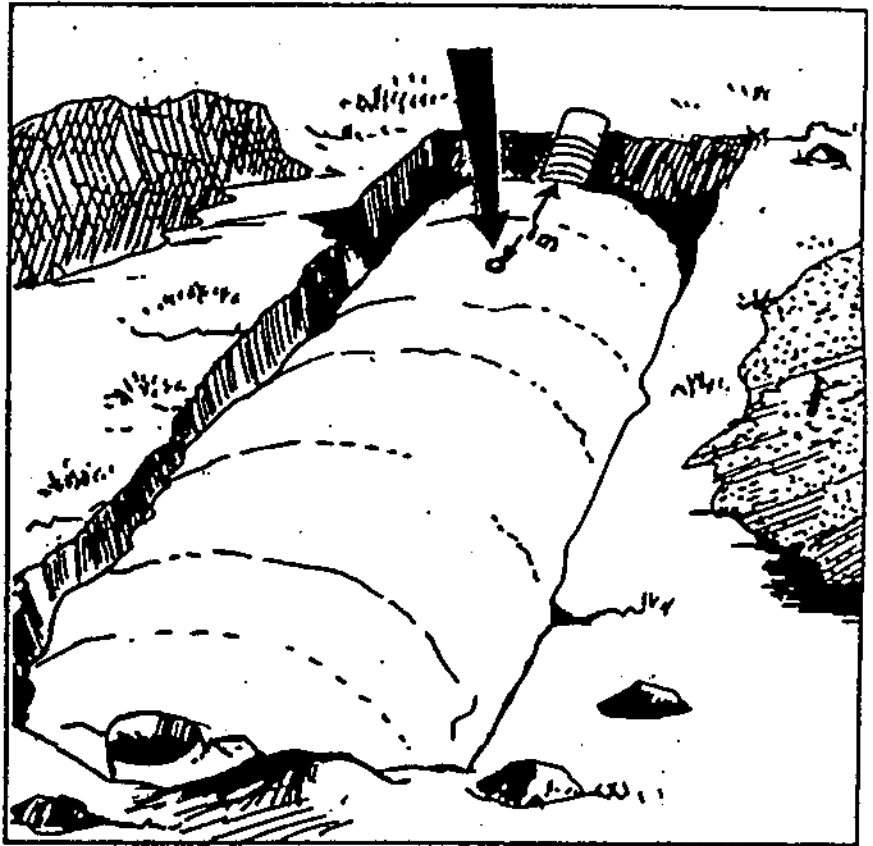
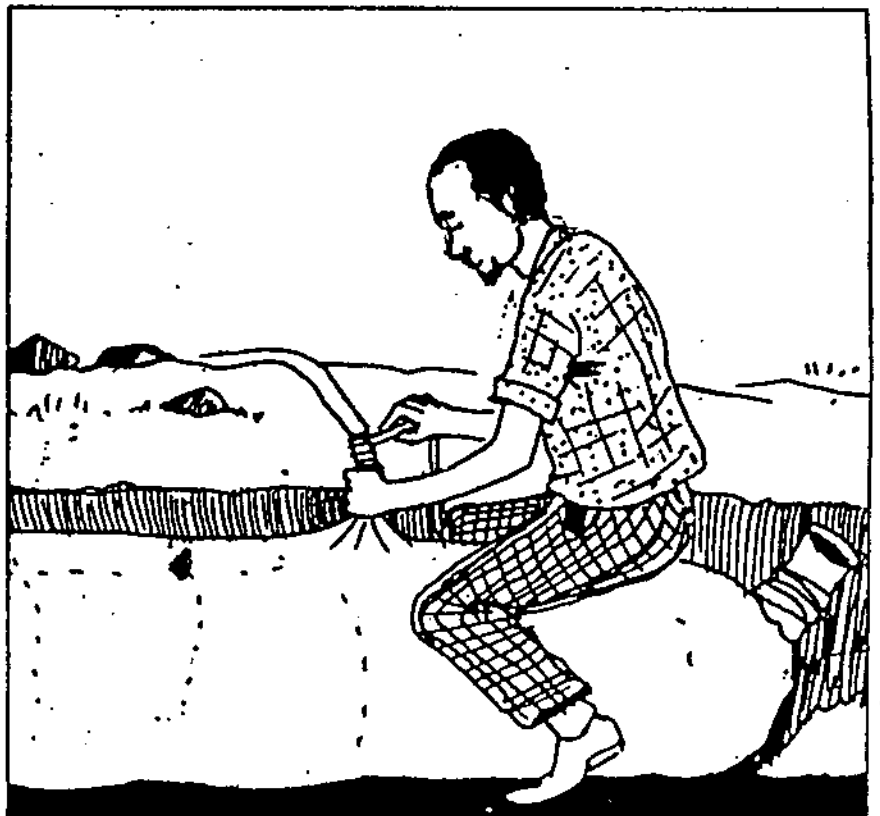

Figure 14:

Insert the small plastic pipe (radius 1 cm) into the hole. Use a 2 cm wide piece of the tube for fastening the pipe to the polythene.



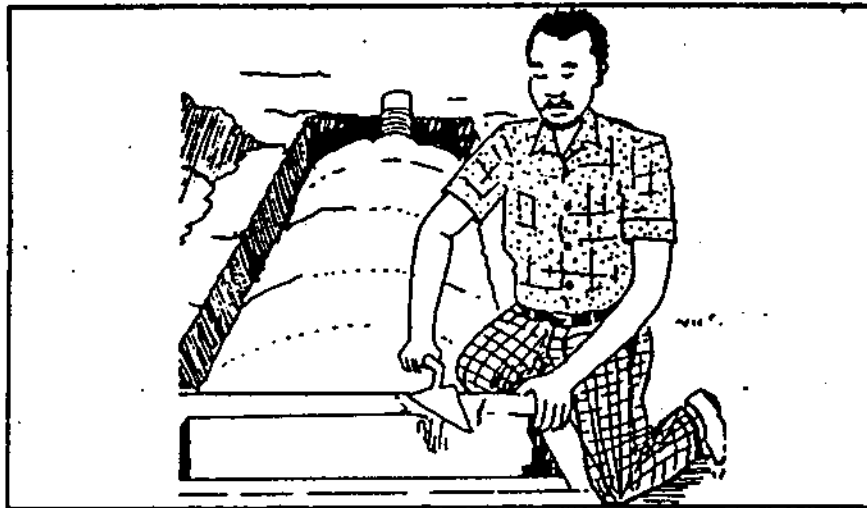
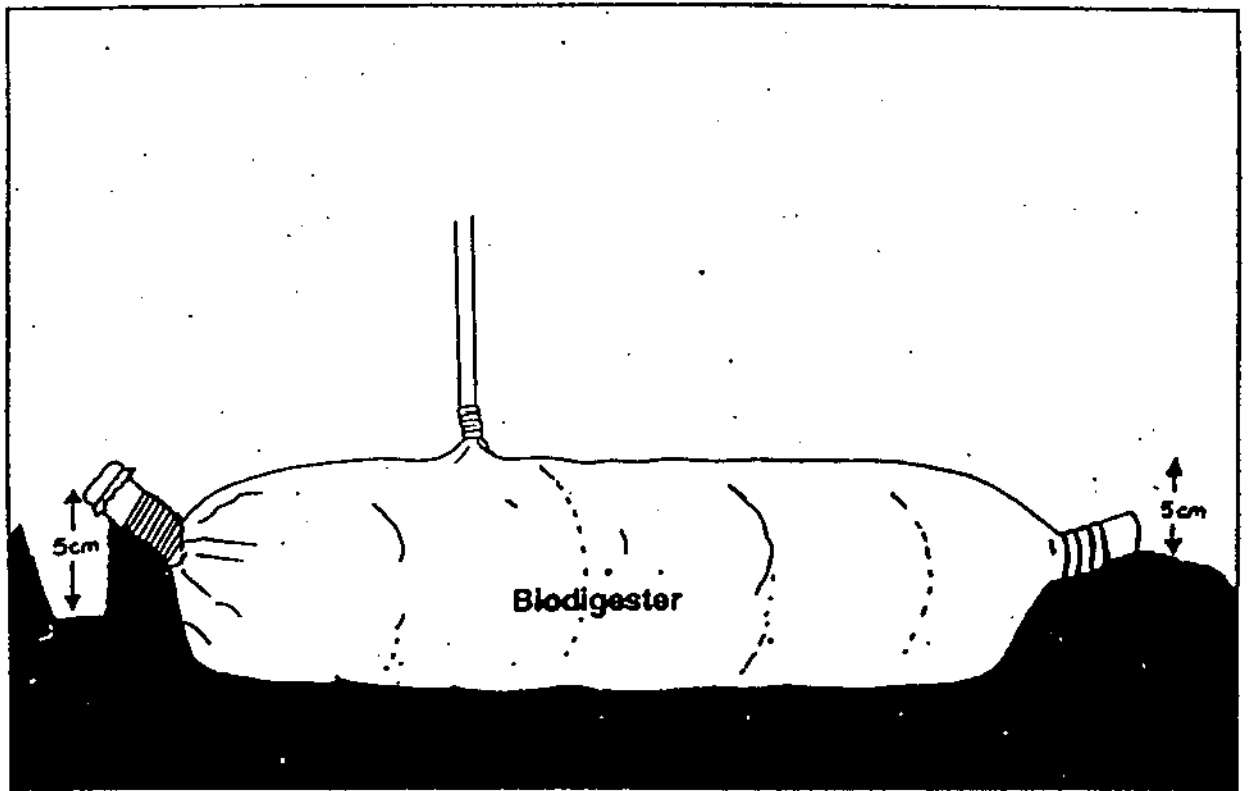
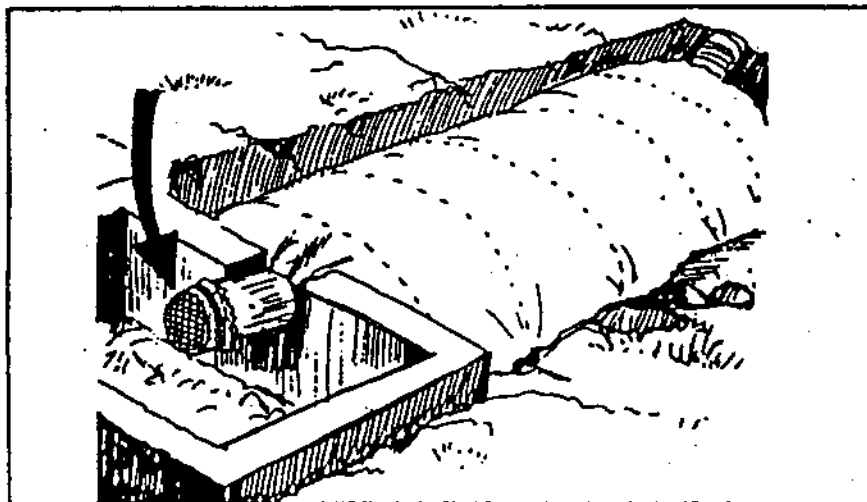

Figure 15 (above):

For the bio-digester to function properly, the outlet should be 5 cm below the top of the digester. The inlet should be 5 cm–10 cm above the outlet.



Figures 16 & 17(left):

At the inlet make a small pit for mixing the dung with water. Cover the inlet with a small wire mesh to avoid unwanted material in the digester.

Figure 18 (right):

Make small streams (courses) on both ends of the pit and have pieces of pipe for letting in water and getting out the slurry. This will ensure that the effluent is directed to a field or small collection point for spreading into the fields later.

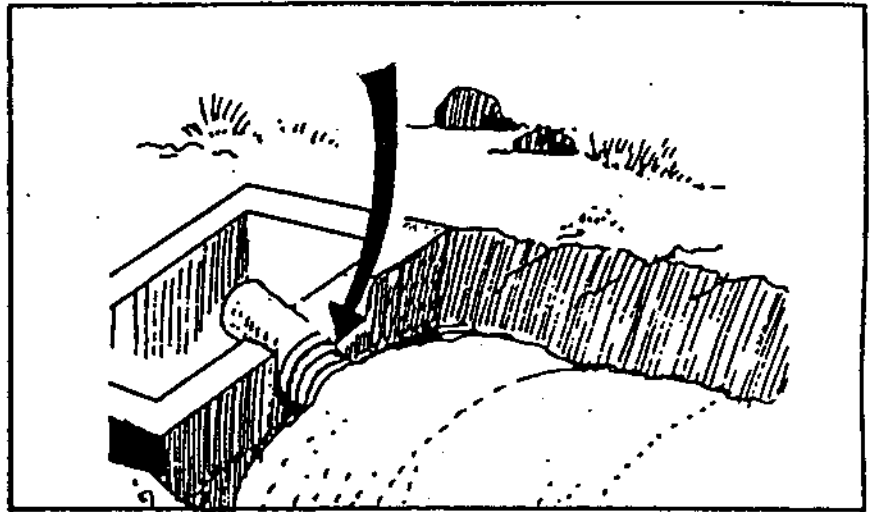
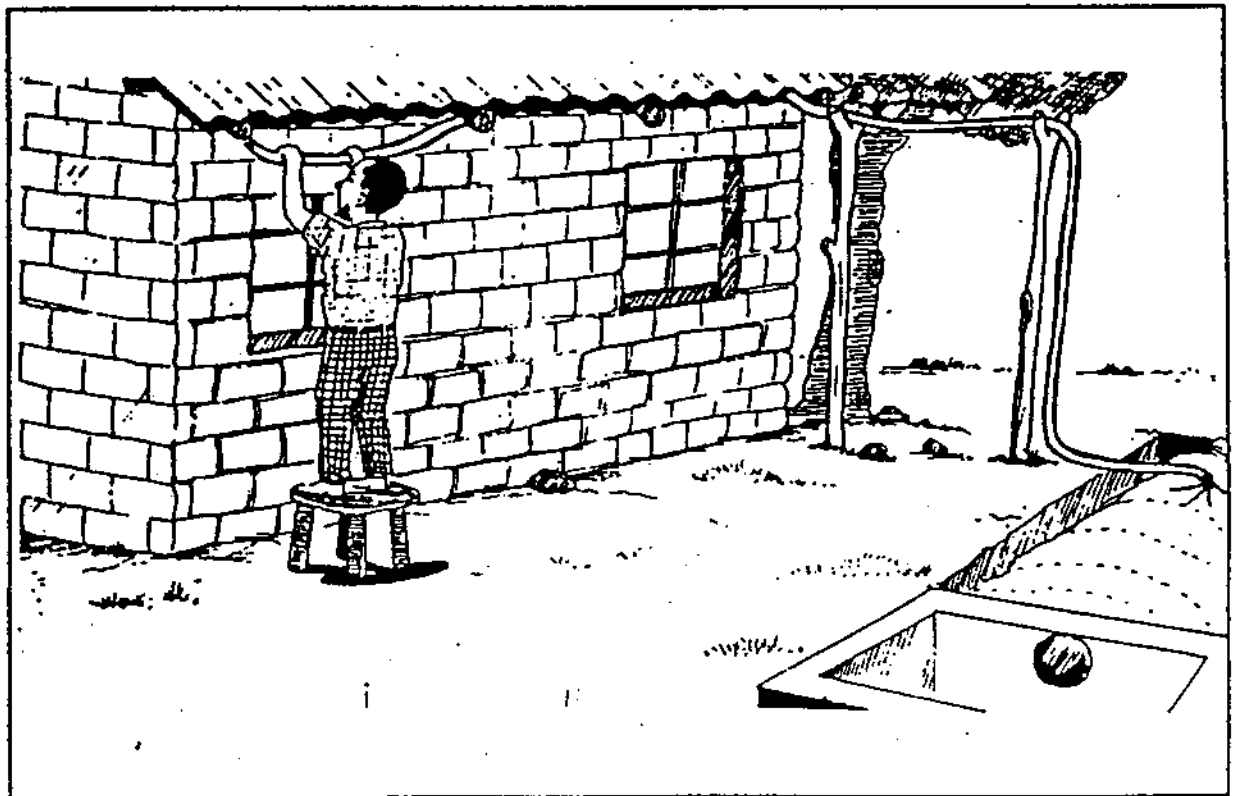
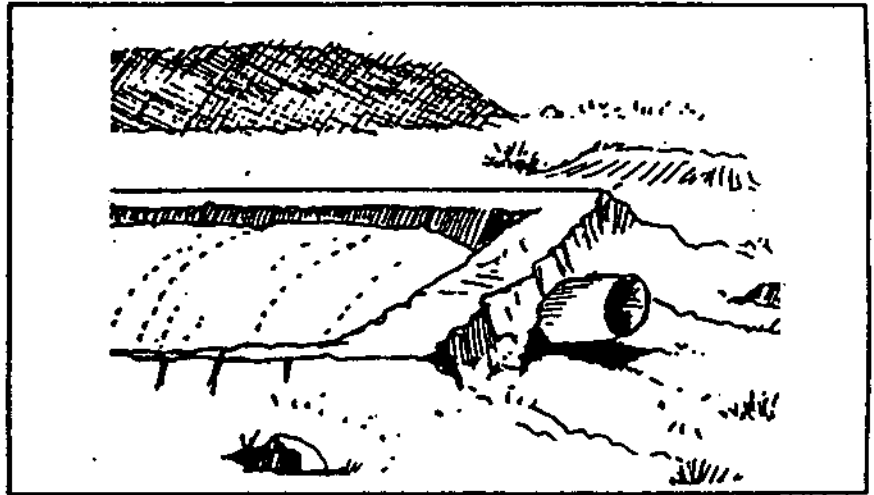

Figure 19 (below):

From the bio-digester, connect the gas pipe to the house. At the end of the gas pipe put a piece of galvanised iron with a gas control knob (valve).



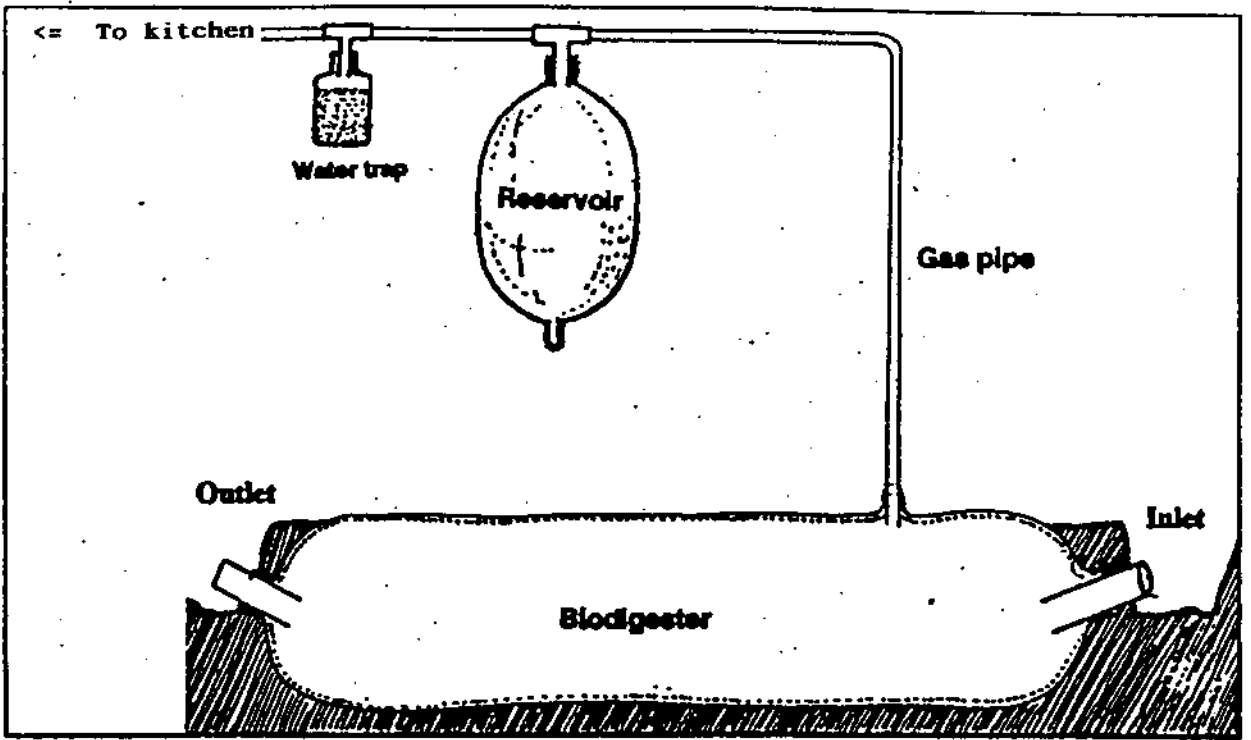
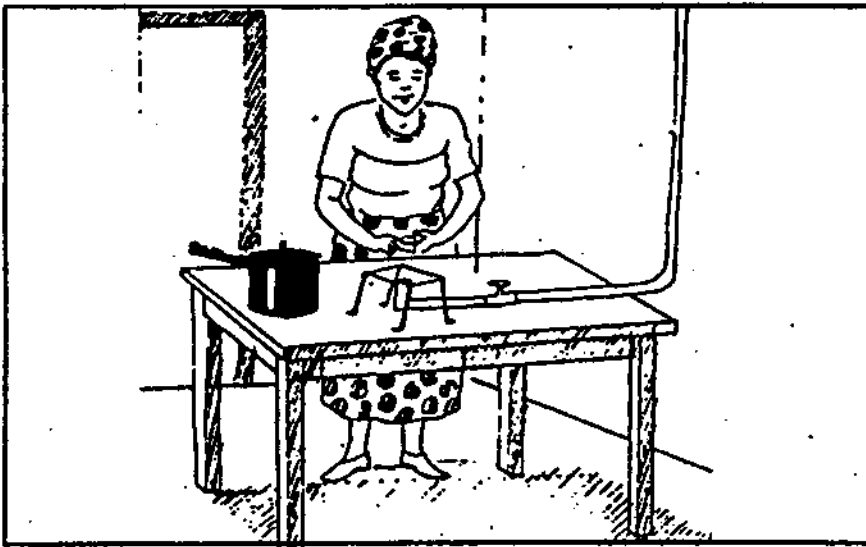
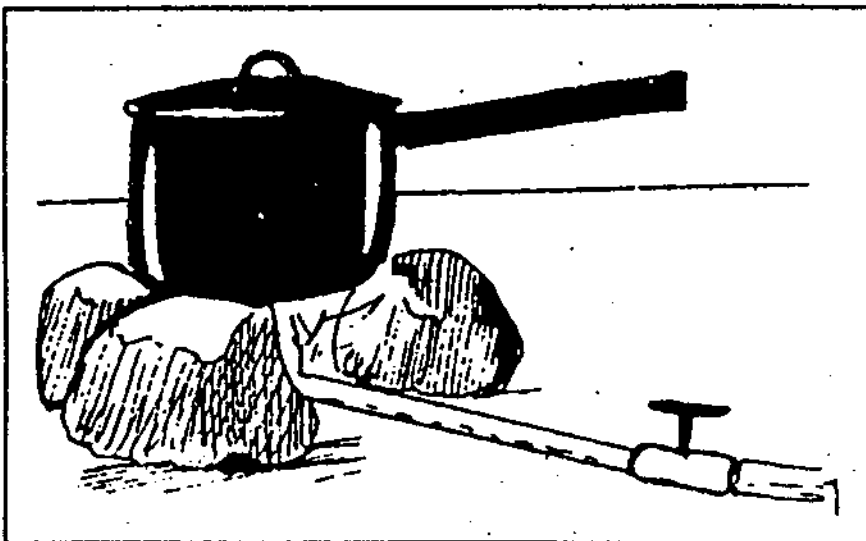

Figure 20 (above):



For a constant supply of gas, make a gas collection tank or a reservoir. The collection tank can be made from the same polythene tube used to make the digester. It is 3 m long and tightly fastened with the tube on both ends. On top of the reservoir, put a "T" shaped pipe, one end receives the gas from the digester and the other end take the gas to the kitchen through a water trap.



Figures 21 & 22 (left):

You can easily make your own cooking stove using iron bar, iron sheet, clay or the traditional three stone stove.

Figure 23:

For good supply of gas, feed one bucket of animal dung plus three buckets of water everyday. Gas production will normally start one week after the first feeding of the digester.

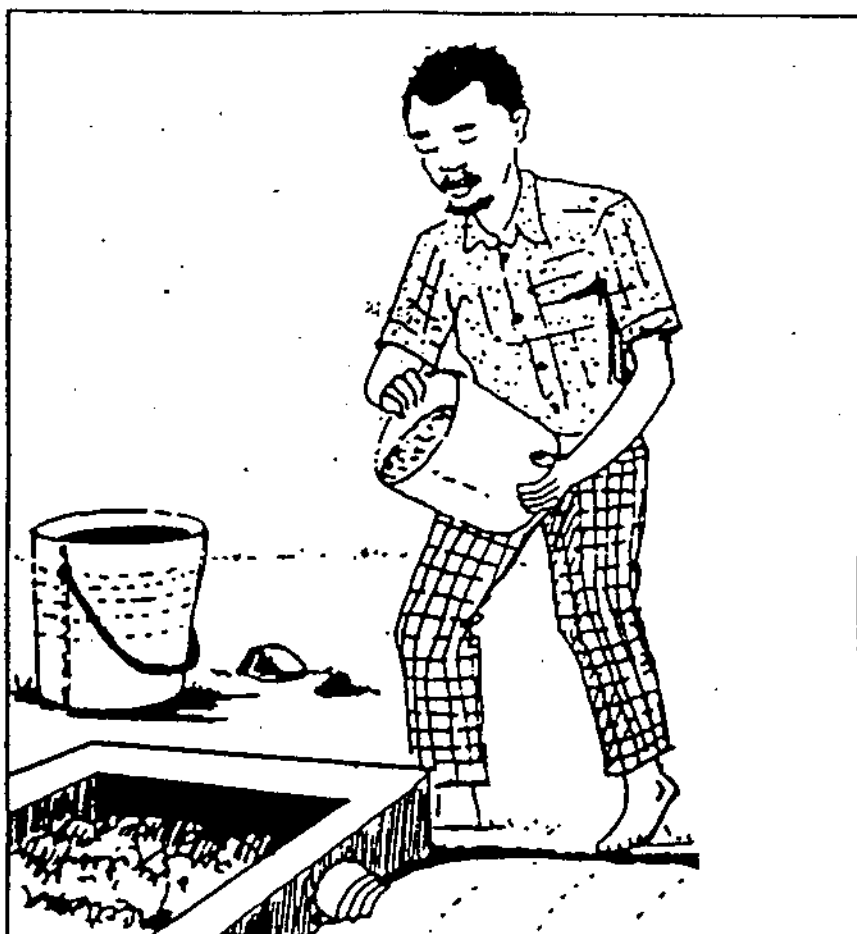
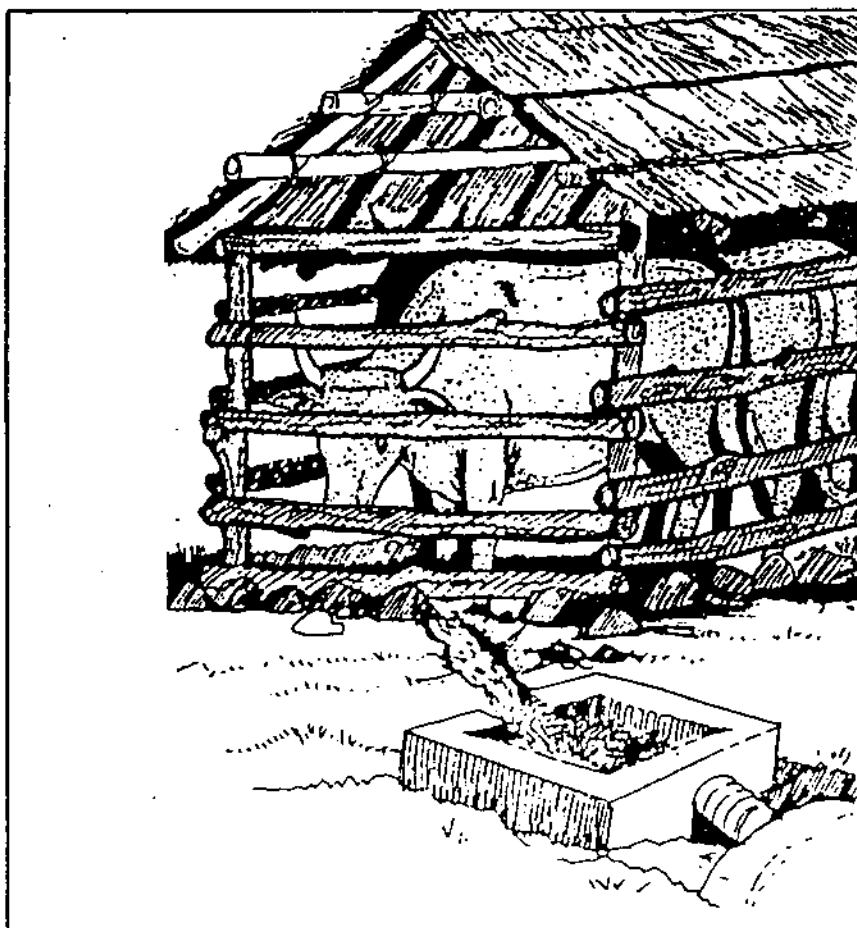

Figure 24:

If you are keeping your livestock in a shed, make a furrow (a stream) from the animal shed to the small inlet pit for mixing the dung and water.

Make sure your pit is covered with either pieces of wood or iron sheet to avoid birds and other animals from piercing or tearing the polythene tube.



Materials for a family sized polyethylene tubular digester.

Biodigester

- Transparent polyethylene tubular film of 280cm circumference (89cm diameter; thickness about 0.2mm). The thickness can be estimated by the weight of a given length of tube which should normally be 10 kg for 20m of length.
- 2 ceramic tubes of 100cm length and 15cm internal diameter (id).
- 2 m of 21mm id plastic hosepipe.
- 2 PVC adapters (male and female) of 21mm id.
- 2 rubber washers (from car inner tube) of 10cm diameter and 1mm thickness with a 21mm diameter central hole.
- 2 PVC washers of 10cm diameter and 1mm thickness with 21mm central hole.
- 2 m of PVC pipe of 21mm id.
- 5 to 20m of PVC 21mm id rigid tube or flexible plastic hose-pipe (the length depends on the distance from digester to the kitchen).
- 4 waste car inner tubes cut into 5cm bands.
- 1 transparent plastic bottle.
- 1 PVC elbow of 21mm id.
- 3 PVC "T" pieces of 21mm id.
- 1 tube of PVC cement.

Single stove for cooking:

- 3 steel tubes of 21mm id, each 10cm long.
- 1 tap of 21mm id.
- 1 metal elbow of 21mm id

Procedure for installing a polyethylene tube digester.

*A trench is dug to receive the biodigester. The walls must be firm and the floor must be flat or with only a minimum slope. There must be no sharp stones or protruding roots in the walls or floor.

*The cross-section of the trench for a tubular film biodigester of 90 cm diameter has dimensions of 90 cm width at the top, 70 cm width at the bottom, and 70 cm depth. The length depends on the amount of manure available. The average is 10 m which requires manure from at least 2 cows or 8 pigs.

*Two lengths of the polythene tube are cut, each 11 m long (for 10 m long biodigester), laid on smooth ground, and one inserted into the other.

*A small hole is made in the two layers of the plastic tube, approximately 1.5 m from one of the ends. One PVC and one rubber washer are fitted on the flange of the male adapter which is then threaded through the hole from the inside to the outside. A second PVC washer and rubber washer are put on the male adapter from the outside of the tube and secured tightly with the female adapter. The exit of the female adapter is closed temporarily with a small square of plastic film and a rubber band.

*A ceramic pipe is inserted to two thirds of its length into one end of the plastic tube. The plastic film is folded around the pipe and secured with 5cm wide rubber bands (made from the used inner tubes). The bands are wrapped in a continuous layer to cover completely the edges of the plastic film, finishing on the ceramic tube. The inlet tube is then closed temporarily with a square of plastic (or a plastic bag) and a rubber band. From the open end, air is forced into the tube in waves formed by flapping the end of the tube. The tube is then tied with a rubber band about 3m from the end so that the air does not escape. The procedure for fitting the outlet tube is the same as for the inlet tube. The complete assembly is then carried carefully to the trench and placed inside. The ceramic tubes are laid at 45° inclination and fixed temporarily.

*A safety valve is made from a transparent plastic bottle, a T-piece and 3 PVC tubes (one of 6 and the other two of 30 cm length). Water is poured into the bottle and maintained at 5 cm depth (above the mouth of the tube).

*The biodigester is filled with water up to two thirds of the depth, moving up and down the outlet (as indicator of the water level inside the tube). The air trapped inside the tube escapes from the safety valve as the volume of water increases.

*The gas pipe leading to the kitchen is then attached (it must not be on the ground and the water trap should be at the lowest point in the gas line).

*The gas reservoir is made from a length of polyethylene tube (3-4 m) and a PVC "T". It can be located horizontally or vertically but should be shaded from the sun and have a weight (brick or stone) suspended from the bottom to increase the pressure. It is fitted into the gas line as close as possible to the kitchen to maximize the rate of gas flow to the burner since the system operates at very low pressure (only 3-5cm water head).

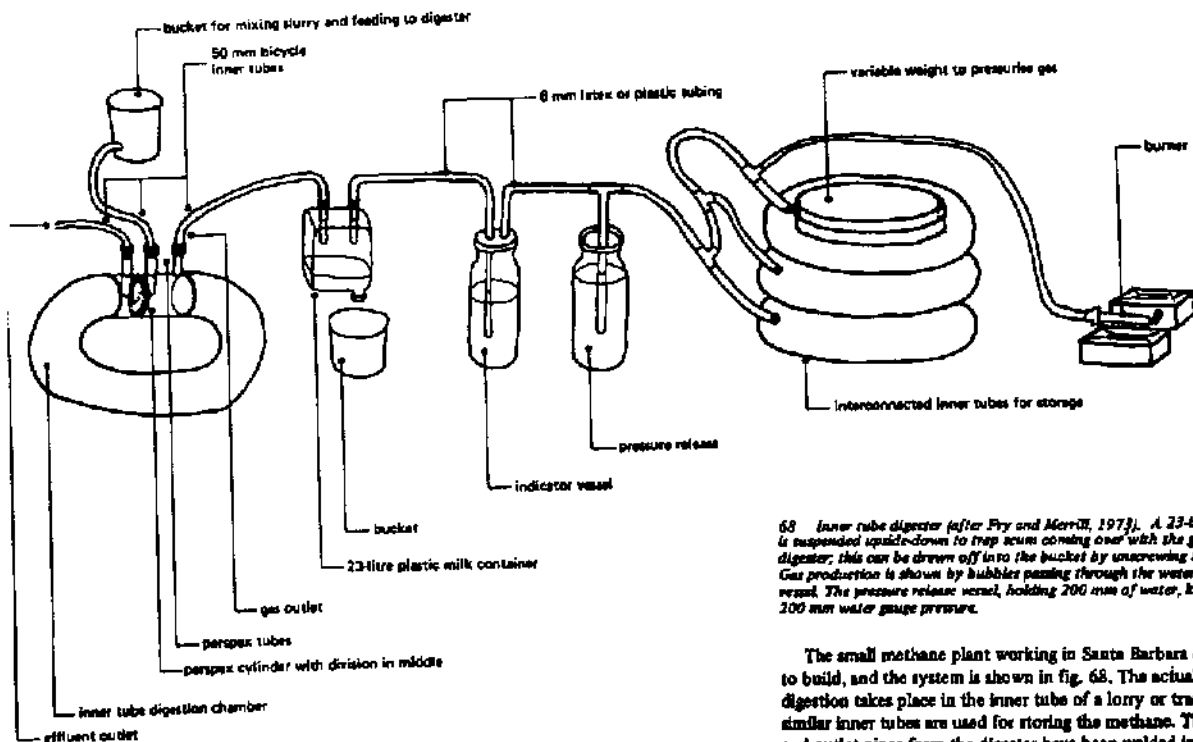

68 Inner tube digester (after Fry and Merrill, 1973). A 23-litre milk container is suspended upside-down to trap scum coming over with the gas from the digester; this can be drawn off into the bucket by unscrewing the container cap. Gas production is shown by bubbles passing through the water in the indicator vessel. The pressure release vessel, holding 200 mm of water, keeps the gas at 100 mm water gauge pressure.

The small methane plant working in Santa Barbara cost around \$20 to build, and the system is shown in fig. 68. The actual process of digestion takes place in the inner tube of a lorry or tractor tyre, and similar inner tubes are used for storing the methane. The perspex inlet and outlet pipes from the digester have been welded into a cylinder of perspex made to the same dimensions as the circumference of the inner tube, and joined to the tube to form a complete doughnut. A circular perspex panel in the middle of the cylinder separates the start of the digestion process, where the slurry inlet and methane outlet are situated, from the end, where the fertilizer effluent outlet is placed. The completed tube digester has an approximate volume of 0.1 m^3 (depending on the size of the tyre tube used), and is fed daily with 1.4 kg of chicken manure. Chicken manure is preferred as it has a finer texture and the likelihood of scum forming on the surface of the digesting wastes is therefore reduced. The chicken manure is mixed with about three litres of water or urine to a slurry in the bucket, which is then raised so that the slurry is fed by gravity into the digester. The digested slurry can be drawn off from the outlet at the other end of the digester every one or two days, the total amount removed being about half the volume of the daily input to allow for gas production and contraction during the fermentation. About 0.14 m^3 of methane gas is produced daily with this system, the gas having an average calorific value of 7.3 kWh/m^3 , which is enough to cook a very simple meal. If the tube digester is constructed in places where the ambient temperature is too low to maintain digestion, the New Alchemy Institute recommends that the inner tube should be placed in an insulated box in which are two 100-W light bulbs connected in series and linked to a thermostat set at 35°C . The other features of the inner-tube system are shown in fig. 68.

For some years before the present increased interest in methane plants, Mr H. Bate of Totnes in Devon has been running a methane plant in conjunction with his pig and poultry holding. Part of the gas produced is compressed and used to power his 1953 Hillman car. For Bate's system, digestion is always preceded by aerobic composting for approximately one week. The manure is mixed with straw and other vegetable waste, well watered and piled up into a traditional compost heap. At the end of the week, the materials are loaded into the digester and sealed from the air. Fig. 69 shows the modification of a domestic hot-water cylinder to form a methane digester. During digestion, gas production is estimated to be 0.3 m^3 for every kilogram of manure decomposed. Bate also suggests modifying a conventional septic tank into a methane digester by fitting a non-return valve to the inlet from the house, fixing a gas outlet in the vent pipe and sealing off the other vents. Gastight holes would have to be made in the lid of the tank, one to take a conventional domestic immersion heater and the other to hold a thermometer to check that the optimum temperature range of $29^\circ - 32^\circ \text{C}$, given by Bate, is maintained. It is uncertain whether this suggestion has actually been tried, although a conventional unaltered septic tank does process its wastes by anaerobic decomposition, the vent pipe affording a release for the gases produced, which include methane, to the air. However, if the digesting wastes are too dilute, methane formation is inhibited, and the use of a normal WC with a 9-litre flush linked to a modified septic tank would produce a water content in excess of that for optimum gas production.

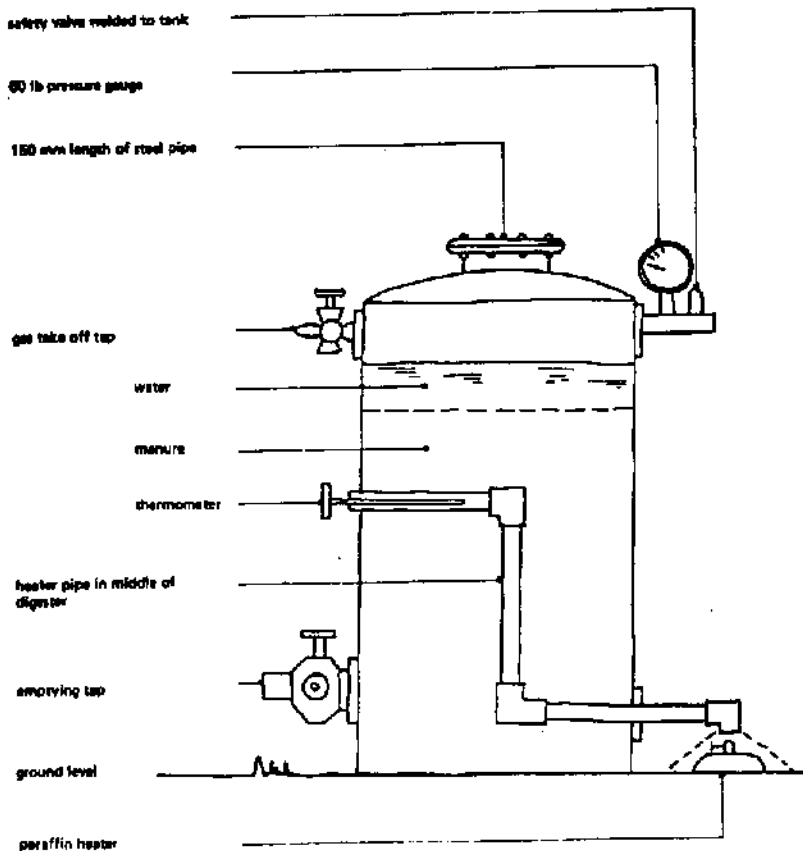

69 Conversion of 1219 mm x 610 mm domestic water heater to a methane digester (after Harold Bate). The digester is filled through the length of steel pipe welded to the top; the cover of this pipe is fixed with 9 mm bolts. The safety valve and pressure gauge, gas take-off tap, and emptying tap are also welded to the tank. The paraffin heater is replaced by a gas jet from the digester itself once digestion is under way.

Deciding on the location of the biodigester

The first step in installing the biodigester is to identify the most appropriate location. In general this should be close to the source of the livestock pen where the waste is produced. It is a distinct advantage if the washings from the pen pass by gravity directly to the inlet of the biodigester. It is relatively easy to transport the gas by pipeline but difficult and tedious to do this with liquid wastes.

Once the site is selected the next step is to determine the size of the biodigester. As a general rule the excreta produced by 10 fattening pigs will require a biodigester of 4 m³ liquid capacity. The standard diameters of polyethylene tubular film are 80, 125 and 200 cm. For a small number of animals, it is advisable to use a diameter of 80cm which gives a cross-section area of

$$0.4*0.4*\pi=0.50\text{m}^2$$

On average 80% of the total volume in the tube corresponds to the liquid fraction, thus to provide a liquid volume of 4 m³ will require a biodigester with a length of:

$$4/0.80/0.5=10\text{m}$$

The recommended dimensions of the trench which will hold a biodigester of the above dimensions are:

Width at the top 90cm; depth 90cm; width at the bottom 70cm; length 10m.

Having decided on the size of the biodigester the upper extremities of the trench should be defined by a string attached to four posts.

The water trap (gas escape valve)

A "T" is prepared from three short lengths of PVC pipe with the longest arm of a length which will fit into "used" plastic bottle.

A 3*3cm hole is cut in the upper part of the bottle, just below the neck, through which water will be added to form the gas seal.

Small holes are made either side of the neck to take a length of thin wire which will be used to attach the bottle to some support structure.

The PVC "T" is inserted in the bottle and water is added to a depth of 4-5 cm above the lower point of the "T"

Small holes are punched into the sides of the bottle at a point 2 cm above the lower end of the "T". This ensures that if the gas pressure inside the system exceeds 2cm water column the gas can escape to relieve the pressure.

The "water trap" is now suspended in a convenient place so that the water level can be easily observed and replenished when necessary

A flexible plastic pipe is attached to the gas outlet and joined to one arm of the "T". The other arm links with another plastic pipe which goes to the kitchen.

Linking the biodigester with the gas reservoir

Either rigid PVC tubing (13mm internal diameter) or flexible plastic pipe can be used to connect the exit of the biodigester with the entrance to the reservoir.

Fixing the gas outlet

The components of the gas outlet and the order in which they are placed in the plastic tube are indicated below.

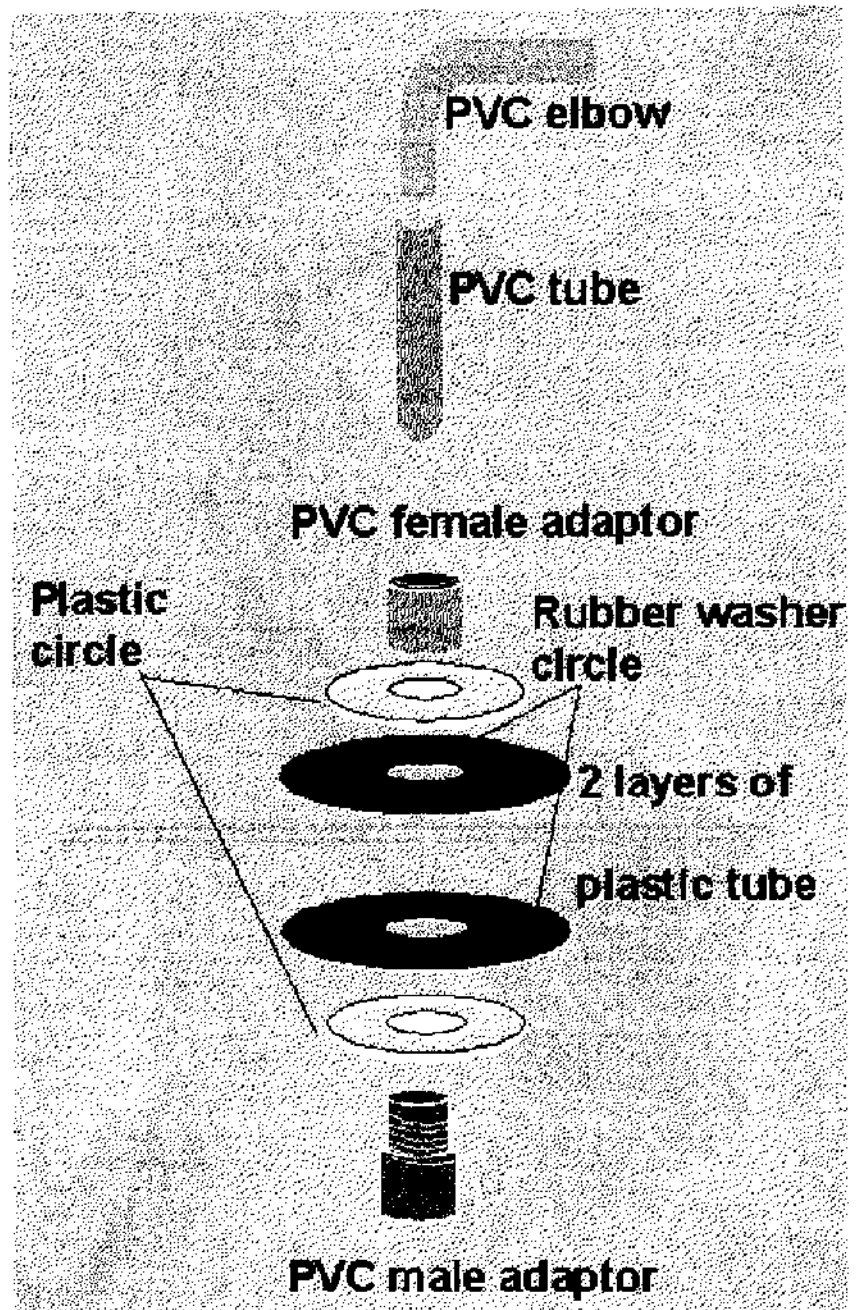

The first step is to mark the place where the gas outlet will be placed. This should be 1.5m from the end of the plastic tube and in the centre of what will be the top of the biodigester.

The size of the hole is determined by the external diameter of the PVC male adapter.

The rubber washer circles are cut from a length of "used" motor cycle or car inner tube, using the plastic (Perspex) circles as a guide.

The components are then assembled to ensure the male and female adapters fit together smoothly.

The male adapter, complete with plastic circle and above this the rubber circle, is inserted from within the plastic tube. The female adapter, with the rubber and plastic circles attached, is screwed tightly on the protruding male adapter.

The installation of the gas outlet is now complete.

PVC elbow

PVC tube

PVC female adaptor

Plastic circle

Rubber washer circle

2 layers of plastic tube

plastic tube

PVC male adaptor

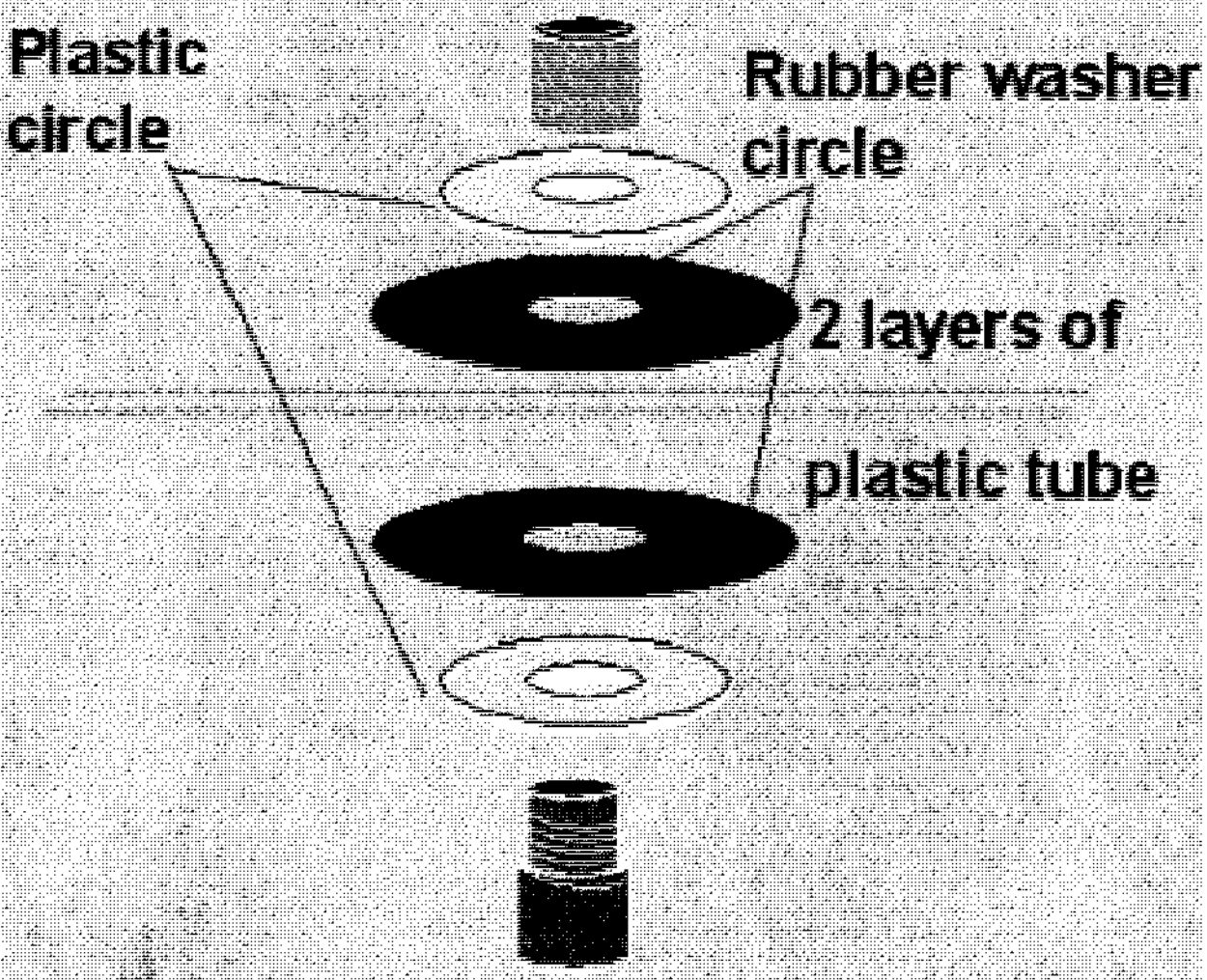

The products of the biodigester

These are:

- Biogas
- The effluent

The biogas flows by tube from the biodigester to the reservoir situated as close as possible to where it will be used, usually near the kitchen.

The effluent is produced daily in accordance with the schedule of charging the biodigester. The volume that comes out is equal to the volume that goes in. The residence time (time taken on average for the "digesta" to pass from the entrance to the exit) will vary usually within the range of 10 to 30 days depending on the quantity of manure and water put into the biodigester. The greater the input volume the shorter the residence time. It is desirable that the residence time is of the order of 20 days so as to secure inactivation of pathogenic organisms and parasites.

There should be a pit to receive the effluent large enough to hold at least the output of 2 days. Normally it is not necessary to line the pit as the floor and walls soon become impervious. If the topography permits a pipe should be laid to take the effluent from the receiving pit to the duckweed ponds.

The two products from the anaerobic biodigestion of livestock wastes are:

- Biogas which is rich in methane (55-65%) and used mainly for cooking
- Effluent which is the residue coming out of the digester and which contains all the plant nutrients present in the original manure

This section of the manual deals with the utilization of the effluent as a fertilizer for crop plants. Since the effluent is voluminous (about 98% water) it is an advantage if it is used as close as possible to the site of production. For this purpose it is necessary to select crop plants which have a rapid growth rate (and therefore high capacity to extract nutrients from the medium in which they are growing) and good nutritive value.

For this purpose it has been found that duckweed (*Lemnaceae*) is the most appropriate because it:

- Has a rapid rate of growth (doubles its biomass in 24 hours)
- Is palatable and has high digestibility for monogastric animals (dry matter digestibility over 65% in pigs according to Rodriguez and Preston 1996a)
- Its protein content is almost doubled (from 20-22% to 35-40%) when grown in nutrient-rich water (Leng et al 1995; Rodriguez and Preston 1996b; Nguyen Duc Anh et al 1997)

The simplest way of moving the effluent is with buckets.

If the topography permits a more convenient method is to lay a pipe (5 cm id is enough) connecting the effluent pit with the duckweed pond and in turn to have each duckweed pond connected in series to the next one.

A 1/4 HP electric pump has the inlet pipe connected directly to the effluent pit and the outlet at the highest point of the slope. In a matter of minutes the effluent is pumped into the duckweed ponds.

Using the effluent from the biodigester

When manure and water enter the biodigester a similar volume of effluent is forced out of the exit pipe.

It is usually adequate to have an unlined pit as very quickly this becomes impervious to filtration.

A pipe from this pit then connects directly to ponds used to cultivate duckweed.

When duckweed is fertilized with biodigester effluent its crude protein content can be between 35 and 40% in the dry matter, making it a valuable supplement for pigs and poultry.

In order to maintain a nitrogen content in the pond water of about 20mg/litre, the volumes of effluent to be added can be calculated from the table below:

- At the beginning when the pond is prepared and filled with water the first time
- Every day (to compensate for the nitrogen removed in the duckweed assuming a daily harvest of 100 g/m² pond surface/day)

The calculations are based on a pond of 20m² area and 20 cm depth of water. For ponds with different dimensions the data should be adjusted accordingly.

**Effluent daily
(litres)
area, m² 20
depth, m 0.2**

		dry matter content of effluent (%)					
N in effluent DM (%)		0.5	1	1.5	2	2.5	3
0.5		288	144	96	72	58	48
1		144	72	48	36	29	24
1.5		96	48	32	24	19	16
2		72	36	24	18	14	12
2.5		58	29	19	14	11	10
3		48	24	16	12	10	8

**Effluent at beginning (litres)
Pond area, m² 20
Pond depth, m 0.2**

		dry matter content of effluent (%)					
N in effluent DM (%)		0.5	1	1.5	2	2.5	3
0.5		3200	1600	1067	800	640	533
1		1600	800	533	400	320	267
1.5		1067	533	356	267	213	178
2		800	400	267	200	160	133
2.5		640	320	213	160	128	107
3		533	267	178	133	107	89

The duckweed ponds

If water is not a limiting resource the most appropriate way of using the effluent from the biodigester is for the cultivation of duckweed (Lemnaceae).

Where there is a high clay content in the soil the floor and wall of the pond soon become impervious to filtration of water. But in sandy soil it is necessary to line the ponds with a mixture of soil and cement. For a pond 40cm deep and with an area of 20 m², the required overall quantities are 2.5 kg of cement and 300 kg of soil.

Smaller mixes of 30 kg soil, 2.5 kg cement and 1.5 kg water are prepared and a thin layer of the mixture is applied to the floor of the ponds and to the walls.

After two days the ponds can be filled with water and seeded with duckweed.

The duckweed pond is connected by a pipe with the exit of the biodigester.

The inoculum of duckweed is prepared and distributed on the pond surface at the rate of 400 g/m².

Each pond is harvested daily. It is a simple operation requiring a bamboo pole slightly shorter than the width of the pond and a plastic basket.

Beginning at the mid-point of the pond the duckweed is pushed steadily to the narrow end of the pond and then scooped out of the water with the basket. It is left to drain for few minutes before being weighed and taken to the animals.

These ponds are producing about 100 g fresh duckweed/m²/day which is equivalent to about 6 tonnes protein/ha/year.

Duckweed has a balance of essential amino acids slightly superior to soya bean meal (Rusoff et al 1980).

Rice bran and cassava root meal are dry, powdery materials. Duckweed by contrast is very wet (94-96% moisture..!!). Mixing fresh duckweed with either rice bran or cassava root meal, or with a combination of the two, produces a feed with a crumbly texture that is more readily accepted by chickens than any one of the ingredients given separately.

Proposed combinations (all on fresh basis) that will give at least 10% protein in dry matter (suitable for growing and laying chickens) are:

- one part rice bran; one part duckweed
- four parts duckweed:one part cassava root meal
- two parts duckweed: one part cassava root meal: one part rice bran

The same principles apply as for chickens and the same mixtures of duckweed with cassava root meal and rice bran can be used.

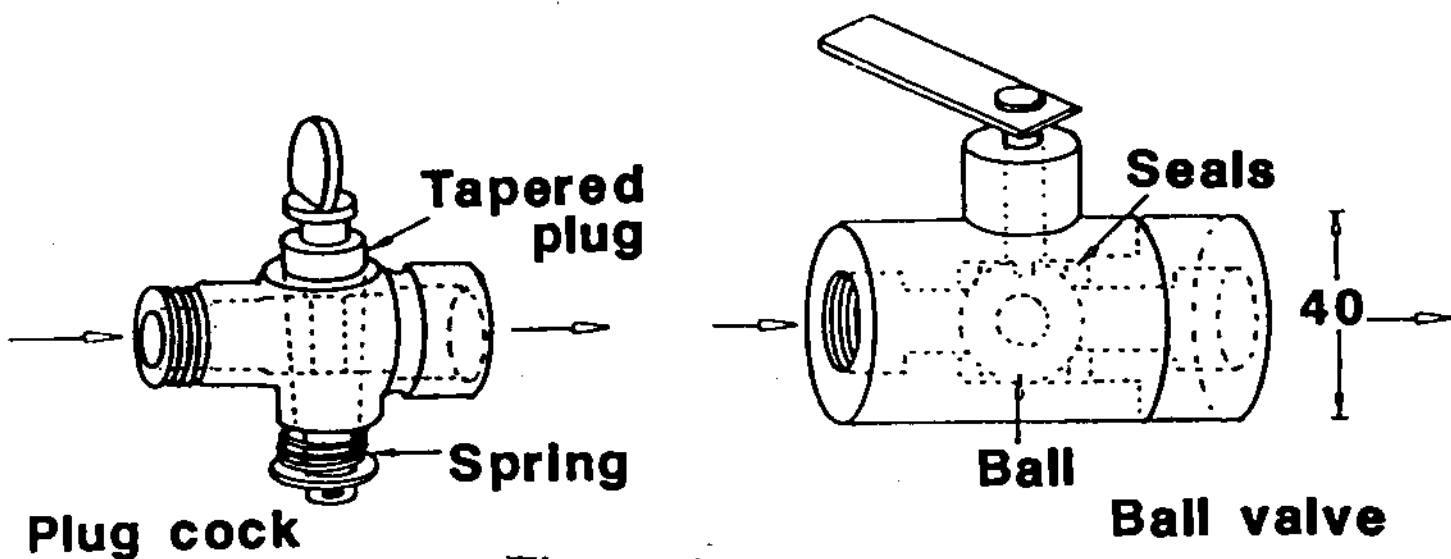
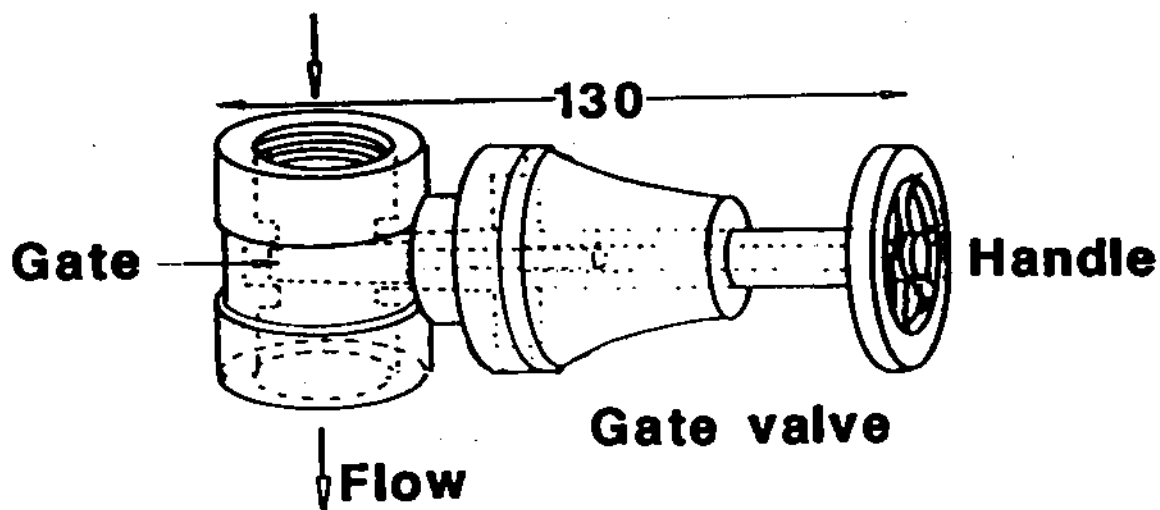

Figure 6.4 Different types of gas valve.

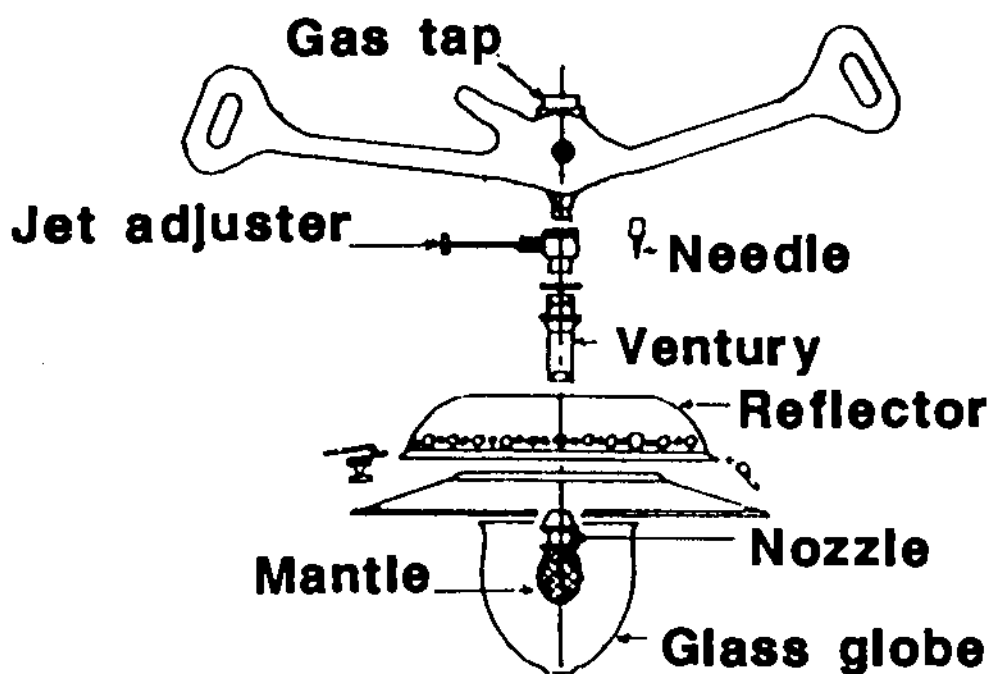

Figure 6.6 Biogas light (made in India)

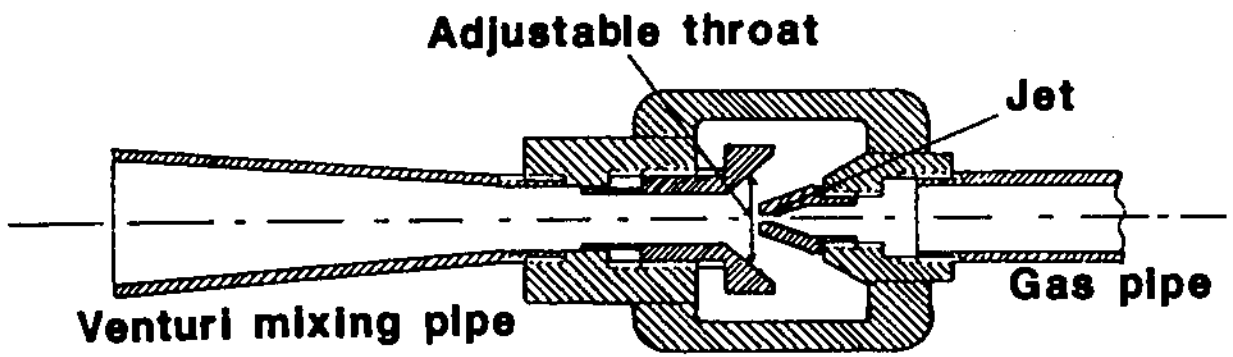

Figure II.6 *Tapered throat design of gas burner*

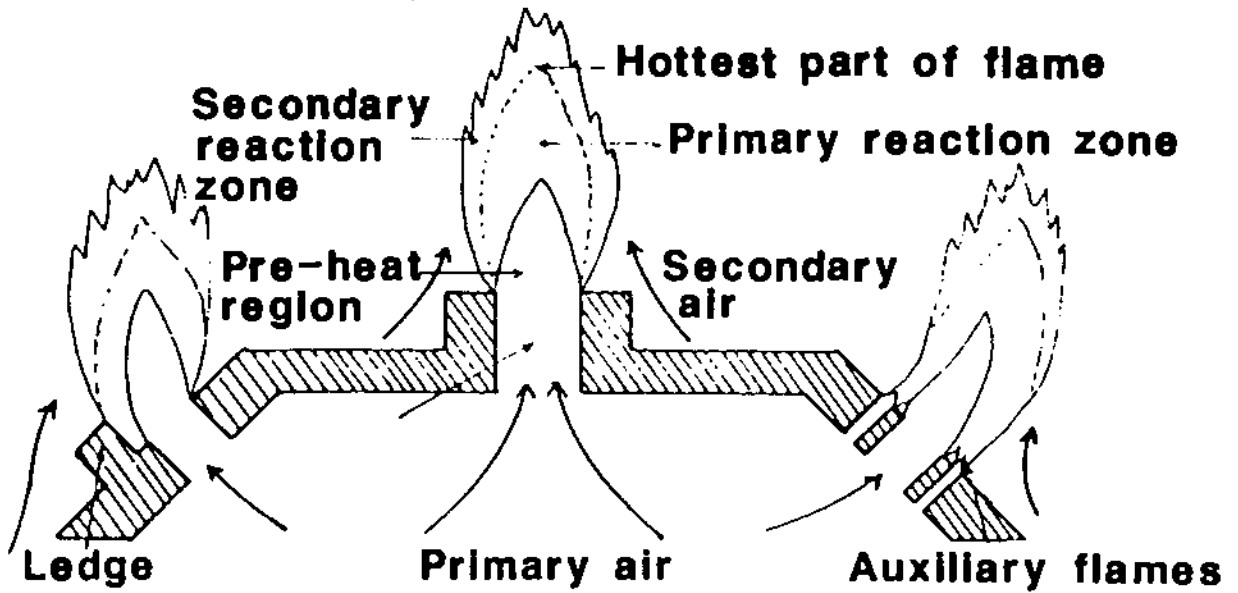

Figure II.7 *Details of gas flame and means of stabilisation*

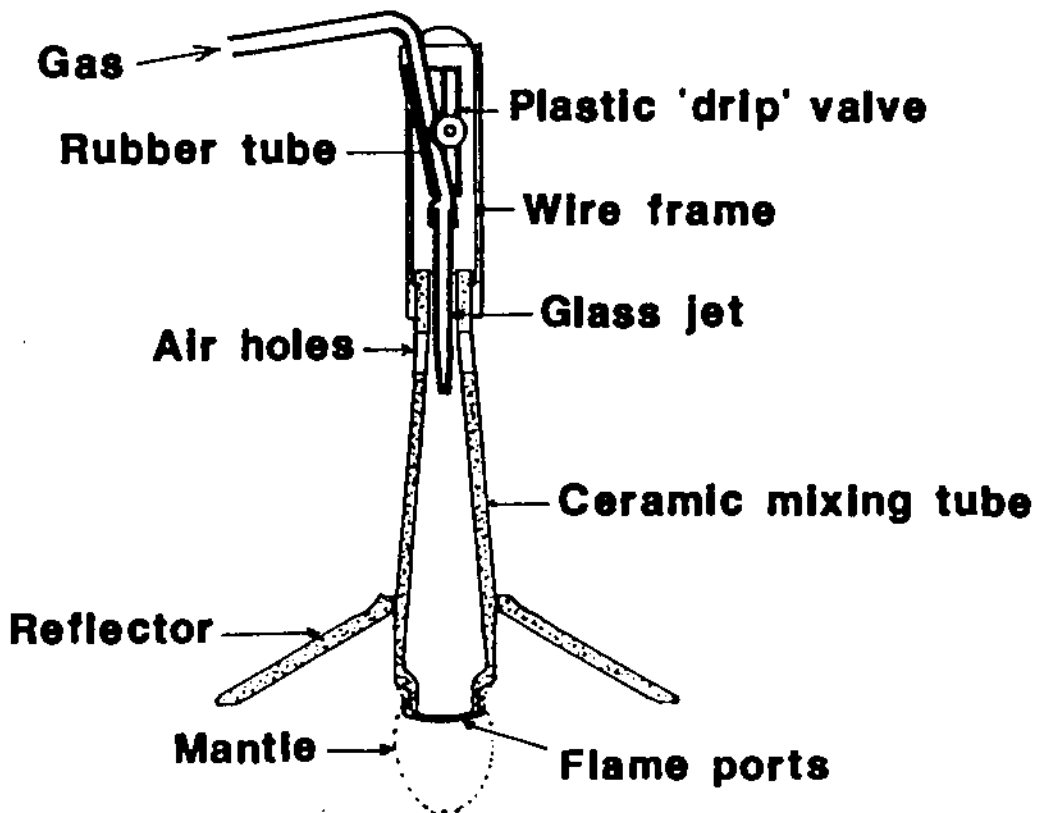

Figure II.8 *Ceramic gas lamp—made in China*

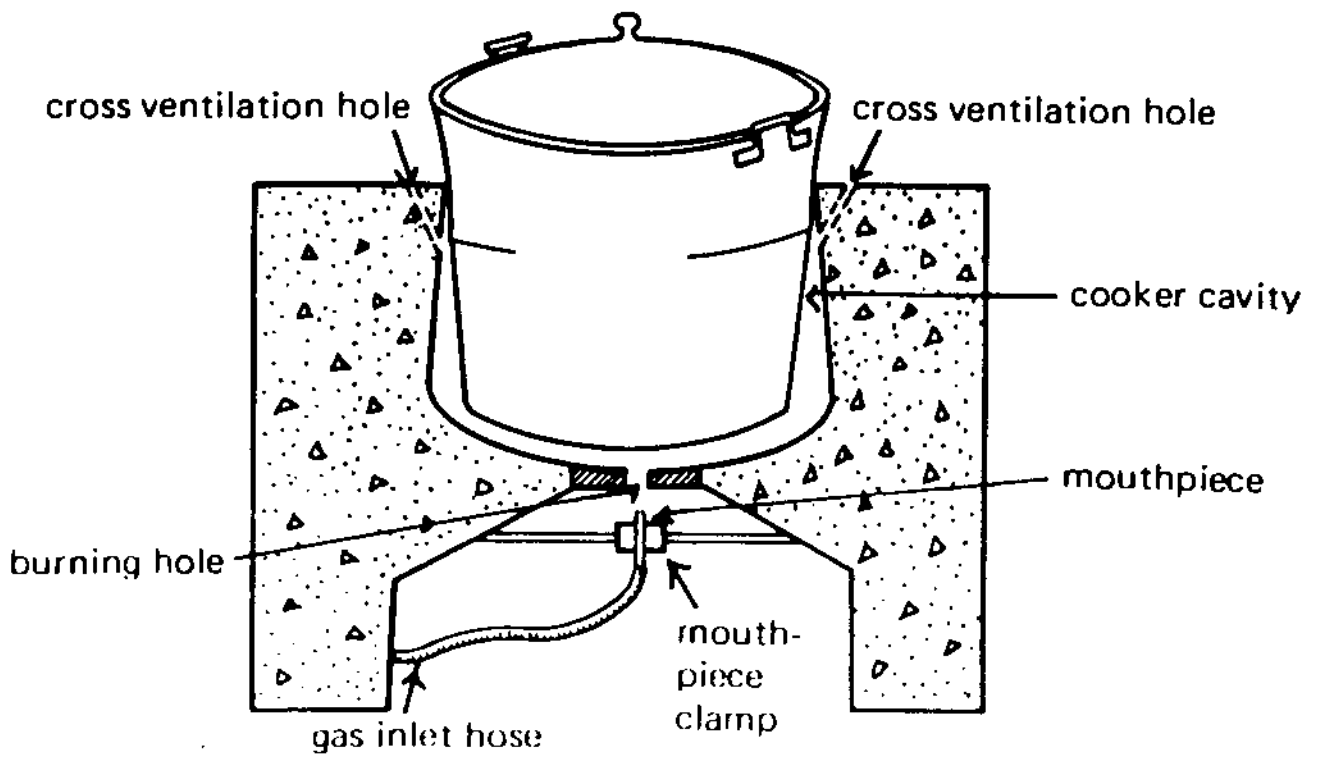

Fig. 7-13. The biogas stove.

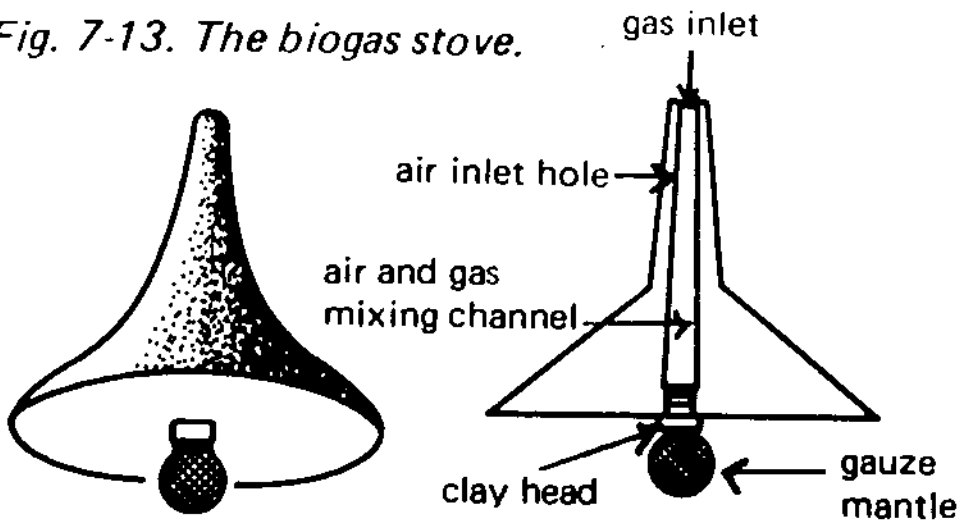

Fig. 7-14. The clay hanging lamp.

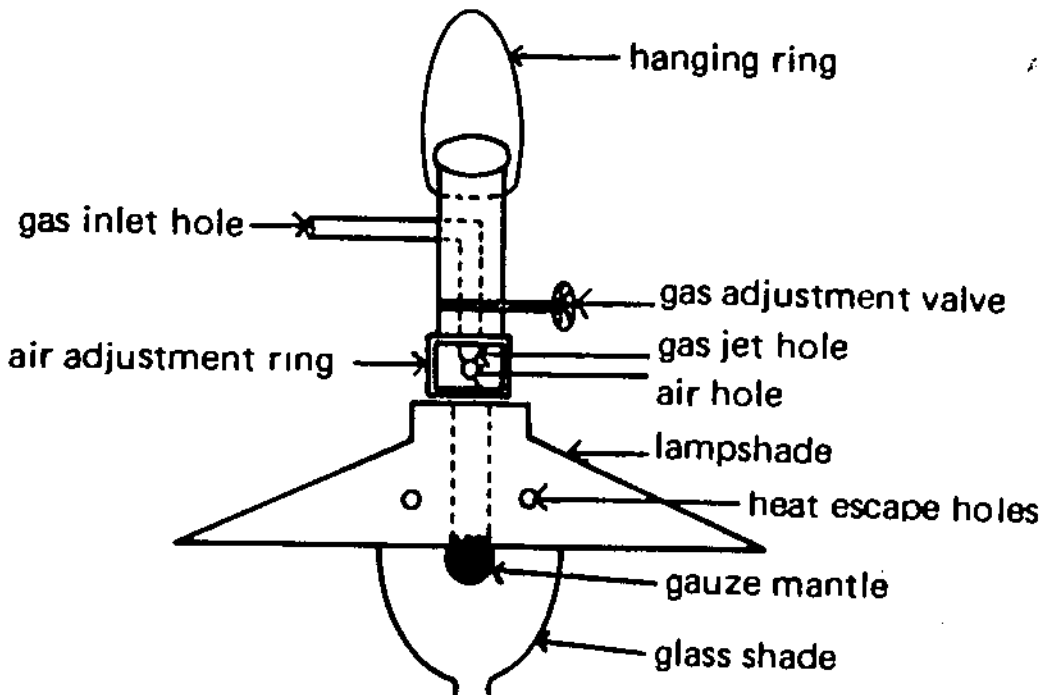

Fig. 7-15. 'Red Star' hanging lamp.

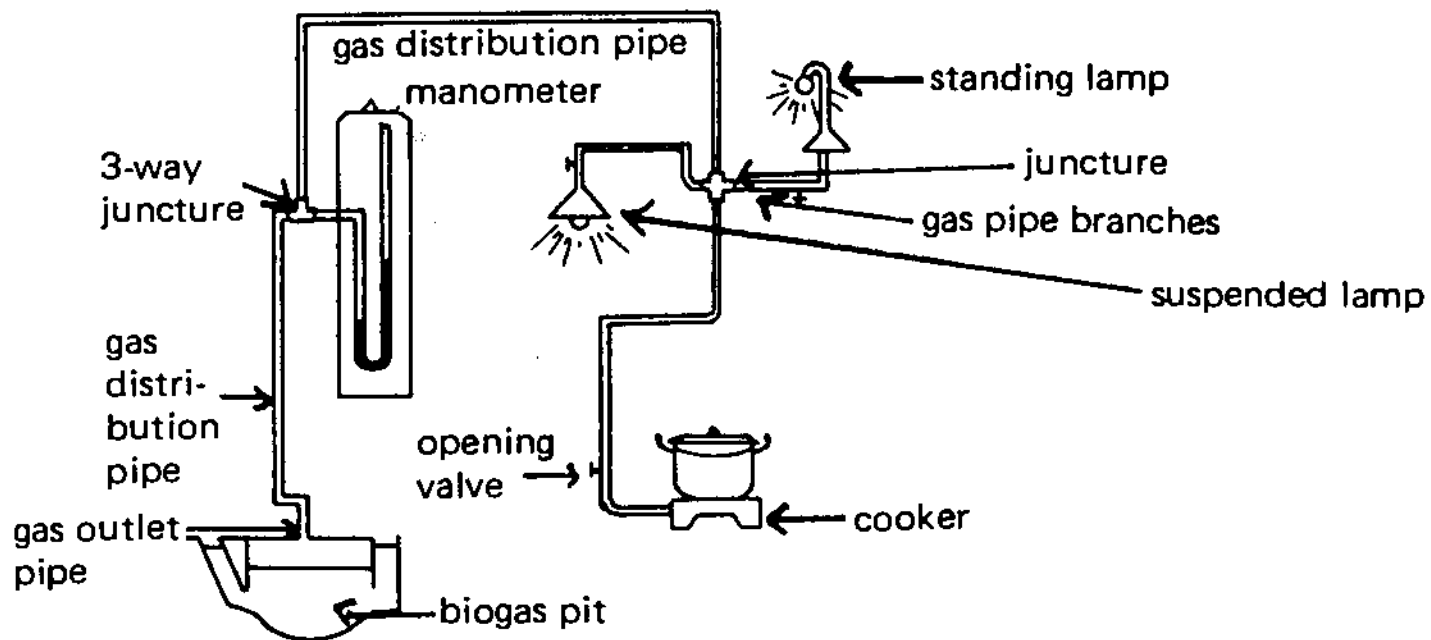

Fig. 7-16. Rough plan of equipment installation for using biogas.

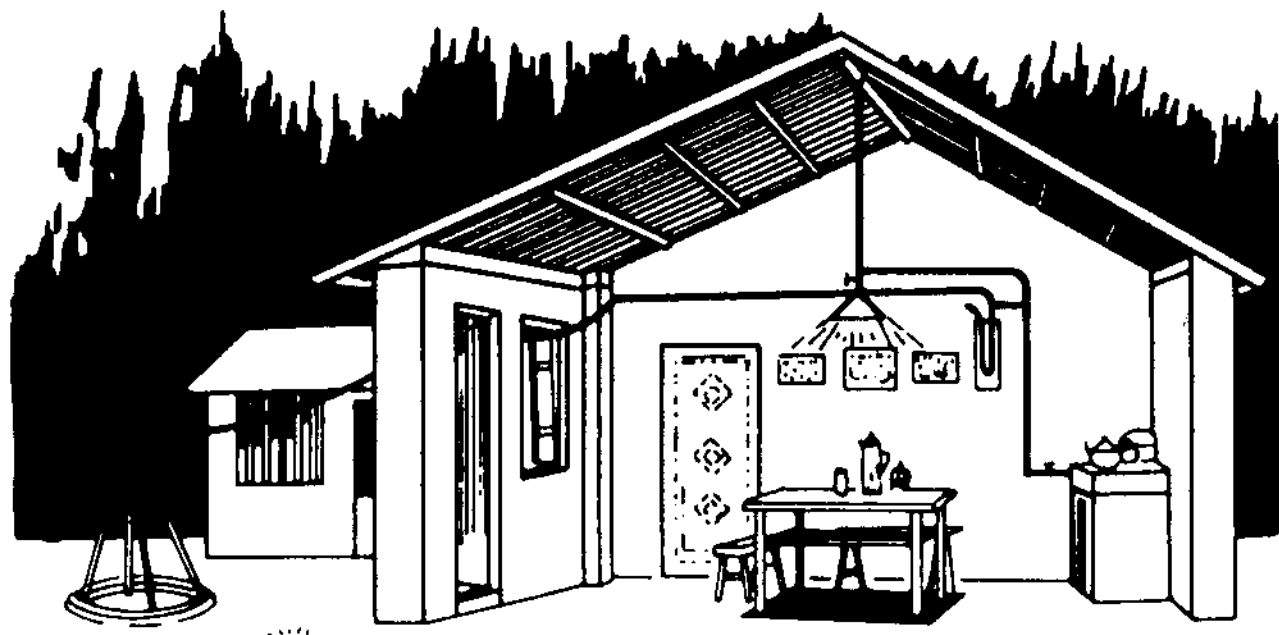

Fig. 7-17. Wall attachment of biogas distribution pipes.

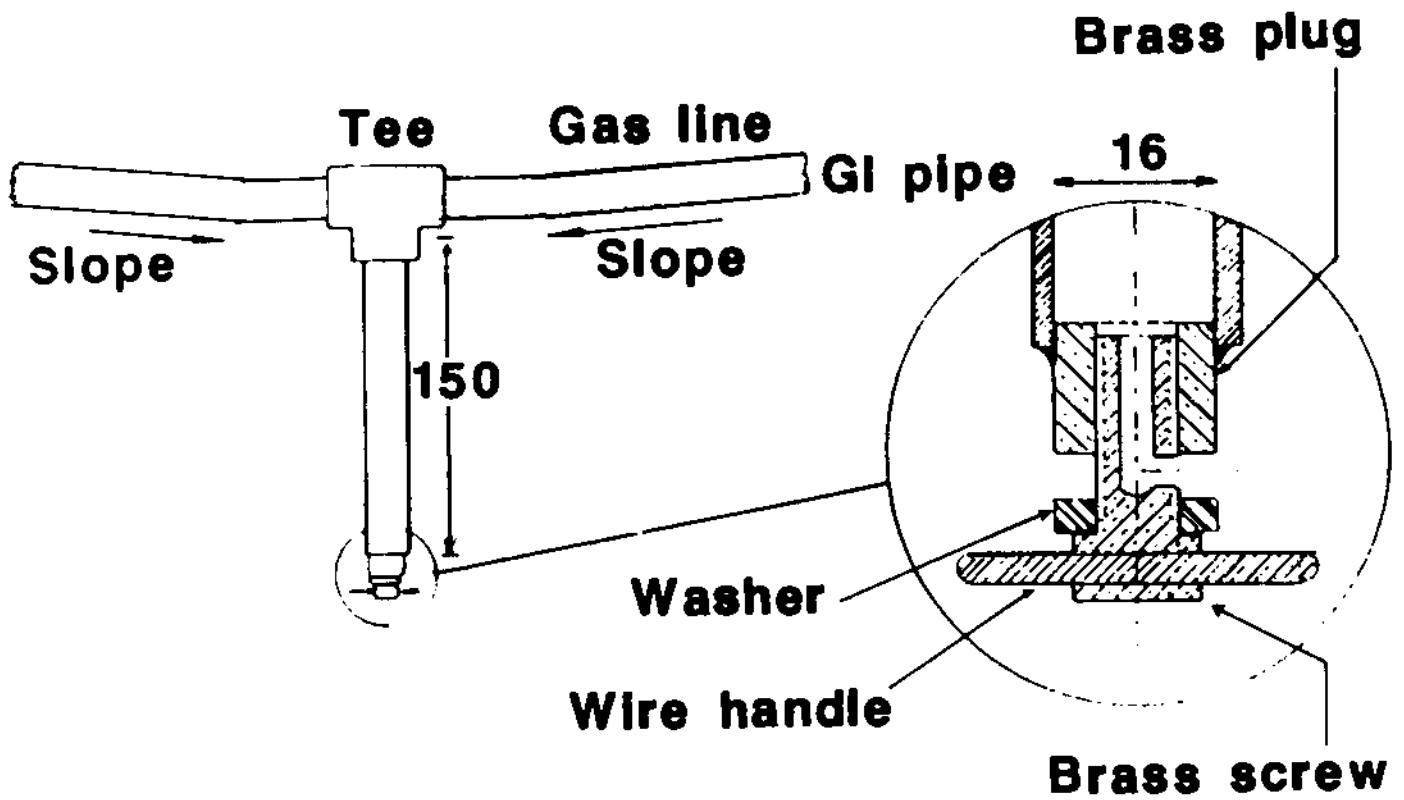

Figure II.1 'T' Type water trap.

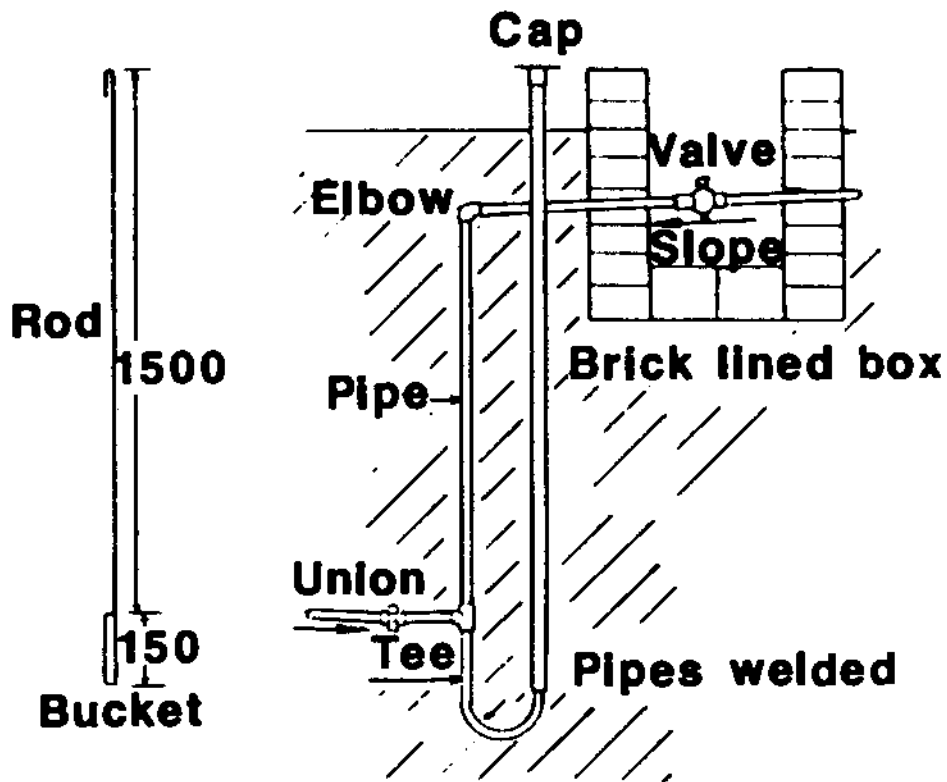

Figure II.2 'U' type of water trap.

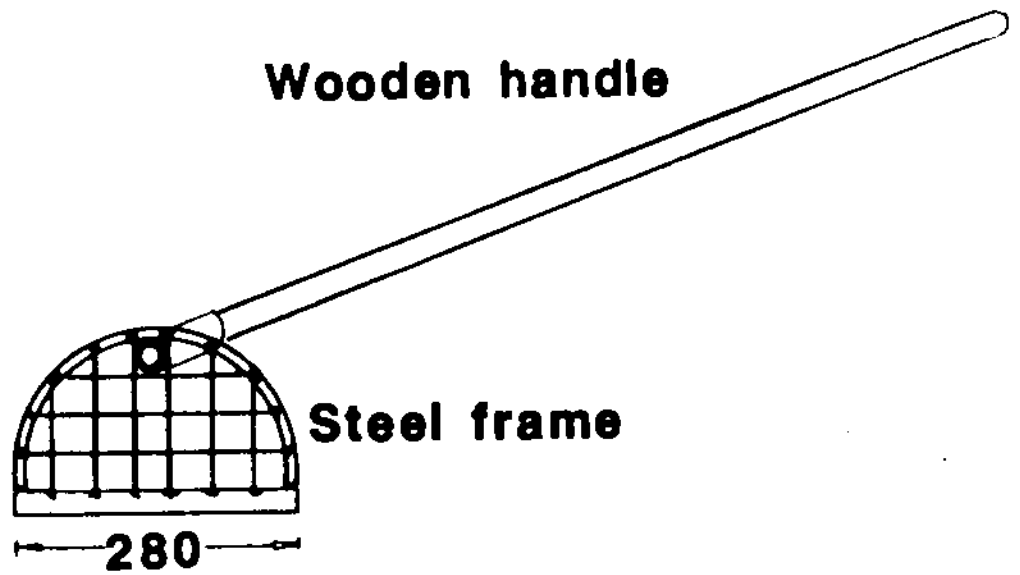

Figure 6.1 *Hand tool for mixing slurry in inlet pit*

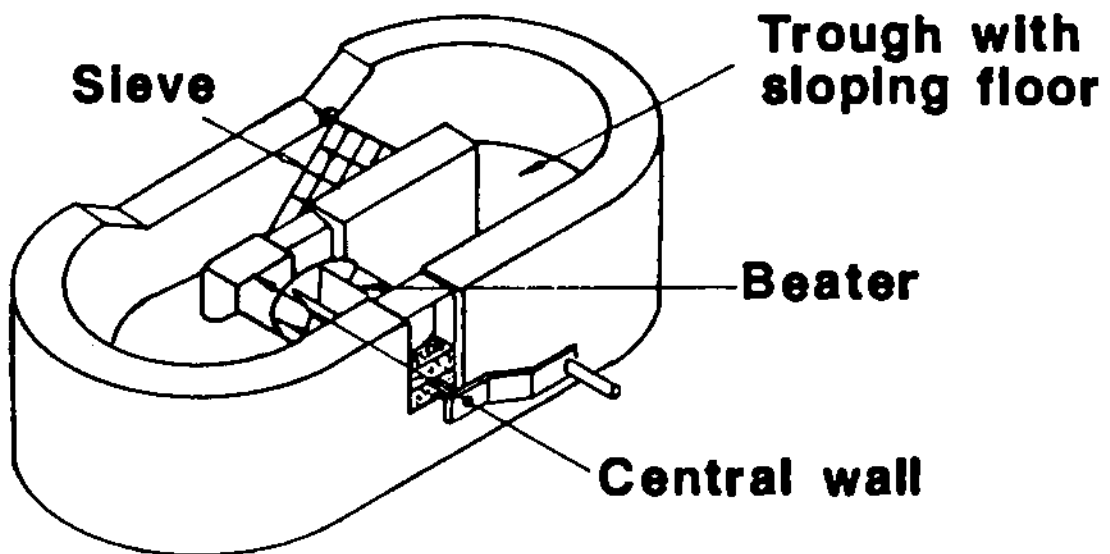

Figure 6.2 *Machine for mixing feed slurry*

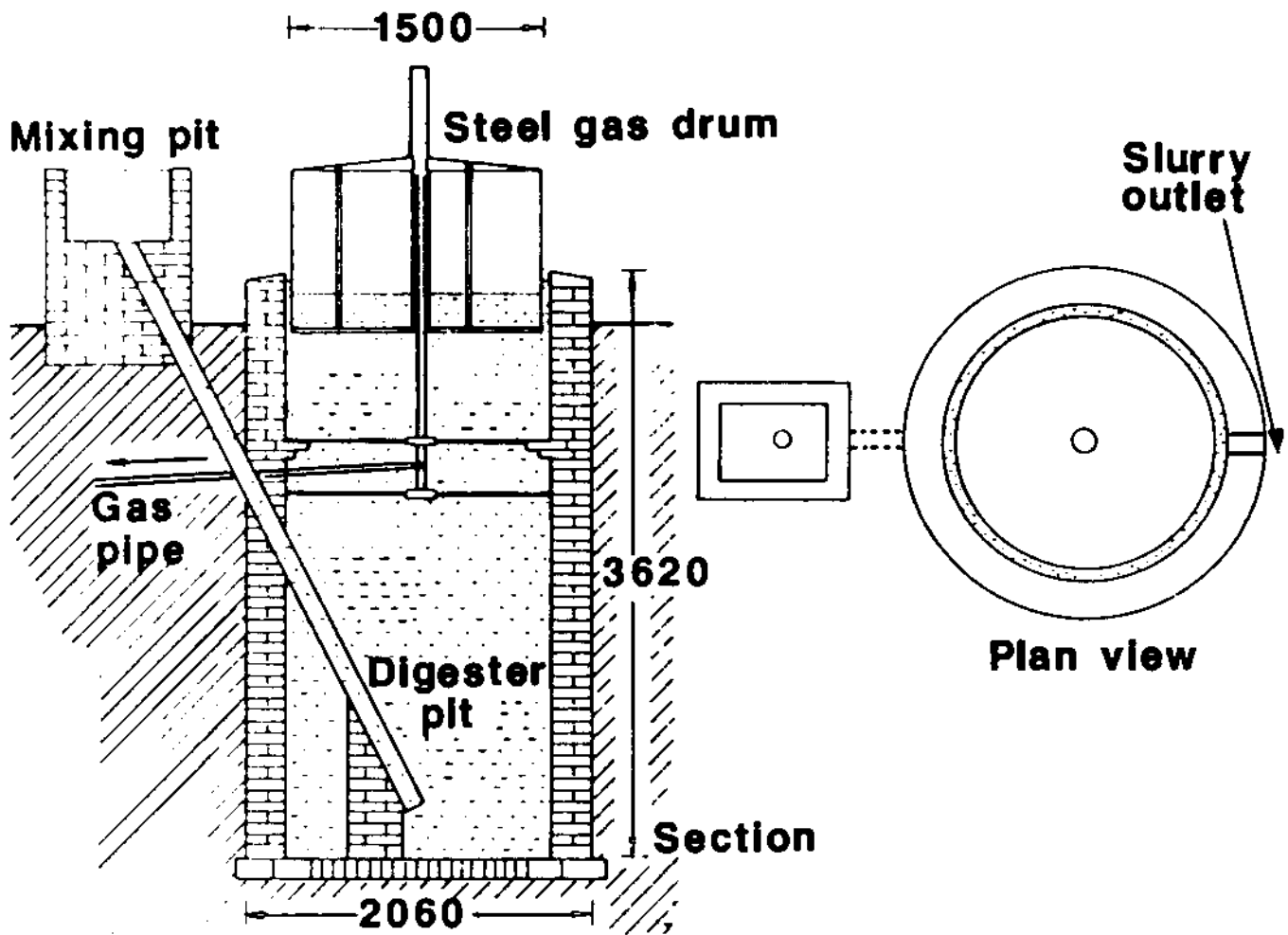

Figure 5.1 *Straight design of steel drum biogas plant*

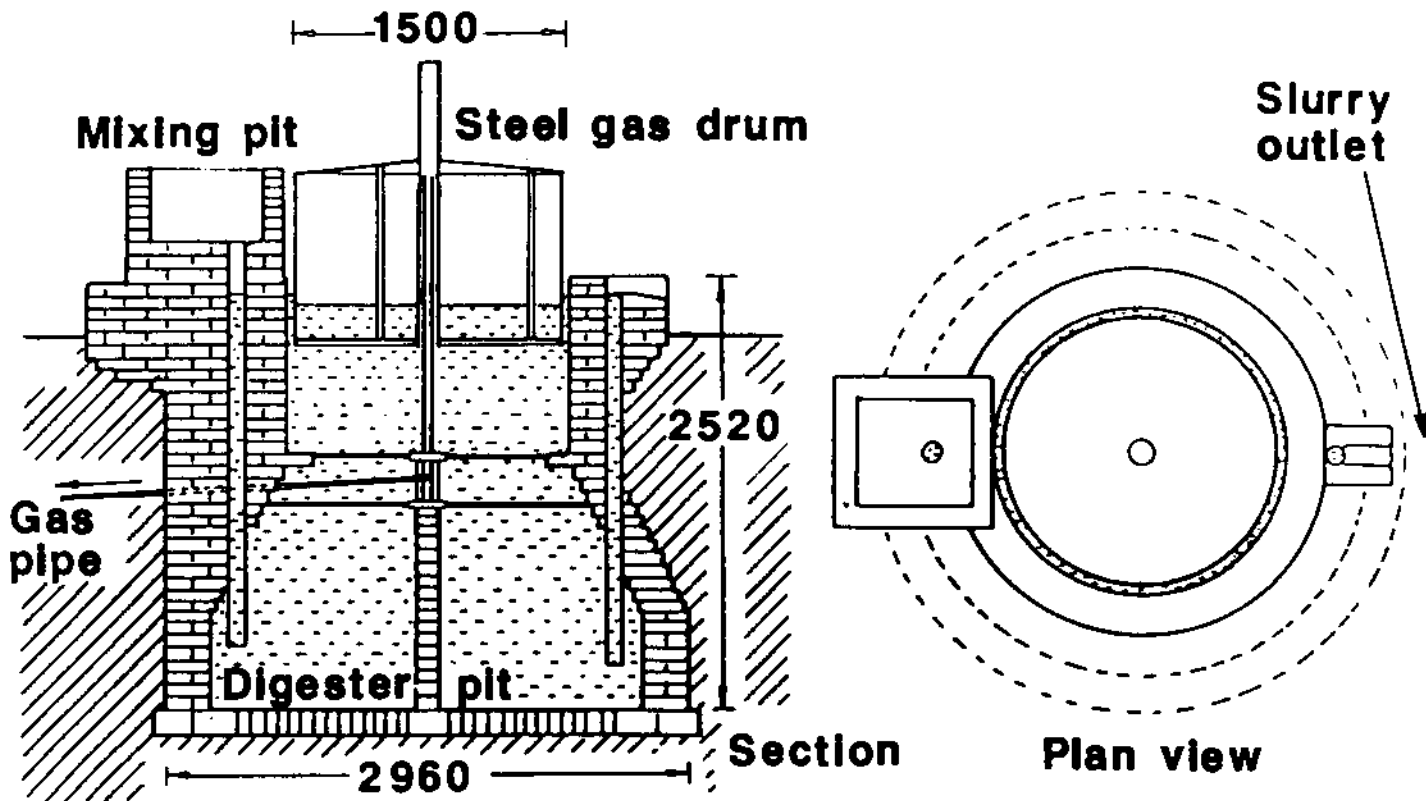

Figure 5.2 *Taper design of steel drum biogas plant*

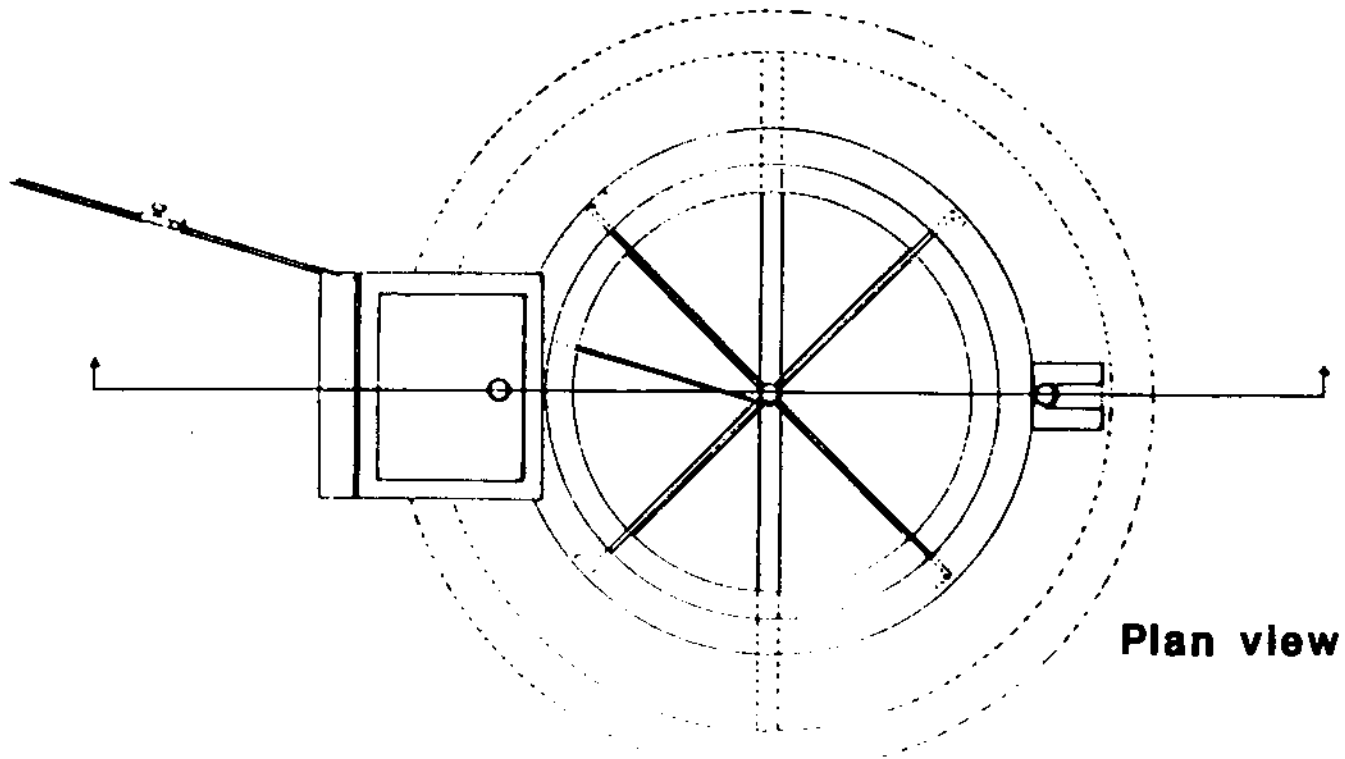
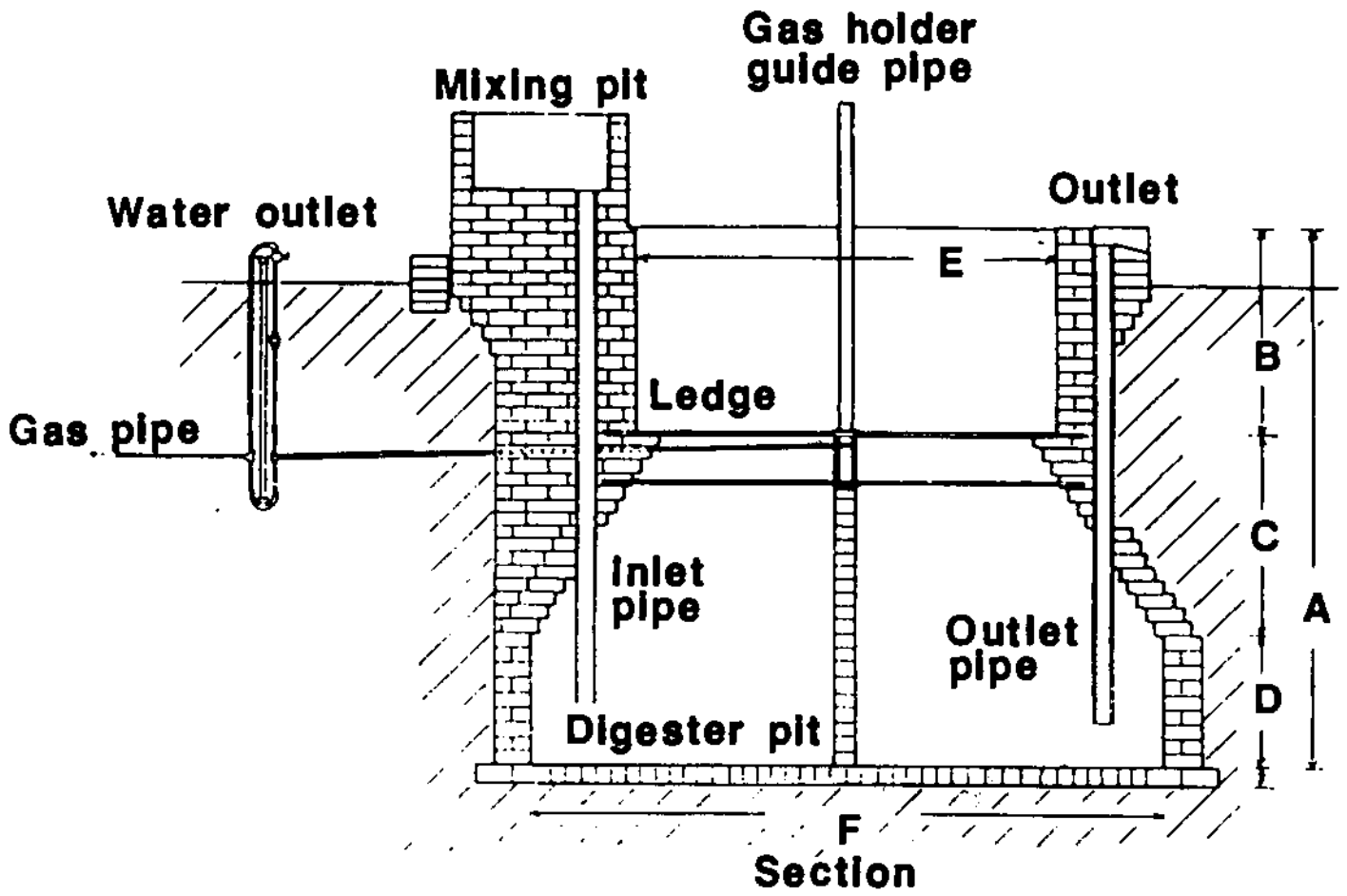
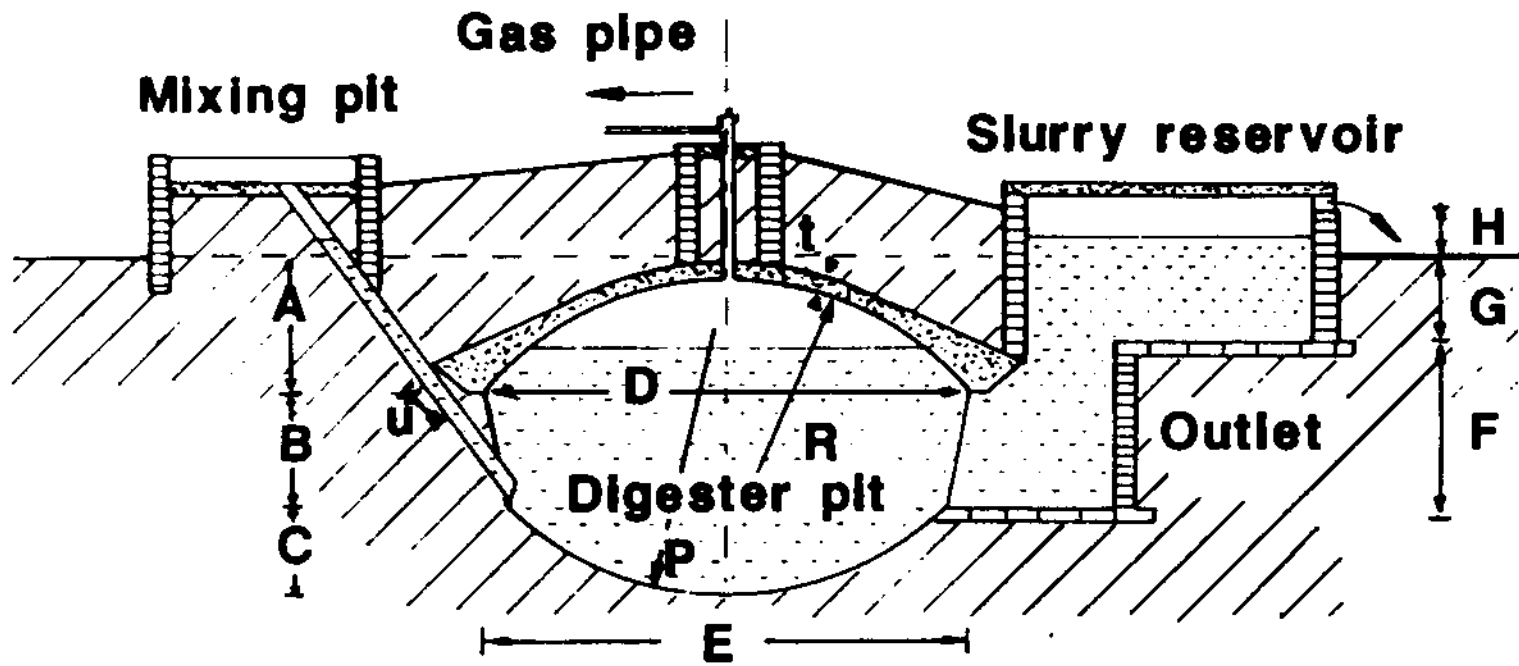

Figure I.2. Floating drum design SD100, 200, 350 & 500 (Taper)



Section

Concrete dome

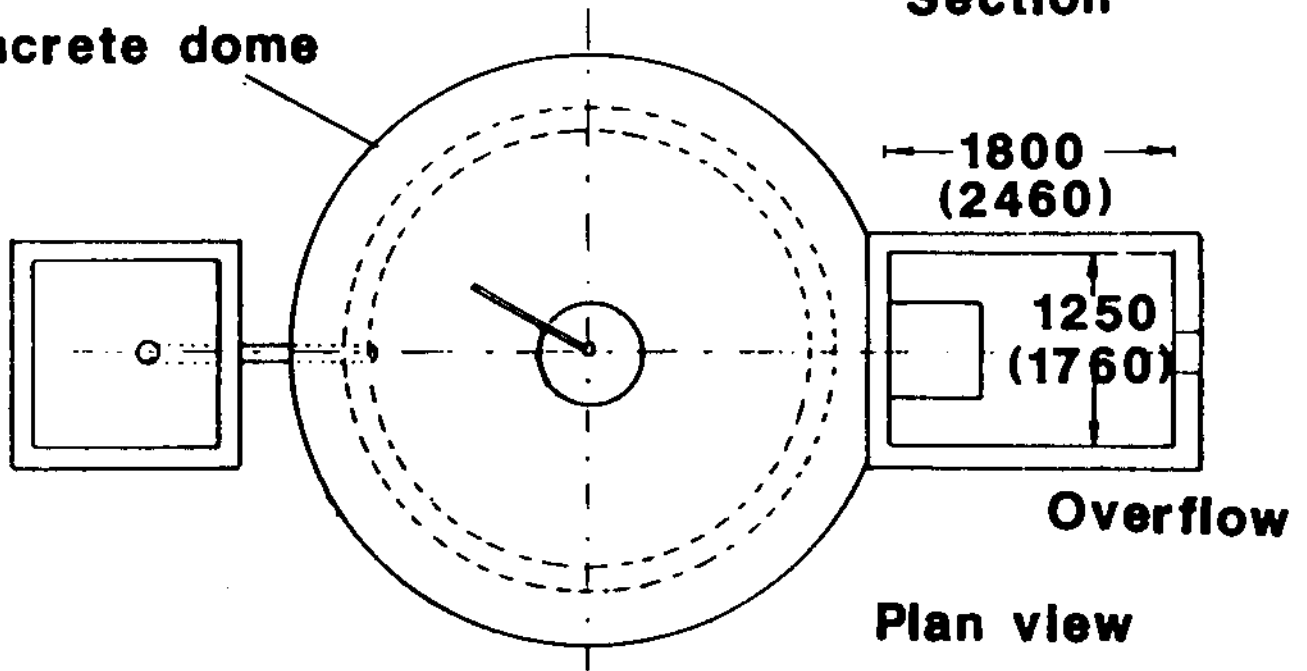

Figure I.3 *Details of fixed dome design*

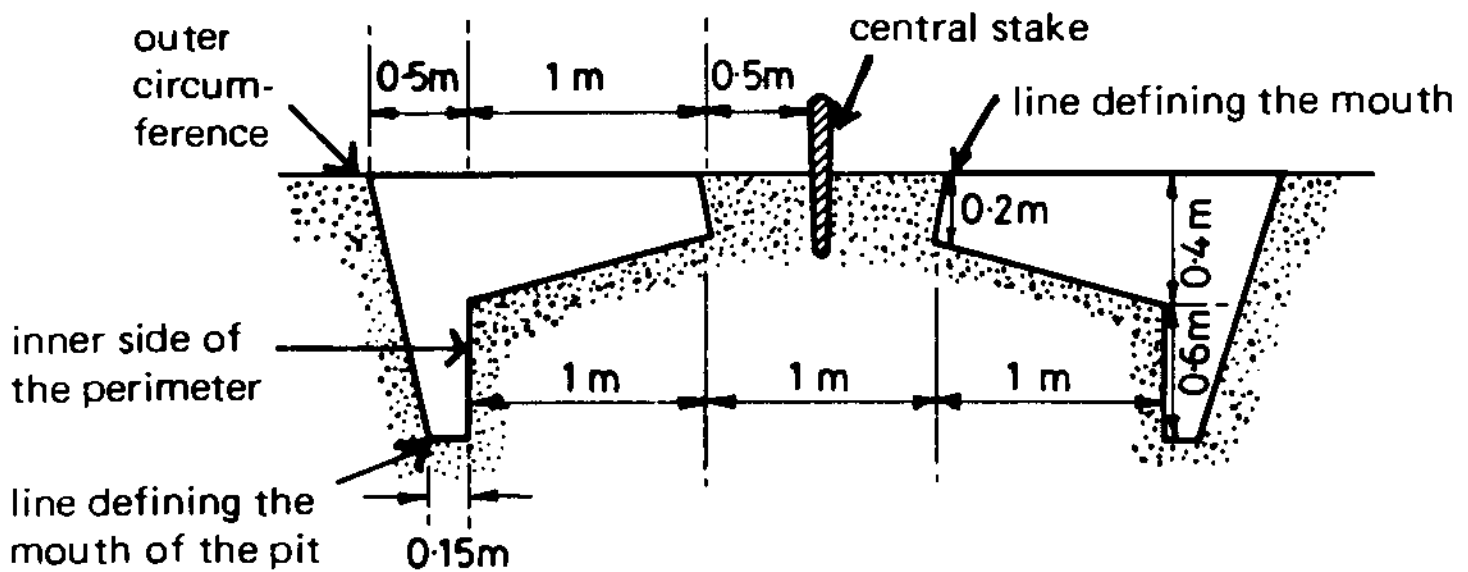

Fig. 4-7. A cross section of 3 m diameter, 2 m deep, 14.19 cu.m capacity, flat-domed one-piece cover pit.

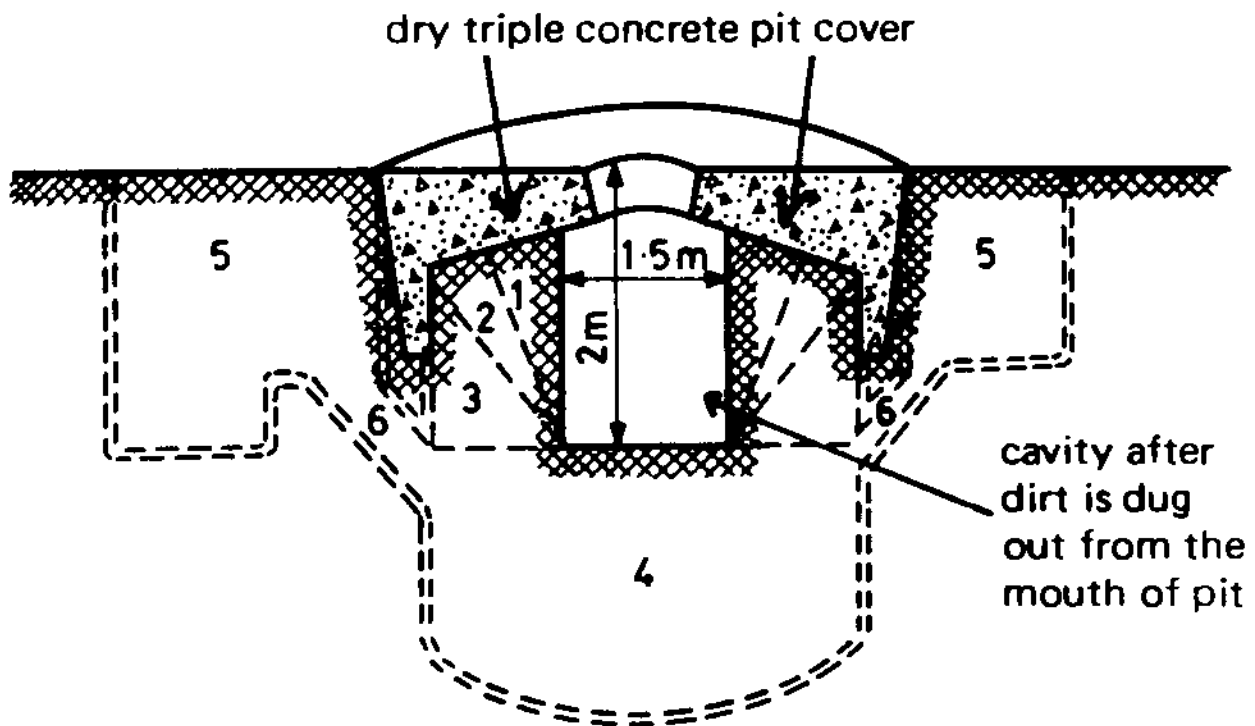

Fig. 4-8. Excavation under the cover. 1-6 describes the order of excavation of the pit: 1, 2 and 3 should be completed before going on to 4, then 5 and lastly to 6 (the connecting passages between the inlet and outlet and the actual pit).

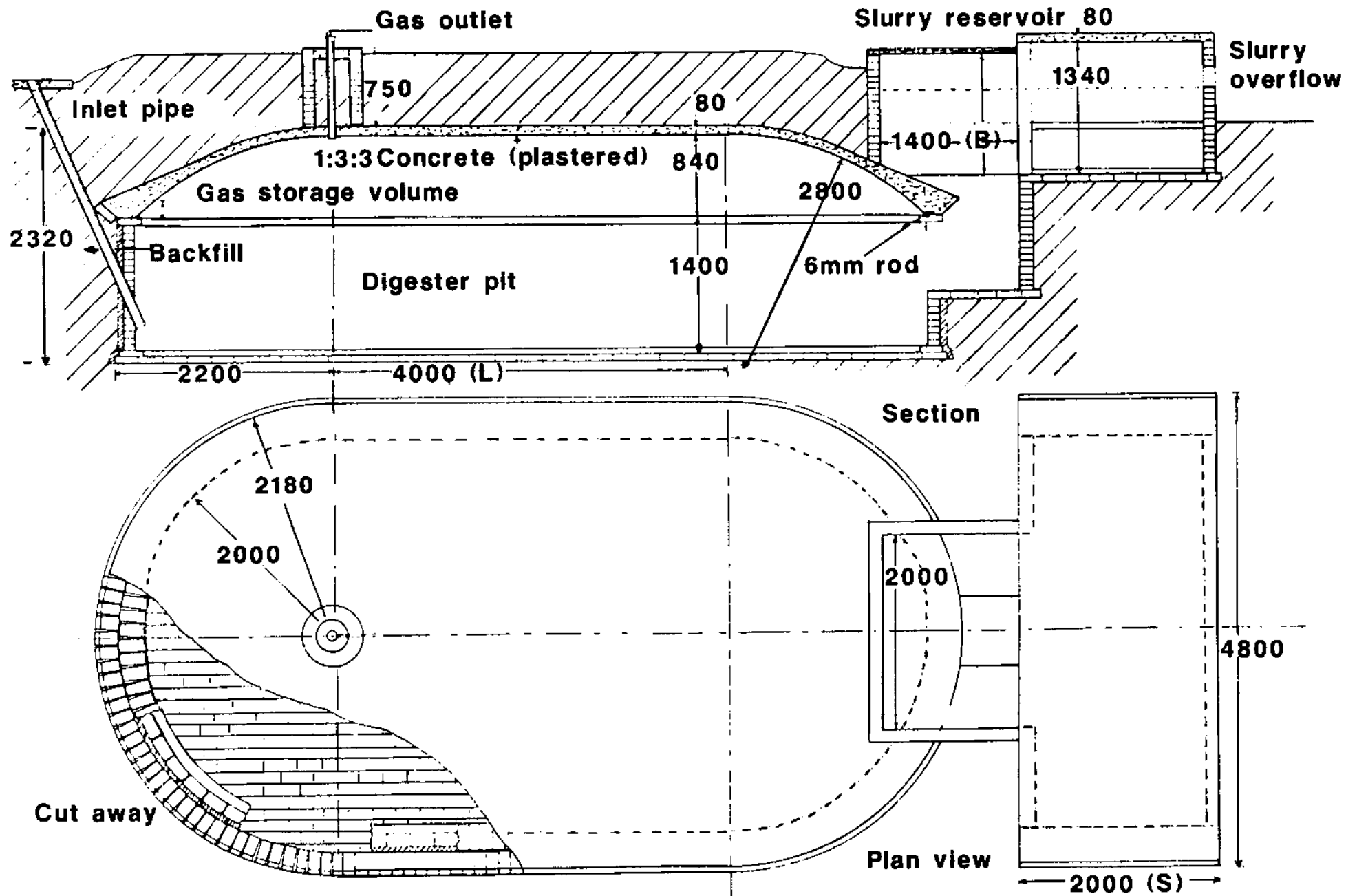

Figure I.4 *Extended dome biogas plant (EP50)*

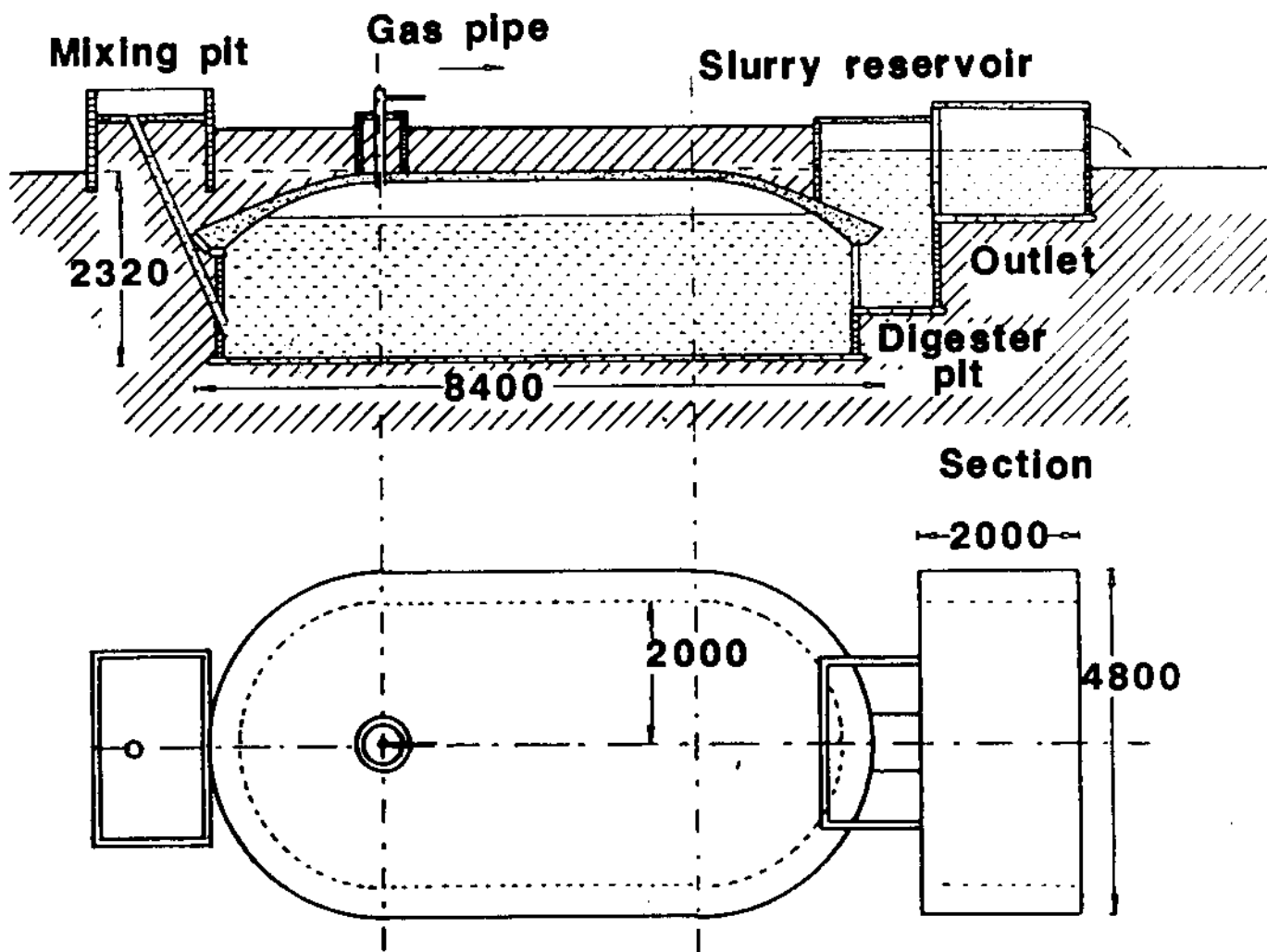

Figure 5.6 *Extended dome design of biogas plant*

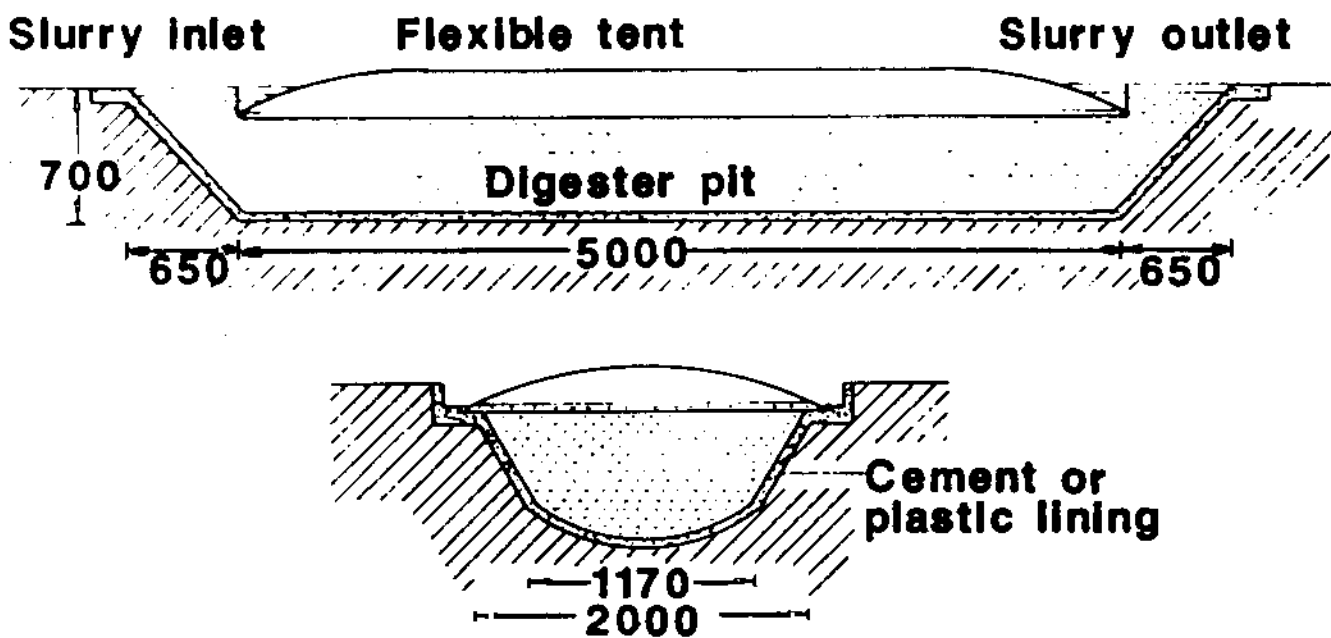
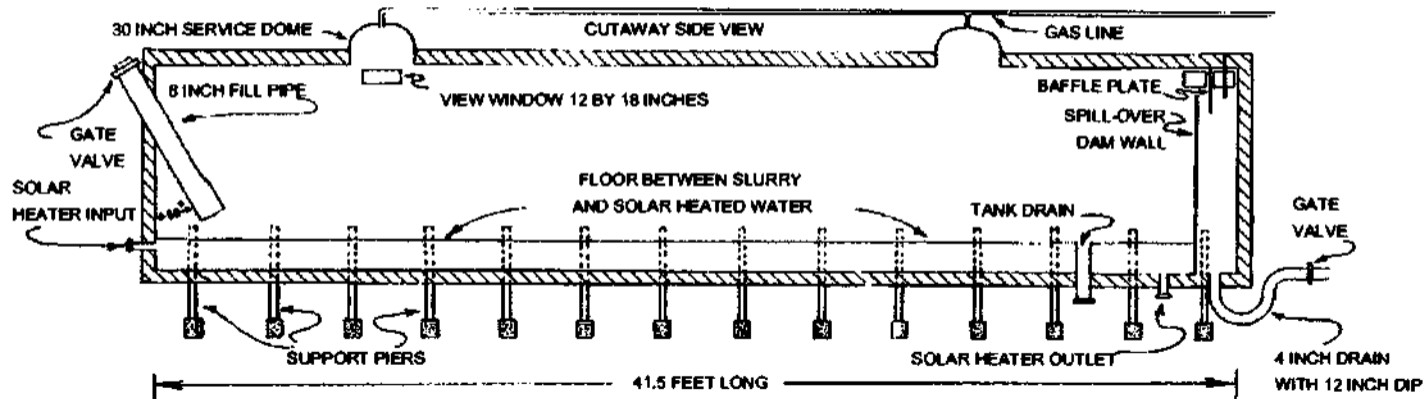
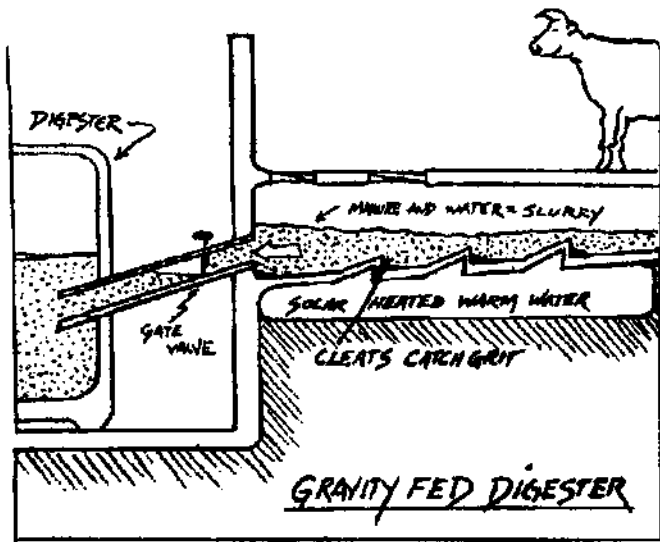

Figure 5.7 *Flexible tent design of biogas plant*

Al Rutan's Methane Digester Design





Mitglied der

Ingenieurbüro

SCHNEIDER

Biogasgruppe
im **Bundschuh**

Bromervörderer Modell

Zur besseren Verbreitung der Biogastechnik haben sich in Bromervörde elf Landwirte zusammengeschlossen, um in wechselseitiger Unterstützung Einzelanlagen zu errichten und gemeinschaftlich Zuschlagstoffe zur Ko-Fermentation zu organisieren.

Pro Anlage wurde eine Grobabschätzung durchgeführt, die den örtlichen Bedingungen Rechnung trägt. Durch mehrere gemeinschaftliche Treffen in gewissen zeitlichen Abständen wurden das Wissen wechselseitig verbessert und eine sichere Lösung für jeden Betrieb diskutiert. Bauanträge und Zuschußbeantragung folgten im "Konvoi".

Die Baubetreuung soll individuell der Schwierigkeit der jeweiligen Anlage angepaßt und evtl. verstärkt werden.

Vorteile dieses Verfahrens:

- Verbesserung der Planung durch mehr Information
- Verbilligung von Planungs- und Beratungskosten
- Gemeinsamer Einkauf von Material und Komponenten
- Vermeidung und schnelle Korrektur von Planungs- und Baufehlern
- Sinnvolle Gemeinschaftsanlagen werden ermöglicht, evtl. mit Nahwärmeverteilung
- Nachbarschaftshilfe beim Anlagenbau wird erleichtert
- Wechselseitige Unterstützung beim Anfahren und Betrieb der Anlagen
- Schnellere Reparaturmöglichkeit durch Austausch von Komponenten
- Mehr Durchsetzungsvermögen gegenüber Behörden und anderen Widerständen

Speicher- /Durchfluß - Biogasanlage

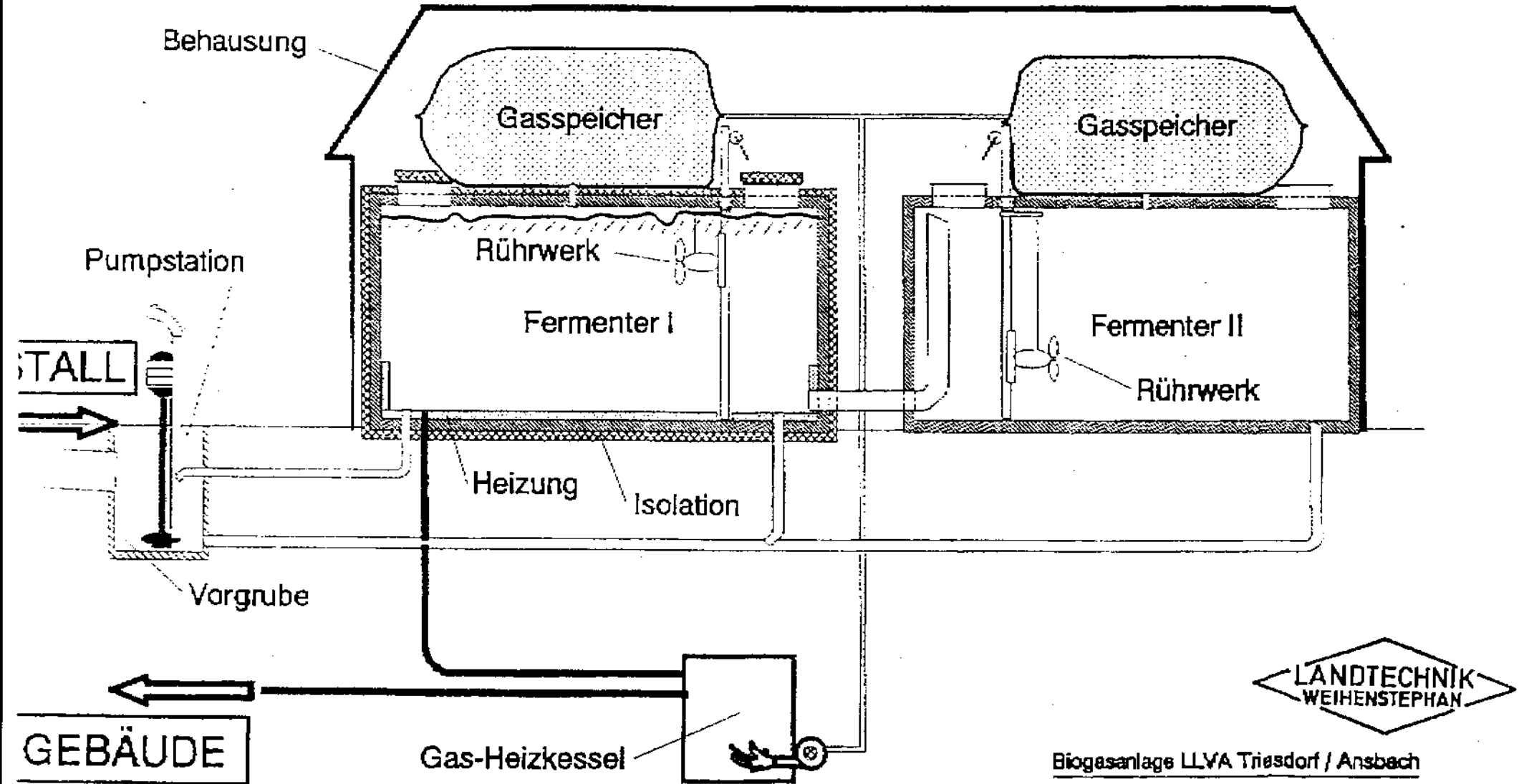

LANDTECHNIK
WEIHENSTEPHAN

Biogasanlage LLVA Triasdorf / Ansbach

Bundschuh
BIOGAS-Gruppe



Speicher- /Durchfluß - Biogasanlage

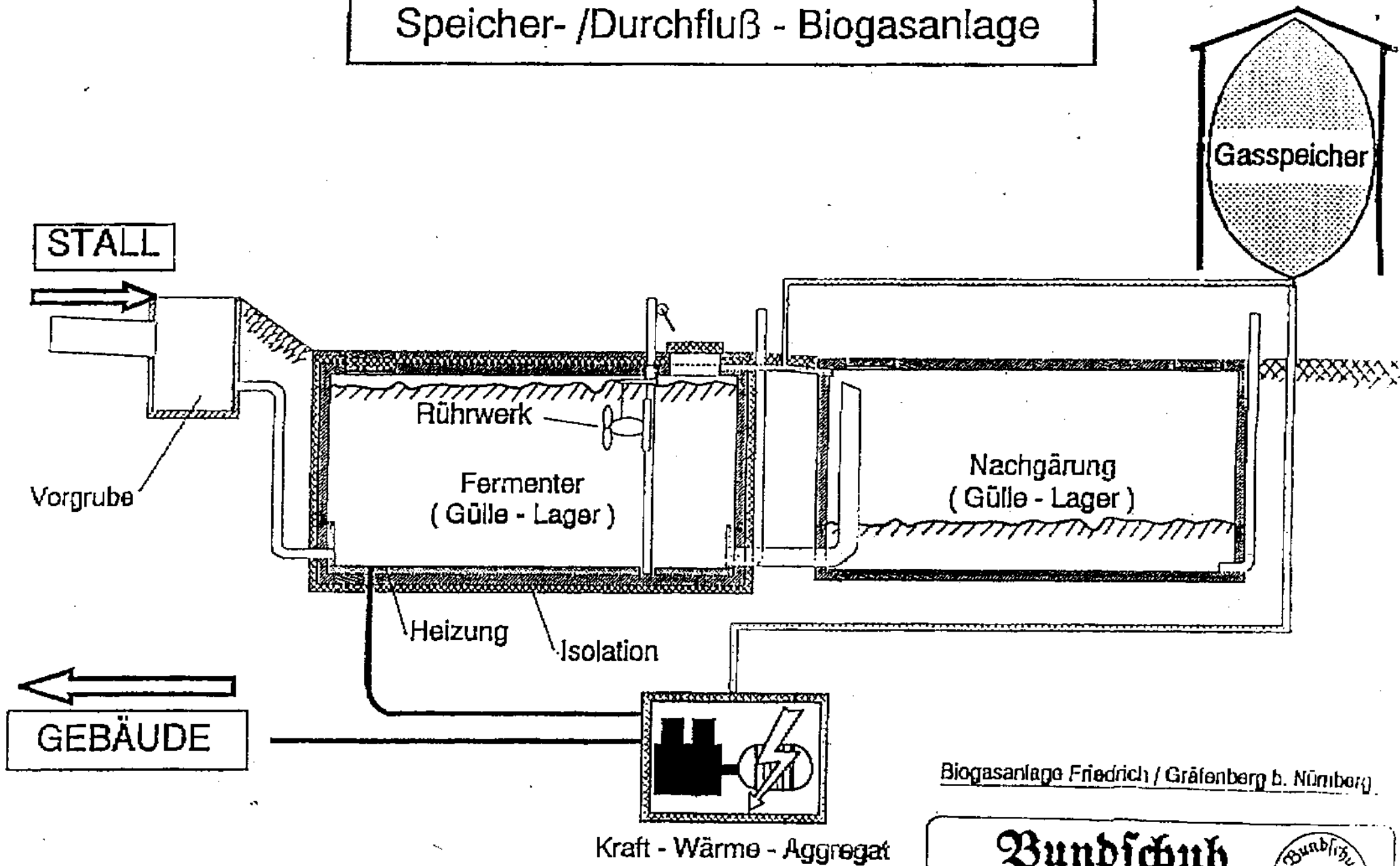

Gasspeicher

STALL

Vorgrube

Rührwerk

Fermenter
(Gülle - Lager)

Nachgärung
(Gülle - Lager)

Heizung

Isolation

GEBÄUDE

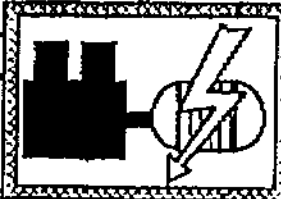

Kraft - Wärme - Aggregat

Biogasanlage Friedrich / Gräfenberg b. Nürnberg

Bundschuh
BIOGAS-Gruppe

Speicher-Biogasanlage

mit Einfach-Folienabdeckung System Bundschuh

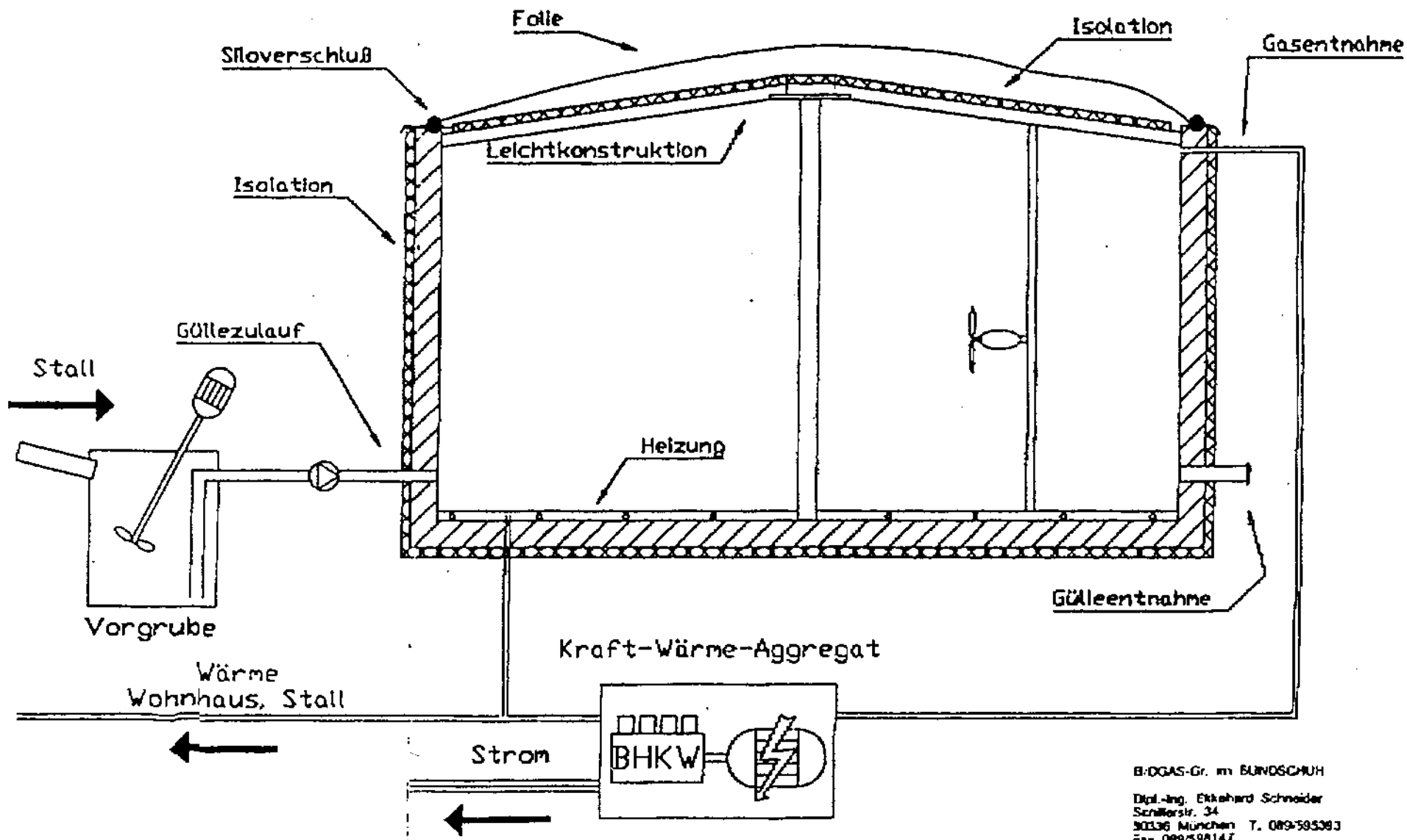

B-DGAS-Gr. im BUNDSCHUH
Dipl.-Ing. Ekkhard Schneider
Schillerstr. 34
90336 München T. 089-595393
Fax 089/598147

ANAEROBIC TREATMENT SYSTEM FOR COFFEE WASTE WATER

Pilas and Naranjo Coffee Mills, Costa Rica

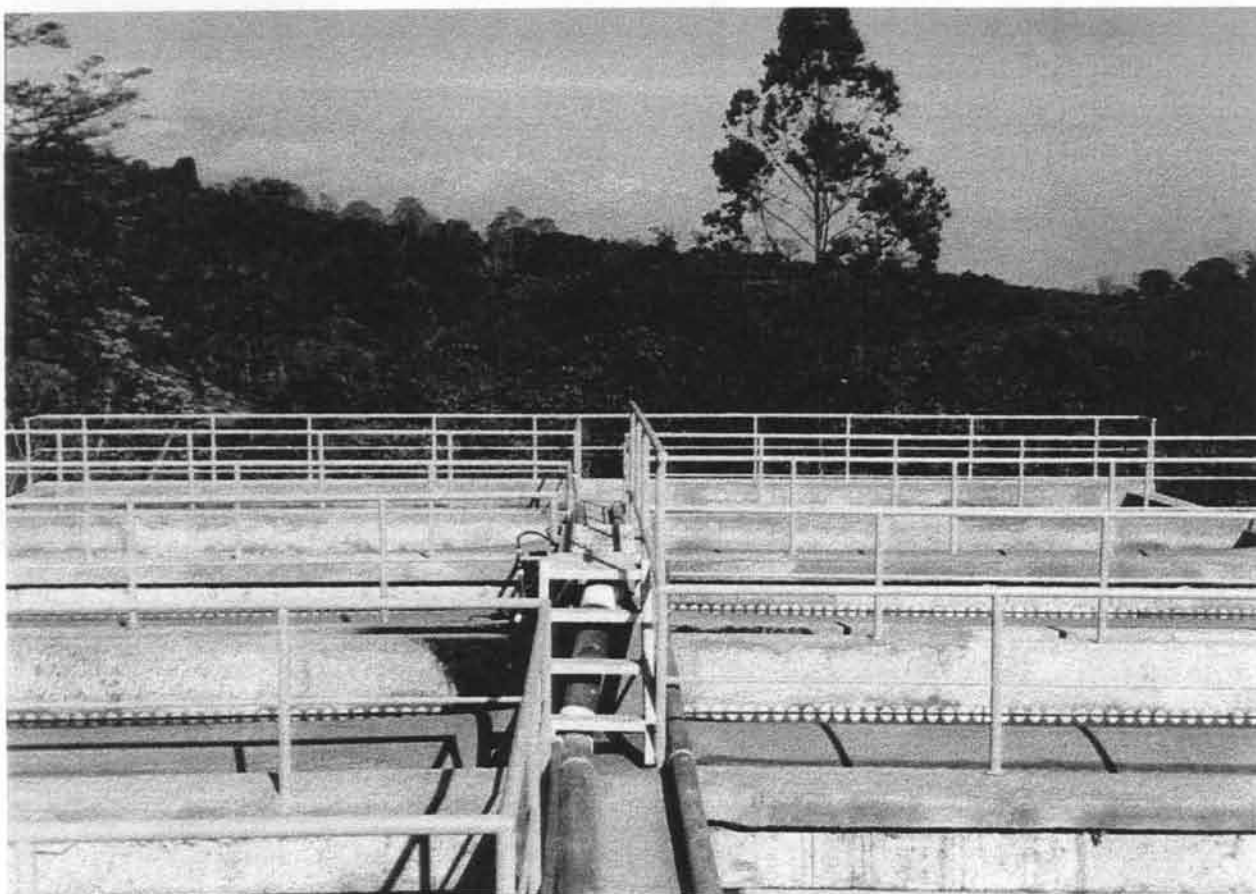

Naranjo Coffee Mill: Panoramic view of the anaerobic reactor

Wastewater treatment and energy generation

BTG Biomass Technology Group B.V. (The Netherlands) and Amanco de Costa Rica have jointly developed an excellent and innovative process for the treatment of industrial waste waters which contains high loads of contaminating organic matters.

It concerns an highly efficient biological process, which in addition to drastically reducing water pollution generates large quantities of combustible biogas as by-product, which can be used for any desirable energy application.

The anaerobic treatment plants installed at the coffee mills in Pilas and Naranjo in Fall 1997 are just two examples of the many projects being executed in the coffee industry by PRENAMSA, our joint-venture daughter company.

We guarantee that the treatment plants we commission comply for the full 100% with Costa Rican laws and regulations concerning the disposal of contaminated waste water by this kind of industry.

The process....

Waste water from coffee mills contains high concentrations of sugars and other organic components, which originate from pulp and mucilage.

These soluble compounds only be removed, at reasonable costs, by biological processes. In such processes, bacteria remove the dissolved organic matter.

In an anaerobic process, these bacteria live in conditions without air (oxygen). Their excretion is in the form of a gaseous product: Biogas.

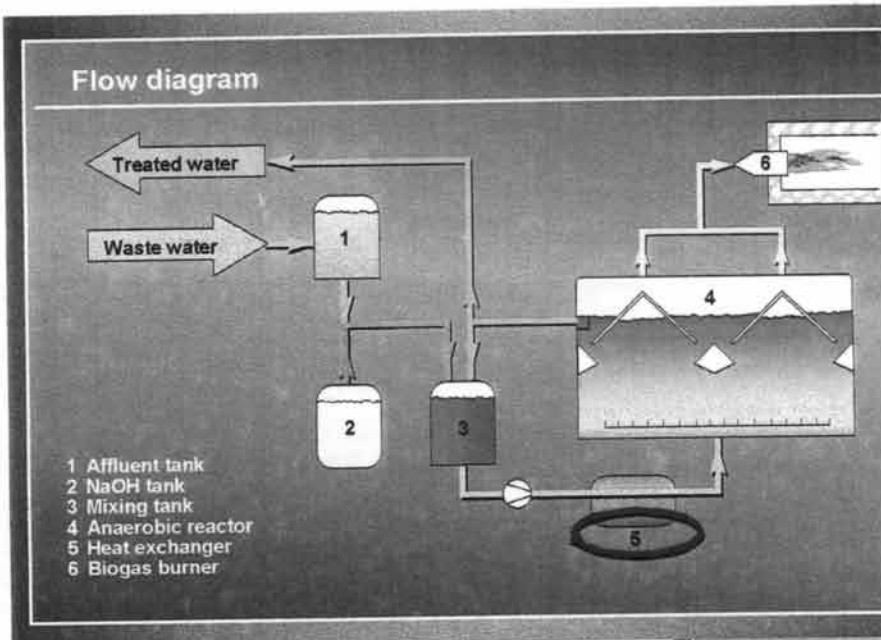

Modular construction...

The design of the PRENAMSA anaerobic treatment plant is fully modular. Each 250 m³ module has the capacity to treat up to 2,500 kg of organic material (COD) per day and to generate up to 750 m³ biogas per day. A treatment plant can contain any number of modules.

The advantages of the modular design are obvious:

- rapid construction
- offering the possibility to implementation in stages
- offering the possibility to future expansion
- reducing the time required for design and engineering

treated v

Beneficial environmental impacts

- Elimination of 80% up to 95% of the contaminating load in coffee waste waters;
- Reduction of 50-80% of the consumption of fuelwood for coffee drying;
- Minimal consumption of electricity;
- Zero emission of the greenhouse gases methane and CO₂.

The biogas...

Biogas is a combustible fuel with a high calorific value, comparable to that of other gaseous fuels such as propane.

In the Pilas and Naranjo coffee mills biogas is combusted in the ovens which generate heat for drying coffee, substituting fuelwood.

Furthermore, biogas can also be used, amongst others, in a coffee roaster or in a combustion engine, for generating electricity.

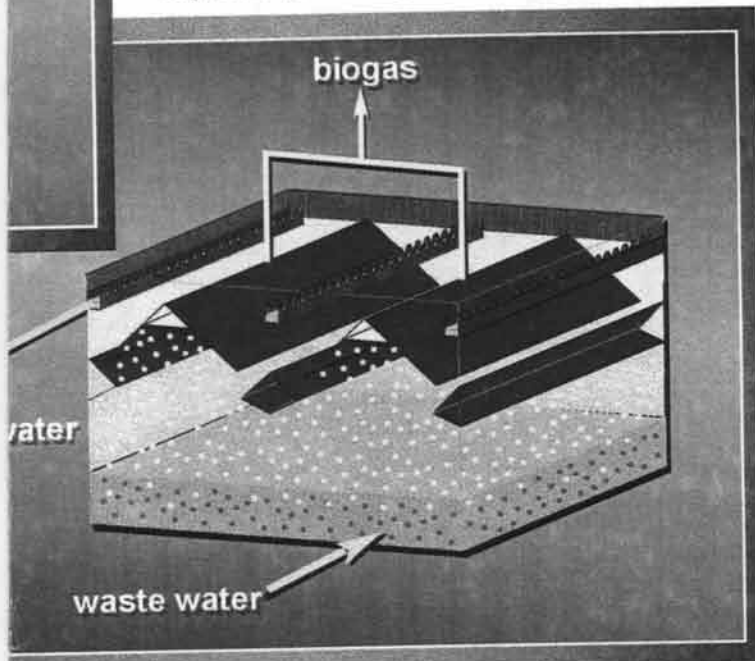

Other environmental aspects...

The treatment system is extremely compact. Minimal space is required for its construction.

The anaerobic process takes place in a hermetically sealed construction. In this manner it is guaranteed that neither gases nor bad odours, which could harm the direct environment, are released.

The energy aspect...

The anaerobic process offers the advantage that no air injection is required, as is the case in aerobic processes.

Consequently, electricity consumption is very low, implying another positive contribution to the environment.

At the same time, the opportunity exists to utilise the generated biogas for a variety of energy applications, including the generation of heat and/or electricity.

Complete package of services.....

Amanco de Costa Rica, through its waste water treatment division, and BTG Biomass Technology Group B.V. (The Netherlands) have extensive experience with the design, planning and implementation of projects.

Our services cover the whole range of plant construction, from design & engineering to the erection, installation, commissioning and -if desired- operation of the plant.

And, of course, we can also handle all required legal procedures.

To summarise...

The system developed by BTG and Amanco can be characterised as follows:

- a Compact and economic design;
- b Polluting compounds are converted into biogas;
- c Biogas is a clean and sustainable energy source;
- d Materials and equipment are readily available in Costa Rica;
- e Low electricity consumption;
- f Low treatment costs;
- g Full-scale operation demonstrated during a number of coffee harvests

	Pilas Coffee Mill	Naranjo Coffee Mill
Aspects of the coffee mill:		
• Plant capacity	450 tonnes of berries per day 22,500 tonnes per harvest	800 tonnes of berries per day 45,000 tonnes per harvest
• Water consumption	1.0 m ³ per tonne of berries	1.6 m ³ per tonne of berries
• Contaminants in waste water	26 kg COD/ tonne of berries	26 kg COD/tonne of berries
Design data:		
• Treatment capacity	5,000 kg COD per day 500 m ³ water per day	15,000 kg COD per day 1,500 m ³ water per day
• Treatment efficiency	90% COD	90% COD
• Biogas production	max. 1,000-1,500 m ³ per day	max. 3,000-4,500 m ³ per day
• Fuelwood substitution	± 300 m ³ per coffee season	± 1,000 m ³ per coffee season
• Power generation capacity	max. 100 kW _a continuous	max. 300 kW _a continuous

Approximate investment costs

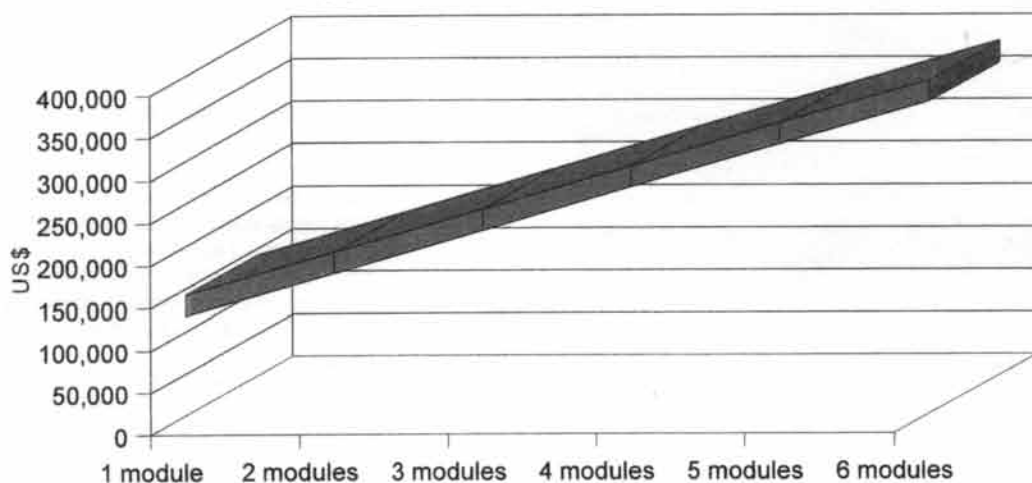

Pilas Coffee Mill: biogas bag (10 m³)



Pilas Coffee Mill: waste water storage (400 m³)



PRENAMSA

Procesos Energéticos y Ambientales S.A.

Una empresa conjunta de Amanco de Centro América S.A. y BTG Biomass Technology Group B.V.

Zona Industrial de Pavas, 125 metros al este de Alimentos Jack's

Apdo. 6402-1000 San José, Costa Rica • Tel: (506) 232-1055 • Fax: (506) 231-5690



THE PURIFICATION OF POLLUTED WATERS

The only long-term insurance of good water supply to a settlement is by rigorous control of a forested catchment, including a total ban on biocides and metallic processing. As there are few such clean areas left in the world, house roof tanks must do for the foreseeable future. The 30-40 additives commonly introduced into water supplies are often pollutants in themselves to that increasingly sensitive sector of society developing allergies to any type of modern pollutant. These additives represent the end point of the technological fix: pollution is "fixed" by further pollution.

Herein, I will stress the *biological* treatment of common contaminants; the only water safe for us is also safe for other living things. For millenia we have existed on water supplies containing healthy plants and fish, and if we keep natural waters free of faecal and industrial contaminants, we can continue to do so. This is not so much a matter of water treatment, as the prevention of polluting activities.

However, for many existing cities and towns, sewage and stormwater supplies must continue to represent a "disposal problem". As the wastewaters of upstream settlements are the drinking waters of downstream areas, our duty is to release from any settlement only water of sufficiently good quality to be safely useable by others.

The problem contaminants most likely to affect drinking water are:

- **TURBIDITY:** silt and fine particles suspended in the water.

- **BACTERIAL** or **ORGANIC** pollution from sewage, and as decay products, e. g. *E. coli*, disease organisms and viral or protozoan pathogens, parasitic worm eggs and so on.

- **METALLIC POLLUTANTS** such as chromium, cadmium, lead, mercury.

- **BIOCIDES**, e.g. Aldrin; Dieldrin; 2, 4-D; 2, 4, 5-T; dioxin; PCB, etc (organophosphates, halogenated hydrocarbons).

- **EXCESSIVE FERTILISER**, especially nitrogenous compounds, phosphates, sodium and potassium salts.

- **ACIDS** or acid-forming compounds (a pH less than 5.5 increases metallic pollution).

Many of these factors interact. Acid rain dissolves out of rocks and soil poisonous forms of aluminium, mercury, lead, cadmium, and selenium, or other metals such as copper, nickel, and lead from drinking tanks, tea urns, and hot water tanks. Organisms may convert inorganic mercury to organic forms (as happened in Minamata, Japan) which are readily absorbed by the body. Sewage in water aids such conversion to biologically active metals.

Mercuric fungicide dressing on seeds has not only caused direct poisoning of people who have eaten the seed, but also poisons the soil. Excessive artificial fertiliser increases aquatic biological activity, which results in further uptake of metals in acidic waters, and so on. In biocides, Aldrin prevents DDT being excreted; the combination is deadly (one can buy this mix in Australia and the third world, or farmers will achieve it by successive sprays. DDT is a stable residual poison co-distilling with water, so that distillation will not help). An additional threat to public health comes from

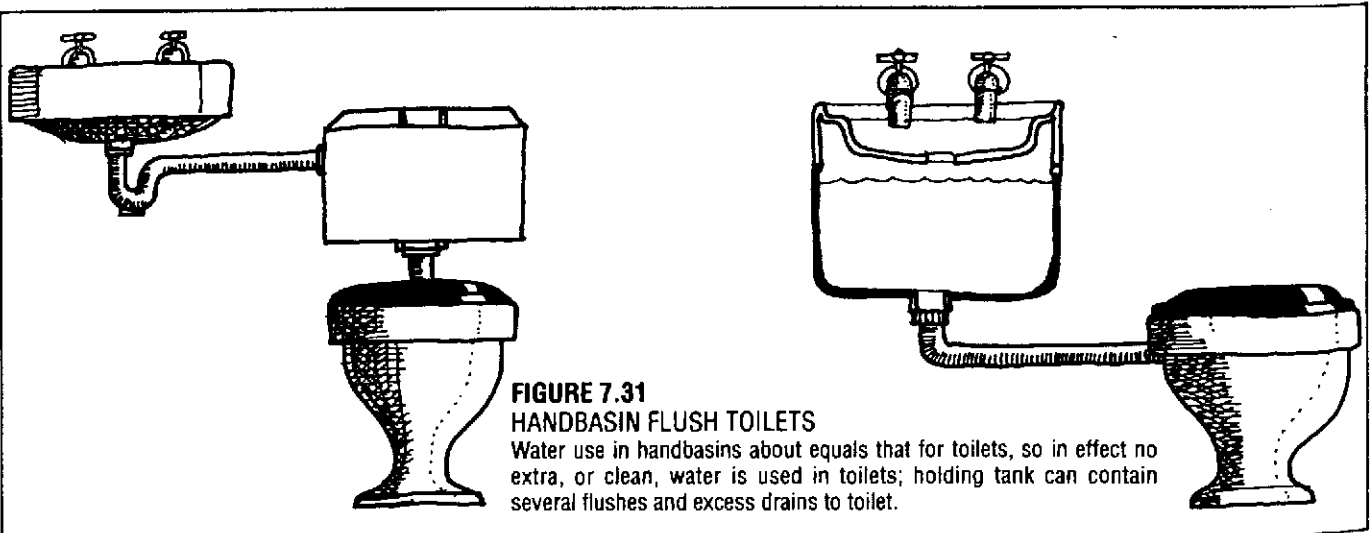

the many miles of asbestos pipe used in public water supply systems; there is a definite threat of both stomach and bladder cancer from asbestos particles in water supplies.

Ferric and aluminium sulphate, salt, and lime are all added to water to cause fine particles to flocculate and settle out as clay. In England, as pH increases due to acid rain, and in fact wherever acid rain occurs, aluminium goes into solution, and with lead and cadmium may bind to protein in vegetables and meat, especially those boiled or steamed. Even if salt is added to cooking water to decrease these effects, levels far exceeding the 30 µg/l allowable for those with kidney problems are experienced. Cooking may increase the water content of metals by a factor of 5 due to this protein binding, and as well make the metals so bound easy to assimilate in the body. Cooking acidic substances in aluminium pots simply worsens the problem. Aluminium from *acidic* rain leaching is now thought to be a major cause of tree and lake death. Ferric sulphate may be safer to use, especially if water is initially or reasonably alkaline. Obviously, these effects need more study and any inorganic salt or metallic salt deserves very cautious use.

WATER TREATMENTS COMMONLY USED

- **AERATION** (oxygenation) by wind, mechanical aeration, or by increasing turbulence in flow. Aeration is also achieved by trickle columns and vegetation, phytoplankton, or injected air.
- **SETTLING**: spreading flow in still-water ponds or rush beds to allow particles to fall out, filter out, or flocculate.
- **SKIMMING** and **SIEVING** to remove large organic particles.
- **FILTRATION** via sand beds or charcoal-fibre columns, soils, the roots of aquatic plants.
- **COAGULATION** or **FLOCCULATION** by using chemical additives (lime, salt, ferric sulphates) or organic (bacterial) gels.
- **BIOLOGICAL REMOVAL** by bacteria, phytoplankton, and higher plants.
- **pH ADJUSTMENT** by adding calcium (as lime) or sulphur compounds as needed.

Filtration

A classical and widely-used filter is sand. Britain and many cities use sand filters followed by chlorination to

clean settled and treated raw sewage water sedimentation. Filtration by slow drip through 1.2 m (4 feet) of sand (top half fine, bottom half coarse) is used even in temporary rural camps for water filtration. For cities, fixed sand beds with brick bases are used, the top 1 cm (0.5 inch) or so of sand periodically swept, removed, and dried or roasted to remove organic particles before the sand is returned.

Activated charcoal, often from bones or plants such as willow or coconut husks, is also used as a fine filter in homes and where purity is of the essence. Fine dripstone (fine-pored stone) is used in water cleaners and coolers to supply cool water in homes.

Trickle filters through sand and gravel columns actually feed resident bacteria which remove the surplus nutrient. In less polluted environments, a similar task is carried out by freshwater mussels.

Carbon is essential for the removal of nitrogen or for its conversion by bacteria to the gross composition $C_5H_7NO_2$, and it is generally added as carbohydrate, which can be liquids, such as methanol, ethanol, or acetic acids, many or all of them derived from plant residues. This is a bit like "adding a little wine to the water" to encourage the bacteria to work. Surplus nitrogen is released by bacteria to air. Unless bacteria are encouraged and allowed to work, nitrates move easily through sub-soils in which no plants or bacteria can live, and can emerge in wells and streams.

In ponds intended for drinking, light exclusion and surface water stabilisation reduce both turbidity, and thus algae, to a minimal quantity. The stabilisation of banks by grasses and clump plants helps considerably. Pond surface stabilisers are water lilies, *Azolla*, and water hyacinth. Bank stabilisers are *Juncus*, *Scirpus*, various grasses and clovers, *Phyla nodosa* (*Lippia*), and bamboo and pampas grass clumps.

With turbidity much reduced, filtration loads are likewise reduced. Liming will further reduce turbidity if pH is 6.0 or less. This is as simple as placing crushed marble or limestone as a layer in a tank, or casting burnt lime over a pond before filling and (if necessary) after filling. Crushed shells or even whole shells in water tanks and ponds have the same effect. Lime flocculates particles, causing them to settle out of the water.

There are several techniques for filtration, some or all of which can be used in series. First, trickle filters of

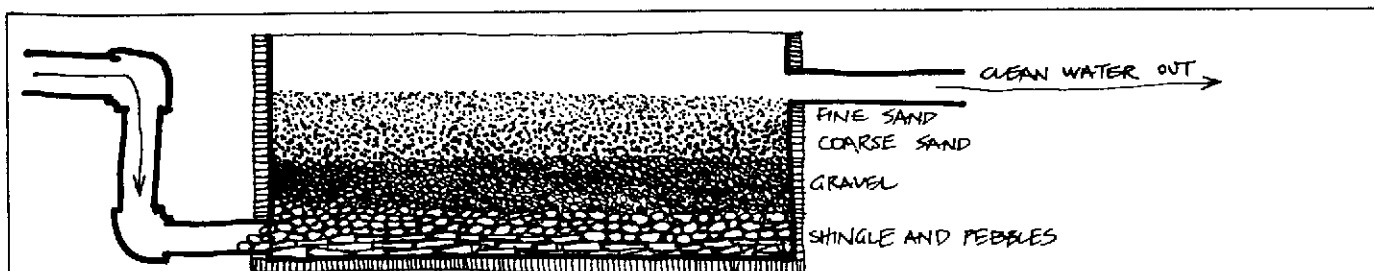

FIGURE 7.32
SAND FILTER

A basic cleanser for microbiological pollution; flow is upwards from

base to surface. Surface sands can be washed or roasted for cleaning as needed usually every 12–18 months.

loose pebbles (2.5–10 cm) can be used to form an active bacterial surface layer to absorb nutrients, then a sand filter can be used to absorb bacterial pollution. Water rising through a sand column is fairly clear.

The shells of water mussels can be substituted for pebbles, and the living mussels in the pond or tank not only monitor acidity (dying at pH 5.5 or thereabouts) but filter, individually, up to 100 l/day, digesting bacteria and depositing wastes in the mud base. Mussels and crayfish are not only susceptible to low pH but are also very sensitive to biocides such as Dieldrin, so that their living presence is a constant monitor on life-threatening pollution.

Water, now fairly clean, can be passed through a bed of watercress to remove dyes and nitrates, and the cress cut and fed to animals or dried and burnt to ash. As a final process, the water can be trickled through a column (a concrete pipe on end) of active carbon (10%) and silicon dioxide (90%), otherwise known as burnt rice, oat, or wheat husks.

The results should be clear, sparkling, safe water to drink. No machinery is involved if the system is laid out downslope to permit gravity flow

Lime (freshly burnt) is often used to remove phosphorus and sludges in a primary settling lagoon, and then water is passed to a trickle tower for ammonia removal by bacteria. In towers, of course, the bacteria are not further consumed, but in open lagoons a normal food cycle takes place, with myriad insect larvae and filter-feeders removing bacteria, and frogs, fish, and waterfowl eating the insects. In small towns, the water can be passed from filter towers to sewage lagoons, which in fact may become rich waterfowl and forest

sanctuaries. It can then be routed to field crop such as forest, pasture, and to crops to be distilled or burnt, which does not directly re-enter the food chain.

Sewage Treatment Using Natural Processes

Raw sewage is a mixture of nutrients, elements, heavy metals, and carbon compounds; it also contains quite dangerous levels of bacteria, viruses, and intestinal worm eggs. A typical analysis is given in Table 7.3. Units are as mg/l; samples are of 30% industrial, 60% domestic wastes at Werribee, Victoria, Australia (Hussainey, Melbourne Metropolitan Water Board Pubs., 1978).

Melbourne is a city of 2,700,000 people and its sewage lagoons cover 1,500 ha (3,700 a.) Thus, there is one hectare of pond (in total) to 1,800 inhabitants (or about 1 a. for 820 people). In the ponds, raw sewage is run into about 724 ha (1,790 a.), where it settles out. Each of these primary settling ponds rarely exceed 7 ha (17 a.) in area, so about 100 ponds receive and settle all raw sewage. Scaled down, this means 1 ha (2.5 a.) of settling pond to 3,800 people.

All these settling ponds are anaerobic, and give off biogas, a mixture of methane (CH_4), carbon dioxide (CO_2) and ammonia gas (NH_3), with traces of nitrous sulphide or marsh gas (NO_2). Biogas is, of course, a useful fuel gas for engines, or a cooking gas for homes. However, it is also a gaseous component of the atmosphere that is creating the "greenhouse effect" and thus should be used, not released to air.

The next set of ponds is facultative (as described below) and the last set aerobic. These, in total, slightly exceed the area of the anaerobic or settling ponds. Most

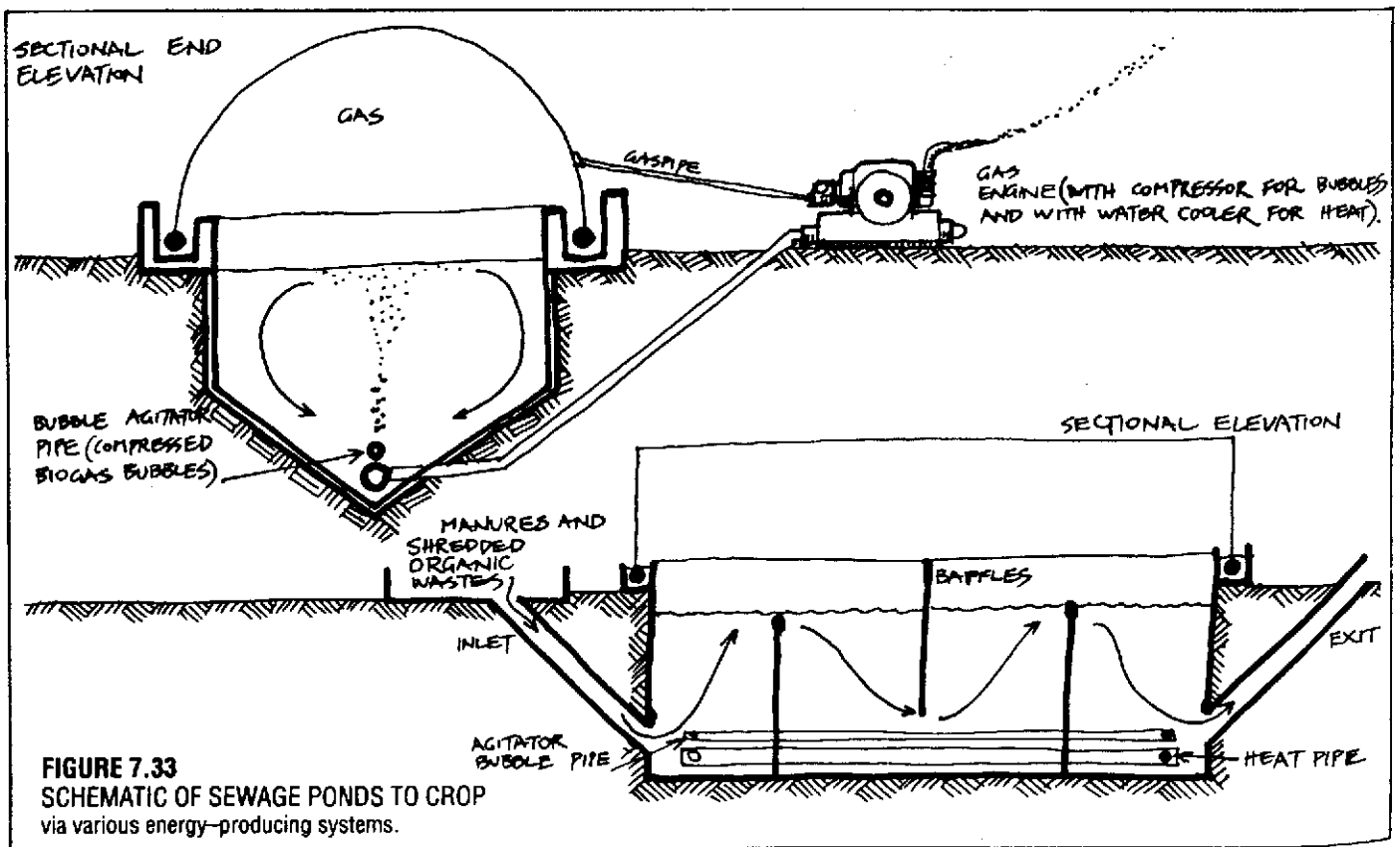

are 7–10 ha (17–25 a.) in size.

Ponds can be built (as they are at Werribee) to fall by gravity flow from one to the other. In the first series of (settling) ponds, the sludge creates an ANAEROBIC condition. In the next series of ponds, some sludge passes over and becomes anaerobic at the pond base, while the surface water in the pond (due to wind or algae) is AEROBIC (oxygen-producing). The final series of ponds is totally aerobic. Thus, from intake to outlet, we have the terms:

- ANAEROBIC, or methane-producing (digester ponds).
- FACULATIVE, or part methane, part oxygen-producing.
- AEROBIC, or oxygen-producing ponds.

Ponds at Werribee are only an average of 1 m (3 feet) deep. Deeper, and the sludge breakdown and wind aeration effects are less.

One thousand townspeople and their associated industries therefore need as little as 270 metres square of settling pond 1 m deep. We could, in fact, achieve this as a "long" pond (or series of ponds) 3 m wide x 90 m long, or 3 side-by-side ponds 30 m long and 3 m wide, or any such combination. We can halve the length by doubling the depth to 2 m, and get a pond 3 m x 45 m long; or treble the depth and condense the pond area to a 3 m deep x 3 m wide x 30 m long "digester" pond.

Such a long and narrow pond is easily made *totally* anaerobic by fitting water seals and a weighted cover over the top (which can be of plastic, metal, butyl rubber, or fibreglass). Note that for these deeper digester ponds we would need to *artificially agitate* the sludge (using pumped biogas to stir it), otherwise it settles and becomes inactive (Figure 7.33).

Sludge is "active" only in contact with the semi-liquid inputs of the sewer; thus when we stir up the sludge, the better we break down the sewage to biogas. Another (critical) benefit in sealed and agitated digesters is that no scum forms on the pond surface, which can slow the breakdown process further and cause an acid condition.

Of the total dissolved solids (or influent) entering such a digester, over a period of 20 days and with a temperature of 25–30°C (77–86°F), a very high percentage of the mass is transferred into methane; a small proportion is also passed on to other ponds, some as living cells (bacteria or algae). As methane forms, so the oxygen demand of the effluent falls; about a cubic metre of methane generated removes about 2.89 kg of solids, reducing biological oxygen demand (B.O.D.) to that extent.

In the digester, 90–94% of worm eggs are destroyed, as are many harmful bacteria. Useful energy is generated, and can be used at that location to run a motor for electricity, or to compress gas for cooking or machinery (or both, as power demands vary). This motor both supplies the heat for the digester process, and also compresses the gas for digester agitation, and for energy supply.

What happens in the digester? The marsh gas

TABLE 7.3
ANALYSIS OF RAW SEWAGE

ANALYSIS	MG/L
SOLIDS	
Total dissolved solids	1,200 (TDS)
Biological oxygen demand	170 – 570 (BOD)
Suspended solids	160 – 620
Volatile liquids	180 – 510
Total organic carbon	110 – 360
Anionic surfactants	1.0 – 3.6
NUTRIENTS	
Nitrite as N	0.05
Nitrate as N	0.1 – 0.3
Ammonia as N	5 – 32
Organic N	7 – 24
Total N	9 – 56.2
Orthophosphate as P	1.5 – 6.0
Total phosphorus	1.5 – 9.0
METALS	
Copper	0.09 – 0.35
Chromium	0.25 – 0.4
Cadmium	0.015
Iron	1.6 – 3.3
Lead	0.3 – 0.4
Mercury	0.003
Nickel	0.15
Zinc	0.4 – 0.8
COLOUR	
(as Pt/Cp Units)	100 – 300
pH	6.9 ± 2.0 (near neutral)

Of the total sewage input, from 45 – 60 % of the volume builds up as sludge in settling ponds.

produced, hydrogen sulphide (H₂S), combines with any soluble forms of heavy metals to produce sulphides, which are insoluble in water above pH 7. A little lime can also achieve or assist this result.

Hussainy found that the following result occurred in anaerobic ponds (see original metal content, Table 7.3):

- Copper is removed 97%, of which 78% was removed anaerobically.
- Cadmium is removed 70%, all anaerobically.
- Zinc is removed 97%, 83% removed anaerobically.
- Nickel is removed 65%, 47% aerobically.
- Lead is removed 95%, 90% anaerobically.
- Chromium is removed 87%, 47% anaerobically.
- Iron is removed 85%, 47% anaerobically. (Up to 92% of iron was removed by the facultative pond process, but some iron was partly dissolved in the aerobic pond again, to give the 85% quoted.)

The results are that solids, metals, and disease organisms are very greatly reduced by the first (anaerobic) treatment of sewage. What, in fact, happens to the sludge? It becomes methane. In an anaerobic shallow pond, or a deeper agitated pond, the more sludge, the more active the pond. Thus, a *self-regulated equilibrium condition soon establishes* where input balances gas output. If we remove the sludge, the process slows down or stops. This is a clear case of

leaving well alone, of active sludge becoming its own solution; rather than being a problem, it generates a resource (methane).

In the anaerobic pond, there are few algae, but there are some specialised sulphur-loving bacteria of the genera *Thiosporallum*, *Chromatium*, and *Rhodospseudomonas*. These (in open ponds) may appear pink and give this colour to the ponds. They use hydrogen sulphide as a hydrogen source for carbon assimilation; their by-product is therefore elemental sulphur (S), which binds to the metals present. About 1.8–2.0 mg/l of heavy metals are precipitated as sulphides at 1.0 mg/l of elemental sulphur. The bacteria help in this process.

Passing now to the facultative ponds, we see both the life forms and the biochemical processes change. Here, algae blooms; four almost universal sewage lagoon algae are forms of *Euglena*, *Chlamydomonas*, *Chlorella*, and *Scenedesmus*. The total algal and bacterial flora (of many species) are called PHYTOPLANKTON (plant plankton).

Bacteria are also phytoplankton, the bacteria benefiting from the oxygen produced by the algae.

Typical bacteria in the open ponds are *Cyclotella*, *Pinnularia*, *Hypnodinium*, and *Rhodomonas*. The sulphur-loving bacteria may linger on in the sludge base of facultative ponds, but are absent or rare in aerobic ponds. The algae fix carbon, releasing oxygen to the bacteria.

With such a rich algal food available, ZOOPLANKTON now thrive: most are rotifers (*Brachionus*, *Trichocerca*, *Haxarthra*, *Filinia*); cladocerans (*Daphnia*, *Moina*, *Chydorus*, *Pleuroxus*); copepods (*Mesocyclops*); and ostracods (*Candancypris*, *Cypridopsis*). Among these are protozoan flagellates, ciliates, and some nematodes. On this rich fauna, waterfowl and fish can flourish.

Some of the remaining metals are gathered by the zooplankton. In mg/l (dry weight) they contain 1,200 of iron, 152 of zinc, 37 parts of copper, 28 of chromium, 12.2 of nickel, 10.3 of lead, 1.7 of cadmium—almost a mine in themselves. Harvested, both zooplankton and algae can be added to foodstuffs for poultry. Pumped into forests or fields, they provide manures and trace elements for growth. In rich algal growth, blooms of such forms as *Daphnia* can be as dense as 100 mg/l.

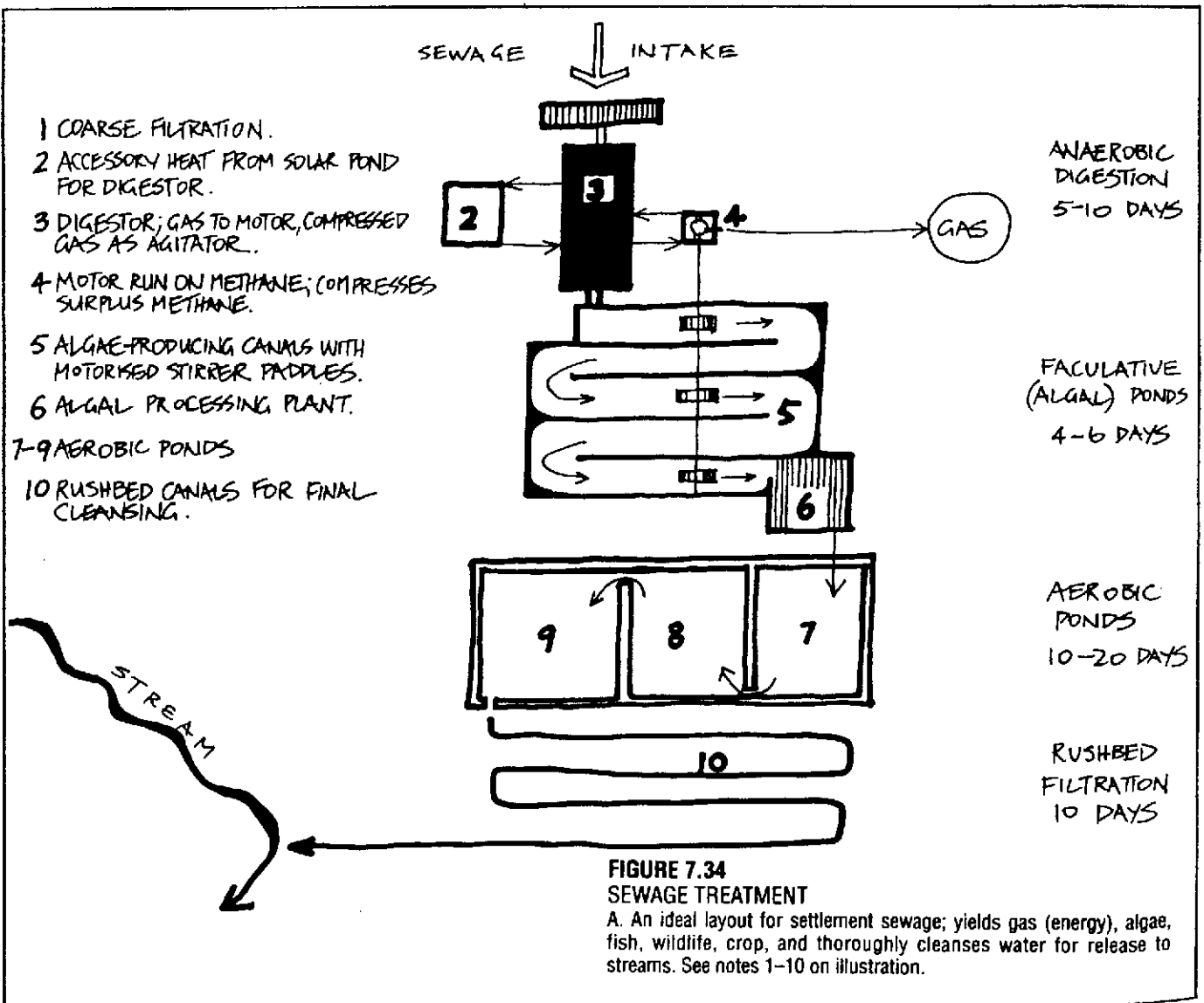

These zooplankton masses are self-controlled by eating out their algal foods, and can in their turn be eaten by fish in subsequent pond systems.

Of the pH, which varies both long-term and in 24-hour cycles, it too increases from stage to stage: anaerobic pH 6.2–7.8; facultative pH 7.5–8.2; and aerobic pH 7.5–8.5. In clogged algal waters at night, it may climb higher.

At the aerobic stage, the B.O.D. is only 3–57 mg/l, due mainly to nitrogenous compounds, the suspended solids 32–50 mg/l (now mainly algae and zooplankton). About 80% of these have been removed and incorporated into life forms, and the metal levels are now down to World Health Organisation standards. The water can be used for irrigation, or filtered via rush beds to streams.

Seasonal changes are noticeable. In winter, more hydrogen sulphide is given off by anaerobic ponds (8–15 mg/l compared with summer's 2–5 mg/l), and winds may contribute more to oxygen levels in open ponds than do algae; in winter too, more ammonia (NH₃) is released to the atmosphere.

Summer sees residues oxidised to nitrates. The oxygen being provided more by algae than by wind, less hydrogen sulphide is given off, and there are greater ranges of temperature. In winter (10–15°C), decomposition slows and sludge levels build up, only to be more actively converted in the summer warmth of 18–22°C (64–72°F). B.O.D. is 495 kg/ha/day in winter, 1034 kg/ha/day in summer (at optimum pond conditions), showing that activity almost doubles as temperature increases. Consequently, almost twice as much gas as methane is given off in summer (or in heated digesters). In winter, the cooling water of methane-powered engines can provide the essential heat to digesters via a closed loop pipe.

In all, this simple lagoon series produces a very beneficial effluent from heavily-polluted influent. However, there are even more sophisticated biological treatments omitted—those effected by the higher plants. As outlined below, some genera of rushes, sedges, and floating plants can greatly assist with removal of heavy metals and human pathogens, but perhaps more importantly, some plants can also break down halogenated (chlorine, bromine) hydrocarbons synthesised as herbicides and pesticides.

Israel (*New Scientist*, 22 Feb '79) leads sewage waters to long canalised ponds, agitated by slowly-revolving paddle-wheel aerators. Ponds are 0.5 m or less deep. Under bright sunlight (or under glasshouse covers) dense algal mats form, and these are broken up by the addition of aluminium sulphate (a pollutant!), skimmed off, drained, centrifuged, steam-dried, and fed to either carp or chickens (although I imagine that carp could self-feed on aquatic algae). Algal protein replaces 50% of soya bean protein in feed rations to poultry. Total treatment by these methods takes about 4 days. The water is alkaline and somewhat anaerobic, needing more agitation in winter or on cool days. Holland runs sewage to similar canals, and reaps reeds or plants as

green crop or for craft supplies.

It has been found (*Ecos* 44, Winter '85) that the artificial aeration of facultative ponds is most efficient if run at intervals of two hours in six (30% of the time). The facultative bacteria follow two digestive modes, and operate best if a rush of air is supplied after a four-hour anaerobic period, excreting carbon dioxide and thus reducing the bulk of sludge. There are corresponding reductions in energy costs for aeration. Nitrogen was reduced from 20 mg/l to less than 5 mg/l, phosphorus from 8.5 mg/l to less than 1 mg/l when ferric chloride was supplied. The process has been dubbed A.A.A. (alternating aerobic and anaerobic) digestion.

Thus, *agitation* of anaerobic systems by bubbling with compressed methane, and A.A.A. of facultative ponds can be used to obtain useful yields of methane and high-protein algae from sewage. As for the aerobic ponds, such higher plants as water hyacinth removed residual metals, surplus nutrients, and the *coli* group of bacilli (*New Scientist*, 4 Oct '79, p. 29). Microwave radiation can also be effective at breaking up algal mats, and sterilising algal products, eliminating toxic aluminium salts.

As for temperatures, solar ponds used in conjunction with compact anaerobic ponds can supply the low grade heat necessary for efficient sludge digestion, and methane will drive any motors needed for both aeration and the gas compression used for the agitation of sludge. The whole processing system can be made very compact, and at the aerobic pond level, throughflow can be led to firewood or fuel forest systems, to irrigated grasslands (as at Werribee), or via trickle irrigation to crops in arid areas.

Final treatment, now in use in Holland and recommended by scientists at the Max Planck Institute in Switzerland, can be released via a sinuous, sealed canal of a variety of rushes and floating water plants.

Waters polluted with metals, biocides, or sewage can be cleaned by travelling through reed beds of *Scirpus*, *Typha*, and *Juncus*; or by harvesting off floating plants such as water hyacinth. The rushes and sedges can be mown and removed periodically for mulch or cellulose. For *untreated* sewage, a holding time of 10–12 days is necessary, or travel through a series of maze-like gravel-filter canals with floating weeds and sedges. For swimming pools and less polluted systems, a pumped "cycle" of water through ferns, rushes, and watercress suffices to remove urine and leaves. Such pools need a 23–30 cm (9–12 inch) coarse river gravel base, with intake pipes below, and a skimming notch for leaves.

Species recommended are:

- *Phragmites communis* and spp., *Typha* spp.: Flocculate colloids, dry out sludges, eliminate pathogens.
- *Schoenoplectus* spp.: Takes up copper, cobalt, nickel, manganese; exudes mould antibiotics.
- *Scirpus* spp.: Breaks down phenols, including toxic pentachlorophenol.

Low to zero populations of *E. coli*, coliform bacteria, *Salmonella*, and *Enterococci* are found after water is

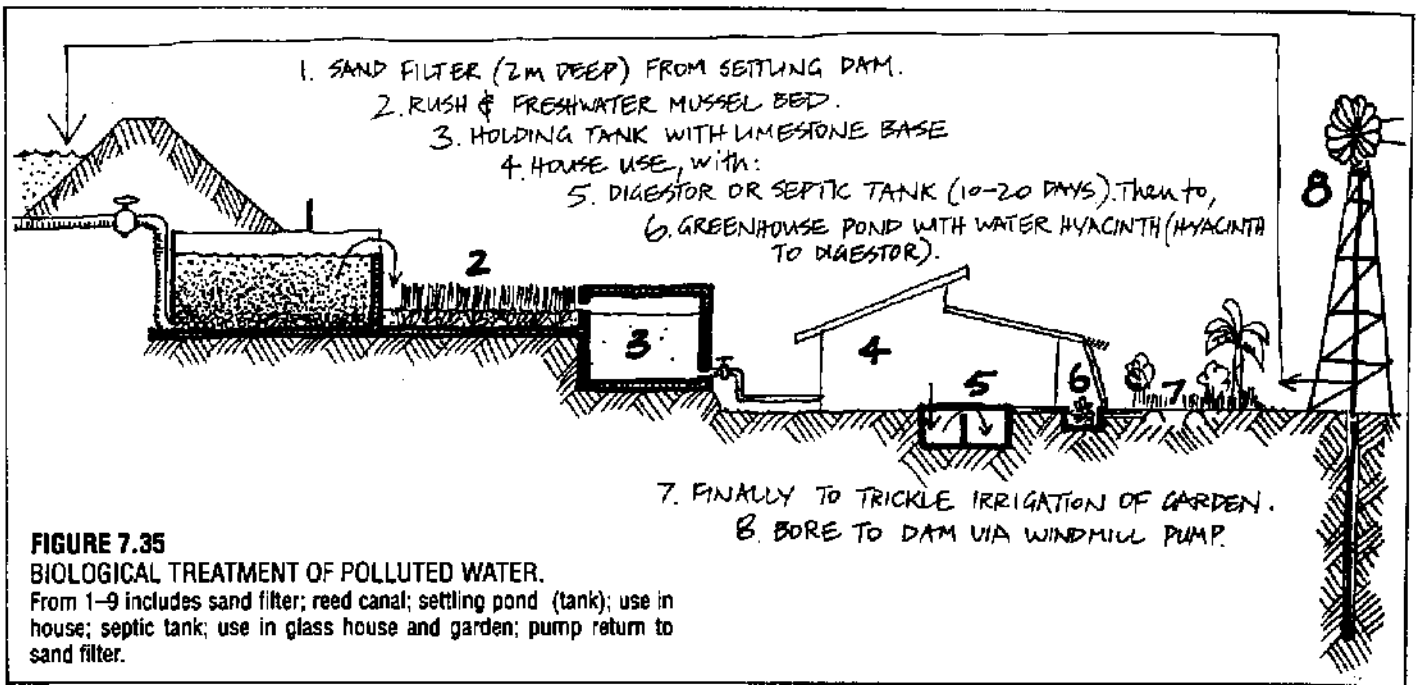

FIGURE 7.35

BIOLOGICAL TREATMENT OF POLLUTED WATER.

From 1-9 includes sand filter; reed canal; settling pond (tank); use in house; septic tank; use in glass house and garden; pump return to sand filter.

treated via the above species. Virus and worm eggs are also eliminated.

Also active in pathogen removal are (although these species must be tested and selected for specific problems): *Alisma plantago-aquatica*, *Mentha aquatica*, *Juncus effusus*, *Schoenoplectus lacustris*, *Spartina* spp., *Iris pseudocorus*.

For chlorinated hydrocarbons, use rush types with large pith cells (*Aerenchyma*), e.g. *Juncus* spp., especially *Juncus effusus*; *Schoenoplectus* spp.

Cyanide compounds, thiocyanates, and phenols were treated in fairly short flow times (7+ hours) with *Juncus*.

Systems must be carefully tended and monitored in field conditions. Water can flow through a gravel base

planted to purifying species, or for longer rest times, passed through lagoons and ditches.

Domestically, a comfrey bed is one way to absorb the faecal products of animals, where wash-water from yards or pens is available. Comfrey can stand heavy inputs of raw faeces in solution, and the crop may then be used for fodder or trenched for "instant compost" under other species of plants such as potatoes. Flowthrough systems for methane production take little plant nutrient from faecal matter, and comfrey or algae ponds deal with the residues, while producing useful by-products for compost and stock feed.

The water from sewage lagoons has been safely used to rear beef cattle at Werribee for 35 years, and at Hegerstown (Maryland, USA), sewage waters supplied

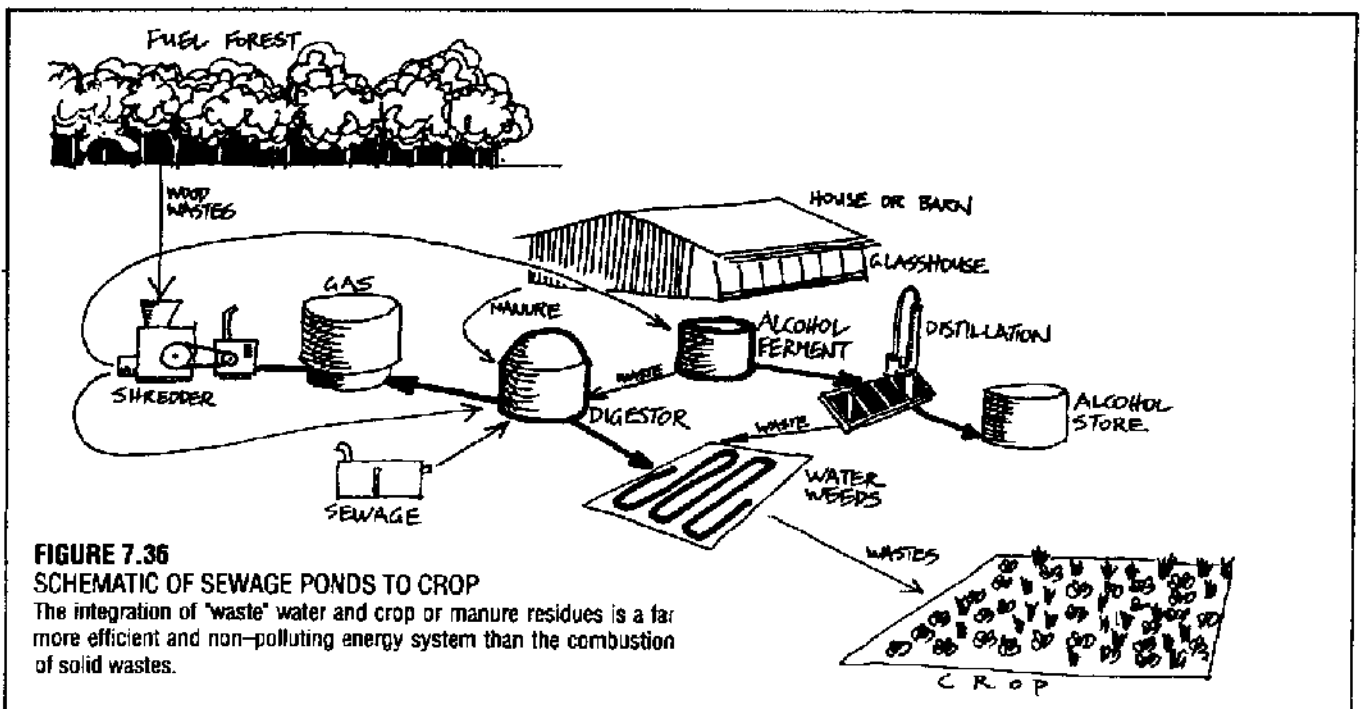

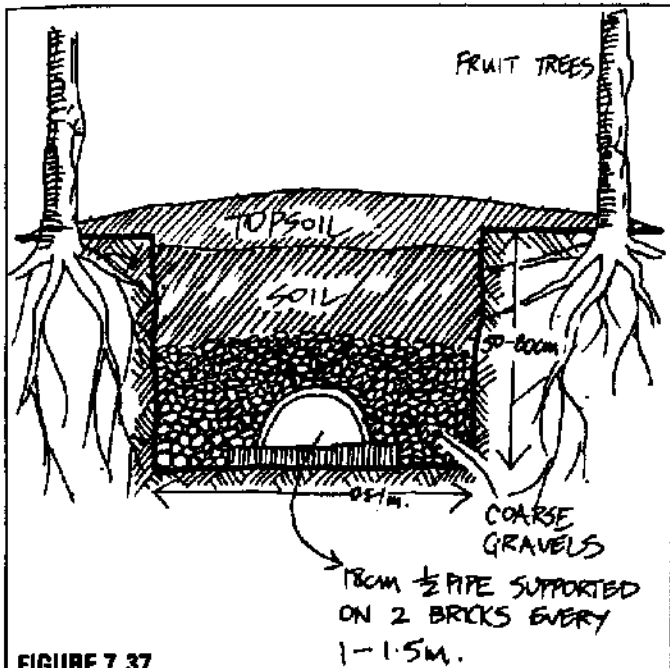

FIGURE 7.37

PITS FOR SEPTIC TANK DISPOSAL

Developed in South Australia as the 'Arbor' system. Supported half-pipe never clogs with tree roots, enables trees to remove waste water from trench which has cross-supports every 1.2 m to create 'pools'.

to selected coppiced poplar plots can produce (as wood chips) some 60% of town energy use. Obviously, water saved from reducing the extent of urban lawn systems can supply the remaining deficit plus food crop for any town.

As waters pass through towns, it may gain from 300-400 ppm in salinity—a grave factor in usage in any dryland area (*New Scientist*, 13 Oct. '77). Saline waters can cause problems in irrigated systems, but algae and plant production and removal will reduce this surplus salinity. Discharge of sewage to subsoils does not remove nitrogen compounds from sewage or farm run-off. Again, it is necessary to use productive pond production of algae to reduce nitrates to safe levels for discharge to soils, or we risk pollution of wells and bores, as has occurred in Israel and the USA.

As with garbage, separation of sewage into solids and liquids at the domestic level has productive advantages; 2% urea sprayed on the foliage of rice plants in padi has increased grain protein yields to 40% (11% protein by weight; *New Scientist*, 1 Sept. '77). Such separation can also be used to recover alcohol and chemicals from urine wastes. Urine diluted with water to a 5% solution controls moulds on cucurbits, and aids garden growth or compost activity generally.

In summary, it has long been apparent that modestly-designed sewage treatment systems based on

FIGURE 7.38

NATURAL SWIMMING POOLS

Water pumped down through base gravels is cleansed in reed beds, aerated via a flowform, and skimmed of leaf. Avoids carcinogenic chloroforms produced by chlorine used in pools. Slow flow through reed bed is essential, as are tests for the presence of *E. Coli* bacteria.

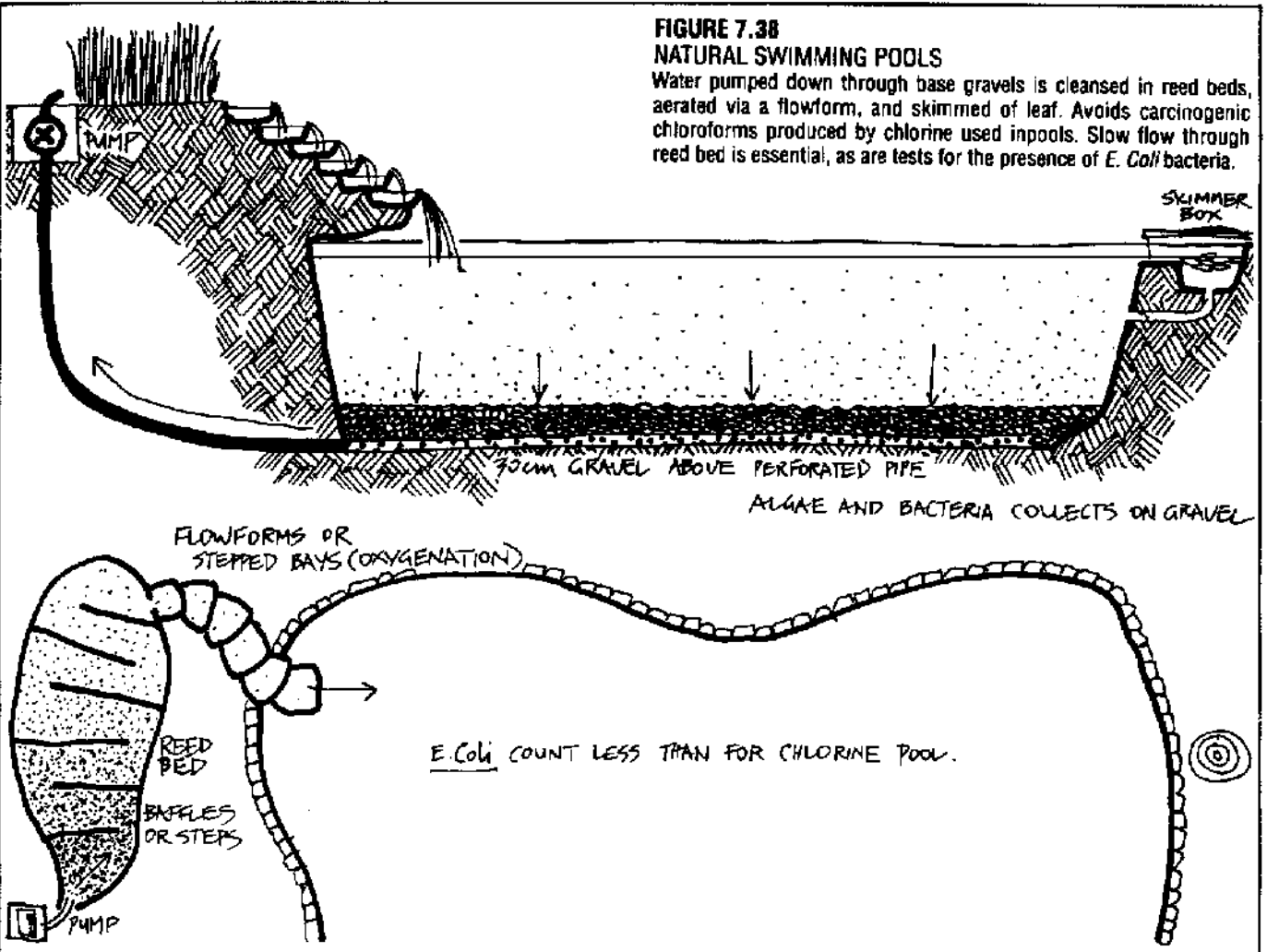

sealed (not leaky) lagoons and their associated biological systems not only function to recycle water efficiently, but to create a variety of yields from the 'wastes' of society. There are simply no modern excuses for continuing with the dangerous disposal of such wastes to seas and subsoils, where they inevitably turn up as pollutants in wells, streams, and on beaches, or add considerably to the greenhouse effect of atmospheric carbon dioxide. It is possible to design small and large systems of water treatment systems which are both biologically safe and productive.

Creative Disposal of Septic Tank Effluent

There are two basic productive disposal systems for septic tank effluent:

- Underground and surface leach fields around which trees are grown.
- Biogas conversion, followed by a pond growing aquatic crop for biogas feed stock, then a leach field.

A leach field is a trench or open gravelled soakage pit through which sewage wastes from a septic tank flows. In clays and clay-loams, tank water from a family home will stimulate fruit tree growth (without other irrigation) for 20 metres or more. The system follows normal procedures in that a long trench with a 1:12 ratio base slope is dug away from the septic tank outlet pipe. Topsoil is put to one side, and the trench is fitted with an 18 cm or larger half-pipe as per Figure 7.37. Coarse gravels or stones are placed in the trench, and

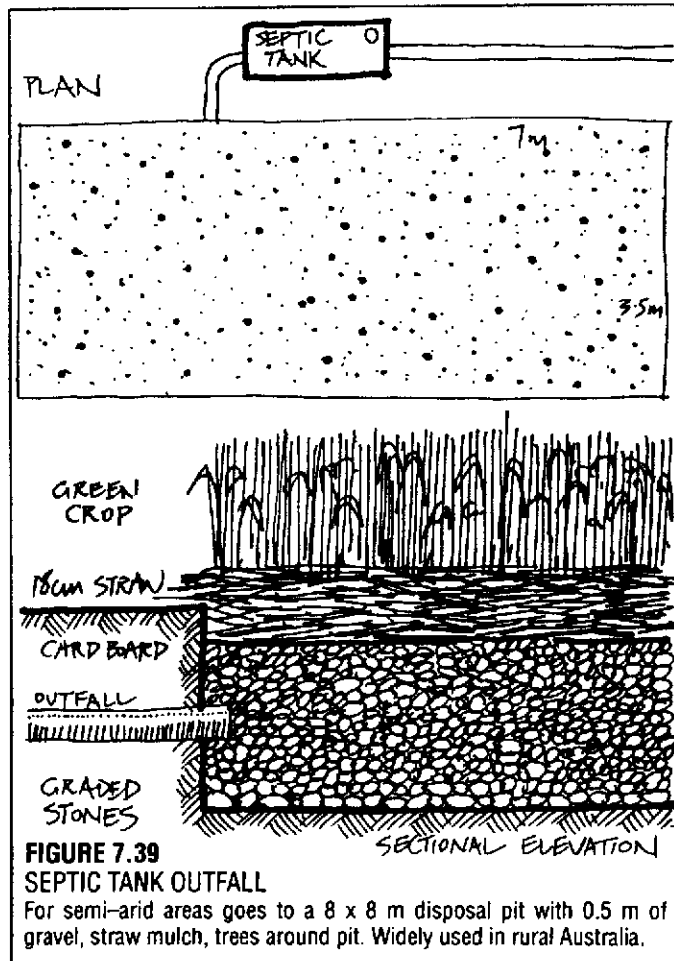

over all this a strip of plastic or tarpaper is placed. The trench is then back-filled and trees planted 1-2 m off both sides as 2-6 m spacing. All fruit and nut trees benefit.

Square or round pits about 25 m square can be dug out and filled with graded stone (coarse 6 cm at base to 2 cm at top). Over this, a layer of cardboard and a thick layer of straw is spread, and the latter sown to oats or green crop. Around the pit, trees can be planted.

For biogas applications, septic tank effluent, weeds, and manures are loaded into a tank 2 to 1.5 m deep and 3-4 m in diameter. A loading chute for weeds and wastes about 20 cm and 30 cm slants to the base. Septic tank effluent also enters at the base. Overflow goes to a pond with baffles, and *Pista*, watercress, or any rampant soft water weed is grown there. These are returned to the tank every week. A perforated pipe at the tank base is worked by a small gas compressor to "bubble" gas back into the tank for 1-3 hours daily on a timer. This breaks up the scum on top of the ferment. Gas caught in an inverted tank is fed to the house cooking range, lights, refrigerators. Surplus from the pond is fed to a leach field.

7.6

NATURAL SWIMMING POOLS

When thou wilt swimme in that live bath
 Each fish, which every channel hath
 Will amorously to thee swimme
 Gladder to catch thee than thou him...
 (John Donne)

Swimming pools have crept across the affluent suburbs so that, from the air, these ponds now resemble a virulent aquamarine rash on the urban fringe. The colour is artificial, like that blue dye that imitates an ocean wave obediently crashing down the toilet bowls of the overly-fastidious. Chemicals used to purify the water are biocides, and we are biological organisms; if fish can't live in our pools, we should also keep our bodies out of the water. When chlorine isn't being used as a war gas, it is being dumped into our drinking, bathing, and swimming water, where it forms carcinogenic chloroform.

Innovative pool designers now filter natural pools below a base pebble bed, using the pebbles as algal/bacterial cleaners, then cycle it through a reed-bed to remove excess nutrients before cascading it back, freshly oxygenated, into the pool. Such pools can be delightful systems with tame fish, crayfish, rock ledges, over-arching ferns, and great good health (Figure 7.38).

They are also reserves for fire-fighting, potential heat sources for heat pumps, barriers to fire, and emergency water supplies rechargeable from the roof, and can be recycled by photovoltaic pumps. Goodbye to the endless servicing, and perhaps hello to an occasional lobster or overgrown trout!

See *Excreta Disposal for Rural Areas and Small Communities* (Wagner and Lanoix) for specific testing and evaluation details. A rule of thumb is to limit the length of tile lines to less than 100 feet, with a distance between lines of at least three times the trench bottom width, assuming a minimum of 6 feet.

If the water table is very low, drain tiles might not be necessary at all; here you can use, for example, a sand filter. If possible, tile pipes should be at least 10 feet from the water table; at any lesser distance, the soil may become saturated by capillary action, thus preventing air from entering. Since the decomposition requires oxygen, we must avoid this condition to operate properly. Assuming that your tile line is properly laid, overloading generally results from poor soil or a faulty tank.

The septic tank, when operated properly, is a very convenient, dependable, and practical manner of disposing of human excreta. Its main drawbacks are that it requires great quantities of flushing water, the proper type and size of drainage area, and considerable amounts of materials and labor to install, consequently increasing the capital cost (which, by the way, can run from \$1000 to \$3000). Also, if clogging does occur, getting the system back into operation can be a sizable and expensive headache.

Oxidation Ponds

The oxidation-pond process offers a very good low-cost, low-maintenance treatment method for domestic wastewater. Oxidation ponds are shallow basins used to treat wastewater by storage under conditions that favor the growth of algae. The process takes advantage of algae's ability to trap solar energy through photosynthesis and to accomplish this capture in a symbiotic relationship with bacteria in the pond which utilize organic waste as their energy source.

There has been considerable use of oxidation ponds throughout the world to treat raw wastewater, but most of these setups are fairly large. How can we utilize this technique on a small-scale basis? And what are some of

the advantages and disadvantages of these ponds?

First, the good news: using an oxidation pond we can dispose of our wastewater; use the pond as an equalizing basin to absorb rapid fluctuations in the flow and strength of wastewater; produce algae for use as chicken feed; under appropriate conditions, provide ourselves with a duck and fish pond or a wildlife refuge; and accomplish all this at a low initial cost, when conditions are favorable and land is available.

But, in exchange for these advantages, we are stuck with a potential health hazard; with aesthetically unappealing conditions when maintenance is not proper; with possible contamination of groundwater and adjacent surface waters (pollution of surface waters can result from the accidental overflow or flooding of the pond); with the cost of maintenance and harvesting our algae; and, under certain conditions, with silting, overgrowth of algae and aquatic weeds, and the prolific breeding of mosquitoes and other flying insects.

Some of these problems are more easily dealt with than others. For example, the breeding of insects—particularly mosquitoes—can be prevented or controlled by raising top-feeding minnows in the pond (assuming there is sufficient oxygen available in the water). And we can avoid some of the dangers of using raw sewage by using only the effluent from a septic tank or methane digester; thus, we dispose of this treatment waste and yet capture the nutrient value still held in the waste effluent (see Figure 5.19). But under no circumstances should a small group consider using *raw sewage* as a *direct source* for the pond; the health hazards are too great.

Because of this risk, let's assume that we are utilizing the effluent from a digester as our main flow source for the oxidation pond. We also assume that the size of the community is about ten families with a total of maybe 40 people. But before moving on to any specific design details, we should spend a little more time exploring some of the process features to get a better conceptual idea of how this system works.

Bacteria and Algae

In shallow ponds, bacterial growth is supported by aerated water and the presence of organic waste. The

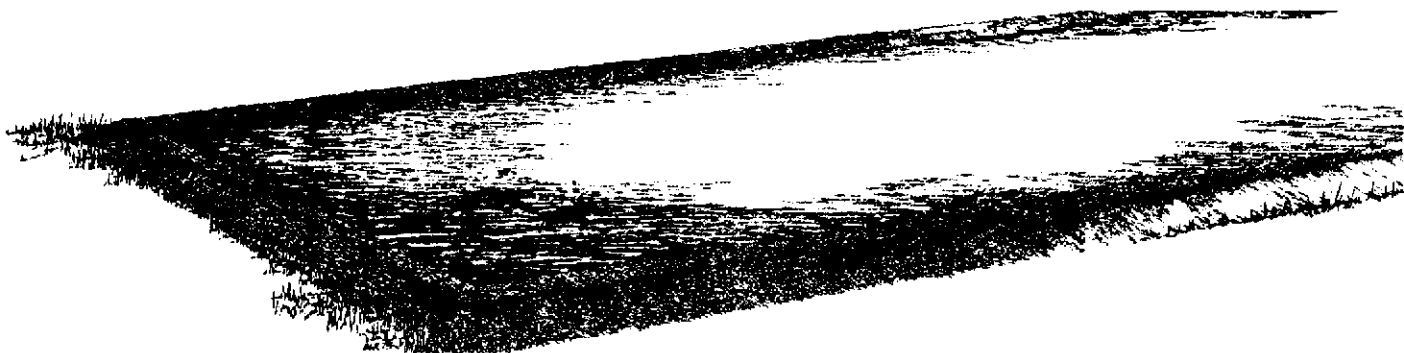

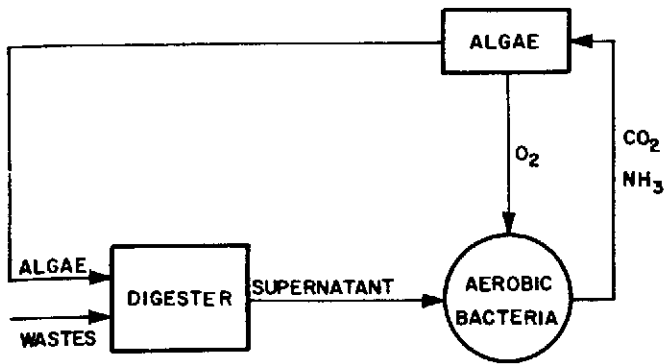

Figure 5.19 Flow diagram of an oxidation pond/anaerobic digester system.

bacteria aerobically oxidize the waste organics in the water, producing carbon dioxide and different mineral-nitrogen compounds. In the presence of light, algae will grow in the pond by using the bacterial by-products of carbon dioxide and mineral nutrients. The algae, in turn, release oxygen into the water. This process is known as photosynthesis and is shown in Figure 5.20.

Since photosynthesis can proceed only with sufficient solar radiation, it is obvious that the symbiosis cannot operate during the night. Because photosynthetic efficiency changes with the intensity of light, seasonal effects also are important.

During the day, aerobic decomposition of the waste occurs. At night, however, as the amount of carbon dioxide increases in the water, anaerobic oxidation takes place and the pH decreases (CO_2 in the water increases acidity) if the load of wastes in the pond is too heavy. When light returns, the algae consume the CO_2 and restore a favorable pH for aerobic action. By producing oxygen, these plants stop possible anaerobic oxidation.

Another source of oxygen is a daily cycle of gentle mixing and destratification by the actions of wind and temperature. The ratio of aeration by daily cycle to aeration by photosynthesis increases with the dimensions of the pond. Since we are considering a pond for a small community, it is assumed that the major source of oxygen is the oxygen produced by the algae. And, since we only consider aeration by photosynthesis in our design, there will be excess oxygen due to gas transfer from the air. This excess may allow the cultivation of fish in the pond (see Chapter 7 for further details).

Because algae play such a vital role, we must pay some attention to their requirements and the rewards they bestow on us. Nitrogen and phosphorus both stimulate algal growth and these two nutrients are important for favorable operation of oxidation ponds. A study of the nutritional requirements of algae in oxidation ponds by Oswald and Gotaas (1955; see Bibliography) determined that normal domestic sewage contains enough phosphorus to support an algae culture concentration of 400 ppm. Nor are magnesium and potassium

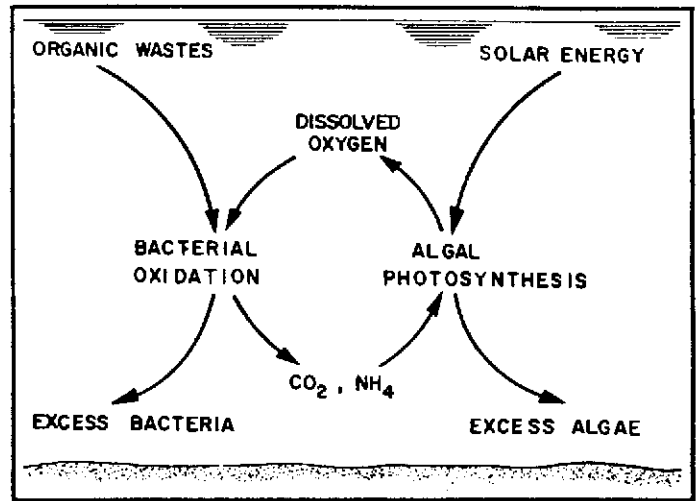

Figure 5.20 The symbiotic processes of bacteria and algae in oxidation ponds.

limiting elements, since normal domestic sewage contains sufficient magnesium and potassium to support a 500-ppm concentration of algae. These workers found that carbon is the usual limiting element. This condition is partially alleviated by the culture becoming basic due to photosynthesis, which in turn causes absorption of atmospheric carbon dioxide, a usable source of carbon. Nutrition seems to be the limiting factor up to 300-ppm concentrations of algae. Beyond that, the limiting factor is the amount of available light for photosynthesis.

The biochemical oxygen demand (*BOD*) is the amount of oxygen required to degrade or destroy organic material via bacterial action. Figure 5.21 (from Oswald and Gotaas) relates algal yield to the *BOD* of a cultural medium. An average *BOD* of 250 ppm can be assumed for our oxidation pond and this would produce concentrations of algae of 280 ppm, just below the limiting values imposed by nutritional or photosynthetic light demands (we will discuss the *BOD* more fully in a while).

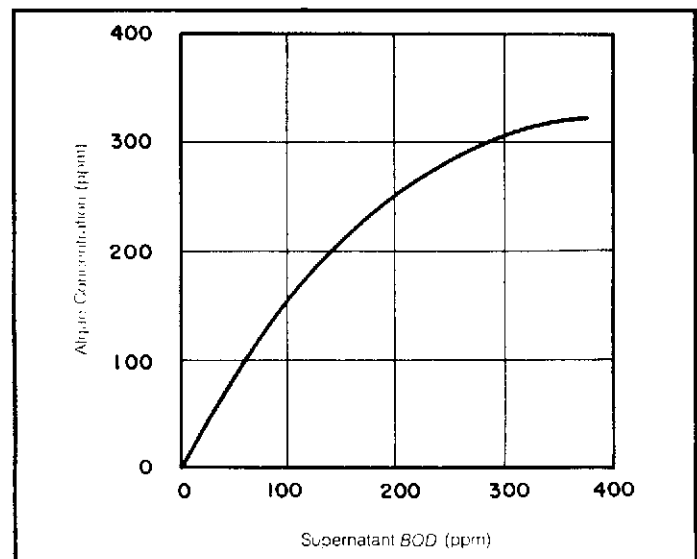

Figure 5.21 The relationship of *BOD* to algae in an oxidation pond.

The ability of algae to scavenge phosphorus, nitrogen, and *BOD* from effluents is highly useful to prevent contamination of water sources close to waste-treatment facilities. During high photosynthetic activity, both nitrogen and phosphorus are removed efficiently, providing an effluent water of a quality generally acceptable for most of the sources into which it may flow. But it is best and most safely used for irrigation purposes.

The quantity of water required to produce a pound of protein by using algae as feed can be less than a hundredth of that required by conventional agricultural methods. Wastewater-grown algae have been fed to a number of animals with no evidence of unsatisfactory results. For example, the value of this kind of food as a supplement to chicken feed is now approximately \$250 per ton. The rate of algal yield may vary from 1 ton per acre per month in winter to 5 tons in summer. If we compare this yield to that of field crops, we find that it is twenty times the agricultural average.

The high protein content (more than 50 percent) is not the only important property of the algae. They may become an important source of vitamins, of raw products for organic synthesis, and also of such elements as germanium (which algae concentrate). Moreover, the fuel characteristics of dry algae are similar to those of medium-grade bituminous coal, although their heat content is somewhat less (ranging up to 10,000 Btu/pound). Algae also may be used as a carbon source for digesters producing methane by fermentation.

Wastewater and the *BOD*

Before we can begin our design calculations, we need to know some basic information about our wastewater characteristics and the quantity of flow. Earlier we mentioned the *BOD* (biochemical oxygen demand), because wastewater strength is generally measured in terms of the amount of oxygen required by aerobic bacteria to oxidize organic wastes biologically (to CO_2 and H_2O). The amount of oxygen required to completely oxidize the organic matter in a wastewater is called the *ultimate* or *maximum BOD*. For a family of four, the average waste load is about 0.695 pounds of *BOD* per day, and the wastewater volume produced is around 200 gallons; the concentration then is about 300 to 400 ppm of *BOD*. After the raw wastewater has been processed by a digester or septic tank, the effluent contains a concentration on the order of 75 to 150 ppm of *BOD*. (If animal wastes and other materials are being added to the digester, the concentration in the effluent may be higher, around 300 to 400 ppm.)

We can estimate the volume of wastewater flow at about 50 gallons per day per person. In the design we are considering, we have ten families with around forty people; this gives us an average daily flow of about 2000 gallons per day.

In temperate areas, winter temperatures can be low enough so that the rates of all biological reactions (photosynthesis, aerobic and anaerobic oxidation) fall severely, even if no ice cover occurs—little waste stabilization takes place beyond sedimentation. For an oxidation pond, consequently, concentration of wastes in winter remains higher than in summer. Because anaerobic oxidation (the primary source of odors, by the way) is also reduced, we design the pond for the winter period.

By way of contrast, in a tropical area during the summer (temperature over 73°F), stratification is intense and anaerobic conditions and fermentation are dominant in the lower two-thirds of the pond. If winter temperatures are high, stratification is absent and waste stabilization is high. In this case, the pond should be aerated mechanically during the summer.

As we have mentioned, a large oxidation pond receives the main part of its oxygen from the air; in a small pond, the oxygen comes from the biological process of photosynthesis. Concentrated wastes require a dense algal growth (which needs lots of light) and so the depth of the pond has to be shallow to allow a sufficient penetration of the light; dilute domestic wastewater may be processed at greater depth. In order to provide a detention period suitable for effective photosynthetic oxygen production during both winter and summer, certain compromises are necessary.

Perhaps a few broader remarks are now in order. We must design for the winter months because that is the period of slowest biological activity. In the summer, the efficiency of a pond designed for winter months is very low. Without proper variations in operating procedures, the result can be overproduction of algae, a part of which may die, decompose, and produce a pond effluent with a high supernatant *BOD*. On the other hand, if we design for midsummer months, our detention time will be very low (about a day or so) and, during the winter, the algae will be unable to grow fast enough to prevent being washed out of the pond. So, in order to provide a detention period suitable for effective photosynthetic oxygen production in both winter and summer and with some capacity to sustain changes in light, temperature, and shock loading, we reiterate: certain compromises are necessary.

In general, we can note that, for most conditions, detention times should not be less than a day for summer conditions nor more than 10 to 12 days for winter conditions. A pond having a detention period of about 3 days and a depth of 12 inches should, for example, satisfactorily produce adequate oxygen by photosynthesis more than 80 percent of the time (latitudes up to 40°N), so long as continuous ice cover does not occur.

Now we must get acquainted with the design equa-

tions and the various parameters necessary for a successful design calculation.

Computation of Depth

We can obtain an approximation of the depth of an oxidation pond by using the following formula:

$$E. 5.36 \quad d = \frac{\ln(I_i)}{C_c \alpha}$$

where d equals the depth (cm); I_i equals the incident light intensity (footcandles); \ln indicates a mathematical operation—the natural logarithm of I_i ; C_c equals the concentration of algal matter; and α equals a specific absorption coefficient.

The estimation of $\ln(I_i)$ can be obtained by the following steps:

1. Find the maximum and minimum total solar radiation for the relevant latitude from Table 5.12.
2. Make necessary corrections for cloudiness and elevation (see Equations 5.37 and 5.38).
3. Multiply the resulting value by 10.
4. Multiply the result of the third step by the fraction of time the sun is visible for the approximate latitude and month as determined from Figure

5.22. This gives us a value for I_i .

5. Refer to Table 5.13 for logarithmic values, using I_i as the value of N . The listed value gives us $\ln(I_i)$ for use in Equation 5.36.

The correction for cloudiness—that is, what percent of the time we actually have clear weather and thus available solar radiation—is given by

$$E. 5.37 \quad \text{Total Radiation} = \text{min} + (\text{max} - \text{min}) \times \left(\frac{\% \text{ time clear}}{100} \right)$$

where minimum and maximum values also are given in Table 5.12 (use “total,” not “visible”). This gives the corrected total for sea level. The correction for a particular elevation is given by

$$E. 5.38 \quad \text{Total Radiation} = (\text{total at sea level}) \times [1 + (0.0185 \times \text{elevation})]$$

where elevation is expressed in thousands of feet: that is, an elevation of 2500 feet would be 2.5 in the above equation. And summarizing from steps “3” and “4”

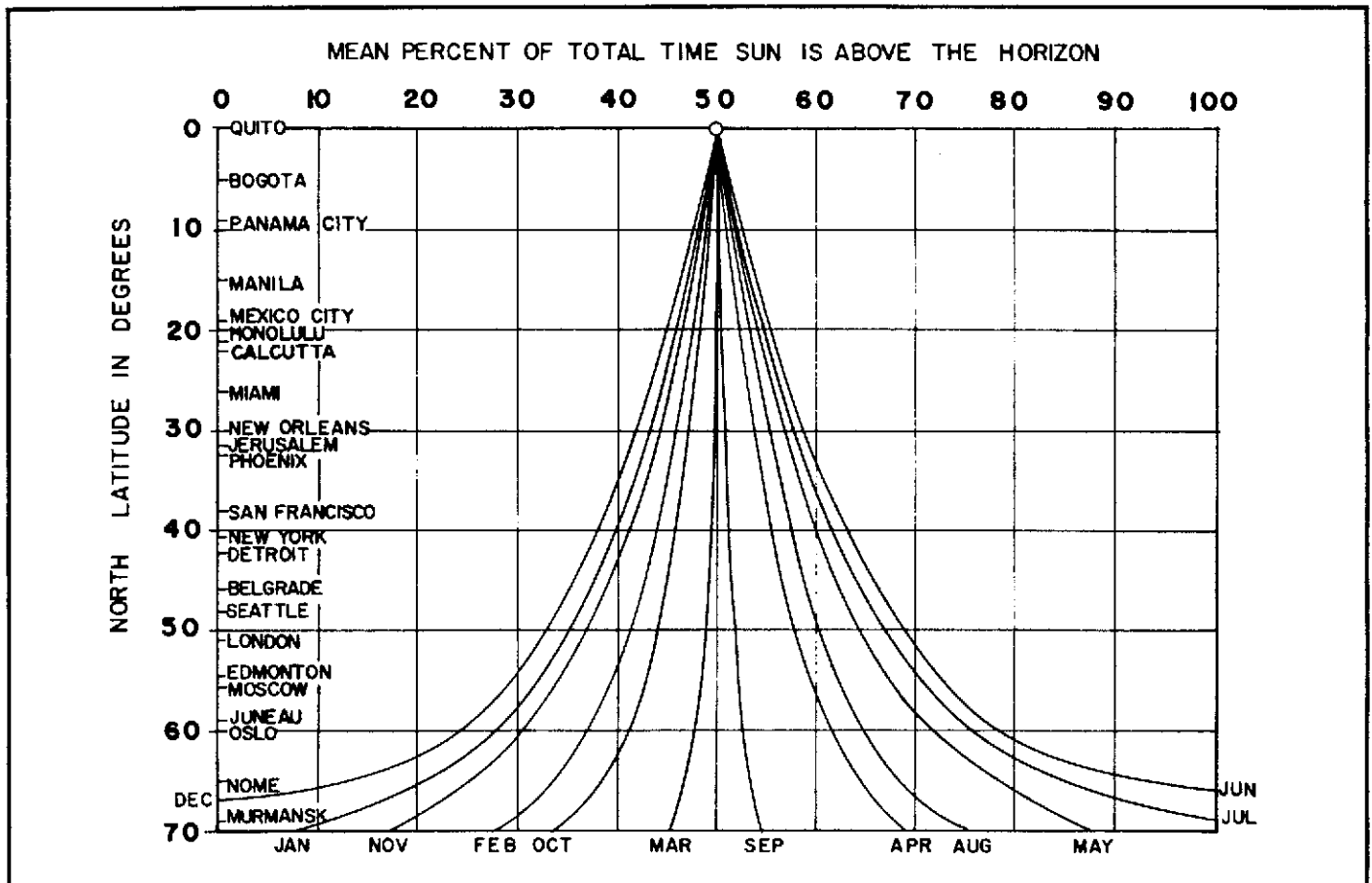

Figure 5.22 The mean percent total time the sun is above the horizon as a function of latitude for the northern hemisphere.

above, we can express I_i as

$$E. 5.39 \quad I_i = 10 \times \left(\frac{\% \text{ time sun above horizon}}{100} \right) \\ \times \text{Total Radiation}$$

It also turns out that we have available figures for C_c and α : C_c is usually from 100 to 300 ppm; α is generally taken to be 0.0015. So, let's try an example to get a feel for all these equations and numbers.

Example: Designing for winter temperatures, we want to estimate the depth of an oxidation pond to be built near San Francisco (latitude 37°N) at an elevation of 1000 feet with clear weather 50 percent of the time in December.

Solution: From Table 5.12, we get maximum total radiation equals 290 Langleys per day and the minimum total radiation equals 111 Langleys per day. Using Equation 5.37 to correct for clear weather only 50 percent of the time, we find

$$\text{Total Radiation} = 111 + (290 - 111) \left(\frac{50}{100} \right) \\ = 200.5 \text{ Langleys/day}$$

The correction for elevation is made using Equation 5.38:

$$\text{Total Radiation} = (200.5) \\ \times [1 + (0.0185 \times 1)] \\ = 204.21 \text{ Langleys/day}$$

Now using Equation 5.39, we must multiply our result by 10 and by the fraction of the time the sun is visible above the horizon (from Figure 5.22 we see that this fraction for December is nearly 40 percent):

$$I_i = 10 \times \frac{40\%}{100} \times 204.21 \\ = 816.8 \text{ footcandles}$$

If you check for $\ln(I_i)$ in Table 5.13, you find that the natural logarithm of 816.8 is about 6.705. Now we can calculate the depth of the pond, using 0.0015 for α and 200 ppm for C_c with Equation 5.36:

$$d = \frac{\ln(I_i)}{C_c} = \frac{6.705}{200 \times 0.0015} \\ = 22.35 \text{ cm} = 8.80 \text{ in}$$

where 1 inch equals 2.54 centimeters.

Computation of Algal Concentration

The concentration of algal cells can be estimated from the following equation:

$$E. 5.40 \quad C_c = \frac{L_t}{P}$$

where C_c equals the concentration of algae cells (ppm; in the depth calculation, we used only an average figure); L_t equals the BOD removal (ppm); and P equals the ratio of the weight of oxygen produced to the weight of algae produced. P has been found to be in the range 1.25 to 1.75, with a value of 1.64 recommended.

Computation of Detention Time and Area

The detention time is the average length of time the wastewater will stay in the oxidation pond and is given by the following formula:

$$E. 5.41 \quad DT = \frac{(h \times L_t \times d)}{(F \times P \times T_c \times S)} \times 0.001$$

where DT equals the detention time (days); h equals the unit heat combustion of algae (6 cal/mg); L_t equals the BOD removal (ppm); d equals the depth (cm); F equals the efficiency of energy conversion (about 0.06); P equals 1.64; T_c equals a temperature coefficient from Table 5.14; and S equals the insolation (visible radiation) from Table 5.12.

The efficiency of light conversion (F) in outdoor oxidation ponds ranges between 1 and 10 percent, with most values in the narrow range of 3 to 7 percent. In general 6 percent is a good approximation.

Table 5.14 Temperature Coefficients for Chlorella

Mean Temperature (°F)	Photosynthetic Temperature Coefficient (T_c)
32	—
41	0.26
50	0.49
59	0.87
68	1.00
77	0.91
86	0.82
95	0.69
104	—

Notes: a. From "Photosynthesis in Sewage Treatment" (1957) by W.J. Oswald and H.B. Gataas. Data determined in pilot-plant studies.

The visible solar radiation (S) can be found in Table 5.12. For example, in Sacramento (38°N) in December, S equals 34 cal/day-cm^2 . Corrections still need to be made for percent clearness and elevation. We still use Equation 5.37 for cloudiness corrections, but there is another formula for elevation corrections for visible radiation:

$$E. 5.42 \quad S = (\text{total visible at sea level}) \\ \times [1 + (0.00925 \times \text{elevation})]$$

Example: Consider a small group of 40 people using flush toilets and a methane digester where the digester effluent has a BOD of about 125 ppm. We want to design an oxidation pond for the winter conditions used in the previous example (the depth calculation in San Francisco, at 37°N latitude and an elevation of 1000 feet; clear weather 50 percent of the time in December). Let us also suppose that the mean temperature is 50°F .

Solution: We can compute C_c by knowing L_i and using the value for P of 1.64. In this case, let's suppose L_i equals 125 ppm. Then

$$C_c = \frac{L_i}{P} = \frac{125}{1.64} \\ = 76.2 \text{ ppm}$$

The depth of the oxidation pond can now be computed as before from Equation 5.36:

$$d = \frac{\ln(816.8)}{76.2 \times 0.0015} \\ = 58.71 \text{ cm} = 23.11 \text{ in}$$

Quite a change! The depth has gone from less than 9 inches to over 23 inches. Now we need to compute the detention time (DT) of the pond. Using Equations 5.37 and 5.42 with the value for visible radiation at 38°N latitude from Table 5.12, we correct for an elevation of 1000 feet for 50 percent cloudiness:

$$S = \text{min} + (\text{max} - \text{min}) \left(\frac{\% \text{ time clear}}{100} \right) \\ = 30 + (77 - 30) \left(\frac{50}{100} \right) \\ = 53.5 \text{ Langley/day}$$

Now correcting for altitude where elevation is in thousands of feet:

$$S = (\text{visible at sea level}) \\ \times [1 + (0.00925 \times \text{elevation})] \\ = 53.5 \times [1 + (0.00925 \times 1)] \\ = 54.0 \text{ Langley/day}$$

From Table 5.14, we find T_c equals 0.49 for 50°F mean temperature. Assuming we remove 80 percent of the BOD (a good average value) from our effluent, we can now compute the detention time with Equation 5.41:

$$DT = \frac{6 \times 100 \times 58.71}{0.06 \times 1.64 \times 0.49 \times 54.0} \times 0.001 \\ = 13.5 \text{ days}$$

From Table 5.9, we estimate the average flow Q to be 2000 gallons per day for a community of 40.

We now know the detention time (DT), the depth (d), and the flow (Q); the surface area of the pond can be computed from the volume (V) which is given by the equation

$$E. 5.43 \quad V = Q \times DT \\ = 2000 \times 13.5 \\ = 27,000 \text{ gal} = 3609.6 \text{ ft}^3$$

The area (A) is then given by

$$E. 5.44 \quad A = \frac{V}{d} \\ = \frac{3610}{23.1} \times 12 \\ = 1875 \text{ ft}^2$$

or roughly a square 43 feet on a side—a fair-sized pond. Notice that the volume was given in cubic feet and the depth in inches; that is why we multiplied V/d by 12.

Construction and Maintenance

The ideal soil for pond construction is relatively impervious so that there will not be excessive seepage (concrete-lined ponds are actually best). Embankments around ponds should be constructed of compacted impervious material and have inside slopes of 2.5:1 as a maximum and 4:1 as a minimum, with outside slopes 2:1 as a minimum. The inside surface should be sodded as well as the outside; for small oxidation ponds, a plastic

coat can be used. Top width should not be less than 8 feet and the freeboard should be 2 feet at a minimum, with more where considerable agitation is expected. Overflows may be constructed at the side. Care should be taken to prevent bank erosion at outlets or inlets if these also are in the embankments. The pond bottom should be level. As a final suggestion, you might enclose the pond to hinder access to animals and children. (For further information on construction details, see Chapters 3 and 7 and the literature listed in the Bibliography.)

Detention times should be kept near 3 or 4 days in the winter and 2 or 3 days in the summer. Ponds should be kept at a depth of 8 to 10 inches in the winter and 12 to 18 inches in the summer. Cultures should be mixed thoroughly once a day, but not continually. These figures assume climatic conditions of Richmond, California, but give a general idea of the ranges you will encounter. Average algal yield under these conditions is about a pound of dry algae per 500 gallons of supernatant from your digester.

Other maintenance consists of elimination of emergent vegetation, care of embankments, and control of possible insects.

Another aspect of the use of oxidation ponds is a reduction in the number of pathogenic organisms in waste. In the case of a single pond, it has been reported that 90 percent of the bacteria are killed during the first 6 days of detention time. But this is for raw sewage, not the already-treated effluent of a digester or septic tank. Even though we recommend detention times shorter than 6 days the prior use of the digester and/or septic tank has reduced the hazard significantly.

For those instances when the oxidation pond is fed raw sewage, the only way to obtain a better efficiency figure is to build ponds in series, which takes the wastewater of several thousand people to be viable. If, instead, we try to increase the detention time to treat the wastes longer, we run the risk of creating anaerobic conditions. Under such conditions, mortality of pathogenic fecal organisms appears to be very low. Rapid oxidation of organic matter accelerates the accumulation of sludge in a pond, especially in a small one. We can offset this sludging, which is a source of anaerobic conditions, by increasing the dilution factor of our supernatant input, controlling our algae crop, distributing the load through multiple inlets or through one in the middle of the pond, and orientating the pond to obtain the maximum benefit of wind mixing and aeration. Normally, the water at the output of the oxidation pond can be used for irrigation, or it can be placed in a stream or receiving water, if necessary; but we recommend you have a bacteriological test done on it first.

Harvesting and Processing Algae

Methods of harvesting and processing depend on the

uses to which the algae will be applied. For example, a high-grade algae is required for use in a digester, and a higher grade yet is necessary when algae are used as a livestock feed.

Processing involves three steps: initial concentration or removal, dewatering, and final drying. The difficulty with harvesting algae lies in the small size and low specific gravity of the particles, characteristics which give them a slow settling rate.

Concentration can be accomplished most easily by precipitation and there are several means available. Cationic flocculants under the trade names Purifloc 601 and Purifloc 602 can be used to gather algae into a cohesive mass. At concentrations of 10 ppm (at pennies per ton of harvest), 100 percent removal of the algae is possible; at 3 ppm, 95 percent removal is possible. In terms of speed, with concentrations of 10 ppm, 90 percent removal is possible with a 4-hour settling time, while 98 percent removal is possible for a 24-hour settling time. The use of lime to raise pH above 11 causes a gelatinous coagulation of the algae. Use of 40 ppm of ferric sulphate and 120 ppm of lime gives the best harvesting results, but the slurry and supernatant then contain objectional amounts of iron. Alum also can be used at neutral pH for precipitation; concentrations of 90 ppm give 98 percent removal with settling complete in 2 to 3 hours.

Dewatering, the second step, can be accomplished by centrifugation, filtering, or by use of a sand bed (ranked in descending order of expense). Centrifugation involves far too substantial a cost for a small-scale operation. But industrial nylon filters give concentrations of 8 to 14 percent solids within 24 hours; the speed of filtering, however, rapidly decreases as an algae cake forms on the nylon. Also, a 2-inch slurry on paper filters on a sand bed dewatered and dried to 12 to 15 percent solids in 24 hours.

A sand bed can be used for both dewatering and drying through drainage evaporation. The amount of sand embedded in the dried product increases with sand particle size. Golueke and Oswald used sand which passed through a 50-mesh screen (opening 0.297 mm); with a slurry depth of 5 inches, they obtained 7 to 10 percent solids after 24 to 48 hours, and after 5 to 7 days the algae contained only 15 to 20 percent water. The dry algae chips then were collected by raking. These chips were sieved over a 0.16-cm mesh screen to remove most of the sand, 2 to 3 percent of the total dry weight. For a slurry of 1.6 percent solids, Golueke and Oswald estimated that a square foot of drying bed would be needed for each 7 square feet of pond area. Although sand dewatering and drying was the most economical of the processes they considered, they indicated that cost increased substantially for all processes as the scale of the operation decreased.

Final Comments

Hopefully, enough now has been said to allow you to select the most appropriate waste-handling technique or process for your needs—be it digester, septic tank, or Clivus Multrum. You will undoubtedly work through several designs as you evaluate the trade-offs between costs, benefits, convenience, and reliability; these systems are most suitable for a rural or suburban setting. But no matter which design (if any) you select, there are always a few things to keep in mind. Always design from a conservative position—overestimate your needs and underestimate your supply, be it your water supply or your gas or disposal needs. A second point is that when you move to the operation and maintenance of your systems, you must always be concerned with factors of health and safety. The potential for explosion with a methane digester is always present and contamination of a water supply is always possible—proper operation and maintenance procedures minimize, but do not remove, dangerous possibilities. With these few points in mind, you should be able to move toward a higher degree of self-sufficiency both safely and efficiently.

Bibliography

Methane Digesters

- Barker, H.A. 1965. "Biological Formation of Methane." *Industrial and Engineering Chemistry* 48:1438–42.
- Buswell, A.M. 1947. "Microbiology and Theory of Anaerobic Digestion." *Sewage Works Journal* 19:28–36.
- . 1954. "Fermentations in Waste Treatment." In *Industrial Fermentations*, eds. L.A. Underkofter and R.J. Hickey. New York: Chemical Publishing Co.
- Buswell, A.M., and Mueller, H.F. 1952. "Mechanism of Methane Fermentation." *Industrial and Engineering Chemistry* 44:550–52.
- DeTurk, E.E. 1935. "Adaptability of Sewage Sludge as a Fertilizer." *Sewage Works Journal* 7:597–610.
- Eckenfelder, W.W., and O'Connor, D.J. 1961. *Biological Waste Treatment*. London: Pergamon Press.
- Erickson, C.V. 1945. "Treatment and Disposal of Digestion Tank Supernatant Liquor." *Sewage Works Journal* 17:889–905.
- Fischer, A.J. 1934. "Digester Overflow Liquor—Its Character and Effect on Plant Operation." *Sewage Works Journal* 6:956–65.
- Fry, L.J. 1974. *Practical Building of Methane Power Plants for Rural Energy Independence*. Santa Barbara, Calif.: Standard Printing.
- Gilbert, K. 1971. "How to Generate Power from Garbage." *Mother Earth News* 3.
- Greely, S., and Valzy, C.R. 1936. "Operation of Sludge Gas Engines." *Sewage Works Journal* 8:57–63.
- Kappe, S.E. 1958. "Digester Supernatant: Problems, Characteristics and Treatment." *Sewage and Industrial Wastes* 30:937–52.

- Kelly, E.M. 1937. "Supernatant Liquor—A Separate Sludge Digestion Operating Problem." *Sewage Works Journal* 9:1038–42.
- Klein, S.A. 1972. "Anaerobic Digestion of Solid Wastes." *Compost Science* 13:6–11.
- McCabe, B.J., and Eckenfelder, W.W., Jr. 1958. *Biological Treatment of Sewage and Industrial Wastes*, vol. 2. New York: Reinhold.
- McCarty, P.L. 1964. "Anaerobic Waste Treatment Fundamentals." A series of monthly articles in *Public Works*, September–December 1964.
- McNary, R.R., et al. 1951. "Methane Digestion Inhibition by Limonene." *Food Technology* 5.
- Merrill, R., and Fry, L.J. 1973. *Methane Digesters for Fuel Gas and Fertilizer*. Santa Barbara, Calif.: New Alchemy Institute.
- Merrill, R.; Missar, C.; Garge, T.; and Bukey, J., eds. 1974. *Energy Primer*. Menlo Park, Calif.: Portola Institute.
- Metcalf and Eddy, Inc. 1972. *Wastewater Engineering—Collection, Treatment, Disposal*. New York: McGraw-Hill.
- Morris, G. 1973. "Methane for Home Power Use." *Compost Science* 14:11.
- Nishihara, S. 1935. "Digestion of Human Fecal Matter, with pH Adjustment by Air Control (Experiments with and without Garbage)." *Sewage Works Journal* 7:798–809.
- O'Rourke, J.T. 1968. *Kinetics of Anaerobic Waste Treatment at Reduced Temperatures*. Ph.D. Dissertation, Stanford University.
- Perry, J.H. 1963. *Chemical Engineers Handbook*. New York: McGraw-Hill.
- Rudolfs, W., and Fontenelli, L.J. 1945. "Relation Between Loading and Supernatant Liquor in Digestion Tanks." *Sewage Works Journal* 17:538–49.
- Sanders, F.A., and Bloodgood, D.E. 1965. "The Effect of Nitrogen-to-Carbon Ratio on Anaerobic Decomposition." *Journal Water Pollution Control Federation* 37:1741–52.
- Sawyer, C.N., and McCarty, P.L. 1967. *Chemistry for Sanitary Engineers*. 2nd ed. New York: McGraw-Hill.
- Singh, R.B. 1971. *Bio-gas Plant—Generating Methane from Organic Wastes*. Ajitmal, Etawah (U.P.) India: Gobar Gas Research Station.
- Speece, R.E., and McCarty, P.L. 1964. "Nutrients Requirements and Biological Solids Accumulation in Anaerobic Digestion." *First International Conference on Water Pollution Research*. London: Pergamon Press.
- Standard Methods. 1971. *Standard Methods for the Examination of Water and Wastewater*. 13th ed. Washington, D.C.: American Public Health Association.
- Talaganides, E., and Hazen, T. 1966. "Properties of Farm Animal Excreta." *Transactions of American Society Agricultural Engineering* 9.

Other Waste-Handling Techniques

- Babbitt, H.E. 1937. *Engineering in Public Health*. New York: John Wiley and Sons.
- Babbitt, H.E., and Bauman, E. 1958. *Sewerage and Sewage Treatment*. New York: John Wiley and Sons.
- Basbore, H.B. 1905. *The Sanitation of a Country House*. New York: John Wiley and Sons.
- Caldwell, D.H. 1946. "Sewage Oxidation Ponds Performance, Operation and Design." *Sewage Works Journal* 18:433–58.
- Canale, R.P., ed. 1971. *Biological Waste Treatment*. New York: Wiley-Interscience.
- Clark, J.W.; Viessman, W.; and Hammer, M. 1971. *Water Supply and Pollution Control*. Scranton, Pa.: International Textbook Co.

- Cox, C.R. 1946. *Laboratory Control of Water Purification*. New York: Case-Sheppard-Mann.
- Ehler, V.M. 1927. *Municipal and Rural Sanitation*. New York: F.D. Davis Co.
- Ehler, V.M., and Steele, E.W. 1950. *Municipal and Rural Sanitation*. 4th ed. New York: McGraw-Hill.
- Fair, G.M., and Geyer, J.C. 1954. *Water Supply and Waste-Water Disposal*. New York: John Wiley and Sons.
- Fair, G.M.; Geyer, J.C.; and Okun, D.A. 1968. *Water and Wastewater Engineering*. New York: John Wiley and Sons.
- Gainey, P.L., and Lord, H. 1952. *Microbiology of Water and Sewage*. New York: Prentice-Hall.
- Golueke, C.G. 1970. *Comprehensive Studies of Solid Waste Management; First and Second Annual Reports*. Washington, D.C.: Bureau of Solid Waste Management, Public Health Service, U.S. Department of Health, Education and Welfare.
- Golueke, C.G., and Oswald, W.J. 1957. "Anaerobic Digestion of Algae." *Applied Microbiology* 5:47-55.
- . 1959. "Biological Conversion of Light Energy to the Chemical Energy of Methane." *Applied Microbiology* 7:219-27.
- . 1963. "Power from Solar Energy—Via Algae-Produced Methane." *Solar Energy* 7:86.
- . 1965. "Harvesting and Processing Sewage-Grown Planktonic Algae." *Journal Water Pollution Control Federation* 37:471-98.
- Herring, S.A. 1909. *Domestic Sanitation and Plumbing*. New York: Gurney and Jackson.
- Hills, L.D. 1972. "Sanitation for Conservation." *Ecologist*, November 1972.
- Hopkins, E.S., and Elder, F.B. 1951. *The Practice of Sanitation*. 1st ed. Baltimore: Williams and Wilkins Co.
- Hopkins, E.S., and Schulze, W.H. 1954. *The Practice of Sanitation*. 2nd ed. Baltimore: Williams and Wilkins Co.
- Imhoff, C. 1956. *Sewage Treatment*. New York: John Wiley and Sons.
- Jayangoudar, I.S.; Kothandaraman, V.; Thergaonkar, V.P.; and Shaik, S.G. 1970. "Rational Process Design Standards for Aerobic Oxidation Ponds in Ahmedabad." *Journal Water Pollution Control Federation* 42:1501-14.
- Kibbey, C.H. 1965. *The Principles of Sanitation*. New York: McGraw-Hill.
- Ligman, K.; Hutzler, N.; Boyle, W.C. 1974. "Household Wastewater Characterization." *Journal of the Environmental Engineering Division, ASCE* 100:201-13.
- Marais, G.R. 1974. "Fecal Bacterial Kinetics in Stabilization Pond." *Journal of the Environmental Engineering Division, ASCE* 100:119-39.
- Minimum Cost Housing Group. 1973. "Stop the Five Gallon Flush." Available from: School of Architecture, McGill University, P.O. Box 6070, Montreal 101, Quebec, Canada.
- Mitchell, R. 1972. *Water Pollution Microbiology*. New York: Wiley-Interscience.
- Ogden, H.R. 1911. *Rural Hygiene*. New York: MacMillan.
- Oswald, W.J., and Gataas, H.B. 1955. "Photosynthesis in Sewage Treatment." *Proceedings American Society Civil Engineers*, Separate no. 686.
- . 1957. "Photosynthesis in Sewage Treatment." *Transactions American Society Civil Engineers* 122:73-97.
- Rich, G. 1963. *Unit Processes of Sanitary Engineering*. New York: John Wiley and Sons.
- Skinner, S.A., and Sykes, G., eds. 1972. *Microbial Aspects of Pollution*. Society for Applied Biology Symposium Series, no. 1. New York: Academic Press.
- Steel, E.W. 1960. *Water Supply and Sewerage*. New York: McGraw-Hill.
- Wagner, E.G., and Lanoix, J.N. 1958. *Excreta Disposal for Rural Areas and Small Communities*. Geneva, Switzerland: World Health Organization.
- Wiley, J.S., and Kochtitzky, O.W. 1965. "Composting Developments in the U.S." International Research Group on Refuse Disposal, Bulletin no. 25. Washington, D.C.: U.S. Department of Health, Education and Welfare.
- Wolman, A. 1967. *Water, Health and Society*. Bloomington: Indiana University Press.

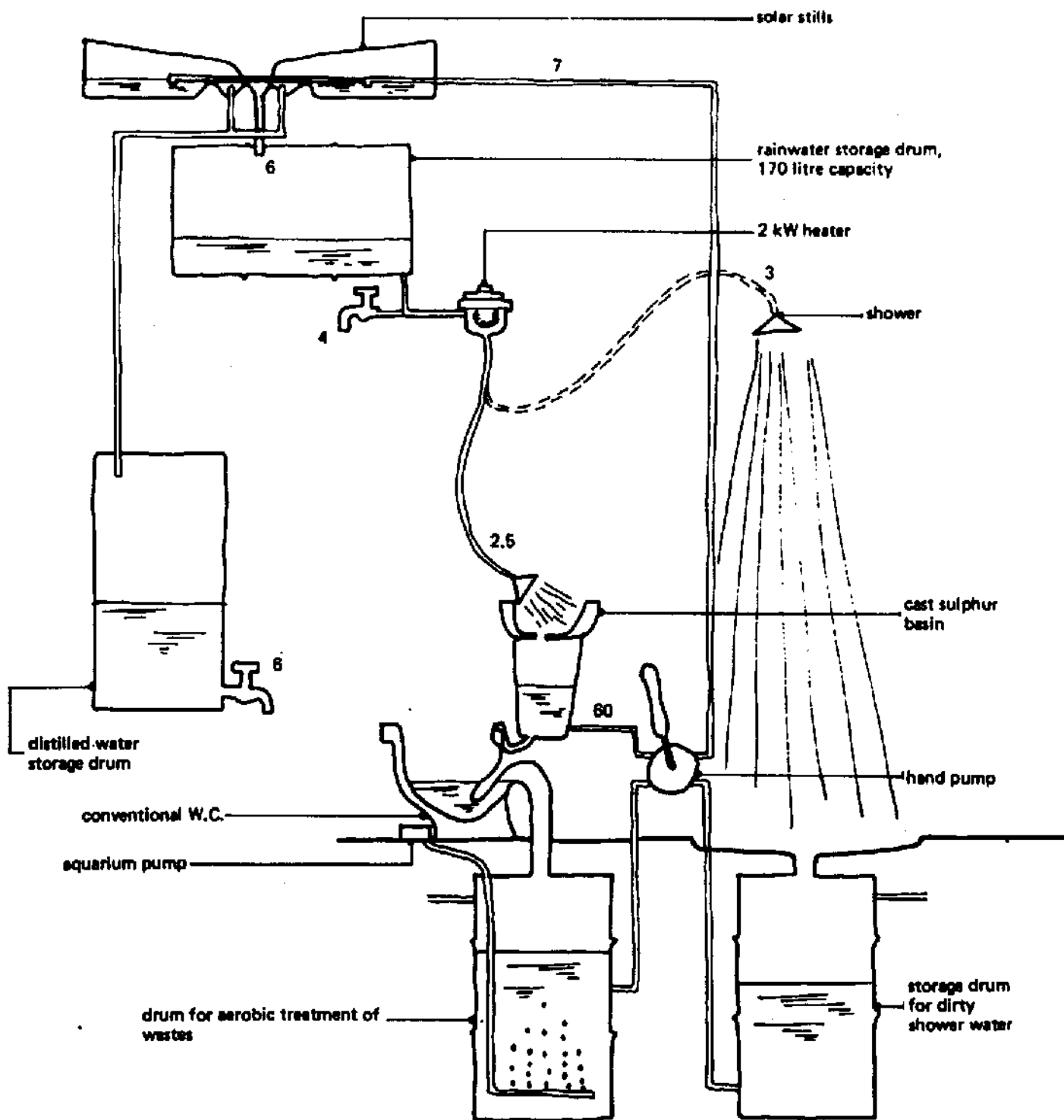
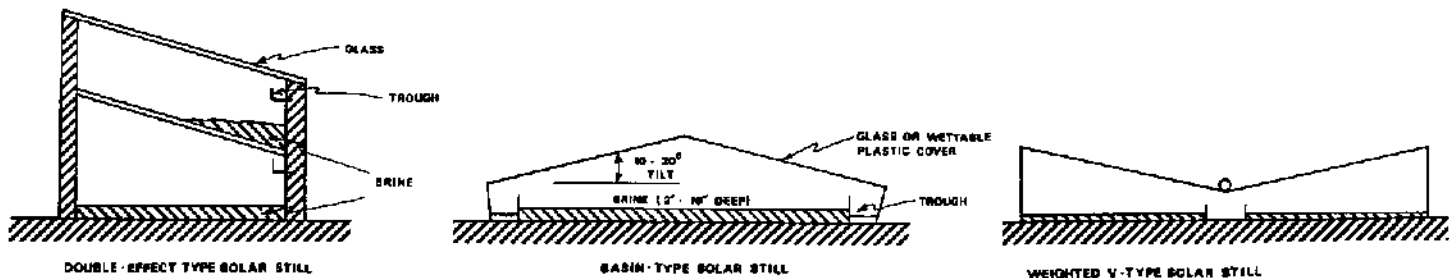

90 *The Ecol water collection, purification and waste treatment system (after Ortega et al., 1972). The figures show the quantities, in litres per head, passing through the system per day.*

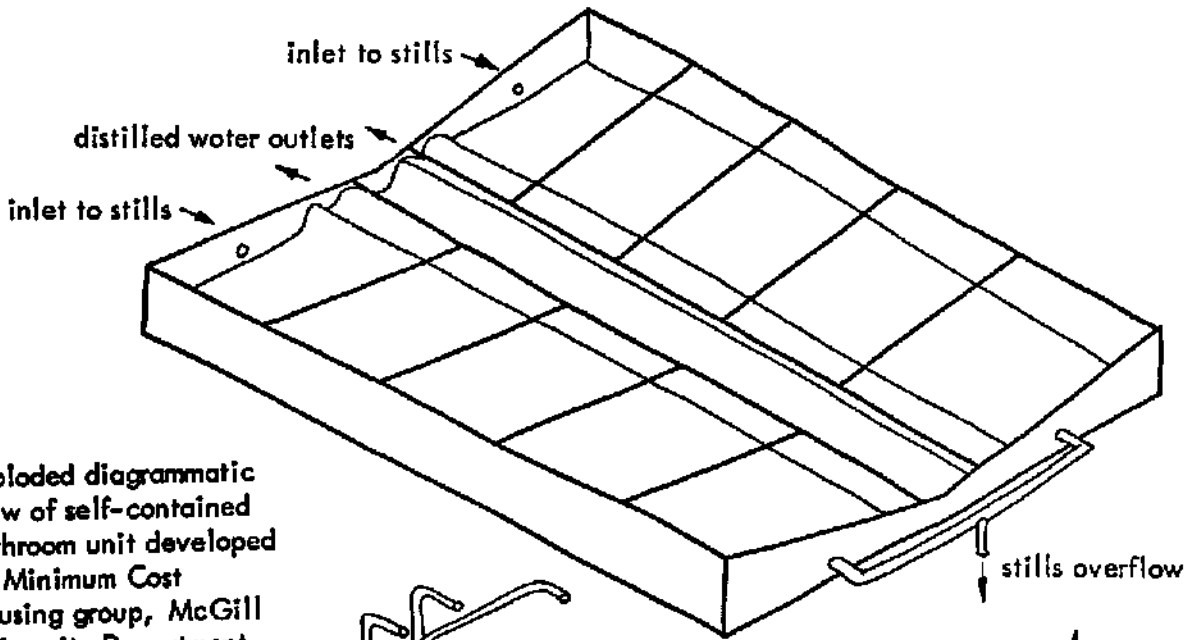

Exploded diagrammatic view of self-contained bathroom unit developed by Minimum Cost Housing group, McGill University Department of Architecture; showing rainwater collection surface and solar still on roof, water storage tanks, fittings and waste and holding tanks. From *The Ecol Operation*, McGill University, Montreal, 1972 p.81

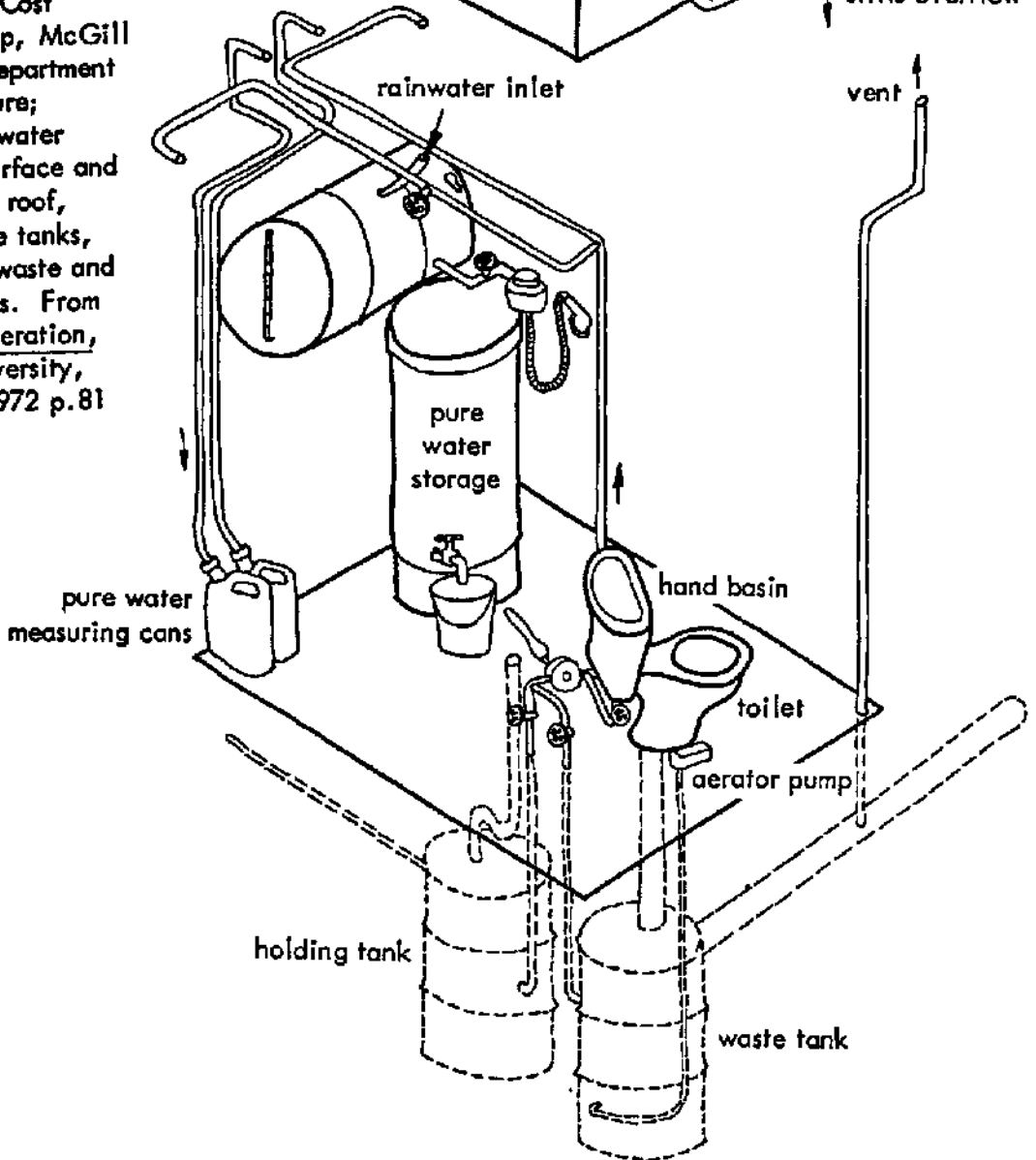

Plumbing codes, now in force, date back to the 1870s when the water-carriage system was first introduced. The erroneous nineteenth-century belief that sewer air causes disease is still perpetuated by law. Sewer-air code requirements require individual venting for each fixture trap. As background information about the function of vents, one may be advised that the fixture trap provides a water seal between the drainage system and the building's interior. When a fixture is discharged, a pressure fluctuation occurs which tends to reduce the water seal in the fixture trap. Therefore, vent pipes are connected at various points in the drainage system so that gases may escape to the outside, thereby reducing the pressure at the fixture. Those plumbing officials who continue to hold the discredited, sewer-gas theory would do well to read Winslow's *The Sanitary Significance of Bacteria in Air of Drains and Sewers*. According to Winslow, as quoted by the American Public Health Service, a person who placed his mouth atop a plumbing stack and breathed the air from it for 24 hours would inhale no more colon bacilli than were then to be found in a quart of New York City drinking water.

If a break in the operation of a fixture trap occurs, its only effect is a musty odor, immediately corrected by refilling the trap. A separate vent pipe for each fixture is not justified on health grounds. Self-siphonage, the discharge from a fixture sucking away its own trap seal, is more likely with bowl-shaped than with flat-base fixtures for the final, slow trickle of the latter insures a refilling of the trap.

Functionally, one 2-inch stack can well serve the total venting requirements for a complete house-plumbing system. Also, this stack can be used to carry discharge from fixtures connected into the drainage system at a higher level. This is called wet venting. However, according to code requirements, the one-stack plumbing layout is only

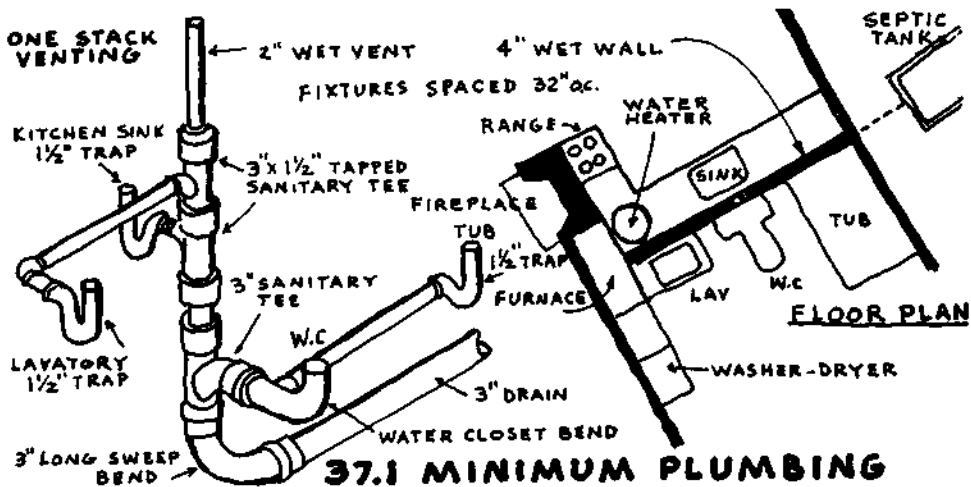

37.1 MINIMUM PLUMBING

permissible when the fixture drain slopes continuously at $\frac{1}{4}$ inch per foot, and when the length of drain between trap and vent does not exceed the following: 5 feet for $1\frac{1}{4}$ -inch drain, 6 feet for $1\frac{1}{2}$ -inch drain, 8 feet for 2-inch drain, and 12 feet for a 3-inch drain. Proper fixture arrangements, therefore, yield substantial material and labor savings.

The number one rule in plumbing-fixture arrangement is *keep fixture placement compact*. Whenever possible, locate the toilet between the tub and the sink, so that the vent for these fixtures can go right up from the toilet fixture. For ease of installation and a saving on materials, bathroom fixtures should line up on one wall. The opposite side of the so-called wet wall could, perhaps, include food preparation or laundry functions. A complete mechanical core might well be planned to include water heater, furnace, fireplace, and the main electrical panel, as well as the bathroom, laundry, kitchen plumbing, and wiring lines. Some progressive plumbing designers have arranged plumbing fixtures so that all supply and drainage pipes are above the floor. This is possible now that the much improved wall-hung toilet is available. With this arrangement, plumbing can be one of the final operations in house construction. Even the fixtures are hung before the pipe is installed. If desired, access to the complete bathroom-plumbing system can be made from behind kitchen counters located on the opposite side of the wall. Above-the-floor plumbing also makes possible the use of less expensive plastic and galvanized-iron drain and waste fittings.

35: Sunshine Revolution. Røstvig, Norway/USA 1992.

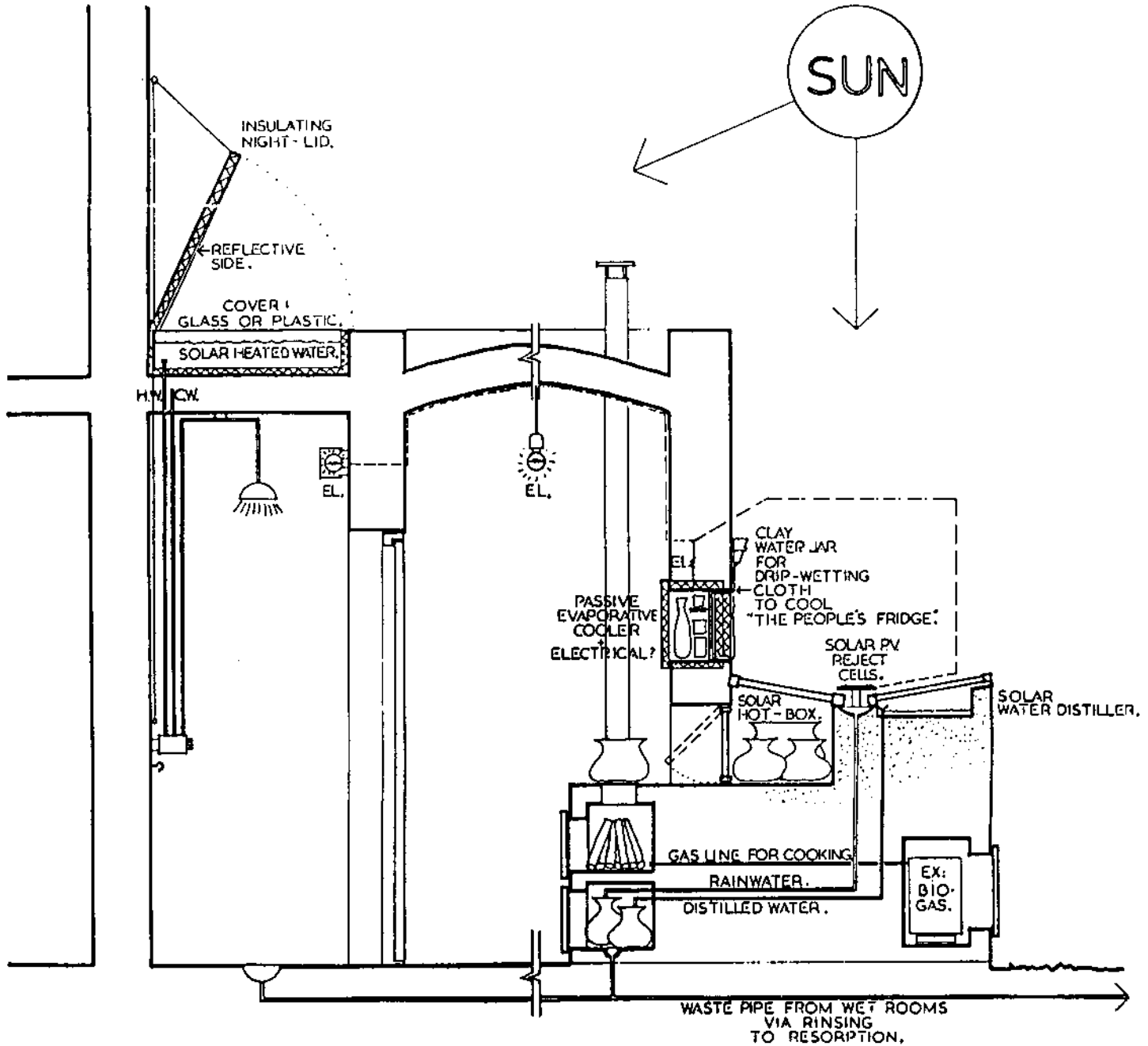
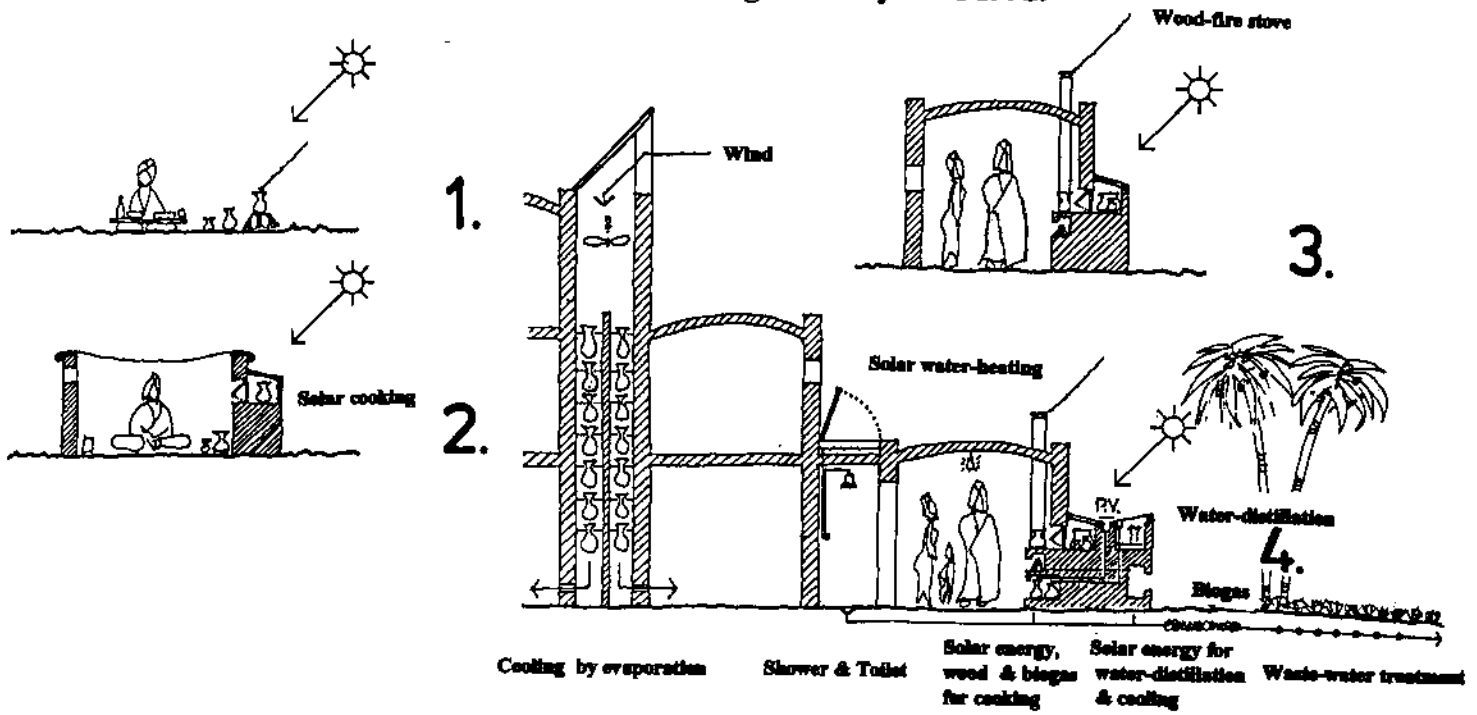



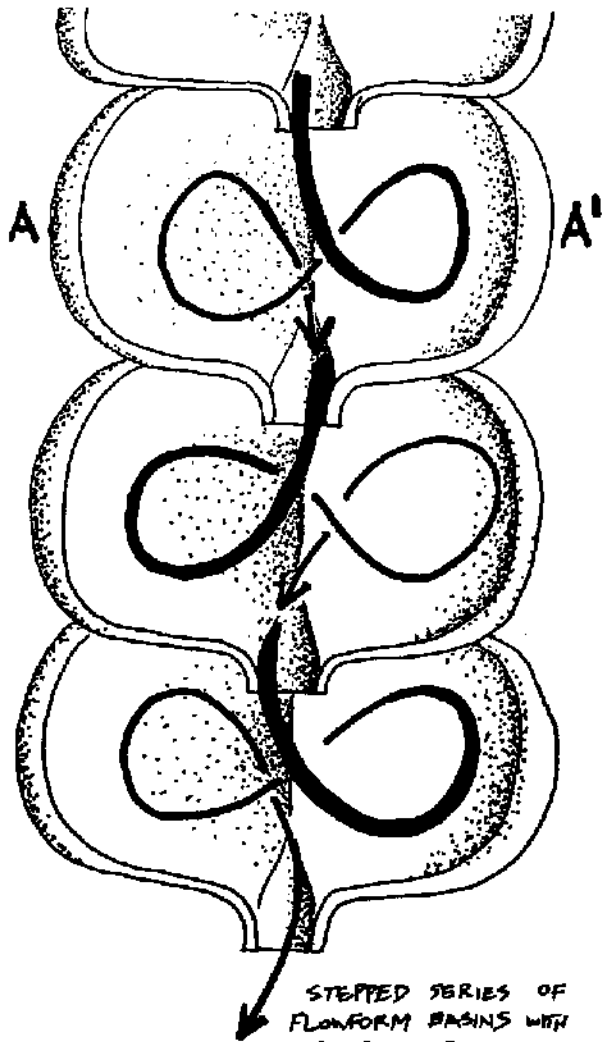

STEPPED SERIES OF FLOWFORM BASINS WITH FIGURE EIGHT HORIZONTAL TURBULENCE. THE OUTFALL FROM EACH BASIN PULSES FROM LEFT SIDE TO RIGHT SIDE AND BACK INDUCING THE OPPOSITE PULSE IN THE NEXT BASIN. (SEE PLATE).



SECTION A-A'

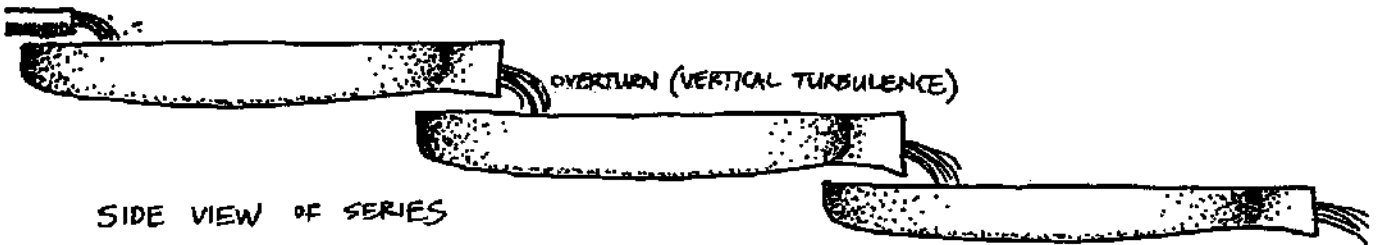

SIDE VIEW OF SERIES

FIGURE 4.33
FLOWFORMS.

Of ancient usage, and natural occurrence, can be neatly fabricated in

concrete or glass reinforced plastic to aerate water in the case of a constant (or little varying) flow.

FIGURE 10.24

DETAIL: Wet food patch.

Roof and tank overflow plus greywater can irrigate a 'wetland' mulch garden of semi-aquatic species; banks accept dryland species.

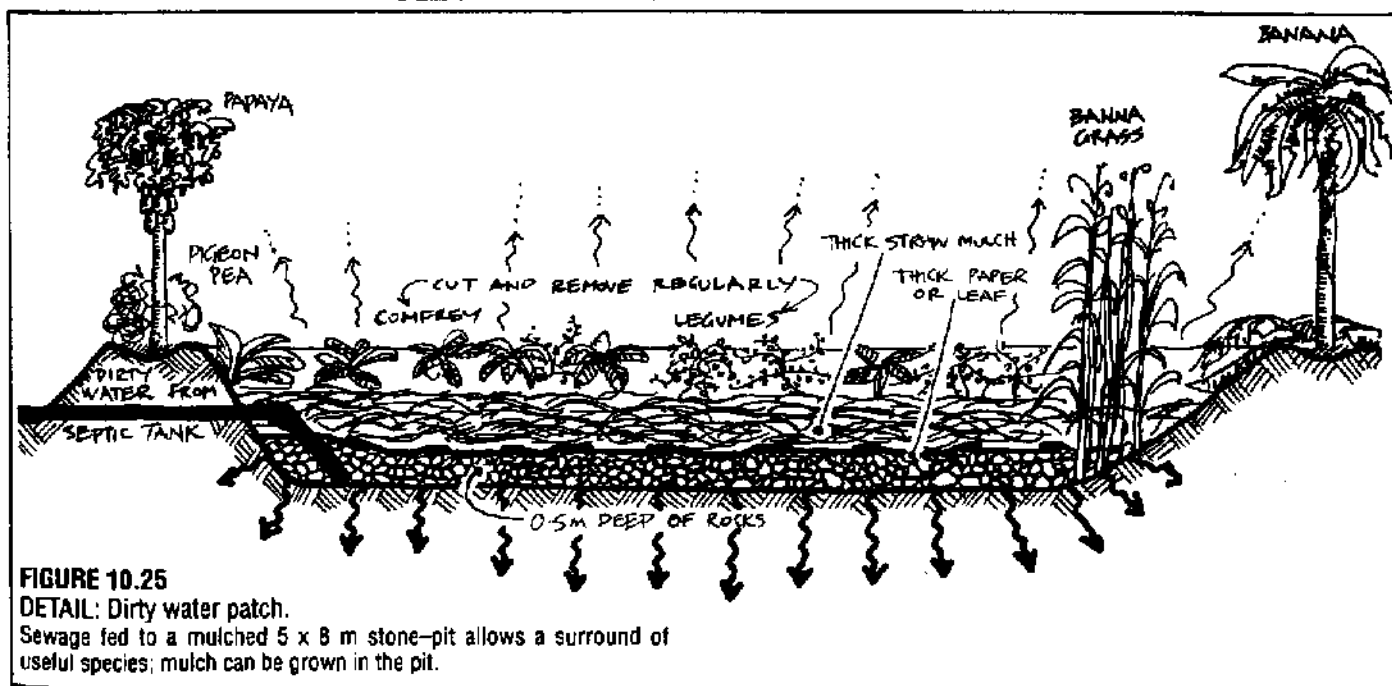
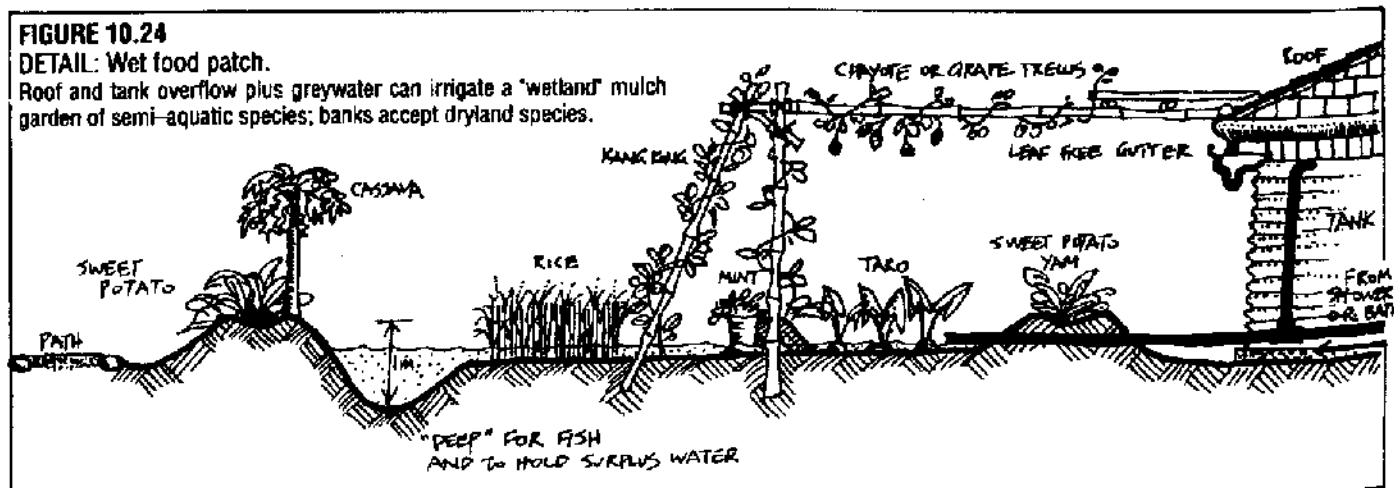

FIGURE 10.25

DETAIL: Dirty water patch.

Sewage fed to a mulched 5 x 8 m stone-pit allows a surround of useful species; mulch can be grown in the pit.

Wells, Ponds & Fish Farming

SINKING A WELL

The easiest way of finding water is to drill a hole with a drilling machine, and if you can get hold of one it is well worth using it. But they are expensive, even to hire, and all they really save is time and energy. If you have got some of each to spare you can dig your well yourself by hand.

In earth or soft rock

Sinking a well in earth or soft rock is very easy if laborious. You just dig in, keeping the diameter as small as you can, just leaving yourself room to use a shovel. As you get deeper, you send the spoil (dug earth) up to the surface in a bucket hauled up by a friend with a windlass, and you go up the same way. It is almost always necessary to line the well as you dig to stop the earth from falling in. The easiest way to do this is with concrete rings sent down from the top. As you dig down you dig under the lowest concrete ring which causes it to fall and all the other concrete rings on top fall with it. From time to time you put another concrete ring on top. Where timber is cheap you can use a timber lining on the same principle.

In soft sand

Sinking a well in soft sand is very difficult, and can only be done using the process of "spiling", which is hammering sharpened planks down below you where you are working so as to form a lining which is already there when you dig all the sand out.

In rock

Sinking a well through rock is harder in that you have to blast it, but easier in that you probably don't have to line it. In days gone by the rock was shattered by building a fire on it and then quenching this with water. The rapid contraction shattered the surface of the rock. Nowadays we are more likely to use explosives.

Gunpowder will do, although you need a lot and it is a slow job. Gelignite, or any of the modern detonating explosives, are much better. To use either you have to drill holes in the rock. If you haven't got a compressor and pneumatic rock drill you can do this by hand with a hand drill, which is a hardened steel bit, like a long cold chisel. Hold it in your left hand, wallop it with a four pound hammer, and turn it in the hole after every wallop. If you don't turn it, it will jam. To get the powdered rock out of the hole you must pour water down, which turns the powder into a paste which spurts out with every blow. To stop it getting in your face wrap a cloth round the bit at the collar of the hole.

Drill four holes near the middle of your well floor to form a pyramid pointing down into the rock. These are your "cut holes". Drill, say, eight more holes around these, this time vertically. These are your "easers". Then drill holes all round the edge of your face. These are your "slippers".

Fill all the holes with "powder", which is the generic term miners and well-sinkers use for all explosives, light your fuses,

and hope that your friend up top who winds you up with the windlass is a real friend and doesn't decide to go away and have a smoke instead.

Gunpowder is set off simply by lighting it, and if you can't buy a safety fuse, which does this job, you can make one yourself by sticking hollow goose feathers into each other, end to end, to form tubes and filling these tubes with gunpowder. In fact any kind of plastic or rubber tube filled with powder will do just as well. Poke one end of the fuse into the gunpowder in the hole and light the other end. Presumably common sense will have told you to test and time a few fuses before you trust your life to them. And remember with gunpowder any spark will light it. A spark struck from a rock with a steel is all it needs, and, if it is in a confined space, it will explode.

Gelignite, plastic H.E. (high explosive), and all the modern detonants are quite different. If you light them they will only burn and make a stink. They have to be detonated, and to do this you need a cap full of fulminate of mercury, called a detonator. Take a measured length of safety fuse, cut one end off straight and clean, put a detonator over this, and crimp the detonator's metal case so it doesn't come off (not with your teeth, with pliers). Then cut the other end off at an angle to expose the powder inside the safety fuse, lay a match head on this powder and strike the match with the box. Light all the fuses thus and shout to your friend to start winding up the bucket. The cut holes must have the shortest fuses because they go off first, then the easers and then the slippers which go off last.

Whichever way you sink a well, when you come to water go on sinking. Even if you have to spend half of each day winding up water in the bucket, go on sinking until the water beats you, because if you don't, when there is a drought and the water table sinks, your well will go dry. When you have got your water the best thing you can do is install a steel pumping windmill (see p. 216). It will pump water from a thousand feet (304 m) and go on doing it for years, free, and will need very little attention.

MAKING A POND

If you are going to keep ducks (see p. 128), or if you want to try the highly rewarding process of fish farming you will need a pond. You can just dig a hole, but if the bottom or sides are porous it will probably be necessary to puddle clay and tamp it in so as to form an impervious sheet, or else bury a large sheet of thick plastic.

Simply piling earth up in a bank to form a dam to impound water seldom works. The fill material may be too porous and "piping" will occur, meaning water will seep through and erode a hole. Or the material may contain too much clay and there will be great drying, shrinkage and cracking. If the soil is just right, and well compacted, and an adequate spillway to take off the surplus caused by rainwater is constructed, a simple earth dam may work, but where there is doubt the dam should be made of porous soil with puddled and tamped clay

embedded in it. Nowadays plastic sheeting is sometimes used instead. If your pond is for fish farming then good topsoil should be placed in the bottom for plants to grow on.

FISH FARMING

Fish are marvellously efficient producers of high protein human food: far better in fact than other livestock. This is because they don't have to build a massive bone structure to support their weight (the water supports it), and they don't have to use energy to maintain their body heat (they are cold blooded). In the tropics, particularly in paddy-growing areas, they are a major crop. Modern commercial fish farming, in which only one species of fish is fed on expensive high protein in water which is kept weed-free with herbicides, is ecologically unsound and requires absurd inputs of expensive feed or fertilizer. We should all start experimenting with water ecosystems which achieve a proper balance of nature, and in which a variety of fish species can coexist with a cross-section of other marine life, both animal and vegetable.

Strangely enough in the sixteenth century the matter was far better understood – even in England. At that time a writer called John Taverner wrote that you should make large shallow ponds, four feet deep and more, and keep them dry one year and full of water the next. When dry graze them with cattle, and when wet fill them with carp. The ponds grow lush grass because of the sediments left by the water, and the carp benefit from the fertility left by the cattle. This is the true organic approach to husbandry. You should have at least two ponds so that there is always one full of fish and one dry. Drain the wet pond dry in late autumn, and take the best fish out then to put in your stewpond near the house, where they are ready for eating. Put a lot of young fish in your newly-flooded big pond.

Carp

Carnivorous fish, such as trout, are poor converters of food into flesh. Vegetarian fish are far better. This is why Taverner and the monks of old in Europe had carp in their stewponds.

Carp will give you a ton of fish per acre per year without any feeding if they are in a suitable pond. The way the monks farmed them was to let them breed in large ponds, but then to catch them and confine them to small stewponds near the house in the autumn. The stewponds were deep enough to keep ice-free and the carp were therefore easy to net. As well as being vegetarian, carp are healthy, quick growing, and they can live in non-flowing water. They need half their food from natural provenance, and can be encouraged by a certain amount of muck or rotting vegetation dumped in the water. This is transformed into the sort of food carp eat by bacterial action, but they will also eat oatmeal, barley, spent malt and other similar food.

The Hungarian strain of the Chinese Grass Carp has been tried in England, with success. In China these fish grow up to 100 lbs (45 kg) in weight; in England 30 lbs (13.6 kg) is a good

fish, but they are fine converters of vegetable food. Unfortunately they need 122°F (51°C) to breed, and so are propagated in heated tanks and released out of doors, where they flourish.

Tilapia

The best fish of all for fish-farming are the African *Tilapia*, but because they are tropical fish they need warm water. Nevertheless, putting yourself out for them may well be worthwhile. Research has shown that the average family could provide all its animal protein requirements in a 3,000 gallon (13,640 litre) covered and heated pool full of *Tilapia*. The water should be about 80°F (27°C): less than 55°F (13°C) will kill them.

Tilapia mossambica, which is one of the best of the many species, can be bought from pet shops. The hen fish produce about twenty five to thirty young, which live in their mothers' mouths for the first period of their lives, and the hens bring off several broods a year. Much of their food can be supplied free with a little labour by incubating pond water, slightly fertilized with organic manure, in tanks. After three weeks or a month carefully pump this water into the tilapia pond with the organisms that it contains. The incubation tanks should be partially roofed with glass, but access for mosquitoes and other flying insects should be provided.

In temperate climates *Tilapia mossambica* can be kept in heated pools, and they don't require constantly running water. A combination of solar heating and wind/electric heating has proved successful for growing them in America. They will produce two tons of good meat per acre per year. When adult they will feed on algae or any vegetation you like to put into the water (within reason) or they will eat oatmeal. When young they need protein, which can be supplied in such forms as mosquito larvae, maggots, worms, or as fish meat, or blood meal. They are probably the most delicious of all fish to eat.

Trout

In Berlin most of the city's sewage is discharged into huge lakes, where rainbow trout are reared to provide a colossal tonnage of fish per acre. Brown trout will not stand up to this treatment. The sewage is not eaten by the trout, which are carnivores, but by phytoplankton, which in turn are eaten by zooplankton, on which the fish feeds.

If you want to farm rainbow trout you must give them some kind of meat protein. You can buy proprietary trout food but it is very expensive. If you have a source of very cheap sea fish you can use it for trout food. Salt any of the oily pelagic fish, pile them in stacks six foot high and put boards and weights on them. This will expel the oil from them. You can then dry them in a kiln, powder them, and use them for trout food.

Several breeds of fish lend themselves to farming. A lot of success is had with American bluegills and catfish.

Few dam builders consider the biological uses of dams, and the necessary modifications that create biological productivity in water systems.

A second essential book for water planning in landscape is P. A. Yeomans' *Water for Every Farm/The Keyline Plan* (1981)⁵. This very important book, written in 1954, is without doubt the pioneering modern text on landscape design for water conservation and gravity-fed flow irrigation. As it also involves patterning, tree planting, soil treatment, and fencing alignment, it is the first book on functional landscape design in modern times.

There are two basic strategies of water conservation in run-off areas: the diversion of surface water to impoundments (dams, tanks) for later use, and the storage of water in soils. Both result in a recharge of groundwater. As with all technologies, earthworks have

quite specifically appropriate and inappropriate uses. Some of the main productive earthwork features we create are as follows:

- Dams and tanks (storages);
- Swales (absorption beds);
- Diversion systems or channels; and
- Irrigation layouts, and in particular those for flood or sheet irrigation.

SMALL DAMS AND EARTH TANKS.

Small dams and earth tanks have two primary uses. The minor use is to provide watering points for rangelands, wildlife, and domestic stock; such tanks or waterholes can therefore be modest systems, widely dispersed and static. The second and major use is to contain or store surplus run-off water for use over dry

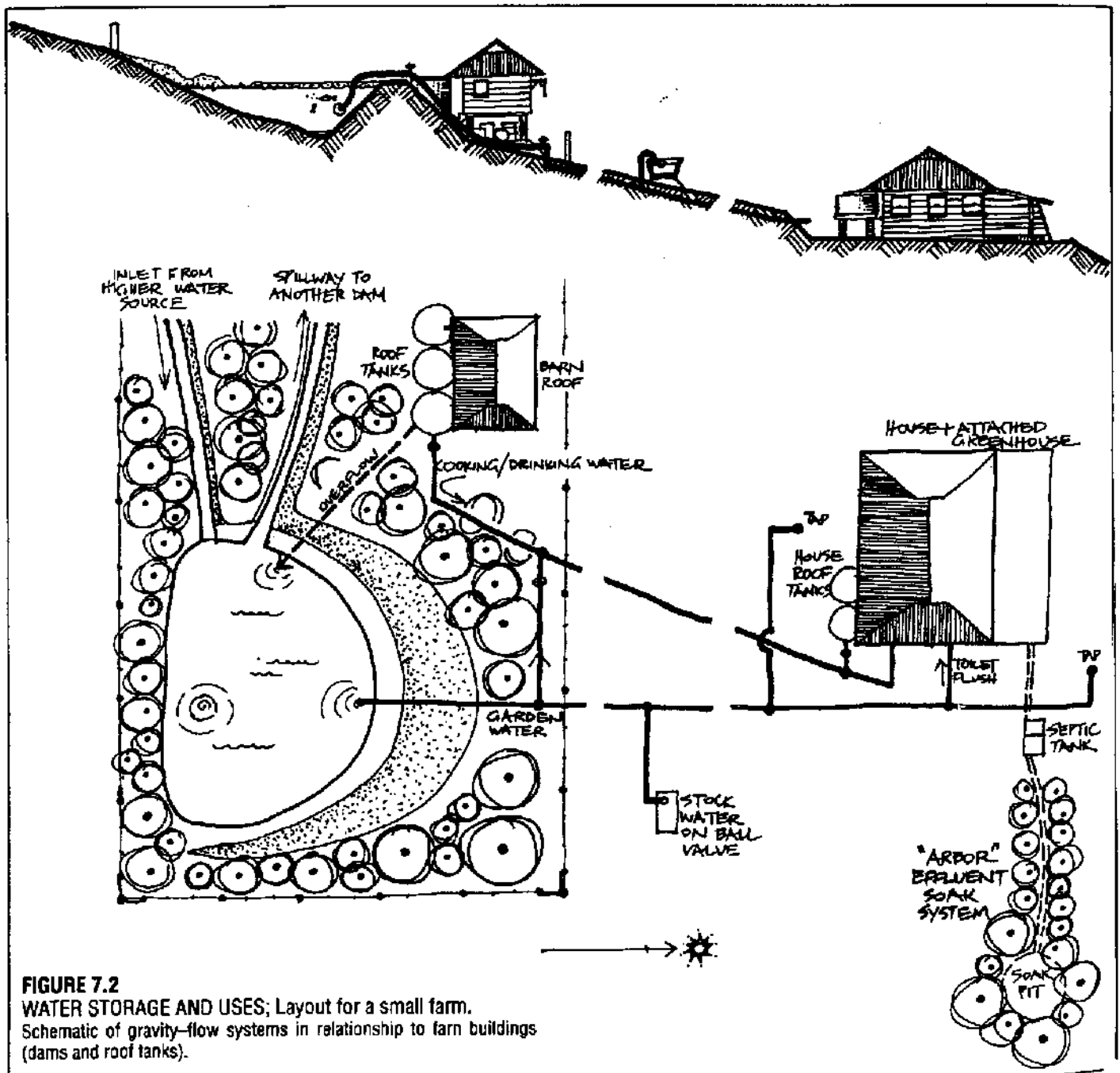

FIGURE 7.2
WATER STORAGE AND USES; Layout for a small farm.
 Schematic of gravity-flow systems in relationship to farm buildings
 (dams and roof tanks).

periods for domestic use or irrigation. The latter storages, therefore, need to be carefully designed with respect to such factors as safety, water harvesting, total landscape layout, outlet systems, draw-down, and placement relative to the usage area (preferably providing gravity flow).

A separate category of water storages, akin to fields for crop or browse production, are those ponds or wet terraces created specifically for *water crop* (vegetation or mixed polycultural systems of aquatic animal species).

Open-water (free water surface area) storages are *most appropriate in humid climates*, where the potential for evaporation is exceeded by average annual rainfall. There is a very real danger that similar storages created in arid to subhumid areas will have adverse effects, as evaporation from open water storages inevitably concentrates dissolved salts. Firstly, such salty water can affect animal health. Secondly, the inevitable seepage from earth dams can and does create areas of salted or collapsed soils downhill from such storages. And in the case of large barrier dams, so little water may be allowed to bypass them in flood time that agricultural soils, productive lakes, and estuaries may lose more productive capacity by deprivation of flush-water and silt deposits than can be made up (at greater cost) by irrigation derived from such lakes.

Dryland storage strategies are discussed in Chapter 11. What I have to say here is *specifically addressed to humid areas and small dams* unless otherwise noted.

Earth dams or weirs where retaining walls are 6 m (19 feet) high or less, and which have a large or over-sized stable spillway, are no threat to life or property if well-made. They need not displace populations, stop flow in streams, create health problems, fill with silt, or block fish migrations. In fact, dams or storages made anywhere *but* as barriers on streams effectively add to stream flow in the long term.

Low barrier dams of 1-4 m (3-13 feet) high can assist stream oxygenation, provide permanent pools, be "stepped" to allow fish ladders or bypasses, and also provide local sites for modest power generation. While almost all modern assessments would condemn or ban large-scale dams (and large-scale power schemes) on the record of past and continuing fiascos, a sober assessment of small water storages shows multiple benefits.

Given the range of excellent texts on small dams (often available from local water authorities, and by mail order from good bookstores), I have therefore avoided specific and well-published construction details, and have here elaborated more on the types, placement, links to and from, and function of small dams in the total landscape. Yeomans (*pers. comm.*, 1978) has stated that he believes that if from 10-15% of a normal, humid, lowland or foothill landscape were fitted with small earth storages, floods and drought or fire threat could be eliminated.

Not all landscapes can cost-effectively store this

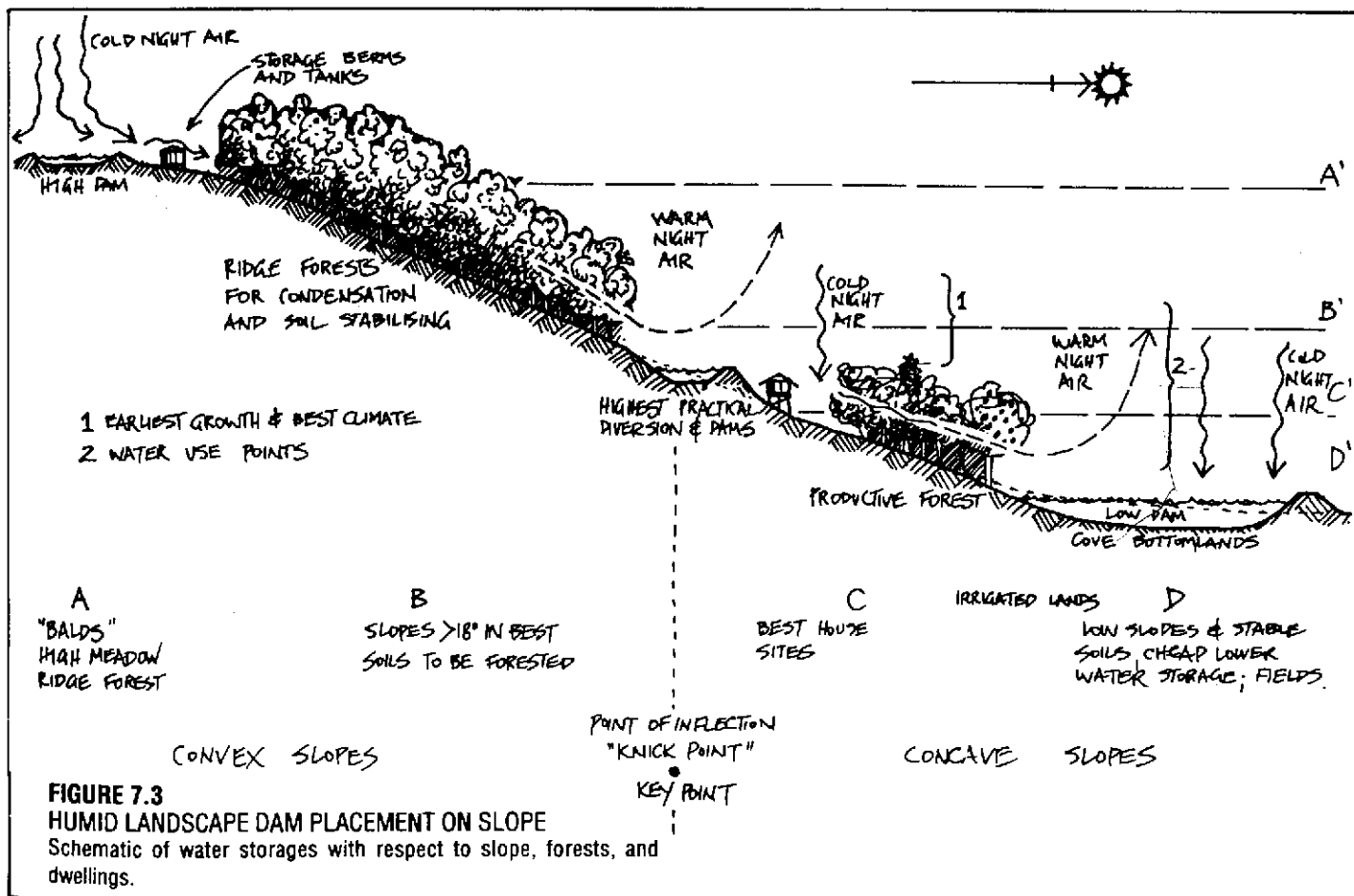

proportion of free surface water; some because of free-draining soils or deep or coarse sands. Other areas are too rocky, or of fissured limestone, and yet others are too steep or unstable. But a great many productive areas of clay-fraction subsoils (40% or more clay fraction) will hold water behind earth dams, below grade levels as earth tanks, or perched above grade as "turkey's nest" or ring dams. There are very few landscapes, however, that will not store more soil water if humus, soil treatment, or swales are tried; the soil itself is our largest water storage system in landscape if we allow it to absorb.

Almost every type of dam is cost-effective if it is located to pen water in an area of 5% or less slope. However, many essential dams, if well-made and durable, can be built at higher slopes or grades, made of concrete, rock-walled, or excavated if water for a house or small settlement is the limiting factor. Each and every dam needs careful soil and level surveys and planning for local construction methods.

DAM TYPES AND LOCATIONS

There are at least these common dam sites in every extensive landscape:

SADDLE DAMS are usually the highest available storages, on saddles or hollows in the skyline profile of hills. Saddle dams can be fully excavated below ground (grade) or walled on either side of, or both sides of, the saddle. They can be circular, oblong, or "shark egg" shaped with horns or extensions at either end (Figure 7.4).

Uses: wildlife, stock, high storage.

RIDGEPOINT DAMS or "horseshoe" dams are built on the sub-plateaus of flattened ridges, usually on a descending ridgeline, and below saddle dams. The

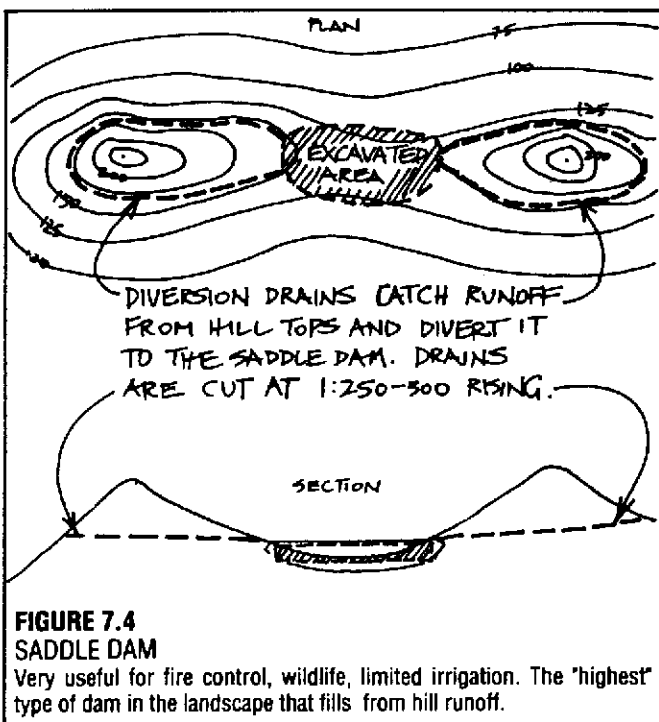

FIGURE 7.4
SADDLE DAM

Very useful for fire control, wildlife, limited irrigation. The "highest" type of dam in the landscape that fills from hill runoff.

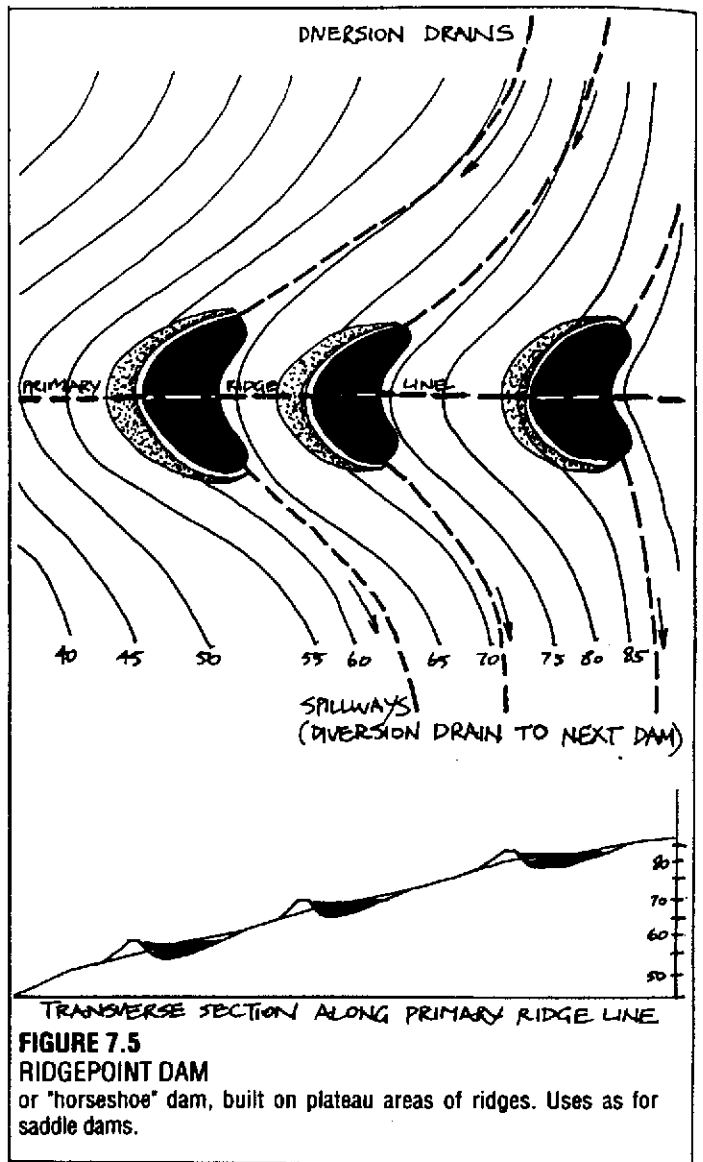

FIGURE 7.5
RIDGEPOINT DAM

or "horseshoe" dam, built on plateau areas of ridges. Uses as for saddle dams.

shape is typically that of a horse's hoof. It can be made below grade, or walled by earth banks (Figure 7.5).

Uses: As for saddle dams. Only of limited irrigation use, but very useful for run-off and pumped storages. Note that both saddle and ridge dams can act as storages for pumped water used for energy generation.

KEYPOINT DAMS are located in the valleys of secondary streams, humid landscapes, at the highest practical construction point in the hill profile, usually where the stream profile changes from convex to concave; this place can be judged by eye, and a descending contour will then pick up all other keypoints on the main valley (Figure 7.6).

Uses: Primarily to store irrigation water. Note that a second or third series can be run below this primary series of dams, and that the spillway of the last dam in a series can be returned "upstream" to meet the main valley, effectively spilling surplus to streams.

CONTOUR DAM walls can be built on contour wherever the slope is 8% or less, or sufficiently flat. Contours (and dam walls) can be concave or convex to the fall line across the slope (Figure 7.7).

Uses: Irrigation, aquaculture, or flood-flow basins in

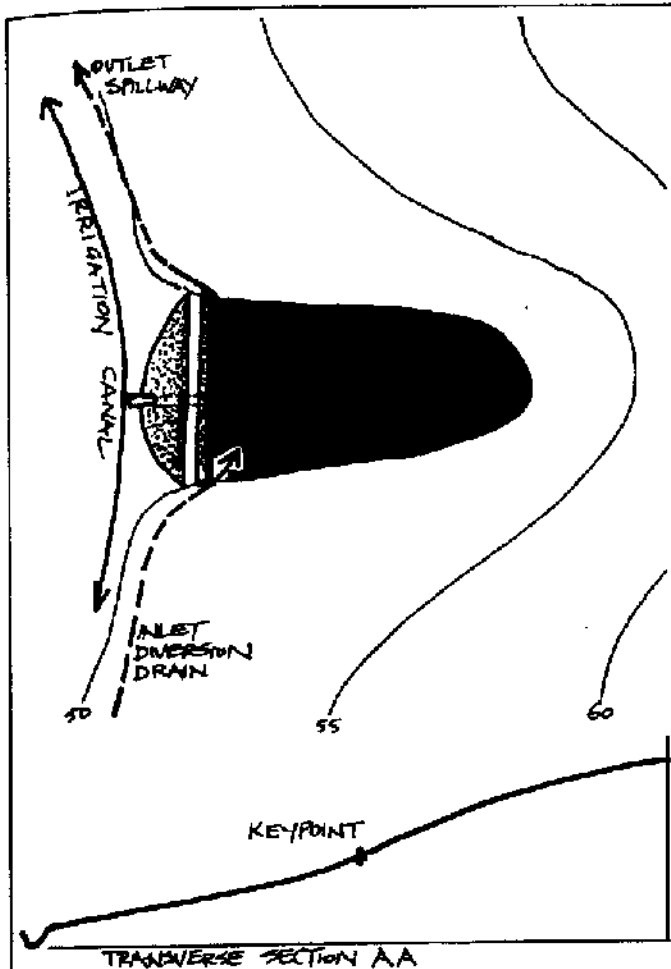

FIGURE 7.6
KEYPOINT DAM

A. If used in series, no spillway is built and the overflow goes to the next dam, and eventually to a stream. Fitted for irrigation on lower slopes.
B. The keyline (heavy dashes) links keypoints in primary valleys.

semi-arid areas.

BARRIER DAMS are always constructed across a flowing or intermittent stream bed. These dams therefore need ample spillways, careful construction, fish ladders on biologically important streams, and are made most frequently as energy systems, but are also used for irrigation if they are constructed well above the main valley floors where crops are grown (Figure 7.8).

TURKEY'S NEST DAMS or above-grade tanks; water has to be pumped in to these, often by windmill or solar pump. They are common in flatlands as stock water tanks or for low-head irrigation (Figure 7.9).

CHECK DAMS. There are many forms of barrier dams not intended to create water storages, but to

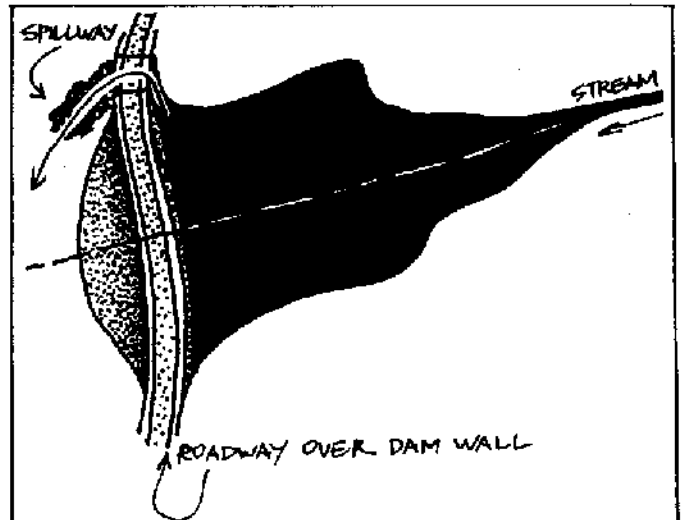

FIGURE 7.8
BARRIER DAM

"The engineer's dam." Can affect fish, migration, and be difficult to spill; works well as part of a keyline series only.

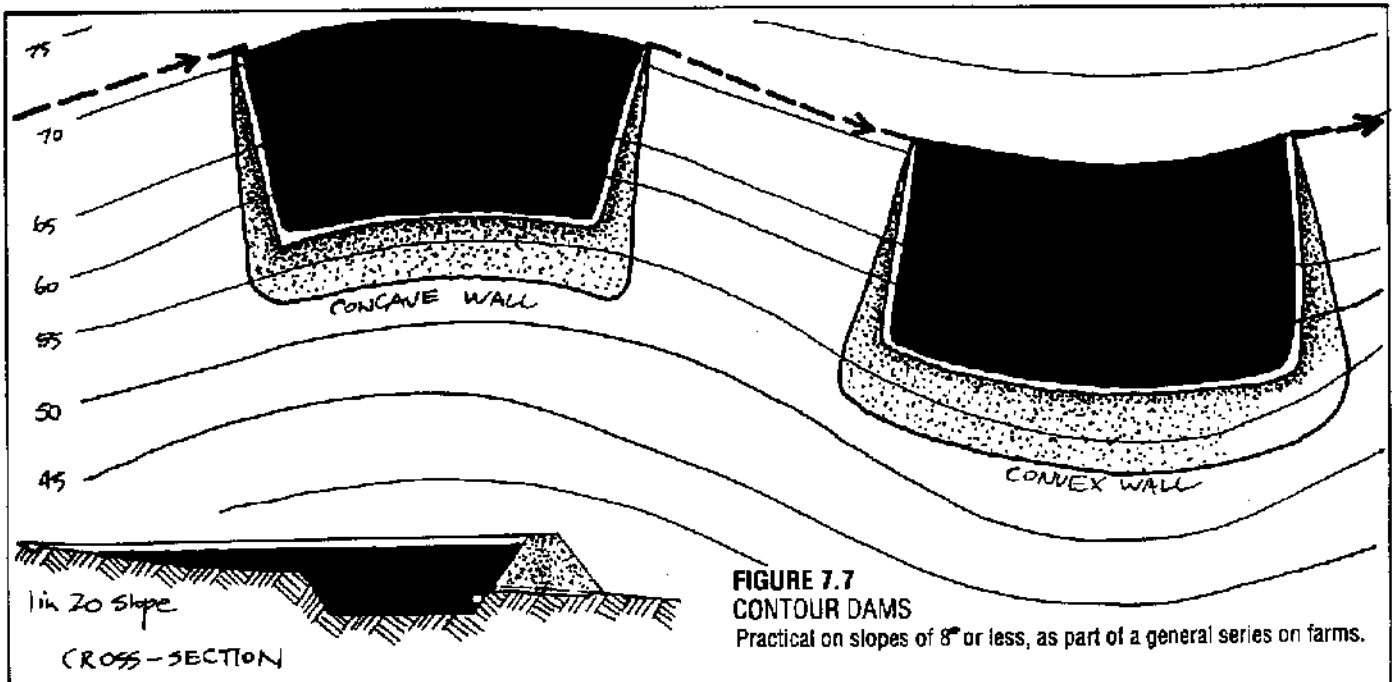

FIGURE 7.7
CONTOUR DAMS

Practical on slopes of 8° or less, as part of a general series on farms.

regulate or direct stream flow. Even a 1–3 m (3–10 foot) wall across a small stream gives enough head to drive an hydraulic ram, to fit a waterwheel, to divert the stream itself to a contoured canal for irrigation, or to buffer sudden floods. Dams intended to regulate flood crests may have a base pipe or fixed opening in the streambed which allows a manageable flow of water downstream while banking up the flood crest behind the dam itself, so spreading the rush of water over time. The base opening allows silt scour and so keeps the dam free of siltation (Figure 7.10–13).

GABION DAMS. In drylands, permeable barriers of rock-filled mesh "baskets" (gabions) will create silt fields and water-spreading across eroding valleys. The

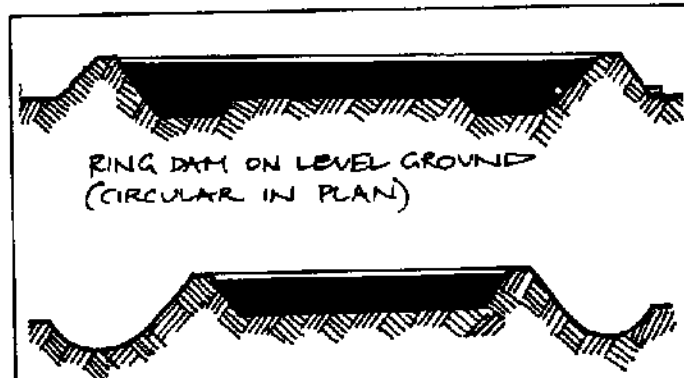

FIGURE 7.9
RING AND TURKEY'S NEST DAM.
Hold water pumped in by a windmill and provides a low head in flat landscapes; can be pipe-filled from a large roof or from parking areas.

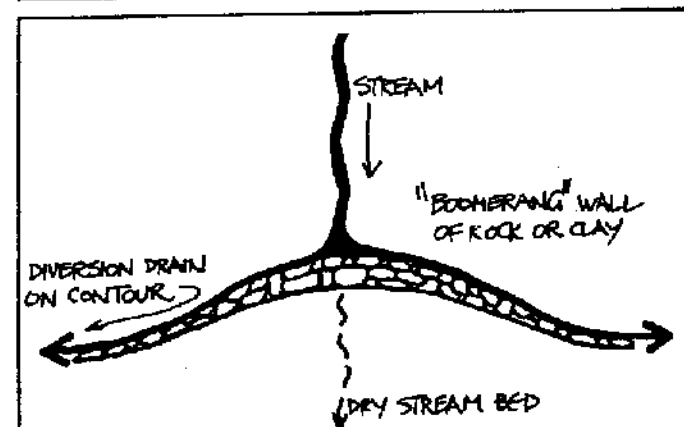

FIGURE 7.10
DIVERSION CHECK DAM
Diverts intermittent flow to ridges, storages, or canals on contour.

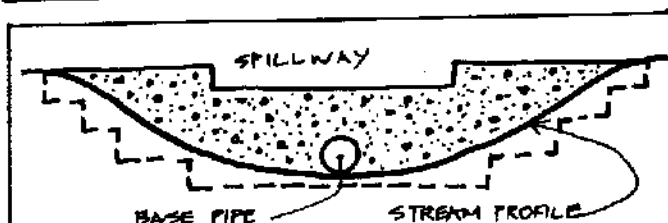

FIGURE 7.11
CONCRETE FLOOD CHECK DAM
Allows normal flow to pass, retards floods, and prevents rapid flood discharge.

scale of these dams varies, but for farm construction, walls 0.5–2 m (2–6.5 feet) high are usual. As with Figure 7.12, the purpose is not to store free surface water, but to create a flat area where silt loads can usefully deposit, and so form absorption beds in flood conditions.

We can see the landscape (as though sliced into layers through contours) as a set of catchment, storage, usage, and revitalisation zones. (Figure 7.15)

BUILDING DAMS

Although we can build dams or tanks on *any* site, given enough material resources, commonsense dictates that storage dams be carefully located with respect to:

- Earth type (core out a sample pit for assessing clay fractions);
- Grade behind wall (lower slopes give greatest

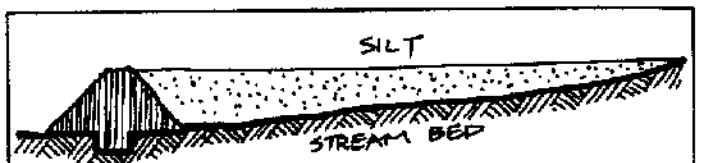

FIGURE 7.12
SILT CHECK DAM
Earth or concrete walls or gabions hold silt fields, spread water, reduce silt load in streams.

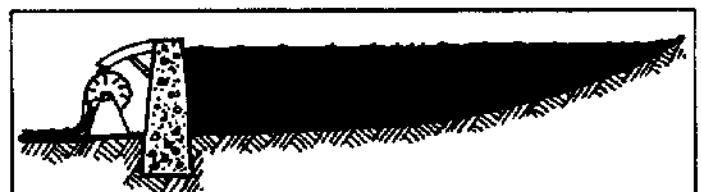

FIGURE 7.13
CHECK DAM FOR RAM PUMP OR WATER WHEEL
Only 1–3 m of head enables modest energy use for mechanical power, lift pumps, or diversion to canals.

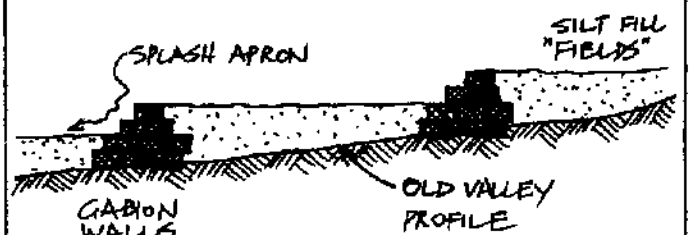
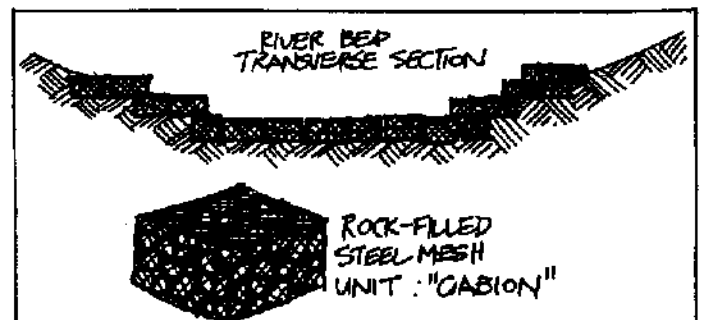

FIGURE 7.14
Eroding gullies are best stabilised using strong wire baskets to contain stones or shingle; these resist floods well.

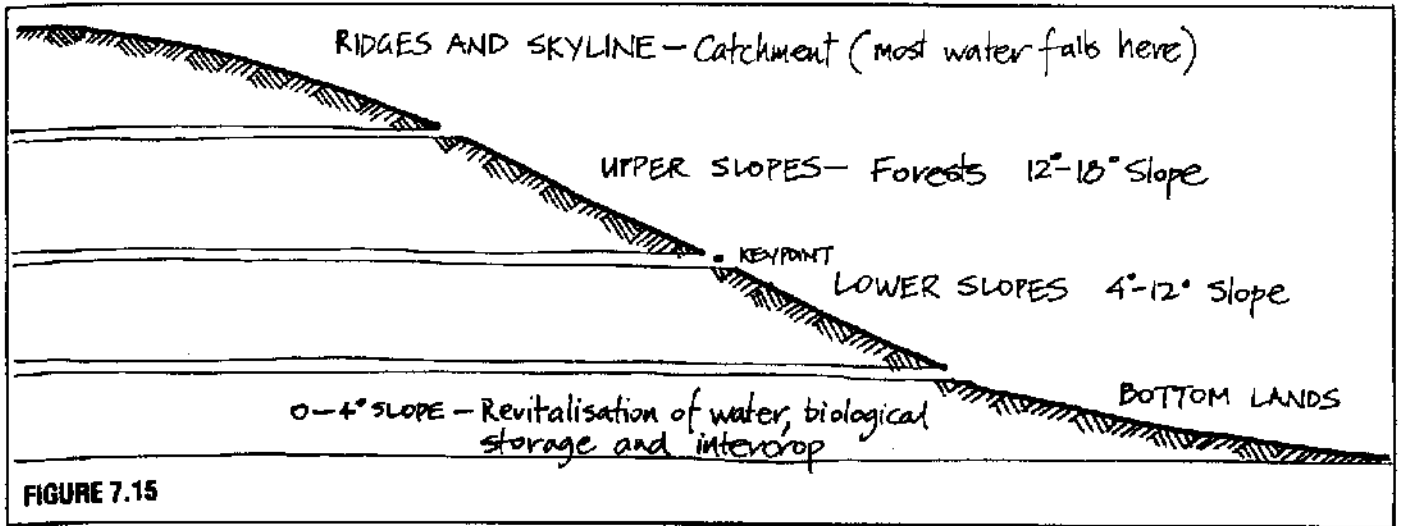

FIGURE 7.15

capacity);

- Downstream safety of structures and houses (a key factor in large dams);
- Height above use points (gravity flow is desirable); and
- Available catchment or diversion.

Tamped earth with some clay fractions of better than 50% is a waterproof barrier up to heights of 3.6 m (12

feet), not counting the holes behind such walls caused by their excavation. Therefore we speak of depths of 4.5-6 m (15-20 feet) for small earth dams. Few of us will want to build farm dams higher, and we must get good advice if we wish to do so.

Slopes to crest should be concave, and every 25 cm (10 inches) a machine such as a roller, or the bulldozer tracks themselves, should ride along and tamp down

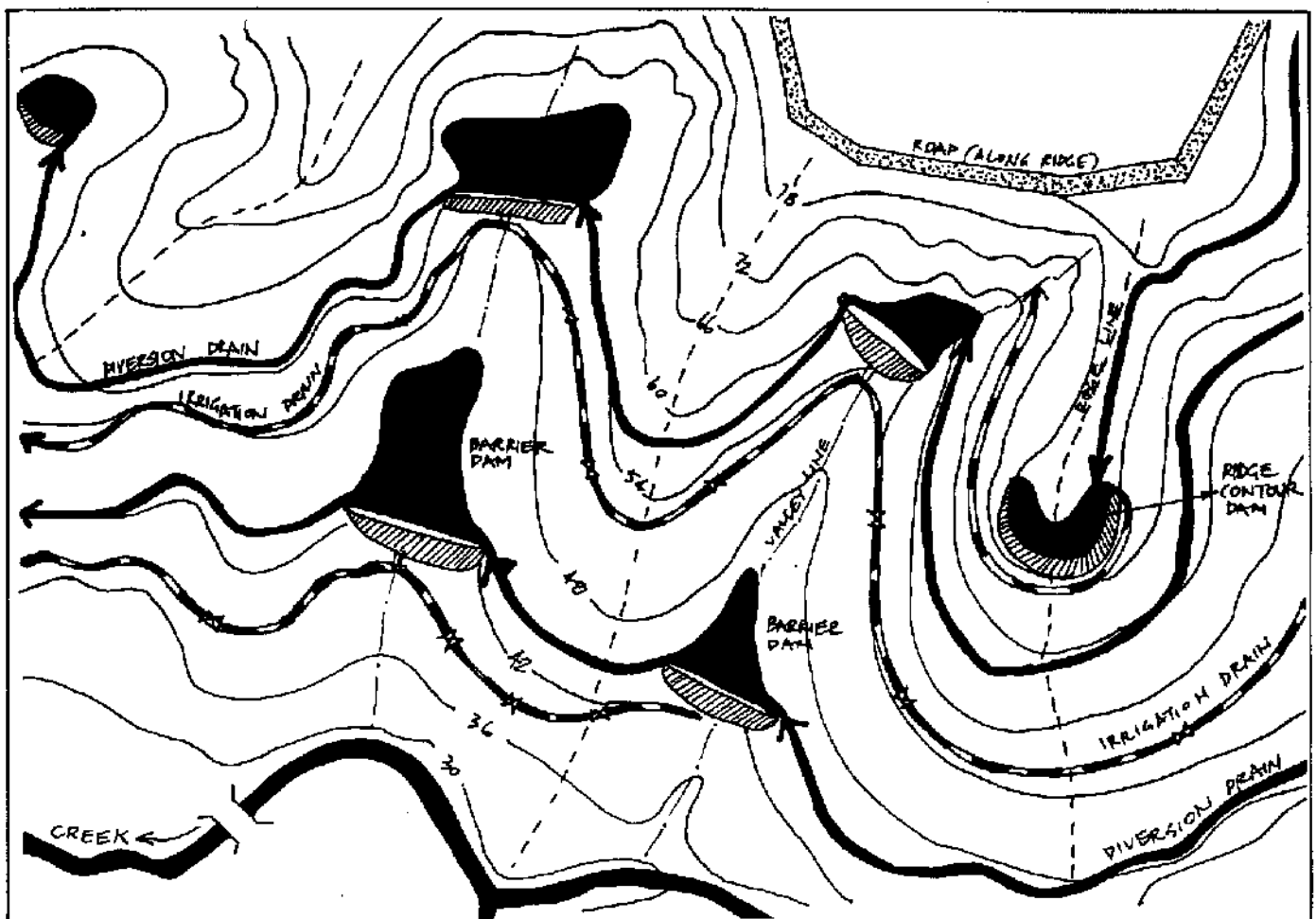

FIGURE 7.16.A

P. A. Yeomans' 'Keyline' system provides drought-proofing for farms with very low maintenance and operating costs; his was the first book

in English on total water design for foothill farms, access, tree belts, soil creation, low tillage, and creative water storage.

PARCEL	m ² 1000's	Imp. gal. 1000's	US gal. 1,000,000's
1	25	5.5	6.6
2	37	8.1	9.8
3	31	6.8	8.2
4	20	4.4	5.3
5	15	3.3	4.0
6	74	16.3	19.5
7	31	6.8	8.2
8	39	8.6	10.3
9	15	3.3	4.0
10	22	4.8	5.8
11	49	10.8	13.0
12	55	12.1	14.5
13	136	30.0	35.9
14	61	13.4	16.1
15	25	5.5	6.6
16	80	17.6	21.1
Tot.	715	157.3	188.9

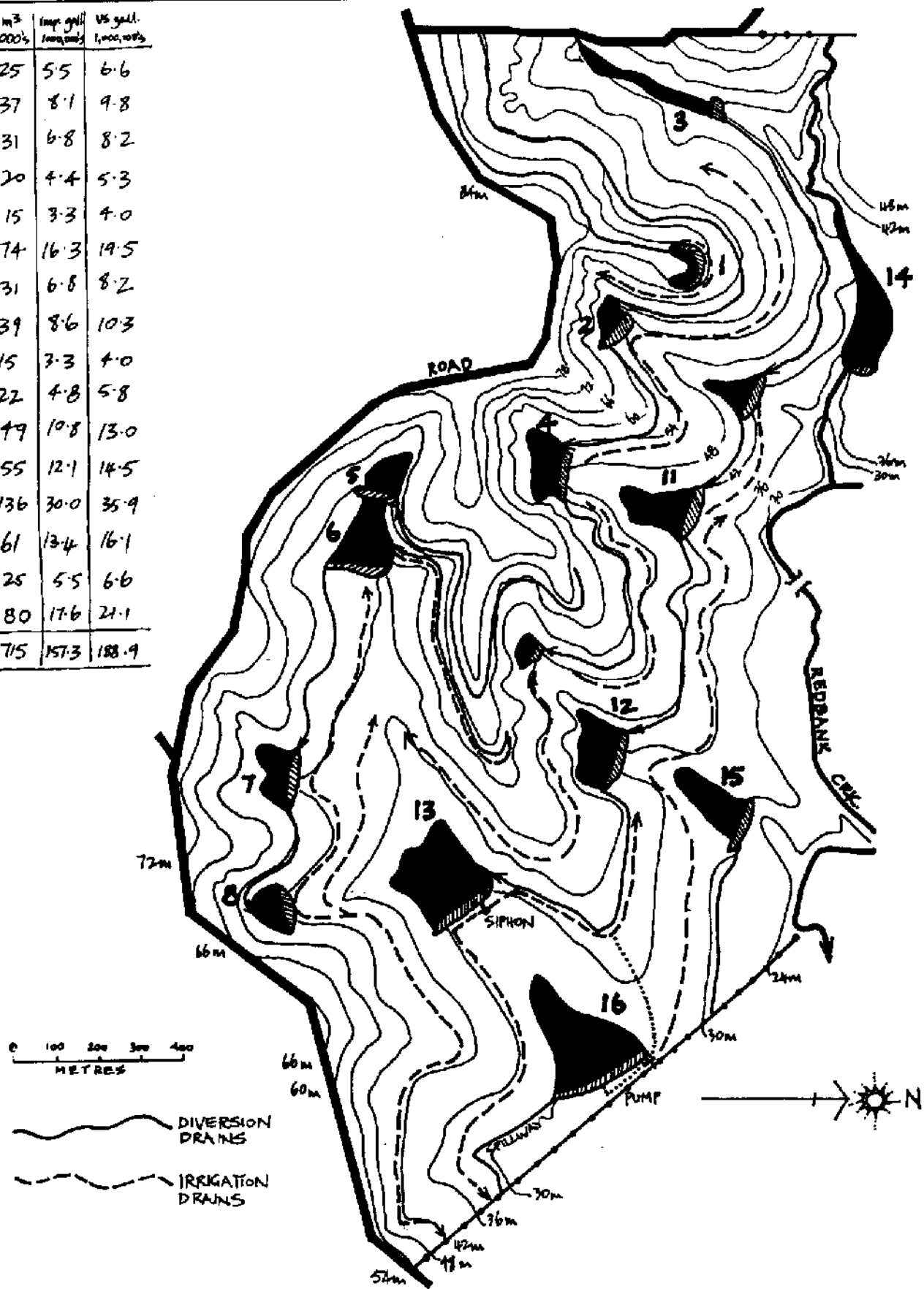

FIGURE 7.10.B
A MAP OF ONE OF P.A. YEOMANS' PROPERTIES.
 P. A. Yeomans' former property "Yobarnie", after 17 years of keyline irrigation development, covering about 307 ha (758a.). The road on

the southern edge of Yobarnie is located along a main ridge. Note the primary valleys and primary ridges falling to Redbank Creek to the North. For further information and photographs see Yeomans⁽⁶⁾.

the earth. This, like the exclusion of boulders and logs, grass clumps and topsoil, is critical to earth stability (shrinkage of well-compacted dams is less than 1%). Earth so rolled should be neither so dry as to crumble nor so wet as to slump or squash out under the roller.

A key should be cut to prevent shear and cut off any base seepage. This is needed on all walls 1.8 m (6 feet) or more high, otherwise the base should be on a shallow clay-filled ditch. Slopes are safe at a ratio of 3:1 (inner) and 2 or 2.5:1 (outer), freeboard at 0.9 m (3 feet), key at 0.6–0.9 m (2–3 feet) deep. In suspect soils, the whole core can be of carted clay (Figure 7.17).

The wall can curve (out or in), but if carefully made as diagrammed and provided with a broad spillway, should be stable and safe forever, barring explosions or severe earthquakes.

The SPILLWAY base should be carefully surveyed at 1 m below crest and away from the wall or fill itself (don't try to judge this, measure it), and a SIPHON or

BASE OUTLET pipe fitted with baffle plates placed to draw off water (Figure 7.18).

The efficiency in capacity of dams depends on the flatness of the area behind the wall. A "V" valley or "U" valley, plateau, or field should be as level as can be chosen for greatest efficiency. The key to efficiency is the length of the dam wall, compared with the "length" of water dammed. If the back-up is greater than wall length, then this is a measure of increasing efficiency of energy used or earth moved for water obtained. A careful survey of grade plus dam length gives this data before starting the wall. Some dam sites are very cost-effective, especially those short dams at constricted sites where the valley behind them is flattish.

Small dams of this nature are a jewel in the landscape. Fenced and planted to 30–60 m of forest and fruit surround, they will provide biologically clean, if sometimes muddy, water, and if the topsoil is returned,

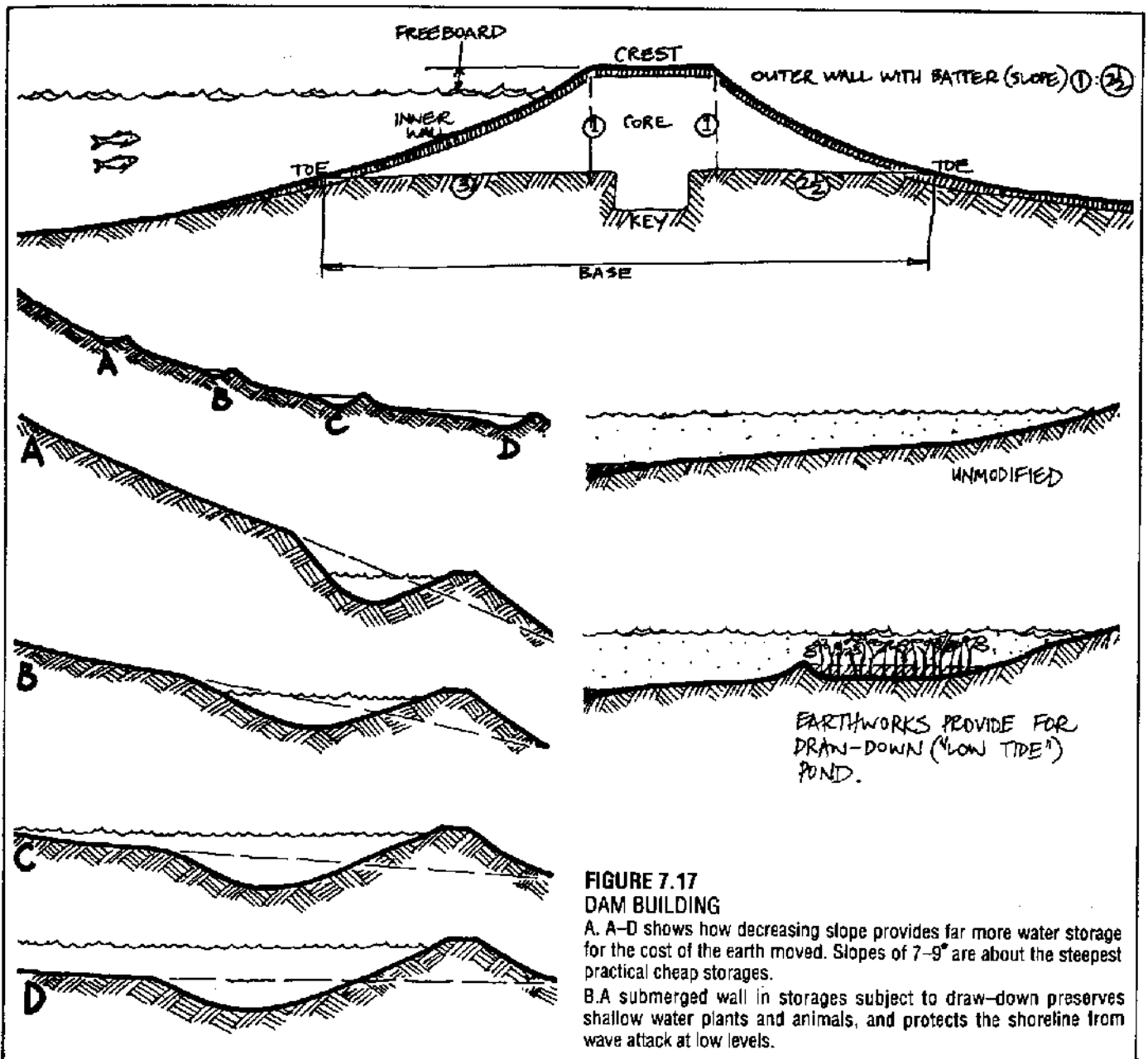

FIGURE 7.17
DAM BUILDING

A–D shows how decreasing slope provides far more water storage for the cost of the earth moved. Slopes of 7–9° are about the steepest practical cheap storages. B.A submerged wall in storages subject to draw-down preserves shallow water plants and animals, and protects the shoreline from wave attack at low levels.

lime used, and edges planted, mud will decrease and eventually clear. For water cleanliness and parasite control, cattle, sheep, and other animals should be watered at spigots or troughs, not directly at the dam. Troughs are easily treated with a few crystals of copper sulphate to kill snails and parasitic hosts; dams stocked with fish will do the same job.

Crests can be gravelled and safely used as roads to cross valleys or bogs, and special deep areas, islands, peninsulas, and shelves or benches made inside the dam for birds, plants, and wild-fire-immune houses.

SEALING LEAKY DAMS

There are several ways to seal leaking dams:

- Gley;
- Bentonite;
- Explosives;
- Clay; and
- Impermeable membranes.

GLEYS are a layer of mashed, wet, green, sappy plant material sealed off from air. Although the very green manure of cattle is preferred, shredded, sappy vegetation will also work. It is carefully laid as a continuous 15-23 cm (6-9 inch) layer over the base and gently sloping sides (ratio of 1:4) of a pond, and is

covered *completely* with earth, cardboard, thick wet paper, plastic sheets, or rolled clay, and allowed to ferment anaerobically. This produces a bacterial slime which permanently seals soil, sand, or small gravels. Once ferment occurs, the pond is pumped or hosed full of water, and the paper or plastic can be later removed. I have used carpets and odd pieces of plastic sheets overlapped with good results. In cold areas, ferment can take a week or two, in tropics a day or so. Lawn or second-cut grasses, papaya and banana leaves, vegetable tops or green manure all serve as the base layer. I believe that in very good soils, especially in the tropics, it may be possible to grow the gley as a mass of *Dolichos* bean and just roll it flat before sealing it (Figure 7.19).

Modifications are:

- To pen and feed a herd of cattle in the dry dam until the bottom is a manurial pug; occasional watering assists this process.
- To strew bales of green hay and manure on ponds that leak slightly, producing algae which seal minor cracks.
- To sow down green crop in the dry dam, spray irrigate and feed it off regularly with cattle.

BENTONITE is a slippery clay-powder derived from volcanic ash. It swells when watered and will seal

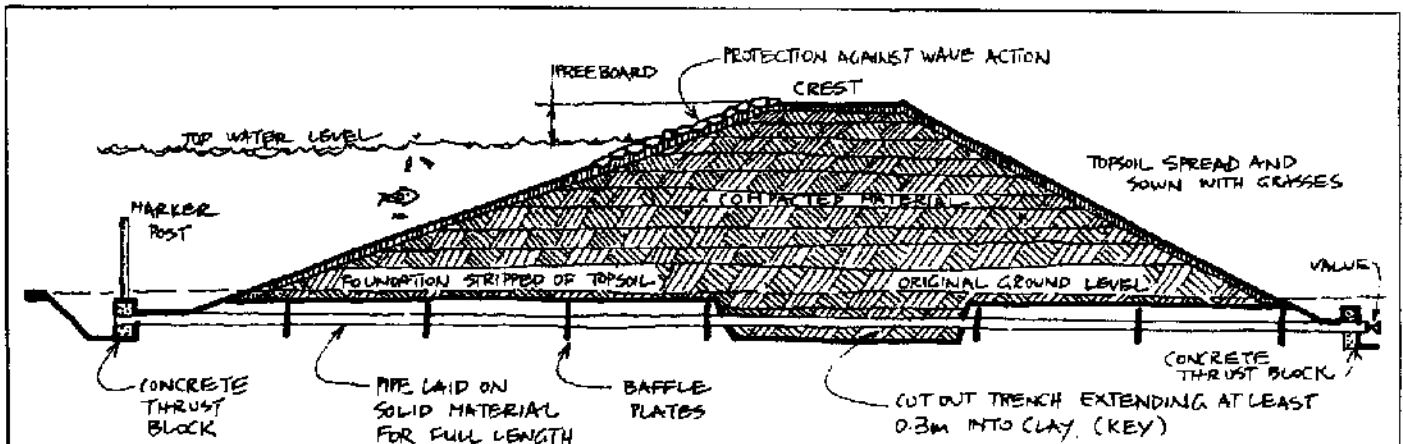

FIGURE 7.18
DAM WITH LOCK PIPES.

A large earth dam feeding irrigation canals in the Keyline system can

be fitted with a base pipe. Smaller dams use siphon over the dam wall to gardens and houses.

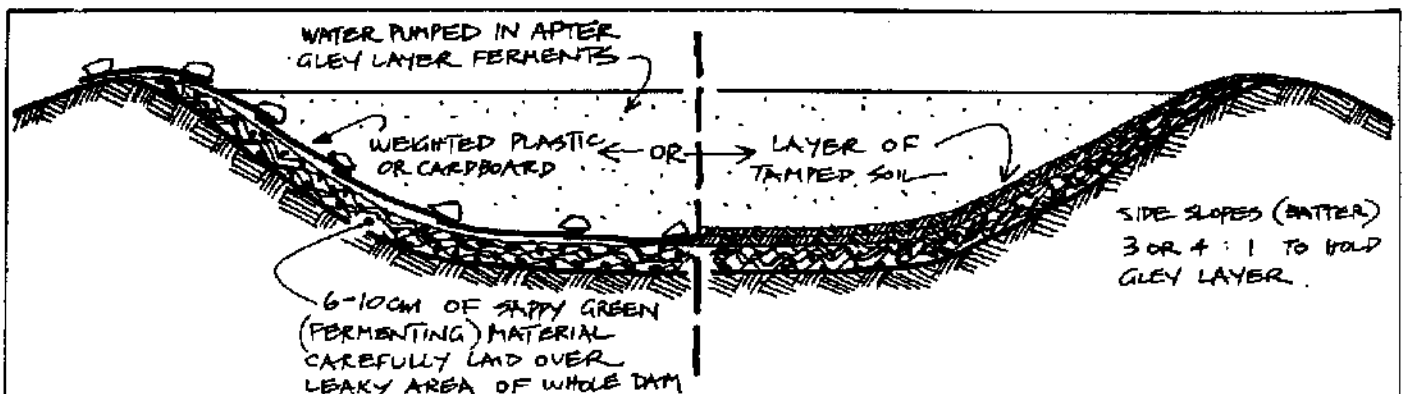

FIGURE 7.19
GLEYSING A POND

With great care taken to slope side and place ferment material, this

technique will seal ponds in sands, gravels, shales, or leaking substrates.

clay-loams if rototilled in at 5-7 cm (2-3 inches) deep and rolled down. However, it is expensive and doesn't always work. Cement and tamping plus sprinkling might be preferable, or a bituminous spray can be rolled in after tilling. In clay soils, salt or sodium carbonate can have the same effect.

EXPLOSIVES are sometimes used to compact the sides of full dams, and consists of throwing in a 3-5 stick charge of dynamite. This works well at times, but is dangerous if you own a retriever, or if the dam wall is poorly compacted to start with.

CLAY is expensive if it has to be carted in, but it is often used to seal dams near a clay pocket. The clay is spread and rolled 23-30 cm (9-12 inches) thick over suspect areas.

IMPERMEABLE MEMBRANES can be of welded plastic, neoprene, or even poured concrete. Impermeable membranes are too expensive to use on any but critical dams, which may mean a guaranteed water supply to a house or garden in very porous areas. Using membranes enables banks to be steeper than in any other earth-compaction or gley system, so that more water can be fitted into smaller space. It is not "biological" unless a sand or topsoil floor is also added over the sealing layer, when fish or plants can be added.

Earth storage is now the cheapest, easiest, and most locally self-reliant method of water conservation. Unless both cities and farms use such methods, clean water will deservedly become known as the world's rarest mineral, ill-health will be perpetuated, and droughts and floods alike become commonplace. None of these are necessary.

Costs vary greatly; as a rough guide, water stored in soil and humus is the cheapest and of greatest volume, surface dams next cheapest, and tanks dear, but still much less expensive than piped water from mains supply. I can only urge all people of goodwill to promote, fund, and investigate water and water storage, water energy and water cleanliness, as the chlorinated, metallic, asbestos-fibred, poisonous water

of modern centralised systems is producing such epidemic disease and illness as cancer, bone marrow failure, and gastrointestinal disorder.

If a 22,500 l tank costs 20 units of money, the same units in a sensible earth storage pays for 2,500,00 l, or about 100 times as much water. Up to 135,000-2,500,000 l tanks get cheaper, as less concrete is used for more water. That is, a large tank is relatively cheaper than a small tank. Above 22,500 l, such tanks are usually poured on site; below this, they are carted from a central manufacturing site.

Dams, in contrast, begin to cost more as the height of the wall rises. About 3 m (10 feet) of retaining wall is the limit of cheap dams. Above this, costs rise rapidly as greater skills, more expensive and massive materials, more complex controls of levels, and much greater environmental risks take their toll.

As noted, "cheap" water in dams depends on the choice of site, so that very low dams on well-selected sites impound 20-100 times more water than the same earth used on steeper sites, where every unit of earth moved equals a unit of water. However, even earth tanks excavated below grade are at one-tenth the price of concrete tanks above grade.

Where are tanks, modest dams, and massive dams appropriate? Tanks are appropriate on isolated dwellings, in flatlands, and everywhere in cities and urbanised areas. Dams of from 22,500 to 4.5 Ml are best built on any good site in country and parkland areas. Massive dams are appropriate hardly anywhere but the the rock-bermed or glaciated uplands of solid and forested hills, subject to low earthquake risk and then only for modest domestic (not dirty industrial) power generation.

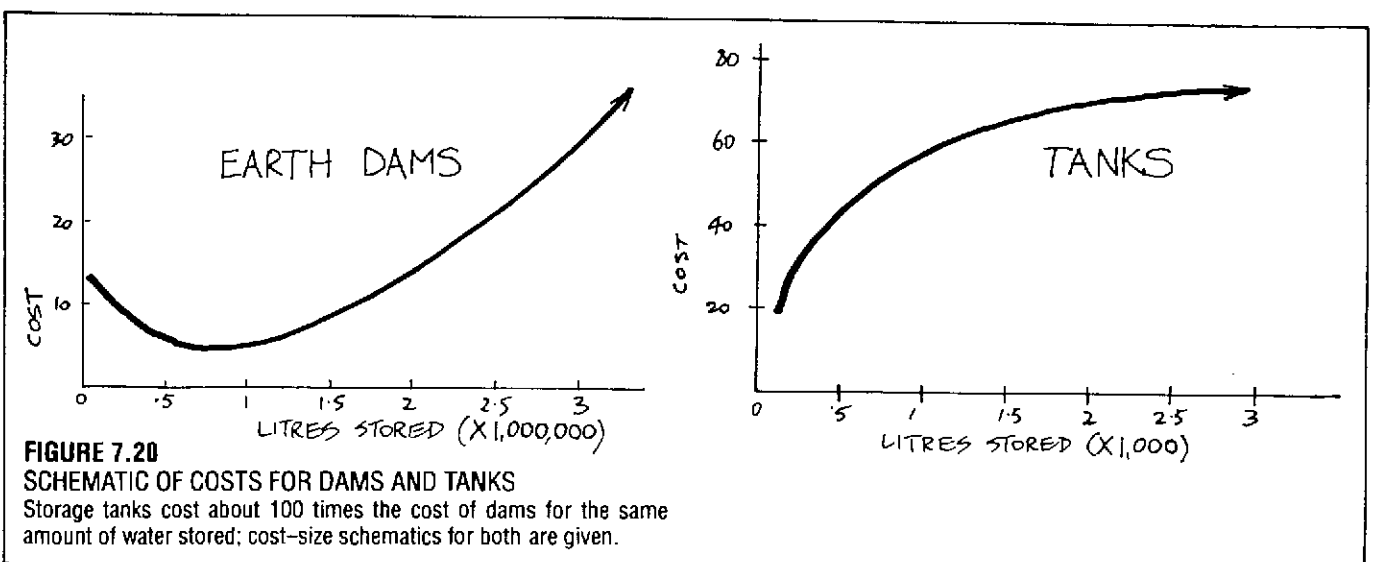

DESIGNER'S CHECKLIST

On any property, identify sources of water, analyse for quality and quantity, and reserve sites for tanks, swales, or dams. Wherever possible, use slope benefits (or raise tanks) to give gravity flow to use points, and detail plant lists that will grow (as mature plants or trees) unirrigated.

In the general landscape, soil samples (for 40% or more clay content) will reveal sites suited to earth-dam construction; such sites need to be reserved for future storages. A sequence of primary valleys may enable a Keyline system to be established for downhill fire control and irrigation.

Where evaporation exceeds precipitation (arid areas), make sure all water run-off is infiltrated to soil storages via soil conditioning (rip-lines), swales, pits, or sandfield soakages. In humid areas, open-surface dams can be used.

Define water "pathways" in use, so that water use is economical in houses, and that greywater is used in gardens (via filtration beds), forests, or (for villages) design for clean-up on site through a common effluent scheme based on maximum use (methane, plant production, irrigation).

Get good advice on (and supervise construction of) all dams. Wherever possible do not impede normal stream flow or fish migration, and site houses out of the way in case of dam failure. In particular, allow adequate stable spillway flow for "worst case" rain intensity.

Make sure that all earth storages, and in particular swales, are planted with trees, to remove infiltrated water and (in arid areas) to prevent salting problems.

Before recommending cloud-seeding, make sure that the area to be affected is warned, and that dams and swales are designed to cope with any increase (up to 30%) in rains.

Design for forested ridges, and maximise forest on strategic uplands; do not lend your skills to high-country deforestation (or any deforestation).

Windbreaks and in-crop trees are essential to reduce water loss in croplands.

REFERENCES

Chorley, R. J. (ed.), *Water, Earth, and Man*, Methuen and Co., London, 1969.

Nelson, Kenneth D., *Design and Construction of Small Earth Dams*, Inkata Press, Melb., Australia, 1985.

Seidl, Kathe, et al, *Contributions to the Revitalization of Waters*, Max Planck Institute, Krefeld-Hulserberg, West Germany, 1976.

Yeomans, P. A., *Water for Every Farm*, Second Back Row Press, Leura, NSW, Australia, 1981.

A New Low-Cost Method of Sealing Fish Pond Bottoms

In no part of the world is aquaculture less developed than in Latin America, despite its great potential there and the shortage of protein foods in much of the region. One of the constraints on the development of Latin American aquaculture has been the porosity of many of the soils — a problem which is by no means limited to Latin America. Such was the case with a 200 m² pond constructed in 1973 at Finca El Uno, located at Tirimbina, Provincia de Heredia, Costa Rica. Compaction of the soil alone was not enough to enable the pond to hold water. The soil at the pond site appears to contain quite a high percentage of clay, but there is a porous, sandy layer at a depth of 2-3 feet. Rainfall in the area is about 120 inches annually.

Similar problems have been solved in a variety of ways in the United States and other affluent countries. Bentonite clay is the most common sealing agent; when mixed with the pond bottom soil in the proper proportions it forms a colloidal seal. A similar effect may be achieved through the application of certain chemical salts. Many American fish farmers have lined their ponds with sheets of polyethylene, butyl rubber, and other synthetics, which are then buried. In extreme cases, small ponds may be cemented.

All the sealing methods mentioned so far share the characteristic of being expensive. This is a disadvantage anywhere, but in situations where capital is a major limiting factor, the expense can be prohibitive. We were able to circumvent this problem by applying a virtually cost-free method of sealing at Finca El Uno. The technique does not originate with us, but is of Russian origin and has not been well publicized. We became aware of it when Marsha Zilles of Santa Barbara, California, sent us a copy of an abstract from an architectural design journal briefly describing how Soviet scientists had sealed ponds by artificially inducing the formation of a "gley" or "biological plastic", as occurs naturally in bogs.¹ The process, as adapted for use in Costa Rica, proceeded as follows:

1. The pond bottom was completely cleared of debris, rocks, etc.

2. The bottom and sides were covered completely with wastes from nearby hog pens. Care was taken to apply the material to the vertical sides of the pond as well as to the bottom. This layer and each subsequent layer of material was added in

quantities sufficient to just cover the previous layer.

3. The hog pen waste was completely covered with freshly cut grass and banana leaves, plus a few discarded cardboard cartons.

4. A third layer, of soil taken from near the pond site, was added and tamped down firmly.

5. After between 2 and 3 weeks, the pond was flooded.

The pond retained water immediately upon filling, with no leakage whatsoever. The cost of sealing was limited to labor costs; the materials used were all "wastes" which would have been discarded in the course of normal farm operations.

The process involved in forming the seal is a bacterial one, which requires anaerobic conditions. It is possible that plastic and rubber pond liners actually act in the same way. While great care is taken to prevent punctures in the installation of such liners, it may be that their long-term effectiveness is, in fact, a result of the creation of anaerobic conditions underneath the liner. The suggestion is that a variety of waste materials, if properly applied, would seal porous soils, thus enabling the Russian method to be adapted for use practically anywhere.

So far as we know, the experience reported here is the first test of the gley formation method of pond sealing in the tropics, or anywhere outside the U. S. S. R. If its application turns out to be universal, as appears likely, the implication is that many areas of the world which, up to now, have been closed to aquaculture (except perhaps by large corporations or government agencies) can now be opened to this method of food production. We would very much like to hear about any experiences our readers may have with pond sealing.

— William O. McLarney
J. Robert Hunter

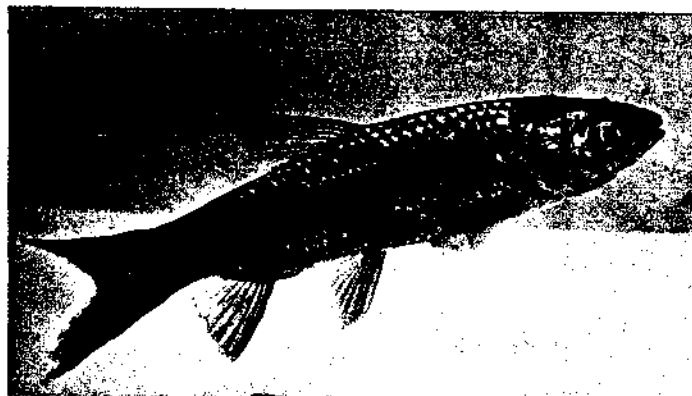

Agricultural Engineer James Waller found that a spring emitting a trickle of water as little as 2 quarts per minute can be harnessed and stored to supply enough water for 35 head of cattle. This same amount is more than sufficient for average homestead requirements.

Traditional water storage facilities have proven to be expensive and inadequate. In a few years a metal tank will rust and a wood tank will deteriorate. Neither can be installed underground—which is essential for the prevention of temperature rise and evaporation. Concrete is the best material to use in building a water storage tank. An underground concrete tank undergoes minimal damage and evaporation.

My earliest contribution to the owner-builder homestead technology has been the development of a low-cost, all-concrete circular reservoir. The foundation-floor of this tank consists of a single concrete slab. The roof is a 2-inch thick concrete folded-plate poured on expanded-metal lath, as illustrated in accompanying drawings. An owner-builder can fabricate this tank for about two cents a gallon of water stored.



10000 GAL TANK

AUTHOR SHOWING WALL-BUILDING TECHNIQUE,
USING HORIZONTAL (SPIRAL) SLIDING FORM

CONCRETE CYLINDRICAL TANK

USING A REVOLVING SLIP-FORM TO SPIRAL
A THIN-WALL MONOLITHIC CONCRETE WALL

DEVELOPED
BY AUTHOR
1957

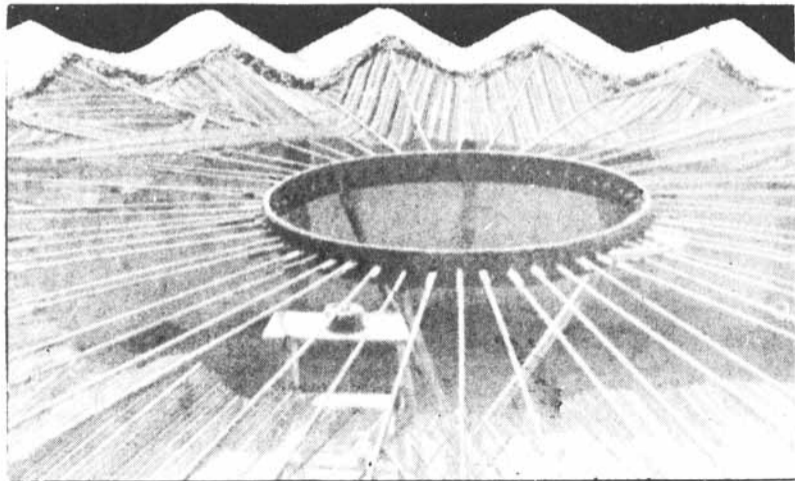

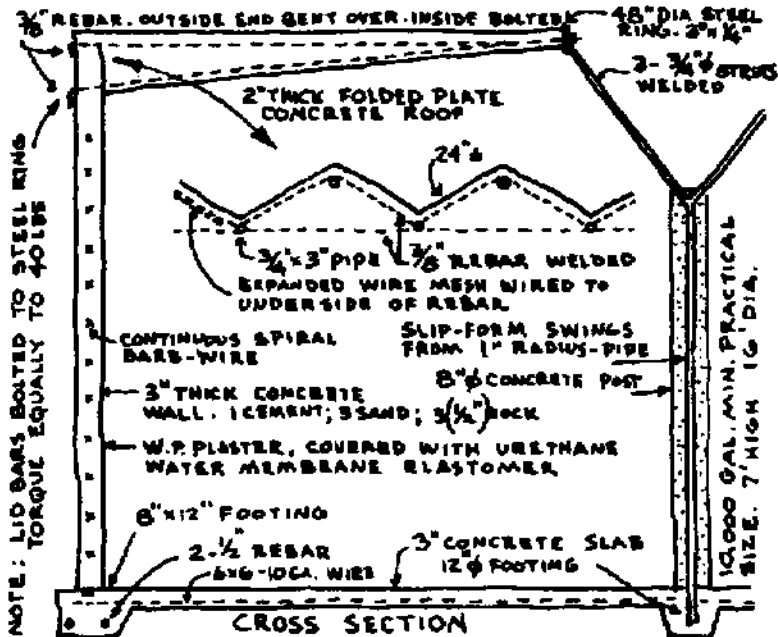



READY
FOR ROOF POUR
30,000 GAL TANK

If a natural spring or artesian well cannot be developed, a homesteader has the choice of *digging, boring, driving, jetting* or *drilling* into the ground for water. Each method, discussed briefly below, has its unique advantages, depending mostly upon the ease of penetration into the earth formation. One's State Geological Survey office will assist in determining what type of earth formation one is likely to encounter: just submit a legal description of your property.

Where the water table is fairly close to the ground surface, a well can be advantageously dug. Depths of from 10 to 40 feet are common. A circular hole, about 40-inches in diameter is usual: being round it is less apt to cave in. Except in cases of solid rock, dug wells require some form of permanent lining. Lining prevents collapse of the hole as well as supporting the pump platform and preventing entrance of contaminated surface water. One unique and practical method of digging deep wells (up to 200 feet) has been developed by the World Health Organization. The first 45 feet is cast-in-place concrete. A system of pre-cast concrete cylinders are then lowered into the well and assembled together. They act as caissons: as earth is removed, the caissons drop lower, guided by upper-level cast-in-place lining.

Bored wells can also be constructed by hand labor, using a simple earth auger. The maximum practical depth is 50 feet, using a 6-8 inch diameter auger. Boring with an auger involves simply forcing auger blades into the soil while turning the tool. When the space between the blades is full of earth the auger is removed from the hole and emptied. As greater depth is attained sections are added to the auger. A pulley-equipped tripod is necessary as greater depths are reached, so that the extended auger rod can be inserted and removed from the hole without unscrewing all sections of the pipe.

11.2.5 Ferrocement water tanks

Ferrocement water tanks are constructed from cement-rich mortar, plastered onto chicken wire reinforced with weld mesh or standard small diameter reinforcement bar. Tanks can be built with basic skills using commonly available equipment in a relatively short period. These are all advantages over reinforced concrete and masonry tanks.

Typically, they may be used to replace Oxfam tanks which can either be dismantled and stored for use elsewhere or used to develop water supplies rapidly in response to changing circumstances.

Table 11.7 gives comparative dimensions, material requirements and

Table 11.7 Dimensions, materials and construction time for ferrocement tanks

Dimensions					
Tank volume, m ³	10	20	30	40	50
Base diameter, m	3.02	4.10	4.95	5.70	6.30
Mesh radius, m	1.36	1.91	2.33	2.70	3.01
Inside radius, m	1.33	1.88	2.30	2.67	2.98
Wall height, m	1.80	1.80	1.80	1.80	1.80
Materials					
Bags of cement, tank	11	18	27	41	51
roof	3	5	7	9	12
Weld mesh: rolls of 2m x 45m, mesh size 150 x 150mm	20	30	40	50	66
Chicken wire: rolls of 1m x 30m, 25mm mesh chicken wire	1	2	2.5	3	4
Binding wire, 16 gauge, kg	6	10	13	16	20
Clean sand, m ³	1.5	2.5	3	4	5
Gravel (< 25mm) m ³	0.8	1.3	2.0	2.5	3
200 litre drums of water	13	20	25	30	35
Construction time, days	8	9	13	14	17

Source: UNICEF, undated

estimated construction time for tanks up to 50 000 litres (50m³). Tanks over 40 000 litres (40m³) require a central column to support the roof.

Box 11.2 outlines the construction procedure for ferrocement tanks based on a technique developed and successfully used in Kenya. A key aspect of the approach is that rigid shuttering is not required. Adapt the procedure for tank sizes up to 50 000 litres (50m³). This particular design is not suitable for tanks above this size. All concrete and mortar mix ratios are by volume. Use well graded clean sand

Box 11.2 Construction procedure for a 20m³ ferrocement tank

Day 1 Refer to Figure 11.10.

- Excavate a shallow circular level foundation, 100mm deep and 2.05m radius. Prepare weld mesh of 2.05m radius for floor reinforcement.
- Prepare the wall reinforcement by forming a 12.30m length of weld mesh into an upright cylinder, with overlap, to give a diameter of 3.82m. Bend the bottom wires of the mesh at 90°. Bend the top wires inwards at an angle of 45°.
- Prepare the roof reinforcement by forming cut sections of weld mesh into a 1.90m radius circle with a 450mm high support at the centre.

Day 2

- Position any outlet or drain pipe in a narrow trench in the earth foundation under the floor and protruding through it as shown in Figure 11.10. Backfill the trench with concrete.
- Cast the concrete floor by laying a 50mm thick concrete base (1:2:4 mix) in the prepared foundation. Place the floor reinforcement on the concrete. Cast another layer of concrete (1:2:4 mix) without delay on top of the reinforcement, working from the centre up to 400mm from the perimeter.
- Position the wall reinforcement without disturbing the reinforcement already concreted. Pull into shape and bind. Place the remaining concrete and tamp firmly around the wall. Cover the concrete.
- Continue preparation of the roof reinforcement by cutting and placing chicken wire on the prepared roof weld mesh.

Day 3

- Keep the concrete wet throughout the day.

- Prepare the wall for plastering:
 - Tightly wrap the weld mesh from the top to the floor with chicken wire. Overlap the ends. Tie the chicken wire to the weld mesh in several places.
 - Tightly wrap 16 gauge binding wire around the wall as follows (see Figure 11.11)
 - 4 times around the top weld mesh wire;
 - every 100mm for the top 600mm;
 - every 80mm for the next 600mm;
 - every 50mm for the next 700mm;
 - 4 times around the bottom and tie to the mesh.
 - Tie sacking to the outside wall. Firmly tie two ladders together to straddle the wall. Inspect the tank and pull it into a cylindrical shape using staked ropes or binding wire (Figure 11.12).
- If it is windy, postpone further work until the wind calms.
- Plaster the inside wall. Add water to a cement/sand mortar (1:3 mix) until it is just workable. The consistency of the mortar is critical. Experiment on a trial section first and note the water required for a successful mix. Start plastering at the bottom and push the plaster into the wire walls from the inside of the tank. Leave a space in the weld mesh for an overflow and any inlet pipe.
- Protect the walls with plastic sheeting.
- Splash the floor with water.

Day 4

- Remove the sheeting and wet the floor and walls. Keep the concrete wet throughout the day.
- Plaster a second layer of slightly wetter mortar on the inside wall. Remove the sacking and plaster a thin layer of mortar (< 10mm thick) over the outside wall.

(Continued over)

Box 11.2 (continued)

- Cover both the inside and outside walls with plastic sheeting.
- Wet the floor.

Day 5

- Remove the sheeting and wet the floor and walls. Keep the concrete wet throughout the day.
- Cut the top overflow section of the weld mesh, bend outwards at 90° and wrap in chicken wire. Support and plaster the top of the overflow.
- Smooth a 10mm thick layer of plaster on the outside wall and cover.
- Prepare the roof for plastering by sewing sacking to the underside of the roof mesh. This may be supported by poles as in a traditional hut.

Day 6

- Wet the floor and walls.
- Complete the inside wall: Plaster and smooth the inside wall to a total wall thickness of 50mm. Make a mix of equal parts of cement and water. Smooth evenly onto the new plaster to within 150mm of the floor.
- Complete the floor: Plaster the floor with cement mortar (1:3 mix) to create a slope towards the outlet. Finish the floor and remaining 150mm of wall with a mix of equal

parts of cement and water, and cover.

Day 7

- Position and plaster the roof: Place the roof reinforcement on the tank wall and bind it to the vertical wall wires. Cut an access hole (450mm × 450mm) in the roof wires. Support the roof on poles. Plaster the roof with cement mortar (1:3 mix) and cover. (See Figure 11.13).
- Cast an access cover in a shallow pit, reinforcing with weld mesh and chicken wire. Cure for a week.

Day 8

- Remove the roof sheeting and wet the roof, floor and walls.
- Plaster the roof (10mm thick) and cover with plastic sheeting.
- The tank should now be strong enough to hold water.

Day 9

- Remove the roof poles and sacking. Plaster the underside of the roof. Plaster a piece of galvanized gauze over the overflow.

Afterwards

Keep the tank covered in plastic sheeting and/or fill it with water to cure for at least two weeks.

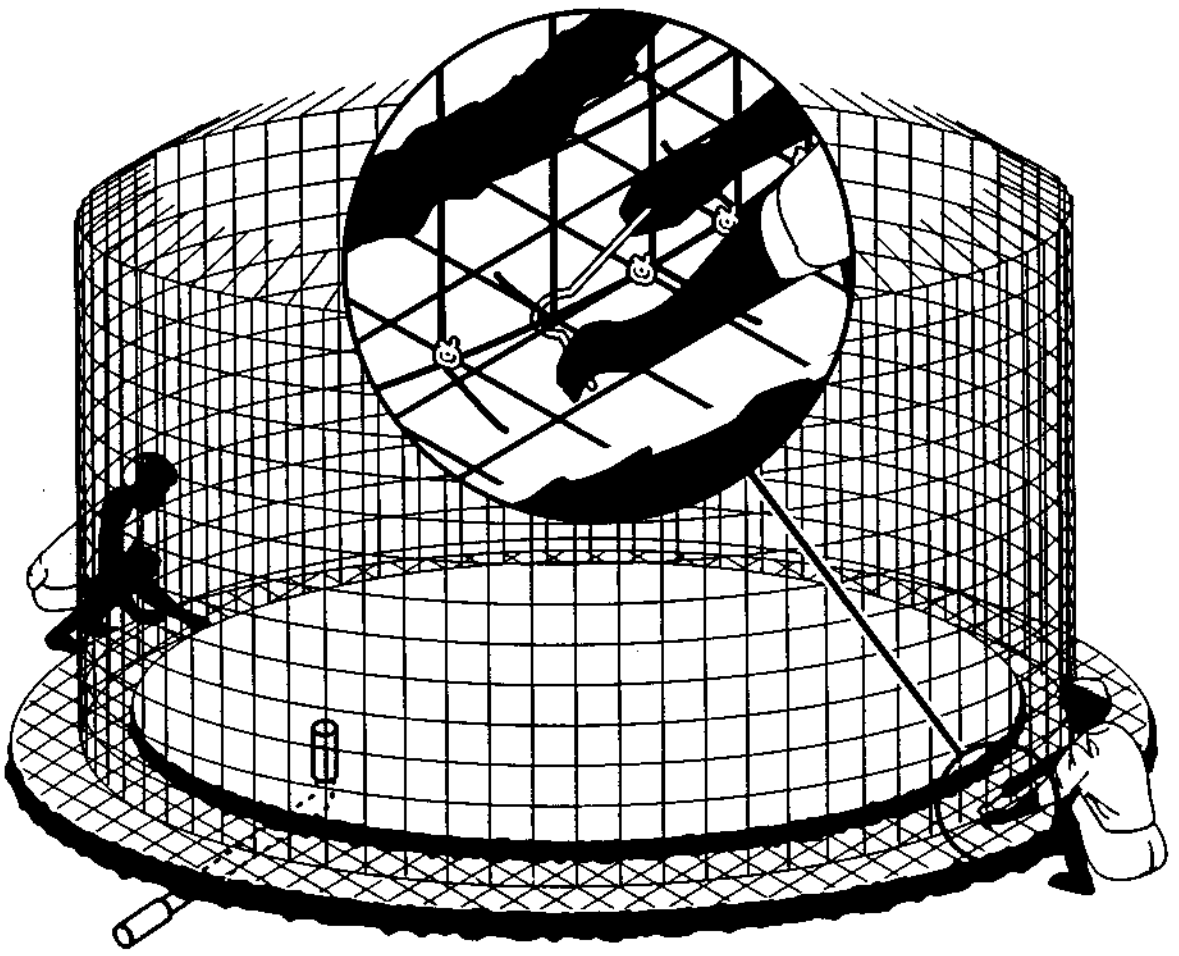

Figure 11.10 Foundation and wall preparation

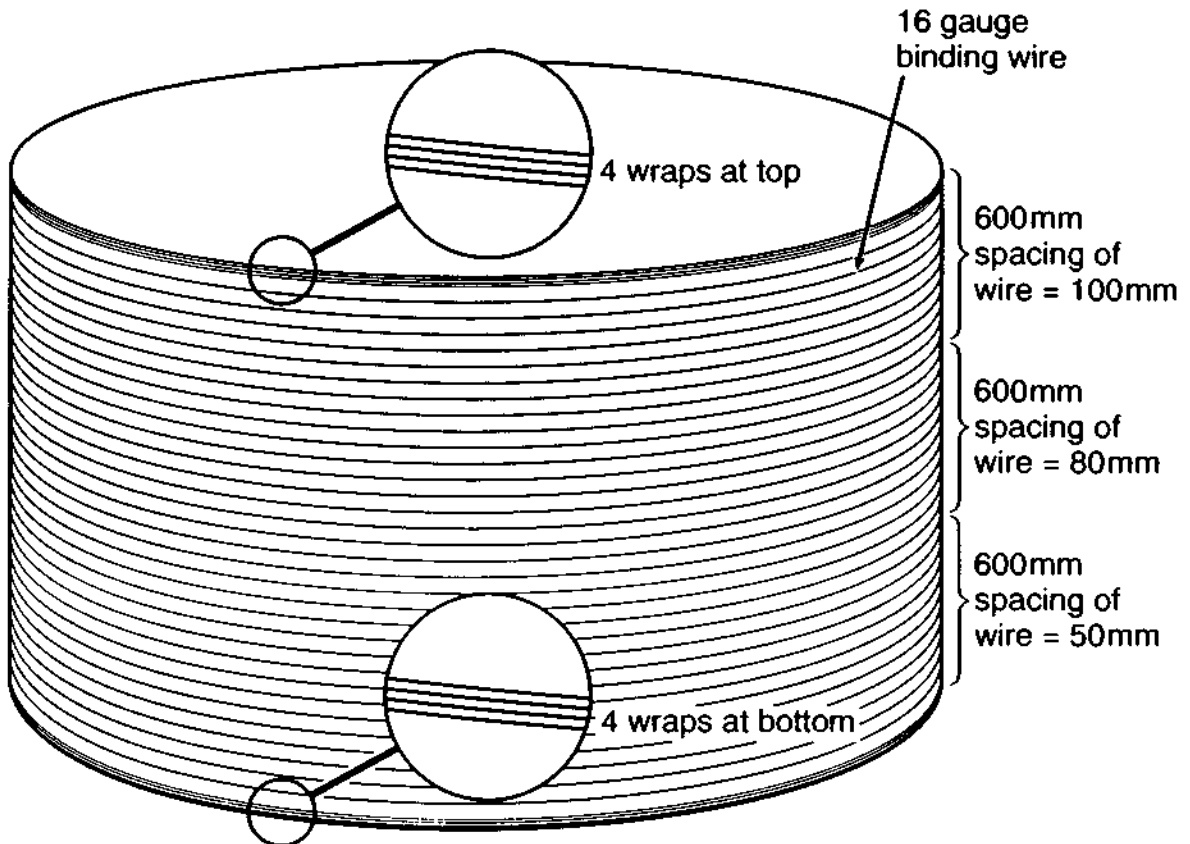

Figure 11.11 Wrapping the binding wire

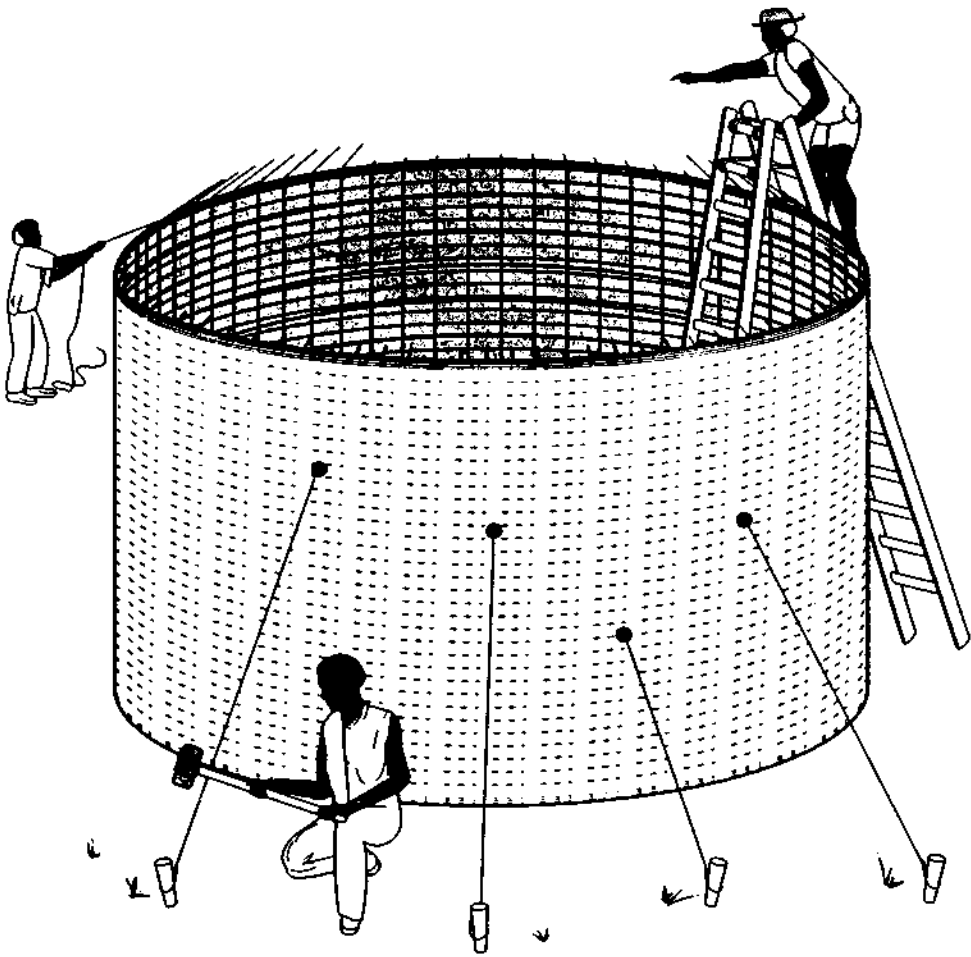

Figure 11.12 Pulling the tank into shape

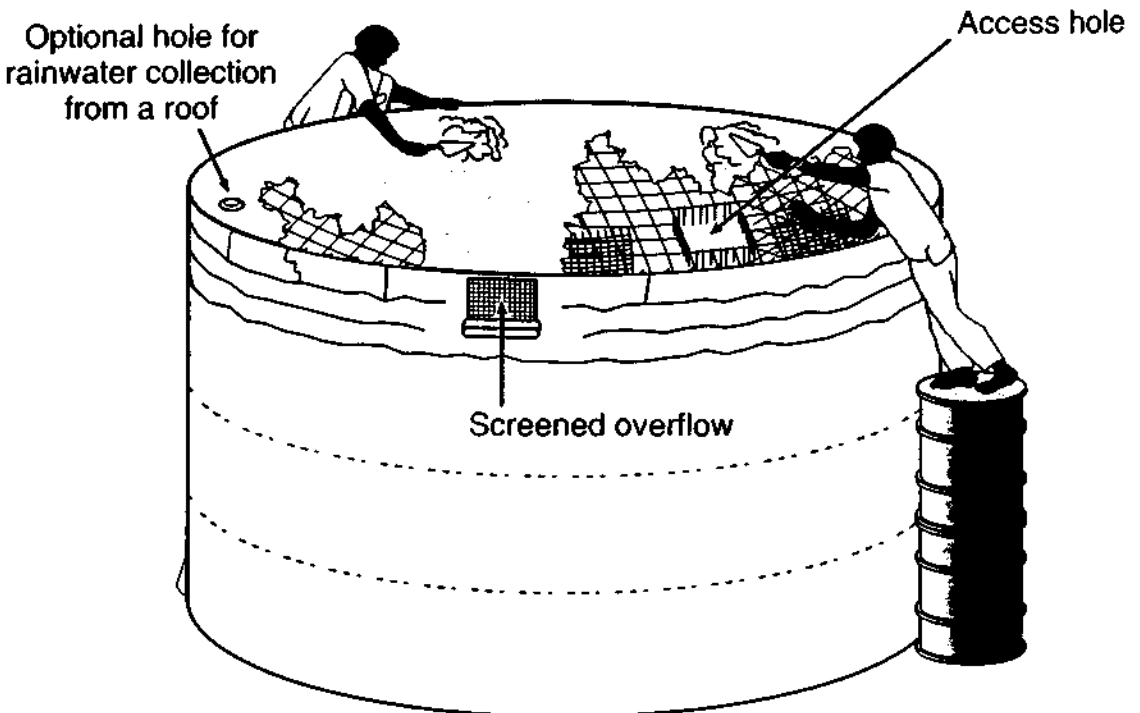
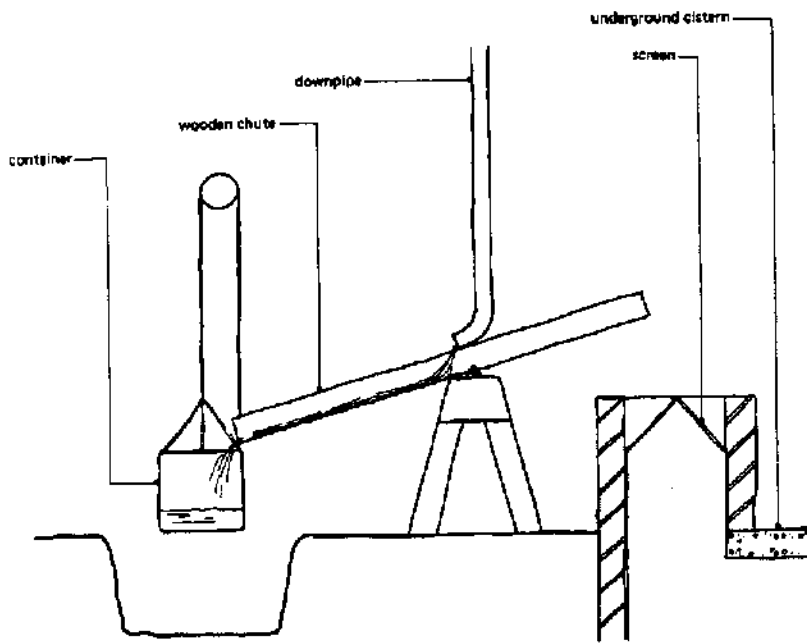
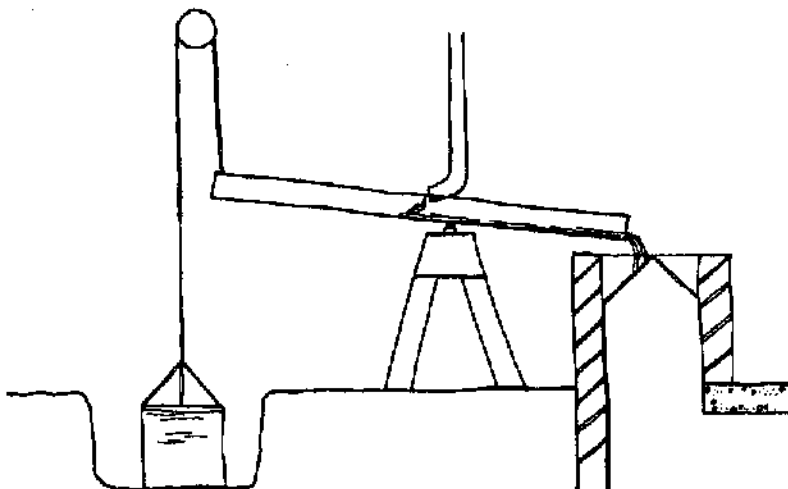
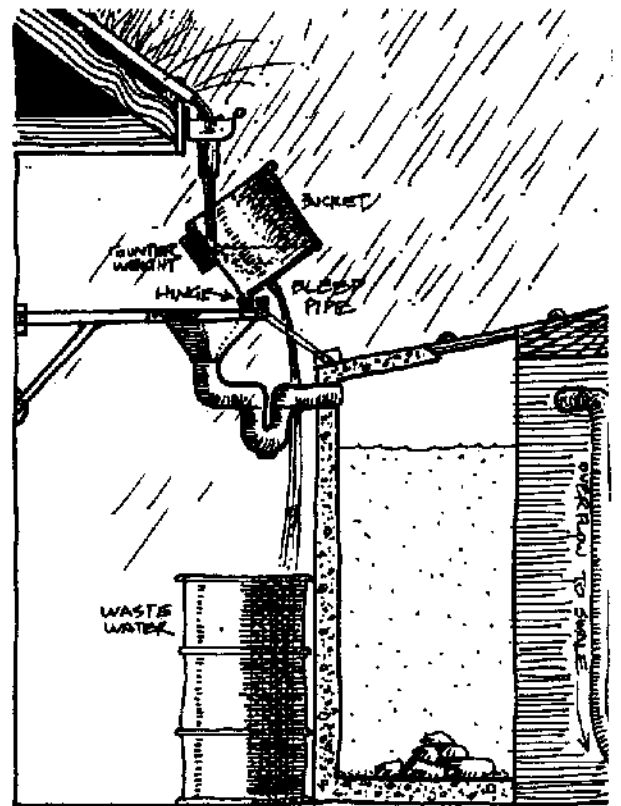

Figure 11.13 Plastering the tank roof



78 A device for separating off the first flow of rainwater from a roof. A wooden chute is pivoted off-centre on a supporting framework and so remains at rest as shown. The first rainwater from the roof runs down the chute and fills the suspended container. When the weight of water in the container is greater than the extra weight in the long arm of the chute the equilibrium is broken, the container falls and the chute is tipped as shown below.



The rain-water now flows down the shorter arm of the chute, over a screen, to an underground cistern. After the rain the container must be emptied and the original equilibrium restored. The container must be of a size to hold sufficient water for washing the roof.

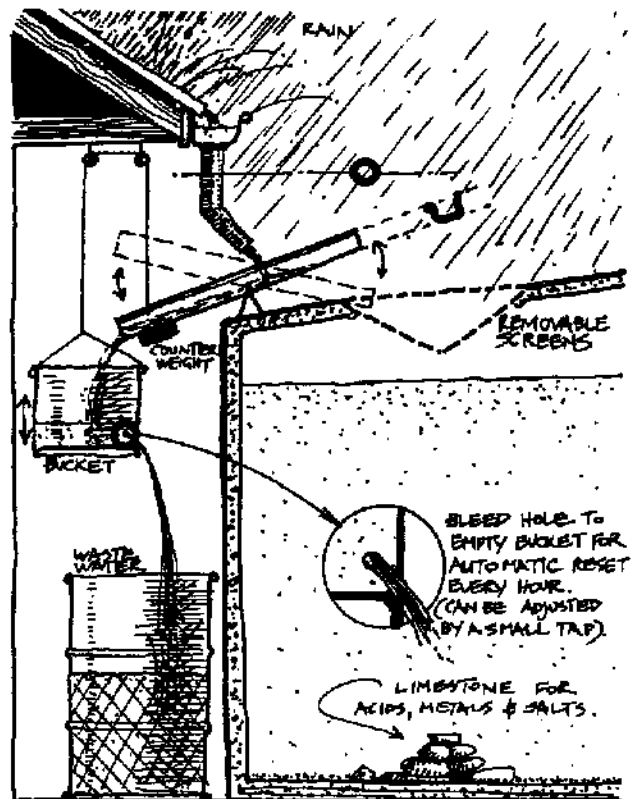
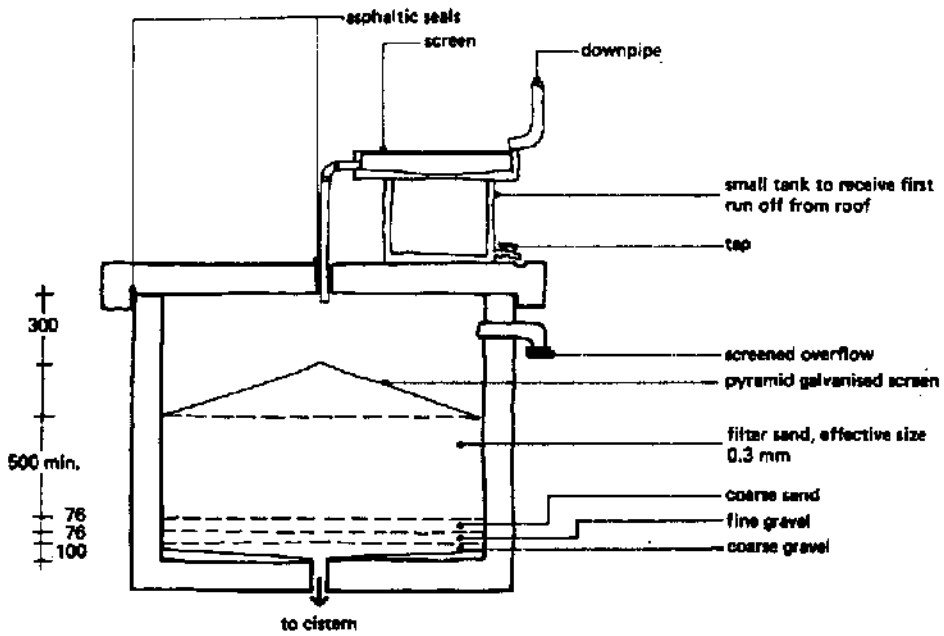
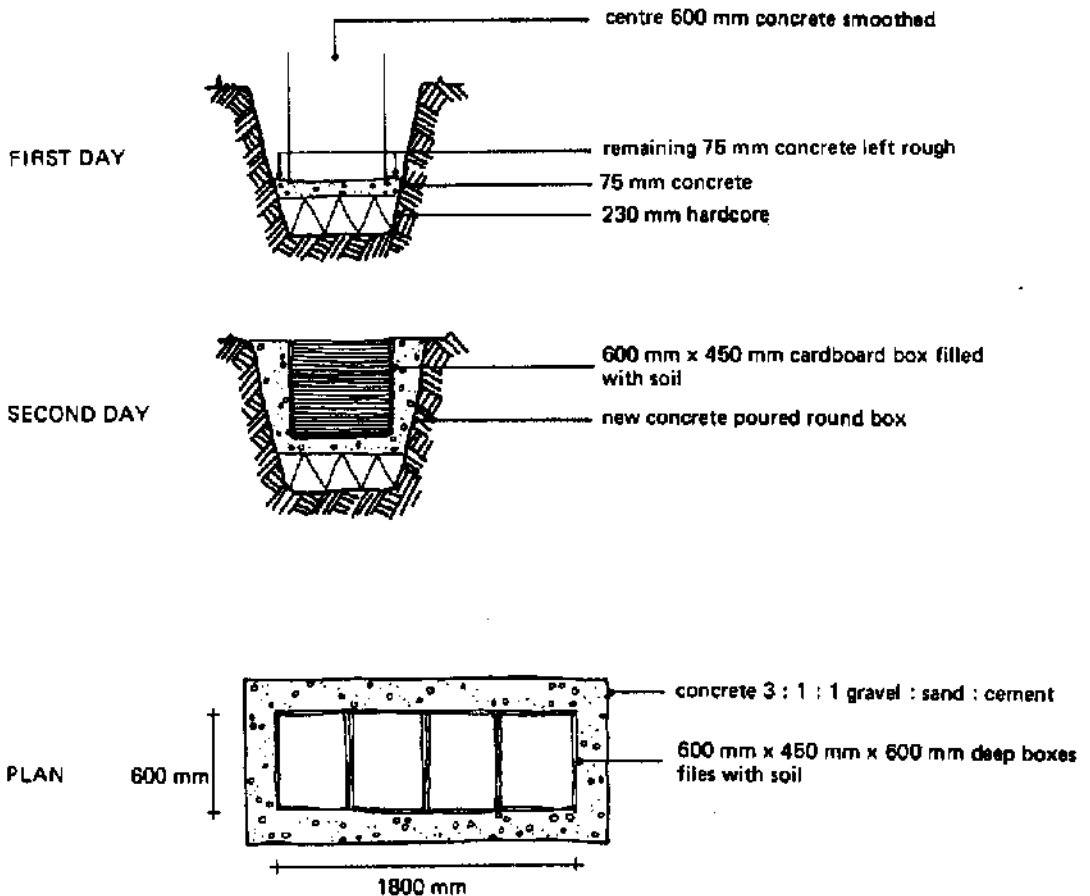

FIGURE 7.21 METHODS OF REJECTION OF FIRST WATER FLOW OFF A ROOF.

The first rains wash the roof, and are rejected; these systems automatically reset when empty.



84 *Slow sand filter with diversion for the first run-off from the roof (after Village Technology Handbook, 1970). The screen helps to distribute the water over the surface of the sand so that it does not make holes in it. To avoid water overflowing the filter the filter area should not be less than one-tenth of the catchment area.*



81 *Construction of an underground concrete water tank to hold approximately 1,365 litres (after Hills, 1971).*

VERSATILITY OF FIBERGLASS MODULES

The Digester Unit (primary/digestion and secondary/settling tanks), Gas Storage Tank, Algae Tank, Fish Tank, Gasholder and Water Tank (last two not shown) are all made in fiberglass from the *SAME MOLD*, which is quite an expensive item. These modules can be easily added to the system at any time to cope with expansion of any of the IFS activities. Mass production of these units, which can be made in sections to fit inside one another and then assembled on site, will bring the cost down considerably.

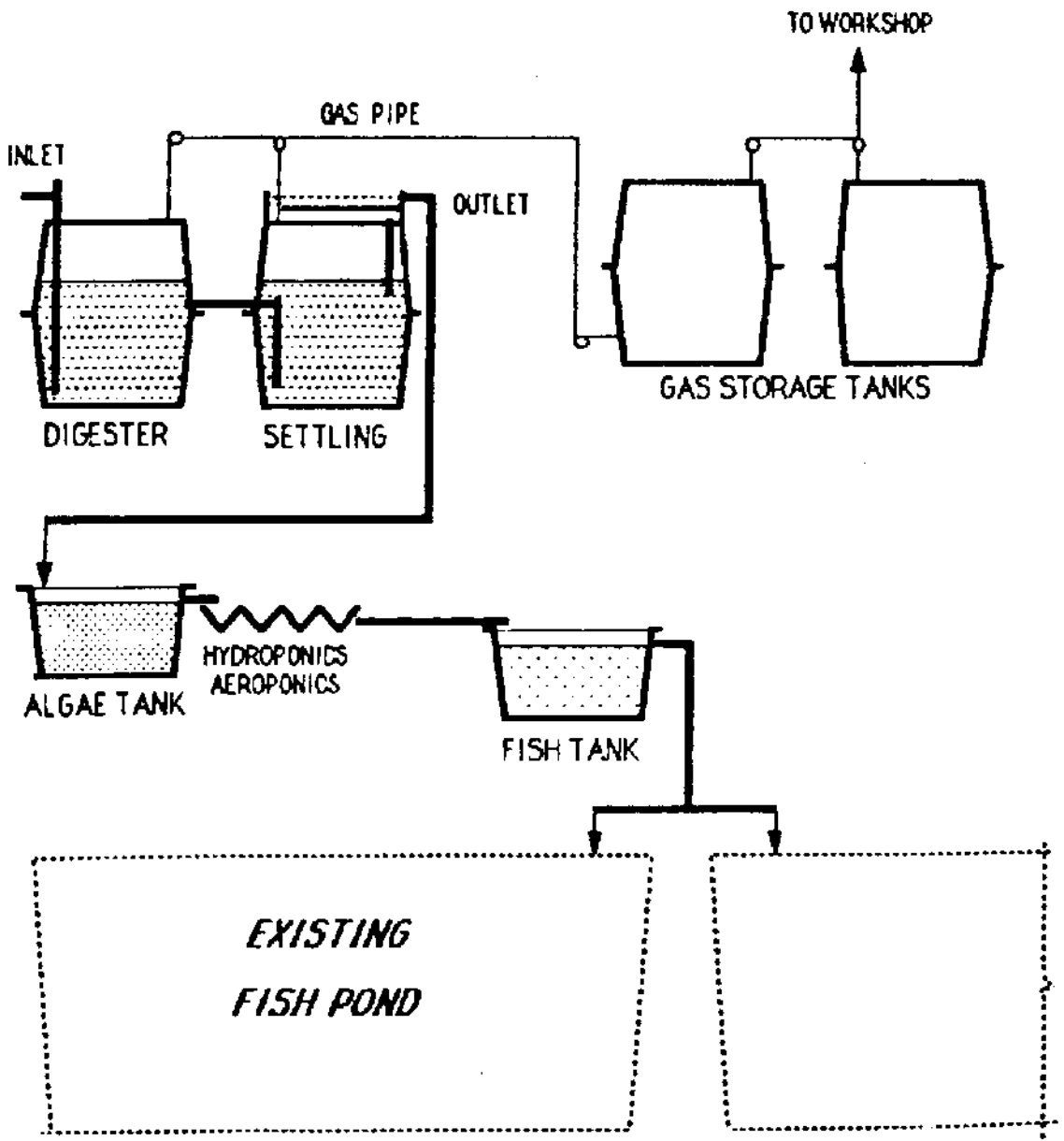

RECIPROCATING WIRE POWER TRANSMISSION

FOR SMALL WATER WHEELS



A reciprocating wire can transmit power from a water wheel to a point up to 0.8km (1/2 mile) away where it is usually used to pump well water. These devices have been used for many years by the Amish people of Pennsylvania. If they are properly installed, they give long, trouble-free service.

The Amish people use this method to transmit mechanical power from small water wheels to the barnyard, where the reciprocating motion is used to pump well water for home and farm use. The water wheel is typically a small undershot wheel (with the water flowing under the wheel) one or two feet in diameter. The wheel shaft is fitted with a crank, which is attached to a triangular frame which pivots on a pole (see Figure 2). A wire is used to connect this frame to another identical unit located over the well. Counterweights keep the wire tight.

Tools and Materials

Wire - galvanized smooth fence wire

Water wheel with eccentric crank to give a motion slightly less than largest stroke of farmyard pump

Galvanized pipe for triangle frames:
2cm (3/4") by 10 meters long (32.8')

Welding or brazing equipment to make frames

Concrete for counterweight

2 Poles: 12 to 25cm (6" to 10") in diameter

As the water wheel turns, the crank tips the triangular frame back and forth. This action pulls the wire back and forth. One typical complete back and forth cycle, takes 3 to 5 seconds. Sometimes power for several transmission wires comes from one larger water wheel.

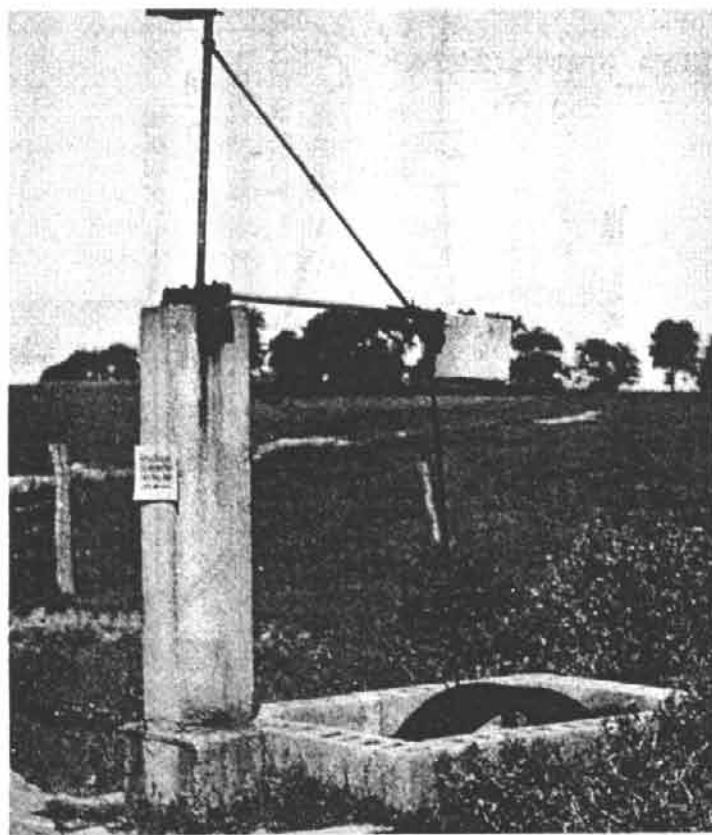

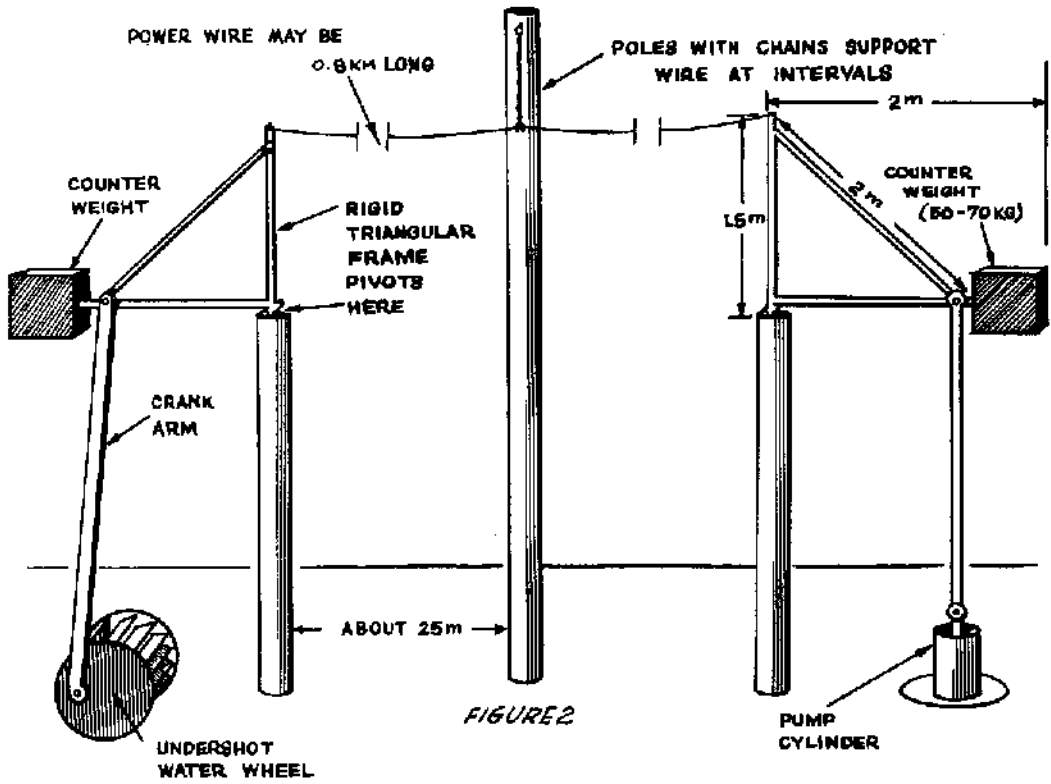

FIGURE 2

Turns can be made in order to follow hedgerows by mounting a small triangular frame horizontally at the top of a pole as shown in Figure 4.

Water Wheel

Figures 5, 6 and 7 show how to build and install a small water wheel made from wood and bamboo.

Source:

New Holland, Pennsylvania VITA Chapter.

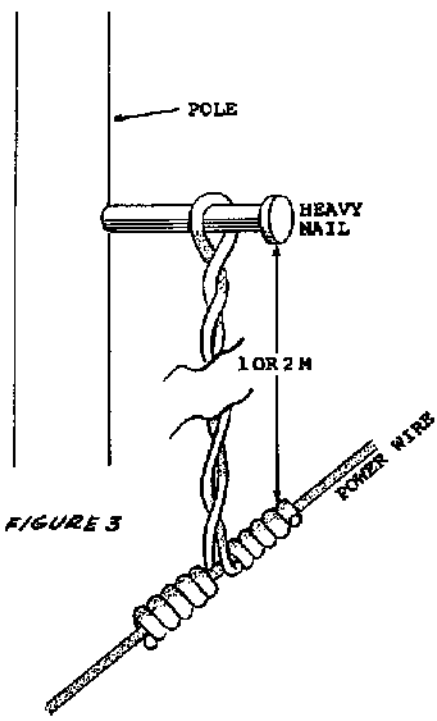

FIGURE 3

The wire is mounted up on poles to keep it overhead and out of the way. If the distance from stream to courtyard is far, extra poles will be needed to help support the wire. Amish folks use a loop of wire covered with a small piece of garden hose attached to the top of the pole. The reciprocating wire slides back and forth through this loop. If this is not possible, try making the pole 1-2 meters higher than the power wire. Drive a heavy nail near the pole top and attach a chain or wire from it to the power wire as shown in Figure 3.

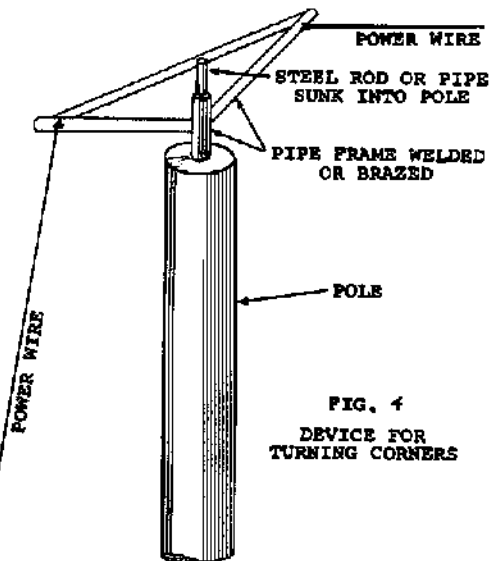
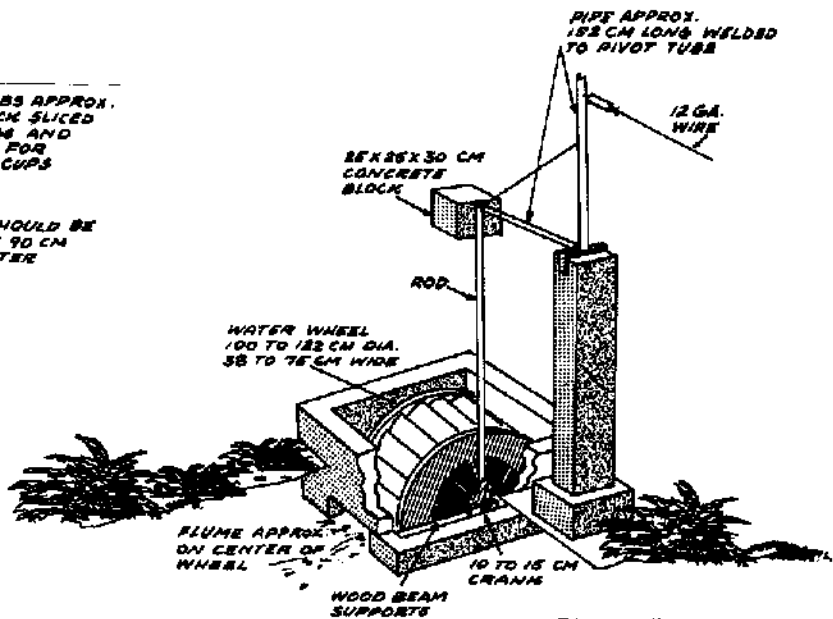
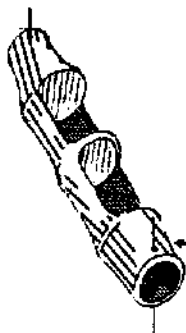
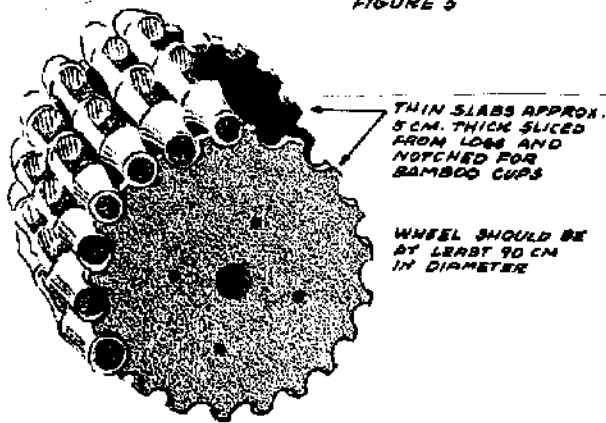

FIG. 4
DEVICE FOR
TURNING CORNERS

FIGURE 5



NOTE: CRANK CAN BE ADDED TO OTHER END OF SHAFT AT 90° ANGLE TO FIRST CRANK TO ATTACH MORE POWER TRANSMITTING WIRES

FIGURE 7

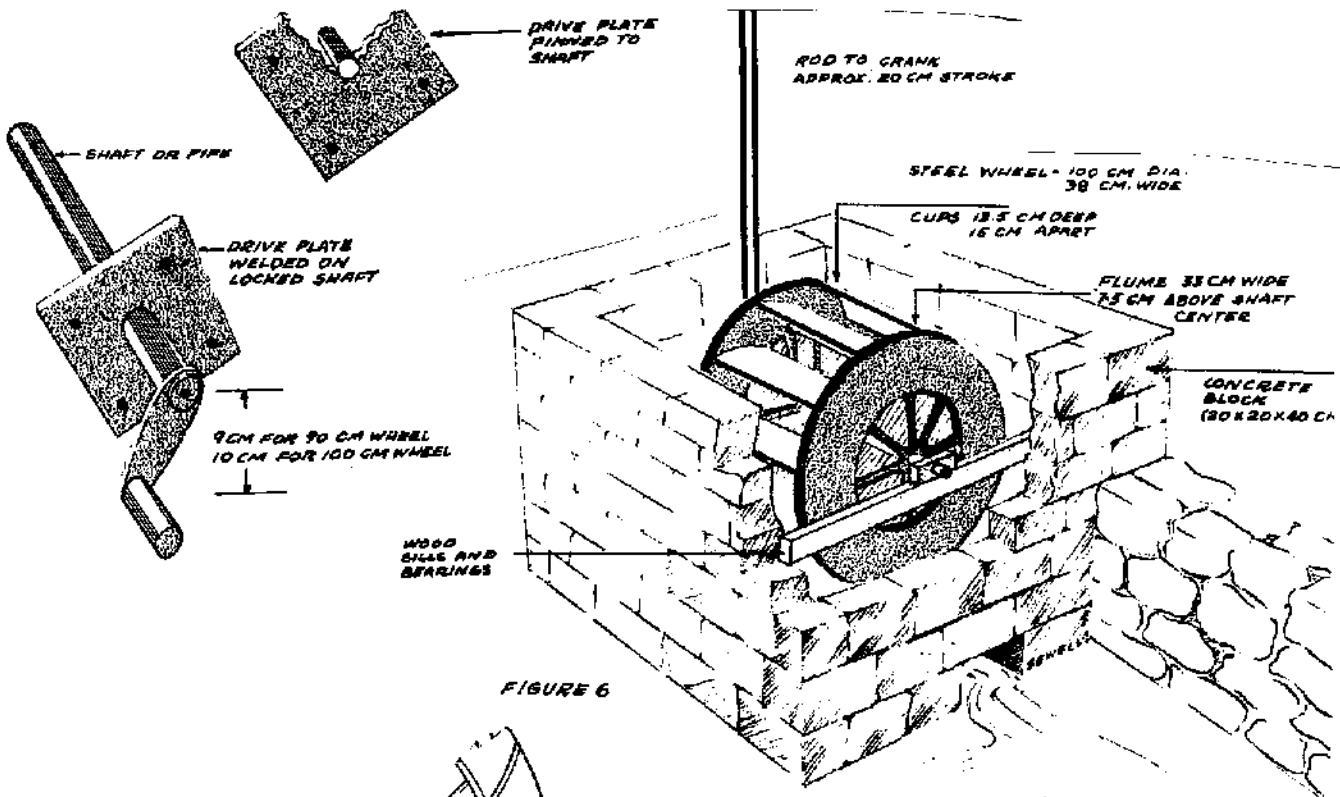
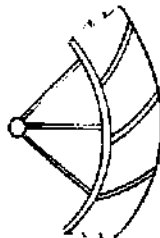
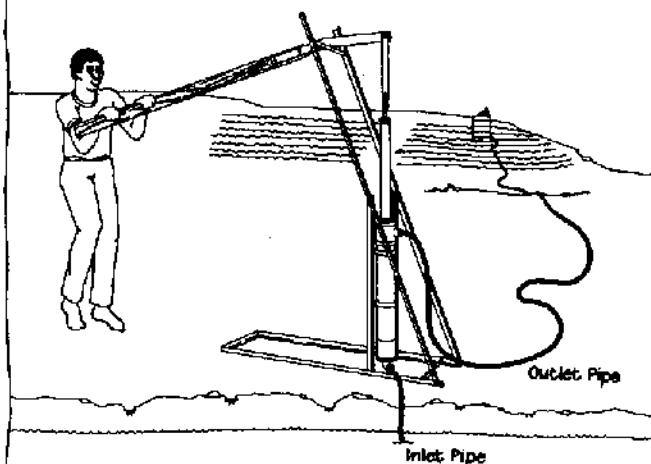

FIGURE 6



HOW TO MAKE A HAND PUMP FOR IRRIGATION



This pump can be used to pump water from a river to a vegetable garden. It can suck up water from a shallow well, if the well is less than 3m deep. It can pump 15m high.

The pump costs R70 and the outlet pipe costs 50 cents a metre. To make the pump you need a workshop with an electric drill and a welder. EDA can make pumps for communities who do not have the equipment or the experience to make their own. If you want to make a pump for a well deeper than 3m, write to us for plans.

How It Works

The pump uses valves to lift water. Each valve is made of a plastic disc with holes in it, and a rubber flap.

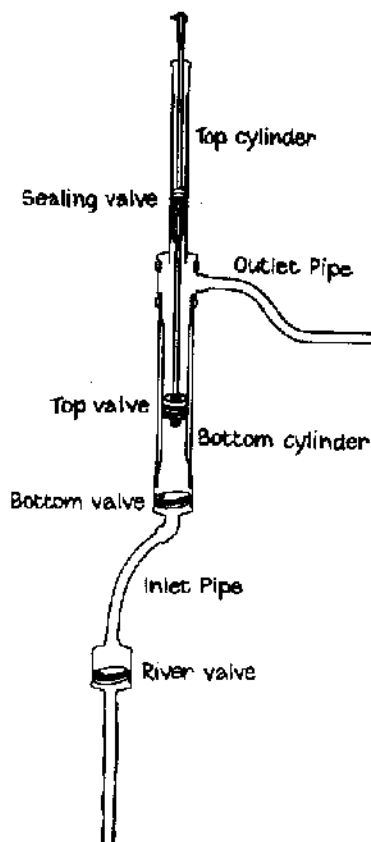

274

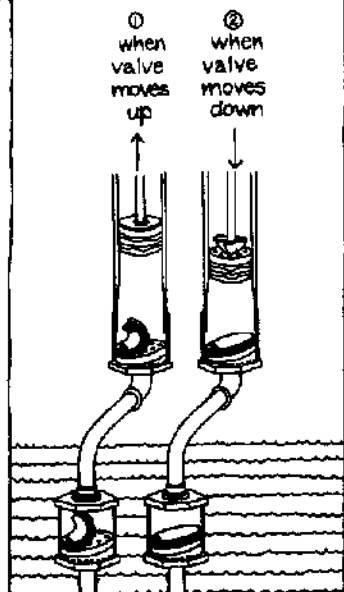

① When you push the handle, the top valve slides up. The flap on the top valve closes and the flaps on the bottom valve and the river valve open. Water is sucked up through the holes in these valves. The flaps let the water flow up but it cannot flow down again.

② When you pull the handle, the top valve slides down, its flap opens, and water passes through the holes. The flaps close on the bottom valve and the river valve.

③ When the top valve is lifted again, the water above it is lifted up and forced out through the outlet pipe.

The sealing valve in the top cylinder makes sure that there is water in the bottom cylinder all the time. Without the top cylinder, too much air would get in and the pump would not work.

275

Making the plastic sleeves

For the bottom cylinder, cut a 50 cm length of 75 cm PVC pipe. Boil it in old motor oil. While it is still soft, squash one end with a funnel of sheet metal to make the end more narrow. Use a piece of sheet metal 15 cm square. Make it into a funnel, 7.5 cm wide at the bottom and 6 cm wide at the top.

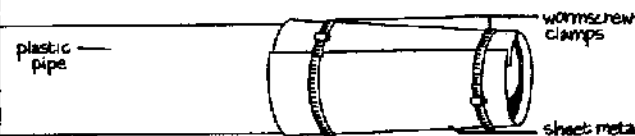

Then cut a 50 cm long piece of 75 cm PVC pipe. Boil one end of the pipe until it is soft. Put it inside the 3 inch steel pipe. Push and hammer the 50 cm PVC pipe into the soft end of the 50 cm pipe so that it presses tightly against the inside of the steel pipe.

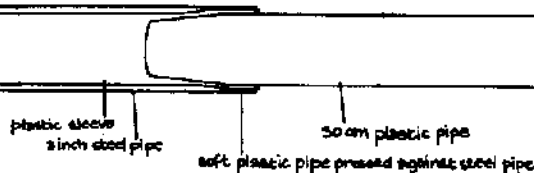

Then take out the 50 cm pipe, boil the other end, and open this end inside the steel pipe in the same way.

When both ends have been opened out, take the pipe out and spread both sealers over both ends. Then push and hammer it back into the steel pipe. Drill 2 holes through the steel and the plastic pipes at the top end. Use 2mm brass nuts and bolts to hold the plastic pipe in place.

Making the Pump

What you need

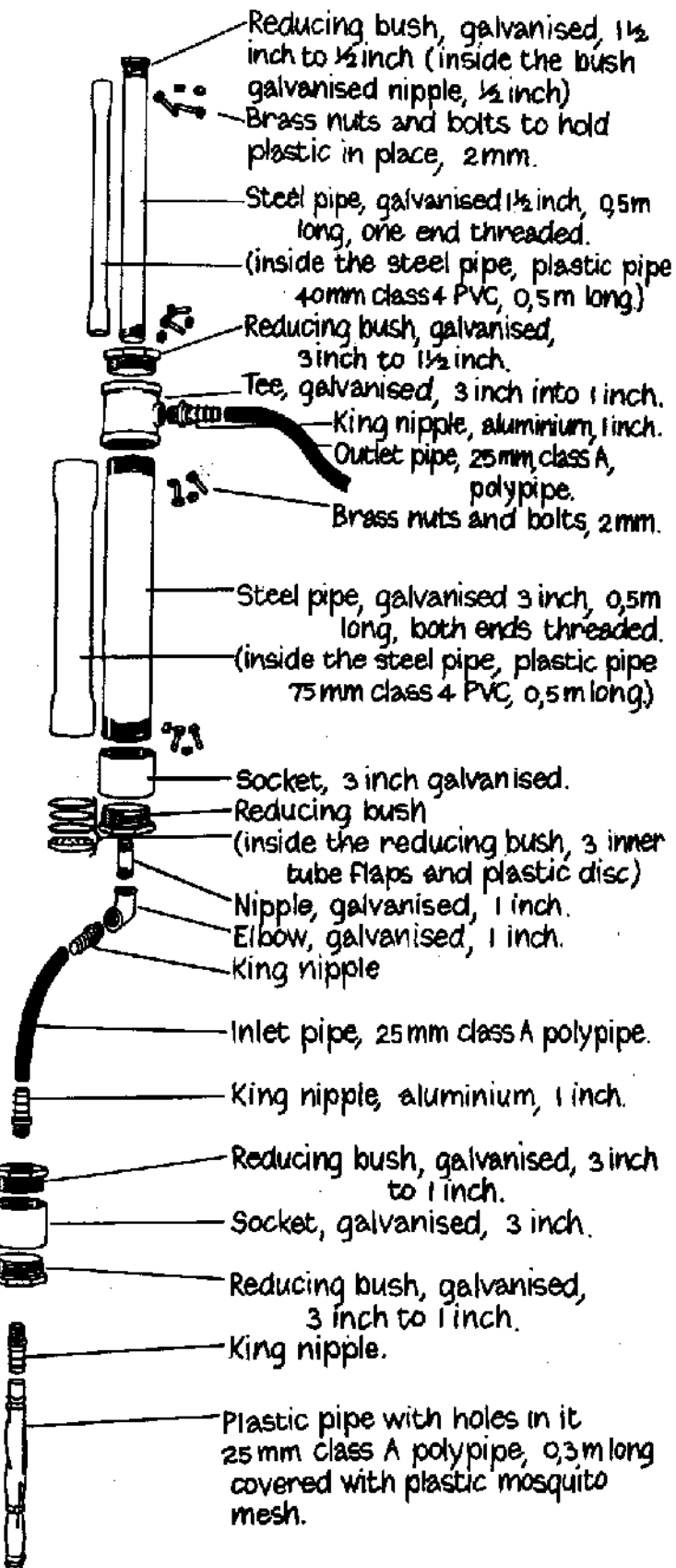
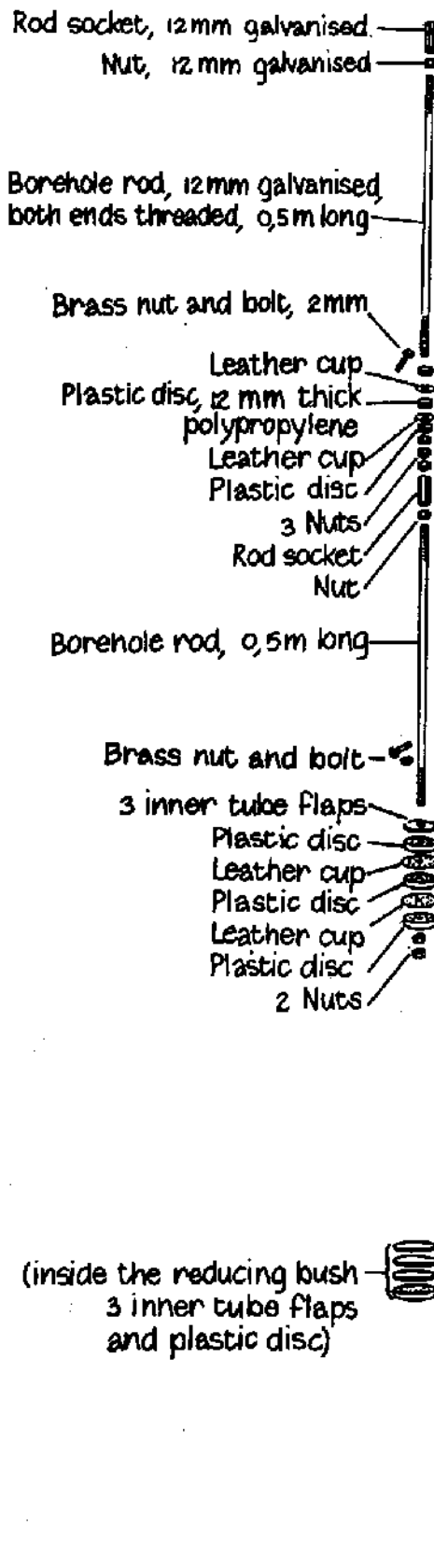

Make the plastic sleeve for the top cylinder in exactly the same way, but here you can use a cold drink bottle instead of a funnel to widen the ends.

Weld the 1/8 inch to 1/8 inch reducing bush to the unthreaded end of the cylinder, then smear beach sealer onto the plastic pipe and put it in the cylinder. Hold it in place with brass screws.

Making the valves

The valves are made from 12 mm thick polypropylene. You can only buy this plastic in 2 sq. metre sheets which are enough for 5 pumps but EDA can send you a strip of plastic for one pump.

Copy these shapes and glue them onto the plastic. You need 3 discs for the top valve, one for the bottom valve, one for the river valve and 2 for the sealing valves. First drill the holes, then cut out the discs with an electric drill routing attachment.

- 1 bottom valve disc
- 1 river valve disc

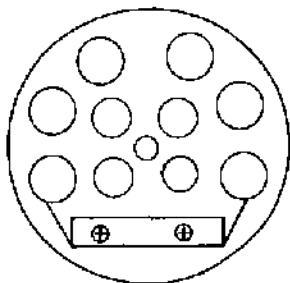

diameter 74 mm.
centre hole 7mm.
6 holes 13mm. for water to
4 holes 10mm. pass through.
2 holes 5 mm for screws.

3 top valve discs

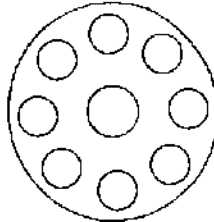

diameter 56 mm.
centre hole 15mm for
the borehole rod.
6 holes 10mm for water
to pass through.
3 holes 2mm for screws.

2 sealing valve discs

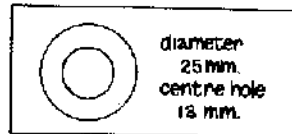

diameter
25 mm.
centre hole
13 mm.

The top valve and the sealing valves

Make 2 leather cups by cutting 85mm diameter leather discs. Put these discs between the 3 plastic discs. Hold them all together with 3 self tapping screws 2mm thick and 36mm long. Then cut 3 56mm diameter rubber discs from a car inner tube. Drill a 13mm centre hole. Measure the thickness of the completed top valve and drill a hole into the end of the borehole rod this deep. Fit a brass nut and bolt into this hole, slide on the completed valve, and tighten it on with 2 nuts. Join the other end of the borehole rod to a borehole socket.

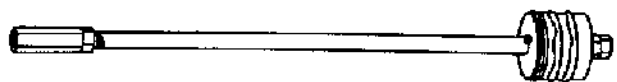

279

280

To make the sealing valve, make 2 leather cups from 45mm diameter leather discs. Slide on the 2 leather cups between 3 plastic discs. Slide the completed sealing valve onto the top section of the borehole rod and connect the sealing valve to the borehole rod.

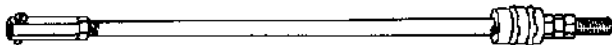

The river valve and bottom valve

These valves are exactly the same. For each valve cut 3 rubber flaps of 75 mm diameter from a car inner tube. Cut a piece of plastic to hold the flaps onto the disc. Drill 5mm holes through the inner tube flaps and the piece of plastic. Hold them together with 4 mm bolts and nuts. Cut a washer from car inner tube to fit around each valve. Knock each valve into its reducing bush, so that it fits tightly.

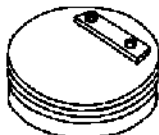

Making the handle



Cut a 0.5m length of scaffold pipe.
Cut a notch 14 cm from one end.

Bend the pipe at the notch and drill a 8 mm hole through at one end. Weld a 23 cm length of 1/2 inch pipe across the bent part of the pipe.

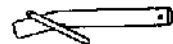

Cut 2 40cm lengths of 50mm steel plate. Weld these plates to the scaffold pipe. Drill 2 13mm holes in each plate.

Cut a 30cm length of 30mm wide flat iron. Drill 2 8mm holes. Join one end of the flat iron to the handle.

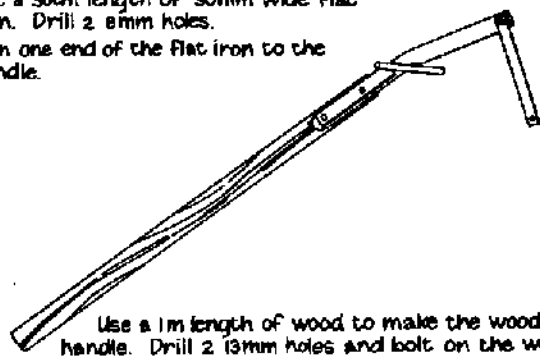

Use a 1m length of wood to make the wooden handle. Drill 2 13mm holes and bolt on the wooden handle.

Putting the pump together

Push the top valve into the 3 inch pipe. Slide the T piece over the sealing valve and screw it into the 3 inch pipe. Screw the reducing bush into the T. Slide the 1/8 inch pipe over the sealing valve and screw it into the reducing bush.

Making the pump stand

Cut angle iron, weld and drill 13mm holes. Attach the pump to the stand with 3 inch galvanised pipe straps.

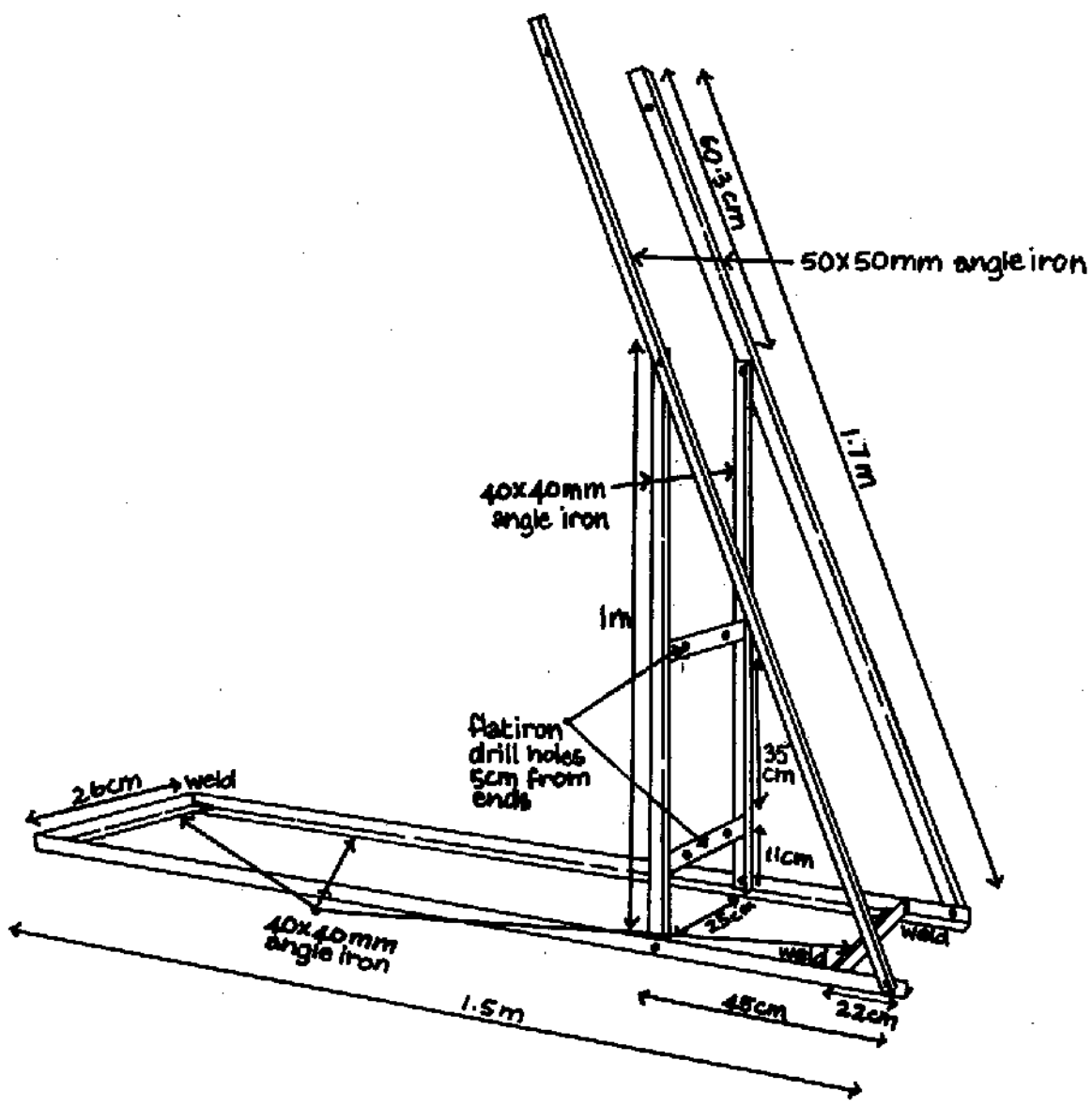

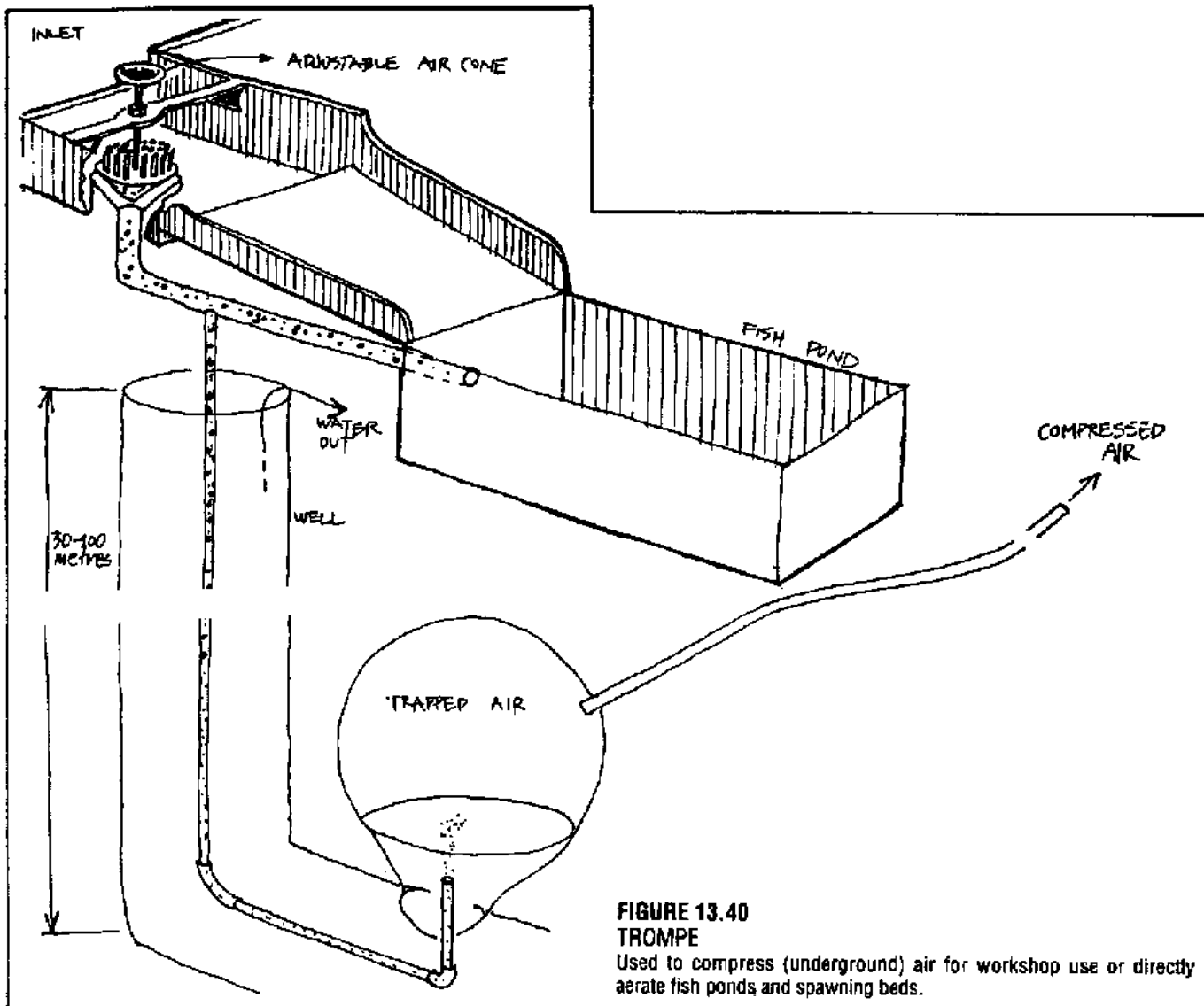
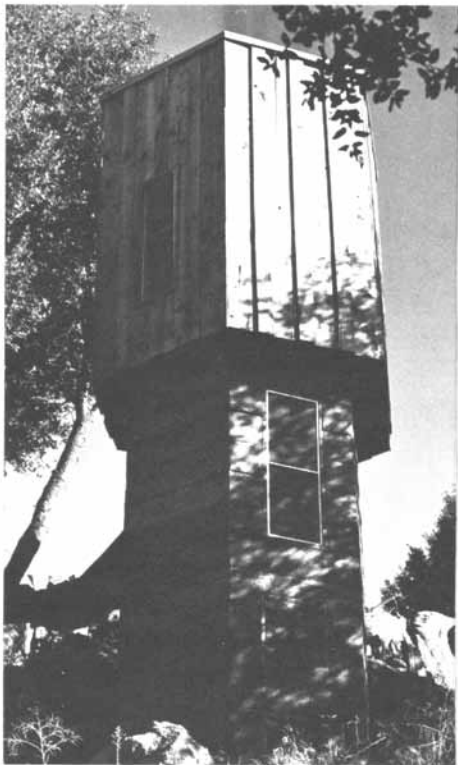

FIGURE 13.40
TROMPE

Used to compress (underground) air for workshop use or directly aerate fish ponds and spawning beds.



37.4 COMPOST PRIVY-SAUNA DESIGNED & BUILT BY AUTHOR
PHOTOS: EAST VIEW, BOB BROOKS - NORTH VIEW, JOHN RAABE

Algae harvest involves algae collection, sun-drying and admixture into animal (or human) food. Its use for human consumption is a consideration when one remembers that natives of the Republic of Chad have used algae as a staple food since prehistoric times. Likewise, Cortez observed in 1521 that, near what is presently Mexico City, natives “. . . sell some small cakes made from a sort of ooze which they get out of the great lake, which curdles, and from this they make a bread having a flavor something like cheese.” The blue-green algae that Cortez referred to has been identified as SPIRULINA — the very same variety of algae that Chad natives to this day collect from oases and form into cakes.

Bacteria and yeasts, discussed above, form the major source of single-cell protein. Fungi are included in the general single-cell food grouping, but they will not be covered in this book. Fungi have no significant food value. At best, mushrooms are a pleasantly-flavored addition to the diet.

Following the algae harvest, purified effluent can then be drained into a fish pond. Scum from the digester should also be drained into the pond. Fish thrive on the nutrient-rich effluent which finally ends up at the bottom of the pond in the form of stabilized sludge. Pond areas during alternate years are planted to a silage crop, as discussed in a previous chapter.

Human excreta — I almost said human “wastes”, but we need to get away from the concept of excreta as waste now that we have techniques for processing excreta in a sanitary and scientific manner — most definitely, human EXCRETA should be included in a homestead program of fuel-food-and-fertilizer production.

The first major obstacle to the utilization of human excreta is the receptacle — the common, stool-variety water closet. If an author is permitted just one chronic complaint or one indulgence-per-book mine will be registered against the flush toilet. A five-gallon wash-down of each evacuation nullifies subsequent utilization of the excreta material since water-borne sewage is destined, irretrievably, for the septic tank. Furthermore, the seat-height evacuation posture is one of the worst of our unhuman, “civilized” habits.

My personal peeve against faulty bathroom design-use goes back a dozen years when I first started developing an improved compost-privy design. A number of schemes were tried but abandoned for one or another reason. The most recently developed facility has worked exceedingly well. Its salient features are enumerated below under the headings of DESIGN — MATERIALS — STRUCTURE — FUNCTION. DESIGN: The fundamental design feature of my compost-privy is its adaptability into the larger homestead complex. It is designed to nestle between the greenhouse and the cooking-utility and sleeping areas, yet, at the same time, it retains an outside, lower-level access for loading and emptying the compost chamber. Ideally, organic-matter ingress and finished-compost egress should be directly accessible to the anaerobic digester or to the garden or greenhouse in the case where finished

compost is to be directly used on crops. The drawing below illustrates the latter arrangement and includes an upper-level sauna and a roof-level sun deck. Where another arrangement is preferred, a single-level privy can include the functions of washing, bathing and excavation.

FUNCTION: Aerobic decomposition takes place in a divided, cast concrete chamber. Twice a year a simple, metal baffle plate is turned to divert material from one chamber to another, and twice a year alternate chambers are cleaned out in preparation for a new batch of compost. Of primary importance to the proper function of the privy is the moisture content of the compost. Where there is too little moisture, aerobic organisms have difficulty securing a soluble food supply, moisture being their main, food-transport medium. Where there is too much moisture air spaces are reduced, preventing oxygen circulation through the mass. As a general rule privy moisture-content should be maintained at 50%. This 50% privy moisture content will include faeces, which is 70% moisture, urine, which is 90% moisture, garbage and vegetable trimmings, which are 20% moisture, and an expectable (but, nevertheless, greatly reduced) water-flush on the order of from one-to-several quarts.

The compost-privy becomes a practical consideration when compared with the standard, five-gallon-flush water closet which uses about four-and-one-half gallons of water too much. A recent booklet, **STOP THE FIVE-GALLON FLUSH!**, \$1.75, just released by McGill University's School of Architecture, Montreal, Canada, lists a number of toilet manufacturers throughout the world who make throne and squat toilets requiring a mere one-quart flush. Since the publication of McGill's booklet, a California plastics engineer has begun producing gel-finished fiberglass squat plates, illustrated below.

All privy washing and bathing water should be diverted from the composting chamber and drained into a separate leach field. The privy's central, two-inch, galvanized pipe handles the drain water adequately, and, at the same time, doubles as a fixture and a chamber vent.

STRUCTURE: The central pipe that provides water drainage and fixture and compost chamber ventilation to the outside also provides alignment during the structure's erection and, when finished, it provides structural support and bracing for walls, floor and roof. Concrete is poured by casting alternate, one-foot high layers in "climbing" plywood forms. As many as four, one-foot castings can be made in one day. Walls are cast vertically in the manner of children's hand-over-hand game. Light-weight plywood forms make it possible for one person to form the walls while working inside the structure without the need for external scaffolding. This is an especially important feature where a two- or three-story structure is involved, as in the case of the silo construction mentioned in the previous chapter. The same form and the same building system is used for both structures.

MATERIALS: Concrete was chosen as the basic wall material. Permanence makes it an essential choice for any underground (earth-covered) sections, for the compost chamber section and, certainly, for the feed-silo walls. When a gravity-fed water supply is desirable, concrete walls can be extended above the cast concrete privy roof to form a second-story, with another cast concrete roof over that to provide a place for a water storage. Inside, sauna-bathing facilities are properly faced with a moisture-absorbing material, such as redwood or cedar.

One finds, currently, very few Sanitation Department codes approving of the compost-privy concept. Fortunately, the majority of homesteaders locate outside building code jurisdiction where approval is not mandatory. Some people inside code-enforced districts have fought septic-tank-oriented City Hall — and won. They have done legal battle with the bureaucracies, armed with authoritative literature from The World Health Organization which, quite frankly, states that pathogenic bacteria and other parasites thrive in the anaerobic putrefaction of the septic tank environment for at least six months! In aerobic privy decomposition high temperatures destroy pathogens in a few hours!

Over the decades a number of people in the fields of medicine and agriculture have devoted their lives to establishing more rational sanitation. F. H. King followed the writings of Dr. Poore whose book, **ESSAYS ON RURAL HYGIENE**, was published in London in 1894. Poore raised vegetables on one-and-one-half acres of land kept fertile by the use of directly-applied but buried excrement from one hundred persons for a period of twenty-two years. It took four years to completely cover the garden, Dr. Poore writes, after which time, “. . . fertility and beauty of the garden have been increased enormously . . . No other crops, except cabbage, seem to flourish in the fresh material, but cabbage may be followed by potatoes, these by celery (planted between the rows), these by peas or beans and, after this, by parsnips or carrots without any fresh manuring and with a most abundant yield.”

Another Poore quote makes a fitting close to this chapter:

“That in a country or semirural district, where it is possible to give a house a decent curtilage or small garden, it is easy for a householder to make the sanitation of his dwelling quite independent of the local authority. In fact, the householder is able, if he be so minded, to make his sanitation complete and to finish, on his own premises and to his own profit that ‘circulation of organic matter’ which is the law of nature and the only true basis upon which the science of sanitation can possibly stand firm. The householder can do piecemeal what no public authority has ever succeeded in doing wholesale, albeit that millions of £’s have been wasted in silly attempts.”

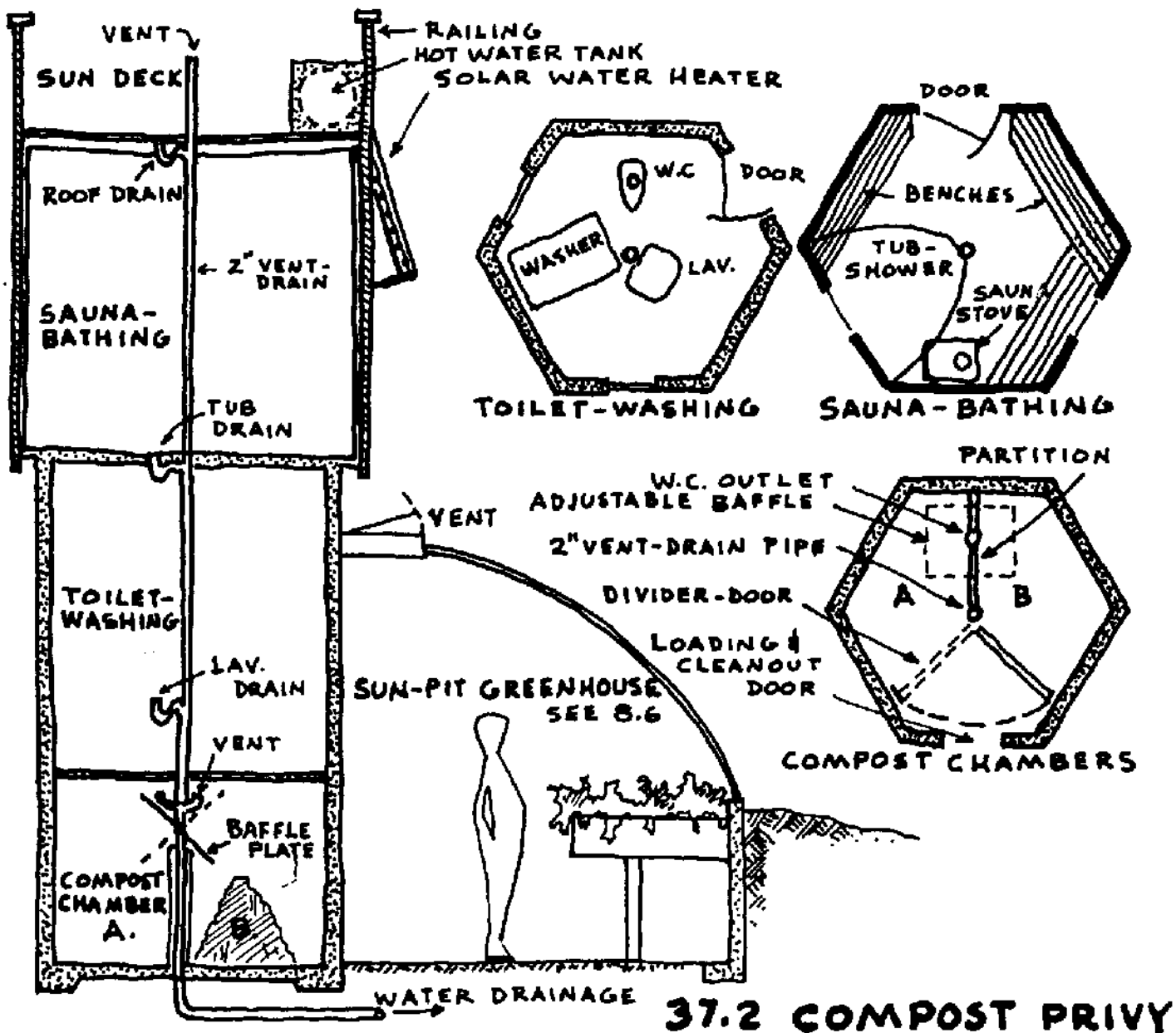

37.2 COMPOST PRIVY

COMPOST PRIVY CONSTRUCTION DETAILS

CONSTRUCTION DETAILS

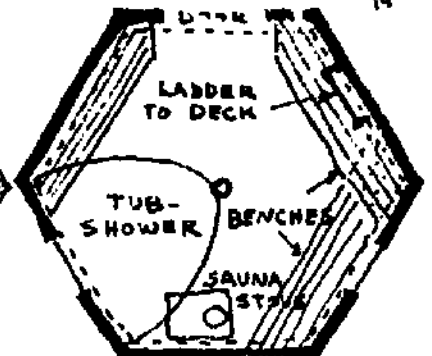
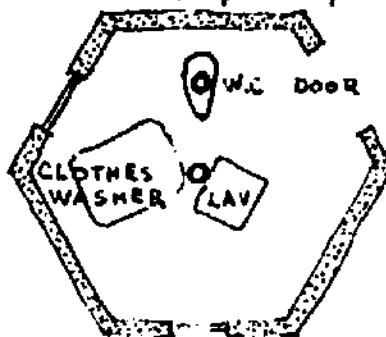
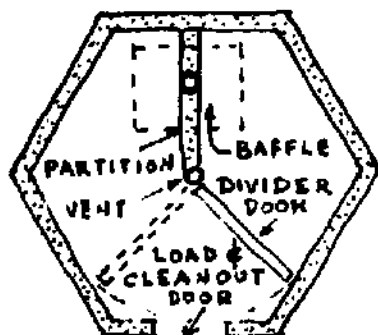
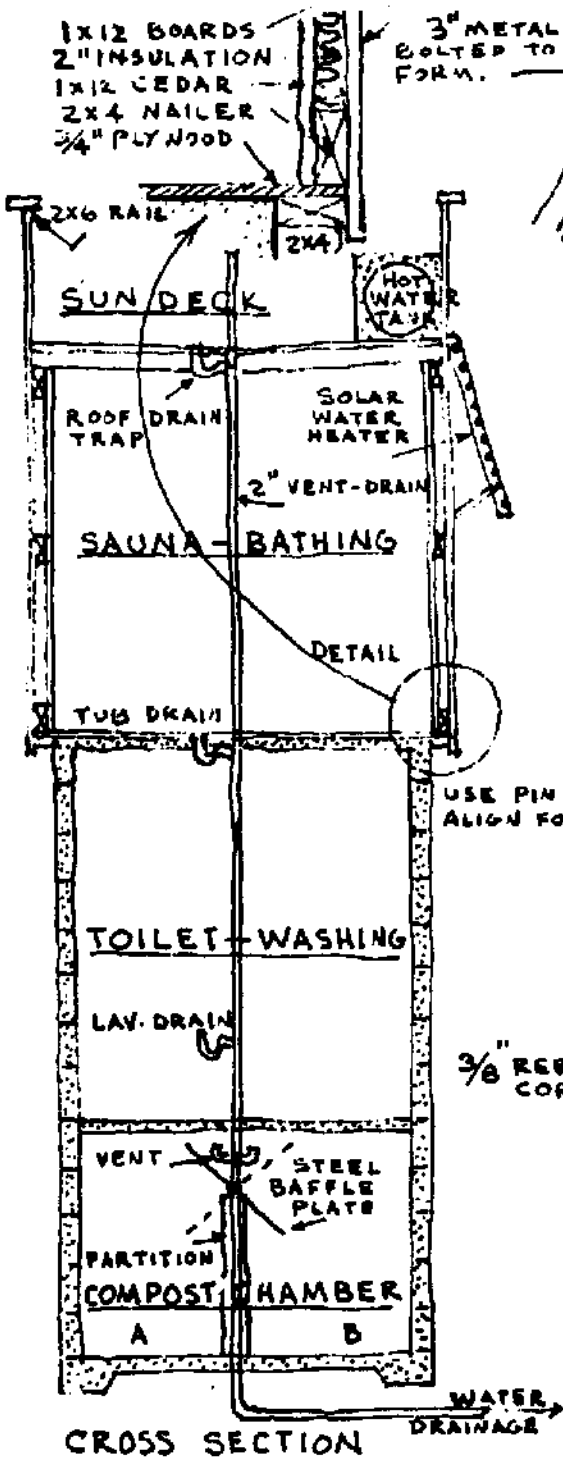

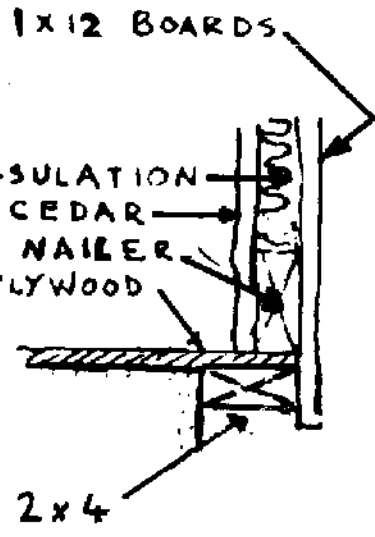
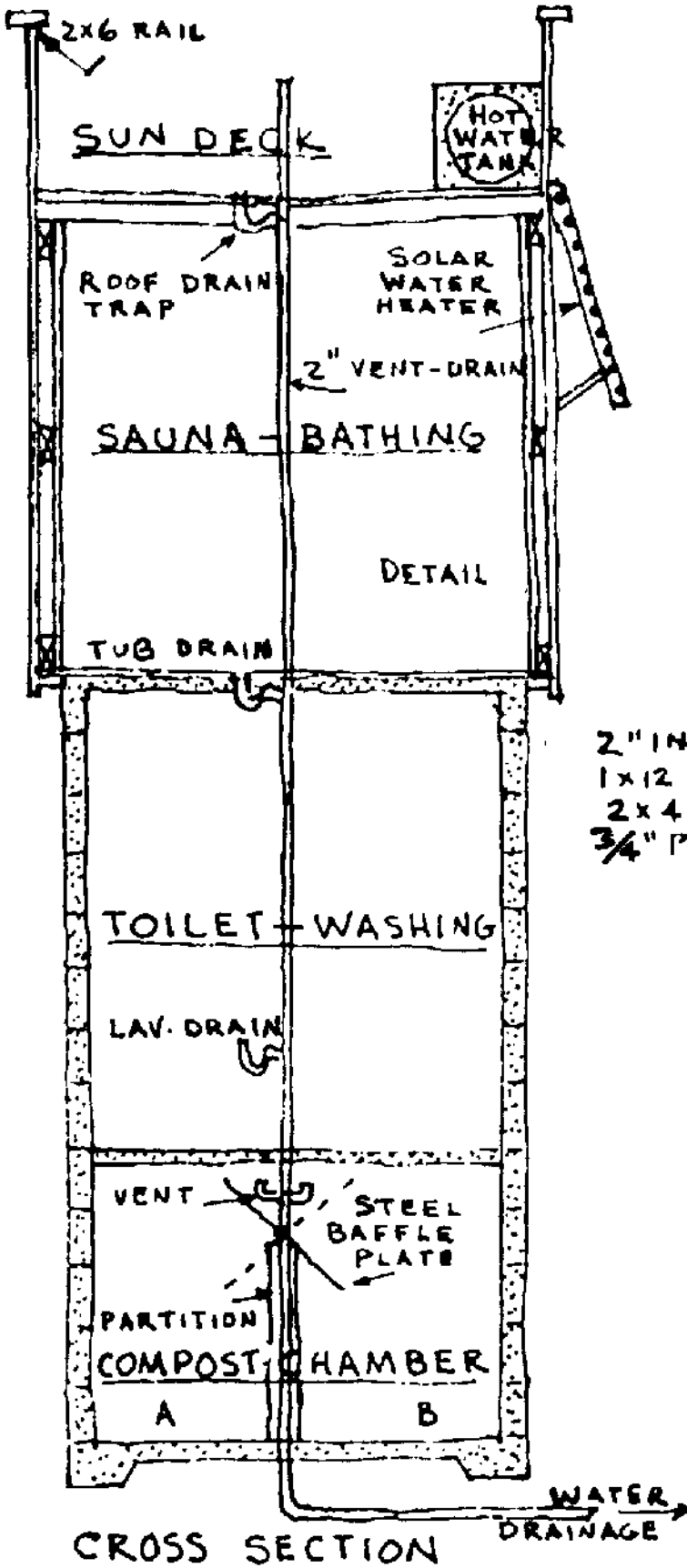

CROSS SECTION

WATER DRAINAGE

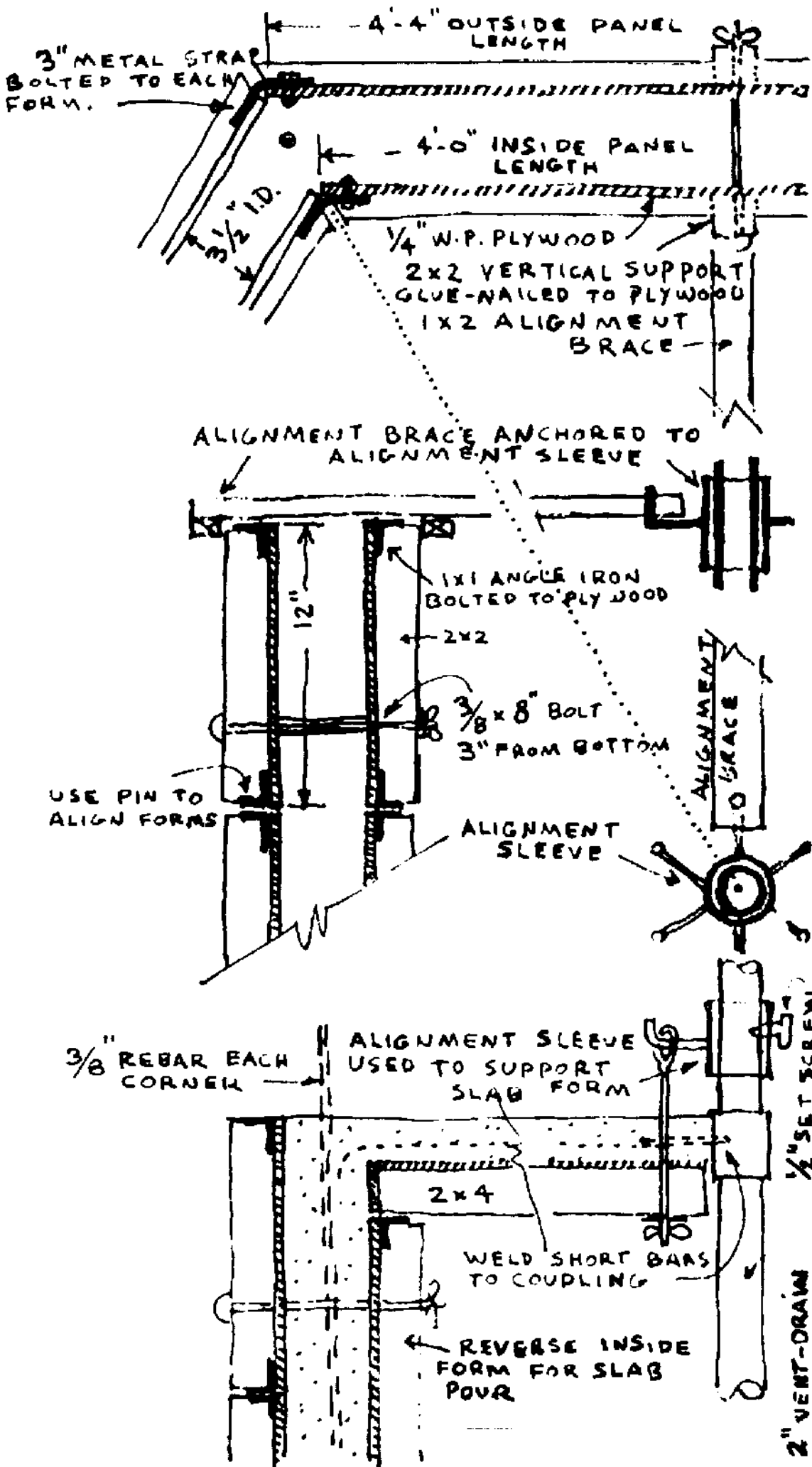

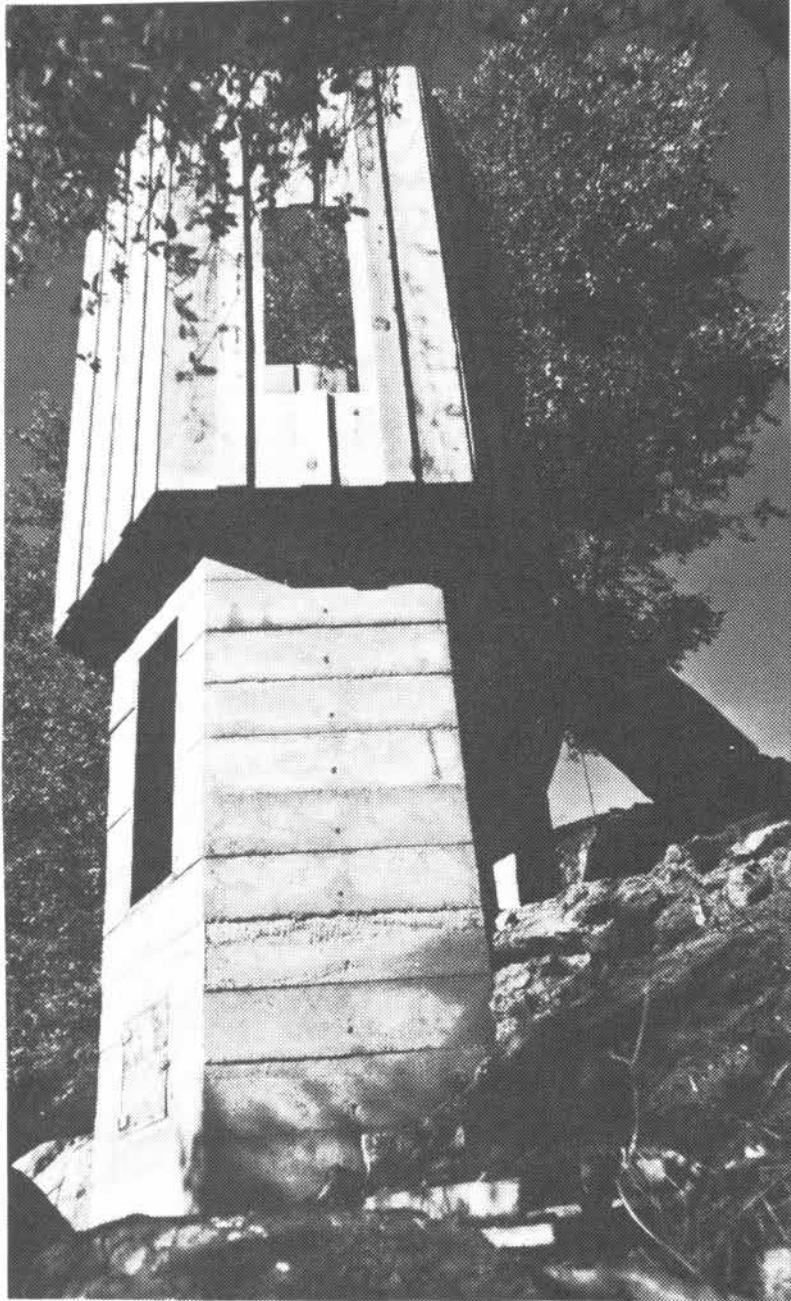

HALF-DOME SUNPIT

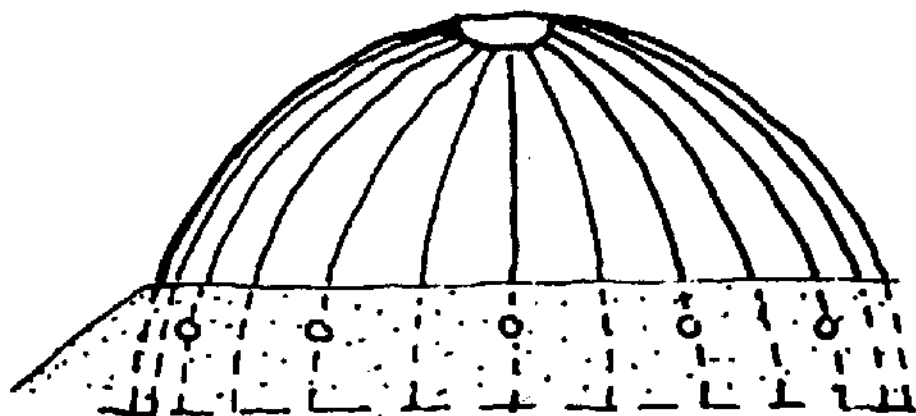

SOUTH ELEVATION

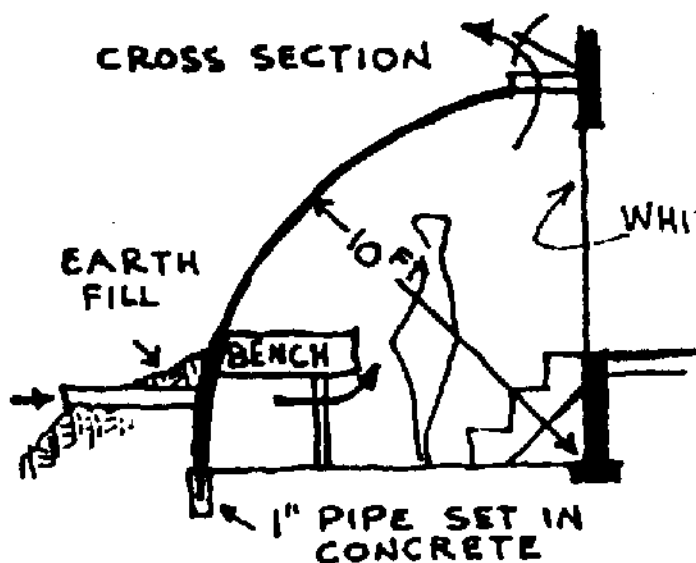

CROSS SECTION

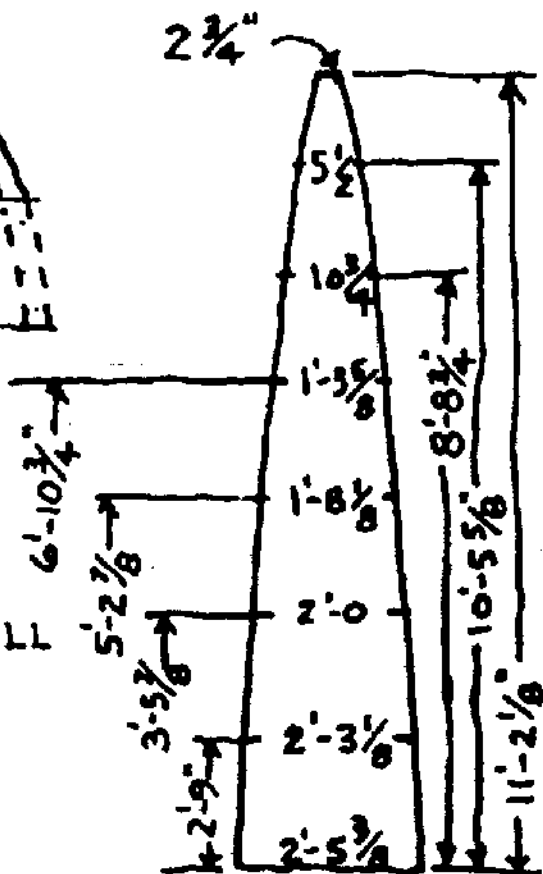

TYPICAL FIBERGLASS PANEL

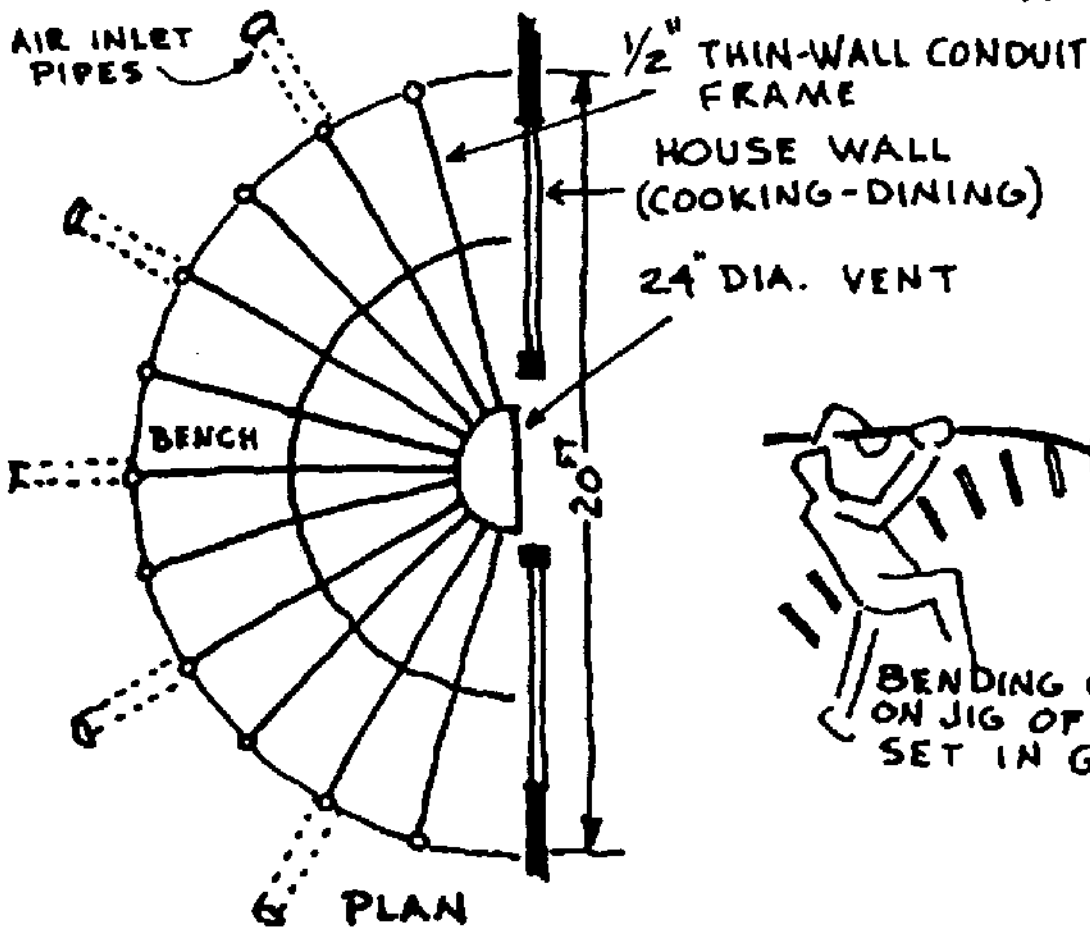

PLAN

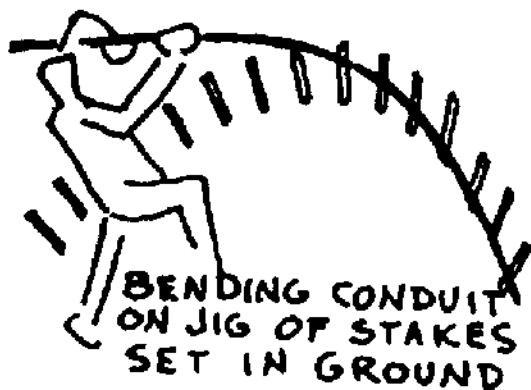

BENDING CONDUIT ON JIG OF STAKES SET IN GROUND

Panel (gore) design for a hemispherical airhouse of any size:

1. Select your diameter and find the resulting circumference ($3.1416 \times \text{diameter}$).
2. Determine a maximum gore width that will go evenly into the circumference. This will also show the number of gores needed. Consider the available fabric widths when determining the maximum gore width.
3. Determine the length of each gore ($\text{circumference} \div 4$).
4. To determine the detailed shape of the gore:
First, divide the gore into 10 equal sections along its length. The tenth line will be the base.
Next, determine the width at each of these division lines by multiplying each of the following numbers times the maximum gore width found in step 2. Take the trouble to carry your figures out to 4 places and lay out your template carefully. Any error will be exaggerated by the number of gores used.

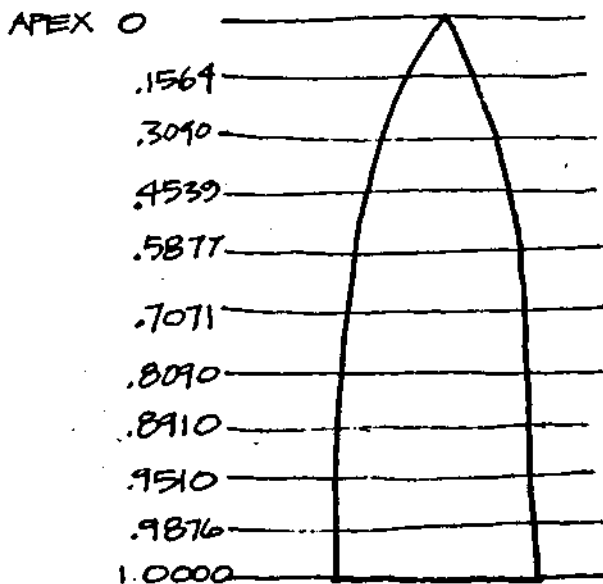

Note: let a little
extend below
base

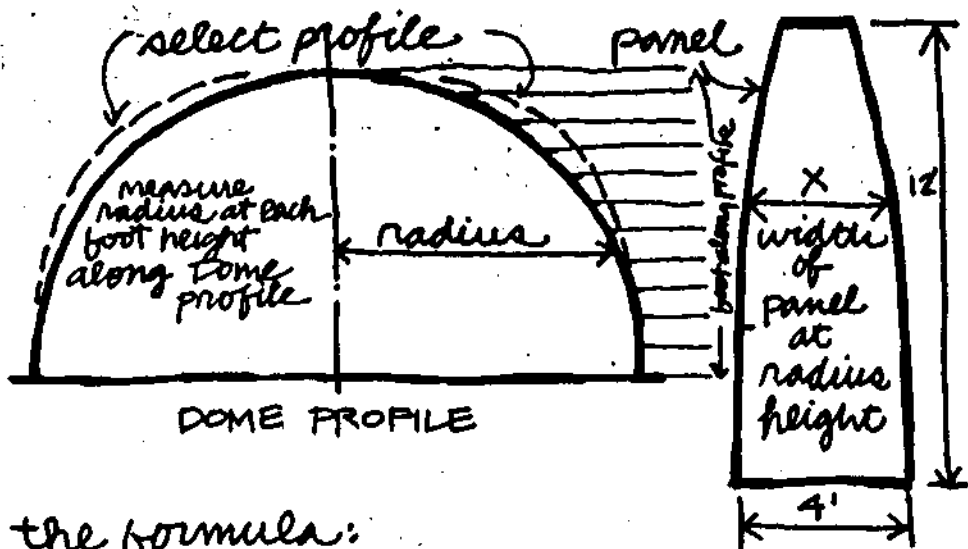

the formula:

$$2 \cdot \text{RADIUS} \cdot \sin\left(\frac{3600}{\text{NO. OF PANELS} \cdot 2}\right) = X$$

$\hookrightarrow X = \text{WIDTH OF PANEL AT RADIUS HEIGHT}$

how to cut panels

First pick the dome profile shape that you want and sketch it out as large and accurately as possible. Next measure the radius at every, say, scale equivalent of a foot *along the curve*. Calculate width of panel at a given height with the formula. Mark the different X's at the appropriate heights and draw a smooth curve thru the end points. Cut along this curve.

A better technique may be to measure radii with a life size model by bending a flexible batten to the profile of the pod.

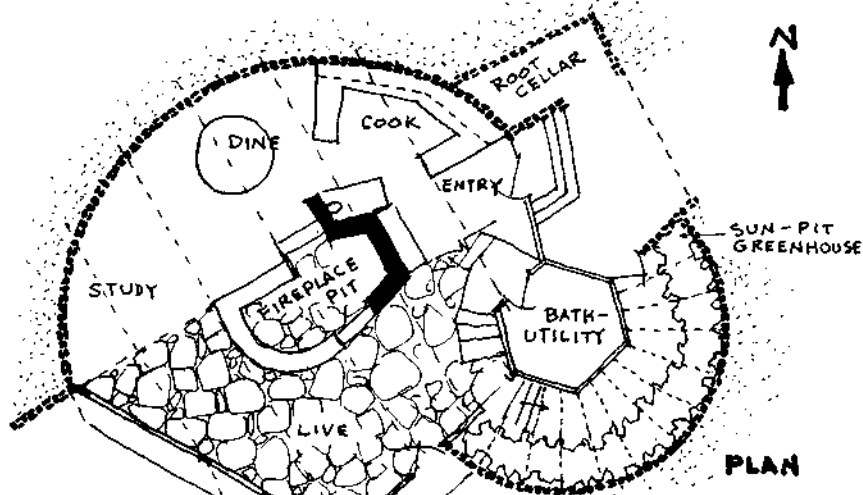
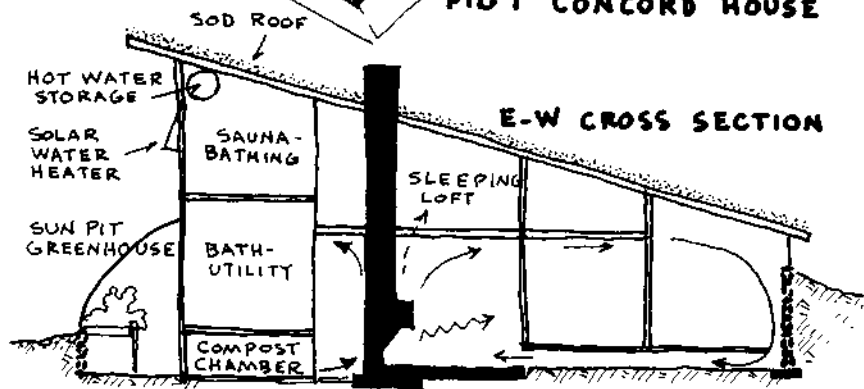

FIG 1 CONCORD HOUSE



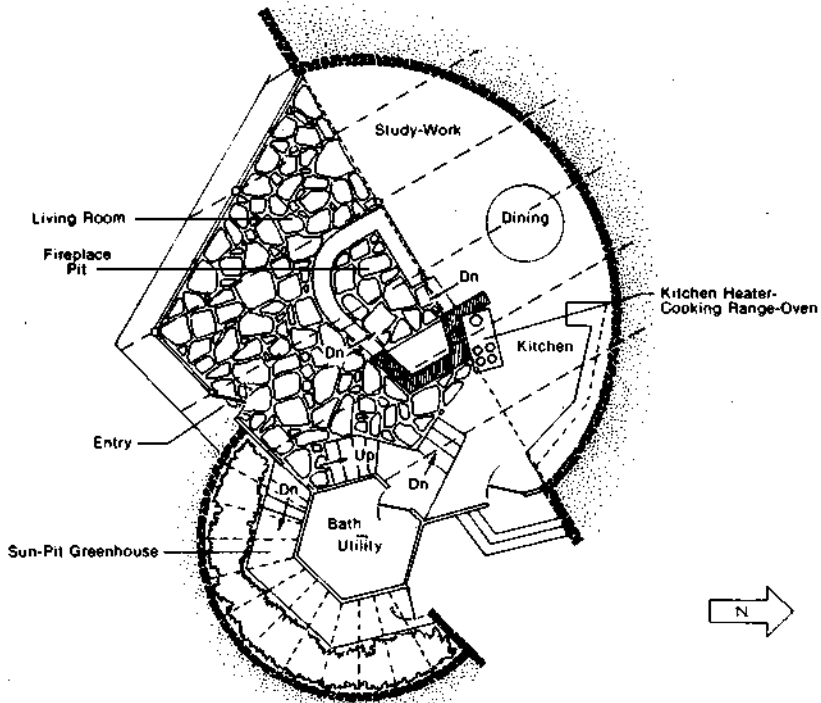

FIGURE 41. Floor plan for Emerson's New Concord house.

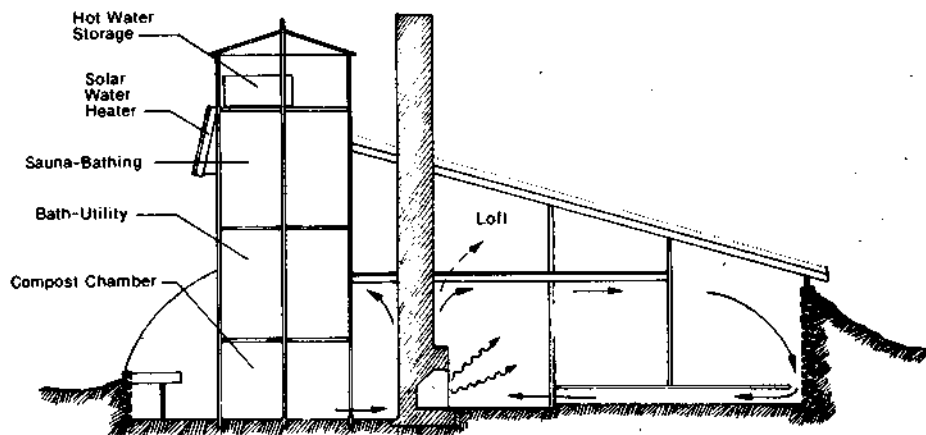
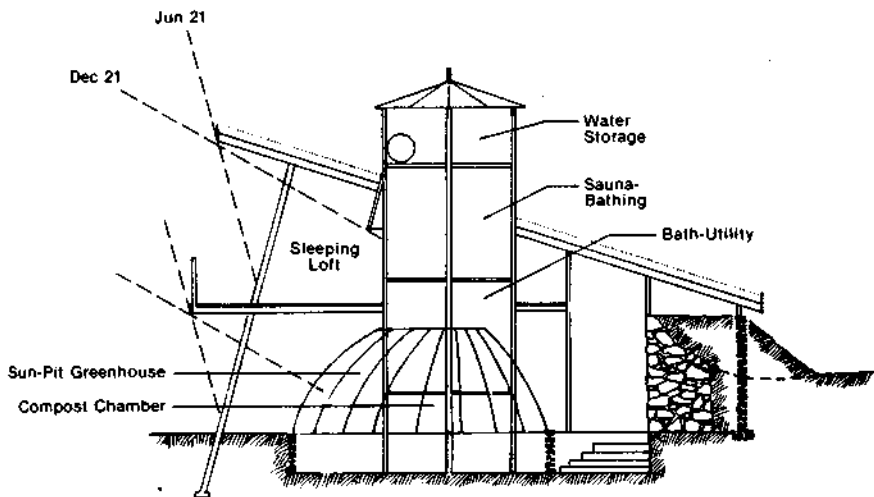
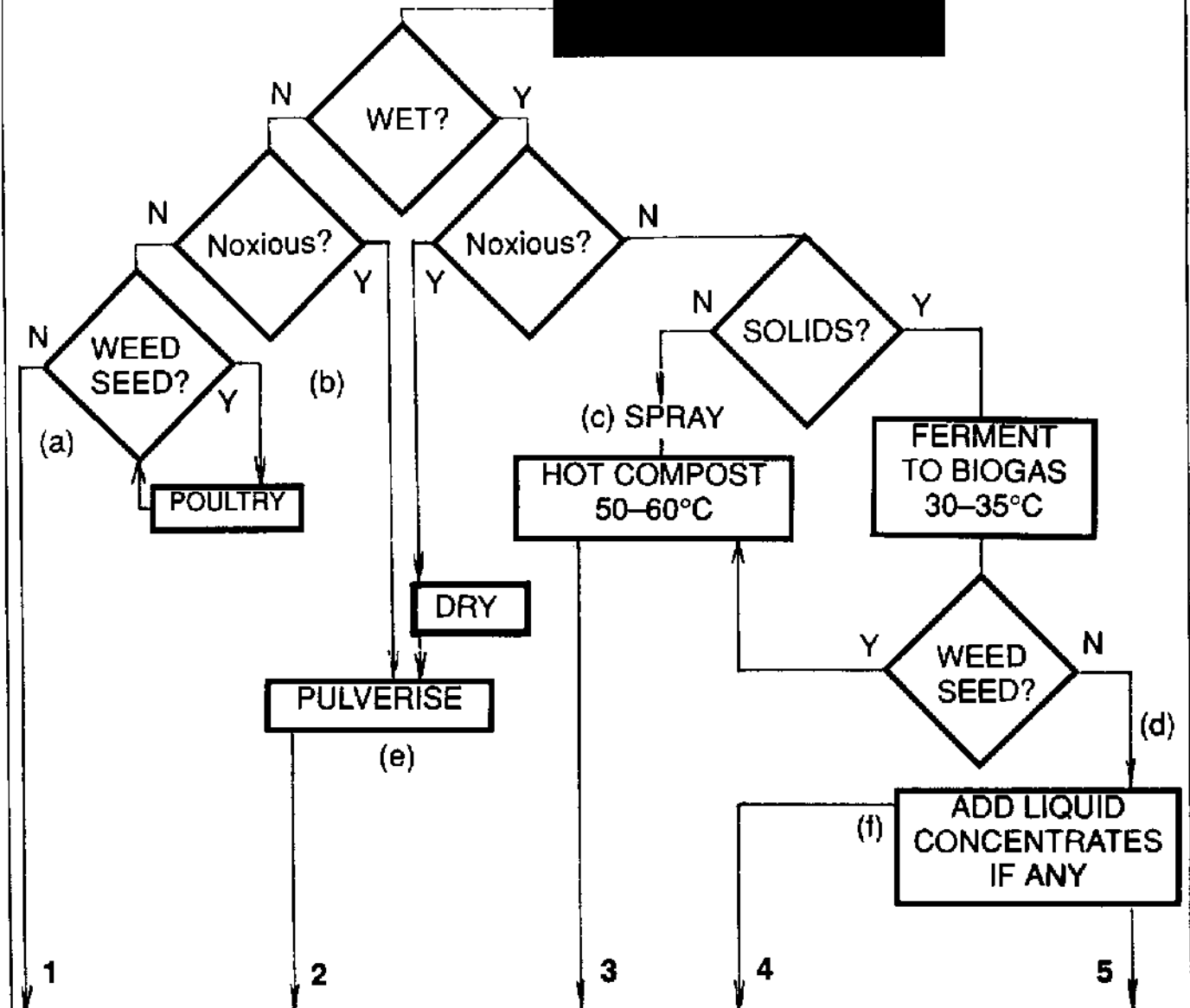

FIGURE 42. Side view of Emerson's New Concord house. Above, N-S section; below, E-W section.

TABLE 8.5
SCHEMATIC OF COMPOST MATERIALS

COMPOST MATERIALS



<p>1</p> <p>Mulch directly on soil surface at >12 cm deep. Least effort for best results in gardens. Controls weeds, lessens labour.</p>	<p>2</p> <p>Use as manures on gardens. Energy used but good results obtained.</p>	<p>3</p> <p>Spread on soils of intensive plots and seed beds. Most effort and most nutrient (ammonia) loss, but effective for specific materials. Energy yields as biogas, heat.</p>	<p>4</p> <p>Drill below soil surface. Good results, no pollution.</p>	<p>5</p> <p>Spray as liquid on fields, foliage, or use in aquatic systems. Little effort for good results. Energy yields as biogas.</p>
--	--	---	--	--

EXAMPLES:

- (a) Nut husks and shells; coffee, teas, and cocoa residues; shredded paper and branches; bark, woodchips, and sawdust; and old carpets, underfelt (*not* pesticide treated ones), bags, canvas (*all made of natural materials*).
- (b) Hay with seed heads, weeds in flower, bulbils or roots of weeds.
- (c) Sewage and sullage, liquid manure and urine, meat

- and animal paunches and trimmings, general household wastes. Add lime and superphosphate (1%) to hot compost; "teas" of seaweed and manure.
- (d) Sludge from digesters and weed-free manures.
- (e) Chicken and bird manures, litter from animal sheds, blood, bone, feathers, hide scraps, seaweeds.
- (f) Dissolved minerals, urine, seaweed and manure "teas".

When a direct connection to an established sewer system is not possible, and, when for some reason or other the compost chamber is not an attractive alternative, the owner-builder must provide himself with a water-carriage waste-disposal system—one in which sewage and liquid wastes are conveyed underground by the flow of water. The septic tank and the accompanying absorption field form the two parts of a water-carriage disposal method. There are countless varieties of septic systems, and, before the Public Health Service Environmental Health Center at Cincinnati, Ohio, issued the results of its thorough investigation of the subject, one was very much at a loss to know which household disposal layout to choose.

A septic tank functions in three ways: as a sewage-settling tank, as a sludge-storage tank, and as a digestion tank. Digestion of sewage in a well-designed tank is fairly complete. Anaerobic bacterial action,

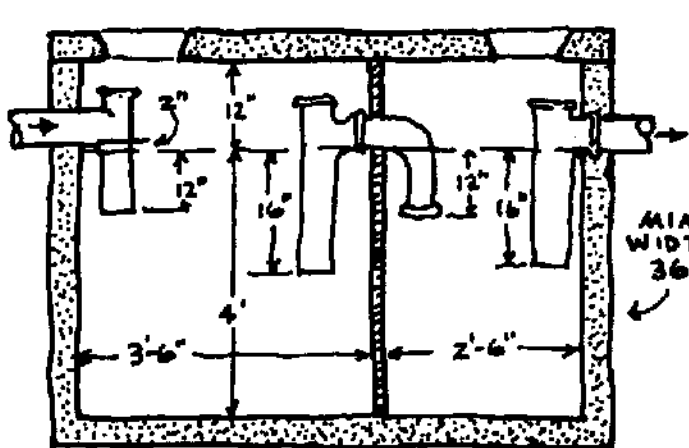

TWO COMPARTMENT SEPTIC TANK - U.S.
OUTLET VENT 10' HIGH

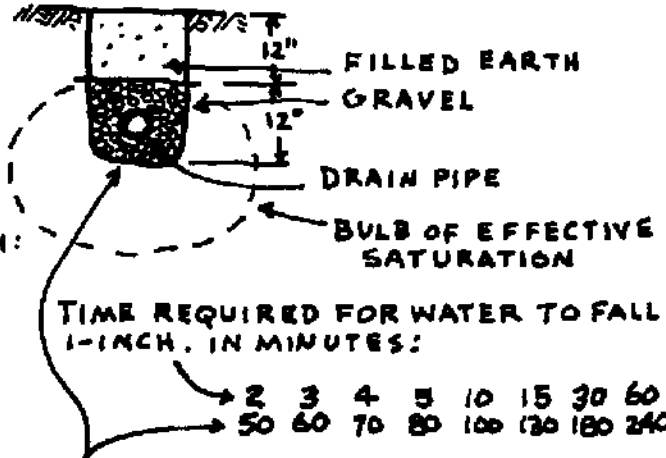

EFFECTIVE ABSORPTION AREA IN BOTTOM OF DISPOSAL TRENCHES IN SQUARE FEET.

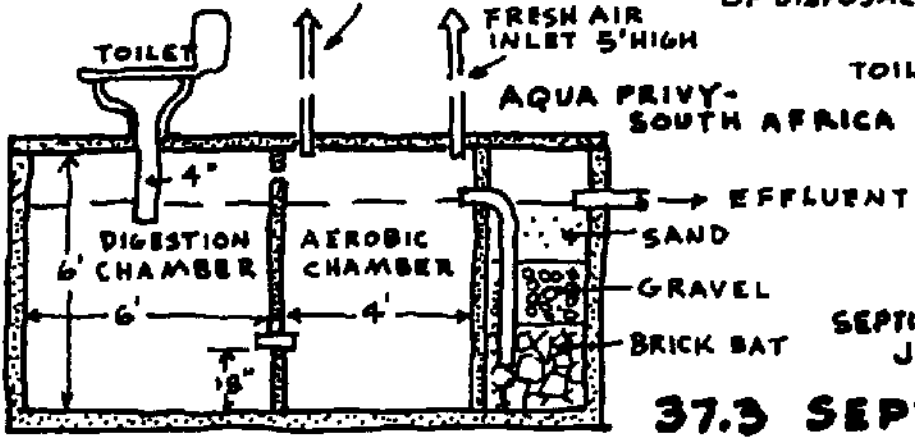

AQUA PRIVY - SOUTH AFRICA

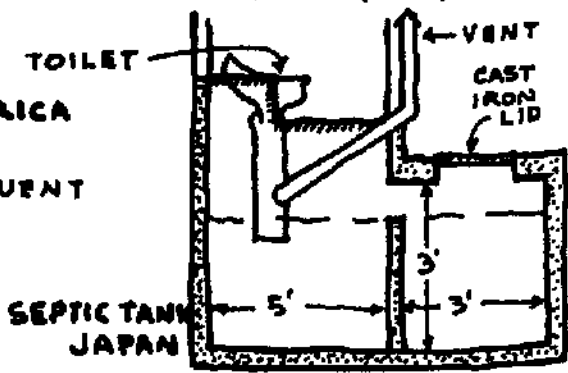

SEPTIC TANK JAPAN

37.3 SEPTIC SYSTEMS

(a) CONCRETE SLAB FOR PIT LATRINE

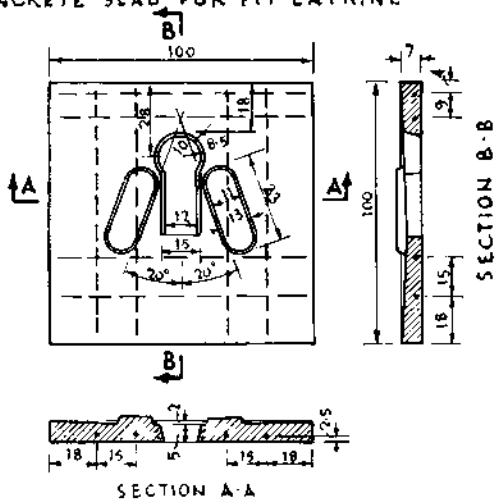

MEASUREMENTS SHOWN ARE IN cms

(b) WOOD FORM FOR PRIVY SLABS 100 CM SQUARE

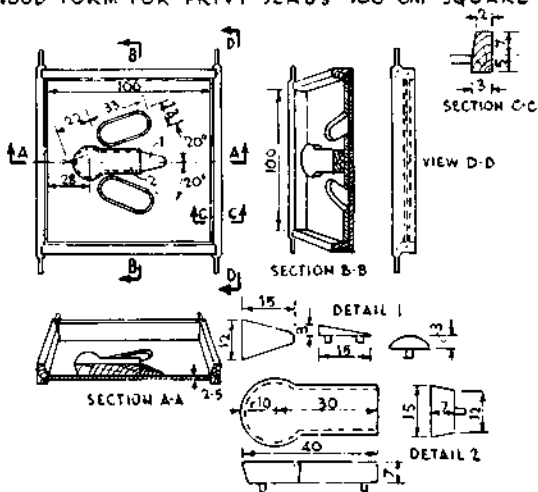
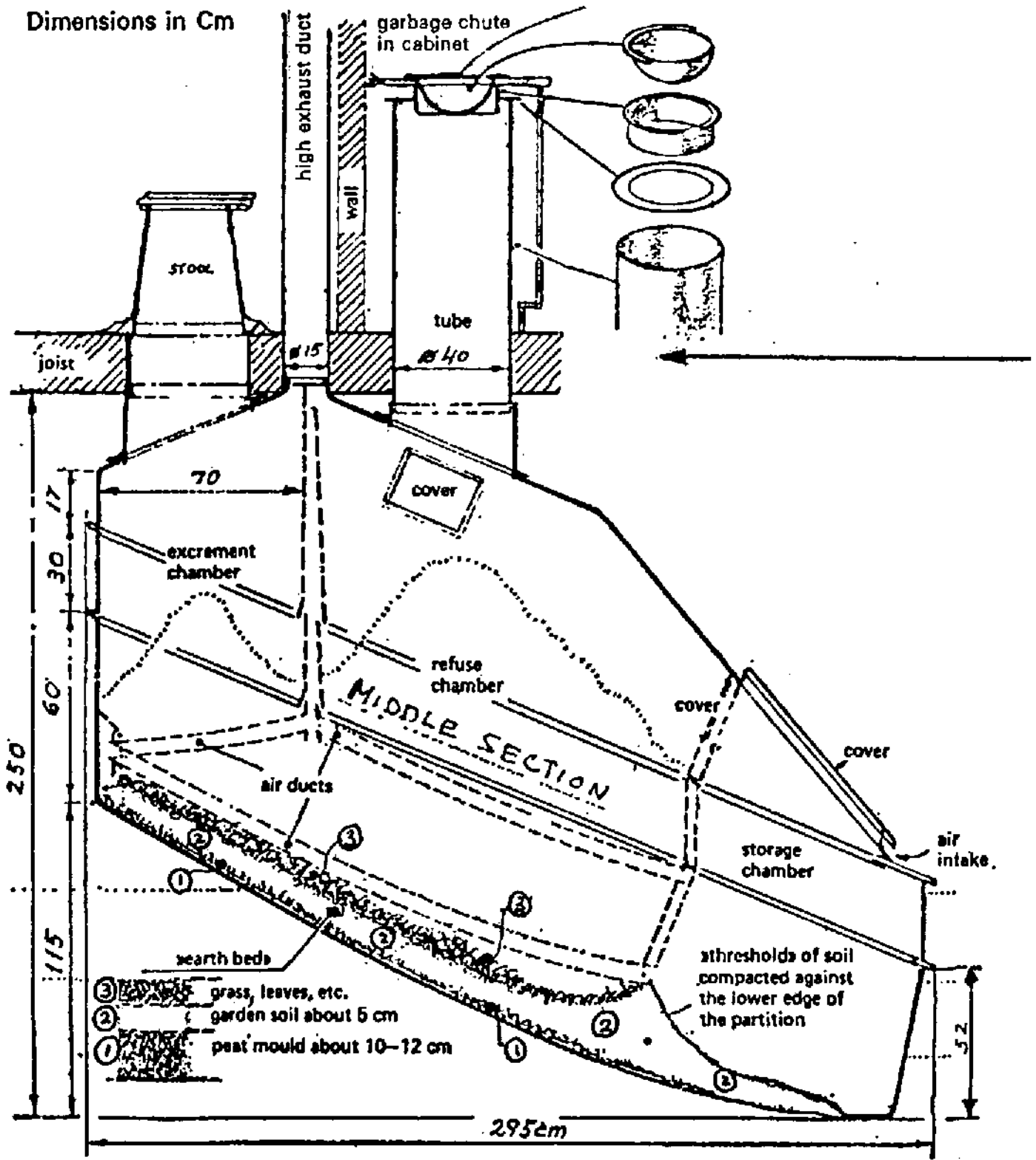
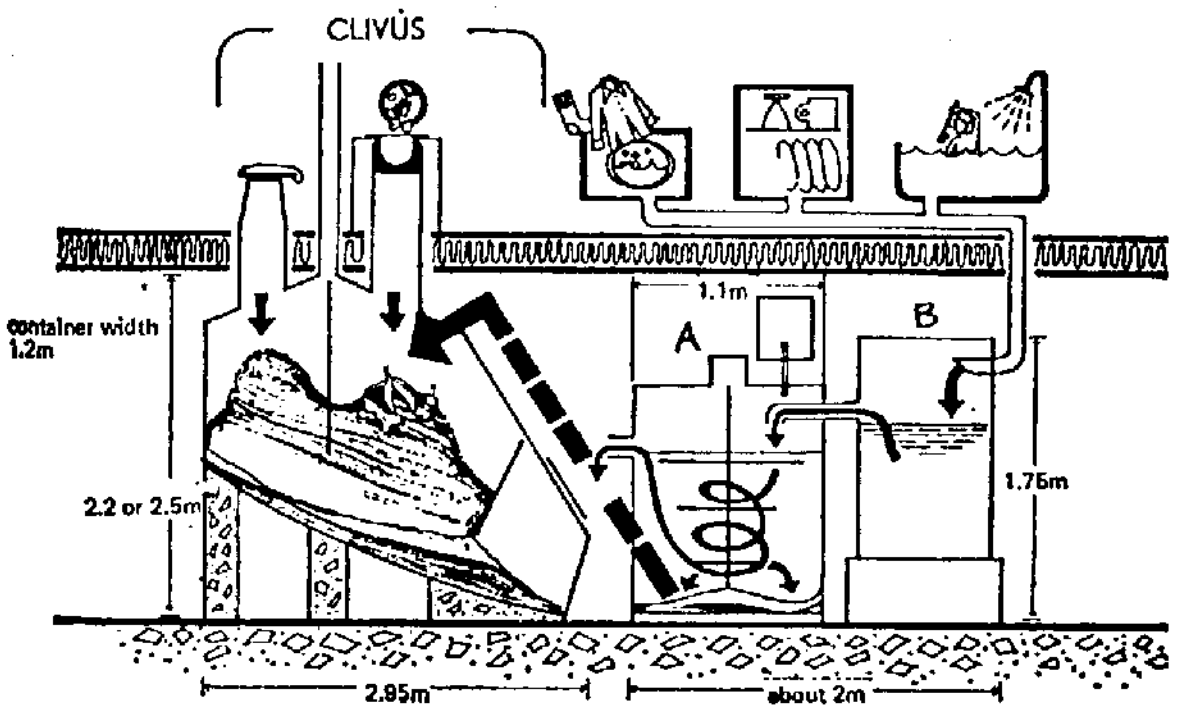
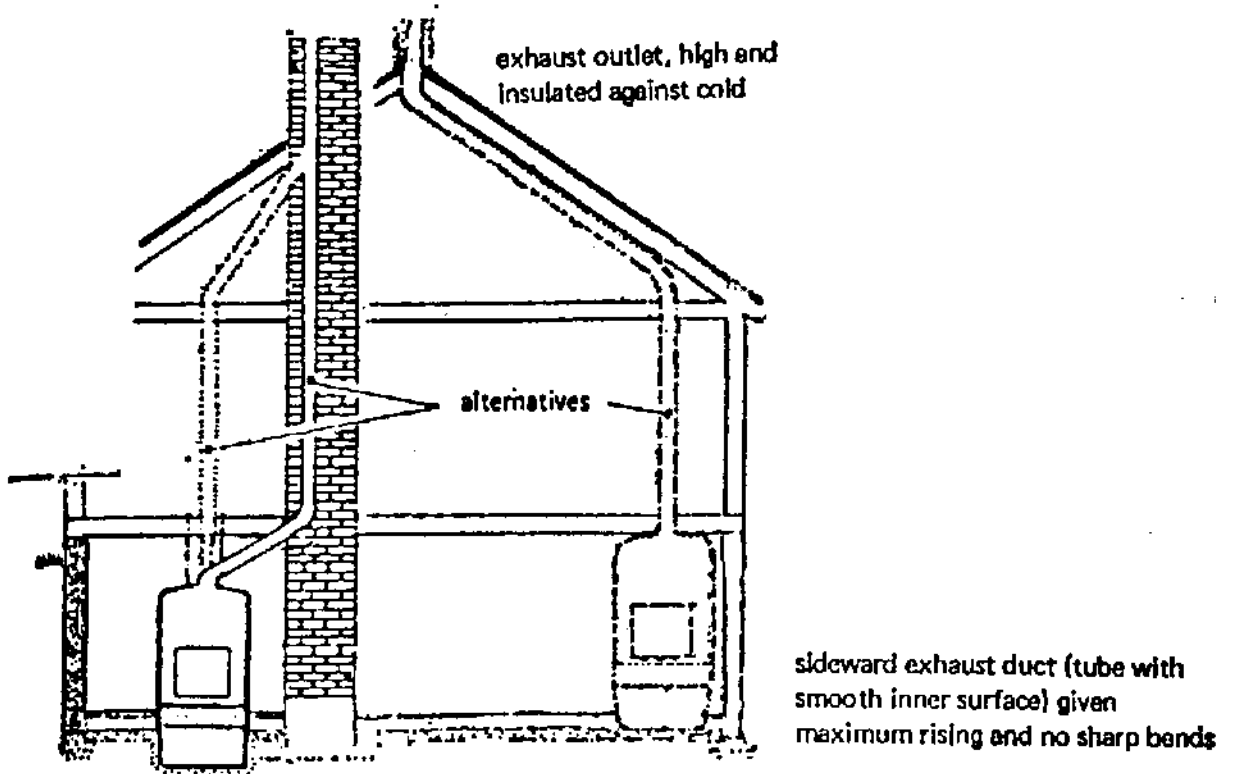

Figure 5.4 Privy floor details.

Clvus: Container consists of a bottom section and, where a greater capacity is required, also middle section(s)

Container in functioning position:
 height 220cm or 250cm or 280cm;
 length 295cm maximum;
 width 120cm





Clivus combined with waste water system

11.4 ADOBE DOME

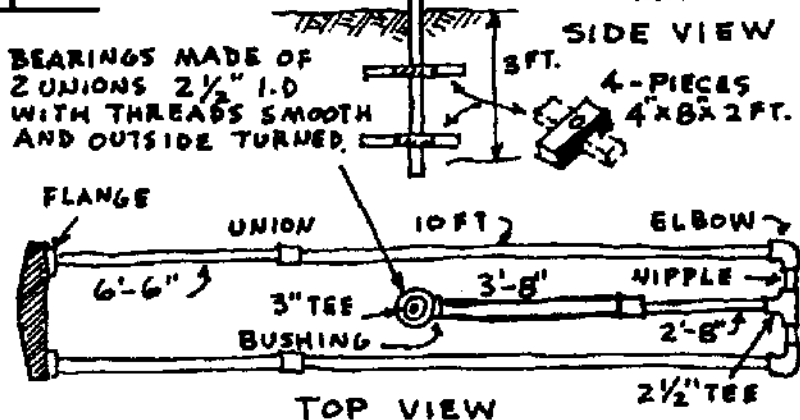
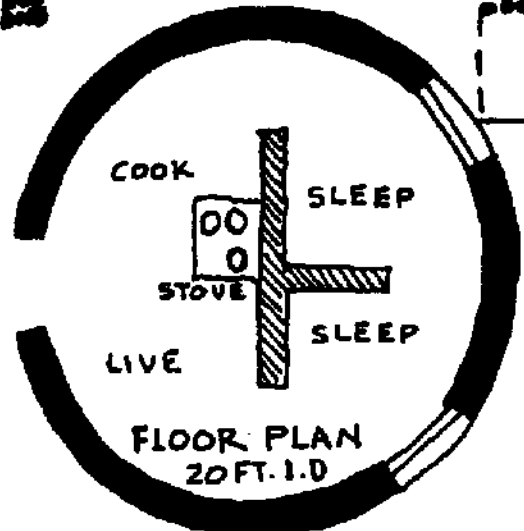
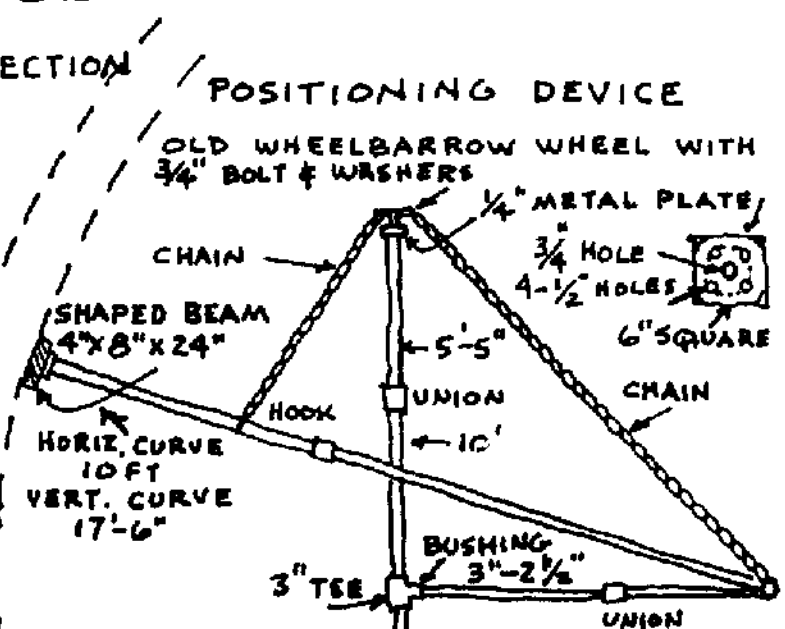
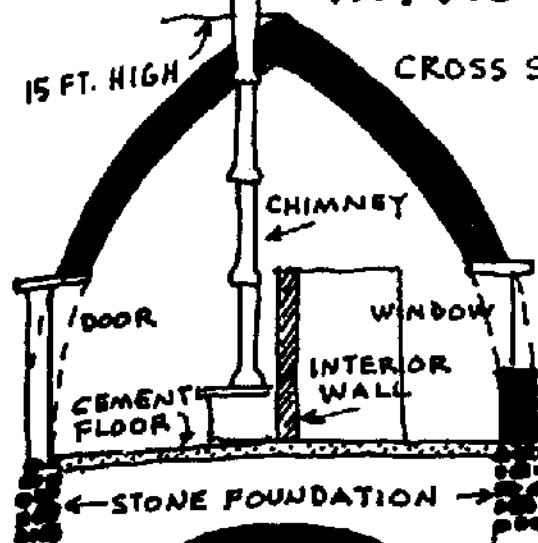

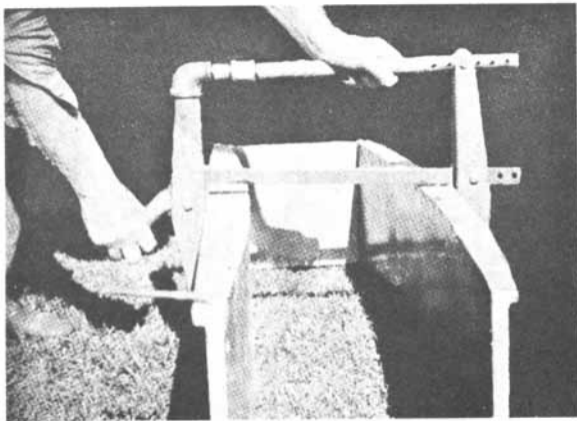

11.5 CURVED WALL BUILDING FORMS

11.6 SPIRAL WALL SLIP FORM

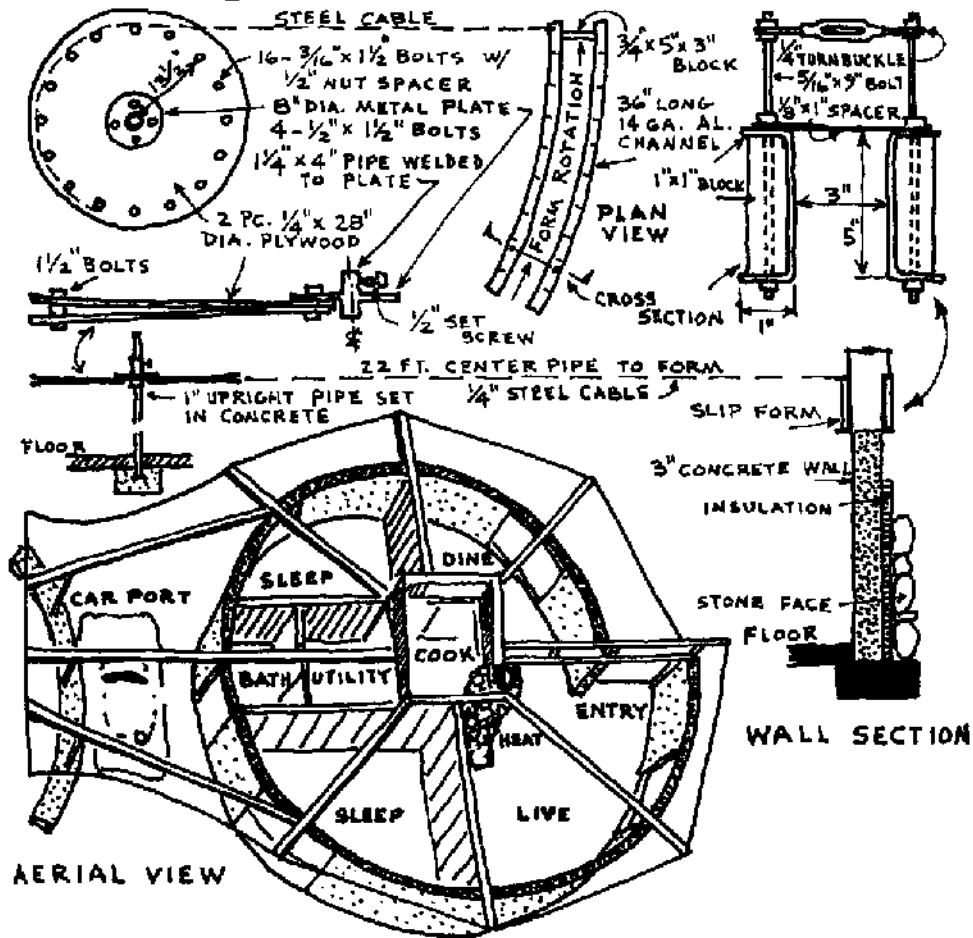

One such system for building circular walls involves the use of a radius rod for determining building circumference. This rod is attached by a sleeve to a central, stabilizing pipe. The author experimented with this technique using a movable form and built rammed earth, concrete, and stone walls, all 6 to 24 inches thick. The principle is entirely sound. As long as the central pipe is set upright and plumb, the walls will, likewise, be plumb. The spacing radius rod, attached at its extremity to the form, runs to the central pipe. The circumference-spacing radius rod and the form are raised to the next higher, level position as the wall progresses in height. The lever mechanism of the form permits immediate release of the formed walls.

This same technique can be employed to build thin-shelled, circular, concrete walls. After establishing the vertical radius pipe, a concrete floor slab is poured, using a screed board that revolves around the radius pipe. To build the walls, a 5-inch-high by 3-foot-long aluminum form is filled with a concrete mixture that is dry enough to firm up, yet wet enough to allow the form to be moved forward to its next position as soon as it is packed. A continuous length of barbed wire reinforcement, running horizontally from foundation to roof, is used in each wall layer. Vertical reinforcement is achieved in the nature of the curved form itself. The form and the construction procedure are similar to those employed in the use of the Geiger horizontal sliding form, which will be illustrated in chapter twenty-two.

Instead of using a rigid rod to guide the slip form and to scribe the radius of a true circle, a flexible cable may be substituted and permitted to wrap around a centrally located, stationary plywood disc. An interesting spiral plan results.

Sequence for building an adobe dome barn & silo:

- 1) Set positioning device to establish 15-foot floor radius, I. D., (more or less footage as required) and 20-foot dome height.
- 2) Pour continuous, reinforced, concrete foundation grade beam.
- 3) Set and brace three, equidistant door frames. Suggested opening = 4' wide by 7' high. Use treated 2 x 8 material.
- 4) Horizontal layers of 12" Cinva Ram block are laid against shaped shoe between door jams. As each layer is completed, support chain is adjusted, raising shaped shoe which guides following courses of brick.
- 5) At door lintel height (7 feet), attach external metal form to shaped shoe and cast 8"-thick reinforced concrete bond beam.
- 6) Block out between brick for 4" x 8" hay loft support beams and resume laying brick on bond beam until a 14-foot diameter opening at top of barn is realized.
- 7) Remove positioning device at 3" tee and erect silo (per design page 171). Provide four 30-inch square openings in one silo wall for silo access. At loft height, embed 1/2" bolts in concrete and continue silo wall to top. After silo concrete is firmly set, bolt on 2 x 6 wooden ribbon which supports loft members.
- 8) Frame 4" x 6" silo roof members to butt into edge of 14-foot diameter barn roof opening.
- 9) Fasten one end of 4" x 8" loft support member to ribbon on silo wall, bearing midpoint on concrete lintel. Other end cantilevers beyond doorway for arbor support.
- 10) Cover hay loft floor with 2 x 6 T & G decking. Retain 24-inch opening around silo for light and ventilation.
- 11) Plaster dome exterior with waterproof cement.
- 12) Install fiberglass-covered panels in loft openings and in lower-level door openings.

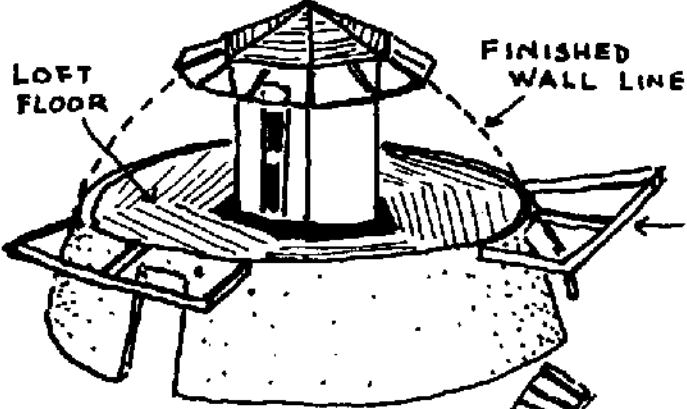
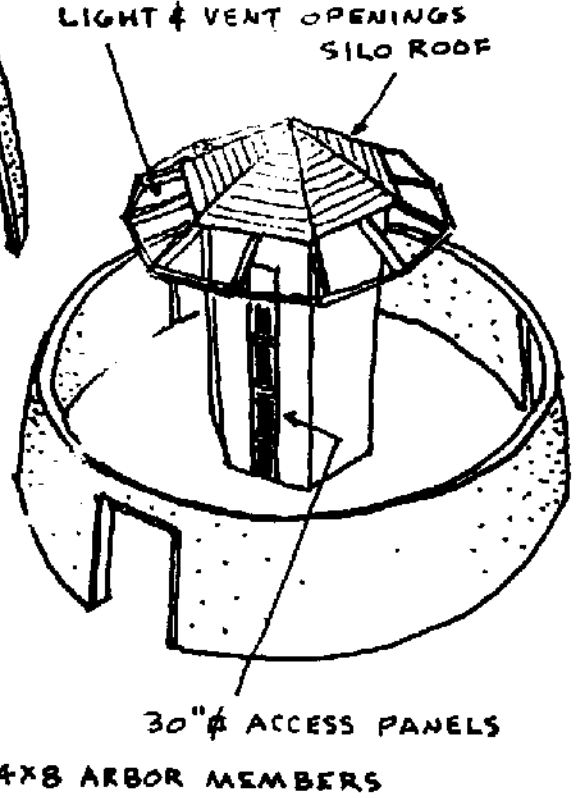
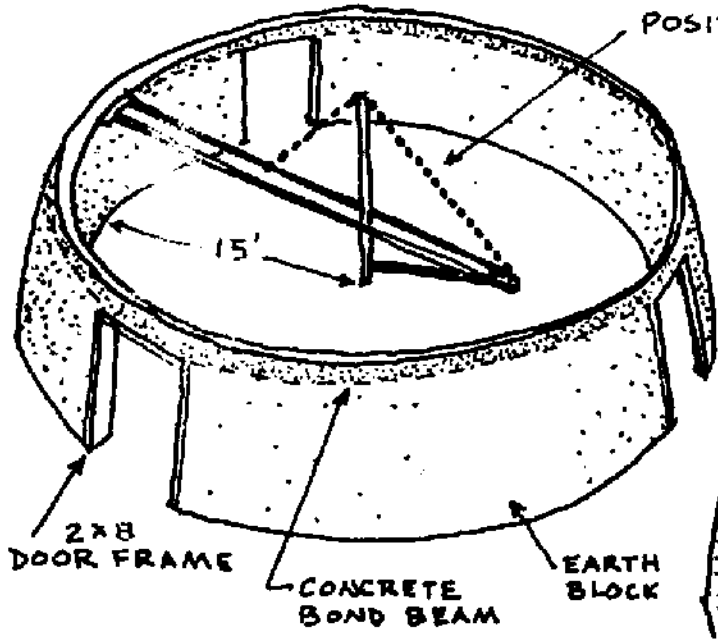

SIDE VIEW OF POSITIONING DEVICE

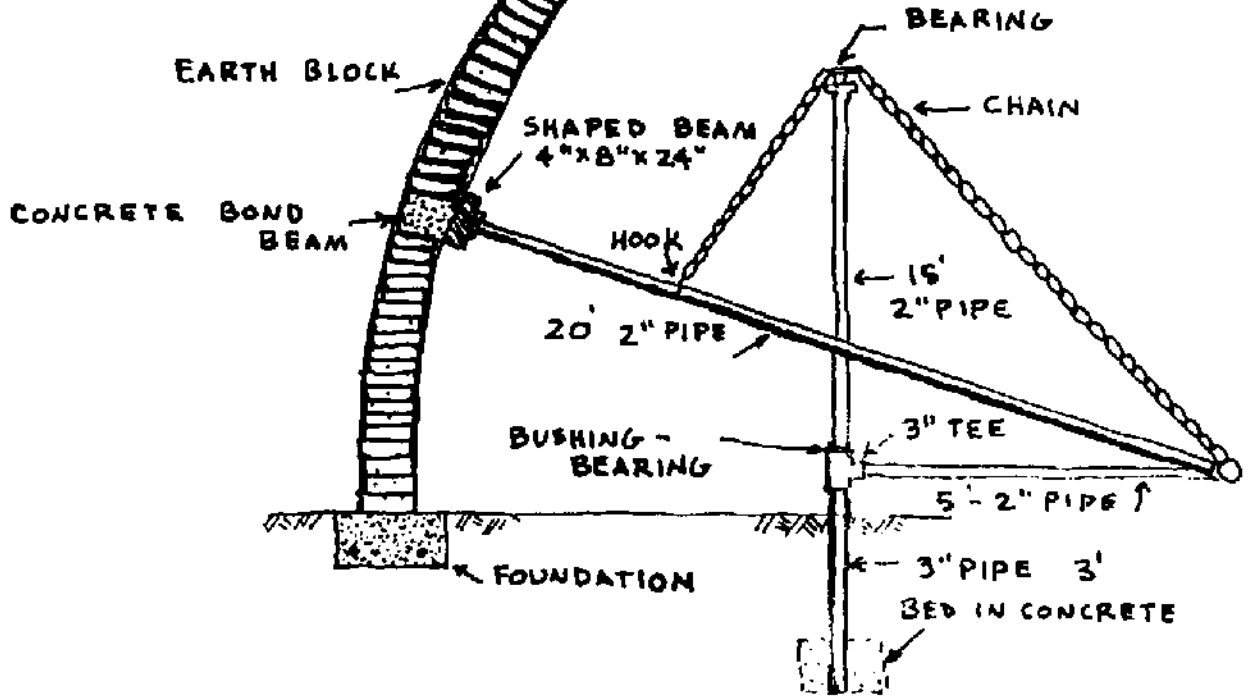

SHAPED SHOE
HORIZ CURVE 15 FT.
VERT. CURVE 20 FT.

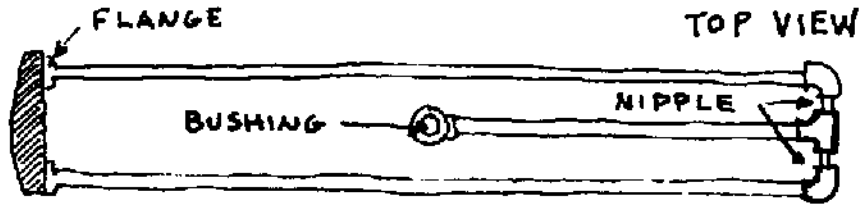
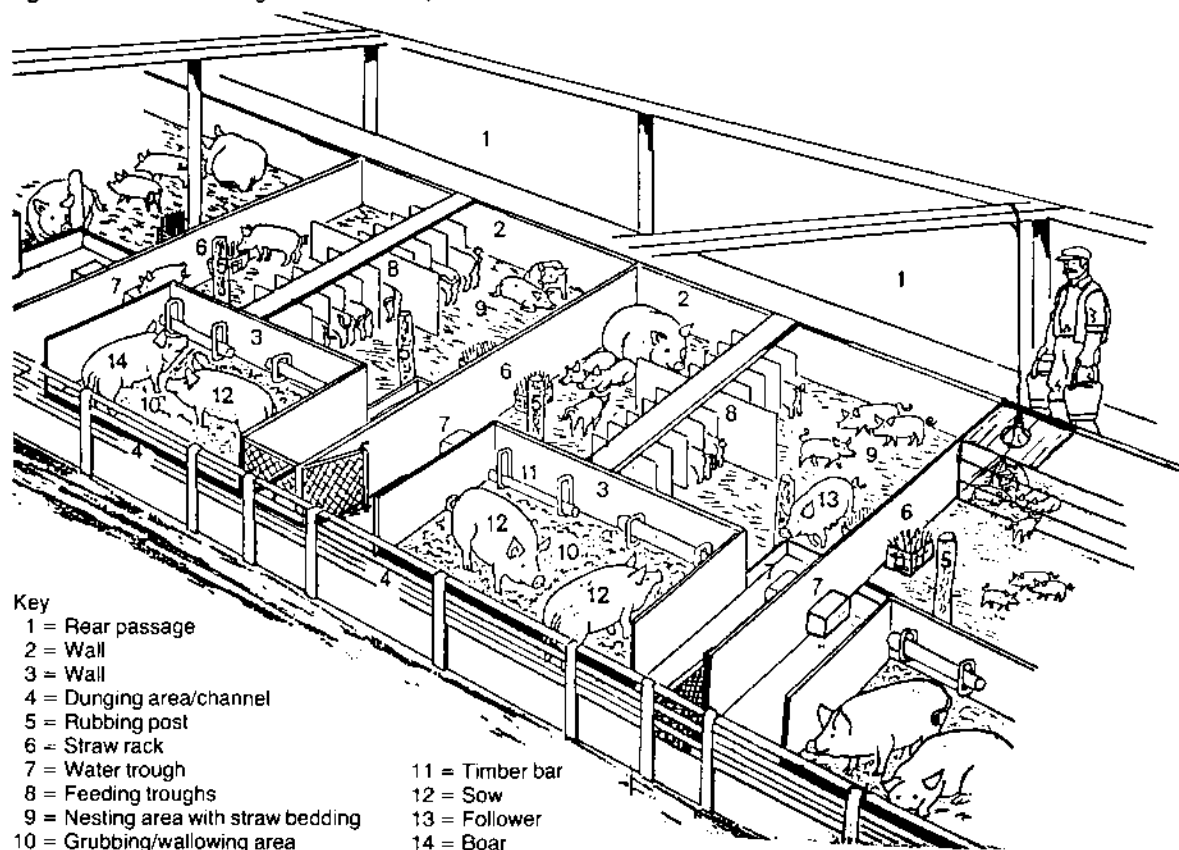

Figure 8.10 The Edinburgh 'enriched' family stall.



Key

- 1 = Rear passage
- 2 = Wall
- 3 = Wall
- 4 = Dunging area/channel
- 5 = Rubbing post
- 6 = Straw rack
- 7 = Water trough
- 8 = Feeding troughs
- 9 = Nesting area with straw bedding
- 10 = Grubbing/wallowing area
- 11 = Timber bar
- 12 = Sow
- 13 = Follower
- 14 = Boar

GREENHOUSES AND INTEGRATED FARMING SYSTEMS FOR COLD CLIMATES.

George Chan, has for many years worked on the concept of Integrated Farming Systems in tropical and subtropical regions, and now is attached to the Institute of Geography in Guangzhou, is concerned about the possibilities for the application of similar concepts in colder, temperate regions of the world. The Integrated Farming System provides the possibility of integrating livestock, aquaculture, agriculture and farm industry into a viable ecological development system, where all organic wastes are recycled to stop diseases and to produce fuel, feed and fertilizer.

There is no dish cheaper than "Oiled Leafy Vegetable" in summer in the southern city of Guangzhou, China, but try to order the same dish in winter in the northern city of Beijing. It makes you lose your appetite besides burning a huge hole in your pocket. The cold weather is not conducive to vegetable growing, but it should not be so in North China because they have the most ingenious greenhouses in the world, with an arched structure made of bamboo covered with multi-layered polyethylene sheets. It is an inexpensive and appropriate technology that should be utilized by more farmers year round.

TYPES OF GREENHOUSES.

There are two main types: the wide and low one that is suitable for the villages outside Beijing, where it seldom snows; and the tall and narrow one suitable for snowy weather. The first one is good for growing leafy vegetables and big squashes, and the other is good for climbing plants such as cucumber, tomato and various types of bean and marrow.

The tall & narrow one is perfect for the Integrated Farming System. It can be the economic version of the commercial greenhouse, as found in Europe and North America, which was used by the author to design an Integrated Farming System for cold climates -- Fig. 1 -- but is prohibitively expensive for China. However, there is such a greenhouse in Shunde County, Guangdong Province, South China, with its own generator and blowers, shading screens, and both overhead and drip irrigation systems, that the Dutch sold to China to grow flowers, but has not been doing well. This outcome was so obvious to everybody in the subtropical county, but the decision for having such a project was made in Beijing. It would be wise to convert it into an integrated farm, similar to the one shown in Fig. 1, and make good use of a white elephant in order to recoup the investment of half-million U.S. dollars.

Apparently, there is another Dutch greenhouse in the North, where it should be, but growing flowers is not the right thing to do.

It should also be converted into an integrated farm that will make big profits in the colder half of the year by selling vegetables to the big tourist hotels. At the moment, they are air-freighting vegetables from Guangzhou to Beijing, and even the waiters call them "green gold" when they serve the few vegetable leaves in the centre of a big oval silver plate to match the price!

TEMPERATURE CONTROL.

No matter what type of greenhouse is used, the principles behind the Integrated Farming System remain the same. The temperature inside the greenhouse must be kept above an agreed minimum, with the trapped solar energy supplying the bulk of the heat, helped with shading screens to prevent excess heat and with rice or wheat straw mats for insulation to prevent heat losses. Some of the biogas is used to supply extra heating at night, if necessary, but this should be avoided by finding other cheaper means of conserving heat.

INTEGRATED FARMING SYSTEM (IFS).

The two ends of the greenhouse are stocked with animals and poultry, and their wastes are automatically washed several times into two tunnel digesters under the walkways. The biogas is stored in special plastic bags or fibreglass containers under the central walkway, which is also ventilated. (No smoking or naked light is allowed inside the greenhouse, of course). The effluent flows into the algae/azolla or weed/kelp channels on the sides of the greenhouse.

The effluent then discharges into the deep ponds (oblong-shaped with load-bearing walls and earth bottom lined with plastic sheet) for polyculture of fish and shellfish, and for growing various aquatic plants as feed. Just outside the edges of the ponds, grass and aquatic plants are grown as food or feed. Floating on the water surface are aquaponic troughs for growing tubers and vines as feed. The effluent from the ponds are stored in underground channels, usually below the walkways, and is used to irrigate and fertilize vegetables, fruits and flowers grown in hydroponic structural channels spanning the sides of the ponds, and on rows of aeroponic towers supported on the channels and secured at the top on overhead beams.

PHILOSOPHY OF THE IFS.

The by-products of the IFS are fuel, fertilizer and feed, and it is possible to have a balanced system to make it self-sufficient, but it will only be an academic exercise and not necessary for practical purposes. It is better to use whatever

Fig. 1 -- Greenhouse IFS for Cold Climates

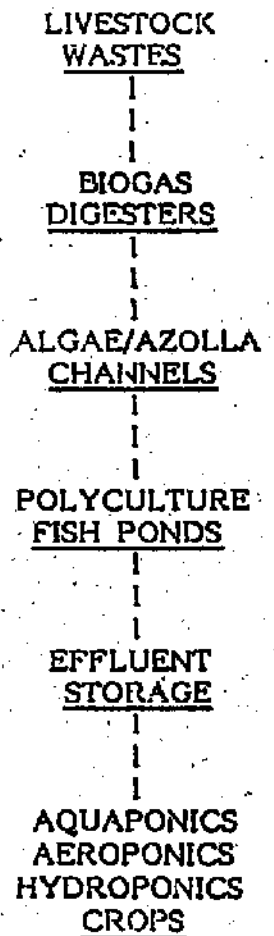
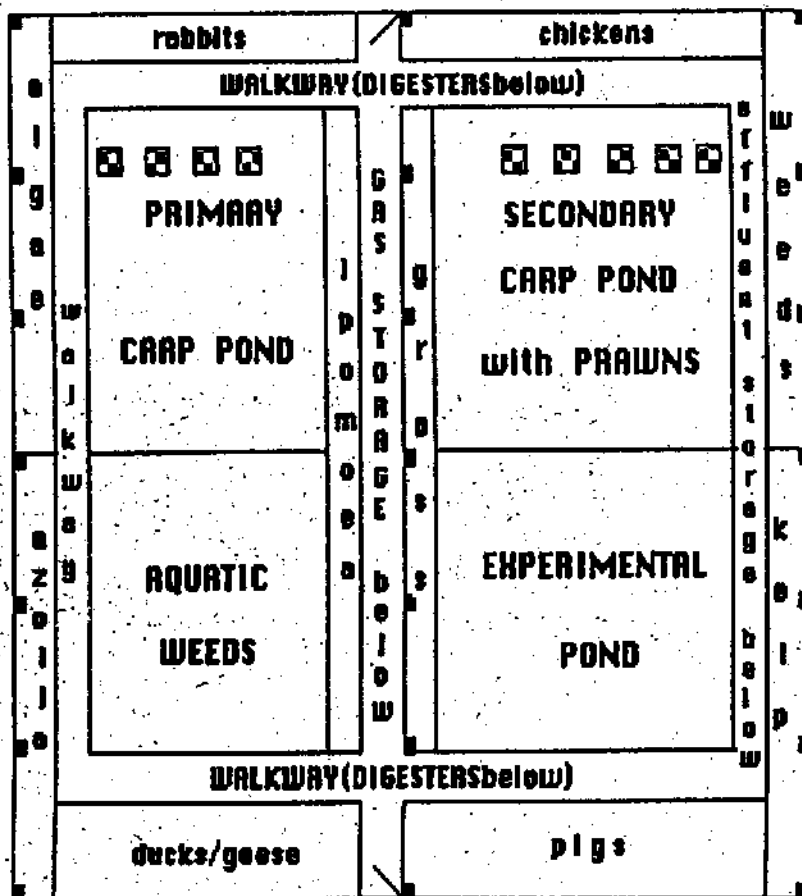
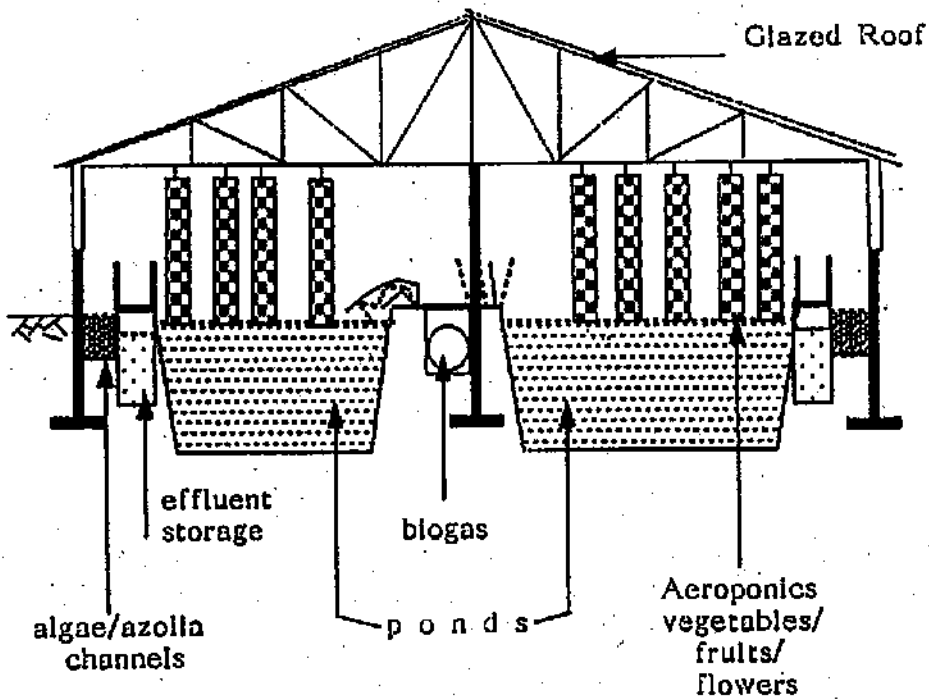

fuel, fertilizer and feed that are available, which represent substantial savings in production costs, and purchase the balance required. The important criteria is that no resource is allowed to leave the system because any unutilized resource is a pollutant. The technology for utilizing all the resources in the IFS already exists. If there is any resource that we cannot take care of, we will not use it in the first place.

VARIETY & VALUE ADDED.

The success of the IFS depends on the intelligent choice of animals, birds, fish, shellfish, crops, and their processing, if required, in order to have a "perfectly" balanced eco-system in terms of preparatory, routine, harvesting and processing work with minimum outside assistance. One very important rule is to get the highest price for the fresh produce; otherwise, it is processed by mechanical, chemical (non-toxic) biological and/or microbial (beneficial) means to introduce variety and/or add value to the produce. Of course, the end result is to have maximum returns for the farm at minimum costs, and there is plenty of scope for creativity, ingenuity and constant improvement in the IFS to achieve such objectives.

CONCLUSION.

Because of the extra costs of the greenhouse and the energy-intensive inputs, besides the scarcity of arable land in North China, farming in cold weather must be highly productive to make it worth while for the farmers. At the same time, the farmers must be able to offer meat, poultry, fish and various kinds of vegetables to the people at reasonable prices. So the system must be intensive but very efficient, resulting in the highest yields of products while reducing energy, fertilizer and feed costs as much as possible. The IFS makes all these things possible. It is now up to the farmers themselves to act... Will they?

George Chan, Visiting Professor, Institute of Geography, 100 Xanlie Road, Guangzhou, Guangdong, China.

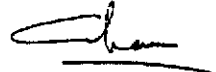

INTEGRATED FARM DOME

OBJECTIVE

The objective of the Integrated Farm Dome is to provide proper environmental conditions for research and development on the integration of livestock, aquaculture, agriculture and agro-industry in a greenhouse during the six cold months of the year.

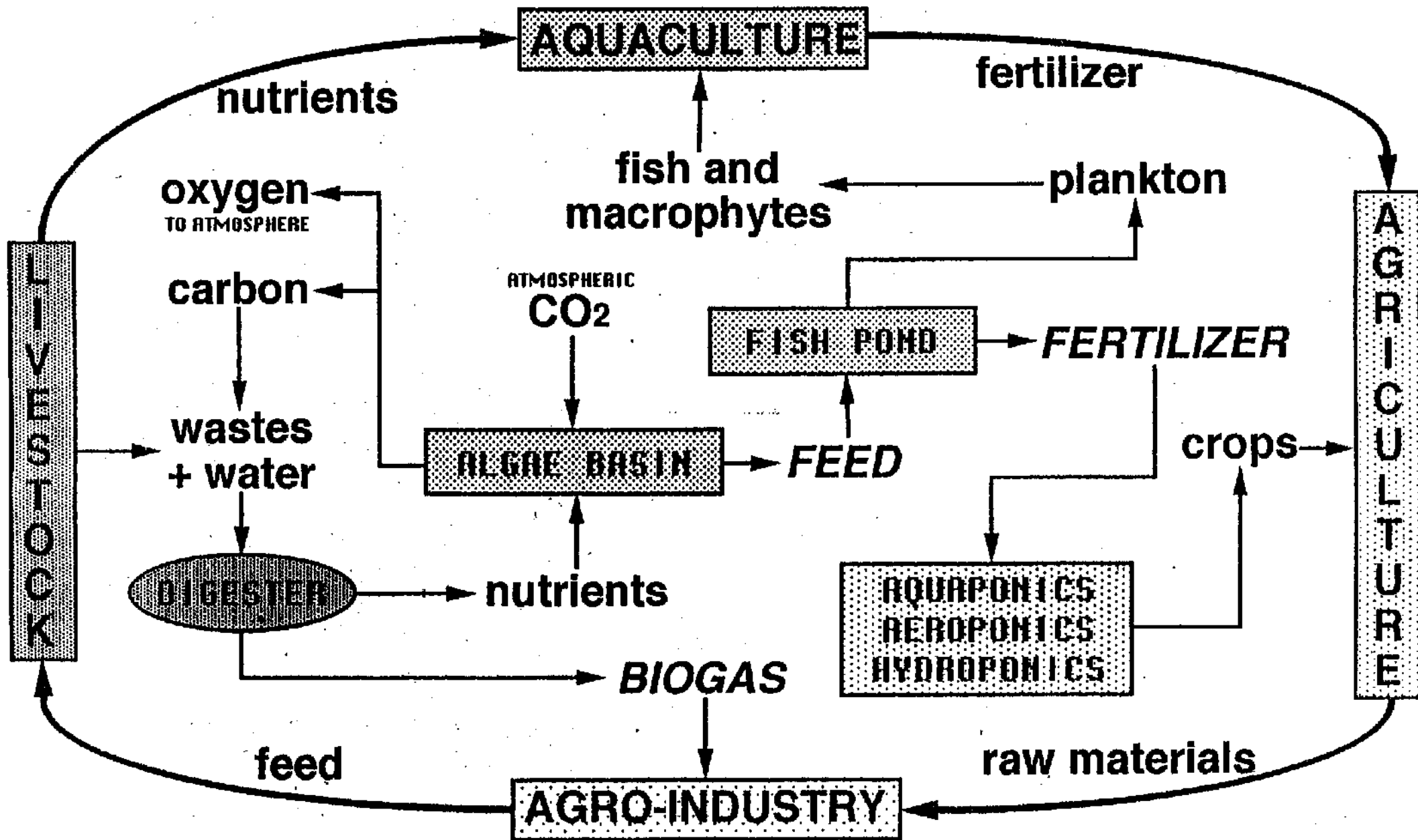

INTEGRATED FARM DOME

INTEGRATED FARM DOME

Trophe / cabinet included sheets for

ventilation

LABORATORY

pulley block

LIVESTOCK
5 piglets every month

biogas storage bags

DIGESTER ON STILTS

ALGAE

BIOGAS-OPERATED
DIFFUSED
AERATION

fertigation pump system

ventilation

STILTS

AQUAPONICS

FLOWERS

bushes

climbers

FISH

HYDROPONICS

WORKSHOP

SECTION

AEROPONICS

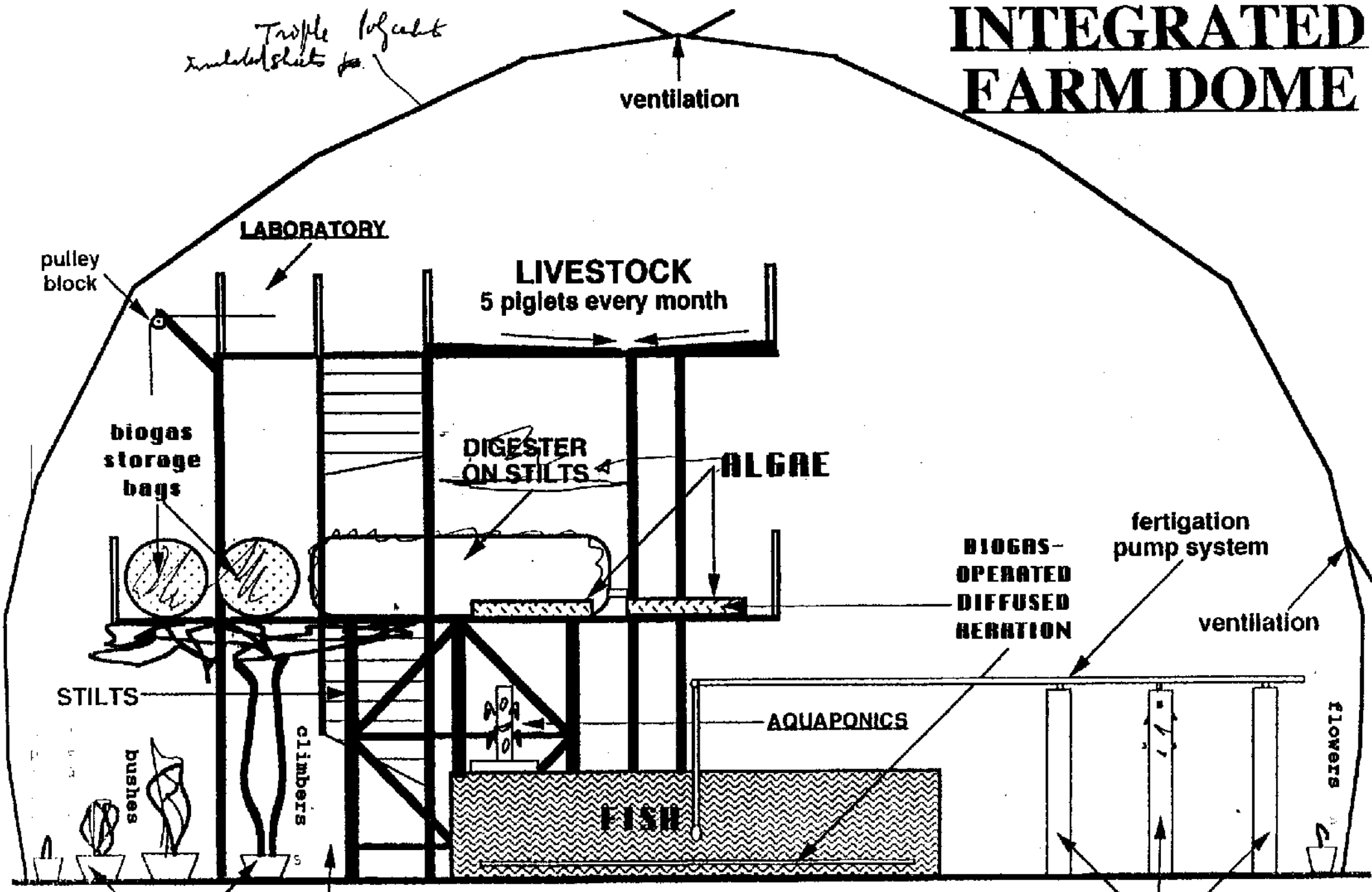

INTEGRATED FARM DOME

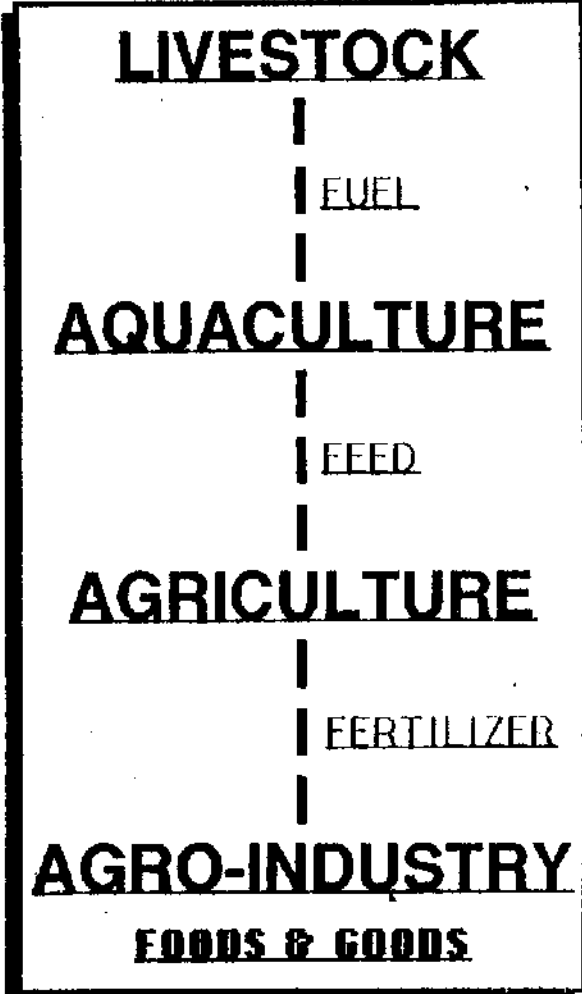
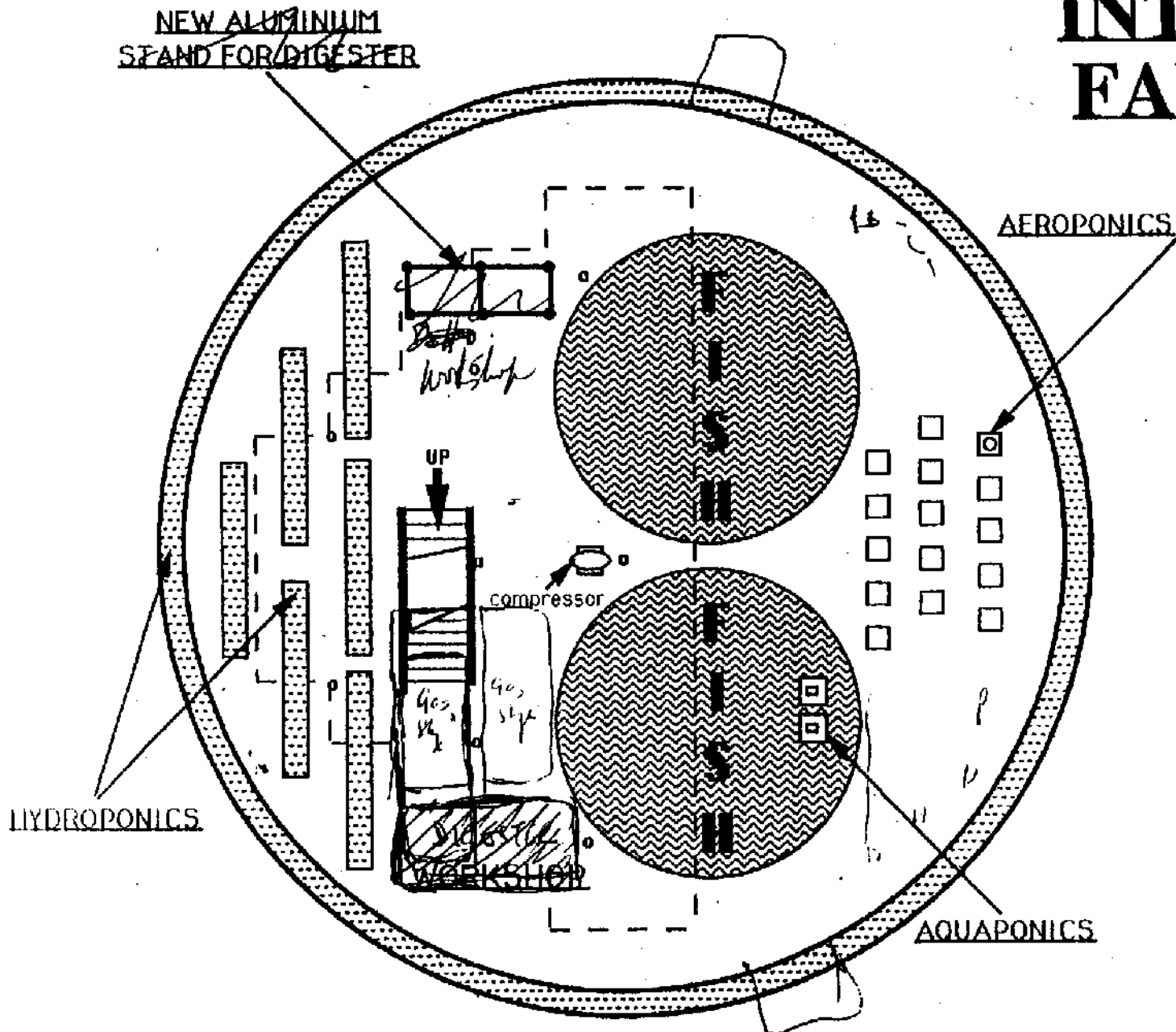

1ST LEVEL PLAN

INTEGRATED FARM DOME

INLET PIPE TO DIGESTER

DOWNPIPE TO DIGESTER

PULLEY BLOCK

OPEN

fish tanks below

LABORATORY

LIVESTOCK

30 ft
slopes
or
38 ft
slopes

- 3. Livestock
- 2. Macrophytes
- 1. Fish & crops

2ND LEVEL PLAN

3RD LEVEL PLAN

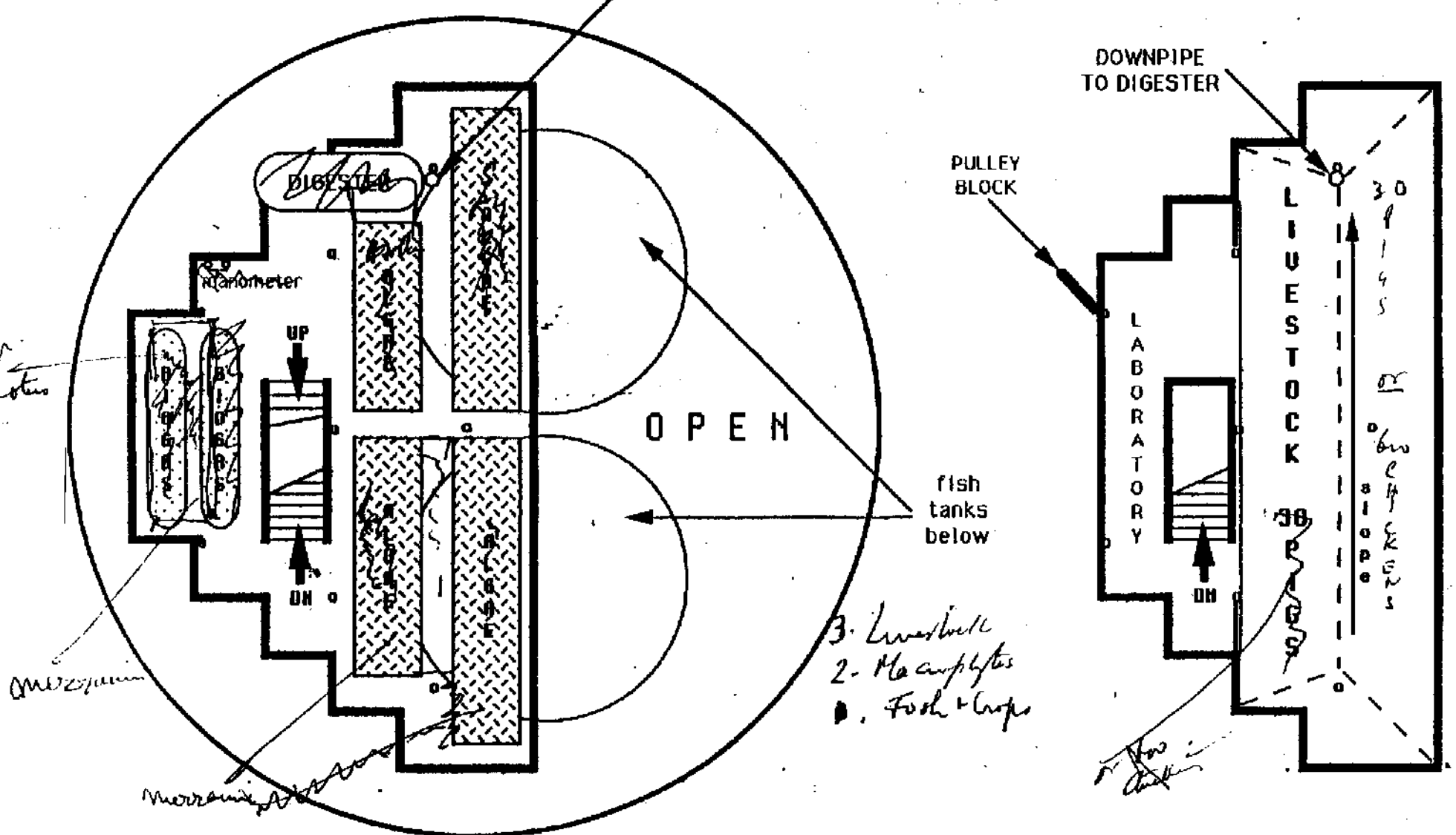

stair

Microphytes

Macrophytes

How is this done?

INTEGRATED FARM ACTIVITIES

LIVESTOCK : 30 PIGS (5 piglets/month) each using 10 litres of water daily = 300 litres

- The water is used to wash the livestock wastes several times daily into a 3 m³ digester
- The digester has a capacity of 10 days' retention & is placed on aluminium stilts & braces
- Two plastic bags of 5 m³ each, fitted with proper manometer, are used for biogas storage
- Solar panels & biogas heat exchanger are used to heat substrate to 35°C for optimum yield
- Biogas-operated engines are used for aeration of wastewaters and space heating of dome
- The digester is designed for reduction of biochemical oxygen demand (BOD) by 60%

ALGAE BASINS : 4 plastic-lined basins of 1m20 wide & 15 cm deep are joined in series

- Lengths are 7m, 7m, 6m & 5m, with total area of 30 m², for growing high-protein spirulina
- Engine exhaust gases & air are blown into basins in daytime for optimum algal growth
- Algae are used as livestock feed or as feedstock in digester if additional biogas is needed
- Algae basins are designed for further reduction of BOD by 30%, providing much minerals

FISH PONDS : 2 plastic ponds of 20 m³ each for polyculture of various kinds of fish

- Diffused aeration is used in the ponds during the night to optimize dissolved oxygen
- The fish wastes are automatically mineralized in the aerated ponds for additional fertilizer
- The grown fish is regularly harvested as livestock feed and replaced with fingerlings
- Floating aquaponic towers drawing rich pond water by capillarity are used to grow crops

MULTICROPPING : Aeroponic towers & hydroponic troughs are used to grow crops

- The highly-mineralized pond water is recycled by a pumping system for total re-utilization
- The water flows through the towers & troughs, and is then used to wash livestock wastes
- High-priced crops are sold for cash, and cheaper feeds purchased to feed the livestock
- Others are processed for preservation & added value by microbes or biogas equipment
- The crop and processing residues are used as livestock feed, with or without processing
- Wastes are not left to pollute the environment but are recycled to reduce production costs



Good Books

The Hydroponic Hot House: Low-Cost High-Yield Greenhouse Gardening

by James B. DeKorne

Reviewed by Chris Greacen

In 1975 James B. DeKorne wrote *The Survival Greenhouse* to advertise greenhouse gardening as a way of providing all of a family's food needs. He was aiming for a greenhouse which would produce vegetables and fish year round, using only organic materials generated on site, and energy from the sun and a small windmill. The quest turned out to be unrealistic.

In the "Author's Confession and Introduction" in this latest book, *The Hydroponic Hot House* (©1992 Loompanics Press), DeKorne writes, "Much of the stuff appearing in the back-to-the-land publications from that era converted unproven hypotheses into proven facts. I am not proud to admit I am responsible for my own share of it... This publication is a description of my on-going experience with those original concepts and an attempt to put them into some realistic perspective."

The result is a down-to-earth book of greenhouse design and techniques which evolved from 20 years and a succession of greenhouses at his New Mexico homesite. The design he was eventually most happy with was an attached greenhouse, providing heating for his home, while the home provided CO₂ for the plants.

Especially strong is a section on hydroponic gardening (growing plants without soil), which DeKorne finds the most successful for growing lots of vegetables in a small space. His low-tech hydroponic approach is automated, using water pumps powered by a small photovoltaic array. The book also covers greenhouse temperature control, greenhouse management (when to plant and when to pull out the plants), and pest control. There is an interesting portion on the response of plants to temperature, photoperiod, and CO₂ (DeKorne had excellent results with Club Soda carbonated water).

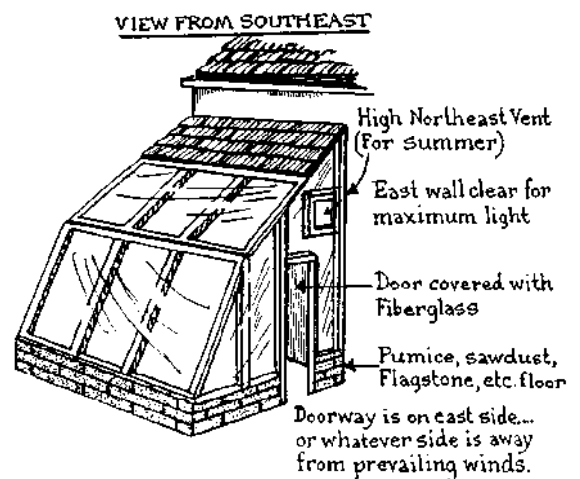
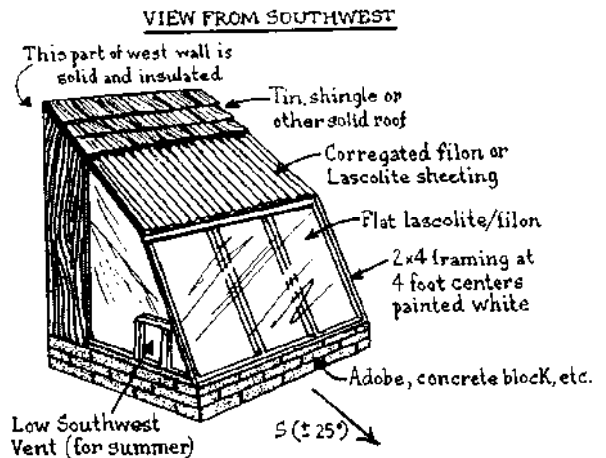

If you're new to greenhouses you'll find this 181 page book informative and easy to read. If you're a greenhouse veteran, this book is still likely to pay for itself a few times over in pointing you towards realistic possibilities and away from dead ends in greenhouse work.

Access

The Hydroponic Hot House: Low-Cost High Yield Greenhouse Gardening by James B. DeKorne (ISBN# 1-55950-079-4) is available for \$20.95 (which includes postage) from Loompanics Unlimited, POB 1197, Port Townsend, WA 98368 • 206-385-5087.



SIERRA SOLAR

Photovoltaic Systems • Solar Hot Water Design, Installation, Sales and Service
"serving the Sierra Nevada"

Jim Harper • CA Contractor Lic. #360454
 HCR-1 Box 1064, Virginia Lakes, CA 93517
 (619) 937-0307

UNDERGROUND HYDROPONIC GREENHOUSE/FISH TANK

ALTITUDE = 7,000 FT. CEMENT BLOCK AND LOG CONSTRUCTION

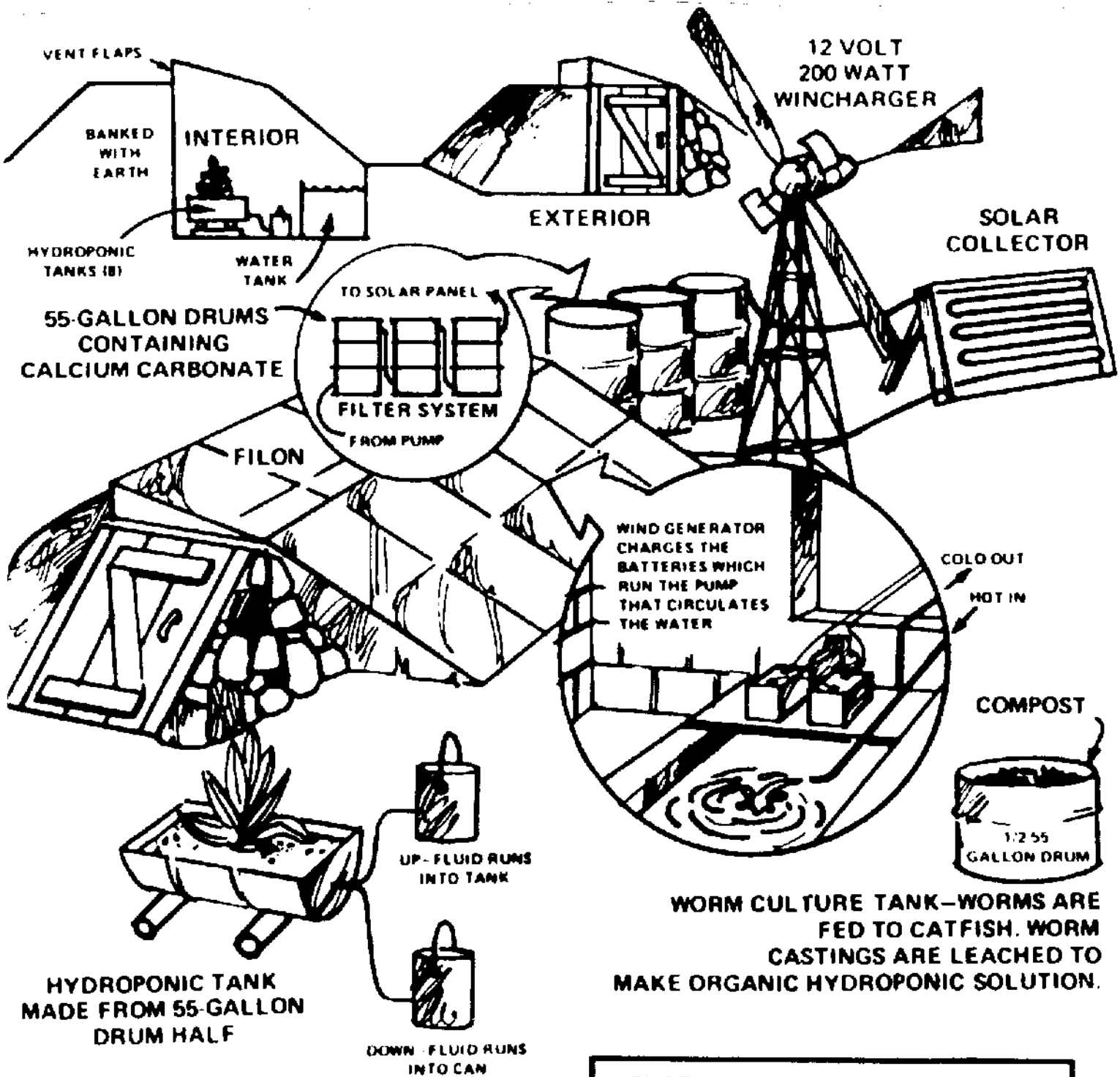

WORM CULTURE TANK—WORMS ARE FED TO CATFISH. WORM CASTINGS ARE LEACHED TO MAKE ORGANIC HYDROPONIC SOLUTION.

LENGTH	22 ft.
WIDTH	11 ft.
DEPTH	4 ft.
TANK CAPACITY	1,400 gal.

A SIMPLE RIGID FRAME GREENHOUSE^(R)

This circular describes a rigid frame greenhouse for home use which is attractive and can be constructed at low cost. It can be built with common tools, and the frames can be prefabricated indoors during inclement weather.

Covering. This greenhouse is designed for covering with rigid fiberglass panels or with film plastics such as weatherable vinyl, or inexpensive polyethylene. Construction of the framing is slightly different for corrugated fiberglass than for flat fiberglass and the film plastics (see plan in the center fold). For descriptions and recommended thicknesses of different plastic materials suitable for greenhouses, refer to University of Illinois Circular 879, *Home Greenhouses*.

Building the frames. The rigid frames are made of 2" x 4" construction grade fir lumber (or other grades and species having equal strength). A jig or pattern forming the dimensions given in the plan (center fold) can be made by nailing boards to a wooden floor, plywood sheets, or to other boards. The 2" x 4" members are then cut and fitted in the jig. The frames are made rigid by gluing and nailing 1/2" AC exterior-grade plywood gussets over the joints (Fig. 1). Resorcinol-resin glue, which is waterproof and which sets under low pressure at normal air temperatures, is recommended for greenhouse construction. The frames should be stored level for 24 hours after nailing and gluing the gussets. A complete frame can be made from two 10-foot 2" x 4" members.

Size of greenhouse. The frames should be spaced according to the width and kind of the plastic to be used, but not wider than 36" on center. Frames can be spaced 32 inches on center for 34-inch wide corrugated fiberglass, or 36 inches on center for polyethylene, vinyl, or flat fiberglass. Convenient greenhouse sizes for these frame spacings are 10' x 10'8" (5 frames) or 10 x 15 (6 frames), respectively. The techniques described in this circular can be used to build frames for a lean-to greenhouse (half frames) or for a greenhouse of larger dimensions.

Foundation. Two solid and inexpensive foundations are shown in the plan (center fold). The concrete foundation is recommended for a permanent, trouble-free installation (Fig. 2). Framing anchors or angle-iron braces attach the frames to the sill plate and foundation. Pieces cut 2 1/2 inches wide from 2 1/2- or 3-inch angle-iron and drilled for 1/2-inch bolts make excellent anchors.

Floor. A center walk can be made of concrete, flagstones, stepping stones, or pea-gravel and should be raised and sloped for run-off of water. Crushed rock or stones can be placed under the benches for neat appearance and to catch excess water.

Installation of plastic. The frames must be notched at the peak and eaves of the roof to receive continuous 1" x 4" members for film plastics or

flat fiberglass (Fig. 3). One edge of the eave and peak members must be beveled to form a smooth corner surface for application of the plastic. This additional cutting and fitting is not necessary for installation of corrugated fiberglass (Fig. 4).

Film plastics (vinyl or polyethylene) are attached with painted 1" x 2" fir or redwood strips nailed to the frames (Fig. 3). Flat fiberglass can be attached with round-head screws backed with neoprene washers.

The roof can be easily covered with corrugated fiberglass by cutting 10-foot panels in half. This will allow a 3- to 4-inch overhang at the eave. Two 34-inch wide corrugated panels, installed horizontally with proper overlap, exactly covers one side. Special rubber or redwood closure strips are used to seal along the edges of the wall and roof (Fig. 4). Detailed installation instructions, available from fiberglass manufacturers and suppliers, should be obtained before construction. Flat, rather than corrugated fiberglass, may be used for easier covering of the ends.

Benches. The greenhouse is designed for two 30- to 36-inch wide benches. The plan shows how to construct supports for the bench shown in Fig. 5. A permanent bench to rest on the pipe supports can be made of cypress or redwood boards. Prefabricated benches made of asbestos cement (Fig. 5) or redwood are available from greenhouse supply companies.

Paint. All wooden framing members should be painted with a good white paint. Special greenhouse paint, which usually contains a fungicide, is preferable. Paints which give off toxic vapors, especially those containing mercury compounds, should be avoided.

Benches and wood members in or near the ground can be treated with a good wood preservative such as 2 percent copper naphthenate. Never use creosote or pentachlorophenol preservatives in a greenhouse.

Heating and ventilation. The greenhouse must be properly heated and ventilated for year-round enjoyment. Thermostatically controlled exhaust fans, rather than manual vents, are recommended for positive ventilation of this rigid frame home greenhouse. Refer to University of Illinois Circular 879, *Home Greenhouses*, for information on heaters for small greenhouses, amount of heat required, and ventilation.

Approximate Material Costs for a 10' x 10'8" Rigid Frame Home Greenhouse

Framing (lumber, glue, nails).....	\$ 50-60
Plastic (including necessary fasteners)	
Fiberglass	125-175
Vinyl.....	25-35
Polyethylene.....	15-20
Foundation	
Post	15-25
Concrete.....	30-50
Heater.....	75-125
Ventilation fan (shutters, wall box, guard, thermostat).....	75-100
Benches (two 3' x 10', redwood or asbestos).....	50-75

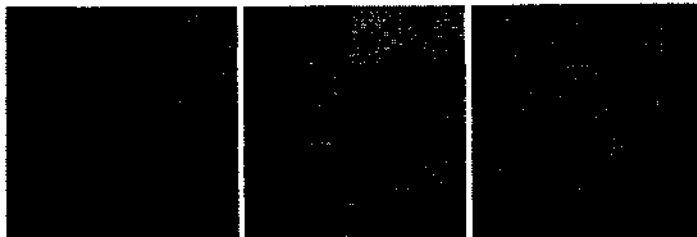

A rigid frame formed in a jig with plywood gussets being glued and nailed over the joints. Note the filler block which may be cut from a 2" x 2" (shown) or 2" x 4" member. Fourpenny nails secure the gussets until the glue dries.



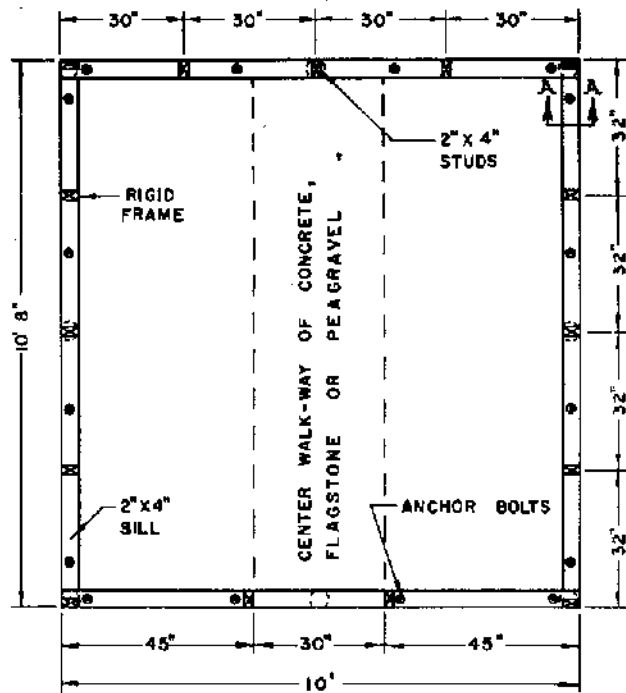

PLAN AND ELEVATION OF STRUCTURE ON CONCRETE

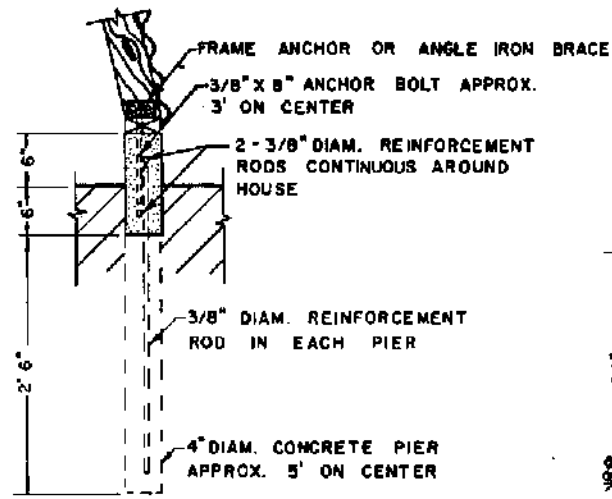

SECTION A-A
CONCRETE FOUNDATION DETAIL

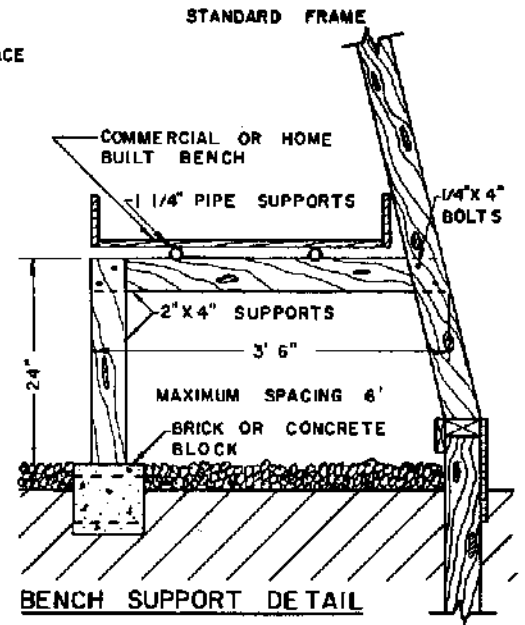

BENCH SUPPORT DETAIL

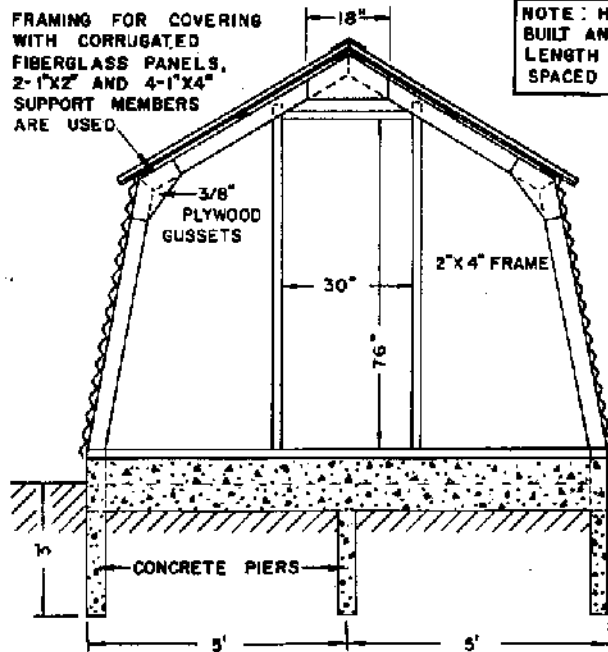

NOTE: HOUSE MAY BE BUILT ANY DESIRED LENGTH WITH FRAMES SPACED UP TO 36" O.C.

FRONT ELEVATION AND DETAIL OF ALTERNATE FOUNDATION

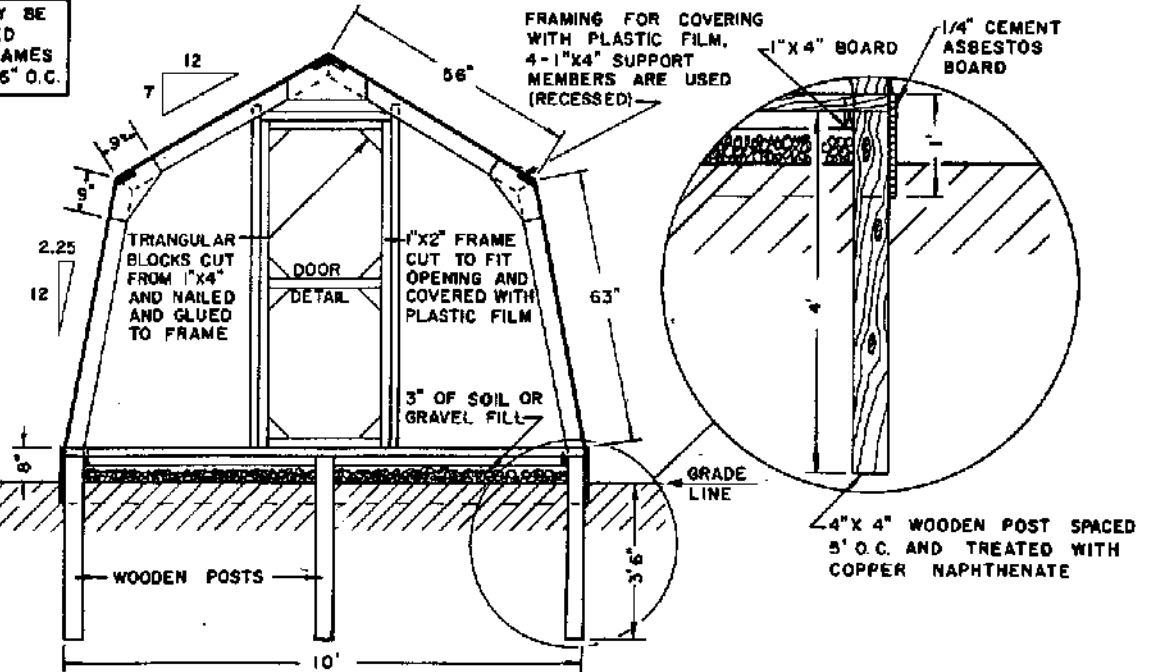

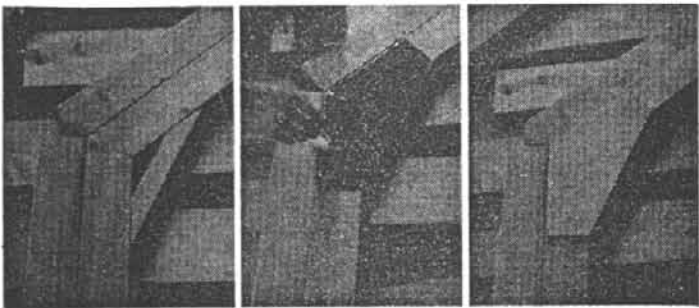

A rigid frame formed in a jig with plywood gussets being glued and nailed over the joints. Note the filler block which may be cut from a 2" x 2" (shown) or 2" x 4" member. Fourpenny nails secure the gussets until the glue dries.

(Fig. 1)

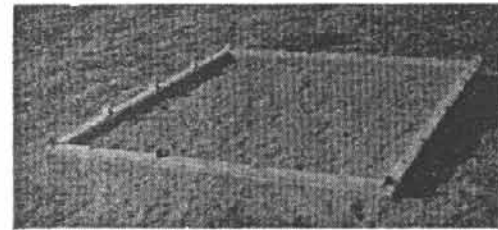

Concrete foundation with sill ready for rigid frames.

(Fig. 2)

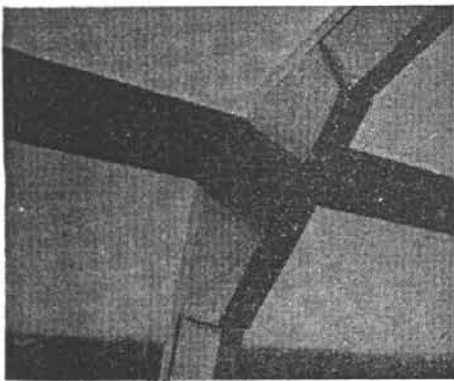

The eaves of the roof, showing the notched frames.

(Fig. 3)

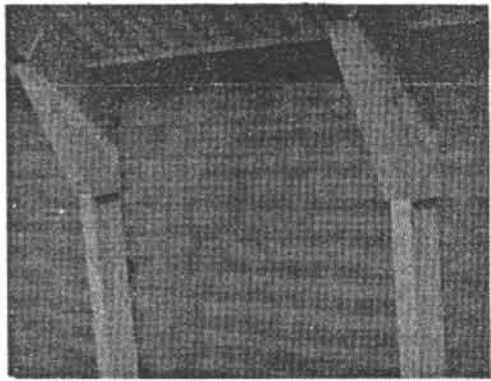

The installation of corrugated fiberglass by means of wood screws and closure strips.

(Fig. 4)

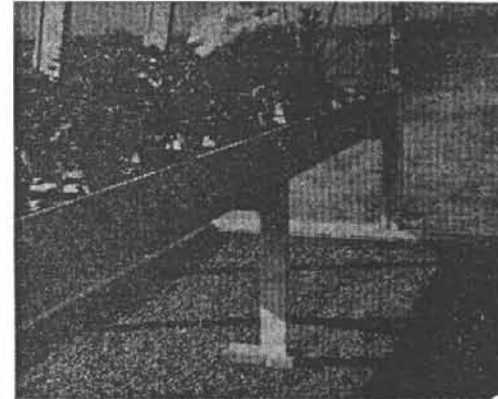

Asbestos cement benches for the greenhouse.

(Fig. 5)

Cold Frame/Greenhouse

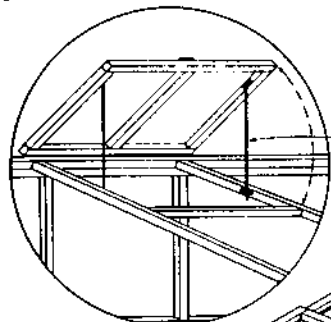

VENT OPEN

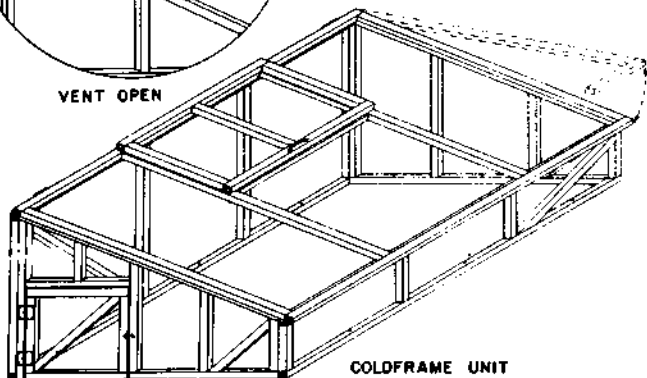
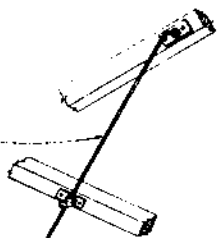

COLDFRAME UNIT

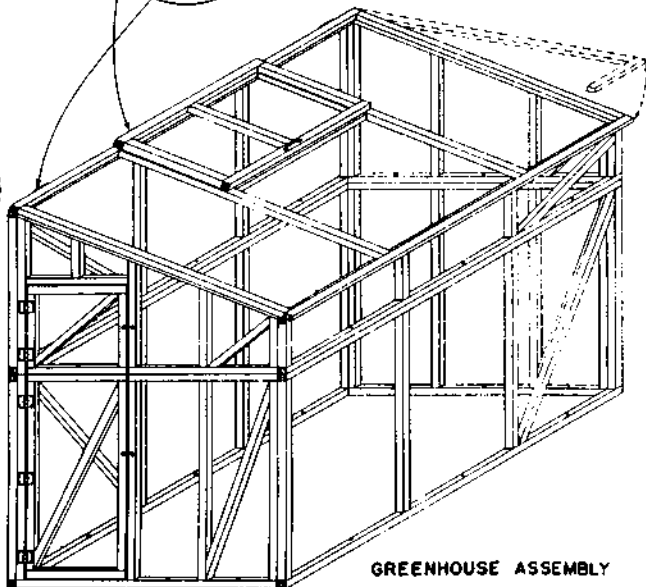
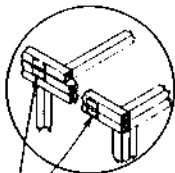

GREENHOUSE ASSEMBLY

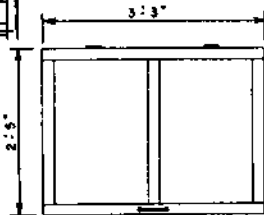
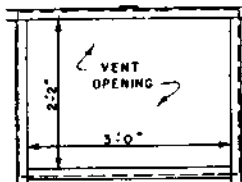

VENT COVER

PANEL FRAMING DETAILS

ALL FRAMING MEMBERS ARE 2" x 2", TREATED WITH PRESERVATIVE AFTER CUTTING. CHECK ALL DIMENSIONS ON THE JOB. ANCHOR TO GROUND WITH 3/8" x 15" STEEL ROOS WITH TOP 2" BENT 90°. 5 PAIR 3" x 3" LOOSE-PIN BUTT HINGES ARE REQ'D.

BATTEN TO HOLD PLASTIC FILM, NAILED EVERY 4"

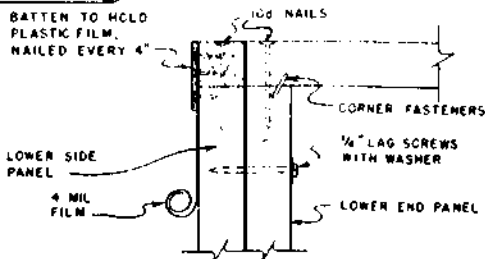

FASTENING DETAIL

From *Small Plastic Greenhouses*, Division of Agricultural Sciences Leaflet 2387, University of California.

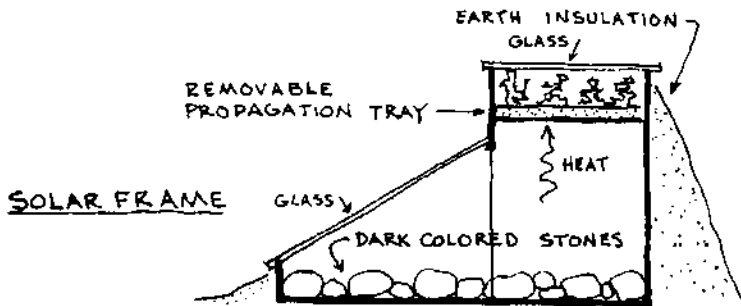
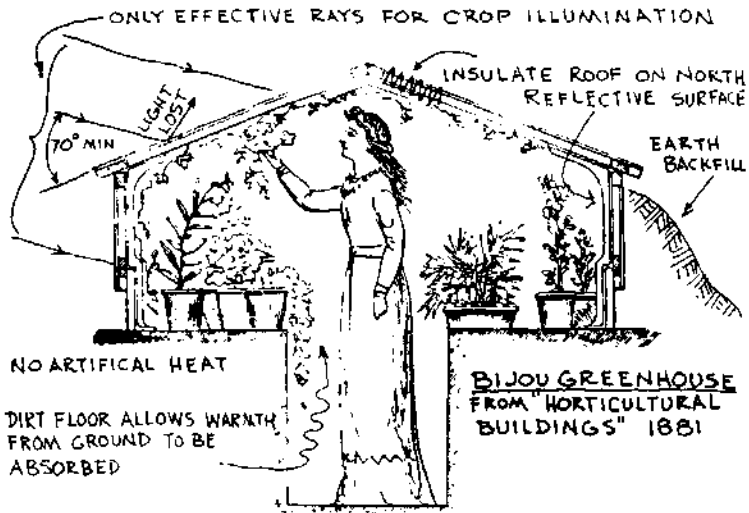

The Sunpit Greenhouse

by Hal & Judy Hinds

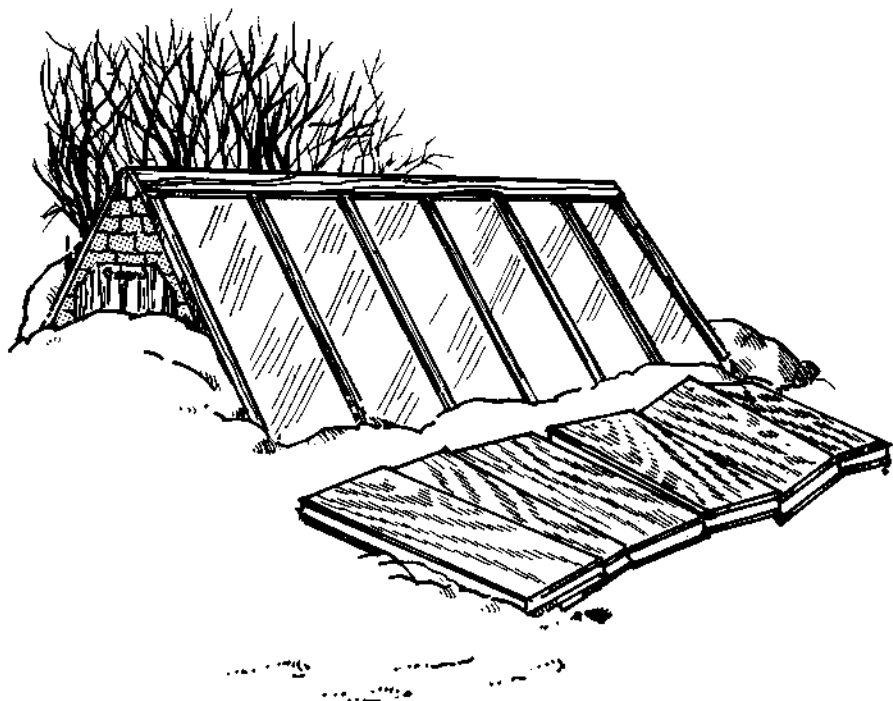

Wintering in cold temperate, or more aptly, intemperate, parts of the world is guaranteed to be much more endurable if you combine a bit of autumn with a lot of spring inside a sun-heated, sunken greenhouse or Sunpit. In a nutshell, a rectangular hole about 4 feet deep is dug with the long axis running NE and SW. A concrete foundation is constructed against the walls of the hole and covered with a roof insulated all around except on the SE side which is fitted with plastic. In the east end a half-size door opens out, and although you have to bend down to enter the Sunpit, a full-size door would mean an exterior stairwell that would fill with snow and ice. In the west end there is a hatch, hinged at the bottom, that is opened for cross ventilation. Earth-heat and moisture rise from the floor and solar radiation through the plastic front heats the interior. Insulated panels cover the plastic at night and during prolonged periods of stormy weather, holding in the heat.

Because the temperature in the Sunpit greenhouse ranges ideally between 35° and 70° F, it is classed as a "cool" greenhouse, a type of structure capable of favouring a wider and more practical spectrum of plants than the tropical or semi-tropical greenhouse built above ground with wall-to-wall glass. The five major types of cultural activities we have tried successfully in the Sunpit indicate its possibilities: we have grown salad greens of several varieties all winter long in broad flats; we have brought a great range of beautiful plants into flower; we have forced many pots of bulbs; we have over-wintered and propagated tender plant material, especially herbs; and we have started flowers and vegetables from seed for the summer gardens. The potential for experimentation and enjoyment is endless.

The Excavation

The excavation for the Sunpit can either be dug by hand or by heavy equipment. We dug ours, four feet deep, nine feet wide and about 19 feet long. We were in no hurry, and used the soil dug from the excavation to fill potholes in the driveway and construct an elevated ramp to the barn. All the larger-than-fist-sized stones were set aside and were later embedded in the mortar of the foundation. Two trenches were also dug, both sloping away from the Sunpit. One trench carries a plastic water line and an electrical cable from the cellar of the house, while the other holds a four inch drainage pipe to carry off any extra water that might enter the Sunpit. The drain pipe goes under the foundation wall and the electrical/water line goes through the foundation in a 2-inch plastic pipe.

The Foundation

Once the trenches were filled, I squared off the excavation by delineating the corners of the forms with batten boards and strings. I decided to use the earthen sides of the excavation as the outer part of the form. In this way, I had only to construct the inner part of the form, carefully reinforced and braced across the centre, and a low form around the outer edge of the excavation where the final foundation would extend above ground level. I used recycled lumber for the foundation forms, plywood, old doors, old floor boards, etc.

Next was to pour the concrete, a big, one-day job. We rented a small gasoline-driven cement mixer for the event. We used a formula of 10 parts mixed sand and gravel to

one part cement with enough water to make a rather runny mix. The stones from the hole were incorporated in the foundation as it was poured and one worker stood inside the excavation and pounded on the form to help settle the mortar around the stones. On the last loads we were careful to level the top of the foundation so that the sills of the superstructure would lie even all around. Just before the last batch set, I inserted two long bolts, thread end up, along each side. These bolts went into the concrete about two inches and were long enough to go up through the sill beams and be fitted with a washer and nut. Our mix of concrete cured rather slowly, but we were not in a hurry. It produced a strong set, and when the forms were removed about three weeks later, it could be seen that only a very few cavities were left unfilled by the concrete. It is best at this time to cover the floor of the pit with 3-4 inches of crushed rock to help drainage.

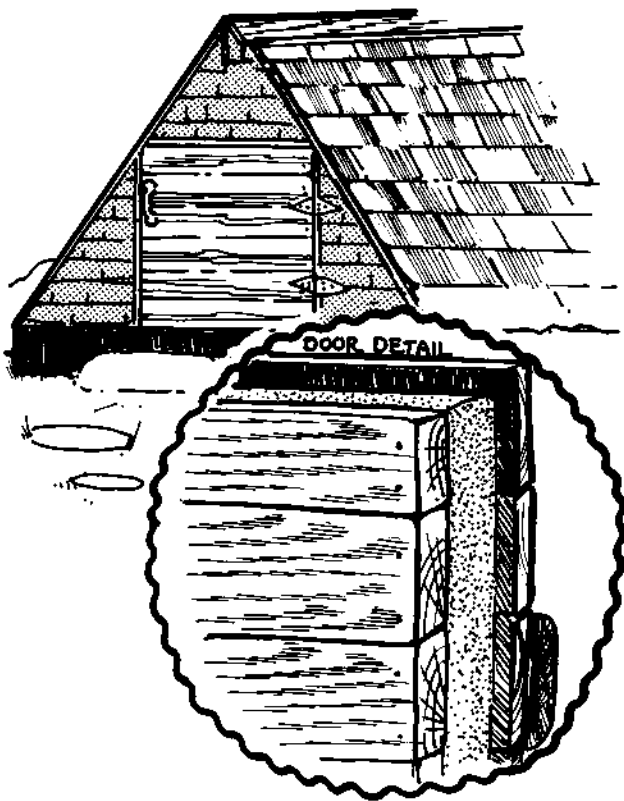
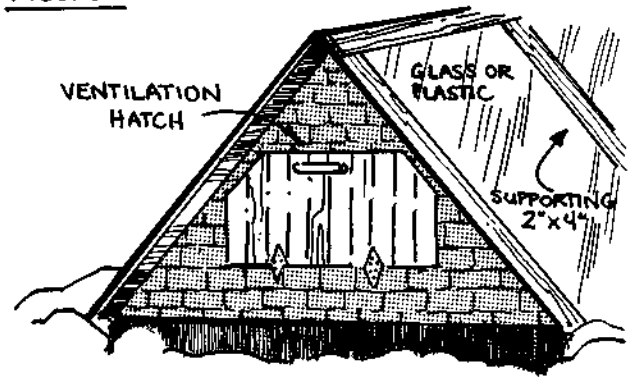

FIGURE 1

The Superstructure

The 4" x 4" sills were attached by drilling and countersinking the bolts, washers and nuts. The straightforward carpentry and the new, unplanned lumber that we splurged on made the job of building the superstructure move along very quickly. In one weekend the roof on the north side was boarded up and covered with tarpaper and shingles. The Sunpit really started to take on a finished look. The front side was covered with a layer of 6 mil plastic fastened down with lath strips. Later another layer was added inside producing a 2-inch space between. Inside the

FIGURE 2



pit, the back side was boarded up and styrofoam pellets were used as insulation. Plastic sheeting was used liberally throughout to seal cracks between boards to keep the insulation from leaking out and as a vapour barrier. The ends of the Sunpit were treated in the same manner, and the door and hatch were built with a space for the pellets also. Styrofoam sheets would be easier to handle for the door and hatch, however.

The Panels

The insulating panels are styrofoam sandwiches. Three inch styrofoam sheets are bonded and bolted to two ¼-inch plywood sheets. The size of the panels will vary with the size of your Sunpit. We used five panels about 5 ft. by 3 ft. You might not need the carriage bolts if you do a careful bonding job. There are special caulking gun adhesives formulated just to bond styrofoam to wood. Make sure the adhesive and panel components are fairly warm before using. At first we tried fastening the panels to the superstructure with hinges at the bottom, but snow tended to pack in and spring the hinges, so it seems best in our climate to leave the panels loose. A canvas cover rolled down over the panels would make the Sunpit a little tighter and protect the panels from rain and snow damage.

The Interior

The success of the Sunpit is immediately apparent upon opening the door: the warm, moist, fragrant air; the mass of variegated foliage greens; the liberal sprinkling of such colours as cyclamen pink, delphinium blue, larkspur orange, snowdrop white, Christmas cactus red and primrose yellow. We used unplanned spruce and fir left over from the superstructure for the interior stagings.

On the left as you enter, underneath the plastic-covered southeast side, is a table three feet wide and four feet high, running the full eighteen foot length of the Sunpit. This table, or front bench, is supported by cedar poles resting on flat rocks, two poles on each corner and two front and back half way along. The entire structure was carefully leveled during the building and is anchored to the sills that rest on the concrete foundation. This bench is bordered all around by a six-inch wooden rim. Within the rim, forming the table top, are three-foot boards of random widths set apart about one inch for drainage. These boards are not

FIGURE 3

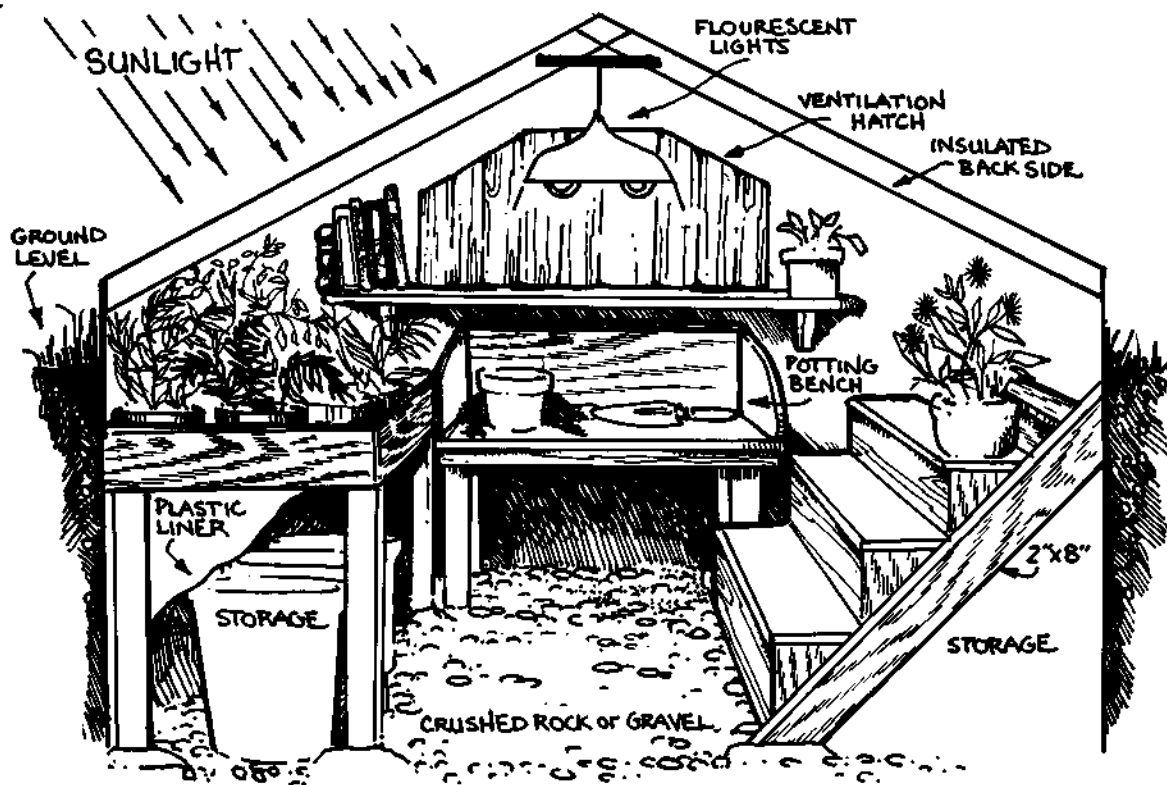

nailed down, but merely rest on two by fours that are attached to the bottom of the bench rim.

The extensive area underneath the front bench makes an ideal storage space for pots, soil ingredients, compost bucket, germination chamber and bulbs for forcing. Care must be taken to avoid drenching these materials with water from the plants above. The problem is easily solved by underlining the front bench with a sheet of 4 mil polyethylene plastic. It is stapled to the underside of the front rim and slopes gently down toward the back.

In the corner immediately to the right of the entrance I have a tub of water under the water faucet. This tub was cut with a chain saw from the bottom half of a wooden barrel and serves admirably as a water reservoir for watering the plants and also as a repository for my stock of watercress that I replant into our little brook each spring. Without this tub I would have to drain the Sunpit water line back to the cellar during frigid weather and turn it on again each time I wanted to fill my watering can.

The staging under the north roof is in the form of bleachers, three long shelves about a foot apart running nearly the full length of the Sunpit. Four 2" x 8" boards running diagonally from the back sill to the floor and resting again on flat rocks make up the supports for the shelves. The shelves are ordinary boards, eight inches wide and fourteen feet long, carefully leveled along their length and supported by brackets cut 45°-45°-90° from the 2" x 8" stock. Two cuts produce two brackets. Near the top of the bleachers where the roof meets the foundation there is a fourth shelf cut and fitted between the diagonal supports of the bleachers. This holds small 3-inch pots with head-

room for about 6 inches of growth.

On the end of the Sunpit under the hatch I built a small potting bench, attached on the left to the front bench, supported on the right by another cedar post and nailed at the back to the concrete foundation with four inch nails. This useful little bench is about 2.5 feet wide, 2 feet deep and rises in the back about a foot. It is constructed of 1-inch plywood. Having sides, this bench serves very well to hold a quantity of potting soil at the back available for quick potting of rooted cuttings or for repotting. It is also a good work surface for starting seeds. Above the bench there is a shelf usually reserved for plants on their way to the house. Underneath is a small storage area for flats, glass plates, labels and other miscellaneous supplies.

Electricity in the Sunpit

Successful management of a Sunpit does not absolutely require the use of electricity. As a precaution, however, provisions were made for both supplementary light and heat. Fluorescent lights were installed the full length of the Sunpit about 2 feet from the ridge. Each fixture is four feet long and all are operated by a switch near the door. I use the top of these fixtures as a shelf for seed-flats once the seeds have germinated. On dull days when the panels are not removed from the front of the Sunpit, the lights are turned on. Also, occasionally during the period of our shortest days, the lights are switched on for a few hours in the late afternoon. In a sunpit without electricity, plant growth would necessarily be slowed down in sunless spells, but the plants could nevertheless be carried over until the brighter, longer days arrive. Some

sort of lighting makes evening work possible in the pit, a most pleasant activity, especially in the dead of winter.

Because we did not know how well our Sunpit would perform during the many sub-zero nights of the central New Brunswick winter, we installed a small blown-air electrical space heater on the floor of the north side. It is controlled by an inexpensive but adequately sensitive thermostat set for 40°F. It comes on periodically during days of cold, overcast weather, but with the insulating panels left on and with the heavy insulation throughout the Sunpit, it takes very little supplementary heat to bring the temperature up. In fact, although the heater was unhooked inadvertently on more than one occasion when the outside temperature fell to -20°F, the max/min recording thermometer showed a low of 35°F and there was no damage to any of the plants. There is every reason to believe, therefore, that careful management will prevent a freezeup in the Sunpit greenhouse without the use of electrical power.

The fixtures for heating and lighting are wired into an electrical control box near the spot where the cable comes in from the cellar. The thermostat is located there along with several electrical outlets. I use other small electrical devices for special purposes, such as warming pad to provide bottom heat in a germination chamber, a small fluorescent fixture to provide light for tender seedlings, and a small fan for providing extra ventilation if the pit gets too hot in the spring. These specialty appliances could be dispensed with, although the range of cultural operations might be somewhat less extensive than mine as a result. In any event, none of these devices takes a large amount of electricity, and the total cost for running the electrical apparatus in the pit is less than we have spent in our indoor plant room in previous years. The effective use and conservation of solar energy makes the Sunpit far cheaper to maintain than a conventional greenhouse.

Sunpit Management

In the morning the Sunpit panels are taken off the plastic front as soon as the sun begins to lend its warmth. During our New Brunswick winter this is about 9 a.m. By about 10 or 11 a.m. the door must be opened widely for ventilation and by March the hatch must be opened by noon. This must be watched carefully or the temperature can quickly mount into the 90°s (F.), a condition that would lead to undesirable soft growth. With proper temperature control, the cool moist atmosphere in the Sunpit eliminates some of the typical problems of indoor gardening. The plants do not become "leggy" or straggly-stemmed even though the insulating panels may cover the plastic for one or more stormy days. Furthermore, pest damage is minimal because most of the greenhouse plant pests prefer a hotter and drier environment. Should mould present a problem, a garlic solution used in a sprayer is helpful. Over-crowding of the plants should be rigorously avoided and all dead material should be placed in a small compost area.

By late spring when the Sunpit is bursting with flats of transplanted seedlings, many of the semi-hardy plants and

maturing bulbs can be moved to cold-frames. And when the transplants have been put into the garden after the last spring frost, the Sunpit takes a well-deserved rest. It is not practical to use it during the summer because it would be very difficult to keep it cool enough and also provide enough light for healthy plant growth.

Cost

We whittled the cash outlay to a minimum by using local and recycled materials, by furnishing our own labor, by solving problems with ingenuity rather than hardware and by not rushing the job. We spent roughly \$350 on such items as delivery of sand, cement, mixer rental, unplanned lumber, asphalt shingles, plastic sheeting, styro-foam and plywood.

Bibliography

Much of my inspiration and Sunpit planning came from the book, **Winter Flowers in Greenhouse and Sunheated Pit**, by Kathryn S. Taylor and Edith W. Gregg. It is published by Charles Scribner's Sons, New York and I believe the revised edition (1969) is still in print. This is presently the Sunpit enthusiast's bible. Kathryn Taylor also published an article on **Cold Pit Gardening** in *Horticulture Magazine*, autumn, 1974. Ken Kern, Sierra Route, Oakhurst, CA 93644 has also written about the Pit Greenhouse, chapter 9 in his **The Owner-built Homestead**, Kern's ideas are not entirely practical for north temperate pit greenhouses which must be dug deep into the ground and covered with insulating panels at night. He does provide a good plan for a half-dome Sunpit which could be attached to an existing structure and could actually provide some of the dwelling's heat, if carefully managed. For information on the plants suitable for the Sunpit, Kathryn Taylor's book can be supplemented by G. W. Robinson's **The Cool Greenhouse** (Penguin Books, 1959), out of print, unfortunately, but perhaps available through a library.



AQUA-DOME

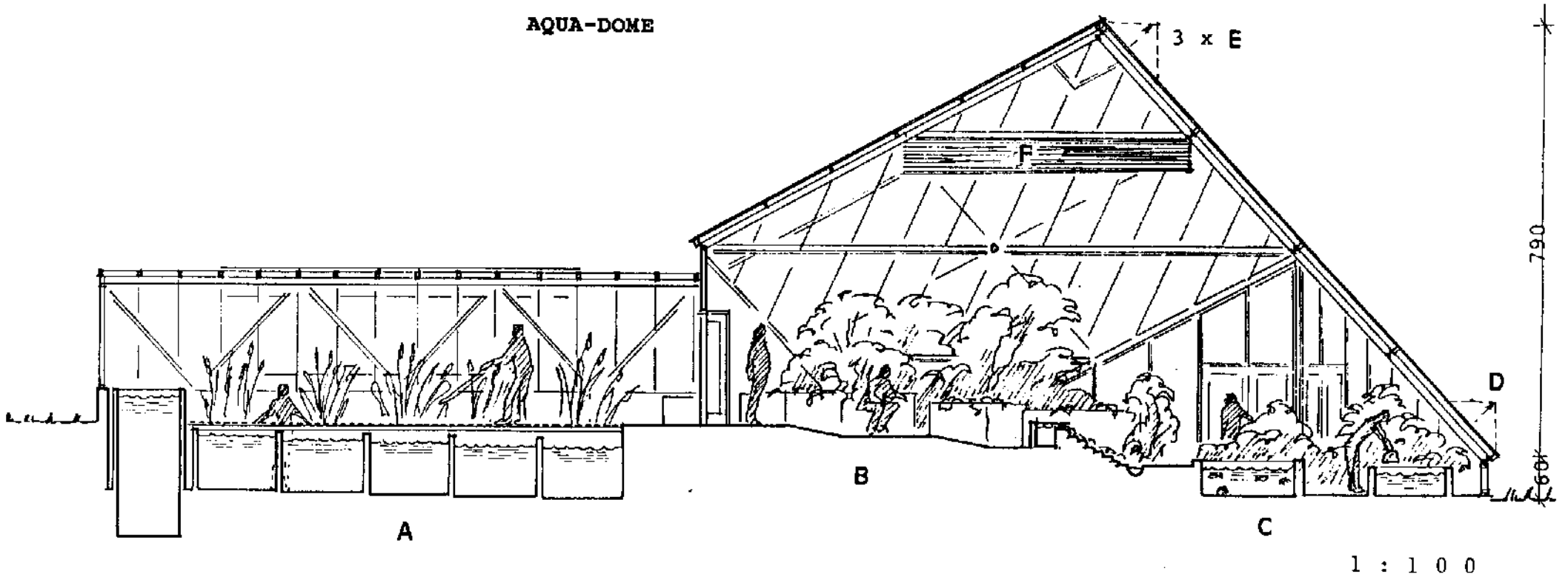

- A: Reed-bed system.**
- B: Plant and algae tanks.**
- C: Fish and crustacean tanks.**
- D: Window opening.**
- E: 3 window openings.**
- F: Cooling unit to condense moisture from air.**

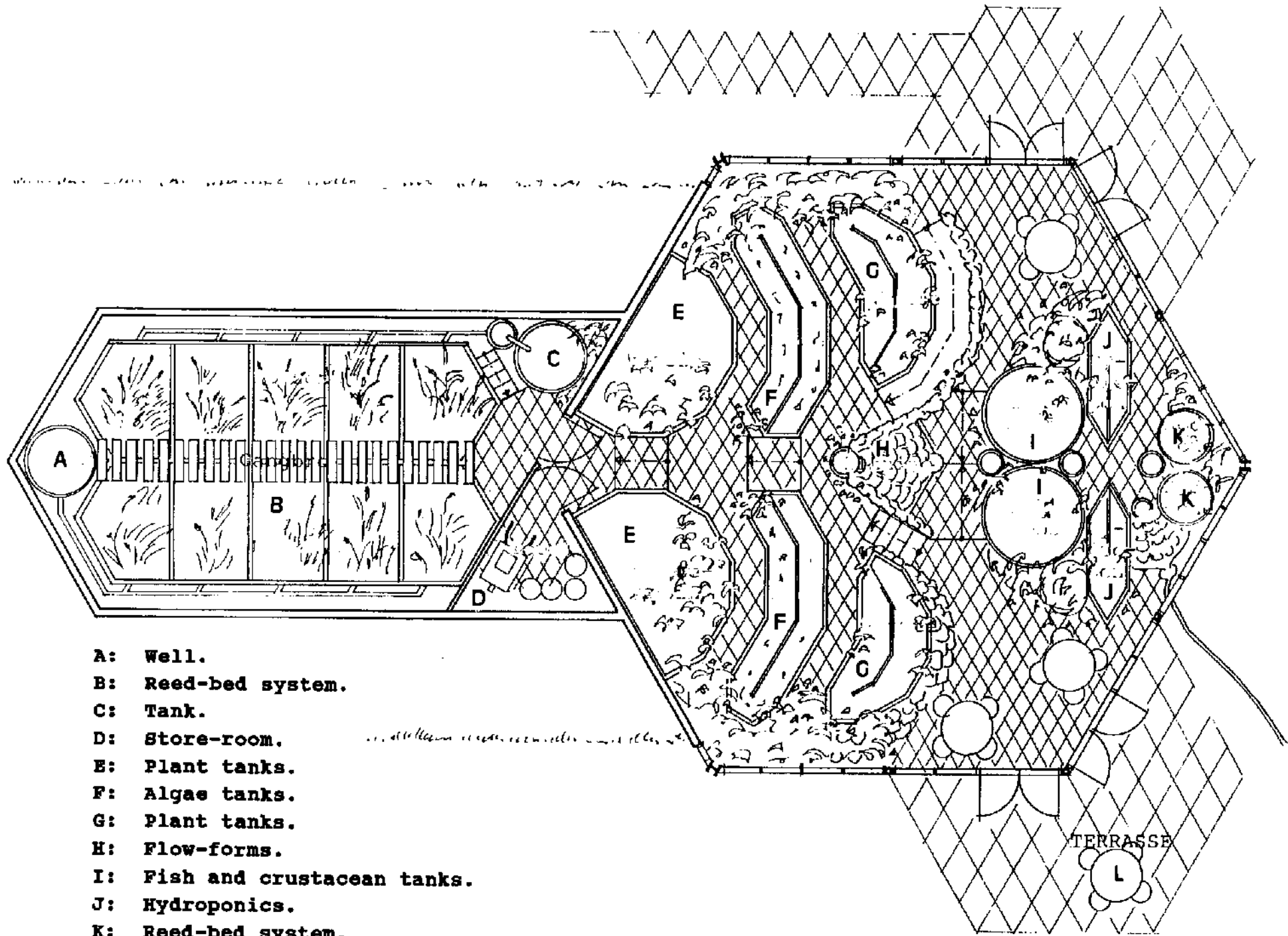

- A: Well.
- B: Reed-bed system.
- C: Tank.
- D: Store-room.
- E: Plant tanks.
- F: Algae tanks.
- G: Plant tanks.
- H: Flow-forms.
- I: Fish and crustacean tanks.
- J: Hydroponics.
- K: Reed-bed system.
- L: Terrace.

PLAN 1:100







FLOWDIAGRAM:

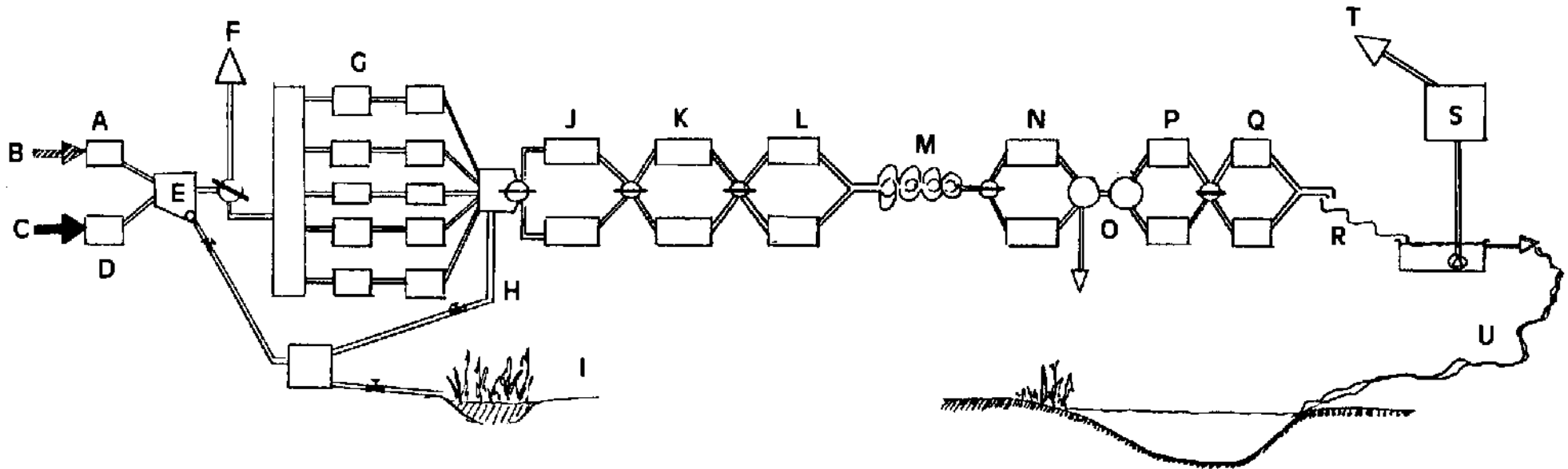

A: Sand-trap.
B: Grey water.
C: Black water.
D: Septic tank.
E: Holding tank with pump.
F: Emergency by-pass drain.
G: Vertical reed-bed system.
H: Sludge removal.
I: Sludge bed.
J: Floating plants.
K: Algae - Zoo plankton.

L: Various plants.
M: Flow-forms.
N: Fish - Crustaceans.
O: Sludge filter section.
P: Hydroponics.
Q: Vertical reed-bed system.
R: Flow-forms.
S: Possible UV-(etc.)-treatment.
T: Return to toilet-flush.
U: To pond.

List of Materials for Simple Dome - Radius app. 3.5 m.

- 65 pieces - 3/4" x 100 mm. x 2.10 m.
- 3 pieces - 50 mm. x 50 mm. x 2.10 m. for windows.
- 10 pieces - 1.5" x 100 mm. x 0.6 m. for foundation.
- 70 pieces - thin wood strips 2.10 m. long to fasten plastic.
- 1 piece - plastic tube strong/black - 10 atm. gas pressure -
63 mm. diameter, 5 mm. thick walls,
- 50 m. roll thin galv. metal fastening strips - cut length 34 cms.
As used in construction industry to hang pipes, etc.
- 150 screws - sharp screws - 4.5 mm x 40 mm.
- 1 packet roofing nails - short zinc nails with large head.
- 1 packet round nails
- 1 roll - strong sheet plastic - 2 m. x 50 m.
- small strips cut from old tyre - as door and window hinges.
- PLUS - material to place under foundation, to prevent damp.

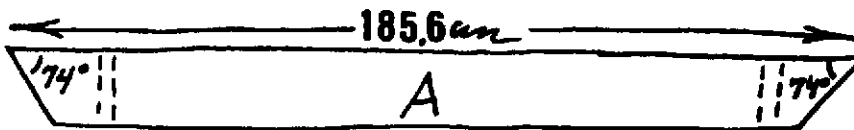

A / Rib 5: 30 pieces - 3/4" x 100 mm. x 185.6 cm. [74°]

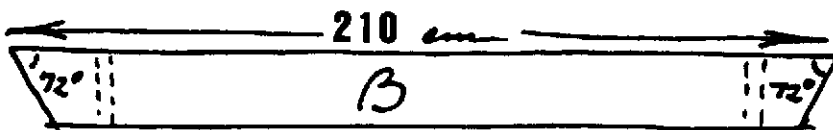

B / Rib 6: 35 pieces - 3/4" x 100 mm. x 210 cm. [72°]

C: 26 pieces, 63mm. strong plastic tube, cut length 105 mm. 

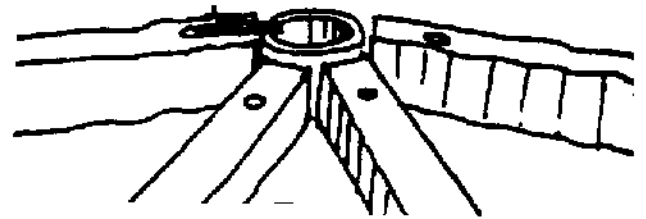
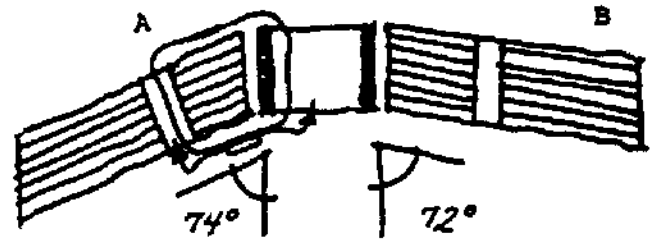
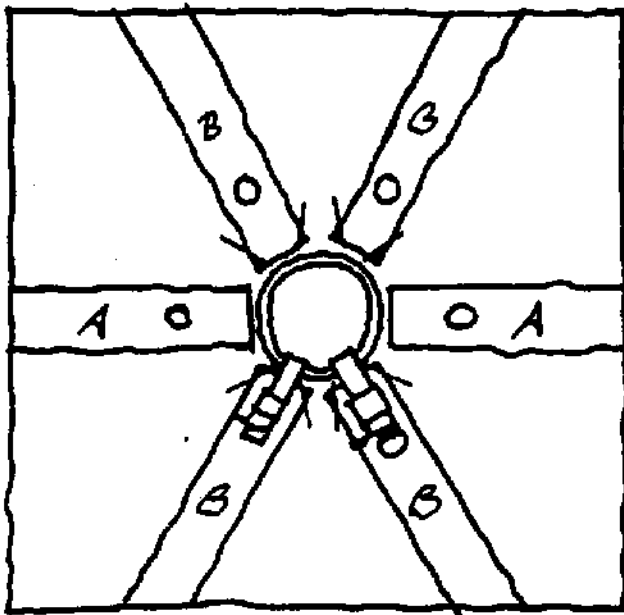
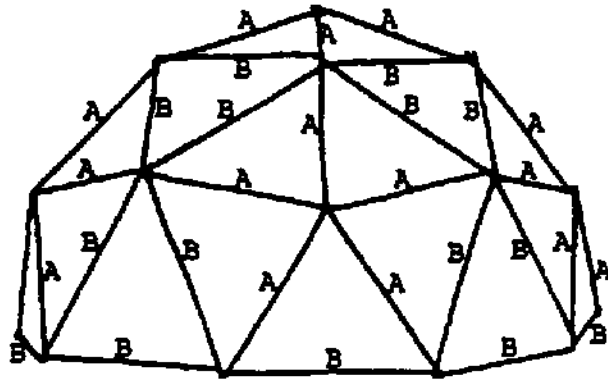

Nylon strapping tape.
 [With metal strips
 fastened with screws or
 nails, - not necessary
 to drill hole in rib]

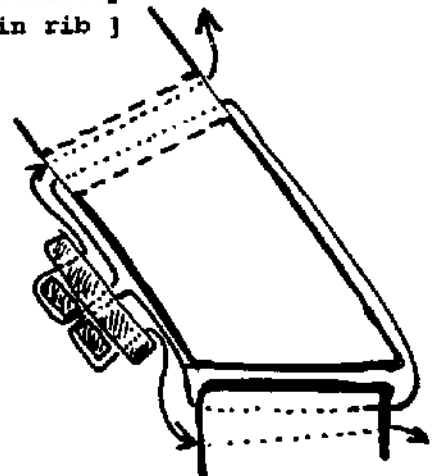
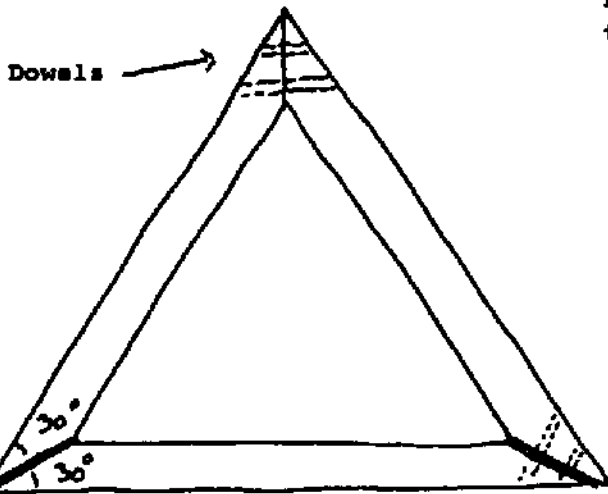

Door - use strip from
 old tyre as hinge.









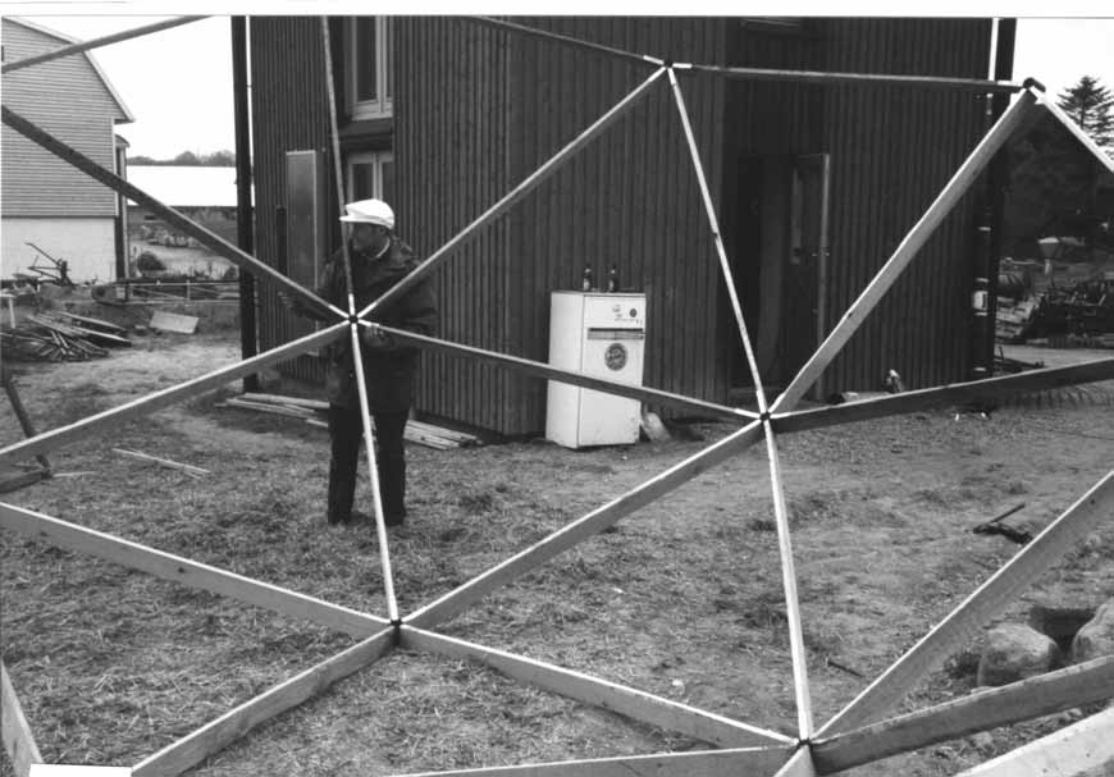





ECO-DOME

Make a photocopy.

- **Cut out.**
- **Bend along the lines.**
- **Join with tape on inside.**

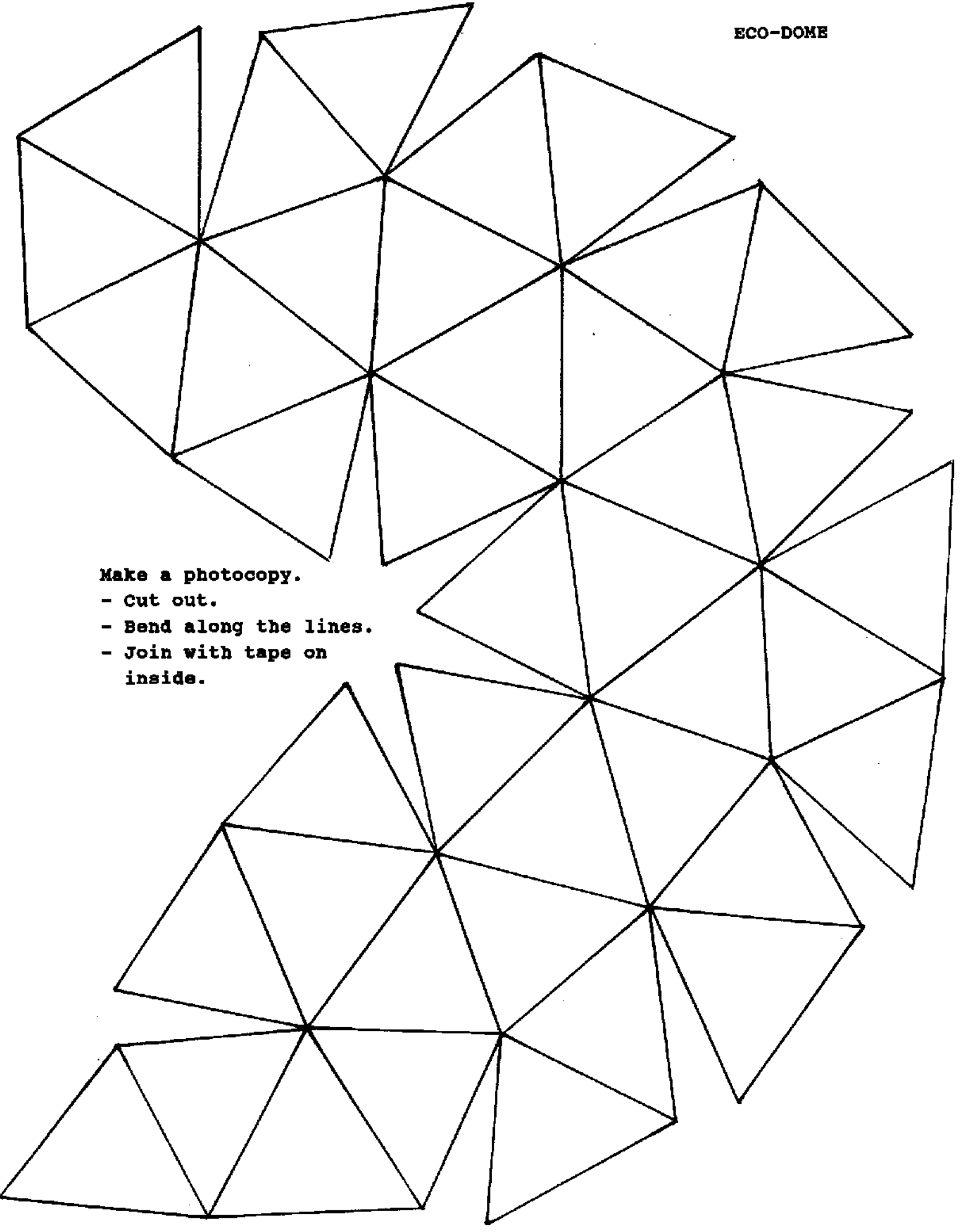

Wayne has built several variations of the Bamboo Dome, p. 95, which he describes here:

Instead of bamboo, I used 1" x 2" strips (1" x 4" ripped down the middle). For a 26' dia. 3/8 sphere, you need the following number of strips with holes drilled at each point.

10 OF THESE:

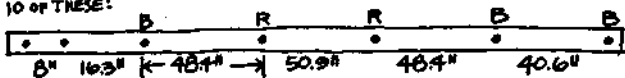

10 OF THESE:

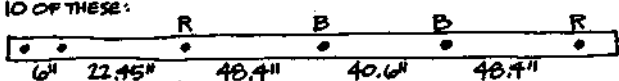

5 OF THESE:

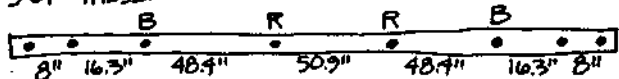

Mark and drill one and use it as template for all the others in group.

The first group goes together like so:

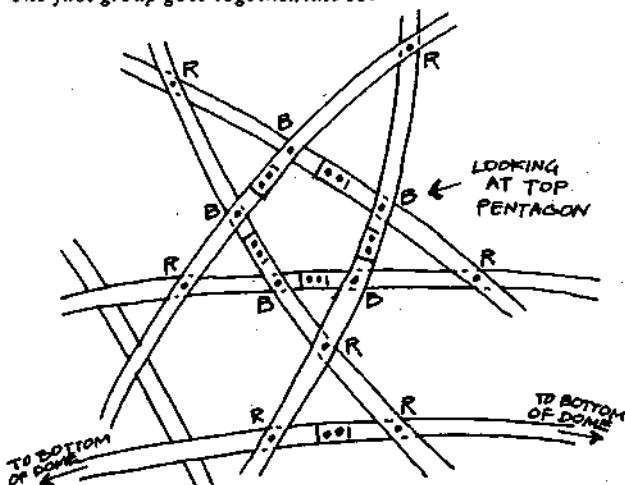

The last group goes around the bottom: I drilled 8th inch holes and used bailing wire to connect the strips. I have covered one dome with paper mache and another with a parachute. Also, I used long strips on the great circle arcs:

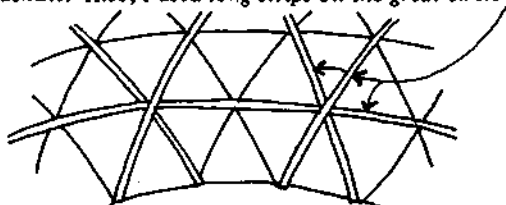

to fill in the hexagons carefully select green fir and get the tightest straightest grain you can find, also to help bending and build smaller size domes it'll help to soak the wood for a week and then bend it on a jig, the one I made looked like this:

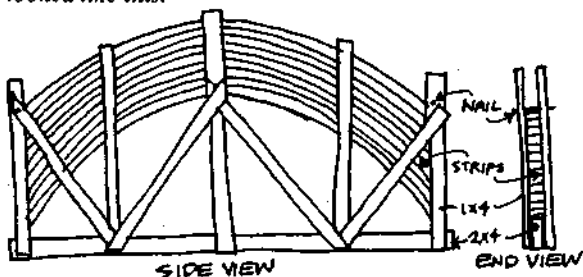

Cost of frame is around \$15 and it ought to be strong enough for ferro-cement.

Wayne Cartwright
1000 Alba Road
Ben Lomond, CA

P.S. I'm putting one of these up Friday for performers dining place at Joan Baez benefit for farmworkers.



Jolan, here's a plywood version soft-line

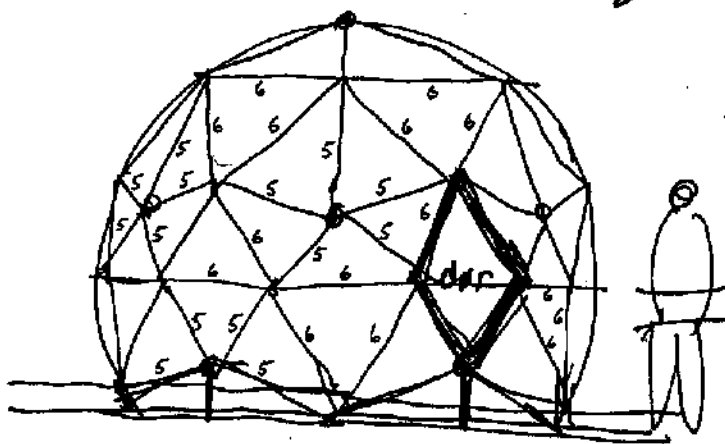

$R = 180 \text{ cm}$

ICELAND
Íslandi
Tel: Int. + 3541 628033
Int. + 3541 668333
Fax: Int. + 3541 637019

P.O. Box 62
IS 121 Reykjavik
Einar Thorsteinn
Diplom Ingenteur

CL CONSTRUCTIONS LAB
Tilraunastofa Burðarforma

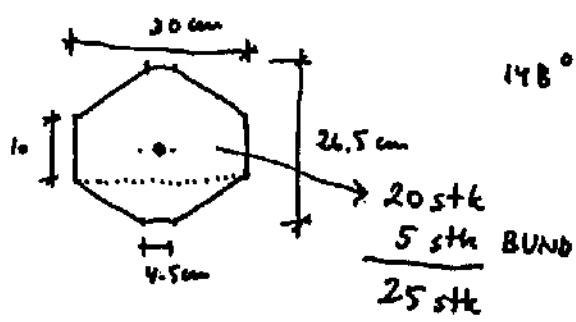
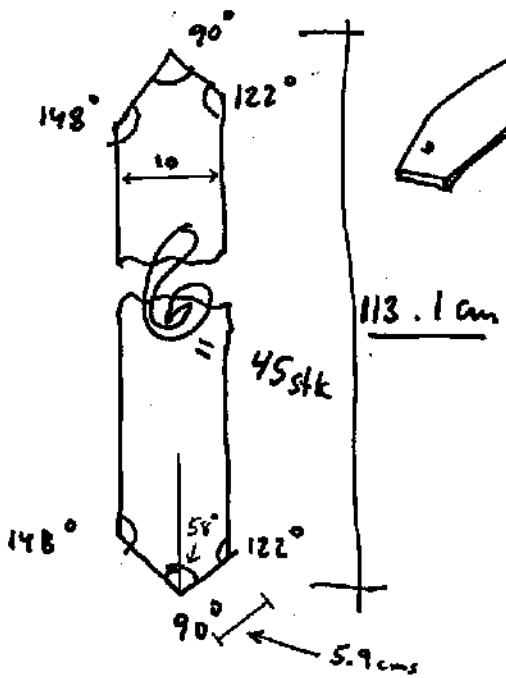
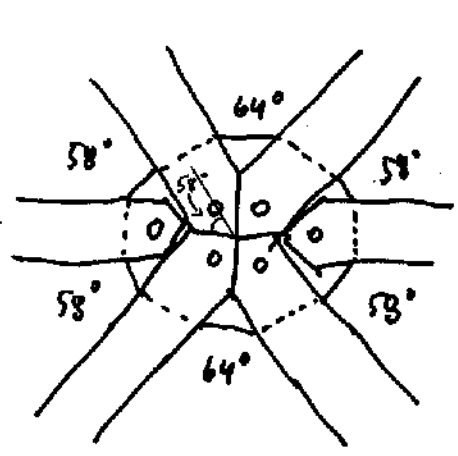
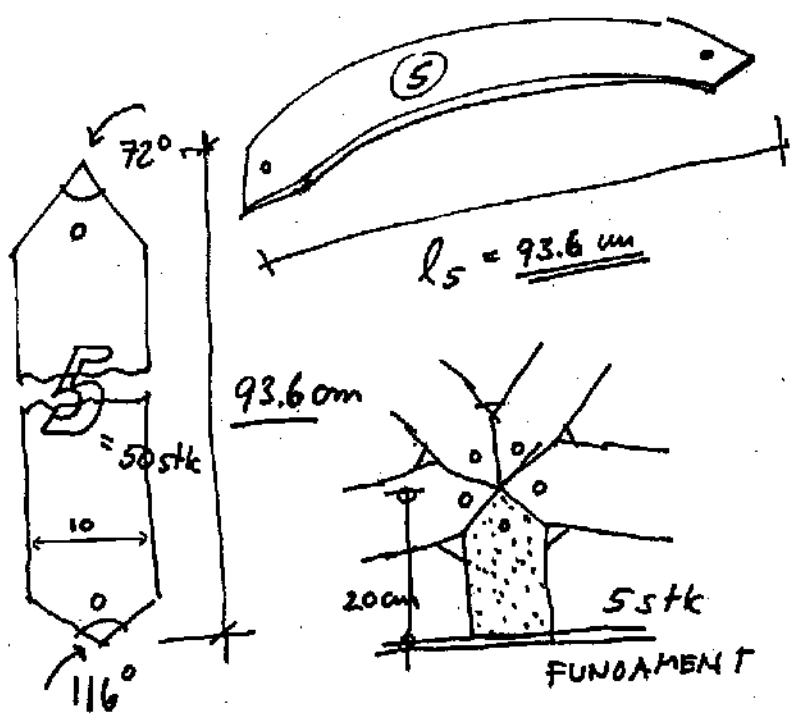
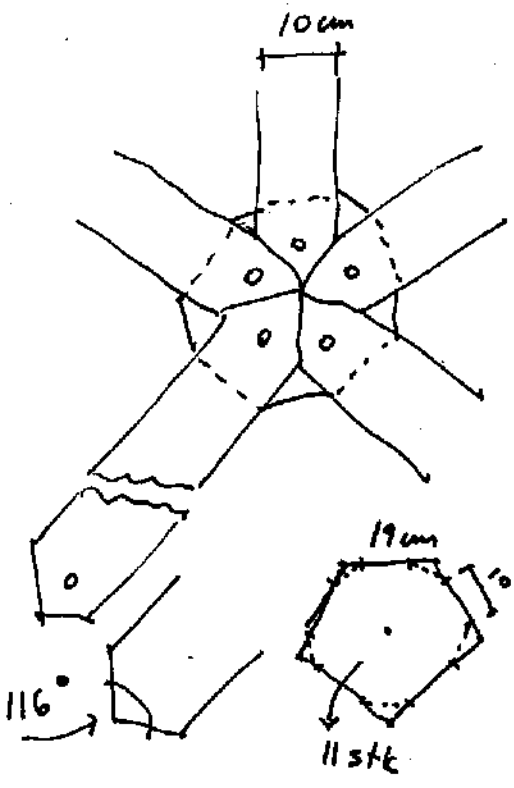

19/8 '92
E.H.

MEASUREMENTS

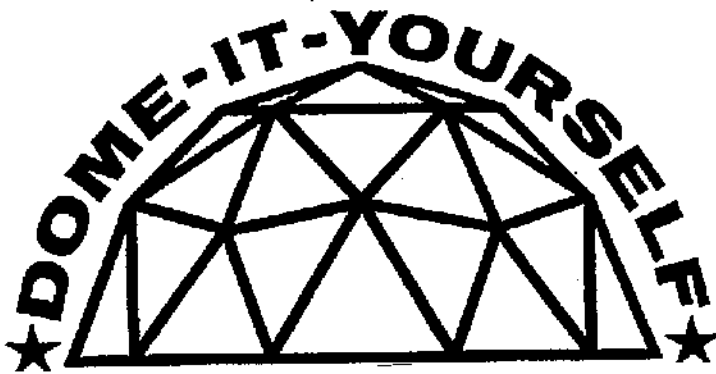

TWO FREQUENCY GEODESIC
DOME BUILDING SYSTEM
RATIO OF RIBS: 884/1000

US © 67 DESIGN: *Ed*

DOME Diameter	MAX Height	sq. Meters	5-RIB		6-RIB		TIMBER SECTIONS	SIZES
			total M	Length ca.	Length ca.	total M		
2,0	1,0	2,94	16,0	53,1	61,4	21,5	1/2 X 2"	MODEL
2,5	1,25	4,59	20,0	66,8	76,9	26,9	1/2 X 2"	
3,0	1,5	6,61	23,7	78,9	91,9	32,2	1 X 2"	
3,5	1,75	9,00	27,8	92,6	107,2	37,5	1 X 2"	
4,0	2,0	11,75	32,0	106,3	122,8	43,0	1 X 3"	SMALL
4,5	2,25	14,88	36,0	119,9	138,3	48,4	1 X 4"	
4,8	2,4	16,92	38,4	128,1	147,5	51,6	1 X 4"	
5,1	2,55	19,11	40,4	134,7	156,3	54,7	1 1/2 X 4"	
5,4	2,7	21,42	42,4	141,4	165,2	57,8	2 X 4"	
5,7	2,85	23,87	43,0	149,6	174,4	61,0	2 X 5"	
6,0	3,0	26,45	47,8	159,3	184,1	64,4	1 1/2 X 6"	
6,3	3,15	29,16	50,3	167,5	193,4	67,7	1 1/2 X 6"	
6,6	3,3	32,00	52,3	174,2	202,3	70,8	2 X 6"	
6,9	3,45	34,97	54,7	182,4	211,5	74,0	2 X 6"	
7,2	3,6	38,08	56,7	189,1	220,4	77,1	2 1/2 X 6"	
7,5	3,75	41,32	59,2	197,3	229,7	80,4	2 1/2 X 6"	
7,8	3,9	44,69	61,7	205,5	238,9	83,6	2 1/2 X 7"	
8,1	4,05	48,20	64,1	213,7	248,2	86,9	2 1/2 X 7"	
8,4	4,2	51,83	67,0	223,4	257,9	90,3	2 X 8"	
8,7	4,35	55,60	69,5	231,6	267,1	93,5	2 X 8"	
9,0	4,5	59,50	71,9	239,8	277,4	97,1	2 X 8"	
10,5	5,25	97,15	83,8	279,2	322,4	116,9	2 1/2 X 10"	RESIDENTIAL
12,0	6,0	105,78	96,1	320,2	368,7	129,0	2 1/2 X 12"	
13,5	6,75	133,88	108,0	359,7	414,7	145,2	3 X 12"	
15,0	7,5	165,28	118,0	399,1	460,6	161,2	3 1/2 X 12"	
16,5	8,25	176,48	132,0	440,0	507,0	177,5	3 1/2 X 12"	
18,0	9,0	238,00	144,3	481,0	553,3	194,0	3 1/2 X 14"	
19,5	9,75	279,33	157,0	522,0	599,7	210,0	3 1/2 X 14"	
21,0	10,5	323,95	169,0	563,0	646,0	226,0	3 1/2 X 15"	* LARGE
22,5	11,25	371,88	181,0	603,9	692,4	242,0	3 1/2 X 16"	
24,0	12,0	423,12	193,5	644,9	738,8	258,5	3 1/2 X 16"	
25,5	12,75	477,66	206,0	685,9	785,1	275,0	3 1/2 X 16"	
27,0	13,5	535,51	217,6	725,4	831,1	291,0	4 X 16"	
28,5	14,25	596,66	230,0	766,4	877,4	307,0	4 X 18"	
30,0	15,0	661,12	242,0	807,3	923,8	323,0	4 X 18"	

* USE LAMINATED TIMBER AND METAL PLATES INSTEAD OF PLYWOOD AT THE JOINTS

DOME Diameter	MAX Height	SQ FEET	5-RIB		6-RIB		TIMBER SECTIONS	SIZES
			FEET INCHES	METRIC	METRIC	FEET INCHES		
5'	2.5'	18.3	1' 3" 13/16	1.316	1.532	1' 6" 7/16	1/2 X 2"	MODEL
6'	3.0'	26.4	1' 7" 1/8	1.589	1.841	1' 10" 1/8	1/2 X 2"	
9'	4.5'	59.5	2' 4" 5/16	2.359	2.755	2' 9" 1/16	1 X 2"	
10'	5.0'	73.4	2' 7" 9/16	2.632	3.064	3' 0" 3/4	1 X 2"	
12'	6.0'	105.8	3' 2" 1/8	3.178	3.682	3' 8" 3/16	1 X 3"	
15'	7.5'	165.3	3' 10" 7/8	3.997	4.609	4' 7" 5/16	1 X 4"	SMALL
16'	8.0'	188.0	4' 3" 1/4	4.271	4.918	4' 11"	1 X 4"	
17'	8.5'	212.3	4' 5" 15/16	4.494	5.212	5' 2" 9/16	1 1/2 X 4"	
18'	9.0'	238.0	4' 8" 5/8	4.717	5.506	5' 6" 1/16	2 X 4"	
19'	9.5'	265.2	4' 11" 7/8	4.990	5.815	5' 9" 3/4	2 X 5"	
20'	10.0'	293.9	5' 3" 11/16	5.313	6.139	6' 1" 11/16	1 1/2 X 6"	
21'	10.5'	323.9	5' 7" 1/16	5.586	6.448	6' 5" 3/8	1 1/2 X 6"	
22'	11.0'	355.5	5' 9" 11/16	5.809	6.742	6' 8" 7/8	2 X 6"	
23'	11.5'	388.6	6' 1"	6.083	7.051	7' 0" 5/16	2 X 6"	
24'	12.0'	423.1	6' 3" 11/16	6.306	7.387	7' 4" 5/16	2 1/2 X 6"	
25'	12.5'	459.1	6' 7" 11/16	6.579	7.656	7' 7" 7/8	2 1/2 X 6"	
26'	13.0'	496.6	6' 10" 1/4	6.852	7.965	7' 11" 9/16	2 1/2 X 7"	
27'	13.5'	535.5	7' 1" 1/2	7.125	8.274	8' 3" 5/16	2 1/2 X 7"	
28'	14.0'	575.9	7' 5" 3/8	7.448	8.596	8' 7" 1/8	2 X 8"	
29'	14.5'	617.8	7' 8" 11/16	7.722	8.905	8' 10" 7/16	2 X 8"	
30'	15.0'	661.1	7' 11" 15/16	7.995	9.214	9' 2" 9/16	2 X 8"	
35'	17.5'	899.9	9' 3" 3/4	9.311	10.746	10' 8" 15/16	2 1/2 X 10"	RESIDENTIAL
40'	20.0'	1175.3	10' 8" 1/8	10.676	12.291	12' 3" 1/2	2 1/2 X 12"	
45'	22.5'	1487.5	11' 11" 7/8	11.992	13.828	13' 9" 3/4	3 X 12"	
50'	25.0'	1836.5	13' 3" 11/16	13.308	15.355	15' 4" 5/16	3 1/2 X 12"	
55'	27.5'	2222.1	14' 8" 1/8	14.674	16.901	16' 10" 13/16	3 1/2 X 12"	
60'	30.0'	2644.5	16' 0" 1/2	16.040	18.446	18' 5" 5/16	3 1/2 X 14"	
65'	32.5'	3103.6	17' 4" 7/8	17.406	19.991	19' 11" 15/16	3 1/2 X 14"	
70'	35.0'	3599.4	18' 9" 1/4	18.772	21.536	21' 6" 7/16	3 1/2 X 15"	* LARGE
75'	37.5'	4132.0	20' 1" 11/16	20.137	23.081	23' 1"	3 1/2 X 16"	
80'	40.0'	4701.3	21' 6"	21.500	24.625	24' 7" 1/2	3 1/2 X 16"	
85'	42.5'	5307.4	22' 10" 7/16	22.869	26.171	26' 2" 1/16	3 1/2 X 16"	
90'	45.0'	5950.1	24' 2" 3/16	24.235	27.703	27' 8" 7/16	4 X 16"	
95'	47.5'	6629.6	25' 6" 5/8	25.351	29.248	29' 2" 15/16	4 X 18"	
100'	50.0'	7345.8	26' 11"	26.917	30.794	30' 9" 1/2	4 X 18"	

* USE LAMINATED TIMBER AND METAL PLATES INSTEAD OF PLYWOOD AT THE JOINTS

Where it cuts them => there you have the lengths you are looking for
 ==> straight down to the bottom line.

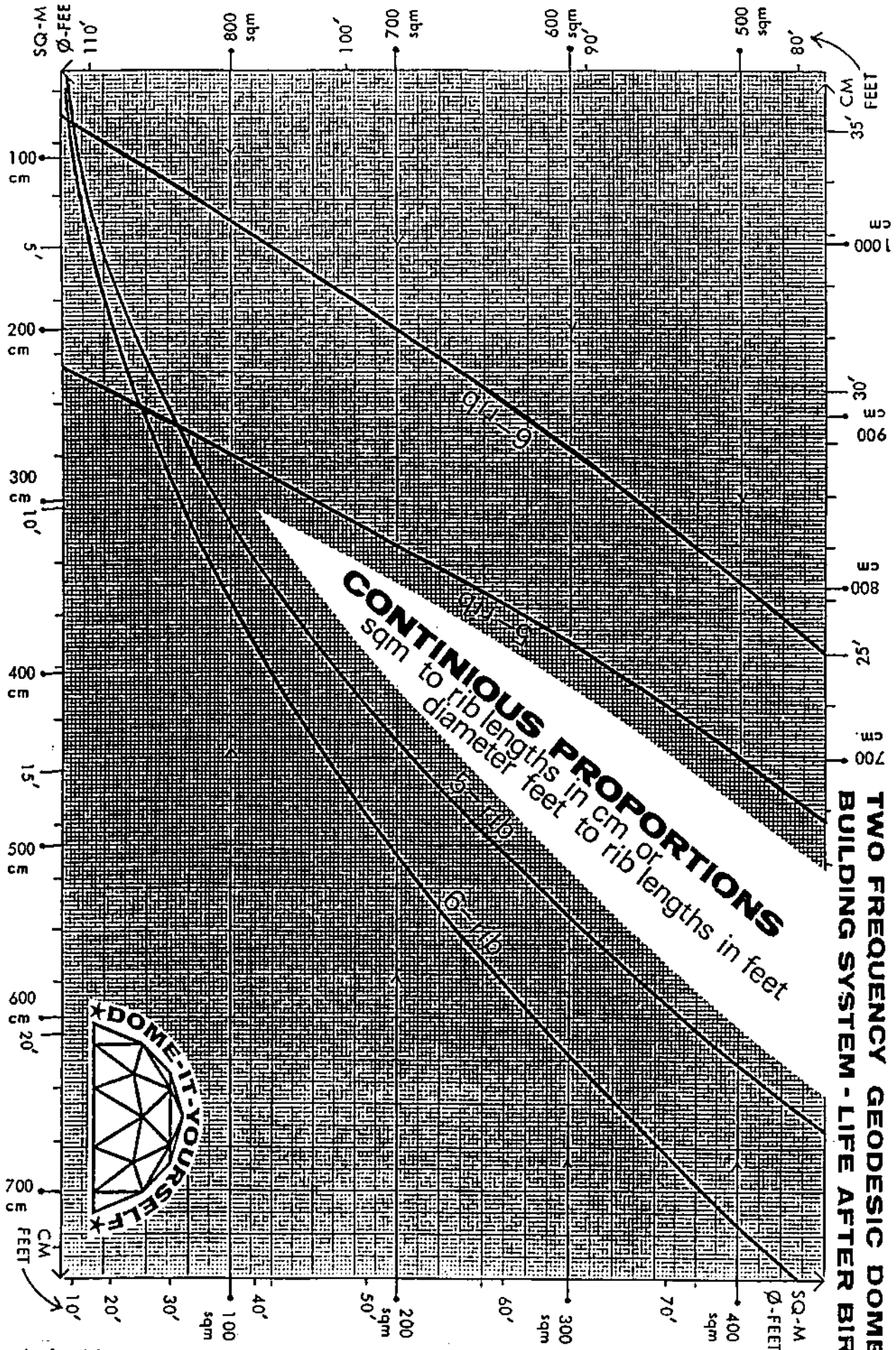

TWO FREQUENCY GEODESIC DOME BUILDING SYSTEM - LIFE AFTER BIRTH

B:

A:

First decide how many sq. m. or diameters in ft. - you want to build. Read on this side, 0 - 450 sq. m. Then go in straight line to the 5 rib and 6 rib curves ==>

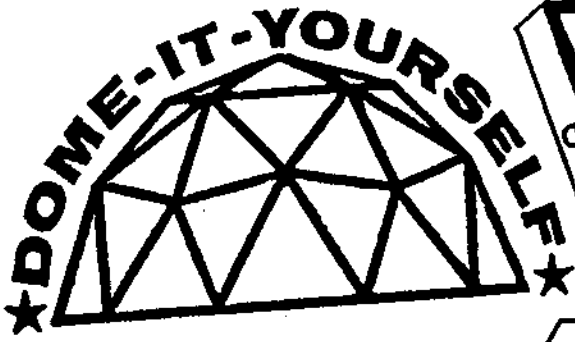

TWO FREQUENCY GEODES.
 DOME BUILDING SYSTEM
 RATIO OF RIBS: 664 / 1000

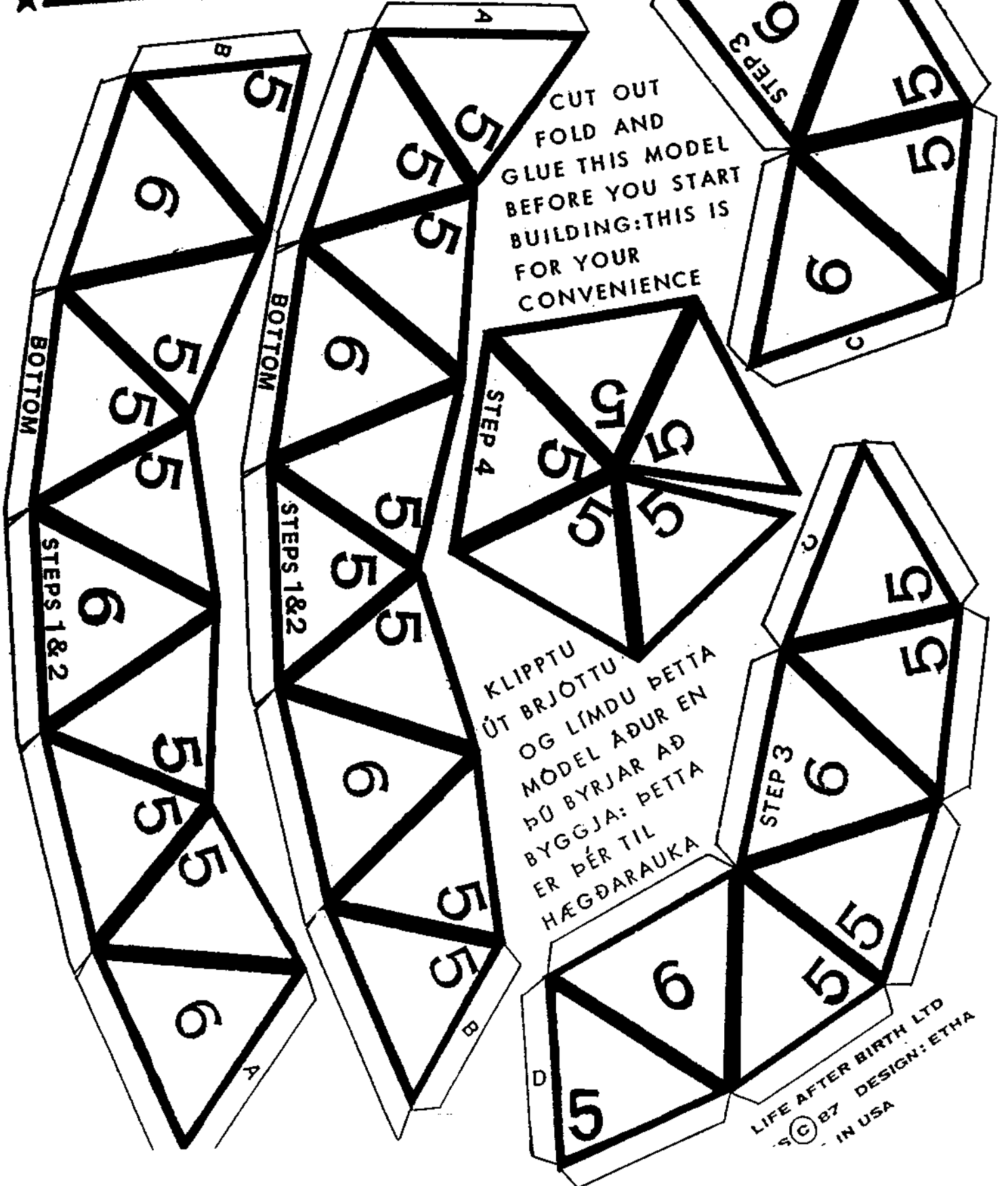

CUT OUT
 FOLD AND
 GLUE THIS MODEL
 BEFORE YOU START
 BUILDING: THIS IS
 FOR YOUR
 CONVENIENCE

KLIPTU
 ÚT BRJÓTTU
 OG LÍMDU ÞETTA
 MÓDEL AÐUR EN
 ÞU BYRJAR AÐ
 BYGGJA: ÞETTA
 ER ÞÉR TIL
 HÆGÐARAUKA

LIFE AFTER BIRTH LTD
 © 87 DESIGN: ETHA
 IN USA

Remote Area Power Supply

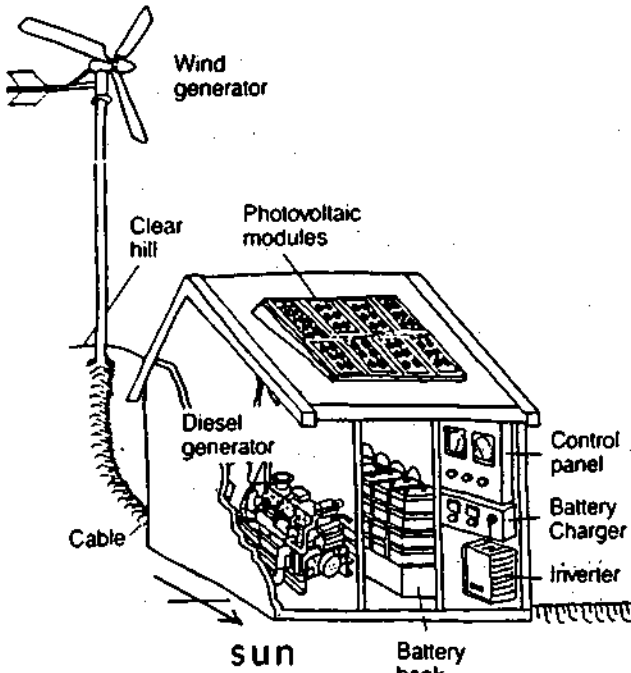

Supplying utility-grade AC power to large stations, remote villages, resorts or commercial enterprises can pose a number of difficulties. Diesel generators have a high running cost as opposed to the high capital cost of installing a large solar array with battery backup. The convention has been to use diesel generators but these usually do not incorporate a battery storage so the generator must be running to have any power. Stations with refrigeration usually run their generator for 10 to 24 hours per day. Those without refrigeration would run it for several hours per night to provide for lighting and television. The problem with such a system is that it wastes fuel.

The system must be sized to cope with heavy demands put on it by a user (eg welding). This load is called the peak load. As well as the peak load, it must also be able to handle the very short term, but very high surge loads caused when an electric motor (such as a freezer, washing machine or pump) starts up. These short term surge loads are often five times higher than the actual power used in normal operation. For most of the time the actual power being used is much less than the peak load that the system was designed to handle.

Diesel Generators

A diesel generator, as the main or back-up power supply, invariably has to be able to handle such peak loads. If, on the other hand, a diesel generator is too lightly loaded it can cause damage to the diesel engine and cause expensive repairs. In some cases a dummy load is turned on (any appliance or equipment to use power) to protect the diesel engine. This load increases fuel consumption for little or no benefit to the consumer. Both oversizing and under-utilization cause fuel wastage.

Generators also require routine maintenance during operation by ensuring regular oil-, air- and fuel filter changes, as well as routine service and operation to manufacturers' specifications. To ensure regular engine operating temperature, the engine must be run with a minimum load of 30%, but ideally with a load of 70-80%. Running of the engine on a low load for long periods will result in carbonization, cylinder bore glazing and poor fuel economy. Engine life will be severely shortened. Well loaded, the engine may achieve 20% - 30% conversion of fuel to shaft power, the remainder is lost as engine heat, exhaust heat, unburnt fuel and noise. Engine protection circuits are included in most diesel-generator systems to ensure the unit will not run in a faulty condition.

The design life of a generator is limited. A diesel generator has a life expectancy of some 10,000 hours before a major engine overhaul is required (typically costing about 50% of the initial cost).

Petrol Generators

Petrol engines in comparison are more light weight, less robust and high revving. The spark ignition system makes for a more portable power supply. However, the system is inherently unsuitable for a continuous stationary power supply. Petrol engines have an expected service life of some 1,000 hours. The engine limitations mean that the generator sets are usually small (0.5 to 8 kVA). Many petrol generators can be converted to run off LP gas which should increase the engine service life and reduce pollution level.

A Hybrid System

The use of a hybrid system, using a generator, solar panels (or wind and hydro) together with a battery bank can give you 'the best of both worlds'.

Generator and Battery Power

The generator lowers the capital cost of the system. The use of a large battery charger powered by the generator to charge batteries can load the generator to make it more efficient and the stored power in the batteries will cut down on generator use. The use of a battery bank can cut fuel costs by 65% to 70%. The use of solar panels to also charge the batteries can further cut down on operating costs.

A large inverter connected to the battery bank provides 240 volt power 24 hours per day or while the generator is switched off. Australian made inverters are available in many sizes including 2, 5, 10, 15 and 25 kVA.

Designed to your Specifications

Our staff can design such a system to meet your requirements. We can supply a generator to suit your situation. In such a system we would normally recommend a generator run on diesel or LP gas.

RPC Microgrid

(100V DC)

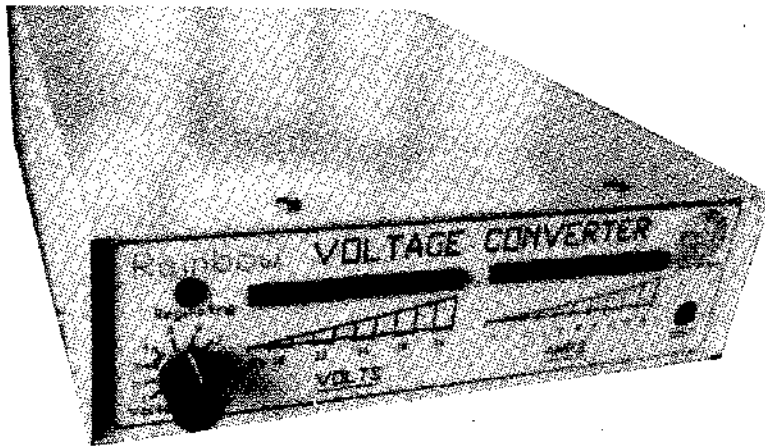

Where there is a requirement for a number of small power systems (eg dwellings) within a few kilometres of each other, it is now possible for each dwelling to have its own power autonomy while sharing generation and surplus power. This century old idea now has a new viability thanks to the invention of a wonderful new transistor, the power mosfet, and a magnet which does not conduct electricity, ferrite.

It is based on a 100 volt DC power distribution and generation system with 12V or 24V battery banks at individual sites (eg house sites). Voltage converters act as two way interfaces between the battery banks and the 100 volt distribution lines. Arrays of panels along with other energy sources (eg shared hydro, wind turbine or back-up generator) provide the power source. The individual 12V or 24V battery banks can also be boosted with their own dedicated solar panels.

A Microgrid can mean more effective outlay of capital through shared resources, greater overall efficiency by better utilisation of available power and greater freedom of choice with such things as placement of solar panels (eg if dwellings happen to be in shaded areas).

Public and Private Interests

One big advantage of a microgrid system is sociological. There is a clear interface between the microgrid which would typically be in public control (village council, body corporate, company, etc) and everything on the other side of the DC/DC converter could be private and run without reference to the operation of the microgrid. The consumer has free choice of earthing, voltage, amount of storage, whether to have an inverter, private generation capacity, or co-generation. Any consumer cannot exhaust public stores of power or have it entirely to themselves. It can allow any consumer to use what is surplus to requirements of other consumers.

The RPC Microgrid

The RPC microgrid is designed for 100 volts DC and to transport average rather than peak power. Also it has quite relaxed voltage constraints, remaining functional for levels between 70 and 130V DC. Wires can be sized at a compromise between power wasted and capital invested. Peak power is supplied by local batteries. If the grid is powered from renewable energy sources, local batteries can supply the loads during periods of low wind or sunshine.

What the Voltage Converter Does

DC/DC converters are used in computer power supplies, optimisers, LCBs (pnmp maximisers), and some inverters.

Specifications

- Power shared between consumers;
 - Will operate with the line between 70 and 130 volts;
 - Short circuit proof;
 - Protected against reverse polarity of both battery and distribution line;
 - Input/output isolation to 5000 volts;
 - Adjustable regulation of battery charge;
 - Will run without a battery;
 - Will deliver amps into a battery which is flat;
 - All day efficiency above 80% (as against peak efficiency);
 - Integral voltmeter and ammeter;
 - Lightning resistant;
 - No holes in the case (vermin proof);
 - 12 or 24 volt models available;
 - 10 amp charge rate at full line voltage;
-

Development of Microgrid

After experience of running grids on 32V AC, 60V DC, 100V DC, and 240V AC we have decided that 100V DC is the best standard because:

- it suits transistors well;
- the voltage is high enough to keep wire size reasonably small;
- it is covered by Extra Low Voltage wiring standards; and
- being DC it is far easier to feed power into the grid without worrying about phase or stability.
- Faults do not take out the whole system. They simply isolate sections of it;
- Fault finding is easy;
- Alteration is easy, and
- Expansion is easy.

A disadvantage of DC is that transformers cannot be used to simply convert voltage up and down again to transmit power long distances.

This has now changed with the advent of modern power electronics and we now have the DC/DC converter which is the equivalent of the transformer, but can actually do more because the ratio of input to output voltage is not fixed and can be continuously varying according to requirements. Behaviour under fault conditions can also be configured so that the system is self managing.

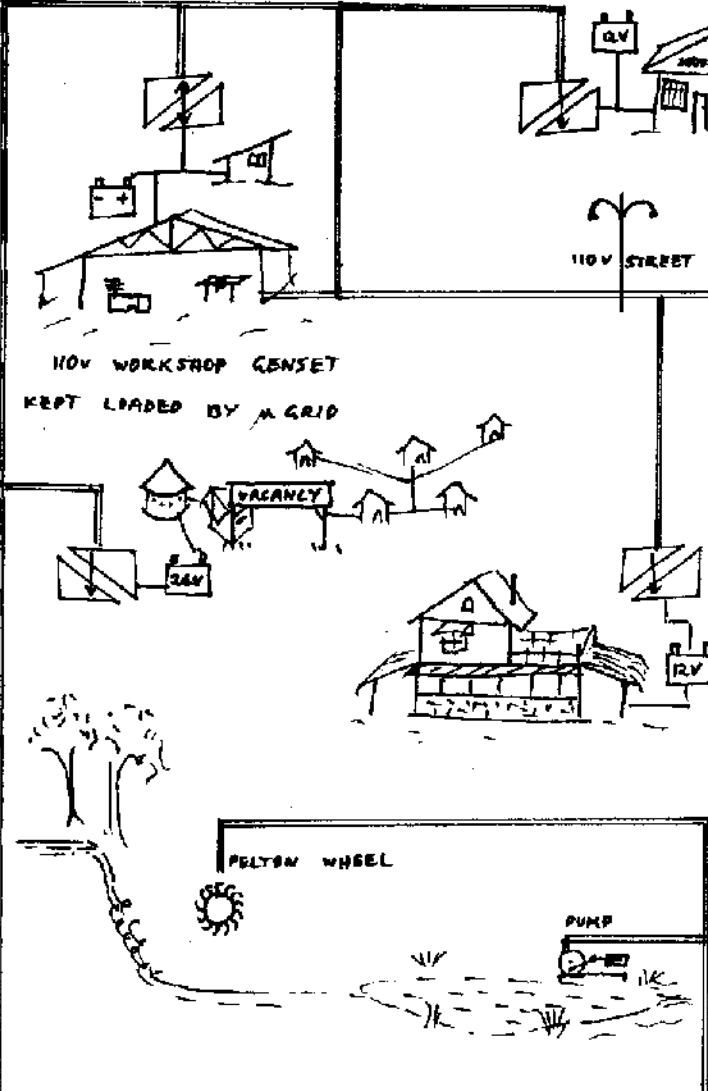
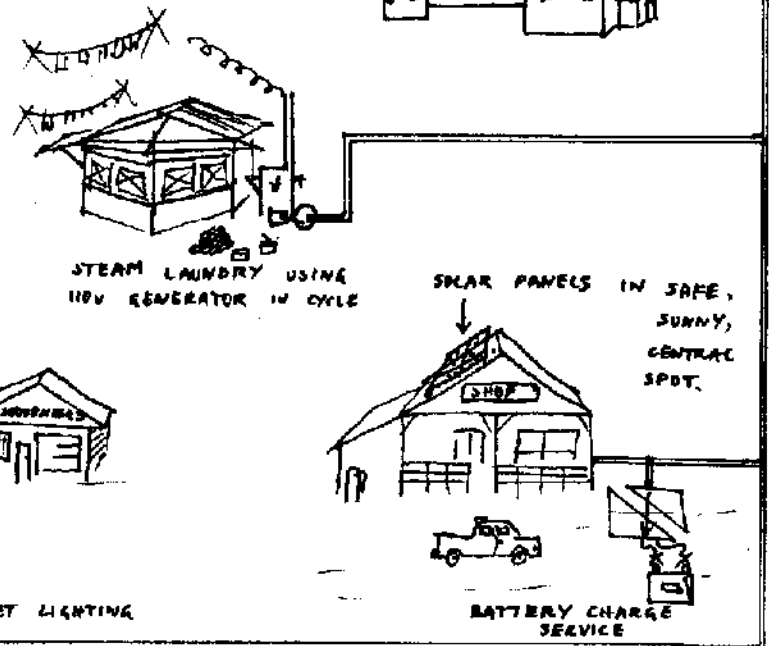
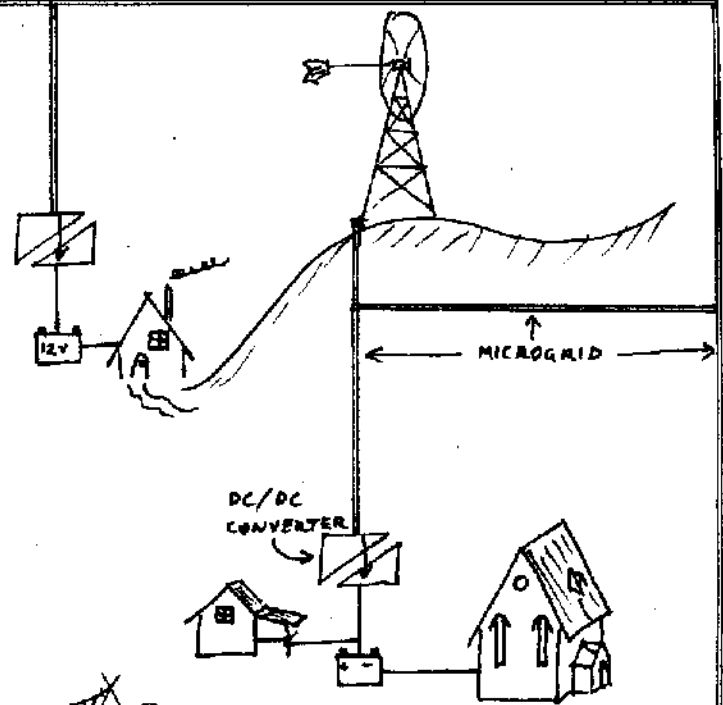

Energy Sources and Locations

Methods of powering a 100V microgrid include arrays of solar panels, a 110 volt generator, 110 volt version of RPC micro-hydro unit, 110 volt wind turbine, a rectifier from a bigger minigrid, the mains grid, or any combination of the above! Note that some of these generators may need a linear shunt regulator to clamp the voltage at 140 in the event of production exceeding demand. This could be a load such as a hot water heater. The geographical layout of the power sources/loads is flexible to suit the site, up to about 2 km.

The loads, as well as the points of generation, can be anywhere required as long as the conductor cross-section is appropriate to the current flowing in that section of the grid. This is one of the key practical advantages of the system.

Disadvantages of AC distribution

The mains power in eastern Australia is an example of a very large AC grid. Such a grid must be sized to supply peak loads to remote areas with 5% voltage tolerance. This means it uses very thick cable, very high voltage, and lots of capital outlay.

WIND SPEEDS & DESCRIPTION.

Description	Speed knots	Mean speed knots	Beaufort force	MPH	km/h	m/s	Weather forecast
Calm	< 1	0	0	0.5	1.0	0.2	Calm
Light air	1-3	2	1	2.3	3.7	1	Light
Light breeze	4-6	5	2	5.7	9.3	2.6	-
Gentle breeze	7-10	9	3	10.4	16.7	4.6	-
Moderate breeze	11-16	13	4	15.0	24.0	6.7	Moderate
Fresh breeze	17-21	19	5	22.0	35.2	9.8	Fresh
Strong breeze	22-27	24	6	27.6	44.5	12.4	Strong
Near gale	28-33	30	7	34.5	55.6	15.4	-
Gale	34-40	37	8	42.6	68.6	19.0	Gale
Strong gale	41-47	44	9	50.6	81.5	22.7	Severe gale
Storm	48-55	52	10	60.0	96.4	26.8	-
Violent Storm	56-63	60	11	69.0	111.2	31.0	-
Hurricane	64-71	68	12	78.3	126.0	35.0	-

**RELATIONSHIP BETWEEN GRIGGS-PUTNAM INDEX [G]
& ANNUAL MEAN WIND SPEED [V] - IN m/sec.**

G	V [m/sec]	MPH	W/sq.m. ‡	Batelle Class *
0	< 3	< 7	< 50	0
1	3 - 4	7 - 9	50 - 80	0 - 1
2	4 - 5	9 - 11	80 - 125	1 - 2
3	5 - 6	11 - 13	125 - 250	2 - 4
4	6 - 7	13 - 16	250 - 400	4 - 6
5	7 - 8	16 - 18	400 - 600	6 - 7
6	8 - 11	18 - 25	600 - 1600	7 - 9
7	> 11	> 25	> 1600	9 - 10

- See also:**
- A: A Handbook on the use of Trees for Wind Power Potential. E.W.Hewson, Wade N.T.I.B. USA 1979
 - B: Siting Handbook for Small Wind-energy Conversion Systems. [PNL-2521 Rev. 1.] Nat. Tech. Info. Service USA Dept. of Commerce Springfield VA 22161 USA
 - C: Wind-Atlas computer-program. RISØ National Laboratory Roskilde Denmark
 - ‡ Measured at standard height of 10 m. [at 50 m. height => a: wind speed + 26 % b: energy + 100 %].

APPROXIMATE WIND SPEED ENERGY EFFECTS:

- A: < 2.5 m/s => Slight effects, no damage to crops or structures.
- B: 4.5 - 6.5 m/s => Damage to very susceptible species.
- C: 9.5 - 12.5 m/s => Mechanical damage to crops, some damage to structures.
- D: 15.5 - 35.0 m/s => Severe structural & crop damage. Damage to some wind-mill types & models. [Most useful wind-turbine electrical energy is produced in wind-sectors B. and C. - However an Australian model can produce useful electricity at app. 2.5 m/sec.].

REDUCTION OF WIND VELOCITY IN FORESTS:

Penetration in meters:	30 m.	Remaining velocity in % :	60 - 80 %
	60 m.		50 %
	120 m.		15 %
	300 - 1,500 m.		Negligible wind.

GRIGGS AND PUTNAM INDEX

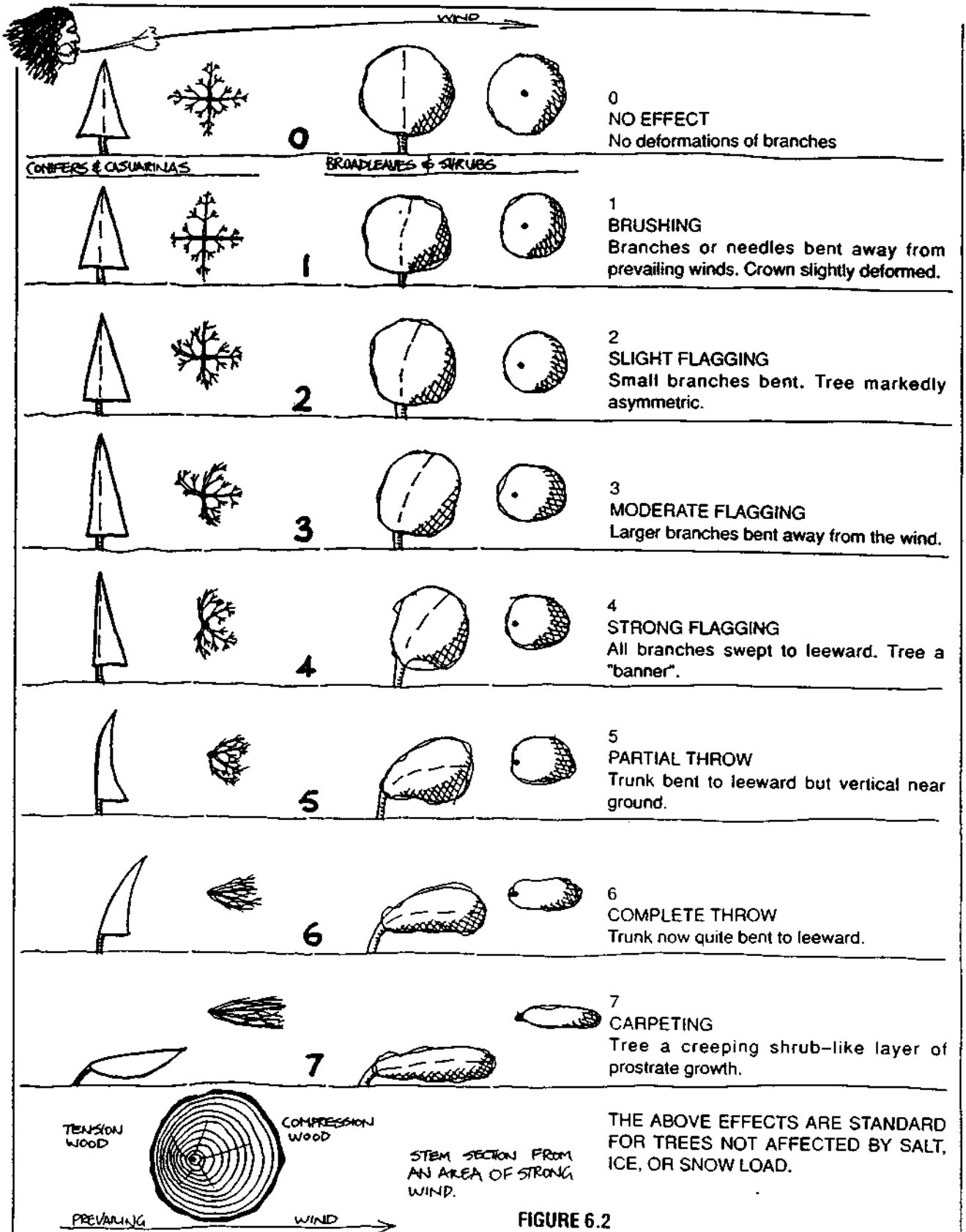

THE ABOVE EFFECTS ARE STANDARD FOR TREES NOT AFFECTED BY SALT, ICE, OR SNOW LOAD.

FIGURE 6.2
WIND EFFECTS ON TREES

As winds cross tree lines they are deflected in a new direction. Trees deform or "flag" permanently in prevailing strong winds and can be used to assess the effects of such winds; they form a site-record of wind history.

A do-it-yourself cup anemometer for measuring average wind speeds.

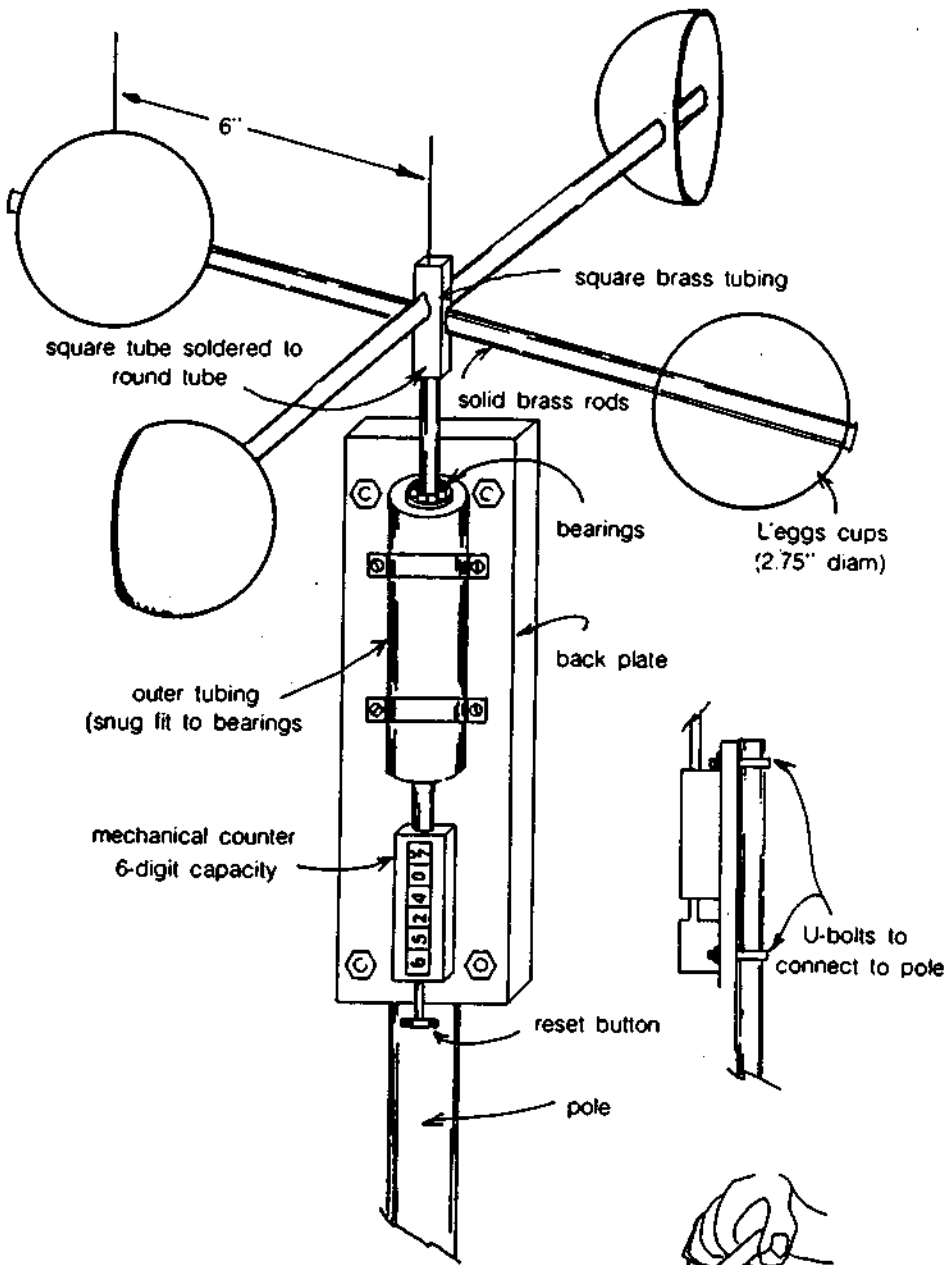

calibration data

angle	mph
90	0
85	5.8
80	8.2
75	10.1
70	11.8
65	13.4
60	14.9
55	16.4
50	18.0
45	19.6
40	21.4
35	23.4
30	25.8
25	28.7
20	32.5

A do-it-yourself, hand-held wind gauge with calibration data (based on C.L. Strong, *Scientific American*, October 1971).

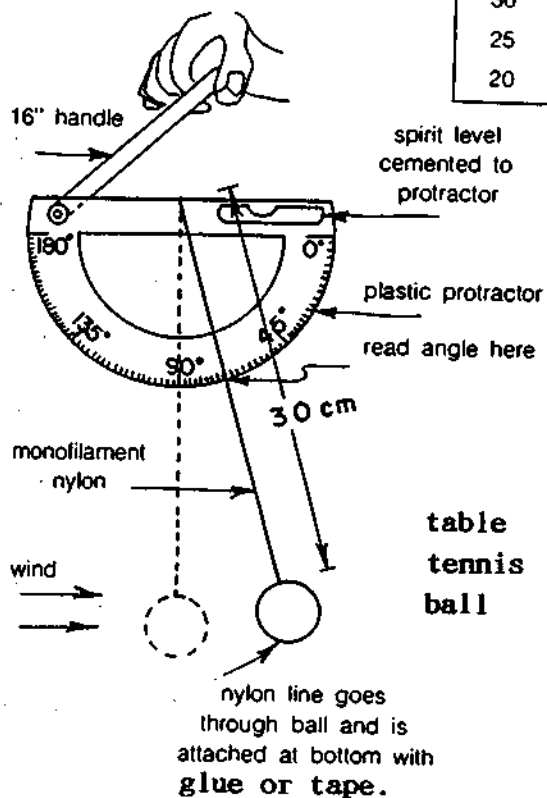

stand away to minimize air disturbance

table tennis ball

nylon line goes through ball and is attached at bottom with glue or tape.

CHOOSING A WINDMILL

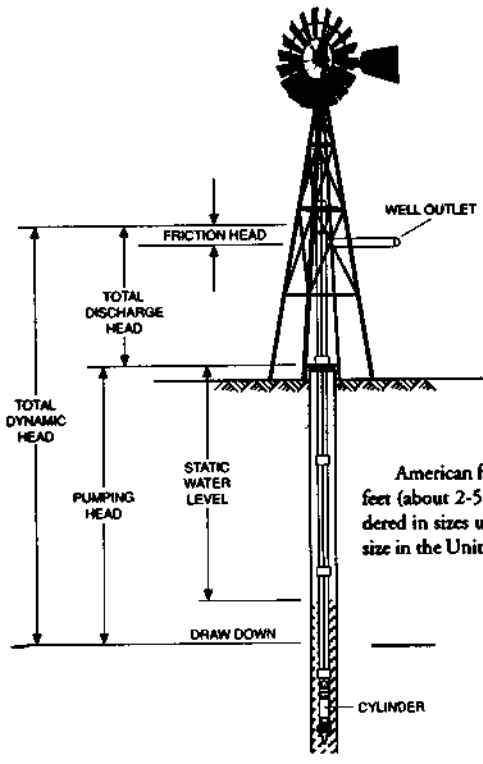

American farm windmills are available in sizes ranging from 6 feet to 16 feet (about 2-5 meters) in diameter. Australia's Southern Cross can be ordered in sizes up to 25 feet (about 8 meters) in diameter. The most common size in the United States is the 8-foot mill.

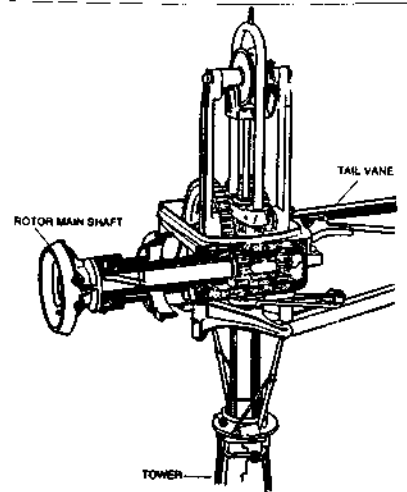

Most farm windmills are back-gearred, that is, the rotor turns several revolutions per pump stroke. (Aeromotor Co.)

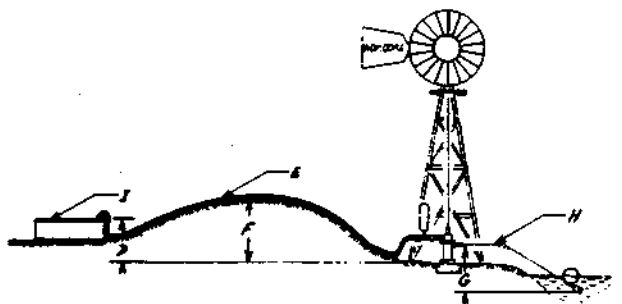
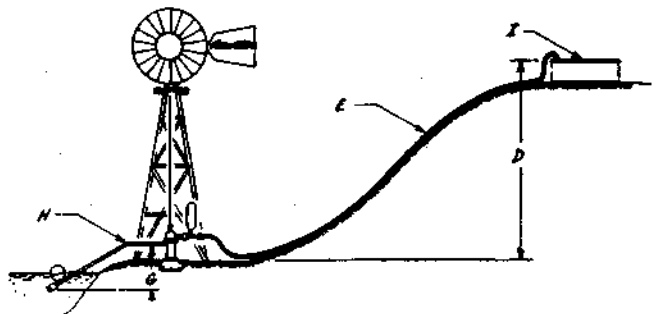
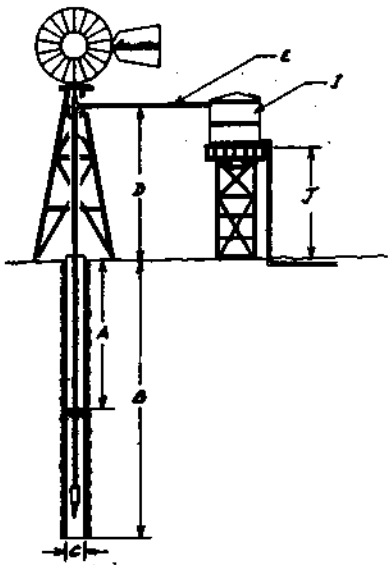

CHOOSING THE CORRECT WINDMILL

Use this pamphlet as a guide of your proposed installation.

1. What size tower is required to place your Aeromotor windmill at least 20 feet above all surrounding obstructions
2. What quantity of water is required per day
3. What quantity of water is the bore, well or soak expected to yield per day
4. Are the average wind conditions, light, moderate or strong
5. Which of the sample pumping installations is similar to your proposed system
6. Are there any piping, pump rod, or pumps already on the job (Give particulars regarding sizes and types)

INFORMATION FROM SAMPLE PUMPING INSTALLATIONS

- A. What is the depth from ground level to the low water mark
- B. What is the total depth of the bore or well
- C. What is the outside diameter of the bore casing or the size of the well
- D. How high is the point of delivery above the ground level at the mill base
- E. What is the length of the delivery pipeline
- F. The vertical height of any rise or depression in the delivery pipeline from the ground level at the mill base, is
- G. What is the height of suction (note: it is not recommended for suction to exceed 18')
- H. How long is the suction pipeline
- I. What type and capacity storage tank do you require
- J. How high do you want your tankstand
- K. What is the length of the pipeline from the tank to the trough
- L. What size and type of trough do you require

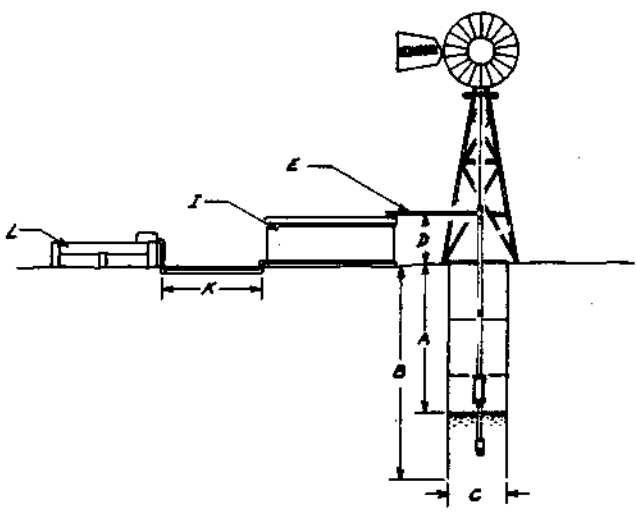

Estimates of Water Pumping Capacity of Farm Windmills

Table 12-3 is adapted from Aermotor's table of standard pumping capacities and pumping heads for winds 15-20 mph when the windmill is set for the maximum stroke. The common 8-foot windmill, when matched with a well cylinder 2 inches in diameter, will pump about 3 gallons per minute from a well about 140 feet deep in winds 15-20 mph. According to Aermotor, the pumping capacity remains the same for the same size well cylinders among rotors 8-16 ft in diameter. By varying the pump's stroke—its vertical travel—Aermotor uses the increased power from the larger diameter rotors to increase the height through which the water can be lifted. A 12-foot farm windmill will pump water at the same flow rate as the 8-foot rotor, but will lift the water through more than twice the total dynamic head.

Table 12-3
American Farm Windmill Pumping Capacity
(15-20 mph wind speed)

Pump Cylinder Diameter (Inches)	Flow (gallons/minute)	Flow (liters/minute)	Maximum Total Pumping Head in Feet for Wind Wheel Diameter (feet)				
			8	10	12	14	16
2	3	12	140	215	320	460	750
2.5	5	20	95	140	210	300	490
3	8	30	70	100	155	220	360
3.5	11	40	50	75	115	160	265
4	14	52	40	60	85	125	200
4.5	18	66	30	45	70	100	160
5	22	82	25	40	55	80	130

Adapted from Aermotor Co.

The traditional farm windmill, because the blades are not true airfoils, is much less efficient than modern wind turbines. The overall operating efficiency of farm windmills is only 4-8 percent. Assuming an overall operating efficiency of 5 percent and a Rayleigh speed distribution, Wyatt's formula is,

$$\text{daily or monthly volume in m}^3 = \frac{0.4 \times D^2 \times S^3}{H}$$

where D is the rotor diameter in meters, S is the average daily or monthly wind speed in m/s , and H is the total pumping head in meters. Table F-1 summarizes the calculations for an 8-foot diameter farm windmill. For a site with an average wind speed of 11 mph (5 m/s) at a hub height of 40-50 feet (12-15 meters), an 8-foot mill will pump about 2600 gallons (10 cubic meters) per day from a well approximately 100 feet (30 meters) deep.

The following tables estimate the amount of water a traditional American windmill of a given diameter will pump daily from a given depth within different wind regimes. The tables assume that the overall efficiency of the windmill is 5% in a Rayleigh wind speed distribution. Actual performance may vary depending on the windmill and whether it's properly matched to the well pump.

To use the tables, first find the total dynamic head in the left most column. Then find the average annual wind speed at hub height. For example, if the total pumping head is about 100 feet (30 meters) at a site with an 11 mph (5 m/s) average wind speed, a farm windmill with an 8-foot windwheel will pump about 2600 gallons (10 m^3) per day.

Table F-1
Approximate Daily Output, American Farm Windmill

8-foot (2.4-meter) Diameter Rotor, in cubic meters/day and gallons/day

Pumping Head		Average Annual Wind Speed, m/s (approximate mph)				
		3 (7)	4 (9)	5 (11)	6 (13)	7 (16)
(m)	(ft)	(m ³) (gal.)	(m ³) (gal.)	(m ³) (gal.)	(m ³) (gal.)	(m ³) (gal.)
10	30	6 1,700	15 4,800	30 7,900	51 13,600	82 21,600
20	70	3 800	8 2,000	15 3,900	26 6,800	41 10,800
30	100	2 600	5 1,300	10 2,600	17 4,500	27 7,200
40	130	2 400	4 1,000	7 2,000	13 3,400	20 5,400

Source: Center for International Development, Research Triangle Institute
Assumes overall efficiency of 5 percent.

Approximate Daily Output, American Farm Windmill

10-foot (3.05-meter) Diameter Rotor, in cubic meters/day and gallons/day

Pumping Head		Average Annual Wind Speed, m/s (approximate mph)				
		3 (7)	4 (9)	5 (11)	6 (13)	7 (16)
(m)	(ft)	(m ³) (gals.)	(m ³) (gals.)	(m ³) (gals.)	(m ³) (gals.)	(m ³) (gals.)
10	30	10 2700	24 6300	47 12,300	80 21,200	128 33,700
20	70	5 1300	12 3100	23 6100	40 10,600	64 16,800
30	100	3 900	8 2100	16 4100	27 7100	43 11,200
40	130	3 700	6 1600	12 3100	20 5300	32 8400

Source: Center for International Development, Research Triangle Institute.

Table F-3

Approximate Daily Output, American Farm Windmill

12-foot (3.7-meter) Diameter Rotor, in cubic meters/day and gallons/day

Pumping Head		Average Annual Wind Speed, m/s (approximate mph)				
		3 (7)	4 (9)	5 (11)	6 (13)	7 (16)
(m)	(ft)	(m ³) (gals.)	(m ³) (gals.)	(m ³) (gals.)	(m ³) (gals.)	(m ³) (gals.)
10	30	14 3800	34 9100	67 17,700	116 30,600	184 48,500
20	70	7 1900	17 4500	33 8800	58 15,300	92 24,300
30	100	5 1300	11 3000	22 5900	39 10,200	61 16,200
40	130	4 1000	9 2300	17 4400	29 7600	46 12,100

Source: Center for International Development, Research Triangle Institute.

Table F-4

Approximate Daily Output, American Farm Windmill

14-foot (4.3-meter) Diameter Rotor, in cubic meters/day and gallons/day

Pumping Head		Average Annual Wind Speed, m/s (approximate mph)				
		3 (7)	4 (9)	5 (11)	6 (13)	7 (16)
(m)	(ft)	(m ³) (gals.)	(m ³) (gals.)	(m ³) (gals.)	(m ³) (gals.)	(m ³) (gals.)
10	30	20 5200	47 12,300	91 24,100	158 41,600	250 66,000
20	70	10 2600	23 6200	46 12,000	79 20,800	125 33,000
30	100	7 1700	16 4100	30 8000	53 13,900	83 22,000
40	130	5 1300	12 3100	23 6000	39 10,400	63 16,500

Source: Center for International Development, Research Triangle Institute.

Table F-5

Approximate Daily Output, American Farm Windmill

16-foot (4.9-meter) Diameter Rotor, in cubic meters/day and gallons/day

Pumping Head		Average Annual Wind Speed, m/s (approximate mph)				
		3 (7)	4 (9)	5 (11)	6 (13)	7 (16)
(m)	(ft)	(m ³) (gals.)	(m ³) (gals.)	(m ³) (gals.)	(m ³) (gals.)	(m ³) (gals.)
10	30	26 6800	61 16,100	119 31,400	206 54,300	327 86,300
20	70	13 3400	30 8000	60 15,700	103 27,200	163 43,100
30	100	9 2300	20 5400	40 10,500	69 18,100	109 28,800
40	130	6 1700	15 4000	30 7900	51 13,600	82 21,600

Source: Center for International Development, Research Triangle Institute.

ESTIMATING SMALL STREAM WATER FLOW

A rough but very rapid method of estimating water flow in small streams is given here. In looking for water sources for drinking, irrigation or power generation, one should survey all the streams available.

If sources are needed for use over a long period, it is necessary to collect information throughout the year to determine flow changes--especially high and low flows. The number of streams that must be used and the flow variations are important factors in determining the necessary facilities for utilizing the water.

Tools and Materials

Timing device, preferably watch with second hand

Measuring tape

Float (see below)

Stick for measuring depth

The following equation will help you to measure flow quickly: $Q = K \times A \times V$, where:

Q (Quantity) = flow in liters per minute

A (Area) = cross-section of stream, perpendicular to flow, in square meters

V (Velocity) = stream velocity, meters per minute

K (Constant) = a corrected conversion factor. This is used because surface flow is normally faster than average flow. For normal stages use $K = 850$; for flood stages use $K = 900$ to 950 .



FIGURE 1

To Find A (Area) of a Cross-Section

The stream will probably have different depths along its length so select a place where the depth of the stream is average.

1. Take a measuring stick and place it upright in the water about 50cm from the bank.
2. Note the depth of water.
3. Move the stick 1 meter from the bank in a line directly across the stream.
4. Note the depth.
5. Move the stick 1.5 meters from the bank, note the depth, and continue moving it at 50cm intervals until you cross the stream.

Note the depth each time you place the stick upright in the stream. Draw a grid, like the one in Figure 2, and mark the varying depths on it so that a cross-section of the stream is shown. A scale of 1cm to 10cm is often used for such grids. By counting the grid squares and fractions of squares, the area of the water can be estimated. For example, the grid shown here has a little less than 4 square meters of water.

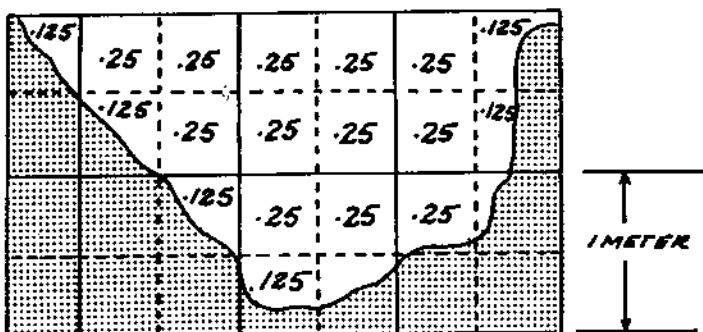

FIGURE 2

To Find V (Velocity)

Put a float in the stream and measure the distance of travel in one minute (or fraction of a minute, if necessary.) The width of the stream should be as constant as possible and free of rapids, where the velocity is being measured.

A light surface float, such as a chip, will often change course because of wind or surface currents. A weighted float which sits upright in the water will not change course so easily. A lightweight tube or tin can, partly filled with water or gravel so that it floats upright with only a small part showing above water, will not change course so easily and makes a better float for measuring.

Measuring Wide Streams

For a wide, irregular stream, it is better to divide the stream into 2 or 3 meter sections and measure the area and velocity of each. Q is then calculated for each section and the Qs added together to give a total flow.

Example (see Figure 2):

Cross section is 4 square meters

Velocity of float = 6 meters traveled in 1/2 minute

Stream flow is normal

$$Q = 850 \times 4 \times \frac{6 \text{ meters}}{.5 \text{ minute}}$$

$$Q = 40,800 \text{ liters per minute.}$$

or

$$680 \text{ liters per second}$$

Using English Units

If English units of measurement are used, the equation for measuring stream flow is: $Q = K \times A \times V$, where:

Q = flow in U.S. gallons per minute

A = cross-section of stream, perpendicular to flow, in square feet

V = stream velocity in feet per minute

K = a corrected conversion factor: 6.4 for normal stages; 6.7 to 7.1 for flood stages

The grid to be used would be similar to the one in Figure 3; a commonly used scale is 1" to 12".

Example:

Cross-section is 15 square feet

Velocity of float = 20 feet traveled in 1/2 minute

Stream flow is normal

$$Q = 6.4 \times 15 \times \frac{20 \text{ feet}}{.5 \text{ minute}}$$

$Q = 3800$ gallons per minute

Source:

Design of Fishways and Other Fish Facilities by C. H. Clay, P. E. Department of Fisheries of Canada, Ottawa, 1961.

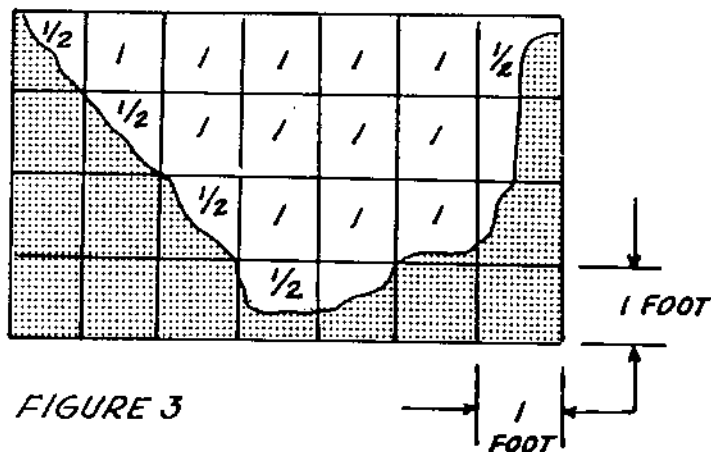
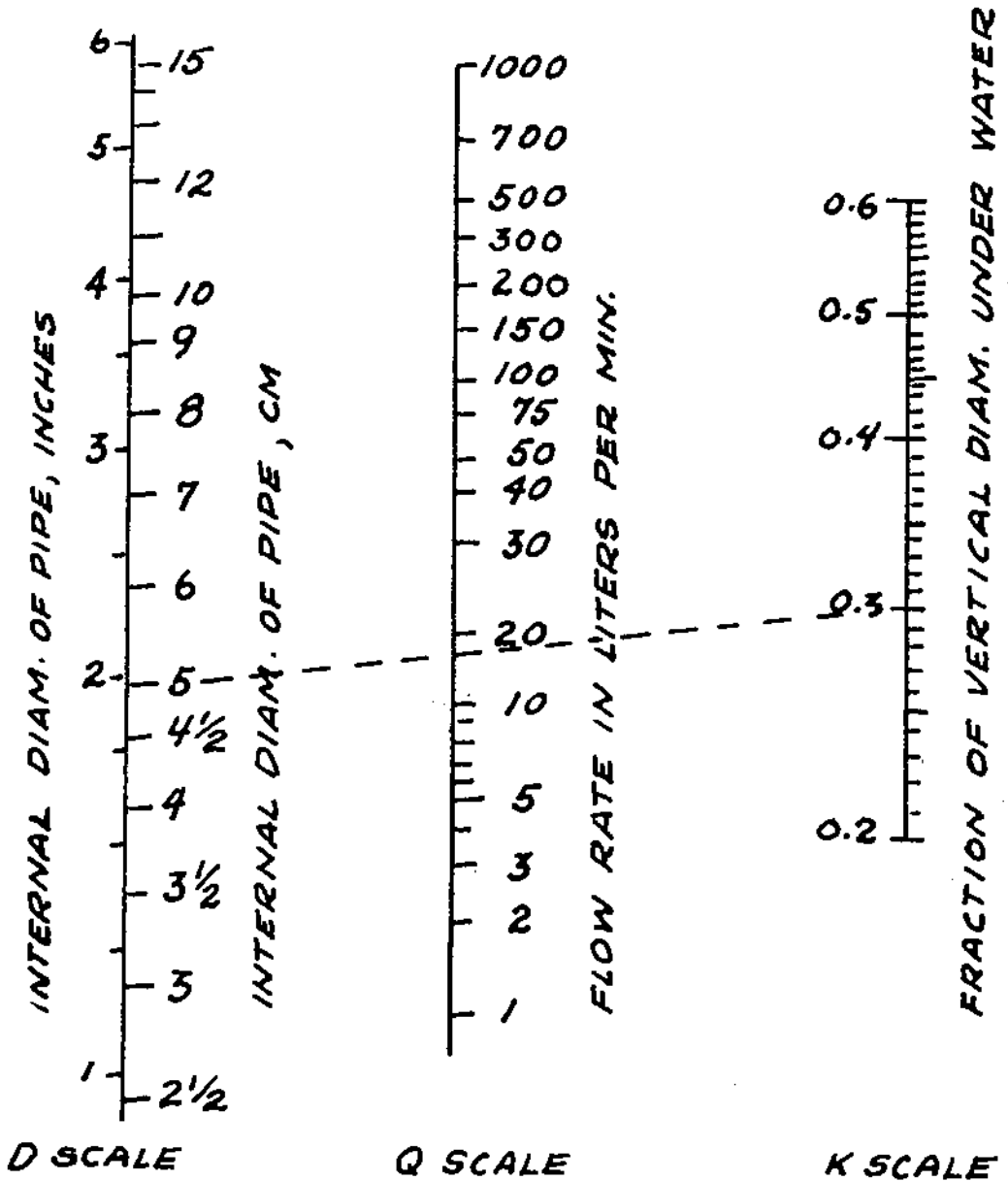

FIGURE 2



MEASURING THE FLOW OF WATER IN PARTIALLY FILLED PIPES

The flow of water in partially-filled horizontal pipes or circular channels can be determined--if you know the inside diameter of the pipe and the depth of the water flowing--by using the alignment chart (nomograph) in Figure 2.

This method can be checked for low flow rates and small pipes by measuring the time required to fill a bucket or drum with a weighed quantity of water. A liter of water weighs 1kg (1 U.S. gallon of water weighs 8.33 pounds).

Tools and Materials

Ruler to measure water depth (if ruler units are inches, multiply by 2.54 to convert to centimeters)

Straight edge, to use with alignment chart

The alignment chart applies to pipes with 2.5cm to 15cm inside diameters, 20 to 60% full of water, and having a reasonably smooth surface (iron, steel, or concrete sewer pipe). The pipe or channel must be reasonably horizontal if the result is to be accurate. The eye, aided by a plumb bob line to give a vertical reference, is a sufficiently good judge. If the pipe is not horizontal another method will have to be used. To use the alignment chart, simply connect the proper point on the "K" scale with the proper point of the "d" scale with the straight edge. The flow rate can then be read from the "q" scale.

q = rate of flow of water, liters per minute
8.33 pounds = 1 gallon.

d = internal diameter of pipe in centimeters.

K = decimal fraction of vertical diameter under water. Calculate K by measuring the depth of water (h) in the pipe and dividing it by the pipe diameter (d), or $K = \frac{h}{d}$ (see Figure 1).

Example:

What is the rate of flow of water in a pipe with an internal diameter of 5cm running 0.3 full? A straight line connecting 5 on the d-scale with 0.3 on the K-scale intersects the q-scale at a flow of 18 liters per minute.

Source:

Greve Bulletin, Purdue University (12, No. 5, 1928, Bulletin 32).

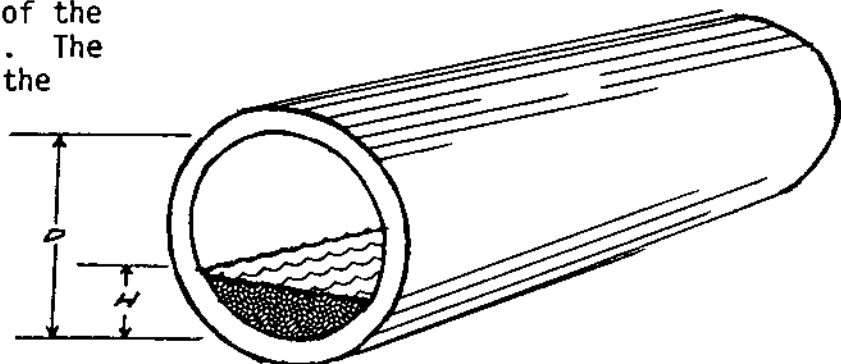
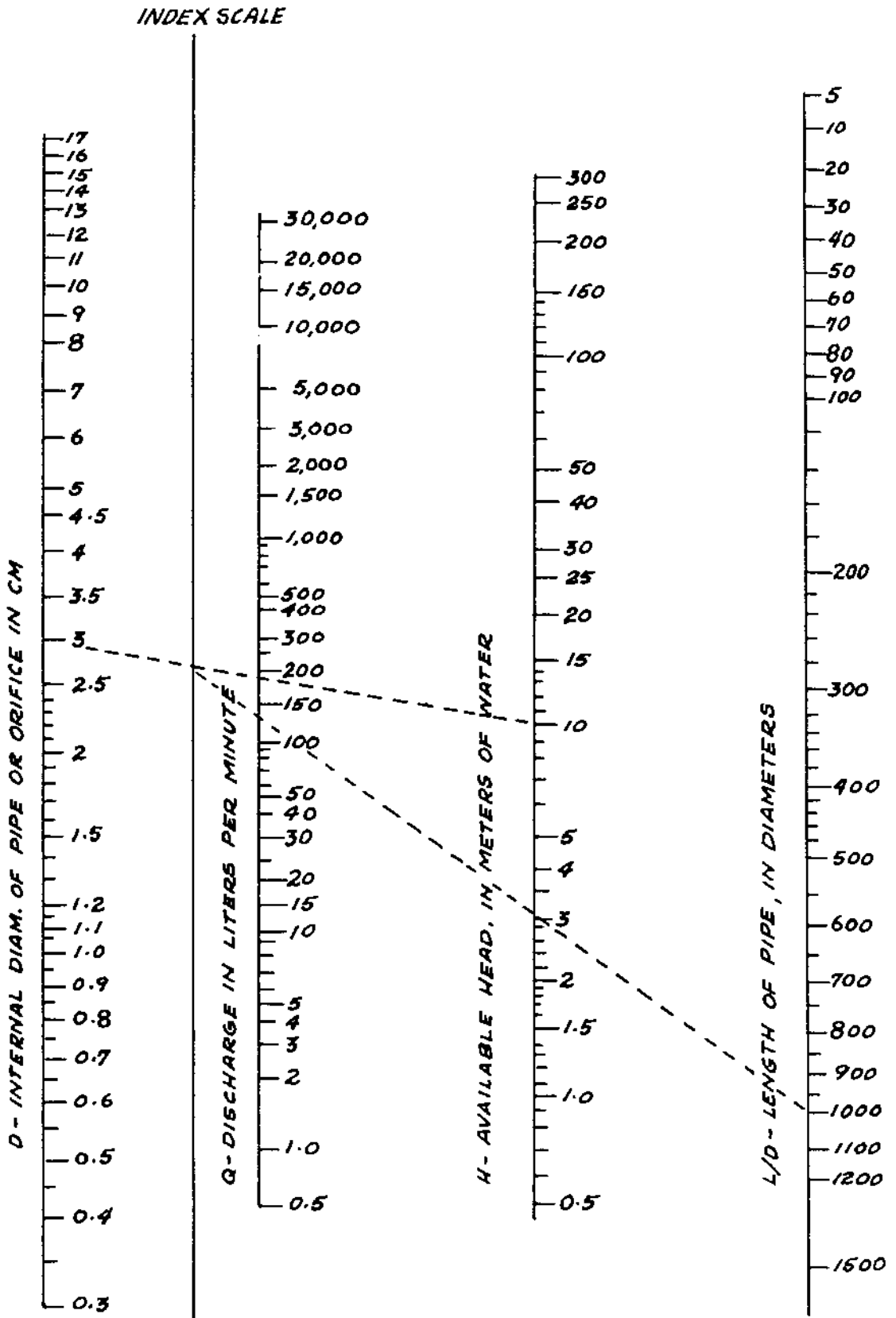

FIGURE 1

FIGURE 1



Alignment chart for determining probable water flow with known reservoir height and size and length of pipe.

DETERMINING PROBABLE WATER FLOW WITH KNOWN RESERVOIR HEIGHT AND SIZE AND LENGTH OF PIPE

The alignment chart in Figure 1 gives a reasonably accurate determination of water flow when pipe size, pipe length and height of the supply reservoir are known.

The example given here is for the analysis of an existing system. To design a new system, assume a pipe diameter and solve for flow-rate, repeating the procedure with new assumed diameters until one of them provides a suitable flow rate.

Materials

Straight edge, for use with alignment chart

Surveying instruments, if available

The alignment chart was prepared for clean, new steel pipe. Pipes with rougher surfaces or steel or cast iron pipe which has been in service for a long time may give flows as low as 50 percent of those predicted by this chart.

The available head (h) is in meters and is taken as the difference in elevation between the supply reservoir and the point of demand. This may be crudely estimated by eye, but for accurate results some sort of surveying instruments are necessary.

For best results, the length of pipe (L) used should include the equivalent lengths of fittings as described in handbook entry "Flow Resistance of Pipe Fittings," p. 80. This length (L) divided by the pipe internal diameter (D) gives the necessary "L/D" ratio. In calculating L/D, note that the units of measuring both "L" and "D" must be the same, e.g.: feet divided by feet; meters divided by meters; centimeters by centimeters.

Example:

Given Available Head (h) of 10 meters, pipe internal diameter (D) of 3cm, and equivalent pipe length (L) of 30 meters = 3000cm.

$$\text{Calculate } L/D = \frac{3000\text{cm}}{3\text{cm}} = 1000$$

The alignment chart solution is in two steps:

1. Connect Internal Diameter 3cm to Available Head (10 meters), and make a mark on the Index Scale. (In this step, disregard "Q" scale)
2. Connect mark on Index Scale with L/D (1000), and read flow rate (Q) of approximately 140 liters per minute.

Source:

Crane Company Technical Paper #407, pages 54-55.

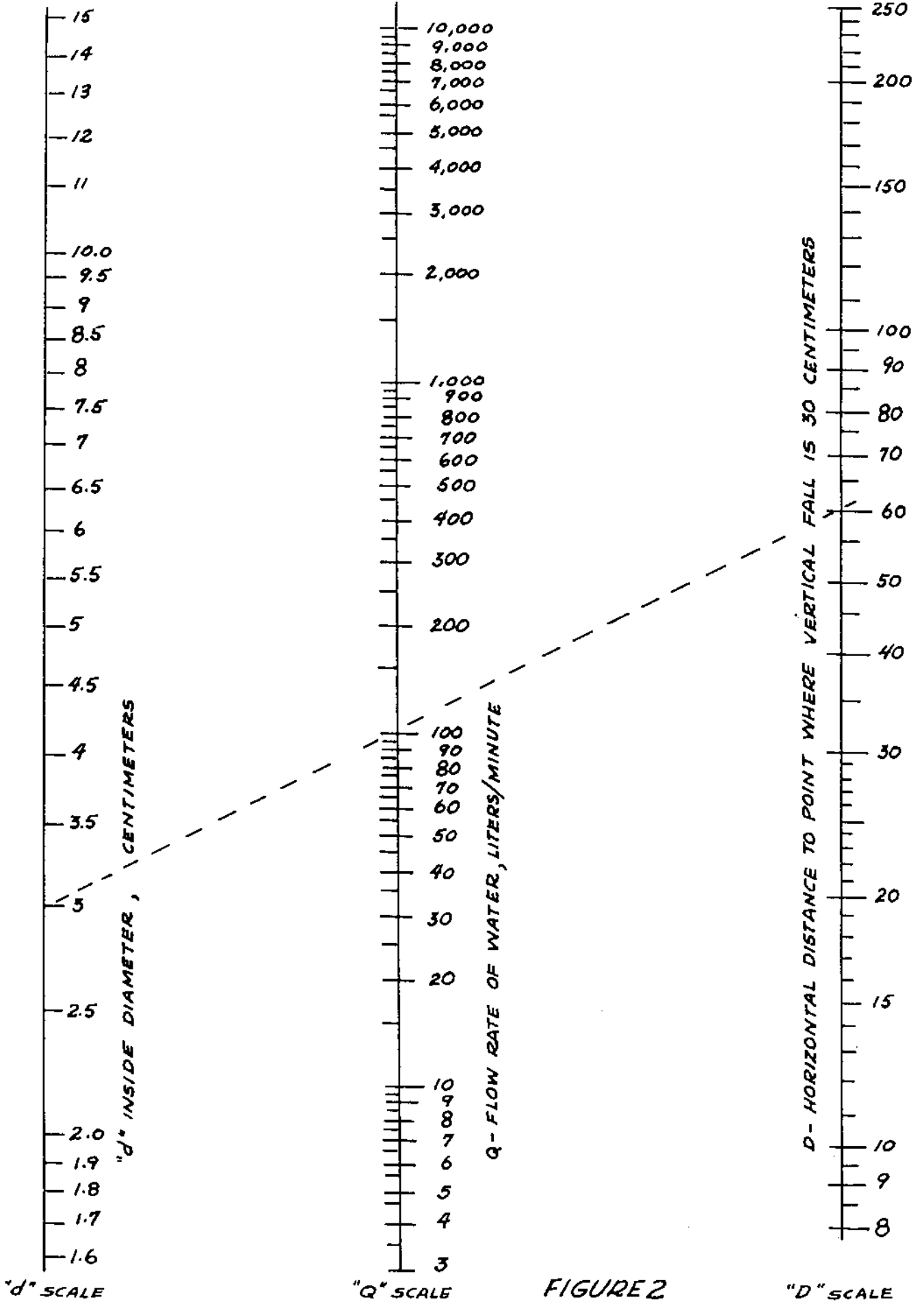

FIGURE 2

ESTIMATING WATER FLOW FROM HORIZONTAL PIPES

If a horizontal pipe is discharging a full stream of water, you can estimate the rate of flow from the alignment chart in Figure 2. This is a standard engineering technique for estimating flows; its results are usually accurate to within 10 percent of the actual flow rate.

Materials

Straightedge and pencil, to use alignment chart

Tape measure

Level

Plumb bob

The water flowing from the pipe must completely fill the pipe opening (see Figure 1). The results from the chart will be most accurate when there is no constricting or enlarging fitting at the end of the pipe.

Example:

Water is flowing out of a pipe with an inside diameter (d) of 3cm (see Figure 1). The stream drops 30cm at a point 60cm from the end of the pipe.

Connect the 3cm inside diameter point on the "d" scale in Figure 2 with the 60cm point on the "D" scale. This line intersects the "q" scale at about 100 liters per minute, the rate at which water is flowing out of the pipe.

Source:

"Flow of Water from Horizontal Open-end Pipes," by Clifford L. Duckworth, Chemical Processing, June 1959, p. 73.

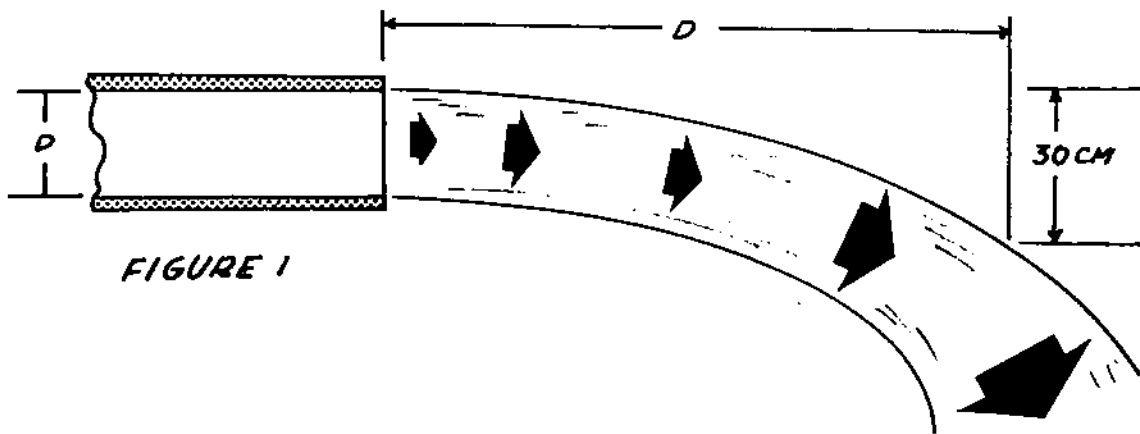
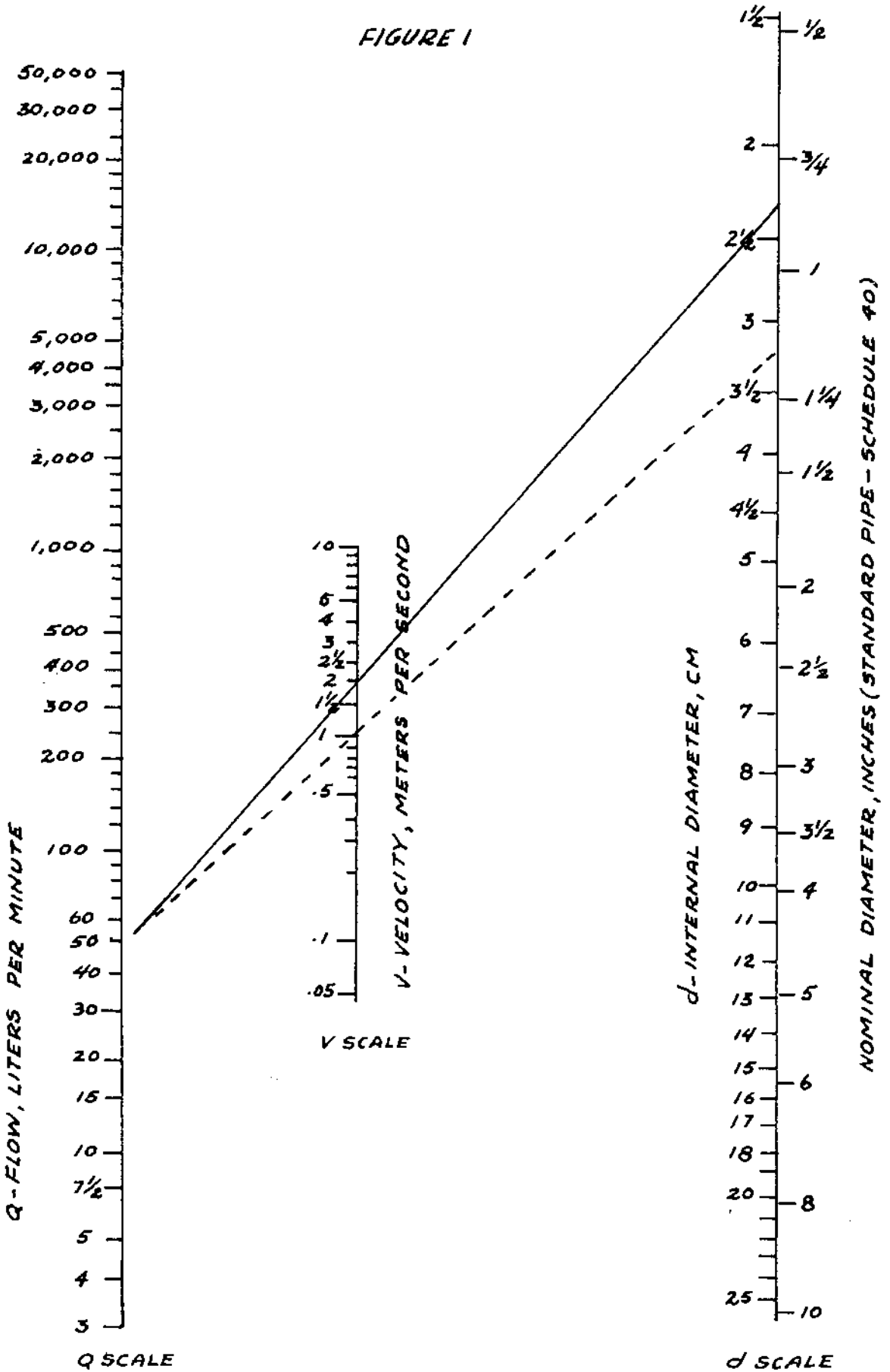

FIGURE 1

FIGURE 1



DETERMINING PIPE SIZE OR VELOCITY OF WATER IN PIPES

The choice of pipe size is one of the first steps in designing a simple water system.

The alignment chart in Figure 1 can be used to compute the pipe size needed for a water system when the water velocity is known. The chart can also be used to find out what water velocity is needed with a given pipe size to yield the required rate of flow.

Tools and Materials

Straightedge and pencil

Practical water systems use water velocities from 1.2 to 1.8 meters per second. Very fast velocity requires high pressure pumps which in turn require high pressure pumps which in turn require large motors and use excessive power. Velocities which are too low are expensive because larger pipe diameters must be used.

It may be advisable to calculate the cost of two or more systems based on different pipe size. Remember, it is usually wise to choose a little larger pipe if higher flows are expected in the next 5 or 10 years. In addition, water pipes often build up rust and scale reducing the diameter and thereby increasing the velocity and pump pressure required to maintain flow at the original rate. If extra capacity is designed into the piping system, more water can be delivered by adding to the pump capacity without changing all the piping.

To use the chart, locate the flow (liters per minute) you need on the Q-scale. Draw a line from that point, through 1.8m/sec velocity on the V-scale to the d-scale. Choose the nearest standard size pipe.

Example:

Suppose you need a flow of 50 liters per minute at the time of peak demand. Draw a line from 50 liters per minute on the Q-scale through 1.8m/sec on the V-scale. Notice that this intersects the d-scale at about 2.25. The correct pipe size to choose would be the next largest standard pipe size: e.g. 1" nominal diameter, U.S. Schedule 40. If pumping costs (electricity or fuel) are high, it would be well to limit velocity to 1.2m/sec and install a slightly larger pipe size.

Source:

Crane Company Technical Paper #409, pages 46-47.

Resistance of Valves and Fittings to Flow of Fluids

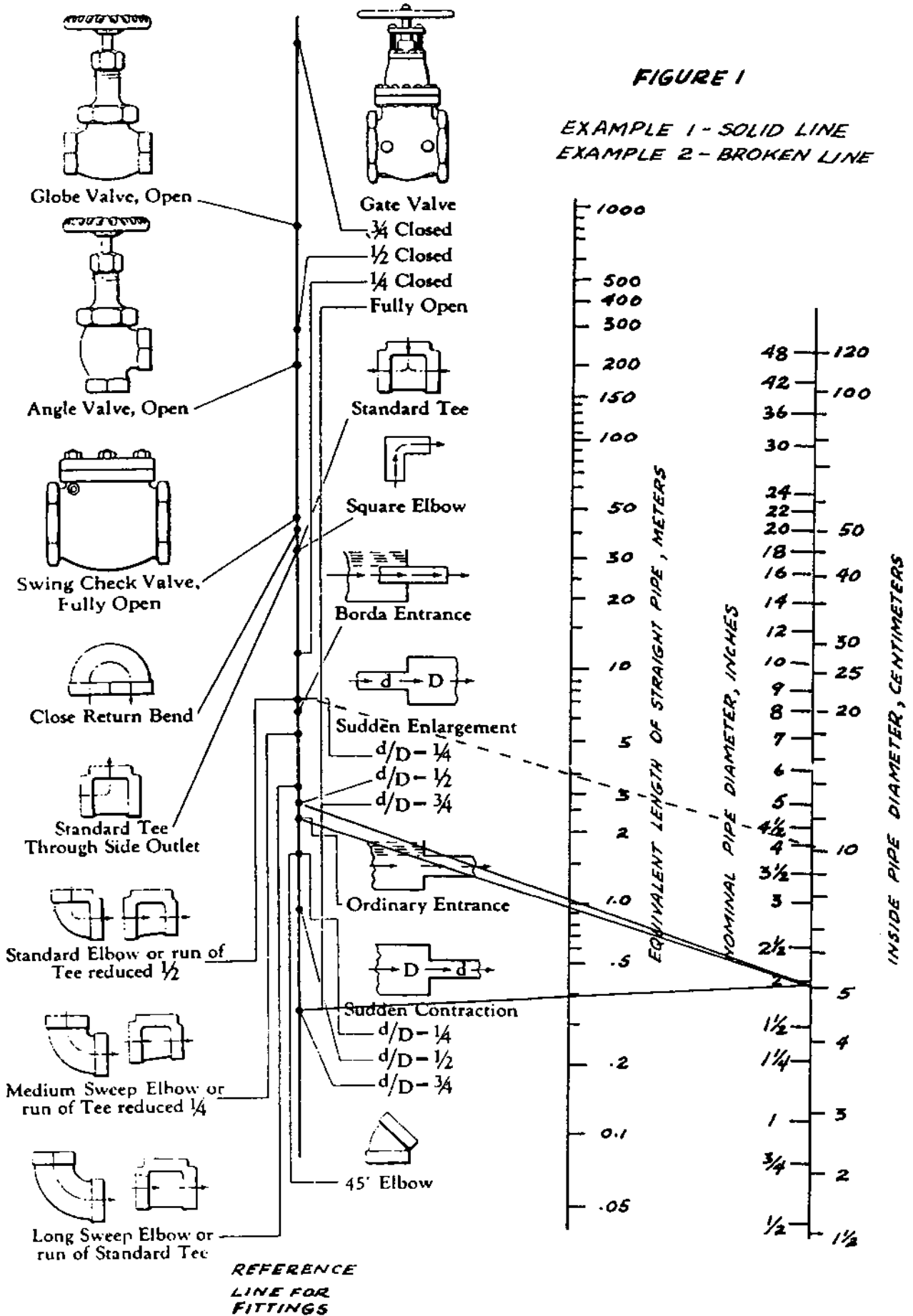

ESTIMATING FLOW RESISTANCE OF PIPE FITTINGS

One of the forces which a pump must overcome to deliver water is the friction/resistance of pipe fittings and valves to the flow of water. Any bends, valves, constrictions or enlargements (such as passing through a tank) add to friction.

The alignment chart in Figure 1 gives a simple but reliable way to estimate this resistance: it gives the equivalent length of straight pipe which would have the same resistance. The sum of these equivalent lengths is then added to the actual length of pipe: this gives the total equivalent pipe length, which is used in the following entry, "Determining Pump Capacity and Horsepower Requirement," to determine total friction loss.

Rather than calculate the pressure drop for each valve or fitting separately, this chart will give the equivalent length of straight pipe.

Valves: Note the difference in Equivalent Length depending on how far the valve is open.

1. Gate Valve - full opening valve; can see through it when open; used for complete shut off of flow.
2. Globe Valve - cannot see through it when open; used for regulating flow.
3. Angle Valve - like the globe, used for regulating flow.
4. Swing Check Valve - a flapper opens to allow flow in one direction but closes when water tries to flow in the opposite direction.

Fittings

Study the variety of tees and elbows: note carefully the direction of flow through the tee. To determine the equivalent length of a fitting, (a) pick proper dot on "fitting" line, (b) connect with inside diameter of pipe, using a straight edge; read equivalent length of straight pipe in meters, (c) add the fitting equivalent length to the actual length of pipe being used.

Source:

Crane Company Technical Paper #409, pages 20-21.

Example 1:

<u>Pipe with 5cm inside diameter</u>	<u>Equivalent Length in Meters</u>
a. Gate Valve (fully open)	.4
b. Flow into line - ordinary entrance	1.0
c. Sudden enlargement into 10cm pipe ($d/D = 1/2$)	1.0
d. Pipe length	<u>10.0</u>
Total Equivalent Pipe Length	12.4

Example 2:

<u>Pipe with 10cm inside diameter</u>	<u>Equivalent Length in Meters</u>
a. Elbow (standard)	4.0
b. Pipe length	<u>10.0</u>
Total Equivalent Pipe Length	14.0

DETERMINING PUMP OUTLET SIZE AND HORSEPOWER REQUIREMENT

With the alignment chart in Figure 2, you can determine the necessary pump size (diameter of discharge outlet) and the amount of horsepower needed to power the pump. The power can be supplied by men or by motors.

A man can generate about 0.1 horsepower (HP) for a reasonably long period and 0.4 HP for short bursts. Motors are designed for varying amounts of horsepower.

Tools

Straight edge and pencil for alignment chart

To get the approximate pump size needed for lifting liquid to a known height through simple piping, follow these steps:

1. Determine the quantity of flow desired in liters per minute.
2. Measure the height of the lift required (from the point where the water enters the pump suction piping to where it discharges).
3. Using the entry "Determining Pipe Size or Velocity of Water in Pipes," page 78, choose a pipe size which will give a water velocity of about 1.8 meters per second (6' per second). This velocity is chosen because it will generally give the most economical combination of pump and piping; Step 5 explains how to convert for higher or lower water velocities.
4. Estimate the pipe friction-loss "head" (a 3-meter "head" represents the pressure at the bottom of a 2-meter-high column of water) for the total equivalent pipe length, including suction and discharge piping and equi-

valent pipe lengths for valves and fittings, using the following equation:

$$\text{Friction-loss head} = \frac{F \times \text{total equivalent pipe length}}{100}$$

where F equals approximate friction head (in meters) per 100 meters of pipe. To get the value of F, see the table in Figure 1. For an explanation of total equivalent pipe length, see the preceding entry.

5. To find F (approximate friction head in meters per 100m of pipe) when water velocity is higher or lower than 1.8 meters per second, use the following equation:

$$F = \frac{F_{\text{at } 1.8\text{m/sec}} \times V^2}{1.8\text{m/sec}^2},$$

where V = higher or lower velocity

Example:

If the water velocity is 3.6m per second and $F_{\text{at } 1.8\text{m/sec}}$ is 16, then:

$$F = \frac{16 \times 3.6^2}{1.8^2} = \frac{16 \times 13}{3.24} = 64$$

6. Obtain "Total Head" as follows:
Total Head = Height of Lift + Friction-loss Head

Pipe inside diameter:	cm	2.5	5.1	7.6	10.2	15.2	20.4	30.6	61.2
	inches*	1"	2"	3"	4"	6"	8"	12"	24"
F (approximate friction loss in meters per 100 meters of pipe)		16	7	5	3	2	1.5	1	0.5

Figure 1. Average friction loss in meters for fresh water flowing through steel pipe when velocity is 1.8 meters (6 feet) per second.

*For the degree of accuracy of this method, either actual inside diameter in inches or nominal pipe size, U.S. Schedule 40, can be used.

- Using a straight edge, connect the proper point on the T-scale with the proper point on the Q-scale; read motor horsepower and pump size on the other two scales.

Example:

Desired flow: 400 liters per minute

Height of lift: 16 meters, No fittings

Pipe size: 5cm

Friction-loss head: about 1 meter

Total head: 17 meters

Solution:

Pump size: 5cm

Motor horsepower: 3HP

Note that water horsepower is less than motor horsepower (see HP-scale, Figure 2). This is because of friction losses in the pump and motor. The alignment chart should be used for rough estimate only. For an exact determination, give all information on flow and piping to a pump manufacturer or an independent expert. He has the exact data on pumps for various applications. Pump specifications can be tricky especially if suction piping is long and the suction lift is great.

Conversion to Metric Horsepower

Given the limits of accuracy of this method, metric horsepower can be considered roughly equal to the horsepower indicated by the alignment chart. Actual metric horsepower can be obtained by multiplying horsepower by 1.014.

Source:

Nomographic Charts, by C. A. Kulman, McGraw-Hill Book Co., New York, 1951, pages 108-109.

FIGURE 2

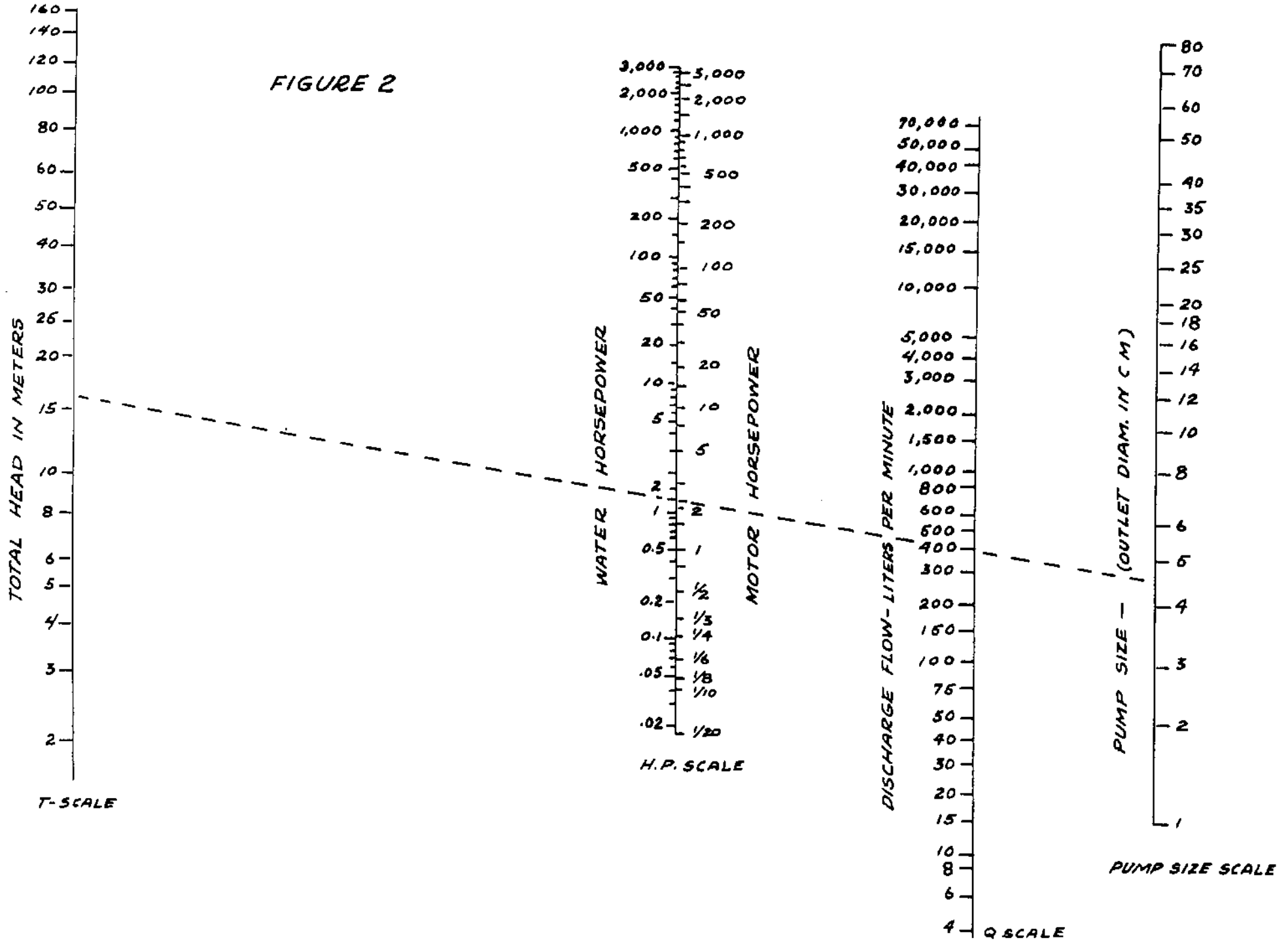

DETERMINING LIFT PUMP CAPABILITY

The height that a lift pump can raise water depends on altitude and, to a lesser extent, on water temperature. The graph in Figure 1 will help you to find out what a lift pump can do at various altitudes and water temperatures.

Tools

Measuring tape

Thermometer

If you know your altitude and the temperature of your water, Figure 1 will tell you the maximum allowable distance between the pump cylinder and the lowest water level expected. If the graph shows that lift pumps are marginal or will not work, then a force pump should be used. This involves putting the

cylinder down in the well, close enough to the lowest expected water level to be certain of proper functioning.

The graph shows normal lifts. Maximum possible lifts under favorable conditions would be about 1.2 meters higher, but this would require slower pumping and would probably give much difficulty in "losing the prime."

Check predictions from the graph by measuring lifts in nearby wells or by experimentation.

Source:

Mechanical Engineer's Handbook, by Theodore Baumeister, 6th edition, McGraw-Hill Book Co., New York, copyright 1958. Used by permission. (Adapted.)

Example:

Suppose your elevation is 2000 meters and the water temperature is 25C. The graph shows that the normal lift would be 4 meters.

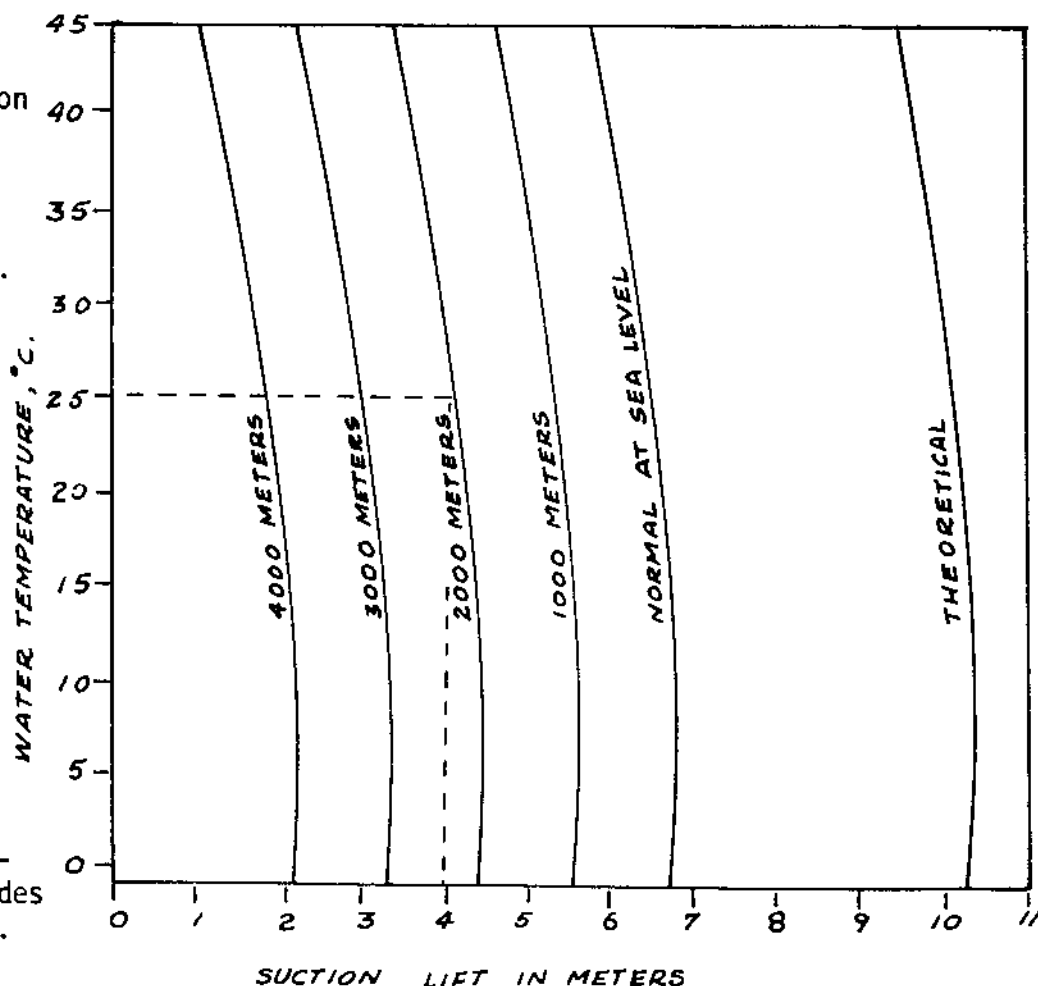

Figure 1. Graph showing lift pump capabilities at various altitudes and water temperatures. Broken lines indicate example given in text.

FIGURE 1

WATER, PRESSURE AND FLOW. Water is composed of two gases, hydrogen and oxygen, in the ratio of two volumes of the former to one of the latter. Water boils under atmospheric pressure at 212 degrees F. and freezes at 32 degrees F. Its greatest density is at 39.1 degrees F., when it weighs 62.425 pounds per cubic foot. The pressure in pounds per square inch of water that is not moving, against the sides of any pipe, vessel, container, or dam is due solely to the "head" or height of the surface of the water above the point at which the pressure is considered. The pressure is equal to 0.433 pound per square inch for every foot of the head, at a temperature of 62 degrees F. For higher temperatures, the pressure slightly decreases in the proportion indicated by the table "Weight of Water per Cubic Foot at Different Temperatures." The pressure per square inch is equal in all directions, downwards, upwards, and sideways. Water can be compressed only in a very slight degree, the compressibility being so slight that, even at the depth of a mile, a cubic foot of water weighs only about one-half pound more than at the surface.

Flow of Water in Pipes. — The quantity of water that will be discharged through a pipe depends primarily upon the head and also upon the diameter of the pipe, the character of the interior surface, and the number and shape of the bends. The head may be either the actual distance between the levels of the surface of water in a reservoir and the point of discharge, or it may be caused by mechanically applied pressure, as by pumping, in which case the head is calculated as the vertical distance corresponding to the pressure. One pound per square inch is equal to 2.309 feet head, or 1 foot head is equal to a pressure of 0.433 pound per square inch.

All formulas for finding the amount of water that will flow through a pipe in a given time are approximate. The formula below will give results within 5 or 10 per cent of actual results, if applied to pipe lines carefully laid and in a fair condition.

$$V = C \sqrt{\frac{hD}{L + 54 D}}$$

in which

- V = approximate mean velocity in feet per second;
- C = coefficient from table;
- D = diameter of pipe in feet;
- h = total head in feet;
- L = total length of pipe line in feet.

Values of Coefficient C

Diameter of Pipe		C	Diameter of Pipe		C
Feet	Inches		Feet	Inches	
0.1	1.2	23	2.0	24	57
0.2	2.4	30	2.5	30	60
0.3	3.6	34	3.0	36	62
0.4	4.8	37	3.5	42	64
0.5	6.0	39	4.0	48	66
0.6	7.2	42	5.0	60	68
0.7	8.4	44	6.0	72	70
0.8	9.6	46	7.0	84	72
0.9	10.8	47	8.0	96	74
1.0	12.0	48	10.0	120	77
1.5	18.0	53

Example. — A pipe line, 1 mile long, 12 inches in diameter, discharges water under a head of 100 feet. Find the velocity and quantity of discharge.

From the table, the coefficient C is found to be 48 for a pipe 1 foot in diameter; hence:

$$V = 48 \sqrt{\frac{100 \times 1}{5280 + 54 \times 1}} = 6.57 \text{ feet per second.}$$

To find the discharge in cubic feet per second, multiply the velocity found by the area of cross-section of the pipe in square feet:

$$6.57 \times 0.7854 = 5.16 \text{ cubic feet per second.}$$

The loss of head due to a bend in the pipe is most frequently given in the equivalent length of straight pipe, which would cause the same loss in head as the bend.

Weight of Water per Cubic Foot at Different Temperatures

Temp. Deg. F.	Weight per Cubic Foot, Pounds	Temp. Deg. F.	Weight per Cubic Foot, Pounds	Temp. Deg. F.	Weight per Cubic Foot, Pounds	Temp. Deg. F.	Weight per Cubic Foot, Pounds
32	62.42	180	60.55	320	56.66	470	50.2
40	62.42	190	60.32	330	56.30	480	49.7
50	62.41	200	60.12	340	55.94	490	49.2
60	62.37	210	59.88	350	55.57	500	48.7
70	62.31	212	59.83	360	55.18	510	48.1
80	62.23	220	59.63	370	54.78	520	47.6
90	62.13	230	59.37	380	54.36	530	47.0
100	62.02	240	59.11	390	53.94	540	46.3
110	61.89	250	58.83	400	53.50	550	45.6
120	61.74	260	58.55	410	53.00	560	44.9
130	61.56	270	58.26	420	52.6	570	44.1
140	61.37	280	57.96	430	52.2	580	43.3
150	61.18	290	57.65	440	51.7	590	42.6
160	60.98	300	57.33	450	51.2	600	41.8
170	60.77	310	57.00	460	50.7

Volume of Water at Different Temperatures

Degrees F.	Volume	Degrees F.	Volume	Degrees F.	Volume
39.1	1.00000	104	1.00767	167	1.02548
50	1.00025	113	1.00967	176	1.02872
59	1.00083	122	1.01186	185	1.03213
68	1.00171	131	1.01423	194	1.03570
77	1.00286	140	1.01678	203	1.03943
86	1.00425	149	1.01951	212	1.04332
95	1.00586	158	1.02241

Experiments show that a right-angle bend should have a radius of about three times the diameter of the pipe. Assuming this curvature, then, if D is the diameter of the pipe in inches and L is the length of straight pipe in feet which causes the same loss of head as the bend in the pipe, the following formula gives the equivalent length of straight pipe that should be added to compensate for a right-angle bend:

$$L = 4 D \div 3.$$

Thus the loss of head due to a right-angle bend in a 6-inch pipe would be equal to that in 8 feet of straight pipe. Experiments undertaken to determine the losses due to valves in pipe lines indicate that a fully open gate valve in a pipe causes a loss of head corresponding to that in a length of pipe equal to six diameters.

APPENDIX: Conversion Factors

To convert from:	To:	Multiply by:
<i>Length</i>		
centimeters (cm)	inches	0.394
feet (ft)	centimeters	30.5
inches (in)	centimeters	2.54
kilometers (km)	miles	0.621
meters (m)	feet	3.28
meters (m)	yards	1.094
miles (mi)	kilometers	1.609
millimeters (mm)	inches	0.0394
yards (yd)	meters	0.914
<i>Area</i>		
acres	hectares	0.405
acres	sq. meters	4047
hectares (ha)	acres	2.47
hectares (ha)	sq. meters	10,000
sq. centimeters (cm ²)	sq. inches	0.155
sq. feet (ft ²)	sq. meters	0.0929
sq. inches (in ²)	sq. centimeters	6.45
sq. kilometers (km ²)	sq. miles	0.386
sq. kilometers (km ²)	hectares	100
sq. meters (m ²)	sq. feet	10.76
sq. yards (yd ²)	sq. meters	0.836
<i>Volume</i>		
barrels (petroleum, bbl)	liters	159
cubic centimeters (cm ³)	cubic inches	0.0610
cubic feet (ft ³)	cubic meters	0.0283
cubic inches (in ³)	cubic centimeters	16.39
cubic meters (m ³)	cubic feet	35.3
cubic meters (m ³)	cubic yards	1.308
cubic yards (yd ³)	cubic meters	0.765
gallons (gal) US	liters	3.79
gallons (gal) Imp.	liters	4.545
gallons (gal) Imp.	gallons, US	1.20
<i>Weight</i>		
grams (g)	ounces, avdp.	0.0353
kilograms (kg)	pounds	2.205
ounces avdp. (oz)	grams	28.3
pounds (lb)	kilograms	0.454
tons (long)	pounds	2240
tons (long)	kilograms	1016
tons (metric)	pounds	2205
tons (metric)	kilograms	1000
tons (short)	pounds	2000
tons (short)	kilograms	907

continued

To convert from:	To:	Multiply by:
<i>Pressure</i>		
atmosphere	grams/sq.cm	1033
atmosphere	pounds/sq.in	14.7
pounds/sq.in (psi)	grams/sq.cm	70.3
<i>Energy</i>		
British thermal units (Btu)	kilojoules	1.054
calories (cal)	joules	4.19
ergs	joules	1×10^{-7}
kilojoules (kJ)	Btu	0.948
joules (J)	calories	0.239
kilowatt-hours (kWh)	megajoules	3.6
megajoules (MJ)	kilojoules	1000
gigajoules (GJ)	megajoules	1000
terajoules (TJ)	gigajoules	1000
<i>Energy Density</i>		
Btu/gal	joules/cm ³	0.27
Btu/ft ³	kJ/m ³	36.5
<i>Power</i>		
horsepower (hp)	Btu/min	42.4
horsepower (hp)	horsepower (metric)	1.014
horsepower (hp)	kilowatts	0.746
kilowatts (kW)	horsepower	1.341
watts (W)	Btu/hour	3.41
watts (W)	joules/sec	1
<i>Miscellaneous</i>		
liter petrol	megajoules	35
kilogram oil	megajoules	43.2
barrel oil equivalent	gigajoules	6.1
ton coal equivalent	gigajoules	29.3
ton coal equivalent	barrels oil equivalent	4.8
pounds/acre	kilograms/hectare	1.1

SI units and conversion factors

Basic SI units, prefixes, and most common derived SI units used

Basic SI units

Quantity	Basic unit	Symbol
Length	metre	m
Mass	kilogram	kg
Time	second	s
Electric current	ampère	A
Temperature	kelvin	K

SI prefixes

Prefix	Symbol	Factor	Prefix	Symbol	Factor
exa	E	10 ¹⁸	deci	d	10 ⁻¹
peta	P	10 ¹⁵	centi	c	10 ⁻²
tera	T	10 ¹²	milli	m	10 ⁻³
giga	G	10 ⁹	micro	μ	10 ⁻⁶
mega	M	10 ⁶	nano	n	10 ⁻⁹
kilo	k	10 ³	pico	p	10 ⁻¹²
hecto	h	10 ²	femto	f	10 ⁻¹⁵
deca	da	10 ¹	atto	a	10 ⁻¹⁸

Most common derived SI units

Quantity	Unit	Symbol
Area	square metre	m ²
Volume (contents)	cubic metre	m ³
Speed	metre per second	m/s
Acceleration	metre per second, squared	m/s ²
Frequency	hertz	Hz (= s ⁻¹)
Pressure	pascal	Pa (= N/m ²)
Volume flow	cubic metre per second	m ³ /s
Mass flow	kilogram per second	kg/s
Density (specific mass)	kilogram per cubic metre	kg/m ³
Force	newton	N (= kg.m/s ²)
Energy/heat/work	joule	J (= N.m)*
Power/energy flow	watt	W (J/s)
Energy flux	watt per square metre	W/m ²
Calorific value (heat of combustion)	joule per kilogram	J/kg
Specific heat capacity	joule per kilogram kelvin	J/kg K
Voltage	volt	V (= W/A)

* NB The joule can also be written in the form watt second (1J = 1W.s)

Conversion of non-SI units to SI units

Although academic scientists and engineers may be strict in their use of SI units for their calculations, a number of non-SI units are still in everyday use. For example, engines are still sold by cc (cubic centimetres) and hp (horse power), and water-pumping windmill manufacturers often quote in terms of cubic feet of

the same type of equipment there is not always consistency. In order to be able to compare different manufacturers' products, therefore, it is important to be able to convert the different data to a common unit. The following tables give some useful conversion factors for many of the common non-SI units.

Conversion factors

Length

Unit (symbol)	millimetre (mm)	metre (m)	kilometre (km)	inch (in.)	foot (ft)	mile (m.)
1		0.001	10^{-6}	0.0394	0.0033	5.4×10^{-7}
1000		1	0.001	39.4	3.28	5.4×10^{-4}
10^6		1000	1	39360	3280	0.5392
25.4		0.025	2.5×10^{-5}	1	0.083	1.4×10^{-5}
305		0.305	3.0×10^{-4}	12	1	1.9×10^{-4}
1.6×10^6		1609	1.609	63360	5280	1

Area

Unit (symbol)	square metre (m ²)	hectare (ha)	square kilometre (km ²)	square foot (ft ²)	acre	square mile (sq. m.)
1		10^{-4}	10^{-6}	10.76	2.5×10^{-4}	3.9×10^{-7}
10000		1	0.01	1.1×10^5	2.471	3.9×10^{-3}
10^6		100	1	1.1×10^7	247.1	0.386
0.0929		9.3×10^{-6}	9.3×10^{-6}	1	2.3×10^{-5}	3.6×10^{-6}
4047		0.4047	4×10^{-3}	43560	1	1.6×10^{-3}
2.6×10^6		259	2.590	2.8×10^7	640	1

Volume

Unit (symbol)	litre (l)*	cubic metre (m ³)	cubic inch (in ³)	US gallon (gal)	Imperial gallon (gal)	cubic foot (ft ³)
1		10^{-3}	61.02	0.264	0.220	0.0353
1000		1	6102	264	220	35.31
0.0164		1.6×10^{-5}	1	4.3×10^{-3}	3.6×10^{-3}	5.8×10^{-4}
3.785		3.8×10^{-3}	231.1	1	0.833	0.134
4.546		4.5×10^{-3}	277.4	1.201	1	0.160
28.32		0.0283	1728	7.47	6.23	1

* L in some countries

Mass

Unit (symbol)	gram (g)	kilogram (kg)	tonne (t)	pound (lb)	ton
1		0.001	10^{-6}	2.2×10^{-3}	9.8×10^{-7}
1000		1	0.001	2.205	9.8×10^{-4}
10^6		1000	1	2205	0.984
453.6		0.4536	4.5×10^{-4}	1	4.5×10^{-4}
10^6		1016	1.016	2240	1

Velocity

Unit (symbol)	metres per second (m/s)	kilometres per hour (km/h)	feet per second (ft/s)	miles per hour (mph)	knots (kt)
1		3.60	3.28	2.237	1.942
0.278		1	0.912	0.621	0.539
0.305		1.097	1	0.682	0.592
0.447		1.609	1.467	1	0.868
0.566		1.853	1.689	1.152	1

Frequency

Unit (symbol)	hertz (Hz)	revolutions per minute (rpm)	radians per second (rad/s)
	1	60	6.283
	0.0167	1	0.1047
	0.159	9.549	1

Conversion factors

Flow rate

Unit (symbol)	litres per minute (l/min)	cubic metres per second (m ³ /s)	Imperial gallons per minute (gal(imp)/min)	cubic feet per second (ft ³ /s)
1		1.7×10^{-5}	0.220	5.9×10^{-4}
60000		1	13206	35.315
4.546		7.6×10^{-5}	1	2.7×10^{-3}
1699		0.0283	373.7	1

Force

Unit (symbol)	newton (N)	kilonewton (kN)	kilogram force (kgf)	tonne force (t)	pound force (lbf)	ton force —
1		0.001	0.102	1×10^{-4}	0.225	1×10^{-4}
1000		1	102	0.102	225	0.100
9.807		0.010	1	0.001	2.205	9.8×10^{-4}
9807		9.807	1000	1	2205	0.984
4.448		0.004	0.5436	4.5×10^{-4}	1	4.5×10^{-4}
9964		9.964	1016	1.1016	2240	1

Torque

Unit (symbol)	newton-metre (Nm)	kilonewton-metre (kNm)	foot-pound (ft.lbf)
1		0.001	0.738
1000		1	738
1.365		1.4×10^{-3}	1

Work/heat/energy (smaller quantities)

Unit (symbol)	calorie (cal)	joule (J)	watt-hour (Wh)	British Thermal Unit (BTU)	footpound force (ft.lbf)	horsepower-hour (hp.h)
1		4.182	1.2×10^{-3}	3.9×10^{-3}	3.088	1.6×10^{-6}
0.239		1	2.8×10^{-4}	9.4×10^{-4}	0.7376	3.7×10^{-7}
860.4		3600	1	3.414	2655	1.3×10^{-3}
252		1055	2.93	1	778	3.9×10^{-4}
0.324		1.356	3.8×10^{-4}	1.3×10^{-3}	1	5.0×10^{-7}
6.4×10^5		2.6×10^6	745.7	2546	2.0×10^6	1

Work/heat/energy (larger quantities)

Unit (symbol)	kilocalorie (kcal)	megajoule (MJ)	kilowatt hour (kWh)	British Thermal Unit (BTU)	horsepower-hour (hp.h)
1		4.2×10^{-3}	1.2×10^{-3}	3.968	1.6×10^{-3}
239		1	0.2887	947.8	0.3725
860.4		3.600	1	3414	1.341
0.252		1.1×10^{-3}	2.9×10^{-4}	1	3.9×10^{-4}
641.6		2.685	0.7457	2546	1

Conversion factors

Power						
Unit	watt	kilowatt	metric horse-power	foot-pound per second	horse-power	British Thermal Units per minute (BTU/min)
(symbol)	(W or J/s)	(kW)	(CV)	(ft.lbf/s)	(hp)	
	1	0.001	1.4×10^{-3}	0.7376	1.3×10^{-3}	0.0569
	1000	1	1.360	737.6	1.341	56.9
	735	0.735	1	558	1.014	41.8
	1.356	1.4×10^{-3}	1.8×10^{-3}	1	1.8×10^{-3}	0.077
	746	0.746	0.9860	550	1	42.44
	17.57	0.0176	0.0239	12.96	0.0236	1

Power flux

Unit (symbol)	watts per square metre (W/m ²)	kilowatts per square metre (kW/m ²)	horsepower per square foot (hp/ft ²)
	1	0.001	1.2×10^{-4}
	1000	1	0.1246
	8023	8.023	1

Calorific value (heat of combustion)

Unit (symbol)	calories per gram (cal/g)	megajoules per kilogram (MJ/kg)	British thermal units per pound (BTU/lb)
	1	4.2×10^{-3}	1.8
	239	1	430
	0.556	2.3×10^{-3}	1

Density (specific mass) and (net) calorific value (heat of combustion) of fuels

	Density (kg/m ³)	Calorific value (MJ/kg)
LPG	560	45.3
Gasoline (petrol)	720	44.0
Kerosene	806	43.1
Diesel oil	850	42.7
Fuel oil	961	40.1
Wood, oven-dried	varies	16-20
Natural gas	—	103m ³ at 1013 mbar, 0°C = 39.36×10^9 J

NB These values are approximate since the fuels vary in composition and this affects both the density and calorific value.

Replacement values

When trying to compare different fuel options, energy planners often use replacement values, which indicate in a specific situation how much fuel it would take to replace another one. For example, the tonne coal

equivalent (tce) would be used to say how much coal it would take to replace a given quantity of oil or natural gas. The table below gives some of the most common equivalence values.

Fuel	Unit	Tonnes of coal equivalent (tce)	Tonnes of oil equivalent (toe)	Barrels of oil equivalent (boe)	GJ*
Coal	tonne	1.00	0.70	5.05	29.3**
Firewood (air-dried)	tonne	0.46	0.32	2.34	13.6
Kerosene	tonne	1.47	1.03	7.43	43.1
Natural gas	1000m ³	1.19	0.83	6.00	34.8
Gasoline (petrol)	barrel***	0.18	0.12	0.90	5.2
Gasoil/diesel	barrel***	0.20	0.14	1.00	5.7

* GJ/tonne is numerically equivalent to MJ/kg

** The energy content of 1 tce and 1 toe varies. The values used here are the European Community norms:

1 tce = 29.31×10^9 J and 1 toe = 41.868×10^9 J

*** 1 barrel of oil = 42 US gallons = 0.158987 m³

Conversion factors

Power equivalents

	<i>Mtoe/yr</i>	<i>Mbd</i>	<i>Mtce/yr</i>	<i>GW_{th}</i>	<i>PJ/yr</i>
<i>Mtoe/yr</i>	1	0.02	1.55	1.43	45
<i>Mbd</i>	50	1	77	71	2235
<i>Mtce/yr</i>	0.65	0.013	1	0.92	29
<i>GW_{th}</i>	0.70	0.014	1.09	1	32
<i>PJ/yr</i>	0.02	4.5×10^{-4}	0.034	0.031	1

Mtoe/yr = Million tonnes of oil per year

Mbd = Million barrels of oil per day

Mtce/yr = Million tonnes of coal equivalent per year

GW_{th} = Gigawatts thermal (see page 203 for further information)

PJ/yr = Petrajoules per year

Conversions: length

Use of the table: the number of inches to be converted, which is made up by the number of inches at the head of a column and the fraction at the side of a line, is converted to the number in the position where line and column meet. For example, 1 1/64 in = 1 in + 1/64 in = 25.797 mm

Inches and fractions of an inch to Millimetres

1 in = 25.4 mm

in →	0	1	2	3	4	5	6	7	8	9	10	11	← in
↓	mm	mm	mm	mm	mm	mm	mm	mm	mm	mm	mm	mm	↓
0	0.000	25.400	50.800	76.200	101.600	127.000	152.400	177.800	203.200	228.600	254.000	279.400	0
1/64	0.397	25.797	51.197	76.597	101.997	127.397	152.797	178.197	203.597	228.997	254.397	279.797	1/64
1/32	0.794	26.194	51.594	76.994	102.394	127.794	153.194	178.594	203.994	229.394	254.794	280.194	1/32
3/64	1.191	26.591	51.991	77.391	102.791	128.191	153.591	178.991	204.391	229.791	255.191	280.591	3/64
1/16	1.588	26.988	52.388	77.788	103.188	128.588	153.988	179.388	204.788	230.188	255.588	280.988	1/16
5/64	1.984	27.384	52.784	78.184	103.584	128.984	154.384	179.784	205.184	230.584	255.984	281.384	5/64
3/32	2.381	27.781	53.181	78.581	103.981	129.381	154.781	180.181	205.581	230.981	256.381	281.781	3/32
7/64	2.778	28.178	53.578	78.978	104.378	129.778	155.178	180.578	205.978	231.378	256.778	282.178	7/64
1/8	3.175	28.575	53.975	79.375	104.775	130.175	155.575	180.975	206.375	231.775	257.175	282.575	1/8
9/64	3.572	28.972	54.372	79.772	105.172	130.572	155.972	181.372	206.772	232.172	257.572	282.972	9/64
5/32	3.969	29.369	54.769	80.169	105.569	130.969	156.369	181.769	207.169	232.569	257.969	283.369	5/32
11/64	4.366	29.766	55.166	80.566	105.966	131.366	156.766	182.166	207.566	232.966	258.366	283.766	11/64
3/16	4.762	30.162	55.562	80.962	106.362	131.762	157.162	182.562	207.962	233.362	258.762	284.162	3/16
13/64	5.159	30.559	55.959	81.359	106.759	132.159	157.559	182.959	208.359	233.759	259.159	284.559	13/64
7/32	5.556	30.956	56.356	81.756	107.156	132.556	157.956	183.356	208.756	234.156	259.556	284.956	7/32
15/64	5.953	31.353	56.753	82.153	107.553	132.953	158.353	183.753	209.153	234.553	259.953	285.353	15/64
1/4	6.350	31.750	57.150	82.550	107.950	133.350	158.750	184.150	209.550	234.950	260.350	285.750	1/4
17/64	6.747	32.147	57.547	82.947	108.347	133.747	159.147	184.547	209.947	235.347	260.747	286.147	17/64
9/32	7.144	32.544	57.944	83.344	108.744	134.144	159.544	184.944	210.344	235.744	261.144	286.544	9/32
19/64	7.541	32.941	58.341	83.741	109.141	134.541	159.941	185.341	210.741	236.141	261.541	286.941	19/64
5/16	7.938	33.338	58.738	84.138	109.538	134.938	160.338	185.738	211.138	236.538	261.938	287.338	5/16
21/64	8.334	33.734	59.134	84.534	109.934	135.334	160.734	186.134	211.534	236.934	262.334	287.734	21/64
11/32	8.731	34.131	59.531	84.931	110.331	135.731	161.131	186.531	211.931	237.331	262.731	288.131	11/32
23/64	9.128	34.528	59.928	85.328	110.728	136.128	161.528	186.928	212.328	237.728	263.128	288.528	23/64
3/8	9.525	34.925	60.325	85.725	111.125	136.525	161.925	187.325	212.725	238.125	263.525	288.925	3/8
25/64	9.922	35.322	60.722	86.122	111.522	136.922	162.322	187.722	213.122	238.522	263.922	289.322	25/64
13/32	10.319	35.719	61.119	86.519	111.919	137.319	162.719	188.119	213.519	238.919	264.319	289.719	13/32
27/64	10.716	36.116	61.516	86.916	112.316	137.716	163.116	188.516	213.916	239.316	264.716	290.116	27/64
7/16	11.112	36.512	61.912	87.312	112.712	138.112	163.512	188.912	214.312	239.712	265.112	290.512	7/16
29/64	11.509	36.909	62.309	87.709	113.109	138.509	163.909	189.309	214.709	240.109	265.509	290.909	29/64
15/32	11.906	37.306	62.706	88.106	113.506	138.906	164.306	189.706	215.106	240.506	265.906	291.306	15/32
31/64	12.303	37.703	63.103	88.503	113.903	139.303	164.703	190.103	215.503	240.903	266.303	291.703	31/64
1/2	12.700	38.100	63.500	88.900	114.300	139.700	165.100	190.500	215.900	241.300	266.700	292.100	1/2
33/64	13.097	38.497	63.897	89.297	114.697	140.097	165.497	190.897	216.297	241.697	267.097	292.497	33/64
17/32	13.494	38.894	64.294	89.694	115.094	140.494	165.894	191.294	216.694	242.094	267.494	292.894	17/32
35/64	13.891	39.291	64.691	90.091	115.491	140.891	166.291	191.691	217.091	242.491	267.891	293.291	35/64
9/16	14.288	39.688	65.088	90.488	115.888	141.288	166.688	192.088	217.488	242.888	268.288	293.688	9/16
37/64	14.684	40.084	65.484	90.884	116.284	141.684	167.084	192.484	217.884	243.284	268.684	294.084	37/64
19/32	15.081	40.481	65.881	91.281	116.681	142.081	167.481	192.881	218.281	243.681	269.081	294.481	19/32
39/64	15.478	40.878	66.278	91.678	117.078	142.478	167.878	193.278	218.678	244.078	269.478	294.878	39/64
5/8	15.875	41.275	66.675	92.075	117.475	142.875	168.275	193.675	219.075	244.475	269.875	295.275	5/8
41/64	16.272	41.672	67.072	92.472	117.872	143.272	168.672	194.072	219.472	244.872	270.272	295.672	41/64
21/32	16.669	42.069	67.469	92.869	118.269	143.669	169.069	194.469	219.869	245.269	270.669	296.069	21/32
43/64	17.066	42.466	67.866	93.266	118.666	144.066	169.466	194.866	220.266	245.666	271.066	296.466	43/64
11/16	17.462	42.862	68.262	93.662	119.062	144.462	169.862	195.262	220.662	246.062	271.462	296.862	11/16
45/64	17.859	43.259	68.659	94.059	119.459	144.859	170.259	195.659	221.059	246.459	271.859	297.259	45/64
23/32	18.256	43.656	69.056	94.456	119.856	145.256	170.656	196.056	221.456	246.856	272.256	297.656	23/32
47/64	18.653	44.053	69.453	94.853	120.253	145.653	171.053	196.453	221.853	247.253	272.653	298.053	47/64
3/4	19.050	44.450	69.850	95.250	120.650	146.050	171.450	196.850	222.250	247.650	273.050	298.450	3/4
49/64	19.447	44.847	70.247	95.647	121.047	146.447	171.847	197.247	222.647	248.047	273.447	298.847	49/64
25/32	19.844	45.244	70.644	96.044	121.444	146.844	172.244	197.644	223.044	248.444	273.844	299.244	25/32
51/64	20.241	45.641	71.041	96.441	121.841	147.241	172.641	198.041	223.441	248.841	274.241	299.641	51/64
13/16	20.638	46.038	71.438	96.838	122.238	147.638	173.038	198.438	223.838	249.238	274.638	300.038	13/16
53/64	21.034	46.434	71.834	97.234	122.634	148.034	173.434	198.834	224.234	249.634	275.034	300.434	53/64
27/32	21.431	46.831	72.231	97.631	123.031	148.431	173.831	199.231	224.631	250.031	275.431	300.831	27/32
55/64	21.828	47.228	72.628	98.028	123.428	148.828	174.228	199.628	225.028	250.428	275.828	301.228	55/64
7/8	22.225	47.625	73.025	98.425	123.825	149.225	174.625	200.025	225.425	250.825	276.225	301.625	7/8
57/64	22.622	48.022	73.422	98.822	124.222	149.622	175.022	200.422	225.822	251.222	276.622	302.022	57/64
29/32	23.019	48.419	73.819	99.219	124.619	150.019	175.419	200.819	226.219	251.619	277.019	302.419	29/32
59/64	23.416	48.816	74.216	99.616	125.016	150.416	175.816	201.216	226.616	252.016	277.416	302.816	59/64
15/16	23.812	49.212	74.612	100.012	125.412	150.812	176.212	201.612	227.012	252.412	277.812	303.212	15/16
61/64	24.209	49.609	75.009	100.409	125.809	151.209	176.609	202.009	227.409	252.809	278.209	303.609	61/64
31/32	24.606	50.006	75.406	100.806	126.206	151.606	177.006	202.406	227.806	253.206	278.606	304.006	31/32
63/64	25.003	50.403	75.803	101.203	126.603	152.003	177.403	202.803	228.203	253.603	279.003	304.403	63/64

Triangulation is an application of the principles of trigonometry to the calculation of inaccessible lines and angles.

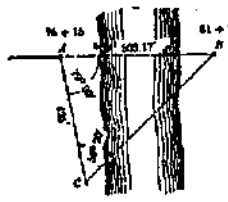

FIG. 1.

A common occasion for its use is illustrated in Fig. 1, where the line of survey crosses a stream too wide and deep for actual measurement. Set two points *A* and *B* on line, one on each side of the stream. Estimate roughly the distance *AB*. Suppose the estimate is 425 ft. Set another point *C*, making the distance *AC* equal to the estimated distance *AB* = 425 ft. Set the transit at *A* and measure the angle *BAC* = say, 79° 00'. Next set up at the point *C* and measure the angle *ACB* = say, 56° 20'. The angle *ABC* is then determined by subtracting the sum of the angles *A* and *C* from 180°; thus, 79° 00' + 56° 20' = 135° 20'; 180° 00' - 135° 20' = 44° 40' = the angle *ABC*. We now have a side and three angles of a triangle given, to find the other two sides *AB* and *CB*. In trigonometry, it is demonstrated that, in any triangle the sines of the angles are proportional to the lengths of the sides opposite to them. In other words, $\sin A : \sin B = BC : AC$; or, $\sin A : \sin C = BC : AB$, and $\sin B : \sin C = AC : AB$.

Hence, we have $\sin 44^\circ 40' : \sin 56^\circ 20' = 425 : \text{side } AB$;
 $\sin 56^\circ 20' = .83228$;
 $.83228 \times 425 = 353.719$;
 $\sin 44^\circ 40' = .70298$;
 $353.719 \div .70298 = 503.17 \text{ ft.} = \text{side } AB$.

Adding this distance to 76 + 15, the station of the point *A*, we have 81 + 18.17, the station at *B*.

Another case is the following: Two tangents, *AB* and *CD* (see Fig. 2), which are to be united by a curve, meet at some inaccessible point *E*. Tangents are the straight portions of a



FIG. 2.

line of railroad. The angle *CEF*, which the tangents make with each other, and the distances *BE* and *CE* are required. Two points *A* and *B* of the tangent *AB*, and two points *C* and *D* of the tangent *CD*, being carefully located, set the transit at *B*, and backsighting to *A*, measure the angle *EB C* = 21° 45'; set up at *C*, and, backsighting to *D*, measure the angle *EC B* = 21° 25'. Measure the side *BC* = 304.2 ft.

Angle *CE F* being an exterior angle of triangle *EBC* equals sum of *EB C* and *EC B* = 21° 45' + 21° 25' = 43° 10'; angle *BE C* = 180° - *CE F* = 136° 50'. From trigonometry, we have:
 $\sin 136^\circ 50' : \sin 21^\circ 45' = 304.2 \text{ ft.} : CE$;
 $\sin 21^\circ 45' = .37056$;
 $.37056 \times 304.2 = 112.724352$;
 $\sin 136^\circ 50' = .68412$;
 $\text{side } CE = 112.724352 \div .68412 = 164.77 \text{ ft.}$

Again, we find *BE* by the following proportion:

$\sin 136^\circ 50' : \sin 21^\circ 25' = 304.2 : \text{side } BE$;
 $\sin 21^\circ 25' = .36515$;
 $.36515 \times 304.2 = 111.07863$;
 $\sin 136^\circ 50' = .68412$;
 $\text{side } BE = 111.07863 \div .68412 = 162.36 \text{ ft.}$

A building *H*, Fig. 3, lies directly in the path of the line *AB*, which must be produced beyond *H*. Set a plug at *B*, and then turn an angle *DB C* = 60°. Set a plug at *C* in the line *BC*, at a suitable distance from *B*, say, 150 ft. Set up at *C*, and turn an angle *BC D* = 60°, and set a plug at *D*, 150 ft. from *C*. The point *D* will be in the prolongation of *AB*. Then, set up at *D*, and backsighting to *C*, turn the angle *CD D'* = 120°. *DD'* will be the line

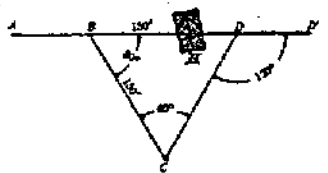

FIG. 3.

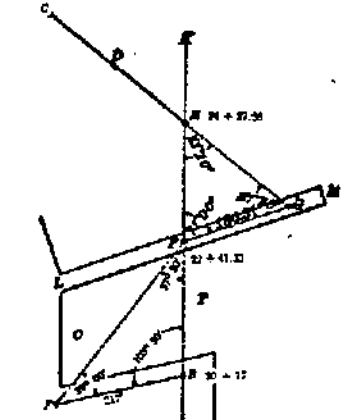

FIG. 4.

required, and the distance *BD* will be 150 ft., since *BCD* is an equilateral triangle.

AB and *CD*, Fig. 4, are tangents intersecting at some inaccessible point *H*. The line *AB* crosses a dock *OP*, too wide for direct measurement, and the wharf *LM*. *F* is a point on the line *AB* at the wharf crossing. It is required to find the distance *BH* and the angle *FHG*. At *B*, an angle of 103° 30' is turned to the left and the point *E* set 217' from *B* = to the estimated distance *BF*. Setting up at *E*, the angle *BE F* is found to be 39° 00'.

Whence, we find the angle $BFE = 180^\circ - (103^\circ 30' + 89^\circ) = 37^\circ 30'$.

From trigonometry, we have
 $\sin 37^\circ 30' : \sin 39^\circ 00' = 217 \text{ ft.} : \text{side } BF$;
 $\sin 39^\circ 00' = .62932$;
 $.62932 \times 217 = 136.56244$;
 $\sin 37^\circ 30' = .60876$;
 $\text{side } BF = 136.56244 \div .60876 = 224.33 \text{ ft.}$

Whence, we find station *F* to be 20 + 17 + 224.33 = 22 + 41.33. Set up at *F* and turn an angle *HFG* = 71° 00' and set up at a point *G* where the line *CD* prolonged intersects *FG*. Measure the angle *FGH* = 57° 50', and the side *FG* = 180.3. The angle *FHG* = 180° - (71° + 57° 50') = 51° 10'. From trigonometry we have

$\sin 51^\circ 10' : \sin 57^\circ 50' = 180.3 : \text{side } FH$.
 $\sin 57^\circ 50' = .84650$; $.84650 \times 180.3 = 152.62395$; $\sin 51^\circ 10' = .77897$; $\text{side } FH = 152.62395 \div .77897 = 195.93 \text{ ft.}$; whence we find station *H* to be 24 + 37.26.

NATURAL SINES

X	0'	8'	12'	18'	24'	30'	36'	42'	48'	54'	Δ	ADD				
	0°·0	0°·1	0°·2	0°·3	0°·4	0°·5	0°·6	0°·7	0°·8	0°·9		1'	2'	3'	4'	5'
	0°	0·0000	0017	0035	0052	0070	0087	0105	0122	0140		0157	18	3	6	9
1	·0175	0192	0209	0227	0244	0262	0279	0297	0314	0332		3	6	9	12	15
2	·0349	0366	0384	0401	0419	0435	0454	0471	0488	0506		3	6	9	12	15
3	·0523	0541	0558	0576	0593	0610	0628	0645	0663	0680		3	6	9	12	15
4	·0698	0715	0732	0750	0767	0785	0802	0819	0837	0854		3	6	9	12	14
5	0·0872	0889	0906	0924	0941	0958	0976	0993	1011	1028		3	6	9	12	14
6	·1045	1063	1080	1097	1115	1132	1149	1167	1184	1201		3	6	9	12	14
7	·1219	1236	1253	1271	1288	1305	1323	1340	1357	1374		3	6	9	12	14
8	·1392	1409	1426	1444	1461	1478	1495	1513	1530	1547		3	6	9	11	14
9	·1564	1582	1599	1616	1633	1650	1668	1685	1702	1719		3	6	9	11	14
10	0·1736	1754	1771	1788	1805	1822	1840	1857	1874	1891		3	6	9	11	14
11	·1908	1925	1942	1959	1977	1994	2011	2028	2045	2062		3	6	9	11	14
12	·2079	2096	2113	2130	2147	2164	2181	2198	2215	2233	17	3	6	9	11	14
13	·2250	2267	2284	2300	2317	2334	2351	2368	2385	2402		3	6	8	11	14
14	·2419	2436	2453	2470	2487	2504	2521	2538	2554	2571		3	6	8	11	14
15	0·2588	2605	2622	2639	2656	2672	2689	2706	2723	2740		3	6	8	11	14
16	·2756	2773	2790	2807	2823	2840	2857	2874	2890	2907		3	6	8	11	14
17	·2924	2940	2957	2974	2990	3007	3024	3040	3057	3074		3	6	8	11	14
18	·3090	3107	3123	3140	3156	3173	3190	3206	3223	3239		3	6	8	11	14
19	·3256	3272	3289	3305	3322	3338	3355	3371	3387	3404		3	5	8	11	14
20	0·3420	3437	3453	3469	3486	3502	3518	3535	3551	3567		3	5	8	11	14
21	·3584	3600	3616	3633	3649	3665	3681	3697	3714	3730		3	5	8	11	14
22	·3746	3762	3778	3795	3811	3827	3843	3859	3875	3891		3	5	8	11	13
23	·3907	3923	3939	3955	3971	3987	4003	4019	4035	4051	16	3	5	8	11	13
24	·4067	4083	4099	4115	4131	4147	4163	4179	4195	4210		3	5	8	11	13
25	0·4226	4242	4258	4274	4289	4305	4321	4337	4352	4368		3	5	8	11	13
26	·4384	4399	4415	4431	4446	4462	4478	4493	4509	4524		3	5	8	10	13
27	·4540	4555	4571	4586	4602	4617	4633	4648	4664	4679		3	5	8	10	13
28	·4695	4710	4726	4741	4756	4772	4787	4802	4818	4833		3	5	8	10	13
29	·4848	4863	4879	4894	4909	4924	4939	4955	4970	4985		3	5	8	10	13
30	0·5000	5015	5030	5045	5060	5075	5090	5105	5120	5135	15	3	5	8	10	13
31	·5150	5165	5180	5195	5210	5225	5240	5255	5270	5284		2	5	7	10	12
32	·5299	5314	5329	5344	5358	5373	5388	5402	5417	5432		2	5	7	10	12
33	·5446	5461	5476	5490	5505	5519	5534	5548	5563	5577		2	5	7	10	12
34	·5592	5606	5621	5635	5650	5664	5678	5693	5707	5721		2	5	7	10	12
35	0·5736	5750	5764	5779	5793	5807	5821	5835	5850	5864		2	5	7	9	12
36	·5878	5892	5906	5920	5934	5948	5962	5976	5990	6004	14	2	5	7	9	12
37	·6018	6032	6046	6060	6074	6088	6101	6115	6129	6143		2	5	7	9	12
38	·6157	6170	6184	6198	6211	6225	6239	6252	6266	6280		2	5	7	9	11
39	·6293	6307	6320	6334	6347	6361	6374	6388	6401	6414		2	4	7	9	11
40	0·6428	6441	6455	6468	6481	6494	6508	6521	6534	6547		2	4	7	9	11
41	·6561	6574	6587	6600	6613	6626	6639	6652	6665	6678	13	2	4	7	9	11
42	·6691	6704	6717	6730	6743	6756	6769	6782	6794	6807		2	4	6	9	11
43	·6820	6833	6845	6858	6871	6884	6896	6909	6921	6934		2	4	6	8	11
44	·6947	6959	6972	6984	6997	7009	7022	7034	7046	7059		2	4	6	8	10
45	0·7071	7083	7096	7108	7120	7133	7145	7157	7169	7181		2	4	6	8	10
46	·7193	7206	7218	7230	7242	7254	7266	7278	7290	7302	12	2	4	6	8	10
47	·7314	7325	7337	7349	7361	7373	7385	7396	7408	7420		2	4	6	8	10
48	·7431	7443	7455	7466	7478	7490	7501	7513	7524	7536		2	4	6	8	10
49	0·7547	7559	7570	7581	7593	7604	7615	7627	7638	7649		2	4	6	8	9

X	0'	6'	12'	18'	24'	30'	36'	42'	48'	54'	Δ	ADD					
	0°-0	0°-1	0°-2	0°-3	0°-4	0°-5	0°-6	0°-7	0°-8	0°-9		1'	2'	3'	4'	5'	
50	0-7660	7672	7683	7694	7705	7716	7727	7738	7749	7760			2	4	6	7	9
51	-7771	7782	7793	7804	7815	7826	7837	7848	7859	7869	11		2	4	5	7	9
52	-7880	7891	7902	7912	7923	7934	7944	7955	7965	7976			2	4	5	7	9
53	-7986	7997	8007	8018	8028	8039	8049	8059	8070	8080			2	3	5	7	9
54	-8090	8100	8111	8121	8131	8141	8151	8161	8171	8181	10		2	3	5	7	8
55	0-8192	8202	8211	8221	8231	8241	8251	8261	8271	8281			2	3	5	7	8
56	-8290	8300	8310	8320	8329	8339	8348	8358	8368	8377			2	3	5	6	8
57	-8387	8396	8406	8415	8425	8434	8443	8453	8462	8471			2	3	5	6	8
58	-8480	8490	8499	8508	8517	8526	8536	8545	8554	8563	9		2	3	5	6	8
59	-8572	8581	8590	8599	8607	8616	8625	8634	8643	8652			1	3	4	6	7
60	0-8660	8669	8678	8686	8695	8704	8712	8721	8729	8738			1	3	4	6	7
61	-8746	8755	8763	8771	8780	8788	8796	8805	8813	8821			1	3	4	6	7
62	-8829	8838	8846	8854	8862	8870	8878	8886	8894	8902	8		1	3	4	5	7
63	-8910	8918	8926	8934	8942	8949	8957	8965	8973	8980			1	3	4	5	6
64	-8988	8996	9003	9011	9018	9026	9033	9041	9048	9056			1	3	4	5	6
65	0-9063	9070	9078	9085	9092	9100	9107	9114	9121	9128			1	2	4	5	6
66	-9135	9143	9150	9157	9164	9171	9178	9184	9191	9198	7		1	2	4	5	6
67	-9205	9212	9219	9225	9232	9239	9245	9252	9259	9265			1	2	3	4	6
68	-9272	9278	9285	9291	9298	9304	9311	9317	9323	9330			1	2	3	4	5
69	-9336	9342	9348	9354	9361	9367	9373	9379	9385	9391	6		1	2	3	4	5
70	0-9397	9403	9409	9415	9421	9426	9432	9438	9444	9449			1	2	3	4	5
71	-9455	9461	9466	9472	9478	9483	9489	9494	9500	9505			1	2	3	4	5
72	-9511	9516	9521	9527	9532	9537	9542	9548	9553	9558			1	2	3	4	5
73	-9563	9568	9573	9578	9583	9588	9593	9598	9603	9608	5		1	2	2	3	4
74	-9613	9617	9622	9627	9632	9636	9641	9646	9650	9655			1	2	2	3	4
75	0-9659	9664	9668	9673	9677	9681	9686	9690	9694	9699			1	1	2	3	4
76	-9703	9707	9711	9715	9720	9724	9728	9732	9736	9740	4		1	1	2	3	3
77	-9744	9748	9751	9755	9769	9763	9767	9770	9774	9778			1	1	2	2	3
78	-9781	9785	9789	9792	9796	9799	9803	9806	9810	9813			1	1	2	2	3
79	-9816	9820	9823	9826	9829	9833	9836	9839	9842	9845			1	1	2	2	3
80	0-9848	9851	9854	9857	9860	9863	9866	9869	9871	9874	3		0	1	1	2	2
81	-9877	9880	9882	9885	9888	9890	9893	9895	9898	9900			0	1	1	2	2
82	-9903	9905	9907	9910	9912	9914	9917	9919	9921	9923			0	1	1	1	2
83	-9925	9928	9930	9932	9934	9936	9938	9940	9942	9943	2		0	1	1	1	2
84	-9945	9947	9949	9951	9952	9954	9956	9957	9959	9960			0	1	1	1	1
85	0-9962	9963	9965	9966	9968	9969	9971	9972	9973	9974			0	0	1	1	1
86	-9976	9977	9978	9979	9980	9981	9982	9983	9984	9985	1		0	0	1	1	1
87	-9986	9987	9988	9989	9990	9990	9991	9992	9993	9993							
88	-9994	9995	9995	9996	9996	9997	9997	9997	9998	9998							
89	0-9998	9999	9999	9999	9999	1-000	1-000	1-000	1-000	1-000							
90	1-0000																

Sines of Angles near 90°

o	sine	o	sine	o	
86 48	0-9985	86-80	87 46	0-9993	87-7
86 54	0-9986	86-91	87 56	0-9994	87-9
87 01	0-9987	87-02	88 05	0-9995	88-0
87 08	0-9988	87-13	88 16	0-9996	88-2
87 15	0-9989	87-25	88 29	0-9997	88-4
87 22	0-9990	87-37	88 43	0-9998	88-7
87 30	0-9991	87-50	89 00	0-9999	89-0
87 38	0-9992	87-63	89 25	0-9999	89-4
87 46		87-78	90 00	1-0000	90-0

The values in the centre columns represent the sines for all angles lying between the successive ranges shown in the outer columns. Thus sin 87° 20' is 0-9989. For inverse use, the best angle for a given sine is the one lying midway between the adjacent ranges; if the difference is odd, choose the angle nearer 90°. Thus if sin x = 0-9988, x = 87° 12'.

For tabulated angles read the sine value in the half-line above; e.g., sin 87° 38' = 0-9991.

See Table below.

x	0'	5'	12'	18'	24'	30'	36'	42'	48'	54'	Δ	SUBTRACT				
	0°-0	0°-1	0°-2	0°-3	0°-4	0°-5	0°-6	0°-7	0°-8	0°-9		1'	2'	3'	4'	5'
0°	1.000	1.000	1.000	1.000	1.000	1.000	0.9999	0.9999	0.9999	0.9999		See table at foot of page.				
1	0.9998	9998	9998	9997	9997	9997	9996	9996	9995	9995						
2	9994	9993	9993	9992	9991	9990	9990	9989	9988	9987						
3	9986	9985	9984	9983	9982	9981	9980	9979	9978	9977	1	0	0	1	1	1
4	9976	9974	9973	9972	9971	9969	9968	9966	9965	9963		0	0	1	1	1
5	0.9962	9960	9959	9957	9956	9954	9952	9951	9949	9947		0	1	1	1	1
6	9945	9943	9942	9940	9938	9936	9934	9932	9930	9928	2	0	1	1	1	2
7	9925	9923	9921	9919	9917	9914	9912	9910	9907	9905		0	1	1	1	2
8	9903	9900	9898	9895	9893	9890	9888	9885	9882	9880		0	1	1	2	2
9	9877	9874	9871	9869	9866	9863	9860	9857	9854	9851	3	0	1	1	2	2
10	0.9848	9845	9842	9839	9836	9833	9829	9826	9823	9820		1	1	2	2	3
11	9816	9813	9810	9806	9803	9799	9796	9792	9789	9785		1	1	2	2	3
12	9781	9778	9774	9770	9767	9763	9759	9755	9751	9748		1	1	2	3	3
13	9744	9740	9736	9732	9728	9724	9720	9715	9711	9707	4	1	1	2	3	3
14	9703	9699	9694	9690	9686	9681	9677	9673	9668	9664		1	1	2	3	4
15	0.9659	9655	9650	9646	9641	9636	9632	9627	9622	9617		1	2	2	3	4
16	9613	9608	9603	9598	9593	9588	9583	9578	9573	9568	5	1	2	2	3	4
17	9563	9558	9553	9548	9542	9537	9532	9527	9521	9516		1	2	3	3	4
18	9511	9505	9500	9494	9489	9483	9478	9472	9466	9461		1	2	3	4	5
19	9455	9449	9444	9438	9432	9426	9421	9415	9409	9403		1	2	3	4	5
20	0.9397	9391	9385	9379	9373	9367	9361	9354	9348	9342	6	1	2	3	4	5
21	9336	9330	9323	9317	9311	9304	9298	9291	9285	9278		1	2	3	4	5
22	9272	9265	9259	9252	9245	9239	9232	9225	9219	9212		1	2	3	4	6
23	9205	9198	9191	9184	9178	9171	9164	9157	9150	9143	7	1	2	4	5	6
24	9135	9128	9121	9114	9107	9100	9092	9085	9078	9070		1	2	4	5	6
25	0.9063	9056	9048	9041	9033	9026	9018	9011	9003	8996		1	3	4	5	6
26	8988	8980	8973	8965	8957	8949	8942	8934	8926	8918		1	3	4	5	6
27	8910	8902	8894	8886	8878	8870	8862	8854	8846	8838	8	1	3	4	5	7
28	8829	8821	8813	8805	8796	8788	8780	8771	8763	8755		1	3	4	6	7
29	8746	8738	8729	8721	8712	8704	8695	8686	8678	8669		1	3	4	6	7
30	0.8660	8652	8643	8634	8625	8616	8607	8599	8590	8581		1	3	4	6	7
31	8572	8563	8554	8545	8536	8526	8517	8508	8499	8490	9	2	3	5	6	8
32	8480	8471	8462	8453	8443	8434	8425	8415	8406	8396		2	3	5	6	8
33	8387	8377	8368	8358	8348	8339	8329	8320	8310	8300		2	3	5	6	8
34	8290	8281	8271	8261	8251	8241	8231	8221	8211	8202		2	3	5	7	8
35	0.8192	8181	8171	8161	8151	8141	8131	8121	8111	8100	10	2	3	5	7	8
36	8090	8080	8070	8059	8049	8039	8028	8018	8007	7997		2	3	5	7	9
37	7986	7976	7965	7955	7944	7934	7923	7912	7902	7891		2	4	5	7	9
38	7880	7869	7859	7848	7837	7826	7815	7804	7793	7782	11	2	4	5	7	9
39	0.7771	7760	7749	7738	7727	7716	7705	7694	7683	7672		2	4	6	7	9

Cosines of Small Angles

cosine	cosine	cosine	cosine
0 00	1.0000	0-0	2 13
0 34	0.9999	0-5	2 21
0 59	0.9998	0-9	2 29
1 16	0.9997	1-2	2 37
1 30	0.9996	1-5	2 44
1 43	0.9995	1-7	2 51
1 54	0.9994	1-9	2 58
2 03	0.9993	2-0	3 05
2 13	0.9993	2-2	3 11
			0.9992
			0.9991
			0.9990
			0.9989
			0.9988
			0.9987
			0.9986
			0.9985
			0.9984
			0.9983
			0.9982
			0.9981
			0.9980
			0.9979
			0.9978
			0.9977
			0.9976
			0.9975
			0.9974
			0.9973
			0.9972
			0.9971
			0.9970
			0.9969
			0.9968
			0.9967
			0.9966
			0.9965
			0.9964
			0.9963
			0.9962
			0.9961
			0.9960
			0.9959
			0.9958
			0.9957
			0.9956
			0.9955
			0.9954
			0.9953
			0.9952
			0.9951
			0.9950
			0.9949
			0.9948
			0.9947
			0.9946
			0.9945
			0.9944
			0.9943
			0.9942
			0.9941
			0.9940
			0.9939
			0.9938
			0.9937
			0.9936
			0.9935
			0.9934
			0.9933
			0.9932
			0.9931
			0.9930
			0.9929
			0.9928
			0.9927
			0.9926
			0.9925
			0.9924
			0.9923
			0.9922
			0.9921
			0.9920
			0.9919
			0.9918
			0.9917
			0.9916
			0.9915
			0.9914
			0.9913
			0.9912
			0.9911
			0.9910
			0.9909
			0.9908
			0.9907
			0.9906
			0.9905
			0.9904
			0.9903
			0.9902
			0.9901
			0.9900
			0.9899
			0.9898
			0.9897
			0.9896
			0.9895
			0.9894
			0.9893
			0.9892
			0.9891
			0.9890
			0.9889
			0.9888
			0.9887
			0.9886
			0.9885
			0.9884
			0.9883
			0.9882
			0.9881
			0.9880
			0.9879
			0.9878
			0.9877
			0.9876
			0.9875
			0.9874
			0.9873
			0.9872
			0.9871
			0.9870
			0.9869
			0.9868
			0.9867
			0.9866
			0.9865
			0.9864
			0.9863
			0.9862
			0.9861
			0.9860
			0.9859
			0.9858
			0.9857
			0.9856
			0.9855
			0.9854
			0.9853
			0.9852
			0.9851
			0.9850
			0.9849
			0.9848
			0.9847
			0.9846
			0.9845
			0.9844
			0.9843
			0.9842
			0.9841
			0.9840
			0.9839

x	0'	6'	12'	18'	24'	30'	36'	42'	48'	54'	Δ	ADD					
	0°·0	0°·1	0°·2	0°·3	0°·4	0°·5	0°·6	0°·7	0°·8	0°·9		1'	2'	3'	4'	5'	
	0°	0·0000	0017	0035	0052	0070	0087	0105	0122	0140		0157	18	3	6	9	12
1	·0175	0192	0209	0227	0244	0262	0279	0297	0314	0332	3	6		9	12	15	
2	·0349	0367	0384	0402	0419	0437	0454	0472	0489	0507	3	6		9	12	15	
3	·0524	0542	0559	0577	0594	0612	0629	0647	0664	0682	3	6		9	12	15	
4	·0699	0717	0734	0752	0769	0787	0805	0822	0840	0857	3	6		9	12	15	
5	0·0875	0892	0910	0928	0945	0963	0981	0998	1016	1033	3	6		9	12	15	
6	·1051	1069	1086	1104	1122	1139	1157	1175	1192	1210	3	6		9	12	15	
7	·1228	1246	1263	1281	1299	1317	1334	1352	1370	1388	3	6		9	12	15	
8	·1405	1423	1441	1459	1477	1495	1512	1530	1548	1566	3	6		9	12	15	
9	·1584	1602	1620	1638	1655	1673	1691	1709	1727	1745	3	6		9	12	15	
10	0·1763	1781	1799	1817	1835	1853	1871	1890	1908	1926	3	6		9	12	15	
11	·1944	1962	1980	1998	2016	2035	2053	2071	2089	2107	3	6		9	12	15	
12	·2126	2144	2162	2180	2199	2217	2235	2254	2272	2290	3	6		9	12	15	
13	·2309	2327	2345	2364	2382	2401	2419	2438	2456	2475	3	6		9	12	15	
14	·2493	2512	2530	2549	2568	2586	2605	2623	2642	2661	3	6	9	12	16		
15	0·2679	2698	2717	2736	2754	2773	2792	2811	2830	2849	19	3	6	9	13	16	
16	·2867	2886	2905	2924	2943	2962	2981	3000	3019	3038		3	6	10	13	16	
17	·3057	3076	3096	3115	3134	3153	3172	3191	3211	3230		3	6	10	13	16	
18	·3249	3269	3288	3307	3327	3346	3365	3385	3404	3424		3	6	10	13	16	
19	·3443	3463	3482	3502	3522	3541	3561	3581	3600	3620		3	7	10	13	16	
20	0·3640	3659	3679	3699	3719	3739	3759	3779	3799	3819	20	3	7	10	13	17	
21	·3839	3859	3879	3899	3919	3939	3959	3979	4000	4020		3	7	10	13	17	
22	·4040	4061	4081	4101	4122	4142	4163	4183	4204	4224		3	7	10	14	17	
23	·4245	4265	4286	4307	4327	4348	4369	4390	4411	4431		3	7	10	14	17	
24	·4452	4473	4494	4515	4536	4557	4578	4599	4621	4642		21	4	7	11	14	18
25	0·4663	4684	4706	4727	4748	4770	4791	4813	4834	4856	22	4	7	11	14	18	
26	·4877	4899	4921	4942	4964	4986	5008	5029	5051	5073		4	7	11	15	18	
27	·5095	5117	5139	5161	5184	5206	5228	5250	5272	5295		4	7	11	15	18	
28	·5317	5340	5362	5384	5407	5430	5452	5475	5498	5520		4	8	11	15	19	
29	·5543	5566	5589	5612	5635	5658	5681	6704	5727	5750		23	4	8	12	15	19
30	0·5774	5797	5820	5844	5867	5890	5914	5938	5961	5985	24	4	8	12	16	20	
31	·6009	6032	6056	6080	6104	6128	6152	6176	6200	6224		4	8	12	16	20	
32	·6249	6273	6297	6322	6346	6371	6395	6420	6445	6469		4	8	12	16	20	
33	·6494	6519	6544	6569	6594	6619	6644	6669	6694	6720		25	4	8	13	17	21
34	·6745	6771	6796	6822	6847	6873	6899	6924	6950	6976		4	9	13	17	21	
35	0·7002	7028	7054	7080	7107	7133	7159	7186	7212	7239	26	4	9	13	17	22	
36	·7266	7292	7319	7346	7373	7400	7427	7454	7481	7508		27	5	9	14	18	23
37	·7536	7563	7590	7618	7646	7673	7701	7729	7757	7785		28	5	9	14	19	23
38	·7813	7841	7869	7898	7926	7954	7983	8012	8040	8069		29	5	10	14	19	24
39	·8098	8127	8156	8185	8214	8243	8273	8302	8332	8361		29	5	10	15	19	24
40	0·8391	8421	8451	8481	8511	8541	8571	8601	8632	8662	30	5	10	15	20	25	
41	·8693	8724	8754	8785	8816	8847	8878	8910	8941	8972		31	5	10	16	21	26
42	·9004	9036	9067	9099	9131	9163	9195	9228	9260	9293		32	5	11	16	21	27
43	·9325	9358	9391	9424	9457	9490	9523	9556	9590	9623		33	6	11	17	22	28
44	·9657	9691	9725	9759	9793	9827	9861	9896	9930	9965		34	6	11	17	23	28
45	1·0000	0035	0070	0105	0141	0176	0212	0247	0283	0319	36	6	12	18	24	30	
46	·0355	0392	0428	0464	0501	0538	0575	0612	0649	0686		37	6	12	18	25	31
47	·0724	0761	0799	0837	0875	0913	0951	0990	1028	1067		38	6	13	19	25	32
48	·1106	1145	1184	1224	1263	1303	1343	1383	1423	1463		40	7	13	20	27	33
49	1·1504	1544	1585	1626	1667	1708	1750	1792	1833	1875		42	7	14	21	28	35

NATURAL TANGENTS

X	0'	8'	12'	18'	24'	30'	36'	42'	48'	54'	Δ	ADD					
	0°-0	0°-1	0°-2	0°-3	0°-4	0°-5	0°-6	0°-7	0°-8	0°-9		1'	2'	3'	4'	5'	
50°	1.192	196	200	205	209	213	217	222	226	230		1	1	2	3	4	
51	.235	239	244	248	253	257	262	266	271	275		1	2	2	3	4	
52	.280	285	289	294	299	303	308	313	317	322		1	2	2	3	4	
53	.327	332	337	342	347	351	356	361	366	371		1	2	2	3	4	
54	.376	381	387	392	397	402	407	412	418	423	5	1	2	2	3	4	
55	1.428	433	439	444	450	455	460	466	471	477		1	2	3	4	5	
56	.483	488	494	499	505	511	517	522	528	534		1	2	3	4	5	
57	.540	546	552	558	564	570	576	582	588	594	6	1	2	3	4	5	
58	.600	607	613	619	625	632	638	645	651	658		1	2	3	4	5	
59	.664	671	678	684	691	698	704	711	718	725		1	2	3	5	6	
60	1.732	739	746	753	760	767	775	782	789	797	7	1	2	4	5	6	
61	.804	811	819	827	834	842	849	857	865	873		1	3	4	5	6	
62	.881	889	897	905	913	921	929	937	946	954	8	1	3	4	5	7	
63	1.963	971	980	988	1.997	2.006	2.014	2.023	2.032	2.041		1	3	4	6	7	
64	2.050	059	069	078	087	097	106	116	125	135	9	2	3	5	6	8	
65	2.145	154	164	174	184	194	204	215	225	236	10	2	3	5	7	8	
66	.246	257	267	278	289	300	311	322	333	344	11	2	4	6	7	9	
67	.356	367	379	391	402	414	426	438	450	463	12	2	4	6	8	10	
68	.475	488	500	513	526	539	552	565	578	592	13	2	4	6	9	11	
69	.605	619	633	646	660	675	689	703	718	733	14	2	5	7	9	12	
70	2.747	762	778	793	808	824	840	856	872	888	16	3	5	8	11	13	
71	2.904	921	937	954	971	2.989	3.006	3.024	3.042	3.060	17	3	6	9	11	14	
72	3.078	096	115	133	152	3.172	172	191	211	230	251	20	3	6	9	13	16
73	.271	291	312	333	354	376	398	420	442	465	22	4	7	10	14	18	
74	.487	511	534	558	582	606	630	655	681	706	24	4	8	12	16	20	
75	3.732	758	785	812	839	867	895	923	952	981	27	4	9	14	18	22	
76	4.011	041	071	102	134	4.165	165	198	230	264	297	29	5	10	14	19	24
77	4.331	366	402	437	474	511	548	586	625	665	33	6	11	17	22	28	
78	4.705	745	787	829	872	4.915	915	959	5.005	5.050	5.097	36	6	12	18	24	30
79	5.145	193	242	292	343	5.396	396	449	503	558	614	39	7	13	19	26	32
80	5.671	5.730	5.789	5.850	5.912	5.976	6.041	6.107	6.174	6.243	42	7	14	21	28	35	
81	6.314	6.386	6.460	6.535	6.612	6.691	6.772	6.855	6.940	7.026	46	8	15	23	31	38	
82	7.115	7.207	7.300	7.396	7.495	7.596	7.700	7.806	7.916	8.028	50	8	17	26	33	42	
83	8.144	8.264	8.386	8.513	8.643	8.777	8.915	9.058	9.205	9.357	55	9	18	28	37	46	
84	9.514	9.677	9.845	10.02	10.20	10.39	10.58	10.78	10.99	11.20							
85	11.43	11.66	11.91	12.16	12.43	12.71	13.00	13.30	13.62	13.95		10	20	30	41	51	
86	14.30	14.67	15.06	15.46	15.89	16.35	16.83	17.34	17.89	18.46		11	23	34	45	56	
87	19.08	19.74	20.45	21.20	22.02	22.90	23.86	24.90	26.03	27.27		13	25	38	50	63	
88	28.64	30.14	31.82	33.69	35.80	38.19	40.92	44.07	47.74	52.08		14	28	42	57	71	
89	57.29	63.66	71.62	81.85	95.49	114.6	143.2	191.0	286.5	573.0							
90	∞																

Differences vary too rapidly for interpolation by P.P.s. See table on page 22.