

# **AT** MICROFICHE REFERENCE LIBRARY

A project of Volunteers in Asia

Elementary Guide to Fish Culture in Nepal

by: Elek Woynarovich

Published by:

Food and Agriculture Organization of the  
United Nations

Via delle Terme di Caracalla

00100 Rome

Italy

Paper copies are \$ 5.50.

Available from:

META Publications

P.O. Box 128

Marblemount, WA 98267 USA

Reproduced by permission of the Food and  
Agriculture Organization of the United Nations.

Reproduction of this microfiche document in any  
form is subject to the same restrictions as those  
of the original document.

**Elementary Guide to  
FISH CULTURE  
in Nepal**

**ELEMENTARY GUIDE TO FISH CULTURE IN NEPAL**

by  
**Dr. Elek Woynarovich**  
**FAO Inland Fishery Biologist**

**FOOD AND AGRICULTURE ORGANIZATION OF THE UNITED NATIONS**  
**Rome, 1975**

#### FOREWORD

This "Elementary Guide to Fish Culture in Nepal" is designed for practical use in the training of extension workers and progressive fish farmers in the techniques of fish culture. Recent experience in a pilot commercial fish culture demonstration in Nepal has shown that it has a promising future in this land-locked country.

The guide was written by Dr. Elek Woynarovich, FAO Inland Fishery Biologist, during his assignment in Nepal on the FAO/UNDP Inland Fishery Biology Project (DP/NEP/68/008) between March 1968 and December 1973. Dr. Woynarovich, a noted international expert in fish culture, has compiled this document based on his many years of experience and his recent work on the project in Nepal.

The detailed and practical information covered in this guide ranges from "fish ponds and their construction", the "biological background of fish production in ponds" and "fish culture" through the "propagation of cultivated fishes". Included are 49 drawings by the author, which depict the various factors involved in fish culture. The cover photograph shows part of the first catch of carp at the Government's Piplely Fish Farm.

Grateful acknowledgement is made for the financial assistance provided for the publication of this document by funds contributed from the joint Unesco/FFHC Gift Coupon Project 390 "Food for all Mankind".

The designations employed and the presentation of the material in this document do not imply the expression of any opinion whatsoever on the part of the United Nations or the Food and Agriculture Organisation of the United Nations concerning the legal or constitutional status of any country, territory or sea area, or concerning the delimitation of frontiers.

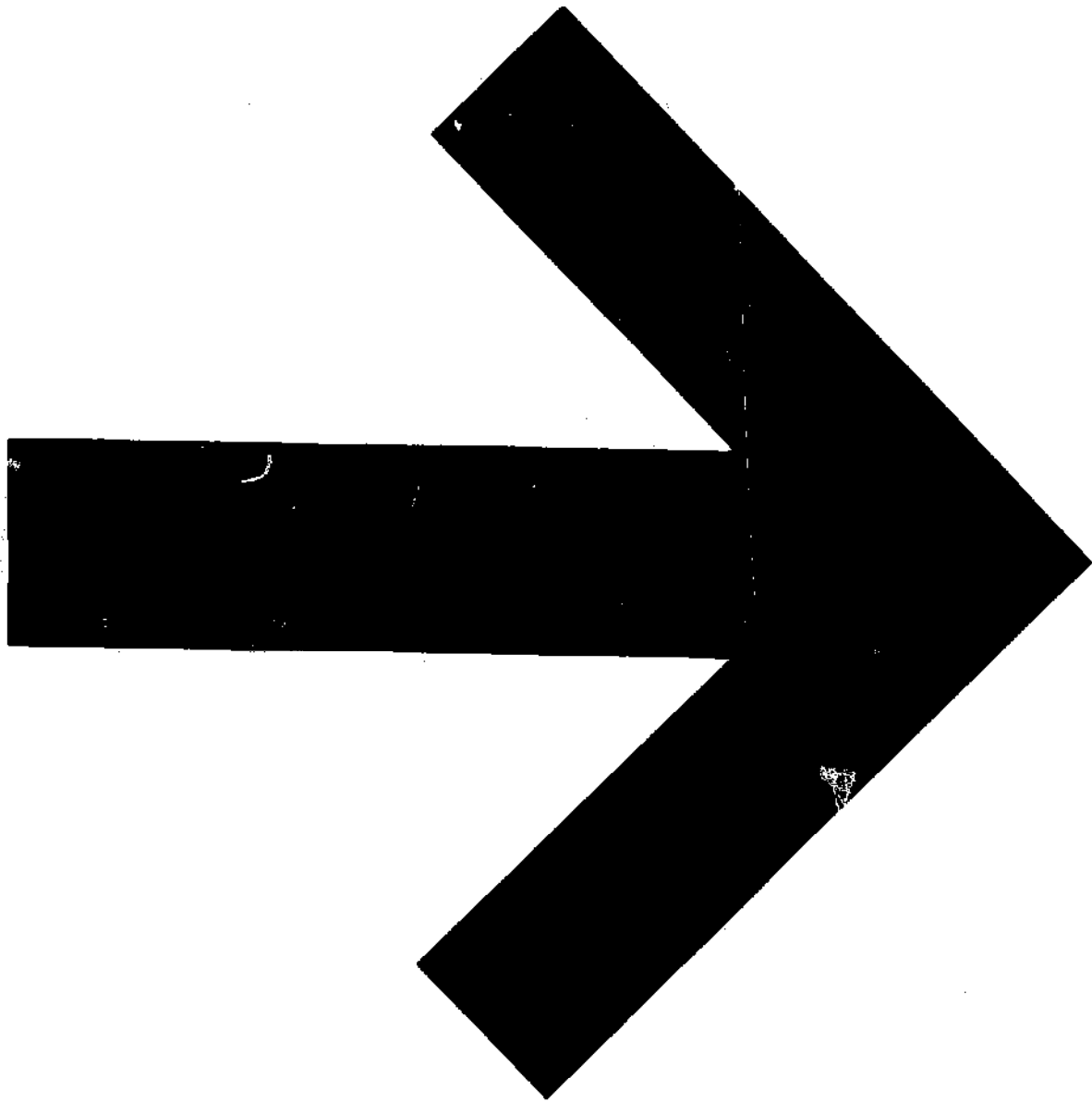

TABLE OF CONTENTS

	<u>Page</u>
<b>1. FISH PONDS AND THEIR CONSTRUCTION</b>	<b>1</b>
1.1 Introduction	1
1.2 The fish pond and its construction	2
1.2.1 General remarks on fish ponds	2
1.2.2 Economic size of fish ponds	2
1.2.3 Economic depth of fish ponds	2
1.2.4 Types of fish ponds	3
1.2.5 Construction of fish ponds	4
<b>2. BIOLOGICAL BACKGROUND OF FISH PRODUCTION IN PONDS</b>	<b>16</b>
2.1 Types of organisms	16
2.2 Important physico-chemical characteristics of a freshwater pond	17
2.2.1 Specific gravity	17
2.2.2 Light penetration	17
2.2.3 Colour	18
2.2.4 Temperature	18
2.2.5 Currents and water movements	18
2.2.6 Dissolved gases	18
2.2.7 Dissolved oxygen	18
2.2.8 Dissolved nitrogen	19
2.2.9 Dissolved carbon dioxide	20
2.2.10 Methane and hydrogen sulphide	20
2.2.11 Chemical constituents of water	20
2.3 The life zones in a pond	20
2.3.1 The shore or littoral zone	20
2.3.2 Open waters	20
2.3.3 Bottom of the pond	21
2.4 Food, feeding and reproduction of important groups of aquatic organisms	21
2.4.1 Decomposing bacteria	21
2.4.2 Unicellular algae	21
2.4.3 Filamentous and other types of algae living in colonies	21
2.4.4 Rotatoria	21
2.4.5 Filtering crustaceans	21
2.4.6 Carnivorous crustaceans	22
2.4.7 Mud eaters	22
2.4.8 Carnivorous insects and insect larvae	22
2.4.9 Tadpoles	22

	<u>Page</u>
2.5 The food chain	22
2.6 Production biology	23
2.7 The production processes in the pond	23
2.7.1 Primary producers	24
2.7.2 Secondary and tertiary production	24
2.7.3 Decomposition and recuperation	24
2.7.4 The production process	25
2.7.5 The role of stocked fish in increasing the productivity of the pond	25
2.8 Plankton investigations for practical purposes	25
2.9 Bottom soil and water interactions	26
2.10 Investigation of bottom animals	27
3. FISH CULTURE	28
3.1 Species of fish suitable for culture	28
3.1.1 The common carp (Israeli carp, German carp), <u>Cyprinus carpio</u>	28
3.1.2 Chinese carps (herbivorous carps)	29
3.1.3 Indian major carps	31
3.1.4 Other fishes for culture	32
3.1.5 Predatory or carnivorous fishes	32
3.2 The management of fish ponds	33
3.2.1 General duties of a good fishery manager	33
3.2.2 Fish culture operations	33
3.2.3 Improvement of environment	39
3.2.4 Feeding of cultivated fish	52
3.2.5 Growth of common carp	54
3.2.6 Feeding of common carp	57
3.2.7 Feeding of grass carp	65
3.2.8 Calculating food utilization	65
3.2.9 Harvesting (cropping)	67
3.2.10 Recording of cropping data	67
3.2.11 Storage and transport of fish	68
4. PROPAGATION OF CULTIVATED FISHES	70
4.1 Sexual maturity	70
4.2 Spawning period	70
4.3 Production of fish seed	71
4.3.1 Natural propagation of the common carp	71
4.3.2 Semi-artificial propagation of common carp	73
4.3.3 Artificial propagation of common carp	74
4.3.4 Hatcheries for cultivated fishes	79
4.3.5 Devices for egg incubation and fry rearing	80
4.3.6 Artificial propagation of Chinese carp	83



LIST OF FIGURES

	<u>Page</u>
1. Small contour ponds built along a canal	91
2. Contour ponds	92
3. A simple method for topographical survey	93
4. Cross sections of dams with different types of slopes	94
5. Dike (dam or wall)	95
6. Brick wall ponds	96
7. Simple inlet made of bricks (plastered), constructed in a feeding canal	97
8. Monk (outlet structure of a fish pond)	98
9. Monk with wing wall	99
10. Sluice (open outlet structure) made of bricks	99
11. Simple barrage	100
12. Secchi disc	101
13. Microscopic algae	101
14. A. Blue green algae (Mixophyceae); B. Filamentous algae ( <u>Spirogyra</u> )	102
15. Common Rotatoria in fish ponds	103
16. Common Cladocera in fish ponds	104
17. Common copepods	105
18. Important fish food organisms living in pond mud	106
19. Mayfly (Ephemeroptera) nymph living in pond mud	106
20. Carnivorous insects and insect larvae	107
21. Backswimmer	106
22. Food and fish pyramids	108
23. Production curve	109
24. Meyer's bottle	110
25. Plankton net	111
26. Column water sampler	112
27. Different forms of the scaly common carp	113
28. Cultivated forms of the common carp	114
29. Simple water filtering structure	115
30. Stone chips chamber filter	116
31. Reverse water filter	117
32. Food relationship in a pond stocked with a mixed fish population	118
33. Larva of the great diving beetle catching a fish fry	119
34. Water bug, ( <u>Nepa</u> sp.) grabbing a fingerling	119
35. <u>Ranatra</u> sp. waiting in ambush to catch fingerlings	119
36. Snake trap	120
37. Backswimmer "hanging" below the water level	121
38. Life cycle of <u>Ichthyophthirius</u> sp.	121
39. Two common gill worms	122
40. Two types of milt collectors	123
41. Small hapa for rearing hatchlings	124
42. Water strainer drum	124
43. Device to change the bottom water in a basin	125
44. Plastic funnel for incubation of common carp eggs	126
45. Sieve-cloth plastic funnel	127
46. Function of the sieve-cloth funnel in a twin cement basin	128
47. Scoop net	129
48. Special hammock for long-distance transport of brood fish	130
49. Development stages of eggs of herbivorous fish.	131

## 1. FISH PONDS AND THEIR CONSTRUCTION

### 1.1 INTRODUCTION

Although the supply of animal protein in Nepal is far below the demand, it is only very recently that sufficient interest has generated toward developing fish culture in the country. During the last decade two commercial fish farms, two small fish farms and three fish breeding centres have been established. In addition to these a few private fish ponds and farms are also functioning in different parts of the country. On the basis of the experience gained from these enterprises, it has been concluded that fish culture has a bright future in this land-locked country.

The productivity of the ponds is very high and the growth of the different cultivated species is excellent. The growing season for the fish is more than twice that in most European countries. The economics of fish culture operations appear to be favourable and the protein-food produced in the ponds is less expensive than in other sectors of animal husbandry.

In the different types of freshwater systems of the world there exist a large number of fish species having widely differing characteristics. All these species are not suited for cultivation. Some of them do not grow bigger than a finger length, while some others are very sensitive and cannot survive culture conditions. Many of them are carnivorous types, which predate on the smaller fishes. The species which have been traditionally chosen for culture are: common carp - the oldest cultivated fish, grass carp, silver carp, big-head carp, three or four species of Indian major carps, selected catfishes, trout, etc.

Experience has taught that some species of fishes grow large and nurturing them in confined water does not affect their growth properties, provided an adequate amount of food is available, either produced naturally or supplied artificially. Under certain conditions some of these fishes have also propagated themselves in impounded waters. These species have established themselves as cultured species and one or more of them are now being stocked in fish ponds. Presence of undesirable fishes in a fish pond will hamper the growth of the cultured ones by consuming at least a portion of the food materials available.

Under the controlled conditions existing in a fish pond, the ultimate yield is very much dependent on the density of fish stocked, fertilization and feeding. The basic principle involved is the conversion of cheap food material and offal into the highly esteemed and protein-rich fish meant for human consumption.

The basic requirement for fish culture is the fish pond. Different types of fish ponds, such as nursery ponds, rearing ponds and stocking ponds, are essential components in the chain of activities resulting in the production of market size fish.

In general, all fish culture practices involve breeding and stocking, measures to increase natural food, artificial feeding, disease and parasite control, removal of undesirable aquatic vegetation and weed fishes, harvesting, marketing, etc. The first step in fish culture relates to merely stocking of suitable species or combination of species in the pond and harvesting when the fishes reach marketable size. The second step involves the elimination of unwanted or wild organisms from the pond before stocking the desirable species. At this stage the productivity of the water varies, depending on the condition of the bottom soil and the fertility of the water. The next step relates to the use of manures or fertilizers to increase the production of natural food organisms in the water. The fourth stage involves artificial feeding

and hence the production varies, depending upon the efficiency of the species cultivated and the nutritive value of the feed. The fifth stage relates to culture with intensive feeding rates in running waters, which process eliminates the waste products.

## 1.2 THE FISH POND AND ITS CONSTRUCTION

### 1.2.1 General Remarks on Fish Ponds

Fish culture is the art of raising and growing fish under controlled conditions in order to achieve the maximum yield. The fish pond needs a stable water source and the water should contain necessary energy, nutrients and fish food organisms. The growth of natural food can be promoted by regular and rational fertilization and/or manuring. If artificial food also is to be added, a profitable ratio between the natural and artificial food will have to be maintained. The number of fish in a given area (stock density) will be directly related to the fertilization and feeding programmes. Other important tasks in fish culture activities are construction and maintenance of ponds, cropping, transport, etc.

A typical fish pond is a drainable water body provided with water through an inlet and emptied by an outlet. It should have depth commensurate with the type of fish cultured. Although most of the species of cultured fish live in stagnant water, it is necessary for the fish pond to have a stable water source for maintaining the water level.

A number of fish ponds integrated economically into a production unit is referred to as a fish farm. Such a fish farm will have different types of ponds, viz., segregation pond (for the segregation of brood fish), spawning ponds, nursery ponds, rearing ponds and production ponds. These different types of ponds vary mainly in size, depth and type of management.

### 1.2.2 Economic Size of Fish Ponds

Each type of fish pond mentioned above has an economic size depending on the specific purpose, the species cultivated and the land available. A small pond satisfying all necessary conditions may perhaps be good for fishes fed entirely on balanced food but not suitable for those which need natural food in addition to artificial feeds.

The economic size of fish ponds may differ in various regions and under different ecological conditions. For instance, in Hungary production ponds may not be less than 15 ha and the economic size is considered to be 5-100 ha. In Israel, where water shortage is a serious problem and fish culture is therefore very intensive, ponds of 5-20 ha are considered as large ones. In Nepal, since land suitable for fish pond construction is rather expensive, the economic size may be from 500 m<sup>2</sup> to 1 ha, and production ponds in farms may be about 0.5 to 5 ha.

### 1.2.3 Economic Depth of Fish Ponds

The optimum depth conditions for fish ponds in Nepal have not yet been determined. However, based on the experience gained in European countries, it may be stated that the fish ponds in this country should not be deeper than 1.5 m. In Europe, the carp ponds with an average depth of 1 m are considered to be most economic.

Certain types of ponds, like breeding and nursery ponds, are generally built shallow and can be dried during the greater half of the year in order to destroy the weeds.

Deeper ponds need stronger walls. Further, the cost of construction of such deeper ponds would be high as the portion above the water level also has to be proportionately higher. In deeper waters, if turbidity occurs, sun rays do not penetrate down to the bottom resulting in the formation of unproductive bottom zones (desert zones).

#### 1.2.4 Types of Fish Ponds

##### 1.2.4.1 Segregation, spawning and nursery ponds

The size of a segregation pond will depend on the number of brood fish to be stocked. If only light feeding is proposed, 25-30 m<sup>2</sup> of water area can be expected to provide natural food for one brood fish and if intensive feeding is contemplated, 10-15 m<sup>2</sup> will be the minimum area for one fish. The best depth will be 1-1.5 m.

A typical spawning pond may not be more than 1 000 m<sup>2</sup> in area and of an average depth of 0.7-0.8 m. Such a pond will have to stand drying during off seasons.

The size of nursery and rearing ponds should not be larger than 2 000 m<sup>2</sup> but they can be smaller in order to facilitate easy netting operations. A nursery pond of 200-600 m<sup>2</sup> in size can be conveniently harvested. Three to four week old fingerlings can be reared in ponds of 500-2 000 m<sup>2</sup>. In actual practice - from the production point of view - the intensity of culture and right management techniques are more important than the size of the pond.

##### 1.2.4.2 Barrage ponds

Barrage ponds are made by constructing a wall across a gently sloping flat 'valley', with a small stream as the source of water. The sides of the ponds are formed by the slopes of the valley and a series of ponds can thus be made, the water passing down from one pond to another. Such ponds should not be constructed in areas which are liable to large-scale flooding. In order to avoid normal flooding, a spillway may be constructed as described later in this manual. Improved versions of such ponds can be made by diverting the water from the stream by means of an artificial canal which can feed the different ponds separately.

It is not advisable to construct barrage ponds in the broad river beds in Nepal. However, construction of such ponds may be feasible in the drier regions of the country. The abandoned or old river beds, resulting from the diversion of the water courses to new sites, can be conveniently used for constructing such fish ponds, making use of natural depressions and slightly sloping places within such areas.

##### 1.2.4.3 Contour ponds

Contour ponds are constructed along the side of a valley, the bottom being of a slightly sloping contour. The water source can be a canal, river or reservoir (see Figures 1 and 2).

#### 1.2.4.4 Paddy ponds

Paddy ponds are constructed on flat ground by building the dikes on all four sides and are fed by a canal or ditch from a river. This type of pond is comparatively larger but more expensive than others. It is cheaper to construct bigger ponds, as illustrated in the following example:

a 400 m long dike will enclose a 1 ha pond, costing about N.Rs. 18 000; an 800 m long dike will result in 4 ha costing N.Rs. 9 000 per ha and a 1 200 m long wall will produce a 9 ha area costing N.Rs. 6 000 per ha.

#### 1.2.4.5 Undrainable ponds

The traditional method of constructing ponds has been to dig out 2-3 m deep in a suitable area in which water accumulates either from rainfall or seepage from the bottom. Currently, such dug-out ponds are constructed only in special circumstances, such as when soil is needed for other purposes or when the size of the pond is small.

In some regions of Nepal there are areas with a high water table and sand or gravel subsoil where non-drainable or dug-out ponds may be constructed. Such water reservoirs can be profitably used for fish culture. They need not have inlets or outlets and the seepage problem will not be detrimental. Even natural or artificial excavations can be modified into such ponds. However, the dug-out ponds have some serious limitations. Harvesting and preventing wild fishes entering into the pond would be difficult. Cost of construction can be attractive only for ponds of less than 500 m<sup>2</sup> in area. An example of the higher cost of construction of bigger ponds is given below:

In a dug-out pond area of 1 ha, 20 000 m<sup>3</sup> earth must be removed for 2 m of depth. With this much soil, a 1 330 m long dike of 1:3 slope, 1.5 m crown width and 2 m height can be constructed, which would enclose an area of 11 ha.

Other disadvantages of undrainable ponds are: the ponds cannot be dried, which is essential for modern fish culture practices; organic detritus will accumulate at the bottom after some years, which can result in large-scale fish mortality; it is rather difficult to control parasites, diseases and weeds; the production rate is comparatively less in undrainable ponds, and intensive fish culture by feeding and fertilization is more difficult in undrainable ponds.

#### 1.2.5 Construction of Fish Ponds

A considerable amount of planning and designing is necessary for the construction of efficient fish ponds. Although the choice of the design is very wide, it is necessary to arrive at a compromise as regards the ease of construction and cost involved. The basic principle to be borne in mind in designing a fish pond is that the construction phase will last for a short period only but the production phase has to be economically advantageous for many years. Therefore, it is essential that the fishery biologist - who knows best about the requirements of a fish pond for achieving best production and the engineer who knows about the possibilities and cost of construction - jointly discuss the various pros and cons and finalise the most suitable design for the selected locality. It may so happen that the fish culturist himself may have to do the designing and construction work and so it is essential that the basic details concerning the construction of fish ponds are reviewed here.

#### 1.2.5.1 Topographical survey and design

A topographical survey in the present context does not necessarily mean a difficult and specialized operation, which must be undertaken only by a qualified engineer. However, when a fish farm is contemplated, it would be necessary to get the services of a civil engineer.

For the purpose of making a topographical survey by the fish culturist himself, the basic equipment required is a small table of 1 m height, a spirit level (generally used by masons), preferably with a rear sight as provided in a gun, and a simple measuring tape (Figure 3).

The first step in the survey operation will be to decide the line along which the main dike is to be constructed. If the site in question is in a broad depression, this line for the main wall should be in the deeper region where the depression is narrowest. If it is proposed to construct more than one pond in a long and sloping terrain or depression, the survey may be started from the deepest area. The line of the proposed main dike should be marked by fixing pegs and the table should be placed in the middle of the line taking care to see that the top surface is horizontal. The spirit level is then placed on the table and levelled horizontally with the help of small wooden pieces. Then, looking through the rear sight or along the top surface of the spirit level, the point on the site which is at the same height can be marked with a peg. Then the spirit level should be moved radially in order to mark and peg the points at the same level across the area. Such a demarcation will indicate that if there is 1 m deep water at the place where the table is, there will be no water at the pegged levels. Or, if there is 2 m deep water at the site where the table is placed, the depth of water along the pegged line will be 1 m. Since it will not be desirable to have more than 1.5 m average depth in a fish pond, and the shallowest part should not be less than 0.5 m, the enclosing dike should be constructed on the pegged line. If the earth necessary for the dike is to be taken from the future pond bottom, the site for the enclosing dike can be shifted further accordingly.

After fixing the approximate line of the second dike, subsequent parts may be marked out in the same way, and then the distances should be measured and recorded.

#### 1.2.5.2 Selection of a suitable site

The success and profitability of a fish pond or farm depends primarily on the selection of the site. Firstly, the type of land suitable for fish ponds must be considered. In general, sites which are known to be not good for profitable agriculture should be considered first. It may also be desirable to reclaim unutilized swampy areas. While it may be proper to think that by adopting proper management practices a fish pond can yield high returns, it is always better to choose those sites where agricultural crop production is rather low or does not exist at all. This means to say that the best policy for developing areas for fish culture would be to utilize unused or reclaimed areas for construction of fish ponds.

The following factors have to be taken into consideration in the selection of fish pond sites: if the site chosen is topographically suitable and the design utilizes natural slopes, deeper areas, etc. and necessary canals exist, the pond will work out to be cheaper and better. A pond made by utilizing natural contours fits itself into the landscape better than one made with rectangular walls.

The general factors to be taken into consideration before selection of the site are: marketing and transport facilities; availability of fertilizers and fish food.

A pond should not border government roads and canals, and telephone and electricity poles should not stand in the water.

### 1.2.5.3 Soil

Generally speaking, gravelly, sandy and peaty soils which allow high rates of seepage are not suitable for fish pond construction. Clay soil has the highest water holding capacity. In order to be certain about the character of the soil at the selected site, it is necessary to study the soil down to 2 m. If there is any doubt regarding the soil characteristics, it would be necessary to get the samples analysed by a competent soil chemist.

In addition to the quality of the soil, another factor to be considered is the quantity of earth required for the embankments. In general, it is observed that if the fertile top soil is removed for wall construction, the productivity of the pond will suffer and only after a long time will a new fertile layer of top soil develop on the pond bottom.

### 1.2.5.4 Water

Availability of sufficient water to fill the ponds and maintain the required level throughout the production phase is one of the essential prerequisites for selecting the site. The quantity of water supply required for a fish pond depends on its capacity and on the quality of the subsoil. The quantity of water that will be required for a 1 ha pond, if the average depth is 1.5 m, will be 15 000 m<sup>3</sup>, plus 25-50 percent to cover losses, i.e. a total of 19 000 to 23 000 m<sup>3</sup>. The rate of evaporation depends on temperature and humidity. (It will be reasonable to calculate 25-50 percent more water, as the bottom soil and walls will allow a certain amount of percolation.) A basis for rough calculation of the quantity of water to maintain a given water level is from the fact that in the driest part of the year, about 3 l of water per second is necessary throughout the day for 1 ha pond surface. If only 1 l per second per ha is available, the same also may be considered just adequate. Evaporation data for Nepal are not yet available and hence the above figures have been obtained from another subtropical country.

A great mass of water running into the fish pond will be very much detrimental to production, as the surplus water flowing out will wash out the fertilizers, nutrients, food organisms developed in the pond, etc.

Nearness of the source of water is important for the economics of pond construction. The water can be diverted from a river, allowed to flow in directly from other sources or through a feeder canal. The same feeding and drain canals can serve many ponds, which of course is desirable, as the non-productive water structures (like canals) should be the barest minimum.

In most cases natural water or spring water is qualitatively suitable for use in fish ponds. Generally speaking, if a source of water is good for irrigation or for human use, the same may also be suitable for fish culture.

The water source should be free from pollutants. At present this danger does not exist in Nepal but the problem of polluted waters, especially pesticide-polluted ones getting into fishery waters, must be avoided.

The desirable pH of the water is between 7 and 8.8 and waters with pH values below 6 are not quite suitable for fish ponds.

The so-called mineral waters with high contents of dissolved chemical compounds (2 000 ppm), can be used only in limited extent for carp culture and it is necessary to mix such water with normal surface water for use in breeding ponds.

The water in a pond is considered as "living water", i.e. it is inhabited by different types of organisms like bacteria, algae, small and big animals, weeds, etc. These organisms play a very important role in the production process in the pond water. The water drawn from a tube well will have no major living organisms and this is considered as "dead water" for fish culture purposes. River water is generally poor in respect to its living matter content. On a rough estimate, it takes at least 3 to 10 days, depending upon the temperature and other ecological factors, to convert "dead water" to "living water".

#### 1.2.5.5 Measurement of water quantity in a river or canal

Although there are different methods and instruments to measure the quantity of water in natural sources, a simple method which can be adopted by the layman is described below. In this method the velocity of the water current is measured and, by calculating the cross-section of the water body, the actual water quantity can be determined.

A simple rough method to measure the velocity of water is to float a thin stick, the length of which is almost the same as the water depth to one end of which is attached a piece of metal or stone which will make it stand on the water about 10-15 cm above the surface, and measure the time taken by the stick to move between two measured points, about 20-30 m apart, on the shore. The distance (in m) between the two points, divided by the time taken for the stick to move between the two points in seconds, will give the average velocity of the water current (V). Then, the average cross section of the water zone between the two points may be estimated by measuring the average depth and the width of the water and, by multiplying these, the cross-section can be obtained in m<sup>2</sup>.

The quantity of water flowing (Q) in m<sup>3</sup>/sec is:

$$Q = F \times V$$

When F = the cross-section of the water zone in m<sup>2</sup>  
and V = the velocity (in seconds) of the water current

The discharge capacity of a tube well can be estimated by measuring the time taken to get 20-50 l water, from which the quantity delivered in 1 minute or 1 second can be calculated.

#### 1.2.5.6 The pond size and yield

The carp ponds in Europe vary very much in respect to their sizes, the smallest being less than 1 ha and the large ones several hundred ha. It will not be possible to follow such examples in Nepal. For practical purposes the fish ponds may be divided as follows:

Small pond	- under 0.1 ha
Medium pond	- between 0.1 and 1 ha
Moderately large pond	- between 1 and 5 ha
Large pond	- over 5 ha

However, in this connexion, it may be noted that from the production point of view, the size of the pond is not so important as the management practices. By adopting intensive production methods, substantially high rates of production can be obtained from smaller ponds, which will compare favourably with the rates obtained from large ponds adopting extensive production techniques. By adopting proper feeding and fertilisation techniques a crop of 1-2 t per year per ha can be obtained and,



using only common carp with intensive feeding and fertilization, 0.8 to 1.5 t per year can be achieved. Ordinary family needs can be met from a small size pond, while medium size ponds can cater to the needs of sections of villages.

#### 1.2.5.7 The structures of a fish pond

The following structures may be distinguished in a fish pond (or fish farm):

##### Earthen structures

- i. dikes (walls or dams),
- ii. harvesting pit (cropping pit or canal),
- iii. canals (inlets and outlets),
- iv. seepage trench.

##### Built-up structures of concrete, bricks or stone

- i. inlet culverts
- ii. monks
- iii. spillways
- iv. structure for diverting water from a river or canal.

##### i. The Dike

The dikes or walls form the most essential part of a drainable fish pond, as they confine the water inside (Figure 4). While the walls of the same pond may differ in size and strength, different kinds of ponds also will have to be provided with varying types of walls. For all practical purposes the types of walls clearly distinguishable are the main walls, walls holding water only on one side and walls that divide two ponds holding water.

The main wall of a pond is the highest one, constructed on the deepest part of the pond area. This wall has to resist the maximum water pressure and the danger of seepage through it is also the greatest. It is highly desirable that this type of wall should be planned as the shortest one in order to reduce the cost of construction. In the construction of such a wall, care has to be taken to remove the top soil at the base and dig a core trench properly, which is to be filled with good water-proof clay soil. If the soil is poor a core of good soil must be built inside the wall.

The wall holding water only on one side (thus one side dry) is not constructed on the deepest part of the area. This also should be carefully constructed, provided with a core trench and made after removing the top soil at the base. The slope of the dry side of the wall can be steeper than on the wet side. A trench should be cut along the dry side of the wall, about 3-5 m from the base, in which water seeping out of the pond can collect and so that it does not spread in different directions making the entire area slushy. The water level in this seepage trench can be controlled by a simple structure or by making a cross-earth wall.

The wall which separates two ponds (thus both sides of the wall being wet) built in a series (barrage ponds) or side by side (contour and paddy ponds), has to withstand water pressure on both sides. Seepage water in such cases is not wasted, and so the wall can be constructed in most cases without core trenches and by removing only the top soil after cutting up to the base.

The slope and width of the crown. A well chosen slope and adequate width of the dike crown determines the strength and life span of a dike. A wrongly designed and constructed wall will require annual repairs entailing considerable recurring expenditure. Brick or stone walls of ponds only can be built vertically and the sides of earthen dikes should have slopes. The gradient (inclination) of the slope is indicated

as the proportion of the height of the wall to its basal width. Thus, if the width is the same as the height, the slope is indicated as 1:1; if one and a half times the height, 1:1.5; and if twice the height, 1:2.

The actual slope of the dike will depend on the type of soil and the height required. Good clayey soil allows a steeper slope than the sandy clay or sandy soil. When the height of the dike is near or over 2 m, it is necessary to make it more sloping.

In the case of high dikes, especially the main ones, it is advisable to construct a "bench" under the expected water level, the width of which may vary between 0.5 to 1 m, depending on the height of the wall and the size of the pond.

The width of the crown (crest) depends on the height of the dike and should not generally be less than 1 m. A 2 m high dike will need a 1.5-2 m wide crown. A 3.5 m high dike will not be able to withstand the water pressure if the crown is not as wide as the actual height. In cases where a road or track is required to be laid on the dike, the width of the crown should be at least 3 m.

Calculation of earth work (Figure 5). The method of calculation of earth work required for construction of dikes will be clear from the following examples:

Example 1

Depth of water along the main wall - 1 m  
Designed height of the wall - 1.5 m  
Crest width - 1 m  
Slope - 1:1.5 m

The width of the wall base will therefore be:

$$2.25 \text{ m} + 2.25 \text{ m} + 1 \text{ m} = 5.5 \text{ m}$$

If the slope is decided as 1:2, then the width of the wall base will be:

$$3 \text{ m} + 3 \text{ m} + 1 \text{ m} = 7 \text{ m}$$

The quantity of earth necessary to construct a 1 m long wall of the above type with slope 1:1.5

$$2.25 \times 1.5 + 1.5 \times 1.5 = 4.875 \text{ m}^3$$

For the same wall with 1:2 slope, the quantity will be:

$$3 \times 1.5 + 1 \times 1.5 = 6.0 \text{ m}^3$$

Example 2

Depth of water - 2 m  
Height of the wall - 3 m  
Crest width - 2.5 m  
Slope - 1:3

The width of wall base will be:

$$9 + 2.5 + 9 = 20.5 \text{ m}$$

The quantity of earth necessary for 1 m long wall:

$$9 \times 3 + 2.5 \times 3 = 34.5 \text{ m}^3$$

If in the same dike the slope is changed to 1:2.5 and the crest is 2 m wide, the wall base will be:

$$7.5 \text{ m} + 2 \text{ m} + 7.5 = 17 \text{ m}$$

and the quantity of earth necessary for 1 m long wall will be:

$$(7.5 + 2) \times 3 = 28.5 \text{ m}^3$$

(The calculation of quantity of earth is, in simple terms, the horizontal projection on one side of the wall (calculated from the slope) plus the crest width, multiplied by the height of the wall.)

In case the two slopes of a wall are not the same, as in the case of one side being wet and the other dry, the calculation will be as follows:

Depth of water	- 1 m
Height of the wall	- 1.5 m
Crest width	- 1 m
Slope on the wet side	- 1:2
Slope on the dry side	- 1:1

The width at the base of the wall will be:

$$1.5 \times 2 + 1 + 1.5 = 5.5 \text{ m}$$

The quantity of earth necessary for a 1 m long wall will therefore be:

$$\frac{1.5 \times 3}{2} + 1.5 \times 1 + \frac{1.5 \times 1.5}{2} = 4.875 \text{ m}^3$$

(In order to make allowance for settling of loose earth, the height of all types of walls must be about 25 percent more at the time of construction.)

Source of earth. The most economical way of getting earth for making the dikes is to dig it out along the proposed line. It has, however, to be ensured that the proposed pond and the pits are drainable. The pit should not be deep and a "bench" about 3 to 5 m wide and with undisturbed top soil must be left between the dike and the pit. In this way the upper fertile layer of soil on the bottom of the pond will be left undisturbed.

When the pond is constructed in a depression, the earth necessary for wall construction can be cut partly or fully from the sides, thus making the pond area bigger than originally planned.

After all the related data for the construction of the wall have been gathered, a suitable design for the pond may be drawn. On the basis of such a design the dike lines can be pegged along with the contour of the pits from which the necessary earth will be taken out.

Pegging of the wall and pit lines. If proper care is not taken to peg the wall and pit layouts, the labourers will cut out earth as they find convenient, resulting in irregular pits which may cause difficulty in draining and cropping operations.

The pegging operations can be understood easily from an illustration. The axis of the wall with a base of 7 m is first pegged and then the sides are demarcated. Subsequently, one side of the pit from which earth is to be cut may be pegged leaving a 3 to 5 m wide area between the wall base and the pit. Sometimes it may be necessary to mark the line of the core trench also but this can generally be omitted by giving suitable instructions to labourers that, after removing the top soil from the wall base, they should dig along the central axis of the wall a 1 m wide and 1 m deep trench.

If it is calculated that 1 m length of the wall will require  $5 \text{ m}^3$  of earth, the opposite side of the pit may be pegged 12 m away from the first line marking the side nearer the dike. It is generally not advisable to dig pits deeper than 0.5 m, which will place the width of the pit at about 10 m. But in actual practice it is essential that the top soil for about 5 cm should be discarded for dike construction and hence the additional 2 m width is indicated. If there are any higher elevations in the area, this can be removed fully and the soil used for making the dikes.

How to construct the wall. After pegging the wall lines it would be necessary to remove all debris, roots, stones, etc., from the marked area and remove the top soil up to 5-10 cm depth. The top soil may be heaped up along the bench of the wall in between the base and the pit site, which could be later spread on the slope of the wall. Thus grass can easily get established on the slope of the new wall quickly, to prevent erosion. If the area is marshy it will be necessary to remove the top soil as deep as the layer of decaying organic matter and debris.

The next operation will be the cutting of a trench of 1 m depth and 1 m width along the axis of the wall. If, however, the soil is very good for wall construction, the area is not infested with termites (white ants) and the pond is not deeper than 1-1.5 m, the depth of the core trench can be reduced to 0.5 m, or it can even be omitted. In such a case the base of the wall should be dug deeper, making certain that an adequate connexion between the "living soil" of the wall base and the constructed wall exists. The earth dug out of the core trench should be kept on the opposite side.

After checking the dimensions of the core trench, it can be filled with good clayey soil, packed layer by layer. Simultaneously the wall construction may also begin. If there are different types of soil present, the better ones must be placed over the centre of the trench and on the wet side of the wall.

When the wall is almost ready, the profiles are to be made with wooden slats as high and wide as the designed height and crest of the wall and the inclination of slope indicated by strings stretched between the top of the wooden slat and the peg marking the side of wall base.

The last phase in the construction of the wall is "fitting out", in which the clods of earth are broken into bits and properly packed according to the profile set up and the top soil kept apart is spread on the slope. The pit also must be evened and levelled.

The top soil covering will help in the establishment of grass quickly, but in many circumstances it may be advisable to place adequate amount of turf on the slope to hasten the growth of grass.

The bottom of the pond must be cleared of debris, stones, etc., so that there will be no difficulty for fishing operations. Unevenness and heaps of soil left on the pond bottom will eventually be levelled when the pond is filled with water.

Ponds constructed with brick walls (Figure 6). In Nepal, where land is very expensive, construction of fish ponds with brick walls may be advantageous in many situations. In the case of small and long spawning and nursery ponds, about 40 to 50 percent of the area available will be required for the construction of earthen dikes. The same purpose can, however, be served by constructing brick walls supported on both sides with soil, so that the whole structure will be 25 cm wide. Such walls should be at least 1.2 to 1.5 m high to prevent large-scale seepage of water. The bricks should be laid with cement mortar and the portion above the original ground level may be plastered. One side dry walls (contour walls) can be constructed 25 cm wide and the width of the separating walls on both sides may be 12.5 cm. The greater portion of such walls will be in the living soil and hence an adequately deep trench is to be dug first. No brick base will be necessary and the wall can be laid on evenly cut soil. When the plastering has dried completely, patch up work may be done wherever necessary. After this, soil should be packed firmly on both sides of the wall and soil filled up to the planned height.

It will be economical to incorporate the inlet and outlet structures in the brick wall itself.

However, in general, brick walls cost about three to four times more than conventional types of earthen dikes. But the benefit in fish production may more than compensate for the extra cost involved. Further, annual maintenance expenditure will be much less in the case of brick walls, as compared to earthen dikes.

ii. The harvesting pit (harvesting ditch or harvesting canal)

The harvesting pit, or ditch or canal, as it may be termed, is an important structure of a drainable fish pond. In ponds of an area less than 0.5 ha, the pit may be 5 to 20 m<sup>2</sup> and in bigger ones it may be at the rate of 50 m<sup>2</sup> per ha. However, in ponds of an area more than 5 ha the pit may be between 500-600 m<sup>2</sup>.

The harvesting pit should be constructed near the draining monk in the deepest part of the pond, dug as a long trench about 50 cm deeper than the surrounding area, and in most cases parallel to the main wall. The width of the pit may normally be 5-6 m and in any case not more than 10 m, in order to facilitate easy netting. The side walls should be cut sloping and the bottom even and level. It would be advisable to provide a 1 m wide bench along the harvesting pit, on which the fishermen can walk during netting operations. The bottom of the harvesting pit should be on the same level as the "threshold" of the monk in order to facilitate draining. In order to avoid rapid silting, the pit may be dug 5-10 m away from the main wall of the pond.

In Europe, a "harvesting pond or pit" is constructed on the dry side of the wall. Often the same harvesting pond is used for many ponds constructed "fan-like" in a semicircular design. Each such pond is connected to the harvesting pond by means of a sluice gate to facilitate draining and harvesting. In some cases small harvesting pits of dimension 60 x 100 x 90 cm each are constructed with bricks under the outflow pipes of nursery and rearing ponds, and by fixing a "net box" inside the pit all fish escaping through the outlet will be caught in it.

iii. Construction of canals

Two types of canals are generally associated with fish ponds, viz., inlet or feeder canal and outlet or drain canal. The drain canal has to be made deeper than the pond bottom.

The quantity of water transported in a canal depends on the area of cross-section of the water passing through ("wet cross-section") and the speed of the current, and can be calculated from the following equation:

$$Q = F \times V$$

Where Q is the water quantity transported in m<sup>3</sup>, F is the wet cross-section in m<sup>2</sup> and V is the speed of water current in m per second.

It is known that, if the bottom of the canal has a slope of 0.1 to 0.2 m in 1 000 m, the speed of water will be about 0.3 to 0.5 m per second. Such a current is desirable in an earthen canal, as a lesser velocity will result in rapid silting while a faster rate may erode the canal rapidly. If the bottom of the canal is 1 m wide and the slope is 1:1.5, the wet cross-section under different water depths will be:

Water depth in m	Wet cross-section (approx.)	Water transported	
		in l/sec	If the speed is 0.3 m/sec in m <sup>3</sup> /day
0.1	0.11	33	2 800
0.2	0.26	78	5 700
0.3	0.43	129	11 100
0.4	0.64	192	16 500
0.5	0.87	260	24 400

In general a canal with 1 m bottom width can transport sufficient quantity of water to feed a medium size pond or a small farm. From the economic point of view it is not advisable to construct feeder canals less than 1 m wide at the bottom.

In situations where water supply may be inadequate during the dry seasons, or the seepage rate is appreciable, it would be advisable to construct feeder canals with brick and cement mortar. The walls of such canals may be vertical and supported on the outside with earth. The velocity of water in such cases can be faster and hence they may be of 0.4-0.5 m width and with a bottom slope of 0.5-1 m per 1 000 m. The maintenance cost of a brick canal under normal conditions will be much less than that of an earthen canal.

It is desirable to have each fish pond capable of being filled and drained individually. In certain cases, however, it has been possible to construct profitable farms when the ponds lying in a long valley are connected in series so that they are fed and drained one after another.

iv. Structures made of concrete, bricks and stones (Figures 7, 8, 9 and 10)

Such structures are meant to ensure a smooth water supply and drainage. They also prevent entry of wild fishes and escape of cultured ones. The main structures in a fish pond are the outlets and inlets. Spillways are necessary only in those ponds where there is the danger of floods.

The dimensions of these structures will naturally be related directly to the area of the pond. The capacity of the structures will depend on the narrowest region which is usually the built-in-pipe or culvert. Some basic data on the water carrying capacity of pipes of different diameters are given below:

Diameter in cm	Water flow in l/sec	Water flow in m <sup>3</sup> /day
2.5	0.5	43
5.0	1.8	150
10.0	8.0	690
15.0	18.0	1 500
20.0	31.0	2 600
30.0	70.0	6 000
40.0	130.0	11 000
50.0	196.0	17 000
60.0	280.0	24 000

The capacity of a pipe can be calculated using the following equation:

$$\text{Water flow capacity in l/sec} = \frac{\text{Cross-section} \times 100}{1000} = \frac{r^2 \times 3.14 \times 100}{1000}$$

If the above value is multiplied by 86.4, the quantity of water flowing in m<sup>3</sup> during 24 hours can be obtained.

Thus, it will be seen that a pond about 0.1 to 0.2 ha in area (2 to 4 ropani) needs an inlet or outlet pipe not larger than 10-15 cm diameter. For a pond of over 2.4 ha the pipe or culvert may be of 30 cm diameter. Pipes of less than 10 cm diameter should not be used as they may get clogged.

Both the inlet and outlet structures in a fish pond must be provided with suitable screens or other devices in order to keep out wild fish as well as prevent escape of cultivated fish. A large mesh screen should be fitted above the inlet in order to prevent drifting debris from coming in.

In the case of water coming from a fall into the pond through a pipe, the best way to prevent wild fish incursion will be to fix a screen basket under the falling current. The basket must be cleaned frequently to prevent clogging.

In the case of small and medium size ponds wooden plugs can be used to stop the flow of water through the inlet and outlet pipes. Two or three pairs of grooves may be provided in the walls of the inflow canal for fixing of screens and control boards.

Outlet structures (Figures 8 and 9). Two types of outlet structures are commonly used in larger fish ponds, the monk and the sluice. Both these structures can be used as inlets also.

The monk is meant to regulate the water level automatically, and the outflowing water can be discharged from its surface, as well as from the bottom. Each monk has two main parts, the vertical tower and the horizontal culvert or pipe, both of which may be made of concrete or brick, or a combination of both.

The height of the tower depends on the highest allowable water level. For ponds up to 3 to 4 ha, a monk with 30 cm wide opening in front of the tower will be sufficient. Large ponds of over 4-5 ha should have a monk with 40 cm wide opening. Each monk should be provided with 2 pairs of grooves in which 2 boards can be inserted, between which wet clay may be packed tightly to check leakage of the water.

In the case of high monks it would be advantageous to construct wings as supports to the tower.

Since both concrete and brick monks are heavy structures, adequately strong bases have to be provided for them. When the monk is constructed on undisturbed soil, a 30 to 50 cm deep base should be provided under the tower, and a 15-20 cm deep one under the culvert. Such a base must be at least 30 cm wide on each side. The bases can be built with boulders and cement mortar. Good cement mortar can be made either with 1 part cement and 4 to 5 parts sand or 1 part cement, 2 parts sand and 4 parts stone chips.

In the case of soft soil, the base must be 60 to 90 cm deep under the tower, 25 to 30 cm under the culvert and 50 to 60 cm wider than the actual size of the structure.

The sluice (Figure 10). The sluice is an open water control structure functioning generally in the same way as the monk. Sluices are constructed when many ponds are connected to the same harvesting pond or pit.

v. The spillway

Spillways are necessary when there is danger of heavy floods. A spillway has a high "threshold" and two side walls. The "threshold" is generally 5 to 10 cm above the maximum permissible water level in the pond. The opening of the spillway will determine the quantity of water flowing through it. Screens should be fitted in the opening to prevent escape of fish and they may have to be cleaned regularly during the flood seasons.

The spillway should always be constructed on well settled "living soil" and should be aligned along one side of the pond in order to minimize the washing out of nutrients.

The spillway may be a very simple structure cut out in the earth and strengthened with logs. The side walls may be strengthened with twigs and stones. Earthen spillways may be covered with turf to prevent erosion.

More complicated spillways are made of stone masonry or bricks and are required where heavy floods are expected. Such spillways will have to be designed by a competent engineer.

vi. Simple barrage for diversion of water (Figure 11)

A temporary barrage made of long planks can be used to divert water to the pond during dry seasons. Such simple structures can dam the river or canal water up to 0.8 to 1 m height. Generally they are ideal for canals not wider than 5 to 6 m. In order to construct such a structure two strong poles may be fixed vertically, one on each bank of the stream. The poles may be 2.5 to 3 m long and about 40 cm in diameter sawed lengthwise into two halves. The logs should be stuck 1 m deep into the earth and supported on both up- and down-stream sides. Then a thinner log, also sawed in half, is to be planted at the canal bottom against each of the previously fixed ones. The other half of the log will then be attached about 1 m above. Above this log a strong plank 2 to 3 cm thick and 20 to 25 cm wide should be so fixed as to allow a series of about 15 cm wide planks to be slipped down vertically to the bottom. When high water occurs some of these vertical planks may be removed from the middle in order to relieve the pressure. A simple earth spillway may also be constructed so that the excess water may flow out over it. During the rainy seasons the entire barrage structure, excepting the two vertical posts on the bank, has to be removed to enable free flow of flood water.



## 2. BIOLOGICAL BACKGROUND OF FISH PRODUCTION IN PONDS

In fish culture the biological production processes are almost similar to those encountered in agriculture. The fish culturist, like his agricultural counterpart has to sow the seed, nurture them properly, take all possible care to get the maximum survival and growth rates, and then harvest the produce at the most appropriate time. So, in practice, man has to interfere in the natural biological production processes in order to achieve the optimum production rates.

As already indicated, each water body on the earth sooner or later becomes "living water", which means water populated with different types of living organisms. Each body of water, however, will have its own characteristics regarding the life it sustains (biomass) and it is necessary that every fish culturist possesses basic knowledge concerning the biological processes normally taking place in a pond, so that he may be able to manipulate them scientifically in order to achieve the desired goal of producing maximum fish from the available water mass.

### 2.1 TYPES OF ORGANISMS

The living organisms in fish ponds can be grouped in different ways, viz., based on their taxonomic position; functional value, i.e. whether they are harmful, harmless or useful to fish life, etc. In this connexion it is important to know that, for the purpose of understanding properly the aquatic organisms, it is essential to be familiar with their ecology. Ecology is the science which deals with the relationships of animal and plant communities to their animate (living) and inanimate (non-living) surroundings. A "community" means a group of different organisms inhabiting a common environment, interacting with each other, specially through food relationships, and relatively independent of their groups. The community of organisms which interact with one another, plus the environment in which they live and with which they also interact, is an ecosystem. A fish pond therefore is an ecosystem. In order to understand such an ecosystem, it is not enough just to know the names of the organisms, but their food and feeding habits, growth rate, reproductive habits, etc.

A water area may be considered suitable for living organisms if it has the necessary oxygen for breathing (or provides "raw material" for other types of respiration), has favourable temperature conditions, produces enough food not only for survival but also to accumulate enough energy for growth and reproduction, and suitable facilities and space for the production and growth of the offspring. This naturally leads to the fact that, for successful fish culture in a pond, these conditions have to be made available. Each species of fish has its own special requirements for its survival, growth and reproduction. In a production pond the requirement for fast growth in the form of food must be provided above the level necessary for survival. For propagation purposes there are additional requirements which have to be provided in breeding ponds. For the growth of the offspring the necessary requirements must be available in nursery and rearing ponds. With some basic knowledge of these aspects the fish culturist can effectively manipulate and govern the production processes which result in producing the fish flesh.

All the important biological production processes in a fish pond are at the maximum when the physical and chemical conditions of the water are normal. The most important of these factors are described below.

## 2.2 IMPORTANT PHYSICO-CHEMICAL CHARACTERISTICS OF A FRESHWATER POND

### 2.2.1 Specific Gravity

The specific gravity is the ratio of the mass of a given volume of a substance to the mass of an equal volume of water at a temperature of 4°C. During winter season the temperature of the top layer of the water in a pond may go much below 4°C and the warmer and deeper layers do not get frozen, which assures the survival of higher organisms in such waters, even though the upper region may be covered with ice.

The specific weight of the water causes the temperature stratification. The coolest water layers generally lie at the bottom of the pond, which enable the survival of fish during the hot summer days.

Since the water content of the bodies of living aquatic organisms is rather high (about 60-98 percent), they are able to float in water and swim about without expending much energy. Many species of fishes have airbladders, with the help of which they can float easily in the water.

The specific weight of the water increases with the quantity of dissolved minerals and organic materials. Water loaded with such items can produce "heavy water" spreading over the bottom, which may be harmful to satisfactory fish life.

### 2.2.2 Light Penetration

Sunlight which is the most important source of energy in the entire universe, enables photosynthesis to take place, thereby building up organic matter out of inorganic substance (utilizing the solar energy), both in aquatic and terrestrial environments. A part of the sun-rays falling on the surface of the water penetrates below and enables photosynthesis to take place, the intensity of which varies with the period of sunshine. Thus, during summer the days are longer and hence more photosynthesis can be expected as compared to winter days.

The most important water plants, viz., algae, can adapt themselves to lesser quantities of sunlight, as compared to the terrestrial plants. The artificially built fish pond is rather shallow and the possibility of the algae migrating to the layer of optimum sunlight is limited as compared to the condition occurring in deeper natural lakes. If the pond water is too transparent, the photosynthesis becomes adversely affected due to strong illumination during the brighter part of the day. Likewise, if the water is too turbid, the insufficient light slows down photosynthesis. Dark parts of a deep pond or the over-illuminated shallow regions of a pond are unproductive.

An ecosystem like a fish pond, is self-regulating under normal conditions. The floating organisms (plankton) can sometimes develop to such a density that natural self-shadowing occurs in the pond, thereby returning to average normal light conditions.

The extent of light penetration in a pond can be measured with a photometer. However, under field conditions a simple "Secchi disc" can give satisfactory results (Figure 12). A "Secchi disc" transparency of about 20 to 50 cm during mid-day can be considered to be satisfactory. Effective photosynthesis can occur up to depths of 50 to 100 cm in addition to the "Secchi disc" transparency. This means that if the "Secchi disc" measurement is 30 cm, effective photosynthesis can be expected to occur up to 80 to 110 cm depth.

### 2.2.3 Colour

The "living water" in a fish pond has a characteristic colour, which is of a definite and practical use. Colloid loam particles make the water greyish yellow; humic acids cause reddish brown coloration and water of low productivity is totally colourless.

A greenish or yellowish colour is generally derived from microscopic algae (not filamentous or blue-green algae). Generally algae produce in the water coloration of green, greenish yellow, bluish green, yellow, red, etc., according to the species. Planktonic animals also produce various colours in the water, e.g. rotatorians, whitish and crustaceans, brownish or reddish. If filamentous or blue-green algae cause a bloom or coloration in the water, it indicates that some abnormality has occurred in the ecosystem as a whole.

### 2.2.4 Temperature

Under natural conditions three main geographical types of fresh waters are distinguished:

- i. cold water, the temperature of which does not rise above  $10^{\circ}\text{C}$  in summer;
- ii. temperate water in which the summer temperature is not higher than  $20-23^{\circ}\text{C}$ ;
- iii. warm water in which the minimum temperature is about  $10-15^{\circ}\text{C}$  and maximum around  $30-35^{\circ}\text{C}$ .

It is necessary to check the temperature of the water in a fish pond, both at the surface and bottom. The metabolism of a fish is directly related to the temperature of water and usually extreme conditions are unfavourable for fish life, especially for those with different temperature adaptation ranges. The dissolved oxygen content of water is also related to the temperature conditions.

### 2.2.5 Currents and Water Movements

Vertical movements of water can be caused by temperature differences. For example, since the specific weight of cold water is higher than that of warm water, the former will sink and the latter will rise. Such movements generally occur in fish ponds during night-time and help in the mixing of nutrients in the water.

Wind often causes waves which may cause damage to dams and other structures in big ponds. They, however, result in a certain amount of mixing of the pond water, which has both good and bad effects from the point of view of biological production.

### 2.2.6 Dissolved Gases

The pond water dissolves gases like oxygen, nitrogen and carbon dioxide from the atmosphere and methane ( $\text{CH}_4$ ), hydrogen sulphide ( $\text{H}_2\text{S}$ ), etc., developing in the mud.

### 2.2.7 Dissolved Oxygen

The dissolved oxygen content (DO) is one of the most important factors affecting the growth and welfare of the fish. It not only provides for respiration of higher organisms but also acts as the oxygen source for aerobic biological processes. The DO may be derived from the atmosphere or released as a by-product during photosynthesis. The solubility of oxygen in water depends on the temperature as shown in the table below:

Solubility of oxygen under different temperatures

Temperature °C	Solubility of oxygen mg/l	Temperature °C	Solubility of oxygen mg/l
0	14.63	18	9.46
1	14.23	19	9.27
2	13.84	20	9.08
3	13.46	21	8.91
4	13.11	22	8.74
5	12.77	23	8.54
6	12.45	24	8.42
7	12.13	25	8.26
8	11.84	26	8.12
9	11.55	27	7.97
10	11.28	28	7.84
11	11.02	29	7.70
12	10.77	30	7.54
13	10.53	31	7.45
14	10.29	32	7.33
15	10.07	33	7.21
16	9.86	34	7.09
17	9.65	35	6.98

Natural waters often contain during the day-time an excess of oxygen in a super-saturated condition. This is due to photosynthetic activity of the phytoplankton and other plants in the water.

The oxygen consuming processes, like respiration of animals and plants, aerobic fermentation, and organic and inorganic reduction taking place in the water and mud, may cause oxygen deficiency in the water resulting in suffocation of the animals. Such drops in dissolved oxygen occur mostly during night-time, the lowest being before sunrise.

Normally, in a fish pond the oxygen producing and consuming processes are in dynamic balance and there is no need for any aeration. Adverse conditions occur only when the equilibrium is disturbed naturally or artificially. The most frequent cause of mass fish mortality is oxygen deficiency.

A significant indication of low oxygen content in water is the tendency of fishes in the pond to come to the surface and passively swim about gasping for air. The oxygen requirement of fishes changes from species to species under differing conditions of temperature and biological action. For each 10°C rise in temperature the oxygen requirement of a fish increases by two to three times. In addition, when the gut of a fish becomes full, the accelerated oxygen demand will be about 40-50 per-cent more.

2.2.8

Dissolved Nitrogen

It has been found that many of the algae can utilize some forms of dissolved nitrogen gas during the protein producing process. The solubility of nitrogen is rather high in water and by using nitrogen salts as fertilizers, the productivity can be increased considerably.

### 2.2.9 Dissolved Carbon Dioxide

Carbon dioxide reacts with water and produces carbonic acid, which in turn reacts with dissolved minerals to form bicarbonates and carbonates. The carbon dioxide, carbonic acid, bicarbonates (hydro-carbonates) and carbonates are generally in equilibrium in pond waters. During photosynthesis the plants take up carbon compounds out of the water. Carbon is essentially the basic material of organic matter. The carbon content of dry organic matter is as high as about 50 percent. The sources of carbon in ponds are

- i. the air (carbon dioxide),
- ii. carbon dioxide produced by respiration,
- iii. carbon dioxide produced by the aerobic decomposing processes, and
- iv. dissolved carbonates and bicarbonates.

### 2.2.10 Methane and Hydrogen Sulphide

The end product of anaerobic decomposition, viz. methane and hydrogen sulphide, occur mostly in mud and, when the air pressure is low, they are released into the water and cause fish kills.

### 2.2.11 Chemical Constituents of Water

The major elements dissolved (ionized) in the water are calcium (Ca), magnesium (Mg), sodium (Na), potassium (K), iron (Fe), chloride (Cl), sulphate (SO<sub>4</sub>), bicarbonate (HCO<sub>3</sub>) and carbonate (CO<sub>3</sub>). Elements like nitrogen, phosphorus and silicon are important from the biological production point of view. Recently the importance of trace elements like boron, cobalt, copper, manganese, molybdenum, vanadium and zinc has also been recognized.

## 2.3 THE LIFE ZONES IN A POND

### 2.3.1 The Shore or Littoral Zone

This zone is mostly occupied by rooted plants which emerge above the surface and some submerged ones with leaves and flowers floating on the surface of the water. These plants turn this zone into an unproductive "desert" and either reduce the dissolved oxygen or produce excess oxygen. The underwater parts of the plants are occupied by other microscopic plants and animals (mostly worms, insect larvae, crustaceans, etc.). It is desirable to construct fish ponds in such a way that the littoral zone occupies only a narrow belt of about 3 to 5 m width along the dikes.

### 2.3.2 Open Waters

This is the main part of the fish pond where no higher plants exist, and it is occupied by plankton and nekton, i.e. swimming organisms. The most important plankton organisms in a pond are: bacteria, algae, protozoans (unicellular animals), rotatorians and crustaceans. The important nekton organisms are: insects and insect larvae, bigger crustaceans, fish, tadpoles, etc.

### 2.3.3 Bottom of the Pond

In a well-maintained pond the bottom is covered with mud rich in organic matter originating mostly from decaying plankters, excreta of higher animals, etc., as well as from the leaves, barks, etc., washed in from surrounding areas. The most important fish food on the pond bottom are worms and insect larvae.

## 2.4 FOOD, FEEDING AND REPRODUCTION OF IMPORTANT GROUPS OF AQUATIC ORGANISMS

### 2.4.1 Decomposing Bacteria

This important group of organisms produces fermentation for breaking the organic compounds and then absorbs them on the body surface. Most of these bacteria need oxygen for this activity. Having absorbed enough "food" they reproduce rapidly by dividing every 1 to 2 hours.

### 2.4.2 Unicellular Algae (Figure 13)

These are the important "producers" of the pond which build up organic material out of carbon components by photosynthesis. They are generally adapted to this process by having a large body surface in relation to the body mass. Since these algae have only small bodies they cannot store the built-up organic matter and react to the intensive "feeding" (photosynthesis which takes the role of feeding) by intensive multiplication. They can thus reproduce every 2 to 4 hours.

### 2.4.3 Filamentous and Other Types of Algae Living in Colonies (Figure 14)

These also produce organic material by photosynthesis which, however, in most cases does not support fish or fish food organisms. The products of this group are therefore generally wastes from the biological production point of view.

### 2.4.4 Rotatoria (Figure 15)

The members of this group, varying in size between 0.06 and 0.2 mm, take out of water small algae and organic particles. For directly utilizing the organic material "stored" in the body of Rotatoria, it is advisable to stock plankton feeding fish along with common carp. They reproduce intensively.

The carnivorous Rotatoria, which are generally in the size range 0.2 to 1.0 mm, eat mostly algae, detritus-feeding Rotatoria and other unicellular animals. This group is harmful from the biological production point of view.

### 2.4.5 Filtering Crustaceans

These feed on small algae, bacteria and very fine organic debris straining them out of water. They are generally in the size range 0.2 to 0.5 mm and are excellent feed for plankton-feeding fishes. Based on the nature of their filtering apparatus, two main groups are distinguishable, as follows:

i. Cladocera (Figure 16)

Under this group are included water fleas with a very complicated filtering apparatus on their feet, which automatically affect filtration when moving. They thus consume small organisms and organic material which most fishes are unable to catch. If the pond water has adequate food, these organisms react by quick and effective reproduction, producing 30 to 100 young in two to three days.

ii. Copepoda (Figure 17)

The members of this group have a simpler filtering system which cannot get clogged easily. The food and reproductive habits are more or less similar to Cladocera.

2.4.6 Carnivorous Crustaceans

Although these organisms occur rarely in fish ponds, some species like the carnivorous Cyclops can be dangerous to fish fry.

2.4.7 Mud Eaters (Figure 18)

These organisms live at the pond bottom eating the mud which is rich in organic matter. The group normally includes worms and insect larvae (e.g. chironomids). The worms, under good feeding conditions multiply in the mud. The insect larvae develop in the mud thereby consuming the food materials and in the adult stage they fly out of the water, thereby depriving the ecosystem of a great amount of organic material (Figure 19).

2.4.8 Carnivorous Insects and Insect Larvae (Figures 20 and 21)

These larvae kill and eat other fish food animals as well as fry and fingerlings of fishes. They, however, can form food of bigger fishes. In general they are harmful in spawning, nursery and rearing ponds.

2.4.9 Tadpoles

Tadpoles eat fish eggs and thrive mostly on the same food items as fish fry and fingerlings. Only some carnivorous fish species eat tadpoles.

2.5 THE FOOD CHAIN

The food chain is the series or cycle of organisms existing in any natural community, through which energy is transferred. Each link in such a chain feeds on and obtains energy from the one preceding it. At the beginning of the chain the green plants represent the first trophic or energy level in the ecosystem.

The quantity of bound energy passing along the food chain becomes less and less as the series progresses. Thus it follows that higher rates of production can be expected from animals having relatively short food chains. The herbivorous fishes available in Nepal, viz., the grass carp and silver carp, have the shortest food chain with only two links. On the other hand, the food chain of a carnivorous fish is at least four-linked, viz., algae - algae-feeding crustaceans - plankton-feeding fish - carnivorous fish.

Each step into the next energy (or trophic) level in a food chain involves about 90 to 95 percent loss of the original energy content, which means that only 5-10 percent of the original energy content will be incorporated as bound energy into the next level.

## 2.6 PRODUCTION BIOLOGY

The production biology in a body of water deals with the continuous energy flow and material relations of the ecosystem.

The main energy forms in a ecosystem are:

- i. radiating energy or solar energy,
- ii. heat energy,
- iii. mechanical energy, and
- iv. bound energy of the organic components, termed also as potential energy.

The solar energy is qualitatively and quantitatively different in the various layers of the pond water. During photosynthesis only about 1 percent of the available solar energy is converted into bound biological energy in the water plants, yet this acts as the driving force for the whole life cycle in the water. The bound biological energy in plants can be mobilized and converted into heat energy or mechanical energy during the life processes of the organisms.

The heat energy is derived mainly from the unutilized solar energy, radiation from the earth, and by the metabolic activities of the living organisms.

The bound biological energy may be differentiated according to the type of organic compounds formed, such as carbohydrates, fats, proteins, etc. The energy value of 1 unit of carbohydrates is 5.42 kcal per g of proteins, 5.65 kcal per g and of fats 9.45 kcal per g. Carbohydrates are easy to mobilize for gaining other types of energies, while it is difficult to convert proteins into other types of energy systems.

It may often happen that production in a pond is high from the biological point of view, but the yield will be low as sufficient animals are not present to provide the yield, or the bound energy produced is unusable for the "yield-producing" animals. If a pond is not stocked or the stock density is low, the yield will naturally be poor. If water weeds or blue-green algae which are not eaten by the fish are produced, the accelerated production level will not lead to comparatively high yields. The fish culturist should therefore arrange the production in such a way that most of the biologically produced bound energy can be converted into the "yield producing" fish.

## 2.7 THE PRODUCTION PROCESSES IN THE POND

Three main groups of organisms which play different roles from the point of view of biological production in an ecosystem can generally be distinguished. They are:

- i. the primary producers,
- ii. the secondary and tertiary producers, and
- iii. the decomposing or reducing organisms (Figure 22).



### 2.7.1 Primary Producers

The primary producers construct organic material or potential energy as carbohydrates, proteins, fats and other organic compounds out of inorganic materials (nutrients) as carbon compounds ( $CO_2$ ,  $HCO_3^-$ ,  $CO_3^{2-}$ ), water ( $H_2O$ ), nitrogen and phosphate compounds, by photosynthesis. The synthesized organic material accumulated in the body of algae enrich the organic content of the algal population as well as the entire ecosystem. Shortage of nutrients or insufficient solar energy slows down the growth of the algal populations, resulting in retardation of the primary production process.

The measures usually adopted to improve the production of useful algal population include controlling the growth of undesirable water plants which obstruct light penetration in the water system.

The most important nutrients in the pond water are the carbon compounds (given in the form of organic manure or in the form of carbamide), phosphate compounds which can become exhausted rapidly as production is proceeding, and the nitrogen compounds which provide nitrogen source for the construction of proteins. Other elements are normally present in ample quantities.

If the pond is covered with emergent and other types of weeds or large quantities of filamentous algae, the nutrients will be utilized by them. However, the presence of species of fish feeding on them can enable their utilization.

### 2.7.2 Secondary and Tertiary Production

The second group of organisms, which are the consumers or secondary and intermediate producers, are, in a sense, accumulative organisms which lift up the organic material built up by the plants to the second production level. It is obvious that the organic material consumed by these animals is only partly used for body growth of the individuals of the population and in most cases this "re-accumulation" or "regrouping" results in about 90-95 percent loss of matter.

It is also obvious that those organisms, like fishes which live for comparatively longer periods, "store" the organic material for much more time than the species with a short life span. A *Daphnia* or *Cyclops* does not live for more than 20 to 50 days and such organisms with small body size react to the rich food with prompt and copious reproduction, thereby increasing the biomass of the population. However, when the quantity of available food drops, the reproduction rate also will be reduced proportionately.

In addition to the plant feeders, in any water system, there are also the so-called animal feeders or zoophagous animals. These feed on the smaller animals with the result that there is another loss of about 90 to 95 percent energy. This group forms the tertiary producers and, in the case of fish, are termed as terminal producers.

### 2.7.3 Decomposition and Recuperation

The lifeless organic material in a pond produced from dead bodies and undigested food material passed out with the excreta form the source of energy for two groups, the decomposing or reducing, and the recuperative organisms. The decomposing organisms are bacteria and fungi which break down the organic material with the help of ferments. Such decomposing process will proceed till all the organic material is exhausted and the remaining inorganic nutrients can then be utilized by the plants

once again. A considerable portion of the lifeless organic material will be eaten by those organisms which are adapted to take in such food and these can be termed as recuperative organisms, as they recuperate the lifeless organic material directly into the secondary production level. Most of the recuperative organisms like the worms, insect larvae, etc., are excellent food for fish. From the point of view of fish production it is immaterial whether the organic material is decomposed or consumed by other organisms.

#### 2.7.4

##### The Production Process

The basic principle in the production cycle is that a growing population needs a continuous increase in its feed resources. The food or inorganic nutrients can thus become a limiting factor in the growth of populations. This applies to production at all levels and can be illustrated by the example given below for the tertiary production level. If a 1 ha pond is stocked with 2 000 fingerlings of 1 g average weight, each of the fingerlings will get 5 m<sup>2</sup> "grazing" area which can produce more food than can be consumed by a fish of this size. Thus the growth of the fish population will be maximum and a major portion of the food will become unutilized and thus wasted. However, the food consumption rate increases with the body weight and after a while the grown-up fish will find only as much food as is just sufficient for maintenance. Now, the "production" (growth) of the fish population will stop as a balance or equilibrium is established with their food production levels (Figure 23).

If the number of fish stocked per unit area of the pond is dense, the equilibrium will be reached with a smaller body size. However, since the denser population can utilize the food resources better than a thinner one, the yield per unit area will be higher in spite of the smaller individual size. If the population density of the fish stock is so high at the beginning that the food producing levels are not sufficient for maintenance, no growth will occur or even there may be a decrease in the total weight of the population. It is therefore obvious that the maximum fish production is obtained with an optimum population density.

Organisms like filamentous algae, many of the blue-green algae, water weeds, back swimmers, etc., have generally no consumers in a pond and hence the production of such items will be a general waste. Although these organisms may contribute to the organic debris after their death, the total loss of energy is much more than in the case of direct utilization.

#### 2.7.5

##### The Role of Stocked Fish in Increasing the Productivity of the Pond

When the fish eats the natural food it thins out the population of its food organisms and makes space for fresh ones thereby speeding up the production process. Further, the amount of faeces produced by the fish is considerable, which as manure will form the energy source for other organisms. The carbon dioxide released by the respiration of fish will be converted into organic compounds during photosynthesis.

#### 2.8

##### PLANKTON INVESTIGATIONS FOR PRACTICAL PURPOSES

It is necessary for a successful fish culturist to be familiar with the important group of plankters in a pond and methods to determine the quantity and quality of the total plankton present. In order to get an acceptable picture of the plankton organisms, a suitable sampling method will have to be adopted (Figures 24 and 25). A useful sample can also be collected with a 1.5 to 2 m long hard plastic pipe of 2 to 3 cm diameter which can be closed at the bottom with a rubber stopper pulled in by a string from above (Figure 26). The pipe should be calibrated in such a way that

the volume is marked from bottom upward. During operation the pipe may be introduced into the water vertically up to the bottom (but not touching it) and then the volume of the water inside has to be read and the stopper closed. The sample of water thus obtained may either be collected in a bucket or directly strained through a quantitative plankton net (100 to 180 micron mesh). The samples must be collected by operating the net across the pond in one direction, thereby covering a large area of the water.

Based on the volume of water strained through the plankton net, a rough estimation of the volume of the plankton can be made. The concentrated plankton should be taken in a calibrated test tube and fixed with formalin. From the volume of the settled plankton the quantity per m<sup>3</sup> of the pond water can be calculated.

If a magnifying glass or microscope is available at the site, a trained person can recognise the main groups of organisms in the plankton sample, either in the living condition or after killing with a few drops of formalin.

During the analysis of the plankton notes should be made regarding the main constituents like rotatorians, cyclopoids, diaptomids and cladocerans. The presence of plenty of eggs (for, e.g., in the egg bags of cyclopoids and diaptomids and in the cavity between the shell and the body in cladocerans) or free-living young ones, indicates a developing population provided with adequate food. On the other hand if the animals have no eggs and young ones are rare, the inference is that it is an old population in starving stage and that the food available for this population in the pond water is only sufficient to cover the maintenance requirements.

If Rotatoria are predominant and crustaceans are rare, which condition often develops in greatly overstocked small ponds, common carp cannot thrive well, as it cannot catch or strain the small organisms. However, Rotatoria are good food for small common carp fry and for the adult big-head. Regular manuring can help in the production of crustacean plankton in such ponds.

Phytoplankton determinations with net-strained samples may not be satisfactory, as the smallest plant organisms which are the most important from the biological production point of view, may pass through even the finest cloth used for making the nets. This situation can be overcome by transferring the water sample collected with the column sampler into a bucket and after thorough mixing, a 100 cm<sup>3</sup> sub-sample may be taken for further investigations. A trained person can recognize blue-green algae, diatoms, small forms of green algae, etc., in such samples.

If microscopic algae are rare in the pond, fertilization with phosphate and nitrogen fertilizers would help. If filamentous algae are predominant, application of copper sulphate (0.1 to 1 ppm) will reduce them, which will enable further growth of useful algae. However, this will have to be done in such a manner that the fish in the pond are not harmed. Stocking of small grass carp in the pond can also help in the control of large populations of filamentous algae.

## 2.9 BOTTOM SOIL AND WATER INTERACTIONS

The bottom soil in a fish pond has very important roles to play in the production process. They are in general:

- i. storage and release of nutrients into the water,
- ii. mineralization of organic bottom deposits, and
- iii. provision of shelter and food for bottom dwelling organisms.

It is well known that fertile soil is the best for pond construction in view of its ability to supply nutrients to the water. The organisms living in or on the bottom soil (benthic organisms) are of great importance in nutrition cycles in ponds and their quality and quantity can be used as indicators of productivity. If a pond is rich in benthic animals, it can be expected to fetch a high yield of common carp. In case the living top soil is removed during the construction of the pond, the yield will be low during the first year and will continue to remain so until a new layer, rich in organic matter, is developed.

#### 2.10 INVESTIGATION OF BOTTOM ANIMALS

In order to estimate the abundance of bottom animals, a fixed quantity of mud sample may be collected with a spade or simple tube sampler and washed in a box fitted with a fine metal or plastic sieve of 0.5 to 0.8 mm mesh. This will yield the coarse components of the soil matter, plants and animals in the sieve. The area of collection of each soil sample may be kept the same and, by counting the number of organisms of different species present in each, rough indices can be obtained.

### 3. FISH CULTURE

#### 3.1 SPECIES OF FISH SUITABLE FOR CULTURE

There is hardly any species of fish that cannot be cultivated under some condition or other but the basic consideration is of species which are worthwhile for culture under different situations. The criteria for selection are:

- i. natural ability to grow fast,
- ii. food habits adapted to the type of living organisms present in ponds,
- iii. compatibility with other cultivated species,
- iv. ability to adapt to crowded conditions,
- v. tolerance of low dissolved oxygen content,
- vi. ease of handling and harvest, and
- vii. reproduction under controlled conditions.

In a fish pond the plant and animal sources of food are all present and continuously produced but the quantity of different food items can vary and hence it will be advisable to select fish species with different food habits in order to utilize all the available food.

The species of fish which can be used for cultivation in Nepal are briefly described below:

##### 3.1.1 The Common Carp (Israeli Carp, German Carp), *Cyprinus carpio* (Figures 27 and 28)

This is the most important cultivated fish in the world and has been domesticated. It is an omnivorous fish, the food consisting of any item which can be digested. It eats zooplankton, animals living in the mud such as larvae of insects, worms, molluscs, etc. and on the stalks and leaves of submerged plants. When hungry, the carp will eat the decayed pieces of water plants, the young shoots of underwater weeds, etc. The natural food of the carp is basically rich in animal proteins.

The artificial food given to the common carp is mostly food grains like maize, barley, millet wheat, grains of leguminous plants like the pea, bean, soybean, lupin tubers such as potato (boiled); and agricultural and industrial wastes such as oil-cakes, flour mill washes and others which have some nourishing value and are not used as food for other animals. The fish eats artificial protein-rich foodstuffs such as fish meal, blood meal, carcass meal, dried insects, silkworm pupae, flesh of molluscs, minced flesh of fish, frog, snake, etc.

During the last decade, the common carp has been grown on poultry feed pellets which have about 20 percent animal and 10 percent vegetable protein content and the results have been satisfactory.

The carp has its maximum appetite when the water temperature is over 20-25°C. Under 10°C the fish takes little food.

The carp is a very fast growing fish. Depending on the quality and quantity of food available, the growth may differ very much. If a carp gets daily food of about 5-6 percent of its body weight, it will grow very fast adding 1-2 percent of the body weight per day. For maintenance of the actual body weight it is necessary to feed roughly 1 percent of the body weight per day.

The different types of common carp available are: the scale carp (called German carp in Nepal), mirror carp (called Israeli carp in Nepal) and the so-called leather carp without scales which is not suitable for culture.

It is well known that the different cultivated strains of the common carp can vary very much as regards their growth. Improving the cultivated carp strains is a very important task of the practical geneticists and fish culturists.

The spawning of common carp may take place naturally or semi-artificially or fully artificially (see Chapter 4).

### 3.1.2 Chinese Carps (Herbivorous Carps)

Beside the common carp the most important cultivated fish group in Nepal can be the Chinese carps. Four different species with very different food and feeding habits belong to this group, all originating from the great rivers of China. (Of these, three species have already been introduced in Nepal.)

Grass carp	( <u>Ctenopharyngodon idella</u> )
Silver carp	( <u>Hypophthalmichthys molitrix</u> )
Big-head carp	( <u>Aristichthys nobilis</u> )
Black carp	( <u>Mycopharyngodon piceus</u> )

#### 3.1.2.1 Grass carp

Its appearance resembles a scaly common carp with elongated body. The fish feeds on water weeds, both soft and hard, and eats leaves of plants and grass thrown in the water. Below 12°C the grass carp does not eat well; over 13°C it starts to eat something, but its appetite grows considerably when the temperature is above 20°C. Between 25 and 30°C, the fish can eat an incredible quantity of plants. The digestive process of the grass carp in high temperatures is very fast and the undigested or scarcely digested food passing through the gut will be emptied in the water and the excreta act as efficient "green fertilizer". At temperatures over 25°C one grass carp can eat plants equal to 25-50 percent of its own body weight within a day. But it is quite natural, due to the very fast and incomplete digestion, that the major portion of the plants eaten returns to the water, forming a well distributed organic manure.

The newly hatched grass carp first eats small plankton animals, mostly Rotatoria, and larvae of Copepoda and Cladocera. Later, when 5-6 cm long, it starts to nibble the underwater plants. Some plants will be eaten by the grass carp only if there is no other choice and it is very hungry.

Thus, the grass carp is beneficial in three ways in the pond. It is useful not only for its production of fish protein but also as a control for undesirable water plants and serving as a "living manuring machine" which provides the pond continuously with a well distributed and highly effective organic manure.

A hungry adult grass carp may eat the fry of fish and hence the fish has to be excluded from nursery and breeding ponds.

The grass carp may eat the food grains supplied specifically for the common carp, but the extent of such utilization will be comparatively little. In order to avoid improper utilization of food grains the grass carp may be fed first and then the common carp.

The grass carp is a very fast growing fish and in subtropical areas it attains sexual maturity in the second or third year. The fish spawns in rivers and under pond conditions it can be propagated only artificially (see Chapter 4).

#### 3.1.2.2 Silver carp

The food of silver carp consists almost solely of microscopic algae, generally not bigger than 0.02-0.025 mm. It strains its food out of the water using the gill filter apparatus. A silver carp with 250 g body weight strains through its gill filter an average of 32 l of water per day. The fish has a comparatively long digestive canal, with the result that the digestion and the utilization of the food are more complete than those of the grass carp.

If the food for the silver carp is rich in the pond (which can be produced by sufficient fertilization) the fish grows very fast, sometimes faster than the grass carp of the same age and initial weight. The young silver carp is an animal eater and consumes about the same food as grass carp of the same age (mostly Rotatoria, Giliata and Nauplius larvae). From about 3-4 cm body length onward the fish starts as an algae feeder. The silver carp can eat only finely ground artificial feeds like flour, added in the water as floating material.

The silver carp attains sexual maturity at the same age as the grass carp. It can be propagated only artificially in ponds.

#### 3.1.2.3 Big-head carp

This fish is very closely related to the silver carp, but its feeding habit is different. It strains food out of the water, eating entirely planktonic organisms. Since its gill filter apparatus is not so fine as that of the silver carp, it feeds on bigger plankton items, mostly animals like Rotatoria, Copepoda and Cladocera. The larger algae like Aphanisomenon, Microcystis, etc., are also consumed. If the food is sufficiently rich, the big-head carp grows faster than the two other Chinese carps. The silver carp and big-head carp feed down to 14 C, but at about 6°C such activity stops. The propagation of big-head carp is similar to that of silver carp and grass carp.

The above-mentioned three Chinese carps, together with the common carp, form a successful group in the pond, utilizing all the main food sources (food niches). By stocking these fishes in the same pond in a proper ratio, high production rates can be achieved easily and cheaply. Grass, other plant material and offal thrown in the water will be eaten by the grass carp and result also in continuous "biological manuring". The so-called weed algae in a well fertilized pond will be successfully controlled by the grass carp and big-head carp.

#### 3.1.2.4 Black carp

This Chinese carp feeds almost entirely on molluscs (e.g. water snails) which occur in great numbers at the bottom of ponds constructed in the Terai and Inner Terai, and hence this carp can be utilized in such areas to exploit the unutilized food resources.

The question of introducing the black carp in Nepal thus deserves serious consideration.

### 3.1.3 Indian Major Carps

#### 3.1.3.1 Catla (*Catla catla*)

This is the fastest growing indigenous carp in India and is a surface feeder. Its upturned mouth and the large gill rakers are adapted to feeding on the numerous organisms floating in the pond water. In ponds with an overgrowth of submerged weeds, its growth is generally unsatisfactory.

Young ones, from the time they begin feeding and until they reach a length of about 15 to 20 mm, feed almost exclusively on water fleas and other plankton animals in the pond. Subsequently they probably eat microscopic plants floating in the water, though at all stages the planktonic animals constitute the most important item of food.

Catla is reported to grow very quickly. In normally stocked waters, a growth of 35-45 cm in the first year can ordinarily be expected.

Catla in the second year is ordinarily sexually ripe and therefore ready to breed in the third season after hatching. Catla breeds naturally in rivers during the rainy season but artificial propagation by hypophysation has been quite successful (see Chapter 4). The eggs of this species float in water and are non-adhesive.

#### 3.1.3.2 Rohu (*Labeo rohita*)

This is considered as the tastiest of all the Indian carps. It is a quick growing species and is a column feeder. Its rather anterior fringe-lipped mouth is well adapted to browsing on shallow pond bottom also. Considerable quantities of bottom sand or mud, plant debris or decaying debris of aquatic plants, planktonic algae, etc., constitute its gut contents. Only the young ones feed on plankton animals.

A growth of 35-40 cm can normally be expected in the first year from rohu in a well stocked pond.

Sexual maturity is attained towards the end of the second year and breeding habits are similar to those of catla.

#### 3.1.3.3 Mrigal (*Cirrhina mrigala*)

The adult mrigal is a bottom feeder while the feeding habits of the young ones are similar to those of catla and rohu. The fingerlings and adults consume relatively large quantities of decaying organic and vegetable debris, phytoplankton organisms, etc. The proportion of animal matter in the diet of the mrigal is generally poor. The thin terminal lips of the fish are adapted to picking up food items from the mud.

Mrigal grows slower than catla and rohu. In a pond stocked at the rate of about 15 000 fingerlings per ha, an average size of 20 cm may be attained within 8 months. By thinner stocking quicker growth may be expected.

Mrigal becomes sexually mature when about two years old. The breeding habits and the technique of artificial propagation of the species are similar to those of catla and rohu.



### 3.1.4 Other Fishes for Culture

Suitable techniques for the cultivation of other important indigenous fishes, such as mahseer (Barbus tor or Tor tor) and Barbus hexagonolepis, both of which are carnivorous; Myxus seenghala, Clarias batrachus, Heteropneustes fossilis and the different snow trout species (Asta sp., Oreinus sp., Schizothorax sp.), which are to be considered for cooler areas, have yet to be evolved.

#### 3.1.4.1 Tilapia

The different species of Tilapia have become the "miracle fish" of the post-war era and many culturists had claimed that these fishes may solve the animal protein problem of the developing world.

Most of the Tilapia species are plant feeders, which property is highly favourable in such countries where food grains produced locally suffice for local human consumption only.

The Tilapia protects its progeny very successfully, which characteristic has both good and bad implications. The easy and successful propagation of the species under controlled conditions is a great advantage but a few pairs of Tilapia may overcrowd a pond within a few months resulting in the progeny becoming small and stunted and therefore not worthy of cropping. Further, if Tilapia is introduced in a pond, there is every possibility of some fish escaping to neighbouring waters.

In Nepal there is a demand for smaller fishes at present, but in the years to come the living standards will improve and consequently the small fish may lose their value for human consumption.

Tilapia species have not yet been introduced in Nepal. If it is envisaged to introduce the fish into the country, the problem should be investigated in its different aspects before a final decision is taken.

#### 3.1.5 Predatory or Carnivorous Fishes

Rearing of predatory fishes together with common carp or other non-carnivorous fish species is necessitated under certain conditions in which the eggs, larvae, fingerlings and in many cases even sexually mature individuals of undesirable fish species (noxious fishes and weed fishes) may invade the pond along with the water supply, despite careful filtration through fine screens. These weed fish species consume the natural and artificial food of the cultivated fishes, thereby diminishing the production. Generally the weed fish species are small, slow-growing and their flesh is of low market value, hence the food which they consume in the pond is to be considered as waste.

Thus, the predatory fish has a two-fold purpose in the first pond; it decreases the number of weed fish which compete for food with the cultured fish species and also transforms fish and other aquatic animal flesh of lesser value into highly valuable meat. Certain species of carnivorous fishes also eat other animals such as frogs, tadpoles, shrimps, prawns, bigger water beetles, etc., which are likely to frequent the fish pond. Predatory fish also render a "sanitary service" by eating underdeveloped, sick or weak carps.

But the predatory fish has to be either of the same or smaller size than the reared fish. It is necessary to mention that the predatory fish should not be of a "shark" type (e.g. Hallago attu) which may be harmful to the stocked fish.

In Europe four species of "domesticated" carnivorous species are cultured in ponds. In India there is no such fish available at present. It appears that some indigenous species such as Mystus senghala or Clarias batrachus or perhaps a proved exotic predatory species may have to be tried in Nepal.

### 3.2 THE MANAGEMENT OF FISH PONDS

#### 3.2.1 General Duties of a Good Fishery Manager

A good management is essential for the whole fish production process, executing the different operations in proper time, checking on the effects of the operations and finding out the best and the cheapest solutions for improving the yield. In order to do this, adequate know-how based on a solid theoretical knowledge and practical experience is essential.

The success of a fish farm is measured by the fish produced and by the low cost of production. For achieving this aim, the conditions to be met are:

**Discipline and punctuality.** In all farms and projects working hours are prescribed, which have to be observed by everybody concerned.

**Order and tidiness.** Many valuable materials and equipment are required in a fish farm. Tools and equipment exposed to nature get destroyed due to wear and tear.

After cropping, each monk should be closed immediately and the unused control boards and screens should be stored in a sheltered place like a shed, until needed again.

The workers should be trained to handle the equipment carefully and at the end of the day's work each item should be returned to its original place.

Special care should be taken about the nets. Even synthetic nets get destroyed if they are not handled carefully. Wet nets left in a heap without clearing the debris and small fish, are liable to be damaged by rats, so after use the nets should be dried well. After complete drying, the nets should be bundled and hung in the store room where rats and other animals have no access.

Accurate and good work is essential. The labourers in the fish farm should be trained to do their work accurately and well. This means that it must be explained to them how to do specific jobs and what the aim of the work is. It should also be made clear to them why the work must be done in the prescribed way.

Recording of the activities is required. The management work in a fish farm is complex and the manager and other responsible personnel have to arrange several things simultaneously. Hence they should note down important tasks to be done on a day-to-day basis. One who is guided by accidental happenings and acts without any mental preparation cannot make his mark as a fish farm manager.

For the sake of efficient control, data on the following aspects should be recorded at the end of the production season:

- i. the percentage of loss in fish stocked
- ii. the duration of the production period in days (time between stocking and cropping)
- iii. the total weight of the cropped fish

- iv. the total yield (weight of the cropped fish minus the weight of the stocked fish)
- v. the yield per hectare
- vi. the yield per hectare per day
- vii. total food supplied in the pond
- viii. how much of food has produced 1 kg fish (food quantity divided by the total yield)
- ix. total cost of food
- x. the cost of 1 kg fish produced.

It would be interesting if a graph is maintained showing the growth of the fish in the different ponds, on the basis of the montly growth checks.

All efforts must be made to prevent the theft of the equipment and fish.

### 3.2.2 Fish Culture Operations

The various steps involved in commercial fish culture operations are described below:

#### 3.2.2.1 Stocking the ponds and fish stock manipulation

What to take care of: stock the pond as soon as possible after calculating the number of each species to be cultivated. The quality and condition of the fish stocked should be satisfactory. Weed fishes if can get access to the ponds reduce the yield considerably. Such species should be avoided by screening or filtering the inflow water properly.

Usual mistakes: understocking the ponds will result in incomplete utilisation of the food available. Overstocking is not a big mistake, only it is too expensive. If the draining monks are not closed fertile water with dissolved minerals will be drained from ponds resulting in loss during the production period.

Data to be recorded: for recording the stocking data, a specimen proforma is suggested below:

Number or name of the pond	Area of water surface	Number and average weight of fish (each species and size group separately)	Number and weight of fish per hectare (each species and size group separately)	Date of stocking	Remarks (health, body condition, etc.)
----------------------------	-----------------------	--	--	------------------	--

#### 3.2.2.2 Stocking ponds with common carp

Stocking a pond means releasing in the pond an adequate number of the selected fish species which are of proper size. The stocked fish should grow within a given time to "market size".

In stocking operations one must pay attention not to stock or release undesirable or unknown fish species in the pond. This is the first rule of pond stocking. A fast-growing strain may produce 20-30 percent more than fish stock of unimproved and obscure origin.

The size, or better the age, of the stocked fish is very important. The young fish grows much faster and will economically utilize the resources of the pond better than the old ones. In Nepal, where the carp attains sexual maturity in one year, it is generally advisable to see that the stocked fish reaches marketable size during the first year. The young fish uses less food for maintenance and more for increasing its actual body weight. The vitality of a young fish is greater and its search for food and utilization of the different food sources are more efficient than of the older ones.

But the food capacity of a small fish is not much, i.e. its gut cannot contain and digest the same quantity of food as a bigger one which has a larger gut capacity and can digest a greater quantity of food during the same time. When a pond is stocked with small fish, some wastage of the natural food is unavoidable during the first period of production.

The food and feeding habits change with age and size of most fish species. This means that the carp and the other cultivated fish of different ages do utilize quite different food items produced in the pond. This is the reason for stocking different age groups of the same fish in the same pond. In Europe, it is a common practice to mix different age groups of carp in the same pond.

The number of the stocked fish depends on:

- i. intensity of culture (manuring, fertilising and feeding),
- ii. desired market size, and
- iii. actual size of the fish stocked.

If intensive culture is not planned or the market size is to be large, the pond should be stocked rather thin or during the production period the stock must be thinned out to provide the remaining stock enough food, thereby increasing the possibility of accelerated growth.

Practically, three size groups of carp fingerlings are used for stocking in the growing ponds (called also fattening or production ponds): small fingerlings 2.5-5 cm total length; medium size fingerlings 5-10 cm total length; and big fingerlings between 10 and 20 cm total length.

### 3.2.2.3 Basic principles involved in stocking operations

Before considering the principle of stocking, it is necessary to be acquainted with the following concepts: growth, growth rate and growing time.

The growth of a fish means increase in the body weight. The growth of a population is the sum of the growth of individuals of the concerned population.

The growth of a fish depends on various factors; the important among them being the age and food capacity of the fish; the time taken for growing, the quality of the strain, the food available, the nutritive value of the food, the health of the fish, the appetite, the oxygen content of the water, etc.

The age and food capacity have already been mentioned.

The time taken for growing depends on the fish culturist or on the natural circumstances. The growing ability is different for the various fish species and strains.

The carp can achieve within three months a body weight of 50-100 g or even more. Within half a year those fish stocked at 3.5-5 cm length may grow up to 250-500 g in weight, depending on the conditions available in the pond the most important of which is the food available. The characteristic of the particular strain of carp used is a very important factor which should never be overlooked. Individuals of the same species of fish may show different growth rates even though they may consume the same quality and quantity of food. The improvement of the fish strains is concentrated mostly on their growth characteristics.

A good fish culturist selects the best individuals for breeding and takes care to maintain the fast growing property of his stock.

If a fish can collect enough food from the natural food sources in the pond, it fills its digestive tract 2-3 times a day and the resultant growth can be expected to be adequate. In cases where the food is scarce, the growth slows down or stops, or the fish may lose its body weight.

The growth rate of a fish is the increase in the body mass during a given time, expressed as daily or monthly growth rate. Another mode for expression of growth is as the time in which the actual body weight will (or can) be doubled. The daily growth rate may generally be expressed as percentage of the actual body weight.

A fish suffering from diseases or infected by parasites will not be able to consume much food and hence cannot grow well.

The appetite of a fish depends on the temperature, which determines the speed of digestion, and different species of fish have widely varying temperature preferences. The carp does not generally eat at temperatures below 8°C, and also its appetite may decrease when the water temperature is over 35°C.

When the concentration of dissolved oxygen is low in the pond water, the fish may stop feeding. Under conditions of low oxygen content, when the fish are seen to gasp for air at the surface, there is no chance for growth.

If the competition between the individuals of a population is great, the weak ones will hardly survive. With age the survival rate will be higher, i.e. in younger individuals there are chances of greater losses.

#### 3.2.2.4 Practical aspects of stocking operations

##### The market size:

Determination of the market size of the cultivated fish depends not only on the culturist but also on the consumers. In Nepal there is a great demand for fish and carps of 100-500 g weight can be easily sold. Such sizes are attainable within 3-5 months by appropriate culture operations. However, if the supply position improves the market size is liable to change.

##### The necessary preparations to be made are:

1. To fill enough water in the pond. When the depth of the water in the pond is 50-60 cm the fish stock can be released.

ii. To keep in good state of repair the necessary gear, tools and transport equipment.

iii. To calculate the number of fish to be stocked in each pond.

The main factors which decide the number of the fish to be stocked are availability of enough natural food, fertilization and feeding. If feeding, fertilization or maring is not planned, stocking should be with 2 000-3 000 common carp fingerlings.

On the basis of the area of the pond the number of fishes to be stocked can be calculated. To make the calculations easier it is better to stock round numbers.

For conditions obtaining in Nepal, experience concerning fish culture in commercial farms is lacking. It seems to be reasonable to stock the ponds, with normal feeding, as follows: small fingerlings (2.5-5 cm total length) 4 000-5 000 per hectare and medium fingerlings (5-10 cm total length) 2 000-3 000 per hectare. When intensive feeding is possible the number can be raised by 20-50 percent.

In case the fish intended for stocking arrive at the site in a weak condition, they should be kept in a holding net or hape near the inflow region so that they can recover before releasing in the pond.

#### 3.2.2.5 Time of stocking

If the average growth rate of fish is 1.5 percent per fish per day, and if 10 000 fish of 20 g average weight are present in the pond, the growth of the stock is about 3 kg per day. A 10 day delay of stocking under these conditions means more than 30 kg loss in fish weight.

The productivity (production ability) of the ponds changes during the different months of the year. In Nepal the maximum productivity is observed during the beginning of the rainy season (June).

Since mostly small or medium fingerlings are used for stocking in Nepal it is not necessary to wait for the ponds to be filled. Fingerlings can survive if the deeper pond has about 50-60 cm water.

The general rule should be to stock as early as possible.

#### 3.2.2.6 Stock correction and growth check

During the main period of production it is necessary to know about the actual weight of the stocked fish or their growth.

In the course of growth checks, about 100-200 fish (about 1-2 percent of the stock) will be caught with a castnet or seine net and measured alive carefully and released back. From the body weight of the stocked population (or the result of previous growth checks) it is easy to calculate the actual growth during the period in question on the daily or monthly growth rates.

An example: for a growth check 138 fish weighing 18.6 kg are caught. The average weight thus is:  $18\ 600 \div 138 = 135$  g. The pond was stocked with 7 500 fish and hence, theoretically, there are  $7\ 500 \times 0.135 = 1\ 012.5$  kg fish in the pond.

The average weight 15 days earlier was 105 g, and hence the half monthly growth rate is 30 g per individual and the daily growth rate 2 g per individual. Usually the fish is caught when "on feed", and therefore it is advisable to subtract 5 per cent (as gut contents) from the measured weight. In the case mentioned, 18 600 - 930 = 17 670 g, the average weight is 127 g. Growth checks are important and help in predicting the crop. The future operations can be adjusted according to the indications derived from regular growth checks. After a growth check one can estimate whether:

- i. the fish stock has sufficient food,
- ii. the fertilisation was effective,
- iii. the population density is adequate for the management measures taken,
- iv. the feeding has a desirable effect,
- v. whether stock thinning is required, and
- vi. whether a young population should be stocked again.

The growth checks have to be done once or twice a month and preferably on the same calendar days.

### 3.2.2.7 Stock manipulation in mixed fish culture

As mentioned earlier, various age groups (size groups) of a species of fish utilise different items of food in the pond. Since the younger fish have smaller food capacity, a part of the natural food available during the early part of rearing remains unexploited and hence is wasted. Later on the same stock will need more food than the pond can produce. So, in the first period an auxiliary stock of bigger fish can be introduced in small numbers and during later periods thinning out should be resorted to make available more food for the remaining ones.

Stock manipulation is of greater importance when different species of fish, which have totally different food and feeding habits, are stocked. The various age groups of different fish species (at least 3-4 species and two age groups of each) can utilise all the natural food resources occurring in the pond, and in this way the highest possible yield can be achieved out of the same biological production of the water.

Monoculture, i.e., stocking only one species of the same size and age, can never utilise all the food resources unlike the so called "poly" or "multiculture".

It is well known that the age group which is smaller in number is more favourably placed in the pond, as the competition for food is less between the members of the group.

There are different methods evolved by practice for stocking different age groups of fishes in a pond. However, the execution of the programme depends on the availability of the particular age groups at the appropriate periods.

A few practical hints in this connexion are indicated here. As an example, either 2 000 medium carp fingerlings and 3 000 small ones, or 500 big, 1 000 medium, and 2 500 small ones per hectare may be stocked. When the bigger ones reach the market size and the thinning-out process should start, it would be advisable to stock again 1 000-2 000 small size fingerlings per hectare.

If "artificial" feed is provided in the pond, it would be advisable to stock smaller age groups as well, which can utilise the remnants of the food and undigested particles passed through the guts of the bigger fish.

The most effective method of stock manipulation is to use different species of fish with different food and feeding habits. In Nepal the Chinese carps (grass carp, silver carp and big-head carp) along with the common carp, have a great potential from the production point of view. The stocking of Indian major carps with common carp also holds promise for higher yields.

### 3.2.2.8 Mixed culture of common carp and herbivorous carps

It is well known that by stocking common carp and herbivorous carps (grass carp, silver carp, and big-head carp) in the same pond, high yields can be obtained. The stocking ratio depends on the environmental conditions in the pond. If the grass carp can be fed with abundant supply of grass as additional food, 500-1 000 can be stocked in 1 ha area. If, however, it is not possible to provide out grass and the fish will have access to only the water weeds growing in the pond, the stocking rate may be about 50-200 per ha. Silver carp can be stocked at the rate of 1 000-1 500 and big-head carp at 300-800. The stocking rate of common carp may be about 1 000-2 000 depending on the size of the fingerlings and other factors, mainly the food available.

In Nepal, since practical experiences on stocking are still meagre, the best rate will have to be determined on the basis of experimental observations. One scheme of stocking (a Chinese practice) which could be applied here also is: 2 000-3 000 silver carp (5-8 cm); 100-300 grass carp (8-10 cm); 100-300 big-head carp (8-10 cm) and 1 000-1 500 common carp (3-4 cm). The scope for addition of Indian major carps to such a stock will have to be determined. The growing time for the mixed stock will be one year, but the "thinning out" operation can begin even when one species has reached the market size.

### 3.2.3 Improvement of Environment

All the environmental improvement in a fish pond must be done simultaneously. Further none of them can be neglected as deficiency in one respect may restrict the benefits of others. For example, if a weed-infested ponds gets manure it will promote further growth of weeds and not contribute to the fish production. Further if a pond is infested with wild fish, they will utilise the increased biological production much more than the cultured ones:

The following environmental improvements can be distinguished:

#### 3.2.3.1 Protection against wild fish

Wild fish are not only a nuisance, but also act as real pests in the fish ponds. In the breeding and nursery ponds they eat the eggs and early fry of the cultivated fish. In the nursery, rearing and production ponds they compete for natural food with the cultivated fish and also consume the artificial feed provided. They can be parasite carriers also. In breeding ponds where many wild fish are present, the common carp may not often spawn.

The intruding wild fish propagate very rapidly in the ponds. A few pairs of such fish can produce thousands of offspring. Some species hide in the mud when the ponds are drained and survive there till water becomes available. Many of the most noxious wild fish species have accessory respiratory organs with the help of which they can breathe directly from the air. They can thus survive in small shallow pools or ditches. Bigger carnivorous wild fish may consume the stocked fingerlings also.



The damage caused by the wild fish is not at all compensated by the fish flesh they represent when caught. Most of the juveniles of these fish pass through the screens during the draining of the pond. Even if they remain in the pond they have no market value. The bigger wild fish will be consumed by the fishermen if they have enough time to collect them.

In most fish farms screens fitted to the inflow structures are used to prevent entry of wild fishes. Such screens, especially those with smaller mesh, may affect the rate of flow of water and often get clogged with debris. Further, there are no screens which can prevent the entry of small larvae or eggs of wild fish into the pond. All screens need daily checking and cleaning. Under these circumstances other structures which can effectively check the entry of wild fish have to be fitted to the fish pond. Some such important structures are described below:

### 3.2.3.2 Water filtering structures (Figures 29, 30 and 31)

#### i. Brush wood bundles

A "fence" made of brush wood bundles packed tightly and constructed in a semi-circle in front of the inflow structure can effectively function as a simple filtering system. Each bundle in the "fence" may be nailed tightly to long pegs dug into the earth and the entire structure should be checked often in order to ensure that no erosion occurs between and underneath the bundles. In order to provide sufficient strength to the structure, a few poles may be driven into the earth behind the fence.

Advantages: Such a "fence" is to be considered as a stop-gap structure which can be constructed with easily available materials. It will work well if properly made, checked often and repaired as and when necessary.

Disadvantages: The structure never lasts long especially during summer seasons. The brush wood bundles may break into pieces, which when washed into the pond get entangled in the net and clog the screen of the outlet structure. The semicircular structure should be large enough to prevent occurrence of erosion behind the "fence".

A more durable structure of the same shape can be constructed with stones and stone chips piled between rows of poles fixed parallel to each other. In order to prevent it from being washed out it would be advisable to make a foundation for the stone pile by laying bigger stones 10-20 cm deep in the earth. The stones should be placed near the poles and the space in between may be filled with bigger stone chips. The structure need not be higher than 30 cm in most cases.

Advantages: This structure can be constructed by the farm workers with cheap and locally available materials. It will be durable if the length of the semicircle is adequate, in which case erosion may not occur.

Disadvantages: If the inflow water transports too much debris or silt, the structure may get clogged in course of time. Once a year the structure must be taken apart and fully repaired. If big holes remain between the stone chips, the structure will not function properly.

#### ii. Screen basket

A screen basket can be fixed where the inflow water is flowing into the pond. The basket may be made of plain iron sheet or of one side open drum at the bottom of which holes are made with a nail from outside. The fish falling into the basket will be hurt or killed by the force of the water.

**Advantages:** The "screen basket" breaks the force of the falling water and helps to prevent washing-out and washing-back effects. It is easy to move from place to place. The fish collected in the basket can be utilized either for making fish feeds or for human consumption.

**Disadvantages:** All the fish falling in the basket may not be killed and the small fry or eggs may easily pass through without damage.

iii. Fixed basket with stones

If the inflow of water is stable, the basket can be fixed to poles driven in the earth and then filled on the sides with stones and in the middle portion with stone chips. The fish falling in the basket will generally be killed on the stone chips. Even if some manage to escape they cannot pass through the stone chip heap. The structure should be fitted about half metre above the water surface to function effectively.

**Advantages:** This structure which is very durable, can be constructed out of locally available materials without the help of skilled workmen. The force of the inflow water is broken totally by the stone chips, which helps to prevent washing-out effects.

**Disadvantages:** If the "stone basket" does not have a hollow in the middle region where the water falls, some of the very dangerous fish species (Ophiocephalus, Clarias, etc.) may jump or climb out and escape unhurt into the pond. The smaller fish caught between the stone chips may rot there. The "basket" may get clogged by debris and silt, and hence must be checked and cleaned often.

iv. Stone chips filter

This is a stable structure constructed on the feeding canals and made of earth or bricks. Since the structure cuts down the quantity of the flowing water and reduces the water current it must be constructed 2-3 times wider than the original canal.

The brick walled chamber has two rough wooden or iron bar screens one in the front and the other at the rear, which keep the stone chip pile in position. If the chamber is constructed on an earthen channel the inflow and outflow portions, each about 1 m length, must be constructed with bricks.

**Advantages:** This is an effective and stable structure which needs simple masonry work and if constructed well, failures will be rare.

**Disadvantages:** The chamber may get clogged with silt and debris in which case the stone chips must be removed, washed, and placed back. The construction of this structure is rather expensive.

v. Reverse filter

This structure can work effectively and provide clean and filtered water. The "stone-stone chip-coarse sand" filling is to be washed out by reverse flow for removing the deposited silt. The inflow water must be screened to prevent the clogging of the cleaning valve by bigger size debris. Because the effectiveness of the filter is rather limited and it is rather expensive, only in situations where clean and filtered water is needed, as for example in a hatchery, should this be constructed.

**Advantages:** The reverse filter can be a successful and stable structure if constructed and maintained properly. It provides clean water.

**Disadvantages:** It is a rather expensive structure and skilled masonry work is needed for its construction. The bigger debris should be screened before the water enters the structure and the filter must be washed out by opening the cleaning valve daily or weekly depending on the quantity of small debris and silt. Improper handling of the filter can cause total failure and repairs are generally very arduous and costly.

Where to place the filtering structure?

The filtering structures should be constructed on the main feeding canals and in such places where an incursion of wild fish could be expected.

In addition to construction of a filtering structure, necessary precautions for preventing entry of wild fish through draining structure also should be taken. Small pools and ditches on the pond bottom should also be checked carefully for the presence of wild fishes.

### 3.2.3.3 Weed control

The fish culturist can distinguish different groups of water weeds which interfere in the fish production process.

These groups are:

- i. submerged weeds;
- ii. floating weeds (rooted and unrooted);
- iii. emergent or hard weeds and
- iv. marginal weeds.

Small growths of these weeds may not be harmful but there is always the danger of their proliferation resulting in adverse effects on fish culture operations.

The submerged weeds absorb the nutrients from the useful primary producers, make the free movement and passage of the fish difficult and hamper the netting operations. Further, the floating weeds and emergent weeds in dense populations keep the pond water dark, where due to the lack of sunlight no primary production can occur.

The shallow fish ponds are prone to be overgrown with different types of water weeds. The most dangerous weeds are those which prevent the entry of sunlight into the water. These include dense growths of emerging water plants and those whose leaves float on the surface of the water. Such plants turn the underlying water into a "desert" where no appreciable biological production can occur.

From the biological production point of view all weed infestations in the pond are undesirable and harmful. However, emerging plants growing within a narrow fringe zone along the dikes can help in breaking the action of waves and thereby prevent erosion.

The general weed control methods fall under three main heads as described below:

#### i. Mechanical methods

Hand clearing of aquatic weeds is the oldest, probably the most frequently used, and the most arduous method. Many species of emerging plants can be pulled out by their roots when the growth starts. Hand raking can be effective for clearing submerged weeds growing near the shore-line. Cutting the weeds with a sickle may also be effective under some conditions. Rooted plants can be removed by dragging a wire rope with a fixed pulley or winch.

The cut or pulled up weeds should always be removed from the pond in order to prevent further sprouting. Dead plants in the water disintegrate quickly causing oxygen deficiency.

Mechanical removal of the water weeds can only be a temporary measure and sometimes the weeds grow faster than can be removed by hand.

Power operated weed cutters are also used to control aquatic vegetation and in such cases the operations should be taken up frequently throughout the growing seasons.

#### ii. Chemical methods

Several herbicides and weedicides are known to effectively control many species of aquatic weeds in ponds, provided that the operator knows the species of the weed present, the appropriate herbicide, the recommended dosages, the best period for treatment and the volume of water to be treated. A few of the important herbicides used for the control of aquatic weeds are mentioned below:

Copper sulphate: This is the oldest and most widely used chemical for the control of algae. Dosages of 0.1 to 1 ppm are usually adequate, but sometimes it would be necessary to resort to repeated applications. The chemical is generally not classed under the "dangerous" category in that a 2.5 ppm copper sulphate solution is not considered harmful in drinking water.

2,4-D (2,4 dichlorophenoxy acetic acid): This is claimed to be very effective in killing the water hyacinth (Eichhornia crassipes), which is now a great menace in Eastern Nepal. An 80 percent aqueous solution of the 2,4-D sodium salt (commercially known as "Taficide - 80") by itself can produce a total kill of the hyacinth at the rate of about 4 to 6 kg per hectare. Its effect appears to be quickened by the addition of a small quantity (0.1 percent) of the detergent "surf" to the aqueous solution. The plants are very susceptible to 2,4-D treatment in summer when the temperature, humidity, and subsequent rainfall help in the quick decomposition and dissolution of the dead vegetation. The treatment does not cause mortality of fishes.

Some other chemicals generally used for aquatic weed control are: 2,4,5-T, Silvex, Dalapon, Simazine. However, the actual effects produced by these formulations have not yet been clearly understood and hence are not recommended for general use by pisciculturists.

#### iii. Biological methods

As indicated earlier, the grass carp can be effectively used for the control of many types of submerged weeds. A population of 100 grass carps can check the growth of weeds in a 1 ha pond. The next best plant-eating fish is Puntius javanicus principally raised in Indonesia. Many of the Tilapia species are also effective water weed eaters.

Unfortunately there are some harmful water weeds which are not eaten by the herbivorous fish. Many other weeds are eaten only when the fish is starving for days. It is also known that only the bigger (above 0.5-1 kg) grass carp can eat the harder water plants.

Another method of controlling the harmful water plants is to raise ducks in the pond. The ducks nibble at the leaves and sprouts continuously checking thereby at least the proliferation of the weeds.

In general it may be stated that a fish culturist should first explore the possibility of adopting biological weed control methods. Mechanical methods come next in the order of preference, followed by chemical methods which incidentally are the most expensive and need maximum technical care and skill.

### 3.2.3.4 Providing nutrients in ponds

The importance of the manuring and fertilization in modern fish culture is indisputable. Both practices aim at direct promotion of the biological production by providing nutrients for the primary producers in the pond. The food relationship in a pond stocked with different species of fish is indicated in Figure 32.

The use of excess amounts of manure or fertilizer is not only economically bad, but also biologically harmful. The manuring and fertilizing has to be done systematically and the resultant effects in the pond have to be checked regularly.

Overdoses of manure are in most cases fatal to fish life. The haphazard ways of manuring and fertilizing may do more harm than good.

The quantity and quality of the manure and fertilizers used must be accurately recorded and economically evaluated after the cropping. It is advisable to record data concerning each pond separately on the proforma given below:

Pond No. or pond name, area		Year	
Date	Kind of manure or fertilizer	Quantity	Price

At the end of the season it should be possible to find out how much fertilizer or manure was necessary to produce 1 kg fish and the expenditure incurred for the same.

#### The role of manuring and fertilizing:

Experiments carried out in various regions of the world have proved that manuring with organic materials and fertilization with inorganic chemical compounds can increase fish yields considerably.

The main factors governing manuring and fertilizing are the quantity of materials used and the frequency of treatments, i.e., the distribution of manure and/or fertilizer in time, and fall under three groups, viz., chemical, biological and economic.

Chemical factors: According to Hepher<sup>1/</sup> the water in a fish pond is "a complicated system of equilibria in which the bottom soil takes an active part. These equilibria govern the cycles of the elements in the pond and their concentration in the water. There is a close interaction between the chemical equilibria and various physical, biological and edaphic (environmental conditions of the soil) factors such as temperature, photosynthesis, bottom soil composition, etc. These factors affect and are at the same time affected by changes in the chemical equilibria and the cycle of events in the pond."

1/ Hepher, B., Some limiting factors affecting the dose of fertilizers added to 1967 fish ponds, with special reference to the Near East. FAO Fish.Rep., 44(3):1-6

The adding of mineral nutrients in a pond by fertilising upsets the chemical equilibrium, which however tends to stabilise itself and the added elements are withdrawn from the water by various chemical and physico-chemical reactions, leaving only a part of the fertilizers at the disposal of biological reactions.

Phosphorus is a very good example of this as it can be absorbed in bottom soil colloids, precipitated as insoluble calcium phosphate, or bound by iron or aluminium in an insoluble form. The nitrogen compounds added in the pond can also disappear in different ways.

The rate of disappearance of the added fertilizer is dependant on the concentration of the nutrients in the water, the higher the concentration the quicker the disappearance. A concentration of phosphates over 0.5 mg per litre is in most cases useless and the same is the case with concentration of N over 2.0 mg per litre. Overdoses of manure may not affect the equilibria of elements but may badly influence the biological processes and the oxygen content in the pond.

Biological factors: A part of the nutrients added as fertilizer is taken up by the phytoplankton and serves the initial purpose of increasing the productivity. By increasing the phytoplankton the whole food chain will theoretically be enlarged resulting in increased fish yields. However, the food chain and the growth of fish are affected by a number of factors of which phytoplankton productivity is only one. If one of those factors which affect the growth of fish becomes a limiting factor, increasing phytoplankton production alone may not result in increased fish yield. In such cases the fertilizer or manure added in the pond becomes useless or even harmful.

Economic factors: The effect of fertilizers on fish yield is governed by the law of diminishing returns beyond a certain stage. This means that each successive portion of the fertilizer causes a smaller return in yield, until such a point is reached from where there is no further increase in yield with the addition of fertilizer. From the economic point of view the optimum dose which repays itself with the highest profit from the yield of fish is reached before such a level. The optimum effect of the fertilizer can be utilized only by an adequate stock of fish which makes use of the increased biological production in the pond.

All the factors mentioned above should be considered before finalising a programme of fertilising and manuring, taking care to avoid a wastage in material and time, and not to endanger the profitability of the whole operation.

### 3.2.3.5 Manuring

Organic manures distributed in the pond water stimulate and promote increased biological production. Since the dry material content of the organic manure for the most part is a compound of carbon (C) (40-50 percent), and carbon is the most important constituent organic material in the body of living organisms, the basis of manuring is obvious. The construction of living material by the plants from complicated organic compounds has already been described.

In old practices the organic manure used to be scattered or placed in heaps at the bottom of ponds. This type of manuring has its limitations, as in the mud of the fish pond there is usually less or no dissolved oxygen present and hence the greater part of the carbon compounds become methane, a useless end-product.

If the manure is dissolved and/or finely distributed in the production space of the pond, i.e., in the column of water where the reducing bacteria are always present, the decomposition of the complicated organic compounds to simpler ones down to carbon dioxide can take place, as the oxygen is usually present in surplus amounts in this zone. The algae present there can immediately utilize the simple organic compounds and carbon dioxide for the construction of living organic materials.

Further, the organic manure has some phosphorus, nitrogen, potassium, etc., which will also be well distributed in the water and can be utilized more fully by this method of application.

A 100 kg lot of pig manure contains about 8 kg of carbon (C), which can theoretically produce about 15-16 kg algae (expressed in dry matter). From practical experience it has been found that out of this amount of manure about 3-4 kg or even more fish can be produced. About the same amounts can be obtained using other organic manures like cow dung, chicken droppings, duck droppings, etc.

1. In the progressive fish farms of Europe manuring is done as follows:

A manuring boat is generally used, which has an installed small motor pump of capacity (5-10 l per second). Water is pumped from the pond into a fixed tube fitted on the side of boat and provided with a hopper. Wet manure is shovelled into the hopper in which the pumped water runs at a high speed. While the boat is driven through strip after strip on the whole surface of the pond, the water jet produced cuts the manure into fine pieces and pulverizes the solid parts. This manure solution is thrown on the surface of the pond, where it will sink and disperse.

In another method a screen basket is hung on the side of the motor boat in such a way that half of it is under water. When the boat moves forward fast water is forced into the basket and will dissolve and disperse the manure, which is shovelled continuously within the basket.

The above methods can be adopted only in bigger ponds of say 20-50 ha. The manuring is generally done daily or once in two days, or at least weekly.

In Nepal, since the fish ponds are generally smaller, the above methods of manuring may not be profitable. Hence the following modifications may be employed.

If a suitable boat is not available at the site, an old blown-up car tube can be used for manuring purposes. In the middle portion of the tube a screen basket may be hung, in which the softened manure is filled. The tube can be pulled to and fro from the bank of the pond, changing uniformly the course on the pond surface and during the process the soft manure (kept soaked a day earlier) will be reduced to small pieces or get dissolved and get dispersed on the surface of the water. The screen basket will have to be refilled as soon as it is empty.

If a small boat (punt) is available the soft manure can be mixed with water in the boat and the solution thus obtained may be dispersed on the surface of the water.

On an average the quantity of the organic manure to be used monthly may be about 0.5-0.8 t per hectare (wet weight). This means a dose of 20-35 kg per day per hectare if the application is daily (with 25 working days per month), 30-50 kg per hectare if once in 2 days (12 t a month) or 120-150 kg per hectare if weekly.

In Nepal since man power is rather cheap it is advisable to undertake manuring daily or at least on alternate days.

Excess of organic manure in the pond can be harmful as decomposing organic material will exhaust the dissolved oxygen content of the water, at first near the bottom, resulting in fish mortality.

Where the bottom of the pond is poor in organic material, organic manure may be distributed at the rate of about 1 t per hectare per year, preferably before inundation. This will favour the development of a richer bottom fauna.

The manuring should be done always before noon so that there will be enough daytime (i.e. illumination) for the algae to benefit from the manure.

ii. Ducks as manuring "machines" in the pond

Rearing of ducks can be a very useful, cheap and highly profitable method of providing organic manure continuously in the pond water. Fish-cum-duck culture is a very wide-spread practice in Europe and it is known that the ducks may raise the natural yield in the fish ponds two-or three-fold.

The effective number of ducks to be reared in a fish pond in the temperate areas is about 500 per hectare per year. But no experience is yet available regarding the number of ducks needed in subtropical areas where the period of fish cultivation is almost double that in Europe.

iii. The main advantages of fish-cum-duck culture are:

- (a) A properly adapted flock of ducks will stay in the pond throughout the day and night. The highly valued manure of ducks (about 5-7 kg per duck in 50 days) is well distributed in the pond water. From the manure of 3-4 ducks an increase of fish production of about 1 kg can be expected.
- (b) If the feeding of the ducks is arranged on a specially made "duck isle", the resultant garbage will be eaten by the fish.
- (c) The ducks eat the soft weeds in the pond and thus control the wild growth of the harmful plants.
- (d) The ducks eat the snails, tadpoles and bigger water bugs in the pond, which otherwise remain unutilized by the carps.
- (e) By the culture of ducks in ponds the production (duck + fish) can be raised by about 1-1.5 t per hectare per year.

The only disadvantage in fish-cum-duck culture appears to be the damage caused sometimes to the dikes, but this can be avoided by appropriate means.

iv. Other methods of organic manuring

In Nepal a large variety of plants grow along the pond walls and on the shallow regions of the pond during the rainy season. They should be cut repeatedly during the latter half of the rainy season, bound with strong wicker into sheaves and nailed to poles driven into the pond bottom along the shore. Fish food organisms, mostly insect larvae, will grow on the rotting sheaves. Further, the common carp and other fish species will eat the decayed plant material. Also the carbon dioxide and other organic and inorganic materials may be released during the decaying, which will benefit photosynthesis and primary production in the pond. If the pond has an appreciable number of grass carps, hewed grass can be thrown daily into the pond as food.

v. Rotation of fish culture and cultivation of plants

Conditions in Nepal favour the alternation of fish culture with cultivation of plants in the same year in order to keep the pond mud rich in organic matter.



An adequate growth of common carp can be achieved in Nepal during the rainy season of about 100-120 days. If an area is enclosed with dikes and provided with necessary inlet and outlet structures, it can be used as a fish growing place during the monsoon and subsequently when the water becomes inadequate for fish life, it can be utilised for irrigation of those areas which are on a lower level than the pond. The pond area itself can be ploughed and sowed with seeds of winter plants like mustard, vegetables, etc. After harvesting the crop the roots and other parts of the plant which remain in the pond soil will contribute to the biological production during the next rainy season.

This type of fish culture can be practised very effectively in areas where

- i. improvement of the soil for agricultural use is necessary,
- ii. frequent floods endanger the crops,
- iii. water supply is not adequate for fish culture during the dry seasons, and
- iv. seepage rate of the soil is high.

### 3.2.3.6 Fertilization

In most cases of organic manuring, the quantity of phosphates and nitrates available is not appreciable and hence for the purpose of obtaining a production of organic material of higher scale, more phosphorous and nitrogen compounds will be needed.

The inorganic and organic phosphate compounds are involved in the production of organic materials, especially of proteins, and hence phosphate fertilizers are beneficial.

The phosphate fertilizer will often be trapped in the mud of the pond. Once the mud takes in the phosphates it will hardly be released again. So it may happen also that phosphates are present in the pond, but cannot be used by organisms, as only those parts of the compounds which are dissolved and well distributed in the water are accessible to the algae.

The need for phosphates is constant and hence the maximum effect can be achieved by phosphate fertilization specially if distributed daily in the pond water. But the daily requirement of phosphate is relatively little with the result that it is quite impossible to distribute it uniformly in the whole pond area. In Hungary, where many fish culturists apply pig manure in the ponds, the daily phosphate dose is mixed with the manure before application, thus achieving a uniform distribution. (Another important reason for mixing the organic manure with inorganic phosphate is that as time passes the latter gets converted into organic phosphate compounds.)

The algae floating in the water cannot search for the necessary phosphates needed for assimilation and so there will be no benefit derived from the latter if they are just thrown in one corner of the pond. Uniform distribution is a must when fertilisers are added in the pond.

The distribution of fertilizers in a pond in time is another important factor to be taken into consideration. Formerly it used to be suggested that application of phosphates once or twice a year will be advantageous. However, at that time very little was known about the trapping of phosphates by the mud.

Where daily manuring is practised the easiest way is to mix the phosphate fertilizer with the manure a few days before application. It has been found by many workers that 0.2-0.5 mg per litre of dissolved  $P_2O_5$  is sufficient to maintain a high level assimilation rate of the planktonic algae.

In Israel a scientifically proved technique has been developed by applying 60 kg superphosphate and 60 kg ammonium sulphate per hectare once every two weeks. Till suitable doses are standardized the same technique can be adopted in Nepal also. However, since labour is cheaper than in Israel distribution can be done weekly, using a half or a quarter of the dose mentioned. Preliminary experiments have shown that fertilizing with half the quantity mentioned (half standard dose) has quite the same effect during the autumn season.

The following fertilisers are available in Nepal:

Complesal (20 percent  $(\text{NH}_4)_2 \text{SO}_4$  and 20 percent  $\text{P}_2\text{O}_5$ )

Superphosphate single (16 percent  $\text{P}_2\text{O}_5$ )

Superphosphate triple (48 percent  $\text{P}_2\text{O}_5$ )  
(this compound is too concentrated)

15-15-15 (15 percent N, 15 percent  $\text{P}_2\text{O}_5$ , 15 percent K)

Complesal and single superphosphate appear to be the most suitable fertilisers for fish ponds and the suggested quantities per hectare are: 30-40 kg complesal or 35-45 kg single superphosphate applied bi-weekly or half of the quantity every week.

In Terai and Inner Terai the production period lasts for 26-28 weeks which means that 400-500 kg of complesal or 450-600 kg of single superphosphate would be required per hectare per year. For the rearing ponds which are in use between March and June, 240-320 kg of complesal or single superphosphate would be needed.

Because the intensity of carp culture in Nepal is now far less than in Israel, it would be advisable to start with lesser quantities of fertilisers. Some suggested initial doses are: 10-15 kg complesal per hectare bi-weekly, 5-8 kg per hectare weekly, 20-25 kg single superphosphate per hectare bi-weekly, or 10-12 kg per hectare weekly.

Applying the fertilisers in the inflowing water will not give satisfactory results as it may flow out directly without mixing with the pond water or the inflow may get stagnated around the inlet structure.

#### 1. Fertilisers with nitrogen compounds

The most important chemical compounds of the living organisms are the proteins. Since proteins have about 17 percent nitrogen content, the importance of the role of the inorganic nitrogen compounds as raw materials in the production process of the pond is obvious.

The beneficial effect of nitrogen fertilisers in agriculture is well known. About 20 years ago European authors used to indicate that fertilising the fish pond with nitrogen fertilisers is useless and uneconomical. It had been claimed that a major portion of the inorganic nitrogen compounds are broken down to nitrogen gas by the so-called "denitrification bacteria" and thereby of no use as raw material for the construction of proteins. According to one particular author about 20 kg per hectare per year nitrogen compounds (mostly nitrites and nitrates) are provided from the air and washed in by the rains. This quantity is equal to about 100 kg 20 percent nitrogen fertiliser. It has also been stated that some bacteria and blue-green algae are able to bind nitrogen gas dissolved in water, producing in this way proteins. About 15 to 20 years ago other scientists found that many algae common in ponds and lakes are able to bind dissolved nitrogen gas. These findings also have supported the theory of "self-supply" of nitrogen compounds as indicated above.

Some other authors have stressed the harmful effects of nitrogen compounds distributed in ponds, stating that the highly poisonous ammonium ion ( $\text{NH}_4^+$ ) can develop from nitrogen fertilizers if the pH is high (approx. 9). Ammonia is a nerve poison and can kill the fish.

On the other hand, very high yields of fish have been achieved year after year in Israel during the last decade by application of inorganic nitrogen compounds as fertilizers. Ammonium sulphate, ammonium nitrate, carbamide, liquid ammonia, etc., are used in such practices.

The contradiction between the European and Israeli experiences can be explained as follows. In Europe, under temperate climatic conditions, the fish yield has been about 0.3-0.5 t per hectare and the stock not denser than about 1 fish per 20  $\text{m}^2$ . But in Israel, under subtropical conditions, the yield is about 2 t per hectare on the average and the stock adequately denser, about 1 fish per 2-5  $\text{m}^2$ .

It thus follows that, for the comparatively lesser intensity of production process in European ponds, nitrogen compounds derived from nature have been found to be sufficient, but for the increased production rates in the subtropical waters extra nitrogen supply is necessary.

It can therefore be generalized that for a lower rate of production the beneficial effects of nitrogen fertilizers are negligible, but where the pond management practices are adequately intensive and the fish population is sufficiently dense, it would be necessary to apply nitrogen fertilizers.

In Nepal sufficient experience is not yet available on the use of nitrogen fertilizers and hence the Israeli example could be followed by using 30-40 kg ammonium sulphate bi-weekly or 15-20 kg weekly, together with the phosphorous fertilizer. The ratio of P and N compounds dissolved in the water may be 1:4 as determined by Swingle and Smith.

#### ii. Calcium fertilizers

Limestone powder, quick lime, slaked lime and industrial wastes rich in calcium are used as calcium fertilizers in fish ponds.

In Europe large quantities of different kinds of calcium fertilizers are applied with obvious beneficial effects. Calcium fertilizers are applied in ponds where the pH is near 7 or less due to presence of humic acids or other chemical compounds, or in those lacking in dissolved inorganic materials. For correction of pH it will be necessary to dissolve a large quantity (1-2 t per hectare) of slaked lime or other calcium fertilizers, to obtain satisfactory results.

For normal fertilizing when the aim is to enrich the calcium content of the water or to keep the hydrocarbonates in solution and to bind the  $\text{CO}_2$  gas, 400-600 kg calcium fertilizer per year per hectare is used.

The usefulness of calcium fertilizers depends on the calcium content of the pond soil and on the dissolved calcium content of the water supply. If the pond water has 50 mg or more of dissolved calcium per litre, application of calcium fertilizer would not be necessary. If the water has a higher magnesium content or even the sodium or potassium content is high enough, all of which can substitute the calcium as hydrocarbonate holder in the pond, application of calcium fertilizers may not be necessary. No experience is yet available in Nepal concerning use of Ca fertilizers.

### iii. Trace elements as fertilizers

Experiments conducted using manganese (Mn), boron (Bo) and molybdenum (Mo) compounds as pond fertilizers have shown the beneficial effect of these so-called trace elements. But no practical method has yet been developed for the application of trace elements as fertilizers in fish ponds.

#### 3.2.3.7 Disadvantages of over-manuring and over-fertilization

The adverse effects produced by decomposed manure at the pond bottom have already been emphasized. Over-manuring can also cause the so-called "self-contamination" (autocontamination) of the water body in which the living organisms die suddenly and their rapidly decaying bodies consume the dissolved oxygen.

The pond water is incapable of storing and economizing the manure added. If the quantity of manure required for one month is given together on one day, the organisms which are responsible for the decomposition of organic materials will act immediately using the oxygen available and cause oxygen deficiency.

It is not advisable to distribute in the pond at one time even the amount of manure required for one or two weeks. For example if the daily requirement is 30 kg per hectare, it would be very dangerous to distribute 400 kg per hectare bi-weekly. The amount which can be distributed should not exceed 150-200 kg per hectare on each application.

Over-doses of phosphate fertilizers may not result in direct fish mortality and hence are not as harmful as excess of organic manure.

All fertilizers with ammonium content can be very harmful if the pH of the water becomes too high, over 8-8.9. In such cases ammonia may develop in the water which is a direct fish poison attacking the nervous system. The ammonia can be absorbed between the mud particles and released by a sudden change of air pressure ("depression") and can cause serious fish kills. It is interesting to note in this connexion that catfishes are very sensitive to free ammonia in the water and they die at 0.2-0.5 ppm, while the carp will die only at 3-5 ppm.

Quicklime used as fertilizer can cause damage to the fine tissue coating of the gills resulting in death of the fish. It is therefore not advisable to use more than 300-400 kg quicklime or freshly slaked lime per hectare per application, the safest limit however being 100-200 kg.

Quicklime and phosphate may react together producing an insoluble compound of calcium phosphate and hence an interval of two weeks should be allowed between the application of phosphates and liming.

It is advisable to carry out manuring or fertilizing during the early hours of the day. During day-time the major part of the distributed materials will be used and the equilibrium in the biological system of the pond, which gets somewhat upset by manuring or fertilizing, can get re-established.

When a new method or new fertilizer is tried it should be done in a single pond with the adequate precautions. On the basis of the experience gained the method may be extended to other ponds.

### 3.2.4 Feeding of Cultivated Fish

#### 3.2.4.1 General remarks on artificial feeding of fishes in ponds

Systematic feeding is essential for successful common carp culture and if the pisciculturist wishes to have higher yields, the fishes have to be kept adequately fed. The feed should be distributed properly every day and suitably checked whether it is eaten by the fish. If food shortage is expected, arrangements will have to be made for providing food for at least maintenance. Sudden interruption of feeding is harmful and hence it would be better to give smaller rations over a longer period.

The common problems in artificial feeding of fish are: over-feeding; the feed supplied is utilised by animals other than fish; the feed is not consumed at all and it rots at the bottom of the pond; too expensive feeds; lesser nutritive value of the feed (than expected); and the feeding is not adjusted in relation to the available natural food and with the fish stock.

Recording of feeding data: the quantity and quality of feed distributed daily in the ponds must be recorded separately for each pond. This is not difficult as the figures may change only bi-weekly or monthly. It is important to record the price of feed also. The following proforma may be used for recording the data:

Year:

Feed supplied						
Date Day and month	Pond No.		Pond No.		Pond No.	
	Feed (kg)	Price (N.Rs.)	Feed (kg)	Price (N.Rs.)	Feed (kg)	Price (N.Rs.)

The quantity and price for each month may be summed up and total made at the end of the production period. From these yield data the effectiveness of feeding and the cost of production can be evaluated.

The fish farms should be self-supporting economic units which produce fish at a price competitive with other sources or other animal products with similar nutritive value.

The first consideration in feeding is whether the operation would be economic and whether the yield based on the ponds' natural food alone will cover the cost of production and leave some profit.

The fixed costs in fish culture are so high that they can be covered only by high yields. The invested capital for constructing the ponds, water supply arrangements, buildings, gears, cost of fertilizers, etc., are almost the same whether the fish are fed or not. There will be some difference in labour costs which are higher when fish are fed. If feed is available at a reasonable cost the increase in yield due to feeding will result in a comparatively higher profit.

The traditional practices of Chinese fish farmers as well as modern scientific findings show that highest yields at lowest costs can be achieved by a mixed culture of fish species with different food habits. By carefully manipulating the number and size of each species stocked in mixed culture, the natural food in the ponds will be fully utilized. Artificial feeding in such ponds can result in additional yields. Food and fertilizers comprise a major component of the production cost (about 40-60 percent) and therefore this problem is considered here in detail.

### 3.2.4.2 Utilization of the food eaten by the fish

The food eaten by the fish will be utilised after digestion and absorption generally in two ways. One part of the food serves to maintain the fish alive and the other for growth.

If a fish gets food only to cover its maintenance needs it will not grow, which means that the food eaten will not contribute to any increase in yield. If the food available does not cover the need for maintenance the fish will lose its body weight. The early fry and small fingerlings have no reserves in their tissues and hence after a few days of starvation they usually die of hunger.

The daily amount of the food for maintenance (maintenance food) is related to the surface of the fish body and not to the body weight; as for example, 10 fish of weight 100 g each need far more food for maintenance than 5 fish of 200 g each or one of 1 000 g weight.

The quantity of food required for maintenance depends also on the activity of the fish, which is closely connected with the temperature of the environment. In cold waters the activity of most fish species slow down considerably and so the need for food for maintenance decreases.

The rate of metabolism and with that the rate of using maintenance energy, changes with the temperature in the "cold-blooded" animals. For a rise in temperature by 10°C the rate of metabolism may be doubled or even tripled. Thus, the maintenance energy in a fish living in water of 25°C will be doubled or tripled over that at 15°C.

Available data on the maintenance food of the common carp are given below:

The maintenance food<sup>1/</sup> requirement of the common carp at 25°C (77°F)

Weight of fish (g)	Daily ration per fish (g)	Food requirement for maintenance as percentage of fish weight	Maintenance food requirement of 1 t of fish, without natural food (kg/day)
10	0.21	2.1	21.0
20	0.41	2.05	20.5
50	0.95	1.9	19.0
75	1.36	1.8	18.1
100	1.7	1.7	17.0
200	2.6	1.3	13.0
300	3.4	1.13	11.3
400	4.2	1.05	10.5
500	5.0	1.0	10.0
600	5.6	0.93	9.3
700	6.2	0.88	8.8
800	6.8	0.85	8.5
900	7.4	0.82	8.2
1 000	8.0	0.8	8.0

<sup>1/</sup> The food here is grains with a food quotient 4-4.5

The carp can generally utilize carbohydrates, fats and proteins for maintenance purposes. But if the carbohydrates are available in the food items they will be utilized first. The common carp can never get sufficient carbohydrates from natural food to cover maintenance needs. In such cases proteins will be used, which amounts to squandering valuable food material. On the other hand the proteins available to the fish in the natural food should be utilized for growth (increasing the body weight). It is therefore imperative that the cheaper carbohydrate feeds capable of covering at least all the maintenance energy needs of the fish are supplied in the fish pond. That part of the food which remains after covering the maintenance needs will be utilized by the fish for increasing the body weight. So we can expect growth of the fish only if they get more food than required for their maintenance.

While the common carp can meet its requirements of maintenance energy solely with carbohydrates, proteins are essential for growth. Certain amount of increase in the body weight can be achieved by carbohydrates also as the carbohydrates can be turned into fats, but this process is better termed as fattening than growth.

The protein sources for the carp may be of animal or plant origin. The proteins of animal origin contain all the necessary amino-acids needed to build fish flesh and other body tissues. The proteins of plant origin may lack some essential amino-acids and therefore they cannot entirely cover the energy needs of the common carp. Experimental observations have clearly indicated that in order to ensure adequate growth, about 20 percent of the diet of the carp should be proteins of animal origin.

If the growth of fish is fast enough due to availability of sufficient quantity of food in the pond, the period of production will be comparatively short and the production balance will be in favour of the part of food serving growth. Because the food eaten for maintenance does not cause any measurable change in the body weight of the fish, one can easily imagine the adverse effect of food shortage in the pond during the growing period. Therefore the population density must be regulated according to the available food (both natural and artificial) in the pond, by harvesting those fish which have reached marketable size.

### 3.2.5 Growth of Common Carp

#### 3.2.5.1 General remarks on growth

It is necessary that a cultured fish should be fast growing. Slow growing species and those which get stunted but attain sexual maturity as "dwarfs" under crowded conditions are generally no suitable for cultivation.

The growth rates of different strains of the common carp show wide variations. Fast growth occurs only if the environmental characters are satisfactory and sufficient food is available. The absolute growth of a fast growing strain is also determined by different factors like age and size, sex and condition of development of the gonads, and last but not least, the state of health. The growth of an older fish is slower than of a younger one. A bigger fish up to a certain limit has a greater food capacity and may grow faster than a small one. Attainment of sexual maturity slows down the growth in most cases and the surplus of the food intake will serve for the development of the gonads. It is known that the male carp grows slower than the female. A fish infected by disease or one in bad health loses its appetite which naturally affects the growth rate. Under conditions of low temperature the carp may lose its appetite resulting in retardation or even cessation of growth. Low oxygen concentrations (0.5-0.8 ppm) may also adversely influence the appetite of the carp.

The growth of a fish is generally expressed as the increase in weight during a given period. Other methods of expressing growth are:

- i. the time required for doubling of the actual body weight,
- ii. daily increase of the body weight within a given time, and
- iii. the daily increase of body weight as a percentage of the actual weight.

The doubling of the body weight and the daily growth as percentage of the body weight are closely inter-related, as will be seen from the table given below:

Daily growth as percent of the actual body weight	Number of days required for doubling the initial body weight
1	70
2	35
3	24
4	18
5	15
6	12
7*	10
8*	9
9*	8
10*	7
15*	5
20*	3.9
30*	2.6
40*	2.0

\* such rapid growth can occur only in case of fry and fingerlings

### 3.2.5.2 Growth of common carp during the early stages

The growth of the carp fry after hatching is rather rapid, as indicated below:

Live weight of a carp after hatching:	0.0026 g
Live weight when starting to feed:	0.0025 g
Live weight 15 days after hatching:	0.0845 g

The above data obtained under laboratory conditions show a daily increase of weight by 20-40 percent. Under natural conditions the growth rate will be much faster.

Such very fast growth rates occur only because the gut capacity of the fry as compared to its body, is rather high. This ratio lessens with increasing weight of the fish. Thus the time for doubling of the weight will be longer when the fish grows bigger. The most important requirement for maintaining the growth rate during the early age of the fish is presence of appropriate density of food material. The fry can find and catch only those food items which it can see and cannot search for them. Such a habit requires the presence of a high density of food items. During its period of life the carp is capable of eating continuously. The daily menu of a 7-12 days old carp fry is an average of 200-400 Cyclops or Diatomus.

The basic food material required for the growth of the fry is animal protein, which is obtained from small planktonic animals. This food can be partly substituted with animal protein-rich artificial feed. Within 20-25 days the carp fry can achieve 1 g weight, presuming the ad libitum (without limit) feeding conditions. In order to produce such conditions for the fry, proper manuring and fertilizing are important and artificial feeding is also of secondary importance.



In a commercial fish farm in Nepal it is desirable to ensure that the common young carp grows to 20-50 g within 60-80 days.

The daily increase in body weight and the doubling time lessen correspondingly with the growth of the fish. A 0.0025 g starting weight of the carp fry shall double about 9 times to become 1 g. A fingerling of 1 g weight will be of 16 g after 4 doublings. Two more doublings will be necessary to increase the weight to 64 g. A total of 9 doublings of weight are needed for a carp of 1 g to become 512 g which is the general marketable size.

### 3.2.5.3 Growth of common carp during advanced stages

The table below indicates the minimum and desirable growth rates of common carp of different weights:

Weight increase: from-to (g)	Desirable daily increase in body weight (percent)	Period (in days) for achievement of	
		Maximum weight	Desirable weight
0.025-1	7-20	45	30
1- 10	4-8	60	30
10- 50	3-6	60-65	30
50-100	1.5-3	50-70	20-30
100-200	1-2	70	30-35
200-400	1-1.5	70	35-50
400-800	0.8-1.2	90	50-65
Total days		435-470	225-270

The table below shows the increase in body weight of common carp in spans of 10 and 15 days when the daily growth is 1 percent and 2 percent:

Date	Month	Weight (g)		Total days	Date	Month	Weight (g)		Total days
		At 1%	At 2%				At 1%	At 2%	
Initial		50.0	50.0	1	10		134.0	370.0	100
10	1	55.3	62.1	10	15	4	140.8	409.1	105
15		58.2	68.4	15	20		148.0	451.7	110
20		61.2	76.5	20	30		163.5	550.6	120
30		67.6	93.1	30					
10	2	74.7	113.5	40	10	5	180.7	671.2	130
15		78.5	125.4	45	15		190.0	741.0	135
20		82.5	138.4	50	20		200.0	818.2	140
30		91.2	168.7	60	30		222.7	997.4	150
10	3	100.4	204.5	70	10	6	256.7	1 194.5	160
15		105.5	225.8	75	15		270.0	1 298.5	165
20		110.9	249.3	80	20		283.5	1 434.7	170
30		121.3	304.0	90	30		313.2	1 738.5	180
					10	7	346.2		190
					15		363.8		195
					20		382.4		200
					30		424.0		210

### 3.2.6 Feeding of Common Carp

#### 3.2.6.1 General remarks

There are four main types of operations concerned with feeding of the common carp:

- i. The fish is not provided with any artificial feed and its maintenance and growth depend entirely on natural food (extensive pond management).
- ii. The fish gets some artificial feed, about 1 to 1.5 percent of the body weight per day, for maintenance needs and the food for growth is derived from natural sources.
- iii. The fish gets about 3-4 percent of its actual body weight of artificial feed (mostly carbohydrate-rich food grains) daily and since this is more than the maintenance need, a part of it is used for growth. However, here also the natural food has an important and indispensable role (about half of the food required for growth is derived from natural sources).
- iv. The fish gets balanced food containing about 30-40 percent protein of which 20 percent is of animal origin, several times a day. Thus the maintenance and growth depends entirely on intensive feeding. Very little natural food is present in the daily diet of the carp, as this type of culture is practised in small and intensively stocked ponds provided with running water.

The population density (stocking rate) for each of the above mentioned type of management will be different. In the first category the stocking rate depends on the natural food sources, which of course can be increased by fertilizing and manuring. The rate can be twice in the second type and three or four times in the third type assuming that the productivity levels of the ponds are more or less similar.

In subtropical countries like Nepal, since food grains are rather expensive and usually needed for human consumption, only by-products, wastes and spoiled grains can generally be chosen as fish feeds. If food grains are available at an acceptable price, it has to be considered whether using them as fish feed will be economical. To find out the profitability of feeding with food grains it is necessary to know their food quotients from which the cost benefit ratio may be calculated.

Example: If the food quotient of a food item is 4.5, the price of 4.5 kg food together with transport and distribution costs and 10-20 percent of the total costs as extras should be less than the selling price of 1 kg fish. The difference between the two values will be the profit.

If the feeding is intended only to provide the maintenance food of the fish stock present in the pond, the calculation of the cost benefit ratio can be more liberal. This type of feeding provides indirect benefits which cannot be calculated beforehand, such as the value of natural protein food saved for growth, better exploitation of the natural food by a denser fish population, etc.

Too dense population of fish without feeding will result in very poor growth as the fish will use the natural food which is rich in proteins only for maintenance. At the same time if high-carbohydrate feeds are added without fertilizing or manuring, the utilization of the artificial feed will be unbalanced as the stock will not get sufficient natural food.

The common carp is capable of growing up to 1 to 1.5 kg within 150-200 days if natural and artificial food is available in adequate quantity. The stock must, however, be thin. On the other hand, if the growth of the stock is too slow due to inadequate management practices the yield cannot be increased by extending the production period. On the contrary the yield may decrease under such circumstances. Optimum yields can be expected with a medium growth rate which does not exceed 1-1.5 percent of the body weight per day.

### 3.2.6.2 Artificial feeds of common carp

The expression "artificial feed" is rather deceptive as it is not meant to include only man-made items like pelleted feeds. The term artificial feed includes in general all foodstuffs which are given to the fish to promote and contribute to growth in a direct way. (The fertilizing and manuring processes also mean a promotion of the growth of the fish but in an indirect way.)

Since the common carp is an omnivorous fish the artificial feeds may be a variety of items like food grains, mill sweepings, bran, distillery wastes, fine pulp of clover, lucerne or tender grass, cooked or ensiled potato (potato ensilage), fish, cadaver meal, etc. The fish eat spoiled food grains and other foodstuffs.

The various artificial feed items of carp can be classified on the basis of their origin, or on the basis of their protein content.

#### Feeds of plant origin

- i. Food grains
- ii. Tubers and roots
- iii. By-products and wastes of the agricultural industry (molasses, bran, mill sweeps, pulp of fermented grains, tubers, etc.)
- iv. Extracted oilseeds (oilcakes)
- v. Remains of grain cleaning (riddle wastes)
- vi. Pulp of green plants.

#### Feeds of animal origin

- i. Meat meal, blood meal, fish meal, etc.
- ii. Dried beetles, silkworm pupae, dried grasshoppers, termites, earth worms, etc.
- iii. Cooked meat of molluscs
- iv. Minced frogs, tadpoles, snakes, etc. (mostly mixed with food-grain flour).

The food values of the different items depend on their chemical composition as shown in the tables below:

A. Plant material

Food items	Dry matter (%)	Digestible protein (%)	Starch (%)	Crude fat (%)	Fibre (%)	Ash (%)	Food quotient <sup>1/</sup>	Digestible protein - others
Maize	87	7.0	60.0	4.5	2.1	1.3	4-4.5	1:12.5
Wheat	87	9.0	65.0	1.9	1.9		4-4.5	1:9.7
Barley	87	7.0	50.0	2.3	3.5	2.4	4.5	1:12.5
Millet	87	7.3	48.0	4.4	8.7		5	1:12
Bean	87	16.6	40.0	1.9	4.3		cooked	1:5.2
Pea	87	17.0	44.0	1.9	5.8	3.0	2.5-3.5	1:5.1
White lupine	87	23.5	28.0	7.3	12.3	3.0	2.5-3.0	1:3.7
Potato <sup>2/</sup> (cooked or fermented)	33.5	1.6	30.0	0.1	1.8	1.0	12-15	1:20
Wheat bran	87	10.0	20.0	4.6	10.1		4.5-7	1:8.7
Riddle wastage	87	12.0	24.0	6.5	14.1		6-7	1:7.2
Condensed flour	87	12.0	70.0	3.9	2.5		4.5-6	1:7.2
Castor oilcake	90	26.0	4.0	1.0	333.0		4-5	1:3.4
Soybean (China)	90.0	29.9	25.0	18.4	4.8	5.0		
Rice (broken)	88.6	7.5	79.9	0.5	0.2	0.5		
Cotton seed (India)	91.0	16.5	29.7	19.3	19.9	4.3		
Sweet potato (Malaysia)	25.4	1.3	22.7	0.1	0.8	0.5		
Mustard seed cake (China)	89.8	24.6	41.7	1.1	7.1	15.3		
Rice bran (coarse)	90.5	6.2	37.8	2.7	33.1	10.7		
Rice bran (China)	89.0	13.7	37.0	17.9	6.8	13.6		
Soybean cake	89.9	40.9	35.7	3.5	4.3	5.5		
Rice meal	89.0	1.3	44.3	11.7	12.9	8.8		

1/ Food quotient denotes the quantity of food in kg that would be necessary to produce 1 kg fish

2/ Cooked or fermented

B. Animal products

Food items	Dry matter (%)	Crude protein (%)	Carbohydrates (%)	Crude fat (%)	Ash (%)
Fish fresh (trash)	28.0	14.2	-	1.5	10.7
Fish meal	87.0	61.0	1.5	3.5	21.0
Blood meal	86.0	81.0	1.5	0.8	2.7
Silkworm pupae (fresh)	35.4	19.1	2.3	12.8	1.2
Silkworm pupae (dried)	90.0	55.9	6.6	24.5	1.9
River snail (whole)	63.2	5.7	2.0	0.7	54.8
River snail (flesh)	21.6	12.2	4.3	1.4	3.7
Mussels (freshwater)	20.4	18.4		0.8	1.2
Dried shrimps (small)	82.8	55.5	4.4	5.5	17.6
Gammarus (dried)	85.9	24.7		5.0	34.6
Aquatic worms	18.9	8.6		4.4	1.4
Locusts (fresh)	34.1	25.5	1.4	2.0	2.2
Chironomids (fresh)	16.1	9.1		13.6	7.1

All feeds of animal origin are rich in protein content.

The general average weights and caloric values of selected animal fish food organisms

Organism	Weight of one specimen (mg)		Water (%)	Caloric value of 1 mg (dry weight)	Nitrogen content (%)
	fresh	dried			
<u>Daphnia pulex</u>	0.343	0.032	90.7	3.98	9.29
<u>Daphnia magna</u>		0.36		3.58	7.14
<u>Diaptomus sp.</u>	0.14	0.018	87.4		8.3
<u>Diaptomus sp.</u>	0.09	0.011	87.9	4.563	24.6
<u>Tubifex sp.</u>	3.58	0.72	79.9	4.19	8.63
<u>Lumbriculus variegatus</u>	11.38	1.73	84.56	4.19	8.80
<u>Asellus aquaticus</u>	26.30	5.74	78.2	2.86	7.26
<u>Chironomus plumosus</u>	40.11	5.15	87.24	3.90	8.47
<u>Chironomus plumosus</u>	21.72	2.55	88.3	4.69	9.06
<u>Chironomus thummi</u>	9.44	1.24	8.16	4.44	8.92
<u>Corethra plumicornis</u>	3.81	0.43	88.88	3.93	10.73
<u>Clocon dipterum</u>	3.54	0.69	80.50	4.51	23.7

### 3.2.6.3 Food capacity of the common carp and the "golden rules" for carp feeding

The amount of food taken daily by a carp depends on its actual food capacity as well as the speed of digestion. The food capacity is determined by the size of the fore part of the gut. The carp and allied fishes have no stomach (new), i.e., after the short oesophagus the intestine follows immediately. (The first part of the intestine is enlarged and looks like a primitive stomach, but no acidic reaction as in the real stomach is observed here.)

The relative capacity of the gut of a smaller size fish is considerably greater than of a bigger one and hence the early fry and fingerlings are able to take more food as compared to its body weight, than the adults. The capacity of the gut can be enlarged artificially by giving the advanced fingerlings bulky food items like flour, crushed grains, bran, oilcakes, etc.

The speed of digestion depends on the temperature of the water and the physiological condition of the fish. At higher temperatures (over 20-25°C) the speed of digestion is rather high and so an adult carp can renew the gut contents 3 or 4 times in a day. At the fry stage the time interval between the ingestion and excretion processes is very short and hence the gut contents can be renewed very often during the day.

At lower temperatures the digestion process slows down and around 10-15°C the gut contents are renewed only once a day. The effectiveness of the digestive ferments (enzymes) is also more at higher temperatures. Likewise the peristaltic movement of the gut is also faster at higher temperatures, which means that the enzymes in the gut can act on the food only for a short time. However, it may so happen that a reasonable part of the artificial feed (eaten hurriedly and poorly chewed) remains undigested and therefore partly wasted. However, other fishes may eat the excreta of high nutritive value and thus the wastage in a densely populated pond where mixed culture is in progress will be very little.

Taking the above facts into consideration the following "golden rules" for fish feeding practices may be followed:

- i. At higher temperatures (above 20-22°C) more food can be offered than at lower temperatures.
- ii. The daily feeding programme may be 5-6 times for fry and 3-4 times for fingerlings using small quantities each time with a view to supplying food continuously.
- iii. In order to achieve better chewing and proper digestion, soaked food grains only may be supplied to the fish.
- iv. If the daily food supply for bigger fish is above 3-4 percent of the body weight, it would be advisable to offer the feed two times a day, producing in this way a sound competition at the feeding places.
- v. The carp can swallow milled or crushed food immediately, whereas the soaked full grains will be consumed only after chewing. It is therefore advisable to offer soaked full grains to those fish which can chew them. Carp of 40-50 g and above 100 g can chew full barley or wheat, and full grain maize respectively.
- vi. When finely milled or crushed food is given without soaking, some of the fine particles will get drifted away in the water and thereby lost as food. This fact must be taken into consideration if one wants to spare the soaking.

- vii. The carp generally gets accustomed to feeding times and hence the feeding schedules worked out may be followed strictly.
- viii. If the food supplied is eaten within 3-4 hours, the food ratio may be considered as adequate.
- ix. Care must be taken in every respect to avoid wastage and gain the best possible benefit from the feed offered. Certain feeding places in the pond may not be favoured by the fish and under such conditions the actual feeding spot may be shifted to another side.

#### 3.2.6.4 Preparation of food

There are four different methods of food preparations:

##### i. Mechanical preparations (milling, crushing, grinding, chopping, pulping, etc.)

All mechanical preparations make the food easier to chew and swallow. However, crushing or grinding of the food is not necessary in all cases and it can sometimes even be disadvantageous. A bigger fish cannot take in small particles of milled food which float in the water, in which case it would be advisable to make a dough by kneading with water. Further, the water dissolves more nutrients from milled or crushed food than from whole grains so that if not eaten immediately, its food value will be reduced. Another disadvantage is that the smaller wild fish can easily eat the small food particles and since they may appear immediately at the feeding place, will eat most of the feed supplied.

The necessity for mechanical preparation, therefore, depends on the size of fish to be fed.

Grass and other plant materials are best prepared by chopping or pulping. The common carp eats finely chopped or pulped plant materials, especially the clover and lucerne (in Europe) and can digest and utilize them effectively. The cultivated catfish Pangasius eats chopped plants mixed with rice bran or meal of other grains. Common carp fingerlings can be fed with finely ground or pulped clover or leaf of lucerne mixed with equal quantity of flour.

##### ii. Soaking

Soaking is the most important method for preparation of food for the common carp. As indicated earlier it is advantageous to soak even the crushed or milled food before supply in the pond. In warm water ponds the carp consumes the grain immediately and hence presoaking is always advisable.

Containers made of wood, brick with cement plastering or concrete are generally used for soaking the food. In bigger farms the containers are kept very near the ponds in order to facilitate easy distribution. In some farms "feeding boats" are used for soaking and distributing the food.

The general organization of the work may be as follows. The feeding programme may be started early in the morning and after emptying the container fresh food may be kept soaked with adequate quantity of water.

##### iii. Cooking or steaming

This is an expensive method of preparation in view of the fuel consumed and work involved. However, for some food items like peas, beans, potato, eggs, etc., this type of preparation is unavoidable. For feeding fingerlings, supply of cooked food is often advisable.

**iv. Mixing with other materials**

The advantages of mixing the food with other substances are many. In some cases the aims will be only palatability, but in other cases it would be necessary to complete the nutritive requirement. Maintenance of adequate protein:carbohydrate ratio is essential in the case of fry, fingerlings and brood fish. In some cases the food mixed with minerals (lime) or yellow clay helps to prevent occurrence of body defects like osteomalacia. In earlier years milled food used to be mixed with 5-6 percent yellow clay in order to keep together the fine particles, to provide necessary calcium for the development of bones, and to achieve better digestibility. It would be very much advisable to adopt this practice for the feeding of fingerlings with flour or other finely milled food materials. The clay used must be pulverised and mixed with the flour in the dry stage, i.e., before a dough is made.

**3.2.6.5 Quantity of food to be given**

If the actual number of carps present in the pond is not correctly estimated, the time required for consumption of the food supplied at specific feeding places in the pond will give approximate indication of the quantity of food to be added. If the fish consume the food within 1 hour, it would mean that about 1 percent of the actual total body weight was supplied, covering only the maintenance need. Two to three percent of the body weight is generally consumed within 3-4 hours, and 4-5 percent within 6-8 hours. To provide an aid to determine the daily food requirements, the following table may be used:

Quantity of feed required (in kg) for 1 000 carps, on the basis of percentage of the actual body weight

Average body weight (g)	Quantity of food for 1 000 carps (kg)							
	1	1.5	2	2.5	3	3.5	4	5
50	0.50	0.75	1.00	1.25	1.50	1.75	2.00	2.50
55	0.55	0.83	1.10	1.35	1.65	1.93	2.20	2.75
60	0.60	0.90	1.20	1.50	1.80	2.10	2.40	3.00
65	0.65	0.98	1.30	1.65	1.95	2.28	2.60	3.25
70	0.70	1.05	1.40	1.75	2.10	2.45	2.80	3.50
75	0.75	1.13	1.50	1.88	2.25	2.63	3.00	3.75
80	0.80	1.20	1.60	2.00	2.40	2.80	3.00	4.00
85	0.85	1.28	1.70	2.13	2.55	2.98	3.40	4.25
90	0.90	1.35	1.80	2.25	2.70	3.15	3.60	4.50
95	0.95	1.43	1.90	2.38	2.85	3.33	3.80	4.75
100	1.00	1.50	2.00	2.50	3.00	3.50	4.00	5.00
110	1.10	1.65	2.20	2.75	3.20	3.85	4.40	5.50
120	1.20	1.80	2.40	3.00	3.60	4.20	4.80	6.00
130	1.30	1.95	2.60	3.25	3.90	4.55	5.20	6.50
140	1.40	2.10	2.80	3.50	4.20	4.90	5.60	7.00



Quantity of feed required (in kg) for 1 000 carps, on the basis of percentage of the actual body weight (continued)

Average body weight (g)	Quantity of food for 1 000 carps (kg)							
	Percentage of body wt.	1	1.5	2	2.5	3	3.5	4
150	1.50	2.25	3.00	3.75	4.50	5.25	6.00	7.50
160	1.60	2.40	3.20	4.00	4.80	5.60	6.40	8.00
170	1.70	2.55	3.40	4.25	5.10	5.95	6.80	8.50
180	1.80	2.70	3.60	4.50	5.40	6.30	7.20	9.00
190	1.90	2.85	3.80	4.75	5.70	6.65	7.60	9.50
200	2.00	3.00	4.00	5.00	6.00	7.00	8.00	10.00
220	2.20	3.30	4.40	5.50	6.60	7.70	8.80	11.00
240	2.40	3.60	4.80	6.00	7.20	8.40	9.60	12.00
260	2.60	3.90	5.20	6.50	7.80	9.10	10.40	13.00
280	2.80	4.20	5.60	7.00	8.40	9.90	11.20	14.00
300	3.00	4.50	6.00	7.50	9.00	10.50	12.00	15.00
320	3.20	4.80	6.40	8.00	9.60	11.20	12.80	16.00
340	3.40	4.10	6.80	8.50	10.20	11.90	13.60	17.00
360	3.60	5.40	7.20	9.00	10.80	12.60	14.40	18.00
380	3.80	5.70	7.60	9.50	11.40	13.30	15.20	19.00
400	4.00	6.00	8.00	10.00	12.00	14.00	16.00	20.00
420	4.20	6.20	8.40	10.50	12.60	14.70	16.80	21.00
440	4.40	6.60	8.80	11.00	13.20	15.40	17.60	22.00
460	4.60	6.90	9.20	11.50	13.80	15.10	18.40	23.00
480	4.80	7.10	9.60	12.00	14.40	16.80	19.20	24.00
500	5.00	7.50	10.00	12.50	15.00	17.50	20.00	25.00

### 3.2.6.6 Feeding methods

Throwing the food haphazardly in a fish pond may result in the loss of a good part of the food in the mud unless the pond is very small, the stock is crowded and the fish are very hungry. The best practice would be to provide the food in fixed feeding places. For production ponds, 3-4 feeding places per hectare would serve the purpose.

Feeding places may be chosen in the interior of the pond if a boat is available. Otherwise the places may be near the shore, the main criteria for selection of the site being that the region should not have soft mud, and the water depth may range between 0.6 to 1 m.

At the initial stage of the feeding programme it would be advisable to use feeding trays which may be made of earthen plates with brim, or of split bamboo or wooden planks. Use of such trays facilitate checking the actual consumption of the food. Subsequently when the fish get used to it feeding trays may not be necessary.

It is preferable to give the food to fry and fingerlings in trays in order to avoid wastage.

### 3.2.6.7 Carp rearing with balanced food

It would be worthwhile to consider the special common carp rearing method developed in Japan, where the ponds are built along the side or close to streams, with an ample supply of clean running water the whole year round. The ponds are small, each about 30-100 m<sup>2</sup> and rectangular or triangular in shape. The bottom of the pond is smooth and sloping toward the outlet structure and is usually cemented and paved with small rounded pebbles. The sides of the pond are generally paved with stones. The inlet and outlet are designed to allow efficient control of water flow from the stream through the pond.

A pond of 50 m<sup>2</sup> area and 1.8 m depth may be stocked with as many as 10 000 fingerlings of common carp, each weighing about 75 g. In one growing season of about 7 months a total harvest of about 8 200 kg of fish can be expected with a net yield of 7 500 kg, the quantity of feed used being 30 000 kg. The food quotient thus works out to 4.0. Feeding is done 12 to 18 times a day from 05.00 hours to as late as 22.00 hours, depending on the temperature of water and size of the fish. The details of feeding are shown below:

First period (100 days): Wheat meal - 500 kg  
Fresh silkworm pupae - 6 100 kg  
Earthworms - 10 000 kg

Second period (40 days): Fresh silkworm pupae - 7 000 kg

Third period (70 days): Fresh silkworm pupae - 7 000 kg

The amount of the food supplied per day is about 7 percent of the actual body weight.

In Europe also experiments on feeding the carp with balanced food have been undertaken using a food mixture containing about 30-40 percent proteins of which 20 percent is of animal origin. The daily ration given is about 6.5-7 percent of the body weight, as pelleted feed distributed several times a day or offered in self-feeders.

### 3.2.7 Feeding of Grass Carp

The grass carp has a high level food capacity. An adult grass carp can devour every day grass amounting to about 15-20 percent or more of its body weight. In China the fish farmer usually gives fodder sufficient to last for about an hour, and the feeding is done 2 times a day. The food is normally placed on a floating enclosure made of three or four bamboo poles.

The grass carp excreta are often consumed by other carps directly as food. On the other hand the grass carp can eat the food grains given for the common carp, but it does not utilize it well.

### 3.2.8 Calculating Food Utilization

The fish yield from a pond is derived from two components, the natural yield and the food yield. The former is from natural food and the latter from artificial feeds.

An example of food yield calculation is shown below:

Food supplied (kg)	Food quotient	Equivalent fish wt. (food yield) (kg)
Maize 1 200	4.5	$\frac{1\ 200}{4.5} = 267$
Wheat flour 600	5	$\frac{600}{5} = 120$
Rice bran 1 500	7	$\frac{1\ 500}{7} = 214$
Mustard oilcake 500	6	$\frac{500}{6} = 83$
<b>Total 3 800</b>		<b>664</b>

If the total yield from the pond is 1 470 kg fish and the food yield as shown above is 664 kg, the natural yield will work out to 1 470 - 664 = 806 kg.

The proportion between the two yields, viz., 45:55 is attractive, especially where intensive feeding has been practised.

The relative feeding coefficient is calculated by dividing the total amount of food given in the pond by the yield.

Taking the above cited example:

$$\frac{3\ 800}{1\ 470} = 2.56 = \text{the relative feeding coefficient}$$

Usually the relative feeding coefficient is about 2 if high value food (i.e., food with low food quotient) is used.

The efficiency of the feeding practices adopted has to be verified after each growth check. The following example will illustrate this point:

	No. of fish sampled	Weight after reducing 5% for gut content	
		Total weight (kg)	Av. weight of one fish (g)
Initial growth check	84	12.5	145
After 15 days	64	11.75	178

Therefore the growth in 15 days = (178-145) = 33 g, i.e., about 22 percent

Growth in one day = 33 ÷ 15 = 2.2 g, i.e., about 1.47 percent

Taking that 6 000 fish were stocked and allowing for a 10 percent loss, the estimated population in the pond will be 5 400. Then at the first growth check there were  $145 \times 5\ 400 = 780$  kg (approx.) and at the second growth check  $178 \times 5\ 400 = 960$  kg (approx.) of carp in the pond. The total growth thus was  $960 - 780 = 180$  kg.

If 420 kg of food (300 kg maize and 120 kg mustard oilcake) were used,  $420 \div 180 = 2.3$ , which means that 2.3 kg food contributed to produce 1 kg fish. This is a satisfactory position.

However, if 785 kg of food (450 kg maize and 325 kg mustard oilcake) were used  $785 \div 190 = 4.15$ , which value is too high. Such a condition would need investigation as indicated earlier.

### 3.2.9 Harvesting (Cropping)

Cropping of a pond may be either partial or total (complete). Partial cropping is a part of the stock manipulation technique in which the marketable size fish are removed from the pond to provide larger living space and natural food for those left behind.

When the fish stock or part of it becomes ready for marketing, the cropping should be commenced without delay.

When the ponds in question are drainable, the modern practice is to crop the fish entirely by discharging the water.

In countries where carp culture is highly developed, the cropping operations are completed as quickly as possible. It is always a risk to leave the crop in a half-drained pond where enemies can decimate the crop and the temptation for stealing is very great. During the draining process the fish become restless, they do not take food, and lose weight. Therefore if the cropping is done piecemeal, losses are inevitable.

When harvesting a big pond the rate of water discharge must be adjusted in relation to the magnitude of catching and transport. Netting is rather difficult in deeper waters, but in very shallow ponds the life of the fish may be endangered. After netting, the haul must be taken to fresh water till released into a storage pond.

During winter season the cropping operation can extend for the whole day, as the water temperature would be low enough not to harm the fish. But when the temperature is rather high it would be advisable to start the cropping during the early morning hours and suspend the operation during the hottest hours of the day.

### 3.2.10 Recording of Cropping Data

After cropping a pond the effectiveness of the culture programme must be precisely evaluated and conclusions drawn in order to achieve better production in future.

After evaluating the data the yield should be calculated per hectare. From the production time in days the increase in growth of fish per hectare per day can be calculated.

From the number of each species of fish stocked and the number cropped the loss can be calculated which may be expressed on per hectare basis and also as percentage of the total stocked fish.

It is advisable to tabulate the data under the following headings: (1) Pond number, (2) Pond area, (3) Date of stocking, (4) Number of stocked fish (separately by species), (5) Weight of the stocked fish (separately by species), (6) Stock corrections (if any), (7) Stocked number per hectare, (8) Cropping date, (9) Number of cropped fish (separately by species), (10) Weight of the cropped fish (separately by species), (11) Loss in percentage, (12) Yield, (13) Yield per hectare, (14) Production period in days, (15) Yield per hectare per day, (16) Fertilizer applied, (17) Value of the fertilizer in N.Rs., (18) Manure, (19) Value of the manure, (20) Total food, (21) Value of the food in N.Rs., (22) The relative food quotient, (23) The relative food quotient value in N.Rs., (24) The relative fertilizer and manure quotient value in N.Rs., (25) The relative fertilizer, and manure and food quotient value in N.Rs. These data can be obtained by adding the costs of fertilizers, manures and feed and dividing the sum by the weight of the yield.

### 3.2.11 Storage and Transport of Fish

#### 3.2.11.1 Storage ponds

Storage ponds in which the live fish are stored before marketing are necessary in all commercial fish farms. In view of the high density of fish in such ponds it is always necessary to provide them with continuous water supply. One ton of common carp will need a water supply of 1 l per second during winter season and 3-4 l per second during summer season.

A typical storing pond under conditions occurring in Nepal may not exceed 400-500 m<sup>2</sup> (in 1 m<sup>3</sup> water 10-50 kg of fish can be stored if continuous water supply is provided). The pond may be constructed with brick walls and should be easily drainable. The storing ponds should be well guarded against theft and for this purpose may be located at the centre of the farm. The ponds should be easily accessible by vehicles in order to facilitate easy loading.

The storage ponds, when not in use for holding the cropped fish, can be used for breeding or as nursery ponds taking necessary precautions to avoid parasites and diseases.

#### 3.2.11.2 Storing live fish

During storage the fish do not usually get any food, which will lead to regular loss of weight. Hence they should be marketed as quickly as possible. If cheap food is readily available feeding may be done in the storage pond up to maintenance level. However, in view of the crowded conditions the utilization of the food will be very poor.

#### 3.2.11.3 Live fish transport within the farm

Fish have to be transported alive between the ponds for stocking or to the storage ponds after cropping. When they are carried in buckets sufficient quantity of water should be available to keep them alive. Greater number of fish can be transported in hammocks as the fish thus carried may not be injured as may happen in buckets. The water in which the fish is kept should be clean and cool, and a fresh supply of water will have to be used for each consignment.

In order to transport large quantities of fish, as it is the case during cropping, it would be advisable to use a motor transport or bullock cart provided with a tarpaulin fixed in the loading area of the vehicle in the shape of a pool and in which

sufficient water can be carried. If the sun is very hot the "pool" should be shaded. After transporting the fish, the tarpaulin should be washed, carefully dried and kept hung in the store.

#### 3.2.11.4 Transporting fish to the market

Carp is often sold alive in the market. It may be advantageous to transport live fish from the Terai farms to Kathmandu. Such transport would be possible if the necessary equipments are made available.

About 500-1 000 kg of live carps can be transported in 1 m<sup>3</sup> water, provided aeration is possible using a compressor, or the water is kept in continuous circulation with the aid of a small pump, or oxygen is bubbled into the water. When transporting live fish care must be taken to see that the water temperature does not increase appreciably. If the transportation period is long, the water should be changed at least partially during intervals. Only conditioned fish, i.e., those in which the guts are empty may be transported in the live condition.

When dead, the fish lose weight at the rate of about 2-3 percent during half a day. During transport the dead fish should be kept cool in order to avoid spoilage. The containers used (baskets, boxes, etc.) may be lined with fresh green leaves, long wet grass, etc., in order to keep the temperature as low as possible.

#### 4. PROPAGATION OF CULTIVATED FISHES

##### 4.1 SEXUAL MATURITY

The smaller fish species generally become ripe earlier than the bigger ones. The warm water fish mature earlier than the temperate species and also earlier than warm water species in colder waters. In some species, the sexual maturity is correlated with a given body size while others mature regardless of their size and sometimes even when stunted. The latter ones are not at all desirable in ponds where carps are cultivated. The common carp females become sexually mature in the fourth year in Europe and in the third year (sometimes even in the second year) under subtropical or tropical conditions. The males become ripe usually one year earlier than the females.

It is always desirable to use well-grown, healthy, well-proportioned and carefully selected fish for breeding purposes. Best results may be expected from common carp females weighing about 4-5 kg and males of 2-3 kg, all of which are 3-4 years old. This is the case with herbivorous carps like grass carp, silver carp and bighead also which have a certain degree of correlation between the body size and sexual maturity. They become sexually mature at 3-5 kg weight when about 3-4 years old.

##### 4.2 SPawning PERIOD

The spawning season varies considerably among the different cultivated fishes and depends on both internal and external factors. The associated internal factors relate to genetic characteristics, general body condition, development stage of the gonads, the hormone system, etc. and the external ones to water temperature, light and other climatic conditions. Both these types of factors are closely interrelated.

Since the climatic conditions in a given area are approximately the same year after year, the spawning occurs at about the same season. Since the main deciding factor for the spawning time is the temperature (which reacts as well on the surroundings) a correlation has been found in Europe between the spawning time of different fish species and the blossoming of trees. The ripening of the gonads is a long process with different stages which must proceed gradually. So the time factor is important. If the brood fish are kept in poor condition and do not get protein-rich diet, the development of gonads will be delayed and the "readiness for spawning" becomes postponed or may even fail to occur. The growth of the mass of the eggs occurs (in the carp) during the first stages of egg development. At that time the female brood fish need protein-rich diet. The most common cause for the failure of the breeding of common carp is inadequate diet (both qualitatively and quantitatively).

The spawning of the common carp under natural conditions occurs usually in spring season when the water warms up to around 18-20°C. The spawning time of the herbivorous Chinese carps is also related to water temperature. The natural spawning season of Indian major carps as well as herbivorous Chinese carps is dependent on the rainy season and the flooding of the rivers.

Many species of fish have no special requirement of spawning grounds and scatter the eggs all over the area available.

Most of the cultivated fishes have, however, special requirements regarding spawning place. The common carp needs shallow and clean water with temperature not less than 16-17°C, a grassy bottom and rising water level. It does not normally spawn in ponds where other fish species are present in good numbers. The Chinese and Indian major carps spawn in well chosen special areas in the rivers and the eggs get drifted away by the water current.

It is well known that the Chinese and Indian major carps do not spawn in ponds or other stagnant waters while the common carp never spawns in river beds.

#### 4.3 PRODUCTION OF FISH SEED

In general, the following main groups of fish propagation methods may be distinguished:

##### 4.3.1 Natural Propagation of the Common Carp

###### 4.3.1.1 General remarks

If a pair of ripe carps are stocked in a shallow pond in which the bottom is partly covered with grass, no other fish are present, and the temperature of the water is suitable, spawning will occur sooner or later. Of course there are many factors which, during the course of the propagation, may totally or partially upset the success of spawning. It will therefore be necessary to eliminate all the factors which may cause uncertainty in connexion with carp propagation.

###### 4.3.1.2 Success of spawning operations

A fish living under natural conditions instinctively looks for a spawning place and spawns when it is ready to do so.

The processes of the gonad development, prior to spawning, run without hindrance under natural conditions. During this period, the fish collects enough protein-rich food for the building-up of the gonads and the temperature of the water enables proper development.

In a farm pond, on the other hand, the brood fish in most cases cannot find the same conditions as in nature. Under crowded conditions they may not get enough protein-rich natural food and carbohydrate-rich "artificial" feed may lead to unnatural fattening and unhealthy gonads.

The building-up of sexual products (eggs and milt) in the gonads starts soon after the previous spawning and the need for protein-rich food occurs mostly at that time. In a well equipped farm, provision for a brood fish pond has always to be made. If the pond is not crowded, the brood fish may find plenty of natural food. If the fish are fed, food with higher protein content (20-25 percent) may be given. Minced wild fish, crabs, frogs and tadpoles mixed with crushed grains, oilcakes or rice bran will be excellent food for this purpose. On the other hand, in order to provide natural food, the pond should be manured and fertilized regularly.

A good female carp may produce 150 000 eggs per kg, which means that a female of 4-5 kg can produce over half a million eggs. If the survival of the eggs is not more than 20 percent (which is quite reasonable under controlled conditions) 100 000



fingerlings can be obtained from one female. It is a fact that ten pairs of adequately prepared brood fish can overcrowd a 50-100 ha farm with fingerlings. On the other hand, if the eggs cannot build up adequately due to lack of essential amino acids in the diet, even 50 pairs of brood fish cannot produce enough fingerlings necessary for stocking a small farm.

#### 4.3.1.3 Control of enemies

A few tadpoles or snake-head fish (*Ophiocephalus*) in a fish pond can graze on thousands of fish eggs in one day. Snails also may do the same. The tiny crustaceans like *Cyclops* may kill thousands of freshly hatched larvae of carp. In a small pond crowded with early fingerlings, insects like backswimmers, dragon fly larvae, etc. can exterminate thousands of early fingerlings. The frogs, birds, snakes, etc. can do the same at later life stages of the carp, viz., juveniles and adults (Figures 33, 34, 35, 36 and 37).

A general rule for successful carp propagation is to keep the spawning ponds dry when not in use. If they are used for other purposes like storing and rearing, they should be dried at least during December. At the time of drying, care should be taken to see that no pools and ditches with water are left over at the bottom.

If high grass is abundant on the bottom of the pond, it would be advisable to cut it short. If adequate grassy patches do not occur, artificial egg collectors like "kakabans" should be placed in the pond.

The ponds may be filled before noon and stocked with brood fish during the afternoon and the inflow rate may be so adjusted as to keep the water level rising slowly.

If the pond is filled with water from another pond, it should be filtered at least with a fine mesh screen.

Fish enemies like birds may be trapped or scared away by different means. Complete protection of the fry and fingerlings against the many enemies cannot be achieved, but the majority can be saved from destruction by adopting measures mentioned above.

#### 4.3.1.4 Provision of satisfactory conditions for the growth of fry

There are better chances for the survival of the fingerlings if they are provided with sufficient food, or provided with greater space to scatter and find food and protection.

Presence of a large number of fry in a small spawning pond may result in the rapid consumption of available food. The fry and early fingerlings have no reserve fat tissues and hence cannot starve for more than a day or two. Even with meagre maintenance food, they become weak and perish soon.

During the first days after "air snapping", the fry will be able to find enough food consisting of small algae and tiny animals which develop in the same water body. The food shortage starts after 7-10 days. When 10-12 mm long, the fry are always hungry, their food capacity increases and they are able to swallow hundreds of small planktonic animals.

Frequent but cautious weaning can help to maintain the balance between the fry and natural food. Artificial food meal can help the fry to keep alive and grow well. If, due to any reason, the fry population is considerably reduced, a fresh stock should be introduced only after removing the remaining individuals and disinfecting with quick lime.

Another important rule of fingerling production is never to stock different age groups of fry in the same pond.

European fish culturists have developed the practice of thinning out the fry when they are 10-15 days old and restocking them in bigger (so-called rearing) ponds which are filled with water 7-10 days earlier. They are generally transported in buckets of water. This way, the number of fry collected can be easily estimated.

#### 4.3.1.5 Control of parasites

As already indicated, keeping the breeding and fry rearing ponds dry when not in use will help the destruction of parasites and pathogens in the pond soil. Addition of quick lime or any other disinfecting agent will give additional benefits.

Many parasites are brought into the breeding and rearing ponds along with the brood fish or with wild fish. The white spot disease (Figure 38) and gill worms (Figure 39) are usually spread in this manner.

It therefore follows that all adult fish must be kept off from the fry rearing pond. If there is a natural spawning, the breeders must be removed from the pond after 1 day. A better method is to let the fish spawn on "kakabans" in a separate spawning pond and stock the nursery ponds with eggs attached to the collectors. A not-so-effective method is to treat the brood fish against parasites before they are released for spawning.

The brood fish may be treated against Ichthyophthirius, which causes the white spot disease, in a solution of 1 m<sup>3</sup> water with 6.7 g of malachite green. The normal period of treatment is 1-1.5 hours. Against gillworms (Gyrodactylus, Dactylogyrus, Diplozoön) treatment in sodium chloride (NaCl) solution prepared by dissolving 2.5 kg common salt in 100 l water for 10-15 min was commonly adopted in earlier years. Recent studies have shown that Dipterex solution gives good results against this parasite. In Nepal 'Dipterex 80' is available and, for the treatment, 1 ppm solution may be used. If 'Dipterex 95' is used, 0.6-0.7 ppm strength will be suitable. A few fish may be treated first and if no bad effects are observed, mass treatment may be done. Dipterex solution is usually spread over the entire pond surface.

#### 4.3.2 Semi-Artificial Propagation of Common Carp

In order to stimulate the spawning of the common carp in a 'hapa' or cement cistern in which "kakabans" is placed, the hypophysis (pituitary gland) solution may be injected into the brood fish. (The technique of hypophysation is described in the following chapter.) The eggs scattered on the "kakabans" may be transferred into a rearing pond, which is kept filled with water, shortly after the spawning has taken place.

The estimation of eggs present on the "kakabans" may be done with the help of a very simple device. Take a 10 x 10 cm piece of hard plastic plate (0.5-1 mm thick)

and out on it 1 x 1 cm squares in rows. Place this device over the "kakabans" and count the number of fertilized eggs visible within each 1 cm square. From this the average number of eggs in one cm<sup>2</sup> can be calculated. By multiplying this number with the total surface area of the "kakabans" in cm<sup>2</sup>, the total (approximate) number of eggs may be calculated. The unfertilized eggs become white and opaque 6-8 hours (sometimes even earlier) after the spawning, while the fertilized ones get a glittering and transparent appearance.

The best time to transport the "kakabans" with eggs over short distances is the first sunset period after the spawning. If, however, the time span between the spawning and dusk on the same day is less than 8-10 hours, the transportation may be done at the time of the next dawn or sunset. When transporting, the "kakabans" should be kept covered with a wet cloth.

The "kakabans" with eggs should be placed in about 30-50 cm deep water on a side of the rearing pond and sometimes it may be necessary to nail the branches to poles driven into the pond bottom. The eggs should be inspected daily and when the larvae hatch out, the bundles may be removed.

#### 4.3.3 Artificial Propagation of Common Carp

##### 4.3.3.1 General remarks

Some of the circumstances under which artificial propagation of the common carp is resorted to are:

- i. where practical experience has proved that natural propagation of the fish is generally unsuccessful;
- ii. where there are many enemies that destroy the eggs, larvae and fry;
- iii. necessity of large-scale production of fry and fingerlings before and after the natural propagation period;
- iv. where carp breeding ponds are not available and natural propagation is limited due to lack of adequate breeding facilities;
- v. where carp eggs, fry and fingerlings are sold for culture purposes;
- vi. where the number of males are insufficient for successful natural propagation;
- vii. where mature carps caught on their way to the breeding places, as for instance in inundated areas of rivers or in lakes, are needed for propagation purposes with a view to maintaining a proper population density of the fish in the natural water in question. (In Hungary, the catching of carp during the breeding season is allowed only in those water bodies where the fish are used for artificial propagation);
- viii. where sudden change of weather conditions may kill the eggs and young larvae produced by natural spawning;
- ix. where improved strains of the fish are to be developed through selective breeding and hybridization.

#### 4.3.3.2 Propagation technique

The technique of artificial propagation of the common carp may be described under five stages as described below:

#### 4.3.3.3 Preparation of brood fish for hypophysation

A female carp is generally considered ready for hypophysation when its belly is large but not swollen, not hard but not too soft and the genital opening is swollen, protruding and reddish in colour. The eggs in such a fish will normally be large, yellowish in colour and semi-transparent, and can be easily separated from the wall of the ovary.

In most cases, when the females get sufficiently ripe in the segregation pond, they can be taken out and hypophysated immediately. In hatcheries where they are kept in troughs, conditioning for 12-24 hours may, however, be necessary.

The males will be ready for hypophysation when their milt can be pressed out by applying a light pressure with the fingers on the hind part of the belly near the genital opening.

#### 4.3.3.4 Hypophysation

The hypophysated males and females must be kept separately or the females should be "stitched in" or "sutured" to close the genital opening. When the water temperature is above 23°C, it is strongly recommended to "stitch in" the females to avoid loss of the eggs.

The hypophysated fish can be kept in a hapa (2-4 females in 2 x 1 m) or a basin (2 females in 1 x 1 m) from which they can be caught easily with a special scoop net or by hand. The hapas can be fixed in a canal with flowing water or in a pond close to the shore near the inflow. If the injected breeders are kept in a basin or trough, continuous water supply would be necessary.

##### Preparation of hypophysis solution

Usually acetone-dried hypophysis is used for the hypophysation of the common carp. The glands are collected from 1-2 kg mature carps and are dehydrated with changes of acetone and then dried. The hypophysis of a carp of the size mentioned will have a dry weight between 2 and 4 mg each.

The dose used for the female fish is 1 hypophysis per 1 kg body weight of the recipient. It has been precisely calculated that 2.5-3.7 mg of dried hypophysis will be needed for each 1 kg of the female. But each male, irrespective of its weight, is given only 1 hypophysis. (By semi-artificial propagation the hypophysation of males can be avoided.) (Fractions of a kg are rounded off for the purpose of such calculations.)

It is advisable to prepare in bulk the entire quantity of hypophysis needed for one day. The dried hypophysis must be pulverized first in a small porcelain mortar before the solvent is added.

The solvent used is a 0.6-0.7 percent NaCl (common salt) solution mixed with pure glycerine in the ratio 70 parts of salt solution:30 parts of glycerine. Such a mixture has the advantage of not flowing back easily after the injection and perhaps may also prolong the period of effectiveness of the hormone. The quantity of solvent needed for each hypophysis is 0.5 ml.

After the hypophysis is thoroughly pulverized, the measured quantity of solvent should be added immediately. The solvent can be measured with the same syringe with which the injection is to be given. The pulverized hypophysis and the solvent should be thoroughly mixed and the insoluble particles allowed to settle down either by gravity or by centrifuging. It is advisable to prepare the solution one hour before injections are given.

The "ripening" period is reckoned from the injection till the time when the fish is "ripe for stripping". This varies according to the temperature of the water in which the females are kept after the injection, as shown below (data relate to common carp):

<u>Water temperature (°C)</u>	<u>"Ripening" time (hours)</u>
15-16	24-26
17	20-23
18-19	18-20
20	15-16
22-23	12-15
25	10
28	8

The proper time for giving injection can thus be fixed so that the fish will be ready for stripping at a convenient hour of the day. "Over-ripening" of the common carp eggs takes place when the eggs are retained in the ovary 2-3 hours longer after "ripe for stripping" stages. It may be mentioned here that the "over-ripening" time for the Chinese herbivorous carps is far shorter, sometimes only 30 min.

If the females are to be stitched-in, a mild anaesthesia will be necessary to keep them quiet during manipulation. The solution generally used is 0.5 g MS 222 (Sandoz, Basle, Switzerland) dissolved in 50 ml water. A sausage-like tube made of cloth filled with cotton is soaked with this solution and put in the mouth of the fish. The solution is absorbed through the capillary system of the mouth cavity and will become effective within 1-2 min.

It is advisable to mark the injected specimens with a coloured thread tied on the dorsal fin. After this, the genital opening is sutured and then the injection administered. The sutured females will be "ripe for stripping" without loss of eggs.

Suturing should be done using a waxed cotton thread and sewing needle and by making cross stitches over the genital opening. The thread should be pulled tight and tied firmly.

The injection of hormone solution should be given intramuscularly between the base of the dorsal fin and the lateral line. A medium size injection needle may be used and, in order to avoid flowing back of the solution, it is usual to massage the spot where the injection is given. When injecting scale carp, the needle is to be inserted under the scales.

The injected specimens should be kept separated by sex in a hapa or basin. If the females are sutured, they can be kept with the males in the ratio of 1:1 for stimulation. In clear water, a "ripe for stripping" female can be recognized by the fact that it will be constantly chased by the male.

#### 4.3.3.5 Stripping of sexual products, fertilization and elimination of the sticky layer of the eggs

At the end of the estimated time required for the ripening of the eggs, the injected females are to be examined to see whether they are ready for stripping. Females swimming to and fro restlessly are usually ready. Fully ripe and "ready for stripping" females will yield eggs freely by applying a very slight pressure on their belly. An unsutured ripe female specimen should therefore be caught in such a way that the forefinger of the operator is pressed on its genital opening. The sutured females are easier to handle and a sure sign of the "ripe for stripping" stage is the swollen and very soft belly. In such specimens the eggs will flow out as soon as the suture thread is cut.

The fish must be dried with a piece of soft cloth before stripping and the eggs may be stripped into a plastic or enamel bowl. The last portion of the eggs may have to be stripped with a light pressure.

Immediately after the eggs are stripped, milt from a male is added over them. The milt can be sucked with a pipette or milt collector (Figure 40). When enough milt has been added, the contents are mixed "dry" immediately with a plastic spoon or strong feather.

A special solution of NaCl and carbamide (urea) ( $\text{CO}(\text{NH}_2)_2$ ) is then poured over the mixture of eggs and milt. This solution prevents the eggs from sticking together and because the virility of sperms lasts longer in this solution than in water (about 20-25 min in the solution as against 1-2 min in water), better fertilization can be anticipated.

The solution is made by adding 30 g carbamide (urea) to 40 g NaCl dissolved in 10 l of clean (not distilled) water.

At first, about the same quantity of the solution as the volume of eggs is used and stirred with a plastic spoon (or feather) for about 5-10 min. Subsequently, the stirring can be done at 5-7 min intervals. The eggs absorb the solution and begin to swell when small quantities of the solution should be added from time to time as required.

After about one to one and a half hours, the swelling of the eggs stops and the sticky layer of the eggs is dissolved. However, if the eggs are put in water, they may tend to stick together in loose clumps due to the presence of the sticky material in between the eggs. In order to get rid of the sticky material completely, a solution of about 7-10 g of tannin in 10 l of water is used. About 2-4 l of this solution is taken in a plastic bucket and a maximum of 2-3 l of swollen eggs may be poured in all at once. After stirring for 1-2 sec, clean water should be poured over. Once the eggs have settled down, the water has to be drained through a strainer. As a precautionary measure, a smaller quantity (1-1.5 l) of tannin solution is then poured into the bucket and after a little stirring, clean water is again added, followed by draining. This operation is to be repeated 2 or 3 times and the mass of eggs should be washed with clean water a number of times. If the tannin solution is inadequate for the quantity of eggs, a slight sticking together may be observed. The eggs which are water-hardened by now, are separated from each other and can be introduced into the jars or other devices for incubation.

The stripped eggs (the so-called raw eggs) having a certain amount of ovarian fluids, appear as a thick flowing mass. One litre of raw eggs contains about 700 000-800 000 eggs, each of which is about 1 mm in diameter. The swollen (water-hardened) egg, if not treated, is 1.5-1.7 mm in diameter and 1 l of the mass contains about 262 000 eggs. The normal diameter of the treated egg is 1.95-2.1 mm and 1 l will contain about 120 000-180 000 eggs.

#### 4.3.3.6 Incubation of fertilized eggs

The normal period of incubation at different temperatures of the water flowing through the jars is given below:

<u>Water temperature (°C)</u>	<u>Time of incubation</u>	
	<u>hours</u>	<u>days</u>
16-17	160-170	7-7½
18	120-125	5
20	80-84	3½
22	70-72	3
25	50-52	2½

The most sensitive stage in the development of the eggs is the period of cell division, which takes place during the first 12-24 hours after fertilization, depending on the water temperature. During this period, the rate of oxygen consumption of the eggs is at its lowest. A strong water current in the jar can harm the eggs at this stage and hence it is advisable to use only a weak water current, just enough to rotate them slightly.

In artificial fertilization an average of 5-10 percent eggs are generally unfertilized. The spoiled eggs are often attacked by fungus (Saprolegnia) and if there are clumps of eggs, as may sometimes happen in spite of the treatment, fungus may spread rapidly and harm the good eggs. So it would be advisable to loosen and separate such eggs with a slight pressure of the fingers.

The most widely used method for controlling fungus in the jars is treatment with malachite green at a strength of 0.02 g per litre water. The measured quantity of the chemical is to be introduced into the jar, the volume of which should be noted so that the resultant solution will be of the required strength. The treatment is to last for 20-25 min and during this period, the flow of water through the jar should be stopped. After the treatment the flow of water is to be resumed when the malachite green solution will get washed away. The best treatment against fungus attack would appear to be treatment with tannin solution (5-9 g tannin in 10 l water).

A few larvae generally hatch out first and this indicates that after about half or one hour the bulk of the larvae will appear. At this stage, the water current in the jar should be slowed down so that the hatchlings will not be injured or killed. This is the time to take the eggs out of the jars into a hatching funnel (sieve cloth-walled funnel) or a hatching box, for which purpose the eggs can be siphoned out with a rubber or plastic tube of 1.5-2 cm diameter into a bucket.

#### 4.3.3.7 Hatching of eggs and rearing of larvae till they start feeding

Hatching of eggs should take place in a separate place, the best arrangement for which is provision of a sieve cloth-walled funnel or a hatching box.

The fry hatching devices must be supplied with at least 5-10 l of oxygen-rich water per minute. Freshly hatched larvae will adhere to the wall of the hatching device and grass stalks, leaves, linen or plastic sheets may be kept in order to provide additional settling places for them. However, they should be removed when the fry start to swim continuously by the second or third day.

Good hatching hapas can be made of synthetic sieve cloth (mesh size: 0.3-0.4 mm) with the following measurements: length: 60-80 cm, width: 30-40 cm and height: 30-40 cm (Figure 41). The hapa is placed in a trough with about 10 cm of its upper edge above the water surface while its base is at least 10 cm above the bottom of the trough.

On the third day, the hatchlings get their air bladders filled with air and start to swim actively. Shortly after this they start to feed. Then they have to be provided with food or transferred to a pond or tank where they can find natural food (e.g., in a nursery pond). The time required for the growth of the larvae to fry stage depends on the water temperature. A low temperature (14-16°C) may delay this development very much, thus making it possible to transfer the larvae to a distant place.

The oxygen consumption of common carp larvae and fry

The oxygen consumption rates of 100 000 carp larvae and fry are as follows:

Water temperature (°C)	Oxygen consumption in mg/hour			
	Newly hatched larvae	Fry ready to feed	10 days old fry	15 days old fry
28	144.0	278.0	790.0	886.0
25	115.0	208.0	530.0	811.0
20	83.0	141.0	290.0	450.0
15	54.0	80.0	100.0	393.0
10	30.0	50.0	63.0	160.0

The fry should be scooped out of the holding device using a bowl or cup as nets may cause serious injuries.

4.3.4 Hatcheries for Cultivated Fishes

Continuous water is the first basic necessity for establishing a successful fish hatchery. Polluted, chlorinated or oxygen-deficient waters are unsuitable for feeding fish hatcheries. If such conditions are inevitable, thorough aeration would be necessary. River, pond or reservoir water, if properly strained and the temperature is at a suitable level, can generally be considered as satisfactory.

Another basic requirement concerning the water supply is that a certain amount of pressure would be needed for continuous supply within the hatchery. A level difference of 1-1.5 m between the water source and the hatchery units should be sufficient to maintain a satisfactory pressure. The temperature of the water during the breeding season of common carp should not be lower than 17-18°C and not higher than 26-27°C. Temperatures around 20-21°C are the best suitable for hatching common carp eggs. In the case of the Chinese carps, the ideal temperature is around 24-25°C, the range being between 20 and 29°C.

The size, fittings and equipment in a hatchery will depend on its use, i.e., whether for large-scale supply of fish seed or for providing stocking material in a farm. In the former case, elaborate arrangements would be necessary, while in the latter a simple structure should suffice.



A pipe 2.5-3 m long and 4-6 cm in diameter and provided with 10 to 12 taps fitted at intervals of 25 cm can serve as an excellent water supply device for the plastic funnels used for the incubation of common carp eggs. The same pipe can also be used for providing water for the sieve-cloth funnels necessary for the incubation of Chinese carp eggs. In order to avoid clogging in the pipe and taps, a strainer drum (Figure 42) about 50-60 cm long and 20-25 cm in diameter made of chicken wire over which a mosquito net material is stretched, may be kept attached to the pipe at one end. The sieve-cloth funnels should be kept in water while they are used for incubation of Chinese carp eggs or hatching of common carp eggs, and so 2 long cisterns (made of bricks with cement plaster) each 3-6 m long, 1 m wide and 1 m deep, would be necessary. The cisterns should have a drain from the bottom.

As incubation of eggs and rearing of early fry are done simultaneously in most cases, 2 pipes with taps and 2 cisterns will generally be necessary. A simple thatched roof may be erected above the containers and a jar stand installed in order for protection from sunshine.

Two strong hapas (2 x 1 x 1 m) fixed in a pond near to the inflow would be sufficient for keeping the injected breeders. But better results can be expected when two small cement cisterns (each 2.2 x 1.2 x 1 m) with adequate water supply provisions are available. For keeping the early fry after they start feeding, some well manured and fertilized small nursery and rearing ponds would also be required.

In a typical small hatchery, 10-15 plastic funnels, 6-10 sieve-cloth funnels and 6-10 hapas (for keeping early hatchlings) will be necessary. A simple device which will facilitate changing the water in a basin is indicated in Figure 43.

#### 4.3.5 Devices for Egg Incubation and Fry Rearing

##### 4.3.5.1 General remarks

In Europe and North America, ready-made glass jars (Zuger jars, Weiss jars or Zug-Weiss jars and MacDonald jars), which may be used for incubating all types of non-sticky eggs of fish, are available in the market. The common carp eggs (from which the sticky layer has been removed) and the eggs of Chinese and Indian major carps and mahasheer may be incubated in such jars.

For use in Nepal, such jars will have to be either imported or substitutes have to be fabricated locally.

The plastic funnels for incubation of common carp eggs and the sieve-cloth funnels for rearing common carp fry and incubation of Chinese carp eggs can be effectively used under conditions in Nepal.

##### 4.3.5.2 Plastic funnel (Figure 44)

###### Materials required:

- i. One strong plastic sheet 75 cm long and 28-30 cm wide;
- ii. One ring made of galvanized iron wire (2-3 mm) of 15-16 cm diameter;
- iii. One small plastic shower rose about 5-6 cm diameter (generally used in water sprinklers);
- iv. One 1 cm wide grip-ring made of aluminium plate 0.5-1 mm thick, which can be fixed by nut and screw;
- v. One iron ring, smaller in circumference than the shower;
- vi. Strong string or rope 2-3 m in length.

The plastic sheet should be cut into two halves diagonally, as shown in Figure 44A and both the parts should be sewn along the cut with 3 mm stitches, leaving an edge of about 1 cm. The two funnels can now be tucked inside each other so that the sewed edge will be on the opposite side. It has been found from experience that a little leakage in the funnel does not matter and subsequently the stitched holes will get closed automatically. In order to fix the ring on the funnel, the upper part of the funnel has to be turned down so that the ring is held tight between the two pairs of plastic sheets. Then the ring is stitched on by hand with a strong thread. Two loops to hang the funnel, fully stretched and vertical, should be fixed under the ring by making a hole in the plastic sheet with the aid of a glowing matchstick or a hot nail.

The shower head may then be fixed on the bottom of the funnel using a grip-ring provided with nut and screw.

For erecting the funnel, the shower stem is to be pushed into the 1.25 cm pipe and the end of the plastic sheet bound tightly to it. At the top end, the funnel should be hung stretched to a horizontal beam, using the loops mentioned earlier.

In order to avoid any possible dislocation and to keep the shower head in place, a ring may be used under the shower which should be tied to the horizontal beam above the funnel.

The capacity of a normal plastic funnel will be about 8-10 l and about 2-3 l of swollen common carp eggs can be incubated in it.

#### 4.3.5.3 Sieve-cloth funnel (Figures 45 and 46)

##### i. Materials required:

Name of material	Size of the funnel		
	Small	Medium	Big
Plastic sheet (strong, soft and flexible)	45 x 75 cm	45 x 110 cm	45 x 150 cm
Linen cloth (strong)	25 x 100 cm	25 x 150 cm	25 x 190 cm
Perlon sieve cloth (0.6-0.8 mm mesh) (i)	25 x 100 cm	25 x 150 cm	25 x 190 cm
or (with same size of linen cloth) (ii)	14 x 100 cm	14 x 150 cm	14 x 190 cm
Galvanized iron ring (2-3 mm diam) - 2 No. (One may be of cane if the same is easily available)	97 cm	147 cm	186 cm
Soft linen ribbon (like shoe lace material)	200 cm	300 cm	400 cm
Kitchen filler (funnel) - 2 No. (with 1.5-2 mm wide brim and 12 cm diam. Height of funnel part: 6-7 cm and length of tube: 5-6 cm)			

Name of material	Size of the funnel		
	Small	Medium	Big
Plastic pipe	According to the circumference of the kitchen fillers + 10 cm		
Elbow pipe (preferably PVC) - 1 No.			
Plastic tube (1.25 cm diam)	1 m	1 m	1 m
Strong thread (preferably reinforced by nylon) for sewing			

### ii. Preparation:

The funnel has a cone-shaped part made of plastic sheet and a cylindrical part made of perlon sieve-cloth at the lower part and linen cloth at the upper part. The water inflow device made of the two kitchen fillers is connected to the cone-shaped part on one side and through an elbow pipe with the water tap.

The plastic material for the cone may be cut in pieces, as shown in Figure 45. For the small, medium and large sized funnels, 2, 3 and 4 pieces respectively have to be stitched together.

The upper part of linen cloth is then made. In order to give sufficient strength, about 8-10 cm width of the linen strip should be folded up and stitched around the ring. The perlon sieve-cloth strip should then be sewed to the linen part with the seam remaining on the outside of the funnel. Then the sieve-cloth strip and cone-shaped plastic sheet parts are sewed together taking care to see that the seam remains outside.

The next step is to stitch about 15 cm long ribbon pieces around the middle part of the funnel where the conical and cylindrical parts meet in order to fix the second stiffening ring. Now the top ring, preferably made out of cane, should be fixed on the upper end by turning outward the upper edge of the funnel and stitching by hand. Two pairs of loops are fixed around the ring for hanging the funnel.

In order to regulate the rate of water flow into the funnel, a special device made with 2 plastic kitchen funnels (fillers) are to be fitted. One of these funnels will serve as water distributor for which purpose 0.9-1 mm diameter holes are to be made with a hot needle in 3 or 4 rows around the brim of the funnel. (The holes should be 2-2.5 mm from each other and 400-600 in total number.) For allowing the escape of air bubbles which may enter in the funnel device with the inflow of water, it is advisable to make some holes on the tube of the funnel which will be kept closed with wooden plugs.

The funnels should be stitched together as shown in the figure and then squeezed inside the cone of the hatching funnel and fastened in a vertical position. The 'U' shaped portion of a split plastic pipe (1-1.5 cm diameter) can be used to keep the funnel device in position with the help of two small screws and nuts. The tip of the lower funnel should be pushed into the 1.25 cm elbow piece and the end of the plastic sheet cone should be bound by a string. To the other end of the elbow a plastic or rubber pipe about 0.8-1 m long is to be fixed, which will connect the bottom of the funnel with the water tap.

The hatching funnel should stand vertically in the water with the help of a weight attached to the bottom.

Technical data on the sieve-cloth funnels are as follows:

	Small	Medium	Big
Diameter of the cylinder	31 cm	47 cm	58 cm
Circumference	97 cm	147 cm	182 cm
Approx. volume of the cone portion	14 l	30 l	41 l
Approx. total volume	35 l	81 l	195 l
Capacity for swollen eggs of Chinese carps	5-7 l	10-15 l	15-20 l
Water supply necessary	0.5-3 l/min	0.8-5 l/min	1.2-10 l/min

iii. Rearing hapa:

The standard dimensions of the rearing hapa are: 60 cm long, 40 cm wide and 40 cm high. The upper part of the hapa may be made of linen and the lower part of 0.5-0.6 mm perlon sieve cloth. The hapa can be kept stretched with split bamboo pieces or a galvanized iron frame.

4.3.6 Artificial Propagation of Chinese Carps

4.3.6.1 Raising and maintaining brood fish

In raising brood fish, care has to be taken to select the best specimens and stock them in small and productive ponds. As such fish approach sexual maturity, adequate food must be given to ensure proper development of the gonads.

Proper maintenance of the brood fish between two propagation periods is also of special importance. Unfavourable conditions may cause infertile eggs, poor fertility ratio, faster over-ripening of the eggs, deformed embryos, weak larvae, etc., and the males may not produce good quality milt.

During the first part of the maintenance period from the end of the breeding season to the end of winter, the brood fish build up new gonad cells and tissues. During this period, supply of adequate quantity of rich food has to be ensured. They may be kept together at this time with other fish species in mixed culture. The second part of the maintenance period is more decisive and calls for not only rich and adequate food, but also special environmental conditions.

The maintenance conditions for the three Chinese carps are different and are therefore treated separately below. Segregation is unavoidable during this period.

Grass carp. The species prefers clean and transparent water 1.5-2 m deep. If the water of the pond is renewed from time to time, good breeding results can be expected. The normal food to be supplied is cut grass, sprouted grains, rice bran,

oil cakes and offals. The quantity of grass given per day should be 15-20 percent of the total weight of the fish stock, while the food grains and offals should not exceed 2-2.5 percent. In about 1 000 m<sup>2</sup> pond area, 20-30 brood fish can normally be kept and they can be held together with prospective silver carp and bighead brood stock. Manuring and fertilization of the ponds are unnecessary.

Silver carp. The species prefers small and fertilized ponds with rich micro-phytoplankton. Renewal of the pond water is necessary only when the dissolved oxygen content goes down, resulting in the fish swimming near the shore in shoals. They can be fed with soybean flour or rice bran. In 1 000 m<sup>2</sup> pond area, 30-50 brood fish can be kept along with 4-6 bigheads. During the second part of the maintenance period, no grass carp or common carp should be stocked with the silver carp brood stock. Manuring is not necessary.

Bighead. The species prefers water rich in zooplankton which can be achieved by frequent manuring and regular fertilization. The food can be the same as that of silver carp. In 1 000 m<sup>2</sup> pond area, 20-25 bighead and 2-4 silver carp brood fish can be kept, but the species must be separated from common carp and grass carp during the second part of the maintenance period.

The spent grass carp can be stocked in ponds where bigger common carp are growing, but it is very risky to do so in ponds where smaller carp fingerlings are abundant. A spent fish is very hungry and may eat the small fish. Spent silver carp can be stocked with bigger carp fingerlings if sufficient small algae are present. Spent bighead can be stocked with bigger common carp, provided the pond is rich in zooplankton.

#### 4.3.6.2 Determination of ripeness of brood fish

When the water temperature remains steady at over 21-23°C, the herbivorous brood fish may be ripe for propagation.

It is known that the inner side of the pectoral fins of the male Chinese carps become rough (due to occurrence of small horny protuberances) when they are fully mature. The females will generally mature 2-3 weeks after this. The ripeness of the males can be judged by the oozing of the milt when a slight pressure is applied on the belly.

The important and definite signs associated with the maturity of the females are indicated below:

Grass carp. The lower part of the belly near the vent becomes puffy and soft and the sexual opening protrudes.

Silver carp. The belly becomes puffy and soft and the vent gets a red or rose colouration and also gets emerged. Sometimes the edge of the vent becomes uneven and the sexual opening gets emerged with pink or red colouration.

In Nepal, the herbivorous carps are newly introduced species and sufficient experience has not yet been gained regarding the best propagation season which, however, most probably is shortly after the spawning season of the common carp. (In Terai - end of March and first half of April; in Inner Terai - second half of April up to the middle of May; and in Kathmandu valley - entire May up to first half of June.)

A both ends open scoop net of about 50-60 cm length with a short handle and an opening of about 16-20 cm diameter, made of strong mosquito net cloth or linen, can be effectively used for catching brood fish (Figure 47).

#### 4.3.6.3 Hypophysation

##### i. The hypophysation of the female

The hormone necessary to ripen the eggs in herbivorous carps is generally administered in two doses. The first preparatory dose is about one ninth or one tenth of the total dose. Generally, 1 dry gland is used for each female as preparatory dose at the beginning of the propagation season. Later, when the ripeness of the fish is more advanced and if the water temperature is about 25-27°C, half a hypophysis should be enough per female as preparatory dose. (The bighead female is always given one gland throughout the propagation time.) The preparatory dose is to be given in 1 ml salt solution.

The time span between the two injections may be 24 hours at the beginning of the propagation season and 14-18 hours on later occasions.

The second and decisive dose of hormone is to be given in 2 ml salt solution (0.65 percent). Some workers advise the use of distilled water but it must be copper-free. The hormone dose depends on the weight of the female brood fish and on the circumference of its body. Usually one gland (3-3.5 mg) is given per 1 kg body weight of small and medium size females. A table showing the precise doses is given below:

Maximum circumference of the body in cm	38	42	46	50	54	58	62
The dose of hypophysis in mg for 1 kg body weight	3.0	3.5	4.0	4.5	5.0	5.5	6.0

(Normal hypophysis gland will be about 3-3.5 mg)

The brood fish should not be handled with bare hands as removal of the mucus on the skin will promote bacterial infections. The fish should therefore be wrapped in a towel or a soft piece of cloth when handling.

The injection is given on the dorsal part of the body as in common carp. It would be advisable to keep the brood fish on a foam rubber cushion, keeping the scoop net or towel around its body.

After the injection, the females are kept in hapas, special basins or ditches 0.8-1 m deep, and oxygen-rich water allowed to flow through continuously.

For long distance transport of brood fish, a special hammock (Figure 48) may be used.

ii. The hypophysation of the male

The male is given only the decisive injection along with the female, the dose being 2 mg hypophysis per 1 kg body weight. When the ripeness is advanced, 1 mg per kg also may give the same result. The males can be hypophysed again after 6-7 days. A fully ripe male may give enough milt even without hypophysation.

4.3.6.4 Incubation

The injected fish of both sexes can be kept separately or together. In Europe, the first method is generally practised. Usually if the sexes are kept separate, the release of eggs may not occur unless the females are disturbed or the oxygen content of the water becomes too low.

The ripening period after injection depends on the temperature of water as shown below:

<u>Water temperature (°C)</u>	<u>Ripening time in hours</u>
20-22	12-10
23-25	11-9
26-28	9-7

This period may be calculated more precisely by measuring the temperature during each hour and adding together the values. The grass carp, silver carp and bighead generally become ripe for stripping when the total of such added values becomes 205-215, 210-220 and 235-245 respectively.

The stripping should start immediately after the fish are ripe and delay by more than 50 min may affect the fertility of the eggs.

4.3.6.5 Stripping of eggs and collecting milt

The equipments necessary for stripping operations are:

- i. Scoop nets - 3 No.
- ii. Dry cloth or towels (2-3 No. for each brood fish).
- iii. Plastic or enamel basin (preferably with lid) of 2-4 l capacity and smooth inner surface (1 for each female plus 2 extra).
- iv. Plastic spoons or strong duck or goose feather.
- v. Milt collectors (or suitable pipettes).
- vi. Plastic buckets (with lid) of 10-15 l capacity (1 for each female plus 1 extra).

When the females are ready for stripping, they should be carefully caught one after another using a scoop net. To avoid loss of eggs when each fish is lifted out from the water, it should be put head forward in the scoop net so that the tail portion sticks out. When the fish is lifted up, a second person should hold the tail with a towel and press his thumb on the genital opening. A third person should hand over another towel in which the anterior portion of the fish will be enveloped. The same person can dry the tail and belly of the fish. Simultaneously, the second person can turn the fish to belly-up position and keep it firmly in his hands. When the fish is dry, the third person will lift the egg collecting basin to the genital opening of the female and the second person can turn the fish belly downward and lift his thumb from the genital opening. The eggs will eject out immediately. When the bulk of the eggs has come out, a gentle pressure may be applied to get the rest of the eggs also.

Because one drop of water can spoil hundreds of eggs, it is necessary to use a completely dry plastic or enamel basin for collecting the eggs and the body and tail of the fish should be dried with the towels before stripping.

Note: Never strip the female fish by force. Forced out eggs will be useless and the fish itself may die. A female in which the eggs do not ooze out may become ripe later on and respond to normal stripping. During stripping, the eggs should be allowed to flow down on the wall of the basin; if they fall down straight on the bottom, many may be spoiled.

The eggs thus collected should be kept in a shaded place and kept covered.

Collecting of milt must start immediately. Since the milt also becomes "spoiled" when mixed with water, the milt collectors should also be completely dry. If sufficient personnel are available, the collection of milt can run parallel with the stripping of the females.

For 1 l of dry eggs, about 10 ml milt will be required.

#### 4.3.6.6 Fertilization of the eggs

The developmental stages of eggs of typical herbivorous fishes are shown in Figure 49.

The fertilization should be undertaken immediately. The milt is spread over the eggs and mixed together with a dry plastic spoon or a strong feather for about 1-2 min and then clean water of temperature 21-24°C is poured over the mixture. About 100 ml water is necessary for 1 l of eggs. Stirring of the eggs must be continued for about 2-3 min.

When the eggs come in contact with water, they begin to swell. More water must be added in smaller doses so that about 3-5 cm water always remains above the egg mass.

The eggs should now be transferred to a bucket in which 1-2 l clean water has already been added. The eggs should be allowed to flow down the side of the bucket.

About 30 min after fertilization, the eggs should be washed by changing the water 3-4 times. Then the eggs can be taken into the incubator jars (plastic funnels or sieve-cloth funnels). (The hatching hapas are not good for incubation as the eggs may die in large quantities due to poor aeration.) The transfer of the eggs to the jars should be done very carefully in order to avoid possible damage.

#### 4.3.6.7 Incubation of eggs

If the eggs are not over-ripe they swell 50-60 times their original volume.

All fish eggs are very sensitive in their first stage of development and the eggs of the herbivorous carps are no exception. On the contrary, they are more sensitive in this stage as compared to the common carp eggs, due to the thinner egg shell and more delicate nature of the cells. A violent shake can displace the cells on the blastodisc of the developing egg. So the water inflow into the incubator must be finely regulated. Since the oxygen demand of the eggs in the early developing stages is rather low, only that much of water to keep the eggs without any noticeable movement should suffice under ordinary circumstances. In each incubator jar, the rate of flow of water may be 0.5-1.5 l per minute. However, during the second half of the



development stage, the rate of flow must be raised gradually to 3-10 l per minute, according to the size of the incubator.

In an incubator jar of 8-10 l capacity, about 2-3 l of swollen eggs may be placed, while in a sieve-cloth funnel, 30-50 percent of the capacity of the conical portion may be filled. One litre of swollen egg mass will contain about 15 000-17 000 eggs.

A plastic funnel or Zuger jar of 8-10 l capacity can take about 50 ml "dry" (unswollen) eggs, (i.e., about 40 000-50 000 eggs of grass carp, 50 000 of silver carp and 30 000 of bighead).

#### 4.3.6.8 Preventing premature hatching

The shell of the floating eggs of Chinese carps is very delicate and often gets infected by bacteria and fungi. The adverse effects produced by water bacteria and fungi include the eggs getting thinner, flabby and deformities. The development of the embryo will also suffer and, in most cases, premature hatching may occur. The fry thus produced are generally not viable and will die during the first days of their life. In this way 90-98 percent of the good eggs may perish. The slimy products of bacterial and fungal infections may lead to aggregation of the otherwise non-sticky eggs in big clumps, which may cause suffocation.

As a preventive measure against bacterial and fungal infections, many European hatcheries adopt the so-called "formaldehyde shadowing" method in which formaldehyde is added continuously in the water in the hatchery at the rate of 1 part in 20 000-30 000 parts of water. However, this process needs sophisticated equipment and strict control of the operation. A very simple but effective control method worked out for use in Nepal is by treating the eggs which have completed the early developmental stages (i.e., when the blastoderm has almost enclosed the yolk mass and shortly before the blastopore is closed) in a solution of 5-10 g tannin in 10 l clean drinking water.

During the treatment, a funnel is placed on the feeding pipe of the hatching device through which about 0.5 l tannin solution and the same volume of water are added alternatively. In one device, 2-4 l tannin solution is given at a time and the treatment is repeated two or three times for 3-4 hour periods. The last treatment is done when the tail of the embryo has grown to about half its size and the yolk sac is still round in shape. Usually, the first treatment is done 6-7 hours after fertilization and the last one 6-8 hours before the hatching is expected.

The tannin solution makes the egg shell stiff and prevents infection by bacteria and fungus. The larvae hatched from tannin-treated eggs have been observed to be very healthy and without any after-effects.

#### Hatching of the eggs

The unfertilized or damaged eggs get disintegrated or become white and float above the good ones. They must be removed by careful siphoning.

If the temperature of water within the incubator is 22-25°C, the hatching of the eggs is generally completed after 32-35 hours. If the temperature is higher (26-28°C) the time taken is about 24-28 hours only.

The healthy larvae of the Chinese carps start to swim vertically immediately after hatching. Eventually they swim out of the jars or funnels and so it is necessary to collect the overflowing water into a hapa (0.6-0.8 mm mesh). In the case

of sieve-cloth funnels, the larvae cannot swim over and so they can be scooped out when a greater number are already hatched.

During the hatching period, the speed of inflowing water inside the hatching device should be lessened.

#### 4.3.6.9 Nursing larvae and fry

The larvae swim continuously on the first day after hatching, but by the second day they generally settle down on the bottom of the hapa. At this period, many of them may die if the oxygen supply at the bottom of the hapa is not adequate. On the third day, they again start to swim along the walls of the hapa. The pigmentation of body starts by this time. By the fourth day, if the water temperature is 21-22°C, the larvae fill up their air-bladders with air (it is called air swallowing) and swim swiftly. The larvae are now ready to feed.

If there are no facilities in the hatchery for feeding the larvae, they must be transferred to small nursery ponds. The first food items of the herbivorous carp fry are Rotatoria and bigger single-celled animals, mostly Ciliata.

During the development of the larvae, the main cause of mortality may be predation by Cyclops. If river water is used in the hatchery, Cyclops infestation can be prevented. Otherwise, non-persistent pesticides may be applied in very low concentration (1 ppm or less) for killing the animals. (Experiments using the locally available pesticides should be conducted beforehand.)

The development of the larvae depends on the water temperature, as shown below:

<u>Temperature °C</u>	<u>Period of larval development (days)</u>
20-22	4-6
22-25	3-4
25-30	2-3

#### 4.3.6.10 Some general notes regarding nursery ponds

- i. The nursery ponds used for herbivorous carps should be kept dry when they are not used or at least 2-3 months before the rearing season starts.
- ii. The inundation of nursery ponds should be started 3-4 days before the stocking through a small mesh screen or a filtering device.
- iii. Adequate manuring and fertilizing should be done in order to increase the plankton content.
- iv. The fry should be fed artificially from the first day onwards with soybean milk (soybean flour dissolved in water) and/or boiled egg yolk powder. After 10 days, fish meal or meat meal with maize flour may be supplied at the rate of about 1 kg food mixture per day for 100 000 fry.
- v. The number of early fry to be stocked in nursery ponds will depend on the quantity of natural food available. Usually 150-500 fry are stocked in 1 m<sup>2</sup> nursery pond surface.

- vi. The early fry of Chinese carps may get infected with Trichodina sp. or other protozoan parasites. Treatment with a 0.5 percent solution of common salt may prove effective against these parasites. The treatment time may be about 5-15 min depending on the health condition of the fry. However, before undertaking mass treatment, trials should be conducted with a few fry so that the appropriate dosages and duration of treatment may be worked out.

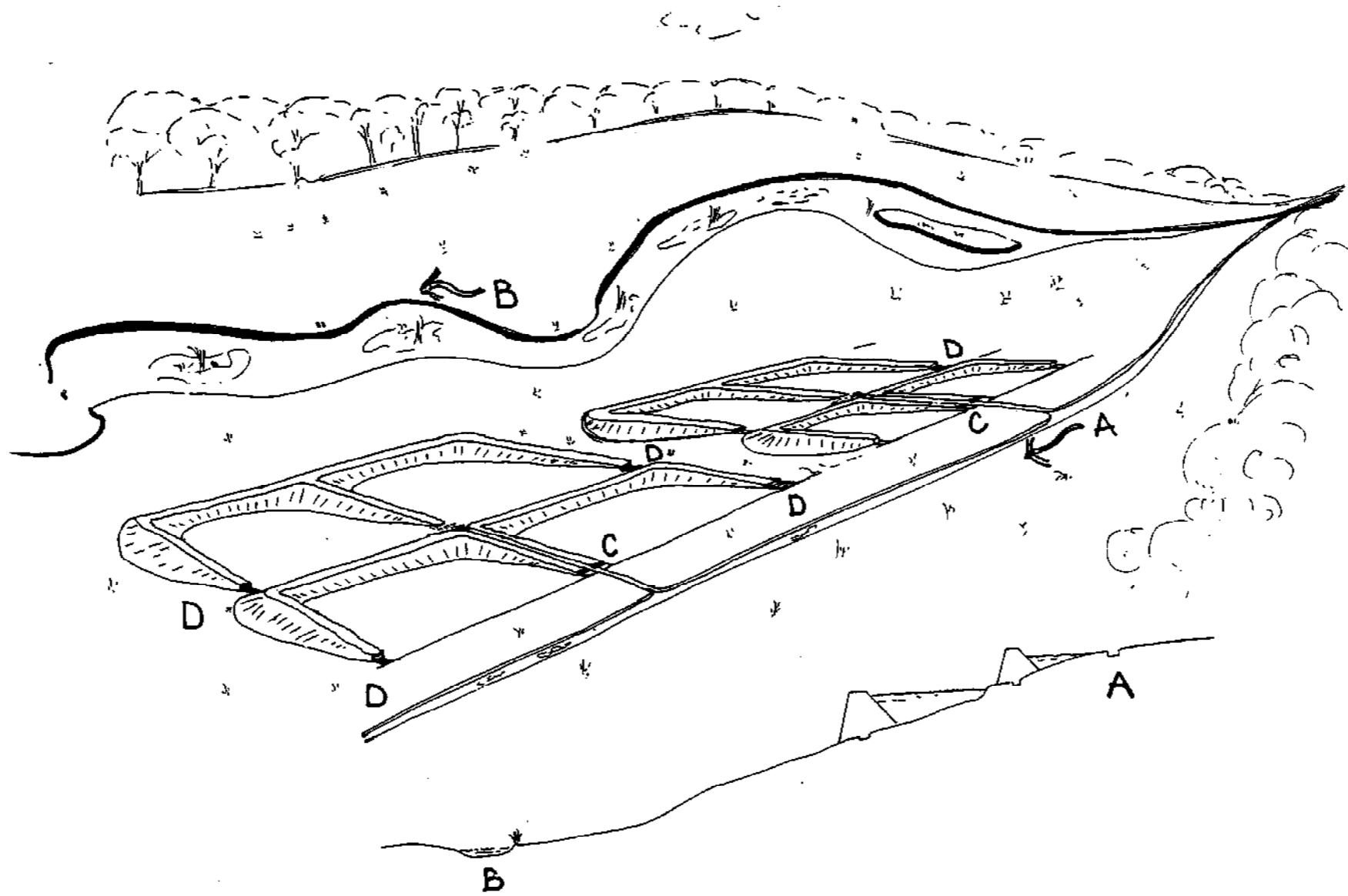

Fig. 1 Small contour ponds built along a canal. A. Feeder canal.  
 B. River from which water is diverted. C. Inlet structure.  
 D. Overflow arrangement (the outlet monks are not shown).

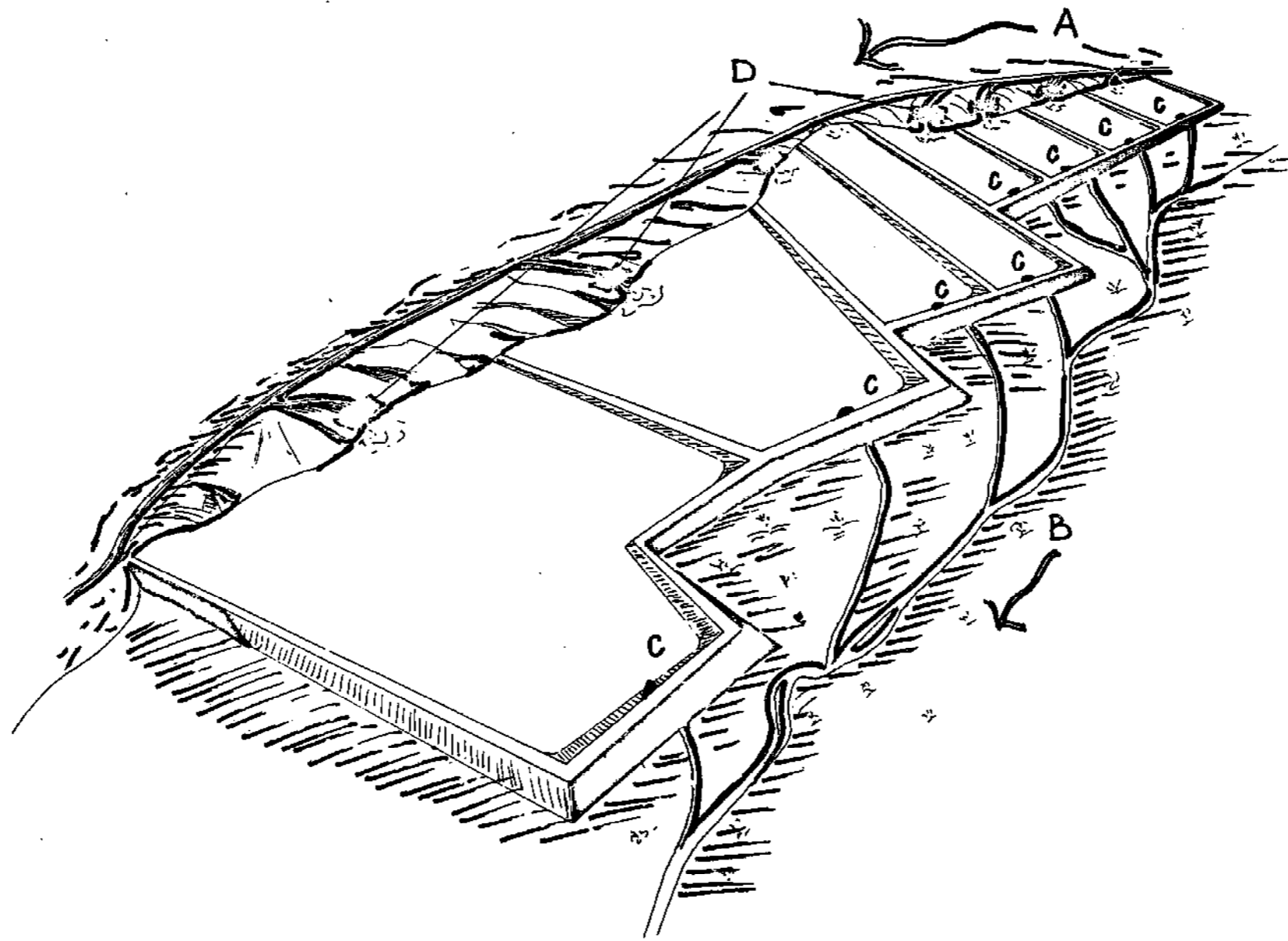

Fig. 2 Contour ponds. A. The feeding stream (all the ponds have individual inlet canals). B. The draining stream (with the individual flow canals). C. Outlet structure. D. Filter chambers to prevent entry of wild fish.

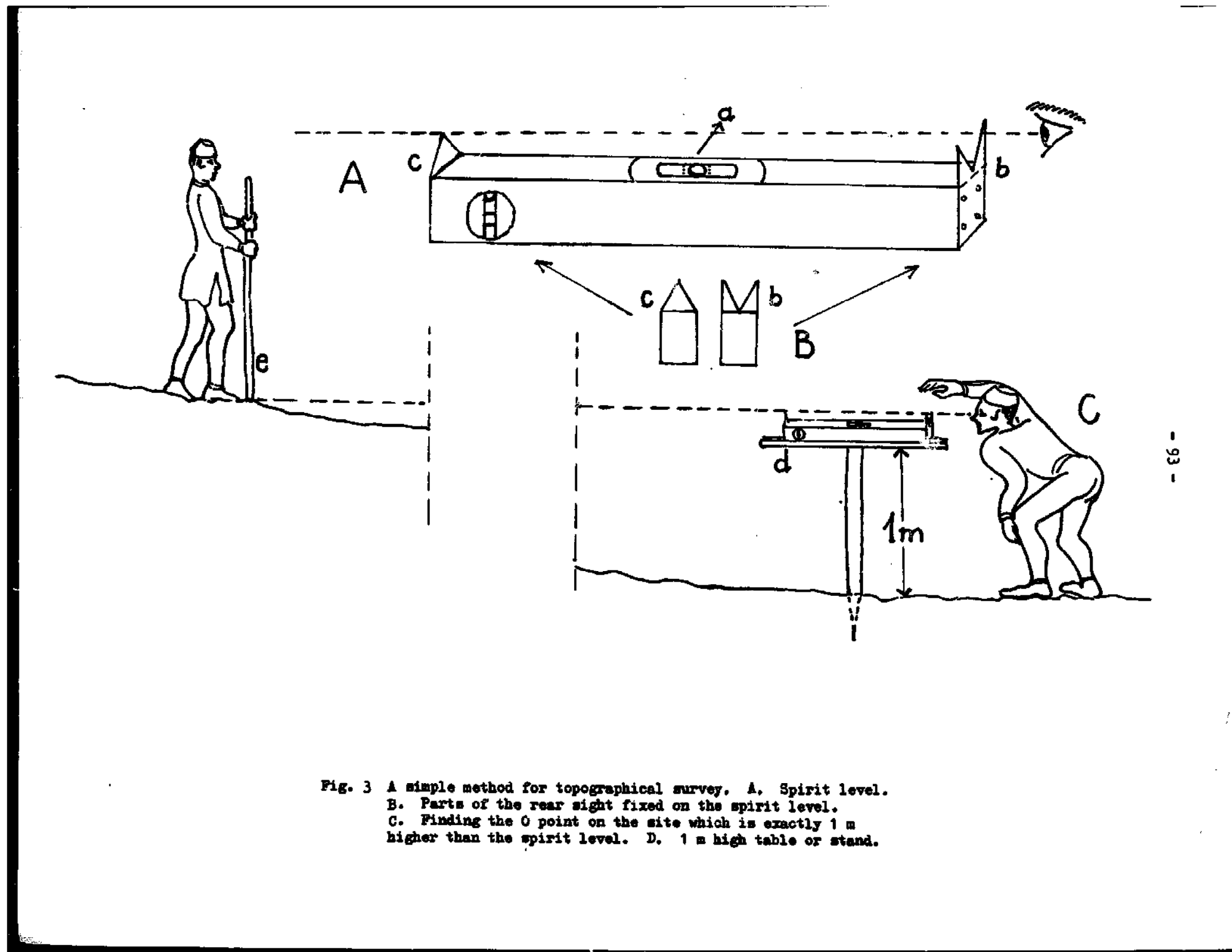

Fig. 3 A simple method for topographical survey. A. Spirit level.  
 B. Parts of the rear sight fixed on the spirit level.  
 C. Finding the 0 point on the site which is exactly 1 m  
 higher than the spirit level. D. 1 m high table or stand.

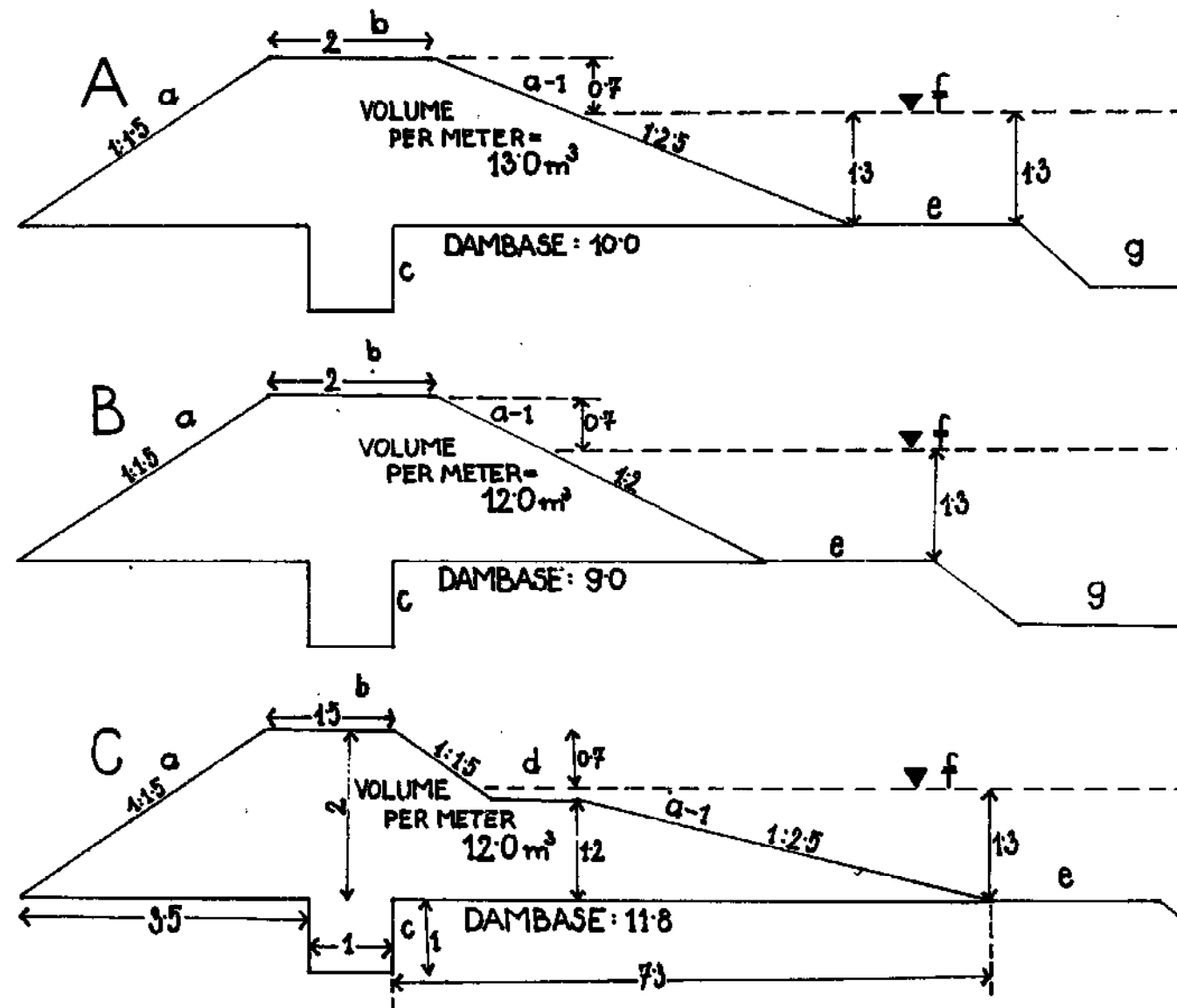

Fig. 4 Cross sections of dams with different types of slopes (height 2 m).  
 A. Normal dam. B. Easily erodable dam. C. Dam with 'slope-shelf'  
 on the water side. a. dry side slope, a-1 slope of the water side,  
 b. dam crown, c. core trench filled with good clayey soil, d. 'slope  
 shelf', e. bench line, f. water level, g. pit from where the soil  
 for the dam is taken.

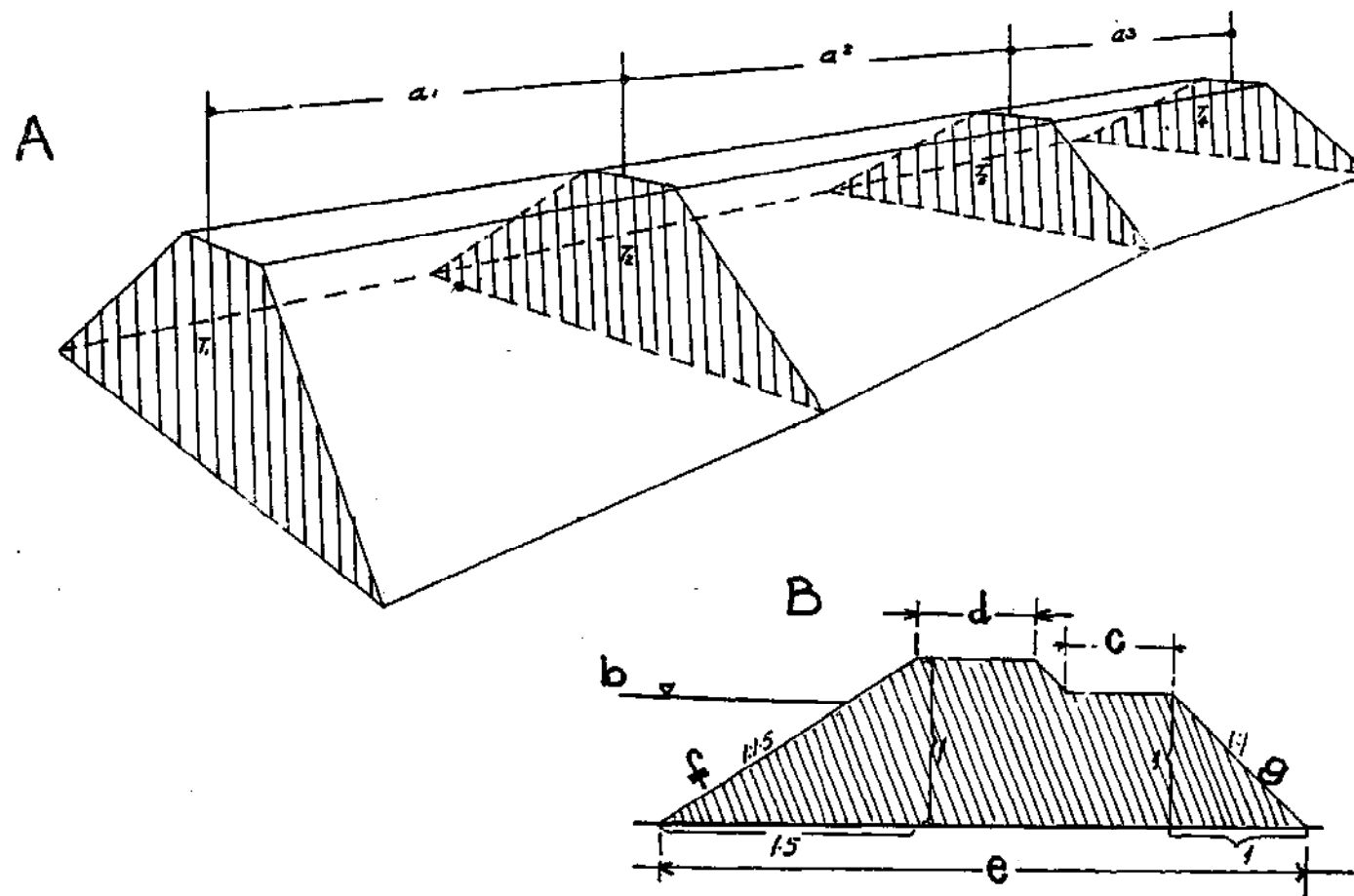

Fig. 5 Dike (dam or wall). A. Calculation of the dike volume with changing height. T. Total volume:  $T_1, T_2, T_3, T_4$ . Cross sections with different dam heights:  $a_1, a_2, a_3$ . Length of the concerned part of the dam. The calculation is according to the equation:

$$T = \frac{T_1 + T_2}{2} \times a_1 + \frac{T_2 + T_3}{2} \times a_2 + \frac{T_3 + T_4}{2} \times a_3$$

B. Cross section of a dike. b. water level, c. outer 'slope shelf', d. dike crown, e. base of the dike, f. water side slope (1: 1.5), g. dry side slope, h. core trench filled with good clayey soil.



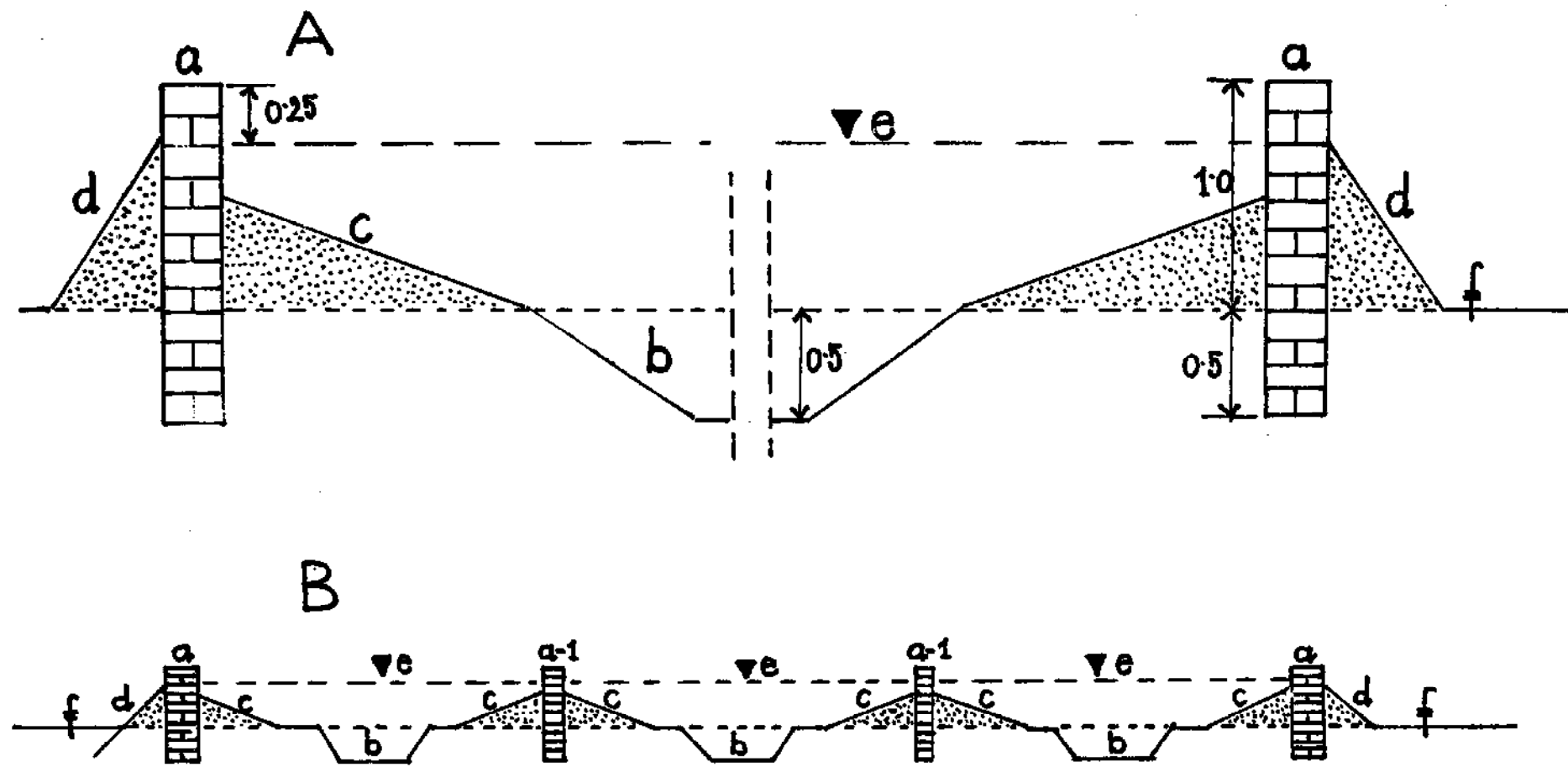

Fig. 6 Brick wall ponds. A. Cross section, a. contour brick wall (10 in wall), b. dug out trench, c. filled up side, d. earth rammed on the dry side, e. water level, f. original level of the site. B. A row of brick wall ponds (cross section), a-1 dividing walls (5 in brick walls).

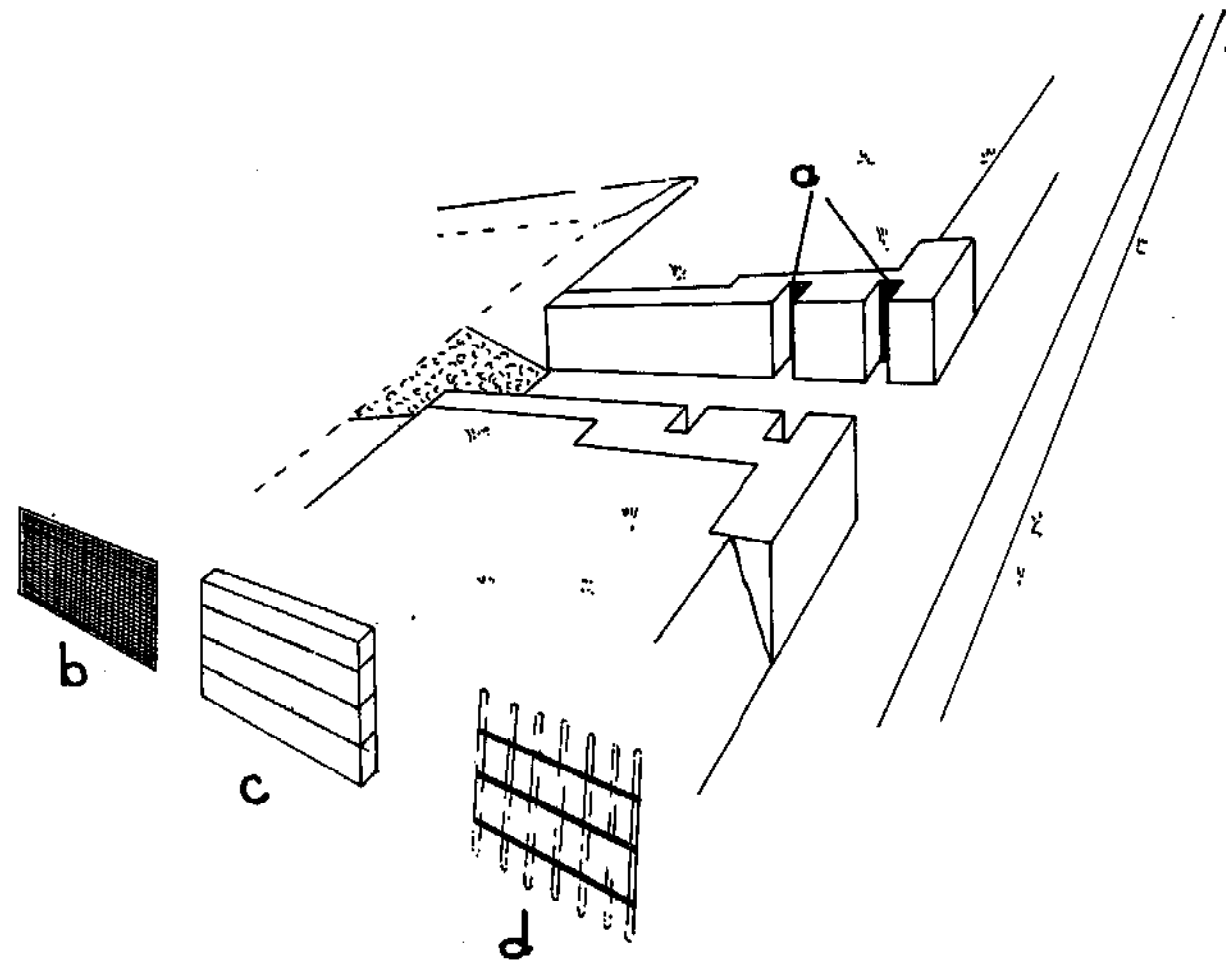

Fig. 7 Simple inlet made of bricks (plastered), constructed in a feeding canal,  
 a. two pairs of grooves, b. metal screen, c. control board,  
 d. bamboo screen for controlling floating debris.

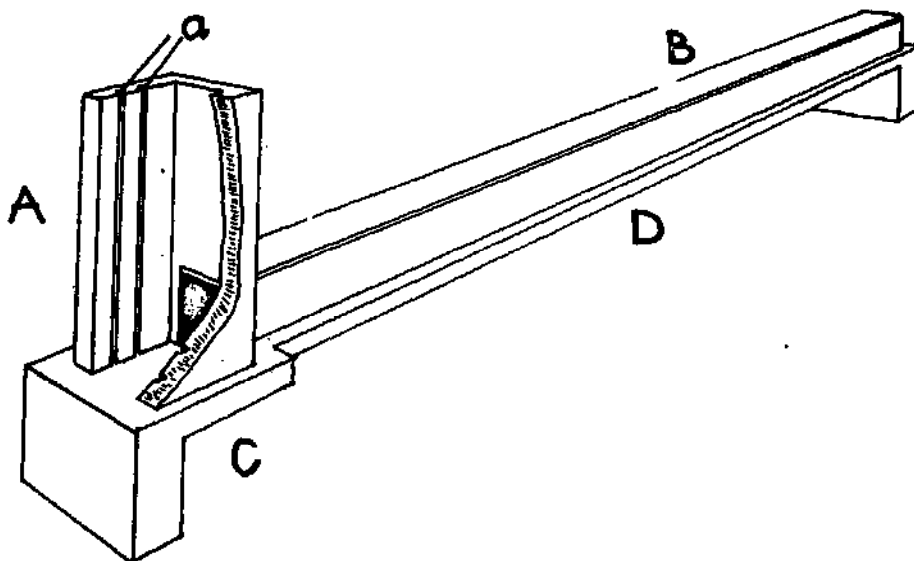

Fig. 8 Monk (outlet structure of a fish pond). A. Monk tower, a. two pairs of grooves for control boards, B. Culvert of the monk for draining the water. C. Base of the monk. D. Base of the culvert.

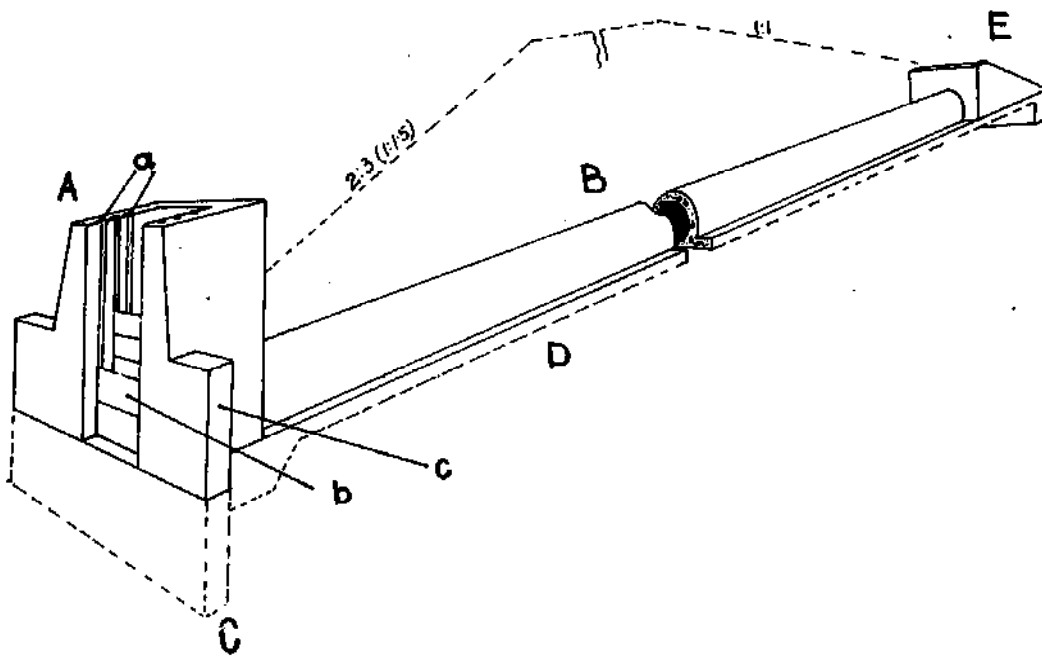

Fig. 9 Monk with wing wall. A. Tower of the monk, a. three pairs of grooves for the screen and control boards, b. wing wall of the monk tower. B. Culvert of the monk made of pre-cast pipes. C. Base of the monk tower. D. Casing of the culvert. E. Head portion of the monk.

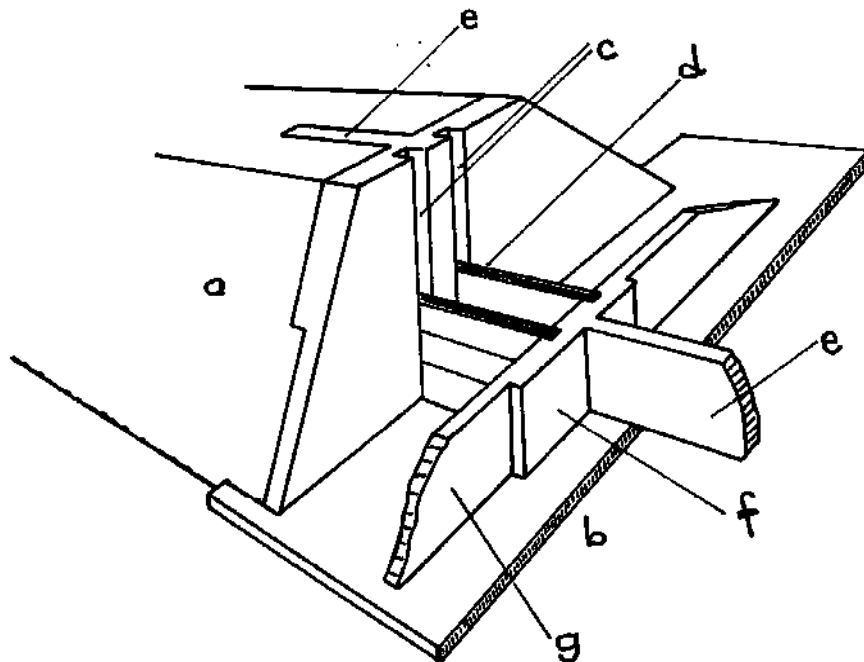

Fig. 10 Sluice (open outlet structure) made of bricks, a. dike, b. base of the structure, c. two pairs of grooves, d. control boards, e. brick-work on dike meant to stop seepage, f. 25.5 cm wide brick wall, g. 12.7 cm wide brick wall.

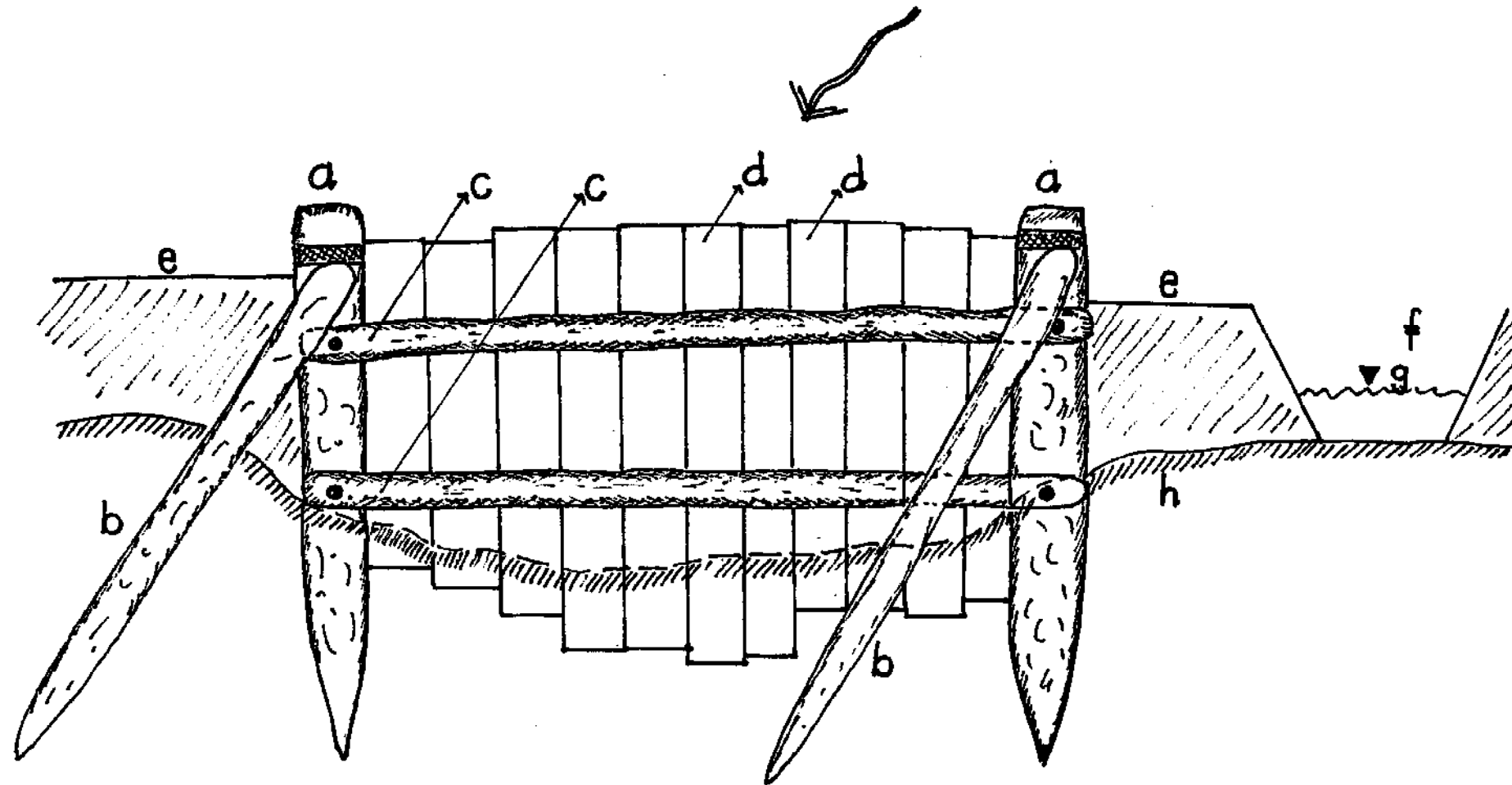

Fig. 11 Simple barrage, a. strong vertical posts, b. supporting posts, c. horizontal logs to which planks are kept pressed, d. vertical planks pushed into the mud, e. earth wall on bank of the river, f. canal, g. water level in canal.

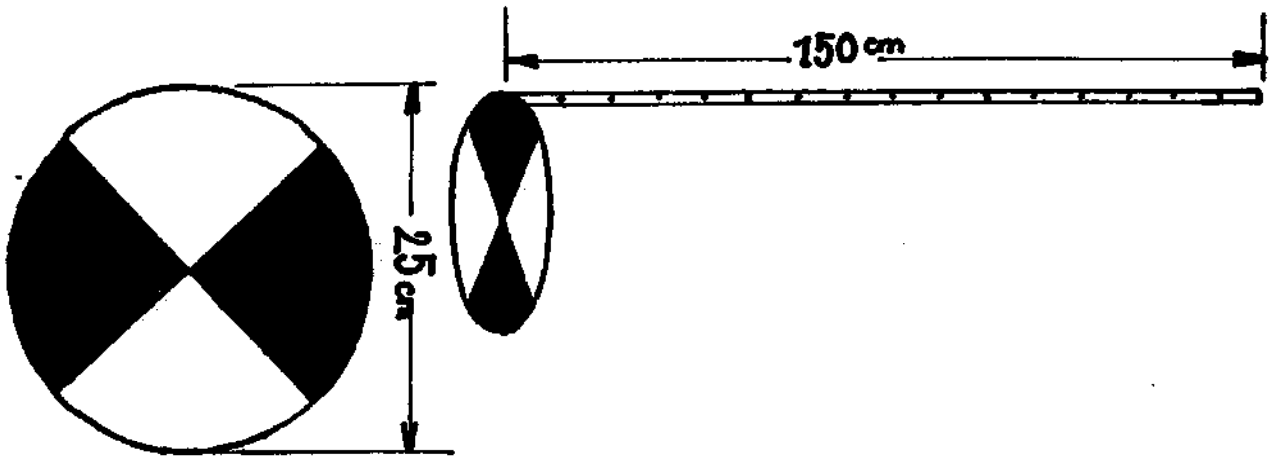

Fig. 12 Secchi disc.

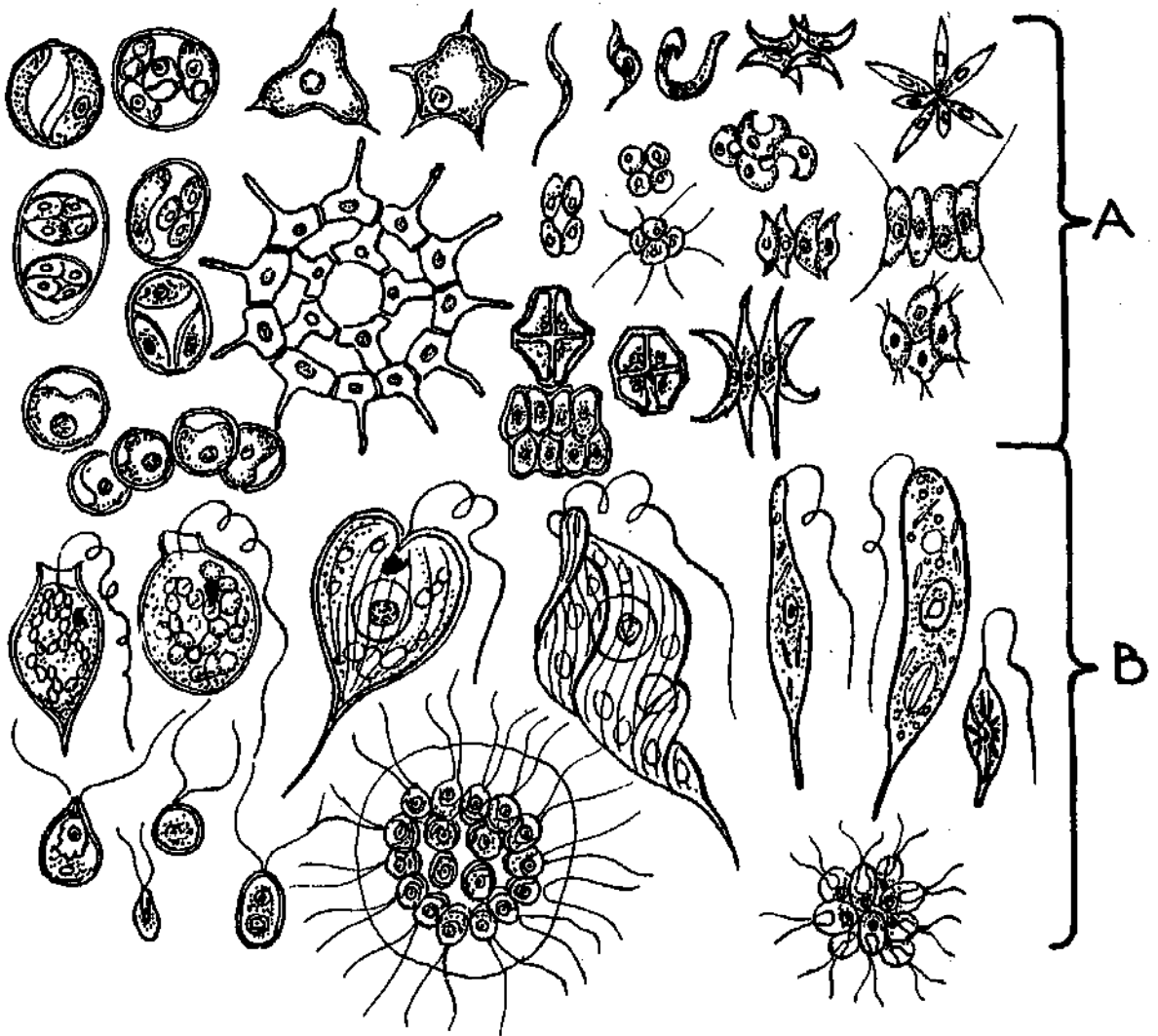

Fig. 13 Microscopic algae. A. Some members of the Chlorophyta group. B. Some members of the Euglenophyta group.

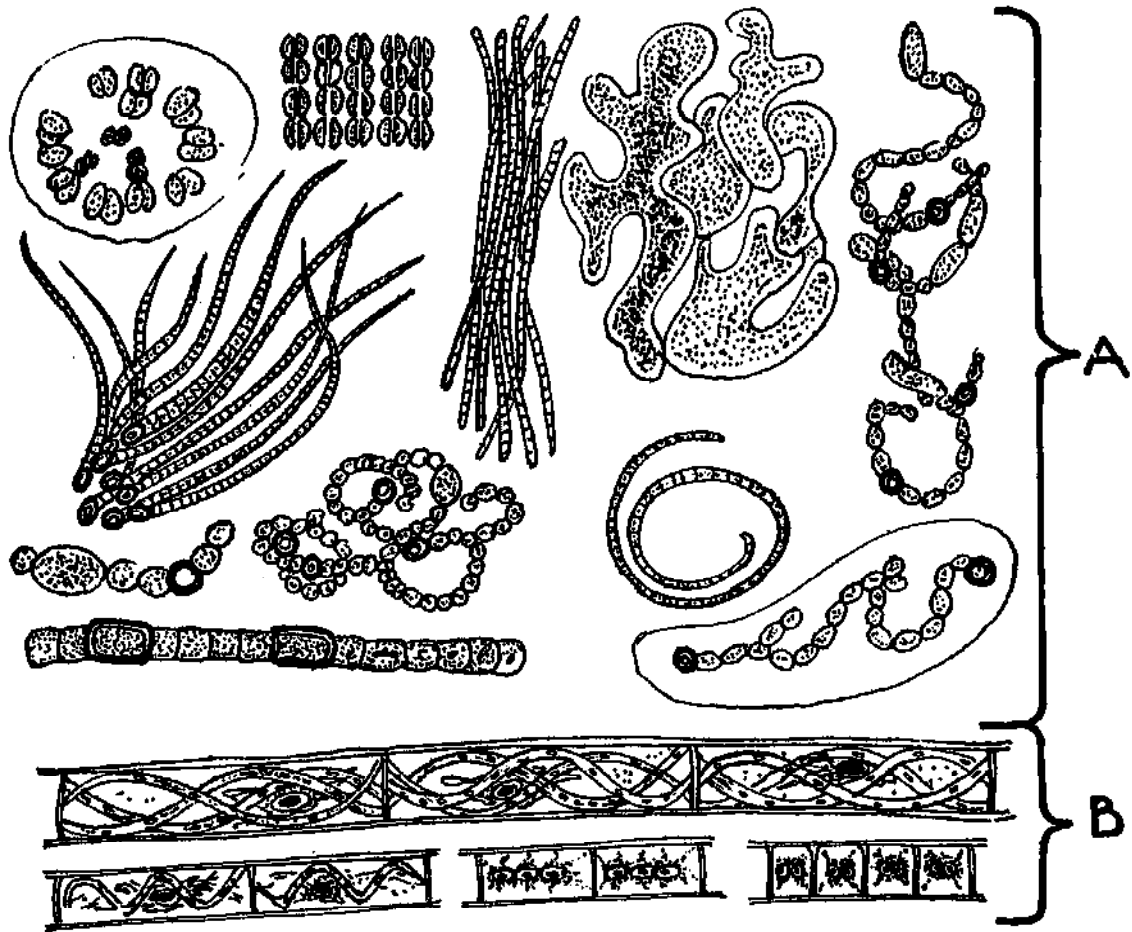

Fig. 14 A. Blue green algae (Cyanophyta). B. Filamentous algae (Spirogyra)

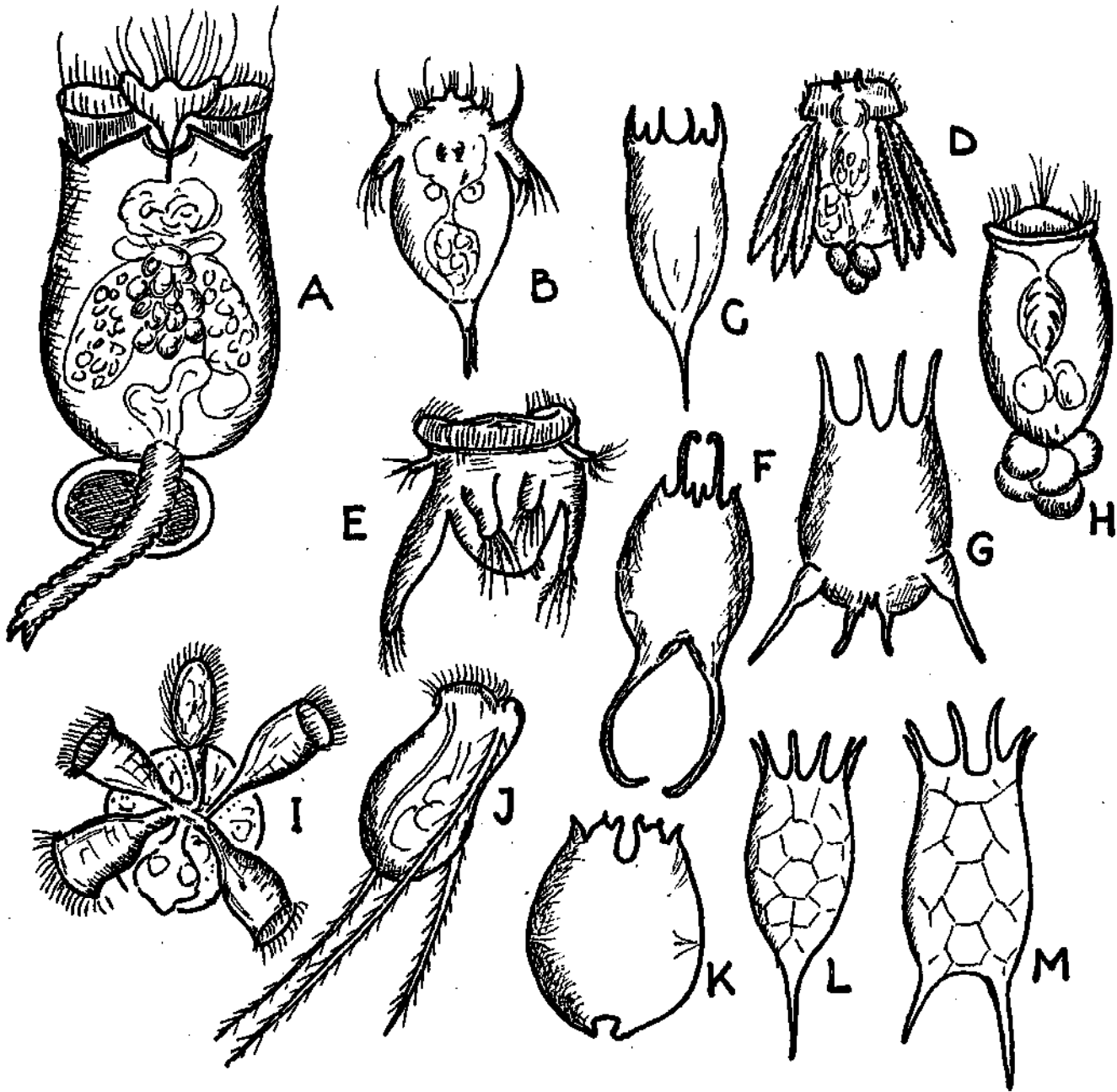

Fig. 15 Common Rotatoria in fish ponds. A. Brachionus calyciflorus (ventral view). B. Synchaeta sp. C. Notholca sp. D. Polyarthra platyptera. E. Hexarthra mira. F. Brachionus falcatus G. Brachionus calyciflorus (shell only). H. Asplanchna sp. I. Conochilus sp. (colony). J. Filina sp. K. Brachionus angularis (shell). L. Keratella cochlearis. M. Keratella quadrata.



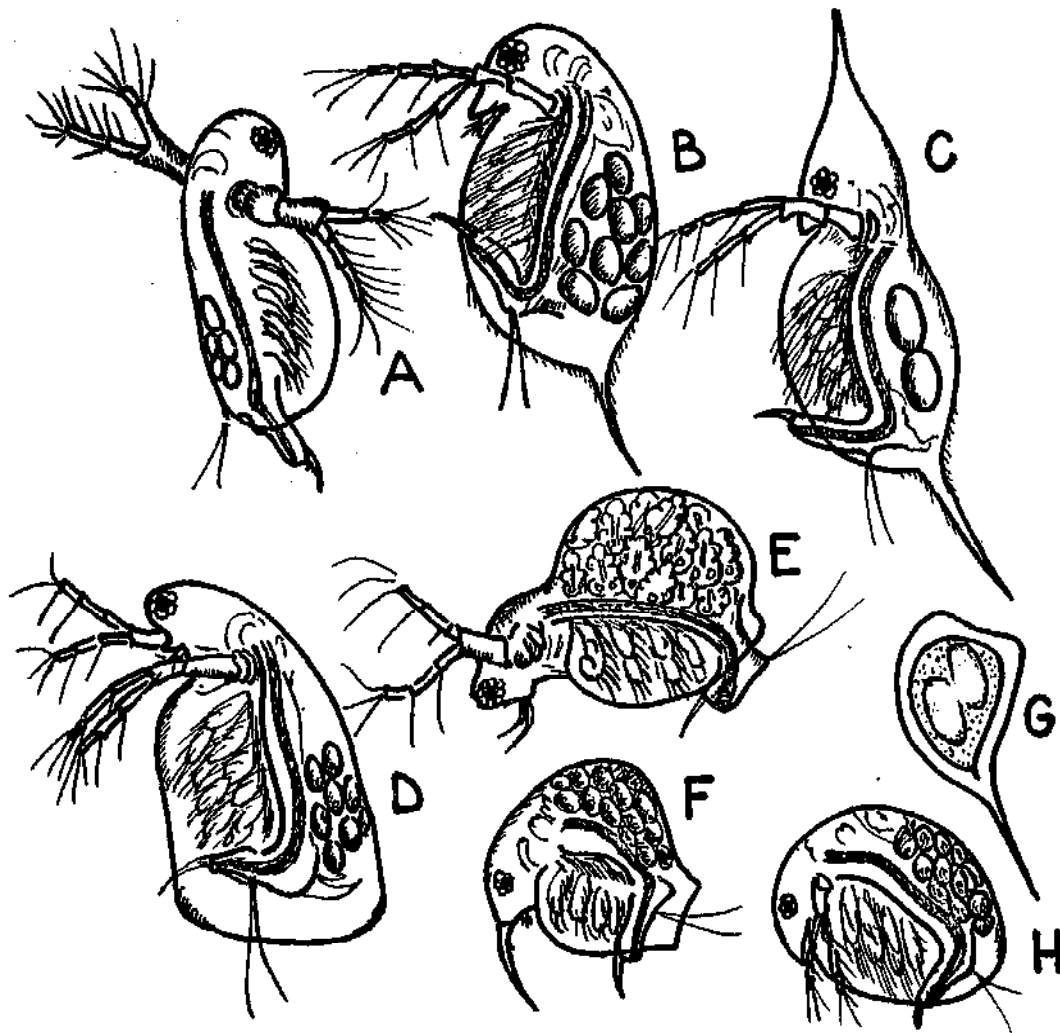

Fig. 16 Common Cladocera in fish ponds. A. Diaphanosoma brachyurum  
B. Daphnia pulex. C. Daphnia cucullata. D. Sida cristallina.  
E. Moina sp. F. Boasina longirostris. G. Ephippium (with  
fertilized eggs of Daphnia. H. Chidorus sp.

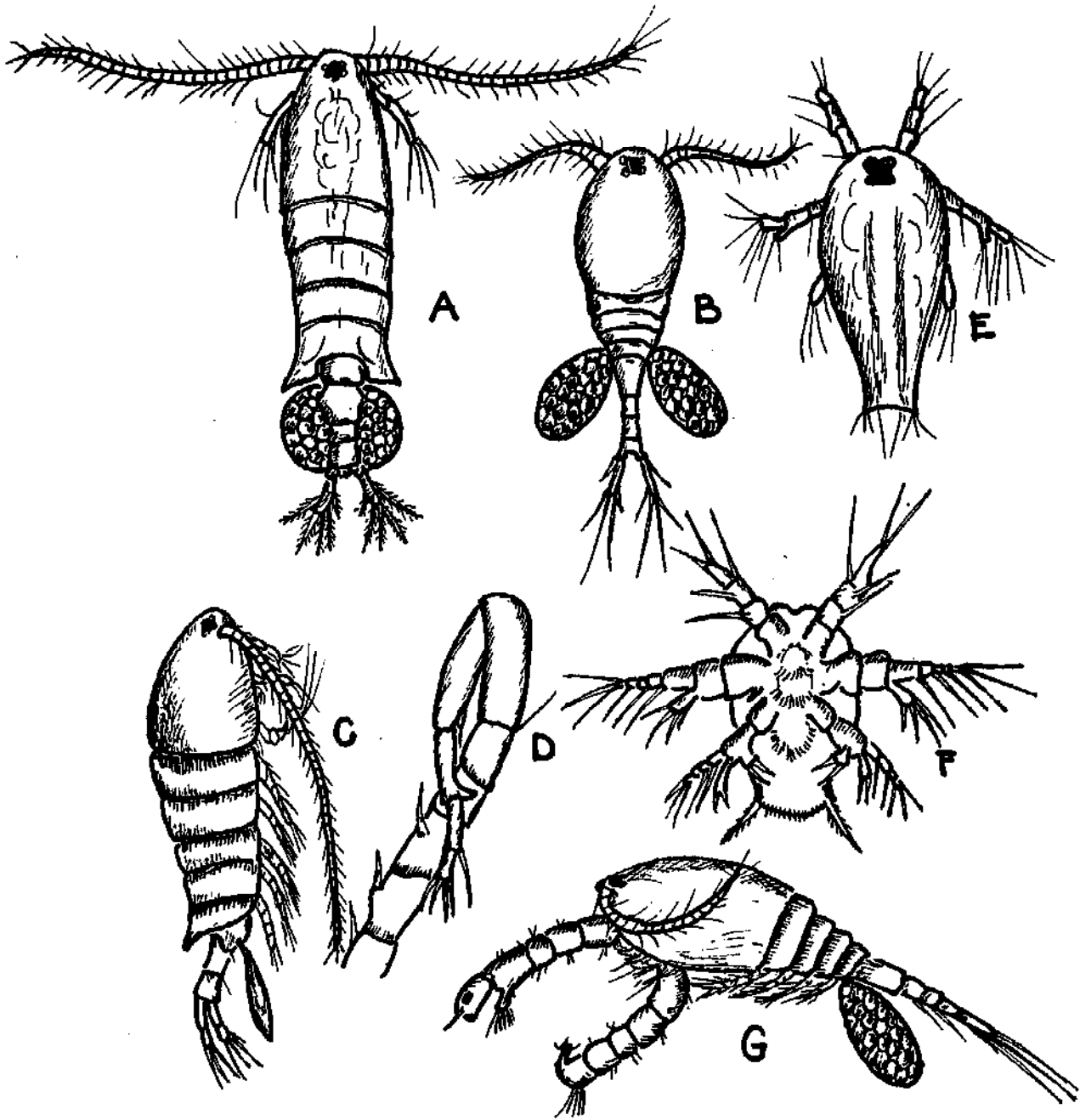

Fig. 17 Common copepods. A. Diaptomus sp. with egg sacs. B. Cyclops sp. with egg sacs. C. Diaptomus (side view). D. Antenna (first paired appendage on head) of a male Diaptomus. E. Diaptomus larva (nauplius). F. Cyclops larva (nauplius). G. Carnivorous cyclopid feeding on chironomid larva.

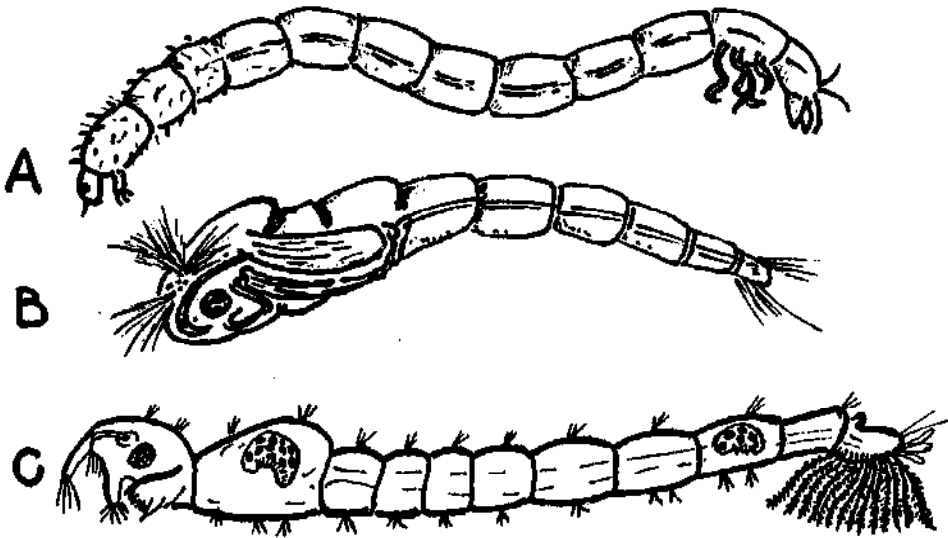

Fig. 18 Important fish food organism living in pond mud. A. Chironomus larva. B. Chironomus pupa. C. larva of Cheoborus plumicornis (This larva lives above the pond bottom).

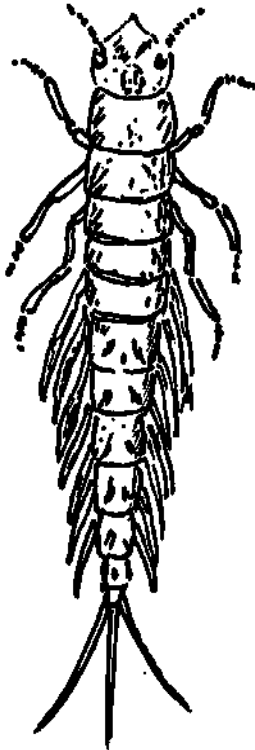
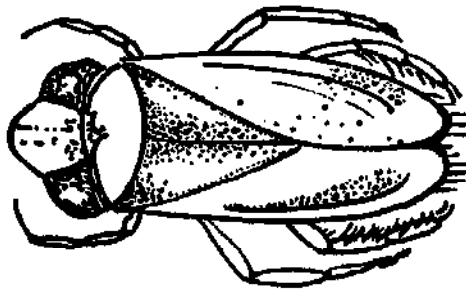

Fig. 19 (left) Mayfly (Ephemeroptera) nymph living in pond mud.

Fig. 21 (below) Backswimmer (adult).



(For Fig. 20 see following page)

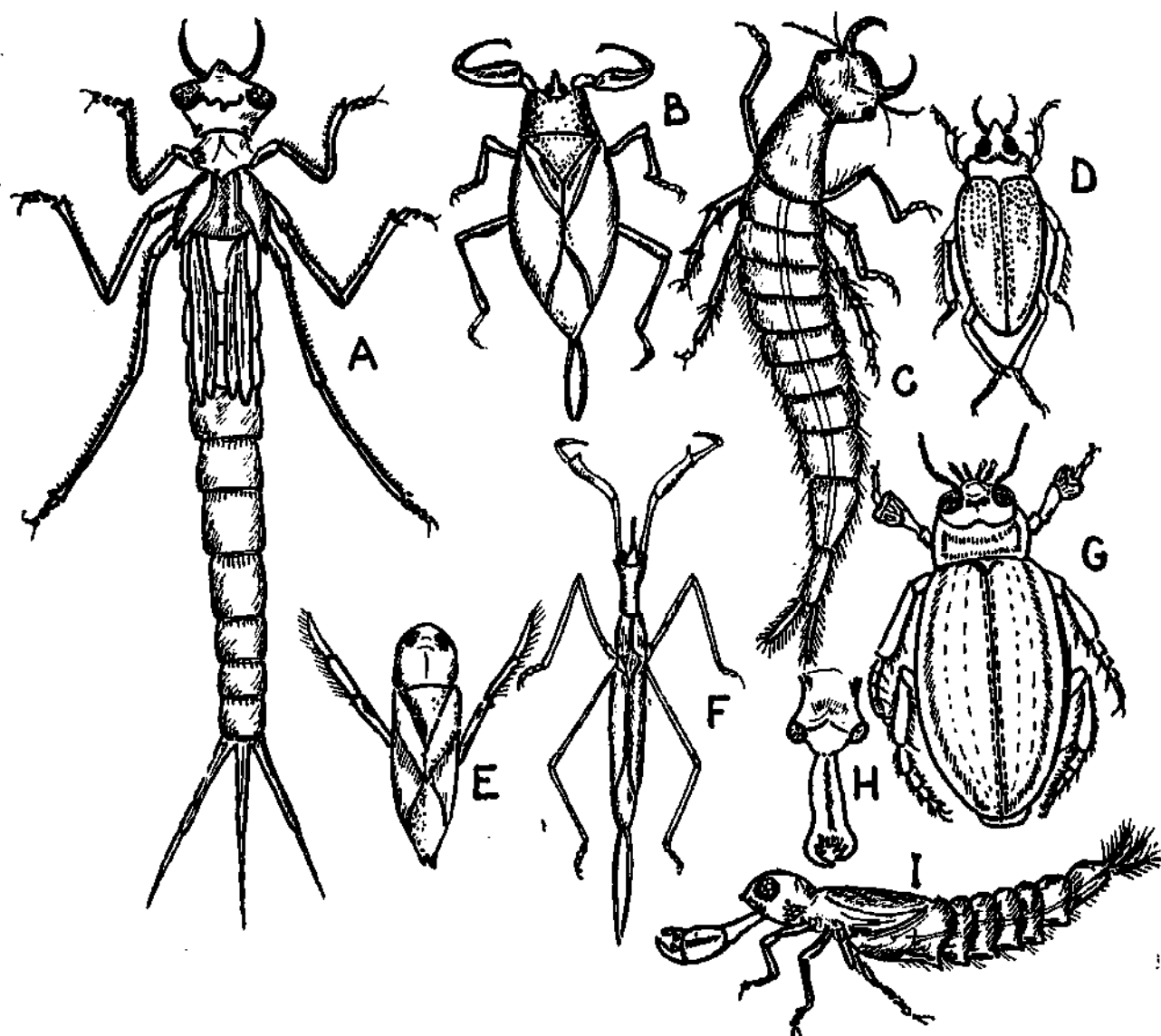

Fig. 20 Carnivorous insects and insect larvae. A. Larva of a damsel fly. B. Water scorpion (*Hemba* sp). C. Larva of great diving beetle. D. Water beetle (*Hydrophilus* sp). E. Backswimmer (young). F. Water stick (*Ranatra*). G. Great diving beetle. H. Head of dragon fly nymph (larva) showing the extended 'mask'. I. Nymph of dragon fly (side view) with the 'mask' extended.

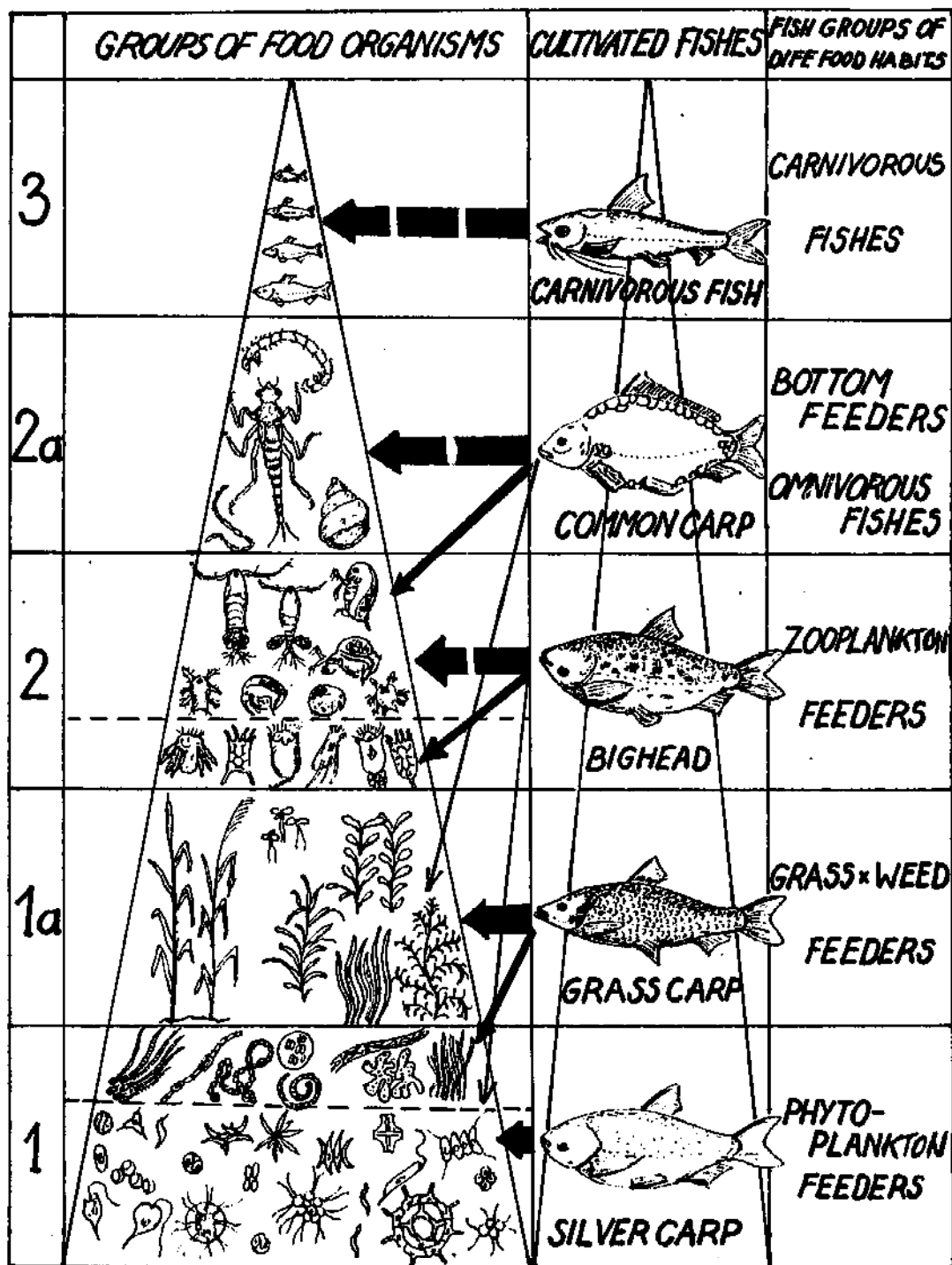

Fig. 22 Food and fish pyramids. First column: 1, 1a Primary producers, 2, 2a. Secondary producers, 3. Tertiary producers. Second column: The pyramid of groups of organisms. 1. Planktonic algae (micro-phytoplankton and filamentous algae), 1a. Emerging and submerged plants, 2. Zooplankton, 2a. Bottom fauna, 3. Weed fishes. Third column: The pyramid of fish groups with different food habits. The main arrows indicate the relative sizes of the food chain of the fish in question. Fourth column: General fish food habits.

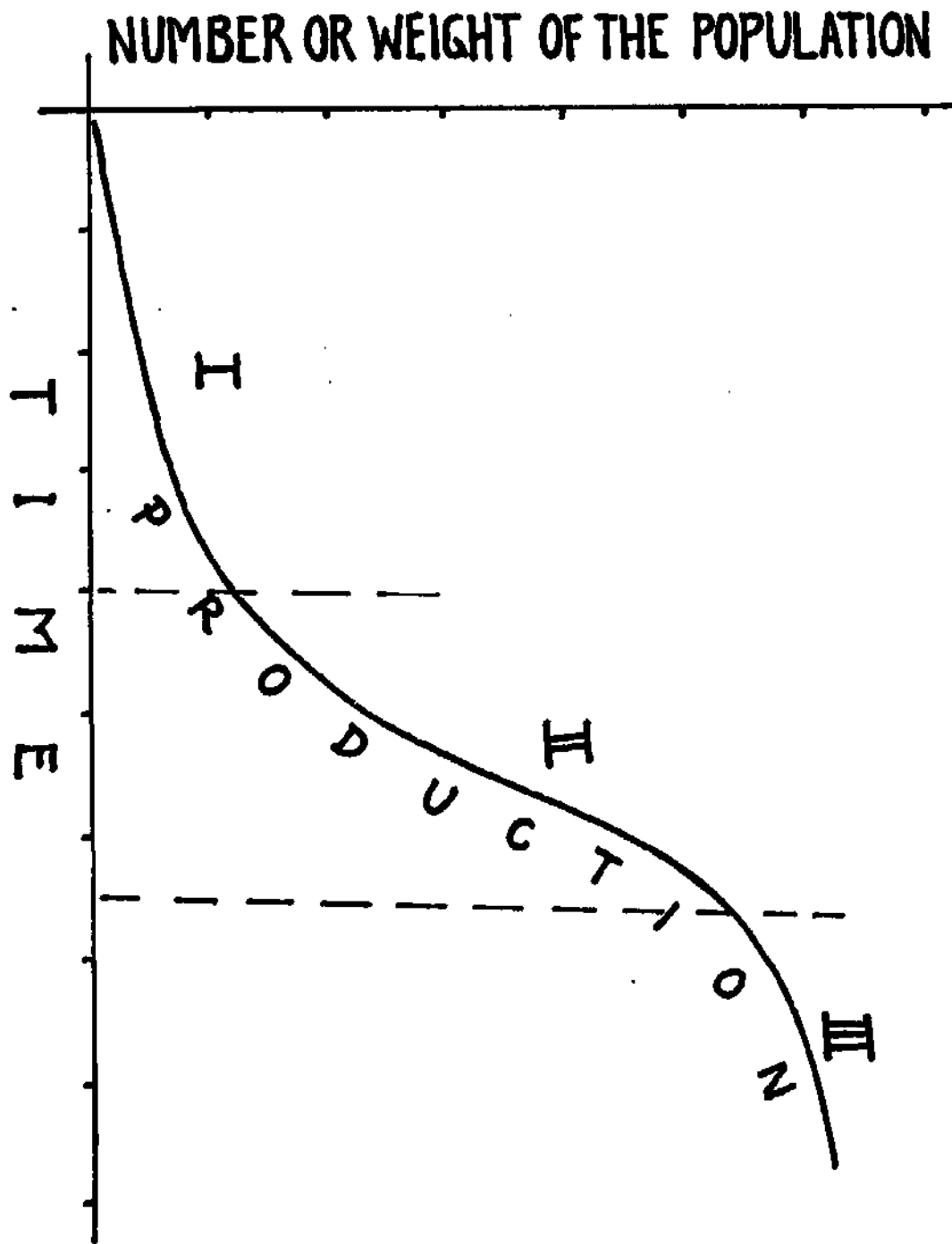
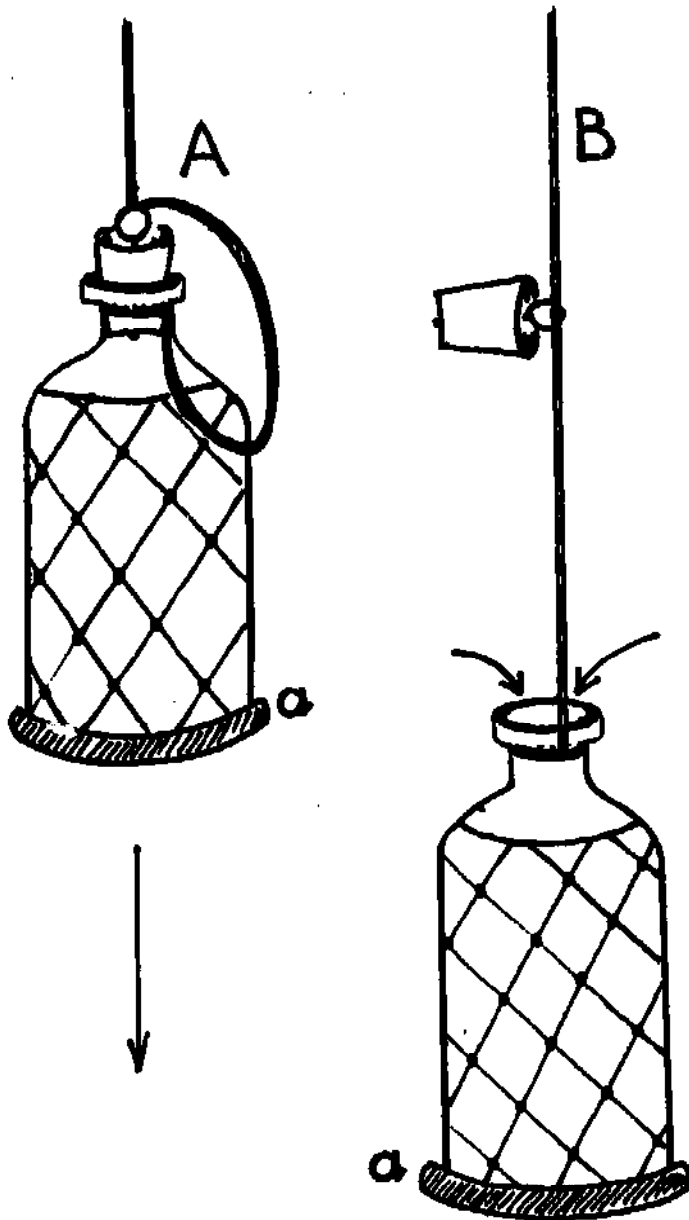

Fig. 23 Production curve. I. First (developing) phase, II. Second (full production) phase, III. Third (declining) phase.



**Fig. 24** Neyer's bottle for collecting water samples from different depths. A. Closed bottle B. Bottle opened under water with a jerk of the rope, a. weight fixed to the bottom of the bottle (preferably of lead).

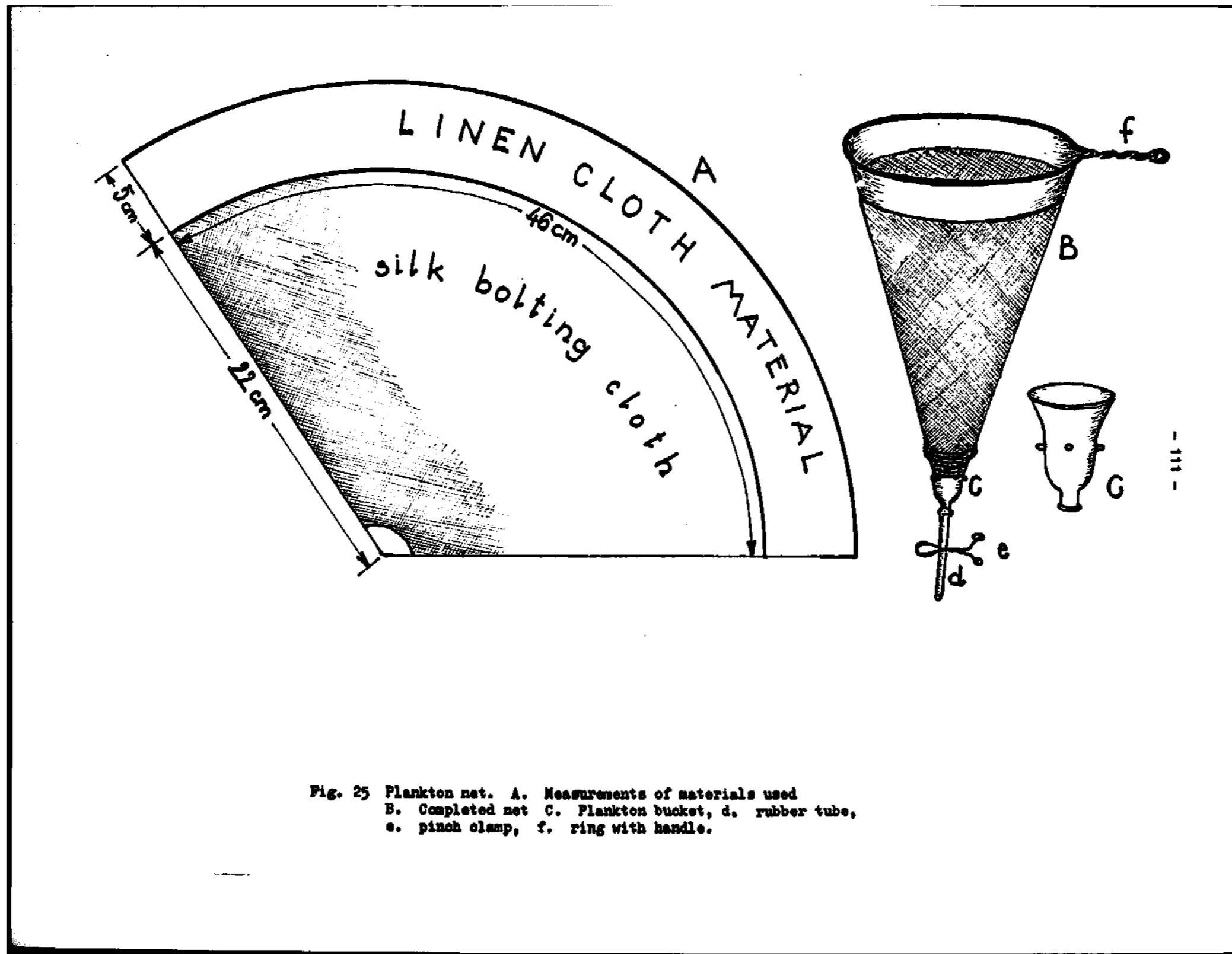

Fig. 25 Plankton net. A. Measurements of materials used  
 B. Completed net C. Plankton bucket, d. rubber tube,  
 e. pinch clamp, f. ring with handle.



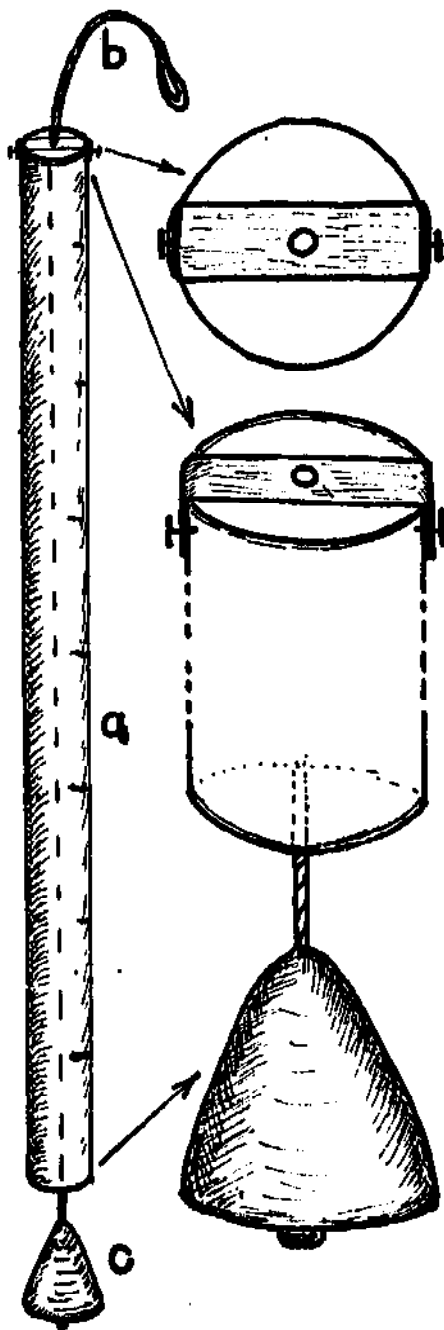
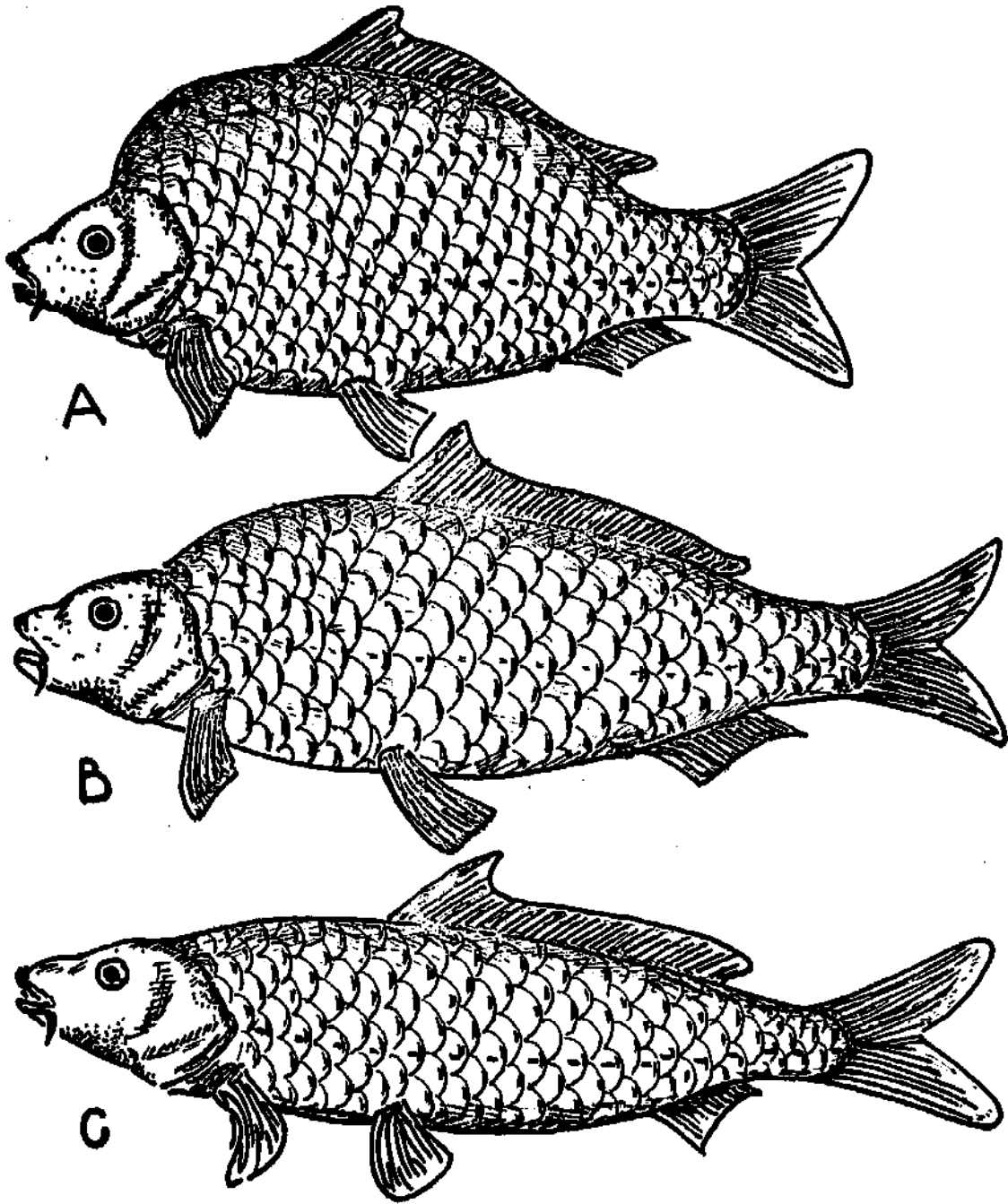

Fig. 26 Column water sampler. a. hard plastic tube, b. string, c. stopper.



**Fig. 27** Different forms of the scaly common carp. A. Cultivated form with flat body B. Cultivated form with elongated body C. Wild form in natural waters.

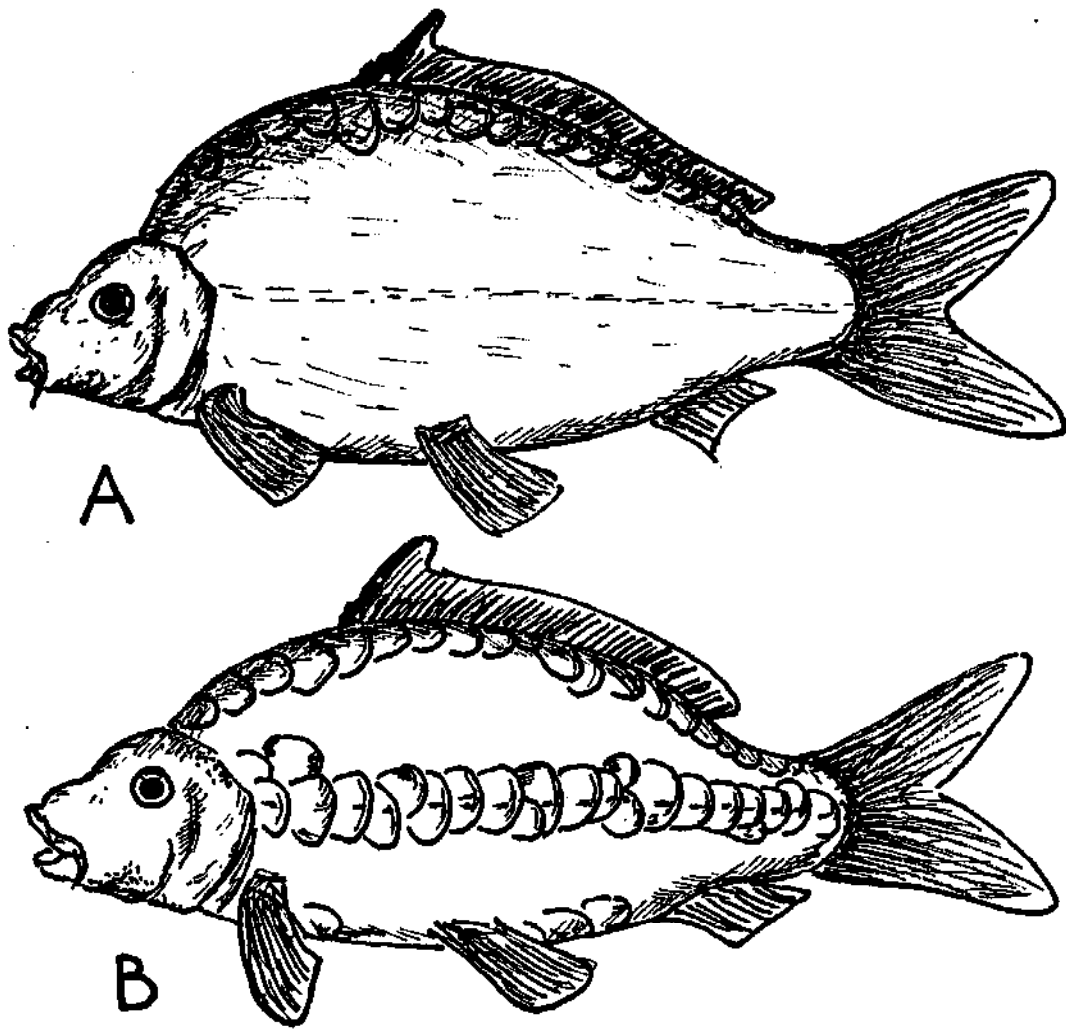

Fig. 28 Cultivated forms of the common carp. A. Mirror carp  
B. Mirror carp with scales along the lateral line.

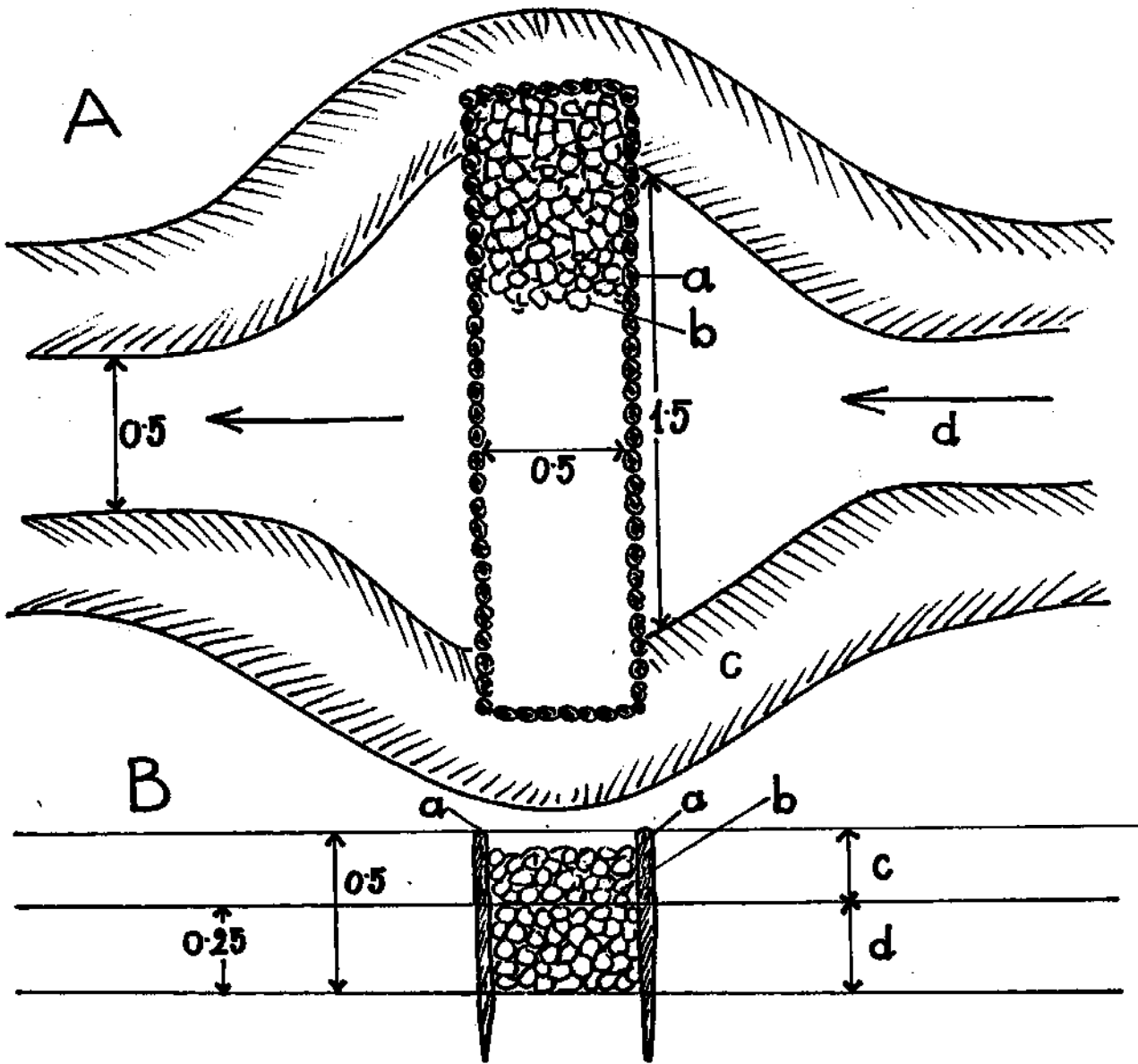

Fig. 29 Simple water filtering structure, a. row of planted poles, b. stone chips (or twig bundles), c. piled up soil along the canal, d. dug out portion of the canal.

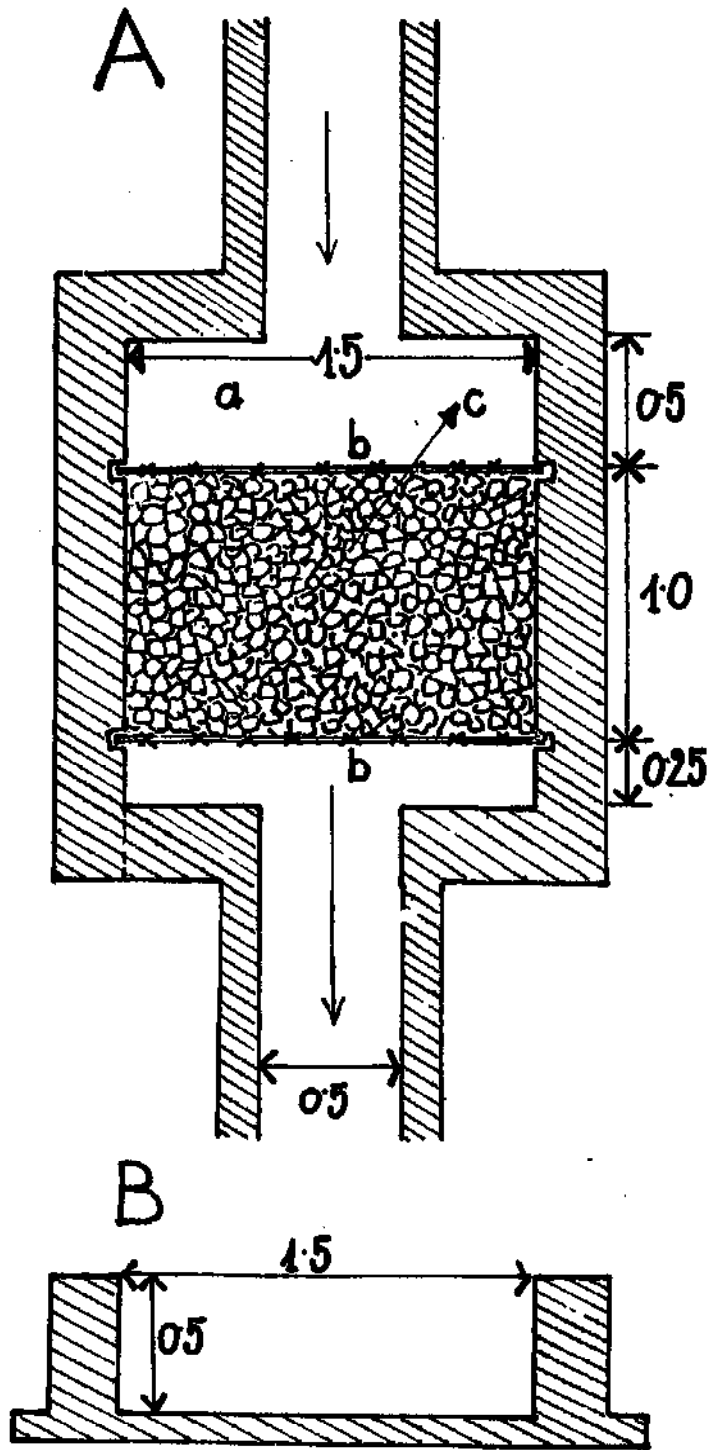

Fig. 30 Stone chips chamber filter. A. View from above  
B. Cross section, a. broad chamber, b. wood or metal  
screen to keep the stone chips in position, c. stone chips.

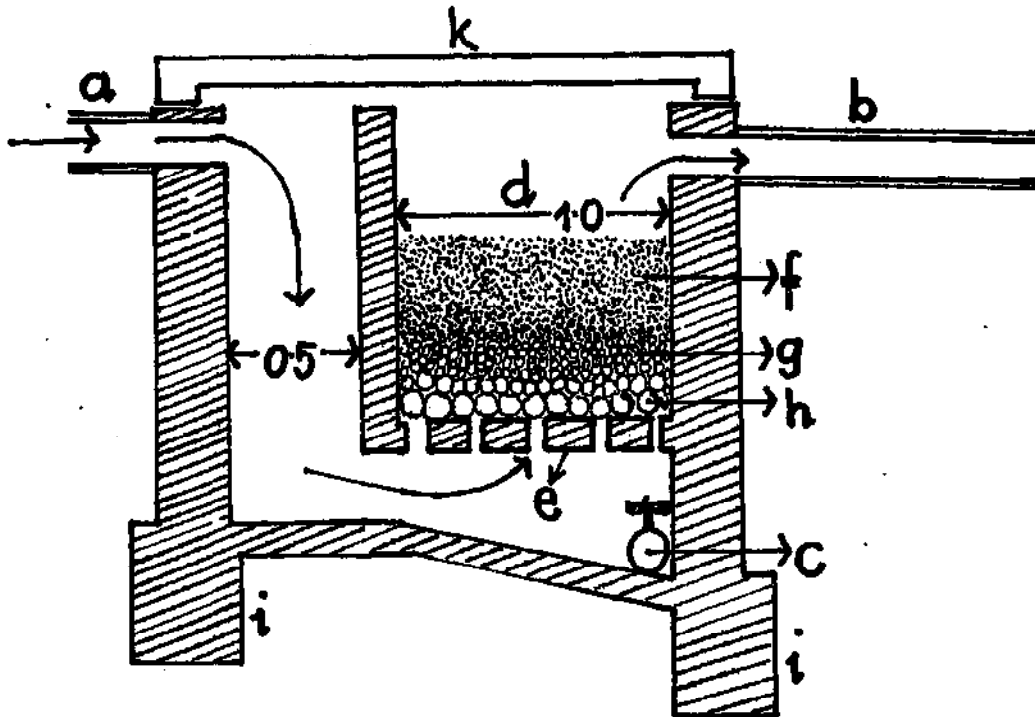
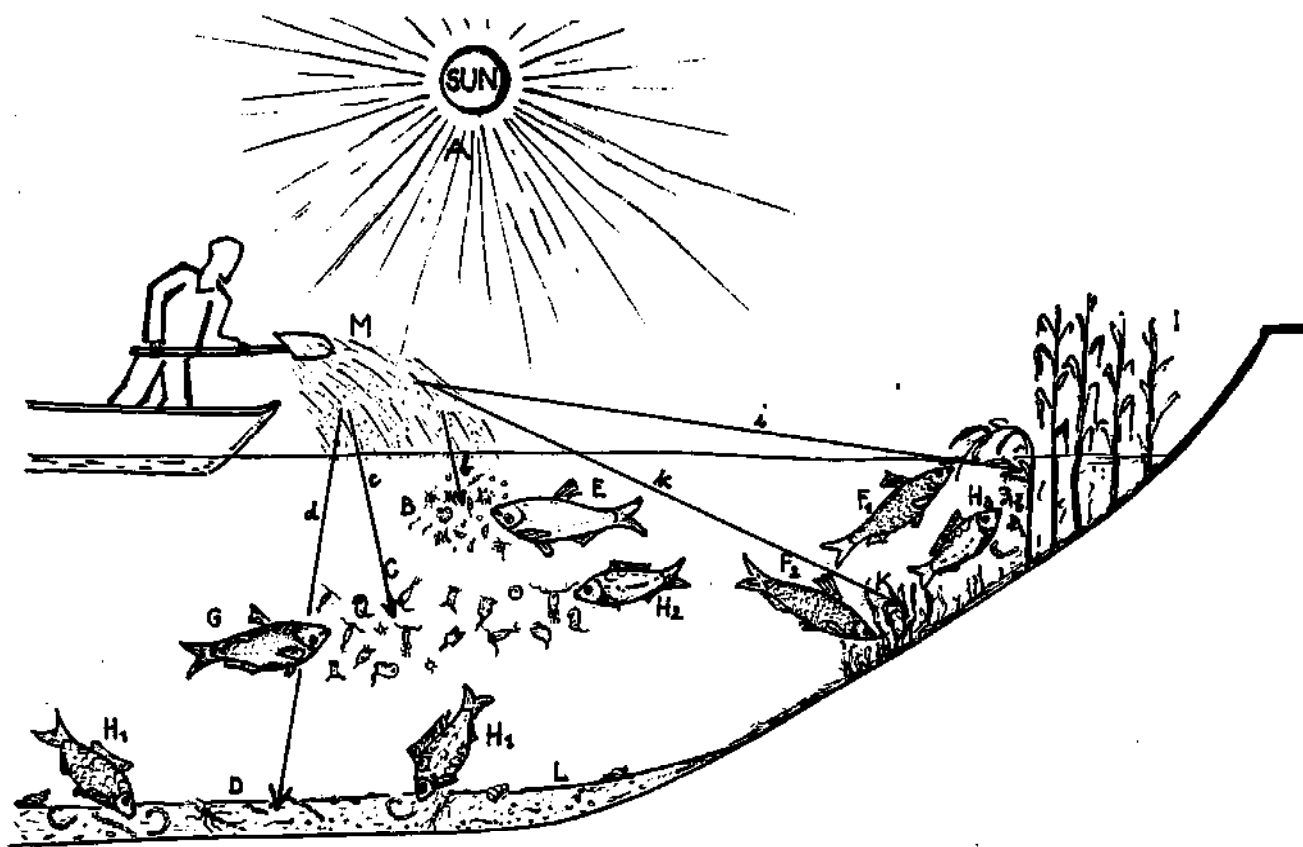

Fig. 31 Reverse water filter (cross section), a. inflow pipe, b. outflow pipe, c. drain valve, d. filter chamber, e. bottom of the filter chamber (flat bricks laid with gaps), f. coarse sand, g. small stone chips or small gravel, h. bigger stones and stone chips, i. foundation, k. concrete slab lid.



**Fig. 32 Food relationship in a pond stocked with a mixed fish population (common carp, grass carp, silver carp, bighead). A. Solar energy, B. Micro-phytoplankton. C. Zooplankton. D. Bottom animals. E. Phytoplankton feeder (silver carp), F-1 Grass carp as consumer of emerging (hard) plants, F-2 Grass carp as consumer of submerged (soft) plants. G. Zooplankton and bigger phytoplankton feeder (bighead) H-1 Bottom feeder (common carp) H-2 Common carp as zooplankton feeder H-3 Common carp as feeder of animals living on the plants I. Emerging weeds K. Submerged weeds L. Pond mud rich in organic matter N. Manuring or fertilizing provides food for the phytoplankton 'C' and zooplankton 'C', enriches the mud directly and indirectly, (d) and affects the growth of the water weeds as well (i) and (k).**

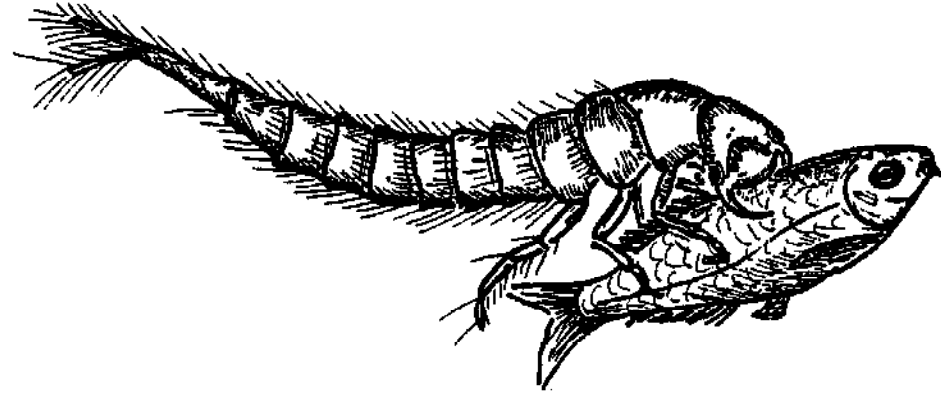

Fig. 33 Larva of the great diving beetle catching a fish fry.

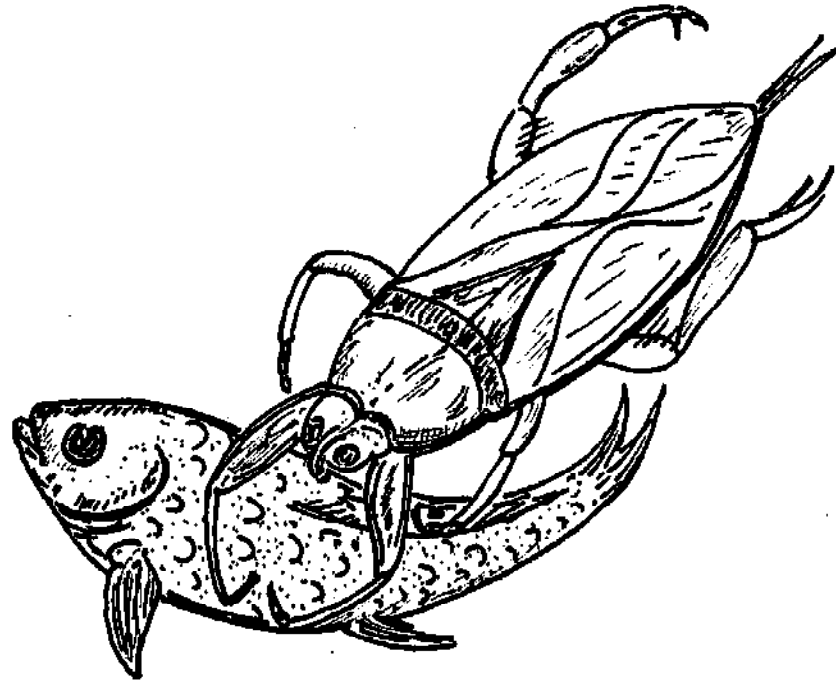

Fig. 34 Water bug (*Nepa* sp) grabbing a fingerling.



Fig. 35 *Ranatra* sp. waiting in ambush to catch fingerlings.



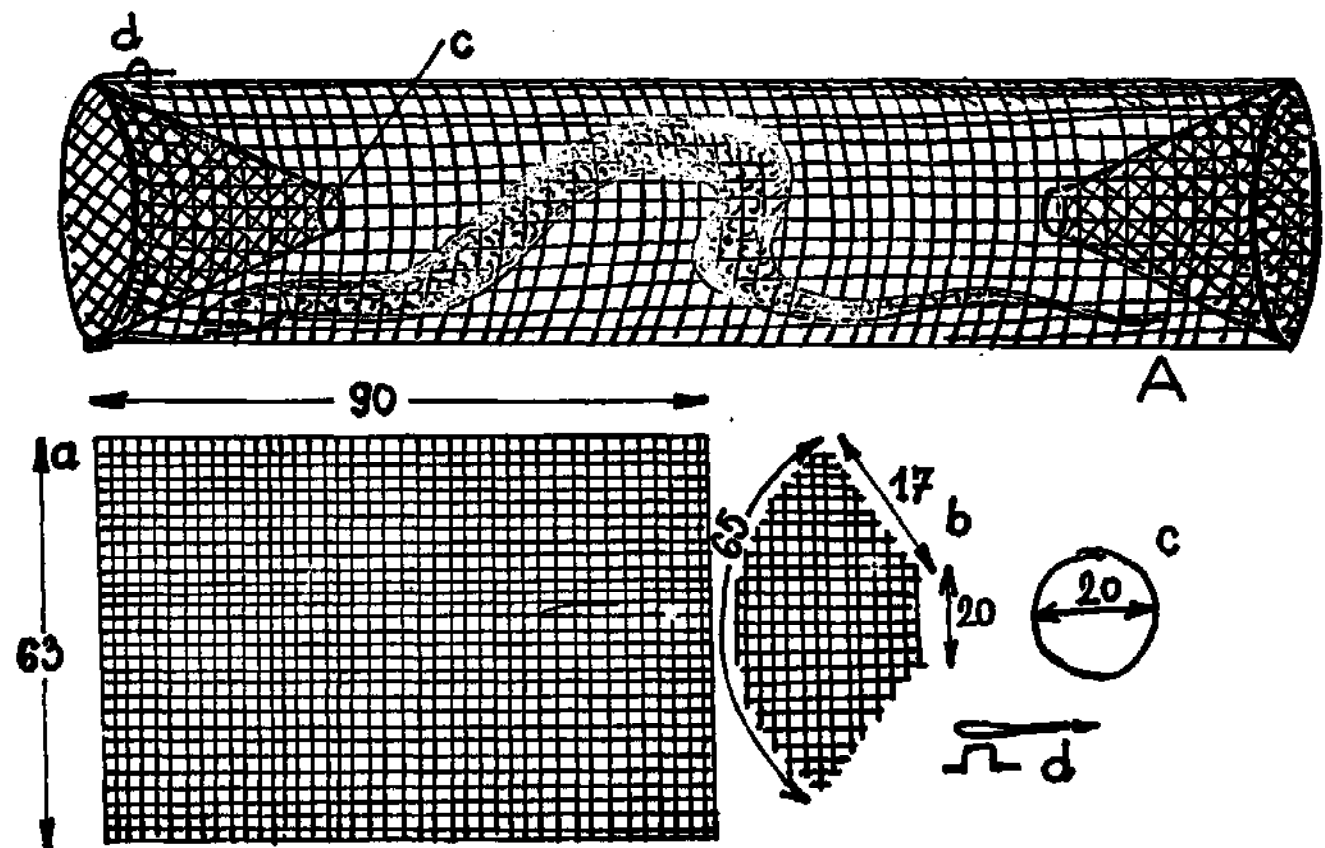

Fig. 36 Snake trap. A. Fabrication of parts, a. cylindrical part  
 b. conical part, c. inner ring of the conical part,  
 d. removable conical part.

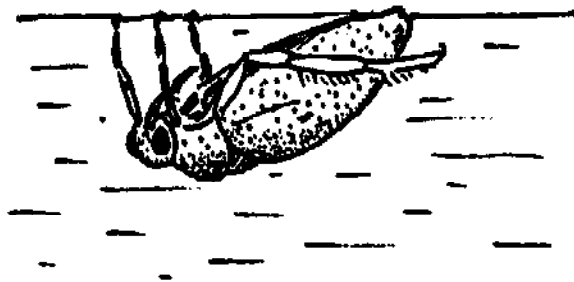

Fig. 37 Backswimmer "hanging" below the water level.

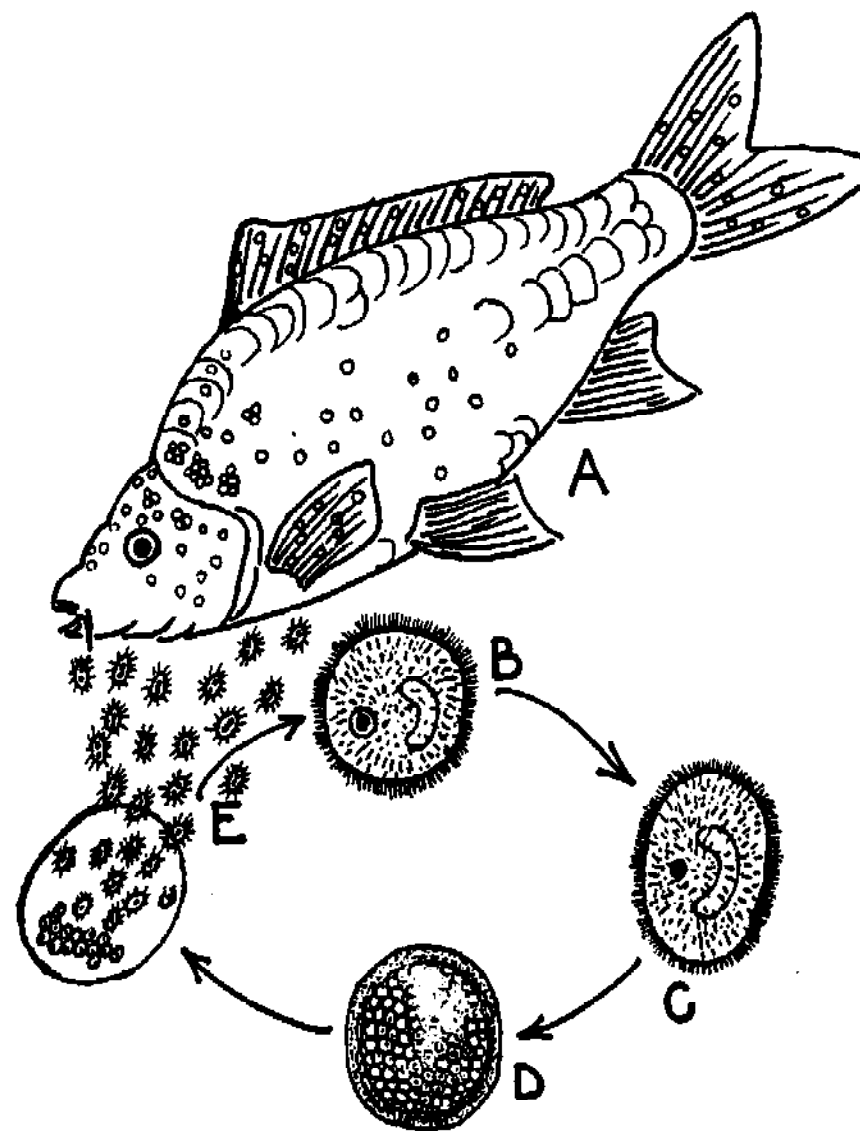

Fig. 38 Life cycle of *Ichthyophthirius* sp. A. Carp infected with the parasite (white spots on the head, fins and body) B. Parasite (1-1.5 mm) living in the skin tissue of the fish C. Mature parasite leaving the fish for propagation D. Cyst with developing young parasites E. Larvae (0.05 mm) of the parasite leaving the cyst, swimming free in the water and becoming attached to host fish. (they can live free for three days only).

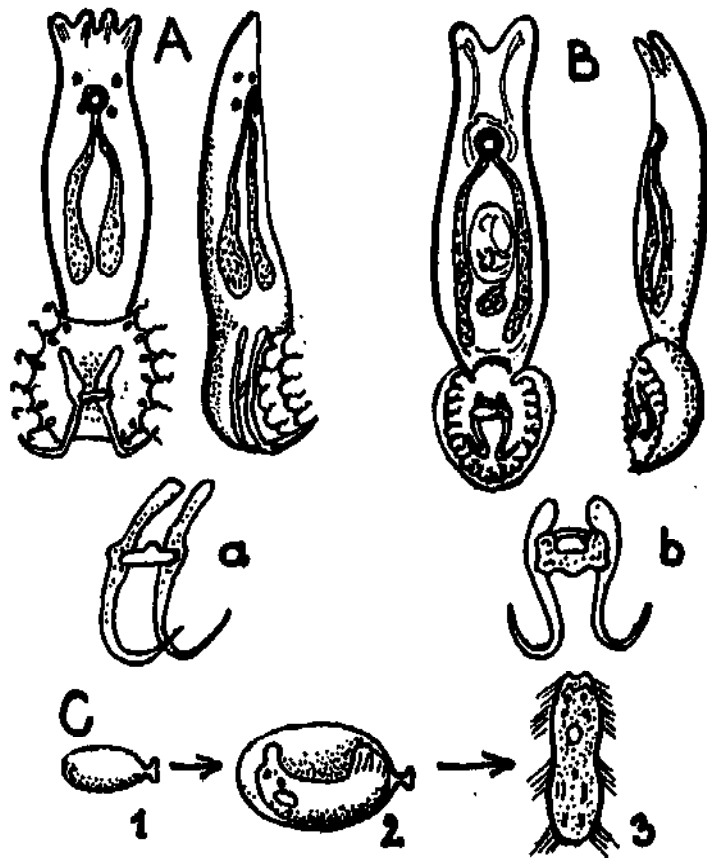

Fig. 39 Two common gill worms. A. Dactylogyrus anchoratus (ventral and lateral views), a. the hooks. B. Gyrodactylus elegans (ventral and lateral views), b. hooks. C. 1. Egg of Dactylogyrus, 2. Larvae (miracidia) developing in the egg, 3. Free-swimming larvae (miracidia).

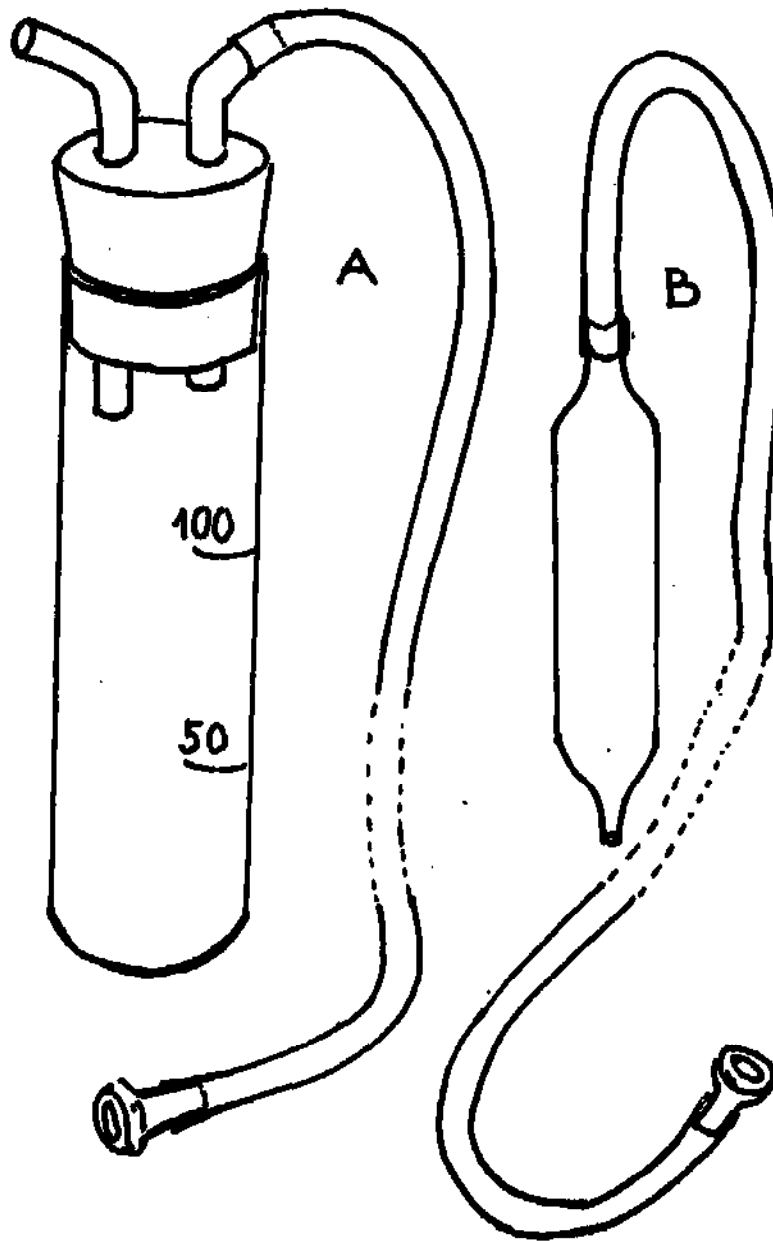

Fig. 40 Two types of milt collectors. A. Milt collector for common carp and grass carp. B. Milt collector pipette.

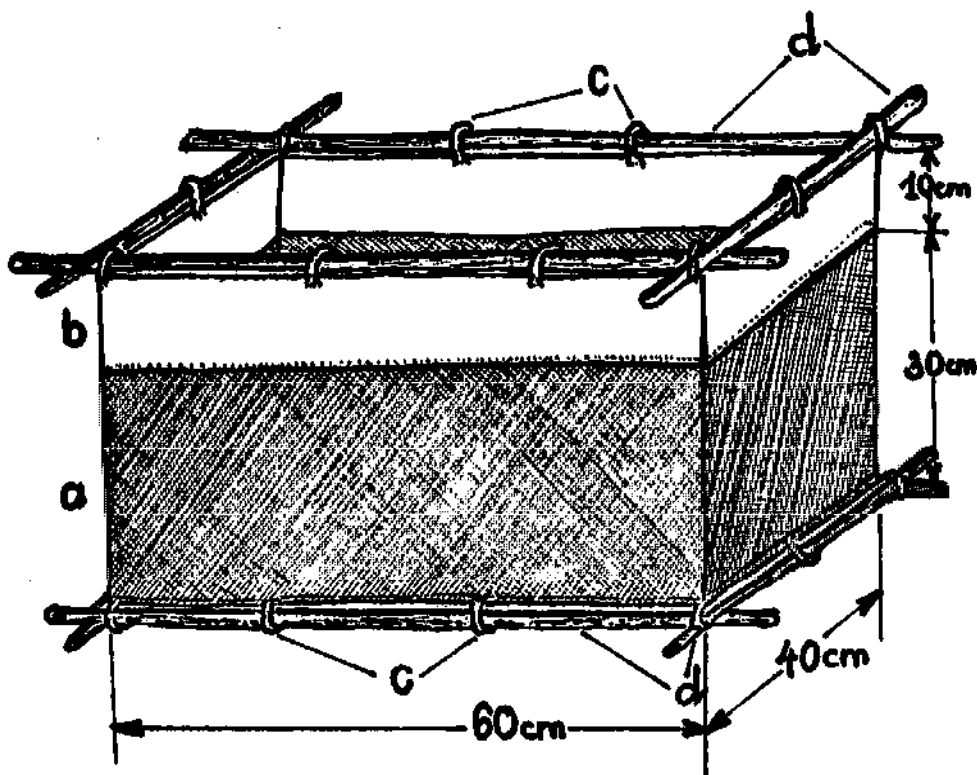

Fig. 41 Small hapa for rearing hatchlings. a. sieve-cloth sides and bottom, b. upper part made of linen cloth, c. loops, d. wooden frame.

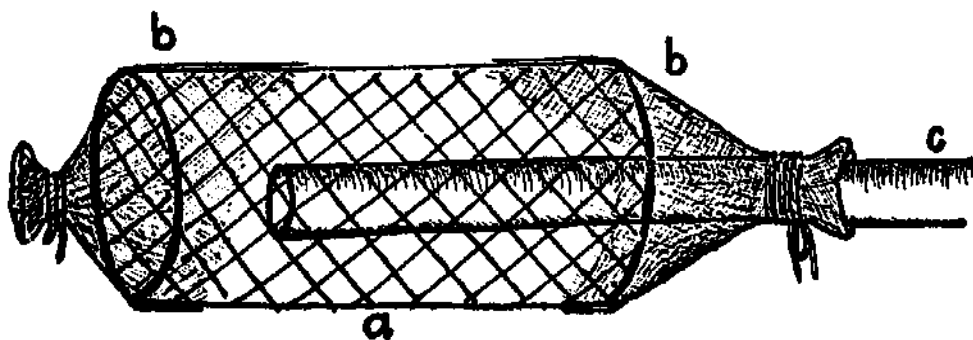

Fig. 42 Water strainer drum. a. cylinder made with chicken wire mesh, b. fine mosquito net cloth stretched over the cylinder, c. water supply pipe.

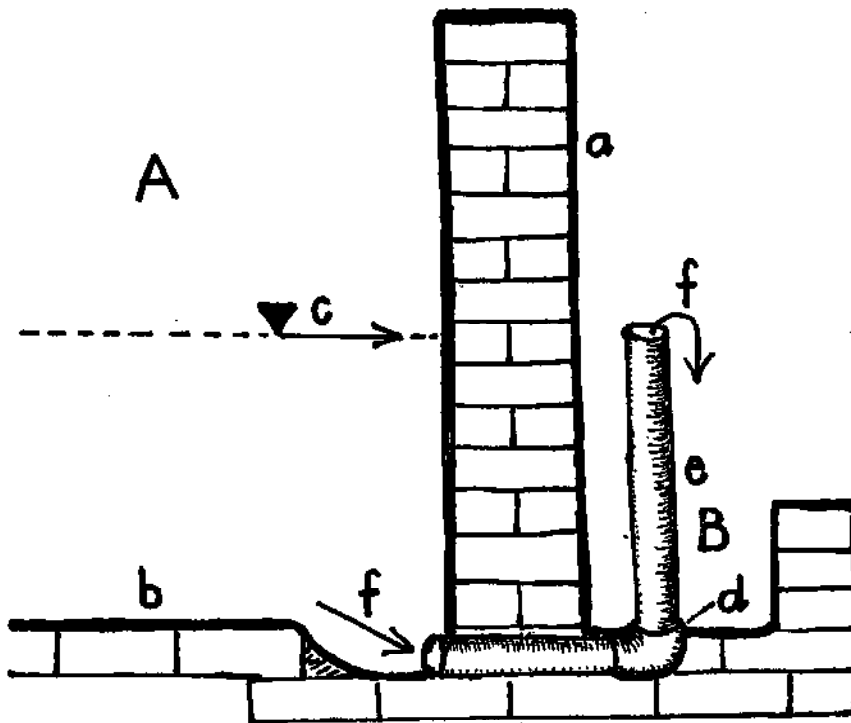

Fig. 43 Device to change the bottom water in a basin. a. wall of the basin, b. bottom of the basin, c. water level, d. iron elbow embedded in the bottom of the draining canal, e. hard plastic pipe to maintain water level, f. direction of water flow.

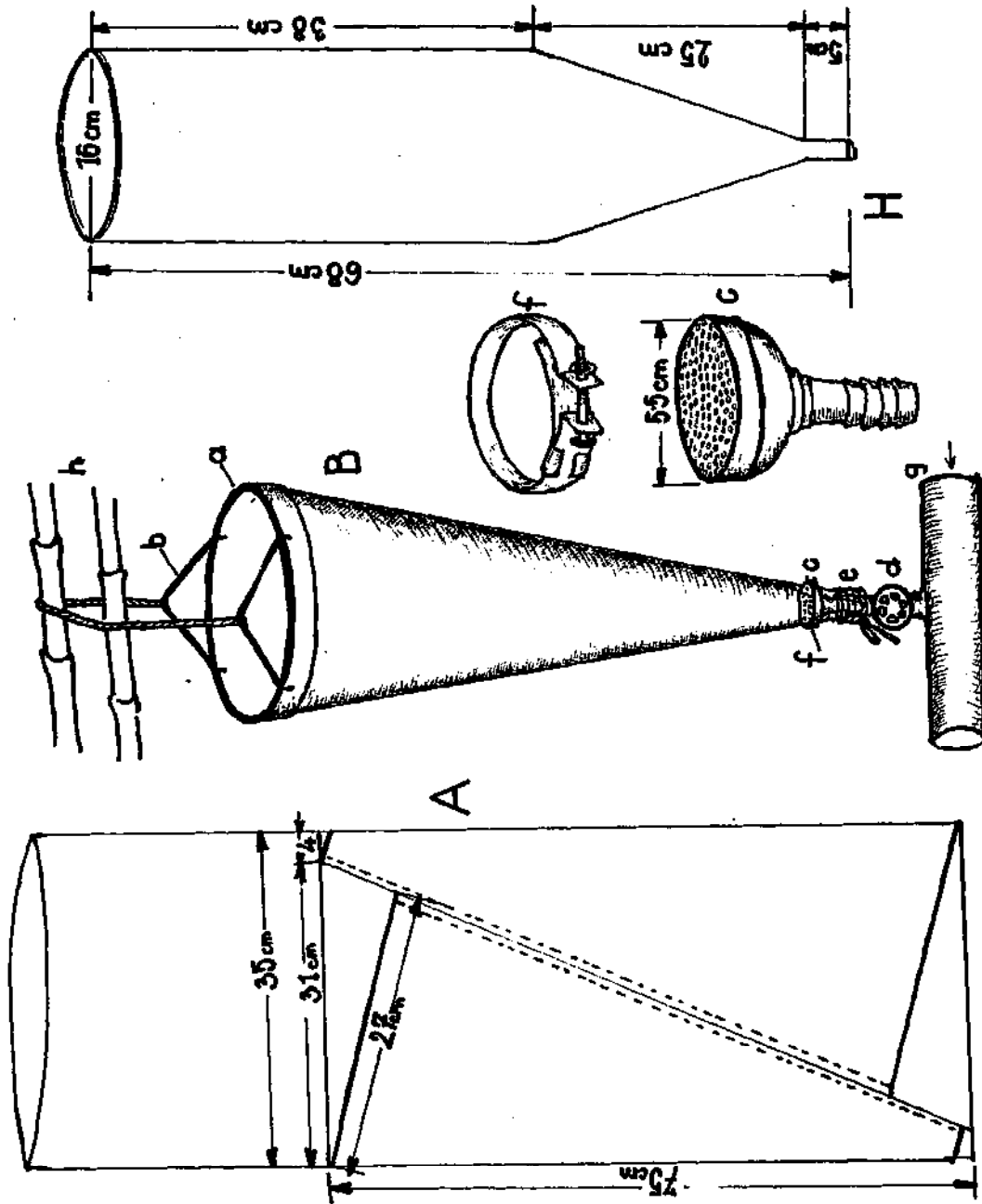

Fig. 44 Plastic funnel for incubation of common carp eggs. A. Measurements of the plastic material. Dotted lines indicate the stitches. B. Plastic funnel in position, kept stretched between the water supply pipe 'g' and fixed beams 'h', a. ring, b. loops, c. shower, d. water tap, e. shower fixed to the plastic funnel, f. grip ring for fixing the shower in position. E. dimensions of a Zuger-glass funnel.

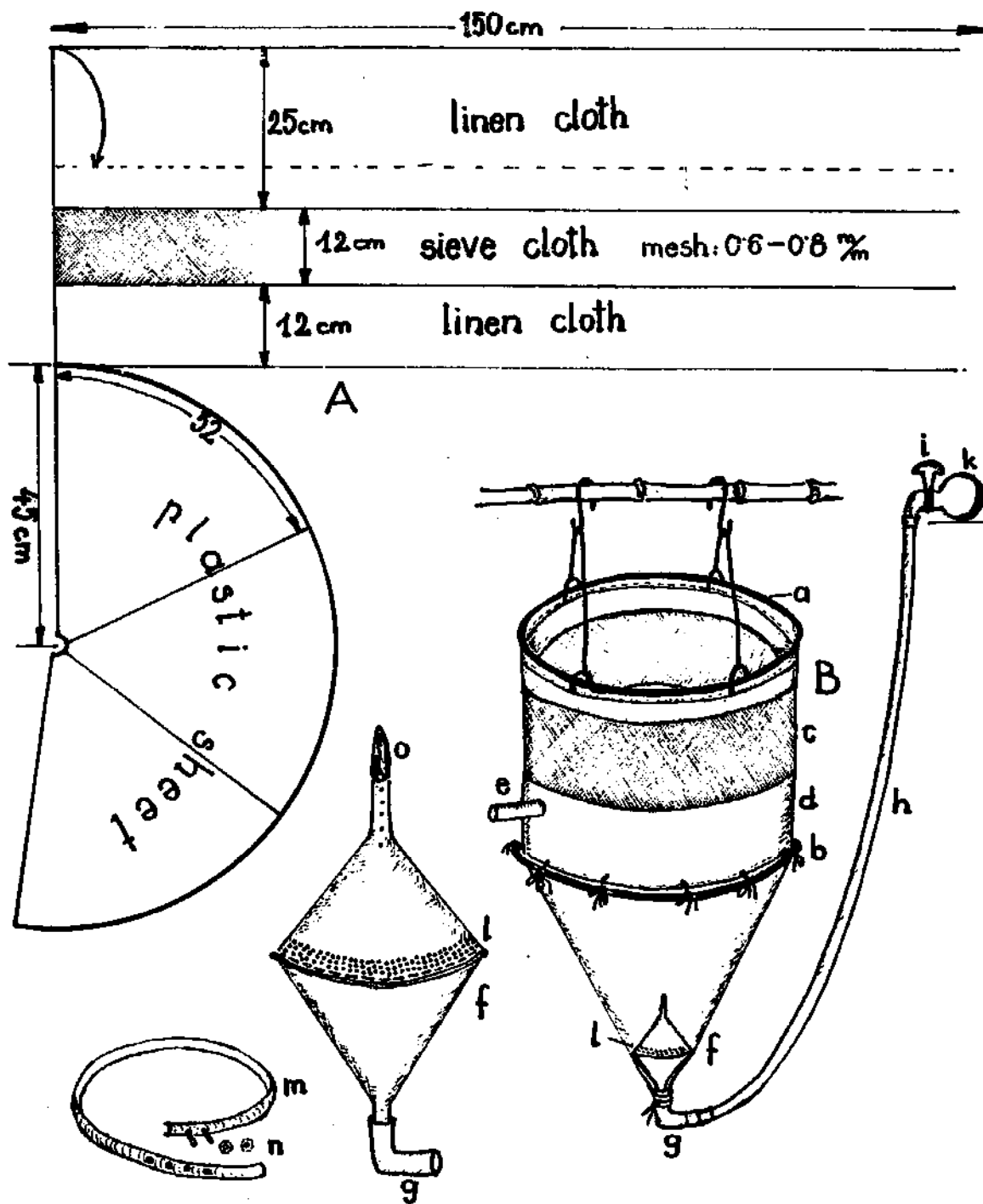

Fig. 45 Sieve-cloth plastic funnel. A. Dimensions of a medium size funnel. B. Parts of the funnel. a. cane ring, b. stretching ring, o. sieve cloth, d. linen cloth, e. nozzle, f. water distributor, g. elbow, h. water supply pipe, i. tap, k. water main, l. rows of holes on the water distributor, m. ring of split plastic pipe to keep the water distributor in position, n. screws and nuts, o. plug on the top of the water distributor.



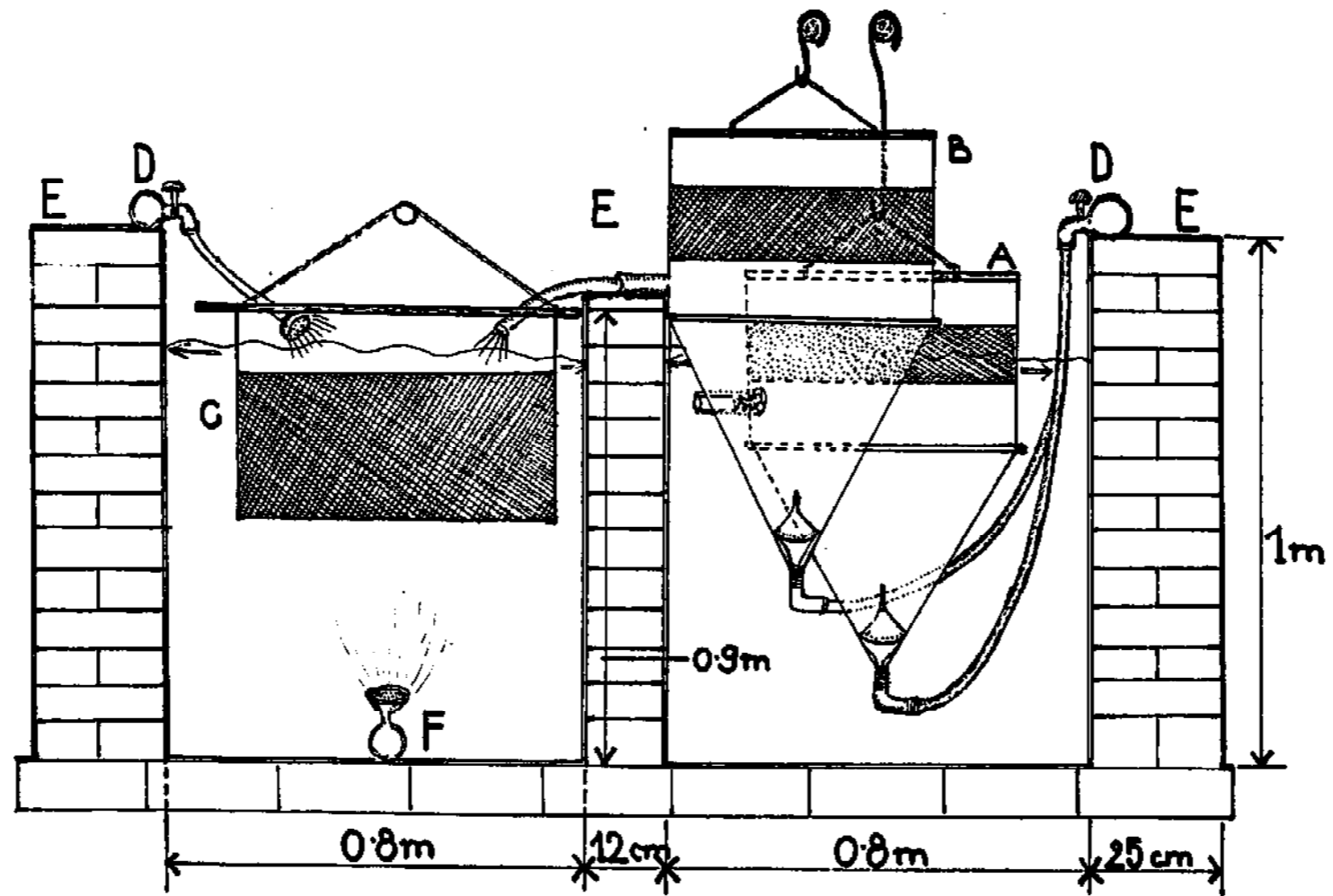

Fig. 46 Function of the sieve-cloth funnel in a twin cement basin. A. Position of the hatchery funnel. B. Position of the hatchery funnel when the eggs begin to hatch (the larvae can swim out from the funnel and will be automatically collected in the rearing hapa). D. Water supply pipe with taps. E. Walls of the twin basin in cross section. F. Shower providing water flow under the rearing hapa.

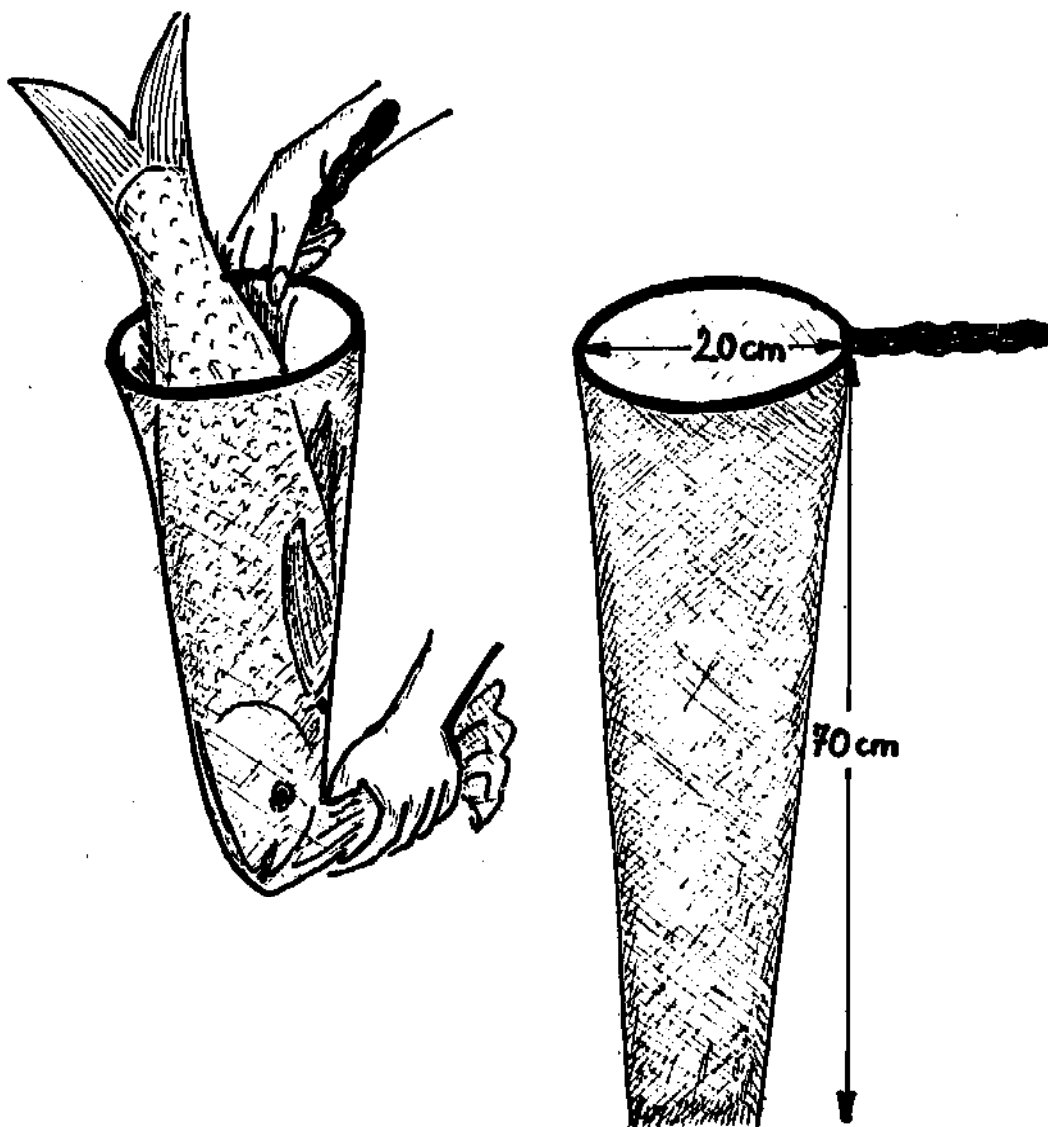

Fig. 47 Scoop net (both ends open) for catching brood fish.

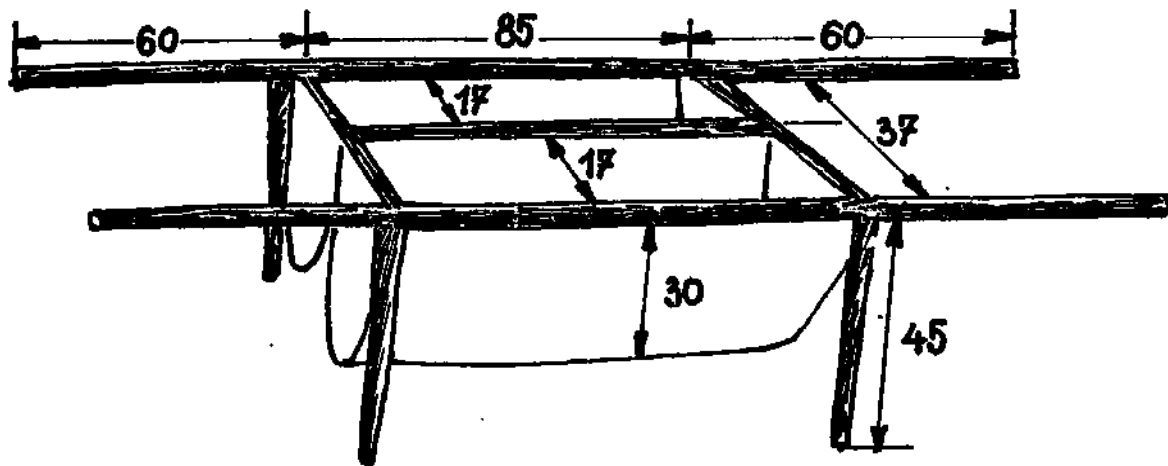

Fig. 48 Special hammock for long-distance transport of brood fish.

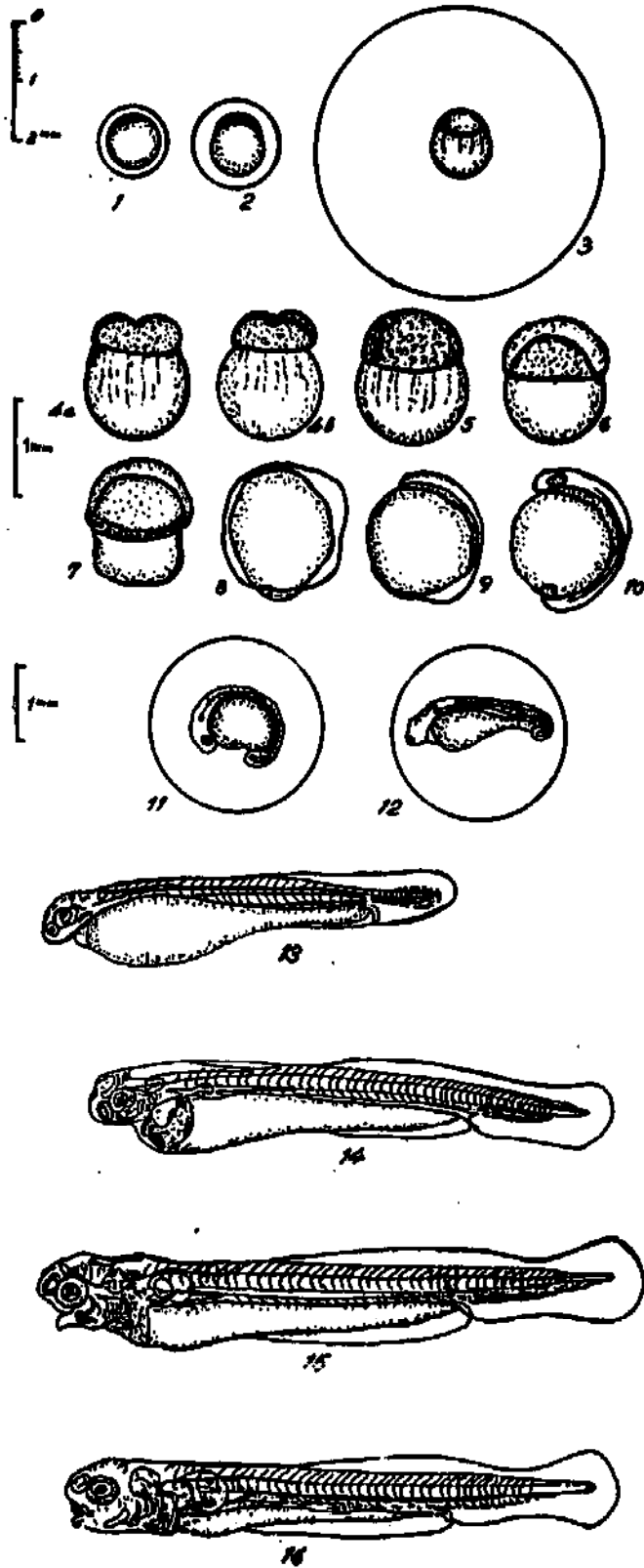

Fig. 49 Development stages of eggs of herbivorous fish.  
 1. Fertilized egg. 2. Swollen egg. 3. Fully swollen and water hardened egg. 4a. Two cells stage (the first cleavage can be seen on the blastodisc), 4b. Four cells stage. 5. Morula stage (blastodisc with big cells). 6. Call-cap stage (beginning of the blastula stage and the cells are very small). 7. Call-cap beginning to enclose the yolk. 8. Yolk fully enclosed by the growing cell layers. 9. Well distinguishable embryo.

10. Formation of eyes and visible segmentation of the body. 11. Beginning of tail bud. 12. Straightening of the embryo (small bubbles containing egg shell dissolving secretion are seen around the egg). 13. Embryo about to hatch. 14. Freshly hatched larva. 15. Well developed larva on the first day after hatching. 16. Larva starting to 'pump air' and fill up the air bladder (the larva now swims horizontally and starts to feed shortly after).