

AT MICROFICHE
REFERENCE
LIBRARY

A project of Volunteers in Asia

Food Cycle Technology Source Book No.3: Cereal Processing

By: Intermediate Technology Development Group
UNIFEM Project GLO/85/W02-
Women and Food Cycle Technology

Published by: United Nations Development Fund for Women
304 East 45th St.
New York, NY 10017

Available from: Food Technologies
UNIFEM
304 East 45th St.
New York, NY 10017

Reproduced with permission.

Reproduction of this microfiche document in any form is subject to the same restrictions as those of the original document.

UNIFEM
THE UNITED NATIONS DEVELOPMENT FUND FOR WOMEN

Cereal Processing

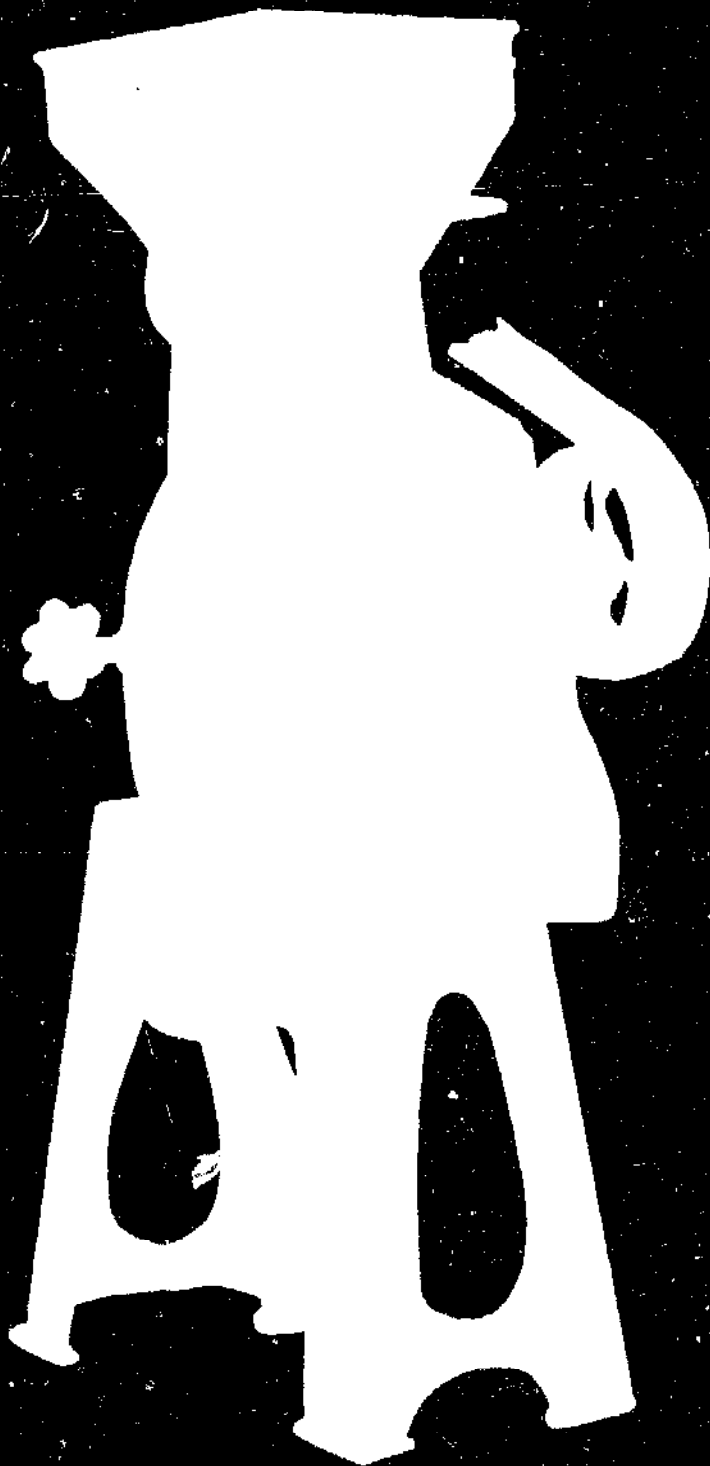

3 FOOD CYCLE
TECHNOLOGY
SOURCE BOOK

UNIFEM - All Rights Reserved.
Copyright © 1988
United Nations Development Fund for Women (UNIFEM)
304 East 45th Street
New York
N.Y. 10017, U.S.A.

Design and layout by Verdegrafica & Pubblicità, Piazza Cairolì 6,
00186 Rome, Italy
Drawings by Peter Dobson, U.K.
Printed by Photosistem, s.r.l. in Rome, Italy

FOOD CYCLE TECHNOLOGY SOURCE BOOK NO. 3

Cereal Processing

UNIFEM

THE UNITED NATIONS DEVELOPMENT FUND FOR WOMEN

**PROJECT GLO/85/WO2 - WOMEN AND FOOD CYCLE
TECHNOLOGY (WAFT) AND PROJECT RAF/86/WO3 -
TRANSLATION AND PUBLICATION OF FOOD CYCLE
TECHNOLOGY SOURCE BOOKS**

With the collaboration of the

**INTERMEDIATE TECHNOLOGY DEVELOPMENT GROUP
United Kingdom**

1988

PREFACE

UNIFEM AND THE FOOD CYCLE TECHNOLOGY PROJECT (WAFT)

The United Nations Development Fund for Women (UNIFEM) was established in 1976 and is an autonomous body associated, since 1985, with the United Nations Development Programme. UNIFEM seeks to free women from under-productive tasks and augment the productivity of their work as a means of accelerating the development process. It does this through funding specific women's projects which yield direct benefits and through actions directed to ensure that all development policies, plans, programmes and projects take account of the needs of women producers.

In recognition of women's special roles in the production, processing, storage, preparation and marketing of food, UNIFEM initiated in 1985 a Food Cycle Technology project (project GLO/85/WO2: WAFT) with the aim of promoting the widespread diffusion of tested technologies to increase the productivity of women's labour in this sector. While global in scope, this five-year project is initially being implemented in Africa in view of current concerns over food security in many countries of the region. The eventual aim of the project is to increase indigenous capacities to respond to the technology needs of women producers and to inform and influence the decision makers who can create the correct policy environment for this to happen. This will be achieved by providing appropriate technical assistance relating to the process of technology choice and diffusion.

This source book is one of a series being compiled as part of the preparatory phase of the Food Cycle Technology project. UNIFEM hopes that these source books will increase awareness of the range of technological options and sources of expertise, as well as indicating the complex nature of designing and successfully implementing technology projects and diffusion programmes.

Titles in this series include: Oil Extraction, Fruit and Vegetable Processing, Cereal Processing, Rootcrop Processing, Fish Processing, Packaging, Drying and Storage. Source books will also be available in French and Portuguese.

ACKNOWLEDGEMENTS

This initial series of food cycle technology source books has been prepared at the Intermediate Technology Development Group (ITDG) in the United Kingdom within the context of UNIFEM's Women and Food Cycle Technologies (WAFT) specialization. During the preparation process the project staff have contacted numerous project directors, rural development agencies, technology centers, women's organizations, equipment manufacturers and researchers in all parts of the world.

UNIFEM and ITDG wish to thank the several hundred agencies and individuals who have contributed to the preparation of the source books. Not all can be mentioned by name, but special thanks are owed for their major contributions to the International Labour Organization (ILO), the Food and Agriculture Organization of the United Nations (FAO), the United Nations Children's Fund (UNICEF), the Economic Commission for Africa (ECA), the German Appropriate Technology Exchange (GATE/GTZ) in Eschborn, the Groupe de Recherche et d'Echanges Technologiques (GRET) in Paris, the Royal Tropical Institute (KIT) in Amsterdam, the International Development Research Centre (IDRC) in Ottawa, the Tropical Development Research Institute (TDRI) in London, Appropriate Technologies International (ATI) in Washington, the Institute of Development Studies, Sussex University (IDS), and the Save the Children Fund.

The preparation of the source books has been funded by UNIFEM with a cost sharing contribution from the Government of The Netherlands.

UNIFEM is particularly grateful to the Government of Italy for providing the funds for translation and printing of the source books and to the Italian Association for Women in Development (AIDOS) for implementing this phase of the project.

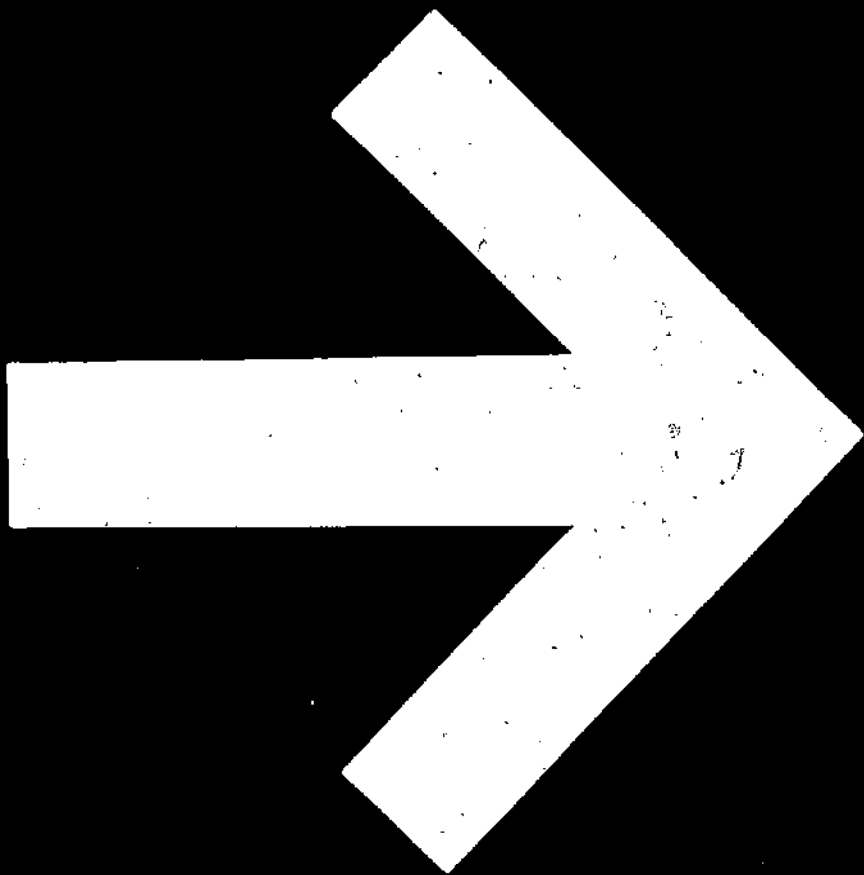

CONTENTS

INTRODUCTION	7	
SECTION 1		
TRADITIONAL POST-HARVEST SYSTEM	10	
Harvesting		
Threshing and winnowing		
Drying		
Storage		
Primary processing methods		
SECTION 2		
IMPROVED PROCESSES AND TECHNOLOGIES	16	
Harvesting		
Threshing		
Winnowing		
Maize shelling		
Drying		
Storage		
Milling, Grinding and Dehulling		
Economic considerations		
SECTION 3		
SECONDARY PROCESSING – CEREAL BASED FOODS	27	
SECTION 4		
CASE STUDIES	29	
SECTION 5		
A CHECKLIST OF QUESTIONS TO ASK WHEN PLANNING A CEREAL PROCESSING PROJECT/ENTERPRISE	51	
SECTION 6		
FACTS AND FIGURES ON EQUIPMENT	54	
REFERENCES		63
FURTHER READING		66
CONTACTS		68

INTRODUCTION

Cereal grains are the seeds of cultivated grasses and all have a rather similar structure which forms, with minor variations the basis for their processing. They contain, towards the base the germ or embryo from which a new plant can develop, which is surrounded by the endosperm, a starchy body which provides nourishment for the developing embryo. The whole grain is surrounded by protective covering layers which include the testa and pericarp. A number of different words are used to describe the various parts of a grain and this can be somewhat confusing. The essential point to remember is that a grain has four main components: the germ, the starchy interior, nutritious outer layers and the external fibrous husk.

This source book will concentrate on four cereal grains of great importance in many developing countries: maize, rice, sorghum, and millet. While wheat is clearly also a very important cereal, in Africa (for which this source book is primarily aimed) it tends to be grown in large farms and processed to flour in large-scale mills. As such it falls outside the scope of the source book.

While each type of cereal requires a specific post harvest treatment, there are certain general principles that may be applied to all. Cereals pass through a number of stages in a long, and sometimes complex chain from harvest to consumption. This is often referred to as the total post harvest system, and is shown in the accompanying flow diagram. It is most important to understand that the total system falls into three distinct areas. The first covers harvesting up to the storage of the grain. The second, primary processing, involves the further treatment of the grain but the products are still not directly consumable. Prior to consumption, materials from primary processing need to pass through a secondary processing stage. The production of fermented cereal beverages is an example.

Projects, therefore, may involve only one or several of the activities in the total chain; such as the growing of corn and its subsequent treatment right through to selling corn tortillas or simply the purchase of wheat flour and the baking of bread.

This source book will look at all these stages although secondary processing steps such as baking are not covered in such great detail as the first two steps.

TOTAL POST HARVEST CEREAL SYSTEM

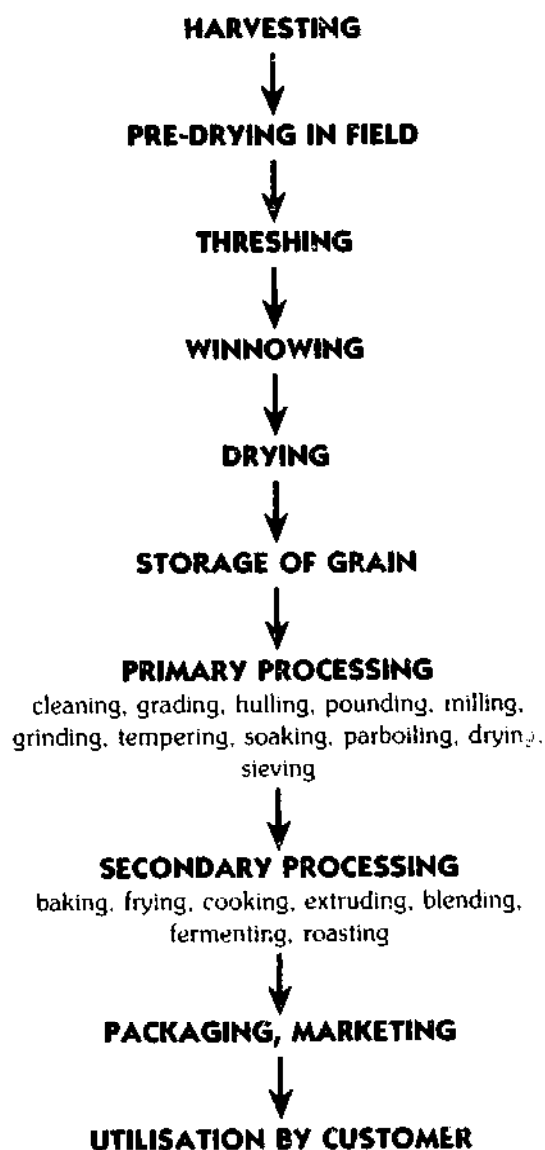

INTRODUCTION

Much of the food grain harvested in the tropics is lost through inadequate handling, storage and processing. A wealth of data on these losses has been published which is often conflicting or site specific. FAO estimates global losses of 10% and DANIDA found 22% field losses of maize in Nigeria due to insect and fungal attack. Early harvesting of rice to catch the market can result in 10% loss of yield (FAO, undated). As well as physical loss there is also loss in quality and factors affecting nutritive value and conservation also need to be considered. The common points at which post harvest losses occur are listed below;

- vermin and insect infestation during the whole of the post harvest chain
- yield losses due to early harvesting
- grain losses due to transport of un-threshed material.
- physical losses at threshing
- incorrect moisture for threshing, milling and grinding
- physical losses due to poor primary and secondary processing techniques.

After looking at these stages in the total system, this source book examines improvements that can be made to reduce some of the time, labour, and losses associated with the post-harvest processing of cereals. One important point must be borne in mind when looking to reduce post-harvest grain losses. Care must be taken to ensure that the losses are real. In some cases it has been found that losses to the mill-owner are in fact gains to the poorest, who pick up the spilt grains. The same can be true for transporting from the field. An 'improved' system, therefore, may lead to greater impoverishment. The economics of an improvement can look more or less attractive depending on how

far the net is cast. Traditional post-harvest systems are often very efficient when viewed within the context of the complete socio-economic system. Marginal improvements to post-harvest activities are often more effective than radical changes.

There are other important considerations when introducing changes to post-harvest systems. If improvements are going to cost money, can women afford the improvements or will they need credit? Will the improvements earn enough to repay the credit? Many changes have in the past led to women losing control over part of the productive process and thus have increased their impoverishment. If changes mean that women have to organise on a co-operative or group basis, do they have the necessary skills, experience, and social structure or will they need to be trained in organisation, management, and quality and financial control?

When new products are being introduced, careful consideration has to be given to marketing aspects: where are the markets, how big are they, how will goods be transported to market, how should the goods be packaged, what is the competition? A detailed list of these vital questions is given in section 5.

Some areas of the post-harvest system such as drying and storage are discussed with specific reference to cereals; however, there are source books covering drying and storage at greater length which should be read in conjunction with this source book.

Before discussing the processing of cereals, a note on their nutritional value is important. Because cereal grains are available and affordable, they are, for the majority of the people in developing countries, a major proportion of their diet. Carbohydrates and protein are the two main constituents by weight in any grain and they offer, after water, the two most im-

INTRODUCTION

portant substances for our survival-energy and protein. Protein can be more readily obtained from fish, meat and dairy produce as, apart from having a greater proportion of protein by weight than cereal grains, they also have an excellent balance of the essential amino acids our body needs for survival.

However, the lack of high protein foods or their high prices is a limiting factor for people existing on diets near subsistence level. The significance of cereal grain protein and carbohydrate for these people cannot be overstressed.

Cereal grains lack, in particular, one essential amino acid, Lysine. When expensive protein sources are unobtainable, beans (which are rich in lysine) are often used to supplement cereal grains.

As children require a higher proportion by weight of protein than adults, the protein:energy ratio becomes a very significant topic. Young children cannot eat enough of a cereal dish to obtain their quota of protein, due to the bulkiness of processed cereals. Supplementing the diet with a good quality protein source is therefore essential, especially to fill the lysine gap.

Consideration must also be given to the effect of processing on the chemical composition of cereal products and hence their nutritional value. The various nutrients are distributed unevenly throughout the different parts of the grain (germ, endosperm, seed coat and fruit coat layers etc.), and there also exists a different pattern of distribution between different types of cereal

grains. There is, therefore, no hard and fast rule regarding loss of nutrients upon processing. It should be borne in mind that the most important effects of processing on nutritional value are brought about by:

1 The separation and removal of parts of the grain leaving only a fraction of the whole grain as the product. Any loss in volume constitutes a loss in nutrients.

2 Parts of the grain being discarded (as above) bringing about a concentration of certain nutrients (ie increasing their proportion by weight of the product.)

3 Processing treatments may themselves bring about changes in nutrients (eg germination, fermentation, parboiling.)

4 The removal of the outer layers of the grain, while causing a loss in some nutrients, may be desirable. For example tannin is concentrated in the outer layers of sorghum and its removal is nutritionally essential and the milling of brown rice to white rice produces a product which is far easier to prepare.

Clearly a publication of this size can only act as a general introduction to the large field of cereals. Its purpose is to give readers a broad understanding of the subject and reference to more detailed documents and consulting with technical specialists would be essential before becoming involved in any project implementation. A suggested reading list and a selected list of technical expertise are to be found at the back of the source book.

Traditional Post-Harvest System

This section outlines the steps involved in traditional processing of cereals. It is vital that project planners and managers consider the traditional technologies in their particular socio-economic context when introducing any technical improvements or adaptations. The following main components of the post-harvest food system are discussed:

HARVESTING
THRESHING AND WINNOWING
DRYING
STORAGE
PRIMARY PROCESSING METHODS

Post harvest grain losses are a major concern in the traditional system. Section 1 deals with the traditional post-harvest system and local methods by which these losses are reduced. Section 2 describes some improved technologies which have been developed to further reduce losses and increase productivity in cereal processing together with essential relevant technical background. Most of the cereals discussed are processed in much the same way, but where relevant, differences in processing techniques are mentioned.

Harvesting

There is an optimum time for harvesting which depends upon the maturity of the crop and climatic conditions (FAO, 1970) and has a significant effect on the subsequent quality of the grain during storage. Harvesting often begins before the grain is fully ripe and extends until mould and insect damage are prevalent. Grain not

fully ripened contains a higher proportion of moisture, and will deteriorate more quickly than mature grains because the enzyme systems are still active. If the grain remains in the field after maturity, repeated wetting from rain and dew at night, along with drying by the hot sun by day, may cause grain to crack (particularly long-grain paddy) and may increase the likelihood of insect damage (especially maize and paddy). Advice is therefore frequently necessary on the correct harvesting time.

Cereal crops are traditionally harvested manually, requiring high labour demand and therefore in many situations providing an important means of work to landless labourers.

Threshing and Winnowing

Threshing is the removal of the grains from the rest of the plant. In the case of maize the removal of the grain from the cob is referred to as shelling. Most manual threshing methods use some implement, the simplest is a stick or hinged flail with which the crop, spread on the floor, is beaten. Such tools are simple and cheap but they are also laborious to use. Maize is shelled mainly with the bare hands, by rubbing one cob against another. Threshing and shelling will contribute to losses if carried out in a manner that results in cracking of grains. Other traditional methods of threshing, such as use of animals to trample the sheaves on the threshing floor or the modern equivalent using tractor wheels may result in loss of unseparated grain. This method also allows impurities to be

SECTION 1

come mixed with the grain, which may cause subsequent storage problems.

Winnowing involves separating the chaff from the grain. If there is plenty of wind, the threshed material is tossed in the air using forks, shovels, baskets, etc. The lighter chaff and straw blow away while the heavy grains fall more or less vertically. Final cleaning may be done with a winnowing basket, which is shaken until any chaff and dust separate at the upper edge. An alternative method is to use winnowing sieves or open weave baskets. Separating impurities from threshed grain can require almost as much labour as the original threshing. (IT Publications, 1985). Once threshed the grains must be dried and stored. In many cases these two functions are performed together so that grain is drying during storage.

Drying

During drying the moisture content of the grain is reduced. This helps prevent germination of seeds, the growth of bacteria and fungi and considerably retards the development of mites and insects. In traditional methods the rate and uniformity of drying is difficult to control, as it is dependent on the prevailing environmental conditions. Moreover, it is essential that food grains be dried quickly and effectively. However, in most cases, regardless of the disadvantages, the small farmer still prefers sun drying because it is cheap and simple.

Air is one environmental factor used as the drying medium, causing water to vaporize and conveying the moisture vapour away from the grain. The moisture carrying capacity of air is dependent upon its temperature and increases with the rise in temperature (e.g. at 30°C the air is capable of holding twice as much moisture as at 16°C). Reducing post harvest grain losses during drying is a

major objective of an improved technology. Some of the following traditional drying methods highlight where losses can occur.

The simplest and most common method is to lay the cut stalks on the ground in the fields, either in swaths of loose bundles or in stacks or heaps, until the crop is dry. When the plants are piled in large stacks they may suffer from lack of circulation leading to sprouting, discolouration, and microbial damage. Sometimes racks are used for hanging unthreshed sorghum, millet, and paddy. Most racks are designed to permit air movement through the drying material.

At the homestead the crop is further dried by spreading on woven mats, hard surfaces including roads, plastic sheets, or on the roof or ground. The drying time depends on the prevailing climatic conditions. Some farmers periodically turn or rake the grain during the drying period in order to obtain uniform drying. During rainy periods the crop must be protected until the weather is again favourable. In other cases some farmers dry their produce on raised platforms of various shapes. In Zambia, Malawi, and Southern Tanzania, the platforms are shaped like a cone, in many other parts of Africa they are rectangular.

After drying many farmers store their produce in the home, where the smoke and heat produced during cooking helps complete the drying of the grain and reduces insect infestation. The smoke produced and heat lost in traditional cooking stoves thus serve a useful purpose which should not be ignored in the development of improved cooking stoves.

Storage

Traditional storage systems have evolved over long periods within the limits of the local culture. Large amounts of grain for human consumption are stored in contain-

SECTION 1

ers constructed of plant material, mud, or stones, often raised off the ground on platforms and protected from the weather by roofing material. The design and materials vary according to local resources and custom. In the humid areas of the Ivory Coast, Tanzania, and Kenya, maize is dried and stored by suspending it in bundles from a tree, by hanging it on tacks, or by suspending it from poles. Because of the fear of theft, and because of the problem of rain, rodents and other predators, these methods are becoming less popular. In parts of East Africa and Central America wood ashes or rice husk ash is mixed with grain being stored to control infestation.

Storage conditions influence the rate of deterioration of grains. High temperatures and humidities encourage mould growth and provide conditions for rapid growth of insect populations. Deterioration is minimal in cool, dry areas, more marked in hot, dry ones, high in cool and damp conditions, and very high in hot, damp climates.

The table lists specific loss factors before milling for the individual commodities (maize, sorghum, millet, and paddy). (NAS, 1978).

Primary Processing Methods

Whole grains store better than ground flour, so in many rural families women grind and pound small amounts of grain for immediate consumption. This part of the section will discuss traditional grinding methods for the various cereals.

Maize

Maize may be either dry or wet milled. In dry milling, maize is usually ground be-

tween stones or by using a small hand powered plate mill; otherwise custom or co-operatively-owned power driven hammer or plate mills are used. At other times, the grain is milled wet after it has been soaked and allowed to ferment slightly to improve its flavour. In Latin America maize is partially cooked in alkaline conditions to facilitate the removal of bran before it is milled. Where very small quantities are needed, the wet maize may be ground at home using a saddle stone or similar device. More commonly today, hand or power driven plate mills are used either to roughly break the grain or to mill it further to a smoother paste.

Maize grain is either pounded using a wooden pestle and mortar or ground by hand on a stone by a quern (a rotating hand driven stone mill). The amount of maize required for several meals is taken off the cob and transferred to a wooden mortar. One or two cups of water are added and the whole is pounded.

If the maize meal is not used whole, it is transferred into a flat basket and, by shaking, the bran is separated from the floury endosperm. The flour is again collected into the mortar and pounded in the same way as before for three or four shorter periods followed by the traditional separation of the bran. The resulting product is called 'pure' and the bran is often used to feed chickens.

Some of this 'pure' meal may be cooked as it is or together with beans, but most undergoes further processing, starting with soaking in water for one or two days until an odour develops owing to fermentation. Fermentation produces acidic conditions which inhibit the growth of undesirable bacteria. The water is then poured off, the soaked 'pure' meal is washed up to three times with fresh water, decanted, and again pounded in the mortar. It is then separated, as before, from the finer parts. The

SECTION 1

bigger particles are kept for further pounding until everything is reduced to a semolina-like flour. This product is ready for preparing into foods such as uji and ugali; it cannot be kept for more than a day. If

dried it may be stored for a few weeks (Steward, 1978). The shelf-life of maize meal is very low because maize has a relatively high fat content, and the meal tends to go rancid quickly.

Causes of losses in cereal processing

	Harvesting	Threshing/Shelling	Drying and Storage
MAIZE	Insects Birds Rodents	Incomplete stripping of cob; damage to grain	Insects, rodents, birds, mould damage
PADDY	Delay leads to shattering; birds, rodents, insects	Breaking of grains; percentage of grain not shed; impurities become mixed with grain	Inability to dry to correct moisture level leads to mould; discoloration, loss in quality; insects, rodents, birds, fermentation
SORGHUM/MILLET	Insects Birds Rodents	Breaking of grains impurities become mixed with grain	Birds, insects, rodents

SECTION 1

Paddy

In some countries paddy is parboiled before it is dehusked. Parboiling is partial cooking which causes the starch of the kernel to gelatinize, making it tougher. There is also a slight change in flavour which is preferred by some. The toughening process makes the seed more resistant to insect attack, to shattering during husking and to the absorption of moisture from the air. Paddy that has been parboiled has a better nutritional quality owing to the migration of nutrients towards the centre of the grain during the process.

The parboiling process involves three stages:

- soaking or steeping of the paddy in cold or hot water to increase its moisture content.
- treatment by steaming to gelatinize the starch in the kernel.
- drying

Traditional parboiling techniques differ greatly from country to country. In West Africa paddy is frequently parboiled in small quantities in earthenware pots or oil drums after soaking in cold water overnight. Sometimes the soaking water is brought to the boil, the fire extinguished, and the pot left overnight. The next day the water is drained off, a little fresh water added and the pot put over a fire until all the water evaporates. The paddy is then sun dried. Traditional paddy parboiling techniques are slow and can only handle small quantities at a time. Off-odour produced during prolonged steeping of the paddy in the first stage of parboiling has been a recognized problem. Two methods to eliminate the offensive smell, which is caused mainly by microbial fermentation, have been (i) to reduce the steeping time by hot soaking (60-80°C) and (ii) to pre-

steam the paddy before soaking, which reduces both the steeping time and the number of micro-organisms in the paddy.

It is stressed that careful drying after parboiling is essential to minimize post-harvest losses.

De-husking of paddy, which is sometimes referred to as milling is the process of removing the outer husk. De-husked paddy is referred to as brown rice. Further milling of the brown rice results in white rice. The most widespread traditional method uses a mortar and pestle. This may be done by one woman working by herself or by a number of women working rhythmically together. The method is very slow and laborious and output rarely exceeds 5 kg per worker per hour.

Hand-pounding produces an undermilled rice which is of greater nutritional value since it retains part of the bran which has high thiamine content and contains protein. Hand-pounding also results in a high proportion of broken kernels. Winnowing is carried out at intervals during this process (Mphuru, 1982).

Sorghum/millet

The outer layers of certain varieties of sorghum seed contain tannins which are slightly toxic, have a bitter taste and inhibit protein digestion when consumed. For these reasons sorghum is generally dehulled (i.e. the outer layers are removed) and then pounded into flour.

Red or brown sorghum continues to be grown in many parts of Africa, due to their bird resistance in spite of the availability of white non-tannin varieties. Traditionally, the processing of sorghum and millet has been carried out by grinding the whole grain in querns, between stones or by pounding the grain using a pestle and mortar. The latter process is the commonest method for sorghum. Once the seed

SECTION 1

has been winnowed to remove foreign matter it is put in a large mortar and wetted. It is then pounded to strip the bran or 'shell' from the grain, followed by winnowing to remove the bran entirely. Pounding and winnowing are repeated several times before a good quality milled seed is obtained. The milled seed is then washed with water to remove any small pieces of bran and soaked in water for twenty-four hours to 'condition' or 'temper' it. This is followed by drying to the correct moisture content and then re-grinding in a pestle and mortar. In order to obtain a good flour, sifting and pounding has to be repeated several times. The flour obtained contains a large proportion of the oil-rich germ and the nutrients

of the grain (Mphuru, 1982). Grains are moistened to facilitate the removal of the bran, but this can result in a slightly fermented flour. Although the keeping quality of this type of flour may be diminished because of fermentation, the resulting flour has a modified flavour which is often considered desirable. The objective of hand-pounding is thus two-fold. In the first stage, the bran and pigmented layers are removed and, in the second stage, the grain is pounded progressively with intermittent sieving into flour suitable for various end-products. It can be seen that these methods of hand-pounding are time-consuming and laborious and an output of only 1-3 kg of flour per person per hour is possible.

Improved Processes and Technologies

At present, in most developing countries, it is the women who are largely responsible for the threshing, winnowing, drying, husking, shelling, and milling necessary to prepare grain for human consumption. These tasks are often arduous, monotonous, and time-consuming.

Care needs to be taken, however, in introducing new techniques into a rural community in case they unintentionally worsen the women's situation instead of improving it. Although a technology may in theory lighten the women's workload it may lead to men taking over a task traditionally performed by women, so depriving them of needed income (FAO, 1986).

Harvesting

Crop harvesting equipment available to small-scale women farmers in developing countries has changed little over the years. Knives, sickles, and scythes continue to be the traditional tools used. Some low horsepower reapers are being developed, but because of their low capacity, high cost, and other problems, they are often not considered a suitable alternative to manual methods. (IT Publications, 1985) The time at which a crop is harvested can have a significant effect on both the quantity of grain obtained and its quality.

Threshing

In the previous chapter traditional manual and animal-powered threshing have been discussed. Although time-consuming and

labourious they should not be condemned out of hand. The problems of impurities and grain damage during manual threshing can be partially overcome with minor improvements, for example, carrying out the task in clean areas.

A range of small hand and engine-driven mechanical threshers is available to improve not only the quality, in terms of damage and yield, but also the efficiency of human effort required. These fill the gap between traditional methods and highly sophisticated machines which are mostly inappropriate for use by villagers due to their high cost and maintenance problems.

Most mechanical threshers operate on the same basic principle and consist of a rotating cylinder or drum armed with teeth which strip the grain from the stalks as it passes between the revolving drum and a metal grate, (known as the concave). Many of these machines have been developed for rice but are applicable to other crops. However it is reported that treadle operated machines are not suitable for threshing wheat as the power requirement is too great.

It is important to note that most mechanical threshers work best with grain dried to the correct moisture content. Under-drying leaves grain still attached to the stems; over-drying leads to excessive grain damage. Threshers are often classified according to the method of feeding, the design of the threshing drum/concave and the power source. (IT Pubs, 1985). For example:

- **Hold-on:** the cut plants are held manually or mechanically in the threshing chamber until the grains have been detached by the rotating drum. **Throw-in:** the whole cut plants are fed into the machine.

SECTION 2

- Peg tooth, rasp bar and wire loop threshers in which small spikes or pegs, parallel bars or wire loops are attached to the rotating cylinder as shown in the illustrations below:

1 Peg Tooth Thresher

2 Rasp bar thresher

3 Wire loop thresher

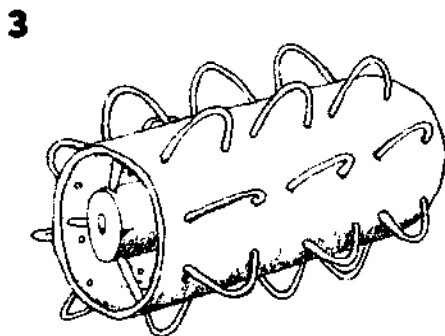
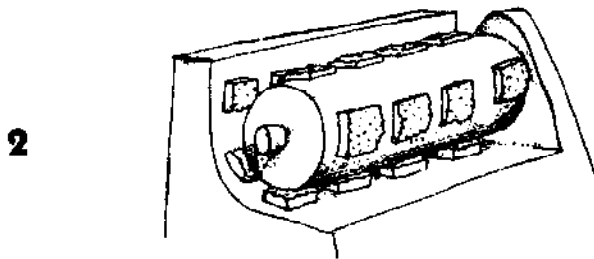
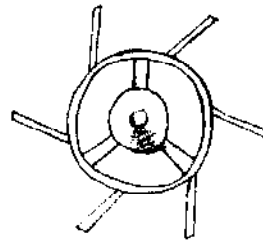
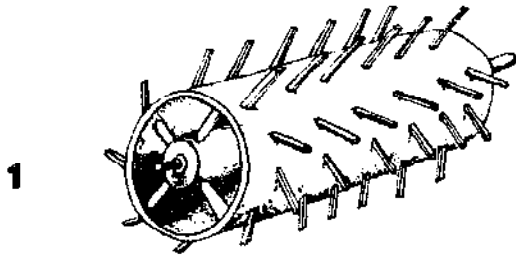

- Human powered and engine powered.

Human powered mechanical threshers will typically have outputs of up to 150-200 kgs/hour (ARCT, 1982) If throughputs above this are required, the use of engine power is necessary.

Engine-powered models are obviously more expensive and have a greater capacity than manual and animal threshers. The majority of engine-powered threshers are throw-in, thus increasing the bulk which has to pass through the machine. There are two main types:

SECTION 2

- Tangential flow machines in which the crop passes directly through the threshing chamber, around the circumference of the drum.
- Axial flow machines which have spirally positioned fins on the upper concave so that material fed in at one end of the drum passes along the drum as it is rotated and is ejected at the other end (pictured below).

Axial flow engine thresher

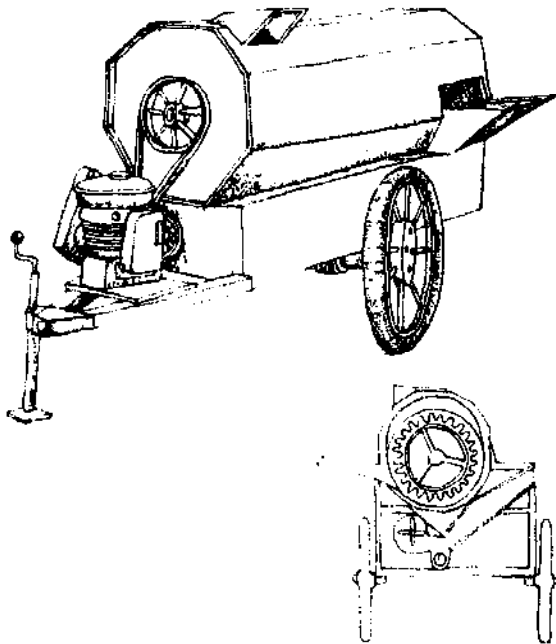

Engine-powered threshers may be driven by a small engine mounted on the machine (2 or 3 hp upwards), or by a tractor. Most machines allow adjustments for various crop and field conditions and a large selection is available with varying drum, power supply, and winnowing/cleaning arrangements. The simplest consist of little more

than the threshing cylinder and concave mounted on a framework and include feeding chute, outlets, and a suitable engine.

Winnowing

Various types of machines have been designed to assist the winnowing process. The simplest are essentially hand or pedal-operated fans: with several rotating wooden blades. Slightly more sophisticated are fanning mills, where the fan is mounted in a wooden housing which contains sieves and screens. The grain is thus graded as well as cleaned. The fan may be manually or motor powered. Fanning mills produce a very clean product but cannot cope with large amounts of straw, so they are more appropriate for final winnowing. Hand operated fans are recommended as being most appropriate for the small scale farmer.

Maize Shelling

There are several types of maize shellers available, ranging from hand-held to manual/pedal and power-driven ones. Although hand-held shellers are cheap they have low throughputs and are normally only suitable for small quantities.

Manual/pedal maize shellers consist of a feeder funnel and a shelling disc which is rotated by a crank. The grain is removed as the cob is drawn down through the machine. The output of this type of sheller ranges between 30-150 kg of grain per hour. Local manufacturers can often supply these.

Engine-powered shellers operate similarly to threshers, with rotating cylinders of the peg or bar type and metal concaves. Cobs

SECTION 2

must be husked before entering the shelling drum. Some maize shellers have husking rollers which husk the cobs before they are passed to the shelling drum. Engine-powered shellers are not suitable for individual small-scale farmers.

Drying

Traditional methods of drying and storage have developed to take into account local environmental conditions. Before any consideration is given to an improved grain drying or storage system, it is essential first to study the traditional methods used in order to understand their shortcomings (if any) and therefore the need for improved techniques, and second to determine what simple, effective improvements are possible. The traditional methods of drying and storage described in the previous section are simply examples, and in every situation consideration must be given to local traditional methods. Building on what people already know and understand is a sound strategy.

Only the principles of improved drying and storage will be discussed as separate source books on both these subjects are available.

The level of moisture in harvested grain depends mostly on the time of the harvest — obviously, grain harvested in the rainy season will contain more moisture than grain harvested in dry, sunny weather. It is important to note that some grains must contain more moisture than others when harvested if they are to be harvested intact without damage. Both maize and rice can be harvested when the moisture content in the kernels is of the order of 20% (FAO, 1970), although maize can be left in the field to dry further before harvesting. Rice, on the other hand, must not be allowed to

dry in the field, or many of the grains will shatter or fall off the stalks.

It is useful for a farmer to know that drying continues only as long as the air around the grain is able to absorb more moisture from the grain. If the air contains a lot of moisture, the grain is likely to take in that moisture from the air. The farmer should understand this fact because it explains the need to keep dry grain away from moisture or moist air, as much as possible. Grain that is not sealed in a closed container will continue to exchange moisture with the air. During the rainy season, for example, grain will take up moisture if left in an open container. In the hot, dry season, grain will lose the moisture again. (Peace Corps/VITA, 1977).

Grain put into storage should not have more than a certain amount of moisture inside its kernels. The level of moisture for safe grain storage depends, to some extent, upon local conditions. Although the amount of moisture grain can safely hold in storage can change, depending upon storage conditions, some general guidelines for safe moisture contents have been established, as shown in the table below (FAO, 1970).

Grain Type	Maximum Moisture content for one year (or less) Storage at 70% relative humidity and 27 °C
Wheat	13.5%
Maize	13.5%
Paddy rice	15.0%
Milled rice	13.0%
Sorghum	13.5%
Millet	16.0%
Beans	15.0%
Cowpeas	15.0%

SECTION 2

In developing countries, the methods available to farmers for drying crops are usually limited to a combination of sun and air drying, although supplementary heat is frequently employed. Drying by a combination of sun and air is often referred to as natural drying.

In all drying, care must be taken to avoid too rapid drying or over-drying and to minimize excessive movement of the grains which causes breakage or damage to the seed coat. Over-drying — which can easily occur in arid regions or after excessive exposure to sun or other heat — can cause breakage of the grain, damage to the seed coat, bleaching, scorching, discolouration, loss of germinative power, and nutritional changes. Too rapid drying of crops with high moisture content can also cause 'case hardening' where the surface of the grain traps moisture within the inner layers (FAO, 1970).

Slow drying, a problem in humid regions, results in deterioration due to the growth of fungi and bacteria, the danger of the grains germinating, and increased losses to predators. In extreme cases this can lead to total loss.

Solar drying is receiving attention because of its negligible running costs in comparison with traditional fuels. However, the fundamental problem with solar devices is that they do not operate effectively when they are most needed — during a wet spell or during the rainy season. Drying is often complicated by the introduction of high-yield varieties that mature and must be harvested during wet seasons, or by the production of a second, irrigated crop ('double cropping') that must also be harvested during the rains. In these cases the grain requires artificial drying.

Artificial drying involves either the use of air at ambient temperatures and a mechanical means of moving it through the produce, or air heated above ambient temper-

ature with or without the mechanical means of moving it through the produce. Artificial methods include the use of fires to heat the grain directly or indirectly, with or without ventilation. Commercial dryers, in which the air is heated by furnaces using oil, the waste heat of an internal combustion engine, or crop residues such as rice husk are also available. Mechanical driers are more appropriate to co-operatives and for service drying, often being owned by small mills.

Please refer to the DRYING SOURCE BOOK

Storage

The wide variety of storage techniques already in use usually depend upon many factors including the quantities to be stored, local construction materials, climate, etc. Many of these traditional methods are appropriate and may be used as a base on which to build improved storage techniques, or continued as methods for storage of the limited amount of grain that is to be used as seed for planting.

Many traditional techniques, however, such as storage in clay pots which are adequate for very small quantities, cannot be adapted to the storage of larger amounts of grain. As the scale of production increases in order to sell grain on the market, so storage techniques also have to change.

To a considerable degree good storage is a matter of good housekeeping, of paying attention to stored material and recognising problems before they become too serious. The air between the grains in a store is in equilibrium with the moisture in the grain. Heating and cooling of the store causes this equilibrium to change and this often

SECTION 2

results in damp layers at the top and bottom of the store. High moisture levels cause the grain to respire at a greater rate giving off heat. Any insect larvae and moulds also begin to grow and reproduce, again giving off heat and hot spots occur in the store. If temperatures rise too high insects migrate to cooler areas causing new trouble spots (Peace Corps/VITA, 1977).

The following points represent a suggested code of good storage practice, and thus offer a set of guidelines in the adoption of an appropriate storage system (Dichter, 1978):

1. Dry grain well before putting it in storage. The grain must be kept dry.
2. Put only clean grain into containers which themselves have had all old grain, dust, straw, and insects removed and burned, for they could recontaminate the new crop.
3. Keep the grain cool and protect it from large changes in outside temperatures. This can be done in a number of ways — by using building materials (e.g. brick, mud, clay, wood) which do not easily pass on changes in outside temperatures to the stored grain, by keeping or building storage containers away from direct sunlight, by applying a coat of white plaster to the outside of the containers.
4. Protect the grain from insects by following the rules for cleanliness and drying and by putting the grain into an insect-proof store.
5. Waterproof the buildings and containers as much as possible when the building is constructed. Storage buildings should be built on well-drained locations and not where they will be flooded by groundwater run-off during heavy rains. This can be achieved by raising the floor of the building off the ground.
6. Make sure containers are rodent-proof in all possible ways.
7. Check the grain regularly while it is in storage to make sure it is not infested. The farmer should put her hand into the grain to check for heating. She should also smell the grain and look for dark kernels, signs of mould, which indicate that the moisture content is rising. If these signs are found, the grain should be tipped out and dried again.
8. Provided they are used in accordance with the manufacturer's recommendations and conform with local government regulations, insecticides mixed into the grain prior to storage, may be used to control infestation. **Proper advice must be sought** (TPI, 1977).

Please refer to the **STORAGE SOURCE BOOK**

Milling, Grinding and Dehulling

As has already been seen there are two basic ways of milling: wet and dry. The latter, as covered in this section, covers the production of cereal flours, mainly from wheat, maize, sorghum and millet. Rice flour is less common in Africa.

Three forces are involved in milling: rubbing (abrasion or shear); impact (hitting with a hammer); compression (squeezing). All three are always present to some extent, but different types of mill use one force more than the other two. Different materials break in different ways and therefore some mills are better suited to particular foods because they use more appropriate forces.

Conditioning of grain to the correct moisture content prior to milling is important for good separation of the constituent

SECTION 2

parts. If grain is too dry it is hard, difficult to break down, and requires more energy to convert it to flour. If grain is too moist, material tends to adhere to machine surfaces and prevent efficient screening. In both cases flour yields and quality are affected.

There is no hard and fast rule for the optimum moisture content of the grain for milling. It will vary with the type of cereal and the particular mill being used. In any case only the larger commercial mills have facilities for moisture measurement. A simple method for assessing whether grain is correctly conditioned is to place a few grains on a hard surface and tap them with a stone. It does not take long to acquire the skill of assessing whether the grain is too hard or too soft.

Dry grain can be conditioned by soaking in water or by leaving it to stand in a closed container with a small amount of water added. Moist grain can be dried by the most convenient method locally available.

There are improved methods of milling, both manual and power driven. The mills discussed first are stone, plate, hammer, and roller mills, followed by dehullers used for sorghum/millet and rice. Milling and dehulling are two separate functions and are presented as such. It must be stressed from the beginning that in some countries mills are readily available and locally produced while it may be more difficult to obtain them in other areas.

Stone mills

Grinding grains to flour between two flat stone surfaces is the simplest and must have been the earliest form of milling. Hand turned stone mills, sometimes known as querns, consist of a stationary circular base stone, over which a second stone is turned. The grain is fed through the centre of the top stone and is crushed and ground as it moves between the stones towards the periphery. Larger stone mills, which are often of local manufacture, are either turned by animal or water

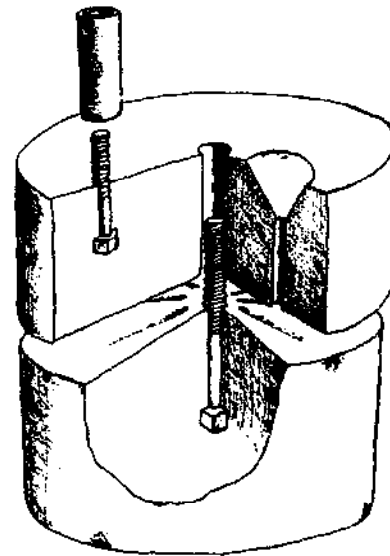

Stone Mill (Quern)

power. Stone mills are also commonly turned by diesel or electric motors. This type of mill will produce not only coarse meal but finer flours which are difficult to obtain using other small scale milling techniques. Small commercial stone mills are available from several countries and stones may be set horizontally or vertically. The most important consideration is the quality of the stone and the precision of the surface dressing.

Plate mills

Plate mills are an adaptation of traditional grinding stones which grind the grain by a constant rubbing action. In such a mill, two metal plates are mounted on a horizontal axis so that one or both of the plates rotates and the grain is ground between them. The pressure between the plates governs the fineness of the product and is adjusted by a hand screw. The grain is ground progressively finer until it emerges and falls into a sack or bowl. The main wearing parts are the plates. If a foundry is available, the plates can be made locally.

SECTION 2

Plate mills are very effective for wet grinding products such as maize. Water may be added by simply pouring it into the feed section as required. Many manual plate mills are available but the work tends to be hard and throughputs are low, generally less than 10 kg per hour. They are however more effective than pounding or grinding stones and will produce a fine meal. If the grain is milled wet it should be cooked as soon as possible.

Power-driven mills are also available. Some of the hand mills mentioned above may be fitted with small motors of up to 1 hp so increasing their output and reducing the amount of labour required. Larger units driven by diesel or electric motors of 3 hp or more are commercially available.

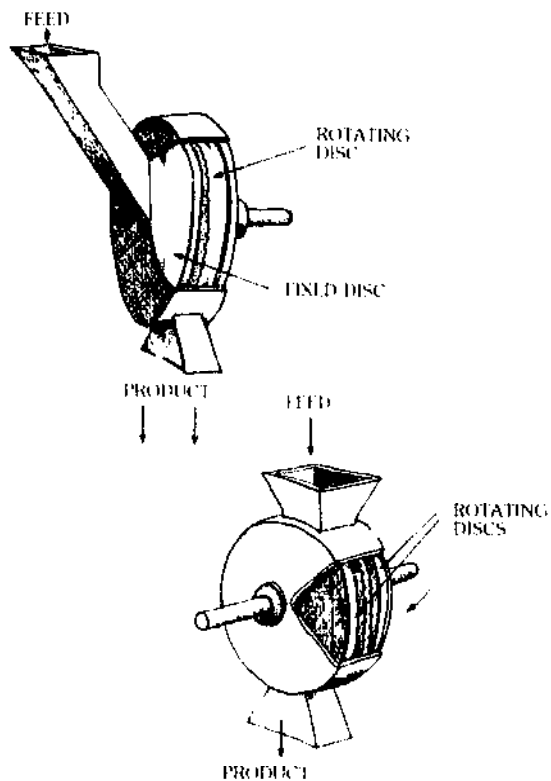
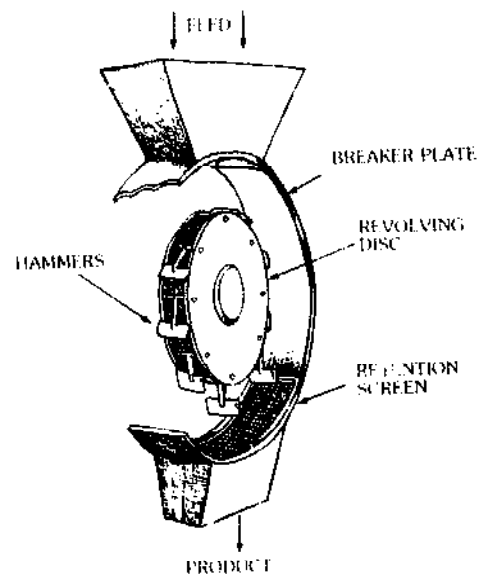

Plate Mill

Hammer mills

Hammer mills essentially consist of a circular chamber in which fixed or swinging hammers rotate at high speed so grinding the product. The ground material passes through a removable sieve at the base of the chamber into a sack or may be sucked by a fan to an elevated delivery point. The mesh of the sieve plate determines the particle size; a 1 mm hole size is suitable for most human foods, whereas a 3 mm hole is preferred for animal feed (IT Pubs, 1985).

The hammers in the mill should be made of hardened steel. Locally made hammers, often made of soft steel do not last long. Good hammers can be made from lorry/Land Rover leaf springs. They should be replaced approximately every three months depending on the amount of use. Each hammer can be reversed so providing a new working surface.



Hammer Mill

SECTION 2

Both hammer mills and plate mills are equally suitable for dry grinding and it is a matter of cost, availability, product type, and tradition which will decide which mill is used. Hammer mills are easier to operate by unskilled labour and useful for custom milling. Once set up they can be used for long periods without need for adjustment and can produce a uniform product. Hammer mills cannot be used to grind wet grains.

Roller mills

A Roller mill consists of a pair of rollers that revolve towards each other, usually at slightly different speeds so producing a shearing force. One roller is held in a fixed bearing, the other has an adjustable spring-loaded bearing so that the gap, and hence fineness of grind, can be adjusted. Roller mills usually operate in series, each pro-

ducing a finer and finer grade of flour. There is separation of the constituents at each stage. While some small roller mills are available the technology is usually too sophisticated and expensive for village level and is found mostly in urban areas for wheat and maize flour production. The discarded bran and germ are often used for animal feed (ILO/JASPA, 1981).

Dehuller: sorghum/millet

Improvements in processing sorghum/millet involve two stages which use a dehuller and a hammer mill. The dehuller is used to remove the bran from the sorghum before it is milled and it is therefore the key element of the milling system. Abrasive discs or stones set on a horizontal shaft rotate at high speed inside a casing. The hulls are 'rubbed' off by the grinding action of the whirling stones and the friction of other

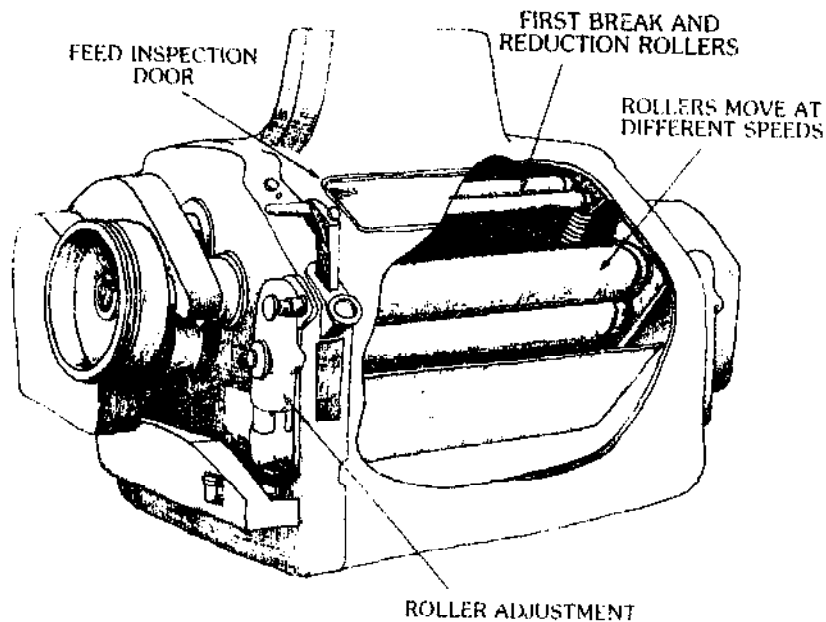

Roller Mill

SECTION 2

Dehuller

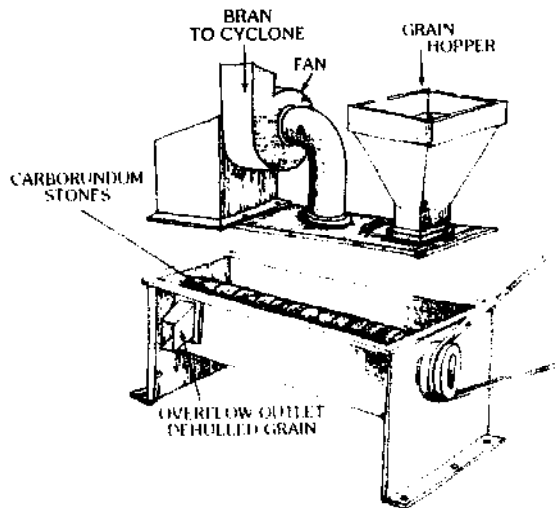

grains. The rate of flow of the grain must be adjusted so that the grain is kept in the casing just long enough to remove the desired amount of bran. The lighter bran is continually removed from the dehulled grain by a fan. A dehuller requires a motor with a minimum capacity of 7-10 hp. (AT Journal, 1985).

The dehulled grain may be used whole as a rice substitute or ground to a flour or meal in a separate mill. This method of processing sorghum is referred to as 'dry abrasion' because unlike traditional processing it does not use water at any stage of processing.

Rice hullers

There are basically three types of rice hullers; a modified version of the 'under runner disc husker', the 'Engleberg steel roller' type, and the 'Japanese rubber-roller'.

The under runner disc, which has been used in Asia and some parts of Africa for a long time, consists of two discs, the lower one stationary and the upper rotating. Paddy grains are fed into a central opening in the upper rotating disc and the husk is removed by friction between the two surfaces. In its simplest form the discs are made of clay mixed with water and dried in the sun. Winnowing must again be carried out after this process to separate the kernels from the husk.

The other two machines work on the principle that if a paddy grain is pressed between two resilient surfaces, moving at different speeds in the same direction, to produce a shearing action, the husk will be stripped off. The Engleberg type polishes the rice and removes the husks; in the rubber-roller design polishing is carried out by a separate machine (Mphuru, 1982).

Rubber-roller mills are becoming increasingly popular for several reasons. The use of rubber rollers reduces the risk of breaking the grain and also reduces the damage to the machine by unskilled operators.

Rice Huller

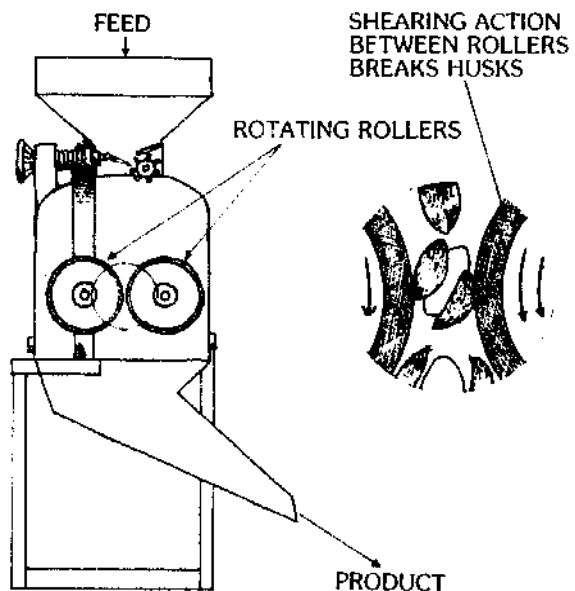

SECTION 2

They tend to work better with short grain varieties than with long grain rice. Rubber-roller mills are mechanically efficient but the rollers have to be replaced periodically and are often difficult to obtain. The steel roller Engleberg mill is more robust, has fewer maintenance problems and usually lasts for many years. It does, however, cause more grain damage and so reduces quality. This may or may not be important in particular village applications.

It is important to remember that rice polishers remove bran and thus a high proportion of nutrients, particularly B vitamins. This may lead to dietary deficiencies in the many areas of the world where rice is a staple food.

Economic considerations

When investing in an improved process, it is important to see whether the improvement will pay for itself. This usually means that the process must earn or save more money than it cost, but not necessarily.

It is possible for processes to be improved without investing in new machines by, for example, improved ergonomics of processing activities. If improvements can be made without financial cost, then they are

likely to be adapted quickly as long as the perceived benefits to the user outweigh any non-financial costs. These costs could be, for example, having to work in a group in some central place rather than working at home, a loss of independence, a loss of control over time allocation in the household. These should not be underestimated, and can often lead to the abandonment of improved practices.

If, as is more often the case, an improved process requires a level of financial investment, then it is important that the investment produces higher income/quality as well as meeting those other non-financial costs. With crop processing, it is especially important to estimate how many days in the year the machines will be in use. Machines that can be adapted for different crops or processes are likely to be better than machines designed for one job.

Availability of skilled mechanics to maintain the machines, availability of spare parts and the availability and cost of energy (e.g. human, animal, or mechanical) can all have serious impact on the economic viability of an improved process.

If the improved process requires credit, it is important that it will pay for itself and repay the credit as well. Great attention should be paid to rates of interest available from local institutions and not simply the national bank rate, as these can vary wildly.

Secondary Processing - Cereal based Foods

After primary processing, cereal products, flour or whole grain are further processed in the home and by small cottage industries into final products. Common final products include foods with a porridge or dough consistency, baked products, whole grain goods, pasta and noodles, fermented drinks, snack foods, and weaning foods. Cereal-based foodstuffs such as these are important both for home consumption and as a potential source of income. Examples of commercial production are given in the next section.

Foods with a porridge or dough consistency

Flours from indigenous crops (sorghum, maize, millet, rice) can be mixed and stirred with boiling water to a dough consistency and formed into balls either with or without prior fermentation. Foodstuffs such as 'banku' and 'ugali' made from maize and consumed in Western and Eastern Africa respectively and 'sankati' and 'tuivo' made from sorghum and consumed in South India and Nigeria respectively, are examples of non-fermented foods. Fermented types such as 'kenkey' in Ghana and 'bagone' in Botswana are prepared by leaving the whole grain to soak in water for a few days to allow fermentation before grinding to a flour for mixing with water as before.

These dough-like cereal foodstuffs provide the basis for a daily meal in many households in Africa.

In India, fermented rice foodstuffs such as 'dosais' (rice cakes) and 'idlies' (rice pudding) are prepared from a mixture of rice and pulses.

Baked products

Unleavened breads made with maize, wheat or sorghum are popular worldwide as a daily food item. For example, 'chapatti' or 'roti' are consumed in India, 'kisra' in Sudan and 'tortillas' in Latin America.

Leavened breads are based on wheat flour and the popularity of these products is in many cases forcing countries to import wheat. Research into composite flour technology; (the supplementation of part of the wheat with non-wheat flours) has produced satisfactory bread formulations. It must not be overlooked, however, that such products are not identical to ordinary wheat flour bread and may therefore cause problems of acceptability.

Whole grain foods

Rice is consumed in the tropics mainly as a whole grain, cooked by boiling or frying. Pearled sorghum may be eaten in a similar way, while maize can be roasted or boiled on the cob.

Pasta and noodles

These are popular foodstuffs consumed in large amounts which form the basis of daily meals in many countries. Pasta products require the use of wheat flours but many noodle-like products, such as Sri Lankan string hoppers, are based on rice.

Fermented drinks

For many women informal beer production is a very important source of income, but competition from the 'modern' sector with

SECTION 3

local production has been observed in many parts of the Third World. It has been shown, for example in Zimbabwe, that as income rises, a larger amount of western or 'modern' beer is consumed to the detriment of local traditional activities. Local brewing, however, is not likely to disappear in the near future. Beers can be made from most cereals after they have been 'malted' or allowed to germinate. Examples include sorghum beer, rice wine and maize beers.

Snack foods

A whole range of snack foods can be made by extruding a flour paste into strands, (eg vermicelli) curls or flakes, by popping (as in puffed rice or popped corn) or by drying to

thin sheets (eg Papads). Flavoured mixes such as 'Bombay mix' are also popular.

Weaning foods

Simple weaning foods based on cereals blended with other ingredients can be produced at a small scale. Obviously great attention has to be paid to the composition of the product, the avoidance of any ingredient that might be toxic and safety from the point of view of hygiene. Young children require essential nutrients such as protein, fat, vitamins and minerals in the correct proportions and a blend must satisfy this need. Expert advice should always be sought before considering establishing projects in this area.

Case studies

Traditionally, crop processing activities are carried out primarily by women. The techniques they use are labour-intensive, time-consuming, and have low productivity. Two categories of women engage in this type of activity: farm women who process their own crops for family consumption; and landless women, or the wives of marginal farmers, who process other people's crops as a way of supplementing family income.

The introduction of crop processing equipment will have varying implications for these different sectors of society. Labour saving equipment may allow farm women to involve themselves in more remunerative kinds of activity (which would help them pay for the machinery), devote more time to child care, or increase productivity in traditional tasks. However much of the time saved may be diverted into travelling to the mill and standing in queues for long hours, thus reducing possible benefits.

Landless women may find themselves displaced by crop processing equipment from their only means of earning a living. For example, as one of the case studies in the following pages points out, the introduction and spread of Engleberg mills in Bangladesh has destroyed millions of part-time jobs for poor women. Given the greater mechanical efficiency of such equipment compared with traditional techniques, it would be difficult to prevent such changes.

In view of the considerable range of technologies for improved traditional processing of cereals, the selection of the most appropriate technology for a given situation requires a careful examination of social, economic, environmental, and cultural factors as well as an analysis of the competi-

tiveness of traditional processing under given conditions. Obviously, women are only willing to accept new technologies which reduce the most arduous aspects while not creating additional tasks, prove to be viable and appropriate to their needs, and do not deprive them of former economic opportunities.

The tools and equipment used to process crops in the traditional way are mainly locally fabricated, by farm families themselves or by rural artisans. Modern machinery, on the other hand, is usually manufactured in urban factories or even overseas. The introduction of such machinery means a decline in demand for the products of rural artisans and a flow of cash away from the rural economy. It also then results in an increased demand for the country's scarce supplies of foreign exchange for imported machines, spare parts and fuels. In the following case studies, the machines that are found to be appropriate are often those which are made locally (in the country or neighbouring country) with local skills, resources, and equipment. This implies that use of locally manufactured equipment should be encouraged through measures such as the training of rural artisans, the upgrading of technology in rural workshops, and the provision of credit and other support services. (IT Publications, 1985)

The case studies in this section seek to provide an overview of the experiences gained in introducing improved cereal processing devices and techniques. Given the lack of documentation on impact of projects introducing the full range of technologies, the case studies cover only two primary processes – hulling and grinding; and two secondary processing activities – baking and preparation of weaning foods.

Imported Mill/Hullers

Hand/pedal-operated

1 Corn Mills in the Cameroons

Summarized from:

Elizabeth O'Kelly,
Aid and Self Help, 1973

An obvious hardship for women in the Cameroons was the work involved in grinding maize between two stones. It could take an hour or more of monotonous work to produce even a small quantity of flour and the women's hands were often covered with calluses. It had already been suggested that corn mills might solve this problem and an opportune grant of £200 (these prices refer to the 1960s) from the Nigerian Ministry of Education made it possible to set up a revolving loan fund to purchase some mills. There were no appropriate mills on sale in the Cameroons, but some were eventually traced to a manufacturer in England. These mills were of cast iron and virtually unbreakable. Maintenance involved only occasional oiling and the tightening of nuts which work loose, and changing the grinding plates after one or two years which is quite a simple operation.

Initially, the women were afraid of the unknown so it took considerable persuasion to have them accept a mill as a gift. Finally, a well respected elderly woman expressed interest and the women reluctantly agreed to a demonstration. The mill, which broke down into a number of separate parts for head loading, was carried to the village and installed in the centre. Maize was poured down the funnel and two women took the handles on either side and pushed but nothing happened. Trial and error eventually

disclosed that new maize (which was being used) must first be dried over a fire if it is not to stick between the grinding plates. Once this was done all was well, but the two women who had been turning the handles had not yet caught the necessary rhythm and were using six times the energy required, pushing against each other. They declared that the work was too hard and the demonstration petered out. In a few days, however, the situation had changed, and several women had become more familiar with the machine. Soon it was in constant use.

The women's boasts coupled with rural curiosity soon began to bring in sightseers from all over the area and very soon there were requests from other villages to set up corn mill societies there. The members of these societies were expected to pay for their machines, but were given a year in which to raise the money. At first they made a charge every time a woman used the mill, but later it was found to be administratively simpler to charge a fixed sum per head each month. By the end of the year thirty villages had repaid their loans and more mills had been purchased.

The mills served a dual purpose. First, they lightened the labours of women and allowed them to participate in other activities such as literacy classes and soap making. Second, they acted as 'bait' to attract members to the societies since anyone who wished to use a mill had to join a cornmill society.

2 Christian Council of Tanzania Handmill Project

Summarized from:

Private Communication, CATE

In 1979 the Christian Council of Tanzania (CCT) initiated a project to provide certain villages with one or more examples of manually operated grinding mills. The pur-

SECTION 4

pose of the project was to test the technical and social acceptability of such mills and, subject to a positive finding on both counts, to encourage others to consider the practicability of manufacturing the mills in Tanzania. The project was based in the Arusha region.

Under the project the following mills were imported:

- 24 Atlas Hand Mills (Model No. 3), 12 of which were distributed in Arusha region and 12 of which were sent elsewhere.
- 50 Wheeler-brand handmills, manufactured in India. Ten of these were distributed in Arusha region, with the remaining 40 being stored in Dar es Salaam.
- 20 German-made handmills, all of which were distributed in the Arusha region.
- 11 pedal-mills developed by the Tropical Development Research Institute, (TDRI), England, some of which were fitted on to bicycles (with a stand support), some on to locally constructed wooden pedal units.

The German and Indian made handmills are both operated by a single handle; the Atlas machine is larger and is designed to be used by two people at the same time. The German and Atlas machines have metal grinding plates, while the Indian mill relies on two grinding stones. The bicycle mill is an entirely different mechanism, being more akin to a hammer mill with the single 'hammer' being rotated by the action of the pedals.

The Atlas No. 3 Mills

This is a large, robustly manufactured plate mill which, according to the manufacturers, has a grinding capacity of 17-20 kg of flour per hour.

The performance of the Atlas mill (and all other non-motor mills) was judged in accordance with the speed at which it produced

an acceptable fine quality flour. Because of villagers' experience with motor mills they expected a machine to produce such a product quickly and immediately (in the sense that the flour should be produced after passing through the mill only once). By this criteria, the Atlas mill did not grind maize satisfactorily.

The process by which flour of an acceptable quality could be acquired was long and tedious (involving several siftings and regrindings) and was not considered an improvement on the traditional method.

On the other hand, with wheat, sorghum, and millet, the results were very different. These grains are much smaller and softer and the mills were popular and well-used to grind these cereals. The machine could produce an acceptably fine flour quickly and immediately (although one village reported milling wheat twice).

It was found that most of the machines had not been maintained since they were distributed. To some extent this may have reflected on the value of the machine to the users, but probably it also indicates a lack of knowledge or ability to look after the machines. For example one or two machines had been slightly damaged because villagers had not been able to undo the nuts with spanners and had improvised with other tools.

In addition, villagers seemed to have difficulty operating the Atlas No. 3, and particularly in co-ordinating their movements to enable them to use both handles at the same time. Without exception the second handle had been removed from the machine, most people preferring to take turns to do the grinding so that one can rest while the other works.

The Wheeler-Plate Mills

It is regrettable that within the context of the CCT grinding mills project there were

SECTION 4

some cases when machines were allocated to villages to do work for which they were entirely unsuited. The most striking example of this was the distribution of Wheeler machines to maize-growing areas. Because of a misunderstanding between CCT and the sales representative for the manufacturing company, CCT believed that these machines were capable of grinding maize. Subsequently the company informed CCT that this was not the case and that they were designed to grind millet. By the time this information had been received, however, numerous complaints had been received by CCT and a lot of damage had been done. This could have been avoided if CCT had pre-tested the machine's technical capability, in which case it is highly unlikely that they would have been distributed, since their performance has been very poor, even with grains for which they were designed. When it was found that the machines were not popular for grinding maize a letter was written to the villagers requesting that the machines (or at least one of them) be returned so that it could be sent to a different area. This caused a lot of bad feeling in the village because the inhabitants had already contributed to the cost of obtaining the machines. They were already disappointed that the machine did not do the job which they believed it would do (i.e. grind maize), and it only made matters worse when the villagers were asked to return one or more of the machines.

These mills were condemned by villagers as a complete waste of time. The CCT technician spent a long time trying to improve the mills and get them to work. He requested the assistance of other technicians at SIDO, Arusha but all efforts were unsuccessful.

The German-made Plate Mills

This mill is rather similar to the Atlas mill in that it utilizes two metal grinding plates. It is

a slightly smaller machine, however, with only one handle. It is also lighter and less well constructed and was simply not strong enough to withstand village conditions.

In a few villages, both an Atlas machine and a German mill were installed. In every case the Atlas machine was preferred, since the German mill broke down or fell into disuse whilst the Atlas continued to give good service. The failure of the German mill seems to be connected with the lighter flywheel and handle and in a number of villages the mill had been used quite regularly until the handle broke.

TDRI Bicycle and Pedal Mills

A TDRI bicycle mill is essentially a mill attached to a bicycle. A pedal mill is one where the bicycle has been replaced by a wooden frame. The following points should be noted about the mills:

- The TDRI mill was originally intended to be used on a bicycle which the villager already owns. Thus if the villager has no bicycle, he could not use the mill. For testing purposes, bicycles were provided. This was unsatisfactory because the men in the village considered grinding maize to be a waste of a good bicycle and they took off the mill and used the bicycle for other things. It is significant that pounding grain is women's work and the men clearly could see no value in the bicycle helping the women to do that job.
- Women were generally not prepared to use a bicycle. Traditionally it is men who ride bicycles and village women find it embarrassing to do so. Such is their reluctance to use the bicycle that there were instances when women got down on their knees and turned the pedal by hand.
- An attempt was made to overcome these social problems by introducing a pedal mill attached to a wooden frame made at

SECTION 4

he Arusha Appropriate Technology Project. This proved unsuccessful because the frame was not strong enough and was very uncomfortable when peddling.

- None of the TDRI mills of either variety are being used now and the villagers seem to have no interest in pursuing this approach. Flour produced by the mill is reasonably good, but output is very low. Once again, maize is the most difficult and requires milling two or three times. Production of a kilo of maize flour takes 2-4 hours.

It was concluded that the TDRI mills were not acceptable for use in Tanzania.

3 Community Development Trust Fund - Handmills in Tanzania

Summarized from:

*Private Communication,
CDTF, Tanzania*

The daily chore of grinding or pounding the basic food requirements of a family is a major burden for the women of Tanzania. During the 1980s, following villagization, there was a drive to supply villages with diesel-powered grinding mills. These were provided, frequently on loan terms because they were considered by a wide range of agencies to be suitable for income-generating projects.

Diesel mills were — and still are — very popular with villagers. The success of the mills, however, depends to a large extent on factors beyond Tanzania's immediate control. In particular, they require substantial amounts of foreign exchange, not only for the initial importation but also for the fuel and spare parts to keep them going. Not surprisingly then, the severe economic problems of recent years have adversely af-

ected the economic and operational viability of diesel mills. Many hundreds, particularly village-owned mills, are now standing idle or have broken down. Inevitably, the problem is more severe in those areas which are geographically isolated and which are relatively underdeveloped economically.

Recognition of the extent of the problems of diesel mills has caused many of the agencies formerly involved in their supply to review the position. Most have reduced the provision of mills and some have put a complete stop on them. Such changes in policy have obvious implications for the thousands of villages in the country which do not yet have a diesel mill. The prospect facing the women of these villages is one of either spending a lot of time and energy walking to and from (and invariably waiting at) the nearest diesel mill or of continuing to use the slow and difficult methods which have not been improved upon for generations. In an attempt to solve this dilemma the hand-grinding mills project was set up.

Initially, research was carried out to identify, from a variety of models, a particular type of hand mill best suited for use in village conditions in Tanzania. Areas for testing the mills were determined by the range of food crops grown, i.e. maize, sorghum, and millet, and the absence of motor mills in a village was one of the factors that determined its selection. It also reflected CDTF's commitment to direct attention to the poorer and/or remote villages.

In examining the social acceptability of handmills CDTF was interested in finding out whether or not the villagers preferred them, and also in investigating ways in which the benefits of handmills could be enjoyed by all the villagers and not just a minority of them. From the beginning it was recognized that there are financial and social differences between individuals

SECTION 4

which could affect the general acceptance of handmills. Thus, a large part of the work was directed towards searching for and then strengthening an ownership pattern that would enable all sections of the community to participate in and benefit from the project, and a decision was made to encourage communal ownership.

A principal objective of the project was to encourage and facilitate the participation of women. CDTF wanted to prevent the introduction of handmills from having a negative effect on women. For example, in the vast majority of diesel mill projects women are reduced to passive recipients of a service which is entirely controlled by men. However the idea of treating the project as a 'women only' activity was rejected because of the fear that this would merely emphasize the current isolation of women from the mainstream of village (and national) development.

The project was implemented in five mainland villages. The villages selected were divided into two categories: those that had been suggested by others active in the area on the basis of their need/remoteness, and those that had already identified grinding as a problem and had put forward applications for a diesel mill.

In initial village meetings the villagers were given the opportunity to hear for themselves the background to the project, its purpose and duration, and what would be their rights and responsibilities in conducting the trials. Models of handmills to be used were displayed and short demonstrations on how to use them were given. After a long question and answer session the villagers were asked to decide whether or not they wanted to take part in the project.

The next meeting, held at the co-operative group level, was to decide at which homesteads the mills would be installed. At this level, the interest of the villagers was very high and attendance at meetings good.

During these meetings it was emphasized that selection of a household did not mean the mill would become the property of that household — rather, that the mill was the property of co-operatives and was being placed with one of their members in trust for use by all. While every member had a right to use the mill, they were also reminded that they had a joint responsibility to build a shelter for it, look after it, and prevent its misuse.

The mills were set up outside, so as to facilitate easy access by all with a minimum amount of disturbance to the householder. Installation was done by the villagers. CDTF remained in the village for one week after installation for intensive supervision. Because the mill was new and the villagers inexperienced in using it, a great deal of attention had to be given to providing training on usage and maintenance. In particular, it was essential that they became totally familiar with the purpose of the grinding regulator, which controls the fineness of the grain and the energy required to operate the mill. Frequent guidance on how and why to adjust it was necessary.

Within a few days of installation a second meeting was called to discuss the issue of maintenance. There was a need for villagers to develop the habit, as well as to acquire the skills, of looking after the mill, for even as simple a machine as a handmill requires regular attention, cleaning, greasing, and so on. Unless specific individuals are given this task there is a danger that each user will leave it to someone else until the machine breaks down. An unpaid maintenance team of two women and one man was selected by the group from among their numbers. A day of intensive instruction was given to the three people concerned, each in turn learning to completely take apart and then reassemble the mill.

The handmills were on trial for 4-6 months. At the end of that period a further

SECTION 4

village assembly was held to decide which, if any, of the handmills were satisfactory and whether or not to take up the option of buying some or all of them. Much still remains to be done including decisions on the ownership pattern to be followed in the future, how future mills will be paid for, and what form of system should be adopted to pay for spare parts and ensure their supply. Although the village, as an institution, accepted this responsibility in the trials stage when the number of mills was small, and therefore easy to keep an eye on, it is doubtful whether it will be the most suitable implementing authority as the project grows. Alternative or supplementary structures are needed and it is the process of identifying them and making them function that is the next challenge.

Diesel/Electric Powered

4 Community Development Foundation, Cornmills in Honduras

Summarized from:

Fennelly Levy, M.

Bringing women into the Community Development Process: A Pragmatic Approach,

Occasional Paper no. 2

Save the Children

South Honduras is the most impoverished area in one of the poorest countries in the western hemisphere. Three-quarters of the rural population hold a mere one-tenth of all cultivated land. Over 70% live in settlements of less than 2000 people.

When the Community Development Foundation (CDF) came to the remote village of Esquimay, they found it situated on a plateau, surrounded by dry, hilly terrain

that afforded one harvest a year for sorghum, beans, and corn. Vegetable gardening simply did not exist. Men would return from long, hot hours in the fields listless and exhausted.

The primary source of income for Esquimay was the sale of rosquillas, hard biscuits made from corn and cheese. Women would have to rise at four in the morning to grind the corn and prepare the dough. Grinding alone would consume such a tremendous amount of time that the supply could only satisfy part of the demand, which was in the hills and towns, some of them 17 kilometres away. The women did all the marketing themselves, making the long journey only after they had baked enough rosquillas.

CDF assistance had been requested by a housewives' club led by a young woman named Lucinda, who had heard that the agency was working with other villages in the area. After hearing a description of the village's economic situation by the club, CDF staff surmised that the community might identify its key development issue as increased income through better rosquilla production. However, they realized that first the whole community, men and women together, would have to see itself as an economic unit, then it could realize its potential as a decision-making unit and collaborate on economic objectives and plans of action. A community meeting in the village church was called at CDF request to determine how this process would best work. As expected, the men were somewhat resentful of women being included, but they seemed to accept it provisionally, probably because they realized that it was a housewives' club that had invited CDF there, and because they were interested in what would happen. CDF staff saw that for both men and women this was to be a strange, new bilateral planning process, and that it would be thoughtful but not ex-

SECTION 4

cessive guidance that would put people at ease with it.

The community was asked to identify their first development objective and their reply was not what the planners had expected. They said that they wanted to build a new school for their children, because the building they had, with a government-supplied teacher, was in a poor condition. This might have been what they thought a voluntary agency would like to hear, that their prime concern was making their children happy through education and that education alone superseded all other priorities in their minds. Nevertheless, CDF planners were not there to reject their priorities, but to get the community to think systematically through its conclusions, and evaluate them in terms of maximum community benefit. Will this money for a school building replenish itself? No, it disappears when spent. Then how would you raise that much money if you were to finance this project yourselves? Through an exploratory discussion they revealed that their only source of income came through the sale of rosquillas and that they had a good market but poor production capacity. Now they were considering means of increasing output to augment their income.

However, before CDF would discuss any labour-saving technology, the community had to identify the major obstacle to full production, and for this the women's role had to be considered carefully. In addition to producing and selling rosquillas, women were responsible for household duties and for caring for their children. Washing clothes and drawing water were endless chores, especially when coupled with the steep climb from the stream back to the village. It was becoming apparent to the community that these responsibilities in themselves were very extensive and that when combined with the rosquilla trade they left the women no free time. How would in-

creased corn production through intermediate farming technology boost rosquilla output when women were already overloaded with work? It was obvious that any labour-saving device would have to alleviate the women's hardship.

The community reasoned that the long hours required to grind the corn caused the most severe strain and was also the major obstacle to increased production. CDF therefore donated the down payment and made a loan of the first instalment for the motor-driven mill which grinds corn in a matter of seconds. Women pay the mill operator a small fee per kilo, which is deposited in the community treasury. Budgeting with CDF, the community has estimated that the \$1000 cost can be repaid within a year and a half. In fact, the treasury will have sufficient funds for a new mill long before the end of this mill's ten-year life span.

Esquimay's accounts show that rosquilla production now exceeds 10,000 per day. Women's work in this area has decreased appreciably, and they are free to become involved in other activities of their own choosing. Furthermore, the process of selecting appropriate small technology and operating it for the common benefit has greatly increased this village's initiative in planning other endeavours. For instance, at community request, the president and other members of the committee have been building an extension to the community centre. With CDF assistance, they began a small co-operative store within it and now they are ready to expand this. The construction work is being completed without remuneration and all store profits are deposited in a community fund which exists in part to pay for the children's education.

Esquimay is well aware of the fact that CDF's presence could, for any number of reasons, terminate in the near future. How-

SECTION 4

ever, the recent improvements that the community has implemented on its own behalf have given it confidence in its own planning capabilities.

Some will say that sex roles have not undergone revolutionary changes here, but it must be recognized that the community has definitely come to some eye-opening realizations: the people recognize that both men and women share an economic stake in the betterment of their lives and they know that there must be communication between them before any planning can occur. Through their own assessment, the people have seen that the roles of men and women must be equalized, both in workload and in decision-making authority. They know that as a community they have not only hope for but influence on their children's future.

5

Women's ('Santanée') Mill Organization in Senegal

Summarized from:

Loose, E.

Women in Rural Senegal: Some Economic and Social Observations, 1979

In Senegal, large amounts of grain are traditionally threshed by a work group or 'santanée'. The village women respond to an invitation to help thresh one woman's grain and bring a tubful or two of their own millet to be threshed at the same time. The 'santanée' usually continues all day, with some women coming and going as their other responsibilities require. Payment to the threshers includes a midday meal and the assurance that they will also be able to recruit help when they have a large threshing task.

With the arrival of the thresher, dehuller, and mill in one project village, the threshing of the family's grain became the realm and financial responsibility of the men. This is probably due to the heavy work involved in

bringing bundles of grain heads to be threshed and subsequent handling of the large quantities of threshed grain. The women were the obvious benefactors in this case, being freed both from the manual threshing task and the expense of employing the machine. It is hard to say why the men took the threshing activity upon themselves with the advent of the machines, yet for the most part did not feel their responsibility extended as far as mechanical dehulling and milling of millet. One clue may be in the ease of these tasks. Maize, for example, which could be ground at one time in one large quantity, was taken to the mill and paid for by the men. It is conceivable that most men did not consider the processing of relatively small amounts of millet for daily consumption as a task worthy of their attention, although they would probably pay for processing any millet specifically destined for sale. In as much as men usually sell millet in the form of threshed grain (dougoub), once they have paid for mechanical threshing for their entire crop, they are free to sell it as they wish.

Users of the mechanical grinder for millet fell into two general categories: regular and irregular users. Paying for the services of the grinder was in many households the wife's responsibility: if she had some cash, she would have that day's millet ground by machine, if not, she would pound. These women were the irregular users. Those women whose husbands paid for the use of the grinder were the regular users and pounded only on days that the mill was not in operation, chiefly Saturday afternoon and Sunday. Probably the most significant factor in determining which women were frequent users of the grinder was whether or not the husband paid.

Many women brought their grain to the centrally located mill on their way to perform some other task such as drawing water and returned later to pick up the flour. It is interesting to note that some received

SECTION 4

more and some less than their due of flour. This was because the women brought their grain to the miller wet and the moisture caused some of the flour to stick in the machine. Then, when this flour dried somewhat, it became dislodged and came out of the machine along with the grain currently being processed, which might have been several bowls later. This woman would receive more flour than she should. The miller asked the women to allow the grain to dry before bringing it to the mill, so as to reduce the sticking problem. The women generally did not comply, however, because they moistened the grain in dehulling so as to produce a cleaner product, and then brought it to the mill in whatever state it was in when they wanted it ground. Perhaps they recognized that even if they lost some grain on one day due to this problem, they might gain some the next day.

It was found that very few women used the dehuller because they found it too expensive. Most women could afford either dehulling or milling. Women preferred to pay for machine milling rather than dehulling because milling by hand was a much more time-consuming and tiring task than dehulling by hand. They also found that the machine produced more broken grains than hand dehulling. Machine dehulling and milling resulted in a product of lower quality, containing more bran, than the flour produced by hand dehulling and subsequent machine (or hand) milling. Many of the women interviewed stressed the low quality of the product produced by the dehuller. They claimed it left too much bran in the flour and some women who used the dehuller pounded the grain slightly with water after machine dehulling and winnowed it to remove the remaining bran. Some women also complained that the dehuller broke too many grains, presumably a problem if the women wanted to pound and winnow the grain again by hand before grinding. The dehuller and mill were donated by IDRC in 1977.

6 Diesel Mills and Women's Education in Burkina Faso

Summarized from:

Brenda McSweeney
AT Journal, Vol 9, No. 3, 1982

The Upper Volta/UNESCO/UNDP Women's Education Project, a non-formal education programme, launched as long ago as 1967, is as relevant today as it was in the 1970s, mainly because its 12-year duration has allowed a thorough evaluation of its objectives and achievements. In addition, the technologies introduced by the project tackled the three work areas which were then and still are the most burdensome for rural women in the Third World: crop processing, collecting and carrying water, and gathering fuelwood.

Following the failure of many formal education projects introduced to try to involve rural women in significant numbers, the non-formal Women's Education Project was launched with two main objectives: to gather data on the barriers preventing the full access of women to education and to initiate experimental programmes to overcome these obstacles. As well as addressing the issue of women's excessive work-loads, the project also tackled the problems of poor health and low standard of living: all factors which preliminary sociological studies had pin-pointed as fundamental problems.

Three labour-saving technologies were introduced, with the idea that the time saved through using these could be devoted to training the women in improved agricultural methods, health and civic education, income-generating activities, and literacy. Dynamic village women and traditional midwives were chosen by the villagers to attend special training courses in knowledge dissemination. Each village association organized by these women was given a

SECTION 4

mechanical grain-grinding mill and carts for the transportation of wood, water, and crops; easily accessible wells were dug, too. The plan was for the village women to utilize the equipment on their own behalf, but to have the opportunity to rent it out in order to earn revenue for the co-operative. From 1976 to 1979 an evaluation of the project was carried out to establish whether lack of time did, in fact, constitute a significant barrier to educational activities; to determine the effectiveness of the appropriate technologies introduced; and to assess how far the project had increased the participation of women and girls in education programmes. The conclusion was that women worked for longer hours than their husbands, averaging over twice as much time on production, supply, and distribution tasks, including food processing, and spent twice as much time on these activities as on the household tasks of cooking, cleaning, washing, and child care. With only 1.3 hours of free time in the women's first 14 waking hours, it is little wonder that the project team gave priority to the introduction of technologies to lighten work-loads.

The grinding/pounding activity absorbs some 84% of total food processing time or an average of more than 1.75 hours a day. Following the introduction of mechanical mills, it was discovered that 14 of a sample of 30 women in the village used the mills to grind their grain. Lack of money was the most frequent reason given for non-use, even though the fee for operating the mills was usually fixed by the women's group and was nominal in comparison with prevailing commercial prices.

The mills were portable and fitted with a 4.5 hp motor. On average, they were grinding 5-12 kg of grain per hour, 54-90 kg per day. All the mills were at the disposal of the women, and the people designated to look after them were either chosen by the women or were the women themselves, except in

two villages where they were kept by the sons of the chief. The mills seemed to reduce the time spent on pounding and grinding activities, and although the time saved tended to be used to do other household tasks, the decision to introduce mechanical mills to reduce the time taken to process grain was clearly a sound one. However, in 1978, six years after the introduction of ten mills in the Kongoussi zone, only five were in working order. Breakdowns were mainly due to inadequate maintenance, such as forgetting to put oil in the motor. Rural mechanics were subsequently trained to maintain the mills. But unfortunately, the delays encountered in acquiring spare parts are still a problem, not to mention the cost of spare parts themselves. Whereas the government had moved, in collaboration with ILO/UNDP, in favour of local production of ploughs, similar results concerning the local production of mills had yet to be achieved. Meanwhile, project personnel were ever on the lookout for less sophisticated devices.

7 Mechanized Rice Hullers in Indonesia

Summarized from:

Dauber, R. and Cain, M.
*Women and Technological Change in
Developing Countries*, 1981.

On governmental initiative, mechanized rice hullers were introduced in Indonesia in 1970-1. The diffusion of hullers occurred very rapidly after 1970, and by 1978 only about 10% of paddy was being hand-pounded, mostly for family consumption. A Japanese model that uses rubber rollers is common in Indonesia. Pasawahan, a village in West Java, has three milling centres that use Japanese hullers and polishers. Rice must be processed through the ma-

SECTION 4

chine four to eight times. It is first poured into the top of the huller; the hulls and excess material (bran) then travel through a pipe and are discarded outside the building. The hulled rice is then run through the polisher three or four times.

During the last five years, the mill has taken over work traditionally done by women: two examples illustrate these changes. A former rice trader, now turned mill owner, stated that he used to employ eight women to hand-pound his rice. Four women working five hours could hand-pound 100 kg of gabah. This rice trader could buy 200 kg per day of gabah. The women's wages were 10% of the rice they provided, which amounted to just under two litres of milled rice per day. Thus, over the harvest season these eight women earned perhaps sixty litres of milled rice each, or enough to feed themselves for four months. In Kendal, Central Java, a farmer said that in the past there were more than 100 women 'hand-pounder' labourers in his village. Now they have no work.

Estimates of jobs lost range as high as 1.2 million in Java alone and as high as 7.7 million in all of Indonesia as a result of the introduction of the new technology. It is estimated that the loss to labourers in earnings due to the use of hullers was US\$50 million annually in Java, representing 125 million woman days of labour.

The rice farmer pays less to the mill and the process is much quicker, but the women are now forced to work longer hours at other jobs, if such work can even be found. The shift from a traditional technology to a more modern one has eliminated one of the more important sources of income for landless villagers. Thus, although the adoption of the use of HYV, tebasan, sickles, scales, and rice hullers has served to increase rice production in Indonesia, it has not helped to solve problems of unemployment and income distribution in Java. Rather, it ap-

pears these problems have been exacerbated. Furthermore, there is little evidence to indicate that the rural unemployed are being taken up by work opportunities in the cities, or have been able to find replacement sources of income in the rural areas.

8 Rural Rice Hullers in Bangladesh

Summarized from:

Scott, G. and Carr, M.
The Impact of Technology Choice on Rural Women in Bangladesh, 1985;
Khan, S.
Evaluation Report on Trainers' Training Programme for Women Group Leaders of Grameen Bank Project, October, 1982

The most significant impact of the spread of rural rice hullers in Bangladesh is the effect they have had on employment. The average rural huller has a capacity of 160 maunds per day, (1 maund = 37.3 kg) as opposed to the dhakis (traditional manual rice huller) capacity of 1.3 maunds per day. This means that every mill (if working at capacity) displaces 123 dhakis, each of which provides part-time employment to 2 to 3 women operators. A significant number of women have lost a traditional source of productive part-time employment as a result.

Three different categories of women are involved in the milling process. First, there are the female members of large surplus farms. In general, they have benefited from the change in technology since although they did not have to do dhaki work themselves, they had to supervise hired labour. If they now use the mill they have more leisure time and their families have benefited economically as husking by rice mill is cheaper than paying dhaki labour. Second, there are female members of subsistence farms who previously had to do dhaki work themselves if they did not use a rice mill,

SECTION 4

they too will have benefitted since they will have been relieved from a time-consuming and physically demanding task. Their level of mill use will however, be restricted by their ability to pay cash for milling and in some cases transportation costs. Third, there are wage-labour women from landless families who do dheki work to augment family income. Due to the lack of alternative sources of equally remunerative employment, these women and their families have suffered badly, in the absence of initiatives aimed at helping them to cope with the introduction of new competitive technologies.

One way of assisting such women is to find income-generating activities other than rice hulling for them. Another is to help the women control and exploit the technology rather than letting it exploit them. One example of the latter response is the formation of the Purba Pol Mogra Women's Association Rice Husking Mill which was set up with a Grameen Bank (GB) loan in 1982.

For some time, Nurjahan Begum had cherished the idea of initiating a joint enterprise. She attended several workshops and discussed the issue with other borrowers and GB workers. When she went to the Madhupur Workshop, she was inspired by the success story of the Narandia Women's Association which had just set up the first all women rice husking mill, and she started an opinion campaign in her own area in favour of setting up a similar enterprise.

During the first few weeks of her campaign, most of the group members considered it was an impractical proposition, but later they were convinced. Grameen Bank workers also stressed the importance of group-based activities and the idea gained more and more support. Forty women divided into eight groups contracted a loan of Tk. 24,000/- from GB to set up a husking machine. The loan was Tk. 600/- per capita and the rate of repayment was Tk. 12/- per instalment.

The machine was installed in a cow shed in the yard of Nurjahan's house. The group members made another shed for Nurjahan's cattle, and they all joined hands in setting up the machine house. They themselves supplied the necessary materials for the construction of the shed except for bamboo and corrugated iron sheets, which they bought with a loan from their group fund. They broke about 50 maunds (3 tons) of rock into small pebbles for flooring.

Nurjahan trained herself to operate the machine and in turn taught other members. There is an 8 member committee to manage the rice mill. Ordinary members participate in cleaning the machine house and changing the water of the reservoir. Nurjahan and her companions are very eager to eliminate dependence on others for running the machine; she has already attained some proficiency in operating the machinery and has also recruited apprentices.

The machine uses diesel fuel. One gallon of diesel is needed to husk 20 - 25 aari of paddy (1 aari = 16 seers = approx 15 kg). They charge Tk. 1.50 for husking 1 aari of paddy. The rate has been fixed according to the price of diesel and the existing market rate. Several aaris of paddy are collected before the machine is started; so far the highest daily husking stands at 67 aaris.

Since the setting up of the husking machine, trade in paddy has received a boost in the neighbourhood. At present, there are 4 women who are full-time rice traders and their income has gone up. Local men have also started to come to husk their rice in this machine when their machine in the market place becomes inoperative owing to electricity failure. As this happens very frequently, the demand for the service of Nurjahan's machine is increasing steadily.

Many of those who opposed the setting up of the mill in the beginning have now become patrons and clients. People come from far away to see the women-operated

SECTION 4

rice mill. It is raising hopes and, though it has not yet attained the break-even point, it is a source of inspiration for others.

Every week Tk. 480/- must be paid back as bank instalment. This requires about 60 – 65 aaris of paddy to be husked every day. The present rate is only about one third of this, but all the signs are that it is going to be a successful venture in the near future.

Alternative Energy

9 Solar Powered Mill in Burkina Faso

Summarized from:

Hemmings-Gapihan, G.
Baseline Study for Socio- Economic Evaluation of Tangaye Solar Site, 1981

In Tangaye, a village with a population of about 2000 inhabitants, women are responsible for processing grain for the preparation of all food consumed in the village. Besides domestic use, grain is usually ground for the purposes of brewing beer and baking cakes commonly sold in the market.

There are two commercial mills in the vicinity. In a village-wide survey it was reported that, though infrequently, almost all families had used commercial mills at one time or another. Approximately 61% of the families used the mills only after 1975, even though they had been there since 1968. The highest frequency of use (55%) occurred during the rainy season. Large quantities of millet, more than eight litres, were usually ground at this time.

Regular users of the mills were generally vendors who sold in the market where the mills are housed. The majority of the residents of Tangaye availed themselves of the mill only on special occasions.

Daily observations at mill sites revealed that more than 90% of the customers utilizing

the mill were women, mostly residents of the village in which the mill was housed, coming to grind small quantities of grain for the evening meal. This proved that the services of the mill were still in great demand even for women who did not market as regularly as vendors.

The mills were powered by imported diesel oil, and the price of milling services increased with the rise in fuel cost. As a result of this, the millers lost so many customers that they were forced to open their mills twice a week, on market days, rather than every day as they had done in the past. Few people in the area could afford the increase in milling rates. Buying fuel makes up 50-60% of the monthly budget of running the mill. Clearly an inexpensive source of energy was essential if the residents of the area were to have access to such labour-saving devices.

In 1978, a solar unit, the first of its kind, was introduced to the village of Tangaye. The unit consisted of two components: a solar cell array designed to transform solar energy into electricity, and a battery designed to store electricity. This photovoltaic system, as it is called, supplies the electric energy necessary to power a food grinding capacity of 92 kg of sorghum per hour. Millet and maize may also be ground, though at a reduced hourly capacity.

Diet, food preparation, and level of consumption vary significantly from the dry to the rainy season. During the dry season women spend at least 60% of their working day processing food and fetching water. In the rainy season, however, they devote the greater part of their day to farming and thus spend less time on processing food, including occasionally cooking whole grains, rather than making flour, and grinding a coarser rather than a finer flour.

It was established, therefore, that the mill would be a great help to women in the dry season when the volume of food process-

SECTION 4

ing was at its height. During the rainy season the presence of a mill might affect the quality of the food consumed rather than contribute to any great degree to the time saved in processing, especially considering the time taken to travel to the mill and waiting to be served.

A system of managing the mill was devised so that the villagers would be able to invest in it and share in the profits from the services provided. The idea of not charging for the services of the mill was dismissed because of potential conflict and monopolization of resources by a certain segment of the population: it would be impossible to equalize access to the mill without excessive policing.

Those willing to invest in the mill by providing services and the money for the operating costs would have a share of the monthly profit, part of which has to be put aside for future investments in development projects within the village that they themselves decide upon. In this way, it was hoped that private investors and the entire community would benefit from the profits of the milling enterprise.

For a system like this to work, it is absolutely necessary to have input from the population. This requires an intensive information programme permitting villagers to criticize the system, detect possible flaws, suggest improvements, or even propose other management plans better suited to their needs.

Even before the mill is installed, it is necessary to inform the villagers of the implications of housing such a system in the village. They should then be asked if, given the risks, they would want it installed. They should then decide, knowing the full implications of housing such a unit. The villagers should make all the decisions relating to the organization of labour, the sharing of profits, etc. Last, but not least, provision must be made for maintenance

and repair of the mill. Permanent members of the village, particularly those most concerned with the services offered (women and vendors) should be trained in the proper maintenance and repair of the mill and pump.

Locally - Produced Hullers/Mills

Diesel/Electric Powered

10 Locally Manufactured Mills in Kenya

Summarized from:

*Private Communication,
VSO Field Officer*

In South Nyanza, grinding mills, referred to as 'posho mills' are locally manufactured in Gilgil. All the mills are owned by men and are primarily commercial ventures. A women's group tried to purchase one of the mills but found the cost prohibitive (approximately Ksh 30-35,000, 1986). They are trying to get a loan, but most of the women have only just started to have bank accounts and so are at the initial stages of becoming acquainted with handling large sums of money.

Women use the existing mills as service mills because it relieves them of grinding chores. A visit to the mill is a social occasion for them, despite the long walk, as they can meet other women there. As a result, markets have grown up around the mills and people are taking advantage of them to sell their produce. Some of the mills charge high prices, so it is not unusual for women to walk greater distances with heavy loads to reach a less expensive mill. However, with large families, service milling can be very expensive, so women still grind using traditional stones and use the mills only when they have some spare money.

SECTION 4

11 Locally-manufactured Millet Mill in Senegal

Summarized from:

Unicef News 1983

In the village of Morry Laye in Senegal, after a harvest that was slightly better than that of previous years, the villagers decided to buy a millet mill. Of course, Morry Laye is not the only village with a mill, but this is a very special one, made (apart from the motor that powers it) by a village craftsman. The locally-manufactured millet mill is an improvement over the imported mills installed elsewhere, according to the Morry Laye villagers.

Traditionally, before the millet or sorghum is ground, it is either washed or moistened to trigger fermentation of the grain. This gives food a better taste, especially in the preparation of lakh (millet porridge) or tiere (couscous).

'You see, imported mills are different from ours' says one of the women in front of the hut housing the millet mill. 'You can't use wet grain in the imported mills. You must always use dry grain and this doesn't give the same taste. Even my husband complained about it — he doesn't like the imported mills. Some women even have to resort to old-fashioned pounding methods because their husbands won't accept the new taste.' Apart from the taste, there are plenty of other problems with the imported mills. For instance, the sieves may be too small and they may clog, with the result that it takes a tremendous amount of time to mill the grain, and fuel consumption is considerably increased.

'With our mill we have no problems. We use moistened millet and the flour comes out very white and fine. This did not happen with the imported mills, which gave us a kind of paste.' When asked 'How

long did it take to pound three kilos of millet in the past?' the woman smiles and says: 'With my two daughters helping me, it used to take me two to three hours a day to pound our grain.' Now it takes three minutes. In addition to the time saved, there are many other advantages.

With the traditional system — pounding, winnowing, washing, and pounding again — as much as a third of the grain was often lost. Also, the grain was first separated from the stalk and the latter, although of great nutritional value, was fed to the livestock. With the mill, the stalk is finely milled and eaten with the flour. Local mills can also be used equally well for millet and sorghum and for peanuts and casava. Different-sized sifters can also produce flour suitable for making couscous. The price of the mill, between US \$1,500 and US \$2,000, includes installation, the miller's training, and the maintenance of the equipment for twelve months. This is less than the cost of an imported mill, and far better adapted to the villagers' real needs.

12 Locally Produced Sorghum Mills in Botswana

Summarized from:

Gary Whitby
AT Journal Vol 12, No. 1, 1985

In 1975 the Government of Botswana asked the Botswana Agricultural Marketing Board (BAMB) to investigate the mechanical processing of sorghum to remove the back-breaking, time-consuming toil of many women who spend hours pounding the grain.

In co-operation with the International Development Research Centre (IDRC), BAMB installed Botswana's first commercial sorghum mill at Pitsane in 1977 and

SECTION 4

this was working completely under local management by late 1978. By making processed sorghum available, the mill regenerated a demand for Botswana's traditional food, which the imported mealie meal (maize), had been replacing. Clearly, even at a cost greater than the mealie meal, the people of Botswana preferred sorghum, or mabele as they call it. The commercial mill was large, however, capable of processing four to five tonnes per day and it relied on large supplies of sorghum from BAMB and on a road and rail network, in order to operate efficiently. Realizing this, and supported by reports on consumer preferences, the Rural Industries Innovation Centre (RIIC), in further collaboration with IDRC, set about designing a smaller and more versatile unit for the varying needs of rural communities who grew their own sorghum. Between 1978 and 1980 RIIC redesigned, developed, and tested various prototypes of a scaled-down dehuller. The eventual outcome was a machine, smaller than the Pit-sane model, which could operate at high speeds and process the same sort of quantities. In 1979 the RIIC installed one of their models in their home village of Kanye and later that year another at Pelegano Village Industries in Gabane for trials. A survey in Kanye clearly showed the need for such machines, as did later reports on the sorghum mills placed elsewhere.

A seminar was held in September 1979 for potential investors in the equipment, with RIIC taking orders. A mill owners' handbook and a promotional booklet were produced which described the benefits of an investment in the equipment as well as giving information on how to run a business as a mill owner. The first course for mill owners took place in February 1980 and production of three dehullers began early that year, followed by eight more later in 1980. Sales to date total thirty-six units with firm orders for eleven more.

With such a rapid development and uptake of a technology it is not surprising that there were a few problems with the early machines. A Post-Harvest Technology Programme was set up by RIIC's parent company, Rural Industries Promotion (RIP), to investigate claims and counter-claims of incorrect user practices and low quality manufacture. The outcome was a need for technical refinements, a need for educational and organizational support for the mill owners and a need for an infrastructure to provide quick and effective support (such as the supply of spares, repair and maintenance). Perhaps more important, however, was the establishment of the Botswana Mill Owners Association in 1983, for the owners to share a forum of mutual interest.

The RIIC design lends itself to batch service milling as well as continuous commercial milling. The RIIC handbook recommends the combination of service milling in the morning and commercial milling in the afternoon. Thus villagers can either buy sorghum meal or bring their own grain for milling.

Service milling for women means relief from a daily and laborious task, as long as they are able to afford it. A survey in 1981 concluded that the mill could release up to four hours per day of a woman's and her children's time. It indicated that this was usefully spent in 'productive' activities such as mixing clay, weeding, knitting, or beer brewing; in the case of children, it was spent studying and reading.

The complete mill comprises a dehuller, to remove the bran, and a hammer mill, to grind the dehulled grain into meal. Currently the system costs about P12,500 of which P5,500 is for the diesel engine. Finance is available from the National Development Bank, the Botswana Government's Financial Assistance Policy, and other sources. The thirty-six mills sold so far are run by co-operatives, brigade cen-

SECTION 4

tres, and private individuals, providing over 250 jobs, as well as the numerous benefits already mentioned.

The credit for this success story is due to the Rural Industries Innovation Centre, for maintaining the momentum of interest through many changes of personnel over the period of the project. Many other institutions suffer from personnel changes every two or three years and a general lack of interest among new recruits in taking over where someone else left off. In this example, however, it was clear that the technology was well researched from the basic need, through consumer preference, technology choice, and carefully monitored implementation, to the impact of the technology on the people it was designed to help. An indication that RIIC was correct in evaluating technology needs was highlighted in the setting up of the Post-Harvest Technology Programme with continued interest in the technology being demonstrated by the establishment of a Botswana Mill Owners Association.

Cereal Product Businesses

13 Bomani Baking Cooperative in Kenya

Summarized from:

Reports Magazine, July 1980

The women of Bomani were challenged by the staff of the nonformal education project in Kenya to identify the needs in their village, and then to work together to fulfil that need. The answer, the women decided, was to start a bakery. They earned the money to get started by selling their traditional handicrafts – *vivywele* and *vivangi* (small baskets and weaving) – through Tototo Home Industries. The women hired help to build the big

brick oven. Two members of the group went to Kanamai to learn how to bake bread and returned to train the other women of Bomani. The women elected a treasurer, pooled their money to buy supplies and worked out a schedule for sharing the baking and marketing of the bread.

The bakery has turned out to be far more than an activity in economic development for Bomani. Health, nutrition, sanitation, family life, business skills, co-operation between men and women, and leadership in the village, were all affected by the women's project.

For a start, the bakery had to be built according to government specifications. A latrine was required by law. The Ministry of Health set standards of cleanliness for workers to follow: workers had to be immunized against certain diseases. When good bread became available throughout Bomani, the children, who had to walk a long distance to school, had something good and wholesome to carry along for lunch.

The men were impressed by what the women had done and many began to help. Some did so by 'allowing' their wives to come to the training sessions, others contributed money or labour. The women have learned to keep records, manage their money, and use the financial services of a bank. Many are now learning to read and write and to use more sophisticated mathematics in accounting for their income and expenses.

Perhaps the most important change for Bomani's future, however, is that new patterns of leadership and responsibility have been established among the women. They have learned that they can carry out an activity that is important to their community. They have learned to work together, to assume and delegate responsibility, and to deal with authorities and agencies that provide access to the resources they need for further activities. More importantly, they have learned to believe in their own abilities.

SECTION 4

The original idea of an oven has grown by now to include a second oven, a bakery building, and a tea and bread kiosk. The women are marketing their bread in other villages. Some women continue to make handicrafts for extra income and some have learned new crafts. They are now talking about starting a poultry project to provide eggs for the bakery and an additional source of income and food. It hasn't been easy, of course. Differing viewpoints had to be reconciled, and raising the money needed was very difficult. The group met weekly and there were continuous problems with those who arrived late or failed to attend. The women were strict, however, about their agreements, and with those who failed to keep to them. Primarily, it was the women's growing enthusiasm that kept the project going. Both the co-ordinator and the facilitator fell ill; each was absent from one meeting and unable to lead the group in others because of 'fever and coughing'. The latrine shed the women were building fell down and they had to start all over again. There were problems with the bread at first, and the women who had originally learned to make it had to go back to Kanamai to learn how to measure ingredients. The women kept at it and the project began to prosper. They decided to keep their money in the bank, rather than at the treasurer's home, in order to earn interest.

Today the group's bread is in demand and, the women are proud of their achievement. They have gained a lot more than a way to earn some money.

14 Roman Catholic Mission Bakery in Botswana

Summarized from:

Unpublished information, ITDG

A bakery was established by a Roman Catholic Mission which ran training courses

for women, who were unable to go to secondary school either because of lack of good academic grades at primary school and/or because of lack of money. The sister in charge of the cooking/baking classes used to sell some of the surplus produce to people in the village. Out of this evolved the idea of building a bakery and employing some of the ex-trainees from the school. Funds were obtained from the US Embassy Small Projects Fund by the Mission. Once the premises were completed, a manager was recruited to run the bakery and train at least 2 of the women in basic business administration skills, and practical management of the bakery.

In a period of 6 to 8 months, sales increased about five-fold. Small business owners came to the bakery and placed regular orders for loaves and scones, and even collected them daily by vehicle, while bread was delivered by hand to some nearby stores. For a while it was hard to cope with demand due to the small unplanned premises and the limited capacity of the oven (it would only turn out 40 loaves at a time).

The bakery employed 10 women. When the trainer was recruited the women were receiving 36 pula per month, the manager 64 pula. About 8 months later the wages were 66 pula and 98 pula. The idea was to turn the bakery into a co-operative after it had been established for a while. The trainer discussed this idea with the women eight months after arriving. However, it seemed hard for the women really to understand what a co-operative was, and it was clear that they preferred to be employed rather than to employ. They saw the mission as their employers. Promoting the idea of women as decision makers was not easy. On the other hand, they organized themselves very well in performing and co-ordinating the various daily tasks in the bakery. About 14 months after the bakery was established bread sales dropped by 60% in

SECTION 4

less than a week, and over the next few months continued to drop. A large bakery which had been operating in the capital of Gabarone 370 km to the south had decided to expand production and sell bread to the whole eastern side of Botswana. The main reasons why the Mission's customers decided to switch to another supplier were as follows:

- The bread was slightly cheaper — the large bakery bought their flour direct from the mill in Pretoria, while the flour bought by the mission bakery passed through two wholesalers, each one taking a small cut.
- The bread was tightly wrapped in plastic by machine, making it look attractive, while the Mission bakery depended on small cheap clear plastic bread bags.
- The Gabarone plant delivered the bread direct to each shop, while theirs was delivered by hand, in baskets, or was collected by the customer.
- The shelf life of the bread produced by the larger plant was about 5 days (because of preservative chemicals) while the Mission bakeries' bread only remained fresh for 2-3 days.

15 Royal Tropical Institute Weaning Food Projects in Benin and Sierra Leone

Summarized from:

Dijkhuizen, P., Korthals Altes, F. W. and Merx, R.

A New Approach to Small-Scale Food Production from Indigenous Raw Material in Tropical Countries, undated.

It is generally recognized that in Africa, as in other parts of the Third World, many infants in the weaning period — the age be-

tween 6 and 30 months in which the infant changes from breastfeeding to the family pot — suffer from protein-energy malnutrition. Therefore young children need a special weaning food, providing sufficient energy, proteins, and other nutrients to supplement their diet.

In many countries recipes based on local ingredients for home preparation have been developed but have yielded very limited success. A number of reasons inhibit mothers actually preparing weaning food at home: lack of understanding of the necessity of a weaning food, ignorance of preparation techniques, seasonal availability of ingredients, as well as lack of time, fuel, and money. On top of these practical difficulties, home-prepared weaning foods have lower prestige and there may be other restricting cultural food habits. A low-cost ready-made weaning food of high nutritional quality can overcome these problems. Such a product, if it is acceptable to and affordable by broad sections of the population, can make an important contribution to improving the health of young children.

In the 1970s a number of projects were established in Africa to manufacture weaning food locally. All were characterized by complex production processes relying on sophisticated technology and high investment, at best a simplified Western industrial process, at worst a complex project unsuited to local conditions and depending on expert management and maintenance. Such projects sometimes required imported raw materials which used up foreign exchange. The level of management competence required for their proper operation was unrealistically high for prevailing conditions.

With all these adverse factors it is perhaps not surprising that almost all of these projects failed. Even during the initial enthusiastic start-up phase it became appar-

SECTION 4

ent that such projects could not become self-sufficient. Either the production plant or the final product required some degree of subsidy because the weaning foods were generally too expensive to reach any but a small elite of consumers.

At the Royal Tropical Institute, it became apparent that to have any chance of success where others had failed, it was important to develop a different approach that met several principal criteria.

- A project should adapt to local conditions in the sense of using familiar patterns of work – domestic, craft-like, and collaborative.
- It should be small in scale, easily understood, and not make too high demands on local management.
- The final product ought to be acceptable to local tastes and, most importantly, be widely available at a price most people could afford.

Following these criteria, small scale semi-industrial production units were established in Benin and Sierra Leone. They did not require sophisticated management or maintenance and they were designed to be self-supporting rather than requiring subsidy. In addition, they were based on the traditional African way of food preparation: made in batches and shared in a group. The process was simple although steps in the production process could be mechanized where feasible, and when a greater capacity was required, the existing set-up could be expanded. This approach has been shown to work in practice. The weaning food manufactured in these plants is made of three basic ingredients with the mixture containing approximately 60% cereals, (rice, maize and sorghum), 15% pulses, (pigeon peas or cowpeas) and 25% oilseeds (groundnuts or sesame). If available, soya beans can substitute for both oilseed and pulses. If required, sugar may be added to sweeten the taste.

Basically the process is composed of five steps: storage cleaning/drying, roasting, mixing and milling and packaging.

Storage

In tropical climates, special attention must be paid to pest-proof storage under hygienic conditions to avoid spoilage. This is crucial when the equivalent of an entire year's production requirements are bought at low post-harvest price to avoid later shortages and price rises. Cheap, effective, and simple methods are available such as the use of oil drums, which are generally available and can be hermetically sealed to be damp, insect, and rat-proof.

Cleaning and Drying

The quality of the final product is largely determined by the thoroughness of cleaning. If machinery is used, hand cleaning should always be used to finish the job. Groundnuts affected by aflatoxins can be easily and safely cleaned by immersing in boiling salted water which turns spoiled beans a different colour so they can be removed. The undesirable effects of soya beans can be easily dealt with by soaking and then steaming. All ingredients that have been washed should be thoroughly dried to avoid spoilage.

Roasting

The roasting process destroys enzymes, insects and bacteria. Thorough roasting improves the shelf-life of the finished product and promotes digestibility.

Mixing and Milling

Batches of beans and cereals, mixed in the right proportions, can be milled into fine flour in a hammer mill. Because of their oily nature, the oilseeds should be milled separately then mixed with this flour in a plate mill.

SECTION 4

Packaging

Good packaging is essential to the final product which is sensitive to spoilage in tropical climates. A suitable material which is often locally available is polyethylene. This gives a shelf-life of about a month. Aluminium foil is better still, but is much more expensive and has to be imported. Buildings should be simple in construction and easy to keep clean. Particular attention should be paid to details like the logical progress of work, easy access to stores, and protection against dust, heat and noise. Building layout should also be designed to allow for future expansion: a capacity of 100 tonne/year is considered optimal; above which management might become too complicated.

16 Babyfood in Tanzania

Summarised from:

New Scientist, Jan 2, 1986

Researchers at the Tanzania Food and Nutrition Centre have found a way of preparing weaning food using the enzymes of germinating grains. In warm climates, grain that is moistened and left for a few hours before grinding starts to germinate (a process known as malting). Flour ground from malted grain is very rich in enzymes which break down starch to short-chain sugars. A spoonful of such flour added to a pot of stiff porridge can in a matter of minutes reduce it to a runny gruel, very rich in semi-digested carbohydrates, which is ideal babyfood.

A Checklist of Questions to ask when Planning a Cereal Processing Project/Enterprise

Following on from the selection of case studies presented in Section 4, it is possible to draw up a list of questions which should be asked by project planners and by decision makers before proceeding with the implementation of a cereal processing project. The following checklist of questions (adapted from ECA Pubs, 1983) will be helpful in designing such a project.

Traditional Cereal Processing

1. What is the extent of traditional and small-scale cereal processing in the area?
2. What does the traditional process consist of and does it tend to vary in different parts of the country?
3. What exactly is the place of women in traditional processing?
 - a) Are they farm women or landless women?
 - b) What role do they play in the different stages?
4. Who owns the raw materials?
 - a) Are there more raw materials available than can be processed in the traditional manner?
 - b) Are there ever any seasonal shortages of raw materials?
5. What is the traditional marketing mechanism and who controls it (e.g. do women have access to markets)?
6. Is traditional cereal processing principally for home consumption or is it also for sale?
— If it is sold what form is it sold in (e.g. flour, bread, beer)
7. If it is sold, what proportion of the income from the processed cereals do women earn and keep?
 - a) What is done with the by-products?
 - b) Can the market absorb an increased supply of products?
 - c) What arrangements exist between men and women for sharing the proceeds of the production?
8. What are the major problems and difficulties of women producers in this field?

Effects of Improved Technology on Traditional Processing Industry

Technical considerations

1. Does the group the technology is intended for, want it?

SECTION 5

2. What types of cereals are produced by the community to which the technology is to be introduced?
3. Are the cereals milled wet or dry?
4. Will the equipment to be introduced process a particular type of cereal or several?
5. Will the use of the improved technology reduce labour input as compared with the traditional method? How?
6. What is the capacity of the improved technology — will it be able to cope with the demands of processing in terms of quantity of raw materials available to processors?
7. Will the equipment produce a greater quantity and better quality of flour than traditional means? (Will the flour have a different taste — if so, will it be acceptable?)
8. Will the process be faster? (If it is to be a service mill, then will speed compensate for the walk to the mill and the wait in the queue?)
9. What are the fuel (i.e. diesel, electricity) requirements of the equipment?
10. Will the users be able to meet those requirements on a regular basis?
11. Are there alternative energy sources?
12. Will the use of the equipment require expenditure on packaging of the material/transport of the material?
13. Can the equipment be maintained using local resources?
 - a) Are spare parts available?
 - b) Can local artisans repair the machinery or do they need to be trained?
14. If parts need to be imported (from abroad or neighbouring country) will the village be able to afford the added cost?
15. Will the users of the equipment need to be trained?
 - a) Will they need technical training and if so how much?
 - b) Is there already some familiarity with this type of technology?

Socio-economic

1. What is the cost of the machine and related equipment?
2. Is the cost manageable on an individual or community basis?
3. If credit is needed is it accessible? Will the women be able to repay the loan?
4. What will the return on the investment be? What will the monthly profit be?
5. How many years will it take the operator(s) to cover the cost of the machinery?
6. Who would control use of the machine? Would it be village controlled or would individual men or women manage it?
7. Who would earn the income after processing?
8. Would availability of the improved technology increase women's income generation?
 - a) If not, why not?
 - b) What proportion of the income would women earn?
9. Will introduction of the equipment bring about any change in the pattern of work and work habits? How?
 - a) Will men take over the equipment?
 - b) Will landless women be displaced?
10. Have any of the tasks attributed to women been delegated to children as a result?
11. Will there be a change in the time of day required to do any task?

SECTION 5

12. Does the improved equipment require more or less raw material than traditional methods?
13. If it requires more, is that supply available and who owns it?
14. Will the improved method change the traditional market mechanisms?
15. If more grain is processed, so that a greater quantity of products such as bread is available, will the market be able to cope with this increase?
16. What will happen to the by-products?
17. If by-products are sold who would earn the income?

Facts and Figures on a Range of Processing Equipment

This section aims to give a guide to the range of improved devices available for use in cereal processing projects/enterprises in the categories described in section 2, namely:

A. Winnowers Cecoco

B. Shellers

- a) TPI
- b) Atlas
- c) Chitetze

C. Threshers

- a) Treadle
- b) Cecoco

D. Stone Mills and Plate Mills

- a) Dandekar Stone Mill
- b) Ndume Hand-Grinding Mill
- c) Atlas No. 1

E. Hammer Mills

- a) Ndume
- b) MGM

F. Dehullers

- a) PRL/RIIC
- b) Engleberg Dehuller
- c) Cecoco Rubber Roller

G. Driers

- a) IRRI Batch Drier

A range of available equipment is described to suit various needs and circumstances. Details are given on the price, size, capacity, and manufacturing requirements of each piece of equipment. This is aimed at helping consultants/project managers to decide whether something exists which is appropriate to local needs and circumstances, and to converse on more equal terms with the technologists who are needed to supply the technical solutions.

Although only a limited number of machines are described here, they are carefully chosen to indicate the range available. The

information at this stage is very limited and is based on references found in books and private communication with individuals in different institutions. The section incorporates as far as possible equipment that is made in developing countries, but this is also limited. Any additional information or comments would be welcome.

It should be stressed that before ordering any equipment it would be beneficial to consult appropriate institutions (listed in the Contacts section), especially those who have had previous experience in introducing the equipment.

SECTION 6

Winnower

Cecoco

Processes: Cereals
Power Source: Manual
Capacity: 650 kg/h
Suitable: Small-scale farmer
Manufacture Requirements: Sheet metal and angle iron
Comments: Many manual winnowers can be adapted to be motor-driven. (IT Pubs, 1985)

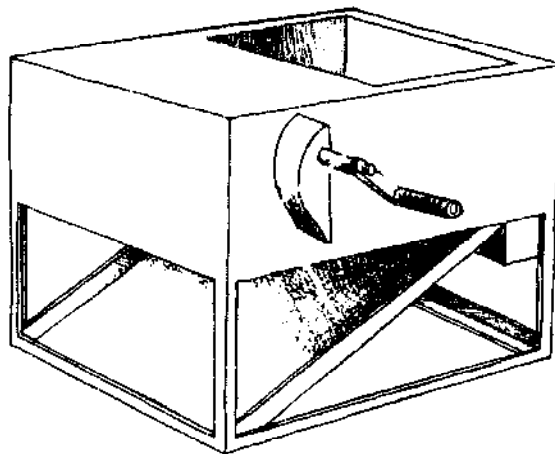

Shellers

TPI Sheller

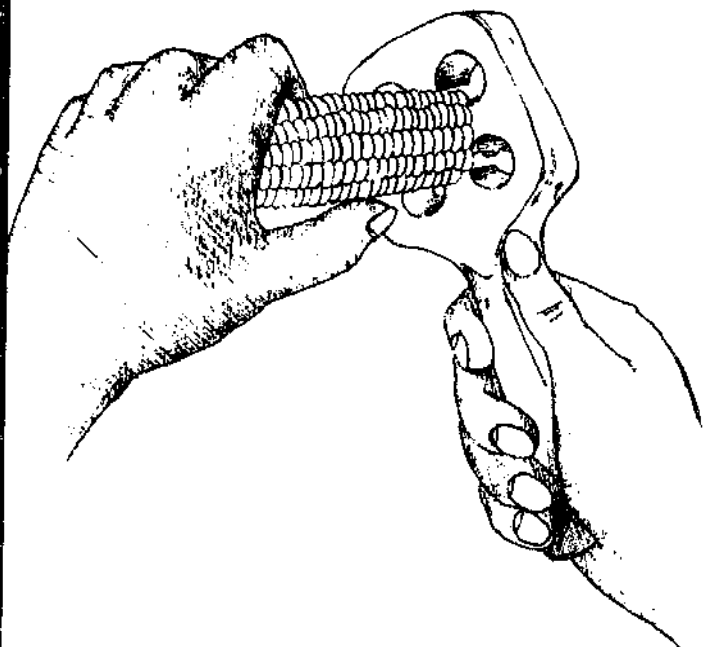

Processes: Maize
Power Source: Manual
Capacity: One cob at a time
Suitable: Small-scale farmer, household use
Cost: Depends on wood
Manufacture Requirements: Carpentry skills
Comments: The process is slow, and will work only with sound, dry cobs. Small cobs and broken cobs cannot be easily handled. (Mphuru, 1982).

SECTION 6

Atlas Sheller

Processes: Maize

Power Source: Manual

Capacity: 56 kg cobs giving 48.5 kg/h kernels, 5.8 rotations per cob.

Suitable: Small-scale farmer

Cost: £51 (1986) (US\$ 71)

Manufacture Requirements:

Castings

Comments: easy to operate; sometimes extra pushing of the cob is needed; few breakages (Mphuru, 1982).



Chitetze Maize Sheller (Malawi)

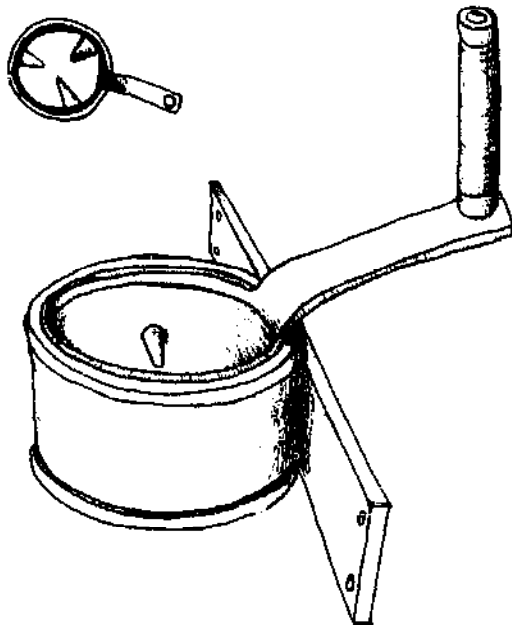

Processes: Maize

Power Source: Manual

Capacity: 45 kg/h

Suitable: Small-scale farmer

Cost: 1986 US\$6

Manufacture Requirements:

Metal workshop, welding

Comments: The shellers are made in three sizes to suit the principle maize varieties in Malawi (IT Publications, 1985).

SECTION 6

Threshers

Treadle Thresher

Processes: Most types of grain

Power Source: Manual

Capacity: 25-30 kg/h

Suitable: Small-scale and large-scale farmer

Comments: Although the threshers can be used for most grains it is particularly suitable for paddy having wire loop blades (IT Publications, 1985).

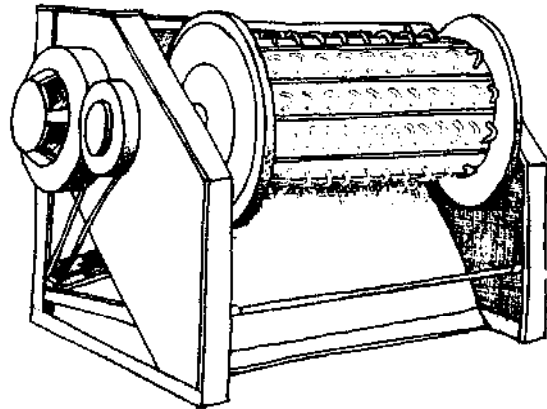

Cecoco

Processes: Paddy

Power Source: Pedal/motor

Capacity: 90-130 kg/h

Suitable: large-scale farmer

Comments: operates by a foot pedal (IT Publications, 1985).

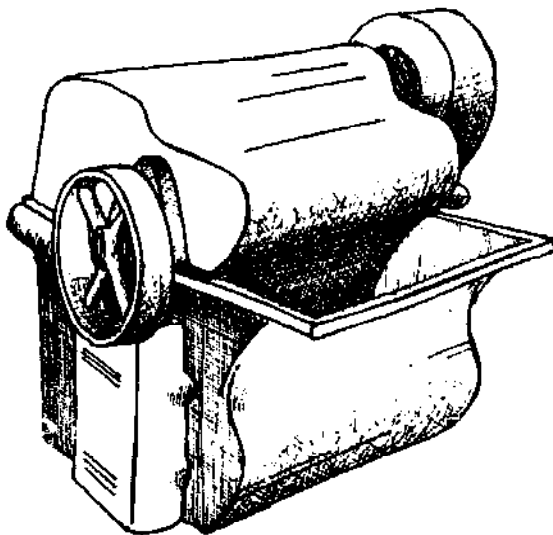

SECTION 6

Stone Mills and Plate Mills

Dandekar Stone Mill (India)

Processes: Most cereals and pulses
Power Source: 6-10 Horse power motor
Capacity: 225-270 kg per hour
Suitable: Custom Milling, co-operative
Comments: Particularly suitable for fine grinding

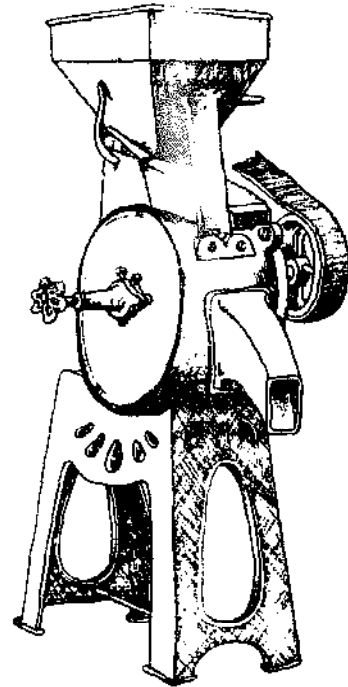

Ndume Hand Grinding Mill (Kenya)

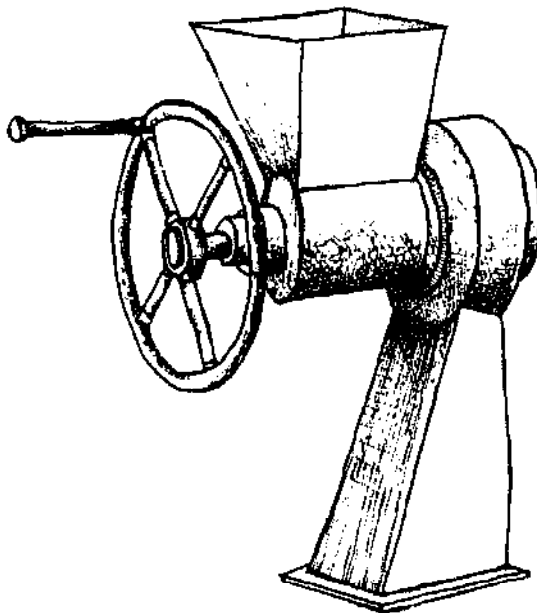

Processes: Maize
Power Source: Manual
Capacity: 20 kg/h
Suitable: Small-scale farmer
Cost: 1000 K sh. (1985) (US\$ 50)
Manufacture Requirements: metal workshop, welding plates need casting
Comments: can be manufactured locally not suitable for fine grinding (IT Publications, 1985).

SECTION 6

Atlas No. 1

Processes: Dry grain
Power Source: Manual
Capacity: 7.9 kg/h
Suitable: Small-scale farmer
Cost: UK £81 (1986) (US\$ 113)
Manufacture Requirements: Casting
Comments: please refer to case studies (IT, Publications, 1985).

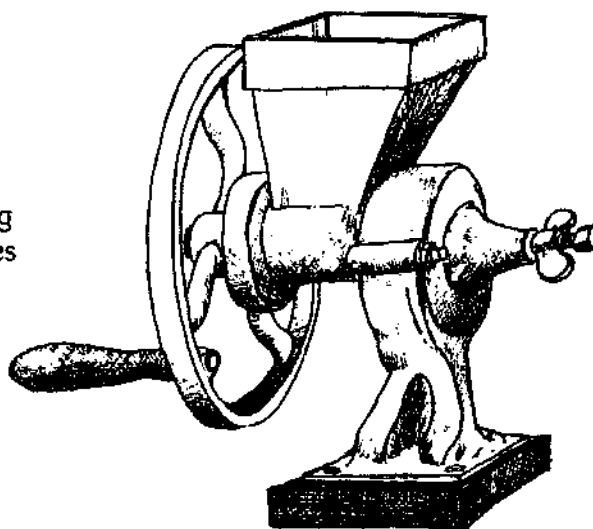

Hammer Mills

Ndume Hammer Mill (Kenya)

Processes: Maize, sorghum, millet
Power Source: Electric motor/
diesel engine (2-20 hp)
Capacity: 70-200 kg/h for small
unit, 400-2500 kg/h large unit
Suitable: Large-scale farmer, co-op-
erative
Comments: If skill and manufactur-
ing requirements are available then
hammer mills can be made locally, as
this one is in Kenya (ECA Publications,
1985).

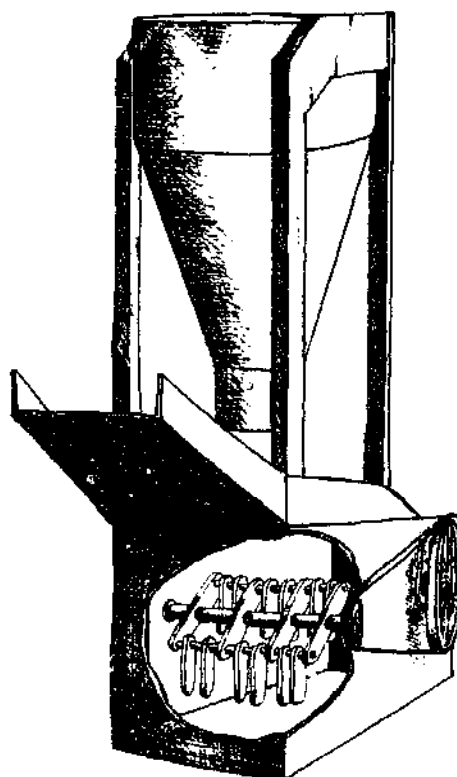

SECTION 6

MGM Hammer Mill (Tanzania)

Processes: Maize, sorghum, millet
Power Source: Diesel engines 8-12 hp

Capacity: 180-200 kg/h

Suitable: Large-scale farmer, co-operative

Comments: Four different models of the MGM series are available with various capacities (ECA Publications, 1985).

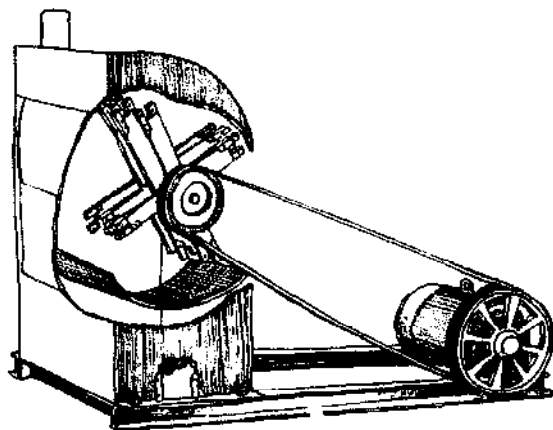

Dehullers

PRL/RIIC (Botswana)

Processes: Sorghum, millet

Power Source: Electric motor/diesel engine

Suitable: Large-scale farmer, co-operative

Comments: Modifications at RIIC enable this machine to be used either on a continuous or batch operated basis. (refer p. 25)

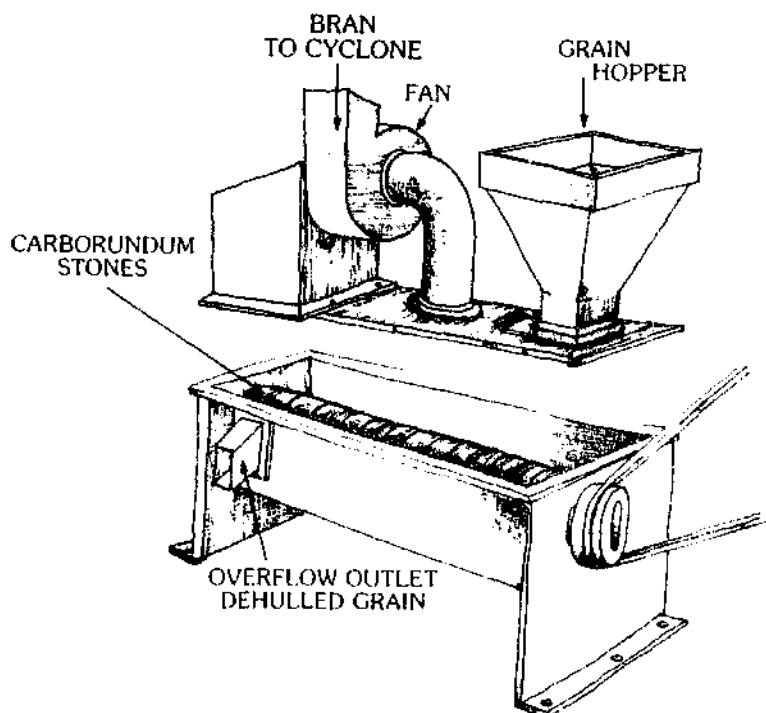

SECTION 6

Engleberg Dehuller (USA)

Processes: Rice

Power Source: Electric motor/diesel engine
3-15 hp

Capacity: 30-300 kg/h
paddy

Suitable: Large-scale farmer, co-operative

Comments: more robust than rubber-roller mills, has less maintenance problems and lasts longer; breaks up the grain — but in some villages broken grains do not matter (IT Publications, 1985).

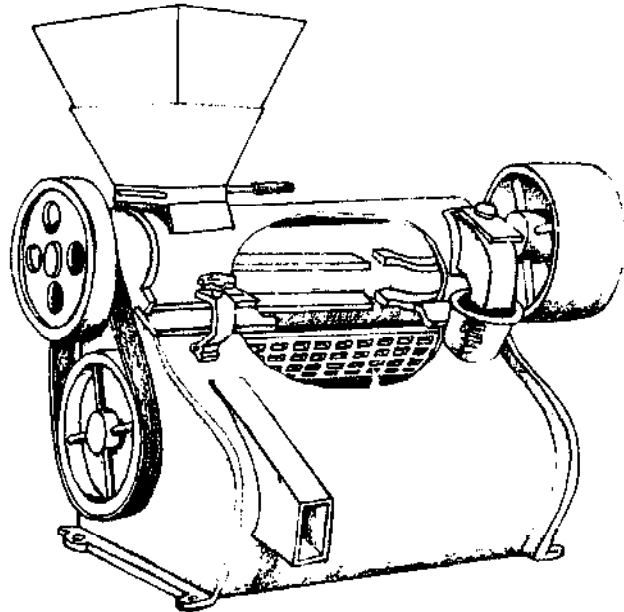

Cecoco Rubber Roller

Processes: Paddy

Power Source: Electric motor/
diesel engine 5-7hp

Capacity: 360 kg/h paddy

Suitable: Large-scale farmer, co-operative

Comments: Gives a better quality grain than the Engleberg; is efficient mechanically, but may be difficult to get spare parts, not recommended for small-scale operation because it is too expensive and needs frequent replacement of parts — in comparison Engleberg rollers will last for 12 months without any problems. (IT Publications, 1985)

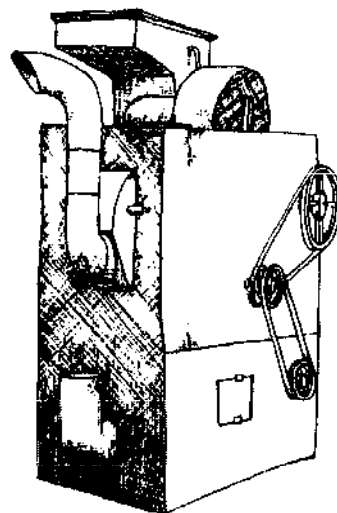

SECTION 6

Driers

IRRI Batch Drier (Philippines)

Process: Paddy and other grains

Power Source: Petrol/Kerosene engine, electric motor or rice husk burner.

Capacity: 1 ton

Suitable: Medium farmer, co-operative

Comments: Good general purpose drier that could be locally manufactured.

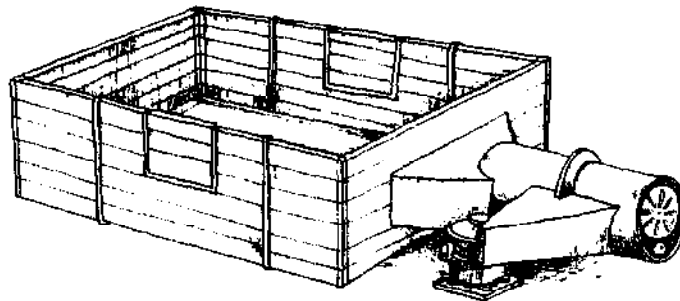

REFERENCES

- Cain, M. (1981)
in Dauber, R., & Cain, M., (eds)
Women and Technological Developing Countries
Westview Press, Connecticut, U.S.A.
- Dichter, D (1978)
Manual on Imported Farm and Village-level Grain Storage Methods
GATE/GTZ, Eschborn, W. Germany.
- Dijkhuizen, P., Korthals
Altes, F.W., & Merz, R.
(undated)
*A New Approach to Small-Scale Food Production from Indigenous Raw Material
in Tropical Countries,*
Royal Tropical Institute, Amsterdam, Netherlands.
- ECA Publications (1983)
*Traditional Palm Oil Processing: Women's Role and The Application Appropriate
Technology,*
ATRCW Research Series, Addis Ababa, Ethiopia.
- ECA Publications (1985)
Technical Compendium on Composite Flours, Addis Ababa, Ethiopia.
- FAO, Rome (1970)
Handling and Storage of Food Grains.
- FAO Rome (undated)
The Lost Harvest.
- Golob, P., (1977)
TPI Rural Technology Guide No. 3
TPI Publications, London, U.K.
- Hemmings-Gapihan, G.S., (1981)
in Dauber R. & Cain M. (eds) *op. cit.*
Baseline Study for Socio-Economic Evaluation of Tangaye Food Solar Site.
- Ihekoronye, A. and Ngoddy, P.O. (1985)
Integrated Food Science and Technology for the Tropics,
Macmillan, London, U.K.
- ILO/JASPA (1981)
Appropriate Technologies in Cereal Milling and Fruit Processing Industries, Addis
Ababa, Ethiopia.

REFERENCES

- ITDG (1985)
Tools for Agriculture
IT Publications, London, U.K.
- Khan, S. D. (1982)
Evaluation Report on Trainers' Training Programme for Women Group Leaders of Grameem Bank Project, Oct 1982, Grameem Bank, Dhaka, Bangladesh
- Loose, E. (1979)
Women in Rural Senegal: Some Economic and Social Observations, Paper Prepared for the Workshop on Sahelian Agriculture, Purdue University, 1979.
- McSweeney, B., (1982)
Time to Learn for Women in Upper Volta
Appropriate Technology Journal, Vol. 9, No. 3, IT Publications, London, U.K.
- Mphuru, A.N.(1982)
On-Farm Handling, Processing and Storage of Food Grains in Africa
African Regional Centre for Technology (ARCT), Dhakar, Senegal.
- NAS (1970)
Post-Harvest Food Losses in Developing Countries
National Academy of Sciences, Washington DC, U.S.A. 1978.
- New Scientist (1986)
New Scientist, 2 January 1986, London. U.K.
- O'Kelly, E. (1973)
Aid and Self-Help.
Knight and Co, London, U.K.
- Peace Corps/VITA (1977)
Small Farm Grain Storage, Vol. III
- IDRC (1980)
A Bakery for Bomani
IDRC Reports, July 1980.
- SCF/CDF (1980)
A Case Presentation of Save the Children Federation Community Development Foundation
Save the Children, Occasional Paper No. 2, U.S.A.
- Scott, G. & Carr. M. (1985)
The Impact of Technology Choice on Rural Women in Bangladesh: Problems and Opportunities, World Bank, Washington DC, U.S.A.

REFERENCES

Siegel, A. (1976)
Maiduguri Mill Project
IDRC Mimeo

Spurgeon, D.
A Systems Approach to Post-Harvest Technology
PAG Bulletin, Vol. VII, No. 1-2

Stewart, F. (1978)
Technology and Underdevelopment,
Macmillan, London, U.K.

UNICEF (1983)
UNICEF News

Whitby, G. (1985)
Successfully Processing Sorghum
Appropriate Technology Journal, Vol. 12, No. 1
IT Publications, London, U.K.

FURTHER READING

- Wageningen Agricultural University, (1983)
Selection of Technology for Food Processing in Developing Countries
Pudoc, Wageningen, The Netherlands.
- The International Rice Research Institute, Manila, Philippines, (1985).
Women in Rice Farming
Gower Publications, London, U.K.
- World Employment Programme, (1984)
Technological Change, Basic Needs and the Condition of Rural Women
ILO, Geneva, Switzerland.
- FAO (1983)
Processing and Storage of Food by Rural Families, Rome, Italy.
- FAO (1985)
Manual on the Establishment, Operation and Management of Cereal Banks, Rome, Italy.
- ILO (1984)
Small Scale Maize Milling, Technology Memorandum No. 7, Geneva, Switzerland.
- ILO (1984)
Improved Village Technology for Women's Activities, Geneva, Switzerland.
- IDRC (1980)
An End to Pounding: A Mechanical Flour Milling System in Use In Africa, Ottawa, Canada.
- Kent, N. L. (1975)
Technology of Cereals with Special Reference to Wheat, 2nd Edn.
Pergamon Press, London, U.K.
- IDRC (1982)
Sorghum Milling in Botswana, A Development Impact Case Study, Ottawa, Canada.
- FAO (1983)
Expert Consultation on Women in Food Production, Rome, Italy.
- Merrick Lockwood, L. (1981)
Development and Testing of a Portable Rice Huller for Bangladesh
The Asia Foundation, Dhaka, Bangladesh.
- Association of Development Agencies in Bangladesh (1980).
ADAB NEWS, Post-Harvest Technology, Vol. VII, No. 11, Nov. 1980.
- Gariboldi, F. (1974)
Rice Parboiling, Rome, Italy.

FURTHER READING

Greeley, M. & Howes, M. (1982)

Rural Technology, Rural Institutions, and the Rural Poorest: The Case of Rice Processing in Bangladesh

CIRDAP/Institute of Development Studies (IDS), University of Sussex, U.K.

Harriss, B.

Rice Processing Projects in Bangladesh: An Appraisal of a decade of proposals

The Bangladesh Journal of Agricultural Economics, Vol. 1, No. 2, December 1978.

Harriss, B.

Post Harvest Rice Processing Systems in Rural Bangladesh: Technology, Economics and Employment

The Bangladesh Journal of Agricultural Economics, Vol. 2, No. 1, June 1979.

Paddy Processing in India and Sri Lanka: a Review of the Case for Technological Innovation

Tropical Science, 1976.

CONTACTS

The following can be contacted for further information on cereal processing and experiences in planning cereal processing projects. Some of these institutions have developed their own equipment which has been or is being used in the field.

CAMERTEC

Centre for Agricultural Mechanization & Rural Technology, P.O. Box 764, Arusha, Tanzania.

CDTF

Community Development Trust Fund, P.O. Box 9421, Dar-es-Salaam, Tanzania.

CIMMYT

Centro Internacional de Mejoramiento de Maiz y Trigo, Londres 40, Mexico 6, D.F. Mexico.

GATE/GTZ

German Appropriate Technology Exchange, Postfach 5180, D-6236 Eschborn 1, W. Germany.

GRET

Groupe de Recherche et d'Echanges Technologiques, 213 rue Lafayette, Paris 75010, France.

ICRISAT

International Crops Research Institute for Semi-Arid Tropics, Patanchero, P.O. Andhra Pradesh 502, 324, India.

IDRC

International Development Research Centre, 60 Queen Street, Ottawa, Canada.

IDS

Institute of Development Studies, at the University of Sussex, Brighton, BN1 9RE, U.K.

IITA

International Institute of Tropical Agriculture PMB, 5320, Ibadan, Nigeria.

IRRI

International Rice Research Institute, P.O. Box 933, Manila, Philippines.

CONTACTS

ITDG

Intermediate Technology Development Group, Myson House, Railway Terrace, Rugby, CV21 3HT U.K.

KIT

Royal Tropical Institute, Mauritskade 63, 1092 A D, Amsterdam, Holland.

RIIC

Rural Industries Innovation Centre, Private Bag 11 Kanye, Botswana.

TDRI

Tropical Development and Research Institute, now known as ODNRI, Overseas Development and Natural Resources Institute, 56-62 Gray's Inn Road, London WC1X 8LU, U.K.

WARDA

West African Rice Development Association, P.O. Box 1019, Monrovia, Liberia.

ADA

Agricultural Development Authority, Enugu, Anambra State, Nigeria.

Root Crop Research Institute, Umudike, Umuahia, Imo State, Nigeria.

UST

University of Science and Technology, Faculty of Agriculture, Department of Engineering, Kumasi, Ghana.

Department of Food Science and Technology, University of Nigeria, Nsukka, Amanambra State, Nigeria.