

AT MICROFICHE
REFERENCE
LIBRARY

A project of Volunteers in Asia

A Pedal-Operated Grain Mill
Rural Technology Guide No. 5

by G.S. Pinson

Published by:

Tropical Development and Research Institute (TDRI)
127 Clerkenwell Road
London EC1R 5DB
ENGLAND

Available from:
same as above

Reproduced by permission.

Reproduction of this microfiche document in any
form is subject to the same restrictions as those
of the original document.



A pedal-operated grain mill



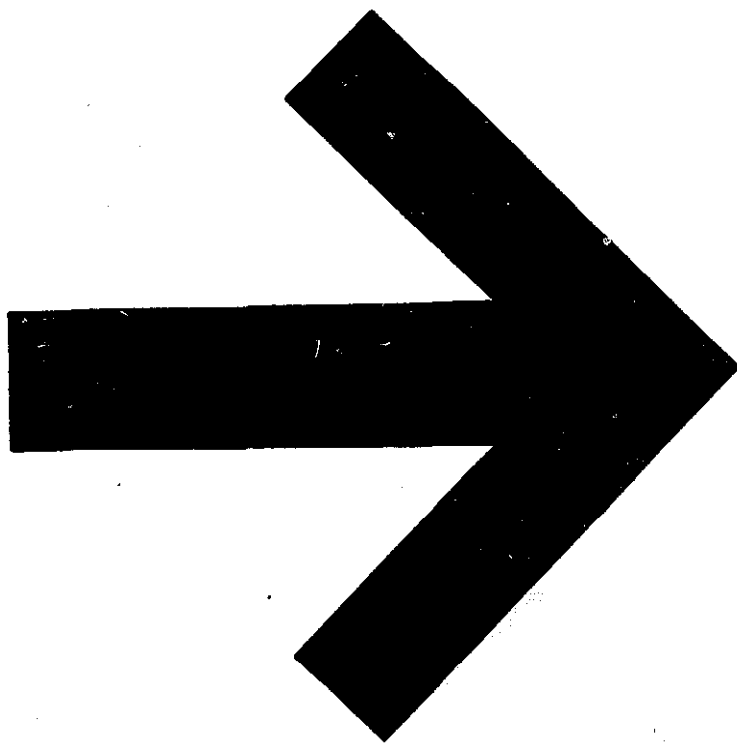

A pedal-operated grain mill

G S Pinson

Contents

Introduction	<i>page</i> 1
Description	3
Parts and materials list	4
Manufacture	5
Make the following components for the mill	6
Assembly of the milling unit	26
Final assembly	28
Using the mill	30

Introduction

This guide describes a simple, pedal-operated mill suitable for grinding hard grains and legumes on a village scale. It shows how to make the mill and how an ordinary bicycle can provide support both for the operator and the drive components.

The mill works at high speed and takes advantage of the smaller effort required when the operator is using his legs rather than his arms to drive it. A second person is needed to feed the mill by hand.

The mill is intended for use over brief periods to meet the day-to-day needs of householders. It is not intended to be used intensively for long periods.

The output of the mill depends on how fine a product is needed and how much energy the operator exerts.

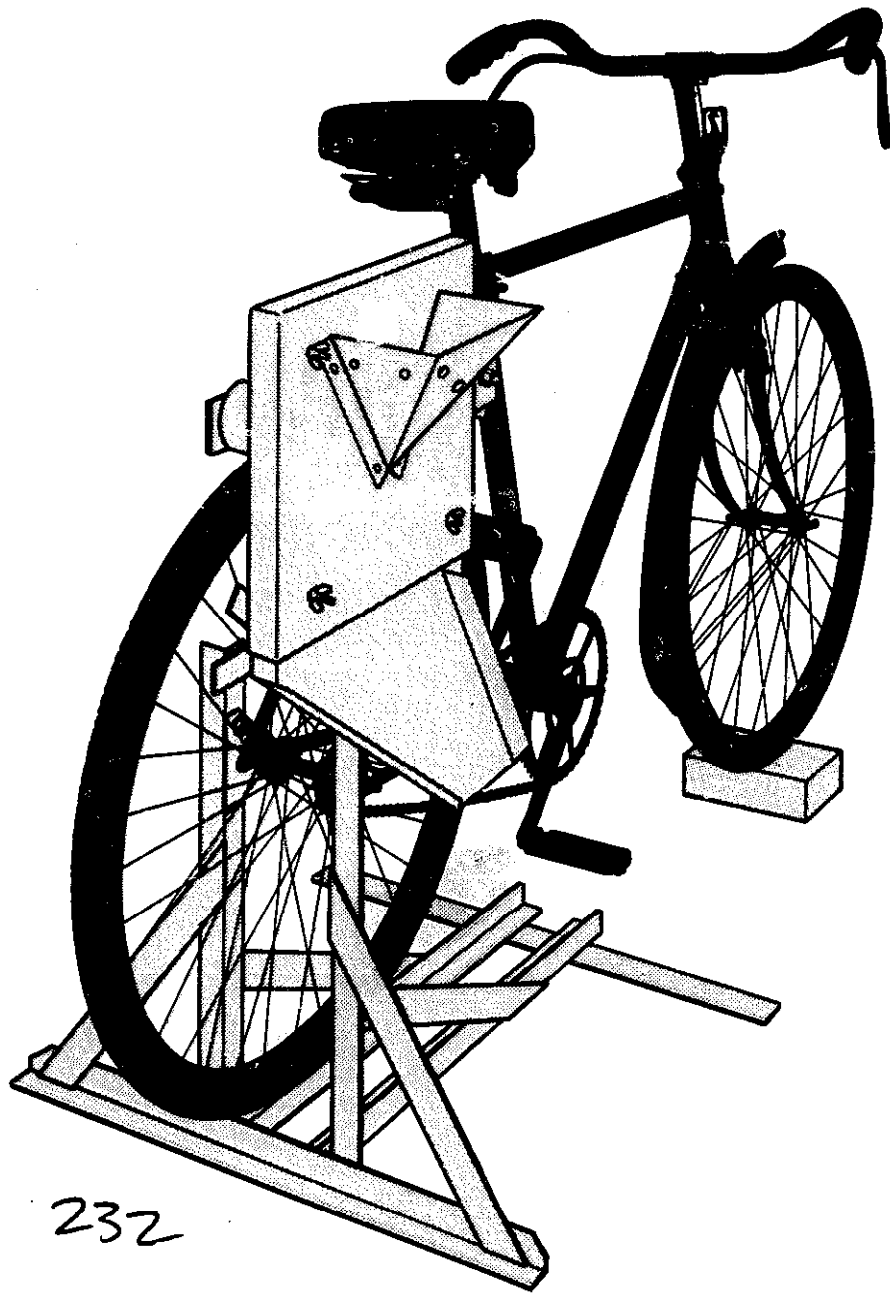

232

Description

The complete mill unit is shown in drawing opposite. The unit is made up of two distinct components; a grinding unit and a mounting frame—in this case a bicycle.

The mill itself uses a high-speed grinding action which is broadly similar to that used by conventional powered hammer mills. The operator turns the pedals at a normal, brisk cycling speed. The cycle wheel in turn drives a roller shaft on its outer edge at a speed of about 5,000 revs per minute. A fixed rotor arm is fitted to this shaft and the grain is broken up after it is struck by the tip of the rotor. A screening mesh controls the fineness of the grinding process.

For a given effort the output of the mill depends on the fineness of the product required. The mill works best on hard, brittle grains such as maize, millet and sorghum and on legumes such as soya beans.

Parts and materials list

Part	Name	Qty	Material	Approximate amount required
1	Front plate	1	$\frac{1}{8}$ in (3 mm) thick steel sheet	15 in \times 15 in (380 \times 380 mm)
			$\frac{1}{16}$ (1.5 mm) thick steel sheet	15 in \times 8 in (380 \times 200 mm)
2	Back plate	1	$\frac{1}{8}$ in (3 mm) thick steel sheet	15 in \times 21 in (380 \times 530 mm)
			$\frac{1}{16}$ (1.5 mm) thick steel sheet	16 in \times 1 in (400 \times 25 mm)
6	Rim setting disc	1	$\frac{1}{8}$ in (3 mm) thick steel sheet	8 $\frac{1}{4}$ in diam (210 mm)
7	Screen rim	1	$\frac{1}{8}$ in (3 mm) thick steel sheet	30 in \times 1 $\frac{1}{4}$ in (760 \times 32 mm)
10	Mounting pivot	1	$\frac{1}{8}$ in (3 mm) thick steel sheet	14 in \times 2 $\frac{1}{2}$ in (350 \times 65 mm)
11	Mounting pivot backing plate		$\frac{1}{4}$ in (6 mm) thick steel sheet	4 in \times 2 in (100 \times 50 mm)
16	Wheel support plate	2	$\frac{1}{8}$ in (3 mm) thick steel sheet	4 in \times 8 in (100 \times 200 mm)
3	Bearing housing	1	2 $\frac{1}{2}$ in (65 mm) diameter steel bar	8 in long (200 mm)
4	Roller shaft	1	1 $\frac{1}{4}$ in (30 mm) diameter steel bar	8 in long (200 mm)
9	Screen clamp	1	$\frac{1}{4}$ in (6 mm) thick steel	3 in \times 1 in (75 \times 25 mm)
12	Upper support arm	1	$\frac{1}{4}$ in (6 mm) thick steel	2 in \times 12 $\frac{1}{2}$ in (50 \times 320 mm)
13	Upper support arm	1	$\frac{1}{4}$ in (6 mm) thick steel	2 in \times 12 $\frac{1}{2}$ in (50 \times 320 mm)
14	Lower support arm	1	$\frac{1}{4}$ in (6 mm) thick steel	1 in \times 12 in (25 \times 300 mm)
5	Rotor	1	$\frac{3}{4}$ in (20 mm) \times $\frac{1}{8}$ in (3 mm) steel strip	8 $\frac{1}{4}$ in long (210 mm)
			1 in (25 mm) diameter steel bar	2 in long (50 mm)
15	Bicycle stand	1	1 $\frac{1}{4}$ in \times 1 $\frac{1}{4}$ in \times $\frac{3}{16}$ in (30 \times 30 \times 5 mm) steel angle	120 in (3000 mm)
			$\frac{1}{4}$ in (6 mm) thick steel	100 in \times 1 $\frac{1}{2}$ in (2500 \times 38 mm)
8	Screens	—	Various: see page 18	26 in \times 1 in (660 \times 25 mm)
17	Bearing	2	Use light series ball bearings which are supplied with grease lubricant which is retained with a <i>shield</i> fitted to each side of the bearing. Bearings with flexible seals which <i>touch</i> the inner race are <i>not suitable</i> . The following $\frac{1}{2}$ in (12 mm) bore bearings are suitable: RHP Type LJ $\frac{1}{2}$ - 2Z (6201 - 2Z metric) SKF Type RLS - 4 - 2Z (6201 - 2Z metric) These bearings have the following dimensions: bore $\frac{1}{2}$ in (12 mm); width $\frac{3}{8}$ in (10 mm); diameter 1 $\frac{7}{16}$ in (32 mm)	

Manufacture

The device can be manufactured in any well-equipped workshop. The following machine tools (and competent operators) should be available:

1. Small lathe equipped for turning between centres, knurling and drilling
2. Small milling machine
3. Acetylene welding set
4. Pedestal drilling machine
5. Band saw (preferably)

The following hand tools are required:

6. engineer's bench and vice
7. hack saw and sheet metal cutters
8. range of twist drills and screw taps
9. marking out equipment
10. files and general engineering hand tools

The mill can be built from normal workshop materials but the following special components are also necessary:

11. two shielded ball bearings (see page 4)
12. screening meshes (see page 18)

The list on page 4 gives details of the material requirements for each component. Construction and assembly instructions are given in the following pages. You are recommended to read these through before starting work.

Dimensions are given in inches with millimetres in brackets. Use only one system and do not mix the units, as, in a number of cases, inch and millimetre dimensions are not directly equivalent.

Unless otherwise stated; dimensions should be limited to $\pm \frac{1}{64}$ in (0.4 mm) from the given value.

Make the following components for the mill

1 Mill front plate

Material

$\frac{1}{8}$ in (3 mm) thick steel sheet

$\frac{1}{16}$ in (1.5 mm) thick steel sheet

1. Construct the front plate *either* by bending over the edges *or* by cutting the edges out separately and welding them on later.
2. Mark out the $\frac{1}{8}$ in (3 mm) thick steel sheet as shown in the drawing. Drill the holes and carefully mark the positions where the chute parts must be fitted later.
3. If the edges are to be folded, cut out the plate as it is drawn and, using a strong vice, press or folding machine, bend the upper and two side edges to form an edge to the plate on the side away from the chute. Make sure that the inside width is $12\frac{3}{8}$ in (314 mm). Join the corners with a continuous weld and file away any sharp edges.
4. If the edges cannot be folded easily, cut out separate pieces for the edges about $1\frac{1}{8}$ in (29 mm) wide and cut the plate out as a $12\frac{3}{8}$ in (314 mm) square). Then carefully weld on the edges, making sure that the inside dimension is still $12\frac{3}{8}$ in (314 mm) as before.
5. Cut out, from $\frac{1}{16}$ in (1.5 mm) thick steel sheet, the chute parts. Fold the larger piece to form the chute. Drill four $\frac{1}{4}$ in (6 mm) dia holes in the front plate to match the holes in the chute and then bolt the chute on. Do not weld it because this will distort the plate.
6. Produce the finger guard and position it inside the chute. Ensure that the guard is fitted to the correct side of the chute and that the gap at the bottom is $\frac{3}{8}$ in (9.5 mm) as shown. The finger guard also prevents grain being knocked out of the mill. **Tack weld the guard securely to the inside of the chute but *not* to the front plate itself.**

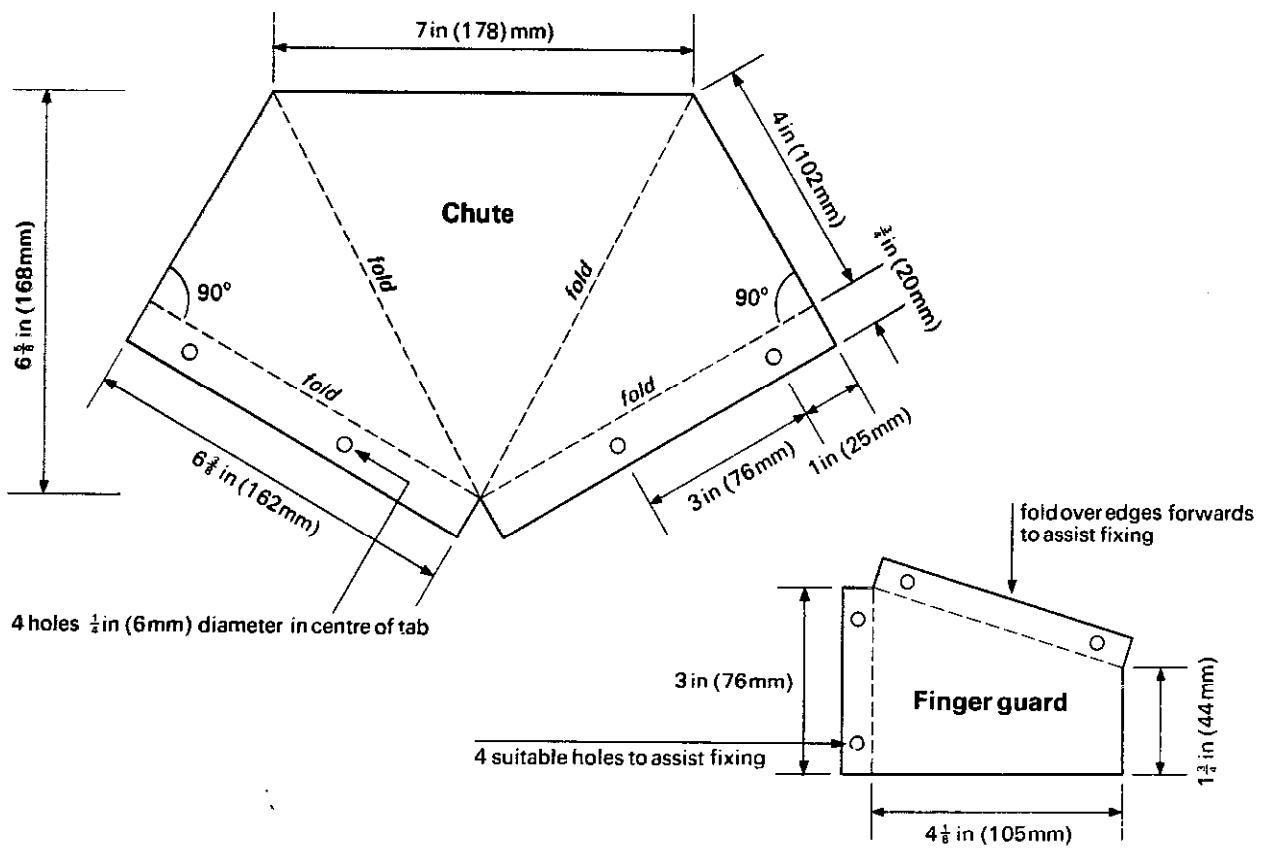
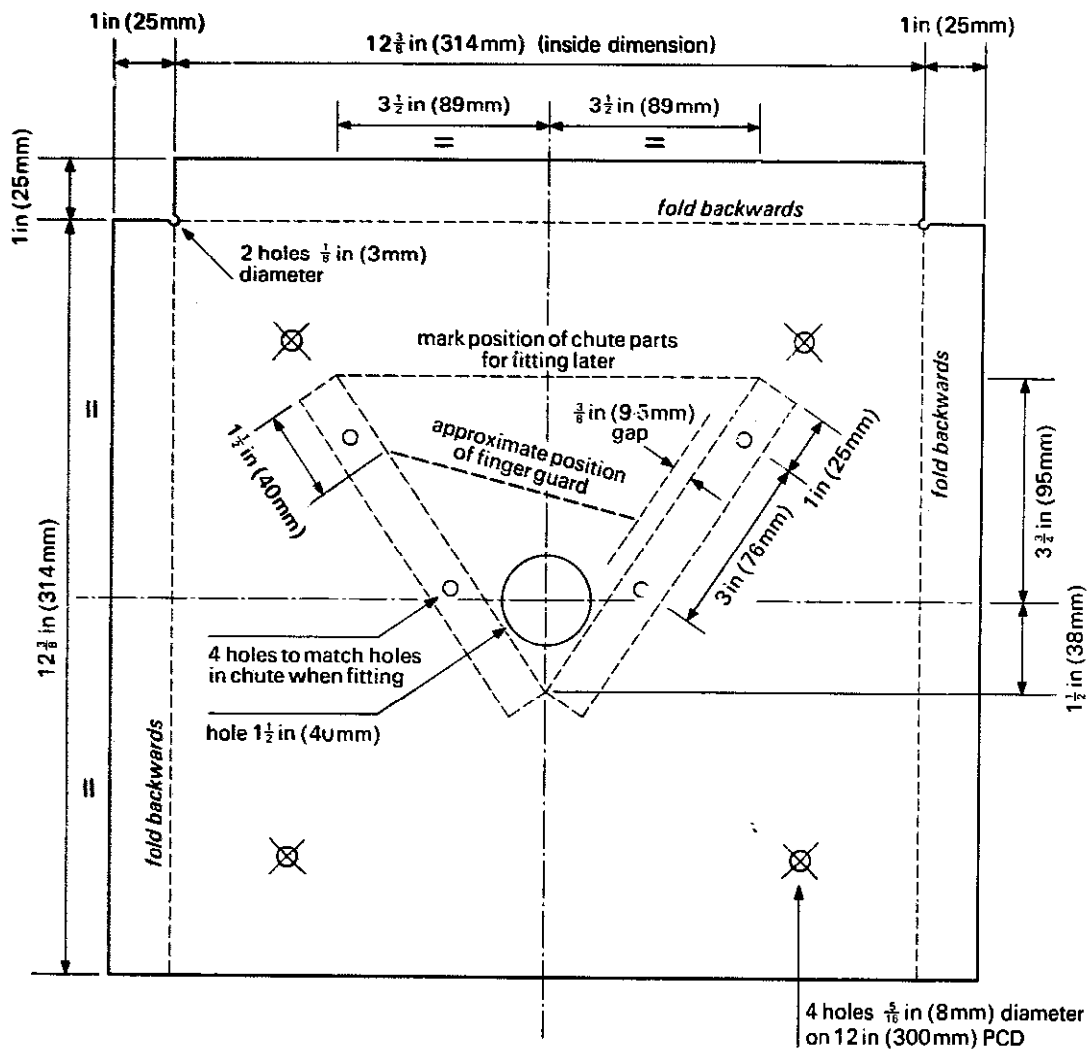

2 Mill backplate

Material

$\frac{1}{8}$ in (3 mm) thick steel sheet

$\frac{1}{16}$ in (1.5 mm) thick steel sheet

1. Mark out the $\frac{1}{8}$ in (3 mm) steel sheet as shown in the drawing. Drill the various holes and then cut out the pattern.
2. Fold over the edges or weld separate edges, as described for the front plate, so that the front plate will fit easily around the back plate. Ensure that the inside width is 12 in (305 mm). Lay the back plate with its edges at the square end, on a flat surface. File away any high spots so that the surface formed by the three edges is flat and of the same height.
3. Bend the tapered end upwards about 20° at the folding line indicated, to provide an outlet chute.
4. When the welding has been completed, file the outside surface to remove any lumps that have formed during welding.
5. Cut out the steel strip and weld to the back in the position shown. The ends can be used to support a collecting bag.

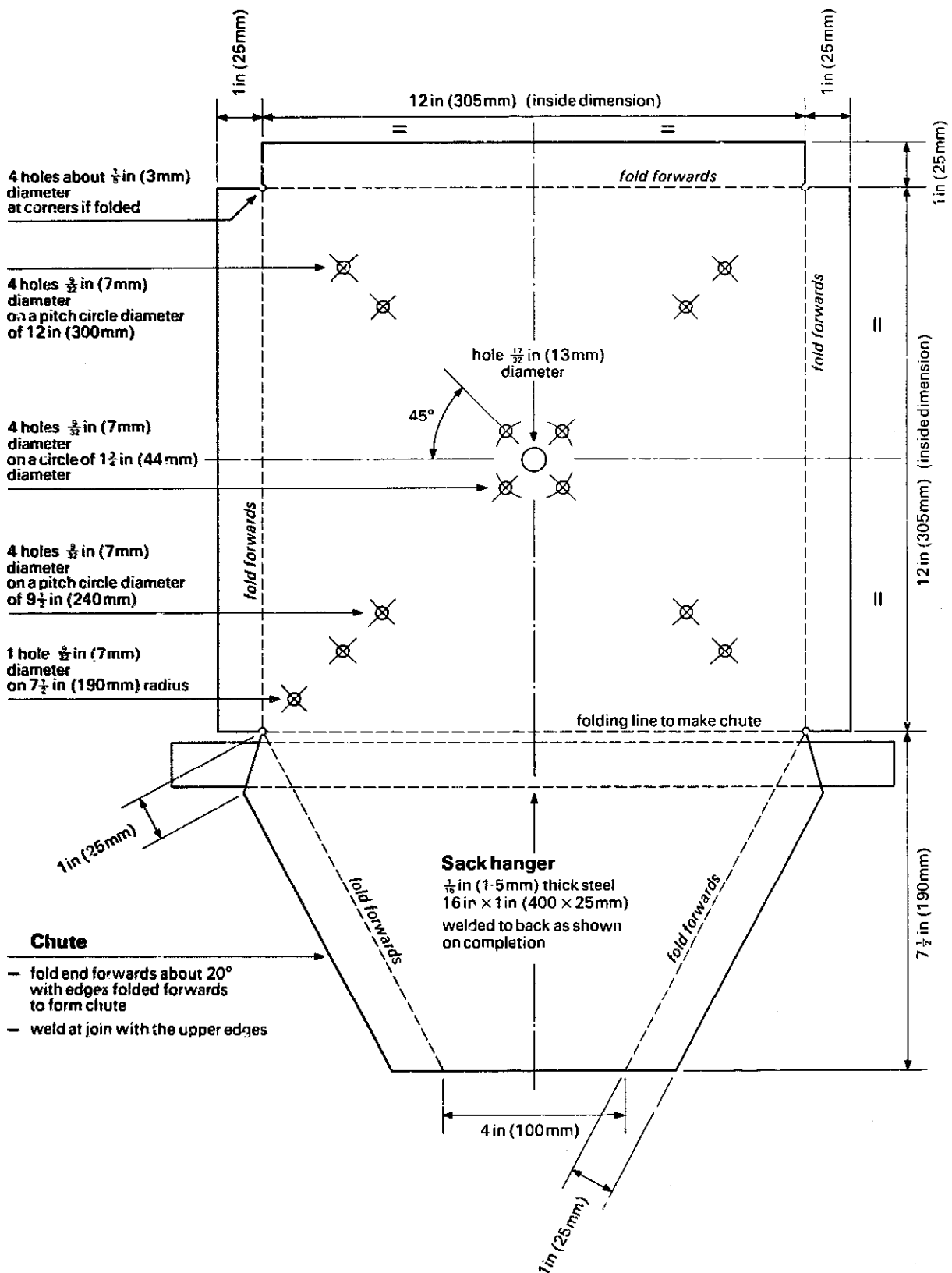

3 Bearing housing

Material

2½ in (65 mm) diameter mild steel bar

1. Machine the bar on a lathe to obtain the correct outside diameter and length.
2. Bore out, in one machining operation, the centre of the housing as shown. Carefully machine the two bearing surfaces.
3. Fit the mounting on to a milling machine to produce the slot between the bearings. Do not clamp the housing too tightly.
4. Drill and tap the mounting holes at each end of the mounting and the hole at the side for the screw to locate the bearings. Remove all sharp edges.

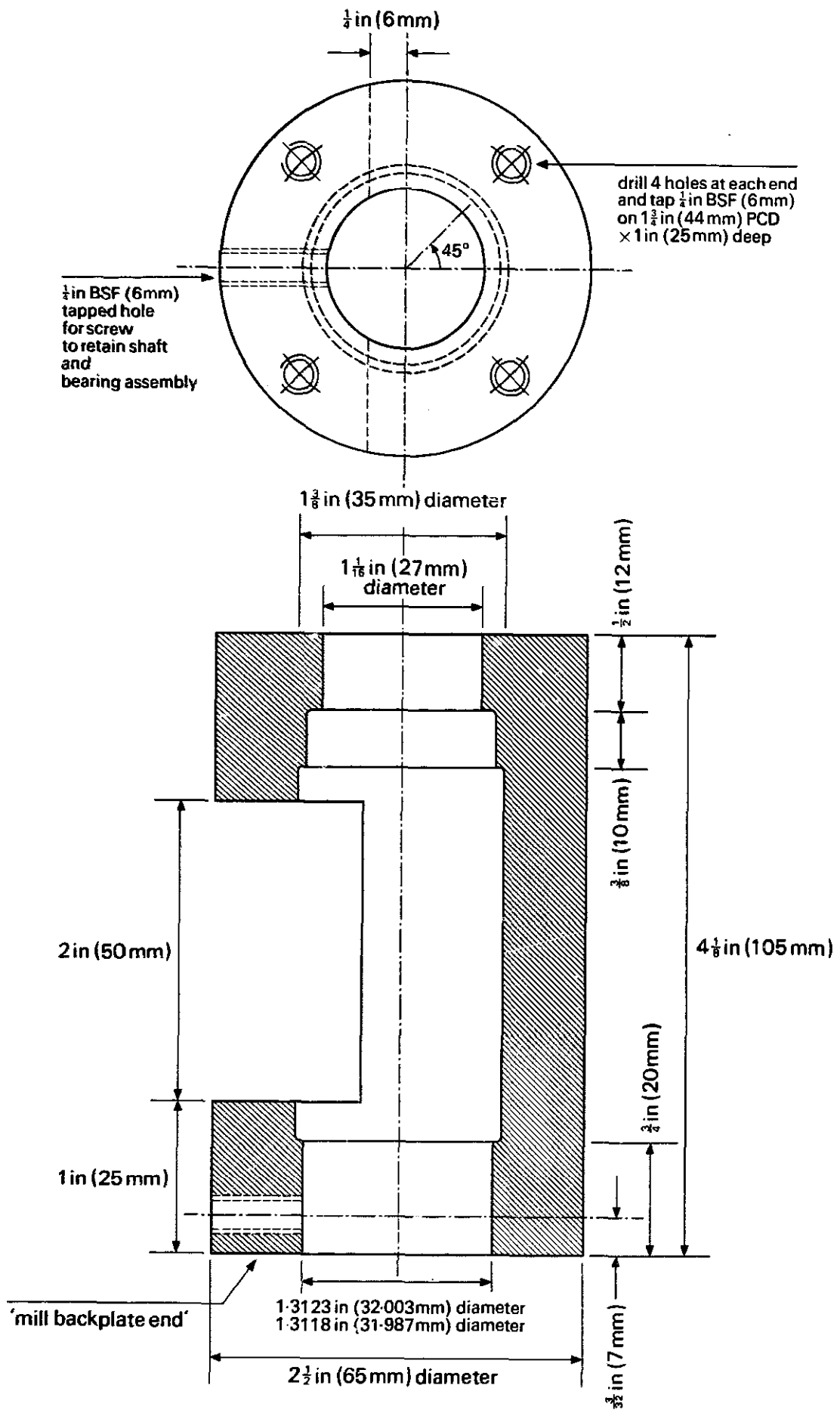

4 Roller shaft

Material

1 ¼ in (30 mm) diameter medium steel bar

1. Fit the bar into the chuck of a lathe, and turn the outside to give a smooth 1 in (26 mm) diameter shaft. Drill each end of the shaft with a centre drill for turning between centres.
2. Fit the shaft into a three-jaw chuck and form a coarse diamond knurl in the position shown.
3. When the knurl has been completed, remove the shaft from the chuck and refit it to the lathe, this time supported between centres. With a sharp tool, skim the peaks from the knurl so that the shaft is restored to its original diameter.
4. Polish the shaft with emery cloth, so that the knurl is smooth and free from any sharp projections which would wear the tyre.
5. Continue machining each end of the shaft. Machine the seating for the bearing to give an interference (tight) fit.
6. Refit the shaft in a three-jaw chuck and drill and tap the thread at the end. (see drawing).

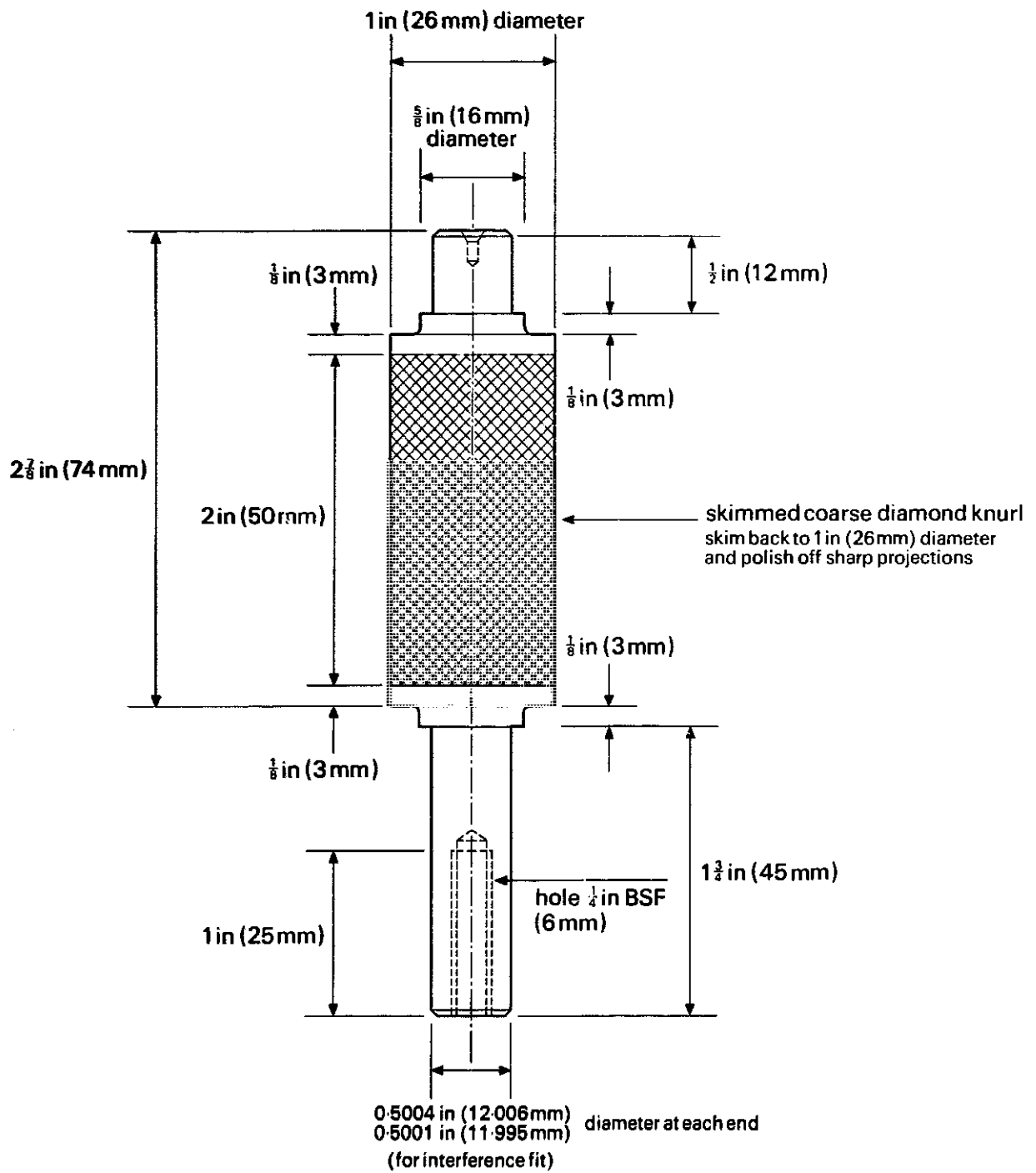

5 Rotor

Material

$\frac{3}{4}$ in (20 mm) \times $\frac{1}{8}$ in (3 mm) steel strip
1 in (25 mm) diameter steel bar

1. Mark the position of the central hole of the rotor arm with a centre punch. Then mark out the position of the tip of the rotor arm at each end.
2. Drill the central hole and cut to length accurately.
3. Turn the hub as shown. Drill its central hole and the small hole on one side of the hub for a split pin (which will be fitted at the assembly stage).
4. Bolt together the roller shaft which has already been made, the rotor arm and hub. Mark the position of the hub on the rotor. Remove from the shaft and securely weld the arm and hub accurately together. Compensate for any warping by straightening out the arm.

Make sure that each side of the rotor has the same length for correct balance.

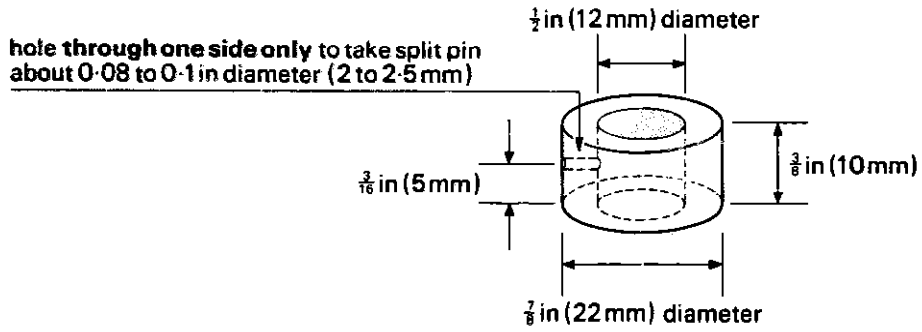
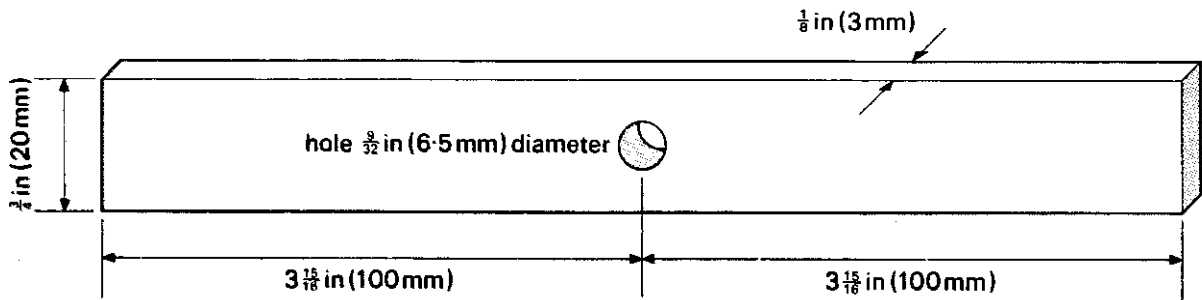
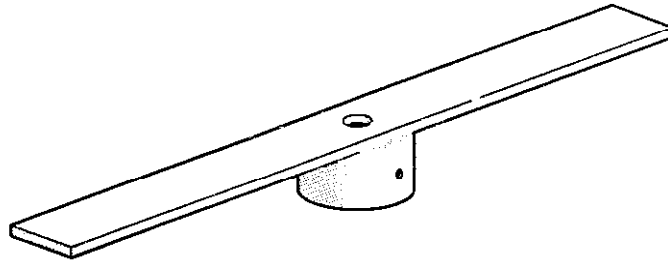

6 Rim setting disc

Material

1/8 in (3 mm) thick mild steel sheet

1. Mark out the disc and the positions of the holes on a clean piece of steel.
2. Cut carefully around the perimeter of the disc, keeping close to the line to produce an 8 in (203 mm) diameter disc. Complete the disc by filing accurately to the line. Alternatively, fit in a lathe and turn the outside diameter. Use the bearing housing, bolted to the disc, to hold it.
3. Drill the holes.

7 Screen rim

Material

1/8 in (3 mm) thick carbon steel sheet (or stainless steel sheet for greater durability), preferably with square edges.

1. Mark out a strip of suitable steel about 25 1/2 in (648 mm) long, and ensure the edges are parallel and mark the position of the perimeter holes as shown in the drawing on the surface that will eventually form the outside of the rim.
2. Drill out the holes using a pedestal drilling machine and sharp twist drills. Always drill from the outer surface side.
3. Carefully remove any sharp projections which have been produced during drilling but do not smooth the actual edges of the holes.
4. Roll the strip around to produce a loop, which when welded, should fit very closely around the edge of the setting disc. File smooth any lumps which form on the inside while welding. The disc will ensure that the rim is kept as circular as possible.
5. Weld the four tabs to the outside as shown and drill the mounting holes.
6. File the top edge flat and square so that no gaps are formed when the front plate is fitted over the rim.

4 holes $\frac{1}{2}$ in (7 mm) diameter on $1\frac{1}{2}$ in (44 mm) PCD

hole $\frac{1}{8}$ in (12.5 mm) diameter

8 in (203 mm) diameter (turn edge to give circular profile)

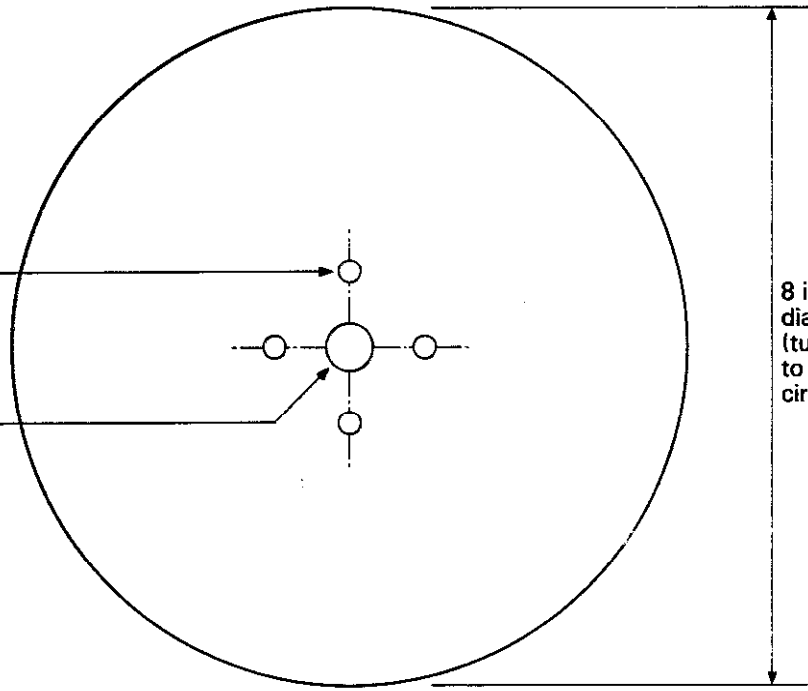

8 in (203 mm) (approximate inside diameter)

Starting about $2\frac{7}{8}$ in (73 mm) from one end of the unwelded strip, about $25\frac{1}{2}$ in (648 mm) long, drill 38 holes $\frac{3}{8}$ in (10 mm) diameter and $\frac{1}{2}$ in (13 mm) apart. Drill the holes from the outside surface, inwards

weld
1 in (25 mm) free of weld above tab

file top surface flat and square

90°

90°

1 in (25 mm)

1 in (25 mm)

$\frac{5}{8}$ in (16 mm) 1 $\frac{1}{4}$ in (32 mm)

4 tabs $\frac{1}{8}$ in (3 mm) thick welded flush with edge, each with hole $\frac{1}{8}$ in (7 mm) diameter on a pitch circle diameter $9\frac{1}{2}$ in (240 mm)

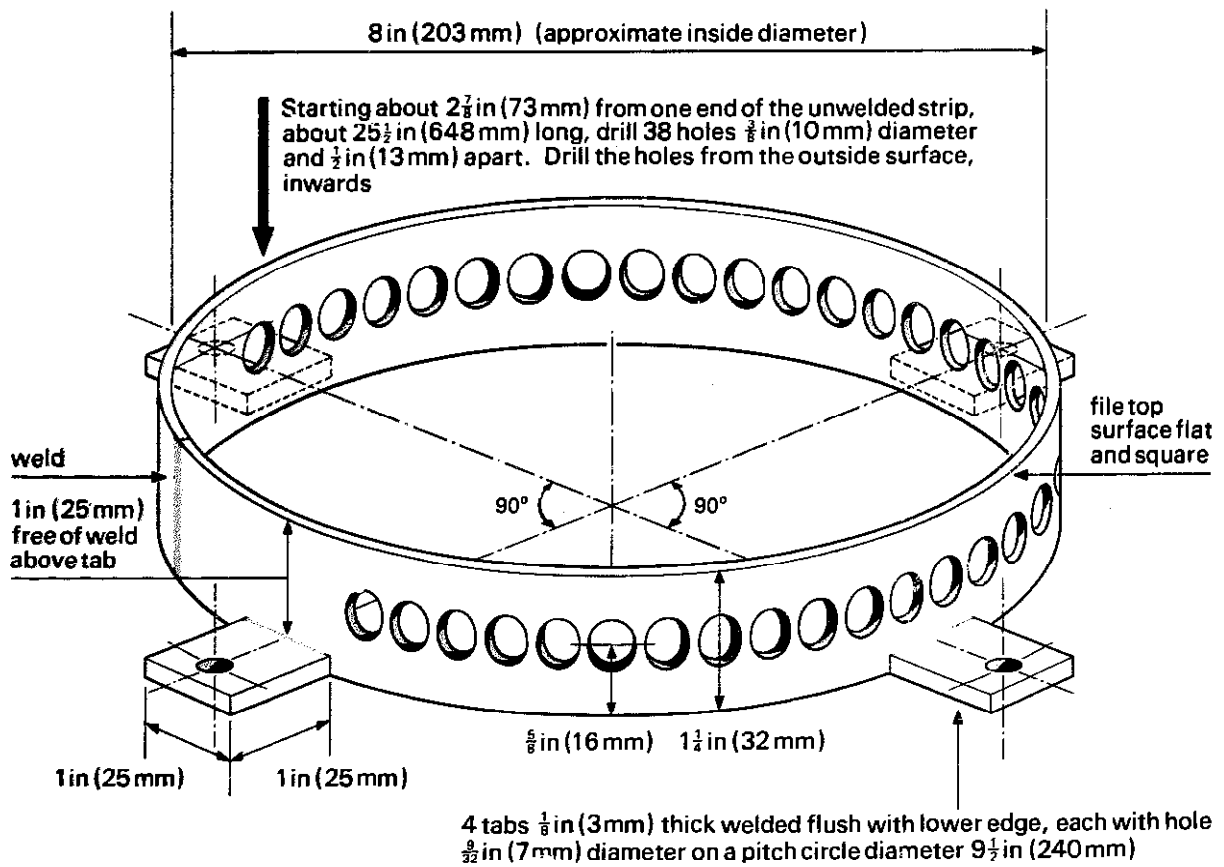

8 Screens

The size of the holes in the screen determines the fineness of the product. Screens can be made of sheet metal with drilled or pressed holes, or of woven wire. Although it may be more expensive, woven wire is better because air and flour can pass through more freely. When the screen is of wire it must be fitted round the screen rim. Sheet metal screens, however, are in one piece, with the outside edge acting as a screen rim.

The mill should operate satisfactorily with screens with hole sizes as small as 0.02 in (0.5 mm) square. Many meshes with different wire and hole sizes are available depending upon the supplier. Meshes with square apertures in the range 0.02 to 0.04 in (0.5 to 1.0 mm) and wire diameters in the range 0.016 to 0.028 in (0.4 to 0.7 mm) can be considered. Stainless steel wire is preferable. Mosquito wire will probably not be strong enough. If supplies of woven wire are difficult to obtain, UK suppliers include:

1. N Greenings (Warrington) Ltd, Britannia Works, Warrington, Lancashire, WA5 5JX, UK
2. Locker Wire Weavers Ltd, PO Box 161, Church Street, Warrington, Lancashire, WA1 2SU, UK
3. Bedford, Steer, End & Co Ltd, 74-84 Long Lane, Borough, London, SE1 4AZ, UK.

Screens produced from sheet steel with drilled or pressed holes are easier to make. Produce a loop with an internal diameter of 8 in (203 mm) from $\frac{1}{8}$ in (1.5 mm)-thick steel with holes all round the edge to act as the rim. Weld four mounting tabs to the edge of the loop as for the screen rim.

Drill all holes inwards from the outside, as close together as possible but not so close as to weaken the screen.

9 Clamp for wire screens

A woven screen can be fitted and tensioned using the clamp as shown in the drawing.

Cut the screen to length and make the four cut-outs at each corner. Position the screen at each side of the clamp (with the end between two screws) and clamp the screen tightly with the four cap screws. Insert a long screw into the central hole.

Fit the screen round the screen rim while this is fitted in position on the mill. Position the clamp in the centre of the undrilled portion; screw the centre screw against the rim until the screen is taut.

Check that all the rim holes are covered by the screen and that there are no gaps at the edge.

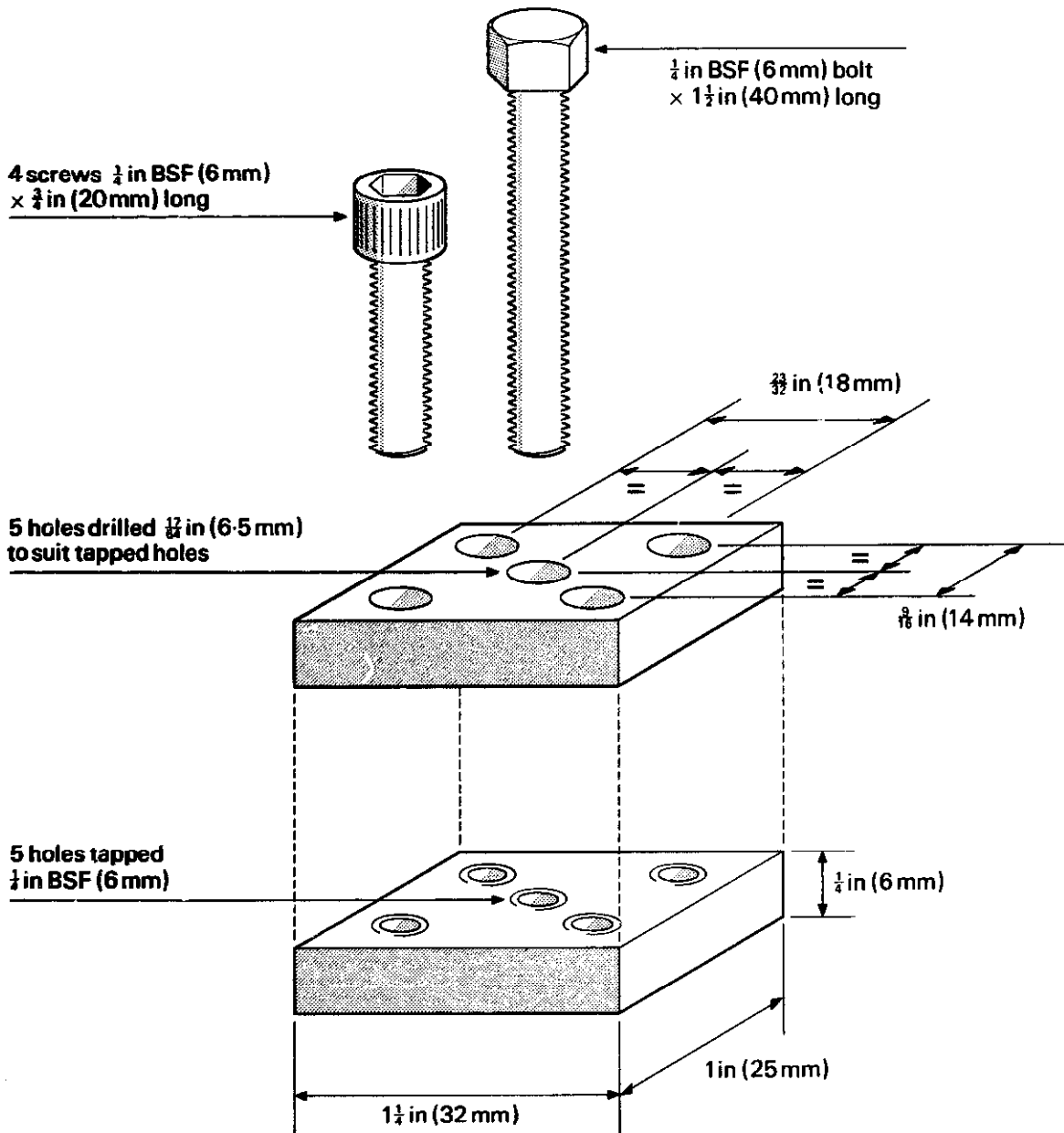
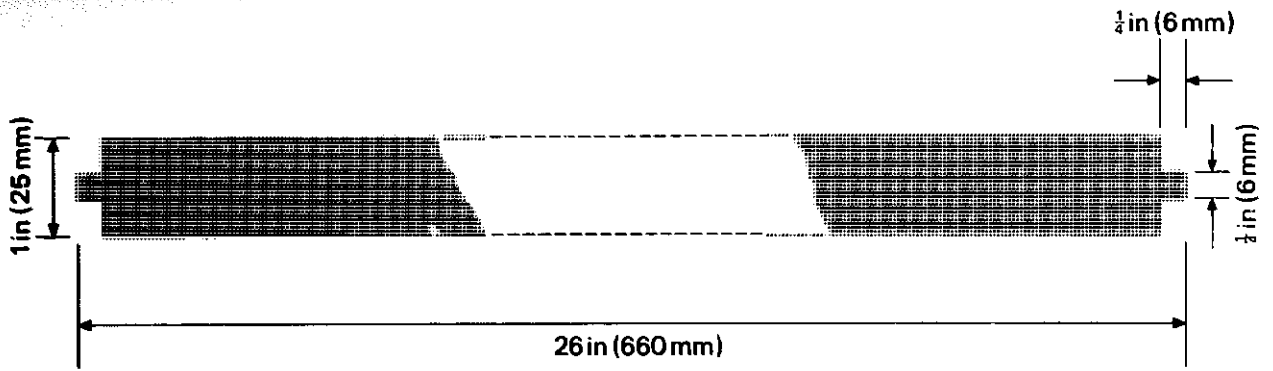

10 Mounting pivot

Material

½ in (3 mm) thick steel

1. Mark out the outline of both of the component parts of the pivot.
2. Bend the sides of the larger piece, and fit the spacing piece between the sides so that they are square and parallel.
3. Weld in the spacing piece and mark the positions of the holes.
4. Drill the holes and remove sharp edges.

11 Pivot backing plate

Material

¼ in (6 mm) thick steel.

1. Manufacture part as shown in the drawing.
2. Fit three ¼ in (6 mm) bolts about 1½ in (40 mm) long through the holes and secure each firmly with a nut to make clamping with the mounting pivot easier.

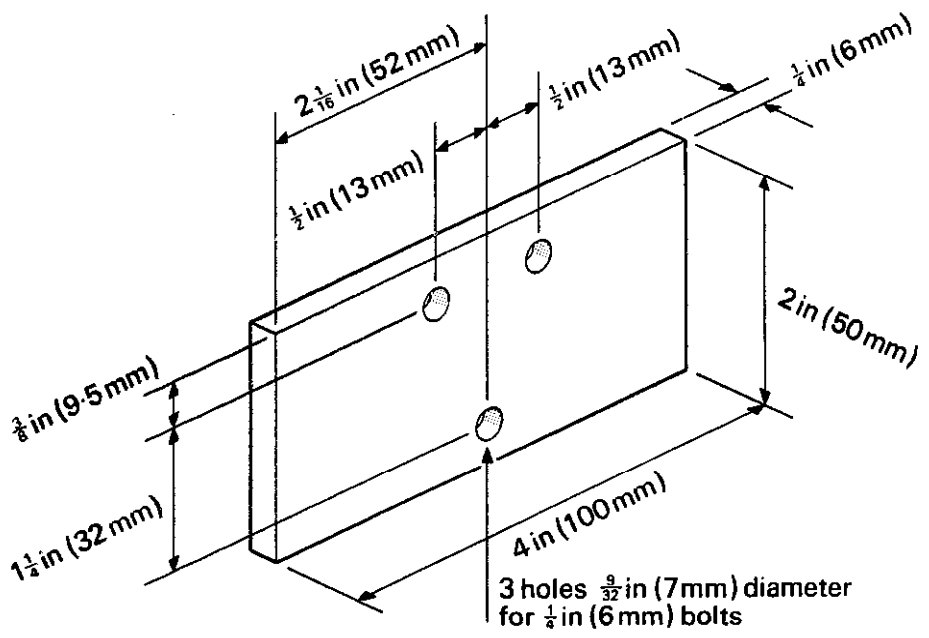
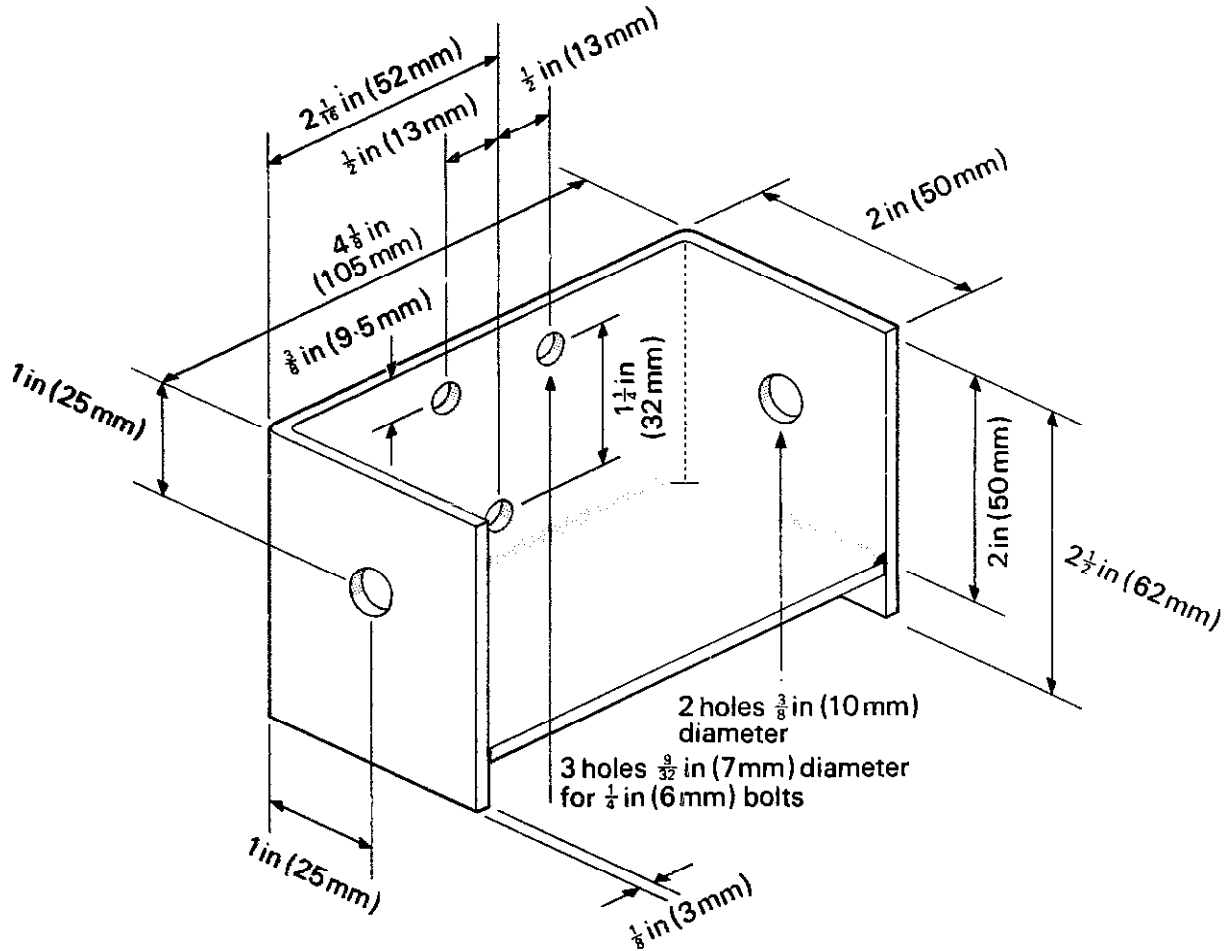

12/13 Upper support arms

Material

¼ in (6 mm) thick steel

1. Manufacture two arms which are both generally similar except that the second arm (part 13) is without the large hole. The dimension marked with an asterisk should allow the mill to be mounted nearly vertically over the rear wheel. Check and produce different arms if necessary.

14 Lower support arm

Material

¼ in (6 mm) thick steel

1. Produce the support bracket generally as shown in the drawing. The holes should be chosen on assembly to locate the mill in its correct position. Bolt the lower end to the top hole in the upright of the support frame and the upper end to the bottom corner of the back plate. The arm should be bent if necessary to keep the mill straight.

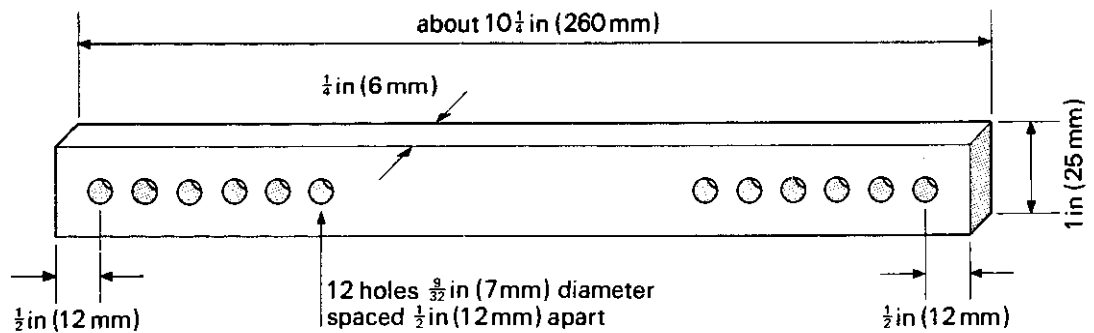
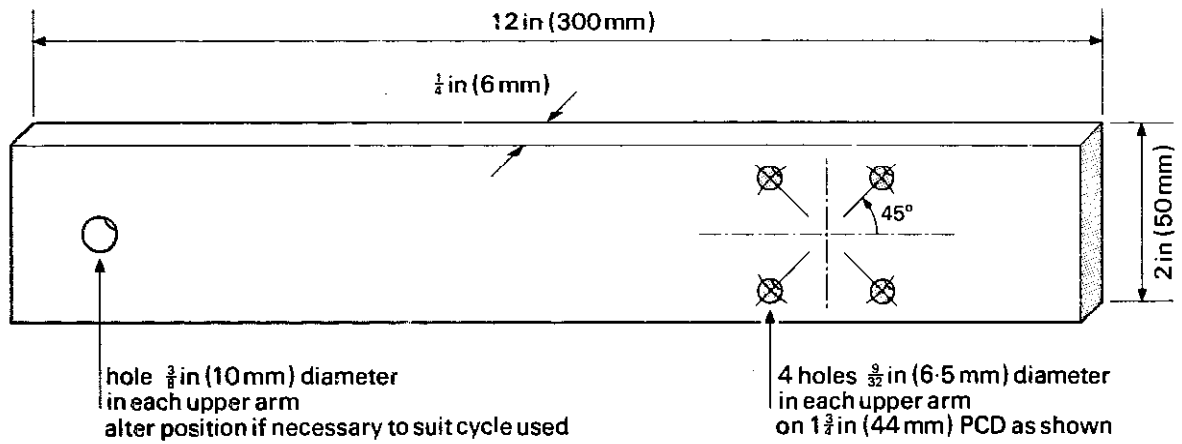
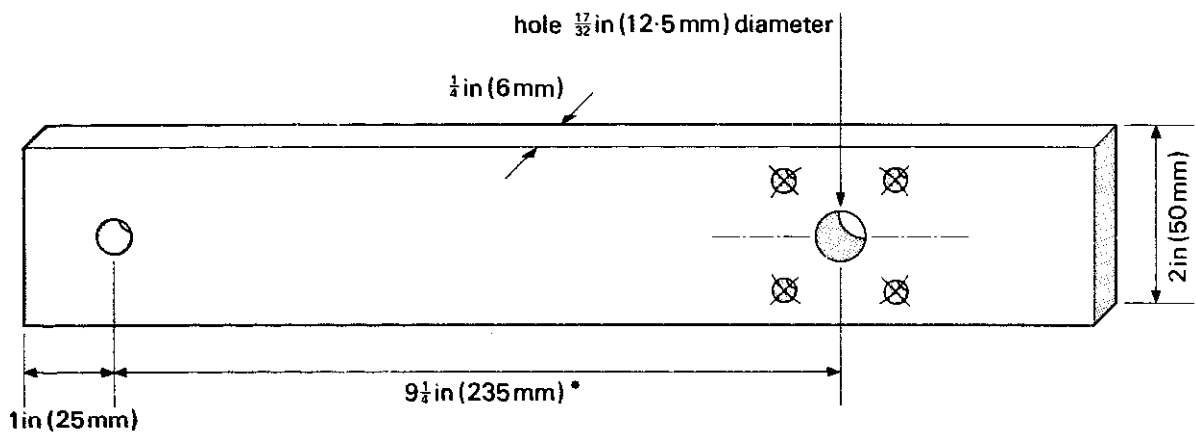

15 Bicycle stand/16 Wheel support plates

Materials

Part	No	Length of each	Material
A	2	20 in (510 mm)	1 ¼ in × 1 ¼ in × ⅜ in angle (30 × 30 × 5 mm)
B	1	24 in (610 mm)	As above
C	2	24 in (610 mm)	As above
D	2	20 in (510 mm)	1 ½ in × ¼ in strip (38 × 6 mm)
E	2	16 ½ in (420 mm)	As above
F	1	24 in (610 mm)	As above

1. Cut to length the pieces of angle steel for items A, B and C. Drill the holes in A.
2. Cut the steel strip to length to make items D, E and F.
3. Mark the wheel support plates and cut to size. Drill the two holes shown in each.
4. Obtain a suitable bicycle and prepare it for use as described under final assembly (page 28).
5. Remove each rear axle nut from the bicycle in turn, fit a plate on to each end of the axle and refit the nuts. Measure the distance between the outside of the two plates.
6. Before welding, set this same distance between the uprights so that the support plates on the bicycle fit easily between them. Ensure that the bicycle is mounted level on the stand before welding.
7. Tack weld the above items together as shown in the drawing to produce a square and accurate structure. Remove the corners from items D and E so that the joints are flush and from the ends of B to prevent injuries to toes during use.
8. Complete the welds to form a rigid structure. Compensate, where necessary, for any warping.

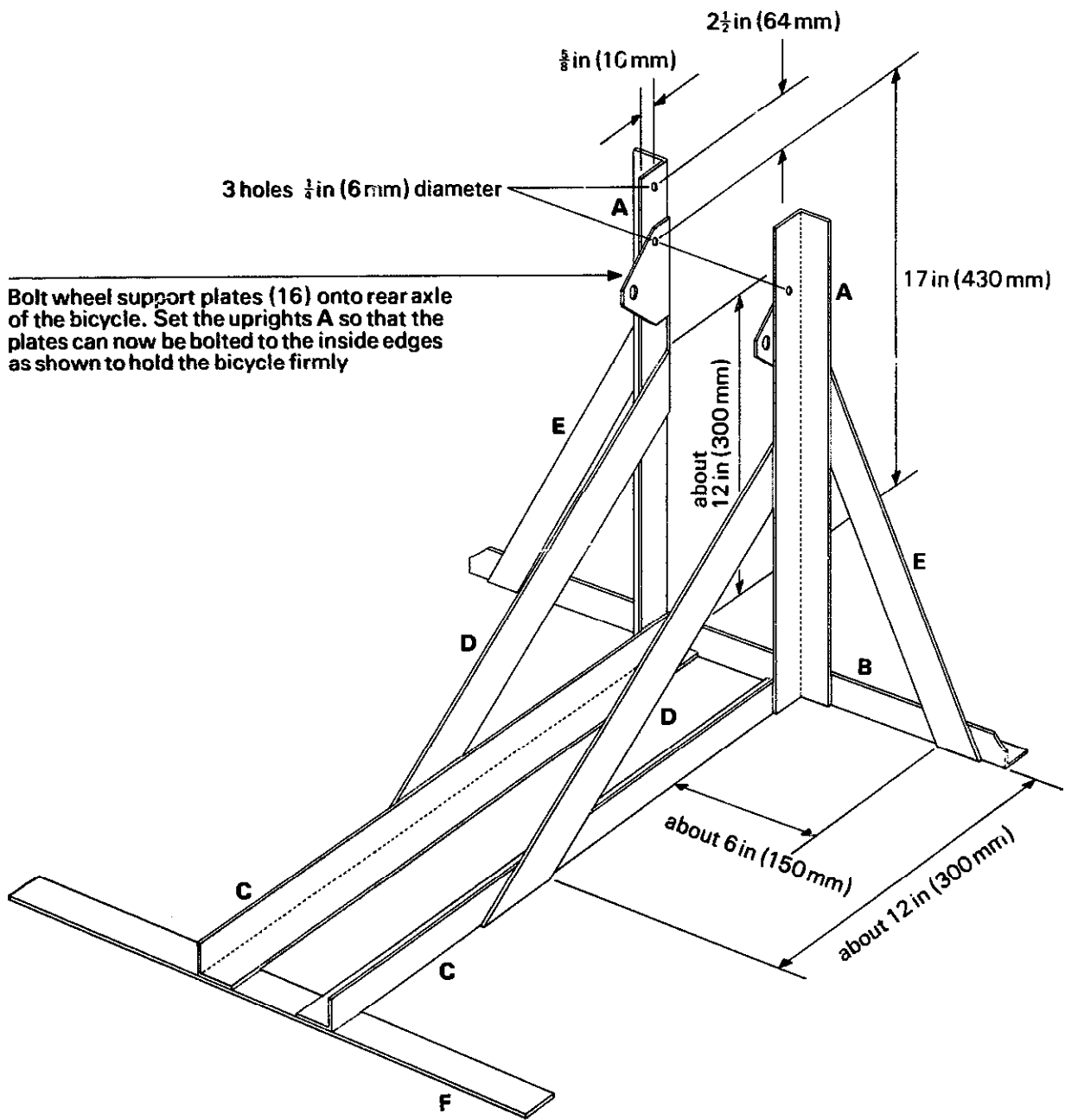

Wheel support plates
 Material $\frac{1}{8}$ in (3 mm) thick steel

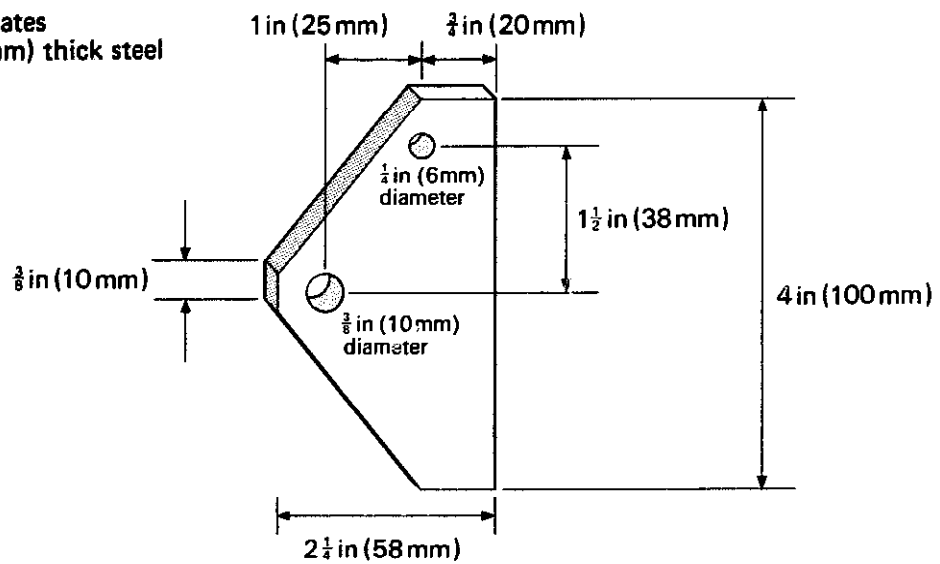

Assembly of the milling unit

1. Position the rotor on the end of the roller shaft and fix with a $\frac{1}{4}$ in BSF (6 mm) screw and lock-washer. Drill a hole through the hub of the rotor, the screw and the shaft large enough to take a suitable split pin. Drill the hole with extreme care. Remove the swarf from the hole regularly and do *not* allow the drill to break. Mark the position of each part so that, later, they can be assembled more easily.
2. Remove the rotor. Push the two ball bearings on to each end of the roller shaft, taking care to push only on to the inner race of the bearing. **Do not allow any dust to enter the bearings themselves.**
3. Push the roller shaft into the bearing housing and retain in position with a $\frac{1}{4}$ in BSF (6 mm) screw and locknut. Ensure that the end with the tapped hole is at the end marked 'mill backplate end'. Do not force the bearings into the housing. When the shaft is running at its normal speed, the outer race of each bearing should not spin. If available use a bearing fixing fluid to prevent this.
4. Position the rim setting disc (part 6) in front of the backplate and the upper support arm (part 12) behind. Using four $\frac{1}{4}$ in BSF \times 1 in long (6 mm \times 25 mm) screws and washers, fix these three items to the 'mill backplate end' of the bearing housing. Check that the shaft moves freely through the central hole; file out a little if necessary. Make sure that the setting disc fits centrally around the shaft.
5. **It is essential that the shaft rotates with the minimum of friction.**
6. Fix the other upper support arm (part 13) with similar screws to the other end of the bearing housing.
7. Fit four $\frac{1}{4}$ in BSF \times 2 in long (6 mm \times 50 mm) screws through the back plate with their heads at the back of the backplate. Fasten, using nuts and lock-washers. Check that the screws line up with the holes on the front plate.
8. Position a screen between the two plates of the screen clamps and tighten up the four screws. Fit the screen around the rim with the clamp in the middle of the undrilled part.
9. Position the screen rim around the setting disc and fix to the backplate with four screws. Tension the screen with the fifth clamp screw so that the clamp is directly above the rim.
10. Check that the top edge of the screen rim is flat and fits closely to the inside surface of the front plate.
11. Refit the rotor with the screw, washer and split pin. Check that the rotor can spin freely inside the rim and does not touch the inner surface. The clearance between the tip and the rim should not be more than $\frac{1}{16}$ in (1.5 mm) although it may be difficult to keep this clearance constant. Check that the rotor tip runs in the centre of the holes in the rim.
12. Fit the front plate using four wing nuts.
13. Paint all exposed surfaces of all components to resist rusting.

Screen

Screen clamp

Mill backplate

Screen rim

Split pin

Rim setting disc

Rotor

Wheel support plates

Stand

Upper support arms

Mounting pivot

Pivot mounting plate

Sack hanger

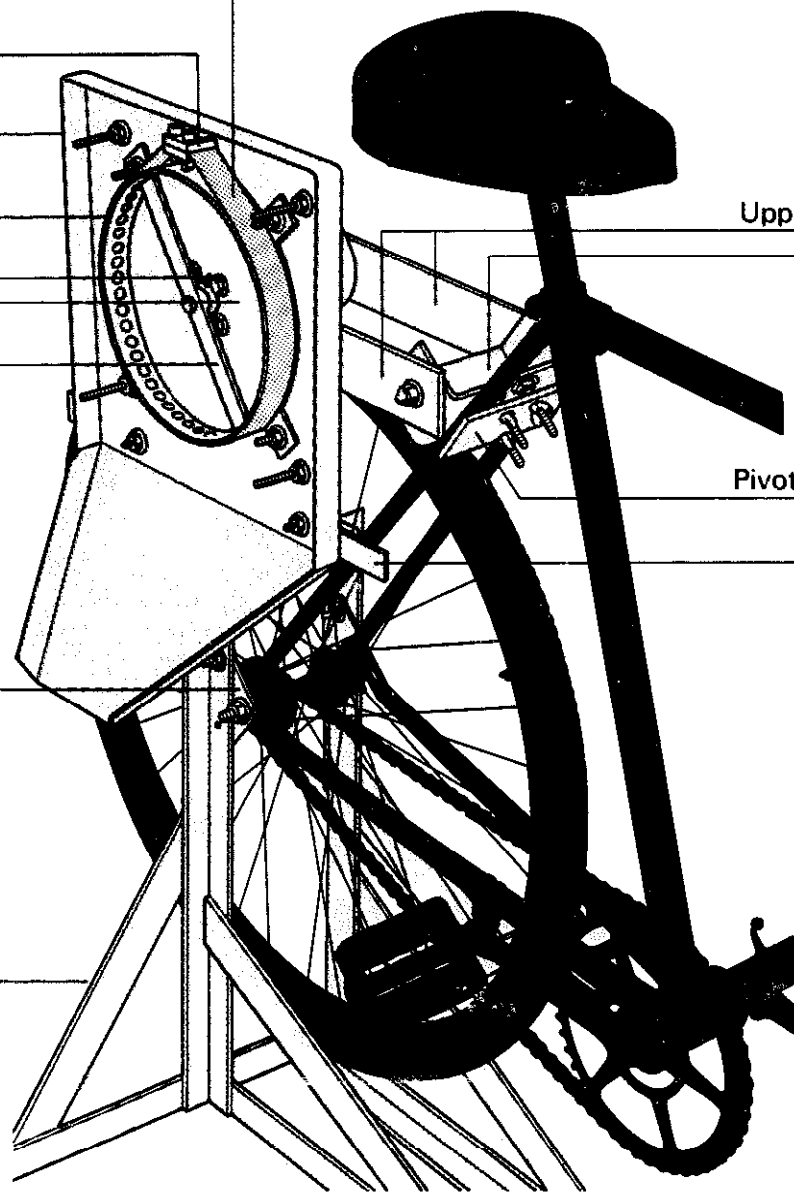

Final assembly

Once the milling unit has been assembled and the bicycle stand completed, a suitable bicycle is needed. If possible this should be one without a cross bar since in many areas it is the women—not the men—who produce the flour. Instructions for using a typical bicycle are given below. The drawing on page 31 shows a wooden frame which could be used as an alternative to the bicycle.

Use a normal, full-sized bicycle in good mechanical condition. Preferably it should have a 26 in (about 650 mm) diameter wheel rim and its tyre should be undamaged and should have a tread pattern with ridges running continuously round the edge. When the tyre is inflated the tread surface should be as near circular as possible. The wheel itself should not have a 3-speed or dynamo hub but should have a free-wheel and a drive sprocket with about 18 teeth.

1. Remove the rear wheel, chain guard, rear mud-guard and, if necessary, adjust the position of the brakes. Remove the pedal shaft bearing assembly, taking care not to lose the ball bearings.
2. Clean out the pedal shaft bearings and refit after packing them with fresh grease. Use the adjustment to remove any excess play in the bearing.
3. Clean and adjust the rear wheel bearings in a similar manner.
4. Fit the two wheel support plates to the rear axle of the bicycle as described on page 24.
5. Position the rear wheel of the bicycle between the uprights of the bicycle stand. Using two $\frac{1}{4}$ in (6 mm) bolts, fix the bicycle by the wheel support plates to the holes in the uprights.
6. Improvise a suitable support to fix the front wheel and to keep the bicycle level.
7. Fit the mounting pivot, (using the backing plate fitted with the 3 small bolts) above the wheel on the rear forks with 3 more nuts and washers.
Never over-tighten these bolts or the bicycle frame may be crushed.
8. Fit the milling unit itself, using two $\frac{3}{8}$ in (10 mm) bolts fitted through the holes in the upper support arms.
9. Select two holes on the lower support arm that will position the mill correctly on the tyre. Bolt one end to the upper hole on the stand and the other end to the back of the backplate, using the fifth hole towards the bottom of the plate. Bend the arm if necessary to keep the mill straight.
10. Whatever the size of the bicycle, you should arrange that the mill unit rests near the top of the rear wheel. Shorten or extend the distance between holes in the arms if necessary.
11. Pump the tyre pressure up to normal hardness and, by sliding the pivot clamp along the rear wheel forks, fix the mill in rolling contact with the tyre. The pressure between them should be as low as possible but, when the pedals are turned there should be no obvious slippage under acceleration or under load. Excessive pressure produces too much friction.
12. With the front plate fitted, check that the friction in the mill is normal by pedalling the empty mill at a speed of about 85 turns per minute and then checking how long the mill takes to stop on its own. This should take not less than 8 seconds (after the bearings have been run-in by turning the mill at speed for a few minutes).
13. Carry out a grinding test and check that no grain particles escape in the gaps at the side between the front and back plates. Bend the edges slightly to close up any gaps.

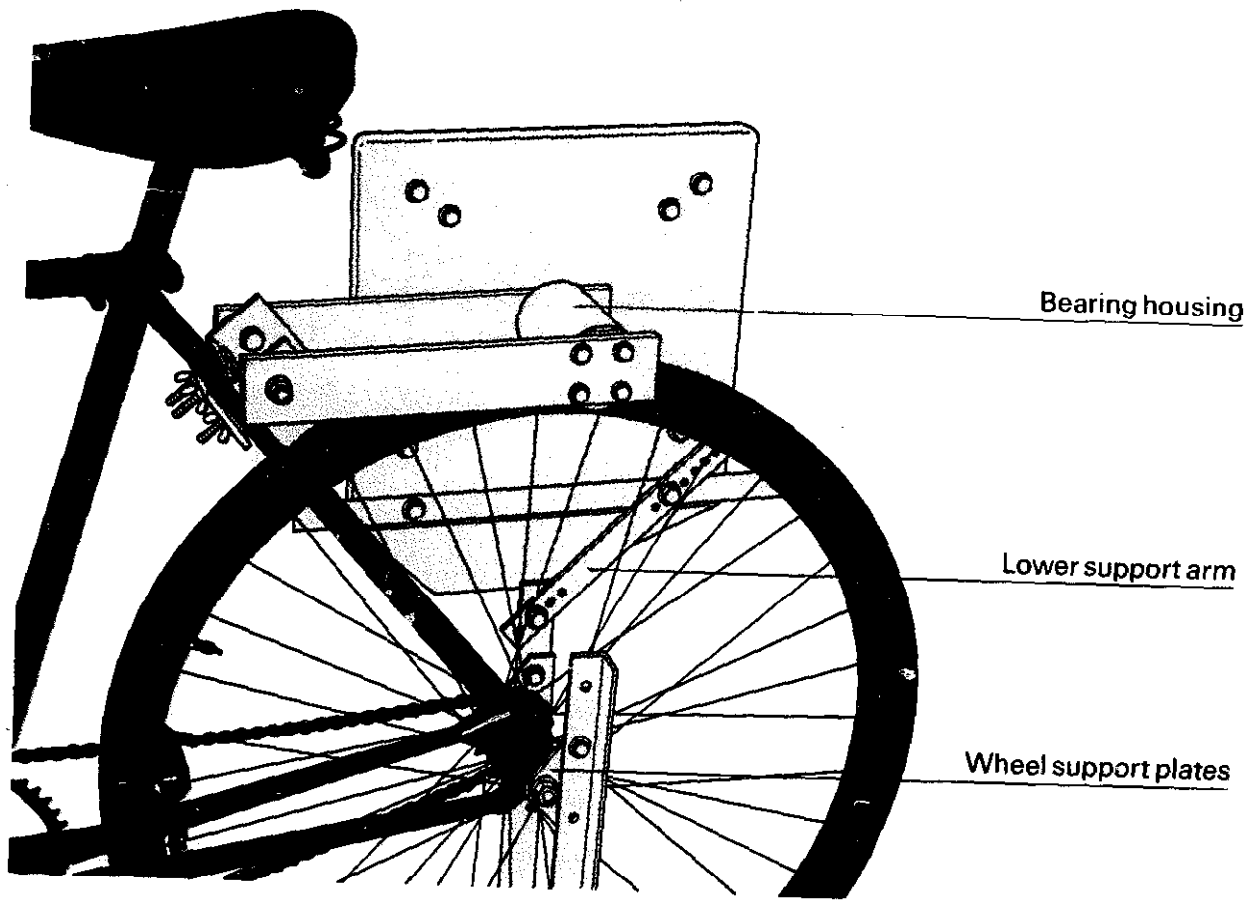

Bearing housing

Lower support arm

Wheel support plates

Using the mill

The mill must be operated correctly to achieve the best results. Bear the following points in mind.

The mill operates only at high speed. Use a brisk pedalling speed at all times.

Never operate the machine without the front plate in position.

Feed the mill by placing small handfuls of grain into the chute every few seconds and *not* by filling the chute to the top.

Control feeding carefully so that the mill is not overloaded and slowed down. Otherwise slippage at the tyre will occur and result in unnecessary wear.

Overfeeding will also lead to the mill becoming choked. The front plate and screen will then have to be removed to clear the mill.

Do not stop the mill while it contains grain.

Always run the machine with the screen rim or perforated screen securely fitted.

Work the mill using two operators, one to drive and the other to feed in the following manner.

1. Select and fit the correct screen for the product required.
2. Fit a clean cloth bag to the outlet chute using the sack hook and secure to make sure that all grain particles are caught in the bag.
3. Pedal the mill up to normal speed and start feeding as described above.

Outline of an Alternative Wooden Frame

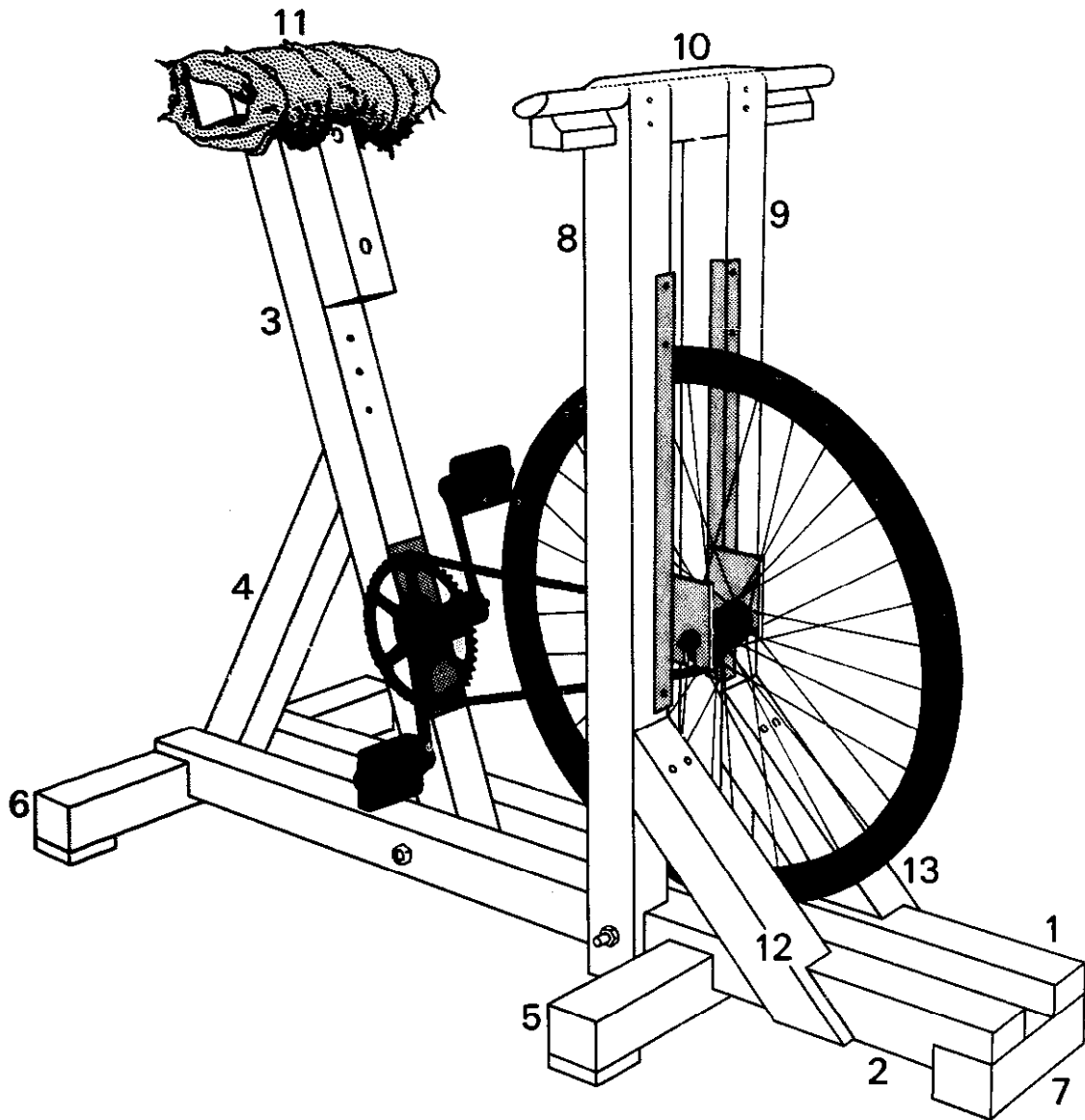

Part No	Part	3" square (75 mm) Planed timber length required
1	base piece	54 in (1400 mm)
2	base piece	54 in (1400 mm)
3	seat support	48 in (1300 mm)
4	seat support strut	24 in (600 mm)
5	foot	24 in (600 mm)
6	foot	24 in (600 mm)
7	foot	12 in (300 mm)
8	upright	48 in (1300 mm)
9	upright	48 in (1300 mm)
10	handle bar	24 in (600 mm)
11	saddle	24 in (600 mm)
12	strut	24 in (600 mm)
13	strut	24 in (600 mm)

TOTAL = 36 ft 11.2 metres

Copyright and Reproduction Rights

The copyright of publication in this series belongs to the British Government and is © *Crown Copyright* 1978.

If it is intended to reproduce this guide, or any part of it, for commercial purposes, such as sale, at a profit or advertising, permission must be obtained in advance from:

The Head
Publications Section
Tropical Products Institute
56/62 Gray's Inn Road
London WC1X 8LU

Otherwise, the guide, or any part of it, may be reproduced (in English or in translation) provided it includes an acknowledgement on the following lines: —

Pinson G S (1978) A pedal-operated grain mill.
Rural Technol. Guide, Trop. Prod. Inst.,
No. 5, 32pp.

Copies of the guide can be purchased from the Tropical Products Institute, price 55p excluding packing and postage. They are available free of charge to public bodies in countries eligible for British aid.

Future Guides

The Institute would be glad to receive suggestions for new devices and techniques which might usefully be described in future publications in this series.

Tropical Products Institute
ISBN 0 85954 076 6

The Tropical Products Institute

The Tropical Products Institute is a British Government organisation which co-operates with developing countries in helping them to derive greater benefit from their plant and animal resources. It specialises in problems which arise after harvest and is ready to provide information and advice on these problems if requests are addressed to:

The Director
Tropical Products Institute
56/62 Gray's Inn Road
London WC1X 8LU

Rural Technology Guides

The purpose of this series of Tropical Products Institute publications is to provide working details of devices or techniques suitable for use in rural communities. Each guide is fully illustrated and written in simple, practical language rather than in complex scientific terms, so that the reader can assess its usefulness and then, if he wishes, make the device or carry out the technique described.

The guides are intended principally for extension workers, instructors and other field staff in rural development. However, it is hoped that they will also be useful to anyone who is interested and can follow the pictures and instructions.

The series is being published in English and each publication will, therefore, be useful only in areas where the English language is widely used. For other areas, it is suggested that the text might usefully be translated into the local language and reproduced locally. It may also be possible to prepare visual aids from the pictures in the guide, for the use of instructors and other field staff.

The Institute will be pleased to give advice to anyone intending to reprint this guide or to make visual aids from the illustrations. Requests for such advice should be sent, with full details, to the Head, Publications Section, Tropical Products Institute, at the above address.