

## TRIPOD LASHING:

**Description** ---- A shear lashing around 3 poles.

**Use** ---- To bind three poles together, for the construction of a tripod. ---- To bind three poles together that contact at the same point in a structure.

**Comments** ----The tripod lashing is a shear lashing that binds three poles together at the same point. ---- The tripod lashing gets its name from the fact that its most common use is the construction of a tripod. ----The tripod lashing can be used just about any where in a structure that three poles cross each other at the same point and the same time in the sequence of construction. ---- Tripod lashing takes two main forms; with racked wrapping turns (the rope is woven between the poles) and with plain wrapping turns (the rope is wrapped around the poles without weaving the rope between the poles). When the lashing is made with racking turns the rope contacts each pole around its entire circumference ; this contact makes the tripod lashing with racking turns the most secure form of tripod lashing: therefore tripod lashing with racking turns should be used when safety is important. However, for light structures where there would be no danger if the lashing slipped, the faster to tie tripod lashing with plain wrapping turns may be used.

**Laying Out The Poles** ---- For most tripod lashings, lay the pole side by side with the butt ends aligned. The alignment of the butts of the pole insures that the tripod legs are the desired length.

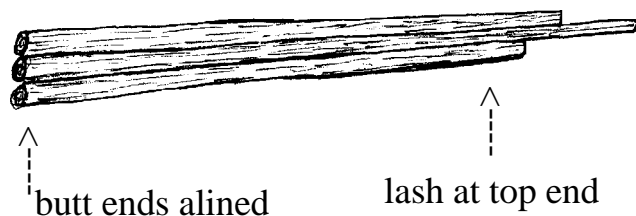

in opposite directions the wrappings must be put on loosely so that when the center pole is rotated to its proper position the lashing is tightened around the poles. If the wrappings are put on to tight, the rope is stretched causing damage to the rope fibers, therefore weakening the lashing. On the other hand, if the rope is wrapped two loosely, the lashing will not tighten enough when the center pole is rotated and the lashing will be able to slip along the length of the pole. Either way, the rope to loose or the rope to tight, a dangerous situation is created.

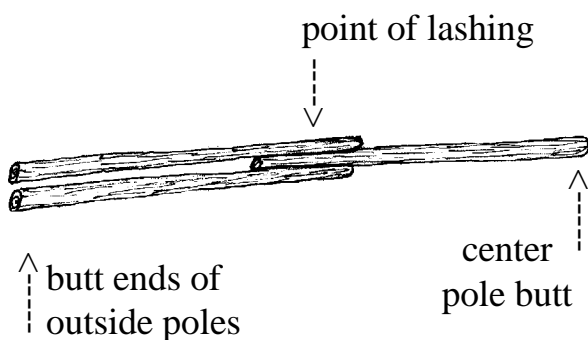

However, if the tripod is to be part of a structure and the center pole will be at an angle greater than  $90^\circ$  to the outside poles, lay the center pole in the opposite direction to the outside poles so that the rotation of the poles at the lashing is less than  $90^\circ$ . See gate way below for an example.

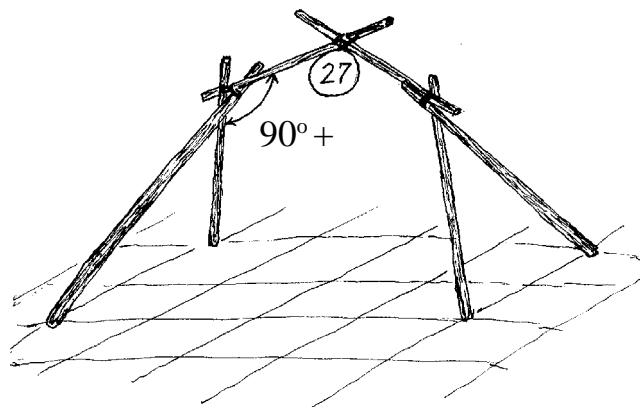

**[NOTE]** The practice of laying the center pole in the opposite direction to the outside poles creates several problems. When the poles are laid

**Setting Up A Tripod -----** Set up the tripod by crossing the outside poles so that the cross point of the poles is under the center pole. Crossing the outside poles under the center pole causes part of the load that is placed on the tripod to be taken up by the wood to wood contact of the poles.

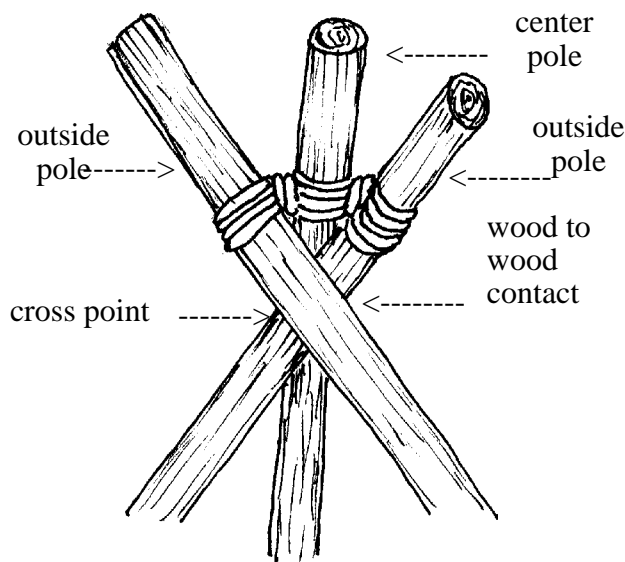

If the outside poles are crossed above the center pole, the rope of the lashing will be required to support all or most of the load; therefore the tripod will not be as strong as when the outside legs are crossed under the lashing.

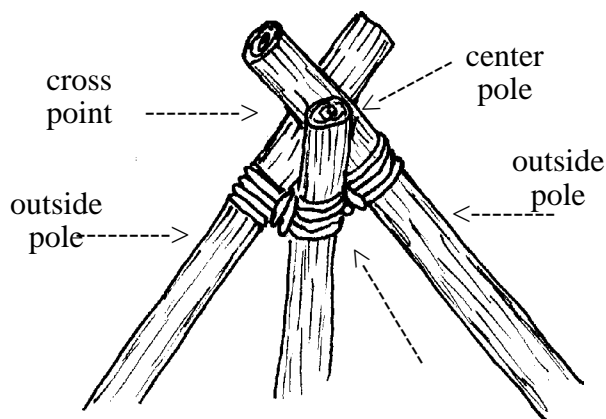

no wood to wood contact, rope supports load

If a symmetrical arrangement of the poles is needed within a structure, the tripod can be set up by rotating the poles around the lashing. This rotation causes the loss of the wood to wood contact so that the load is supported only by the ropes, and the joint between the poles becomes very flexible; therefore the tripod may be unstable.

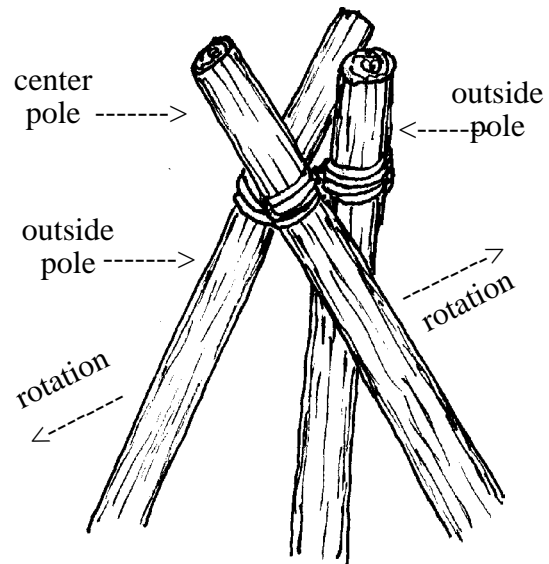

## **TRIPOD LASHING:** **(With Racking Turns)**

**Narration ----** (For tripod lashing with racking turns knotboard.) (1) Tie a clove hitch around one of the outside poles. (2) Secure the standing part by wrapping it around the running part. [NOTE] Wrapping the standing part around the running part prevents the clove hitch from slipping around the pole. If the clove hitch slips the lashing will loosen up from the inside. (3) Start the racked wrapping turns by weaving the rope between the poles. (4) Take a total of 5 to 7 wrapping turns. Pull each wrapping turn tight as it is made. [NOTE] The stiffness of the tripod lashing depends on the number and tightness of the wrapping turns. As the tightness of the wrapping turns or the number of wrapping turns increases, the stiffness of the tripod will increase. (5) Take the first frapping turn by taking the rope around the pole that the clove hitch



**+** **TRIPOD LASHING** **+**  
WITH RACKING TURNS

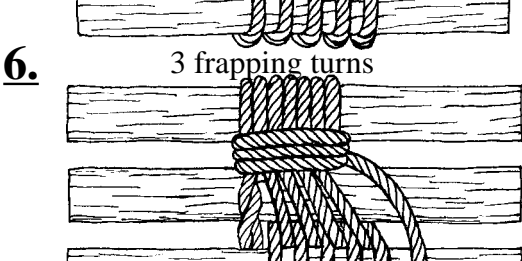
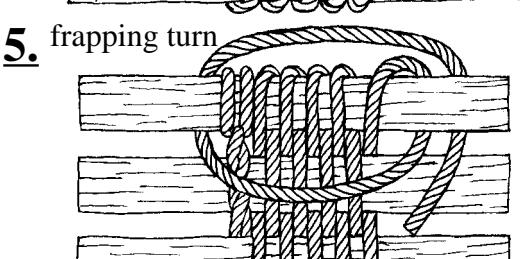
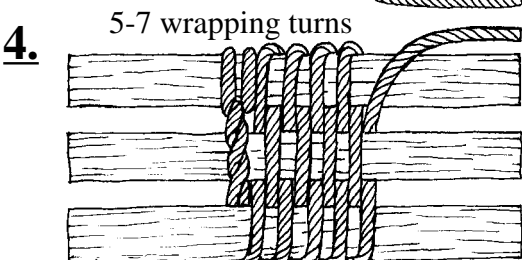
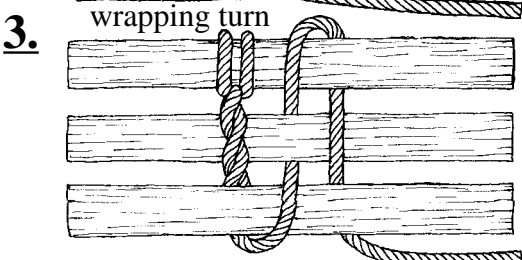
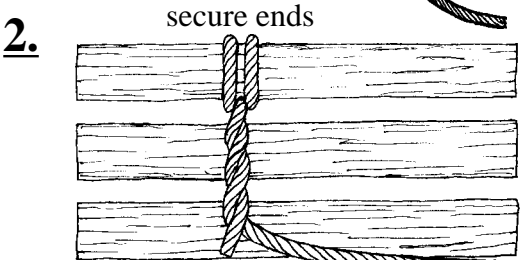
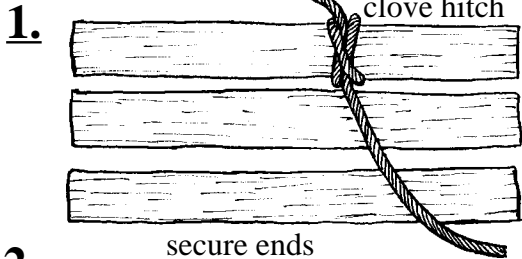

pull each turn tight

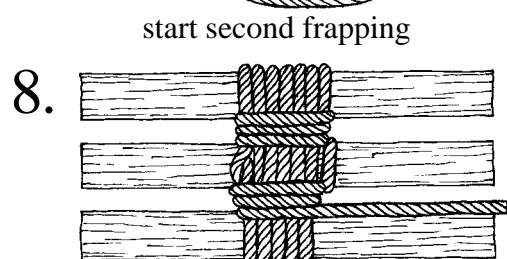
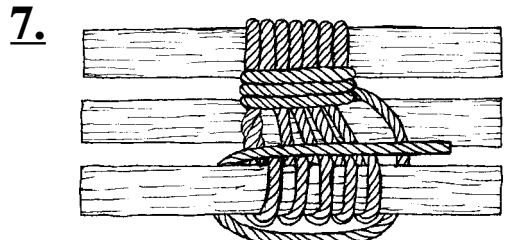

pull each turn tight

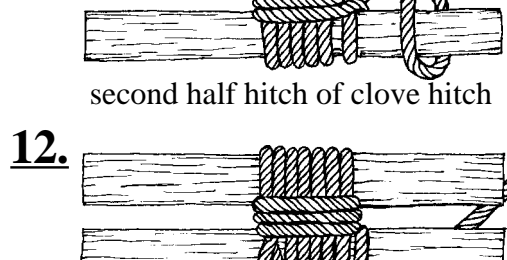
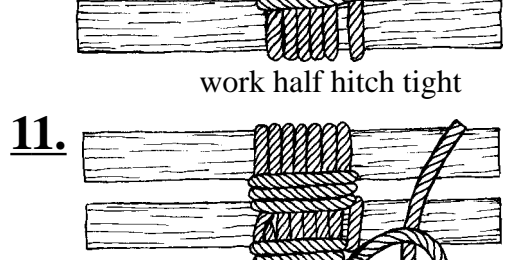
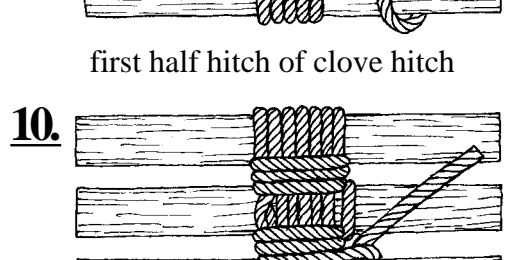
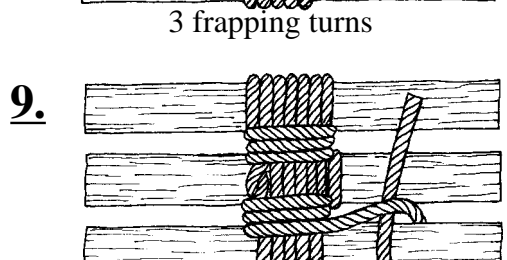

work clove hitch tight

**+**

**+**

was tied to, then between the outside pole and the center pole. (6) Take 3 frapping turns. Pull each frapping turn tight as it is made. (7) Start the second set of frapping turns by taking the rope across the center pole and reeving it between the second outside pole and the center pole. Take the second set of frapping turns in the opposite direction to the first set of frapping turns. [NOTE] Taking the second set of frapping turns in the opposite direction to the first set of frapping turns prevents the rope from crossing the wrappings at a diagonal. Unnecessary crossing of the rope increases friction between the strands of the rope making it difficult to tighten the lashing properly. (8) Take a total of 3 frapping turns. Pull each turn tight. (9) Take the first half hitch of the ending clove hitch around the second outside pole by taking the rope past the pole and then around the pole. (10) Work the half hitch tight so that it is locked against the lashing. [NOTE] See the narration for square lashing for instructions on working the half hitch tight. (11) Take the second half hitch of the ending clove hitch. (12) Work the half hitch tight to complete the ending clove hitch. [NOTE] If the clove hitch is not worked tight so that it is locked against the lashing the clove hitch will slip around the pole allowing the lashing to loosen. [NOTE] If very smooth rope is being used, a 3<sup>rd</sup> half hitch should be added to the clove hitch to insure that the lashing will stay in place.

## **TRIPOD LASHING:** **(WITH PLAIN TURNS)**

**Narration ----** (For tripod lashing with plain turns knotboard.) (1) Tie a clove hitch around one of the outside poles. (2) Secure the standing part by wrapping it around the running part. [NOTE] Wrapping the standing part prevents the clove hitch from slipping around the pole. If the clove hitch slips the lashing will loosen up from the inside. (3) Start the wrapping turns by wrapping the rope around the poles. Take a total of 4 to 6 wrapping turns. Pull each wrapping turn tight as it is made. [NOTE] The stiffness of the tripod lashing depends on the number and tightness of the wrapping turns. As the tightness of the

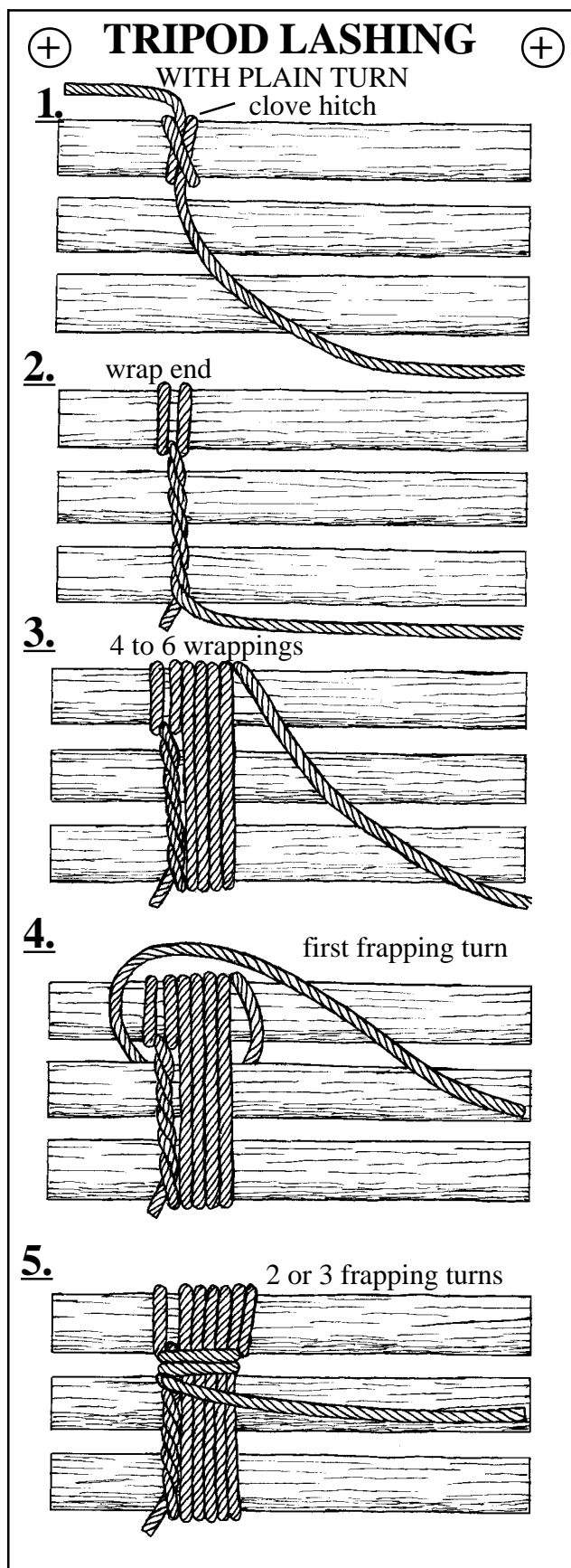

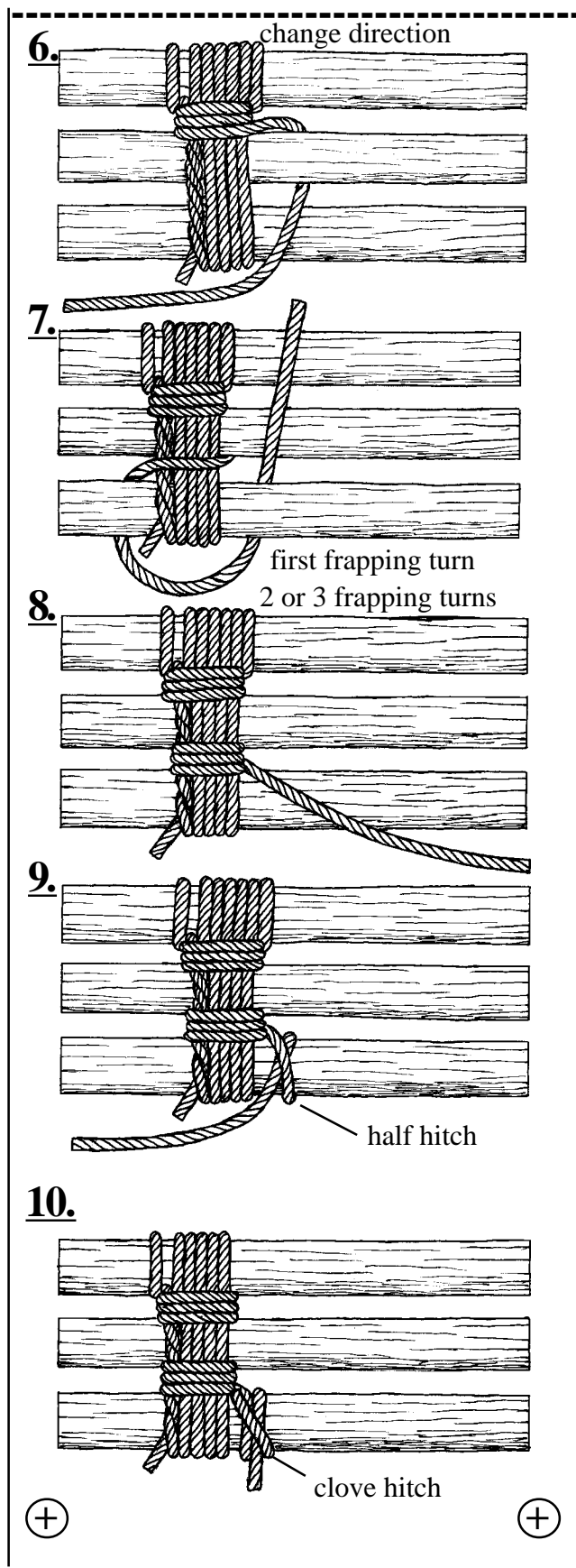

wrapping turns or the number of wrapping turns increases, the stiffness of the tripod will increase. (4) Take the first frapping turn by passing the rope around the pole that the clove hitch was tied to, then between the outside pole and the center pole. (5) Take 2 or 3 frapping turns. Pull each frapping turn tight as it is made. (6) Start the second set of frapping turns by taking the rope around the center pole and reeving it between the second outside pole and the center pole. (7) Take the second set of frapping turns in the opposite direction to the first set of frapping turns. [NOTE] Taking the second set of frapping turns in the opposite direction to the first set of frapping turns prevents the rope from crossing the wrappings at a diagonal. Unnecessary crossing of the rope increases friction between the strands of the rope making it difficult to tighten the lashing properly. (8) Take a total of 2 or 3 frapping turns. Pull each turn tight. (9) Take the first half hitch of the ending clove hitch around the second outside pole by taking the rope past the pole and then around the pole. Work the half hitch tight so that it is locked against the lashing. [NOTE] See the narration for square lashing for instructions on working the half hitch tight. (10) Take the second half hitch of the ending clove hitch. Work the half hitch tight to complete the ending clove hitch. [NOTE] If the clove hitch is not worked tight so that it is locked against the lashing the clove hitch will slip around the pole allowing the lashing to loosen. [NOTE] If very smooth rope is being used, a 3<sup>rd</sup> half hitch should be added to the clove hitch to insure that the lashing will stay in place.

## QUICK TRIPOD LASHING:

**Comments ----** The tripod quick lash is one of the fastest ways to construct a tripod. However the tripod quick lash is not as secure as the more conventional methods, therefore the tripod quick lash tripod should not be use for heavy loads.

### **Directions -----**

**STEP 1]** Lay the poles side by side with the with the butt ends alined. Wrap 5 to 8 wrappings around all three poles.

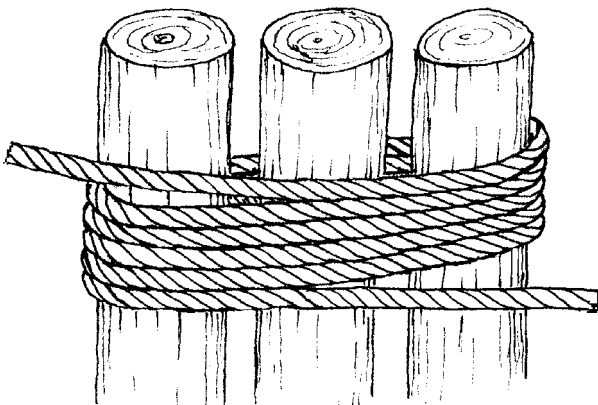

**STEP 2]** Start the frapping turn by taking each end around an outside pole and then between the outside pole and the center pole.

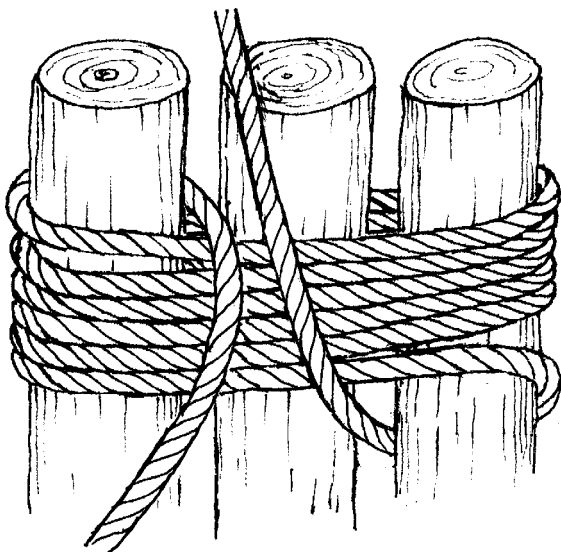

**STEP 3]** Take 1 or 2 frapping turns with each end. Pull the frapping turns tight; this will also tighten the wrappings.

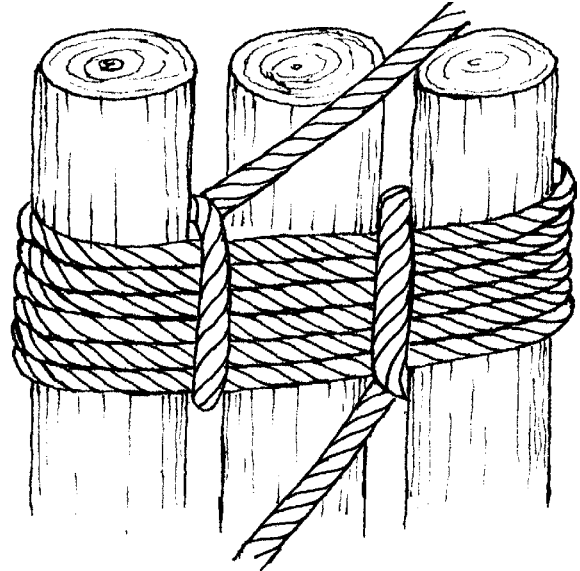

**[NOTE]** The frapping turns are taken in opposite directions.

**STEP 4]** End the lashing by tying the ends of the rope together with a square knot.

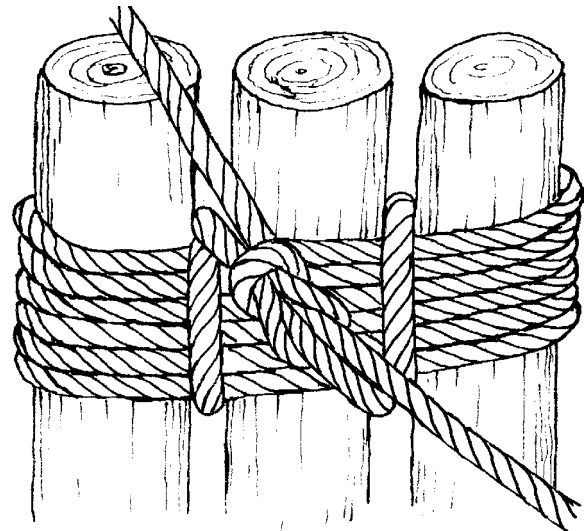

### **[WARNING]**

If one end of the square knot is pulled it can be up set into a lark's head knot. When this happens the knot will slip causing the entire lashing to loosen and fail.