

**AT** MICROFICHE  
REFERENCE  
LIBRARY

A project of Volunteers in Asia

Appropriate Technology for Water Supply and  
Sanitation, Volume 1b: Sanitation Alternative for  
Low-Income Communities -- A Brief Introduction

by: D. Duncan Mara

Published by  
The World Bank  
1818 H Street, N.W.  
Washington, DC 20433 USA

Available from:  
The World Bank  
Publications Unit  
1818 H Street, N.W.  
Washington, DC 20433 USA

Reproduced by permission of the World Bank.

Reproduction of this microfiche document in any  
form is subject to the same restrictions as those  
of the original document.

# Appropriate Technology for Water Supply and Sanitation

## Sanitation Alternative for Low-income Communities —A Brief Introduction

By Duncan Mara

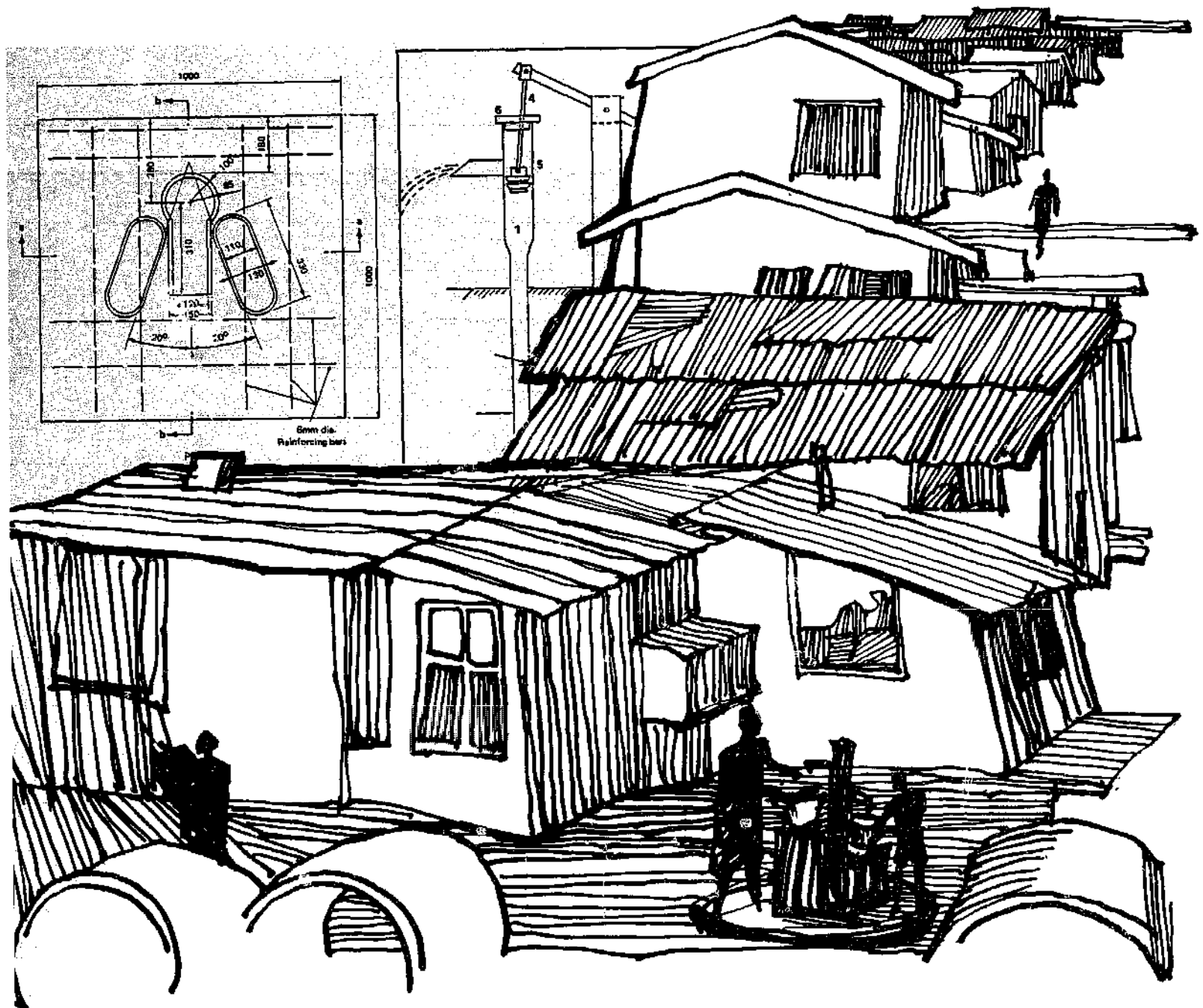

World Bank, February 1982

A Contribution to the International Drinking Water Supply and Sanitation Decade

1-B

Copyright © 1982 by the International Bank for Reconstruction and  
Development/The World Bank

The World Bank enjoys copyright under Protocol 2 of the Universal Copyright Convention. Nevertheless, permission is hereby granted for reproduction of this material, in whole or part, for educational, scientific, or development-related purposes except those involving commercial sale provided that (a) full citation of the source is given; and (b) notification in writing is given to the Director of Information and Public Affairs, the World Bank, Washington, D.C. 20433, U.S.A.

APPROPRIATE SANITATION ALTERNATIVES FOR LOW-INCOME COMMUNITIES

A BRIEF INTRODUCTION

The work reported herein represents the views of the author and not necessarily those of the World Bank, nor does the Bank accept responsibility for its accuracy or completeness.

Transportation, Water, and Telecommunications Department

The World Bank

February 1982

APPROPRIATE SANITATION ALTERNATIVES

FOR LOW-INCOME COMMUNITIES:

A BRIEF INTRODUCTION

Abstract

This short paper describes in non-technical language the various low-cost sanitation technologies that are currently available for low-income communities in developing countries and presents a general methodology for low-cost sanitation program planning.

Prepared by: D. Duncan Mara (Consultant)

Copyright © 1982  
The World Bank  
1818 H St. N.W.  
Washington, D.C. 20433  
United States of America

TABLE OF CONTENTS

	<u>Page</u>
PREFACE	iii
I - INTRODUCTION	1
II - SANITATION PROGRAM PLANNING	1
Planning Methodology	1
Public Health Aspects	5
Economic and Financial Aspects	7
Sociocultural Aspects	12
III - SANITATION TECHNOLOGIES	15
Water Supply Service Levels	15
Conventional Sewerage	19
Ventilated Improved Pit Latrines	20
Pour-Flush Toilets	23
Vault Toilets	24
Septic Tanks	26
Other Technologies	29
Communal Facilities	31
Sullage Management	35
Off-Site Treatment	35
Resource Recovery	37
IV - TECHNOLOGY SELECTION	41
V - SANITATION UPGRADING SEQUENCES	45

ANNEX I

List of Appropriate Technology for Water Supply and Sanitation Publications.

PREFACE

In 1976 the World Bank undertook a two-year research project on appropriate technologies for water supply and sanitation in developing countries. The results of this research project are available in a series of publications which are listed in Annex I of this booklet. In 1978 the United Nations Development Programme appointed the World Bank as the executing agency for Global Project GLO/78/006 entitled "Demonstration Projects in Low-Cost Water Supply and Sanitation", the purpose of which is to aid governments in providing appropriate water supply and sanitation facilities for low-income communities. The results of the World Bank research project are thus being translated into actual projects.

This booklet is intended for economic, urban, and health planners; its purposes are to introduce in general non-technical terms the alternative sanitation technologies that are currently available for low-income urban communities in developing countries, and to present a suitable planning methodology for providing these communities with the sanitation facilities they need. More detailed information is available in Annex I.

## I - INTRODUCTION

The ten year period from 1981 to 1990 has been adopted by the General Assembly of the United Nations as the International Drinking Water Supply and Sanitation Decade. The goal of the Decade is that, by the end of 1990, all people should possess an adequate water supply and satisfactory means of excreta and sullage<sup>1</sup>/ disposal. The best current estimate is that some 2.4 billion people will require to be provided with water and sanitation if this goal is to be realized--that is, over 650,000 people per day for the next ten years.

The conventional solution to the problem of excreta and sullage disposal in urban areas is waterborne sewerage. As noted in Section III, this solution is by no means technically perfect. Moreover, its cost is so high that it is beyond the bounds of affordability for low-income communities in developing countries; for example, per-household investment costs in eight cities studied by the World Bank ranged from \$650 to \$4000 and the corresponding total economic costs were between \$150 and \$650 per household per year at 1978 prices. Such costs are clearly unaffordable: total annual household incomes are generally less than \$1,000 and often below \$500.

The development of conventional sewerage in industrialized countries spanned a period of nearly 100 years. Although in its initial stages the emphasis was on the improvement of public health, later refinements to the system were designed to maximize user convenience, and the present high standard of convenience has been achieved at substantial economic and environmental costs. In developing countries, where excreta-related diseases exact a terrible toll of morbidity and mortality, the primary objective of sanitation programs must be the improvement of public health (see Section II); refinements to increase user convenience are of secondary importance and can be made at a later date when the community can afford them (see Section V).

This primary health objective can be fully achieved by sanitation technologies which are much simpler and cheaper than conventional sewerage; these technologies are described in Section III. In order to ensure that the most appropriate technology is selected for any given community and that, once installed, it is properly operated and maintained, it is essential that sociocultural aspects are considered during the planning process, in addition to the usual economic, financial and technical aspects. A suggested planning methodology which incorporates the participation of the intended beneficiaries is presented in Section II.

## II- SANITATION PROGRAM PLANNING

### 1. Planning Methodology

Sanitation program planning is the process by which the most appropriate sanitation technology for a given community is identified,

1. Sullage is domestic wastewater from sinks, showers, and baths.



designed and implemented. The most appropriate technology is defined as that which provides the most socially and environmentally acceptable level of service at the least economic cost.

The process of selecting the appropriate technology begins with an examination of all of the alternatives available for improving sanitation; these are described in Section III of this booklet. There will usually be some technologies which can be readily excluded for technical or social reasons. For example, septic tanks requiring large drainfields would be technically inappropriate for a site with a high population density. Similarly, a composting latrine would be socially inappropriate for people who have strong cultural objections to the sight or handling of excreta. Once these exclusions have been made, cost estimates are prepared for the remaining technologies. These estimates should reflect real resource cost to the national economy, and this may involve making adjustment in market prices to counteract distortions or to reflect development goals such as employment creation. Since the benefits of various sanitation technologies cannot be quantified, the health specialist must identify those environmental factors in the community which act as disease vehicles and recommend improvements which can help prevent disease transmission. The final step in identifying the most appropriate sanitation technology rests with the intended beneficiaries. Those alternatives which have survived technical, social, economic and health tests are presented to the community with their attached price tags, and the users themselves decide what they are willing to pay. Technology selection algorithms which incorporate economic, social, health and technical criteria are presented in Section V.

Figure II-1 shows how the various checks are actually coordinated in practice. The checks themselves, of course, are inter-related. A technology may fail technically if the users' social preferences militate against its proper maintenance. The economic cost of a system is heavily dependent upon social factors, such as labor productivity, as well as technical parameters. However, because it is operationally difficult to employ simultaneous (or even iterative) decision processes, a stepwise approach with feedback across disciplines is suggested.

For simplicity it is assumed that separate individuals or groups are responsible for each part, although in practice responsibilities may overlap. In Step 1 each specialist collects the information necessary to make his respective exclusion tests. For the engineer, public health specialist and behavioral scientist<sup>2/</sup> this data collection would usually take place in the community to be served. The economist would talk with both government and municipal officials to obtain the information necessary to calculate shadow rates and to obtain information on the financial resources likely to be available. The behavioral scientist would consult with and

- 
2. The term "behavioral scientist" is used to describe the person skilled in assessing community needs, preferences and processes. The person's training may be in anthropology, communications, geography, sociology or psychology, or it may come from a wide variety of education and experience.

Figure II-1. Recommended Structure of Feasibility Studies for Sanitation Program Planning

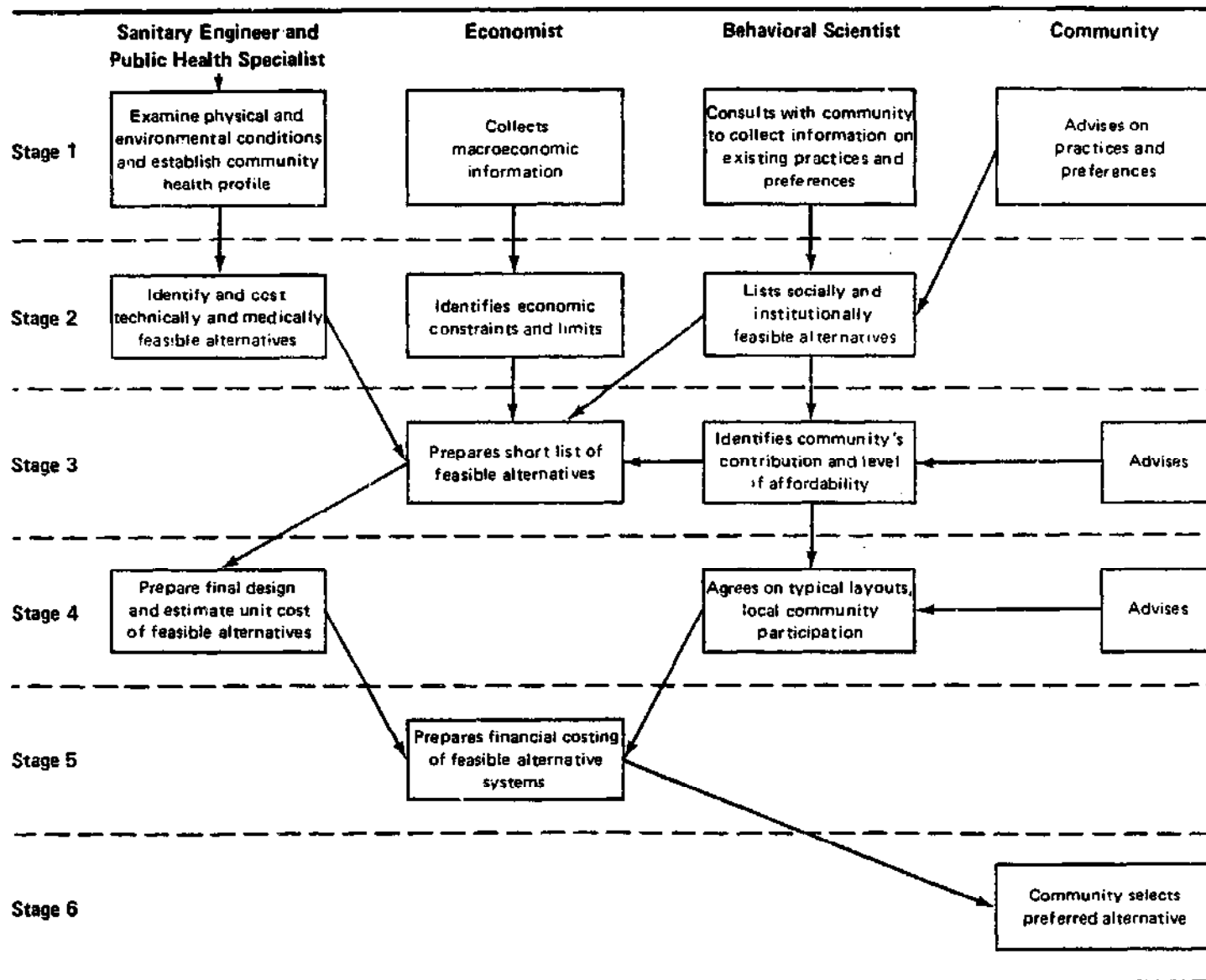

survey the potential users and community groups. Then the engineer and behavioral scientist apply the information they have collected to arrive at preliminary lists of technically and socially feasible alternatives. The public health specialist relates the most important health problems to any relevant environmental factors involving water and excreta. In the third step the economist prepares economic cost estimates for those technologies which have passed the technical and social tests, and selects the least cost alternative for each technology option. As the fourth step the engineer prepares final designs for these remaining choices. At this stage the social information collected in Step 1 should be used to determine the siting of the latrine on the plot, the size of the superstructure, the materials to be used for the seat or slab, and other details whose technical and economic import may be low but which make a major difference in the way the technology is accepted and used in the community. The designs should also incorporate features necessary to maximize the health benefits from each technology. Final designs are turned over to the economist in the fifth step so that financial costs can be determined, including how much the user would be asked to pay for construction and maintenance of each alternative. The last step is for the behavioral scientist to present and explain the alternatives, their financial costs, and their future upgrading possibilities to the community for final selection.

As part of the sanitation planning process the existing or likely future pattern of domestic water use should be ascertained so that the most appropriate method of sullage disposal can be selected. This is particularly important in the case of properties with a multiple tap level of water supply service, as the large wastewater flows may, according to conventional wisdom, preclude the consideration of technologies other than sewerage or, in low density areas, septic tanks with soakaways. However, it is not necessary, either for reasons of health or user convenience, for domestic water consumption to exceed 100 liters per capita per day (lcd). The use of low volume cistern-flush toilets and various simple and inexpensive devices for reducing the rate of water flow from taps and showerheads can achieve very substantial savings in water consumption without any decrease in user convenience or requiring any change in personal washing habits. These savings can be as high as 75% in high water pressure areas and 30-50% in low pressure areas.<sup>3/</sup> If wastewater flows can be reduced by these means, then the options for sanitation facilities are much broader than only conventional sewerage. In addition, separation of toilet wastes from other wastewater by simple modifications in household plumbing coupled with improved designs of septic tanks (see Section III) may make non-sewered options feasible much more widely.

---

3. Romm, Jerry K. "Marin County, California". Paper read at the American Society of Civil Engineers 1981 international convention during the session on project monitoring and appraisal in the International Drinking Water Supply and Sanitation Decade, May 11-15, 1981, New York. Processed.

The framework suggested above for the identification of the most appropriate technology is probably more time-intensive than that of traditional feasibility analysis. It also requires the recruitment of staff in additional disciplines such as behavioral scientist. Yet it is clear that the planning methodology discussed above has a far greater chance of achieving operational success, because the most appropriate sanitation technology is drawn from a wider range of alternatives, imposes the least cost burden on the economy, maximizes the health benefits obtainable and is selected after extensive interaction with the intended beneficiaries.

## 2. Public Health Aspects

Improvements in public health are generally considered to be one of more important benefits of sanitation programs. Over fifty infections can be transferred from a diseased person to a healthy one by various direct or indirect routes involving excreta. Coupled with malnutrition, these excreta-related diseases exact a terrible toll of morbidity and mortality in developing countries, especially among children. For example, in one Middle Eastern country, half of the children born alive die before reaching the age of five as a result of the combined effects of disease and malnutrition; in contrast only two percent of children born in the United Kingdom die before reaching their fifth birthday.

The recent classification of excreta-related infections developed by Feachem, et al<sup>4/</sup> is shown in Table II-1. This classification is useful to sanitary engineers and health planners as it is an environmental, rather than biological, classification; that is to say it classifies the excreta-related infections into groups with similar environmental transmission patterns, rather than simply listing the causative agents of the infections by their biological type (i.e. as viruses, bacteria, protozoa and helminths). It thus becomes possible to determine fairly readily appropriate environmental strategies to control any particular excreta-related infection, given a knowledge of the life cycle and in particular the latency, persistence and multiplication<sup>5/</sup> characteristics of its causative agent. Thus, for example, to control the transmission of a water-based helminthic (Category V) infection such as schistosomiasis, it is very important to ensure that everybody uses a suitably designed toilet so that no excreta reach a surface watercourse since one person's excreta contaminating the watercourse have the potential of infecting many other people as the causative agent multiplies many thousands of times in its intermediate aquatic snail host.

---

4. Feachem, Richard G., et al. Appropriate Technology for Water Supply and Sanitation, Volume 3: Health Aspects of Excreta and Sullage Management--A State-of-the-art Review. The World Bank, December 1980.

5. These terms are defined in the footnote to Table II-1.

TABLE II: ENVIRONMENTAL CLASSIFICATION OF EXCRETA-RELATED INFECTIONS

CATEGORY	FEATURES*	INFECTIONS	DOMINANT TRANSMISSION FOCI	MAJOR CONTROL STRATEGIES
I	Non-latent, low infectious dose (< 100 organisms)	Enterobiasis Enteric virus infections Hymenolepiasis Amoebiasis Giardiasis Balantidiasis	Personal contamination Domestic contamination	Domestic water supply Sanitary education Improved housing <i>Provision of toilets</i>
II	Non-latent medium or high infectious dose (> 10 000 organisms), moderately persistent and able to multiply	Typhoid Salmonellosis Shigellosis Cholera Path. <i>E. coli</i> enteritis Yersiniosis <u>Campylobacter</u> enteritis	Personal contamination Domestic contamination Water contamination Crop contamination	Domestic water supply Sanitary education Improved housing <i>Provision of toilets</i> Treatment prior to discharge or reuse
III	Latent and persistent with no intermediate host; unable to multiply	Ascariasis Trichuriasis Hookworm infection Strongyloidiasis	Yard contamination Field contamination Crop contamination	<i>Provision of toilets</i> Treatment prior to land application
IV	Latent and persistent with cow or pig intermediate host; unable to multiply	Taeniasis	Yard contamination Field contamination Fodder contamination	<i>Provision of toilets</i> Treatment prior to land application Cooking of meat Meat inspection
V	Latent and persistent with aquatic intermediate host(s); able to multiply (except <u>Diphylobothrium</u> )	Clonorchiasis Diphylobothriasis Fascioliasis Fasciolopsiasis Gastrodiscoidiasis Heterophyiasis Metagonimiasis Paragonimiasis Schistosomiasis	Water contamination	<i>Provision of toilets</i> Treatment prior to discharge Control of animal reservoirs Control of intermediate hosts Cooking of fish and aquatic vegetables
VI	Excreta-related insect vectors	Bancroftian filariasis (transmitted by <u>Culex pipiens</u> ), and all the infections listed in Categories I-III which may be transmitted by flies and cockroaches	Insects breed in various fecally contaminated sites	Identification and elimination of suitable breeding sites

Source: Feachem *et al.* (in press)

\* Latency: a latent organism requires some time in the extra-intestinal environment before it becomes infective to man. Persistency refers to the ability of an organism to survive in the extra-intestinal environment.

The theoretical potential for control of excreta-related infections by sanitation improvements alone and by personal hygiene improvements alone is shown in Table II-2. The outstanding difference is between Categories I and II together, which depends so strongly on personal and domestic hygiene, and the other categories which do not. Category I and II infections are thus much more likely to be controlled if water availability is improved concurrently with sanitation and if an effective and sustained program of sanitary education is organized. If improvements are made only in the water supply, there will be some reduction in the incidence of Category I and II infections, but full health benefits will not be realized until excreta disposal improvements are made as well. Some Category I and II infections are unlikely to be controlled completely; for example, enteroviral infections, rotavirus infections, salmonellosis (other than typhoid or paratyphoid) and infections caused by Shigella sonnei, Giardia lamblia, Enterobius vermicularis and diarrhea causing serotypes of Escherichia coli. These excreta related infections are all still commonly transmitted within affluent communities in industrialized countries which have the full 'benefits' of multiple tap in-house water supplies and conventional sewerage.

If one considers the changes necessary to control Category III through VI infections they are relatively straightforward: the provision of toilets which people of all ages will use and keep clean and the effective treatment of excreta and sewage prior to discharge or reuse. The reason why the literature on the impact of latrine programs often does not show a marked decrease in the incidence of Category III through VI infections is because, although latrines were built, they were typically not kept clean, often not used by children, nor by adults when working in the fields.

Sanitation improvements are thus necessary but in themselves not sufficient for the control of excreted infections. Without them, excreted infections can never be controlled. But other complementary inputs, such as improved water supplies and sustained sanitary education programs, are essential for success. In some cases, the provision of sanitation improvements and these complementary inputs for the urban poor may necessitate major social and economic changes.

### 3. Economic and Financial Aspects

Once those sanitation technologies which are technically infeasible and socially unacceptable have been eliminated by the project engineer and sociologist, it is necessary to rank the remaining technologies by some meaningful scale, in order that the most appropriate one may be selected. Implicit in this is the need for a common basis for the objective comparison of the remaining technologies which reflects both the positive and negative consequences of adopting each of them. Comparative economic costing is the process best suited for this purpose.

Ideally a cost-benefit analysis should be used to rank alternatives. Unfortunately, as is true of many public services, it is impossible to quantify most of the benefits (such as those of improved health

**Table II-2: THEORETICAL POTENTIAL FOR CONTROL OF EXCRETA-RELATED INFECTION BY IMPROVEMENTS BY SANITATION AND PERSONAL HYGIENE**

Disease category from Table II-1	Impact of sanitation alone	Impact of personal hygiene alone
I	negligible	great
II	slight to moderate	moderate
III	great	negligible
IV	great	negligible
V	moderate	negligible
VI	slight to moderate	negligible

Source: Feachem et al. Appropriate Technology for Water Supply and Sanitation, volume 3: Health Aspects of Excreta and Sullage Management--A State-of-the-Art Review. Washington, D.C., World Bank, 1980.

and user convenience) of a sanitation system. In general, there is no completely satisfactory way to get around this difficulty. Only in the case of mutually exclusive alternatives with identical benefits can one safely select the least expensive one. Where there are differences in the levels of service provided by the various alternatives, the least-cost choice will not necessarily be the one which is economically optimal. For this reason a comparison based on those figures will not normally provide sufficient information to select the most appropriate sanitation technology. Nonetheless, if properly applied, it will provide a reasonably objective basis for comparison which reflects the trade-offs corresponding to different levels of service. Once comparable cost data have been developed, the users or their community representatives can make their own determination of how much they are willing to pay to obtain various standards of service.

### Economic Costing

The basic purpose behind the economic costing of sanitation technologies (or of any other development activity) is to give policy makers a basis for their decisions by providing a price tag for a given level of service which represents the opportunity cost to the national economy of producing that service. Three principles must be followed in preparing estimates:

- (1) all relevant costs must be included;
- (2) each must be properly evaluated; and
- (3) the assumptions used for different technologies must be mutually consistent.

The first principle is that all costs to the economy, regardless of who incurs them, should be included. In comparing different sanitation technologies, too often only those costs met by the administrative (usually municipal or state) authority are considered in the comparison, while those borne by the household or of complementary services (e.g., water for flushing) are often ignored. In analyzing the financial implication to the authority of alternative technologies such a comparison would be appropriate. However, for an economic comparison (i.e., the determination of the least-cost technology with respect to the national economy) it is necessary to include all costs attributable to a given alternative irrespective of who bears them. On the other hand, some financial costs such as subsidies and taxes should be excluded from the economic comparison, since these represent a transfer of money within the economy rather than a cost to it.

The determination of which figures to include should rest on a comparison of the situation over time both with and without the project. This is not the same as a simple "before and after" comparison. Rather than using the status quo as the "without" scenario, it is essential to estimate



how the current situation would improve or deteriorate over the project period if the project were not to be undertaken. In addition, a broad enough view of the project must be taken so that all relevant costs will be included. For example, the additional water required for flushing is often ignored in sewerage systems.

Once the relevant costs have been identified, the second principle concerns the prices which should be used to value them. Since the objective of economic costing is to develop figures which reflect the cost to the national economy of producing a good or service, the economist is concerned that unit prices represent the actual resource endowment of the country. Thus a country with abundant labor will have relatively inexpensive labor in terms of its alternative production possibilities. Similarly, a country with scarce water resources will have expensive water, in the economic sense, regardless of the regulated price charged to the customer. Only by using prices which reflect actual resource scarcities can one ensure that the least-cost solution will make the best use of a country's physical resources.

Because governments often have sociopolitical goals which may be only indirectly related to economic objectives, some market prices may bear little relation to real economic costs. For this reason it is necessary to adjust market prices in the exercise so that they represent more accurately "real" unit costs (in the sense of reflecting their impact on the national economy), instead of using actual market prices which may be fixed for sociopolitical reasons. This adjustment of market prices to reflect opportunity costs is known as "shadow pricing".

The calculation of these shadow rates, or conversion factors, is a difficult task which requires intimate knowledge of a country's economy. It is rarely (if ever) worthwhile for an economist or engineer involved with sanitation program planning to take the time to collect data and calculate conversion factors directly. Rather he or she should check with the ministry of planning or economic affairs to see if the figures have already been determined.

In the economic costing of sanitation technologies there are four shadow rates which normally need to be incorporated into the analysis. These are:

- (1) the unskilled labor wage shadow factor;
- (2) the foreign exchange shadow factor;
- (3) the opportunity cost of capital; and
- (4) the shadow price of water, land, and other direct inputs.

These shadow rates and their application to sanitation technology costing are

fully described by Kalbermatten and others<sup>6/</sup>, to whom readers requiring further information are referred.

### Financial Costs

The purpose of deriving economic costs is to make a meaningful least-cost comparison among alternatives. Such a comparison is extremely useful to the planner and policy-maker. However, the consumer is much more interested in financial costs; i.e., what he will be asked to pay for the system and how the payment will be spread over time. The difficulty in developing financial costs is that they are entirely dependent upon policy variables which can change dramatically. Whereas economic costs are based on the physical conditions of the community (e.g., its abundance or scarcity of labor, water, etc.) and therefore are quite objective, financial costs are entirely subject to interest rate policy, loan maturities, central government subsidies, etc. For example, the financial cost of a sanitation system for a community can be zero if the central government has a policy of paying for them out of the general tax fund. Thus financial costs cannot be used to make judgments about least cost alternatives.

To promote the economically efficient allocation of resources, of course, financial costs should reflect economic costs as closely as possible given the government's equity goals and the degree of distortion in other prices in the economy. This could be accomplished with sewerage, for example, by setting a surcharge on the connected consumer's water bill which is equal to the economic cost of sewerage per cubic meter of water consumed (i.e., if 75% of water consumption reaches the sewers, the AIC of sewerage per cubic meter would be multiplied by 0.75 to arrive at the water surcharge). In the case of most of the on-site systems, the consumer would pay to construct the original facility (either in total or through a loan at the interest rate which reflects the opportunity cost of capital) and then pay a periodic sum to cover its operation and maintenance expenses, if any. In cases like these, the financial cost would be identical to the economic cost except for any taxes and shadow pricing of those inputs which must be purchased in the market. To the extent that they account for a significant part of total economic costs, financial costs may be above or below economic costs.

In deriving financial costs in any particular case it is necessary to talk with central and local government officials to determine their financial policies and non-economic objectives. If the government places a high priority on satisfying the basic needs of all of its citizens, then it may be willing to subsidize part or all of the construction cost of a simple sanitation system. The general policy of international lending agencies such as the World Bank is that if the cost of the minimal sanitation facility necessary to provide adequate health is more than a small part of

---

6. Kalbermatten, John M., DeAnne S. Julius, and Charles G. Gunnerson. Appropriate Technology for Water Supply and Sanitation, Volume 2: A Planner's Guide. The World Bank, December 1980.

the household income (say, 5-10%) then the central or local government should attempt to subsidize its construction to make it affordable. Any operation or maintenance costs should be borne by the beneficiary. If, however, some customers wish to have better or more convenient facilities, they should pay the additional cost themselves.

In general it is necessary to calculate several sets of financial costs based on different assumptions about municipal or central government subsidies. The first set, which is hereafter called the base financial cost, is that which assumes no financial subsidy. For an on-site system with a very short construction period and little requirement for municipal maintenance, the engineer's estimate of construction costs (in market places) is simply annuitized over the life of the facility at the prevailing (market) interest rate. If self-help labor can be used for part of the construction, the cost of hiring that labor should be subtracted from the total before annuitizing. To this annual capital cost must be added any operating and maintenance costs which will be required. Then this total base financial cost can be compared with household incomes to check affordability. If the technology is deemed affordable by the target population, then the only financial arrangements which will be required at the outset are those necessary to aid consumers in securing loans from commercial and public banks. If the technology's base financial cost is not affordable by the households to be served, and if lower-cost solutions are infeasible or unacceptable, then various options involving increased self-help input, deferred or low interest loans, partial construction grants, etc. should be used to compute alternative sets of financial costs. Before any of these are offered to the consumer, however, it is obviously necessary to obtain local and/or central government funding to cover the financing gap.

#### 4. Sociocultural Aspects

The involvement of the intended beneficiaries during the planning process is crucial for the success of the sanitation programs. The reasons for this are both practical and psychological. Sanitation facilities that are socially unacceptable will not be used by their recipients; it is therefore clearly worth the effort involved to determine the likes and dislikes of the intended beneficiaries. If this is done, the beneficiaries will feel involved in the design of their sanitation system; the system becomes essentially theirs and will not be perceived as some cheap alternative foisted upon them by some remote government agency. Moreover, if the intended beneficiaries are involved in the planning process, it becomes much easier for the local authority to train the community to operate and maintain household systems properly, and also to mount a successful health education program in order that the potential health benefits can be fully realized.

Community participation should ordinarily include six phases. The first three should be undertaken at the very beginning of the program development (they are part of Step 1 in Figure II-1) and the fourth toward the end of the selection phase (Step 6 of Figure II-1); the final two depend upon technical requirements and opportunity patterns. In the first phase

unstructured interviews are conducted with a few local leaders (such as political officials, religious leaders and school teachers) and a small number of households. The purpose of these preliminary interviews is to identify user attitudes and other factors which are likely to determine the engineering design and acceptance criteria listed below. In this phase it is essential to determine what kind of description or model of a technology is needed for the householders to understand it. A socially acceptable glossary of defecation terms also must be prepared so that local sensitivities and taboos may be protected, and local communication channels and boundaries should be defined. In the second phase a community questionnaire is designed and tested.

The types of information which this questionnaire should elicit include:

- (1) the desire of the community for sanitation and water supply improvements, and then as expressed in terms of willingness to contribute to the costs through cash contributions and/or labor and materials;
- (2) preference for private or communal facilities (e.g., do the latter represent opportunities for socializing or do they lead to crowding and quarreling?);
- (3) health, sickness and nuisance as they are perceived to be affected by water supply and sanitation practices;
- (4) attitudes toward convenience as measured by latrine or standpipe location, abundance or capacity of water supply systems, and reliability of service;
- (5) water quality preferences in terms of color, taste, odor, temperature, etc.;
- (6) aesthetic features of sanitation alternatives such as superstructure color and materials or squatting plate design;
- (7) attitudes towards visibility, means of removal, etc. of fresh or stabilized wastes, and towards conservation, reuse or reclamation (biogas, fertilizer, aquaculture, stock and garden watering, etc.) of wastes;
- (8) importance attached to local autonomy which might be lost if a higher authority were to assume part or all of the responsibility for funding, fee collection, construction, operating and maintenance of the improved facilities;
- (9) community or peer pressure for joining and supporting "unity and progress" groups, etc.; and
- (10) confidence in local or visiting political and technical authorities.

Other factors about which information is essential for design or implementation include land tenure, housing and public health by-laws, and the customary manner in which local committees are formed.

In the third phase structured interviews are conducted, using the questionnaire developed (and modified if necessary) in the second phase. At least 30 households should be interviewed, and care must be taken to ensure that they are representative of the social and income groups of the community; usually, information gained in the unstructured, preliminary interviews can be used to select representative households. Interviews should include the women since they are both knowledgeable about water use and responsible for training children in personal hygiene and sanitation. After the formal interviews, the responses should be evaluated by the program behavioral scientist. This information is then used by the engineer and economist to develop a list of socially acceptable, technically feasible, least-cost alternatives.

In the fourth phase, a meeting should be held between the program behavioral scientist and the community or its representatives at which the former presents the alternative technologies and their costs. The benefits of each service level and the manner in which each alternative can be upgraded should be presented. At a follow-up meeting conducted at an early date, a technology option or options should be selected.

The fifth phase occurs either in parallel with the technology selection or as a result of it. The local authority together with the community will have to organize the implementation and subsequent operation and maintenance of the facilities to be constructed. If there is a formal organizational structure in the community, it may be used to organize project implementation and operation. If no structure exists, special arrangements will have to be made for the project. These can vary from the selection of a local craftsman to check a piece of equipment periodically to the hiring of full-time staff to operate and maintain a communal facility. Some of the aspects involved in a successful construction program are the site selection for communal and private facilities; the purchase of materials not available in the community; the distribution of materials needed to construct individual facilities; prompt delivery by the community of materials provided in lieu of cash contributions; organizing work parties and keeping records of time, cash, or materials provided by community members; supplying technical assistance for the construction and initial operation of the facilities and external input from the technical support agency.

Phase 6 is the operation and maintenance of the facilities. In the case of communal systems this involves regular operation, maintenance, occasional repairs and the collection of funds to pay for recurrent expenses. In addition, performance should be monitored by the local authority, in collaboration with the community, and information disseminated to other communities so that lessons learned from the success or failure in one can be used in the design and implementation of programs in others. Any training not accomplished during phase 4 and 5 should take place now, and the

relationship between the operators and the local authority should be established. The latter should make periodic visits to the community to help solve minor problems, provide routine technical assistance, order spare parts, and mobilize additional support if major problems arise. Provisions also should be made for rapid contact in cases of emergency (failure of equipment, suspected water contamination, etc.).

In summary, the degree of community participation and its willingness to pay for improved service levels by contribution of money, labor or materials, depends fundamentally upon household income levels and perceived needs. Whether a feasibility study results in a project that properly meets the needs of the community depends upon the accuracy, completeness and timeliness of information exchanged between the residents and those who are conducting the feasibility study. The analysis of social factors and conduct of the interviews should be the responsibility of people accepted by the community; they are too important to be entrusted to strangers.

### III - SANITATION TECHNOLOGIES

#### 1. Water Supply Service Levels

It is important to commence this section by discussing water supply, rather than sanitation, as decisions taken regarding water supply service levels influence, often very strongly, the choice of sanitation technology and the options for sullage disposal. There are basically three levels of water supply service in urban areas:

- (1) public standpipes;
- (2) yard taps;
- (3) multiple tap in-house connections.

Typical water consumption figures and the options available for sanitation and sullage disposal for each level of service are given in Table III-1. As discussed in Section V, it is possible to design a sequence of water supply and sanitation improvements by which low-income communities can move progressively from low service levels to high service levels in a manner which matches improvements in their socio-economic status, while at the same time providing substantial health benefits from the start.

#### Water-Saving Plumbing Fixtures

Water consumption in households which have a multiple tap in-house level of water supply service is often much in excess of 100 lcd. Such high consumption is not necessary for reasons of either health or user convenience. The reason why water consumption in houses with a multiple tap level of water supply service generally exceeds this figure is that plumbing

**Table III-1: WATER SUPPLY SERVICE LEVELS AND ASSOCIATED OPTIONS FOR EXCRETA AND SULLAGE DISPOSAL IN URBAN AREAS.**

Water supply Service level	Typical water consumption (lcd)	Options for Excreta Disposal <sup>1/</sup>	Options for Sullage Disposal <sup>1/</sup>
Standpipes	20-40 <sup>2/</sup>	Pit latrines Pour-flush toilets <sup>3/</sup> Vault toilets <sup>3/</sup>	Soakage pits
Yard taps	50-100	Pit latrines Pour-flush toilets Vault toilets Sewered pour-flush toilets Septic tanks	Soakage pits Stormwater drains Sewered pour-flush toilets Septic tanks
Multiple tap in-house connections	>100	Sewered pour-flush toilets Septic tanks Conventional sewerage	Sewered pour-flush toilets Septic tanks Conventional sewerage

<sup>1/</sup> The options are not listed in any order of preference.

<sup>2/</sup> Consumption depends on standpipe density.

<sup>3/</sup> Feasible only if sufficient water carried home for flushing.

**Table III-2. Generic Classification of Sanitation Systems**

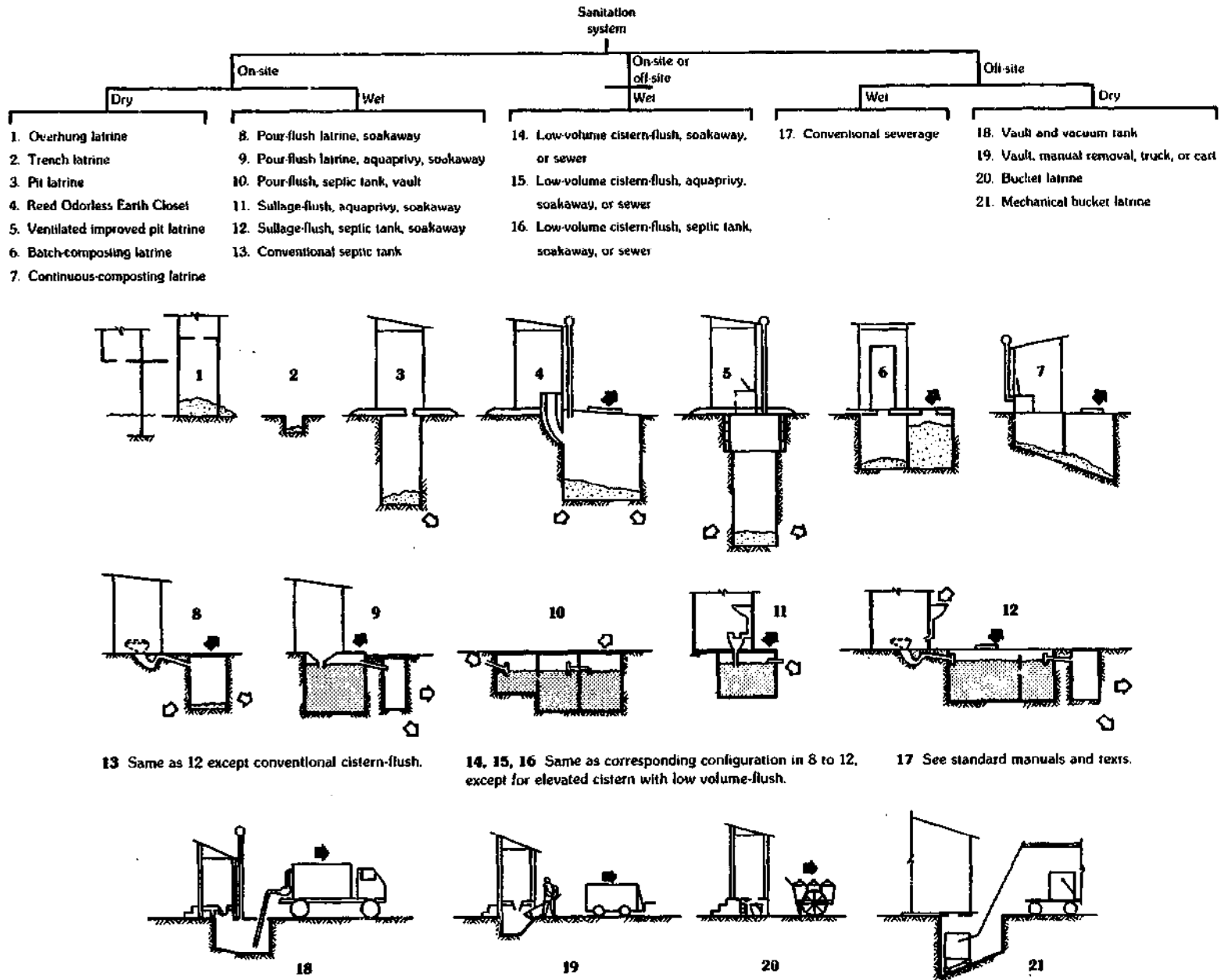

Movement of liquids;   
 movement of solids.

Source: The World Bank, Water Supply and Waste Disposal, Poverty and Basic Needs Series (Washington, D.C., September 1980).



fixtures which are unnecessarily extravagant with water have been installed. These plumbing fixtures--cistern-flush toilets, taps and showerheads--were developed in an era of plentiful water supplies and their continued use in an age of diminishing water resources and rapidly increasing supply costs needs to be reconsidered.

It is possible to reduce water consumption to around 100 lcd, without adversely affecting user convenience, by installing a variety of simple devices which reduce flow rates from taps and showerheads from unnecessarily high levels (often in excess of 30 liters per minute) to perfectly acceptable lower levels of around 10 liters per minute; and cistern-flush toilets, which generally account for 30-40 percent of total domestic water consumption, can be designed (or existing cisterns easily modified) to reduce the volume of flush water used from 10-20 liters per flush to around 5-10 liters per flush. Details of suitable water-saving plumbing fixtures are available in other publications<sup>7/</sup>.

A reduction in water consumption to about 100 lcd in middle and high income communities not only reduces water supply costs but also substantially reduces the costs of wastewater collection and disposal. For example, if water-saving plumbing fixtures are installed in middle-income communities, the modified septic tank shown in Figure III-6 can be designed with a smaller volume and its associated drainfield is also smaller, thus permitting the system to be used at higher housing densities. Since the modified septic tank is less expensive than conventional sewerage, more money becomes available to the municipality to provide sanitation facilities for its low-income communities.

### Wells

Many low-income communities obtain their water from public or private wells. In such communities on-site excreta and such disposal presents a potential hazard of groundwater contamination and hence also of disease transmission. The contaminants are excreted pathogens and certain inorganic compounds, especially nitrates.

It is not possible to establish universally valid guidelines for horizontal and vertical separation of on-site disposal systems and wells. Much further work is required to determine the travel distance and survival of pathogens entering the soil through latrines and drainfields. It is clear, however, that the greater the groundwater abstraction, the more porous or fissured the soil, the greater the distance should be between a latrine and a well. It is generally accepted practice to keep a minimum distance of 10 meters between on-site disposal systems and wells and increase the distance up to 30 meters in gravel and sand. Clearly, the most serious problem exists where a latrine penetrates the groundwater which provides drinking water by means of shallow wells located nearby. In such a

---

7. For example, J. O. Nelson. North Marin's Little Compendium of Water Saving Ideas. North Marin County Water District, Novato, California, 1976.

situation, vault latrines should be used or the water piped to standpipes from a protected well. The most favorable situation exists where the water supply is already a piped system, latrines do not reach groundwater and soil porosity is low.

In every case, however, the guiding principle should be that all feasible combinations of water supply, sanitation and sullage disposal should be evaluated so that total costs can be minimized.

## 2. Conventional Sewerage

Conventional Sewerage is a high cost, high convenience sanitation technology. Excreta are deposited in a cistern-flush water-seal toilet from where they are flushed by 10-20 liters of clean, potable water into a network of underground sewer pipes, into which is also discharged all domestic sullage; these pipes transport the wastewater to a treatment works, where the solid and liquid fractions of the wastewater are separated and treated to remove most of the organic pollutants present in the wastewater. Generally 30-40% of the domestic water consumption is used for toilet flushing.

Conventional sewerage, long considered to be the best (and often the only) form of sanitation suitable for urban areas, has two main disadvantages which mean that it is not generally suitable for many low-income urban communities in developing countries. These are:

- (1) its very high cost (see page 1); and
- (2) its requirement for a multiple tap in-house level of water supply service.

### Health Aspects

Conventional sewerage is often considered to be the sanitation technology that provides the best health benefits. The fact is however that conventional sewerage does pose risks to public health. For example, the cistern-flush toilet liberally contaminates the toilet area with excreted viruses and bacteria by aerosol droplet formation, so putting subsequent users at risk (and this may in part explain the continued transmission of certain Category I and II infections within affluent communities in industrialized countries). Moreover, sewage treatment works, in spite of the fact that they can be designed to achieve very low or even zero survival of excreted pathogens, generally have poor pathogen removal efficiencies and discharge effluents containing significant numbers of whatever pathogens are present in the raw sewage. Sewage effluents are one of the major environmental sources of drug resistant bacteria. Aerosolized bacterial pathogens have been recovered 1 kilometer downwind from well designed extended aeration sewage treatment works.

These potential health disbenefits should not of course obscure the major health benefits of the system; yet they are potential hazards and should be recognized as such. Nevertheless it is now known that the health

benefits of conventional sewerage are attainable with other sanitation technologies that are not only less expensive but also do not require such large volumes of water for their proper operation.

### 3. Ventilated Improved Pit Latrines

The two principal disadvantages of simple (unimproved) pit latrines--namely that they smell and have serious fly nuisance--are reduced in the type of pit latrine known as ventilated improved pit (VIP) latrines. The single pit version, shown schematically in Figure III-1, was developed in principle in Zimbabwe in the 1970s<sup>8/</sup>, although its key component--the external vent pipe--has been used in somewhat similar latrines in South Africa since the early 1940s. The vent pipe eliminates odors completely since the air inside it heats up under the influence of solar radiation. For this reason the vent pipe should be painted black and located wherever possible on the sunny side of the superstructure. The warm air inside the vent pipe thus rises and escapes to the atmosphere so creating a downdraught of air through the squatting plate to replenish the air exhausted up the vent pipe. This circulation of air effectively exhausts odors emanating from the fecal material in the pit.

The vent pipe also has an important role to play in fly control; few flies will enter the pit as they will be attracted to the top of the vent pipe by the odors coming therefrom; if the vent pipe has a fly screen, they will not be able to fly down it and so enter the pit. Nonetheless a few flies may be expected to enter the pit via the squatting plate and lay their eggs. When new adult flies emerge they instinctively fly towards the light; however the only light they can see is that at the top of the vent pipe. The new flies will not however be able to pass the fly screen, and they will eventually fall down and die in the pit. Controlled experiments in Zimbabwe<sup>9/</sup> showed that during a 78-day period 13953 flies were caught from an unvented pit latrine, but that only 146 were caught from a vented (but otherwise identical) pit latrine.

Although the single pit VIP latrine can be designed with a long life (up to 10 or more years) and to permit it to be desludged so that it can be a permanent structure, it is often more convenient and possibly less expensive to install a twin pit VIP latrine of the type shown in Figure III-2. In this version one pit is used for a given period (at least 12 months) until it is full, when the second pit is put into use; when that is full, the first is emptied and used again. Thus the excreta are never handled until they are at least 12 months old, when only a few Ascaris ova at most will be viable. Unlike a double vault composting toilet, no organic or inorganic materials are added to the pits, which both act as normal leaching

8. Morgan, P. R., "The pit latrine--revived," Central African Journal of Medicine 23, 1-4 (1977).

9. Ibid.

**Figure III-1. Ventilated Improved Pit Latrine (measurements in millimeters)  
(millimeters)**

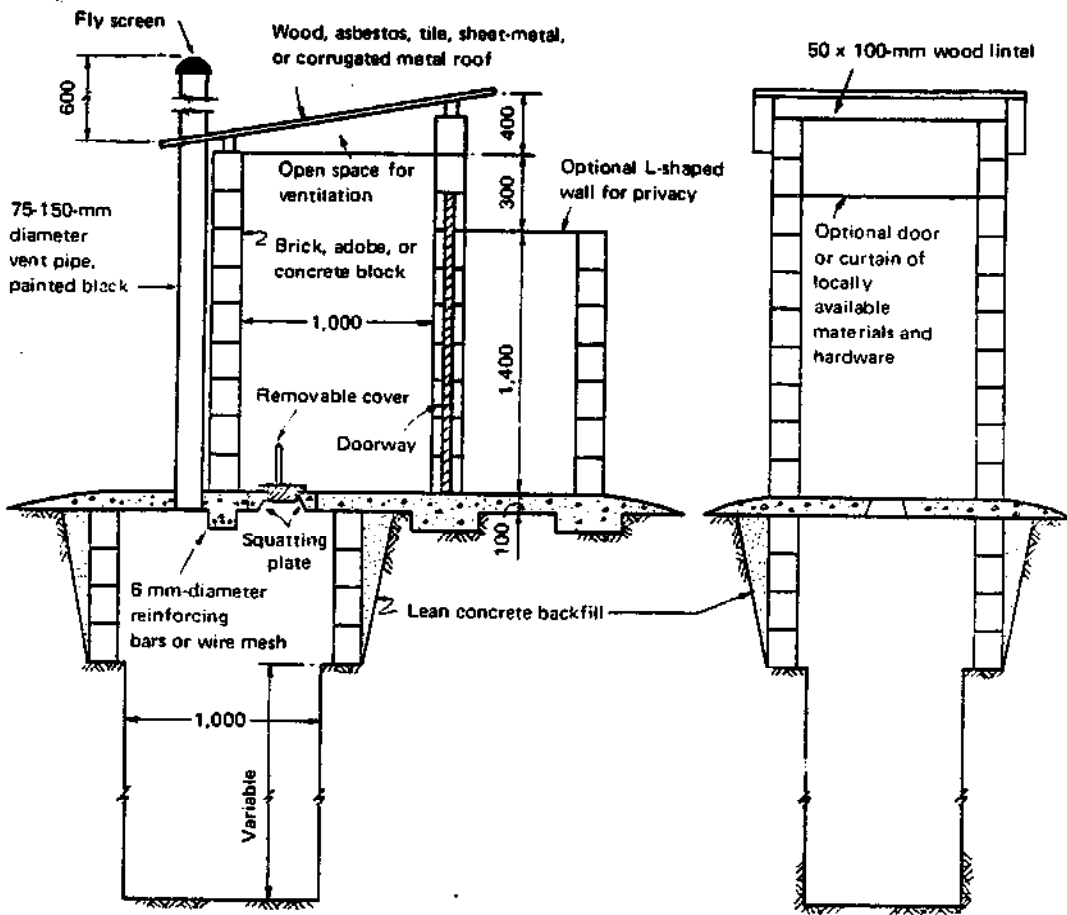

**Side view (section)**

**Front view (superstructure;  
L-shaped wall and vent not shown)**

Note: Side view. Pedestal seat or bench may be substituted for squatting plate. An opening for desludging may be provided next to vent. Dimensions of the bricks or concrete blocks may vary according to local practice. Wooden beams, flooring, and siding may be substituted for concrete block walls and substructure.

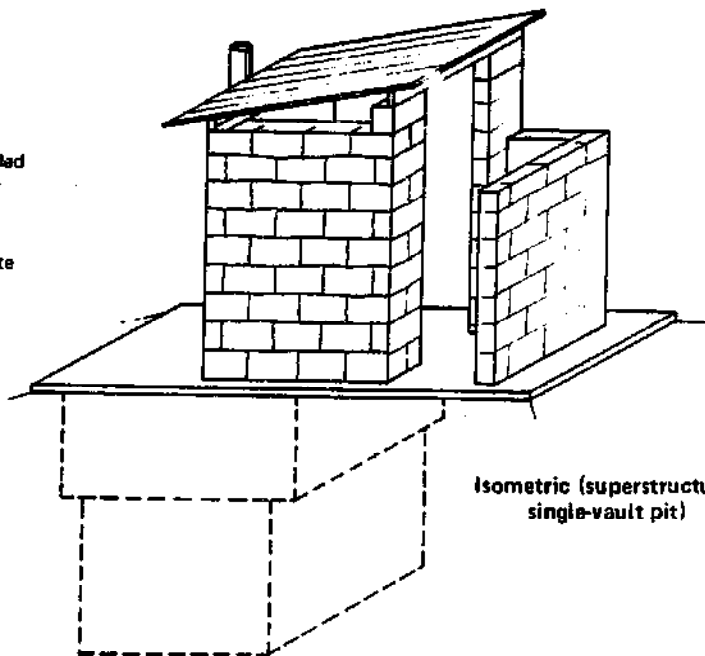

**Isometric (superstructure;  
single-vault pit)**

Figure III-2. Ventilated Improved Double-pit Latrine (millimeters)

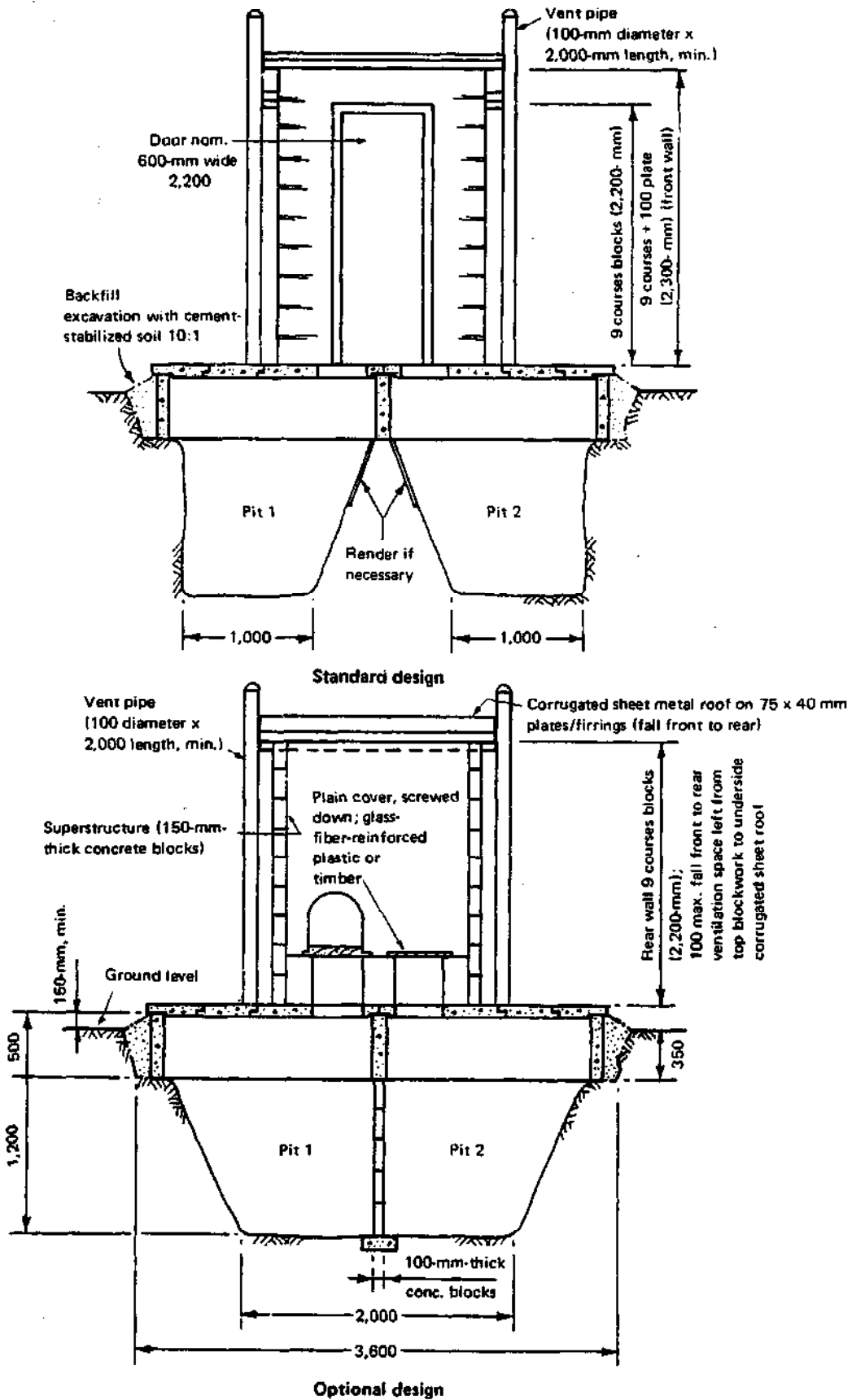

Source: Adapted from R. Carroll (1979).

pits. Unvented twin pit latrines are in fact traditional in some parts of the world, for example in the state of Santa Catarina in Brazil; the addition of a vent pipe to each pit is relatively inexpensive and reduces fly and odor nuisance.

The use of twin pit VIP latrines in urban areas presupposes of course the existence of a pit emptying program. Pit emptying may be done by the householder if he is able to use the humus-like material on his plot if he does not consider this operation to be socially unacceptable. Pit emptying may alternatively be a municipal function, which in practice may well have administrative difficulties, or it may be a private-sector function, for example collection by local farmers or by a private concern which sells the material to local farmers or otherwise disposes of it.

#### 4. Pour-Flush Toilets

Pour-flush toilets (Figure III-3) are very common in the Indian subcontinent and the Far East. They have three main advantages: low water requirements (1-3 liters per flush as opposed to 9-20 liters per flush for most cistern-flush toilets); complete odor elimination by the shallow water seal; and they can be located, if desired, inside the house, and not necessarily only on the ground floor. They are particularly suited wherever water is used for anal cleansing. Since flushing is done manually, they do not require a multiple tap in-house level of water supply; they are thus best used in conjunction with a yard tap level of water supply, although they can be used in conjunction with public standpipes if the standpipe density is such that the users can and will carry enough water home for their operation. As in the case of VIP latrines, probably the better long-term solution is to have twin pit pour-flush toilets, although this depends on the ease with which the pits can be desludged, whether desludging is to be done manually or mechanically and whether in high density areas there is sufficient room for twin pits. If desludging is to be done by hand, then to protect the health of the person carrying out this operation and to avoid the need for sludge treatment, twin pits each with a life of at least 12 months are preferable.

If the soil conditions are not suitable for on-site disposal, a pour-flush toilet is still feasible, but in this case it should discharge into a small two-compartment septic tank (Figure III-4); to reduce costs the septic tank may be shared by two or more adjacent houses. The first compartment receives only the pour-flush wastewater; after settlement, this passes into the second compartment which also receives directly all the sullage. This strategy ensures that the septic tank effluent contains fewer excreted pathogens and fewer fecal solids. The effluent may then be discharged into a small bore sewer or a covered stormwater drain. The small bore sewer is the preferred solution, although as an initial improvement it is often more cost effective to discharge the effluent into a stormwater drain. Simple treatment, such as an anaerobic upflow filter, may permit discharge of the effluent to stormwater drains on a permanent basis. The small bore (100- to 200-mm diameter) sewers need only be laid at nominal

Figure III-3. Pour-flush Units for Displaced Pits  
(millimeters)

A. Cement mortar or ceramic pan

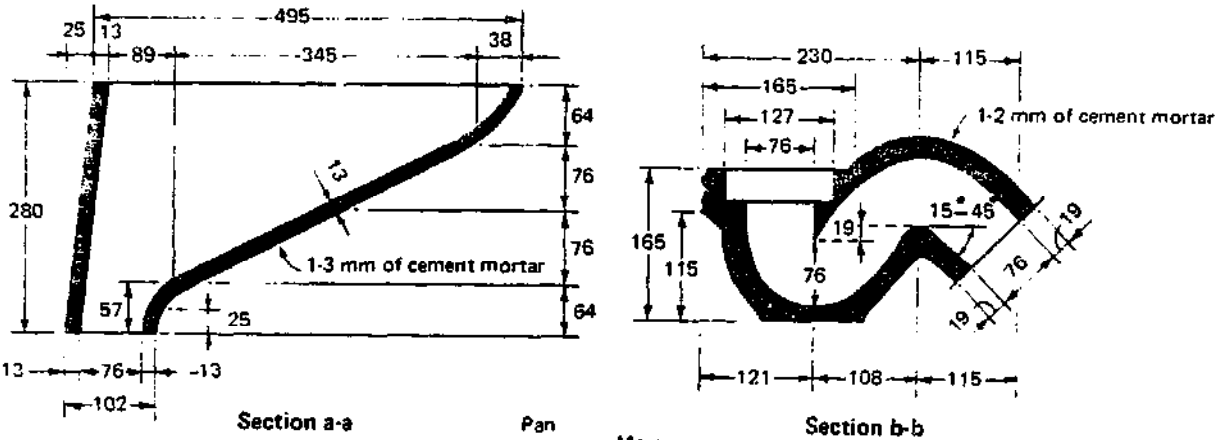
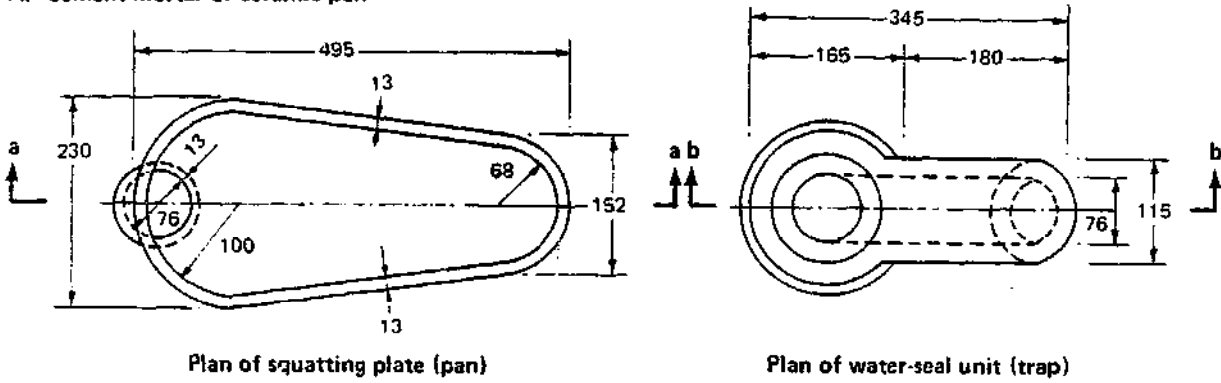

B. Ceramic pedestal

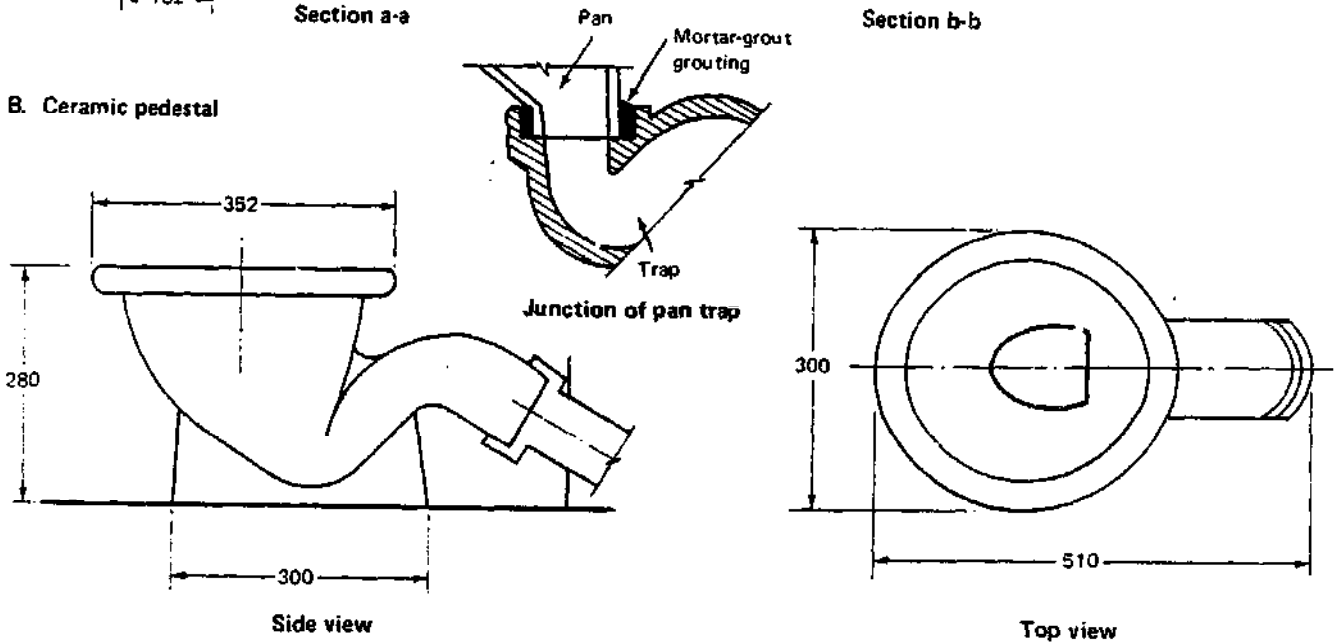

Source: A, adapted from Wagner and Lanoix (1968).  
B, adapted from CIMDER Colombia.

Figure III-4. Pour-flush Toilet – Septic-tank Systems

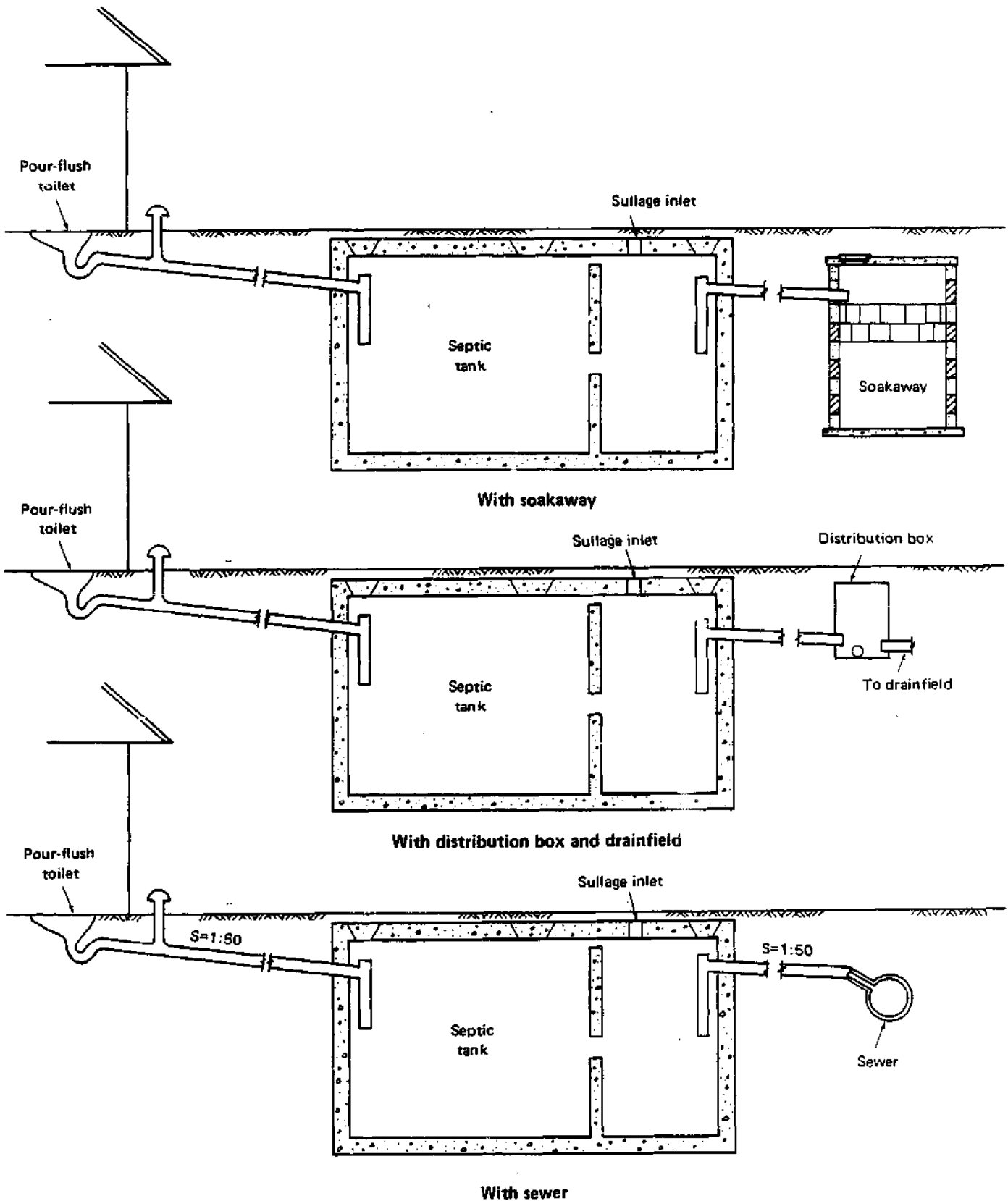

S = Slope.

Note: See chapter 14 for details of septic tanks, soakaways, and drain fields.



gradients (say, 1 in 200) as it is not necessary to provide for self-cleansing velocities since all the large fecal solids are retained in the septic tank; usually the design velocity is only 0.3 m/s. The flat gradients obviate the need for both deep excavation and pumping, and in flat areas this gives the seweried pour-flush system a considerable economic advantage over conventional sewerage.

#### 5. Vault Toilets

The vault toilet (Figure III-5), popular in Japan and other countries in the Far East, is essentially a pour-flush toilet which discharges into a watertight vault which stores the toilet wastewater for some 2 to 4 weeks. It is then removed by a vacuum tanker and taken away for treatment. It is a hygienic form of night-soil removal, although it has high operating costs (but less than waterborne sewerage) and is very demanding in terms of the required level of municipal organization. It is however a very flexible form of sanitation compared with conventional sewerage: changes in land use patterns (for example, from high-density low-income residential to industrial usage) are easily accommodated by merely rerouting the tankers; such an advantage is impossible with sewers laid in the ground. The vacuum tanker does not have to be a large, expensive vehicle; animal drawn carts with small tanks and manually operated diaphragm or vacuum pumps could be a perfectly feasible alternative. In general, operating costs should be significantly reduced by the use of appropriately designed systems, even though this may require considerably more ingenuity on the part of the design engineer.

#### 6. Septic Tanks

Septic tanks are generally of the single or double compartment variety; in conventional design practice they receive both the effluent from cistern-flush toilets and all the household sullage. In double compartment tanks the first compartment receives both types of wastewater. The tank effluent is discharged to a soakage pit or preferably to a drainfield, although in many tropical cities it is common to see septic tank effluent being discharged to a (commonly blocked and open) stormwater drain. The conventionally designed septic tank works well in low density areas (less than about 100 persons/ha) where the soil conditions are suitable. By modifying the design, it should be possible to use septic tanks at higher densities, provided the soil is suitable for on-site disposal. The suggested design modification is as follows: the septic tank should have three compartments (Figure III-6); the first receives only the cistern-flush toilet wastewater which after settlement passes to the second compartment for further settlement and thence into a third compartment which also receives directly all the household sullage. The advantage of this strategy is the same as that stated above for the seweried pour-flush toilet--the effluent contains fewer pathogens and fewer fecal solids; additional settlement for the toilet wastewater is provided in the second compartment as the hydraulic disturbance in the first compartment caused by the discharge of the

**Figure III-5. Alternative Designs for Vault Toilets (millimeters)**

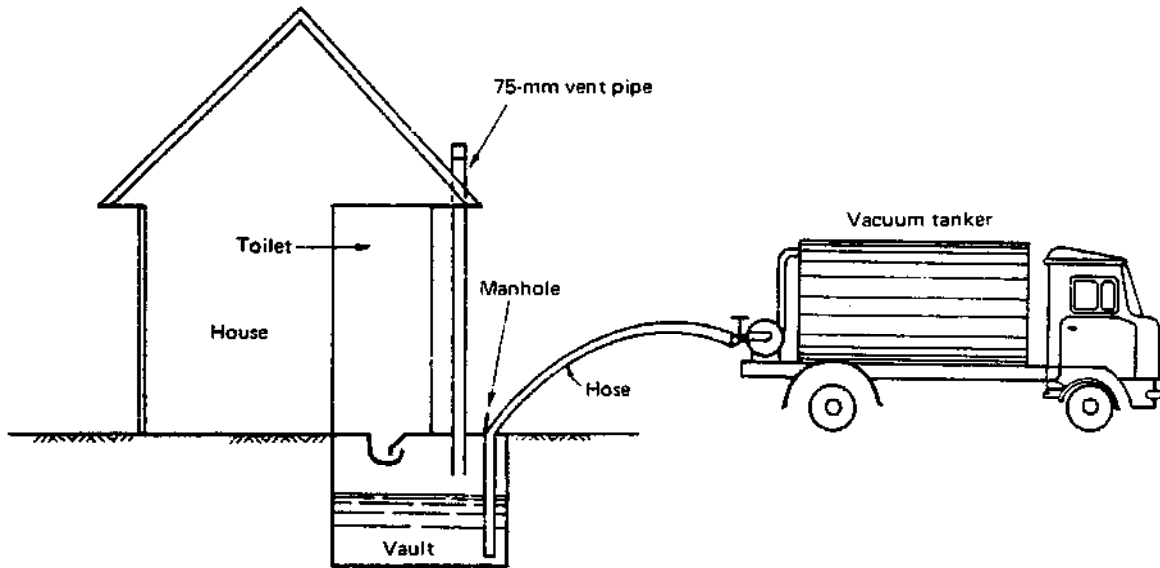

**Vault below squatting place**

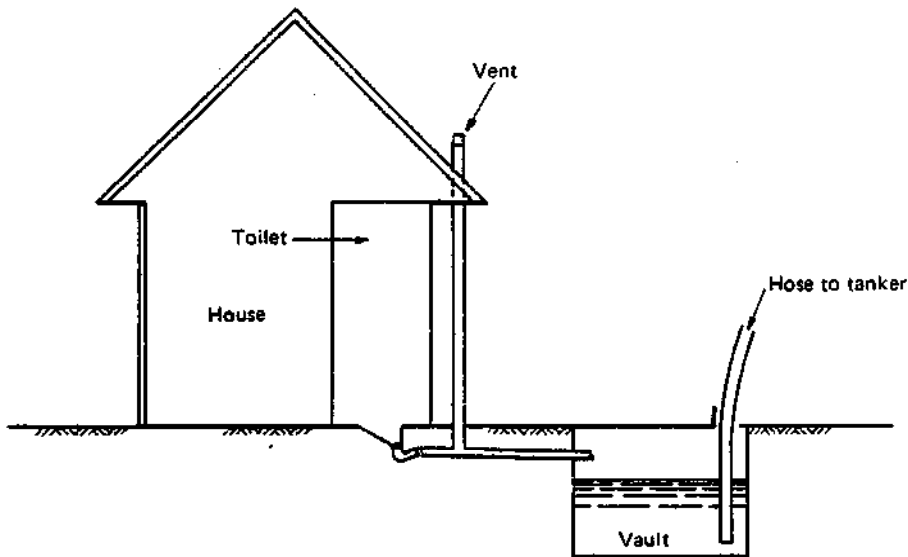

**Offset vault**

Figure III-6. Alternative Septic Tank Designs (millimeters)

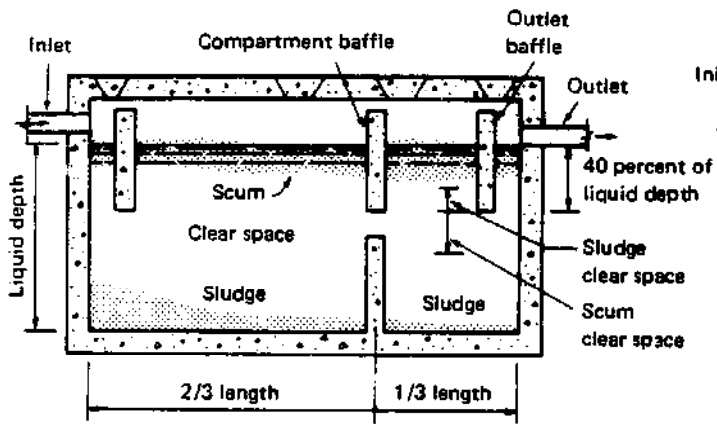

Conventional two-compartment septic tank with baffle walls

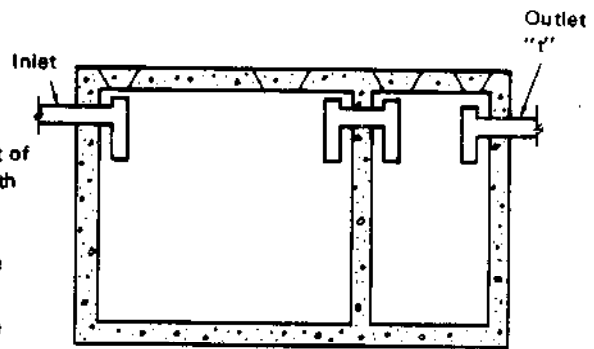

Conventional two-compartment septic tank with inlet connector and outlet "t"

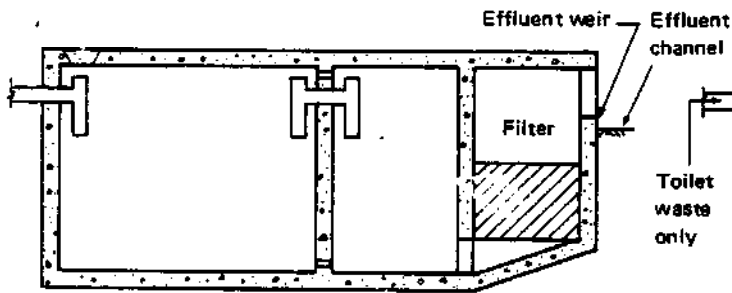

Two-compartment septic tank with upflow filter

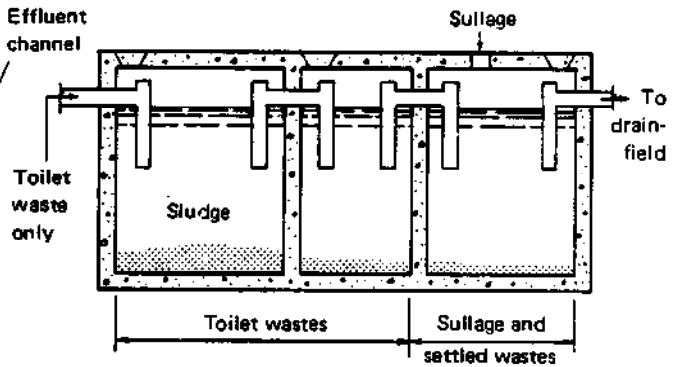

Three-compartment septic tank

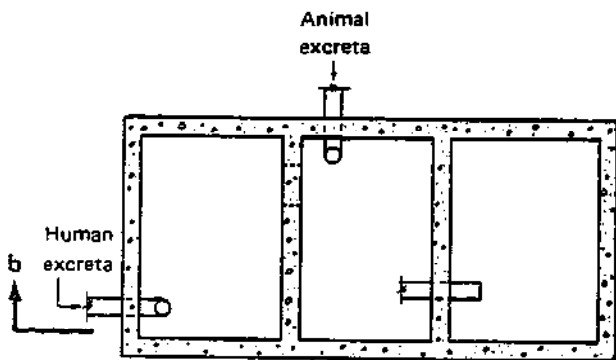

Section a-a

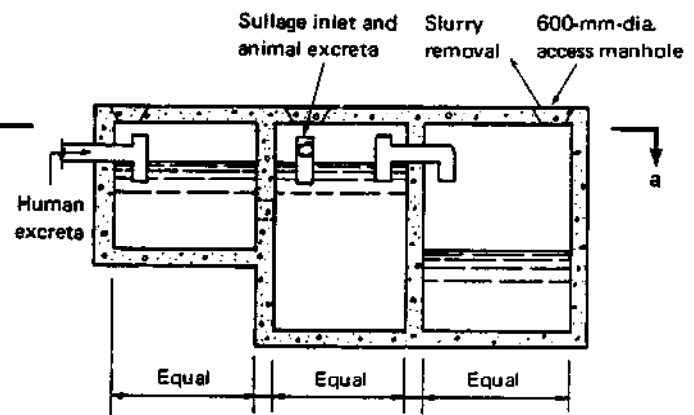

Section b-b

Three-compartment septic tank for resource recovery

cistern-flush toilet is much greater than with a pour-flush toilet and the solids' carry-over correspondingly greater. The net result of having three compartments and initially separating the toilet wastewater and the sullage is that the effluent can be expected to have a long-term infiltration rate some two to three times greater than the effluent of a conventionally designed septic tank, so that the drainfield can be two to three times smaller. Thus the modified septic tank could be used at higher densities, at least 200 persons/ha and possibly 300 persons/ha, so obviating the need for conventional sewerage in areas with these densities. If the soil conditions are not suitable for on-site disposal, then a small bore sewerage system to receive the septic tank effluent should be considered; in any given situation it is simply to determine whether such a system has a lower economic cost than conventional sewerage. The main point is, as always in sanitation program planning, that all feasible alternatives should be examined and the one with lowest cost adopted.

## 7. Other Technologies

### Aquaprivies

Aquaprivies (Figure III-7) are essentially small septic tanks located directly below a squatting plate which has an integral 100- to 150-mm diameter drop-pipe which extends some 100 mm below the liquid level in the tank, so forming a crude waterseal. The tank effluent is discharged into an adjacent soakaway. In practice, maintenance of the waterseal, which is necessary to prevent mosquito and odor nuisance, has proved difficult; even discharging sullage into the tank has not proved entirely satisfactory. With relatively high sullage flows (in excess of 50 lcd) soakaways often are not feasible (especially in high density areas) and the tank effluent is discharged into a small bore sewer.

The basic design of aquaprivies is, however, questionable. Is it sensible, for example, to build an expensive watertight tank which discharges into an adjacent soakaway? At low sullage flows probably not, because the aquaprivy is essentially equivalent either to a VIP latrine with a separate soakaway for sullage or to a pour-flush toilet whose offset soakaway can also receive the sullage. These systems are less expensive than aquaprivies and less prone to malfunction. In the case of the pour-flush toilet, its waterseal is much superior to that of the aquaprivy, it does not require a watertight tank, it can be located inside the house and it is more easily upgraded to a cistern-flush toilet. Similarly, the sewered aquaprivy is functionally equivalent to the superior sewered pour-flush system.

Nevertheless, in some areas, especially those where aquaprivies have been successfully used and where the common anal cleansing materials are

**Figure III-7. Conventional Aquaprivy  
(millimeters)**

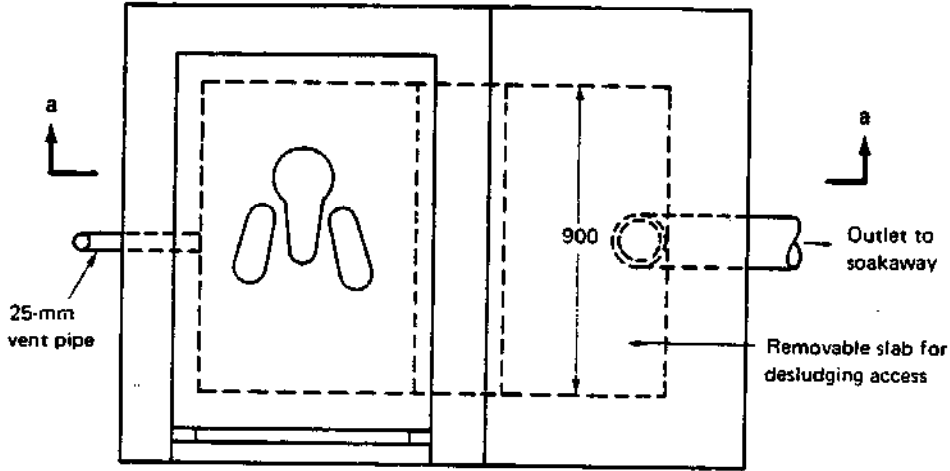

**Plan**

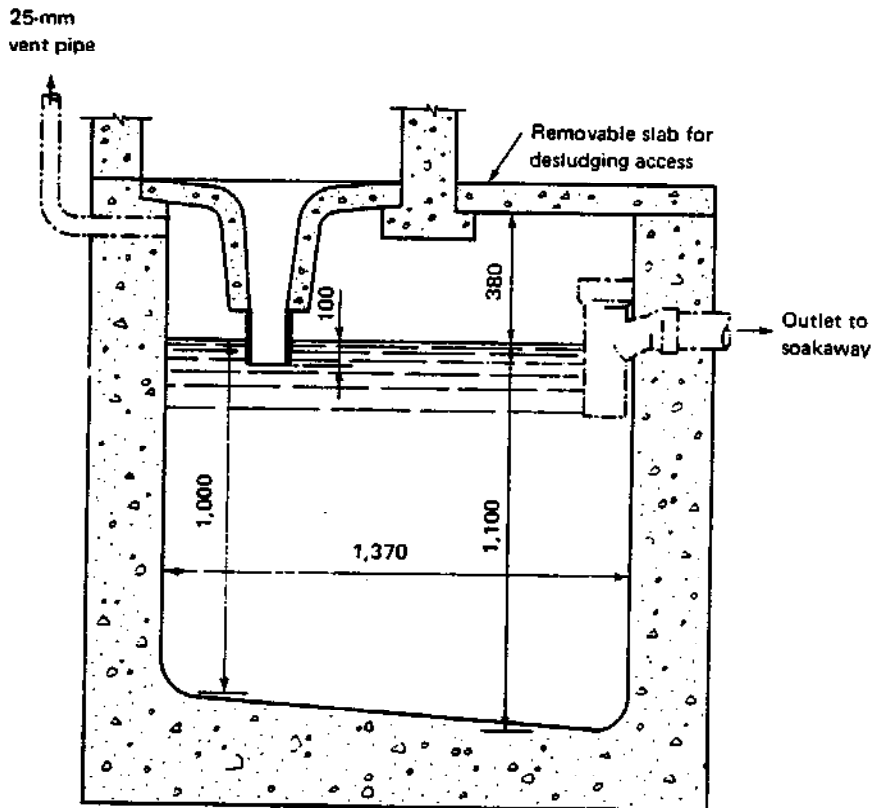

**Section a-a**

Source: Adapted from Wagner and Lanoix (1958).

incompatible with pour-flush toilets, it may be necessary to continue using aquaprivies. In such cases an improved design is available<sup>10/</sup>.

### Compost Toilets

Compost toilets are either single vault, continuous units or double vault, discontinuous units (Figures III-8a and III-8b). Excreta are deposited into the vault, to which must also be added ash or biodegradable material such as grass, leaves etc. in order to control the moisture content of the vault contents to around 60% and to provide a suitable carbon-nitrogen ratio for efficient aerobic thermophilic composting. The results of experimental compost toilets of both the single and double vault variety in Botswana and Tanzania<sup>11/</sup> have shown that they are not suitable forms of sanitation in many tropical developing countries, although they have found widespread application and acceptance in Vietnam<sup>12/</sup>.

The reasons why compost toilets are unsuitable include the following: (1) they require a considerable amount of conscientious user care and maintenance in that the correct amount of ash or biodegradable organic matter must be added at the correct time to control the moisture content and the carbon to nitrogen ratio; (2) even if such material is available throughout the year--and it is unlikely to be so in dense urban areas--it is doubtful that the users will be sufficiently motivated to produce a good quality humus which they may not have a use for or be able to sell; and (3) in the case of the continuous compost toilet, it is impossible to ensure, as a result of solids shortcircuiting, the safety of the humus produced.

For these reasons, the use of continuous compost toilets is not recommended unless proper care by well educated users is ensured.

### 8. Communal Facilities

The principal advantage of communal sanitation facilities is their low cost. Because they serve many people they are substantially cheaper on a per capita basis than individual household facilities. They have many disadvantages, however, and the decision to install communal facilities is one which should never be taken lightly. The basic problem with a communal facility is that it appears to belong to no one so that there is little

- 
10. Kalbermatten, John M., et al., "Appropriate Sanitation Alternatives: A Planning and Design Manual," Johns Hopkins University Press (1981).
  11. See R. G. Feachem, et al., "Appropriate Technology for Water Supply and Sanitation, Volume 7: "Alternative Sanitation Technologies for Urban Areas in Africa," The World Bank (1980).
  12. Kalbermatten, John M., "Health in the Third World: Studies from Vietnam," Spokesman Books, London (1976).

Figure III-8a. "Multum" Continuous-composting Toilet

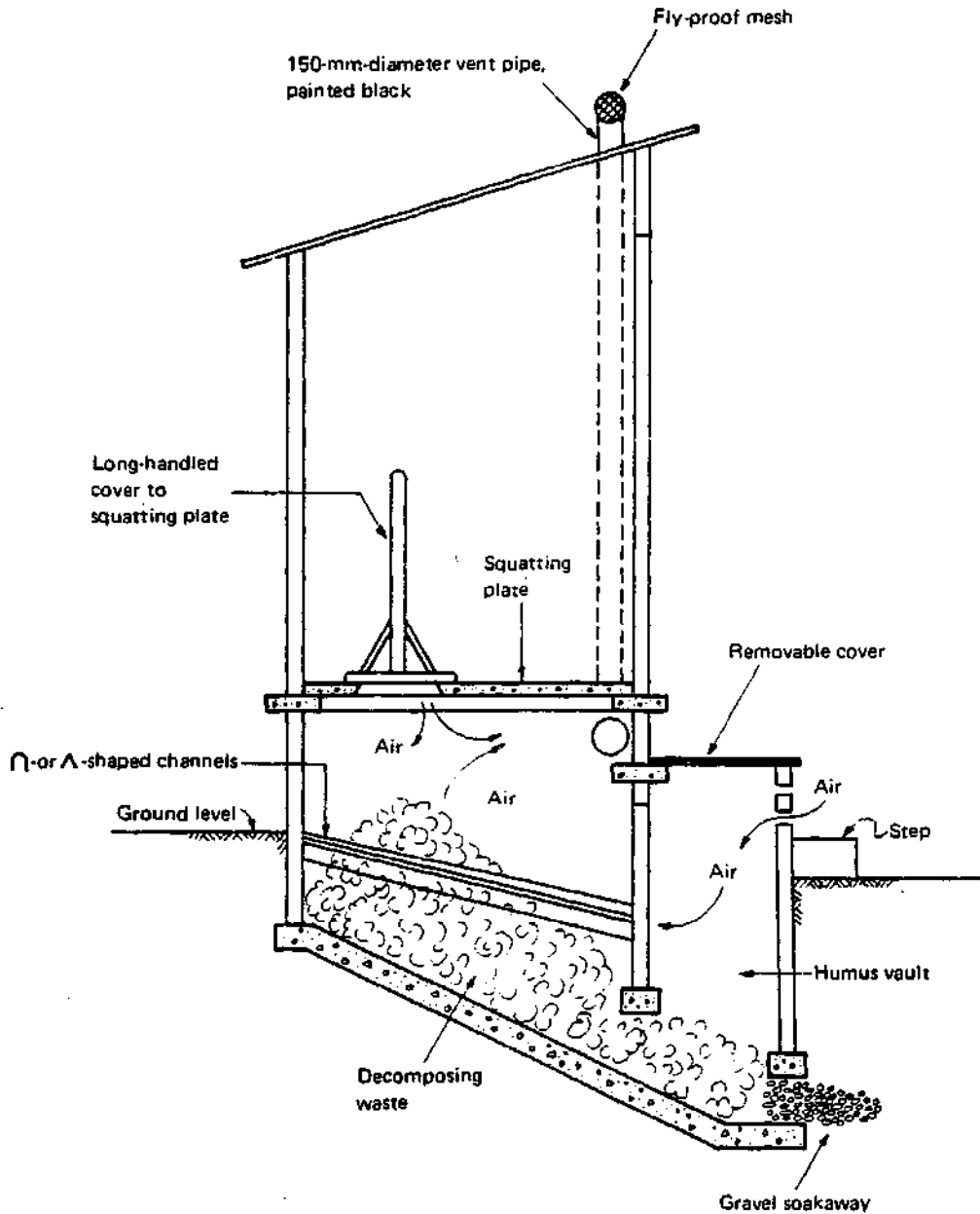

Source: Adapted from a drawing by U. Winblad.

Note: U. Winblad reports that this continuous "multum" type toilet could not be made to function properly despite careful attempts at user education. Its use is therefore not recommended.

Figure III-8b. Double-vault Composting Toilet Used in Vietnam (millimeters)

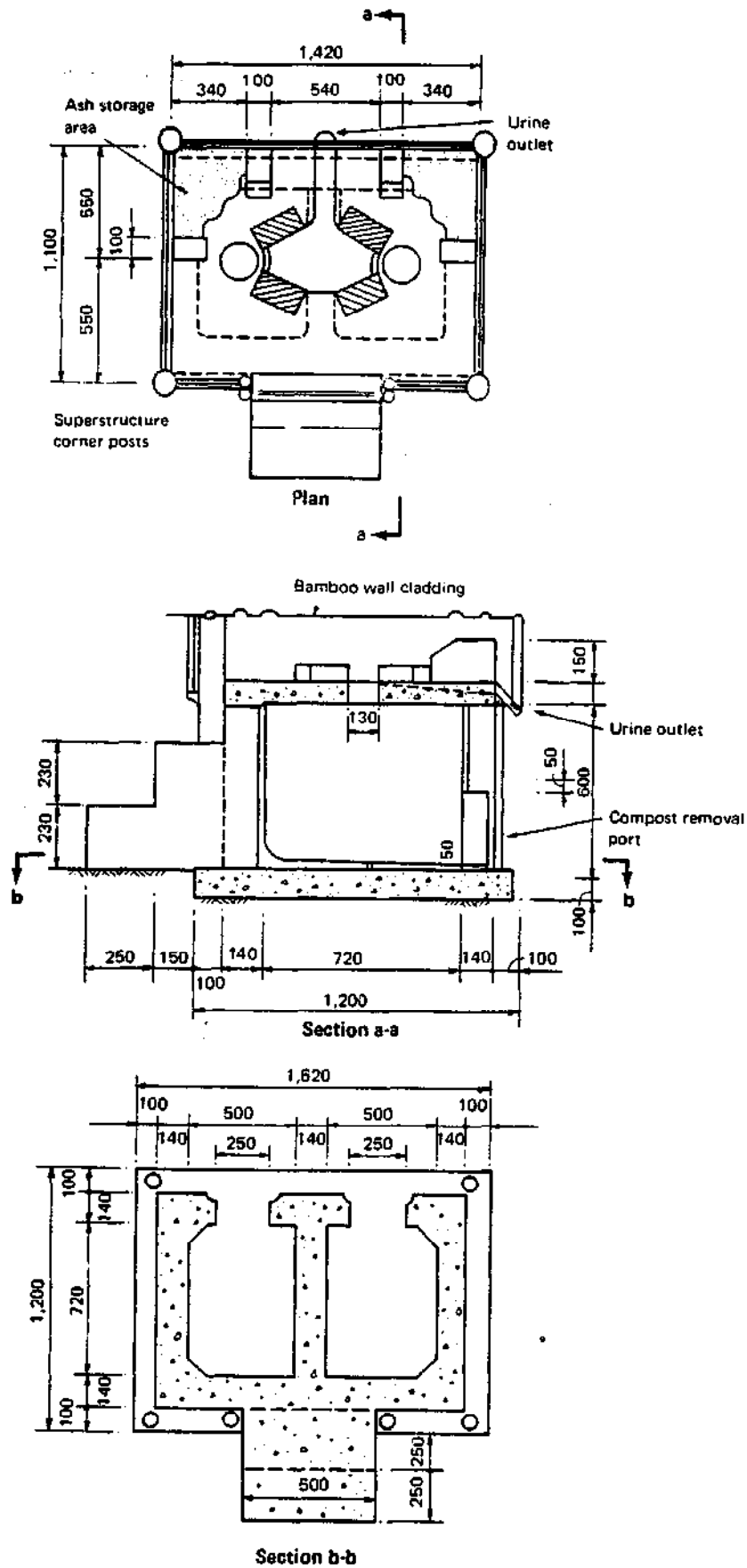



commitment by individual users to keep it clean and operating properly. Once a toilet compartment is fouled, the next user may have no choice but to foul it further. As a result many communal toilet blocks are in a very unhygienic state. To avoid this it is essential to provide one or more well-paid attendants to keep the facilities in good operational order. It is essential that the employers of the attendants (often the municipality) should regularly inspect the facilities to make sure that they are being properly maintained.

There are three other major disadvantages of communal sanitation facilities. Firstly, there is the difficult question of privacy. A community's requirements for privacy must be clearly understood and respected. Cultural attitudes to defecation vary, but generally it is regarded as a private personal act. Thus, at the least, each toilet within the communal block should be designed as a separate compartment and provided with a door which can be bolted; this may appear obvious, but there are many public toilet blocks which comprise merely a row of holes with no internal partitioning whatsoever. However, in some societies privacy is not so highly coveted. It is clear that questions of privacy must be discussed with the community by the program sociologist. Secondly, there is the problem of defecation at night and during wet or cold weather. If the communal block is not lit, it may not be used at night. In any case it is surely unreasonable to expect even fit adults--let alone the young, the old or the infirm--to walk 100 meters or more in the middle of the night or in torrential rain, often along a dark or muddy street or alleyway. There must be some general provision (including guidance to the community) for the disposal of nocturnal and "bad weather" excreta.

If it is accepted that the provision of individual household facilities (of whatever type) is the ultimate objective of sanitation program planning, then the third disadvantage of communal facilities is that they cannot be upgraded, so that they are essentially temporary units, even though "temporary" may mean many years. This does not mean that they should be built to low standards, but it does mean that wherever possible they must be designed with eventual replacement by individual household facilities in mind. In this connection it is sensible to tie the provision of sanitation facilities to residential upgrading programs; this is especially advisable in the case of slum development schemes.

There are basically two approaches to the design of communal sanitation blocks. The first is to have a truly public system in which a user can enter any toilet compartment not in use at the time. The second approach is to provide within the communal block cubicles for the exclusive use of one household. This system, essentially a compromise between public and private facilities, has been tried with considerable success in some parts of India; experience has shown that each household will zealously guard its own cubicle and keep it clean but that maintenance of the communal parts (e.g., the passageways and particularly the effluent disposal system) can cause organizational problems. This system is undoubtedly superior to the truly public system, but it is also more expensive as a greater number (depending on the average household size) of toilet compartments is needed.

It has the advantage to the municipality that it is relatively easy to levy rental fees and collect payment from each household using the facility.

#### 9. Sullage Management

Sullage always contains some pathogens, but at a concentration much lower than in sewage, usually four to six orders of magnitude lower. Sullage thus poses a health risk, but one much less than sewage and very much less than excreta. In planning sanitation interventions in low-income communities this means that the first priority is to remove excreta from the immediate environment (the house, the yard and the street); if this is done, the major risk to health is removed. A second priority is proper sullage disposal; generally this may be done by special sullage soakaways if the soil conditions are suitable, by discharging sullage into a stormwater drains (and seeing that these do not become blocked with, for example, domestic refuse) or, of course, into sewers if these should be available (for example as part of a sewerage pour-flush system). Some ingenuity on the part of design engineers is required to provide low-cost sullage disposal facilities; for example if sullage is to be discharged into stormwater drains, the drains may need to be of a cross-section that permits the sullage to flow at a reasonable velocity in the dry seasons. Treatment of the sullage may be necessary to prevent gross pollution of the receiving water-course at these times: one solution might be a facultative waste stabilization pond, but to protect the pond in the rainy season it would be necessary to install a stormwater overflow weir. Sullage management is important as ponded sullage encourages the breeding of Culex pipiens mosquitoes which are not only a major nuisance but in many parts of the world are also vectors of Bancroftian filariasis (a Category VI excreted infection).

#### 10. Off-site Treatment

The degree to which excreta and sewage are treated is largely influenced by what is to be done with the sludge, compost or sewage effluent. Thus it is accepted practice to discharge untreated sewage to sea provided the outfall is designed to ensure that no pollution of beaches or shell-fish growing areas occurs. However, if it is intended to reuse an effluent for the irrigation of edible crops, the designer's goal should be the absence of excreted pathogens on the surface of the crops, and the treatment works should be designed accordingly.

In general the treatment of human wastes in developing countries has two principal objectives:

- (1) the destruction of excreted pathogens, and
- (2) the oxidation of organic matter.

The first objective is required to protect public health and the second to prevent pollution in the watercourse receiving the works effluent. In

communities where the incidence and prevalence of excreta-related infections are high and where the density of excreted pathogens in human wastes is therefore also high, the first objective is the more important. It is achieved by providing a suitable combination of time and temperature in the treatment works. It is fortuitous that the commonly selected combinations of time and temperature for pathogen destruction enable the second objective to be achieved as well.

### Conventional Sewage Treatment

Conventional sewage treatment<sup>13/</sup> has three major disadvantages in developing countries:

- (1) extremely poor pathogen removal efficiencies<sup>14/</sup>;
- (2) very high capital and running costs (usually with the need to import all or much of the mechanical equipment, with a consequent foreign exchange cost); and
- (3) a requirement for a very high level of maintenance skill.

This disadvantages cannot be overemphasized. Although there are many conventional sewage treatment works in developing countries, only a minority operates satisfactorily. The majority is not maintained properly, a problem which is often exacerbated by long delays in importing spare parts.

### Waste Stabilization Ponds

Waste stabilization ponds are large shallow ponds in which organic wastes are decomposed by micro-organisms in a combination of natural processes involving both bacteria and algae. Stabilization pond systems can treat raw sewage, the effluent from sewered pour-flush toilets or diluted night soil.

- 
13. Primary sedimentation and secondary biological treatment by activated sludge or biofilters followed by secondary sedimentation, together with sludge treatment (often anaerobic digestion and drying beds).
  14. Removal efficiencies are generally only 90 to 95%; such figures are misleadingly impressive, but the effluent from a works receiving a sewage with for example 10,000 salmonellae per 100 ml, and achieving a 95% removal, will contain an unacceptably high concentration of 500 salmonellae per 100 ml. A properly designed series of waste stabilization ponds, on the other hand, can achieve pathogen removal efficiencies greater than 99.9999% (for the above example this means an effluent concentration less than 1 Salmonella per 10 liters.)

Waste stabilization ponds are the most economical method of sewage treatment wherever land is available at relatively low cost. Their principal advantages in developing countries are that they achieve very low survival rates of excreted pathogens at a much lower cost than any other form of treatment and with minimum maintenance requirement. In fact a pond system can be designed to achieve, with a high degree of confidence, the total elimination of all excreted pathogens. This is not normally done because the additional benefits resulting from achieving zero survival, rather than very low survival, are less than the associated incremental costs. Waste stabilization ponds are the recommended form of treatment in tropical developing countries where sufficient land is available, except when marine discharge is cheaper.

Well-designed pond systems, incorporating a minimum of 3 ponds in a series and having a minimum overall retention time of 20 days, produce an effluent which will either be completely pathogen free or will contain only small numbers of enteric bacteria and viruses. Pathogenic helminths and protozoa will be completely eliminated. Any residual bacterial or viral pollution can be reduced or eliminated by adding more ponds to the system. The effluent is suitable for direct reuse or discharge into receiving waters.

The design of waste stabilization ponds is fully described in "Sewage Treatment in Hot Climate"<sup>15/</sup> to whom readers requiring more information are referred.

#### 11. Resource Recovery

Human excreta, in whatever form, is a resource which may be conserved and reused rather than discarded. Excreta and sewage contain many essential nutrients for the growth of terrestrial and aquatic plants; sewage is also a valuable source of water. The anaerobic digestion of excreta yields biogas (60-70% methane) which can be used as a source of energy for cooking and lighting. Some form of treatment is always required to reduce the health risks due to excreted pathogens to an acceptable economic minimum. The only exception to this is biogas production, but if the digested sludge from the biogas generator is to be reused on the land, additional treatment is necessary.

There are three principal ways in which excreta and sewage can be reused:

- (1) agricultural reuse;
- (2) aquacultural reuse; and
- (3) biogas production.

---

15. Mara, D. Duncan. "Sewage Treatment in Hot Climates." London: John Wiley and Sons, 1976.

### Agricultural Reuse

Agricultural reuse is the most common form of excreta reuse and in many ways is the simplest. However, there are health risks to those who work in the fields and to those who consume the crops. The latter group includes both man and animals. There are also problems associated with the chemical quality of the compost, sludge or sewage effluent, for example, crops may concentrate heavy metals, and high sodium concentrations can damage the soil structure.

All types of excreted pathogens present in the waste reach the field. Different treatment technologies will remove different pathogens to differing degrees. Where sewage effluent is reused, the only treatment processes which will produce an effluent free (or almost free) from pathogens are waste stabilization ponds and conventional treatment followed by maturation ponds, land application or sand filtration. Where sludge or night soil are reused, the only processes which will produce a pathogen-free material are batch thermophilic digestion, thermophilic composting or drying for a minimum of 2 years.

### Aquacultural Reuse

Human excreta can be used to promote the growth of aquatic plants and animals. This practice is termed aquaculture. Four main types of aquaculture are practiced:

- (1) freshwater fish farming;
- (2) mariculture (the culture of marine animals such as fish, shellfish and shrimps);
- (3) algal production; and
- (4) aquatic macrophyte production.

Of these freshwater fish farming is the most common (especially in Asia), and also the easiest. Mariculture is by its nature restricted to coastal communities; it is not as widely practiced as freshwater fish farming and it requires more facilities and greater care in operation. The production of microalgae and aquatic macrophytes has received considerable research effort, but current knowledge is still very limited. Algal harvesting is a complex and expensive process in practice and there are doubts that the yields from small experimental ponds can be achieved in large operational ponds. Although practiced traditionally in a few parts of the world, the fertilization of aquatic macrophytes with excreta and sewage (and its converse, the treatment of excreta and sewage by aquatic macrophytes) are processes which have not yet been fully evaluated, either economically or technically; nor have the associated health risks been adequately assessed. Considerably more research is needed before mariculture and the production of algae and aquatic macrophytes can be considered routinely suitable reuse technologies in developing countries (and much of this research needs to be done in the developing countries themselves).

### Biogas Production

When organic wastes are digested anaerobically a mixture of methane, carbon dioxide and other gases is given off. This gas has become known as "biogas" and can be produced on various scales by various different technologies. In conventional sewage treatment works, anaerobic sludge digestion produces biogas which is sometimes used to heat the digestors or for some of the energy needs of the works. However, the term 'biogas production' is usually used to describe the production of methane on a small scale by individual farmers, communes or rural institutions in developing countries.

Biogas plants are found in large numbers in China, and it is probably in this country that the technology has become most developed. Significant numbers are also in operation in India, Korea and Taiwan. The units are fed with diluted animal feces, with or without human excreta and with or without vegetable refuse. The effluent slurry is commonly reused in agriculture, and it can be used to enrich fish ponds. The gas is used primarily for domestic cooking and lighting. The dung from one medium sized cow, or similar animal, can produce around 500 l of gas per day; it contains 50-70% methane and its calorific value is around 4-5 kcal/l. In contrast human excreta yields only 30 liters of gas per person per day. The process is very sensitive to temperature. In the mesophilic range, optimum gas production occurs at around 35°C. In rural areas digesters are not heated although they may be buried, and so they operate in their ambient temperatures. Gas production falls off considerably at lower temperatures and is negligible below 15°C.

There are two basic designs for rural biogas plants. These are shown in Figure III-9. The Chinese design is advantageous in that it contains no moving parts, avoids the need for a metallic gasholder (which has corrosion problems) and permits the gas to be stored at a constant pressure. Its main disadvantage is that its open liquid surface can permit mosquito breeding, although this can be prevented by adding a thin layer of kerosene.

The process design of biogas plants is empirical and currently somewhat confused, as little rigorous experimental work has been done. Gas production may be expected to be around a third to a half of the digester volume per day if the digester is operated semi-continuously (i.e., fed daily or twice daily). Semi-continuous operation is preferable to batch feeding as the rate of gas production is fairly constant. Of course, several batch digesters can be connected in parallel to obtain a reasonably constant gas output. This is, however, generally possible only on a medium or large scale. Batch units have the advantage that they do not require daily attention, and there is some evidence that they can cope with material of rather lower bio-degradability than can semi-continuous digesters.

Figure III-9. Two Designs for Biogas Plants

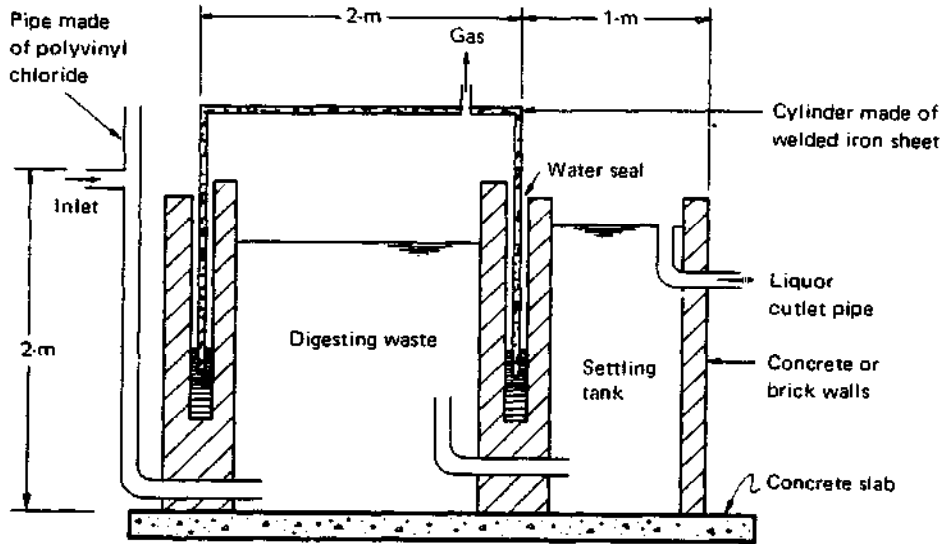

Biogas plant from South Pacific

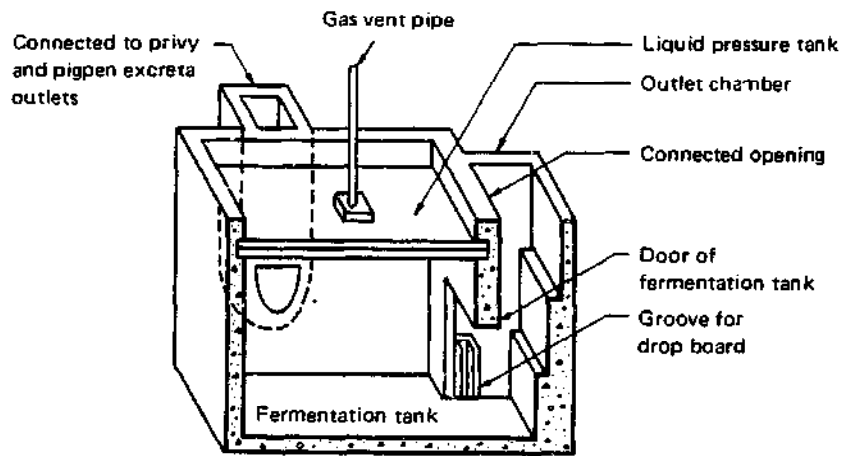

Biogas plant from China

Sources: South Pacific, Solly (1976); China, McGarry and Stainforth (1978).

#### IV - TECHNOLOGY SELECTION

Sanitation program planning is the process by which the sanitation technology most appropriate to the needs and resources of the community is selected. This selection, which should be based on a combination of economic, technical and social criteria, essentially reduces to the question: which is the cheapest, technically feasible technology which the users can afford and maintain, and prefer to cheaper alternatives, and which the local authority is institutionally capable of operating?

Figures IV-1, 2 and 3 present an algorithm which can be used as a guide to the selection of the most appropriate sanitation technology for any given community in developing countries. It should be stressed that the algorithm is meant only as a guide to the decision-making process. Its main virtue is that it prompts engineers and planners to ask the right sort of questions, which perhaps they would not otherwise ask; some answers can only be obtained from the intended beneficiaries. Although it is believed that the algorithm is directly applicable to most situations encountered in developing countries, there will always be the occasional combination of circumstances for which the most appropriate option is not that suggested by it. The algorithm therefore should not be used blindly in place of engineering judgment, but as a tool to facilitate the critical appraisal of the various sanitation options, especially those for low-income communities. The algorithm is most useful when there are no existing sanitation systems, other than communal facilities, in the community under consideration. In general the type of any existing household sanitation systems will influence the technology chosen to improve excreta and sullage disposal. Additionally, it is important to consider the existing or planned sanitation facilities in neighboring areas.

Once a tentative selection of the most appropriate technology has been made, several questions should be asked again as checks. These are:

- (1) Is the technology socially acceptable? Is it compatible with cultural and religious requirements? Can it be maintained by the user and, if appropriate, by the municipality? Are municipal support services (e.g., educational, inspectional) required? Can they be made available?
- (2) Is the technology politically acceptable?
- (3) Are the beneficiaries willing (as well as able) to pay the full cost of the proposed facility? If not, are user subsidies (direct grants or "soft" loans) available? Is foreign exchange required? If so, is it available?
- (4) What is the expected upgrading sequence (see Section V)? What time frame is involved? Is it compatible with current housing and water development plans? Are more costly technologies in the upgrading sequence affordable now?



Figure IV-1. First-stage Algorithm for Selection of Sanitation Technology

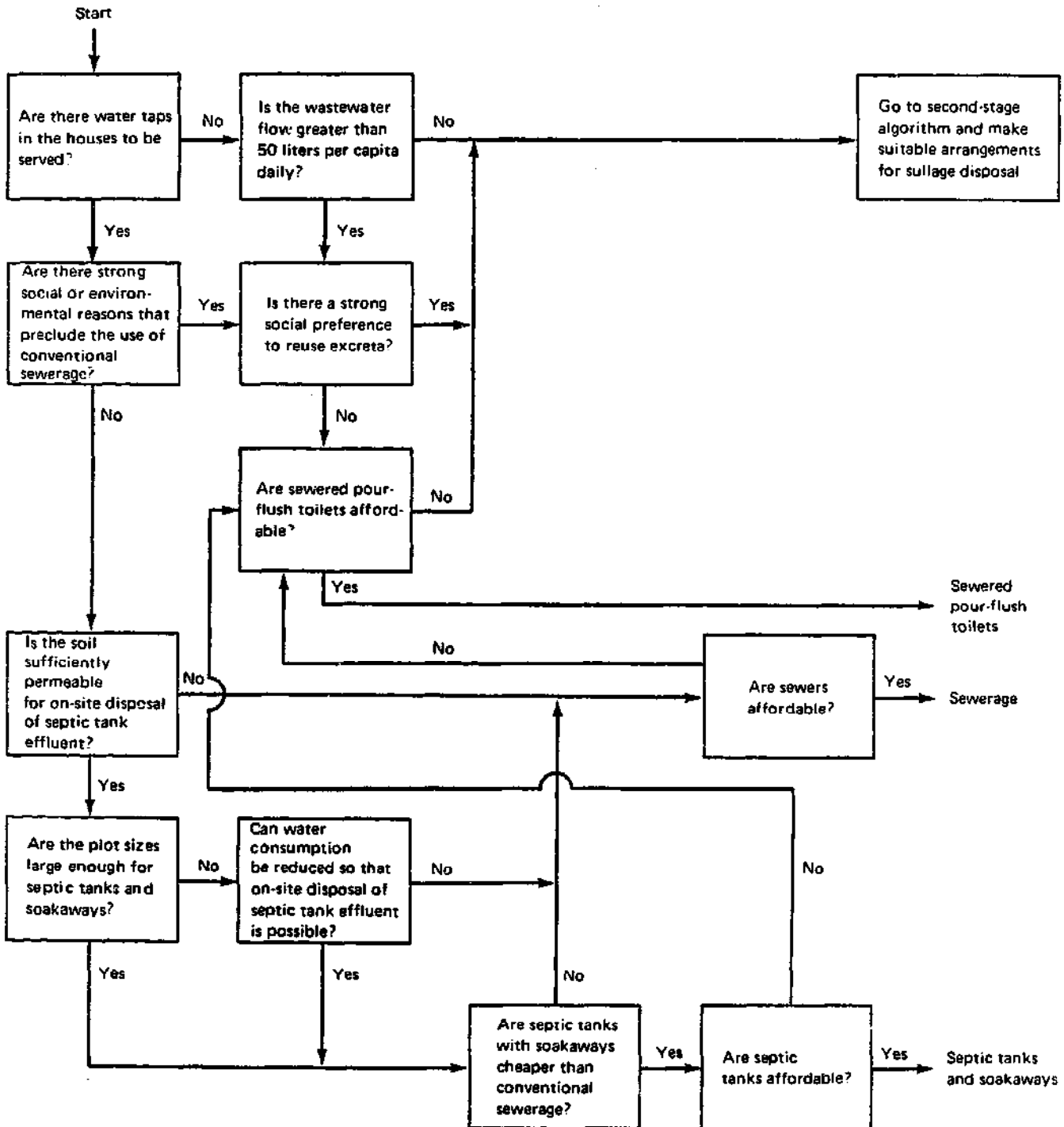

Figure IV-2. Second-stage Algorithm for Selection of Sanitation Technology

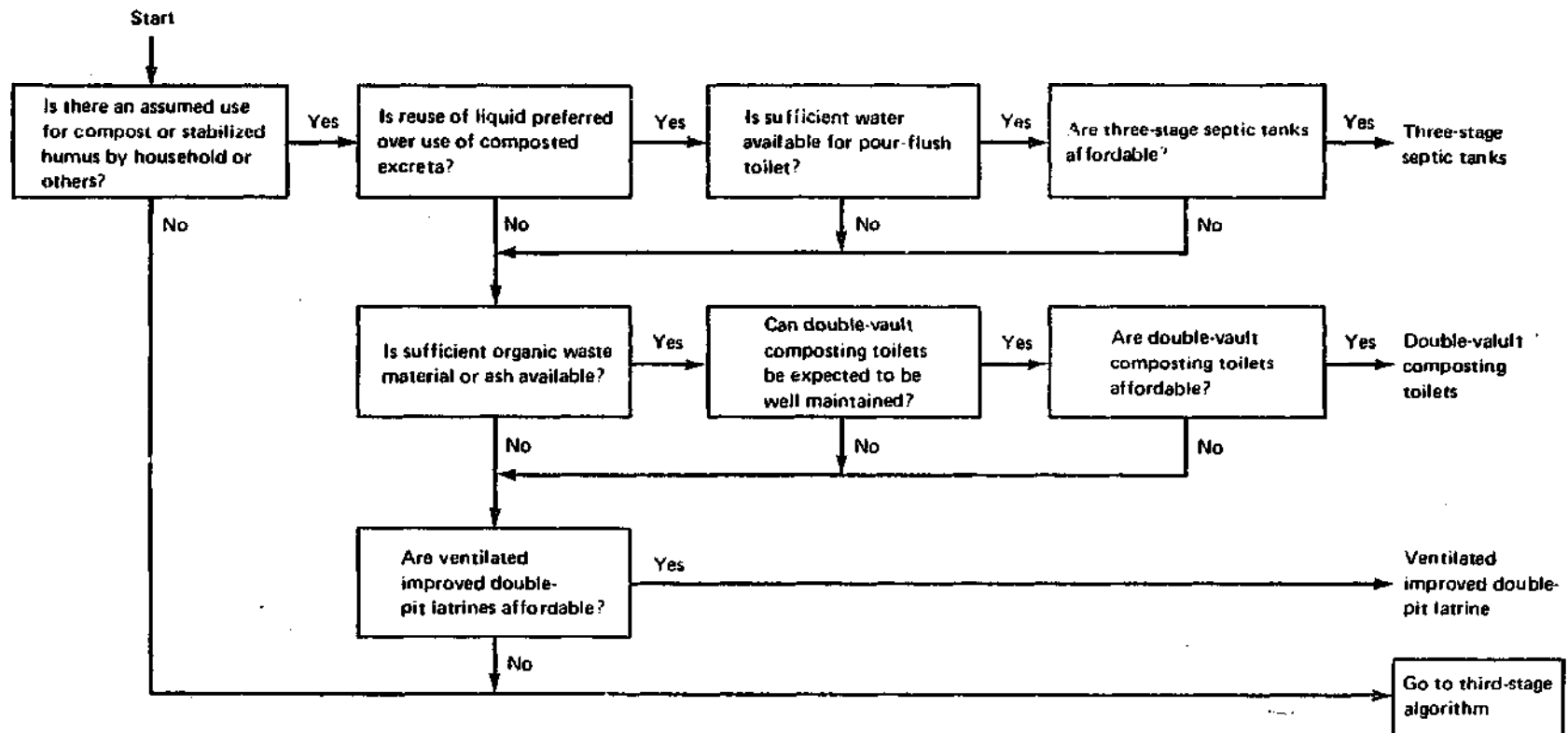
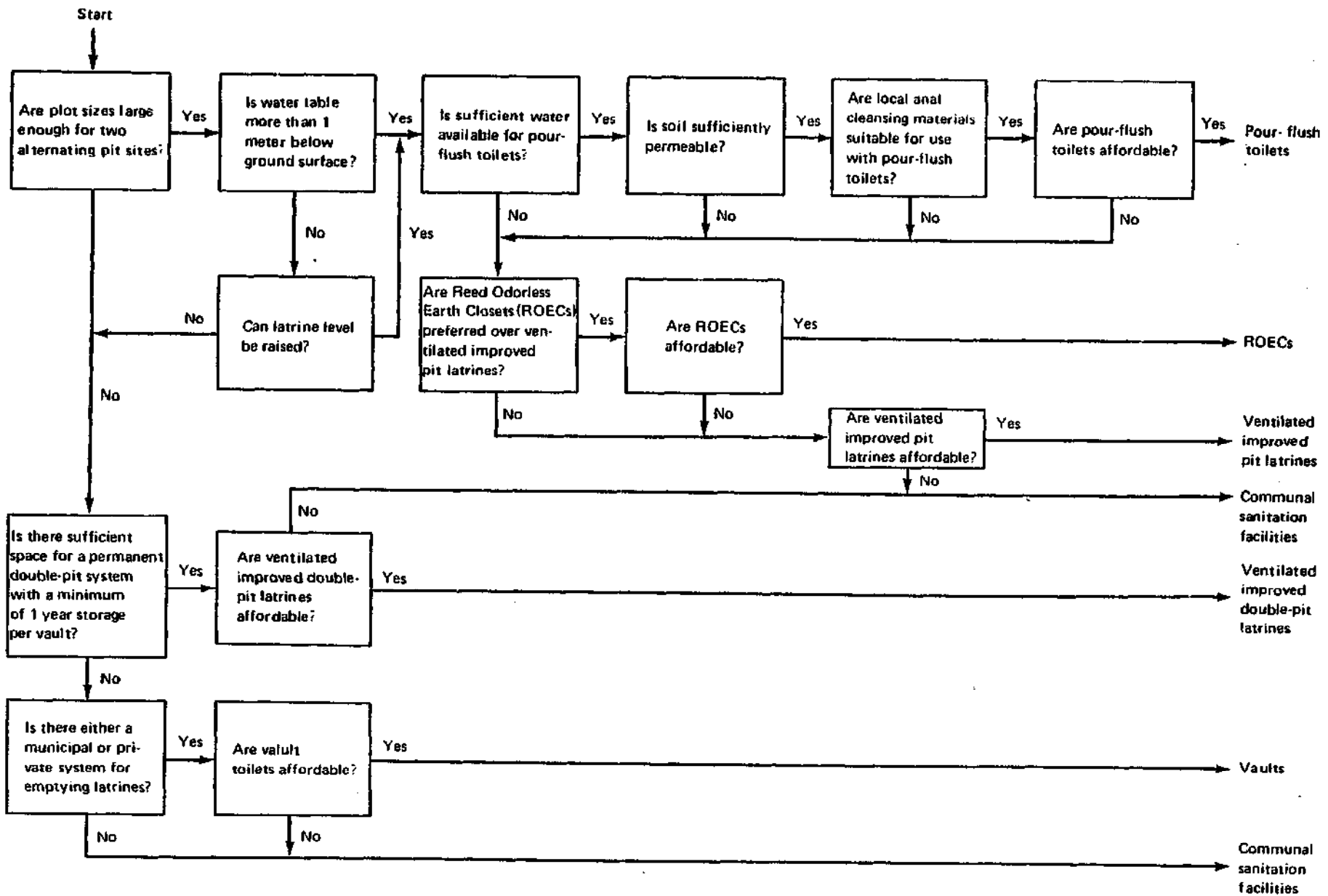

Figure IV-3. Third-stage Algorithm for Selection of Sanitation Technology



- (5) What facilities exist to produce the hardware required for the technology? If lacking, can they be developed? Are the necessary raw materials locally available? Can self-help labor be used? Are training programs required?
- (6) Can the existing sanitation system, if any, be upgraded in any better way than that shown in the algorithm?
- (7) Is there a neighboring area whose existing or planned sanitation system makes a more costly alternative feasible (e.g. small bore sewers discharging to an existing sewer system)?
- (8) What is the potential for reuse? If low, would the adoption of a technology with a higher reuse potential be economically justifiable?
- (9) If the selected technology cannot deal with sullage, what facilities for sullage disposal are required? Is the amount of sullage water so low, or could it be reduced, so as to preclude the need for sullage disposal facilities?

#### V - SANITATION UPGRADING SEQUENCES

Consider a very low-income community living in a periurban slum area. Typically this community has a precarious water supply (for example, one or more shallow contaminated wells) and no formal sanitation facilities, and the incidence of water- and excreta-related infections is high, especially amongst young children. Many of the water-related infections have a waterwashed mode of transmission<sup>16/</sup> and probably most, if not all, six categories of excreta-related infections are also present. We are thus considering a community which is living at the margin of existence: malnutrition is common, most housing is substandard, few people have employment, infant and child mortality is high and life expectancy low. To improve living conditions and to raise the quality of life in this community will be, given the severe financial constraints faced at all levels of government, a very slow process requiring inputs from several disciplines. On the sanitary engineering side, an increase in water quantity, availability and reliability which raises water consumption from its probable present level of around 10 lcd to 30-50 lcd and the provision of a suitable toilet will make a very real impact on the incidence of water- and excreta-related infections, provided that a sustained program of sanitary education is mounted by the responsible authorities concurrently. It does not really matter whether the level of water supply service is of the public standpipe, yard tap or multiple tap in-house variety, or what type of sanitation facility is provided, as long as water use increases sufficiently to have an

---

16. Waterwashed diseases are those feco-oral diseases and skin and eye infections whose transmission occurs primarily due to a lack of sufficient volumes of water for personal and domestic hygiene.

Figure V-1. Potential Sanitation Sequences

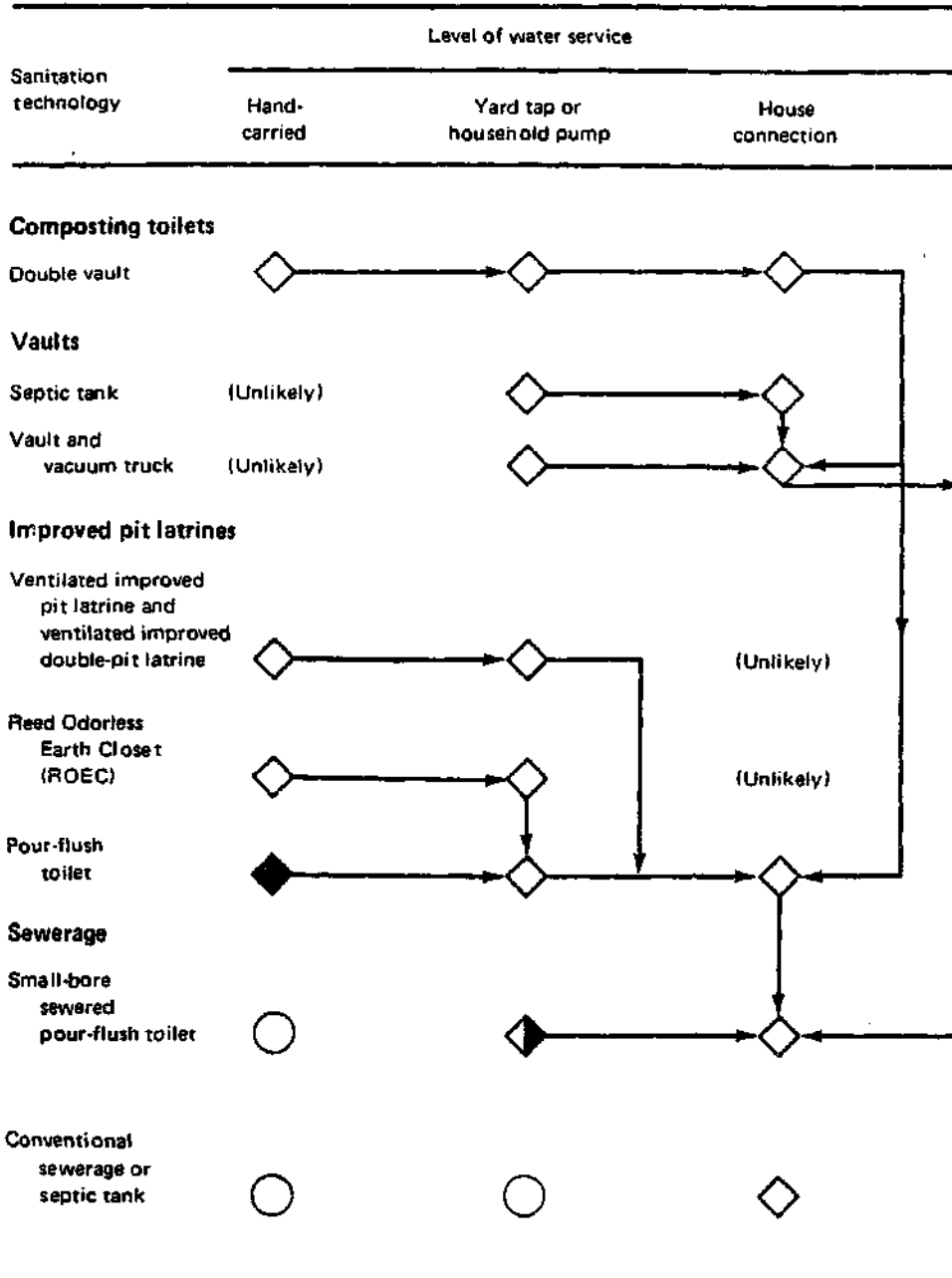

◇ , Technically feasible; ◆ , feasible if sufficient pour-flush water will be hand carried;  
 ○ , Technically infeasible; ◇ , feasible if total wastewater flow exceeds 50 liters per capita daily.

impact on the incidence of waterwashed diseases and as long as the sanitation facility is properly designed and correctly used and maintained, so that the fecal contamination of the immediate environment is substantially reduced to permit a correspondingly substantial reduction in the transmission of excreta-related infections.

Yet central governments in most developing countries are faced not only with hundreds, often thousands or tens of thousands, of communities like the one described above, but also with a chronic shortage of resources with which to improve not only water supply and sanitation but all aspects of life in these communities. As far as water supply and sanitation are concerned (and probably all other aspects as well) the least economic cost solution is a series of planned incremental improvements spread over several years, possibly decades. A major impact on community health can be achieved initially by the provision of standpipes and VIP latrines, for example. In the years to come and as the socio-economic status of the community increases, the water supply and sanitation can be first upgraded to, for example, yard taps and pour-flush toilets and then later (again matching future increases in the socio-economic status of the community) to a multiple tap in-house supply and a seweried pour-flush toilet system, for example. This is one upgrading route; others are shown in Figure V-1.

It is noteworthy that none of the upgrading sequences in Figure V-1 leads to conventional sewerage. This is not because conventional sewerage schemes should not be built (they are a good form of sanitation for those who can afford them and have plenty of water), but because they are not necessary to provide the highest standard of sanitation. The seweried pour-flush system, which can eventually include a low volume cistern-flush toilet for added user convenience, is an equally high standard sanitation system which has two big advantages over conventional sewerage: it is substantially cheaper and it can be reached by staged improvement of several different sanitation technologies. Thus sanitation program planners can confidently select one of these "base line" technologies in the knowledge that, as socio-economic status and sullage flows increase, it can be upgraded in a planned sequence of incremental improvements to a sophisticated "final" solution. The important fact to remember is that sewers are required to dispose of large volumes of sullage, not excreta, and that the elimination or reduction of non-essential water use is thus the key element in an economic solution to sanitation problems. This is particularly significant in development countries where the increasing competition for investment funds often limits the amount of resources which can be allocated to the water and sanitation sector. Because planned incremental sanitation sequences are so much more cost-effective than conventional sewerage (Table V-1), many more people can be provided with satisfactory excreta disposal facilities for the same amount of money, and these facilities can be upgraded as more money becomes available in the future. Given the huge service backlog and the severe investment capital constraints in developing countries, incremental sanitation may be the only, as well as the best, way to meet the sanitation goals of the International Drinking Water Supply and Sanitation Decade.

Table V-1: COMPARATIVE COSTS OF SAMPLE PLANNED  
SANITATION SEQUENCES

Sequence*	Relative economic cost per household per year over a 30-year period
1. Years 1 - 10 : VIP Years 11 - 20 : PF Years 21 - 30 : SPF	23
2. Years 1 - 10 : VIP Years 11 - 30 : SPF	42
3. Years 1 - 30 : SPF	51
4. Years 1 - 30 : CS	100

Source: Kalbermatten et al. (1979)

\*VIP: Ventilated Improved Pit latrine;  
PF: Pour-Flush toilet;  
SPF: Sewered Pour-Flush;  
CS: Conventional Sewerage;

For example, in Sequence 1, a VIP is installed in year 1 and changed to a PF in year 11; the PF is then changed to a SPF in year 21; corresponding changes in water supply would be standpipes to yard taps to multiple in-house connections.

APPROPRIATE TECHNOLOGY FOR WATER SUPPLY AND SANITATION

Publications in this series include:

- (Vol 1) Technical and Economic Options, by John M. Kalbermatten, DeAnne S. Julius, and Charles G. Gunnerson [a condensation of Appropriate Sanitation Alternatives: A Technical and Economic Appraisal, forthcoming from Johns Hopkins University Press].
- (Vol 1-a) A Summary of Technical and Economic Options, by John M. Kalbermatten, DeAnne S. Julius, and Charles G. Gunnerson.
- (Vol 2) A Planner's Guide, by John M. Kalbermatten, DeAnne S. Julius, Charles G. Gunnerson, and D. Duncan Mara [a condensation of Appropriate Sanitation Alternatives: A Planning and Design Manual, forthcoming from Johns Hopkins University Press].
- (Vol 3) Health Aspects of Excreta and Sullage Management--A State-of-the-Art Review, by Richard G. Feachem, David J. Bradley, Hemda Garelick, and D. Duncan Mara [a condensation of Sanitation and Disease: Health Aspects of Excreta and Wastewater Management, forthcoming from Johns Hopkins University Press].
- (Vol 4) Low-Cost Technology Options for Sanitation--A State-of-the-Art Review and Annotated Bibliography, by Witold Rybczynski, Chongrak Polprasert, and Michael McGarry [available, as a joint publication, from the International Development Research Centre, Ottawa, Ontario, Canada].
- (Vol 5) Sociocultural Aspects of Water Supply and Excreta Disposal, by Mary Elmendorf and Patricia K. Buckles.
- (Vol 6) Country Studies in Sanitation Alternatives, by Richard A. Kuhlthau (ed.)
- (Vol 7) Alternative Sanitation Technologies for Urban Areas in Africa, by Richard G. Feachem, D. Duncan Mara, and Kenneth O. Iwugo.
- (Vol 8) Seven Case Studies of Rural and Urban Fringe Areas in Latin America, by Mary Elmendorf (ed.)
- (Vol 9) Design of Low-Cost Water Distribution Systems, Section 1 by Donald T. Lauria, Peter J. Kolsky, and Richard N. Middleton; Section 2 by Keith Demke and Donald T. Lauria; and Section 3 by Paul B. Hebert.



ANNEX A  
Page 2 of 2

- (Vol 10) Night soil Composting, by H. I. Shuval, Charles G. Gunnerson, and DeAnne S. Julius.
- (Vol 11) Sanitation Field Manual, by John M. Kalbermatten, DeAnne S. Julius, Charles G. Gunnerson, and D. Duncan Mara.
- (Vol 12) Low-Cost Water Distribution--A Field Manual, by Charles Spangler.

Additional volumes and occasional papers will be published as ongoing research is completed. With the exception of volume IV, all publications may be obtained from the World Bank's Publications Unit.