

AT MICROFICHE
REFERENCE
LIBRARY

A project of Volunteers in Asia

Make Your Own Precision Milled Lumber from
Logs and Trees: Alaskan MKII

Published by:

Granberg/Firmont Inc.
244 South 24th Street
Richmond, California 94804
USA

Available from:

same as above

Reproduced by permission.

Reproduction of this microfiche document in any
form is subject to the same restrictions as those
of the original document.

**Make your own precision
milled lumber from
logs and trees.**

Alaskan[®] MK III.

**Mounts on any chain saw bar.
Easy to use. Fast. Rugged.**

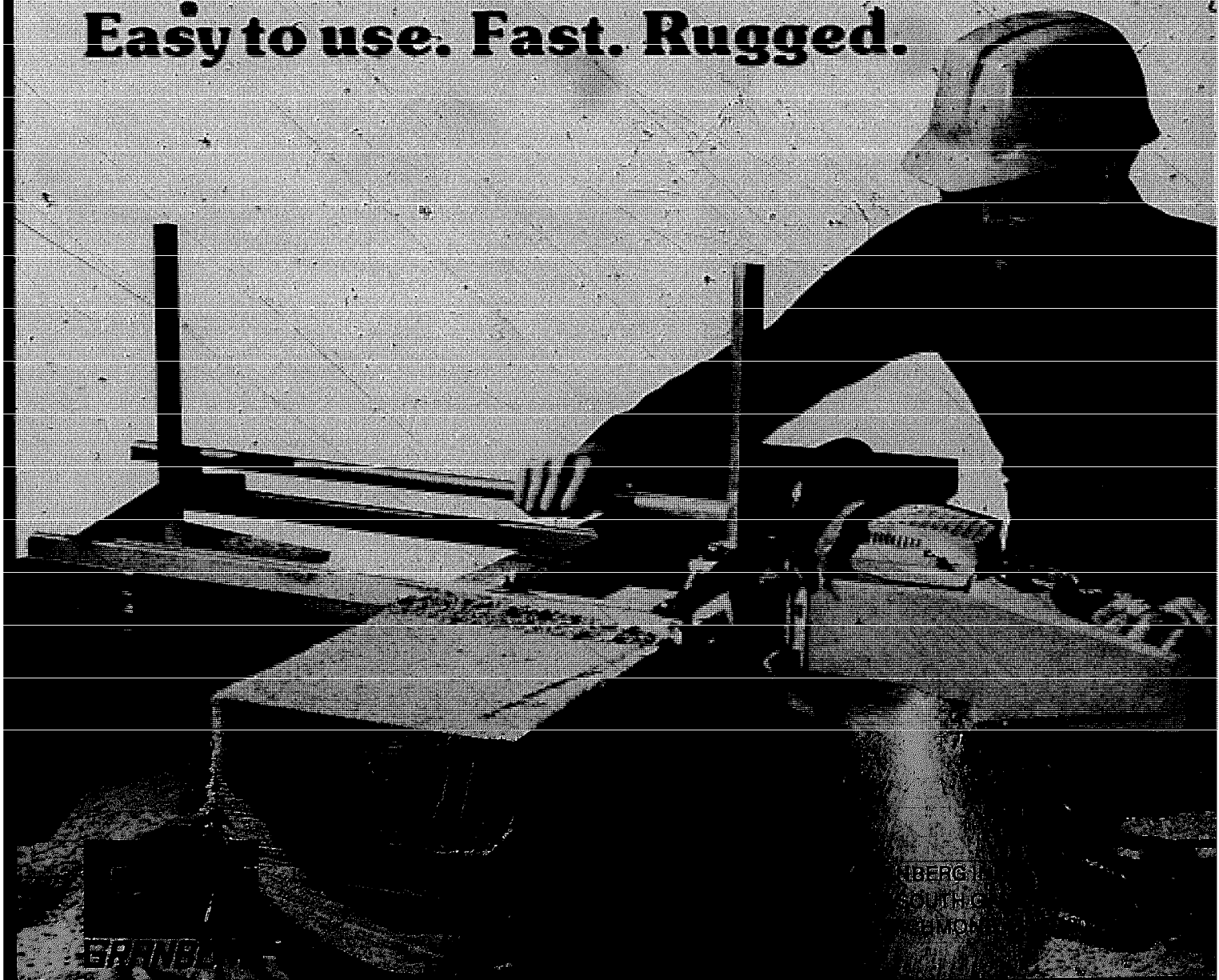

BERG
OUR HIC
DIVISION

Alaskan[®] MK III makes lumber for home or cabin, furniture, decks, fences, bridges, etc. Thicknesses 1/2" to 13", widths to 54", no limit on length.

MK III is the advanced design lumber mill for versatile, heavy duty use. Used with your chain saw, MK III can be taken into the woods to make lumber from trees or logs. MK III clamps on the bar in seconds — is easily adjusted to produce exact lumber thickness. Converts rough logs into perfectly dimensioned lumber with a beautiful, even, re-sawn finish. Safe, easy to use and fast, MK III produces lumber for almost any imaginable use.

1. MK III is easily mounted on bar of any size chain saw. No holes to drill; mill is held in place with clamping pads.

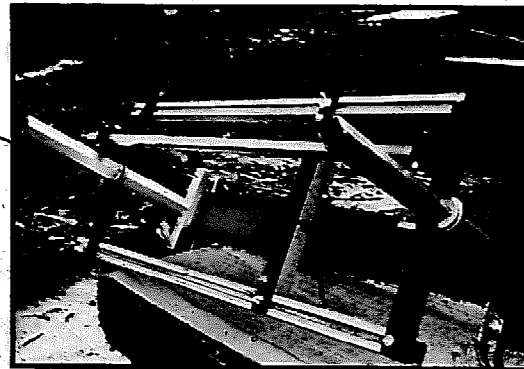

2. Key to precise milling is use of guide rail or plank for first cut.

3. Using guide rail, slab top of log; rotate log and slab two other sides.

4. You are now ready to produce lumber to exact dimension; MK III will glide evenly on slabbed surface.

5. Determine thickness desired — 1/2" to 13" — set vertical thickness rails.

6. MK III on-off guide bar will lead saw in and out of cut for perfectly dimensioned ends.

7. MK III produces ready-to-use lumber, precision milled to desired thickness, width and length.

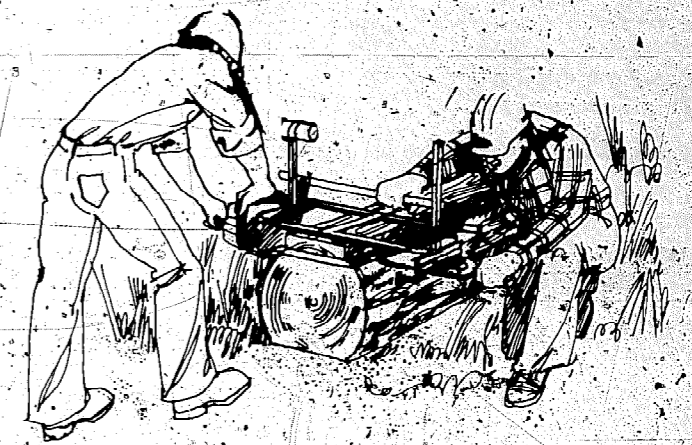
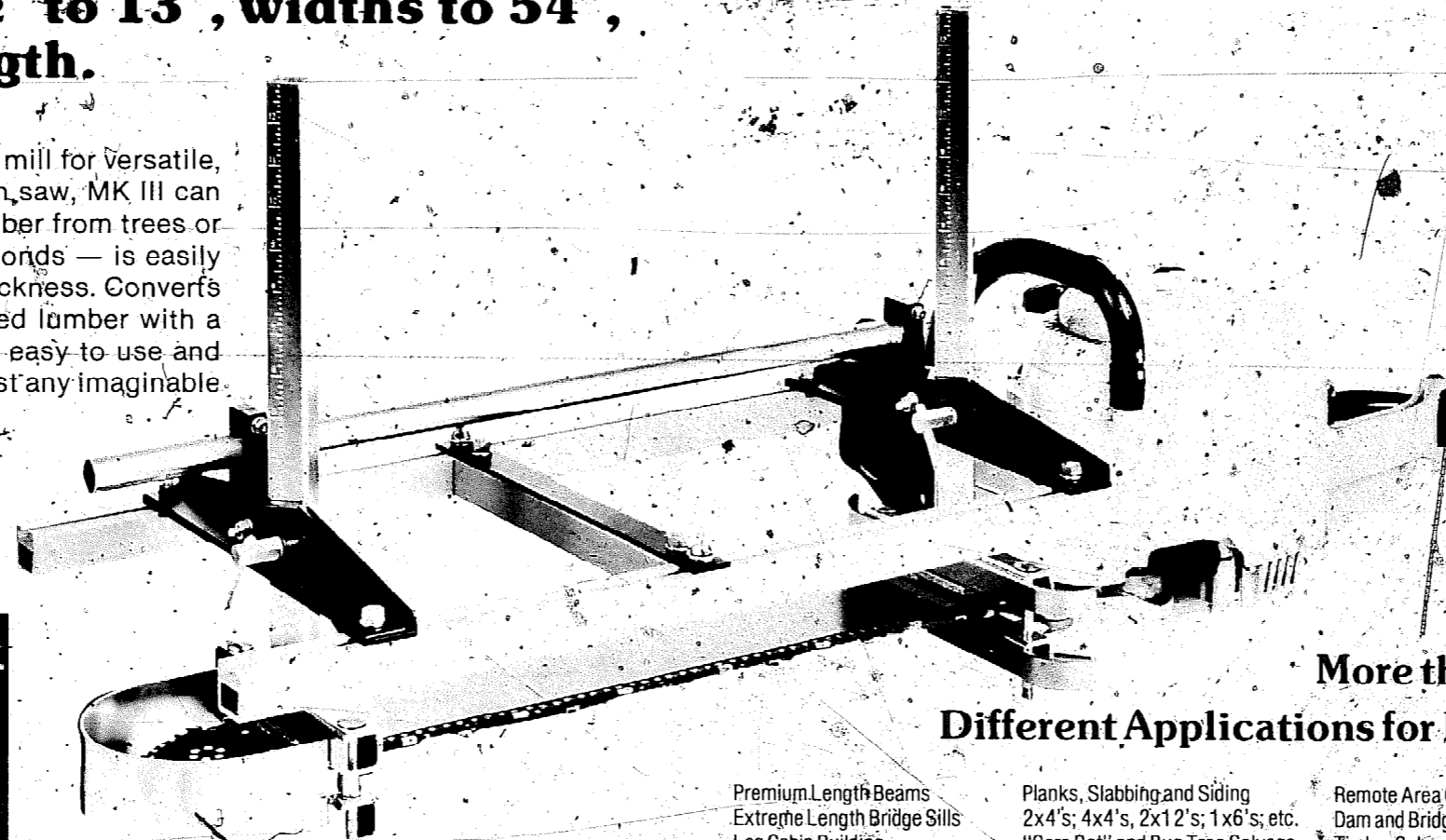
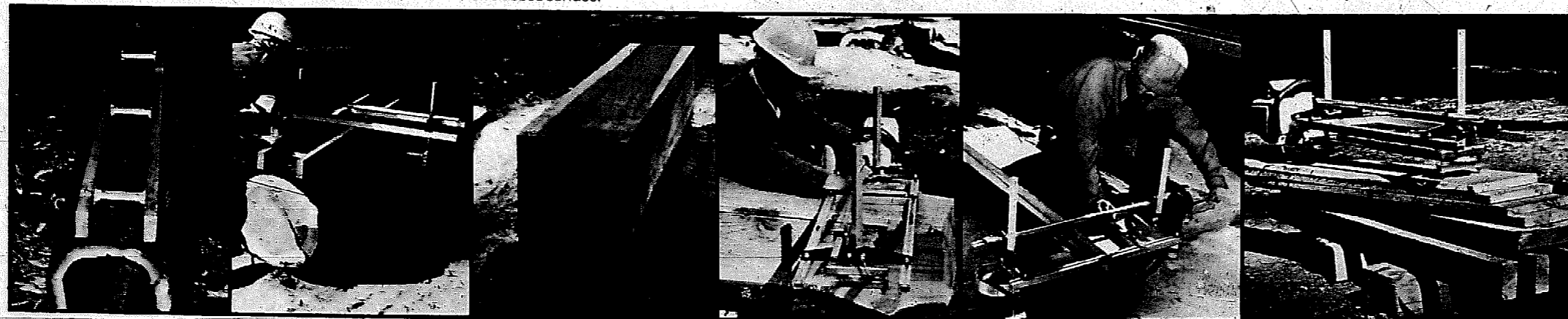

Alaskan[®] MK III Double End

MK III becomes an even more productive lumber mill in the double end model. While the basic model is designed for one person operation, the double end version can be equipped with a helper handle on one end or supplied for use with two powerheads for high volume production.

More than 20 Different Applications for MK III

Premium Length Beams
Extreme Length Bridge Sills
Log Cabin Building
Railroad Track Cross Ties
Mine and Dam Special Timbers
Hardwood and Softwood Cants
Tree Farm Harvesting
Fence and Corral Posts

Planks, Slabbing and Siding
2x4's; 4x4's; 2x12's; 1x6's; etc.
"Core-Rot" and Bug Tree Salvage
Shoring and Sluice Box Material
Ranchers and Farmers
State, National Parks and Forests
Private Forest Owners
Mountain Resort Operators

Remote Area Constructors
Dam and Bridge Contractors
Timber Salvage Crews
Hardwood Cant Cutters
Pulp Cutters for Tie Cutting
Premium Beam Cutters
Tree Farm Operators
"Off-Season" Loggers

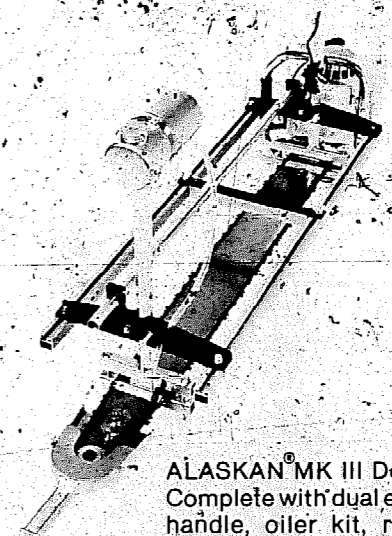

ALASKAN[®] MK III Double End — Complete with dual end bar, helper handle, oiler kit, ripping chain and File-N-Joint[®] (not shown).

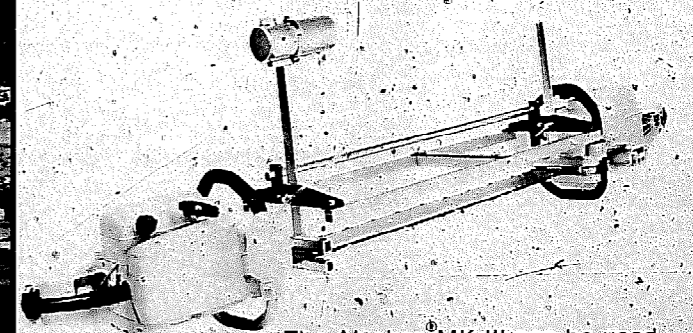

The Alaskan[®] MK III can be used with two power heads, as shown.

Finished Lumber Guide

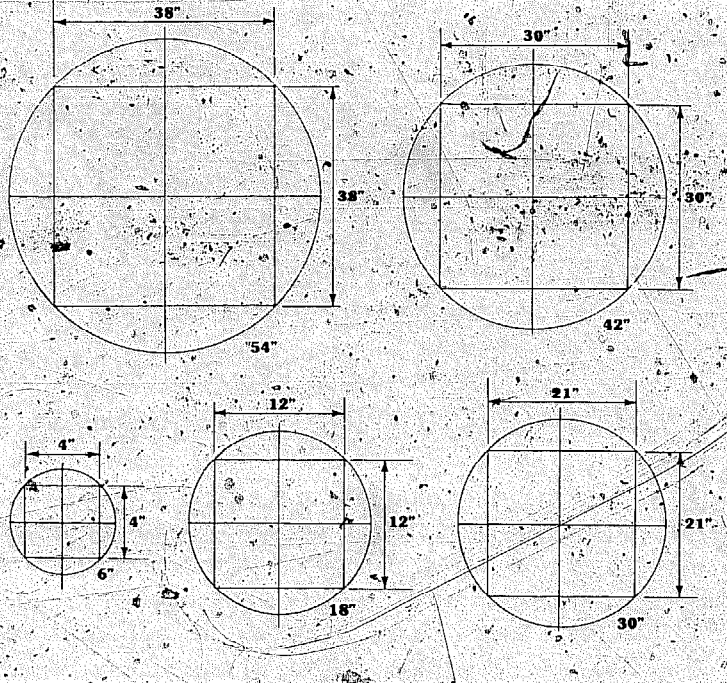

The Finished Lumber Guide indicates the approximate units of dimensional lumber possible from logs of various sizes. Calculations are estimates only and are based on a kerf of 1/2".

	DIAMETER OF LOG				
	6"	18"	30"	42"	54"
1" x 4"	3	33	95	196	324
1" x 6"		22	57	112	216
1" x 8"		11	38	84	144
1" x 12"		11	20	56	108
2" x 4"	2	15	50	98	162
2" x 6"		11	30	56	108
2" x 8"		5	20	42	72
2" x 12"		5	10	28	54
4" x 4"	1	7	25	49	81
4" x 6"		6	15	42	54
4" x 8"		2	10	21	36
4" x 12"		2	5	14	27

Chain Saw Mill Accessories

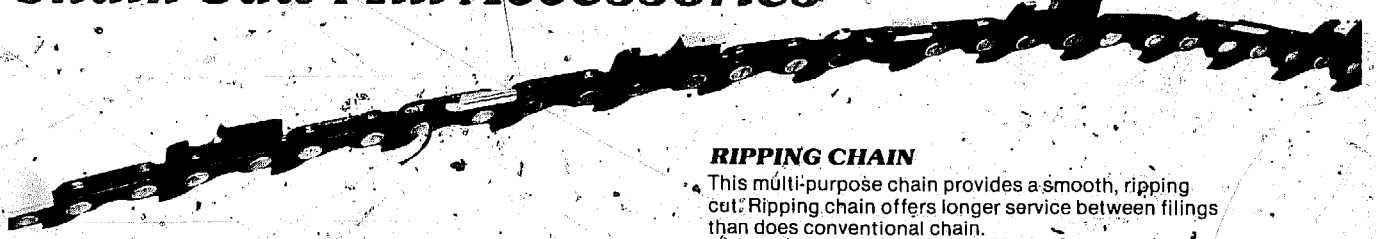

RIPPING CHAIN

This multi-purpose chain provides a smooth, ripping cut. Ripping chain offers longer service between filings than does conventional chain.

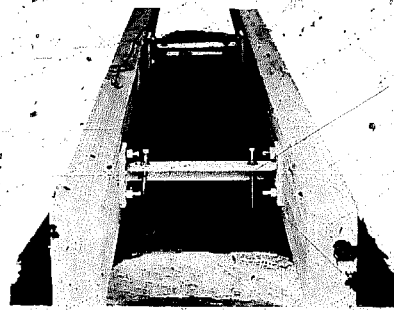

SLABBING RAIL BRACKETS

For the greatest accuracy in milling with the Alaskan chain saw mills, the initial cut must be smooth and level. A set of slabbing rail brackets helps make the ideal guide for the mill to follow.

HELPER HANDLES

Designed for use with any of the MK III models, helper handles are available for two person operations.

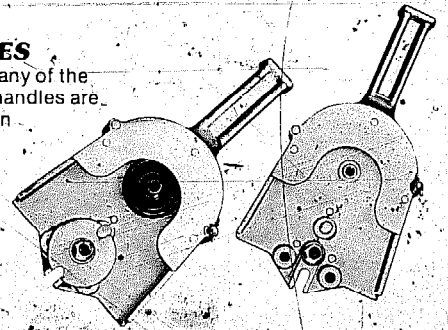

DOUBLE END SAW BARS

These special saw bars will accommodate either two powerheads or one with a helper handle. They are available in 44", 50", 56" and 66" lengths.



OILER KIT

Proper auxiliary chain oiling results in greater chain life and increased production. This oiler kit from Granberg consists of a reservoir tank, mounting bracket, clamps, valves and tubing.

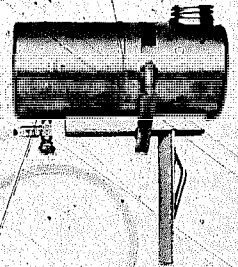



Alaskan[®] MK III G-776

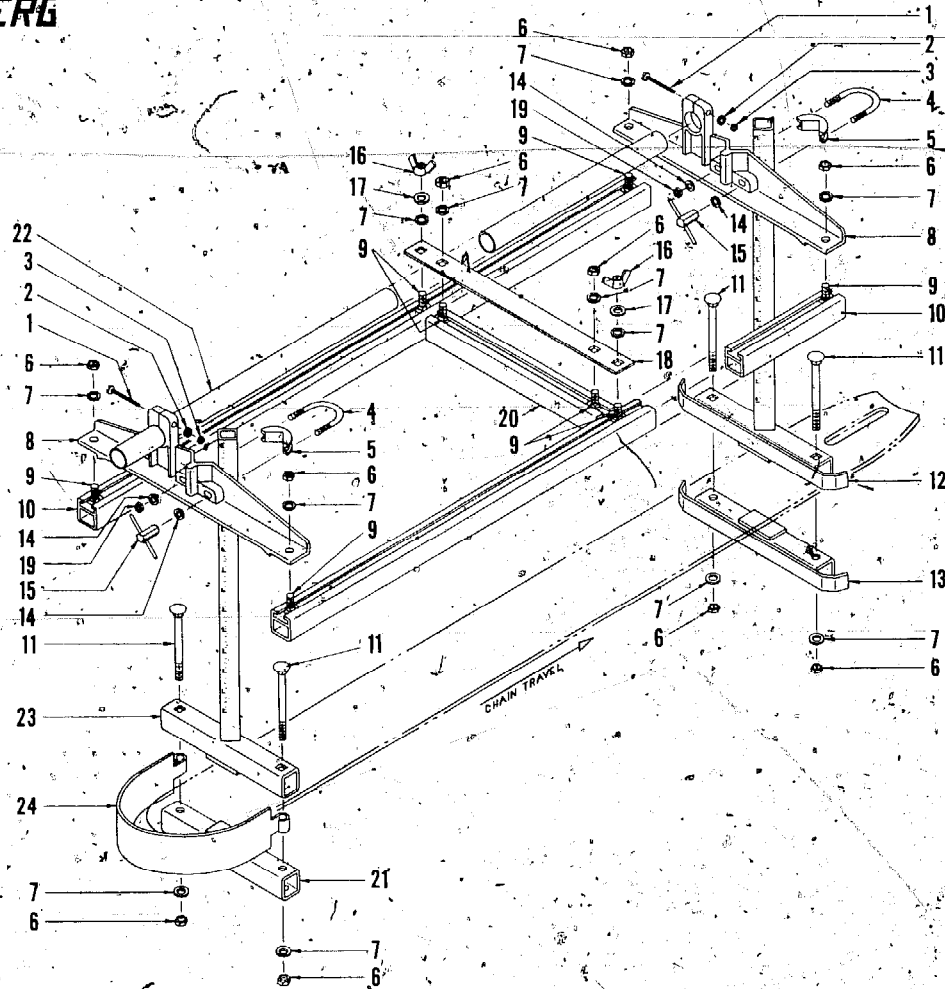

END BRACKET MOVED

ITEM NO.	PART NO.	QTY	DESCRIPTION
1	809	2	Pan-Hd. Screw 10-32
2	323	2	Lock Washer # 10
3	935	2	Hex Hd. Lock Nut 10-32
4	794	2	U-Clamp
5	804	2	Post Clamp
6	684	10	Hex Nut - 5/16-18
7	685	12	Lock Washer 5/16
8	782	2	End-Bracket
9	805	8	Carriage Bolt 5/16-18x3/4 lg.
10	781-2	2	Thickness Rail - G-776-24
	781-3	2	Thickness Rail - G-776-30
	781-4	2	Thickness Rail - G-776-36
	781-5	2	Thickness Rail - G-776-48
	781-6	2	Thickness Rail - G-776-56
11	808	4	Carriage Bolt 5/16-18x3-1/2 lg.
12	791	1	Adjustment Post (thrust end)

ITEM NO.	PART NO.	QTY	DESCRIPTION
13	790	1	Clamping Bracket (thrust-end)
14	666	4	Flat Washer - 1/4
15	798	2	T-Handle Ass'y
16	806	2	High Crown Wing Nut 5/16-18
17	871	2	Flat Washer - 5/16
18	784	1	Tie Bar
19	833	2	Hex Nut - 1/4-20
20	799	1	On-Off Guide Bar
21	781	1	Clamping Bracket (nose-end)
22	793-1	1	Handle - G-776-24
	793-2	1	Handle - G-776-30
	793-3	1	Handle - G-776-36
	793-4	1	Handle - G-776-48
	793-5	1	Handle - G-776-56
23	792	1	Adjustment Post (nose end)
24	795	1	Nose Guard

GRANBERG INDUSTRIES, INC.
200 So. Garrard Blvd., Richmond, CA 94804

776-L5A

TOP VIEW
FIG. II

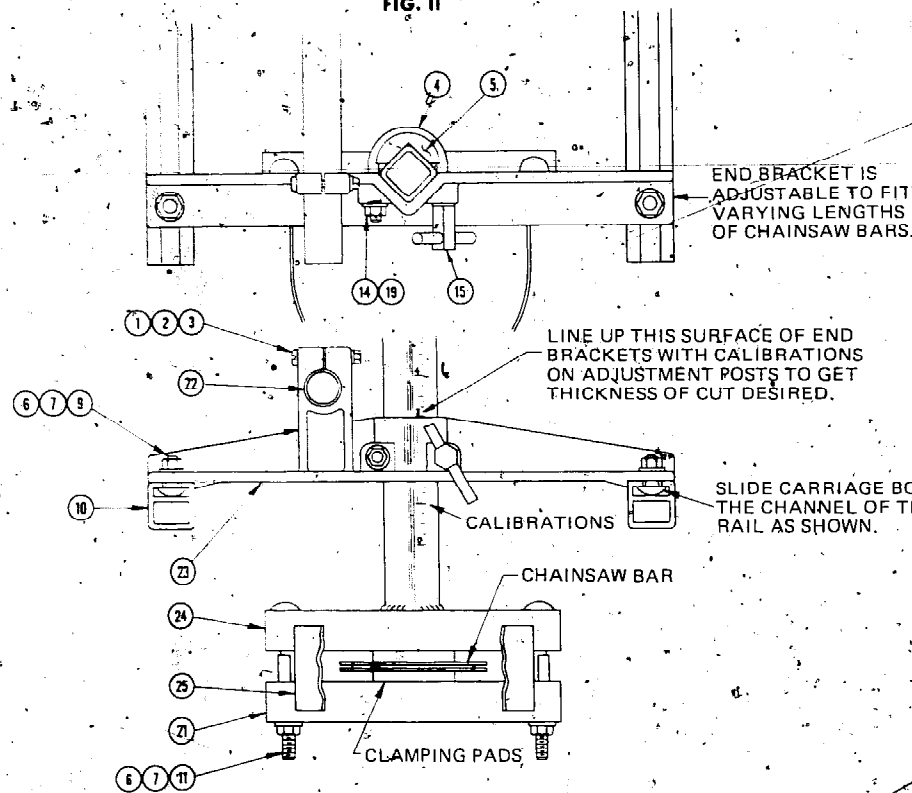

SIDE VIEW
FIG. II
NOSE END

TOP VIEW
FIG. I

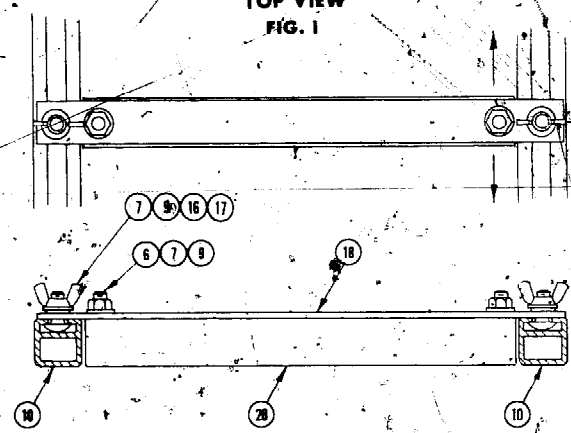

SIDE VIEW
FIG. I

TOP VIEW
FIG. III

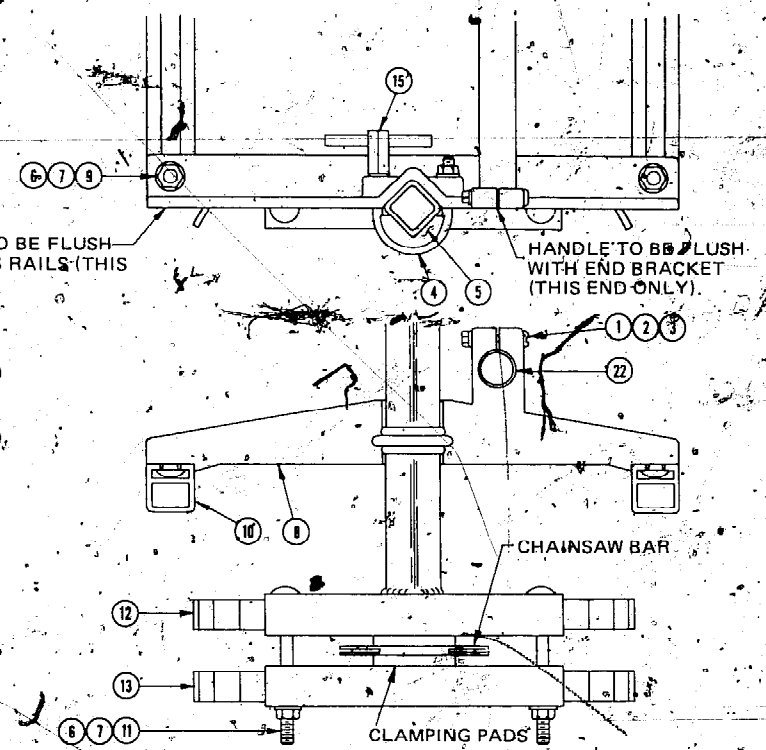

SIDE VIEW
FIG. III
THRUST END

HOW TO ASSEMBLE MK III

STEP 1 (See Figure I)

Attach tie bar (Item 18) to on-off guide bar (Item 20) using two 5/16 - 18 x 3/4 LG carriage bolts (Item 9) two 5/16 lock washer (Item 7) and two 5/16 - 18 hex nuts (Item 6). Then attach unit to thickness rails (Item 10) using two 5/16 - 18 carriage bolts (Item 9) two 5/16 lock washers (Item 7) two 5/16 flat washers (Item 17) and two 5/16 - 18 wing nuts (Item 16).

STEP 2 (See Figure II)

Attach end bracket (Item 23) to thickness rails (Item 10) using two 5/16 - 18 x 3/4 LG carriage bolts (Item 9) two 5/16 flat washers (Item 7) and two 5/16 - 18 hex nuts (Item 6). Tighten hex nuts finger tight only.

STEP 3 (See Figure III)

Attach end bracket (Item 8) to thickness rails (Item 10) using two 5/16 - 18 x 3/4 LG carriage bolts (Item 9) two 5/16 flat washers (Item 7) and two 5/16 - 18 hex nuts (Item 6). Now tighten hex nuts. Be sure that end brackets are flush with thickness rails (See Figure III top view).

STEP 4 (See Figure II & III)

Slide handle through large holes in end brackets. Secure handle at thrust end (Figure III) flush with end bracket using No. 10-32 x 1-1/2 LG pan hd. screw (Item 1) No. 10 lock-washer (Item 2) and No. 10-32 hex nut (Item 3). The same applies to nose end (Figure II) but do not tighten lock nut.

STEP 5 (See Figure II Side View)

Insert two 5/16 - 18 x 3-1/2 LG carriage bolts (Item 11) through holes in adjustment post (Item 24). Carriage bolts should nest in square holes of adjustment post. Slide bolts through the nose guard (Item 25) and then through clamping bracket (Item 21). Secure assembly with two 5/16 lock washers (Item 7) and two 5/16 - 18 hex nuts (Item 6). Leave hex nuts loose so that you have approximately 3/8" to 1/2" gap in clamping pads for mounting chainsaw bar.

STEP 6 (See Figure III Side View)

Insert two 5/16 - 18 x 3-1/2 LG carriage bolts (Item 11) through adjustment post (Item 12). Carriage bolts should nest in square holes of adjustment post. Slide bolts through clamping bracket (Item 13) secure assembly with two 5/16 lock washers (Item 7) and two 5/16 - 18 hex nuts (Item 6). Leave hex nuts loose so that you have approximately 3/8" to 1/2" gap in clamping pads for mounting to chainsaw bar.

STEP 7 (See Figure II)

Attach nose end post assembly to end bracket using U-clamp (Item 4) post clamp (Item 5) two 1/4 lock washers (Item 14) 1/4-20 hex nut (Item 19) and T-handle (Item 15). Tighten T-handle after setting calibration at 3" (See Figure II Side View).

STEP 8 (See Figure III)

Attach thrust end post assembly to end bracket using U-clamp (Item 4) post clamp (Item 5) two 1/4 lock washers (Item 14) 1/4-20 hex nut (Item 19) and T-handle (Item 15). Tighten T-handle after setting calibration at 3" (See Figure II Side View).

STEP 9

Slide nose of chainsaw bar between clamping pads of thrust end and between clamping pads of nose end (See Figure IV & V). Slide thrust end within 1" of power head of chainsaw, center clamping pads on the bar (See Figure VI). On nose end of the mill slide end bracket (23) along rails (10) so that clamping pads on nose end of bar do not interfere with chain, center clamping pads on the bar (See Figure VI), tighten hex nuts (6) on end bracket (23), also tighten lock nut (3) on end bracket (23); now tighten hex nuts (6) on clamping brackets (13 & 21). BE SURE THAT CLAMPING PADS ARE CENTERED ON BAR (See Figure VI).

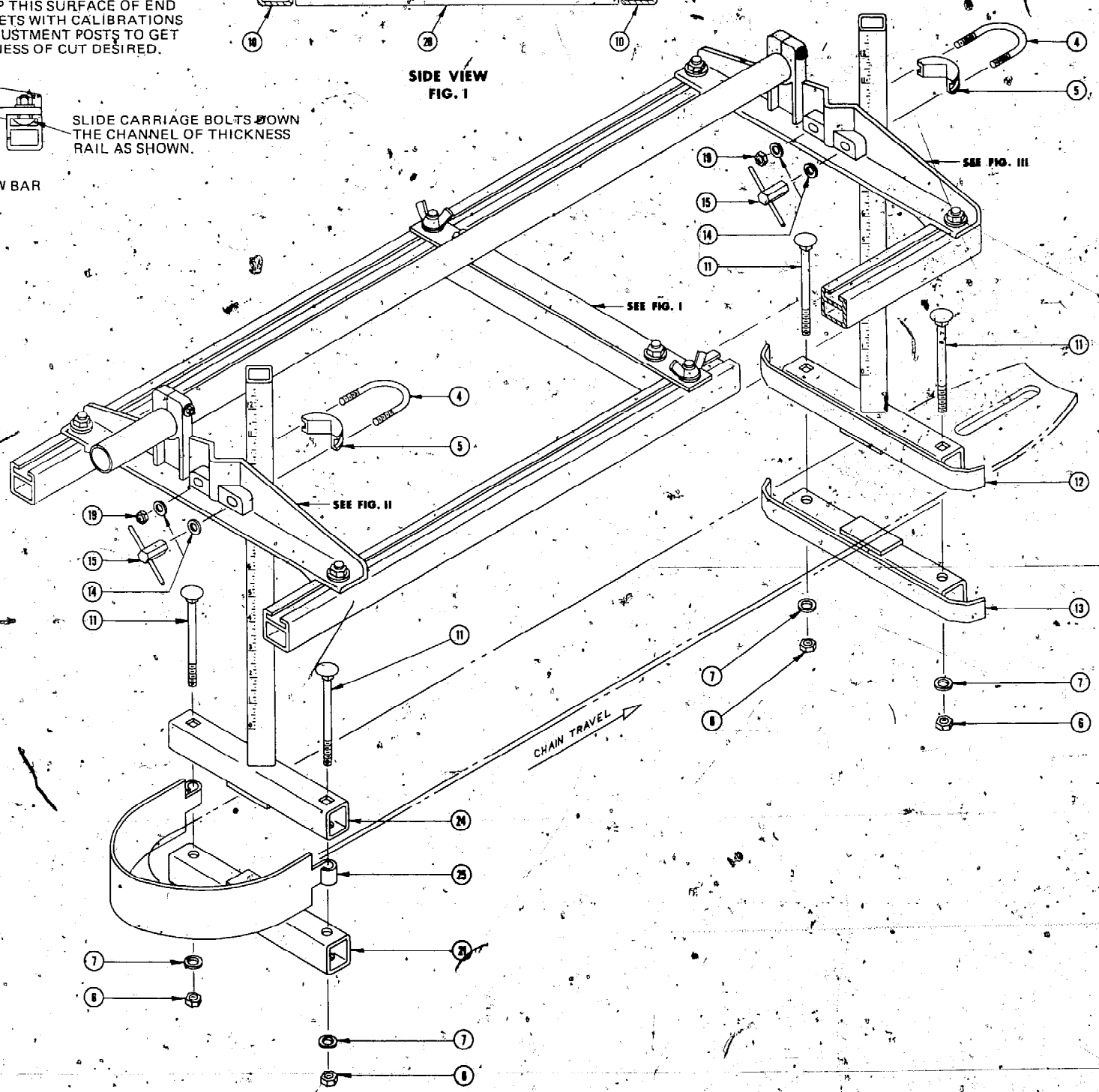

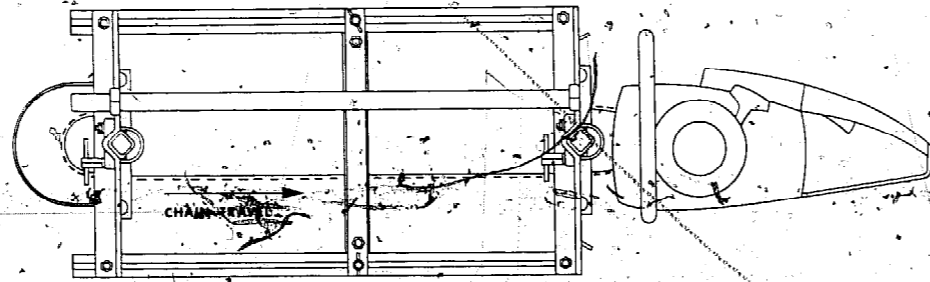

FIG. IV

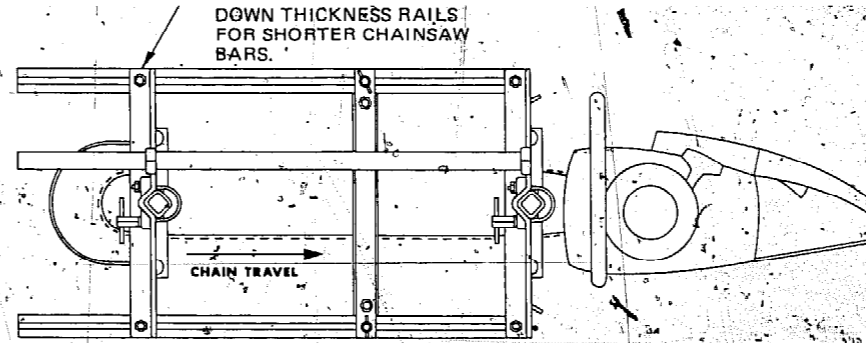
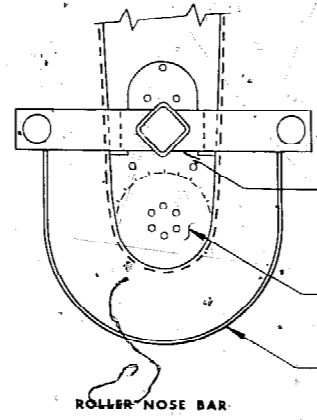

FIG. V



KEEP CLAMPING PADS FAR ENOUGH AWAY FROM ROLLER NOSE SO THAT THE PADS DO NOT PINCH OR BIND ROLLER NOSE.

ROLLER NOSE

NOSE GUARD

ROLLER NOSE BAR

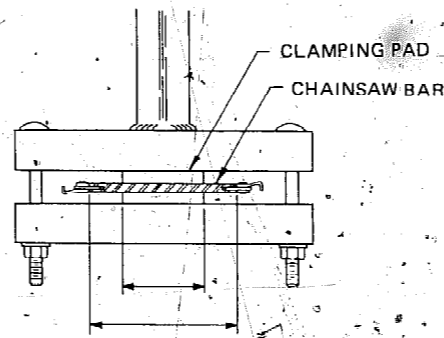
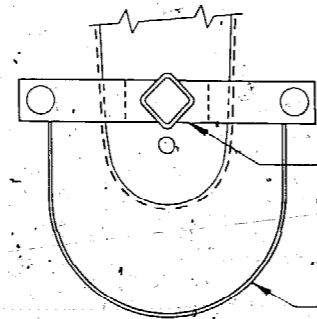

FIG. VI

CLAMPING PAD
CHAINSAW BAR



KEEP CLAMPING PADS FAR ENOUGH AWAY FROM TIP OF BAR SO THAT THE PADS DO NOT INTERFERE WITH SAW CHAIN.

NOSE GUARD

SOLID NOSE BAR

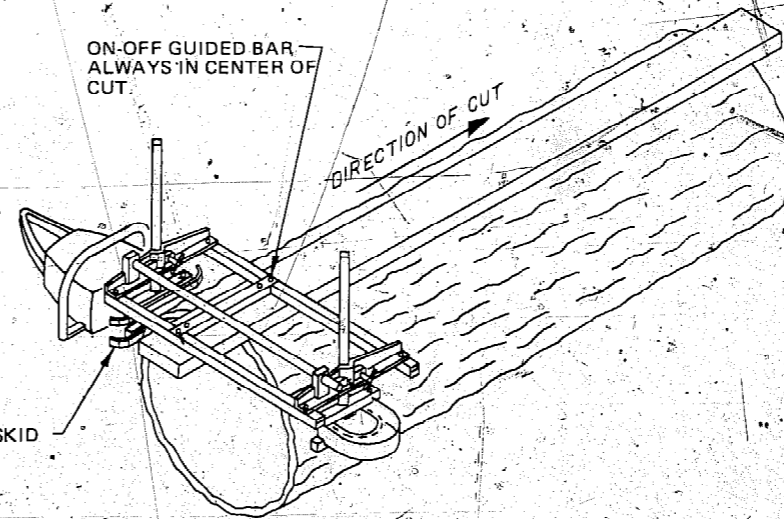

THRUST SKID



G-776-56C2
56" LONG MK-III MILL WITH
66" LONG DOUBLE END BAR
SHOWN ASSEMBLED WITH
DUAL POWER HEADS

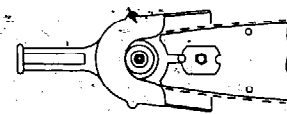
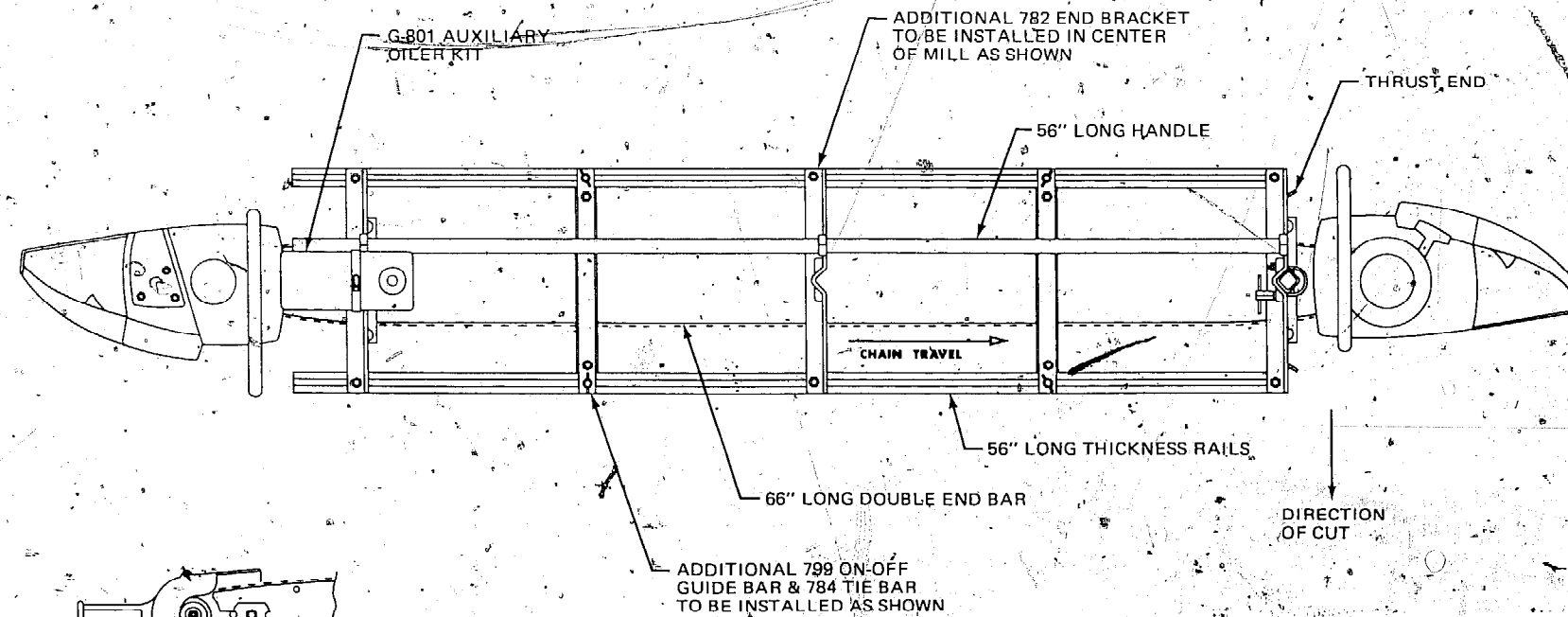

DOUBLE END BAR
SHOWN WITH G-975
HELPER HANDLE



HOW TO MAKE LUMBER WITH THE ALASKAN® CHAINSAW MILL MK. III

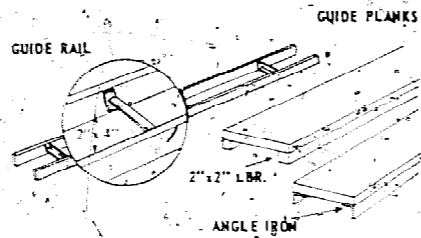

PREPARING GUIDE RAIL OR GUIDE PLANK

An accurate dependable guide system is absolutely necessary before attempting to operate your ALASKAN® Granberg Industries has perfected a steel spreader bracket, anchoring rivets. When spaced and bolted in position every four feet between two straight 2" x 4's make the ideal guide rail for your chainsaw mill. If you have not as yet obtained these brackets, a guide may be fashioned from a good straight 2" x 12" plank with 2" x 2" or angle iron securely fastened to the plank edges to form a saddle rest when plank is placed on the log in preparation for the first cut.

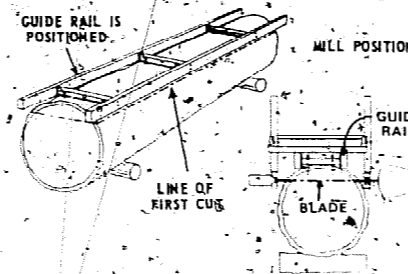

SETTING UP FOR THE FIRST CUT

Place the guide rail or plank on the log and secure. The guide rail must project at least six inches beyond the ends of the log so that the saw will leave the cut level and evenly. This basic or first cut determines the accuracy of all later cuts, so make sure it will be true and level and that the greatest amount of lumber will be produced from the log.

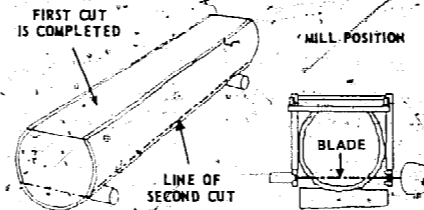

MAKING READY FOR THE SECOND CUT

Remove the guide rail and slab as the mill will now slide on the level surface of the first cut while making the parallel second cut. Lower the blade, using the thickness gauge to the lumber dimension desired. If, for instance, you are planning to make planking—the slab to be taken from the bottom of the log will be approximately the same size as the slab from the first cut. Wedge this cut open as the saw comes out of cut to prevent the saw bar from pinching.

CENTER ON OFF GUIDE BAR IN MIDDLE OF LOG TO LEAD SAW IN AND OUT OF CUT

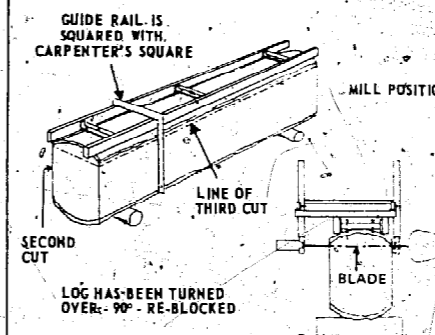

PREPARING TO MAKE THE THIRD CUT

Now rotate the log 90° and brace the log firmly. Replace and fasten the guide rail. Use a carpenter's square to insure that the third slabbing cut will be at right angles to the faces of the first and second cuts.

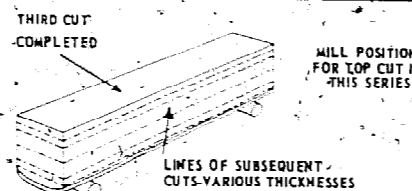

ON OFF GUIDE BAR GIVES A LEVEL START (FINISH IN & OUT OF LOG) CENTER ON OFF GUIDE BAR ON CANT

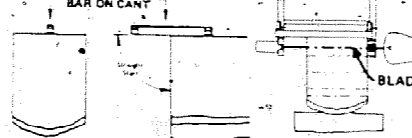

READY TO CONVERT CANT INTO LUMBER

You are now ready to convert the cant into lumber. Remove the slab and guide rail. Determine the thickness of the planks or boards to be produced and set the gauge to the correct thickness. Remember that the mill slides on the level surface of each previous cut so take care that the on-off guide bar is centered on the cant to insure the saw enters and leaves the cut evenly.

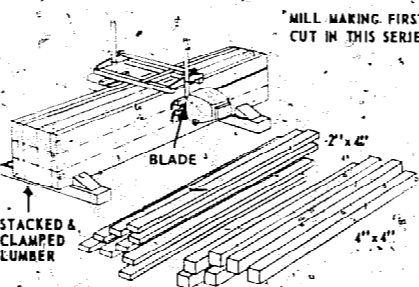

MAKING DIMENSION LUMBER FROM SAWN PLANKS

When you desire to make dimension lumber, gather the saw planks as shown and clamp firmly. Now adjust the thickness gauge as required so as to cut 2" x 2", 2" x 6" or 2" x 12" as an example. Keep in mind that if various sizes are planned to be taken from the same log, such as 4" x 4", 6" x 6", 4" x 8", etc. the various dimensions needed must be allowed for when making the previous cuts. See Step Five.

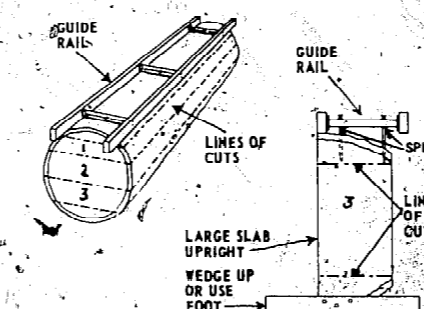

TIMBERS—CANTS—BEAMS—ETC. FROM LARGE LOGS

To split larger logs into two or more sections, proceed as in Step Two. The sizes of these heavy pieces are controlled by the setting of the thickness gauge. The guide rail is used in the same manner as previously described (Step Two). The cuts may require wedging open due to heavy weight.

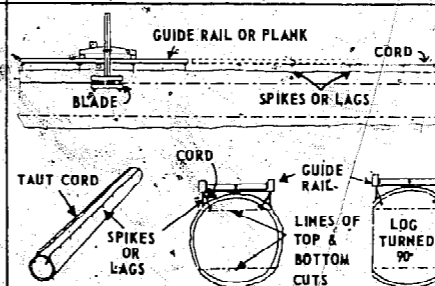

STEPS TAKEN IN THE MAKING OF PREMIUM LENGTH BEAMS

When cutting extra long or premium beams, use two guide rails or planks for the initial cut. Before placing the guide rails, stretch a heavy cord from one end of the log to the other. Drive spikes or lags to the height of the cord as a means of keeping the guide rails true and level. When the mill has passed beyond the first guide rail, remove the guide rail. Proceed in this step and repeat process for the entire length of the log. When using one guide rail, raise the mill and slide the guide rail ahead along the heads of the logs or spikes.



Alaskan[®] MK III

C2 SERIES (2 MAN MILL)

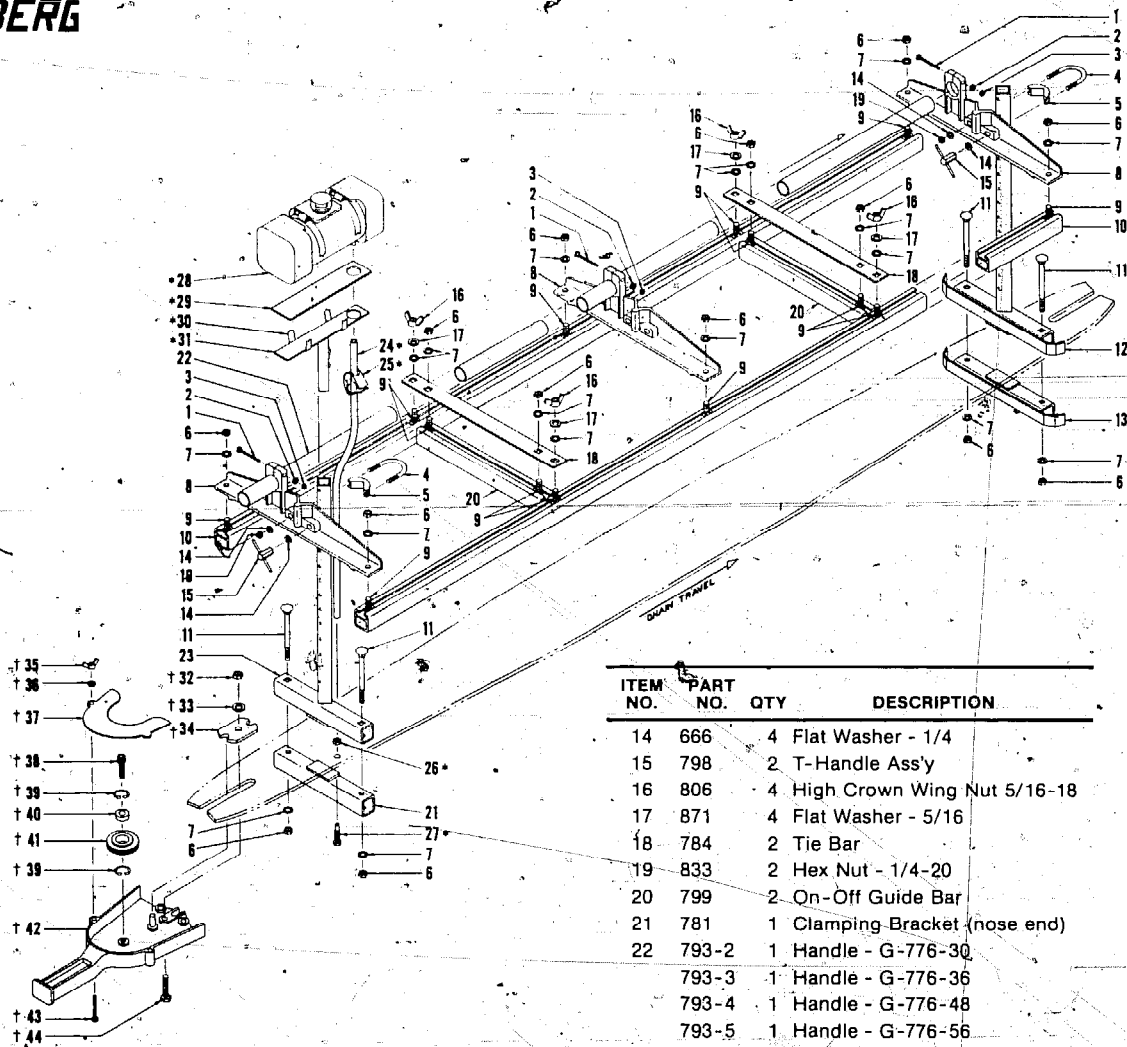

*G-801A Oiler Kit Ass'y

†G-975 Helper Handle Ass'y

ITEM NO.	PART NO.	QTY	DESCRIPTION
1	809	2	Pan Hd. Screw - 10-32
2	323	2	Lock Washer #10
3	935	2	Hex Hd. Lock Nut - 10-32
4	794	2	U-Clamp
5	804	2	Post Clamp
6	684	14	Hex Nut - 5/16-18
7	685	18	Lock Washer - 5/16
8	782	3	End Bracket
9	805	14	Carriage Bolt 5/16-18x3/4 lg.
10	781-3	2	Thickness Rail - G-776-30
	781-4	2	Thickness Rail - G-776-36
	781-5	2	Thickness Rail - G-776-48
	781-6	2	Thickness Rail - G-776-56
11	808	4	Carriage Bolt 5/16-18x3-1/2 lg.
12	791	1	Adjustment Post (thrust end)
13	790	1	Clamping Bracket (thrust end)

ITEM NO.	PART NO.	QTY	DESCRIPTION
14	666	4	Flat Washer - 1/4
15	798	2	T-Handle Ass'y
16	806	4	High Crown Wing Nut 5/16-18
17	871	4	Flat Washer - 5/16
18	784	2	Tie Bar
19	833	2	Hex Nut - 1/4-20
20	799	2	On-Off Guide Bar
21	781	1	Clamping Bracket (nose end)
22	793-2	1	Handle - G-776-30
	793-3	1	Handle - G-776-36
	793-4	1	Handle - G-776-48
	793-5	1	Handle - G-776-56
23	792	1	Adjustment Post (nose end)
*24	689	1	Hose
*25	712	1	Shut-Off Valve
*26	687	1	Jam Nut - 5/16-24
*27	967	1	Bar Oil Injector
*28	677A	1	Oil Tank
*29	828	1	Rubber Pad
*30	699	2	Gear Clamp
*31	802A	1	Mounting Base
†32	690	1	Hex Nut - 3/8-24
†33	660	1	Lock Washer - 3/8
†34	767	1	Disc
†35	27	1	Wing Nut - 10-24
†36	666	1	Lock Washer - 1/4
†37	976	1	Cover
†38	973	1	Cap Screw - 3/8-16x1
†39	970	2	Grip Ring
†40	969	1	Bearing
†41	968	1	Idler Roller
†42	971	1	Helper Handle
†43	341	1	Pan Hd. Screw 10-24x1-1/2
†44	762	1	Hex-Hd. Bolt 3/8-24x1-1/2

GRANBERG INDUSTRIES, INC. 200 SOUTH GARRARD BLVD., RICHMOND, CA 94804
A WILLIAMS, CRAIG & NEER COMPANY

776-L8A



GRANBERG INDUSTRIES INC. • 200 S. GARRARD BLVD. • RICHMOND, CA 94804

TELEPHONE: 415-236-0400

TELEX: 337-773 GRNBR RICH.

PRICE LIST

April 1, 1983

CAT. NO.	DESCRIPTION	SUG. LIST EA.	QTY.	AMOUNT
CHAIN CARE				
G-45	ADJUSTABLE FILE GUIDE	3.95		
G-60	ROUND FILE 5/32	1.00		
G-61	ROUND FILE 3/16	1.00		
G-62	ROUND FILE 7/32	1.00		
G-70	KWK-KNOB FILE HANDLE	.30		
G-76	DEPTH GAUGE FILE	1.75		
G-81	PITCH-N-GAUGE	1.25		
G-104C	FILE-N-JOINT®	19.95		
G-106A	FILE-N-JOINT®	21.95		
G-109	FILE-N-GUIDE®	16.95		
G-180	ROLL FILER W/FILE 5/32	3.95		
G-181	ROLL FILER W/FILE 3/16	3.95		
G-182	ROLL FILER W/FILE 7/32	3.95		
G-400C	GUIDE VISE BENCH MODEL HAND FILER	37.95		
"G" BRAND GRINDING WHEELS FOR USE WITH G-612, G-810, G-910, G-912 & G-1012				
G-417	GRINDING WHEEL 5/32	1.75		
G-418	GRINDING WHEEL 3/16	1.75		
G-419	GRINDING WHEEL 7/32	1.75		
G-420	GRINDING WHEEL 1/4	1.75		
G-421	GRINDING WHEEL 9/32	1.75		
G-422	GRINDING WHEEL 3/8	1.75		
G-440	KOOL GRIND	1.75		
G-605	BREAK-N-MEND	24.95		
G-612	SHARP-N-QWK 12V GRINDER	24.95		
G-810	GRIND-R-GUIDE 110V GRINDER	51.95		
G-910V	BENCH MODEL SAWCHAIN SHARPENER 110V	82.95		
G-912B	GRIND-N-JOINT 12V GRINDER	32.95		
G-914	CONVERTER 110V TO 12V D.C.	20.95		
G-1012B	PRECISION GRINDER 12V W/FILE-N-JOINT® BASE	52.95		
CHAIN SAW LUMBER MAKING ATTACHMENTS				
G-555	MINI-MILL (CLAMP ON CHAIN SAW MILL)	67.50		
ALASKAN® COMPLETE LESS ENGINE (700 SERIES)				
G702C2	26" ALASKAN® CHAIN SAW MILL	640.00		
G-703C2	34" ALASKAN® CHAIN SAWMILL	670.00		
G-704C2	38" ALASKAN® CHAIN SAW MILL	695.00		
G-705C2	48" ALASKAN® CHAIN SAWMILL	740.00		
ALASKAN® MK-III (776 SERIES)				
G-776-24	24" ALASKAN® CHAIN SAW MILL	132.50		
G-776-30	30" ALASKAN® CHAIN SAW MILL	142.50		

CAT. NO.	DESCRIPTION	SUG. LIST EA.	QTY.	AMOUNT
CHAIN SAW LUMBER MAKING ATTACHMENTS (CONTINUED)				
G-776-36	36" ALASKAN® CHAIN SAW MILL	152.50		
G-776-48	48" ALASKAN® CHAIN SAW MILL	172.50		
G-776-56	56" ALASKAN® CHAIN SAW MILL	202.50		
	ALL ALASKAN® C2 MILLS COMPLETE LESS ENGINE INCLUDES: D. E. BAR, RIPPING CHAIN, AUX. OILER HELPER HANDLE W/ROLLER AND FILE-N-JOINT®			
G-776-30C2	26" WIDTH OF CUT	360.00		
G-776-36C2	34" WIDTH OF CUT	387.50		
G-776-48C2	46" WIDTH OF CUT	425.00		
G-776-56C2	54" WIDTH OF CUT	500.00		
G-776	BASIC UNIT MK III ALASKAN® MILL	102.50		
	HANDLE & RAIL FOR MK III			
G-781-24	HANDLE & RAIL FOR MK III 24"	35.00		
G-781-30	HANDLE & RAIL FOR MK III 30"	46.00		
G-781-36	HANDLE & RAIL FOR MK III 36"	57.00		
G-781-48"	HANDLE & RAIL FOR MK III 48"	73.00		
G-781-56"	HANDLE & RAIL FOR MK III 56"	106.00		
G-781-72"	HANDLE & RAIL FOR MK III 72"	119.00		
G-781-80"	HANDLE & RAIL FOR MK III 80"	130.00		
	PITCH RIPPING CHAIN GAUGE			
G-727-0	.250	.050	7.25 ft.	
G-728-0	.325	.050	7.25 ft.	
G-728-3	.325	.063	7.25 ft.	
G-729-2	.375 (L.P.)	.050	7.25 ft.	
G-729-0	.375	.050	6.55 ft.	
G-729-8	.375	.058	6.55 ft.	
G-729-3	.375	.063	6.55 ft.	
G-730	.404	.058	6.55 ft.	
G-730-3	.404	.063	6.55 ft.	
G-732	.500	.058	7.25 ft.	
G-732-3	.500	.063	7.25 ft.	
	RIPPING CHAIN-CUT LENGTHS FOR DOUBLE END BARS SPECIFY PITCH AND GAUGE			
	LENGTH	FITS MILL NO.	BAR NO.	PITCH
	8'-4"	G-702C2	G-742-3	.375 & .404
		G-776-30C2		OTHER
	9'-4"	G-703C2	G-743-3	.375 & .404
		G-776-36C2		OTHER
	10'-4"	G-704C2	G-744-3	.375 & .404
		G-776-48C2		OTHER
	12'-2"	G-705C2	G-745-3	.375 & .404
		G-776-56C2		OTHER

CAT. NO.	DESCRIPTION	SUG. LIST EA.	QTY.	AMOUNT
	DOUBLE END BARS			
	DOUBLE END BARS - .063 GA. ONLY (USE WITH 2 ENGINES OR 1 ENGINE WITH ROLLER HELPER HANDLE G-975)			
	O.A.L. FITS MILL NO.			
G-742-3	44" G-702C2 G-776-30C2 ⁵ .063 GA.	121.00		
G-743-3	50" G-703C2 G-776-36C2 .063 GA.	137.50		
G-744-3	56" G-704C2 G-776-48C2 .063 GA.	154.00		
G-745-3	66" G-705C2 G-776-56C2 .063 GA.	181.50		
G-692	AUX. OILER KIT (700 SERIES MILLS)	18.90		
G-801A	AUX. OILER KIT (776 SERIES MILLS)	19.95		
G-820	SLABBING RAIL BRACKETS (SET OF 3)	16.50		
G-971	HELPER-HANDLE	16.00		
G-975	HELPER HANDLE W/ROLLER	27.50		
	ADDITIONAL EQUIPMENT			
G-112A	CLIP-N-TRIM 18"	9.95		
G-114A	CLIP-N-TRIM 14"	10.95		
G-116A	CLIP-N-TRIM 16"	11.95		
G-120A	CLIP-N-TRIM 20"	12.95		
G-184	DIX SOLDER	3.49		
G-250	LOG LIFTER	33.95		
G-530	FOLDING BUCK SAW	11.95		
G-942	CUT OFF WHEEL 11-7/8 x 1/8 x 1 (METAL) HAVE ADAPTERS TO 7/8 AND 20 M.M.	6.00		
G-944	CUT OFF WHEEL 11-7/8 x 1/8 x 1 (MASONRY) HAVE ADAPTERS TO 7/8 AND 20 M.M.	6.00		
G-945	CUT OFF WHEEL 11-7/8 x 1/8 x 1-5/32 (METAL)	6.00		
G-946	CUT OFF WHEEL 11-7/8 x 1/8 x 1-5/32 (MASONRY)	6.00		
G-955	CUT OFF WHEEL 14 x 1/8 x 1 (METAL) HAVE ADAPTERS TO 7/8 AND 20 M.M.	8.75		
G-956	CUT OFF WHEEL 14 x 1/8 x 1 (MASONRY) HAVE ADAPTERS TO 7/8 AND 20 M.M.	8.75		
G-957	CUT OFF WHEEL 14 x 1/8 x 1-5/32 (METAL)	8.75		
G-958	CUT OFF WHEEL 14 x 1/8 x 1-5/32 (MASONRY)	8.75		
G-950	EUTECTIC OIL 12 OZ. CAN	2.42		
G-951	EUTECTIC OIL 5 GAL. PAIL	81.37		
G-952	EUTECTIC OIL 55 GAL. DRUM	809.43		