

# **AT** MICROFICHE REFERENCE LIBRARY

A project of Volunteers in Asia

How to Build a House Using Self-Help Housing  
Techniques

Published by:

Office of International Affairs  
US Department of Housing and Urban Development  
Washington, DC 20410 USA

Paper copies are \$ 1.40; ask for stock number  
023-000-00276-1 when ordering. Bilingual edition  
in Spanish and English.

Available from:

Superintendent of Documents  
US Government Printing Office  
Washington, D.C. 20402

Reproduction of this microfiche document in any  
form is subject to the same restrictions as those  
of the original document.

# HOW TO BUILD A HOUSE ...USING SELF-HELP HOUSING TECHNIQUES

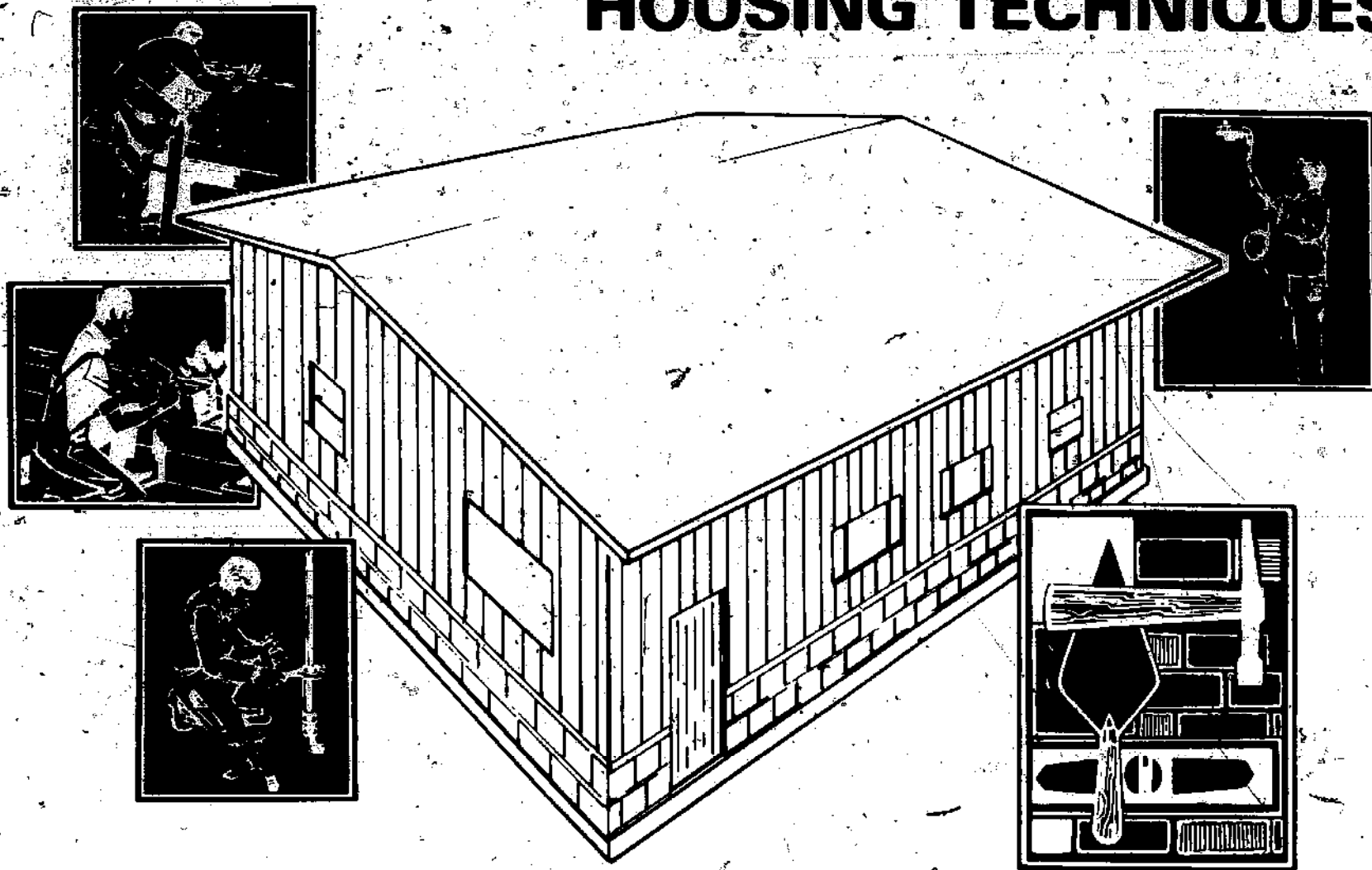

CÓMO FABRICAR UNA  
CASA... USANDO TÉCNICA  
AYUDA PROPIA

The Office of International Affairs, Department of Housing and Urban Development, has published this manual on self-help housing in the interests of the dissemination of information and knowledge of interest to U.S. domestic and other low income family needs. The techniques presented are not necessarily representative of construction in any given geographical area.

MAY 1974

---

For sale by the Superintendent of Documents, U.S. Government Printing Office  
Washington, D.C. 20402 - Price \$1.40  
Stock Number O23-000-00278-1  
Catalog Number HH 1.6/3:H81/4

You can build your own house!

This manual is designed as a graphic means of demonstrating the basic methods and techniques used in building a home, whether it be a one room cabin or a more complicated dwelling with an electric, plumbing and sewage system. It has been conceived as a basic technology handbook for use by either individuals or groups of individuals who have the goal of building, or adding to, a home of their own, and for those involved in self-help home building or home improvement projects.

Much of the graphics material has been reproduced from a manual on the same subject produced by the Inter-American Institute for Housing located in Bogotá, Colombia, in collaboration with the National University of Colombia, and the Institute for Territorial Credit, the Colombian Government agency for the development of low cost housing.

**¡Usted puede fabricar su propia casa!**

Este manual ha sido diseñado con el objeto de demostrar en forma gráfica, los métodos y técnicas básicas que se utilizan en construir una casa; sea esta del tipo de cabaña de un cuarto o un tipo de vivienda más complicada - con electricidad, instalación de agua y sistema de alcantarillado. Este manual ha sido concebido como un texto básico y tecnológico para ser utilizado ya sea individualmente o por grupos de personas cuyo objetivo sea construir su propia vivienda, o ampliar en parte su propia casa, y para aquellos involucrados en proyectos de construcciones de viviendas - por auto-construcción - o de mejoramiento de viviendas. Gran parte del material gráfico ha sido reproducido de un manual que trata sobre la misma materia presentado por el Instituto Interamericano de Vivienda ubicado en Bogotá, Colombia, en colaboración con la Universidad Nacional de Colombia, y el Instituto de Crédito Territorial, la agencia del Gobierno de Colombia encargada de programas de desarrollo de viviendas de bajo costo.

**TABLE OF CONTENTS  
EL CONTENIDO**

	Page Página	
<b>Shelter Types</b>	6	<b>Tipos de Casas</b>
Units for Rainy Climates	6	Casas en Clima Húmedo
Units on Sloped Terrain	6	Casas en Desnivel
Units for Hot Climates	6	Casas en Clima Caliente
Units Designed for Temperate Climates	7	Casas en Clima Templado
Units Designed for Hot and Humid Climates	7	Casas en Clima Caliente y Húmedo
<b>Parts of a House</b>	8	<b>Los Cuartos de una Casa</b>
Kitchen	8	La Cocina
Dining Room	8	El Comedor
Living Room	8	La Estancia
Bedroom	9	Las Camas
Bathroom	9	El Baño
<b>The Drawing</b>	10	<b>El Plan</b>
<b>Laying Out A Building</b>	11	<b>Contorno de la Construcción</b>
Squaring the Layout	11	Localización de la Casa
Layout-Levelling	12	Contorno y Nivelación
Staking Out the House	14	Apuntando y Localizando la Casa
<b>The Foundation</b>	16	<b>La Fundación</b>
Materials and Construction Methods	16	Materiales y Métodos
Equipment and Tools	16	Utensilios
<b>The Walls</b>	18	<b>Los Muros</b>
Brick or Cement Block Walls	19	Muros de Ladrillos
Village Brick Works	20	Para Hacer Ladrillos
Adobe Walls	22	Muros de Adobe
Making Adobe Bricks	23	Ladrillos de Adobe
Stone Walls	24	Muros de Piedra
Using Plaster to Finish Walls	25	Aplanado de Yeso
Windows and Doors	26	Ventanas y Puertas
Thresholds and Window Sills	28	Sardineles y Repisones

**TABLE OF CONTENTS**  
**EL CONTENIDO**

	Page Página	
<b>The Floors</b>	<b>30</b>	<b>Los Pisos</b>
Concrete	30	Cimiento
Stone Floor	31	Piso de Piedra
Flagstone Floor	31	Piso de Piedra Laja
Wood Floor	32	Piso de Madera
<b>The Roof</b>	<b>33</b>	<b>El Techo</b>
Clay Tile Roof	34	Techo con Tojas de Barro
Aluminum Roof	35	Techo de Aluminio
Asbestos Roof	36	Techo de Asbestos
Thatched Roof	38	Techo de Zacate
<b>Water Supply Systems</b>	<b>39</b>	<b>Agua Para Usos Domésticos</b>
Water Purifications	40	Filtros Domésticos
House Plumbing	40	Instalación y Drenaje
<b>Sewerage Disposal Systems</b>	<b>43</b>	<b>Alcantarillado-Letrinas</b>
Septic Tank System	44	Sistema de Alcantarillado con Tanque Séptico
Household Septic Tanks	44	Tanque Séptico para Uso Doméstico
Outhouses and Latrines	46	Letrinas
<b>Electrical Systems</b>	<b>47</b>	<b>Sistemas Eléctricos</b>
Wiring Diagrams	47	Instalación de Alambres
House Wiring Layout	48	Sistema de Alambres para una Casa
Electrical Components	50	Componentes Eléctricos

# Shelter Types

## Tipos de Casas

Units for Rainy Climates

Casas para Clima Húmedo

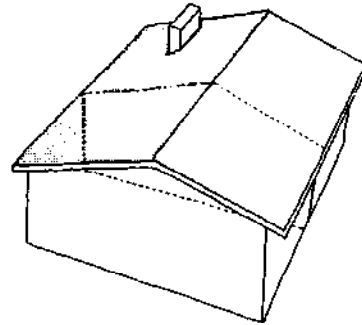

Units on Sloped Terrain

Casas en Desnivel

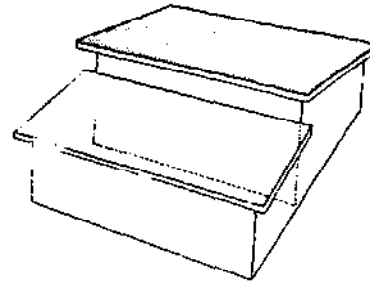

Units for Hot Climates

Casas en Clima Caliente

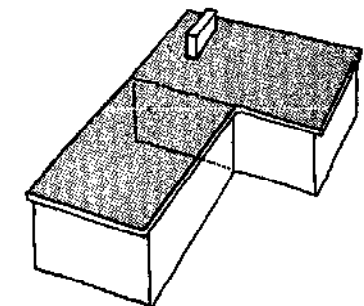
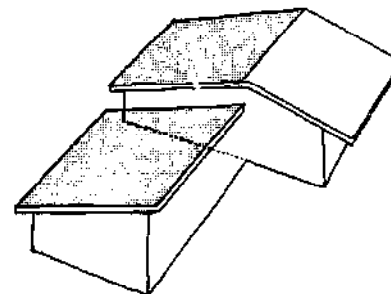
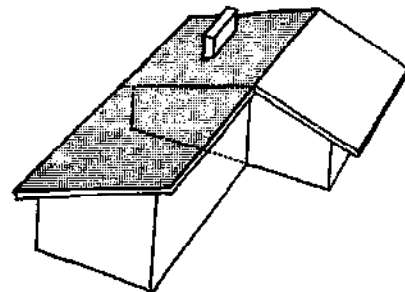
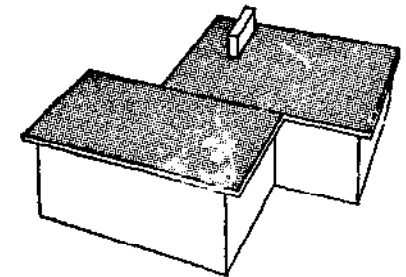
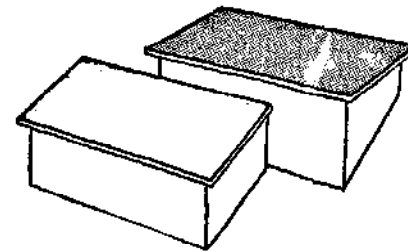
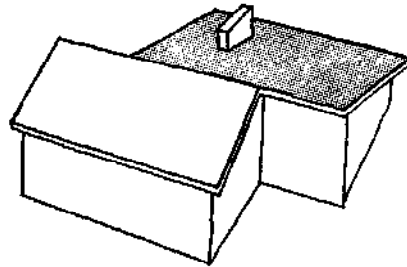
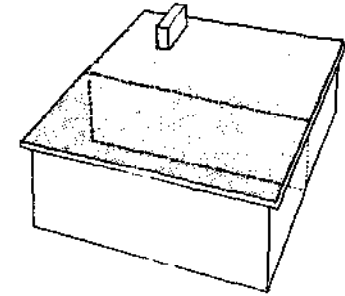



Units for Temperate Zones  
Casas en Clima Templado

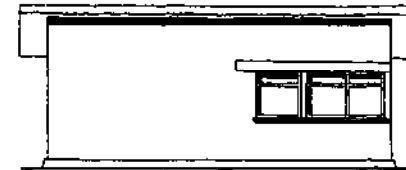
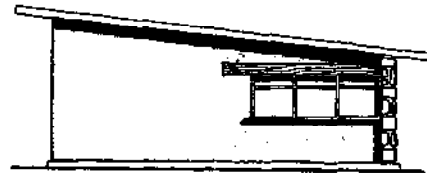
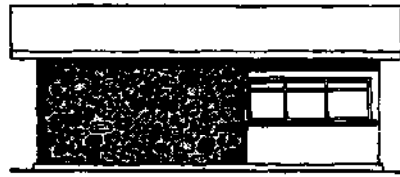

Units for Hot, Humid Zones  
Casas en Clima Caliente Húmedo

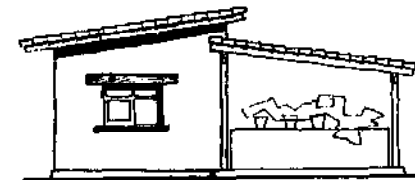
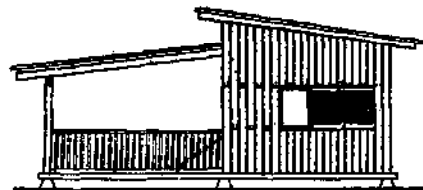
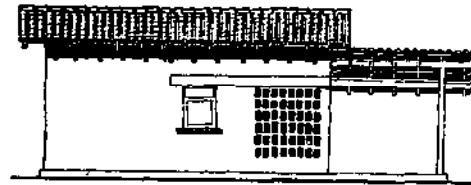

# Parts of a House

## Los Cuartos de una Casa

Kitchen  
Cocina



Shows Space Required for Equipment and Circulation  
Muestra del Espacio Necesario para Muebles y Circulación

Dining Room  
Comedor

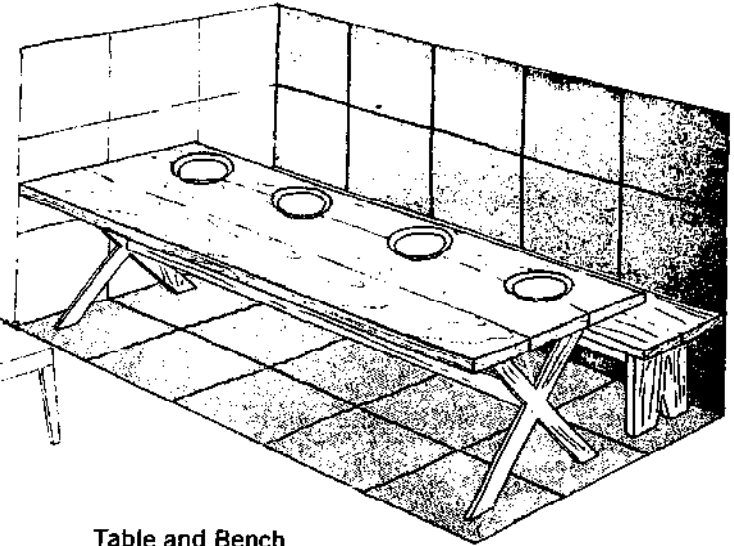
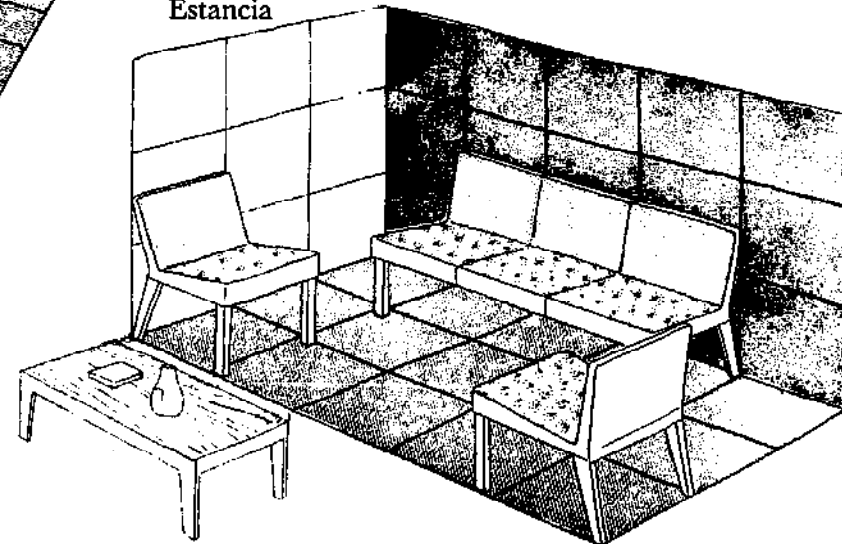

Table and Bench  
Mesa, Banco-Silla

Living Room  
Estancia



Couch and Table  
Sofá y Mesa

**Bedroom**  
**Las Camas**

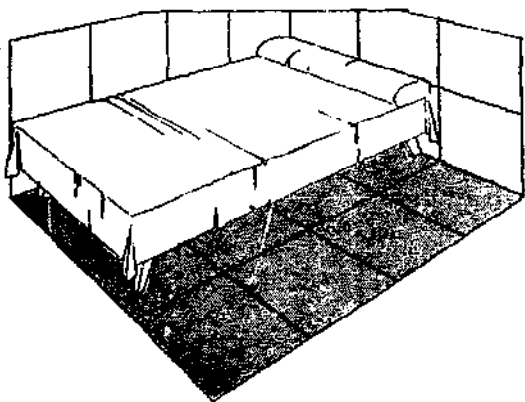

**Single Bed Space**  
**Espacio para Cama Individual**

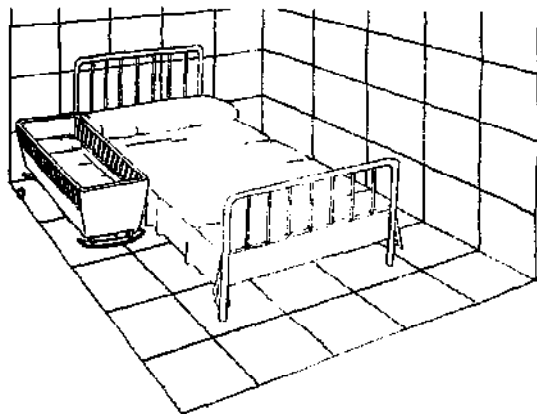

**Bed with Crib**  
**Espacio para Cama Mediana y Cuna**

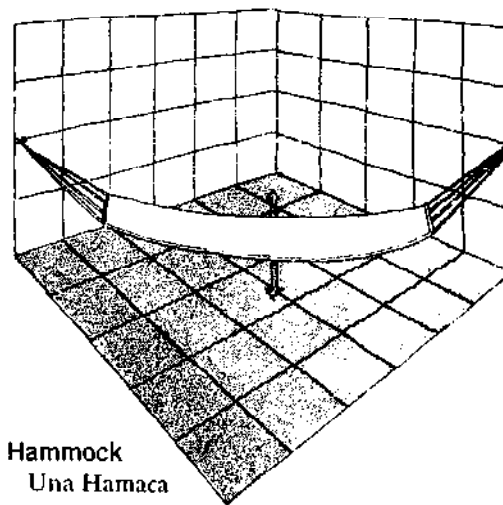

**Hammock**  
**Una Hamaca**

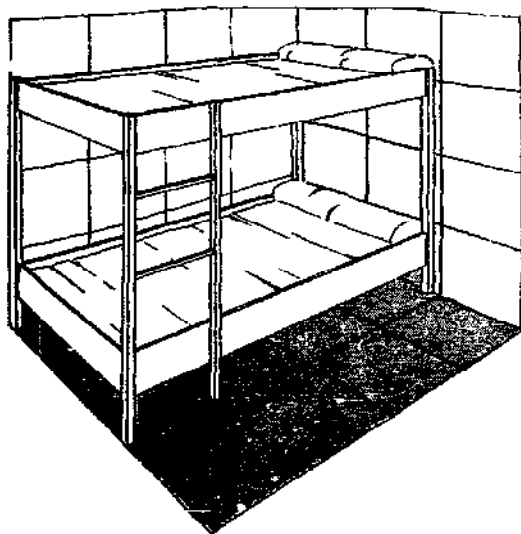

**Bunks**  
**Espacio para Dos Literas**

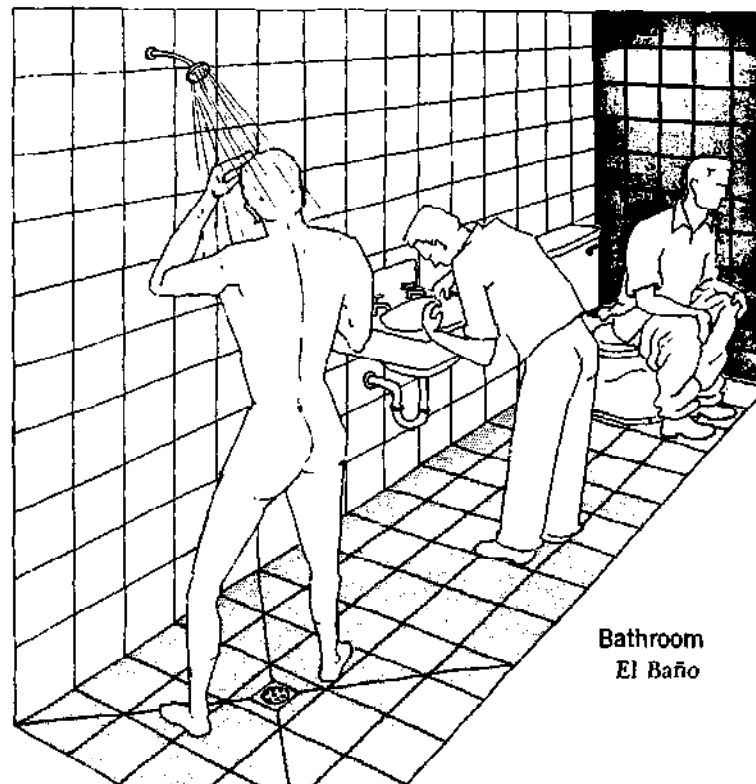

**Bathroom**  
**El Baño**

# The Drawing El Plan

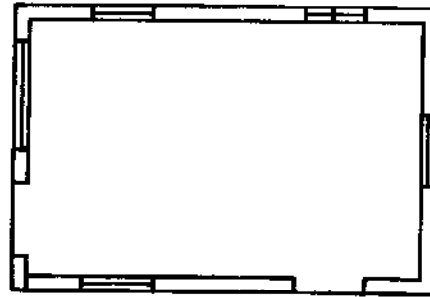
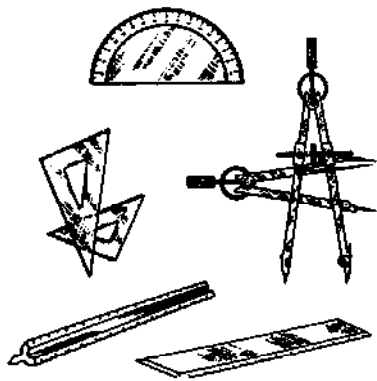
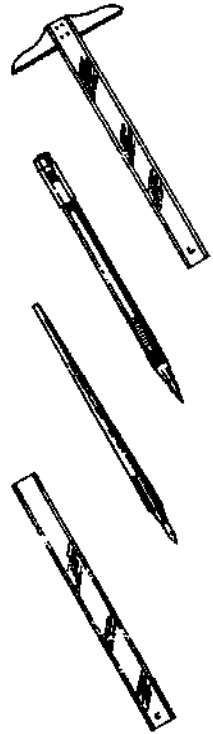

View from Above  
Vista de Arriba

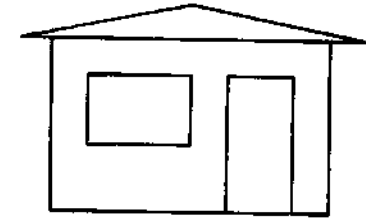

Side View (Left)  
Vista de Izquierda

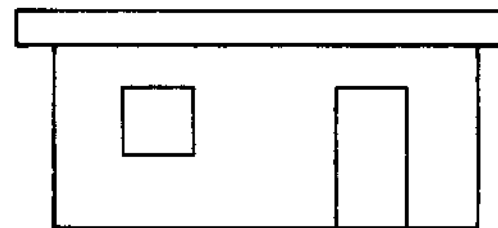

Front View  
Vista de Enfrente

# Laying Out a Building

## Contorno de la Construcción

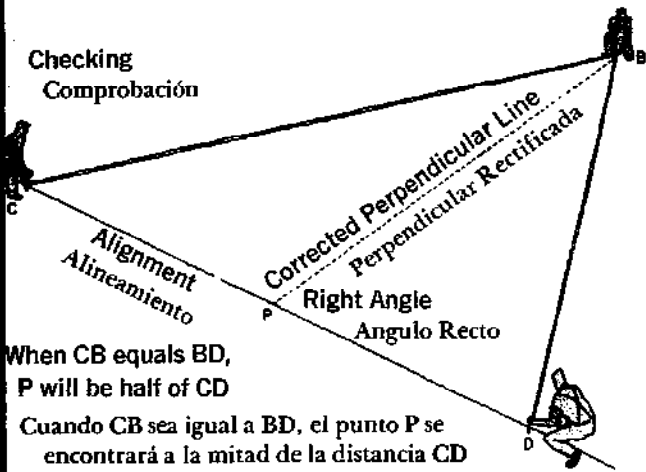

## Squaring the Layout

### Localización de la Casa

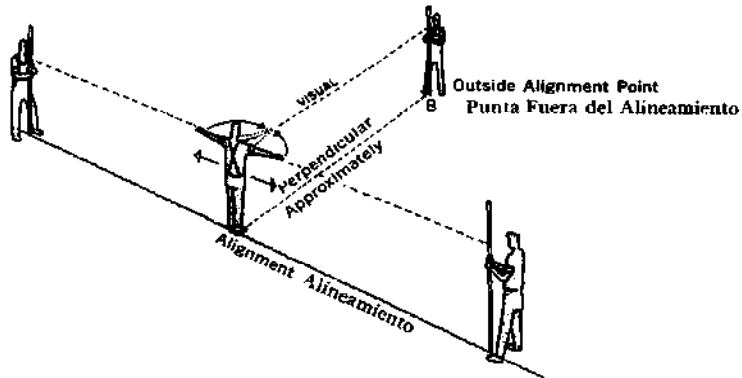

## Squaring Off the House

### Alineamientos

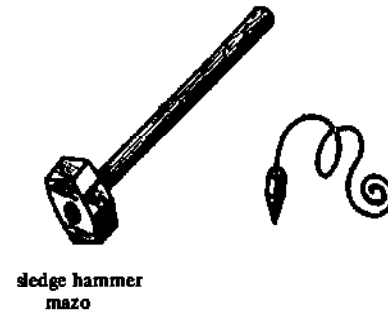
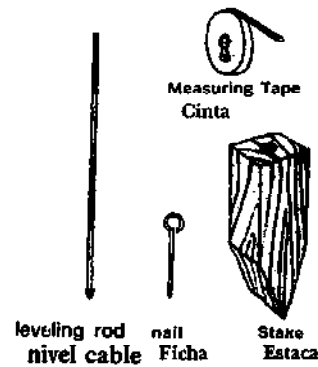
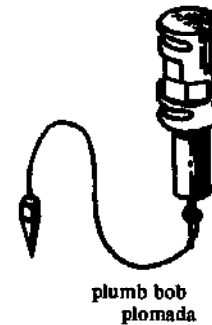
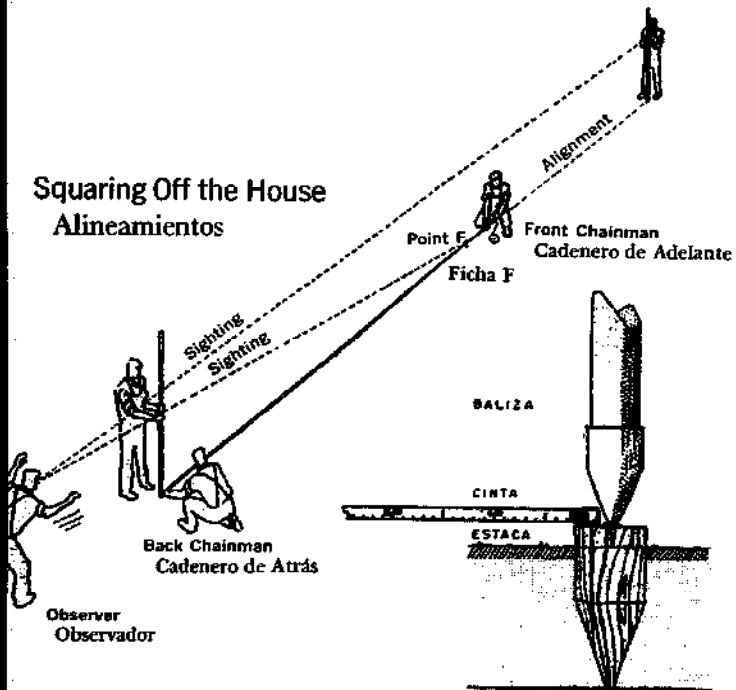

# Layout and Levelling Contorno y Nivelación

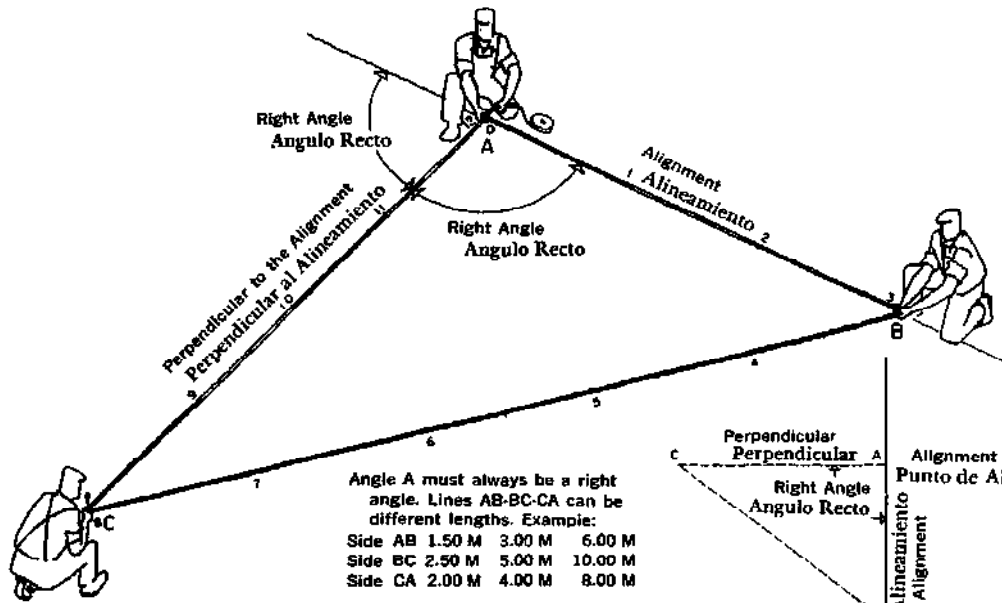

Angle A must always be a right angle. Lines AB-BC-CA can be different lengths. Example:  
 Side AB 1.50 M 3.00 M 6.00 M  
 Side BC 2.50 M 5.00 M 10.00 M  
 Side CA 2.00 M 4.00 M 8.00 M

El ángulo en A siempre será recto. Las distancias AB-BC-CA pueden variar según convenga. Ejemplo:  
 Lado AB 1.50 M 3.00 M 6.00 M  
 Lado BC 2.50 M 5.00 M 10.00 M  
 Lado CA 2.00 M 4.00 M 8.00 M

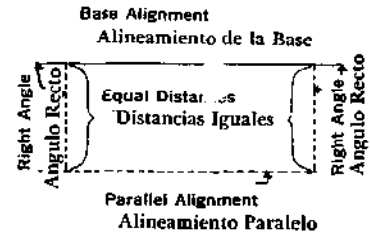
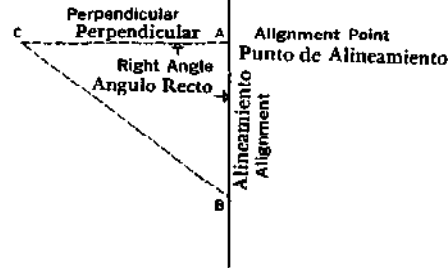

## Tools Utensilios

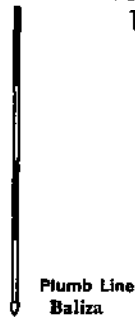

# Establishing a level between two points

## Nivelación entre dos puntos

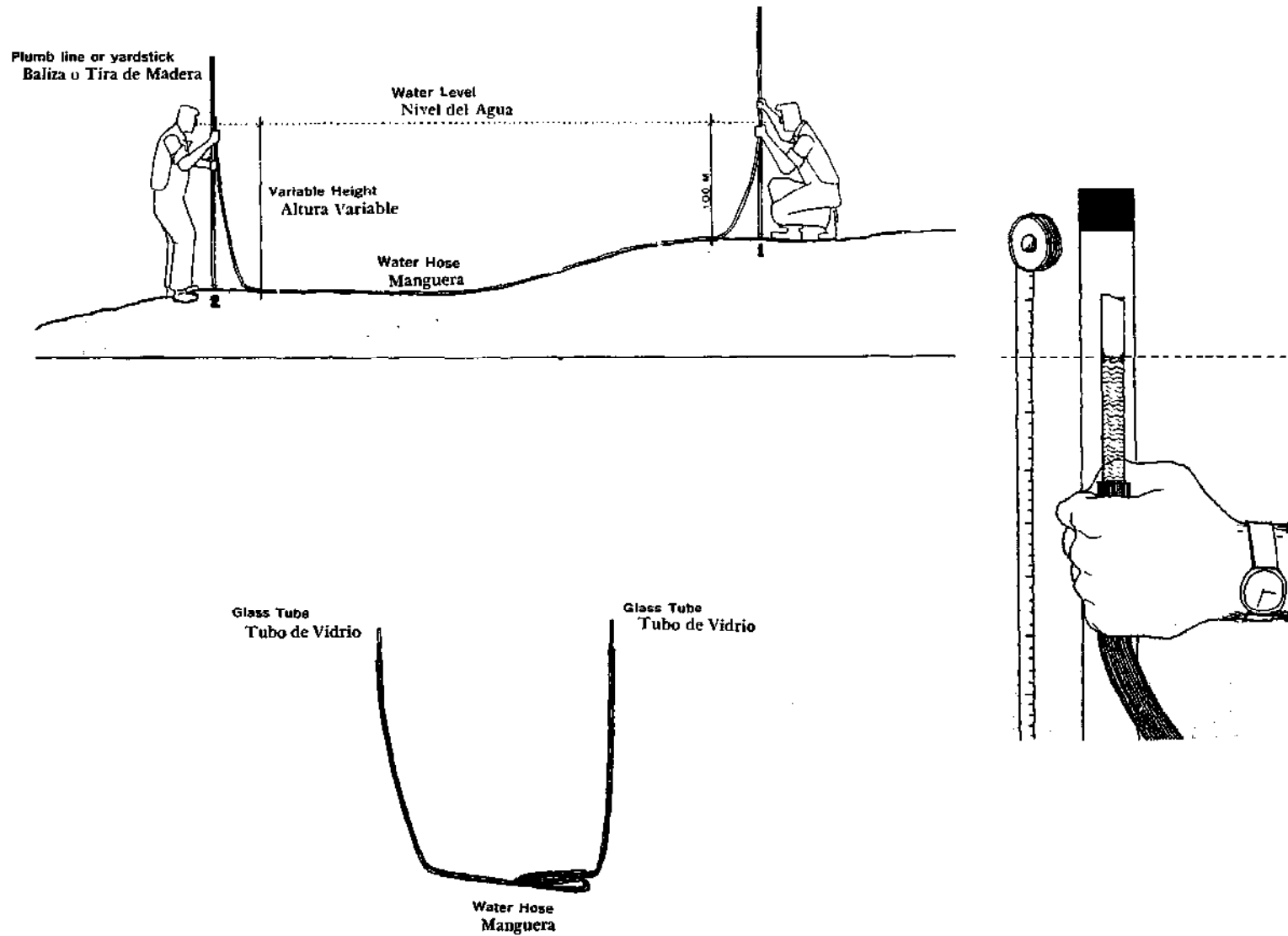

**Staking and Laying Out the House**  
**Apuntando y Localizando la Casa**

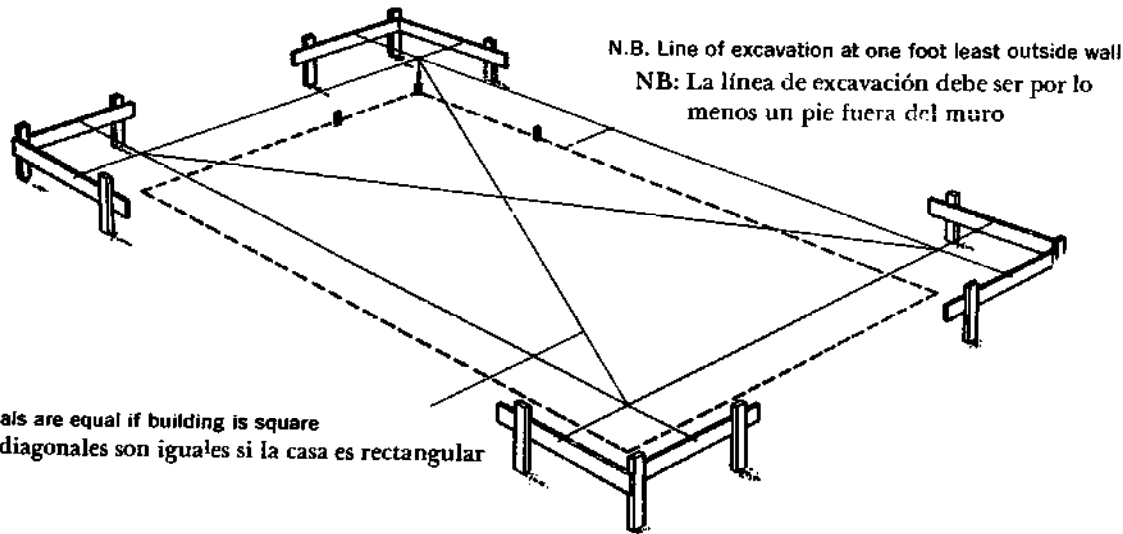

Diagonals are equal if building is square  
 Los diagonales son iguales si la casa es rectangular

Outside line of foundation wall  
 Línea externa de la fundación

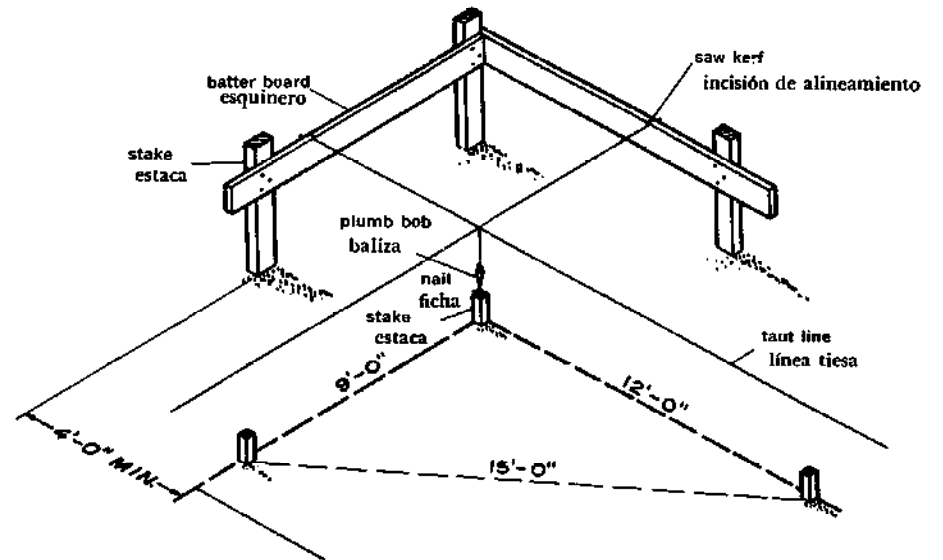



Establishing corners for excavation and footings

Estableciendo los rincones para la excavación y las bases

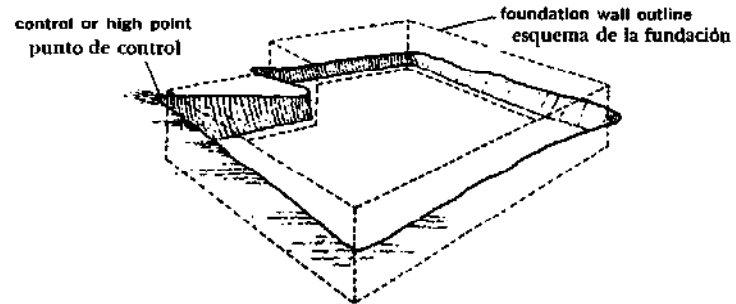
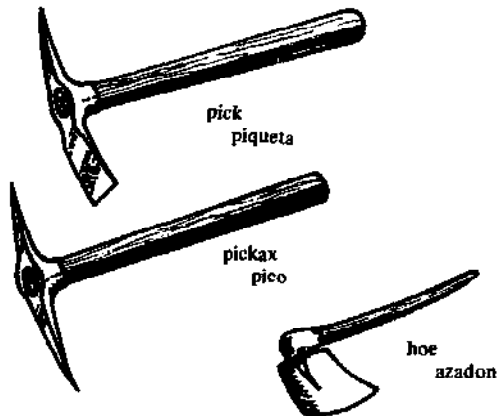
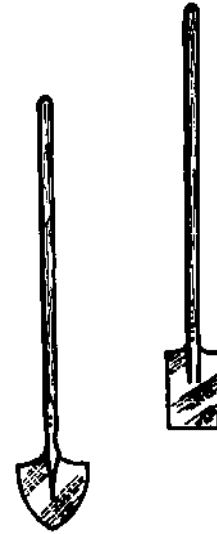
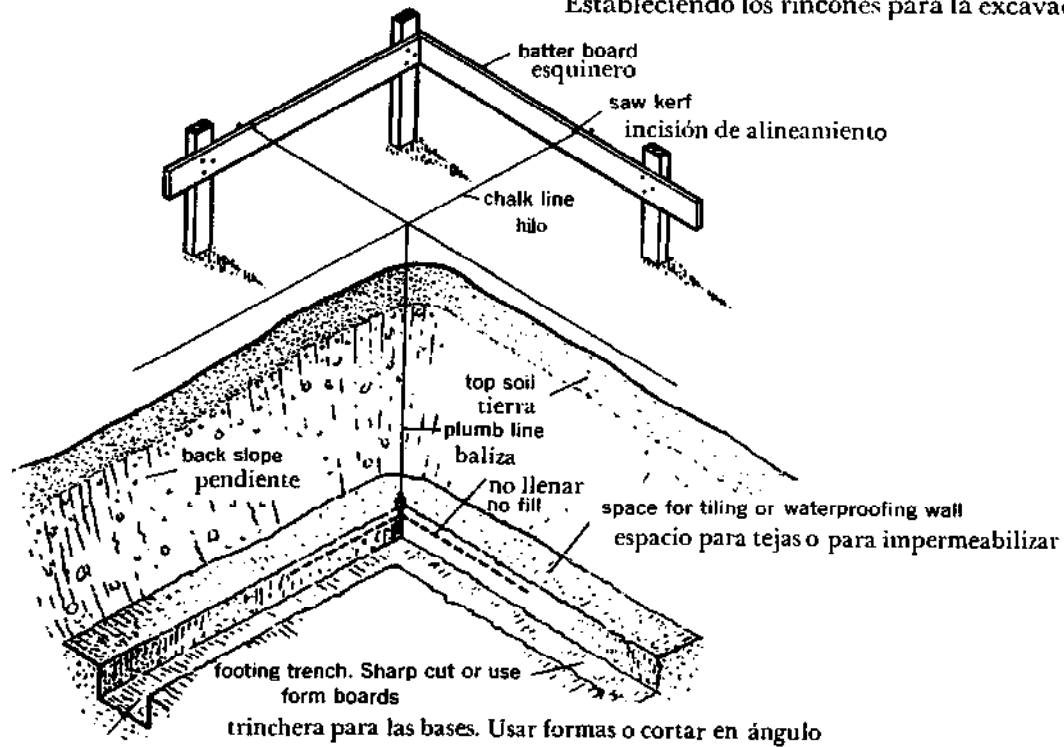

Establishing Depth of Excavation

Estableciendo la profundidad de la excavación

# The Foundation La Fundacion

foundation wall made up of solid concrete blocks  
muro contruido de bloques  
de cimiento 20 cm anchos

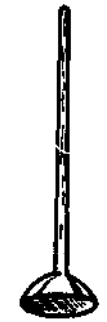
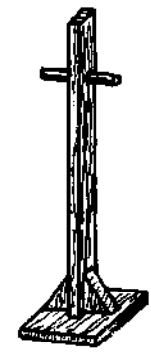
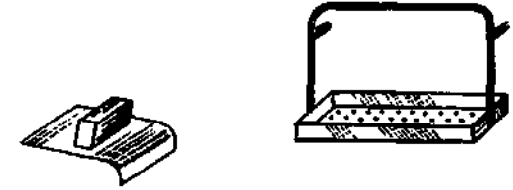
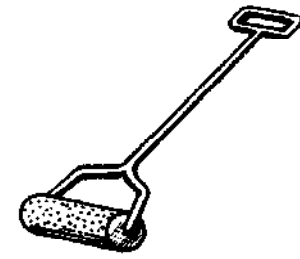
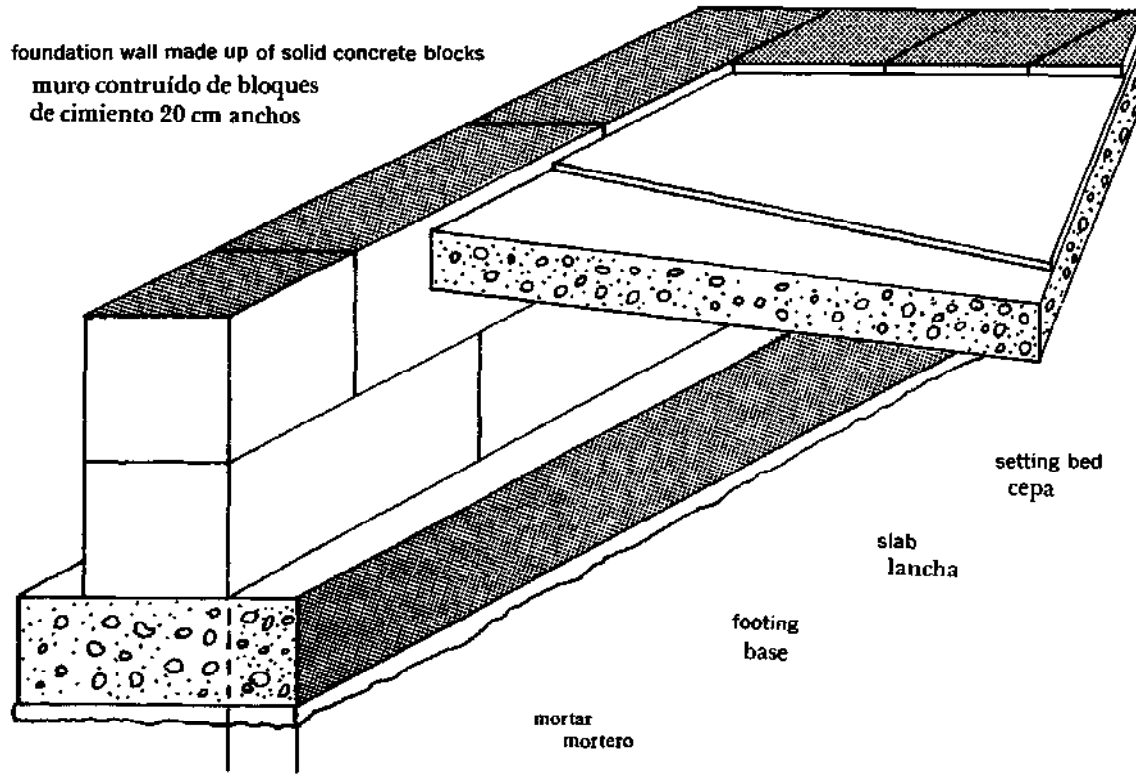

sloped ground  
terreno inclinado

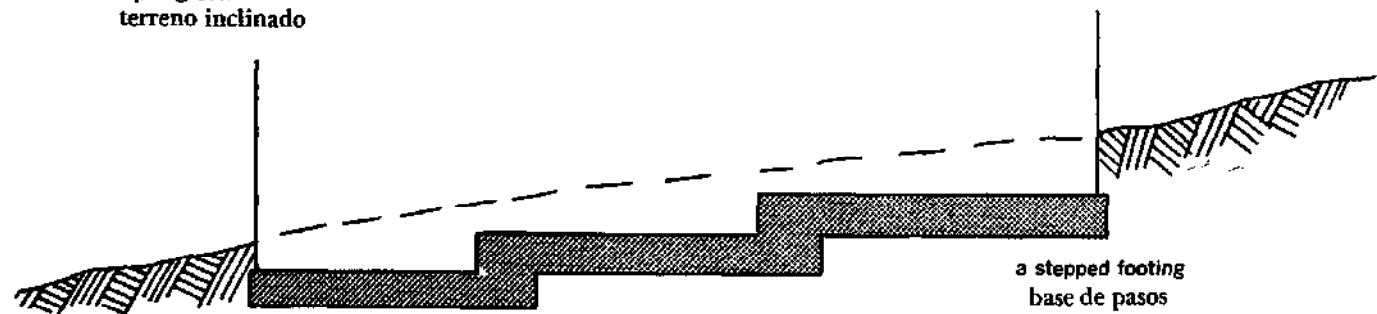

Reinforced Concrete  
Cimientos de Concreto Armado

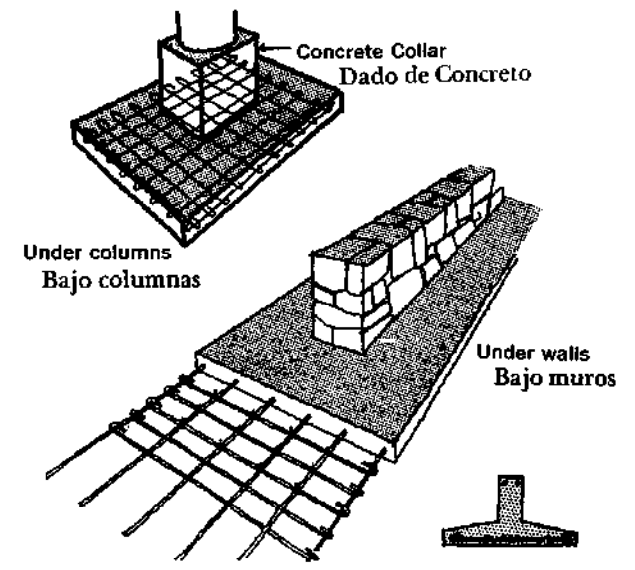
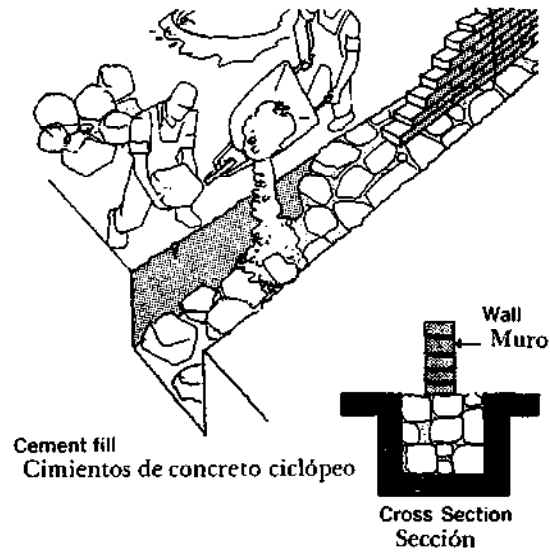
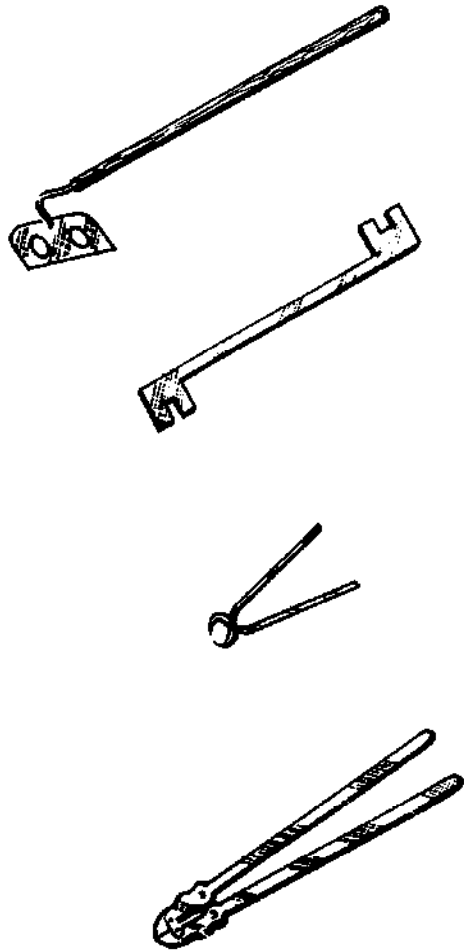

# The Walls

## Los Muros

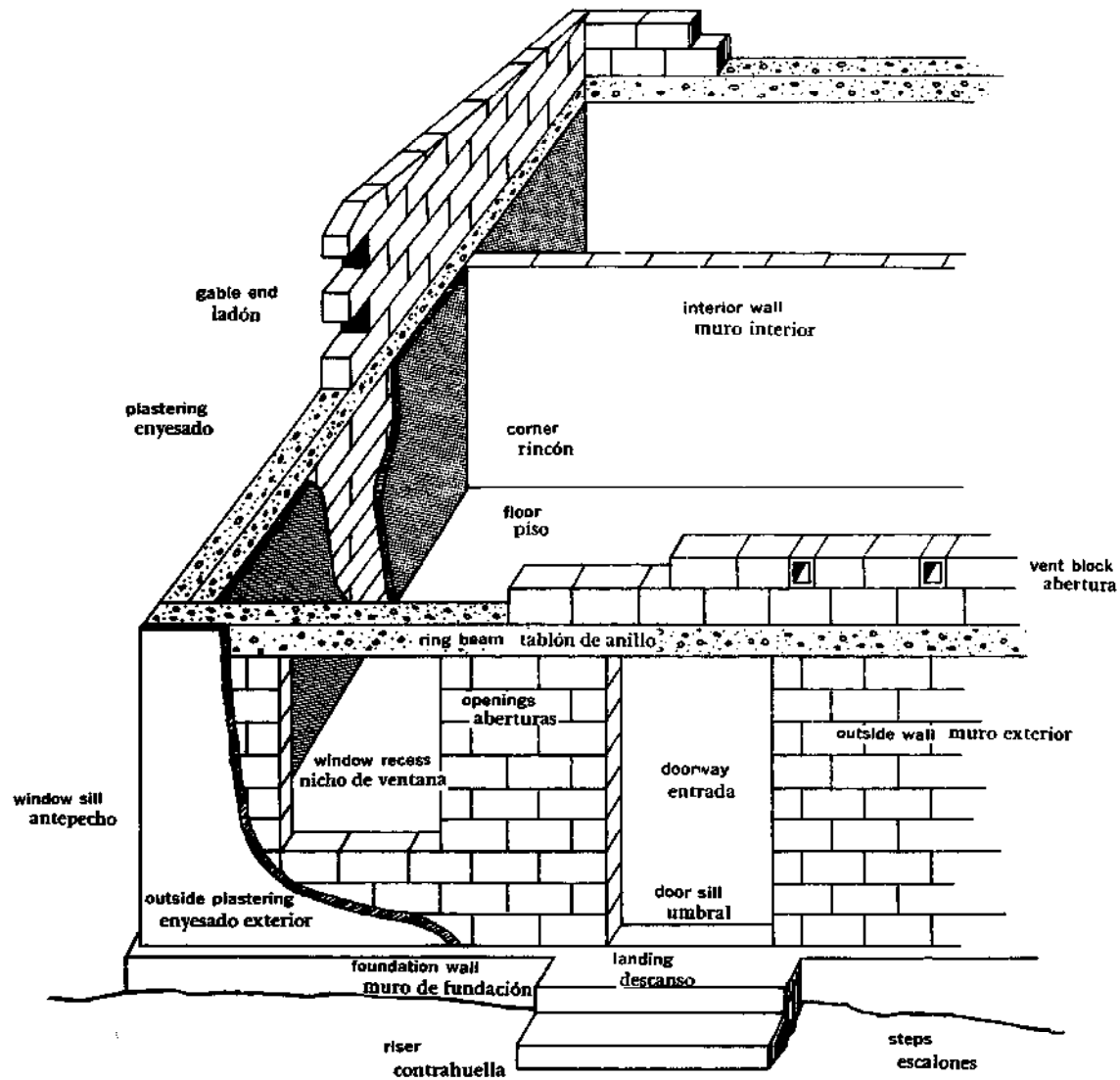

**Brick or Cement Block Walls**  
**Muros de Ladrillo**

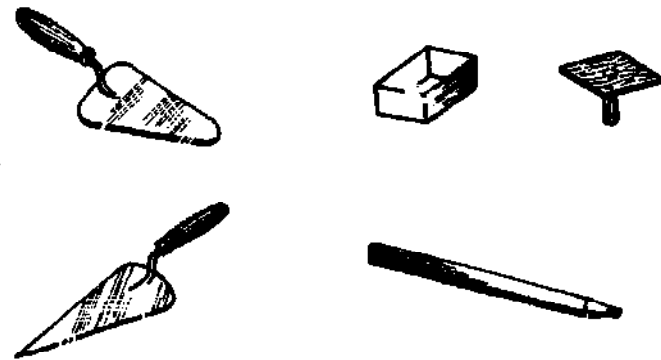
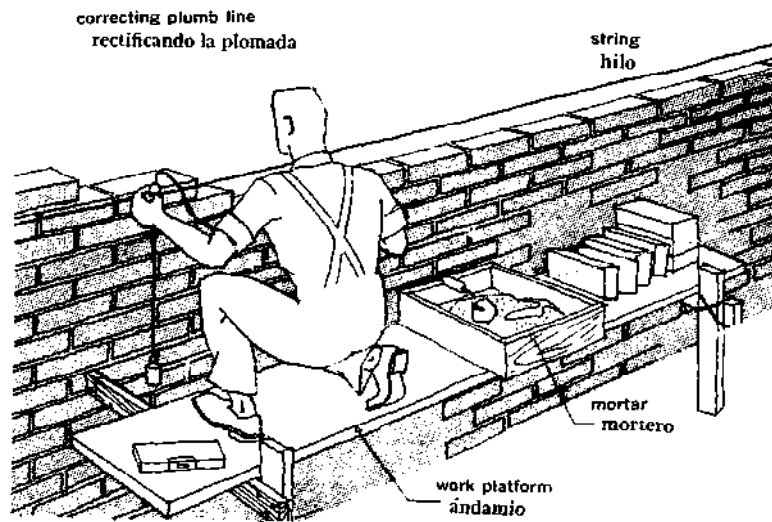

mixer and mortar  
mezclero y mortero

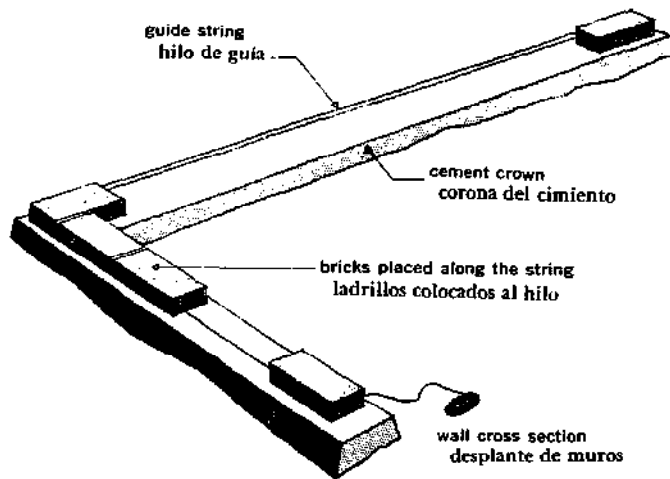
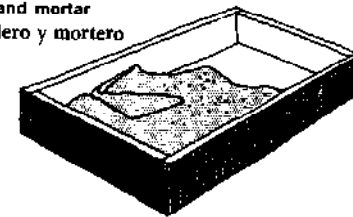

metric tape  
cinta métrica

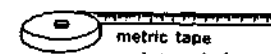

level  
nivel

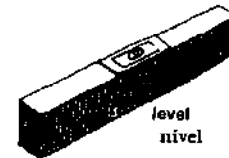

plumb bob  
plomada



string  
hilo



trowel  
cuchara



Village Brick Works  
Para Hacer Ladrillos

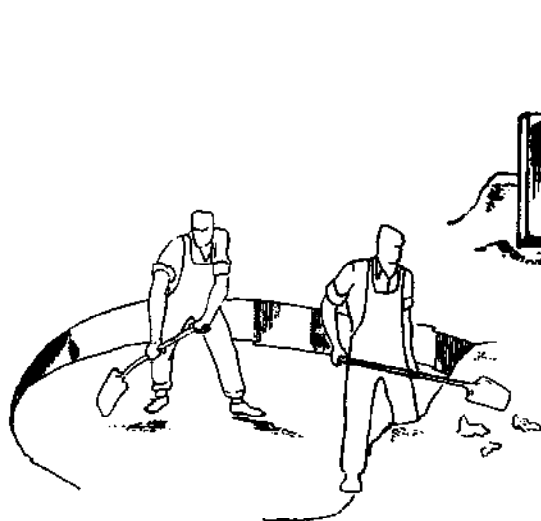

Remove large stones from clay or sieve through fine mesh.

Eliminar las piedras grandes del barro, o pasar por cedazo fino.



If not moist, add water. Cover to retard evaporation. To mold, place 4 inches of clay in level, lined pit. Tramp thoroughly, turn and tramp again.



Si el barro es seco, añada agua. Cubrir para atrasar evaporación. Para moldar, pon 4" de barro en hoyo nivelado y forrado con masonería. Mezcle completamente, voltee y mezcle de nuevo.

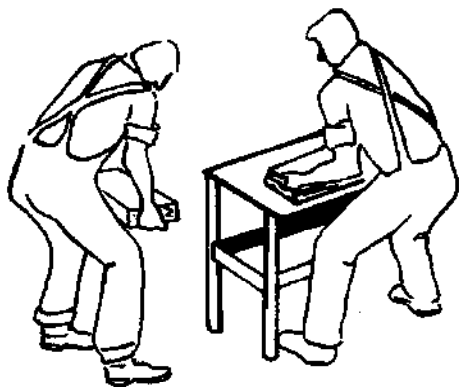

On metal covered table, form bricks in wood mold. Then take off mold and place bricks in drying area. Stack bricks a finger apart on level platform and cover to slow drying. In 3 to 7 days (depending on drying speed), stack to make room for new production. Cover again to complete drying before firing.

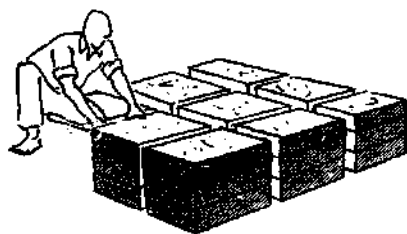
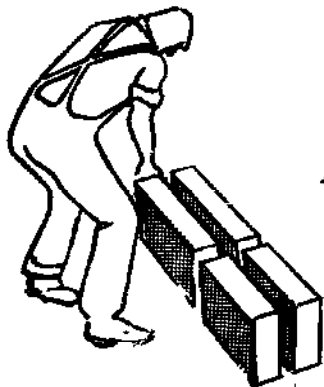

Sobre una mesa cubierta de metal, forme ladrillos en un molde de madera. Después saque el molde, y ponga los ladrillos hechos en otra área para secar. Amontone los ladrillos un dedo separado sobre un tablado nivelado y cubra para atrasar el secamiento. Entre 3 a 7 días (dependiendo de la rapidez del secamiento) amontone los ladrillos para dejar espacio para nueva producción. Cubre otra vez para completar el secamiento antes de ponerlos al fuego.

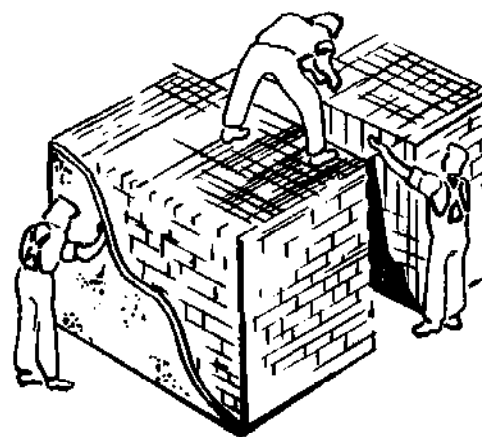

To fire, stack bricks a finger width apart, alternating headers and stretchers, providing minimum touching area and greatest stability. Stack bricks to form rough vaulted tunnels in the kiln. Cover outside of kiln with heavy layers of clay and previously fired bricks (when possible).

Para ponerlos al fuego, amontone los ladrillos un dedo separado, alternando a tizón o al hilo dejando el menos espacio posible entre ellos, y formando rudos arqueados túneles en el horno. Cubre el horno con capas espesas de barro y ladrillos previamente cocinados (cuando posible).

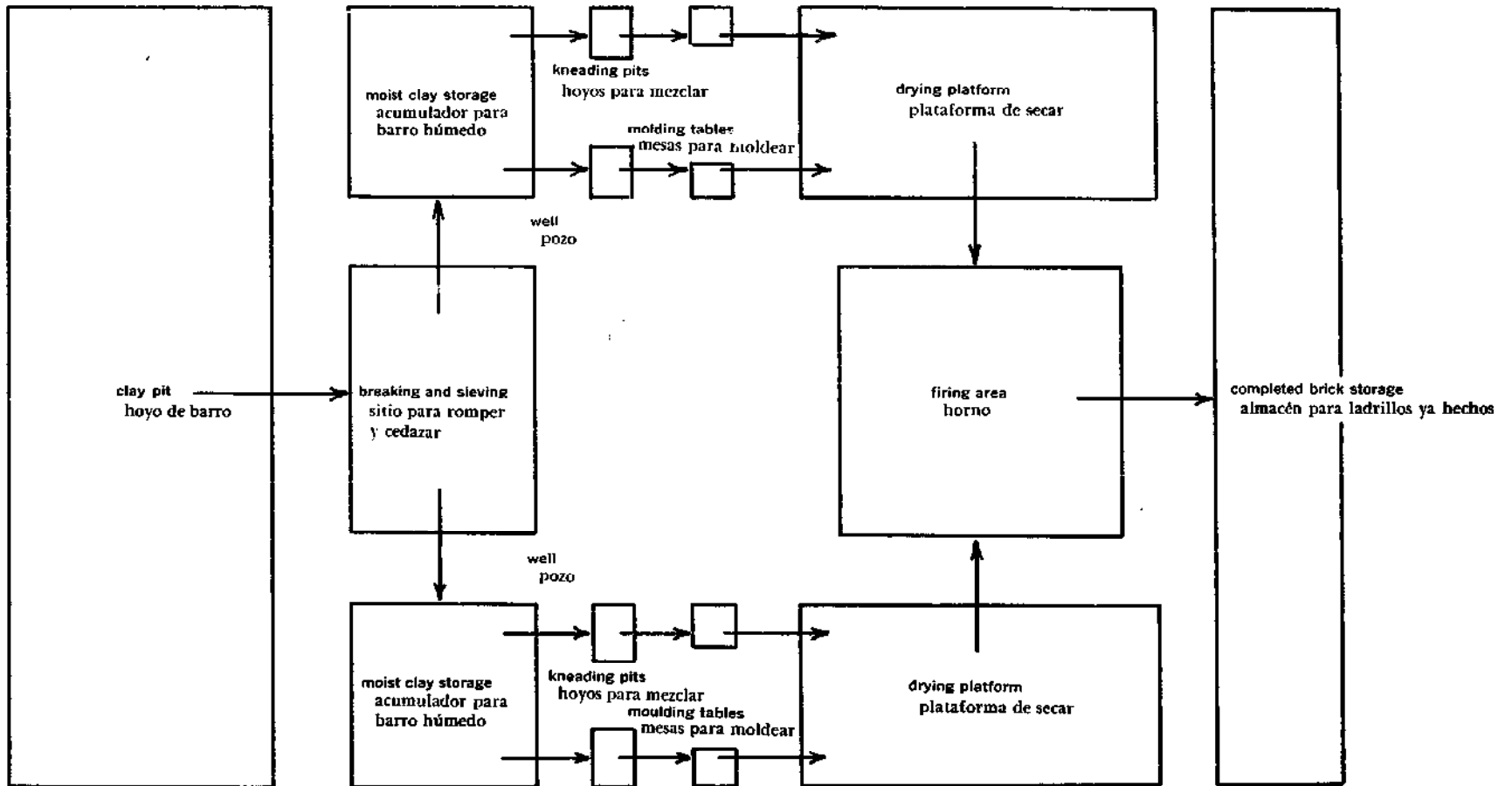

Work Sequence To Make Bricks  
Lugares de Trabajo Para Hacer Ladrillos

# Adobe Walls Muros de Adobe

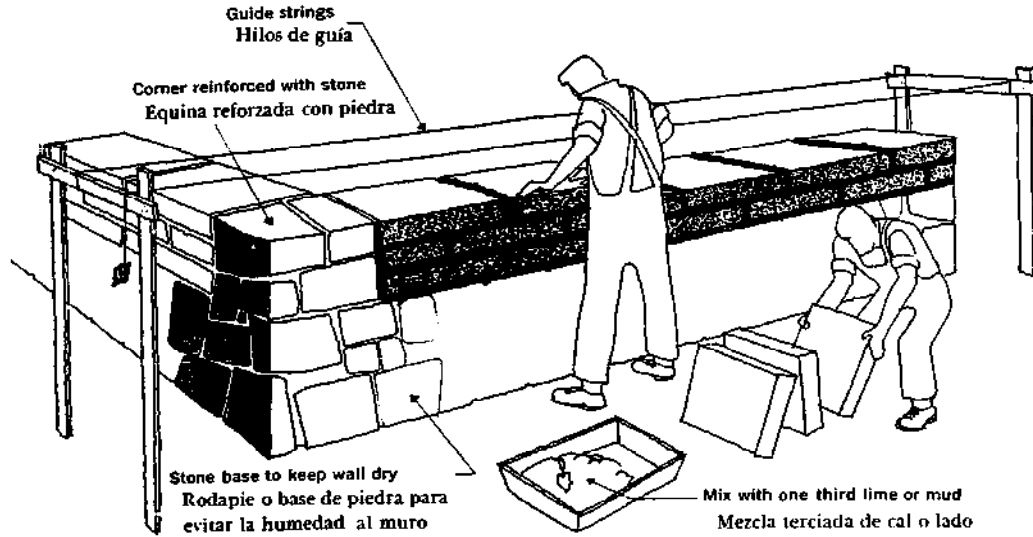

Cover layer made up of one third lime or kneaded mud  
Capa de mezcla de cal terciada o lodo amasado

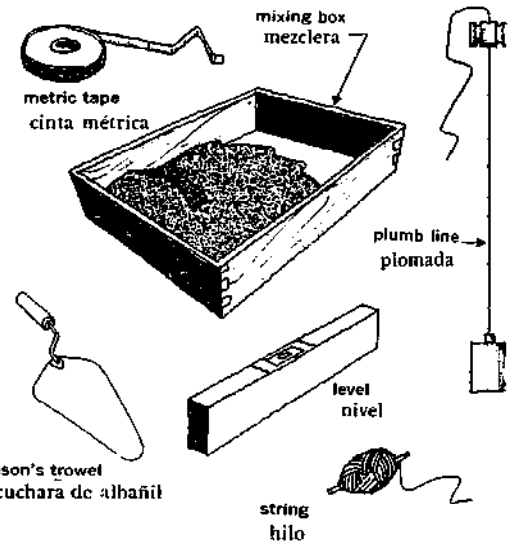
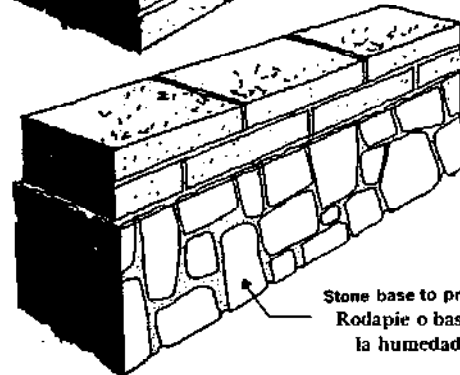
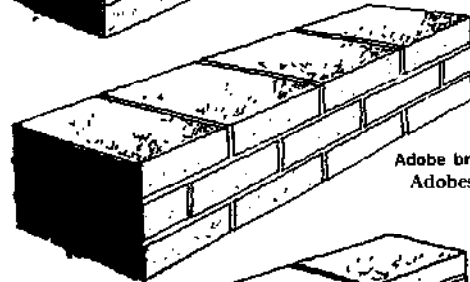
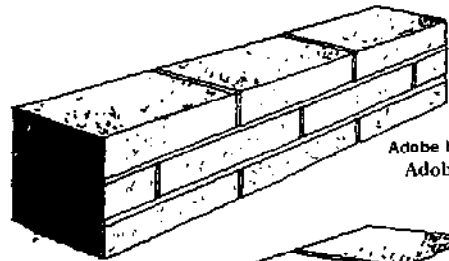
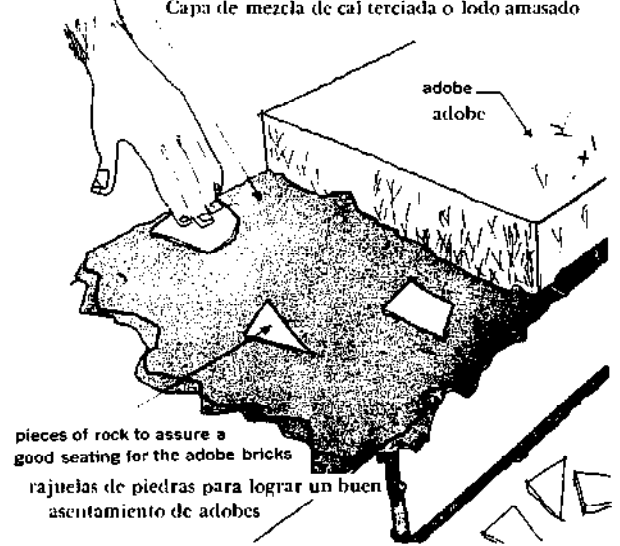



**Making Adobe Bricks**  
**Ladrillos de Adobe**

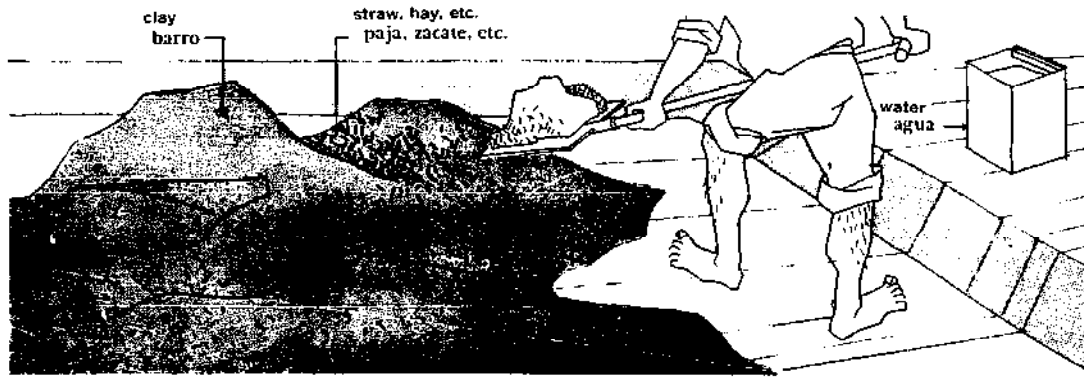

wood mold  
 molde de madera o "garrilla"

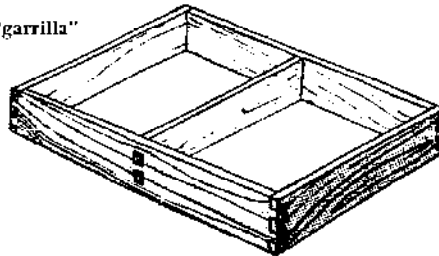

presionando el lodo  
 pressing the clay (mud) into the form

molding adobe bricks is done with wood forms, as shown, having the following dimensions: 40 cms long; 30 cms wide; 8 cms deep. Another good size is: 40 cms long; 20 cms wide; 8 cms deep.

el moldeo de los adobes se hace en formas de madera, como el de la figura, con las siguientes dimensiones: 40 cms largo; 30 cms ancho; 8 cms alto. Otro tamaño muy conveniente es: 40 cms largo; 20 cms ancho; 8 cms alto.

supply of recently made adobe bricks  
 reposo de adobes recién hechos

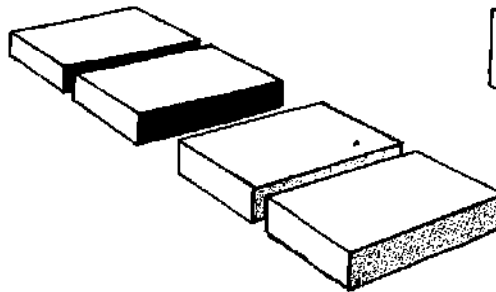

pieces in drying position  
 colocación de las piezas para secar

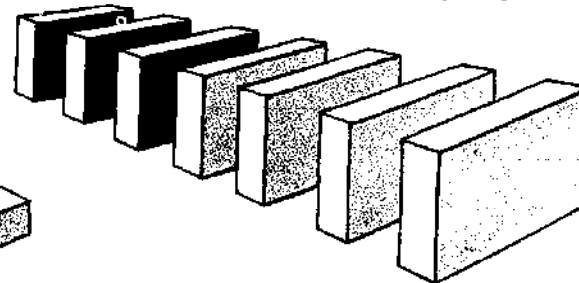

Stone Walls  
Muros de Madera

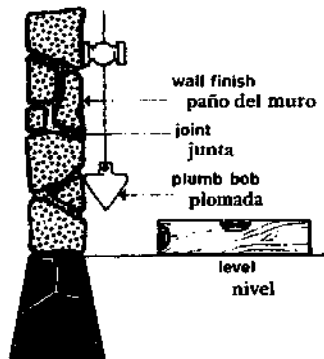
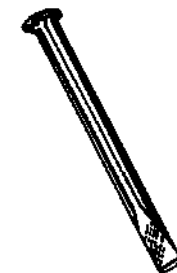
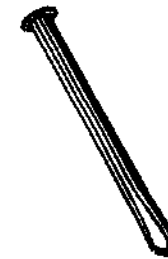
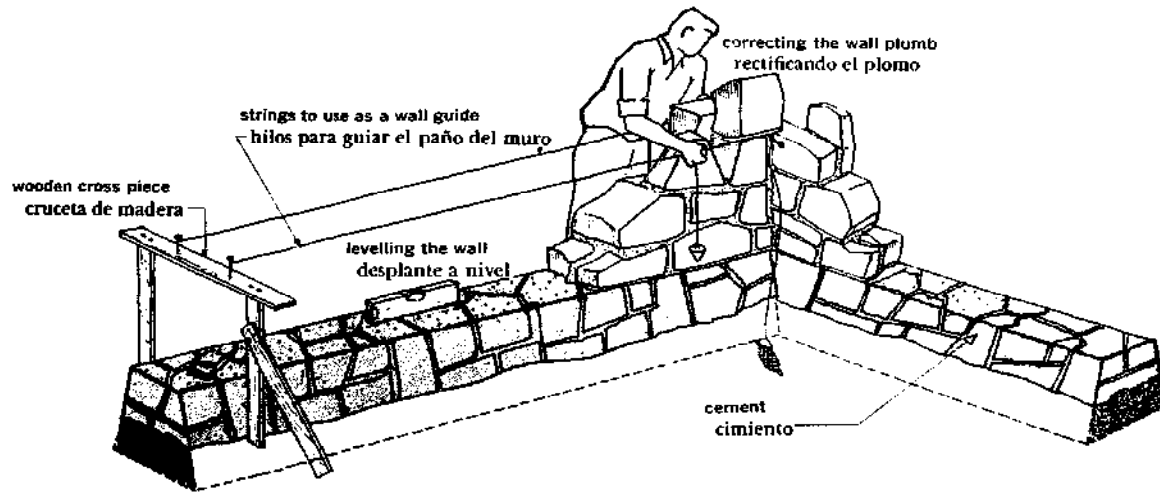

joints should alternate vertically and horizontally: correct  
juntas cuatrapeadas: correcto

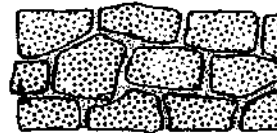

joints incorrectly laid  
juntas no cuatrapeadas: incorrecto

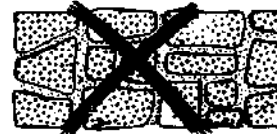

Using Plaster to Finish the Walls  
Aplanado de Yeso

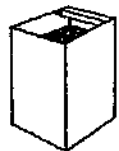
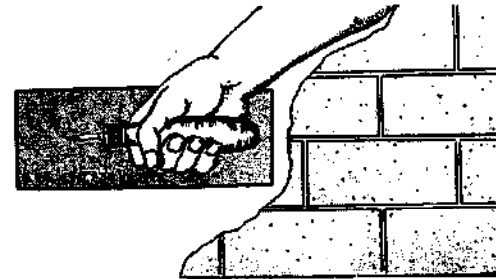
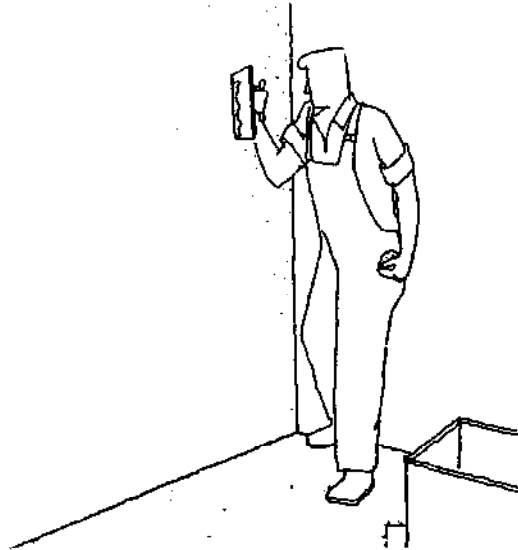
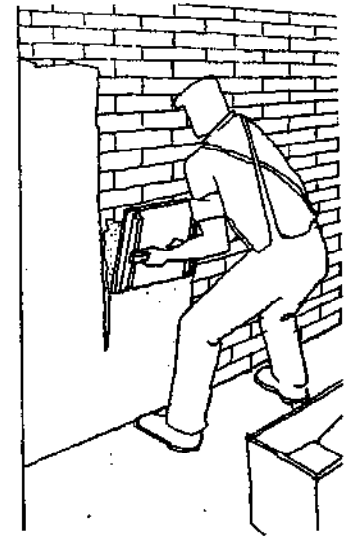
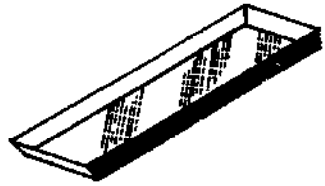

30 liters water  
30 lts. agua

Proportions:  
Proporción:



40 kgs. plaster  
40 kgs. yeso



2 kgs. cement  
2 kgs. cemento

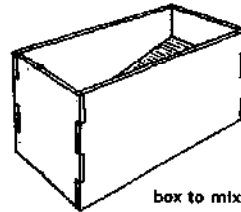

box to mix plaster  
yesera o artesa

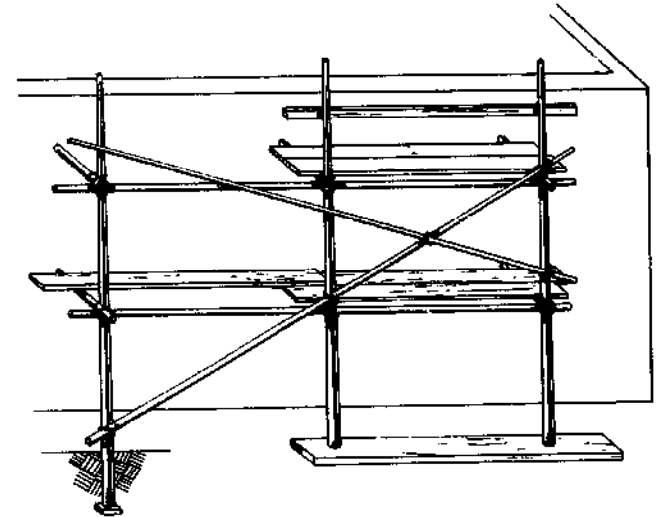

Windows (wood and metal)

Ventanas (de madera y hierro)

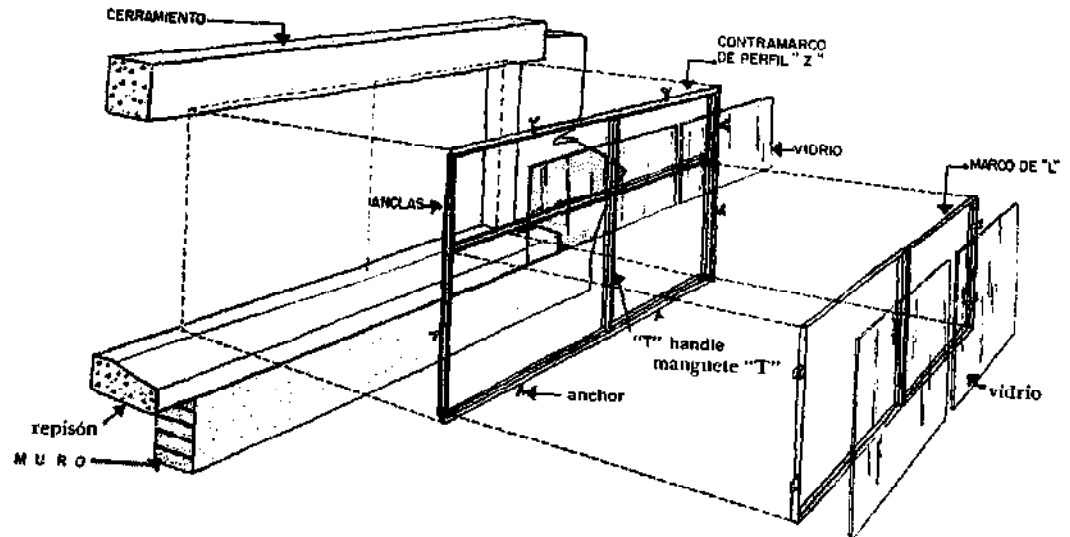
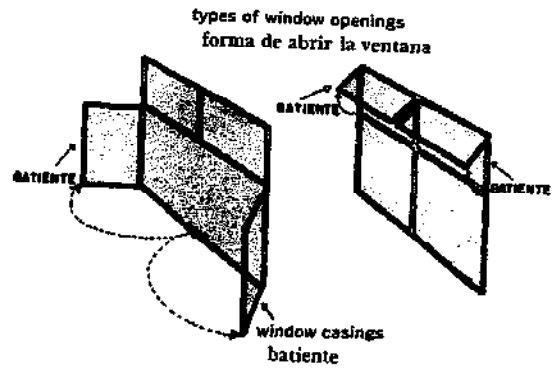
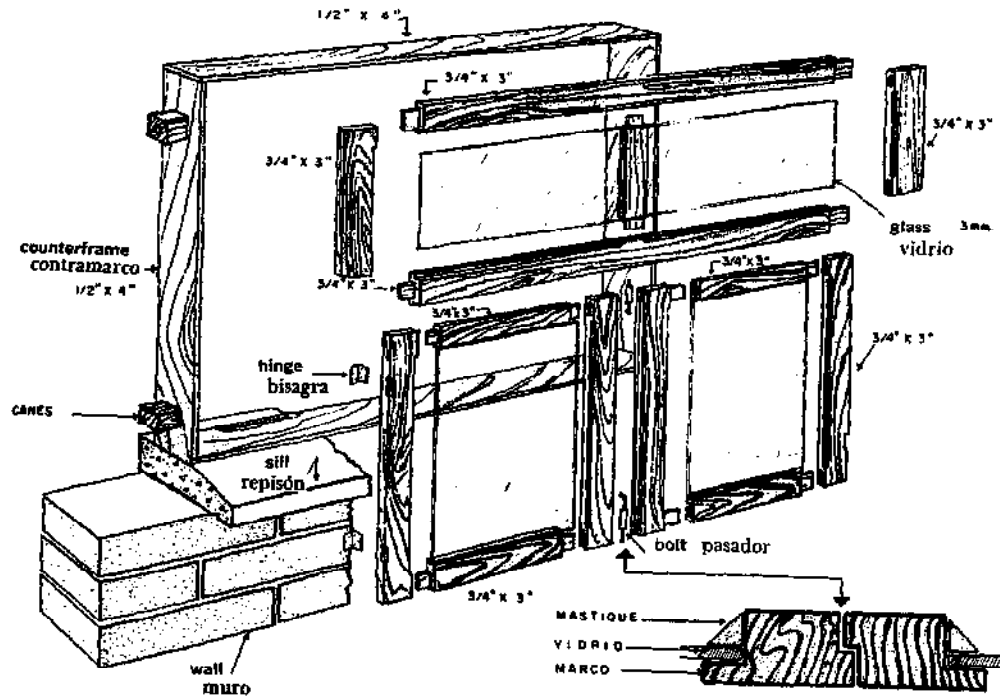

Doors  
Puertas

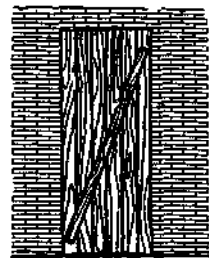
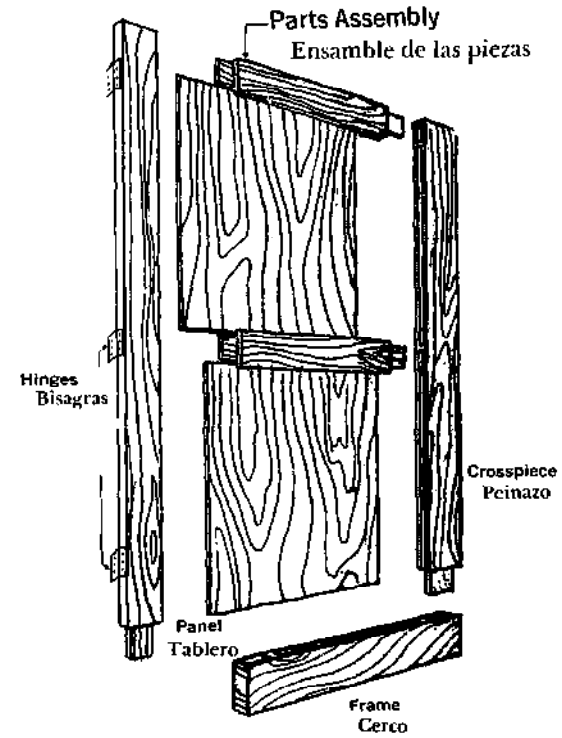
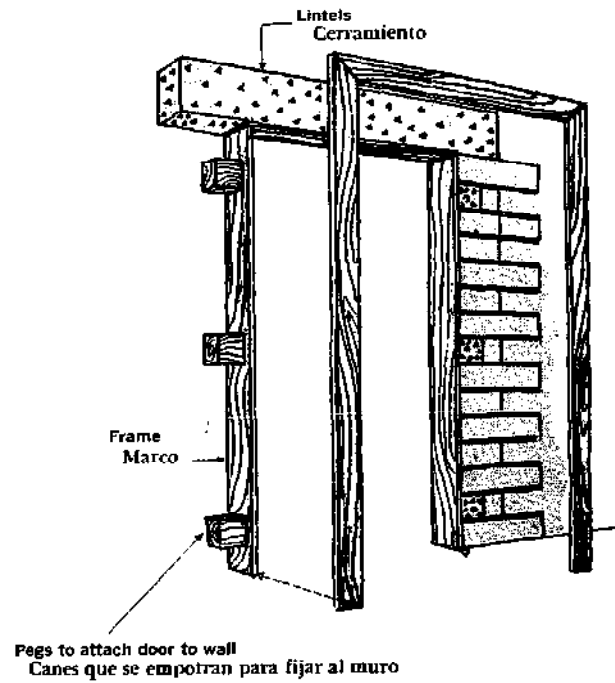

Plank Door  
Puerta de Tablones

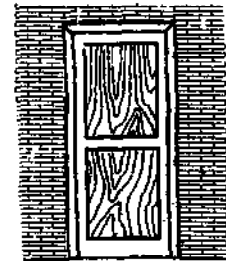

Panel door  
Puerta entablada

Thresholds and Window Sills  
Sardineles y Repisones

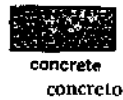
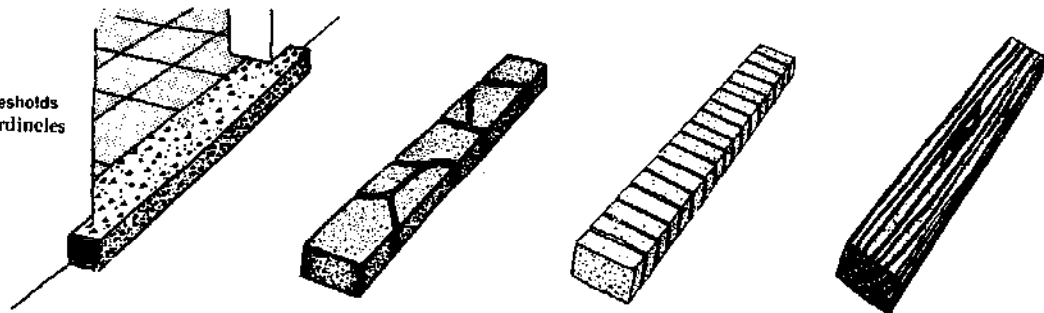
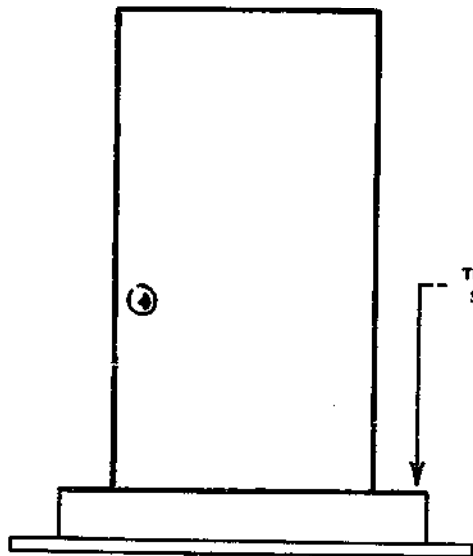
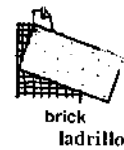
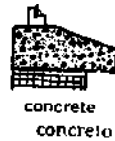
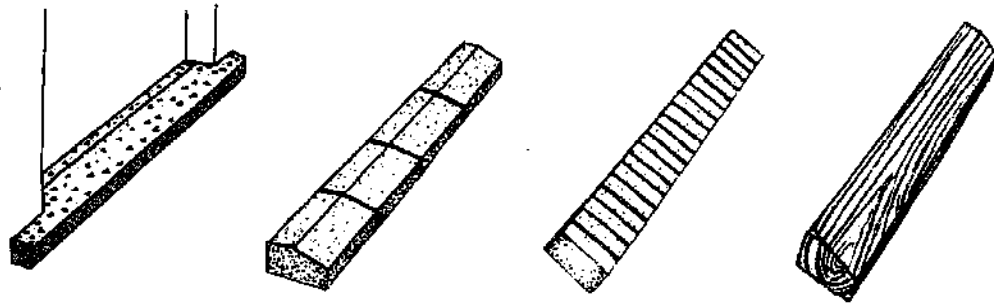
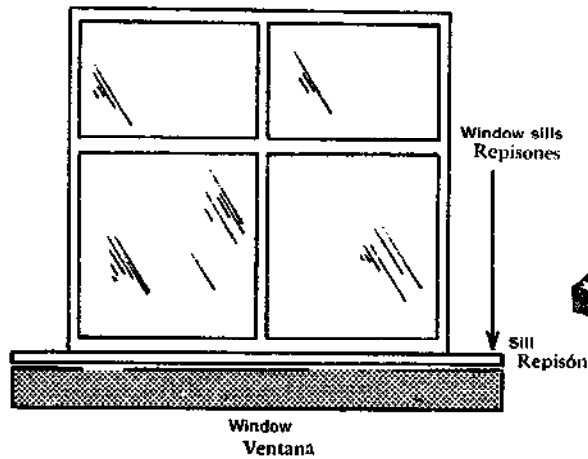

# Windows and Doors

## Ventanas y Puertas

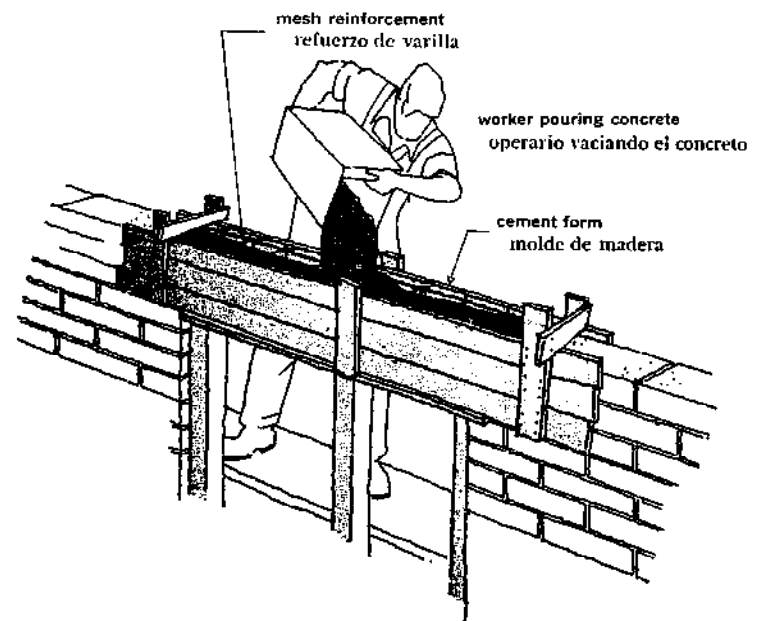
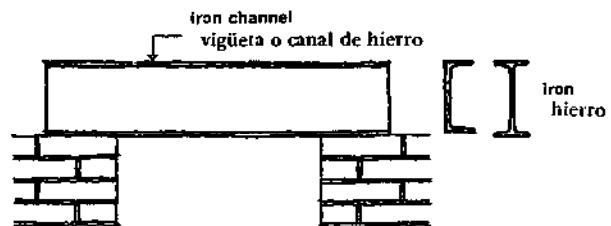
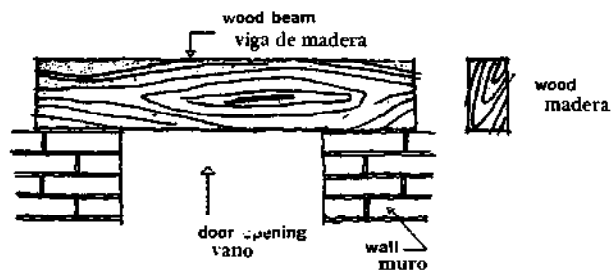
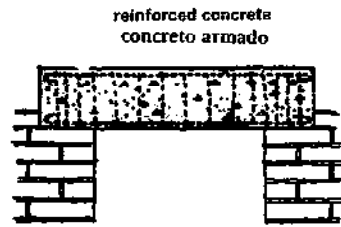

# The Floors Los Pisos

## Concrete Cimiento

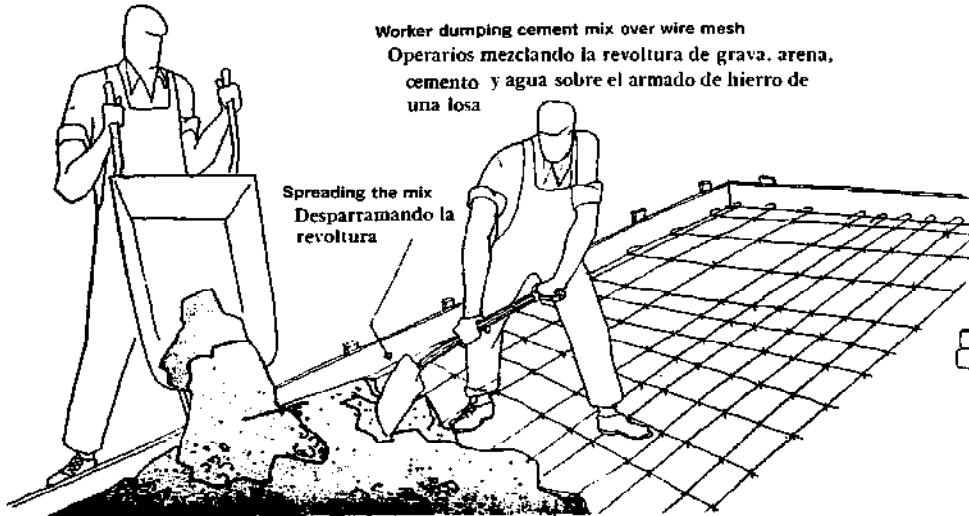

## Mixing Concrete Mezclando el cimiento

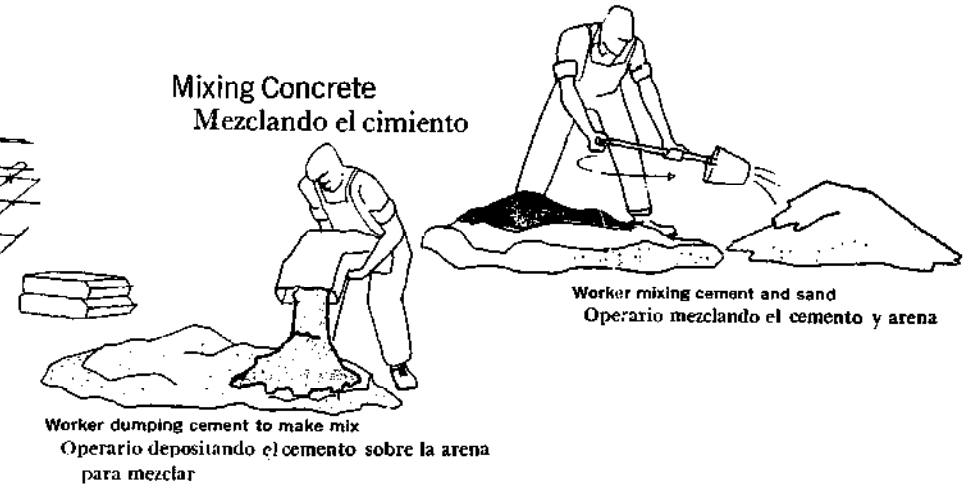

simple concrete floor over tamped earth  
piso de cemento sobre suelo apisonado

worker tamping ground  
operario apisonando

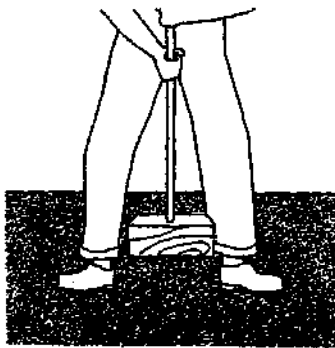

establishing floor level  
by placing markers  
colocación de "maestras"

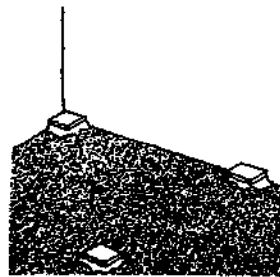

putting on coating  
vaciado el firme



smoothing off floor  
puliendo el acabado

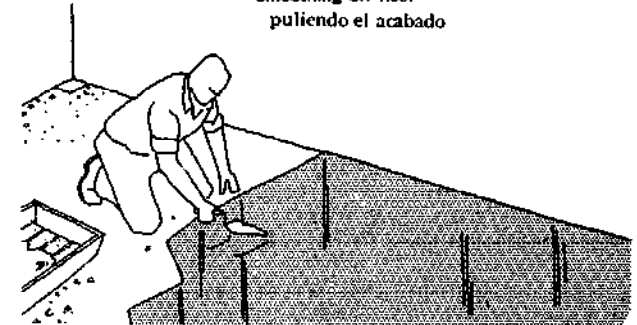



## Stone Floors Pisos de Piedra Laja

Worker tamping ground for cement layer  
Operario apisonando el suelo para tender el firme de cemento



Worker placing markers  
Operario colocando las muestras que servirán de guía para colocar las piezas del piso terminado

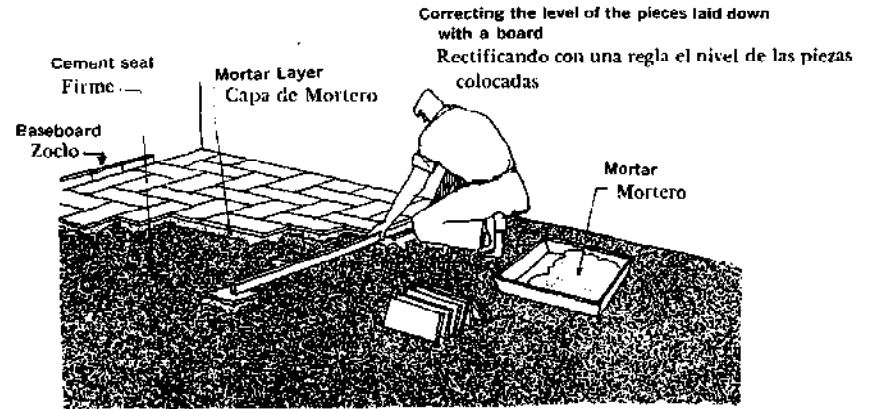
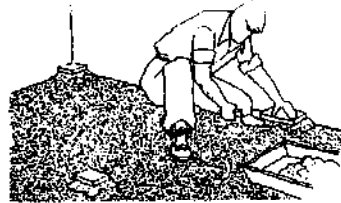

## Flagstone Floor Pisos de Piedra

Tamping  
Apisonando



Correcting the level of the finished floor  
Rectificando el nivel de piso acabado



Wood Floor  
Pisos de Madera

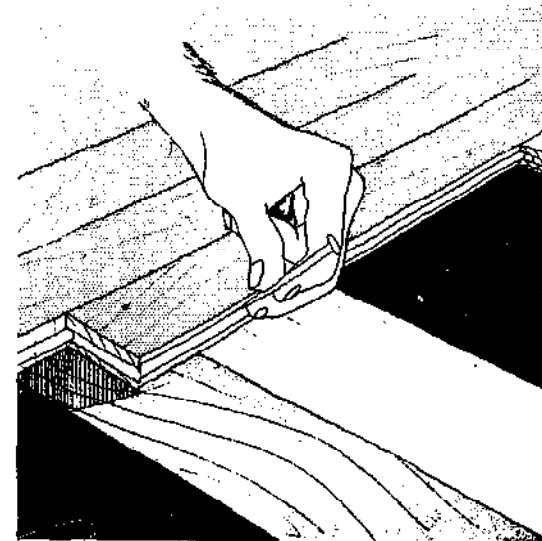
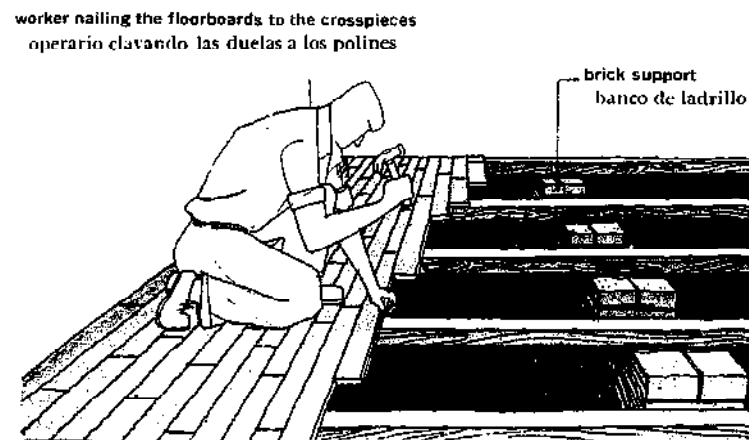
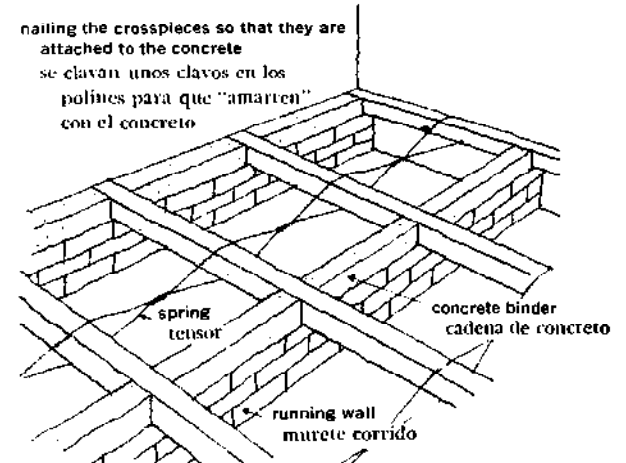
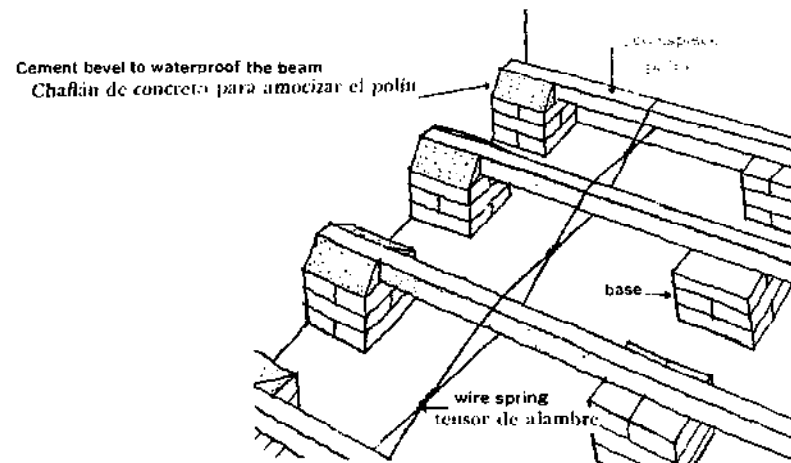

# The Roof

## El Techo

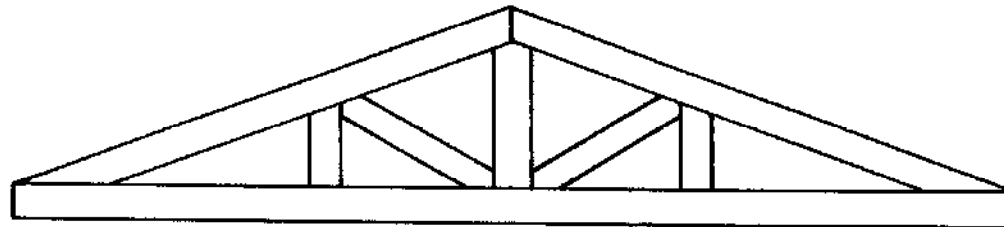
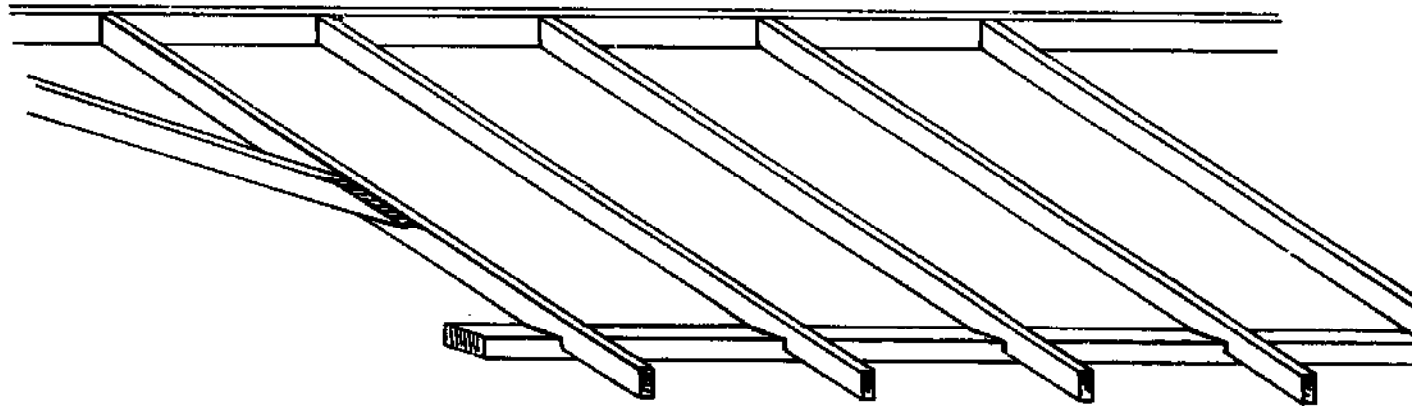
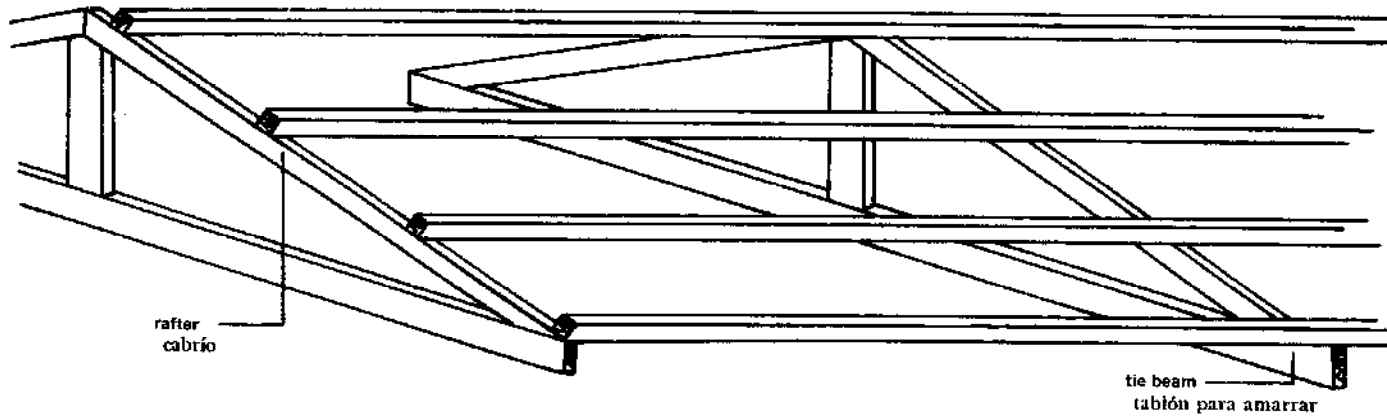

Clay Tile Roof  
Techo con Tejas de Barro

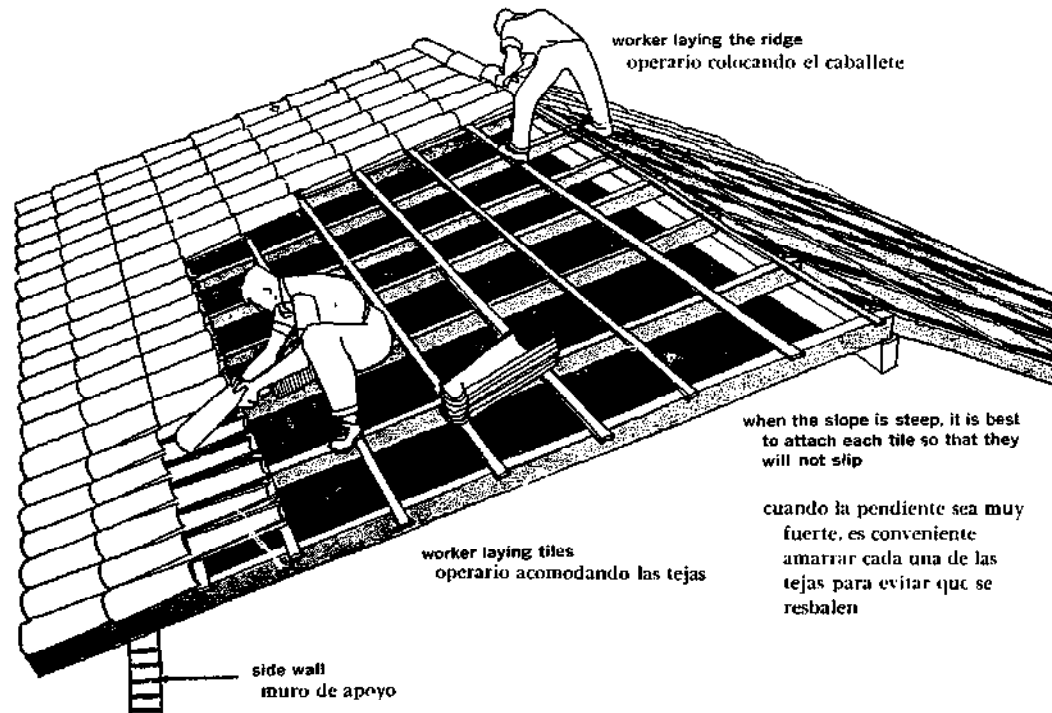
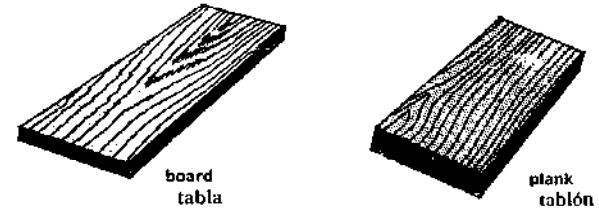
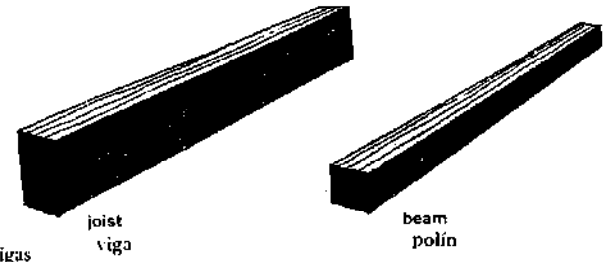
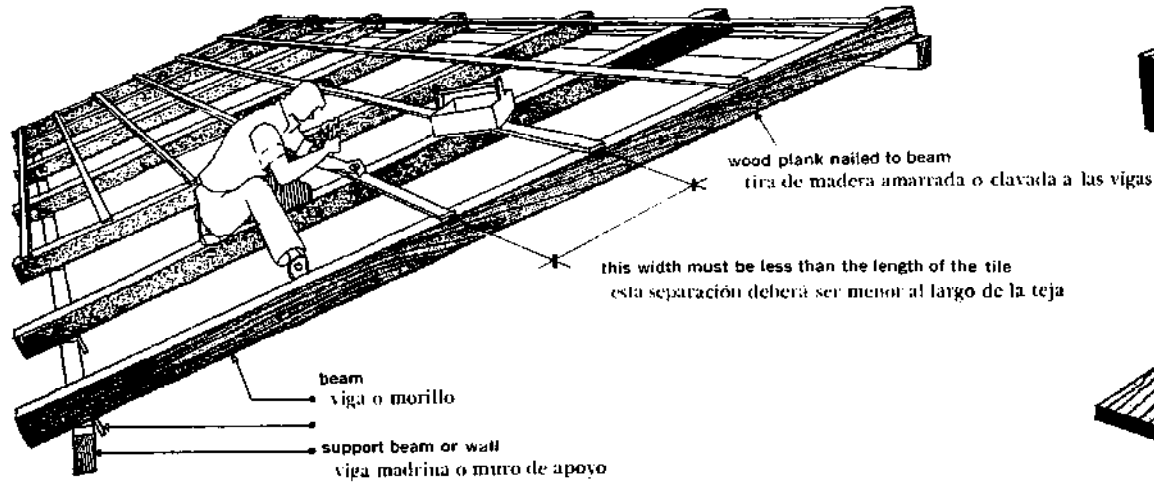

when the slope is steep, it is best to attach each tile so that they will not slip

cuando la pendiente sea muy fuerte, es conveniente amarrar cada una de las tejas para evitar que se resbalen

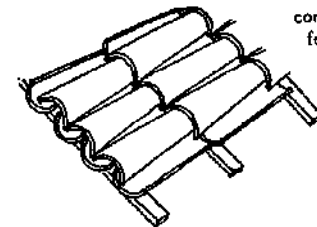

correct method of laying tiles  
forma correcta de colocar las tejas



gutter tile  
canal

Aluminum Roof  
Techo de Aluminio

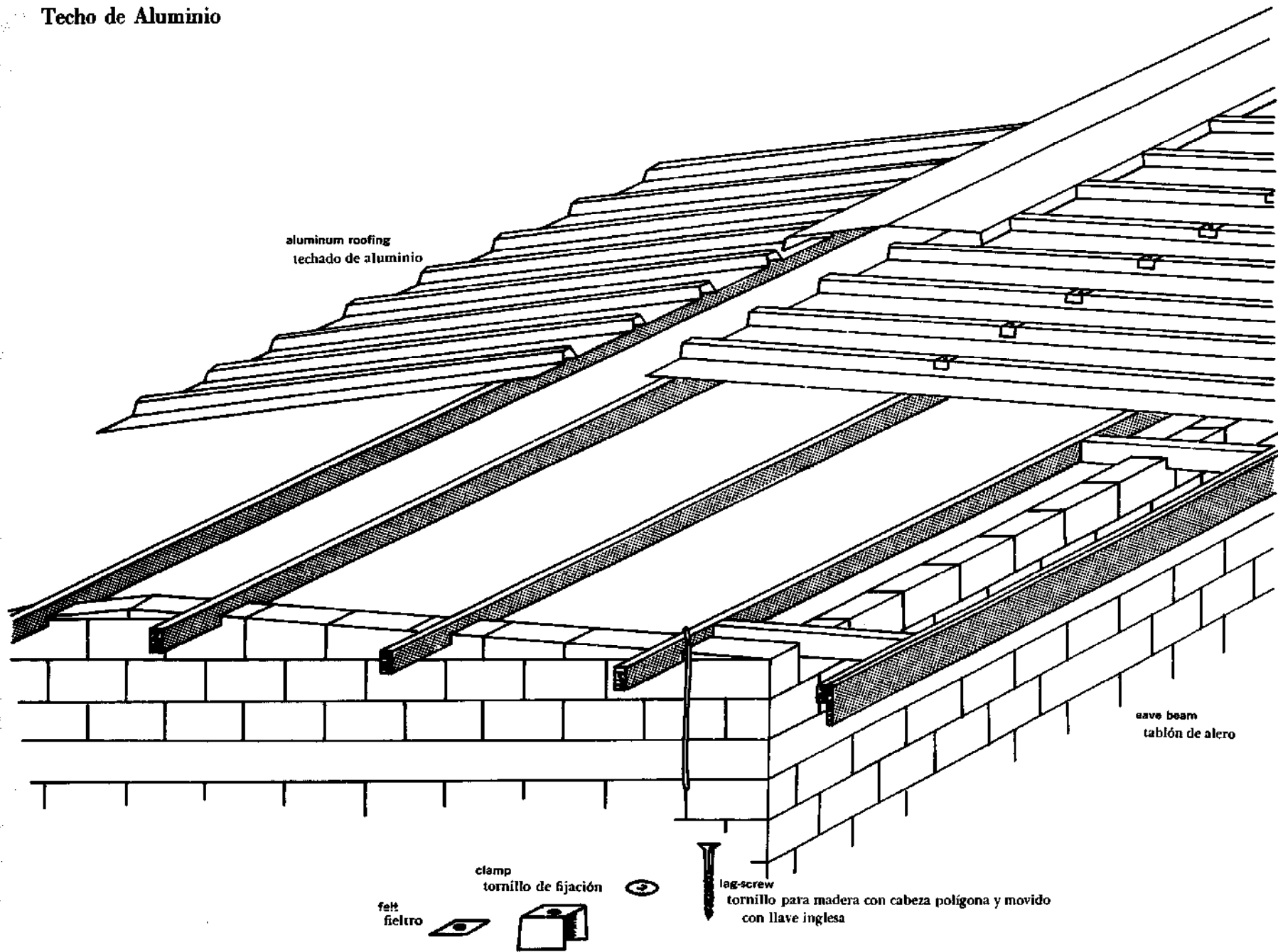

# Asbestos Roof

## Techo de Asbestos

Asbestos-cement sheets are made industrially by a method which mixes these two materials, and produces sheets of different thicknesses and sizes. These sheets are used for house roofs or industrial and store roofs. They are water and fireproof, good as insulation against both heat and cold, and their resistance to rot and deformity make them very useful in building.

Las láminas de asbestos-cemento están hechas por un procedimiento industrial que mezcla estos dos materiales produciendo placas duras de diferentes espesores y dimensiones. Estas láminas se usan indistintamente para techar casas y locales industriales o para bodegas. Sus cualidades impermeables, incombustibles, aislantes de calor y el frío del medio ambiente, su indeformibilidad, su imputrescibilidad y su resistencia las hacen ser de gran utilidad para la construcción.

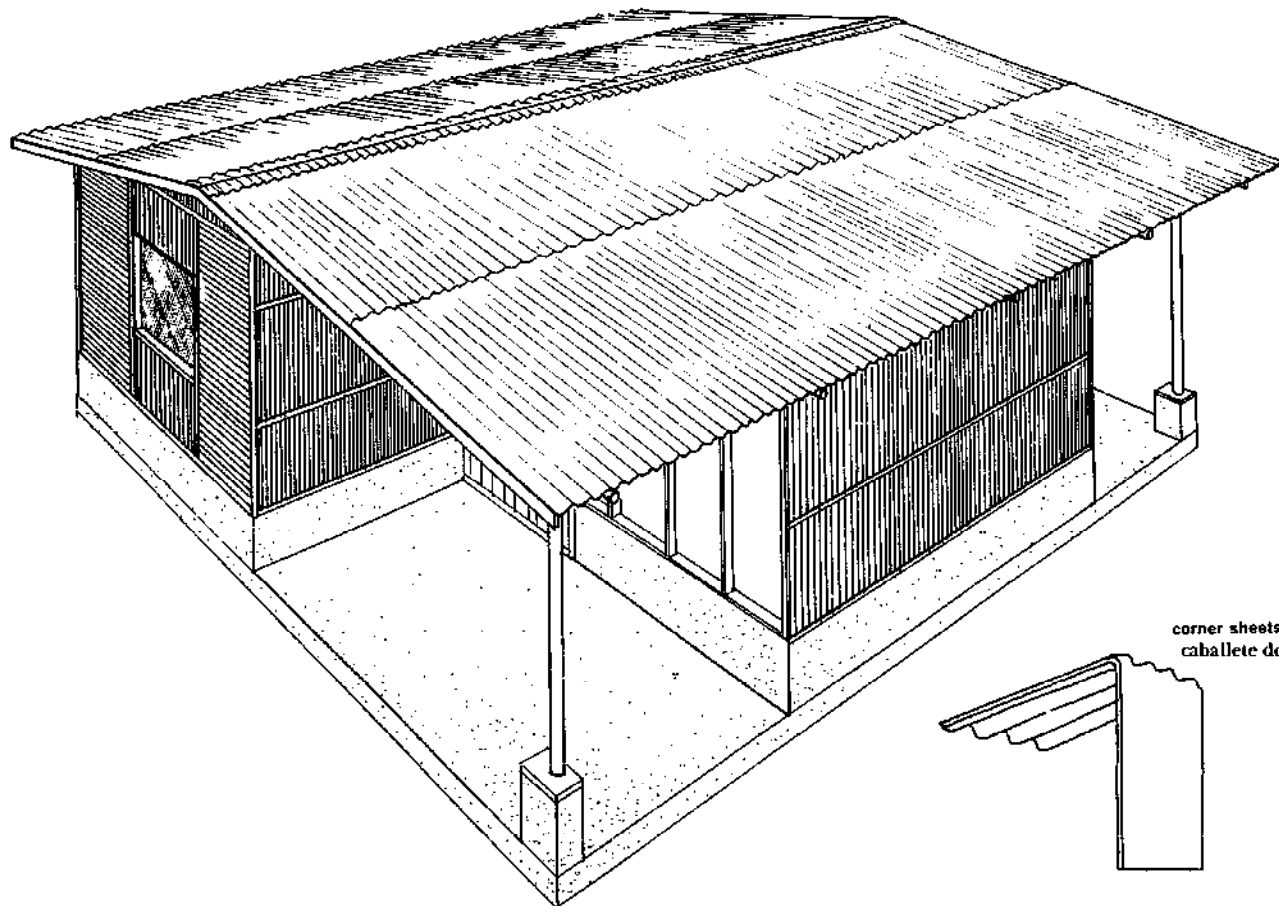

corner sheets  
caballete de esquina

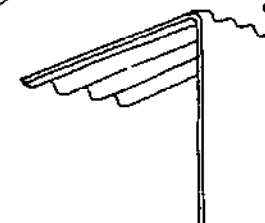

shapes and sizes needed for assembly  
formas y tamaños necesitados para construir

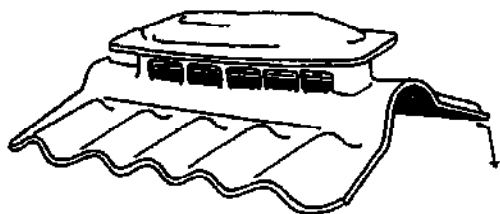

ridge sheets  
caballete de centro



different types of sheets  
diferentes clases de láminas

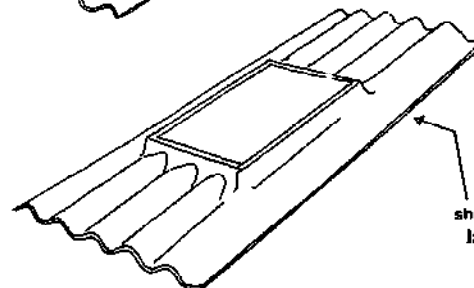
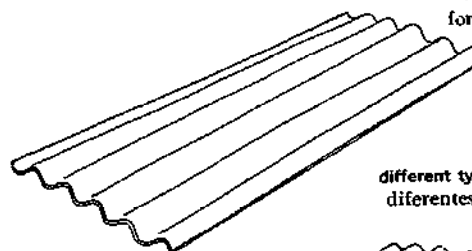

sheet with skylight  
lámina con tragaluz

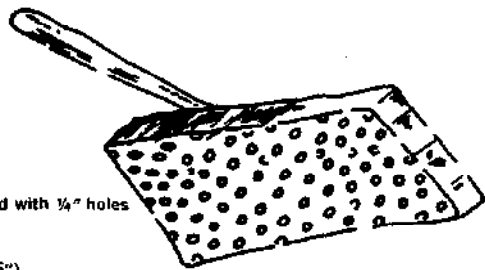

thatching board 12" x 16" drilled with 1/4" holes  
completed section

tabla para empajar (12"x16")  
perforada con hoyos de 1/4"  
de diámetro

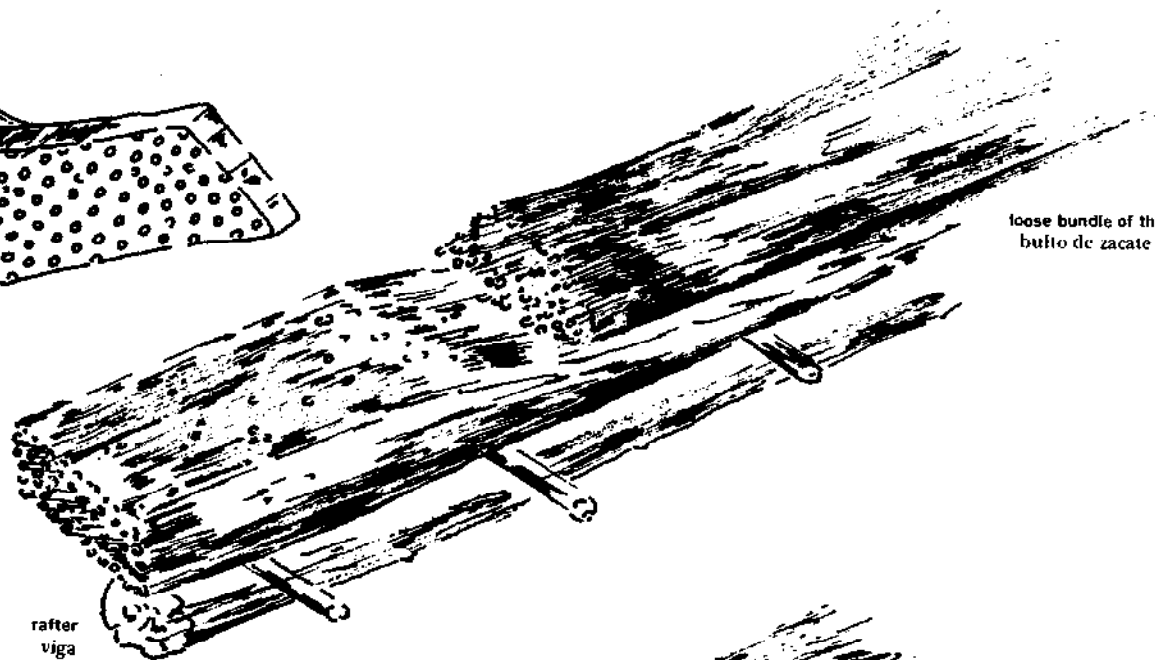

loose bundle of thatch grass  
bulto de zacate

rafter  
viga

starting from the top of bundle,  
push thatching board against  
grass ends repeatedly until  
surface is even and level.

comenzando a la cima del  
bulto, empujan la tabla para  
empajar contra las puntas  
de la paja repetidamente  
hasta que la superficie esté  
uniforme y nivelada

completed section  
sección acabada

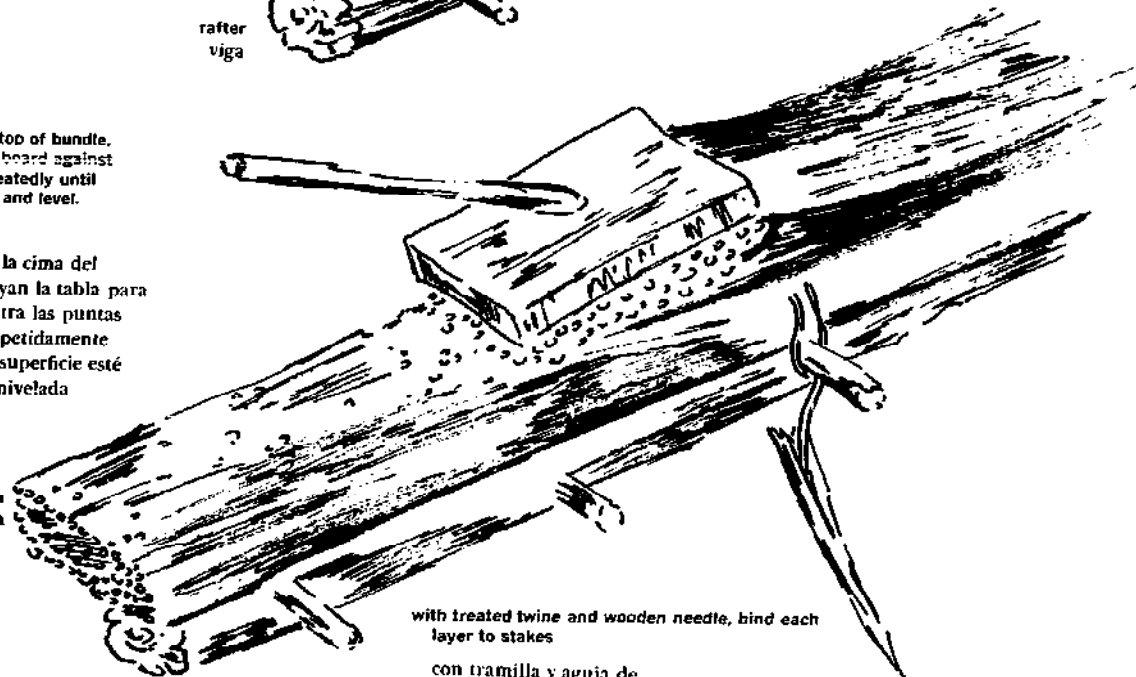

with treated twine and wooden needle, bind each  
layer to stakes

con tramilla y aguja de  
madera, se debe atar cada  
capa a las estacas

Thatched Roof  
Techo de Zacate

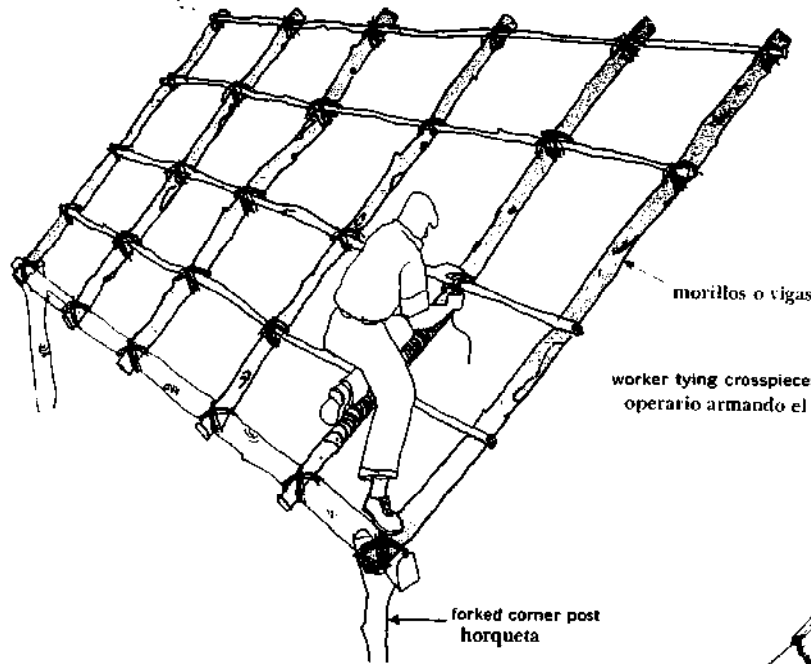

morillos o vigas  
worker tying crosspieces to beams  
operario armando el entramado

forked corner post  
horqueta

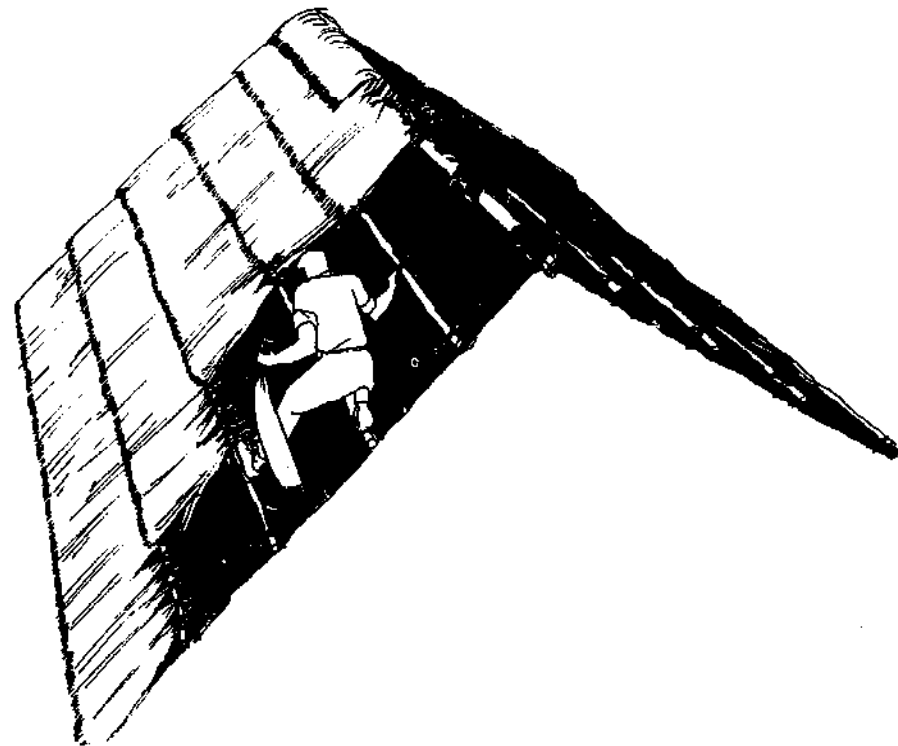



# Water Supply Systems

## Agua Para Usos Domesticos

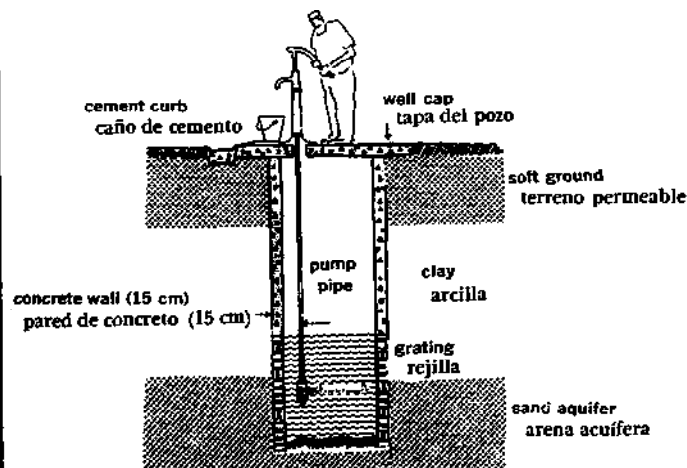
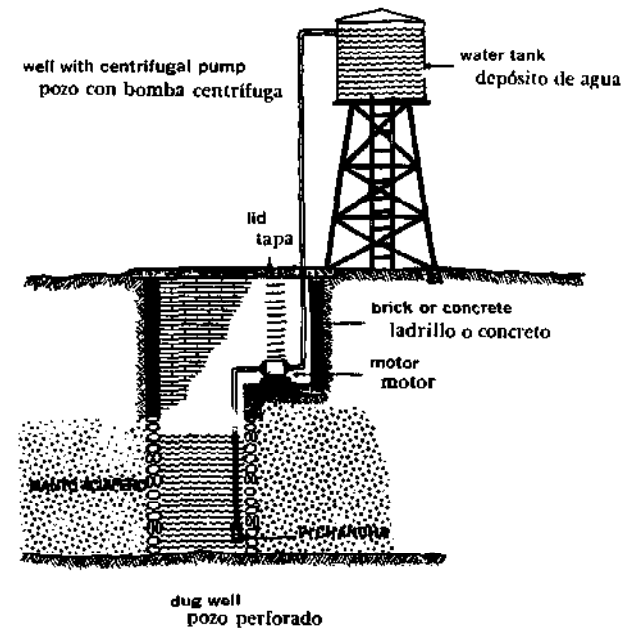
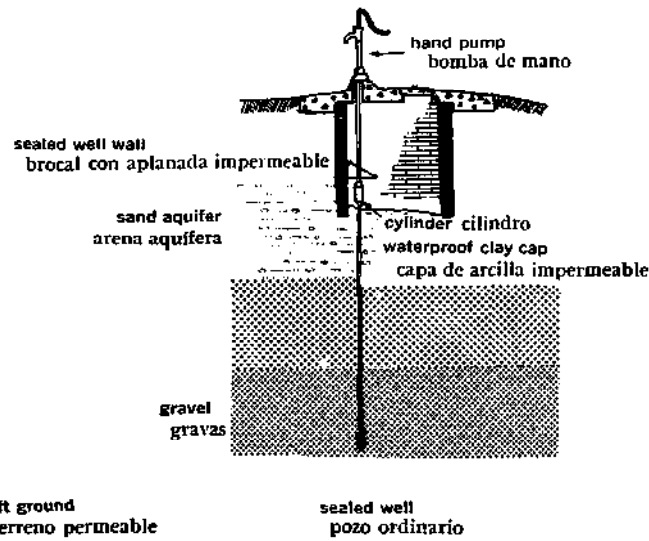
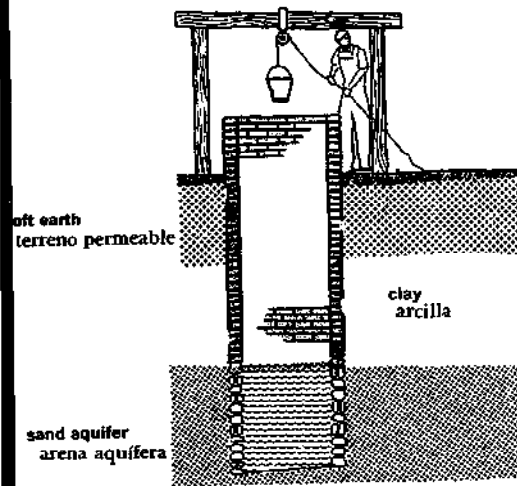
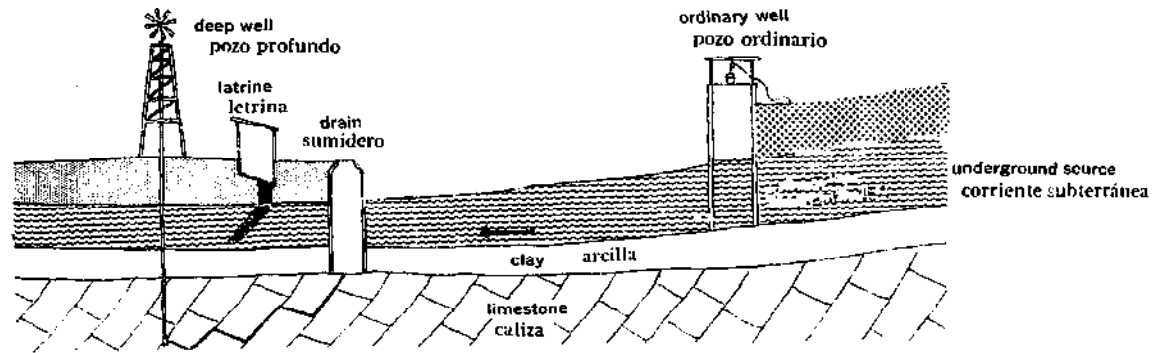

# House Plumbing System Instalación y Drenaje

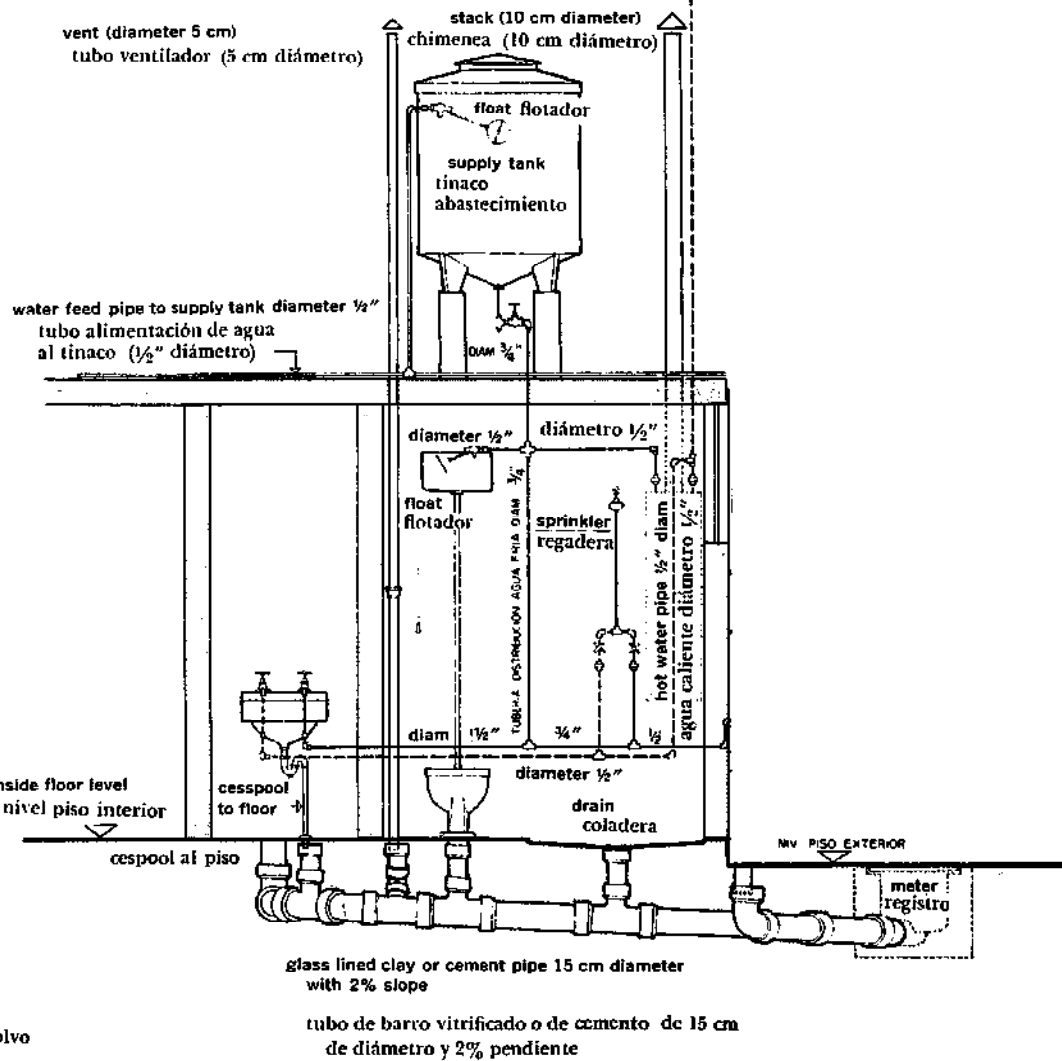

## Water Purification Methods Filtros Domésticos

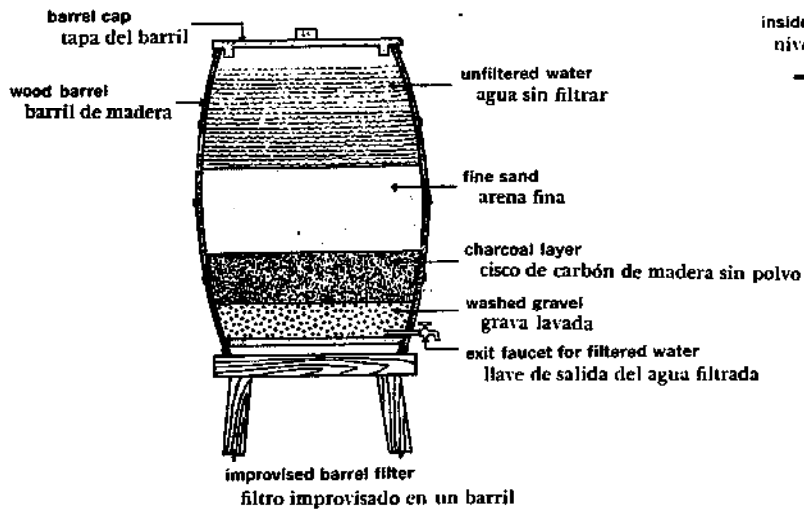

Plumbing  
Tubería

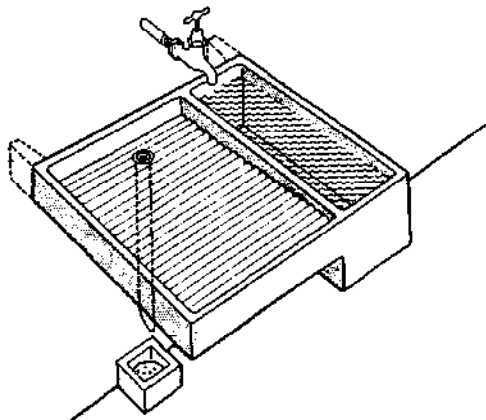

prefabricated concrete sink  
lavadero prefabricado de cemento

Kitchen  
Cocina

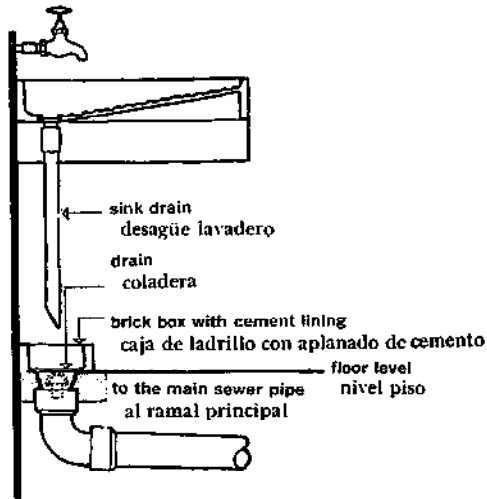

sink drain  
desagüe lavadero  
drain  
coladera  
brick box with cement lining  
caja de ladrillo con aplanado de cemento  
to the main sewer pipe  
al ramal principal  
floor level  
nivel piso



double lead trap with meter  
cespool doble de plomo con registro



simple lead trap with meter  
cespool sencillo de plomo con registro

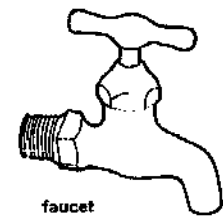

faucet  
llave de nariz

Bathroom

Baño

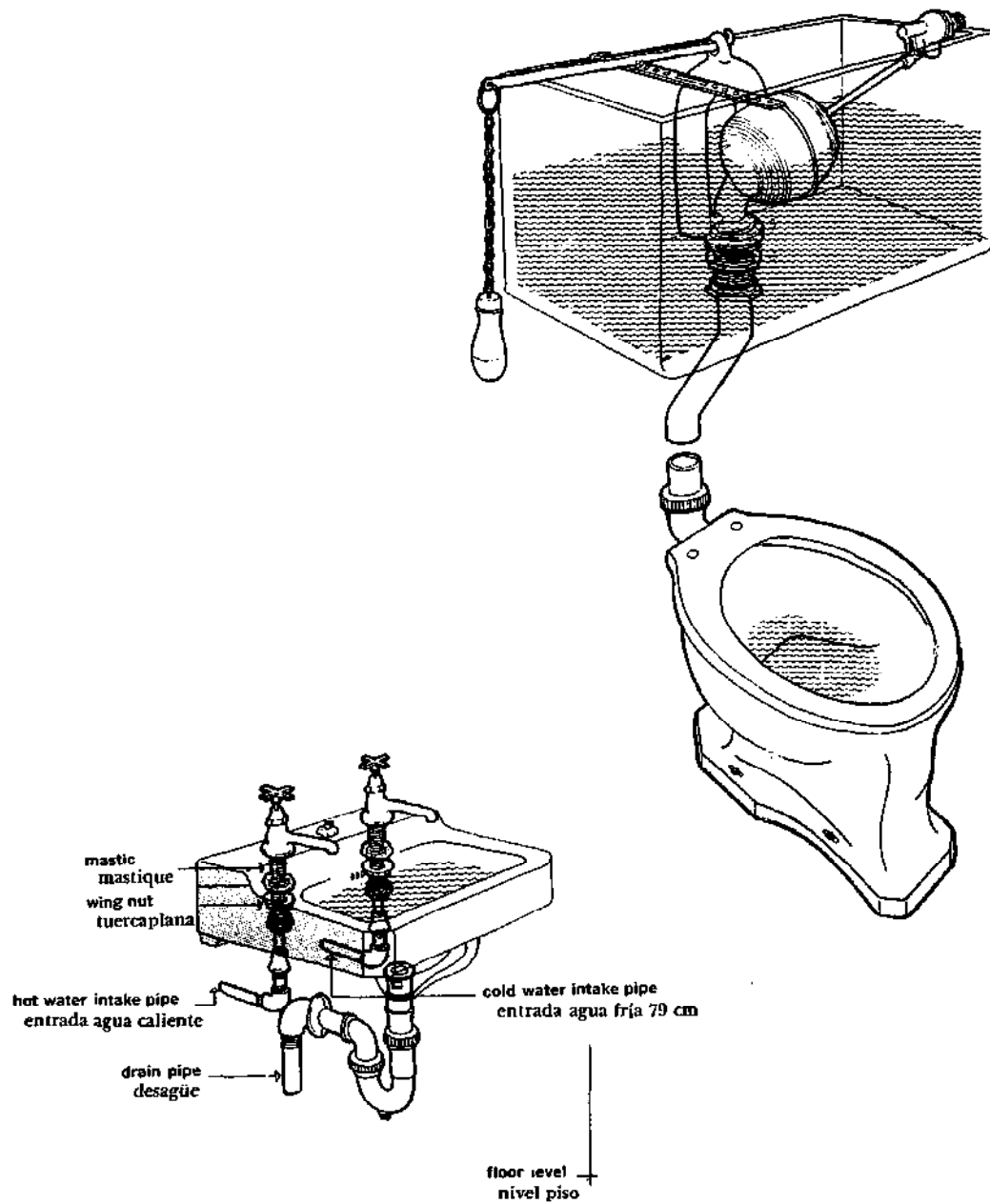

Shower  
Ducha

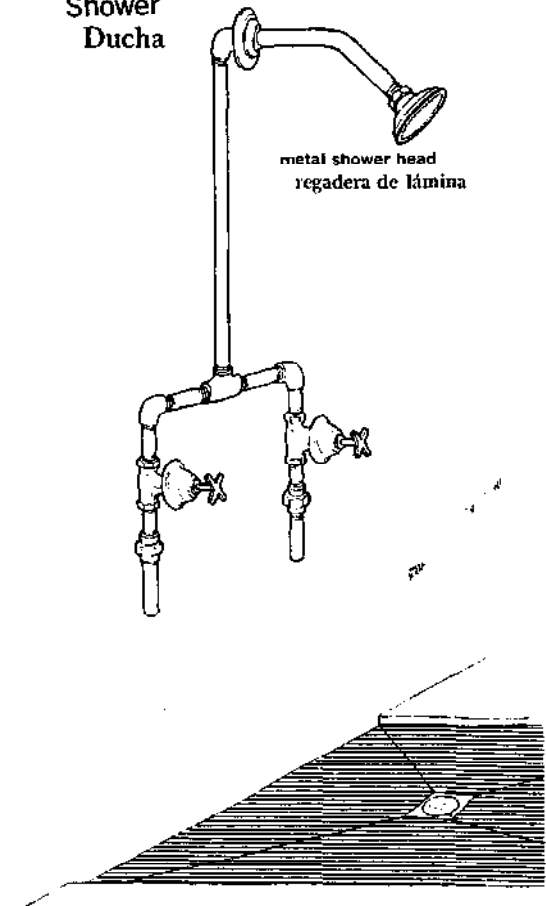

## Sewerage Disposal Systems Alcantarillado-Letrinas

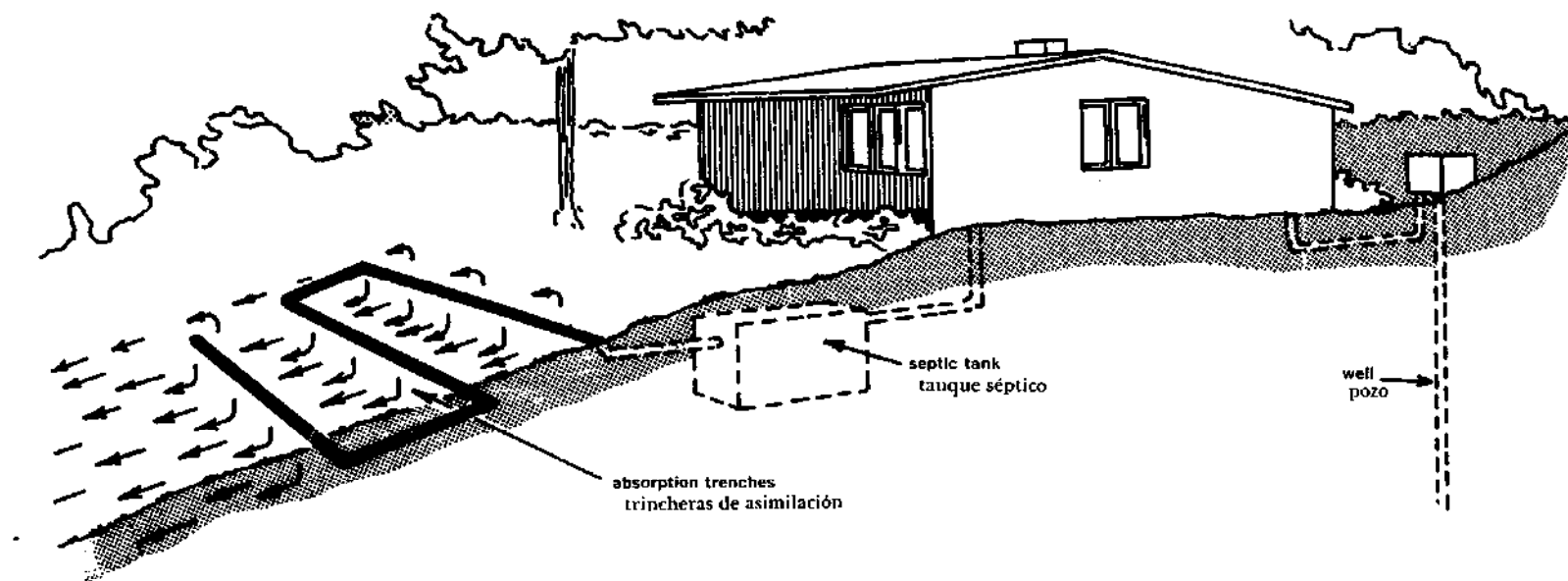

the well should be at a  
higher level than the  
septic tank system  
to protect it from  
sewage contamination

el pozo debe ser más alto que el  
alcantarillado para protección  
contra contaminación

**Absorption Trench and Lateral**  
**Trinchera de Asimilación y Lateral**

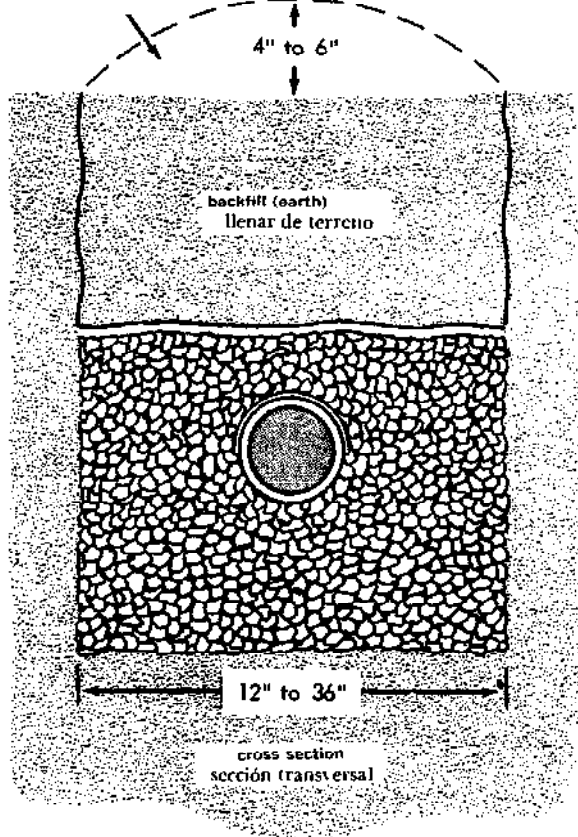

**Household Septic Tank**  
**Tanque Séptico para Uso Doméstico**

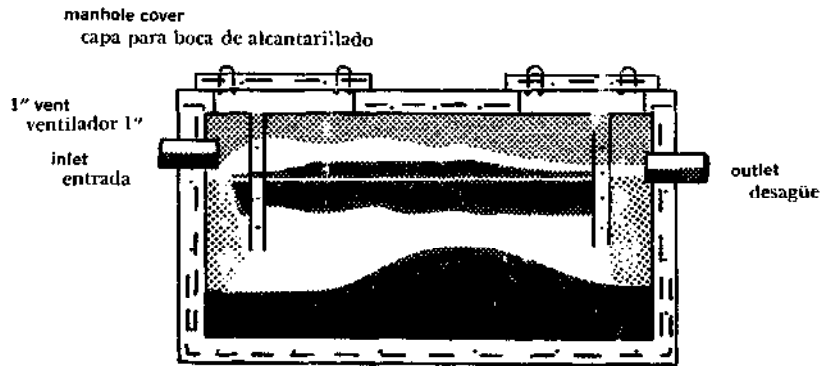

NB: make inlet at least 1-3" above outlet  
 NB: la entrada debe ser 1-3" sobre el desagüe

**Septic Tank Sewage Disposal Systems**  
**Sistema de Alcantarillado con Tanque Séptico**

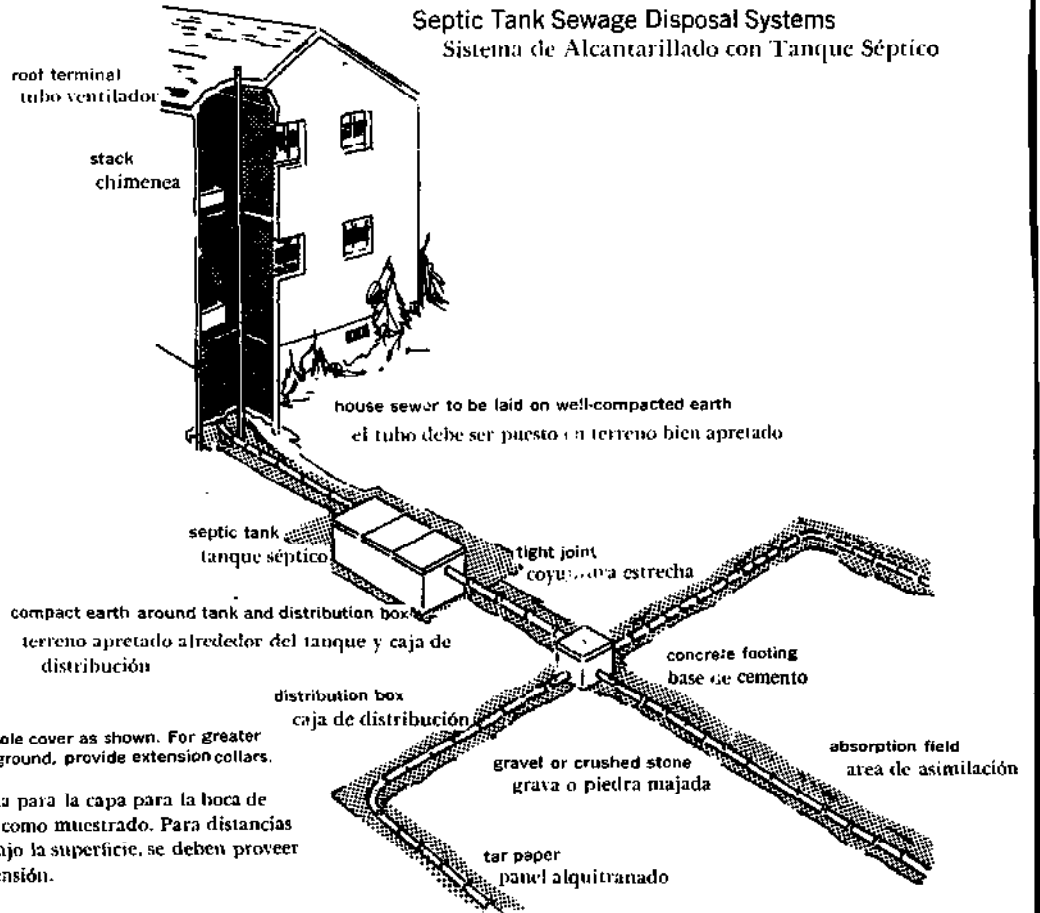

Maximum for manhole cover as shown. For greater distances below ground, provide extension collars.

Distancia máxima para la capa para la boca de alcantarillado como muestrado. Para distancias más grandes bajo la superficie, se deben proveer cuellos de extensión.

Penetration of outlet baffle generally 40% of liquid depth (for rectangular tanks)  
 Penetración del ventilador generalmente 40% de la hondura del líquido (tanques rectangulares)

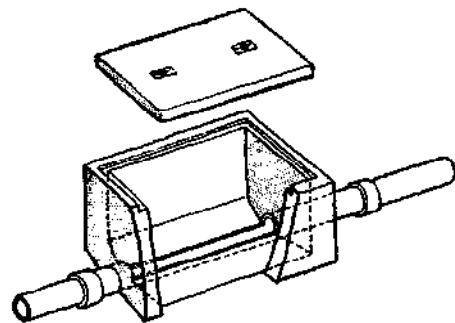

side view of junction box  
corte en perspectiva de un registro

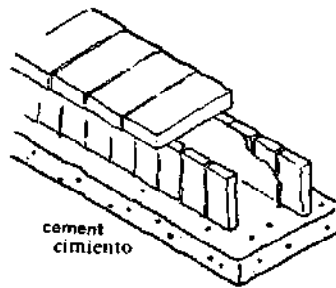

cement  
cemento

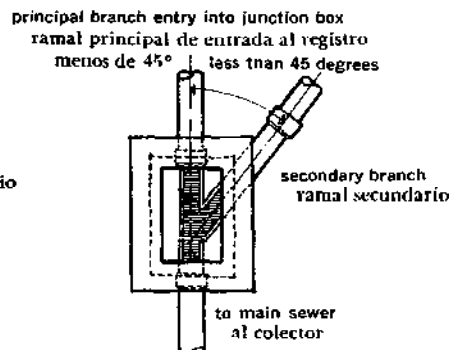
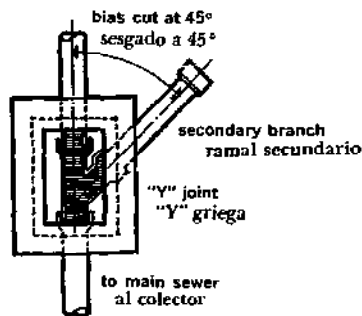
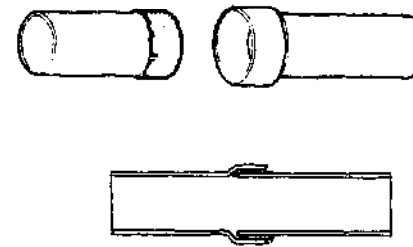

connection at less than 45 degrees  
conexión a menos de 45°

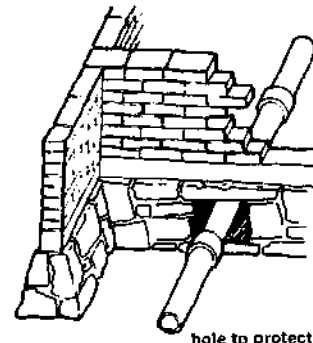

hole to protect the sewer from possible  
collapse  
Hueco para proteger el albañal de posibles  
hundimientos

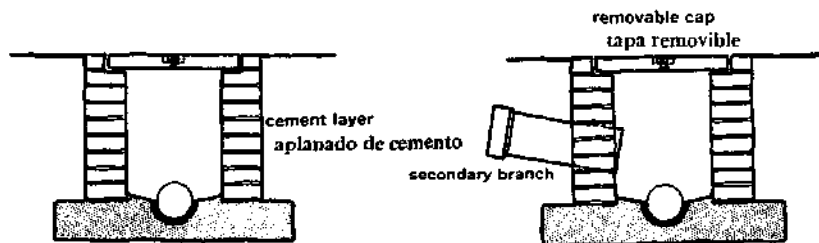
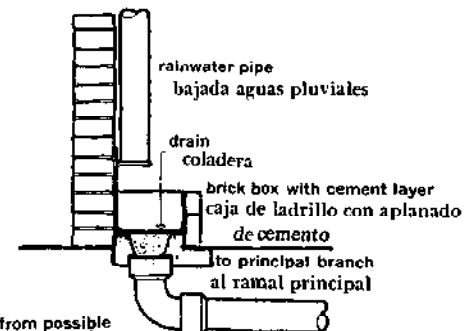

depth of medium sized junction box  
fondo de registro con medio tubo

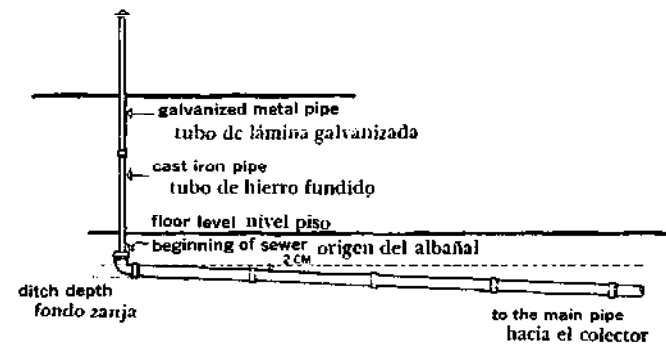

Outhouses or Latrines  
Alcantarillado-Letrinas

Bucket Latrine  
Letrina a Pozal

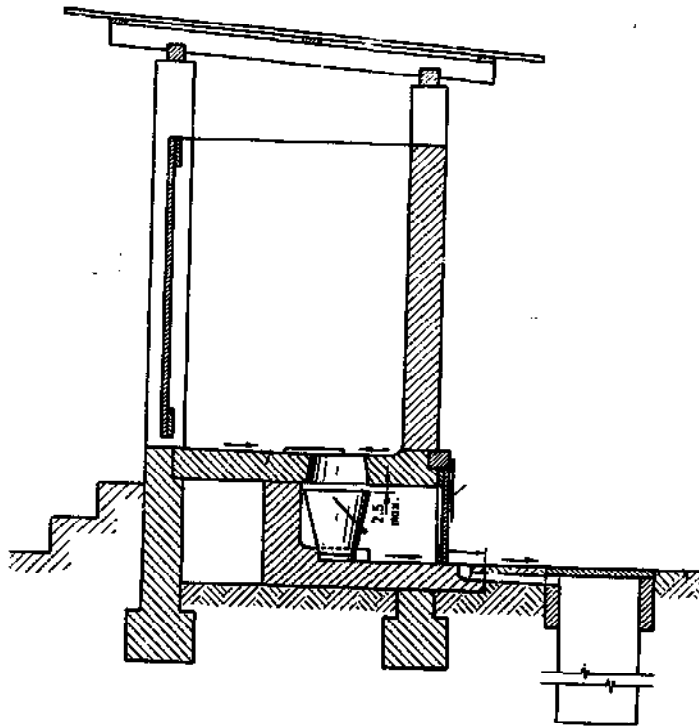

latrine of cut lumber with corrugated metal or  
asbestos cement roof

letrina de tablas con techo de metal acanalado  
o asbestos-cemento

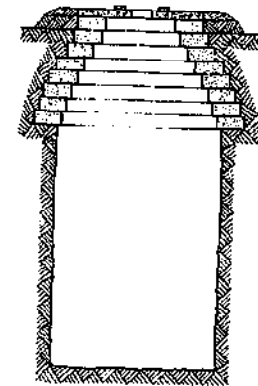
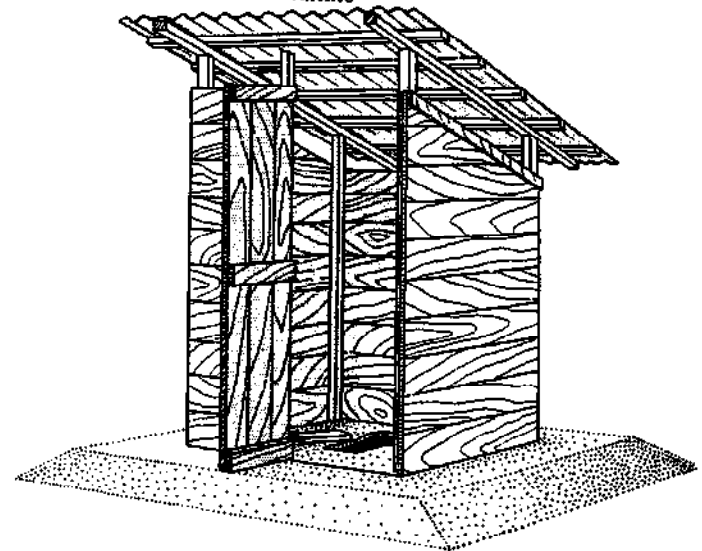

Large volume pit  
Hueco con volumen grande



# Electrical Systems

## Sistemas Eléctricos

A three wire system is used in homes to provide both 120 and 240 volts. 120 volts is used for lights and small appliances. 240 is used for large appliances such as electric stove, water heaters, etc.

Un sistema a tres alambres se emplea en casas para 120 and 240 voltios. Se emplean 120 voltios para las luces y recipientes. 240 voltios se emplean para estufas eléctricas, etc.

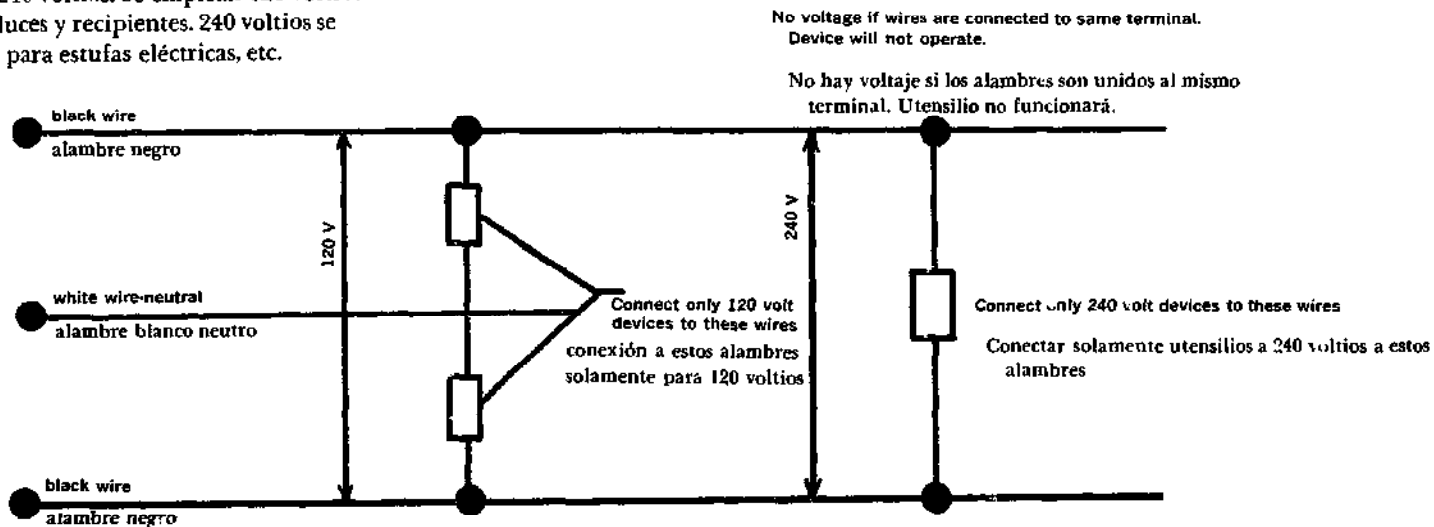

Switch Box  
Toma de Corriente

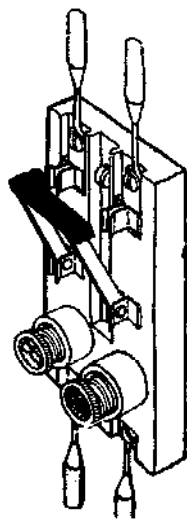

fuse  
tapón fusible

two-fuse circuitbreaker  
interruptor de navajas con fusibles, dos polos

for inside installation  
a la instalación interior

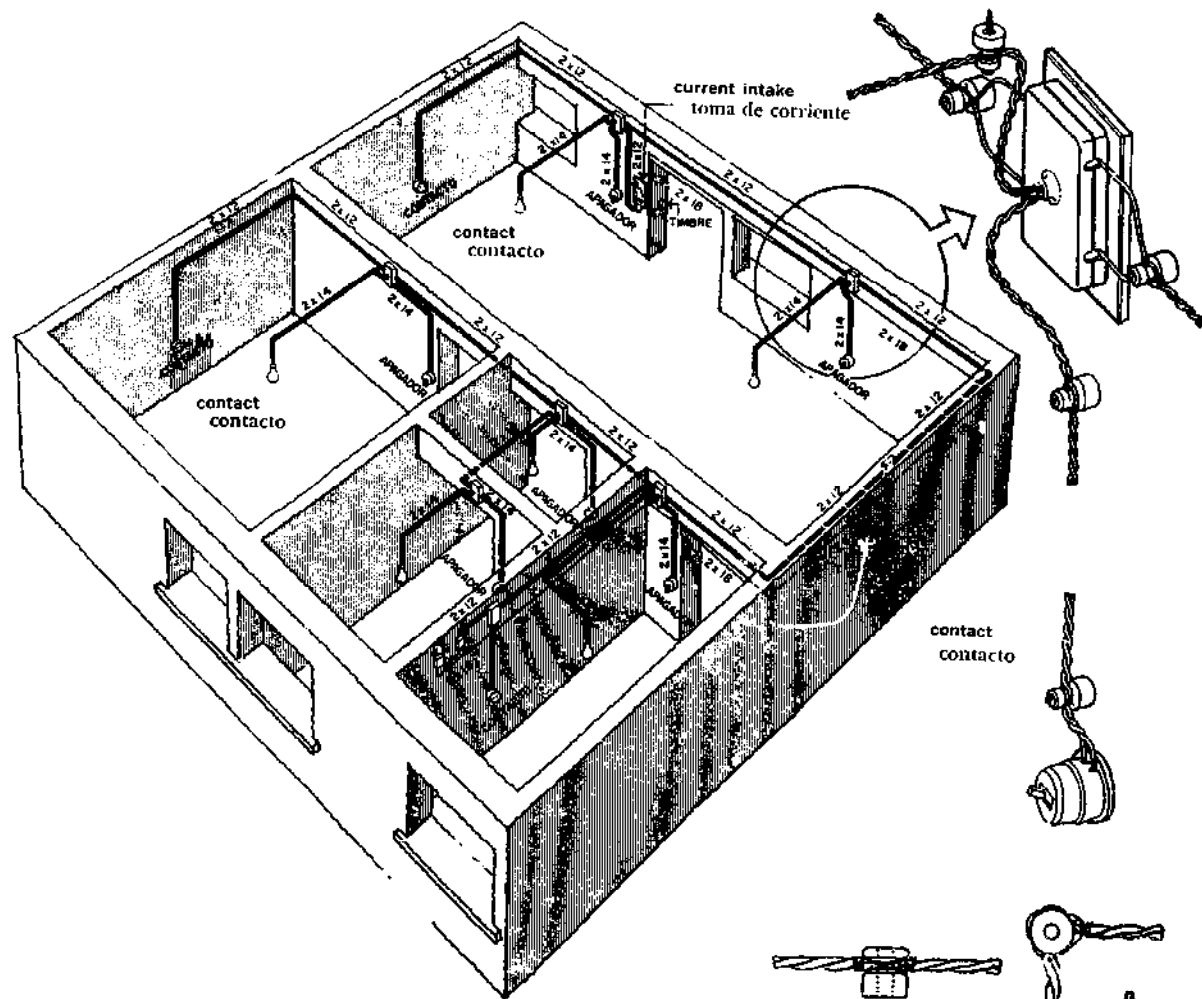

contact  
contacto

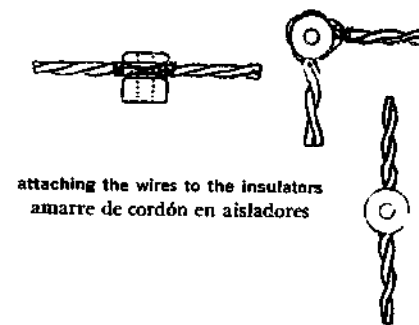

attaching the wires to the insulators  
amarre de cordón en aisladores

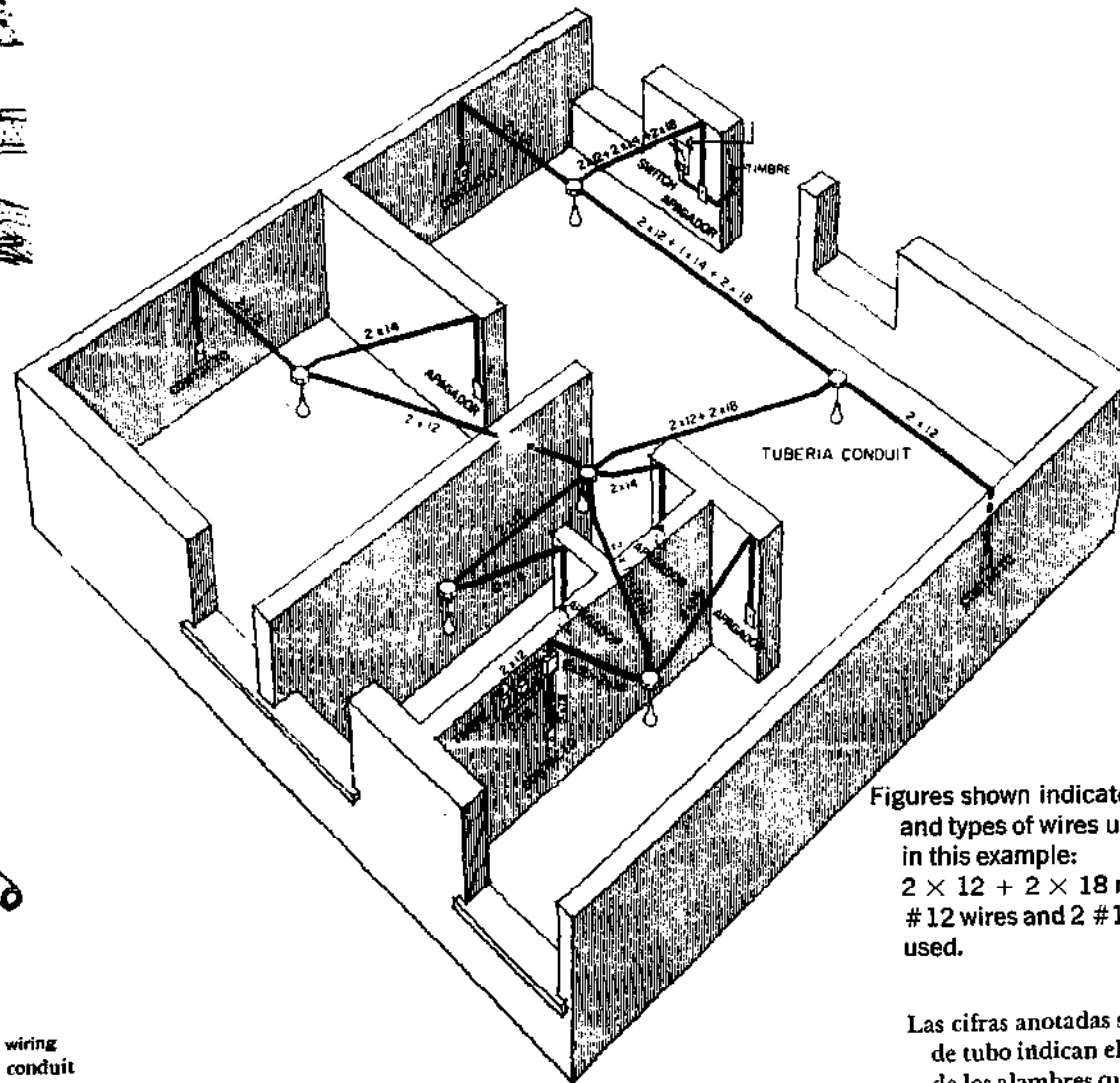
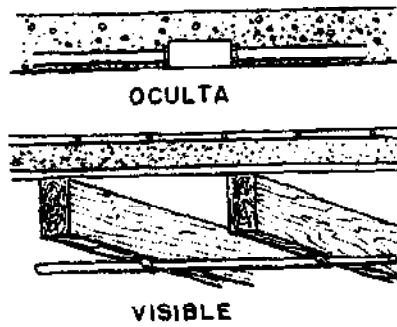

Figures shown indicate the number and types of wires used in this example:  
 $2 \times 12 + 2 \times 18$  means that two #12 wires and 2 #18 wires were used.

Las cifras anotadas sobre cada tramo de tubo indican el número y calibre de los alambres que van en ese tramo (ejemplo:  $2 \times 12 + 2 \times 18$  significa que se pondrán 2 alambres del 12 y 2 alambres del 18.)

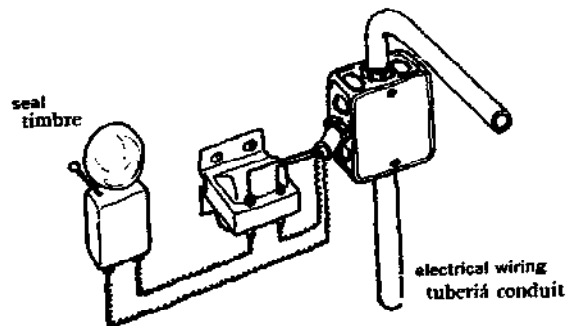

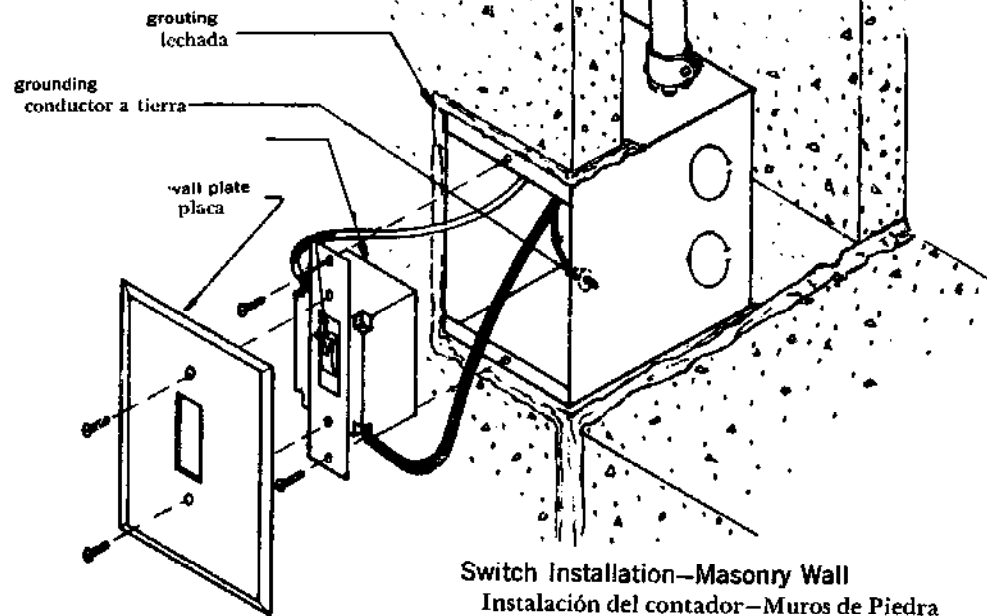

Switch Installation—Masonry Wall  
Instalación del contador—Muros de Piedra

