



Above: Solar cookers ready to shine in HP's Solar Cooking Contest. Photos by Richard Perez

A Kitchen in the Sun

Therese Peffer

We've all heard the saying about too many cooks in the kitchen. But what happens when you move your kitchen into the sun? You get a myriad of solar cooker designs, great food, and lots of fun in the sun. We found this out recently at Home Power's 2nd Annual Solar Cooking Contest.

Last February, we offered a challenge to our readers: design and build a simple, cheap, and easy to use solar cooker that works well. The rules were simple: the cooker had to cook, meaning it should boil water. The cooker should use common tools and materials appropriate to your area. Durability and easy duplication would score high points.

And our readers responded. We received twelve cooker designs for the contest. Of these twelve, three contestants sent their cookers. Two cookers arrived at the contest with their designers. We built three designs for a total of eight entries in the contest. (We built the designs appropriate to the contest — original designs that were easy to duplicate with complete instructions).

The day of the contest

Saturday, July 31, dawned clear and bright — a beautiful day for the cooking contest. By nine am, solar cookers covered a fair portion of Camp Creek campground. Besides the eight contestants, we had eleven other solar ovens smiling at the sun. Jim Shoemaker from Redding brought his cardboard and foil Sun Star type cooker. The Solar Man himself, Phil Wilcox, brought two solar ovens. One small commercial cooker, a Sunspot, could easily fit into a backpack; the other design was part of a U.S. Air Force survival pack in the '50s! Yes, solar cooking has been around for awhile. We also had four Sun Ovens, a Sun Chef, and three other homemade models cooking ribs, peach cobbler and other tasty goodies.

By ten o'clock, we placed a cup of pre-soaked pinto beans and a cup of rice in each of the contesting cookers. One result of having this number of solar cooks — you get an incredible variety of cookers! Each cooker reflected the designer's carefully spent time, creativity and imagination; no two were alike. Walking around the cookers, you could hear how the cookers sparked the imagination of all those who came. We looked, appreciated, and used other's creations as a stepping stone for our own solar cooker dreams.



Dan Freeman



David Baty & Cody Brewer



Jack Thompson

Bohuslav Brudik



Jay Campbell



Peter Pearl



Rodrigo Carpio

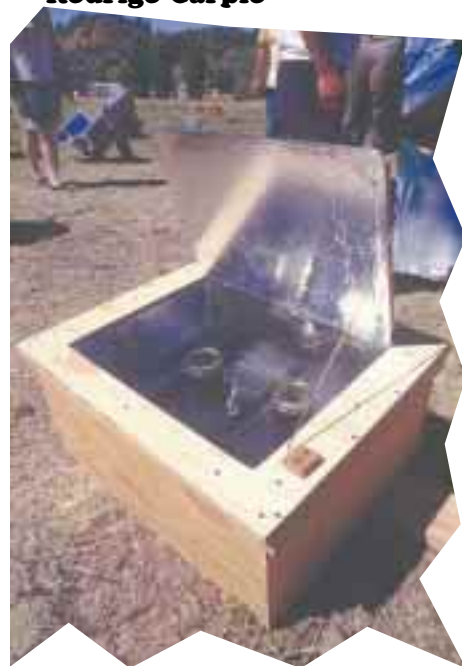

The Contestants

Unfortunately, we don't have the space to fully cover the designs for every cooker. What will have to suffice is a brief description, photographs and the designer's name and address (at the end of the article). So take a close look at the photos and be inspired by the ingenuity of the designers! Keep in mind next year's contest.... As with last year's contest, the first place cooker design is described in full.

The parabolic cookers added a new dimension to the contest — they really cook! Two cookers used parabolic dishes to reflect and focus the sun's energy onto a cooking pot.

Jack Thompson from San Diego, California sent a design that used a cardboard-ribbed foil-covered parabolic dish. A galvanized pipe frame held the dish and cooking pot. Kathleen and Bob-O built this cooker from Jack's plans and "rib" template.

The other parabolic design arrived with David Baty and Cody Brewer, who hail from Berkeley, California. Their cooker consists of a four foot diameter sand & cement dish that rests in an old car tire. They used aluminum flashing for the reflective interior. David and Cody had already impressed us the day before by making espresso in their parabolic cooker. On contest day, their rice and beans kept boiling over and needed additional water a few times. Both parabolic cookers cooked the rice and beans to perfection in less than two hours. This left plenty of sun time for a solar cooker first for all of us at the contest — solar popped popcorn!

Lu Yoder from Albuquerque, New Mexico sent a simple design that used two 2 foot by 3 foot cylindrical concentrators. His plans called for a flexible substrate such as hard plastic, thin plywood or masonite covered with a reflective material, such as polished aluminum cans. The panels were curved to concentrate the sun's energy on a cooking pot that sat on an insulated box on the ground. We made the cooker with masonite and aluminum litho sheets from our local newspaper.

Dan Freeman sent his cooker from his home in Peoria, Arizona. Dan's creative portable design used aluminized bubble pack material (similar to Reflectix) as both reflector and insulation. This material was velcroed to a folding aluminum frame. His cooking box sported a unique curved parabolic-section shape.

We were thrilled to receive an international entry. Rodrigo Carpio from Cuenca, Ecuador sent beautifully detailed designs in Spanish for his rugged, but surprisingly lightweight box type cooker. Bill Battagin and I built the cardboard and plywood cooker from Rodrigo's design. The cooker walls consisted of 2x2 wood frames covered with cardboard and then wrapped

in foil — light, sturdy insulation. We screwed the walls together to form a box, and finished the outside with ¼ inch plywood. The plans called for the walls to lie inside the box for storage — in storage mode, the cooker was only half the height! We didn't have the materials to finish the box with aluminum sheeting as per plans, so we painted the outside instead. Quite a weatherproof design. The wide flat interior of this box cooker is especially suited for climates near the equator.

From Las Vegas, Nevada came a cooker designed by Bohuslav Brudik. This clever design used a store-bought rectangular bamboo basket, insulated with cotton batting and rags and covered with cardboard painted black. Bohuslav used plexiglass for glazing and fashioned reflectors from flattened honey cans supported by dowels. Simple and worked great!

Peter Pearl drove from Bisbee, Arizona to share his solar cooker design and other great ideas. His compact solar cooker had a black beveled steel interior in a small wooden box with a single polished reflector.

And finally, Jay Campbell, who won first place in last year's contest, sent another original cooker from Albuquerque, New Mexico. He designed the cooker using a washtub, insulated with straw, with a box interior. Jay made foldable reflectors of foil-covered masonite. The cheery green cover added to the festive atmosphere at the contest.

The envelope please...

Now the toughest job of all. Six judges walked around the cookers to judge the performance, buildability, ruggedness and beauty of design of each entry (see sidebar for details). Anita Jarmann, Sherri Reiman, Selina S-Wilcox, Karen Perez, Kathleen Jarschke-Schultze, and Dan Lepinski spent a few hours studying the cookers, sampling their fares, and marking numbers on their detailed sheets. Most cookers had no problem with the rice, but the beans presented a challenge. We decided the point system would allow impartial judging. (After sampling the espresso, Karen was a bit biased towards the cement parabolic cooker. As it is, that cooker now resides at HP Central. If you want your own too, see directions on page 34 this issue.)

When the judging was finished and the numbers tallied, we had our winners. Cookers were ranked by total number of points from all judges. Jay Campbell won a Solarex MSX-60 photovoltaic panel for first place with his washtub design. Peter Pearl will be installing a PowerStar 200 watt inverter for winning second place. David Baty and Cody Brewer shared the solar/dynamo radio for winning third place with their cement parabolic cooker. Finally, time to eat rice, beans, salsa, guacamole, hot dogs, ribs, peach cobbler....

Judging the Cookers

Each judge carried a judging sheet for each of the eight contestants. The cookers were given points in four categories: Performance, Buildability, Ruggedness, and Beauty of Design. The four categories in turn consisted of two to five subcategories, worth 15 to 25 points.

Performance of the cooker included how well it cooked, high temperature reached, ease of use, and ease of set-up. Each subcategory here was worth up to 25 points for a total of 100 points for this category.

Elements of buildability consisted of clarity of instructions, easy of assembly, imaginative use of materials, amount of tools needed for construction, and common skills needed for assembly. The subcategories here were worth up to 15 points each, a total of 75 points.

In the ruggedness category, points were given for portability, wind resistance, site preparation needed and moisture resistance. Up to 20 points each were allotted for these subcategories for a total of 80 points.

And finally, beauty of design included physical appearance of the cooker and originality of design, worth up to 25 points each — 50 points total. The most points possible from each judge was 305.

While sometimes it can be difficult to assign numbers to different qualities, we think it allows for easy and fair judging since all the cookers were judged in the same fashion. The details of the judging are provided for those of you interested in entering the contest next year. And, (ahem) we've asked Jay to be a judge next year....

And now as promised, are the details of the winning design by Jay Campbell.

The Winning Design — the Navahorno

This year, I chose to work with a developing country right in my own back yard. I designed and built a solar oven based on the needs, foods and materials common to the Navajo Nation. This stunning land spreads across 24,000 square miles of New Mexico, Arizona and Utah, and is home to more than 175,000 people. Of the 500+ tribes in the United States, the Navajo tribe is the largest, and their landholdings the most extensive. They were chosen for this project not for their size, however, but for their need.

Despite the beauty of the land, life on the reservation is hard. Much of the tribe has never been on the grid, so

The Winning Cooker!



Jay Campbell, Albuquerque, NM

the concept of going off it is meaningless. Wood and propane supply the primary sources of household energy. The climate and terrain of the Navajos are typical of many tribes in the area. The air is dry, vegetation is sparse and the sun shines brightly. Wood is not available in many areas, so it is hauled in from the distant mountains. The tribal government has been promoting solar electricity for some time now, funding small systems at remote sites, and encouraging members to utilize this abundant resource. They will play a key role in the promotion of this oven.

This project would have been impossible without many consultations with JoAnn Willie, a lifelong resident of the rural Navajo land. She is also a graduate student in Mechanical Engineering at the University of New Mexico. Her combination of skills was invaluable in the development, testing and promotion of this oven. The information she gave on materials, foods, cookware and eating habits was all blended into this design, and its ultimate success is hers to enjoy.

The Oven

The oven is built around several common items in rural Navajo life. The outer box consists of a two foot diameter galvanized washtub, commonly used for washing kids, clothes and produce. When they no longer hold water, they are used to feed animals, store wood, and haul whatever needs hauling. These are truly a ubiquitous item in daily living. They are common, abundant, durable and used ones can be found for next to nothing.

Solar Cooking

Materials and Tools for Jay's Navahorno

Materials	Tools
One 2 foot diameter washtub	wood saw
One 15 in. x 15 in. 1/8 in. glass	measuring tape
One 4 ft. x 4 ft. Masonite	paintbrush
One 4 ft. x 4 ft. 3/8 in. plywood	hammer
6.5 ft. old garden hose	razor knife
1/10 bale straw	C clamps
Two small hinges with screws also leather strips, white glue, 3/4 in. nails, and aluminum foil	

The insulation used is straw. The dry land doesn't provide sufficient grass for grazing, so hay, alfalfa and straw are widely used for fodder. This oven requires about 1/10 of a bale of straw, costing about a quarter.

The inner box is sized around the most common types of cookware — enameled steel stew pots. The volume is large enough to feed a family of six. All other materials are made from commonly available items, down to using leather for hinges and weatherstripping. A piece of garden hose, split lengthwise, is used to seal the inner and outer boxes together.

The collapsible reflectors reduce storage space requirements when not in use. The exposed surfaces are either painted or galvanized, helping to assure a long life. For outdoor storage, however, a cover would be recommended. A door on top swings open for access to the hot section. The reflectors are mounted securely to the door, and have withstood winds of up to 30 mph. The leatherwork is oiled, to protect it from the elements. The colors of this oven represent something the Navajos are world famous for — their turquoise and silver jewelry.

A set of cardboard risers is included to size the cooking space for the cookware. The appropriate riser is placed into the oven, and then covered with a black cardboard square. This way, the food can be raised to the hottest part of the oven, regardless of the cookware.

The highest temperature achieved was 330°F (165°C). The time required to boil one liter of 20°C water was 56 minutes at this elevation (about 6000 feet). The total cost as built is \$10.83, assuming a used washtub. A new one would add about \$10 to that price. About 6 hours was spent on the actual construction; this could be reduced significantly for any future copies.

Construction

Gather tools and materials. Measure and cut wooden pieces (right). Put together the inner box, top, glass frame, and reflectors, then assemble these together.

Cut the following out of plywood:

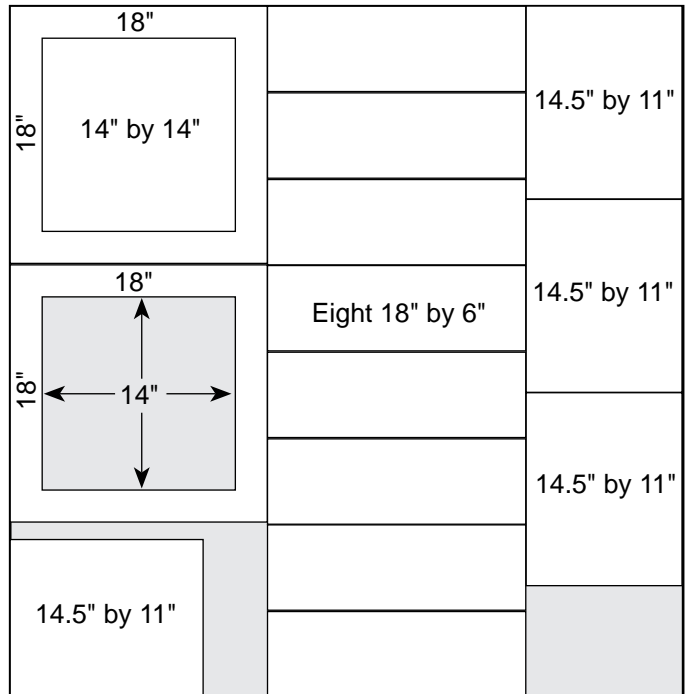

Cut reflectors and glass frame pieces from Masonite:

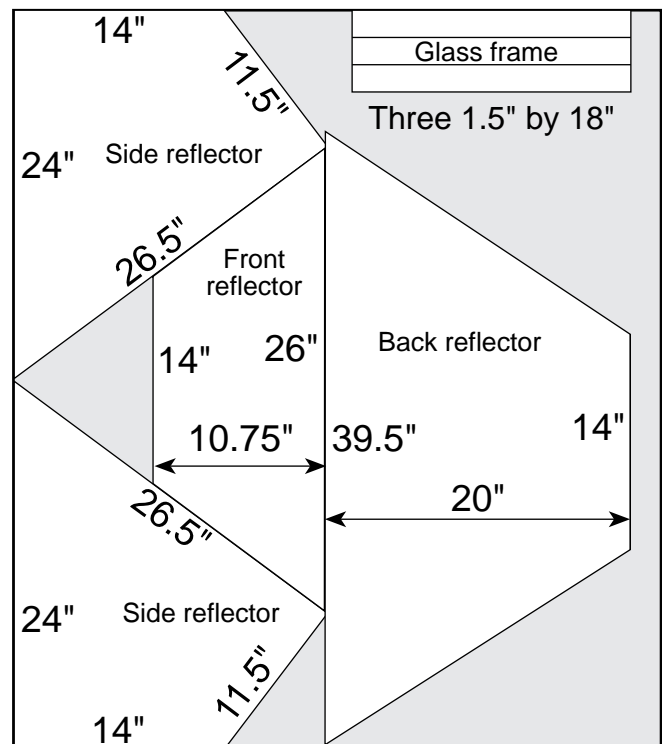

Inner Box

Nail the four sides (11 inch by 14.5 inch) to the edge of the 14 inch square, overlapping the corners as shown top right. Glue joints before nailing together. Cover both the inside and outside of box with aluminum foil, using a 1:1 glue to water mixture and spread with a paintbrush.

Two sides of the inner box glued and nailed to the bottom. Note overlapping corners.

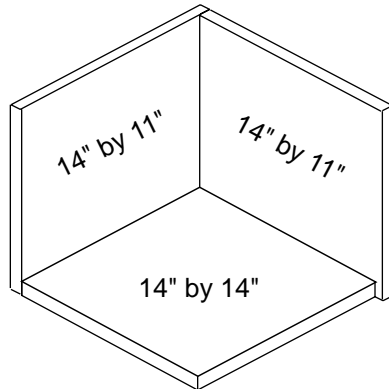

Top

Turn the inner box upside down. Stack the eight 18 inch by 6 inch strips snugly around the box (below). Once fitted, glue and nail the strips together. When the glue has dried, nail the box to the top from the inside.

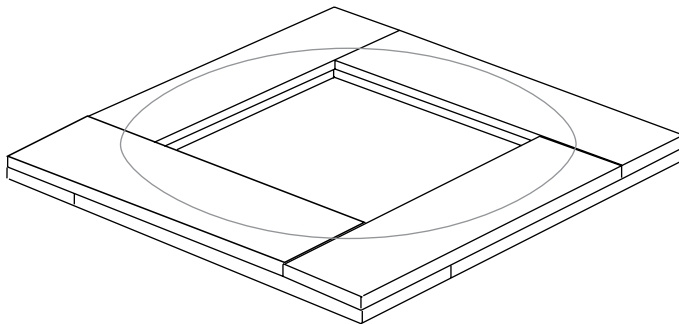

Now set the inner box/top upside down. Place the washtub over it, and center it. Draw a circle around the edge of the washtub. Next, cut a slit in the whole length of garden hose. Nail the garden hose to the top, just inside the circle you just drew. Use one nail every 4–5 inches to assure a strong joint. Once the glue has dried, trim off the excess wood beyond the hose/seal.

Glass Frame

Set the piece of glass on one of the 18 inch squares. Place three 1 inch by 15 inch masonite strips around the glass, snug, but not so tight that the glass is locked into place. Set the other 18 inch square on top. Glue and nail these together. The glass should slide in and out of the frame like a drawer, so it can be replaced.

Reflectors

Cover the reflectors with aluminum foil. Once dry, trim the foil back to the edge of the masonite. Align the large reflector and a side reflector (see top right). Cover one side of a leather strip with glue and clamp along the edge of the two reflectors. Repeat with the other side reflector. Align the small front reflector to the edge of the window. Glue a piece of leather to the back of this reflector and the window frame, as a hinge.

The Final Assembly

Use the two metal hinges to attach the glass frame (opposite side from the front reflector) to the top. Glue

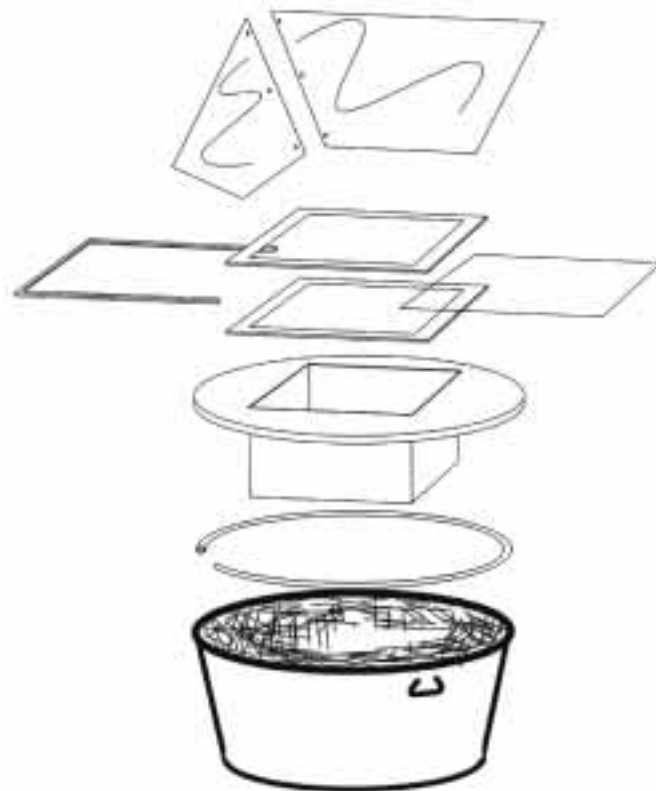

strips of leather on the top, where the frame rests. This seals the box from the wind. It should fit snugly and make a continuous ring around the glass. Attach an eye hook to a corner of the frame and another eyehook to the top. Hook a sturdy string through both eye hooks. Now when you open the cooker lid to get to the food, the string holds the frame and reflector.

Use

This oven works similar to most multiple reflector ovens. Food is prepared and placed into the oven, using the appropriate riser to keep the food at the top of the oven. Dark enameled steel cookware (the standard in the area) works extremely well in this oven, but a variety of glass and aluminum has also been used. The oven can be left unattended for long periods, but stays hottest if it is turned every hour or so. The round base and handles makes turning it easy. Like most solar

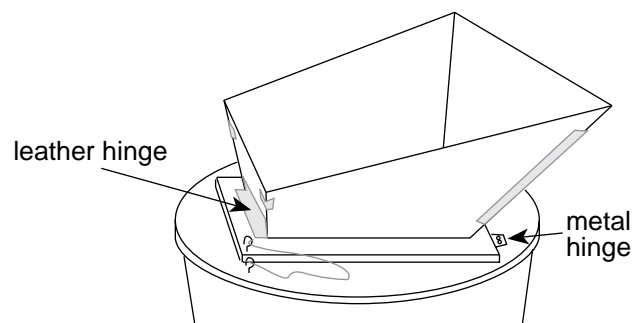



Above: Note the deep interior of the washtub cooker. Different sized cardboard inserts (bottom right) can be added to raise shallow cooking pans to the warmest part of the oven. The inserts are covered with a 14 inch square of cardboard painted black.

ovens, cooking times are about double those of a conventional oven. Foods which require a long, slow simmer are especially well suited to solar cooking.

Traditional Navajo meals include green chile stew, mutton stew, roast meats, breads and corn mush. A gallon of stew will cook up nicely in an afternoon, as will a few quarts of beans. Cornbread has been baked in this model in about 40 minutes. When the food is ready, the reflectors are folded together. The door swings open and the food can be removed. If desired, the pot can be covered with a couple of towels, and left inside the oven. This way it will retain its heat for quite some time, and even keep on cooking.

Alternatives

The main alternative design tested was with galvanized sheet metal reflectors. The dimensions and overall performance were essentially the same as the model submitted. The increased durability comes at a higher financial cost, and it didn't seem worth it. The masonite reflectors are good enough, and last long enough that occasional replacement would still be cheaper.

Better insulation could be used, but only if it were free or very cheap. The multiple radiant barriers (foil and sheet metal) provide much of the thermal protection, and the straw is only a defense against conduction.

Conclusions

This oven will cook many of the staple foods used in the Navajo Nation. It can be built easily by individuals, or produced in quantities by a small shop, using only basic hand tools. The investment in materials will repay itself in about a month, and continue paying dividends for years to come. The climate in the region will allow its use for over 200 days per year, which can make this a primary, rather than secondary, means of cooking.

Although specifically designed around the materials and foods of the Navajo, it is suitable for use over a wide region. Promotional efforts have begun in New Mexico, and show a strong amount of interest.

Calling all Cooks

Thanks, Jay, and all those who entered or participated in our contest this year. The more cooks that move their kitchen into the sun, the better the broth will be! More people entered the contest this year. We saw a wider variety of cookers from a greater number of people, reflecting their creativity, ingenuity, and love of solar-cooked food. The solar spark catches and spreads to even more people, so put on your thinking caps and start dreaming of your ideal cooker. If you don't know how to use some tools, find someone who does (and make him cookies for a job well done). Build a cooker. Cook your meals without fuel, and keep your kitchen cool in the summer. Enjoy some solar-cooked food (and win a PV module next year).

Access

Solar Cooker Contestants:

Jay Campbell, PE, Applied Engineering, 218 Dartmouth SE, Albuquerque, NM 87106 • 505-256-1261 • Fax 505-260-1339

Bohuslav Brudik, 4387 Salton Ave #2A, Las Vegas, NV 89109 • 702-792-6662

Dan Freeman, 10735 W. Laurie Ln, Peoria, AZ 85345 • 602-876-8036

Peter Pearl, POB 867, Bisbee, AZ 85603

David R. Baty and Cody Brewer, 2929 M. L. King Jr. Way, Berkeley, CA 94703 • 510-848-5951

Lu Yoder, Liberation Technology, 315 Harvard SE, Albuquerque, NM 87106 •

Rodrigo Carpio C, POB 607, Cuenca, Ecuador • 881501

Author/Eater: Therese Peffer, c/o Home Power, POB 520, Ashland, OR 97520 • 916-475-3179



Home Power's Third Annual Solar Cooker Contest

Richard Perez

©1994 Richard Perez

Thirty brave souls attended the 100°F cook-off at Camp Creek, California on August 6, 1994. The day sizzled with sunshine and solar cooking. Five contestants cooked off for the prizes!

Home Power has been running this solar cooker design and construction contest annually for the last three years. Our objective is to promote new designs in cookers, particularly those suited to home construction. This year's contest was judged by four experienced solar cooks: Jay Campbell, Kathleen Jarschke-Schultze, Therese Pepper, and Serena Somers. Each cooker was judged by these criteria: performance, buildability, ruggedness, and beauty of design. Each cooker cooked an identical large tamale pie.

This year's solar cooker contest was won by Jeff Gilbert's parabolic cooker named the Yellow Cradle (all winning cookers are pictured on page 34). Jeff scored 971 out of a possible 1220 points to win first place. The complete construction plans for Jeff's *Yellow Cradle* follow on pages 35–37. Second place was won by Rodrigo Carpio of Ecuador, whose cardboard cooker scored 957 points. Rodrigo is an experienced solar cook and the author of an excellent solar cooker construction manual written in Spanish. Third place was won by Jim Reiman's plywood, four reflector cooker which scored 925 points. Jim's cooker scored high marks for both performance and ruggedness. Kevin Reiman, Jim's nephew, (solar cooking must run in this family) placed

Right top: Judges mark their ballots.

Right second from top: Jim Reiman and Jay Campbell discuss solar cooker construction.

Right third from top: An ultra compact and inexpensive solar cooker designed to purify water. This cooker boiled a quart of water in two hours.

Right bottom left: Jay Campbell who is designing the water purifying cooker shown above and promoting solar cooking worldwide. Jay came all the way from Albuquerque, New Mexico to be the Head Judge of this contest.

Right bottom left: The commercially made Solar Chef cooks a dozen hot dogs in minutes.



fourth with his plywood cooker scoring 911 points. Jim Shoemaker placed fifth (829 points) with a novel cooker made from a car tire.

While the contest cookers were cooking the official tamale pies, other solar cookers produced the rest of the feast. Mounds of food — hot dogs, BBQ ribs, dolmas, banana bread, nachos, a 14 pound turkey, apple cobbler, and fresh baked bread — appeared, all cooked in over a dozen solar cookers. Everyone sat down to solar feast!

Special thanks to Jay Campbell. Jay won our last two contests and was our head judge for this one. Jay added his years of solar cooking experience to the event, telling us of his new solar cooking projects in South America. Jay is working on a fold-up ultralight, water purification cooker designed for emergencies and refugee camps. This cooker folds up to the size of a book yet it boiled a quart of water in about two hours. The only accessories required are a few rocks, a black jar and an oven bag.

Not all the cookers present were home made however. Sam Erwin of Solar Chef brought two of his commercially made cookers. One is pictured here in hot dog mandala mode. These cookers amazed Karen and Kathleen by cooking a turkey in about three hours and a loaf of bread in about 45 minutes. Karen bought one of the Solar Chefs and Kathleen bought the other.

One of the main pleasures of solar cooking contests is the leftovers. The HP Crew reheated these goodies for days afterward, in solar ovens of course.

Access

Author: Richard Perez, c/o Home Power, PO Box 520, Ashland OR 97520 • 916-475-3179 voice or FAX. Email via the HPBBS 707-822-8640 or via Internet: richard.perez@homepower.org

First Place Contest Winner: Jeff Gilbert, 409 Christopher Avenue, Gaithersburg, MD 20879 • 301-258-0728

Second Place Winner: Sr. Rodrigo Carpio Cordero, Fundacion Inti Uma, PO Box 01-01-607, Cuenca, Ecuador, South America.

Third Place Contest Winner: Jim Reiman, 195 Gorden Way, Grants Pass, OR 97527

World-wide Solar Cooking Superhuman: Jay Campbell, Applied Engineering, 218 Dartmouth SE, Albuquerque, NM 87106 • 505-256-1261. Or Email via 73670.3236@compuserve.com

Sam Erwin, Solar Chef, 2412 Robinson Road, Grants Pass, OR 97527 • 503-471-4371



The Winning Solar Cookers

Complete plans for the winning cooker.

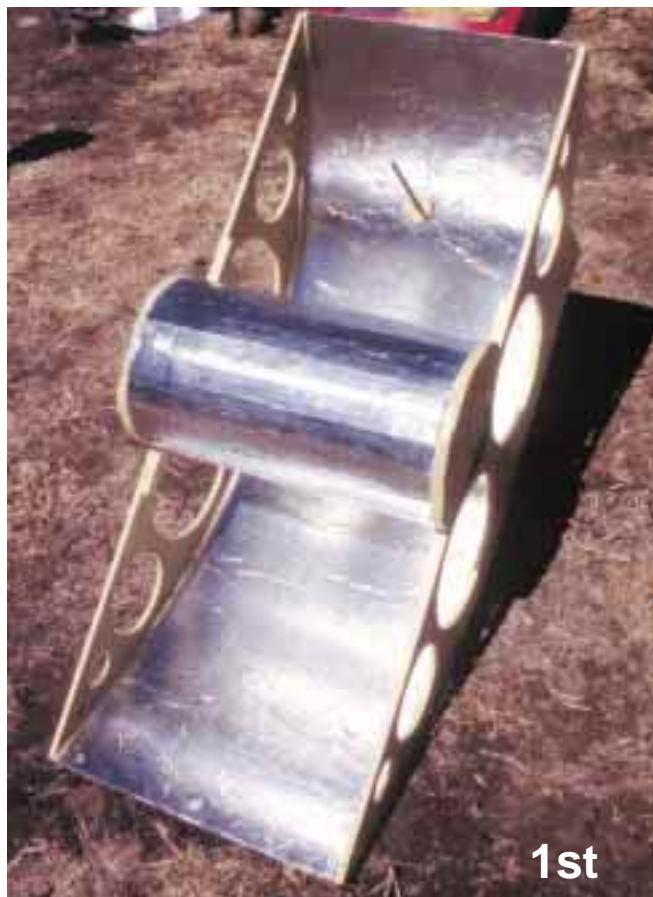

Above: The 1st place cooker and winner of a Solarex MSX60 PV module, the Yellow Cradle by Jeff Gilbert.

Below left: The 2nd place cooker and winner of a Solarex MSX10 Lite PV module, Rodrico Carpio Cordero.

Below right: The 3rd place cooker and winner of a Solarex MSX5 Lite PV module, Jim Reiman.



The Yellow Cradle

Jeff Gilbert

©1994 Jeff Gilbert

The Yellow Cradle is a simple to use solar cooking design that can be made from common material such as plywood, cardboard, aluminum foil and glass.

Steps for Construction

1. Mark a 4 foot x 8 foot piece of 1/4 inch plywood into four 13 inch x 48 inch sections as shown in the diagram below. Cut out these sections.

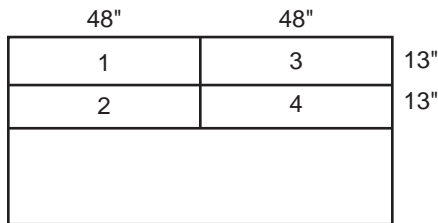

2. Draw a line across the plywood spaced every 2 inches. The 24 inch line (halfway between the ends) will become the center point of the parabola ($x = 0$).

Example: The coordinates ($\pm 2, .08$) simply means that 2 inches either side of the center point, you should measure .08 inches from one edge of the plywood and make a mark. Don't worry if you never could grasp plotting graphs in school; this is not complex.

Below: Template for the Parabolic "Yellow Cradle"

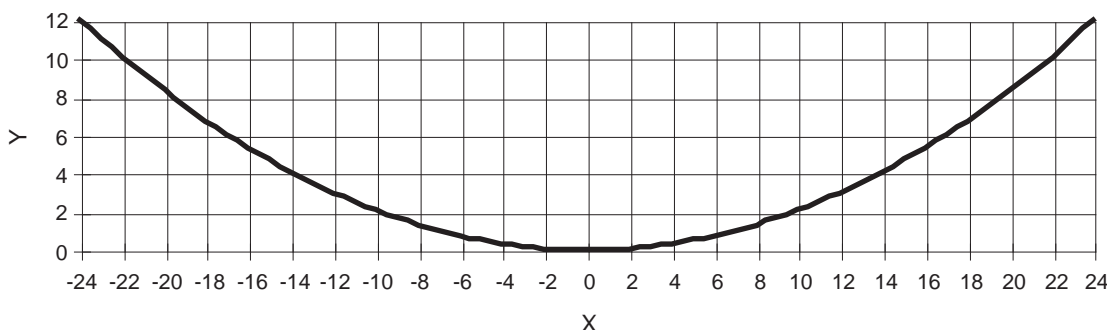

The parabola used for this cooker has the formula

$$x^2 = 4Fy$$

where F is the height of the focus, (i.e., where the light will focus).

For this design, the F is at = 12 inches

3. Draw a line joining the marks which form the outline for the parabola and cut along this line. Use the first piece as a template for marking the same cut on another of the 13 inch x 48 inch plywood pieces. Cut carefully and accurately. Note: Do not cut out the 8 inch wide pieces yet (see measurements diagram on page 37 to see what is meant by the 8 inch wide piece).

Template

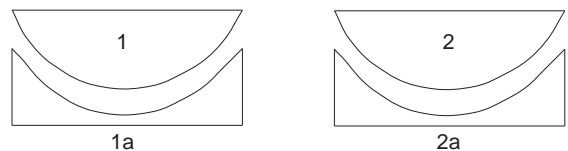

4. Using your template parabola, trace and cut the other two pieces of plywood according to the measurements diagram, including the 8 inch pieces. The parabola template should be positioned 1 inch down from the top edge before you begin tracing.

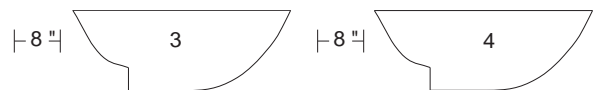

5. Glue piece 1a to piece 3 with the bottom edges flush to each other and the parabolas facing up (see main diagram). Repeat this step with piece 2a and piece 4. Note: Use clamps or weights to hold pieces firmly together while glue is drying.

6. Mark and cut out piece 5 from the main stock of plywood. This piece will be used to form the curved surface of the cooker.

7. Glue pieces 1a – 3, 2a – 4 and 5 together as shown in the main diagram. With pieces 1a – 3 and 2a

$\pm X$ inches	Y inches
0	0.00
2	0.08
4	0.33
6	0.75
8	1.33
10	2.08
12	3.00
14	4.08
16	5.33
18	6.75
20	8.33
22	10.08
24	12.00

Solar Cooker Contest

– 4 parallel and 18 inches apart, lower piece 5 between 1a – 3 and 2a – 4 so that it bends and rests on the ledges formed by 1a and 2a. Note: This step may require two or more people, however, one person can do it with some ingenuity, props and tape.

8. Glue pieces 2 and 3 in place as shown in main diagram. Be sure to push pieces 2 and 3 down firmly, sandwiching piece 5 in place.

9. After glue has dried, turn the assembly over and cut pieces 1a and 2a to follow the contour of pieces 3 and 4.

10. Glue heavy duty foil onto inner surface of reflector. Note: An alternative way to secure the foil is to paint the inner surface and apply the foil while the paint is still tacky. I recommend this way because it tends to secure the foil better.

11. Mark and cut out the rest of the pieces according to the measurement diagram. See diagram below for details on pieces a, b, c, d, e and f.

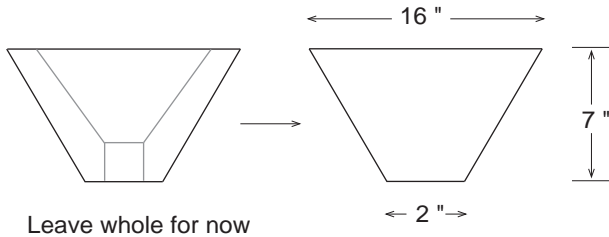

12. Glue pieces 6 and 7 into place as shown below.

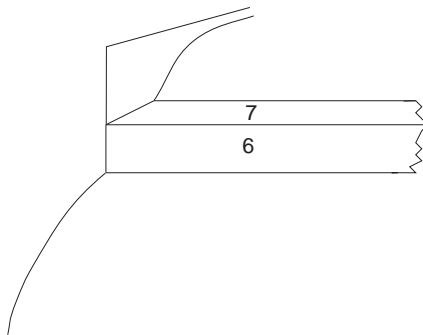

13. Glue two of the 2 inch diameter circles together to make a 2 inch circle of double thickness. Repeat this step for the other two circles.

14. Repeat step 13 for the 5 inch circles.

15. Glue three of the 3 inch x 18 inch pieces together (faces together).

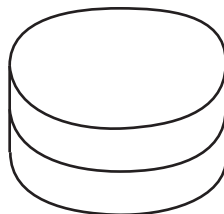

16. With reflector assembly up-side-down, glue one of the 2 inch circle pieces to piece 7 such that it is in the

middle of piece 7 and centered 1.5 inches from the edge where piece 7 joins piece 6.

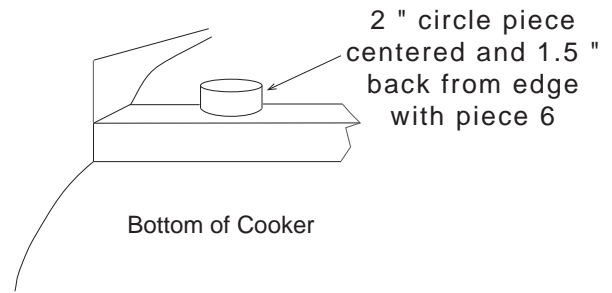

17. After glue has dried, drill a 3/8 inch hole vertically through the center of the 2 inch piece and down through the reflector surface.

18. Glue the other 2 inch circular piece over the hole that you just drilled through the reflector surface. Position the 2 inch piece high on the slope of the reflector so that when you drill through it from the other side, the bit will come through near its center. Then drill the hole all the way through.

19. Glue pieces a,b,c and aa,bb,cc together. Repeat this for d,e,f and dd,ee,ff.

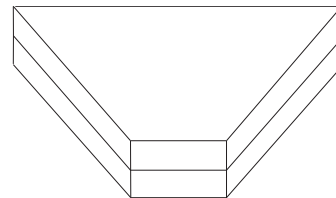

20. After the glue dries, make the cuts separating pieces a, b, c, d, e and f as well as the notch that fits piece 8. See main diagram if you get confused.

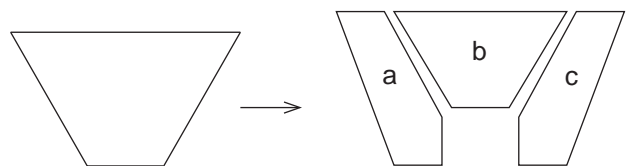

21. Glue pieces 8, a, b, c, d, e and f into place leaving a 1/8 inch gap between pieces a and b, c and b, d and e, and f and e. See diagram below.

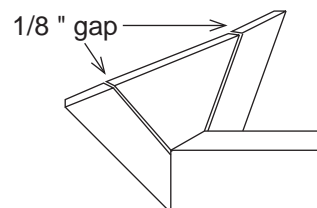

22. Drill small holes in the two 5 inch circles and insert metal rods (coat hanger wire or whatever is available) to form the cooking rack.

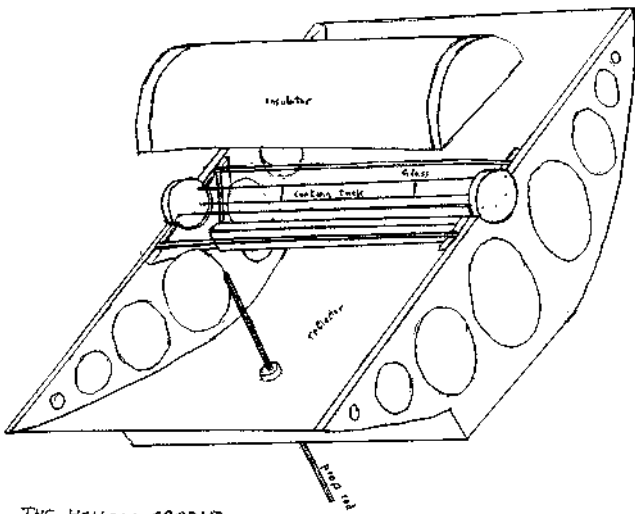

THE YELLOW CRADLE

by Jeff Gilbert
409 Christopher Ave. #22
Gaithersburg MD 20879
(301) 258-0728

Measurements Diagram

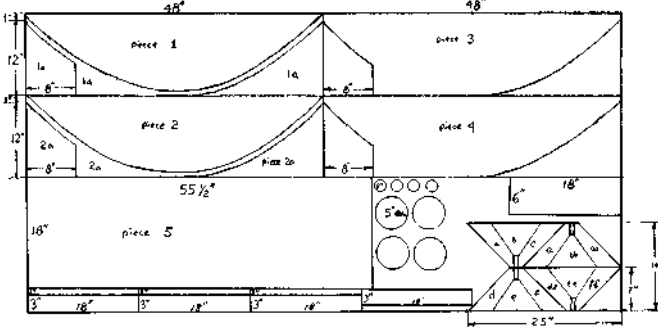

Main Diagram

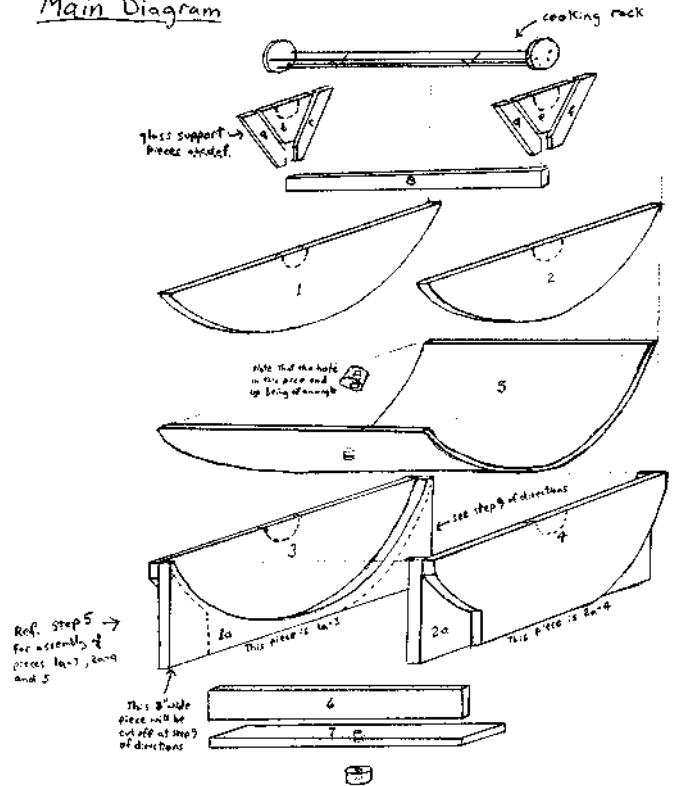

Using the Yellow Cradle solar cooker

The Yellow Cradle cooker is simple to set up.

Step One: Insert a 3/8 inch threaded steel rod (or something similar) into the hole in the reflector surface. The angle of the cooker can be adjusted to track the sun by lifting or lowering the cooker on the rod. The position will become secure by pulling the foot of the rod out a bit.

Step Two: Insert cooking rack. The angle of the rack can be adjusted to keep a level cooking surface by rotating it.

Step Three: Place cooking pot on rack and place insulating lid on top.

The angle of the cooker should be adjusted every 15 minutes or so to keep maximum light focused on your pots.

Performance: This cooker has been tested. It took one hour and forty-five minutes to boil water at sea level with a clear but hazy sky in Washington DC. The maximum temperature recorded was 260°F.

Access

Jeff Gilbert, 409 Christopher Avenue, Gaithersburg, MD 20879 • 301-258-0728

23. Fashion an insulator lid out of corrugated cardboard such that it forms an 8.5 inch diameter half cylinder that's about 1 to 1.5 inches thick and cover with foil (use glue). Bending the cardboard over a cylinder works well. This lid could also be box shaped.

24. Cut two pieces of glass to fit into the 1/8 inch slots formed by pieces a-b, c-b, d-e, and f-e. The dimensions are about 17.75 x 5.5 inch. These pieces of glass need to be tailored to avoid gaps that would diminish the performance of the cooker. Slide them into place. Cutting glass is easy, however you do need a glass cutter. All you have to do is score a straight line on the surface and break the glass along the score.

25. Cut out 5 inch half circles to fit the cooking rack.

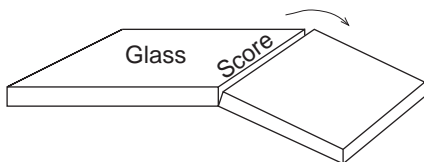

26. The cutout circles on the sides in the main diagram are purely decorative .