

# **AT** MICROFICHE REFERENCE LIBRARY

A project of Volunteers in Asia

A Cooking Place for Large-Sized Pots

by Andreas Bachmann and Thondup D. Kongtsa

Published by:

UNICEF  
P.O. Box 1187  
Kathmandu  
NEPAL

Available from:

same as above

Reproduced by permission.

Reproduction of this microfiche document in any form is subject to the same restrictions as those of the original document.

NEW EDITION

A  
COOKING PLACE  
FOR  
LARGE-SIZED POTS

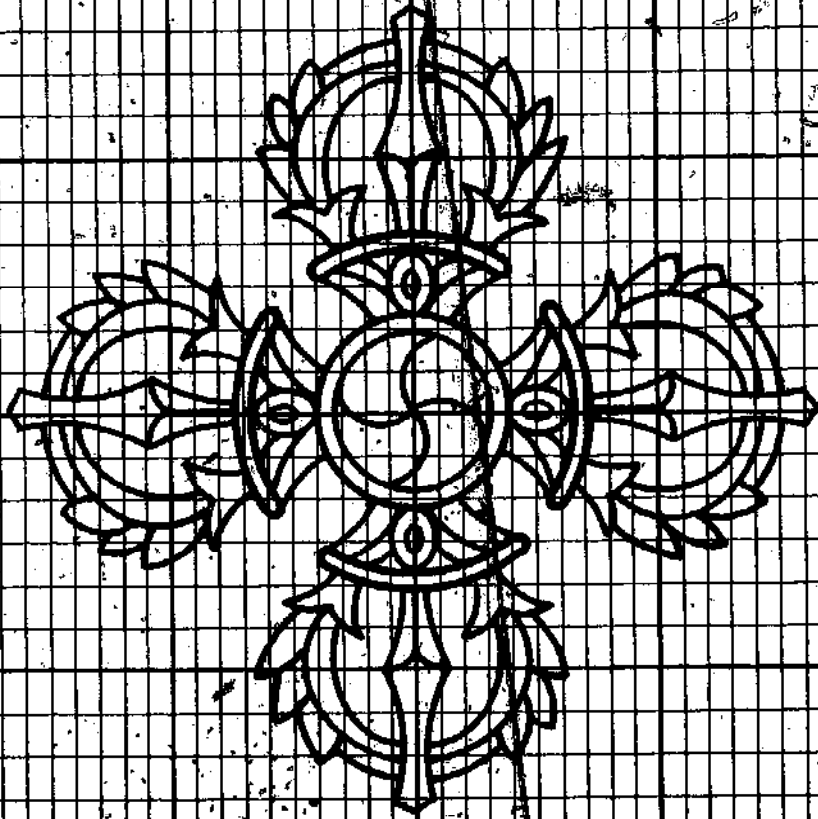

# A BRIEF CONSTRUCTION MANUAL FOR BETTER COOKING PLACES FOR LARGE-SIZED POTS

## USEFUL FOR:

- WOOL DYEING
- CHEESE MAKING
- OTHERS

## FOR REASONS OF:

- MORE EFFICIENT USE OF FUELWOOD
- SAFER WORKING ENVIRONMENT
- SMOKEFREE ROOMS
- BETTER QUALITY OF DYEING

BY

ANDREAS BACHMANN

&

THONDUP D. KONGTSA

WITH THE COMPLIMENTS

OF



U N I C E F

P.O. BOX 1187

KATHMANDU / NEPAL

\*\*\*\*

SECOND, REVISED EDITION

OCTOBER 1984

 The opinions expressed and arguments employed in this publication are the responsibility of the authors and do not necessarily represent those of any organization.

Copyright is reserved by the authors, but permission is hereby granted for the reproduction of any part, text or drawing, for non-profit publication; however the whole booklet, or any major portion, should not be reproduced without permission. Anyone making use of material presented herein is requested to acknowledge the source and submit to the authors a copy of the excerpt.

INTRODUCTION

Cottage industries, such as cheese making and wool dyeing are large scale users of firewood. The firewood they consume is much for boiling large volumes of liquids in large sized cooking pots.

Several attempts have been made to improve domestic cooking devices. For large-sized pots alternatives were studied (electricity) and projects started, but without much success. After many years it is still not clear what is likely to be the best solution!

Much wood is wasted in large, rather primitive stoves that are used to heat big pots. These stoves have several disadvantages, being smoky and inefficient. In addition they are often quite unsafe structures for the support of heavy pots with boiling liquids.

More and more such cooking places are being built, increasing firewood use. At present few people have access to alternative energy supplies, which in any case require a rather high initial investment that restricts their application.

A trial on personal initiative has been started at a small carpet factory in Jawalakhel, and initial results have been encouraging. This experiment may be of interest to others, so it was decided to share the results.



Small-scale wool dyeing with a "Three-stone stove".

SIMPLE METHODS FOR HEATING LARGE-SIZED POTS CAN BE A QUITE WASTEFUL, EXPENSIVE USE OF FIREWOOD!



A widely-used system for wool-dyeing. There is a chimney (however, without a flow-control), without a grate and no door. Certainly a firewood consuming installation.

## PRINCIPLE

To meet most of the user's requirements a good cooking stove should satisfy the following requirements:

- safety
- reduced fuelwood consumption
- low smoke pollution in rooms
- convenient handling

For safety reasons the heavy pots need to be placed on a solid base. A chimney is necessary to enable smoke to flow to the outside of the house.

Reduced fuelwood consumption can be achieved through careful construction and by including certain essential parts. Very important is the draught control in the chimney pipe (= damper) - a device which is quite often forgotten (and then fuelwood consumption is even increased)!

The critical components of such a stove:

- grate, for ashfall and airflow
- door, with airflow holes
- chimney pipe with damper
- properly fitted pot

As well it should be designed to burn pieces of fuelwood about one meter long.

### Chimney

- A chimney can be made of masonry or of sheet metal. It needs to be at least 2.5 meters long and with an inner diameter of not less than 20 cm. The connection to the stove needs a draught-control (= damper). Chimneys need to be cleaned regularly and must therefore have openings at the bottom to remove soot.

#### Before constructing a new stove for large-sized pots:

A new stove should be built according to the size of the vessel to be used. Materials, such as: -pot, -grate and frame, -chimney pipe with damper, -4 pieces of pipes (1 1/4" G.I. pipes) for secondary air flow, -lintels, over ash duct and door (concrete or iron rods), approx. 2000 bricks and mud will be needed.

Note that it is important to have a good foundation to carry the weight of the entire structure and pot with its liquid contents. For reasons of high temperature clay/mud is a good construction material, as binder of bricks. Where cement mortar is used the mixture must be of high sand percentage (to reduce crackings).

#### Diameter of construction.

The internal diameter of the masonry work should be 10 to 12 cm greater than the pot diameter. After deciding the layout, a foundation can be laid.



Operation

- Use dry, if possible hard wood, cut into thin pieces
- To begin with, the damper should be completely open -but little by little closed until fire intensity is satisfactory.
- During firing it is essential that the wood is moved in regular intervals, so that the ash can fall through the grate and fresh air from below gets to the fire.

Note that during operation the front door should be kept closed!

USEFUL TOOLS FOR STOVE'S OPERATION

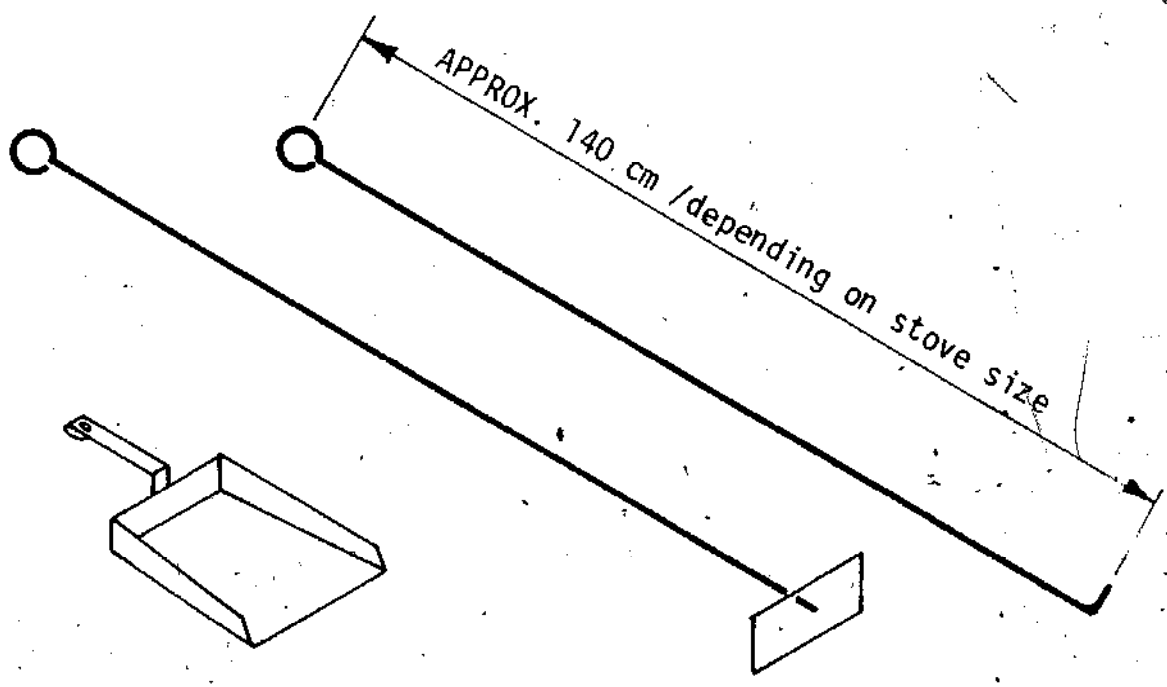

### Maintenance

Keep the fire chamber and ash pit free from materials when cooking is over. Chimney needs to be cleaned regularly.

### Economics

Normal, traditional methods of wool dyeing here in Kathmandu use between 1 kg to 6 kg of firewood per 1 kg of wool. First results of the new installations show that 50 percent of firewood can be saved, as compared with the old method. For example, for 200 kg of wool now 94 kg of firewood are required.

The costs of firewood per kg range between Rs. 1/- to Rs. 2/- (1 US\$ = Rs. 17/20, October 1984). In addition, the dyeing capacity could be increased: previously eight loads were processed in a day, this could be increased to eleven loads a day.

This shows that the improvement of such places can save trees and money. In addition it provides safer working conditions and even better quality dyeing!

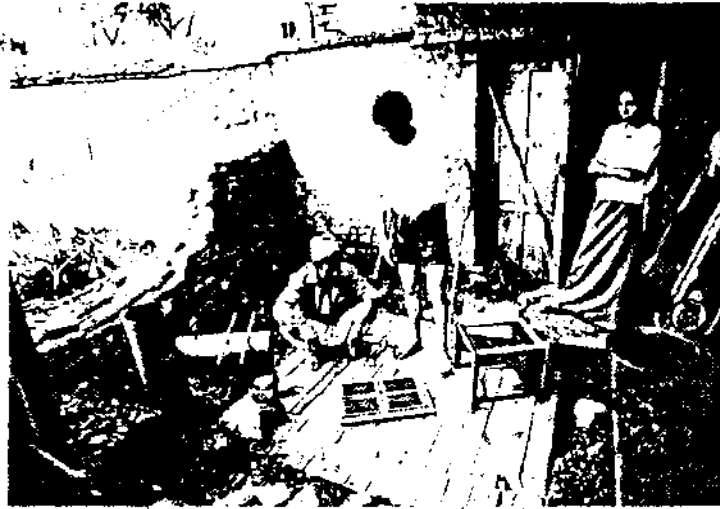

To start with, have a proper foundation made to carry the entire weight. Considering the diameter of the dyeing pot and then having the metal parts placed at the site, the measurement of the construction can be identified. Clay/mud is a suitable material to join the bricks.



Have the ash-fall / air duct specified. The grate is fitted in the centre. The size of the duct / ashfall depends on the grate measurement. The height of the duct can vary, but should not be less than say four to five bricks.

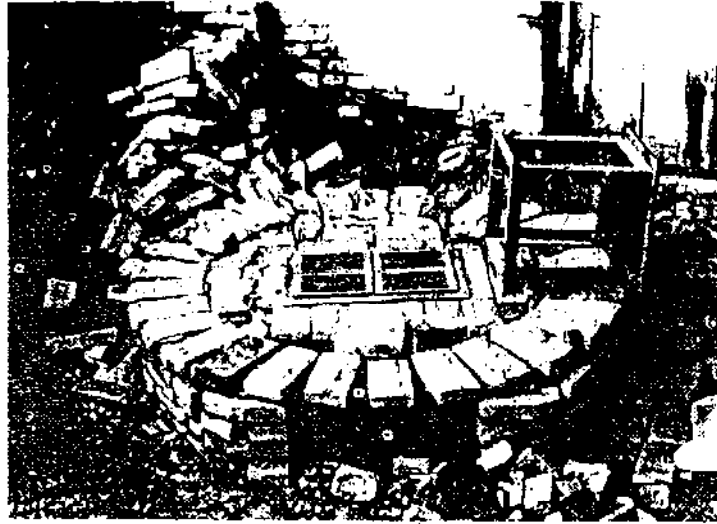

The duct is covered with a lintel. This one was made with iron rods. (It could also be made of reinforced concrete).

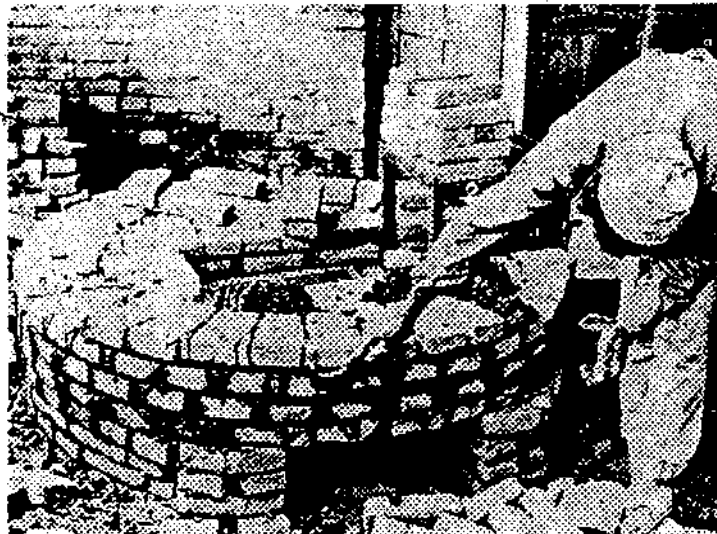

The door frame will be fitted to the same level as the grate, and brick work can continue. Note that the fire chamber is firstly just a "rectangular box" of approx. six bricks' height.



For proper construction it is advisable to incorporate some pipes for secondary air flow. These pipes bring sufficient additional air from the outside to the fire chamber to ensure thorough combustion.



Lay bricks up to the upper level of the door frame.



The pot is then set on top of this fire chamber, leaving a gap of two bricks. Note the brick on which the pot is sitting.

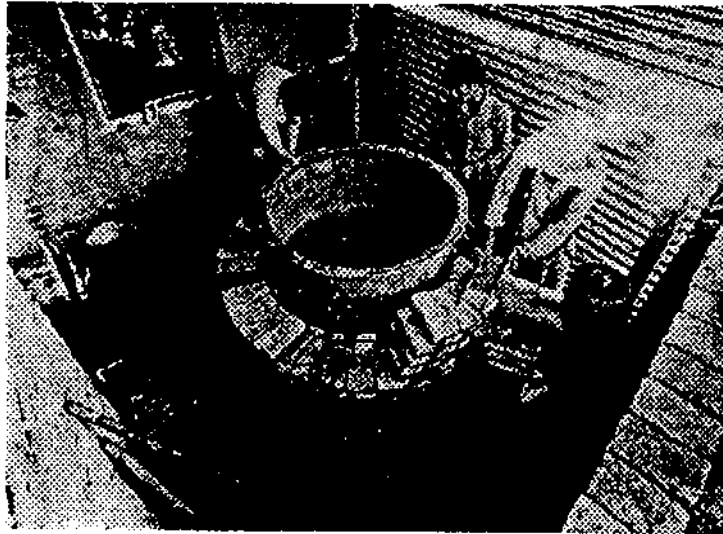

The wall is then built up till it is level with the top of the pot, by keeping an air gap all around of 5 to 6 cm measurement. Of course the chimney is incorporated and the brick construction closed on the top.



This photograph shows the 5 cm gap between pot and the brick wall. This gap is important as it provides an effective heat flow up to the top.



The damper in the chimney (key-ring handle is seen) is an essential part of the installation: it controls the smoke exit and heat escape!





The result is a fine cooking place: safe, smoke-less working conditions, and fuel saving.

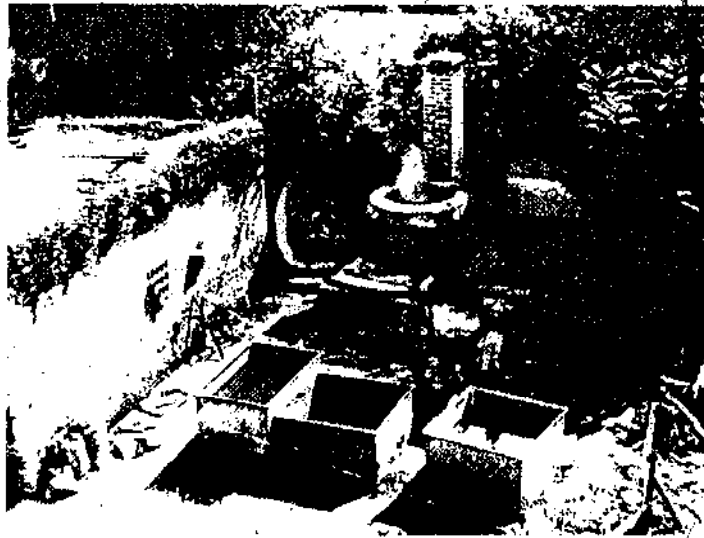

Another dyeing place with a newly constructed and improved stove: reduces the firewood consumption by fifty percent!





A new stove at the Jawalakhel Handicraft Center in Kathmandu. With this they have an increased dyeing capacity (previously eight loads to presently eleven loads per day) and a saving of approx. fifty percent firewood consumption.



The thorough combustion of firewood leaves almost white and fine ashes only.

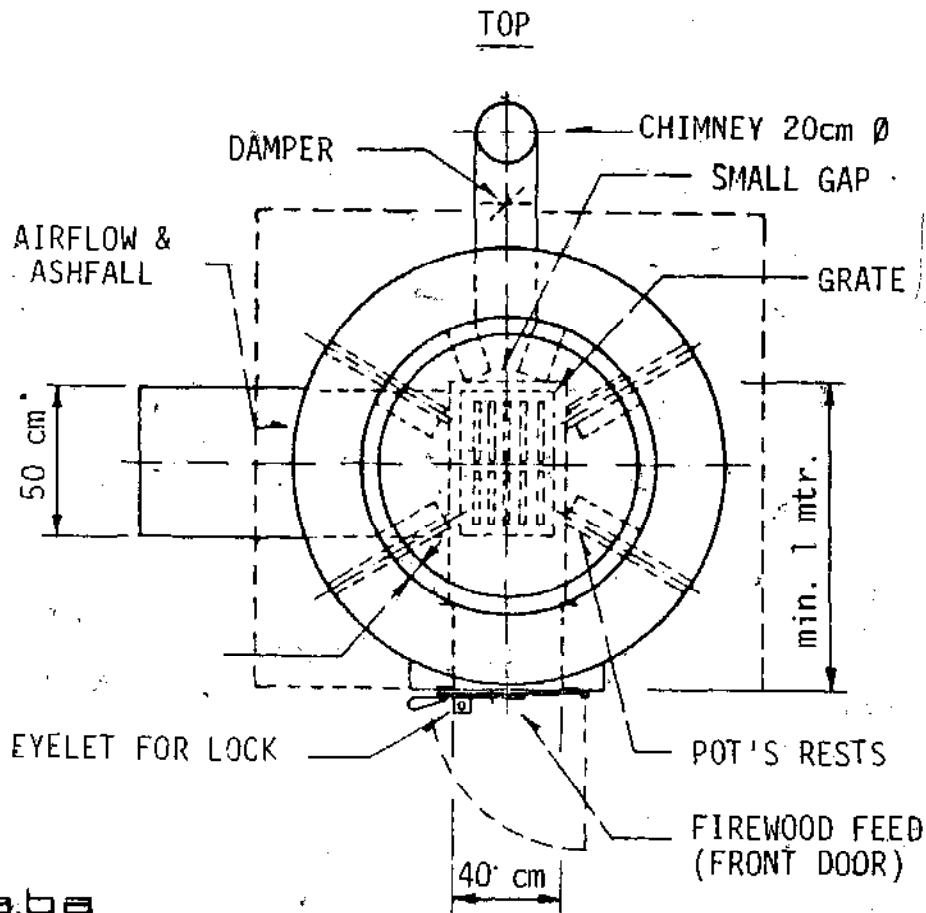
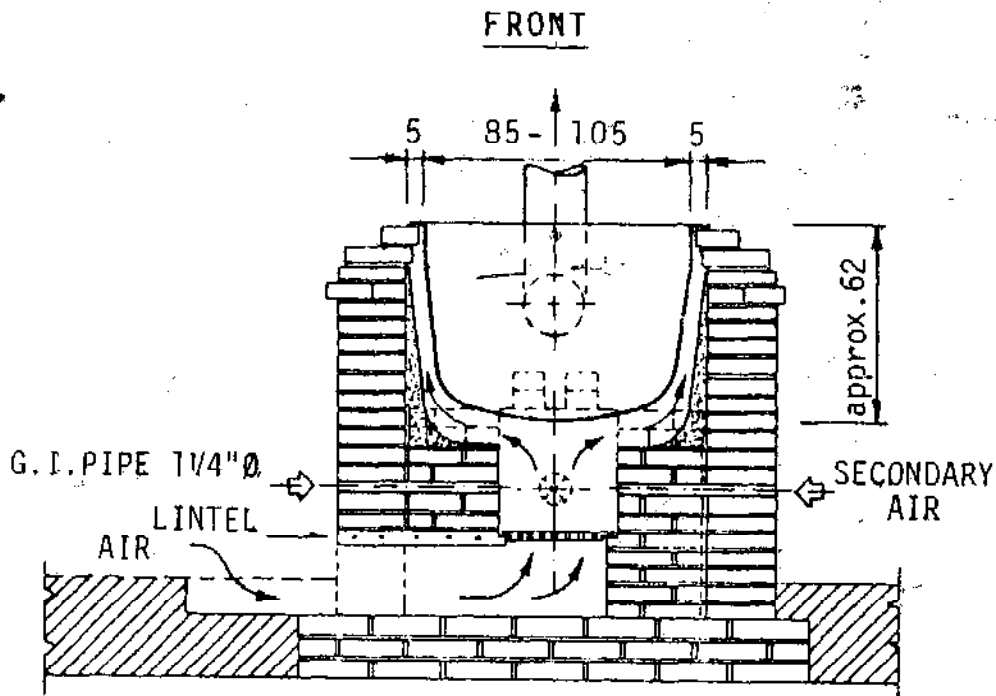

a,ba

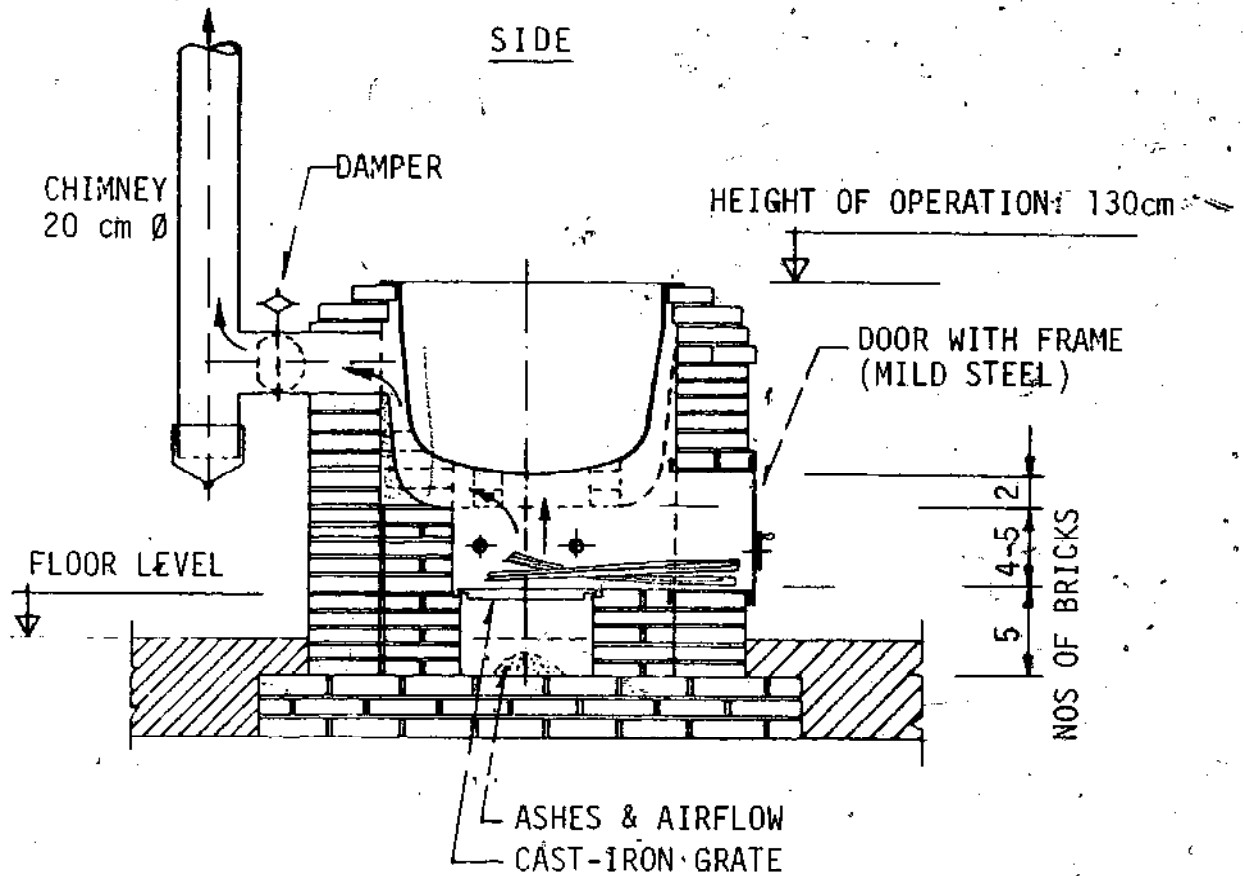

MATERIAL REQUIREMENTS

- pot
- grate and frame
- chimney pipe with damper
- 4 pcs of pipes (1 1/4" G.I.)
- lintels, over ash duct and door
- approx. 2000 pieces of bricks
- mud/ clay.

wood-fired cooking place  
for  
LARGE-SIZED POTS  
with sheet-metal chimney

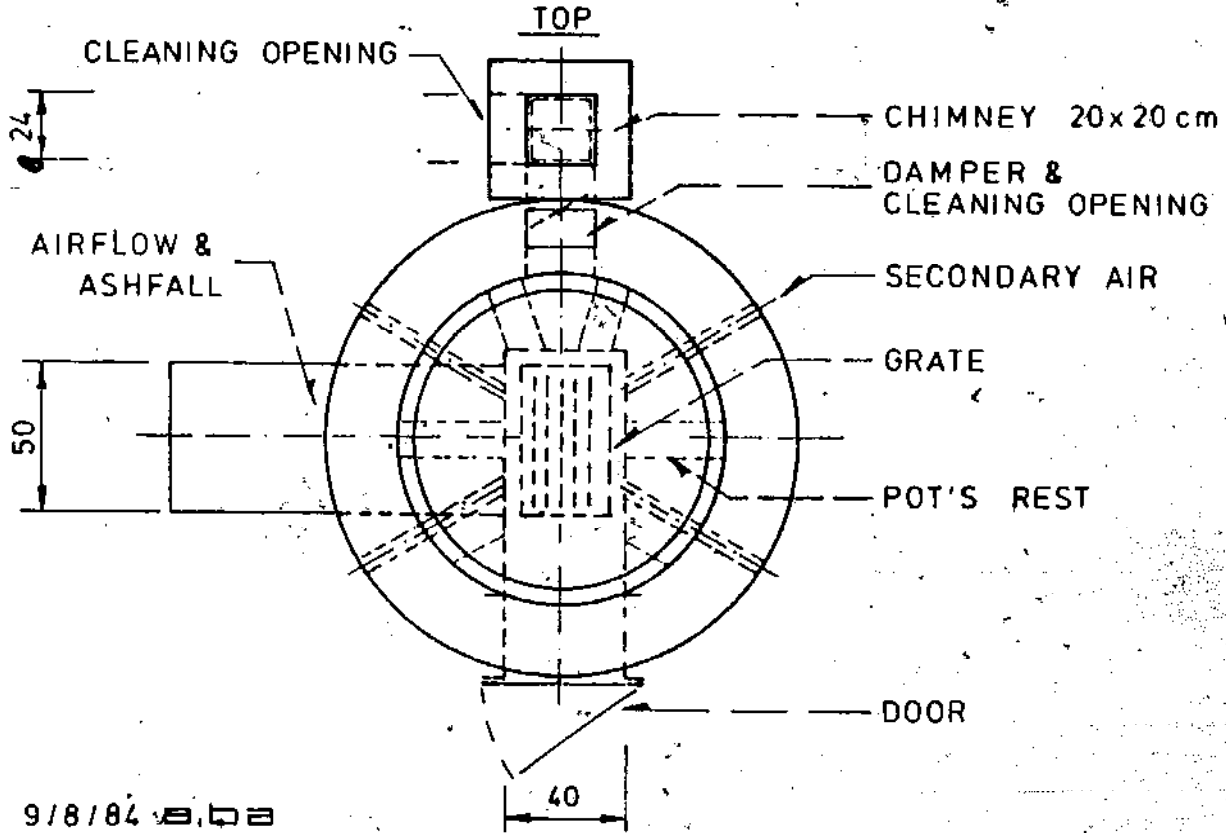
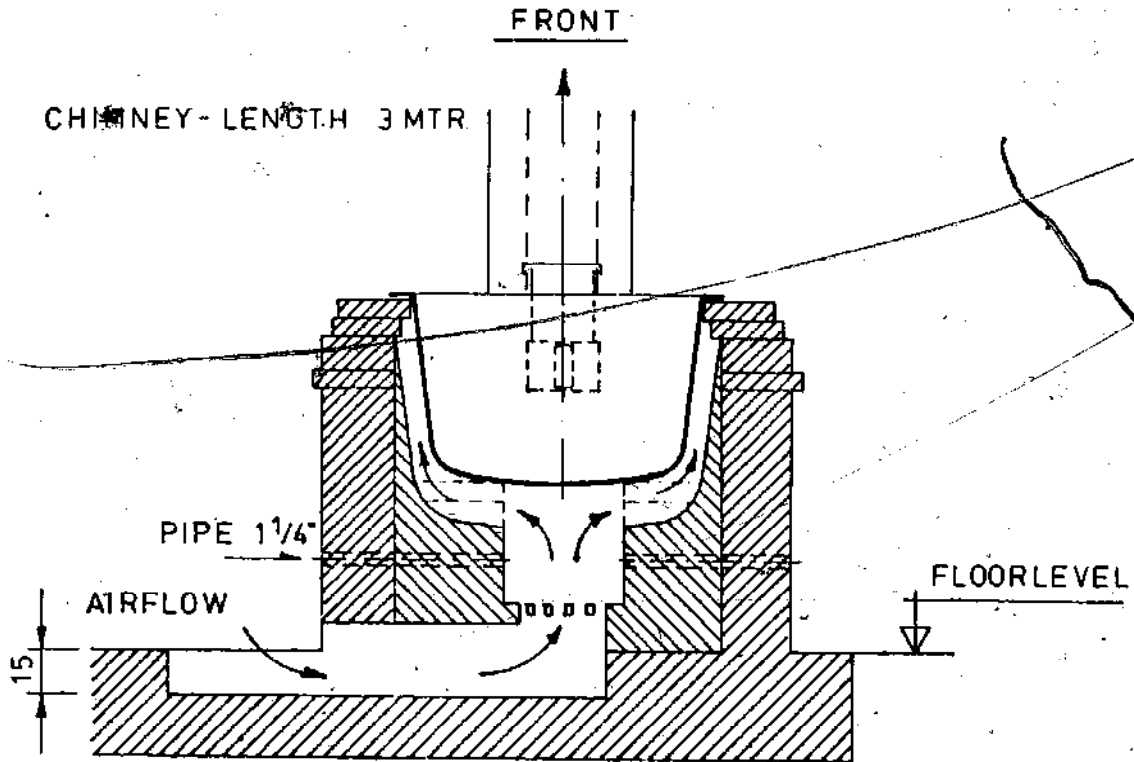

9/8/84 SDB  
MEASUREMENTS IN CM

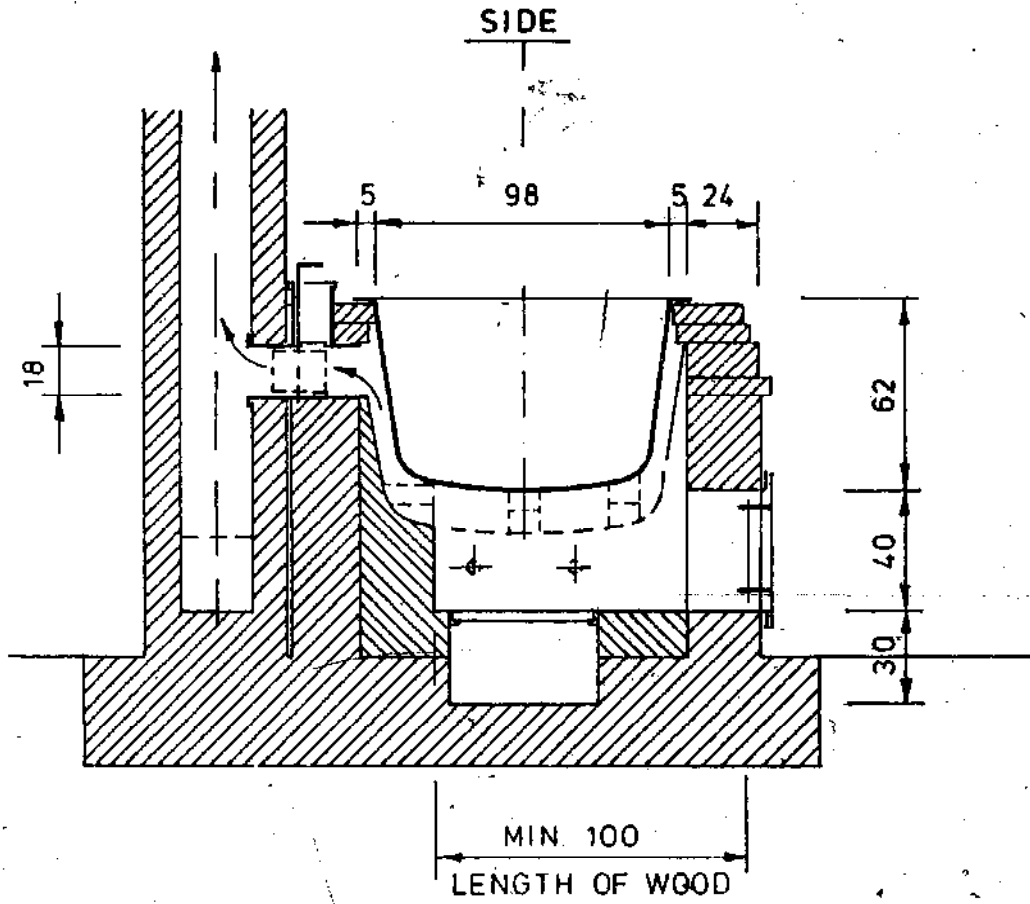

wood-fired cooking place  
for  
LARGE-SIZED POTS  
with brick chimney

SOME PRINCIPLES FOR PROPER CONSTRUCTION

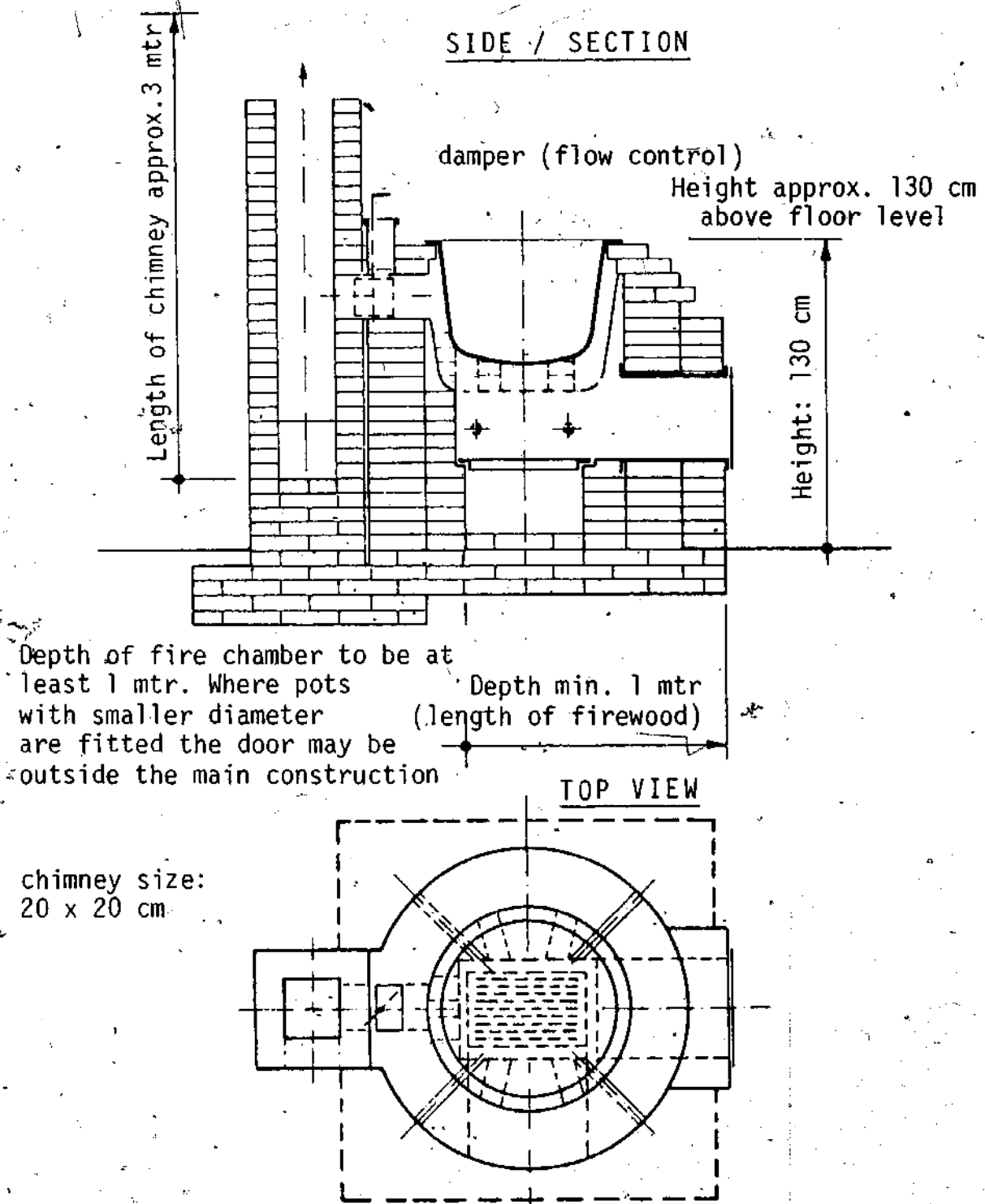

Some dyers prefer to have a construction with a square surface; the corners serve as a table for the various small materials used during the dyeing process.

LARGE - SIZED COOKING POT  
COMBINED WITH HOT WATER PRODUCTION

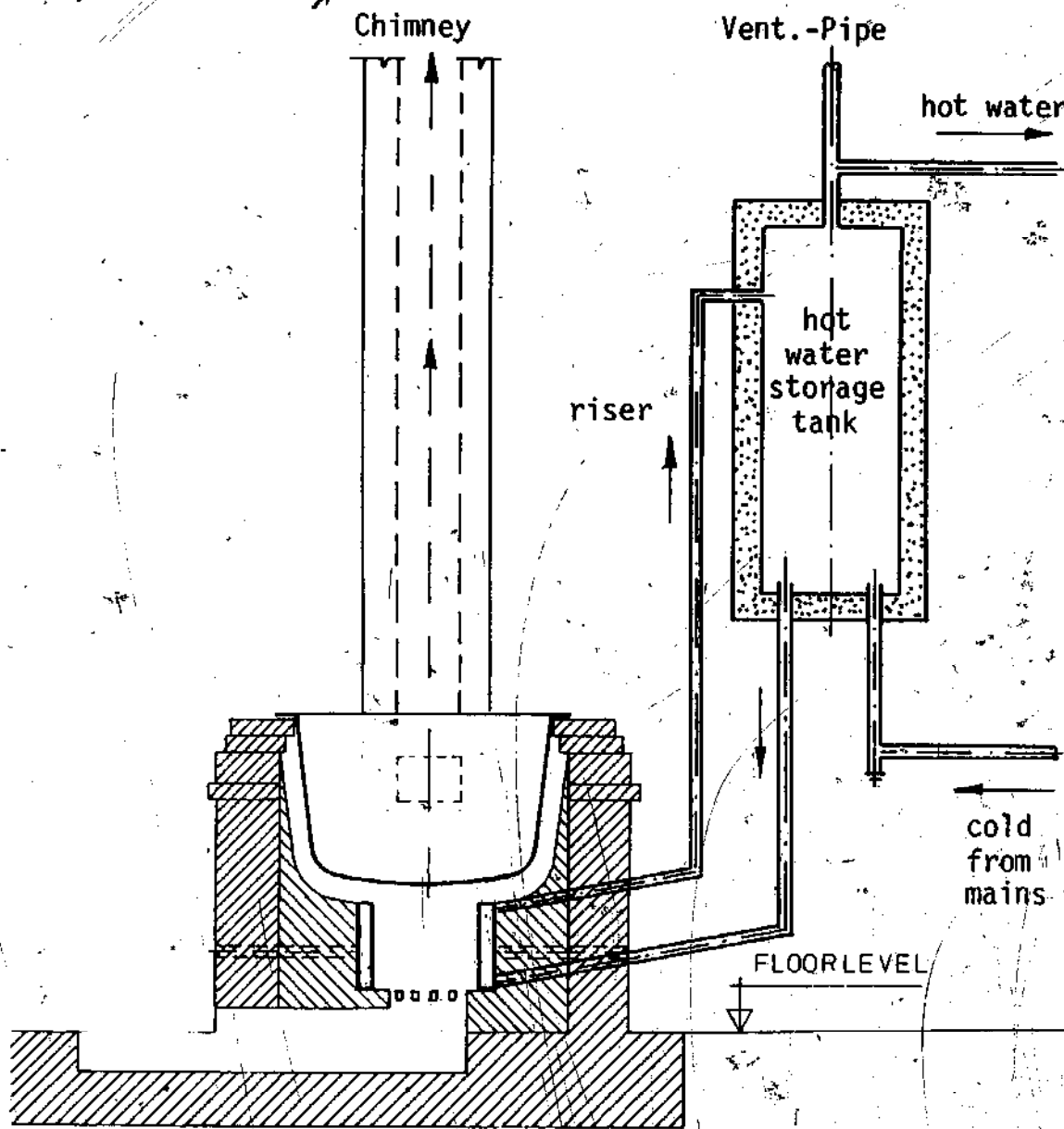

a,ba

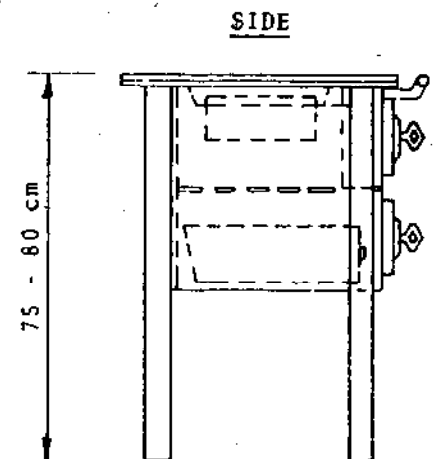
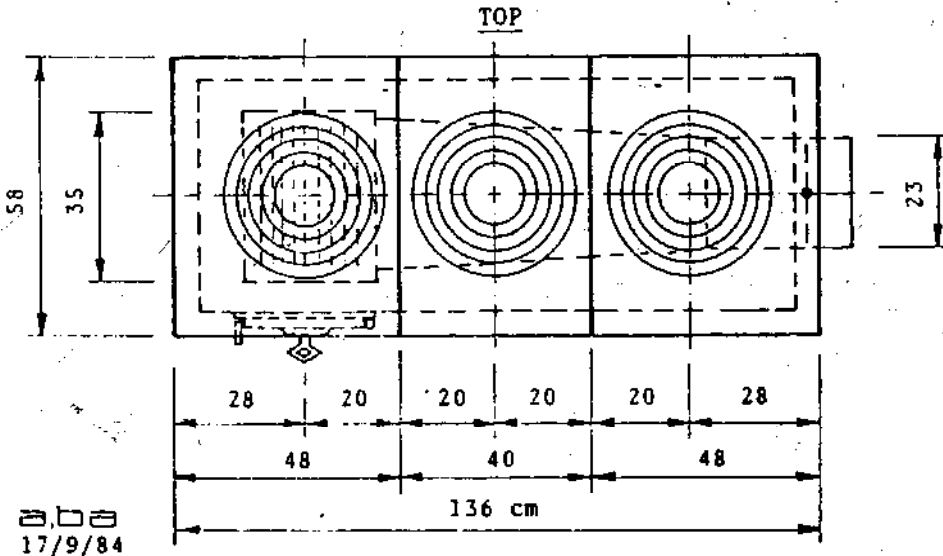
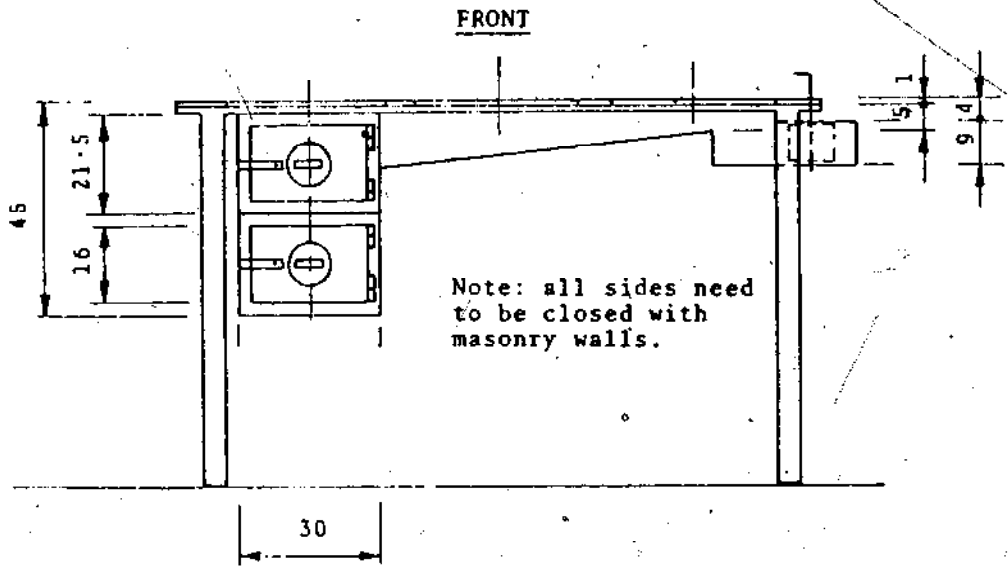

- Size of grate: 35 x 24 cm
- Diameter of rings:
  - No. 1: 35 cm
  - No. 2: 29 cm
  - No. 3: 24 cm
  - No. 4: 19 cm
- Cover plate: 14 cm

**CAST-IRON STOVE**

developed for UNICEF/UNESCO  
Feeder Hostels

by: KATHMANDU METAL INDUSTRY  
12/514 Quadon, Nagal  
Chhetrapati / Kathmandu / Nepal



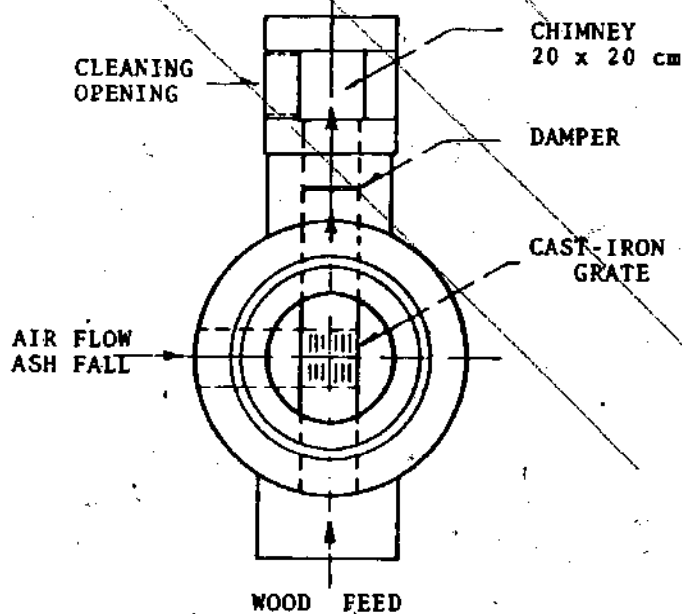
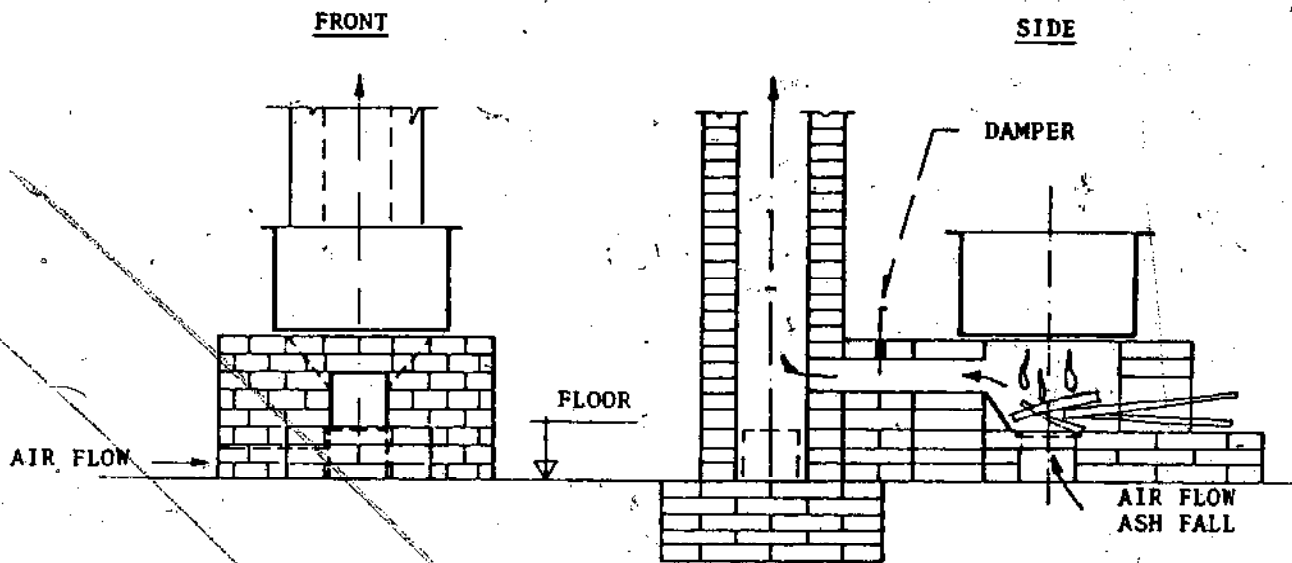

Note: fuel-efficiency can be increased if a door is fitted in front of the fire chamber.

improved  
COOKING STOVE  
for large-sized pots  
(for restaurants, hostels)

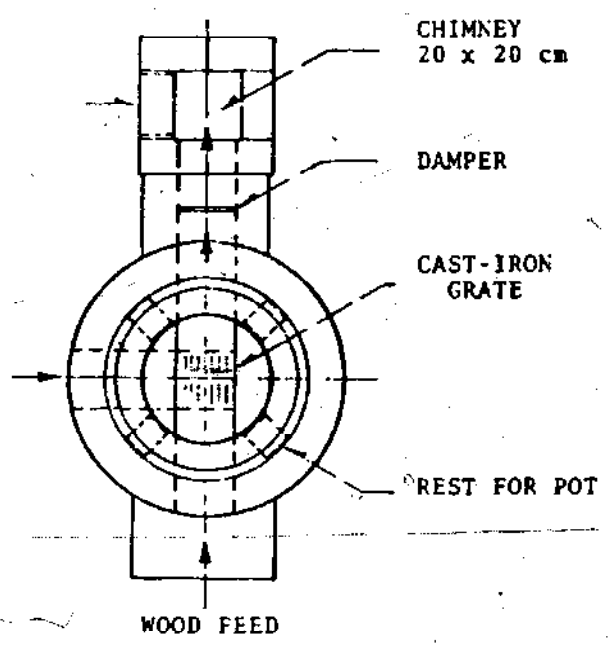
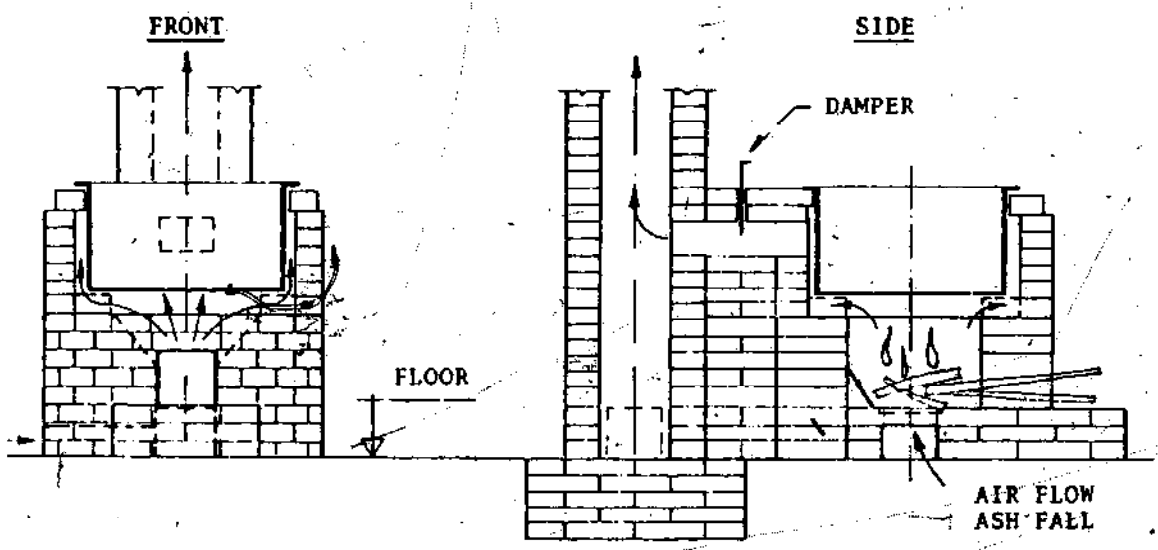

Note: fuel-efficiency can be increased if a door is fitted in front of the fire chamber.

improved  
COOKING STOVE  
for large-sized pots  
with increased efficiency  
through fixed pot construction

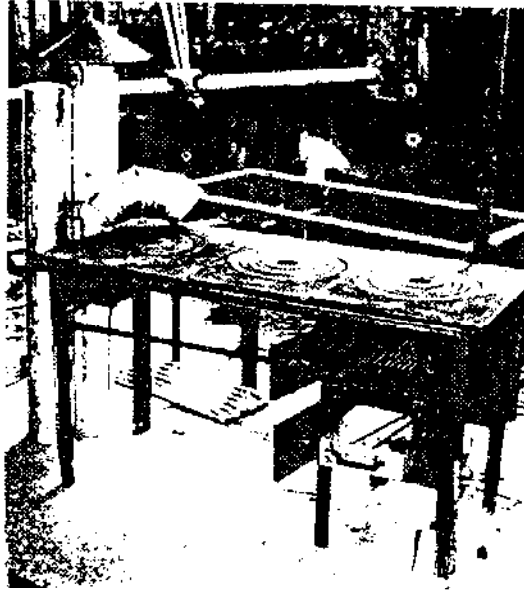

Metal stove with cast-iron parts, developed for hostels with many students. Manufactured at Kathmandu Metal Industry, Chhetrapati, Kathmandu.

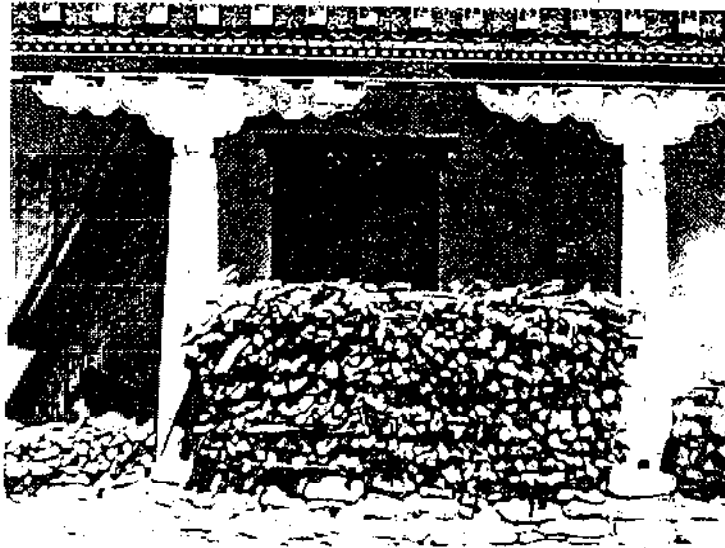

USE DRY WOOD for better performance, safety and firewood savings.

ACKNOWLEDGEMENT

Thanks to: Gebr. Ott AG, Cheese Processing Equipments, P.O. Box, CH- 3076 Worb / Switzerland for their help in forwarding the construction plans of improved cheese processing stoves, and to Mr. Gerry Neville for his assistance in improving this print.

ADDRESSES IN KATHMANDU

Pilot installations of large-sized cooking places:

Mr. Thöndup D. Kongtsa G.P.O. Box 1903 Dobighat / Ward No. 4 Jawalakhel / Kathmandu	& Jawalakhel Handicraft Center (near Ring Road) Kathmandu
---	--

A skilled mason may be available through Mr. Thöndup Kongtsa  
(his carpet shop is near the large tree in front of SATA)

Manufacturer of metal parts (door with frame, grate, damper):

Mr.  
Akkal Man Nakarmi  
Kathmandu Metal Industry  
12 / 514 Nagal, Quadon / Ward No. 17  
Kathmandu / Tel: 214 069

## ALTERNATIVE RENEWABLE ENERGY RESOURCES

Forests are renewable resources, however, due to many reasons they are disappearing much too fast (for example because of population increase; paper/timber industry, management, etc.). Probably the rural population is suffering most, and different measures are required. One of these is improved forest management, another is the improvement of wood fired devices.

In addition there are also other useful alternatives:

- . Solar Utilization
- . Electricity (Mini Water Power Utilization)
- . Fuel Gas from Cowdung (Gobar Gas)
- . Other Natural Resources

Of course each of them has its own potentials and limitations, but several alternatives may prove an advantage, if made available and to function properly.

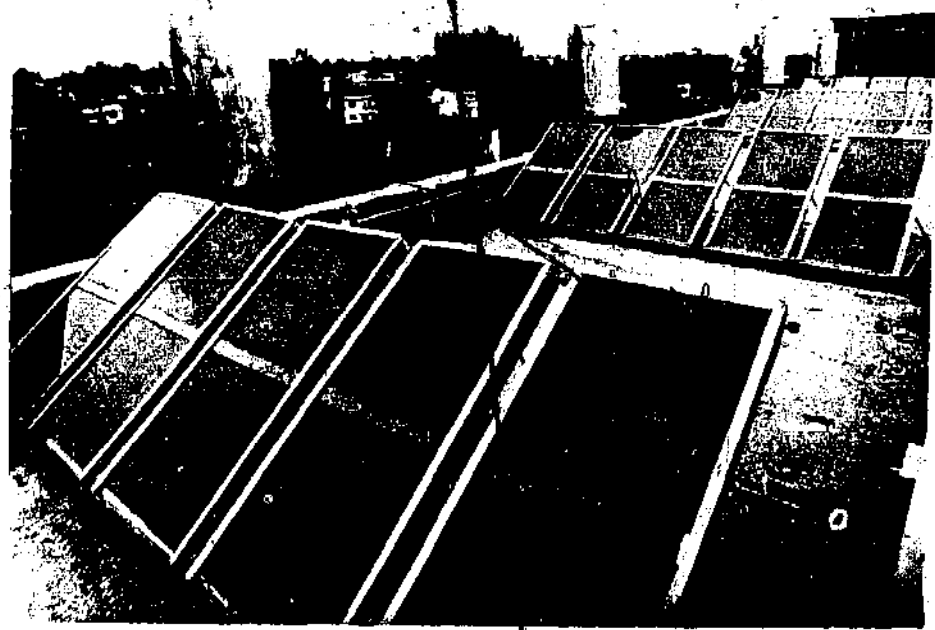

Nepal's solar water heater can produce hot water at reasonable costs; keep the water warm in insulated tanks. This may be useful for industries working with wool dyeing, cheese production, etc.

---

**MORE INFORMATION ON STOVES**

---

**NEW NEPALI COOKING STOVES**

---

by A. Bachmann  
UNICEF-Nepal, 1982 (English and Nepali)

**LESS SMOKY ROOMS**

---

by A. Bachmann  
UNICEF-Nepal, 1984

---

**OTHER INFORMATION ON APPROPRIATE TECHNOLOGY**

---

**MINI TECHNOLOGY**

---

Vol. I , 1978, 1983  
Vol. II 1983

by B.R. Saubolle and A. Bachmann  
Sahayogi Press, Tripureshwar, Kathmandu

**MULTI-PURPOSE POWER-UNIT, with horizontal water turbine**

---

Vol. I : BASIC INFORMATION 1982  
Vol. II : MANUAL - OPERATION & MAINTENANCE 1984

by A.M. Nakarmi and A. Bachmann  
Sahayogi Press, Tripureshwar, Kathmandu (Vol. 1)  
UNICEF-Nepal, (Vol. II)

**NEW HIMALAYAN WATER WHEELS**

---

by A. Bachmann and A.M. Nakarmi  
Sahayogi Press, Tripureshwar, Kathmandu, 1983

**FUEL GAS FROM COWDUNG / III Edition - 1983**

---

by B.R. Saubolle and A. Bachmann  
Sahayogi Press, Tripureshwar, Kathmandu

---