

AT MICROFICHE
REFERENCE
LIBRARY

A project of Volunteers in Asia

Small Farm Equipment for Developing Countries

Proceedings of the International Conference on Small Farm
Equipment for Developing Countries: Past Experiences and
Future Priorities, 2-6 September 1985

Published by: The International Rice Research Institute
P.O. Box 933
Manila, Philippines

Available from: The International Rice Research Institute
P.O. Box 933
Manila, Philippines

Reproduced with permission.

Reproduction of this microfiche document in any form is subject to the same restrictions as those of the original document.

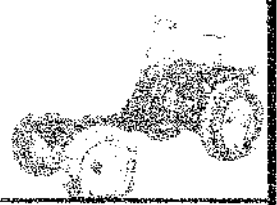

Small Farm Equipment for Developing Countries

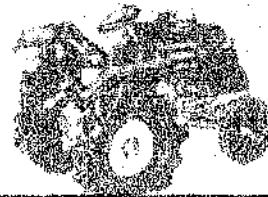
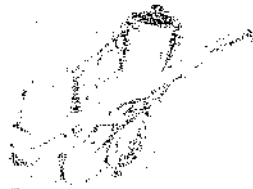
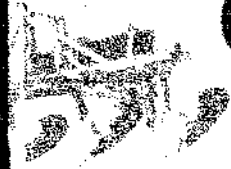

Small Farm Equipment for Developing Countries

Proceedings of the International
Conference on Small Farm
Equipment for Developing
Countries: Past Experiences and
Future Priorities

2-6 September 1985

sponsored by
The United States Agency for
International Development
The International Rice Research
Institute

1986

The International Rice Research Institute
P.O. Box 933, Manila, Philippines

The International Rice Research Institute (IRRI) was established in 1960 by the Ford and Rockefeller Foundations with the help and approval of the Government of the Philippines. Today IRRI is one of the 13 nonprofit international research and training centers supported by the Consultative Group for International Agricultural Research (CGIAR). The CGIAR is sponsored by the Food and Agriculture Organization (FAO) of the United Nations, the International Bank for Reconstruction and Development (World Bank), and the United Nations Development Programme (UNDP). The CGIAR consists of 50 donor countries, international and regional organizations, and private foundations.

IRRI receives support, through the CGIAR, from a number of donors including the Asian Development Bank, the European Economic Community, the Ford Foundation, the International Development Research Centre, the International Fund for Agricultural Development, the OPEC Special Fund, the Rockefeller Foundation, the United Nations Development Programme, the World Bank, and the international aid agencies of the following governments: Australia, Canada, China, Denmark, France, Federal Republic of Germany, India, Italy, Japan, Mexico, Netherlands, New Zealand, Norway, Philippines, Saudi Arabia, Spain, Sweden, Switzerland, United Kingdom, and United States.

The responsibility for this publication rests with the International Rice Research Institute.

Copyright © International Rice Research Institute 1986

All rights reserved. Except for quotations of short passages for the purpose of criticism and review, no part of this publication may be reproduced, stored in retrieval systems, or transmitted in any form or by any means, electronic, mechanical, photocopying, recording, or otherwise, without prior permission of IRRI. This permission will not be unreasonably withheld for use for noncommercial purposes. IRRI does not require payment for the noncommercial use of its published works, and hopes that this copyright declaration will not diminish the bona fide use of its research findings in agricultural research and development.

The designations employed and the presentation of the material in this publication do not imply the expression of any opinion whatsoever on the part of IRRI concerning the legal status of any country, territory, city, or area, or of its authorities, or concerning the delimitation of its frontiers or boundaries.

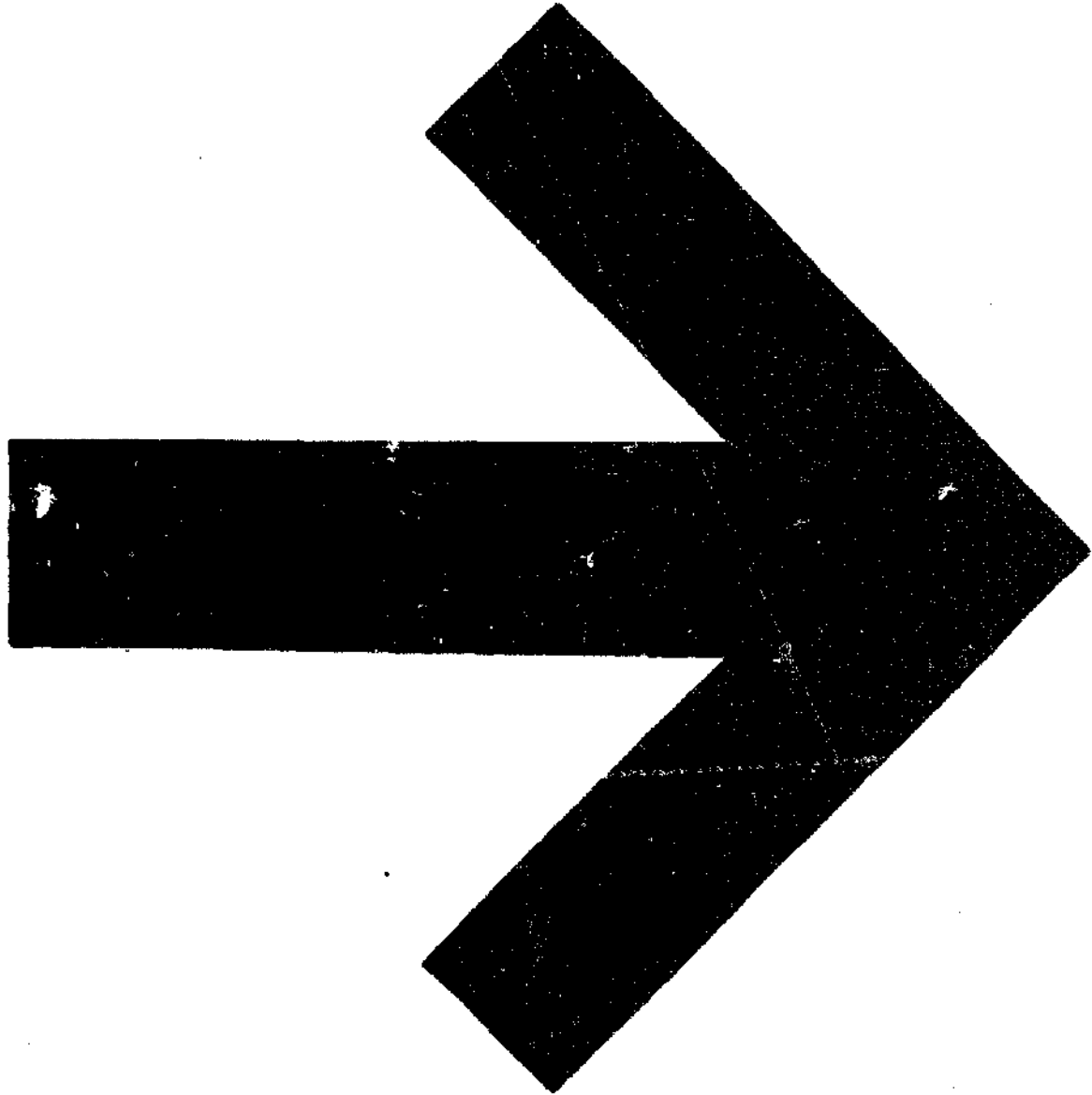

CONTENTS

Foreword

THE ROLE OF SMALL FARM EQUIPMENT 1

The role of farm mechanization in developing countries: experiences in Asian countries 3

A. G. Rijk

Farm mechanization issues and policies 23

G. Donovan, G. Binswanger, and P. Pingali

Mechanization for rice in Japan and Korea 35

R. M. Lantin

Some consequences of agricultural mechanization in the Philippines, Thailand, and Indonesia 59

B. Duff

Mechanization policy and the impact of tractors in South Asia: a review 85

J. Farrington

Agricultural equipment needs of Africa 125

M. Le Moigne

IITA's experience in mechanization for small farmers in Africa 131

N. C. Navasero

LAND PREPARATION 139

Power tiller manufacturing in the Philippines 141

L. G. Bernas

Development of four-wheel tractors and implements in Thailand 151

C. Chakkaphak and B. Cochran

Establishment of the tractor industry in India 161

C. Mohan

The floating power tiller in the Philippines 173

M. S. Villaruz

IRRIGATION 179

The twin-treadle pump: manual irrigation in Bangladesh 181

G. Barnes

The axial-flow low-lift pump in Thailand 195

W. Chinsuwan and B. J. Cochran

SEEDING AND PLANTING 205

Rice seedling transplanters in China 207

D. Z. Qiang

Rice seedling transplanters in the Philippines 213

G. Salazar, L. Ebron, H. Icatlo, B. Duff, and R. E. Stickney

Mechanical rice transplanters in Burma 233

M. Thein

Rice transplanting machinery in Korea 237

K. H. Ryu

Seed-cum-fertilizer drills in India 255

S. R. Verma

PLANT PROTECTION AND SOIL FERTILITY 287

Pest control equipment for small-scale farmers 289

G. A. Matthews

Efficient fertilizer injectors for paddy farmers 295

A. U. Khan, E. U. Bautista, and A. Vasallo

Improved weeding and cultivation systems in Zamboanga del Sur,
Philippines 309

B. J. Short and B. T. Ole

HARVESTING 327

Wheat and paddy reapers in China 329

Bai Ling

CAAMS-IRRI mechanical reaper: experiences in the Philippines 341

*R. E. Stickney, G. C. Salazar, H. T. Manaligod, F. S. Juarez, B. Duff,
C. W. Bockhop, and C. P. Fernandez*

The tractor-mounted reaper in Pakistan 359

Z. U. Rahman and K. M. Butt

THRESHING 371

The Asian axial-flow threshers 373

A. U. Khan

Axial-flow paddy threshers in Thailand 389

J. Mongkoltanatas

Axial-flow paddy threshers in Indonesia 399

V. R. Reddy

Wheat power threshers in India 405

A. Alam

GRAIN DRYING 419

Conditions for successful use of mechanical dryers in Asia 421

N. C. Teter

- Case studies of mechanical dryers in the Philippines: lessons learned 431
A. G. Cardino
- Evolution of paddy drying in Japan 439
R. Yamashita and Y. Ikeda
- IMPROVING RESEARCH AND DEVELOPMENT, MANUFACTURING, MARKETING,
 EXTENSION, AND USE OF SMALL FARM EQUIPMENT 453
- Establishing priorities for research and development of agricultural machinery
 in developing countries 455
R. D. Bell and I. M. Johnson
- Transferring small-farm equipment technology between nations: RNAM's
 experiences 465
Z. U. Rahman
- The IRRI industrial liaison program 479
*C. W. Bockhop, R. E. Stickney, M. M. Hammond, B. J. Cochran,
 V. R. Reddy, F. E. Nichols, and S. C. Labro*
- Enhancing the innovational and entrepreneurial capabilities of farmers and
 small manufacturers 487
W. G. Broehl, Jr.
- Design and development of small farm equipment to simplify fabrication,
 operation, and maintenance in developing countries 505
J. K. Campbell
- Organization and development of the Comilla Cooperative Karkhana, Ltd. 515
A. R. Bose
- Improving access to and use of appropriate agricultural machinery by small-
 scale farmers 525
W. J. Chancellor
- Finding effective channels for marketing small farm equipment 545
B. K. S. Jain
- DEFINING PRIORITIES FOR SMALL FARM EQUIPMENT 557
- A systems framework for small farm equipment research and
 development 559
A. M. Mandac, P. B. Moran, and M. J. G. Novenario
- Use of human and animal power on small farms in Africa 577
H. J. Dibbits
- Filipino women in rice farming systems: some empirical evidence 583
G. T. Castillo
- Recommendations 623
- Participants 627

FOREWORD

Smallholder agriculture plays a very important part in the economy of most developing countries; a large proportion of their population is engaged in the production of food and feed. In Asia, over 60% of the farms are less than 2 ha.

Much research has been directed toward farmers cultivating these small areas. New high yielding varieties, improved management practices, chemicals for pest control, and the introduction of chemical and new organic fertilizers have all contributed to higher yield potential. For example, varieties of rice that have been developed produce in 100-120 d a grain yield equal to or greater than that of traditional varieties requiring 130 to 150 d.

To take advantage of the new varieties, improved practices, and chemical and fertilizer inputs, the small farmer needs to mechanize the operations of crop production.

However, many constraints limit the introduction of machines into the agriculture of developing countries. Small landholdings, excess labor in the agricultural sector, and the lack of capital have limited the adoption of mechanization. Above all, the introduction of mechanization should not create serious problems where rural labor is plentiful. The impact of agricultural mechanization on female labor needs particular attention. The aim should be to reduce drudgery, improve efficiency and productivity, and generate diversified opportunities for labor employment.

Many workers in international and national research centers have developed and introduced machines to assist small farmers. Some programs have been very successful; others have failed to meet their objectives.

Eighty-seven research workers from 22 countries gathered at IRRI 2-7 September 1985 for the conference "Small Farm Equipment for Developing Countries: Past Experiences and Future Priorities." They shared experiences in developing machines for small farmers and reviewed and evaluated the results. After presentation of papers, committees met to develop recommendations for future work. The recommendations provide guidelines for those who will be developing programs of mechanization for small farms.

The conference was made possible by a grant from the United States Agency for International Development; we extend our gratitude to them.

We also express our gratitude to the organizing committee and the many others who assisted in a most successful conference.

M.S. Swaminathan
Director General
International Rice Research Institute

The role of small farm equipment

THE ROLE OF FARM MECHANIZATION IN DEVELOPING COUNTRIES: EXPERIENCES IN ASIAN COUNTRIES

A. G. RIJK
Asian Development Bank
Manila, Philippines

Agricultural development depends largely on technological innovation and its successful transfer. Both are influenced by factor prices, factor scarcity, and incentives. Modernized agriculture can contribute substantially to economic growth; the question is what forms of capital investment are most appropriate. Should the (scarcely) available funds be used for land development (e.g., improved drainage and irrigation), high-yielding technology (e.g., improved seeds, fertilizer, pesticides), technology to improve labor productivity (mechanization), or for augmenting the knowledge and skills of the farmer through investments in education, training, and extension? Development requires incentives to guide and reward farmers. Once there are investment opportunities and effective incentives, farmers usually respond quickly and apply improved technology.

In this paper *agricultural mechanization* embraces the utilization of hand tools, implements for draft animals, and mechanically powered machinery for agricultural land development, production, harvesting, and on-farm processing.

The important questions in relation to mechanization technology are *what type* of mechanization is required to develop the agricultural sector, and *when and how* should technology be applied at the farm level.

Three major objectives of mechanization may be identified: a) *to increase labor productivity* by substituting mechanization for labor (or by bringing a larger area of land under cultivation with the same amount of labor), b) *to increase land productivity* by removing bottlenecks which hamper higher land productivity, and c) *to decrease costs of production* by reducing expenditures for labor and draft animals and by more efficient operations.

Mechanization has often been associated with rural unemployment and other negative social developments. Most of the controversy has emerged because mechanization is commonly associated with mechanical power technology, especially tractors.

Three major levels of mechanization technology are available: *hand tool technology*, *animal draft technology*, and *mechanical power technology*. Each level has different degrees of sophistication (Fig. 1). Each level and degree

Function or operation	Level of mechanization technology ^a		
	Hand tool	Draft animal	Mechanical power
Land clearing	Brush hook Hand saw Motor chain saw	Buffalo and elephant for skidding and loading	Track-type tractor for clearing Skidders for log transport
Land development	Spade, hoe Basket Wheelbarrow	Earth scoop Leveling scraper Bund former	Wheel tractor Track-type dozer Motor scraper Excavator
Land preparation	Hoe Spade	Wooden plow Steel plow Spike harrow Disk harrow	Single-axle tractor Power tiller Two-axle tractor with various implements
Planting or seeding	Seed distribution by hand Planting stick Jabber Row marker Hand-pushed seeder	Furrow opener Marker wheel for dibbling Seed drill Seed-cum-fertilizer drill	Tractor seed drill Seeding with aircraft
Transplanting	Hand-operated paddy transplanter		Motorized paddy transplanter
Harvesting	Finger-held knife Sickle Scythe Threshing table Pedal thresher	Peanut lifter Cutter bar mower Reaper Reaper binder Treading (threshing)	Power reaper Power reaper-binder Power thresher Combine harvester
Crop husbandry	Hoe Weeding hoe Hand sprayer Water can Irrigation scoop	Wooden interrow weeder Walking-type tool carrier Riding-type tool carrier Spraying machine Persian waterwheel	Interrow weeder Motor knapsack sprayer Tractor boom sprayer Spraying with aircraft Diesel or electric irrigation pumps
On-farm processing	Pestle and mortar Flour grinding stone Hand-operated paddy husker	Animal-powered sugarcane crusher Power gear for driving processing machinery	Single-pass rice mill Rubber roll rice milling unit Hammer mill
Crop storage	Sun-drying Bag storage		Artificial dryer Bulk storage
Handling	Carrying Wheelbarrow Sack truck		Elevator Fork-truck
Rural transport	Porter Push cart Rickshaw	Sled Pack harness Bullock cart	Power tiller with trailer Two-axle tractor with trailer Truck

^a Within each operation, the degree of sophistication increases vertically.

have different technical, financial, economic, and social consequences. Therefore, the mechanization issue is complex and its impact, positive or negative, depends on the type of technology selected for a specific situation in a particular locality.

Debate continues on the negative aspects of mechanization, in particular on employment, use of foreign exchange, dependence on commercial energy, and adverse social change.

The agricultural labor force continues to rise substantially in absolute terms in most developing member countries (DMCs). Consequently, governments have become increasingly concerned about *unemployment and under-employment* and this is reflected in a reluctance to increase or introduce agricultural mechanization. Even in developed countries, this is becoming an issue because of unemployment and slow economic growth. In theory, mechanization would decrease labor requirements either by direct displacement or forgone employment opportunities. In reality, mechanization often increases overall employment. It is difficult, however, to isolate the relationship between mechanization and employment because higher levels of mechanization are often accompanied by higher levels of other inputs and management and/or changes in cropping patterns. Many employment problems associated with agricultural mechanization would be avoided if proper technology were selected and if its price reflected the real costs of capital.

Increases in cultivated area and irrigation can aid productive employment growth in the agricultural sector; mechanization complements this by reducing labor peak demands but it may increase overall labor demand. However, there is a physical limit to the output per unit of cultivated land and, therefore, a limit to the number of people that can be productively employed in the farm sector.

Agriculture alone will not solve the employment problem (12) and off-farm employment will be a critical development issue for many developing Asian countries in the remainder of the 1980s (17). Additional rural employment opportunities, e.g., land and infrastructure development and agro-related industries, are required in most DMCs to absorb the growing rural labor force. If labor productivity (or real income) has to increase, some forms of improved technology including mechanization are required. In Thailand, mechanization has contributed substantially to increased production and farm income by facilitating the rapid expansion of commercial upland farming.

Mechanization and other new technologies can contribute to positive *social changes*. For example, release of family labor may result in longer and higher school education; successful mechanization can increase rural income; machines may create interest in modern technology and stimulate practical training in operating, maintaining and repairing them; and tractors frequently provide rural transport and thus change and improve rural market systems.

However, mechanization is also held responsible for negative social developments. For example, it may worsen the distribution of income among economic groups within a region. Unlike typical innovations of the green

revolution, farm machinery is not infinitely divisible and is often characterized by considerable economies of scale; therefore, it tends to favor larger farms. It has sometimes encouraged landowners to take over more farming operations, thus converting renter-tenants into laborers (9, 21). However, appropriate selection and distribution of mechanization can prevent many of these negative socioeconomic side effects.

Agriculture accounts for only a small part of total *commercial energy consumption*, which is less than 5% in most Asian countries. Including noncommercial energy uses, developing countries often use more energy per unit of output than industrialized countries. In Asian countries, manufacture and operation of farm machinery use only about 8% of commercial energy while chemical fertilizer accounts for 84% (7).

This leaves little room for energy conservation in the agricultural sector. In fact, modernization of agriculture, intensification of land use, and increase of production would necessarily increase energy uses (1). Nevertheless, more efficient use of human and draft animal power technology would reduce the increased need for fossil-based power technologies; better operation, repair, and maintenance of farm machinery would prolong their life span and reduce the energy required for manufacture and operation. Conversion of crop residues and agricultural waste into energy will become increasingly attractive as prices of commercial energy increase, but these technologies are often associated with economies of scale and are usually uneconomic for farmers and small rural enterprises.

THE PROCESS OF MECHANIZATION

Despite variations in agroclimatic conditions and in cultural and economic systems, similar economic opportunities and constraints lead to similar patterns of agricultural mechanization. Analyses in developed and developing countries conclude that the following stages may be distinguished in the agricultural mechanization process. As the descriptions of these stages suggest, labor productivity increasing technology may be a better term than mechanization because at later stages, the employment of machines also has to be accompanied by changes in other production technology and environment.

Stage I: Power substitution (3)

At the earliest stage of mechanization, draft animal power substitutes for human power, and mechanical power replaces draft animal power. This mechanization is straightforward and machinery is simple and inexpensive. Crop production practices are hardly changed and mechanization basically takes advantage of lower costs of the new power sources compared to traditional ones. When a larger area can be cultivated (idle land), mechanization often contributes to increased production. An example is the expansion into upland areas in Thailand. Sometimes increased levels of power change the farming systems; mechanization may allow land preparation before the rain

starts and may shorten crop turnaround time, thereby increasing land productivity.

Stage II: Mechanization of the human control functions

Stage II emphasizes substitution of human control functions. Depending on the complexity of control and the degree of mechanization, machinery may become increasingly complicated, more sophisticated, and costly: an improved hand-weeding tool is simple but a cotton harvester replaces manual picking and is complex and expensive.

Stage III: Adaptation of the cropping system to the machine

Even with today's electronics, it is difficult or costly to mechanize certain human control functions. For example, weeds in broadcast crops cannot be removed with machines, so row seeding and seed drills were introduced. Many mixed cropping systems disappeared because of this in Europe even though they were superior to monocultures. Monocropping became financially more attractive since it could be mechanized and, therefore, gave higher returns to labor. Another example is the increase in row distance and its normalization to accommodate heavier and larger machinery without need to adjust wheel tread when changing to another crop.

Stage IV: Adaptation of the farming system and production environment to facilitate mechanization

At this stage, the farming system is usually adapted to increase labor productivity and to benefit from economies of scale. A classic example is the disappearance of mixed farming systems in Europe when farmers specialized in dairy, poultry, hog, or crop production.

In the DMCs, the rapidly emerging specialized poultry and swine contract farms are not so much aiming at benefits of economies of scale for capital investment, but rather are reacting to the fact that the demand for a uniform quality product requires specialization.

At this stage, crops (or varieties) which are difficult to mechanize may rapidly decrease in acreage or even totally disappear, especially if acceptable substitutes become available (e.g., flax and fodder beets). Also, new production systems may be developed, e.g., minimum and zero-soil tillage systems, which became technically possible with the introduction of herbicides.

At this stage, mechanization also becomes an important justification for investments in land development and land consolidation. The higher the level of mechanization technology, the bigger the investment in land clearing, field layout, drainage, and access roads. For example, a fully mechanized farming system requires a completely clean land clearing; fully mechanized paddy farming requires a well-developed drainage system in fields with year-round paddy farming; big and heavy machines require better access to plots, wide and strong rural roads and bridges, and large plots for high operation efficiency.

Stage V: Adaptation of crops to the mechanization system

At this stage, an increase in labor productivity requires adapting plant to machines. Breeders increasingly consider suitability of new plant material for mechanized production, e.g., resistance to lodging and threshability of grain crops, and resistance to bruise damage of potato for mechanized harvesting.

Stage VI: Automation of agricultural production

Stage VI is beginning in countries with high labor costs and sophisticated demands on production and quality. Examples are automated feeding of poultry, automated sprinkler irrigation systems being activated by soil moisture, and automated and computerized rationing of concentrate feeding for dairy cows based on their milk production. In field crop production, this stage is still at the research level: for example, controlled traffic farming with automatic guidance systems which relieve the operator of the monotonous task of steering, and multipass harvesting systems using techniques for selecting the maturity of fruits and vegetables.

Generally, more sophisticated (higher stage) mechanization requires larger investments, not only in machinery but also in research and development, land consolidation, plant breeding, training, etc. In most Asian countries, mechanization is still in stage I, although it may be more advanced in areas such as the Punjab in India, the Central Plain of Thailand, and the Muda Scheme in Malaysia. Exceptions are the Republic of Korea and Republic of China at stages II and III. Further, investments in land development and consolidation projects in some Asian countries suggest that stage IV has begun, but these investments usually were not made for mechanization but to increase land productivity.

CONTRIBUTION OF MECHANIZATION TO INCREASED PRODUCTION

Planners as well as farmers are interested in quantified data on increased output value, lower production cost and/or lower risks that may be expected if farm operations are mechanized. It is very difficult, however, to isolate the specific economic benefits that accrue from machines because mechanization is frequently introduced with other inputs such as irrigation, improved seeds, higher rates of fertilizer and pesticides, and higher levels of management and know-how. Studies on this including the ADB's staff study papers on the "Role of Agricultural Mechanization in Asia" produced these findings:

1. Mechanization contributes to increased production and labor productivity when the available farm power is insufficient to cultivate all available land. For example, the rapid increase in production of upland cash crops in Thailand would not have been possible without the availability of an efficient system of private tractor hire services (19).
2. Where mechanization has been a complementary input to improved farming systems with modern inputs and higher levels of skills and management, it helped increase crop production and labor productivity.

In the Central Plain of Thailand, a combination of water control investments and mechanization contributed to rapid increase in cropping intensity. However, in cases where mechanization has the potential to contribute to increased land productivity, introduction of machinery has usually not been accompanied by complementary programs to improve soil and crop management techniques or incentives for higher land productivity.

3. Except for mechanization of water lifting (pumps), there is no significant evidence that mechanization *by itself* increases production per unit of land.
4. The dominant factor determining crop intensity appears to be the quality of irrigation systems rather than mechanized land preparation, harvesting, and threshing (13, 14, 16).

These findings disagree with the theory that mechanization usually accomplishes operations faster and, therefore, shortens turnaround time and thus increases cropping intensity. In countries with low wages relative to the cost of capital, there is no evidence of differences in cropping intensities between farms using different farm power technologies. High utilization rates are needed to make machines economically competitive with low animal-human labor costs; and therefore the density of machines remains too low to obtain shorter turnaround times and high cropping intensities (13).

RATIONALE FOR MECHANIZATION

At the macrolevel, planners and politicians are interested in mechanization as a means to increase agricultural production. As the previous paragraph indicates, mechanization does not always increase production. Yet farmers invest in machinery. Assuming they are rational, there must be reasons why farmers find it attractive to invest in machinery when it does not increase, and in some cases even reduces, physical output. The reason is that the farmer's objective is to increase family income. He chooses the type of technology (or combination) which maximizes his income. If (family) labor is cheap and abundant and land is scarce, the farmer will invest in technologies which increase land productivity (e.g., irrigation, fertilizer) rather than in mechanization. Therefore, not surprisingly, East Asian farmers first emphasized biological and chemical technologies plus irrigation and drainage to increase production (land productivity) and mechanization became important only when the expanding industrial sector forced real labor wages to increase.

When labor and draft animals become more expensive relative to machinery, farmers will mechanize to reduce production costs. High land productivity becomes less important if farmers can supplement income through attractive off-farm activities; they may stop farming altogether, enabling other farmers to take over their land and take advantage of economies of scale. Not surprisingly, cropping intensities declined in East Asia when wage costs increased but investment in mechanization increased rapidly.

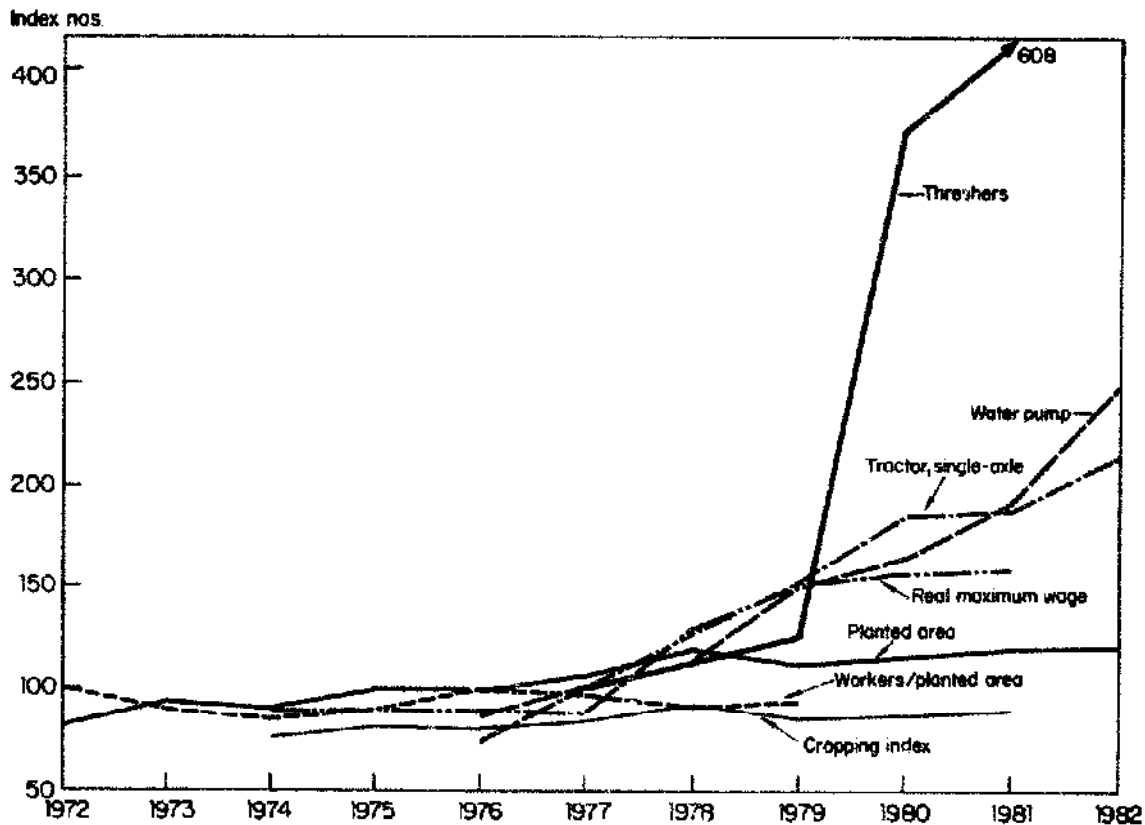

2. Indexes of relevant indicators for farm mechanization (19).

In countries where there is still a possibility to expand the area while labor becomes relatively scarce, farmers will first invest in mechanization (labor saving) technology rather than land-productivity-increasing technology. This happened in the USA and is presently the case in some Asian countries, for example, Thailand (Fig. 2). The underlying reason for this is that, in terms of labor productivity, low-input extensive farming systems are usually more productive than high-input intensive farming systems. In Thailand, most upland crops give higher returns to labor than (irrigated) paddy (19). In fact, irrigation schemes constructed in northeast Thailand in the 1960s were hardly utilized, while expansion of marginal upland farming increased steadily in the same area when labor-substituting technology (tractor hire services) became available at low costs.

If machinery is not available to increase labor productivity (thus, labor wage) to the levels of nonfarming sectors, farm labor will disappear and land will become idle. This is happening in Peninsular Malaysia, where an estimated 880,000 ha of land remains idle because of labor shortage (15).

ADB'S INVOLVEMENT IN MECHANIZATION

ADB has extended assistance to its DMCs in overcoming development problems in various economic sectors, with particular attention to agriculture and rural development. Total Bank lending for agriculture and agro-industry

as of 31 Dec 1984 (involving 228 projects) amounted to \$4.83 billion, about 31% of Bank lending. Agriculture-related technical assistance extended to DMCs (involving 311 projects) amounted to \$77.2 million. Irrigation and rural development have accounted for more than half of the Bank's lending in the agriculture sector, followed by fisheries, agricultural support services, and industrial crops and agro-processing.

ADB has been involved in agricultural mechanization for some time, mainly through financing mechanization components under its project loans. Especially through agricultural credit projects, ADB has been financing agricultural machinery (usually pump sets, power tillers, two-axle tractors, and, in some instances, draft animals). Under other project loans, e.g., for irrigation development and estate agriculture, significant machinery components may be included as part of the overall technology investment. In several cases, ADB financed investments in rural workshops to ensure that the machinery supplied would be properly serviced. So far the only loan ADB has provided solely for agricultural mechanization was through government-operated mechanization centers in Malaysia.

EXPERIENCES WITH MECHANIZATION

On the basis of ADB's experience and other relevant data and information, conclusions and recommendations can be drawn on ownership and credit for agricultural machinery, research and development, machinery manufacture, and supporting institutional arrangements.

Ownership and operation of machinery

The type of ownership depends on the profitability of owning and operating farm machinery, required capital investment, and the availability of finance. In general, low-cost mechanization inputs (hand tools and simple animal-drawn implements) may be individually owned for exclusive use on small farmholdings. For the more capital-intensive machinery, some form of multifarm use is required for economical utilization. Most DMCs have had experience with the following forms of ownership: 1) public hire service, 2) private hire service, 3) private owner-user with hire service for excess capacity, 4) exclusive private owner-user, 5) cooperative ownership, and 6) informal joint ownership.

In India, Pakistan, Sri Lanka, Malaysia, Thailand, and several other DMCs, private entrepreneurship is by far the most efficient way to provide mechanization technology (i.e., machinery hire-services, distribution and repair services) to farmers. Public hire services and cooperative ownership of farm machinery have been unsuccessful worldwide. In several DMCs, public hire services have been directly and indirectly subsidized and offered at rates below actual costs, thus preventing private entrepreneurs from entering the market. This usually perpetuates inefficient public hire schemes and delays full development of efficient, competitive, private custom hire services.

Credit for machinery

Agricultural credit can set the pace and direction of mechanization in DMCs. In Pakistan, large quantities (about 15,000 units) of two-axle tractors are imported each year. Demand is facilitated by an International Development Association (IDA) loan to the Agricultural Development Bank of Pakistan (ADBP). The recent mechanization of wheat threshing has also been accelerated because ADBP made credit available to thresher manufacturers and farmers. In the Republic of Korea, an estimated 90% of mechanical power technology is financed through the National Agricultural Cooperative Federation. On the other hand, discontinuation of these institutional credit programs for farm machinery might immediately decrease the import, manufacture, distribution and repair, and maintenance sector, causing established enterprises to go out of business.

The conditions (e.g., interest rate, repayment period, own finance, collateral, foreign assistance) under which agricultural credit is supplied influence the direction of mechanization development. Sometimes institutional credit is available for purchasing power technology but not for draft animals, even though draft animal technology may be more appropriate. Land titles are usually required as security for the purchase of mechanization technology. This excludes tenants or small farmers from owning tractors when they could use them to generate extra income from contract work. This can be overcome if the machine, rather than land, is used as security (chattel mortgage), some with credit supplied through commercial banks. In Thailand, most credit for mechanization has been supplied through private distributors who repossess machines in case of payment defaults. Such a system requires a rather high down payment to avoid too high a loss in case of repossessing, and may also prevent potential tractor owners from making financially unsound decisions. The higher interest rates charged by the private distributors/commercial banks reflect the cost of capital and lending risk.

Loan repayment of institutional credit for agricultural machinery has sometimes been unsatisfactory. Commonly, credit programs for mechanization do not reflect the farmers' cash flow. For example, in the short term, cash is required almost daily to operate mechanical power machinery throughout the growing season (e.g., fuel, oil, maintenance and repair for pump sets), while cash becomes available only after the crop has been sold.

Deficits in the long-term cash flow are an even more serious cause of repayment default. During the first year, say 1500 h or so of tractor operation, cash is required for fuel, maintenance, and minor repair. After that, repair and maintenance expenditures sharply increase. Few tractor owners reserve funds for this purpose, and they may end up in a situation whereby cash earnings no longer cover the cash required for the operation, major repairs and maintenance, interest payment, and loan amortization.

Defaults can be prevented if the total monthly cash requirements for operation, repair, maintenance, interest, and principal amortization remain constant during the life of the machine. As a practical guideline, loans for tractors may have to be repaid within 3 to 4 yr (often a common requirement

with credit from commercial banks) and may require substantial down payments. The latter is certainly justified when a draft animal is being replaced by a single-axle tractor. For example, a good draft buffalo represents about one-third of the cost of a single-axle tractor in Thailand.

In Thailand, hire-purchase has been highly efficient and is usually offered by importers and local dealers with funds borrowed from local and foreign commercial banks. For locally made machinery, a down payment of 30-50% is required; monthly interest rates are usually 2-3% but may go up to 4% (20). Although these rates may appear high, they represent the opportunity cost of capital and the substantial risk borne by the dealer or financier. Repossession is estimated at 10 to 40% of sales for the medium-sized two-axle tractors (6).

Traditionally, tractors have been financed by distributors with the loan secured by the tractor itself. A 1970 survey (4) indicates that, at that time, down payment was one-third of the procurement price and, on the average, loans had to be repaid within 16 mo. Both buyer and financier could tolerate these tight conditions to maintain the business; however, both had to perform efficiently. Down payments covered most of the losses from repossessions but because of the high down payments and rapid loan amortization, owners would also lose when tractors were repossessed.

Because of increased competition in recent years, down payments on imported tractors were sometimes lowered to only 10% of value. As a result, farmers could make more money by having the tractor repossessed after less than 1 yr of intensive operation (sometimes 24 h/d) than by repaying the loan (5, 6). Poor repayment was further caused by bad crop years and low prices for agricultural produce. Consequently, several suppliers of imported two-axle tractors experienced financial difficulties and stopped financing operations because of poor repayment of tractor loans and heavy losses in repossessing tractors which had received minimum maintenance. The Thai experience explains that commercial credit arrangements reflect the cost of risk.

A frequent problem associated with supply of credit to subsistence farmers is that these farmers do not produce marketable surpluses nor do they have off-farm work to generate cash income required to pay interest and loan amortization. This problem can be resolved if these small farmers own technologies that they use on their own land and with which they might earn off-farm income. For instance, by owning a bullock with implements and cart or a power tiller, a subsistence farmer may undertake custom hire services or transport business to supplement his family income and earn the cash required for operation and loan repayment. This view seems justified because small, less affluent farmers have, in many cases, shown better discipline in repaying institutional credit than the richer farmers.

Research and development in mechanization

Imported technologies can benefit importing countries, but inappropriate technology may be transferred when the relative factor prices differ between the technology importer and exporter or if institutional structures and policy objectives differ between countries. Therefore, local adaptation and the

development of appropriate mechanization technologies require substantial increase in DMCs' indigenous research and knowledge disseminating capacity. There is no need for research activities aimed at invention or rediscovery, but researchers and developers should concentrate on utilizing existing mechanization technology and know-how from other countries and modify and redesign them to suit local conditions. The IRRI agricultural machinery program is a good example of this strategy, but it also confirms that substantial investments in research are required if tangible results are to be produced, and that concentration of research is likely to be more successful than proliferation.

In many DMCs, research on agricultural mechanization and engineering is not yet well established. The mechanization engineers from DMCs are often trained in Western countries where much emphasis is on research having little relevance to their own country's agricultural systems. Lacking a mechanization strategy, few DMCs have established effective procedures to establish priorities for mechanization research.

Indigenous manufacture of mechanization technology

Mechanization technology production falls into four categories:

1. *Production by village artisans* of hand tools and simple draft-animal implements. Investment is very low.
2. *Production in small workshops* of draft-animal and simple tractor implements and machinery. Investment is generally low while production volume is small, often through job orders.
3. *Manufacture* producing all products using mass production techniques for forming parts.
4. *Advanced manufacture* producing complicated machinery utilizing automated mass-production processes for forming, cutting, and assembling.

Most simple hand tools and traditional animal-drawn implements are made in small village workshops. With few exceptions, all other agricultural machinery production in DMCs takes place in small and medium-scale industries. Therefore, the agricultural machinery industry in most DMCs has the following common features (18).

- The predominant small- and medium-scale industry lacks sufficient turnover to make economic investments in modern and superior production technology, design, engineering, research and development, marketing and management.
- Demand for agricultural machinery is usually highly seasonal causing an extra financial and management burden.
- Small manufacturers have difficulty in obtaining the proper quality material or components since they usually cannot directly import these.
- Most DMCs do not have strict quality control standards. Cheap and inferior products cannot compete with better and more expensive ones and may even destroy the market.
- Absence of a long-term agricultural mechanization strategy and reliable estimates of effective demand makes it difficult for industrial engineers to plan manufacturing capacity.

Some problems associated with small-scale industry may be overcome if manufacturers cooperate to obtain advantages of economies of scale. Another approach is to encourage agricultural machinery component production in smaller specialized industries, with assembly in one factory. This would prevent unnecessary proliferation of makes and models. Nevertheless, an ADB study of industry in the ASEAN countries found that even at prevailing prices (uncorrected for possible distortions introduced by government policies), small- and medium-scale establishments were more efficient than large-scale enterprises in about half of all industrial subsectors (10).

ADB has supported small-scale and medium-scale industry development principally through loans to Development Finance Institutions (DFIs). In recent years, DFI loans have contributed about 10% of total ADB lending. It is necessary for ADB to channel these loans through DFIs as the foreign exchange component of small-scale industry loans is rather small and DFIs are better placed to evaluate the viability of small borrowing enterprises.

In conformity with DMCs' goals of industrialization, improving balance of payments, and self-reliance, the local manufacture of agricultural tools, implements and machinery should be encouraged whenever technically and economically feasible, both for import substitutions as well as for export. Local manufacture also ensures that tools and implements are most appropriate from the technical and economic point of view. It also warrants improved supply of spare parts, repair and maintenance facilities, especially if the machinery is produced in rural areas.

Some countries are highly successful in local agricultural machinery manufacture; others have failed. Realistic strategies, combined with adequate and realistic government support policies and incentives are a precondition for establishment and development of the mechanization input industry. Experience in India, the Republic of Korea, and the Republic of China indicates that to manufacture sophisticated power technology, joint ventures with foreign manufacturers are necessary, at least in the first years.

Agricultural machinery manufactured in Asia has plenty of room for expansion. Here are some appropriate possibilities:

- Agricultural hand tools and implements whose manufacture is labor-intensive and requires only low levels of investment, know-how, and management, and which is not affected by economies of scale, are most suitable for production in low-wage countries for local market and export. These include all hand tools, hand-operated implements, animal-draft implements now in use in Asia. Hand tools are usually most economically produced by local artisans using scrap steel, while the animal-drawn and conventional tractor-drawn tillage implements can be produced in local workshops, employing simple cutting and welding technology.
- Manufacture of tools and machinery which require precision and durability (e.g., manually operated pesticide applicators or power-take-off driven implements) may require substantial investments in manufacturing technology and, therefore, requires medium-scale to large-scale operations, or an efficient system of subcontracting and quality control.

- Other sophisticated machinery such as engines, power tillers, and two-axle tractors can only competitively be produced in large quantities and require high levels of management and know-how. To market large volume usually means export market or export competitive quality has to be obtained. Careful analyses are required before investments in such manufacture.

Local manufacture or assembly of sophisticated modern power technology in most DMCs is usually more expensive than importation because of absence of economies of scale and know-how. Also labor intensive production may not be able to compete with modern production machines which reflect high quality and innovation. Modern mass production technologies may be less capital intensive per unit of output, require less material, and be more energy efficient. For similar reasons, locally manufactured content usually remains substantially less than originally planned, and therefore, the contribution to the industrialization process is less than envisaged. In some cases, erroneous industrial development policies keep inefficient and expensive local machinery manufacturers in business. Ultimately, the farmer pays the higher equipment prices created by poor industrialization policies.

Institutional arrangements and infrastructure

In most Asian countries, except the Republic of Korea, Republic of China, and India, mechanization has received little government investment in education, extension, training, and research compared to other modern technologies, such as irrigation and drainage, modern fertilizer technology, plant breeding, and seed technology. Yet farm power (mechanization) is already an important production factor in many DMCs.

Adequate institutional and infrastructural support may substantially reduce the private and social cost of mechanization, but policies must fit the particular needs of the country. In many instances, it may be more economical to purchase less equipment but ensure longer life and higher utilization by encouraging custom hire services by private entrepreneurs rather than public enterprises or cooperatives, simultaneous investment in training and adequate repair and maintenance facilities, and budget allocations for purchase of replacement parts.

Education, training, and extension. Rural development programs have accelerated the need for skilled manpower to operate, repair, and maintain mechanical technology. Manpower training has rarely kept pace with the introduction of new technology and in some DMCs migration of skilled labor to work abroad has exacerbated this situation.

In rural areas, operation, repair and maintenance skills are usually obtained through on-the-job training and trial and error. Few DMCs have specialized courses in appropriate mechanization. Hand tool and draft animal technology predominates in most DMCs, but only India has sufficiently recognized this type of technology at the college and university level. Many engineers consider that type of technology outdated and beneath their status. Universities and colleges must increasingly produce practically trained mechanization en-

gineers who specialize in agricultural tools and machinery and know how to manage related business such as manufacturing, distribution, repair and maintenance, and custom-hire services.

Extension advice on agricultural mechanization is weak in almost every DMC. Most extension programs concentrate on yield-increasing biological and chemical technology, with little attention to complementary tools and machinery (e.g., hand sprayers and pump sets). In regions with significant mechanization (e.g., lift irrigation projects), a proportionate number of extension workers should specialize in the particular mechanization technology. The private sector (suppliers) should play a more active role in extension and training. More use must be made of exhibitions, demonstrations, and modern communication technology such as radio and television to educate the rural population.

Supply, repair, and maintenance network. Depots, stores, sales outlets, and transport facilities are required to ensure that farm machinery, fuel, spare parts, and other essential supplies are available where and whenever they are needed. Although roadside repair shops often produce work of very low quality, low labor costs relative to cost of capital ensure that the economic life of machinery is usually longer than in developed economies.

In several DMCs, semigovernment institutions and corporations are involved in the manufacture, importation, distribution, sales and after-sales services. Often, those agencies are inefficient, draining the public sector budget; and because of direct and indirect subsidies obtained, they often preempt private sector initiative. Fortunately, many governments are turning to privatization.

IMPLICATIONS FOR FUTURE OPERATIONS IN MECHANIZATION

Adequate and appropriate farm power is a key element in programs to increase agricultural output and labor productivity. Mechanization, in all its forms, will become increasingly important for most of ADB's DMCs. In some DMCs, annual investment or costs of mechanization are substantial and exceed the expenditure on fertilizer, as in India (11) and Thailand (19). But in Malaysia, which lacks mechanization, labor productivity in food crop production is insufficient to maintain acceptable wage levels, and large areas of land are left idle because of labor shortage.

The annual growth rates for draft animals and machinery are estimated at over 8% annually up to the year 2000, and annual investment in mechanization will be around \$10 billion in ADB's region of operation (8). It is likely that DMCs will increasingly request technical assistance and financing for mechanization as part of crop intensification, irrigation, and credit programs or projects; some may also request exclusive financing of mechanization projects and programs. The medium- to long-term nature and the size of these investments require that comprehensive studies be made to develop an optimum strategy. In agricultural sector studies, an assessment and projection of demand and supply for farm power should be included. Where lack of farm

power constrains production, mechanization programs (investment for machinery and infrastructural and institutional support) should be developed for the particular DMC.

Asian countries differ in their technical and economic conditions; each needs its own pattern of mechanization. However, similarities in relative factor abundance and the tasks required in similar agroecological production systems produce common elements. Although Japanese and Korean farm production significantly differs from that of Southeast Asia, most Asian countries follow the East Asian pattern much more closely than the mechanized agricultural production systems of Australia and North America. But because of the highly supported (subsidized) agricultural prices in Japan (for example, the rice price in recent years was about eight times higher than in Thailand) and high subsidies on machinery, mechanization will progress on a much slower pace in East and Southeast Asia than in Japan. For the Republic of Korea and the Republic of China, mechanization will become increasingly sophisticated and soon will match the Japanese technology.

The process of mechanization is basically a response to economic forces, i.e., the increase in real wage and draft animal cost in relation to the cost of using machines. In the foreseeable future, relatively low farm wages will limit mechanization in South and Southeast Asian countries to relatively low-cost technology for power-intensive operations only. An exception will be Malaysia which already has relative high farm wages, and Thailand where stage II will become important, provided that mechanization technology is made easily accessible to farmers.

- For most DMCs, increased levels of mechanization are required to support agricultural development or even to sustain present production. Sound decisions will be needed on the following issues:
 1. projections of total demand and supply for farm power, considering increases or decreases in agricultural labor force and draft animals and increases in arable land, new cropping and farming systems and increases in productivity;
 2. the appropriate combination of hand tool, animal draft, and mechanical power technologies for specific farming systems, considering technical suitability and economic and social development objectives;
 3. selection of efficient systems to provide the individual farm with the appropriate mechanization technology or services; and
 4. assessment of supporting institutions and infrastructure needed to implement the proposed mechanization programs successfully.
- Because of the pessimistic employment outlook in some DMCs, mechanization's impact on employment should be carefully scrutinized. Some countries may want to establish special committees with members representing all aspects of technologies, their economics, and their net contribution to employment.
- The introduction of mechanization at the local level should be based on assurance of efficient use. Beyond supplying machinery, the institutional (e.g., training, extension, research and development) and infrastructural

- (e.g., distribution, repair and maintenance, manufacture, land consolidation) requirements must be assessed and simultaneously developed.
- Mechanization projects and programs should be implemented through competitive private sector. Experience shows the private sector is much more efficient than the public sector and cooperatives in providing mechanization and related services.
 - Adequate research and development, and information dissemination of appropriate mechanization technology is lacking or insufficient in most DMCs, especially on hand tool and draft animal technology. More attention should be paid to appropriate mechanization research and the dissemination of results to manufacturers and farmers.
 - Institutional credit programs for agricultural mechanization must suit the specific requirements and features of investment in agricultural machinery. Certain types of mechanization can conflict with the broad aim of national policies; therefore well-thought-out mechanization strategies are required before concessional or subsidized credit is made available.
 - Foreign assistance programs need to pay more attention to hand tool and draft animal technology and the promotion of appropriate technologies.
 - Several DMCs have a competitive local agricultural machinery industry catering to needs of farmers but not suited to International Competitive Bidding (ICB) procedures. Bilateral and multilateral financing institutions should carefully reassess their procurement conditions and promote appropriate mechanization based on locally manufactured agricultural tools, implements, and machinery.
 - During project implementation, more attention must be paid to the technical aspects of mechanization to ensure that the project is efficient and carefully implemented and achieves its objective.
 - Funds for financing machinery must be allocated to keep machinery operating throughout their projected life. In foreign exchange starved countries, budget allocations for repair, maintenance, and fuel are often insufficient. For example, during an operational life of 6,000 h, a 60-hp tractor would consume \$25,800 of fuel and lubricants, at \$0.40/liter diesel fuel or \$4.30/h on the average for fuel and lubricants. About 75% of purchase price would be spent on replacement parts. Thus, with an initial investment of \$12,000, a foreign exchange allocation of \$35,000 is required if all fuel, lubricants, and parts are imported. Local costs for operator, mechanics, repairs, etc. may account for another 50% of initial investment. Repair and maintenance and replacement cost of equipment used with the tractor have to be added.

BROAD STRATEGIES FOR MECHANIZATION

The scope for production increases based on crop intensification is considerable in most countries. Mechanization programs should focus on areas with abundant land with labor shortages, and with potential for crop intensification.

tion. In the labor surplus economies, agricultural mechanization should not be implemented in isolation from crop intensification and land development and irrigation programs. The mechanization strategy to be followed depends largely upon the agroecological conditions, farming structure, socioeconomic factors, relative factor prices especially of labor and land, and the level of agricultural prices.

In selecting the appropriate production technology for Asian countries, these considerations apply:

- In most Asian countries, human labor and draft animals will remain the major power sources. Therefore, priority should go to the introduction of more efficient tools and implements fitted to these power sources.
- Where land is abundant and labor the limited factor (for example, Malaysia and outer islands of Indonesia), mechanization must be introduced to increase production per worker and area under cultivation.
- Where land is scarce and costly and labor is abundant and inexpensive (e.g., Bangladesh), biological and chemical technology should be emphasized to raise land productivity. Certain mechanization technology (water pumps, pesticide applicators) may be required as supporting, complementary input to biological and chemical technology.
- Where both land and labor are abundant and underutilized (in semi-arid areas), a well-balanced package of biological, chemical and mechanization technology is required.
- Where both labor and land are scarce (Republic of Korea and Republic of China), a combination of labor-saving mechanization and biological and chemical technology may be applied to achieve high productivity of both labor and land.
- Where the cost of labor is relatively high compared to capital (Malaysia, East Asia), mechanization is required to reduce cost of agricultural production.

REFERENCES CITED

1. ADB (Asian Development Bank). 1984. Agriculture in Asia, its performance and prospective role of ADB in its development. *Bank Staff Working Paper*.
2. Beets, W. C. 1982. Multiple cropping and tropical farming systems. Gower Publishing Company, Hampshire, England.
3. Binswager, H. P. 1982. Agricultural mechanization: a comparative historical perspective. Report prepared for the conference "Mechanization of Small-Scale Farms — Economic and Social Implications." Hangzhou, China, 22-26 Jun 1982. World Bank Rep. ARU 1.
4. Chancellor, W. J. 1970. Survey of tractor contractor operations in Thailand and Malaysia. Report prepared for the Agricultural Development Council, New York, USA; Ministry of Agriculture, Bangkok, Thailand; and University of Malaya, Kuala Lumpur, Malaysia, August 1970.
5. Chancellor, W. J. 1983. The sustainability of mechanization in Thailand. Paper presented at Workshop on the Consequences of Small Rice Farm Mechanization in Thailand, Bangkok, Thailand, 10-11 November 1983.

6. Donovan, G. 1984. Conditions for sustained farm mechanization. Paper presented at "84 Mechanization: the Fifth International DLG Symposium," Bad Nauheim, Federal Republic of Germany, 26-29 May 1984.
7. FAO (Food and Agriculture Organization). 1979. Energy for world agriculture. FAO Agric. Ser. 7, Rome.
8. Gifford, R. C., and A. G. Rijk. 1980. Guidelines for agricultural mechanization strategy in development. ESCAP/RNAM.
9. Haji Omar, A. B. Social implications of farm mechanization in the Muda Scheme.
10. Hiemenz, U., and M. Bruch. 1983. Small- and medium-scale manufacturing establishments in ASEAN countries: perspectives and policy issues. ADB Econ. Staff Pap. 14.
11. Jain, B. K. S. 1984. A critical review of the Indian tractor industry. Agric. Mech. Asia, Africa, and Latin America 15(3).
12. Jayasuriya, S. K., and R. T. Shand. 1983. Technical change and labour absorption in Asian agriculture: an assessment. Paper presented at the conference on Off-Farm Employment in the Development of Rural Asia, Chiang Mai, Thailand, 23-26 Aug.
13. Jayasuriya, S. K., A. Te, and R. W. Herdt. 1982. Mechanization and cropping intensification. Economic viability of power tillers in the Philippines. IRRRI Agric. Econ. Dep., Pap. 82-14.
14. Juarez, F., and B. Duff. 1979. The economic and institutional impact of mechanical threshing in Iloilo and Laguna. Working Pap. 1, Consequences of Small Rice Farm Mechanization Project, International Rice Research Institute, Los Baños, Laguna, Philippines.
15. Juman, M. 1982. Idle acres — its utilization and problems in agricultural development. *In* Proceedings of the seminar The State of Malaysian Agriculture — A Critical Review, Kuala Lumpur, 12-14 Aug 1982.
16. Laxminarayan, H. et. al. 1981. Impact of harvest combines on labor use, crop pattern and productivity. Agric. Econ. Res. Cent., University of New Delhi.
17. Oshima, H. T. 1983. The significance of off-farm employment and incomes in post-war East Asian growth. Paper prepared for the Conference on Off-Farm Employment in the Development of Rural Asia, Chiang Mai, Thailand, 23-26 Aug.
18. Rijk, A. G. 1983. Role of agricultural mechanization in Asia. Staff Study Paper. Agriculture and Rural Development Department, Asian Development Bank.
19. Rijk, A. G., and C. L. J. van der Meer. 1984. Thailand, agricultural sector assessment. Staff Study Paper, Agriculture Department, Asian Development Bank.
20. Taenkam, P. 1980. The small tractor industry. Master's thesis, Faculty of Economics, Thammasat University, Bangkok, Thailand.
21. World Bank. 1975. The consequences of farm tractors in Pakistan. Staff Working Paper 210.

FARM MECHANIZATION ISSUES AND POLICIES

G. DONOVAN, G. BINSWANGER, and P. PINGALI

The World Bank
Washington, D.C., USA

Farm mechanization continues to be a contentious component of modernization in developing countries. There are numerous issues regarding the pattern and pace of mechanization, problems in sustaining the technologies at high levels of productivity, and mistakes in formulating policy responses to issues and problems. International donors provide significant amounts of financing for farm mechanization, particularly through rural credit programs, where the issues and problems are largely hidden. During the past 10 yr, one quarter of all agricultural operations supported by the World Bank have had farm mechanization components and the Bank has committed around \$700 million for financing farm equipment and machinery (Table 1). The projects include at least 110,000 tractors, not all financed by the Bank. Mechanization in developing countries will likely continue to accelerate, even as it levels off in the industrialized world. Policy issues relating to this process will play an increasingly important role in dialogs between the Bank and borrowing governments.

GROWTH AND EQUITY

Those who adopt mechanical innovations do so to increase the profitability of their operations. It does not necessarily follow that such mechanization promotes growth, however, and in a distorted policy environment it may not even promote efficiency. Through its effects on labor employment and wages, farm size and land tenure, mechanization frequently hurts certain groups and has disqualifying effects on income distribution.

Concern about these inequities in all phases of mechanization continues today (1). Labor-saving mechanization always damages the relative economic position of labor unless the growth effects, either in agriculture or (by backward and forward linkages) in nonagricultural sectors, are sufficiently great to create replacement employment or maintain wages. The key variables here are those stimulating mechanization, and the conditions of final demand for agricultural output.

We distinguish four cases which illustrate these growth and equity effects, classified by reasons for mechanizing:

Table 1. Agricultural operations financed by the World Bank and those including farm mechanization components, 1975-84.

	1975	1976	1977	1978	1979	1980	1981	1982	1983	1984	Total 1975-84
<i>Total agricultural projects</i>											
No.	72	68	84	88	84	85	83	67	68	62	761
World Bank (US\$ million)	4,246	4,187	5,941	8,685	6,896	8,394	9,906	9,030	9,089	8,743	75,118
IBRD/IDA (US\$ million)	1,858	1,628	2,308	3,270	2,522	3,458	3,763	3,078	3,698	3,434	29,017
<i>Agricultural projects with farm machinery</i>											
No.	28	20	25	26	14	15	9	15	15	10	177 ^a
World Bank (US\$ million)	1,534	1,425	2,212	3,490	1,654	2,484	1,200	3,543	3,493	1,239	22,276
IBRD/IDA (US\$ million)	660	575	740	921	362	817	352	866	1,137	408	6,838
Farm machinery costs (US\$ million)	124	123	279	283	195	350	58	531	664	153	2,760

^a 23% of projects.

When land is abundant, as in the USA in the 19th century, mechanization allows per unit output costs to fall and the development of more land than can be dealt with by available labor. Output expands, and the resulting growth effect is larger or smaller depending on the elasticity of final demand. Agricultural employment will likely expand under these conditions, although not by much if elasticity of final demand is low. From 1870 to 1900, the area farmed in the USA more than doubled (from 408 million acres to 839 million acres), and so did the number of farms (from 2.7 million to 5.7 million), implying a significant expansion of employment in agriculture (2).

Similarly, land-augmenting new technologies such as improved crop varieties and investment in irrigation systems will induce mechanization, depending upon the initial labor-land ratio. If final demand is elastic, such mechanization will likely be accompanied by expanded agricultural employment of labor.

In the Indian Punjab between 1965-66 and 1977-78, tractor intensity grew at 15.6%/yr, gross irrigated area at 4.3%/yr, gross cropped area at 2.3%/yr, and cropping intensity at 1.4%/yr. An NCAER survey showed that tractorized farms on the average cultivated significantly more land than bullock-powered farms (25-85% more), and that they employed somewhat less labor per cropped hectare (10-15% less). The reduction in land preparation labor was largely offset by increased employment for irrigation, application of fertilizers and plant protection chemicals, harvest, and threshing (10).

Labor-capital price ratio rises because wages rise. Rising wages, as a result of increased demand for labor outside or within the agricultural sector, may trigger mechanization which will reduce the subsequent rise in output costs. In this case, total output may fall, or it may grow more slowly than if production costs had not risen, but mechanization is likely to mitigate both of these effects; i.e., without mechanization output would fall more, or grow even more slowly. Agricultural employment is likely to fall under these circumstances, but the usual reason for the rising wages is that employment is growing outside agriculture. Examples of these conditions are found in the USA after 1940, and in Japan and Europe after 1955.

From 1940 to 1970, when the true mechanical revolution took place in US farming, the input of farm labor fell by 70%, while tractor numbers grew from 1.5 million to 4.6 million (reaching a peak of 4.8 million by 1965). From 1970 to 1980, total farm employment fell by a further 20% and tractor numbers also declined, but total available horsepower increased by 30%. In Japan from 1960 to 1980, the number of male workers in agriculture fell by 53% from over 5 million to 2.4 million while available tractor horsepower increased by more than 700%.

During the same 2 decades in 8 countries of Western Europe (Belgium, Denmark, France, Germany [FR], Italy, Luxemburg, Netherlands, and UK), the male agricultural labor force fell by 54% to 4.8 million, while tractor horsepower increased by 265% (2, 4, 7). In most low income countries, the agricultural labor force continued to grow from 1960 to 1980 in spite of significant increases in the availability of tractor horsepower.

In the major countries of South Asia (Bangladesh, India, Pakistan, and Sri Lanka), Hayami and Ruttan (7) estimate a 15% increase (to 122.5 million persons) in the male agricultural labor force between 1960 and 1980, while tractor horsepower rose more than twentyfold from the low base of 816,000 to almost 18 million (Table 2,3).

Labor-capital price ratio rises because capital is subsidized or machine operating costs are reduced through subsidies on energy. In this common case (modern Brazil, Pakistan, and China are examples), output costs may be held constant or may fall, usually modestly, and output is likely to grow only modestly. Agricultural employment, on the other hand, may decline sharply, and the equity effects of machinery subsidies are therefore usually adverse. The most common machinery subsidy is subsidized credit, although an overvalued exchange rate may have a similar effect.

In Brazil, after the mid-1960s, the growth rate of rural wages began to significantly outpace the increase in tractor prices, a process reinforced by highly negative real interest rates on farm loans for tractors. From a base of 100 in 1959, the price index for tractors was 3,510 in 1970 and 36,166 in 1979 while that for total labor was 4,941 and 89,560, respectively. Real interest rates ranged from minus 4% to minus 42% during the 1960s (17).

A tax on machinery may be justified if the adverse equity effects of mechanization would be unusually high, but the individual farmer, for whom such effects are merely externalities, may still find it profitable to mechanize. Usually this would be a situation of labor abundance with constraints on downward movements of wages or some other reason for a divergence between private and social rates of return.

Mechanized technique allows production opportunities previously prohibitively costly. A prime example is the use of engines for pumping from depths which was unprofitable using animal draft. Production cost with the mechanized technique is lower than the output prices; output increases, constrained only by the elasticity of final demand; and employment of labor also increases, with the same constraint. The change of technique may involve little or no substitution for labor, and employment may expand indirectly.

We have described effects, sometimes indirect, of mechanization on agricultural output, and employment of labor. Assessing these effects, particularly those relating to employment, in agriculture alone, gives a very limited and partial view. Farm mechanization also has backward and forward linkages, and second round effects.

Backward linkages involve the industry in which farm machinery is designed, adapted, and manufactured, the dealers in both machines and spare parts, credit supply agencies, and the network of repair and maintenance shops, fuel suppliers, etc. Evidently, these backward linkages only slightly soften the impact of labor substitution in agriculture.

In Thailand, if one assumes 380 h of mechanics' time per large tractor and 34 h per smaller tractor, as estimated by Chancellor (3), this repair work would generate about 10,000 full-time jobs, or 20,000 for half a year. This is probably on the high side. Manufacturing employment in the Thai tractor industry has

been estimated at 5,000 workers (18), with up to 2,000 workers employed in making small tractors in registered establishments (15).

Forward linkages arise from growth in agricultural output and will be similar whether such growth arises from mechanization or from some other investments or technical changes. The employment effects from such growth linkages may be substantial, however, in the transport/processing/storage/marketing chain between farmer and consumer, and there may be important trade-offs in mechanization of activities in this chain. Further removed are the second round employment effects induced by expenditure of incomes earned by farmers in the course of agricultural growth. They depend on who in agriculture is most likely to receive income gains from mechanization, and what may result from their expenditure patterns.

POLICY INTERVENTION

Various government interventions have an impact on the speed and success of adoption of mechanization, on its productivity and equity effects, and on domestic industrialization.

Policy distortions affecting mechanization may occur outside mechanization activities themselves. If irrigation water is cheap, for example, and machinery expensive, it is rational for farmers to use a lot of water in a trade-off for less farm power, for wet cultivation, especially of rice, and for weed control, a trade-off for both machines and chemicals. This pattern fits Sri Lanka, which also is experiencing attempts to induce dry cultivation using tractors. Some observers argue that while tractors are necessary for completely dry cultivation, other options include cultivation on early rains or residual rains, for which animal draft is adequate (6, 11).

We will focus on the following policy areas:

- policies affecting the cost of buying and operating machines: exchange rate regimes, credit subsidies, tariffs or tariff exemptions, taxation of parts or fuels;
- policies affecting supply of machinery, spare parts, and fuels: foreign exchange regulations, quotas, preferential trade arrangements, credit rationing;
- policies affecting the development of a domestic industrial capacity: patent laws; licensing and foreign collaboration; domestic content laws; standardization; tariffs and regulations governing importation of machines, materials, and parts; provision of transport and communications infrastructure;
- policies influencing availability and price of labor: unionization, minimum wages;
- policies regarding land tenure and settlement; and
- project interventions such as tractor hire schemes; animal draft projects; foreign assistance in research and development; tied aid; training schemes for operators and mechanics.

Table 2. Intercountry cross-section data (7).

Country	Agricultural land area (thousand ha)		Agricultural output (thousand wheat units)		No. of male workers in agriculture (thousand)			Tractor horsepower (thousand hp)				
	1960	1970	1960	1970	1960	1970	1980	1960	1970	1980		
Argentina	171,500	177,701	178,420	51,626	60,407	77,872	1,478	1,373	1,221	3,485	6,086	8,610
Australia	467,000	493,359	492,293	42,054	57,760	71,489	405	341	279	7,782	15,060	20,219
Austria	4,052	3,896	3,662	9,419	11,515	12,798	309	205	141	2,247	8,836	12,928
Bangladesh	9,546	9,695	9,730	23,916	30,373	34,200	12,140	15,633	19,097	7	48	128
Belgium (and Luxembourg)	1,857	1,734	1,560	11,361	14,486	15,726	239	147	90	1,405	2,887	5,881
Brazil	148,000	188,122	207,720	82,162	110,026	150,425	8,852	10,622	11,380	1,972	5,755	13,440
Canada	62,848	67,520	68,100	36,633	49,262	57,692	554	432	298	16,800	29,111	40,499
Chile	14,000	16,195	17,678	6,607	7,876	8,539	581	466	432	473	1,121	869
Colombia	21,047	22,138	22,800	16,594	22,391	31,324	1,999	2,025	1,826	741	1,025	1,155
Denmark	3,127	2,975	2,916	14,378	15,221	16,275	310	173	124	3,227	6,808	9,692
Egypt	2,569	2,843	2,848	17,737	23,713	26,153	4,024	4,839	5,644	220	645	1,029
Finland	2,849	2,869	2,589	5,756	7,662	8,645	189	145	83	2,288	5,498	8,568
France	34,586	32,495	31,853	86,093	114,982	130,186	2,660	1,845	1,279	18,996	50,460	76,126
Germany, FR	14,254	13,579	13,217	57,023	71,631	79,113	1,535	950	696	16,173	39,432	59,173
Greece	8,911	9,155	9,175	10,911	15,644	20,242	1,200	907	786	818	2,370	5,460
India	174,820	178,050	181,820	185,986	228,552	286,384	86,352	86,947	92,030	686	2,315	13,649
Ireland	4,715	4,794	4,877	7,182	8,964	11,623	358	264	198	1,243	3,029	5,727
Israel	1,210	1,227	1,231	2,229	4,554	6,107	86	78	60	214	579	1,075
Italy	18,430	17,680	17,608	62,709	77,187	87,575	4,319	2,567	1,826	7,536	23,769	46,527

Japan	6,071	5,797	5,474	52,436	67,536	66,920	5,097	3,661	2,404	5,234	19,263	42,544
Libya	9,809	9,567	9,264	476	681	1,264	133	141	98	71	128	546
Mauritius	98	112	114	655	806	819	65	67	77	9	10	14
Mexico	102,908	100,268	97,719	27,354	39,914	51,072	5,316	5,886	6,825	1,229	4,235	4,788
Netherlands	2,317	2,195	2,034	16,709	21,438	28,694	388	339	263	1,857	5,814	7,967
New Zealand	13,128	13,520	14,443	15,882	21,537	24,671	113	104	105	2,452	4,402	5,298
Norway	1,033	954	900	3,195	3,342	3,760	103	46	40	1,568	3,248	5,250
Pakistan	23,489	24,332	25,175	21,209	32,662	40,721	6,768	8,674	9,805	110	772	3,228
Paraguay	14,300	15,445	16,395	1,153	1,582	2,218	235	265	341	17	81	130
Peru	29,720	29,933	30,550	7,751	10,186	11,273	806	609	1,112	204	403	571
Philippines	7,076	7,795	8,442	14,946	19,922	29,289	4,542	4,326	4,987	128	198	672
Portugal	4,660	4,305	4,085	7,937	9,175	8,071	1,112	769	432	309	1,034	2,730
South Africa	102,448	97,200	95,720	16,547	24,269	28,671	1,482	1,380	1,715	2,250	8,085	7,560
Spain	32,884	32,119	31,538	36,727	50,143	67,756	3,974	2,478	1,512	1,273	9,455	20,647
Sri Lanka	2,239	2,418	2,580	4,906	6,553	7,698	1,353	1,409	1,597	13	281	904
Surinam	46	47	59	205	371	568	15	14	12	17	33	57
Sweden	4,282	3,743	3,720	9,971	10,542	11,905	232	120	97	4,682	6,064	7,896
Switzerland	2,017	2,024	2,021	6,827	7,860	9,161	234	167	118	652	3,095	3,717
Syria	14,566	13,459	13,960	4,504	5,593	9,013	623	728	901	123	332	1,065
Taiwan	871	907	918	9,009	14,054	17,117	1,261	1,448	1,384	37	121	450
Turkey	54,018	55,178	55,445	31,856	45,181	60,367	5,245	5,166	4,746	1,375	3,657	18,501
UK	19,894	18,879	18,452	38,605	50,285	57,085	821	572	491	12,989	18,108	22,981
USA	439,941	432,974	430,331	352,619	414,416	497,438	3,759	2,566	1,745	155,540	204,372	264,915
Venezuela	19,174	21,082	22,207	5,437	9,244	12,197	695	660	537	320	687	1,554
Yugoslavia	14,923	14,626	14,239	17,075	22,825	28,531	2,591	2,318	1,989	1,134	2,940	16,174

Table 3. Intercountry cross-section data.

Country	Agricultural output (thousand wheat units)		Agricultural labor force (thousand)		Tractors (thousand)	
	1970	1978	1970	1978	1970	1978
Burundi	3581	4246	1458	1610	--	--
Cameroon	7695	8435	2804	3100	0.2	0.4
Kenya	9056	12257	3538	4403	7.2	6.4
Malawi	3103	4774	1764	2083	0.9	1.1
Nigeria	33737	33689	16115	16592	3.0	8.1
Tanzania	12142	13909	5024	6037	17.7	18.4
Zambia	1985	2566	1184	1333	3.2	4.4
Zimbabwe	5725	8002	1136	1313	17.0	19.8
Thailand	62596	95781	13589	16285	8.0	33.0 ^a

^aExcludes tractors under 45 hp, of which there were possibly around 300,000 in Thailand in 1978.

Machinery costs

Policies concerning the costs of purchasing or operating farm machinery usually give mechanized techniques an advantage over other techniques. The most common are overvalued exchange rates and subsidized credit. We advocate more strenuous efforts by international lending agencies to change these policies, and not to be associated with financing farm machinery where exchange rates are strongly distorted or credit subsidized. The latter will be the most difficult to attain, because provision of credit for tractors and other machines is highly attractive to banks since it allows relatively large, discrete, medium or long-term loans to be disbursed against items readily attachable as collateral. Subsidized credit is also highly advantageous to larger farmers, and tends to end up in their hands because they are preferred customers, on risk and collateral grounds, when credit has to be rationed. Since such policies do not enhance efficiency and are likely to have an unusually adverse equity impact, they should not be supported. It is important also to analyze carefully the effects of tariffs commonly applied to the farm machinery trade, and particularly the adverse consequences of applying higher tariffs to spare parts than to new machines.

Machinery supply

In examining policies which affect the supply of machinery, spare parts, etc., it is relevant to examine the effects of practices such as the World Bank's requirements in a range of situations, inasmuch as they bear upon problems of matching implements to power sources and provision of spare parts. It is likely that regulating foreign exchange and rationing credit mean machinery mostly in the hands of larger farmers, as well as nonemergence of locally adapted machine designs and manufacture. Case studies may be developed to illustrate the effects of standardization interventions by governments, beginning with the observation for Pakistan, that "by controlling imports, the government has

effectively removed competition among tractor sellers, resulting in poor service, inadequate supply of spare parts, and lack of interest in training in tractor use and machinery maintenance facilities" (9).

In Pakistan in the late 1950s, at least 30 makes or models of tractors were operating, but the government in 1978 restricted imports to 7 makes. There are currently five licensed foreign manufacturers, and until recently imports were restricted to 2 horsepower categories, medium (about 40) and high (about 60). Additional production capacity is now permitted for tractors in the 20-30 hp range.

In Thailand, an initially crowded field of foreign tractor brands sorted itself out and was reduced to manageable proportions without substantial government interference.

In Thailand in the late 1960s, 27 brands of tractors were imported from 22 countries, but a much smaller number later dominated the market (5). By the late 1970s, more than 85% of imported tractors came from 3 countries and in most size categories, more than 80% of imports were of two brands (16).

In discussing preferential trade arrangements, a review is also needed of counter trade deals and their likely impact on supply and use of farm machinery.

Domestic industry

One important backward linkage of farm mechanization is to domestic manufacturing industries. More emphasis is needed on ties between policies in agriculture and industry, which are frequently overlooked. We argue for minimal protection of domestic industry, except for measures to help build up local capabilities in early stages.

In Thailand, after local manufacturers of small tractors continually complained they were not protected, but actually discriminated against, the Government in 1982 increased tariff rates on imported machines and engines, and established import quotas (8). During the late 1970s, in spite of "negative protection," local tractor production increased at almost 14%/yr, while imports in the market dropped to below 7%. In 1981, imports had begun a vigorous comeback in secondhand tractors. However, it takes strong political will to resist pressures for protection under such conditions.

Many countries protect their farm machinery manufacturing or assembly industries from the beginning. In Argentina, domestic production of tractors built up during the 1950s, protected by tightly rationed foreign exchange plus generous tax incentives to farmers, and credit at substantially negative real interest rates, together amounting to a 50% subsidy on the purchase price. Even these subsidies did not compensate fully for domestic manufacturing costs considerably higher than world prices (17).

In Turkey, quantitative restrictions in 1981 added an estimated 16%, for a 32% implicit tariff rate. Implicit tariffs on agricultural machines and diesel engines were still higher at 67% and 78%, respectively. Except for brief periods in the early 1960s and 1970s, the official exchange rate was also overvalued until 1980 (19).

Some argue that it is difficult to establish local manufacture of spare parts without local manufacture or assembly of the machines themselves. While specialized manufacture of spare parts by firms other than the machinery makers is an irritant to the latter, such competition may serve the end-users of machinery well by keeping down costs of spare parts. The scope and importance of problems relating to false labeling, i.e., violation of patent laws, need to be assessed. For the network of reaper and maintenance facilities to function well, with adequate and timely supplies of spare parts, good transport/communications infrastructure is of prime importance. This is a major area where public support for mechanization can be valuable.

Labor wages and land tenure

Rising wages for labor encourage mechanization, whether caused by changes in demand and supply, labor organization, or minimum wage legislation. It seems that unionization and legislation have done little to induce mechanization compared with demand and supply changes in labor markets. There is truth, however, in the assertion that "machines are more docile than men" (Joan Robinson), with its implication that nonwage costs may contribute to perceived diseconomies of scale in handling large labor forces. If so, there may be a payoff to explicit development of labor supervision techniques and skills rather than meeting the challenge with mechanization. Regarding land tenure, in those cases where mechanization tends to lead to an increase in farm size, land ceiling laws may be useful to prevent accumulation of land and minimize adverse equity effects from this source.

The evidence for increases in farm size in Pakistan as a result of mechanization was reviewed at an earlier IRRI conference (9). We hope to examine this matter further by analyzing data from the 1980 census of agriculture.

Animal draft

The change from animal draft to mechanical draft is a change in technique, but the initial introduction of animal traction is a change in farming system. Sub-Saharan Africa contains large areas that have yet to make the transition from hand hoe agriculture to animal draft. The transition is a direct result of increasing population pressure on the land (whether such pressure arises from natural population growth, immigration, or restriction on movement into new lands), or of improved access to markets. The agricultural system, in response, changes from forest fallow to annual cultivation, and eventually to multiple cropping. This change is a necessary, but not sufficient, condition, for a switch from human power to animal power, which will take place when it becomes profitable to plow. This profitability is, in turn, determined by the workability of soils, the place in the toposequence where farming is concentrated, responses of crops to tillage, and the degree to which equipment can be used to potential capacity.

The important concerns in successful transition from hand methods to animal draft are animal health, feeding, a blacksmith industry, and training of

livestock. Projects containing these components, with credit backing where necessary, should be continued. Once a few farmers in any new area have learned how to train animals for draft, this component no longer needs to be in the public domain.

Project initiatives

A strong argument can be made for training, particularly for tractor operators and mechanics, and foreign technical assistance can be helpful. We distinguish between merely driving a tractor, which requires little skill, and operating it for high performance. Some estimates suggest that repair costs for a typical driver may be three to four times as high as for a good operator. One aim in training is to arrive at a situation where preventive maintenance rather than forced repairs is the rule. Because of turnover in such occupations, the training task is large and continuing, but can spread knowledge of mechanized technology throughout the economy. It is therefore appropriate for public sector involvement, especially in the early stages of farm mechanization. On the other hand, we argue strongly against public involvement in farm machinery, manufacture, marketing and finance, operation, repairs and maintenance, all of which are commercial activities. They do not flourish under public sector management. In particular, involvement of the public sector in machinery hire schemes and maintenance workshops has been singularly unsuccessful.

In a detailed study of 21 examples of public farm machinery hire schemes (mostly for tractors), only one was judged an economic success (14).

Adverse equity cases

Within the overall assessment of growth and equity consequences of mechanization, we must look carefully at cases where equity effects are unusually adverse and offsetting growth effects unlikely. One example is the introduction of combine-harvesting equipment into areas where major output effects from higher-yielding crop varieties have already been experienced. Put starkly, the question may be something like, "Should combine-harvesters be restricted or taxed in the Indian Punjab?"

Another example is the introduction of modern milling equipment which would reduce employment opportunities for women under circumstances where the resulting income losses would not be readily replaceable.

In Bangladesh it is estimated that modernized rice milling techniques have already eliminated productive part-time employment for 1.4-2.0 million rural women, and that a further 100,000 to 140,000 women are being displaced each year. For landless women, the loss is calculated to represent 55% of their annual income, and 15% of family income (13). All who work in development planning must be aware of such losses that so markedly reduce equity. In examining such a case in the USA, Schmitz and Seckler (12) concluded: "the talents of science and industry combine to create enormously productive innovations, but the very success of these sectors of society create consequences which bear unfavorably . . . on less organized and therefore more

vulnerable sectors . . . it is the social scientist's task to devise a variety of institutional structures appropriate to the problems with which society is afflicted."

These are difficult policy questions because of the need to take into account the ways incomes and work are allocated within rural households, and the options for creating employment opportunities in other sectors of the economy. If discouraging mechanization is desirable, we advocate interventions through the price mechanism rather than quantitative controls, in order not to stifle the exceptions.

REFERENCES CITED

1. Berardi, G.M., and C.C. Geisler, eds. 1984. *The social consequences and challenges of new agricultural technologies*. Westview Press.
2. Binswanger, H.P. 1984. *Agricultural mechanization: a comparative historical perspective*. World Bank Staff Working Pap. 673.
3. Chancellor, W.J. 1970. *Survey of tractor contractor operations in Thailand and Malaysia*. Agricultural Engineering Department, University of California, Davis, California.
4. Cochrane, W.W. 1979. *The development of American agriculture: a historical analysis*. University of Minnesota Press, Minnesota, USA.
5. Duncan, A. 1984. *Tractors and Thailand: the rapid mechanization of an expanding agriculture*. World Bank, AGREP Division Working Pap. 92.
6. Farrington, J., F. Abeyratne, M. Ryan, and S. Bandara. 1980, 1982. *Farm power and water use in the dry zone, Sri Lanka*. Agrarian Research and Training Institute Res. Stud. 43 and 52.
7. Hayami, Y., and V. W. Ruttan. 1985. *Agricultural development: an international perspective*. Rev. ed. Johns Hopkins Press.
8. Lochawenchit, C. 1983. *Manufacturing farm machinery in Thailand*. Workshop on the Consequences of Small Farm Mechanization in Thailand, Bangkok.
9. Lockwood, B., M. Munir, K. A. Hussain, and J. Gardezi. 1983. *Farm mechanization in Pakistan: policy and practice*. Pages 16-30 in *Consequences of small-farm mechanization*. International Rice Research Institute — Agricultural Development Council.
10. NCAER (National Council of Applied Economic Research). 1980. *Implications of tractorization for farm employment, productivity and income*. New Delhi, India.
11. Ranatunge, A. S., J. Farrington, and W. A. T. Abeysekera. 1981. *Some issues confronting the rehabilitation of major irrigation schemes in the dry zone, Sri Lanka*. Agrarian Research and Training Institute Res. Stud. 44.
12. Schmitz, A., and D. Seckler. 1970. *Mechanized agriculture and social welfare: the case of the tomato harvester*. *Am. J. Agric. Econ.* 54(4):569-577.
13. Scott, G. L., and M. Carr. 1985. *The impact of technology choice on rural women in Bangladesh, problems and opportunities*. World Bank Staff Working Pap. 731.
14. Saeger, P. J., and R. S. Fieldson. 1984. *Public tractor hire and equipment hire schemes in developing countries*. World Bank, Agricultural Research Unit Discussion Pap. 30.
15. Sukharumana, S. 1983. *A history of mechanization in Thailand*. Workshop on the consequences of small farm mechanization in Thailand. Bangkok.
16. Taenkam, P. 1980. *The small tractor industry (Thailand)*. Master of Economics thesis, Thammasat University, Bangkok. (unpubl.)
17. Thirsk, W. R. 1985. *The growth and impact of farm mechanization in Latin America*. Report to the World Bank.
18. World Bank. 1983. *Thailand: rural growth and employment*. Washington, D.C.
19. Yagci, F. 1984. *Protection and incentives in Turkish manufacturing: an evaluation of policies and their impact in 1981*. World Bank Staff Working Pap. 660

MECHANIZATION FOR RICE IN JAPAN AND KOREA

R. M. LANTIN

Regional Network for Agricultural Machinery
Los Baños, Philippines

Among the countries of Asia, Japan and the Republic of Korea (hereafter called Korea) have the most intensive use of mechanical power technology for agriculture and no longer use animal power for rice cultivation.

This paper traces the development of mechanization in Japan and Korea and analyzes their unique experiences and the common grounds which triggered and sustained development. The paper also identifies some significant problems and describes how the government reacted to or solved them.

MECHANIZATION IN JAPAN

Historical development

During the early Meiji era, hand tools were used for farm operations and animals only for transportation.

During World War I, mechanical power was used for rice milling and water lifting, but not for cultivation. In the 1920s, manufacturing expanded and engineers from the U.S. were invited to develop stationary petrol engines for agricultural use.

Power threshers were among the first engine-powered machines used in agriculture. Application of mechanical power to tillage started only when foreign-made farm machines were introduced in the 1920s. As tractors were unsuitable for wetland farming, Japan looked to an appropriate power unit, the power tiller. Commercial production started in about 1925. The development of petroleum engines boosted the popular use of power tillers, power threshers, and self-feeding threshers.

Kisu (3) divided the development of farm mechanization after World War II into three-decade stages starting in 1950 (Fig. 1).

1950-60. During 1950-60 farm labor started moving to nonfarm jobs as a result of the phenomenal rapid economic growth. Furthermore, the government encouraged mechanization by enacting the Agricultural Mechanization Promotion Law in 1953.

Machineries (no.) on farms

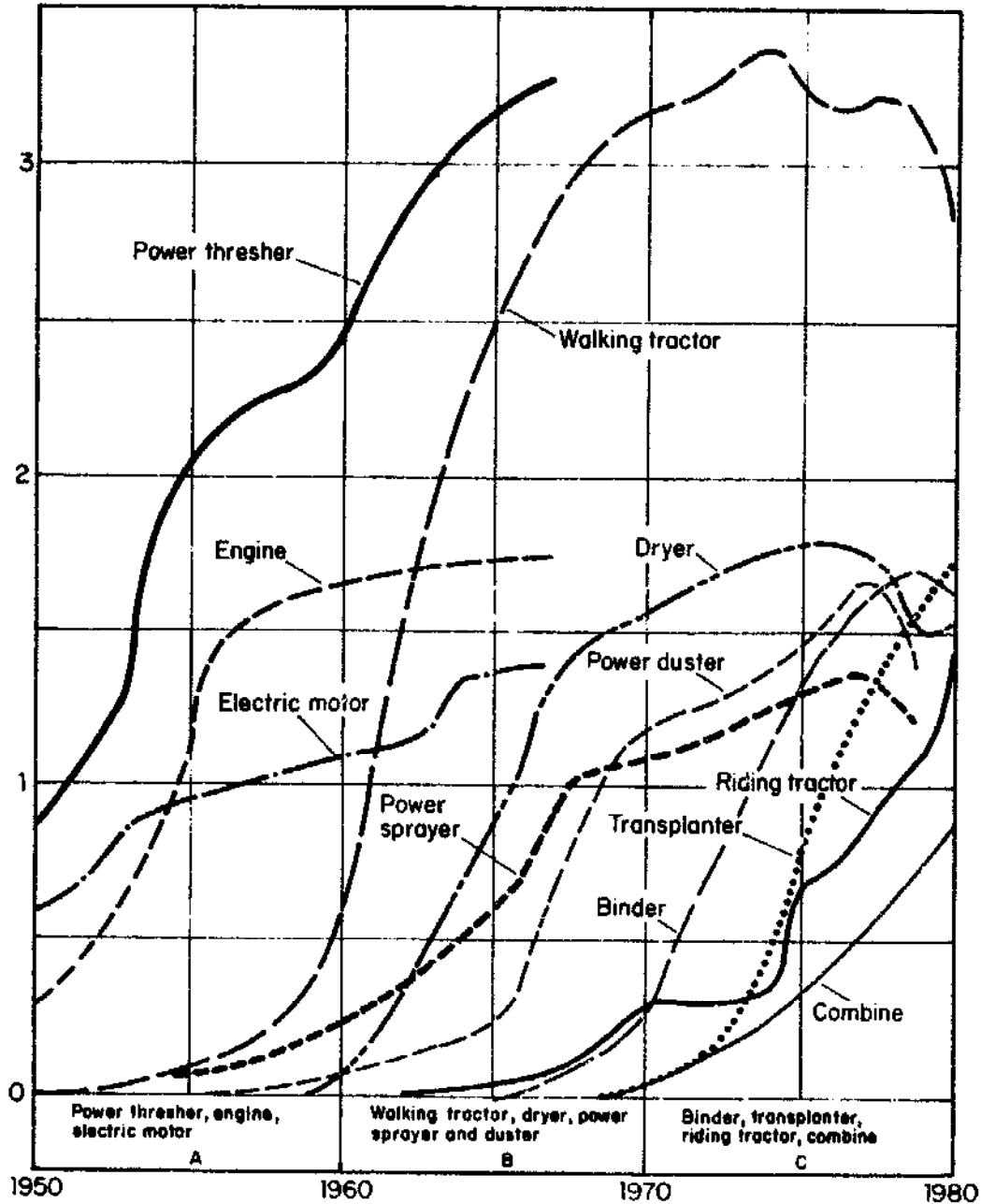

1. Development and diffusion of major farm machineries, 1950-80 (3).

Manufacturers rapidly developed machinery and improved the engine as a suitable power unit. Farmers willingly adopted agricultural innovations.

1960-70. During 1960-70, the walking tractor totally replaced animal power.

In 1961, the Agricultural Basic Law was enacted to enlarge the scale of farm management. It stimulated land improvement and consolidation, policies for subsidies to promote cooperatives, and efficient use of large machinery including riding tractors. Interest shifted from small to medium or large machines.

Two significant milestones in the mechanization of rice farming were the development of rice transplanters and harvesters, and the introduction of storage facilities such as rice milling and country elevators.

1970-80. During 1970-80, medium and large machines were developed; riding tractors replaced power tillers as the core power unit. The rapid shift from walking to riding tractors began in 1972 when high-lug tires for soft soil and four-wheel drive were adopted, even for smaller riding tractors.

During this decade, rice cultivation in Japan became fully mechanized. Thus, the labor requirement was drastically reduced from 1,960 h/ha in 1952 to only 720 h in 1978. Beyond rice mechanization, machines for animal husbandry and horticulture were developed.

1980-90. The 1980s are characterized by totally mechanized, automated systems and increased popularity of four-wheel tractors. In 1983, 94% of Japan's rice area was transplanted mechanically. There were 1.58 million riding tractors in 1983.

In the early 1980s, quality and performance of farm machines rapidly improved. The direction was toward high-powered four-wheel tractors, multirow riding rice transplanters, and greater automation in head-feed combines.

Manufacturers not only supplied the domestic market but also exported an ever increasing volume of machinery.

Development of major farm machinery

Since the enactment of the Agricultural Mechanization Promotion Law in 1953, manufacturers responded with vigorous production especially since the early 1960s. The development of four machines from 1965 is outlined here.

Riding tractor. Riding tractors of 10-20 hp range were already marketed in the early 1960s and were used for rotary tilling and puddling of paddy fields. These modified versions of imported tractors were heavy and lacked waterproofing for working in flooded paddy fields. Manufacturing increased in the early 1970s when high-lug tire and four-wheel drive features were added. Recent demand for the 20-30 hp class has increased.

Figure 2 illustrates the trends leading to the total replacement of animals with walking tractors (1950-63) and to partial substitution of riding tractors for walking tractors (1970-80).

Rice transplanter. The first patent for a mechanical rice transplanter was granted in 1980, but a satisfactory machine was not developed until the end of the 1950s. In response to the acute labor shortage of the early 1960s, several types of transplanters were developed but not sold until 1965. The man-powered, single-row transplanter was sold in 1966 but lost its market by 1970. It was overtaken by the engine-powered, 2-row rice transplanter which captured 84% of the market in 1975.

Figure 3 shows the trend in rice transplanter usage with the corresponding trend in labor requirements.

Plant protection machinery. Until the 1950s, manual sprayers were used to apply chemicals in liquid form; however, hand dusters were popular during

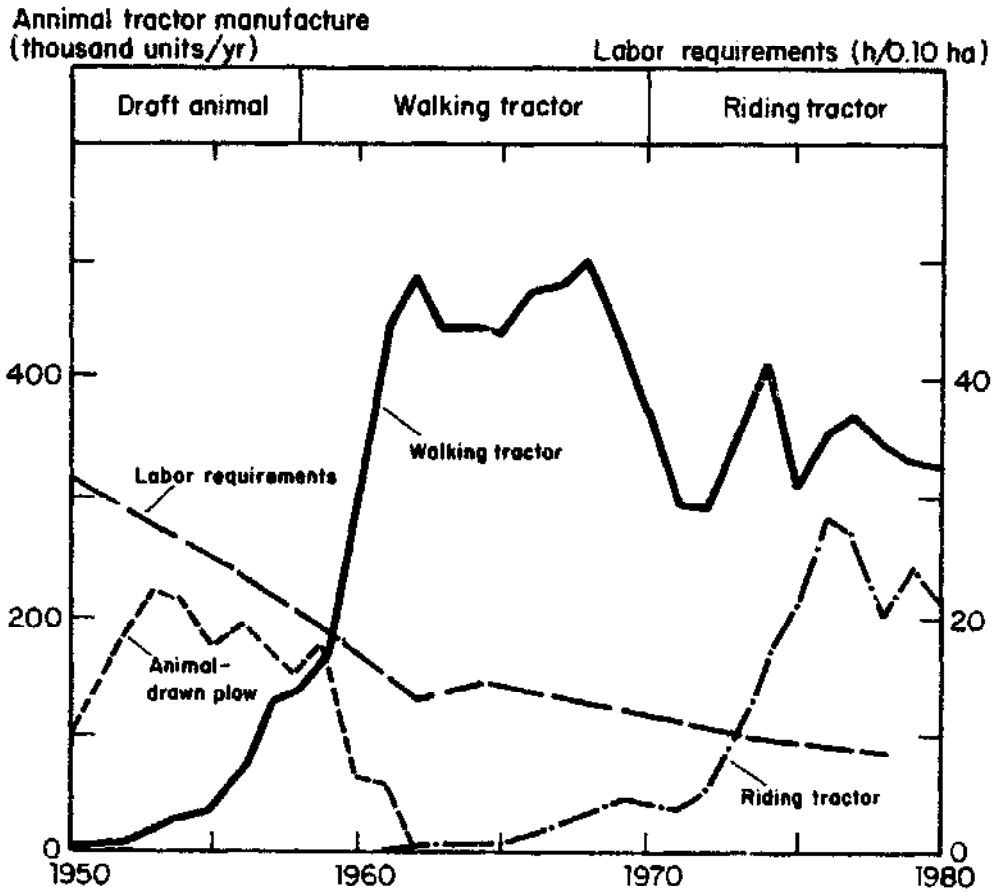

2. Distribution of tractors manufactured and labor requirements for tilling and puddling.

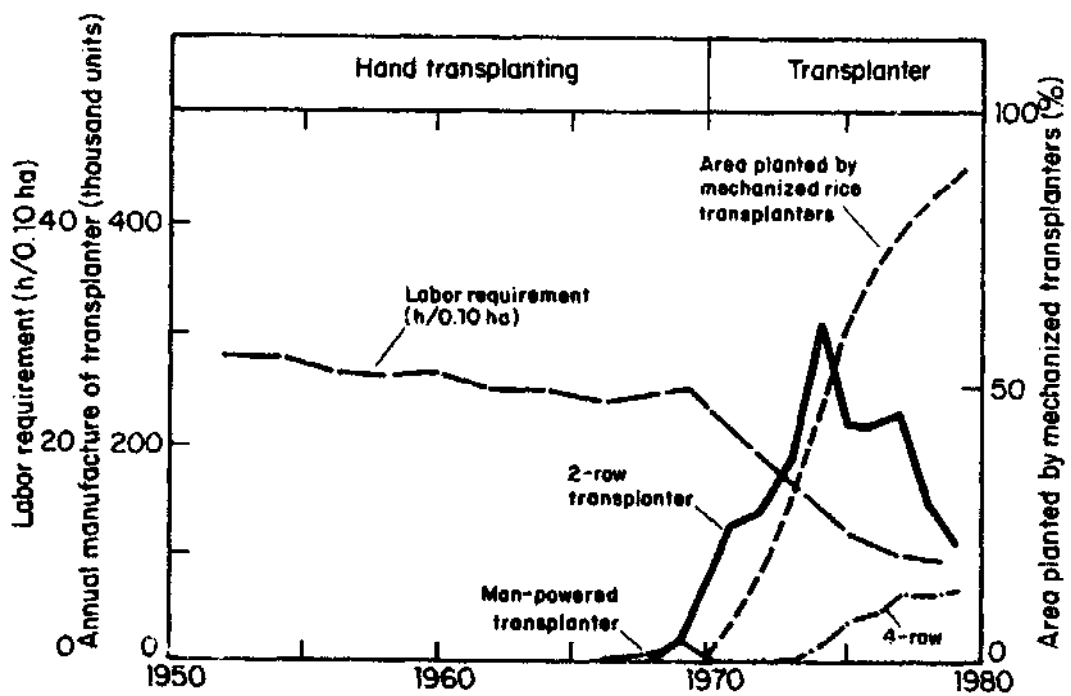

3. Trend in the development of mechanical rice transplanters and labor requirements for transplanting (3).

the 1960s. After 1965, engine-powered sprayers took over, reaching peak popularity in the late 1960s. In the mid-1960s the pipe-duster, consisting of duster and boom with perforated polyethylene hose, started to become popular.

Hand rotary weeders were very popular during the late 1950s but were almost completely out by 1970. The powered, three-row rotary weeder in paddy fields started to become popular in the mid-1970s.

Herbicide use increased since 1960. The knapsack power duster having a boom-type blower with 20- to 30-m swath has become more popular than the power sprayer. Figure 4 shows the pattern of changes in type of machinery used and labor requirements for crop protection.

Harvesting machine. Before 1950, rice was harvested by sickle and bound into 10- to 30-cm-diameter bundles, left in the field or hung on racks to dry. Powered reapers and droppers reached peak sales of 10,000 and 15,000 units until the 3-row powered binders were sold in 1966. The 1-row type predominates, but demand declined after a peak of about 330,000 units in 1970. Though the reaper-binder conformed with conventional harvesting, it required much labor. The self-propelled threshers were developed along with the reaper-binder and shared 84% of the total thresher sales in 1979.

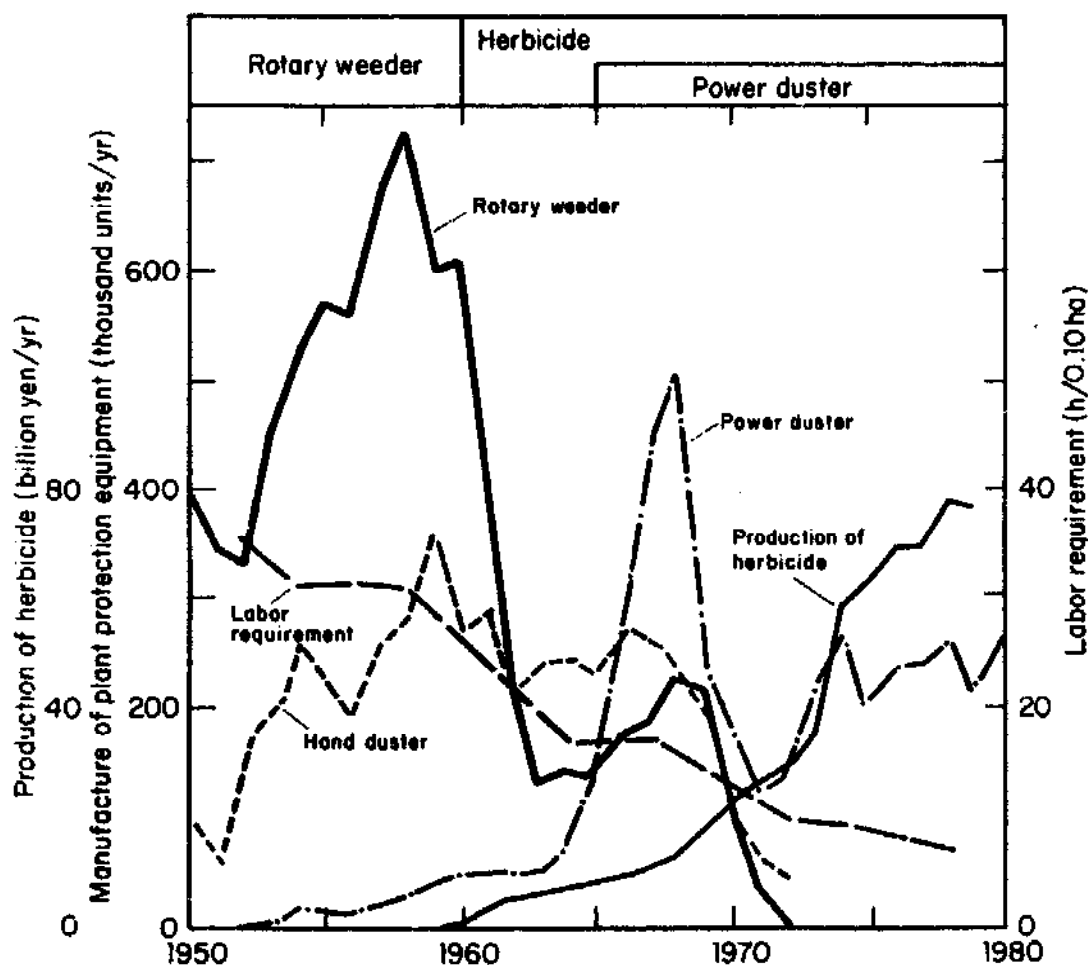

4. Changing pattern in the use of plant protection equipment and resources and labor requirements for weeding.

The present trend in combines is toward multipurpose machines to harvest wheat and other grains. Efforts are also directed toward improving durability, safety, automatic bagging, steering, travel speed, height of cut, and feed depth controls.

Figure 5 shows the pattern in the use of harvesting/threshing machines and the declining labor requirements.

JAPANESE POLICIES AND STRATEGIES

Agricultural Mechanization Promotion Law

To stimulate mechanization, the government passed the Agricultural Mechanization Promotion Law of 1953. Implementation of the Japanese reform program increased the enthusiasm of owner-farmers in improving their farming operations. The law was also a response to the phenomenal exodus of rural labor to meet rapid economic growth in the early 1950s. The law obliges central and local governments

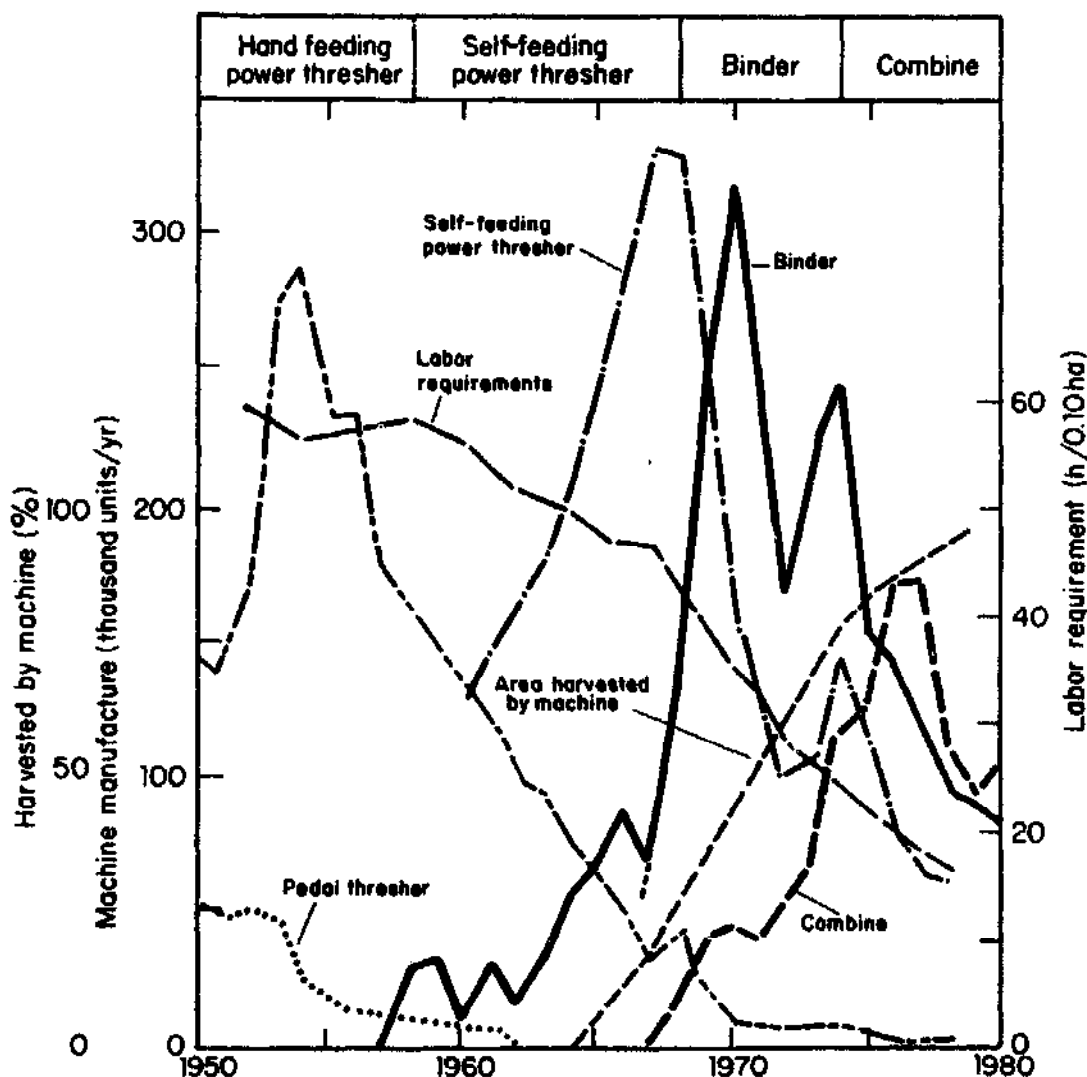

5. Changing patterns in the use of rice harvesters/threshers and labor requirements for harvesting (3).

(prefectures) to train, guide, conduct experiments and research, and assist farmers in the purchase of farm machineries necessary to accelerate agricultural mechanization.

In anticipation of over-investment — an increasing apprehension — the law required establishing guidelines for the introduction of high-powered machinery, testing farm machinery and implements, and the setting up of the Agricultural Mechanization Council (AMC) and the Institute of Agricultural Machinery (IAM).

Guidelines for developing farm machinery. The Ministry of Agriculture, Forestry, and Fisheries (MAFF) made basic guidelines for developing 13 types of farm machinery: wheel tractor, trencher, rice transplanter, speed sprayer, self-propelled duster, binder, self-propelled sprayer, head-feed combine, pass-through combine, forage harvester, beet harvester, bean harvester, and sugarcane harvester.

Farm machinery testing. The main problems after World War II were the shortage of raw materials for the manufacture of machinery and the generally poor quality and performance of machinery. To improve machinery quality, MAFF issued in 1949 a regulation on commissioned testing of farm machinery.

The procedure was as follows: upon request of a manufacturer or other clients, the machine undergoes testing. If it passes the test and meets the criteria set by MAFF, IAM issues a certificate and returns the machine and test results to the client. MAFF makes the results public. The client labels the machine "PASSED THE TEST" when he sells it. To ascertain that subsequent units of approved machines conform to standards, the government spot tests approved models. Violations may incur revoked accreditation.

Agricultural Mechanization Council. To help MAFF ensure proper implementation of the Agricultural Mechanization Promotion Law, AMC is empowered to study and deliberate upon matters pertaining to farm mechanization, e.g., preparation of basic guidelines for the introduction of high-powered machinery, decision on types of farm machinery subject to testing, and test methodology.

Institute of Agricultural Machinery. IAM, jointly sponsored by the state and private sector, aims to accelerate farm mechanization, expand research activities, and strengthen farm machinery. Established in 1962, IAM has provided important results from basic research for the development and improvement of various machines, conducted testing and evaluation of farm machinery, and collected and published studies and data on agricultural machinery.

Production and marketing of farm machinery

The extreme shortage of production materials from 1945 to 1950 impeded the production and supply of farm machinery. MAFF allocated materials among machinery manufacturers and rationed the farm machinery supply to ease the situation. In 1951, the manufacture and distribution of agricultural machinery was decontrolled.

The Ministry of International Trade and Industry (MITI) provided guidelines in manufacturing while MAFF provided guidelines in technological aspects, including machinery performance. MITI facilitated low-interest loans and advised on reducing production costs and improving farm machinery quality. It also implemented standardization of components and spare parts of agricultural machinery in accordance with the Japan Industrial Standard (JIS) Law.

Farm machinery is distributed by commercial traders and agricultural cooperatives. Since 1962, MAFF has designated commercial traders as eligible for assistance under the Small and Medium Industries Modernization Law, which provides low-interest loans, tax exemptions or deductions, and guidance on management.

Extension and training in farm mechanization

Agricultural extension. The Agricultural Improvement Promotion Law of 1984 provides for agricultural extension services jointly by national and prefectural governments. More than 9,500 extension agents disseminate new knowledge and technology among farmers through training and visits. Of 680 subject matter specialists in farming, 37 work in farm machinery in 37 of 47 prefectures.

Introduction and demonstration of new machinery. The national government subsidized the prefectural governments to encourage demonstration and training in the use of power tillers, and for purchasing equipment required for automobile services including trouble shooting.

Prefectures were responsible for providing guidance in the use of farm agriculture, especially with large machines. It established 11 farm mechanization testing centers in villages for studying the use of high-powered machines.

Starting in 1964, a 3-yr project tested the practicality of Western type pass-through combines. In 1968, the national government subsidized research into adaptability to local conditions of rice transplanters, binders, and head-feed combines already manufactured in the country.

Agricultural mechanization training unit. The Agricultural Mechanization Training Unit was established at Uchihara, Ibaraki Prefecture in 1960 as a national institution for training in farm mechanization. It subsequently became the Agricultural Mechanization Training Institute (AMTI). AMTI is now the national training center for agricultural extension agents, trainers from prefectural farm mechanization training centers, leaders of mechanization farming units, and MAFF officials. Since 1963, the national government has subsidized prefectural mechanization training centers.

Education for efficient and safe use of farm machines. Because of accidents involving high-powered machinery, the national government has, since 1965, subsidized prefecture governments in educating farmers on efficient use and safe operation of farm machines. In 1976, it expanded the subsidies to cities, towns, and villages. The mass media, including nationwide television, have been used in the educational campaign.

The government has also required safety standards in farming operations,

standards for daily and periodic check on farm machinery, and safety standards in their manufacture.

Other assistance to promote farm machinery

The government subsidized the subsoil improvement project, 1951-71, to enable deep tillage cultivation of areas with poor volcanic ash and heavy clay soils. A deep tillage project initiated in 1960 encouraged the use of large tractors and application of compost in less productive areas. This project boosted the development of tractorized farming.

Three sources of loans made available to farmers for purchase of farm machinery follow:

- Agricultural Improvement Farming Scheme — interest-free loans for specified purposes;
- Agricultural Modernization Farm Scheme — loans at reduced interest rates subsidized by national and prefectural governments; and
- Agricultural Forestry and Fisheries Corporation — long-term loans at low interest rates to complement the first two schemes.

The government provided schemes for land consolidation, acquisition of farm machinery, and other joint-venture facilities to modernize agriculture through a plan to ultimately cover about 3,000 areas.

IMPACT OF AGRICULTURAL MODERNIZATION IN JAPAN

According to Kagayama (2), chairman of the Agricultural Mechanization Council in Tokyo, government measures to promote farm mechanization have been overshadowed by the efforts and enthusiasm of manufacturers to develop machinery appropriate to Japanese conditions.

Use of agricultural machinery

Total mechanization of rice cultivation reduced the labor input/ha by more than half — from 1,410 h in 1965 to only 640 h in 1981 (Fig. 6). In general, farm machines are owned individually by farmers exclusively for their own use.

The cooperative or joint use of high-powered machines such as large tractors, combines and rice transplanters amounted to only 10% of total farm machinery use. The average machine use per year is reported to be 67.5 h for riding tractors, 17.2 h for rice transplanters, and 29.3 h for head-feed combines.

Agricultural machinery investment

The average farm household in Japan increased the annual value of farm machinery purchased from 37,000 yen in 1965 to 160,000 yen in 1982. Its proportion to agricultural income increased from 10% in 1965 to 17% in 1982. Such investments, however, represent only 3 to 4% of the average farm household income and show a recent decline because of the increase of farm household income shown in Table 1 (5).

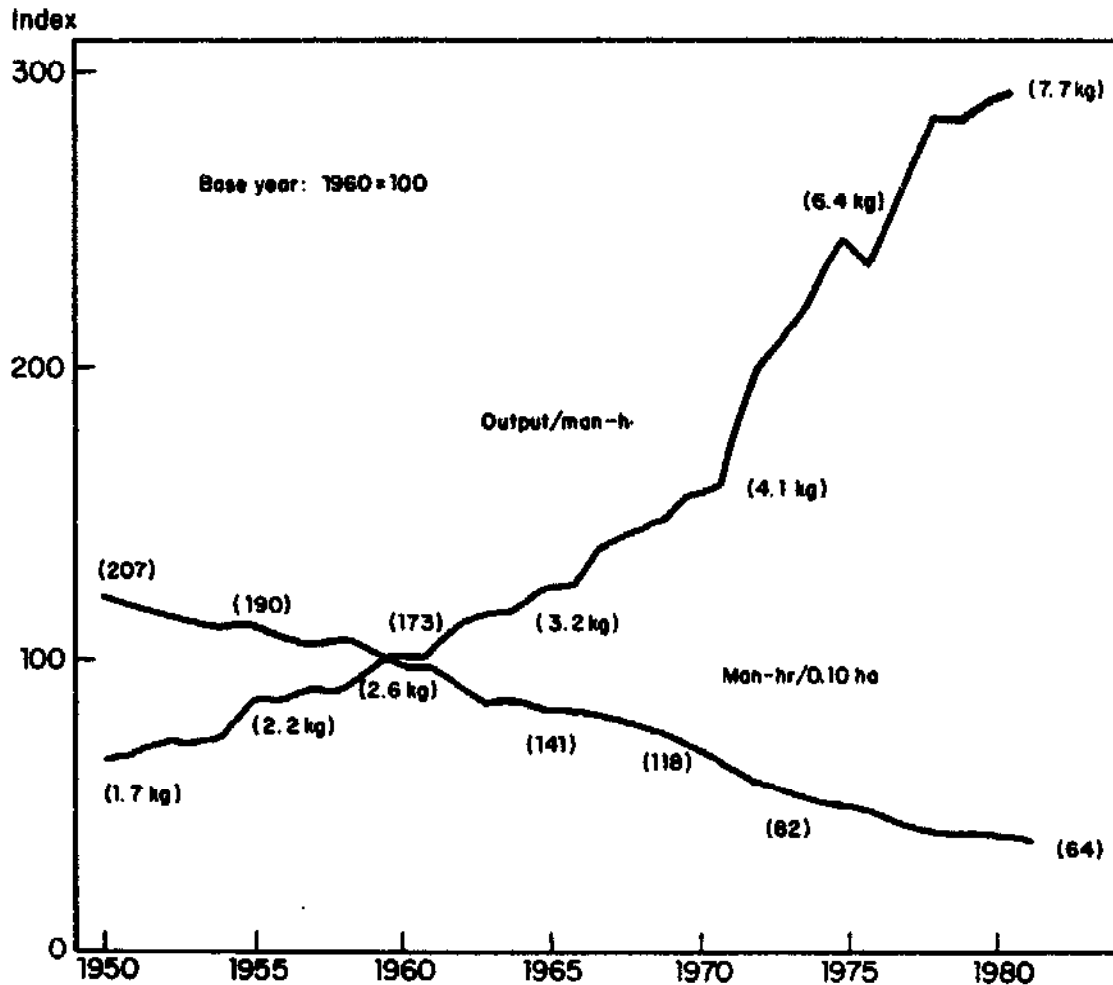

6. Trends in labor input and productivity in lowland rice production (5). Figures in parentheses show actual numbers.

Societal impact

The development of agricultural mechanization in Japan, as elsewhere, should be considered as part of the total socioeconomic and technological development. The level and type of mechanization constitute a response to the change from an agricultural to an agro-industrial and largely industrial economy during the last two and one-half decades. There have been decreases in farm households, in agricultural income as a percentage of total farm household income, in agricultural land area, in relative growth of agriculture, in per capita consumption of rice, and in labor input per hectare. Concurrently, farm labor movement to the industrial and service sectors creates a vacuum in the agricultural sector (4).

This transformation is unique in that farming was continued through heavy infusion of locally designed and manufactured machinery. Farming has largely become a part-time job. Farm labor is essentially being supplied by women and the elderly (over 65 yr old).

To combat apprehension about over-investment in farm machinery, steps are being taken to rationalize the management of machinery through joint or cooperative use.

Table 1. Trends in purchase of farm machinery and implements.

Year	Thousand yen/av farm household				
	Farm household income (A)	Agricultural income (B)	Purchase of farm machinery and implements (C)	Percentage share	
				C/A	C/B
1965	835	365	37	4.5	10.2
1970	1,592	508	52	3.3	10.2
1975	3,961	1,146	160	4.0	13.9
1977	4,671	1,173	180	3.9	15.3
1980	5,594	952	169	3.0	17.7
1981	5,920	968	152	2.6	15.7
1982 ^a	6,047	943	159	2.6	16.8

Source: Ministry of Agriculture, Forestry and Fisheries, Farm Household Economy Surveys.
^aProvisional.

In spite of situations pointing toward noneconomic use of machinery, the farmers have opted to invest in them. Tsuchiya (6) enumerates five theories on adoption of power tillers:

Income effect theory. The farmer's income has increased and, irrespective of its source, the income enables him to afford the machine. The farmer is induced to this investment not because of a favorable result of farm management analysis but because household economy and business enterprises are not clearly distinguished in Japanese agriculture. The motive for purchasing power tillers is similar to that for purchasing durable consumer goods, such as a washing machine, rather than that for pure producer goods.

Demonstration effect theory. Farmers buy power tillers to compete with next-door farmers who already use them. Again, the assumption is that power tillers are regarded as consumer rather than producer goods.

Disintegration of patriarchal family theory. Power tillers stimulate sons and daughters, who might abandon family farms, to remain in agriculture.

Increased leisure evaluation theory. Power tillers are not bought to increase earnings but rather to increase leisure time.

Farmers' physical mutation theory. The increased schooling time of children has deprived them of early training in farm work, decreasing body strength; they shy from hard work and adopt power tillers.

The machinery banking system also helps to neutralize the uneconomic effects of over-investment. Through agricultural cooperatives, farmers can turn in their machine for hiring services. The system, together with individual custom services and joint ownership/operation, is a model of mechanization at the farm level.

Efficiency is also encouraged through land consolidation, training of operators, ensuring safety, promoting the market for used farm machineries, strengthening repair and maintenance work, intensifying research and development, and testing and evaluating farm machineries.

Marketing and distribution

In Japan, the private sector and agricultural cooperatives almost equally share the market.

No sales taxes are imposed on farm machinery. Instead, government schemes and projects give as much as 50% subsidy to buyers of high-powered machinery and equipment for common use. Individual purchases are often facilitated through credit arrangements providing installment payments just like for automobiles.

After-sales services

The success of mechanization can be attributed to farmers' confidence in machine performance and in services from manufacturers and distributors. Competition generates good attitudes of service personnel, mutually benefiting farmers and distributors. One farm machinery distributor operates 22 service stations with 4-7 technicians per station, providing a ratio of 1 technician to every 500 farm households. Farm machinery dealers have initiated a reconstruction program for used machines, which are either resold at low prices or exported.

Research and development

Four types of institutions conduct research and development of machinery including testing and evaluation, to ensure efficiency and safety and to meet farmers' needs:

- universities conducting basic research,
- IAM in prototype design and invention of new machinery,
- factories working in close collaboration with IAM and the universities, and
- national and prefectural agricultural experiment stations on the use of farm machines.

The Asian Agricultural Machinery Institute, established by a Japanese firm and based in Bangkok, Thailand, reflects the desire of the firm to develop appropriate machines for tropical agriculture. If successful, it might lead to joint manufacturing ventures; however, it might also stifle the fledgling local machinery manufacturing industry.

MECHANIZATION IN KOREA

The Republic of Korea achieved a phenomenal 8.3% annual economic growth rate with the success of 4 consecutive 5-yr economic plans during the last 2 decades. In the last decade, rapid industrialization caused a yearly decline of 1.8% in the proportion of rural farm population. The rural farm population is now only 25% of the total population. Farm labor shortage has increased farm wages. As a result, labor-saving farm machinery was adopted to cope with agricultural production needs. About 65% of farmers 25 yr old or younger felt a great need to acquire farm machinery.

Agricultural mechanization, starting in the late 1960s, ushered in an increasing supply of farm machinery in the 1970s. Early mechanization

revolved around the power tiller, equipped with 8 to 10 hp engine and used for pumping, threshing, hauling, and tillage.

Other developing countries of Asia with small farms may note the fact that the Korean average landholding of 1.35 ha has not hindered agricultural mechanization. In 1983, about 50% of farm households owned 3 machines: power tiller, rice transplanter, and reaper binder.

Like Japan, Korea used human and animal draft technology before the 1960s. In 1965, mechanical power ownership was only 47% of animal power; by 1979, it had increased more than three times. Draft animals continue to be used in hilly areas, but with present plans for mechanization, at least 50% of the hilly areas will be using mechanical power by the end of the 1980s.

DEVELOPMENT OF FARM MECHANIZATION

Powered machines used in Korea before the 1960s were mainly postharvest equipment, not field machinery. The power tiller started to become popular as the basic power unit in the early 1960s, but the rate of diffusion was slow until after the middle 1960s.

Chung (1) divides the development of mechanization into two stages: infancy and rapid promotion.

Infancy (1967-76)

In the two Five-Year Economic Development Plan (FYEP) periods, 1967-71 and 1972-76, the industrial sector grew rapidly, outpacing the agricultural sector. Industrial growth attracted farm labor, and by 1968, labor shortage obliged agricultural leaders to establish policies and plan for farm mechanization. Accordingly, with fledgling private enterprises and farmers still incapable of pushing through agricultural mechanization on their own, the government in 1974 established the Farm Mechanization Division (FMD) in the Ministry of Agriculture and Fisheries (MAF) to plan and execute farm mechanization development.

During the second FYEP, the first national agricultural mechanization program emphasized dissemination of irrigation water pumps and power sprayers. During the third (1972-76), power tillers, pest control machinery, water pumps, and threshers were disseminated rapidly. Animal draft power for plowing, harrowing, and hauling was displaced by power tillers.

Until 1971, the farm households relied on government loans and subsidies for machinery purchases.

Rapid promotion of farm mechanization (1977-82)

Farm mechanization was further strengthened and led to the rapid dispersal of machinery, starting with mostly imported machines or those manufactured locally under joint-venture schemes.

In 1979, the Agricultural Mechanization Promotion Law was enacted to strengthen production, supply, and utilization of farm machinery; creation of funds; inspection; and other activities.

High effectiveness (1983 onwards)

The Agricultural Mechanization Institute, Rural Development Administration, anticipates that by 1983 manufacture of all kinds of machinery will be completely localized.

Figure 7 shows the growth and projected use of farm machinery from 1950 to 2000.

KOREAN POLICIES AND STRATEGIES

Institutional infrastructure; role of government

Farm Mechanization Division of the MAF. As earlier indicated, the government formulated a system to administer farm mechanization by establishing the MAF-FMD in 1974.

Agricultural Mechanization Promotion Law. A 1979 legislation — the Agricultural Mechanization Promotion Law — obliges the central and local governments to promote agricultural mechanization. The law requires the Minister of Agriculture and Fisheries to plan and execute the “Basic Program for Agricultural Mechanization,” which should deal with demand and supply, utilization promotion, technical training, ex post facto service, research, development and inspection, safety control, financial support, and other support for mechanization. The text of the law is in Appendix I.

National Farm Mechanization Committee. This Committee was established in 1979 upon recommendation of RNAM, in which Korea is a participating country. Advisory to MAF, the committee is headed by the deputy minister of MAF. It has 12 members representing offices and bureaus of ministries, mostly at the director-general level, plus 3 technical persons nominated by MAF from universities.

The committee has subcommittees for designating facilities for farm machinery after-sales service, for farm machinery parts price control, and for quality improvement measures.

The national involvement in farm mechanization is shown in Figure 8.

Licensing of manufacturers. For licensing, the government in 1977 classified manufacturers into integrated farm machinery manufacturers (IFMM) and specialized small-to-medium-sized manufacturers (SSMSM). The IFMM are required to produce internal combustion engines for agriculture and at least one machine classified in IFMM; they should satisfy the facility, manpower, and quality control requirements separately set by the governments; and their products must pass the material inspection test. The SSMSM are expected to manufacture at least one item classified in the SSMSM.

Agricultural Machinery Institute (AMI). AMI, located at Suweon, leads in the promotion of 1) local manufacture of farm machinery, 2) laissez-faire system of trading farm machineries, and 3) greater mechanization of paddy production.

Research and survey results carried out by institutes, universities, and manufacturers were collated and given to help shape government policy and implementation of machine design improvement, after-sale service, and marketing. The research and extension procedure is outlined in Figure 9.

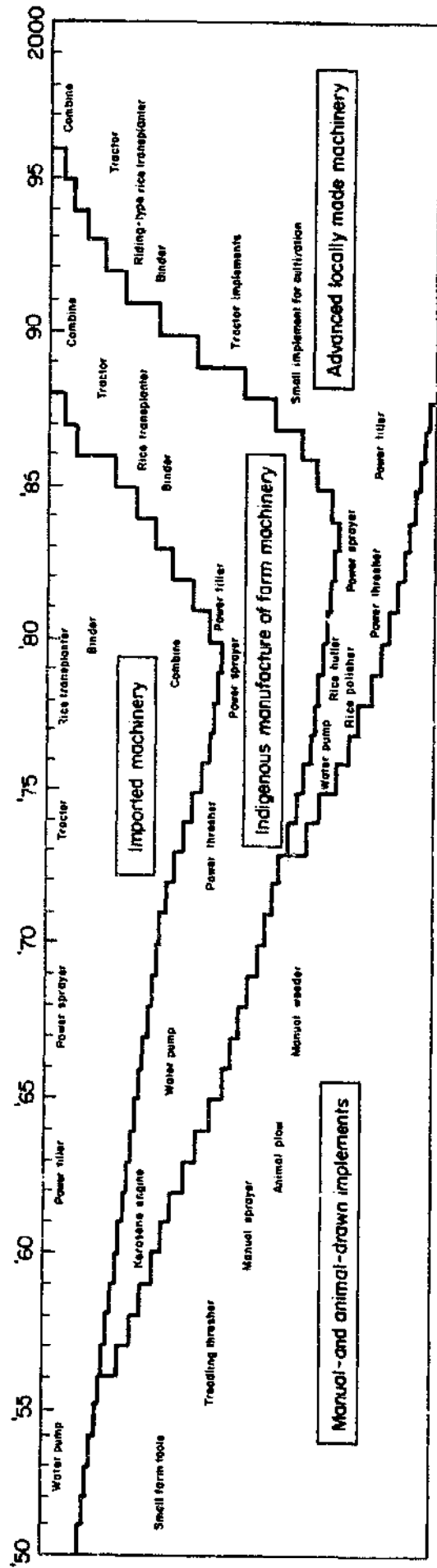

7. Farm mechanization in the Republic of Korea: past, present, and future.

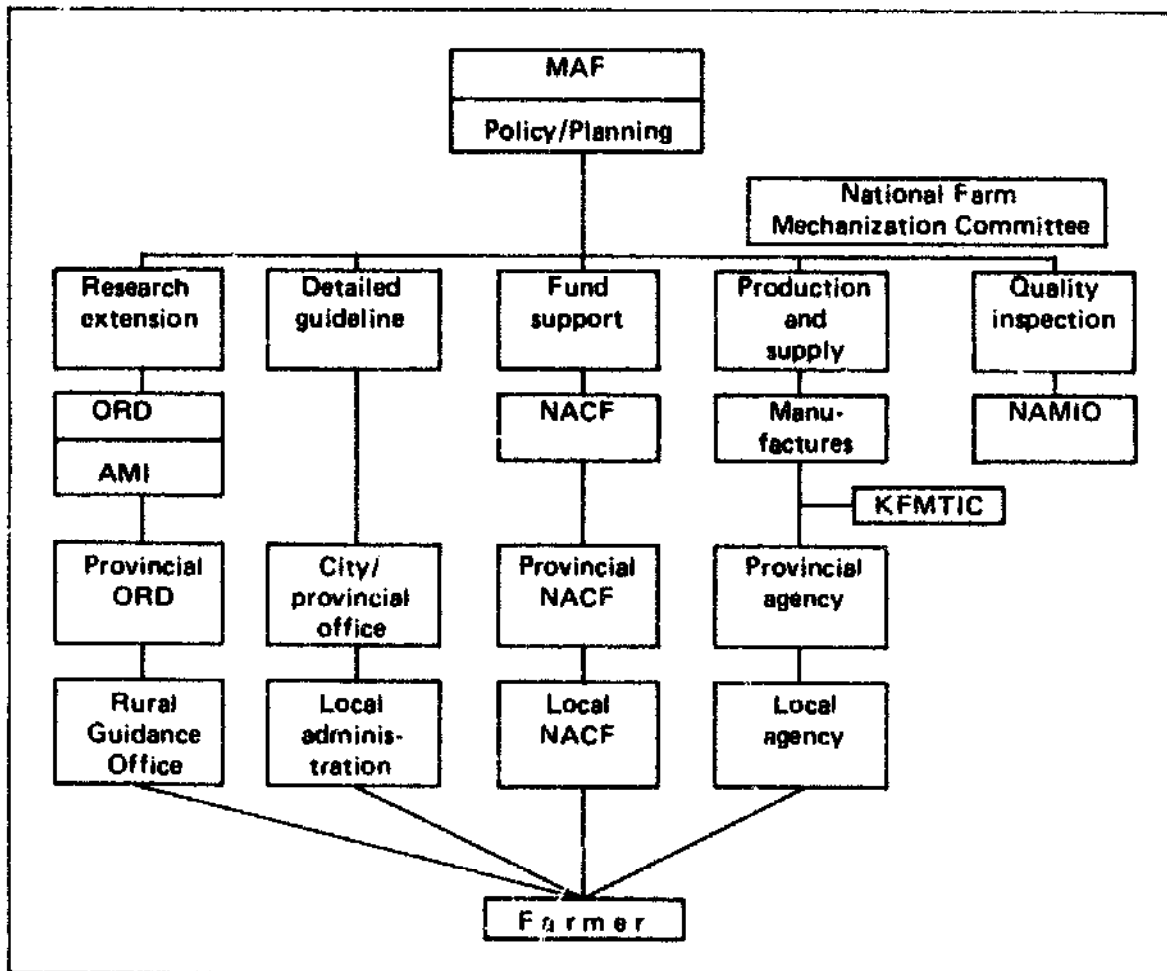

8. National involvement in farm mechanization. MAF = Ministry of Agriculture and Fisheries, RDA = Rural Development Administration, NACF = National Agricultural Cooperative Federation, NAMIO = National Agricultural Materials Inspection Office, KFMTIC = Korea Farm Machinery and Tools Industrial Cooperative.

A well developed and funded institute, AMI has an exhibit of modern and primitive machinery. Its training activities cater to participants ranging from housewives and 4-H club members to farmers and engineers.

National Agricultural Materials Inspection Office (NAMIO). NAMIO inspects machines before they are disseminated to farmers whose feedback information is coursed to the appropriate division.

Integrated farm mechanization project. Every province has a mechanization project servicing 300 ha. The national government subsidizes the purchase of about 50 units of large and high-powered farm machines such as rice transplanters, combines, tractors, and dryers and the construction of the machinery shed, dryer warehouse, and paddy nurseries. The project aims to hasten farm mechanization at the provincial level.

Government at the village level. The government links with agricultural cooperatives and the Saemaul movement (see below) in promoting farm mechanization. The village cooperative may have a Farm Mechanization Centre (FMC) pilot or demonstration project servicing 30 to 50 ha of paddy fields and administered through the National Agricultural Cooperative

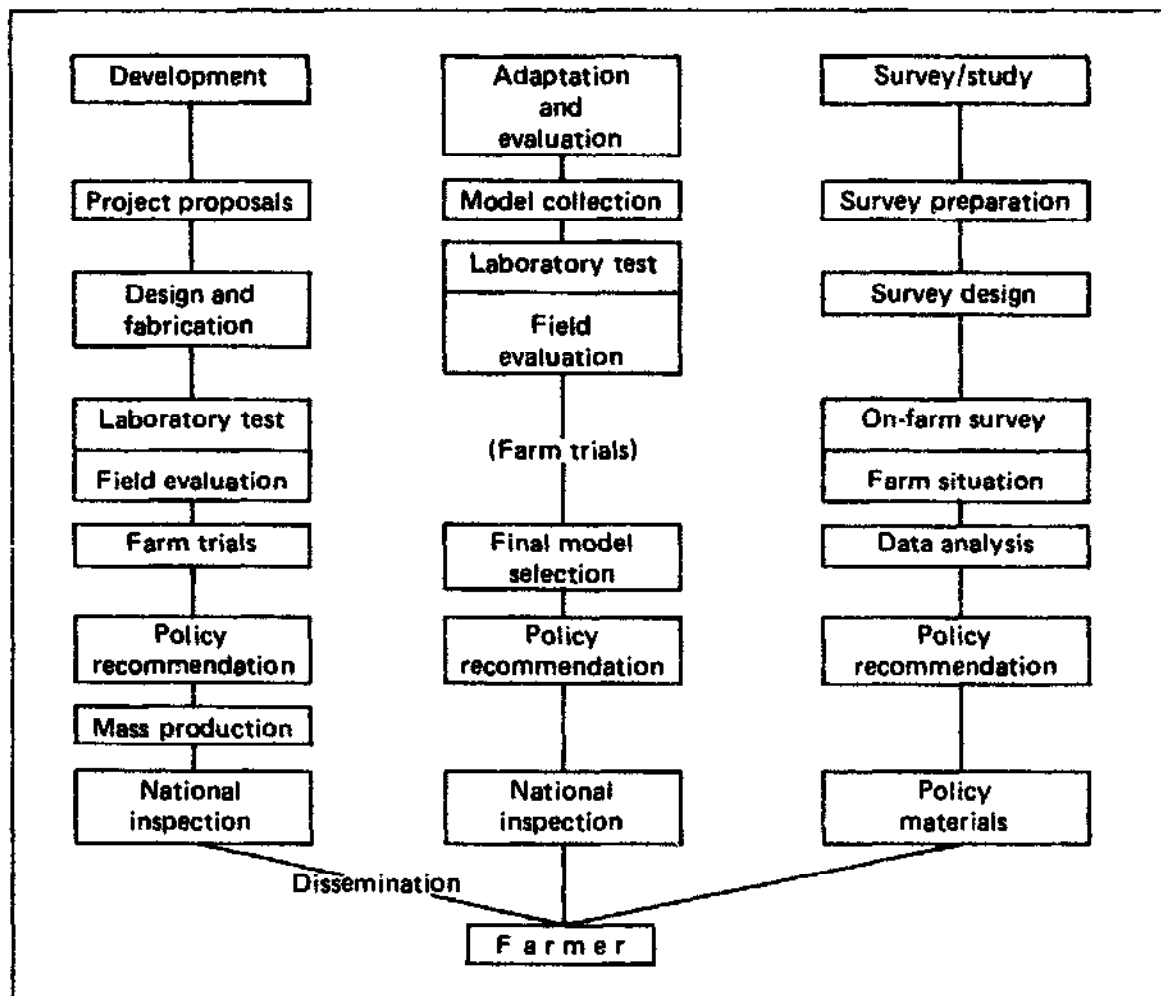

9. Research procedure for farm mechanization.

Federation (NACF) as an initial step in promoting farm mechanization. The government provides low-interest-rate loans (70-80% of cost) for major farm machinery purchases.

The Saemaul Mechanization Farming Group. The SMFG is a small cluster of farmers (about 20 each) with common interest, organized through the Ministry of Home Affairs. The SMFG purchases farm machines for members and/or provides custom work for them through joint ownership and operation of machines. As much as 40% of the cost is subsidized by the government. In 1981, 695 SMFGs were operating, and the government envisions 20,000 SMFGs by 1990.

Role of the private sector

Manufacturers responded to the government's call to manufacture the needed machinery. Firms are widely scattered throughout the country to serve even the remote areas.

After-sales service system. Both the government (NACF) and the private sector (repair centers) render after-sales services. Manufacturers are required to produce and supply a fixed quantity of spare parts according to the quantity of machines they have supplied. Provincial parts centers are linked sys-

tematically to the smallest village unit service centers and repair shops. There is a 12 billion won security fund for spare parts for private service centers. April, August, and November have been designated as months of regular joint-round after-sales service for remote areas. The mobile group of technicians from the factories and dealers are equipped with repair shop tools and parts.

MAF provides loans to manufacturers, dealers, and repair shop owners for securing stocks of replacement parts. MAF also collaborates with the Ministry of Trade and Industry (MTI) so that manufacturers can produce or import replacement parts of old model machinery for the duration of its working life. The MTI appoints specialized parts factories — some 260 in 1983.

Development plans

The Government expects that 100% of Korea's farm machinery needs will be produced locally in 1986 and mechanization of plain areas will be completed by 1987.

Planners recognize the need to improve machines for harrowing, operations on sloping areas, transplanting, and pest control. Comfortable riding tillers need to be developed.

AMI is developing various attachments for the power tiller, specifically an onion harvester, seeder, paddy harrow, and mower. The multipurpose power tiller is much sought because it is light and simple.

Production of other crops may also be mechanized. AMI continues to survey farmers' experiences with machinery to get information on features to be improved and developed. Results of eight surveys have already been used to formulate government policy. A study to analyze the socioeconomic impact of transplanters will be conducted in 1985-86.

ANALYSIS OF KOREA'S EXPERIENCE

The Government guided the development of agricultural mechanization and enthusiastically pushed the rice production mechanization program.

Before planned mechanization started with the second FYEP (1967-71), the machinery supply consisted largely of manual and animal-drawn implements. Kerosene engines, water pumps, and power threshers were the first indigenously manufactured machines, starting in the late 1950s. Between the early 1950s and early 1970s, water pumps, power tillers, and power sprayers were imported. By 1974, the mechanization technology picture was a mix: rapidly declining numbers of manually operated tools and animal-drawn implements; increasing numbers and improving quality of locally manufactured farm machinery, especially water pumps, rice polishers, rice hullers, power threshers, and power sprayers; and an introduction of imported high-powered machinery consisting of riding tractors, combines, binders, and rice transplanters.

These developments were meticulously planned; and their implementation was monitored and supported by institutional infrastructures, policies, and a

law for mechanization. The plans were a clear response to the emerging rapid economic growth which drew farm labor to the nonagricultural sector.

The private sector, especially industrialists, felt the Government's enthusiasm and firmness in pushing mechanization. The light metal industry saw very favorable environment for business, because the government set clear-cut targets for the supply of machinery. In the beginning when farmers were unable to acquire machinery because of low wages, the Government heavily subsidized their purchases. When the farmers obtained high family income from agriculture and industry, the Government gradually withdrew the subsidies but retained the low-interest loans.

The private sector has manufactured the needed machinery and rendered after-sales services. The Government has considered these services indispensable to mechanization and has made sure the farmers get the right machines through an inspection system. The manufacturers were supported by a strong research and development group, and training and extension in agricultural mechanization.

A current issue, fear of over-investment, is being mitigated by promotion of joint or cooperative use of machinery. The extension arm is well-organized and effectively reaches the village level.

The manufacturing industry has expanded from simple small-scale machines to large ones employing modern techniques of industrial production, especially combines, binders, and rice transplanters.

Korea is influencing other developing countries in its export of power tillers and plow/tiller attachments. It has found markets in nearly all Southeast Asian countries where the power tiller is popularly used and it competes with Japan where the technology of design and manufacture originated.

The capability to export machinery began mostly through joint ventures in manufacturing during the late 1970s. Since the manufacture of power tillers, water pumps, pest control equipment, threshers, and grain mills has already reached 100% domestic production, joint-venture manufacturing has ceased. Although sophisticated machinery like tractors, combine harvesters, and binders is still manufactured through joint venture programs, it is expected to be 100% localized by 1986. As of the end of 1984, localization rates were as follows: tractors, 60-98%; rice transplanters, 88-99%; combine harvester, 38-74%; and binders, 75-90%. The joint ventures on 23 models by 5 large-scale manufacturers are with USA, Japan, and Italy.

Korea's example is worth emulating. The fast economic growth which spawned the promotion of mechanization was planned rationally and implemented with determination to overcome a recessed economy, a situation common among other developing countries.

SUMMARY

Mechanization development in Japan and Korea is recent. In fact, 20 yr ago, the 2 countries were practically in the same or worse situation as most other developing countries are in today.

The experience of Japan and Korea shows that farm mechanization does not have to be limited by farm size. Japan and Korea went through a tenancy stage before World War II and both underwent land reform; farmholdings now range from 1 to 2 ha only. In some developing countries, farms are larger.

Geography and climate do not favor mechanization in Japan and Korea. Although these countries are in the temperate zone, any advantage (except possibly for the richer and unleached soils) seems doubtful. In fact, only one crop per year can be raised compared with possible multiple cropping in the tropics. Further, the two countries are less endowed with natural resources, and the limited growing season pressures them.

The triggering device for mechanization in Japan and Korea was the industrial development boosting economic growth. Mechanization has come as a result of the exodus of farm labor to the nonagricultural sector. Japan led Korea by almost 10 yr in this process.

This is not to argue that full or rapid industrial development must be awaited before planning for mechanization. In fact, the two countries planned ahead of development, and when the right time arrived, they pursued their plans systematically, providing environment conducive to manufacturers and farmers.

REFERENCES CITED

1. Chung, Chang Joo. 1984. Farm mechanization in the Republic of Korea; status, problems and prospects. *Agricultural mechanization in selected Asian countries*. Asian Productivity Organization, Tokyo, Japan.
2. Kagayama, K. 1983. Evolution of government policies for farm mechanization. Asian Productivity Organization, Tokyo, Japan.
3. Kisu, M. 1983. Mechanization of rice farming. Asian Productivity Organization, Tokyo, Japan.
4. Matsuki, Y. 1983. Farm mechanization from farm management's point of view. Pages 211-228. Asian Productivity Organization, Tokyo, Japan.
5. Nakamaru, N. 1984. Agricultural mechanization and government policies in Japan — a brief review. *In Agricultural mechanization in selected Asian countries*. Asian Productivity Organization, Tokyo, Japan.
6. Tsuchiya, K. 1972. Mechanization and relations between farm, non-farm and government sectors. Pages 27-49 *in Farm mechanization in East Asia*. H. Southworth, ed. The Agricultural Development Council, Inc., New York, N.Y. 10020.

Appendix I

**AGRICULTURAL MECHANIZATION PROMOTION LAW, 1979
REPUBLIC OF KOREA**

Article 1. Purpose

The purpose of this law is to increase agricultural productivity and contribute to rural modernization by the popularization and utilization of agricultural machinery.

Article 2. Definitions

The terms in this law are defined as follows:

- A. "Agricultural Machinery" are the machines and implements needed to accomplish agricultural operations such as: plowing, harrowing, seeding, transplanting, irrigation, fertilizing, cultivating, pest and disease controlling, harvesting, processing and preparing, cattle breeding and like or related activities. But "heavy equipment" referred to in paragraph 1, article 2, Heavy Equipment Management Act is excluded.
- B. "Agricultural Mechanization Project" is for improving the agricultural structure with advancing agricultural production, technology in the area of production, popularization, utilization, training, ex post facto service, safety control, research and survey on machinery.

Article 3. Governmental Obligations

Central and local governments are obliged to promote agricultural mechanization in accordance with the national policies and strategies set forth in this law.

Article 4. Financial Supports

1. The Government can provide capital, in whole or part, to those purchasing agricultural machinery and building up facilities necessary for machinery utilization.
2. In order to popularize the Notified Machinery (see the provision of article 7 of this law) smoothly, the government can provide loans for machinery production to the manufacturers, in whole or part.

Article 5. Basic Program for Agricultural Mechanization

1. Minister of Agriculture and Fisheries should plan "Basic Program for Agricultural Mechanization" (hereinafter called "Basic Program") and make public notice. And changing it, the Minister should make public notice.
2. Following matters on the agricultural machinery should be mentioned in the Basic Program.
 - A. Matters on the demand and supply.
 - B. Matters on the utilization promotion.
 - C. Matters on the technical training.
 - D. Matters on the ex post facto service,
 - E. Matters on the research, development, and inspection.
 - F. Matters on the safety control.
 - G. Matters on the financial supports and others for the mechanization.

Article 6. Execution Program

Minister of Agriculture and Fisheries should scheme the program to execute the Basic Program every year.

Article 7. Notified Machinery

Minister of Agriculture and Fisheries should make public notice on the main kinds of the machinery for promoting its production and popularization. Hereinafter it is called Notified Machinery.

Article 8. Establishment of the Fund

The government shall establish the Agricultural Mechanization Promotion Fund (hereinafter called the Fund) to get financial resources for the mechanization promotion.

Article 9. Sources of Fund

The Fund shall be built up with following sources:

- A. Contributions from the government
- B. Loans from other countries
- C. Contributions from individuals or organizations
- D. Profits from the operation of the Fund.

Article 10. Operation and Management of the Fund

1. The fund shall be used for supporting the following items on the agricultural machinery:
 - A. Purchase and production
 - B. Promotion of cooperative utilization
 - C. Research, development, and survey
 - D. Technical training and ex post facto service
 - E. Other project by Minister of Agriculture and Fisheries, by executing the Basic Program.
2. The Fund shall be managed by the Minister of Agriculture and Fisheries.
3. Details on the operation and management of the Fund shall be regulated in the Presidential Decree.

Article 11. Control of the demand and supply

Minister of Agriculture and Fisheries can order the following items to the manufacturer or saler of the notified machinery against the emergency situation like countermeasures against calamities.

- A. Control of the balance on the production plant of the machinery.
- B. Control of the regional balance on selling amounts of the machinery.
- C. Control of the balance on the numbers of saler.
- D. Special items for the countermeasure against calamities.

Article 12. Control of the Price

Minister of Agriculture and Fisheries can appoint the highest price of the Notified Machinery under the provision of article 2, "Act on Price Stability and Fair Business" for the smooth popularization.

Article 13. Cooperative Utilization

In order to promote the cooperative utilization and heighten the utility of the agricultural machinery, government can provide the performer with the capital needed for purchasing the machinery, building up the accessory facilities and their operation and management, in whole or part.

Article 14. Inspection of the Notified Machinery

1. The manufacturer and importer of the Notified Machinery should have their Notified Machinery inspected by Minister of Agriculture and Fisheries. Only to the imported Notified Machinery, the inspection can be omitted in whole or part, according to the ordinance of Minister of Agriculture and Fisheries.
2. To perform the inspection under the provision of paragraph 1, Minister of Agriculture and Fisheries can make his officials inspect the accountbooks and other documents of the manufacturer or importer, and collect the test samples.
3. To do inspection under the provision of paragraph 2, the official inspector should show the inspectorial identification voucher to the manufacturer or importer.
4. The classifications of the inspection, test codes and procedures and custody or disposition of the test samples shall be regulated in the ordinance of Minister of Agriculture and Fisheries.

Article 15. Ex Post Facto Service

1. The manufacturer or seller of the Notified Machinery should establish the ex post facto service networks system under the ordinance of Minister of Agriculture and Fisheries.
2. Who will manage the workshop should have qualifications and facilities under ordinance of Minister of Agriculture and Fisheries.

Article 16. Safety Control

Minister of Agriculture and Fisheries can direct to attach the safety device to the manufacturer.

Article 17. Operating License

1. The operator of the agricultural machinery appointed by the presidential decree, should have the license from Minister of Agriculture and Fisheries, but who has the automobile driving license by the other act, shall not need the operating license under the ordinance of the Minister of Agriculture and Fisheries.
2. The details on the operating license shall be regulated in the ordinance of Minister of Agriculture and Fisheries.

Article 18. Registration of the Agricultural Machinery

The owner of the machinery under the provision of the paragraph 1, article 17, should register it to the provincial governor.

Article 19. Consignment of the Agricultural Mechanization Project

Minister of Agriculture and Fisheries can consign some part of the Agricultural Mechanization Project to the agricultural cooperatives (included National Agricultural Cooperative Federation: NACF) and cooperations or organizations established for the agricultural mechanization promotion.

Article 20. Consignment of the Authority

In accordance with the presidential decree, Minister of Agriculture and Fisheries can consign some parts of his authorities to provincial governors, Director of Office of Rural Development or Director of National Agricultural Material Inspection Office.

Article 21. Penal Regulation

The manufacturer or importer who sell the Notified Machinery without inspection under the provision of paragraph 1, article 14, shall be punished with a fine not exceeding a million won for the violation.

Article 22. Penal Regulation

Following offender each shall be punished with a fine not exceeding 50 thousands won for the fault.

- A. One who drives the appointed machinery under the provision of paragraph 1, article 17, on the road under the provision of "Road Act," not withhold the driving licenses.
- B. One who does not register the machinery against the provision of paragraph 1, article 18.

Article 23. Both Penal Regulation

In case that cooperations, its representatives, employers, and individuals are punished by the provisions of article 21 and 22, not only the offenders but also the cooperations or individuals concerned, shall be punished with a fine for the violation or fault.

Article 24. Presidential Decree

The needful matters to execute this law shall be regulated by the presidential decree.

SOME CONSEQUENCES OF AGRICULTURAL MECHANIZATION IN THE PHILIPPINES, THAILAND, AND INDONESIA

B. DUFF

The International Rice Research Institute

Much of the controversy in using agricultural engineering technologies in the developing countries revolves around the impact of machines on total employment, labor and land productivity, and income levels and distribution. Lack of empirical evidence clearly quantifying these impacts and characterizing the underlying conditions accounts for much of the conjecture surrounding small-farm mechanization issues. In the past 20 yr, numerous studies dealing with mechanization have covered agroclimatic, agronomic, and socioeconomic conditions. Most, however, are not directly comparable nor are their results generalizable.

Table 1 contains indices describing the agroclimatic and economic status of several Asian countries. The data highlight the difficulties in developing general rules governing mechanization issues. Even countries at similar levels of development as measured by Gross Domestic Product (GDP) per capita do not necessarily show similar levels of agricultural mechanization. Contrast, for example, tractor populations in Pakistan and Sri Lanka. In addition, the data mask major regional differences in countries such as Indonesia, the People's Republic of China, and India. For guidance in planning projects, programs, and policies, information should be location specific, systematically collected, and rigorously analyzed.

Several papers presented in this volume enumerate in detail the conditions for successful (and unsuccessful) development, introduction, and use of equipment in national mechanization programs. Others describe experiences with specific technologies. Representatives from the manufacturing sector examine the requirements for success in the fabrication, marketing, and servicing of farm equipment in small-scale agriculture. A restatement of these issues is not necessary.

This paper briefly highlights the major research findings from a project to examine consequences of small rice farm mechanization in selected countries of Asia. The findings are confined to the issues of employment, production, and income effects of mechanization.

Table 1. Agricultural indices for selected Asian countries (6).

Country	GDP (\$/capita)	Area cultivated (%)	Area irrigated (%)	Cultivated area (ha/capita)	Workers/ ha	Population in agriculture (%)	Tractors (thousand/ha)
Bangladesh	121	64	18	.10	2.8	83.8	.45
Burma	138	15	10	.28	.7	51.8	.93
China	na ^a	10	46	.10	2.8	59.8	7.46
India	205	51	23	.25	1.0	63.2	2.47
Indonesia	331	10	28	.13	1.5	58.9	.67
Japan	8627	13	67	.04	1.4	11.0	224.50
Nepal	129	17	10	.16	1.7	92.6	.22
Pakistan	291	25	70	.23	0.6	53.5	2.26
Philippines	646	33	13	.20	0.8	46.0	1.71
Sri Lanka	240	33	24	.14	1.3	53.2	11.30
Thailand	590	35	15	.38	0.9	75.4	2.06

^a Not applicable.

THE CONSEQUENCES OF MECHANIZATION PROJECT

Recognizing the limitations of previous attempts to measure the impact of mechanization, IRRI, in cooperation with a number of collaborating institutions in Asia and with the Agricultural Development Council, developed a research project to assess the effects of agricultural engineering technology on employment, income, and production in small rice farming environments. Although components of the project were in nearly all countries of South and Southeast Asia, major field surveys were undertaken in the Philippines, Thailand, and Indonesia. Four survey sites were selected in the three countries and information was gathered from more than 1,200 farm and landless households over a 2-yr period.

Ancillary case studies were also carried out on topics of special interest at each site and a special farm record-keeping component encompassing a subset of the household sample was introduced. Sample characteristics are summarized in Table 2. The sample at each site had seven to eight villages. A census was carried out in each village. From the pooled census data, a stratified sample was drawn to include mechanized, nonmechanized, irrigated, rainfed, and landless households. The details of the sampling methodology are presented elsewhere (8).

Intensive data collection began in 1979, over a period of three to four seasons. Two survey rounds were conducted each season, one after land preparation and the other after harvest.

The "with and without mechanization" procedure used in the Consequences Project is subject to numerous limitations. Failure to incorporate all important institutional variables is an example. Also, cross-sectional data often had insufficient variability in the economic variables to permit meaningful statistical comparisons. A challenge of the study was therefore to explore and develop new analytical approaches to examine the mechanization question.

Table 2. Characteristics of sample villages derived from household census data.^a

Characteristic	Site			
	Nueva Ecija	Supanburi	West Java	South Sulawesi
Occupation (no.)				
Farm operator	1,042	892	1,021	1,367 (9,529)
Landless laborer	233	63	331	15
Nonagricultural worker	401	75	19	197
Total	1,676	1,030	1,371 (22,582)	1,579 (13,375)
Irrigation status (ha)				
Irrigated	1,033	1,813	2,022 (10,397)	1,465 (13,596)
Rainfed	1,112	2,616	0 (943)	526 (1,406)
Total	2,145	4,429	2,022 (11,340)	1,991 (15,002)
Average farm size (ha)	2.06	4.96	1.98	1.46

^a Numbers in parentheses are values for the entire village as derived from secondary data.

Subsequent analysis has included application of a wide range of methodologies including decomposition (25), regression and covariance analysis (13, 14, 15, 16), factor share and domestic resource cost analysis (22, 23, 24), and a series of simulation and general equilibrium models (2, 26).

PRODUCTION IMPACT OF MECHANIZATION

One issue in the mechanization controversy is the impact of machines on small-farm production. Mechanization may provide a direct increase in land productivity by increasing yields or reducing losses, increasing crop intensification, or expanding cultivated area.

The Consequences Project examined the yield, crop intensification, and cultivated area components of mechanization.

Yield effects

Land productivity did not significantly differ between farms employing tractors and those using animal or manual power for land preparation. This finding confirms many previous investigations addressing the same issue (4). The data in Figure 1 compare yields from mechanized and nonmechanized farms for wet and dry seasons at each site, and those for irrigated and rainfed farms in the Philippines and South Sulawesi. During wet season, there were no significant yield differences between farms using tractors and power tillers for land preparation and those using manual or animal techniques. During dry season, use of minitractors in South Sulawesi appeared to have increased rainfed yields by about 1 t/ha. Of the four sites, only South Sulawesi demonstrated improved yields directly attributable to use of machinery (18).

Table 3 compares yields and selected inputs for West Java, the Philippines, and Thailand. Statistical analysis does not demonstrate a significant difference in yield by mechanization class. When the yield figures in West Java were adjusted to represent an equivalent level of fertilizer use, the yield differences disappeared (23).

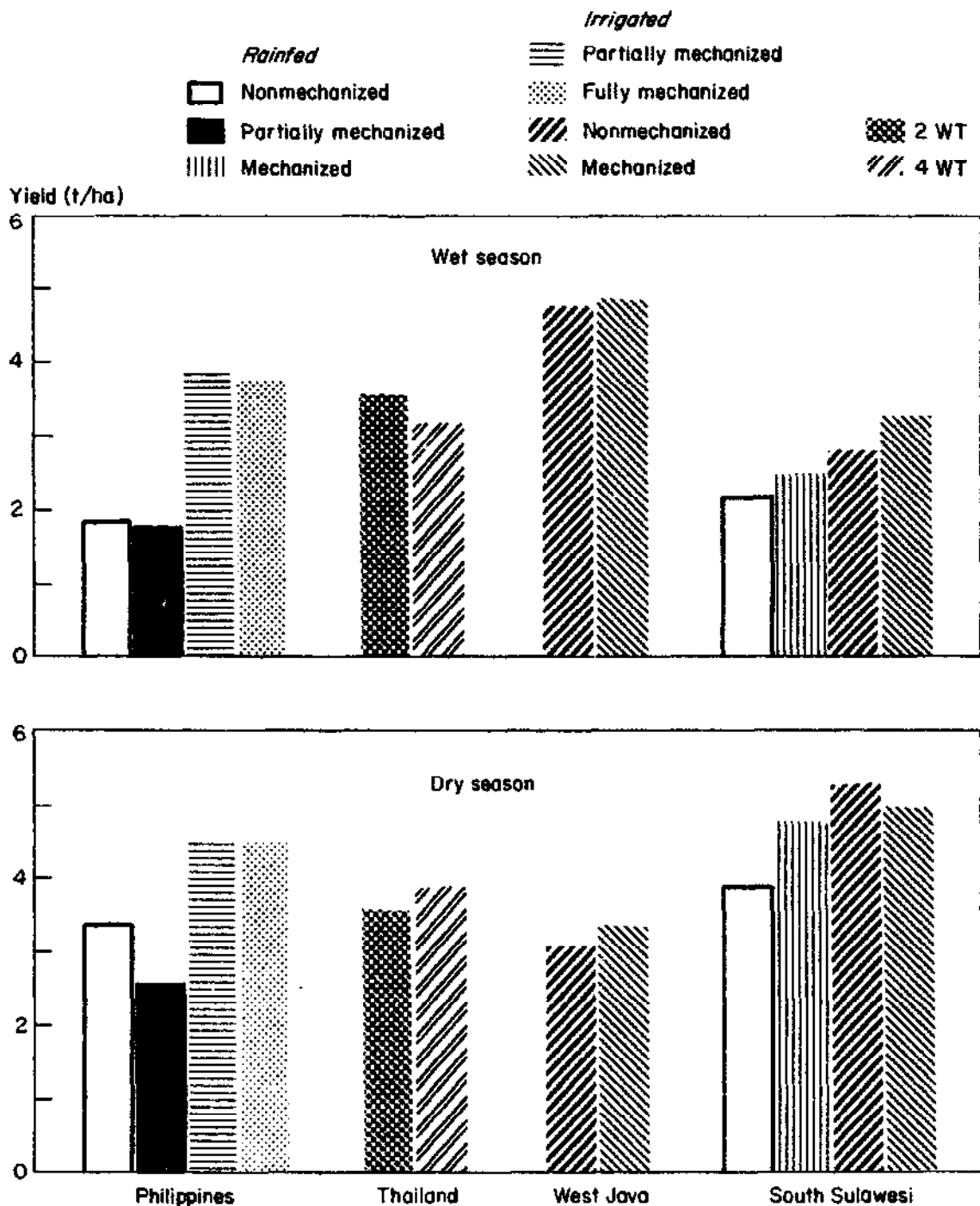

1. Yield, by mechanization class, in rice farm households in selected villages of the Philippines, Thailand, West Java, and South Sulawesi, crop year 1979-81.

Effects on cropping intensity

It is often argued that machinery allows more rapid, timely performance of crop production tasks, thereby permitting intensified cropping. The historical evidence on this issue is relatively clear. Japan, Taiwan, and Korea all achieved their highest levels of cropping intensification prior to widespread adoption of mechanized techniques (7). Intensification in general was not constrained by lack of power for field work, but by scarcity of irrigation water. Data in Table 4 show no significant differences in cropping intensity between mechanization classes, although intensity differs between rainfed and irrigated farms.

Table 3. Yield and production inputs for mechanized, partially mechanized, and nonmechanized farms in West Java, Philippines, and Thailand, 1979-81.

Site	Mechanized	Partially mechanized	Non-mechanized
<i>West Java, Indonesia (irrigated)</i>			
Yield (t/ha)	4.76	—	4.4
Fertilizer (kg/ha)	231	—	202
Tractor (h/ha)	24	—	—
<i>Philippines (irrigated)</i>			
Yield (t/ha)	3.80	3.86	—
Nitrogen (kg/ha)	52	52	—
Tractor (h/ha)	42	23	—
<i>Thailand (irrigated)</i>			
Yield (t/ha)	3.18	3.60 ^a	—
Fertilizer (kg/ha)	233	286	—
Tractor (h/ha)	49	49	—

^aTwo-wheel tractor.

Table 4. Cropping intensity index in rice farm households in selected villages of the Philippines, South Sulawesi, and West Java, crop year 1979-81.

Location	Cropping intensity index				
	Rainfed		Irrigated		
	Nonmechanized	Mechanized	Nonmechanized	Partially mechanized	Mechanized
Philippines	117	124		196	199
South Sulawesi	141	136	167		171
West Java			188		182

Related to crop intensification is the question of timeliness. This issue was examined in two ways. First, a cumulative frequency distribution relating time of planting with percentage of total area planted was developed at each site. Within the distribution was a further breakdown by mechanization class. Figure 2 shows the relative time required for land preparation in the irrigated areas of South Sulawesi (3). While mechanized farms began land preparation sooner, manual and animal-powered households quickly overtook them, finishing land preparation 2-3 wk earlier. The tractor was able to begin land preparation earlier because of its increased capacity to handle dry soils. With the onset of rains, nonmechanized farmers quickly mobilized their land preparation resources.

During wet season, rainfed farmers in the Philippines showed no major differences in the speed of land preparation between mechanized and nonmechanized farms (Fig. 3). In Figure 4, a similar picture emerges for dry season. Land preparation took much less time, regardless of the technique employed, but was completed in slightly less time with mechanization than without it.

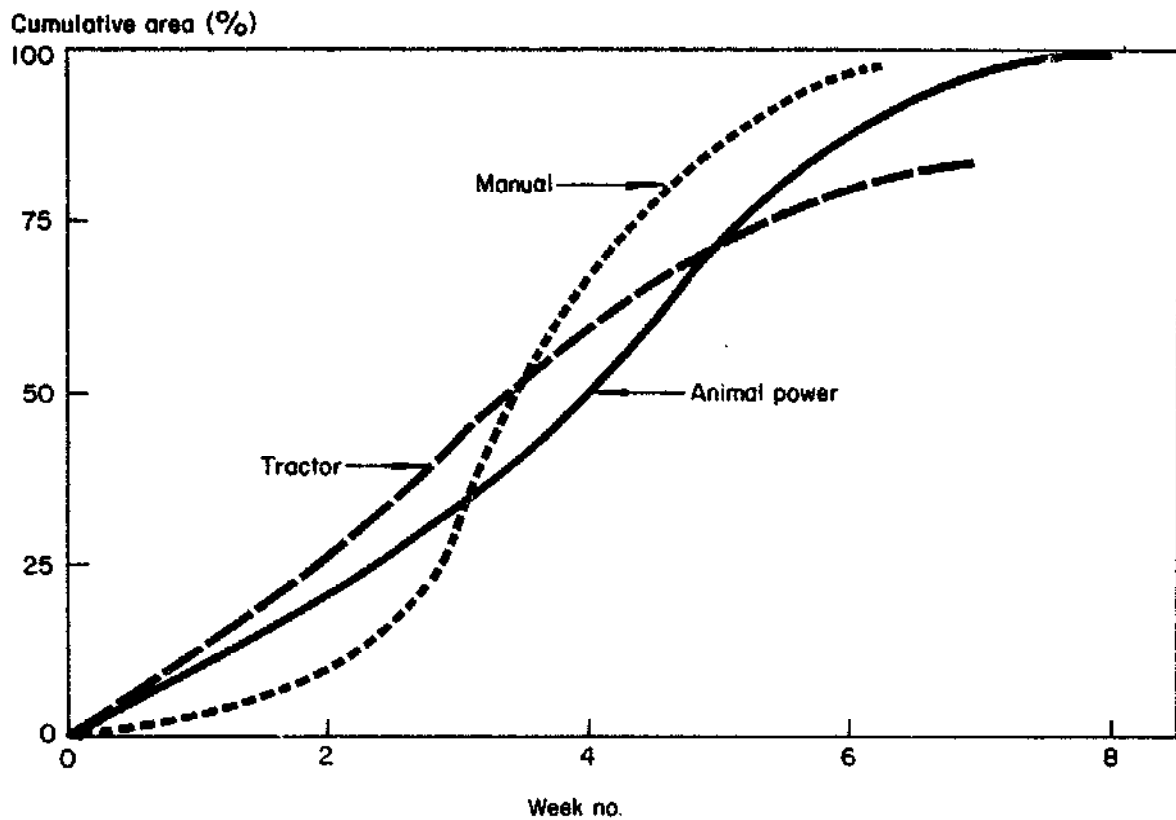

2. Cumulative frequency distribution of land preparation time for sample cooperators in South Sulawesi, Indonesia, 1979-80 wet season.

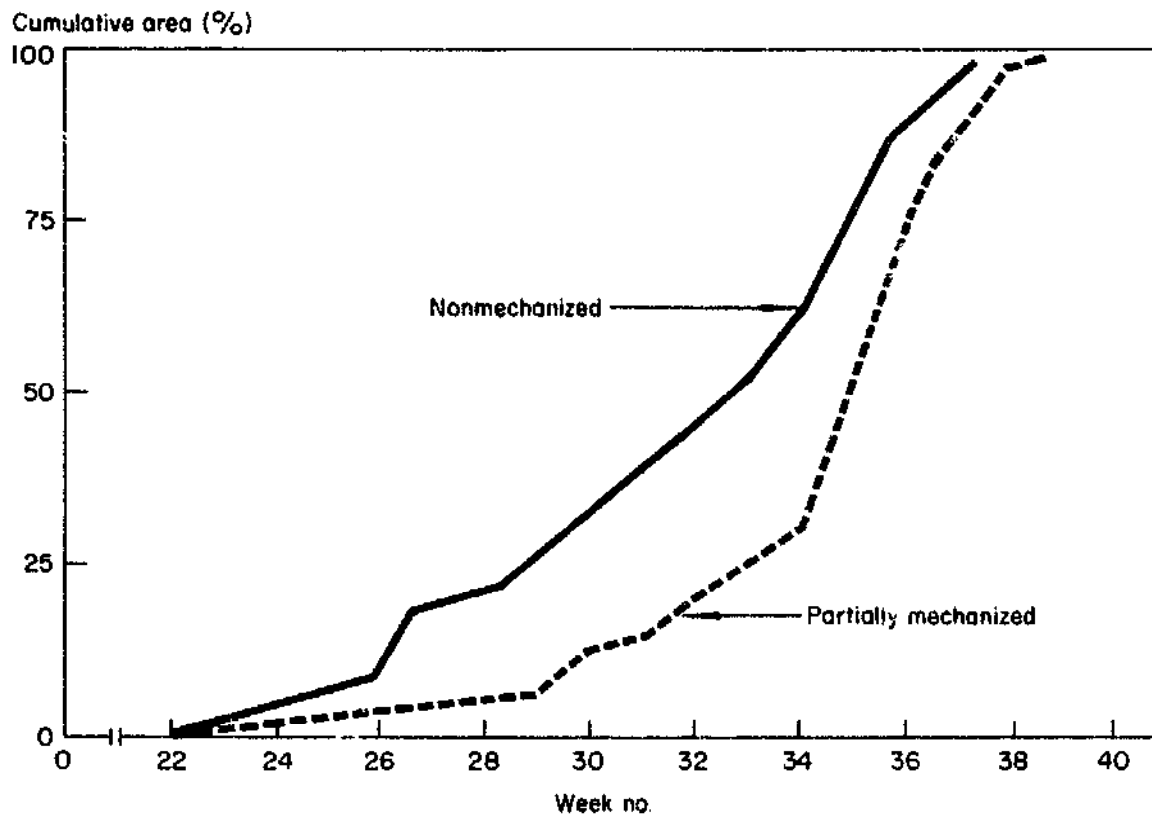

3. Cumulative frequency distribution of land preparation time for rainfed farms, Central Luzon, Philippines, 1980 wet season.

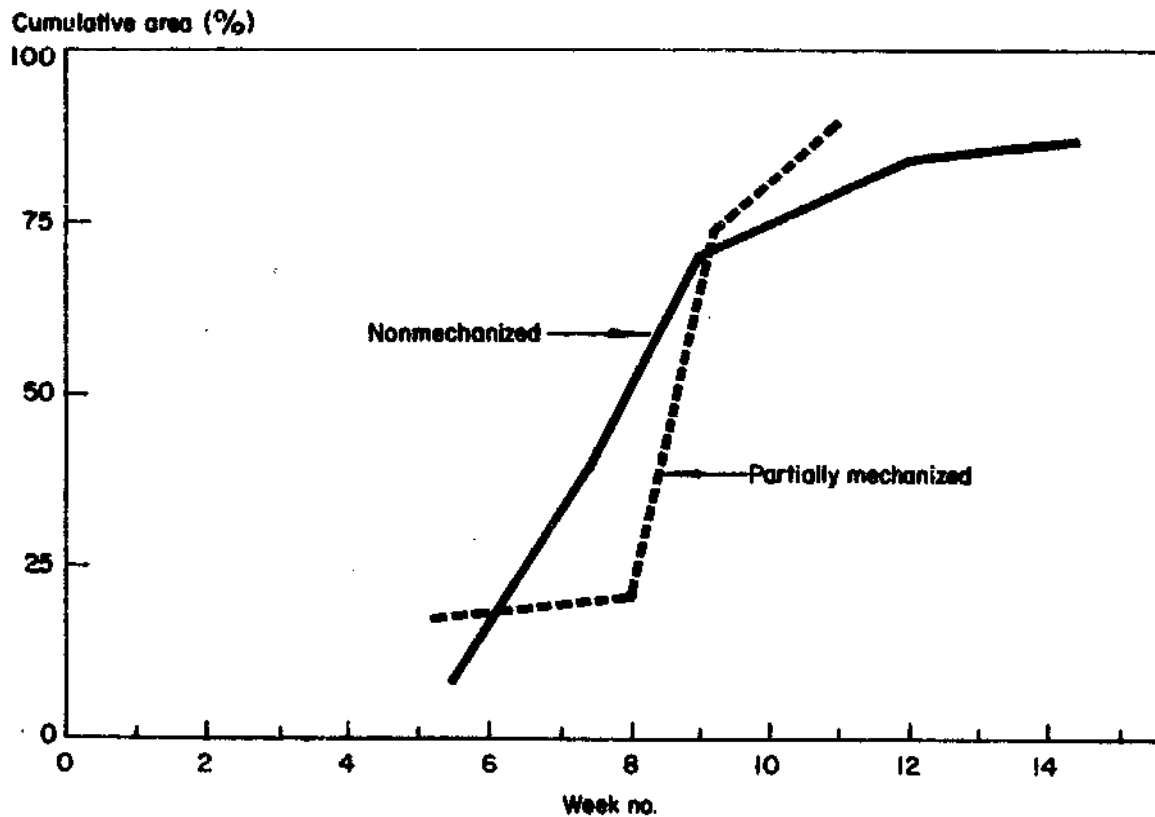

4. Cumulative frequency distribution of area planted, by date of planting and by type of mechanization on rainfed farms, Central Luzon, Philippines, 1980 dry season.

Mechanized farmers were slower in completing land preparation in gravity irrigated areas during wet season than farmers using animal power (Fig. 5), perhaps because many farmers depended on contract services. But during dry season, the gravity irrigated farms using machines were able to start and complete land preparation earlier than their nonmechanized neighbors (Fig. 6).

A second approach used to examine the timeliness issue is to measure the length of the turnaround interval. Jayasuriya et al (9) speculated that at current prices for mechanical power, the supply of mechanical horsepower available in Central Luzon and South Sulawesi was inadequate to achieve a major change in timeliness or turnaround time. They argued that with animal power available at a rate which establishes a competitive equilibrium contract rate lower than required to induce additional investment in the stock of mechanical power, major reductions in turnaround time and increased timeliness were not likely. An increase in the cost of animal power or the introduction of a lower cost mechanical alternative could change this conclusion. This scenario assumes that timing and availability of water deliveries are not constraints in modifying land preparation or planting dates.

Table 5 summarizes the data relating to turnaround time in gravity and pump irrigated villages in the study. While mechanized farms in the gravity irrigated category were only slightly faster, those having access to supplemental irrigation water used mechanical power much more advantageously to

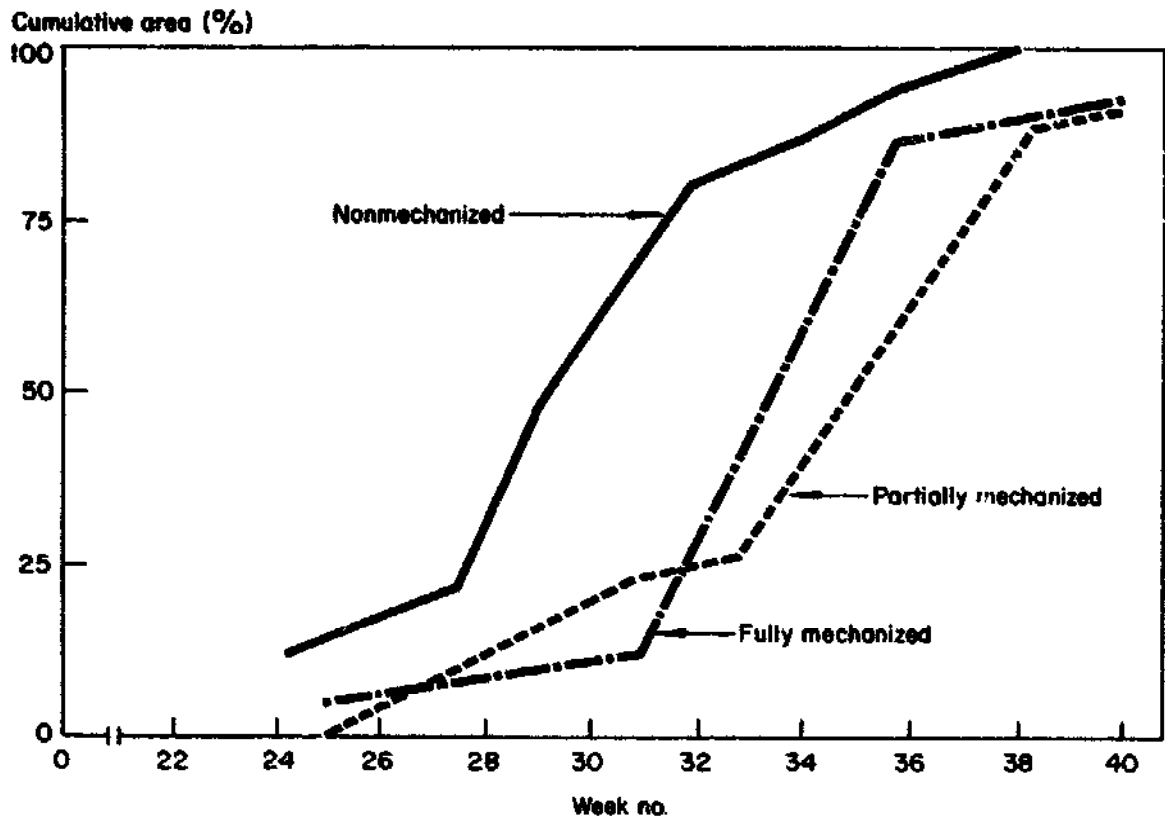

5. Cumulative frequency distribution of area planted, by date of planting on gravity irrigated farms, Central Luzon, Philippines, 1980 wet season.

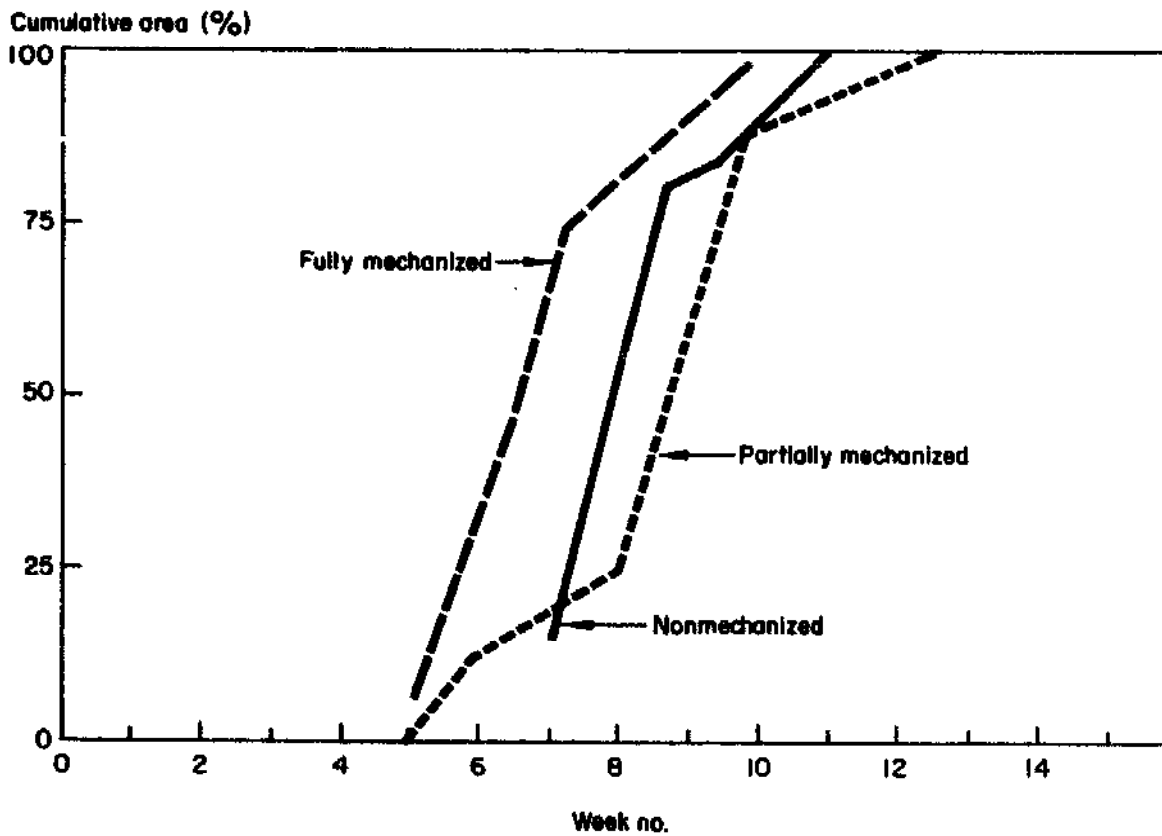

6. Cumulative frequency distribution of area planted, by type of mechanization on gravity irrigated farms, Central Luzon, Philippines, 1980 dry season.

Table 5. Turnaround time by mechanization level and irrigation type. Luzon, Philippines, 1980-81.

Irrigation type	Turnaround time (d)	
	Mechanized	Nonmechanized
Gravity irrigated	72	78
Pump irrigated	20	61
All	69	74

reduce the turnaround interval. On the average, however, the sample did not show a significant difference in turnaround time between mechanization classes.

Juarez (11) demonstrated a similar finding in reviewing the use of mechanical threshers in Iloilo. She found that farmers using mechanical threshers initiated and completed threshing significantly earlier than those using traditional techniques. However, the total turnaround time was not significantly different from that of farmers using traditional threshing techniques. Water availability again appeared to be the major constraint. The synchronous planting schedule farmers used within each village to reduce pest and rodent damage also contributed to the long intercrop interval. Farmers using mechanical threshers, however, indicated that they used for other productive tasks the time made available to them from use of the thresher.

Except for South Sulawesi, all sites studied were old established villages with no scope for expanding the area cultivated. No evidence indicated an eviction of tenant farmers following mechanization as McNerney et al (19) observed in Pakistan. Tractor owners tended to rent slightly more land than nonowners, but it was impossible to ascribe this to machine availability.

MECHANIZATION AND AGRICULTURAL EMPLOYMENT

The project examined the employment issue from three perspectives. First it determined the quantity of labor used for each task in each farming environment and each mechanization category. Secondly, it carefully examined patterns of labor use. This was of crucial concern because machines released labor which became available for use in alternative tasks. Lastly, the impact of mechanization on family and landless labor use in rice production was evaluated.

Figure 7 presents labor use in wet and dry seasons and disaggregated by irrigation and mechanization. Except for gravity irrigated farms, total labor requirements were higher during dry than during wet season. Mechanization clearly reduced labor requirement in land preparation in all classes.

Figure 8 describes the patterns of hired and family labor use. On rainfed farms, mechanization reduced hired labor as a percent of total labor. For each of the irrigated classes, hired labor was significantly higher for mechanized farms in both dry and wet seasons. In absolute terms, hired labor increased on farms using mechanical power. Use of family labor declined appreciably with the introduction of machines.

Labor use (labor d/ha)

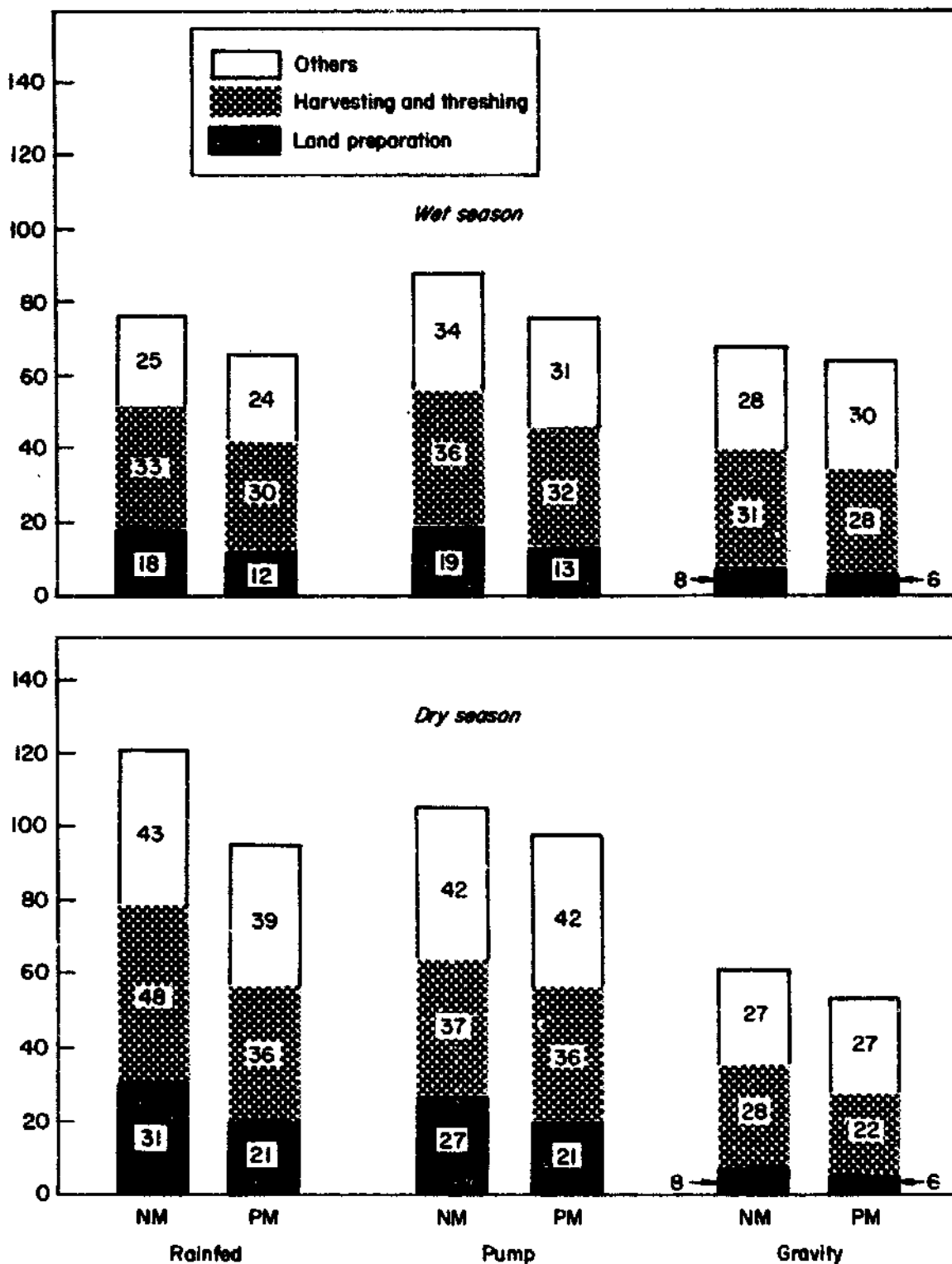

7. Labor use for rice production in selected villages, Guimba and Cabanatuan, Nueva Ecija, Philippines. NM = nonmechanized, PM = partially mechanized.

West Java, the survey site with the highest population-to-land ratio and the highest proportion of landless labor (35% of total households), also exhibited a major shift in labor use with the introduction of mechanized land preparation techniques. Until the mid-1970s, all land preparation in West Java was

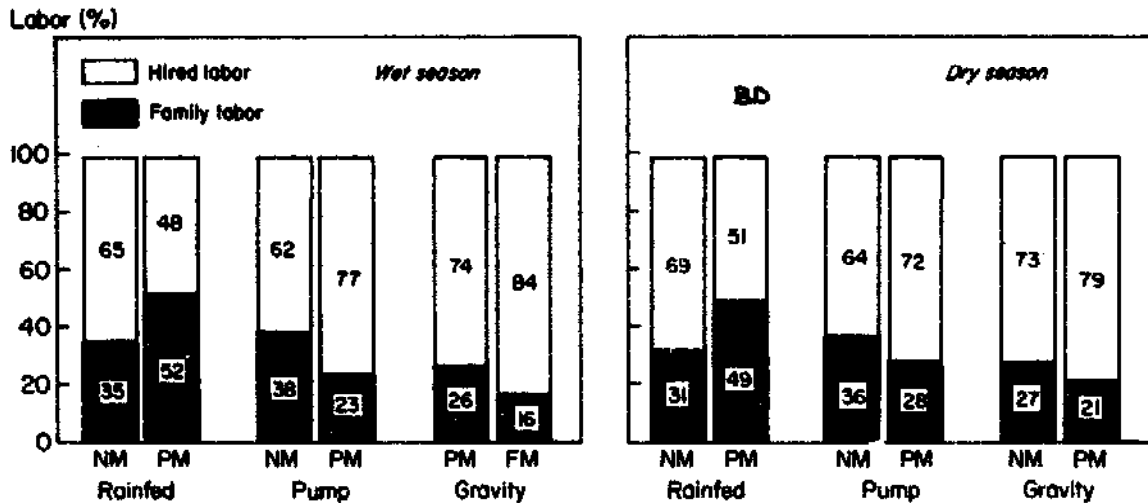

8. Contribution of hired and family labor to total labor requirement in selected villages, Guimba and Cabanatuan, Nueva Ecija, Philippines, 1979-80. NM = nonmechanized, PM = partially mechanized, FM = fully mechanized.

performed manually with as much as 65 labor d/ha required to prepare a plot for transplanting. When 2-wheel tractors were introduced, the Jathilahur irrigation project began to deliver significantly more water to farmers. Major extension efforts were also under way to convince farmers to plant a third crop. New varieties and attempts to introduce synchronized planting on 50,000-ha blocks for pest control introduced a series of confounding factors into the West Java study.

Data in Table 6 show the percentage differences in labor use between farms using mechanized equipment (2-wheel tractors) and those using manual methods. Total labor use declined only slightly in both wet and dry seasons, with the largest decrease occurring during land preparation.

Changes in the composition of labor use by rice farming households are shown in Table 7. The major source of labor decrease was the farm operator's family. Permanent and seasonal hired labor were used differently during wet and dry seasons, although in the Philippines absolute hired labor requirements did not change significantly compared with farms using traditional land preparation technology.

For South Sulawesi rainfed farms, labor use differed greatly between wet and dry seasons. Land preparation labor requirements declined in both seasons; however, total labor requirements for planting and crop care activities also declined during dry season. The decline in land preparation labor requirements for the dry season crop was highly significant as were the increased requirements for harvest and postharvest operations. This may to some degree reflect the higher yields attributed to mechanization on rainfed farms in South Sulawesi.

In Table 8, changes by type of labor are shown for rainfed farms in South Sulawesi. As in West Java and the Philippines, the farm operator and family were affected most significantly by changes in land preparation technology. Total labor did not change significantly. Irrigated farms showed no major decrease in labor use in wet or dry season.

Table 6. Percentage difference in labor use on mechanized compared with nonmechanized farms, by activity. West Java, Indonesia, 1979-80.^a

Activity	Difference ^a (%)	
	Wet season 1	Dry season 1
Land preparation	-35.6***	-28.7*
Planting	+2.6	+4.6
Cultivation	-0.8	-6.1
Harvesting	+8.8	+5.8
Total	-13.0*	-8.9

^a A negative sign signifies a reduction in labor use and a positive sign an increase in labor use on mechanized farms. Significance at 0.1% (***), 1.0% (**), and 5.0% (*) levels.

Table 7. Percentage differences in labor use on mechanized compared with nonmechanized farms. West Java, Indonesia, 1979-80.

Source	Difference ^a (%)	
	Wet season 1	Dry season 1
Operator	-7.3	-58.0***
Family	-88.2	-46.6*
Permanent	-38.3	-29.0
Seasonal, hired	-1.9	-12.0

^a Significant at 0.1% (***), and 5% (*) levels.

Table 8. Percentage difference in labor use on rainfed mechanized and irrigated mechanized farms, by source. South Sulawesi, Indonesia, 1980.

Labor source	Difference ^a (%)	
	Wet season 2	Dry season 2
	<i>Rainfed mechanized</i>	
Farmer	-65.3	-20.2**
Family	-8.7	87.0
Seasonal	76.5	105.3
Others	28.0	-30.3
Total	-23.0	28.9
	<i>Irrigated mechanized</i>	
Farmer	1.8	-15.0
Family	-30.4	-45.5
Seasonal	21.3	0.9
Others	-1.3	-9.2
Total	4.6	-9.0

^a Significant at 1.0% (**) level.

The findings show that mechanized farms required less labor per hectare than those using traditional techniques. The major reduction in labor use was from family and operator sources. Hired labor use increased on most mechanized farms. Labor requirements per hectare declined, especially on large farms.

IMPACT OF MECHANIZATION ON FARM INCOME

The income effects of mechanization are closely interlinked with the employment issue. Total income and source by season are presented in Table 9 for the Philippine site. There were marked differences in income between mechanized and nonmechanized classes in the gravity irrigated category. Rainfed farms had lower yields and cropping intensities with consequent lower income than irrigated farms in both seasons. Note, however, that the percentage of total income derived from nonfarm incomes was highest for both the nonmechanized and partially mechanized rainfed categories and lowest for the fully mechanized gravity irrigated category.

An attempt was made to disaggregate farm categories based on size. Small farms were 0.5-1.5 ha; medium farms, 1.5-2.5 ha; and large farms, 2.5-5 ha. Figure 9 indicates small and insignificant differences in income levels for all mechanized classes in small and medium categories. In the largest farm category, however, partially and fully mechanized farms had significantly higher per capita incomes than comparably sized nonmechanized farms. Sources of total farm income for the Philippine sites are shown in Figure 10. Mechanized farms in irrigated areas clearly derived a greater share of income from on-farm sources. Conversely, mechanized rainfed farms produced more income from nonfarm sources than their nonmechanized counterparts.

Table 9. Farm income,^a by source, in selected villages of Central Luzon, Philippines, 1979-80.

Source	Farm income				
	Rainfed		Gravity irrigated		
	Nonmechanized	Partially mechanized	Nonmechanized	Partially mechanized	Fully mechanized
			<i>Wet season</i>		
Total farm (P)	1300	1910	1820	4470	3730
% off-farm	4	10	15	2	0
% nonfarm	22	37	24	24	6
			<i>Dry season</i>		
Total farm (P)	1890	2300	3250	7280	6490
% off-farm	3	9	4	7	1
% nonfarm	22	26	16	10	5
			<i>Annual income</i>		
Total farm (P)	3190	4210	5430	11750	10220
% off-farm	3	9	8	5	1
% nonfarm	22	31	19	15	5

^a P7.60 = \$1.

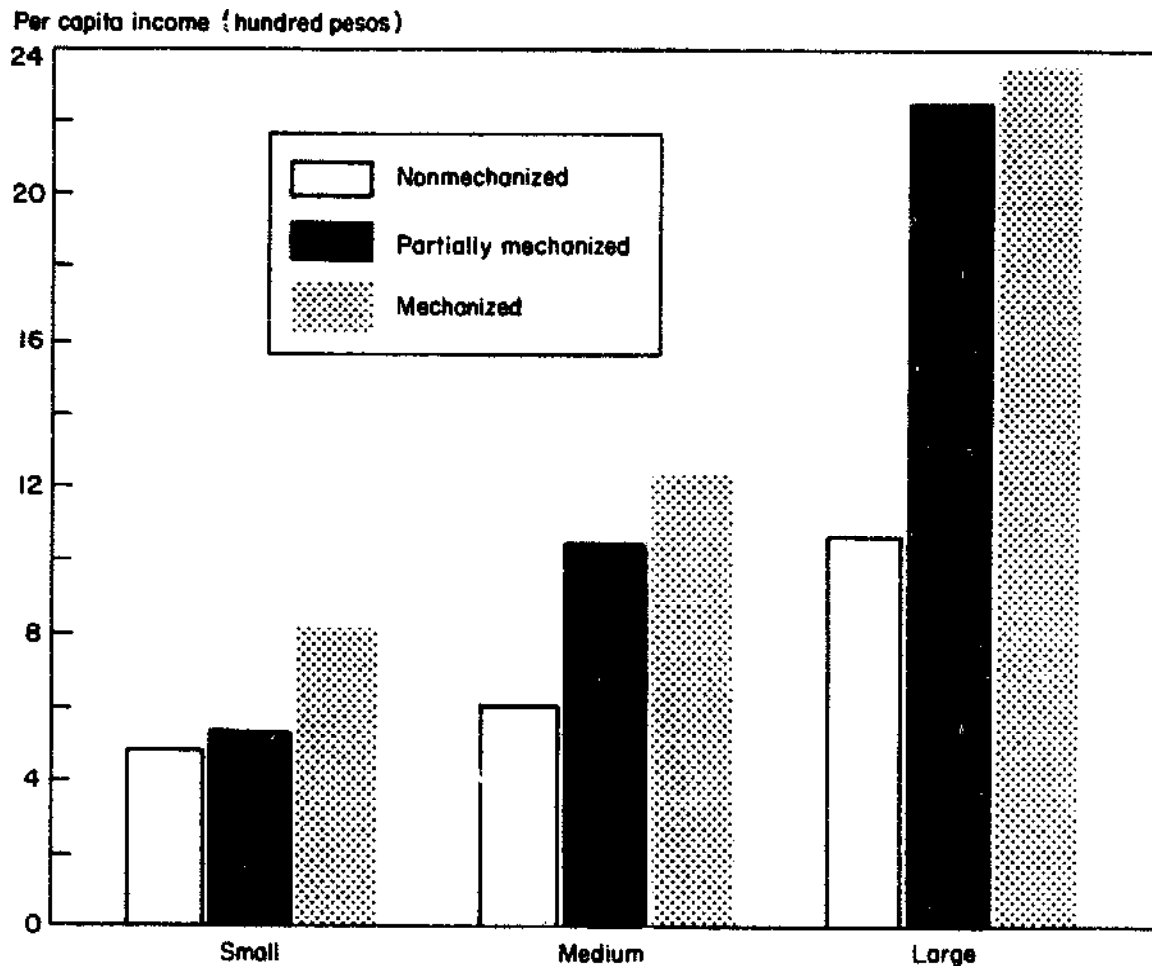

9. Per capita income, by area class and mechanization group, in rice farm households in selected villages of Cabanatuan and Guimba, Nueva Ecija, Philippines, crop year 1979-80. The 1980 exchange rate was ₱7.60 = \$1.

The study also examined differences in the distribution of income for the mechanized and nonmechanized farm categories. A simple way of analyzing this issue is to employ the concept of factor shares, which shows each production factor's contribution to total productivity. Figure 11 shows that in all cases in the Philippines, the largest share accrued to the residual representing the operator's share. The second largest share was attributed to labor. Slightly lower shares were attributed to labor on partially and fully mechanized household farms, largely as a result of the decline in use of family labor.

In contrast to the Philippines, in West Java a higher percentage of total income for both mechanized and nonmechanized households came from on-farm sources. Very little nonfarm income was included in total household income for West Java. That was likely the result of the very high population of landless families in the area that competed for off-farm and nonfarm employment.

A factor share analysis for West Java in wet season (Fig. 12) indicates that labor increased its share of earnings slightly on mechanized than on nonmechanized farms. Hired labor's share also increased and family labor earnings declined.

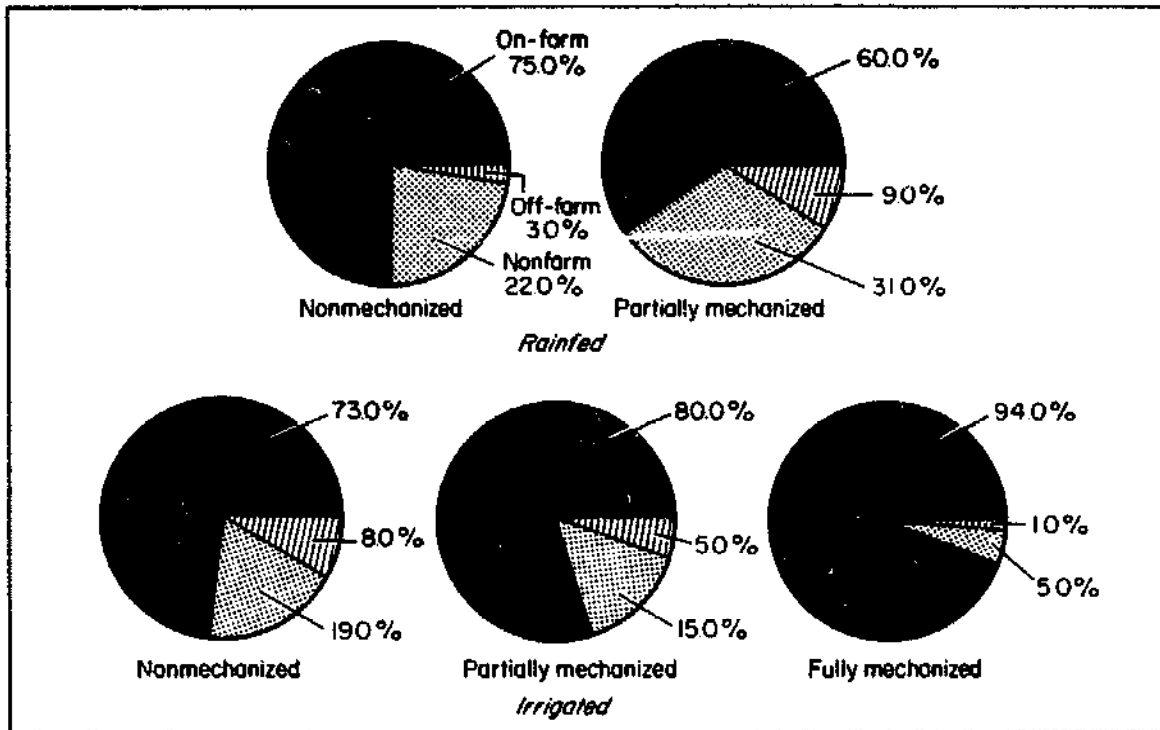

10. Percentage distribution of annual income sources, by mechanization class, in rice farm households in rainfed and irrigated environments in selected villages of Guimba and Cabanatuan, Nueva Ecija, Philippines, crop year 1979-80.

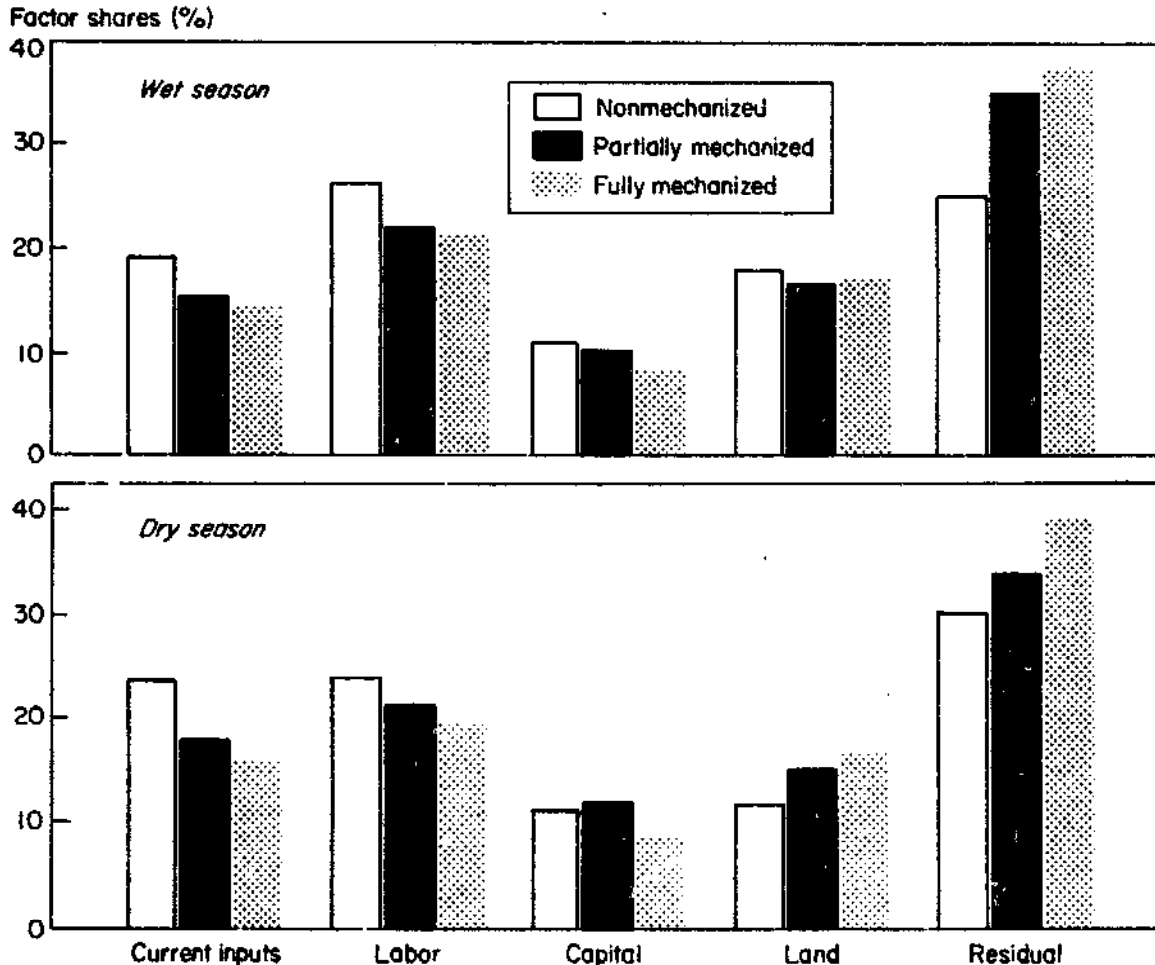

11. Factor shares for gravity-irrigated farms in selected villages of Guimba and Cabanatuan, Nueva Ecija, Philippines, crop year 1979-80.

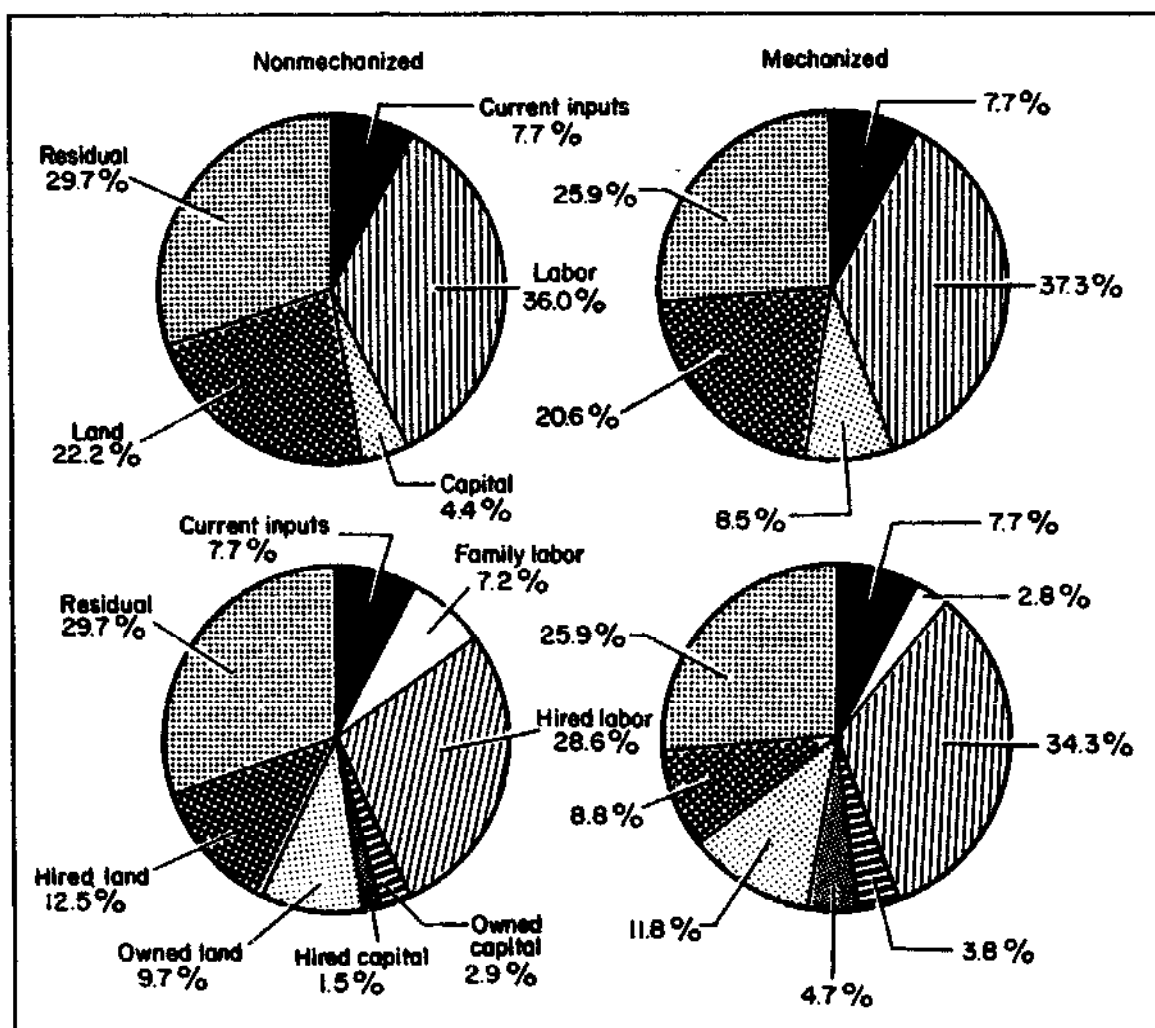

12. Factor shares, by mechanization class and category, in rice farm households in selected villages of Subang and Indramayu, West Java, Indonesia, 1979-80 wet season.

Figure 13 shows the sources of income for households in South Sulawesi. Of particular interest is the high percent of income derived by both rainfed and irrigated mechanized farms from off-farm and nonfarm sources. Rainfed farms were unable to fully use their land resources during dry season. Mechanization allowed families on those farms a higher degree of flexibility in seeking off-farm and nonfarm work.

THE ECONOMICS OF LAND PREPARATION

Table 10 shows the use of 2- and 4-wheel tractors at each survey site. The benefit-to-cost ratio indicates that machines were operating at or near economic levels. A notable exception was 2-wheel tractors in the Philippines (20).

All machines were used for contract work, particularly 4-wheel tractors in the Philippines and South Sulawesi. Rental services were very common in Thailand; however, that is not shown in the data from the site survey because contracting in Thailand was largely handled by nonfarmers. Figure 14 shows changes in tractor use during a 5-yr period in South Sulawesi. As additional

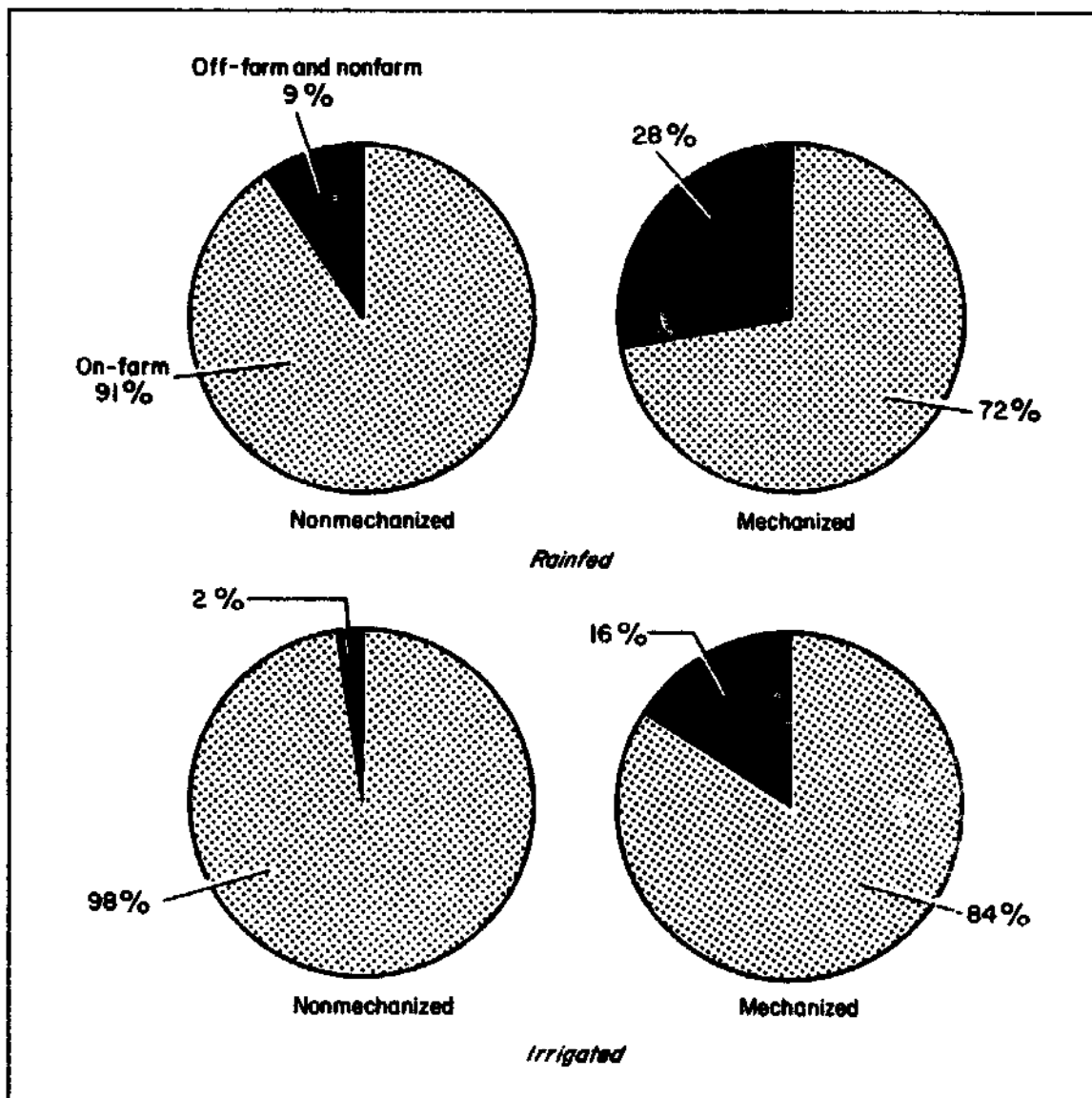

13. Percentage distribution of annual income sources, by mechanization class, in rice farm households in rainfed and irrigated environments in selected villages of Sidrap and Pinrang, South Sulawesi, Indonesia, crop year 1980-81.

tractors entered the contract market, total annual use and the quantity of contract work declined markedly. Tractors purchased at the introductory stage of the process were very profitable (17, 18). Those purchased in recent years were much less profitable because of lower use and higher cost.

In South Sulawesi, inadequate service and maintenance of machines also contributed to low use. Most tractors were small, 4-wheel imported units provided on very liberal credit terms. One result of this policy was a poor record of repayments and a high percentage of inoperable machines.

In a recent experiment in South Sulawesi, locally built 2-wheel tractors were introduced and operated under conditions similar to those for 4-wheel units. Figure 15 presents economic data derived from a study comparing tractors operated in the Luwu area of South Sulawesi (21). During the 2-yr period of the study, the 2-wheel machines offered substantial economic advantages compared to the 4-wheel units.

Table 10. Comparative economic characteristics of 2- and 4-wheel tractors in the Philippines, Thailand, and Indonesia, 1980.^a

Item	Philippines		Thailand		Indonesia		
	2 wt	4 wt	2 wt	4 wt	South Sulawesi	West Java	2 wt (diesel)
Average horsepower	9	68	9	11.5	13.2	6.4	7.9
Average production cost (\$/US)	1,710	25,296	958	1,450	4,015	1,250	2,170
Average use (ha/yr)	15	172	9	11	52	21	24
Break-even point (ha/yr)	33	185	5.8	9.28	62.8	22.28	25.12
Benefit-cost ratio	.72	.96	1.2	1.1	.96	.96	.97
Use pattern (%)							
Own farm	65	17	79	77	13	48	32
Contract	35	83	21	23	87	52	68

^a At 1980 exchange rate of \$1 = Philippines ₱7.60, Thailand baht 20.63, Indonesia Rp 626.70.

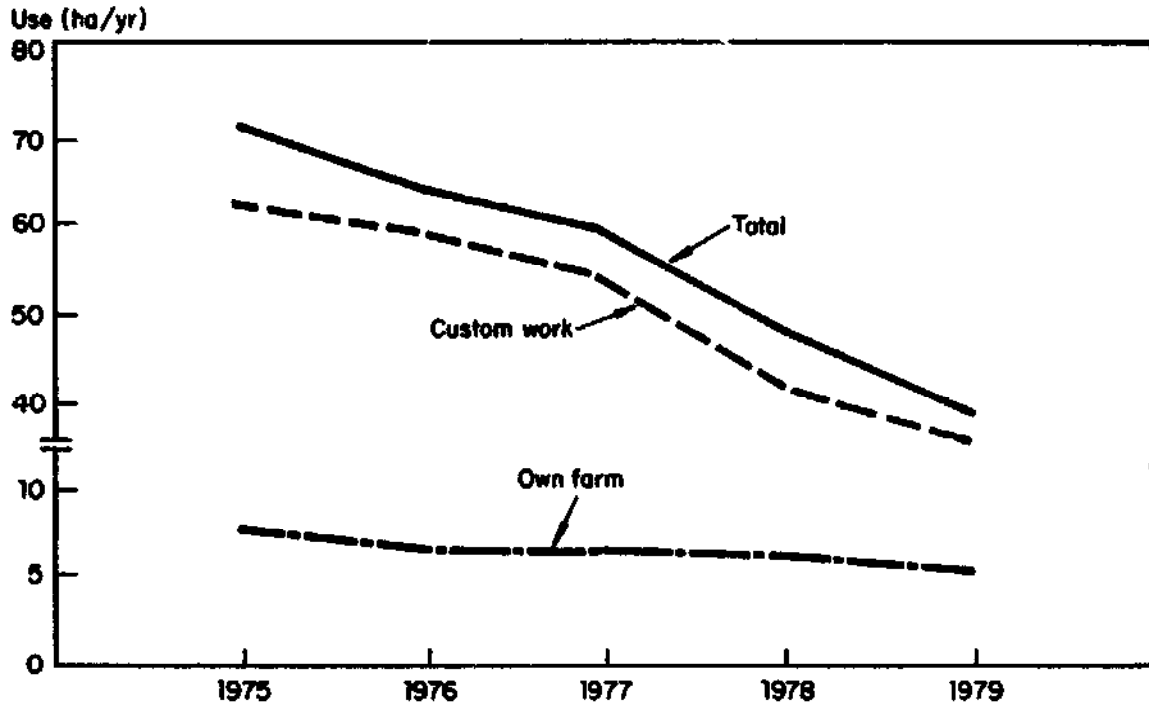

14. Tractor use in Pinrang and Sidrap districts, South Sulawesi, Indonesia, 1975-79.

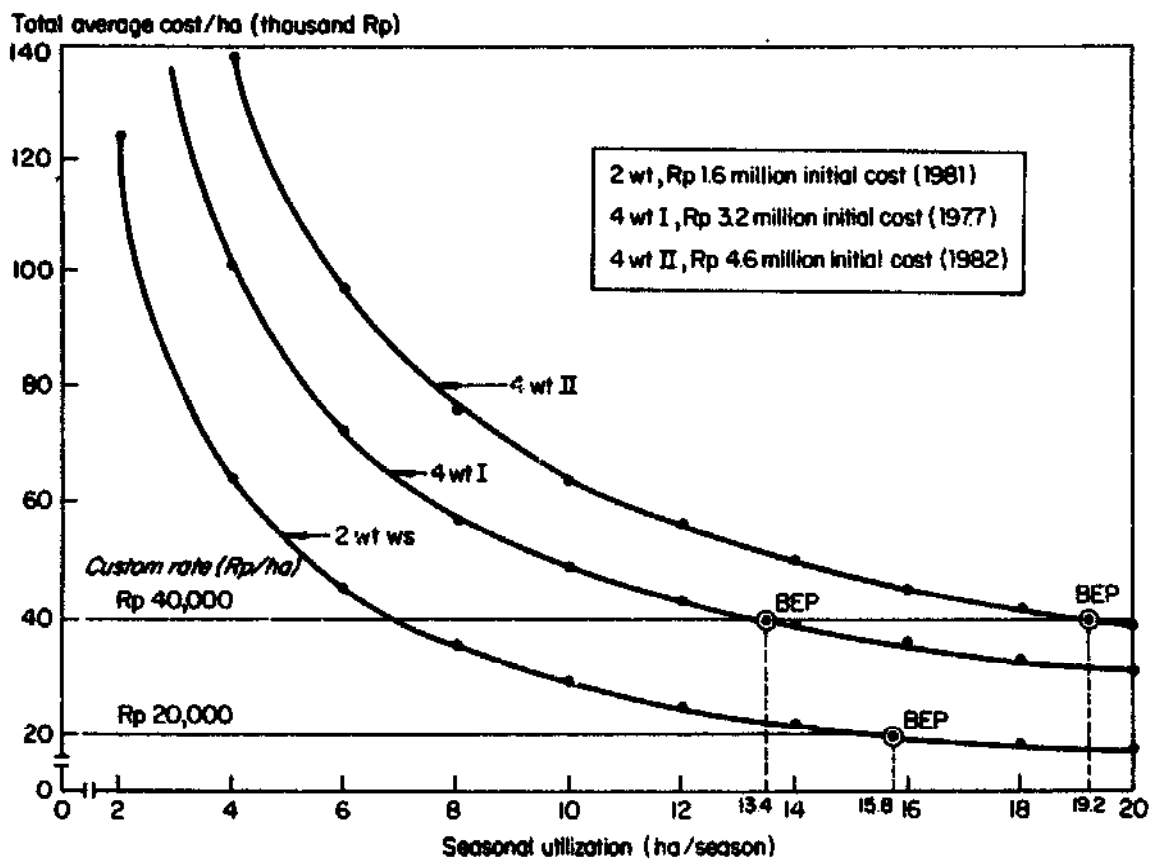

15. Break-even analysis for 4-wheel tractors at 2 alternative investment costs, and for 2-wheel tractors, Luwu, South Sulawesi, Indonesia. BEP = break-even point.

Similar economic studies of threshing machinery in Thailand and the Philippines indicated a high degree of economic viability during the introductory stages. The rapid spread and high use of axial-flow threshing equipment in Thailand and the Philippines indicate the profitability of the machines (10, 12).

GENERAL EQUILIBRIUM MODELING OF MECHANIZATION

In addition to the direct, farm-level impact of mechanization on production, employment, and income, secondary effects link the agricultural and non-agricultural sectors. Farmers and laborers working in agriculture purchase consumer and producer goods from nonagricultural sources. Conversely, agriculture provides the nonagricultural sectors with goods and products used for production and consumption. These relationships are presented conceptually in Figure 16.

Farm machinery is an input in agricultural production. A farmer exchanges goods or money to acquire a machine from a vendor who acquired it from an importer or local manufacturer. The composition of the marketing chain depends on the nature of the equipment and its source. If the product is produced locally with a high domestic content, more resources will circulate in the national economy and import leakage will be minimized. This strategy produces a larger "multiplier" effect through enhanced production and

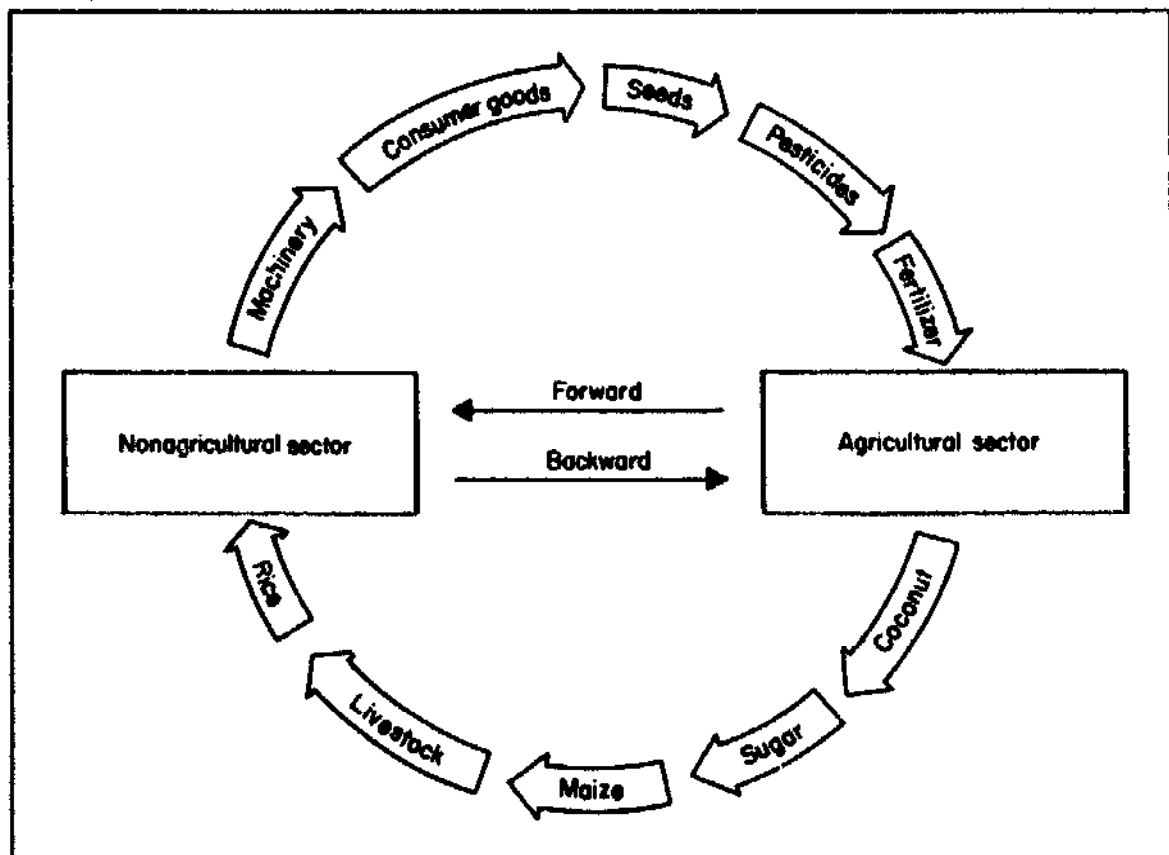

16. Diagram of linkages.

consumption linkages with agriculture. Resources used to purchase the equipment are, in turn, used by the manufacturers to acquire raw materials and component assemblies from vendors, and to hire labor. Vendors, in turn, use these funds for transportation, acquisition, fabrication of components, and hiring labor. The chain effect from a single investment in agricultural machinery is often called a backward linkage or multiplier effect.

To evaluate the multiplier effect on national employment and income, a modified Leontiff-type input-output model was developed to describe the production and consumption sectors in the Philippine economy (2, 1). This question was posed: what are the employment and income impacts of a 1% increase in rice demand using alternative mechanization packages? The employment effects are shown in Table 11. The model evaluated the impact of obtaining the extra output from 1 of 13 alternative production subsectors consisting of combinations of power, irrigation, and threshing technologies.

To maximize both direct and indirect employment effects from the increase in demand, irrigation pumps are combined with animal land preparation and manual threshing. The difference in total employment from this alternative compared with the mechanized alternative of using a 2-wheel tractor and a small portable thresher is not great. All three strategies have relatively high backward production and consumption linkages, producing expanded employment in the nonagricultural sector. This contrasts with the strategy of relying on imported tractors in combination with large axial-flow threshers. This alternative has a much weaker direct effect on farm employment, and decreases indirect employment because of weaker links with local industries and higher reliance on imports.

The impact of these options on income distribution is shown in Table 12. As with employment, the solution involving pumps, water buffalo, and manual threshing produces the largest increment in national income. Total income is

Table 11. Employment impact of a 1% increase in demand for rice (2).

Production sector			Workers (thousand)			Indirect:direct
Power	Irrigation	Threshing	Increased employment	Direct	Indirect	
Carabao	Gravity	Hand	42	14.5	27.5	1.89
Tiller	Gravity	Hand	43	15.9	27.1	1.70
Tiller	Gravity	Small thresher	40	12.4	17.6	2.23
Tractor	Gravity	Large thresher	36	11.2	24.8	2.21
Carabao	Pump	Hand	55	23.7	31.3	1.32
Tiller	Pump	Hand	53	21.7	31.3	1.44
Tiller	Pump	Small-thresher	49	17.4	31.6	1.82
Tractor	Pump	Large-thresher	37	7.0	28.0	3.11
Carabao	Rainfed	Hand	31	11.0	20.0	1.81
Tiller	Rainfed	Hand	28	9.7	18.3	1.89
Tiller	Rainfed	Small thresher	27	7.3	19.7	2.70
Tractor	Rainfed	Large thresher	23	5.3	17.7	3.34
Carabao	Upland	Hand	18	5.1	12.9	2.53

Table 12. Income distribution impact by sector from 1% increase in demand for rice (2).

Rice production sector			Absolute increase						
Power	Irrigation	Thresher	Rice farm		Nonrice farm		Nonfarm		Incremental (million P)
			million P	%	million P	%	million P	%	
Carabao	Gravity	Hand	121.0	28.0	95.3	22.2	215.3	49.8	413.6
Tiller	Gravity	Hand	124.5	23.4	94.9	21.6	218.5	50.0	437.9
Tiller	Gravity	Small	122.3	28.5	91.6	21.4	214.3	50.1	428.2
Tractor	Gravity	Large	106.6	27.6	83.8	21.7	195.5	50.7	385.9
Carabao	Pump	Hand	152.2	28.7	118.3	22.3	260.2	49.0	530.7
Tiller	Pump	Hand	152.8	29.0	115.1	21.8	259.1	49.2	527.0
Tiller	Pump	Small	147.7	29.0	109.5	24.6	250.2	49.4	507.7
Tractor	Pump	Large	112.9	27.1	87.8	21.1	215.8	51.8	416.5

nearly 200 million pesos larger using traditional techniques with irrigation pumps, compared with using large mechanized equipment operated in gravity irrigated systems.

The model is most useful in exploring alternative policy options when considering strategies to enhance output, employment, and production.

CONCLUSIONS

The following are some general findings from the Mechanization Consequences project.

1. Large farms are early innovators and adopt mechanization before small farms.
2. At the early stages of mechanization, early innovators are able to realize higher returns on investment.
3. Over time, annual use levels and contract rates for equipment use decline, and contract rates reach an equilibrium with existing traditional methods. For later investors, these equilibrium levels reduce the profitability of equipment. Those acquiring equipment later are often unable to realize the same economic benefits as early innovators.
4. Mechanization of paddy land preparation shows no significant impact on crop yield, cropping intensity, or expanded cultivated area. An exception was noted in South Sulawesi where rainfed yields were higher on mechanized farms.
5. Threshers and 2-wheel and 4-wheel tractors have reduced labor requirements significantly.
6. Mechanization of land preparation and threshing has reduced family labor requirements significantly more than hired labor.
7. Hired labor contributes a significantly higher proportion of total labor on mechanized than on nonmechanized farms.

8. The study did not find a major redistribution in income shares between labor and capital as a result of small-scale mechanization. The analysis does not, however, explicitly consider the landless class.
9. The machines introduced initially were substitutes for animal or human power or both. The motivation was to reduce costs. Notable exceptions were low-lift and tubewell pumps which augment irrigation and produce higher yields and cropping intensities.
10. Backward linkages are normally underestimated or ignored, but should be considered in developing mechanization strategies. Both employment and income appear to be augmented more through investments in water resource development. If the choice, however, is between alternative mechanization technologies, a clear case can be made for small-scale domestically produced equipment where local wages are low and capital resources are scarce.

Adoption and use of machines on small farms in Asia is increasing. Contrary to many predictions, engineering innovations in agriculture have not resulted in major social upheavals. Evidence from the Philippines, Thailand, and Indonesia do not strongly support findings of excessive labor displacements or inequities in income distribution attributable to use of small machines. Conversely, the relationship between mechanization and improved productivity measures — increased yields, cropping intensities, or expanded area under cultivation — is weak or nonexistent. Currently, the major incentive to mechanization in paddy production is to reduce costs.

The composition and growth of future mechanization will be strongly dictated by government policies affecting exchange rates, credit availability, indigenous manufacturing, research and development, and the development of and support for an infrastructure capable of sustaining use of rural-based machinery. Table 13 provides information for predicting in which countries agricultural mechanization will likely grow. Nations with an abundance of land per rural worker, a high or rising rural wage, a low to moderate draft animal population, a reasonable ability to maintain and support mechanization, and moderate paddy yields are better candidates for rapid expansion of mechanization. Note, however, that the profitability of mechanization depends on government policies. It is essential that programs or projects to mechanize small farm agriculture consider technical, economic, and political realities to avoid misallocation of resources.

Table 13. Levels of mechanization, key indicators of agricultural productivity, and resource endowments in Bangladesh, Indonesia, Thailand, Sri Lanka, the Philippines, and Malaysia (5).

Indicator	Indonesia			Thailand	Sri Lanka	Philippines	Malaysia
	Bangladesh	Java	South Sulawesi				
Land frontier	Closed	Closed	Open	Moderately open	Moderately open	Semiclosed	Open
Land:human ratio	Very low	Very low	High	High	High	Medium	High
% working population in agriculture	High	High	High	High	High	High	Medium
Rural wage	Low	Low	Moderate	Moderate	Moderate	Moderate	High
Degree of water control	Low to moderate	High	Moderate	Moderate	Moderate	Moderate	Moderate
Adoption of modern varieties	Moderate	High	High	Low	High	High	High
Paddy yields	Low	High	Moderate	Low	Moderate	Moderate	Moderate
Percent landless labor in work force	High	High	Low	Low	Low	Moderate	Low
Draft animal population	High	Low	Low	Low to moderate	Moderate	Moderate	Low to moderate
Power type used in paddy preparation	Animal	Manual	Animal or mechanical	Mechanical	Animal or mechanical	Mechanical	Mechanical
Level of mechanical threshing	None	None	None	High	None	High	High
Importance of indigenous manufacturing of agricultural machinery	Low	Low	Low	High	Low	Moderate/high	Low
Degree of government intervention in mechanization	High	High	High	Low	High	Moderate	High
Private profitability of mechanization	High	Low	Low	High	High	Moderate	High
Social profitability of mechanization	Negative	Negative	Low	High	Negative	Neutral	High

REFERENCES CITED

1. Ahammed, C.S., and B. Duff. 1985. Farm mechanization strategies in an economy-wide model: Indonesia. Pages 69-88 in *Modeling the impact of small farm mechanization*. PIDS Monogr. Ser 5. Philippine Institute for Development Studies and the International Rice Research Institute.
2. Ahammed, C.S., and R. Herdt. 1985. A general equilibrium analysis of the effects of rice mechanization in the Philippines. Pages 89-104 in *Modeling the impact of small farm mechanization*. PIDS Monogr. Ser. 5. Philippine Institute for Development Studies and the International Rice Research Institute.
3. Bernsten, R.H., Y. Saefudin, Y. Maamun, S. Igp, J. Hafisah, H. Siswosumarto, M. Siregar, and R. Sinaga. 1984. Consequences of the mechanization of land preparation in Indonesia: South Sulawesi and West Java. Pages 161-195 in *Farmpower and employment in Asia*. J. Farrington, F. Abeyratne, and G.I. Gill, eds. The Agricultural Development Council, Bangkok, Thailand.
4. Duff, B. 1978. Mechanization and use of modern rice varieties. Pages 145-164 in *Economic consequences of the new rice technology*. International Rice Research Institute, Los Baños, Laguna, Philippines.
5. Farrington, J., F. Abeyratne, and G. I. Gill. 1984. Farm power and employment in Asia: conclusions toward better policy options. Pages 407-425 in *Farm power and employment in Asia*. J. Farrington, F. Abeyratne, and G. Gill, eds. The Agricultural Development Council, Bangkok, Thailand.
6. Gill, G.J. 1984. Tractorization and rural employment in Bangladesh. Pages 89-112 in *Farm power and employment in Asia*. J. Farrington, F. Abeyratne, and G. Gill, eds. The Agricultural Development Council, Bangkok, Thailand.
7. Herdt, R. 1981. Mechanization of rice production in developing Asian countries: perspective, evidence and issues. The Consequences of Small Rice Farm Mechanization Project Working Pap. 15. International Rice Research Institute, Los Baños, Laguna, Philippines.
8. International Rice Research Institute. 1978. The consequences of small rice farm mechanization on production, incomes, a project proposal. International Rice Research Institute, Laguna, Philippines.
9. Jayasuriya, K., A. Te, and R.W. Herdt. 1982. Mechanization and cropping intensification: economic viability of power tillers in the Philippines. International Rice Research Institute Saturday seminar, October.
10. Juarez, F. 1984. The institutional and economic impact of mechanical rice threshing in Laguna and Iloilo, Philippines. Unpublished MS thesis, University of the Philippines at Los Baños, Laguna, Philippines.
11. Juarez, F., and B. Duff. 1979. The economic and institutional impact of mechanical threshing in Iloilo and Laguna. The Consequences of Small Rice Farm Mechanization Project Working Pap. 1. International Rice Research Institute, Laguna, Philippines.
12. Juarez, F., and R. Pathnopas. 1981. A comparative analysis of thresher adoption and use in Thailand and the Philippines. The Consequences of Small Rice Farm Mechanization Project Working Pap. 28. International Rice Research Institute, Laguna, Philippines.
13. Lim, P. 1982. Problems and solutions in the analysis of survey data: a Philippine case study. The Consequences of Small Rice Farm Mechanization Project Working Pap. 60. International Rice Research Institute, Laguna, Philippines.
14. Lim, P. 1985. Effects of agricultural mechanization on farm income patterns. *J. Philipp. Dev.* 12(1):198-210.
15. Lingard, J. 1981. Measuring the impact of mechanization on output. The Consequences of Small Rice Farm Mechanization Project Working Pap. 55. International Rice Research Institute, Laguna, Philippines.
16. Lingard, J., and J. Wicks. 1982. The impact of mechanizing small scale rice production in the Philippines, Indonesia and Thailand: some empirical evidence. The Consequences of Small Rice Farm Mechanization Project Working Pap. 59. International Rice Research Institute, Laguna, Philippines.

17. Maamun, Y. 1983. Economic analysis of tractor ownership and utilization in South Sulawesi, Indonesia. Unpublished MS thesis, University of the Philippines at Los Baños, Laguna, Philippines.
18. Maamun, Y., and B. Duff. 1983. The economics of tractor ownership and use in South Sulawesi, Indonesia. The Consequences of Small Rice Farm Mechanization Project Working Pap. 71. International Rice Research Institute, Laguna, Philippines.
19. McInerney, J.P., and G.F. Donaldson. 1975. The consequences of farm tractors in Pakistan. IBRD Staff Working Pap. 210.
20. Maranan, C. 1981. A comparative analysis of tractor contract operation in Nueva Ecija, Philippines. The Consequences of Small Rice Farm Mechanization Project Working Pap. 24. International Rice Research Institute, Laguna, Philippines.
21. Maranan, C., Y. Maamun, and B. Duff. 1983. Results of a comparative evaluation of four-wheel, two-wheel and traditional land preparation methods in Luwu, South Sulawesi, Indonesia. The Consequences of Small Rice Farm Mechanization Project Working Pap. 73. International Rice Research Institute, Laguna, Philippines.
22. Saefuddin, Y. 1983. The domestic resource cost of mechanization in West Java, Indonesia. Unpublished MS thesis, University of the Philippines at Los Baños, Laguna, Philippines.
23. Saefuddin, Y., and B. Duff. 1983. Comparative advantage, mechanization and rice production in West Java, Indonesia. The Consequences of Small Rice Farm Mechanization Project Working Pap. 69. International Rice Research Institute, Laguna, Philippines.
24. Saitan, S. 1983. The impact of mechanization on annual income and income distribution in Supanburi, Thailand. The Consequences of Small Rice Farm Mechanization Project Working Pap. 79. International Rice Research Institute, Laguna, Philippines.
25. Tan, Y., and J. Wicks. 1981. Production effects of mechanization. The Consequences of Small Rice Farm Mechanization Project Working Pap. 36. International Rice Research Institute, Laguna, Philippines.
26. Webster, J.P., and R. Herdt. 1985. Modeling income distribution effects with a computer-assisted policy model of the Philippine rice sector. Pages 1-38 in Modeling the impact of small farm mechanization. PIDS Monogr. Ser. 5. Philippine Institute for Development Studies and the International Rice Research Institute.

MECHANIZATION POLICY AND THE IMPACT OF TRACTORS IN SOUTH ASIA — A REVIEW

J. FARRINGTON

Tropical Development and Research Institute
Overseas Development Administration
London, U.K.

Farm mechanization is much debated in developing countries, especially in those of Asia having dense rural populations and relatively few employment opportunities outside agriculture. The selection of policies toward farm mechanization and the effects of tractors are discussed here for four South Asian countries — Bangladesh, India, Pakistan, and Sri Lanka. Ideally, this review would assess the impact of all types of mechanized farm equipment. However, government intervention has centered on the tractor market and tractorization has been heavily researched.

Duff and Kaiser (17) indicate that mechanization levels remain low in South Asia, especially in Bangladesh. Equipment is generally restricted to tractors, threshers, sprayers, and pumps, with heavy investment in 4-wheel tractors (4wts), as opposed to the concentration on 2-wheel tractors (2wts) in many other Asian countries (Table 1).

Natural resource endowments of countries influence equipment choices. For instance, Sri Lanka's topography and hydrology lend themselves to gravity irrigation, limiting opportunities for pump set investment. However, mechanization also depends on the economic opportunities for, and constraints on, the deployment of production factors across a range of opportunities, and the extent to which government intervenes in resource allocation.

Given the imperfections in developing country markets, particularly in the capital market, the role of the government in defining and implementing policies toward farm mechanization assumes particular importance. Herdt (31) summarizes official lines adopted in Asia:

- One view, associating mechanization with modernization, was adopted by the People's Republic of China in the 1970s, and made mechanization a requirement and an indicator of development.
- A second view suggests that output will respond to increased power inputs as it does, for instance, to fertilizer. Therefore development requires power beyond that from traditional sources. This corresponds broadly with Binswanger's (7) net contribution view.
- A third view holds that mechanization can promote greater labor absorption in agriculture by intensifying land use (75).

Table 2. Population and wage indicators for Asian countries (17, 24, 31).

	Estimated overall population growth rate 1977-2000	Estimated growth rate of agricultural labor force 1977-2000	% of working population employed in agriculture	% of GNP generated by agriculture	Persons employed in agriculture per hectare of agricultural land	Farm wage rate (kg rough rice/d)
Bangladesh	2.7	1.68	83.8	53	2.8	3.3
Burma	1.9	1.46	51.8	46	0.7	7.0
China			59.8	31	2.8	n.a.
India	1.9	1.46	63.2	31	1.0	2.1
Indonesia	1.9	0.97	58.9	28	1.5	4.3
Japan	0.8	-9.03	11.0	5	1.4	15.6
Korea	1.9	-2.38	29.0	20	2.1	9.3
Malaysia	3.0	0.71	51.0	24	0.5	12.9
Nepal	2.1	n.a.	92.6	58	2.7	n.a.
Pakistan	2.8	1.86	53.5	29	0.6	3.3
Philippines	2.6	1.74	46.0	24	0.8	3.1
Sri Lanka	2.2	0.92	53.2	36	1.3	2.6
Taiwan	1.6	-3.84	22.0	n.a.		17.1
Thailand	2.3	1.94	75.4	26	0.9	7.9

CRITERIA FOR ASSESSING THE IMPACT OF TRACTORIZATION

Various advantages have been attributed to tractorization. The Pakistan Farm Mechanization Committee (PFMC) predicted an increase in cultivated area, yields, and cropping intensity, and a reduction in fallow and land allocated to fodder (45). In Sri Lanka, improved timeliness (with secondary effects on yields, cropping intensity, and production costs) was anticipated in irrigated areas, with agricultural expansion in rainfed areas. Space does not allow detailed analysis of the mechanisms (e.g., deeper tillage, reduced turnaround times between crops) by which tractors were to achieve these benefits, but Farrington and Abeysekera (21) have presented a detailed analysis for Sri Lanka.

Binswanger (7) presents criteria suitable for analyzing findings from the four countries examined here.

Cropping intensity

High annual cropping intensities have been achieved in many areas (coastal Andhra Pradesh, Bihar, and Tamil Nadu in India; dry zone irrigation schemes in Sri Lanka; and floodplain regimes in Bangladesh [7, 18, 23]) with use of human labor and draft animals. However, tractors may generate benefits by faster land preparation, thereby increasing cropping intensity.

Yield increase

The deeper plowing possible with tractors may improve yields directly, although research suggests this is unlikely. See Tsuchiya (77) for Japan, and Farrington and Abeysekera (21) for Sri Lanka. Yields seem more likely to increase from secondary effects, e.g., improved timeliness, irrigation, and agrochemical use.

Timeliness

A much vaunted benefit of tractorization, timeliness may improve yields in rainfed areas and increase cropping intensity in irrigated or rainfed systems. It may also induce a switch to higher value crops not previously grown because of difficulty in meeting a target sowing date. However, there is a trade-off between the degree of timeliness achievable and the capacity use of a tractor: higher use will spread capital costs over more operating hours, but will reduce timeliness because the area to be plowed will increase per tractor.

Mechanized threshers may release both tractors and draft animals for plowing during the critical turnaround period between crops. Timeliness may also be improved by seasonal migrant labor and by growing shorter-duration varieties.

Value of crop production

The value of the crop may increase through cropping intensity, yield, cropping patterns, a residual interaction between the three (7), and through product price, where tractor hauling confers a marketing advantage. A cropping

pattern benefit directly attributable to tractors is the extent to which fodder crops may be replaced by those of higher value as bullock herds decline. Cropping patterns may also be influenced by improvements in irrigation, capital availability, and managerial ability.

Displacement effects

When tractors replace draft animals, land and fodder are released for other, potentially more productive uses. Other resources released, such as family labor for feeding bullocks, may have little opportunity cost, so social savings may be slight or negative.

Regarding labor displacement, the pure net contributor view holds that all labor input differences between bullock and tractor farms are due to tractor technology. The pure substitution view holds that farmers deprived of tractors would try to maintain all other inputs at existing levels, and would have to hire labor and animals to replace the tractor, so labor use would increase beyond that on bullock farms which never had tractors.

With the net contributor view, measuring difference in labor input per unit of land between tractor and bullock farms is appropriate. With the pure substitution view, measuring per unit of output is appropriate. The true labor effect of tractors will generally lie between these extremes. Because other factors influence labor input, causality is difficult to ascertain. Analysis should include off-farm labor use and type of labor, e.g., permanent or casual.

Agricultural expansion

Expansion of the agricultural frontier, though receiving little attention in Binswanger's review, applies to Sri Lanka and to Pakistan. Expansion using traditional methods (slash and burn, bullock plowing) may be slow and poorly timed, missing critical periods for planting. Tractors can plow hard soil and work in shifts without rest, generating net benefits through more rapid land expansion.

POLICIES AND IMPACT IN SOUTH ASIAN COUNTRIES

Bangladesh

Bangladesh lacks an agricultural frontier, with virtually all agricultural land already exploited and 68% of its land cultivated. Production would therefore increase through intensifying cultivation. Population density is high, with 0.12 ha of cultivated land per person. Agriculture generates 53% of GNP and 84% of the population depends on agriculture for a living. Only 14% of cultivated land is irrigated, mainly by pump sets in the dry season (boro paddy and dryland rabi crops). Timing of cultivation and cropping patterns during the wet season are dominated by how rapidly monsoon floodwaters subside.

The low average farm size (1.25 ha) does not prevent highly unequal land distribution. The lowest decile of farmers occupy only 1.1% of cultivated land, while the top 10% occupy 35%. The Gini coefficient is 0.5 (23). Approximately half the farmers have less than 0.81 ha, 12% own less than 0.2 ha, and 15% own

no land. Rice is cultivated on 80% of farmland, generating 12.5 million t/yr. Wheat production is 0.8 million t/yr. More than 1.5 million t of rice and 1.2 million t of wheat are imported each year to meet subsistence needs.

Agricultural mechanization policy for East Pakistan (later Bangladesh) was defined by the PFMS's reports (59, 60), which, Lockwood (45) argues, were strongly influenced by the mechanistic application of a technical coefficient (defined by FAO and a US Presidential Science Advisory Committee) of 0.5 hp/ha as a desirable minimum for third world countries. Bangladesh independence prevented this policy's implementation.

A few 4wts had been imported in the late 1950s, first for government farms, and later for other public organizations. More were imported on aid terms and sold at subsidized prices, as was the first large batch of 2wts in the mid-1960s. In 1972, 500 2wts and 500 4wts were imported on concessional terms to make up for losses of draft animals during the war of 1971. They were distributed among government farms, cooperatives, tractor hire pools, and individuals. From the early 1960s to 1983, 6,362 2wts were imported, with two-thirds sold to the private sector on highly subsidized credit (35). However, bullocks now plow an estimated 98% of Bangladesh land, with later operations done manually or by animal draft.

Investment in irrigation pumps is substantial, with low-lift pumps (1/2 cusec) increasing to almost 40,000, shallow tubewells to 120,000, and deep tubewell (2 cusec) pumps to 25,000 in 1985. Motorized pumps have generally been sold at low-interest credit, but high rates of default make subsidy expensive.

Hand tools and animal-drawn equipment are entirely supplied by national producers, as have been 30,000 manually operated threshers (28).

Bangladesh was the first country in the region to express interest in promoting appropriate technology: a cell representing this topic was incorporated into the Bangladesh Agriculture Research Council in 1975.

Subsidies for 2wt introduction in Bangladesh in 1980 (23) included

- an official exchange rate overvalued by 25%;
- 15% import duty, compared to 75% on trucks and buses;
- 8% handling charge, compared to the usual 25%;
- credit at 11.5%, compared to 15% or higher;
- similar import concessions for spare parts; and
- diesel fuel subsidized to about 50% of world price.

These subsidies lowered the retail price of a 2wt to approximately \$1,800 compared to a true value of more than \$4,100, or a 2.21 difference (23).

For 4wts, generally operated on hire-service from government pools, subsidies were so high that revenue did not cover operating costs. Per hectare hire charges were one-third of those for draft animals (23).

Diesel fuel is still priced at about half that of petrol, and tractor imports are restricted by foreign exchange licensing.

Gill (23) reports the Bangladesh government agreed to locally manufacture the IRRI PT3, a 2wt, but most components and materials had to be imported. The 200 units manufactured in 1980-82 were not reliable and not readily adopted.

The debate over desirability of mechanization in Bangladesh also involves draft animal quality (34). However, reports from almost 100 yr ago state that Bangladesh cattle have always been small (24). Cows are increasingly used as draft animals, either indicating a worsening power situation or reflecting the decline in farm size due to increasing population. This would make maintenance of two multipurpose animals more economical than that of two bullocks. Further, pregnancy and lactation are less likely to reduce work output on small farms with low draft needs (50).

Currently, the draft animal herd is 10.3-10.9 million head, averaging 1.54 ha/pair. This work requirement would put poorly conditioned animals at capacity.

Little analytical work was available when Binswanger reviewed tractor effects in 1978. Studies now available include a frequent visit survey of 2wt use conducted over 15 mo in 1977-79 by Gill (23) in Rangpur, Dacca, Nuakhali, Munshiganj, Bogra, and Comilla (n=360); an extensive survey of 160 farmers using 4wt hire services in Comilla in 1974-75 by Martius (48); and single interview studies of 63 owners and 56 users of 2wts in Mymensingh and Munshiganj in 1979-80 by Jabbar et al (35), and of 63 households, 11 paddy processing groups, and 2 rice mill laborers in Mymensingh by Ahmed (2) in 1980.

Results of these studies are remarkably consistent (Table 3). *Cropping intensity* effects are neutral or negative as are, on the whole, *yield effects*. Where yields rise with tractorization, irrigation and fertilizer account for it. Gill quotes extensive experiment station evidence showing no direct tractor effect on yield. Both Jabbar et al and Martius note greatly reduced *bullock capacity* per hectare. Gill, however, presents only reductions in use time, indicating that all 2wt owners had disposed of their animals but that hired 4wts weren't yet reliable enough to permit widespread disposal of bullocks. In one village surveyed by Jabbar et al, only 3% of 2wt owners had replaced all draft animals, against 53% in the other village.

Labor use analysis is complicated by different methods of reporting data. Jabbar et al note a 44% reduction in permanent hired labor. Reanalysis of Gill's data indicates a 9.7% drop in casual labor use, and he contends permanent hired labor is not a feature of the study locations. Martius indicates an overall reduction in labor use, but hired labor rose 13% on irrigated farms and 29% on nonirrigated farms.

Tractorization appears to substitute heavily for family labor as Farrington and Abeyratne (18) noted for Sri Lanka. Martius notes large quantities of female labor in postharvest work, of very low opportunity cost given social restrictions (*purdah*) on work outside the household. Ahmed discusses this at length (2). He notes postharvest processing by traditional methods (transport from field to house, stacking, threshing, winnowing, soaking, parboiling, drying, storing, husking, polishing, and cooking) accounts for about 25% of all agricultural employment. He records a labor requirement of 36.7 d/t with traditional methods, and higher in aus and boro seasons because of drying problems. Apart from men threshing, accounting for 14% of postharvest

Table 3. Results of tractor surveys in Bangladesh.^e

Author and area	Sample size and study year	Comparison ^b	Labor ^c days/ha per yr	Bullocks ^d (no./ha)	Cropping ^e intensity	Yield ^f (kg/ha)		Fertilizer inputs (kg/ha)
						Rice	Potato Mustard	
Gill (see text)	360 1977-79	B B-PTO	(47.3) -9.7%		(2.07) +0%	(3108) +8.3%	(19327) +10.7%	(1237) -14.0%
Martius Comilla	160 1974-75							
	Nonirrigated	B B-TO	(378) -12%	(0.45) -55%	(1.68) -11.3%	(2160) -14.9%		(163) -3.2%
	Irrigated	B B-TO	(392) -8%	(0.28) -14%	(1.75) +0.01%	(2390) +3.8%		(184) -40.7%
Jabbar et al., Mymensingh Munshiganj	119 1979-80	B B-PTO	(2.125) -44%	(0.20) -59%				

^aThe conventions adopted here in presentation of summary data are adapted from those in Binswanger (7). Data in parentheses are the base values in the units indicated for the item on the left in the comparison column (i.e. bullock owners achieved an annual cropping intensity of 2.07 in Gill's survey). Percentage figures in the following line represent the change from this base noted on farms with the degree of mechanization indicated. For instance, on farms of 2 wt owners, labor used was 9.7% less than on bullock farms. ^bB = bullock owner, PTO = power tiller owner, TO = tractor owner. ^cFor Gill, data are for hired labor only. For Martius, figures are family plus hired labor. For hired labor only, Martius reports an increase of 29% on non-irrigated and 13% on irrigated farms. All data from Martius exclude postharvest labor. Jabbar et al note additionally that seasonally employed plowmen were employed by 53% less on tractor farms, from a base of 0.55 men/ha per annum. Jabbar's data are for no. of regular hired laborers. ^dGill notes a displacement of approximately 10 d of bullock labor/ha per annum. This was translated directly into reduced bullock ownership by 2 wt owners, but data are not presented. ^eJabbar et al note some increased cropping intensity in Munshiganj but figures are not given, and the effect could well be due to differences in initial sizes of holding. ^fYield data are averages across study locations: potato and paddy, average of 4 sites; mustard, average of 3 sites. Averages conceal wide variation among sites (Gill).

The debate over desirability of mechanization in Bangladesh also involves draft animal quality (34). However, reports from almost 100 yr ago state that Bangladesh cattle have always been small (24). Cows are increasingly used as draft animals, either indicating a worsening power situation or reflecting the decline in farm size due to increasing population. This would make maintenance of two multipurpose animals more economical than that of two bullocks. Further, pregnancy and lactation are less likely to reduce work output on small farms with low draft needs (50).

Currently, the draft animal herd is 10.3-10.9 million head, averaging 1.54 ha/pair. This work requirement would put poorly conditioned animals at capacity.

Little analytical work was available when Binswanger reviewed tractor effects in 1978. Studies now available include a frequent visit survey of 2wt use conducted over 15 mo in 1977-79 by Gill (23) in Rangpur, Dacca, Nuakhali, Munshiganj, Bogra, and Comilla (n=360); an extensive survey of 160 farmers using 4wt hire services in Comilla in 1974-75 by Martius (48); and single interview studies of 63 owners and 56 users of 2wts in Mymensingh and Munshiganj in 1979-80 by Jabbar et al (35), and of 63 households, 11 paddy processing groups, and 2 rice mill laborers in Mymensingh by Ahmed (2) in 1980.

Results of these studies are remarkably consistent (Table 3). *Cropping intensity* effects are neutral or negative as are, on the whole, *yield effects*. Where yields rise with tractorization, irrigation and fertilizer account for it. Gill quotes extensive experiment station evidence showing no direct tractor effect on yield. Both Jabbar et al and Martius note greatly reduced *bullock capacity* per hectare. Gill, however, presents only reductions in use time, indicating that all 2wt owners had disposed of their animals but that hired 4wts weren't yet reliable enough to permit widespread disposal of bullocks. In one village surveyed by Jabbar et al, only 3% of 2wt owners had replaced all draft animals, against 53% in the other village.

Labor use analysis is complicated by different methods of reporting data. Jabbar et al note a 44% reduction in permanent hired labor. Reanalysis of Gill's data indicates a 9.7% drop in casual labor use, and he contends permanent hired labor is not a feature of the study locations. Martius indicates an overall reduction in labor use, but hired labor rose 13% on irrigated farms and 29% on nonirrigated farms.

Tractorization appears to substitute heavily for family labor as Farrington and Abeyratne (18) noted for Sri Lanka. Martius notes large quantities of female labor in postharvest work, of very low opportunity cost given social restrictions (*purdah*) on work outside the household. Ahmed discusses this at length (2). He notes postharvest processing by traditional methods (transport from field to house, stacking, threshing, winnowing, soaking, parboiling, drying, storing, husking, polishing, and cooking) accounts for about 25% of all agricultural employment. He records a labor requirement of 36.7 d/t with traditional methods, and higher in aus and boro seasons because of drying problems. Apart from men threshing, accounting for 14% of postharvest

Table 3. Results of tractor surveys in Bangladesh.^a

Author and area	Sample size and study year	Comparison ^b	Labor ^c days/ha per yr	Bullocks ^d (no./ha)	Cropping ^e intensity	Yield ^f (kg/ha)		Fertilizer inputs (kg/ha)
						Rice	Potato	
Gill (see text)	360 1977-79	B B-PTO	(47.3) -8.7%		(2.07) +0%	(3108) +8.3%	(19327) +10.7%	(1237) -14.0%
Martius Comilla	160 1974-75 Nonirrigated	B B-TO	(378) -12%	(0.45) -55%	(1.68) -11.3%	(2160) -14.9%		(163) -3.2%
Jabbar et al, Mymensingh Munshiganj	119 1979-80	B B-PTO	(392) -8%	(0.28) -14%	(1.75) +0.01%	(2390) +3.8%		(184) -40.7%

^aThe conventions adopted here in presentation of summary data are adapted from those in Binswanger (7). Data in parentheses are the base values in the units indicated for the item on the left in the comparison column (i.e. bullock owners achieved an annual cropping intensity of 2.07 in Gill's survey). Percentage figures in the following line represent the change from this base noted on farms with the degree of mechanization indicated. For instance, on farms of 2 wt owners, labor used was 9.7% less than on bullock farms. ^bB = bullock owner, PTO = power tiller owner, TO = tractor owner. ^cFor Gill, data are for hired labor only. For Martius, figures are family plus hired labor. For hired labor only, Martius reports an increase of 29% on non-irrigated and 13% on irrigated farms. All data from Martius exclude postharvest labor. Jabbar et al note additionally that seasonally employed plowmen were employed by 53% less on tractor farms, from a base of 0.55 men/ha per annum. Jabbar's data are for no. of regular hired laborers. ^dGill notes a displacement of approximately 10 d of bullock labor/ha per annum. This was translated directly into reduced bullock ownership by 2 wt owners, but data are not presented. ^eJabbar et al note some increased cropping intensity in Munshiganj but figures are not given, and the effect could well be due to differences in initial sizes of holding. ^fYield data are averages across study locations: potato and paddy, average of 4 sites; mustard, average of 3 sites. Averages conceal wide variation among sites (Gill).

labor, women perform all other operations, with 70% of this labor from within the farm family.

Up to 1980, 1,000 engine-powered threshers had been introduced, at 380/yr. In the survey area, 37% of families had adopted mechanical hulling, reducing family labor from 68 to 55% and hired labor from 32 to 16%. Using Ahmed's estimate of 52% of postharvest labor used in husking, the 29% drop in husking by traditional methods reduces overall employment 15.1%, i.e. from 36.7 d/t to 31.2 d/t. Wages fell slightly for female labor in areas where mills were introduced, and real wages fell substantially in areas with and without mills.

Gill noted little difference in *timeliness of cultivation* between bullock- and tractor-plowed plots in the critical aus-aman turnaround. Even with 2wts and small farms, plots which had to queue for tractor service were likely to be plowed later than animal-tilled plots.

Gill notes that *cropping intensity* varies more according to elevation and irrigation available for bore and rabi crops than according to tractorization. Smaller, more labor-intensive farms achieved higher cropping intensities, as Martius also found. Gill found 2wt owners were more likely to grow potatoes, a high-value, high-input crop. They planted potatoes significantly earlier than did animal users and reduced costs by dispensing with manual labor for breaking clods behind animal plowing.

Martius noted an increased preference for rice cultivation with tractorization, and general streamlining of production into two or three main crops. High-value, labor-intensive crops such as vegetables were left to bullock farms. Tractor owners with high opportunity cost of labor may search for crops needing little labor input and giving high return to labor, though not necessarily to land or irrigation.

On *tenant displacement*, Gill notes that a subset of 5 2wt owners in Munshiganj increased their holdings by 60%, of which 46% was newly rented, 38% repossessed from tenants, 3% mortgaged, and 13% newly purchased. Jabbar et al note tractor owners increased holdings by 46%, against 22% for nonowners. For 2wt owners, 38% of the increase came from land repossessed from tenants, with tenancy declining 44%, from 4.5 to 2.5 per farm.

In contrast with Pakistan and parts of India and Sri Lanka where cattle are open-grazed, Bangladesh cattle are fed crop residues, thinnings, weeds, and whatever is collected from roadsides. As Gill emphasizes, the opportunity cost for animal feed is low.

India

India lacks an agricultural frontier, with little change in the 17 million ha of cropped land. Approximately 25% of cultivated land receives some irrigation. Rice (54 million t in 1981-82) and wheat (38 million t) account for 70% of food grain production. Imports of food grains vary widely, from 0.5 to 10 million t.

Average landholding is small at 2 ha, but distribution is highly skewed — 36.8% of holdings are below 0.5 ha. Skewness has worsened since 1953-54 (15).

In 1981, 59% of the national work force relied on agriculture, but 38% of these workers owned no land.

India has a wide range of mechanized and nonmechanized agricultural equipment. On one hand, 70 million draft animals are used in tillage, intercultivation, and stationary operations. Yet in 1984, lift irrigation relied on over 8 million diesel and electric pump sets, and in 1985, 750,000 tractors were in use.

All 4wt requirements were met by imports until 1961, when local production began. This reached 60,000 4wts/yr, enough to displace imports completely (Table 4). Further, installed capacity for 2wt production was 10,000 units/yr in the mid-1970s. In 1974-75, however, production was only 2,221 units (7).

Tractorization varies from one state to another, and is associated with irrigation and with cropping intensity. For instance, the Punjab has more than 12 4wts/1,000 ha, and around 75% of its area is irrigated. The figures are 2.8/1,000 ha and 40% for Uttar Pradesh, and 1.0/1,000 ha and 9.2% for Kerala (58).

To develop indigenous tractor manufacture, India restricted imports by quotas and tariffs. Imports dropped to 1,000 units and domestic production increased to 24,000 units in 1974. Tariffs have varied, but those imposed on a consignment of British tractors in 1971-72 were typical: 30% import tariff, 10% excise tax on ex-factory price, central sales tax of 3% on retail price, and state taxes varying between 1 and 9%.

Before 1971, tractors were exempt from import and excise taxes. From 1971 to 1973, a gift scheme allowed citizens residing abroad to buy a tractor in foreign currency and send it free of taxes to friends or relatives in India. All imports were banned in 1973. As in Bangladesh, diesel fuel is heavily taxed and retails at half the price of petrol. Taxes applied to domestically produced tractors apply also to other inputs such as fertilizers. Internal taxes on tractors amount to 30% of the ex-factory price, compared with 45% for cars. Interest on credit for tractor purchase is concessional, at 10-12% against a general rate of 20%.

Prices of imported tractors to farmers ranged from Rs 30,000 to 45,000, almost double that of comparable domestic models (14).

To further promote domestic production, indigenous tractor prices were raised slower than were foodgrain prices. From the early 1960s to 1968,

Table 4. Tractor stock and production trends in India (58).

Year	4 wt (no.)		National stock (no.)	
	National production	Imports	4 wt	2 wt
1971-72	18,100	19,739	148,300	10,000
1973-74	24,425	1,000		
1979-80	60,986	—	444,192	23,000
1983-84	81,000	—	800,000 (est.)	25,000 (est.)

foodgrain prices rose 30% faster than tractor prices. By 1971, the balance had evened somewhat, but the rate of tractor price increase still had not caught up with that of food prices (49). From 1975 to 1979, however, tractor prices rose 25%, whereas those of cereals declined. This followed removal of controls on prices and distribution in 1975, and the granting of \$175 million by the National Bank for Rural Development for tractor loan re-finance.

One explanation for the relatively slow adoption of 2wts is their high price compared with that of 4wts. An 8-hp 2wt cost one-third of the price of a 30-60 hp 4wt between 1965 and 1980 (69), in contrast with other countries, e.g. Sri Lanka where the ratio is between 1:4 and 1:5 (18).

The growth rate in irrigation, via pump sets, was twice that of tractors in the 1960s. In the 1970s, however, the situation reversed (69).

Threshing is highly mechanized in some areas. Virtually 100% of wheat in the Punjab is mechanically threshed. By 1975, 160,000 motorized threshers, all domestically manufactured, were used for wheat in the Punjab (3). Combine harvesters in the Punjab number 600 self-propelled units and 2,500 tractor-drawn units. These are estimated to have harvested 15% of Punjab paddy area and 7% of the wheat area in 1984-85 (pers. comm., S.R. Verma).

Virtually all tools and accessories, from hand tools to tractor-mounted equipment, are entirely produced domestically.

In this broad-focus paper, it is impossible to more than briefly summarize the research on the impact of tractorization in India. As the NCAER (58) notes, more than 160 studies on this topic were conducted in India before 1980.

Binswanger (7) summarized the 4wt information up to the mid-1970s, and the following information draws on his presentation.

The Punjab and Haryana studies reported by Binswanger (63, 27, 71, 67, 37, 13) give little evidence that tractors increased *cropping intensity*. Gains were from zero to 10% more than those on animal-draft farms or those before tractorization, with only one gain statistically significant. Virtually no increase in intensity is reported from studies of Uttar Pradesh (72, 56) or of Delhi Territory (54). In irrigated areas of Gujarat, the cropping intensity gain of 13.9% (66) was associated more with irrigation than with tractors, as was the 15.5% gain in the tobacco zone (62). Data from other studies show low (5.5%) or no gains from tractors (16).

In semiarid areas (Gujarat, Maharashtra, Karnataka, Madhya Pradesh), cropping is generally restricted to one season, so it is not surprising that tractors do not seem to increase cropping intensity (52, 16). In fact, intensity declined 5.7% in one area (12).

In Bihar and Andhra Pradesh (47, 61), tractors generally did not increase cropping intensity. Exceptions were in one area of Andhra Pradesh (55) and in Tamil Nadu (78).

The major NCAER study (58) after Binswanger's review presents no information contradicting the view that cropping intensity effects of tractors are minimal. Table 5 shows tractor owners achieve 11% higher cropping intensity than do bullock owners, and 5% higher than tractor users. However,

the availability of irrigation is disproportionately higher (38 and 24%, respectively), so it would be wrong to attribute the increased intensity to tractors alone.

A major study on harvest combine impact in 1977-78 (44), using 116 users and 63 nonusers in Punjab, Karnal, and Ganganagar, indicates that combine use does not change cropping intensity in wheat or rice.

Singh and Goswami (73), in a study in Bihar, note a slight decrease in cropping intensity with tractorization, but this may be largely a farm size effect (Table 5).

Of studies reviewed by Binswanger, only Kahlon's (37, 38) Punjab study quantifies the extent tractors improve *timeliness* of cultivation. A 2-mo sowing period is split into 4 periods of 2 wk for a wheat-wheat rotation. All four categories of farmers (bullock owners, tractor hirers, tractor owners, tractor and bullock owners) complete roughly one-third of their sowing in the first period. Pure bullock farms do only marginally worse than tractor owning and tractor hiring farms in sowing delayed to period four. Further, tractors are not more advantageous in areas where they show the biggest yield advantage.

Of other crops, tractors clearly achieve greater timeliness only with American cotton in the kharif season. In paddy and maize, no clear advantage is detected.

Laxminarayan et al (44) indicate earlier completion of harvest with combines: harvest was 75% completed by the third week in October compared with 55% for nonusers; in another area, percentages were 65 for combines and 45 for nonusers. The third area showed no differences because combines were hired out and queuing reduced timeliness. Combines also permitted earlier sowing, but completion of sowing did not differ. Similar timing gains are noted for the kharif wheat crop.

Jodha (36) indicates the more opportune sowing which tractors offer motivated their spread in the dry, western part of Rajasthan. Tractor expenses were partly covered by cultivating land formerly allocated to fodder and by selling fodder after reducing the bullock herd by more than 50% in 1964-73.

In many studies, higher *yields* on tractorized farms are associated with higher levels of fertilizer and irrigation use, but without statistical testing. An exception is Kahlon's Punjab study which found no statistically significant yield effects. Where wheat yields increased significantly, fertilizer use increased in one area. In the two other areas, the effect did not apply to all farms. No significant differences for modern rice varieties (MVs) were found. Differences were significant for maize in one area and cotton in another.

In Delhi Territory (54), yields increased significantly for paddy (13.7%), wheat (15.9%), and sugarcane (29.7%). However, tractor farms used 35% more fertilizer, so these increases cannot be entirely, if at all, attributed to tractors. In Uttar Pradesh, tractors gave a yield advantage of 17.6% in sugarcane and 41% in wheat, but significance tests and fertilizer inputs were not reported (72). In the NCAER study, yield increases with tractors accompanied increased fertilizer use, but sample sizes were small. In other areas, large yield increases were reported for summer paddy in Bihar (28.6%), for desi paddy in

kharif (region III) and MV paddy (region IV) in Andhra Pradesh, and for groundnuts in Coimbatore (23.9%). However, fertilizer applications were also higher (Bihar, 31.8%; Andhra Pradesh, 36.3%; Coimbatore, 28.7%) so that causality is not clear. Finally, Singh and Chancellor's regression analysis (70) on 26 maize farms in Meerut District shows no significant effect of tractorization.

As Binswanger notes, only 6 of 118 instances reported show large yield differences without large increases in fertilizer input.

The NCAER (58) study indicates that tractor owning farms obtained rice, wheat, and sugarcane yields almost 20% higher than those on bullock farms. Jowar yields were 72% higher and cotton 7% higher. Yields for tractor hirers were usually intermediate. This study advances reasons against trying to quantify the contributions inputs make to yield variations. However, Table 5 data clearly show that both irrigation and material inputs/ha are much higher on tractor farms than on bullock farms, with tractor hirers intermediate.

Laxminarayan et al (44) report 6% grain loss in harvesting and threshing with traditional methods, and 2-4% with combines. A multiple regression analysis indicated that greater fertilizer use mainly explained combine users' higher yields.

Singh and Goswami note complex yield effects in Bihar (Table 5). Early MV rice yields are slightly higher with tractorization, late MV rice and maize show massive yield increases, and MV wheat yields decrease slightly. No adequate explanation of these results is provided by the authors or by studying the input data.

Binswanger adopts value of crop production per ha per yr as a proxy to determine any cropping effects attributable to tractorization. Production value is a function of cropping intensity, yields, cropping patterns, and a residual interactive effect (7). Since tractorization has increased the first two only slightly, it is reasonable to suppose that the increase in production value is attributable to a tractor-based cropping pattern or to another factor such as irrigation, credit, or managerial capacity.

Binswanger finds a cropping pattern effect greater than 5% in 15 of 39 cases, but not always unequivocally attributable to tractors. In areas I and II of Kahlon's (37, 38) Punjab study, the substantial switch from fodder to higher-value crops is clearly a tractor effect. In area II, the switch to potato appears tractor-related. In the Delhi Territory, the cropping pattern effect is related to fodder reductions, as well as to increased cultivation of rice MVs and other high value crops. In other areas, cropping pattern effects seem due to a combination of tractors, education, and irrigation. The precise impact of tractors is difficult to identify, particularly since no study quantifies the effect tractors may have had in capturing benefits of more opportune marketing.

The NCAER study notes increased concentration of tractor owners on rice and wheat, a trend noted for the Punjab by Kahlon, and greater concentration on commercial crops such as sugarcane, cotton, and tobacco. Tractor owners' gross value of output was 63% higher than that of bullock owners, and that of tractor hirers, 31% higher. This appears attributable more to yield increases

Table 5. Results of tractor surveys in India.³

Author, area	Sample size, study year	Comparison ^b	Labor (d/ha per yr)	Bullock (d/ha per yr)	Cropping intensity ^c	Value of gross output (Rs/ha)	Yield (q/ha)			Inputs				
							MV (early)	MV paddy (late)	MV wheat	Material inputs ^d (Rs/ha)	Irrigation (% operated area)	% cropped area under MV		
NCAER (1980)	815													
	1977-78													
Whole sample		B	(104.8)	(16.5)	(1.49)	(2442)	(24.5)	(18.2)	(552)	(58)				
		B-TO	+5.4	-83.0	+11	+63	+20	+19	+56.7	+38				
		B-TH	+0.8	-60.0	+5	+31	+8	+14	+35.0	+24				
Punjab		B	(89.3)	(31.3)	(1.84)	(2593)	(47.8)	(19.5)	(446)	(57)				
		B-TO	-15.5	-89.5	+5	+18	+8	+27	+37	+54				
		B-TH	-11.6	-61.0	+5	+9	-4	+21	+26	+51				
Haryana		B	(66.8)	(14.4)	(1.66)	(2171)	(21.7)	(21.6)	(344)	(70)				
		B-TO	-15.6	-88.8	+1	+17	+18	+12	+35	+33				
		B-TH	-18.4	-43.1	+0	-4	+3	-3	-14	+11				
Uttar Pradesh		B	(131.3)	(15.8)	(1.84)	(2626)	(23.2)	(21.0)	(741)	(95)				
		B-TO	-26.8	-80.4	+5	+19	+11	+6	-3	+2				
		B-TH	-8.9	-43.1	+3	+5	+12	+3	-9	+3				
Tamil Nadu		B	(173.7)	(18.7)	(1.34)	(2435)	(14.7)		(489)	(80)				
		B-TO	+12.3	-78.6	+17	+79	+36		+58	+15				
		B-TH	+2.4	-66.8	+1	+25	+16		+19	+8				

Andhra Pradesh	200												
	1971-72												
B	(85.1)	(17.8)	(1.22)	(2461)	(24.2)	(607)	(79)						
B-TO	-2.9	-71.9	+10	+47	+8	+24	-30						
B-TH	-19.7	-70.8	+2	+11	+1	+36	-33						
B	(52.6)	(10.6)	(1.04)	(837)	(15.2)	(9.3)	(7)						
B-TO	+17.1	-96.2	+14	+94	+73	+48	+414						
B-TH	+6.1	-70.8	+7	+89	+25	+29	+343						
B	(134.6)	(7.1)	(1.43)	(3965)		(19.6)	(44)						
B-TO	+53.5	-67.6	+22	+139		+19	+80						
B-TH	+36.9	-69.0	+17	+86		+29	+84						
Roy and Blasse ^e	200												
	1971-72												
B	(139.3)		(1.57) ^f	(2753) ^f		(187.8)	(89)						
B-TO	+0		+11.5	+12.9		+25	-1.1						
B	(120.8)	(38.1) ^g	(1.54)	(938)	(16.7)	(8.1)	(36)						
B-TO	-27.4	-80.2	-7.9	+7.0	+33.3	+153.8	+8.2						
B-TH	-5.7	-23.4	-5.3	-5.4	+11.6	+87.8	+5.1						
Singh and Goswami	100												
	1975-76												
B	(120.8)	(38.1) ^g	(1.54)	(938)	(16.7)	(8.1)	(36)						
B-TO	-27.4	-80.2	-7.9	+7.0	+33.3	+153.8	+8.2						
B-TH	-5.7	-23.4	-5.3	-5.4	+11.6	+87.8	+5.1						

^a Please see footnote ^b of Table 3. Values with + and - signs are percentages. ^b B = bullock owner, TO = tractor owner, TH = tractor hirer. ^c The NCAER study notes that cropping intensity (CI) for all power types consistently increases by 7-10% as farm-size category decreases. CI does not appear to be influenced by irrigation availability since it does not vary systematically with farm size. ^d Value of unspecified material inputs for NCAER; value of fertilizer for Roy and Blasse, and for Singh and Goswami. ^e For Roy and Blasse, results were not distinguished between TO and TH. The TO category therefore contains both. ^f CI and output value differences were significant at P=0.01. ^g Number of bullocks per operated ha was 0.76 on bullock farms and 49.6% and 17.7% less on tractor-owner and tractor-hirer farms, respectively.

(however caused) than to changes in cropping patterns. Singh and Goswami, however, note negligible changes in gross output value/ha (Table 5).

Changes in *labor use per hectare* were tested for statistical significance in 19 of 58 bullock-tractor comparisons reported by Binswanger. Despite a range of -22.6% to +24.4% in labor input, no difference proved significant. The distribution was not skewed, so tractor use appears unassociated with increased or decreased labor use per hectare. The largest increase is associated with a switch in cropping pattern to potato, a labor-intensive crop.

Binswanger cites evidence of per hectare labor-use increases in Gujarat and Nepal, but these appear more associated with irrigation than with tractors. He dismisses all increased labor/ha as results of changes in cropping patterns or irrigation, which are linked to "improved overall capital availability rather than to tractors per se." This doesn't account for the cited contribution of tractors to cropping pattern changes in Punjab and Delhi. Nor does it account for the apparent contradiction in Patel and Patel's (62) data for Gujarat in which labor use falls by 25.2% in bullock and tractor owner comparisons, but rises by 17.4% between bullock and tractor hirer farms. Krishna's (42) analysis of changes in labor/ha in the Punjab between 1968-69 and 1973-74 indicates that tractor plowing accounts for only a 1% decline, compared with 12.7% for mechanized threshing and 6.2% for the switch to pump set irrigation. Although not mentioned by Binswanger, tractors contributed to the spread of PTO-powered threshers, so the 12.7% cannot be attributed to threshers alone.

Labor reductions generally involve permanent labor, i.e., fewer bullock drivers. Both family and casual hired labor increase somewhat.

Binswanger does not report reductions in labor on draft animal maintenance (other than the permanent labor mentioned). That can be substantial, varying in Sri Lanka between 100 and 600 d/4wt per yr (18). In contrast, labor required for maintaining a 4wt is reported as only 18.6 to 22.2 d/yr (56, 58).

Even if studies Binswanger analyzed show little reduction in labor per hectare, that in itself cannot establish that tractors do not displace labor. Such a conclusion can be upheld only under an extreme net contributor view which attributes all differences in production per ha to tractors. Other simultaneous changes, e.g., irrigation and fertilizer use, would generally increase per ha labor. Much of this increase appears nullified by reduced labor in mechanized operations, so a finding of "no change" does not adequately describe the tractor effect.

The NCAER study reports an overall increase of 5.4% in labor/ha on tractor owner farms, with negligible impact among tractor hirers. Overall means are greatly influenced by increases of 53.5% for owners and 36.9% for hirers in Maharashtra, where irrigation use was 80% and 84% higher for tractor owners and hirers than for bullock owners. Removing the Maharashtra data shows a negative impact on labor use/ha: -5.3% for tractor owners and -7.3 for hirers.

Changes reported by NCAER in composition of the labor force with tractorization differ markedly from those cited by Binswanger and from trends in Bangladesh (23) where displacement mainly affected hired, not family, labor. However, family labor displacement agrees with the pattern observed in

Sri Lanka (18). According to NCAER, family labor in cropping is 37% of the total on bullock farms (38.3 d/ha) but only 19% among tractor owners (21.3 d/ha) and 26% among hirers (27.3 d/ha). Hired labor (no distinction between casual and permanent) increases relatively and absolutely with mechanization. Part of the apparent drop in per ha family labor is spurious, insofar as the tractor owners' sample has a larger average farm size than hirers or bullock owners. Insofar as the reduction is real, it seems to represent a withdrawal of female and child family labor into less arduous activities and the channelling of male family labor into supervisory activities. Even when adjusted for land area, family labor input on 4wt farms is 49% below that on animal-draft farms, and 30% lower on 2wt farms.

Subsidiary employment (animal husbandry etc.) represents 55.6 d/ha per year on bullock farms (87% family), 43.8 d on hirer farms (77% family), and only 29.2% (60% family) on tractor owner farms. Employment generated by tractor maintenance and repair has been estimated by NCAER (56, 58) at 18.6 and 22.2 d/tractor per year (3.5 and 2.3 d/cropped ha), and that in manufacture and distribution of tractors and their implements at 403 d/tractor per year (40 d/cropped ha). Precise data are not available on labor for bullock maintenance nor on manufacture and maintenance of bullock equipment.

For traditional methods of harvesting and threshing wheat, Laxminarayan et al (44) report labor use of 23.0 d/ha, reduced to 1.3 d/ha with combines. The 21.7 d replaced represents 13.7 d of casual (mainly migratory) labor, 5.0 d of family and 3.0 d of permanent hired labor. In paddy, 43.3 d/ha are displaced: 36.1 d of casual migratory labor, 4.3 d of family labor, and 2.9 d of permanent hired labor.

A combine operating on 117 ha/season of wheat in rotation with 85 ha/season of paddy will displace 6,232 d/yr. The 190 combines at survey time (1977-78) covered only 0.97% of the Punjab wheat area and 2.67% of paddy area, but displaced 3,947 labor years.

These results fit earlier, less rigorous observations which suggested displacement of 37.3 labor d/ha by combine (51).

Harriss (30) calculates that modern rice mills (MRM — integrated drying, parboiling, and rubber-roller hulling of 2-4 t/h capacity) are 12 times less generative of employment than are traditional mills. For the capital cost of one MRM, 50 small mills could be constructed, requiring 150 salaried employees and 500 laborers. The MRMs surveyed operated at much higher cost per ton than did traditional mills and were less able to cope with a range of paddy varieties.

Singh and Goswami note a 27% decrease in labor d/ha per year on tractor owner farms for Bihar, but only a 5.7% decrease among tractor hirers.

The studies Binswanger reviewed usually indicate reduced *bullock use* with tractorization, with greater reduction in bullock hours than in bullock numbers that indicates farmers retain bullocks for tasks difficult to mechanize and, at least initially, for fear that tractors will prove unreliable. In most areas, bullock hours dropped more than 60% with tractorization. In specific

conditions (e.g., in parts of Maharashtra where heavy soil makes tractor work difficult in kharif), bullock hours are much less reduced.

The NCAER study confirms this trend, indicating an average 83% decline in bullock hours between bullock owners and tractor owners, and 60% for tractor hirers. Bullock stocks declined from 0.42/ha on bullock farms to 0.17/ha (-59.5%) on tractor owner farms and 0.25/ha (-40.5%) on tractor user farms.

Mishra et al (51) report that introduction of combines in the Punjab displaced 18.1 d/ha of bullock labor.

Singh and Goswami (Table 5) present the exception of much greater decline in bullock time/ha per year than in bullock stocks/ha. No explanation is given.

Little information was available on impact of 2wts in India at the time of Binswanger's review. Citing the NCAER study (57), he notes that 2wts are mainly used for puddling in mudland paddy. The 2wts reduced bullock stocks more than 50% and labor inputs by 15%/ha. Effects on cropping intensity are negligible, but crop value/ha more than doubled, evidently from yield increases. However, lack of input data prevent precise detection of causality.

Pakistan

Pakistan has an open land frontier. About 38% of its land area is suitable for agriculture, and of the two-thirds that has been cultivated (40), about 66% receives some irrigation. Agriculture accounts for 36% of GNP, and over 50% of the population depends on land for a living, chiefly as smallholders, tenants, or landless laborers. The distribution of landholdings is highly skewed: 12% of the population control 43% of land, and 28% with farms under 2 ha control less than 5%.

Of principal food crops, rice and wheat occupy similar areas (1.9 million ha). While rice generates foreign exchange of more than \$200 million/yr, wheat production has not reached self-sufficiency and 2 million t were imported in 1978-79.

Most cultivated land is irrigated (74%) by gravity, but the late 1960s and early 70s witnessed expansion of canal capacity and tubewell investment, parallel with increased use of agrochemicals and new varieties. This increased the demand for farm power, which, up to 1965, had been provided by 10.5 million work animals and 10,000 tractors. Between 1966 and 1970, 18,000 tractors, mainly 36-55 hp, were imported, but increasing concern about possible draft power shortages led to the establishment of a Farm Mechanization Committee (FMC) (1968-70). Farm mechanization in Pakistan has involved pervasive government intervention, the effects of which are outlined below.

In 1968, the FMC estimated farm power of 0.1 hp/acre of cultivated farmland, 14% supplied by tractors and 75% by work animals. The FMC decided that more farm power would allow expansion of cultivated area, reduce fallow, and increase cropping intensity and yields. It saw urgent need to reduce the bullock population so land in fodder could be planted to higher value crops. The FMC proposed import of tractors to raise the total in use to

81,300 in 1980 and 122,400 in 1985, which would then meet 59% of national power needs. As data in Table 6 show, imports to 1980-81 were in line with these projected needs.

The FMC recognized that tractors would continue to be used mainly on large farms which would repossess land cultivated by tenants. However, it foresaw displaced tenants being employed as farm laborers, and felt displacement would not be a problem on small farms.

The Pakistan Government attempted to standardize tractorization by restricting to seven the makes of tractors imported after 1958. However, these restrictions changed periodically as offers of tractor-aid were accepted, with 13 makes accepted in 1977, but restricted to 5 in 1978.

Policies have substantially supported tractorization. For instance, prices of sugarcane, wheat, maize, and rice in the 1960s and 70s were fixed well above world market prices (at an overvalued exchange rate). Additionally, International Development Agency (IDA) credits for tractor purchase were available at 6-7% interest compared with 12-15% charged by commercial banks, and foreign exchange for purchasing tractors was available at the official exchange rate of Rs 4.75/\$, whereas its real value was widely held to be twice that (46).

Further, tractors initially escaped duty and sales tax applied to other imports. In 1970, however, a 5% import duty was imposed, plus a 15% sales tax and a defense surcharge amounting to one-quarter of the sales tax. Since 1979, all agricultural machinery has been imported free of duty, but a 5% sales tax and defense surcharge have applied. Those qualifying for tractor loans were generally in the more than 20 ha farm size group (less than 4% of farms). With these supports, tractors were imported at about Rs 14,000 and had immediate resale value of more than Rs 25,000, reflecting their true value in production.

Authority was granted in 1979 for import of 2,000 12 hp two-axle power tillers of Chinese manufacture. These were subsidized by Rs 8,000 per unit and sold to farmers at Rs 25,000 (41). Although 877 were imported, power tillers have not proved popular in Pakistan. Operating costs are apparently higher than for 4wts and they do not perform well on hard soils (64). In the late 1970s, 250 motorized paddy transplanters were imported from South Korea, but poor land leveling, seedbed preparation, and water control discouraged this technology.

Table 6. Pakistan 4-wheel tractor imports and number in working order (45; ESCAP-RNAM, pers. comm.).

Period	Units imported (no.)	Cumulative total	Cumulative total assuming 10-yr life
1965-66	1,665	10,828	10,828
1970-71	3,879	31,109	26,777
1975-76	10,809	60,395	43,787
1980-81	14,302	136,251	99,251
1983-84	31,000	158,845	120,000 (est.)

Estimates of local manufacture of a range of equipment are provided by Qureshi (64) and presented in Table 7. While normally favoring local manufacture, the Pakistan government has not consistently followed this policy. Bergman and Mai (6) indicate that local assembly of Massey Ferguson (MF) tractors began in 1964 at Millat Tractors. This company was incorporated as a parastatal into the Pakistan Automobile Corp. in 1972 and licensed to produce up to 10,000 units/yr of Fiat and MF. A further (private) enterprise was licensed to produce annually 6,000 units of IMT and Belarus tractors. Virtually all tractors above 40 hp are now locally produced, but local content varies from 60% in MF 50 hp to 20% in most other models.

Khan and Khan report that in the early 1970s, the government banned imports of small, high- and medium-speed diesel engines in the 6-12 hp range to encourage local production. The ban introduced distortions, since local production was extremely limited. The State Corporation produced only 300 units/yr of a 5.5-9.7 hp medium-speed diesel up to the late 1970s. Consequently, many tubewells (estimated 150,000 units in 1979) were powered by 15-20 hp diesels, delivering 0.75-1.5 cusecs, and subsidized by \$750-1500 per unit. The units were too large for smallholders, a situation worsened by scarcity of smaller diesel pumps and lack of rural electrification. Similarly, local production of motorized knapsack and PTO-powered sprayers was hampered by policies restricting import of suitable engines, by the 50% subsidy applied to imported sprayers (39), and by the subsidized aerial spraying practiced until the early 1980s.

Import of combines, mainly of tractor-drawn models and some of Indian manufacture, is recent and may, as Indian data indicate, severely displace

Table 7. Estimated local production and import of farm machinery in Pakistan.

Farm machinery type, source	Locally manufactured units (no.)		Imported units (no.) as assembled	
	1978-79	1982-83	1978-79	1982-83
Wheel tractors ^a				
30-60 hp	—	—	74,041	88,400
Above 60 hp	—	—	2,000	3,000
Diesel engine	107,406	151,000	—	—
Motors	71,077	74,000	—	—
Power threshers	15,600	35,500	—	—
Manual sprayers	16,190	61,200	—	—
Power sprayers	—	—	3,238	9,100
Power weeder	60,832	113,700	—	—
cultivators				
Pumps	178,483	202,400	—	—
Trailers	45,625	87,200	—	—
Head feed combines	—	—	94	120
Tractor attached combine	—	—	315	430

^a In addition, 46,000 units of wheel tractors were imported on a knocked-down basis in 1982-83.

labor. About 400 tractor-drawn and 100 self-propelled combines are in use. Since 1982, 2,000 4wt-mounted reapers have been manufactured per year, and approximately 80,000 PTO-powered threshers, all locally manufactured, are threshing about 90% of the wheat crop.

In all, 300 small and 100 medium-scale firms manufactured farm equipment in 1982, with annual turnover of more than \$60 million. They have been hampered by scarcity of quality materials.

Initially, many tractor imports were financed by World Bank (IDA). Credits totalled \$43 million for mechanical power sources, associated implements and irrigation facilities. By 1970, the Bank became concerned about possible adverse effects of this strategy and commissioned a study by J.P. McInerney and G.F. Donaldson, which was published in 1975. Their report is considered below.

In spite of the problems outlined, the Pakistan Government remains committed to a heavy program of 4wt-based mechanization. During the Sixth Five-Year Plan, it proposed increasing 4wt stocks from 137,400 in 1982-83 to 250,000 by 1987-88, especially of smaller tractors of 20-35 hp.

Early studies of tractorization impact in Pakistan were commonly the "predictive engineering" type (46), relying extensively on assumptions to generalize findings from case-study data. Many of the effects later detected in large surveys were foreshadowed in this work.

For example, Finney (22) predicted from an LP model that tenant displacement would be high on large (60+ ha) farms, and fewer than half of those displaced would find other agricultural work. Given sharecropping prevalence in the Sind and Punjab (on 5.4 million ha), mechanization could eventually displace 0.7 million tenants, making 1.4 million landless, equivalent to 20% of adult labor in these areas. While private returns on these large farms would increase with tractor use and tenant ejection, social returns would be greatest in a less mechanized system relying only on motorized threshing, improved bullock implements, and retention of sharecroppers. On smaller farms (-20 ha), motorized threshing, plowing by traditional implements, and retention of sharecroppers offer highest returns at private and social levels. Finney set the opportunity cost of farm labor at zero in all cases.

Ahmed (1), adapting Gotsch's model (76) and deriving coefficients from an intensive survey of 50 farmers (bullock owners, tractor owners, and tractor hirers, in three locations), distinguishes mechanization options according to groundwater availability. The projected private rate of return at 1970-71 market prices for tractorization in sweetwater areas was around 40%, whereas that in saline areas, with less prospect for intensification, was low. In the saline areas, the motorized thresher brings higher private returns.

Divergent assumptions have led to contradictory findings among programming studies. A well-known conflict is between findings of Bose and Clark (9) and of Lawrence (43). Bose and Clark predicted a net social disbenefit of Rs 130 million by 1975 (of total social cost of Rs 330 million) attributable to tractorization. Lawrence showed strong social benefits, assuming a 10-15% yield increase due to tillage, a further 5-10% to timeliness,

and an achievable cropping intensity of 200%, whereas Bose and Clark assumed zero yield increase and a maximum intensity of 150%.

Gotsch (25) helped explain conflicting estimates of this kind, pointing out variations in cropping intensity achievable in saline and nonsaline areas and those attributable to market access. He concludes that yield and intensity effects are likely to be so low that savings from substituting bullock power will not generate net social returns. Private returns, though variable among areas, are high. Both subsidies on tractorization and the capacity it affords for displacing tenants and thereby permitting owners to capture full benefits of new technologies in seeds, water supply, and agrochemicals, account for the divergence between private and social costs and benefits.

Pressures for tractorization made it inevitable that larger-scale studies would attempt to quantify principal issues more clearly. The most comprehensive of such studies (46, 45) are reviewed here.

McInerney and Donaldson's study in 1969-70 was conducted at the World Bank's request, following concern over the distributional impact of tractors purchased through IDA credits in mid and late 1960s. The findings of their comparative time series study (Table 8) indicate that overall improvement in *cropping intensity* has been small (7%) and is likely somewhat attributable to increased tubewell ownership (from 45 to 60% of farmers). This figure may be overestimated, as it is based on land originally operated by tractor owners; that repossessed from tenants may have had a higher original intensity.

Yield effects in rice, cotton, and sugarcane are negligible, but those in wheat and maize rose substantially. These are associated with high increases in fertilizer use, and the wheat yield increase may further be associated with learning effects as wheat MVs were introduced in the mid-1960s.

McInerney and Donaldson do not report effects on *timeliness* of cultivation, and indicate that cropping patterns have changed little. They report a decline of 79% in bullock use and of 38.9% in labor/ha. Much of this is due to tenant displacement, amounting to 4.5 tenants/tractor over 4 yr. Some labor displacement may relate to the spread of MVs and to changes in crop prices which made farming more profitable. These may have stimulated cultivation and land reclamation, but tractor adoption and tractor size (45-55 hp under IDA credit) should also have encouraged farm expansion.

The 202 farms studied increased in size from 18.2 to 44 ha, but only 26.2% of this was newly cultivated land; the remainder comprised reductions in land rented out (32.3%), increased renting (28.6%), and land purchase (13%).

Lockwood's (45) results agree broadly with McInerney and Donaldson's (Table 8). In particular, Lockwood notes a 91% increase in farm size among tractor owners, of which 70% came via repossessing tenant land. Smaller farms (-20 ha) increased in size more than larger ones, possibly to spread capital costs of tractors over more hours use per year. *Cropping intensity* increases were small (4-5%) but, again, nothing is known of intensity on previously tenanted land. The only *cropping pattern* change directly attributable to tractors was a 5% drop in area in fodder crops.

Table 8. Results of tractor surveys in Pakistan.

Reference	Sample size, study year ^a	Comparison	Labor (yr/ha)	Bullock ^b (no./ha)	Cropping intensity ^c	Yield (q/ha)			Inputs (Rs)			
						Wheat (MV)	Rice (desi)	Maize	Wheat	Rice	Maize	
McInerney & Donaldson	202 1966-67	Before-after										
		B	(0.49) ^d	(0.31)	(1.12)	(17.2)	(18.2)	(10.0)	(63.4)	(29.3)	(7.8)	
	B-TO	-38.9%	-79.0%	+7.0%	+37.0%	-1.1%	+61.5%	+17.6%	+115.2%	+1027%		
	I	B			(1.22)							
Lockwood	1978-79	Before-after										
		B	(0.15) ^e	(0.39)	(1.41)							
	B-TO	-17%	-74%	+4.0%								
	I	B			(1.04)							
McInerney & Donaldson	202 1966-67	Before-after										
		B	(0.49) ^d	(0.31)	(1.12)	(17.2)	(18.2)	(10.0)	(63.4)	(29.3)	(7.8)	
	B-TO	-38.9%	-79.0%	+7.0%	+37.0%	-1.1%	+61.5%	+17.6%	+115.2%	+1027%		
	I	B			(1.22)							
Lockwood	1978-79	Before-after										
		B	(0.15) ^e	(0.39)	(1.41)							
	B-TO	-17%	-74%	+4.0%								
	I	B			(1.04)							
McInerney & Donaldson	202 1966-67	Before-after										
		B	(0.49) ^d	(0.31)	(1.12)	(17.2)	(18.2)	(10.0)	(63.4)	(29.3)	(7.8)	
	B-TO	-38.9%	-79.0%	+7.0%	+37.0%	-1.1%	+61.5%	+17.6%	+115.2%	+1027%		
	I	B			(1.22)							
Lockwood	1978-79	Before-after										
		B	(0.15) ^e	(0.39)	(1.41)							
	B-TO	-17%	-74%	+4.0%								
	I	B			(1.04)							

^aData collected for 1969-70. "Before" refers to 1966-67. Most tractors were acquired in 1967. Farm-size classes are based on size groups after tractorization. For McInerney and Donaldson, I = 0.0-24.3 ha, II = 24.3-48.6 ha, III = 48.6-72.8 ha, IV = >72.8 ha. For Lockwood, I = <10.1 ha, II = 10.1-19.9 ha, III = 20-40 ha, IV = >40 ha. ^bBullocks owned per ha operated. ^cLand use intensity "before" is only for the area operated before the acquisition of new land. Data are not available on the cropping intensity of acquired land prior to acquisition, but if it had been greater than 126% (which is possible, given the high cropping intensity of small farms from which much was acquired), then the cropping intensity under tractorization would have fallen. ^dLabor is in man-yr/ha operated. Casual labor is converted to a full-time man-equivalent by dividing the observed expenses for casual labor by a permanent worker wage. Labor displacement includes all that on acquired land. Family and permanent labor decreased by 59.3%, while casual employment increased by 75.2%. Family labor includes the labor of displaced tenants. With each tractor, at least five full-time employment opportunities disappeared. ^eLabor is in man-yr of permanent labor/ha operated. In addition, casual labor requirements for threshing were reduced from 101 to 67 man-h/ha of wheat (i.e. by 34%).

At first glance, *labor use* appears to have increased: 184 permanent laborers were employed in 1979 compared to 164 before tractor ownership. However, 17 of 88 owners sampled were not farmers before the survey, meaning that permanent employees fell by 8%. Considering the increase in cultivated area, this is a 17%/ha decline. Labor composition shifted also: 86 tenant families were expelled. Even if tenants joined the casual labor pool, the amount of labor retained on farms was reduced.

A further study in 1979 in the Pakistan Punjab by Bergman and Mai (6) broadly confirms the cited results. This study, covering 94 farmers owning tractors and tubewells, 186 owning tubewells only, and 202 owning neither, produced these findings:

- Land area operated by tractor owners increased approximately 50%, with 14% attributable to repossession, 13% to cultivation of new land (due to tubewell ownership), 7% to leasing, and 5% to purchase.
- Seventy-four tenants were evicted by the 94 owners.
- Bullock ownership dropped from 5.3 to 1.4/farm (0.17 to 0.05/ha).
- Cropping intensities rose from 1.5 to 1.7/yr, but the tractor effect was not separable from tubewell owning.
- Yields were higher on tractor farms, but so were irrigation and agrochemical use.

Sri Lanka

Sri Lanka has small average paddy holdings (0.9 ha) and a size distribution less distorted than that in other countries in the region. Of paddy land, 63% receives some irrigation, mainly canal. MVs are grown on 80% of the riceland and fertilizer use (more than 200 kg/ha) is high. Herbicides are the major weed control method. Less than 20% of riceland is transplanted.

The dry zone land frontier remains open.

Pressures for an official strategy of tractorization began to emerge in the late 1940s and early 1950s. These coincided with accelerated resettlement from the wetter (south and west) to the drier (north and east) parts of the island, an attempt to reduce food importation and relieve wet zone population pressure.

Tractorization was sought to solve two problems which emerged in the early days of settlement policy. First, when land allocations were relatively large (3 ha of irrigated land), settlers had to rely on hired labor for peak season activities of land preparation-planting and harvesting-threshing. Labor was often not available, since many potential laborers preferred to obtain their own land allotments. Further, seasonal migrant labor had just begun to emerge.

Second, security-oriented strategies first used in dry zone village irrigation, but later in settlement schemes, required irrigation tanks to hold water sufficient for a complete season of paddy irrigation before land preparation could begin. This scheme underused rainfall while the tank was filling and left less water for minor-season cropping. Tractors were seen as a way to advance and synchronize cultivation and increase productivity of irrigated land.

The tractorization strategy, initially with 4wts but since 1970 also with 2wts, was pursued vigorously. Thus Sri Lanka now has a tractor density near that of

the Indian Punjab, and 45% of paddy area is tractor-plowed. However, not much other mechanized equipment has been introduced; threshing, for instance, is by tractor wheels or animals.

Tractorization began with direct government intervention, followed by support for private ownership.

Tractor pools. About 350 4wts were deployed in tractor hire pools, by cooperatives, by the Food Production Department, and by the Department of Agriculture in 1952-56. Thereafter, only tractors in the Department of Agriculture continued to operate, on a reduced scale, up to the late 1960s. Charges for plowing, equivalent to 100 kg paddy/ha, were much below those for animal draft, and demand for hire services outstripped supply. However, revenues were not adequate to cover operating costs, so tractor pools lost some Rs 12 million of current account in 1952-65 and almost Rs 6 million on the capital account. Official hire charges probably amounted to less than one-third of the real cost of plowing, the remainder comprising the subsidy implicit in the losses.

Private ownership. Official tractor pools operated more tractors than did the private sector from 1952 to 1955. Official support for the private sector later included the following:

- A preferential import duty of 1% for tractors and spare parts until 1967, when it became 10% on tractors and implements and 5% on spares.
- Preferential allocations of foreign exchange, in the 1950s and 1960s, for tractor imports when other capital imports were severely limited. In 1968, foreign exchange allocations were subjected to 45% levy under the Foreign Exchange Entitlement Certificate Scheme (FEECS). In 1972, the levy rose to 55% on 4wts, but 2wts had preferential treatment of a 25% duty since 1970.
- Misvalued currency (the real value of foreign exchange in the late 1960s and early 1970s was at least 100% above the official rate), so that imported draft technology was heavily subsidized relative to indigenous technology.
- Hidden subsidies, provided by several medium-term credit schemes for tractor purchase from the mid-1960s. They featured concessionary rates of interest and less strict criteria for borrowers. One scheme applied to irrigation schemes involving purchase of 2wts in the early 1970s, another to youth settlement schemes in the southern dry zone, and others to rehabilitation of irrigation schemes. Rates of default on credit repayment were high, and ability of the lending agency to repossess tractors was limited, so tractor purchase cost was, in effect, heavily subsidized.

When the FEECS was abolished in 1977 and a floating exchange rate adopted, much of the hidden subsidy on tractors was removed. By then, however, 13,300 4wt and 6,150 2wt tractors were registered. Tractor use, particularly short haul transport when truck imports were severely limited, was highly profitable. Tractor imports increased under liberal foreign trade policies following the 1977 general election, to satisfy pent up demand and the expected profit from hiring operations.

Two main subsidies remained after 1977. The Lump Sum Depreciation Allowance was continued to March 1981. It allowed the full value of all capital items used for agricultural production, including tractors, to be deducted from gross income in paying taxes. This benefit promoted tractor purchase; tractor advertisements in early 1980 frequently referred to it once the program's impending discontinuance was known. Second, diesel fuel remained less taxed than petrol, and cost about two-thirds its pump price.

Tractors are currently imported free of duty, but are subject to low, nondiscriminatory sales taxes. Recently, subsidized credit schemes were introduced for draft animal purchase.

The rapid increase in tractors, particularly in the late 1960s and late 1970s, is indicated in Table 9.

Estimates of the impact of subsidies on tractorization are provided in Table 10. The heavy subsidies granted to tractors during their introduction (1950s) and again in the 1970s helped increase their popular appeal. By 1980, however, with massive investment in dry zone development, support for gravity irrigation was almost 50% of agricultural spending, fertilizer subsidy 33%, and tractor subsidy a mere 5% (20).

In spite of support for tractors, policies on local manufacture have not been strong, and Sri Lanka, despite its tradition of engineering skills in ship-repair and tea machinery maintenance, still lacks an agricultural engineering industry producing engine-powered equipment.

The major advances have been in hand-tool manufacture: more than 300,000 heavy hoes were manufactured annually in the late 1970s, representing half the nation's need. Plans were to increase this to 1,000,000 by the mid-1980s. Recently, a rice thresher was manufactured after trials of imported models. During the 1960s, a local assembly line was erected for the British Landmaster 2wt, but this was displaced with the import of more powerful and sophisticated Japanese machines. In 1971, a syndicate of local manufacturers formed to produce components (except engine) for a Sri Lankan 2wt. But in reaction to civil disorder in 1970-71, many 2wts were imported, and the potential market for a national product was saturated. National production of a 4wt has never been seriously considered.

Table 9. Draft power available^a for agriculture in Sri Lanka.

Year	4 wt		2 wt		Buffalo pairs (thousand)	
	Units	Density ^b	Units	Density	Units	Density
1960	1,966	4.2	—	—	161.9	344
1965	2,653	5.2	—	—	150.6	292
1970	7,729	13.6	—	—	139.1	244
1975	8,455	13.8	3,681	6.0	127.7	208
1980	11,950	18.1	9,590	14.6	116.4	179
1984 (estimated)	20,000	28.0	11,000	15.7	120.0	171

^aCalculated by deducting estimated numbers in other uses. See Farrington and Abeyratne (18).

^bPer 1000 ha of land leveled and banded for paddy cultivation.

Table 10. Subsidies on 4wt use by source, and 4wt charges^a relative to paddy yields over time (10, 18, 79).

Year	Subsidy per tractor p. a. (\$) arising from				Value of subsidy ^f		Paddy equivalent value (kg) of per ha subsidy	Hire charge (\$)/ha cultivated	Paddy equivalent cost of per ha hire charge (kg)	Average yield (kg/ha)	% of yield paid for plowing
	Non-repayment ^b of credit	Artificially low interest rates ^c	Subsidized foreign exchange ^d	Subsidized fuel ^e	All cultivated	\$/kg of paddy produced					
1953	1000	30	-	111	1141	31.34	0.022	273.3	103	1444	7.1
1963	91	36	91	135	353	14.56	0.007	128.9	346	2011	17.1
1973	117	47	398	233	795	32.73	0.013	243.4	402	2424	16.6
1980	96	96	-	119	311	25.66	0.009	185.7	413	2888	14.3

^a All prices and costs relate to the years in question. No allowance was made for inflation. Original rupee values are converted into dollars at contemporary exchange rates: 1953, \$1 = Rs 5.0; 1963, \$1 = Rs 5.5; 1973, \$1 = Rs 6.4; 1980, \$1 = Rs 15.6. ^b 1953 figure from the losses incurred in 1963, 1973 by tractor pools (10, p. 189). Assumed that 25% of capital cost of tractors was not repaid because of poor enforcement of credit schemes (1980-10%) and that tractor costs are depreciated in linear fashion over 10 yr. Assumed tractor costs: 1963, Rs 20,000; 1973 Rs 30,000; 1980 Rs 150,000. ^c 1953, 2% was commonly charged, against a more realistic commercial rate of 8%. For 1963 the respective figures were 5% and 15%; 1973, 5% and 15%; 1983, 10% and 20%. ^d For 1963 it was assumed that the official exchange rate was broadly correct, but the official bias in foreign exchange rationing was worth 25% of the rupee face value of tractors. The same assumption was made for 1973, with the additional assumption that the shadow price of a \$ in rupees was 1.6 times its FEECS value applied to tractor imports. ^e For 1953, the real value of diesel was assumed to be Rs 1 higher than its pump price per gallon; in 1963, Rs 2; in 1973, Rs 4; in 1980, Rs 10. ^f Assumed that one 4wt cultivates 36 ha (90 acres) per annum in 1963; 24 ha (60 acres) in 1963 and 1973; and 12 ha (30 acres) in 1980. The high rate for 1953 is calculated from data supplied by Burch (10) and reflects the sole use of a relatively new tractor stock in agriculture. The low 1980 figure is from field observations of Farrington and Abeyratne (18, p. 24).

Two major surveys of the effects of farm tractors have been carried out. The first, by Carr (11) in 1971-72, involved 150 owners of 4wts in the dry zone (30 in the intermediate zone), 40 owners of 2wts in the dry zone (10 in the intermediate zone), and 60 buffalo owners. The second, an intensive daily-recording survey by Farrington and Abeyratne (18), covered 14 mo in 1979-80. It sampled 237 nonowners of draft power, most of whom hired tractors or buffalo; and owners of 56 4wts, 72 2wts, and 56 buffalo at 3 dry zone irrigation schemes selected to reflect resource pressures, infrastructures, and levels of economic opportunity.

Because Carr found water management practices partly determined farm power use and impact, Farrington and Abeyratne distinguished between water-availability effects and those of farm power. Results of the studies are summarized in Table 11, showing consistency in the criteria Binswanger set forth.

Labor displacement effects are similar, as is the absence of a *cropping intensity* effect, except Carr notes a positive intensity effect for 2wts not fully accounted for. Rice yields are slightly higher among tractor owners, but fertilizer use is considerably higher, so the effect is not likely due to mechanization *per se*. Multivariate analysis by Farrington and Abeyratne indicated that fertilizer and water inputs explained yield variations better than did power type.

These criteria, however, do not adequately describe effects of tractorization in complex hydraulic regimes of Sri Lanka's irrigation schemes. For instance, irrigation water largely determines cultivation timing, not availability of power. For these reasons, mechanized tillage shows no timing advantage over animal draft. Paradoxically, low income farmers at tail ends of canal systems, who generally rely on animal draft or manual methods, cultivate early for fear they will lack irrigation water later in the season. Farmers who cultivate with the first rains and therefore economize on irrigation water cannot use this saving for the second crop, since water is released later at a time convenient for everyone.

Further, the farmers' (and extension workers') lack of experience with gravity irrigation on high value crops less resilient than paddy under conditions of over- and under-watering and more susceptible to adverse soil conditions, has prevented widespread diversification. Adoption of MVs has proceeded independently of tractorization. In contrast, Carr reports that tractor owners operating rainfed plots outside canal-irrigated areas have improved timing and expanded land cultivated faster than they could have with animal draft or slash-and-burn methods. Farrington and Abeyratne, however, indicate that 4wt owners operated 2.23 ha of irrigated paddy in the main monsoon season, against 1.02 ha for those who did not own draft power (1.67 ha for 2wt owners, and 1.38 ha for buffalo owners). But the difference in nonirrigated land operated, while relatively greater, was smaller in absolute terms (0.66 ha for 4wt owners, 0.50 ha for 2wt owners, 0.53 ha for buffalo owners, and 0.29 ha for nonowners).

Evidence is not clear, but tractor owners seem to have concentrated on expanding their paddy holdings and diversifying into custom hiring and small

Table 11. Results of tractor surveys in Sri Lanka.^a

Author ^b , area	Sample size/ study year	Comparison ^c	Labor (d/ha per yr)	Draft animals (pair-days/ha per yr)	Cropping intensity	Value of gross output (\$/ha per yr)	Rice yield (kg/ha per season)	Inputs- fertilizer (kg/ha per season)
Carr	290 1971-72	Cross-section						
Dry zone		B B-TO B-PTO	(348.9) -12.4 -10.2		(1.56) -11.0 +16.6			
Intermediate zone		B B-TO B-PTO	na na		(1.61) -7.4 +21.7			
Farrington and Absyaratne	421 1979-80	Cross-section						
Dry zone		B B-TO B-PTO	(225) -25.8 -18.1	(45.7) <i>d</i> <i>d</i>	(1.33) +0 +0	(218) +28 +29	(3090) +3.7 +3.7	(168) -9.2 +22.6
	I	B B-TO B-PTO	(225) -3.4 -13.0		(1.75) +25.1 +8.0		(2495) +7.2 -1.6	(156) +5.8 +6.5
	II	B B-TO B-PTO	(269) -11.7 -12.9		(1.43) +4.9 +0		(3330) +13.1 +13.5	(183) -23.8 +60.7

	III	(163)	(1.03)	(2286)	(151)
B			-2.9	+5.8	+3.7
B-TO		-27.1	-2.9	+15.2	+17.0
B-PTO		-6.3			
NO	(237)		(1.28) ^e	(2820)	(111)
NO-TO		-29.5	+3.9	+13.7	+37.2
NO-PTO		-22.4	+3.9	+13.4	+83.5

^aPlease see footnote ^a of Table 3. Values with + and - signs are percentages. ^bAlthough both surveys were basically cross-section, they contain elements of time-series comparisons used to cross-check the data on, e.g., changes in cropping intensity. For Farrington and Aberyatne, I, II and III refer to separate major canal irrigation study locations at Uds Walswa, Kauduile, and Padaviya, respectively. ^cB = bullock owner, TO = tractor owner, PTO = 2-wheel tractor owner, NO = nonowner. NO generally hired in 4wt, 2wt, or animals. ^dPractically all 4wt owners had stopped using animal power, thus displacing the full 45.7 d. Some 2wt owners continued to use (mainly hired) animals for threshing. ^eCropping intensity varies greatly according to availability of irrigation water, and, therefore, position within the canal network. TO were almost invariably "top-enders." The cropping intensity of 1.28 refers to a sample made up equally of top- and tail-end NO. A more appropriate criterion is the cropping intensity of top and NO, which is 1.40, superior to 1.33 for 4wt and 2wt owners. Cropping intensities were generally low due to lack of water for a second crop at one of the study locations. They refer to irrigated paddy only, the principal crop at all locations. In the same way, top-end NO yields are only 2.2% below those of both types of TO, and the differences in fertilizer inputs are only approximately half those indicated above. Overall averages for Farrington and Aberyatne do not necessarily fall within the range defined by observations I-III since they are weighted by sample size and, in the case of labor, by annual cropping intensity.

Table 12. Summary of policy makers and relative draft power prices.^a

Country	Extent of local manufacture ^b		Degree of restriction on imports of tractors ^c	Subsidies on			Prices in kg of rough rice equivalent of		
	Motorized equipment	Animal/hand equipment		Tractor purchased ^d	Diesel fuel ^e	35 hp 4wt ^f	Japanese 8 hp 2wt ^g	Animal draft pair ^h	Diesel fuel (litres)
Bangladesh	L	H	M	M	L	65,800	10,500	3,000	1.5
India	H	H	H	M	L	43,300	15,300	1,950	2.1
Pakistan	M	M	L	M	L	23,800	-	1,850	0.9
Sri Lanka	L	M	L	M	L	88,900	20,280	2,400	3.8

^aH = high, M = moderate, L = low. ^bApproximately half the annual national requirement of hand tools was imported up to the early 1980s. ^cMethod of restriction varies widely - see text. ^dBy subsidized availability of foreign exchange and/or low interest credit. Tax concessions to tractor firms in the Indian case, plus low interest and tractor purchase loans. ^eBut note that diesel prices in all countries are low relative to the price of petrol. ^fOf local manufacture in India; locally assembled in Pakistan; otherwise imported. ^gNot generally available in Pakistan. Of local manufacture in India. ^hCondition described as "good," but varies widely among countries. ⁱPrices in Sri Lanka appear generally high in view of the relatively recent stagnation of paddy prices.

The main trends in recent (approximately 1975-85) policy in the four countries are presented in Table 12. Relative prices are for 1984-85. The restrictive import policies accompanying establishment of local manufacturing in India are noted, as are the relatively low prices of 4wts in India, at least partly attributable to this strategy. However, if the quality of the Indian product is low, costs per hour of operation will rise toward those of imported 4wts in other countries. Draft animal prices are particularly high in Bangladesh, possibly reflecting unsatisfied demand, although animal quality is not high. The gap between 4wt and 2wt prices is wide in Bangladesh, but narrow in India, possibly accounting for the limited popularity of 2wts in India.

Regarding tractor *impact*, Binswanger (7) presents a useful overview of survey results. Based on data presented above, his summary is expanded (Table 13).

Additional data consolidate Binswanger's analysis: for 4wts, more surveys show a reduction in per hectare labor of 10 to 30%. The 2wts increase crop value/ha consistently higher than do 4wts, though the few observations require cautious interpretation; the impact of fertilizer use appears greater than that of 4wts, and displacement of labor more severe.

In spite of few 2wt observations, these differences may be real. Certainly in Sri Lanka, and possibly elsewhere, 2wt owners were more serious farmers than 4wt owners, who divided their attention between farming and contract work, the latter being essential considering the small 4wt farms. Consequently, the additional fertilizer and increased yields are not a surprise. Again, 2wts are mostly used in flooded paddy cultivation and provide a more complete total tillage substitute for draft animals than do 4wts. With 4wts, substantial labor is generally required for tidying up field corners, repairing damaged bunds, and leveling.

The low contribution of tractors to cropping intensity and yields suggests that they are more appropriately *substitutes* for labor than *net contributors* to output. This argument is presented for Bangladesh by Gill (23) and for Sri Lankan irrigated areas by Farrington and Abeyratne (18). The supply of labor and animal draft (since separate fodder cultivation is not needed) incurs little social cost to the economy in these cases, and tractorization substitutes a costly resource for cheaper ones, with little net contribution to output. In drier parts of Sri Lanka, Carr (11) has shown that tractorization can bring improved timeliness and net production benefits. However, with the increased use of tractors, advantages from timeliness are lost as Gill (23) and Binswanger (7) have noted. The potential for increased cropping intensity diminishes also. Perhaps the fear of timeliness losses has kept tractor-use hours low (7, 18).

In northern India and Pakistan, the situation differs because it is possible to bring fodder land into higher-value production, and the relatively open frontier in Pakistan allows net tractor benefits through land clearing and reclamation. Benefits can be obtained in drier parts of India through the more opportune seeding that tractors allow. Usually, however, the popularity of tractors lies in the ease of farming larger areas, allowing owners to reap benefits

Table 13. Summary of survey results on impact of tractorization.

Effect	Observations ^a (no.)	Observations (%) indicating a percentage difference of				
		Less than -30	-30 to -10	-10 to +10	+10 to +30	greater than +30
Cropping intensity	91 (63)	0	5.5	69.2	22.0	3.3
Crop yields	176 (107)	1.4	4.3	36.3	36.3	21.7
Total crop value/ha	62 (46)	0	1.6	19.4	43.5	35.5
Fertilizers etc. ^b	58 (36)	4.5	4.5	27.3	22.7	40.9
Labor/ha ^c	82 (58)	3.7	34.1	43.9	14.6	3.7
Labor/unit of production	55 (49)	32.7	40.0	27.3	0	0
		<i>4-wheel tractors</i>				
Cropping intensity	8	0	0	75.0	25.0	0
Crop yields	11	9.1	9.1	54.5	27.3	0
Total crop value/ha	4	0	0	0	25.0	75.0
Fertilizers, etc.	8	0	0	12.5	25.0	62.5
Labor/ha	12	16.7	58.3	25.0	0	0
Labor/unit of production	9	0	77.7	22.3	0	C
		<i>2-wheel tractors</i>				

^aAs in Binswanger's original table, each observation represents a paired bullock-tractor comparison. Figures in parentheses are the numbers of observations in Binswanger's original presentation. Data for 2 wt include the two surveys presented in Table 9. ^bFertilizer data sometimes include other agrochemicals. ^cLabor/ha and labor/unit of production represent, respectively, the amounts of labor which would be displaced under the extreme net contributor view (where all output differences are attributed to the tractor) and the extreme substitution view (where tractors are seen as merely substituting for labor with no net production effects). The true impact on labor displacement will lie between those bounds.

of HYV technology, dispensing with some manual labor and tenants. Within Punjab, Binswanger (8) finds the origins of tractorization in the rise in real wages around 1968, as benefits of MV technology became apparent. This rise attracted migrant labor from eastern India, but once power demands of new rice and wheat technologies had been satisfied, real wages fell back in line with those prevailing in the stagnant labor market in the rest of the economy.

Tenant displacement has been particularly strong in India and Pakistan, where the size distribution of land holdings is already heavily skewed and landlessness is a severe problem without, especially in Pakistan, effective land reform (6). In Bangladesh, 2wts have allowed landlords to displace tenants, but it is less so in Sri Lanka, where irrigation schemes offer some control of land transactions and scale-diseconomies in managing several plots under different irrigation channels.

The composition of labor displacement may vary systematically: in poor areas of Bangladesh (23), hired labor is the first to be displaced; in wealthier areas such as Comilla (46) and dry zone irrigated areas in Sri Lanka (18), predominantly family labor is withdrawn into domestic activities for women and children and into higher productivity activities for men, by both owners and hirers of tractors.

Private tractor owners clearly benefit. Gill calculated a 254% internal rate of return (IRR) for 2wts in Bangladesh. In Sri Lanka, Harriss (29) estimated an average annual return on capital of 53.5% for 4wts and 58% for 2wts, with payback periods of 2 yr and 18 mo, respectively. By 1981, Farrington and Abeyratne (18) estimated payback periods at 5 and 3 yr, but at low use rates. For Pakistan, McInerney and Donaldson (46) calculate an IRR of 57%.

With removal of subsidies, Gill's IRR falls to 48%. Attempts to shadow price inputs and outputs, especially labor and foreign exchange, are less common. Exploratory calculations by Farrington and Abeyratne for Sri Lanka, however, indicate that the social benefits attributable to 4wts since tractor imports began in the early 1950s have covered only 70% of their social costs. For 2wts, only 44% of costs have been recovered. McInerney and Donaldson calculate an economic rate of return at 24%, substantially below the financial IRR of 57%. They stress this would be smaller if social accounting methods were available for quantifying the deteriorations in wage employment and tenancy patterns.

CONCLUDING OBSERVATIONS

The patterns of mechanization and impact of tractors in the four South Asian countries examined here are necessarily different from those in parts of East and Southeast Asia. The high labor:land ratios are the crux of the issue. First, they reflect a closed agricultural frontier, so that, in contrast with Thailand, for example, net productivity gains from tractors can come only via farm *intensification*. Such intensification (by higher yields, increased cropping intensity, adoption of higher value crops) is rarely attributable to tractors

alone, being commonly the result of improved irrigation, new varieties, and more intensive use of agrochemicals. Tractors play, at best, a complementary role.

Second, economies in which labor is abundant and heavily dependent on agriculture are unlikely to achieve nonagricultural growth rates high enough to increase wages, and therefore to permit tractors to stimulate growth through reallocation of labor to more productive (nonagricultural) uses, as in Japan, Korea, and Taiwan.

An elementary tenet of investment appraisal is commonly overlooked in tractor studies, but repeatedly emphasized by Gill (23, 24) and Binswanger (7), and implicit in Binswanger's concepts of the substitution and net contribution effects of tractors: evidence of a high rate of return from tractors, albeit at social prices, is not enough justification for investing in them.

In countries where capital, especially in the form of foreign currency, is scarce, funds should be allocated to the investment offering the highest social rate of return. Gill calculates for Bangladesh, for instance, that to make good the estimated (5) draft power shortage of some 2.1 million animals by 2wts, at a substitution rate of one 2wt for 22 pairs of animals, would require 48,500 2wts with an opportunity cost equivalent to 800,000 t of wheat. If spent on fertilizers, the foreign exchange cost of these machines could produce 1.6 million t of rice, enough at current consumption rates for 10 million persons for a year. Similarly, the 115 million litres of fuel required by these tractors have an opportunity cost of 93,000 t of fertilizer, or, if allocated instead to low-lift pumps, could irrigate up to 0.9 million ha of land.

These calculations give a broad impression of the alternatives to investment in tractors. Empirical studies of the impact and social rate of return attributable to tractors will be useful only if they include a broader assessment of the opportunity cost of foreign exchange required by tractor programs.

ACKNOWLEDGMENTS

This paper is partly based on data from a joint study between the Agrarian Research and Training Institute (Colombo) and the University of Reading, financed by the Overseas Development Administration. The author is indebted to these institutions for support, but the views expressed here are his own.

REFERENCES CITED

1. Ahmed, B. 1975. The economics of tractor mechanization in the Pakistan Punjab. Pages 47-64 in *Linear programming and agricultural policy - microstudies of the Pakistan Punjab*. C. Gotsch, ed. Food Res. Inst. Stud. 14, i, Stanford.
2. Ahmed, J.U. 1983. Labor use patterns and mechanization of rice postharvest processing in Bangladesh. Pages 139-149 in *Consequences of small-farm mechanization*. International Rice Research Institute/The Agricultural Development Council, Inc. Los Baños, Laguna, Philippines.
3. Alam, A. 1985. Evolution and adoption of wheat power threshers in India. Pages 405-418 in *Small farm equipment for developing countries*. International Rice Research Institute, Los Baños, Laguna, Philippines.

4. APO (Asian Productivity Organization). 1984. Study mission on agricultural mechanization in selected Asian countries — report — 1984. APO OSM/3/83.
5. Bangladesh, Government of. 1980. Draft of the second Five-Year Plan, 1980-85. Planning Commission, Dhaka.
6. Bergman, T., and D. Mai. 1984. Mechanization and agricultural development. 2. Country report — Pakistan. Socioeconomic studies on rural development. Vol. 50. Gottingen, Hendot.
7. Binswanger, H.P. 1978. The economics of tractors in South Asia. Agriculture Development Council (New York) and ICRISAT (Hyderabad).
8. Binswanger, H.P. 1984. Agricultural mechanization: a comparative historical perspective. IBRD Staff Working Pap. 673.
9. Bose, S.R., and E.H. Clark. 1969. Some basic considerations on agricultural mechanization in West Pakistan. *Pak. Dev. Rev.* autumn:273-308.
10. Burch, D. 1980. Overseas aid and the transfer of technology: a case study of agricultural mechanization in Sri Lanka. Ph D thesis, Institute of Development Studies, University of Sussex. (unpubl.)
11. Carr, M.N. 1975. Patterns of tractorization in the main rice-growing areas of Sri Lanka. Ph D thesis, Institute of Development Studies, University of Sussex. (unpubl.)
12. Chandramouli, K.S. 1975. The effect of tractor use in the transition and dry tracts of Dharwar District, Karnataka State. M Sc thesis, Department of Agricultural Economics, University of Agricultural Sciences, Dharwar.
13. Chopra, K. 1974. Tractorization and change in factor inputs: a case study of the Punjab. *Econ. Pol. Weekly* 9:52.
14. Dalton, G. 1976. British aid tractors in India — an ex-post evaluation. Report for the Ministry of Overseas Development, London.
15. Dasgupta, B. 1977. Agrarian change and the new technology in India. UNRISD, Geneva.
16. Desai, D.K., and C. Gopinath. 1975. Impact of farm tractorization on productivity and employment in Gujarat State. Centre for Management in Agriculture, Indian Institute of Management, Ahmedabad.
17. Duff, B., and M. Kaiser. 1984. The mechanization of small rice farms in Asia. Pages 9-37 in *Farm power and employment in Asia. Proceedings of a regional seminar held at the Agrarian Research and Training Institute, Colombo, 25-29 Oct 1982.* Agricultural Development Council (Bangkok) and ARTI. J. Farrington, F. Abeyratne, and G.J. Gill, eds.
18. Farrington, J., and F. Abeyratne. 1982. Farm power in Sri Lanka. *Dev. Stud.* 22. Department of Agricultural Economics, University of Reading, England.
19. Farrington, J., and F. Abeyratne. 1984. The impact of small farm mechanization in Sri Lanka. Pages 113-137 in *Farm power and employment in Asia. Proceedings of a regional seminar held at the Agrarian Research and Training Institute, Colombo, 25-29 Oct 1982.* Agricultural Development Council (Bangkok) and ARTI. J. Farrington, F. Abeyratne, and G.J. Gill, eds.
20. Farrington, J., F. Abeyratne, and G.J. Gill, eds. 1984. Farm power and employment in Asia. *Proceedings of a regional seminar held at the Agrarian Research and Training Institute, Colombo, 25-29 Oct 1982.* Agricultural Development Council (Bangkok) and ARTI.
21. Farrington, J., and W.A.T. Abeysekera. 1979. Issues in farm power and water use in Sri Lanka. *Occas. Pap. 17.* Agrarian Research and Training Institute, Colombo.
22. Finney, C.E. 1972. Farm power in West Pakistan. *Dev. Stud.* 11, Department of Agricultural Economics, University of Reading, England.
23. Gill, G.J. 1981. Farm power in Bangladesh, Vol. 1. *Dev. Stud.* 19, Department of Agricultural Economics and Management, University of Reading, England.
24. Gill, G.J. 1984. Tractorization and rural development in Bangladesh. Pages 89-112 in *Farm power and employment in Asia. Proceedings of a regional seminar held at the Agrarian Research and Training Institute, Colombo, 25-29 Oct 1982.* Agricultural Development Council (Bangkok) and ARTI. J. Farrington, F. Abeyratne, and G.J. Gill, eds.
25. Gotsch, C. 1973. Tractor mechanization and rural development in agriculture. International Labor Organization. Geneva.
26. Gotsch, C. 1975. Linear programming and agricultural policy — micro studies of the Pakistan Punjab. *Food Res. Inst. Stud.* 14, i, Stanford.

27. Grewal, S.S., and A.S. Kahlon. 1972. Impact of mechanization on farm employment in the Punjab. *Ind. J. Agric. Econ.* 27:214-219.
28. Haq, U.A. 1985. Development of an animal driven pump for groundwater pumping in Bangladesh. Paper presented at the international conference on agricultural equipment for developing countries. International Rice Research Institute, Los Baños, Philippines, 2-6 Sep 1985.
29. Harriss, B. 1977. Tractors, profits, and debts in Hambantota District (Sri Lanka). Page 429 in *Green revolution? H.B. Farmer, ed. MacMillan, London.*
30. Harriss, B. 1977. Paddy milling: problems in policy and the choice of technology. Page 429 in *Green revolution? H. B. Farmer, ed. MacMillan, London.*
31. Herdt, R.W. 1983. Mechanization of rice production in developing Asian countries: perspective, evidence, and issues. Pages 1-13 in *Consequences of small-farm mechanization. IRRI/ADC. Los Baños, Philippines.*
32. ILO (International Labor Organization). 1973. *Mechanization and employment in agriculture. Geneva.*
33. IRRI/ADC (International Rice Research Institute, Agricultural Development Council). 1983. *Consequences of small-farm mechanization. Los Baños, Philippines. 184 p.*
34. Jabbar, M.A. 1980. Draught power shortage and mechanization of tillage operations in Bangladesh. *Bangladesh J. Agric. Econ.* 3:1.
35. Jabbar, M.A., M.S.R. Bhuiyan, and A.K.M. Bari. 1983. Causes and consequences of power tiller utilization in two areas of Bangladesh. Pages 71-83 in *Consequences of small-farm mechanization. IRRI/ADC. Los Baños, Philippines.*
36. Jodha, N.S. 1974. A case of the process of tractorization. *Econ. Pol. Weekly* 9:92.
37. Kahlon, A.S. 1975. Impact of mechanization on Punjab agriculture with special reference to tractorization. Department of Economics and Rural Sociology, Punjab Agricultural University, Ludhiana.
38. Kahlon, A.S. 1976. Impact of mechanization on Punjab agriculture with special reference to tractorization. *Ind. J. Agric. Econ.* 31(4):54-70.
39. Khan, A.U. 1978. Agricultural mechanization and farm machinery production in Pakistan. UNIDO international forum on Appropriate Industries Technology. New Delhi, 20-25 Nov 1978.
40. Khan, A.U., and A. Khan. 1979. Small farm mechanization and technology for Pakistan. IRRI-Pak. Agricultural Research Council IRRI-Pak. Agricultural Machinery Program seminar, 1979.
41. Khan, A.U., and S.H. Zaidi. 1979. Mechanization of rice cultivation in Pakistan. IRRI-Pak. Agricultural Research Council. IRRI-Pak. Agricultural Machinery Program seminar, 1979.
42. Krishna, R. 1976. Measurement of the direct and indirect employment effects of agricultural growth in technical change. In *Employment in developing nations. E.O. Edwards, ed. Columbia University Press.*
43. Lawrence, R. 1970. Some economic aspects of mechanization in Pakistan. USAID, Islamabad.
44. Laxminarayan, H., D.P. Gupta, P. Pangaswamy, and R.P.S. Malik. 1981. Impact of harvest combines on labour use. *Agricole, New Delhi.*
45. Lockwood, B., M. Munis, K.A. Hussain, and J. Gardezi. 1983. Farm mechanization in Pakistan — policy and practice. Pages 15-30 in *Consequences of small farm mechanization. International Rice Research Institute, Los Baños, Laguna, Philippines.*
46. McInerney, J.P., and G.F. Donaldson. 1975. The consequences of farm tractors in Pakistan. *World Bank Staff Working Pap.* 210.
47. Mandal, G.C., and R.N. Prasad. 1975. Economics of tractor cultivation: a study of the District of Shahabad, Bihar. Santiniketan, Agro-Economic Research Centre, Visva Bharati.
48. Martius, H. 1981. Development-oriented mechanization of agriculture in Bangladesh. *Socio-economic studies on rural development, No. 28/e. Saarbrücken/Fort Lauderdale, Breitenbach.*
49. Mettrick, H., S. Roy, and D.S. Thornton. 1976. Agricultural mechanization in Southern Asia. A report for the Ministry of Overseas Development. Dep. Agricultural Economics and Management, University of Reading, England.
50. Mettrick, H., and D.P. James. 1981. Farm power in Bangladesh, Vol. 2. *Dev. Stud.* 20, Dep. Agricultural Economics and Management, University of Reading, England.
51. Mishra, M.S., P.K. Dattanaik, and K. Sundaran. 1975. Some aspects of the economics of harvest combines in the Punjab. *Econ. Pol. Weekly* 10(39):A65-A75.

52. Misra, S.P. 1976. Impact of tractorization: a study of Tehsil of Madhya Pradesh. *Ind. J. Agric. Econ.* 31:3.
53. Mohan, C. 1985. Establishment of the tractor industry in India. Pages 161-172 in *Small farm equipment for developing countries*. International Rice Research Institute, Los Baños, Laguna, Philippines.
54. Motilal, G. 1971. Resource allocation, production efficiency and comparative economics on tractor and bullock operated farms in the Union Territory of Delhi. Ph D thesis, Division of Agricultural Economics, Indian Agricultural Research Institute, New Delhi.
55. Narayana, D.L. 1977. Economics of tractor cultivation, Chittoor District, Tirupati. Sri Venkateswara University, Tirupati.
56. NCAER (National Council of Applied Economic Research). 1973. Impact of mechanization in agriculture on employment. New Delhi.
57. NCAER (National Council of Applied Economic Research). 1977. Demand for power tillers. New Delhi.
58. NCAER (National Council of Applied Economic Research). 1980. Implications of tractorization for farm employment, productivity and income. 2 vols. New Delhi.
59. Pakistan, Government of. 1969. Report of the farm mechanization survey. Farm Mechanization Committee, Government of Pakistan Planning and Development Department, Lahore.
60. Pakistan, Government of. 1970. Farm mechanization in West Pakistan. Pakistan Ministry of Agriculture and Works, Islamabad.
61. Parthesarathy, G., and V. Abraham. 1975. Impact of tractorization on agriculture. *ICSSR* 4(1+2):60-86.
62. Patel, N.T., and M.S. Patel. 1976. Impact of farm energy on cropping intensity, level of use of inputs and the profitability of farming in the Anand Taluq of Gujarat. *Ind. J. Agric. Econ.* 31(3):232.
63. Punjab (India), Government of. 1974. Economics of tractor cultivation and economics of production and cultivation practices of high yielding varieties of wheat, maize, and paddy in Punjab, 1969-70 to 1971-72. Combined Report.
64. Qureshi, K. 1984. Agricultural mechanization in Pakistan. Ch. 6 in *Study mission on agricultural mechanization in selected Asian countries — report — 1984*. APO OSM/3/83. Asian Productivity Organization.
65. Roy, S., and M.B. Blase. 1978. Farm tractorization, productivity and labour employment: a case study of the Indian Punjab. *J. Dev. Stud.* 14(2):193-209.
66. Sharan, G., D.P. Mathur, and M. Viswanath. 1974. Characterization of the process of mechanization and farm power requirement. Centre of Management in Agriculture Monogr. 45, Indian Institute of Management, Ahmedabad.
67. Sharma, A.C. 1976. *Mechanization of Punjab Agriculture*. New Delhi, Eurasia Publishing House.
68. Sheikh, G.S., J.K. Sial, and M. Afzal. 1979. Comparative performance of two-wheel and four-wheel tractors. *Agric. Mech. Asia* 10(2).
69. Shrivastava, S.N. 1984. Farm mechanization in India. Ch. 3 in *Study mission on agricultural mechanization in selected Asian countries — report — 1984*. APO OSM/3/83.
70. Singh, G., and W. Chancellor. 1974. Relation between farm mechanization and crop yield for a farming district in India. *Trans. Am. Soc. Agric. Engineers* 17(5):808-813.
71. Singh, A.J., and S.S. Miglani. 1976. An economic analysis of energy requirements in Punjab agriculture. *Ind. J. Agric. Econ.* 31(3):165-173.
72. Singh, R., and B.B. Singh. 1972. Farm mechanization in western U.P. In *Problems of farm mechanization*. Indian Society of Agricultural Economics. Seminar Ser. 9.
73. Singh, R.P., and H.P. Goswami. 1977. A comparative study of tractorised and bullock operated farms in Purnea District (including Katihar), Bihar. Agro-Economic Research Centre, University of Allahabad.
74. Southworth, H.M., ed. 1972. *Farm mechanization in East Asia*. Singapore, Agricultural Development Council.
75. Southworth, H.M. 1974. Some dilemmas of agricultural mechanization. Page 347 in *Experience in farm mechanization in Southeast Asia*. H. Southworth and M. Barnett, eds. Agricultural Development Council, New York.

76. Southworth, H.M., and M. Barnett, eds. 1974. Experience on farm mechanization in Southeast Asia. Agricultural Development Council, New York.
77. Tsuchiya, K. 1972. Mechanization and relationships between farm, non-farm and government sectors. Page 433 in Farm mechanization in East Asia. H.M. Southworth, ed. Agricultural Development Council, Singapore.
78. Umakesan, R. 1971. A comparative study of tractor and non-tractor farms in Coimbatore Taluq — an economic appraisal. MS thesis, Agricultural College and Research Institute, Coimbatore.
79. World Bank. 1980. Sri Lanka: key development issues in the 1980s. 2 vols. Washington.

AGRICULTURAL EQUIPMENT NEEDS OF AFRICA

M. LE MOIGNE

International Cooperation Centre for Agricultural Research
for Development (CIRAD)

Tropical Agricultural Machinery Centre (CEEMAT)

CURRENT STATE OF MECHANIZATION

Numbers of implements in use in Africa are usually estimated from rural development project reports. Table 1 gives estimations, from CEEMAT studies, of animal draft implements in 11 African countries.

Animal draft implements

Mechanization with animal power mainly concerns soil preparation (plows, cultivators, ridgers), weed control, and transport. Planters were first used for groundnuts and then for maize; some drills for rice seeding are being distributed. These implements are first adapted for rainfed farming and can be used with oxen, horses, and donkeys. There is no draft harvesting implement except the groundnut lifter in Senegal. Hand (ultralow volume) sprayers are widely used in cotton production in francophone countries.

African farmers prefer single-purpose tools over multipurpose implements, given financial resources.

Distribution of implements depends on many factors:

- historical introduction (Guinea),
- traditional know-how (plowing in Mali),
- weed control priority (plowing in Ivory Coast or Senegal),
- long-term extension service influence (sowing in Senegal),
- soil conditions (cultivators and sand soils), and
- size of area (hydro-agricultural parceling in Niger).

Ratios of equipment available to area served are not usually meaningful; with animal draft equipment, observed ratios often exceed calculated ones. For instance:

- South of Mali: 6 ha/plow (cotton area)
- Senegal: 2-4 ha/planter according to climatic zone
1.5-2.7 planters/family in groundnut area
1.5-2.7 hoes/family in groundnut area
- Niger and Burkina Faso (Upper Volta): less mechanized than Senegal or Mali but 1 cultivator/production unit is the ratio in some schemes.
- Whenever a farmer can, he buys a cart.

Table 1. Animal draft implements in some African countries.

Country	Implements (no.)					
	Planters	Hoes	Carts	Plows	Ridgers	Lifters
Senegal	145,000	228,000	101,000	52,000	8,900	67,000
Mali	11,000	55,000	52,000	107,000	—	—
Ivory Coast	—	9,000	4,000	—	—	—
Niger	3,000	14,200	19,000	8,500	2,300	6,000
Burkina Faso	—	31,000	26,000	29,000	15,000	—
Benin	—	10,100	5,600	—	—	2,000
Mozambique	—	—	—	36,000	—	—
Ghana	—	—	—	6,000	—	—
Cameroon	—	—	—	25,700	—	—
Tchad	—	5,800	19,000	79,000	5,800	—
Madagascar	—	41,000	126,000	162,000	—	—

Equipment use exceeds standards when animal draft cultivation reaches a level that is part of the way of life. In Guinea, plows are used after many years without extension services — the plow has become a traditional tool. Then, implements are borrowed or rented extensively among farmers; differences between levels of mechanization tend to disappear and field work requires hand tools as well as draft equipment. This is the process in Senegal and Mali.

Draft cultivation generally increases productivity of human labor and increases the area cultivated. A recent survey in Ivory Coast gives data illustrating this. Two parallel scales show the progression between amount of human and animal work needed in extensive and intensive situations when cultivating 1 ha:

- from 10 to 70 h of animal work to cultivate 1 ha
- from 60 to 150 d/ha of human complementary work in a highly intensive system.

The survey showed a maximum of 1.15-1.20 ha/labor unit with hand tools and 1.20-1.27 ha/labor unit with animal-drawn equipment.

Motorized agriculture

Even a simple description of motorized agriculture has to distinguish between pre-mediterranean countries plus South Africa, and countries south of the Sahara. Here are tractor numbers for countries in these two groups:

South Africa	200,000 (1980)	Nigeria	8,000 (1980)
Egypt	34,500 (1984)	Kenya	7,500 (1982)
Algeria	43,700 (1980)	Ivory Coast	2,500 (1982)
Morocco	24,500 (1980)	Zaire	3,500
Sudan	7,600 (1984)		

In Algeria, Egypt, and Morocco, from 3,000 to 5,000 combines are in use.

Government ownership presents more problems than private ownership, including technical choice, profit-earning capacity, and servicing difficulties. That traditional farmers are rarely involved may explain many failures.

Equipment ownership in the private sector depends largely on cash crops or monetary flow between main towns and villages. For instance, more than half of the 4-wheel tractors in Ivory Coast are located in the forest zone, paid for by producers of banana, coffee, cacao, and pineapple. Tractors are used for tillage, weed control, spraying, and transport. In some countries, such as Zaire, tractors are used for nonagricultural transport.

Nonconventional motorized agriculture (intermediate technology)

Many countries have been thinking of intermediate technology since the seventies: Europe, United States, the Philippines (IRRI), and French- and English-speaking countries in Africa.

CEEMAT has no bias toward forms of power and implements, whether human hand tools, animal-powered implements, or motorized equipment such as tractors. The motorized equipment chosen in West Africa were intended to

- allow the agricultural upper class (large availability of land and labor) to proceed beyond the limits of animal power, and
- answer the humid country problem of diseases making animal power impossible.

Intermediate motorization (Tractor Bouyer TE-20hp) began in 1977 in six countries: Senegal, Mali, Burkina Faso, Ivory Coast, Cameroon, and Chad. Concurrently, the tractor Tinkaby (hydraulic transmission) was introduced in Swaziland.

CEEMAT observed that TE tractor use by 1985 totaled 853; 109 in Burkina Faso, 463 in Ivory Coast, 77 in Mali, and 204 in Cameroon. Ten tractors were irreversibly damaged. At the beginning (1977-80) the tractor was essentially a prototype and many mechanical problems had to be solved. Operating costs were high.

Tractors are bought directly by farmers in Burkina and Mali, and by groups of farmers in Ivory Coast. A hiring system is established in Cameroon. Most use is in cotton production, with programs to improve farmer knowledge and tractor maintenance.

Tractors and implements are bought on credit (6-7 yr, 9-10% interest). A down payment equal to the annual installment must be paid before delivery in Burkina and Mali.

Farm size varies from 20 to 25 ha in Ivory Coast and Burkina to 30+ in Mali. All farms use substantial human labor.

After 8 yr, these are the results:

- Cultivated area is stabilized around 1 ha/worker (more than 1 with motorized agriculture, less than 1 or about 1 with animal draft agriculture). Farm size has increased little.
- Type of work is similar with tractor or animals, but tractor use is 3-6 times more efficient, is more timely, and allows incorporation of manure or straw into soil.
- Farmers keep animals for weed control, ridging (cotton, maize), and to plow out stocks and roots. They usually hire out their animals rather than their tractors.

- Tractor use seems economical, with costs balanced by income from increased crop production.
- Training and maintenance are easy; farmers learn quickly.

CRITICAL NEEDS TO INCREASE PRODUCTIVITY OF SMALLHOLDINGS

Crop harvesting is still largely unmechanized. Manual harvesting is slow, increasing crop losses. With rural depopulation, even in Sahelian countries, the labor supply is decreasing and cost is rising (example: palm-tree harvesting in Ivory Coast). When intensification is successful, labor peaks increase.

Farmers and consumers are concerned about postharvest losses. Storing and drying remain priorities for research and training.

With tuber crops such as cassava, processing into food products is traditional and difficult to valorize. This is why research concerning processing of tuber crops is a priority for CIRAD and CEEMAT.

For decades, research and extension organizations put all their effort into cash crops (groundnut, cotton, maize, etc.). As a result, these crops are partially mechanized. Cereal crops need similar attention from sowing to harvesting, and tuber crops from tillage to harvesting.

The high cost of energy increases the production cost of many underdeveloped countries. For example, in 7 yr in West Africa, the quantity of cotton fiber needed to pay for one liter of diesel fuel has increased two to three times. Even intensification in modern agricultural countries cannot respond to such increases.

Therefore, research for alternative energy is a priority. Results look good for gasification for stationary engines, and for liquid substitution of diesel fuel by oil or alcohol for tractors and cars.

Survey of needs

In 1980-81, CEEMAT and SEDES surveyed need for agricultural mechanization in African countries north of the equator. The survey involved these stages:

- identification of homogeneous zones (soil, climate), rural and ethnic population, density of population, crops, etc.;
- farming system analysis in every zone;
- mechanization approach and problems in each zone;
- identification of solutions through machines in use or through innovations; descriptions of these innovations;
- typology of units of production;
- analysis of political decisions concerning mechanization in each country; and
- socioeconomic analysis in each case.

This study covers agricultural needs, but market capacity also needs attention. Table 2 gives the estimated needs for agricultural implements in 15 countries for 10 yr beyond the 1980-81 survey.

Table 2. Need for agricultural implements in 10 yr in Egypt, Morocco, Algeria, Tunisia, Central African Republic, Guinea, Niger, Senegal, Burkina Faso, Togo, Cameroon, Nigeria, Ivory Coast, Mali, and Benin.

Implements	No.
Animal draft implements	340,000
Two-axle tractors	78,700
Intermediate motorization	40,000
Conventional motorization	17,300
Tractors for forest	25,000
Rice harvesting equipment	580,000
Tuber harvesting equipment	100,000
Cotton harvesting equipment	43,000
Fruit harvesting equipment	3,000
Small pumps	120,000

CONCLUSIONS

Studies and projects have provided better sociological and socioeconomic understanding of agricultural production units. Everyone notes differences between development objectives and reality: labor organization, motivations and priorities, time and space relationships, profit appreciation against vital needs. Mechanization is an answer to a country's specific characteristics and problems; it cannot follow another country's experience. Further, there is no appropriate technology apart from appropriate human development.

In West Africa, farmers always depend on projects and schemes. This permanent aid removes the farmer from voluntary effort. Experience in intermediate tractorization shows that farmers can succeed when they have responsibilities. Extension and training services must exchange information with farmers, not take the farmers' place in decision-making. Farmers need advisers in learning how to manage farm resources; they do not need controllers.

Whenever constraints to mechanization are analyzed, it is obvious that credit, marketing, farm product prices, and input costs have major importance. Mechanization constraints cannot be solved by technical proposals alone. The level of mechanization, for instance of tractor or oxen power, suitable for one zone will not necessarily fit another. There is no standard solution for underdeveloped countries in Africa or elsewhere.

Factories are producing agricultural implements in such African countries as Senegal, Mali, Ivory Coast, and Cameroon. Manufacturing animal draft equipment adds local value and can aid a country's trade balance. But this is not necessarily true of motorized equipment if it only involves local assembly of premounted elements. The system must also provide spare parts, training, and advice to farmers. Yet manufacturers are likely to be partners with development schemes and not with farmers. A decentralized system is important — from a central level providing scale economies to the village

blacksmiths, close to farmers. In countries where manufacture of implements ceased (Guinea, Senegal), blacksmiths proved they could supply spare parts and machines to farmers.

For intermediate technology to work, it requires intermediate levels of manufacture. Local manufacturers, including blacksmiths, need training, organization in steel supplying, additional tools and better quality materials, and perhaps improved access to credit.

The agricultural infrastructure and organization must meet the farmers' needs. The state, the development scheme, and the farmer are key factors of production. But the farmer needs professional association to defend his interest and create conditions for development. This lack of representation holds back agricultural modernization, and mechanization is the first victim.

IITA's EXPERIENCE IN MECHANIZATION FOR SMALL FARMERS IN AFRICA

N. C. NAVASERO

The International Institute of Tropical Agriculture (IITA)
Ibadan, Nigeria

The African hoe and the cutlass are the main tools for almost all African cultural practices. The few attempts to improve the hoe by lengthening the handle were probably done to correct the posture of the user rather than to improve the hoe's efficiency. Some of these long handled hoes are used in Rwanda, Kenya, Burundi, northern Nigeria, and other places where hoeing is practiced.

After bush clearing, land preparation and weeding are the most laborious cultural practices. They limit the area cultivated and normally reduce farmers' leeway to crop in time and space.

Since no manual tool is better than the African hoe for these operations, IITA engineers have been looking into other alternatives. The search for alternative tools for manual farming is not easy because of these reasons:

1. Different staple foods demand different cultural practices. Farmers grow yam, cassava, maize, cowpea, sorghum, millet, groundnut, rice, and vegetables like okra, amaranthus, garden egg, egusi melon, pepper, and tomato.
2. Farmers vary their land preparation from heaps or ridges to tilling flat fields.
3. Farmers have fused cultural practices like using the whole field for growing rice seedlings where seeds are hill planted on the edges of small ridges. When the seedlings are ready, farmers knock the ridges to cover the weeds and spread the rice seedlings by random planting. Asian wetland rice culture is also followed, mostly manually.
4. Farmers follow relay cropping, intercropping, and mixed cropping.
5. Farmers practice minimum tillage after bush fallow and killing the weeds.
6. Farmers' most tedious, time-consuming, and ever-recurring practice is clearing the bush fallow.

With these varied field activities, the selection of alternatives for mechanization would involve considering agricultural priorities, commodity preferences, and cultural practices. Possibly a completely new cropping system would facilitate appropriate mechanization. Earlier works of IITA engineers focused on these priorities.

With zero tillage for flat surface after clearing bush fallow, IITA developed three packages for different size farms:

1. IITA selected the portable rolling injection planter (RIP), fertilizer band applicator, and the 5-m boom sprayer. This package would help a farm family to crop 3 to 5 ha/season (1).
2. Success with the RIP stimulated design and development of the farmobile for spraying and fertilizing, using a power tiller as the prime mover. This package could help a farmer with higher background in crop production to farm from 15 to 20 ha/season (1).
3. A 6-row, 4-wheel tractor was developed for farming up to 32 ha/season (1). Packages 2 and 3 require stumping of the area after bush clearing.

Commodity and cultural practice-oriented alternatives were also developed to supplement the main priorities:

<i>Tools</i>	<i>Capacity</i>
1. Cassava lifter	100 to 150 kg/work h
2. "Hampasan" rice and cowpea thresher (rice)	80 to 100 kg/work h and 250 to 300 work h/ha ^a
3. Maize sheller	25 kg/work h
4. Bag holder and husking pin for maize harvesting	Faster than traditional
5. IFRI transplanter	30 to 40 work h/ha
6. IRRI thresher	300 to 400 kg/work h
7. IRRI power tiller	—
8. Rotary weeder	75 to 125 work h/ha
9. Brush cutter for alley crop pruning and slashing	5 and 85 work h/ha
10. Row marker	1 ha/day
11. Modified power tiller for ridging and breaking ridges	New project
12. Interrow sprayer	6 to 10 work h/ha
13. Modified mower for interrow weeding and cowpea harvesting	13.54 and 8 h/ha
14. Modified hammer mill for splitting cowpea and grinding	New project
15. IRRI row seeder for lowland rice	7-10 work h/ha
16. Electrodyne	—
17. Low volume sprayer	—
18. Turtle power tiller	1 to 1.5 ha/8 h

^aIncludes harvesting, threshing, and cleaning.

Most of the listed implements were rated through experimentation or by manufacturers (Tables 1-5). Most farmers have never seen these tools. These ratings may be meaningless if they do not match farm use of these tools. Some of them still need modifying to suit local conditions.

Table 1. Mechanical weed control on no-till cowpea, second season.^a

Implement, frequency	Weeding time (man h/ha)	Yield (kg/ha)
Hoe 2x	362.54 d	1253.96 a
Brush cutter 1x	82.62 c	950.32 ab
Rototiller 1x	54.84 bc	894.14 abc
Cutter bar 1x	17.80 a	877.87 abc
Mower 1x	13.54 a	750.15 bc
No weeding	0.00 a	493.18 c
CV	26.43	27.65

^aSeparation of means in a column by Duncan's multiple range test at the 5% level.

Extension workers in Nigeria are scarce and many of these tools are still new to the extension workers. Therefore, the research program was modified to try to make experimentation more effective and closer to end users.

Beginning in 1985, most testing and evaluation of agricultural tools is being done in farmers' fields. Participation of government agricultural agencies and farmers is heavy.

Small-tool work now focuses on inland valley swamps and other places where rice is grown. This program includes adaptation or "Africanization" of some Asian implements to suit local conditions and also the introduction of powered tools for land preparation. The initial experiment centers on three major practices: traditional land preparation vs land preparation with powered tools, random planting vs straight row planting with the marker, and weed control using rotary weeder vs traditional vs herbicide.

Initial testing has led to some useful improvements of tools. The sandy soil settles rapidly after puddling and turns very hard soon, even when submerged. This heavily affected the performance of the turtle power tiller when tried on paddy field submerged 1 wk before puddling. Excessive pressure on the rotors stopped and burned the V-belt. Tall grasses wrapped into the space between the rotors and the transfer case. The handle was too short for the operator to control the machine. The problems were minimized by knocking off some of the rotor spikes on the inner and outer edges to reduce aggressive action of the rotors, by welding a plain, cylindrical plate to the sides of the rotors to avoid wrapping of the weeds, and by providing a longer handle to control the machine with lighter pressure.

Plots were marked for straight row planting soon after final puddling before the soil turned hard.

Because similar problems may affect weeding, the rotary weeder was modified to work on a harder surface by converting the skid into a container for additional weight, and making the front rotor narrower but with stronger tines for a more aggressive action. Initial trial showed the rotary weeder can also be used for weeding upland rice by adding weight in the skid.

In addition to these experiments, we also see to it that small tools which generate farmer interest are made available by identifying local welders who

Table 2. Tools for silage crop pruning and their effects in cutting 1-yr-old *Leucaena*.^a

Tool	Main branches (no.)	Rate of pruning (h/ha)	Average height of cut (cm)	Angle of cut vertical axis (°)	Average number of sprouts 20 days after	Average number of branches 39 days after	Average length of die-back (cm)	Split stem ha after cutting	Average diameter before cutting (mm)
Heavy duty pruning shear	3.90 a	16.305 a	38.85 a	65.29 b	9.44 a	1.48 b	3.17 a	1608.75 ab	16.46 a
Standard cutlass	3.02 a	13.4925 a	37.19 a	33.04 a	9.40 a	1.61 b	3.99 a	2922.00 ab	18.74 a
Light duty pruning shear	3.525 a	18.2925 a	41.04 a	67.96 ab	8.27 a	2.13 a	2.56 a	458.25 b	19.55 a
Woodman's mate	4.125 a	14.8075 a	47.22 a	41.84 c	9.27 a	2.27 a	2.92 a	5165.00 a	17.36 a
Brush cutter (2.5 hp)	3.675 a	2.6325	42.11 a	32.84 a	9.31 a	1.84 ab	0.48	151.75 b	18.00 a
Howard rotor slasher	2.60	0.87	89.88		8.13	1.93	9.54	8078.50	20.29

^aSeparation of means in a column by Duncan's multiple range test at the 5% level.

Table 3. Average man-hours per hectare of cutting, pruning back and spreading cut materials of 4-m-row alley crop *Leucaena leucocephala*. IITA Agricultural Engineering, 1984.

Tool	Man-h (no.)				
	1st cutting	Spreading ^a	Pruning back	Spreading	Total
HD shear	22.80	60.40	64.44	25.03	172.47
STD cutlass	15.55	62.20	20.74	20.05	118.57
Short cutlass	16.30	65.20	33.70	18.67	133.91
Thick blade cutlass	17.04	78.16	20.37	25.71	141.28
Modified machete	15.19	60.76	52.22	23.06	151.23
2.5 hp brush cutter	3.70	70.15	4.44	15.00	93.29
70 hp slasher	1.11	—	5.56 ^b	15.00	22.78

^aIncludes removal of branches of big stems. ^bPruning back was done by 2.5 hp brush cutter.

Table 4. Alley crop pruning per season.^a

Tool	Rate (h/ha)		Dry weight (kg/ha)			
	25-cm cut	50-cm cut ^b	Stem at 25-cm cut ^c	Stem at 50-cm cut ^c	Leaves at 25-cm cut	Leaves at 50-cm cut
Howard rotor-slasher ^c	6.66 a	6.67 a	889.82 b	413.43 b	990.96 b	624.98 b
Brush cutter (2.5 hp)	7.40 a	8.14 a	1676.98 ab	770.50 ab	1569.50 ab	989.86 ab
Heavy duty shear	39.63 b	87.04 b	1677.74 ab	770.84 ab	2191.00 a	1381.83 a
Woodman's mate	44.45 b	50.00 b	1862.12 a	855.56 a	2026.03 a	1381.83 a
Thick bladed cutlass	37.02 b	37.41 b	2185.17 a	1007.32 a	1751.66 a	1104.75 a
Standard thin bladed cutlass	37.41 b	36.30 b	1968.03 a	904.22 a	1474.98 ab	930.26 ab
CV (%)	35.57	32.89	28.17	28.05	21.64	21.64

^aSpreading time not included. ^bSecond pruning was done by brush cutter. ^cRotor-slasher stems and leaves were chopped and spread all over during the process (not easy to collect).

Table 5. Cowpeas harvesting experiment, 1984.^a

Tool ^b	Harvesting and windrowing (man-h/ha)	Harvesting threshing (man-h/ha)	Threshed grain (kg/ha)	Harvesting losses (%)	Moisture content (%)
1	8.26	301.91	1036.67	5.12	12.66
2	70.83	327.43	1188.54	0.48	16.28
3	—	257.29	979.17	4.61	12.98
4	—	302.09	1315.00	5.56	21.37

^aManual pod picking alone = 451.07 man-h/ha, yield of 1.0 to 1.2 t/ha (FSP Agricultural Engineering 1982 annual report). ^b1 = mower windrower, hampasan threshing sieve cleaning; 2 = manual windrowing, machine threshing and cleaning; 3 = hand pulling and hampasan combined, sieve cleaning; 4 = hand pulling and hampasan combined, machine cleaning.

can fabricate them (see list in Appendix). These strategies will probably perpetuate farmer interest if the tools being tested are effective. Since most farmers are nonreaders, the extension work in the country is inadequate. If the tools being tested are useful, the technology and skill of using them will be transferred before the result of the experiment is written.

REFERENCE CITED

1. Garman, C.F., D.S. Ngambeki, and N.C. Navasero. 1982. Appropriate mechanization for no-tillage in the tropics. ASAE Pap. 80-5002.

APPENDIX

SOME ADDRESSES OF ACTIVE MANUFACTURERS TO WHICH
TENDER NOTICES MAY BE SENT*Active manufacturers*

- | | |
|--|---|
| 1. Ela Agric. Machinery Manufacturing
and Engineering Company
<i>Attention:</i> Mr. Lapido
E/9914B, Iwo Road
Ibadan | 1-row rolling injection planter
4-row rolling injection planter |
| 2. Mr. Patrick Awelewa
Polytechnic Road
Beside Success Twins Fish Company
Before Polytechnic South Campus Gate
Sango, Ibadan | Rolling injection planter
Small tools fabrication |
| 3. Oke Osun Purethought Eng. Enterprises
<i>Attention:</i> Mr. L. O. Fawole
P. O. Box 8127, Mapo
Ibadan | Auto feed jab planter
1-row rolling injection planter
4-row rolling injection planter
Fertilizer band applicator |
| 4. A. J. Oduntan Engineering Works
<i>Attention:</i> Mr. Ola Odunta
Block XI, Plot 26, K Close
Oluyole Estate, Ring Road
P. O. Box 4587
Telephone: 312073
Ibadan | Maize sheller |
| 5. Mr. David Ikpe
National Teaching Institute of Bahai
Sapele Road
Ogharefe
Bendel State | Rolling injection planter
Small tools fabrication |
| 6. Mr. Emmanuel O. Obafemi
(Africa Welders)
Panel Beater and Welder, Iron Bender
Minna Garage
No. M23, Bida
Niger State | Hampasan rice thresher
Rotary weeder |

Passive manufacturers

- | | |
|--|--|
| 7. Steel Works Limited
<i>Attention:</i> Mr. E. A. Zard
P. O. Box 260
Ibadan | Small tools fabricator
1-row rolling injection planter
4-row rolling injection planter
Fertilizer band applicator
Cassava lever
Rice pedal thresher |
| 8. Western Nigeria Technical Co. Ltd.
Private Mail Bag 5148
Ougbe Area
Ibadan | Cassava lifter
1-row rolling injection planter
4-row rolling injection planter |
| 9. Mr. Olukayode (Morohunfolu Original)
Oke Afin
P. O. Box 2
Oyo
Oyo State | Auto feed jab planter |

Land preparation

POWER TILLER MANUFACTURING IN THE PHILIPPINES

L. G. BERNAS
Kubota-Marsteel Machinery Co., Inc.
Philippines

Since farm mechanization began in the Philippines, more tractors have been sold than power tillers, partly because mechanization started first in sugar farming. Mechanization moved in to rice in the mid-60s when modern varieties (MVs) were introduced with improved agricultural technology.

The boom in sugar from 1962 to 1964 boosted tractor sales, averaging slightly over 800 units annually. With the implementation of the Central Bank-International Bank for Reconstruction and Development (CB-IBRD) Rural Credit Program, sales of imported power tillers significantly increased.

Tractor and power tiller sales, however, declined considerably in 1970 due to the "de facto" devaluation (when the exchange rate of the peso relative to the US dollar was allowed to float) which affected prices of imported machinery.

From 1971 to 1975, sales of power equipment again climbed, averaging 18% a year for tractors and 93% for power tillers. The substantial surge in sales in 1975 was generally attributed to the outbreak of hoof and mouth disease which infected 14,000 work animals. In a special financing program, the Land Bank of the Philippines (LBP) financed around 2,500 tillers while the Development Bank of the Philippines (DBP) financed 600 four-wheel tractors.

Sales were also aided by the Land Reform Program, the introduction of low-cost power tillers in 1972, and the availability of financing support for locally built farm equipment from LBP. The 93% increase in sales during this period was of locally made power tillers.

By 1975 there were 32 known power tiller manufacturers: 5 made the IRRI type transmission and others the Bicol type started by (MAGICO) Machinery Industries Co., Inc., of Naga City in 1967.

LOCAL POWER TILLER MANUFACTURERS

In 1975, an IRRI survey identified 32 power tiller manufacturers, 5 assemblers, and 11 distributors. The power tiller market then was 11,077.

In 1984, however, the total sales among the Agricultural Machinery Manufacturing Association (AMMDA) members dropped to 1,233 units

Table 1. Power tiller sales by AMMDA members, Philippines, 1978-84.

Engine	1978	1979	1980	1981	1982	1983	1984
Imported							
Gasoline	2067	1078	568	440	512	367	146
Diesel	1508	975	899	812	402	331	220
Locally produced							
Gasoline	4163	3209	1502	1256	1131	699	801
Diesel	65	117	117	393	112	238	66
Total	7803	5379	3036	2901	2157	1635	1233

(Table 1). The total industry sales were about 2,500 units, more than 85% locally fabricated.

Luzon accounts for at least 70% of annual sales, with the rest in Visayas and Mindanao.

During the early stage of local manufacture of power tillers, there were some large firms. Size varied from 5 to more than 500 production workers. Smaller firms limited their production to power tillers, while medium and large companies also fabricated industrial or other agricultural machines.

The large firms expected continuous growth in demand for power tillers which eventually peaked in 1975. However, as the market declined, medium and large companies stopped production, leaving smaller companies to continue, mostly on an intermittent basis.

Power tiller manufacturing is now dominated by small firms producing up to 100 units a month. Many have much smaller capacities and serve only the immediate farming area.

TECHNOLOGY

Locally fabricated tillers in the Philippines can be classified as either 1) the IRRI types; 2) the Bicol type, now more popular among manufacturers; and 3) the Turtle type.

Production of power tillers started in 1967 in Bicol, while the IRRI type was introduced in 1971-72. Both are built from locally available materials combined with imported components. When the industry started, major components such as engines, bearings, gears, sprockets, roller chains, and throttle control cables were all imported.

While the engines are still imported, local sources provide most other components, including steel bars, round and hexagonal shaftings, gears and sprockets, castings, belts, oil seals, nuts and bolts. The only imported parts are *bearings* and *chains*.

Further, the tiller has been simplified, compared to those imported from advanced countries. Although these tillers do not possess many of the convenient features of the imported models, they are more acceptable because they cost less, have fewer moving parts, are less troublesome, last longer, and are suitable for local conditions.

With more local parts, they are less sensitive to foreign exchange fluctuations, and cost much less than imported tillers.

Manufacturers have modified their designs to differ from the IRRI, Bicol, and turtle type tillers for these reasons:

- To avoid purchase of new machine tools, manufacturers adapted designs and processes to fit their existing facilities.
- Sizes or dimensions of components were gradually changed to match field conditions or to increase field capacities.
- Type of engines used influenced the design and dimensions. In general, gasoline-driven models were built with light materials with double bearings installed.
- The IRRI type has a more efficient transmission, but has more internal reduction parts; consequently, fabrication of the gear box is more complicated. Also the original design is suitable for a 5-hp gasoline engine drive, regarded as small by those who opted to use 10-hp gasoline engines with bigger tiller bodies. IRRI did not acknowledge this trend and never built an upgraded model; however, it developed a power tiller with steering clutch, up to now not regarded as necessary by manufacturers and users.
- The type of implements to be used also influenced changes in the tiller body.

The introduction of the spiral plow in 1975 boosted the Bicol type tiller, as the spiral plow needed a more rigid power tiller frame and more engine power. The spiral plow was popular in the early 80s. As the disk plow requires less power than the spiral plow, manufacturers are again fabricating lighter power tillers with smaller engines, lowering power tiller cost.

At the peak of the power tiller market from 1975 until 1980, some manufacturers adopted some features of imported tillers, such as multiple speed transmission, steering clutch, and mounting of a rotary tiller. Because of the added cost, technological problems, and market uncertainty, none of these features were continued.

However, to keep up with the competition, some manufacturers developed new implements such as the disk plow, and some concentrated on improving the quality, craftsmanship, and durability of their machines. There has been practically no significant change in the design and working concept of the power tiller since its introduction.

Horizontal integration, an innovation in manufacturing, is very common among power tiller manufacturers. The main components fabricated by manufacturers are the transmission housing, handles, and implements. The other components are supplied ready for assembly from machine shops, foundries, and hardware stores.

Plant capacities are still relatively small, although adequate to supply present demand. Some manufacturers keep regular production volumes and are among the best quality producers. Others produce intermittently, using their facilities to produce nonagricultural equipment.

MARKETING AND BUYER PREFERENCES

Power tillers are used mainly for land preparation of lowland rice, but the type or make varies among areas.

Southern Luzon

The Southern Tagalog region, particularly Laguna Province, has many power tillers. Although large four-wheel tractors were available in the area because of the sugarlands, few rice farmers attempted to use the tractors for rice cultivation as they did in Central Luzon.

Mechanization of rice cultivation in Laguna started with the imported power tiller. Japanese gasoline engine-driven power tillers and later on Landmasters became very popular. Compared to other Southern Luzon provinces, Laguna emphasized lightweight, imported power tillers because of the deep field condition. Although IRRI's presence in Laguna enhanced early development of one of the largest manufacturers of axial-flow threshers, Laguna or Southern Tagalog has no power tiller manufacturers, which explains slow acceptance of local-made tillers in the area.

In the Bicol region, commonly known as southern Luzon, Camarines Sur Province had one of the most successful power tiller manufacturers. But internal squabbles among its shareholders created a split among owners that stimulated the growth of other small manufacturers in the area. Since the technology is simple, many small metal fabrication shops can make power tillers.

As locally made power tillers are very popular in the area, production is fragmented. The first and possibly the best manufacturer in Camarines Sur in Naga expanded its market into Central and northern Luzon, 500 km away, and suffered because of this distance from factory to market. Although this manufacturer has constantly maintained or even improved product quality many shops, some operated by the firm's former employees, began to compete.

Of the 20 manufacturers in Bicol or Camarines Sur in 1976, some built their own manufacturing facilities in Central Luzon, employing technicians from the original factory in Naga.

Central and northern Luzon

Central Luzon is by far the biggest market for locally made power tillers. In this area, sugarmills originally used tractors for sugarcane land preparation. Since most sugar planters owned riceland, they began using tractor-mounted implements on rice. Tractors were used for land preparation and to drive the McCormick type, large-capacity rice threshers.

When the implementation of Land Reform was intensified in the mid-sixties, Central Luzon was a priority area. The fragmentation of landownership altered the level of technology in mechanization. The first CB-IBRD program launched in 1965 contributed to an increase in sales of tiller business. This was of great significance, as finally a pedestrian type machine had gained acceptance where before only riding tractors were used.

In 1970, the de facto devaluation of the peso reduced sales of tractors and power tillers. In 1971, the first revaluation of the Japanese against the US dollar came about, increasing the prices of power tiller imports from Japan, then gaining acceptance in the Philippine market.

Although retail credit financing continued under the CB-IBRD Credit Program, the escalating prices of imported machines made farmers look for cheaper alternatives.

In 1972 the IRRI-type power tiller was introduced, apparently to support IRRI's success in increasing rice production with MVs and associated technology. Many manufacturers, mostly in Metro Manila, manufactured the IRRI-designed power tillers. Some of these firms were relatively large and already distributed agricultural machinery. The entry of big firms in the manufacture of IRRI power tillers gave a big boost to the industry. Some were successful, and with aggressive promotion, locally made tillers became widely known among farmers and among government agencies.

When LBP financed around 2,500 power tillers after the outbreak of hoof and mouth diseases in 1975, most units financed were in Central Luzon, making this area the biggest user of locally made power tillers.

Most power tillers sold were driven by gasoline engines, primarily because of the popularity of a certain brand of engine; but continuing increase in the cost of fuel prompted some farmers to use diesel engines. However, the price difference between gasoline and diesel engines could not justify immediate shift to diesel power.

In the early 80s the supply of the preferred gasoline engine was disrupted and dealers of this engine took advantage of the situation by demanding unrealistic prices. Some farmers shifted to diesels priced almost at the same level as the popular 10-hp gasoline engine. Preference for type of engine continues to be affected by technical considerations and by price.

Visayas and Mindanao

The province of Iloilo was the birth place of the turtle type tiller, primarily developed to meet the extremely deep conditions of irrigated rice areas. The initial success encouraged the manufacturers to expand into Luzon, but expansion was not very successful. The machines were also introduced in northern Mindanao and eventually in Cotabato, both areas being swampy with deep or sometimes almost no hardpan. Due to the machine's excellent flotation, it rapidly gained acceptance. However, some farmers still prefer IRRI or Bicol types because they are lightweight and easily transported with a trailer.

As with the Bicol type, the original inventor and manufacturer of the turtle type faces competition from new manufacturers in the area. Because of the varying field conditions in Panay and Mindanao, it is difficult to determine which type of locally made tiller is most preferred. With manufacturers of all types in the area, markets seem to be expanding. The Cotabato area, for many years a big, almost exclusive market for imported diesel power tillers, is now a growing market for local manufacturers.

DISTRIBUTION CHANNELS

Manufacturers usually sell their tillers directly to users, either from the factory, or from a company branch as the market expands in areas away from home base.

Another system is to appoint dealers. The dealer is a separate agency which merely distributes the product and is not directly under the manufacturer's control.

Some manufacturers operate a combination of branches and dealers.

For 19 mo in 1984-85, until the International Monetary Fund (IMF) approved to restructure our external debt, the Philippines could not obtain any new loans or credit from external sources. Tight credit and increased interest rates hurt all sectors, including power tiller manufacturers.

During this period, manufacturers' major source of credit for manufacturing supplies, including engines, was the Binondo (Manila) hardware stores. As business relationships between manufacturers and component suppliers became well established, a new twist in the marketing and distribution of power tillers evolved.

Hardware stores in Binondo, operating as dealers of engine distributors, expanded their markets by appointing provincial subdealers. Gradually, a swapping arrangement was established. The Binondo hardwares would accept payment or locally fabricated power tillers in exchange for manufacturing supplies and engines. The power tillers were shipped to their provincial dealers. Small and medium size manufacturers preferred this arrangement, as it assured them of a continuous supply of raw materials and guaranteed a sure market. In fact, it was even possible to get cash advances for future deliveries.

Similar arrangements are in practice among manufacturers in Luzon, in Visayas, and, to a limited extent, in Mindanao.

GOVERNMENT POLICIES

The general policy of the Philippine Government concerning farm mechanization has been articulated in the country's development plans since the early 1970s.

The Four-Year Development Plan, FY 1972-75, states that "in order to provide timely land preparation, controlled and sufficient water for irrigation and other requisites of increased farm output, a program providing non-labor displacing agricultural machinery to the farmer will be intensified."

Incidentally, sales of machinery, particularly power tillers, were significantly high during this period. From a low level of 680 units of power tillers sold in 1971, sales continued up to 11,077 in 1975.

In the succeeding 4-yr development plan, FY 1974-77, no mention was made of the use of farm machinery as a policy. However, the 5-yr development plan, 1978-82, states that "better farming systems will also be developed in rainfed areas, in order to increase the productivity of these lands. Farm mechanization will be applied on a selective basis and will be adapted to local conditions and available resources."

Major government programs and policies affecting the power tiller industry may be classified according to farm machinery supply, farm machinery prices, and financing.

Farm machinery supply

Investment incentives. The Board of Investment (BOI) is the government agency that implements the country's farm investment loans, namely: RA 5186 or Investment Incentive Act, RA 6135 or the Export Incentives Act, RA 5455 or the Foreign Business Regulations Act, and PD 1159 or the Agricultural Investment Incentive Act, currently undergoing revision at the Batasan Pambansa under Cabinet Bill No. 3, also known as Agricultural Investment Incentive Act of 1985. These Acts are designed to speed the country's industrialization and to raise living standards through increased economic opportunities and a more equitable distribution of the benefits of development. The BOI also prepares annually priority plans which indicate the areas of economic activity considered essential to the country's economic development. These preferred areas can avail of various incentives specified in the Acts.

- **Investment Priority Plan (IPP).** Since the first IPP in 1968, the BOI has listed agricultural machinery as a preferred area of manufacturing. This listing allows both local and foreign entrepreneurs to avail of the set of incentives granted by the Investment Incentives Act (5186) for the production of agricultural equipment in the country. These incentives are mostly in the form of tax deductions that will enhance the commercial viability of preferred manufacturing activities. Farm machinery listed annually in the IPP follows:
 1. 1968 — Agricultural machinery and equipment such as power tillers, agricultural tractors, plows, rice and maize milling machinery, crop drying equipment, etc.
 2. 1969 — Power tillers. The BOI removes certain areas of manufacturing activity from the IPP when the demand has been met by production capacities of registered manufacturers of products listed under the plan; or when such products are found to be not economically feasible to manufacture.

As of 1980, power tillers and various other machines have been removed from the list because production capacities have already met industry requirements. Ironically, these capacities have most likely been filled by non-BOI registered firms, an apparent indication that the incentives were not attractive enough.

- **Agricultural Investment Priorities Plan (AIPP).** The Agricultural Investment Incentive Act provides the mechanisms for preparing an annual AIPP, which is a listing of specific agricultural activities that can qualify for incentives.

Formulated jointly by BOI and the Ministry of Agriculture and Food (MAF), AIPP lists projects that are being promoted in line with the long-range plan of the government for balanced development of urban

and rural sectors and to achieve the immediate national objective of self-sufficiency in basic food and raw material requirements. Although AIPP is primarily concerned with food and feed grain production, it also indirectly affects farm mechanization and, thus, the power tiller industry. AIPP opens up incentives and opportunities for the private sector to provide tractor pools, irrigation, pest control, and other specialized service. As earlier mentioned, AIPP is currently undergoing revision at the Batasan Pambansa and one of its noted criticisms is its apparent lack of a strong provision that could fit the small farmer, that would enable him to adopt better farming technology and equipment that perhaps could contribute to the growth of the power tiller industry.

Tariff and tax policies. 1. *Tariff.* Under the present tariff and customs mode of the Philippines, imported *power tillers* are allowed to enter the country and are subjected to a 30% + 5% ad valorem rate of duty. The ad valorem rate of duty is imposed on this type of imported agricultural machinery which is being produced in the country in quantities sufficient to meet the local demand. This rate of duty has invariably protected the local power tiller manufacturing industry.

To discourage importation and thus conserve foreign exchange, and apparently to minimize technical smuggling, the duty becomes payable at the time of the opening of the foreign letter of credit.

Power tillers fall under Tariff Heading 87.01, description B: Power tillers or walking tractors.

2. *Advance sales tax.* An advance sales tax of 10% is currently imposed on all types of agricultural machinery intended for resale in the same form or on imports of raw materials, used for the manufacture of such machinery for eventual sale. The tax is payable prior to withdrawal of the machinery from the custom custody and is computed on the basis of the published dutiable volume or price plus other various charges and a mark-up of 25% of the total landed cost. The total advance sales tax effective rate amounts to about 12.5% of the total landed cost of the imported machinery.

With the combined effect of excessive taxes and duty and the present deteriorating value of the peso, power tiller importation has practically stopped or dropped to an insignificant volume.

Agricultural Machinery Testing and Evaluation Center (AMTEC). The establishment of AMTEC was approved on 11 May 1976, with project development and implementation in 1977. AMTEC is a joint undertaking of MAF and the University of the Philippines at Los Baños (UPLB).

AMTEC intends to establish a system for testing and evaluating agricultural machinery to promote agricultural mechanization through the development of the manufacturing industry. Specifically, its objective is to test and evaluate locally manufactured power tillers and other locally fabricated agricultural machineries.

In the process, AMTEC also contributes to the improvement or redesign of locally fabricated machines in cooperation with manufacturers. It has also been given the function of doing the technical evaluation of machines for the Agricultural Machinery Distributors Accreditation Committee (AMDAC).

Farm machinery financing

Various government programs have been designed to extend financing assistance for the acquisition of farm machinery. The programs were undertaken mainly by government financial institutions namely, the Central Bank of the Philippines through the Rural Banks, Development Bank of the Philippines (DBP), and LBP. But the most active bank in supporting the financing of locally produced power tillers was LBP, specifically through branches in Baliwag, Bulacan; Cabanatuan City; and San Fernando, Pampanga.

Because of the relatively lower cost of locally fabricated tillers, financing to farmers was also undertaken by manufacturers, dealers, and rice traders. Usually a down payment was required prior to delivery and the balance payable after the first and second cropping.

Other programs and policies

The continuous drive of the government to attain self-sufficiency in food and feed grains brought about programs and policies which also contribute to the growth of the industry. This includes irrigation programs, introduction of high yielding varieties, land reform, wage policies, and price policies for major food crops and export crops as well as prices of fuel and finally foreign exchange policies. The implementation of these programs and policies has directly and indirectly affected the demand for agricultural machineries including power tillers.

CONCLUSION

Many consider power tiller manufacture as the backbone of the local farm machinery industry, although rice thresher manufacturing has also evolved into a major industry.

Price levels are kept at acceptable limits, but a primary setback is the high cost of imported engines. Despite lack of local engine manufacturers, taxes and duties remain high. High priced engines increase the total cost of a complete power tiller.

Local manufacturing capability is adequate; in fact, plant capacity and local skilled labor are underutilized in spite of overseas employment and migration of Filipino workers.

The power tiller industry remains in the development stage because of the depressed and uncertain market. Manufacturing technology and the basic simple design characteristics will remain while demand remains slow.

Any favorable change in the overall economy that will improve purchasing power is expected to also change the level of manufacturing technology as well as mechanical function and design. Future tillers may be more attractive, with features for comfortable, easy operation.

DEVELOPMENT OF FOUR-WHEEL TRACTORS AND IMPLEMENTS IN THAILAND

C. CHAKKAPHAK

Agricultural Engineering Division

Department of Agriculture

Thailand

and

B. COCHRAN

International Rice Research Institute

Thai-IRRI Industrial Extension Project

Thailand is a major world food exporter in Southeast Asia. The country has held this position for over 20 yr. The political and economic upheavals of colonial domination have never been experienced in Thailand. This has contributed to the country's economic stability and solid agricultural base.

Thailand has a tradition of small farmholdings. The current average farm size is approximately 4 ha. The country's agriculture produces annual surpluses of rice, maize, tapioca, and sugar. Agricultural products account for 40% of all exports, with rice being the major export commodity. A record 3.6 million t of rice was expected to be exported during 1984.

Thailand's fifth Five-Year National Economic and Social Development Plan, 1982-86, called for an increase in agricultural production efficiency, coupled with a target annual growth rate of 4.5%. To facilitate such an increase, the government emphasized the need to switch, from increasing production by expanding the areas under cultivation, to increasing production by increasing yields per hectare. The sixth five-year plan now being developed emphasizes the need to increase farm productivity through mechanization.

BACKGROUND

The steam-powered tractor was first experimented with in Thailand in Samut Prakarn during 1891-92. In 1907 the Government of Australia sent an expert to Thailand to introduce an Australian engine plow. The plan was to enable farmers to prepare land before the monsoon rain started each year. The Australian plow performed well in the Rangsit area. In about 1910, an engine plow from Austria was tried, but there is no record of its performance or adoption by Thai farmers. The imported steam plow was costly and faced some technical constraints. The imported machines used for land preparation performed better than the native implements in dry season; during wet season, however, the steam plows were too heavy and cumbersome in the submerged rice fields.

In the first Bangkok Agricultural Show in 1910, imported farm implements were displayed. The 1911 exhibition compared the performance of the farm

implements. The American iron plow won first prize for being able to plow the land deeper and maneuver in the field better than the conventional Thai plows. But Thai farmers rejected it because it was heavier and more expensive.

In 1919, the Thai Government established an agricultural experiment station in Rangsit. The station experimented with imported tractors, harvesters, threshers, and combines. Reports from the experiment station supported the use of farm machinery because land preparation with tractors saved valuable time. But high prices prevented farmers from buying the new machines (4).

Two important events contributed to the slow introduction of farm machinery in Thailand: the great depression of the 1930s and World War II. After the war, farm mechanization began to arouse public interest. Thailand developed other production technology such as irrigation facilities, expanded research and extension services, and developed local farm machinery manufacturing capability.

The introduction and extension of tractors to farmers can be traced back to the early 1950s when a tractor station was started, using imported tractors. The station rented the imported tractors to farmers in the Rangsit and Pathumthani areas. Farmers were reluctant to accept mechanization because they believed the heavy tractors would compact the soil and reduce yields. Some thought the tractors plowed too deep and would turn the underground lime onto the soil surface. Many farmers worried that the oil dripping from the tractors during operation would spoil their soil. The tractors also met mechanical problems, especially the presence of many buried tree stumps.

After the establishment of the rice department in 1953, research on farm machinery was given to the Agricultural Engineering Division of the Department of Agriculture. M. R. Debriddhi Tavakul started developing a small walking tractor during 1953. His idea was to power the tractor with the same small engine being used with the low-lift pump which he had developed. Therefore, the early models of his walking tractor used a small Lister diesel engine rated at 4.5 hp.

Modifications continued to be made on the two-wheel tractor until the small four-wheel tractor known as the "Iron Buffalo" came along. Since a seat and the added weight of the operator was included on the Iron Buffalo, the engine size was increased to around 8.5 hp. The specifications and details of the performance of the Iron Buffalo are presented in Table 1. During the mid-1960s, the Engineering Division terminated development of the four-wheel tractor and released the designs to private manufacturers. That tractor is illustrated in Figure 1. Manufacturers designed the tractor for use in paddy fields and felt the price of the tractor and components should be as cheap as possible. They also attempted to produce a tractor to work in all types of field conditions. However, the industry was not successful in producing an acceptable four-wheel tractor due to inefficient production capability. The commercial tractor sold for 30,000 baht and could not compete with cheaper imported models. Twelve years later, improved production technology and the invention of a simple gear system enabled commercial production of three four-wheel tractor models.

Table 1. Specifications of the Iron Buffalo.

Inventor	M. R. Debridhhi Tavakul	
Engine	Lister, air-cooled diesel engine 2 cylinder — 4 stroke cycle 8.5 hp at 1800 rev/min	
Tractor speed at 1800 rev/min		
1st gear	3.16 km/h	
2d gear	4.56 km/h	
3d gear	8.74 km/h	
reverse	2.86 km/h	
Pull at rated drawbar hp		
Rubber tires	<i>Pull (kg)</i>	<i>Drawbar hp</i>
Dry asphalt surface	800	5.6
Dry paddy field	610	4.4
Steering wheel on the rear in wet paddy field	413	3.1
Wheel sizes	Front rubber tire	4.00 X 15 — 4
	Rear rubber tire	7.00 X 30 — 4
	Steel wheel (32 blades)	1.00 m X .30 m

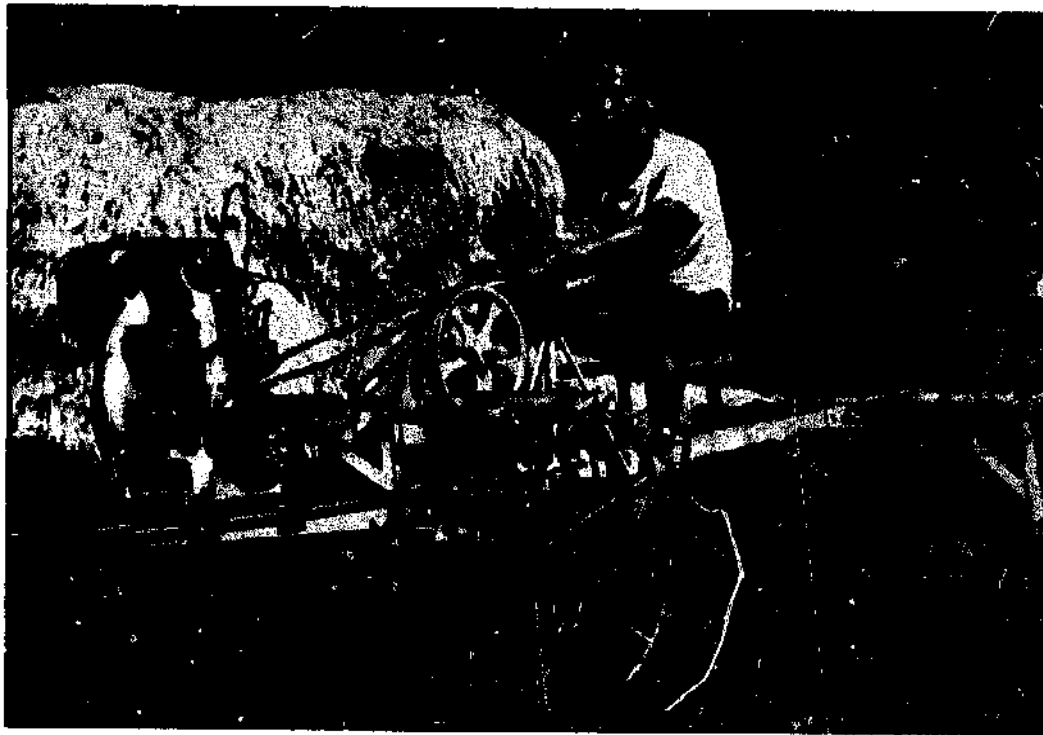

1. A four-wheel tractor prototype being field tested.

The original Thai four-wheel tractor was powered with a 12 hp diesel engine operating at 2000 rev/min. The chassis of one of the first models manufactured by J. Charoenchai of Ayutthaya is shown in Figure 2. Power to the rear wheels was transmitted through three V-belts. The drive sheave was approximately 10 cm in diameter with a maximum forward speed of 15 km/h. Typically, the three belts needed replacing three times in a crop season. Improvements in the drive design increased belt life by increasing the size of

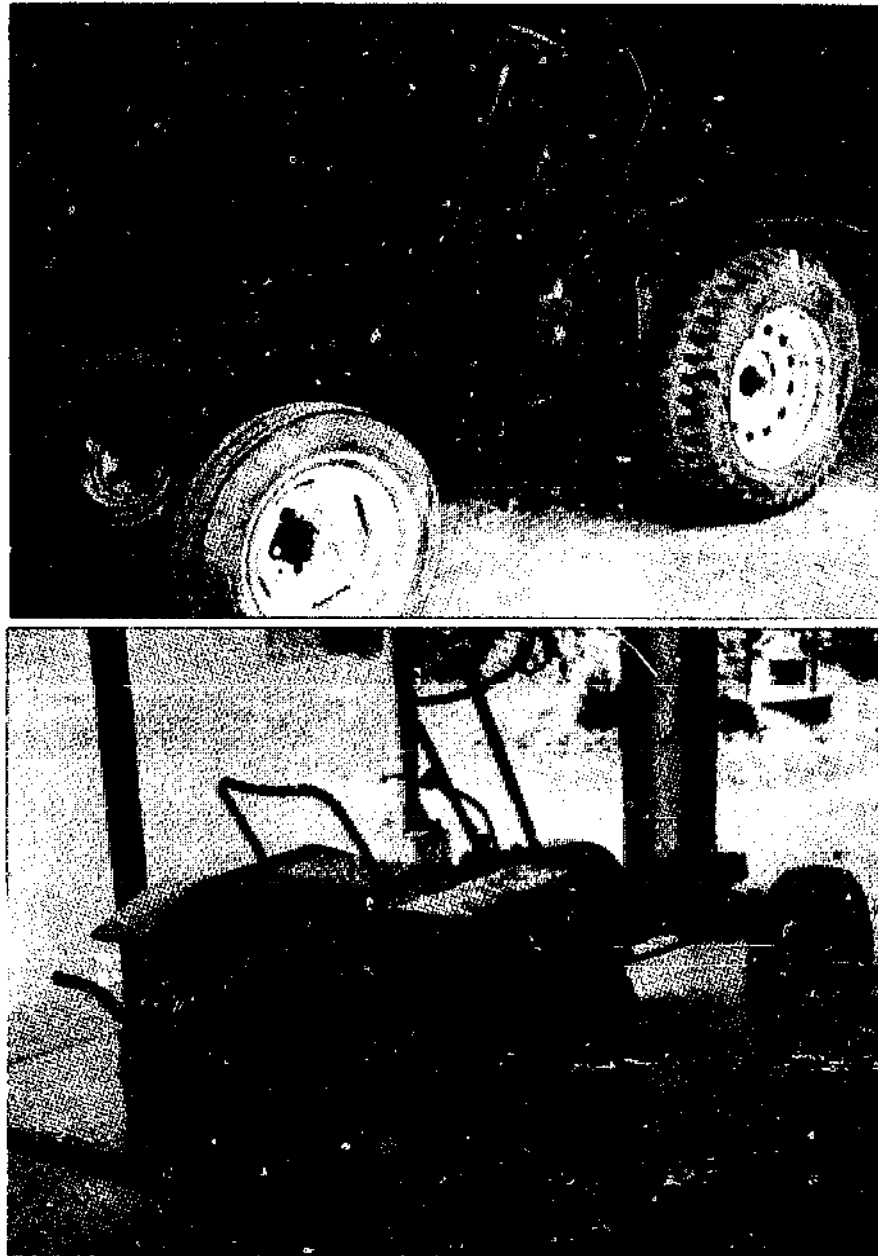

2. An early model of the four-wheel tractor produced by J. Charoenchai Co. of Ayutthaya, Thailand.

the drive pulley, adding a belt idler and belt tightening mechanism, and improving the shift gears. The belt-driven models are still being manufactured, providing farmers with relatively inexpensive and simple four-wheel tractors. New models can be purchased with a direct mechanical drive shaft from the engine to the rear wheels.

Some of the first four-wheel tractor models used the articulated steering principle, i.e., the front and rear wheels turned at the center of the tractor chassis. Someone then added two wheels onto the back of the two-wheel tractor to make it an articulated steering four-wheel tractor. It was used in heavy clay soils but did not become widely accepted, even though the price was lower. Turning was accomplished through a chain and sprocket arrangement

connected to the steering wheel. Tests conducted by the Agricultural Engineering Division found the tractor turning radius averaged 5.1 m on concrete at a speed of 2.5 km/h (5). The new models now provide front wheel steering through a gearbox or with hydraulic assist steering.

The Thai four-wheel tractor was originally used primarily for land preparation in rice paddy. As the market expanded, manufacturers found the tractor not suitable for upland preparation. A brief description of the types of tractors produced is as follows:

Thai four wheel tractor

1. Standard type

- a. single bar hitch, manual lift
- b. single bar hitch, hydraulic lift
- c. three-point hitch, hydraulic lift

2. Articulated type

- a. single bar hitch, manual lift, 1 speed
- b. single bar hitch, hydraulic lift, 1 speed
- c. single bar hitch, manual lift, multispeed
- d. single bar hitch, hydraulic lift, multispeed

The tractor weight-to-horsepower ratio was low and additional weight was needed to improve performance of the small four-wheel tractor with upland crops. Heavier, higher horsepower and more expensive imported tractors are used for heavy-duty crop operations. Additional implements for planting, weeding, and harvesting are being developed, necessitating a more versatile tractor.

The origin of the 21 firms which produced four-wheel tractors varied:

- five firms originally made four-wheel tractors,
- four firms started by repairing and making two-wheel tractors,
- one firm was started by a former employee of another four-wheel tractor manufacturer, and
- two firms started by making other farm implements.

The cost of manufacturing a four-wheel tractor depends on the size of the manufacturer, and cost of materials, labor, and interest rates. In 1979, the Bank of Thailand estimated the proportionate costs of inputs in manufacturing a standard four-wheel tractor (Table 2). The manufacturing cost and average estimated selling prices for 1980 are presented in Table 3. Although the data are not current, the figures can be compared on a relative basis.

Table 2. Four-wheel standard tractor cost breakdown.

Type of cost	Percentage
Material	68.5
Labor	14.6
Utilities	7.8
Others	9.1
Total	100.0

Table 3. Manufacturing costs and selling prices of four-wheel tractors, 1980.^a

Type of tractor	Manufacturing cost (\$)	Selling price (\$)
Articulated		
Large	690.00	1,035.00
Medium	715.00	935.00
Standard — with manual lift		
Large	1,092.50	1,322.50
Medium	1,100.00	1,210.00
Small	935.00	1,650.00
Standard — with hydraulic lift		
Large	1,495.00	2,070.00
Medium	1,540.00	1,925.00
Small	1,485.00	2,035.00

^aThe 1985 figures are approximately double due to inflation and devaluation of the baht.

PRODUCTION AND USE OF THE FOUR-WHEEL TRACTOR

Four-wheel tractors have been principally used for land preparation and transportation. A four-wheel tractor can save labor by 74%, or 18.37 work days per season. Rice farmers using buffalo power, two-wheel tractors, and small four-wheel tractors require 875, 613, and 482 work hours per hectare, respectively. From 1974 through 1978, the average annual demand for four-wheel tractors was 3,000 to 4,000 units, compared to 37,000 to 42,000 units for the two-wheel tractor (2). The current estimated demand is 4,000-5,000 units a year. The average annual growth rate from 1974 through 1978 for two-wheel, small four-wheel, and large four-wheel tractors was 20, 16, and 20%, respectively. Two-wheel tractors are still the predominant mechanical power for Thai farmers (Table 4). The economy of Thailand depends heavily on having a more efficient agricultural sector, so that continued priority will be given to mechanization and increasing productivity.

Mechanization generates employment in the farm machinery and parts industries. The number of workers manufacturing four-wheel tractors varies seasonally, from 684 during the peak production season in 1979 to 549 persons in the slack season. Of total manufacturing cost for four-wheel tractors, labor is approximately 10%, and marketing, including transportation, handling, interest and profit margin for the dealer, is 15-20% of the factory price (7).

Figure 3 shows a 1985 four-wheel tractor being produced for Thailand and also for export. Thailand exports to other countries, including Malaysia, Laos, Philippines, Indonesia, and Burma. The agricultural industry is exporting two-wheel tractors, four-wheel tractors, threshers, water pumps, and planters throughout Southeast Asia. The industry realizes that improving the quality and standardization of the Thai four-wheel tractor would increase its export.

Farmers who cannot afford the cost of a four-wheel tractor may hire services through contract operators. The contract cost for land preparation varies among crops and in 1984 ranged from 200 baht (\$7.40) to 300 baht (\$11.12) per hectare, depending on the crop and location in the country. Farmers with

Table 4. Number of two-wheel and four-wheel tractors (2).

Type	Units (no.)			
	1979	1980	1981	1982
	<i>Manufactured in the country</i>			
Two-wheel	54,124	51,000	49,500	39,495
Four-wheel	4,920	4,900	4,850	6,530
	<i>Total on farms</i>			
Two-wheel	230,591	280,591	284,351	323,846
Four-wheel	31,158	36,158	39,158	45,688

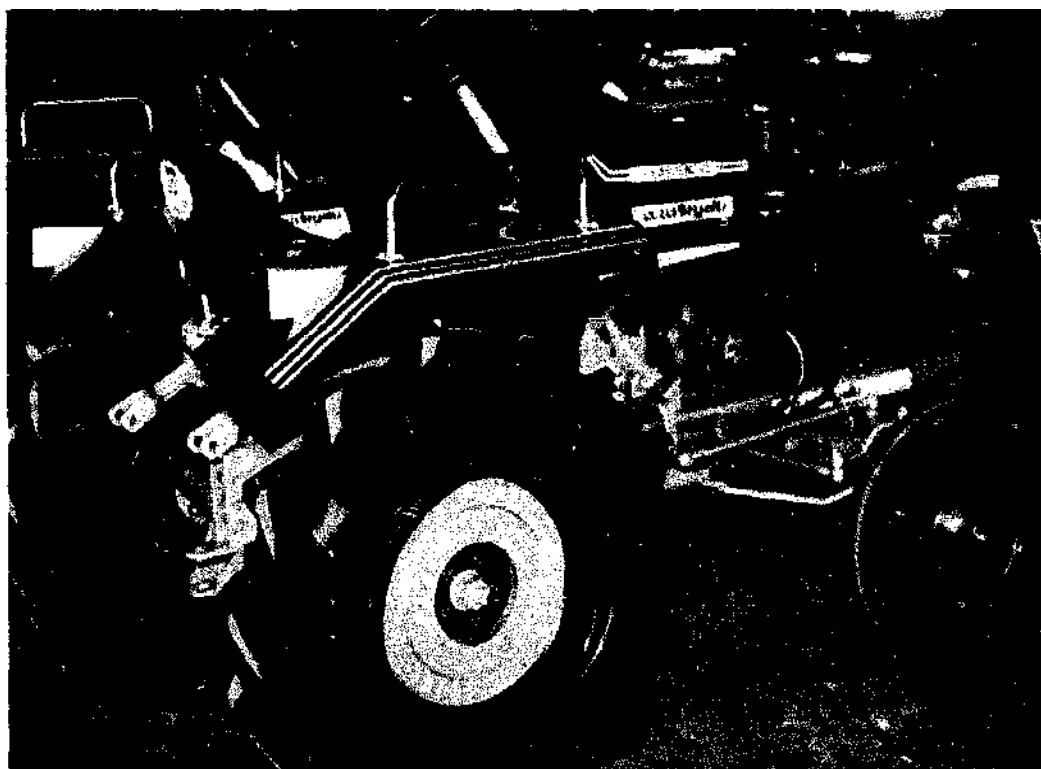

3. A 1985 four-wheel tractor produced in Thailand.

inadequate capital may also obtain loans through the BAAC (Bank for Agriculture and Agricultural Cooperatives) or nongovernment financing institutions to pay for contract services. Land preparation, planting, maize shelling, and threshing are performed through contract services.

There are approximately 10 manufacturers of small four-wheel tractors in the country. Except for hydraulic components and steering wheels, all parts, including engines, are made in Thailand. Tractor size is increasing slightly. Medium-size tractors with 25 to 40 hp and large tractors above 40 hp still are imported, but the industry anticipates producing all sizes.

Asian countries including Pakistan, Malaysia, Philippines, and Indonesia have purchased the Thai four-wheel tractor and evaluated it for use in their agricultural production programs. Since the Thai tractor was initially simple in design and was manufactured using many automobile parts, the tractor could be accepted by other countries or used as a prototype.

Tests in Pakistan indicated need for design modification to better accommodate local requirements. Therefore a new standard three-point linkage with a spring-loaded, counterbalanced mechanical implement lift was developed. Manufacturers' interest is high. It is not known how much effect the four-wheel Thai tractor had in the development of the current mechanization in Pakistan.

Agricultural engineers in Thailand considered developing a four-wheel drive tractor by coupling two of the wheel tractors and attaching a seat for the operator. The Thai-IRRI engineers considered this concept to have the following advantages (pers. comm. with J. A. McMennamy, 26 Sep 1979):

1. The four-wheel drive tractor will have better traction.
2. Cost for equivalent horsepower may be lower.
3. There will be fuel savings (one engine for road transport, one engine for powered implements).
4. A farmer owning a tiller could double his power capability by acquiring one tiller and a coupling package.
5. In case of a breakdown, the farmer could uncouple the two and use the good two-wheel tractor.
6. It will double the power range of a given tiller manufacturer with the addition of a minimum of new parts:
 - a. little new tooling for production
 - b. few new parts for stock and service.
7. Existing implements will be adaptable.

Some disadvantages and questionable features are as follows:

1. Appearance.
2. Turning: a comparable turning radius to the Thai four-wheel tractor would require 15% slip on all wheels.

Table 5. Field performance of the Thai four-wheel tractor (5, 6, 7).

	Moldboard plow (2-bottom)	Disk plow (3-disk)
Tractor	J. Charoenchai	J. Charoenchai
Engine	Yanmar ES 155C	Yanmar ES 155C
Wheel spacing	Front 99 cm Rear 114 cm	Front 99 cm Rear 114 cm
Tire size	Rear 9-20	Rear 9-20
Width of cut	40 cm	55 cm
Depth of cut	18 cm	10 cm
Type of soil	Sandy loam	Sandy loam
Av forward speed	3.75 km/h	3.90 km/h
Theoretical field capacity	0.15 ha/h, 6.66 h/ha	0.22 ha/h, 4.50 h/ha
Effective field capacity	0.09 ha/h, 11.0 h/ha	0.14 ha/h, 7.38 h/ha
Field efficiency	61.0%	60.9%
Fuel consumption	1.33 litres/h 14.6 litres/ha	1.14 litres/h 8.41 litres/ha

3. Higher fuel consumption when using both engines.
4. Operator discomfort, for he would be located directly above the engine.
5. Nonsynchronization of the two engines.

Field performance results with the standard tractor plowing with a two-bottom moldboard plow and a three-disk plow are summarized in Table 5.

REFERENCES CITED

1. Bunyawanchkul, S. 1981. Studies of locally made four-wheel tractor. MS thesis, Asian Institute of Technology, Bangkok, Thailand.
2. Jongsuwat, N. 1980. Productivity growth and farm machinery adoption in Thai agriculture. Master of economics thesis, Thammasat University.
3. Sirichaimanus, K. 1979. Field performance of Thai tractor in plowing. Thai-IRRI Industrial Extension test report 4. (unpubl.)
4. Sirichaimanus, K. 1979. Thai tractor test report. Thai-IRRI Industrial Extension Project Rep. 3.
5. Sirichaimanus, K. 1979. Turning space and turning circle of Thai tractor. Thai-IRRI Industrial Extension Test Rep. 1. (unpubl.)
6. Steel, J. 1985. Increased demand for agricultural machinery. Thailand equipment market analysis. Asian Agribusiness 2(1).
7. Sukharomana, S. 1982. The farm power strategy of Thailand. The Consequences of Small Rice Farm Mechanization Project, Working Pap. 25.

ESTABLISHMENT OF THE TRACTOR INDUSTRY IN INDIA

C. MOHAN
Punjab Tractors Ltd.
Chandigarh, India

THE TRACTOR INDUSTRY IN INDIA — A PERSPECTIVE

Till independence, Indian agriculture followed tradition: dependence upon rain except in a few isolated pockets irrigated through canals, tubewells, and persian wheels; wooden plows drawn by 45 million sickly bullocks; seed strains handed down through generations; and no chemical fertilizer or pesticides. The country with 132 million ha under cultivation did not produce enough to feed its 369 million people and famines were common.

After independence, agriculture received the highest priority of the national government. In the 1950s, major initiatives were taken in agricultural education and research, and agricultural mechanization began with the introduction of imported tractors. Acceptance of mechanization was slow, however, and by 1960, tractor numbers barely exceeded 10,000.

The beginning

The Indian tractor industry was born in 1959-65 when imports were restricted and five tractor manufacturing units were set up by the private sector, all with foreign collaboration. Despite government emphasis on rapid indigenization, the activities of all five units during the early years consisted largely of assembly of completely knocked down (CKD) kits. Indigenization was confined to the simpler machined and sheet metal components. Total indigenous production of tractors by 1965 had risen to 6,000.

With the successful introduction and acceptance of the high yielding seeds, however, tractor demand surged after 1967, multiplying at an annual rate of nearly 50% (1967: 13,000; 1970: 33,000). The high demand and supply shortage boosted tractor prices. To help meet demand, import of tractors was liberalized and in 1970, 13,000 tractors were imported above the domestic production of 20,000.

The second phase

Since indigenization of the five tractor manufacturing units was far below expectations (local content varying between 50 and 70%), the government

delicensed the tractor industry in 1968 and invited new entrepreneurs. Eighteen fresh entrants approached the government, but most wanted quick profits through sale of imported tractors. Nevertheless, six new manufacturers entered the industry: four in the private sector and two in the government. Combined output of the 11 units rose to 32,000 by 1975.

Two new units have come recently: one in the government sector with United Kingdom collaboration, and the other in the private sector with Indian know-how. Their production, however, remains marginal.

In 1984, India's 13 tractor manufacturing units produced 81,000 tractors. Although production capabilities are substantially higher, actual production which simply meets demand is lower.

Of the 13 units, 7 manufacturers account for 95% of total production; 5 are in the private sector and 2 in the government.

The maturing years

With the entry of the new units in 1970 and increasing government pressure, the pace of indigenization picked up. By 1978, almost all tractors manufactured were nearly 100% indigenous. Indigenization was aided by overall industrialization, as ancillary manufacturers established themselves and began supplying a wide variety of tractor components.

The liberalization of imports in 1970 sharply set back the nascent Indian tractor industry from 1970 to 1973. Low-cost imports, particularly from East European countries, became far more attractive. But in 1973, the government ban on imports and increased competition boosted local production and spurred indigenization.

Domestic demand grew sharply from 1975 onwards (compound rate of 18%). However, industry suffered another major setback in 1982 when severe credit restrictions by the government curtailed bank credit for retail purchase of tractors by farmers and demand fell sharply by 19% to 68,000. The industry is recovering, however, and 1985 sales are expected to be back to the 1981 level of 85,000. Figure 1 shows the growth of the Indian tractor market/industry over the years.

Choice of collaborators

In the choice of foreign know-how for local manufacture, India opted for the widest (Table 1).

Choice of foreign collaborators was primarily dictated by the initial contact between the prospective Indian entrepreneurs and the foreign manufacturers. Massey Ferguson, International, Ford, Zetor, and Russian tractors had been introduced earlier in the fully imported condition and had received farmer acceptance. Choice also depended upon the interest which foreign collaborators showed in entering the Indian market as a part of their own global strategy: either building a permanent market out of initial success with fully built up tractors, or finding fresh export outlets for increasing production capacities (Zetor, Leyland, Ursus).

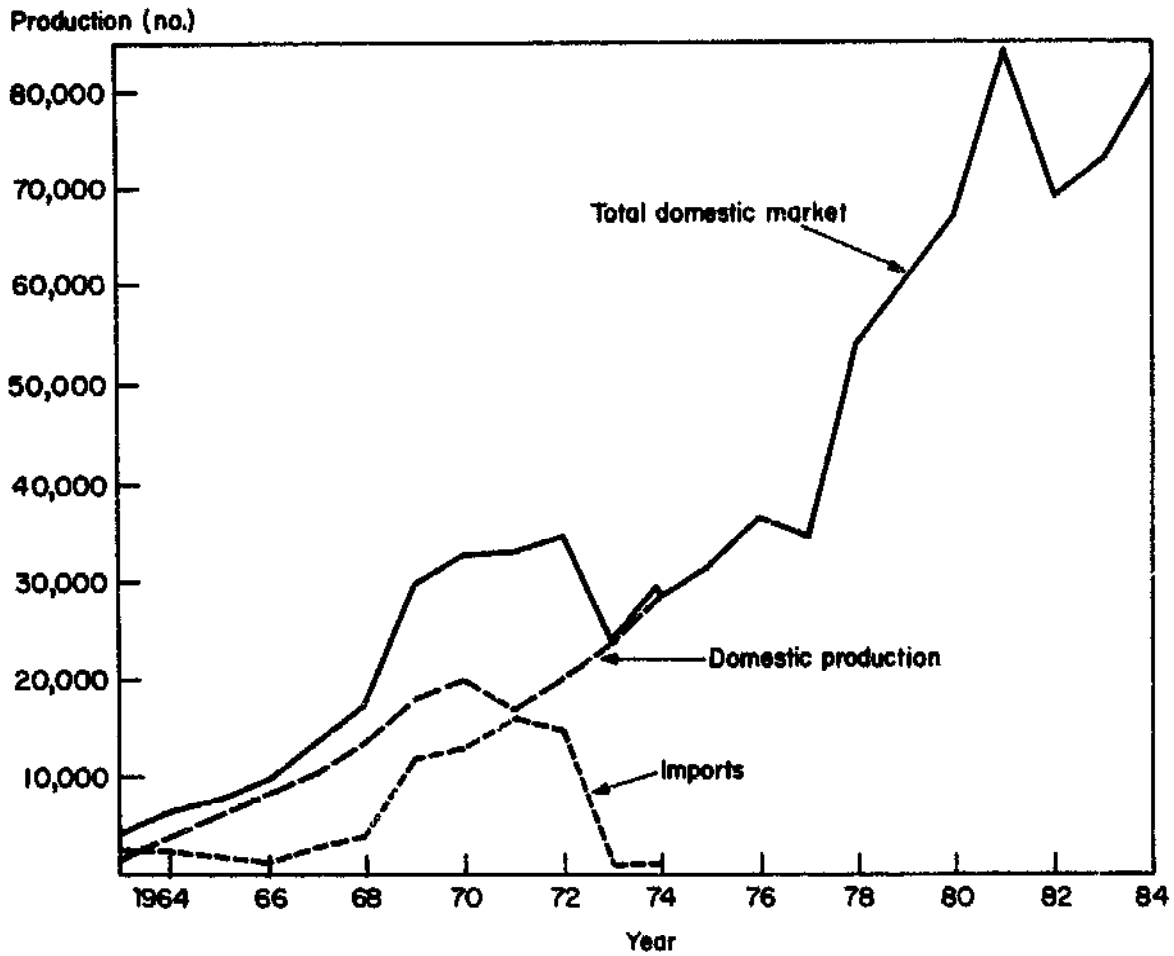

1. Growth of the tractor industry, 1963-84.

Table 1. Know-how origins.

Country	Manufacturing units (no.)	International brand name	Local brand name
U.K.	4	Ford	Ford
		Massey Ferguson International Harvester	Massey Ferguson International
		British Leyland	Pratap
West Germany	2	Eicher	Eicher
		Deutz	Kirloskar-Deutz
Eastern Europe	4	Zetor, Czechoslovakia	HMT-Zetor
		Zetor, Czechoslovakia	Hindustan
		Ursus, Poland	Escorts
		Tractoroexport, USSR	Harsha
Purely Indian	3		Swaraj Pittie Veer-Pratap

In addition to contributing know-how, almost all the foreign collaborators from western Europe have an equity stake in the local companies: International 17%, Ford 40%, Massey Ferguson 49%, Eicher 23.71%.

Of 13 units, 7 principal manufacturers accounted for 95% of the market of 81,000 in 1984:

<i>Manufacturer</i>	<i>Local brand name</i>
Mahindra & Mahindra Ltd., Bombay	International
Eicher Good-earth Ltd., Faridabad (Delhi)	Eicher
Escorts Ltd., Faridabad (Delhi)	Escorts
HMT Ltd., Pinjore (Chandigarh)	HMT Zetor
Escorts Tractors Ltd., Faridabad (Delhi)	Ford
Tractors & Farm Equipment Ltd., Madras	Massey Ferguson
Punjab Tractors Ltd., Mohali (Chandigarh)	Swaraj

Choice of horsepower and size

In selecting models for local manufacture, Indian companies invariably chose the lowest HP model then in production.

Of the manufacturers in 1960-65, U.K. collaborators opted for 35 hp tractors, then the most common model in U.K., while Eicher opted for a 25 hp tractor, the lowest power it made in West Germany.

In the second phase (1970-75), collaborators of West European firms shifted to 45 hp models, then common in western Europe. Models were also considerably more sophisticated in transmission, hydraulic controls, etc.

The choice of model in current production with the principals was a technical necessity. Local manufacture always involved a period of phased indigenization (at least 5 yr) and CKD kits were only available for models in current production.

Today, when tractors in the United States are generally in the 100 hp range, American principals will prove 100 hp tractors with all their sophistication as the most suitable; European manufacturers will promote 60-70 hp tractors as the eminent choice.

In such a situation, developing countries must decide for themselves what serves their own needs best.

THE INDIAN TRACTOR TODAY — COMPETITION AND THE CUSTOMER

A highly competitive industry

Although the 13 manufacturers produced 81,000 tractors in 1984 and the market is expected to grow to 85,000 in 1985, the industry's production capability is substantially larger. Competition to raise respective market shares is therefore intense, a situation prevailing since 1977. This intense competition has benefited customers in many ways.

Wider purchase options

Because of competition, manufacturers constantly introduce new models. Today more than 30 models are available, ranging in horsepower from 15 to

Table 2. Horsepower and price spectrum of Indian tractors.

Brand name	Model	Feature	PTO HP	Retail price (US \$)
<i>PTO 25 PTO hp tractors</i>				
1. Swaraj	720	Handle start	13	3950
2. Swaraj	720	Electric start	13	4200
3. Eicher	241	6-speed	18	4500
4. Eicher	242	8-speed	18	4650
5. Eicher	243	8-speed, Automatic hydraulics	18	4850
6. HMT	2511		19	5000
7. Pratap	284		19	5250
8. Harsha	T-25A		21	5450
<i>25-35 PTO hp tractors</i>				
9. Kirloskar	D 3006K		27	6900
10. Escorts	330	Mechanical hydraulics	28	5550
11. Escorts	335	Automatic hydraulics	28	6150
12. Eicher	352		28	6250
13. Massey Ferguson	1035		28	6500
14. Escorts	345		29	6200
15. HMT	3511		30	5950
16. International	B-275		31	6250
17. Swaraj	735		31	6450
<i>35-45 PTO hp tractors</i>				
18. International	B-444		37	6700
19. Hindustan	G-453		37	7200
20. Kirloskar	D 4003K		37	8150
21. Swaraj	855		38	8000
22. Ford	3600		39	8700
23. Escorts	355		40	7500
24. Massey Ferguson	245		42	9500
<i>Above 45 PTO hp tractors</i>				
25. Hindustan	HWD-50		46	7500
26. International	500		46	7550
27. HMT	5911		49	8450
28. Hindustan	G614		53	8050

60. Almost all principal manufacturers offer a model in each of the main hp ranges: 25-35, 35-45, and 45-60 (Table 2).

Manufacturers also offer product variants in each model including different transmissions, mechanical or automatic hydraulics, mechanical or electrical starting, and special features for regional needs.

Indian customers have a wide price range to choose from: from US\$ 3,800 to \$9,500.

Customer service

With increasing competition, product quality and reliability have steadily improved. In 1979, free-replacement warranty was universally increased from 6 mo to 12 mo. The depth of distribution and service also increased steadily. About 81,000 tractors are retailed through nearly 3,000 direct outlets franchised by the manufacturers, an annual average of 30 per outlet.

Advantages of this wide distribution and service network are 1) availability of outlets/service, 2) availability of spare parts, and 3) reduced down times and higher availability of usage.

Most outlets employ technical staff trained at the shops or schools of the manufacturers. Some manufacturers also train farmers in routine servicing, at dealer premises.

Research and development

Because of intense competition and the need to enlarge the product range constantly over the last 7-8 yr, Indian manufacturers have emphasized development of their research and development (R&D) capabilities. Capital investment in R&D facilities today approximates \$5 million. Recurring R&D expenditure is \$2 million.

With more intense competition, R&D facilities are steadily becoming more sophisticated and diversified. The process of absorption/assimilation of foreign know-how is complete and Indian industry can grow on its own strengths.

Implements

Implements commonly used with tractors in India today are cultivators, disk harrows, levelers, trailers (generally two-wheeled), cage wheels for paddy puddling, and threshers.

These relatively simple implements are manufactured by small-scale industries. For reasons of economics, none of the tractor units manufactures implements.

Although manufacture of implements by small-scale industry has its drawbacks of inconsistency in quality, poor durability, etc., easy availability through local industry has been an advantage. It has also helped spread industry throughout the country. Contact of the local industries with farmers has helped adapt implements to local requirements, and has stimulated manufacture of new implements.

With the steady development of Indian agriculture and the recognition of the importance of mechanization toward productivity/efficiency, the need is for more sophisticated implements. The following have found increasing acceptance over the last few years: potato planters and diggers, reapers, tractor-drawn combine harvesters, disk plows, and sprayers.

Indian tractors and the international scenario

Indian tractor exports have been criticized. But it has to be appreciated that the need of the Indian market is totally different from that of developed countries.

Developed countries need much larger hp/size because of larger farms and low labor availability. In developing countries, farmers of much larger farms use a wide variety of implements with exceedingly sophisticated and versatile tractors. Such versatility is not required in developing countries and represents superfluous, unproductive investment.

Less sophisticated, low-cost, low-horsepower tractors manufactured in "sister developing countries" are likely to be more suitable in other developing countries; South-South trade is a better answer. In fostering South-South trade, however, a mechanism for arranging credit will have to be developed.

GOVERNMENT POLICIES AND THE TRACTOR INDUSTRY

As is inevitable in a changing scenario, government policies toward tractors and the tractor industry have been changing over the last two and a half decades. Government policies must be viewed in the context of the government prevailing when the policies were framed.

Phase I (1959-70)

In 1959-70, the government encouraged the establishment of the Indian tractor industry, favoring foreign collaboration and foreign equity participation. Fairly equitable, phased localization programs were approved in consultation with manufacturers. Imports were also restricted. With this positive approach, five units were established.

The industry, however, failed to live up to the promised indigenization programs. The government soon recognized that indigenization was hindered by the cost penalties local manufacture suffered vis-a-vis imports. To balance production economics, duty on imported components was raised to 40% in 1969. Despite the heavy import duty, component import was cheaper, particularly for intricate components, and industry continued imports. Localization was also hampered by the large capital investments required for local development. Import was certainly the softer and more economic option.

To encourage acceptance of tractors and mechanization, easy credit facilities were organized through Cooperative Land Development Banks established by the government in all parts of the country. Margins for credit were low (generally 15%), interest was substantially lower than commercial credit, and extended repayment periods up to 7 yr were allowed. Easy availability of cheap credit spurred the rapid acceptance of tractors.

Fearing profiteering, the government imposed statutory price controls on tractors in 1967-68. Controls were also imposed on their resale and distribution.

Phase II (1968-75)

With the Green Revolution beginning in 1967, tractor demand rose sharply. Seeing the inability of the established five units to meet demand and their slow pace of indigenization, the government delicensed the tractor industry in 1968 and invited new entrants. The government also decided to enter tractor manufacture. Consequently, six new units emerged during 1971-75. Further, imports of complete tractors were liberalized and rose to 16,000 in 1971.

By 1973, the government realized that its import liberalization had disastrous consequences on the young tractor industry. It, therefore, banned imports in 1973, primarily because the industry's annual production of 23,500 was meeting the enlarged domestic demand.

By 1975, six new units had begun manufacture. Production of all 11 units reached 32,400. The explosion in tractor demand after the onset of the Green Revolution had also abated. Domestic supply and demand had reached a balance, with adequate production capacity established to meet future growth. With 11 production units balancing the growing domestic demand, a high but comfortable degree of market competition had been ensured.

A healthy market situation having been reached, price and distribution controls were removed in 1975 and the industry was allowed to grow on its competitive strengths vis-a-vis the market.

During this period, the government stepped up its pressure on industry to indigenize. By 1975, the older units had become near 100% indigenous and the newer units were soon to follow suit.

Phase III (1973-81)

In recognition of the contribution of mechanization to agriculture development and consequent need to increase tractor demand, credit channels for farmers were widened. Agricultural lending, hitherto a neglected area in Indian commercial banking, was made a high priority portfolio with clearcut lending goals. As part of a national drive, commercial banks were forced to open rural branches. The banking network today comprises nearly 60,000 branches spread in remote villages.

The government further augmented resources of commercial banks for agricultural lending through refinancing by an apex Central Financing Institution-Agricultural Refinance and Development Corporation (ARDC), now restructured and renamed as the National Bank of Rural Development (NABARD). NABARD's refinance toward tractor purchase in 1984 was \$175 million.

With liberal and easy credit, tractor demand rose steadily after 1975 and a growth of 18% multiplied demand to 84,000 by 1981. A spur to the high growth rate was that in commercial banks, tractor loans were the most attractive portfolio of agricultural lending, with the cleanest repayment record.

Phase IV (1982-84)

In a bid to control inflation which had reached 13-15%, the government in the latter half of 1981 decided to impose severe restrictions on all forms of bank credit and the ax also fell on retail credit to farmers for tractor purchase. Demand fell sharply and the tractor industry was suddenly faced with mounting finished inventories. Drastic production cutbacks followed.

By the end of 1982, the government realized the disastrous impact of its severely restricted credit measures on the Indian economy and industry, and relaxed the credit restrictions. The tractor industry began to recover in early 1983, and 1985 demand is expected to return to 1981 levels.

The sharp setback after rapid expansion has stimulated introspection in the tractor industry:

- Marketing networks were strengthened and enlarged by the principal manufacturers.

- Industry started paying more attention to the mechanization of agriculture in rice-growing areas. Rice areas in India have been slow to accept mechanization and tractorization had virtually been confined to the wheat areas.
- In-house R&D has assumed greater importance and new models or product variants are being introduced at an increasing rate.
- Quality of service is steadily improving.

Phase V (1985 onwards)

After a turbulent 3 yr of readjustment, the Indian tractor industry is set for orderly growth in a highly competitive market, with each manufacturer gearing to meet the challenges of competition: emphasis on the customer and his needs, and increased organization efficiency.

In the current environment of healthy competition, government emphasis has shifted toward the following:

- Efforts to develop a coordinated long-term credit plan for tractors and mechanization, which is linked to the growth of financial resources of the banking sector. In this long-term planning a crucial role is planned for NABARD which already has developed linkages with the entire banking sector as regards rural credit.
- Encouraging industry to improve its products in terms of greater fuel efficiency, improved operator comfort and convenience, and lesser environmental pollution. National standards are being formulated or implemented.
- Encouraging industry to rapidly diversify their product base to meet specialized agricultural needs.

COULD THE INDIAN APPROACH BE BETTER?

Making judgments by hindsight is easy because the rationale behind decision-making and the then prevailing environment and compulsions are most often forgotten. Perception of situations by decision-making individuals will inevitably vary, and in policy-framing such individuals are a most relevant factor. Subsequent analysis should therefore be treated more as a guide to thinking.

Should India have had 13 tractor manufacturing units with almost equal collaborations?

This question is repeatedly asked, within and outside India: for a market which even today is only 100,000 units, should the government have permitted the establishment of 13 units? Should the government have approved so many foreign collaborations, each with its own phased manufacturing program? Would not concentration of resources into four or five units have conserved foreign exchange, made investments more productive, and given advantages of economies of scale? Were 13 units needed, if 7 units now cover 95% of the total market?

In considering this criticism, it must be remembered that the government initially permitted only five units or collaborations. Only when these units were not indigenizing in line with their promises and stepping up production to meet the needs did the government open its doors to new units in 1968.

It is also difficult to assess capabilities or seriousness of prospective entrepreneurs. The last two units to enter could have easily been screened out, particularly the one in the government sector which entailed substantial investments. But its establishment was due to local compulsions. The other was admitted in line with the national policy to encourage Indian know-how.

Looking to the brighter side of government decision-making, intense competition among seven principal manufacturers is benefiting the customers. The remaining six units which have not been able to keep pace with the competition will perhaps fade out, an inevitable consequence of the process of industrialization.

Should India have adopted technologies from different countries?

In setting up its tractor industry, India obtained technical know-how from practically every developed country in the world. Each foreign collaboration brought in different national standards (BSS, DIN, GOST, CSH, etc.) for steel, fasteners, bearings, etc., with all the attendant problems of low volume production and higher tooling costs. It also posed major problems in indigenization and production costs. Some relief was provided by the Indian Standards Institution which undertook a major exercise in rationalization of steels in 1965-1970 to reduce the varieties to around 80. Manufacturers have steadily adopted the "more common" steels for reasons of economics and easier availability.

In the author's view this aspect should be considered when deciding sources of know-how. The totally open Indian approach is certainly detrimental.

Choice of technologies

An issue often faced by developing countries pertains to large capital investments indicated for manufacture of "modern technology" tractors. Investment figures varying between \$100 million to 250 million are indicated for production levels of 5-10,000 per annum and local content of around 50%. The Indian experience has been totally different. Even in terms of today's costs, investments would not exceed \$20-25 million.

Additionally, for a tractor plant to grow, an overall industrial infrastructure must exist in the country: forging industry, foundries, specialized ancillary manufacturers for items such as electricals, instrumentation, hydraulics, etc. Without this industrial infrastructure and culture, "a large highly integrated tractor plant" will come to grief. Management expertise for large integrated complexes takes long to build in any country, as the Indian experience amply proves.

Technologies adopted in India have been more "labor-oriented" than "capital intensive" and such adaptation of manufacturing methods must be deliberately pursued by any developing country. In selecting technologies, it is

relevant to consult other developing countries that have gone through the experience.

Local manufacturers vis-a-vis imports

Any developing country must appreciate the fact that "local manufacture" would always be more expensive than imports for a substantial length of time, till the domestic infrastructure and industry have grown to internationally competitive volumes or organizational levels.

Whenever any developing country sets up local manufacture, it must protect its nascent local industry against imports. This is all the more relevant today when, due to recession, developing countries offer very attractive prices, credits, etc. Developing countries cannot afford to feel shy against protectionism when the most developed countries are protecting their own industries against the Japanese or Korean onslaught. Protective measures should suit local conditions: import duties, import ban, equalization of raw material costs, etc. Policies should also be reviewed periodically to ensure pragmatism in a changing environment.

In viewing protective measures, it should be appreciated that the local industry generates local employment, particularly for the educated. It also generates internal resources, and a steady increase in internal resource generation is essential for national development.

Governments must also recognize that indigenous manufacture of complicated equipment such as a tractor will involve a long period of localization, which could easily vary between 5 and 10 yr. If industry has to proceed systematically, governments should ensure adequate availability of foreign exchange during the protracted period of localization. Erratic translocation of foreign exchange would be a major setback.

Market growth must parallel establishment of local industry

To ensure steady growth of a local industry, the government must ensure a steady growth of market. In developing the market, farmers' purchasing power is a major constraint in all developing countries. Steady flow of credit on easy terms and credit channels are therefore essential prerequisites.

The Indian tractor industry would not have grown but for the government's steady increase in credit for farmers since 1965. Terms have always been easier than for commercial credit. Parallel steps must be taken by the government to ensure regular repayment of loans.

Research and development

Another issue often emphasized pertains to research and development for local adaptation, establishment of local capabilities, and institutions for R&D, etc; R&D often overshadows the manufacturing aspect.

In the Indian experience, for R&D to have relevance and widespread acceptance beyond the laboratory, establishment of the manufacturing industry must take precedence. Let developing countries start manufacture of whatever equipment they are using extensively today. The start of the local

manufacturing industry will develop managerial talent and capabilities and industrial infrastructure and culture. Local R&D and its translation into commercial technology could follow in the course of time, when local industry has the technological and financial strength to produce and market newly developed products.

THE FLOATING POWER TILLER IN THE PHILIPPINES

M. S. VILLARUZ

SV Agro-Industries Enterprises, Inc.
Iloilo, Philippines

Millions of farmers in Asia and other parts of the world know from experience that preparation of muddy, water-soaked, rice fields is a hard job; it is difficult for farmers, water buffalo, and even for power tillers.

Frequently, the soft-mud layer is so deep that tillage becomes a near hopeless task for men, animals, and machines. The time, human energy, animal energy, mechanical energy, and expenses required are high and seriously affect the cost of production, and also the income and standard of living of the rural labor force.

For these reasons, we designed a floating power tiller.

We began years ago by purchasing a 24-ha riceland in Pototan, Iloilo. Neighboring farmers had reasons to ridicule us. The land was uneven, heavily waterlogged, full of tall reeds, and a swimming pool for ducks; land preparation was an immensely difficult task. For months we were faced with a rice field that defied cultivation. Much time was required. Laborers, animals, and machines frequently got stuck in the mud. Energy input was excessive and costs were high.

Could we, we wondered, introduce a mechanized approach that could overcome the unfavorable conditions of our muddy riceland? Would it be possible to do the job of tillage more efficiently by not having our small but rather heavy power tiller get stuck in the mud? This was a frequent topic of our daily family discussion.

Then an idea struck! At an offshore construction site of an oil company, I noted they were welding pipelines in the middle of the ocean, using empty drums to float their welding equipment. So I said, why not develop a buoyant power tiller that could cultivate a flooded field?

With the help of my husband and brother, we began to develop a floating power tiller. We produced the first prototype at our welding shop in Jaro, Iloilo City. It took us 2 yr of patient trial and error research before we were able to perfect the floating power tiller. The first unit was a simple, slow moving, flat contraption, a floater with an engine, then an assembled unit of a hand tractor on a floater, each time improving the machine's speed and efficiency. It was tested, adjusted, retested and readjusted. Finally, in 1976 a working model of a Turtle power tiller (Fig. 1) was released and used on our own farm in Pototan, Iloilo.

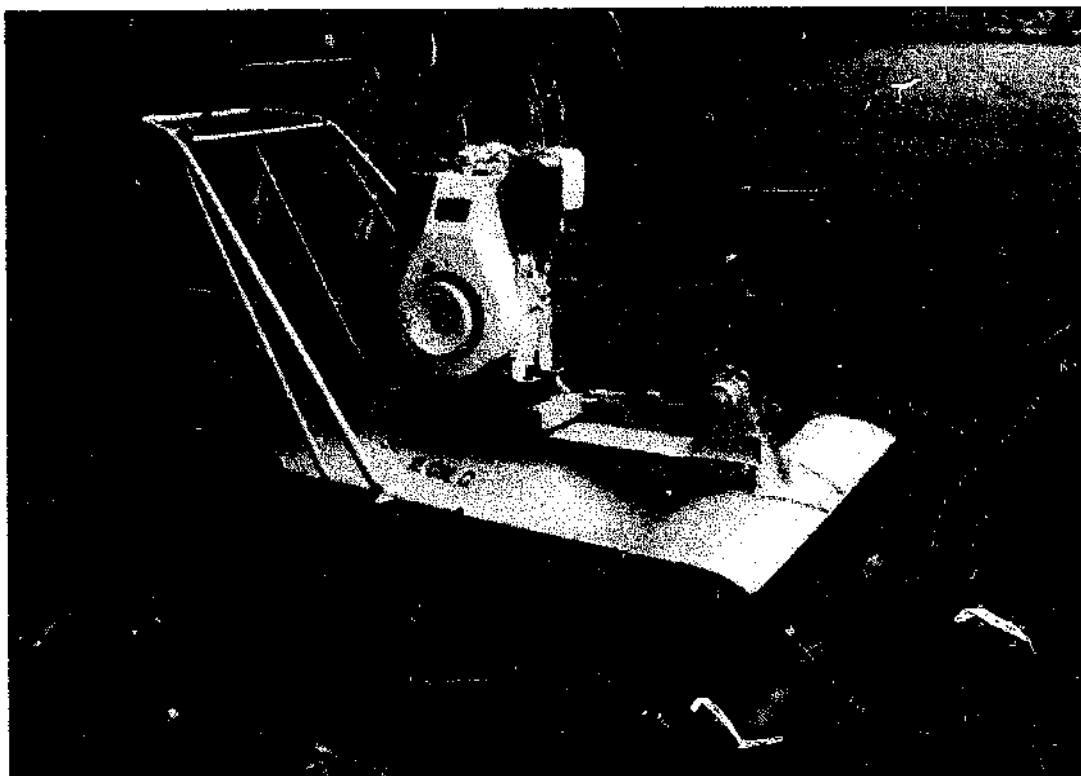

1. Turtle power tiller (MSF model) with 14 hp air-cooled diesel engine.

We urgently needed a patent. How to get one is not something you learn in college. I went to the Philippine Inventor's Commission (PIC, now the PIDI), and was referred to a patent examiner. I told him that we wanted to apply for an "Invention Patent" but he rejected the idea for reasons that it would take time, that the design was just an improvement of the existing hand tractor, and it was better to just have a "Utility Model" (UM) patent. Being a greenhorn, I took his advice and paid ₱2,000 for the whole patent application. I later realized that it was just a "paper patent" which gave me no strong protection at all, because 4 mo later, when I sold 2 units to a person in Bacolod City, he also applied for a patent and it was granted.

My enthusiasm did not wane. I entered the Inventor's Contest a year later but was totally disappointed when one of the judges told me — "Your entry is impractical." The irony of it was that we had already sold, like hot cakes, thousands of Turtle power tillers. From that time on, we never entered our invented and designed products in any contest.

We started our small welding shop in 1964 with an initial working capital of \$25. In 1969, the first hand tractor was introduced in Iloilo. However, cage wheels and other attachments of these imported power tillers were not suited to the soil conditions of our area. It was a drum-like design that local importers and distributors requested us to redesign.

We had no immediate intention to become industrialists. We just wanted to solve our own farm cultivation problem. However, the news of our invention spread. Farmers came and were eager to buy. With our small workshop, we

could not accommodate the demand. We then applied to the Development Bank of the Philippines (DBP) for SMI Loan and to the Private Development Corporation of the Philippines (PDCP) to purchase some machineries. These lending institutions were really very kind to us. In 1977, a World Bank consultant visited us at Jaro and suggested that I take further technical training through the BSMI-SBAC, Iloilo. I then went to mainland China for such training under the UNIDO Study Mission on rural and medium industry.

Farmers' feedback on the operation of the initial models led us to introduce a number of renovations and redesigns. We had initial problems:

1. The machine was too heavy and too big; we made it smaller and lighter.
2. Balance was a problem; we overcame it by redesigning.
3. Weeds wrapped around the crushing wheel shafts; we developed a device that automatically cut wrapped weeds.
4. A more durable transmission was needed; we improved the chain tightener, used a draw die to make the sides more accurate, and put a quality control on the sprocket.
5. Tillage was not thorough enough; we increased the number of teeth on the rototiller.

In general, design changed to a lighter, stronger, and more reliable machine.

We never followed the usual concept of marketing which is purely profit oriented. Human needs (farmers' needs) and service were our main concerns.

When we started, we manufactured, distributed, and marketed our products; we opened branches; we partly subsidized dealers; and we also house-financed some farmers who could not afford to purchase in cash. Later, we established sales repair shops in Panay and Mindanao. Our great advertisers and salesmen were satisfied farmers to whom we in turn gave commissions for every unit they sold to a farmer-friend, neighbor or relative.

Our biggest distributor, based in Cebu City, has 23 branches located mostly in Mindanao. Our branch operations now produce 60% of our sales. Our chief sales area is the Central Philippines or the Visayas; next is Mindanao. Now we are working on the Luzon market (Fig. 2).

In Figure 3, you can see our sales history and our expected sales for 1985. In 1980, the big OPEC oil price increase injured our business, and in 1983 inflation did the same. We are now coming out of this strongly. We started exporting as early as 1977 to Indonesia, Thailand, Kenya, and Nigeria. SV Agro-industries Enterprises, Inc., is a duly registered Board of Investment (BOI) company.

The entire machine is made in our factory except some parts like bearings, chains, pulleys, and oil seals purchased from local suppliers. Our work force is highly motivated, working on incentives, and we have some craftsmen of great skill in welding and machining. Most are out-of-school youth; some are technical students from vocational schools whom we took in after they took the practical training at our factory, a requirement for their graduation.

The patents for our machines give relatively little protection, but we have worked hard to defend our designs. Initially we had seven large imitators. One

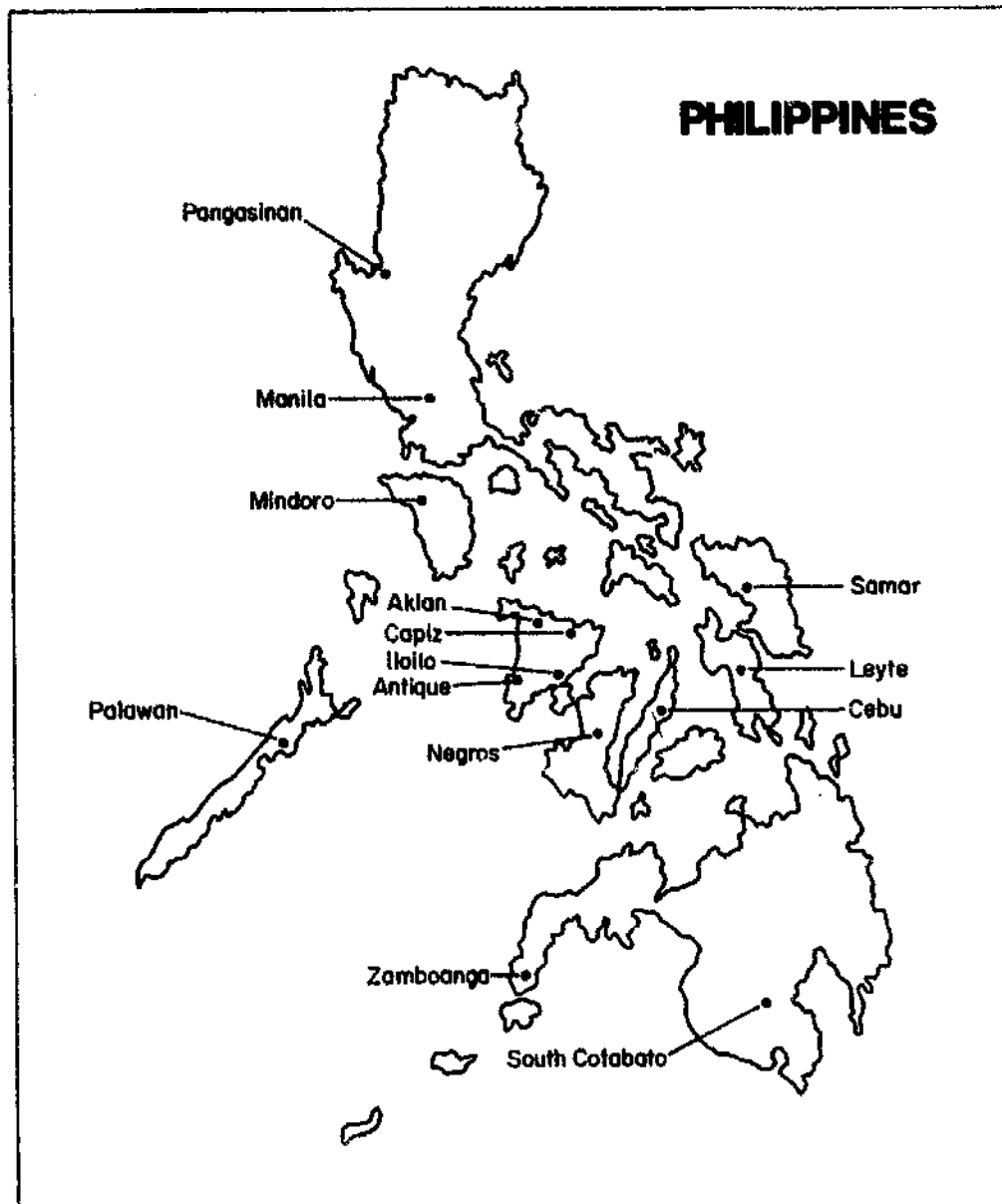

2. Principal sales areas of the SV Turtle power tiller.

died, we won a court case against one, two went broke, one case is still to be decided, and we are filing suit against the last two. Other small shops have imitated on a smaller scale, but usually quit when we threatened suit.

Under Republic Act Number 3850, as amended by Presidential Decree Number 1423, known as the "Philippine Inventors Incentive Act," we were granted tax shield for 5 yr.

I feel it necessary to briefly mention the alternative uses of the floating power tiller concept for Asia and other countries. These alternative uses are based on proven ability through trials.

E. J. Calilung and R. E. Stickney of the International Rice Research Institute recently carried out field tests to compare the performance of various types of tillage equipment used by rice farmers in the Philippines. Based on their results for one soil type, they tentatively suggest that

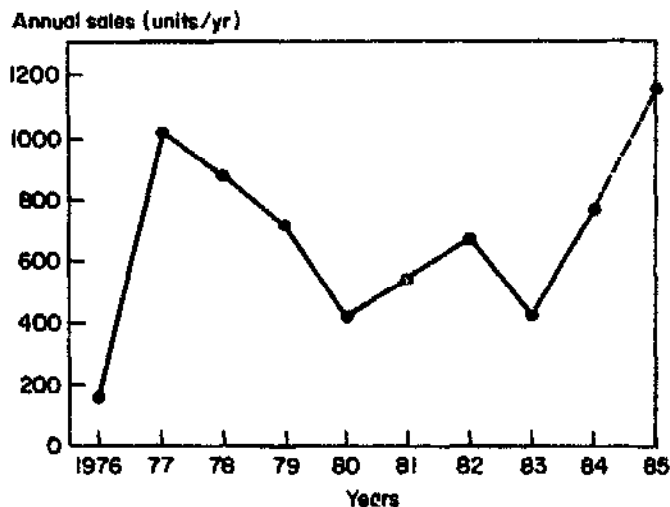

3. Sales statistics for the SV Turtle power tiller. Dotted lines show projection: 1985 projection . . . 1,165 units.

Table 1. Benefit-cost ratios for alternative tillage technologies at 3 levels of annual utilization (25, 50, and 75 d/yr).^a

Technology	Benefit-cost ratio at annual utilization of								
	25 d/yr			50 d/yr			75 d/yr		
Buffalo/moldboard plow ^b	0.50	0.26	0.18	0.78	0.44	0.31	0.97	0.59	0.43
HT/moldboard plow ^c	0.83			1.11			1.26		
HT/disk plow	0.91			1.23			1.41		
HT/spiral plow	0.91			1.23			1.41		
HT/cage wheels + harrow	0.99			1.33			1.52		
Floating tiller	1.37			1.81			2.04		

^aSource: E. J. Callilung and R. E. Stickney, 1985. Comparison of tillage equipment for small rice farms. International Rice Research Institute. ^bThree estimates for buffalo/moldboard plow based on different assumptions (0%, 50%, and 100%) for the opportunity cost of labor required for buffalo maintenance (i.e., watering and grazing). ^cHT = hand tractor (conventional two-wheel power tiller).

1. The floating power tiller appears to be the most economical alternative of the six technologies considered (Table 1). Contrary to general belief, this tiller excels for normal soil condition as well as for the very soft conditions (Table 2) for which it was originally designed.
2. The floating power tiller may be appropriate for other countries with waterlogged areas.

Farmers prefer the floating power tiller, as already mentioned, because it can plow wet rice fields where mud is knee deep, and also because of the following advantages.

1. The machine can trim and clean rice fields near corner dikes.
2. It is very suitable for cutting weeds and rice straw from newly harvested rice fields.
3. It can work in fields choked by tall reeds and on farmlands that have been abandoned.
4. It is useful in fishpond operations: it cleans and removes grasses in shallow fishponds; it loosens the hard pond soil to produce more and better moss; and it levels the pond soil after loosening.

Table 2. Summary of test data for first-pass tillage by alternative technologies.^a

Technology ^b	Soil depth = 10-20 cm		Soil depth > 30 cm	
	h/ha	litres/ha	h/ha	litres/ha
Buffalo/moldboard plow	24	0	<i>e</i>	<i>c</i>
HT/moldboard plow	9.3	18	12	29
HT/disk plow	6.6	15	<i>d</i>	<i>d</i>
HT/spiral plow	6.6	15	<i>d</i>	<i>d</i>
HT/cage wheels + harrow	6.6	15	9	23
Floating tiller	4.2	13	3.7	12

^aSource: E. J. Callung and R. E. Stickney, 1985, Comparison of tillage equipment for small rice farms. International Rice Research Institute. ^bHT = hand tractor (conventional two-wheel power tiller). ^cData not available for buffalo/moldboard plow for soil depth > 30 cm. ^dEquipment not operable at soil depth > 30 cm.

To recapitulate, I have discussed our experience in the design, development, and commercialization of the Turtle power tiller, particularly on

- how the design was conceived;
- how we decided to go into production of the Turtle;
- obstacles encountered and how they were overcome;
- modification of the design;
- marketing strategies, local and export sales statistics, and geographical locations of buyers;
- influence of Philippine Patent Laws: waiver of paying income tax; prevention of having other manufacturers copy Turtle design;
- how many manufacturers have copied the design and how SV was able to stop them; and
- advantages in using the Turtle power tiller and why it is preferred to the conventional power tiller under certain conditions.

Our company is also involved in the manufacture of threshers, maize shellers, another model of power tiller (the "Snapper" power tiller), and many other farm implements.

Lastly, I would like to express my thanks to IRRI and MAF-IRRI Industrial Extension Program for their assistance in providing and sharing their technical know-how with SV Agro-Industries Enterprises, Inc., and other small and medium entrepreneurs.

Irrigation

THE TWIN-TREADLE PUMP: MANUAL IRRIGATION IN BANGLADESH

G. BARNES

Lutheran World Federation/World Service (RDRS)

This paper analyzes — for the wider purpose of identifying patterns of evolutions in agricultural implements — the little events that led to the marketing and adoption of the treadle pump by small-scale farmers in Bangladesh.

PLACE AND TIME

**Rangpur/Dinajpur, Bangladesh
1977-1982**

Although development and wider adoption continue, the first pump was designed and made in November 1980.

AGENCY

Rangpur-Dinajpur Rehabilitation Service (RDRS) is a voluntary agency operated by the Lutheran World Federation (LWF).

IMPLEMENT DESCRIPTION

The twin-treadle pump has three main parts (Fig. 1, 2, 3).

- 1. Twin (two identical, parallel) cylinders with suction inlet,**
- 2. Two plungers with rope and pulley, and**
- 3. Two treadles.**

A framework holds the components in their positions, and in its normal application the pump and framework are bedded in the soil.

FEATURES

- The pump makes use of the operator's body weight and main muscles — those of the legs. Operator fatigue depends on endurance in normal, brisk**

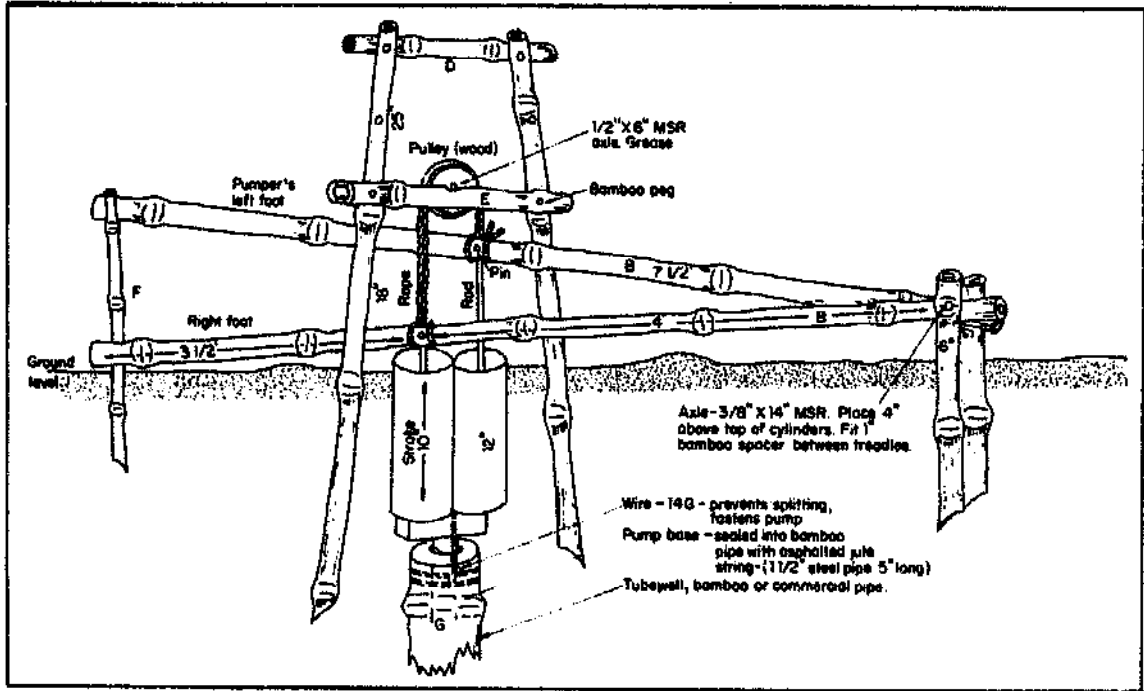

1. Sketch of twin treadle pump.

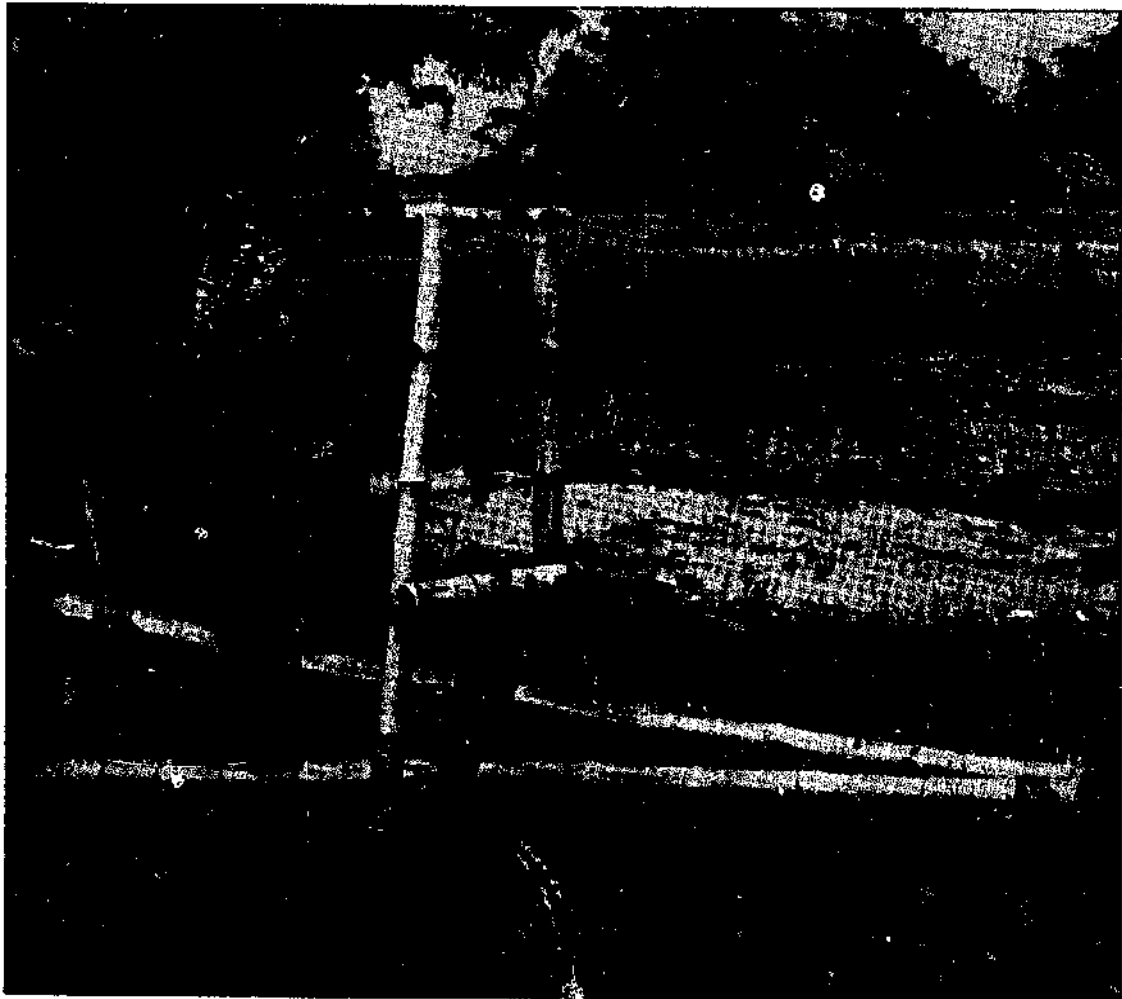

2. Paddy irrigation in North Bangladesh.

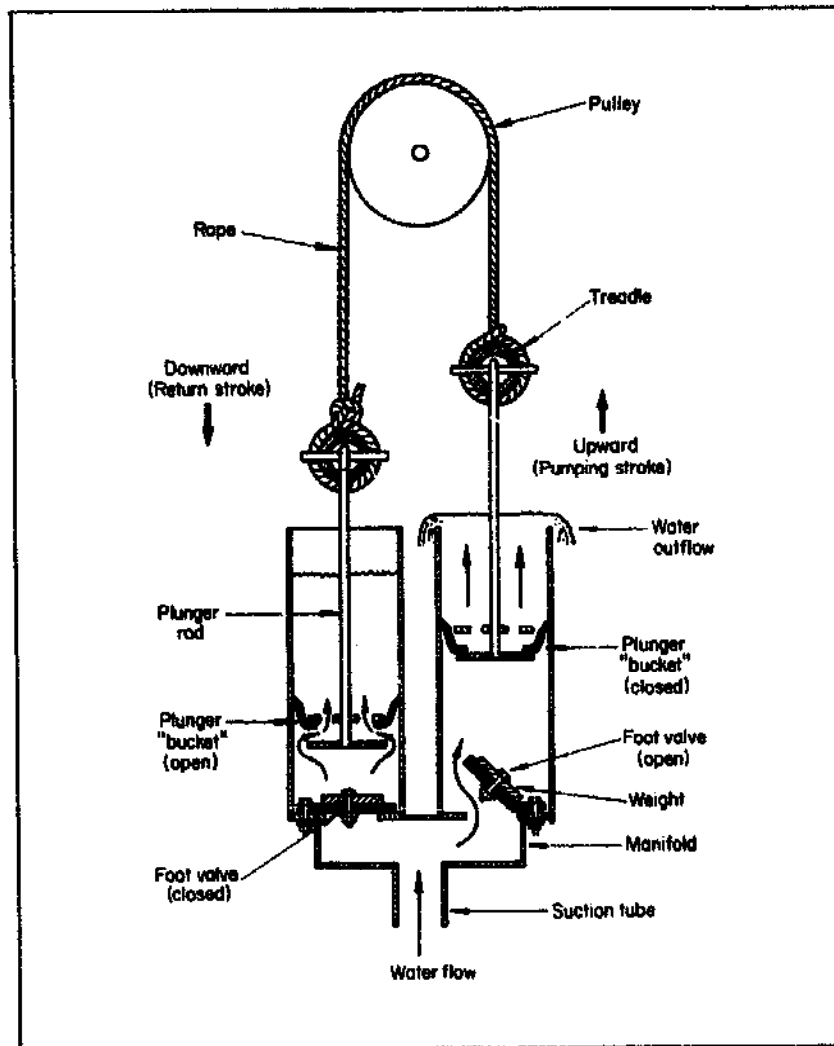

3. Schematic of twin treadle pump components and operation.

walking. A seasoned operator can work in 2-h sequences, keeping up a flow of 2-3 liters/s at 2- to 4-m lift.

- There are no operational hazards. Children, 2-3 together, enjoy playing the treadles.
- It is a suction pump limited to 6-7 m lift.
- Irrigation water is delivered at ground level, over the edge of the cylinders. This is desirable if the land is level or sloping away from the pump. However, irrigation of higher level land is difficult.
- Tolerances are wide and noncritical; materials, components, and principles used are familiar or understandable to most farmers. Although beyond the designer's intentions, the pump introduces farmers to a few useful mechanical and hydrological principles, and demonstrates (one may say too frequently) the need for and reward of regular maintenance of mechanical devices.
- The use of two parallel cylinders and alternating strokes can provide a continuous flow with low pipe diameter-to-yield ratio, and little need of a vacuum chamber.

DESIGN CRITERIA

Minimum cost

Total cost of pump and installation was not to exceed the value of 1 bag paddy rice. Sale against credit was ruled out.

Simplicity at all stages

The pump should be simple enough to be made locally, and installed and maintained by the farmer or a village pump-contractor, using standard materials and spare parts available in local shops.

Sustainable, high output

The pump should be friendly to the user, and have a sustainable output good enough for at least 0.5 ha of wheat irrigation — the target farmer being one who has no mechanized alternative.

LONGEVITY

High durability is normally incompatible with *low cost* in machinery. In the desire to keep investment and capital costs low, no particular priority was given to durability, though attempts were made with cheap, lasting material such as concrete and glass-liners in concrete.

In the end, a useful life of 4 to 5 yr was aimed at.

RELEVANCE

Following a local rule of thumb, a dry season wheat crop needs at least 10 cm of irrigation water to do well. That means 100 t/1000 m² (1 decare). There is no denying this means hard work, and it is wishfulness to sit waiting for a manual pump that can do it the easy way. In pumping hours, it means 28 h if the pump issues one liter/s — a level obtainable only with considerable effort using manual devices common in Bangladesh in 1980.

Yield of a swing basket is higher, but its elevation is limited to around 1 m. Scarcity of power pumps and of land, and uncertainty of a good monsoon harvest drove farmers to the buckets, swing baskets, or hand pumps.

Many agencies intensely wanted to find or produce a better alternative.

ALTERNATIVE DEVELOPMENT

Diaphragms, chain-and-washer devices, bicycle pedals, twin cylinders, and a few tediously imported technologies gained initial attention, but later became backyard rust-aways in the pursuance of excellence and small-farm revolution in irrigated cropping.

Farmers were the least impressed and stuck to their traditions. UNICEF wisely improved the old *No. 6* cast-iron pitcher pump, and it was promoted on a large scale for small-scale irrigation. The *Rower* pump — a direct-action,

long-stroke, plunger pump using a standard PVC pipe for cylinder, did away with the high costs, low output, rapid breakdowns, and the essentially hard work characterizing most irrigation devices.

BACKGROUND TO THE TREADLE PUMP

With 200 agricultural extension workers posted in the villages and working in disaster-prone areas, RDRS, in 1976 joined in the development of pumps by fielding a pedal-operated, flywheel-assisted, one-cylinder plunger pump. It gained some popularity, possibly because of the happy associations the flywheel (a regular ox-card wheel) brought to the farmer's mind. But it was expensive and had a low yield because it lacked the essential double cylinder setup (continuous flow).

The next pump, a very simple seesaw type, brought in the two cylinders, but it had limited user appeal and probably didn't deserve much either because it exhausted the idling leg of the operator as much as the pumping leg.

A third device had the two cylinders placed in a Y-shape on top of the suction pipe, had them buried in the ground, and had a foot- and hand-operated rocking frame driving the two plungers. Its main significance was a technical attractiveness and popularity sufficient to keep up our search for yet better pumps.

Finally came the idea of using treadles connected with a rope to engage the operator's legs and full body weight. When the following day the first treadle pump was assembled mostly from components at the workshop and installed among other pumps on the roadside, it immediately attracted passing farmers in a way other pumps had not. They sized up the ease of operation, the output, and the price tag, and demanded their own specimen.

IRRIGATION, THE SMALL-SCALE FARMER IN BANGLADESH AND HOW HE REACTED

Exploiting the groundwater

Large tracts of Bangladesh have annually recharged groundwater at less than 7-m depth. Diesel-operated centrifugal pumps often deliver around 12 liters/s from wells only 15 m deep.

The use of one such pumping unit to service a dozen small farms, each with a cheap bamboo shallow tubewell, would seem like a good proposition, and we tried to introduce it.

Installing one deep tubewell, with a pump four times larger, to serve the same farms plus some larger ones, appears less efficient, but it is a common method, advanced by heavy subsidies.

These irrigation cooperatives are commonly exploited by the larger hectareage farmers. Any mechanized method seemed to fail farmers with 1 ha. They could not quite cope with the capital, logistics, and managerial problems, or hold their own in a group. Few of them have, however, alternative employment opportunity as good as in irrigation on their own farms.

Calculations showed that by passing the current daily wage to manual-pump operators, after investing only 10-15% of the initial capital needed for a diesel-driven pump, the running cost of *manual pumping* would roughly come out level with the running cost of the diesel unit.

In a society where mechanization tends to *throw workers out of jobs*, the economic competitiveness of manual irrigation is important.

Philosophy in irrigation — extension

- Growing two crops instead of one works like doubling the available land.
- Irrigation, resulting in extra yield, provides good alternative employment for small hectare farmers.
- There is cost consciousness in both administration and recommendations.
- Shallow groundwater allows frequent spacing of wells and shorter distribution canals.
- Quality in material and demonstrations is especially important in the early stages. A small subsidy on the pumps provided opportunity for systematic checks.
- Subsidized pumps were generally sold to appointed well contractors or direct to users.
- Irrigation, a top priority service, was best promoted in a comprehensive parcel of extension activities.

Training

Because of relative fragility, possibility of faulty installation, and only 4-6 yr probable life span with frequent small repairs, we thought it important to properly *train craftsmen* in each community, and check up on these teams until the skills become a *tradition*.

The better of these teams (2-3 men), mostly with homemade tools, can make the bamboo pipes, strainers, and superstructure, and sink and install a pump in a day, boring the 10-cm \times 15-m well in their own ingenious traditional way (Appendix).

Farmer's motivation

We promoted irrigation as top priority, realizing that no other investment could give similar returns to the small-scale farmers. To see an extra crop through the dry season, he would need to spend 45-60 h on the pump for one acre (0.4 ha) of land, a reasonable command-area for a pump (15 h/acre-inch = 100 t water).

Once a farmer knows he has an efficient tool, he will keep it operational (to some degree), provided he does not have to consult a spare parts catalog to do so.

HOW COULD THESE PUMPS BE IMPROVED?

Itchy problems

Suction only. On level land with shallow water levels having no push, only

suction, there is no particular problem. In most other cases, *deepset cylinders* or *uphill* or tank delivery would be advantageous.

Breakdowns. Wearing parts (rope, buckets pulley, and pins) are cheap, but still worry small-income users. Alternative rope material such as bamboo tape could be tried.

Lack of longevity. Useful life depends mostly on how much money the general buyer will invest.

In Bangladesh, we aimed at the poorer investors, but even by careful cost-trimming and designing pump and installation (including tubewell) for US\$15, we could *not reach the poorest*. We felt the longevity of these pumps matched that of the tubewells (bamboo/coir) widely used.

The useful life of a bamboo pipe or post can be cheaply extended to 10-15 yr by simple, in-field chemical treatment.

By increasing the thickness of the steel sheets used, say from 1.6 mm (16 SWG) to 2.0 mm (14 SWG) for the cylinders, one may expect 2 yr longer useful life, while manufacture is probably still possible with the same simple machines.

Improvements tried

Cylinders (Fig. 4a)

1. Alternative materials

- Concrete block containing the two cylinders, valves, and inlets was tried. With high class workmanship, harder and better polished cylinder surface, this could work.
- Glass lining was tried, worked well, but was vulnerable to cracking.
- Soldered, galvanized sheet cylinders, sometimes with bottom made from hard wood, are not recommended. But a gifted farmer or village craftsman can make pumps without using machinery.
- Cast-iron cylinders work well, at a cost. They are very durable and recommendable as an improved version.
- Bamboo cylinders have proven possible, very functional and cheap to make from large bamboo sections, but they are not recommended for general situations.

2. Cylinder length at present is 12 inches (30 cm) and allows 25-cm stroke, which appears to be the maximum comfortable step-height.

3. Cylinders with a single spout make it easy to collect clean drinking water.

4. Cylinder diameter has direct correlations with maximum yield and comfortable lift height.

Cylinder diameter	Max yield ^a	Comfortable lift height
3-1/2" (89.0 mm)	35 GPM (2.2 liters/s)	3-5 m
4-3/4" (120.5 mm)	50 GPM (3 liters/s)	2-3 m
6" (152.4 mm)	65 GPM (4 liters/s)	2 m
7" (178.0 mm)	75 GPM (4.7 liters/s)	1.2 m

^aGPM = Imperial gallons/min.

Yield and lift figures are approximate and flexible, and vary with operator and quality of installation. *Maximum* lift height is about 7 m.

Plunger

- Leather seals (buckets) function smoother than plastic ones, and allow a very simple design. Shrinking is a problem when common leather is left to dry out.
- Disk plungers are designed for low-cost and fast flow. Traditional plungers tended to restrict output.

Pulley and rope

- Several alternatives were tried and worked: bicycle chain and sprocket, wire rope, and welded mild-steel wheel.
- A pulley made from babul (*Acacia nilotica*) wood and rope of nylon was found economical and easy to mass-produce.

Treadles (Fig. 4b, c)

- Hardwood is better than bamboo, but the given situation will influence the choice.
- We tested treadles made into triangles that could be operated with foot and hand simultaneously, but found no ergonomic advantage. Extra-length treadles can be used, but they strain other components.

Frame. Pumps have been set in a frame as a compact unit to allow full mobility for special uses.

Tubewells. A range of material can be used for filter and pipe: burnt clay tubes, plastic (PVC, PE) pipes, bamboo, steel pipe, brass screen, coir rope, or polypropylene cloth.

CONCLUSION AND PROSPECTS

Treadle pumps with twin cylinders, yielding from 1.5 to 5 liters/s were developed for irrigation on flat or gently sloping land where the water table is high (1-7 m) and where manual pump operation is acceptable. Possible command area is 1/2-1 ha per unit. In the first 4 yr of manufacture, 27,000 small holders in Bangladesh bought these pumps.

The chief gains follow:

- more land is irrigated,
- there is security from dry spells,
- jobs are created,
- market widens because of low demand on investment capital, and
- as an alternative to mechanical pumping, it saves foreign exchange, eliminates parts and fuel import, reduces lengthy breakdowns, and can nurture a local industry.

We stuck with bamboo, coir rope, and used fertilizer bags (polypropylene cloth) for small diameter wells. Bamboo pipe above groundwater level is exposed to rotting, so we adapted a technique of chemical impregnation, using

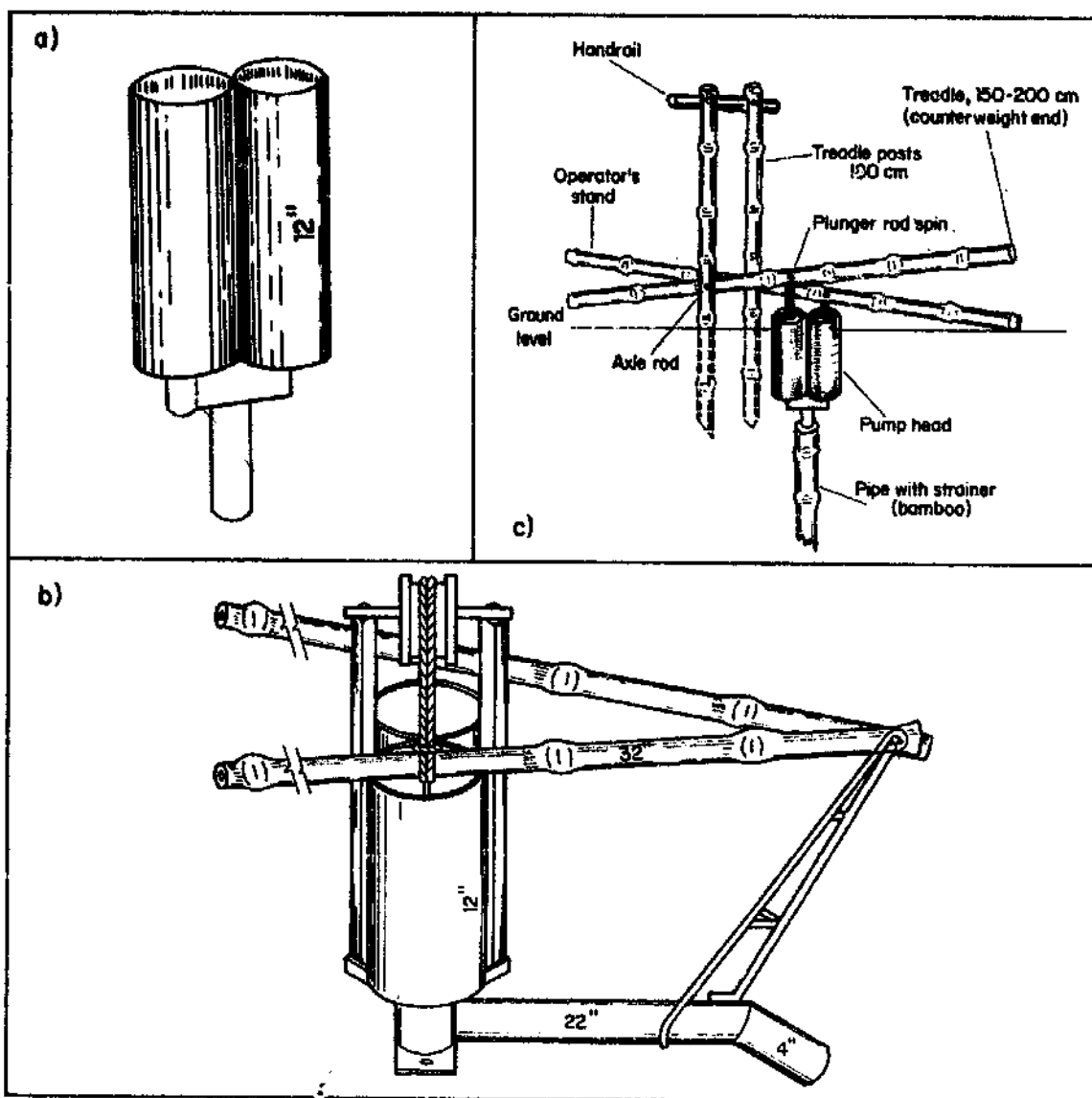

4. a) Pump head, tubewell type. Internal diameter is normally suited to existing bucket sizes. Materials may be mild steel, cast-iron, PVC, or other materials. b) Sketch of twin treadle pump, mobile type. c) Twin treadle pump, Bangladesh (Dheki model), pulley and rope eliminated.

- a small pressure container (Fig. 5),
- a tire-pump,
- copper sulfate as fungicide,
- potassium or sodium chromate as fixing salt,
- borax or boric acid as insecticide (optional) (arsenic pentoxide was considered too dangerous),
- acetic acid (vinegar) mainly as solvent, and
- water (90%).

Copper sulfate at 100-200 g is deposited under pressure in the walls of an average 6-m bamboo section.

Strainers are made by winding the coir rope or polypropylene cloth over a skeleton of split bamboo.

Pipes are bamboo sections hollowed out by using a simple, cranked boring rod.

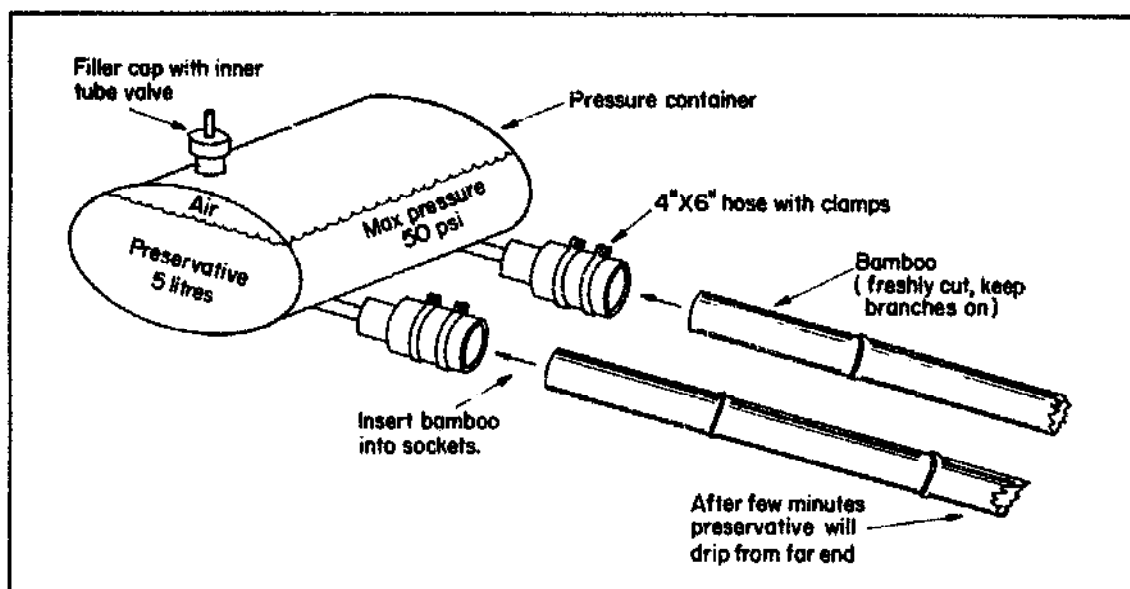

5. Pressure container for bamboo preservation.

Cylinder diam (i. d.)	Mode of use	Max capacity ^a (GPM)	Suitable lift range (m)	Price (US\$)
3½" (89 mm)	Buried head tubewell model	35 (at 4 m head)	3-6 (max 7)	8
	Mobile unit	35 (at 4 m head)	3-6 (max 7)	13
4½" (120.5 mm)	Buried head tubewell model	50 (at 2.5 m head)	1.5-3.5	10
	Mobile unit	50 (at 2.5 m head)	1.5-3.5	15
6"	Mobile unit	65 GPM (at 1.8 m head)	1.2-2.2	—
7"	Mobile unit	75 GPM (at 1.2 m head)	0.6-1.5	—

^aGPM = imperial gallons/min.

6. Capacities and costs of various models of twin treadle pumps, Bangladesh.

Bangladesh market

During introduction, some extra benefits were offered.

- A small subsidy (about 15%) was offered on the pump. Thus a high quality standard could be maintained for the infant technology.
- Tubewell contractors were trained, relevant follow-up was made, and suitable tools were developed.
- Marginally suited areas were avoided.
- In special cases or areas of doubt, reimbursements were given if the installation failed.
- Pump users received technical and agronomic advice.

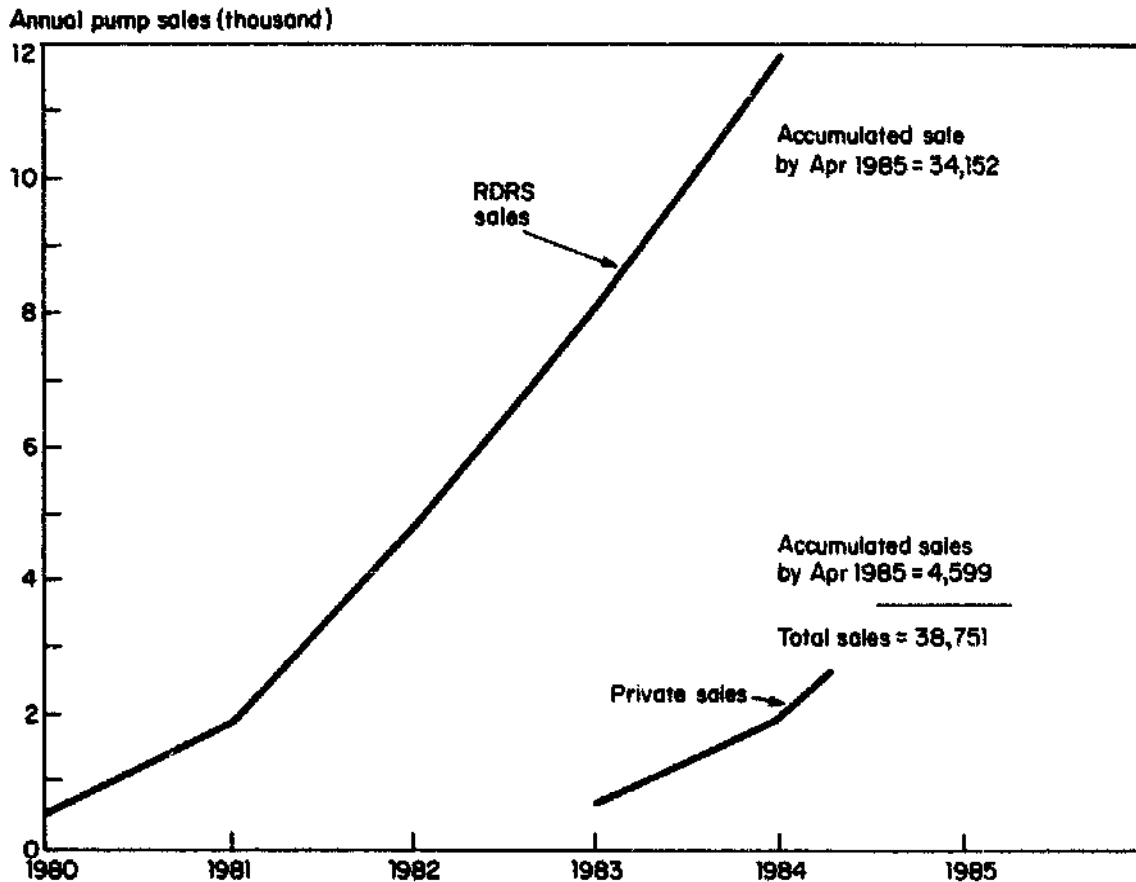

7. Sales of twin treadle pumps. Bangladesh, Nov 1980-Apr 1985.

Cost of the complete pump installation (ready for use) was around US\$15-20 (subsidies removed) (Fig. 6).

By April 1985, accumulated sales stood at around 38,000 pumps (Fig. 7).

Manufacturing is done mostly in very small private workshops. Over 80% of the sales were through RDRS channels, and mostly in working areas in northern Bangladesh.

The potentials for small farm irrigation in other large areas are equally good.

The technology is being taken to other countries where it will be relevant: China, the Philippines, Mauritania, and Tanzania.

APPENDIX. MANUAL SLUDGE BORING OF WATER WELLS

Using the equipment

- Dig a sedimentation pool, about 1 × 1 m wide and 10-20 cm deep. To catch the water as it spurts out of the drill stem, slope its sides toward the pool.
- Dig a starter hole for the bore stem, about 0.5 m deep, 10-15 cm diam, connected to the pool via a 1-2 ft canal.
- Erect 2 of the sticks half a meter behind the starter hole, half meter apart, and bridge them with a third short pole that will double as a stand for the drill operator and a fulcrum for the fourth stick (used as a handle to pulsate the drill stem).
- Tie the first short length of pipe to the handle with rope, using a slip-knot on the pipe.
- Fill water in the pool.
- Man the handle and the drill stem.
- The whole operation so far may be done in 15-20 min (provided water is readily available), and drilling can begin.
- At first the water column in the pipe is short and does not have the weight that later on will give high speed and large carrying capacity.

Boring the well

The work of two experienced operators is a rhythmic perfect coordination — one using the handle to repeatedly jerk the drill-stem upwards in short strokes, the other using his one hand to create a vacuum on top of the water column during the upstroke, thereby pulling the whole column along and accelerating it to a high speed at the end of the upstroke. At that point the water spurts out, carrying with it sand, gravel, and clay from the bottom of the bore-hole. The lumps of clay thrown out are sometimes long strings filling the whole diameter of the pipe (1-1/2" diam), and the drill stem will then rapidly sink into the ground, interrupted only briefly each time a new pipe needs to be added at top.

Performance

- a. Under suitable conditions sludging is one of the fastest drilling methods; an experienced team can often sink two 12-m wells/d at reasonable effort. The secrets behind such high performance are
 - a minimum of field transport,
 - easy mounting,
 - small team (minimum 2),
 - a surprisingly high speed as the water spurts from the drill pipe, and
 - continuous sludging out of mud.
- b. Well sizes within 4-inch diam and 20-m depth are easiest to make, but depths can be far deeper, and diam may be increased to 6 inches, usually in 2 or 3 stages.

APPENDIX. MANUAL SLUDGE BORING OF WATER WELLS

Using the equipment

- Dig a sedimentation pool, about 1 × 1 m wide and 10-20 cm deep. To catch the water as it spurts out of the drill stem, slope its sides toward the pool.
- Dig a starter hole for the bore stem, about 0.5 m deep, 10-15 cm diam, connected to the pool via a 1-2 ft canal.
- Erect 2 of the sticks half a meter behind the starter hole, half meter apart, and bridge them with a third short pole that will double as a stand for the drill operator and a fulcrum for the fourth stick (used as a handle to pulsate the drill stem).
- Tie the first short length of pipe to the handle with rope, using a slip-knot on the pipe.
- Fill water in the pool.
- Man the handle and the drill stem.
- The whole operation so far may be done in 15-20 min (provided water is readily available), and drilling can begin.
- At first the water column in the pipe is short and does not have the weight that later on will give high speed and large carrying capacity.

Boring the well

The work of two experienced operators is a rhythmic perfect coordination — one using the handle to repeatedly jerk the drill-stem upwards in short strokes, the other using his one hand to create a vacuum on top of the water column during the upstroke, thereby pulling the whole column along and accelerating it to a high speed at the end of the upstroke. At that point the water spurts out, carrying with it sand, gravel, and clay from the bottom of the bore-hole. The lumps of clay thrown out are sometimes long strings filling the whole diameter of the pipe (1-1/2" diam), and the drill stem will then rapidly sink into the ground, interrupted only briefly each time a new pipe needs to be added at top.

Performance

- a. Under suitable conditions sludging is one of the fastest drilling methods; an experienced team can often sink two 12-m wells/d at reasonable effort. The secrets behind such high performance are
 - a minimum of field transport,
 - easy mounting,
 - small team (minimum 2),
 - a surprisingly high speed as the water spurts from the drill pipe, and
 - continuous sludging out of mud.
- b. Well sizes within 4-inch diam and 20-m depth are easiest to make, but depths can be far deeper, and diam may be increased to 6 inches, usually in 2 or 3 stages.

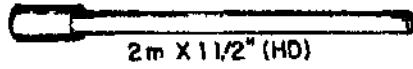

Drill stem
GI pipe with sockets



Cutting tools
a Flared socket, or
b Reducing socket
c, d Socket with chisel point

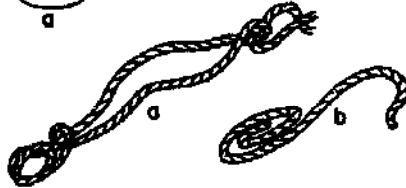

Rope, jute 1/2" - 3/4"
a Slip-knotted, linking drill stem to handle
b For tying scaffold

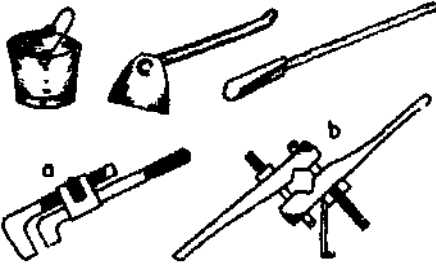

Bucket
Hoe
Hole digger

Pipe, grip
a Common pipe wrench or
b Simple clamp

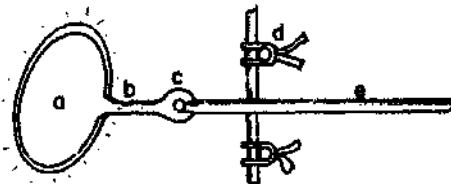

Bird's view
a Sediment pool
b Canal
c Bore hole with drill stem
d Scaffold
e Handle

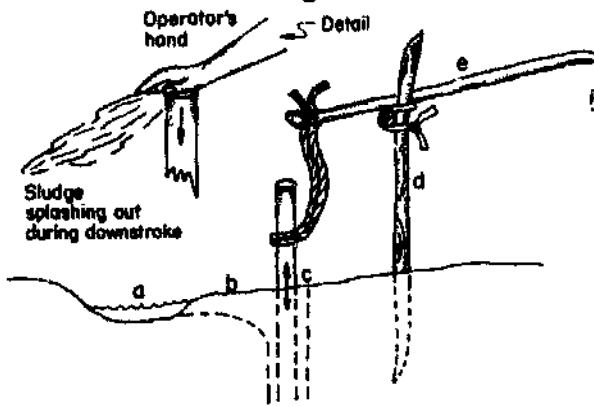

Profile
When working with long drill stem, operator will perch on the crossmember
The rope is slid up the pipe as the hole gets deeper

THE AXIAL-FLOW LOW-LIFT PUMP IN THAILAND

W. CHINSUWAN

Department of Agricultural Engineering
Khon Kaen University
Thailand
and

B. J. COCHRAN

Thai-IRRI Small Farm Mechanization Project

The axial-flow pump is the most widely used small farm machine in Thailand. It was designed to suit local requirements of low lift and high capacity. The original design was not commercially available until 1957 when steel pipe and shaft materials were used and the impeller was modified. Since 1957, the pump has replaced the traditional wooden trough water-lift system. Using the original basic concept that met the requirements of small farmers, the private sector provided most of the modifications and adaptation to use the 2-wheel tractor as a power source. Over 600,000 units of the axial-flow pump were used in Thailand during 1983.

The axial-flow pump has contributed a lot to Thai agriculture as well as to the small farm machinery industry. It contributes about \$3 million a year to industry in Thailand. The pump enables single cropping in some areas, double cropping in others, and continuous cropping in the central plain.

ORIGIN OF THE AXIAL-FLOW DESIGN

The wooden trough water lift had been the primary water-lifting device in Thailand for years. The first axial-flow pump was designed in 1941 by the late M. R. Debriddhi Tavakul, the founder of the Agricultural Engineering Division (5). His objective was to design a simple, low-cost, efficient low-lift pump that small manufacturers and farmers could fabricate. For the initial design, most components were of wood. The square pipe was made of 2.5×35 cm and 2.5×31 cm lumber. Triangular wedges were placed along the four inside corners of the pipe. The impellers, shaft, and drive pulley were made of wood. Nine impellers, spaced 23 cm apart, were used for the 2.13-m-long pipe. The pump was first demonstrated in 1941. It had greater capacity than the wooden trough water lift, but no detail is available on its performance. The successful pump was named Debriddhi pump by the Ministry of Agriculture and Cooperatives, formerly the Department of Agriculture and Fisheries. However, the initial design was not commercially available.

In 1955, Tavakul modified the design (4) (Fig. 1). The main pipe and the discharge pipe were made of sheet steel. The discharge pipe was attached to the main pipe at right angles. The drive shaft was totally in the main pipe. The single impeller, similar to that of the deep-well turbine pump, was attached to the suction end. A screener was attached to the inlet end. Small gasoline engines (3-5 hp) powered the 25- and 33-cm pumps. The design became available to manufacturers in 1957. The use of a small 4-wheel tractor as a power source was also introduced.

For the 25-cm pump, the capacity for 0.80-m head with a 30 degree inclination was 2,346.7 liters/min at 1,400 rev/min impeller speed; for the 33-cm pump, it was 5,677.5 liters/min at 850 rev/min. Pumping in a vertical position was possible using an electric motor (2). The capacity of the 33-cm pump was much higher than that of the wooden trough water lift (1,700 liters/min) when operated at the same head (3).



1. Second version of the Debriddhi pump, pumping in a vertical position.

MODIFICATION AND ADAPTATION

After dissemination of the second prototype to manufacturers in 1957, 80,000 units of the axial-flow pump were fabricated by at least 6 manufacturers in the Bangkok area by 1967 (4). During this decade, Tavakul was still modifying and adapting the pump:

- The impeller was provided with three blades (Fig. 2).
- The discharge pipe was attached to the main pipe at a 30-degree angle.
- Pump sizes for commercial use were reduced to 10, 13, 15, 18, and 20 cm.
- The pump was modified so it could propel a boat (Fig. 3) as well as pump water. For this version, separate impellers for pumping and propelling were provided. To pump water while the pump was still on the boat, the discharge pipe was longer than for the standard version. However, this version was not popular.



2. Three-blade impeller.

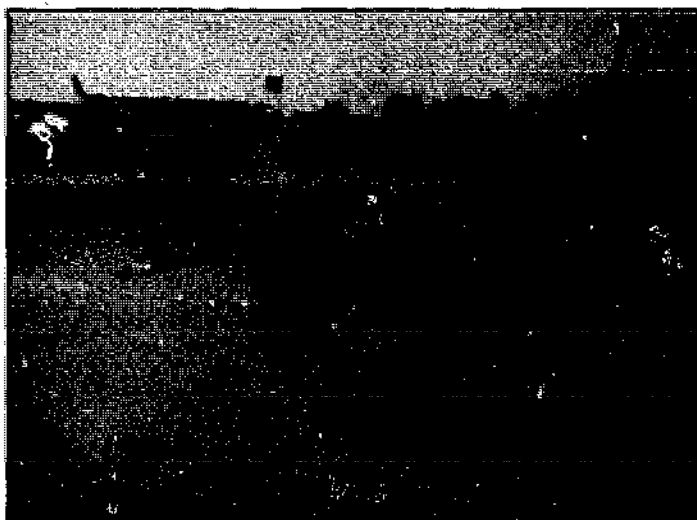

3. The Debridhi pump propelling a boat.

Most pumps during this period were powered by small gasoline engines attached to the axial shaft. Using the 10-cm pump, a capacity of 1,090 liters/min could be obtained (1).

The axial-flow pump spread very fast in the central plain during the late 1960s. From then on, the private sector modified and adapted the pump to allow use of the 2-wheel tractor as a power source. At present, the two major areas producing the axial-flow pump are Chachoengsao and Suphanburi Provinces. However, pump designs differ.

In the Chachoengsao area,

- a straight pipe without a discharge pipe is used (Fig. 4);
- the drive shaft is outside the pipe, except at the impeller end; and
- a two-blade impeller made of cast aluminum is used. Two types of impellers, low speed and high speed (Fig. 5), are available. The high-speed impeller is used when a gasoline engine is the power source and the low-speed impeller is used with a diesel engine.

These changes make the pump easier to fabricate and maintain, and require less power because flow restriction is less. This design is popular in the lower part of the central plain.

In the Suphanburi area, major modifications have been made on the design of a low-speed impeller powered by a diesel engine. Figure 6 shows the present design of the low-speed impeller in the Suphanburi area. This impeller has six blades made of mild steel. The inlet portion of the pump is enlarged (Fig. 7). This design is popular in the upper part of the central plain.

The efficiency of the 18-cm pump having a 6-blade impeller was greater than that of 13-cm and 15-cm pumps with a 2-blade impeller. For the 18-cm pump, a capacity of 4,260 liters/min could be obtained (6).



4. Present design of the axial-flow pump in the Chachoengsao area, Thailand.

The latest modification was done in 1979 by C. Thammathorn, Aree-Arthorn Manufacturer, with some technical assistance from the Thai-IRRI Small Farm Mechanization Project. A double-suction impeller (Fig. 8) was attached to the inlet end of the pump. The drive shaft is totally outside the main pipe (Fig. 9). Two standard sizes are available, 15 cm and 20 cm in diameter, both 5 m long with extension pipes 2.5 and 5 m. Capacity is 4,000 liters/min for the 15-cm pump and 6,000 liters/min for the 20-cm pump. The pump can pump water from a river or canal.

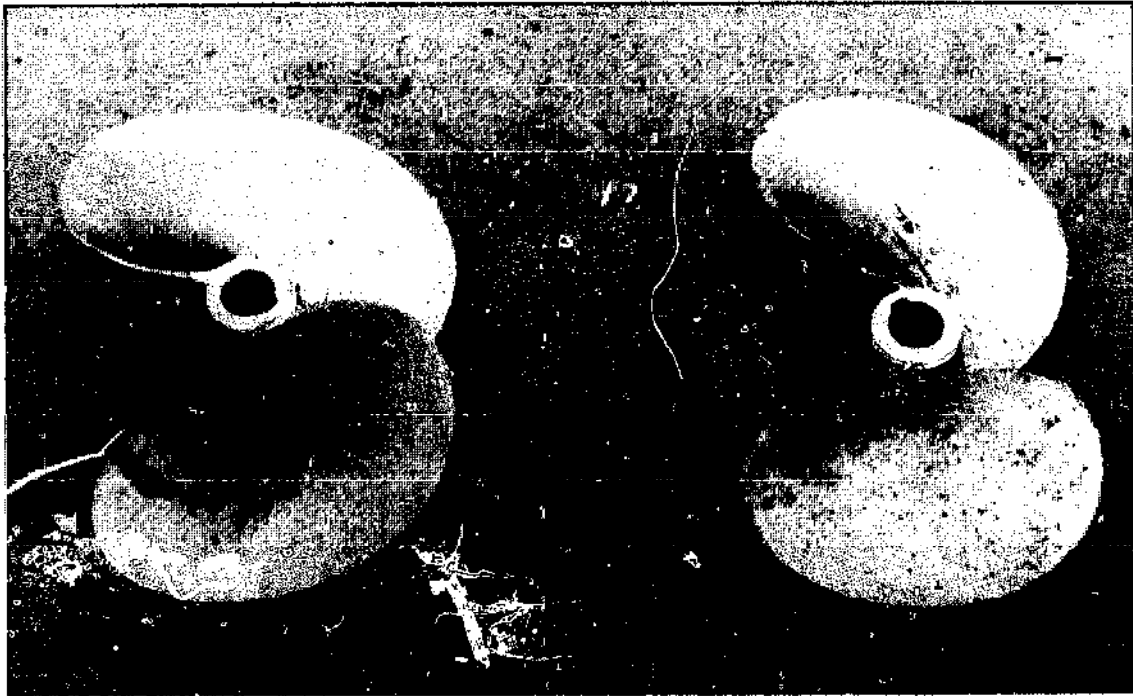

5. Low speed (left) and high speed (right) impellers for the axial-flow pump in the Chachoengsao area, Thailand.



6. Low-speed impeller for the axial-flow pump in the Suphanburi area, Thailand.

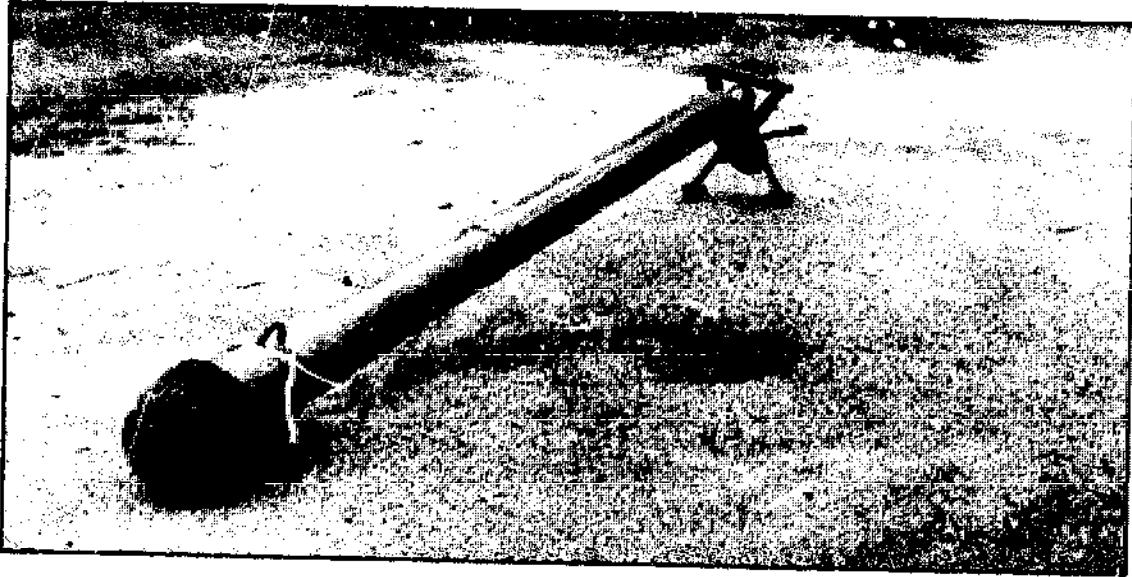

7. Present design of the axial-flow pump in the Suphanburi area, Thailand.

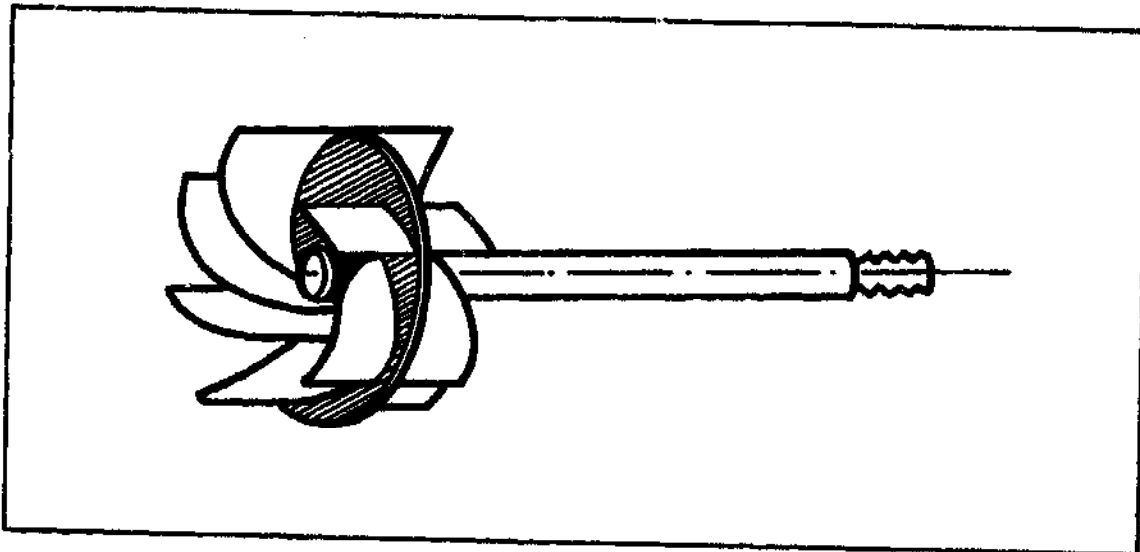

8. Double-suction impeller.

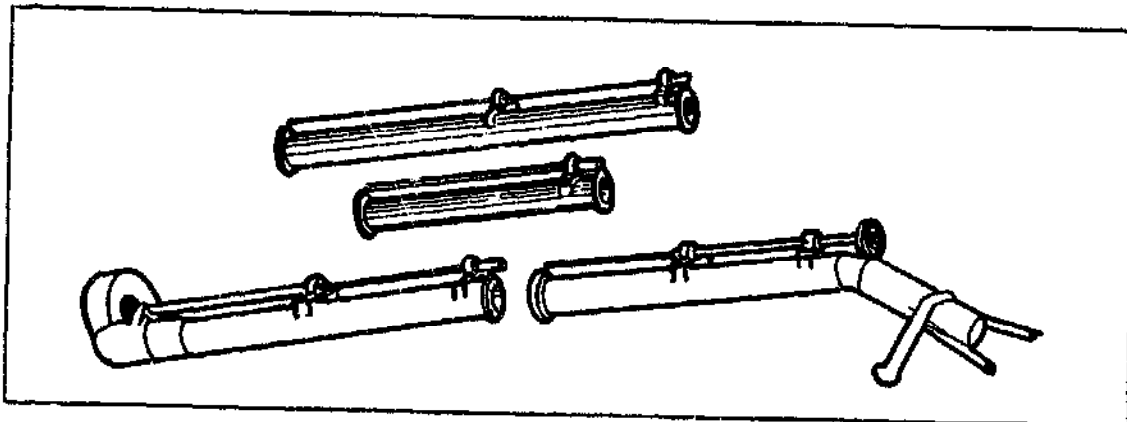

9. Low-lift pump by Arce-Arthorn manufacturer.

PRODUCTION

In 1957, a few manufacturers in the Bangkok area began producing the axial-flow pump and those in the central plain started fabricating the pump without technical assistance from the government. The number of pump manufacturers is unknown, but most are in the central plain.

The axial-flow pumps gradually increased from 80,000 units in 1967 to about 175,000 in 1975 (Table 1). With increase in irrigated land area and the wide use of the 2-wheel tractor in the central plain, pumps increased to about 600,000 units in 1983. Most pumps are powered by 2-wheel tractors with 8-12 hp diesel engines. In other parts of the country, where 2-wheel tractors are less used, many pumps are powered by small gasoline engines.

The pipe diameter of the most common commercially available pumps are 13, 15, 18, and 20 cm. Typical prices not including engines appear in Table 2.

Pump prices have increased only 50% during the last 14 yr — a 13-cm diam, 3-m-long pump was \$22.22 in 1971 and \$33.33 in 1985 — because of the simple design of the pump, high volume of sales, and competition among manufacturers.

Table 1. Number of axial-flow pumps and rice area in Thailand, 1967-83 (4, 6).

Year	Pumps (no.)	Axial-flow pumps ^a (no.)	Area planted to rice (thousand ha)
1967	—	80,000	—
1975	251,288	175,902	7,982.24
1976	277,084	193,959	8,896.32
1977	317,328	222,130	8,575.20
1978	359,308	251,516	9,031.04
1979	473,975	331,783	10,026.72
1980	517,975	362,583	9,435.36
1981	603,548	422,484	9,617.60
1982	780,610	546,427	9,595.20
1983	858,671	601,070	9,621.44

^a Axial-flow pumps are estimated to be 70% of the total pumps.

Table 2. Typical prices of common axial-flow pumps. Thailand, 1985.

Length (m)	Price ^a (US\$)			
	13 cm diam	15 cm diam	18 cm diam	20 cm diam
3	33.33	37.04	38.89	40.74
4	38.89	48.15	50.00	51.85
5	46.30	53.70	57.41	59.26
6	55.56	59.26	62.96	66.67

^a Based on the exchange rate of US\$1 = Baht 27. Prices quoted by J. Chaidee Panich, Chachoengsao.

DISCUSSION AND CONCLUSION

The axial-flow pump is a good example of local design for local needs. The required pumping head in Thailand is usually not greater than 3 m. The low lift but high capacity characteristics of the axial-flow pump together with its low price make it more suitable and preferable to a more efficient centrifugal pump. This indicates that efficiency alone does not always dictate success for small farm equipment.

The pump has rapidly become popular with minimum assistance from the government. The private sector modified the design and adapted it for use with the 2-wheel tractor as a power source. The pump rapidly replaced the traditional wooden trough water lift because of these advantages:

- higher capacity;
- portability and ease of setup. The axial-flow pump can be set up within 10 min; at least 2 h is required to set up the water trough;
- lower price. A water trough in 1985 costs at least 2 1/2 times as much as an axial-flow pump. But the axial-flow pump has a service life of about 4 yr, while the water trough has about 10 yr. The axial-flow pump is widely used, but some water troughs are still in use, mainly for pumping saline water.

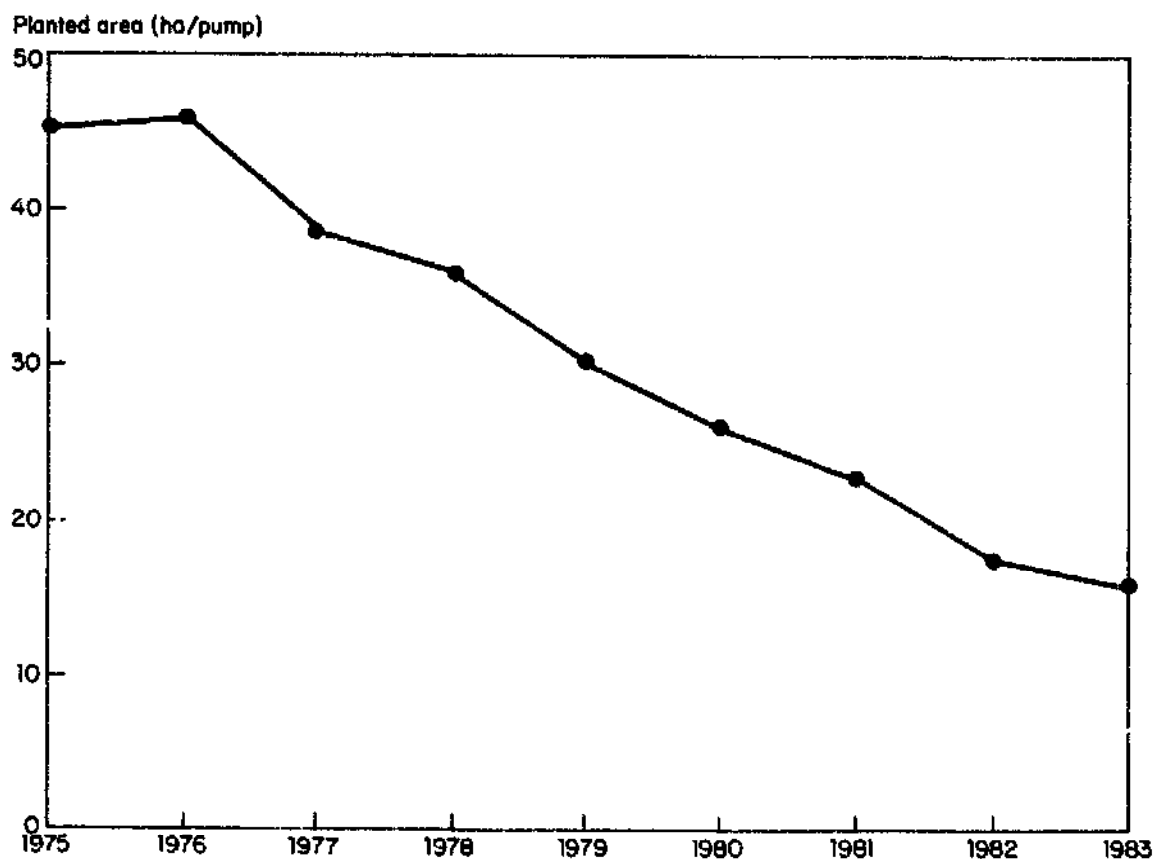

10. Rice area planted per axial-flow pump during 1975-83 in Thailand.

The low price of the axial-flow pump is mainly due to its simple design. Most axial-flow pumps in Thailand use wooden bushings instead of bearings for submerged parts. Bushings cost only 7-11 cents (2-3 bahts) each, and can be replaced by the farmers. However, they must be inspected frequently for wear, especially those at the impeller end. When impeller bushings wear, the impeller can make a swirling rotation and cut the pipe.

One farmer in Pathumthani Province indicated the total annual cost of the axial-flow pump was about \$100 (2,700 bahts) each for double-cropped 3.2 ha (20 rai) of paddy land. With his average yield of 6.25 t/ha, the total annual cost of the axial-flow pump is \$2.5/t. This cost can be interpreted in many ways. Without the pump, however, there is no guarantee for a second crop and for the same high yield.

The planted rice area per unit of axial-flow pump was reduced from about 45 ha/pump in 1975 to 16 ha/pump in 1983 (Fig. 10). Even though most pumps are now used in the central plain, use in other parts of the country is increasing and production for replacement is required.

REFERENCES CITED

1. Chinsuwan, W., C. Rukarcheep, and P. Chanurai. 1973. Testing the performance of a Debriddhi pump. Undergraduate thesis, Khon Kaen University, Khon Kaen, Thailand. (unpubl.)
2. Noparat, S. 1960. A study on the use of Debriddhi pumps of ten- and thirteen-inch-diameters [in Thai]. Undergraduate thesis, Kasetsart University, Bangkok, Thailand. (unpubl.)
3. Sidnarane, S., and K. Limptrakul. 1973. The water lift efficiency. Undergraduate thesis, Khon Kaen University, Khon Kaen, Thailand. (unpubl.)
4. Tavakul, D. 1967. Research and development of irrigation equipment [in Thai]. *Technology and Agriculture*. pp 20-24.
5. Tavakul, D. 1941. Debriddhi pump [in Thai]. *Kasikorn J.* 14(2):281-283.
6. Thailand Ministry of Agriculture and Cooperatives, Center for Agricultural Statistics, Office of Agricultural Economics. 1981-84 Agricultural Statistics 150, 168, 202, and 213. Bangkok.
7. Toonim, N., V. Kamoltiprong, and S. Loahakanvanich. 1985. Testing and evaluation of locally made axial-flow pump [in Thai]. Undergraduate thesis, Kasetsart University, Kamphangsean Campus, Thailand. (unpubl.)

Seeding and planting

RICE SEEDLING TRANSPLANTERS IN CHINA

D. Z. QIANG

Chinese Academy of Agricultural Mechanization Sciences
The People's Republic of China

Rice, a major crop in China, occupies more than 29% of the area sown with grain crops and comprises more than 45% of grain crop production. Rice seedlings have been hand transplanted for more than 1,000 yr. Because the rice planting season is very short, timeliness of transplanting is essential to high yield. Hand transplanting is laborious, low-efficiency work. Therefore, working masses look forward to the improvement of working conditions and to mechanization of paddy rice transplanting. As early as the Sung Dynasty, there was a *transplanting boat* on which a peasant sat to transplant seedlings by hand. To eliminate finger pains, peasants created a simple transplanting tool made of bamboo. After the founding of the People's Republic of China, research work on rice seedling transplanting machines has advanced in a planned way.

The development of rice transplanting machines has undergone three stages. In the first stage (1953-60), engineers explored and created rice seedling transplanters. In the second stage (1961-69), they built the machines and began to develop power-operated machines. In the third stage (1970-80), the transplanters were popularized, with the appearance of the dual-purpose rice transplanter and a series of diversified hand-operated and power-operated machines.

EXPLORATION AND CREATION

Organized research on rice seedling transplanters began in 1953. The East China Agricultural Research Institute first explored the principle and functional mechanism of the transplanter. In 1956 the preliminary seedling-separating mechanism with vertical pulling by claw-grippers was researched; it was continuously improved in later years. The first animal-drawn rice planter developed in China was field tested in September 1956 and received favorable comment.

Several technical exchange meetings on rice transplanters were organized by the Ministry of Agriculture. When the fifth on-the-spot technical exchange meeting on rice transplanters was convened in 1958, 40 models of rice

transplanters were exhibited and 5 were recommended to the nation. At the sixth meeting (1959), 63 models were evaluated and 18 were recommended for trial production after some improvement. More than one million machines were manufactured in 1960. Most were manual or animal-drawn. Because of unstable performance with animal draft, the machines gradually fell into disuse.

Regarding transplanting principles, seedling-feeding and seedling-separating were gradually perfected. Longitudinal feeding combined with the transverse moving of the seedling box, and the grippers picked the number of seedlings cyclically from the seedling mass. On machine structure, the corrugated boat body supported the weight of the machine. The boat body had advantages over the flat sled: less clogging with soil and easier closing to the row.

REFINEMENT

Putting one million prototype machines into operation in 1960 showed that the machines evaluated had unstable performance and could not satisfy the agronomic requirements. The machine structure needed improvement. After the establishment of the Ministry of Agricultural Machinery, close attention was paid to improving and perfecting the transplanters. After several years, the Guangxi-65 manual rice transplanter was evaluated and produced on small scale in 1965. This machine was the first finalized hand-operated, pincers-type machine, while the first comb-type manual machine, Jinggangshan-67 model, was evaluated by Jiangxi Province and put into production in 1967.

The power-operated rice transplanter was developed by cooperation of several research institutes. Dongfeng-2S self-propelled machine was evaluated at the ministry level in 1967 and won the national invention award. It was the first power-operated rice transplanter evaluated in China. It was driven by 3-4 hp petrol engine with a single front driving wheel and was suitable for root-washed seedlings.

The Chinese Academy of Agricultural Mechanization Sciences (CAAMS) played an important role in organization, promotion, and technical advising during the development and evaluation of these machines.

POPULARIZATION

The development of rice transplanters turned from small-scale experiments to large-scale operations after 1969. In 1970 the country had more than 150,000 manually operated machines, 4 times the quantity in 1967. Power-operated machines grew to more than 2,000 units in 1970, 150 times that of 1967.

Because China has a vast region planted to rice and its agronomy is complicated, two or three models of machines are inadequate for the needs of peasants. In this period, besides further research on the machine for root-washed seedlings, the machines for soil-bearing seedlings and dual purpose were developed.

Some rice transplanters evaluated in the 1970s became the main models popularized in different regions. In 1975, about 100,000 manual machines were produced. Power-operated machines manufactured in 1977 peaked at about 30,000 units. Manual machines used peaked at 510,000 units in 1977, while power-operated machines reached the peak of 100,000 units in use in 1979. Areas transplanted by machines peaked at more than 666,000 ha in 1976.

However, too many types of transplanters led to troubles in both manufacture and popularization. Therefore, CAAMS unified work for the power-operated rice transplanters in 1977. The power-operated machine series was designed and evaluated in 1979 and put into production in 1980, with a total output of more than 1,000 units. Interchangeability of assembly in machines of this series comes to 70% and that of parts amounts to 85-95%. This series is suited to paddy fields with depth of hardpan up to 400 mm and length of root-washed seedlings 150-450 mm; it provides various plant and row spacing to meet the needs of different regions.

Equipment for raising seedlings and transplanters for soil-bearing seedlings were introduced from Japan in 1979-80. Their adaptability was tested in several provinces and municipalities. Results showed this mechanized system for rice cultivation was suitable for conditions in northeast China and single-cropped rice and first crop of double-cropped rice in other regions. Integrating the advantage of the Japanese equipment and our experience on developing the rice transplanters led to several machines for soil-bearing seedlings.

PRESENT SITUATION

Since 1980, agricultural mechanization plans have been revised and production of agricultural machinery had turned from its peak to a stable developing stage. With economic reform in rural areas, the agricultural production system has greatly been reformed, and development of the specialized peasant households and family-managed farms has not progressed much. Therefore, production of rice transplanters is not high. But the equipment still is in use on some state farms in northeast China and north China and in regions where the cultivated area is large. For example, in 1984 the area transplanted by machines accounts for 40% of the total area planted to rice in Jilin Province, the highest level in China.

Research work today is progressing mainly on rice pulling machines matched with rice transplanters, and on a new type of transplanter for hybrid rice varieties.

Two types of rice transplanters are produced at present. The Dao Xiang manual rice transplanter is suitable for root-washed seedlings. Its output was 12,413 units in 1984 and will come to 17,000 units in 1985. The 2ZT-935 power-operated transplanter is suitable for soil-bearing seedlings. Its output reached 600 units in 1984 and will be 620 units in 1985.

The quantity of rice transplanters in use and area transplanted by machines in 1980-84 is given in Table 1.

Table 1. Quantity of rice transplanters in use and area transplanted by machines in China in 1980-84.

Year	Manual transplanters (no.)	Power-operated transplanters (no.)	Power (hp)	Area planted by machine (ha)	Ratio ^a (%)
1980	331,845	83,399		195,800	0.58
1981	279,037	66,355	250,880	133,800	0.4
1982	195,129	44,418	151,937	120,600	0.4
1983	149,942	27,936	97,132	123,540	0.37
1984	212,265	17,930	61,982	167,149	0.5

^aCf area transplanted by machine to total area planted to rice.

Because the rice transplanters were developed for agricultural practice in China, they have marked Chinese features:

1. The seedling-gripping principle is used: seedlings are directly separated from the seedling masses by an improved transverse and longitudinal feeding mechanism. Seedling gripping is well-matched with seedling-checking. The transplanter separates seedlings from the seedling mass, gripping layer by layer, so as to ensure seedling-separating quality and to improve seedling-separating efficiency. The contradiction between the higher planting density and the lower rate of manual seedling-separating is resolved. The principle of continual seedling-gripping is realized and allows a manual machine field capacity up to 0.1-0.17 ha/labor-day and power-operated machine, 0.33-0.53 ha/labor-d.
2. To better anchor them, seedlings are planted without disturbing the soil since furrow opening and covering are not easy operations in flooded paddy. When a cycloid is used to follow a "zero-relative ground speed," the smaller spacing in a row cannot be ensured. Also, continuous seedling-gripping at different spacings for power-operated machines is difficult to attain. The power-operated rice transplanter in our country uses the prolate cycloid transplanting mechanism which permits the gripper to move with an unrestricted movement after the seedling has been transplanted into soil.
3. The overall design of rice transplanting machines shows driving wheels with spade lugs and a high floating body structure. The design improves flotation and mobility, thereby eliminating uneven transplanting caused by irregular movement. A rice transplanter of this design and total weight of 500 kg (machine plus operator plus seedlings), powered with a 3-4 hp engine, can be satisfactorily operated with a 6-8% wheel slippage in fields with hardpan depth up to 300 mm. This slippage is less than that of conventional drive wheels used for paddy fields.
4. To meet the needs of a vast territory and differing requirements of peasants, the rice transplanter series consists of interchangeable components. Peasants can more easily master the operating techniques of machines and it is convenient to organize supply of spare parts.

The developed transplanters are not perfect and they have to be extensively investigated and continuously improved. The problems follow:

1. Rice transplanters are not suitable for the current change in China's economic system. Use of the manual rice transplanter indicates relatively high labor intensity. Field capacity of power-operated machines is too high for the present rural production responsibility system in which the area under cultivation per capita of labor is limited. Popularization of these machines depends on development of the specialized peasant households. If the area of paddy fields in the production unit is more than 7 ha, then it is possible to give full play to the superiority of mechanical rice transplanting.
2. The rice seedling puller has not been used in production, which is affecting the popularization of transplanters. Now transplanted rice seedlings are mainly root-washed, and so a nursery seedling puller to match the transplanters is needed. Although great progress has been made in developing rice seedling pullers, they still cannot be used in agricultural production. Therefore, more intensive research and development work on them must be made.
3. Rice seedling transplanters do not meet the requirements of new rice varieties. Existing machines cannot transplant hybrid rice. This affects the popularization of hybrid rice which is one of the important achievements in scientific research in China. Therefore intensive research and development work will be done to resolve as early as possible the problem of transplanting hybrid rice.

RECOMMENDATIONS

1. The technology of raising mat seedlings and the transplanter for soil-bearing seedlings should be gradually popularized.
2. Research work on the rice seedling puller matched with rice transplanters should be speeded.
3. Cooperation between the scientific and technical sectors of agricultural machinery and agronomy should be strengthened. Beginning from the technique of seedling raising, a systematic research on the mechanization of rice seedling transplanting should be carried out.
4. The existing rice transplanters should be improved so as to meet the needs of the specialized peasant households.
5. A new type of transplanter for hybrid rice varieties should be developed.

RICE SEEDLING TRANSPLANTERS IN THE PHILIPPINES

G. SALAZAR, L. EBRON, H. ICATLO,
B. DUFF, and R. E. STICKNEY
International Rice Research Institute

Hand transplanting of rice seedlings in puddled soils is the most common method of planting rice in most Asian countries. It has the advantages of requiring less precise land preparation than does direct seeding, of creating conditions for better water and weed control, and above all, of saving up to 20 d in crop use of the field.

Transplanting, however, is very labor intensive, requiring about 10-20 labor-d/ha (3). This high labor input often results in labor shortages during the planting season. In areas practicing double-cropping, land preparation and transplanting of the second crop and harvesting of the first crop take place simultaneously, making it difficult to complete these operations quickly with traditional methods. Consequently, farmers in the Philippines are changing from transplanting to direct seeding at an increasing rate.

The traditional method of seedling preparation does not permit complete mechanization. For several decades, engineers from rice producing countries, notably Japan, China, and India, tried to mechanize the transplanting of rice seedlings. Success came in the late 1960s when Japanese engineers developed a new method of seedling preparation (1). The seedlings are grown in a wooden or plastic tray with a perforated bottom, on a layer of specially prepared soil. The soil holds the seedlings together. When removed from the tray with the aid of a scraper, the seedlings look like a mat and so are known as mat-type seedlings.

Use of mat seedlings facilitates mechanized rice transplanting. Pulling single seedlings from the holding tray is easier, so a simpler picking mechanism can be used. The soil helps protect the roots from damage by the mechanical fingers. In Japan, where farm labor is acutely scarce, seedling preparation is fully mechanized.

In China, traditional seedlings are used in machines. The Chinese have tried to mechanize the pulling of the seedlings from the nursery bed, but without success so far.

Japan and China are the forerunners in the export of rice transplanting machines. The Japanese machines are mostly power-driven with sizes ranging from 2 to 4 rows for the walking type and 6 to 8 rows for the riding type.

The Chinese produce both manually operated and power-driven machines. The powered machines from China have more rows but closer spacing between rows (4). A disadvantage is the frequent reloading of seedlings. Consequently, two seedling tenders ride on the machine with the driver. Machines of other countries are generally patterned after the Japanese and Chinese designs.

The price of imported power-driven transplanters is beyond the reach of small farmers in developing countries. The complex design of power-driven transplanters and the skill required to operate and maintain them may not suit the ordinary farmer. Recognizing these problems, the IRRI Agricultural Engineering Department designed and developed a manually operated transplanter for transplanting mat seedlings. This paper summarizes IRRI's experiences with the transplanter, including recent extension efforts in the Philippines with the MAF (Ministry of Agriculture and Food)-IRRI Industrial Extension Program.

THE IRRI TRI 5-ROW TRANSPLANTER

Development

A feasibility study conducted at IRRI in 1977 (2) indicated that it may be too costly for small rice farmers to use powered transplanters. As a result, the IRRI Engineering Department began a low-cost manual transplanter project. The initial work concentrated on redesigning a Chinese-type, 5-row machine (Fig. 1) with 20-cm row spacing, to make it less expensive and easier to operate. The machine was redesigned to simplify the picking and planting mechanism. The original machine required four motions of the transplanting arm (Fig. 2): opening the picker fingers, picking the seedlings from the tray, pushing the seedlings into the soil, and then releasing the planted seedlings. This operation was complicated and tiring to the operator. The redesign (Fig. 3) involves only two motions: the downward stroke picks a group of seedlings (3 to 7) from the tray and plants them into the soil, and the upward

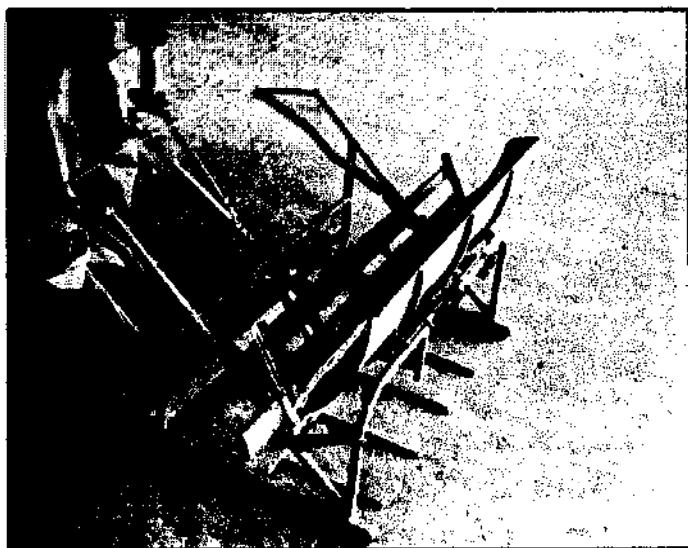

1. Commercial model of Chinese-type transplanter manufactured in the Philippines.

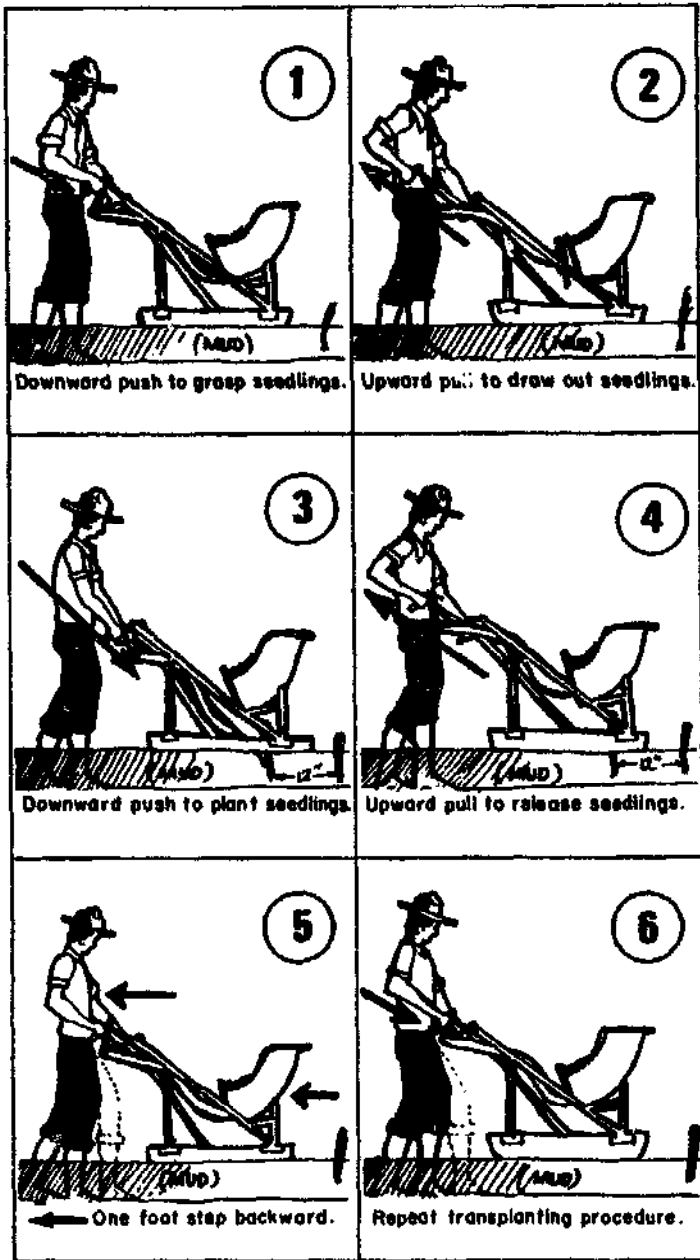

2. Operating procedure for Chinese-type, manual rice transplanter.



3. IRRI TR1 5-row rice transplanter.

stroke releases them. The redesign replaced the pincer pickers, first with a blade picker (Fig. 4a) and finally with a fork picker (Fig. 4b).

Each time the handle is pushed down, a simple pawl lever indexing assembly (Fig. 5) moves the tray laterally to ensure that seedlings are in position to be picked in the next cycle. After the seedlings are planted, the handle is then pulled back toward the operator. Near the end of the retraction stroke, a cam deflects the picker to prevent it from touching the seedlings (Fig. 6). At the end of the retraction stroke, the operator continues to pull the handle to slide the machine a desired distance to the next planting position. The machine is provided with side markers to guide the operator for the next pass. These changes produced a relatively lightweight (25 kg), low-cost machine.

As the machine was being developed, a new seedling preparation method evolved. Seedlings are prepared in a modified wet bed on 1-m-wide seedbeds. Bottomless wooden frames with 5 compartments (the same size as the seedling tray division) are arranged so that 10 frames can be accommodated on a 1-m-wide \times 5.5-m-long bed (Fig. 7). Each compartment is filled with mud and leveled to a uniform thickness of about 1.5 cm. About 180 ml of pregerminated seeds is uniformly spread in each compartment and then pressed lightly. The seeding rate is 40-50 kg/ha. After 15-20 d, the wooden frames are carefully lifted. A sharp-edged seedling remover is pushed carefully under the seedlings to sever the seedling mat from the seedbed. This cuts the roots that have penetrated the seedbed but does not unduly harm the seedlings.

INTRODUCTION

After extensive laboratory and field testing, the IRRI Industrial Extension Section began to introduce the TR1 5-row transplanter. In 1978, the machine was demonstrated in several Philippine locations to determine farmers' interest. Blueprints were distributed to interested manufacturers. Except in a corporate farm of the Philippine Packing Corporation (PPC) in Musuan, Bukidnon, the transplanter failed to generate sustained interest.

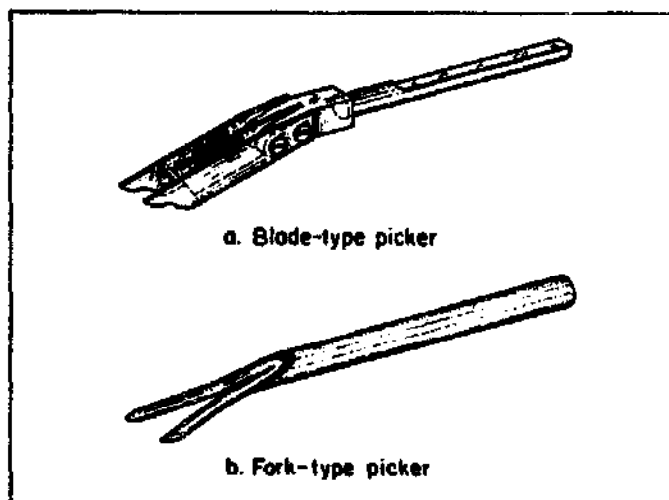

4. Type of rice seedling picker.

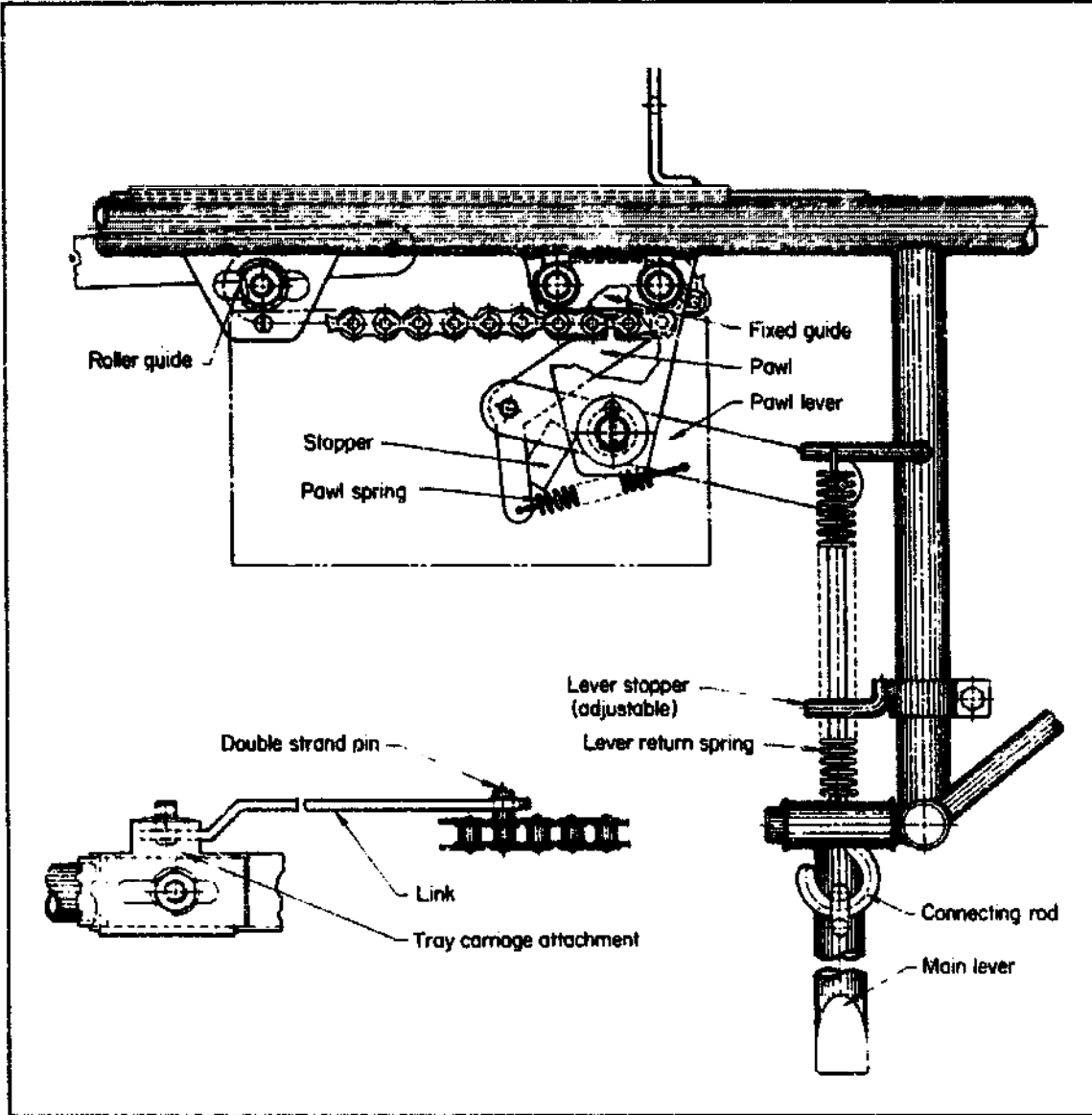

5. Pawl lever tray drive mechanism.

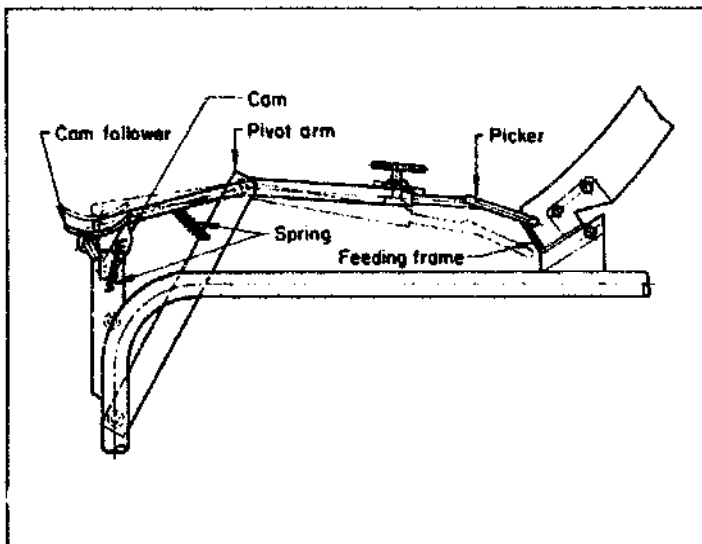

6. Cam and picker assembly of IRRRI TR1 5-row rice transplanter.

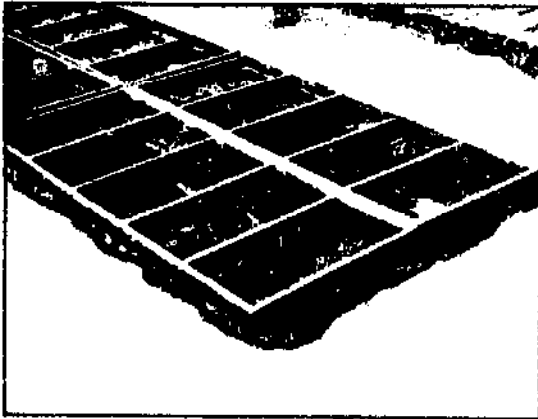

Single frame seedbed.

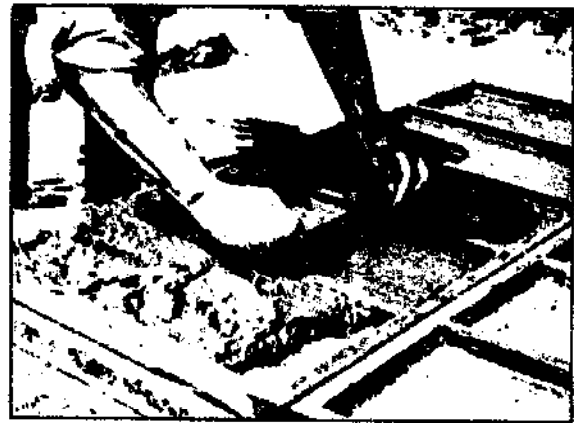

Seedbed preparation.

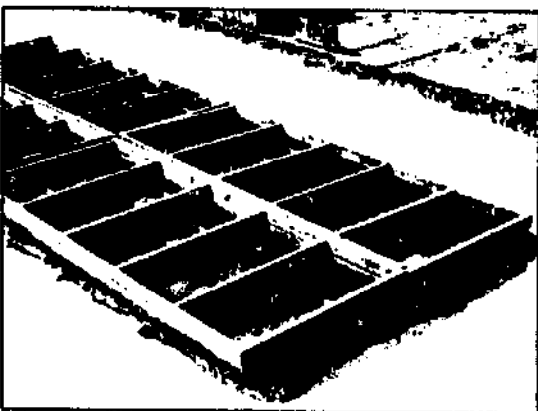

Double frame seedbed.

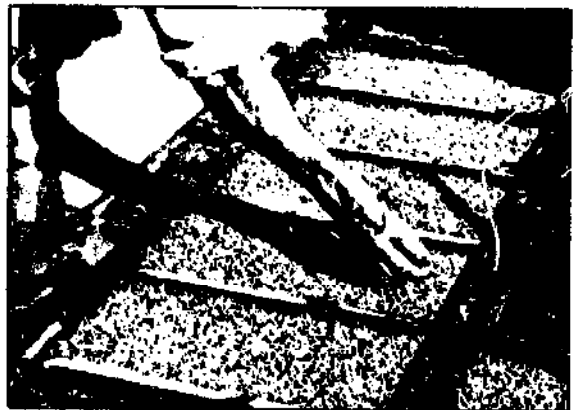

Sowing the seed.

7. Seedling preparation for IRRi transplanter.

Beginning in 1981, the PPC rice farm used the transplanter for several cropping seasons. They adopted their own method of seedling preparation, a modified "dapog" method in which 1.0-1.5 cm of dry, screened soil mixed with fertilizer is used as the seedling mat soil. The top of the seedbed is covered with plastic, and wooden frames are placed around the edge of the seedbed, thereby eliminating the more expensive compartment frames used in the original method. An ordinary sickle can be used for cutting the seedling mat (Fig. 8) which can be rolled for ease of transport.

In 1982, the MAF-IRRI Extension Program evaluated these experiences to estimate the potential market for this machine. The principal results follow (5):

1. For experienced transplanter operators at PPC, the average field capacity was approximately 0.2 ha/d (7.5 h of operation), slightly lower than IRRI's estimate of 0.25 ha/d.
2. The middle row of the transplanted seedlings fell directly in the operator's footprints, increasing the percentage of floating hills.
3. Tension springs in the cam and in the picker holder lost their resilience after only 2 wk of operation.

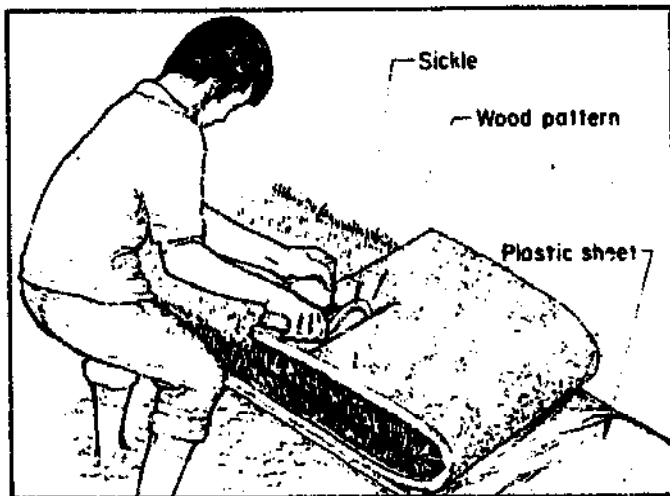

8. PPC method of seedling preparation.



9. IRRI TR4 6-row rice transplanter.

4. It was difficult to move the unit from one paddy to another, especially when the adjoining field was already transplanted.
5. Some operators, especially inexperienced ones, found the pulling effort slightly heavy.
6. Seedling preparation needed further simplification. Farmers did not like to use many wooden frames.
7. Manufacturers complained that the machine was difficult to fabricate and had too many parts.

THE TR4 6-ROW TRANSPLANTER

Development

Improvement of the transplanter, begun in late 1982, produced the IRRI 6-row transplanter (Fig. 9), having the following features:

Increased field capacity. Changing the 5-row model to a 6-row version increased the capacity to 0.3-0.4 ha/d, and reduced the percentage of floating hills since the operator's footprints fall between the 3d and 4th rows of the transplanted seedlings. The tray length was also increased, reducing the loading frequency.

Better operator comfort. The pulling force was considerably reduced:

- Instead of a single, wide skid, two long, narrow skids are used. Thus skid weight and drag are reduced.
- The total weight was further reduced to 20 kg.
- Rubber grips on the handle help prevent blisters on operators' hands.

Easier fabrication. Redesign uses fewer parts, the seedling tray is now straight instead of curved, and a bicycle free-wheel sprocket assembly (readily available in rural areas) serves as a tray indexing assembly. Furthermore, the whole transplanter mechanism can be bolted as one unit to the skids.

Less troublesome operation. The tension springs in both the cam and picker assembly were eliminated by the new *inertia control* mechanism. The new mechanism only requires a slight jerk at the start of the downward stroke so that the picker lever will move forward against a stopper to position the picker properly (Fig. 10). On the return stroke, the picker will not hit the seedlings because the picker lever will move slightly backward against the opposite stopper.

Versatility. To change seedling density, the number of teeth in the free wheel sprocket assembly can be changed, varying the tray displacement per stroke (Table 1).

When, on the last pass, rows to be planted are less than the number of tray divisions, one of the skids is placed between the transplanted rows and the seedling mats above the transplanted rows are removed (Fig. 11). This was not possible with the old design.

To facilitate the adoption of the new transplanter, two simplified methods of growing seedlings were developed. In the *modified "dapog" method*, minor changes were made in the seedling preparation method used by the PPC rice farm. Mud soil from the sides of the seedbed is placed on top of a surface covered with plastic sheet or banana leaves to form a layer 1.0 to 1.5 cm thick. This method requires a wooden frame around the seedbed.

An experienced operator from the PPC rice farm demonstrated that the transplanter can be operated continuously for 8 h by one person. The directors of the Irrigators' Association were impressed with the transplanter performance.

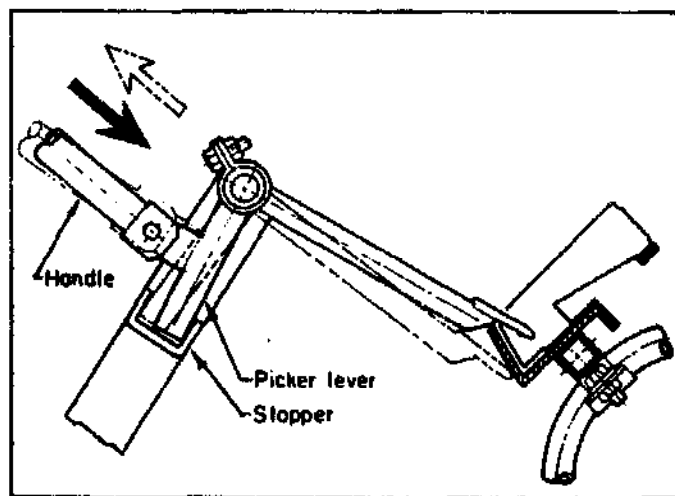

10. Inertia control picking mechanism.

Table 1. Examples of tray travel adjustment, TR4 or TR5 IRRI rice transplanter.

Tray travel per stroke (cm)	Free wheel sprocket teeth (no.)	Free wheel description recommended		Seeding density of seedling mat	
		Brand	Origin	g/m ²	Classification
0.9	16	SY	Japan	800-1000	Higher
1.0	16	Rocket	Taiwan	800-1000	Higher
1.0	16	Sport Compe	Taiwan	800-1000	Higher
1.2	20	SY	Japan	500-700	Lower
1.3	20	Rocket	Taiwan	500-700	Lower
1.3	20	Sport Compe	Taiwan	500-700	Lower

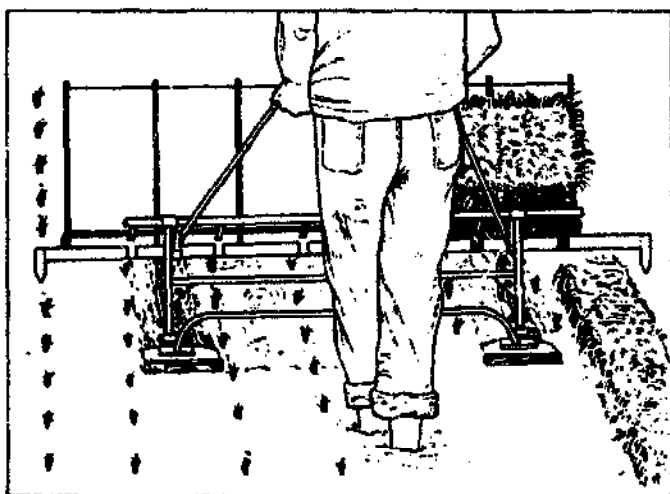

11. Planting when remaining rows are less than 6.

After the demonstration, farmers agreed to buy the first 9 units of the 6-row transplanter, provided their operators would be trained. Six units were ordered from three welding shops in Libmanan and three units were fabricated at IRRI. The local manufacturers received technical assistance and materials not available in the area.

A 2-wk training program was held 28 May to 8 Jun 1984 (Appendix A). Trainees learned seedbed and seedling preparation; operation, maintenance and adjustment of the machine; and trouble shooting. Units used during training were sold at special prices to farmers.

Since many farmers used 15-cm row spacing, an 8-row model (TR5) (Fig. 12) with 15-cm row spacing was fabricated in the IRRI prototype shop. It was sent to Libmanan as a guide to manufacturers. One manufacturer had built at least 10 units as of September 1984.

These experiences in Bicol guided transplanter promotion in other Philippine areas. In Iloilo Province, for example, we collaborate with the KABSACA Program, a rainfed cropping systems project of the MAF. The objective is to promote MAF-IRRI equipment, including the transplanter. We provided 1-wk training at IRRI for 6 KABSACA specialists and cooperating manufacturers. The lone transplanter manufacturer in Iloilo has sold more than 20 units.

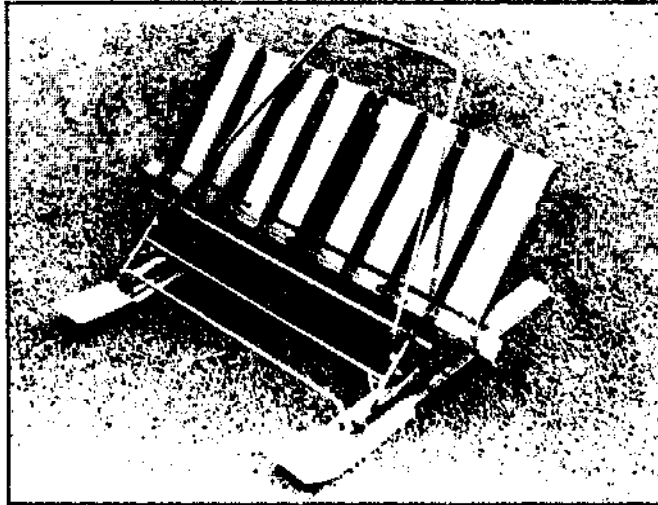

12. IRRI TR5 8-row rice transplanter.

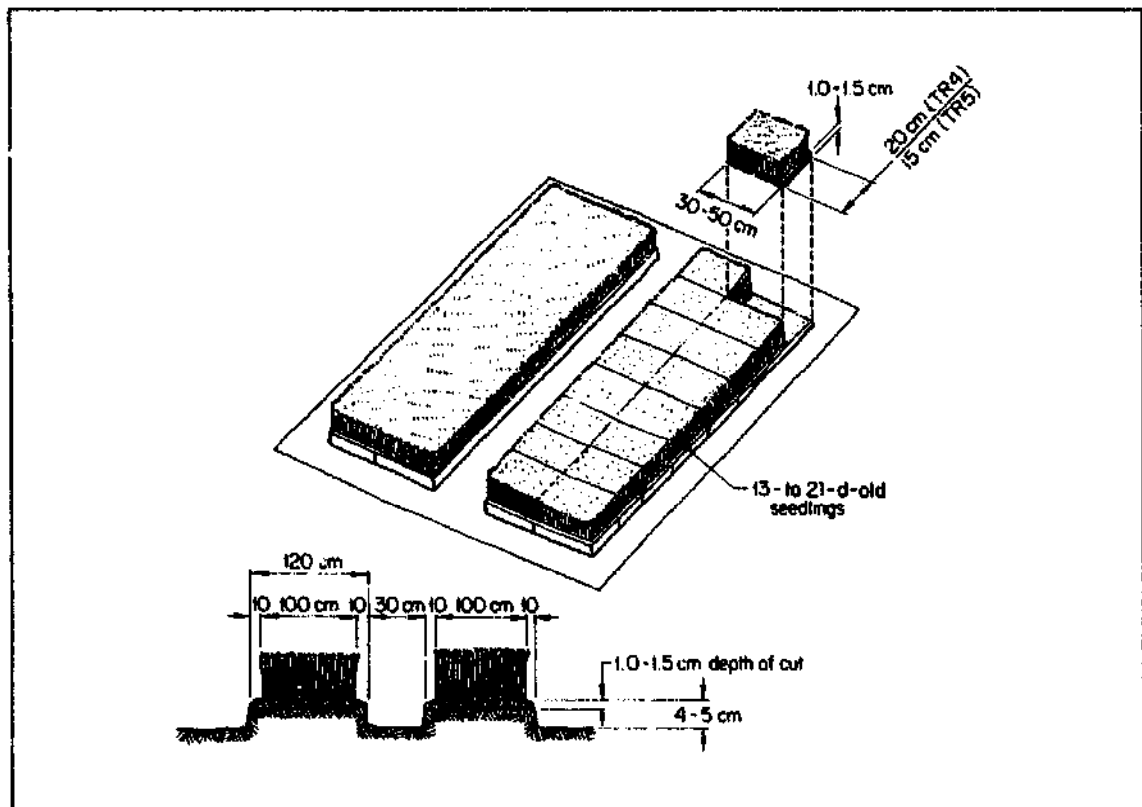

13. Modified wet-bed method of seedling preparation.

TECHNICAL AND ECONOMIC STUDY

As the machine was being introduced in Bicol, a benchmark survey was conducted with these objectives:

- to describe transplanting practices and problems,
- to describe the characteristics of the labor used for transplanting, and
- to compare the cost of present practices with the use of mechanical transplanters.

The *modified wet-bed method* is a minor modification of the traditional "laplap" method widely practiced in Bicol (Fig. 13). No wooden frames are

Table 2. Comparison of the modified "dapog" method and the modified wet-bed method of seedling preparation.

Advantages	Disadvantages
<i>Modified "dapog"</i>	
1. Seedling mats are easier to handle.	1. Seedbeds are more difficult to prepare.
2. Thickness of mat is more uniform.	2. Wood frames are required.
3. Seedling roots are not cut.	3. The practice is suitable for 13- to 16-d-old seedlings only.
4. Less time is required to cut seedling mats.	4. Greater force is required to pick seedlings.
	5. This method is not suitable for hand transplanting.
	6. Frequent watering for the first few days after sowing is required.
<i>Modified wet-bed method</i>	
1. Seedbed preparation is easier.	1. More care is needed in handling the seedling mat.
2. Wood frames are not required.	2. Mat thickness is less uniform.
3. The practice is suitable for 13- to 25-d-old seedlings.	3. Seedling roots must be cut.
4. Less force is needed to pick seedlings.	4. A special knife is required.
5. The method is suitable for hand transplanting.	5. More time is required to cut seedling mats.

needed. A special knife is used to cut the roots and the seedling mat into the required dimension.

These two methods have advantages and disadvantages (Table 2).

Introduction

Machine performance greatly depends upon the quality of seedling preparation and somewhat on the quality of land preparation. This is the main reason why the IRRI mechanical transplanter requires more time and effort to promote than do other agricultural machines like threshers, reapers, and power tillers.

Even though we developed an improved model, we did not have a simple seedling preparation method which could be easily used by an average farmer until we visited Libmanan, Camarines Sur, in the Bicol region in August 1983. There, an IRRI-organized demonstration of the power tiller, reaper, and transplanter was attended by members of the Libmanan-Cabusao Irrigators' Association and IRRI cooperating manufacturers in Bicol.

Using the modified "dapog" seedlings brought from the IRRI nursery, the TR46-row transplanter performed satisfactorily. Seedlings prepared from the local "laplap" method were also tried and found suited to the machine.

In the "laplap" method, instead of pulling and bundling, seedlings are cut into mats 12-15 cm² with 0.5-0.7 cm thick soil (Fig. 14). During transplanting one hand holds a seedling mat and the other holds plants. Farmers claimed that this method incorporates the best feature of the "dapog" and the ordinary wet-bed methods (Table 3):

- Both young and old seedlings can be transplanted.
 - It requires less seedbed area than the wet-bed method.
 - Slicing seedling mats requires less time than pulling and bundling.
- Farmers also devised a simple seedling transporter (Fig. 15) for easier handling of seedling mats.

Manual transplanting practices and problems

Both random and one-way straight planting are practiced. Row spacings range from 15 cm to 18 cm, and more farmers prefer the closer spacing. Bad weather before, during, or shortly after transplanting is a big problem to most farmers interviewed. It stops transplanting and farmers must continue to feed idle laborers until work resumes.

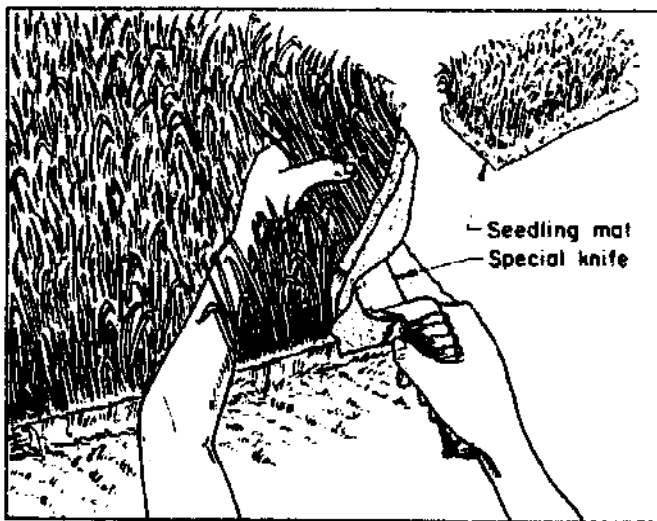

14. "Laplap" method of seedling preparation.

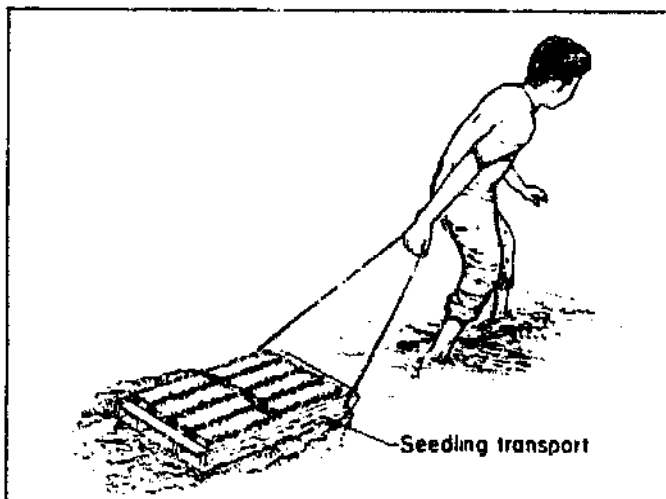

15. Transporting seedlings in Bicol region.

Table 3. Comparison of different types of seedling preparation for hand transplanting.

Seedling preparation	Seedbed area (m ² /ha)	Age of seedlings before transplanting (d)	Pulling and bundling (man-d/ha)	Mat cutting (man-d/ha)
"Dapog"	10-15	10-13	—	0.2
"Laplap"	40-50	10-25	—	1.0
Wet-bed	400-500	25-35	4.5	—

Table 4. Problems during transplanting, reported by 98 farmers in Libmanan and Cabusao, Camarines Sur, Philippines, 1984.

Item	Respondents (no.) by farm size				All
	1.0 ha or less	1.1-2.0 ha	2.1-3.0 ha	Over 3.0 ha	
Number reporting	19	28	24	27	98
Problems					
Bad weather	11	13	10	22	56
Lack of labor	10	10	12	19	51
High cost of hand transplanting	10	12	6	17	45
Poor quality of work	3	5	7	11	26
Supervision required	1	4	4	9	19

Lack of labor is also a problem. Farmers who cannot advance a portion of the payment to workers find it very difficult to get workers.

Other problems are listed in Table 4.

Characteristics of labor for transplanting

Transplanting appears to be a light farm job as reflected by the age and sex of transplanters. Women represent 63% of available labor. Labor is local: 80% of workers reside in the village where they work (Table 5). Two-thirds of the workers are regularly hired to do transplanting; farmers expect them to work every season.

Economic analysis of the mechanical transplanter

The break-even point analysis (Fig. 16 and Appendix B) estimates that the mechanical transplanter is more profitable than hand transplanting when the annual use is greater than 4.4 ha, or at 6.2 ha if machine cost is increased to ₱3,500. Break-even points are lower when wage rates are higher. This suggests that a machine purchase is justified for a 2.2-ha farm planted twice a year. Farmers who intended to buy the machine stated that they were not so much concerned with reducing cost as they were in *easing* the problem of labor procurement.

Nine months after the transplanter was introduced, owners of mechanical transplanters were interviewed to examine adoption and use, to find out how

Table 5. Characteristics of labor for transplanting, reported by 100 farmers in Libmanan and Cebuano, Camarines Sur, Philippines, 1984.

Item	Characteristics of labor (%) by farm size				
	1.0 ha or less	1.1-2.0 ha	2.1-3.0 ha	Over 3.0 ha	All
Age distribution					
Below 12 yr	5	2	3	5	4
12-20	27	22	24	24	24
21-30	35	38	30	35	35
Over 30	33	38	43	3	37
Sex					
Male	42	37	34	35	37
Female	58	63	66	65	63
Origin					
Within village	82	81	78	70	78
Outside village	18	19	22	30	22
Status					
Regular	74	67	53	72	66
Casual	26	33	47	28	34
Method of contact					
Individual	40	25	21	14	24
Group	60	75	79	86	76
Manner of recruitment					
Workers ask for work.	2	8	10	7	7
Farmers look for workers.	98	92	90	93	93

owner-users and non-users evaluate the transplanter's performance, and to assess changes in preplanting activities such as seedbed, seedling, and land preparation.

The 15 owners surveyed owned 20 transplanters: 12 of the 6-row model and 8 of the 8-row model. Ten units were in an area where land is waterlogged and flood prone. Two farmers owned 4 units in Ibig where soil and drainage conditions are excellent. The follow-up survey showed that

1. Machine use was low on the waterlogged farms. In three cases, however, machines were taken to places where soil and water control conditions were better and where the machines reportedly did well.
2. Some owners, after preparing seedlings to suit the machine, were not able to use the machine because heavy rains and flooding scattered seeds and rendered seedlings unfit for machine use.
3. Use was more successful in Ibig village with good soil condition and drainage. Owners are using the transplanters on entire farms (22 ha) and have rented them to neighboring farmers. They own water pumps to supplement gravity irrigation. Both farmers have taught their neighbors the proper way to raise seedlings to be used with their machines. Both intend to buy more units and train operators to do custom transplanting.
4. There were no significant changes in seedling preparation methods, except that the width of the seedbed was reduced to 1 m to produce uniform seedlings.

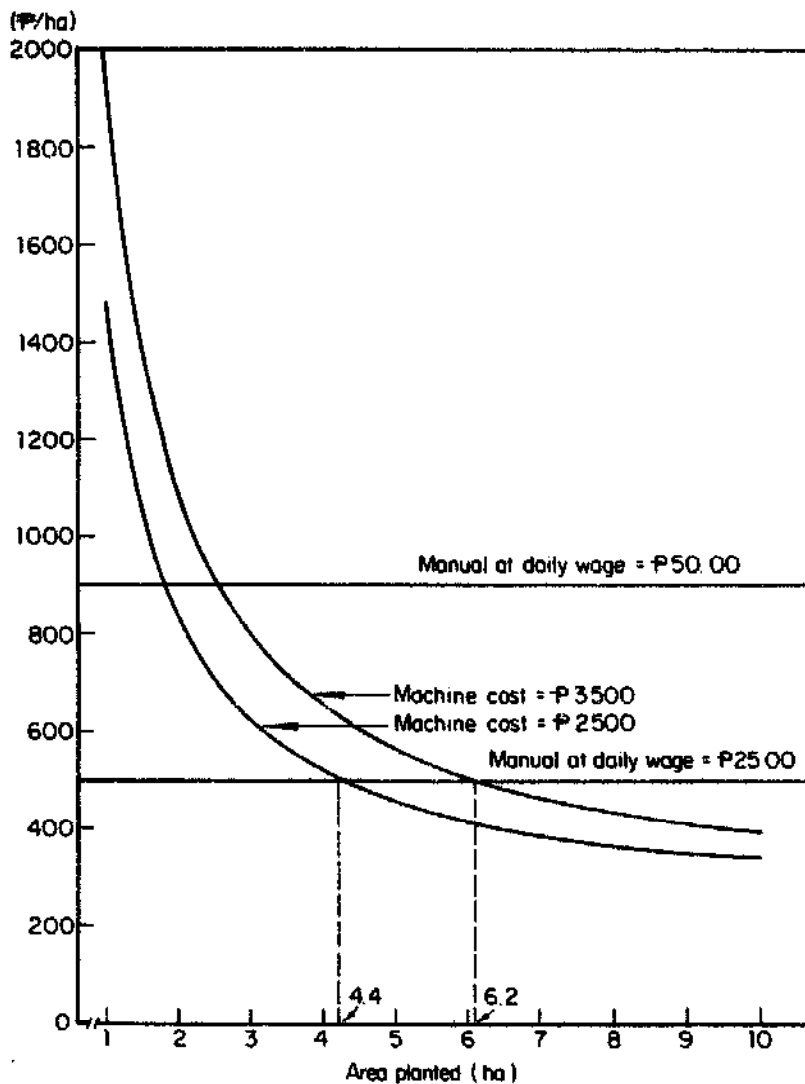

16. Comparative average costs for manual and mechanical methods of transplanting. Exchange rate: \$1 = ₱18.60.

SUMMARY AND RECOMMENDATIONS

1. Training of operators in seedbed and seedling preparation, operation, maintenance and adjustments of the machine, and trouble shooting are necessary components in the extension program of the mechanical transplanter.
2. The required seedling preparation can be done by ordinary farmers. Most farmers knew how to prepare good seedlings at a density suitable for the IRRI transplanter. Farmers showed ingenuity in their method of slicing the seedling mat to the required thickness by a special knife, and in methods they employ in transporting the seedlings. This indigenous technology was adopted by the researcher.
3. Most Japanese literature on seedling preparation for mechanical transplanters does not recommend the use of heavy clay for mat soil. Our experience shows that with 1.0-cm-thick seedling mat, and with 1-3 cm standing water in the field, the machine performed well with the clay mat soil prevalent in Bicol.

4. Fabrication of the transplanter requires precision. To minimize errors, manufacturers are given technical assistance in building jigs and fixtures.
5. The machine fits areas where random and one-way straight planting are usual practices. Field capacity will be much lower if uniform distance between hills is required in both directions.
6. The machine works well in a fairly level field and with a standing water level of up to 5 cm.
7. The main limitation is that the transplanter is not suitable for water-logged areas since the skids will sink deeper, thereby reducing the stand of seedlings. Such areas should be drained 3-7 d before transplanting.
8. Carefully planned demonstrations are essential to avoid negative comments from farmers. It is very hard to convince farmers once you have failed them.
9. The transplanter design should be adapted to farmers' needs and preferences. The TR5 8-row model was designed to meet the farmers' 15-cm row spacing. Likewise, the type of land preparation in Isabela, northern Luzon, requires the optional attachment of a wooden leveler, placed across the two skids to level the path of the machine.
10. Promotion of the mechanical transplanter, or of any farm equipment, will be easier if coordinated with well-organized farmer associations.

To speed up the popularization of the mechanical transplanter, these actions are recommended:

1. A simple instruction manual on seedling preparation and transplanter operation and maintenance should be given to every buyer. It should be in local dialects and have many illustrations and few words.
2. In areas with labor shortages, the possibilities of helping landless workers to acquire transplanter units on a loan basis should be explored. In this way, the productivity of manual labor will be increased by as much as 3 to 5 times, avoiding delays in transplanting. This will also raise the income of landless workers while discouraging the spread of direct seeding practices which drastically displace labor.
3. Several Philippine areas urgently need a manually operated transplanter which can plant 30- to 40-d old seedlings in fields having 15-20 cm standing water.
4. For areas with extreme labor shortages and available hand tractors, a transplanter attachment for lightweight hand tractors could be appropriate.

REFERENCES CITED

1. Ezaki, H. 1963. Research on rice transplanting in Japan. Paper presented at the Conference on Agricultural Engineering Aspects of Rice Production, International Rice Research Institute, Philippines.
2. International Rice Research Institute (IRRI). 1977. Semi-annual Rep. 25, Rice Machinery Development and Industrial Extension.
3. Johnson, L. 1963. Power requirements in rice production. Paper presented at the Conference on Agricultural Engineering Aspects of Rice Production, International Rice Research Institute, Philippines.
4. Manalili, I. 1963. Rice seedling transplanter, Agricultural Engineering Aspects of Rice Production, International Rice Research Institute, Philippines.
5. Salazar, G. C., and R. E. Stickney. 1984. Improved rice seedling transplanter and simplified method of growing seedlings. Paper presented at the Conference of MAF-IRRI Cooperator-Manufacturers, Maligaya Rice Research and Training Center, Nueva Ecija, Philippines.

APPENDIX A

IRRI TRANSPLANTER OPERATOR TRAINING COURSE
 Libmanan, Camarines Sur

<i>1st day</i>	
0800-0815	Welcome address
0815-0845	Opening remarks
0845-0915	Brief description of progress of the MAF-IRRI Program
0915-1000	Introduction of the board of directors, trainees, trainers, and manufacturers
1000-1015	Coffee break
1015-1100	Development of mechanical transplanter at IRRI
1100-1200	Economic consideration in the use of mechanical transplanter
1200-1300	Lunch and short program
1300-1330	Brief description of the training program
1330-1500	Seedlings for mechanical transplanter
1500-1515	Coffee break
1515-1545	Transplanter construction and operation
1545-1700	Sequence of movements in mechanical transplanter operation
<i>2d day</i>	
0800-1000	Field practice - seedbed preparation and sowing
1000-1015	Coffee break
1015-1100	Seedling mat cutting and transport
1100-1200	Transplanter field operation without seedlings
1200-1300	Lunch
1300-1620	Transplanter field operation with seedlings (three 20-min intermittent operation per trainee)
<i>3d day</i>	
0800-1000	Seedbed preparation and sowing (1 m wide X 20 m long seedbed/trainee)
1000-1015	Coffee break
1015-1200	Seedling mat cutting and transport
1200-1300	Lunch
1300-1630	Transplanter field operation (two 0.5-h intermittent operation per trainee)
<i>4th day</i>	
0745-1700	Transplanter field operation (two 1-h intermittent operation per trainee)
<i>5th day</i>	
0700-1700	Transplanter field operation (two 1.5-h intermittent operation per trainee)
<i>6th-11th day</i>	
0745-1700	Transplanter field operation (two 2-h continuous operation per trainee)
<i>12th day</i>	
0800-1200	Field day (a contest was held to determine the 3 best operators. They were judged on the quality of planting, speed, straightness of row, and uniformity of spacing.)
1200-1300	Lunch
1300-1500	Disassembly, assembly, and adjustment of the machine
1500-1700	Graduation

APPENDIX B

Break-even point analysis for the 6-row transplanter

I. Basic information

A. *Machine use*

Machine cost	P2500.00
Machine life	3 yr
Repair and maintenance	5% of machine cost
Interest on investment	25%
Salvage value	Nil
Machine utilization	20 ha/yr
Machine capacity	0.33 ha/d
Labor requirement	Two men alternating
Operator's wage	P25.00/d
Food provided to operators	P9.60/person per d

B. *Manual method*

Labor	P396.00
Food provided to workers (P6.25/worker per d X 16 workers)	P100.00

II. Cost items

Fixed costs

Depreciation:	$\frac{\text{Initial cost} - \text{salvage value}}{\text{Machine life}}$	
	$\frac{P\ 2500.00 - 0}{3}$	<u>P833.3</u>
Repair and maintenance:	Machine cost X 0.05	<u>P125.00</u>
Interest on =	$\frac{\text{Machine cost} + \text{salvage value}}{2}$	interest rate
	$\frac{P2500 + 0}{2} \quad 0.25$	

Variable costs

		<u>P312.50</u>
Labor:	P25.00/person per d X 3 d X 2 persons	<u>P150.00</u>
Food provision:	P9.60/person per d X 3 d	<u>57.60</u>

Break-even point:

$$= \frac{\text{Fixed cost}}{\text{Variable cost for manual method} - \text{Variable cost for machine use}}$$

$$= \frac{P1270.83}{P496.00 - P207.60}$$

$$= 4.40 \text{ ha.}$$

Average total cost per hectare by level of annual use (operator's wage at P25.00/d).

Annual use (ha/yr)	Fixed cost (P/ha)	Variable cost (P/ha)	Total cost (P/ha)
1	1270.83	207.60	1478.43
2	635.42	207.60	843.02
3	423.61	207.60	631.21
4	317.71	207.60	525.31
5	254.17	207.60	461.77
6	211.81	207.60	419.41
8	158.85	207.60	366.45
10	127.08	207.60	334.68
12	105.90	207.60	313.50
14	90.77	207.60	298.37
16	79.43	207.60	287.03
18	70.60	207.60	278.20
20	63.54	207.60	271.14

MECHANICAL RICE TRANSPLANTERS IN BURMA

M. THEIN

Agricultural Mechanization Department
Ministry of Agriculture and Forests
Burma

Burma grows 4.8 million ha of rice: 79% rainfed lowland, 17% irrigated, and 4% upland. Traditional hand transplanting is laborious and costly. But large areas must be transplanted quickly when rains come, when time is short and labor scarce.

To overcome the problems, local authorities have evaluated many kinds of mechanical transplanters. In 1980, an IRRI prototype, manual, 5-row machine was introduced in Burma by the IRRI-Burma project. The Agricultural Mechanization Department (AMD) evaluated it for adaptation to Burma.

EVALUATION, ADAPTATION, AND MANUFACTURE

Based on the IRRI prototype, AMD produced six transplanters for testing and evaluation, aiming to use local materials and to simplify the mechanism. Next, AMD fabricated 30 transplanters and distributed them for further evaluation in other locations. Since the transplanter seemed workable, 300 more machines were fabricated and widely distributed in Burma.

The AMD continued to improve the transplanter each year, with agricultural engineers working in their townships and at the Agricultural Tractor Station (ATS). After each transplanting season, seminars and meetings were conducted on how to improve the transplanter. Machines were modified, replaced, and refabricated for better efficiency and simplicity. After intensive evaluations, AMD produced 1,000 machines in 1981 and in 1982. From 1983 onward, the Heavy Industries Corporation (HIC) continued production (Table 1).

DESIGN CHANGES

Figure 1 shows design features, including the following changes made by AMD.

Operating handle. The telescoping pipe was replaced with a continuous pipe flattened at the ends, with holes to adjust length and to prevent the handle from slipping off.

Table 1. Manufacture of transplanters in Burma.

Year	Manufacturer	Number produced
1980	AMD	300
1981	AMD	1000
1982	AMD	1000
1983	HIC	1000
1984	HIC	500
1985	HIC	100

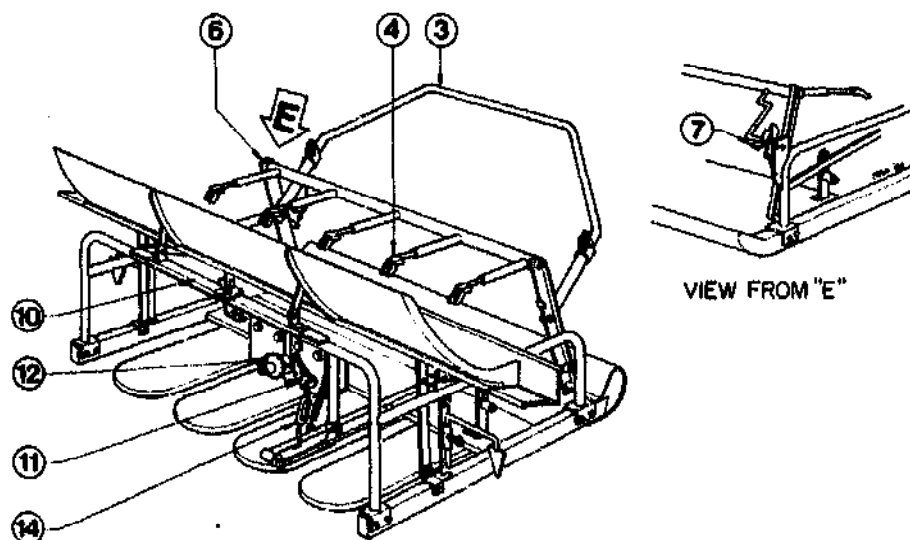

TRANSPLANTER COMPONENTS

- | | |
|--------------------------|-------------------------------|
| 1. Skid assembly | (10) Carriage bar assembly |
| 2. Main frame assembly | (11) Ratchet assembly bracket |
| (3) Operating handle | (12) Sprocket (ratchet) |
| (4) Picker arm assembly | 13. Tray drive lever |
| 5. Picker holder bar | (14) Turn buckle |
| (6) Stop block | 15. Seedling feeder |
| (7) Cam and cam follower | 16. Row guide |
| 8. Pivot arm | 17. Depth control bracket |
| 9. Seedling feed tray | 18. Feeding frame |

1. Design changes in the IRRI 5-row transplanter.

Picker arm assembly. Extensive use distorted the picker arm holder frame. A reinforcing bar was added between frame members to achieve smooth retraction. Two tension coil springs were added between the reinforcing bar and the picker holder bar.

The telescopic picker often twisted and the picker fork was distorted when encountering a hard patch, resulting in uneven picking of seedlings. An

inverted U-shape holder was introduced to hold the picker firmly.

An 8-gauge rod was used as picker fork for good penetration and thorough picking.

Cam and cam follower. In place of the spring-loaded cam, a freely hanging counterweight cam was used on both sides for better retraction of the picker.

Carriage bar assembly. The original flat carriage bar was eliminated and the carriage left to slide freely on the rear pipe frame for better movement of the seed tray.

Stop block on pivot arm. An adjusting screw was added at the stop block to adjust the picking angle.

Tray. An additional seedling guard plate was added at the seed tray to prevent the seed mat from deforming from the back and forth tray movement.

Pin bracket. Additional reinforcement brackets for each pivot pin of the pivot arm were added for durability at that high pressure point.

Ratchet. The ratchet was replaced by a bicycle free wheel, and the chain roller by a star wheel for proper movement and as antislip. Three ratchet assembly brackets were combined into one piece and a reinforcing rod was added for sturdiness.

Turn buckle. The turn buckle for planting depth adjustment was replaced by a hook screw and nut for easier fabrication.

CHANGES IN SEEDLING PREPARATION

The manual rice transplanter's usefulness depends on its ability to handle seedlings; therefore, simple, low-cost seedling preparation is required. The IRRRI method used wooden frames, single and double frames with wire gauze. The AMD and Agricultural Corporation (AC) personnel attempted to improve this method by using banana leaves in place of wire gauze in the seedbed. Further, bamboo slice walling was substituted for wooden frame, without lining. In transplanting, seedlings were cut with a knife, and measuring sticks were fitted into the transplanter tray. Farmers liked this simple, low-cost method.

TRAINING TRANSPLANTER OPERATORS

AMD trained its tractor operators and AC personnel for machine operation, then trained farmers at selected townships. To further improve skill and efficiency, transplanting contests, supervised by local authorities, were held among farmers.

TRANSPLANTER USE

After modifications, the machines became well adapted to field and crop situations. The extensive training program supported transplanter use among farmers (Table 2).

Transplanted area was largest in 1982 because of favorable weather. In

Table 2. Transplanter use in Burma.

Year	Townships (no.)	Transplanters (no.)	Transplanted area (ha)
1982	12	750	4608
1983	35	1000	4219
1984	33	697	1624
1985 (target)	33	1400	8097

Table 3. Comparison of transplanting costs.^a

<i>Seedling preparation and traditional hand transplanting cost for 10 acres</i>			
Plowing	K15.00 X 3 d		K 45.00
Harrowing	K15.00 X 2 d		K 30.00
Rotary puddling	K15.00 X 1 d		K 15.00
Seeds requirement	K12.00 X 10 basket		K120.00
Incubation and sowing	K 6.00 X 2 man-d		K 12.00
Uprooting and transport	K 7.00 X 40 man-d		K280.00
Hand transplanting	K 6.00 X 70 man-d		K420.00
		Total	K922.00
<i>Seedling preparation and mechanical transplanting cost for 10 acres</i>			
Preparation of seedling bed	K 6.00 X 3 man-d		K 18.00
Incubation and sowing	K 6.00 X 2 man-d		K 12.00
Manure application	K15.00 X 1 cartload		K 15.00
Seeds requirement	K12.00 X 15 baskets		K180.00
Seedling cutting, transporting, and transplanting by machine	K 7.00 X 40 man-d		K280.00
Cost of transplanter for 10 acres			K 93.50
Maintenance cost for 10 acres (10%)			K 9.35
		Total	K607.85
Hand transplanting cost	K922.00 US\$108.47	=	US\$26.79/ha
Transplanter planting cost	K607.85 US\$ 71.51	=	US\$17.66/ha
Amount saved	K314.15 US\$ 36.96	=	US\$ 9.13/ha

^aUS\$1 = kyats (K) 8.50. 1 basket of paddy = 20.86 kg. Cost of transplanter for 10 acres = K935.00 X $\frac{10 \text{ acres}}{20 \text{ acres}}$ X 1/5 yr = K93.50. The cost calculation was jointly prepared with the Agricultural Corporation.

1983, transplanted area declined because the monsoon came too late at sowing time and water was unavailable at transplanting time. Lack of fine tilth and level fields was another problem due to lack of water management.

The government will continue to promote transplanters. Hand transplanting costs \$26.79/ha while manual machine transplanting costs \$17.66, a difference of \$9.13 per ha (Table 3).

CONCLUSION

The AMD's agricultural engineers have continuously improved machine performance and component functions, simplifying the mechanisms and handling. The AMD research team has evaluated other farm implements, including transplanters from other countries. The government now has a project with UNDP for evaluating and producing 2,000 more transplanters and other small farm machinery.

RICE TRANSPLANTING MACHINERY IN KOREA

K. H. RYU

Department of Agricultural Engineering
Seoul National University
Suweon, Korea

Hand transplanting is one of the most laborious operations in rice production in Korea as in other Asian countries. In addition, labor demand peaks during rice transplanting because of overlapping operations such as barley harvesting.

Until the mid-1960s, no effort for mechanizing rice transplanting had been made. After the successful completion of the first five-year economic development plan (1962-66), however, the need for mechanized transplanting was recognized due to the labor shortage resulting from off-farm migration.

This paper reviews the evaluation, modification, and distribution of transplanters in Korea.

CHANGES IN AGRICULTURE

During the past two decades, great changes in Korean agriculture accelerated mechanization. Industrialization and consequent growth in the nonfarm sector, stemming from a series of successful economic development plans, provided off-farm employment for agricultural workers.

From 1960 to 1984, the farm population decreased 38.1% (Table 1) even though the total population increased 62.6%. Farm mechanization is clearly viewed as the replacement for the diminishing farm labor force. Due to the decline in farm population and the rapid economic growth, farm wages rose 29.8 times in constant prices from 1967 to 1984, whereas the price of rice rose 11.2 times and that of power tillers 4.6 times for the same period (Table 2). Rising farm wages pressured farmers to mechanize.

DEVELOPMENT OF RICE TRANSPLANTERS IN JAPAN

Japan developed the first rice transplanters, with the first patent obtained in 1898 (3). But development did not progress until the 1960s when massive research work was attempted to develop commercial transplanters.

In 1965, a rice transplanter for seedlings with washed roots was marketed. In 1966, another type of rice transplanter for soil-bearing seedlings was first marketed. Thereafter, various transplanters were developed (4).

Table 1. Decrease in farm population (9).

Year	Total population (thousand)	Farm population	
		Thousand	Percent
1960	24,954	14,559	58.3
1965	28,705	15,811	55.1
1970	31,435	14,421	45.9
1975	34,681	13,244	38.2
1980	38,124	10,826	28.9
1984	40,578	9,014	22.2

Table 2. Increases in farm wages relative to prices of rice and power tillers^a (8, 9).

Year	Daily wages (male) (W)	Price of 80-kg bag rice (W)	Price of 10-hp power tiller (W)
1967	307 (100)	5,150 (100)	285,405 (100)
1976	1,903 (620)	23,200 (450)	642,700 (225)
1984	9,134 (2,975)	57,650 (1,120)	1,309,800 (459)

^a1967 base is 100. Figures in parentheses are percentages. US\$1 = won (W) 880.

Japanese transplanters can be classified according to types of seedlings used (7).

Washed-root seedlings

Plants are pulled from the nursery. Soil is washed from the roots, and then the plants are placed in transplanters. The seedlings are the same age as those for hand transplanting.

Soil-bearing seedlings

The seeds are sown and grown in a nursery box, then transplanted with the soil in the root zone.

Soil-bearing seedlings are grown by four methods. In the *strip type*, the seedlings are grown in narrow strips of soil in a box, originally between plastic folded partitions. The strips were fed into the machine which clipped a segment and placed it in the soil at the desired depth.

Later, plastic molded boxes (Fig. 1) were developed to increase the leaves through better root development in the field soil under the box.

In the *continuous strip type*, seedlings are grown in continuous strips in a box between plastic folded partitions (Fig. 2).

The seedlings are taken out of the box and fed into the machine in the continuous strip. To increase the tensile strength of the strip, a film of porous artificial fibers is laid in the bottoms of boxes.

These seedlings reduced the percentage of missing hills to an acceptable level, but required high labor and costly materials. This type is no longer used.

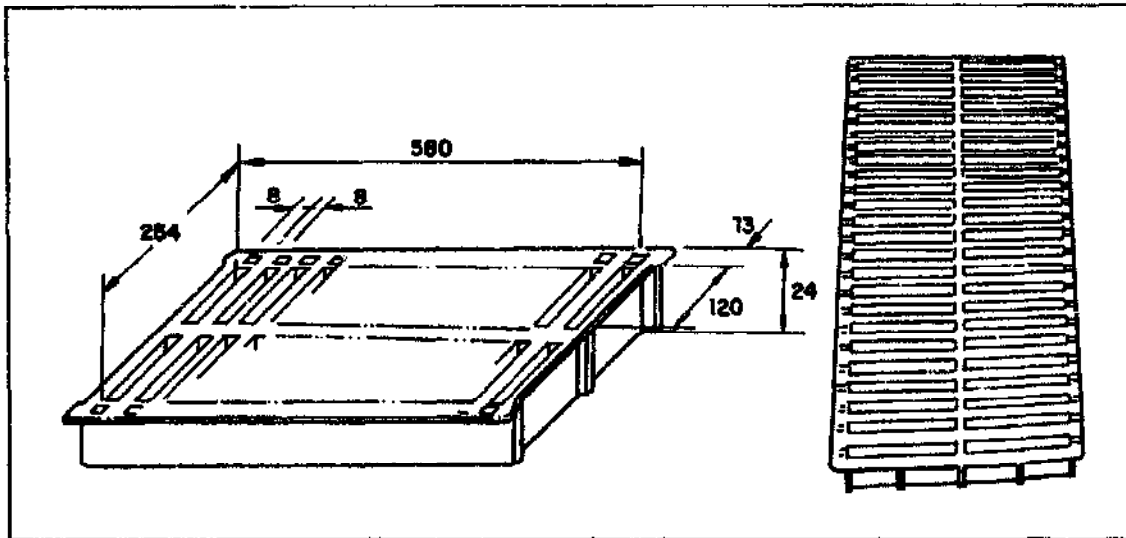

1. Nursery box for strip seedlings.

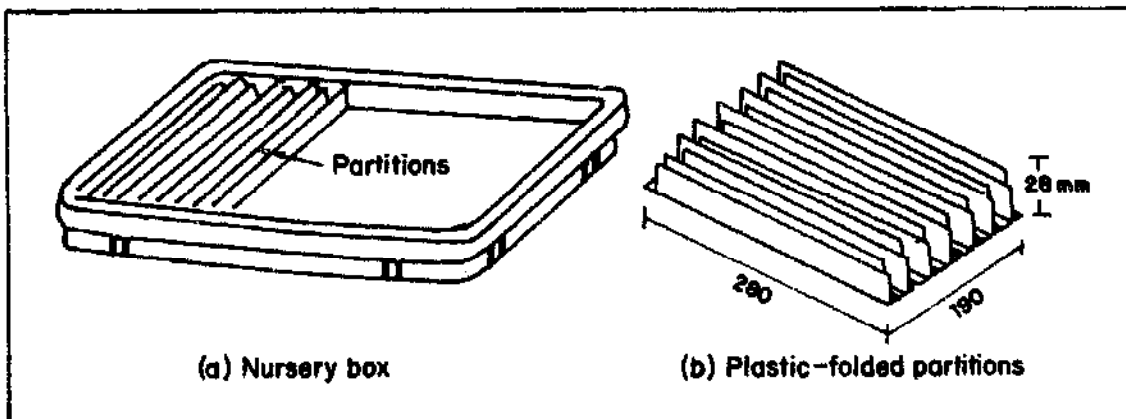

2. Nursery box (a) and partitions (b) for continuous strip seedlings.

In the *mat type*, seeds are broadcast in a box (Fig. 3a). After 20 to 35 d, the seedlings look like a mat, as the name indicates.

They are removed from the boxes and placed on the sloped seedling tray of the machine. Seedlings are taken out and placed in the soil by a planting device.

Commonly, holes in the bottoms of boxes help increase the leaves through further root development in the field soil.

This type of seedling is most widely used because of its low cost and labor requirements for the nursery.

Pot type seeds are sown and grown in rectangular columns of soil of a honeycomb-like nursery box and placed in the field nursery bed (Fig. 3b).

At transplanting, the roots developed under the box are cut. The seedling boxes are placed in the machine, which pushes out the seedling pots one by one and places them in the soil as the box moves sideways and downward.

This seedling method is obsolete because of high cost and labor requirement and high percentage of missing hills.

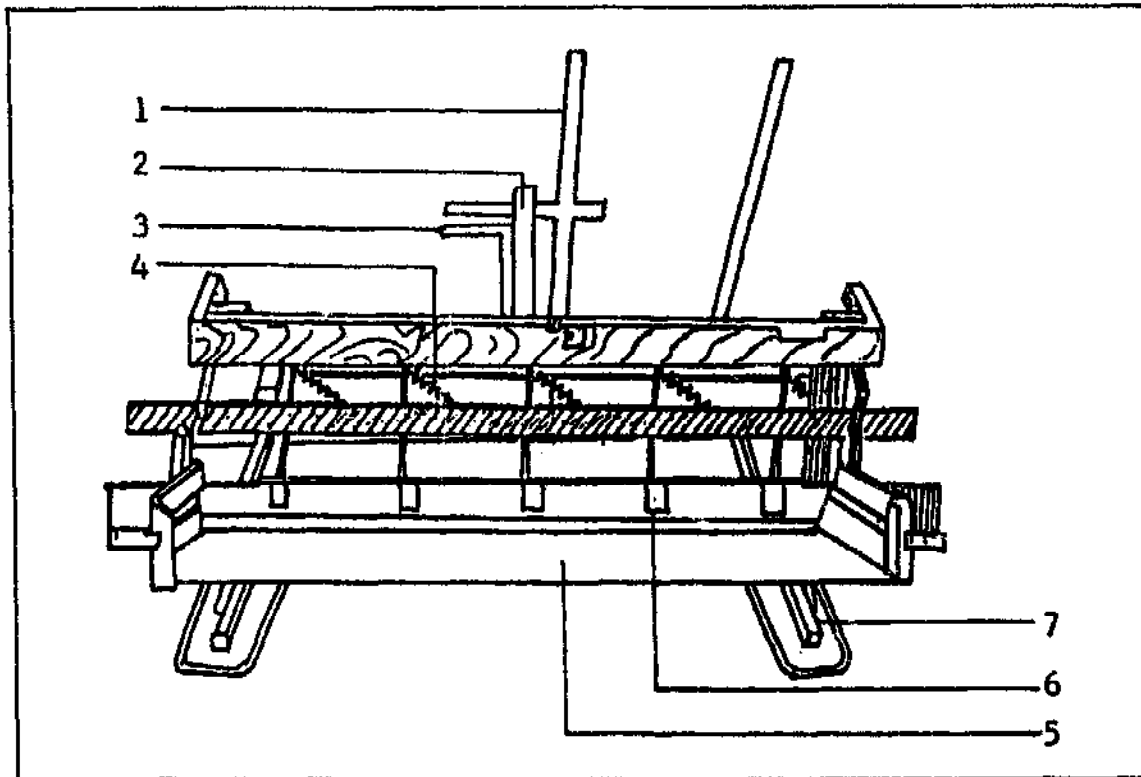

4. Manual rice transplanter. 1 = pull bar, 2 = transplanting handle, 3 = pincette lever, 4 = pincette spring, 5 = seedling tray, 6 = pincette, 7 = skid.

Transplanters for soil-bearing seedlings

From 1967 through 1972, AMI evaluated several transplanters (Table 3) for soil-bearing seedlings, imported from Japan.

Strip type. In 1967, a hand-push, one-row transplanter (KANRYU) was tested. It was regarded as suitable for Korean agriculture because of its simplicity and low cost. A belt conveyor conveys each seedling strip to the feeding roller (Fig. 5a). A planting hoe in a circular disk clips the root zone of the seedlings and carries it to the ground. This machine left a high percentage of missing hills (13.5%) caused by frequent disconnections between the seedling strips (1).

Continuous strip type. In 1967, three engine-powered, two-row transplanters (YANMAR FP-2A, MITSUBISHI PA-202, DAIKIN TL-20N) on the market in Japan were evaluated at AMI (8).

The planting mechanism of MITSUBISHI PA-202 was basically the same as for the strip-type transplanter shown in Figure 5a. The planting mechanism of YANMAR FP-2A is shown in Figure 5b. The percentage of missing hills for these transplanters was as low as 1.1-1.5%, since the seedling strips in a box are fed continuously. DAIKIN TL-20N is unique in that it uses free fall or gravity.

These machines were expensive, as were the nursery boxes and materials to make continuous strips.

Table 3. Japanese transplanters evaluated at AMI, 1967-72 (8).

Make and model	Seedling type	Rows (no.)	Missing hills (%)	Year
KANRYU	Strip	1	13.5	1967
YANMAR FP-2A	Continuous strip	2	1.1	1967
DAIKIN TL-20N	Continuous strip	2	1.3	1967
MITSUBISHI PA-202	Continuous strip	2	1.5	1967
SHIBAURA GE-135K	Washed roots	2	10.8	1967
MAMETORA UP-2	Washed roots	2	34.0	1967
SATOH PS-20	Mat	2	5.6	1971-72
KUBOTA SPS-28	Mat	2	3.9	1971-72
ISEKI PC-20	Mat	2	2.4	1971-72
MINORU LTD-2F-B	Pot	2	5.5	1972

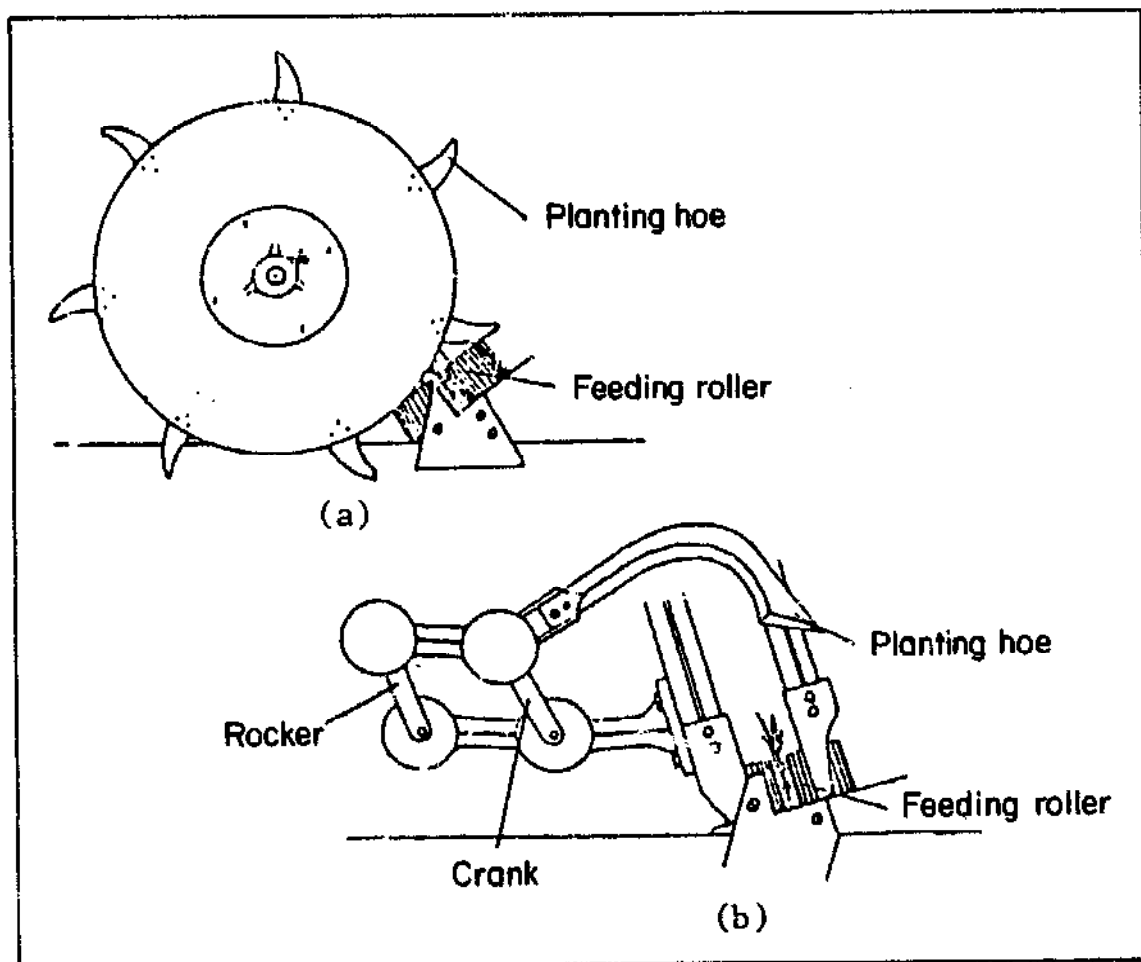

5. Schematic diagrams of transplanting mechanisms for strip-type (a) and continuous strip-type (b) seedlings.

In 1967, AMI started developing a hand-push transplanter for continuous-strip seedlings since this type seemed most suitable for reducing the cost of machine and percentage of missing hills. The planting mechanism was basically the same as that of the YANMAR FP-2A, shown in Figure 5b (11). Modifications continued until 1971 (3). In 1972, 10 of the prototypes (Fig. 6)

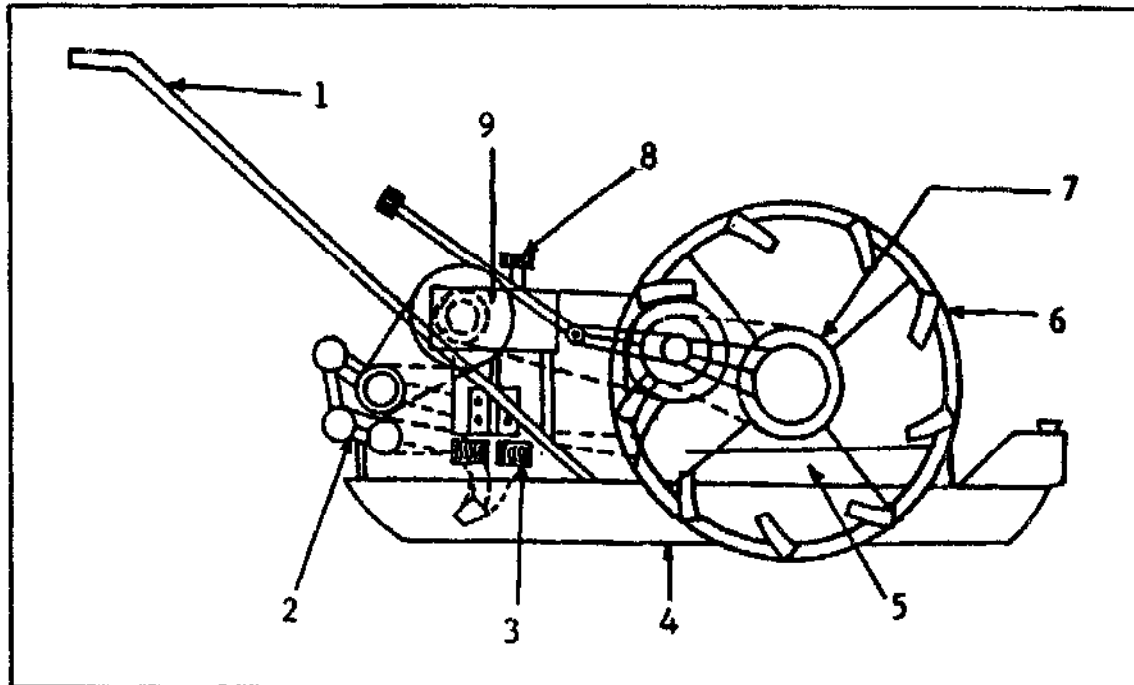

6. AMI manual rice transplanter using continuous strip seedling. 1 = handle, 2 = planting mechanism, 3 = rubber feeding roller, 4 = float, 5 = seedling tray, 6 = seedling tray, 6 = wheel, 7 = sprocket, 8 = feeding roller handle, 9 = gear box.

manufactured for farmer trials met no acceptance. The machine was difficult to push and labor requirement for growing seedlings was high.

Mat type. In 1971, AMI evaluated the engine-powered two-row transplanters (SATOHP S-20, ISEKI PC-20, KUBOTA SPS-28) using mat-type seedlings imported from Japan. The percentage of missing hills for these machines was slightly higher than for the continuous strip seedlings. The cost and labor required for growing mat seedlings were much less than with continuous-strip seedlings (1).

From 1975 through 1978, a 4-row transplanter (Fig. 7) for a small power tiller (5 hp) had been developed at AMI. The planting mechanism was the same as for the Japanese mat-seedling transplanters. Twenty of the prototypes were manufactured in 1979, and are still under farmers' evaluation. Drawbacks include difficulty in machine operation and a longer turning radius.

In 1977, a comparative test was done on 4-row transplanters using mat and strip seedlings. Machine performance was almost the same; the strip machine had a slightly lower transplanting capacity but better planting accuracy (Table 4).

In 1980, an IRRI-RT mat type transplanter was tested as a RNAM subnetwork activity. The major drawbacks were the high percentage of missing hills and damaged hills and difficulty of machine operation.

In 1981, AMI developed a hand-push two-row transplanter using mat seedlings, similar to the conventional mat type transplanters. In 1982, 12 prototypes of the transplanter were manufactured for experimental purpose by farmers. But operation of the machine was arduous.

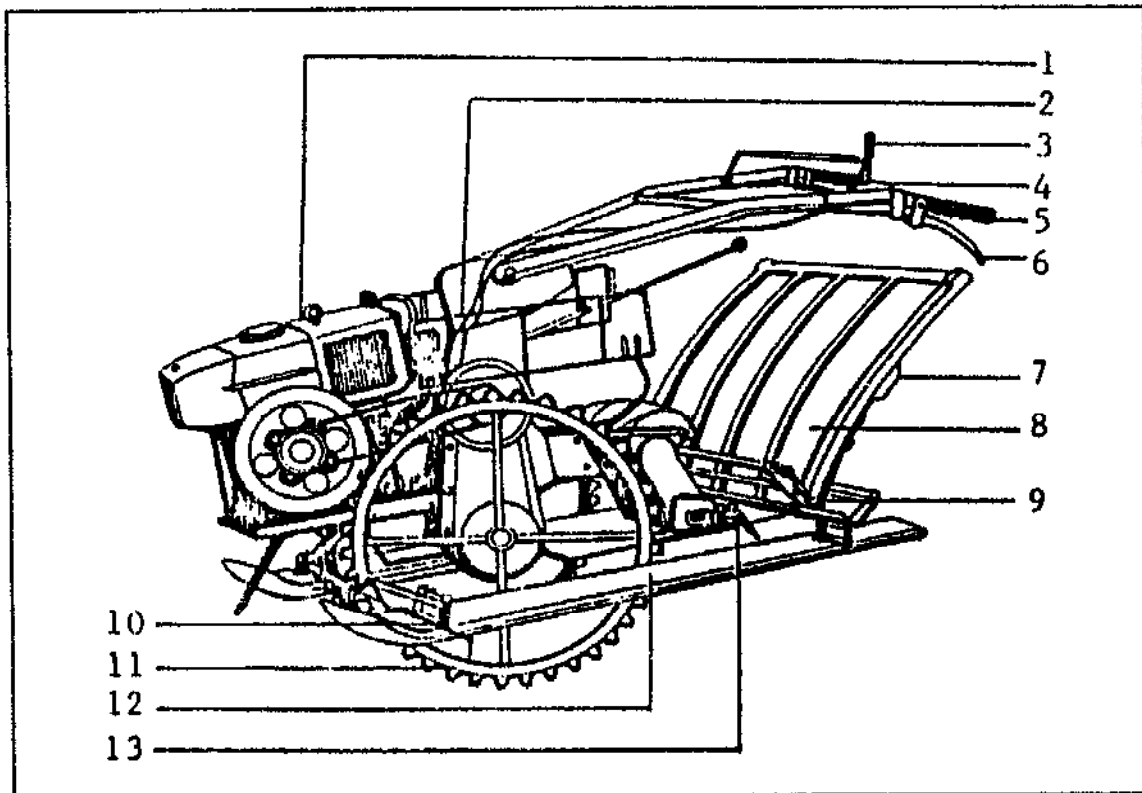

7. Schematic drawing of AMI 4-row rice transplanter using mat seedlings. 1 = engine, 2 = shelves of reserve seedlings, 3 = brake, 4 = main clutch, 5 = handle bar, 6 = side clutch, 7 = transplanter clutch, 8 = seedling tray, 9 = transplanter arm, 10 = guider, 11 = traction wheel, 12 = float, 13 = fork.

Table 4. Field capacity and planting accuracy of 4-row transplanters using mat type and strip type seedlings (8).

Machine	Capacity (min/0.1 ha)			Planting accuracy			
	Nursery	Transplanting	Total	Percent missing hills	Plants per hill	Planting depth (cm)	Percent damaged hills
4-row mat type (ISEKI PF 450)	471	79	550	2.3	3.2	2.94	1.3
4-row strip type (MINORU LT-4F-D)	462	88	550	2.0	4.1	2.95	0.4

MECHANIZATION OF RICE TRANSPLANTING IN KOREA

Size and type of transplanters distributed

Since 1973, a number of 4-row transplanters using mat seedlings have been imported from Japan and distributed for farmers to evaluate their adaptability (Fig. 8).

To offset labor loss to off-farm migration, the Government of Korea has provided farmers with equipment loans since 1977. As a result, the distribution of transplanters increased rapidly (Table 5).

In 1978, 34 transplanters using strip seedlings were first distributed, and the

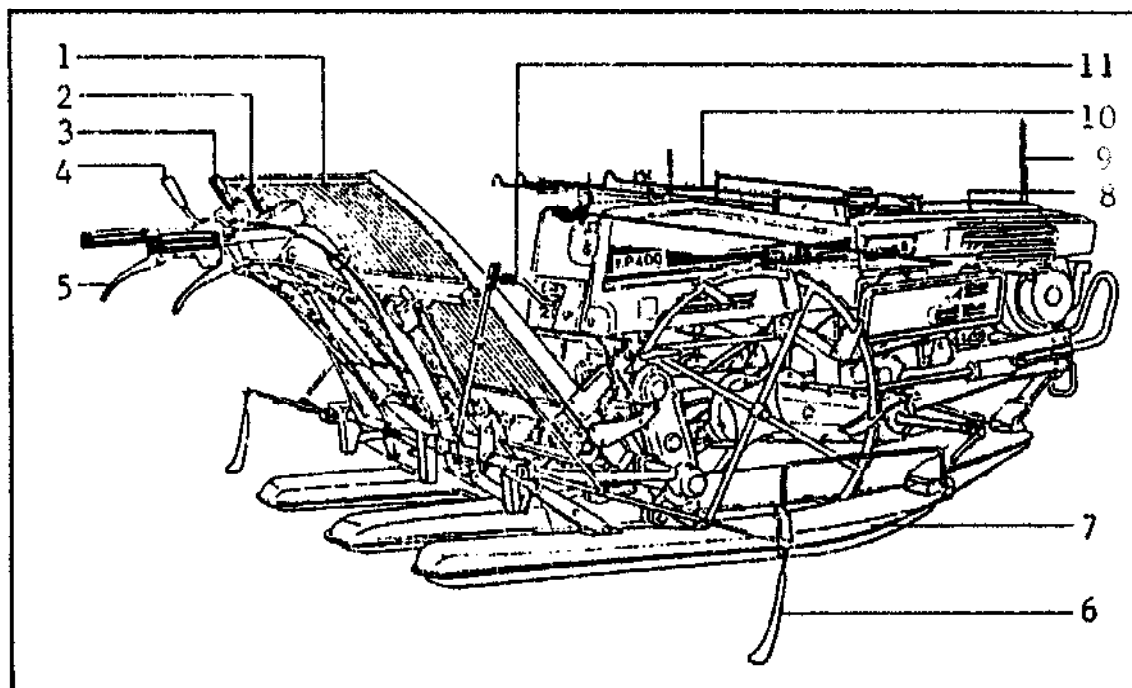

8. Schematic diagram of 4-row mat-type transplanter (Kukje KP 400). 1 = seedling tray, 2 = hydraulic lever, 3 = transplanting clutch, 4 = main clutch, 5 = side clutch, 6 = side guide bar, 7 = float, 8 = engine, 9 = center guide bar, 10 = seedling shelf, 11 = transmission lever.

Table 6. Distribution of rice transplanters in Korea (6).

Year	Rice transplanters (no.)	
	Supplied with government loan	Total in use
1973	--	6
1974	--	12
1975	--	16
1976	--	24
1977	53	121
1978	320	531
1979	1,758	2,416
1980	9,033	11,061
1981	4,114	15,271
1982	4,236	19,660
1983	6,914	24,818
1984	7,670	30,893

number increased to 2,983 in 1985 (Table 6). The advantages of these machine are as follows:

1. The seedlings can be grown better since the roots can penetrate fully into the field nursery bed.
2. No hand transplanting is required along the levees unlike with the transplanters using mat seedlings. Transplanters using mat seedling leave at least one row unplanted since they have side-floats for stability.

Table 6. Types of rice transplanters distributed with Government loan (8).

Particulars	Rice transplanters (no.)								
	1977	1978	1979	1980	1981	1982	1983	1984	1985
4-row mat type	53	286	1,221	8,888	4,114	4,186	6,097	5,304	7,000 ^a
2-row mat type	0	0	0	0	0	0	95	170	20
4-row strip type	0	34	537	145	0	50	722	2,196	2,983
6-row mat type	0	0	0	0	0	0	0	0	300
Total	53	320	1,758	9,033	4,114	4,236	6,914	7,670	10,303

^aEstimated.

Since 1983, 2-row transplanters distributed to small farmers have not seemed attractive because of lower capacity and difficulty in operation.

In 1985, 6-row ride-type transplanters were first distributed for the joint-use groups named "Saemaul Mechanized Farming" (Fig. 9).

Table 7 lists the specifications of the rice transplanters produced in Korea.

Domestic production of transplanters

It was inevitable to domestically produce transplanters for better after-sale service and lower machine price.

In 1980, following the government mandate, Korean firms started manufacturing transplanters in cooperation with Japanese firms as shown in Table 8.

Ahead of the government schedule, the goal for complete domestic production of 4-row mat-type transplanters has almost been achieved as shown in Table 9.

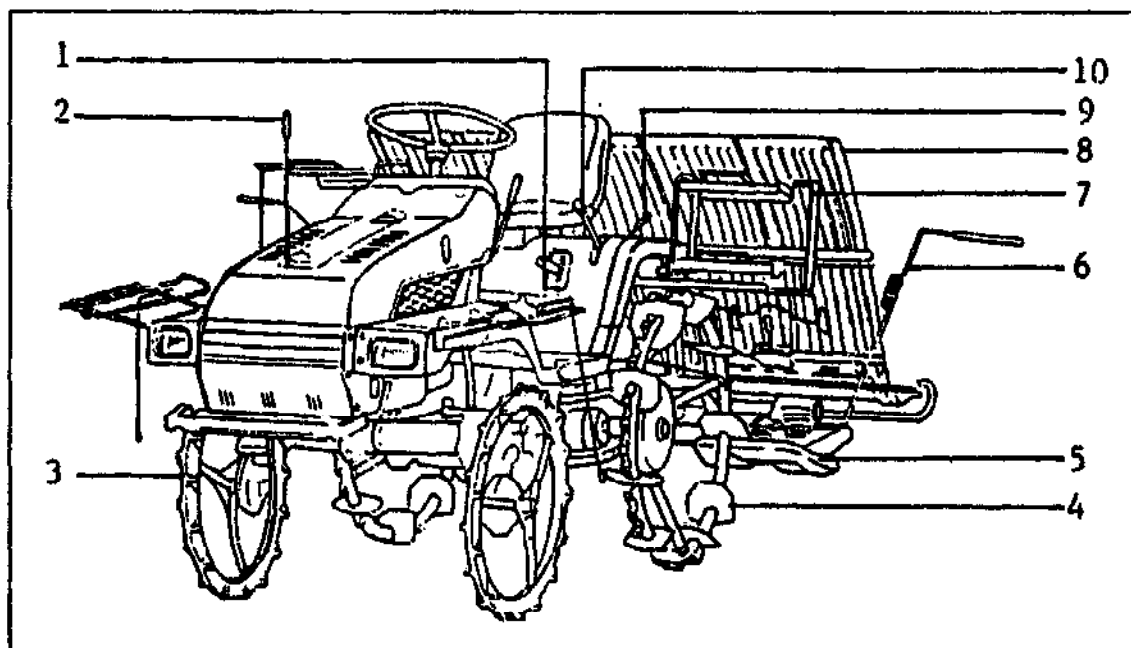

9. Schematic diagram of 6-row mat-type transplanter (Gold Star MPR 601D). 1 = transmission lever, 2 = guide bar, 3 = front wheel, 4 = rear wheel, 5 = float, 6 = ground marker, 7 = seedling shelves, 8 = seedling tray, 9 = transplanting clutch, 10 = hydraulic lever.

Table 7. Specifications of transplanters produced in Korea.

Particulars	Make and model						
	Dae Dong NS-400B	Kukje KP-400	Kukje LT-4F-D2S	Dong Yang PF251-90RW	Dong Yang PF451A	Asia MSP-4U	Gold Star MPR 601D
1. Type	Walking type Mat	Walking type Mat	Walking type Strip	Walking type Mat	Walking type Mat	Walking type Mat	Fiding type (4WD) Mat
2. Type of seedlings	247	241	261	204	244	233	294
3. Overall dimensions (cm)							
Length	148	153	128	88	148	140	220
Width	98	103	93	85	95	86	134
Height	173	170	189	102	158	185	440
4. Weight							
5. Engine	2.3	2.3	2.3	2.3	2.3	2.3	5.0
Power (hp)	3,600	3,600	3,600	3,600	3,600	3,600	3,600
Speed (rev/min)	4-stroke, gasoline	4-stroke, gasoline	4-stroke, gasoline	4-stroke, gasoline	4-stroke, gasoline	4-stroke, gasoline	4-stroke, gasoline
Type							
6. Planting device	Needle	Knife	Knife	Needle	Needle	Needle	Needle
Type of fingers	4	4	4	2	4	4	6
Planting rows (no.)	30	30	31	30	30	30	30
Row spacing (cm)	12, 15, 7	12, 14, 16, 18	11-18	12, 14, 16	12, 14, 16	12-21	12, 14, 16
Hill distance (cm)	3-5	3-5	3-5	3-5	3-5	3-5	3-5
Seedlings/hill	0.3-0.7	0.3-0.7	0.25-0.68	0.33-0.74	0.33-0.74	0.3-0.7	0.5-0.7
7. Operating speed (m/s)	5-7	5-7	5-7	10	5	5	3.3-4.0
8. Field capacity (h/ha) (announced)	1,412,800	1,412,800	1,562,000	938,000	1,412,800	1,412,800	3,168,900
9. Retail price in 1985 (won) ^a	Dae Dong Industrial Co., Ltd.	Kukje Machinery Co., Ltd.	Kukje Machinery Co., Ltd.	Dong Yang Malsan Co., Ltd.	Dong Yang Malsan Co., Ltd.	A. I. C. Machinery Co., Ltd.	Gold Star Cable Co., Ltd.
10. Manufacturer							

^a US\$1 = 880 won.

Table 8. Import of technology for rice transplanters (8).

Model	Source	Period
Daedong NS 400B	Kubota, Japan	19 Dec 1980-18 Dec 1983
Kukje KP-400	Yanmar, Japan	19 Dec 1980-18 Dec 1983
Kukje LT-4F-D2S	Minoru, Japan	1 Oct 1984-1 Sep 1987
Dongyang PF 451	Iseki, Japan	19 Dec 1980-18 Dec 1984
Asia MSP-4U	Mametora, Japan	26 Jan 1981-25 Jan 1984
Gold Star MPR 601D	Mitsubishi, Japan	16 Feb 1984-15 Feb 1987

Table 9. Domestic production rate of rice transplanters (6).^a

Type	1980	1981	1982	1983	1984	1985
4-row mat type	25.0	31.5 (25)	82.2 (50.0)	90.0 (70.0)	96.6 (85.0)	— (100)
6-row mat type	—	—	—	—	40.1	—
4-row strip type	—	—	10	26	60.3	—

^a Numbers in parentheses indicate the government mandate.

Government policy

Subsidies and loans. Government subsidies and loans were provided, along with a training program for operators of farm machinery. Through 1984, 30,893 transplanters had been distributed (Table 5). This is only a beginning, considering the two million farms.

Through 1983, amounts equal to purchase prices of transplanters and nursery boxes were loaned for 5 yr to private owners; 60% was loaned to joint-use cooperatives and the rest was subsidized.

Since 1984, only 80% of the purchase price has been loaned with the same repayment period to private owners, because of the tightened government budget. The interest rate was increased from 6 to 10%. The percentage loaned to joint-use cooperatives decreased from 60 to 50%.

Training. Training programs in Korea so far have depended heavily on government action, in contrast to Japan where the machinery industry has played a major role in training.

As shown in Table 10, from 1977 through 1984 operators for transplanters were trained at various levels. Since 1979, only the county-level machinery training centers have trained operators.

Table 10. Transplanter operators trained at various centers (6).

Level	Operators trained (no.)							
	1977	1978	1979	1980	1981	1982	1983	1984
National	76	1,304	805	—	—	—	—	—
Provincial	—	—	1,938	—	—	—	—	—
County	—	—	14,410	20,000	22,112	10,564	5,620	6,774

After-sale service. Repair services are a major concern to farmers. The government has increased the number of service centers for agricultural machinery. There are about 3,000 service facilities, one for every 700 farms (Table 11).

Joint utilization. Farm sizes have not increased even though the farm population has decreased rapidly (Table 12). As of 1984, the average farm size was only 1.1 ha, too small for owning a transplanter.

To achieve an economical utilization rate for large-scale machinery from 1977 to 1981, 513 public hire service centers were established through government organizations such as the National Agricultural Cooperative Federation and the Association for Land Improvement. But these schemes have been unsuccessful primarily because of management problems and bureaucracy.

Since 1981, the government has been encouraging the farmers to form their own farming groups named "Saemaul Mechanized Farming Groups." Forty percent of transplanters' price is subsidized for the cooperatives. Table 13 shows the status of the groups and the number of transplanters they owned.

Survey of farms. According to the AMI survey results in 1983, farmers prefer larger transplanters. About 60% of the farmers wanted to buy 4-row transplanters, and 38% 6-row transplanters.

Of the major problems encountered by transplanter owner (Table 14), frequent breakdowns gave the greatest concern, and difficulty in machine operation was a close second. The complaint on frequent breakdowns is attributed partly to the rapid domestic production of transplanters.

The average annual utilization was 7.6 ha in 1983. The average custom rates were W67,000/ha for transplanting only and W156,800/ha for transplanting plus seedlings.

Table 11. Service facilities for agricultural machinery (6).

Particulars	Facilities (no.)						
	1978	1979	1980	1981	1982	1983	1984
Dealers	322	366	508	537	552	587	608
Service centers	—	150	465	790	1203	1441	1607
Total	322	516	973	1327	1755	2028	2914

Table 12. Trend in farm sizes (9).

Year	Households (no.)	Farms (no.) of given size				Av size (ha)
		Less than 1.0 ha	1.0-2.0 ha	2.0-3.0 ha	3.0 ha	
1965	2,506,899	67.3	25.9	5.4	1.4	0.90
1970	2,483,318	68.0	25.5	5.0	1.5	0.92
1975	2,379,058	67.8	26.0	4.7	1.5	0.94
1980	2,155,073	64.4	29.2	5.0	1.4	1.02
1984	1,973,539	66.6	27.9	4.3	1.2	1.09

Table 13. Transplanters distributed to the joint-use groups (Saemaul Mechanized Farming Groups) (6).

Particulars	1981	1982	1983	1984	Total
		<i>Number</i>			
Groups	612	1,010	1,005	1,058	3,685
Farmers-participating	9,600	18,500	16,700	17,500	62,300
Transplanters distributed	4,153	4,435	6,914	7,670	23,172
Transplanters distributed to the groups	716	1,269	1,335	1,664	4,984
		<i>Percent</i>			
	17.2	28.6	19.3	21.7	21.5

Table 14. Problems associated with transplanter utilization (1).

Problem area	Responses	
	Number	Percent
Frequent equipment breakdown	11	32.3
Low field capacity	2	5.9
Machine repair parts difficult to find	5	14.7
Machine operation difficult	8	23.5
Operation cost too high	4	11.8
Others	4	11.8
Total	34	100.0

Cost analysis. Cost indicators have been worked out for machine transplanting as well as hand transplanting (Table 15, 16). The total operating cost of mechanical transplanting with either 2-row or 4-row transplanters is higher than labor cost of hand transplanting for the average farm size of 1.1 ha. The break-even point appeared to be 2.1 ha for 2-row transplanters and 2.8 ha for 4-row transplanters. Lowering depreciation cost by increasing the transplanted area is indispensable for lowering operating cost.

Table 17 illustrates how the break-even points have dropped and would drop further in the future. The driving force for lowering the break-even points would be a sharp increase in farm wages.

LIMITATIONS ON MECHANICAL TRANSPLANTING

Mechanical transplanters have been distributed slowly compared with other small-scale machinery such as power tillers, power sprayers, and power threshers (Table 18).

Growing period

Because of Korea's temperate climate and limited growing season for rice, the duration from seed germination to maturity must be kept in mind. This duration is fairly well fixed by variety. When rice is transplanted, the duration period is divided into two parts: time in the nursery and time in the field. If less

Table 15. Cost indicators^a for mechanical rice transplanting, 1984.

Particulars	2-row transplanters	4-row transplanters	Nursery box
Purchase price (W)	938,000	1,412,800	246,000 ^b
Machine life (yr)	6	6	5
Annual use ^c (ha)	A	A	A
Fixed cost (W/yr)	140,700	211,920	44,280
Depreciation ^d	78,136	117,686	-
Repair ^e	51,590	77,704	13,530
Interest ^f	270,426	407,310	-
Subtotal	(1) 270,426/A	(2) 407,310/A	(3) 57,810
Fixed cost (W/ha)			
Variable cost (W/h)	858	858	-
Fuel and lubricant ^g	1,142	1,142	1,142
Labor ^h	2,000	2,000	1,142
Subtotal	20.1	11.6	81.6
Effective field capacity (h/ha)			
Variable cost (W/ha)	(4) 40,200	(5) 23,200	(6) 93,197
Operating cost (W/ha)	(1) + (3) + (4) + (6)	(2) + (3) + (5) + (6)	
	191,197 + 270,426/A	174,197 + 407,310/A	

^aIn won (W). W890 = US\$1. ^bW820/box X 300 boxes/ha = W246,000. ^cA = annual planted area; it is variable. ^dSalvage value: 10% of purchase value. ^eRepair cost: 8.33% of purchase price. ^fAverage investment = (purchase price + salvage value)/2, interest rate = 10%/yr. ^gGasoline: W660/litre, lubricating oil: W1,618/litre. ^hWages: W9,134/d.

Table 16. Cost indicators for hand transplanting of rice.

Particulars	Nursery	Transplanting	Total
Labor (h/ha)	95.7	184.0	279.7
Wages (won/d)	9,134	9,134	—
Work hour (h/d)	8	8	—
Cost (won/ha)	109,265	210,082	319,347

Table 17. Trend in break-even points for major machinery (4).

Machine	Break-even point (ha)				
	1971	1976	1981	1986	1991
4-row transplanter	11.1	8.1	4.1	1.9	1.0
2-row binder	16.3	11.2	4.3	2.8	0.9
Power tiller (8 hp)	8.2	6.1	3.2	1.5	0.6
Tractor (46 hp)	113.9	83.7	43.2	17.1	7.7
Combine (3-4 row)	32.0	24.3	13.4	5.9	2.6

time is spent in the nursery, more time must be spent in the field and vice versa. Consequently, rice seedlings are mechanically transplanted at a younger age than those transplanted by hand to avoid cold damage in the later growing period.

Based on agronomic research, rice seedlings with 2.0-2.5 leaves must be transplanted 7-10 d in advance of hand transplanting (Table 19). There will be a time constraint on double cropping in the south. The transplanters have been introduced further north where rice is grown alone. Seedlings could also be grown up to the stage of 4.0-4.5 leaves, which is still younger than seedlings for hand transplanting at 6.5-7.0 leaves. In this case, the time constraint on double cropping will be lessened to 3-5 d, but the increased cost and labor for more nursery boxes will increase the cost of mechanical transplanting and decrease machine efficiency.

Paddy rearrangement and irrigation

Paddy rearrangement is a prerequisite to using rice transplanters, especially the 4-row ones widely distributed at present. However, paddy rearrangement projects have been implemented slowly (Table 20) because of high cost. The projected area of paddy rearrangement is only 53.5% of the total paddy area.

Irrigation is also important for mechanical transplanting. Since younger seedlings are mechanically transplanted earlier than for hand transplanting, stable water supply is mandatory. But most reservoirs do not have enough water for the extra period, and 30% of the total paddy area is still left unirrigated.

Small landholdings

As mentioned previously, landholdings (1.1 ha average) are too small for a transplanter, and transplanters distributed at present are too large and expensive for most farms.

Table 18. Major farm machinery on farms (6).

Machine	Farm machinery (no.)				
	1965	1970	1975	1980	1984
Tractor	--	61	564	2,664	9,864
Power tiller	1,111	11,884	85,722	289,779	538,273
Transplanter	0	0	16	11,061	30,893
Power sprayer	--	--	32,958	108,632	244,802
Mist-and-duster	7,578	71,200	104,742	222,031	227,383
Binder	0	0	0	13,652	22,635
Combine	0	0	56	1,211	8,417
Power thresher	18,909	41,038	127,105	219,896	186,647

Table 19. Characteristics of various seedlings (4).

Particulars	Seedlings for mechanical transplanters		Seedlings for hand transplanters (matured)
	Younger	Medium	
Use of box	Yes	Yes	No
Boxes (no.)/ha	150-200	250-400	--
Depth of seedbed	2.5 cm	2.5 cm	Not limited
Density of sowing	180-200 g/box	110-130 g/box	250 g/3.3 m ²
Days after seeding	15-20	35+5	40-45
Leaf stage	2.0-2.5	4.0-4.5	6.5-7.0
Height	10-15 cm	15-20 cm	15-20 cm
Delays in heading	7-10 d	3-5 d	0

Table 20. Status of paddy rearrangement and irrigation (9).

Year	Rearranged		Irrigated	
	Thousand ha	Percent	Thousand ha	Percent
1945	43	3.3	--	--
1975	278	21.1	790	59.8
1980	369	28.0	893	67.7
1981	383	29.0	908	68.8
1982	400	30.3	917	69.5
1983	415	31.4	929	70.4
1984	431	32.6	--	--

Most transplanter owners provide hire services to lower their operating costs. However, using custom hire services reduces income of farmers, especially hurting those who lack off-farm employment.

The government has been encouraging farmers to form the Saemaul Mechanized Farming Groups to reduce operating costs and alleviate labor shortages. Mechanization of rice transplanting in Korea depends heavily on the successes in these groups even though the human nature for private ownership and the importance of timely transplanting are limiting factors.

Recently, the government launched a new project to establish so-called "agriculture-industry complexes" in the rural areas, which can create off-farm wage income for small farmers.

SUMMARY

After the successful completion of the first five-year economic development plan (1962-1966), the need for mechanized rice transplanting was recognized because of labor shortages resulting from off-farm migration.

Since 1967, engineers have been developing simple low-cost transplanters suitable for Korea with its small landholdings and intensive management.

Transplanters using root-washed seedlings lacked planting accuracy. Manual transplanters using soil-bearing seedlings were developed but not accepted by farmers primarily because of arduous machine operation and low capacity.

In 1973, six mat-type transplanters imported from Japan were distributed to farmers. Since 1977, government subsidies and loans have been provided to speed dissemination of transplanters. Through 1984, about 31,000 transplanters had been distributed, only a beginning compared with the total of two million farms.

The major drawback of conventional transplanters is the high operation cost due primarily to the high machine price and the small landholdings. Joint utilization through Saemaul Mechanized Farming Groups has been strongly recommended by the government.

REFERENCES CITED

1. AMI (Agricultural Mechanization Institute). 1967-84. Research reports.
2. Editorial Department, Shin-Norinsha Co., Ltd. 1971. The latest mechanization of rice transplanting in Japan. *Agricultural Mechanization in Asia* 2:119-124.
3. Han, S.K., S.R. Kim, and H.Y. Kim. 1971. Study on the new design of hand rice transplanter. Research Report of Agricultural Utilization, ORD, Vol. 1.
4. Hoshino, S. 1977. Development of rice transplanters. Proceedings of the seminar on mechanization of small farms. Office of Rural Development, Korea.
5. Kim, S. R. 1980. Special report on mechanization of rice transplanting in Korea. Presented at the 2d RNAM subnetwork workshop on rice transplanters held in Suweon, Korea.
6. Korean Society for Agricultural Machinery. 1978-85. *Agricultural machinery yearbook*.
7. Lantin, R.M., and T. Miura. 1980. Coordinator's and expert's report on testing, evaluation, and adaptation of rice transplanters. Presented at the 2d RNAM subnetwork workshop on rice transplanters held in Suweon, Korea.
8. Ministry of Agriculture and Fishery. 1982. *Progresses in farm mechanization in Korea*.
9. Ministry of Agriculture and Fishery. 1984. *Statistical yearbook of agriculture, forestry and fishery*.
10. RNAM (Regional Network for Agricultural Machinery). 1983. Testing, evaluation and modification of rice transplanters.
11. Ryu, K. H. 1972. Kinematic analysis of planting mechanisms for rice transplanters.

SEED-CUM-FERTILIZER DRILLS IN INDIA

S. R. VERMA
Punjab Agricultural University
Ludhiana, India

India has made spectacular progress in agricultural production during the last two decades. The country recorded an all-time high production of 150 million t of food grains in 1984 as against 55 million t in 1950-51.

Prior to 1960, the traditional methods for sowing crops included hand broadcasting, kera (drawing furrows by a country plow and dropping seeds by hand), and pora (dropping seeds in the furrow through a bamboo or metal funnel attached to a country plow). For small areas, dibbling (making holes or slits by a stick or tool and dropping seeds by hand) was practiced. Those methods did not uniformly distribute or accurately place seeds at the desired depth; therefore they reduced the plant population and yield.

A new agricultural strategy was evolved in India by the beginning of the 60s. Two important earlier events were the consolidation of fragmented farmholdings and augmentation of irrigation facilities. The new strategy aimed to enhance farm production and productivity through intensive farming and multiple cropping by using biological, chemical, and mechanical inputs: high yielding seed varieties, higher and balanced doses of fertilizer, water, pesticides, improved sources of power, and better farming tools.

Experiments by agricultural scientists and engineers at various research stations, agricultural universities, and Intensive Agricultural District Projects (IADP) in six districts proved that an indispensable tool for judicious application of seed and fertilizer inputs was the mechanical drill that could apply the right quantity of seed and fertilizer inputs at the right time and in the right place. A crop sown by a seed-cum-fertilizer drill gave, on the average, 8 to 10% higher yield per hectare than a crop sown by traditional methods. The increase was attributed to uniform seed distribution, accurate band placement of fertilizer, and regulated depth of sowing, which increased plant populations and fertilizer use efficiency. Timeliness of operation was crucial, correlating positively with yield per hectare. Wheat yields declined by 100 kg/ha for each week of delay beyond the optimum time of sowing.

The drill also enabled higher work output, reduced cost and labor requirements, and eased weeding and hoeing in the crops sown in lines. Today more than 100,000 tractor-operated and 200,000 animal-drawn seed-cum-fertilizer drills are in use in India.

DEVELOPMENT OF SEED-CUM-FERTILIZER DRILLS IN INDIA

Although a few, imported, tractor-driven seed drills could be found in India, mainly at government and big private farms during the 50s, the research and development (R&D) effort for the evolution of seed-cum-fertilizer application equipment suited to Indian conditions essentially commenced in the early 60s. At first, manufacturers developed seeding attachments (Fig. 1, 2) for local equipment, viz., plows, cultivators, and *bhakhra*. Soon, however, prototypes of seed-cum-fertilizer drills were designed and developed by agricultural engineers in various institutions and research centers. The new equipment was accepted for commercial production by the small-scale manufacturers (6, 8). Many tractor companies started producing tractors in India by the mid-60s and as the demand grew, the demand for seedbed preparation and seedling equipment also rose (8).

The Massey Ferguson seeding attachment (Fig. 1), mounted on a tine-cultivator from U.K, was promptly adopted by Indian farmers. Using the design, some manufacturers made models of tractor-operated drills. One notable contribution was made by Swastik Limited, Secunderabad (A.P.), which manufactured animal- and tractor-operated drills in the early 60s. This design was developed through the joint efforts of Indian agricultural engineers, Ford Foundation specialists, and the manufacturer. By the mid-60s, several manufacturers in the Punjab were manufacturing drills (8).

About this time, the Punjab Government gave a subsidy of 33% to all farmers buying drills. A target for introducing about 50,000 improved drills set in 1968-69 was reached. Animal- and tractor-operated seed planters also developed in the late 60s were sold to farmers. During the 70s R&D work was devoted to developing new models, refining the seed metering mechanisms, power transmission systems, frame designs, and evolving suitable types of furrow openers. A notable achievement was a planting attachment which could be mounted on a conventional animal- or tractor-drawn seed drill.

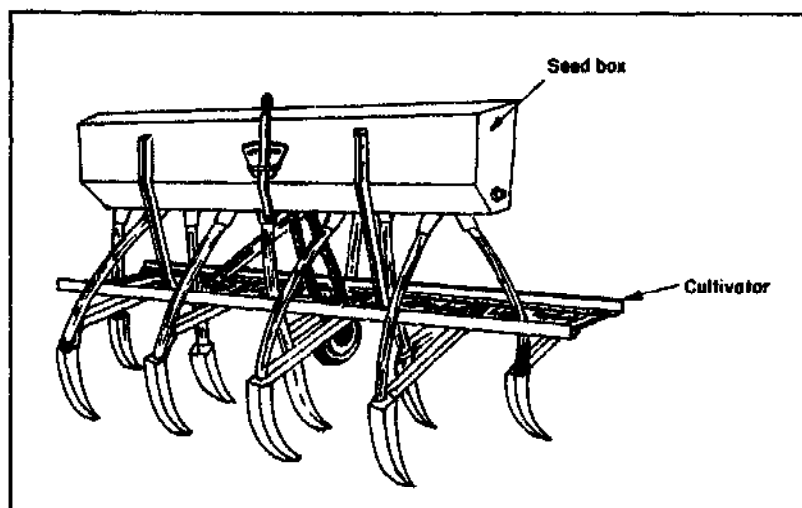

1. A 9-row seeding attachment for a tractor-mounted cultivator.

Evaluation and testing of various types of drills and planters under varying soil and field conditions also intensified during the 70s. Indian Standards Institution (ISI) formulated several standards relevant to the seeding equipment (5). The manufacturers considerably improved equipment quality and started using jigs and fixtures for making components. R&D in the 80s focused on drills for rainfed areas and more difficult clod-forming soils, and drills for no-till conditions or reduced tillage. Details of the types of equipment developed in India during the last two decades are given in the literature cited (1, 2, 3, 6, 9, 10, 11, 12, 22) and briefly discussed in the following paragraphs.

COMMON TYPES OF DRILLS AND ASSOCIATED EQUIPMENT

Seed and fertilizer attachments to local soil-working tools

The simplest device for line sowing of seeds and band placement of fertilizer is a bamboo or metal pipe with a bowl, attached to a country plow or local implement. Such devices, used in many parts of India, are made for one to five rows (Fig. 3). Seeds and fertilizer are metered and dropped by hand; accuracy depends on the operator's skill and experience. This method is superior to hand broadcasting of seed and fertilizer and leads to better fertilizer use efficiency. To improve this system, mechanical metering replaced hand metering (Fig. 2).

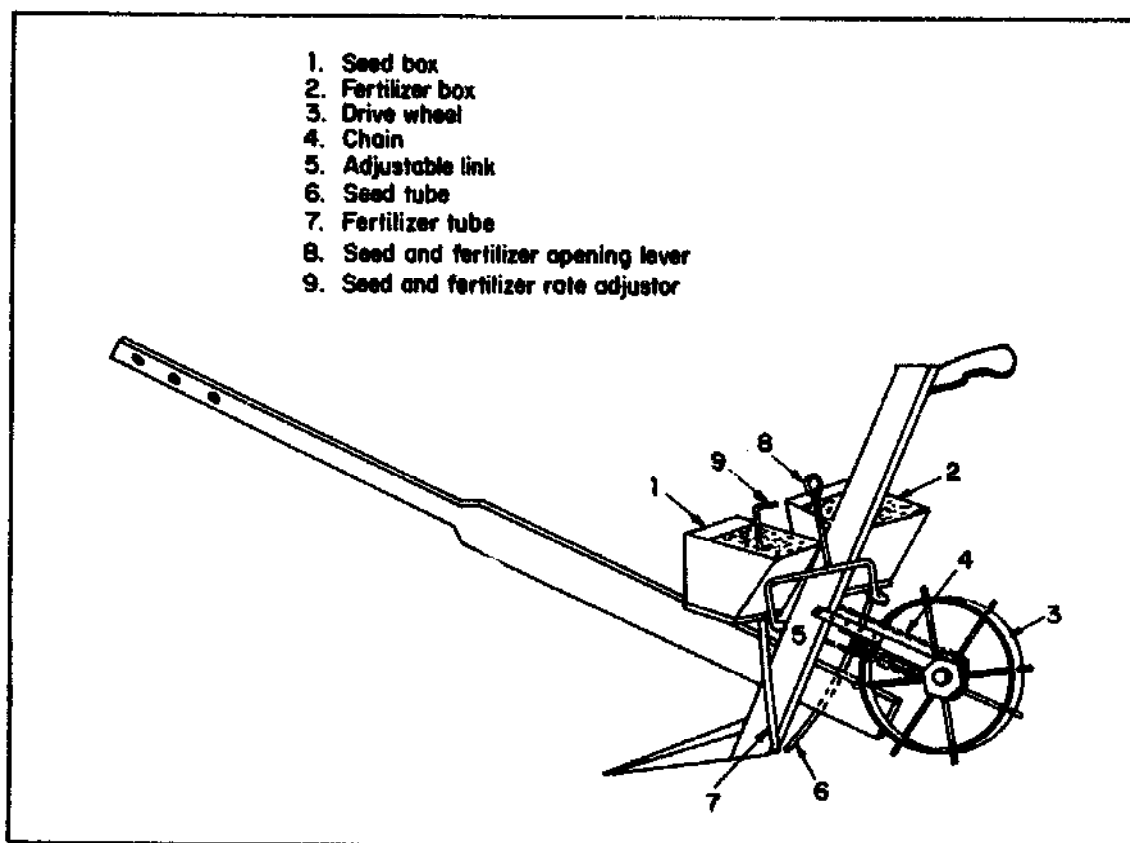

2. Single-row seed and fertilizer attachments for a country plow.

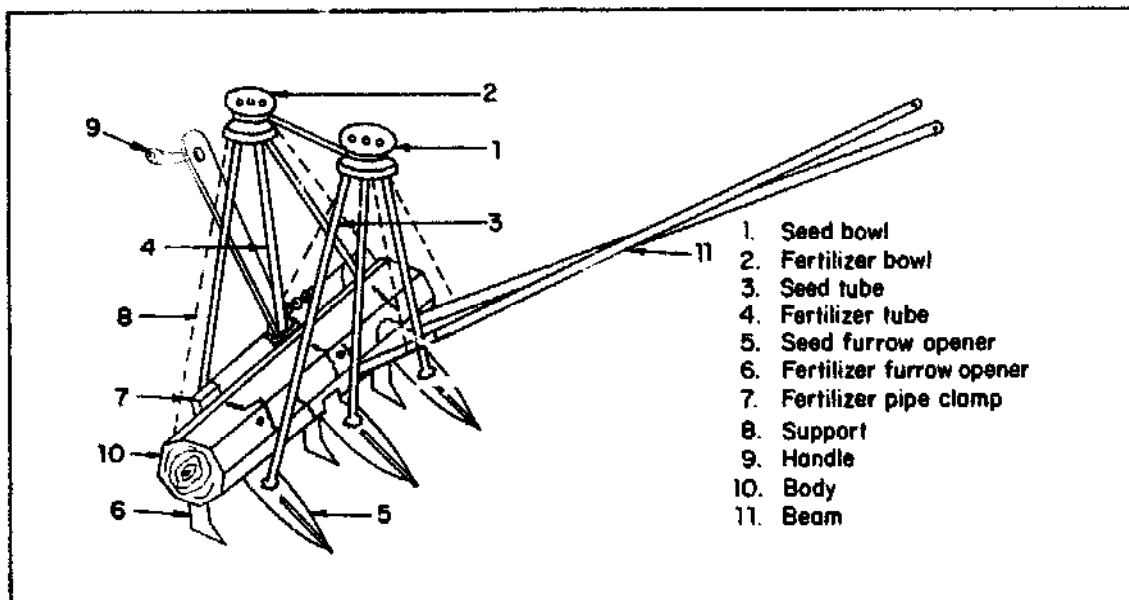

3. Three-row seed and fertilizer attachments for local implement used in heavier soils in southern states of India.

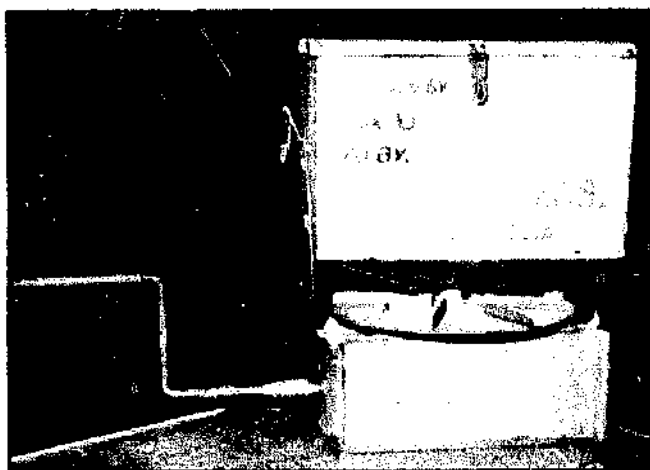

4. A manually operated seed and fertilizer broadcaster.

Manually operated broadcasters

Manually operated knapsack seed and fertilizer broadcasters have been developed in India by agricultural engineers of agricultural universities at Pantnagar and Ludhiana (Fig. 4). These devices consist of a metallic box, a circular disk with dividing ribs, and a gear box. A handcrank rotates the disk, provided under the hopper, at about 360 rev/min. A sliding plate adjusts the size of the opening for dispensing seed or fertilizer. The opening adjustment and forward speed determine the application rate. The seed or fertilizer falling on the disk is spread uniformly in front of the broadcaster. Table 1 compares the tool's performance with hand broadcasting.

Manually operated drills

Manually operated seed-cum-fertilizer drills (Fig.2), suitable for small holdings in the plain and hilly tracts, have been developed at the Indian Agricultural Research Institute of Agricultural Engineers (CIAE) in Bhopal.

The drills use gravity or fluted-feed metering devices to control seed and fertilizer rates. An agitator is usually provided to ensure uniform flow with gravity metering. Usually, two persons are required to operate such drills. Field capacity ranges from 0.3 to 0.4 ha per 8-h day.

Animal-drawn drills

Several designs of 2- to 5-row animal-drawn drills with variations in metering services, power transmission systems, and frame and furrow openers were developed during the last two decades in India (Fig. 5). The seed and fertilizer are held in different compartments. Draft of a typical 3-row animal-drawn drill varies from 80 to 175 kg and area covered from 1 to 1.6 ha/d. Seed

Table 1. Comparative performance of a manually operated fertilizer broadcaster and hand broadcasting (22).

Application method	Effective width of swath (m)	Av field capacity (ha/h)	Uniformity of distribution (% variation)	Time required (h/ha)	Approximate cost of operation ^a (Rs/ha)
<i>Urea (60 kg/ha)</i>					
Hand broadcasting	3.35	0.36	35.0	2.78	3.47
Manually operated broadcaster	6.40	1.20	25.0	0.84	1.35
<i>Diammonium phosphate (60 kg/ha)</i>					
Hand broadcasting	3.55	0.345	30.4	6.5	8.12
Manually operated broadcaster	6.30	1.18	17.5	3.39	5.50

^a Indian Rs 12 = US\$1.

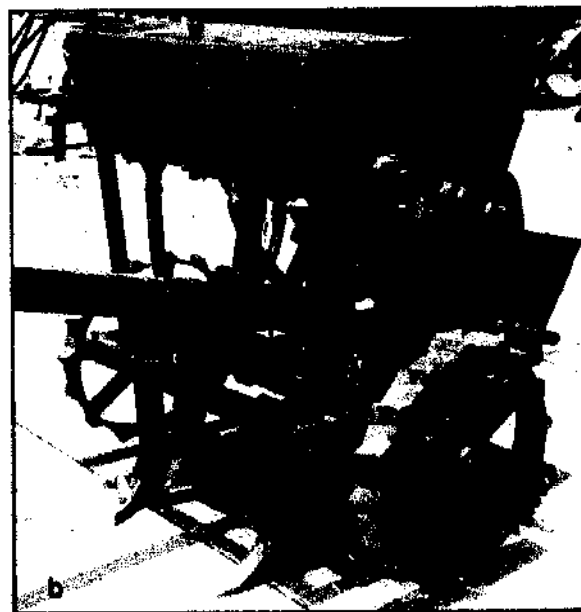
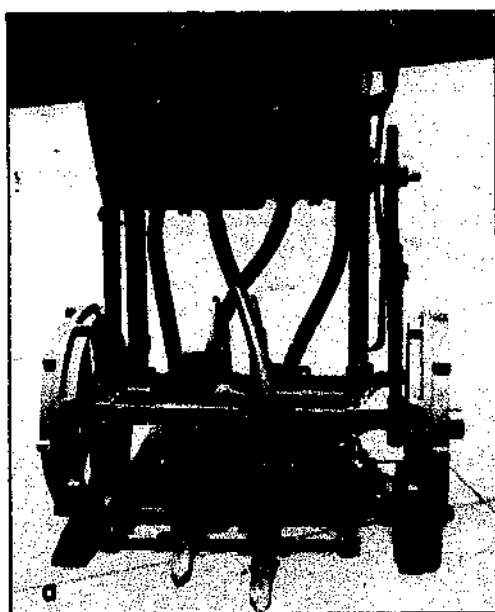

5. a) A two-row, animal-drawn seed-cum-fertilizer drill with cast-wheels, hoe type openers, and V-belt drive with an idler pulley to serve as clutch. b) A three-row, animal-drawn drill with a planter attachment.

metering is done either by fluted-feed rollers, vertical rotors with cells or grooves on the periphery, or by gravity with an adjustable opening with an agitator. Granular fertilizer usually is metered by gravity with an adjustable opening with agitator disk or spur wheel (Fig. 6). An agitator prevents fertilizer from bridging over the opening and ensures uniform flow. The seed and fertilizer are conducted through transparent plastic tubes and dropped in the furrows opened by the furrow openers. Transparent plastic tubes help in detecting the clogging of the seed or fertilizer and also avoid corrosion.

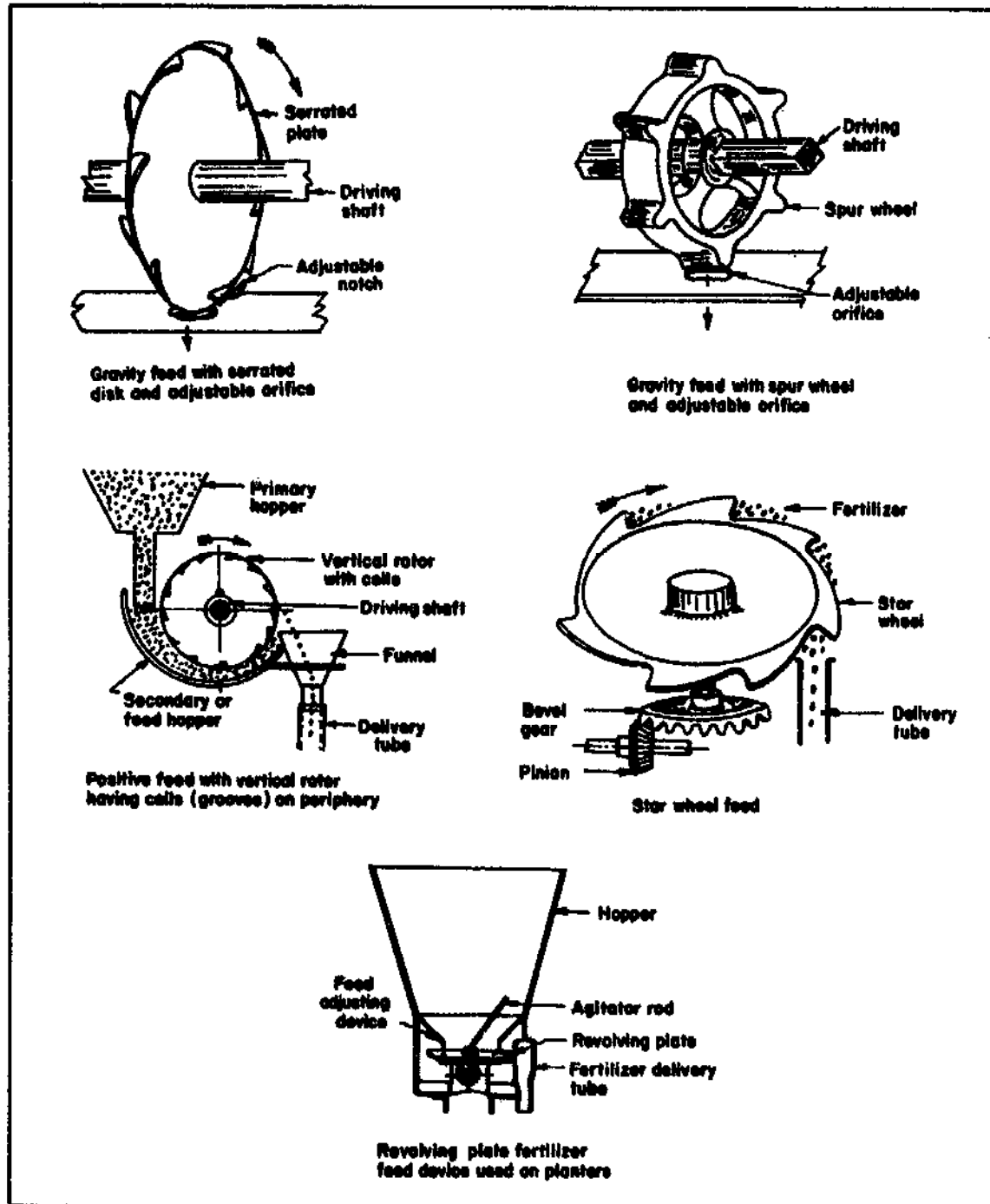

6. Common types of fertilizer metering devices used on Indian seed-cum-fertilizer drills.

Main features of animal-drawn drills are summarized in Table 2. Even though specifications have been laid in IS:6813-1973 by the ISI, the design features vary widely (5).

Table 3 gives information on the suitability of different furrow openers (Fig. 7) for various soil and field conditions. The split-boot furrow opener, commonly known as single-hoe double pore opener, is the most common opener used on animal-drawn drills in northern India because of its simple design, low cost, and low draft. Adequate space is available between openers, thereby avoiding chances of clogging by weeds and stubble and ensuring proper placement of seed and fertilizer. This type places the fertilizer in a band about 2.5 cm to the side and about 2.5 cm deeper than the seed.

Animal-drawn planters

Mechanical sowing equipment developed in India during the last 1-1/2 decades can be broadly categorized as solid drills and precision planters. In solid drilling, the seeds are dropped continuously and randomly without controlling the seed-to-seed distance precisely. In precision planting, the distance between individual seeds or hills is precisely regulated. Examples of

Table 2. Features of animal-drawn fertilizer seed drills in use in India.

Item	Specifications and details
No. of rows	2 and 3
Hopper capacity	Seed: 15 to 20 kg (about 5-6 kg/row). Fertilizer: 20-25 kg
Row-to-row spacing	Adjustable, 8-20 cm.
No. of tool bars	Two, with holes at 25-cm distance
Types of hoppers	Continuous, trapezoidal in X-section made of M. S. sheet
Type of metering	For seed <ol style="list-style-type: none"> 1. External fluted-feed rollers 2. Vertical rotors with cells on the periphery 3. Gravity with adjustable opening and agitators For fertilizer <ol style="list-style-type: none"> 1. Gravity with adjustable openings with spur wheel or serrated disks 2. Vertical rotors with cells on the periphery
Power transmission	Chain and sprockets, V-belt and pulleys
Type of furrow openers	Hoe-type with reversible shovels with split boot or double-pores
Type of furrow shovels	M.S. angle, box or channel sections
Diameter of wheels	22.5 to 40 cm
Speed ratios	Ground wheel-to-seed metering shaft and ground wheel-to-fertilizer shaft = 1:2 to 2.5
Gross weight of empty drill (without beam)	60-110 kg

Table 3. Suitability of types of furrow openers used in seed-cum-fertilizer drills and planters.

Type of furrow opener	Description	Suitability
Hoe type	Single or double pointed shovel with one or two pores/boots.	Suitable for light, medium soils, free of excessive trash. Has good penetration.
Stub or full curved runner	Resembles a curved sword with a thin sharp cutting edge with single or double boots at the rear.	Widely used on row crop planters. Suitable for shallow sowing. Sharp blade cuts through the clods and sod. Low draft and minimum soil disturbance.
Single disk opener	One disk slightly curved, fastened to the boot and set to run at a slight angle.	Good penetration, cuts the trash, and does not clog.
Double disk opener	Two disks facing each other, placed at a slight angle.	Suitable for deep sowing at relatively higher speeds. Ideal for sowing small seeds in trashy seedbeds.
Chisel-type furrow opener	A body with bar shape. Has the shape point projecting over the shoe.	Especially suited to very hard and cloddy soils typical in the black soil belt in the rainfed areas of Madhya Pradesh and Maharashtra.

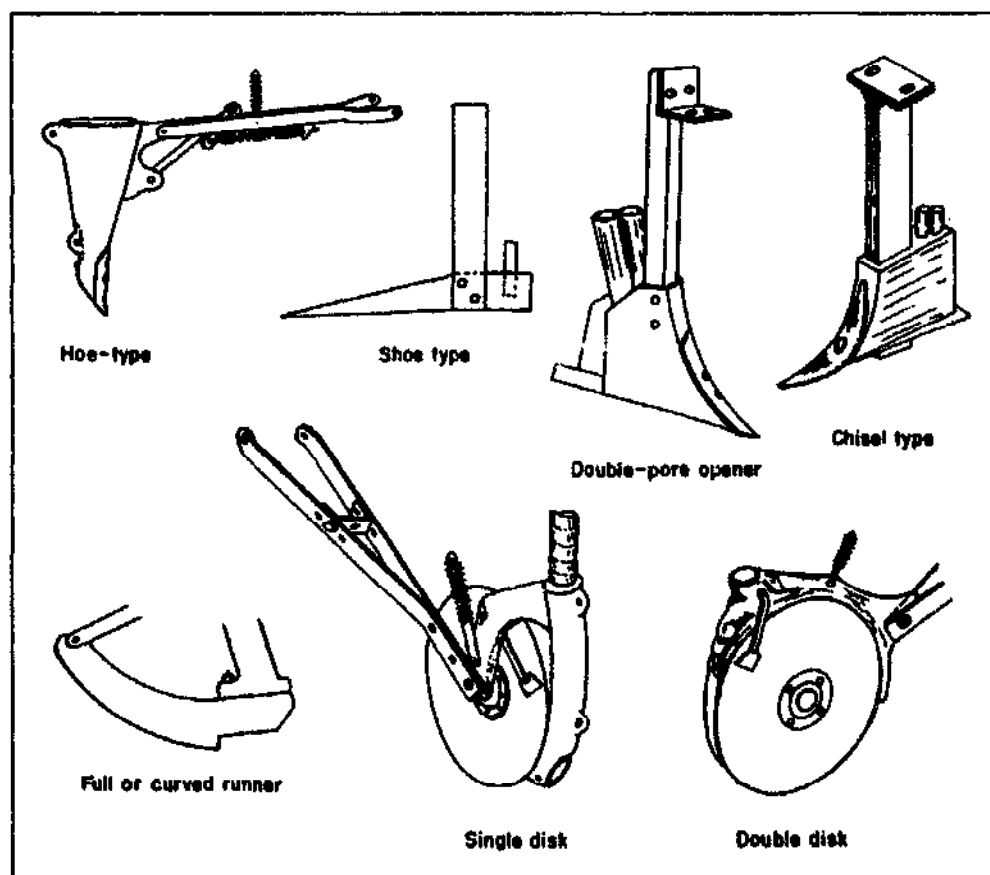
**7. Common types of furrow openers used on seed-cum-fertilizer drills and planters.**

crops sown through solid drilling in India are wheat, barley, paddy (when directly sown), oats, oilseeds, fodder crops like maize, and sorghum. For solid drilling, fluted-feed rollers, or vertical rotors with cells on the periphery or gravity metering devices with adjustable openings with rubber rollers or flaps are used.

For precision planting on the other hand, these metering devices are in use (Fig. 8):

- vertical rotors with seed cells or indents,
- inclined seed plates with seed cells,
- vertical seed plates with seed cells, and
- horizontal seed plates with seed cells.

The commonly planted crops in India are maize, cotton, groundnut, soybean, and pigeonpea. Figures 9 and 10 show the animal-drawn planters with inclined and vertical seed plates.

For each seed type, a separate seed plate with a specified number of cells is used. Fertilizer metering is done by a revolving plate with a stationary plow or gravity (Fig. 6). One type is a positive metering device which meters both powdered and granular fertilizers. The second is the gravity device. The weight of an animal-drawn planter varies from 75 to 100 kg. Hoe, runner, and disk furrow openers are in use. Band plates are provided on runner openers to

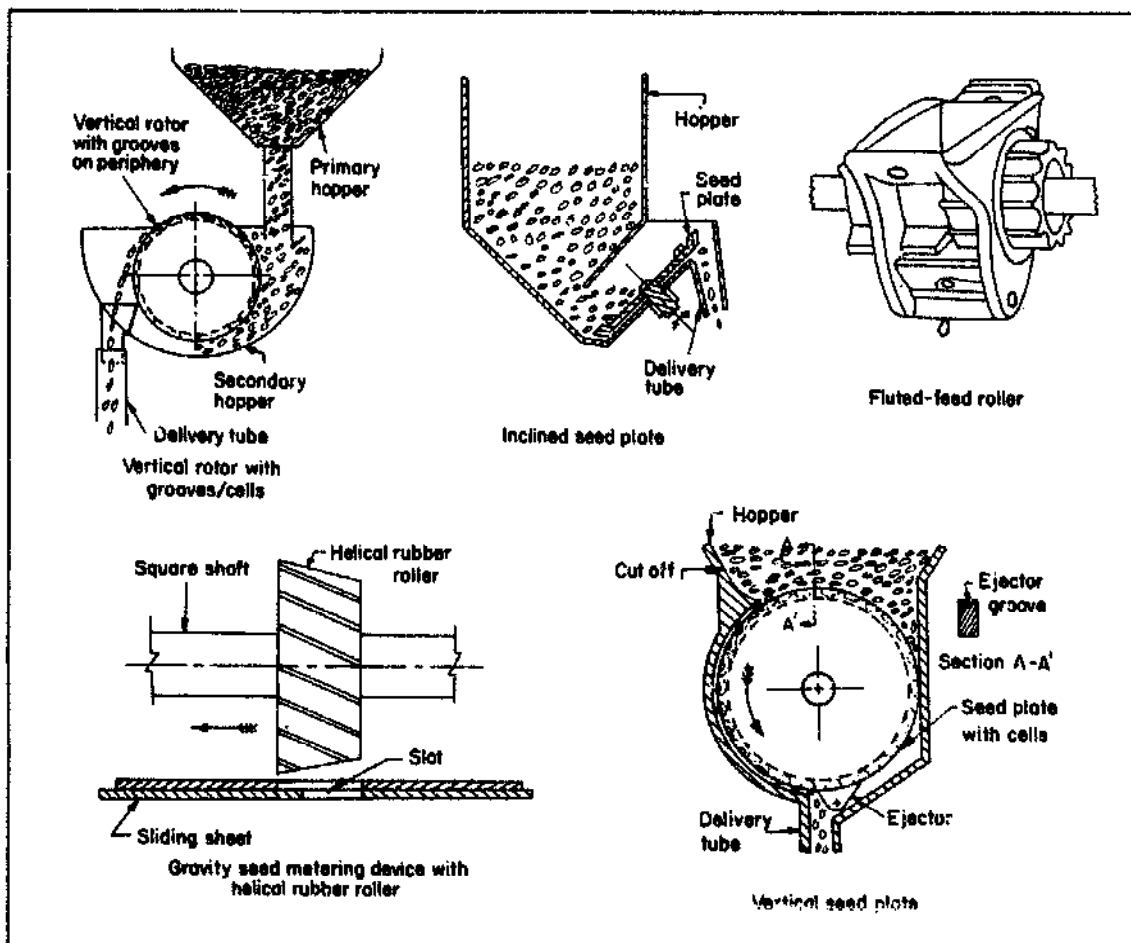

8. Common types of seed metering devices used on drills and planters.

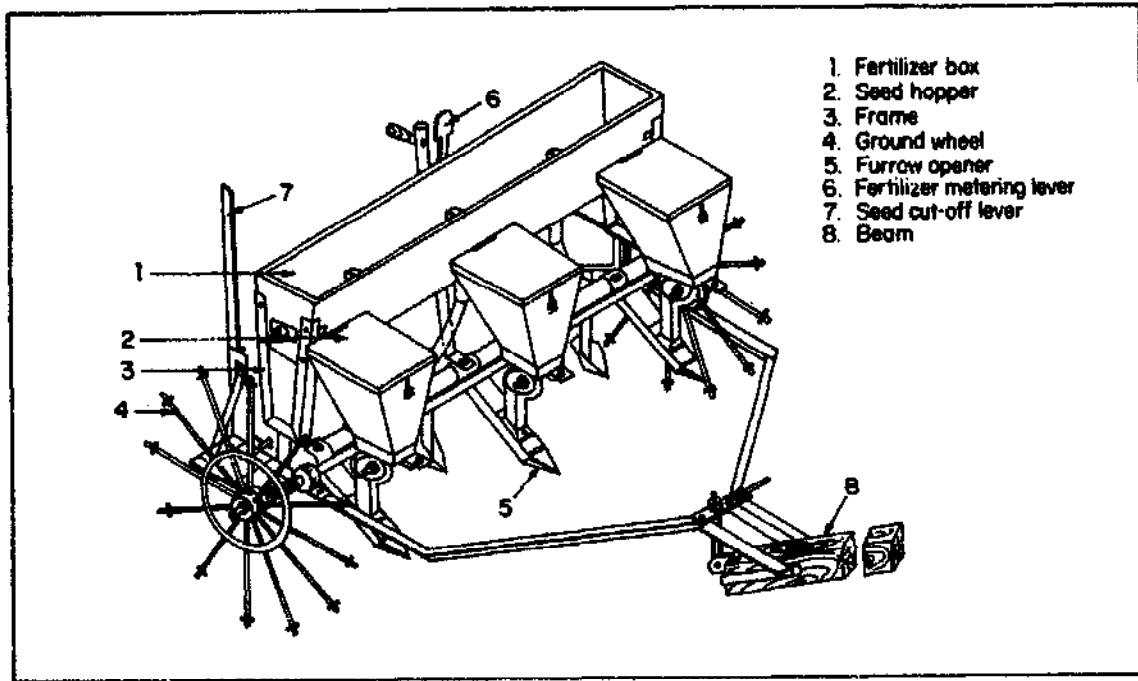

9. A three-row, animal-drawn planter with fertilizer application provision.



10. An animal-drawn, single-row seed planter with fertilizer attachment.

adjust and control planting depth (Fig. 10). The plant-to-plant spacing is adjusted by using the right size of pockets or change gears and seed plates of specified number of cells for a given crop. The manufacturers supply the seed plates and change gears/sprockets to get the desired plant-to-plant spacings in different crops.

Tractor-operated drills

Several types of tractor-operated drills (Fig. 11, 12) and seed planters with fertilizer attachments (Fig. 13, 14) have been developed and introduced in India. For ease of maneuvering and transport, these devices are mounted on the three-point linkage of the tractor. Drill size ranges from 7 to 15 rows for tractors of 20 to 55 hp. Figure 15 shows the common types of ground wheels. Seed-metering devices are in Figures 8 and 16 and fertilizer metering devices are in Figures 6 and 17. Furrow openers are shown in Figure 7. Once again, the most common seed-metering device in drills is the external fluted-feed roller and that on planters is the inclined or vertical plate with cells. All Indian drills and planters band place fertilizer usually on one side of the seed at the same or slightly higher depth than the seed. Agronomic research shows fertilizer placement in a band about 2.5 cm to the side and about 2.5 cm deeper than the seed leads to about 8 to 10% increase in the yield of wheat and other cereal crops. Table 4 gives salient features of tractor-operated drills and planters in use in India.

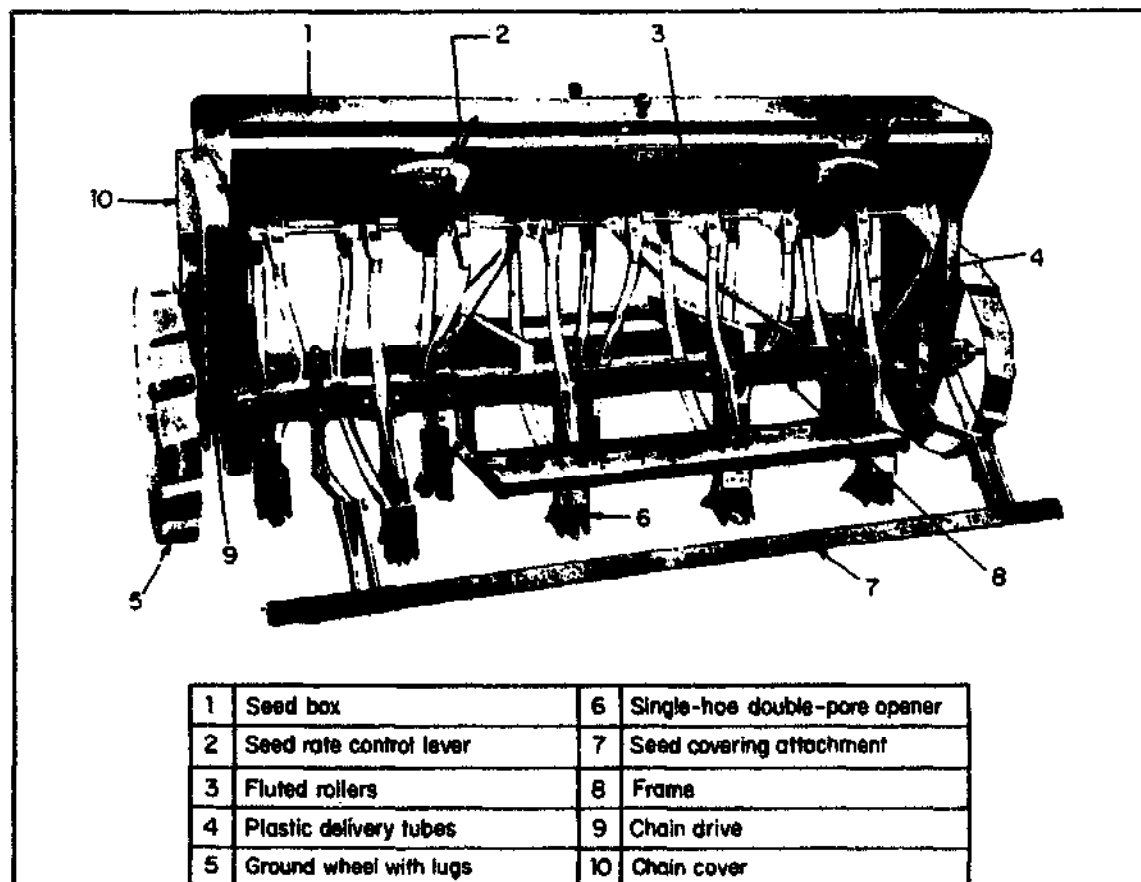

11. A typical, tractor-mounted seed-cum-fertilizer drill.

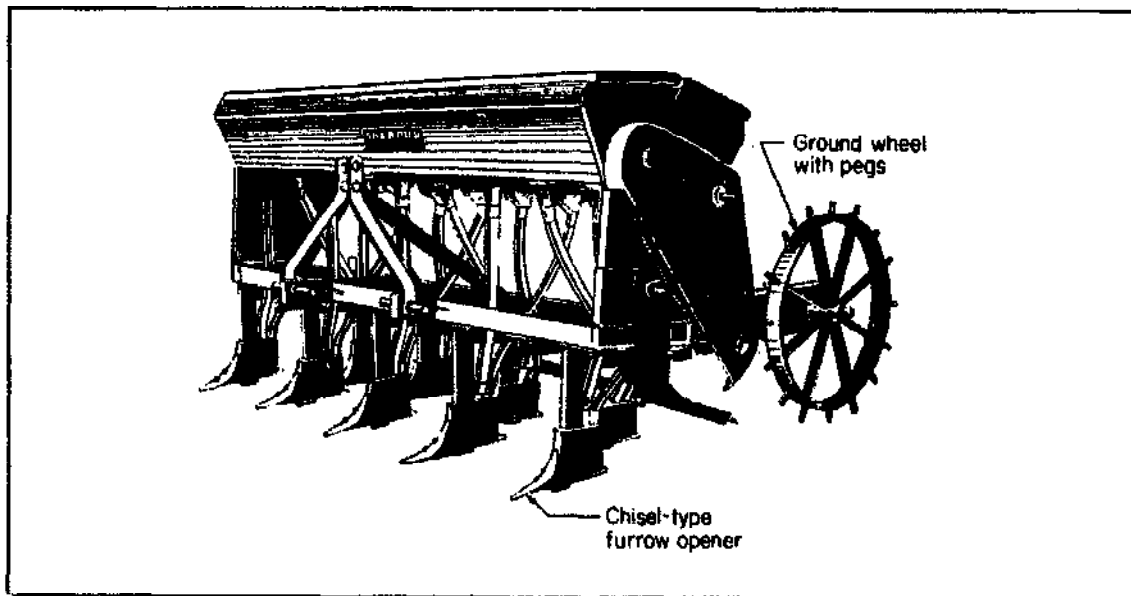

12. A tractor-mounted seed-cum-fertilizer drill with chisel-type furrow opener and ground drive wheel with pegs, for clod-forming soils.

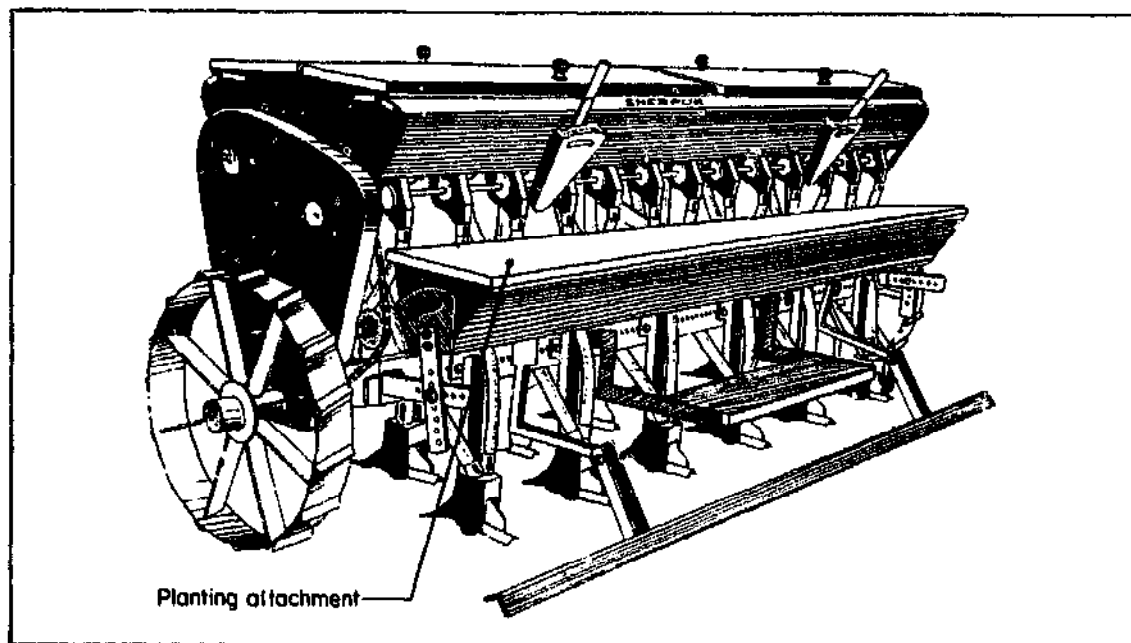

13. A tractor-mounted seed-cum-fertilizer drill with planting attachment.

Tables 5 through 7 give the results of laboratory and field calibration at different settings of the rate control lever and forward speed for seed with two types of metering devices commonly used on tractor-operated drills. A close examination reveals that fluted rollers perform better in inter-row uniformity of seed distribution. Tables 8 and 9 show results for the fertilizer calibration. A positive metering device with vertical rotors with cells on the periphery leads to comparatively low inter-row variation compared to gravity metering with adjustable opening with spur wheel or serrated agitator plates. Therefore, the type of metering device significantly affects drill performance in uniformity

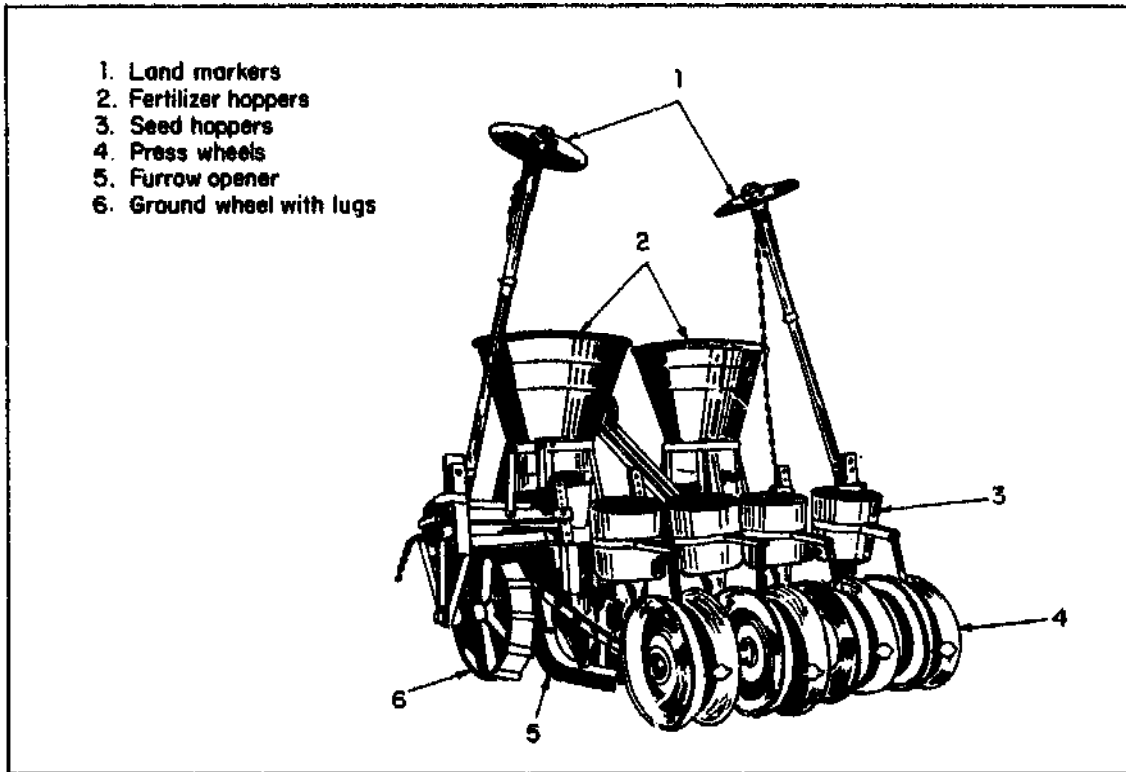

14. A typical four-row tractor-mounted seed-cum-fertilizer planter.

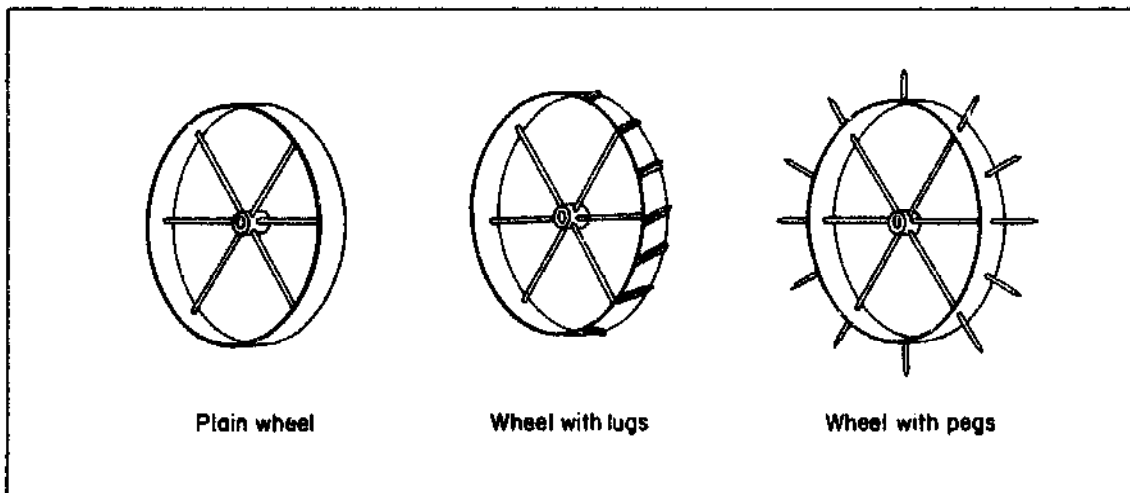

15. Common types of ground wheels used on seed-cum-fertilizer drills in India.

and distribution of fertilizer in the rows. Tables show that in the drill with a positive metering device, increasing the fertilizer rate does not change the percent variation much. In the gravity metering device, however, percent variation generally decreases as the fertilizer rate is increased by increasing the opening size. This can be attributed to better flow of fertilizer with no or minimum bridging when the opening is larger.

Tables 10 and 11 give the qualitative performance of the metering devices used with Indian drills.

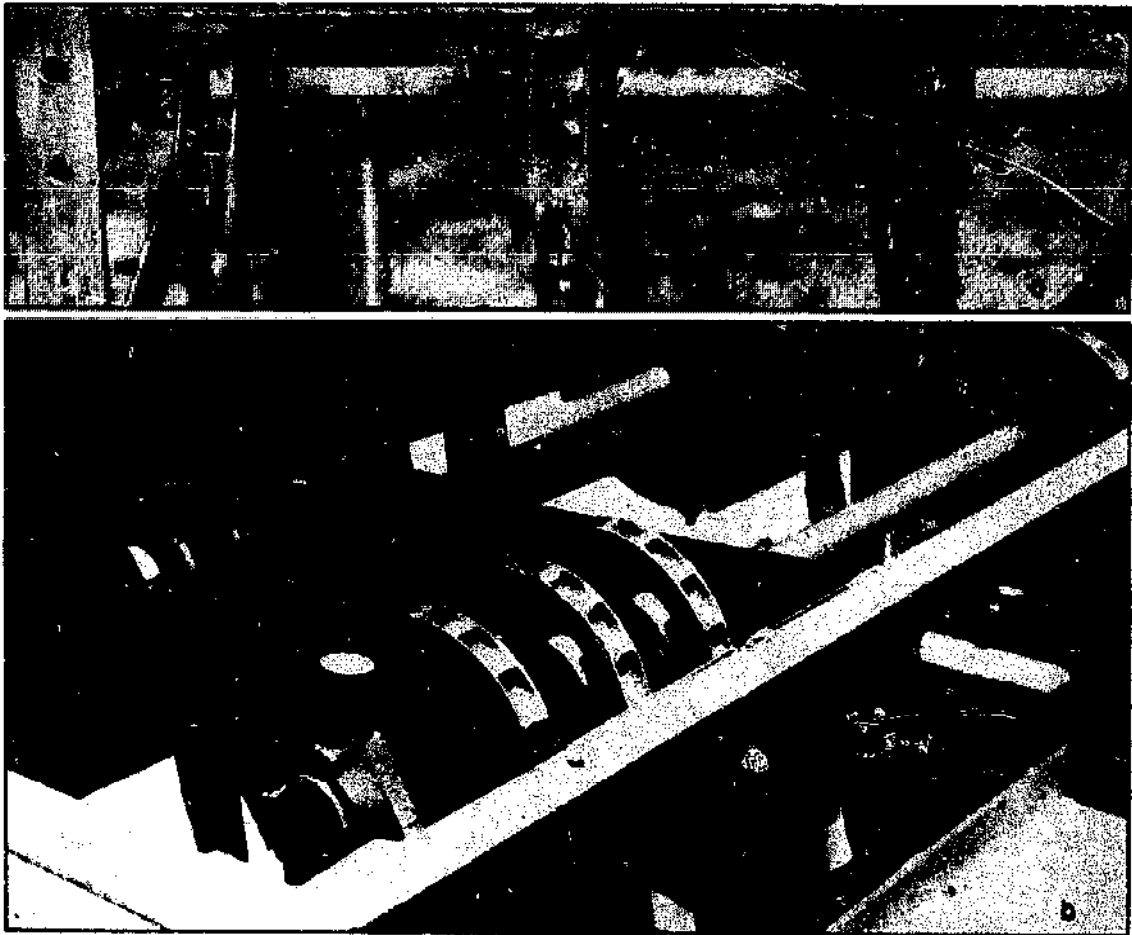

16. Two common types of seed-metering devices used on animal- and tractor-operated drills. a) external fluted-feed rollers, b) vertical rotors with seed cells on the periphery.

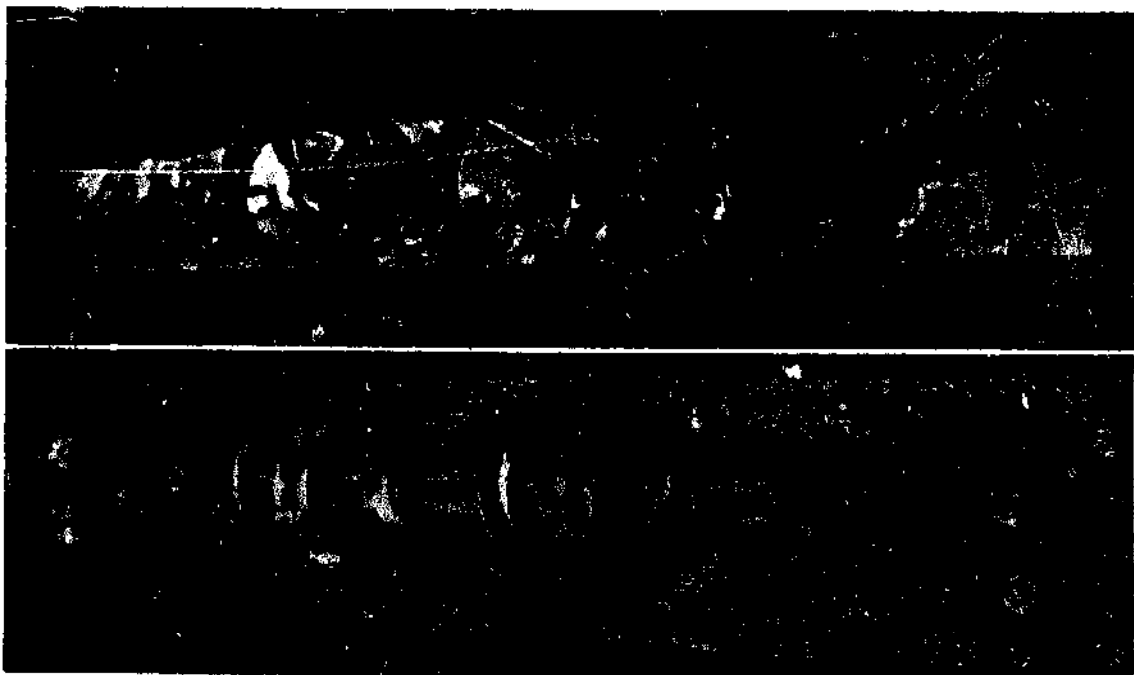

17. Two common types of gravity-type fertilizer metering systems used in animal- and tractor-operated drills: a) with adjustable orifices and serrated agitator plates; b) with adjustable orifices with spur wheels and augers.

Table 4. Features of tractor-drawn drills used in India (18).

Item	Specifications, details
Size (no. of rows)	7 to 15 for tractors of 20 to 55 hp
Hopper capacity	Seed = 60-70 kg; fertilizer = 80-100 kg
No. of tool bars	Two with holes at 55 mm and 10 mm diam
Row-to-row spacing	Adjustable, 20-22 cm
Type of hoppers	Continuous, trapezoidal in cross section
Type of metering device	For seed <ol style="list-style-type: none"> 1. External fluted-feed rollers 2. Vertical rotors with cells on the periphery For fertilizer <ol style="list-style-type: none"> 1. Gravity type, adjustable opening with spur wheel or serrated disks 2. Vertical rotor with cells on the periphery
Power transmission system	Chain and sprocket or belt and pulley
Type of furrow openers	Hoe-type with reversible shovel with double split boots (single hoe double pass opener), chisel type or disk openers.
Speed ratio	<ol style="list-style-type: none"> 1. Ground wheel-to-seed metering shaft 1:2-2.5 2. Ground wheel-to-fertilizer metering shaft 1:2-2.5
No. of ground wheels	One, two, and three wheels with drive from one or two wheels
Depth-adjusting arrangement	By raising or lowering the depth/ground wheel along with axle or adjustable screw or by moving furrow openers up or down by holes in the shanks
Diameter of ground wheels	40 to 60 cm
Gross weight of the empty drill	280 to 300 kg
Hardness of shovels	120 to 140 Brinell hardness no. (BHN) as against 350 to 450 BHN specified by ISI
Draft requirements at a forward speed of 4 km/h to 5 km/h (sandy loam, soil 10% moisture content and 5 to 6 cm depth)	175-230 kg
Field capacity	0.65 to 0.8 ha/h
Interrow variation in dropping of seed and fertilizer	Seed <ol style="list-style-type: none"> 1. +14 to -12% (fluted-feed rollers) 2. +20 to -40% (gravity with adjustable opening) Fertilizer <ol style="list-style-type: none"> 1. +240 to -90% (gravity with adjustable opening) 2. +10 to -16% (vertical rotors with cells on the periphery) (permissible variation: 76% seed and 12.5% of fertilizer)
Range of seed rate per hectare	Seed: up to 125 kg/ha Fertilizer: up to 250-1000 kg/ha
Wheel slippage	14 to 25% (normally should not exceed 10%)
Provision of instant cut-off device	Rarely available

Table 5. Results of laboratory seed-calibration for a 9-row, tractor-mounted seed-cum-fertilizer drill equipped with fluted-feed roller metering device at different rate settings and forward speeds.^a

Seed index setting	Manufacturer's stated seed rate (kg/ha)	Observed rate (kg/ha) at		Variation between furrow openers (% over average)			
		3.5 km/h	5.0 km/h	3.5 km/h		5.0 km/h	
				+	-	+	-
3.0	44.5	37.46	44.30	9.11	6.25	9.02	2.62
4.0	61.1	54.33	60.13	7.69	4.47	4.77	4.20
5.0	79.0	74.13	78.66	3.58	6.89	2.96	2.74
6.0	96.3	91.30	96.86	5.12	3.09	3.10	5.53

^aUsing wheat variety WG-357 at 20-cm row spacing.

Table 6. Results of laboratory seed-calibration for a 9-row, tractor-mounted seed-cum-fertilizer drill equipped with adjustable stationary /opening with an agitator at different rate settings and forward speeds.^a

Seed index setting	Manufacturer's stated seed rate (kg/ha)	Observed rate (kg/ha) at		Variation between furrow openers (% over average)			
		3.5 km/h	6 km/h	3.5 km/h		6 km/h	
				+	-	+	-
2.5	26.2	45.5	35.8	23.7	40.5	25.9	49.6
3.0	40.6	97.8	63.5	10.9	7.8	24.1	64.5
3.5	87.5	141.5	98.7	10.0	7.4	11.6	8.8
4.0	N. A.	225.0	141.7	6.0	18.0	11.1	12.6

^aRow spacing: 20 cm.

Drills with planting attachment

An example of a drill with planting attachment is the multicrop-seed-cum-fertilizer drill shown in Figure 13. When a farmer grows both the solid-drilled and planted crops, he needs a seed-cum-fertilizer drill as well as planter. The combined cost ranges from \$800 to 900, rather prohibitive for many farmers. Researchers in the Department of Farm Power and Machinery, Punjab Agricultural University, Ludhiana, developed a new concept, involving the use of a planter attachment on an animal- or tractor-operated drill. Thus, the farmer can use the same machine for drilling and planting. Several manufacturers in the Punjab fabricate such equipment.

An important consideration in planter design is the height from which the seed is dropped. Ideally, it should be 50 cm or less. Therefore, the planting attachment is bolted on the tool bar of the drill at the lowest possible height. It uses a continuous hopper with standard inclined or vertical seed plates with

Table 7. Results of field calibration of tractor-mounted seed-cum-fertilizer drills equipped with different seed (wheat) and fertilizer (calcium ammonium nitrate) metering devices at different rate settings and at about 4.5 to 5 km/h.^a

Position of rate setting lever for		Expected rate supplied by the manufacturer		Observed rate		Percentage error over expected		Wheel slippage (%)
Seed	Fertilizer	Seed (kg/ha)	Fertilizer (kg/ha)	Seed (kg/ha)	Fertilizer (kg/ha)	Seed	Fertilizer	
<i>Seed metering – fluted-feed rollers</i>								
<i>Fertilizer metering – adjustable stationary opening</i>								
14	4	75	125	76.5	105.0	+20	-20.0	25.2
15	5	–	–	89.5	211.0	na	na	27.4
16	6	–	–	93.0	259.0	na	na	25.2
<i>Seed metering – fluted-feed roller</i>								
<i>Fertilizer metering – grooved peripheral disks</i>								
3.0	5.0	na	137	52.5	118.8	–	-13.3	23.0
4.0	4.0	75.0	175.0	68.0	194.0	-9.3	+10.8	25.2
5.0	3.5	na	na	93.0	237.0	–	–	25.2
6.0		112.50	–	19.5	–	+6.2	–	25.2
<i>Seed metering – adjustable stationary opening</i>								
<i>Fertilizer metering – adjustable with serrated disks</i>								
2.0		–	125	71.50	157.50	na	+30.5	17.3
2.15	3.0	–	–	77.0	186.19	na	na	21.8
2.25	3.25	75.0	–	103.50	230.50	+38.0	na	17.3
2.5	3.5	87.50	–	139.0	315.0	+58.8	na	17.3

^ana = not applicable.

Table 8. Results of fertilizer calibration for a 9-row, tractor-mounted seed-cum-fertilizer drill equipped with a gravity-type fertilizer metering device, with adjustable opening and agitator at different rate settings and forward speeds (1).

Position of rate setting lever	Observed fertilizer rate (kg/ha)		Maximum variation between rows (% over average)			
	3 km/h	5 km/h	3 km/h		5 km/h	
			+	–	+	–
<i>Calcium ammonium nitrate (granular)</i>						
2.0	66.46	67.38	30.82	29.92	21.93	20.01
3.0	180.17	172.13	13.62	21.25	14.53	10.35
3.5	311.92	269.75	17.36	18.02	12.07	9.37
4.0	423.75	369.93	18.10	13.06	10.23	7.53
<i>Urea (prills)</i>						
1.5	68.58	47.42	66.19	52.57	63.02	66.05
2.0	101.13	80.96	42.37	33.87	42.98	58.61
2.5	151.71	118.50	50.84	56.27	43.85	54.91
3.0	228.33	178.08	26.18	36.72	33.41	51.57

Table 9. Results of fertilizer calibration for an 11-row, tractor-mounted seed-cum-fertilizer drill equipped with a positive metering device of vertical wheel with grooves at different rate settings and forward speeds (1).

Position of rate setting lever	Observed fertilizer rate (kg/ha)		Maximum variation between rows (% over-average)			
	3 km/h	5 km/h	3 km/h		5 km/h	
			+	-	+	-
<i>Calcium ammonium nitrate (granular)</i>						
0	540.0	533.0	7.55	13.50	5.4	9.4
3	346.0	356.0	6.20	8.80	7.0	8.9
4	256.0	251.0	0.10	11.80	10.5	12.3
6	194.0	196.8	11.84	16.0	13.7	16.0
<i>Urea (prills)</i>						
0	517.75	459.75	5.85	9.24	11.91	8.72
3	272.50	261.16	7.31	9.17	6.0	6.0
6	153.25	143.31	11.79	10.4	10.77	8.37

cells (Fig. 13). The desired row-to-row spacing is adjusted by laterally shifting the furrow openers. The seed chamber for a particular seed plate can also be blanked/plugged, if needed. The number of rows which can be planted is shown in Table 12. The planting attachment is detached when the machine is used as a drill. While planting a crop, seed plates with specified number of cells and sprockets with a given number of teeth are used (Table 13). Tables 14 and 15 give the field capacity and approximate cost of the seeding and planting equipment currently in use in India.

Tractor-mounted fertilizer broadcaster

There are two types of tractor-operated fertilizer broadcasters (Fig. 18). Table 11 gives the types of metering devices and their comparative performance. The oscillating spout fertilizer spreader can also be used for topdressing fertilizer in row crops by providing a band-spreading attachment.

A tractor-operated fertilizer broadcaster has a hopper capacity of 250 to 300 kg fertilizer. It spreads the fertilizer over a swath 6 to 8 m wide and requires a 35 to 40 hp tractor. It distributes uniformly and is recommended for applying free-flowing granular fertilizers in soils with adequate moisture.

ROLE OF AGENCIES IN EVOLUTION AND EXTENSION OF DRILLS

These agencies contributed toward the design, development, evaluation, manufacture, testing, and adoption of drills in India during the last two decades:

1. R&D organizations such as research and development centers in the agricultural engineering departments or colleges of state agricultural universities, ICAR, and CSIR
2. Farm machinery manufacturers

Table 10. Qualitative performance of different types of seed metering devices commonly used in Indian drills and planters.

Metering device	Suitability for low and high application rates	Suitability for types of seeds	Seed rate control	Simplicity of mechanism	Ease of cleaning	Relative cost	Ease of manufacture	Remarks
<i>For seed drills</i>								
Gravity type with adjustable opening having rubber rolls or flaps	Good	Good	Difficult	Quite simple	Quite easy	Low	Quite easy	Nonpositive
External fluted-feed rollers	Very good	Suitable for small and medium-sized seed for solid drilling	Easy	Relatively difficult	Easy	Higher	Precision manufacturing difficult	Positive type
Vertical rotors with cells/grooves on the periphery	Very good	Good	Difficult	Simple	Quite easy	Moderate	Easy	Positive
<i>For planters</i>								
Inclined plate with cells on edge	Very good	Good for seeds sown by planting	Relatively difficult	Relatively difficult	Easy	Higher	Precision manufacturing difficult	Positive type
Vertical plate or rotor with cells on periphery	Very good	Good for large seeds sown by planting	Relatively difficult	Relatively difficult	Easy	Higher	Precision manufacturing difficult	Positive type

Table 11. Qualitative performance of different types of fertilizer metering devices commonly used in India.

Metering device	Suitability for low and high application rates	Suitability for types of fertilizers	Fertilizer rate control	Simplicity of mechanism	Ease of cleaning	Relative cost	Ease of manufacture	Remarks
<i>Gravity-type metering devices</i>								
Adjustable delivery opening with notched, agitating disk	Good	Suitable for dry crystalline or granular fertilizers only	Easy	Simple	Quite easy	Low	Precision manufacturing difficult	Interrow variation high
Adjustable delivery opening with spur wheel	Good	Suitable for dry crystalline or granular fertilizers only	Easy	Simple	Easy	Low	Easy to manufacture	Interrow variation high
<i>Positive metering device</i>								
Vertical rotor with cells on the periphery	Very good	Suitable for dry crystalline or granular fertilizers only	More difficult	More difficult	Relatively more difficult as individual cells have to be cleaned	Moderate	Precision manufacturing difficult	Interrow variation low. Sensitive to topography of field
Revolving-bottom type	Good	Suitable for dry crystalline or granular fertilizers	More difficult	More difficult	More difficult	High	More difficult	Particularly suited to row crop planters and high application rates

Star wheel	Very good	Suitable for granulated and crystalline fertilizers only	More difficult	Not so simple	More difficult	High	More difficult	Quite suitable for combined seed-cum-fertilizer drills
<i>Metering devices for fertilizer broadcasters</i>								
Circular spinning-plate type	Very good	Suitable for granulated and crystalline fertilizers	Easy	Quite simple	Moderate	Moderate	Moderate	Calibration difficult. Maintaining constant forward speed for accurate spreading essential. More versatile than the circular plate type. Can also be provided with band attachment
Oscillating spout type	Very good	Suitable for granulated and crystalline fertilizers	Easy	More difficult	Not so easy	High	More difficult	

Table 12. Number of rows for crops sown by the multicrop drill-cum-planter.

Crop	No. of rows drilled/planted	
	Animal-drawn	Tractor-operated
Wheat	3	9
Barley	3	9
Paddy	3	9
Oats	3	6
Bajra	3	6
Taramira	3	6
Rapeseed	3	6
Groundnut	3	6
Maize	2	4
Cotton	2	3
Soybean	2	4
Peas	2	4
Okra	2	4
Arhar	2	3

Table 13. Speed of seed plates and size of sprockets for crops.

Crop	Seed plate cell (no.)	Plant-to-plant distance (cm)	Row-to-row spacing (cm)	Sprocket teeth (no.)
Groundnut	8	15	30	9
Soybean	16	7.5	45	9
Maize (corn)	8	22	60	13
Pigeonpea	8	25	75	13
Cotton (local)	8	30	60	16
Peas	32	7.5	45	16
Cotton (America)	6	45	60	19

3. Central and state departments of agriculture and rural development
4. Voluntary organizations
5. National Research and Development Corporation of India
6. Indian Standards Institution
7. Government of India testing and training centers
8. State corporations: agro-industrial corporations, state farms, National Seeds Corporation, etc.
9. Farmers' training centers
10. Banking institutions
11. Rural polytechnics
12. Farmers

Significant contributions toward the design, development, and perfection of the drills have been made by public and private institutions and organizations. Several improved designs of drills and planters have been evolved under ICAR Coordinated Project on Farm Machinery and Implements, and the Dryland Agriculture Project. Various state governments have

Table 14. Size and field capacity of seed and fertilizer application equipment for power sources used in India.

Equipment	Size	Power source	Output capacity (ha/d)	Remarks
Seed-cum-fertilizer drill	1-row	Two persons	0.30 - 0.40	Requires 2 persons to operate
	1-row	Pair of oxen	0.40 - 0.60	
	3-row, 20 cm	Pair of oxen	1.2 - 1.5	Sows at recommended row-to-row spacing and depth. Ensures band placement of fertilizer
	6-row, 1.2-1.3 m	Tractor of 20 hp	4.0 - 4.5	Sows at recommended row-to-row spacing and depth. Ensures band placement of fertilizer
	9-row, 2.82 m	Tractor of 35 hp or higher	5.0 - 6.0	Sows at recommended row-to-row spacing and depth. Ensures band placement of fertilizer
	11-row, 3.2 m	Tractor of 45 hp or higher	7.0 - 8.0	Sows at recommended row-to-row spacing and depth. Ensures band placement of fertilizer
Seed-planter with fertilizer attachment	1-row	Pair of animals	0.60 - 0.75	Ensures accurate seed-to-seed spacing at proper row spacing and depth. Also band placement of fertilizer
	2-row	Tractor of 25 hp or higher	2.0 - 2.5	
	4-row	Tractor of 35 hp or higher	2.5 - 3.0	

Table 15. Approximate cost of animal and tractor-drawn drills with or without planting attachment currently in use in India.

Type of drill	Rows sown (no.)	Approximate cost ^a (Rs)
Animal-drawn seed-cum-fertilizer drill	3	800-1000
Animal-drawn planter	1	800-1000
Animal-drawn seed-cum-fertilizer drill with planter attachment	2-3	1000-1200
Tractor-drawn seed-cum-drill	9	4000-5000
Tractor-drawn seed planter with fertilizer attachment	2.4	5000-5500
Tractor-drawn seed-cum-fertilizer drill with planter attachment	6-9	6000-6500

^a Indian Rs 12 = US\$1.

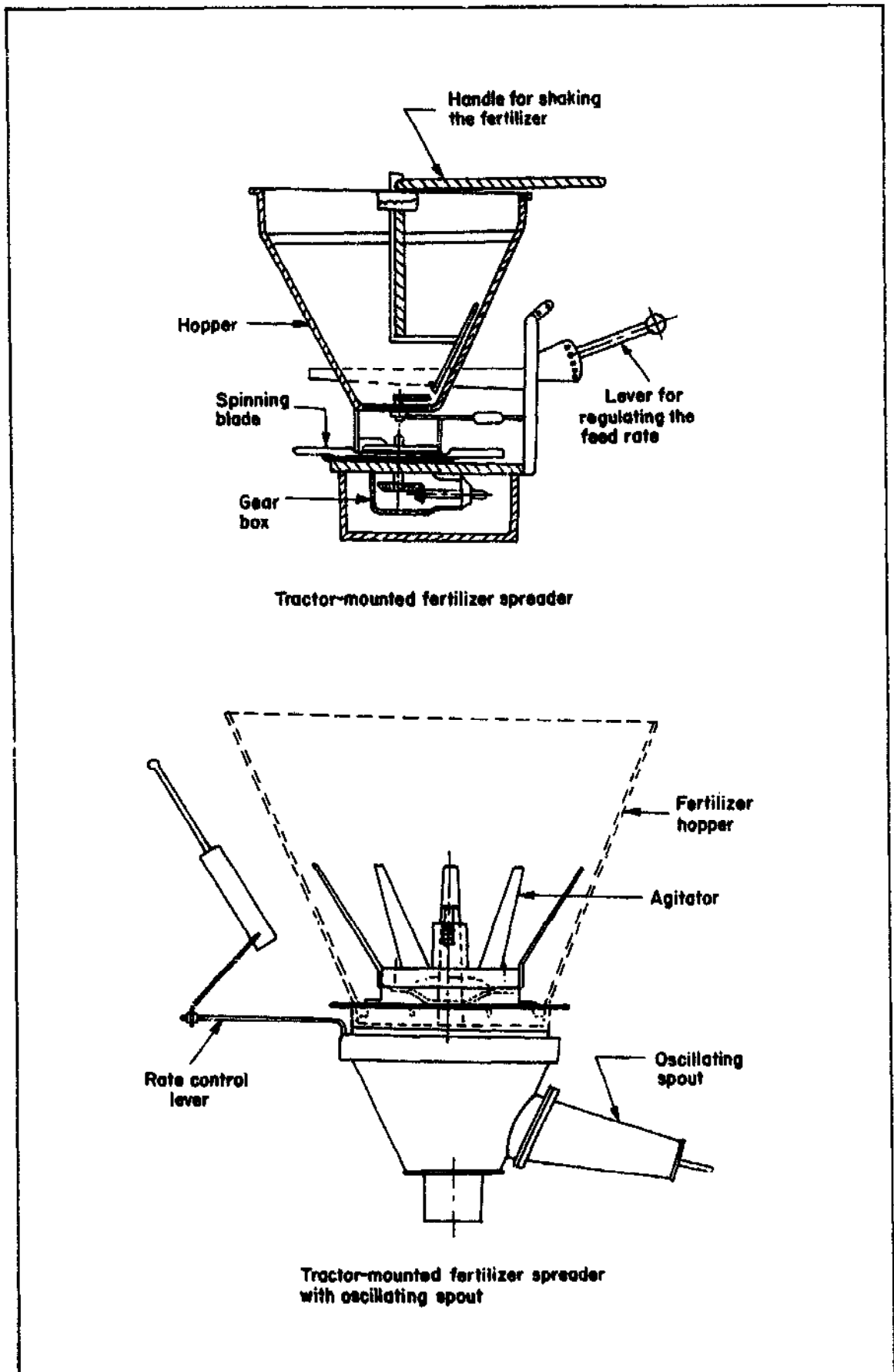

18. Common types of fertilizer metering and stirring devices for tractor-mounted fertilizer spreaders.

made significant contributions by strengthening the farm mechanization research and development base in various agricultural universities. Testing agencies have also played a vital role in this direction. Indian Standards Institution through its Technical Committee AFDC59: Sowing, Fertilizer and Manure Application Equipment, has developed specifications and test procedures for seeding and planting equipment. The private manufacturers, usually comparable to artisan shops, have manufactured seeding and planting equipment based on the improved designs evolved by research organizations and incorporated significant improvements based on farmers' suggestions.

Demonstrations on the use of drills through the National Demonstration Project and extension engineers of agricultural universities and state departments of agriculture/directorates of agricultural engineering resulted in faster adoption. Training in proper adjustments, calibration, use, and care promoted much-needed awareness. Demonstrations on farmers' fields brought out the advantages of a drill in uniform distribution and accurate placement of the seed and fertilizer, establishment of recommended plant population, ease of weeding and hoeing in line-sown crops, economy in seed and fertilizer rates, saving in time, money and drudgery. The cumulative effort led to an 8 to 10% increase in yield per hectare.

R&D engineers have contributed by judicious selection and design of proper metering devices, simple and rugged power transmission systems, adapted ground wheels to minimize slippage, simple adjustments during operation and transport, and the right type of furrow openers to ensure proper functioning of the drill under varying soil-field conditions. The seed drills and planters were designed in sizes compatible with the draft capacity of the animals and the drawbar hp and hydraulic lift capacity of Indian tractors. Construction materials have also been selected and incorporated in the designs to provide proper resistance and strength as well as ensure easy availability and workability with the shop facilities and gadgets available in the small artisan shops.

R&D organizations have helped manufacturers by supplying blueprints and lending prototypes and technical guidance during fabrication. ICAR, through its coordinated research project on manufacture of prototypes, has multiplied promising designs, making it possible to conduct feasibility trials under different soil and crop conditions. After evaluation, designs were modified, improved, and propagated in various areas. The National Farm Machinery Release Committee of the Ministry of Agriculture and Rural Development is helping in prompt release of well-tested and proven designs of seed-cum-fertilizer application equipment developed by various R&D centers and other agencies.

The role of manufacturers and fabricators in introducing drills has also been noteworthy. They have developed appropriate tools, jigs, and fixtures for manufacturing various components and producing the machines, and have demonstrated to farmers, through agricultural fairs and exhibitions, the function and utility of various designs.

Farmers' organizations including the Indian Farmers Fertilizer Coopera-

tive, National Marketing and Cooperative Federation, Farmers' Clubs, Young Farmers' Forums, and many individual progressive farmers have contributed toward speedy transfer of the know-how about drills. Adoption by progressive farmers induced other farmers to adopt drills and thus realize higher yields.

Government policies helped too. The Government provided subsidies of 25 to 33% to small and marginal farmers under the Integrated Rural Development Programme of the Ministry of Agriculture, and other incentives. Banking institutions provided credit for buying the equipment. The establishment of the National Bank for Agricultural and Rural Development during the Sixth Five-Year Plan also helped the farmers and artisans in this direction. More than 20,000 agro-service centers and the agro-industries corporations setup in almost all states also helped in manufacture, marketing, and custom-hiring of the seeding and planting equipment in India.

STANDARDIZATION OF SOWING AND FERTILIZER APPLICATION EQUIPMENT

Because of the importance of interchangeability, proper material, requisite tolerance in critical components, and proper quality control, formulation of relevant standards for sowing and fertilizer application equipment assumed crucial importance. The ISI has been engaged in this task since early 60s. A separate technical committee, AFDC 59: Sowing, Fertilizer and Manure Application Equipment, was constituted in the early 80s. The following standards, test codes, and other documents have been issued by the ISI for wider adoption:

IS:

- 3310-1965 Single row cotton drill, animal drawn
- 6316-1971 Test code for seed-cum-fertilizer drill
- 6813-1973 Seed-cum-fertilizer drills
- 6816 (Part I)-1973 Fluted-feed roller type seed-metering mechanism: Part I Seed feed rollers
- 6816 (Part II)-1973 Fluted-feed roller type seed-metering mechanism: Part II Seed feed cut-off
- 6816 (Part III)-1973 Fluted-feed roller type seed-metering mechanism: Part III Retaining ring and cover
- 6816 (Part IV)-1973 Fluted-feed roller type seed-metering mechanism: Part IV Seed feed cup
- 6817 (Part I)-1973 Plate type seed-metering mechanism: Part I Seed plates
- 6817 (Part II)-1973 Plate type seed-metering mechanism: Part II Seed feed roller
- 8781-1978 Single-row jute seed drills manually operated
- 9219-1979 Seeding attachment for animal-driven cultivators
- 9855-1981 Glossary of terms relating to sowing, planting, fertilizer, and manure application equipment.

Efforts are being made to formulate standards for specifications of fertilizer metering devices and other drill components.

The Test Codes have enabled the testing of drills on a uniform basis to ensure comparable results. The standards on specifications have provided necessary information regarding functional requirements, shape, size, construction materials, tolerances, hardness, and quality control of various components and complete machines. Some components, especially fluted-feed rollers, are now being produced according to ISI specifications. Thus, ISI has played a pivotal role not only in bringing together agencies, namely, R&D engineers, manufacturers, farmers, and government agencies on a common platform, but has helped to formulate guidelines, codes, and standards for minimizing variations, enabling interchangeability and promoting necessary quality control in equipment.

MANUFACTURE OF DRILLS

Drills are being manufactured by many private firms in India, especially in the states of Punjab and Haryana, where more than 100 small-scale firms are producing drills and planters driven by animal and tractor power. A 1978 study by the Department of Farm Power and Machinery, Collège of Agricultural Engineering, PAU, Ludhiana, indicated that drills' components were being fabricated without employing modern production techniques and processes (7). That led to variations in dimensions of components, hindering interchangeability. The study also revealed that nonstandardized metering mechanisms resulted in as much as 30 to 59% inter-row variation.

Almost all shops manufacturing drills buy chains and sprockets, V-belts and pulleys as well as metering components, viz., fluted-feed roller assemblies, vertical rotors with cells, spur wheels, agitators, plastic tubes, bearings, and fasteners from the local market. However, seed and fertilizer hoppers, frame, ground wheels, and furrow opener assemblies are fabricated in shops. Some manufacturers make their own chains, sprockets, and V-pulleys, and some specialize in casting of fluted-feed rollers, vertical seed rotors, spur wheels, augers, and agitators. Fairly simple and low-cost die-casting processes have been developed which led to good quality casting of fluted-feed rollers and seed cup assemblies. However, almost all manufacturers of drills and planters follow fabrication methods rather than batch or assembly-line production.

Most manufacturing units are owned by skilled technicians or artisans who lack formal technical education. Very few work with blueprints and production drawings. Quality control is, therefore, the major casualty in manufacture of components. Proper fits and tolerances are rarely maintained. This, then, is an area open to improvements and is crucial to better the quality, interchangeability, and durability of components and complete equipment. Industrial extension services must be strengthened to promote awareness among manufacturers. Design and adoption of appropriate jigs and fixtures for components will help improve quality, enhance productivity, and reduce cost.

Most manufacturers own lathes, shapers, drills, welding sets, hacksaws, and mechanical/hydraulic presses. Hand- and power-operated roller-type bending machines are used for bending sheets, flats, angles, squares, and rounds. For cutting material to required sizes, hand- and power-operated shears or mechanical/hydraulic presses are used. Progressive manufacturers use jigs and fixtures for fabrication of ground wheels, frames, seed, and fertilizer hoppers and furrow openers.

CHALLENGES, TRENDS, AND PROBLEMS

In the coming years, seed-cum-fertilizer drills will get widely adopted in many more areas where farming is predominantly rainfed. Interchangeability, quality control, and precision are likely to improve considerably in the coming years. R&D organizations are likely to develop new, precise, and versatile mechanisms. Evaluation of imported seeding and fertilizer equipment will get intensified. Aspects needing attention include

- testing of spiral versus straight fluted-feed rollers for inter-row and intra-row variation in seed distribution;
- feasibility studies on comparative advantages and disadvantages of nylon versus metallic fluted-feed rollers and other components for seed and fertilizer metering;
- critical evaluation of drills, planters, and drill with planting attachments;
- development and evaluation of pneumatic drills and planters;
- comparative evaluation of types of furrow openers under varying soil and field conditions and standardizing of three or four main types suited to Indian soil, crop, and field conditions;
- designing and developing furrow openers for sowing pregerminated seeds in puddled fields;
- design, development, and evaluation of fertilizer application equipment for wetland conditions, especially in puddled fields with standing water;
- intensifying research on reducing draft and power requirements of animal- and tractor-operated drills for dry farming areas, especially for both bed and furrow as well as flat planting of such crops as maize, groundnut, sorghum, millets, and pigeonpea (Fig. 19);
- intensifying research and development of no-till drill equipment (Fig. 20);
- intensifying industrial extension activities on drills to motivate and educate manufacturers in selection of proper raw materials, heat treatment, manufacturing techniques, and tools;
- standardization of vital components, namely, metering devices for planters, depth-regulating mechanisms, ground wheels, and power transmission systems to minimize variations and permit interchangeability and quality control; and
- design and development of appropriate jigs and fixtures for manufacture of various components of drills and educating small-scale manufacturers in their adoption and use.

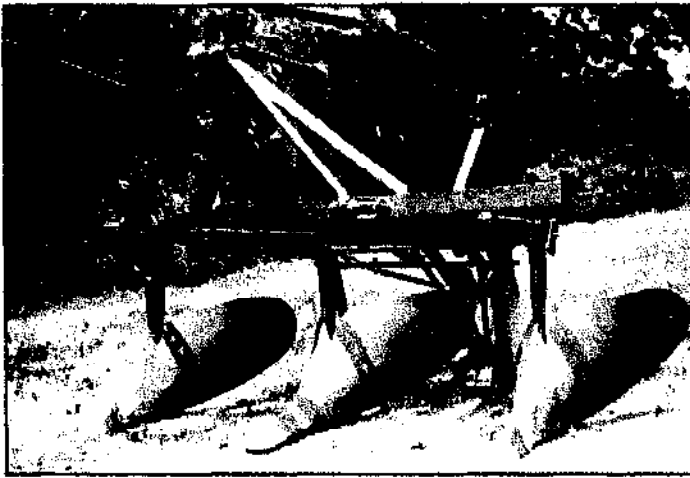

19. A two-row, tractor-mounted ridge planter for maize.



20. A 9-row, tractor-mounted, no-till seed-cum-fertilizer drill with colter-attachment.

R&D work on drills and planters in India is being directed toward refining and standardizing the methods and equipment to suit different soil ecosystems.

Problems being discussed include the following:

Inadequate design data

Even though several designs of drills, planters and broadcasters have been developed and adopted during the last two decades, adequate design and performance data for different seeds and fertilizers under various soil and field conditions are still lacking. Data are scattered and heterogeneous. Batch testing of drills under different soil-field conditions may help to generate reliable data. The promising metering devices for seed and fertilizer as well as

furrow openers for irrigated, dry and wetland conditions including black soils (Vertisols) need to be standardized for different regions or zones. It will help to optimize the seed and fertilizer use efficiency and minimize wastage.

Standardization and quality control of components

The major concentration of drills is in northwestern states of Punjab, Haryana, Uttar Pradesh, Madhya Pradesh, Rajasthan, and Gujarat. Most drills use gravity metering systems, leading to nonuniform distribution of seed and fertilizer. Unless components are manufactured with utmost precision and farmers use machines carefully, gravity metering devices leave up to 50% inter-row variation. This defeats the very purpose of using a drill. There is a need to identify and standardize metering systems, especially for fertilizers.

Performance efficiency also depends on the furrow openers. The different furrow openers developed for different field conditions need improvement in standardization, construction material, and manufacturing techniques.

Precision and accuracy in the dispensing parts is the first prerequisite to attain high application efficiency. Small-scale manufacturers are, by and large, ignorant and rarely appreciate the need for stringent standards and tolerances in the dimensions of the dispensing parts. Manufacturing processes often are improper. There is a need to standardize these parts and entrust their manufacturing to a few selected manufacturers. All components must conform to ISI or ISO standards. Industrial extension education must also be geared up to promote awareness of needed improvements.

Good quality raw materials

Even though material for drill components has been specified in the Indian standards, its quality varies greatly. This affects the durability and performance of equipment. Corrosion of fertilizer hoppers and metering systems is common. These components should be made of corrosion-resistant materials or painted against chemical deterioration. Information is needed on use of fiberglass, nylon and other polymer materials for hoppers and metering components.

Instant closing of delivery opening

Many drills waste fertilizer, especially while turning corners, because they lack a way to instantly close delivery openings. A hand-actuated or tractor hydraulic lift-operated mechanism should be provided in all drills to close the delivery openings.

Design of ground wheels

Drive to the metering shafts is provided from the ground wheels. Excess wheel-slippage impairs field performance. Standardization of the shape, size, and other parameters of ground wheels for different soil and field conditions for animal- and tractor-drawn drills can minimize slippage and improve performance.

Dependable calibration

Drills need proper indexing plates and calibration charts. Constantly, farmers find it hard to calibrate the drills and maintain the required rates. All drills need easy and dependable rate control mechanisms, calibration charts, and operators' manuals.

Ease of maintenance

Leftover fertilizer corrodes the components. Many drills do not last for their designed life because of improper maintenance and difficulty in cleaning components after use. With many drills, it is difficult to empty hoppers, especially fertilizer hoppers, and time-consuming to dismantle agitators and components of metering mechanism for cleaning.

REFERENCES CITED

1. Ali, N., S. K. Patra, and R. R. Lall. 1979. Catalogue of improved agricultural tools, implements and equipment of India. Central Institute of Agricultural Engineering, Rabi Bagh, Berasia Road, Bhopal 462010, India.
2. Annual Test Reports No. 7, 8, 9, 10. 1978. Farm Machinery Testing Centre, Department of Farm Power & Machinery, PAU, Ludhiana, India.
3. Chauhan, A.M., H.S. Klakat, and S. R. Verma. 1977. Modification and evaluation of tractor-mounted multi-crop seed-cum-fertilizer drill with seed planter attachment. Annual Report 1976-77, Department of Farm Power & Machinery, College of Agricultural Engineering, PAU, Ludhiana.
4. Chauhan, A.M., and R. Kumar. 1972. Review of research and development in seed-cum-fertilizer drills in India and areas for further work. *J. Agric. Eng'g.*, ISAE 9(3):31-43.
5. Sharma, R.N. 1984. Standardization of sowing and fertilizer application equipment. *Agric. Eng'g. Today* 8(6):7-9.
6. Shaugugham, C. R. 1981. Farm machinery and energy research in India. Central Institute of Agricultural Engineering, Nabi Bagh, Berasia Road, Bhopal 462010, India.
7. Singh, J., S. C. Mandher, and S. R. Verma. 1978. Study of existing manufacturing techniques and processes for selected farm equipment in Punjab. College of Agricultural Engineering, PAU, Ludhiana.
8. Singh, C. P., S. R. Verma, and S. K. Tandon. 1984. Status of agricultural mechanization in India. Proceedings of the 2d international conference, Development of the Agricultural Machinery Industry in Developing Countries, Amsterdam.
9. Sridharan, C. S. 1977. Research and development of sowing devices. *Agric. Eng'g. Today* 1(11): 2-5.
10. Srivastava, N. S. L. 1971. Fertilizer application machinery for sugarcane. *Farm Ext. Dig.*, Escorts Farm Ext. Serv. 3.
11. Tandon, S. K., L. N. Shukla, and S. R. Verma. 1984. Seed-cum-fertilizer drills and planters in use in Punjab. *Agric. Eng'g. Today* 8(5):4-14.
12. Verma, S. R., and S. K. Tandon. 1982. Critical evaluation of farm implements and methods of fertilizer application. Proceedings of FAI national seminar 1981 on strategies for achieving fertilizer consumption targets and improving fertilizer use efficiency. The Fertilizer Association of India, New Delhi.

Plant protection and soil fertility

PEST CONTROL EQUIPMENT FOR SMALL-SCALE FARMERS

G. A. MATTHEWS
Imperial College
Berks, England

Pesticide use in tropical countries is low compared to extensive use on farms in North America and Europe. This has often been attributed to the lack of foreign exchange and to a plentiful supply of labor for hand weeding or hoeing. Nevertheless, small-scale farmers have increased their use of pesticides, particularly on certain crops such as cotton, and where they have changed agronomic practices, such as direct seeding of rice.

Traditionally, modifying pesticide application recommendations for small-scale farmers has centered on the use of manually operated knapsack sprayers. Principal exceptions are use of motorized equipment to project spray into tree crops and application of granules when the pesticide is systemic or too hazardous to apply as a spray.

For knapsack equipment, the farmer has been expected to dilute the pesticide in at least 200 liters of water/ha. This quantity of water may be readily available in lowland irrigated rice, but on most small-scale farms the supply is irregular and far from the fields requiring treatment. Reduction of spray volume with smaller nozzles has been advocated (18), but this approach is often impractical because sand or other particles in the water may block the nozzles.

Even when water is available, farmers seldom have sufficient instruction or the ancillary equipment to measure out, mix, and dilute correct quantities of the pesticide. There is little chance of the correct dosage being applied. In the Philippines, Litsinger et al (8) reported that even when farmers did mix the correct spray concentration, the manual effort needed to operate the sprayer pump was such that many farmers failed to apply the correct volume; rice fields received less than half the recommended dosage.

Considerable criticism of pesticide use by small-scale farmers arises from incidents of pesticide poisoning, not always fully documented in official records (2). Farmers are highly exposed to contamination while measuring out the concentrate and mixing it. Further, studies indicate that, as operators invariably hold lances in front of them during spraying, they are heavily contaminated on their legs (12). Most equipment breaks down rapidly and as spare parts are seldom available, leakage from trigger valves, hoses, and spray

tanks increases operator contamination. Hot climates not only tire users, favoring accidents, but restrict the choice of protective clothing (12).

High temperature and low humidity increase evaporation of water-based sprays, and heavy rainfall washes away water-based spray deposits (11). Further, the ideal knapsack sprayer does not exist; each design has poor as well as good features (4).

The small-scale farmer needs a lightweight, durable sprayer, easily operated with little energy and with preset pesticide dosage rates. Research toward these requirements led to ultra-low-volume (ULV) spraying that significantly reduces the water used and, more recently, to controlled droplet application with electrostatic charging of the spray droplets (3).

This paper presents case histories of the use of knapsack, ULV, and electrostatic sprayers.

CASE STUDIES

Spraying cotton in Central Africa

Recommendations were made in 1960 to modify a knapsack sprayer to adjust the spray volume in relation to plant height and direct spray to the rear of the operator, thus reducing the risk of contamination (16). This method reached about 25% of the farmers in areas with boreholes, and they increased production significantly (7). Farmers were provided with prepacked sachets containing sufficient product for one knapsack load, and a calibrated mixing drum so that correct spray concentration was achieved easily. Several spraying machines were tested to assess their durability (13, 9). Even if a sprayer was slightly more expensive, the importance of meeting design criteria was stressed to ensure reliability throughout the season. This led to the publication of a Central African Standard for knapsack sprayers. The extension service had to keep appropriate spare parts in farm centers accessible to farmers.

Lack of water prevented extension of this technique. Some farmers collected rainwater in polyethylene sheets on house roofs or in small ponds; but these systems were impractical on the scale needed.

Research from 1969 to 1972 was, therefore, aimed at ULV spraying. It led to recommendations for the use of hand-carried, battery-operated, spinning-disk sprayers (10). The technique was adopted elsewhere in Africa on cotton, particularly in francophone West Africa and in Tanzania, Mozambique, and, more recently, in Indonesia. In some cases, spraying was organized centrally with mobile spray teams. In Malawi, the high cost of the relatively involatile solvent-based formulations led to further research with wetttable powder formulations applied through the spinning-disk sprayers (14), used in Gambia and in Zimbabwe where molasses is added to the spray (6). These spinning-disk sprayers required eight or more D-size batteries, which are costly and are often inadequate to provide the power needed.

Cotton in Nigeria

In the 1960s, few farmers followed the recommendations to protect their

tanks increases operator contamination. Hot climates not only tire users, favoring accidents, but restrict the choice of protective clothing (12).

High temperature and low humidity increase evaporation of water-based sprays, and heavy rainfall washes away water-based spray deposits (11). Further, the ideal knapsack sprayer does not exist; each design has poor as well as good features (4).

The small-scale farmer needs a lightweight, durable sprayer, easily operated with little energy and with preset pesticide dosage rates. Research toward these requirements led to ultra-low-volume (ULV) spraying that significantly reduces the water used and, more recently, to controlled droplet application with electrostatic charging of the spray droplets (3).

This paper presents case histories of the use of knapsack, ULV, and electrostatic sprayers.

CASE STUDIES

Spraying cotton in Central Africa

Recommendations were made in 1960 to modify a knapsack sprayer to adjust the spray volume in relation to plant height and direct spray to the rear of the operator, thus reducing the risk of contamination (16). This method reached about 25% of the farmers in areas with boreholes, and they increased production significantly (7). Farmers were provided with prepacked sachets containing sufficient product for one knapsack load, and a calibrated mixing drum so that correct spray concentration was achieved easily. Several spraying machines were tested to assess their durability (13, 9). Even if a sprayer was slightly more expensive, the importance of meeting design criteria was stressed to ensure reliability throughout the season. This led to the publication of a Central African Standard for knapsack sprayers. The extension service had to keep appropriate spare parts in farm centers accessible to farmers.

Lack of water prevented extension of this technique. Some farmers collected rainwater in polyethylene sheets on house roofs or in small ponds; but these systems were impractical on the scale needed.

Research from 1969 to 1972 was, therefore, aimed at ULV spraying. It led to recommendations for the use of hand-carried, battery-operated, spinning-disk sprayers (10). The technique was adopted elsewhere in Africa on cotton, particularly in francophone West Africa and in Tanzania, Mozambique, and, more recently, in Indonesia. In some cases, spraying was organized centrally with mobile spray teams. In Malawi, the high cost of the relatively involatile solvent-based formulations led to further research with wettable powder formulations applied through the spinning-disk sprayers (14), used in Gambia and in Zimbabwe where molasses is added to the spray (6). These spinning-disk sprayers required eight or more D-size batteries, which are costly and are often inadequate to provide the power needed.

Cotton in Nigeria

In the 1960s, few farmers followed the recommendations to protect their

cotton with insecticides because yield increases were poor on crops sown late. The first priority for most farmers was to sow their food crops and keep them weeded; only later would they have time for crops such as cotton. Through specially financed development schemes, spinning-disk sprayers were used in the 1970s. A major problem was that farmers could only buy the insecticides in 25-liter drums, more than what they required. This led to between-season loss during storage when containers leaked.

Herbicide application

Recognizing that labor was insufficient on many farms during critical periods, Ciba-Geigy pioneered the use of spinning-disk sprayers for herbicide application in collaboration with Micron Sprayers (1). Initially atrazine was recommended for weed control in maize using a handy sprayer. Later developments broadened the range of products, and Ciba-Geigy has promoted a manually operated spinning-disk knapsack sprayer, the Birky, especially for herbicides. A significant adoption of spinning-disk sprayers for weed control is in plantation crops in Southeast Asia (17). Other equipment being tested include the Pullalong sprayer having a shrouded spinning disk and a peristaltic pump so dosage is related to walking speed (5).

Electrodynamic spraying

Coffee (3) described a new low energy system, marketed by International Cotton Institute, using a prepacked "Bozzle" of specially formulated pesticide with a nozzle and flow restrictor preset in the factory. Using only 4 D size batteries, the nozzle is operated at 25 kV to produce electrostatically charged spray droplets. Improved deposition on foliage is achieved, although penetration of crop canopies is less than with other spraying techniques. This system, initially evaluated on cotton, is being extended to crops such as cowpea.

Studies in India illustrate the considerable advantage in time and labor achieved with the Electrodyn compared to other spraying techniques (Table 1, 2). This technique eliminates the need for water and does not expose the operator to contamination during mixing. The range of products suitable for

Table 1. Estimated time required to spray 1 ha with different sprayers (15).

Equipment	Time (h)					Total
	Spraying	Calibration	Preparing spray mix	Refilling tank	Operator rest	
<i>For cotton</i>						
Knapsack sprayer	20.45	0.3	2.82	2.64	3.41	29.62
Mist blower	7.58	0.16	1.19	1.54	1.26	11.73
ULV sprayer	3.69	—	—	—	0.31	4.00
Electrodyn sprayer	5.32	—	—	—	0.44	5.76
<i>For okra</i>						
Knapsack sprayer	16.64	0.21	2.7	2.26	2.77	24.58
Electrodyn sprayer	4.91	—	—	—	0.41	5.32

Table 2. Cost^a of operation for spraying 1 ha with different sprayers (15).

Equipment	Labor ^b		Energy other than labor			Total	
	Hours (no.)	Rate/h	Cost (Rs)	Spraying time (h)	Rate/h		Energy cost (Rs)
<i>For cotton</i>							
Knapsack sprayer	29.62	1.88	55.70	—	—	—	55.7
Mist blower	11.73	1.88	21.05	7.58	7.20	54.55	75.6
ULV sprayer	4.00	1.88	7.50	3.69	1.90	7.00	14.5
Electrodyn sprayer	5.77	1.88	10.85	5.32	0.35	1.85	12.7
<i>For okra</i>							
Electrodyn sprayer	5.31	1.88	10.00	4.51	0.35	1.70	11.7
Knapsack sprayer	24.59	1.88	46.20	—	—	—	46.2

^aIn Indian rupees (Rs). US\$1 = Rs 12.07. ^bCost of labor is Rs 15/d of 8 working hours.

Table 3. Basic requirements for pesticide application on small-scale farms.**Farmer needs**

- Knapsack sprayer, durable and modified, if necessary, e.g., tailboom
- Appropriate nozzles with filters, e.g., Y3 Cone + 50 mesh filter
- Prepacked pesticides — in knapsack loads, e.g., 90 g carbaryl 85 to make 0.5% ai spray in 3 gallons, or dispenser to measure out correct quantity
- Ancillary equipment — calibrated mixing drum with spout and filter
- Protective clothing — overalls or at least long trousers, long sleeved shirt, hat and boots
- Water supply — sufficient to treat crop plus water for washing and clean water to drink
- Soap — for washing
- Spare parts, e.g., nozzles, washers, pump seal
- Training, e.g., operation of equipment, mixing procedure, walking speed while spraying, pumping rate to achieve recommended pressure, maintenance/replacement of worn parts
- Time: An estimated 4 d/ha.

In areas where water or time is less readily available

- CDA sprayer (e.g., spinning disk; electrodynamic sprayer)
- Batteries D size, or rechargeable type with access to recharging unit
- Prepacked pesticides, e.g., ULV formulation
- Water and soap for washing
- Water to drink, if necessary, as work involved is less arduous
- Protective clothing — overalls, or at least long trousers, long-sleeved shirt, hat, and boots
- Access to repair facilities, e.g., motor on spinning disk
- Training, e.g., operation of equipment, use of batteries, walking speed and cleaning procedures
- Time: Less than 0.75 d/ha

this system needs to be increased to make it more appropriate to a farming system rather than to individual crops.

In each of these examples, successful adoption of a system has depended on integrating all the components, including proper packaging of appropriate formulations, supplying *all* items the farmer requires (e.g., batteries and spare parts), and providing suitable training (Table 3). Often with one missing component, the farmer gives up and grows crops which require less effort. Some agrochemical companies have attempted to meet the challenge of

promoting their products in new areas, but the task of extension work to large numbers of small farmers has restricted this primarily to international aid schemes and on cash crops, especially cotton. Government policies of cheap food have seldom given developing country farmers the incentive to invest in more inputs to achieve higher yields.

THE FUTURE

Because use of water-based pesticides will undoubtedly continue despite the enormous amount of time and effort needed with application equipment, improvements are needed in the packaging of pesticides, supply of simple measuring devices and mixing containers, and design of equipment with appropriate spare parts. Nevertheless, the adoption of the newer ULV spinning disk and electrodynamic types of equipment must be encouraged especially where water supplies are uncertain. Poor-quality and expensive batteries for sprayers have contributed to the delay in their adoption, but will increase interest in photovoltaic recharging systems and use of rechargeable batteries.

Perhaps more agrochemical companies can tap the potentially enormous market in the developing countries, and assist with the development of more appropriate application technology for small-scale farms. This includes the need for new formulations of less hazardous pesticides and methodology for herbicide application. We also need pest management training to optimize the rapid and timely use of pesticides in relation to economic threshold levels and provide more durable chemical control. A crucial need is independent research on pesticide application, thus far largely ignored, so that entire programs appropriate to particular farming systems can be developed and introduced in the farming community.

REFERENCES CITED

1. Bals, E. 1975. Development of a CDA herbicide handsprayer. *Chemicals and Equipment, PANS* 21(3).
2. Bull, D. 1982. Pesticides, a growing problem. OXFAM.
3. Coffee, R. A. 1979. Electrodynamic energy - a new approach to pesticide application. *Proceedings, 1979 British crop protection conference - pest and diseases.*
4. Fisher, H. H., and E. Deutsch. 1985. Lever-operated knapsack sprayers: a practical scrutiny and assessment of features, components, and operation - implications for purchasers, users and manufacturers. IPPC document.
5. Garnett, R. P. 1981. The wheel-barrow sprayer - low herbicide application for the tropics. *Trop. Pest Manage.* 27(2):195-199.
6. Gledhill, J. A. 1975. A review of ultra low volume spray usage in Central Africa since 1954 and some recent developments in Rhodesia. *Proc, first congress of the Entomological Society of South Africa:259-267.*
7. Gower, J., and G. A. Matthews. 1971. Cotton development in the southern region of Malawi. *Cotton Growing Rev.* 48:2-18.
8. Linsinger, J. A., E. Price, and R. T. Herrera. 1978. Small farmer pest control practices for rainfed rice, corn and grain legumes in three Philippine provinces. *Philipp. Entom.* 4(1-2):65-86.

9. Matthews, G. A. 1969. Performance of some lever-operated knapsack sprayers. *Cotton Growing Rev.* 46:143-148.
10. Matthews, G. A. 1971. Ultra low volume spraying of cotton - a new application technique. Supplement 2/71, *Cotton Handbook of Malawi*.
11. Matthews, G. A. 1983. Problems and trends in pesticide application technology. *In Pesticide application technology*. G. S. Lim and S. Ramasamy, eds. Malaysian Plant Protection Society.
12. Matthews, G. A. 1985. Protective clothing and machinery. OXFAM/SCI/BAA Meeting. In press.
13. Matthews, G. A., H. E. H. Higgins, and E. W. Thornhill. 1969. Suggested techniques for assessing the durability of lever-operated knapsack sprayers. *Cotton Growing Rev.* 46:143-148.
14. Mowlem, M. D., G. Nyirenda, and J. P. Tunstall. 1975. Ultra low volume application of water-based formulations of insecticides to cotton. *Cotton Growing Rev.* 52:360-370.
15. Sastry, V.C.S., S. N. Pathak, and A.A.K. Reddy. 1985. Agricultural engineering. *In Annual report 1983-84, Central Plant Protection Training Institute, Hyderabad, India.*
16. Tunstall, J.P., G.A. Matthews, and A.A.K. Rhodes. 1961. A modified knapsack sprayer for the application of insecticides to cotton. *Cotton Growing Rev.* 38:22-26.
17. Turner, P. D. 1985. Economies in weed control costs following changes from conventional knapsack spraying in plantation crops. *Proceedings, 1985 British Crop Protection Council symposium - application and biology. BCPC Monogr.* 2:33-38.
18. Wijewardene, R. 1982. Pneumatic VLV knapsack spraying of agrochemicals. *Trop. Pest Manage.* 28:170-174.

EFFICIENT FERTILIZER INJECTORS FOR PADDY FARMERS

A. U. KHAN, E. U. BAUTISTA, and A. VASALLO
International Rice Research Institute

BACKGROUND

Asia has substantially increased its rice production through increased use of inorganic fertilizers. In 1983, Asian use of nitrogen (N) and phosphate (P) fertilizer accounted for about 38% and 27% of world use, respectively (7). Urea has emerged as an important N fertilizer in rice production. About 30% of world use of N fertilizer is in urea. In Asia, exclusive of China, urea accounts for 69% of N used (Table 1).

In spite of this high use of urea and other nitrogenous fertilizers, average paddy yields in Asia are still quite low. Only 15% to 35% of the total applied N is recovered by the rice plant. Any improvement in fertilizer use efficiencies can have an immense economic impact in tropical Asian countries. For example, a 10% increase in fertilizer use efficiency can reduce N fertilizer consumption by 2.53 million metric tons, saving about \$460 million at current prices.

Many efforts have been made to improve fertilizer use efficiencies in lowland rice production. As early as 1941, research in Japan demonstrated that deep placement of fertilizer in flooded fields can increase yields. Numerous experiments at IPRI and in China subsequently demonstrated that fertilizer use efficiencies could be doubled, from about 30 to 60%, when fertilizer is deep placed in flooded soils. Generally, placement depth was thought to be the reason for improved fertilizer use efficiency in the experiments, so a 10-15 cm placement depth was recommended (6).

Unfortunately, farmers have not been able to benefit from these findings, primarily because they lack suitable fertilizer placement equipment. Because of the difficulties of deep placing commercially available prilled urea (PU) in wet fields, large urea supergranules (USG) have been developed to be deep placed manually in flooded soils. In experiments, USG has demonstrated fairly high fertilizer efficiency; however, manual placement is laborious, requiring 64,000 placements/ha.

In Philippine experiments, no significant yield differences have been observed between USG and PU whenever PU was properly deep placed (5). A disadvantage of USG is that it costs 15-20% more than PU, the most popular

Table 1. Total global and regional nitrogen consumption and percentage, by form, 1981 (nutrient basis) (1).

Region	Total (thousand t)	% of total N as				
		Ammonium sulfate	Ammonium nitrate	Urea	Other straights	Compounds
Western Europe	10,045	4	47	10	8	31
Eastern Europe	5,180	8	46	26	2	19
USSR	8,383	4	42	22	13	19
Africa	1,936	6	34	33	2	26
North America	11,002	1	9	11	58	22
Central America	1,397	28	5	36	17	14
South America	1,191	17	11	47	2	24
Oceania	295	22	8	39	14	16
Asia (excluding China)	10,000	6	4	69	1	20
China	11,285	2	7	38	52	2
World	60,714	5	22	30	24	19

commercially available fertilizer currently used in rice. Since USG use is still experimental, widespread use in rice production, at least soon, is doubtful.

More recently, incorporation of PU in drained fields has been advocated for increasing fertilizer efficiency (7). Rice farmers are generally reluctant to drain fields because irrigation water is scarce. Sometimes it is difficult to drain fields during the wet season because of rains. It is doubtful that Asian rice farmers would accept this practice on a large scale.

So far, deep placement of commercially available fertilizers with some type of equipment seems the most practical way to increase fertilizer use efficiencies in lowland fields. Since the early 1940s in Japan and China, attempts to develop deep placement applicators have had little success. IRRI scientists have been developing deep placement applicators for over 10 yr. Machines have generally performed inconsistently on farms even though they successfully met placement depth and covering criteria.

REASONS FOR POOR APPLICATOR PERFORMANCE

Since fertilizer use efficiencies in upland farming are much higher than in flooded cultivation, we felt that the presence of floodwater was affecting applicator performance and reducing fertilizer use efficiencies. Therefore, a series of simulated fertilizer placement experiments, with different water regimes, was conducted by the IRRI Agricultural Engineering Department (3). The amount of fertilizer transferred to floodwater was surprisingly high in all the experiments (Fig. 1). The experiments profoundly affected applicator designs for improving fertilizer use efficiencies in lowland rice. The major conclusions follow:

1. Dissolution of fertilizer in floodwater, rather than placement depth, is the critical factor affecting fertilizer use efficiencies in lowland rice. With greater dissolution in floodwater, N volatilization losses are high.

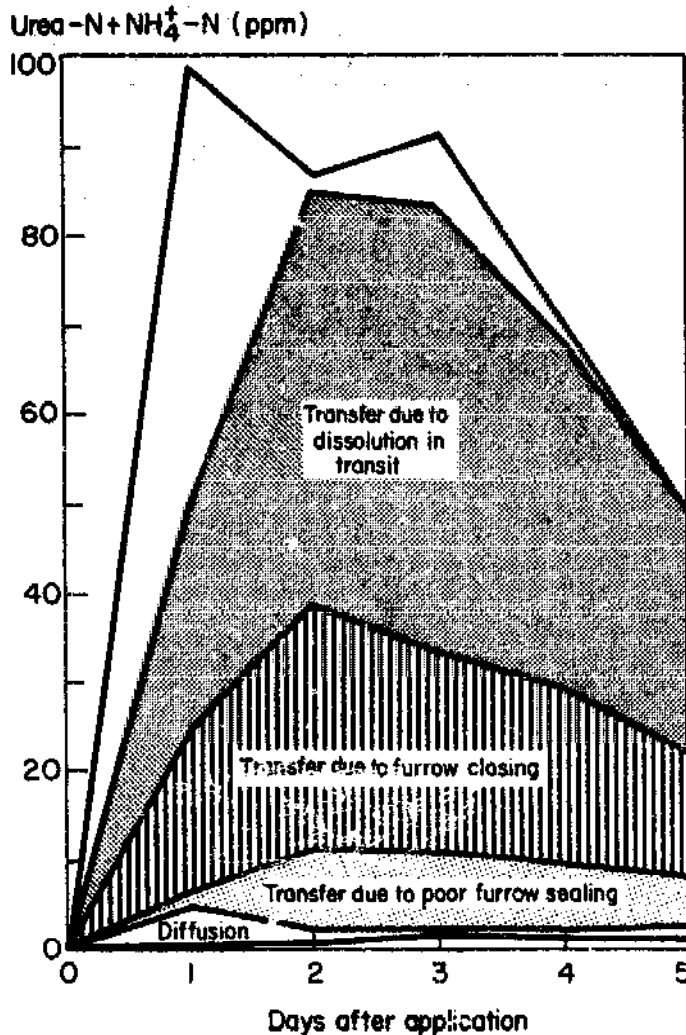

1. Major avenues for N transfer to floodwater during prilled fertilizer placement at 5-cm depth in flooded Maahas clay.

2. Depositing fertilizer in a flooded open furrow and then closing the furrow was not suitable; 80 to 90% of the fertilizer was almost instantly transferred to floodwater.
3. The variations in floodwater level and the amount of fertilizer dissolved in floodwater were mainly responsible for the variable performance of applicators.
4. Minimizing contact between fertilizer and floodwater is critical for improving fertilizer use efficiencies in lowland rice. Injecting fertilizer into soil through tubes to avoid contact with floodwater can substantially increase fertilizer use efficiencies.
5. In Maahas clay soils, sealing the deposited fertilizer with a 3- to 5-cm soil layer can keep it from diffusing to floodwater. Thus, a placement depth of 3-5 cm will improve fertilizer use efficiency.

Based on these findings, an applicator concept (Fig. 2) was developed for continuous injection of prilled or granular fertilizers into flooded soils with minimum dissolution in floodwater.

Plunger metering

In 1982 IRRI developed a deep placement applicator (Fig. 3) which used an

oscillating plunger to meter and inject fertilizer into flooded soils (2). The machine was discarded because the delivery tube frequently clogged due to fertilizer wetting. This applicator, however, metered fertilizer accurately at different rates by simply changing the plunger stroke length. Also, the fertilizer metering cavity was thoroughly flushed during each stroke of the plunger. This prevented fertilizer from accumulating in the metering cavity, resulting in a highly uniform fertilizer discharge.

A laboratory study assessed the plunger's metering performance. A 13-mm diameter plunger, inclined at 30 degrees from the horizontal and oscillating at 45 strokes/min, could meter PU at 56 kg N/ha to 100 kg N/ha with plunger stroke lengths ranging from 30 to 70 mm. The tests also indicated that

- variations in the metering rate increased from 6 to 10% with increasing stroke length; and
- the fertilizer metering rate increased steadily with increasing oscillation speed.

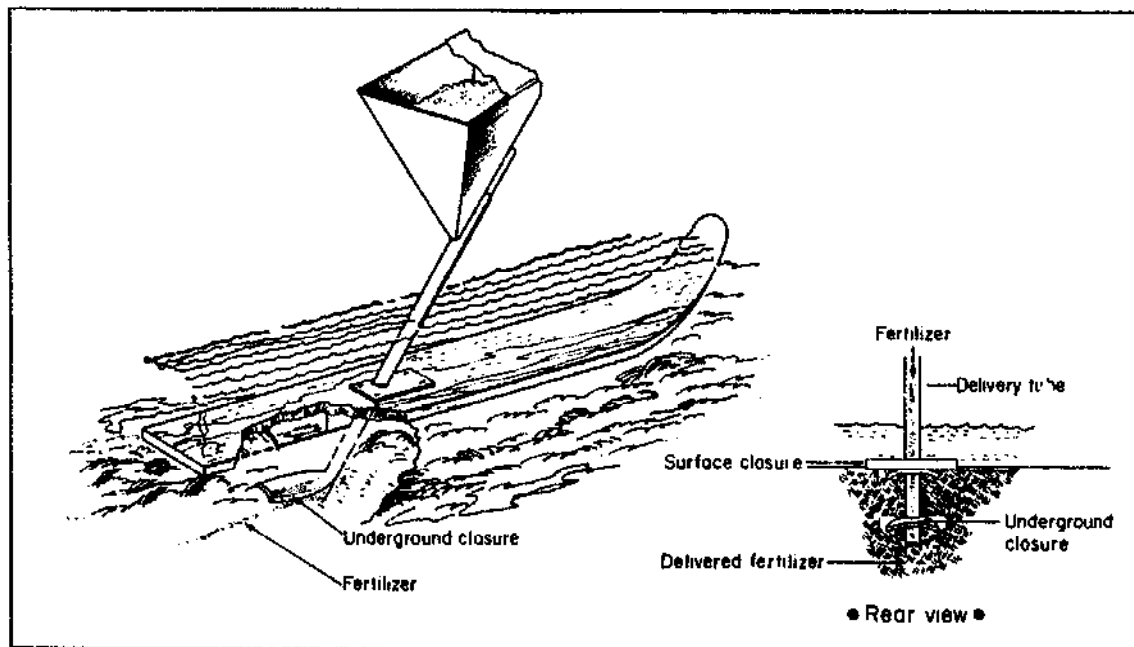

2. Combined underground and surface closure for minimizing N transfer to floodwater during deep placement.

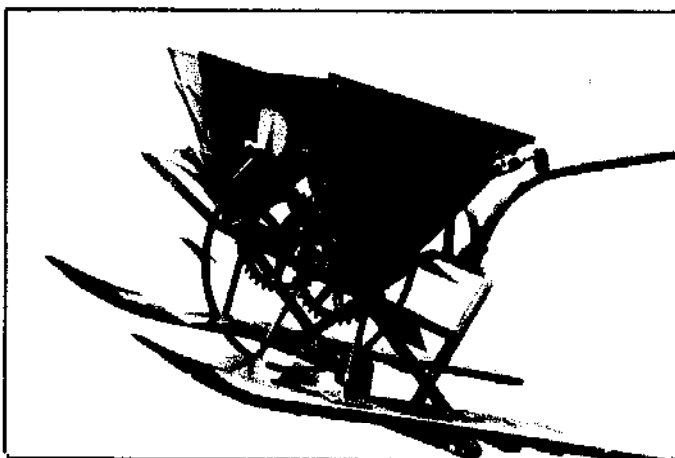

3. The oscillating plunger applicator.

Auger injection

Experience with an earlier IRRI wire auger applicator (Fig. 4) and the conventional augers of fertilizer applicators in China indicated that an auger could satisfactorily convey fertilizer into flooded soils (4). Augers were, however, not accurate for metering. The wire auger used with an earlier IRRI machine permitted free flow of fertilizer through its hollow central core, distributing fertilizer unevenly in the row. To overcome these problems, a spiral auger, made of a sheet metal strip (Fig. 5), was tested in the laboratory with these results:

1. The 16-mm-diam sheet spiral auger could inject PU into flooded soils at a maximum rate of 85 kg N/ha.

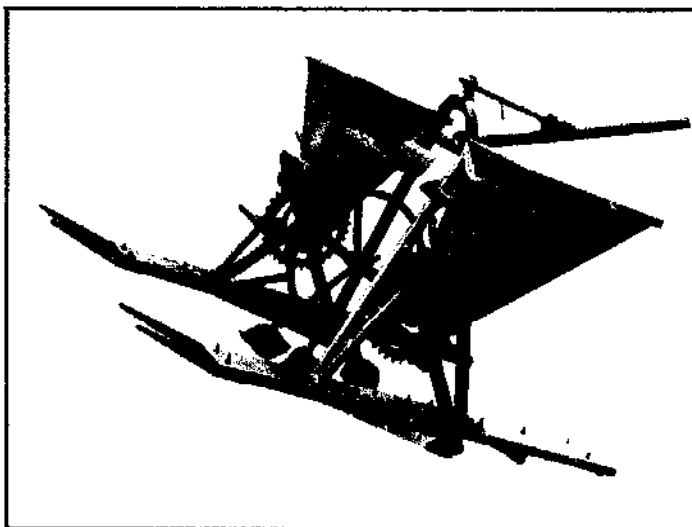

4. The spring auger applicator.

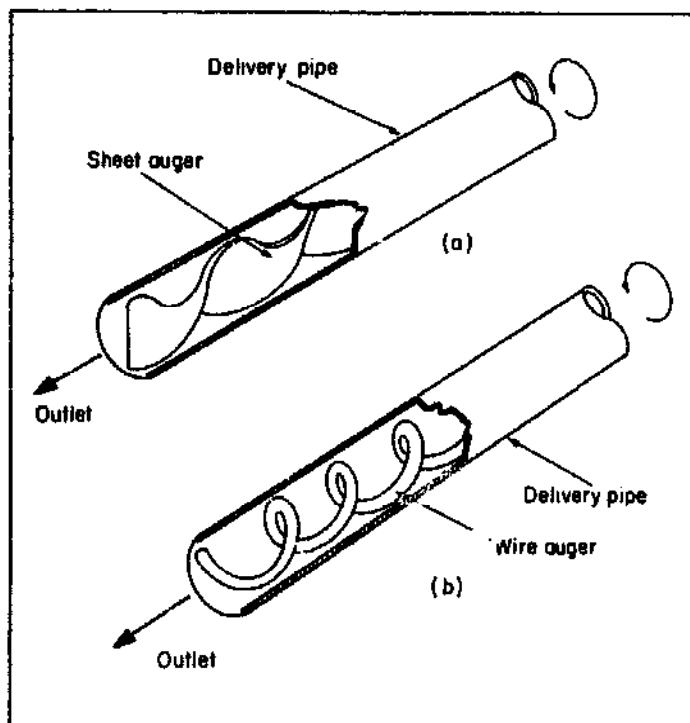

5. Sheet (a) and wire (b) augers used in fertilizer applicators.

2. The fertilizer delivery rate increased slightly when the pitch/diameter ratio was increased from 1.00 to 1.75; however, this change was not linear. The rotational speed and the angle of inclination of the auger had a small influence on fertilizer delivery.

The findings of these laboratory studies were used to develop a new hybrid machine with a plunger for metering fertilizer and a sheet auger for injecting it into the soil.

THE PLUNGER-AUGER FERTILIZER INJECTOR

Using findings of the preceding studies and criteria developed in consultation with IIRI scientists (Table 2), a new fertilizer injector was developed (Fig. 6, 7). The machine places fertilizer 4-5 cm deep in flooded soils with minimal dissolution in floodwater. The two-row machine has two hoppers, each fitted with a plunger to meter the desired amount of fertilizer. Fertilizer metering

Table 2. Design features of manually operated deep fertilizer applicator.

Essential features

- Must apply prilled fertilizer 5 to 10 cm deep
- Continuous (non-intermittent) operation
- Must apply commercial-grade fertilizer without further grading
- Rate of application 45 and 75 kg N/ha (2 to 3 bags urea)
- Must function in up to 5-cm-deep standing water
- Must be capable of functioning from 5 to 20 d after transplanting
- Maximum labor requirement - 8-12 h/ha per application
- Lightweight (10-18 kg) so it could be lifted at the end of row
- Approximate selling price: P400-P600 (\$30-\$60)
- Must adequately seal ground placement opening
- Sturdy to last at least 4-6 seasons
- Pulling or pushing force of 7 to 10 kg
- Smooth unidirectional manual movement during operation

Desirable features

- Could be used for both prilled or USG
- Rotary rather than oscillating mechanism
- Rolling on wheels rather than on skids
- Push-type for post-transplant operation
- Multirow operation, 2 to 4 rows
- Nonfurrow opener type
- Mechanical injector type
- Easy to manufacture by small shops
- Should not need high precision in production
- Pull type for pretransplant operation
- Can also be used for random seeded crop

Undesirable features

- Intermittent operation
 - Multidirection action during operation
 - Use of liquid conveying mechanism
 - Complex mechanisms
 - Delicate mechanisms
-

can be controlled by selecting the proper plunger stroke length (Fig. 8). Each hopper is fitted with an oscillating wire agitator to ensure smooth flow of fertilizer into the metering plunger cavity.

As the machine is pushed in the field, the plungers deliver metered fertilizer into the groundwheel-driven augers. The augers convey and inject fertilizer into the soil. The two skids momentarily displace water from the auger tubes while fertilizer is being injected. The auger tubes extend 4 cm below the skid to deposit the fertilizer at 4 to 5 cm depth. Small furrow openers, mounted ahead of the auger tubes, open V-shaped furrows to ensure precise placement depth. Two furrow closers and a press plate, located at the trailing end of the auger tubes, push soil back into the furrows to help seal the fertilizer.

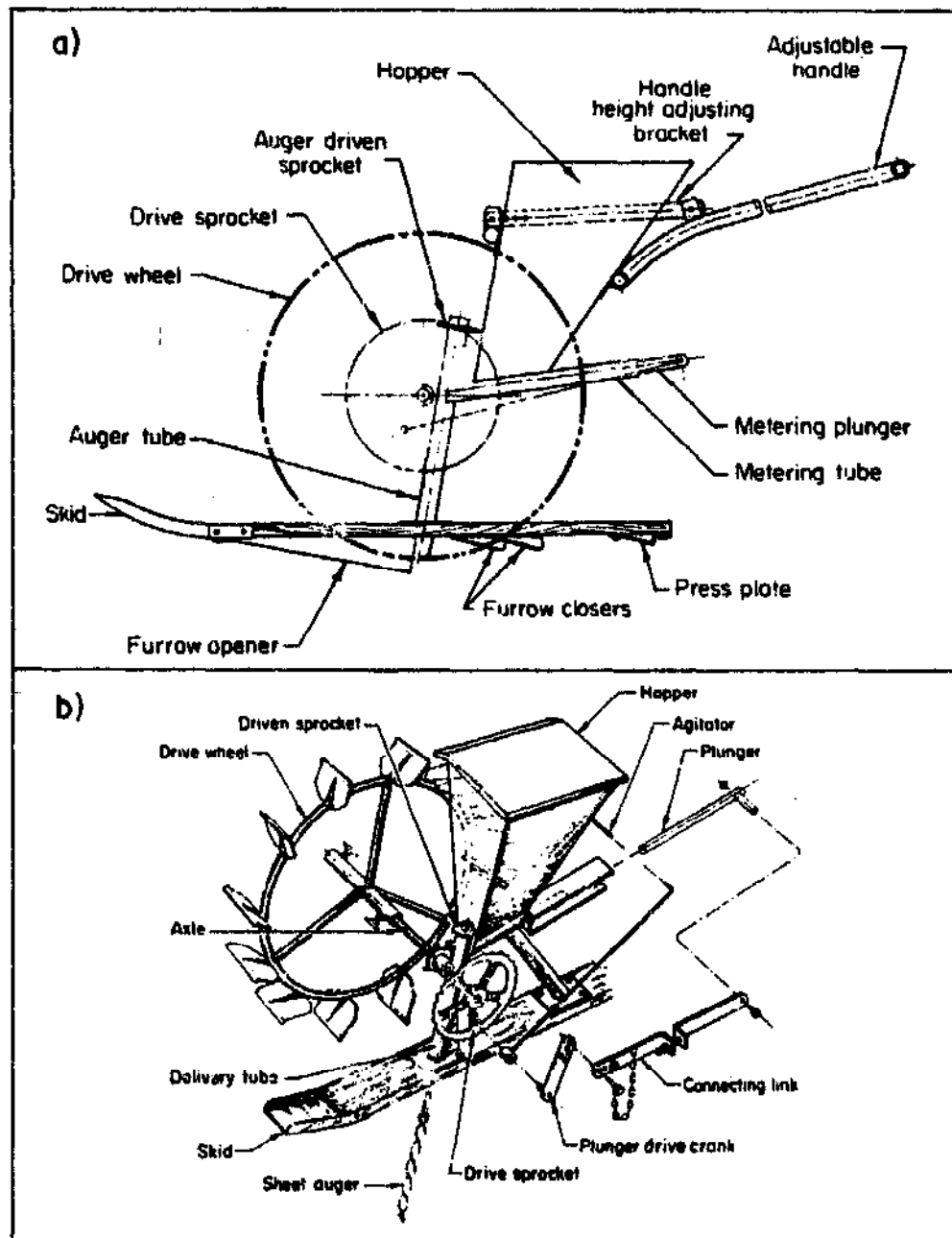

6. a) Schematic drawing of the plunger-auger fertilizer injector for PU. b) Exploded view of fertilizer injector showing the left plunger-auger assembly.

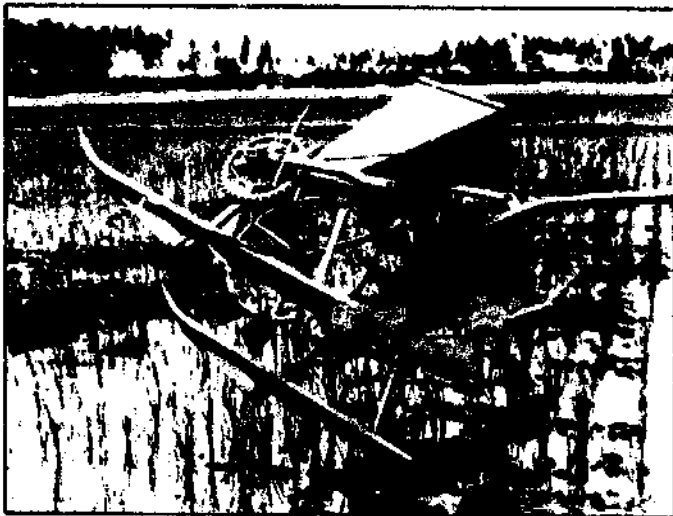
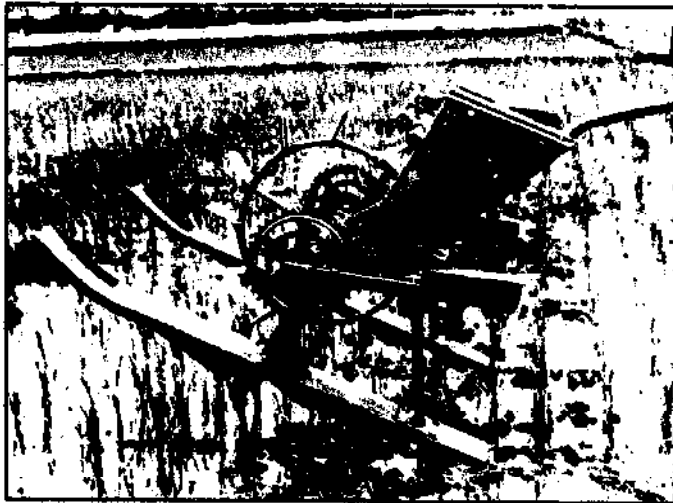

7. Two views of the plunger-auger injector.

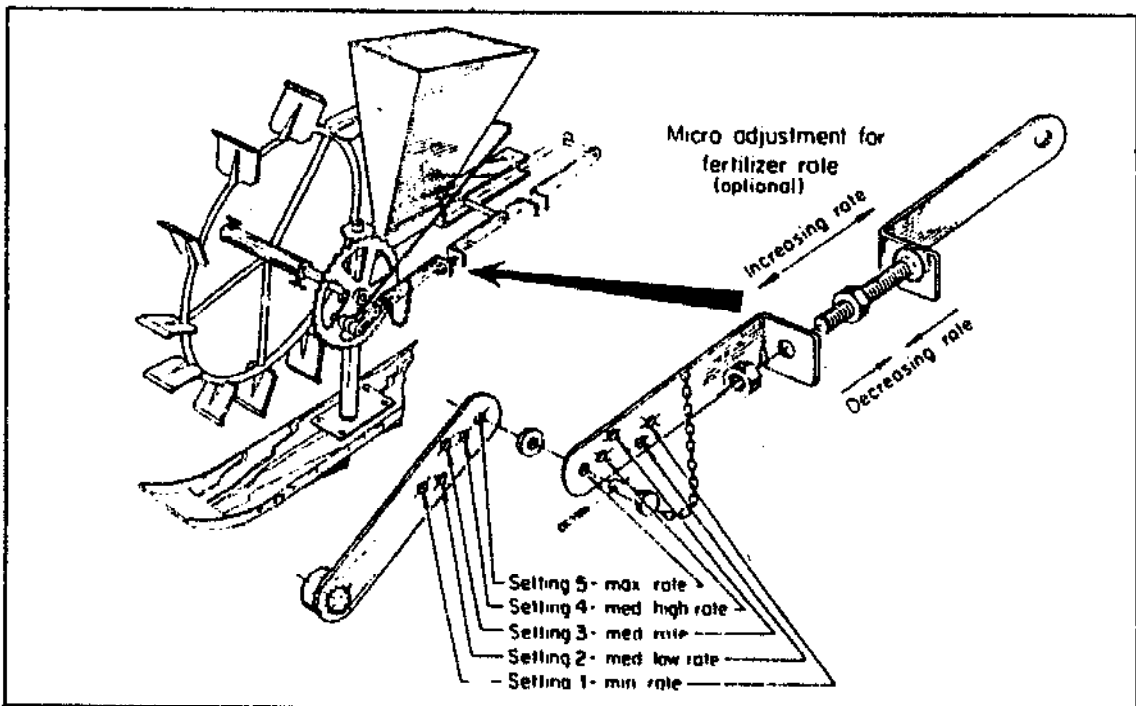

8. Plunger-auger injector showing method of setting fertilizer rate.

The machine can apply PU and other commercially available granulated fertilizers at five different rates. Because of its light weight, 7.5 kg, the machine is easy to transport to fields and to push during operation (Fig. 9). The row spacing width can be adjusted from 15 to 22.5 cm (Fig. 10). The machine can be used to apply fertilizer as late as 4 wk after transplanting. It requires 16 h to apply 1 ha (see Appendix for more details).

The machine can also be used in fields that are randomly direct seeded by applying fertilizer 21 d after direct seeding. In such fields, the skids trample some plants; however, that does not reduce yield since plant population in direct-seeded rice is generally quite high.

TEST AND EVALUATION RESULTS

The machine has been extensively field tested to determine fertilizer metering accuracy. An increasing fertilizer rate with increasing plunger stroke length was observed. With coarser grain, the fertilizer rate was slightly higher than with fine powdery PU. Fertilizer metering variations with any kind of fertilizer material were less than 10% during these tests.

The plunger auger injector has consistently demonstrated high fertilizer use efficiency in tests conducted. In 6 farmers' field trials in Laguna, Philippines, an average yield increase of 0.73 t/ha was obtained with the machine compared to farmers' traditional broadcast methods. This represented an average increase of 41% in fertilizer use efficiency (kg grain/kg N) over traditional broadcast practice (Table 3).

Many deep placement studies have demonstrated that the benefits of deep placement are relatively more pronounced at lower fertilizer rates. In another set of farmer trials with this machine, deep placement of 50 kg N/ha and 80 kg N/ha (Table 4) produced the same yields. Thus, the machine can be especially effective for small farmers who generally apply fertilizers at fairly low rates due to increasing costs.



9. Plunger-auger injector a) operating in flooded field, and b) being transported to field.



10. Arrangement for setting row spacing from 15 to 22.5 cm.

Table 3. Plunger-suger injector farmer trials by the IRRI Agricultural Engineering Department, Calauan, Laguna, Philippines, 1985 dry season.

Farmer, cooperator	Mode of application	Fertilizer rate (kg N/ha)	Yield (t/ha) 14% MC	Fertilizer efficiency (kg grain/kg N)	Increase (%) in fertilizer efficiency
L. Calong-calong	Broadcast	90.0	5.37	59.55	20.76
	Machine	79.5	5.69	71.62	
A. Velecina	Broadcast	96.0	4.36	46.40	53.04
	Machine	80.0	5.68	71.01	
A. Sarmiento	Broadcast	119.0	6.03	50.70	61.89
	Machine	83.0	6.82	82.08	
L. San Gabriel	Broadcast	71.0	4.74	66.63	25.84
	Machine	70.0	5.85	83.85	
F. Belen	Broadcast	81.5	4.39	53.76	13.97
	Machine	82.5	5.06	61.27	
N. Mendoza	Broadcast	138.0	6.18	44.83	70.49
	Machine	83.0	6.34	76.43	
Average = 40.92%					

Table 4. N application trials in farmers' field by Bureau of Soils and IRRI Agricultural Engineering Department, Pagsanjan, Laguna, Philippines, 1985 dry season.

Treatment	Grain yield (t/ha)				Fertilizer efficiency (kg grain/kg N)
	Site 1	Site 2	Site 3	Mean	
Zero N	4.54	4.54	4.85	4.65	—
Farmer's practice (50 kg N)	5.82	5.94	6.40	6.05	28.0
Researcher's split (80 kg N)	7.16	6.90	7.66	7.24	32.4
Plunger-suger injector (50 kg N)	7.08	6.88	7.06	7.01	47.2
Plunger-suger injector (80 kg N)	6.94	7.20	7.12	7.09	30.5

PRESENT STATUS OF THE MACHINE

IRRI is currently evaluating and test marketing the plunger-auger machine in the Philippines in cooperation with three agencies of the Philippine Ministry of Agriculture and Food (RIARS, NFAC, and Bureau of Soils). The machine is also being evaluated by the Philippine Phosphate Fertilizer Corp. and the IRRI Training and Technology Transfer and Agronomy Departments. Several farmers in Laguna and Bicol Provinces showed interest in these machines after they observed the agronomic advantages and fertilizer savings. The farmers borrowed or purchased applicators to use on their farms during the current season.

Two manufacturers in the Philippines have started limited production (Fig. 11) and test marketing at a price of ₱1,200 (\$65.00). Three other firms are fabricating prototype units for inspection and approval of IRRI. The machine is expected to be released for regular commercial production in the Philippines by the end of this year.

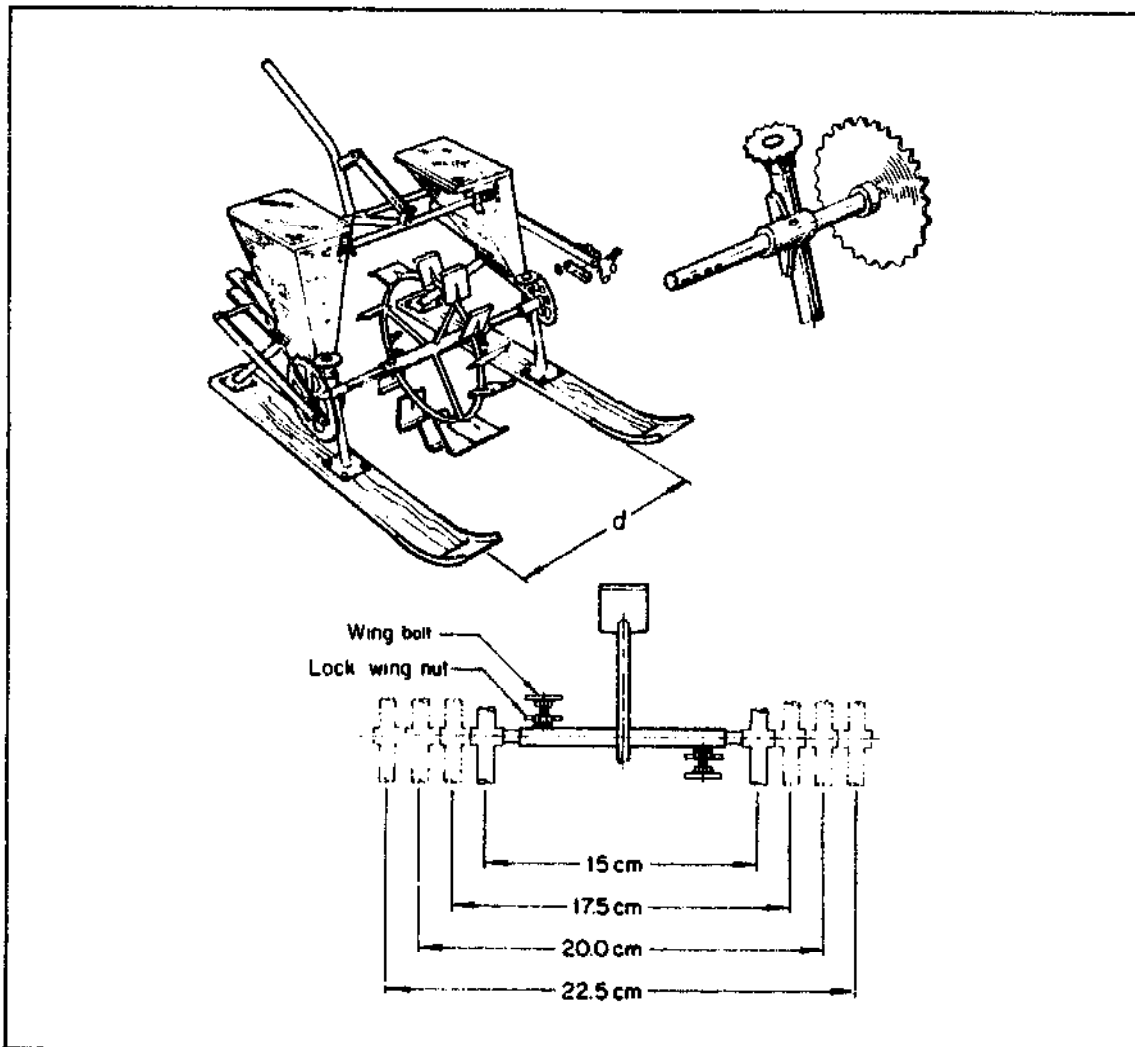

11. The plunger-auger injector being manufactured on an experimental basis by a small shop in the Philippines.

Several Asian countries have shown interest in popularizing this machine among rice farmers. A few units are being evaluated in Bangladesh, Indonesia, and Thailand. Requests have been received from Burma and Madagascar for machines which could apply fertilizer in 15-cm-deep floodwater. Machines modified for operation in this deep floodwater are being tested at IRRI. The Republic of Vietnam has also requested manufacturing drawings.

SUMMARY

The finding that minimizing N transfer to floodwater was critical for increasing fertilizer use efficiency in flooded fields helped to explain the poor performance of earlier applicators. This led to the development of the plunger-auger applicator which has consistently performed well in the field. This machine has potential to substantially increase efficiencies of commercially available fertilizers in Asian rice production.

REFERENCES

1. British Sulfur Corporation, Ltd. 1983. World statistics — fertilizer products. British Sulfur Corporation, Ltd., London, England.
2. Khan, A. U. 1984. Deep placement applicators for improved fertilizer use efficiency. *Agric. Mechanization in Asia, Africa, and Latin America* 15(3):25-32.
3. Khan, A. U., L. Kiamco, and V. Tiangco. 1983. Fertilizer transfer to floodwater during deep placement. IRRI Res. Pap. Ser. 96.
4. Kiamco, L., I. Camacho, G. Salazar, and B. J. Cochran. 1982. Development of deep placement fertilizer applicators at IRRI. Paper presented at the Annual Convention of Philippine Society of Agricultural Engineers, Manila, 29-30 Apr.
5. Lapitan, J. A., A. U. Khan, J. Calabio, J. Descalsota, and E. U. Bautista. 1985. Evaluation of fertilizer placement machines and their current developments. Paper presented at the International Rice Research Conference, International Rice Research Institute, 1-5 June.
6. Prasad, R., and S. K. De Datta. 1979. Increasing fertilizer nitrogen in wetland rice. Pages 465-484 in *Nitrogen and rice*. International Rice Research Institute, Los Banos, Laguna, Philippines.
7. Stangel, P. J., and S. K. De Datta. 1985. Availability of inorganic fertilizers and their management — a focus on Asia. Paper presented at the International Rice Research Conference, International Rice Research Institute, 1-5 June.

APPENDIX

IRRI plunger-auger fertilizer injector for lowland paddy cultivation



Saves fertilizer and increases paddy yields.

Recent experiments at the International Rice Research Institute have demonstrated that dissolution of fertilizer in floodwater during placement plays a significant role in reducing fertilizer use efficiencies in lowland rice production. These findings have led to the development of this plunger-auger fertilizer injector which continuously injects commercially available fertilizers, 3-5 cm below the soil surface, without dissolving it in floodwater. Rice farmers can now save fertilizer and increase paddy yields through the use of this machine.

FEATURES

Increases fertilizer use efficiency

- : Can inject fertilizer in bands 4 to 5 cm in flooded fields to increase fertilizer use efficiency by 30 to 60% over broadcast method.

Versatile

- : Applies urea, ammonium sulfate, or any small granular fertilizers at five different rates. Permits use in paddy grown at 15- to 22.5-cm row spacing.

Easy fertilizer rate adjustment

- : Can apply 1-4 bags (50 kg each) of fertilizer per ha. Easy to set fertilizer rates.

Simple and economic to operate and maintain

- : Simple and lightweight construction for convenient operation. Easy to push in flooded paddies. Requires few adjustments. Low cost, pays for itself in one season's use.



Machine specifications:

Power requirement	Manual – 1 person
Fertilizer hopper capacity	2 kg/hopper
Output per day	About 0.5 ha
Labor requirement	About 16 man-h/ha
Width of swath covered per pass	4 plant rows
Plant row spacing	Adjustable from 15 to 22.5 cm
Depth of injection	4-5 cm
Floodwater depth at application	0.5 to 5 cm
Time of application	1 to 4 wk after transplanting
Construction material	Thin wall tube, sheet metal and wood
Machine weight (without fertilizer)	8 kg
Machine length	170 cm
Machine width	48 cm

IMPROVED WEEDING AND CULTIVATION SYSTEMS IN ZAMBOANGA DEL SUR, PHILIPPINES

B. J. SHORT and B. T. OLE
Zamboanga del Sur, Philippines

The Zamboanga del Sur Development Project (ZDSDP) is an integrated rural development project jointly funded by the Philippine and Australian Governments and covers the Province of Zamboanga del Sur. While the major emphasis was on road construction, agricultural programs received more attention during the latter half of the 10-yr project. The major agricultural program was the Multiple Cropping Project (MCP) which sought to increase and diversify the production of small upland farmers. The counterpart agency of ZDSDP for the MCP was the Ministry of Agriculture and Food (MAF).

The Agricultural Engineering Program commenced in late 1981 as part of the MCP. The objectives were

1. to assist in developing tools, implements, and technology appropriate for small farm production;
2. to assist local industry to manufacture and service this equipment;
3. to improve the capability of MAF, farmers, and others to identify and find solutions to agricultural engineering problems.

This paper describes the evolution of the Agricultural Engineering Program in terms of

1. responding to identified farmer needs to develop appropriate technologies for cultivation and weeding on small upland farms;
2. developing a research and development system to test the proposed equipment;
3. developing a manufacturing and distribution system appropriate to local conditions; and
4. specifying the extension methods used to reach the upland farmers.

FARM SITUATION AND PRACTICES

Upland farms, averaging 3 ha, occupy about 80% of the agricultural area of Zamboanga del Sur. The traditional farm is a mixed enterprise with a cropping pattern of maize followed by maize with small areas of upland rice and grain legumes. Coconuts are grown on about 30% of farms. Currently, land is not a constraint to increased productivity and most farms have idle land suitable for cropping or land under coconuts suitable for intercropping.

The average household income in the province is \$490/yr, with a median of \$325 (2). Almost all farmers have a large subsistence food component in their agricultural production. Most augment their income with sales of livestock, mostly poultry and swine, and goats to a lesser extent. The importance of off-farm income to total available income is a function of the overall productivity and enterprise mix of the farm, farm area, and proximity to roads and population centers.

Most farmers are above the subsistence level and consider themselves above the primary basic needs of food, shelter, or clothing (1). The major staple food is white maize, with rice used only for fiestas and special occasions.

The traditional and most common system of crop cultivation involves

1. a primary cultivation consisting of two or three plowings using a carabao-drawn steel, moldboard plow;
2. secondary cultivation using a spike-tooth harrow;
3. planting by opening a furrow with the moldboard plow and placing seeds at a certain spacing by hand and then covering the seed and firming the soil by foot;
4. weed control varying with types of crop. With maize, control consists of off-barring at 10-15 d after emergence (DE) and hilling up at 25 DE with a moldboard plow. With upland rice and grain legumes, the most common methods uses a weeding knife ("bolo" or "bunlay"). Hand weeding is usually done by a group of workers: family members or hired laborers. The hired laborers are normally paid in cash, rarely in a harvest share; and
5. harvesting is most commonly done by hired laborers paid in a harvest share.

IDENTIFICATION OF FARMER PROBLEMS

Early in 1981, an Agricultural Monitoring and Evaluation Unit was established within the MAF/ZDSDP structure to examine MCP. The unit carried out farmer case studies, surveyed MCP cooperators, and collected farmer yield performance data, so as to

1. identify characteristics of target farmer cooperators,
2. monitor and evaluate crop and technology performance, and
3. examine farmer acceptance of technology.

A socioeconomic study of the province (1) provided data both on household and farm conditions and facilitated comparison of cooperators with the overall farming sector.

A series of crop budgets and labor budgets were made for each of the crops (Table 1, 2). The inclusion of traditional native maize was necessary for comparison with the MCP crops. The increased input levels for the MCP crops were financed through a credit scheme which lacked allowance for labor cost; it was felt that farmers should have some financial input and therefore more commitment to the crop. The program moved away from the medium technology levels of the first 4 yr, to a low technology—low input—local

variety system. This was a result of unacceptable risk associated with the medium technology and the inability of farmers to cope with or accept the higher level of technology.

A major difference between the MCP crops and traditional maize was the labor input level. MCP crops required almost twice the labor of traditional maize, mainly for weeding upland rice and grain legume crops because the narrower row spacing prohibited using the moldboard plow.

In 1982, the MCP was expanding and repayment percentages were averaging 87%. However, the Monitoring and Evaluation Unit found that the proportion of farmers achieving break-even yield level was much less than the proportion repaying loans. The unit found too that an average of 47% of cooperators had left the MCP each cropping and had not returned to the program. Therefore, while the MCP has a high repayment rate, indicating acceptance and success, the exit rate was also high. This indicates technology acceptance, success and exit for self-financing, or technology rejection.

Exit farmers were surveyed to determine reasons for exit. Surveys after different cropping seasons produced similar results, showing these major reasons for exit:

1. low yield or low profitability — 57%
2. high labor input — 15%
3. no carabao or draft animal — 12%

Exit farmers had significantly smaller farms (2.1 ha) than the continuing cooperators (3 ha). They also had a smaller area of coconut and rainfed lowland rice, both considered reliable cash crops. However, they had not fully rejected the MCP technology. They tended to retain components of the various technologies, especially crop varieties and fertilizer inputs. The exit farmers retained a higher level of crop diversification than did non-MCP farmers. While they applied less fertilizer than recommended, their fertilizer use was well above that expected for non-MCP farmers.

The implication was that technology levels were too high for most farmers, especially smaller farmers. This resulted in the current technology approach of MCP. Another implication was that many farmers lacked crop management capability sufficient for the MCP crops; more training and extension input was needed to improve crop husbandry.

Farmers continuously referred to the high labor input of MCP. Their low cash availability, especially during the first cropping after the dry season, prevented them from hiring weeding laborers. Project staff decided to emphasize crop weeding. With this background, the agricultural component began its work on the development and extension of crop weeding technologies.

SELECTION OF TOOLS AND IMPLEMENTS

Traditional tools

The upland farmers of Zamboanga del Sur have three basic tools and implements for land preparation and weed control:

Table 1. Crop budgetary analysis per hectare. MAF-ZDSDP, Zamboanga del Sur, Philippines.

Crop	Yield (kg/ha)	Price (\$/kg)	Gross receipts ^a (\$)	Variable costs (\$)				Other costs (\$)			Net cash receipts ^c (\$)	
				Seed	Inoculum	Fertilizer	Chemical	Total cash costs	Harvesters share	Interest on insurance		Total variable costs ^b
<i>MCP</i>												
Upland rice (1st crop only)	2000	0.19	380.00	12.97	—	58.92	4.81	76.70	54.29	16.97	147.96	232.04
Mungo	500	0.65	324.32	14.27	0.16	27.57	11.14	53.14	46.33	11.35	110.82	213.50
Peanut	1000	0.43	432.43	51.89	0.32	—	—	42.21	72.05	9.08	133.34	299.09
Soybean	1000	0.43	432.43	25.95	0.22	41.35	—	67.52	61.78	15.14	144.41	287.99
Maize	1500	0.19	283.78	6.49	—	72.70	—	79.19	28.38	15.14	122.71	161.07
<i>Traditional</i>												
Native maize	750	0.19	141.89	1.89	—	—	—	1.89	14.22	—	16.11	125.78

^a Price X yield. ^b Cash input costs + other costs. ^c Gross receipts minus total variable costs.

Table 2. Labor input by crop and by activity. MAF-ZSDSP, Zamboanga del Sur, Philippines.

Activity	Labor days ^a																																																																																																																																																																																																																											
	Upland rice		Maize		Peanuts		Mungo		Soybean		Native maize																																																																																																																																																																																																																	
	M	C	M	C	M	C	M	C	M	C	M	C																																																																																																																																																																																																																
Land preparation													First plowing	6	6	6	6	6	6	6	6	6	6	6	6	Second plowing	6	6	6	6	6	6	6	6	6	6	6	6	Harrowing	2	2	2	2	2	2	2	2	2	2	2	2	Shelling	-	-	-	-	3	-	-	-	-	-	-	-	Furrowing	4	4	2	2	3	3	3	3	3	3	2	2	Fertilizing													Basal	6	-	5	-	-	-	4	-	4	-	-	-	Sidedressing or topdressing	3	-	2	-	-	-	-	-	-	-	-	-	Planting	8	-	6	-	6	-	6	-	6	-	4	-	Spraying or baiting	4	-	-	-	-	-	2	-	-	-	-	-	Cultivation and weeding													First weeding or off-barring	25	-	4	4	20	-	20	-	20	-	4	4	Second weeding or hilling	15	-	4	4	4	4	-	-	-	-	4	4	Harvesting	15	-	10	-	15	-	20	-	10	-	7	-	Threshing, shelling, cleaning, drying	22 ^b	-	20	-	7	-	10	-	18 ^c	-	7	-	Total	116	18	67	24	72	21	79	17	75	17	42	24
First plowing	6	6	6	6	6	6	6	6	6	6	6	6																																																																																																																																																																																																																
Second plowing	6	6	6	6	6	6	6	6	6	6	6	6																																																																																																																																																																																																																
Harrowing	2	2	2	2	2	2	2	2	2	2	2	2																																																																																																																																																																																																																
Shelling	-	-	-	-	3	-	-	-	-	-	-	-																																																																																																																																																																																																																
Furrowing	4	4	2	2	3	3	3	3	3	3	2	2																																																																																																																																																																																																																
Fertilizing													Basal	6	-	5	-	-	-	4	-	4	-	-	-	Sidedressing or topdressing	3	-	2	-	-	-	-	-	-	-	-	-	Planting	8	-	6	-	6	-	6	-	6	-	4	-	Spraying or baiting	4	-	-	-	-	-	2	-	-	-	-	-	Cultivation and weeding													First weeding or off-barring	25	-	4	4	20	-	20	-	20	-	4	4	Second weeding or hilling	15	-	4	4	4	4	-	-	-	-	4	4	Harvesting	15	-	10	-	15	-	20	-	10	-	7	-	Threshing, shelling, cleaning, drying	22 ^b	-	20	-	7	-	10	-	18 ^c	-	7	-	Total	116	18	67	24	72	21	79	17	75	17	42	24																																																																														
Basal	6	-	5	-	-	-	4	-	4	-	-	-																																																																																																																																																																																																																
Sidedressing or topdressing	3	-	2	-	-	-	-	-	-	-	-	-																																																																																																																																																																																																																
Planting	8	-	6	-	6	-	6	-	6	-	4	-																																																																																																																																																																																																																
Spraying or baiting	4	-	-	-	-	-	2	-	-	-	-	-																																																																																																																																																																																																																
Cultivation and weeding													First weeding or off-barring	25	-	4	4	20	-	20	-	20	-	4	4	Second weeding or hilling	15	-	4	4	4	4	-	-	-	-	4	4	Harvesting	15	-	10	-	15	-	20	-	10	-	7	-	Threshing, shelling, cleaning, drying	22 ^b	-	20	-	7	-	10	-	18 ^c	-	7	-	Total	116	18	67	24	72	21	79	17	75	17	42	24																																																																																																																																															
First weeding or off-barring	25	-	4	4	20	-	20	-	20	-	4	4																																																																																																																																																																																																																
Second weeding or hilling	15	-	4	4	4	4	-	-	-	-	4	4																																																																																																																																																																																																																
Harvesting	15	-	10	-	15	-	20	-	10	-	7	-																																																																																																																																																																																																																
Threshing, shelling, cleaning, drying	22 ^b	-	20	-	7	-	10	-	18 ^c	-	7	-																																																																																																																																																																																																																
Total	116	18	67	24	72	21	79	17	75	17	42	24																																																																																																																																																																																																																

^aM = man-days, C = carabao or draft animal day inputs. ^bThreshing done by foot, but would require 5 man-d if threshed mechanically. ^cThreshing done by hand, but would require 7 man-d if threshed mechanically.

The moldboard plow (Vargas type). The moldboard plow is made of steel. It is constructed and produced by most blacksmiths in the province. The beam is reused many times. The share is fashioned from broken truck springs and is replaced several times before the main moldboard has to be remade. The plow is used for primary and subsequent plowings, furrowing, and weed control in maize.

The peg-tooth harrow. Harrows are made from lumber and steel spikes. Frame shapes may be square, rectangular, trapezoid, and triangular. Harrows are used to break down large clods, for seedbed preparation, and for a final light weeding prior to planting. Some shops make harrows totally of steel, costing more but lasting longer.

The hand bolo or bunlay. Every farmer in the province owns a hand bolo, a simple flat piece of sharp-ended spring steel fitted to a wooden handle. This is the only tool available to farmers on the steep upland who practice the "kaingin" system of a slash and burn or shifting agriculture, and who do not have access to a carabao. The hand bolo is used to prepare the hillside, for hand planting, and weeding. Farmers who own a carabao and plow still use the hand bolo for hand weeding and narrow-row crops such as upland rice (25-35 cm row spacing) or mungbean, soybean, and peanut (50-60 cm).

Introduced tools

Any new tools or implements introduced were required to fit the following criteria:

1. be suitable for crops with row spacings of 25-60 cm,
2. be able to perform the traditional task to an equal or higher standard,
3. be cost effective and affordable to most farmers,
4. be capable of being manufactured locally without establishing a new infrastructure, and
5. be strong and durable.

Introductions were based on knowledge and experience with suitable tools in Australia and the Philippines.

Three-pronged cultivator. The three-pronged cultivator is a light weeder widely used by home and market gardeners throughout Australia. The Australian version is a factory-produced assembly, using forged and stamped components bolted together. This manufacturing technique was unsuitable for local conditions so the tool was redesigned into a fully welded assembly. The prongs of early versions were fabricated from low carbon steel square bar. However, these bend under field use and are now being fashioned from spring steel by blacksmiths (3). The effective working width is 10 cm, which makes it ideal for weeding upland rice planted at 25-cm row spacing.

Five-pronged cultivator. The grain legume crops grown in the MCP are planted in rows spaced 50-60 cm apart. An enlarged version of the three-pronged cultivator with working width of 20 cm was designed for this spacing.

Push-pull hoe. A flat, cutting blade sharpened on both edges is attached to a wooden handle. A pivot arrangement allows 20 degrees of movement. During operation, this hoe is pushed and pulled by the operator so that the sharp

cutting edges dig shallow in the soil to cut and lift the weeds. This implement was recommended to ZSDP by International Rice Research Institute (IRRI) staff. It is an effective weeder, but local workers don't like the effort required to use it. Its design (moving parts) makes its long-term durability doubtful.

The chipping hoe. The chipping hoe is widely used in Australian cotton fields and in most countries throughout the world, but is not common in southern Philippines. Available in a variety of shapes and sizes, its simplicity, strength, and wide range of uses makes it an obvious choice for introduction. A sample with a blade 10 cm wide and 17 cm long was introduced in Zamboanga del Sur. The full forged factory sample has been modified to a welded assembly for local manufacture.

Digging or spading fork. The digging or spading fork was introduced to lift peanuts, especially during the drier second cropping. Peanut pod loss can be high when soils are hard and considerable hand sifting of soil is required to retrieve the pods. Local blacksmiths make the fork with thin strips of truck spring fitted to a handle fashioned from water pipe. A wide, curved foot rest has been fitted for barefoot work.

Minifurrower (mini-plow). The minifurrower is a light implement originally designed by Eng. Jun Manalac, Ipil, Zamboanga del Sur. It looks like a miniature plow with a double winged furrower, and was introduced as a furrower for the shallow planting of soybean and as an interrow weeder of legume crops and upland rice.

The minifurrower originally was very lightly constructed and did not withstand constant use with animal draft. Its advantage was a fast work rate combined with a satisfactory capital cost. Subsequent improvements to ensure durability have significantly increased the cost. Nevertheless, the implement is keenly sought by farmers (see Table 3).

Lithao. The lithao has only recently been introduced (April 1985). It was copied from implements in use in Batangas Province, Luzon. Three prototypes have been constructed for trial. Evaluation is currently under way to determine the most efficient combination of practices with which this implement can be used. Preliminary results indicate that labor savings are possible in both planting and weeding.

RESEARCH AND DEVELOPMENT

Infrastructure

A temporary Agricultural Engineering workshop was established at the Betinan Research Station (BRS). Much of the initial prototype construction and testing was carried out there. To expand the activities of the Agricultural Engineering Program (AEP) and to obtain more staff from MAF, a permanent workshop was later established at the MAF complex in Pagadian City.

This facility has been used to

1. fabricate templates and welding fixtures,

2. prepare extension materials (e.g., display boards and fitting of tool handles),
3. prepare and predeliver blacksmith welding machines (see the section Manufacture and Distribution),
4. construct prototypes,
5. train MAF staff in workshop techniques, and
6. carry out other AEP activities not related to weeding and cultivation.

Field testing of introduced tools

Field testing has been undertaken both at BRS and on nearby farms. Both research-managed and farmer-practice trials have been possible.

Hand weeding tools. The three- and five-pronged cultivators, the chipping hoe, and the push-pull hoe have been tested extensively during the last 3 yr. All give faster work rates than the hand bolo. Rates vary between 7 and 15 d/ha as compared to between 20 and 40 d/ha for the hand bolo. However, rates depend on a) weed population, b) growth stage, c) condition and type of soil, d) variation between different groups of laborers and working conditions at the time of measurement, and e) the degree of control achieved (i.e., weed free or farmer practice).

The three- and five-pronged cultivators and the push-pull hoe work well when weeds are small and the soil is not hard. They do not dig deeply without extra effort. Under favorable conditions, they allow a faster work rate than the chipping hoe. The chipping hoe is most suitable when the weed population is high, weeds are taller, and soil is hard.

Digging fork. The digging fork was introduced as a convenience tool to aid peanut harvesting and for use in backyard gardens. Farmers' response to the half-price scheme (Table 3) indicated a firm demand. It has been field tested for strength and durability and has had limited extension.

Minifurrower (miniplot). This implement offers the most significant labor savings of all the weeding tools introduced by the ZDSDP agricultural program. Early failures (3) have been rectified with the implement beam being fashioned from spring steel. The average retail cost is \$14.85. Work rates when pulled by a carabao vary between 2 and 5 d/ha depending on the conditions and row spacing. Farmers report a greater work rate from their carabao when using a minifurrower. Presumably the lighter draft requirement does not tire the animal as quickly and therefore it does not need to wallow as often.

The minifurrower can be pulled by a person. Farmers using Sloping Agricultural Land Technology (SALT) on very steep slopes are buying the minifurrower for human pulling (A.G. Kent, extension agronomist, Pagadian City, pers. comm., 1985).

Lithao. The first research trial with this implement is under way at BRS and will end after rice harvest in September 1985. Both planting and weeding techniques are being studied. Preliminary data (unpubl., 1985) show that planting times can be reduced by more than 50% when seed is broadcast compared to traditional furrowing, hand drilling, and covering by foot. Similar reductions in weeding times were achieved using a combination of

Table 3. Tool sales recorded by cooperating blacksmiths of MAF/ZDSDP, Zamboanga del Sur, Philippines.

Period	Tool or implement (no.)					
	3-pronged cultivator	5-pronged cultivator	Chipping hoe	Push-pull hoe	Minifurrower	Digging fork
Jul 1982-15 Apr 1985 ^a	21	86	130	3	24	7
Half-price Scheme ^b	299	514	492	132	721	194
15 Apr 1985-30 Jun 1985						
	\$2.15	\$3.25	\$3.25	Current retail price \$2.70	\$14.85	\$4.85

^a Cooperating blacksmiths were 1 in 1982, 5 in 1983, 11 in 1984, and 17 in 1985. ^b Tools were sold at one-half the current retail price.

lithao weeding and hand bolos as compared to two traditional weedings with the hand bolo. Preliminary data, not replicated by site, indicate considerable labor can be saved by introducing the lithao into present upland rice production.

EVALUATION

An economic evaluation of the implements and tools in the agricultural engineering program is summarized below:

1. Strip weeding is still needed when using the new tools. Results of research trials have shown that weeding with the hand bolo alone or using the pronged cultivators or minifurrower together with strip weeding (i.e., weeding with a hand bolo within the row) gives significantly higher yields than use of the new tools without strip weeding.
2. The labor input was higher for the hand bolo alone. The pronged cultivators plus strip weeding required similar inputs. The input for the minifurrower plus strip weeding was significantly less, but still greater than that for all the new tools without strip weeding.
3. Despite this, the profitability per hectare was highest for the crops weeded with the hand bolo or weeded with the new tools plus strip weeding. The yield difference was sufficiently high to overcome any reduction in labor cost from using the new tools without strip weeding.
4. No significant difference was found in the return to labor between the hand bolo treatments, the new tools plus strip weeding treatments, and the new tools without strip weeding treatments.

In terms of overall profitability, traditional weeding with the hand bolo or new tools plus strip weeding gave the highest net receipts per hectare. However, other factors not relating to profit maximization may influence farmers' decision to adopt the new tools and implements.

1. *Availability of cash.* The lack of cash is a major constraint, especially after the dry season. The main priority then is purchase of food for the family until the first cropping harvest is completed. This means the farmer has little cash available for hiring laborers to weed the crop at the crucial time. The farmer who borrows money will likely pay an interest rate equivalent to 20% to 30%.
2. *Timeliness.* Timing of weeding is crucial to the final crop yield. If the farmer uses hand weeding with only family labor, weeding will be unduly long; weeds will reduce yield.
3. *Self-sufficiency.* In many areas of the province, labor for weeding is difficult to obtain. The laborers are usually farmers who, after completing the work on their farms (generally less than 2 ha), organize themselves into groups to hand weed for other farmers. The difficulty of being able to hire these laborers and to obtain them at the right time can reduce yields. Farmers need to be self-sufficient; the use of the new cultivator and minifurrower allows the farm family to do their own weeding or minimize the number of persons hired.

Some disadvantages of the new implements and tools should be considered:

1. *Cost.* While cost is not exorbitant, these tools may still be out of the reach of many of the poorer farmers. Trying to keep the cost of the tools as low as possible without decreasing their sturdiness has been a constant problem for the program.
2. *Distribution of wealth.* If these new tools and implements are accepted, then the demand for hired labor will decrease, thereby depriving poorer farmers of a source of off-farm income. However, this adjustment will occur gradually and as incomes rise due to increases in productivity and new crop areas are opened up, then demand for hired labor should rise.

MANUFACTURE AND DISTRIBUTION

The response of farmers and technicians to initial extension activities indicated that the ZDSDP-supported distribution of tools was not suitable. The program was creating an undesirable artificial demand based on handouts which were becoming increasingly difficult to sustain. There was little likelihood of this system surviving after the completion of ZDSDP in 1985. Farmers were asking if tools could be purchased from ZDSDP. However, the Memorandum of Understanding between the Government of the Republic of the Philippines and the Government of Australia prohibits the sale of goods to private individuals. It was obvious that a capability to produce the tools closer to the farmer needed to be established.

Manufacturing capability

There are three categories of metal working shops in Zamboanga del Sur:

1. engineering shops which specialize in engine overhaul,
2. small manufacturers of mechanical tillers for lowland rice (e.g., MAF/IRRI), and
3. blacksmiths.

The program centered its efforts on the blacksmith sector. Zamboanga del Sur's blacksmith industry is well developed. The quality of implements is generally good and most blacksmiths are adept at copying a sample. Blacksmiths are well distributed throughout the province with most municipal centers having one or more shops. The more intensive cropping areas are also serviced.

Blacksmith activities prior to the ZDSDP included

1. manufacture and repair of steel moldboard plows,
2. manufacture of lowland and upland harrows, and
3. manufacture of the wide range of bladed tools used in the province (e.g., knives, grass slashing tools, coconut huskers, and the hand bolo).

Selection criteria

Two ZDSDP agricultural components, the Multiple Cropping Project and the Agro-Forestry/Hillside Farming Projects cover 35 of the 41 municipalities in the province. Sites for cooperating blacksmiths were selected to give as wide

a coverage as possible to these projects. Priority was given to areas receiving program assistance for the longest period. A goal of one blacksmith per municipality was set; one per two municipalities has been achieved.

Minimum requirements

Cooperators were required to satisfy the following criteria:

1. have a reputation for quality and a regular clientele;
2. be highly visible and located centrally in a farming areas;
3. possess the basic blacksmith equipment (i.e., forges, bellows/blowers, grinding wheels, and smithing tools);
4. possess a welding machine or have access to one, or have access to an electricity supply; and
5. be recommended by the local Municipal Agricultural Officer, MAF technician, or local official.

Evaluation of blacksmiths

Selected blacksmiths interested in becoming cooperators were provided with samples of the tools and were asked to reproduce one item of each. Templates and fixtures were not provided then, so as to assess their workmanship and ingenuity. If the finished products were of acceptable quality and the proprietor was willing to become a cooperator, establishment assistance was then provided.

Establishment assistance

The tools and implements being introduced, although simple in design, required a welding machine for fabrication. The rapid electrification of the province by the local electricity cooperatives, which followed road construction by the ZDSDP, enabled some blacksmiths to acquire welding machines. Cooperators were established in the following sequence:

1. those with full facilities (i.e., tools, forges, grinding wheels, and welding machine), six sites;
2. those with full facilities except a welding machine, but with access to a 10 KVA electrical transformer, or where one could be installed upon entry into a rental agreement with the local electrical cooperative, eight sites; and
3. those with full facilities except a welding machine but where transformers were only available by purchase, three sites.

Sites in group 3 were more expensive to establish than those in group 2; however, they were situated in areas essential to the program with strong farmer interest.

Upon the connection of the electricity supply, blacksmiths in groups 2 and 3 were provided with

1. the necessary electrical plans for submission to the electrical cooperative,
2. the electrical wiring and equipment necessary to install a welding machine of 250-ampere capacity, and

3. a 250-ampere welding machine and accessories. (These machines were manufactured in the Philippines and were purchased at a cost which varied between \$85 and \$100.)

Assistance cost about \$170/blacksmith.

Technical and extension assistance

All cooperating blacksmiths were then supplied with

1. templates to ensure uniformity of components,
2. welding fixtures to enable mass production of tools to a uniform standard,
3. specialized tools for fabrication of selected parts (e.g., handle sockets),
4. a display board to show (visiting) farmers the tools available,
5. a set of tools for demonstrations to farmers, and
6. copies of extension booklets (see Extension).

As of June 1985, 17 blacksmiths were cooperating in the MAF/ZDSDP program (Fig. 1). Cooperators were provided with record books and asked to record sales of each item, detailing the farmer's name and location so that follow-up surveys could be carried out.

EXTENSION

The ZDSDP Agricultural Project has developed networks of field technicians. The technicians live in barangays central to their allotted areas. The technician network is based on the World Bank Training and Visit System.

The ZDSDP Agricultural Engineering Program did not develop a separate group of field technicians because existing networks were suitable, staff were not available, and local MAF officials did not regard extension as an agricultural engineering role.

Extension activities began following field evaluation in 1982-83. Demonstrations were held at barangay assemblies and field days and sample tools were usually left with farmer leaders or barangay captains. This procedure led to the realization that a commercial manufacturing capability must be established before large-scale farmer extension could be undertaken. Extension activities were suspended until the first cooperating blacksmiths began operation, and were progressively expanded as the blacksmith network grew.

Extension aids

A range of extension aids was developed based on the Visayan phrase "Ang Bag-ong Galamiton sa Uma," which means, "New tools for the farm." The components are as follows:

1. A display board containing each tool with the Visayan name underneath. These boards were placed in blacksmith shops and municipal agricultural offices.
2. A set of working tools, distributed to each technician in the cropping programs. Technicians were encouraged to demonstrate these tools at regular farm meetings, and to loan them to interested farmers.

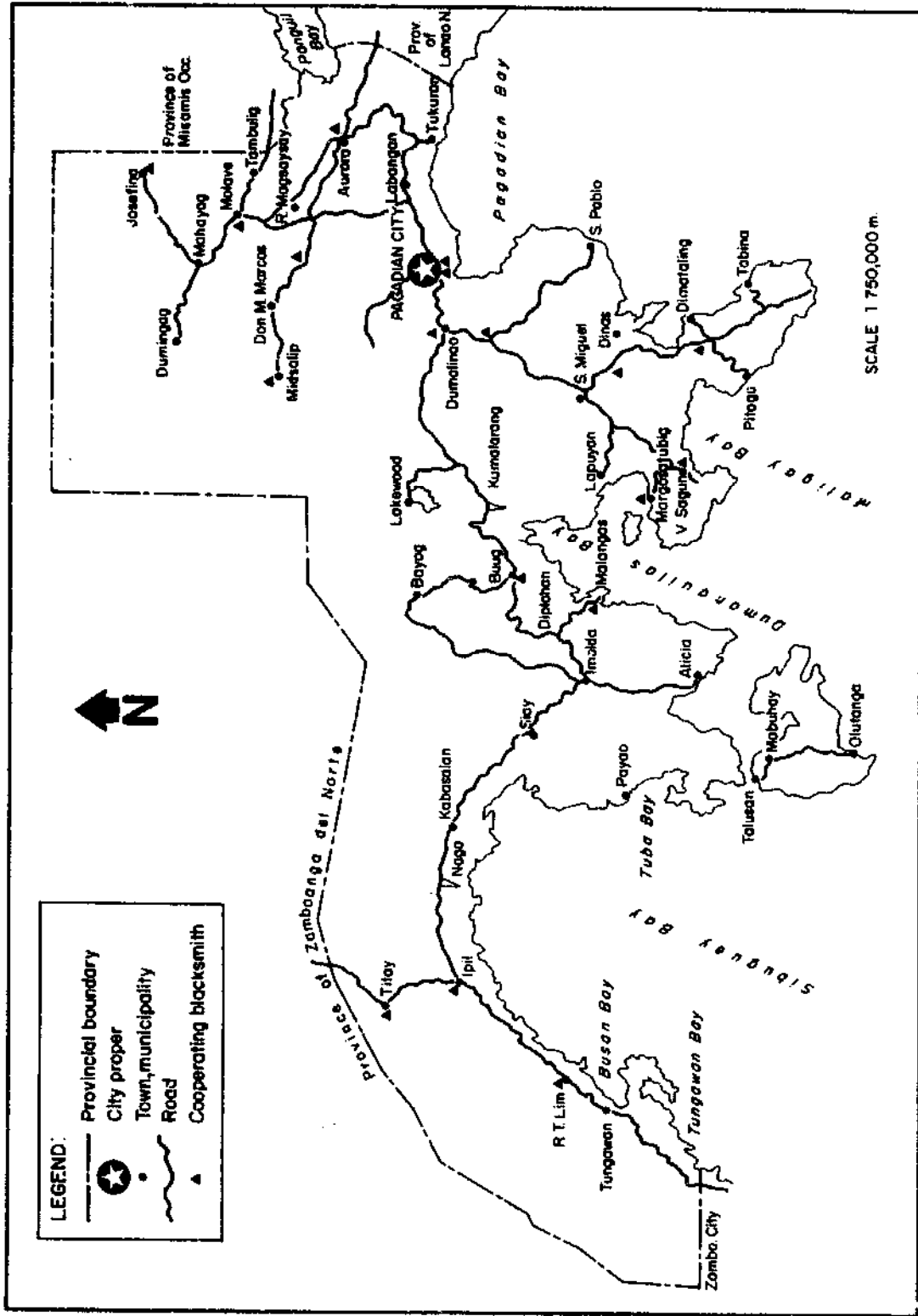

1. Distribution of cooperating blacksmiths, Agricultural Engineering Program (MAF/ZDSDP), Zamboanga del Sur, Philippines.

3. A series of comics-style extension booklets written in the Visayan dialect. About 7,000 copies of each booklet have been distributed to farmers, technicians, municipal agricultural officers, and blacksmiths. These simple publications are designed to reinforce the principles of early weed control, and to explain the labor-saving aspects of the introduced tools.

Field extension and training

Wherever possible, program staff attend the monthly farmer meetings organized by the field technicians. These visits support the technician and allow demonstrations of the tools by more experienced staff. The extension booklets are distributed and farmers are informed of the nearest cooperating blacksmiths.

Similar demonstrations are given at larger field days organized by the MCP and at agroindustrial fairs held occasionally throughout the province. At MCP training seminars, technicians are given refresher instruction on tool use.

Promotion and incentive schemes

Although sales at the blacksmith shops gradually increased, it was decided to conclude the ZDSDP Agricultural Engineering Project with a scheme to create a greater awareness of the new tools throughout the farming community and to disseminate many tools to create a spin-off demand.

An incentive scheme which consisted of the following was devised:

1. A One-half-price Scheme, whereby the farmer purchased his tool from the blacksmith at half-price and the ZDSDP reimbursed the blacksmith for the balance.
2. A Technician Incentive Scheme, whereby technicians were paid a bonus for each tool that a farmer purchased on his or her recommendation.

Both schemes used a system of numbered vouchers, which recorded farmers' and technicians' names and locations, and which should be cross checked.

Much equipment had been handed out free of obligation in the early days of ZDSDP, and this hurt some later programs including Agricultural Engineering. Project staff felt that a farmer having to pay a portion of the cost of a tool would value and use it more, and that any future survey results would show more genuine answers than those involved with free handouts.

The technician incentive scheme was designed to encourage the technicians to more actively promote and demonstrate the tools at their disposal, and to provide a supplement to their low salaries and traveling allowances which were not commensurate with their work load.

The scheme, commencing in late April 1985, proved to be a resounding success with farmers (Table 3) and had to be closed down half-way through its term because of a budget overrun.

IMPACT AND ADOPTION

In the 3 yr from 1982 to 1985, there was only a slight acceptance of the new cultivators and minifurrower (Table 3). This acceptance began to increase in 1984-85 as a result of the increased extension activities and outreach distribution centers (blacksmiths). In a recent survey (December 1984), the minifurrower was found to be the most common implement used by cooperating MCP farmers. The major reasons for acceptance or non-acceptance by farmers as recorded by the survey follow:

1. Minifurrower

- suitable for weeding, especially in upland rice crops.
- suitable for furrowing, especially in soybean crops.
- not suitable for stony areas.

2. Pronged cultivators

- suitable only for gardening.
- not suitable for use in wet soil.
- suitable only for seedling weeds.

3. Chipping hoe

- suitable for seedling weeds.
- not suitable for stony areas.

This survey showed reasonably bright prospects for the minifurrower. However, farmer understanding of the uses for and benefits of the pronged cultivators and chipping hoe seemed limited and further extension work was required.

The research has shown that the implement most likely to be accepted is the minifurrower, which does not maximize profit but allows for optimization under various socioeconomic constraints as stated in Evaluation. This was proven during the promotional one-half price scheme, when 721 minifurrowers were sold throughout the province. Despite the relatively high price of \$14.85, the minifurrower has gained acceptance as farmers realize its benefits. Considerable numbers of pronged cultivators and chipping hoes were also purchased under the scheme. The success of the scheme has justified the decision to expand the distribution and manufacturing bases to private commercial organization, namely the blacksmiths. It has also shown that the extension component of the program has stimulated farmer awareness of solutions to their problems and thereby created a demand for such technology.

A follow-up survey of farmers who purchased the tools and implements will be conducted to determine use of items and the effectiveness with which they do the tasks.

CONCLUSION

Two major conclusions can be drawn from the Agricultural Engineering Program in Zamboanga del Sur. First, any similar introduction of improved technology should be moved into the commercial sector as soon as that technology is proven to be viable to ensure the continued availability of service to the farmer. Government agencies are constrained by policy and limited resources, with their orientation being toward technical support.

Second, with the successful development of the commercial infrastructure, the blacksmiths, it has been necessary to ensure successful use of the introduced tools. Therefore, research and development must be complemented by a strong extension effort to disseminate the necessary crop husbandry techniques.

REFERENCES CITED

1. IPC (Institute of Philippine Culture). 1983. The socioeconomic impact of development programs in Zamboanga del Sur.
2. NEDA (National Economic Development Authority). 1985. Regional development communicator. 6(4).
3. ZDSDP (Zamboanga del Sur Development Project). 1985. Ministry of Agriculture and Food and Zamboanga del Sur Development Project. Multiple Cropping Project. Annual report 1983-84.

Harvesting

WHEAT AND PADDY REAPERS IN CHINA

BAI LING

The Chinese Academy of Agricultural
Mechanization Sciences,
China

It is nearly 10 yr since the first vertical windrowing reaper was born in 1976, and its great development has been witnessed since then in China.

Its early prototype with a rear windrowing mechanism was matched with a two-wheel tractor with a cutting width of 1.85 m, mainly used in intercropped fields. The machine conveyed standing cut crop backward and laid the crop behind the tractor by the rear windrowing mechanism (Fig. 1).

The machine was likely to be blocked by the change of the moving direction of the conveyed crop through 90 degrees and the long conveying distance. In addition, it was limited to cutting intercropped plants with a cutting width of 1.85 m and therefore failed to be popular.

In average wheat and paddy areas, the machine was modified as a side windrowing reaper with the rear windrowing mechanism removed. The modification led to easier operation, and therefore has received popular welcome. Furthermore, a new series of 7 vertical platforms with side windrowing mechanisms was introduced in 1977 with cutting widths of 0.7 m, 1.0 m, 1.3 m, 1.6 m, 1.9 m, and 2.5 m, with the original structure of the platform unchanged.

A great deal of field operation proved that this modification was far from perfect in structure and reliable in performance, and so further improvements were made in the following aspects from 1979 to the end of 1980.

1. The clearance between the ledger plate and the knife section is liable to increase, leading to unsatisfactory cutting performance, breakage of the knife back, and its short life.
2. Grass and straw can wrap around the star wheel, impairing performance.
3. The frame is liable to deform, impairing the drive.

Tests in 1980 proved that the improved platform was stable, performed well, and was reliable. Nevertheless, mounting and power drive remained unsatisfactory. For example, the belt drive was simple in construction but on undulating ground the drive became unstable and, hence, platform performance suffered. In addition, the machine was too heavy and used too much metal.

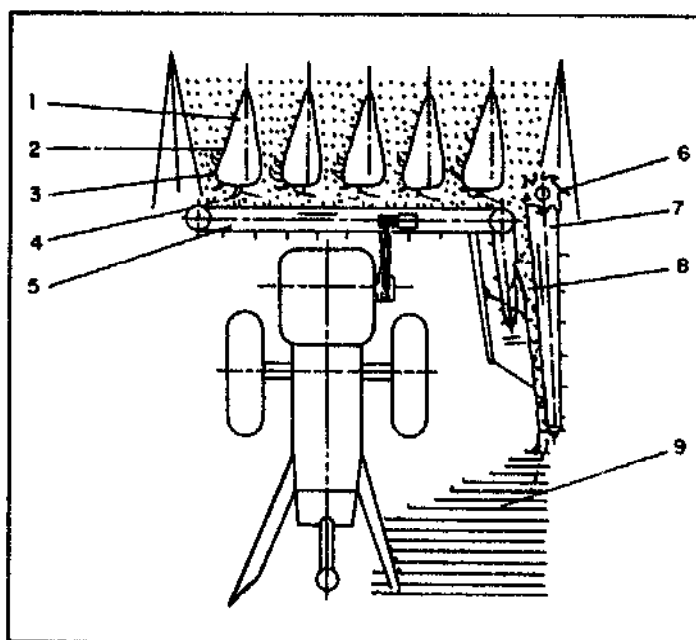

1. The model Beijing 4GL-1.85 reaper at work. 1 = star wheel lifter, 2 = V-belt, 3 = star wheel, 4 = compression spring, 5 = conveyor belt, 6 = steering star wheel, 7 = rear conveyor belt, 8 = rear conveyor compression spring, 9 = windrowed crop.

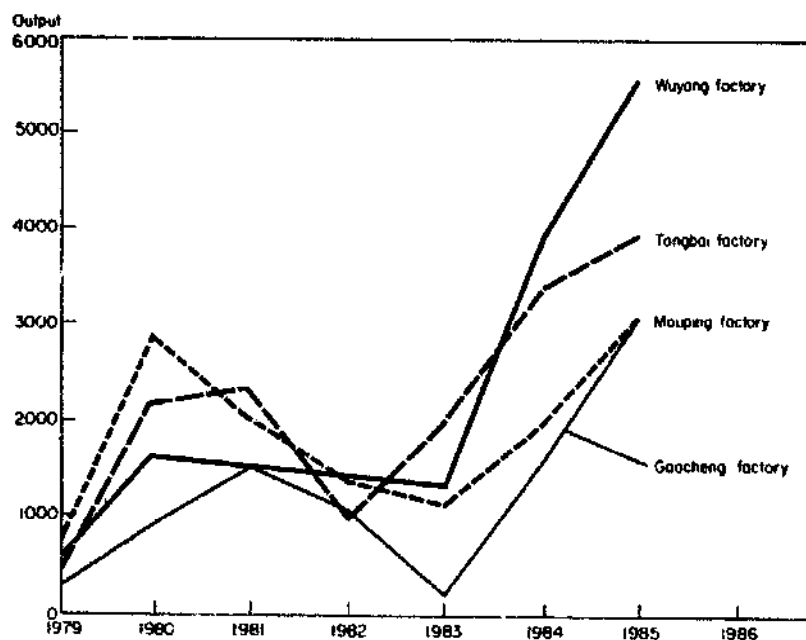

2. Output of reapers.

To further improve performance, a new series was designed in 1984 with cutting widths of 1.219 m, 1.524 m, and 1.828 m, and they have been put into production. To meet the expanding market for the machines, a trade cooperation of small reapers appeared, comprising 9 factories, each having a yearly output of 2,000-5,000 machines.

The ever-increasing output of the machine at present cannot meet the expanding need of the market. Figure 2 shows the trend for four factories. According to incomplete statistics, China now has 80,000-100,000 machines. The year 1985 will add about 30,000. Most machines are being used in North China. They are less popular in the South because of the unsuitability of the traveling mechanism to field conditions.

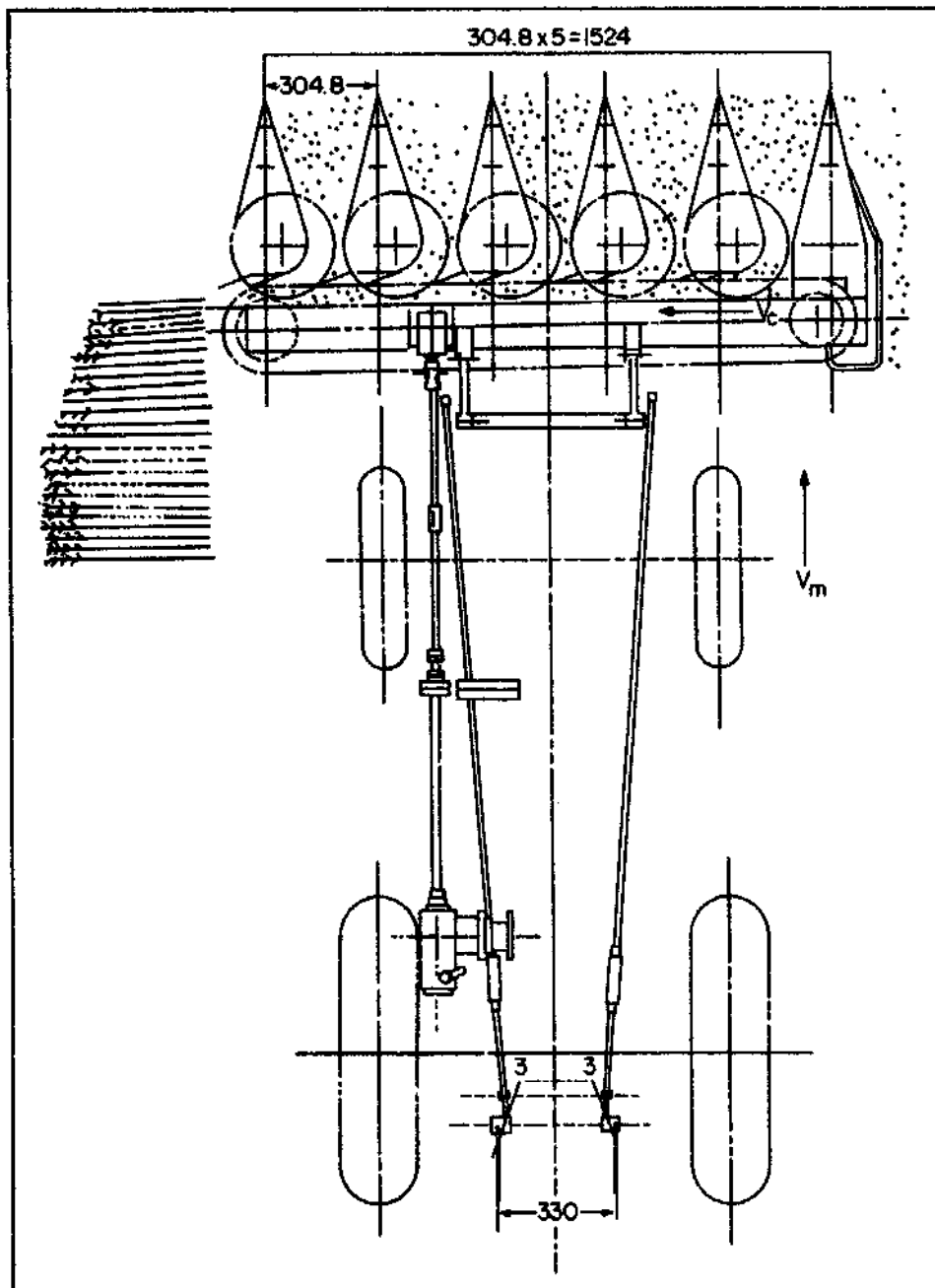

3. Working process of windrowing reaper.

PROBLEMS IN REAPER DESIGN AND DEVELOPMENT

Stability of the cut crop bunches on the vertical platform

Working process of the machine. When the machine travels at a given speed, the divider separates the crop to be guided to the cutter bar with the help of the star wheel, and the crop is cut by the cutter bar (Fig. 3). The cut crop is conveyed to one side by the belt and windrowed with the ears sidewise and the windrow and the moving direction of the machine forming an angle of 90 degrees for easy collection and bundling. For this purpose the machine must convey the cut crop bunch on a vertical platform, continuously and without any blockage.

Conditions under which the standing cut crop can be conveyed on a vertical position in the platform. The forces acting on the cut crop bunch on the vertical platform can be seen in Figure 4. If the cut crop bunch is to be conveyed standing transversely in a vertical position, the sum of torques which act on the bunch should be zero.

$$\Sigma M = P_6 \cdot c + P_7 \cdot b - P_5 \cdot a = 0 \quad (1)$$

where

P_6 = acting force by the lugs of the lower conveyor belt,

P_7 = acting force by the lugs of the upper conveyor belt.

$$P_5 = Q + T$$

where

Q = implicating force between cut crop bunches,

T = friction force between the crop and perpendicular plate.

$$T = f(P_2 + P_3 + P_4)$$

where

f = parameter of friction,

P_2 = reacting inertia force from the pull P ,

P_3 = squeezing force from the uncut crop on the cut crop,

P_4 = squeezing force from the compression spring and star wheel on the crop bunch.

Two points should be regarded:

- The distance between the two conveyor belts are from 130 to 230 mm in China as long as the torque is balanced.
- Two compression springs (one upper and one lower) are required in designing. The nearer the acting point of the spring to the conveyor belt, the better. In case of unbalance the spring compression should be adjusted.

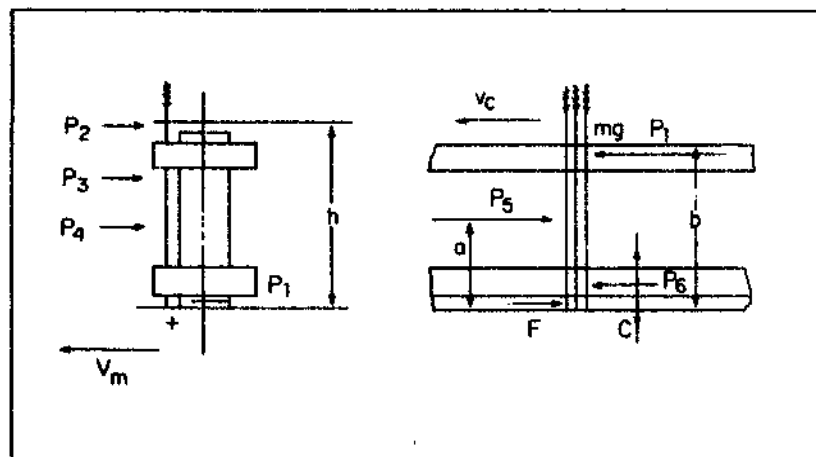

4. Forces acting on cut crop bunch on platform.

The bunches of the crop can be continuously conveyed without any blockage only when the conveyed output per unit time is greater than or equal to the cut output, that is:

$$Q_{\text{conv.}} \geq Q_{\text{cut}}$$

$$h \cdot B \cdot \rho_2 \geq \rho_1 \cdot B^2 \cdot V_m / V_c \quad (\text{Fig. 5})$$

then:

$$h \geq \frac{B \cdot V_m}{q \cdot V_c} \quad (2)$$

where

- h = height of lugs,
- B = cutting width,
- V_m = traveling speed,
- V_c = speed of conveyor belt,
- ρ_1 = density of plant in the field,
- ρ_2 = density of cut crop on the vertical platform,
- q = gathered cut crop parameter.

$$q = \rho_2 / \rho_1 = S_1 / S_2 = 1 / \pi R^2 = \frac{1}{\pi \left(\frac{C}{2\pi}\right)^2}$$

$$= 4\pi / C^2$$

where

- S_1 = 1 m² of area in the field;
- S_2 = area of the circle of the bunched cut crop from 1 m² of area in the field, its tightness being similar to the cut crop on the vertical platform; and
- C = circumference of the cut crop bunch whose area is S_2 .

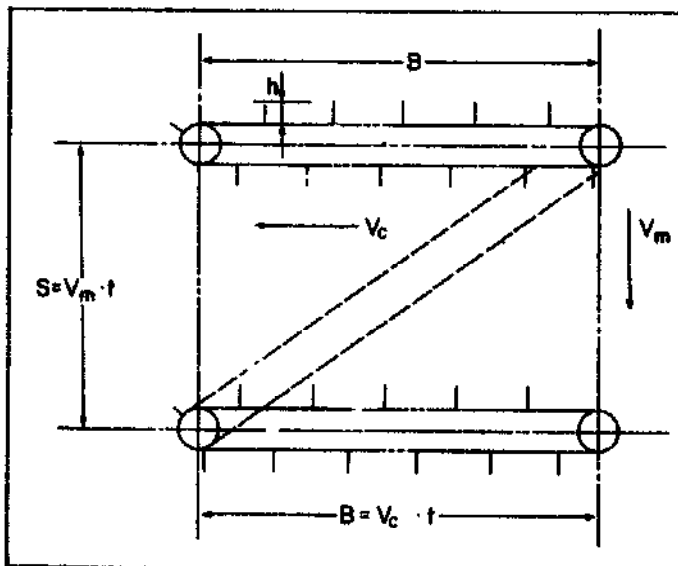

5. Relation between conveyor belt movement and machine forward travel.

In this equation, the principal design parameters are closely related, i.e., height of lugs h , cutting width B , traveling speed V_m , gathered cut crop parameter q , and the speed of conveyor belt V_c .

1. Determination of the speed of the conveyor belt V_c . If V_c is too great, the cut crop bunches will be roughly ejected instead of being smoothly conveyed, resulting in uneven windrows and losses. Greater attention should be paid in cutting paddy. If V_c is too small, the conveyor will fail to handle the cut crop. In cutting wheat, V_c can be switched to higher speed, say, 2.0-2.5 m/s, for the field conditions are good and the traveling speed is high. In cutting paddy, V_c usually ranges from 1.6 to 1.9 m/s.
2. q is closely related to the density of the crop, the diameter of stalks, and the pressure in bundling cut crop. Generally the tightness of the bunches of the crop (the value of c) should be as similar to the density of bunches in the machines as possible, which requires experience. The value of q varies with different areas in China. When the acting force was kept constant, a greater value of C (i.e., a smaller value of q), which means a high crop output, is preferred so as to increase the adaptability of the machine.
3. Most wheat and paddy reapers in China are matched with two-wheel tractors or four-mini wheeled tractors, requiring no special chassis. If the traveling speed can meet the requirements of the speed ratios of the working parts, it is considered possible. Take Changchun-12 Mini-wheeled Tractor for example. The following speeds are appropriate for reaping:

1st gear: 4.5 km/h = 1.18 m/s

2d gear: 5.72 km/h = 1.59 m/s

In South China where ground conditions are bad for tractors but more walking tractors are available, the traveling speed for reaping is more often than not below 1 m/s.

4. From the equation, $h \geq B \cdot V_m / q \cdot V_c$, it can be seen that when h , V_m , q , and V_c were kept constant, the increase of the cutting crop width alone will mess the equation. The greater the value of B , the more the crop bunches, when the value of h should be increased accordingly. Otherwise, a dreadful mess will occur at the outlet if cut crop bunches cannot be accessed by the lugs.

In calculating Q_{conv} , cut crop bunches are supposed to be evenly distributed on the vertical platforms at the density of ρ_2 . Actually they are not (Fig. 6). Instead, at the full cutting width the load is distributed triangularly with the smallest density at the inlet and the greatest density at the outlet of the conveyor. If only the cutting width B is increased, the value of q would be extreme at the outlet and the machine would be blocked and would stop working now and then.

With increase in cutting width, the conveyor belt will be lengthened accordingly with sunk lugs and can hardly be tightened.

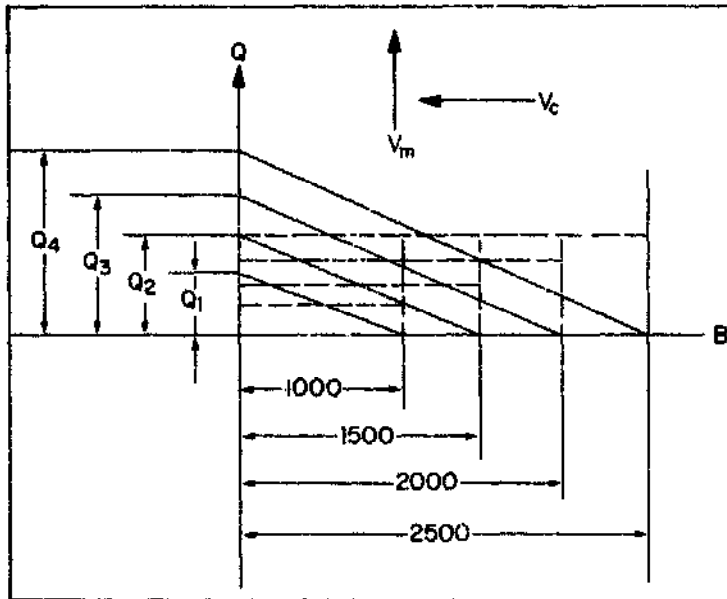

6. Load distribution on conveyor belt at full cutting width.

Due to the interaction of the above parameters, the height of lugs should not be arbitrary but should be matched with the star wheel, which is generally situated above the knife. In China the height of lugs is usually 50 mm and the cutting widths are 130 cm (1219 mm), 160 cm (1524 mm), and 190 cm (1820 mm). The cutting width over 2 m is not available at present.

Improved design of lifter

The original design of the lifter can be seen in Figure 7. Four improvements were made.

1. The horizontal component velocity of the star wheel and the lugged V-belt should be greater than or equal to the traveling speed of the machine when they can do the job well, guiding the crop to the cutter bar, or the crop will push the star wheel and the lugged V-belt. In some areas of China, the lugged V-belts fail to meet the above requirements and are therefore removed. In designing, the speed of the conveyor belt and the star wheel are also increased.
2. To prevent weeds from winding around the star wheel and to ensure proper working of the star wheel, two antiwind protectors (one upper and one lower) are supplied, leaving only the star wheel teeth exposed for working.
3. The welding point of the drop rod is made tangential to the lower part of the bend pipe to avoid missing any crop.
4. To insert the lifter smoothly into the crop (not push it), the smaller the angles of the cover, α or β , the better. And it is advisable to have $\beta > \alpha$, as the star wheel is involved with the side of angle β . Experimentation shows that it is preferable to change the deflection distance to 50 mm with $\alpha = 12^\circ$ and $\beta = 16^\circ$ (Fig. 8).

The above modifications not only have improved the performance of the lifter and raised its reliability but also markedly reduced the metal consumption.

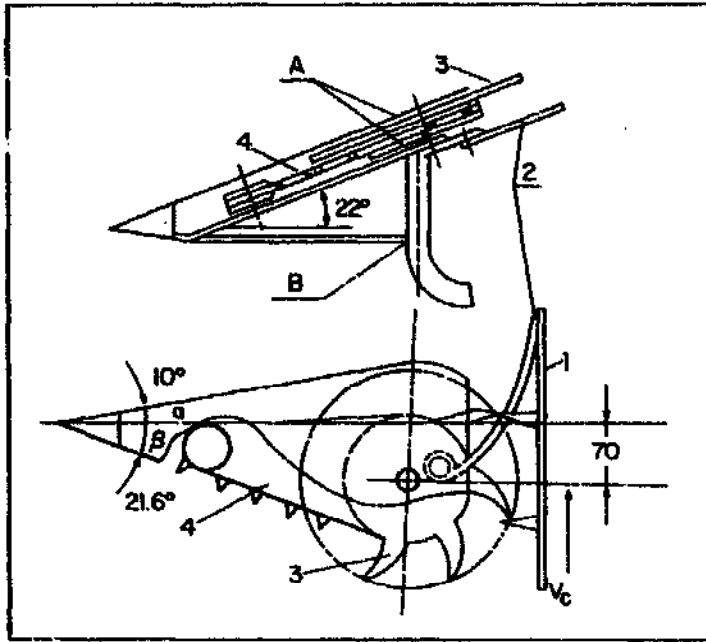

7. Original prototype of lifter.

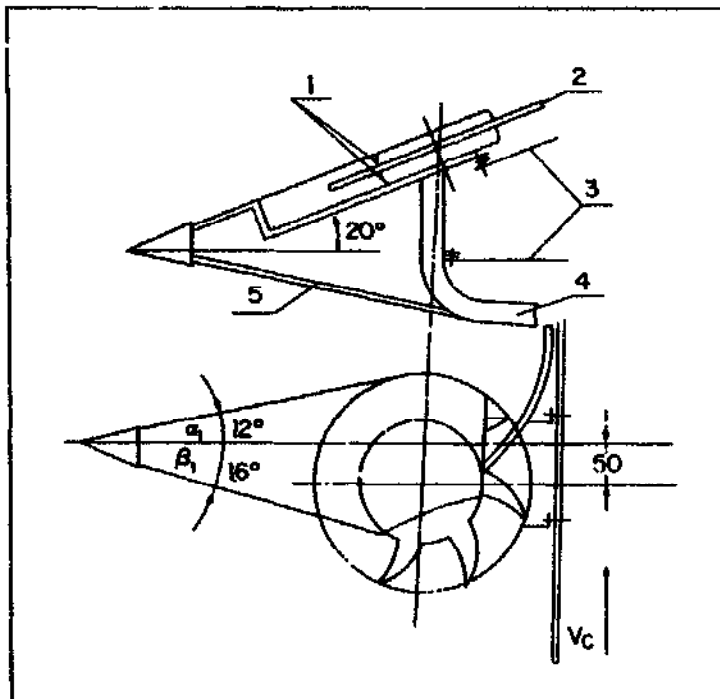

8. Modified lifter: 1 = antiwind protector for star wheel, 2 = star wheel, 3 = compression spring, 4 = bend pipe, 5 = drop rod.

Modification of the cutter bar and its drive

Field experience shows that the life of the original knife back is rather short, sometimes failing after cutting only 20-30 ha of crop.

Figure 9 shows the knife head drive of the original reaper. The knife back, driven by the crank-connecting rod mechanism, moves in a reciprocating motion via the triangular pin-plate with a deflection distance h of 90-100 mm, which produces additional torque, whose magnitude is:

$$M = p \cdot h = (m \cdot r \cdot \omega^2) + (q \cdot l + F) \cdot h$$

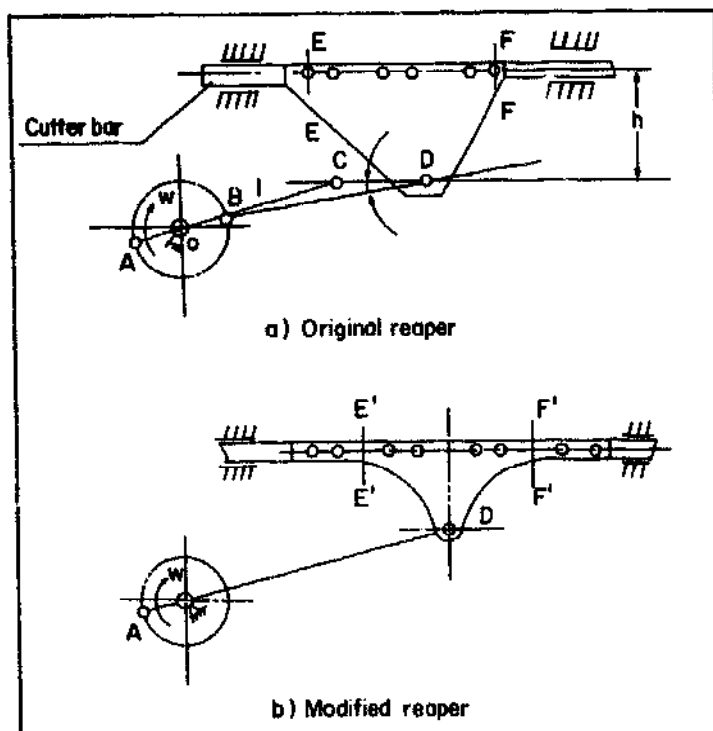

9. Cutter bar drive.

where

$m.r.w^2$ = inertial force,

m = mass of knife back and part of connecting rod,

r = radius of crank,

w = angular acceleration of crank,

$q \cdot l$ = cutting resistance,

q = resistance per meter length of knife bar, ranging from 40-50 kg/m with maximum of 70-80 kg/m in cutting wheat,

l = length of cutter bar,

F = sum of frictional forces including that of knife bar weight and that due to improper installation and design.

The incessant variation of direction of the torque breaks the knife back at sections E - E or F - F. From the above equation, methods have been found to lengthen the life of the knife back.

- The value of M can be reduced by reducing the value of h . The smaller the value of h , the better; however, the value of h of average machines is 80-90 mm.
- A proper crank speed is selected, say, 500-600 rev/min.
- An appropriate cutting width is fixed. It is not advisable to increase the width blindly when other parameters are kept constant. A width not more than 2 m is generally accepted in China so as to obtain steady performance.
- The triangular pin-plate can be changed to a curved one (Fig. 9) to distribute the stress evenly (Fig. 9, 10).
- The cutter bar can be changed to reduce the additional forces and the cutting resistance.

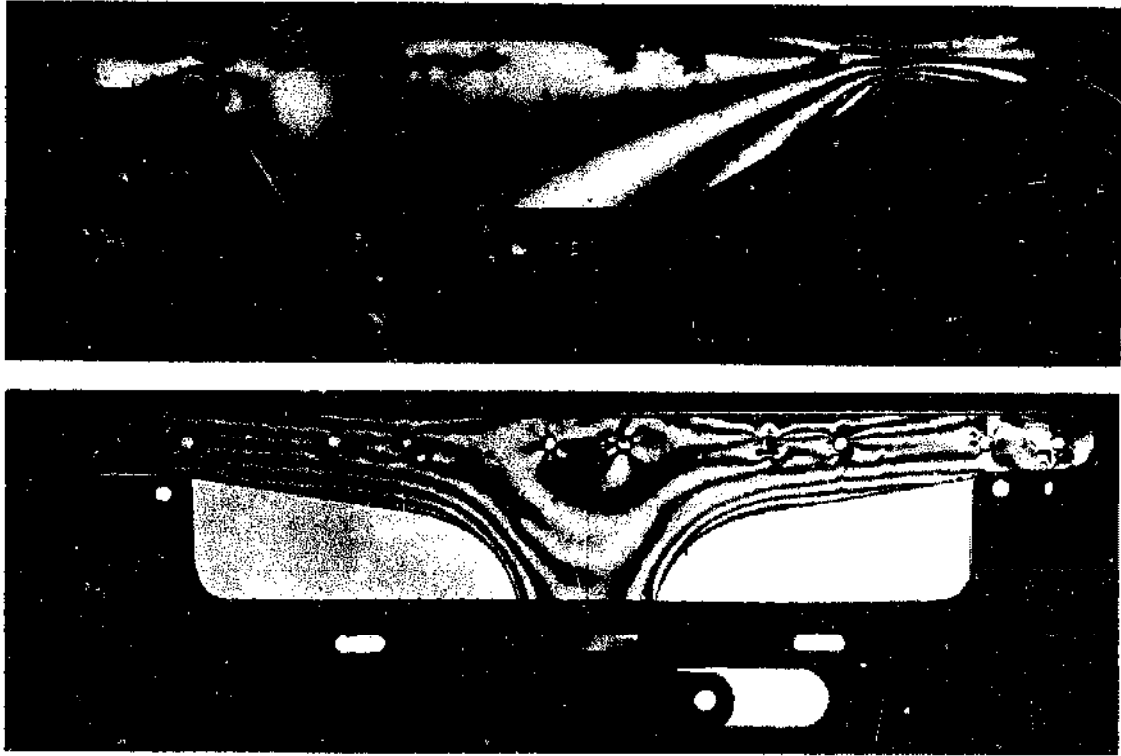

10. The elastic test of pin-plate by light: stress of triangular pin-plate gathered together (top), and stress of curved pin-plate distributed evenly (bottom).

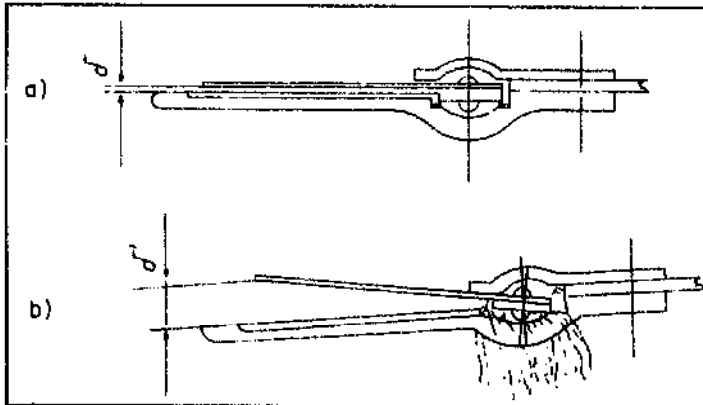

11. Cutter bar of original prototype.

In the original cutter bar, a lipless guard is adopted with a clearance δ between the ledger plate and the knife section (Fig. 11a). After working for a period of time, clearance δ increases with intrusion of weed, mud, and water into the guide of the knife back to lift the knife back, resulting in changing δ to δ' (Fig. 11b). The cutting performance thereby drops with increase of cutting resistance, unevenness of stubble, and tearing of the crop instead of cutting it; the machine is then easily blocked and goes out of order.

These shortcomings can be overcome when the cutter bar is modified as shown in Figure 12. Moreover, the punched guard is only $1/3$ as heavy as the cast guard, reducing the balance weight for two-wheel tractors and of the loads on the front wheels for four-mini-wheeled tractors.

These modifications greatly improved machine performance and prolonged the cutter bar life to more than 250 h.

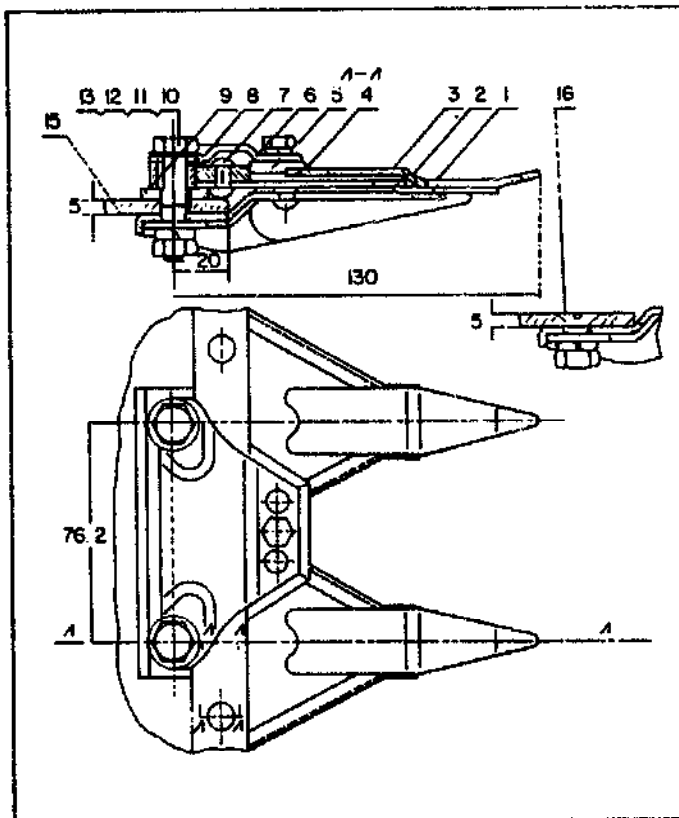

12. Light-duty cutter bar. 1 = guard, 2 = ledger plate, 3 = knife section, 4 = rivet for ledger plate, 5 = knife clip, 6 = knife back, 7 = rivet for knife section, 8 = upper wearing plate, 9 = lower wearing plate, 10 = bolt, 11 = plain washer, 12 = spring washer, 13 = nut, 15 = guard bar, 16 = flat bolt.

CONCLUSION

After several years of efforts using basic theory, we gradually improved the design of the machine, perfected a stable and reliable performance, and increased machine life by 3-5 times. Moreover, the operating speed range has been expanded, the height of the frame lowered, the rigidity of the machine increased, the weight of the consumed metal reduced by 20 kg/m of cutting width, the processing technology simplified, manufacturing material saved, and the cost thereby greatly reduced.

The machine has become one of the most commonly used harvesters in China.

FUTURE PRIORITIES

1. To design handy walking harvesters for paddy fields and small plots.
2. To design stacking reapers for low output regions.
3. To further research binders.

CAAMS-IRRI MECHANICAL REAPER: EXPERIENCES IN THE PHILIPPINES

R. E. STICKNEY, G. C. SALAZAR, H. T. MANALIGOD
F. S. JUAREZ, B. DUFF, and C. W. BOCKHOP
International Rice Research Institute

and
C. P. FERNANDEZ
Bureau of Plant Industry
Ministry of Agriculture
Philippines

In the developing countries of South and Southeast Asia, nearly all paddy fields of small farmers are reaped manually by groups of laborers using knives or sickles (5, 15, 18). Reaping (cutting only, not hauling or threshing) requires a high labor input (10-16 d/ha) and, because it is the most strenuous activity of rice production, the labor wage rate (in cash or in kind) is often substantially higher than for other activities. Consequently, reaping is a major expense in rice production. Moreover, in areas having labor shortages during the peak harvest period, delaying reaping past the optimum date reduces grain yield and quality (6). This problem is particularly serious in areas where typhoons hamper harvest.

History indicates that reaping changes from a manual operation to a mechanized operation when the cost of labor increases to the point that machine use is more economical (2). Japan exemplifies this change, and similar trends are occurring in Malaysia, Taiwan, and Korea. On the other hand, mechanical reapers used in middle- and high-income countries are too costly to be economically viable in low-income, developing countries. Furthermore, these reapers are generally too large for small farms, too heavy for waterlogged fields, insufficiently durable for intensive use, difficult to maintain, and costly to repair.

Numerous efforts to develop a simple, low-cost reaper appropriate for small farms in developing countries have not been particularly successful. However, a reaper developed in the People's Republic of China (1, 9) may be a breakthrough. It has recently been modified by several institutions (11, 12, 17) to adapt it to conditions in developing countries.

This paper summarizes International Rice Research Institute (IRRI) experiences in adapting and promoting the Chinese reaper in the Philippines. We describe the collaboration of the Chinese Academy of Agricultural Mechanization Sciences (CAAMS) and IRRI to modify the original Chinese reaper design so it better suits agricultural and industrial conditions of developing countries in South and Southeast Asia. This collaboration is a unique illustration of the potential benefits of technology transfer and cooperation between countries and international organizations.

We then briefly summarized the promotion of the CAAMS-IRRI reaper in the Philippines by the Ministry of Agriculture and Food (MAF) and IRRI. This collaboration directly involves local manufacturers.

We also report results of technical and socioeconomic surveys to evaluate the extension, performance, and impact of the reaper in the Philippines.

Finally, we pull together the lessons learned from this experience, including suggestions for future work in the Philippines and other developing countries.

DEVELOPMENT OF THE CAAMS-IRRI REAPER

Development of the vertical-conveyor reaper in China began in the early 1960s (1, 9). The advantages of this design compared with the conventional horizontal or inclined conveyor designs are light weight, simple construction, and ease of front-mounting on small two-wheel and four-wheel tractors to improve maneuverability in small fields. Improvements were made during the 1960s and 1970s, and the design illustrated in Figure 1 was manufactured in China beginning in the late 1970s. There were two principal innovations: (Fig. 2)

1. Lugged V-belts and star wheels gather the crop and feed it to the cutting mechanism. The star wheels also hold the crop during cutting and then help feed the cut crop into the conveyor. The V-belt and star wheels are driven (rotated) by direct contact with the moving lugs of the conveyor belt.



1. Mechanical reaper developed in the People's Republic of China.

2. The conveyor consists of two flat belts with lugs suitable for transporting the cut crop laterally across the reaper to the side where it is gently released to fall into a uniform windrow on the ground. The cut crop is held against the conveyor belt by pressure springs.

During a visit to China in the late 1970s, an IRRI engineer observed the Chinese reaper and was enthusiastic about its potential applications in developing countries. This led to the agreement between CAAMS and IRRI to collaborate in modifying the design for small rice farms in South and

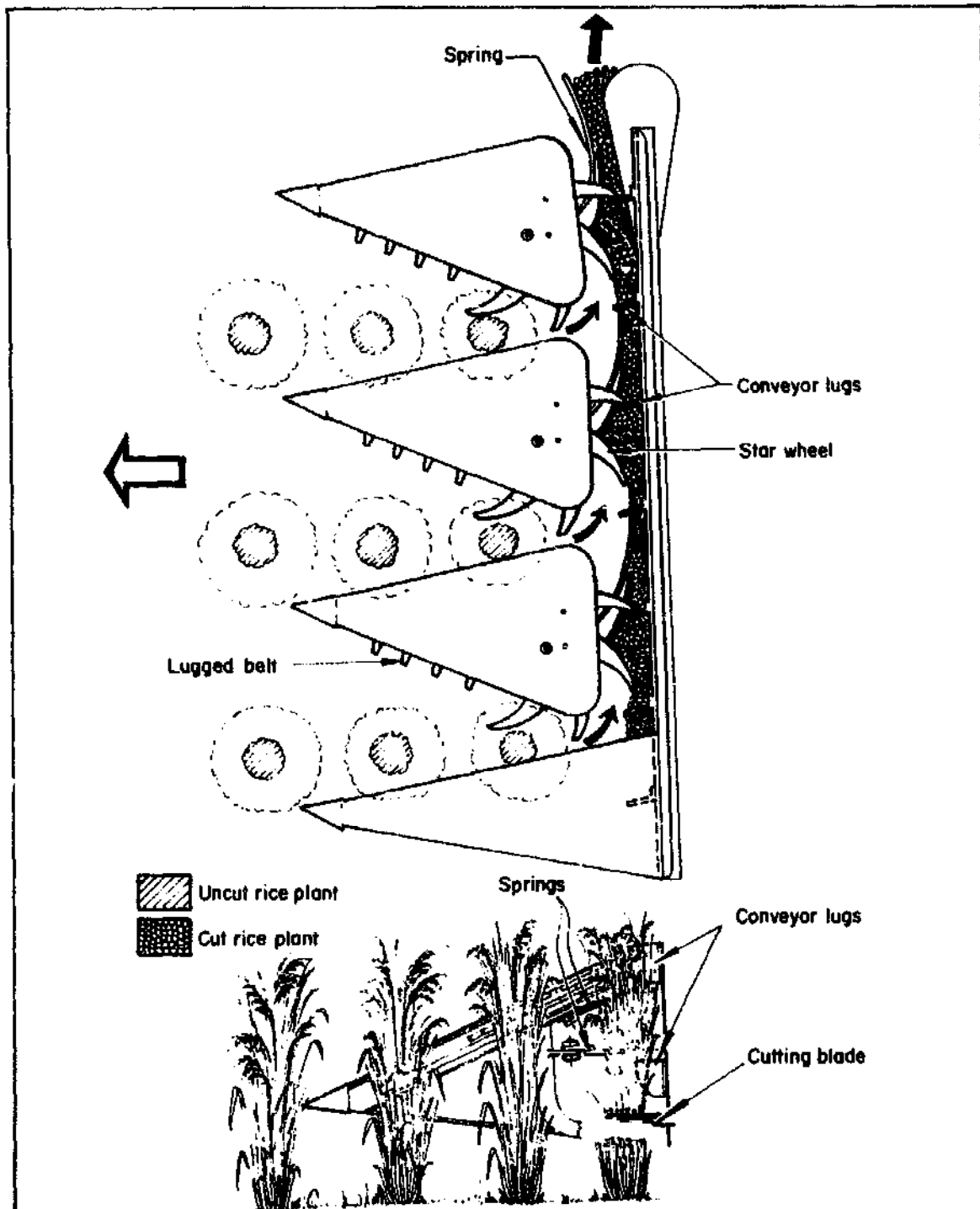

2. Schematic illustration of principal components of the Chinese reaper.

Southeast Asia. In 1980 three Chinese engineers worked with IRRI engineers in the Philippines to develop a simplified reaper which was lighter, less expensive, and easier to fabricate with shop tools, materials, and components (bearings, belts, etc.) generally available to small-scale manufacturers in the Philippines and other developing countries. The design eliminated the lugged V-belts and simplified the power take-off, conveyor drive, and cutter mechanism (11, 17). The reaper unit was designed as an attachment for hand tractors which are also used for plowing, transport, and other operations. Two models were developed: the 1.0-m-wide unit fits the IRRI PT5 hand tractor, and the 1.6-m-wide unit matches larger conventional hand tractors.

EXTENSION OF THE CAAMS-IRRI REAPER IN THE PHILIPPINES

MAF-IRRI program

In 1981, MAF-IRRI started collaboration to develop and extend agricultural equipment appropriate for small farms and produced by local industry in the Philippines (14).

Over 200 manufacturers have become cooperators in the MAF-IRRI program by signing a memorandum of agreement. These cooperators, located throughout the Philippines (Fig. 3), range from small blacksmith and metalcraft shops to large-scale industries. Special attention is given to manufacturers located in agricultural areas, thereby ensuring availability of parts and service while creating rural employment and stimulating innovations and adaptations to local conditions and farmer preferences. The MAF-IRRI program provides manufacturers with agricultural equipment designs, training, and technical assistance. In turn, the cooperators agree to provide annual production statistics and to sell units only after testing and authorization by MAF-IRRI.

The program organized workshops for farmers, agricultural technicians, and R&D engineers to help identify priorities for small farm equipment in the Philippines (10). Identified as high priority was a mechanical reaper suitable for small rice farms in areas having labor shortages at harvest time. Consequently, the program began promoting the CAAMS-IRRI reaper to cooperating manufacturers in 1982. The 1.0-m reaper was chosen over the 1.6-m model because of lower cost and better maneuverability in small fields. A copy of the promotional leaflet for the 1.0-m reaper (Annex A) provides the technical specifications. Because of its light weight and low cost, the reaper could minimize problems encountered with imported reapers — which Philippine rice farmers did not accept — and could compete with similar machines recently imported from Japan.

Selection of target areas

The first task was to identify Philippine areas where the reaper might be appropriate, i.e., areas where labor shortages lead to significant delays in harvesting. Mindanao and the Cagayan Valley (principally Isabela) were selected as the priority areas for reaper extension.

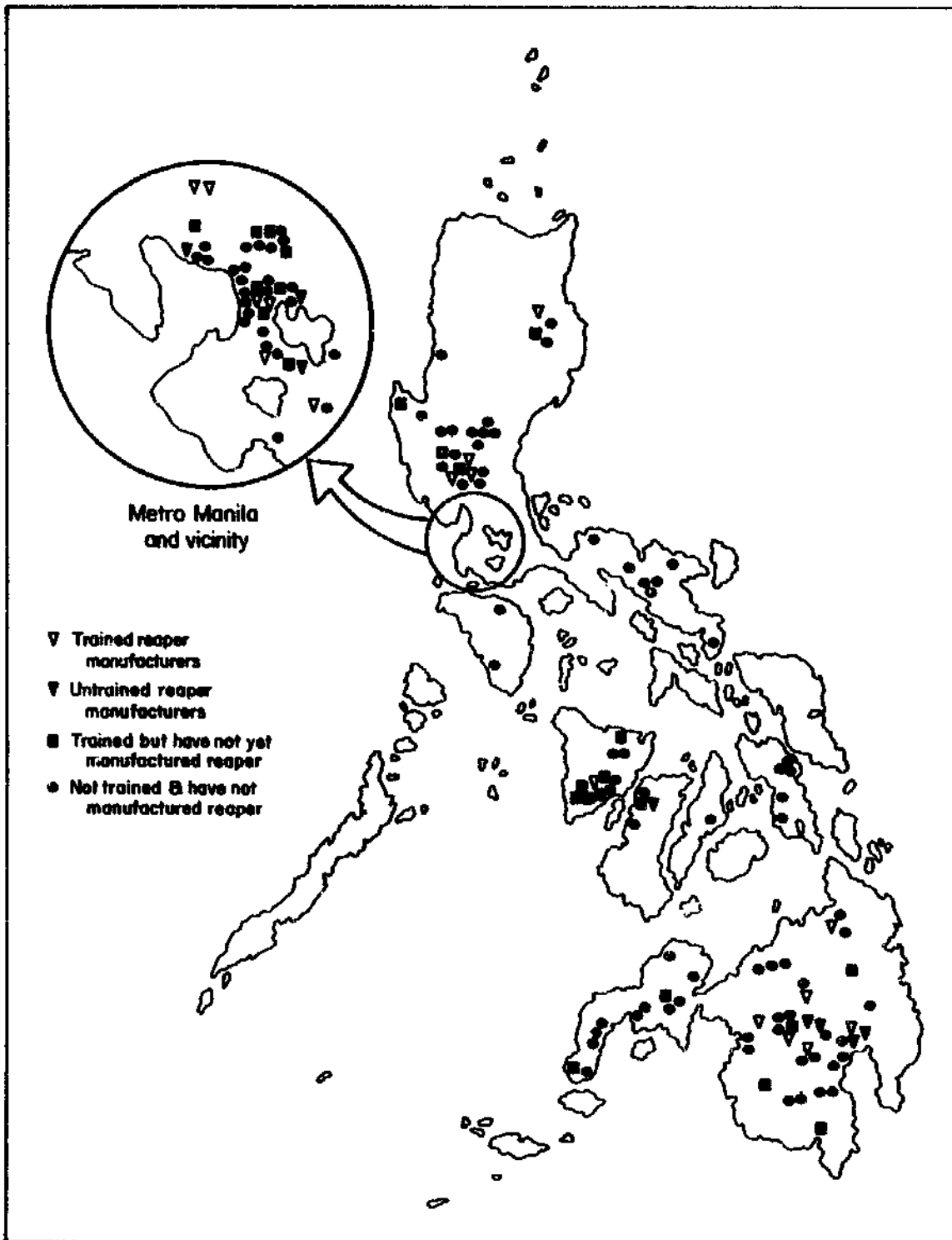

3. Geographical location of cooperating manufacturers of the MAF-IRRI industrial extension program for small farm equipment.

Field demonstrations, evaluations, trials

The second step was to conduct field demonstrations and evaluations of the reaper in the major rice-producing areas of Mindanao and the Cagayan Valley. The MAF-IRRI Regional Project engineers in these areas are regular employees of the Ministry's regional offices and experiment stations, and

devote part of their time to the MAF-IRRI program. They were vital to the coordination of the demonstrations, particularly in ensuring that the attendees included outstanding farmers, leaders of cooperatives, local manufacturers, agricultural extension technicians, and rural bank officials.

The demonstrations had these major results:

1. During evaluation sessions held immediately after the field demonstrations, most farmers stated that the reaper would be appropriate and beneficial in their areas;
2. Observing the enthusiasm of farmers for the reaper, many manufacturers became interested in fabricating it;
3. The MAF-IRRI engineers became better acquainted with the manufacturers of the area, thereby recruiting new cooperators and bringing technical assistance to those interested in fabricating the reaper.

Performance and durability of the reaper and hand tractor were intensively tested in Mindanao on a 370-ha farm where rice is grown continuously during the year. Reapers could be used regularly on up to 2.5 ha/d, 6 d a week, throughout the year. The test results served as the basis for modifying the reaper and hand tractor to improve operation and durability.

Training courses

A 2-d intensive training course on fabricating the reaper and hand tractor was given twice in Manila during 1982 for cooperating manufacturers and MAF-IRRI engineers. It was designed to help trainees to understand a) the blueprints for the reaper and hand tractor, b) the main steps of fabrication and assembly, c) operation, maintenance, and repair, and d) the economics of fabrication and reaper use.

All 68 cooperators in the program were invited to attend the first course (Feb 1982). Twenty-four (35%) attended. Ten attendees had successfully fabricated at least one reaper and hand tractor by the end of the first survey (May 1983).

For the second course (Aug 1982), 86 of 110 cooperators who had not attended the first course, were invited. Nineteen (22%) attended, and 6 successfully fabricated at least 1 unit by survey time. Eleven cooperators who did not attend either training course had also fabricated at least one reaper and hand tractor.

Many attendees were from small-scale firms located in Mindanao and other areas far from Manila, the training site. The attendees paid for their transportation and lodging expenses, and the program provided them with blueprints and instruction materials.

Technical assistance and prototype testing

MAF-IRRI engineers periodically visit cooperating manufacturers to provide technical assistance in fabricating the reaper or other equipment (e.g., threshers and pumps) promoted by the program. If an engineer cannot provide the requested assistance, he contacts the MAF-IRRI central office for information or for help from an engineer familiar with the problem.

These are the most common forms of technical assistance given:

1. Helping manufacturers understand the blueprints and locate suppliers of special components (e.g., reaper blades).
2. Loaning the equipment (e.g., reaper) to manufacturers who have difficulty reading blueprints.
3. Performing the prototype test of the first unit fabricated by a manufacturer. This test determines if the unit has been fabricated and assembled correctly and if it functions properly in the field. It is also an opportunity to advise manufacturers on critical adjustments and operating procedures. The manufacturer who passes the prototype test is authorized to proceed with production.
4. Assisting manufacturers in field demonstrations for farmers (often at meetings of farmers organizations) and, in a few instances, in loan applications.
5. Maintaining two-way communication with manufacturers on both problems and improvements in design, fabrication, or operation of equipment promoted by the program.

TECHNICAL AND SOCIOECONOMIC EVALUATION OF THE CAAMS-IRRI REAPER

Reaper production statistics

Table 1 gives the number of CAAMS-IRRI reapers produced by MAF-IRRI cooperating manufacturers 1982-84. Production rose sharply in early 1983, but fell off during the second half of 1983 because of decreasing sales. Reasons for the disappointing sales are discussed in the following sections.

1983 survey

One year after reaper introduction, the program surveyed cooperating manufacturers to a) evaluate the impact of extension efforts, b) detect problems encountered by manufacturers and owner-operators, and c) determine the actions to be taken to overcome the problems. The main conclusions (7) follow:

1. Reaper introduction to manufacturers was rapid, with 27 firms successfully fabricating at least one unit within the first 15 mo.

Table 1. Production of CAAMS-IRRI reapers in the Philippines, 1982-84.^a

Year	Reapers produced (no.)	Reaper manufacturers (no.)
1982	68	18
1983	363	27
1984	40	12

^aBased on annual surveys of cooperating manufacturers of the MAF-IRRI Industrial Extension Program for Small Farm Equipment.

2. Fabrication of the reaper and hand tractor was sufficiently simple for small manufacturing firms having limited capital, personnel, and equipment (Table 2).
3. Many firms, including small firms in agricultural areas far from Manila, were willing to devote their own money and time to attend the reaper training course.
4. Although the training course helped introduce the reaper to firms it was not indispensable in all cases because 41% of the initial reaper manufacturers did not attend the course. Many of these untrained reaper manufacturers either purchased reapers to copy or hired experienced reaper fabricators (Table 3).

Table 2. Classification of cooperating firms according to assets, labor, reaper training, and reaper manufacturing^a. Data expressed as percentages.

Range	Percent			
	All cooperators (124)	Trained cooperators ^b (30)	Reaper manufacturers	
			Trained (16)	Untrained ^c (11)
Capital assets^d				
< \$10,000	44	40	31	45
\$10,001 to \$100,000	44	37	38	27
\$100,001 to \$400,000	10	13	25	9
> \$400,000	2	10	6	18
Labor (no. of employees)				
< 5	29	20	31	36
6 to 15	45	53	31	18
16 to 50	21	13	19	36
> 50	6	13	19	9

^aData as of 1 Mar 1983. Numbers in parentheses represent firms in the sample. ^bThose who attended the reaper training course. ^cThose who have fabricated at least one reaper without attending the training course. ^dApproximate conversion rate: ₱10 = US\$1 in early 1983.

Table 3. Principal methods used by reaper manufacturers in fabricating their first prototype units^a (7).

Method	Manufacturers (no.)	Percentage
Followed blueprints provided by MAF-IRRI	11	41
Utilized reaper loaned by MAF-IRRI ^{a, b}	8	30
Utilized reaper purchased by firm ^b	6	22
Hired services of experienced reaper fabricator ^b	2	7
Total	27	100

^aMAF-IRRI loaned reapers only to manufacturers in the target areas: Mindanao and Cagayan Valley. ^bAlso utilized blueprints provided by MAF-IRRI.

5. Since most reaper manufacturers were unable to fabricate a machine from engineering drawings alone, the program loaned them reapers to copy.
6. Manufacturers identified aspects of the reaper design, fabrication, and operation which should be improved (Table 4). Several manufacturers made improvements (7).
7. Reaper sales were extremely low, primarily because of the depressed economic conditions of Philippine rice farmers. Furthermore, farmers were understandably reluctant to buy a new machine of unproven performance and durability, or which may cause problems with hired farm workers.
8. This early survey provided only preliminary information on sales but no direct information on buyers (farm size, location, cropping intensity, etc.) or on use (e.g., only on owners' farms, contract work on other farms, costs and returns, use rate [ha/yr], and labor displacement). Fernandez et al (7) recommended that a second survey be conducted in 1984 to obtain data on buyers and use, including a study of the positive and negative impacts of the machine on those who own reapers, those who hire reapers, and laborers who are displaced by reapers.

1984 surveys

IRRI economists and engineers collaborated in 1984 to study the status and potential impact of the reaper in the Philippines (13, 16). The first step was to visit reaper manufacturers and dealers. This verified that sales of CAAMS-

Table 4. Manufacturers' suggestions on improvements of the CAAMS-IRRI reaper^a (7).

Suggestion	Frequency ^b
Increase width of cutter bar to 25 mm (1 inch)	7
Provide clutch to disengage reaper from hand tractor PTO	6
Modify reaper skid to reduce bumping and facilitate turning	4
Improve maneuverability of machine	3
Change hand tractor clutch lever to motorcycle type	3
Increase diameter of vertical shaft of reaper	3
Modify transmission or pulley ratios to reduce forward speed of machine	2
Eliminate need for twisted V-belt between PTO and reaper	2
Reduce problem of straw wrapping around star wheel shaft	2

^aBased on responses of 27 reaper manufacturers, some of whom have made more than one suggestion. ^bThe number of manufacturers who have either suggested the particular improvement or actually incorporated the improvement in their unit.

IRRI reapers had declined markedly in late 1983 and throughout 1984. The principal reasons given for the decline (13) follow:

1. *Technical problems.* The major technical problem was that cutter knives often became dull after reaping only 5-20 ha. This was especially serious because knives are costly imported items and are difficult to sharpen or replace without the help of an experienced mechanic. Main causes of dulling are a) insufficient rigidity of the cutting mechanism due to deviations from the specified materials or dimensions; b) improper assembly and adjustment of the cutter, producing faulty knife alignment and clearance; and c) failure of reaper owners to check and adjust knife clearances at appropriate intervals. Of the remedies undertaken by MAF-IRRI, the most difficult task will be training manufacturers, repair shops, and owners to adjust and sharpen the knives at appropriate intervals. Other technical problems are easier to correct, such as improving the useful life of the star wheels, pitman arm, flat conveyor belts, and V-belt (13).

2. *Performance limitations.* The reaper was not acceptable in fields which cannot be drained before harvesting because the cut crop will be laid in the water and the grain will become wet. The reaper's performance was also unacceptable in fields having excessive weeds or deep, soft mud.

3. *Socioeconomic problems.* Since many farm laborers earn much of their total annual income from manual reaping, some farmers and manufacturers decided against using mechanical reapers which displaced labor. We were told of laborers protesting against the reaper either by threatening to boycott the farm (i.e., refuse to provide labor for transplanting, weeding, and other farm operations) or by sabotaging the reaper (e.g., putting metal bars in the rice field to damage the cutter).

We did not survey owners of CAAMS-IRRI reapers: they were spread over a wide area and the reapers had not been used significantly as most owners were part-time farmers with above average incomes. We were unable to find reaper owners who were using their machines intensively on a contract-hire basis as is common with the axial-flow thresher.

As an alternative we surveyed owners of the Kubota AR120 reaper which were most conveniently concentrated in the province of Bataan (16). The AR120 reaper is based on the CAAMS-IRRI design but has a 1.2-m cutting width and involves a much higher level of technology: lightweight materials and die-cast components, a transmission with forward and reverse gears, and a drive shaft with a clutch for transmitting power from the engine to the reaper assembly. The AR120 is designed only for reaping and cannot be used for plowing or other operations.

Bataan has features favoring reaper acceptance: a) farm labor is scarcer than in most Philippine areas because of employment opportunities at the Bataan industrial complex (export processing zone), the nearby US Navy base, and construction projects such as the country's first nuclear power plant; b) many Bataan workers have overseas employment and use their savings to finance businesses in Bataan, such as purchasing reapers to be hired out on a contract basis; c) since much of the rice area in Bataan is irrigated, farmers wish to

reduce the time required for harvesting so that the next crop may be planted with minimum delay; and d) the Kubota dealer who is highly respected in Bataan, initially offered the reaper on a trial basis, providing reliable service parts and repair.

During 1982-84 the dealer sold more than 100 AR120 reapers. The 1984 survey (16) included 15 owners of AR120 reapers, 41 farmers who have hired the reapers, 37 farmers who hired manual labor rather than mechanical reapers, and 58 laborers who earned part of their income by manual reaping.

Results show owners used their reapers on an average of 45 ha/yr, with only 6% of total use on their own farms. Therefore, reapers were primarily used (94%) to earn income from contract hiring to reap for other farmers. Reaper owners usually charged farmers an average of \$22/ha (P309/ha, converted at P14=\$1, the exchange rate in late 1983 and early 1984), with the owners providing the machine, fuel, operator, and helpers. This fee was slightly lower (12%) than the average cost of manual reaping.

The main reasons surveyed farmers preferred the mechanical reaper to manual labor are the difficulty in hiring labor and the speed of the reaper (Table 5).

Most reaper owners were very satisfied with the AR120, and a few purchased two or three units. Their main complaint was that the reaper blades became dull easily and had to be sharpened or replaced. Kubota provided instructions and training on blade sharpening. New blades (\$165/set) were purchased by 82% of the owners after an average of 49 ha of use.

Owners found the reaper's performance unsatisfactory when fields had deep mud or were small, flooded, weedy or densely seeded, or when crops were lodged or wet (Table 6). In severe lodging, flooding, or deep mud, farmers resort to manual reaping.

The surveyed owners preferred the AR120 to the CAAMS-IRRI reaper because it is easier to operate and to transport, provides more space between windrows, and is more reliable because of its higher quality and excellent service from the Kubota dealer. The price of the AR120 is substantially higher

Table 5. Principal reasons for 41 Bataan (Philippines) farmers' decisions to hire mechanical reapers instead of manual labor, 1984 dry season (16).

Reason	Percent responding
It is difficult to hire laborers for manual reaping.	28
Mechanical reaping requires shorter time.	27
Mechanical reaping is less expensive.	12
Paddy cut by mechanical reaper dries more rapidly.	10
Other reasons and unclear responses	23

Table 6. Responses of 15 Bataan (Philippines) reaper owners regarding adverse effects of field conditions, crop conditions, and season on suitability of AR120 reaper, 1984 (16).

Condition	Frequency of response
Adverse field conditions	
— deep mud	12
— weedy field	12
— small field	8
— high levees	1
Adverse crop conditions	
— lodged crop	13
— low height of crop	10
— wet crop	9
— densely planted	8
— direct seeded	8
— unfavorable variety	1
Adverse conditions for wet season crop versus dry season crop	
— flooded fields	4
— lodged crop	3
— deep mud	3
— wet crop	2

than that of the locally produced reaper — \$2,400 versus \$1,400 in mid-1983 (\$1 = ₱10) — and its replacement parts are more expensive. However, owners felt this difference was more than offset by the AR120's superior operation and durability. The price difference would have been even greater if exchange rates and tariff structures had not been so favorable for imported equipment during this period. This illustrates how government policies can discourage local production by subsidizing imports (4). Fortunately, the Philippine Government has recently taken steps to correct this problem.

In late 1982 and early 1983, owners found the reaper to be a highly profitable investment; some informally reported reaper earnings were sufficient to pay off investments in less than 1 yr. However, the situation has since changed markedly with devaluation of the currency (from ₱8.50/\$1 in 1982 to ₱18.50/\$1 in August 1985), restrictions on importation, sharp increases of interest rates to 40% or higher.

Economic analysis indicates the AR120 is not a profitable investment under present conditions (16). To illustrate this point, we have computed the break-even curve for a range of values for interest rates and initial costs of the reaper (Fig. 4). The computation is based on these assumptions: the contract rate is ₱400/ha for either mechanical or manual reaping; for mechanical reaping, 25% of the contract rate goes to labor and ₱50/ha to fuel and oil; annual costs for taxes, insurance, repair and maintenance are 7% of the initial cost of the reaper; the reaper is used on 45 ha/yr and has an estimated life of 5 yr. As seen in Figure 4, the AR120 reaper was profitable (i.e., well below the break-even curve) in late 1982-early 1983 when interest rates were 20-30% and the average price for the reaper was about ₱18,000. In 1985, interest rates increased to 40%

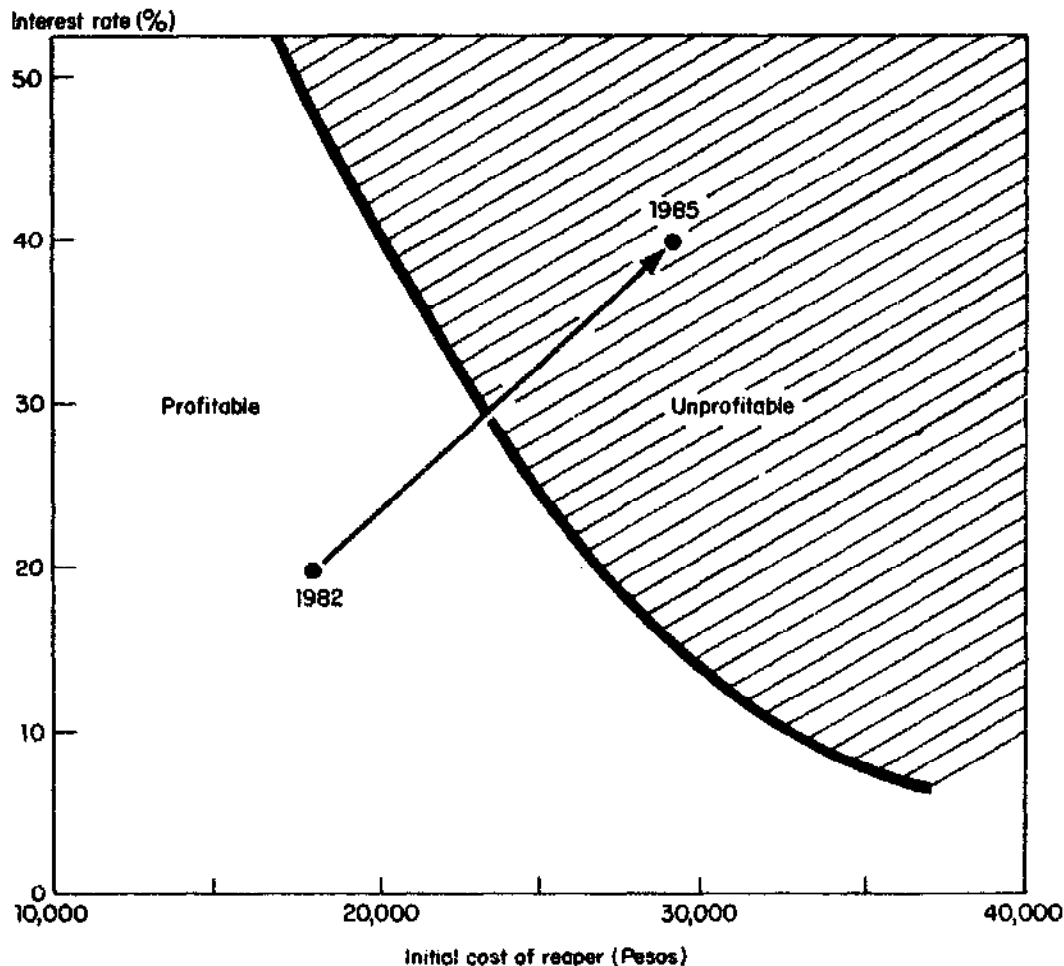

4. Approximate illustration of change of profitability of AR120 reaper in the Philippines, 1982-85.

or higher and AR120 price is at least ₱29,000, thereby causing the reaper to be unprofitable. This result is consistent with sharply falling AR120 sales. The devaluation and import restrictions should favor sales of locally produced CAAMS-IRRI reapers, but these effects have been overpowered by high interest rates, inflation, and low wages for labor used for manual reaping.

Since labor displacement was a principal consideration in the survey of Te et al (16), farmers were asked to estimate the amount of labor required for manual and mechanical reaping. The average values were 17 d/ha for manual reaping and 2 d/ha for mechanical, indicating a labor displacement of 15 d/ha. This indirect estimate is substantially higher (15 versus 10 labor d/ha) than direct measurements obtained in an earlier study in Mindanao (8). But in both cases, labor displacement is sufficient to markedly reduce employment.

The Bataan survey of farm laborers indicates that manual reaping provides an average of 22% of total annual household income, and this income component has declined by 47% since the introduction of the mechanical reaper in 1982. Their average household income is \$760/yr (₱10,060 then), with 29% of the samples falling below \$360/yr. An average of 72% of their total income is from work as hired laborers on rice farms. Sixty-nine percent are

landless, and the remainder have small farms (av size 0.9 ha). Only 14% of these laborers work more than 200 d/yr, indicating substantial under-employment. In 46% of the surveyed laborer households, some alternative employment helped compensate for the decline in manual reaping opportunities; however, only 40% reported sufficient new income to counterbalance the loss in income from reaping. Reaper impact has been most severe for the lower income households (i.e., below \$360/yr) who are less capable of finding equivalent income opportunities.

A detailed study of one community of farm workers in Bataan indicates that the number of seasonal migratory laborers from other provinces has declined markedly since the introduction of the AR120 reaper and that community members tend to migrate readily to other areas (rural or urban) to find employment opportunities (3).

SUMMARY AND CONCLUSIONS

The experiences with the CAAMS-IRRI and Kubota AR120 reapers in the Philippines show how technical and socioeconomic factors combine to influence the degree of acceptance of new technology. In this case, the reaper was a radically new technology compared with the labor-intensive manual reaping. Although history generally indicates that extreme changes of this nature are, at best, slowly accepted, we initially expected that the CAAMS-IRRI reaper might prove to be an exception because a) farmers were extraordinarily enthusiastic about it at field demonstrations; b) manufacturers were eager to attend the training courses, and many were able to fabricate units shortly thereafter; c) preliminary economic analyses indicated that the machine was highly profitable in areas where there are labor shortages at harvest time; and d) results of an intensive field test on a continuous cropped farm in Mindanao indicated that the reaper's performance and durability were satisfactory, although the machine required careful maintenance and repair. After a brief period of encouraging sales during late 1982 and early 1983, however, farmer acceptance fell off due to a combination of factors:

1. *Limited utility.* Farmers recognized that mechanical reapers are not as versatile or dependable as manual reaping. The reaper cannot be used in fields having lodged crops, excessive water, or mud frequently present in typhoon-prone areas. The reaper's utility is further reduced by mechanical problems (e.g., dull cutter knives or broken drive mechanism) which occur without warning and delay harvesting while repairs are being made. Philippine rice farmers generally have small farms, limited savings, and uncertain agro-climatic conditions; they cannot risk adopting radically new technology with limited utility and dependability unless there are overpowering economic benefits.

2. *Undesirable labor effects.* Although most farmers have complained about the cost, scarcity, and inconvenience of hiring laborers for manual reaping, many have decided against adopting the mechanical reaper because of their moral concern for displaced laborers or their fear of forceful reactions by

laborers, such as sabotage or boycotts. At present, this concern is a real issue in the Philippines because of the economic recession or rising underemployment, and increasing reprisals by armed groups of dissidents.

3. *Unfavorable economic conditions.* Although preliminary analyses in 1981 suggested that the reaper would be economically viable in the Philippines (10), conditions changed markedly during 1981-85 due to inflation, devaluation, rising interest rates, and a decline in the real cost of labor. Considering these changes, Te et al (16) concluded that the reaper is no longer a profitable investment in most Philippine areas.

Although our engineers and cooperating manufacturers can devise improvements to reduce the technical problems with the reaper, we do not expect that this will significantly increase its acceptability under present Philippine socioeconomic conditions. A few areas like Bataan may be exceptions. Because of widespread underemployment in the country, the Philippine Government should further its recent efforts to avoid policies (e.g., import and credit subsidies, overvaluation of local currency) which subsidize machinery at the expense of labor (4).

This study illustrates how strongly the acceptance of technology depends upon socioeconomic conditions. Initially during the development of the reaper, some persons were concerned that the machine's performance was so extraordinary that acceptance would be rapid and widespread, thereby causing serious unemployment of landless laborers. We now see that the reaper is not so extraordinary that it will be widely accepted in areas where farm labor is cheap (roughly \$1.50/d) and underemployed. On the other hand, we believe that the CAAMS-IRRI reaper will gain increasing acceptance in the Philippines when the economy recovers and labor costs begin to rise. This trend has been consistent throughout the history of agricultural mechanization (2).

IRRI and RNAM have disseminated information on the CAAMS-IRRI reaper to developing countries, in some cases with prototypes for evaluation under local conditions. Although the reaper has not been significantly accepted in areas of small rice farms, it has had substantial sales in several wheat areas of Pakistan and India (Punjab). The case of Pakistan, described in the paper by Butt and Rahman, illustrates the importance of adapting the basic design to the particular needs and conditions of the area. In China, the reaper has also been more readily accepted for wheat than for rice (1, 9). Rice areas present a more difficult challenge to the reaper because fields are smaller and more subject to flooding and the crop is more apt to lodge.

REFERENCES CITED

1. Bai Ling. 1985. Wheat and paddy reapers in China. Pages *in* Small farm equipment for developing countries. International Rice Research Institute, Los Baños, Philippines.
2. Binswanger, H. P. 1982. Agricultural mechanization: a comparative historical perspective. Paper presented at the ADC conference on mechanization of small-scale farms: economic and social implications. Hangzhou, China, 22-26 Jun 1982.

3. Crissman, L. 1985. Livelihood among landless laborers after introduction of mechanical reapers. Seminar paper, International Rice Research Institute, Philippines.
4. David, C. C. 1983. Government policies and farm mechanization in the Philippines. Proceedings of the Workshop on the consequences of small rice farm mechanization in the Philippines. Development Academy of the Philippines, Tagaytay City, Philippines, 1-2 Dec 1983.
5. De Datta, S. K. 1981. Rice production principles and practices. John Wiley & Sons, New York. 514 p.
6. Duff, B. 1979. Grain losses in small farm rice post-production systems in the Philippines. International Rice Research Institute, Philippines.
7. Fernandez, C. P., H. T. Manaligod, and R. E. Stickney. 1984. Introduction of the CAAMS-IRRI mechanical reaper in the Philippines. *Philipp. Agric. Eng. J.* 15(1):3-9.
8. Lingard, J., P. Moran, and R. E. Stickney. 1981. Unpublished study of manual and mechanical reaping, International Rice Research Institute, Los Baños, Philippines.
9. Ma Ji. 1980. Research and development on a wide swath vertical-type reaper with star wheel lifters. Paper presented at the Second subnetwork workshop on cereal harvesters. Regional Network for Agricultural Machinery, Los Baños, Philippines, 5-8 Aug 1980.
10. MAF-IRRI (Ministry of Agriculture and Food -International Rice Research Institute). 1982. Report, Workshop on small farm equipment R&D, Maligaya, Muñoz, Nueva Ecija, Philippines. 3-4 Dec 1981.
11. Manalili, I., Ma Ji, and B. Duff. 1981. Technical and economic factors in adapting mechanical reapers to small rice farms. Pages 96-108 in Proceedings of the regional seminar on appropriate mechanization for rural development with special reference to small farms in the Asean countries, 26-31 Jan, Jakarta, Indonesia.
12. RNAM (Regional Network for Agricultural Machinery). 1983. Testing, evaluation and modification of cereal harvesters. Tech. Ser. 14. Economic and Social Commission for Asia and the Pacific, RNAM, Los Baños, Laguna, Philippines.
13. Salazar, G., and R. E. Stickney. 1984. Unpublished reports.
14. Stickney, R. E., B. C. Gonzalo, and C. W. Bockhop. 1984. Extension of small-farm equipment in the Philippines. Paper presented at the Chinese Academy of Agricultural Mechanization Sciences, Beijing, People's Republic of China, Oct 1984.
15. Taneja, M. L. 1963. Harvesting of rice in India. Paper presented at the workshop on agricultural engineering aspects of rice production. International Rice Research Institute, Los Baños, Philippines, 11-17 Aug 1963.
16. Te, A., F. Juarez, C. Bantilan, and B. Duff. 1985. Assessing the impact of mechanical reapers on employment, income, and production in the Philippine rice sector. Paper in preparation, International Rice Research Institute.
17. Tianco, V. M., M. S. Diestro, and M. L. Nafziger. 1982. Critical design parameters and development of CAAMS-IRRI reaper. Paper presented at the 32d annual convention of the Philippine Society of Agricultural Engineers, Philamlife Auditorium, Ermita, Manila, 29-30 Apr 1982.
18. Toquero, Z. F., and B. Duff. 1974. Survey of post-production practices among rice farmers in Central Luzon. Saturday Seminar, 7 Sep, International Rice Research Institute, Los Baños, Philippines.

ANNEX A

CAAMS*^{*}-IRRI 1.0m reaper



Harvests paddy of different varieties

FEATURES:

- HIGH CAPACITY 2.4 hectare per day
- LOW HORSEPOWER REQUIREMENT 3-hp engine
- LOW LABOR REQUIREMENT One to three men to operate, prepare plots and gather crop
- EASE OF OPERATION Simplicity of design - reduces operation and maintenance problem.
- HIGHLY MOBILE Can be operated and carried with ease

* CHINESE ACADEMY OF AGRICULTURAL MECHANIZATION AND SCIENCES

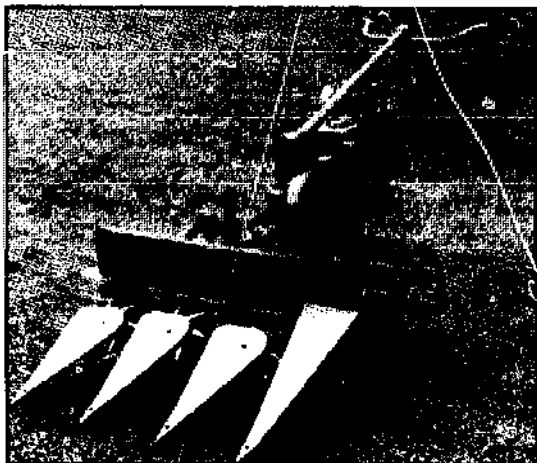

Compact design

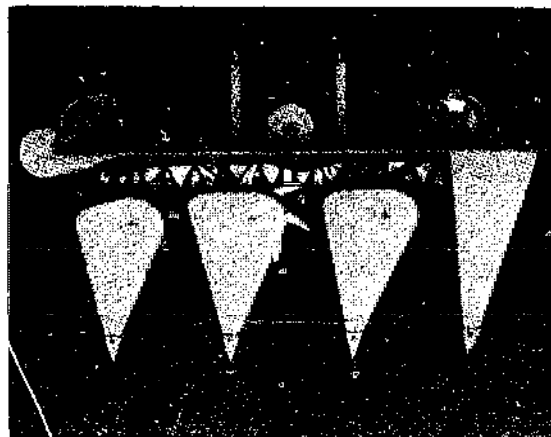

Reaper is adaptable to other hand tractor unit

Machine specifications:

POWER	3 hp gasoline engine
WEIGHT OF REAPER-TILLER UNIT	135 kg
WEIGHT OF REAPER ALONE	48 kg
TOTAL LENGTH OF REAPER PLUS 3 HP TILLER	218 cm
TOTAL WIDTH	117 cm
TOTAL HEIGHT OF 3 HP TILLER, MINIMUM	90 cm
FIELD CAPACITY	2.4 hectare per day
FIELD LOSSES	Less than 1%
MINIMUM CUT	7 cm
FORWARD SPEED	2.5 to 4.5 kph
KNIFE AVERAGE SPEED	1.3 x forward speed
CONSTRUCTION	All steel except the nonmetallic star wheels
ADJUSTMENT	Throttle (synchronized with cutting speed), flat belt tension, windrow deflector
FUEL CONSUMPTION	Approximately 1 liter per hr

For further information write

Agricultural Machinery Development Program
International Rice Research Institute
P O Box 933, Manila, Philippines
Cable: RICEFOUND, MANILA

THE TRACTOR-MOUNTED REAPER IN PAKISTAN

Z. U. RAHMAN

Regional Network for Agricultural Machinery
and

K. M. BUTT

Sayyed Machinery Limited, Lahore, Pakistan

For the last quarter century, Pakistan has been undergoing a gradual transformation from traditional methods of agriculture to mechanized farming. In the 1960s, tractors were imported in substantial quantities and mechanized tillage was introduced. In the mid-1970s, the early onset of monsoons and the migration of farm labor to the urban centers and the Middle East necessitated mechanization of wheat threshing. Today, over 40% of the land is mechanically tilled, and almost 100% of the wheat crop is threshed mechanically. These experiences illustrate the following mechanization patterns; farmers will mechanize first those operations which

- are labor intensive;
- are critical in timing (such as timely harvesting to protect from inclement weather, or to prepare land for the next crop); and
- provide substantial monetary benefits and for which appropriate machines (including service) are readily available to perform the tasks effectively and efficiently.

Thus, after mechanizing tillage and wheat threshing, the next logical operation to mechanize in Pakistan is harvesting. At present only wheat reaping is mechanized since labor shortage is not so severe during rice harvest. Also, rice harvesting involves a contract for both cutting and threshing. No suitable thresher is in popular use yet, so mechanical reaping of paddy is still in the future. The following factors created an immediate need for a suitable reaping machine:

1. Farm labor available in abundance a decade ago was becoming scarce and expensive because of migration to other countries and to urban industrial areas within the country.
2. Due to use of high yielding varieties and other inputs like chemical fertilizers, pesticides, irrigation water, etc., wheat production increased substantially.
3. Wheat reaping was one of the most tedious, time-consuming, tiring operations in harvesting, so farmers began to look for easy alternatives.
4. The harvesting season is short, and with bad weather, crop loss is likely. A quick method of reaping and harvesting is a *must* in such a situation.

5. The tractor population had increased rapidly; therefore, the power for mechanical reaping was available.

Efforts to develop a suitable wheat harvester in Pakistan started in the late 1970s. As a condition for receiving a commercial loan, the Agricultural Development Bank of Pakistan (ADBP) required one large manufacturer to develop and popularize a mechanical harvester, perceived at that time to be badly needed (10). The Agricultural Mechanization Research Institute (AMRI) in Multan was also assigned to develop such a machine.

In 1980, the RNAM Project, under its subnetwork on harvesters, supplied each participating country with a commercial unit of the Chinese vertical reaper. Adaptation work on the reaper in Pakistan did not start until after engineers from the Farm Machinery Institute (FMI), Islamabad, visited IRRI in mid-1981 and observed the 1-m machine in operation. Thus, there were three simultaneous efforts to develop and introduce a suitable reaping machine in Pakistan in the early 1980s. The most successful has been the Chinese vertical reaper.

Two prototypes of the Chinese vertical reaper were fabricated in 1981. One was a power tiller-mounted 1.0-m machine, much like the one adapted at IRRI. The other, a 2.0-m tractor front-mounted machine, was a redesigned version powered from the PTO shaft. Both operate similarly: as the tractor moves forward and the reaper power is engaged, the inclined star wheels (driven by lugs on a flat belt conveyor) hold the crop, the cutter bar cuts it, and the two conveyor belts convey it vertically to the side. The tractor's hydraulic system operated the lifting mechanism. The 2.0-m width was later increased to 2.2 m, now the standard width for most tractor-mounted reapers made in Pakistan.

REAPER DEMAND

After successfully testing the first prototype in the fall of 1981, engineers decided to survey the demand for the reaper. Survey data were collected in early 1982 and the results published in 1983. Because few imported combine harvesters and reaper binders were operating, mostly on large farms, most farmers had never seen one. Therefore, surveyors described these machines to the farmers and got their reactions. The FMI is planning a follow-up survey.

Table 1 (5) gives the farmer demand for reapers; 61% of the tractor-owner farmers in Pakistan indicated that they would be willing to buy such a machine. Since there were nearly 120,000 tractors (mostly 45 hp, some 65 hp) in the country then, this put the total reaper demand countrywide at over 70,000 machines. Only 12% of the nontractor owners showed willingness to buy the machines. Figure 1 (5) indicates that the percentage of farmers wanting to hire the machine was much greater. Thus, there was great potential for commercializing the reaper in Pakistan.

ECONOMIC ANALYSIS

Cost analysis of the mechanical reaper was undertaken and cost compared with

Table 1. Farmer demand for reapers.

Category	Farmers (%)				
	Punjab	Sind	Baluchistan	NWFP	Pakistan (mean)
Size of holding					
>20 ha	64	30	57	37	50
10 < 20 ha	40	22	33	40	35
5 < 10 ha	15	16	38	38	28
<5 ha	4	3	13	14	5
Tenure					
Owner	20	22	39	34	25
Owner-tenant	20	5	67	—	20
Tenant	9	—	24	—	5
Tractor ownership					
Owner	64	53	67	55	61
Nonowner	9	6	33	23	12
Overall mean	19	10	37	27	19

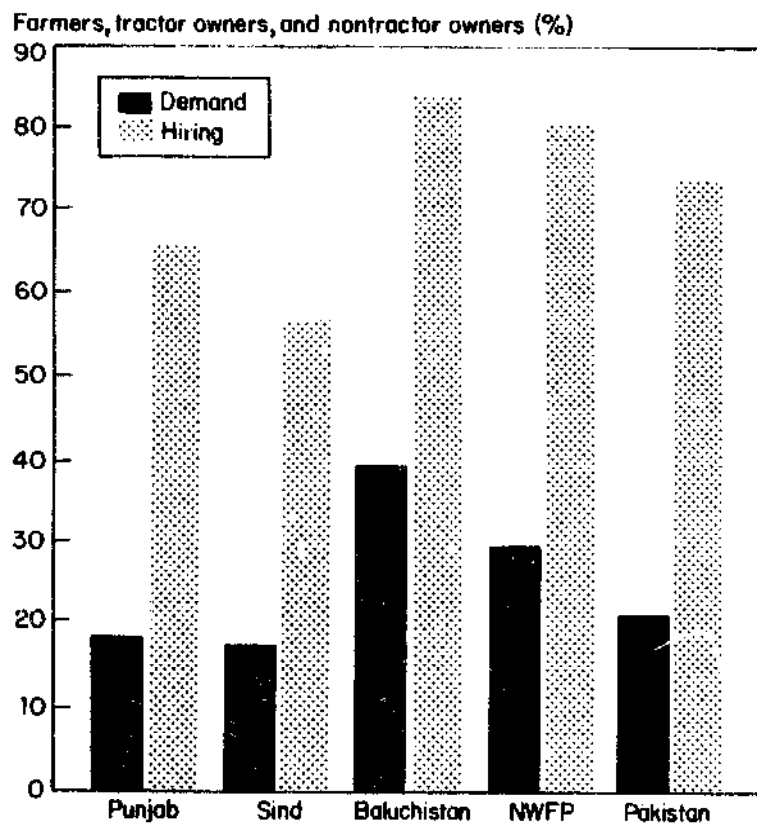

1. Percent of total farmers, tractor owners, and nontractor owners who hire and demand reapers.

that of manual reaping. Table 2 (8) gives the details of fixed and variable costs. These costs were used to determine the break-even point, as shown in Figure 2. With a harvesting capacity of 0.4 ha/h, the reaper breaks even at about 24 ha/yr of use. The initial cost of the machine (around \$1,000) compares favorably with the cost of a combine (around \$10,000).

Table 2. Comparative economics of machine and traditional reaping of wheat (1983 Economics).^a**Manual reaping**

Payment in wheat grain for harvesting 1 ha	= 247 kg
Cost of 1 kg of wheat	= Rs 1.60
Cost of manual harvesting	= Rs 395/ha

Machine reaping (FMI reaper windrower)

Price	Rs 14,000
Life	2,000 h or 5 yr
Yearly use	400 h
Interest rate	12%/annum
Average value	Rs 7,000
Field capacity	0.4 ha/h

Fixed costs/yr

Depreciation	$\frac{\text{Price}}{\text{Life in yr}} = \frac{14,000}{5}$	Rs 2,800/yr
Interest	$7,000 \times .12$	Rs 840/yr
Taxes, insurance, and shelter (2% of price)		<u>280/yr</u>
		Rs 3,920/yr

Variable cost

Cost of MF 240 tractor/ha (40 × 2.47)	Rs 98.80/ha
Cost of labor to collect crop (30 man-h at Rs 3.50/man-h)	105.00/ha
Repair and maintenance (0.25 of initial cost/h)	<u>8.75/ha</u>
	Rs 212.55/ha

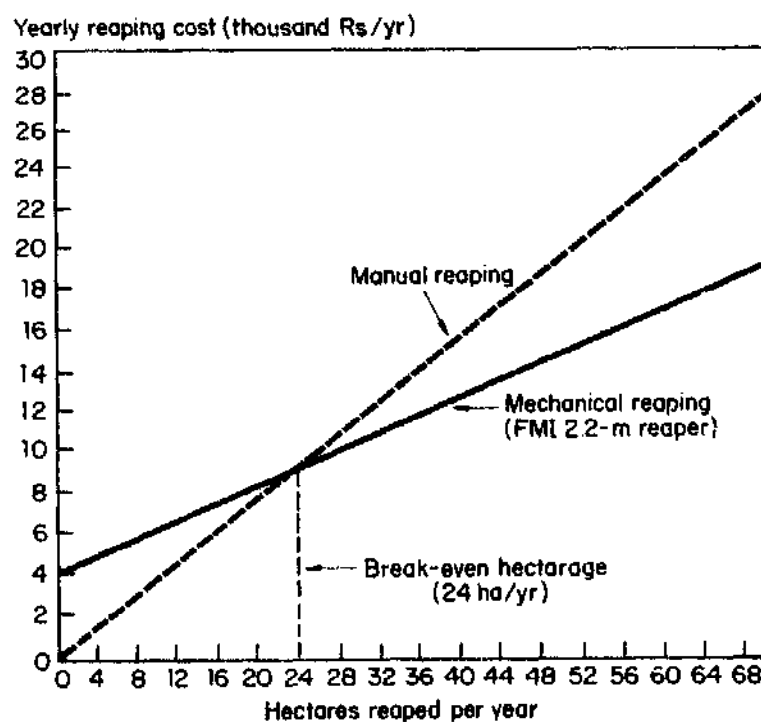
^a Rs 14 ≅ US\$1.

2. Break-even analysis of the 2.2-m reaper, 1983.

DESIGN PARAMETERS (4, 7, 11)

The star wheels, flat belt conveyors, cutter bar, drive train, and lifting mechanisms are the major components of the machine (9). The parameter relationships recommended by the Chinese and IRRI (Appendix I) were used for the first three (6). The drive shaft on the drive train was analyzed for critical vibrations as follows:

Since the shaft was supported at ends by two self-aligning bearings, this was treated as a case of a simply supported shaft with a weight W (weight of shaft itself) concentrated in the middle (Fig. 3). The natural frequency of the system (2, 3, 12) is given by:

$$\omega_n = \sqrt{\frac{kg}{W}}$$

where n = natural frequency of the shaft,
 k = lateral stiffness of the shaft, and
 g = acceleration due to gravity.

From this the critical r.p.m., N_c can be expressed as:

$$N_c \text{ (rpm)} = \frac{60 \omega_n}{2\pi} = \frac{60}{2\pi} \sqrt{\frac{g}{\delta_{\max}}} = \frac{187.7}{\sqrt{\delta_{\max}}}$$

where δ_{\max} = static deflection at the midpoint of the shaft

$$= \frac{W L^3}{48EI}$$

where L = length of shaft,
 E = modulus of elasticity, and
 I = moment of inertia about the neutral axis.

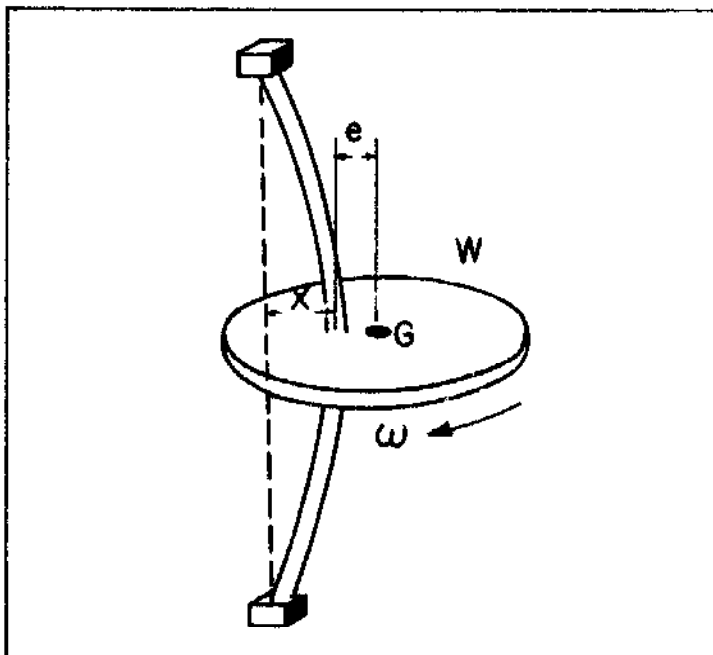

3. Simplified model of drive shaft.

There was no mechanical difficulty in using the tractor hydraulics for lifting since the machine weighed only 150 kg — well within the lifting capacity of a 45 hp tractor hydraulic system. The machine and all attachments weighed 210 kg.

MODIFICATIONS

Headers

Because of the rugged working conditions in Pakistan, i.e., uneven fields and frequent need to negotiate bunds, the headers had to be considerably strengthened. They were redesigned for a much sturdier configuration.

Star wheels

The star wheels, initially made from aluminum and later from high impact plastic, were modified to a lighter design having hollow-ribbed construction. To prevent the crop from wrapping around the star wheel spindle, a stationary cup was used with lips fitting inside a groove cut in the underside of the star wheel (Fig. 4).

Cutter-bar drive mechanism

The cutter-bar drive mechanism on the original machine failed frequently and was completely redesigned as shown in Figure 5.

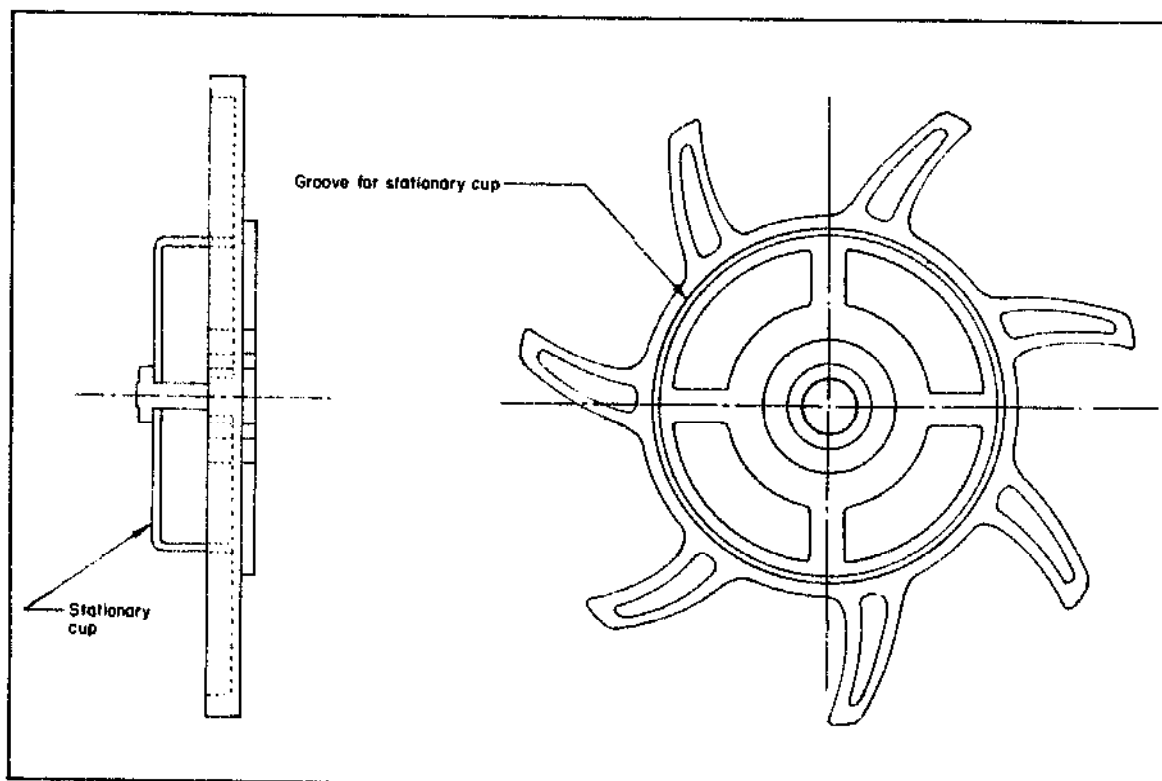

4. Star wheel.

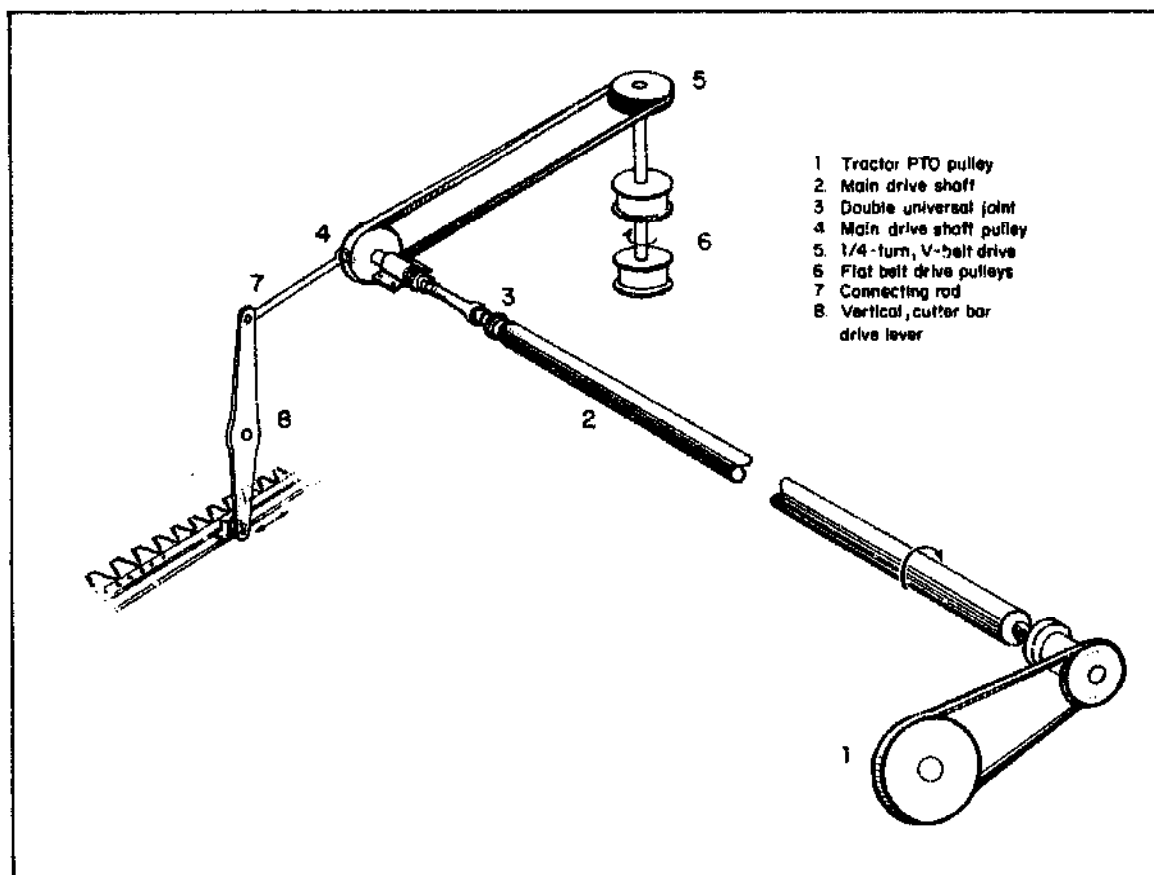

5. Cutter-bar drive system of FMI reaper windrower (FMI RW22).

Cutter-bar knives

One manufacturer started making knives, but tests showed they were not made to specifications. Thus, in the first 2 yr, the blades were imported from Italy and the Republic of Korea. Another manufacturer is making them satisfactorily.

Back retaining wall

The back retaining wall was increased in height to handle taller varieties of wheat and rice.

Drive train

The drive train (1) consists of several V-belt pulleys, belts, and a shaft (Fig. 6, 7). For ease of manufacturing and because belts slip when the cutting mechanism gets jammed, no gears were used in the train, thus providing an automatic over-ride clutch operation. The original machine used all gears.

Lifting mechanism

The machine is mounted on a pair of 4-bar mechanisms having driver links operated by steel ropes pulled by the tractor hydraulic arms (Fig. 6, 7). The arrangement allows raising or lowering the machine to the desired cutting height or positioning it for transportation (fully raised).

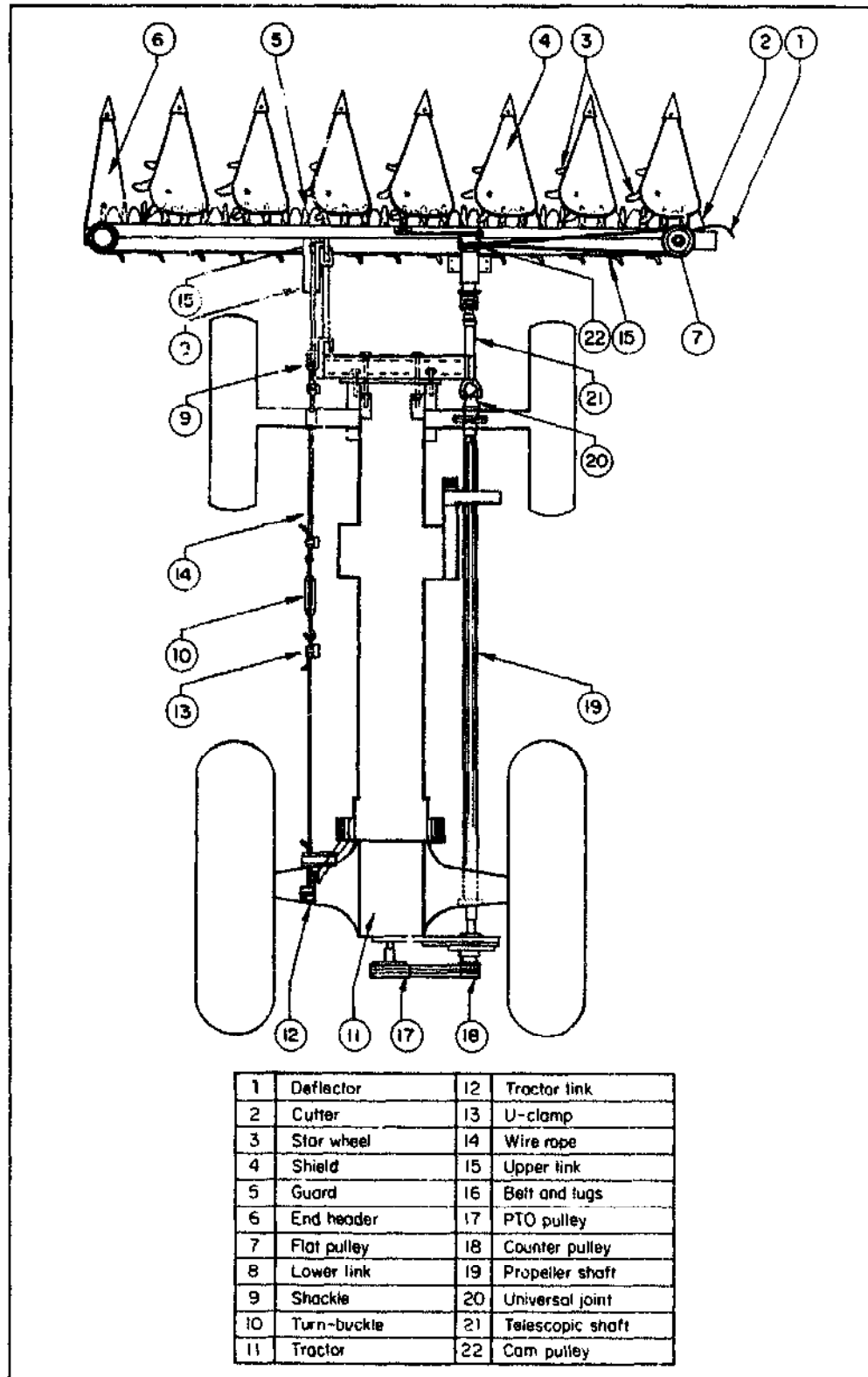

6. Top view of FMI reaper, showing drive train and lifting mechanism.

Chain-type crop conveyor

Two major problems were encountered with the belt-type conveyors: frequent misalignment and slippage. Slippage was especially frequent with thick growth of weeds close to the ground (common in fields near FMI). FMI decided in 1981 to use a chain-type conveyor instead of the flat belt conveyor.

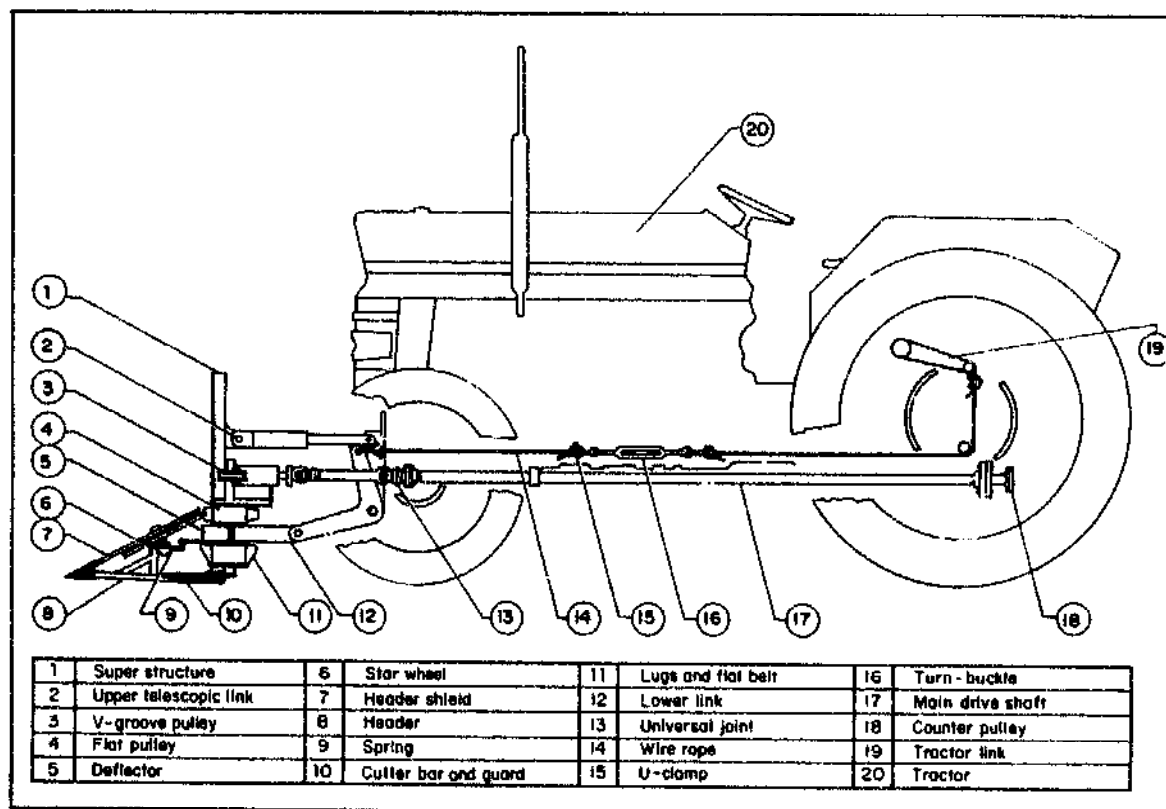

7. Side view of FMI reaper (RMI RW22), showing drive train and lifting arrangements.

The chain-type conveyor was tried on wheat in the spring of 1983. Even though it worked extremely well, the chain and sprocket mechanism could not be commercialized because of difficulties in manufacturing the type of chain needed.

INDUSTRIAL EXTENSION

After the first successful test of the machine, FMI personnel prepared a set of slides and traveled from town to town showing it to manufacturers. The first prototype was demonstrated to farmers and manufacturers on rice in the fall of 1981 and on wheat in the spring of 1982. About half a dozen manufacturers showed interest in producing the machine, but only one made it in commercial quantities in 1982. Unfortunately, this one was unable to maintain the desired quality of materials and manufacturing. He was also not very cooperative in accepting technical advice from the Institute staff. The machine was sold to farmers at Rs 10,000 per machine in the beginning of the harvesting season and as the demand got higher, the price increased to Rs 20,000 per machine.

All 81 machines sold were brought back to the factory because they either did not perform well or broke down too frequently. In Pakistan, the farmers generally buy machines before harvest and pay for them after the season. This provides a built-in warranty: the machines are returned to the manufacturer if they do not work satisfactorily. This was a setback to the program because now, in addition to introducing a new machine to farmers, the promoters had to fight bad publicity. In the fall of 1982, however, several other manufacturers

came into the field and produced quality machines. According to a recent survey, about 80% of the farmers are now satisfied with their machines.

More than 20 small- and medium-size manufacturers produce about 1,500 to 2,000 machines a year. All manufacturers were helped by the Industrial Extension Department of FMI in producing the first prototype and are being provided assistance in troubleshooting problems during production.

POPULARIZATION

FMI embarked on an elaborate demonstration program in 1982 and 1983. During the 1983 wheat harvesting season, over a hundred demonstrations were arranged from the southern tip of Pakistan in Sind to the northern areas, covering nearly 1,600 km. These demonstrations exposed the farmers to the machine and helped create the demand for it. Newspapers, radio, and television were also extensively used. FMI published an operator's manual for distribution to farmers. In 1983, the Institute arranged for operators a roving training program on the proper use and maintenance of the machine.

PROBLEMS AND CONSIDERATIONS

- One of the early problems was maintaining quality of materials and production standards. This was solved by involving firms with high standards of quality control.
- The machines had to be made rugged to cope with the rugged fields and often ill-trained operators.
- Before the farmers bought reapers, some manufacturers had to demonstrate in the field that the reaper did save labor.
- The manufacturer should introduce their machines only in areas where they can provide effective after-sales service. Some manufacturers made it a point to visit all their reapers once or twice during the season.
- The success of the reaper depends to a large extent upon the tractor operator. If he is too timid and not well trained, he is likely to be overcautious and waste time. On the other hand, overconfidence often causes accidents and loss of time and money. FMI and some manufacturers arranged 1-d training courses for reaper operators. Often a dealer representative was present for the first 4 h of operation of the machine.
- Prospective buyers were warned of the need for tractor reliability and operator training and informed that damage was likely to occur without those.

CONCLUSION

The Chinese vertical reaper is a breakthrough in harvesting cereal crops. This low-cost machine is simple to construct and easy to operate. It is an effective answer to an urgent need for mechanizing of wheat in Pakistan. There is a good potential for its popularization in other countries of South Asia.

REFERENCES CITED

1. Amjad, N., and M. Khan. Field performance of FMI reaper-windrower. FMI, PARC publications, Islamabad. (undated)
2. Baumeister, T., E. A. Avallone, and T. Baumeister III. 1978. Marks' standard handbook for mechanical engineers. McGraw Hill Book Company.
3. Beer, F. P., and E. R. Johnston, Jr. 1977. Vector mechanics for engineers-dynamics. McGraw Hill Book Company.
4. Kanafojski, Cz., and T. Karwoski. 1976. Agricultural machines, theory and construction. Vol. 2, Crop harvesting machines. United States Department of Agriculture, and National Science Foundation, Washington D. C.
5. Mustafa, U., M. Afzal, and T. Ahmad. 1983. Demand survey of reaper. FMI, PARC publ., Islamabad.
6. Nafziger, M., V. Tiangco, L. Kiamco, M. Aban, M. Diestro, and I. Manalili. 1981. Design and development of IRRI reaper-harvester. IRRI publication, Los Baños, Philippines.
7. Quick, G., and W. Buchele. 1978. The grain harvesters. ASAE publ.
8. Rahman, Z. U. 1985. Agricultural mechanization and farm labor. Paper presented at SEARCA seminar on development strategies and planning for farmers' communities, Los Baños, Philippines.
9. Rahman, Z. U. 1981. Reaper development at AMD. Paper presented at the second semi-annual convention of the Pakistan Society of Agricultural Engineers, University of Agriculture, Faisalabad, December.
10. Rahman, Z. U., and J. Akhtar. 1981. Mechanical harvesting and threshing of wheat crop. Progressive Farming.
11. Smith, H.P., and L. H. Wilkes. 1976. Farm machinery and equipment. McGraw Hill, New York.
12. Timoshenko, S., and D. H. Young. 1955. Vibration problems in engineering. Van Nostrand Reinhold Company.

Appendix I.

DESIGN PARAMETERS

I. Star wheels (Fig. 4)

The optimum inclination of the star wheels, empirically arrived at by the Chinese, is 22° with the horizontal. The minimum required speed is as follows based on simple geometry:

$$V_w = \frac{V_f}{\cos \alpha} \quad (1)$$

where:

V_w = average star wheel velocity,

V_f = machine forward velocity,

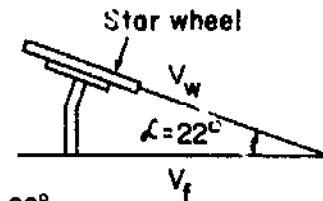

and α = angle of inclination of star wheel. Thus, for a 22° angle the above expression simplifies to:

$$V_w > 1.08 V_f \quad (2)$$

II. Flat belt conveyors

The velocity of the flat belt conveyor is derived from the star wheel tip velocity and is given by

$$V_b = \frac{V_{wo} PN}{\pi} \quad (3)$$

where:

V_b = velocity of flat belt conveyor,

V_{wo} = velocity of outer tip of star wheel lugs,

N = no. of star wheel lugs,

and P = pitch of flat belt lugs, which is given by

$$P < D \sin \frac{\pi}{N} \quad (4)$$

where:

D = diam of star wheel.

The Chinese experience indicates that

$V_b = 1.4 V_f$ gives the best results.

III. The knife velocity is again a function of the forward speed of the machine. The velocity ratio between the two is expressed as

$$K = \frac{V_k}{V_f} \quad (5)$$

where:

V_k = average knife velocity.

Again the empirically derived value of K falls between 1.3 and 1.4. With the available cutter knives and selected stroke length, this translates into 900 strokes/min of the cutter bar.

Threshing

THE ASIAN AXIAL-FLOW THRESHERS

A. U. KHAN

International Rice Research Institute

IRRI MACHINERY DEVELOPMENT PROGRAM

The International Rice Research Institute established its Small Farm Machinery Development Program in 1967. This program focuses on providing demand-oriented farm machines to small rice farmers through indigenous manufacturing channels in the developing countries. Over the last 18 yr, several new machines originating from this program have become popular in Asia. The IRRI axial-flow threshers, developed at IRRI in the early seventies, are now widely used in some ASEAN countries, notably the Philippines, Thailand, and Indonesia. This paper briefly reviews the development and commercialization of the IRRI axial-flow threshers. It concludes that more cooperative efforts are needed to foster manufacture of these threshers in the ASEAN countries.

THE AXIAL-FLOW THRESHER

Work on the development of paddy threshing machines began at IRRI in 1967. The objective was to produce low-cost threshers for small farmers and contract thresher operators in the Asian rice-producing countries. Since paddy is often harvested during the rainy season at a fairly high moisture level, threshers must be able to handle freshly harvested paddy. They must also be lightweight and fairly mobile for easy transport from one field to another for contract threshing. Their designs must be simple for local production by small metal working shops in rural areas.

Initially, efforts at IRRI were concentrated on developing hold-on-feed threshers (11) since such machines were simple and able to thresh wet paddy. During 1967-70, two hold-on-feed threshers, the Drum Thresher and the Table Thresher (Fig. 1, 2) were developed. These machines were commercialized through a few manufacturers in the Philippines but were not successful in the market. Experience gained with them, however, indicated that farmers wanted machines with higher threshing outputs, generally not possible with hold-on-feed machines.



1. Drum thresher.



2. Table thresher.

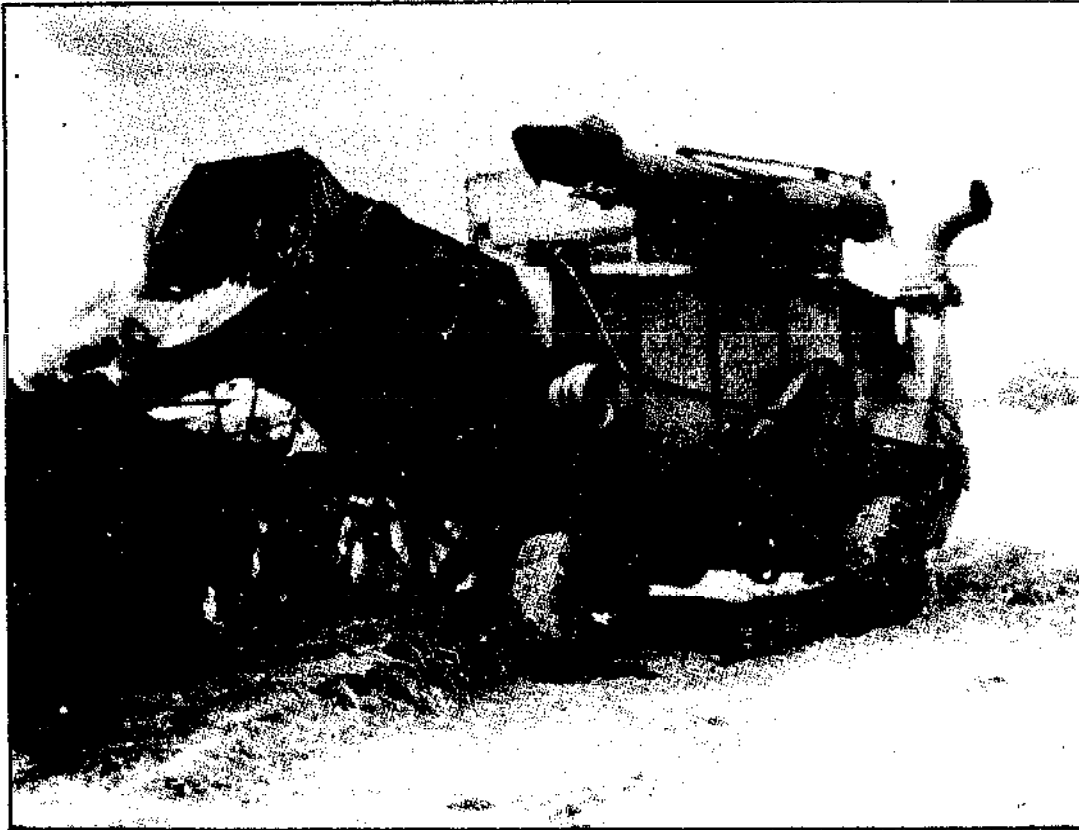

3. McCormick-type (tilladora) thresher used in Central Luzon for custom threshing of paddy.

By 1970, IRRI concentrated on developing throw-in-feed threshers. A few, large, throw-in-feed threshers, based on the McCormick Threshing Machines and locally known as the *tilladoras* (Fig. 3), were used in the Philippines for contract threshing. These machines were not suitable for threshing freshly harvested paddy, so farmers had to dry their crop in the field in stacks, or *mandalas*, for weeks before threshing. The McCormick-type machines required a huge investment and were too heavy and bulky for convenient transport in paddy fields.

THE AXIAL-FLOW CONCEPT

For threshing freshly harvested paddy and to reduce the machine weight, an axial-flow concept was investigated. Such a design offered possibilities for a lighter machine due to the absence of straw walkers and less susceptibility to choking with wet crops. Several threshers were developed at IRRI to try the axial-flow concept for threshing wet paddy. The efforts led to the development and commercialization of the IRRI Model TH3 axial-flow thresher. This thresher served as the basic design from which a range of axial-flow threshers evolved; they, in turn, were forerunners of all the axial-flow threshers now popular in the Asian rice-producing countries.

The axial-flow concept was a major departure from threshing mechanisms used up to that time in threshers and combine harvesters worldwide. In conventional threshers, the crop passes only once between the rotating threshing cylinder and the concave along a tangential path (Fig. 4a). This arrangement subjects the crop to the threshing action very briefly. Because of the brief threshing exposure, high threshing cylinder speeds are necessary, increasing grain damage. Furthermore, only a small quantity of grain is separated from straw at the concave, so large straw walkers are used to separate grain and straw.

In the IRRI axial-flow machine, the material being threshed spirals a few times between the threshing cylinder and the concave while it gradually moves along the axis of the threshing cylinder (Fig. 4b). A set of spirally mounted louvers in the threshing cylinder-cover moves the material along the axial direction. The spiral movement provides a long threshing exposure, permitting more aggressive and versatile threshing and requiring slow thresher cylinder speeds. Such machines damage less grain and work better under adverse threshing conditions. Most grain is separated from straw at the concave, thereby eliminating need for bulky straw walkers. Thus, axial-flow threshers are much more compact than conventional threshers with comparable output.

The IRRI axial-flow threshers are today the most popular paddy threshers in tropical Asia. While many attempts were made in Europe and USA for over a hundred years to develop axial-flow threshers, the IRRI machines were the first successful, commercially produced machines. More recently, several leading U.S. farm machinery manufacturers have developed combine harvesters which use the axial-flow principle (16).

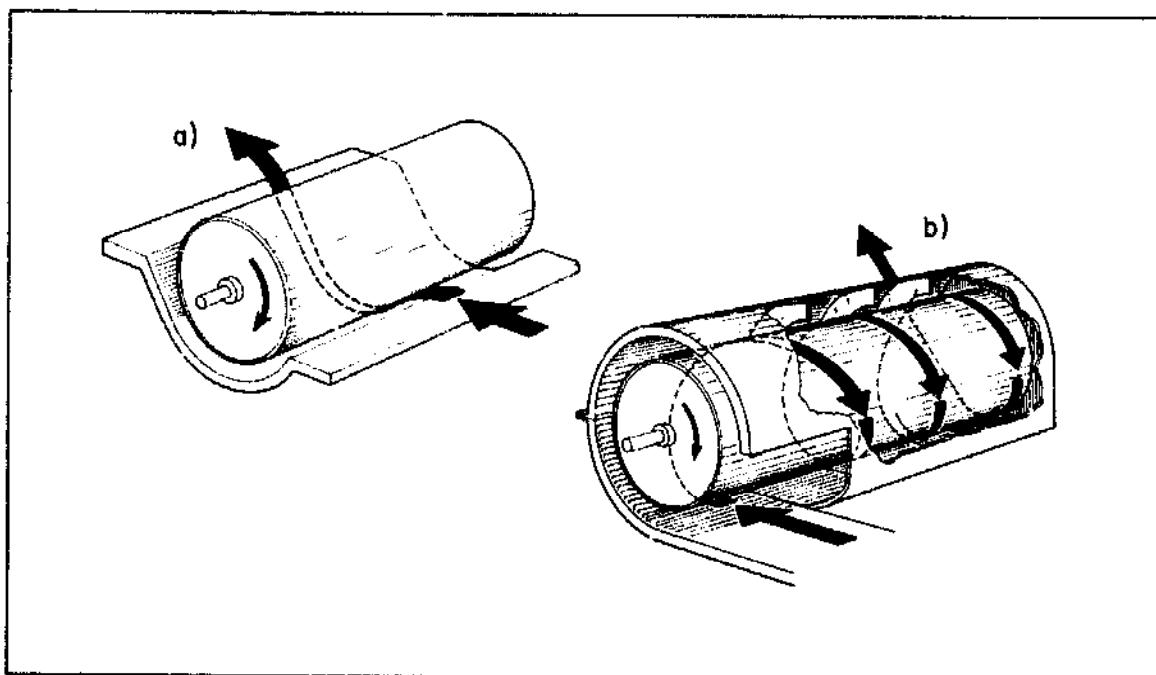

4. Crop movement path through a) conventional and b) axial-flow threshers.

THE TRACTOR P.T.O. THRESHER

The first axial-flow thresher developed at IRRI was a large tractor P.T.O. powered machine (Fig. 5) with a rotary grain separating and cleaning mechanism (10, 11). This machine was developed to compete with the tractor-powered McCormick-type threshers popular in Central Luzon, Philippines. This machine was, however, not commercially introduced in the Philippines because of concerns of displacing too much labor. In Pakistan, which has a large tractor population and a shortage of labor at harvest time, a P.T.O.-powered thresher was developed in 1976-81 by the IRRI-PAK Agricultural Machinery Program (Fig. 6). It incorporates many features of the original IRRI tractor-powered thresher (5) and is now commercially produced in Pakistan.

ENGINE-DRIVEN AXIAL-FLOW THRESHER

A smaller axial-flow thresher, Model TH3, was developed at IRRI during 1971-72 (Fig. 7a, b) for Southeast Asian markets (9, 12). It was powered with a 7-hp aircooled gasoline engine. The machine had a 4-ft-long spiketooth threshing cylinder with a slightly oval, full-length concave. Louvers, fitted in the upper half of the concave, moved the material in an axial direction during threshing. The machine had no straw walkers as most of the grain and straw was separated at the concave. A rotary screen cleaner was used for secondary separation. During 1972-73, the machine was improved through repeated field tests in many parts of the Philippines (15). It successfully threshed wet paddy with an output of 1 t paddy/h and threshing loss of less than 1%.

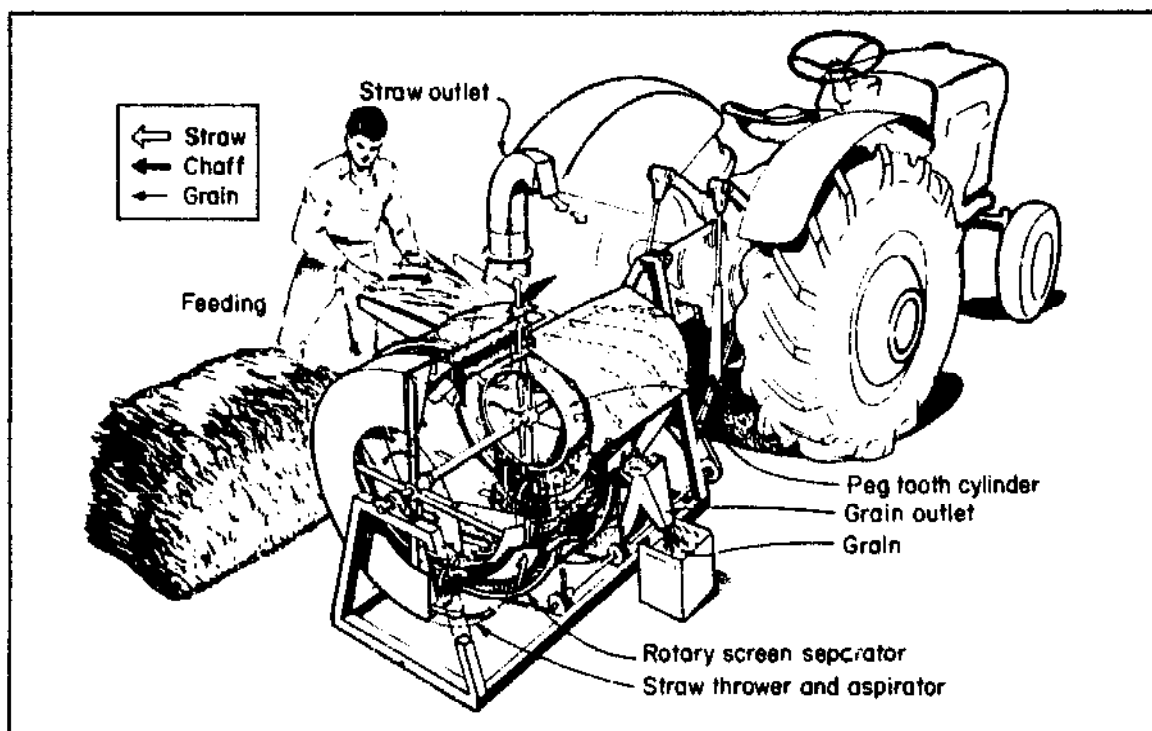

5. Original tractor PTO-operated, axial-flow thresher with rotary screen separator.

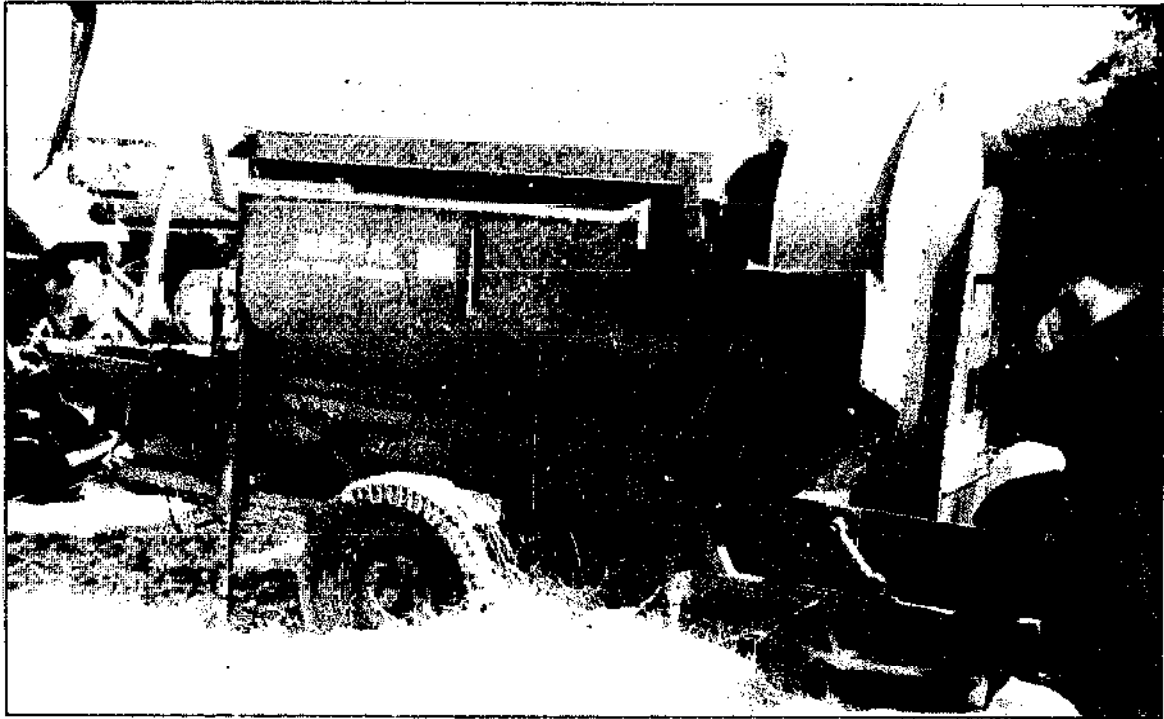

6. Tractor PTO-powered, axial-flow thresher, Model IR-1-PARC-30 being used for threshing paddy in Pakistan.

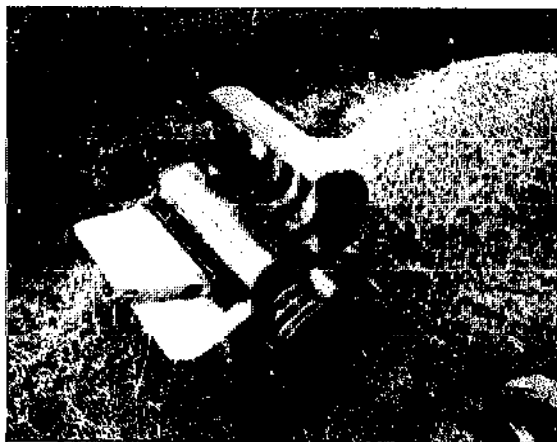

7. a) Original prototype axial-flow thresher Model TH3. b) Original engine-powered, prototype axial-flow thresher Model TH3 being used for threshing paddy.

COMMERCIAL PRODUCTION OF MODEL TH3 AXIAL-FLOW THRESHER

By June 1973, the thresher design was released to four manufacturers in the Philippines for commercial production (Fig. 8, 9). Sales were brisk from its introduction and manufacturers had difficulty keeping up with the demand. By mid-1974, five companies were producing the axial-flow threshers in the Philippines (2). Prototype machines were also fabricated by manufacturers in Thailand, Sri Lanka, Indonesia, Pakistan, and Vietnam.

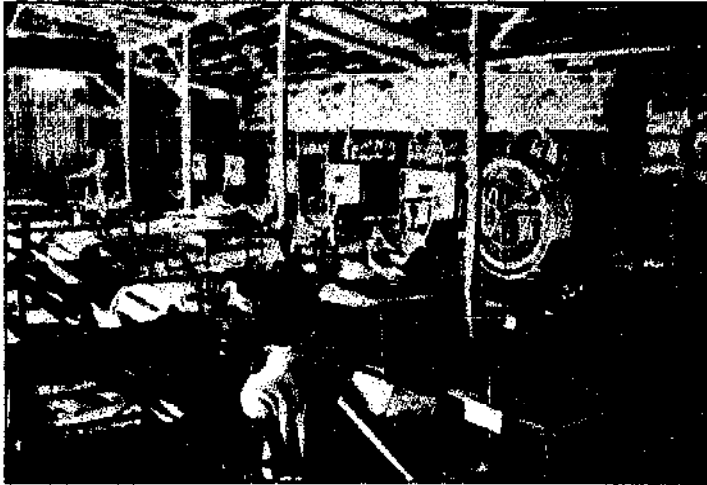

8. Axial-flow thresher Model TH3 production in a rural shop (M/s C&B Crafts, San Rafael, Bulacan) in Luzon, Philippines.

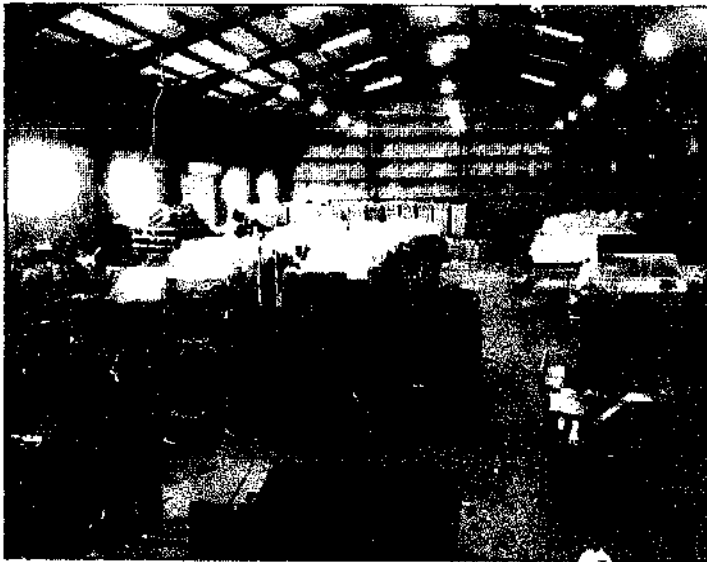

9. Axial-flow thresher Model TH3 in production in a large factory in Manila, Philippines.

Several Filipino manufacturers gradually introduced improvements on the original IRRI design to gain a competitive edge. More powerful engines, spring suspension, shock absorbers, and pneumatic tires were installed to increase sales and improve machine mobility. By late 1974, eight companies were producing the axial-flow thresher in the Philippines and all were having difficulty keeping up with the demand. By 30 June 1975, the axial-flow thresher was being produced by 15 companies in 5 countries (10). As the number of manufacturers increased rapidly, some poor quality machines were produced by manufacturers who were not quality conscious.

At this stage, two manufacturers, Kaunlaran Industries in Calamba (Fig. 10) and Oberly & Co. Inc. on Mayon Street, Manila (Fig. 11), replaced the rotary screen of the original IRRI thresher with a flat oscillating screen. This arrangement improved grain-straw separation and resulted in a more compact machine. Most farmers liked the oscillating screen feature, and it was quickly copied by other Philippine manufacturers.



10. Axial-flow thresher manufactured by Kaunlaran Industries, threshing paddy in the Philippines.



11. Axial-flow thresher with an oscillating screen manufactured by Oberly & Co., Inc.

With increasing competition, manufacturers producing quality machines rapidly expanded their operations and dominated the market. By 1976 two firms — C&B Crafts in San Rafael, Bulacan, and M/s Kaunlaran Industries (now known as ATIN Engineering Co.) of San Pablo City, Laguna (Fig. 8, 12) — had become major manufacturers of top quality IRRI threshers in the Philippines. The two firms started humbly, employing only two to three workers. In a few years, they had multimillion peso capitalization and employed 40 to 100 workers. Both firms were owned by enterprising and creative individuals who were conscious of offering good quality machines. The two firms still produce threshers; however, many other firms are also producing IRRI threshers of comparable quality in the Philippines.

THE IRRI PORTABLE AXIAL-FLOW THRESHER MODEL TH6

The commercialized versions of the IRRI Model TH3 thresher were widely used on the larger farmholdings and for contract threshing in the Philippines. But during wet season, when fields were not sufficiently dry, these machines were difficult to transport into fields. Under such conditions, harvested crop had to be manually transported out of the paddy fields to firmer sites for threshing. This extra handling not only required much labor but resulted in 2-7% shattering losses. Further, few small farmers could afford an investment of about \$1,700 for Model TH3 thresher. In 1975, IRRI engineers decided to develop a smaller portable model that weighed 100 kg, had threshing output of 400 kg/h, and sold for about \$500.00. This thresher was intended for ownership by farmers with less than 5 ha holdings.

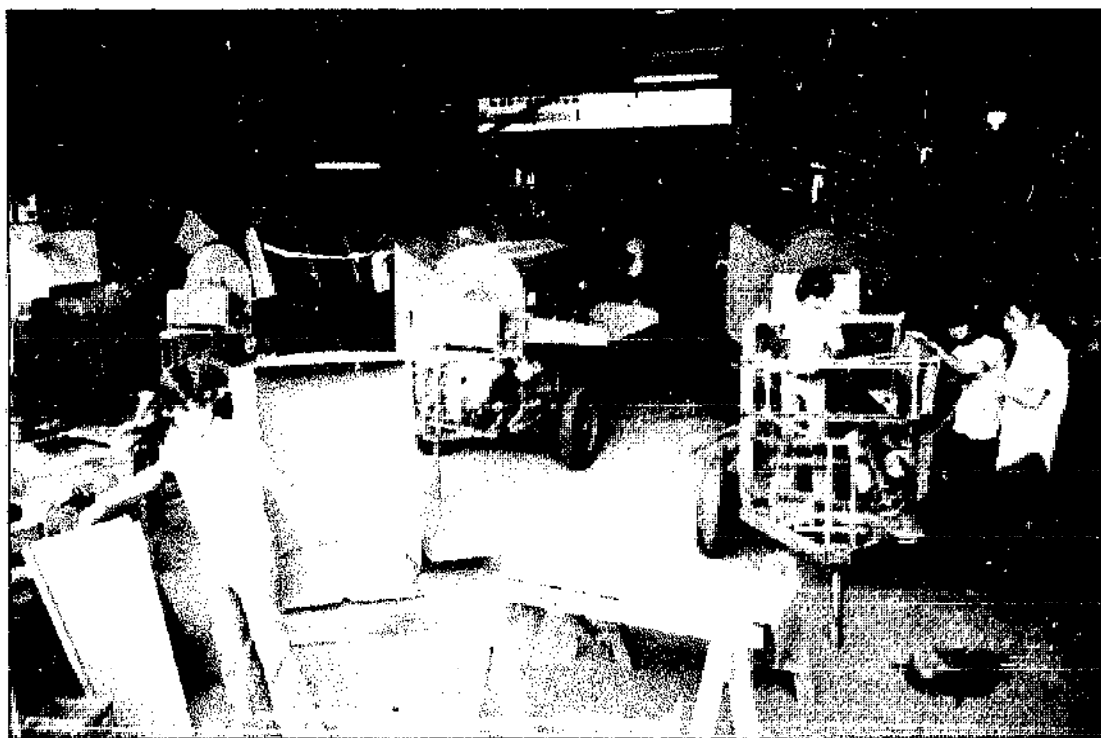

12. Axial-flow thresher Model TH3 production by a medium-size firm (M/s Kaunlaran Industries, San Pablo) in the Philippines.



13. a) Portable axial-flow thresher, Model TH6, being carried into the fields. b) Portable axial-flow thresher Model TH6 being used for threshing paddy.

The IIRI portable thresher, Model TH6, was developed during 1975-76 (Fig. 13a, b). It was light enough for two operators to carry into fields, thus eliminating the need to carry harvested crop out of the field for threshing. Model TH6 was released in early 1977 to manufacturers in the Philippines.

MARKET ACCEPTANCE

Within a few years, IIRI threshers totally replaced the McCormick-type threshers, popular for contract threshing in the Philippines. The portable thresher Model TH6 was received enthusiastically in the market and gained rapid popularity, especially in the Iloilo, Pagsanjan, Zambales, and Lanao areas of the Philippines. The larger machine, Model TH3, continued to gain popularity in the Nueva Ecija, Laguna, Bulacan, and Pampanga Provinces of the Philippines (13). In 1975, IIRI TH3 axial-flow threshers were introduced in Thailand. Manufacturers quickly started fabrication. Thai manufacturers, highly innovative, soon adapted the design of the TH3 to better suit local crop and weather conditions. Many different and some very large versions of the IIRI threshers are manufactured in Thailand today. The smaller portable thresher Model TH6, however, was not accepted by Thai farmers.

Table 1. Axial-flow thresher production in some South and South-east Asian countries.

Country	Cooperating manufacturers (no.)	Axial-flow threshers fabricated (no.)	Year
Philippines	208	18,785 ^a	1975-83
Indonesia	64	2,411 ^b	1979-84
Thailand	29	30,000 ^c	1975-85
Pakistan	17	150 ^d	1981
India	17	164 ^e	1983
Sri Lanka	1	1,000 ^f	1983-85
Nepal	1	100 ^g	1984 (started)
Vietnam ^h			

^aC. W. Bockhop et al (1). ^bMachines manufactured in West and North Sumatra, South Kalimantan, South Sulawesi, and Java (4). ^cPersonal communication with J. Monkoltanates, Agricultural Engineering Division, Department of Agriculture, Bangkok, Bangkok. ^dTractor-powered paddy thresher, Machinery Development and Testing, Industrial Extension Project (3). ^eCIA-IRRI Industrial Extension Project, Oct 1983-Sep 1984. ^fPersonal communication with T. S. Jinesena, Jinesena Ltd., Colombo, Sri Lanka. ^gPersonal communication with A. B. Karki, Agricultural Tools, Factory Ltd., Birganj, Nepal. ^hProduction in Vietnam has been going on since 1976; no production figures are available.

Threshers very rapidly gained popularity in the Philippines. A 1978 survey of some irrigated and nonirrigated villages (6) indicated that within 1 yr of introduction, IRRI axial-flow threshers were used by 75% of farmers in irrigated villages and 45% in rainfed areas. A follow-up survey in 1981 registered 100% farmer use of the threshers.

Currently, IRRI threshers and adapted versions are commercially produced in seven Asian rice producing countries: Philippines, Thailand, Indonesia, India, Pakistan, Sri Lanka, and Vietnam (Table 1). By the end of 1983, an estimated 19,000 IRRI axial-flow threshers had been commercially manufactured by 75 cooperating IRRI manufacturers in the Philippines. At present more than 140 firms are producing the IRRI axial-flow threshers in all major rice growing areas of the Philippines (Fig. 14). By 1985, more than 100 manufacturers had produced 30,000 threshers in Thailand. The IRRI thresher was introduced in Indonesia in 1977. By 1984, about 30 manufacturers had produced 3,500 units in that country. In Sri Lanka, one manufacturer had produced over 1,000 portable IRRI threshers by 1984.

SOCIOECONOMIC BENEFITS

Contract threshing has become very popular among farmers who are not able to buy machines. Most thresher owners not only use machines on their own farms but also provide contract threshing to other farmers. Net savings in threshing costs and substantial reduction in threshing-grain losses have been the two major advantages for thresher owners. The total benefits for IRRI thresher users range from \$7 to \$18/ha in Thailand and from \$1.0 to \$18/ha in

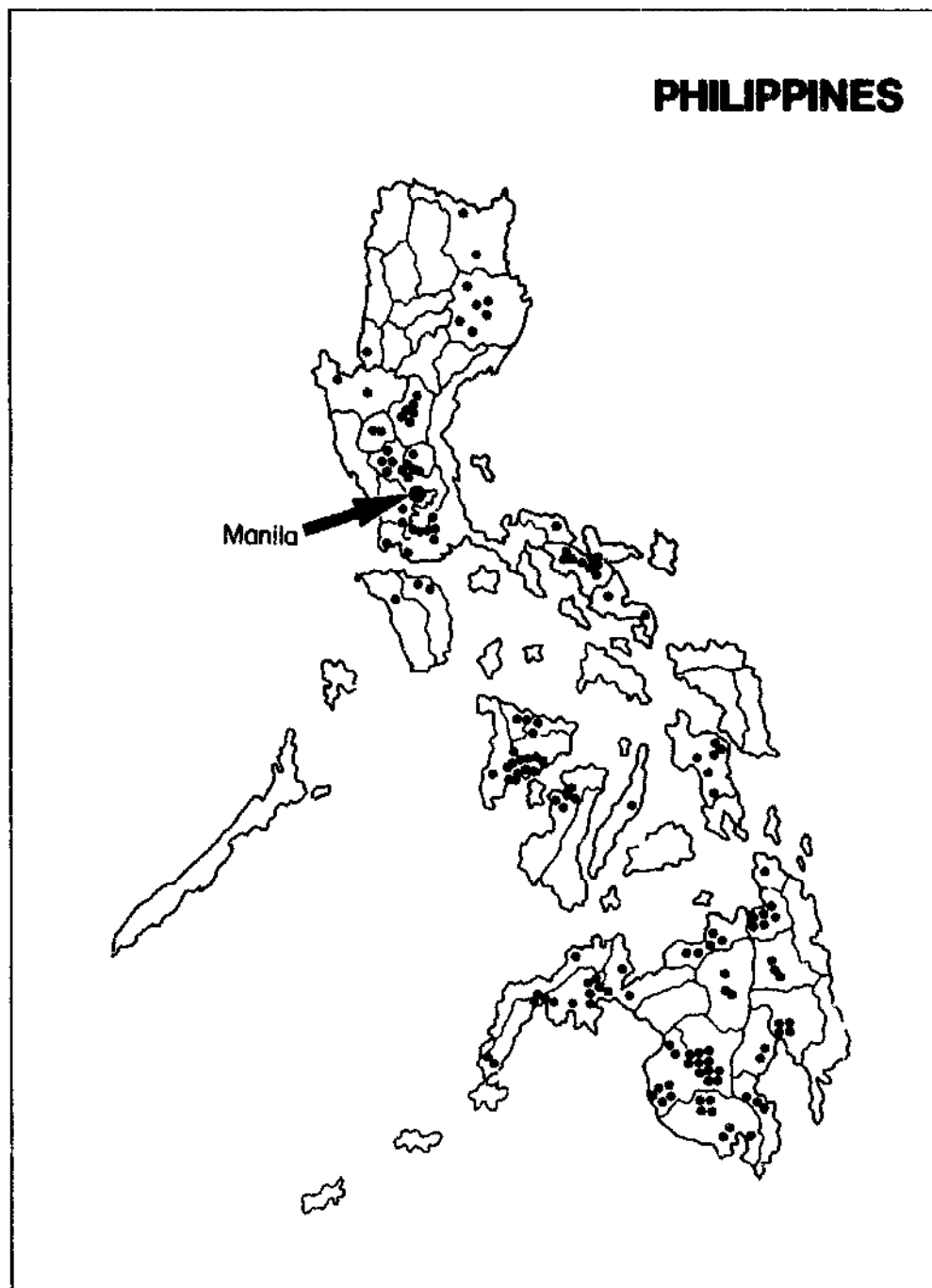

14. Location of cooperating IRRI manufacturers of threshers in the Philippines.

the Philippines. The average gains per farm range from \$31 to \$82 in Thailand and \$3 to \$120 in the Philippines (6).

Use of axial-flow threshers in tropical producing countries has substantially reduced crop losses. An estimated 2 to 5% grain has been saved because of reduced threshing and transportation losses. Timely threshing has also reduced spoilage from inclement weather and rodent damage. A recent analysis of the socioeconomic benefits of the IRRI axial-flow threshers, excerpted from a report to the Consultative Group for International Agricultural Research (14), is in the Appendix.

The IRRI threshers have been successful in overcoming the peak labor demand constraints that farmers face at harvest time, and have enabled farmers to introduce intensive cropping techniques making better use of the new seed-fertilizer technology. Widespread use of the threshers has saved farmers from the drudgery of manual threshing, traditionally one of the most backbreaking operations in farming. The widespread practice of custom threshing has permitted even small and subsistence farmers to take advantage of modern threshing technology. Many farmers have supplemented their meager earnings through contract threshing operations.

Production of the IRRI threshers by numerous small shops in rural and semirural areas of rice growing countries has led to the establishment of small metalworking industries, the creation of many new industrial jobs, and substantial savings of foreign exchange.

SOME LESSONS LEARNED FROM THE IRRI THRESHER EXPERIENCE

1. The large variety of commercial designs that evolved from the original IRRI axial-flow thresher amply demonstrates the abundance of innovative talents among local manufacturers in developing countries. It also highlights the need for key innovations which can catalyze this vast pool of talent.
2. The IRRI thresher experience illustrates that the responsibility of a research institution does not end with the development of a working prototype of a new machine, but continues until the machine is either successfully commercialized or is proven unacceptable in the market.
3. Design, test, and commercialization are three important elements of the technology delivery chain and must be handled in a well-coordinated manner.
4. Without careful assessment of the commercial viability of proposed machines, new machinery development projects can be costly exercises. Research institutions must develop in-house capabilities to conduct market research and product planning studies. Because of the lack of such studies, many different threshers had to be developed at IRRI before one was commercially successful.
5. Many socioeconomic studies have been conducted in developing countries on issues related to general mechanization, e.g., impact on labor, unemployment, income distribution, equity participation, etc. Such studies generally document past mechanization experience and are of primary interest to policy makers, but they have little significance in the development of new machines. Market and product planning studies, which develop specifications of future, potentially marketable machines are needed to improve and refine machinery development.
6. In their enthusiasm to introduce new machines, designers often prematurely release designs for widespread commercial production. This practice can result in a rejection of potentially good machines. New machines must undergo test, production, and marketing phases to

eliminate teething problems and better fit manufacturing and market needs.

7. Most manufacturers in a hurry to market their machines sometimes sell a defective machine. Every effort must be made, particularly during the introductory stage, to ensure that machines are free from production defects. Research institutions must develop detailed manufacturing inspection procedures and closely monitor initial production to ensure that machines are produced strictly according to original specifications.
8. A new machine must be introduced only through a few carefully selected manufacturers. Once it has been successfully test marketed, the design can be released to other manufacturers. This cautious approach helps develop a close working relationship between designers and manufacturers, permits careful monitoring and control of production quality, and minimizes manufacturers' risks in introducing new machines.
9. The following factors seem important in selecting the first few manufacturers for introducing new machines:
 - a. *Size of operation.* Generally a medium-size manufacturer, employing about 5 to 20 workers, is better suited. The very small manufacturer, with 1-4 employees, operates on a shoestring and is liable to cut corners in production. On the other hand, larger manufacturers, with more than 20 employees, often have lucrative product lines and may be unwilling to devote attention essential for proper introduction of new products.
 - b. *Innovative ability.* The initial manufacturer must be sufficiently innovative to solve problems that farmers encounter in the field rather than be heavily dependent on the research institution for solutions. Such manufacturers often end up introducing their own innovations in the machine and take greater personal interest in the project.
 - c. *Quality consciousness.* Manufacturers conscious of product quality are generally the ones who can successfully commercialize and expand their production. The few initial manufacturers must be gauged by the quality of products they already manufacture.
 - d. *Long-range objectives.* The initial manufacturers must show serious interest in producing new machines on a regular basis. Manufacturers primarily interested in supplying machines on specific orders should be avoided.
 - e. *Location.* Initial manufacturers should preferably be within commuting distance of the research institution. This provides closer interaction between designers and manufacturers; such contact is needed to overcome the numerous problems that crop up during the introductory stage.

CONCLUSIONS

The experience with the IRRRI axial-flow threshers exemplifies the many benefits that could accrue to farmers and other sectors of the developing

country societies through the development and commercialization of appropriate mechanization technologies. The coordinated efforts on thresher design on one hand and on local production on the other were the two key elements of the success of the thresher.

The close interaction between private rural-based manufacturers and an international research center, without any financial transactions, was an unusual example of cooperation which helped to deliver modern technology to small farmers. In many ways, the cooperating manufacturers served as extension agents for introducing and popularizing the IRRI-developed machines.

Most national agricultural engineering research institutions suffer from insufficient contact with local manufacturers. If their efforts are to have any meaningful impact at the farm level, it is essential that close working relationships are established with local industry.

REFERENCES CITED

1. Bockhop, C. W., R. E. Stickney, M. M. Hammond, B. J. Cochran, V. R. Reddy, F. E. Nichols, and S. C. Labro. 1985. The IRRI industrial liaison program. Pages 479-486 in *Small farm equipment for developing countries*. International Rice Research Institute, Los Baños, Laguna Philippines.
2. Duff, B., F. E. Nichols, J. K. Campbell, and C. C. Lee. 1974. Semi-annual progress report 10 USAID/IRRI Machinery Development Project, Agricultural Engineering Department, International Rice Research Institute, Los Baños, Philippines.
3. IRRI (International Rice Research Institute). 1983. Annual report for 1981. Los Baños, Laguna, Philippines.
4. IRRI-DITPROD (International Rice Research Institute-Directorate of Food Crops Production). 1984. Annual report of the IRRI-DITPROD Industrial Extension Project in Indonesia.
5. IRRI/PAK Agricultural Machinery Development Program. 1976-81. Progress Report, Pakistan Agricultural Research Council, Islamabad, Pakistan.
6. Juarez, F., and R. Pathnopas. 1981. A comparative analysis of thresher adoption and use in Thailand and the Philippines. Working Pap. 28, The Consequences of Small Rice Farm Mechanization Project. Agricultural Engineering Department, International Rice Research Institute, Los Baños, Laguna.
7. Khan, A. U. 1969, 1970. Semi-annual progress reports 8, 9, 10, and 11. USAID/IRRI Machinery Development Project, Agricultural Engineering Department, International Rice Research Institute, Los Baños, Laguna, Philippines.
8. Khan, A. U. 1983. Combination threshing and separating machine. United States of America. Patent No. 3776242.
9. Khan, A. U. 1974. Axial-flow threshers. Philippine Patent No. UM-1379.
10. Khan, A. U., B. Duff, C. C. Lee, and D. Kuether. 1975. Semi-annual progress report 20. USAID/IRRI Machinery Development Project, Agricultural Engineering Department, International Rice Research Institute, Los Baños, Philippines.
11. Khan, A. U., and S. Johnson. 1967, 1968. Semi-annual progress reports 5 and 6. USAID/IRRI Machinery Development Project, Agricultural Engineering Department, Los Baños, Philippines.
12. Khan, A. U., F. Nichols, and B. Duff. 1972, 1973. Semi-annual progress 5 and 6. USAID/IRRI Machinery Development Project, Agricultural Engineering Department, Los Baños, Philippines.
13. McMennamy, J. A., and J. S. Policarpio. 1978. Development of a portable axial-flow thresher. In *Proceedings of International Grain and Forage Harvesting Conference*, ASAE, Ames, Iowa. Also available as Paper No. 77-06.
14. NIAE (National Institute of Agricultural Engineering). 1985. Review of the impact of the agricultural engineering component of the work of the CGIAR institutes. Wrest Park, Silsoe, Bedford, MK45 4HS.

Appendix

The consequences of the use of IRRI-type threshers in the Philippines and Thailand

By using estimates of the number of IRRI-type threshers in use, their annual utilization, and work rates, the rice quantities threshed with these machines can be estimated. To determine the "net" impact, data from the IRRI "Consequences"^{1,2} studies are used.

Difference in threshing losses between more traditional methods and the IRRI threshers gives the impact in terms of tons of rice gained or lost.

Net benefit is measured in monetary terms to the farmer as an individual using market prices and to the society as a whole using shadow costs where the market value is not a true reflection of actual value to society.

The assumptions used and the physical and monetary impact of the IRRI-type threshers are given below:

		Philippines	Thailand
Number of threshers	a) large 10-16 hp	9,200 (46%) ³	18,000 ⁴
	b) portable 5-7 hp	10,800 (54%)	
Rates of work	a) large	1,000 kg/h ⁵	1,000 kg/h
	b) portable	400 kg/h	—
Annual utilization	a) large	169 h ⁶	170 h
	b) portable	70 h	—
Total production of rice for the country		8,150,000 t ⁷	18,535,000 t
Total threshed with IRRI types (% total production)		1,856,400 t (23%)	3,060,000 t (11%)
Savings/ha, /ton		40 kg/ha ⁸	77 baht/t ⁹
Aggregate saving (financial and physical)		18,654 t ¹⁰ (US\$2,784,600) ¹¹	235,000,000 baht (US\$10,244,348) ¹²
Net social benefit		See notes, especially no. 2.	

Notes on Appendix

¹Workshop Papers. The Consequences of Small Rice Farm Mechanization in Thailand. 10-11 Nov 1983, Bangkok, Thailand. ²Workshop Papers. The Consequences of Small Rice Farm Mechanization in the Philippines. 1-2 Dec 1983, Tagaytay City, Philippines. ³Overall figure of 20,000 taken from Agricultural Engineering report to the Trustees of IRRI, Oct 1984. Percentages come from Juarez, p. 261, "Consequences" (Note 2). In this paper 14,800 is quoted as a minimum number of threshers in use, 1982. ⁴18,000 taken from Report to the Trustees (Note 3). Assumed that the vast majority are large threshers. Sukharomana, p. 226, "Consequences" (Note 1) says the attempt to introduce the portable threshers to Thailand was unsuccessful. ⁵"Consensus" figure from "Consequences" reports (Note 2) and personal communications with members of Overseas Division. ⁶Juarez p. 269 Philippines, "Consequences" (Note 2). ⁷FAO Production Yearbook 1983. ⁸As cited by Gonzales et al, Philippines, "Consequences" (Note 2) - Toquero et al. Also cited is a figure of a 242 kg/ha saving. IRRI Agricultural Engineering Semi-Annual Report Nos. 21-28. At 7.3% saving of gross yield this seems high, so the more conservative figure of 40 kg/ha is used. For Thailand a loss over traditional methods of 0.54% - 0.72% is mentioned. (Sukharomana, p. 231) (Note 1). This is negligible and is ignored for this report. ⁹Sukharomana, p. 231, "Consequences" (Note 1).

Gain

Animal treading to rice thresher	95 baht/t
Tractor treading to rice thresher	53-64 baht/t

An average of 77 baht/t is taken.

¹⁰A yield of 4,000 kg/ha is used to convert "total amount threshed" to ha and then calculate "total savings" at a rate of 40 kg/ha. ¹¹Assuming a "world price" for paddy of US\$ 150/t in 1983. ¹²Exchange rate US\$ 1:23 baht (Mar 1983).

AXIAL-FLOW PADDY THRESHERS IN THAILAND

J. MONGKOLTANATAS
Ministry of Agriculture and Cooperatives
Bangkhen, Bangkok, Thailand

The mechanical paddy thresher was first introduced to Thai farmers about 30 yr ago. However, mechanical threshers were not adopted until the IRRI axial-flow thresher was introduced through the Thai-IRRI Agricultural Machinery Program during crop year 1975-76. Now it is one of the widely used agricultural machines in the country because of factors such as double cropping, contract services, availability of loans, and effective extension.

Development and adoption of the thresher involved several years of modifying and improving the performance of the original prototypes to suit local conditions. However, the pattern and speed of its adoption still differ from region to region due to differences in agro-socioeconomic conditions. New agricultural machines will be rapidly adopted if they can solve farmers' problems at reasonable cost.

PATTERN OF MECHANICAL THRESHER DEVELOPMENT

The Japanese pedal thresher was introduced to Thai farmers about 30 yr ago (2). Although the government imported about 1,000 such threshers and offered them at subsidized prices, none was sold. The Japanese thresher was not adopted because

- Time was no constraint, as farmers grew only one crop. They had plenty of time to carry out their farm activities properly.
- Even though the thresher was offered at subsidized prices, it was still too expensive for farmers.
- The machine had only a threshing mechanism. Farmers still had to do associated tasks with traditional methods which are sometimes not compatible with machine use. The increased threshing capacity was not sufficient incentive.
- The innovation plan was not effective; it ignored many related factors such as socioeconomic situation of farmers, biological factors, and follow-up activities.

After the failure of the Japanese pedal thresher, no other thresher was introduced for about 10 yr. The Agricultural Engineering Division, Depart-

ment of Agriculture, carried out research on paddy threshers but produced no successful prototype.

The development and introduction of modern varieties (MVs) by the Department of Agriculture, coupled with irrigation development, enabled farmers in some areas to double-crop rice. Timeliness became critical to such farmers. The gap was very short between harvesting the first crop and planting the second. Farmers had to accelerate their work and needed more labor. Labor shortage in such areas became serious, forcing farmers to look toward mechanization.

Rice mechanization in Thailand began to take roots. The locally produced power tiller was being successfully adopted, so more farm machine manufacturers were started. However, no locally produced paddy thresher was available. Some Japanese power threshers were imported, but their performance was not satisfactory.

In 1974, the Agricultural Engineering Division, Department of Agriculture, revived distribution of the Japanese pedal thresher. About 400 units, stored for about 15 yr, sold out in a few months for these reasons:

- The threshers were sold at about \$30-40 without any direct subsidy. Many farmers could afford to buy.
- New threshing techniques were introduced through agricultural extension program on radio, followed by thresher advertisement.
- Most important, threshers were urgently needed by farmers who were double-cropping rice.

Important changes in the thresher design enabled it to use engine power instead of human force.

The increasing demand and sale of the Japanese pedal thresher convinced local manufacturers that mechanical threshers would succeed in the agricultural machinery market (3). Because the capacity of the Japanese pedal thresher, even when powered, was too low to cope with increased yields, local manufacturers and governmental agencies tried to change the design or produce new types of threshers with improved performance. The Agricultural Engineering Division began research to develop a new thresher.

In 1975, the Department of Agriculture-IRRI (DA-IRRI) cooperative project for the development of agricultural machinery made blueprints of the axial-flow thresher available to Thai manufacturers. After testing and modifications, blueprints were distributed to interested manufacturers until the thresher's performance was acceptable. The first locally produced machines came from three manufacturers in 1976. At present, about 30 manufacturers produce 3,500-4,000 units annually. A 1984-85 survey by the Agricultural Engineering Division showed about 25,000 axial-flow thresher in use, mostly for contract-hire services in the central region.

INNOVATION AND ADOPTION OF IRRI AXIAL-FLOW THRESHERS

Figure 1 shows the early stages of innovation of the IRRI axial-flow thresher (6).

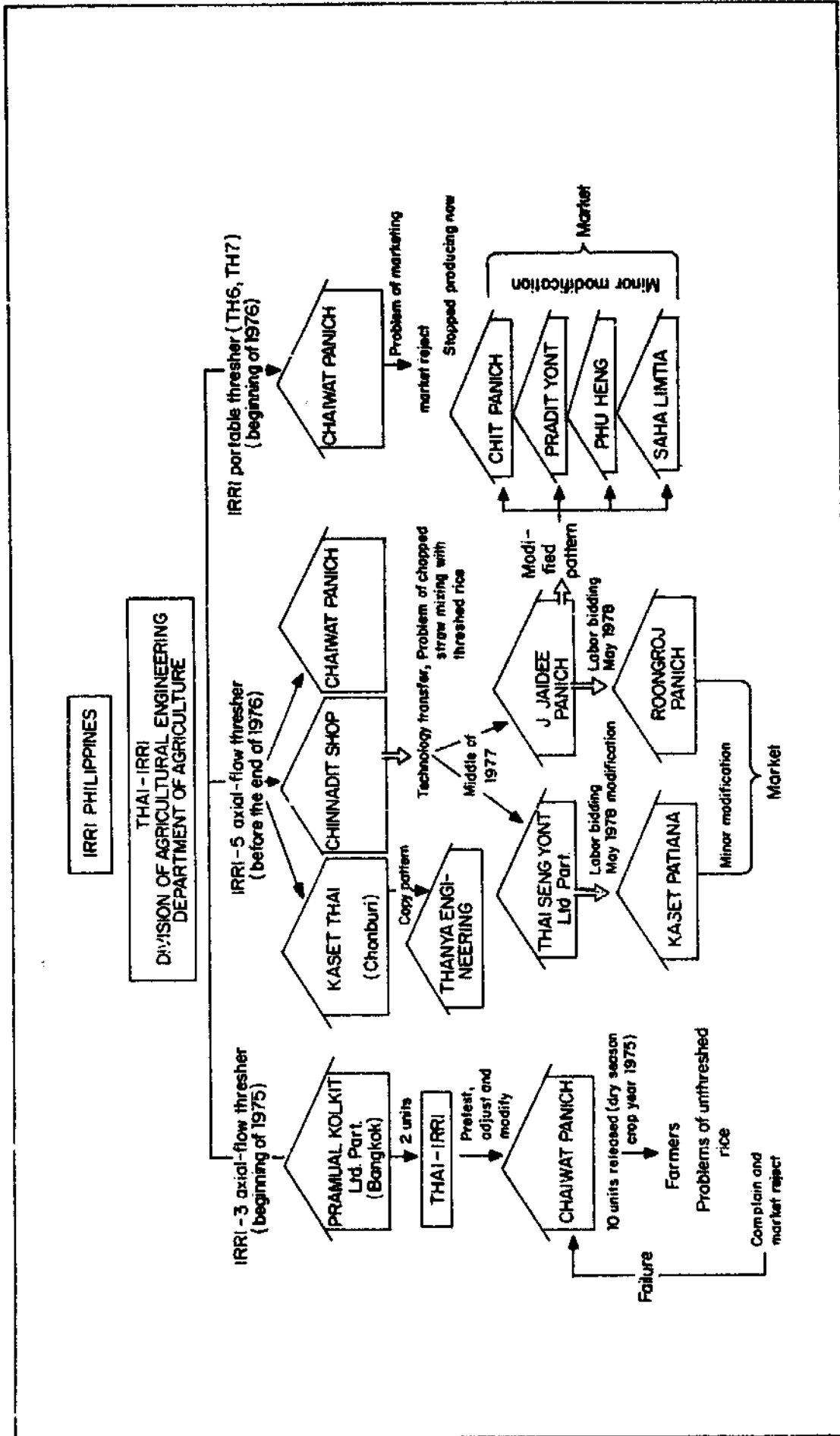

1. Flow chart of the development of the axial-flow thresher and its adoption.

Blueprints of the IRRI axial-flow thresher model TH-3 were sent to Thailand in 1975 through the DA-IRRI cooperative project. Two prototypes were fabricated for testing and modification. These performed satisfactorily with a few selected varieties.

Manufacturers in double-cropped areas were informed about the IRRI-3 thresher through personal contacts and demonstrations by the project staff. In Chachoengsao, one of the most progressive farming areas, Chaiwat Panich produced 10 units with project assistance. However, the machines were not acceptable to farmers because of problems such as poor cleaning and high losses in separating and screening. The project staff and the manufacturer tried to solve these problems but removed only a few defects in the first 2 yr. The shortcomings of the machines were communicated to IRRI for their consideration.

At the end of 1976, while the IRRI-3 thresher was being modified, a new model designated as IRRI-5 was sent to the project. Notwithstanding remaining weak points, three manufacturers including the first one requested the new prototype and began production. Only Chinnadit, a new manufacturer, was successful in modifying the IRRI-5 thresher to suit local conditions; about 135 units were sold to farmers. Later, several manufacturers in nearby areas copied this modified model.

New manufacturers usually further modified designs to meet local needs. In fact, all manufacturers wanted to claim that their products was their own modification and had some advantages over the others. Since then, axial-flow thresher innovation has been one of continual modification of the machine in the light of local and regional field experiment and needs.

In 1976, blueprints of a new IRRI-designed, small, portable thresher were sent to the project. The design attempted to ease transporting the machine and reduce labor requirement and cost. After field testing, evaluation, and modification, a manufacturer asked for the modified prototype with additional blower, oscillating screen, and screw conveyor. Nine units were produced and sold, but were not adopted because they had low threshing capacity.

In 1980, the project received blueprints of a new IRRI axial-flow thresher, TH-8 model, with double oscillating screen and open-threshing drum. A prototype was fabricated and tested. After modifications, the performance seemed acceptable to farmers. However, no thresher manufacturer showed interest in producing this new version. Most felt that because the locally modified models which had been widely adopted performed satisfactorily, it was not advisable to shift to a new model which had undergone only limited tests. Moreover, they thought that the TH-8 model was more difficult to produce and would cost more. Today, only 2 of 30 manufacturers are producing the TH-8 thresher.

The close cooperation between the Thai-IRRI project and local manufacturers played an important and significant role in the successful development of the axial-flow thresher. Collaborators continually modified machines to produce mechanical threshers that would satisfy farmers. Important modifications include the following:

- A transverse oscillating screen was used with a tailing auger.
- A larger, higher-speed fan was used.
- To overcome a panicle problem, a portion of the lower concave rods at the feed end of the threshing drum was replaced by sheet metal or perforated sheet.
- The straw discharge housing and chute were modified to throw straw farther and eliminate straw accumulation near the machine.
- Sheet metal on the oscillating screen was lengthened to prevent broken straw from falling through the perforated sheet and mixing with clean threshed paddy.
- Some manufacturers changed the configuration of threshing pegs from a straight line along the skeleton into a spiral form which they claimed produced a better feeding rate (Fig. 2).
- The louver on the upper concave was modified to be adjustable.

Notwithstanding the close relation between the project and manufacturers, it is not easy to introduce a new design to manufacturers who have been producing acceptable models for sometime. They have full confidence in and experience with their products. Furthermore, their workers are familiar with existing models. Therefore, to change their models to newly designed ones with limited testing seems unadvisable. These are some of the reasons behind the slow development of the new TH-8 model in Thailand.



2. Modified spiral threshing peg configuration.

FACTORS INFLUENCING ADOPTION

The axial-flow thresher was introduced to farmers through demonstrations by the project and the manufacturers. Rapid diffusion occurred when farmers who purchased the early machines hired them out to others. Consequently, the merit of axial-flow threshers was spread by farmers themselves. At present, diffusion is proceeding on to new areas mostly by contractors and manufacturers. The rate of diffusion and reasons for adoption depend on conditions which vary from area to area. Sukharomana (7) indicated factors that may influence thresher adoption: 1) irrigation and double cropping, 2) high yielding rice varieties, 3) the net benefit from using and investing in a rice thresher, 4) the ability of the farmer to purchase the machine, 5) the contract system, 6) the establishment of the local farm machinery industry, and 7) the demonstration effect. Some factors are interrelated and can be elaborated as follows:

Double-cropping system

The development of MVs accompanied by expansion of irrigation enabled farmers in some areas, especially the central region, to raise two crops of paddy. Double-cropping necessitates mechanization to overcome problems of timing and labor. The result is the rapid adoption of threshers.

Contractor-service system

Although the paddy thresher is important for farmers in double-cropping areas, small landholdings prevent farmers from owning machines. The contractor-service system makes threshers available to farmers. At present, more than 80% of paddy is threshed through contractor service. Furthermore, contractors moving from farm to farm spread the idea of threshers. The wider the contract or service area, the more threshers are needed and the more new contractors enter the market. Since services are demanded over a short period, the larger the thresher capacity, the larger is the market share. This factor has led to the development of bigger threshers with 3-4 t of output/h. Recently, the contract charge rate decreased because of severe competition among contractors.

Availability of loans

As threshers are expensive, only well-to-do farmers can afford to buy them. However, farmers know that a paddy thresher is a beneficial investment. During the initial stage of innovation, most farmers purchased the machines from their own savings or borrowed from moneylenders at interest rates of 20-30%. Lack of capital retarded the rate of IRRI axial-flow paddy thresher adoption. In 1979-80, the Bank for Agriculture and Agricultural Cooperatives (BAAC) started a new scheme of loans. BAAC used to provide agricultural machinery loans to farmers at a limit of about 6,000 baht (6), or one-fifth of the thresher price. BAAC now provides sufficient loan for farmers to purchase a complete machine, but not in cash. Farmers get the loan in kind

in the form of machines they request from manufacturers registered with the Bank. BAAC's interest rate is 12% with reasonable terms of repayment. This has helped boost the rapid dissemination of modified IRRI axial-flow threshers during the last 5 yr.

Effective extension activities

As most farmers are not familiar with new agricultural technology, especially machinery, purchase of an expensive thresher seems risky. Effective demonstrations during the initial stage of development by the Thai-IRRI Agricultural Machinery Project, the Agricultural Engineering Division, and manufacturers proved to farmers that the thresher was a reliable machine which could solve their timeliness problem. Manufacturers' guarantee that they would take care of any performance problems alleviated the investment risk and resulted in large-scale adoption.

STATUS AND TREND OF PADDY THRESHER USE

Three types of mechanical threshers are currently in use: axial-flow, hold on, and batch types. The most widely used is the first. Most threshing machines are owned by farmers who, after threshing their own crop, hire out their machines to other farmers at a reasonable cost of around \$4-5/t of threshed paddy. Usually the machines work about 500-600 h/yr (1). Due to differences in agro-socioeconomic conditions among the 4 regions of Thailand, the axial-flow thresher is successfully adopted in the central plain where almost 80% of the country's threshers are used in double-cropping areas.

In the northern region, farmers usually grow mushroom, soybean, or garlic as a second cash crop. Mushroom or garlic cultivation requires long straw in good condition, but the axial-flow thresher cuts straw into small pieces. Few axial-flow threshers are used in the north, but there are some small mechanical, hold-on types modified from Japanese threshers.

In the southern region, farmers usually harvest only the paddy panicles with knives; therefore, the grain-straw ratio is very high. Because the varieties grown are difficult to thresh, the axial-flow thresher is not satisfactory (4). As in other regions, however, farmers need threshers. Some indigenously designed and produced small batch threshers, although used, are inefficient.

In spite of regional constraints, the axial-flow thresher will soon replace the small types used in the north and south because the government is expanding the double-cropped area by providing more irrigation facilities and new MVs in both regions and in the northeast. The timeliness problem will force farmers to use more effective axial-flow threshers. Expansion will differ from region to region.

In the central region, higher-capacity axial-flow threshers are being produced (5). The original design was 4 ft long, operated by a 10-hp engine and with a capacity of about 1 t/h. Now contractors are using 6 to 6-1/2 feet threshers powered by the P.T.O. with 65-75 hp tractor or 100-120 hp used



3. Large, mobile axial-flow paddy thresher powered by 90-120 hp secondhand, diesel-truck engine.

engine of diesel trucks (Fig. 3). Output is around 3-4 t/h. This use in the central region and in the lower part of the northern region is due to increasing competition among contractors.

Farmers complain about high separating loss and crackage of threshed paddy from large threshers. This might be caused by irresponsible contractors who are interested only in output and operate the machine at speed too high for quality paddy. Or else, large-size threshers need some modification.

Operational safety is also a critical issue. Serious accidents were reported, especially with large threshers. The feeding end is most dangerous. Operators' bodies have been dragged into the machines due to carelessness and high speed. This demands attention.

Recently, some manufacturers successfully modified large axial-flow threshers to thresh paddy and soybean satisfactorily. This will expand thresher use in the north.

There are no technical constraints to axial-flow thresher adoption in the northeast. The main constraint is the economic condition of farmers. Farmers there have the lowest average income of any Thai region. Poor soil fertility, lack of water, and unreliable climate cause low yields. Furthermore, only a very small percentage of the total planted area can double-crop paddy. A high-capacity thresher is not attractive to farmers and contractors; however, very small threshers have a use. More than 90% of farmers in the paddy area, usually women, employ the beating method, flailing paddy bundles against the ground or an object (Table 1). Drudgery and labor shortages make a mechanical thresher appropriate. One manufacturer is producing a small

Table 1. Paddy threshing methods, 1984-85.

Region	Threshing methods used in percent of paddy cultivated areas				
	Beating or treading	Animal treading	Power tiller treading	Tractor treading	Thresher
Central	1.36	5.53	28.84	11.91	52.37
North	34.62	3.34	16.72	19.43	25.89
Northeast	93.77	0.79	0.79	0.18	4.51
South	51.28	6.27	1.15	0.12	41.91
Total	54.92	2.81	11.48	7.76	23.01

axial-flow thresher with a 1-m-long threshing drum for these farmers. However, adoption and diffusion are slow because of the noted constraints.

Labor shortage in the south is much more serious than in other regions, and the government is implementing a project to change subsistence paddy cultivation to commercial farming. There, the axial-flow thresher will soon outweigh the batch type.

Most threshers are under contractor service, and performance quality is low because contractors and farmers lack operating knowledge. Unfortunately, manufacturers do not provide instruction manuals. Users, therefore, do not know how to adjust threshers to suit the conditions of paddy. Although the Thai-IRRI Agricultural Machinery Program translated the IRRI axial-flow paddy thresher manual into Thai and provided it as a sample to manufacturers, it drew little response. Manufacturers have not accepted the extra cost and difficulty of writing a practical manual understandable to poorly educated farmers. The Agricultural Engineering Division is still trying to persuade manufacturers to provide manuals for all their products, especially threshers.

SUMMARY

Although the mechanical paddy thresher was introduced to Thai farmers about 30 yr ago, initial adoption was only in 1975. The IRRI axial-flow paddy thresher was introduced to manufacturers and farmers through the cooperative project on agricultural machinery program between IRRI and the Agricultural Engineering Division. After a few years of adjustment, it has proved to be an appropriate machine which can solve farmers' problems and meet their needs. Double-cropping, contractor services, availability of loans, and effective extension activities have stimulated the rapid adoption of this thresher. About 80% of the threshers are in use in the central region, on rent from contractors.

In the central region, thresher use is expanding and machine capacity is increasing. The most popular model for farmers uses a 6-ft-long threshing drum with an output capacity of about 3-4 h. Contractors who own standard 4-ft threshers have difficulty in getting demand from farmers. Timeliness is becoming more and more critical in the central region. This situation, however, has created performance problems. Farmers complain about high

separating loss and crackage of threshed paddy. Safety of the feeding operator is a serious problem.

Expansion of the irrigation system in other regions, increasing of double-cropping areas, and the emergence of contractor service are promoting rapid axial-flow thresher adoption. However, the rate of adoption depends upon the agro-economic conditions of each region. Rapid adoption takes place if the machine solves farmers' problems at a reasonable cost. Farmers have always the final say in the adoption of new technology. The lesser the risk in adoption, the more rapid is technology diffusion.

REFERENCES CITED

1. Makeham, J. 1980. A reaper for Thailand? A before-the-event case study. ESCAP regional network for agricultural machinery.
2. Mongkoltanatas, J. 1979. Potentiality of mechanization in Thailand in relation to energy use and rural development. Paper presented at the workshop on energy and rural development, Pattaya, Thailand.
3. Mongkoltanatas, J. 1980. Development and problems facing rice thresher manufacturers in Thailand. Paper presented at the RNAM subnetwork workshop on manufacturing technology of threshers and seed drills. Lahore, Pakistan, January 20-23.
4. Mongkoltanatas, J., et al. 1981. Testing and evaluation of rice thresher for the South [in Thai]. A research report of the Agricultural Engineering Division, Department of Agriculture, Ministry of Agriculture and Cooperatives.
5. Mongkoltanatas, J. 1982. Agricultural mechanization development in Thailand. Paper presented at the regional seminar on dissemination of technology to rural communities. Chulalongkorn University, Bangkok, Thailand.
6. Pathnopas, R. 1980. The economics of rice threshing machines in Thailand: a case study of Chachoengsao and Supanburi provinces. MS thesis, Faculty of Economics, Thammasat University, Bangkok, Thailand.
7. Sukharomana, R. 1983. The economics of mechanical rice threshing in Thailand. Paper presented at the workshop of the consequences of small rice farm mechanization. Bangkok, Thailand.

AXIAL-FLOW PADDY THRESHERS IN INDONESIA

V. R. REDDY

**International Rice Research Institute-Directorate of Food Crops Production
(IRRI-DITPROD) Industrial Liaison Project
Indonesia**

INDONESIAN AGRICULTURE

Indonesia is an agricultural country, with more than 80% of the population living in rural areas and 62% of the labor force in agriculture. Average farmholding is less than 0.5 ha in the densely populated inner islands (with more than 2/3 of the total population of 150 million people) and between 1 and 2 ha in outer islands. Of 11 million ha in food crops production, about 8 million ha (more than 70%) is in rice and about 65% of rice is modern varieties.

The already inadequate cattle population is said to be decreasing at the rate of 2 to 3%/yr. Only 58% of total land is being cultivated by draft animal power. The total tractor population in Indonesia was less than 30,000 units in 1984. Due to lack of inadequate power available to Indonesian rice farmers, they spend 180 to 200 labor-d/rice crop compared to less than 100 labor-d in other parts of Asia.

Within a decade (from 1967 to 1977), however, rice milling mechanization increased from 20 to more than 98.5% with more than 50,000 small rice milling units throughout rural parts of the country. This development apparently has taken place spontaneously without much assistance from government or outside agencies.

IRRI INDUSTRIAL LIAISON PROJECT

The IRRI machinery program has had a subcontract arrangement with DITPROD since 1974. In 1977, at the request of USAID mission Jakarta, a 3-mo study tour was undertaken by an IRRI consultant to determine the status of farm equipment in Indonesia and indicate the possibility of starting an industrial liaison project.

Subsequently, USAID Jakarta mission funded the industrial liaison project (IRRI-DITPROD) from March 1978 to August 1980. After evaluation, a regional project (Philippines, Thailand, and India with similar industrial liaison projects through IRRI) was funded by USAID Washington for Sep 1980-Sep 1985.

From 1974 to 1978, IRRI supplied technical drawings and samples of IRRI-developed small farm equipment to DITPROD and provided small

funding to encourage local manufacturers to produce prototypes. Six workshops supported financially and technically were held in Java to produce prototypes.

The early attempts, while not particularly fruitful in sustaining continuous growth of local manufacturing, did provide the opportunity to develop a strategy for the project since 1980.

EARLY ADAPTATION

After the tested designs and detailed drawings from IRRI Philippines arrived in Indonesia, many modifications had to be made to use locally available materials. Every change was thoroughly tested until a satisfactory model emerged. Only then was a new set of drawings made with instructions in the Indonesian language for distribution to local manufacturers.

This procedure modified IRRI designs to suit local conditions and also provided thorough training of the counterpart staff involved in the project.

FIELD EXTENSION WORK

West Sumatra

Our first choice of a pilot area to test our ideas and learn our lessons in field extension work was West Sumatra Province.

Initially, a few sets of demonstration equipment (consisting of hand tractors, TH6 model paddy threshers, axial-flow pumps, weeders, transplanters, and one vertical bin dryer) fabricated in Jakarta were sent to DIPERTA (Agricultural Department) in West Sumatra. They served as models for fabrication in the department's workshop, in training of provincial staff, and in demonstrations in farmers' fields.

Simultaneously, we motivated a few local small shops to take up the manufacture of TH6 threshers, and we provided technical assistance.

For the successful diffusion of these threshers in the province, we soon discovered it was not enough to conduct a few demonstrations by DIPERTA and encourage small workshops to fabricate the threshers. *We found the following measures were needed to create sustained demand from farmers:*

1. We identified leader farmers in selected areas and provided them a well-tested thresher for at least one full season with periodic monitoring by the DIPERTA staff.
2. We encouraged and assisted small fabricators in fabricating the equipment and in renting it out to nearby farmers. This not only demonstrated threshers and helped create a market, but also showed which components needed further improvement, leading to reliable equipment. We found this crucial in the early stages of product introduction.
3. We coordinated through local banks to provide credit to needy farmers by hypothecating the equipment to the bank, a policy decision from Bank Indonesia in West Sumatra, and also to provide credit to small fabricators for working capital and expansion.

Table 1. Number of threshers by Kabupaten municipality in West Sumatra, 1980-84.^a

Kabupaten	Threshers ^b (no.)			
	1980 (2)	1982 (4)	1983 (8)	1984 (12)
Agam	6	50	141	520
Pasaman	1	22	73	210
50 Kota	3	13	33	85
Tanah Datar	4	20	42	120
Padang/Pariaman	2	49	164	215
Solok	1	14	44	95
Pesisir-Selatan	3	12	33	125
SL/Si junjung	5	9	26	175
Total threshers	25	189	556	1535

^aSource: Dinas Pertanian, West Sumatra. ^bNumbers in parentheses indicate number of manufacturers.

When carried out effectively in the initial stages, these measures have contributed greatly to achieving self-sustained growth in production and sales of paddy threshers in West Sumatra. Table 1 presents the number of IRRI cooperative manufacturers and their production figures, showing how rapidly thresher fabricators have been growing in West Sumatra.

This successful experience encouraged the International Labor Organization to fund a study on the diffusion of postharvest equipment technology in West Sumatra. This study found the following critical extension inputs that stimulated rapid dissemination of the technologies and their successful commercialization: 1) promoting farmers' acceptance through initial demonstrations in their fields, thus creating local demand; 2) identifying local fabricators, motivating them, and providing technical assistance through training programs and assisting them in field testing of their equipment; 3) coordinating and communicating with all the concerned institutions to forge and strengthen linkages among them through the periodic workshops; and 4) creating the suitable environment for growth.

SELF-SUSTAINING GROWTH ACHIEVED

With more fabricators and higher production, the quality of threshers by some producers has markedly improved. These are some of the improvements:

1. Thresher weight has been reduced from 105 kg to 85 kg.
2. Much better cleaning of threshed paddy resulted from an improved cleaning system.
3. Portability is better with incorporation of wheels.
4. Thresher capacity increased from 400 kg/h to 600 kg/h from increased drum speed and faster feeding.
5. The general finish and welding have improved considerably.

The price of the thresher without the engine has also decreased in 4 yr from Rp 500,000 to Rp 300,000, even after absorbing the yearly inflation rate of 10 to 15%.

Table 2. Profitability of leasing small hand tractors and paddy threshers in West Sumatra.^a

	Tractor P.T. 3	Thresher TH 6
Fixed costs		
Purchase price	Rp 1,000,000	Rp 650,000
Av yearly interest (12%/yr over 4 yr)	75,000	48,750
Av yearly depreciation (salvage value 10% of purchase price)	225,000	146,250
Total fixed cost/yr	<u>300,000</u>	<u>195,000</u>
Variable costs/ha (28 h/ha)		
Labor (2 operators - Rp 2,500/d)	17,500	8,750
Maintenance	2,380	804
Petrol + oil	19,740	8,400
Total variable cost/ha	39,620	17,954
Work capacity ^b	= 26 ha/yr	= 60 ha/yr
Total cost/ha	= $\frac{\text{Rp } 300,000}{26} + \text{Rp } 39,960$	= $\frac{\text{Rp } 195,000}{60} + \text{Rp } 17,954$
	= Rp 51,158,-	= Rp 21,204,-
Leasing rate	= Rp 60,000,-	Leasing rate (5% of crop value) Rp 26,250
Profit/ha	= Rp 8,842	Profit/ha = Rp 5,046
Profit/yr	= 8,842 x 26 = Rp 229,892	Profit/yr = 5,046 x 60 = Rp 303,000/yr
Return on initial investment (after providing for interest and depreciation)	= 23%	Return on initial investment (after providing for interest and depreciation) = 47%

^a US\$1 = Rp 1113. ^b In two seasons working 45 d/season.

Table 3. Profitability for manufacturer of IRRI small hand tractor and paddy thresher, West Sumatra.^a

Tractor P.T. 3		Thresher TH 6	
<i>Fixed costs</i>	<i>Rp</i>	<i>Fixed costs</i>	<i>Rp</i>
Materials (including engine)	400,000	Materials (including engine, Rp 180,000)	350,000
Labor (30 labor d)	100,000	Labor (7 labor d)	25,000
Total fixed cost	500,000	Total variable cost	375,000
<i>Variable costs</i>		<i>Variable costs</i>	
Overhead (electricity + tools)	100,000	Overhead	65,000
After sales-service, advertising, demonstration	100,000	After sales-service, advertising, demonstration	60,000
Total	200,000	Total	125,000
Fixed cost + variable cost	700,000	Fixed cost + variable cost	500,000
Selling price	1,000,000	Selling price	650,000
Profit	300,000	Profit	150,000
% profit on selling price		% profit on selling price	
$\frac{\text{Rp } 300,000}{1,000,000} \times 100$		$\frac{\text{Rp } 150,000}{650,000} \times 100$	
= 30%		= 23%	

^aUS\$1 = Rp 1113.

Hand tractor adoption, however, is growing much less slowly compared to that of the TH6 threshers.

The major reasons follow:

1. The profitability of leasing a TH6 thresher is more than twice that of a small hand tractor with the present wages or rates prevailing in the province (Table 2, 3).
2. The selling price of a hand tractor is almost twice that of the TH6 thresher; therefore, it is more *difficult to purchase hand tractors without the liberal credit facilities available from local banks.*
3. It is much simpler to fabricate a TH6 thresher than a hand tractor and its attachments.

FIELD EXTENSION WORK EXTENDED TO SOUTH KALIMANTAN AND SOUTH SULAWESI

With the successful experience in West Sumatra, DITPROD requested that the project be extended to South Kalimantan and South Sulawesi. Our experience in these two provinces has been different and not as successful as in West Sumatra.

In addition to the general backward economy and slower tempo of development in these provinces compared to West Sumatra, we felt less enthusiasm and involvement of the local DIPERTA (Provincial Agricultural Department) staff in our project activity.

Although the project has put in more efforts to introduce hand tractors in South Sulawesi and axial-flow pumps in South Kalimantan according to their

identified needs, TH6 thresher production in both these provinces is increasing slowly but steadily without much additional extension effort. The preceding three factors in favor of TH6 threshers seem to explain this development in the two provinces.

For the same reasons, TH6 threshers are becoming popular in several adjacent provinces, particularly in Aceh and North Sumatra.

WHEAT POWER THRESHERS IN INDIA

A. ALAM

Indian Council of Agricultural Research (ICAR)
New Delhi, India

In India, where agricultural traditions have evolved over thousands of years, farmers have preferred methods of harvesting and threshing of food grain crops. Unlike in Western countries, Indian farmers want not only clean wheat after threshing but also wheat straw reduced to 1-2 cm long, bruised and split to make good "bhusa" for much-needed cattle feed. This requirement of quality "bhusa" makes combining unattractive to small farmers.

In farm families, marriages are usually organized after wheat harvest. As soon as the wheat crop is ready, the farmer is under pressure to pay back his loans and debts. There are fire and weather hazards to harvested stalks on the threshing floor. Wheat threshing coincides with the onset of summer, too hot and dry to work in the open sun. Conventional practice of threshing by bullock treading involves walking behind the bullocks, stirring and turning, a strenuous task.

For these reasons, wheat growers began to look for faster and less tedious ways to thresh wheat. The earliest successful attempt was a bullock-drawn thresher known as the Olpad thresher. It consisted of gangs of serrated mild-steel disks mounted on a steel frame with a wooden platform-cum-guard on the top, pulled by a pair of bullocks. It reduced treading time to less than half and avoided continuous walking. A manually operated, blower-cum-cleaner Hoshangabad winnower, as a companion to the Olpad thresher, remained as the improved wheat threshing equipment for almost two decades.

In the mid-1950s, the Ludhiana thresher appeared, ushering Indian agriculture into the power thresher age. It was followed by the low-cost Drummy threshers, better-designed Naini or Shergpur threshers, and low power-requiring Syndicator/Toka threshers capable of handling even moist stalks of wheat. Recently, bulk automatic feeding with auto-reverse, and multicrop threshers have come on the scene. In Punjab, Haryana, western Uttar Pradesh and a few other pockets, tractor-mounted and self-propelled combines are increasingly being indigenously manufactured and used.

TRADITIONAL WHEAT THRESHING

The most common traditional method of wheat threshing is bullock treading followed by winnowing in natural air. Depending upon the local size and

situation, farmers use trampling under feet, beating with a flail, bullock treading, bullock treading supplemented with a rough-surfaced drag, wooden roller, or stone roller. For separation and cleaning, they winnow in the wind or in an airstream created by a device. Small lots are separated and cleaned with the help of cleaning baskets "sup," "supa," or "supada," mostly by women. Manual screens are also used for cleaning.

Bullock treading requires a specially prepared threshing floor — level, compact, and smooth, about 10 m × 10 m. Threshing floors are prepared every season before crops are harvested. Resourceful farmers and institutional farms have concrete threshing floors. Harvested stalks are transported, stocked and dried, spread in a circular sheave, and bullock-treaded till the desired size of "bhusa" is achieved. Thereafter, it is winnowed by dropping threshed material in a thin layer from a height of 1.5-2.5 m. Lighter fractions are carried away; grain and heavier fractions fall nearby. Women manually separate straw pieces and node sections with a broom. When air velocities are low, winnowing is stopped, or the desirable velocity is created with a cloth sheet or winnowing fan. Tables 1 and 2 indicate labor and time taken by traditional methods and power threshers. Normally it takes 3-4 d for a team of 5 workers and 4 animals to thresh and clean 1 ha of wheat.

REQUIREMENTS OF WHEAT THRESHING

Wheat is a rabi (winter) crop. By the time it ripens, weather is usually hot and dry with maximum temperature approaching 40° C. The work is difficult and harvested stalks are vulnerable to fire hazards. For socioeconomic reasons, farmers need cash as early as possible. Labor supply is reduced because of festivities and social functions. Wheat straw, valued as quality roughage for livestock, must be reduced to 1-2 cm long, well bruised with least awns. A power thresher is useful

- to thresh wheat and separate grain and straw with speed;
- to clean grain enough to market directly without any penalty for quality, independent of weather;
- to separate straw from grain because of difference in prices of the two;
- to reduce energy use;
- to provide mobility on the threshing floor and from one threshing floor to another without a large labor force; and
- to reduce drudgery of threshing without undue hazard to operators.

THRESHER TYPES

Olpad thresher

Before tractors were introduced in India, draft animals were the prime source of farm power. Bullock treading, the common practice for threshing wheat, was slow and strenuous. Bullock-drawn Olpad threshers were developed and introduced in India in the 1940s to reduce treading time and reduce drudgery. These threshers borrowed concepts from threshing rollers, straw-chopping roller threshers, and Egyptian threshing carts (9).

Table 1. Labor input for wheat harvesting in 250 case studies (10).

District, state	Manual harvesting (man-d/ha)	Animal treading and manual winnowing		Power thresher		Tractor treading and manual winnowing		Pull type (man-d/ha)	Self- propelled (man-d/ha)
		Man-d/ha	Animal pair d/ha	Man-d/ha	Thresher h/ha	Man-d/ha	Tractor h/ha		
Ludhiana, Punjab	17.4	19.1	6.9	12.7	11.5	14.5	12.2	2.9	2.2
Karnal, Haryana	17.6	19.1	7.1	13.0	11.5	15.0	13.7	2.7	2.2
Nainital, U.P.	18.4	19.1	7.3	13.0	12.0	16.7	14.5	2.9	2.2
Av	17.9	19.1	7.1	13.0	11.8	16.7	13.5	2.9	2.2

Table 2. Time required in harvesting and threshing wheat by different methods (24).

Area (acres)	Time (h)					
	Manual ha. vesting and bullock treading ^a		Manual harvesting and power threshing by 12 men	Reaper harvesting and power threshing	Tractor- operated combine	Self- propelled combine
	Team of 12 men	3 bullock pairs				
4	98	77	80	60	14.3	5
20	494	396	400	300	71.5	25
40	988	772	800	600	143.0	50
Av/ha	24.7	19.3	20	15	3.6	1.25

^aSuperimposed.

Design features. It consists of three gangs of 10-gauge notched disks of about 450 mm diameter mounted on a frame with gangbolt ends in a bush bearing designed to roll over a circular thin layer (300 mm) of dry crop stalks when pulled by one or two pair of bullocks. Machines are available in 8-, 11-, 14-, and 20-disk sizes. An expanded sheet-metal guard and wooden platform provide safety and a seat for operator. Two cast-iron wheels provide transport. They can be removed or raised while the thresher operates. The Indian Standards Institution (ISI) issued IS: 3153-1965 on Olpad threshers.

Performance capabilities. The Olpad thresher reduces threshing time and cost by bullock treading to less than half.

Economic analysis. Cost of an 18-disk Olpad is about Rs 1,000. Unit cost of threshing by Olpad is about one-half of bullock treading (Rs 160/ha). Unit cost of bullock treading is about one-half of manual threshing with a flail.

Impact on agriculture. Together with a Hoshangabad winnower or a pedal-operated winnowing fan, the Olpad thresher was the only improved thresher available to wheat farmers till the power threshers came. Many bullock-owning farmers still use them and they are still manufactured.

Hoshangabad winnower and winnowing fans

Bullock treading of wheat or use of Olpad thresher yields a mixture of grain and bhusa. Threshing is not complete till the grains are separated by winnowing in natural air stream. In the event of too low wind velocities, winnowing is poor or sometimes suspended, wasting labor. To overcome this problem, hand-cranked, pedal-operated and power-operated winnowers and the Hoshangabad winnower, a manual blower-cum-cleaner, were developed and introduced in the late 1940s.

Design features. Various types of hand-cranked and pedal-operated fans have 3-4 blades (sweep diam of 0.90-1.25 m) made of mild-steel sheet on wooden or steel frames. These are designed to operate at 200-350 rev/min. The Hoshangabad winnower is a manually cranked, blower-cum-cleaner. It is designed to crank 20-30 rev/min, magnified with a gear drive to 300-350 rev/min at the blower. A sieve shoe with 2-3 screens of 0.6 × 0.6 m area of

choice aperture oscillate in 2 dimensions, effecting winnowing and screening simultaneously.

Performance capabilities. Irrespective of natural wind velocities, a Hoshangabad winnower can clean 1-2 ha threshed lot in a day with a team of 3 workers.

Economic evaluation. Depending on design, a winnowing fan may cost Rs 250-500, whereas a Hoshangabad winnower may cost Rs 900-1500.

Impact. These served their purpose and are still used on some farms.

Ludhiana thresher

After independence, the thrust was toward selective mechanization of agriculture. Punjab made efforts in agricultural mechanization. Around the mid-1950s, agricultural engineer (implements) S.K. Paul and Sardar Sunder Singh, a progressive small-scale manufacturer and proprietor of Friends Own Foundry, Ludhiana, developed the Ludhiana thresher (21). This was the first indigenous power thresher to be commercialized and accepted; it threshed, cleaned, and facilitated bagging. In 1957, the Indian Council of Agricultural Research (ICAR) honored inventors of the Ludhiana thresher.

Design features. The thresher employs the hammer mill principle. A rotor having 13 bearers was designed to rotate inside a drum with radial fixed flat iron pieces. The threshing drum has a diameter of 1000 mm and allows 26 mm from the rotor. Dry wheat stalks fed from a feeding chute on one side of the drum are broken into small pieces, detaching grain from stalks. Grain and straw fall to a double screen sieve. An aspirator sucks the light fraction. The remaining mixture of grain, heavier pieces of straw, and foreign material are separated by screening. The lower screen retains the wheat gathered by auger and bucket elevated for bagging. Weed seeds and other foreign matter fall on the ground. For on-farm transport, it had iron wheels.

Performance capabilities. The Ludhiana thresher recommended to run with a 12.5-hp electric motor or a 25-hp tractor has rated output of 0.3 t/h. At optimum speed of 500 rev/min, it required 17.8 hp electric power, giving an average output of 0.26 t/h (12). Specific power consumption was 40.96 kWh/t (60.65 hph/t) as against 6.7-1.5 kWh/t (9-2 hph/t) in case of Western power threshers not making bhusa. Later designs of wheat threshers use less energy than does the Ludhiana thresher.

Economic evaluation. The Ludhiana thresher costs about Rs 12,000. Because of high initial cost and relatively low output for the power required, its unit cost of operation is highest of all power wheat threshers.

Impact. It was the first indigenous power thresher and it became very popular in Punjab and adjoining states. Units were exported to Pakistan, Oman, and Bhutan. But with the cheaper Drummy threshers, and the Naini or Sherpur type spike-tooth wheat threshers becoming popular, it is going out of use. By 1975, Punjab had 160,000 wheat threshers of which 60,000 were Drummy type, and 12,000 spike-tooth type.

Drummy thresher

After the power thresher was accepted in pockets of the northern wheat belt in the mid-1950s, there was a spurt in evaluation of foreign designs and

development of local threshers. ICAR announced price awards for low horsepower threshers in 1965-66. P.N. Pangotra and International Machinery Co., Jagraon, Ludhiana, were honored by ICAR for developing the Drummy thresher. This simply designed power thresher, capable of threshing and winnowing, was accepted by farmers.

Design features. It employs the hammer mill principle for threshing and a centrifugal blower to pneumatically separate (winnow) grain and chaff. Drummy threshers require low horsepower (5-10) for threshing crops like wheat, barley, sorghum, and pearl millet. They do not screen, so cleaning is relatively poor. A typical 7.5-hp unit may have a 680-mm diam and 350-mm-wide threshing drum. The rotor inside has 10-16 beaters designed to rotate at 450-550 rev/min (960-1193 m/min). Ribs on the upper half of the drum provide better threshing. The bottom half has a rectangular opening, made out of MS squares, serving as a concave. Clearance between the beaters and the concave is kept about 18-20 mm. Feeding is from one side of the drum through a feeding chute.

Performance capabilities. A 3-hp electric motor unit may have output of about 0.1 t of wheat/h whereas a 5-hp unit may give 0.1-0.2 t. A 7.5 unit gives output of about 0.2-0.3 t with a threshing efficiency of 99% and cleaning efficiency of about 95%. Total grain loss may be around 5%, including crackage of about 2%.

Economic evaluation. These are the cheapest power threshers available in the country. Without a motor, a 5-hp thresher costs about Rs 2,000-2,500 and a 10-hp unit may cost Rs 3,500-4,000.

Impact. Because of their low cost and simple design, these popular power threshers contributed to mechanization of threshing in Punjab and other states. However, accidents with them are frequent. Cleaning is not so good. Energy use is not so efficient, and it is gradually being replaced by spike-tooth or Syndicator threshers.

Naini or Sherpur spike-tooth thresher

Research and development (R&D) carried out at Allahabad Agricultural Institute under a Ford Foundation funded project, Agricultural Implements Design and Development Centre, provided the design for a 5-hp unit. This was commercialized first under the trade name Sherpur thresher in Ludhiana, Punjab. It became popular with farmers and is manufactured by many firms with minor modifications.

Design features. It has a threshing drum with spikes or studs as beaters. Material fed radially through a feed chute is threshed and passes through a closed concave, light fraction is aspirated and blown, and the grain and heavier fractions are screen separated so that clean grain flows into an attached bag. A variation subjects clean grain to another aspirator blower to improve cleaning efficiency. A typical 5-hp thresher has a 660 × 270 mm threshing cylinder having 40 beaters 20 mm square, recommended to operate at 700 rev/min (tip velocity of 1,450 m/min). A flywheel of CI 550 mm diam, weighing 53 kg, is provided. The blower aspirator mounted on the main shaft (38 mm) has 3

blades of 130 mm creating an overall diam of 710 mm. The cleaner has 2 screens: the top one has an area of 720×620 mm with 4.5 mm hole, 1.7 holes/cm²; the bottom screen has $1,160 \times 620$ mm with 2.5-mm hole, 4-5 holes/cm². Drive to the cleaner is provided from the main shaft through a cross belt drive. For transport by towing, the thresher is mounted on 4 CI wheels 260×65 mm size with 985 mm tread and front wheels equipped with integral steering hitch. Overall dimensions of the thresher are $1,280 (2,220) \times 1,050 (1,700) \times 1,845$ mm. Other size models run on 3-hp to 30-hp motors. Up to 15-hp feeding is through a chute; larger units use a bulk feed hopper with a starwheel feeder. Beater design varies greatly and threshers with spikes use less energy than those with bolts or struts.

Performance capabilities. The thresher described in the preceding paragraph yields 0.21 t/h from wheat stalks at 8.3% moisture and grain content of 38%. At recommended speed, grain loss through bhusa, tailings, and grain crackage are reported at 1.6%, 3%, and 2%, respectively. Specific energy requirement was at 20 kWh/t. Average power was found to be 5.31 hp and the peak power 8.76; thus, the prescribed 5-hp motor was too small.

Impact. The spike-tooth thresher is most popular now.

Syndicator/Toka type thresher

Earlier threshers required dry brittle stalks for threshing. They did not produce bhusa easily from moist stalks and got overloaded or choked, resulting in operation breakdown. Postharvest rains may require threshing wet stalks. A solution was found by adopting the chaff-cutter to power threshing. Chaff cutter Syndicator/Toka type threshers have become very popular in Punjab and adjoining areas. They thresh moist stalks without any problem, use little energy, and produce bhusa of uniform size (6, 7).

Design features. The Syndicator/Toka type thresher is essentially an adaptation of the chaff-cutter. Stalks are fed into the feeding rollers, pushed into the threshing chamber, and chopped by 2-4 serrated blades fastened on radial arms of the flywheel. Chopped material is rubbed between the concave and flywheel by corrugations or burrs on the flywheel rim. Additional beaters provide impact. Thus, threshing is effected by cutting, impact, rubbing, or abrasion. The threshing cylinder is usually 925×200 mm size with closed concave. Threshed material is cleaned by an aspirator and oscillating screens. The whole unit is mounted on CI wheels for towing and limited transport. The design is prone to accidents (Table 3). Some threshers now have auto-reverse of the feeding rolls.

Performance capabilities. A Toka thresher recommended to operate with 10-hp motor or 15-hp diesel engines 27 bhp tractor was claimed to give 0.7 t wheat/h. However, tests showed the output at optimum speed of 430 rev/min was 0.2-0.26 t/h with threshing efficiency of over 99.5% and cleaning efficiency of 99.8-100%. Average and peak power required were 5-7 kW and 10-13 kW. Total loss was 2.5-3.0%, including crackage of about 0.5%.

Impact. The thresher is quite popular with farmers because it can handle moist stalks and average power requirement is low.

Table 3. Types of threshers involved in 1976 accidents in Punjab and their relative probability (22).

Type of thresher	Accidents reported (%)	Probability (%)
Drummy	45.16	0.222
Ludhiana type	16.13	0.124
Syndicator	37.42	0.220
Naini/Sherpur type (spike-tooth)	1.29	0.033

PAU multicrop thresher

As wheat, paddy, and maize are major crops in Punjab, a multicrop thresher design was developed under the All India Coordinated Research Project on Farm Implements and Machines. Multicrop threshers based on conventional rasp-bar design can thresh most crops except groundnut. However, farmers need bruised straw to feed cattle. Thus, a new design used a tractor-operated rasp-bar thresher to yield bruised straw (17).

Design features. The conventional rasp-bar threshing and separation mechanism has indigenous options including a wheat straw bruising attachment which can be removed while threshing paddy and maize.

The threshing cylinder was 675 mm wide and had a diameter of 540 mm with 6 rasp bars. Adjacent bars had opposite rasp angles to balance side thrusts. The concave covered 120° of the cylinder, about 90° with a grill with MS rounds passing through MS flats 20 mm apart. The rest of the concave was an extension of the rounds to form a finger grate. A stripping beater 650 mm wide and 250 mm in diameter was used to prevent wrapping of straw. The straw walkers were made in three sections, each 260 mm wide, with total length of 2,000 mm in 4 steps. Straw walkers were made out of wire mesh with 5 × 10 mm opening instead of punched sheets.

The cleaning system consisted of chaffer and chaffer extension with adjustable openings, sieves with round holes, and a fan 400 mm in diameter with 4 blades. The bruising attachment consisted of a spike-tooth cylinder, concave, and an aspirator blower. Diameter of the cylinder was 700 mm with rows of spikes as used in paddy combines.

Performance capabilities. Though initially designed for feed rate of 2.1 t/h, its specific fuel consumption increased beyond 18 t/h. At feed rate of 1.8 t/h, it yielded 0.7 t wheat/h, with 97% threshing efficiency and less than 2% crackage. But on long-duration tests, only 1.1 t/h could be fed, yielding 0.48 t/h. Specific fuel consumption was 9.6 litres/t. The feeding system and thresher transport posed operational problems. With paddy, it operated satisfactorily at a feed rate of 2.05 t/h yielding 0.9 t/h separation, cleaning losses of about 2%, and cleaning efficiency of 91.5-97.5%. At normal setting, damage to maize was excessive, requiring cylinder speed reduction to 18 m/s.

Economic evaluation. Cost of wheat threshing was comparable to conventional threshers. With paddy, however, it was unfavorable. Labor saving was

160 h/ha as compared to manual threshing of paddy. The estimated cost of the machine was Rs 13,000 against a comparable capacity wheat thresher of about Rs 7,000.

Impact. It could not get commercialized for reasons of high cost and bulky design.

IRRI-PAK multicrop thresher

Drawings of a wheat-paddy power thresher were obtained from the IRRI-PAK project. A prototype was fabricated, tested, and evaluated for adoption and potential in Punjab (2).

Design features. It has a 1,200 mm-wide spike-tooth cylinder consisting of the threshing and bruising portions. The threshing portion has a diameter of 520 mm with 44 round sections (bolts); the bruising portion has 495 mm diameter with 88 rectangular section spikes. The beaters are arranged helically, together with louvers in the casing. Crop materials enter one end and are ejected out the other end after taking about 3.5 turns. Grain and chaff fall through the concave. Blowers fitted on the cylinder shaft blow away the lighter chaff. Grains and larger straw fraction fall on the sieves below. Straw is scalped. Final cleaning is done by an aspirator blower. Five gangs of cutters can be flipped in or out of the cylinder casing. One to two gangs may be used for long, wet-stalked paddy, whereas all five are used for wheat straw bruising.

Performance capabilities. The average output of the multicrop thresher was 0.29 t/h with a 5-hp electric motor. Power requirement varied from 6.7 to 16.7 kWh/t, lower than ISI Standards (IS: 6284-195, 24 kWh/t). However, quality of straw bhusa was not acceptable to farmers in terms of length, split straw, and awns. Separation was lacking, resulting in overloading of the sieve and high sieve losses. Broken grain percentage varied from 2.7 to 3.0% at recommended speed. Throw of bhusa was not sufficient, involving machine shifting every 4 h. With 5-hp motor, it gave 0.5 t of clean paddy with 1.53-2.73% grain losses (13, 15).

Economic evaluation. Estimated cost of the machine was Rs 8,000 against Rs 4,500 for a comparable capacity wheat thresher. It could save about 120 h of labor/ha with paddy, but none with wheat.

Impact. Because of its limitation in giving quality bhusa, it could not be recommended for adoption. However, a new R&D exercise was undertaken combining strong features of this thresher and of the traditional spike-tooth cylinder.

PAU wheat-cum-paddy thresher

In Punjab, wheat threshing has been fully mechanized, but rice is still threshed by manual beating. Introduced paddy threshers have not been very acceptable. Hoping that the wheat-cum-paddy thresher may become popular, AICRP on Farm Implements and Machine Centre of Ludhiana undertook this R&D activity (1, 18, 19).

Design features. The thresher has a spike-tooth cylinder with 8 rows of staggered spikes mounted on 4 rings of 340 mm diameter. The cylinder has

three portions. The first section is 375 mm long with 15 mm spikes on flats spaced at 62.5 mm. Spike projections on one side of the flat are 70 mm for wheat; those on the other side are 70 mm for paddy. The second portion is 690 mm long with 12.5 mm spikes; the first 11 spikes are at 62.5 mm pitch and the remaining at 125 mm. The third portion, 150 mm long, has 4 straw throwing paddles. The full cylinder length is useful for paddy, but for wheat, only the first portion is used. The remaining two portions serve as a flywheel.

The 180° concave is a round bar cage, having 2 distinctive portions: the first is 375 mm long, 515 mm in diameter, and made of 6-mm rounds with 8-mm openings between the bars. The second portion is 640 mm long and 549 mm in diameter with 15-mm openings. Cylinder-concave clearances in the first portion are 12.5 and 32.5 for wheat and paddy. In the second portion, it is 45 mm.

Axial flow of the material is facilitated with the help of 7 louvers at 150-mm spacings in the hexagonal cylinder casing, allowing 20-mm clearance between the cylinder tip and louvers. For threshing wheat, the first three louvers are replaced with ribbed casing and side plates mounted in top casing to prevent flow of material to the two other sections. An aspirator mounted on the cylinder shaft and a set of reciprocating sieves help separate and clean grains. The feeding chute of the machine has been provided as per IS: 9020-1979.

Performance capabilities. An output of 200 kg/ha corresponding to a feed rate 500 kg/h can be considered within the limits of a 5-hp motor unit. With paddy at 21.4 wb grain moisture, 47.7% wb straw moisture, freshly harvested stalk length of 70-75 cm, and straw grain ratio of 2.7, full load yielded 450 kg/h at a feed rate of about 1,650 kg/h. Total loss did not exceed 0.81% and cleaning efficiency was 91.3-94.7%. A second model designed to operate with a 30-hp tractor has an output of 0.4 t wheat/h and 0.8 t clean paddy/h.

Economic evaluation. Wheat-cum-paddy threshers cost about 50% more than comparable wheat threshers. Because of increased annual use, unit cost of wheat threshing decreased from Rs 55.2 to Rs 5.19. Labor requirement remained the same as for a wheat thresher — 10.0 d/ha. With paddy, labor required decreased from 25 d/ha for manual to 12.5 for thresher.

Impact. This new design has yet to gain acceptance and preference over the existing designs. A multicrop thresher has a social constraint in Punjab. Harvesting and threshing of paddy are done by migratory labor. This labor does not contract for harvesting alone. With the growing popularity of the vertical conveyor reaper, acceptability of rice power threshers and multicrop threshers will improve.

CIAE multicrop thresher

The Central Institute of Agricultural Engineering (CIAE) wanted to provide a thresher operated by a 5-hp electric motor that could thresh wheat, paddy, Bengalgram, soybean, sorghum, and maize with acceptable quality of bhusa (5).

Design features. The CIAE thresher incorporates the desirable features of the IIRI axial-flow thresher and the Naini type spike-tooth thresher. It has

spike-tooth cylinder with tip to tip diameter of 495-505 mm and width of 600 mm. There are 92 forged spikes mounted on 8 bars in staggered fashion. The cylinder is closed with 180° concave with front clearance of 25 mm and rear clearance of 10 mm. There are 3 sets of concaves with between-bar openings of 7, 9, and 25 mm. Cylinder casing is hexagonal, having 5 spiral louvers at 140 mm pitch to move the material axially from feed to discharge end. Clearance between the spikes and the louvers is 40 mm. For crops other than paddy, louvers are covered with a ribbed casing reducing the clearance to 25 mm, and semi-circular plates to prevent flow of material into the throwing chamber. An aspirator and a set of reciprocating sieves separate and clean. The aspirator is mounted on a separate shaft with two section openings, one at separating chamber and the other at grain outlet. Cleaning sieves are hinged at the bottom of the cylinder concave on adjustable hangers. Three top sieves 540 × 860 mm in size are provided for different grains.

Performance capabilities. It threshes wheat, soybean, sorghum, maize, paddy, and gram at the rate of 0.28, 0.2, 0.54, 1.635, 0.39, 0.35 t/h, respectively; with threshing efficiency of 99.8, 98.8, 98.9, 99.9, 99.1, and 99.2%; and cleaning efficiency of 99.0, 93.0, 96.9, 99.3, 94.5, and 94.6. Total losses recorded are 0.62, 4.01, 1.66, 2.2, 1.86, and 1.86%, respectively. It meets ISI specifications.

Economic evaluation. Estimated cost of the thresher is Rs 8,000, excluding prime mover. Unit cost of operations (1984) are Rs 31.2, 41.85, 15.72, 5.96, 21.73, and 23.88 per ton of grain, respectively.

Impact. Manufacturing drawings have been released to 10 manufacturers.

IRRI-PANT multicrop thresher

The IRRI axial-flow thresher has been modified to thresh wheat. To thresh wheat, the louvers are covered, making it a fully closed cylinder. Two blowers of different sizes are fitted to blow away the chaff and straw. An auger gathers the clean grain. It is designed to operate with 15-20 hp electric motor or a 30-hp tractor. Recorded output is 0.6-1.4 t/h. So far, it has not become popular (4).

JNKVV multicrop thresher

It is a modified wireloop type thresher with closed concave designed to operate with a 2-hp electric motor to thresh wheat, paddy, and soybean. Separation is by a blower and cleaning is by an oscillating set of two sieves. Performance of this thresher was satisfactory for three crops tested. However, it could not be commercialized (20).

PUSA-40 thresher

The PUSA-40 thresher is a portable 5-hp, electric motor-operated multicrop thresher designed to thresh wheat, barley, paddy, pearl millet, safflower, and sorghum. It has 1,015-mm-long, spike-tooth cylinder with overshot concave. Cleaning and separation were done by a blower. It threshed 0.2 t wheat. However, bhusa was not of acceptable quality. Eventually, a bhusa bruising

attachment was developed, capable of making bhusa at the rate of 0.15 t/h. The PUSA-40 thresher was commercialized, but could not compete with other designs (20).

SAFETY IN POWER THRESHERS

Wheat threshing is 100% mechanized in Punjab. The State has 260,000 threshers and 1,900 combines (14). A survey by the Punjab Agricultural University (PAU) in 1976 and 1980 revealed that about 300 persons were injured every year while operating power threshers (essentially wheat threshers). Usually, the person feeding the thresher is the victim. Human causes, including inattentiveness, lack of skill, overwork, physical incapability, loose clothes, and consumption of intoxicants, accounted for 73% of the accidents. Machine factors such as defective design, wrong design of feeding chute, and substandard material accounted for 13% of the accidents. Crop factors such as short crop, stalks, moist stalks, feeding panicles contributed to 9% of the accidents. Site factors such as illumination, crowded surroundings, and slippery threshing floor accounted for 5% (22, 23).

Following the first survey by PAU, Ludhiana, ISI issued two Indian Standards — IS: 9020-1979 General and Safety Requirements for Power Threshers and IS: 9229-1979 Technical Requirement for Safe Feeding Systems for Power Threshers (16). These standards cover the right kind of materials to be used, proper selection of the components from the market, guarding of transmission and moving parts, improved feeding system such as the use of star-wheel mechanism rotating at 25-35 rev/min, feeding conveyors, feeding rollers with feed reversing mechanism. In the manufacture of power threshers, testing and quality control play a vital role. IS: 6284-1975 Test Code for Stationary Power Threshers for Wheat indicates various tests and their methods. Certification facilities are available in almost all the states under State Quality Marking Scheme as well as by ISI at the national level. Certification by ISI is in accordance with IS: 6320-1971 Specification for Wheat Power Thresher, Hammer Mill Type.

BASIC STUDIES

Several M. Tech. and Ph D theses have been written on in-depth studies of wheat threshing and thresher design aspects like energy of detachment, rub threshing (8), design of spike on cylinder (11), and application of dimensional analyses to dependent and independent variables involved in wheat threshing (3). Studies have been conducted to determine the power requirements of different components of spike-tooth threshers as influenced by feed rate and rev/min. Prediction equations have been developed to determine the performance of spike-tooth type threshing systems (13).

RECENT TRENDS IN WHEAT THRESHING

1. Energy-efficient power threshers.
2. Threshers that thresh with least loss and damage.

3. Threshers safe for operators, with safe feeding chutes or automatic feeding.
4. Multicrop threshers appropriate for dominant crop rotation of the region.
5. Custom hire power threshing.
6. Harvester combining.

CONCLUSION

In the mid-1950s, an indigenous design of a wheat power thresher came in the market under the brand name Ludhiana thresher. Its utility sparked more designs, including Drummy thresher, spike-tooth thresher, Naini or Sherpur type, and chaff-cutter or Syndicator or Toka types, all commercialized and used widely. Punjab State has reached 100% mechanized wheat threshing. Finer aspects are now receiving attention — reducing energy consumption, safety, quality control, and standardization. The threshers are being manufactured on a small scale or at cottage industry level. Ancillary units produce components required by thresher manufacturers. A few designs of multicrop threshers have potential for commercialization.

REFERENCES CITED

1. Anon. 1983. Consolidated report (1980-82), AICRP on Farm Implements and Machines, Punjab Agricultural University, Ludhiana.
2. Ahuja, S.S., V.K. Sharma, I.S. Dhaliwal. Performance evaluation of IRRI-PAK axial-flow thresher on wheat and paddy. Paper submitted for publication in J. Agric. Eng. Punjab State University, Ludhiana.
3. Banga, K.L., V.K. Mittal, and V.K. Sharma. 1984. Study of selected parameters affecting performance of spike-tooth type wheat threshing system. J. Agric. Eng. 21(142):25-40.
4. Chhabra, S.D., and K.N. Singh. 1977. Effect of cylinder speed and peg spacing of axial-flow thresher on wheat threshing. J. Agric. Eng. 15(4):141-144.
5. Davnani, R.S. 1983. 1983. Consolidated report on AICRP on Farm Implements and Machines, CIAE, Bhopal.
6. Mehta, M.L., and V.K. Sharma. Studies on delinking of cutting and threshing systems of chaff-cutter type wheat thresher. M. Tech. study, Punjab State University, Ludhiana.
7. Mehta, M.L., and V.K. Sharma. Studies on threshing system of chaff-cutter type thresher. M. Tech. study, Punjab State University, Ludhiana.
8. Panesar, B.S., and B.S. Pathak. 1974. Investigations into mechanics of rub threshing I - threshing efficiency and grain damage. J. Agric. Eng. 11(3):1-8.
9. Quick, G.R., and W.F. Buchele. 1978. The grain harvesters. ASAE, St. Joseph, Michigan.
10. Rao, T.R. Some reflections on the demand for harvesting combines and their introduction. National Council of Applied Economic Research. (unpubl.)
11. Sandhar, N.S., V.K. Sharma, and R.C. Sharma. 1984. Studies on spikes of conventional paddy combines for threshing wheat. J. Res. Punjab Agric. Univ. 21(2):227-234.
12. Saxena, J.P., B.S. Siroi, and A.K. Sharma. 1971. Power requirements of Ludhiana type thresher. J. Agric. Eng. 82(2):34-43.
13. Sharma, V.K., P.K. Gupta, S. Singh, and C.P. Singh. Paper submitted for publication in J. of Institution of Engineers, Punjab State University, Ludhiana.
14. Singh, M.L., and S.R. Verma. 1984. Efficient and safe use of power threshers. Coll. Agric. Eng., Punjab State University, Ludhiana.
15. Sharma, V.K., C.P. Singh, and P.K. Gupta. 1984. Paper presented at the All India Seminar on the Role of Agricultural Engineering in Rural Development, Institution of Engineers, New Delhi.

16. Sharma, R.N. 1979. Prevention of power thresher accidents: role of manufacturers. *ISI Bull.* 31 (Sep):295-298.
17. Sharma, V.K., B.S. Pathak, and S.S. Ahuja. 1983. Design, development, and evaluation of multicrop thresher. *J. Agric. Eng.* 29(3&4):16-26.
18. Sharma, V.K., S.S. Ahuja, N.S. Sandhar, I.K. Garg, and I.S. Dhaliwal. 1984. Development and evaluation of PAU wheat-cum-paddy thresher. *J. Agric. Eng.* 21(3):15-23.
19. Sharma, V.K., S.S. Ahuja, N.S. Sandhar, I.K. Garg, P.K. Gupta, and J.S. Sandha. 1984. Design, development, and evaluation of tractor operator multicrop thresher. *Agric. Mech. in Asia, Africa, and Latin America* 15(4):26-30.
20. Shanmugham, C.R. 1981. Farm machinery and energy research in India. CIAE, Bhopal.
21. Sridharan, C.S. 1976. Design and development of threshers. *Agric. Eng. Today* 1(3):2-9.
22. Verma, S.R., G.S. Rawal, and B.S. Bathia. 1978. A study on human accidents in wheat threshers. *J. Agric. Eng.* 15(1):19-23.
23. Verma, S.R., and B.S. Bathia. 1981. Thresher accidents in Punjab during wheat season of 1980. *Coll. Agric. Eng.*, Punjab State University, Ludhiana.
24. Verma, S.R. 1971. Economics of different harvesting and threshing methods. Punjab State University, Ludhiana.

Grain drying

CONDITIONS FOR SUCCESSFUL USE OF MECHANICAL DRYERS IN ASIA

N. C. TETER

Agricultural engineer, Post-harvest Processing
Lincoln, Nebraska, USA

For successful use of any dryer, the following conditions apply. 1) The market structure must provide financial benefit to operators of both sun dryers and mechanical dryers. 2) The volume of paddy to be dried must match the dryer capacity so that ton drying costs are competitively favorable. Further, the losses involved by not being able to dry on a sun-drying floor must be included in the operational costs of sun drying. 3) When harvest becomes highly mechanized, mechanical dryers are preferred to sun dryers. 4) Sun drying is much more costly in labor requirements than mechanical handling and drying, making mechanized drying more attractive as labor costs increase. 5) The most successful mechanical dryers depend upon electrical power and controls; a reliable supply of electrical power makes mechanical drying more feasible.

ECONOMIC BENEFITS OF DRYING

Drying is essential for normal preservation of paddy, both for food and for seed, because it reduces the rate of deterioration. Although the dry matter loss (DML) may be small, the economic loss from damaged and discolored kernels is great. Most international rice markets allow no more than 0.5% of yellowed kernels in their specifications for the quality of rice, and more yellowed or discolored kernels depress the money received. Damaged and discolored kernels affect grade; grade affects value. This value can be estimated because percentage of damaged kernels correlated with deterioration (% DML). The loss of money value is much more serious than the small loss of dry matter. Value of paddy does not abruptly change from fully acceptable food to complete garbage; the rate of change depends on the environment.

In a study in Southeast Asia, percentage value of wet paddy that was held without drying was estimated as follows:

$$\% \text{ paddy value} = 100 - (3.51 \times D^{0.35}) \times [(M-15)^{0.69}]$$

where D = days held starting at 2000 h on the day of harvest,
and M = moisture content, % wet basis.

Table 1. Estimated value of paddy of various moisture contents held without aeration for several days, compared with 100% value of paddy for which drying is started by 2000 h on the day of harvest.^a

No. of days paddy is held	Value (%) of paddy with indicated moisture content				
	24%	22%	20%	18%	16%
1	84.0	86.6	88.3	92.5	96.5
2	79.6	82.4	85.4	90.4	95.5
3	76.5	80.3	84.4	89.0	94.8
4	74.0	78.2	82.7	87.8	94.3
5	72.0	76.4	81.3	86.8	93.8
6	70.1	74.8	80.1	86.0	93.4
7	68.4	73.4	78.9	85.2	93.1
10	64.2	70.0	76.1	83.2	92.1
13	60.8	67.0	73.9	81.6	91.4
16	57.8	64.5	71.9	80.2	90.7
19	55.2	62.3	70.1	79.0	90.2
21	53.6	61.0	69.1	78.3	89.8

Table 1 shows the estimated value of paddy held without drying after harvest. The first day of holding may drastically reduce paddy value. This observation leads to the following principle of minimization of penalty cost for failure to dry: if drying facilities are not great enough to dry paddy immediately after harvest, it is less costly to immediately dry the incoming paddy to 18% moisture content than it is to dry paddy that is spoiling. Of course if paddy is dried to only 18%, it should be held in heavily aerated storage until the drying can be completed.

If paddy of 22% moisture is held 10 d without drying, the rice that is milled from that paddy will be worth 70% of the value of rice that is milled from the same paddy that is immediately dried. Dryers reduce the value loss of paddy. Example:

What yearly cost is justified to dry paddy if the inflow-outflow diagnosis of a normal year shows the following drying backlogs, and the price of the best grade paddy is \$215/t?

Backlog	Tons	Days held	% moisture content	% value	Tons × % value
	898	16	24	57.8	51,904.4
	1410	10	22	70.0	98,700.0
	1026	19	20	70.1	71,922.6
	4200	21	18	78.3	328,860.0
Total	7534				551,387.0

Solution:

$$\text{Weighted \% value} = 551,387.0 / 7534 = 73.2\%$$

$$\text{Value of paddy if immediately dried} = 7534 \times \$215 = \$1,619,810$$

$$\text{Actual value of paddy} = 7534 \times \$215 \times .732 = 1,185,701$$

$$\text{Justified drying cost} = \$ 434,109$$

$$\text{Justified drying cost per ton} = \$57.62$$

At this time of change from high labor to lower labor in agricultural industry, the overpopulated regions of the world face serious economic stress that can perhaps be lessened by the adoption of appropriate or intermediate methods of drying. In designing these intermediate-sized dryers, the economist has a difficult task because the economic analyses usually show cost benefits for the larger dryers because of the lesser fixed costs per ton, and the lower labor costs wrought by handling machinery usually associated with the larger dryers.

Cost of sun drying, like all costs of drying, includes fixed costs (overhead) and variable costs (operating). Fixed costs are investments in land, floor, and implements. Containers may be considered fixed costs, but container costs are usually charged to transportation. Variable costs are labor for drying and the upkeep costs (maintenance).

Example:

A paddy buyer who buys, cleans, dries, cleans, and resells paddy has loaned production costs to farmers who plant 350 ha that in the main season produce 3.8 t/ha, harvested over a 2-mo period. In the off season, production is about 3.2 t/ha on 200 ha. The buyer expects to buy 60% of both crops. What should be the size of his concrete drying floor? What are his estimated drying costs?

Solution:

There is no one solution to this problem because the economic, social, and technical requirements are linked to the buying and selling regulations, and money costs. Some assumptions will be made.

After study, the buyer thinks that 75 m²/t per day is a reasonable floor capacity expectation. He hopes to buy at a maximum rate of $0.6 \times 350 \times 3.8/60 = 13.3$ t/d.

Floor area = $13.3 \times 75 = 998$ m², say 32×32 m.

Fixed costs:

Initial investment -

Land for floor and access	
1500 m ² @ \$5000/ha	= \$ 750
Drying floor 1024 m ² @ \$12/m ²	= 12,288
Total	= 13,038

Floor life should be 30 yr, a long-term investment that may become obsolete because of the rising costs of labor. Both ravages of time and change of technology should be considered when making judgment on life expectancy of drying investments.

Depreciation @ 30-yr life	= \$ 435
Interest, 16% on 13,038/2	= 1,043
Equipment allowance	= 100
Subtotal	= 1,578

Variable costs:

Labor — 1,182 d @ \$8/d	9,456
Maintenance	150
Total yearly costs, fixed and variable	\$11,184

$$\begin{aligned} \text{Tons dried} &= (0.6 \times 350 \times 3.8) + (0.6 \times 200 \times 3.2) \\ &= 1,182 \text{ t/yr} \end{aligned}$$

$$\text{Drying costs per ton} = 11,184/1182 = \$9.46$$

Discussion:

Maranan and Duff(1) estimated sun-drying labor at an average of 8 h/t dried. The economy of sun drying depends upon the labor costs. At 1984 prices, sun drying can break even with mechanical drying in medium-sized operations if labor costs \$1/h. Another aspect of labor is the need for emergency hands when a rain shower approaches and dry paddy is on the floor. Rain on almost dry paddy wreaks havoc with the head rice yield. If enough people are not available to bag and carry the paddy out of the rain before it gets wet, a serious financial loss may occur, especially if the paddy is to be milled for export or for sale under grade. A paddy loss of more than 20% may result from rewetting (about \$40/t). The probability of loss needs to be estimated and the cost weighed against the cost of maintaining an option to call in enough labor to protect the paddy from bad weather.

Dryer efficiency depends upon the climate, the type of dryer, and the moisture content of paddy dried. Table 2 shows estimated efficiencies of nine dryer types operating in Midwest, USA. This table is adapted from the ASAE Yearbook.

OBSERVATIONS ABOUT DRYER SYSTEMS

Successful systems

The most highly structured markets are those of international trade, and the countries involved in export, such as Thailand, China, and Burma, find that the strict tolerable limits on yellow rice (0.5%) mandate the immediate drying of rice to be exported. In the dry season of Burma and Thailand, paddy will sun dry to 14% moisture within 2 d after reaping. However, some buyers and exporters use mechanical dryers quite advantageously during both the dry and the wet seasons.

Rice exporters regularly employ the columnar type of dryer, the Louisiana State University (LSU) dryer being the most popular. Columnar dryers, on the average, improve the quality of parboiled paddy. One large exporter of parboiled paddy in Thailand uses dump trucks in spreading paddy on sun drying floors. After the sun removes the high moisture, the paddy is raked into piles, loaded on the trucks, and hauled to the surge bins which feed columnar LSU dryers, where the drying is finished.

In large rural rice mills, the type of drying is determined somewhat by the flow of paddy into the plant. Where large combines are used, like those in the

Table 2. Energy efficiencies of various drying techniques.

Drying technique	Drying efficiency ^a (kg/liter of LP gas)	Comments
Batch or continuous flow with cooling in dryer (82 to 104°C)	43.5	High capacity, flexible, high kernel stress from fast drying and cooling, incomplete air saturation.
Batch or continuous flow with dryeration ^b (82 to 104°C)	54.2	Increased capital investment, 2 handlings to storage, 50 to 60% increase in throughput, improved product quality.
Bin drying without stirring, 5.6° rise with 55% relative humidity control	61.6	Overdrying the bottom layer, difficult to manage for optimum performance.
Bin drying with stirring device (43 to 60°C)	61.6	Mechanical reliability may be a problem, flexible in grain depth, fast batch drying.
Bin batch-drying, cooling in bin (49 to 60°C)	68.3	Modest price, medium capacity, additional manual labor for daily leveling and unloading.
Electric bin drying ^c (1 to 4°C rise)	51.5	Slow drying rate, increased threat of mold, good grain quality, limits on grain moisture content.
Combination system, 50% with batch or continuous flow drying, 20% with dryeration, and 30% with aeration ^d	84.4	Same as technique 1 or 5, except final drying (without heat) and cooling done in another bin; increase in potential for mold during final drying.
Drying with ambient air (1°C rise)	—	Slow drying, grain must be below 20% in moisture content, vulnerable to mold, weather conditions critical.
Solar collected heat drying	—	Still in development stage, use as a supplemental source of heat may become practical with new technology.

^aBased on drying from 25 to 15% wet basis using 4885 kJ/kg of water for high temperature drying, and 3489 kJ/kg of water for bin drying systems. ^bDryeration response is a constant drying of 2% moisture content, assuming kernel temperatures of 49 to 60°C. ^cElectric drying based on 13.75 Watt h/kg dried 1% moisture content. ^dBased on dryeration airflow of 1.11 m³/min through a ton for 20 h plus aeration airflow of 0.55 m³/t min for 30 d.

Kedah State of Malaysia, tilted bed dryers like those used in Surinam are acceptable to at least one paddy buyer. The beds are tilted at 45 degrees to promote gravity loading and unloading. Vertical boards installed at intervals across the top level of the bed prevent avalanching as the paddy dries. These dryers, like the flat bed dryers, use airflows of about 10 m³/min for each ton of paddy. This relatively low airflow is used because the bed depth may be as much as 0.8 m, and a higher flow is too costly. With such low airflow, the drying air temperature must be kept low (42-45°C) to prevent overdrying grain at the bottom of the bed and to reduce broken grains in subsequent milling. These plants require electrical power for handling equipment, fans, and burners.

Where delivery of paddy to the buying plant is slower and more uncertain, fans driven by diesel motors dry paddy either in bags placed over air ducts, or in bins gated to a main air tunnel. This system is most successful at a cooperative buying station in Indonesia. The sun drying floors are supplemented with a building containing a series of drying bins, each with 1) a plenum chamber below it like a flat bed dryer and 2) a sliding gate used as a valve to admit air from a pressurized drying-air tunnel. The tunnel is pressurized by a fan connected directly to the crankshaft of a gasoline or diesel engine. The fan draws air over the engine, picking up engine heat. This dryer requires no electrical power, but does require careful attention and considerable labor for loading and unloading the drying bins. Such systems are generally abandoned as soon as electrical power is accessible. They may use auxiliary direct-fired burners to heat air entering the fan.

A fourth type of successful drying system, observed in the Philippines, is used by a company that supplies special packaged rice products to the elite trade. This rice is not sold at controlled price because it is a special variety. This permits more money to be put into drying. As a result, this company uses a small columnar recirculating dryer like those in Japan. The dryer has a large garner bin in relation to the small drying chamber, so requires no tempering bins. The paddy passes through the dryer and is returned to the top of the garner bin where, theoretically, it is held for some time before it returns to the small drying chamber below. The word theoretically is inserted here because unpublished tests of the movement of paddy through garner bins of columnar dryers show that flow is not uniform. Instead, paddy tends to flow from the top down through the center, bypassing, to some extent, the higher friction areas in the corners and the sides. Reliable electrical power is needed to operate this small columnar recirculating dryer.

Seed producers find that germination is greatly enhanced by proper mechanical drying, compared to sun drying, providing an economic advantage. The successful mechanical dryers used by seed producers include all types mentioned: columnar dryers, tilted bed dryers, bagged paddy dryers, and small recirculating dryers. Large seed companies usually use columnar dryers, while smaller seed farmers find that bed dryers or the IRRI cross-flow columnar dryers are better suited to their volume.

Government paddy buying stations have quite successfully employed large

columnar dryers completely equipped with aerated tempering bins. The only problem is lack of capacity to keep up with wet paddy, especially critical in Malaysia where larger combines are employed in the harvest. Wet seasons also strain the capacity of dryers in Indonesia and the Philippines. These dryers sometimes lie idle because of improper maintenance or variable procurement. The dryers are more successful in the more highly mechanized harvest of Malaysia than in the less mechanized harvest of Indonesia and the Philippines.

In summary, these successful drying systems are used where market conditions emphasize high quality paddy, where electrical power is usually available, where a continued supply of paddy permits extended use of the drying equipment, and where reaping, threshing, and combining are also mechanized.

Less successful drying systems

Although large columnar dryers are successfully used in private and governmental paddy handling plants in Southeast Asia, idle plants indicate failures. These fall into two categories: plants improperly designed mechanically, and plants improperly designed from a marketing standpoint, including policy, geography, transportation, consumption, and supply and demand.

Although low-cost, in-bin drying systems are quite successful in Australia and the United States, they do not work well in the tropics where the natural air seldom has the drying potential of that in temperate regions, where paddy is harvested more nearly at 25% moisture than at 17%. The bins with bin stirrers and augers for recirculation do not withstand the sandpapering effect of the silica in the paddy husks, so equipment has a short life. When airflow is very low through the deep beds within the bins, molds grow and the rice yellows. Some systems were abandoned because of such problems.

Nevertheless, we should not discard the possibility of natural air drying in Southeast Asia. Research in Indonesia and practice in Malaysia show that natural air drying is possible for paddy below 18% moisture, and aeration holds paddy quite well when the moisture is 15%. The problem is getting the moisture to below 18% within 24 h after reaping to prevent costly damage to paddy. I believe in the thesis that paddy drying in Southeast Asia should consist of two phases: rapid removal of moisture to below 18%, and discrete drying to 14% at a rate that will prevent excessive fissuring. Research to test this thesis has not been conducted because mechanized drying is new to Southeast Asia, and the usual initial moisture is below 18% in most regions of the world where mechanized drying is widely practiced.

In-bin drying systems of Australia and the United States must certainly be adapted to conditions of Southeast Asia before they can be successful.

Several types of imported dryers have failed, including the inclined thin-bed, continuous-flow dryer very popular for barley, and the continuous belt dryer which does not have the capacity to remove enough moisture in one pass through the machine. The excessive handling and wear make the dryer unsuitable for the normal paddy drying. This is not to claim that fluidized bed dryers will not be successful. Such dryers have been successfully used to

remove the initial high moisture from parboiled paddy in many rice mills.

The high moisture and trash contained in the paddy entering most buying stations make it a very difficult product to handle, and the normal grain handling equipment will have neither the ability nor the capacity to serve satisfactorily. The high moisture and trash must be carefully considered. Normal grain handling capacities and specifications may need to be examined very carefully, for experience has shown that the equipment will not function up to specified capacity. If the scalpers cannot clean and deliver up to the dryer's capacity, the system is unsatisfactory. The fault may lie in either the system feeding paddy to the dryer, or in the system taking paddy away from the dryer.

Fault in the mechanical design is a major category of dryer failure. However, dryers in a system of excellent mechanical design may still sit idle because of social failure, not mechanical failure. Social failure may be caused by the motivation for building the plant. Appropriate motivation comes when a buyer of paddy sees that he can make an economic gain by buying wet paddy at a discount and immediately drying it. This person carefully plans how to build the dryer, how big it should be, and how it should fit into his system. Chances for success are high.

On the other hand, government intervention may not succeed or be appropriate. An official sees that drying is important to preserve food for the people, and so seeks a loan to build drying equipment to reduce postharvest loss. Development agencies are happy to make such loans to accomplish these worthy objectives. Construction men want to build the plants and technicians are challenged to provide equipment that will work. In this chain of social communication, the system of grain flow and marketing becomes secondary. If a processing plant is built outside the market channels, it may have nothing to dry. It may not be in the channel of flow, but on a bypass. An idle plant deteriorates quickly.

When such plants fail, the question is asked, "Who should be responsible for drying? Is the farmer responsible, the buyer, the miller, the government?" Most farmers retain quite an acceptable quality of paddy to be milled for their consumption, but many sell wet paddy because it is to their economic advantage to do so. Buyers and millers dry the greater portion of the paddy. From the viewpoint of paddy flow, this seems most logical because they are directly in the channel of flow and they have the best economic incentive. The farmers can be responsible by organizing a rice growers' cooperative for cleaning, drying, storing, and milling. All of Australia's rice flows through such a cooperative.

Governmental agencies could stabilize markets and play a role in maintaining a healthy market situation without getting into the business of buying, processing, and selling rice. This could avoid having operable plants standing idle because those who built them and those who operate them do not have to live from the income they generate. This type of failure is not confined to Southeast Asia, but is evident throughout the world where unrealistic relationships exist between developers and grain dealers.

For finest quality, paddy should be dried immediately after harvest; time must not be lost in transport. The paddy should be dried near the field where it is harvested. If consumers decide that this is desirable, then as a society, the marketing system can be devised to pay the farmers to dry and perhaps even hull paddy on the farm. The society of Southeast Asia has not made such a decision.

Consumers have locally adapted their preference to the quality of rice that has been traditionally available to them. In some geographic areas, drying has failed because the poor quality of rice milled from heat damaged paddy is accepted as the normal product. Such pockets of acceptance exist in the Philippines, Malaysia, India, and Indonesia. There is no penalty cost for yellowed rice. In such a market system, most mechanical dryers are uneconomical.

Dryers sometimes fail because they are not adapted to the climatic, economic, and social requirements of the place in which they are located.

REFERENCE CITED

1. Maranan, C. L., and B. Duff. 1978. Farm-level post-production systems in the Bicol region of the Philippines. Pages 276-356 in *Proceedings of the 1st annual post-harvest workshop*, Southeast Asian Regional Center for Graduate Study in Agriculture, Los Baños, Philippines.

CASE STUDIES OF MECHANICAL DRYERS IN THE PHILIPPINES: LESSONS LEARNED

A. G. CARDIÑO

National Post-Harvest Institute for Research & Extension
Philippines

Mechanical drying technology has long been available in the Philippines. Research on the development of appropriate drying technologies for local conditions started as early as the 1950s and was conducted by the Department of Agricultural Engineering of the University of the Philippines at Los Baños (UPLB).

At first, mechanically heated air dryers were imported. These were designed for dry, temperate-climate commodities like wheat and barley, not for paddy. Drying air, temperature, airflow rate, tempering requirement, and provision for grain cooling differ for paddy and temperate-climate commodities.

Lately, results of research and development have enabled the proper design of drying units for local application and manufacturing. Batch dryers of varying capacities, continuous-flow dryers (CFD) with tempering bins, and recirculating dryers are now in the local market. Several brands and innovations were introduced and several studies to evaluate their performance have been conducted.

As a needed alternative to sun-drying, mechanical dryers have been promoted by several government agencies concerned with the grain industry: the Ministry of Agriculture and Food (MAF), National Irrigation Administration (NIA), Farm System Development Corporation (FSDC), and National Food Authority (NFA). Those agencies provided financial and technical assistance for promoting the dryers at farm and mill levels. The millers were allowed to expand their businesses, provided they acquired mechanical dryers as part of their expansion programs.

Mechanical dryers were also promoted among farmers and farmer associations by encouraging them to use mechanical dryers rented out by the NFA. From 1974 to 1984, the NFA bought 400 flatbed dryers to support the equipment assistance program and distributed them in rice producing areas. Some government agencies bought mechanical dryers for demonstration and sold them to cooperators at cost. The FSDC provided long-term loans to groups of farmers for investment in postharvest facilities, including mechanical dryers.

In addition to its facility assistance program, the NFA has also been extending incentive fees for good quality dried grain. They have given ₱0.03

incentive fee for every kilogram of good quality, dried paddy purchased.

Technical assistance in assembling and operating the 2-t capacity flatbed dryers was also provided. NFA personnel directly supervised the initial operation of the dryers by the farmer or trained the operator. Both the technical and facility assistance programs of NFA were disseminated through postharvest seminars conducted at farms and mills.

Lately, NFA launched a new incentive program to encourage farmers to sell good quality dried paddy to them: annual life insurance to all farmers who sell at least 1,144 kg of paddy to NFA. The annual coverage depends on the volume of paddy the farmer sells.

Despite promotion programs, the adoption of mechanical dryers for drying paddy during wet season remained low, especially in the private sector. By 1981, the private sector had only 169 units with a total capacity of 2,359 t, sufficient to dry less than 1% of paddy produced in the country. Thus, the bulk of paddy handled by the private sector, approximately 90% of the total, has been sun dried.

NFA now owns 706 mechanical dryers with a capacity of 321 t/h. However, it dries only 10% of all paddy.

In sum, only 12% of Philippine paddy can be mechanically dried, 90% by government dryers which handle merely 10% of the total produce.

Research has focused on evaluating the technical performance of the dryer. Only a few researchers have examined its social acceptance and economic viability in the specific environment in which it was intended to function.

Among them, Sison et al (2) evaluated the social acceptance of UPLB-designed machines, including flatbed dryers with a 2-t capacity. The study revealed that constraints to wide adoption were more socioeconomic than technical. Users responded they were likely to accept and continue to use the machine if it proved to be more economical than the method they were using. The foremost constraints were the dryer's high fuel cost, higher labor requirement, and slow rate of drying. The poor quality of processed paddy was another impediment expressed.

In another study not limited to dryers, Alviar et al (1) showed that high cost of fuel and oil was a constraint to successful adoption of farm machinery. Likewise, high cost of repair and maintenance of farm machinery due to frequent breakdowns was another factor. Corollary to this, consequent delays in machinery use resulted in great opportunity losses, particularly during times of critical farming operations, and further discouraged machinery use.

To further understand the barriers to the adoption of mechanical dryers and evaluate possible remedies, a study on the socioeconomic factors affecting the use of mechanical dryers was conducted by the National Post-Harvest Institute for Research and Extension. The rest of this paper discusses the results of this research.

A two-level survey at farms and mills was conducted in Bicol and Iloilo, two major rice producing areas in the Philippines. Farmers, farmer associations, and millers were the respondents, stratified into users and nonusers of mechanical dryers. Users were further stratified into continuing and former

users. Case studies were conducted with four users: two private millers and two farmer associations. Cooperators were interviewed about their management and operation practices. Financial conditions of each cooperator were analyzed.

CONSTRAINTS REPORTED BY FORMER USERS

Constraints in the use of mechanical dryers at farms and mills were basically socioeconomic. Previous users reported high fuel cost had been the main constraint (Table 1).

Fuel cost ranged from 30-40% of the total operating cost of mechanical dryers, depending on type of fuel used. Since fuel used by former users was expensive and its price increased faster than did prices of other inputs, mechanical dryers using fossil-based fuels (e.g., kerosene and diesel) became uneconomical. Furthermore, the margin received from mechanically dried paddy decreased with time because the price of paddy remained stable, while input costs rose.

Because sun drying was still preferred whenever possible, the dryer lay idle most of the year. Since no benefits could be derived while the dryer was idle, recovery of investment was slow.

Previous users claimed that uneven drying produced poor quality dried paddy, indicated by grayish paddy and brittle grain. Low milling recovery and more brokens were observed. However, viewed against the exhaustive technical performance tests conducted on dryers before their manufacture, the poor quality of paddy may not be due to technical failure of the equipment but rather to 1) poor initial quality of paddy prior to drying, 2) improperly adjusted burners and blowers, and 3) a general lack of knowledge about operating dryers.

Likewise, inconvenience in operating dryers, primarily heat and dust from mixing paddy during drying, reflected a lack of skill in proper operation. Flatbed dryers, provided the correct adjustments are made, are designed to dry a static mass of grain.

On the other hand, dryer capacity was not carefully selected. The dryer capacity was not properly matched with the drying requirements of the users.

Table 1. Constraints on the use of mechanical dryers by former users.

Rank	Constraint
1	High fuel cost/high operating cost
2	Poor quality of processed paddy ^a
3	inconvenience ^b
4	Limited capacity
5	Short time of use
6	Abolition of association

^aUneven drying, grayish grain color, more brokens, low milling recovery. ^bDust and heat encountered while mixing the paddy during drying.

Thus, former users sometimes experienced flash drying and delays in drying. They found flash drying expensive and laborious because paddy was dried again, either through mechanical drying or sun drying, to attain the required moisture content before milling.

Lack of a strongly organized farmer association reduced use of mechanical dryers. Mechanical dryers owned by some farmer associations were junked when the associations were abolished due to internal weaknesses and mismanagement.

CONSTRAINTS REPORTED BY NONUSERS

Constraints to the use of mechanical dryers reported by nonusers were likewise socioeconomic (Table 2). Among cited constraints at farms and mills, only the first four were directly experienced by nonusers. Other constraints were just heard by nonusers from previous users.

Farmer nonusers usually had small farms (either rented or borrowed), ranging from less than 1 ha to 4 ha with an average production of 3 t/ha. Of the total production, only about 30% was left after deducting the landlord's share (25%), harvester/thresher share (20%), irrigation fee (2%), and payment for production loans (23%). Considering the small volume of paddy handled by farmers and the high operating cost of a dryer, the value of paddy dried might not be enough to compensate for expenses incurred.

Similarly, limited volume of procurement restrained the miller nonusers from using mechanical dryers. Millers said that, given additional capital, they would first use the funds to expand their operations; investment in a dryer would be a lower priority.

Some miller nonusers, however, were interested in using or investing in mechanical dryers but were inhibited by the high investment cost. Small capacity dryers had lower investment cost, but a larger capacity dryer was appropriate for their needs, and capital investment for it was high.

Mechanical dryers were not common on farms. Only a few farmers surveyed were owners or users of the equipment. They were usually the large or commercial farms ranging from 20 to hundreds of hectares. Because of the limited number of mechanical dryers used, specially at the farm level, a big percentage of farmers interviewed had never seen nor heard of a mechanical dryer. This low level of awareness among the targeted population exists despite the seemingly vigorous government efforts to promote mechanical dryers.

BENEFITS REPORTED BY CONTINUING USERS

Despite several constraints to the use of mechanical dryers, a number of users intended to continue using them because of the benefits derived: 1) prevention of grain fermentation, 2) better price for grain, 3) opportunity to procure more paddy or dry more paddy for storage, 4) less labor requirement and less spillage, 5) production of good quality paddy, and 6) service to members.

Table 2. Constraints on the use of mechanical dryers by nonusers.

Category and rank	Constraint
A. Deliberate choice not to use mechanical dryer	
1	Limited production or procurement
2	Limited or no capital or high investment cost
3	Limited space for dryer
4	Limited capacity of dryer
5	Poor quality of processed paddy
6	High fuel cost
7	Short time of use
B. Have not seen mechanical dryer or dryer not available	

Using mechanical dryers, the continuing users were able to dry their paddy on time, thus avoiding quality deterioration. Consequently, they produced good quality milled rice and received better prices. Farmers could dry paddy during the wet season and store it while waiting for better prices. On the other hand, millers and farmer associations engaged in paddy trading could procure as much wet paddy as they wanted to. This gave them a distinct advantage over others with no dryers because 1) there were fewer buyers during wet season, 2) most farmers sold paddy to avoid the risk of spoilage, and 3) the buying price of wet paddy during wet season was lower (₱0.90/kg to ₱1.00/kg) than in dry season (₱1.54/kg, 1983 data). However, the price of milled rice was the same regardless of season.

In mechanical drying, only trained operators and a few laborers were needed for bagging and debagging. Less handling meant less spillage. Also operators or owners could control the batches of grain to be dried, thus preventing the mixing of poor and good quality paddy which often happens with sun-drying.

REQUIREMENTS FOR SUCCESSFUL USE OF MECHANICAL DRYERS

Knowing the constraints in the use of mechanical dryers and the benefits derived from the equipment, the researchers conducted case studies of successful users to further understand conditions and constraints.

Four continuing users — two private millers and two farmer associations — cooperated in the case studies.

The first private mill was a family-owned business corporation. The mills' main objective in using mechanical dryers was to increase procurement during the wet season. The second private mill, on the other hand, was owned by one of the biggest corporations in the country. It was bound by law to provide milled rice for its employees. Mechanical drying was part of the overall milling operation established to service the requirement.

Both farmer associations were service oriented; however, one treated and processed paddy. The first farmer association purchased paddy from members and sold milled rice. It used mechanical dryers to support its operation during wet season and to dry paddy for members. However, the total capacity of its four flatbed dryers was insufficient to meet these needs.

The second farmer association was mainly service oriented, and was not engaged in marketing. It rented out postharvest equipment, namely threshers, reapers, and flatbed dryers, to its members for a reasonable fee. However, its dryer was not fully used. Most members still preferred sun-drying or selling their produce wet even at a lower price. Also, the 2-t capacity was not enough to accommodate the volume of paddy that members wanted to dry at the same time. So to avoid conflict, the association preferred not to use its dryer.

The case studies reveal these requirements for successful use of mechanical dryers: 1) large volume of paddy to achieve economy of scale, and a significant increase in profit to offset opportunity costs; 2) integrating dryer operation with the milling and marketing operation to appreciate the benefits derived in terms of better quality milled rice and increased capability to purchase paddy during wet season; 3) matching of dryer capacity with volume of paddy to be dried to avoid delays in drying and maximize dryer use; and 4) sufficient technical knowledge in operating the dryer to maintain good performance of the equipment and prevent any technical problems.

IMPLICATIONS

1. Unprofitability and lack of technical knowledge in operating dryers underlie the expressed constraints in using mechanical dryers.
2. Most farmers individually cannot afford mechanical dryers. Grouping themselves into associations to pool their resources may provide volume necessary to allow investment in mechanical dryers. However, the lack of strongly organized farmer associations and necessary management skills prevents group use of mechanical dryers.
3. The low level of awareness of mechanical drying technology indicates that despite the government effort to disseminate it, current programs may still be inadequate and ineffective.
4. Considering that mechanical dryers are not totally rejected by the private sector, widespread adoption is still possible provided these requirements are met: 1) large volume of paddy to achieve economy of scale; 2) mechanical drying integrated into milling operation or other post-harvest operation since mechanical drying benefits are best perceived at a systemwide level rather than on an individual level; 3) dryer capacity compatible with the volume to be dried to avoid delays in drying; and 4) technical knowledge in operating the dryer to avoid technical problems.
5. The benefits in using dryers can be fully realized if dryers are integrated with milling operations or with other postharvest operations. The production of good quality milled rice and the opportunity to increase the

volume of operation during wet season are two important benefits which enhance the profitability of mechanical dryers.

6. Farmer associations could be tapped as possible venues for the introduction and adoption of mechanical dryers at the farm level, provided the necessary organizational strength, management, and technical operation skills are present. Furthermore, associations engaged in aggressive trading and processing are more likely to profitably use mechanical dryers.

REFERENCES CITED

1. Alviar, N. G., M.E.S. Piadozo, E.C. Castro, Jr., and J.H. Lopez. 1981. Studies on the application of available agricultural engineering technologies in rice production. College of Development Economics and Management, and Institute of Agricultural Engineering and Technology, University of the Philippines at Los Baños. (unpubl.)
2. Sison, O. F., M.S. Adriano, C.R. del Rosario, and C.A. del Rosario. 1983. Technological and socioeconomic dimension of the transfer of agricultural engineering technology packages to small farmers. Department of Agricultural Education, University of the Philippines at Los Baños. (unpubl.)

EVOLUTION OF PADDY DRYING IN JAPAN

R. YAMASHITA and Y. IKEDA
Kyoto University
Kyoto, Japan

In Japan, paddy was dried only by sun until 1930. However, mechanical drying was required to supplement the erratic and inefficient sun drying. Mechanical dryers gradually diffused from 1956, and amounted to one million in 1966. With the development and spread of binders and combines, circulating grain dryers using heated air have been developed and diffused. Now, paddy dryers are controlled by microcomputers, yet once again the sun is important: solar energy as the heat source for drying air saves energy and increases the operating ratio of equipment.

FROM SUN DRYING TO MECHANICAL DRYING

Sun drying

The transition of grain drying technology and the number of farm households involved are presented in Figure 1. Until the 1950s, paddy had been dried almost entirely by sun. Sun drying's effectiveness varied according to the conditions of the paddy field and local climate. The typical early sun drying is depicted in Figure 2 and an example of the wooden frames for drying is shown in Figure 3 (1, 2). The drying frame was often constructed using living trees on the levee.

In areas with suitable climate and on days of fair weather, paddy could be dried below the moisture content of 14.5% (wet basis). Poor weather could prevent satisfactory drying. Table 1 shows the moisture content of unthreshed rice dried on the levee (1). Paddy could not be dried uniformly in a day. Table 2 shows moisture reduction during drying of unthreshed rice on the frame and of threshed paddy on the rice straw mat (3). Such experimental results show that sun drying was time-consuming and required supplementary sun drying after threshing. Figure 4 indicates the moisture reduction pattern of rice; a post for drying straw is shown in Figure 5 (4). Since not enough moisture was removed by the sun, paddy was spread or piled on the straw mat after threshing for additional drying.

The Japanese islands lie between lat. 30°N and 45°N, producing remarkable variation in the climate between the northern and southern parts. Climate

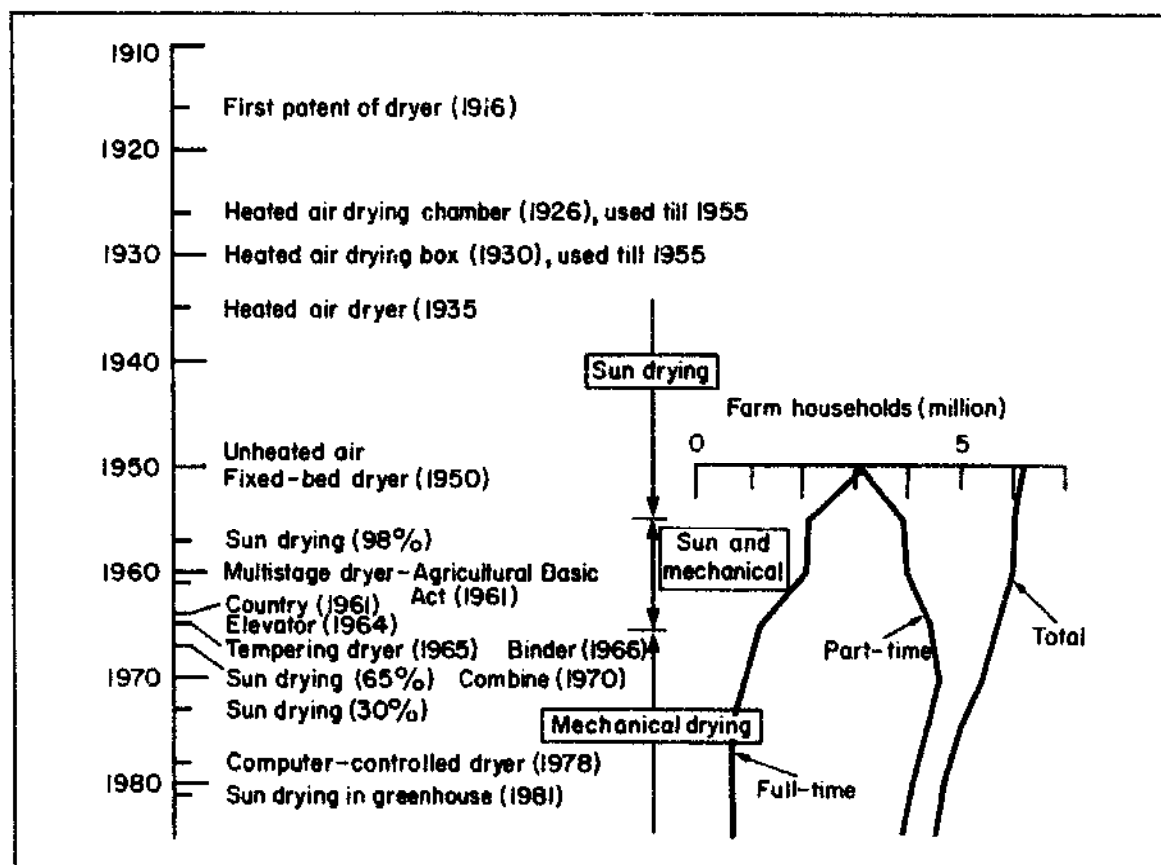

1. Transition of drying techniques in Japan.

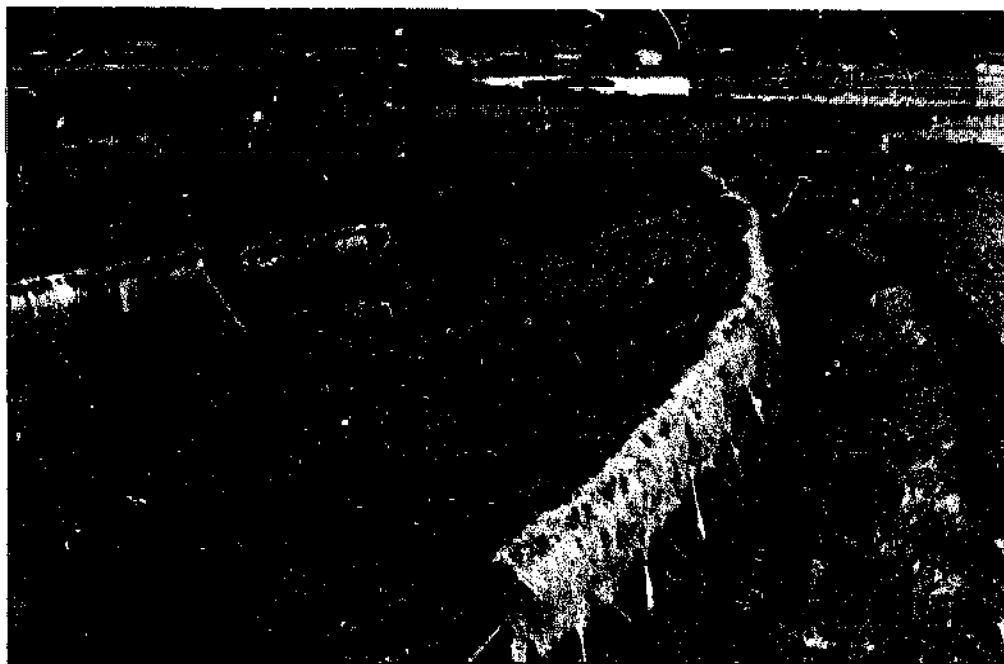

2. Sun drying of rice in field.

varies also between the Japan Sea coast and the Pacific coast. The paddy is not sufficiently dried in half of those areas in Japan (Fig. 6). There, paddy is allowed to dry 15.5 or 16.0%, a level higher than the examination standard moisture content (m.c.) of 15.0%, as shown in Table 3.

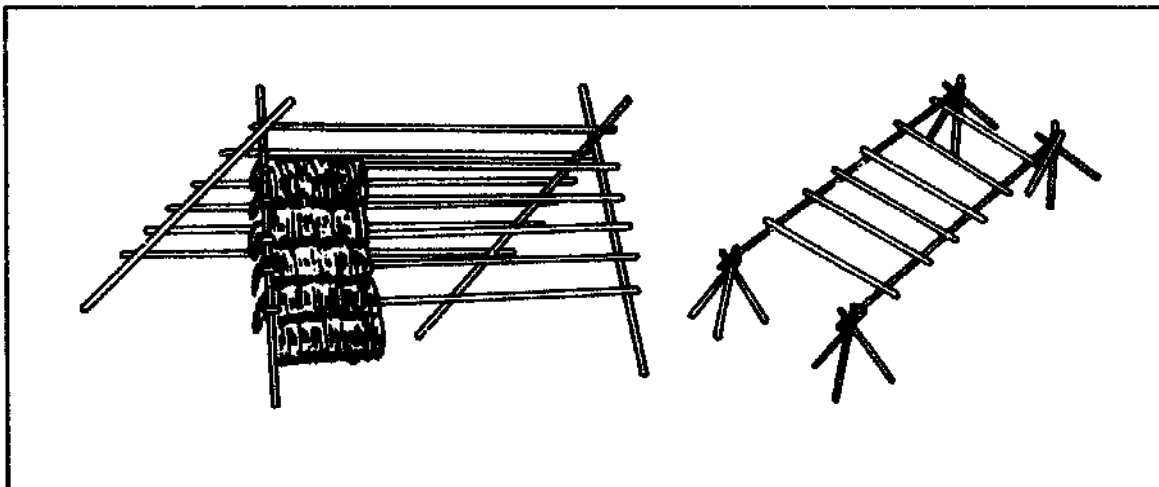

3. Wooden frame for drying rice.

Table 1. Moisture content of paddy dried on the levee. Chuhgoku Province, Japan, early September.

Drying	Location	Moisture content (%)		Grains fissured (%)	Drying time
		Before drying	After drying		
Levee	Upper spike	20.7	13.5	12	1000-1800 h
	Middle spike	20.7	17.8	0	
	Lower spike	20.7	18.5	1	
Field		22.7	12.0	43.6	4 d

Table 2. Moisture reduction pattern during sun drying.

Drying location	Moisture content (%)			
	<i>Sheaf in field</i>			
Wooden frame	<i>Day 1</i>	<i>Day 7</i>	<i>Day 14</i>	<i>Day 21</i>
Field	22.4	14.8	14.0	13.8
	22.4	15.1	14.5	14.2
	<i>Paddy on rice straw mat</i>			
Field	<i>Day 1</i>	<i>Day 3</i>	<i>Day 5</i>	<i>Day 7</i>
Farmer's yard	18.6	14.0	12.8	12.6
	18.5	14.1	12.7	12.2

The defects of sun drying techniques are as follows:

1. **Instability.** In some years, paddy did not dry sufficiently because of rainy or cold weather. Paddy of 25% m.c. dried to 14% m.c. in 5 to 7 d, but required more than 20 d when weather was rainy or cloudy.
2. **Quality reduction.** Paddy quality grade was influenced by the weather in which rice was harvested. Figure 7 indicates how weather influenced rice quality. For example, the percentage of brown rice of 2d grade paddy in a fine year was 42%, but decreased to 14% in a bad year.
3. **Labor and time use.** Labor and time were necessary to construct drying

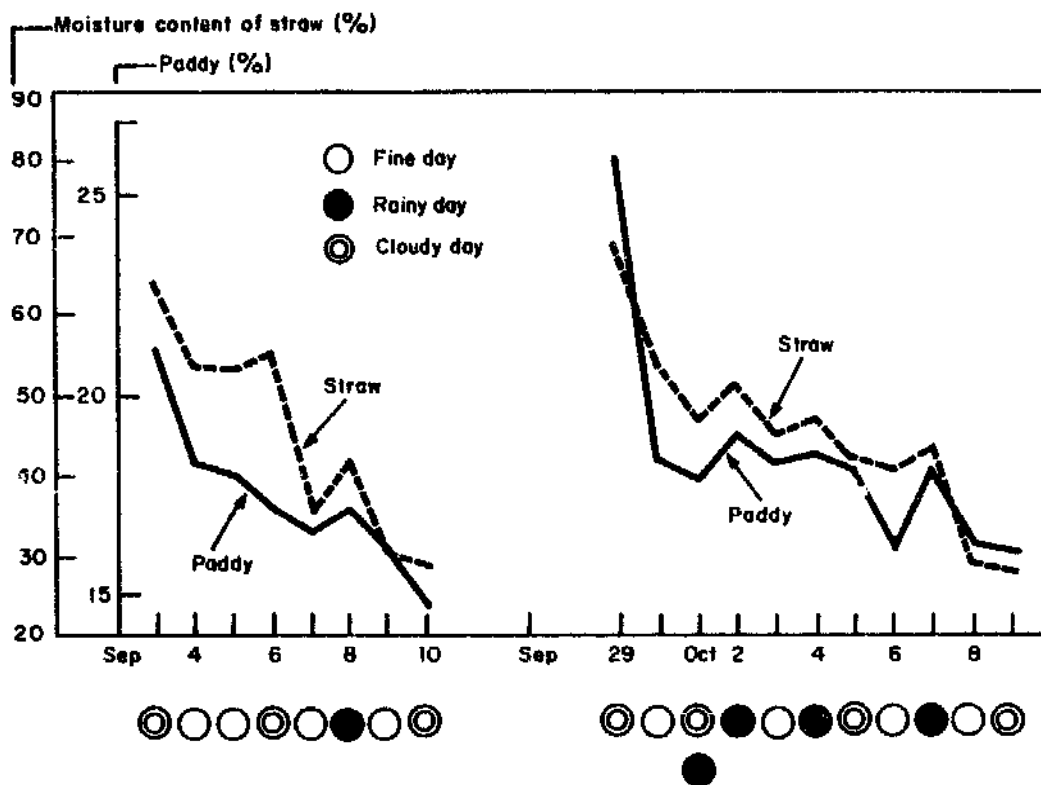

4. Moisture reduction pattern of rice.

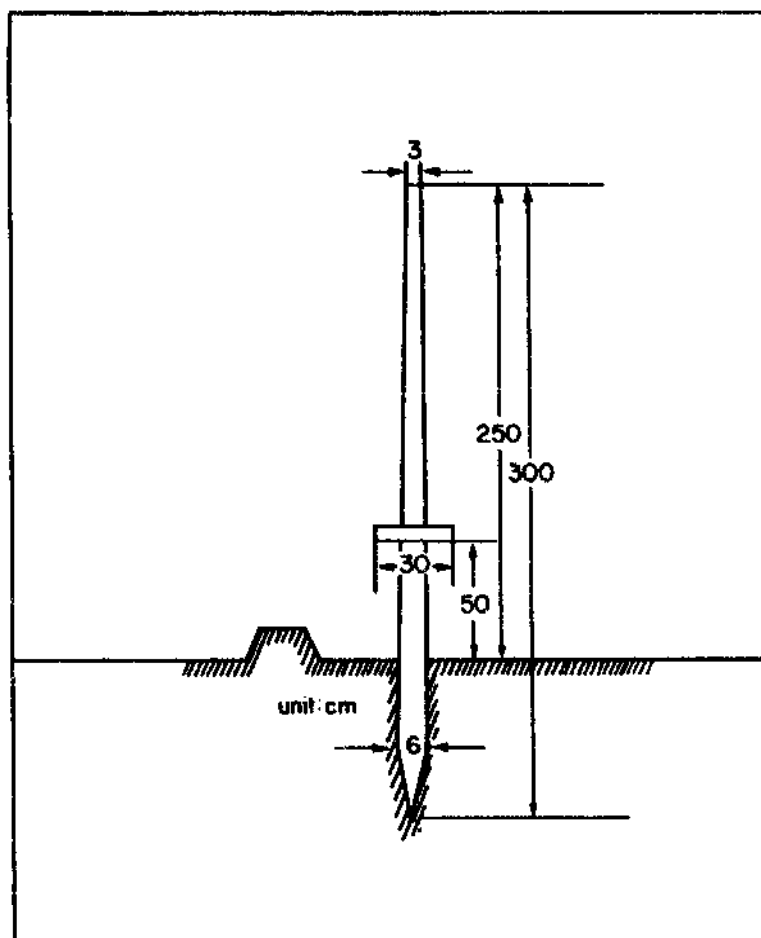

5. Drying post.

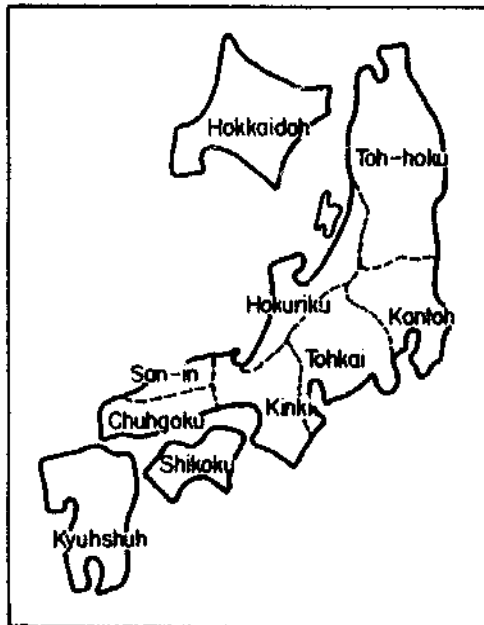

6. Provinces of Japan.

Table 3. Moisture standards of grain in Japan.

	Maximum moisture content (% wet basis)				Moisture content allowed to add in	
	1st	2d	3d	Subgrade	Location	%
Nonglutinous brown rice	15	15	15	15	Hokkaido, Tohoku	1
Barley	13	13	14	14	Hokuriku, San-in	0.5
Malting barley	13	13	—	13	Hokkaido	1
Wheat	12.5	12.5	13.5	13.5	Tohoku, Hokuriku	0.5

wooden frames, hang the bound sheaves of rice, and remove them from the frames after drying.

MECHANICAL DRYING

Because of natural sun drying's shortcomings, mechanical dryers were researched and developed in the 1930s. They included the drying chamber or the drying box with a heater using briquet or charcoal fire but without a fan. Mechanical dryers were not affected by the weather, saved labor, and produced high quality paddy.

Figure 8 represents the simple-structured drying chamber (a) and the multi-tunnel type drying box (b) (5, 6). These dryers, using natural convection of heated air, were used to supplement sun drying. They were used from 1931 to 1955 only in regions where sun drying was not enough because of bad weather. These dryers had a drying capacity of 300 to 500 kg, and mean drying rate was about 0.1 to 0.3%/h. The prototype of the grain circulating dryer equipped with the fan and grain elevator was already manufactured on trial in

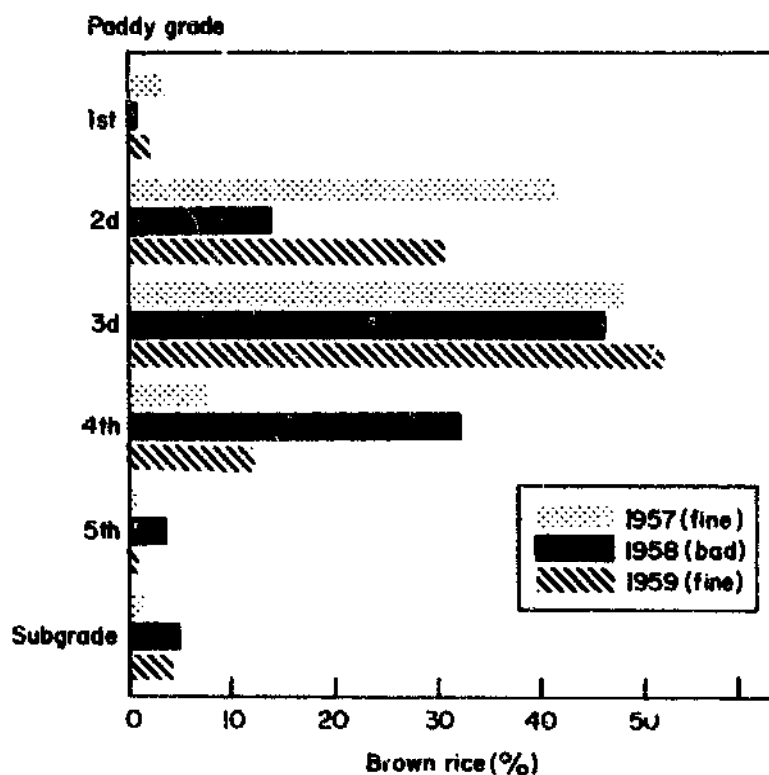

7. Paddy grade and weather.

1935. This dryer had grain capacity of 600 to 2,000 kg, and a husk furnace heated the drying air. The mean drying rate was 0.5 to 0.8%/h.

In 1950, the flatbed dryer using unheated drying air was developed. Figure 9 shows the dryer with an oil burner for heating the drying air (7). These dryers came into use in the late 1950s (Fig. 10) for final drying after paddy was threshed and initially dried to 18% m.c. by sun. In 1958, however, paddy dried only by sun amounted to 98% and that dried after row crop threshing was only 2%.

The binder (the machine for cutting rice plants and binding them into sheaves), developed to increase harvesting efficiency and saved labor, spread from 1966 (Fig. 11), and the flat- and fixed-bed dryer was generally propagated along with the binder. The binder was used for labor-saving in harvesting; the mechanical dryer was required for labor-saving in drying large amounts of paddy rapidly.

To increase the drying rate, the oil burner was added to the flatbed dryer as shown in Figure 9. Because of moisture differences between the upper and lower layers of grain in the bed, grain had to be turned during drying. Grain bins were 1.7 to 7 m² and the dryer generally used was about 3.3 m². According to a 1967 survey, one million farmers used the fixed-bed dryer and 848 cooperative drying facilities were used.

Probably 35% of the total paddy might be dried by mechanical dryers. At that time, however, raw crop threshing and mechanical drying were rarely accepted.

Figure 12 represents the fixed- and upright-bed dryer with the auxiliary heating device and fan (8). The first dryer of this type was produced in 1964 to save labor in loading and discharging the grain. The fixed-bed dryer capacity

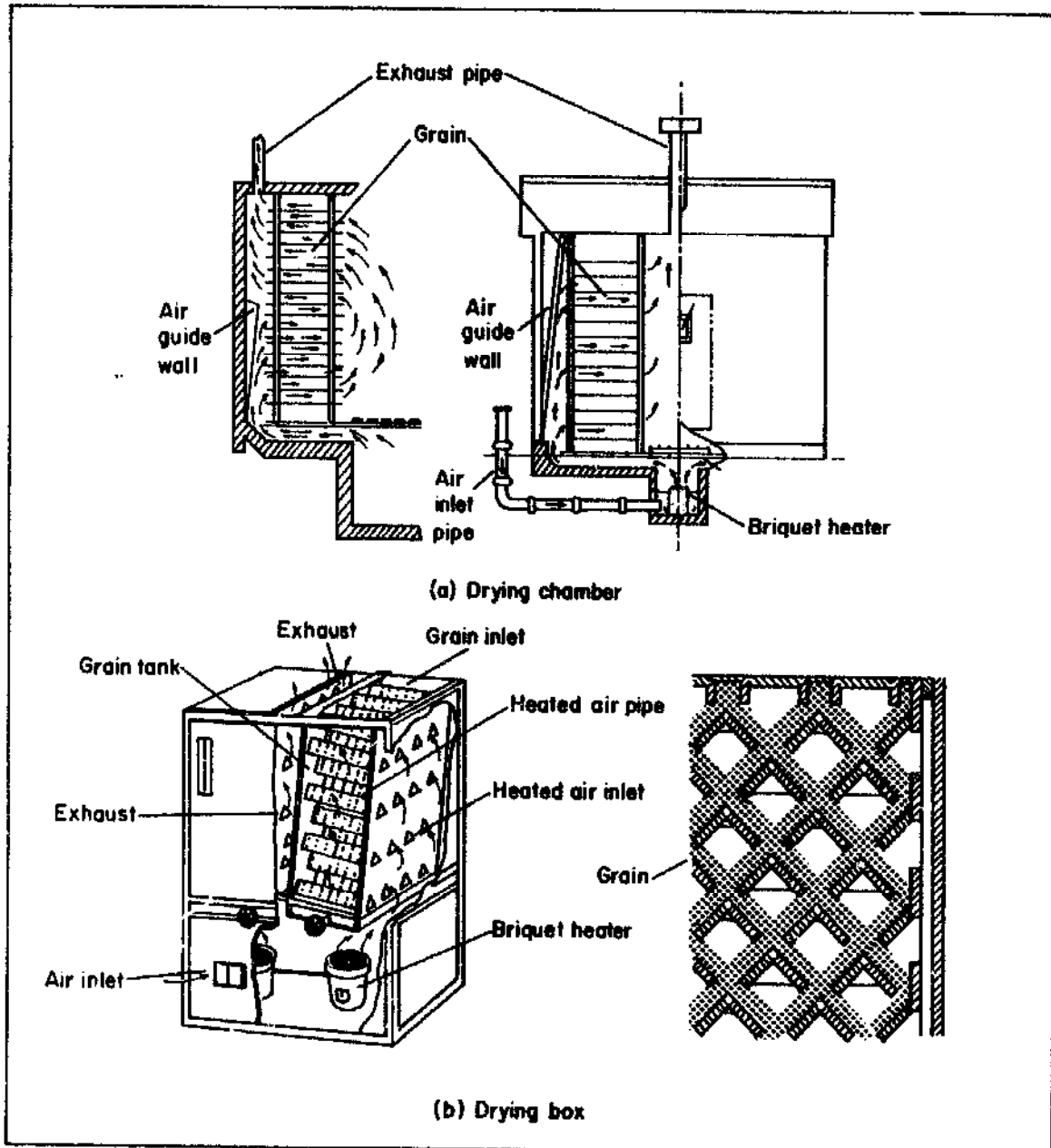

8. Grain dryer developed in 1930s.

was from 300 to 1,000 kg and the airflow rate/1,000 kg paddy was from 0.5 to 1.0 m^3/s . The mean drying rate was 0.5 to 1.0%/h.

When combines were used, the paddy was dried mainly or only by the mechanical dryer. The large foreign-made combine was introduced in 1963 to improve the agricultural structure in Japan. Since the m.c. of paddy harvested by the large combine was very high, about 26%, a large floor space and a high drying rate were required to dry the high moisture paddy with the fixed-bed dryer. Then the grain circulating dryer with the air heater (Fig. 13) was developed and generally used (9).

In the grain-circulating dryer, the slightly dried grain was discharged by the screw conveyor located at the bottom of the grain tank and returned to the upper layer of the tempering section by the bucket elevator. Grain drying was

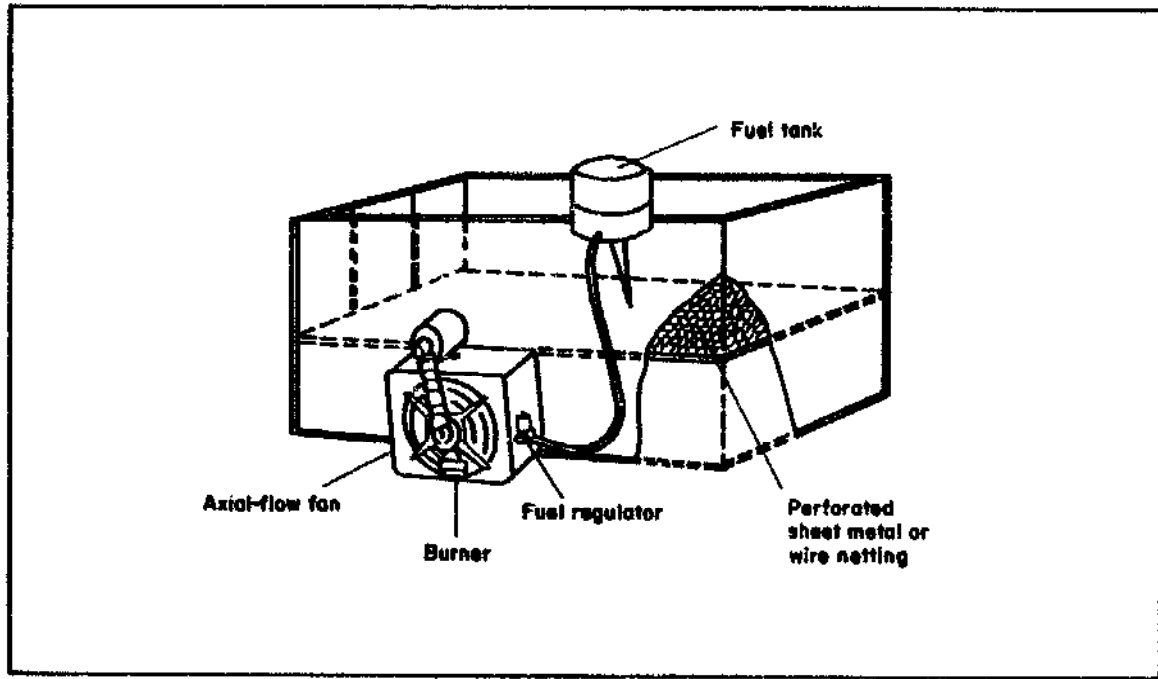

9. Fixed- and flat-bed dryer.

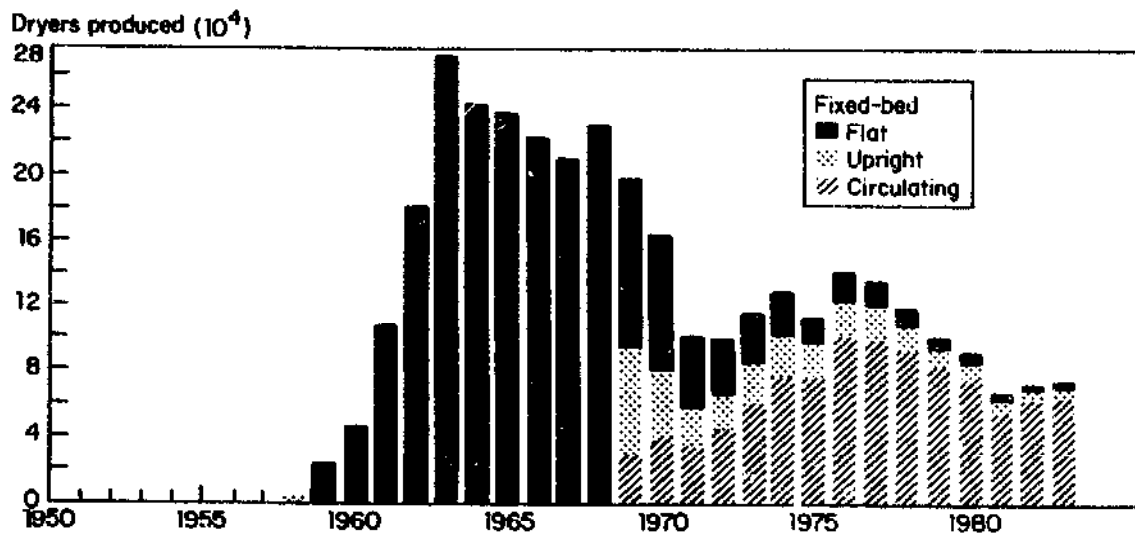
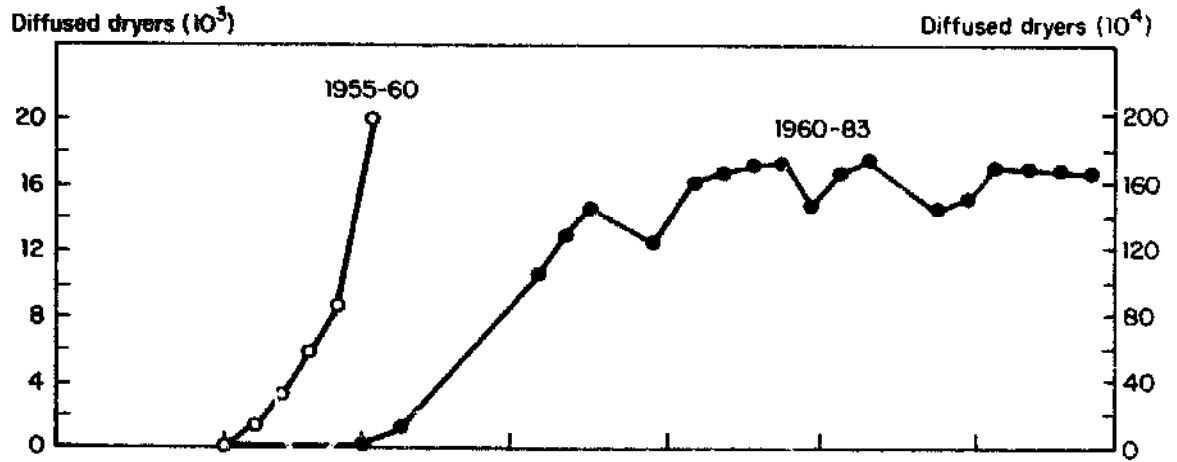

10. Number of produced and diffused dryers in Japan, 1955-83.

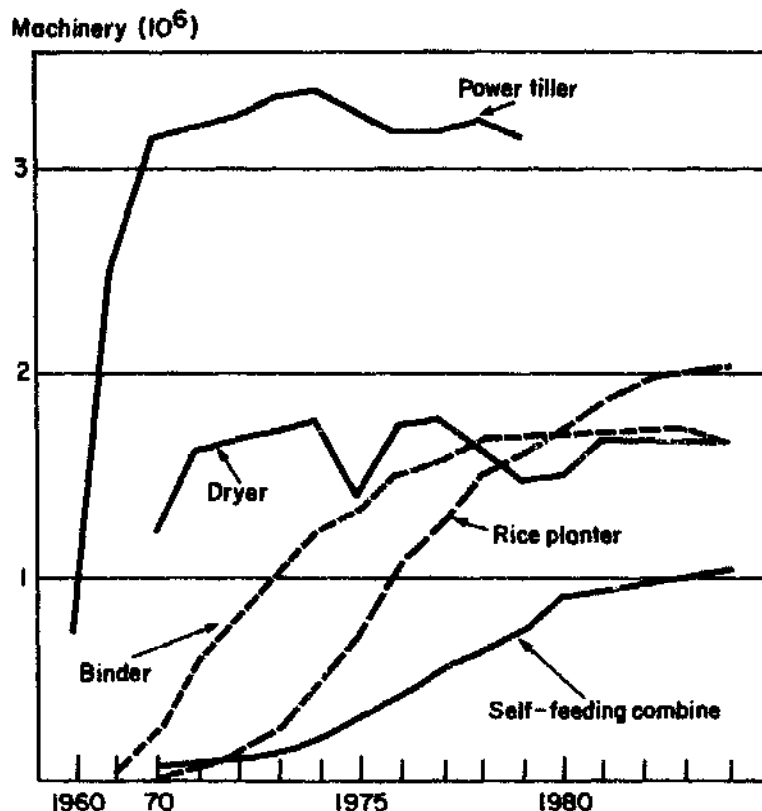

11. Spread of agricultural machinery in Japan, 1960-84.

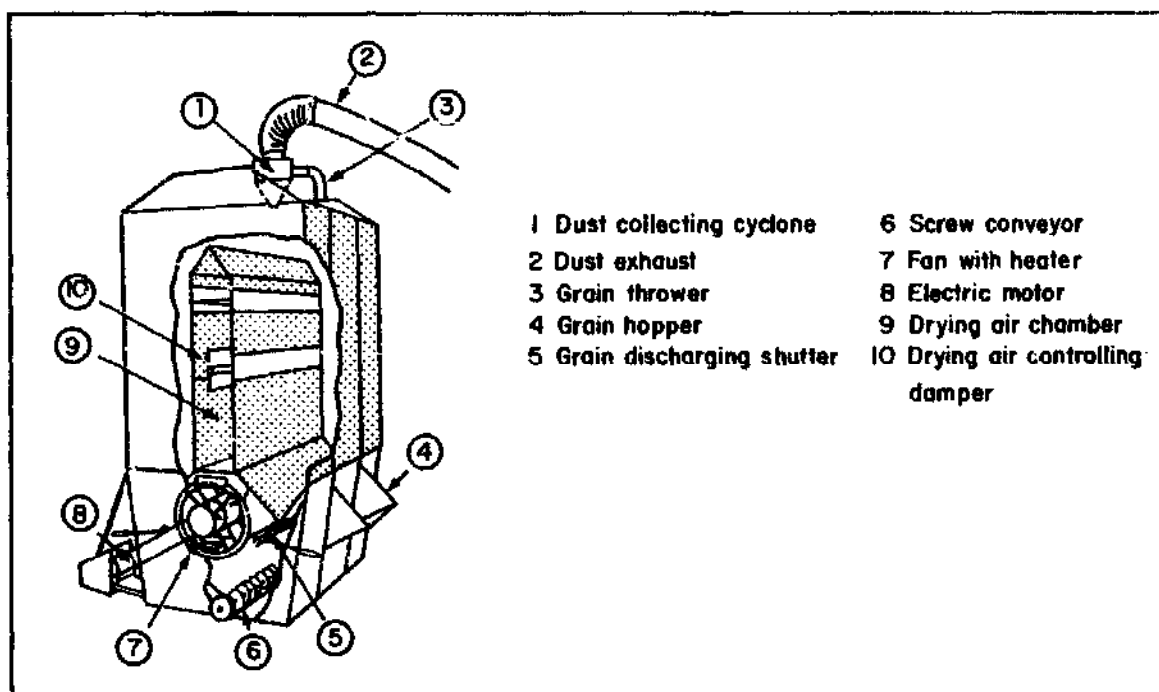

12. Fixed- and upright-bed dryer.

intermittent to flatten the moisture gradient in the grain kernel and prevent it from fissuring due to moisture change. The country elevator for cooperative and large-scale grain drying, processing, and storage was also constructed for the first time in 1964.

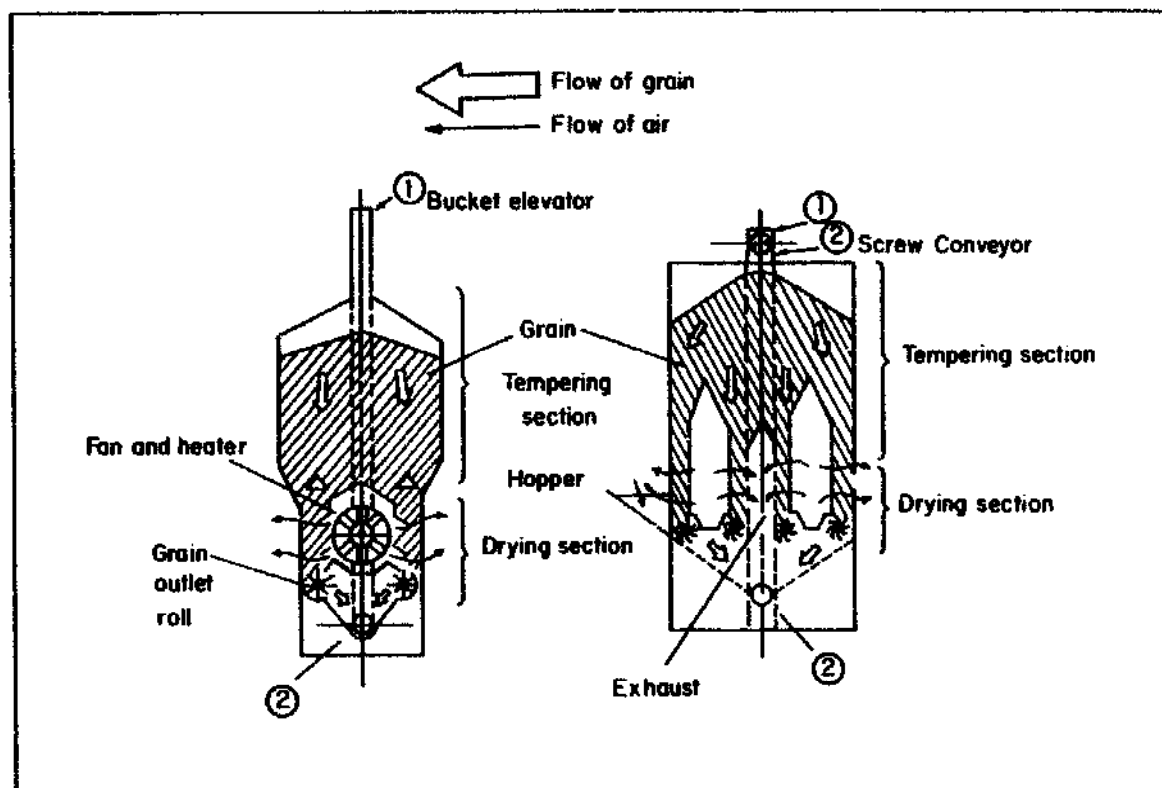

13. Grain circulating dryer.

Though the large combine developed in Europe and the United States was highly efficient, for example 4-11 ha/h, it was too heavy for the paddy field in Japan and its grain loss was comparatively high — 5.2 to 5.5%. The head-feeding combine peculiar to Japan was developed in 1965. Small self-feeding combines were introduced in 1970 as shown in Figure 11. The self-feeding combine has a harvesting rate of 2.5-10 ha/h and a grain loss of 0.4 to 1.8%.

Grain-circulating dryers gradually replaced fixed-bed dryers, reaching 80 to 90% of all dryers in recent years. The cooperative drying facilities have been constructed in many places and amounted to 2,960 in 1983. Of all paddy in Japan, 10% or less was assumed to be dried in cooperative facilities in 1975, and about 18% in 1984. In 1984, paddy was dried by these methods in Japan:

1. Dried by individual farmers mechanically	67%	7.04 million t
2. Sun-dried by individual farmers	15%	1.57 million t
3. Dried in cooperative drying facilities	18%	1.89 million t
Total	100%	10.50 million t

COMPUTER-CONTROLLED GRAIN DRYER

The dryer is usually operated at night, as shown in Figure 14 (10). Since 60% of the dryers were operated after 1800 h, automatic controls became necessary for operating safely and preserving paddy quality. The functions of the automatically controlled dryer are as follows:

1. to set the appropriate initial drying parameters, such as the drying air

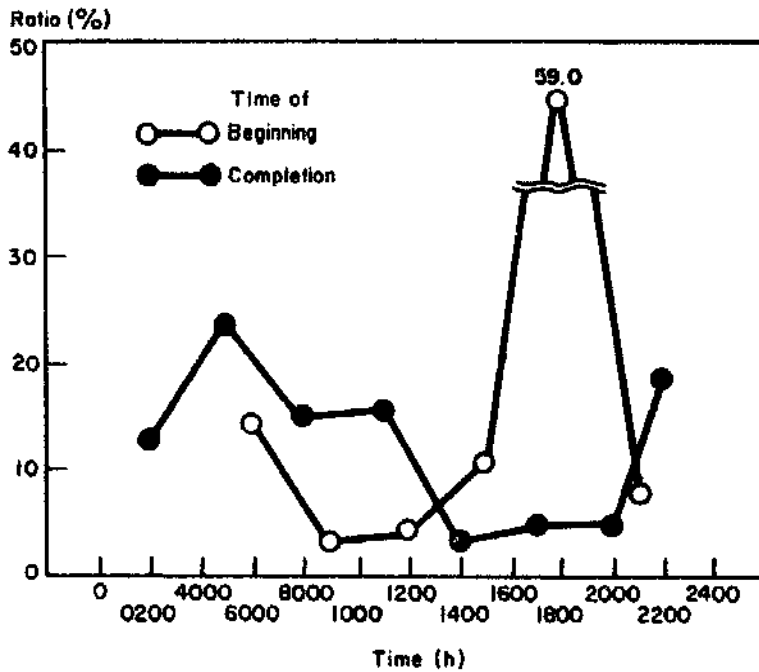

14. Operating time of dryer.

- temperature, considering the initial grain moisture content, temperature, and volume as well as the ambient air temperature;
2. to control the drying air temperature by regulating the fuel flow rate;
 3. to measure the moisture content of paddy during drying and to stop drying at the desired moisture level; and
 4. to realize all-night drying with no operator. However, someone must monitor the dryer at all times and be ready to respond to an emergency such as fire.

Figure 15 gives the schematic diagram of the computer-controlled grain dryer (11).

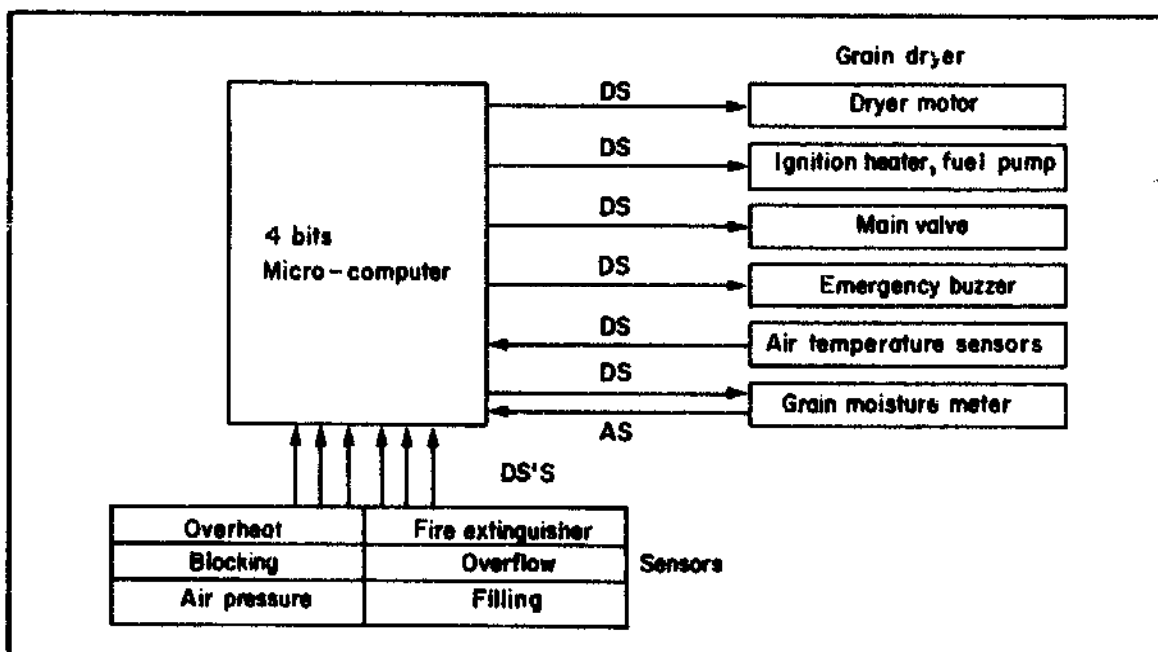

15. Block diagram of computer-controlled grain dryer. DS = digital signal, AS = analog signal.

MECHANICAL SUN DRYER

Most farmers use dryers only for 10 to 15 d/yr, and get a slow return on their investments. Recently, paddy was test-dried in the greenhouse, the steel-pipe-structured plastic house used by many farmers to grow vegetables out of season (Fig. 16). Drying paddy in greenhouses would use solar energy and increase equipment efficiency. The greenhouse could be used not only for drying paddy, wheat, oat, and soybean, but also for growing rice seedlings as well as vegetables. The greenhouse is thus used for 10 mo/yr.

Figure 17 schematically shows grain drying in the greenhouse (12). In this dryer (19.5 m^2), wheat of 20% m.c. and 12-cm thickness was dried at the rate of 0.23%/h to 18.3% moisture level. The temperature inside the greenhouse was higher by 2 to 3 degrees than the temperature outside it. This greenhouse could be used as the predryer for a large quantity of paddy harvested at one time; however, it is laborious to spread the undried paddy and gather the dried paddy in the hot and dusty greenhouse.

Other experiments used a flatbed dryer of 13.2 m^2 in a 19 m^2 greenhouse with a drying rate of 0.37 to 0.42%/h. The paddy of 1 to 1.1 t was covered by black or blue net with a fine mesh. The nets prevented reflection of the solar energy from the paddy layer surface and brown rice fissure due to the rapid increase of grain temperature. The airflow rate was 0.3-0.5 m^3/s per 1,000 kg paddy.



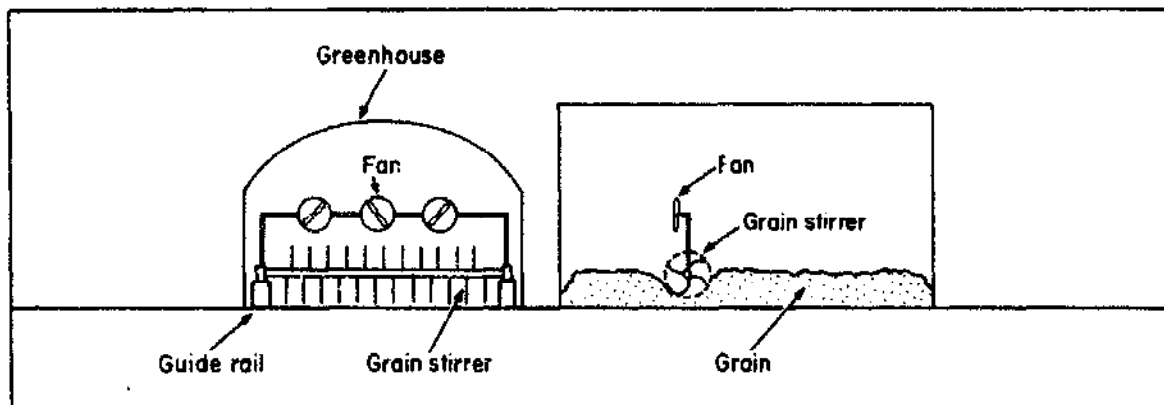

17. Grain drying and storage in the greenhouse.

Figure 18 shows the combination of the flat- and fixed-bed dryer and the greenhouse as the heating device (12). This combination avoids spreading and gathering the paddy in the hot and dusty greenhouse.

The combination of the grain-circulating dryer and the greenhouse was also examined. With this combination, the energy cost was 37% that of the circulating dryer using an oil burner to heat the drying air.

FUNDS FOR AGRICULTURAL MECHANIZATION

In Japan, funding for agricultural mechanization includes farmers' own funds, borrowed funds, and subsidies.

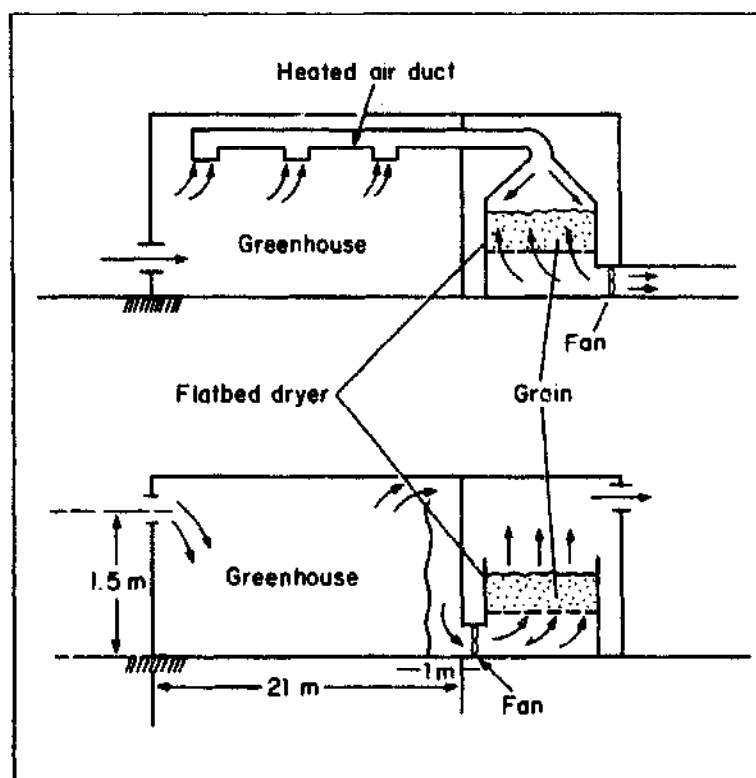

18. Fixed- and flatbed dryer using air heated by sun in the greenhouse.

Borrowed funds originate from agricultural cooperatives; Agricultural, Forestry, and Fisheries Financing Corporation; other government institutions and commercial banks, and other private financial institutions. The Agricultural Modernization Funds, mainly for agricultural mechanization, provide most of the funding. Farmers borrow these funds through agricultural cooperatives, normally paying 9.5% interest. This interest rate is subsidized by 3-4%/yr for individual farmers, and by 1.5-2.5%/yr for government expenditure. Since 3% is subsidized by the government, the actual interest rate that the farmers must pay is 6.5%. The funds of the Agricultural, Forestry, and Fisheries Financing Corporation provide long-term loans for introducing agricultural facilities and machinery and livestock, planting fruit trees, and acquiring and improving land. Interest rates are much lower than commercial rates.

The total loan made to the farmers under the Agricultural Modernization Funds policy were US\$1.085 billion in 1978 and US\$ 806 million in 1983 for agricultural machinery and facilities investment.

REFERENCES CITED

1. Esaki, H., ed. 1984. Handbook of farm machinery. 3d ed. Korona Publishing Co., Ltd., Japan.
2. Ikeda, Y. 1982. Automatic control of grain dryer. J. JSAM 44(3):555-562.
3. Kaburagi, H., ed. 1969. Handbook of farm machinery. 2d ed. Korona Publishing Co., Ltd., Japan.
4. Kaburagi, H., and S. Izumi. 1960. Mechanization of grain processing. Shin-Norin Sha Co., Ltd., Japan.
5. Nigata Agricultural Experiment Station. 1960. New drying method of rice grain. Japan.
6. Sato, J., and M. Irie. 1982. Utilization of solar energy for grain dryer. J. JSAM 44(3): 563-570.
7. Shoji, H. 1971. Introduction of farm machinery. Yoken-do Co., Ltd., Japan.
8. Takao, H. 1978. Technical trends of recent grain dryer. Farming mechanization. Shin-Norin Sha Co., Ltd., Japan.
9. Watanabe, T. 1958. Rice and seedling drying method for early cultured rice. Asakura Book Co., Ltd., Japan.
10. Yamashita, R. 1982. Grain dryer in Japan. J. JSAM 44(3):545-554.
11. Yamashita, R., M. Kodama, and M. Fujii. 1958. On drying of early cultured rice. Kansai Branch Report of JSAM 8:50-53.

**Improving research and development,
manufacturing, marketing, extension,
and use of small farm equipment**

ESTABLISHING PRIORITIES FOR RESEARCH AND DEVELOPMENT OF AGRICULTURAL MACHINERY IN DEVELOPING COUNTRIES

R. D. BELL and I. M. JOHNSON
National Institute of Agricultural Engineering
Bedford, England

Agricultural mechanization is one of many complementary inputs available to farmers who wish to increase production and profitability. Farmers will seek to optimize their farming systems and output according to criteria they perceive as important: availability of labor, land, and water; cost of inputs and value of outputs; social factors; risk; and cash flow.

The optimum level and style of mechanization is that which facilitates the best use of *all* the resources available to the farmer at the current time. However, these criteria are not static and may be changed by market forces or national policies over a much shorter time span than is necessary for the development, introduction, and adoption of a new agricultural machine or mechanization system. In planning agricultural engineering research, it is necessary, therefore, to look both at present and future requirements utilizing the best available forecast of farming patterns.

To attract an adequate level of financial and political support, agricultural engineering must, in part, address current problems, conducting applied research to utilize science and technology. However, if agricultural engineers are to play a full role in future developments involving significant change in farming systems, there must also be an adequate level of long-term, fundamental research which will provide the basis for the next generation of applied research.

ANALYSIS OF NEED FOR R&D AND IDENTIFICATION PRIORITIES

In selecting priorities for research and development (R&D), the agricultural engineer, together with colleagues in other relevant disciplines, should first consider what factors limit production within farming systems. If these constraints can be overcome by the application of science and technology, then the way may be open to introduce or develop machinery. Otherwise it will be necessary first to draw up a research program that will supply the knowledge required.

Before embarking on a research program, the research management team should identify and assess trends in the relative value of inputs and outputs,

because the economic and social environment will change in the 5 to 12 yr likely to elapse between the concept of a machine and its availability for purchase by farmers. It is also important that there be interdisciplinary discussions concerning possible developments in plant breeding, weed control, pest control, etc. which may result in crops which can be more easily grown, harvested, and stored. The sensitivity of demand for the end product of the research program should also be assessed.

The benefits of agricultural engineering R&D can only be realized when the products are manufactured and marketed, and adopted by the farmers. The following sections examine some factors which determine whether R&D will lead to real benefits.

THE PRODUCT AND ITS PLACE IN THE FARMING SYSTEM

A major factor in determining rate of adoption of any new machine is the scale of change in technique or farming system which must be made to introduce the new machine and the degree of skill or management necessary to use it effectively.

For this purpose it is useful to categorize new equipment as follows.

New model of a type of machine already in use locally

Animal draft plow. No really new technology is introduced in the animal draft plow and potential users may readily see the role of the machine in the farming system.

Only the technical or economic superiority has to be demonstrated for it to penetrate the market.

With such simple tools, resistance to adoption of the new model may arise from the artisan making and repairing traditional plows. It may be very difficult to demonstrate a level of improvement sufficient to encourage investment in a new plow while the old plow is still being used effectively.

Power tiller. The technical and economic superiority of the new power tiller must be clearly demonstrated for at least a subsector of the market.

Machines which change one component of production of a crop

Threshing. Where threshing is traditionally manual or involves treading by oxen, the thresher may be introduced without significant change of farming system, although a change from communal threshing to contract hire threshing may significantly change social patterns.

The introduction of new varieties may require new methods of threshing, illustrating corollary incentive to adopt. In other cases the new method may appear more expensive than the traditional methods. Axial-flow threshers, introduced in Sri Lanka several years ago, had no market demand until a series of wet harvests hampered treading out the grain and crop losses in stack were very high. Sale of threshers then grew rapidly.

Reaping. The IRRI-type reaper replaces labor in harvesting wheat at times of peak demand. It changes only one operation, leaving the tying, stacking, and

handling as before. If power tillers are available and underutilized at that season, then the machine may well be readily adopted. In some countries (i.e., Pakistan), the cost is substantially the same with or without a reaper, but if the arduous work of cutting is mechanized, laborers may be more willing to undertake the bundling.

Machines which change one or two stages in a crop production system

Whole-crop harvester. The whole-crop harvester is a new concept with no established market. It replaces the harvesting and threshing operations and necessitates change in the system of handling the grain and straw, but none in the farming system. Unlike the combine harvester, it collects all the straw at the time of cutting, and breaks it up into a form suitable for animal feeding.

Harvesting and threshing operations are attractive for custom hire operation since a ripe crop is at risk. Also, payment may often be made in kind, or only short-term credit will be required. The widespread adoption of the axial-flow thresher may be partly attributed to this.

Such machines may be purchased or hired and introduced in the farm without any prior change in the farming system.

Machines which require simple but significant changes in the farming practice

Animal-drawn weeders. Row weeders can only be demonstrated on row planted crops. Adoption of such hoes is likely to be linked to the adoption of seed drills or transplanters. Introduction is more difficult than where a single operation may be mechanized.

Machines requiring a substantial change in farming system

Wheeled animal-drawn tool carrier. Although known for many years, the wheeled animal-drawn tool carrier has not been generally adopted because its benefits have not, in the eyes of the farmer, compensated for its high cost relative to "walk behind" tools. Efficient use of a wheeled tool carrier requires a farming system which includes multirow seeding and weeding. It also requires good access to fields and complete clearance of stumps. It is well suited to the ICRISAT broad bed system which offers many advantages for soil and water conservation if a number of farmers introduce the system together. Thus, the social and technical change required is much greater than in any of the preceding examples and adoption is likely to be slow.

With official support and subsidy, the wheeled tool carrier is being manufactured and sold in several states of India, but it is used mainly for flat land cultivation and for transport. Its availability on farms may subsequently encourage adoption of bed cultivation.

Rotary injection planter (RIP). The RIP was developed to plant seeds through mulch in a no-till system — weeds being controlled by herbicides. As with the ICRISAT broad bed and furrow system, the farmer is required to adopt a new farming system of which the implement is an important part. However, in areas where all mulch and weed is grazed off, the implement has

been used as a simple planter with some success. The machine potential can only be realized if the farmer adopts a complete new farming system and has the sprayers, chemicals, and expertise necessary for weed control.

Some early models were made and sold by manufacturers who produced inferior machines resembling better machines. These inferior units were awkward to handle and had poor seed control. Their sale damaged the prospects of introducing improved machines in those areas.

Machines developed in the national interest

Some operations may be desirable in the interest of the community but may be of little interest to some farmers.

Cotton stalk pullers. In many areas, a quarantine period between crops, when all crop residue is destroyed, would reduce the quantity of chemicals needed to control pests and diseases. Often, such a quarantine is legally required but is not enforced. Farmers are unwilling to pull stalks because the operation is laborious and expensive, and all benefits are in the future and can only be realized if all farmers cooperate. Pulled stalks are commonly stored and used for fuel. In the 1970s, the National Institute of Agricultural Engineering (NIAE) responded to requests from Sudan and Swaziland to develop efficient cotton stalk pullers — both for tractor and animal power. These were not adopted because although the machines were *needed*, they were not *wanted* by the farmers.

Research for the future

Gross inefficiencies exist in our present use of seed, fertilizer, water, and power. Alternative methods which conserve these inputs are often not financially attractive to farmers, but this situation could change rapidly with a change in the relative value of inputs and outputs. Since work to develop suitable equipment may take several years, such research is a proper task for the research institute.

Fertilizer placement in paddy. Earlier laboratory work showed that placement of fertilizer could lead to its more efficient use, but field trials did not confirm the benefit at an adequate level. Further investigations explored the reasons, and equipment now can place fertilizer effectively. However, the ratio of fertilizer prices to cost of labor and machinery may encourage farmers to use more fertilizer rather than to adopt a more complex application system. The parameters of performance can be established and this knowledge banked until the cost parameters are favorable.

A pull-along sprayer. The pull-along sprayer was developed by NIAE to give a measured quantity of controlled size droplets of herbicides over an adjustable swath width.

Developing new machines is often speculative. NIAE developed the pull-along sprayer knowing there was no current market for it, and that adoption would depend on chemical companies providing appropriate sprays. Greatest demand was expected in no-till farming, for which the International Institute of Tropical Agriculture (IITA) had developed very promising systems not

likely to be widely adopted until equipment for accurate and economical application of herbicides was available. The machine is inexpensive and very suitable for row crop work as well as for innovative farmers adopting no-till farming. When no-till farming is adopted, we expect a rapid rise in demand for this sprayer, which will mean it can be mass produced, so the price will fall even more, leading to a greater demand.

FORECASTING THE PRICE OF A MACHINE TO BE DEVELOPED

The rate of adoption of a machine is greatly affected by its price since all mechanization depends on the manufacturer's willingness and ability to produce and market a machine at a price farmers can afford. Therefore, it is prudent to estimate a price at an early stage in the research program.

Many machines developed by universities and research organizations fail because these organizations do not realize the true cost of manufacturing and marketing, and frequently assume that a machine will be sold at little more than the cost of materials and labor. This might make the machine attractive to the farmer, but not to the manufacturer who would expect a higher return on his investment, especially in introducing any new technology.

Most innovations have depended on identifying a need and determining what the consumer can afford and is prepared to pay. If the manufacturer can produce and market the machine for less, production begins.

Once a market has been created, the original producer can usually cut his margins to cope with competitors who may have realized that they could market the same item at a lower cost.

What are the margins between production and marketing? These are usually closely guarded secrets of the trading companies, but they are obviously not small, and cannot be ignored. However, without wide markets it is impossible to support a manufacturing industry. The wider the market, the greater the output of the factory and the lower the unit cost. Sales or marketing is essential, and can be up to three times the cost of production depending on the amount of persuasion or demonstration required, cost of training, financing, etc.

Selling is a difficult job that depends on the buyer's confidence in the salesman. In the developing countries, promotion of new techniques too often is left to a government extension service. Frequently this means a sales force with no incentive to sell, and a customer with an inherent distrust of the salesman.

A first estimate of cost may be obtained by examining the relation between the cost of raw materials and the selling price of a machine. Here are ranges of raw material costs for agricultural equipment in the United Kingdom:

Farm tractors	\$6-14 per kg
Cultivation implements	\$3-8 per kg
Seed drills	\$8-10 per kg
Combine harvesters	\$8-14 per kg

For any new machine, a tentative cost may be estimated by referring to the local manufacture cost of machines of similar complexity.

It is instructive to look at how the price of a machine relates to raw material cost, and to the total cost of the machine over its life.

Table 1 shows that any machine that requires active selling (i.e., almost any machine for which the operator and farmer need training on use) is likely to cost as much to sell as it cost to produce. Any attempt at production without the equivalent effort in sales is unlikely to achieve significant market penetration.

The calculations provide an estimate of the price at which the machine would be attractive for the manufacturer. It is equally important to consider whether it will be attractive to the user. The lower the economic level of the consumer, the larger the benefit he must receive to make it attractive for him to change. A large industrial company may well change a complete process for a 1% improvement in productivity. A large-scale farmer may be interested in improvements of the order of 5%, but the subsistence farmer, whose life depends on the food he produces, will often not change for a 50% improvement if there is any uncertainty about the operation, or if the cost of credit is very high.

Very few small-scale farmers have any training in economics, but once they are out of the subsistence economy they respond very rapidly to prices, and will soon be producing the crops that maximize their profits. How they make decisions on purchasing equipment is not clear. They certainly do not know about discounted cash flows or net present values, so however right these techniques are for economic analysis they are useless as a guide to what the farmer is prepared to pay.

Table 1. Lifetime cost of machine or implement relative to material costs.

Element	Cost relative to material cost		
	Tractor	Plow	Hoe
Raw materials	100	100	100
Development costs	50	20	
Manufacturing labor	100	100	100
Overhead	100	100	
Sales costs and profit	<u>300</u>	<u>300</u>	<u>50</u>
Total sale price	650	620	250
Finance	250		
Spares	300	200	
Repairs	300	200	50
Fuel and oil	700		
Other costs	100		
Total cost to farmer	2300	1000	300
Ratio of total cost to material cost over lifetime use of item	23:1	10:1	3:1

It is certain that cost is only one element of the decision-making process. In one country where one make of tractor was cheap, but had unreliable hydraulics, almost all the road transport was done with the cheap tractor, but for field work the contractors willingly paid 30% more for a tractor with reliable hydraulics. Conversely farmers were reluctant to buy a relatively expensive, high-output, sophisticated cotton stalk puller, preferring instead a cheap cutter with low work rate, even though the high output machine gave by far the lowest cost per hectare when total cost of machine and tractor were considered.

Most farmer/contractors work on relatively crude costings that tend to ignore repair costs. They hope to recover the initial costs of machines in hire fees in 1 or 2 yr. This may be why some countries go for reliable high technology machines while others opt for the cheaper local product of uncertain life and reliability.

The market price may differ markedly from the estimates based on cost to manufacture and benefit to user. The laws of supply and demand apply to agricultural machinery, so there is no question of a simple price for a machine at which all farmers will buy. Farmers follow a normal distribution; a few will buy a machine almost regardless of cost and some would never use a machine even if you gave it to them. One manufacturer in the United Kingdom said there were about 100 farmers who could be relied on to buy anything new. From the manufacturer's point of view, such farmers were invaluable, as they guaranteed the sales of the first batch of production machines and gave valuable field testing.

The few farmers prepared to pay for something new are the ones to aim at. As the machine becomes established, the cost can be brought down and the volume increased. Setting the price too low in the first place can give problems: if costs are underestimated initially, it is difficult to raise prices without sales resistance. However, if the price starts high it can easily be lowered, and few farmers can resist a bargain.

MANUFACTURE AND SERVICE

In machinery development, it is very important to identify the type of center likely to produce it and the type of organization likely to sell and service it. Each of these depends on the sophistication of the machine.

Village-level workshop

The village craftsman, carpenter, or blacksmith sells directly to the user. The craftsman may use some modern tools such as welders or small power tools, but likely crafts each item individually. He will provide service to local users but is unlikely to carry any parts in stock. He is unlikely to work from engineering drawings and will probably need to copy a model. He is unlikely to have access to high quality materials, or to be able to work to precise limits.

District workshop factory

Typically, district factories are in market towns and employ about 10 craftsmen. They usually work on small batches with a minimum of jigs and special tooling, producing a reasonably standard product and supplying replacement parts. Selling is usually direct to the farmer. The manufacturer is unlikely to provide any field service, but will repair machines returned to the factory. Manufacturing standards are higher than those of the village craftsmen, but if precise dimensions are to be maintained, then a support organization may need to provide the necessary jigs.

National factory

A factory producing goods for national distribution usually employs more than 20 craftsmen and may subcontract specialist work. Such factories will probably use extensive jigs and tooling to give a consistent product. Sales may be through retailers, but the company will probably employ some to its own demonstrators/salesmen and will provide parts and service. In some cases the company may combine sales and contract work by hiring out equipment to potential buyers. Factories at this level should be able to produce variants of the basic machine to suit district preferences and design their own jigs to facilitate accurate manufacture.

International factory

International factories produce a standard product for sale mainly through accredited agents and/or retailers. The manufacturer supports specialist sales and operator training. The equipment produced is likely to need specialist service mechanics and tools.

Such companies usually engage in substantial R&D and may redesign any machine to suit their own manufacturing systems and their product image.

Industrial extension

The level of industrial extension necessary to carry a machine from the prototype prepared by the R&D organization through to commercial production clearly depends on the sale and sophistication of the interested manufacturers. Industrial extension requires different skills from those required for R&D. Some changes in design may be required to facilitate manufacture. It is therefore desirable that the commercial model be tested by the R&D team before its manufacture in quantity.

CONCLUSIONS

Whether R&D is directed to simple or sophisticated machinery, or whether it is short, medium, or long term, the following considerations are important.

- R&D must be carefully planned to meet specific objectives important to agricultural production and rural development. The anticipated benefits must be of a scale the farmer can appreciate.

- The research must be scientifically sound, all experiments and trials carefully monitored and recorded, and analysis and interpretation of results made early enough to guide later phases of the work.
- The work should be assessed at stages in the development, and the continued validity of the criteria on which the project was based reassessed at those points.
- As soon as possible in the development program, i.e., when equipment is in the early prototype stage, there should be consultation with industry, with farmers, and with extension services to identify constraints which might hinder the marketing of a technically satisfactory machine.
- The manufacture and marketing phase of any development is *not* the responsibility of the R&D team. However, the probable scale of manufacture and the method of marketing are relevant to later stages of development, and must be considered when assessing the likelihood that the product of R&D will succeed and in determining the priority to be given to any particular project.

TRANSFERRING SMALL-FARM EQUIPMENT TECHNOLOGY BETWEEN NATIONS: RNAM'S EXPERIENCES

Z. U. RAHMAN

Regional Network for Agricultural Machinery

Since World War II, the traditional manual and animal methods of farming in Asia have been giving way to more efficient and precise farming with the help of machines. This change is more rapid in some countries than in others. Many socioeconomic factors, often complex and intangible, are responsible for this change.

- Rapidly increasing populations require more food. Since most land is under cultivation, the only way to increase production is to increase yield and grow more than one crop a year. Thus, timely operations become crucial and these can be handled effectively only with machines.
- Compared with traditional varieties, high yielding varieties require more exact applications of inputs. Machines are better suited to meet this requirement.
- Casual farm labor transfers to urban centers and the Middle East for more permanent and lucrative jobs, thus creating labor shortages in critical operations such as sowing, harvesting, and threshing.
- Changing attitudes toward dirt farming, especially of younger generations, are causing labor shortages and compelling farmers to use machines.
- Perhaps most significant, the emergence of strong nationalistic feelings in many countries impelled them to make the transition from the inefficient and often demeaning dirt farming to more efficient and respectable farming with the help of machines. Countries having stronger political will for this change are further along in agricultural mechanization.

In the late 1960s, the Asian Industrial Development Council (AIDC) recognized that most agricultural machines and implements available in Asia were designed and produced in America and western Europe and were generally not suited to the peculiar agroclimatic and socioeconomic conditions in the Asian countries. Hence, there was a need to develop machines for the unique farming conditions in this region.

Some countries, notably Japan, China, and India, had already started developing indigenous machines. Experts' meetings, sponsored by UNDP, evolved a network concept in which the countries of the region would share

experiences and technologies to promote local development, manufacture, and popularization of suitable machines. The Regional Network for Agricultural Machinery (RNAM) is the practical realization of this concept (Fig. 1).

RNAM was established in 1977 with eight member countries: India, Indonesia, Iran, Pakistan, the Philippines, Republic of Korea, Sri Lanka, and Thailand. Each country has its own national network of institutes, organizations, and agencies involved in the farm mechanization efforts; one institute, designated as the national institute, plays the pivotal role in the national network and coordinates activities with other member countries of RNAM. The Regional Office is on the campus of the University of the Philippines at Los Baños (UPLB).

OBJECTIVES OF RNAM

The broad objectives of RNAM are

- to assist national institutes (NIs) in formulating policies and strategies to promote agricultural mechanization;
- to strengthen the capabilities of NIs in design and development;
- to strengthen the capabilities of NIs in testing, evaluating, and modifying prototype equipment to meet local manufacturing conditions;
- to promote manufacture of agricultural machinery;
- to popularize farmers' use of agricultural machinery; and
- to exchange information on implements and tools, agricultural mechanization programs, and relevant technological developments in the field of agricultural machinery.

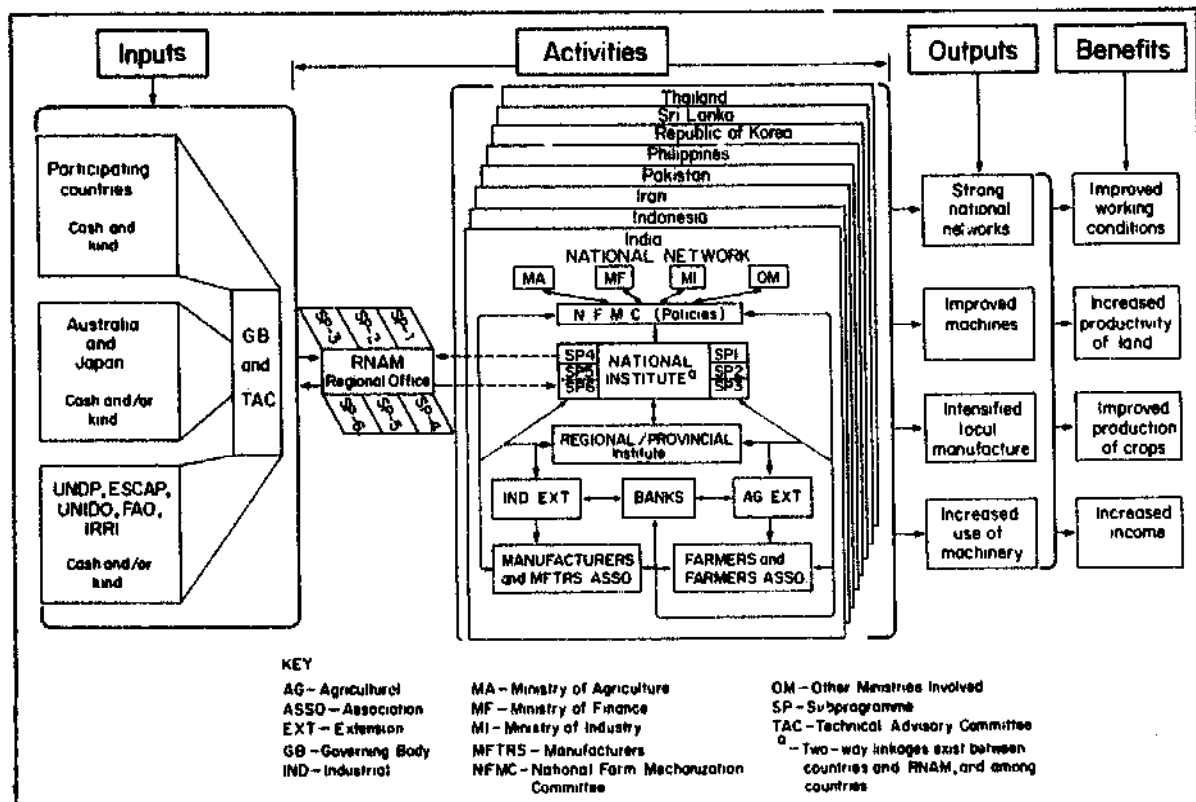

1. The RNAM System.

TRANSFER OF SMALL FARM EQUIPMENT TECHNOLOGY
BETWEEN RNAM COUNTRIES

RNAM has used several models of assistance to accomplish its objectives.

Supply of prototypes

During the first phase (1978-81) of the project, four areas in the crop production cycle were identified for immediate assistance: transplanting, harvesting, weeding, and seeding and applying fertilizer. For the first two areas, an expert visited several Asian countries and identified four types of transplanters (from India, China, and Japan) and five types of harvesters (from India, China, Japan, and IRRI) which could be used in the participating countries.

Transplanters. RNAM shipped 19 transplanters to the requesting countries for testing and adaptation. An expert introduced these machines in the eight participating countries. The Annapurna from India and Mametora from Japan were found unsuitable by all recipients. The Chinese Tang-Hong has been modified by the Philippines' National Institute (AMDP), and the first prototype is undergoing testing.

The IRRI machine holds the best potential; however, the handicaps of poor land leveling, poor water management, and inability of farmers to grow the nursery in the prescribed manner must be overcome before the machine becomes popular. In addition, the manual part of the planting operation must be mechanized (engine or power tiller). The current status of these machines is given in Table 1.

Harvesters. Similarly, on the recommendation of the first expert, 20 units of 5 types of harvesters (TNAU reaper from India; Iseki, Mametora, and Satoh reapers from Japan; and the vertical conveyor reaper from China) were supplied to the countries. A harvester expert helped initiate work on the machines in the recipient countries. The machines from India and Japan were found unsuitable, but the Chinese machine, a gift to RNAM by the Chinese Government, was most successful, especially in India and Pakistan. In Pakistan, more than 3,000 units of a tractor front-mounted version, modified by the Farm Machinery Institute (FMIT), Islamabad, have been locally produced and sold in the last 3 yr.

Table 1. Status of RNAM-supplied prototypes of rice transplanters, 1978-81.^a

Country	Annapurna 77	Mametora TA-2	Tang Hong 2S	IRRI RT
India	—	x	x	b
Indonesia	x	x	—	—
Iran	x	x	x	—
Pakistan	x	x	—	—
Philippines	—	x	b	c
Republic of Korea	x	—	x	x
Sri Lanka	x	x	—	c

^a x = unsuitable. ^b Undergoing modification and intensive testing. ^c Being popularized.

Table 2. Status of RNAM-supplied prototypes of cereal harvesters, 1978-81.^a

Country	Mametora reaper	TNAU reaper	Satoh reaper	Iseki reaper	Vertical conveyor reaper
India	x	—	x	—	1.9 m ^b
Indonesia	x	x	—	—	1.6 m ^c
Iran	x	x	—	—	—
Pakistan	x	x	—	—	2.2 m ^b
Philippines	x	x	—	—	1.6 m ^d
Republic of Korea	—	x	—	x	—
Sri Lanka	—	—	—	—	1.6 m ^d
Thailand	x	x	—	—	x

^ax = unsuitable, ^bBeing commercially produced, ^cUndergoing modification and intensive testing, ^dBeing popularized.

The Central Institute of Agricultural Engineering (CIAE) Bhopal evolved its own version of the tractor front-mounted machine. In addition to the original Chinese machine, the CIAE was also provided in 1983 with a commercial unit from Pakistan under the RNAM's program for mutual exchange of prototypes. More than 500 of these machines were produced and sold last year and a few thousand this year. Other countries where the reaper holds potential for popularization are Indonesia, Thailand, and Sri Lanka. The status of various machines in the eight participating countries is given in Table 2.

Weeders. An expert visited India, Indonesia, Philippines, Republic of Korea, Sri Lanka, and Thailand and assisted them in improving the local weeders. Iran and Pakistan did not participate in this program.

The project did not provide an expert for *seeders and fertilizer applicators*. The NIs were urged to use indigenous resources in improving the function and quality of such equipment.

Mutual exchange of prototypes

At the beginning of the second phase (1981-84), the national directors of 8 participating institutes selected 53 machines for mutual exchange. Of the 32 received so far, one machine, the vertical reaper (from Pakistan to India) has been commercialized, and another machine, a sugarcane planter (from India to Pakistan), has reached the popularization stage, though without the dramatic success of the vertical reaper. Four other machines — a bullock-drawn disk harrow from India to Indonesia, an IRRI portable pump from the Philippines to Pakistan, an automatic thresher from Korea to India, and a direct hand-seeder from Thailand to the Philippines — are being extensively tested under local conditions and hold some potential for eventual popularization. Other machines being modified to suit local conditions are a bullock-drawn disk harrow from India to Sri Lanka, a bullock-drawn cultivator from Pakistan to Indonesia, the IRRI portable axial-flow pump from the Philippines to India, and the automatic thresher from Korea to Pakistan. The status of the remaining 43 machines is given in Table 3.

Table 3. Status of mutual exchange of prototypes, as of 15 Jun 1985.

Prototype	Requesting country	Status
<i>From India</i>		
1. Bullock-drawn disk harrow ^a	Sri Lanka	Modification
2. Bullock-drawn disk harrow	Indonesia	Extensive testing
3. Two-wheel tool carrier	Thailand	Initial testing
4. Two-wheel tool carrier	Indonesia	Unsuitable
5. Helical blade puddler ^a	Philippines	Initial testing
6. Paddy husk stove	Indonesia	Unsuitable
7. Semi-automatic sugarcane planter ^{a,b}	Pakistan	Popularization
8. Groundnut digger-shaker windrower ^{a,b}	Pakistan	Unsuitable
9. Multicrop seed drill	Sri Lanka	Dispatched
10. Two-row seed drill	Thailand	Pending
11. Potato digger-cum-elevator	Pakistan	Pending
12. Seed drill-cum-planter with fertilizer attachment	Pakistan	Pending
13. Potato planter	Pakistan	Pending
<i>From Indonesia</i>		
1. Cassava slicer	India	Pending
2. Single-pass rice mill	India	Cancelled
3. Sprayer	Philippines	Initial testing
4. Sprayer	Thailand	Initial testing
5. Weeder fertilizer applicator	Sri Lanka	Pending
6. Weeder fertilizer applicator	Thailand	Pending
<i>From Pakistan</i>		
1. Bullock-drawn cultivator	Indonesia	Modification
2. Bullock-drawn cultivator	Thailand	Unsuitable
3. Bullock-drawn disk harrow	Indonesia	Initial testing
4. Bullock-drawn disk harrow	Thailand	Unsuitable
5. Bullock-drawn groundnut digger	Sri Lanka	Initial testing
6. Corn sheller	Sri Lanka	Unsuitable
7. Reaper windrower FMI-RW22 ^b	India	Commercial production
8. Ridger-cum-cotton planter ^b	India	Initial testing
<i>From Philippines</i>		
1. IRR1 portable axial-flow pump	Pakistan	Extensive testing
2. IRR1 portable axial-flow pump	India	Modification
3. UPLB peanut sheller	Sri Lanka	Initial testing
4. UPLB peanut sheller	Indonesia	Dispatched
5. UPLB peanut sheller	Thailand	Initial testing
6. Animal-drawn maize planter	Sri Lanka	Initial testing
7. Animal-drawn maize planter	Thailand	Initial testing
<i>From Republic of Korea</i>		
1. Grain dryer	India	Unable to supply
2. Rotary seeder	India	Unable to supply
3. Rotary seeder	Thailand	Unable to supply
4. Automatic thresher	India	Extensive testing
5. Automatic thresher ^a	Pakistan	Modification
6. Automatic thresher	Thailand	Unsuitable
7. Combine harvester TC 1710 three-row	India	Unable to supply
8. Rice transplanter NS 400-3	India	Pending
9. Power sprayer	India	Pending
<i>From Sri Lanka</i>		
1. Pedal pump	Indonesia	Lost in transit
2. Single-row hand seeder	Indonesia	Lost in transit
3. Blade hoe	India	Initial testing
4. Two-row hand seeder	India	Initial testing

Table 3. Continued.

Prototype	Requesting country	Status	
5. Two-row hand seeder	Thailand	Unsuitable	
6. Three-row seeder for walking tractors	Philippines	Lost in transit – unable to supply replacements	
7. Animal-drawn cultivator	Thailand	Lost in transit – unable to supply replacements	
<i>From Thailand</i>			
1. Direct hand seeder	Indonesia	Dispatched	
2. Direct hand seeder	Philippines	Extensive testing	
3. Hand-operated winnower	Sri Lanka	Unsuitable	
<i>Summary of status</i>			
Initial testing	13	Cancelled	1
Extensive testing	4	Dispatched	3
Modification	4	Lost in transit	4
Unsuitable	9	Pending	9
Popularization	1	Total not received	17
Commercial production	1	Unable to supply	4
Total received	32	Total received	32
		Grand total	53

^a Test report released. ^b Additional request.

The mutual exchange program has not been as great a success as anticipated because of these reasons:

- Time is insufficient for the machines to be thoroughly tested and adapted for local conditions. Lack of funds and trained personnel, along with cumbersome procedures followed by public institutions in allocating resources for crash programs such as this one, are generally responsible for these delays.
- Most machines chosen were from the experimental models developed at the various institutes; they were not successful machines in commercial production.
- Some countries are unable to supply machines requested by others, mostly because of budgetary constraints. The mutual exchange program required the donor country to pay for the cost of the machine and any local transportation. RNAM paid for the international shipment and the recipient country paid the duty and internal transportation.

Development of infrastructure

Soon after the project was launched, it was realized that effective technology transfer between nations requires an elaborate infrastructure. This infrastructure was fairly well developed in some countries, but needed strengthening. Essential elements of this infrastructure are given below.

National Farm Mechanization Committee. Appropriate mechanization policies, as they relate to import of technologies, machines, raw materials,

import/export duties, local manufacture versus import, credit, etc., are crucial. Upon continuous urging from the project, all eight participating countries now have National Farm Mechanization Committees, responsible for formulating appropriate policies for farm mechanization.

National institutes and test centers. The project is providing catalytic assistance to the NIs and test centers in the form of instruments and other equipment for upgrading their design and testing capabilities.

Manpower. The project has trained 71 engineers in farm machinery design, testing, manufacturing technology, and industrial extension. The courses were conducted in both developing and developed countries (Table 4). The major thrust in training has been on design and development. The countries still lack well-trained manpower and the project will continue to allocate major resources in building up this essential resource.

Exchange of experiences and ideas

The project holds regular meetings of the Technical Advisory Committee (TAC) where directors from the eight participating NIs as well as experts from various international agencies (ESCAP, FAO, IRRI, UNDP, and UNIDO) discuss in detail the mechanization problems facing the countries and suggest solutions. In addition to the TAC meetings, the project has arranged 14 workshops on rice transplanters, harvesters, manufacturing technology, weeders, standardization, testing, planning and policies, extension and popularization of agricultural machinery (Tables 5-7).

The project has been encouraging the NIs to exchange design drawings and other information related to mechanization.

PROSPECTS

During the first three phases, 1977-86, the project concentrated on machinery for crop production. However, other areas urgently need mechanization. An estimated 30% of the cereal crops are lost due to inadequate postharvest facilities and machines. Thus, appropriate postharvest machines need to be developed and popularized. Up to 40% vegetables and fruits are lost because of lack of proper storage and preservation facilities. Thus, the scope of the project will be widened by the introduction of postharvest and food preservation machinery at the village/farm levels.

Farm mechanization should also be extended to agro-industries such as poultry, livestock, dairy, and fisheries. These industries need to be re-established at the village/farm levels, so the rural population can benefit from increased value added to the produce and generation of additional employment, and labor which may be released by mechanizing field operations can be absorbed. This concept of integrated rural industrialization is highly developed in Japan; the Republic of Korea is following in its footsteps. The project will encourage participating countries to emulate the Korean experience through pilot projects in each country and later through larger efforts. The fourth phase will provide catalytic funding for the establishment of integrated

rural agro-industrial pilot projects in participating countries. These projects and their subsequent expansion will be carried out through each country's national network infrastructure.

The final decision on the future direction of the RNAM Project for the fourth phase, 1987-91 will be taken by the TAC, scheduled to meet in Indonesia the second week of October 1985.

RNAM is a limited life project projected to last until 1991. By then the NIs must be able to carry out their activities on a self-sustaining basis.

SUMMARY AND CONCLUSION

The success in transferring small farm-equipment technology between nations depends on complex interrelated factors.

Policy factors include the

- decision to mechanize,
- will to promote local manufacture,
- import-export policies,
- availability of credit to farmers, and
- availability of credit to manufacturers.

Socioeconomic factors include the following:

- machines must save time and provide economic advantages to farmers;
- they should efficiently perform the tasks they are designed for;
- they should be affordable;
- they should be simple, reliable, and easy to maintain;
- service and spare parts facilities must be readily available to the farmers;
- and
- they must reduce drudgery of farm operations.

For any machine to be successfully introduced, all or most of these factors must be resolved. This is a time-consuming process, given the organizational and managerial limitations of the developing countries. Hence, the process of agricultural mechanization in the region is not expected to be significantly accelerated.

Table 4. RNAM Training Fellowship Grants, 1978-84.

Training institute	Fellowship grants (no.)										Total	
	India	Indonesia	Iran	Pakistan	Philippines	Rep. of Korea	Sri Lanka	Thailand				
<i>Testing and evaluation</i>												
Agricultural Machinery Industry, Tokyo, Japan	-	3	-	-	-	-	-	-	-	-	-	3
Tamil Nadu Agricultural University, Coimbatore, India	-	1	-	-	-	-	-	-	-	-	-	1
Institute of Agricultural Machinery, Omiya, Japan	1	1	-	2	2	-	1	-	3	-	-	10
National Institute of Agricultural Engineering, Silsoe, U. K.	-	1	-	-	1	1	-	-	-	-	-	3
Tractor Training & Testing Centre, Budni, India	-	-	1	-	-	-	-	-	-	-	-	1
<i>Design and development</i>												
Egyptian International Centre for Agriculture, Dokki, Egypt	-	-	-	1	-	-	-	-	-	-	-	1
International Rice Research Institute, Los Baños, Philippines	1	-	-	2	-	-	-	-	-	-	-	3
University of Hohenheim, Stuttgart, West Germany	-	-	-	-	-	1	-	-	1	-	-	2
Institute of Agricultural Machinery, Omiya, Japan	-	-	-	1	-	1	-	-	-	2	-	4
Agricultural University Wageningen, The Netherlands	1	1	-	1	1	2	1	1	1	1	1	8
ILO International Centre for Advanced Technical & Vocational Training, Turin, Italy; and Punjab Agricultural University, Ludhiana, India	1	2	2	-	2	1	2	2	2	2	2	12

Table 4. Continued.

Training institute	Fellowship grants (no.)										Total	
	India	Indonesia	Iran	Pakistan	Philippines	Rep. of Korea	Sri Lanka	Thailand				
<i>Manufacturing technology</i>												
Tamil Nadu Agricultural University Coimbatore, India	—	1	—	—	—	—	1	—	—	—	2	
Zhenjiang Institute of Technology Zhenjiang, People's Republic of China	1	—	—	1	1	—	—	—	—	1	4	
Indian Standards Institution, New Delhi, India	2	2	—	2	2	—	1	—	—	2	11	
<i>Industrial extension</i>												
Jiangsu Institute of Technology Zhenjiang, People's Rep. of China	1	—	—	—	1	—	1	—	—	1	4	
International Rice Research Institute Los Baños, Philippines	—	1	—	—	—	1	—	—	—	—	2	
Total	8	13	3	10	10	7	9	11	—	—	71	

Table 5. Country participation in subnetwork/regional workshops, 1979-84.

Workshop	Participants (no.)						Countries represented (no.)		
	India	Indonesia	Iran	Pakistan	Philippines	Republic of Korea			
1. First subnetwork workshop on weeders 24-27 Apr 1979 Peradeniya, Sri Lanka	1	1	—	—	1	1	31 ^a	1	6

2. First subnetwork workshop on rice transplanters 30 May-1 Jun 1979 Los Baños, Philippines	1	1	1	1	16 ^a	1	-	-	6
3. First subnetwork workshop on cereal harvesters 3-6 Jul 1979 Coimbatore, India	42 ^a	1	1	1	1	1	-	1	7
4. First subnetwork workshop on manufacturing technology 20-23 Jan 1980 Lahore, Pakistan	1	-	1	30 ^a	1	1	1	1	7
5. Second subnetwork workshop on cereal harvesters 5-8 Aug 1980 Los Baños, Philippines	2	1	-	1	34 ^a	1	-	1	6
6. Second subnetwork workshop on rice transplanters 26-29 Aug 1980 Suwon, Republic of Korea	1	-	1	1	2	32 ^a	1	1	7
7. Second subnetwork workshop on weeders 23-26 Sep 1980 Bandung, Indonesia	-	19 ^a	-	-	1	-	1	1	4
8. Second subnetwork workshop on manufacturing technology 6-8 Oct 1980 Bangkok, Thailand	-	2	-	2	2	2	2	13 ^a	6

^a While RINAM sponsored only one or two engineers or government officers coming from each country, the host and some other countries sent additional participants at their own expense.

Table 6. Country participation in Technical Advisory Committee Meetings, 1978-84.

Country	Participants (no.)										Total meetings attended
	1st session 16-20 Jan 1978 Bangkok	2d session 17-19 Oct 1978 Los Baños	3d session 26-28 Sep 1979 Manila	4th session 9-11 Oct 1980 Bangkok	5th session 15-20 Jul 1981 Los Baños	6th session 16-18 Nov 1981 Manila	7th session 13-19 Oct 1982 Tokyo	8th session 25-31 Oct 1983 Paradeniya	9th session 24 Jul-1 Aug 1984 Los Baños		
India	1	1	1	-	1	-	-	1	-	-	5
Indonesia	1	1	-	1	2	1	1	1	1	1	8
Iran	1	-	1	-	-	1	-	-	1	1	4
Pakistan	1	-	1	2	1	-	1	1	1	1	7
Philippines	1	1	2	1	2	2	1	1	2	1	9
Republic of Korea	1	1	1	1	2	1	1	1	1	1	9
Sri Lanka	1	1	1	1	1	1	1	3	1	1	9
Thailand	1	1	1	2	1	1	1	1	1	1	9
Countries represented (no.)	8	6	7	6	7	6	6	7	7	7	

Table 7. Country participation in governing body meetings, 1978-84.^a

Country	Participants (no.)							Total sessions attended
	1st session 13-14 Sep 1978 Los Baños	2d session 17-18 Oct 1979 Los Baños	3d session 25-26 Nov 1980 Bangkok	4th session 20-21 Nov 1981 Manila/Los Baños	5th session 15-16 Dec 1982 Los Baños	6th session 14-15 Dec 1983 Los Baños	7th session 28-29 Nov 1984 Manila	
India	—	1 (DDG)	—	—	—	—	—	1
Indonesia	1 (ND)	3 (MI) (MIDC)	1 (ND)	1 (ND)	1 (ND)	2 (ND) (MI)	2 (DG) (E)	7
Iran	—	1 (DG)	—	1 (E)	—	1 (E)	1 (VDM)	4
Pakistan	—	2 (E)	1 (ND)	1 (DS)	1 (E)	1 (E)	—	5
Philippines	1 (C)	1 (C)	1 (C)	3 (NI) (NEDA)	(C) 2 (NI)	(C) 3 (NI) (NEDA)	1 (C)	7
Republic of Korea	1 (ND)	—	1 (ND)	1 (ND)	2 (SE) (SP)	1 (VD, MA)	1 (DH)	6
Sri Lanka	—	1 (E)	—	2 (E) (CE, DA)	—	1 (AS, MA)	1 (AS, MA)	4
Thailand	1 (ND)	1 (ND)	1 (ND)	2 (DG) (DH)	2 (DDG) (SH, MA)	2 (VDG) (ND)	2 (DDG) (ND)	7
Countries represented (no.)	4	7	5	7	5	5	5	

^a AS (MA) = additional secretary, Ministry of Agriculture; C = Chancellor, University of the Philippines at Los Baños; CE (DA) = chief engineer, Department of Agriculture; DDG = deputy director general, Ministry of Agriculture; DG = director general, Ministry of Agriculture; DH (MA) (DA) = division head, Ministry/Department of Agriculture; DS = deputy secretary, Ministry of Food, Agriculture, and Cooperatives; E = embassy; MI = Ministry of Industry; MIDC = Metal Industries Development Centre; ND = national director; NEDA = National Economic Development Authority; NI = National Institute; SE = senior engineer; SP = specialist; SH (Ma) = section head, Ministry of Agriculture; VD (MA) = vice director, Ministry of Agriculture; VDG = vice director general; VDM = vice deputy minister, Ministry of Agriculture.

THE IRRI INDUSTRIAL LIAISON PROGRAM

C. W. BOCKHOP, R. E. STICKNEY, M. M. HAMMOND,
B. J. COCHRAN, V. R. REDDY, F. E. NICHOLS, and S. C. LABRO
The International Rice Research Institute

The Industrial Liaison Program evolved from the Agricultural Machinery Development Program started in 1963. The Industrial Liaison Program now includes projects in Burma, Egypt, India, Indonesia, Philippines, and Thailand.

Machines are developed at the International Rice Research Institute at Los Baños, Philippines. After machines are thoroughly tested and determined to be within the technical capabilities of farmers and local manufacturers, blueprints are given to fabricators. Manufacturers are assisted in producing their first units and in introducing them to farmers.

A project is established with an appropriate national program and liaison is maintained to provide needed support in designing, testing, and introducing equipment to farmers. Each country has unique requirements and thus equipment must be modified and adapted to local conditions.

THE AGRICULTURAL MACHINERY DEVELOPMENT PROGRAM

Asian rice farmers have small landholdings; 66% of rice farmers in 10 countries cultivate less than 2 ha. The goal of the IRRI machinery development program is to help small farmers obtain machines which will raise their productivity beyond the subsistence level and improve their income and welfare. The program fosters the manufacture of farm equipment in developing countries.

The program is compatible with the increasing use of high yielding varieties, fertilizers, and chemicals for weed and insect control.

Background

The farm machinery development program at IRRI was established in 1963 when it became apparent that as farmers increased their production and cropping intensity, they would need machinery to prepare land and to harvest crops.

Large machines available then were unsuited to small rice farms. Small machines later developed in Japan were expensive to import and maintain, and often were not adapted to local conditions.

An "ideal" machinery delivery system, as found in countries where agriculture is highly mechanized, includes

1. the manufacturer, who possesses and controls the research and development capabilities;
2. a sales distribution system, usually controlled by the manufacturer; and
3. a dealership system to supply original equipment, spare parts, and service to the farmer.

In industrialized countries, the manufacturers are far away from farmers, but dealers are close and extend service and mechanization training to the farmers. In developing countries, few such systems can provide needed equipment and markets are too small to support sales and service systems and needed research and development.

The IRRRI program performs research and development for small manufacturers who then provide machines to farmers. Thus, the manufacturer is also the dealer who provides after-use services and needed spare parts.

As the sales of machines increase, a marketing system of dealers will develop. In some countries, manufacturers have started sales and dealership systems.

Industrial liaison at IRRRI

The needed machines are designed and developed by IRRRI engineers. After a prototype has been fabricated and thoroughly tested, blueprints are provided to manufacturers at no cost. Extension engineers help manufacturers fabricate prototypes and introduce the first machines.

Because small manufacturers generally do not have engineers on their staff or personnel who can read blueprints, IRRRI helps manufacturers fabricate their first prototypes. Often, IRRRI lends one of its units to the manufacturer.

To help maintain quality and improve efficiency, manufacturers are encouraged to fabricate jigs and fixtures to facilitate rapid assembly and welding. Manufacturers are taught modern production techniques to improve their efficiency and lower production costs.

In the Philippines, the average manufacturer of farm equipment is relatively small, employing an average of 10 or 11 persons. Large manufacturers are usually not interested in the agricultural market because of small volume. Many small manufacturers are located in rural areas near farmer customers and thus can provide parts and services needed.

The Industrial Extension Network

The success of this program in the Philippines stimulated Agricultural Engineering to organize the Industrial Extension Network to introduce appropriate machinery to farmers in other Asian countries. The network now involves Burma, Egypt, India, Indonesia, Philippines, and Thailand. Pakistan, once a part of the network, developed its program sufficiently to operate without IRRRI assistance.

In each country, an Industrial Extension Group is organized in the Ministry of Agriculture or comparable organization. An IRRRI representative is

stationed with the group as an adviser. The adviser and his counterpart develop a strategy statement and work plan.

The strategy statement defines the target group and establishes work priorities. The definition of the target group includes the type of farmers, their economic situation, the state of mechanization, and their needs. A work plan is then developed to introduce the needed machinery expeditiously.

Strategy statements and work plans differ to meet the unique requirements of each country.

COUNTRY PROGRAMS

Burma

Burma has traditionally used animals as a power source, so improvement of animal-powered equipment has high priority. An animal-powered reaper has been designed and will soon be field tested. An improved wagon for one animal instead of two has been designed. The lighter weight cart will be widely accepted.

Several pumps of the axial-flow design have been fabricated and are being tested. A 10-inch-diam pump and a 12-inch-diam pump have been fabricated. Both use vertical lift. The 10-inch pump will lift about 4,000 liters/min with a 5 hp engine.

A local plow has been improved to incorporate a replaceable share. The replaceable share costs 50¢ (U.S.), considerably reducing plowing costs.

Egypt

The 1-m reaper was fabricated by a manufacturer in Cairo and successfully demonstrated to farmers. Because of increasing farm labor shortages, it is expected to be popular.

The grain cleaner and thresher are also being tested, evaluated, and introduced to farmers. However, a larger grain cleaner is needed and the thresher needs to be modified to thresh wheat. The equipment needs other changes to meet Egyptian conditions. The traditional varieties have longer straw, for example, and a thresher needs to accommodate that. On the other hand, farmers are beginning to plant the short-stemmed high yielding varieties and the IRRI threshers are most suitable for them.

Egyptian farmers are experiencing labor shortages and they need equipment to reduce their production costs and perform timely operations. The potential for mechanization is great.

India

Through contact with local manufacturers, farmers, and university personnel, the project leader determined the potential for the vertical conveyor reaper (CAAMS-IRRI reaper), the TH-8 axial-flow thresher, and the 6-row transplanter. Design drawings were provided to interested manufacturers and orders placed for an initial production sample.

Samples of the reaper and transplanter have been received by the project and are under test and evaluation. Two manufacturers are building prototypes of the axial-flow thresher. In the first year of operation, three manufacturers produced eight reapers, three produced three transplanters, and three produced two threshers.

As harvesting and threshing are a combined contract operation in most areas, we have attempted to demonstrate and evaluate the reaper and thresher together. It was impossible to count the farmers and other potential purchasers present during the 20 h of reaper demonstration and 10 h of thresher demonstration conducted to date. However, manufacturer enthusiasm has steadily increased and our collaboration continues as we modify the design to suit local manufacturing technology and farmers' request and suggestions for improvement.

A similar approach is planned for the transplanter. A method of seedling raising developed by the project leader has raised considerable interest in the transplanter. A collaborative effort with the manufacturers is planned to demonstrate the unit to farmers, and farmer training programs on seedling production techniques are planned.

Taking designs to manufacturers and working with them in manufacturing, testing, demonstration, market development, and further product improvement is yielding positive results.

Indonesia

The program in Indonesia began in 1978. The offices and shops are located near Jakarta. The project has been actively introducing the axial-flow thresher, axial-flow pumps, power tillers, and the grain cleaner.

Indonesia is large, with a widespread geography and a diversified agricultural area. In some areas, land remains to be cultivated and labor is in short supply. Mechanization is just starting.

A video tape is used to inform agricultural extension personnel and others in the outlying areas about the IRRI-Directorate of Food Crops Production program.

A study entitled "Diffusion and Commercialization of Rice Postharvest Equipment in West Sumatra" was conducted for the International Labor Organization.

A total of 64 cooperating manufacturers fabricated 10,116 machines between 1979 and 1984, primarily hand tractors, axial-flow pumps, transplanters, threshers, and dryers.

Pakistan

During the Pakistan project, 1976-82, the PTO thresher was developed and a 2.2-m reaper was introduced.

The thresher is manufactured in large numbers and can thresh wheat as well as rice.

The reaper was designed for a 4-wheel tractor and is used in wheat and rice. Over 2,165 were sold in 1984.

The Philippines

Because IRRI is located in the Philippines, there has been more liaison with the small industries in that country than in other countries. The profile of typical IRRI cooperators is shown in Table 1.

Most fabricators have difficulty in manufacturing the first units solely with blueprints, and usually borrow a prototype from IRRI (Table 2).

Figure 1 shows that Philippine manufacturers are concentrated in the major crop areas of the country.

Table 3 shows that although the economic situation in the Philippines has been severe the last 3 yr, sales of IRRI-designed machines have been steady.

Machines successfully introduced in the Philippines through the MAF-IRRI program include the axial-flow thresher, the power tiller, the reaper, the seed and fertilizer applicator, and the *tapak-tapak* pump.

Table 1. Profile of MAF-IRRI cooperating manufacturers according to capital assets and labor.^a

	Range	Cooperators (%)
<i>Capital assets^b</i>		
Cottage industry	Below US\$10,000	43
Small industry	\$10,000 to \$100,000	43
Medium industry	\$100,000 to \$400,000	10
Large industry	Above \$400,000	4
<i>Labor (no. of employees)</i>		
	Below 6	29
	6 to 15	44
	16 to 50	21
	Above 50	6

^aData as of Mar 1983. ^bConverted from pesos, using ₱10 = US\$1 (Mar 1983).

Table 2. Number of cooperating manufacturers who requested blueprints and borrowed demonstration units of MAF-IRRI equipment, 1982-84.

Equipment	Cooperators (no.)	
	Requested blueprints	Borrowed unit
Thresher (TH6, 7 and 8)	65	6
Reaper (RE2)	126	26
Hand tractor (PT5)	132	27
Axial-flow pump (PU)	18	5
Transplanter (TR3 and 4)	58	9
Seed and fertilizer applicator (SFA)	24	15
Rolling injection planter (RIP)	14	9
Total	437	97

Table 3. Production statistics^a for MAF-IRRRI cooperating manufacturers, Philippines, 1975-83.

Equipment	Production (no.)										Total
	1975 (14)	1976 (19)	1977 (17)	1978 (20)	1979 (21)	1980 (31)	1981 (33)	1982 (55)	1983 (75)		
Hand tractor (PT5 and variations of PT3)	2,178	2,586	856	795	1,337	978	1,107	2,310 ^b	2,268	14,415	
Axial-flow thresher (TH7 and 8)	275	552	494	689	1,850	1,059	1,417	1,689	1,162	9,187	
Portable thresher (TH6)	-	-	827 ^c	1,746	2,290	1,218	1,275	1,113	1,129	9,598	
Batch dryer: BD1, horizontal bin	33	93	64	34	47	66	102	41	12	492	
BD2, vertical bin	-	-	-	-	-	16 ^d	16	6	14	52	
Axial-flow pump (PU4)	-	-	-	-	13 ^e	55	66	38	86	258	
Transplanter (TR1 and 4)	-	-	-	-	-	17 ^f	82	73	31	203	
1.0-m reaper (RE2)	-	-	-	-	-	-	-	37 ^b	363	400	
Seed and fertilizer applicator (SFA)	-	-	-	-	-	-	-	50 ^g	67	117	
Total	2,486	3,231	2,241	3,264	5,537	3,409	4,065	5,357	5,132	34,722	

^a The number of manufacturers reporting in each year is in parentheses. These statistics should not be interpreted as representative of the total production of agricultural equipment in the Philippines because a) data were obtained only from MAF-IRRRI cooperating manufacturers, and b) the number of co-operators has increased markedly over the past 4 yr. ^b Introduced in early 1982. ^c Released late 1979. ^d Released in 1979. ^e Released in 1979. ^f First released late 1979; modified version released in 1983. ^g Introduced in 1983; data include existing designs.

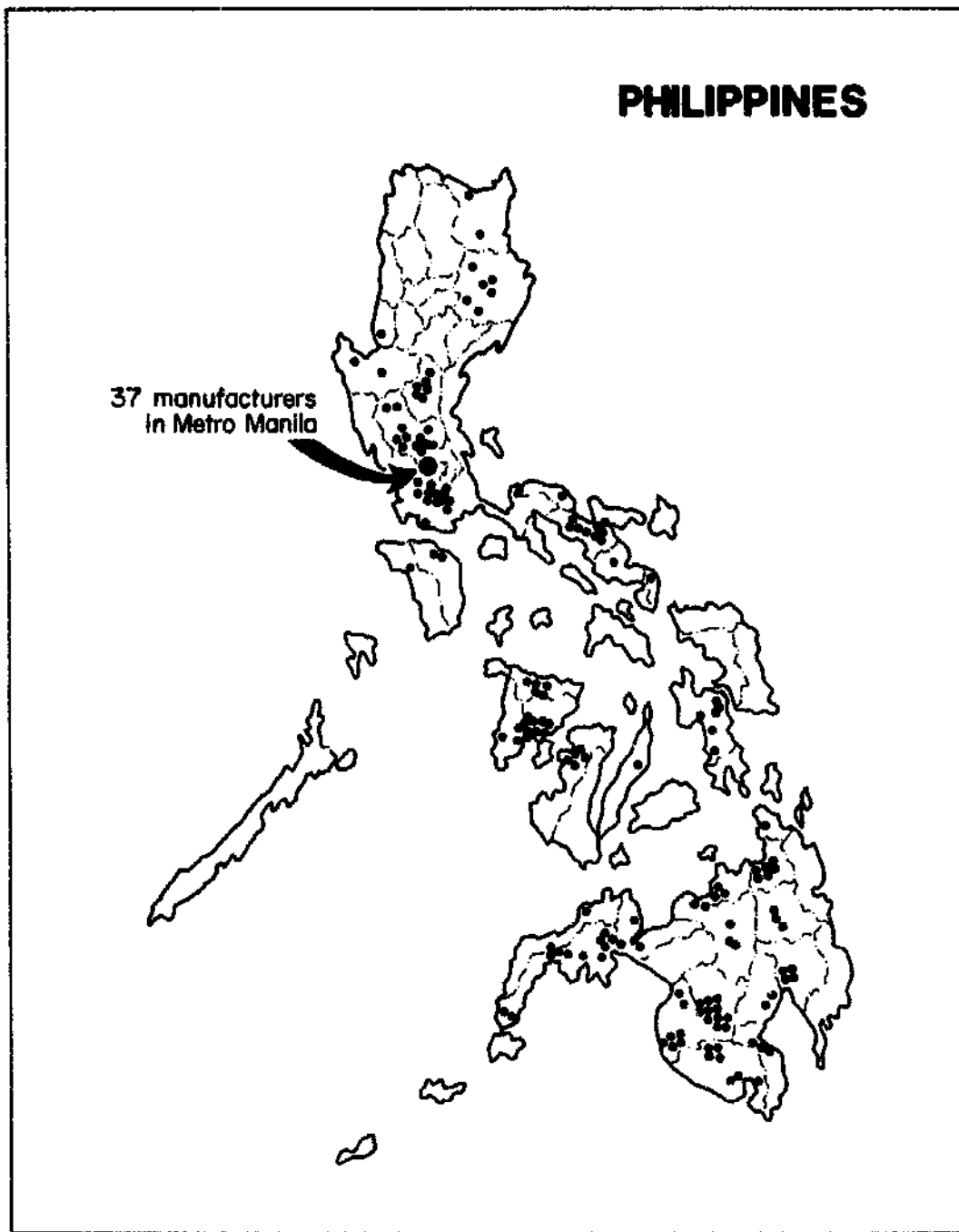

1. Location of cooperating manufacturers of the MAF-IRRI Industrial Extension Program for small farm equipment.

Thailand

Training is an important component of the IRRI-Thai program. Training programs were developed for government and project staff, manufacturers, village leaders, and progressive farmers.

A typical course consists of 4 d of intensive training through lectures and laboratory and field exercises on the operation, adjustment, and maintenance of machines designed for small farms. Lecturers completed the IRRI Agricultural Engineering Training Course in Los Baños.

During the course, IRRI-Agricultural Engineering Division staff learned from participants what machines are needed and have the greatest potential. Completing the course enables project leaders to organize and conduct mechanization training programs in villages. Four field managers developed a program and trained farmers and village leaders for a limited number of machines. The IRRI-Thai project provided machines and resource support for the training.

In November 1984, a training course was conducted cooperatively with the IRRI-Thai mechanization project and the Industrial Services Division (ISD) in Bangkok. Twenty IRRI cooperating manufacturers or supervisors participated in the 12-d program. The general objective was to improve the quality of machines produced in Thailand. The course consisted of basic manufacturing techniques including welding, foundry metal hardening, jigs and fixtures, drawing, and blueprint reading.

In the past year, four implements have become commercially available: the inclined plate planter, designed by IRRI, Los Baños; improved buffalo plow, designed by the Thai Agricultural Engineering Division; push-pull weeder, imported prototype; and the cyclone broadcast seeder. Thai cooperating manufacturers have produced and sold them to farmers through the integrated extension program.

Demand for the inclined plate planter increased so that six manufacturers are now monitored to produce quality machines. The largest manufacturer is tooling up to produce 500 units during the first half of 1985. Other manufacturers will produce less than 10 units each.

A program between the Bank of Agriculture and Agricultural Cooperatives (BAAC), manufacturers, and farmers will provide loans for equipment manufactured through the IRRI-Thai Mechanization project. In December 1984, manufacturers, through dealerships and in cooperation with BAAC, organized 4 training sessions for more than 1,500 farmers on operating and maintaining the inclined plate planter. Lectures were given by the IRRI project staff.

This project demonstrates the objective of creating a complete industry that includes coordination among bankers, manufacturers, and farmers. The inclined plate planter is being accepted as an established commercial implement through the project guidelines. Now manufacturers, BAAC, and progressive farmers are extending the machine. After 1985, its production should be established, and emphasis will be put on three other machines.

ENHANCING THE INNOVATIONAL AND ENTREPRENEURIAL CAPABILITIES OF FARMERS AND SMALL MANUFACTURERS

W. G. BROEHL, JR.
Dartmouth College, Hanover
New Hampshire, USA

The past two and one-half decades of development in the less developed countries (LDCs) — roughly the period since the formation of the International Rice Research Institute in 1960 — have witnessed major successes in the generation of new agricultural technology and acceptance of this technology in the field. Still, the use of technology has not matched the promise of its generation. The continuum between development of an agricultural innovation by the engineer or scientist and the eventual effective use of that innovation in the field is lengthy indeed. All along the way are pitfalls; what starts as a good idea easily can become unused — or even unusable.

The problem is much more complicated when developed world technology is moved through some form of adaptation or transfer to the developing world. The innovative idea is worth little unless it is translated to an end user through some process of diffusion by a series of entrepreneurs. Entrepreneurship in the less developed world seems at first blush to be simpler. But with the critical shortage of requisite information and the lack of educational and financial support systems, diffusion generally turns out to be an extremely complex process. For the past three decades, the record is outstanding for technological innovation in agricultural machinery. At the same time, the translation of this technology into an appropriate context has been less than perfect. At the level of the individual entrepreneur, performance is spotty.

If, in surveying the prolific body of development literature, we look for the humans along the chain from technology to application, our magnifying glass quickly spots the eventual adopter — the end recipient in the diffusion process. But we search much harder for individuals farther back on the chain of diffusion. In particular, we need more light on individuals who take innovations provided by the scientific and technical specialists and bring them to fruition for end users; we need to focus on individuals who provide the entrepreneurial spark to bridge technology and use.

In development literature, it is surprising how frequently the entrepreneur is just assumed. Malcolm Harper put this well in a recent issue of *Appropriate Technology*: “Schumacher himself begs the question in *Small is Beautiful*; he

comments that 'spreading familiarity' with intermediate technology would 'undoubtedly help to increase the supply' of entrepreneurs, but he does not address the question of how or by whom this familiarity should be spread. He makes some suggestions about the appropriate forms of ownership for different scales of enterprise, but does not comment on who is to set up such enterprises or how they are to be persuaded to use intermediate technology."

Indeed, the notion of entrepreneurship does not appear at all in IRRI's plan for its "third decade;" nor does the entrepreneur have a very high profile in the otherwise excellent work done by RNAM, the Regional Network for Agricultural Machinery of the United Nations Development Programme (14, 28). Entrepreneurship is a critical factor in increasing the reach of appropriate small farm equipment in developing countries. Yet here the entrepreneur is only dimly perceived. There are reasons for this myopia, many of them rooted in the lack of understanding of the very word itself.

WHAT IS AN "INNOVATION?" WHO IS AN "ENTREPRENEUR?"

Analysts frequently confuse these closely related terms. We can gain perspective by turning to one of the seminal thinkers on this subject, Joseph Schumpeter. Schumpeter's model starts with an equilibrium; into this equilibrium an entrepreneur intrudes. This intrusion, which Schumpeter calls the introduction of a new "production function" (his terminology for an innovation), may involve a new product, or perhaps a new method of production; it may open up a new market or exploit a new source of raw materials or intermediate technology. It may also, but not always, involve the formation of a new firm. Key to any of these, though, is the entrepreneur's extraordinary ability to visualize potentials in unproven commodities, organization, methods and/or markets — and to *act* on these.

Entrepreneurship is not synonymous with invention. Although entrepreneuring is a highly creative function, it does not rest solely on original creativity. An invention sometimes leads to innovation, sometimes not. Further, while the entrepreneur may be the one who furnishes the capital, the actual financial risk bearing is not part of the entrepreneurial function. A capitalist bears the risk; the entrepreneur acts to bring about the changed production function. The entrepreneur also becomes a central mediator between the larger society and the single operating unit. As the entrepreneur alters and changes the production function, he generates a process that is likely to mediate changes for *both* the economic unit and the environment around it. Out of this come systemwide effects and feedback.

THE "LESS DEVELOPED ENTREPRENEUR"

Special problems arise in understanding the entrepreneur in I.D.Cs, where it is often difficult to distinguish between the economy and other social institutions. Complex patterns of interaction between rural entrepreneurs and their counterparts in the metropolitan, industrial economy are generally the rule.

Foreign capital may play an especially significant role. Corporate organization structures are more heterogeneous, often fragmented, and frequently dominated by noneconomic influences (family, religion, etc.). There are profound complications in meshing developed-world technology with this scene.

Sometimes an innovation in the less developed world also becomes an innovation in worldwide terms; the rice and wheat dwarf varieties of IRRI and CIMMYT may be legitimate candidates. More often it is the opposite — large-scale innovation moves from the developed world to the developing country by a process of technology transfer. Occasionally the developed world innovation can be successfully fitted into place. More likely, there will have to be a process of adaptive innovation. This adaptation is intrinsically different — not just a lower-technology, less complex variation of the original innovation, but an important new link in the innovational chain — itself an original, innovative act.

I will term this a “meta-innovation.” Innovators in the developing world are not typically Schumpeterian; they are more likely what James Berna calls “humbler entrepreneurs” (4). While I agree with Berna’s basic notion, I feel that an innovation which is small or intermediate does not necessarily involve a “humbler” process or one easier to carry through. I believe the process is almost always *more* complex.

Recent development literature on appropriate technology highlights the importance of distinguishing between meta-innovations and transferred technologies. When the original term “intermediate technology” was popularized by Schumacher, it was distinguished, first, from indigenous technology, which Schumacher considered “in a condition of decay,” and second, from high technology by being more labor-intensive and on a smaller scale. Intermediate technology was not seen as necessarily less complex or less sophisticated; on the contrary, advocates envisioned a system of miniaturization of machines that would yield production at costs not much different from the rudimentary traditional means, yet provide the efficiencies of higher technology. The recent shift in terminology from “intermediate” to “appropriate” puts an additional focus on developing packages of workable, understandable optimizations that build upon on-the-scene infrastructures and input characteristics of local field situations. Highlighting these adaptive forms of innovation, and focusing on the entrepreneurial function inherent in them is critically important. Once we have identified the process, then we can say some important things about how it might be enhanced.

Rural innovation and entrepreneurship bring problems beyond those of larger-scale urban efforts. P. Srivastava put these difficulties well in a recent paper: “Rural entrepreneurship is beset with problems largely unexplored by past research. Rural entrepreneurs are farmers, artisans, merchants/traders, or tribesmen. They have lower awareness of economic opportunities, and low educational and skill levels. They hold strong world views shaped by their cultural heritage, local customs, and religious values which influence their economic behavior. The institutional framework within which they operate is not conducive to individual entrepreneurship (30).”

It is hard to identify innovation in a rural setting in the LDCs. At first glance, little innovation appears; indeed, one searches hard for an entrepreneur. A closer look, though, reveals a special form of innovation. I have discussed these unique dimensions in my recent book *The village entrepreneur*, and argue that the special constraints of rural entrepreneurship can be overcome (7).

MACRO PREREQUISITES FOR ENTREPRENEURSHIP

This paper focuses on what can be accomplished within and around the individual agricultural firm (and certain farmers) to enhance innovational and entrepreneurial behavior. In taking this micro view, we cannot forget that some critical macro influences already have operated on the leaders of these firms and the cultivators they serve. The reward system for innovation and entrepreneurship is particularly central. This reward system is an ingredient, explicit or implicit, in the overall economic system of the particular country involved. Often these overall incentive systems are influenced by subcountry regional or state economic choices.

Sometimes incentive systems can be successfully fostered for groups; more often, individual self-interest is the most effective rubric. There are profound questions about the interrelationship between individualism and collective norms; these questions often find expression in the debate over choices between private enterprise firms and public counterparts — the state itself, cooperatives, and other group entities. In turn, the structural makeup is further complicated by political and social structures that add further macro specifics. Around the world, there are successful models of widely differing persuasions; central to all is a reward system that encourages individual enterprise. The remarkable recent success in the People's Republic of China, under a socialist system, and the advances in agriculture in Zimbabwe caution us that private enterprise, out of the capitalist mode, is not the only way to obtain this thrust (6, 7). Whatever the system, however, we will assume a structure containing an incentive system for innovation, and a vehicle for carrying innovation through an entrepreneurial act.

ENTREPRENEURSHIP IN THE LESS DEVELOPED WORLD

Meta-innovation in an LDC is different from innovation in a developed country (Fig. 1).

In the less developed world, values are typically influenced by linguistic, family, tribal and religious linkages, and often compounded by passionately held political beliefs. These values lead to practices uniquely different from those of the developed world. The LDC entrepreneur, seen in the large circle at top center in Figure 1, is searching for a meta-innovation. "Searching" may be too action-oriented a word — more likely, the entrepreneur will be assimilating linkages for this idea without realizing it, until that magic moment of the hortatory "aha" arrives.

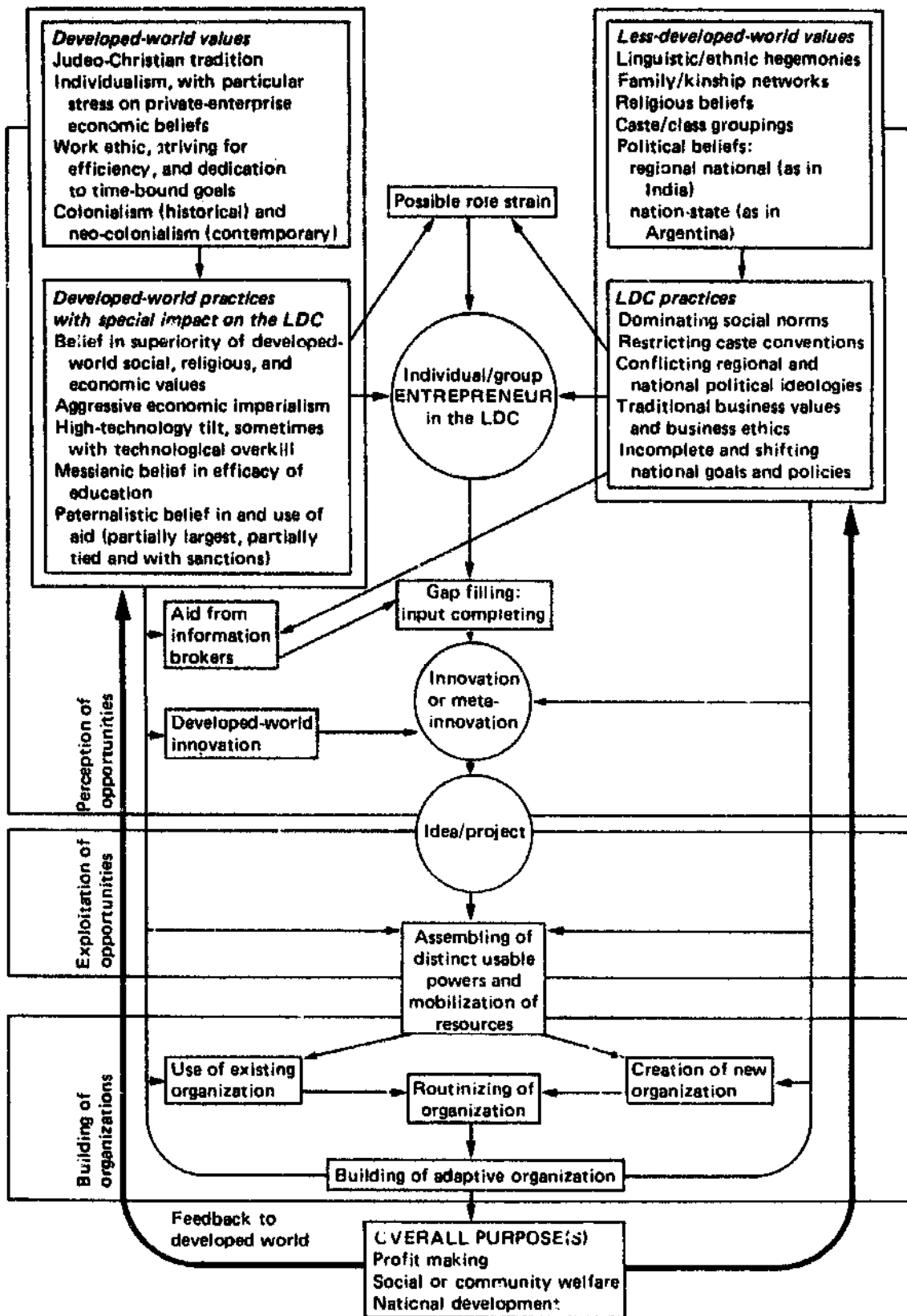

1. A model of entrepreneurship in the less developed world.

I. Kirzner, in his seminal book on entrepreneurship (17), puts this unthinking nature of the process well: "The truth surely is that, of the mass knowledge, beliefs, opinions, expectations, and guesses that one holds at a given moment and that inspire and shape action, only a fraction can be described as being the result of deliberate search or learning activity. A very great volume of one's awareness of one's environment . . . is the result of learning experiences that *occurred entirely without having been planned.*"

Thus, successful entrepreneurs often exhibit a subliminal, almost conscious sixth sense about ideas that literally pop out at them. Though the ability to learn without a deliberate search varies greatly among people, it is possible to heighten the incidence of a successful "aha" (as we will explore later in this paper).

LDC meta-innovations are initially ill-defined, with critical gaps in the flow of necessary information that must precede them. Some data are not available, and others are political rather than economic (in the politicized entrepreneurial environments of many LDCs, business advantage often is sought through political institutions). Gaining information is more difficult in a LDC — the economic systems are "obstructed, incomplete, and 'relatively dark,'" to use the words of economist H. Leibenstein (21).

Leibenstein suggests that all over the world the seeking of maximization is a less-than-perfect process — that there is an "X-efficiency" short of optimization that is almost always the norm. This is particularly so, he argues, in the less developed world. Individuals and groups often do not work as hard or as efficiently or are as capable of searching for new information as in the developed world. This kind of situation can trigger entrepreneurial activity.

However, some gap-filling and input-completing must precede this, and here the information dimension becomes critical. Individuals who can fill the gaps in information, who can complete the input linkages — who can connect different markets, who can make up for market deficiencies — these persons become the entrepreneurs. The entrepreneur searches for and discovers new economic information, translates this new information into new markets, techniques, and goods. He seeks new economic opportunities, evaluates them, marshals financial management. Once this set of information need is in place, the innovation becomes an "idea/project" and the process described in Figure 1 of assembling resources, building an organization (or using an existing one), and routinizing the process logically follows.

What we have described here is a model of the behavior of a classic entrepreneur, one who implements, carries through, and makes real a new production function.

There is another individual in the innovation chain that we must focus on, an individual who carries through *quasi*-entrepreneurial acts of great importance under our umbrella of entrepreneurship. This person is the "early adopter" of an innovation being diffused.

In his superb book, *Diffusion of innovations*, E. M. Rogers (29) clearly distinguishes between the two. On the one hand, "there are venturesome innovators," eager to try new ideas; their interests lead them out of a purely

local circle of peers into a more cosmopolite set of social relationships, and they draw widely on communication patterns and friendships among their peer-clique of innovators. The salient value of the innovator is venturesomeness. He or she desires the hazards, the rash, the daring and the risk . . . While an innovator may not be respected by the other members of a social system . . . the innovator plays gate-keeping role in the flow of new ideas into a social system." The early adopter, on the other hand (according to Rogers) is "respectable," an opinion leader within the social group, a critically important change agent and local missionary for speeding the diffusion process. This special person is, however, "not too far ahead of the average individual in innovativeness . . . the embodiment of successful and discreet use of new ideas."

I find these distinctions useful. Nevertheless, the adoption act itself — the "aha" — is clearly present, and in this sense the early adopter is entrepreneurial. Thus my decision to include farmers within the title of this paper, for *certain* farmers — the change agents/adopters — carry through essentially entrepreneurial acts in their choice to adopt a manufacturer's or a research agency's innovation. While the farmer-adopter does not, except under very exceptional circumstances, institute a new organization, nevertheless, he can be fitted cleanly into the circle for the entrepreneur in Figure 1.

THE "INSTINCT OF COMBINATION"

Information alone is inherently sterile; it is the entrepreneur's active linking of information that brings about the idea/project. Thus it is the *alertness* to information, rather than its possession alone, that brings about the entrepreneurial spark. In one of his earlier books on entrepreneurship, Kirzner (16) noted that "entrepreneurial knowledge may be described as the 'highest order of knowledge,' the ultimate knowledge needed to harness available information already possessed (capable of being discovered)." Appropriate village-level technology is often far more complicated than is imagined, and the village entrepreneur in carrying through an innovation has probably utilized an information-gathering process of daunting complexity.

For example, the fertilizer distributors in my research on village entrepreneurship in India were typically one-person firms, yet the quantum of decisions was quite large. Some distributors learned this to their surprise when they tried to train a second person to open a sub-distributorship — the education and training was far more demanding than they had imagined. I found similar unexpected complexity in my earlier research in Venezuela, Brazil, and Argentina, where new types of fishing companies, mechanized contract plowing operations, poultry farms, and supermarkets (urban) were tried for the first time.

The means by which entrepreneurs fill gaps and complete inputs in part depends upon the useful information they can accumulate. A certain critical mass of data is necessary for the most astute gap filler/input completer to discern the innovation. Sufficient connecting ideas produce the new idea — a profound leap across a discontinuous innovational barrier to a fruitful innovation.

What *makes* the spark? First, pieces of information synergize to produce a critical mass. Leibenstein calls this the "critical minimum effort, built upon a critical minimum of information." The more precisely we can identify these minimum or necessary sufficiencies, the more effective the innovational process will be. Many years ago, sociologist Vilfredo Pareto noted man's basic "instinct for combination." It is this ability of linking — or "networking" — that carries through an active process of combination to the fruition of an idea/project.

This process can be fundamentally aided by others playing the role of information broker. Family linkages and kinship affiliations aid information sharing. This helps to explain why large, extended family connections often give the vested oligarchy so much power. Sometimes information brokers may be formalized as professional suppliers of information, ideas, and projects. In the less developed world, considerable information brokerage may come from outside the country — supplied on a formal or informal basis by developed-world agencies, firms, and individuals. (Of course, this advice from outside the country is not always appropriate — unperceived subtleties and complexities of traditional societies often lead the developed-world analysts to make serious errors.)

One of the most striking features of my findings about village entrepreneurship, both in India and in Latin America, was the wide, almost miscellaneous, range of sources used by successful village entrepreneurs. Those who drew upon this full range, and linked these seemingly unrelated pieces of information, were those who appeared to have the highest innovational thrust. The most innovative of the fertilizer distributors in India, for example, read widely, listened to the radio more often, talked with friends and business peers almost every day, even had more time for the cinema. This finding is corroborated by recent social science research on innovativeness of executives in American management. One analyst recently put particular focus on what he called "cognitive complexity." The hallmarks of this were "the ability to plan strategically without being rigidly locked in to one course of events; the capacity to acquire ample information for decision-making without being overwhelmed, and being able to grasp relationships between rapidly changing events." The author also pointed out that high I.Q. was itself not a good measure of this cognitive complexity. Rather, it was this ability to grasp and manage large amounts of disparate information.

This is what I have seen through my studies of village entrepreneurship. No single information source is critical in entrepreneurial behavior. Instead, entrepreneurs use a "package" of many information sources to produce the types of thought and idea patterns leading to innovation. Rural sociologists concerned with innovations note, for example, that different channels of information tend to be associated with various phases of the diffusion process. Rogers found that earlier adopters start out by being more cosmopolite than later adopters, and have more change agent contact, greater exposure to mass media communication channels, and greater exposure to interpersonal communication channels. They tend to seek this information more actively

than the later adopters do. In effect, the early adopters have a greater knowledge of innovations than later adopters do, and thus are more likely to belong to highly interconnected systems.

I have been helped in understanding this distinction by an interesting article by Y. V. Lakshmana Rao (19), who studied the information flows in two south Indian rural villages. He found four types of recipients of information: 1) the information indifferent, 2) the rumormongers, 3) the information seekers, and 4) the information carriers. Of these, the information carrier is critical. Leibenstein identifies a similar categorization: there are "scanners," "transmitters," "evaluators," and finally the "promoters" of change. The latter group is the one who puts the information finally together for action.

It is important not to overstate the efficacy of a collection of information. Researchers have pointed out that the central nervous system can handle only a small part of the information that the sense receptors and the peripheral nervous system can receive. Many years ago, G.A.P. Miller (24) published a provocative article with a pregnant title: "The Magical Number Seven, Plus or Minus Two: Some Limits on our Capacity for Processing Information." Miller pointed out that the span of immediate memory imposes severe limitations on the amount of information that people are able to receive, process, and remember. One must organize the stimulus inputs into dimensions — in effect, to parse — in order to use successfully the quantum of input.

The balance between paucity and surfeit is elaborated upon by Lawrence and Dyer (20). They believe that just the right amount of information complexity is critical to innovation. When information complexity is very low, they hold, there is little external stimulus and variety to stir up the cognitive processes in innovation. On the other hand, when too much information complexity surrounds a choice, information overload may inhibit innovation. The Lawrence and Dyer schema links this to the related presence or absence of resources; here also a surfeit of resources can be as inhibiting as a paucity. In Figure 2 their view of a two-way interact is reduced to an arresting 3×3 matrix; the center cell is, to their minds, the most promising for the development of an adaptive organization. In our entrepreneurial terms here, both resources and information inputs to the entrepreneur help to define this ability to reach the goal of an idea; too much or too little of both the resources and information make the job more difficult.

KANBAN IN AGRICULTURE

There is one more dimension of information and the LDC entrepreneur, a subtle one, that I consider to be of utmost importance. To understand this, we need to look to developed-world businessmen, in their current startled recognition of "the Japanese challenge." Recently I analyzed elsewhere what I consider to be a heightening "just-in-time" mentality in agriculture (8). The thrust for "just-in-time" has come particularly from the Japanese; their "Kanban" system of production control has made this terminology a

INFORMATION DOMAIN	High	Competitive variations	AREA 1 High IC Low RS	AREA 2 High IC Intermediate RS	AREA 3 High IC High RS	
		Technical variations	AREA 4 Intermediate IC Low RS	AREA 5 Intermediate IC Intermediate RS	AREA 6 Intermediate IC High RS	
		Customer variations				
	Product variations	Low	Government regulatory variations	AREA 7 Low IC Low RS	AREA 8 Low IC Intermediate RS	AREA 9 Low IC High RS
	Information complexity (IC)		Low	Intermediate	High	
	Resource scarcity (RS)		Availability of raw materials, human resources, capital Customer impact on resource availability Competitor impact on resource availability Government impact on resource availability Organized labor impact on resource availability			
	RESOURCE DOMAIN					

2. Interaction between the information and resource scarcity domains in American industry (20).

household word, and brought striking new additions to the management concepts of business all around the world. It is clear that Kanban goes much beyond manufacturing efficiency into the reevaluation of all aspects of the use of time and the emphasis of appropriate technology.

Though one might not immediately see the linkage, there *are* agricultural equivalencies. In the past, farmers' philosophies in the developed world have often militated for more equipment, of greater capacity than needed for the job. Farmers have always been dominantly concerned with the width of the window at planting time and at harvesting. The farmer often applied a "worst case" mentality toward these two time periods. Because of this "catastrophic contingency" view, the farmer overbought on size and quantity of equipment (and often on other inputs as well) — fertilizer, for example).

There is evidence, though, that farmers' consciousness in the developed world has been so heightened by the recent downturn that they are taking a far harder look at both input and land requirements, and are beginning to apply their own version of "just-in-time." This will likely result in the farmers using more appropriate technology in the future; developed-world agricultural machinery company executives have already had their consciousness raised by this unexpected change in farmer mentality.

Central to Kanban efforts in manufacturing is a focus on information and understanding at every juncture along the line — the right knowledge to reach the decision maker at just the right time. Central to the use of appropriate technology at the farm level is this same focus on information and understanding.

Kanban concepts also have considerable relevance to the developing world, but now the process reverses. Seldom does a developing-world agriculturalist err on the side of too many inputs. Indeed, his "worst case" is putting too much money into inputs, then not gaining enough return to carry him through the next year. Thus, conventional thinking in the developing world is to shade the needs on the underside. I will call this a "not-in-time" mentality. A new seed variety is used, but not enough fertilizer is ordered by the cultivator, or it just didn't get delivered to the cooperative on time. A small, rural manufacturer of planters orders raw materials for making a new, exciting product — but the drawings and templates aren't ready. "Not-in-time" information is an endemic problem in the less developed world. It involves not only slippage in information transmittal but also a torpor in the desire for new information. In the developed world there is a tempo, an immediacy about the search for information. Advertising heightens this sense of urgency. In the LDCs the dominance of tradition often carries, as a corollary, unwillingness to look at new ideas.

Clearly, there are analogues for this delicate calibration between "more-than-needed" and "not-in-time" for the field of agricultural machinery. As we look at this calibration, we return to the question of appropriate technology. Developed world agricultural equipment manufacturers have not had a particularly effective record, for example, in downsizing their innovations for adaptation to the less developed world. One industry executive was quoted (in March 1985) as saying, "Maybe we farm equipment manufacturers are shooting ourselves in the head because we refuse to design simple, low-cost machinery" (10). In a recent editorial in *AMA* (*Agricultural Mechanization in Asia, Africa, and Latin America*) the editor discussed the issue of size of farm tractors: the "Agricultural machinery industry in many countries seems to be at a crossroad of self-assessment in regard to the size of farm tractors to design, promote, and manufacture in large scale . . . The end users or farmers, more than the manufacturers, are the best allies of designers/engineers/manufacturers because the farmers who are governed by the peculiarities of conditions under which tractors are used are in the best position to help shape the size and power of the tractors" (18). The editor went on to discuss downsizing in Japan, in the People's Republic of China, and elsewhere. And downsizing is only one example of many efforts to ratchet toward the truly appropriate.

CHANGING INFORMATION FLOWS FROM "NOT-IN-TIME" TO "JUST-IN-TIME"

We have posited two theses: 1) bringing together requisite information — a "package," or "network" of information — can by a process of the "instinct of combination" actually trigger and "grow" innovation and entrepreneurial followthrough; and 2) in the less developed world, adequate information to innovate often does not reach the smaller agricultural machinery manufacturer nor, in turn, the ultimate user. Thus a key question is begged, namely, how can these information flows be made more effective for the developing-world small manufacturers and users?

Information brokers, in the persons of both trainers and purveyors, appear all along the line from initial development of technology to final use. Key agencies in appropriate technology dissemination include such noted entities as the Intermediate Technology Development Group (London), the Appropriate Technology Development Unit (Varanasi, India), the Volunteers in Technical Assistance (United States), the Appropriate Technology Center (Pakistan), the Division of Microprojects (Netherlands), and the various international agricultural research centers (IARCs), particularly those under the aegis of the Consultative Group on International Agricultural Research (the International Rice Research Institute and its companion, the International Maize and Wheat Improvement Center) have been in the forefront in this international networking (27, 31).

There are also some interesting examples of private corporation interest in fostering entrepreneurship and disseminating information in the developing world. The work of Control Data Corporation in developing a data base specifically related to third world needs is an innovative extension of its involvement in international development services (2, 25).

The Japanese have been especially interested in the "internationalization" of information to free it from bounds of linguistic differences. A recent article by the Japanese government in *Scientific American* (1) discussed this concern in relation to its computer technology: "To make possible the free international flow of information, we must especially overcome the language barriers. The realization of the "automatic translation system" that we are pushing forward in development now is the key to building a world-scale information society. In this C&G technology development, the most important factor henceforth will be software. Articles in R. C. O'Brien's recent book (26) also discuss this culture-limited feature of information networking.

Still, despite the increased effectiveness of these national and international information networks, the interface with local needs must always be made. This is never easy. Blume (5) discusses some of these issues: "Participants' frustration can limit interest and willingness to take part in a network, especially in light of the inconvenience and obstacles involved in long-distance access to the data base by telephone, Telex, and even mail (given the length of much overseas mail delivery). This is related to a larger issue which has great significance for the success, or lack of success, of information networks in general: the issue of incentives for participation. Participants must feel the ends justify the means."

Much the same point is made in an important new book (15) on rural energy innovations in Asian villages: "Diversity in choices for combining these inputs has been emphasized as the 'critical factor in the efficient use of scarce resources' in intensive farming systems . . . the knowledge held by rural residents is a crucial base for discovering and utilizing diverse opportunities. The complexity of identifying and obtaining pertinent external information that will add to their knowledge in useful ways is evident."

Blume (5) describes a more interactive mode, directly involving local feedback into the information system, a mechanism developed by Denver Research Institute to answer user information requests and to input information into the data base. "The basic idea is simply to satisfy the users and to help develop the data base along lines that directly reflect actual user needs . . . In essence, this is a 'bottoms-up' approach to data base development, although the data base is being simultaneously augmented in the more traditional mode by general identification and compilation of information that exists in the field."

If the actual mechanisms for machinery manufacture and service are located nearer these "local" sources, the interactive process can be heightened. This is what IRRI has advocated, as described in *Plan for IRRI's third decade* (14): "If the simple, low-cost designs developed at IRRI are to be used, it is essential that they be manufactured, and if servicing facilities are to be available they should be manufactured in the areas where they are to be used. An important component of IRRI's machinery program is the identification of manufacturers in rural areas who will, with IRRI's assistance, produce and distribute the machines designed by IRRI. By concentrating on manufacturers in rural areas some influence is exerted on the development of manufacturing capacity, and employment opportunities, in the rural areas."

The importance of the machinery manufacturer in bridging this gap between global and local information cannot be gainsaid. A significant part of this information is technical: here the machinery manufacturers have done a generally admirable job. Marsden (3, 23) discussed this in relation to his work in Thailand: "A particular advantage of the training provided by machinery suppliers is that it is associated with a specific technology and is undertaken at the time the new technology is introduced into the customer's factory or office. Thus, unlike more general institutional training, it enables the skills acquired to be applied immediately and prevents them from atrophying through lack of opportunity to use them." He also highlighted material suppliers as important sources of information. He concluded: "On the basis of the sample of firms and organizations surveyed, it appears that small- to medium-sized engineering firms have access to a wide range of services through existing market networks and that these commercial sources are better qualified technically and more highly motivated than public institutions providing similar services. However, the options available to very small firms (those with fewer than 20 workers) may be more restricted. They have less chance of being selected as subcontractors, they buy machinery less frequently (perhaps relying on the secondhand market), they may depend upon wholesalers (with limited

technical knowledge) for material supplies and sales, and they may not have the time or the money to attend trade fairs or read trade journals."

The problem of how to reach the very small manufacturers, especially those in rural areas, and of how to reach, in turn, the individual cultivator has long been an enigma to those concerned with the diffusion of innovations. A key entity here is the extension service; IRRI discussed this in its "third decade" statement (14): "The role of extension services, and their interface with research workers and farmers, is an area that has been inadequately studied in relation to adoption of new practices. There is a scope for much innovative research to develop the most appropriate methods of disseminating knowledge of new technology among small farmers."

The extensive study of existing research on diffusion by IRRI authors (12, 13) has confirmed the importance of the extension agent, along with the influence of friends, relatives, and neighboring farmers (the influence of the extension agent diminishes, though, at the trial and adoption stages because more informal, personal sources exert a more direct demonstration effect). The recent RNAM (28) regional workshop on manufacturing technology, held at Bangkok, Thailand, on 24-29 Sep 1984, also stressed the "establishment or strengthening of industrial extension services for agricultural machinery manufacturers."

ENHANCING THE "INSTINCT OF COMBINATION"

Increasing the supply of requisite technical information, from machinery manufacturers, extension agents and others, is a laudable goal indeed. Yet we have advanced that something unique and special, of a broader nature, is likely also needed to trigger more "aha's" — to actually "grow" entrepreneurship. How might such a process be fostered?

One mechanism used widely around the world is the "entrepreneurship development program" (generally called EDP). These programs typically provide technical and management training, sometimes accompanied by financial assistance, and also usually have a motivational component (often "achievement and motivation" sessions, based on David McClelland's teachings). Harper (11), among others, has expressed considerable skepticism about EDPs: "It may be that training . . . can marginally increase the management ability and possibly even the entrepreneurial quality of some proportion of those who are trained, although the evidence from worldwide experience is hardly conclusive . . . The vast majority of successful entrepreneurs, everywhere, have never had any form of entrepreneurship training, and . . . owe their entrepreneurial qualities to their upbringing and to national or personal hardship such as military defeat, forced emigration or loss of employment. Trainers should not be encouraged to exaggerate their own importance." Srivastava (30) echoes this concern: "EDPs have focused on providing technical, marketing, and financial support, and business skills and motivational training to individuals who want to start their own businesses. This focus is necessary but incomplete for promoting entrepreneurship in the

developing countries. Attention must be paid to economic activity. A precondition for entrepreneurship to emerge in rural areas is the overcoming of ignorance about social and economic opportunities available to rural peasants. The state of ignorance is perpetuated by powerful local interests with the help of repressive social institutions, and sometimes abetted by the state . . . education is needed to develop in rural peasants the awareness and the will to create and organize (7)."

I share these analysts' caution about the potentials for inculcating entrepreneurship. Yet, I think it can be done. As an end product of my research on entrepreneurship among fertilizer distributors in India, I experimented with a series of innovation seminars, which I called "Distributors for Change." In these seminars I used gaming, storytelling and other change-emphasizing devices to plant new ideas to heighten their instinct of combination. By following these groups over time, with nonparticipant control groups, we saw higher performance in innovating at the margin (9). I am not yet prepared to write off the formal EDP approach as a mechanism for heightening entrepreneurship.

Another approach may have a particularly high potential for payoff. This is the general-information bulletin, disseminated widely through small manufacturer and farmer channels. The operative word here is "widely." If such a bulletin can be put in the hands of a great many people, far beyond that smaller group who might voluntarily go to an EDP or themselves choose to be put on a mailing list, then everyone involved is adding to his personal data bank for possible linkages toward their own "aha." One of the larger fertilizer manufacturers involved in our study in India adopted this idea from our research and distributed widely throughout South India a general-news agricultural letter, entitled appropriately "Change." While it has gained many kudos, we have no realistic way of knowing just how much entrepreneurship it has fostered — it would be difficult to "prove" such a thesis. Intuitive judgments support a positive effect.

A much more ambitious example of this general-news device, on a worldwide scale, is the farmer publication of Deere & Company, *The Furrow*; I have discussed this remarkable program in detail in my recent book, *John Deere's Company* (9). *The Furrow* has a worldwide circulation of 2.2 million; it is published in 36 regional editions, in 12 languages. While the focus is on the developed world, there are 3 editions for Latin America, with total circulation of 175,000. This publication dates back to 1895; its editors continue to be drawn widely from all over the world. Thus, its substantive, noncommercial articles inherently have a worldwide focus. Were one to develop a *Furrow*-like publication for all of Africa and developing-world Asia, the potential for reducing that "state of ignorance" mentioned by Srivastava should be excellent.

CONCLUSION

The act of entrepreneurship *does* matter. Raw technology becomes good technology only when it is translated into reality by an individual. This critical

moment of innovative action is the particular purview of the entrepreneur.

Entrepreneurs have a more difficult job of being effective in the less developed world. In particular, information shortfalls stemming particularly from a "not-in-time" pattern leave the incipient entrepreneur with too little with which to work. Practical, usable information of both global and local content is needed all along the chain of information and throughout the developing world. National and international agencies and governments can heighten global information; manufacturers and extension agents can heighten local information.

Finally, with better information channels, more broadly based information will allow many individuals to learn more about their world. This can heighten that "instinct of combination" that triggers the highly sought "aha" that makes a potential innovation into a real one. One important goal for development practitioners should be the elimination of "not-in-time" information.

REFERENCES CITED

1. Abegglen, J., and A. Etori. 1984. Japanese technology today — 1984. *Scient. Am. Advertisement J.*
2. Adelberg, C. R. 1984. Public sector intervention in the technology-intensive economic sector: a framework for assessing effects on entrepreneurship. Staff Pap. Ser., Department of Agricultural and Applied Economics, University of Minnesota, February.
3. Bell, R. D. 1980. Future priorities in developing agricultural machinery in the developing countries. *The Agric. Engineer* 35 (winter):104.
4. Berna, J. 1950. Industrial entrepreneurship in Madras State. Asia Publishing House, Bombay, India.
5. Blume, J. 1980. Technological information exchange among developing countries: developing an appropriate technology data base. Pages 256-261 in R.S. Ganapathy, ed. *Agriculture and rural development. Selected proceedings, International Association for the Development of Appropriate Technology in Developing Countries (1980)*, Division of Research, University of Michigan.
6. Broehl, Jr., W. G. 1968. International basic economy corporation. National Planning Association, Washington.
7. Broehl, Jr., W. G. 1978. *The village entrepreneur*. Harvard University Press, Cambridge.
8. Broehl, Jr., W. G. 1984. A fresh look at productivity in agriculture and agribusiness. 75th Anniversary Colloquium Series, Division of Research, Harvard Business School.
9. Broehl, Jr., W. G. 1984. *John Deere's company*. Doubleday and Co., New York.
10. "Can we ever get back to square one?" 1985. *Implement and Tractor* 40, March 1985.
11. Harper, M. 1983. Appropriate technology and the entrepreneur. *Appropriate Technol.* 10:11.
12. Herdt, R. W., and C. Capule. 1983. Adoption, spread, and production impact of modern rice varieties in Asia. International Rice Research Institute, Los Banos, Laguna, Philippines.
13. Huke, R. E., and J. Duncan. 1969. Spatial aspects of HYV diffusion. Seminar on Economics of Rice Production in the Philippines. International Rice Research Institute.
14. International Rice Research Institute. 1982. A plan for IRRI's third decade. Los Banos, Laguna, Philippines.
15. Islam, M. N., R. Morse, and M. Hadi Soesastro. 1984. Rural energy to meet development needs: Asian village approaches. Westview Press, Boulder, Colorado.
16. Kirzner, I. 1978. *Competition and entrepreneurship*. University of Chicago Press, Chicago.
17. Kirzner, I. 1979. Perception, opportunity, and profit: studies in the theory of entrepreneurship. University of Chicago Press, Chicago.
18. Kishida, Y. 1984. Farm tractors: a question of scale. *AMA (Agricultural Mechanization In Asia, Africa, and Latin America)* 15 (autumn):9.
19. Lakshmana Rao, Y. V. 1966. *Communication and development: a study of two Indian villages*. University of Minnesota Press, Minneapolis.

20. Lawrence, P. R., and D. Dyer. 1983. *Renewing American industry*. The Free Press, New York.
21. Leibenstein, H. 1968. Entrepreneurship and development. *Am. Econ. Rev. Pap. Proc.* 58:77, 99.
22. McClelland, D. C., and D. Winter. 1967. *Motivating economic achievement*. Free Press, New York.
23. Marsden, K. 1984. Services for small firms: the roles of governmental programmes and market networks in Thailand. *Int. Labor Rev.* 123:235.
24. Miller, G. A. P. 1966. The magical number seven, plus or minus two: some limits in our capacity for processing information. *Psychol. Rev.* 63:81-97.
25. Norman, H. R., and P. Blair. 1982. The coming growth in appropriate technology. *Harvard Bus. Rev.* (Nov-Dec):62.
26. O'Brien, R. C. 1983. *Information, economics, and power: the north-south dimension*. Westview Press, Boulder, Colorado.
27. Plucknett, D. L., and N. J. H. Smith. 1978. Networking in International agricultural research. *Science* September 7:989.
28. *Regional Network for Agricultural Machinery, Economic and Social Commission for Asia and the Pacific*. 1984. *RNAM Newsl.* 21:3.
29. Rogers, E. M. 1983. *Diffusion of innovations*. 3d ed. The Free Press, New York.
30. Srivastava, P. 1985. Entrepreneurship and social progress in developing countries. Conference on entrepreneurial development in a small scale industry sector in developing countries, RVB Delft, The Netherlands, 1-3 May 1985.
31. Swannuck-Nunn, S. U.S. Business and the Transfer of intermediate technology; agricultural equipment and the developing nations. *J. Int. Bus. Stud.* 9:119.

DESIGN AND DEVELOPMENT OF SMALL FARM EQUIPMENT TO SIMPLIFY FABRICATION, OPERATION, AND MAINTENANCE IN DEVELOPING COUNTRIES

J. K. CAMPBELL
Agricultural Engineering Department
Cornell University
USA

It is exciting and satisfying to go into a workshop and build a prototype machine from raw materials at hand without first going through the trouble of making drawings and ordering special materials. Within perhaps a week, the prototype can be taken to the field and tested. Unfortunately, this method of machine development is usually inefficient and uses more parts than necessary.

Some will argue that since most small shops in developing countries build machines by copying and adapting, drawings are not required. This is true for the small shop which is building a machine after it has been developed and found acceptable to farmers, but it is not the case for an engineer who is developing or modifying a tool or machine.

Step 1 of designing or redesigning a machine should take place at the farm of the farmer who will invest his time and money to purchase and to use your design. As professional agriculturists and engineers, we often reach a point where we believe we know what farmers want. Many times we do, but many other times we do not. In discussing with farmers whether a particular machine is needed, attempting to determine why similar machines have not been successful, and emphasizing that the machine would need to be purchased instead of being a governmental giveaway, the engineer may be disappointed to learn that farmers are not waiting for his pet idea. However, he may discover a need for a modified machine or a need for a tool or machine to alleviate a condition of which he was unaware.

A simple example of producing an agricultural tool without consulting farmer beneficiaries is the experience of USAID's Project North Shaba in Zaire. A primary goal was to increase maize production in North Shaba to provide shelled maize for the miners in South Shaba. The intermediate technology subsystem of the project manufactured one-piece, cast-iron shellers which work by a simple rotary motion of the wrist. This type of sheller is commonly used by plant breeders to obtain clean shelled maize from small lots.

Although the hand shellers were subsidized, farmers did not purchase them. Why? North Shaba farmers sell their shelled maize to traders suspected of

being dishonest. Therefore, the farmers shell their maize by beating a gunnysack of cob maize with a stout stick. The method is fast and requires no purchased tools. If some pieces of broken cob remain with the shelled maize when the cobs are picked out, it only helps to balance the scales of justice in dealing with the maize traders. Under these conditions, the farmers have no incentive for purchasing a hand maize sheller.

After reviewing case studies of farm equipment innovations in Kenya, Tanzania, Malawi, Uganda, Southern Sudan, and Zambia, Ahmed and Kinsey (1) concluded that "since the case studies provide no evidence for widespread adoption of any single item of farm equipment originating from any R&D institution, despite decades of research, we are led to the inescapable conclusion that something is fundamentally wrong with most past and current R&D efforts (in Eastern Africa)." The R&D efforts referred to illustrate farm equipment developments which address situations as viewed by researchers, not necessarily by farmers. A simple *technological fix* cannot be expected to do much to alleviate a complex socioeconomic condition.

After discussions with farmers, traders, and economists, it is time to develop design specifications. Give the farmers' comments the greatest weight, for the farmers will eventually determine the success or failure of the machine. After all, the objective is to enhance their production and quality of life.

Farm equipment designers should also seek advice and opinions from professionals in other sections or departments of their organization. The wisdom of an organization does not reside in one discipline. Furthermore, agricultural tools and machines work with crops in fields. Frequently an agronomic practice or crop variety must be developed along with the machine. Other professionals can provide insights and might become allies and salespersons for the machine being developed.

Above all, agricultural machines must be locality specific. Rarely is a machine equally appropriate on a countrywide basis. In Indonesia, for example, farmers in South Sulawesi have no need for mechanical threshers since the manual threshing rack is considered adequate. In West Sumatra, however, the small IRRI axial-flow thresher is well accepted and numerous small manufacturers are building them (7). Farmers who thresh rice accepted threshers but traditionally hire contract workers to reap it. The contract workers continue to reap, but the farmers buy or rent threshers to ease their work. When wet rice sheaves remain too long in a stack between reaping and threshing, grain yellows and rice quality drops. Since the small axial-flow thresher can thresh wet paddy and thus reduce the time between reaping and dry storage, rice quality has improved (9, 10).

Step 2 is to draw up the design specifications for the machine, be it simple or complex. Design specifications should reflect practical goals such as

1. selling cost to farmers,
2. manufacturing cost,
3. weight,
4. overall physical dimensions,
5. power and operator requirements,

6. crop throughput and quality,
7. operating cost, and
8. hours of life and return on investment.

The physical design specifications are clear, but frequently the selling cost is underestimated. Research engineers often consider the "cost of the machine" to be only the sum of direct labor and direct material costs. In fact, the price that a farmer must pay for a machine is normally twice the direct material and labor costs. For a typical machine such as a thresher, each \$1.00 of direct material and labor is accompanied by a factory overhead of 35¢, factory profit of 30¢, and 35¢ for marketing and dealer's profit.

Step 3 is to design the machine *on the drawing board*. There, only an eraser and a pencil are required to make a change. In designing a machine on the workshop floor, a shaft, an engine, or some other part may not be put in its optimum location because a large portion of the machine is already constructed. For example, a processing machine being designed requires two shafts to be driven by V-belts from the main shaft. As design of the machine develops and the speeds of the two shafts are determined, it appears that the same size V-belt can be used for both shafts if the centerline of one shaft is moved several centimeters. This is easily accomplished on the drawing board, but if the machine is being designed on the shop floor, will the shaft position be changed although such a change will mean that fewer V-belts will need to be kept in stock when the machine is marketed?

Designing the machine on the drawing board will also enable the engineer to use materials more efficiently and to accommodate tolerance accumulation because of the ease in shifting parts on paper.

The design engineer and the test engineer must *pay attention to details*. A tool or machine fails to operate properly or stops working because of the failure of one part — the failure of a detail.

When the machine design is complete on the drawing board, the engineer has a full description of the machine as designed. After the prototype is constructed from sketches made from the layout, and then tested, the design layout becomes the record of the details of the machine built and tested. When a machine is designed and built on the workshop floor, and then modified during testing, too often there is no record of the various versions of the machine. This is like an entomologist conducting research by beginning with an insecticide, changing the formulation as the research progresses, but not making any notes; there is no certainty as to which changes were effective. The machine layout showing modifications is the *laboratory notebook* of the engineer. It also enables the machine to be described to an engineer or machinist anywhere in the world.

Step 4 is to build the prototype machine from the engineering layout and drawings. The prototype must be constructed according to the drawings. This will check the accuracy of drawings of the parts. This machine — a prototype — can also reveal conditions which may adversely affect maintenance and reliability. Assembly of the prototype will verify whether bolts can be easily tightened, sheaves and sprockets are in alignment, parts mate properly, and

that the prototype to be tested and later used for copying by small shops is in fact the machine as described by the engineers' layout and drawing.

Step 5 is to field test the machine to determine how well it meets the engineering specifications in Step 2. The engineer should be present during early testing, but when the machine appears to meet the specifications and operate satisfactorily, the testing should be done by persons not responsible to the design engineer so the machine will not be *babied*. A *feedback loop* must operate between the persons testing the machine and the design engineer so that inadequacies may be corrected and improvements made. Simplicity of design should always be a goal when developing agricultural implements. But, whether simple or complex, a machine must be *reliable*. A study in eastern Africa revealed that farmers are willing to pay more for a tool or implement which is durable and reliable. When the feedback loop is inadequate and a machine with deficiencies is being tested in farmers' fields in several countries, the effort will be costly and lose *goodwill*. For example, the large (diesel-powered) IRRI pedestrian single-axle tractor manufactured in the Philippines exhibited gear box failures at several test sites in Indonesia; yet months later, because of an inadequate feedback system, unmodified tractors from the same manufacturer were being sent by IRRI to Burma for field use.

Step 6 is to sell the machine. Governmental organizations usually call the selling effort outreach or extension. The effort is required by whatever name it is called. Just as farmers will not adopt a new rice variety, pesticide, or agronomic practice without a governmental outreach program or private industry selling campaign, neither will they accept a new and useful machine. This step must also provide a way for farmers to obtain spare parts as well as a feedback loop so farmers can relate their experiences to the manufacturers in order that designs may be modified to better fit local conditions.

In many developing countries, feedback is inadequate because one governmental agency is responsible for manufacturing, while another is responsible for distribution. I saw an example of this in Sri Lanka in 1973. The warehouse of a government factory was stacked high with manual seeders, but the plant manager was not concerned, for his job was manufacturing, not distribution.

The appropriate technology movement, as popularized by E. F. Schumacher, has until recently emphasized technical solutions which appear to be appropriate, but yet the technology has not been widely adopted. The Immediate Technology Development Group in the United Kingdom is now taking a harder look at marketing because of the poor response to most of the appropriate technology developed over the past 15 yr (5).

EXAMPLES OF HOW DESIGN AFFECTS PERFORMANCE AND ACCEPTANCE OF AGRICULTURAL MACHINERY IN DEVELOPING COUNTRIES

Power source

Manual, animal, or internal combustion engine for power? This is a basic question for the engineer. Quite often the reason an agricultural tool or machine is desired is because of the need to overcome a restraint such as hard

soil or limited time to perform an essential task.

Many technically competent people have substituted the desirable for the feasible when selecting the source of power for agricultural machinery in developing countries. For example, the manually powered wire loop treadle thresher is widely used for threshing rice throughout Asia. In 1979, researchers at Comilla, Bangladesh, attempted to modify the British NIAE rasp-bar thresher (powered by a 2.2 hp engine) by making it a manually powered machine for wheat (2). Unfortunately, wheat requires more power to thresh than does paddy, and a person is a very limited source of power. Time and money were wasted because of the failure to recognize these facts. At the same time, a researcher at the National Agricultural University in La Molina, Peru, attempted to adapt the basic NIAE thresher to a two-person-powered wheat thresher, but with the same unfortunate results.

Manually powered irrigation pumps are quite often touted as appropriate technology. Many IRRI visitors who spent a minute or two pumping water with the IRRI bellows pump saw it as an answer to the need for a low-cost irrigation pump. Yet no small manufacturer or farmers copied the pump as they did the IRRI axial-flow thresher and pedestrian tractor. Why? The pump did not give a satisfactory return to the farmer's cost or effort for the irrigation water pumped. In Bangladesh, however, the manually operated treadle pump has been well received; about 15,000 were installed from 1981 through 1983 (8). The treadle pump has a bamboo framework and dual pump cylinder, pistons, and valves of thin wall steel tubing, steel plate, and rubber. The pump is designed for irrigation in that water is lifted only to the ground surface and the treadle mechanism and stationary handrail take advantage of a person's strong muscles. The pump has a 10-inch stroke, but the diameter of the pump cylinders is sized for the distance the water must be lifted in order to match the required pumping force to a man's optimum force on the treadle. The treadle pump is successful in Bangladesh because many paddies are small (405-1,350 m²); labor is available; and the return on investment is satisfactory — to pump 1,100 mm of irrigation water for a rice crop requires 23% of the crop as *fuel* for the men doing the pumping (3).

Where agriculture is based on paddy rice production, single-axle and double-axle pedestrian tractors such as the IRRI tillers are appropriate in many situations. Small riding tractors are frequently recommended for small farmers in developing countries.

The Tinkabi tractor developed in Swazilana and the Tuff Bilt and the Agritech developed in the U.S. are hydrostatic-powered, 4-wheel (2-wheels driving) riding tractors advertised as appropriate for small farmers in developing countries. The facts indicate they are not appropriate. With the Tinkabi, it is difficult to keep a moldboard plow running at selected depth. Although the tractor can be used as a transporter, its top speed is only about 6 km/h. It cannot be towed since there is no neutral gear, and the hydrostatic transmission requires hydraulic fluid as well as imported parts. Swaziland farmers do not anticipate a good return on investment, and some think the Tinkabi does not "look like a tractor."

The diesel version of the Tuff-bilt tractor is powered by a 17 hp engine. The transmission, consisting of a hydrostatic drive and a 3-speed gearbox, provides a speed range of 0 to 12 km/h. The tractor appears to have been designed for cultivation, not tillage. In Indonesian tests, the Tuff-bilt tractor plowed poorly and the hydrostatic transmission failed. Furthermore, the type of transmission fluid required is not available in Indonesia. A tractor such as the Tuff-bilt manufactured in the U.S. and shipped to Pakistan without implements would cost US\$6,000. Thus, if the tractor were technically adequate, it might not be economically feasible. Return on investment is very important to the farmer.

Animal power is often appropriate for agricultural machines, but where animal power is not now used, training of farmers in the use and care of draft animals is essential. Social constraints are sometimes encountered when introducing animal power and land must be available to provide "fuel" for the animals (6).

Accommodating tolerance accumulation

All parts fit nicely on a drawing board layout of a machine. However, when the drawings are translated into machined, casted, formed, or welded parts, those parts may not fit well unless their design accommodates the amount by which they are oversize or undersize relative to the nominal size. Where raw materials are difficult to obtain, the design must also accommodate wide variation in steel sheet thickness without compromising the machine's performance. For example, the design may call for 2 mm (0.0787 inch)-thick steel sheet, but only 16 gauge (0.0625 inch) may be available. If the design does not accommodate such differences in sheet sizes, the result may be difficulties for the manufacturer and poor performance for the farmer.

For example, assume that dimension XXX is very important since the performance of some gears depends upon it. Design A allows no accommodation of tolerance accumulation while design B provides adjustment to accommodate tolerance accumulation.

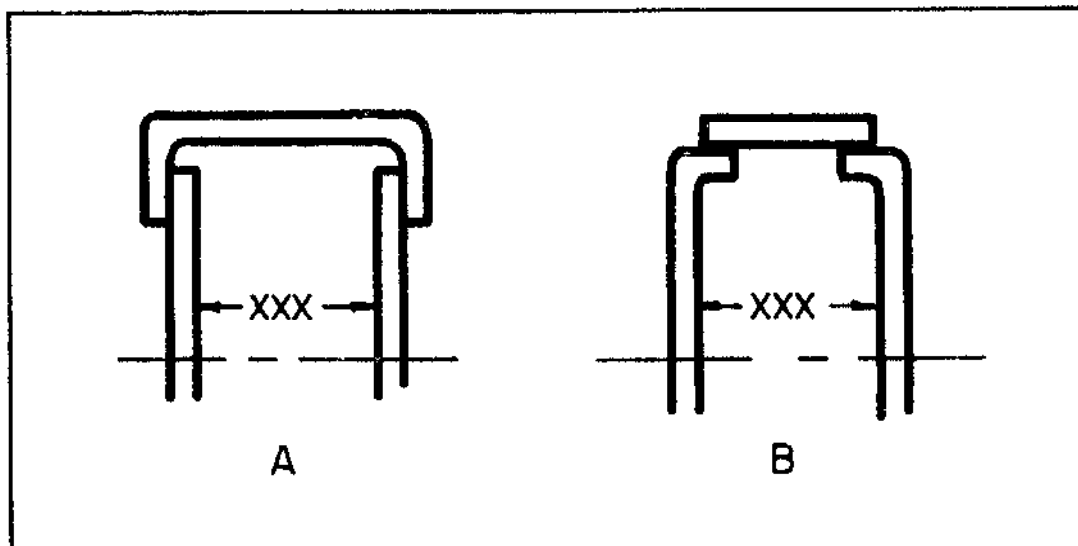

If the two joints are welded, A will be more difficult to weld than B since it must be welded from two sides and perhaps *overhead*, whereas B can be welded from one side and on the flat.

Some machine elements require less precision in manufacturing than others. For example, the chain and sprocket transmission in the IRRRI single-axle pedestrian tractor provides a greater accommodation of tolerance accumulation and misalignment than would a gear transmission. Furthermore, constructing the chain and sprocket transmission requires less capital in machine tools.

Cutting scrap loss

The first IRRRI axial-flow thresher used a closed cylinder as the threshing cylinder. As the thresher was being released for production in 1973, it was discovered that only one cylinder could be formed from a 4- × 8-ft sheet. By going back to the drawing board and shortening the cylinder length by several inches and reducing the cylinder diameter, 2 cylinders could be made from one sheet. The effort required about a week of engineering design and shop time because all the parts interacting with the threshing cylinder had to be altered. *Hidden* design such as this helps to make machines successful.

The IRRRI axial-flow thresher is an excellent example of the importance of a feedback loop between small manufacturers, farmers, and engineers. Initial worry about poor threshing and excessive power consumption of an *open* cylinder was unfounded. Many of the successes of the current IRRRI axial-flow thresher are due to small manufacturers making changes to meet local conditions. But the manufacturers got off to a good start by copying prototypes constructed according to drawings of a tested design.

Reducing parts

The fewer the parts, the less the opportunity for error. When designing a machine on the shop floor, there is a tendency to use more parts than necessary. For example, brackets to support bearings may be welded to the frame because the frame had been built before the final position of the shaft supported by the bearings was determined.

It is worth the effort to attempt to make one part perform the function of several; this lowers costs and minimizes opportunities for mistakes on welding and assembly.

Symmetry

The use of symmetry in design may not reduce the total parts in a machine, but it will reduce the *different* parts. The CIP 208 liter Peladora (potato peeler) is a good example of using symmetry to reduce parts (4). The Peladora consists of a rotating drum, hopper, and frame. Using a symmetrical design cut the numbers of frame parts in half, eliminated several brackets, and allowed peeled potatoes to be directed to either side.

Symmetry can occasionally cause problems. For example, it is good design to use a symmetrical piece for left and right hand parts of a weld assembly. But

if mounting holes in the assembly are not also symmetrical, positioning may not match hole alignment. This can be avoided by using a jig which engages the holes in the pieces. Or, extra holes can be put into the symmetrical pieces so there will always be a hole where required.

Fasteners

Bolts, cap screws, set screws, cotter pins, etc. are necessary on practically all agricultural machines since wearing parts must be attached to the body of the machine so that they can be easily replaced, and most machines must be dismantled for economical shipment. Examination of equipment in fields of developing countries will reveal missing fasteners and inoperative machines. The fastener problem is exacerbated by the farmer's lack of wrenches and spare fasteners.

What can be done? At the design stage, use as few fasteners as possible. Perhaps a peg or a threaded "L" or "T" bolt that require no wrenches should be used instead of conventional bolts or cap screws. The Ariana tool bar uses such fasteners. Use one large size of bolts and cap screws throughout if possible; the farmer will then require only one wrench, which should be furnished with the machine.

Bolts must be placed a sufficient distance from flanges and other obstructions so that nuts can be tightened with an open end or adjustable wrench. Most farmers and many shops in developing countries do not have socket wrenches.

Safety

Safety has received too little consideration in the design of agricultural tools and machines for developing countries. Covering dangerous parts with shields may be effective, but it is a reaction to a design problem. Furthermore, manufacturers may produce machines without shielding in order to reduce costs, and farmers may not replace shielding. Open chain and sprocket drives amputate many fingers. One method of shielding is to place the drive behind an essential element of the machine such as a hinged seat, beneath a grain hopper, or within the confines of the frame. Safety of the operator must be incorporated in the design as it evolves on the drawing board. Safety should not wait until the machine is designed and someone asks about shielding.

Maintenance

Every agricultural tool and implement will need to be maintained by replacing lubricants and worn or broken parts. Since motorcycles, trucks, buses, and automobiles require repair parts, maintenance of agricultural implements will be advanced by using components such as bearings, roller chain, and V-belts used by the most popular vehicles. Do not use special parts unless absolutely necessary. For example, the IRRI axial-flow thresher with the peg tooth threshing cylinder would be designed to use hardened steel pegs if it were being built for the North American or European market. Because of the lack of such pegs in most developing countries, the designer specified threaded mild

steel rods which could be turned for additional wear and later replaced by a bolt with the head removed.

Failure of fasteners can compound maintenance difficulties. For example, the large IRRRI single-axle pedestrian tractor has the transmission cover fastened with small (about 6 mm) cap screws without lock washers. The small cap screws are sometimes twisted off or stripped when being tightened. Vibration may loosen the cover since no lock washers are used. If the cap is loose, water and grit can enter the transmission and ruin it as the tractor is used in a paddy. Larger cap screws and lock washers could avoid that. A more radical change would be to redesign the transmission box so it opens from the top as do some Thai type pedestrian tractors.

CONCLUSION

A machine's level of performance as well as price, operating cost, and operator's safety are set when the engineer conceives the design. Therefore, the machine must be designed against realistic specifications and in accordance with good engineering and manufacturing practices. A machine not so designed will likely bring disappointments and losses to the engineer, factory workers, and purchasers.

REFERENCES CITED

1. Ahmed, I., and B. H. Kinsey, eds. 1984. Farm equipment innovations in eastern and central Southern Africa. Gower Publishing Co., Brookfield, Vermont.
2. Bose, A. R., and J. A. Infield. 1982. Experiences in the design of a manually operated wheat threshing machine. *Appropriate Technol.* 9 (1):11.
3. Campbell, J. K. 1983. Report of three-week study in Bangladesh for the Cornell/USAID Water Management Synthesis II Project. Ithaca. (unpubl.)
4. Campbell, J. K. 1982. Machinery for village-level processing potatoes. *American Society of Agricultural Engineers Pap.* 82-6513.
5. Charnock, A. 1985. Appropriate technology goes to market. *New Scientist* 1455:10-11.
6. Munzinger, P. 1982. Animal traction in Africa, *Deutsche Gesellschaft für Technische Zusammenarbeit (GTZ); Dag-Hammarskjöld - Weg 1, Eschborn, Fed. Rep. of Germany.*
7. Nurmawan. 1984. Development of agricultural tools and machineries in West Sumatra, Indonesia. Paper presented in the Regional Seminar on Farm Machinery and Rural Industry, Pattaya, Thailand.
8. Rangpur Dinajpur Rehabilitation Services. 1983. Irrigation at low cost among small scale farmers as adapted to conditions in Rangpur & Dinajpur. Rev. Chanmondi, Dhaka.
9. Van Ruiten, H. Th. L. 1984. Indonesia travel report HVR-III-No. 42. Asean Crops Post-Harvest Programme, Manila. (unpubl.)

ORGANIZATION AND DEVELOPMENT OF THE COMILLA COOPERATIVE KARKHANA LTD.

A. R. BOSE

The Comilla Cooperative Karkhana Ltd.
Ranirbazar, Comilla
Bangladesh

DEVELOPMENT OF THE COMILLA COOPERATIVE KARKHANA LTD.

The Comilla Cooperative Karkhana Ltd. is one of the oldest cooperative societies and the only of its kind in Bangladesh. Every regular employee is a shareholder and owner, and takes active part in production and management.

The cooperative was established in 1950 by Dr. Akhter Hameed Khan, a social scientist, a founder of the Bangladesh Academy for Rural Development, and launcher of the Comilla-type cooperative for integrated rural development through cooperatives. After the partition of the Indian subcontinent in 1947, artisans who migrated to Bangladesh (then East Pakistan) sought Khan's help. Instead of giving financial help, Khan started the Karkhana (meaning workshop in Hindi and Bengali) with these refugees and some local landless people, with initial capital of only Taka 26.87 (approximately US\$1.00). The value of assets has grown to the current \$1.2 million. Starting from small hand looms, then to padlocks, building fittings, hinges, and paper weights, the Karkhana took up iron castings. Eventually, it engaged in research, manufacturing, and training in use of improved types of agricultural implements such as pedal thresher, rice weeder, hand hoe seed-drill, and winnower, which proved useful and popular wherever introduced.

In 1950, the Karkhana received from the governor's refugee relief fund a loan of Taka 40,000 for development and expansion. The funds were invested in equipping the workshop with a foundry for heavy casting, cast iron molding, and for buying machinery — lathe, shearing machine, and drills.

The society imported a few machines from Japan and locally purchased other foreign-made machines to turn into a light engineering workshop for producing improved agricultural implements to meet the increasing needs of farmers.

How the Karkhana works

The cooperative now has 157 regular members: workers and office staff. The elected managing committee consists of six directors who elect their chairman and vice chairman. The committee meets at least once a month. To help the

managing committee, a supervisory committee of all section heads meets every 2 wk to discuss production. The Karkhana has administration, sales, and production sections. Production units include the foundry, forging and drilling, lathe, milling, press, fitting, assembly, wood and carpentry, and sawmill.

Membership

An apprenticeship course provides additional workers. Young people who finish the course and are able to work become regular members or seek employment elsewhere. Share-money is deducted from their salaries. The value of each share is about \$0.40. The society has an authorized capital of \$8,000, a paid-up capital of about \$6,000, and working capital of \$264,000.

PRODUCTS FABRICATED

In early 1960 when high yielding IRRI rice varieties and improved small implements were introduced in the Comilla area, Karkhana pioneered in making agricultural implements.

Rice weeder

Because farmers have learned the art and usefulness of row-sowing, weeding by small push rotary weeders has become popular. In the beginning jaws were made of 18-gauge sheet and flanges of 1/8" sheet metal. Sheets were cut and bent by hand. Now, special blanking cutting and bending die and punch are used in a 50-t power press for rapid production. In 22 yr, Karkhana has sold 60,000 weeders, mostly 6" wide, suitable for 8"- to 9"-wide rows but also 5" width weeders for narrower rows. A 6"-weeder costs \$7-8.

Other manufacturers make cheaper weeders of 1" x 1/8" flat bar, welded together. As the spokes are straight, these weeders are difficult to push in the mud and require two laborers to push them.

Recently, the Bangladesh Rice Research Institute (BRRI) developed a push-weeder made of a round log where some lugs are fitted in radius. It seems effective in Bangladesh, and is in our production trials. It will be cheaper than the BRRI weeder.

Deep tubewell equipment

In Upa-zilla (subdistrict), there are as many as 400 deep tubewells. These have been sunk by percussion or jet drilling. The jet drilling rigs which are popularly used have the following components manufactured by Karkhana: tripod stand, 5-t capacity winch, different size cutters, wooden clamps, joles, and casing pipes.

Besides these tubewell boring rigs, brass strainer pipes, and mild steel bends and foot-valves have been manufactured by the Karkhana. When the price of brass rose, a special machine was designed at the Karkhana to cut slots in PVC pipe to make PVC strainers. The rig design was received from Lyallpur Engineering College, Lahore, Pakistan. The Karkhana has manufactured at

least 80 to 90 boring rigs, and materials for about 500 deep tubewells. It is unfortunate that power rigs are being imported, displacing labor. Manually operated boring rigs are becoming obsolete except in remote places where power rigs cannot be moved.

Hand pump

In the last 2 yr the Karkhana has manufactured about 6,000 no. 6 hand pumps made of cast iron. The design came from UNICEF. Farmers use the pumps for shallow tubewell irrigation. They are very much suitable for backyard gardens and small paddy fields up to 0.5 acre and wheat land covering 1 acre. They can lift 8-10 gallons/min where the water level is 5 to 10 ft. During an extremely dry season when the water level is below 15 ft, it is difficult to draw water. We are searching for a design of another type of pump having a suction chamber near the water level.

Pedal thresher

As modern rice variety stocks are very tough, threshing by cattle feet or beating over drums is difficult and expensive. Therefore, the Karkhana developed a machine which can thresh easily and economically.

The Comilla Cooperative Karkhana Ltd. is the only workshop in the country that produces threshers and other agricultural machinery on a large scale. In 1960, the first prototype pedal thresher was brought from Japan and was reproduced in the Karkhana. Since then, production of threshing machines has progressed rapidly, from 218 in 1975-76 to 2,350 in 1983-84.

The pedal thresher has a rotating drum 18" in diameter and 16" long. The drum rotates at 300 rev/min when pedaled at 60 times/min. The gear-box uses two spur-gears at a ratio of 4:1. Machine efficiency depends mainly on the gear-box. Karkhana gears are high quality cast-iron manufactured by a gear hobbing machine, and can be pedaled smoothly.

At present, Karkhana is making two models of pedal threshers: a light drum with plain sheet sides and a heavier one with cast-iron sides. The heavier drum rotates at a higher speed.

Power thresher

The introduction of wheat production in Bangladesh stimulated the Karkhana management to develop a wheat thresher. Threshing of high yielding wheat varieties requires more energy than does threshing of paddy. Wheat has tough, brittle straw and requires husking, so the pedal thresher used for paddy is not suitable. The only manual system used now is beating the wheat with wooden sticks over a pucca floor. Because it is hard work, some farmers are reluctant to produce wheat the following year.

Wheat is harvested in late March or in April. This is a season of unpredictable weather; rain is needed for sowing aus paddy or jute but hinders threshing wheat. The wheat crop can deteriorate quickly without a mechanized system for quick threshing.

Furthermore, demand for labor is high at wheat threshing time because

farmers are busy preparing land for sowing paddy and jute. The increased cost of labor raises the cost of production, making farmers reluctant to grow more wheat. The Karkhana threshers were made from engineering drawings produced in Pakistan by the International Rice Research Institute — Pakistan (IRRI-PAK), under IRRI Agricultural Engineering Extension. The basic IRRI design of the power rice thresher was modified to thresh wheat, sorghum, and maize. The long communication gap prevented the Karkhana from obtaining the latest set of drawings, so production of a better quality thresher was hampered. There is no real agricultural machinery extension work at BRRI or at Bangladesh Agricultural Research Institute (BARI).

Design and operation. The axial-flow thresher is designed for wheat, paddy, and other crops. The whole crop is fed into the machine at one end from a waist-level feeding tray and passes along the length of the rotating drum where pegs and cutters separate grain. Grains fall through the concave underneath, passing through the wind generated by fans and onto oscillating screens. Most straw is thrown out of the opposite end of the drum, chopped into small pieces, but some is separated from the grains by the oscillating screens. These deliver the grain out of a chute passing under an aspirator which sucks away any remaining dust. If the straw is not to be chopped because of other uses such as feed, then the crop is held and only the heads are fed in. This, however, reduces output by about half.

The machine has the following parts:

1. Frame. Made of $2 \times 2 \frac{1}{4}$ " angle. Though the structure is adequate, it needs minor reinforcement particularly where there is welding. Cracks due to fatigue stress may grow quickly as the machine vibrates considerably.
2. Threshing drum. Of $\frac{1}{8}$ "-thick steel sheet, the threshing drum has 40 peg teeth and 88 cutters. It should be balanced to minimize vibration. The drum threshes, helped by the concave situated just below the drum and the deflector on the top. Threshing is very efficient, with very few unthreshed grains going out with straw and chaff. The drum rotates at 700 rev/min for wheat and 550 for rice.
3. Concave. The concave is made of $\frac{1}{4}$ " diameter steel rod welded equally spaced. This remains stationary just below the drum, rubbing the crop to thresh it. It also acts as a screen to protect the long straw from going with the grains.
4. Drum cover with deflectors. The drum cover, of 16-gauge sheet, regulates the flow of crops axially.
5. Oscillating screen. In the oscillating screen assembly, the upper screen, of 16-gauge sheet perforated with $\frac{5}{8}$ " holes, prevents straw from going with the grain. The lower screen has $\frac{3}{8}$ " holes at the end, again keeping fine chaff and straw from going with grain. The oscillating screen has a stroke length of $\frac{3}{8}$ " and frequency of 350 cycles/min. It also has a windshield to stop the grain from being discharged with dust, immature grain, and chaff blown by the winnowing fan.
6. Winnowing fan and aspirator. Two 10"-diameter centrifugal fans rotate

at 1,000 rev/min, blowing out dust, immature grain, and chaff. The aspirator runs on the same shaft.

7. Power transmission. Power comes from the engine via the fan shaft to the drum and from there to the oscillating screen camshaft using belts and pulleys.
8. The machine also has two jeep wheels and a draw bar so it can be transported manually or by jeep or tractor.

Problems of manufacture and operation. Although the power-thresher has been simplified from designs produced in the West in Japan, the design still needs improvement.

Vibration is very high, leading to fatigue, welding failure, and loosening of nuts and bolts. Such vibration is due mainly to the heavier construction of the oscillating screen and sometimes to an unbalanced threshing drum or insecure bolting of the engine. The engine itself, a Deutz Diesel with 6-10 hp, has vibrations. Legs supporting the machine during threshing are not well fitted, adding considerably to vibration.

Output of the thresher largely depends on the skill of the operator, type of grain used, length of straw, and the proportion of grain to straw. As the entire straw passes through the axis of the threshing drum, it needs a lot of power for satisfactory threshing. Generally, output is lower than the quoted output. As feeding is manual, the rate of feed should be uniform and continuous; otherwise, output will be low or the engine will stall due to excessive feeding. The present output is about 300 kg clean wheat per hour.

Power transmission is difficult in this machine, especially from engine to fanshaft and drum to camshaft. The fanshaft cannot take a large power input as it is designed using a 1"-diameter pipe with 1"-shaft welded at both ends. The transmission between drum and camshaft is also difficult because they have not been placed parallel. Fitting a V-belt in crosswise is not good design.

Modifications. We are modifying the thresher as follows:

To control vibration, we are making the oscillating screen lighter: the wind screen is separated, the screen frame is made of light wood, wire net is used instead of 16-gauge perforated sheet which is not available locally, and the discharge chute is made of lighter-gauge galvanized sheet. We are trying to change the rocker arm links of the oscillating system to leaf springs with a double cam and con rod to drive it, which is more widely used on this type of mechanism. The rocker arm is difficult to fabricate to exact specification, its parts wear and need maintenance and replacement, and it absorbs too much power.

Cost of the thresher. The thresher including a 6-10 hp Deutz Diesel engine costs \$2,000. It requires \$4,000-6,000 to import a machine of equal performance. For operation, the thresher requires three persons. Fuel cost is about \$0.02/40 kg of wheat.

Simplified design. Experience with the power thresher led us to produce a new machine in which the whole oscillating screen and winnowing system is separate. Cleaning is done on a separate hand-operated winnowing machine. This system, though laborious, will eliminate the vibration and power input

problem and will be easier to manufacture and operate. The frame has been made lighter but stronger using "C" channel. The cost is lower.

Manually operated wheat thresher

After making three different prototypes since 1980, we conclude that the amount of power necessary to thresh wheat means that a manually operated machine cannot thresh more than 40 kg/h. This is uneconomical in labor cost and machine cost.

Mini power thresher

A mini power thresher with a 1 hp electric motor has been designed. It can thresh 150 to 200 kg/h. This is encouraging but it has the constraint of scarce electric power in rural areas. The machine is still under trial.

Winnower

Although the Karkhana has been making winnowers for years, the recent design from Bangladesh seems very fruitful. It uses all sheet metal work consisting of a fan and hopper. The fan has an involute blade rotating on bearings and driven by pulleys. The paddy and husked rice from a rice huller mill can be cleaned. The capacity is about 200 kg/h, and 200 units have been sold.

Power winnower

The Karkhana has designed a power winnower for rice mills. Its capacity is 2 t/h. It has a centrifugal fan and separating louvers in front. (Sales = 5 units)

Moldboard plow

The moldboard plow is made of cast iron and can be drawn by an animal. The cattle should be strong as the plow runs deeper than traditional plows. (Sales = 1,000 units)

Oil mill

The Karkhana manufactures complete oil mills which extract oil from oil seeds, such as rapeseed, mustard, and groundnut. The mill uses an oil ghani, a rotating chamber which puddles seeds by heavy weight from the top. The oil drips through the bottom and the oil cakes are taken out from the top. The cakes are then passed through an oil expeller, a powered screw press, to take out remaining oil. About 14% of oil can be extracted with the 2 machines. Oil is then filtered through a filter machine made by the Karkhana. (Manufacture = 50 units)

Other products

The Karkhana also produces irrigation and flood control gates, machinery for pottery industry, and textile mill spares.

Future products

The Karkhana plans to produce more technically sophisticated machinery for increasing agricultural production, for example, centrifugal and turbine pumps, 1-t capacity automatic rice mill, and power tillers.

SUPPORT ACTIVITIES

Though Karkhana is doing continuous research and development work, the cost is greater than the cooperative can afford. In Bangladesh, research institutes such as BARI, BRRI, Bangladesh Agricultural Research Council, Mymensingh Agricultural University, and Bangladesh Engineering University have very little link with this cooperative. Support activities nowadays come mainly from the Volunteer Services Overseas, United Kingdom (VSO-UK) — a voluntary organization providing engineering manpower. The VSO volunteers who have been working here are gathering technical information from various sources. Intermediate Technology Development Services (ITDS) is one of them.

MARKETING

Product marketing, administered by the Karkhana's sales section, consists of direct sale to farmers, independent dealers, and other customers, and in setting orders by tender system from government agencies.

Our four main independent dealers from the north are mainly interested in buying our two best selling products, the rice threshers and rice weeders. They come to our workshop, giving us cash advances at the beginning of both the harvesting and weeding seasons. All our private customers pay us cash in advance. Government agencies do not.

Product purchasing constraints

Our main customers for threshers and weeders are marginal farmers with approximately 3 acres of land. This is because land owners who have more land are usually absentee and have little interest in farming. Completely landless or farmers with less than 3 acres of land find it very difficult to get our products for a lump sum payment. A credit facility could greatly increase the purchasing power of the latter group, but the Karkhana does not have the financial resources to arrange for that. This year, a nongovernment organization called grameen bank, helped us sell machines to organized landless groups. The grameen bank is a good example of how credit can effectively be arranged for landless groups, and we intend to expand our activities through it.

Extension service

Extension service such as practical demonstrations, posters, leaflets, and canvassing have promoted much interest in our products. We intend to increase this activity soon as part of our marketing plan in the new areas where

we intend to expand our sales. Dealers are expected to participate in future extension work.

Several years ago, the Karkhana experimented with its own sales centers in certain locations, but overhead proved prohibitive and extension work was minimal.

Availability

Due to financial constraints, we have not been able to produce enough threshers in advance of the harvesting season to satisfy the demand at that time. Paradoxically, in the areas where we believe have a large potential market for threshers and weeders, we have not yet motivated local dealers into selling them.

Problems with government agency tenders

The Karkhana has problems in competing in the open tender system practiced by government agencies. The Karkhana has no agent in Dhaka who can negotiate with the various tenders. Government agencies in agriculture are interested mainly in irrigation equipment. Many tenders are limited or tied to international grants, and local manufacturers cannot compete.

STEPS IN FORMING A COOPERATIVE

The Karkhana has a long history of development. To form such an organization, the following steps could be taken.

1. Start with a small project plan.
2. Select a good manager.
3. Write the article of memorandum and register the organization.
4. Try to motivate potential members with cooperative ideas and membership.
5. Give them work and working capital as much as possible.
6. Cut some portion of the earnings of the members as share and saving to form capital of the organization. This may be a very small amount.
7. Fix a day for a weekly meeting, mandatory for every member.
8. Present the budget and accounts at the meeting.
9. Arrange annual general meeting and elect managing committee members as well as the chairman of the organization.
10. The managing committee will hold a meeting at least once a month to make important decisions on the various affairs of the organization to be administered by the manager who is also the secretary of the organization.
11. Try to form more capital.
12. Have an expansion plan to build the unit to a specified size.

The motivation of individuals in the right direction is one of the most critical and difficult tasks of cooperatives such as ours. That is why participating is absolutely necessary. Mandatory attendance in the meeting and presentation of budget and accounts solves the problems in many ways. Support from the government and other organizations through jobs is also necessary.

CONCLUSION

If the Karkhana is a successful cooperative, it is because of the active participation of the members in production and management. Members know they are owners and employees; if the organization runs well and goes ahead, they and their future generation can earn their bread for many years to come. In Bangladesh, where unemployment is increasing geometrically, the Karkhana has been continuously training employees to become good mechanics. Even if they are not ultimately employed by the cooperative, this training paves the way for the start of business outside. Thus, they can employ other people in their business and render service to farmers. The profit we are earning is distributed to members in bonuses and dividends according to the salary and shares, respectively.

The Comilla Cooperative Karkhana Ltd. contributes to the economic development of the country by producing prime and essential implements for farmers. This helps boost agricultural production and saves much foreign exchange.

The Karkhana can improve its role in agro-based economic development of the country, provided it receives guidance from the research institutes.

IMPROVING ACCESS TO AND USE OF APPROPRIATE AGRICULTURAL MACHINERY BY SMALL-SCALE FARMERS

W. J. CHANCELLOR
University of California
Davis, California, USA

Asia's agriculture is based on a multitude of small-scale farming units on which operators and their families make managerial decisions. If farm machinery is to have value on these farming units, the farmers must first perceive potential value. Then the costs of machines and their supply systems must come into balance with the value perceived and the value eventually obtained.

In the past, the supply and use of trained draft animals represented one of the most extensive systems on which farmers depended, yet it seldom reached beyond the neighboring village. With machinery, the supply systems for the machine, its fuel and repair parts frequently extend halfway around the world. The money to pay for machines and services may depend on the consumption of the farmers' products in distant countries. These worldwide systems must mesh and function together repeatedly, with net benefits accruing to all persons involved, if machinery is to benefit the operators of small Asian farms.

BALANCING FLOWS IN WORLDWIDE SYSTEMS

Farm machinery is supported by several long and diverse supply lines which furnish the equipment design, the equipment itself, fuel and lubricants, and repair parts and skills. Flows of resources from the general economy to the farm cannot occur without compensating return flows from agriculture to the balance of the economy.

The seasonal nature of farm crops, the 5- to 10-yr useful life of farm machines, the random occurrence of repair needs, and the near continuous demand for farm products give rise to temporal imbalances between supply-line flows and return flows, imbalances which could easily prevent farm machinery systems from working. Social and economic institutions can be or have been developed to absorb these imbalances. For accommodating imbalance of economic flows, these institutions are as vital to machinery use on Asian farms as are the technical characteristics of the machinery and the biological characteristics of the crop-soil-climate system.

Because these institutions can tolerate temporary imbalances, they can mask uneconomic on-farm acceptance of machinery, at least for short periods. In the long term, however, they frequently deny access to machinery when machines chosen are physically or economically inappropriate.

ACCESS TO MACHINERY BY SMALL-SCALE FARMERS

Access to machinery by small-scale farmers depends on developments related to

- technical aspects of the machines;
- physical, biological, and economic characteristics of the cropping system to which the machines would be applied; and
- institutions used in linking physical and economic flows associated with machinery application.

Generally, these developments should

- increase the value of production more than the costs incurred,
- maintain production while reducing costs, and
- allow restructuring of farm-family-resource patterns so that each resource may be used in its most productive role.

Because of the great improbability of the convergence of worldwide technical and economic systems resulting in machinery use on millions of small-scale Asian farms, when a workable system is found among the multitudes of nonworkable ones, such a system is worthy of attention and analysis. During a conference on farm mechanization for 1- to 10-ha farms (31), several workable systems were described. The juxtaposition of these descriptions revealed a common thread — minimization of the capital resources consumed relative to the value gained from one unit of machine service. Five avenues toward such a goal are now in use (individually or in combination) for small Asian farms:

1. Small equipment for small farms
2. Equipment designs offering low initial cost per unit of performance
3. Second-hand equipment use
4. Multipurpose use of a given machine or component
5. Multifarm use through custom hire services or group use

SMALL EQUIPMENT FOR SMALL FARMS

Three main reasons exist why minimizing capital and capital service costs per unit of equipment performance is vital to machinery use on small Asian farms. First, when a machine is purchased, the buyer pays an amount equal to about half of the value of all the work that the machine will perform in the next 5 to 10 yr. Second, in most rural areas of Asia, capital is scarce and interest rates are very high and administration of loans is expensive because of small loan size and high probabilities of default. Third, the most common pattern of farm machine management (for most farm machines in North America and Europe and for traditional farming tools in Asia) is that of farmer-owner-operator.

When this pattern of management is applied to small-scale farms, the capital-related costs and labor costs per unit of machine work delivered are much higher than on large farms — even when equipment size is optimally scaled to match farm size (Table 1). This is primarily because the low annual hours of use of even optimally sized machines on small farms necessitates high interest charges due to capital invested in any given piece of equipment for many years before its full service life is reached. Furthermore, smaller equipment requires more operator labor hours for a given amount of work than does larger equipment optimal for larger farms.

Economically optimum machine size

The following equations describe the economics of the farmer-owner-operator system (4):

$$\text{Total annual machine cost} = Z = HAK + BLW + LW(C + LD)/H \quad (1)$$

Then by differentiating with respect to H and setting the result equal to zero,

$$\text{Optimum machine horsepower} = H^* = \sqrt{LW(C + LD)/AK} \quad (2)$$

Introduction of H^* in the first equation gives:

Optimized total cost per unit work =

$$\left(\frac{Z}{LW}\right)^* = B + 2\sqrt{(AKD/W) + (AKC/LW)} \quad (3)$$

in which:

A = ratio of annual fixed costs to new machine price (0.2 in Table 1)

B = fuel, repair, and wear costs per rated horsepower-hour (0.35 kg of unhusked rice per hp-h in Table 1)

C = operator wage/h (1.5 kg/h in Table 1)

D = average penalty per unit land area for one working hour of delay (0.5 kg/ha-h in Table 1)

H = horsepower rating of the machine

K = price/rated hp (1250 kg/hp in Table 1)

L = land area to be serviced annually (farm size)

T = annual hours of operation = LW/H

W = tractor work required/ha (275 rated hp-h/ha in Table 1)

* = an optimized level of the variable designated.

Coping with the cost penalties of small machines

Equation 3 shows that the cost per unit of machine work has two components not affected by farm size, and has a third component inversely proportional to the square-root of farm size. This last component, (AKC/LW) , is responsible for farm machinery being of reduced financial feasibility (and thus less accessible) for small-scale farmers using the farmer-owner-operator mode of machinery management. This financial feasibility constraint is much less severe, however, if small-scale farmers can obtain sufficiently high prices for

Table 1. Costs of tractor-powered operations on various sized farms.^a

	Farm size (ha)						
	1	2	4	8	16	32	64
Optimum tractor size (hp)	1.5	2.3	3.9	7.0	12.9	24.8	48.5
Annual fixed costs (kg/ha)	375	287	244	219	202	194	189
Annual labor costs (kg/ha)	279	176	105	59	32	17	9
Annual cash and capital costs (kg/ha)	745	565	448	373	330	307	294
Annual timeliness losses (kg/ha)	93	118	140	158	171	178	182
Total annual costs (kg/ha)	838	683	588	531	501	485	476
Annual hours of operation	186	235	280	316	341	363	367
Cash and capital costs per unit work (kg/hp-h)	2.71	2.05	1.62	1.36	1.20	1.12	1.07

^aFor the case of one optimally sized tractor per farm. All costs given as kg of unhusked rice equivalent.

their products to offset the highest cost of machine work associated with their small farms.

Consequently, industries, first in Japan and later in Taiwan and South Korea (12), have produced equipment sized for small farms. Many, designed for wet rice culture, have potential application to many areas of Asia. However, because these machines were developed to initially serve a market in which farmers received high crop prices and had off-farm employment opportunities at good wages, these machines when exported to other parts of Asia made them accessible mainly to buyers who had a strong financial status — due either to high farm income or access to low-cost capital resources. Because many of these machines were designed for small farms, they did not have the long-range mobility, the power, or the durability for extensive multifarm use.

Factors making optimum machine size larger and more economical
The four remaining approaches to minimizing capital resources consumed relative to the value gained from one unit of machine service are primarily concerned with reducing the term (AKC/LW) , as reckoned on the basis of the total economic system served by one farm machinery unit (tractor with associated equipment, thresher with power unit and towing vehicle, or self-propelled combine). Furthermore, all but the multifarm use approach act to also reduce the quantity (AKD/W) (related to the cost of timeliness losses) so that small-scale farmers employing these approaches may have even lower costs for machine work than would large-scale farmers using the farmer-owner-operator mode of management for conventional farm machines purchased new.

Special equipment designs offering low initial cost per unit of performance serve to reduce the value K in equation 3, the price per unit capacity of the machine. The use of second-hand equipment by small-scale farmers also reduces K . Multipurpose use of farm machinery or machinery components, such as engines, tends to increase W , the amount of work performed per unit of

land area served by the machine unit. Finally, the various forms of multifarm use tend to increase values of L in equation 3. However, in the formulation of equations 1, 2, and 3, land area L is considered to be the land area designated for service by a given machine, subject to timeliness delays as the machine works its way through the assigned hectareage. With multifarm use in different crop-climate zones, the land area can be divided into portions requiring service at different times. The number of such portions, N , should be applied to the term (AKD/W) to modify it to the form (AKD/NW) . This also can give small-scale farmers access to machine work at a lower cost compared to a larger-scale farmer using machinery in the farmer-owner-operator mode.

EQUIPMENT DESIGN FOR LOW INITIAL COST PER UNIT PERFORMANCE

Much farm equipment manufactured in Europe and North America is designed to meet the multipurpose-use requirements, convenience requirements, and the severe labor constraints of those markets. It is possible, however, to design farm equipment for specific uses in small-scale Asian conditions, simple equipment and low cost per unit of capacity. Examples are the 2-wheel tractor in Thailand (8), the drum thresher in India (19), and the power tiller and small axial-flow thresher developed by the International Rice Research Institute (13). Those machines have few frills and make more use of low-cost support labor than more elaborate machines. Nevertheless, the tractors cost 0.78 and 0.95 t paddy/engine hp respectively for the Thai and Philippine units. This is approximately 64% of the cost of similarly powered units from Japan when sold in Thailand or the Philippines and 49% of the cost of large tractors in those countries (10). The threshers (both large and small in the Philippines and the large units in Thailand) have cost 16 t paddy/ton-per-hour capacity (16). The Indian unit costs about 12 t wheat/ton-per-hour of capacity, excluding the cost of the power unit which was usually purchased for wheat/ton-per-hour of capacity (11).

Designs of these machines involve small numbers of simply made parts, and are especially suited to local manufacture. If local industry can produce units cheaply, costs of imported units may also be held down due to competition. Local production eliminates a lot of shipping and associated clerical and handling costs and uses low-cost labor from nearby agricultural economies. Manufacture can usually be done with general-purpose machine tools, holding down capital costs. Small-scale manufacturers serving their local community can minimize distribution costs and costs associated with stocking spare parts.

With the small tractor in Thailand and the drum thresher in India, prices were so low that the farmer-owner-operator system of management could be practiced, allowing these items to form part of a larger, more efficient, integrated system of farm equipment. In Thailand, attachments for fitting used truck tires to the tractors have made many of these machines sufficiently mobile for road travel and transport with an attached trailer. Disk plow attachments have allowed these machines to work in upland environments.

Furthermore, the ease with which the tractor belt drive can be disconnected has made the tractor engine a frequent source of pumping power. With Indian drum threshers driven by the same stationary power source that operated irrigation pumps, cane crushers, and other farmstead equipment, this shared power source reduced the capital costs per unit work delivered.

SECOND-HAND EQUIPMENT

Most Asian countries have, besides small farms, commercial and government-operated large farms. Such farms commonly have large fleets of tractors, and may find it economical to replace these units before they are completely depreciated. Small farm operators can take advantage of the low price per unit of capacity of these tractors bought second-hand, and because of low annual use on small farms, be able to extract years of service from them. Small-scale operators also may have the time to do necessary repairs on the machines.

In some cases the demand for second-hand tractors has far exceeded the supply. Private entrepreneurs have imported them from Europe or Japan. Reconditioning such tractors provides a basis for a local industrial activity. But if spare parts are not available for the models transferred from Europe or Japan, the anticipated economic advantages may not materialize.

MULTIPURPOSE USE OF A FARM MACHINE OR ITS COMPONENTS

In 1983, the locally manufactured 2-wheel tractor in Thailand (8) cost 1/4 t paddy/hp (without engine), while the engine cost 2/3 t paddy/hp. To minimize the capital costs, the engine was used for water pumping, or was installed in a transport vehicle locally fashioned from used automotive parts. This illustrates multipurpose use of capital-intensive equipment to spread costs over several operations.

Because tractor operating costs are very high compared to small-farm income in Asia, tractors are not generally used for odd jobs around the farm, but only for high-value or high-return tasks. Some innovation (both technical and institutional) is required to find off-season use for farm machinery. Transportation is the most common application, but other uses include crop processing, rural road maintenance and repair, and electricity generation (from farm crop residues).

Technical developments to increase multipurpose use are both modular design (such as with the tractor engine cited above) and the manufacture of attachments which adapt a machine to different categories of tasks. Availability of a broad range of implements or attachments can make purchase of the power unit more feasible economically.

MULTIFARM USE OF FARM MACHINES

One major disadvantage of multifarm use of farm machinery, as contrasted with farmer-owner-operator machinery management, is lack of control over

timing and quality of work. Also, farmers renting equipment are not as free to find innovative ways to make use of machines as are machine owners. Besides spreading capital cost over many hectares, multifarm use permits farm machine services to be rendered at costs considerably lower than those with farmer-owner-operator management even on large-scale farms. This cost advantage is linked to the potential for extremely intensive use of the equipment. This not only minimizes interest charges as a proportion of total costs, but spreads interest over more hectares. Under these circumstances, capital-intensive high-capacity machines are more advantageous than smaller units because of reduced labor charges per unit work and because a few large machines are easier to manage than many smaller ones. This potential for low-cost machine work provides the incentives for innovative institutional approaches to gathering the large packages of capital necessary for machine purchase from within a capital-constrained economy. Some of these approaches will be described here.

Group use

Group farm field work is traditional in many parts of the world. Forms of group use follow:

1. In a machinery ring (20), each member owns a particular machine and makes it available to others. This has advantages where many small diversified farms need a broad range of machinery. Extensive communication and cooperation are necessary for effective operation. Individual responsibility for a machine is advantageous to management.
2. Machinery pools are similar to machinery rings except that all machines are owned jointly.
3. Joint ownership has been a feature of machinery use in Asia (2) (Table 2). In Malaysia, Chancellor (6) found two types of joint ownership groups (3-5 persons). In one, all members were of about the same age and landholding status, and shared equally in driving, repair work, and operating costs. In the other, one person was uniquely qualified to be in charge of the tractor operation, and charges for his services were uniformly shared. In both forms, members were closely linked by family, friendship, or locality.
4. Group farming is discussed by Kanazawa (17) who describes methods of machinery use by groups in Japan that managed their farmland on a combined basis. Some methods were similar to the joint ownership forms. Other methods involved a village farmers' union which owned machines, hired operators, and contracted with individuals or joint farming groups for work to be done. In some cases, larger-scale or full-time farmers took charge of much of the operation on land held by part-time farmers on either a contract or group-managed basis. In either case the management expertise of full-time farmers had some influence on the productivity of the entire farming unit.
5. Group action to secure subsidized farm machinery has been described by Cho (9). Farmers' groups received government assistance in buying

Table 2. Incidence of group ownership of farm machines in certain Asian countries.

	Percent of machines owned jointly	Percent of owners who are joint owners ^a
<i>Japan</i>		
All tractors and tillers	3.6	
under 5 hp	1.8	
over 30 hp	21.4	
Combines	13.0	
Transplanters	16.2	
<i>Indonesia</i>		
Power tillers	20	30.2
Tractors	23	17.6
<i>Pakistan</i>		
Tractors	4	
<i>Sri Lanka</i>		
Power tillers	20	
Tractors	5	
<i>Philippines</i>		
Power tillers	8	13.2
Tractors	2	11.4
Pumps	10	
Threshers	10	
Trucks	31	

^aPercent of machines owned jointly could theoretically not be more than half of the percent of owners who are joint owners.

machines. In one form, a public agency purchased machines and loaned them to farmers' groups.

Major problems associated with group use are providing incentives for users to continue good maintenance, deciding who will use equipment during the busy season, deciding how costs for repairs will be assessed of owners or users, and deciding how, when, and to whom money transfers will be made from those receiving machine service to those managing machine operations.

Experience of one farmers' association

One farmers' association in Malaysia (6) had worked out a fairly successful pattern of machine operation.

- Membership was divided into "small agricultural units," each consisting of 50 or more families in one area.
- Before the tillage season, the families in each unit prepared a request for the entire unit, listing all fields to be served, and the time when service would be require.
- The board of directors of the association, with representatives from each unit, decided on the order to serve units. Units to be served last were notified so they could hire outside contractors if necessary.
- A supervisor was appointed for each tractor or group of tractors working together. He was responsible for scheduled work and collected money for work done.

- A copy of each approved work request form was sent to the association office, the tractor supervisor, the tractor operators, and the chief of each "small agricultural unit." The agricultural unit chief, the tractor operator, and the tractor supervisor all sign when the work was completed.
- After fuel costs, drivers' wages, and minor repair costs were deducted from the gross tractor income, 5% was deducted from the balance and paid to the tractor supervisor as his wage for services.
- Tractor service credit accounts were handled with fertilizer credit accounts. Although many farmers' associations attempted to allow tractor service on credit, the high cash flow for operating tractors caused severe financial burdens for associations not requiring members to pay at time of service.
- The drivers were sons of members, and received one week's training from the commercial firms from which the tractors were purchased. Each tractor had two drivers paid on an hourly basis.
- The tractors were purchased with special low-interest, government-sponsored loans available to the association for a limited time and in limited amount.
- The number of tractors was insufficient for the needs of the farmers in the association. Therefore, the association began operating the agency for selling 2-wheel tractors to area members and nonmembers.

The success of this particular association was greatly due to thorough management and to utilization of the knowledge of persons trained in management. A large amount of time was spent by members and officers in executing these procedures. This nonmonetary investment, however, appeared to have been worthwhile.

Custom hire services

Probably most farmers in Asia who have used motorized farm machinery have done so first by hiring custom operators. Custom hire services transform machine work into an almost infinitely divisible input which even small-scale farmers can purchase in trial amounts as small as 0.1 ha of tillage or 100 kg of grain threshed. Furthermore, the cost per unit of machine work may be less with custom hiring than for a large-scale farmer-owner-operator with his own large machine (compare the values in Table 3 with those in Table 1). The values in Table 3 also show that custom hire services in Asia can provide field work at costs considerably below the value of this work to Asian farmers (see Table 4).

Information on the incidence of custom-hiring of engine-powered farm machinery in Asia (2) has taken several forms.

In India, 57% of the users of engine-powered farm machinery hire it. The work done constitutes 47% (one figure) or 28% (another figure) of the tractor-tilled hectareage. About 60% of the land represented by the latter figure was served by farmer-owned tractors and the balance by tractors owned by agencies and tractor centers. A third figure (22) indicated 69% of all tractor hours were spent in hire service. For tractor owners having less than 2 ha, 89%

Table 3. Costs of tractor-hire services in terms of unhusked rice per rated horsepower-hour.

Country	Year	Reference	Tractor type	kg unhusked rice per rated hp-h
Thailand	1968	Chancellor (1970)	Four-wheel (60 hp)	0.77
Thailand	1979	Wattanuchariya (1983)	Four-wheel (60 hp)	0.80
Malaysia	1969	Chancellor (1970)	Four-wheel (50 hp)	0.75
Malaysia	1969	Chancellor (1970)	Power tiller (8 hp)	1.67
Philippines	1972	Orcino and Duff (1973)	Four-wheel (60 hp)	0.71
Philippines	1980	Maranan (1981)	Four-wheel (60 hp)	0.69
Philippines	1980	Maranan (1981)	Two-wheel (9 hp)	1.32
Nepal	1980	Sharma (1983)	Four-wheel (45 hp)	0.72
Pakistan	1979	Qureshi (1983)	Four-wheel (45 hp)	1.35
Sri Lanka	1979	Kathirkamathamby (1983)	Four-wheel (45 hp)	0.75
Indonesia	1980	Bunaser and Lingard (1984)	Power tiller (7 hp)	1.13
Av				0.97

Table 4. Value farmers place on tractor work in terms of unhusked rice per rated horsepower-hour (7).

Country	Year	Reference	Tractor type	kg unhusked rice per rated hp-h
Japan	1955	Umeki (1961)	Power tiller	1.13
Philippines	1964	Johnson (1966)	Various	0.6 - 1.0+
Thailand	1968	Chancellor (1970)	Four-wheel	1.29
Malaysia	1969	Chancellor (1970)	Four-wheel	1.23
Pakistan	1970	Ahmed (1975)	Four-wheel	1.31
India	1972	Singh and Chancellor (1975)	Four-wheel	1.33
Av				1.20

of the tractor hours were spent in hire service; the figure for tractor owners having more than 10 ha was 54%. Of the 21,168 farmers represented in a national survey, 68% hired tractor service.

Hired equipment serviced 40% of the land in Indonesia.

Custom work is done by 25 to 30% of tractor owners in Pakistan. The land serviced by hired machines is 2 to 4% of that tilled.

On Philippine farms, 71% of the large 4-wheel tractors are used primarily for custom-hire work. Eighty-one percent of farmers using large tractors hire them. The corresponding figure for power tillers is 77%.

In Taiwan, 85% of farmers using power tillers hire the equipment. Power tillers spend an average of 63% of their time in custom work (83% for owners having less than 1 ha and 34% for those having more than 5 ha). The average share of working time spent in hire service was 52% for transplanters, 22% for sprayers, and 52% for combines.

In Thailand, 95% of large 4-wheel tractors do custom work, as do 80% of the small 4-wheel tractors and 50% of 2-wheel tractors. Threshers do 95% custom-hire work.

Most custom-hire services were provided by equipment owned by individual farmers.

Four types of organizations supply farm machine custom-hire services: private owners (farmers and nonfarmers), cooperative associations, government tractor stations, and crop processing or crop buying firms.

Private ownership. A businessman who operates a store performs a function much like that of private, nonfarmer owners of farm machines used for custom-hire. Capital is invested in both fixed assets and in stock, with timed offering of services and a storing of potential services until demand. Offering custom-hire farm machine services can provide more net income per unit of capital investment than operating a shop selling everyday household needs. As a result, a portion of the universally used tractor-hire services and most of the dominant combine harvest services in northwestern peninsular Malaysia are provided by machines owned and frequently managed by private, nonfarmer owners (14). This mobilization of private urban capital depends on efficient machine management, and on farm product prices high enough to allow farmers to afford cash outlays for farming services.

Most private farmer owners of custom-hire services would like to have the machine for personal use, but the high capital costs make it necessary to use the machine in hire services.

Individual farmer ownership has several advantages:

- Machines are distributed throughout the farming area and so can serve local areas without extensive travel.
- The normal channels of rural communication can be used to connect owner and hirer.
- Farmer operators are familiar with the form and quality of field work required.
- Farmer-owners usually have extended family members who can also operate the equipment — family members who have an established link of responsibility to the owner and his objectives.

When private owners provide services at some distance from their homes, they often employ brokers. Some brokers gather local order for machine service and find equipment contractors to meet these needs. Or machine owners ask brokers to find hire-service customers. Brokers are usually paid 5% of the contract charge. Using brokers makes hire services more efficient by minimizing unnecessary between-job transport of the equipment.

Cooperative associations for tractor hire service. General-purpose farmers' cooperative associations have provided tractor hire service, especially in Japan (17), some in Taiwan (25), and also in peninsular Malaysia (29). The cooperatives frequently channel extension information and special promotional credits to farmers and serve as implementation agencies for agricultural programs.

When farmer cooperatives are financially strong and machinery hire service is a minor activity, the hire service can succeed with thorough management and detailed scheduling. Extensive and rapid communication is needed between cooperative management and the members using hire services. A common pitfall is management's assumption that because all members share financially in the hire-service system, they would be willing to tolerate

irregularities in scheduling or reduced quality of work for their farms if these resulted in major savings for the cooperative. Such an assumption has usually proven incorrect in a competitive environment.

There have been common problems involved in adding machine hire service to the activities of financially small-scale farmer cooperatives:

1. Few drivers or members in charge of maintenance had much technical experience, so repair cost and time wasted during tractor breakdown were often high.
2. The member in charge of finance frequently had to approve expenditures, large or small. Such coordination complicated and delayed decisions on tractor operations.
3. Frequently, members were served on a first-come, first-served basis, which necessitated extensive tractor travel.
4. Because fertilizer credit accounts were frequently used in the cooperatives, many members chose to add the tractor service fee to their credit account. Tractor operations then became cash deficient.
5. Nonmembers (neighbors of members) often requested tractor service, thus delaying the tractor in its progress to the next member's field. The tractor supervisor at times served nonmembers first to get sufficient cash to continue tractor operations.
6. Member's fields were all grouped in a given area, and all required service at approximately the same time. The limited tillage season available for service frequently left some members' fields unserviced.
7. Tractor income from servicing members' fields was sometimes insufficient to meet credit repayment charges. The tractor was then sent to other districts to earn additional income. This pattern resulted in many members hiring outside contractors, while their jointly owned tractor was busy servicing fields of nonmembers and distant farmers.

Farmers' cooperatives experienced in tractor operation have successfully used the following methods to resolve some of the problems.

- Requests for tractor service were sought ahead of time, and then arranged in blocks so that tractor travel was minimized.
- Training for the head driver was arranged. He then supervised the technical aspects of other drivers' work and took care of tractor maintenance. This resulted in significantly lower repair cost and breakdown times.
- One person performed all scheduling, supervising, and financing of tractor operations, and was paid a commission for this work. This avoided unauthorized collections by drivers and other members.
- Credit accounts were not permitted. In exchange, slight reductions in charge rate were sometimes made for members. This also tended to keep members loyal to their own tractor.

Cooperative tractor services often began where tractor service had not been offered before. Tractor contractors usually bypassed such areas because of technical problems or difficulty in securing cash payments from farmers with low incomes. Cooperative pioneering in tractor service has frequently been

followed by itinerant tractor owners who undercut the association's charges and doomed the cooperative's project; however, this brought low-cost tractor service to more farmers.

Government tractor stations. Government-sponsored tractor stations have been a feature of many Asian countries, and India has a number of semiprivate, semigovernment State Agro-Industries Corporations that have operated tractor and combine hire-service stations in addition to farm machinery assembly, sales and parts/repair functions (24). Government sponsorship avoids having to first accumulate capital from the farm area served.

Government stations can demonstrate machinery hire services, and may allow farmers to undertake more intensive cropping programs such as double-cropping, the planting of crops requiring dry season tillage or of crops needing a ridge-and-furrow field surface.

Conventional governmental administrative procedures and civil service policies are frequently not compatible with the needs of tractor-hire services. A 24-h daily operation is often necessary. Repair authorization, as well as purchase of supplies by drivers and field personnel, can frequently not be done with competitive bids or fully documented receipts. Government employee salaries and security of employment cannot be directly linked to repair costs or to income augmentation. Responsibility for capital repayment, for profits gained or for losses sustained, is complex under governmental procedures. Even the question of "to whom does the hiring farmer pay the charges" can be a problem.

For efficient supervision, tractor stations usually have many tractors and other machines at a single location. Because the area served is spread out, transport time and expense are much greater than if single machines owned by individuals were distributed over the farming area. These same transportation and communication problems face farmers who want to subscribe for services from the station (5). See Table 5.

The rate charged for hire services for government tractor stations is particularly important. If rates are set at a level reasonable to farmers and at which private contractors can make a profit, entrepreneurs may enter the field. Ensuing competition will decrease charges as in Malaysia for both tractor and combine services (14), and for tractor services in Thailand (5).

If government charges are low, usually many more farmers will subscribe than can be served in a timely way. Oversubscription can also allow a few private contractors to charge whatever the market will bear as farmers become desperate for tractor service. Usually, capital constraints make it impossible for government stations to serve all subscribers if charge rates are set unusually low.

Frequently the availability of service and the charge rates levied by government tractor stations are subjects for politically based promises and arguments. Many farmers may feel that since the government sponsors the station and encourages increased agricultural production, the charge rates should be subsidized or services provided free. Subsidized rates tend to

Table 5. Effects of headquartering various numbers of custom-hire service tractors at a single location.^a

50-60 hp tractors (no.)	1	2	4	8
Net annual income per tractor (US\$)	1370	1129	822	466
Time spent traveling annually (h/tractor)	172	232	308	396

^aData based on optimized operating conditions in northwest Peninsular Malaysia in 1969 (5).

prevent the mobilization of private capital by persons who could (at unsubsidized charge rates) visualize making a profit by investing in farm machinery for hire services.

The collection of hire service fees by government personnel such as extension agents can damage relationships between them and farmers.

Tractor hire services from crop processors or buyers. When a large-scale centralized processing facility (or a large-scale buying facility) is established for an agricultural crop product, it is advantageous for farmers near the facility to be encouraged to produce that crop and sell it to the facility. Such facilities may offer farm machinery hire services to cooperating farmers. When the crop is new for that locality or requires special field practices, such hire services can help in introducing the new information. Facilities of this type can uniquely encourage farmer cooperation by offering tractor hire services on credit with charges to be assessed only when the crop is sold to the facility. If, however, there is more than one buyer in the area, farmers may sell to another facility, jeopardizing the financial feasibility of the equipment-hire service. Large-scale facilities frequently have the same difficulties as do government tractor stations, with regard to transport and communication when many machines are headquartered at a single location. Some processing organizations have overcome this problem by contracting with certain private tractor owners distributed throughout the buying area to carry out these services in the name of the facility.

CREDIT AS IT AFFECTS ACCESS TO FARM MACHINERY

The cost-effectiveness of using a farm machine system depends not on credit but on increasing the value of production more than costs, maintaining production while reducing costs, or restructuring family resources to increase total productivity. If none of these conditions can be met, then commercial credit for farm machine purchase is not viable on a continuing basis. In fact, credit adds costs to farm machine systems without contributing directly to productivity. What credit does do is to permit capital-constrained small-scale farmers to take over the management of farm machines without first having to accumulate capital in the amount of about half of the value of the work that the machine will perform in the next 5 to 10 yr.

Even when machines contribute to productivity, the costs of machine operation often must be paid in different "currency" than the production costs saved or the productivity generated. Problems of "currency" differences are

partially mitigated when the farmer enters a money economy; but where he must exchange family labor for money, satisfactory wage rates may not be available.

Where the purchase and use of farm machinery is certain to be lucrative, credit is not necessary. Many first-time farm machinery sales agents are surprised at the ability of small-scale farmers to raise money from within family resources under the circumstances of sure high returns. When sales agents are unable to increase supplies to satisfy demand or to raise prices to stem demand, black marketeers in farm machinery may even appear.

Reasons for supplying credit

Some main reasons for supplying credit for farm equipment purchase are the following:

- to encourage capital-constrained farmers to take up modernized, high-productivity methods;
- to compensate farmers for economic problems such as those from a high incidence of some disease of draft animals such as foot-and-mouth disease, or farm product prices held artificially low to protect consumers;
- to encourage farm machine sales and manufacturing; and
- to find a high-return use for surplus capital resources.

When credit is offered to directly aid farmers, farmers quickly realize that if they offer as collateral any part of their agricultural production enterprises such as land or livestock, the credit agency cannot foreclose on this collateral for delinquent repayment without contradicting the basic purposes for supplying the credit. Under these conditions, the best economic strategy for farmers is to borrow as much as possible and to extract as much value as possible from the machine bought on credit, and to use this value to meet their local capital needs and opportunities for as long as possible before repayment is required. If foreclosure is a real prospect, farmers who have high capital resources can afford to delay repayment until the last minute. Farmers without such capital resources, however, face serious loss upon foreclosure and thus can be expected to be less delinquent in repayment.

Credit supplied for commercial reasons must rely on commercially viable collateral which is frequently the farm machine itself, since a repossessed machine can usually be resold within the framework of the farm machinery business involved. With commercially oriented credit, a crucial element is the proportion which the down payment is of the machine value. Higher proportions increase security but decrease the number of potential buyers. If the down payment is very low, the buyer may be willing to face repossession, and may use the machine intensively without regard for its life. Only extreme competition among equipment sales agents would lead to down-payment percentages low enough to encourage such a pattern of use.

Credit links machinery system participants

In the system of farm machinery use, principal operatives are the manufacturer- or importer-distributor, the local sales agent, and the owner-operator.

An effective system requires each participant to be efficient. A properly designed credit contract can provide incentives that encourage and guide each system member.

The central distributor, because of the size and stability of his business, is in the best position to obtain large blocks of credit at reasonable interest rates from commercial sources, including international sources. He is also able to know of and select from the broad range of farm machinery types in the world market. Furthermore, in his close association with manufacturers, he is in a position to have products modified, have access to spare parts, and be fully knowledgeable about repair procedures. Because of his central location he cannot know many machine owners personally or be concerned with the operating status of each machine.

The local sales agent is in a position to know the financial status and farming program of machine buyers in his business community. In addition, his business activities routinely involve stocking items for sale and hiring and supervision of employees with various skills. He cannot, however, take time to be concerned with the day-to-day effective use of each machine.

The farmer-owner-operator knows the functions the machine performs, and the maximum cost he can tolerate. He also has local contacts with others who may wish to rent his machine. The farmer-owner-operator may not be familiar with the range of equipment available, may not be knowledgeable about repair procedures or those for obtaining spare parts, and may be in a disadvantageous position for obtaining credit.

A well-designed credit contract can link the strengths of each of the three types of participants into an effective farm machinery supply system (5). The features of such a contract are as follows:

1. The distributor acquires credit at favorable commercial rates. The distributor selects local sales agents according to their ability to stock spare parts, provide repair service, and assess buyer credit-worthiness.
2. The local sales agents evaluate the financial soundness of prospective credit buyers of machines and, upon approval, execute the credit contract calling for the buyer to make a down payment (usually 25-35% of machine value). All or most of this down payment is forwarded to the distributor, who then holds the contract involving periodic payments by the buyer to complete the transaction within 1 1/2 to 3 yr. These periodic payments are made to the sales agent who deducts amounts needed to cover business expenses and to provide his profit, and forwards the balance to the distributor.
3. The farmer-owner-operator, who must usually make a serious capital-accumulation effort among his extended family members to obtain the funds for the down payment, faces the prospect of losing these funds upon repossession if he cannot make the periodic payments on the short-time repayment schedule. Consequently the advantages of using the machine in custom-hire service become evident, and thus most machines sold on such contracts are intensively used.

Credit contracts help keep machines running

Breakdowns halt income from custom-hire service. Frequently, the buyer's farm income is insufficient to meet the repayment schedule of the credit contract, so payments stop. This stoppage reduces the local sales agent's income, and so it is in his interest to help get the machine running again by supplying spare parts and repair service. The local sales agent is eager to have his service personnel trained by the distributor. The distributor's business is threatened by default on credit contracts, so he is motivated to supply spare parts and to offer centralized training for service personnel.

The distributor quickly learns which machines can be sufficiently cost effective in the hands of farmer-owner-operators to allow credit contracts to be viable and completed without undue delay. In addition, the distributor learns which machines are durable and which weak points need strengthening. He then takes steps to have the machines improved at the manufacturing stage or makes modifications on the machines before distributing them.

Thus, a credit contract of the type described keeps participants' attention focused on their particular expertise and efficiency to make the system operate effectively. Credit, therefore, not only improves access of small-scale farmers to machines, but also mobilizes the forces of knowledge and care to prevent the loss of access, once achieved.

REFERENCES CITED

1. Ahmed, B. 1975. The economics of tractor mechanization in the Pakistan Punjab. *Food Res. Inst. Sud.* 14 (1): 47-64. Food Research Institute, Stanford University, Stanford, CA, USA.
2. APO (Asian Productivity Organization) Secretariat. 1983. Trends in farm mechanization and farm machine supply in the region. Pages 19-68 in *Farm mechanization in Asia*. Tokyo, Japan.
3. Bunasor, S., and J. Lingard. 1974. Power tiller use on farms in West Java, Indonesia: an analysis of their employment effect and private profitability. Pages 323-347 in *Consequences of small farm mechanization in Indonesia*. F. Kasryno, M. Syam, Y. Saefuddin, S. O. Manurung, and P. Mundy, eds. Agency for Agricultural Research and Development, Directorate General for Food Crops, and the International Rice Research Institute, Jakarta, Indonesia.
4. Chancellor, W. J. 1969. Selecting the optimum-sized tractor. *Transactions of the ASAE* 12(4):411-414, 418.
5. Chancellor, W. J. 1970. Survey of tractor contractor operations in Thailand and Malaysia. *Agr. Eng. Dep., University of California, Davis*, 179 p. (also in Japanese, T. Mukumoto, translator, Shin-Norinsha Co., Ltd., Tokyo)
6. Chancellor, W. J. 1972. Social and institutional factors in mechanization of agriculture in Thailand and Malaysia by tractor hire services. Pages 22-26 in *Spec. Publ. SP-01-72*, American Society of Agricultural Engineers, St. Joseph, MI.
7. Chancellor, W. J. 1979. Patterns of tractor management in agricultural development: costs benefits and farmer responses to system characteristics. *CIGR Paper No. II2-47*, ASAE, St. Joseph, MI. 10 p.
8. Chinapant, U. 1974. Marketing of and demand for the domestically produced small farm tractors in Thailand. Master of Economics thesis, Thammasart University, Bangkok, Thailand. 80 p.
9. Cho, K. H. 1983. The status of farm mechanization in the Republic of Korea. Pages 234-372 in *Farm mechanization in Asia*. Asian Productivity Organization, Tokyo, Japan.

10. Duff, J. B. 1984. The composition, growth and impact of small farm mechanization in Asia. Pages 273-298 *in* Consequences of small farm mechanization in Indonesia. F. Kasryno, M. Syam, Y. Saefuddin, S. O. Manurung, and P. Mundy, eds. Agency for Agricultural Research and Development, Directorate General for Food Crops, and the International Rice Research Institute, Jakarta, Indonesia.
11. Grewal, S. S., and H. S. Sandhu. 1974. Comparative economics of harvesting wheat with combines and other methods. Dep. of Economics and Sociology, Punjab Agricultural University, Ludhiana, India. 10 p. (mimeo.)
12. Herdt, R. W. 1983. Perspective, issues and evidence on rice farm mechanization in developing Asian countries. Pages 111-147 *in* Farm mechanization in Asia. Asian Productivity Organization, Tokyo, Japan.
13. IRRI (International Rice Research Institute). 1976. Rice machinery development and industrial extension. Semi-annual progress report 22, Agricultural Engineering Department, International Rice Research Institute, Los Baños, Laguna, Philippines. 67 p.
14. Jegatheesan, S. 1982. Progress and problems of rice mechanization in peninsular Malaysia. Pages 281-288 *in* Research for the rice farmer. Proceedings of the national rice conference 1980, Malaysian Agricultural Research and Development Institute, Kuala Lumpur, Malaysia.
15. Johnson, L. 1966. Is mechanization possible where rice is king? *Agric. Eng.* 47(3):132-135.
16. Juarez, F., and R. Pathnopas. 1983. Comparative analysis of thresher adoption and use in Thailand and the Philippines. Pages 119-137 *in* Consequences of small farm mechanization. International Rice Research Institute, Los Baños, Laguna, Philippines.
17. Kanazawa, N. 1972. Group activities in the mechanization of rice farming. Pages 319-330 *in* Farm mechanization in East Asia. H. Southworth, ed. Agricultural Development Council, 630 Fifth Avenue, New York, NY, USA.
18. Kathirkamathamby, S. 1983. The status of farm mechanization in Sri Lanka. Pages 453-471 *in* Farm mechanization in Asia. Asian Productivity Organization, Tokyo, Japan.
19. Kaul, R. M., P. Kumar, and D. L. Sharma. 1972. Anand thresher. Test Rep. THR-10/72, Farm Machinery Testing Centre, Dep. of Agric. Eng'g, Punjab Agricultural University, Ludhiana, India. 8 p.
20. Lonnemark, H. 1967. Multifarm use of agricultural machinery. FAO Dev. Pap. 85. Food and Agriculture Organization of the United Nations, Rome, Italy. 113 p.
21. Maranan, C. L. 1981. A comparative analysis of tractor contract operations in Nueva Ecija, Philippines, 1972 and 1980. Consequences of small rice farm mechanization in Asia, Joint ADC/IRRI Workshop, 14-18 Sep 1981, Paper in Session II.1 31 p. International Rice Research Institute, Los Baños, Philippines.
22. NCAER (National Council for Applied Economic Research). 1980. Implications of tractorization for farm employment, productivity and income. Vol. 1. New Delhi, India. 147 p.
23. Orcino, N., and J. B. Duff. 1973. Technical and economic characteristics of tractor contract operations in Central Luzon. Saturday Sem. Pap., International Rice Research Institute, Los Baños, Laguna, Philippines. 23 p.
24. Pangotra, P. N. 1983. The status of farm mechanization in India. Pages 287-328 *in* Farm mechanization in Asia. Asian Productivity Organization, Tokyo, Japan.
25. Peng, T. S. 1983. The status of farm mechanization in the Republic of China. Pages 249-282 *in* Farm mechanization in Asia. Asian Productivity Organization, Tokyo, Japan.
26. Qureshi, K. 1983. The status of farm mechanization in Pakistan. Pages 393-417 *in* Farm mechanization in Asia. Asian Productivity Organization, Tokyo, Japan.
27. Sharma, R. P. 1983. The status of farm mechanization in Nepal. Pages 373-392 *in* Farm mechanization in Asia. Asian Productivity Organization, Tokyo, Japan.
28. Singh, G., and W. J. Chancellor. 1975. Energy inputs and agricultural mechanization under various regimes of mechanization in Northern India. *Trans. ASAE* 18(2):252-259.
29. Ujang, A. B. 1981. Farm mechanization development strategies for small farmers in Malaysia. Pages 121-129 *in* Agricultural engineering in national development. S. L. Choa, M. Z. Bardaie, N. C. Saxena, and V. V. Tran, eds. Penerbit Universiti, Pertanian, Malaysia, Serdang, Selangor, Malaysia.

30. Umeki, T. 1961. Effects of power tiller use on farm income in the Sage plain area. Saga Prefecture, Japan, English Bull. 3. Dep. Agric. Econ. Kyushu University, Fukuoka, Japan.
31. University of Illinois at Urbana-Champaign, American Society of Agricultural Engineers, and Interfaith Center on Corporate Responsibility. 1978. Agricultural technology for developing nations — farm mechanization alternatives for 1-10 hectare farms. 105 p.
32. Wattanutchariya, S. 1983. Economic analysis of the farm machinery industry and tractor contractor-business in Thailand. Pages 39-49 in Consequences of small-farm mechanization. International Rice Research Institute, Los Baños, Laguna, Philippines.

FINDING EFFECTIVE CHANNELS FOR MARKETING SMALL FARM EQUIPMENT

B. K. S. JAIN

B. K. S. Jain & Associates

Marketing, Management and Agro Consultants

Bombay, India

Marketing the equipment designed for small farms in developing countries is the weakest link in the agricultural mechanization chain. This paper deals with some major problems and suggests solutions. A small farm is taken to be less than 4 ha. Most farms in developing countries are small; in Indonesia, Republic of Korea, and Sri Lanka, more than 90% of the farms are small. The three-tier mechanization on small farms will call for equipment such as

- manual and animal-operated tools and implements;
- power-operated machinery such as pump sets, sprayers, and threshers; and
- power tillers and tractors, with equipment for haulage, tillage, sowing, intercultivation, and harvesting.

THE DEALERSHIP SYSTEM

The main marketing channel is the dealer — a village blacksmith, a hardware store, a cooperative society retail outlet, or a well-equipped outfit with showroom, workshop, spare parts counter, and mobile sales and service personnel. To make the channel effective, the dealer needs to be efficient. With his proximity to the farmer, he can render prompt and efficient services. In a seller's market, manufacturers are mainly concerned with the deposit and the off-take commitment from the dealer. The dealership, in fact, has to be a well-organized system, in which all operative elements — selection, appointment, development, appraisal, and even termination — are given proper attention.

Dealer loyalty is directly proportional to the money he makes on the franchise. For an effective coverage, he must have a viable territory. Given inadequate margins, services to the farmer suffer. Training of the dealer-proprietor and his sales and service personnel is imperative. Such training is a continuous process. Because of crop seasons and remote locations, timeliness of operations is essential. Repairs, supply of spare parts, and services must be prompt so that the farmer does not lose the season.

Dealers of small farm equipment have received little attention. They suffer from inadequate margins, lack of training and guidance, insufficient funds to run the business, and heavy payoffs to bank officers and other corrupt officials. They are expected to incur expenses on demonstrations, training farmers, advertising and sales promotion. There are not many case studies on their cash flow, profitability, and other financial and commercial problems. Dealership as a subject needs to be researched in all aspects. We need to know this important influencing agency better. Manufacturers who have invested in a sound dealership structure have developed their business well, have been more successful in launching improved machinery, and are better prepared to face a recession.

MARKET RESEARCH

Small farm equipment business suffers from lack of market data. Marketing executives have difficulty in developing buyer and dealer profiles, assessing demand, building models for forecasting, and doing regression analysis, even though they have access to latest marketing technology. In some countries, data are available from census and livestock census reports, national sample surveys, and surveys on rural household income and expenditure pattern, but are old. The rural scene is changing fast and it is difficult to base 1985 marketing decisions on 1971 or even 1977 figures.

The market research data are mainly from two sources:

- The primary source involves a field survey in which questions are put directly to the farmers, dealers, manufacturers, government officers, bank personnel, and other respondents depending upon the study parameters.
- The secondary source covers library and desk research and scanning relevant available data.

In a well-planned rural market research, the study objectives have to be defined. Methodology has to determine number of category of respondents and criteria for their selection. Districts or locations can be stratified. Structured questionnaires can be prepared, properly coded. In case of a large sample size, compilation, tabulation and analysis can be computerized. Questionnaires require pretesting. Interviewers need to be properly briefed and debriefed. It is quite an art eliciting replies from a rural audience.

Primary data collection is expensive. Commercial research costs in India vary from US\$10 to 30 per respondent depending on the depth of interview. In an urban survey, comparative costs are only 25%. Travel and spotting prospects are time-consuming and daily output in terms of samples covered is low. Because of the literacy level, questions have to be simple and sometimes illustrated.

Some academic, government, and quasi-government institutions could handle such rural studies on a regular basis. Some of these agencies in India include the Agro-Economic Research Centre, agricultural universities, the Reserve Bank of India, National Sample Surveys Organization, Programme Evaluation Organization of the Planning Commission, Bureau of Economics

& Statistics attached to the Department or Ministry of Agriculture, National Productivity Council, and the National Council of Applied Economic Research.

Initially, a simple, practical, rule-of-thumb approach can be used in assessing the market. For example, calculating the demand for power tillers for rice cultivation would require these data:

- rice crop area,
- number of farmholdings 2 to 10 ha in size,
- irrigated area of those holdings,
- command area per power tiller,
- judgment regarding the degree and spread of power tiller adoption in the next 5 yr, and
- population of power tillers and growth during the last 5 to 10 yr.

The Indian Society of Agricultural Engineers used such a methodology to assess the demand for inputs to farm mechanization and it gave better results than the armchair bureaucratic guesswork. It is important that the government agencies undertake some serious work in assessing the market for small farm equipment. Figure 1 outlines some data requirements. Table 1 presents data on some developing countries. Table 2 contains the projected demand for farm equipment, developed by the Central Institute of Agricultural Engineering in India.

MARKET DEVELOPMENT

After market assessment, the next step is to procure or develop designs which meet the market needs. Small farm equipment manufacturers have to rely heavily on government academic and R&D institutions for equipment designs. Quantitatively, some equipment museums are full of half-baked designs, few of them proven in the field. Design work is not developed to a stage where equipment can be released for sale. There is a gap here which needs to be bridged. With proper interaction among R&D and extension agencies, industry, trade and the farmers, prototypes of promising designs should be built and field tested. Then the industry must be involved in their manufacture and marketing.

Demonstrations are the most effective media for developing the market. They have to be properly planned and organized. A network of sales and service points throughout the target territory must be established. Proper training should be given to equipment operators and, in some cases, even to draft animals. Village blacksmiths, wayside garage owners, and mechanics have to be trained in repairs. Replacement parts must be easily available. The service points have to render the entire gamut of presales and postsales services, including installation, warranty, repairs and replacement of parts. Such services have to be prompt, efficient, and economical. Petrol pumps (gas stations) in rural areas can be developed as an important base of operations for a wide variety of products and services.

1. Total no. of
 - Tractors
 - Power tillers
 - Draft animals
 - Pump sets
 - Other farm machinery items like threshers
2. Area (ha) under
 - Cultivation
 - Irrigation
 - Multiple cropping
 - High yielding varieties
3. Operational holdings: numbers and area under cultivation
 - Small - up to 4 ha
 - Medium - 4-10 ha
 - Large - 10 ha
4. Installed power input - HP/ha
5. Current annual demand
 - Tractors
 - Power tillers
 - Pump sets
 - Other major items like threshers
6. Equipment pricing
7. Human population
 - Total (million)
 - Rural - %
 - Agricultural workers - %
 - Literacy - %
8. Major crops, area under each crop, yield, prices and production costs
9. Consumption of other farm inputs: kg/ha
 - Fertilizer
 - Pesticides
 - High yielding varieties of seeds
10. Other relevant items

1. Outline of data for an agricultural mechanization survey.

Training is imperative in developing countries, particularly for the frontline blue-collar worker. Governments are advised to establish a national institute for training in agro-industrial services (NITA). Such an institute can train trainers and develop training aids, with emphasis on audiovisual material.

Manufacturers and the marketing organizations have to keep track of market developments and adjust their policies to meet changes in market conditions. Sensitivity factors have to be identified and monitored. Market intelligence has to be regularly gathered. Market development for small farm equipment may be a slow process, but with a good foundation laid, growth will be steady.

Farmers have responded well to equipment meeting some of the following criteria:

<i>Characteristic</i>	<i>Popular equipment</i>
Alleviating drudgery	Pumps, threshers, animal carts, tractors
Reducing losses	Threshers, plant protection equipment
Increasing yields	Seed and fertilizer drills, pumps, plant protection equipment

Table 1. Data on agricultural mechanization for some developing countries.^a

	India	Pakistan	Philippines	Rep. of Korea	Sri Lanka	Thailand
Population (1984)						
Tractors	725,000	150,000	20,000	7,500	20,000	105,000
Power tillers	30,000	—	73,000	500,000	20,000	330,000
Draft animals, million, (APO, 1976-79)	85.8	4.5	3.4	1.5	0.4	4.0
Annual demand (1984)						
Tractors	80,000	31,500	300	5,000	300	15,000
Power tillers	2,000	na	2,000	80,000	3,000	60,000
Installed power input (HP/ha)	0.5	0.4	0.5	1.7	0.4	0.4
Area (FAO, 1981)						
Arable (million ha)	169.4	20.3	9.9	2.2	2.2	18.3
Irrigation (%)	29	70	13	55	23	15
Farmholding (million)	81.6	3.8	2.4	2.3	1.8	4.5
Small = up to 5 ha (%)	84.8	73.4	84.7	88.7	97.0	57.9
Medium = 5 to 10 ha (%)	11.2	17.4	10.2	1.3	3.0	28.1
Large = 10 ha and above (%)	4.0	9.2	5.1	—	—	14.0
Population (million)	722	92	52	40	15	50
Agricultural workers 1970-82 (%)	69-62	59-52	53-45	51-24	55-45	80-74
Literacy rate (%)	36	24	75	93	85	86
Fertilizer consumption (kg/ha)	34	53	32	351	na	16
Paddy yield (kg/ha)	2,122	2,612	2,359	6,203	2,376	1,915

^a Source: Asian Development Bank, Asian Productivity Organization, and Food and Agriculture Organization publications.

Table 2. Projected demand for improved farm equipment in India.^a

Item	Annual demand		Unit cost (US\$)	Total value, 1985-88 level (million US\$)	Population 1983-84
	1985-86	1989-90			
<i>Power units</i>					
1. Tractors	90,000	110,000	5,800	522	725,300
2. Power tillers	4,000	12,000	2,000	8	30,000
3. Electric pump sets	500,000	700,000	400	200	6,500,000
4. Engine pump sets	350,000	550,000	625	218.76	3,600,000
<i>Tractor implements</i>					
5. Trailers	90,000	110,000	800	72	400,000
6. Plows	20,000	28,000	600	12	
7. Harrows	20,000	28,000	600	12	
8. Cultivators	25,000	33,000	400	10	
9. Seed drills	65,000	85,000	400	28	
10. Puddlers	12,000	20,000	400	4.8	
11. Cage wheels	12,000	20,000	200	2.4	
12. Harvesters	3,000	22,000	800	2.4	
13. Sugarcane planters	500	1,500	400	0.2	
14. Planters	1,000	3,000	400	0.4	
15. Potato planters	1,000	3,000	400	0.4	
16. Potato diggers	1,000	3,000	300	0.3	
<i>Animal-drawn implements</i>					
17. Steel plows	500,000	600,000	8	4	
18. Blade harrows	200,000	300,000	12	2.4	
19. Disk harrows	25,000	33,000	50	1.25	
20. Puddlers	25,000	33,000	40	1	
21. Cultivators	50,000	70,000	33	1.65	
22. Seed drills	100,000	140,000	65	6.5	
23. Weeders	100,000	140,000	33	3.3	
24. Tool carriers	5,000	15,000	500	2.5	
25. Carts	10,000	18,000	170	1.7	13,250,000
26. Cane crushers	5,000	13,000	170	0.85	
<i>Manual</i>					
27. Weeders	200,000	300,000	8	1.6	
28. Sickles	500,000	600,000	1.7	0.85	
29. Decorticators	5,000	13,000	33	0.165	
30. Maize shellers	25,000	45,000	1	0.025	
31. Rice transplanters	5,000	25,000	70	0.85	
32. Cotton delinters	300	700	170	0.051	
33. Graders/cleaners	20,000	40,000	70	1.4	
34. Chaff cutters	25,000	45,000	8.5	2.125	
<i>Plant protection equipment</i>					
35. Sprayers/dusters	100,000	180,000	40	4	1,500,000
<i>Power-operated machines</i>					
36. Threshers	100,000	140,000	330	33	900,000
37. Combines	1,000	3,000	30,000	30	
38. Maize shellers	5,000	15,000	400	2	
39. Cane crushers	500	1,500	400	0.2	
40. Oil expellers	5,000	13,000	800	4	
<i>Processing equipment</i>					
41. Solar cabinet dryers	1,000	3,000	125	0.125	
42. Community dryers	100	300	8,000	0.8	
43. Batch dryers	1,000	3,000	800	0.8	
44. Storage bins	100,000	140,000	170	17	
45. Mini rice mills (500 kg/h)	5,000	7,000	4,000	20	

continued on next page.

Table 2 continued.

Item	Annual demand		Unit cost (US\$)	Total value, 1985-86 level (million US\$)	Population 1983-84
	1985-86	1989-90			
46. Large rice mills (1 TPH)	100	180	33,000	3.3	
47. Dal mills	50	90	16,700	0.835	
48. Manual dal mills	2,000	2,800	800	1.6	
Total demand 1985-86			US\$1,242 million = Rs. 15 billion		

^a Area under cultivation: 163 million ha. Number of farmholdings: 81.6 million. Source: Central Institute of Agricultural Engineering, Government of India, Bhopal.

Popular equipment items include pump sets, plant protection equipment, threshers, and tractors (for custom hiring work). Items requiring R&D priorities are land preparation for irrigation, sowing/planting with fertilizer application, intercultivation, harvesting and postharvest operations. In India and Pakistan, power tillers have not been popular with farmers, because when they were introduced, tractors had already found good acceptance. The farmer is looking for labor-saving equipment. Obsession with price has kept modern technology away from small farms.

COMMUNICATIONS

Communication with the small farmer is a problem. With prevalent literacy levels, we have to use a simple language or dialect he understands, and at a wavelength he is comfortable with. He responds well to audiovisual media, including demonstrations, TV and radio programs, films and slides. Politicians and the movie industry in developing countries have been more successful than the marketing professionals in motivating rural masses.

The media choices are listed below. Their degree of utilization will vary according to equipment, audience, environment, advertising and sales promotion (ASP) budget and marketing objectives.

- Audiovisuals: films, TV, video, radio, and cinema slides. (In 1984, India had 12,284 cinemahouses, including 7,428 permanent and 4,768 touring cinemahouses.)
- Demonstrations, including participation in fairs and *melas*.
- Outdoor — hoardings, wall paintings, posters, kiosks, illuminated ads and transit ads.
- Advertising in newspapers, journals, periodicals, and diaries.
- Calendars, diaries, and good-will gifts.
- Direct mailing campaigns, as per specially compiled and categorized mailing lists.
- Sales literature.
- Other media such as puppet shows and rural folk programs, loudspeakers, balloons, buntings and banners, and use locations such as railway stations, bus stands, courts and *mandis* (market places).

The ASP industry in many developing countries is well equipped to provide required services to manufacturers and marketing organizations. In some countries, regular readership or listenership surveys yield useful data on audience habits. A recent National Readership Survey (NRS III) in India covered 54,000 persons at a cost of \$250,000, but unfortunately its rural content was low.

GOVERNMENT SUPPORT

The small farm equipment industry needs government support, particularly in areas such as

- short- and long-term policies and strategies to accelerate the pace of agricultural mechanization;
- preventing further fragmentation of landholdings and encouraging their consolidation;
- collection and compilation of market research data and conducting market studies on assessment of demand, buyer and dealer profiles, media habits, etc.
- effective R&D and extension services to popularize promising designs;
- giving farmers remunerative crop prices;
- encouraging local manufacture of farm equipment;
- establishing institutions for mass scale training of farmers' and dealer personnel;
- financial incentives to farmers and the industry, through nil to low taxation and tariffs and liberal loans at concessional terms; and
- improvement of logistics and infrastructure, through better energy services (fuels and power supply), wider insurance protection, and safety education.

CASE STUDIES

In Appendix 1, we have some case studies on some products and companies — successful ones and others which have not done well.

RECOMMENDATIONS

The following are some important recommendations for finding effective channels for marketing small farm equipment.

- Build a strong and extensive dealership network and develop it with proper personnel, premises, mobility and services, so as to be the farmer's friend in need.
- Train farmers, equipment users, operators, mechanics, dealer personnel, and others in proper use, maintenance, operation, and repairs.
- The government and its agencies should, in close cooperation with industry, farmers, and financing institutions, organize various services mentioned above, particularly on market research, assessment of demand, logistics, infrastructure, R&D, extension and financial incentives.

- **Develop effective communications media so as to motivate farmers, industry, trade, and other agencies into accelerating the pace of agricultural mechanization.**

SUMMARY

Agricultural mechanization is inevitable and indispensable to development. Small farms will need more equipment. It is time now to properly develop effective channels of marketing, well-equipped with trained mobile personnel and adequate premises, to render prompt and efficient services, so as to accelerate the pace of agricultural mechanization and achieve better and quicker results in agricultural and rural development.

Appendix 1

CASE STUDIES

American Spring & Pressing Works Pvt. Ltd. (ASPW), Malad, Bombay 400064, India

ASPW began as a small-scale operation and grew into the country's largest plant protection equipment manufacturer. In 1947, it started production of rotary dusters with seven employees. It now has 546 employees and a campus that sprawls over 5.26 ha. The installed production capacity is 163,000 sprayers, dusters and mist blowers per shift per year. The sales turnover in 1984 was \$8.33 million.

The strength of the organization lies in these areas:

- good quality products, backed by own R&D, wide product range;
- an efficient marketing setup with 685 distributors/dealers in India and overseas, excellent relationship among the manufacturer and the dealers, a successful dealer development program;
- emphasis on prompt and efficient presales and postsales services;
- commitment to agricultural and rural development through charitable trust and foundations; and
- core management provided by three full-time working directors from the family — father (L. M. Patel, managing director) and two sons (S. L. Patel, technical director/and K. L. Patel, sales director).

The company, however, has not been so successful with such items as threshers and seed drills.

Yantra Vidyalaya, an Institute for Rural Technologies, Bardoli 394601, Gujarat, India

The Institute has earned a good reputation in the field of small farm tools and implements. The success is due mainly to the efforts of the director, Mr. Mohan Parikh, a dynamic and dedicated rural development enthusiast. It is a public charitable trust and operates as a nonprofit, nongovernment voluntary organization. It was started in 1970, though its R&D setup — Agricultural Tools Research Centre — was established in 1959. The Centre has designed and developed about 60 hand tools and implements. It is a small-scale operation. Sales turnover in 1983-84 was \$81,278. It has sold about 130,000 pieces of equipment in the last 13 yr, with unit prices ranging from \$0.60 for a hand weeding hook to \$80 for a low lift 8" hand pump.

Its strength lies in the following areas:

- own R&D; good quality products;
- dedicated, dynamic leadership with missionary zeal; and
- economical prices (no profit motive).

Kirloskar Group of Companies, Pune, India

Kirloskar is the largest manufacturer of agricultural diesel engines, electric motors and pumps. Its prices are the highest, yet it dominates the market. Its strong points are

- own R&D, good quality products, wide product range;
- large network of own offices and dealers, with emphasis on efficient services; and
- old, established, large-scale organization with good reputation.

Its annual sales turnover on diesel/electric pump sets is estimated to exceed \$50 million. Established 1920. Forty dealers.

Some of the companies in the Group have not had much success with items like tractors and agricultural implements.

Allahabad Agricultural Institute, Allahabad 211007, India

The Institute pioneered in research, development, extension, and manufacture of small farm implements for over 20 yr, beginning with the late 1940s, under the leadership of an American missionary, Mason Vaugh. His efforts were truly path breaking; they could not be sustained after he left India on retirement. The Institute established manufacturing facilities in a new Company — Agricultural Development Society (ADS). ADS ran into management and legal problems and it is a pity that such promising work faded away.

Krishi Engines Private Limited, Hyderabad (A. P.), India

Krishi pioneered manufacture of power tillers in the late 1960s. They were licensed in 1963 to

manufacture 3,000 units a year in 5-6 HP size, in collaboration with Akitu of Japan. The annual production during 1965-72 ranged from 171 to 668 units. The Company folded up and is now a subject of a case study at the Indian Institute of Management Ahmedabad (Kotis Power Tillers, reference No. Agco 226 and 243).

Some of the main factors contributing to its collapse include

- lack of working capital,
- wrong product selection and specifications,
- high product and market development expenses,
- uneconomical production, and
- poor image, bad quality of products, lack of services, inadequate marketing setup.

Power tillers

In India (also in Pakistan), power tillers have not been so popular with farmers, even though they have been on the market for more than 20 yr. The main reason is that tractors have already been widely accepted. The Indian farmer has directly graduated from draft animals to tractors, without going through the stage of power tillers. The following Indian statistics are self-explanatory:

	<i>Tractors</i>	<i>Power tillers</i>
Population in 1984	725,300	25,000
Annual sales in 1985	80,000	2,000
Unit price (US\$)	5,800	2,000
No. of active manufacturers	10	2

Some reasons for lack of popularity include

- ergonomics;
- inability to meet dual requirements of tillage and haulage;
- uneconomical production, high prices; and
- insufficient marketing network, lack of services.

For further reading on this subject, please refer to the article "Power-tillers in Indian Agriculture: their place and problems," by B.K.S. Jain, AMA, Japan, XI-I, 1980.

Wheeled tool carriers — animal-drawn

Animal-drawn wheeled tool carriers (WTC) were on the Indian market late in the 1950s. Voltas introduced the Otto frame, named after designer Otto Mueller, a Swiss engineer working with Voltas. About 3,000 Otto frames were sold in 1955-60. It was a pneumatic-tired multipurpose tool bar, with a wide range of equipment for tillage and haulage. Sales were discontinued; reasons for its failure follow:

- Design not fully tried out. There were product failures, mainly stub axles and wheel disks.
- Premature release for sale throughout India. It would have been better to expand the market in stages.
- Heavy draft on the animals. Both the operator and the animals needed proper training.
- At that time, unit price for the frame alone was \$80 — all attachments were extra. A full set price totaled \$250.

ICRISAT Hyderabad now has for sale various WTC versions:

- Tropicultor, designed by a French Engineer Jean Nolle, some time in the 1950s.
- Nikart, designed by NIAE (U. K.) in collaboration with ICRISAT.

Only one manufacturer (Mekins of Hyderabad) is in the field so far. He has manufactured about 600 WTCs 1979-83. About 74% sales are to government bodies at a high subsidy of 80%. The selling price is about \$833. Reports are not encouraging. Further details can be had from Mr. R. K. Bansal, Agricultural Engineer, ICRISAT, Patancheru 502324 (A. P.), India.

The Central Institute of Agricultural Engineering (CIAE), Government of India, Bhopal, has also developed an animal-drawn, multipurpose tool frame. After test results, the frame has been recommended for large-scale popularization. CIAE has estimated a selling price of \$500 and that the annual sales may rise from 5,000 units in 1985-86 to 15,000 units in 1989-90. From available evidence, it is unlikely that commercial sales will begin in 1985-86.

Defining priorities for small farm equipment

A SYSTEMS FRAMEWORK FOR SMALL FARM EQUIPMENT RESEARCH AND DEVELOPMENT

A. M. MANDAC, P. B. MORAN, and M. J. G. NOVENARIO
International Rice Research Institute

Often farmers, extension workers, agricultural engineers, or economists do not provide directors of equipment research and development (R & D) projects with information necessary for them to establish priorities for developing equipment for Asian rice farmers.

This information problem is often acute for several reasons. First, where the farm family or others with social ties provide most of the labor, where land is not freely sold, and where much of the crop is retained for consumption, the market prices of these items may not reflect their value to farmers. As a result, the demand-induced concept, where prices influence priorities in machinery R & D as Hayami and Ruttan (12) claim was the case in America and Japan, may not operate. Further, Ruttan (29) later seems to doubt whether atomistic market forces induce desired changes for the less advantaged.

Second, low resource farmers may not recognize the problem-solving opportunities offered by new equipment. Even if they do, they are often not in the position to make research planners aware of the R & D which could alleviate their problems. This contrasts with machinery development in North America and Australia, where almost all machinery innovations have come from farmers, through purposeful market research by manufacturers as opposed to structured agricultural research.

Third, policy makers lack information on small farmers' environments, on constraints farmers face, and on interactions between these constraints. Thus planners may have difficulty translating the production problems faced by rice farmers into research projects with appropriate design and evaluation criteria, given the conditions most low resource farmers face.

Technology must not be based on conditions at research stations or on the circumstances of prosperous landowners who do not represent most farmers.

Appropriate technology means different things to different people. What seems appropriate to an engineer or policy maker may not be so to the low resource farmer. A new product is not appropriate until farmers adopt it. In most Asian countries, the farmer has freedom to accept or reject innovations, and will not adopt unless he perceives that benefits exceed risks.

Lantin (20) suggests that appropriate technology has these characteristics:

1. requires low capital cost;
2. uses local materials;
3. creates jobs, employing skills and labor;
4. fits small-scale farms and small groups of farmers;
5. can be understood and controlled by villagers without Western-style education;
6. can be produced in a small metal-working shop or in a village blacksmith shop;
7. recognizes groups rather than individuals as decision makers in bringing improvements to communities;
8. involves decentralized energy sources such as wind power, solar energy, water power, methane gas, and animal and human power; and
9. makes technology understandable to people who use it.

Collinson (3) argues that the first characteristic of appropriate technology is its acceptability to farmers, and that an innovation will be appropriate if

- its introduction will increase farmers' incomes consistent with their priorities,
- its cost is within the capital resources or debt ceilings of farmers, and
- farmers can manage any repercussions it creates on their farming systems.

Farmers also accept innovations which make income more reliable, or reduce drudgery of work, or have social value. However, for the low resource farmer, expected increases in income and income stability probably dominate other objectives.

These criteria relate to farmers' needs as individuals. However, society through government, organizations, and groups frequently judges the appropriateness of equipment from other angles. From a social viewpoint, appropriate technology may be that which

- is consistent with the political philosophy of the nation or region,
- has a set of distributional (equity) consequences tolerable to society, and
- has a cost that society is willing to bear to make it available to the farmer and, if necessary, to maintain it.

Clearly, appropriateness depends on the farmer, the rural community, and national policy.

Therefore, a systems framework may help in developing engineering priorities for small farm equipment R & D. The framework should allow the R & D team to understand the interrelationships between the various functions of the rice production system and their impact on those involved in farm production systems. To the extent that the R & D team is multi-disciplinary, the framework should serve to integrate different perspectives.

The primary purpose of this paper is to describe a systems framework for small farm equipment R & D. The potential of the framework is evaluated by reviewing results of studies designed to alleviate the constraints to increased rice production in the Philippines. Solutions to these constraints usually

Table 1. Number of farm operational holdings, by size, in Asian countries (1).

Country	Farm holdings (thousand) by size (ha)										Total	Year
	0.5	0.5-1.0	1.1-2.0	2.1-3.0	3.1-5.0	5.1-10.0	10.1-20.0	Over 20.0				
India ^{a b}	9,102	10,783	11,191	6,165	7,466	2,958	1,795	514			49,874	1961
Indonesia ^c	5,332	3,245	2,223	693	431	221	69	22			12,236	1963
Bangladesh ^{a c}	1,492	1,677	1,615	698	442	188	27	<i>d</i>			6,139	1960
Pakistan ^a	742	856	806	581	759	729	388	<i>d</i>			4,860	1960
Thailand ^{c e}	na	595	945	na	884	616	163	11			3,214	1963
Philippines ^f	89	161	642	459	404	290	100	21			2,166	1960
Nepal ^g	630	300	313	na	341	492	<i>d</i>	<i>d</i>			2,076	1965
South Vietnam ^c	692	355	411	182	143	70	19	<i>d</i>			1,872	1960
Sri Lanka ^{c h}	411	350	222	132	na	38	8	6			1,167	1962
West Malaysia ^{c k}	46	158	99	72	57	13	4	1			450	1960
Total	18,536	18,480	18,467	8,982	10,927	5,614	2,573	575			84,054	
% of total units	22.0	22.0	22.0	10.7	12.9	6.6	3.1	0.7			100.0	
% of total area	2.5	7.6	12.1	10.8	19.1	18.4	15.5	14.0			100.0	

^a Size categories are <0.4, 0.4-1.01, 1.01-2.02, 2.02-3.04, 3.04-5.06, 5.06-10.12, 10.12-20.23, over 20.23. ^b Source: India Ministry of Agriculture Directorate of Economics and Statistics (15). ^c Source: FAO (9). ^d Included in previous size class. ^e Size categories are <0.96, 0.96-2.4, 2.4-4.8, 4.8-9.6, 9.6-22.4, over 22.4. ^f Source: Philippine Bureau of Census and Statistics (27). ^g Source: Nepal Ministry of Economic Planning (25). Size categories are <0.5, 0.5-1.0, 1.1-2.0, 2.1-4.0, over 4.0. ^h Size categories are <0.4, 0.4-1.0, 1.1-2.0, 2.1-4.0, 4.1-10.0, 10.1-20.0, over 20.0. ^k Size categories are <0.4, 0.4-1.2, 1.3-2.0, 2.1-3.0, 3.1-6.0, 6.1-10.0, 10.1-20.0, over 20.0.

involve introduction of innovations, mechanical or otherwise, into the key functions of rice production.

A PROFILE OF RICE FARMS AND FARMERS IN ASIA

A first step in determining priorities for engineering R & D is to examine the major rice farming systems in Asia, specifically as to farm size, water control, and labor use. Most farms are small; many are extremely small. Forty-four percent of farms are 1 ha or less but account for only 10% of the cultivated area (Table 1). Approximately one-third of rice farms are irrigated, with most growing modern varieties (MVs). MVs are grown on only a small percentage of rainfed farms, which account for nearly half of the rice area, and even less in upland and deep water areas. But in rainfed and upland areas with potential for growing more than one crop, the short season MVs may soon be adopted.

Eight rice farming systems based on degree of water control are sketched out in Table 2. The levels of infrastructural investment (irrigation, roads, etc.), cash inputs, and labor use are designated for the typical farm in each category (H = high, M = moderate, L = low). The IRRI engineering program focuses on small farms using moderate cash inputs and labor (100 d/ha). These include most of the irrigated area now growing MVs, and rainfed and upland areas with potential for intensifying cropping (systems 1-4).

The remaining four systems include the relatively small but well-irrigated farms in Japan, Taiwan, and Korea, where wage rates are rising and labor-saving technology is being rapidly adopted. At the other extreme are the less commercialized rainfed, upland, and deep water areas where capital and labor inputs are low.

The first four systems account for more than 60% of the farm units and 45% of the farm area, but these percentages vary considerably from one farming system to another. While there are pressures to serve the very small farmers, it would be difficult to design for this group machinery that would substantially increase production. IRRI machinery designs so far have been more appropriate for system 1, although considerable thought has been given to extending services of equipment owned by farmers in this group to those in system 2 through contract hire or joint ownership.

Most farmers in system 2 have cash income too low to generate capital for owning and operating machines independently. There are, however, selective opportunities to design and introduce small, low-cost devices which use labor intensively and could improve resource productivity and output on these small farms.

Rice farms in Asia typically hire a high percentage of labor needed. Except in East Asia, 60% of labor is hired. The hired force includes a growing number of landless laborers who depend on this work for much of their income. Thus, mechanization of tasks now using hired labor should receive low priority. We list labor requirements for the major tasks in traditional irrigated rice, designated as high (H), medium (M), and low (L):

	Total labor	Hired labor
Land preparation	H	L
Transplanting	H	H
Fertilization	L	L
Plant protection	L	L
Weeding	H	H-M
Water management	M	L
Harvesting	H	H
Threshing	H	H

This listing shows that transplanting, harvesting, threshing, and, in some cases, weeding, require large amounts of hired labor. However, labor requirements and the mix of family and hired labor will vary by region and country.

Table 2. Rice farming systems in South, Southeast, and East Asia, by water control and showing different levels of input intensity (1).

	Rice farming systems ^a							
	IRRI focus				Others			
	1	2	3	4	5	6	7	8
	Irrigated		Rainfed multiple crop	Upland multiple crop	Irrigated ^b East Asia	Rainfed single crop	Upland single crop	Deep water
Small	Very small							
Infrastructure	M	M	L	L	H	L	L	L
Cash input	M	M	M	M	H	L	L	L
Labor	M	H	M	M	M	L	L	L
Estimated percent of farms	15	40	6	1	12	17	4	5
Estimated percent of area	23	9	10	2	6	32	8	10

^aL (low), M (moderate), or H (high). ^bJapan, Taiwan, and Korea.

A SYSTEMS FRAMEWORK

Figure 1 presents a qualitative model for small farm equipment R & D. The model shows inputs and outputs of the stylized rice production system. It could be used to identify changes needed in equipment or to design new equipment to alleviate physical and biological constraints on rice production.

Each function illustrated can be completed in several ways (e.g., crop establishment by dry or wet seeding or transplanting) which in turn will influence other aspects of crop management and the distribution of any benefits from changes.

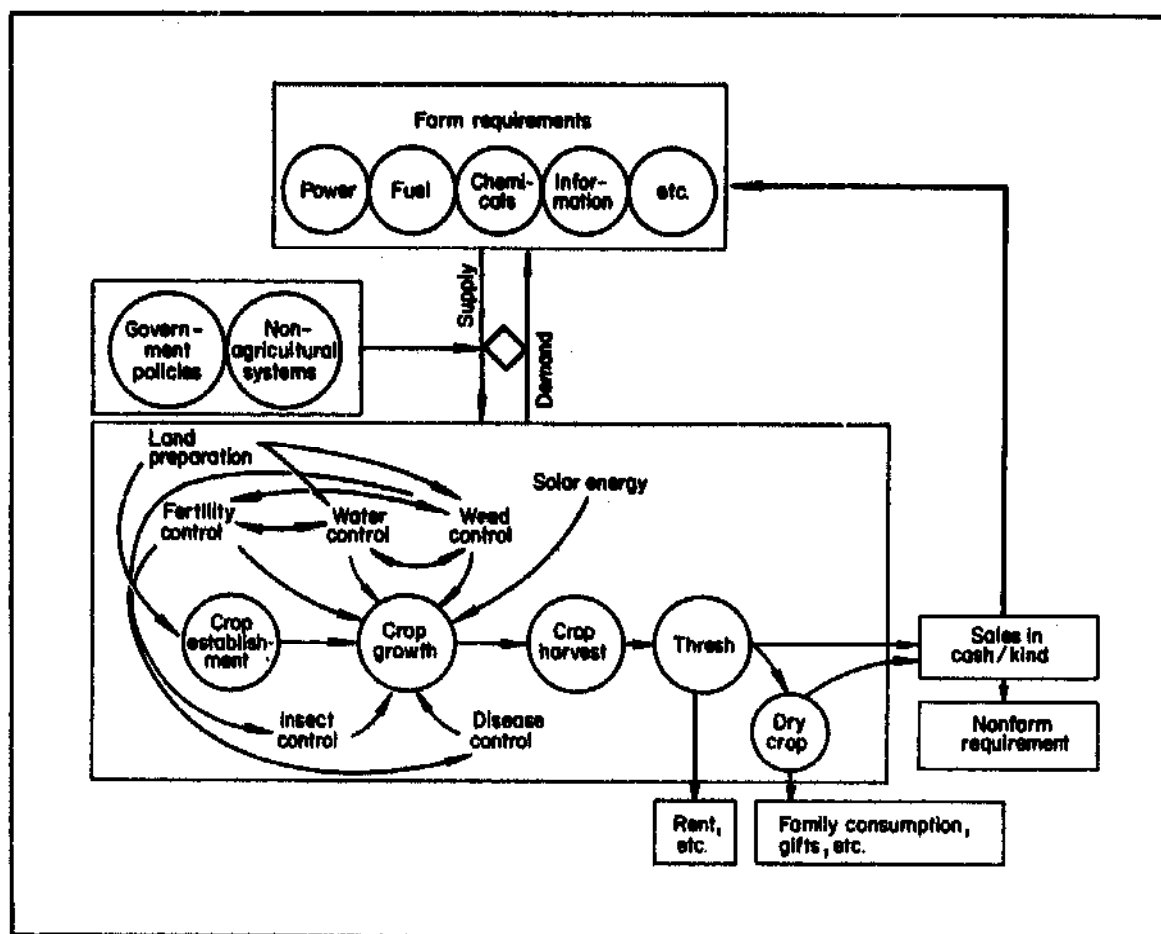

1. Conceptual framework for equipment research and development.

How one function is performed influences other areas of management. Water, weeds, and fertilizer interact. Good water control helps control weeds and prevents fertilizer (particularly N) loss; weeds use water and fertilizer and so compete with rice for these scarce inputs. High levels of fertilizer and weeds seem to encourage higher levels of diseases and insects, thereby requiring greater effort in pest control.

The point is that while a particular function may be mechanized, the efficiency with which that function is performed must be considered in terms of other functions it interacts with and, eventually, in terms of output.

When examining equipment priorities for rice culture, the product of interest is usually rice output — usually kg/ha — or whether the technology reduces costs. Thus, these questions should be considered each time new equipment is proposed:

- How will this equipment help solve the rice production problems of target farmers?
- Why is this task necessary; what does it achieve?
- What other options are available to reach the same result?
- What are the technical feasibilities of other options?
- What are the social implications of the alternatives?
- Will demand be sufficient for the proposed innovation to justify its R & D costs and to induce commercial production?

Many trade-offs or substitutions are possible in rice production, for example:

- more power but less water for land preparation
- less land preparation but more weed control
- insect resistant varieties and less pesticide
- fertilizer placement versus slow release fertilizers

Obviously, the most appropriate management strategy and equipment mix will depend on comparative prices of alternatives, any differences in yields, changes induced or required in other aspects of crop production, and the farmer's resource base and scale of operation.

The supply of rice production machinery is satisfied by imports and domestic production. Government policies and market forces in the non-agricultural sector determine the supply of agricultural machinery. Government investment in R & D of farm machinery encourages supply, while taxation and import restrictions are barriers. Therefore, one has to look at interrelationships between machinery R & D and national development policy.

MACHINERY DEVELOPMENT POLICIES IN THE PHILIPPINES

Equipment R & D priorities should be examined within the context of a country's development plans and priorities. The Philippines provides an example. The general policy of agricultural mechanization has been in the country's development plans since the early 1970s (30). In the 1972-75 plan, farm mechanization was geared toward attaining self-sufficiency in rice production. The priority was for mechanization which does not displace labor. In the 1978-82 plan, farm mechanization was promoted to improve production but still ". . . it shall be applied on a selective basis and shall be adapted to local conditions and available resources . . ." (30).

This general policy is supplemented by specific policies and programs which directly or indirectly alter the supply (or production) and demand (or purchase) for farm machinery, such as investment incentives and tariff and tax policies. Major policies affect credit, wages, prices, and foreign exchange.

Policies affecting supply of farm machinery

Investment incentives. Under the Investment Incentives Act, the Board of Investment (BOI) grants incentives, mostly tax deductions, to local manufacturers of agricultural machinery. Farm machinery listed in Investment Priorities Plans includes:

1968-69	power tillers, tractors, and implements
1970-78	rice threshers, disk plows and harrows, rototillers and grain dryers
1979-80	grain dryers

Tariff and tax policies. Under the Tariff and Tax Code, ad valorem taxes of 10 and 30% are imposed on imported agricultural machinery, based on prices of equipment landed in Manila. The 10% duty, regarded as nonprotectionist, is generally imposed on agricultural equipment produced in insufficient quantity in the Philippines (e.g., 4-wheel tractors, sugarcane harvesters). The 30% duty, a protectionist rate, is imposed on machines produced in sufficient quantity in the country (e.g., power tillers, threshers).

The government's tariff and tax policies are designed to encourage local manufacture. However, if local supplies are not adequate, the government allows importation at low duty to meet local demand. It can be debated whether local production is sufficient to impose a higher tax on imports, and whether local manufacturers in equipment-deficient areas may be induced to expand production if protected by a 30% tariff. Imposing the 30% tariff means imported tillers must be sold at 30% over cost. Therefore local manufacturers can sell at a higher price than they otherwise would.

A 10% advance sales tax is imposed on imported agricultural machinery which the country is deficit in, and on imported raw materials needed for their manufacture. When other general input taxes are added, the effective tax rate on imported machines or their components is 12-16%, CIF prices.

Private and government organizations. Organizations involved in production and sale of farm machinery include the Agricultural Machinery Manufacturers and Distributors Association (AMMDA), Agricultural Machinery Testing and Evaluation Center (AMTEC), and Agricultural Machinery Distributors/Manufacturers Accreditation Committee (AMDAD). These bodies

- develop, select, and test appropriate equipment for Philippine agriculture,
- provide parts and service support, and
- accredit companies and products and approve prices of imported and locally made farm machinery.

Credit programs. Purchases of farm machinery are financed through three major credit programs — Central Bank: International Bank for Reconstruction and Development (CB:IBRD), the Agricultural Credit Administration (ACA), and the Land Bank of the Philippines (LBP). These programs provide credit for purchase of tractors not exceeding 68 hp, power tillers, threshers, irrigation facilities, dryers, and farm equipment and attachments. The CB:IBRD credit project has the most significant impact on farm mechanization (30), reflected in sales of power tillers and tractors and the loans granted in 1966-79 (Fig. 2).

Farmer repayment has been a problem. A recent survey of 450 borrowers showed 70% encountered repayment problems due to inadequate earnings, high production costs, low crop prices, and lack of money for household needs (30).

Wage policies. Increasing wage rates may encourage substitution of machinery for labor (30). However, the International Labor Organization (ILO) argues that wage legislation is not very relevant because wages and

salaries represent the major source of income for less than 50% of Filipino families (14). Among farmers and farm laborers, only 14% are wage and salary workers; most are self-employed (48%) or unpaid family workers (37%) (2). Also, minimum wage standards are enforced mainly in large firms. Therefore, unless agricultural wages become extremely high, wage policy may not affect mechanization.

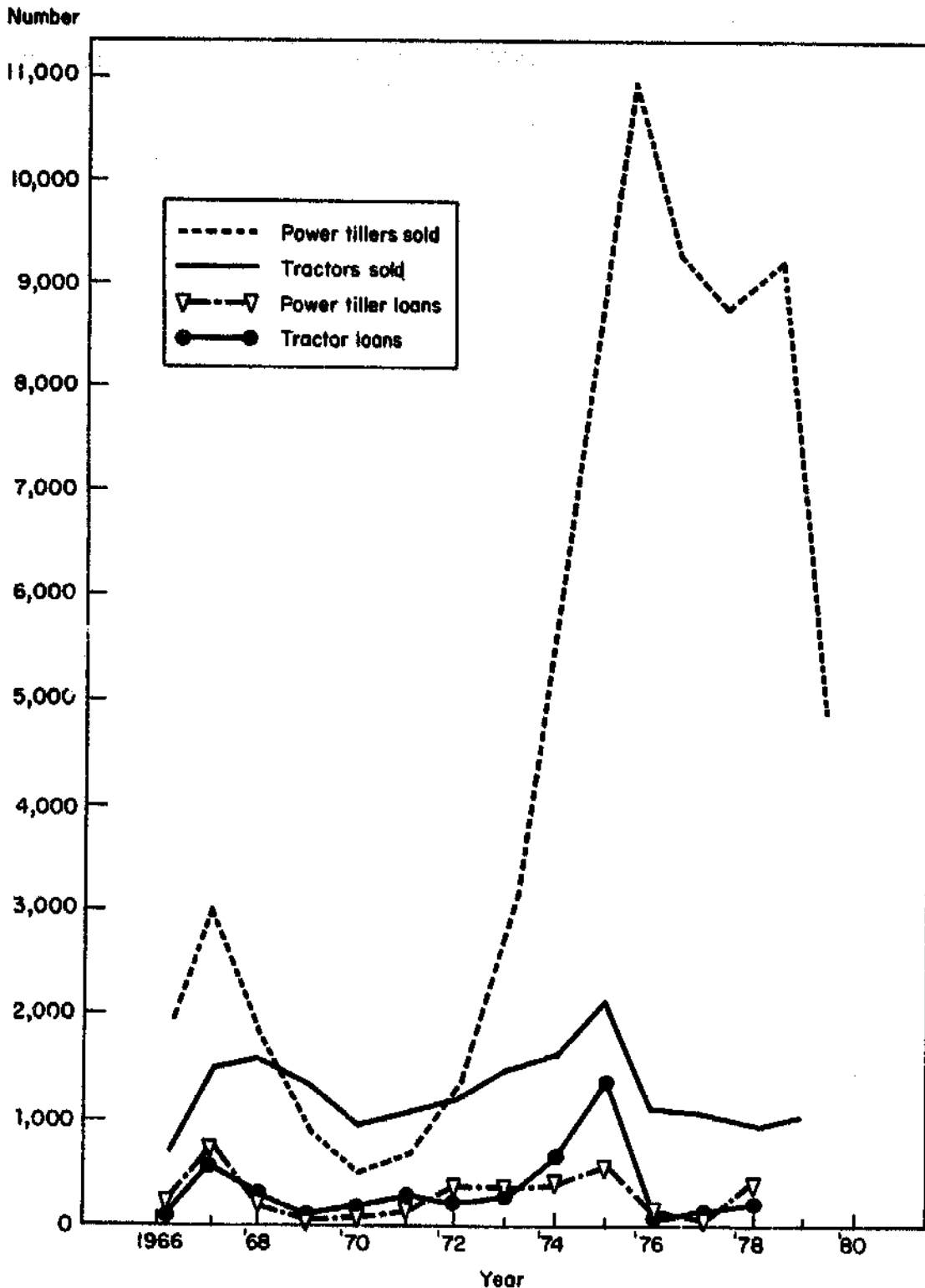

2. Annual sales of tractors and tillers and number of loans granted under the CB:IBRD rural credit projects, 1966-79.

Price policies. The government controls two prices which affect a farmer's decision to purchase a machine: the price of rice and the price of fuel. Lifting support prices for palay may improve palay prices, which may encourage farmers to mechanize. The government's tax on oil accounts for more than 50% of the retail price of fuel (11). Without a subsidy on fuel for farming, the economic viability of a machine may decrease, leading to lower demand for that machinery.

Foreign exchange policy. Foreign exchange policies of the Central Bank affect the rate of farm mechanization through their effect on farm machinery prices. For example, the peso devaluation in 1960 and the peso floating in 1970 led to declines in farm machinery imports.

This section has suggested that the government is sympathetic to local manufacture of agricultural machinery. Further, though the government recognizes the importance of improving income levels and distribution, the immediate goal is to increase land and labor productivity. However, policies should consider the welfare implications of mechanization, as mechanization may displace labor and redistribute income from owners of labor to owners of capital.

Rice yield constraints

The rice yield constraints project was designed to examine the reasons for differences between potential and actual yields of MVs. A yield gap may be due to a combination of environmental, technical, and managerial constraints. The farmer-effective costs of inputs and the value of rice, and the socio-economic constraints faced by the farmer contribute to biological and managerial constraints (Fig.3).

As environmental constraints are typically beyond the farmer's control, the project methodology focused on biological, managerial, and economic constraints to higher yields (23,24). An evaluation of the researcher's and farmer's crop production practices calculated whether it was profitable, from the farmer's viewpoint, to reduce the yield gap.

Constraints research integrates farm experiments designed to measure the yield gap and contributions of test variables to that gap, and socioeconomic surveys providing detailed information on how and why farmers manage rice crops as they do (7). The managed variables tested in the Philippine experiments were fertilizer, and insect and weed management. One level (normally the lower one) was the farmer's current practice; other levels were set by the researchers. Thus the project examined differences between farmer practices and those thought to be optimal. Results of the Philippine constraint experiments are summarized in Figure 4.

Economic analysis of the yield gap data shows that the high input levels were generally less profitable than farmer practices in the wet season. However, in the dry season, farmers in the three study areas could increase their net profits by ₱850/ha by spending ₱1,200 more/ha on inputs. The economically recoverable gap (ERG) averaged 0.7 t/ha in the wet season and 1.2 t/ha in the dry season.

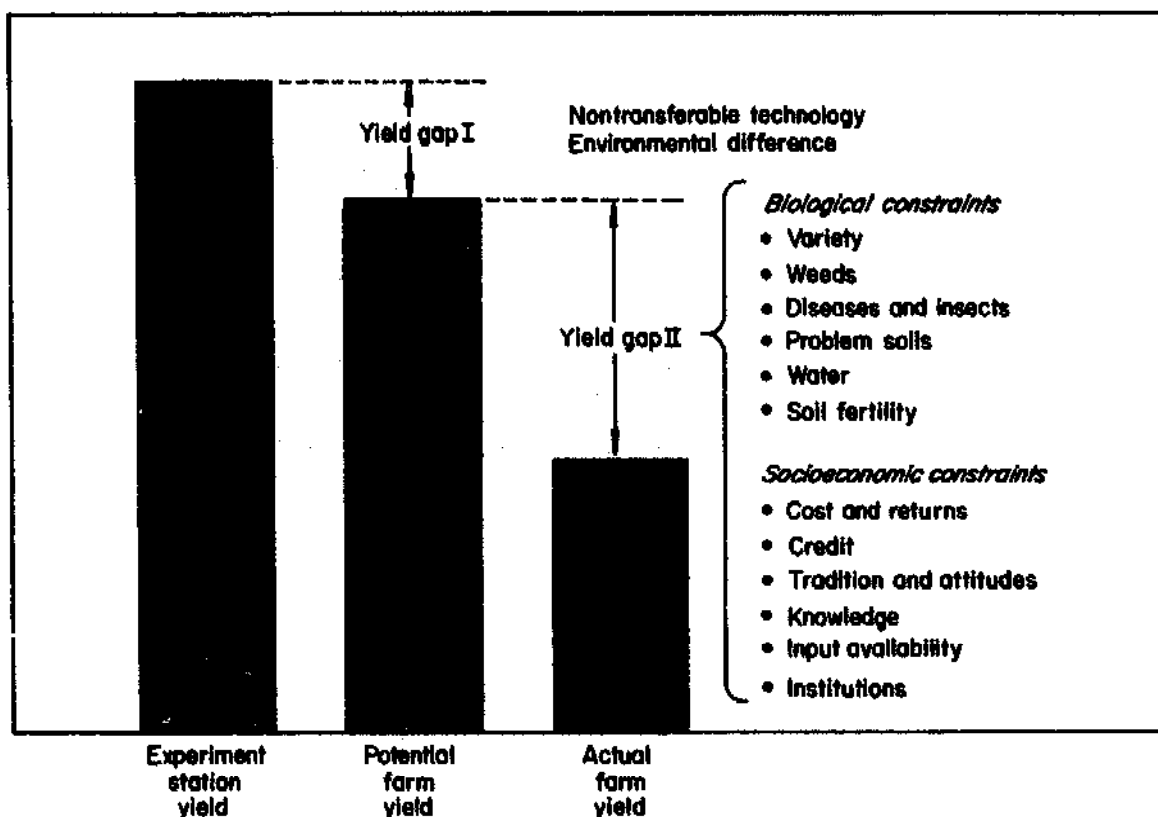

3. The concept of yield gaps between experiment station rice yield, potential farm yield, and actual farm yield (10).

Many aspects of rice production of interest to the agricultural engineer, e.g., land preparation, crop establishment, harvest, and postharvest operations, were not examined in this project. We therefore discuss them in the following sections.

Land preparation. Although land preparation was initially tested in the rice yield constraints experiments in Central Luzon, results show that the recommended method of land preparation did not change yields measurably, implying that farmers' practices were adequate (16). Earlier, Orcino and Duff observed that mechanization of land preparation had no significant effect on yield (26). Yet, repeated reference is made to the need for timeliness in rice farming with MVs, especially in double-cropped rainfed rice. The study of Roxas in Iloilo, however, indicates that turnaround time between first and second crops did not depend on the farmer's power base (28).

This evidence suggests that engineering research in land preparation may not imply designing a better plow or alternative power source. Given current land preparation methods, which become more costly as energy prices rise, there is probably need for agronomic and engineering collaboration to examine alternative ways of reducing cost, e.g., minimum tillage.

Crop establishment. Transplanting is a major use of labor in rice production. Where transplanting labor is scarce and its costs increasing, direct seeding is popular. The planting method interacts significantly with other activities such as land preparation and weed control. Broadcast seeding, for example, requires a level, well-prepared seedbed. Further, good water and weed control

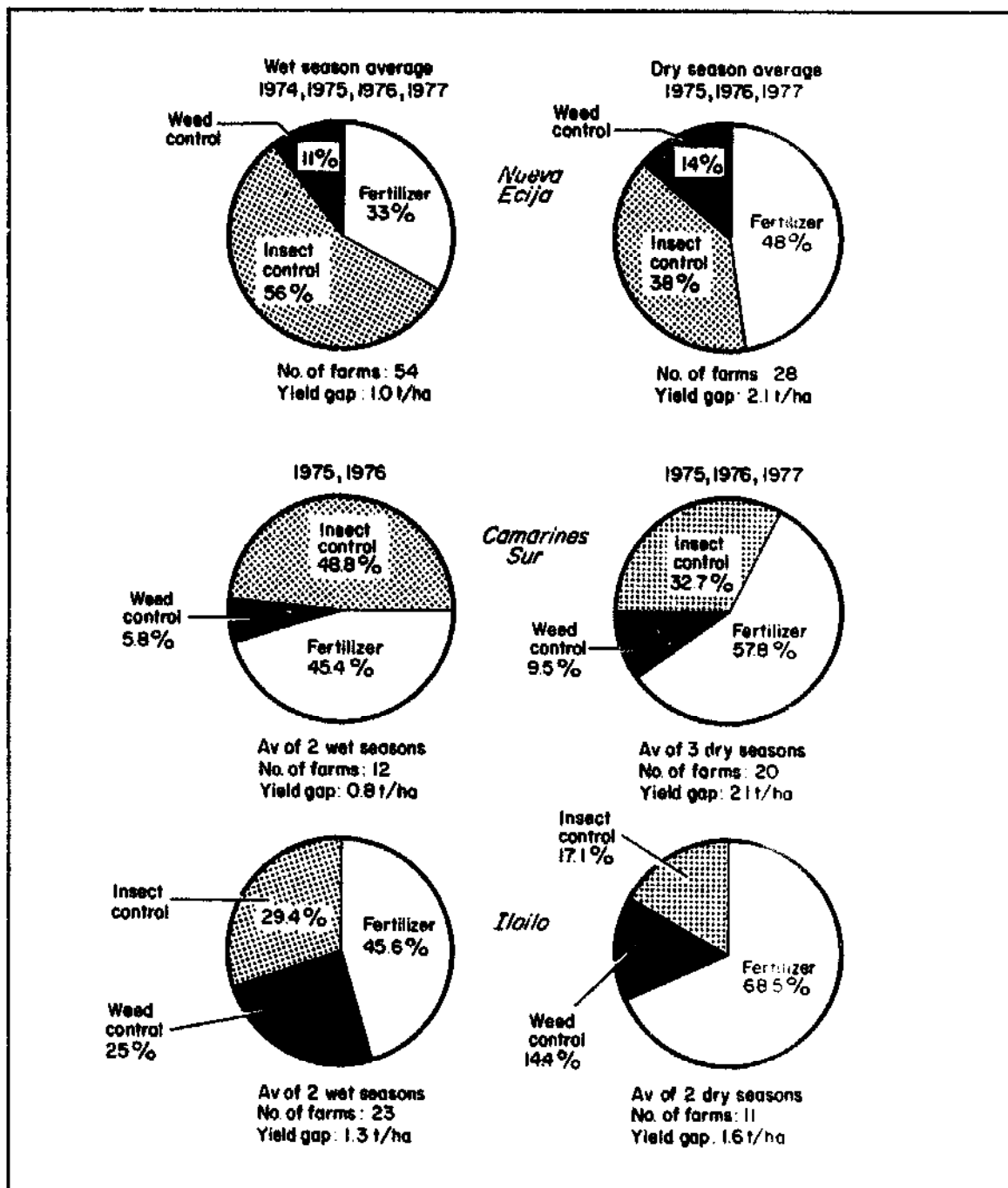

4. Yield gap and relative contribution of 3 inputs (insect, fertilizer, and weed control) to improvement of rice yields in farmers' fields. Philippine constraints experiments (6).

are prerequisites to high yields in broadcast-seeded rice (5). Transplanting in standing water helps control weeds. Transplanting in straight rows, or row seeding, facilitates manual weeding and allows use of small weeders. However, under optimal conditions of water and weed control, yields with broadcast and direct transplanting are similar.

In rainfed areas, moisture regime, land preparation, planting method, and weed control strongly interact (24). For example, wet seeding is most frequently used on fields with higher levels of moisture stress. In Bicol, where much of the rice crop is rainfed, establishing the crop early so that harvest will

coincide with the low-typhoon months of August and September will give farmers a better chance to avoid heavy crop loss. Therefore, agronomic and engineering studies for early crop establishment may not only increase first crop yields but enhance the second crop.

Fertilizer and chemical application. Lack of fertilizer, or its improper application, limits yields (13). Most rice farmers use less than the optimum level of fertilizer in the dry season.

In contrast, a small yield gap due to weed control methods implied that farmers in irrigated areas controlled weeds effectively. However, for adverse rainfed conditions, we do not yet have efficient weed control technology that enables farmers to profit from controlling weeds.

Results on insect control are highly variable; application of recommended levels of insecticides often proved uneconomical.

Increasing energy costs have forced the Philippines to divert foreign exchange to purchase energy. Also, as government priorities shift between sectors, and as the government seeks to reduce subsidies on agricultural inputs, notably fertilizer, farmers are likely to continue to face increasing fuel, fertilizer, agrochemical, and transportation costs. With self-sufficiency in rice, Philippine farmers may well face resource costs increasing faster than the price of rice, as supply increases more rapidly than demand.

Under deteriorating price relationships, a realistic approach to maintaining yields is to improve productivity of resource use by improving plant type and by increasing application efficiency. To improve fertilizer efficiency, for example, experiments at IRRI have shown that root zone application can save 50% of fertilizer applied without hurting yield (8). The same effect has been noted with chemical insecticides. Developing and introducing low-cost applicators should alter profitability of maintaining current levels of fertilizer application (8).

Water control. Lack of a timely water supply is probably the most serious constraint for most rice farmers. Substantial yield losses arise from drought stress in irrigated and rainfed areas (24, 31). Water may be delivered inefficiently in gravity irrigation systems or be inadequate in rainfed areas.

Mechanical devices can improve water delivery and water use efficiency. In areas with good groundwater sources, pump installation can be profitable.

Harvesting and threshing. Harvesting and threshing are two of the most labor-intensive farm operations, requiring 108 and 122 h/ha respectively (33). In some areas, this high labor requirement creates labor shortages, delaying harvest and increasing grain loss.

Mechanical threshers can solve the threshing constraint. Since 1974, the thresher has been adopted widely in areas with relatively good irrigation and those with double cropping. Thresher use has not aided cropping intensity; however, it increases yield by reducing grain loss (7% for hand beating against 1.3-1.6% for mechanical threshing).

Where scarcity of harvesting labor prevents timely harvest, using mechanical reapers may reduce field losses due to harvesting delays (22). Considering that the reaper requires only about 13 labor h/ha, labor saved will

be 95 h/ha compared to manual cutting. This makes reapers attractive, but poses a socioeconomic issue. In an economy with half the labor force in agriculture, labor-saving technology can seriously hurt employment and income distribution.

Preliminary results of a study among landless laborers in a village in Bataan show that adoption and use of reapers have substantially reduced harvesting jobs available. This lack of employment stopped immigration and stimulated emigration (4). Reaper use in Bataan reduced average income to harvesters 43% in the wet season and 53% in the dry season (32). So, unless the manufacture of reapers can generate sufficient employment, it can displace labor and reduce income, a problem for policy makers, engineers, and researchers.

Drying. Lack of drying facilities on farms is a constraint, particularly during rainy months when solar drying is difficult. Farmers are forced to sell wet paddy at a discounted price. For example, the effective price for admittedly wet palay in Bicol during the first crop of 1980 was only 72% of the government support price for cleaned, 14%-moisture rough rice (24). Moreover, insufficient drying creates problems in storage, resulting in poor quality rice that is discounted when offered for export.

EVALUATING RELEVANCE OF EQUIPMENT R & D

While appropriate equipment can no doubt be developed to alleviate or ameliorate these constraints, the question remains whether it is feasible and efficient for the nation to develop such equipment. Two questions should be asked about each proposed piece of equipment:

- Are resources (labor, finance, facilities, etc.) sufficient to develop the equipment within an acceptable time?
- Will benefits from developing the equipment be adequate to justify the investment and will they exceed benefits of other equipment?

The formula to calculate the expected net benefits of developing an appropriate piece of equipment provides a way to evaluate benefits of alternative types of equipment (14):

$$ENPV_i = \sum_{t=j}^n \frac{P_{B_i}^t B_i^t}{(1+r)^t} - \sum_{t=1}^k \frac{P_{C_i}^t C_i^t}{(1+r)^t}$$

where:

$ENPV_i$ = expected net benefit of research alternative i ;

$P_{B_i}^t$ = coefficient indicating the subjective expectation of decision makers (researchers, planners) of the likelihood of obtaining net benefit B_i ;

j = first year of benefits derived from the research work of alternative i ;

B_i^t = benefits in yr t derived by national economy or farmers from adopting research alternative i . B measures net benefits, i.e., additional benefits minus the cost of additional inputs. (With several objectives [value added, employment, income distribution], a common denominator is required. Recent developments in multiple goal decision making (21) provide a procedure for examining nonadditive and competing objectives);

r = discount rate. The social time preference (usually less than the market rate of interest) is normally used when the research alternative involves the national economy;

n = last year with benefits;

$P_{C_i}^t$ = coefficient indicating likelihood of having costs amounting to C_i /yr;

l = time of decision making, beginning of research costs;

k = last year of research expenditure; and

C_i^t = research costs of research alternative i in yr t .

It is not surprising that researchers are rather uncertain whether a given research activity will lead to an appropriate piece of equipment. It is courageous to estimate these probabilities (P). But experienced engineers have some notions about chances of success of alternatives, the resources required, and the timing involved. They estimate these chances, even if implicitly. The problem is to attach a numerical value to P based on the most informed subjective expectations.

A similar problem applies to estimating net benefits. Many field-oriented research workers have notions of the farm-level increase in output that may result and the additional inputs required with new technology. Agricultural economists must be willing to work with agricultural engineers and agronomists to estimate these benefits. The expectations of added output and additional (or reduced) inputs must be interpreted in the light of farm size and the numbers of farmers likely to adopt.

Thus, when examining equipment R & D options, it may be productive to consider

- the areas and rice environments where the innovation may be relevant,
- the probability of the gain,
- the time period between development and adoption, and
- the likely R & D costs.

This framework can sharpen the focus of mechanization programs, permit measurement of potential costs and benefits of projects, and forge closer working relationships among complementary program areas.

REFERENCES CITED

1. Barker, R., and B. Duff. 1975. Identifying priorities for research and development in rice mechanization systems. Paper presented at the Quinquennial Program of International Rice Research Institute, 4 Dec 1975, Los Baños, Philippines.
2. Castillo, G. 1979. Beyond Manila, Philippine rural problems in perspective. IDRC-116e, Ottawa.
3. Collinson, M. P. 1977. Diagnosing the need for new technology. CIMMYT, Mexico. (mimeo.)
4. Crissman, L. 1985. Livelihood among landless laborers after introduction of mechanical reapers. International Rice Research Agricultural Economics Department Seminar Paper, 31 May.
5. De Datta, S. K. 1981. Principles and practices of rice production. John Wiley and Sons, New York.
6. De Datta, S. K., F. V. Garcia, A. K. Chatterjee, W. P. Abilay, Jr., J. M. Alcantara, B. S. Cia, and H. C. Jereza. 1979. Biological constraints to farmers' rice yields in three Philippine provinces. IRRI Res. Pap. Ser. 30.
7. De Datta, S. K., K. A. Gomez, R. W. Herdt, and R. Barker. 1979. A handbook on the methodology for an integrated experiment-survey on rice yield constraints. International Rice Research Institute, Los Baños, Philippines.
8. Duff, B. 1975. Output, employment, and mechanization in Philippine agriculture. Paper prepared for the FAO Expert Group Panel Meeting, 4-7 Feb, Rome.
9. FAO (Food and Agriculture Organization). 1971. Report on the 1960 world census of agriculture Vol. 5. Analysis and international comparison of census results. Rome.
10. Gomez, K. A., R. W. Herdt, R. Barker, and S. K. De Datta. 1978. Measuring yield constraints in farmers' fields: a methodology. Paper presented at the Conference on Farm-level Rice Yield Constraints, International Rice Research Institute, 24-26 Apr 1978.
11. Gonzales, L. A., R. W. Herdt, and J. P. Webster. 1981. Evaluating the sectoral impact of mechanization on employment and rice production in the Philippines: a simulation analysis. Paper presented at the joint ADC/IRRI workshop on the consequences of small rice farm mechanization in Asia, 14-18 Sep 1981. International Rice Research Institute, Los Baños, Philippines.
12. Hayami, Y., and V. W. Ruttan. 1971. Agricultural development: an international perspective. The Johns Hopkins University Press, Baltimore.
13. Herdt, R. W., and A. M. Mandac. 1981. Modern technology and economic efficiency of Philippine rice farmers. *Econ. Dev. Cultural Change* 29(2):375-399.
14. ILO (International Labor Organization). 1974. Sharing in development. National Economic Development Authority, Manila, Philippines.
15. India Ministry of Agriculture Directorate of Economics and Statistics. 1971. Indian agriculture in brief - 4th ed., New Delhi.
16. IRRI (International Rice Research Institute). 1977. Constraints to high rice yields on Asian rice farms: an interim report. Los Baños, Philippines.
17. IRRI (International Rice Research Institute). 1979. IRRI long range planning committee report. Los Baños, Philippines.
18. IRRI (International Rice Research Institute). 1985. Research highlights 1984. Los Baños, Laguna, Philippines.
19. Juarez, F., and R. Pathnopas. 1983. Comparative analysis of thresher adoption and use in Thailand and the Philippines. Pages 119-137 in *Consequences of small-farm mechanization*. International Rice Research Institute and Agricultural Development Council, Los Baños, Laguna, Philippines.
20. Lantin, R. M. 1977. Problems and prospects of agricultural mechanization in the Philippines. Institute of Agricultural Engineering and Technology, University of the Philippines at Los Baños, College, Laguna. (mimeo.)
21. Lee, S. M. 1972. Goal programming for decision analysis. Auerbach Publishers, Philadelphia.
22. Manalili, I., Ma Ji, and B. Duff. 1981. Technical and economic factors in adopting mechanical reapers to small rice farms. Regional Grains Post-Harvest Workshop, 26-31 Jan, Jakarta, Indonesia.
23. Mandac, A. M., and R. W. Herdt. 1979. Environmental and management constraints to high rice yields in Nueva Ecija, Philippines. IRRI Saturday Seminar, 8 Sep.
24. Mandac, A. M., K. P. Kalirajan, and J. C. Flinn. 1982. Economic limitations to increasing shallow rainfed rice productivity in Bicol, Philippines, IRRI Res. Pap. Ser. 80.

25. Nepal Ministry of Economic Planning and Tribhuban University Economics and Commerce Departments. 1966. Physical input-output characteristics of cereal grain production for selected agricultural areas in Nepal, crop year 1965-66. Kathmandu, Nepal.
26. Orcino, N., and B. Duff. 1974. Experimental results from alternative techniques of land preparation. Department of Agricultural Engineering, International Rice Research Institute, Los Baños, Philippines.
27. Philippine Bureau of Census and Statistics. 1960. Census of the Philippines: 1960. Agriculture. Vol. 2. Summary report. Manila, Philippines.
28. Roxas, N. M. 1981. The economics of timeliness in crop intensification of rainfed farms in Iloilo, Central Philippines. Master of Agricultural Development thesis, Australian National University.
29. Ruttan, V. W. 1978. Induced institutional change. *In* Induced innovation: technology, institutions and development. H. P. Binswanger, and V. W. Ruttan, eds. The Johns Hopkins Press, Baltimore.
30. SGV (Sycip, Gorres, and Velayo) 1980. CB: IBRD mechanization study: progress report. Central Bank of the Philippines.
31. Small, L. E., C. Capule, and M. Oallares. 1980. Economic evaluation of improved irrigation system management: a progress report. IRRI Saturday Seminar, 17 Jul.
32. Te, A., F. Juarez, C. Bantilan, and B. Duff. 1984. Assessing the impact of mechanical reaper on employment income and production in the Philippine Rice Sector. Draft report. Agricultural Economics and Agricultural Engineering Departments, International Rice Research Institute.
33. Toquero, Z., C. Marana, L. Ebron, and B. Duff. 1977. Assessing quantitative and qualitative losses in rice post-production systems. FAO workshop on post-harvest rice losses, Malaysia.

USE OF HUMAN AND ANIMAL POWER ON SMALL FARMS IN AFRICA

H. J. DIBBITS

Department of Agricultural Engineering
University of Nairobi, Kenya

In most countries the main energy source on small farms is still the human being, using physical working capacity (power) for carrying out farm work. Even when human labor is supplemented by other energy sources to lighten the task or to increase work capacity, for instance by animal traction and small motorized equipment, the human energy expenditure might still be considerable.

The average human capacity for farm work is often indicated as 0.1 hp or 0.07 kW. Unfavorable health conditions and work environment will reduce this capacity.

Other influences are the tools and equipment used for the work, e.g., weight of tools, distribution of weight, sharpness and quality of cutting blade, length of handles..

The International Livestock Centre for Africa (ILCA) estimated the number of draft animals in sub-Saharan Africa to be 10 million. These animals represent a power source of about 4 million kW, equal to 80,000 medium-size tractors.

The tractive effort obtained from a draft animal depends on its breed, age, weight, training, harnessing system, etc. Studies on energy expenditure of draft animals have shown that over a long working period, the energy furnished by the animal and available for work is about 10% of the total energy contained in its food. This illustrates also that an animal can only work efficiently if it receives sufficient food.

The power an animal can develop depends greatly on the average tractive effort maintained during traction. The traction capabilities of animals depend first on their weight: a pair of oxen can develop about one-tenth to one-seventh of their weight, depending on field conditions, including obstacles (roots or stones) causing peaks in tractive effort. With working speeds ranging from 2 to 3 km/h, and a pair of oxen weighing 700-1000 kg, the power delivered will be about 0.5 to 1.0 kW. The effective working hours are between 3-8/d, depending on feeding and climatic conditions.

While human power can be used for all farm operations, more or less effectively, depending on the availability and suitability of hand tools, animal

power is mainly used for tillage, weeding, and transport. In Africa, implements for other operations such as harvesting have hardly been developed.

HUMAN POWER

Many areas have no access to sources of energy except human power. Small tractors on small individual farms are not feasible and government-owned tractor-hire services often have failed.

Animal power could be the most appropriate additional power on small farms. However, many farmers are not familiar with the use of draft animals; some areas are not suitable for keeping draft animals (trypanosomiasis); the human population density is so high that there is insufficient land for grazing; and the use of locally available draft animals is socially constrained.

Timely tillage and planting, especially in semiarid areas, and timely weeding will reduce the risk of crop failure. In spite of unemployment, labor may be scarce during these operations. Many children go to school. Many farmers have temporary or permanent off-farm jobs because their farm income does not cover extra costs like school fees. This leads to a high involvement of women in small farming, who, with their children, also take care of cooking and fetching of water and firewood.

The mechanical aids are limited. A basic set of tools consists of panga (knife for weeding and for cutting vegetation), shovel, and hand hoe (blade or fork type). These are multipurpose tools, unsuitable for any of the operations, and ergonomically inappropriate.

Surveys have shown that many farmers have a shortage of these basic tools and maintain them poorly, contributing to even lower efficiency and work output (4).

ANIMAL POWER

A mechanization system based on animal power will never be very efficient if the animals are not properly trained (controlled) and able to develop the necessary traction. Although the size of implements and depth of tillage can be reduced to adapt them to available power, low traction force will cause late plowing, planting, and weeding, and result in low yields. Therefore, improving animal power starts by improving the breed of the animal or its health, weight, and food. It also requires developing more efficient harnessing systems and appropriate implements. The animal, harness, and implement should be considered as one unit.

Harnessing systems

In Africa the most widely used draft animals are oxen and donkeys. Oxen are used with double neck yokes and double head yokes. Head yokes are usually used with humpless oxen (*Bos taurus*) and neck yokes with hump oxen (*Bos indicus*), but exceptions prove the rule. Double neck yokes, cheap and easy to construct, are more common. Farmers mostly use a long wooden pole with

sticks through it to separate and position the animals. The center of the yoke has a ring or U-bolt to attach the implements by a chain. This kind of yoke is almost never adapted to the shape of the neck, with the contact area so small that too much pressure is placed on one area of skin.

It is advisable to have a concave part in contact with the neck. Adding a lining of cotton waste, hair, or straw covered with cloth, canvas, or leather will give more comfort to the animal.

Single neck yokes are used for pulling carts with a single ox. They are also suitable for light work such as cultivation between rows, especially in small plots.

Any type of neck yoke has one marked disadvantage: the pulling point is relatively high (1). The line of pull from the pulling point (on the neck in front of the hump) to the implement hitch lies above the imaginary axle (or center of gravity) in the animal (Fig. 1). The animal tries to improve this situation by lowering his head (and pulling point) and bending his back. With this unnatural posture, it takes longer to train the animal to reach full performance.

These problems can be solved using a three-pad collar (Fig. 2). It has a lower pulling point, slightly above the shoulder joints, and prevents deflection from the natural posture during pulling. A three-pad collar has the same advantages as the neck yoke (free movement of the shoulders), but a much larger contact area (2).

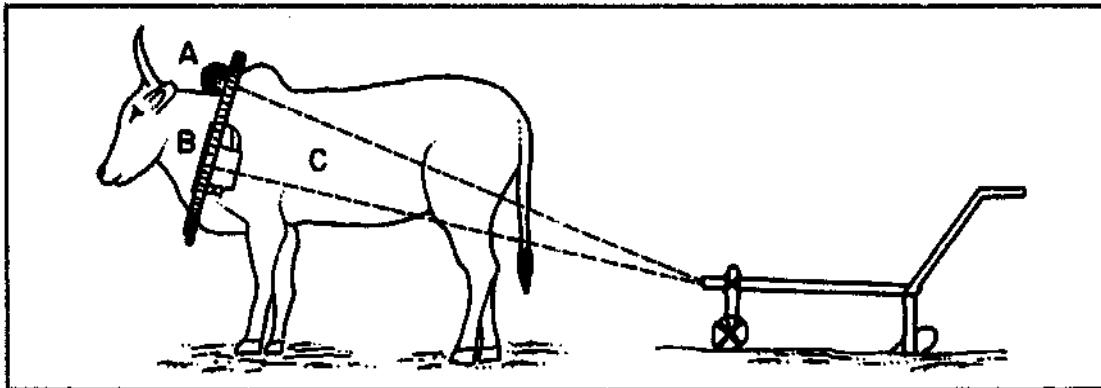

1. Lines of pull of a neck yoke (A) and a collar harness (B), in relation to the center of gravity (C).

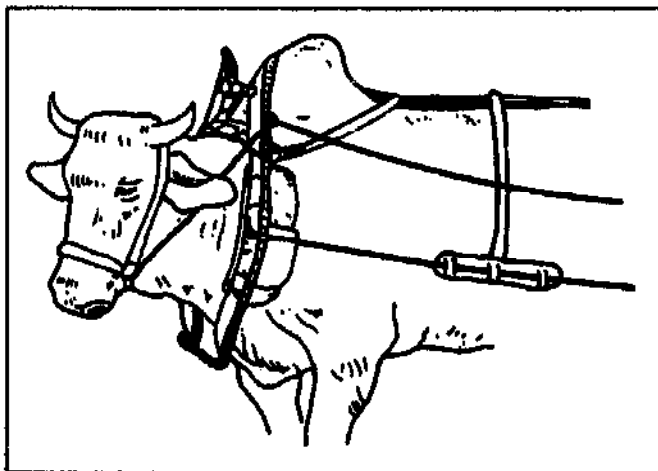

2. Three-pad collar harness adapted to *Bos indicus*.

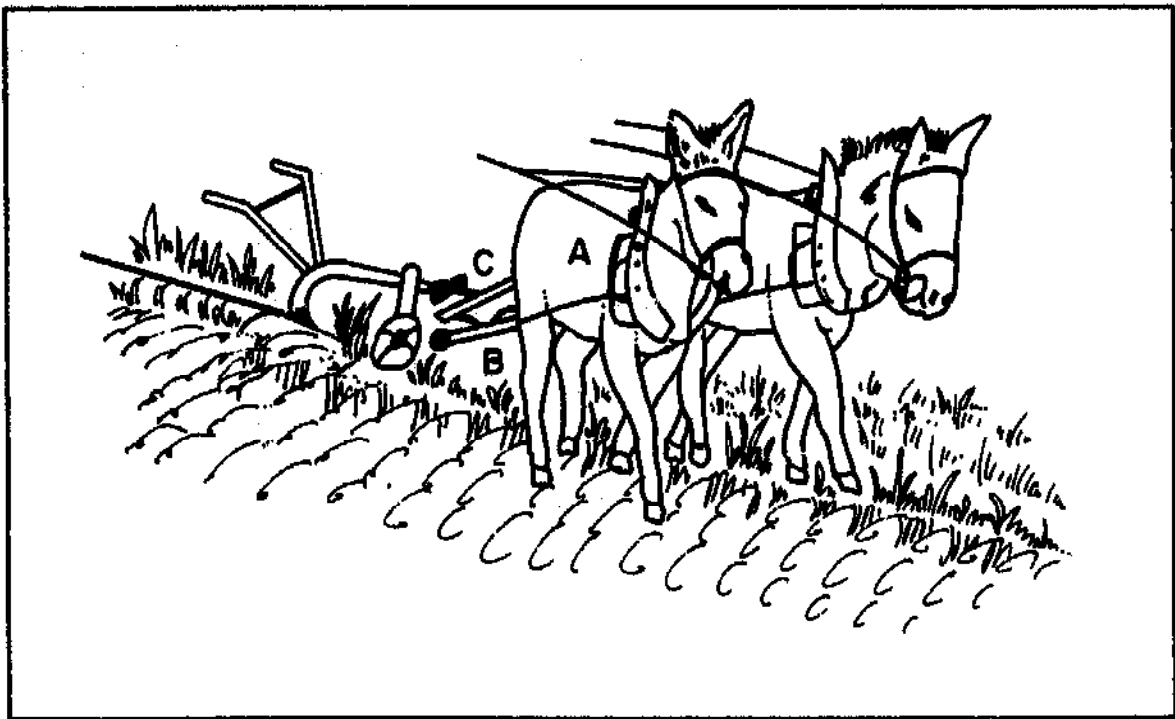

3. Plowing with two donkeys using collar harnesses (A), swingletrees (B), and evener (C).

The higher efficiency of the collar harness can be proven mathematically and also shown by a practical example. In a tug-of-war competition, you pull as low as possible to be able to use your full weight in developing more force. The collar harness is very suitable for single-ox cultivation but enables farmers to work with more oxen if they wish, like in the USA where combine harvesters used to be pulled by up to 32 horses. The main drawback of collar harnesses is their construction complexity and higher cost.

Donkeys are used to pull carts or as pack animals. Pulling plows, cultivators, and weeders is possible but less common except in West Africa. The harness consists of two sacks around the neck (East Africa). This poor harnessing system does not transmit power from the donkey to the cart or farm implements efficiently and often results in injuries. A proper collar harness (Fig. 3) will increase the power output. Donkeys have a high drought and disease tolerance and low feed requirement, making them very useful draft animals, especially in arid and semiarid areas. During severe drought in areas where oxen die, donkeys survive. Well-harnessed donkeys can compete with light oxen.

Implements

In Africa one can find a wide range of ox-drawn implements. Generally, this wide range is not available in a single country. Small farmers as well as the large-scale farmers have almost no choice. In East Africa farmers can only buy the moldboard plow (the most common implement in Africa) which they use for plowing, ridging, weeding, and harvesting. It is badly designed and made of low-standard material.

In many regions, implements are ill-adapted not only to animal traction (no sufficient width and depth adjustments), but also to ecological requirements. Using plows in semiarid zones is considered potentially damaging to the environment. Implements available to farmers seem far better adapted to needs in most West and Central African countries, where efforts have long been made to develop light implements more in line with the traction capabilities of local stock (3).

Only a few manufacturers specialize in farm machinery, employing agricultural engineers and contributing to further development of implements. For most manufacturers, production of ox-drawn implements and hand tools is a minor part of their total business. They copy imported implements and do not seem to be interested in making improvements. Steel has to be imported and only mild steel is widely available. Its quality is inferior for constructing soil-engaging parts like plowshares and cultivating tines. They wear out very fast, sometimes lasting only 1 wk in sandy soils. This low-quality steel is also used to make the solid plow beam; although it has a section area of about 1,800 mm², it is often bent at the bottom end. Lack of quality steel and technical capacity for processes such as hardening and tempering as well as lack of understanding of the forces acting on the parts, contribute to the problem.

Many traditional hand tools constructed by local blacksmiths are made of scrap metal. They soon become dull, but farmers continue to use them until they are worn beyond efficient use (4). Farmers buy locally produced ox-drawn implements and hand tools because there are no alternatives.

Several institutions are developing and improving ox-drawn implements. Test results and farmer acceptance trials are reported. The stage of large-scale production, extension, and marketing is mostly beyond the scope of the project. If manufacturers do not get assistance (financial and technical) to improve quality and standardization and assistance in marketing, then the new developments and improvements will never reach the small farmer. In the case of hand tools, research institutes should supply the manufacturer with ergonomic criteria. The idea that ox-drawn implements should be produced locally by small and medium-scale farm-machinery manufacturers so as to generate employment outside urban areas should be supported if that can guarantee standardization and quality control.

CONCLUSIONS AND RECOMMENDATIONS

The power of human beings and draft animals will never be used efficiently if energy is lost because of poor transmission systems, and improper tools and harnessing systems.

A wide range of high quality hand tools, ergonomically well-designed and suitable for specific jobs, should be developed. If farmers cannot afford better hand tools, ways should be found to subsidize and stimulate them to produce their own food rather than rely on food from work programs.

More attention should be given to developing and introducing improved yokes and collar harnesses for oxen. Single ox-cultivation, where possible, should be promoted.

In the semiarid and arid areas of Africa, more attention should be given to the use of donkeys for carrying out agricultural operations such as plowing and weeding. Therefore, production of efficient collar harnesses from locally available materials, as well as suitable implements, should be encouraged.

Projects to develop and improve locally manufactured hand tools and animal-drawn implements should involve local manufacturers from the very beginning. Training in production engineering, quality control, and standardization should be part of every project.

Joint ventures between farm machinery manufacturers from developed and developing countries, whereby transfer of technology is part and parcel of the cooperation, should be encouraged.

Manufacturers of ox-drawn implements should develop a wider range of animal-drawn implements, each for a specific task and adapted to the power of the draft animals available in the area.

REFERENCES CITED

1. Dibbits, H. J. 1984. Proper harnessing: key to better use of draught animals. *Kenya Farmer* 40: 6-9.
2. Hopfen, H. J. 1969. Farm implements for arid and tropical regions. *FAO Agric. Dev. Pap.* 91. 159 p.
3. International Livestock Centre for Africa. 1981. *ILCA Bull.* 19. Addis Ababa, Ethiopia. 18 p.
4. Muchiri, G. 1983. Production and use of agricultural machinery in Kenya. *Ind. Dev.* 9:13-38.

FILIPINO WOMEN IN RICE FARMING SYSTEMS: SOME EMPIRICAL EVIDENCE

G. T. CASTILLO
College of Agriculture
University of the Philippines at Los Baños
Laguna, Philippines

One indisputable fact of life in the Philippines is the primacy of rice in our diet, in our politics, and in our agricultural economy. But why women in rice? Because 1985 marks the end of the International Development Decade for Women, this is a time for assessing what has been or has not been achieved by and for women of the developing world. It is probably fair to say that the past decade has done some things for professional women, but not much, if anything, for women in agriculture. If we are to move beyond the rhetoric of women-in-development, we need, for example, an analysis of what women do in rice farming before designing strategies to improve that situation. This paper puts together empirical evidence on the participation of women in rice farming systems so that we can identify problems, issues, and prospects for technology development, farm management, and community organization. Four aspects are presented here:

1. participation in rice production,
2. decision-making in rice farming activities,
3. rice-farming systems as a source of employment and income, and
4. membership and leadership in irrigation organizations and other farm-related projects.

Because data for this analysis come from different studies conducted in different areas of the country by different researchers, and partly because of data limitations, this synthesis is suggestive or indicative of trends, not definitive. The purpose of this paper is to sensitize us to the issues.

PARTICIPATION IN RICE PRODUCTION

Using data from 320 farm households in 8 villages — 4 from the predominantly rainfed Guimba district and 4 from Cabanatuan, an irrigated district relatively close to Cabanatuan City — this section examines what women do in rice production. The 320 farm households represent different levels of irrigation and of mechanization, the focus of IRRI's research project on "The Consequences of Small Rice Farm Mechanization in the Philippines." Data were gathered in 1979-80.

One major weakness of this data set for our analysis of female participation in rice production is the frequently *undetermined sex*, especially of seasonal hired labor. Since male farmers are respondents, they are not always aware of how males or females work on their farms, particularly for seasonal jobs like transplanting, harvesting, and threshing. The male/female participation was estimated on the basis of the male/female proportion of workers which is known.

With this caveat, an attempt is made to identify trends from Tables 1 to 13.

1. Irrigated farms tend to be mechanized and therefore absorb less labor. Rainfed farms use more operator/family labor than the gravity-irrigated ones which use seasonal labor most. Total labor is lower on gravity-irrigated farms.
2. Total rice crop uses more seasonal than operator and family labor. The use of permanent labor is minimal perhaps because of the tenancy right which such an arrangement could lead to. Exchange labor is only 6% in the dry season (DS) and 7% in the wet season (WS).
3. The estimated female contribution to total rice crop labor-hours is 31% for WS and 24% for DS. There is higher female participation on nonmechanized than on mechanized farms and on rainfed and pump irrigated than on gravity-irrigated farms.
4. Labor for land preparation is all-male and about two-thirds by operator-family. Transplanting is estimated to be 55% female in WS and 45% in DS. Transplanting is also about 80% seasonal labor, most probably including a high proportion of labor from landless households. However, we cannot be certain about this since lower-income farm household members also work on other farms seasonally.
5. Rainfed farms use more operator-family labor, 57% (even for harvesting) than gravity-irrigated farms (11%) during WS, but during DS more operator-family labor is used for gravity-irrigated than rainfed farms (40 vs 33%). In WS, 80% of harvesting on irrigated farms is seasonal, but total labor-hours is only about half that on rainfed farms. Nonmechanized farms have higher estimated female participation in harvesting (43% vs 27%) than for gravity-irrigated, fully mechanized farms.
6. Of all farms studied, total female labor in harvesting is estimated to be 38% in WS and 35% in DS. Relatively speaking, female input in harvesting is lower than in transplanting, but seasonal labor is higher (80%) for the latter (55% in WS and 67% in DS).
7. About 40% of harvesting labor is contributed by operator-family during WS and 28% during DS. This disturbing trend suggests that the farmer and his family are taking on the task for themselves. Is it possible that "sharing the harvest" with others has become less of a community norm and therefore the landless have even less opportunity to participate?
8. Comparing nonmechanized and mechanized farms, rainfed and gravity-irrigated ones, the following observations may be made:
 - a. Nonmechanized, rainfed farms use more labor per hectare for rice

Table 1. Percent of labor input for total rice crop by labor type, water source, and level of mechanization. Nueva Ecija, Philippines, 1979-80.

Type of labor	Percent of labor input											
	Nonmechanized				Partially mechanized				Fully mechanized, irrigated			
	Rainfed	Pump irrigated	Gravity irrigated	Total	Rainfed	Pump irrigated	Gravity irrigated	Total	Rainfed	Pump irrigated	Gravity irrigated	Total
	<i>1979 wet season</i>											
Operator	29	29	31	29	31	18	18	23	30	26	17	25
Family Permanent	15	9	23	14	21	5	7	12	16	8	7	12
Seasonal Exchange	-	1	6	1	1	1	1	1	-	1	2	1
	47	49	39	46	39	68	69	58	45	55	70	55
	9	12	1	9	8	8	5	6	9	10	4	7
	<i>1980 dry season</i>											
Operator	30	30	37	31	41	19	19	25	34	26	19	26
Family Permanent	9	6	44	11	9	9	9	9	10	7	12	10
Seasonal Exchange	1	1	-	1	-	-	3	1	1	1	3	1
	54	60	14	52	45	69	65	61	50	63	60	57
	6	3	5	5	5	3	4	4	5	3	6	6
Mean man-hours												
1979 wet season	515	568	826	538	334	500	245	303	458	546	324	320
1980 dry season	776	820	736	788	651	710	225	344	734	781	248	418

Table 2. Mean man-h and percent of labor input for total rice crop by sex, water source, and level of mechanization. Nueva Ecija, Philippines, 1979-80.

Sex	Nonmechanized				Partially mechanized				Fully mechanized,				Water source				
	Rainfed	Pump irrigated	Gravity irrigated	Total	Rainfed	Pump irrigated	Gravity irrigated	Total	Total gravity irrigated	Rainfed	Pump irrigated	Gravity irrigated	Total	Rainfed	Pump irrigated	Gravity irrigated	Total
Total	514.80	567.22	825.55	537.51	333.68	500.42	245.45	303.11	371.60	458.49	545.70	323.71	413.23	47.42	46.62	131.10	82.18
Undetermined	54.31	47.88	295.41	62.27	33.09	44.03	82.98	61.14	173.07	279.11	326.61	143.41	228.51	131.95	171.27	49.16	102.37
Male	302.60	337.78	323.05	310.54	225.13	303.64	132.95	183.40	139.93	131.95	171.27	49.16	102.37	131.95	171.27	49.16	102.37
Female	157.89	182.05	207.08	164.69	75.44	149.11	29.50	58.18	58.52	131.95	171.27	49.16	102.37	131.95	171.27	49.16	102.37
										1979 wet season (man-h)							
Undetermined	11	8	36	11	11	9	34	20	47	10	8	40	20	10	8	40	20
Male	59	60	39	58	67	61	54	61	37	61	61	44	55	61	61	44	55
Female	30	32	25	31	22	30	12	19	16	29	32	16	25	29	32	16	25
Estimated female	34	35	39	35	25	33	18	24	30	32	34	27	31	32	34	27	31
Estimated male	66	65	61	65	75	67	82	76	70	68	66	73	69	68	66	73	69
										1980 dry season (man-h)							
Total	776.10	819.80	736.37	788.39	650.82	710.09	224.56	344.04	252.54	734.38	780.83	247.76	417.86	154.06	263.36	110.36	140.44
Undetermined	192.99	268.01	73.97	209.34	98.92	254.93	113.13	125.31	110.30	154.06	263.36	110.36	140.44	429.62	364.21	113.67	212.21
Male	420.28	408.04	483.72	422.53	448.73	299.10	99.51	176.56	98.21	429.62	364.21	113.67	212.21	146.53	147.97	22.66	64.75
Female	162.77	143.53	174.46	156.73	102.69	156.03	9.15	39.59	22.63	146.53	147.97	22.66	64.75	146.53	147.97	22.66	64.75
										1980 dry season (% of labor input)							
Undetermined	25	33	10	26	15	36	50	36	47	21	34	44	33	21	34	44	33
Male	54	50	66	54	69	42	44	52	42	59	47	46	51	59	47	46	51
Female	21	17	24	20	16	22	6	12	11	20	19	10	16	20	19	10	16
Estimated female	28	25	27	27	19	34	12	19	21	25	29	18	24	25	29	18	24
Estimated male	72	75	73	73	81	66	88	81	79	75	71	82	76	75	71	82	76
Total n	78	40	7	125	46	15	79	140	54	125	55	140	320	125	55	140	320

Table 3. Percent of labor input^a for land preparation by labor type, source of water, and level of mechanization. Nueva Ecija, Philippines, 1979-80.

Type of labor	Percent of labor input												
	Nonmechanized			Partially mechanized			Fully mechanized			Water source			
	Rainfed	Pump irrigated	Gravity irrigated	Rainfed	Pump irrigated	Gravity irrigated	Total	Gravity irrigated	Total	Rainfed	Pump irrigated	Gravity irrigated	Total
	<i>1979 wet season</i>												
Operator	53	58	80	54	35	56	43	55	58	49	51	58	52
Family	13	12	18	13	15	17	14	19	16	14	11	17	14
Permanent	-	1	-	-	-	5	4	10	10	-	2	8	1
Seasonal	21	22	-	22	32	18	27	16	16	24	29	14	22
Exchange	13	7	2	11	18	4	12	-	-	13	7	3	11
	<i>1980 dry season</i>												
Operator	55	75	63	63	76	54	62	34	37	62	69	47	59
Family	6	1	32	7	5	21	16	13	13	5	7	19	10
Permanent	1	2	-	2	-	6	4	13	13	1	2	8	10
Seasonal	27	16	-	20	18	14	15	12	12	24	17	11	4
Exchange	11	6	5	8	1	5	3	28	25	8	5	15	17
Mean man-hours													
1979 wet season	110	120	106	112	67	36	51	31	31	96	105	36	72
1980 dry season	189	170	176	180	120	33	55	38	39	162	149	41	80

^a All male.

Table 4. Percent of labor input for transplanting by labor type, water source, and level of mechanization. Nueva Ecija, Philippines, 1979-80.

Type of labor	Percent of labor input													
	Nonmechanized				Partially mechanized				Fully mechanized, gravity irrigated				Water source	
	Rainfed	Pump irrigated	Gravity irrigated	Total	Rainfed	Pump irrigated	Gravity irrigated	Total	Rainfed	Pump irrigated	Gravity irrigated	Total	Pump irrigated	Gravity irrigated
	<i>1979 wet season</i>													
Operator	9	9	22	10	18	8	6	9	3	11	8	5	8	8
Family Permanent	3	1	20	4	9	3	2	4	1	5	2	2	4	4
Seasonal Exchange	77	68	39	72	64	74	88	79	95	74	70	88	79	79
Female	11	22	1	13	9	15	4	8	1	10	20	3	8	8
Male				45				29	17	43	50	21	35	35
Undetermined				33				32	21	34	32	23	28	28
Estimated female				22				39	62	23	18	56	37	37
Estimated male				58				48	43	55	61	49	55	55
				42				52	57	45	39	51	45	45
	<i>1980 dry season</i>													
Operator	13	10	23	13	17	7	7	9	3	14	9	6	9	9
Family Permanent	11	3	34	10	12	4	2	5	1	11	4	4	6	6
Seasonal Exchange	70	85	35	72	70	87	80	83	90	70	85	85	81	81
Female	6	2	8	5	1	2	3	3	5	5	2	4	4	4
Male				33				18	11	37	28	10	22	22
Undetermined				33				26	18	36	25	22	27	27
Estimated female				34				56	71	27	47	68	51	51
Estimated male				50				41	38	41	53	31	45	45
				50				59	62	49	47	69	55	55
Mean man-hours														
1979 wet season	182	219	288	194	98	173	123	121	202	155	204	166	166	166
1980 dry season	329	296	283	311	235	323	122	161	149	292	306	140	193	193

Table 5. Percent of labor input for harvesting by labor type, water source, and level of mechanization. Nueva Ecija, Philippines, 1979-80.

Type of labor	Percent of labor input												
	Nonmechanized				Partially mechanized				Fully mechanized,				
	Rainfed	Pump irrigated	Gravity irrigated	Total	Rainfed	Pump irrigated	Gravity irrigated	Total	Rainfed	Pump irrigated	Gravity irrigated	Total	
	<i>1979 wet season</i>												
Operator	29	17	18	26	31	7	2	18	2	30	14	5	21
Family Permanent	24	15	27	23	32	5	5	19	-	27	11	6	19
Seasonal	1	-	-	-	-	-	-	-	-	-	-	-	-
Exchange	40	65	55	46	33	88	93	61	83	38	73	80	55
Female	6	3	-	5	4	-	-	2	15	5	2	9	5
Male				38				22	14	31	40	16	31
Undetermined				51				61	37	58	54	38	52
Estimated female				11				17	49	11	6	46	17
Estimated male				43				26	27	35	42	30	38
				57				74	73	65	58	70	62
	<i>1980 dry season</i>												
Operator	13	10	21	13	31	4	3	16	14	21	8	11	14
Family Permanent	7	10	78	15	8	3	-	5	29	12	8	29	14
Seasonal	-	-	-	-	-	-	-	-	-	-	-	-	-
Exchange	76	77	1	69	48	89	97	71	57	60	80	60	67
Female	4	3	-	3	13	4	-	8	-	7	4	-	5
Male				23				13	27	18	23	10	19
Undetermined				31				41	50	45	31	30	36
Estimated female				46				46	23	37	46	60	45
Estimated male				43				24	35	29	43	25	35
				57				76	65	71	57	75	65
Mean man-hours													
1979 wet season	181	155	375	183	130	176	44	88	98	166	162	81	130
1980 dry season	182	281	206	222	217	214	30	81	8	205	257	28	94

Table 6. Average labor input per hectare in various crop activities by farm type, source and sex of labor. Nueva Ecija, Philippines, 1979-80 dry season.

Crops and activities	Av labor input/ha			
	Nonmechanized		Mechanized	
	Man-hours	%	Man-hours	%
		<i>Labor source</i>		
Rice crop	503		395	
Operator		31		16
Family		12		8
Permanent		1		4
Exchange		5		9
Seasonal		51		63
Nonrice crop	132		—	
Operator		75		
Family		25		
Permanent		—		
Exchange		—		
Seasonal		—		
Male		69		
Female		31		
All crops	1035		395	
Operator		37		16
Family		14		8
Permanent		1		4
Exchange		4		9
Seasonal		44		63
		<i>Labor sex</i>		
Fertilizing	11		11	
Male		99		100
Female		1		—
Spraying	19		12	
Children		—		—
Male		100		100
Female		—		—
Weeding	5		1	
Children		—		—
Male		38		55
Female		62		45
Irrigation and drainage	26		nil	
Children		—		—
Male		100		100
Female		—		—
Drying	3		nil	
Male		93		88
Female		7		12

Table 7. Average labor input per hectare in various crop activities by farm type, and source and sex of labor. Nueva Ecija, Philippines, 1979-80 dry season.

Crops and activities	Av labor input/ha			
	Reinfed		Gravity irrigated	
	Man-hours	%	Man-hours	%
		<i>Labor source</i>		
Rice crop	873		421	
Operator		34		19
Family		10		12
Permanent		nil		3
Exchange		6		7
Seasonal		50		59
Nonrice crop	2		47	
Operator		24		75
Family		26		25
Permanent		—		—
Exchange		50		nil
Seasonal				
Male		100		69
Female		—		31
All crops	875		468	
Operator		47		20
Family		15		14
Permanent		1		3
Exchange		8		6
Seasonal		29		49
		<i>Labor sex</i>		
Fertilizing	10		12	
Male		100		100
Female		—		—
Spraying	15		13	
Male		100		100
Female		—		—
Weeding	6		1	
Male		64		57
Female		36		43
Irrigation and drainage	30		nil	
Male		100		100
Female		—		—
Drying	3		1	
Male		95		98
Female		5		2

Table 8. Average labor requirement per hectare in the care of livestock by farm type, source and sex of labor, and livestock group. Nueva Ecija, Philippines, 1979-80 dry season.

Livestock group	Av labor input/ha			
	Nonmechanized		Mechanized	
	Man-hours	%	Man-hours	%
	<i>Labor source</i>			
Labor for care of draft animals	267		7	
Operator		70		64
Family		28		—
Permanent		1		38
Exchange		1		—
Seasonal		—		—
Labor for care of productive animals	200		98	
Operator		78		60
Family		21		3
Permanent		—		—
Exchange		—		—
Seasonal		—		37
Total labor (livestock)	467		105	
Operator		74		60
Family		25		3
Permanent		1		2
Exchange		—		—
Seasonal		—		35
	<i>Labor sex</i>			
Labor for care of draft animals	267		7	
Male		100		100
Female		—		—
Labor for care of productive animals	200		98	
Male		48		54
Female		52		46
Total labor (livestock)	467		105	
Male		78		57
Female		22		43

Table 9. Average labor requirement per hectare in the care of livestock by farm type, source and sex of labor, and livestock group. Nueva Ecija, Philippines, 1979-80 dry season.

Livestock group	Av labor requirement/ha			
	Rainfed		Gravity irrigated	
	Man-hours	%	Man-hours	%
		<i>Labor source</i>		
Labor for care of draft animals	211		76	
Operator		60		70
Family		39		23
Permanent		—		7
Exchange		1		—
Seasonal		—		—
Labor for care of productive animals	234		69	
Operator		83		69
Family		17		5
Permanent		—		2
Exchange		—		—
Seasonal		—		24
Total labor (livestock)	445		144	
Operator		72		69
Family		28		15
Permanent		—		5
Exchange		—		—
Seasonal		—		11
		<i>Labor sex</i>		
Labor for care of draft animals	211		76	
Male		93		100
Female		7		—
Labor for care of productive animals	234		69	
Male		37		41
Female		63		59
Total labor (livestock)	445		144	
Male		64		72
Female		36		28

Table 10. Average labor input per hectare in various crop activities by farm type, and source and sex of labor. Nueva Ecija, Philippines, 1970 wet season.

Crops and activities	Av labor input/ha			
	Nonmechanized		Mechanized	
	Man-hours	%	Man-hours	%
				<i>Labor source</i>
Rice crop	603		481	
Operator		29		13
Family		14		5
Permanent		1		1
Exchange		9		5
Seasonal		47		76
Nonrice crop	24		—	
Operator		48		
Family		48		
Permanent		—		
Exchange		4		
Seasonal		—		
All crops	627		481	
Operator		30		13
Family		16		5
Permanent		1		1
Exchange		9		5
Seasonal		44		76
				<i>Labor sex</i>
Fertilizing	6		8	
Male		93		100
Female		7		—
Spraying	9		11	
Male		98		100
Female		2		—
Weeding	16		2	
Male		69		64
Female		31		36
Irrigation and drainage	4		1	
Male		100		100
Female		—		—
Drying	1		2	
Male		70		96
Female		30		4

Table 11. Average labor input per hectare in various crop activities by farm type, and source and sex of labor. Nueva Ecija, Philippines, 1978 wet season.

Crops and activities	Av labor input/ha			
	Rainfed		Gravity irrigated	
	Man-hours	%	Man-hours	%
		<i>Labor source</i>		
Rice crop	532		466	
Operator		30		17
Family		16		7
Permanent		nil		2
Exchange		9		4
Seasonal		45		70
Nonrice crop	nil		35	
Operator		.03		57
Family		.04		36
Permanent		—		—
Exchange		—		7
Seasonal		—		nil
Male		—		64
Female		—		36
All crops	532		501	
Operator		30		20
Family		16		10
Permanent		nil		2
Exchange		9		5
Seasonal		45		63
		<i>Labor sex</i>		
Fertilizing	5		8	
Male		94		99
Female		6		1
Spraying	7		12	
Male		97		99
Female		3		1
Weeding	16		4	
Undetermined		—		7
Male		66		82
Female		34		10
Irrigation and drainage	1		nil	
Male		100		100
Female		—		—
Drying	1		1	
Male		67		90
Female		33		10

Table 12. Average labor requirement per hectare in the care of livestock by farm type, source and sex of labor, and livestock group. Nueva Ecija, Philippines, 1979 wet season.

Livestock group	Av labor requirement/ha			
	Nonmechanized		Mechanized	
	Man-hours	%	Man-hours	%
	<i>Labor source</i>			
Labor for care of draft animals	132		8	
Operator		85		72
Family		13		23
Permanent		2		5
Exchange		1		—
Labor for care of productive animals	80		23	
Operator		87		87
Family		13		3
Permanent		—		10
Exchange		—		—
Total labor (livestock)	213		30	
Operator		85		82
Family		13		9
Permanent		2		10
Exchange		—		—
	<i>Labor sex</i>			
Labor for care of draft animals	132		8	
Male		100		97
Female		—		3
Labor for care of productive animals	80		23	
Male		25		12
Female		75		88
Total labor (livestock)	213		30	
Male		72		34
Female		28		66

Table 13. Average labor requirement per hectare in the care of livestock by farm type, source and sex of labor, and livestock group. Nueva Ecija, Philippines, 1979 wet season.

Livestock group and activities	Av labor requirement/ha			
	Rainfed		Gravity irrigated	
	Man-hours	%	Man-hours	%
	<i>Labor source</i>			
Labor for care of draft animals	99		82	
Operator		80		91
Family		17		6
Permanent		3		3
Exchange		—		—
Seasonal		—		—
Labor for care of productive animals	77		32	
Operator		86		88
Family		12		9
Permanent		—		3
Exchange		—		—
Seasonal		—		—
Total labor (livestock)	176		144	
Operator		82		90
Family		8		7
Permanent		9		3
Exchange		—		—
Seasonal		—		—
	<i>Labor sex</i>			
Labor for care of draft animals	99		82	
Male		100		100
Female		—		—
Labor for care of productive animals	77		32	
Male		25		14
Female		75		86
Total labor (livestock)	176		114	
Male		67		76
Female		33		24

crops than do mechanized farms. For nonrice crops, gravity-irrigated farms use more labor for both cropping seasons than do rainfed farms. Nonmechanized, rainfed farms use more operator-family labor. Mechanized, gravity-irrigated farms use more seasonal labor relatively speaking, but total labor used is less.

- b. Fertilizing, spraying, and irrigation and drainage are practically all-male tasks. Even drying is predominantly male. Weeding on nonmechanized farms is more female for DS, more male for WS whether rainfed or gravity-irrigated. Nonrice crop is practically all operator-family and mainly male labor. Labor for care of draft animals is mainly operator-family and male. Some permanent labor and some seasonal labor is used by mechanized, gravity-irrigated farms for taking care of productive animals. Noteworthy is the labor for care of productive animals contributed mostly by female operator-family labor, which probably means the farmer's wife.

Tables 14 and 15 present in more detail the types of labor used by 320 farm households in rice production tasks. The most obvious conclusion from these two tables is that the farmer's wife is only a minimal participant in rice production tasks such as transplanting, pulling seedlings, seeding seedbed, weeding. A few are involved in topdressing fertilization. Daughters participate even less. Sons are much more involved in rice production. The few permanent laborers, all male, perform most tasks the farmer performs. Male laborers hired for temporary work mostly transplant and pull seedlings.

In general, the female contribution to physical production is limited mostly to transplanting, harvesting, and care of productive animals. In the first two tasks, women are not even the major participants.

Much less is known about the involvement of women in rice processing, distribution, and use. D. M. Torreta et al (11) studied 16 women entrepreneurs from Laguna whose income levels are as follows:

Occupation	No.	Average annual income (₱)	
		Household	Per capita
Rice milling	2	126,000	22,909
Rice retailing	2	1,524,000	277,091
Rice milling and dealing	2	46,374,000	7,134,461
Native rice delicacy making as hired workers in pinipig factory	5	8,478	1,766
Native rice delicacy entrepreneur	1	No data	No data
Native rice delicacy making and selling	4	23,986	3,423

Rice milling is a part-time involvement, with wives performing a minor role in attending to customers and receiving payment, while their husbands operate the milling machine. In rice retailing, women play a major full-time

role by attending to bodega delivery or inventory, cash payment of rice delivery (100% involvement), selling and receiving payment. In rice milling-dealing businesses, the wife is involved full time in the office, attending to wholesale buying and selling with the help of hired workers while the husband attends to paperwork and legal matters with the aid of a full-time secretary.

Rice delicacy making and selling, in small and large entrepreneurial scale, is also full-time work. Five women work as hired workers in a pinipig factory for 5 or 6 d a week. Sundays are rest days generally for all except rice retailers who work 7 d a week. Makers and sellers of rice delicacy appear to have less sleep time than other women.

Rice milling and dealing seems to bring the highest income but also needs the most capital. This is followed by rice retailing and small rice milling. Lowest income accrues to the hired workers.

The owner/operator/seller activities in rice use consist of preparing and cooking, transporting to market, selling, and buying ingredients. The wife is the major actor in all these activities, with minor participation of husband and children, except for transporting goods to market, shared equally among husband, wife, and children. Buying ingredients is 100% the wife's task.

DECISION-MAKING IN RICE FARMING ACTIVITIES

The preceding discussion tells us that woman's role in physical production is limited. But does this mean she is not involved in the management of the farm? Since the Filipino woman is the usual family treasurer and household manager, resources for the farm are most likely part of the overall household budget. One would therefore expect the wife to have some influence over resource allocation.

Although many studies have established the wife's participation in farm-related decisions, Bascug's research in Baybay, Leyte, examines the problem in greater and more specific detail (1). Table 16 shows the following:

1. Wives are much involved in decisions concerning allotment of money for farm activities such as land preparation; purchase of planting materials, inputs, farm equipment; and hiring of laborers. About a third of the wives "alone" allocate money for this purpose and another third do so with their husbands. Procurement of budget for farm activities is decided in much the same way. But handling the budget for the different farm activities is a task which predominantly belongs to the wife.
2. Although decisions on land preparation (who and when), selection of planting materials (what and where to purchase), weeding the farm (which tools to use and when), fertilization of the farm and application of chemicals (use, kind, amount, and when to apply), harvesting of produce (when, who to hire, and sharing arrangements), transportation of farm produce (place, arrangements, persons to hire), and marketing of produce (where, contact outlets, and price) are more *husband alone* (40% or more) than *wife alone*, 20-25% are *wife alone*, and another 20-25% are both *husband and wife* decisions. This means that more than half of the

Regular irrigation	57	1	1	3	3	3	1	2	1	28	10	6
Harvesting-bundling-transporting	1	2	1	2	1	2	1	2	1	28	2	21
Bundling-piling	2	1	1	1	1	1	3	1	1	74	1	69
Harvesting	22	18	15	1	15	1	3	1	5	90	2	10
Harvesting-threshing	1	1	1	1	1	1	1	2	1	2	2	2
Harvesting-threshing-winnowing	9	9	9	9	9	9	3	1	1	10	10	21
Threshing-winnowing	2	1	3	3	3	3	1	12	1	1	1	74
Threshing	2	1	1	1	1	1	1	10	1	1	1	69
Winnowing	22	8	15	15	15	15	2	40	21	1	1	34
Transporting	12	8	8	8	8	8	2	1	1	1	1	3
Drying	4	1	1	1	1	1	2	2	1	1	1	6
Milling	82	22	7	7	7	7	28	28	3	6	6	64
Marketing												
<i>Care of productive animals</i>												
Watering	21	10	30	30	30	30	2	2	2	2	2	2
Bathing	9	86	1	1	1	1	6	6	6	6	6	6
Watering-bathing	132	123	48	48	48	48	8	8	8	12	12	12
Grazing	128	11	66	66	66	66	2	2	2	11	11	11
Stall-feeding	22	204	1	1	1	1	12	12	12	3	3	3
Cutting grass	16		6	6	6	6	1	1	1	1	1	1
Herding	10		6	6	6	6	1	1	1	1	1	1
Processing-marketing	14	33					1	1	1	1	1	1
Cleaning shed	8	64	2	2	2	2	4	4	4	4	4	4

Table 16. Decision-making on farm-related activities,^a Baybay, Leyte, Philippines, 1981 (1).

Areas for decision-making	Decision maker (%)			
	Husband alone	Wife alone	Both husband and wife	Others: relatives, landowner, children, tenants, parents
Allotment of money for farm activities				
Land preparation	20	37	33	10
Purchase of planting materials	22	34	33	11
Purchase of farm inputs	23	35	33	10
Purchase of farm equipment	20	37	34	10
Hiring of laborers	17	42	34	7
Procurement of budget for farm activities	32	32	30	5
Handling the budget for different farm activities				
Land preparation	4	79	8	9
Purchase of planting materials	4	79	8	9
Purchase of farm inputs	3	81	6	10
Purchase of farm equipment	1	85	4	10
Hiring of laborers	5	79	9	7
Listing of farm expenses ^b	3	68	4	5
Land preparation decisions				
Decides the persons who will prepare the land	39	27	23	11
Decides the period when land will be prepared	43	25	23	9
Selection of planting materials				
Selects the variety or materials to plant	41	22	20	17
Decides where to purchase planting materials	42	23	19	16
Weeding the farm				
Decides what tools to use on the farm	43	25	24	8
Decides when to weed the farm	45	27	22	6
Fertilization of the farm				
Decides use of fertilizer	45	20	21	14
Chooses the kind and amount of fertilizer to apply	47	20	18	15
Decides when to apply fertilizer	47	22	18	13
Application of chemicals on the farm				
Decides the use of chemicals	45	20	21	14
Chooses the kind and amount of chemicals to apply	50	20	15	15
Decides when to apply chemicals	48	22	18	12
Harvesting of farm produce				
Decides when to harvest	41	24	27	8
Decides persons to hire or help in the harvesting	42	26	22	10
Decides the sharing arrangements	34	23	23	20
Transportation of farm produce				
Decides where to transport farm produce	44	27	25	4
Makes necessary arrangements in transporting	48	28	19	5
Chooses the persons to hire or help in transporting	46	26	20	8

Table 16 continued.

Areas for decision-making	Decision maker (%)			
	Husband alone	Wife alone	Both husband and wife	Others: relatives, landowner, children, tenants, parents
Marketing of farm produce (n = 104)^c				
Decides where to market	28	26	44	3
Selects kind of market, contact, outlets	32	24	40	4
Decides the price of farm produce	11	13	10	66
Borrowing of money for farm activities (n = 74)^d				
Initiates loaning/borrowing for the farm	34	20	40	6
Decides the loaning/borrowing system	31	20	45	4
Decides the amount to be borrowed	19	24	54	3
Processes the credit papers	37	20	15	28
Membership in organizations^e				
Affiliation with organizations (n = 103)	4	72	14	10
Holding of positions in the organization (n = 13)	8	54	30	8
Participation of wives in community projects				
Number of projects involved in (n = 129)	4	78	13	5
Initiates implementation of community projects (n = 106)	3	65	8	24
Participation in rural development projects				
Nutrition program (n = 30)	—	83	10	7
Production program (n = 26)	4	54	23	19
Family planning program (n = 42)	—	59	36	5

^a Respondents were 141 farmers' wives in 2 barangays. ^b Twenty percent did not list farm expenses. ^c Twenty-six percent did not market farm produce. ^d Forty-eight percent did not borrow. ^e Twenty-seven percent did not belong to any organization; 17% of 141 respondents belonged to the Samahang Nayon.

wives participate in these more "technical" decisions. The question is: "Are the wives sufficiently knowledgeable to contribute effectively to these decisions?"

3. Although a third of the farm households studied did not borrow money for farming operations, among those who did, the decision was more *joint husband and wife* rather than *husband alone*, particularly on amount to be borrowed. About a fifth said it's a *wife alone* decision. Again, the question is: "How much do the wives understand the intricacies of the loan procedures and requirements and the productive application of such loans?" Twenty percent of them, for example, did not bother to list farm expenses. The use of credit for productive purposes is a sophisticated management undertaking. In general, the farmers' wives are not a deliberate target audience of agricultural credit programs.
4. Membership in organizations is very much of a *wife alone* decision, although holding of positions in the organization includes some joint endeavor. For the 27% who did not belong to any organization, is it

possible that the husbands wielded the veto power? Only 17% belonged to the *Samahang Nayan*. Participation in community projects is mostly a *wife alone* decision and so is participation in nutrition programs. However, production and family planning programs tend to have more husband participation although more than half say they are *wife alone* decisions. More importantly, few households participate in these programs: 21% for nutrition, 18% for production, and 30% for family planning.

5. Table 17 indicates the characteristics of farm wives and the decision-making patterns. Independent decisions (*wife alone*) on procurement of budget for farm activities, harvesting period, and amount to borrow are more likely to be made by women in agricultural occupations who have higher income, have been married for a longer time, have smaller households, and are older. Wives with high school and college education make more joint decisions, and so do those engaged in nonagricultural occupations with respect to deciding on amount to borrow for the farm. The *husband alone* decision-making pattern tends to be associated more with lower family income, shorter married life, younger age, and lower education of wife.

Perhaps wives' exposure to and experience in farm-related matters contributed to greater wife participation in decision-making.

RICE-FARMING SYSTEMS AS A SOURCE OF EMPLOYMENT AND INCOME

Data from the May 1968 Bureau of Census and Statistics Survey of Households reported that "Of the total number of persons employed in agriculture, hunting, and fishing, 68% of 7.2 million are in rice and corn farming. Of the total males in agriculture (5,339,000) as of 1968, about 66.3% are engaged in rice and corn farming and of the total females (1,863,000) in agriculture, 73.1% are in the same category."

Seventeen years ago, agricultural and residential landlessness was not yet an issue. The share-tenant then was regarded as landless because he did not own the land he was tilling. Nowadays, he is not considered landless because he has access to land. The truly landless of today are those who have no land to till, let alone own. His major source of income is the "sale" of his labor to those who have land, either as share-tenant, lessee, certificate of land transfer (C.L.T) holder, or owner. If we had manufacturing industries, agroindustrial enterprises, and other agricultural pursuits galore, employment for the agriculturally landless, the underemployed member of the farm household, and the general overflow of the rural labor force would quickly find a niche for themselves. But such is not the current state of affairs.

Although we have not yet found the 1980 or 1985 statistics equivalent to the 1968 figure cited as to the number of females in agriculture and in rice and corn farming, we know that there are about 54 million Filipinos at the moment. In 1968, our population was about 36 million. In the absence of the neat national figures, we present a micro view of the employment and income situation from

Table 17. Patterns of decision-making on farm-related activities by selected characteristics of farm wives. Baybay, Leyte, Philippines, 1981 (1).

	Decision maker (%)			
	Husband alone	Wife alone	Both husband and wife	Others
Procurement of budget for farm activities				
Occupation of wife				
Agriculture	17	42	37	4
Nonagriculture	39	28	27	6
Family income				
Low (P405 or less/mo)	38	28	29	7
High (>P405/mo)	19	46	33	2
Household size				
Small (5 or less members)	25	40	27	8
Big (> 5 members)	41	22	35	2
Number of years married				
Short (< 22 yr)	40	22	32	6
Long (> 22 yr)	23	44	29	4
Harvesting period of farm produce				
Age of wife				
Young (< 44 yr)	52	11	33	4
Old (> 44 yr)	30	37	20	13
Education of wife				
Low (Grades 1-8)	44	25	22	9
High (high school and college)	24	19	52	5
Occupation of wife				
Agricultural	14	51	25	10
Nonagricultural	56	10	28	7
Family income				
Low (P405 or less/mo)	50	19	20	11
High (> P405/mo)	25	33	40	2
Length of marriage				
Short	50	9	34	6
Long	31	40	18	11
Amount to borrow for farm activities				
Occupation of wife				
Agricultural	16	48	36	-
Nonagricultural	21	12	63	4
Number of projects involved in				
Length of marriage				
Short (< 22 yr)	4	70	20	6
Long (> 22 yr)	3	88	3	6

rice farming systems from several studies conducted in Bicol, Central Luzon, Laguna, Negros Occidental, and Iloilo.

In assessing the labor participation of working wives, it is necessary to differentiate farm households from landless households. Illo's study shows 40 to 54% of wives from landless households engaged in wage jobs at different times of the year compared to only about 21% of farmers' wives (6).

Furthermore, contributions of the wives' labor earnings as a proportion of total weekly family income differ. Table 18 shows that working wives from Gatbo contribute 26 to 31% as against only 14 to 18% from working wives in Ayugan.

Illo (6) explains this difference in the role of market production activities in the two villages:

At the same time that village wives continuously kept house for their families and looked after the welfare of their spouse and children, they also engaged in an array of activities which would either produce marketable commodities or earn them some income. The percentage of women with non-zero market production time varied from one period of the year to another, but never did the figure fall below 64% in Ayugan and 86% in Gatbo. And in at least 5% of the sample families, the wife was in the labor force while the man was either ill or could not find work in the village. The more common arrangement, however, had both the woman and her spouse involved in market production. This was particularly true in Gatbo where at least 8 of every 10 sample families had a working man and wife team; in Ayugan, the proportion was about 6 of every 10 sample cases.

The preponderance of working-wife cases in Gatbo appears to be associated with the generally lower family earnings in the area. The average annualized earnings of Gatbo families stood at ₱5,951, which was but 61% of that estimated for Ayugan families (₱9,683). With annual minimum food requirements in 1979 valued at about ₱8,000 for a family of 6, about 81% of Gatbo families as compared with 57% in Ayugan, may be considered 'absolutely poor.'

Average annual family earning, 1979

<i>Access to riceland</i>	<i>Ayugan</i>	<i>n</i>	<i>Gatbo</i>	<i>n</i>
Farming	₱11,394	69	₱6,655	68
Landless	₱ 5,875	31	₱4,454	32

The variation in average family earnings between the two villages and among families within each community may be partly traced to the access which families have to productive resources. In Ayugan, farming families generally had irrigated land where crop turnaround time could be facilitated with the use of farm machines. Consequently, the divergence between the earnings of farming families and those of landless households had been dramatic; the latter's average earnings were only about half of the former's. In contrast, a majority of farming families in Gatbo were either operating non-irrigated land or cultivating irrigated farms without sufficient resources to maximize returns to rice farming. Probably because of the minimal advantage which farming households enjoyed over landless households in this village, annual earnings did not vary significantly with families' access to riceland. In Gatbo, more than in

Table 18. Estimates of workers' wives' contribution to weekly family earnings in 2 Philippine villages, 1970 (6).

Survey round and village ^a	Average hours worked	Total labor payment for the week (P)	Total weekly family earnings (P)	Percent of total labor payment from wives' labor earnings
Mar-Apr				
Ayugan	18	33	240	14
Gatbo	30	45	147	31
Overall	25	41	187	22
Jun				
Ayugan	32	41	230	18
Gatbo	27	38	145	26
Overall	28	38	177	21
Sep-Oct				
Ayugan	22	34	232	15
Gatbo	25	42	147	29
Overall	23	38	186	20

^a Ayugan is the irrigated village using power tillers and threshing machines. Gatbo has farms irrigated from a nearby spring, but the irrigated area contracts by about half during the dry season. Plowing is by carabao and threshing is manual.

Ayugan, therefore, families seemed to differ in economic status very minimally: most were poor, a few were a little less poor.

What is the significance of rice farming in these market production activities? Seventy-four percent of total reported activities during the 8-mo research period are in rice production (transplanting, weeding, harvesting, and threshing); 16% are in stripping of abaca, sugarcane harvesting, and other agricultural activities; 10% are in nonfarming activities such as teaching, dressmaking, and doing laundry.

Of the possible market activities, unpaid work in agricultural enterprises of the household other than rice farming accounted for the largest proportion of married female workers in Ayugan and Gatbo. Probably because of the low time requirement of these activities, working wives had sometimes combined their backyard gardening and livestock or poultry raising with wage employment. At other times, married women from farming households actively engaged in rice-farming activities while keeping their gardens and a brood of chicken or one pig.

Meanwhile the 20 or so wives who worked for wages during the research period were found to be involved in different tasks in rice farms, stripping of abaca or harvesting sugarcane. However, there tended to be a concentration of female workers in harvesting and threshing of rice crops in March and April, and again in September and October; in June, a number of working wives joined transplanting teams. A comparison of the wage employment of married women in Ayugan and Gatbo underscored two points. One, overlaps in rice-farming activities seemed to occur in a community like Ayugan where farms have access to irrigation facilities, realized at least two crops in a year, and planting schedules are staggered rather than uniform for all. And two, shortfalls in

labor demand from rice farms could be covered by other crop farms' demand. This would tend to obtain when a semi-upland village like Gatbo had diversified cropping system; thus wage employment opportunities particularly for landless workers would not depend exclusively on low-cropping intensity rice farms.

Although the village economy might dictate the degree of involvement of women in the formal labor market, family circumstances like poverty appear to unveil strategies and mechanisms through which women could help support their family. Production activities which are commonly referred to as petty gainful occupations provide the meat of such strategies. The higher participation of women from a poorer village like Gatbo in growing vegetables and fruit trees, and in tending pigs which could be sold later presents itself as a refutable evidence of informal market work as a response to poverty.

In an analysis of labor allocation patterns of women in rainfed rice farm households, Res (9) noted the effect of the household's developmental cycle and its wealth status on labor allocation of its members. Only in the low income households do women engage in farm wage labor. In addition, those women also contribute more labor to rice production on their own farm because they cannot afford to hire labor. Furthermore, during the second phase of the household developmental cycle, when children are growing up, women increase their contribution to rice production because they are freed from housework and child care and because of the necessity to meet family needs. Their participation in rice production occurs mainly during peak periods. They contribute about 11% of the total family labor in rice production, against 20% in production of other crops. Women, however, grow vegetables at any phase of the life cycle and at any income level. Their labor input in nonrice crops is spread throughout the year. Small areas of vegetables are grown, allowing a steady market income. In households with higher wealth, women spent more time in pig raising.

Changes in female labor in rice production over 15 yr were traced to

1. Replacement of the kayog (small harvesting knife) by the sickle as harvesting tool for women, caused by the introduction of the relatively short-statured variety (BE-3) in the sixties. In 1974 the sickle, a labor-saving device, was used by all female harvesters.
2. Since 1970 the modern varieties have been gradually introduced in the village. Direct seeding of pregerminated seeds on puddled fields (wet seeding) is possible with these varieties. By skipping laborious transplanting much hired labor was saved.
3. The introduction of the photoperiod-insensitive varieties made possible double rice cropping and expanded the harvesting period from 13 to 21 wk, leveling off harvesting labor peaks. Extra labor was needed, but was spread over a longer time span.
4. Dry seeding in the end of the seventies had the same labor-saving effect that wet seeding had had earlier.

5. In 1977 the portable mechanical thresher was introduced. Since then threshing labor need has started to decline. Almost all the village rice harvest could be threshed by three mechanical threshers introduced in 1979.

As a consequence of those changes in rice production, the decade 1970-80 shows a decrease of 9% in total labor use even though the crop area increased 36%. The labor use decline was due mainly to direct seeding and somewhat to mechanical thresher use.

From 1970 to 1978, the decreases in labor use are well counterbalanced by the increasing crop area. However, the population which increased by 13% during this period could not be absorbed.

Female labor use decreased from 1970 to 1980 because of the decline in transplanting, harvesting, and threshing. Women's contribution to rice production declined absolutely and relatively. Due to double-cropping, men's labor use increased in typically male activities, such as land preparation and fertilizing, which increased with the crop area.

This largely made up for the decrease in male labor use in other operations. Furthermore, the spread of harvesting labor allowed male labor to be substituted for female labor. Both female family and hired labor declined. Total female contribution to rice production was 18% in 1978 and 16% in 1979, and decreased to 13% in 1980. The 1979-80 decrease was mainly in hired labor.

Not all women reduced their labor input in rice. Only women of the higher income households who could afford it retreated from rice production work. Women of low income households remained heavily involved in rice farm labor. Like female-headed households, they remain dependent on the income-earning opportunities rice production gives them.

The contribution of rice harvesting opportunities to nonrice workers is illustrated in Ruttan's (10) account of subsidiary activities in a sugarcane plantation:

When at the end of the off-season the rice harvests start, in the "poor" months of August and September, all people of the hacienda are eager to participate. Women and men, old and young, harvest rice not only on the 3 ha² of riceland of Hacienda Milagros and on the planter's upland hacienda, but also on other haciendas and some tenanted rice farms close to Hacienda Milagros. Whereas all are allowed to join the harvest on their own hacienda (at least in 1977), personal introductions are needed to gain access to rice harvests on tenanted land or on land of other haciendas. These introductions are obtained through kin, ritual kin, or neighbors — either women or men. When the rice was harvested on the nearby land of a tenant farmer whose son lives and works on Hacienda Milagros, 26 people from Hacienda Milagros participated — women, men, and children. They were the neighbors of the tenant's son, the tenant's ritual kin, or just "friends." During the rice harvest at the neighboring Hacienda Maria, some women and men from Hacienda Milagros were able to participate through an introduction by a truck driver of Hacienda

Maria, who lives with his wife on Hacienda Milagros in the house of his wife's parents.

Because of the limited harvesting opportunities in the area close to Hacienda Milagros, some people also move in more distant haciendas to participate in the harvests there. They choose haciendas where some of their close relatives are living, through whom they are able to gain permission to participate. For example, one woman went with her husband and two eldest daughters to a hacienda in the municipality of La Carlota where her sister's married daughter lives. And a young man went to harvest rice on the hacienda where his father lives, in the uplands of Murcia.

Usually, wife, husband, and older daughters and sons harvest together; on the hacienda itself, young children participate as well. In the off-season of 1977 some households harvested a total of 4 to 8 cavans of palay (about 190 to 300 kilos of unmilled rice), good for 4 to 10 wk of rice consumption depending on the specific household size. The rice harvests are thus very important in supplementing the small cash income during the off-season. All the rice is used for home consumption. The rice stock, stored in sacks in a corner of the house, is controlled by the wife; she decides how much rice to prepare for each meal, and she sees to it that rice is bought in time before the stock is exhausted.

Given the present unemployment in the sugar industry, opportunity to participate in rice harvesting is much-coveted among sugar workers. Illo's (5) study in Bicol showed some landless women in rice-growing villages engage in sugarcane harvesting. Now, this is less likely, and the pressure on labor absorption in rice farming will likely increase.

The Ebron et al (4) study of 46 landless households in Nueva Ecija (Cabanatuan City and Guimba) showed that 68% of all household members are nonworking. Seventy-eight percent of spouses, 65% of males (10 yr and over), and 72% of females (10 yr and over) are nonworking. For all the households, 69% of the working household members are males and 31% are females. The study shows very little seasonal or permanent outmigration by landless household members. Only 12 or 4% had left permanently since the introduction of mechanization and all these left to get married.

On household employment and income, Ebron et al (4) found the following:

In both wet and dry seasons, almost all landless households derived their income exclusively from agriculture. Only two had income from both agricultural and nonagricultural employment. Average employment per household was 122 man-days in wet season, 121 in dry season or a total of about 243 for the whole year. By village, average employment in rainfed villages was higher than in irrigated villages in both seasons.

Not surprisingly the average household income in wet season was thus higher in rainfed than in irrigated villages (P1325 vs P1136). In dry season, however, average income in irrigated villages was higher than in rainfed villages (P1347 vs P1085), despite the average man-days worked

in the rainfed villages being slightly higher. Combining the 2 seasons, the average annual household income was a little over ₱2400.

In general, the male household head made the greatest contribution in terms of employment and income. In wet season, male household heads accounted for about 55% of the household labor and 64% of the household income. In dry season their contribution was about 46 and 52%, respectively. Male adults (10 yr and over) accounted for the second largest source of household labor and income, contributing about 19% each to labor and income in wet season and 30% to labor and 27% to income in dry season. Contributions by female household heads were 81% and 12.6% for income and labor in wet season and about 3% and 5% in dry season. Contributions by spouses were less than 5% in wet season and 12% in dry season. The minimal contribution of female household heads and spouses can be explained by mothers and wives allocating a major share of their time to housekeeping and child-rearing. Since nearly a third of the landless households' population consisted of children below 10 yr, female household heads and wives could not contribute significantly to the household labor pool.

Because most (about 75%) of the landless workers' income is derived from crop shares and wages in the harvesting and threshing tasks, changes in these tasks have substantial impact on their income. Of 64 landless workers (44 from the irrigated and 20 from rainfed areas), 77.7% reported they had derived income from harvesting jobs before the introduction of mechanized threshing. At present only 66.3% derive income from these jobs. In the rainfed areas, the corresponding percentages are 79.5 to 76.0%. Fifty-five percent from irrigated and 40% from rainfed areas reported decrease in income; 11 and 55%, respectively, report increase in income; 34 and 5% report no change. Among the reasons cited for the decrease are fewer farms to work on, other farm jobs taken, displacement by machines, nonfarm employment, and old age. The reasons for increase in income are increased yields, more farms to work on, and additional family labor.

While 75% of those in irrigated and 35% of those in rainfed areas consider their present better than 5 yr before, 46 and 55%, respectively, perceive that their condition 5 yr ahead will be worse. Reasons cited are more people and fewer jobs, displacement by machines, and decreased harvesting rates.

This pessimism about the future is rather disturbing because many other studies have identified *optimistic fatalism* i.e., the past may be bad, the present worse, but the future is always bright. Farmers' reasons for the pessimistic assessment of the future are also very perceptive. Can we stop or reverse these disturbing developments?

The landless households make up 14% of farm households in 8 villages. Although there is a slight tendency for more landless to be present in irrigated areas, this is not always the case. Hence a better explanation has to be found for the greater or lesser presence of the landless in a particular locality.

To those who would argue that alternative employment opportunities are

available or could be made available, the most potent retort could be: "Like what?"

The following evidence deserves serious thought:

1. IRRRI data show that 53% of farm household members have no work outside their own farm and 25% who do, are also engaged in agriculture jobs. Sixteen percent are in services. Ninety-eight percent of the landless workers in the sample indicated that their first job at present is in agriculture.
2. Malabuyoc's (7) data on work opportunities for farm households indicate that about two-thirds do not have other sources of household income. The situation has not changed much in this regard from 1977 to 1984 (Table 19). Nonagricultural sources dropped from 25 to 3% of the reporting households, with a corresponding shift toward more households receiving income from children who have left the household — 6 to 24%. Eighty-three percent work on their own farms and, in addition, 31% work on other farms.

The results of these studies suggest the following:

1. Employment in and income from rice production is more important to landless than to farm households, to low-income than higher-income farm households, and to farm households with less access to resources.

Table 19. Work opportunities of farm households (7).

	1977 n = 83	1984 n = 72
Other sources of household income (%)		
Nonagricultural	25	3
Miscellaneous	2	11
Income from children separated from household	6	24
None	67	62
Household size (no.)	7.9	6.3
Do family members work on their own farms?		
	n	Percent
Yes	60 ^a	83
No	12	17
Total	72	100
Do family members work on other farms?		
	n	Percent
No	50	69
Yes	22 ^b	31
Total	72	100
Nature of work done		
Weeding	12	
Land preparation	5	
Harvesting	2	
Clearing of dikes	1	
Planting	2	

^aSon, 45; wife, 11; son-in-law, 2; daughter, 1; others, 3. ^bSon, 12; household head, 5; daughter, 3; wife, 2.

2. The household's developmental cycle affects the labor allocation of its members. During the second stage when children are growing up, women increase their contribution to rice production.
3. Introduction of certain technologies, such as change from small harvesting knife to the sickle, direct seeding, dry seeding, and the mechanical thresher, contributes to a reduction in total labor use, particularly in hired labor. Despite the decline in female labor, however, women of low-income households remained heavily involved in rice production.
4. Rice production tasks, particularly harvesting, are an important source of rice for home consumption of sugar workers. On the other hand, sugarcane harvesting is a supplementary source of income for households in rice growing areas. The distressed state of the sugar industry makes this opportunity to participate in rice harvesting even more crucial. On the other hand, sugarcane harvesting is less likely to be available to rice production workers now.
5. Most of the income of landless households is derived from crop shares and wages in harvesting and threshing; hence, any changes in technology which displace labor make landless workers pessimistic about the future.
6. Employment outside agriculture is limited for farm households and almost nonexistent for the landless.

MEMBERSHIP AND LEADERSHIP IN IRRIGATION ORGANIZATIONS AND OTHER FARM-RELATED MATTERS

Illo (5) makes a significant contribution to our understanding of female participation in organization and leadership activities in her intensive analysis of experiences in two irrigation projects, Aslong and Zona Cuatro, in southern Luzon. Her data belie the general impression that women leave involvement in development projects to their menfolk, as evidenced by the following observations:

1. *"In both the areas studied, a number of women, married or widowed, displayed considerable interest in the irrigation project, attended meetings and joined field inspections of proposed location of irrigation facilities. Together with the men, women engaged in discussions which would determine the canal layout in their area, attributing their interest to their desire to ensure that water would reach their farms with the minimum loss of land to canals. Even among households which would not benefit from the projects, women tended to register concern as to how the construction of project facilities would affect their property. While in the majority of cases the men were more actively involved in working the land, ownership of the land or the right to cultivate it and management of the farm were shared by women with their spouses. Moreover, while care of the children and management of the house remained the dominant occupations of women in the two project sites, a number of these women attended to association or project matters either on their own behalf or of their spouses." It appeared that when women were adequately informed*

about the project and their interest sufficiently aroused, they could accommodate project demands on their time. Furthermore, where the organization allowed more than one member from each household, the proportion of female to total membership rose. In Aslong, where the "one household, one member" rule was observed, women accounted for but 10% of the total membership. In Zona Cuatro, where multiple ownership of households was possible, the proportion of female members rose to about 20%.

2. *While a number of women became active participants in the irrigation projects in Aslong and Zona Cuatro, the majority of women in the two areas shied away from direct involvement. One reason which these female nonparticipants shared with the less active male members was preoccupation with family matters . . . This, however, does not necessarily imply that they totally withdraw from projects or organizational affairs. A number of these female nonmembers attended meetings and sometimes engaged in on-site negotiations over canal routes. They deemed themselves nonparticipants primarily because they are not registered members of rotational-area groups or of the irrigators' association.*
3. *The Aslong and Zona Cuatro experiences underscore the fact that beyond what formal records often showed, women were interested in programs and projects affecting the household's economy. When allowed or encouraged to participate, they had considerable impact. They served as leaders, improved attendance during meetings and other activities, and lent firmer support to the contributions which their respective households had to make to the irrigators' association. Female leaders assisted in the negotiations for rights of way, record keeping, and management of association finances. The employment of female community organizers provided the farmers immediate role models or active female participants in the project. The experience in Zona Cuatro indicated that when organizers initially chose some female contact leaders, and subsequently arranged membership rules to open up membership to women, greater female participation was stimulated.*
4. *The effect of fielding community organizers, however, needed to be reinforced by the organizers' overt or covert efforts to encourage female participation in the project. This might mean, as in Zona Cuatro, going along with the community's initial predisposition to involve women in the project. In areas where sex-based prejudices inhibit women's participation, discussing the project with both men and women could constitute the first step. A second move could be opening up the association membership to households, with husband and wife as alternate representatives. These two-step opening moves present attractive starting points for rousing women's interest in the project and for allowing them to directly engage in project activities."*

Illo (5) points out that although women in the Philippines are not as intimately associated with agriculture as women in Africa, *preoccupation with their households' economy governs their interest in projects like irrigation in Aslong*

and Zona Cuatro. The focus is on the likely effects which these projects would have on their farm and, by extension, on their family's chances of survival.

Rebancos (8) reported on women's participation in upland barangays. Their attitudes toward participation in community activities and projects of the Buhi-Lalo Upland Development Pilot Project are reflected in the following:

1. By participating in community activities, 73% of 132 women members of the community organization think they can gain more knowledge than by doing household work. (The association deliberately recruited not only men but also women.) Women believe they are able to learn more about agricultural production when they participate in the project. They likewise attach a great deal of value to new experience or knowledge in the use of new technology. This value given to gaining new knowledge about agriculture comes despite the fact that 65% of them reported devoting only 3 h or less daily to physical farm activities.
2. Of even greater interest is their reaction to this statement: "If my husband wants me to stay at home for household affairs rather than participate in community activities, then I shall prefer to stay at home." Fifty-seven percent of the women respondents disagreed or strongly disagreed. In other words, the husband's word does not seem to be the "law" on this matter although 32% still chose the traditional "wife is for the home" response.

All these experiences point out the untapped potential of women not always as laborers but as farm managers, entrepreneurs, organizers, and leaders. What do we need to do to allow these potentials to blossom?

IMPLICATIONS

This empirical evidence leaves us four major issues to think about.

First, since women's involvement in rice farming systems is mainly in transplanting and harvesting as seasonal labor, and since earnings from these tasks performed by women from lower-income, less resource-endowed farm families, and landless households are a substantial contribution to family income, any technologies or institutional arrangements which take these tasks away from them will always have adverse consequences on their welfare. Studies on impact of technology should focus not just on farmers but also on the landless. Are the increases in productivity attributed to such technologies sufficient to offset the social costs to other sectors of the community? Also worth noting is that many farm households themselves seem to be undertaking production tasks which they used to leave to the landless or poor farm households. Was the "ethic of sharing" with the less privileged people of the community diminished?

Second, it is obvious that nonagricultural jobs are limited for farm household members and almost nonexistent for the landless who, in general, are less qualified for alternative jobs. During these hard times, can we consider institutional mechanisms such as deliberate labor recruitment during season

of peak labor as one alternative or complement to inventing machines to break labor "bottlenecks?" Furthermore, when we develop technologies to relieve people of drudgery, we must consider the possibility that *one woman's drudgery may be another woman's livelihood.*

Third, although women from farm households do not do as much work in the physical production of rice, farmers' wives are very much involved in the decisions concerning resource allocation in farm management. Can we provide these women exposure to the science, technology, economics, and even welfare considerations of rice farming systems to improve the quality of their farm management decisions? They must be deliberate recruits into relevant training programs, especially those dealing with livestock production. The present realities require greater sophistication in the intricacies of farm management because resources are limited and costs are high.

Fourth, in our organizational efforts for agricultural projects, the door must be left wide open for the entry of women as leaders, organizers, and trainers.

As scientists and technology developers, we can no longer be cavalier and say: "my responsibility is to develop technology; it is not my task to increase employment and worry about the landless." If we cannot create new jobs, we must at least try to protect those that exist, especially for people whose alternatives in life are limited.

There are two illustrations of available technologies which have direct implications for women's employment and income-earning opportunities. Coxhead's (2) study in 4 barangays of Gapan found that by 1984 there was almost 100% adoption of *wet seeding* which started in 1975. The change from transplanting to wet seeding also meant a shift from hired to family labor. Fully two-thirds of the work force for wet seeding is provided by the farmer and his family, with contributions from exchange labor especially in broadcasting of seeds. Wet seeding increased the use of herbicides and fertilizers by 23% each and seeds by 70%, but yield difference between transplanted and wet seeded plots is only 8.5%. However, the use of family labor has reduced the real cost of rice production for the farmer. Interviews with *kabesilyas* (transplanting contractors) indicate that "amount of labor available for transplanters and weeders has fallen by half in the last 5 yr. The size of the transplanting gang has reduced from 70 regular members to just more than 30. Less than 10% of them cultivate their own rice farms. Two-thirds to three-fourths of members are women for whom opportunities to travel in search of alternative employment were limited. None of the gang members had nonfarm jobs. After transplanting, most simply waited for the harvest."

And if the harvesting task is also taken over by some other technology, then there is little or nothing to wait for.

The second illustration is that of the *mechanical reaper (harvester)* which has just come into the Philippine scene in rice farming. Crissman (3) described the origin of the reaper and doubts about its appropriateness:

An IRRI design and a comparable design by the Kubota Company of Japan were both introduced in 1982. The IRRI design was the result of collaborative efforts between the Chinese Academy of Agricultural

Mechanization Sciences and the Agricultural Engineering Department of IRRI. The IRRI blueprint was made available to local producers, the four major producers being located in the provinces of Pampanga, Bulacan, and Rizal. Between three to four hundred local reapers are estimated to have been sold between late 1982 and June of 1984.

In 1981, the Economics Department and the then separate economics section of Agricultural Engineering at IRRI decided to collaborate on an analysis of the impact of the mechanical reaper. This was prompted by doubts as to the appropriateness of reaper use in a situation such as we have in the Philippines. In the as yet unpublished collaborative analysis of the reaper, the problem is referred to as "the potential of this machine for substantial displacement of . . . hired labor." Our economists have already been able to calculate the amount of labor that is displaced per hectare when the reaper is used so there is no need to discuss whether displacement exists. The appropriateness of the reaper is called into question because it displaces labor in areas where it has been introduced in the Philippines, a country which has a large rural labor force and in which harvesting provides a significant share of hired labor's income. In other words, this may be a case of the right machine being in the wrong place. The question is — when the reaper "frees" this labor, what does labor do instead?

Crissman's findings from Barangay General Lim in Orion, Bataan, include the following:

1. Harvesters do not only fieldwork but a variety of other income-generating activities all of which are important to them.
2. Some laborers have access to land (mostly as squatters on marginal areas) which they cultivate and some do not, but only a few are technically termed "farmers" and therefore eligible for government assistance such as productive loans.
3. People who do or have done harvesting agree that there are far fewer harvesting jobs available now because of reaper use. The harvest season, for them, has become far shorter in terms of employment opportunities. (Some employment in harvesting is still available especially in the wet season when the mechanical reapers bog down in the fields, but overall, people indicate that the duration of the harvest season has been halved and that employment is difficult to obtain. Consequently more people vie for the jobs that do exist. Since payment for harvesting is pakyawan — a set price for a given area — the more people who harvest, the lower the pay.)
4. Seasonal in-migration of rice harvesters from other provinces has more or less ceased due to reaper use.
5. A large percentage (67%) of offspring who establish their own households do so outside the barangay.
6. Employment for adult offspring in the sample households is 43% for those who stay in the barangay and 31% for those who leave the barangay.

7. Most nonagricultural types of income generation within the barrio are illegal or environmentally degrading.

8. Employment outside the barrio is difficult to obtain . . .

Given the apparent "negative" indications of impact from these two technologies with respect to employment opportunities for the agricultural landless and lower-income farm households including women, can we look to developments in the cropping-farming systems to open new potentials, not only for output growth but also for labor absorption?

An early statement from IRRI describing cropping pattern testing says that "a pattern *fits* if it produces more food and farmers accept it." A more recent description of IRRI's Rice-Based Farming Systems Program (1984) states that "evaluation of farming systems changes through introduction of new technology is made not only in terms of impact on income, but also in terms of effects on family and hired labor and nutritional and social factors." A further elaboration is made by the IRRI director-general (28 Nov 1984) with regard to the aim of the internetwork coordination (International Rice Testing Program, International Soil Fertility and Fertilizer Evaluation for Rice, and the Asian Rice Farming Systems Network): "To generate a vast pool of knowledge based on sound principles of ecology, economics, energy conservation, and employment generation."

In other words, wet seeding and the mechanical reaper are probably best regarded as components of the farming system and their impact will have to be viewed in terms of the total system. The role of women in the total farming system must therefore be identified and defined if we are to monitor the impact of changes in the system or in any of its components on women's welfare.

ACKNOWLEDGMENT

The author acknowledges the assistance of Laarni Atienza, IRRI Department of Agricultural Engineering. Data for the first part of this paper was made available by B. Duff, IRRI Department of Agricultural Engineering, from the project "The Consequences of Small Rice Farming Mechanization in the Philippines."

REFERENCES CITED

1. Dascug, M.N. 1981. Decision-making and leadership patterns of rural women in two Leyte villages, Philippines. MS thesis, University of the Philippines at Los Baños, Philippines.
2. Coxhead, I.A. 1984. The economics of wet seeding: inducements to and consequences of some recent changes in Philippine rice cultivation. Master of Agriculture Development Economics thesis, Australian National University.
3. Crissman, L. 1985. Livelihood among landless laborers after introduction of mechanical reapers. International Rice Research Institute seminar, June 1985.
4. Ebron, L.Z., G.C. Castillo, and P.M. Kaiser. 1983. Changes in harvesting-threshing arrangements and landless laborers. Working Pap. 90, The Consequences of Small Rice Farming Mechanization Project, International Rice Research Institute.

5. Ilo, J.F.I. 1984. Women's participation in two irrigation projects in the Philippines. Development Academy of the Philippines.
6. Ilo, J.F.I. 1983. Wives at work: patterns of labor force participation in two rice-farming villages in the Philippines. Paper presented at the Conference on Women in Rice Farming Systems. International Rice Research Institute, 26-30 Sep. 1983.
7. Malabayoc, M.M. 1985. Farm labor patterns of rice farmers in selected areas in Laguna. MS thesis, University of the Philippines at Los Baños, Philippines.
8. Rebancos, C. 1984. Women's participation in selected upland barangays in Buhi, Camarines Sur. MS thesis, University of the Philippines at Los Baños, Philippines.
9. Res, L. 1983. Changing labor allocation patterns of women in rice farm households - a rainfed rice village, Iloilo Province, Philippines. Paper prepared for the Conference on Women in Rice Farming Systems, International Rice Research Institute, 26-30 Sep.
10. Rutten, K. [1983]. Women workers of Hacienda Milagros; wage labor and household subsistence on a Philippine Sugarcane Plantation. Pages 107-108 in No. 3 Publikatreserie Zuid en Zuidoost-Agie Antropologisch -Sociologisch Centrum Universiteit van Amsterdam.
11. Torreta, D.M., M.J. Tubelleja, M.U. Garcia, R.C. Piadozo, C.B. Colanta, and V.P. Fernandez. 1984. Rural women in rice enterprise: a case study. In FAO-NEDA project on Linking Rural Women's Production, Enterprise to Family Benefits and to Country Programmes. College of Human Ecology, University of the Philippines at Los Baños.

RECOMMENDATIONS

Strengthen the work of international institutions, programs, and donors

1. Place less effort on on-site adoption of mechanization and more on new areas such as upland mechanization and farming systems.
2. Identify problems and create methodologies for national programs to use: establish problem priorities, select interdisciplinary teams, schedule technology introduction, obtain institutional support, and develop appropriate national policies. The international institutions should concentrate on development of machines that national programs cannot handle.
3. Counterbalance technologies developed through multinational firms, such as genetic engineering of crop varieties that requires manufactured inputs.
4. Continue to create methodologies, promote technology exchange, generate improved technology, create information data banks, standardize terminology, facilitate academic training, train trainers for national programs, and assure free flow of information.
5. Provide information to those who frame national policies by researching the implications of technology on production, resource allocation, and economic impact of technologies.

Improve agricultural mechanization in mid-Africa

1. Recognize needs of semi-arid areas: better weed control; emphasis on hand tools, especially sprayers; use of animal power, especially donkeys; improvement of intercropping systems; improved water harvesting methods; postharvest technology for drying and storing; processing feed for intensive animal production; erosion control; firewood plantation development; and small enterprise development.
2. Recognize needs of the humid tropics: minimum or zero tillage to conserve soil and water and maintain fertility; agroforestry and fodder crops to forestall desertification; and postharvest processing, especially of root crops.
3. Improve preharvest operations by applying equipment innovations based on human and animal power that need little adaptive development, integrating them with soil and water management, and providing training and extension to manufacturers and farmers.
4. Improve postharvest operations, including solar crop drying and mechanical drying using alternative energy sources.
5. Improve primary processing of food for local market and feed for livestock, including cassava, gari, fermented soya, banana drink, and flour.
6. Improve agro-industries for processing and packaging based on local materials.
7. Provide the institutional framework by strengthening linkages between engineering R & D and farming systems programs and manufacturers, and between farmers and farming system programs and manufacturers and their after sales service.

Strengthen national institutions

1. Help strengthen national institutions with roles in research, development, and extension of agricultural mechanization; facilitate their work with inventors, manufacturers, and farmer associations; and help them formulate mechanization policies.
2. Strengthen linkages between international and national institutions.
3. Encourage basic research in international institutions and applied research in national institutes.
4. Continue the Industrial Extension Program of IRRI as a successful model of technology dissemination in order to further strengthen national institutes and sustain national agricultural mechanization development.
5. Provide training, particularly on machinery design, and exchange experts between IRRI and national institutes.
6. Ensure appropriate mechanization technology through socioeconomic research.

Stimulate local innovations and manufacture of small farm equipment

1. Strengthen national technical, engineering, and industrial services and orient them to serve small and medium size manufacturers.
2. Stimulate small-medium scale entrepreneurship through improved national policies and liberal credits from industrial financial institutions.
3. Establish an integrated national program for upgrading capabilities of small-medium industries and entrepreneurs, with appropriate policies for technology, training, management, and manufacture. Provide raw materials; training in use of jigs, fixtures, and tool engineering; awareness of quality control, standardization, and cost analysis.
4. Interlink international aid agency programs with cooperation between R & D institutions and manufacturers at national and regional levels.
5. Facilitate these objectives by IRRI's: development of the model draft of the memorandum of understanding between R & D institutions and manufacturers; promotion of wetland and dryland equipment developed and manufactured by developing countries; expansion of its industry service program through collaboration with donor agencies and industrial organizations such as UNIDO, stressing local production and strengthening of national engineering technical services; development of pilot demonstration programs for national use, financed by international donors.

Improve marketing and accessibility of agricultural equipment for small farmers

1. Evaluate appropriateness of hand tools, small human- and animal-powered equipment, and power equipment.
2. Consider marketing alternatives for hand tools such as through local blacksmiths, in village markets and hardware stores, through mail order, and through cooperatives and farmer associations.
3. Strengthen distribution of small human and animal powered equipment by encouraging government and private organizations to train local manufacturers and users; encourage government to supervise quality control at the introductory stage; encourage private distributors to use commissions and bonuses to stimulate sales.
4. Facilitate marketing of power equipment by encouraging appropriate national mechanization policies for selection of equipment to be introduced, pricing, and imports; encouraging custom hiring cooperatives and individual hiring enterprises; encouraging government and banks to provide special credit for establishing such enterprises; and providing subsidies for equipment users, avoiding use of farmland as collateral.
5. Encourage IRRI to concentrate on defining priorities, restricting introduction of new equipment to a few selected manufacturers and dealers, allowing them to make a profit and thus improve quality and marketing; provide market research; and improve feedback from national adoption programs.

Identify characteristics of appropriate equipment for small farms

1. Identify characteristics of small farmers before selecting and designing equipment, assess farmers' needs and socioeconomic status, and facilitate interaction between engineers, other professionals, and users.
2. Identify farming/cropping systems of farmers, including constraints which mechanical intervention can alleviate.
3. Provide more attention to animal-powered equipment.
4. Consider physical stress on users and user safety.
5. Develop local power sources and match implement design to those sources. Use materials and fabrication techniques that produce energy-efficient equipment.
6. Introduce reliable equipment with short payback period.
7. Develop machines for incorporating organic matter, improving soil properties, and reducing weed populations.
8. Design equipment that uses standardized parts and can be repaired and serviced at the village level.
9. Design simple machines, yet ones that can accept attachments for different operations.
10. Remember the basic design criteria: economically viable, technically feasible, and socially acceptable.

PARTICIPANTS

- N. Agdepa, Ministry of Trade and Industry, Tordesillas St., Buendia Avenue Extension, Salcedo Village, Makati, Metro Manila
- A. Alam, c/o Indian Council of Agricultural Research, Krishi-Bhavan, New Delhi, India
- E. Ananto, Sukamandi Research Institute for Food Crops (SURIF) - Balai Penelitian Tanaman Pangan, Sukamandi Subang, West Java, Indonesia
- N.K. Awadhwal, ICRISAT, Patancheru P.O., Andhra Pradesh, India
- A. Baclig, Philippine Packing Corporation, P.O. Box 503 Commercial Center, Makati, Metro Manila, Philippines
- Z. Bardaie, Faculty of Agricultural Engineering, Universiti Pertanian Malaysia Serdang, Selangor, Malaysia
- G. Barnes, Tanganyika Christian Refugee Services (TCRS), P.O. Box 3955, Dar es Salaam, Tanzania
- E. Bautista, Agricultural Engineering Department, IRRI, Los Baños, Laguna, Philippines
- J. Beduya, AMMDA, c/o Makati Machineries, 1142 Pres. Quirino Avenue, Paco, Metro Manila, Philippines
- R. Bell, National Institute of Agricultural Engineering, Wrest Park, Silsoe, Bedford MK45 4HS United Kingdom
- L. Bernas, AMMDA, c/o Makati Machineries, 1142 Pres. Quirino Avenue, Paco, Metro Manila, Philippines.
- C. Bielenberg, Appropriate Technology, 1331 H Street N.W. Washington D.C. 20005, USA
- C.W. Bockhop, Agricultural Engineering Department, International Rice Research Institute, Los Baños, Laguna, Philippines
- A. Bose, Comilla Cooperative Karkhana Ltd., Ranirbazar, Comilla, Bangladesh
- W. Broehl, The Amos Tuck School of Business Administration, Dartmouth College, Hanover, New Hampshire 03755, USA
- R.J. Buresh, IFDC, Agronomy Department, International Rice Research Institute, Los Baños, Laguna, Philippines
- K.M. Butt, Sayyed Machinery Ltd., 65 Shahrzh-3-Quaid-e-Azam, Lahore 3, Pakistan
- J. Campbell, Agricultural Engineering Department, Cornell University, Ithaca, New York 14850, USA
- G.T. Castillo, Department of Agricultural Education, University of the Philippines at Los Baños, College, Laguna, Philippines
- C. Chakkaphak, Agricultural Engineering Division, Department of Agriculture, Bangkok, Bangkok 9, Thailand
- W. Chancellor, Department of Agricultural Engineering, University of California, Davis, California, 95616, USA
- W. Chinsuwan, IRRI Thai-Cooperative Project with the Ministry of Agriculture and Cooperative, G.P.O. Box 9-159, Bangkok, Bangkok, 10900, Thailand
- B.J. Cochran, IRRI-Thai Cooperative Project with the Ministry of Agriculture and Cooperative, G.P.O. Box 9-159 BKN Bangkok 10900, Thailand

- P. Datt, CIAE-IRRI Industrial Extension Project, Lawley Road, Coimbatore, 641003, India
- C. del Rosario, CEAT, University of the Philippines at Los Baños, College, Laguna, Philippines
- H.J. Dibbits, Department of Agricultural Engineering, Agricultural University, Wageningen, Monsholtlaan 12 Wageningen, Netherlands
- G. Donovan, 1-8-153 The World Bank, 1818 H Street, N.W., Washington, D. C. 20433 USA
- B. Duff, Agricultural Engineering/Economics Department, International Rice Research Institute, Los Baños, Laguna, Philippines
- M. Esmay, Department of Agricultural Engineering, Michigan State University, East Lansing, Michigan, 48824, USA
- J. Farrington, 37 Warren Road, Woodley, Reading RG5 3AR United Kingdom
- D. Gee-Clough, Division of Agriculture and Food Engineering, Asian Institute of Technology, G.P.O. Box 2754, Bangkok, 10501, Thailand
- N. Gonzales, Ministry of Agriculture, Quezon City, Philippines
- B. Gonzalo, Bureau of Plant Industry, San Andres St., Malate, Metro Manila, Philippines
- P. Gregory, University of Reading, 4, Earley Gate, Whiteknights Road, Reading RG6 2AR, England
- M. Guntz, Farm Mechanization Research Center, FMRC-German Team, Maha Illuppallama, Sri Lanka
- M. Hammond, Cooperative IRRI-Burma, Project, P.O. Box 136, Rangoon, Burma
- A. Haq, Agricultural Engineering Department, BARC, Joydebpur, Bangladesh
- Tung Mang Hoang, The Institute of Agricultural Engineering, Quan Dongda, Hanoi, Vietnam
- S. Hulangamuwa, Farm Mech. Research Center, FMRC-German Team, Maha Illuppallama, Sri Lanka
- Y. Ikeda, Faculty of Agriculture, Kyoto University, Oiwakecho, Kitashirakawa, Sakyo-ku, Kyotoshi, Japan
- Wan Ishak Ismail, Faculty of Agricultural Engineering, Universiti Pertanian Malaysia, Serdang, Selangor, Malaysia
- B.K.S. Jain, B.K.S. Jain & Associates, 7 Neeltarang, 208 Savarkar Marg Bombay 400016, India
- Y.W. Jeon, Agricultural Engineering Department, International Rice Research Institute, Los Baños, Laguna, Philippines
- A.B. Karki, Agricultural Tools Factory Ltd., Post Office Box No. 2, Birganj, Nepal
- A.U. Khan, Agricultural Engineering Department, International Rice Research Institute, Los Baños, Laguna, Philippines
- R. Lantin, RNAM, University of the Philippines at Los Baños, College, Laguna, Philippines
- M. Le Moigne, Centre d'Etudes et d'Experimentation du Machinisme Agricole Tropical, Parc De Tourvois 92160 Antony, France
- Bai Ling, Chinese Academy of Agricultural Mechanization Sciences #1 Beishatan, Deshengmen Wai Beijing, China
- E. Lozada, CEAT, University of the Philippines at Los Baños, College, Laguna, Philippines
- J. Mamat, Crop Protection Division, MARDI, Serdang, Selangor, Malaysia
- A. Mandac, Agricultural Economics Department, International Rice Research Institute, Los Baños, Laguna, Philippines
- F. Mateo, Jr., Board of Engineering Professional Regulation Commission, P. Paredes St., Sampaloc, Manila
- R. Maxon, Programa de Estabilizacion de Precios en Investigacion de Mercadeo en Honduras Apartado Postal No. 727 Tegucigalpa, D.C., Honduras
- B. May, Silsoe College, Silsoe, Bedford MK45 4DT, England
- A. Mitarai, JICA c/o Embassy of Japan, 375 Sen. Gil Puyat Avenue, Makati, Metro Manila, Philippines
- J. Mongkoltanatas, Agricultural Engineering Division, Department of Agriculture, Bangkok 9, Thailand
- G. Muchiri, Department of Agricultural Engineering, University of Nairobi, P.O. Box 30197, Nairobi, Kenya
- H. Muhtar, International Maize and Wheat Improvement Center, Apartado Postal 60641 Londres 40, Mexico 6, D.F.

- H. Musa, Department of Agricultural Engineering, Institute of Agricultural Research, Ahmadu Bello University, P.M.B. 1044, Zaria, Nigeria
- I. Navasero, International Institute of Tropical Agriculture, Oyo Road, P.M.B. 5320 Ibadan, Nigeria
- J. Nichols, CIAE-IRRI Industrial Extension Project, Lawley Road, Coimbatore 641003, India
- K. Northurft, Rangpur Dinajur Rehabilitation Service, G.P.O. Box 618, Ramna, Dhaka 2, Bangladesh
- L.P. Ojha, Central Institute of Agricultural Engineering, Shri Guru Tegh Bahadur Complex, T. Nagar, Bhopal 462003, India
- M. Ole, PADAP/Pagadian City, c/o Australian Embassy, Makati, Metro Manila, Philippines
- N. Prastowo, Maros Agricultural Research Institute for Food Crops (MARIF) - Balai Penelitian Tanaman Pangan Maros, Ujung Pandang, S. Sulawesi, Indonesia
- O. Du Zhi Qiang, Chinese Academy of Agricultural Mechanization Sciences, #1 Beishatan, Deshengmen Wai Beijing, China
- P. R. Quimbao, National Post Harvest Institute for Research and Extension, Food Terminal, Inc., Metro Manila, Philippines
- Q. Z.U. Rahman, RNAM, University of the Philippines at Los Baños, College, Laguna, Philippines
- R. A.A. Swamy Rao, Industrial Operations Division, UNIDO, Vienna International Centre, P.O. Box 300, A-1400, Vienna, Austria
- S. V.R. Reddy, IRRI-DITPROD Industrial Extension Project, P.O. Box 18/KBYPM Pasarminggu, Jakarta, Selatan, Indonesia
- T. A. Rijk, c/o V.P. Operations, Asian Development Bank, P.O. Box 789, Metro Manila, Philippines
- U. K.H. Ryu, Department of Agricultural Engineering, College of Agriculture, Seoul National University, Suweon, Korea
- V. G. Salazar, Agricultural Engineering Department, International Rice Research Institute, Los Baños, Laguna, Philippines
- W. I. Sarmiento, AMTEC, University of the Philippines at Los Baños, College, Laguna, Philippines
- X. U Sien, c/o IRRI-Burma Project, P.O. Box 1369, Rangoon, Burma
- Y. Soedjatmiko, Agricultural Tools & Machinery Dev. Subdirector, Direktorat Bina Produksi Tanaman, Pangan, Pasarminggu, Jakarta, Selatan, Indonesia
- Z. R.E. Stickney, Agricultural Engineering Department, International Rice Research Institute, Los Baños, Laguna, Philippines.
- AA. A. Sukra, Agricultural Engineering Branch, MARDI, P.O. Box 202, University Pertanian, Serdang, Selangor, Malaysia
- BB. N. Teter, c/o Agricultural and Farm Produce Trade Corp., 70 Pansodan Street, Rangoon, Burma
- CC. U Mya Thien, c/o IRRI-Burma Project, P.O. Box 1369, Rangoon, Burma
- DD. B. Uichanco, Agrid Ford, Inc., Femii Building, Aduana St., Metro Manila, Philippines
- EE. M.R. Vega, IRRI, Los Baños, Laguna, Philippines
- FF. S.R. Verma, College of Agricultural Engineering, Punjab Agricultural University, Ludhiana 141004, India
- GG. M. Villaruz, SV Agro Industrial Enterprises, Inc., 65 Commission Civil Street, Jaro, Iloilo City, Philippines
- HH. Trinh Ngoc Vinh, Institute of Agricultural Engineering, The Ministry of Agriculture, Quan Dongda, Hanoi, Vietnam
- II. R. Wijewardene, 133, Dharmapala Mawatha, Colombo 7, Sri Lanka
- JJ. Zhang Bao Zhao, Agricultural Engineering Department, China National Rice Research Institute, Hangzhou, China