

**AT** MICROFICHE  
REFERENCE  
LIBRARY  
A project of Volunteers in Asia

Workshop Equipment: How to Make Twelve Woodworking  
Tools

By: Aaron Moore

Published by: Intermediate Technology Publications  
9 King Street  
London WC2 8HW  
U.K.

Available from: Intermediate Technology Publications  
103/105 Southampton Row  
London WC1B 4HH  
U.K.

Reproduced with permission.

Reproduction of this microfiche document in any form is subject to the same restrictions as those of the original document.

---

# How to make twelve woodworking tools

---

Aaron Moore

---

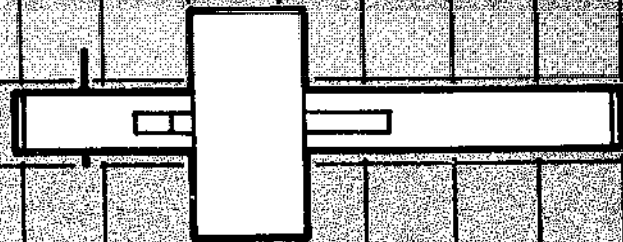
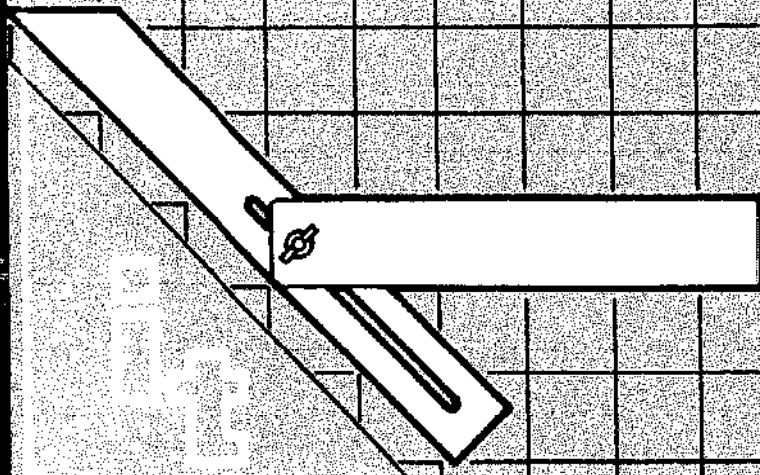
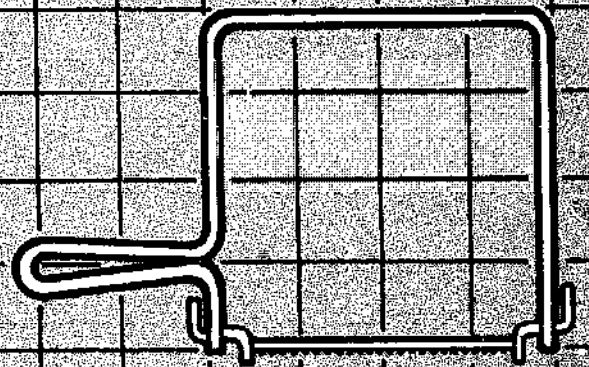
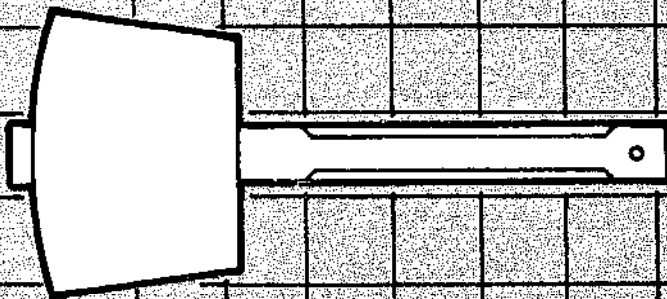
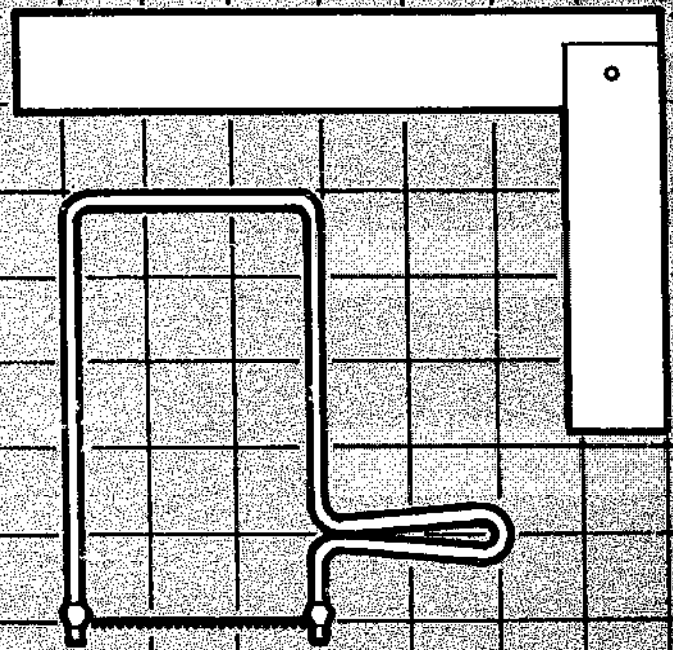
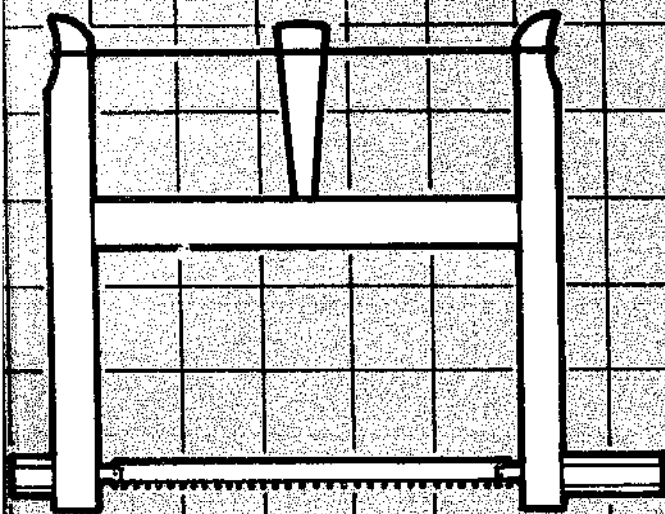

# **How to Make Twelve Woodworking Tools**

*Written and illustrated by Aaron Moore*

Step-by-step instructions on how to make a: Try square, Bevel square, Marking gauge, Cutting gauge, Mortise gauge, Panel gauge, Mallet, Bow drill, Bow saw, Coping saw, Fret saw and Hack saw.

# Acknowledgements

Financial assistance in the production of this manual was made available through the Intermediate Technology Development Group, from a grant given by the Overseas Development Administration. Their assistance is gratefully acknowledged.

The author would also like to thank Rob Hitchings and his colleagues at ApT Design and Development, Blockley, Gloucestershire, UK, who assisted with the publication.

## Contents

	page
Introduction	3
The tools	4
Glossary	5
Metalworking techniques	6
Try square	7
Bevel square	13
Marking gauge	19
Cutting gauge	27
Mortise gauge — Wedge version	35
— Locking screw version	41
Panel gauge	51
Mallet	59
Bow drill	67
Bow saw	75
Coping saw	87
Fret saw	95
Hack saw	101

© Intermediate Technology Publications 1986.  
9 King Street, London WC2E 8HW, U.K.

ISBN 0 946688 53 2

Printed by the Russell Press Ltd., Bertrand Russell House,  
Gamble Street, Nottingham NG7 4ET, U.K.

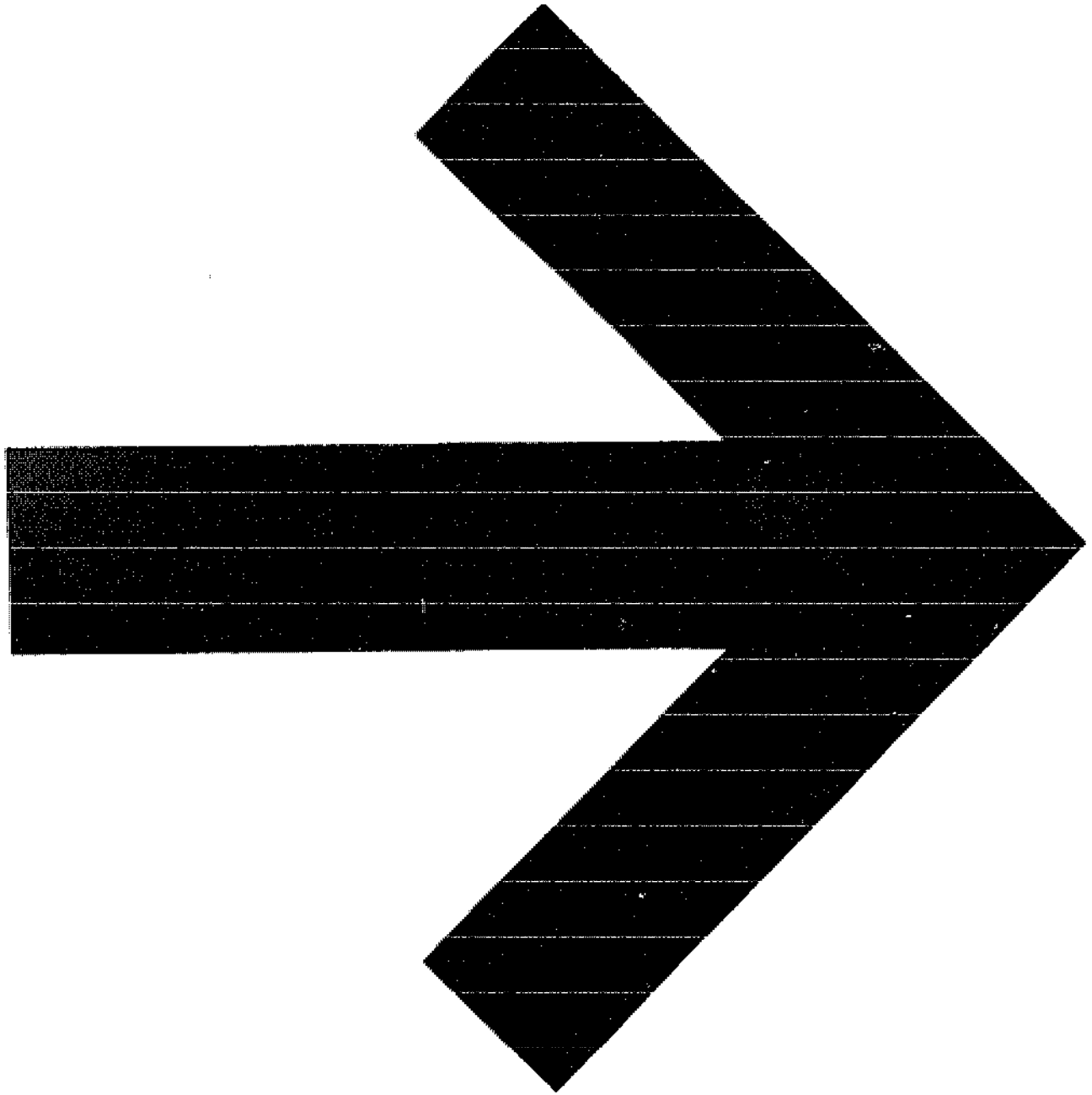

# Introduction

This manual describes, in detail, how to make twelve different woodworking tools. The use of each tool and the directions for construction are in the form of step-by-step illustrations, backed up by a short descriptive text. In most cases the drawings supply all the information necessary, but verbal explanation has been given to minimize error, and to give some extra detail.

The tools described are a: TRY SQUARE, BEVEL SQUARE, MARKING GAUGE, CUTTING GAUGE, MORTISE GAUGE, PANEL GAUGE, MALLET, BOW DRILL, BOW SAW, COPING SAW, FRET SAW and HACK SAW. They are all very practical, cheap to make, and will prove to be useful additions to any carpentry workshop. A craftsman with many different tools to hand is capable of producing more varied and interesting work than one with a limited range. Once you realise you are able to make your own tools you will use them to do more specialized work, and in the process improve your range of skills and products.

These tools have been developed to be made in situations where money is not available to equip a workshop completely with expensive, imported, Western tools. They are appropriate for both large training institutions, where students can make tools for the school and for their own use, or for a small village workshop where the craftsman can make his own tools as and when he needs them. It may even be possible to set up a small tool-making business, supplying schools, colleges and tool shops in the surrounding area.

This is not a carpentry text-book; the author has assumed that the reader has a basic knowledge of woodwork, that he is capable of preparing timber to dimensions, that he is familiar with a number of simple woodworking techniques, and that he has the enthusiasm to overcome set-backs and mistakes.

To begin with, a bench and a good kit of tools, including some whose construction is described in this manual, is essential. This should include a: JACK PLANE, TRY SQUARE, MORTISE GAUGE, HAMMER, CENTRE PUNCH, MALLET, SCREWDRIVER, WHEELBRACE, CARPENTER'S BRACE, SET OF DRILL BITS, VARIOUS CHISELS and an OIL STONE. A PLOUGH PLANE and REBATE PLANE would also be useful but not essential. Not all of these tools are needed to make each design.

It is up to the reader to choose which tools to make, bearing in mind the material and equipment available, and the requirements of the local situation.

The quality of the tools whose construction is described in this manual depends a great deal on the workmanship and the materials used. In many cases the metal parts will have to be bought. Wherever possible, use the best timbers, and take as much time and care in construction as possible.

None of the tools described is perfect, they may require practice to use properly, they may even break; but compare the cost of a home-made tool

and a similar one in a shop. Now also consider the problem of a broken shop-bought tool: spare parts are expensive and often unobtainable, and the cost of a replacement would be greater than the original cost because of inflation. To repair a home-made tool may cost next to nothing. Of course, there is nothing to stop you buying tools once your workshop is making money, on the other hand you may find it unnecessary. But in the beginning is there any other way of starting out with little or no support?

## **The tools**

### **Gauges**

There are four different types of gauge described here, and three methods of locking the fence to the stem. The wedge method (see page 19) is the easiest to make but cannot be used with the single stem mortise gauge. All the other fences use locking screws, and these will work with all of the stems.

### **Squares**

Both the try square and the bevel square are fairly simple tools to make. They are not as durable as those with steel straight edges, but they can be just as accurate.

### **Saws**

All the blades for the saws described must be bought. All but the hacksaw blade may be unobtainable locally, but this can be modified to cut wood and thereby used in the bow saw.

### **The Mallet**

This is one of the simplest tools to make and requires little explanation.

### **The Bow Drill**

This is an adequate solution to the problem of drilling small holes. It may seem out-dated, but it is surprisingly efficient.

The dimensions in this manual are all in millimetres; and for best results they should be adhered to quite strictly unless otherwise stated. Before making a tool, read through the text and follow the drawings until every detail is understood. In many cases the sequence of work is important.

Choose the timber to be used carefully. It must be hard, with a close, straight grain, with no knots or splits, and it must be dry. The wooden parts of these tools can be finished with sandpaper and coated with linseed oil or varnish. Metal parts should have any sharp edges smoothed off with a file, and could be painted with enamel paint.

It is always very important to take account of the direction of the grain of the wood before starting work.

Hopefully the manual will stimulate ideas and imagination, and the reader will think twice before walking into a tool shop.

# Glossary

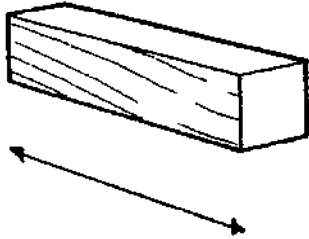

## Grain

The grain is the lines and patterns seen on the surface of a smooth piece of wood. The arrows show the direction of the grain.

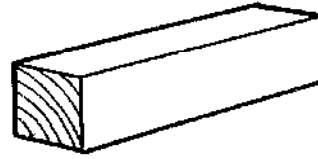

## End grain

This is the term used for the grain at the end of a block of timber. It is shown in this manual, only where necessary, by the shading in this diagram.



## Dowel

This is a small pin of wood with a round cross-section. It is often used to fix wood joints together instead of nails.



## Wedge

A wedge is a piece of timber with its edges forming a shallow point at one end.

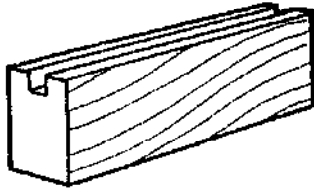

## Groove

A groove is a channel or a hollow cut into one side of a piece of wood.



## Rebate

A rebate is a rectangular recess or step along the edge of a piece of wood.

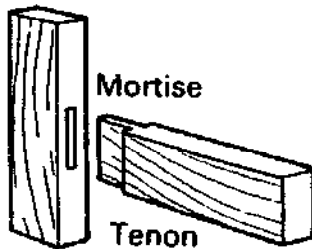

## Mortise and Tenon Joint

This consists of two parts, the mortise, which is a square or rectangular hole, and the tenon, which fits securely into the mortise.

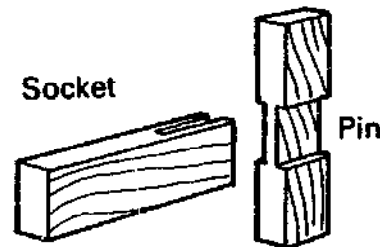

## Bridal joint

The two parts of this joint consist of a socket and a pin.



## Metalworking techniques

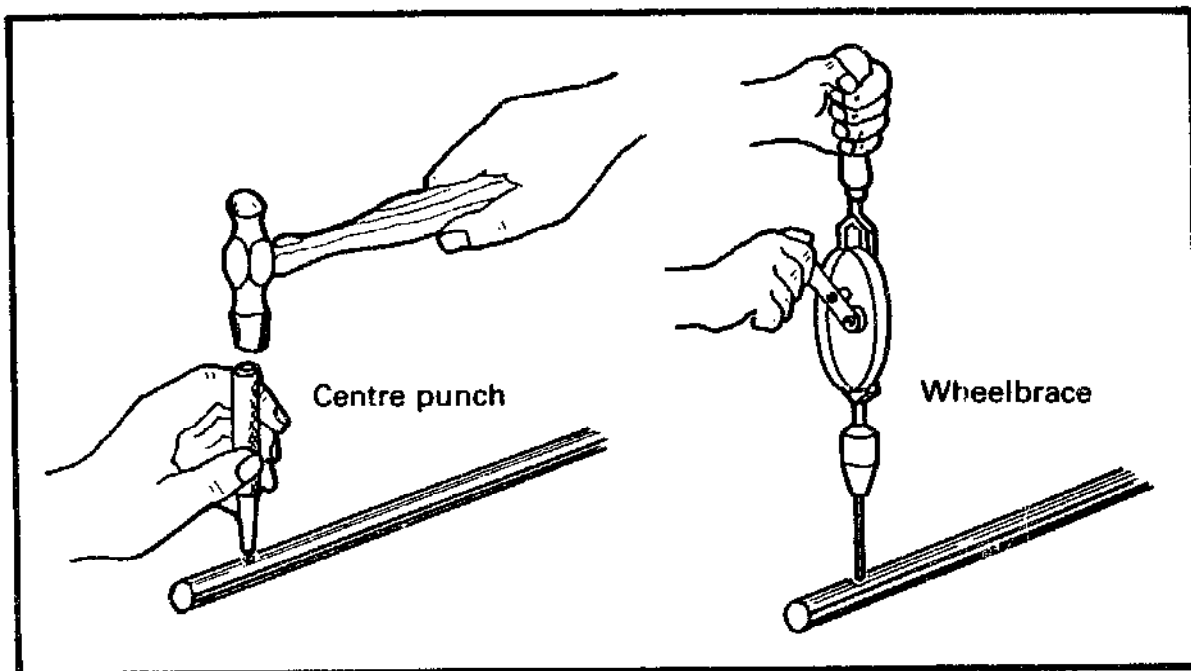

*Drilling a hole.* It is important to punch a small dent in the workpiece first. This will keep the drill bit from wandering off the mark.

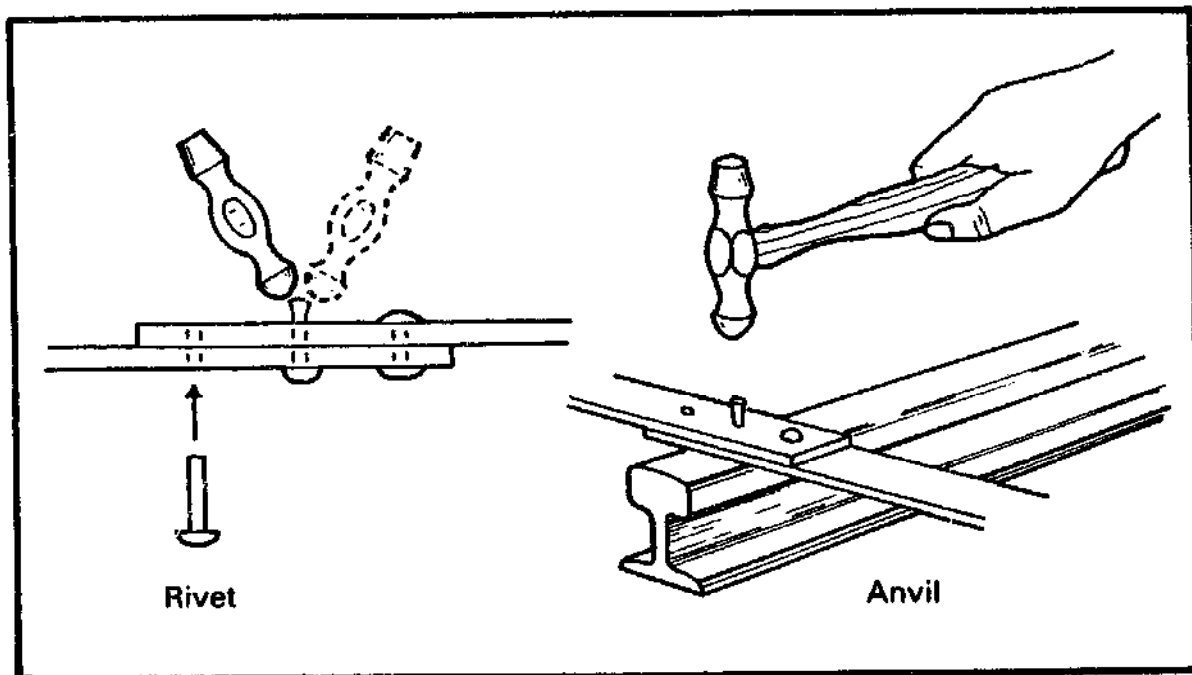

*Riveting.* This technique can be used to fix two pieces of metal, or sometimes a combination of wood and metal, together. Rivets can be bought or made from nails. They should be about 5mm longer than the thickness of the joint. Push the rivet through the hole, and spread the end by hitting it at differing angles round the head with a ball peen hammer.

## Try square

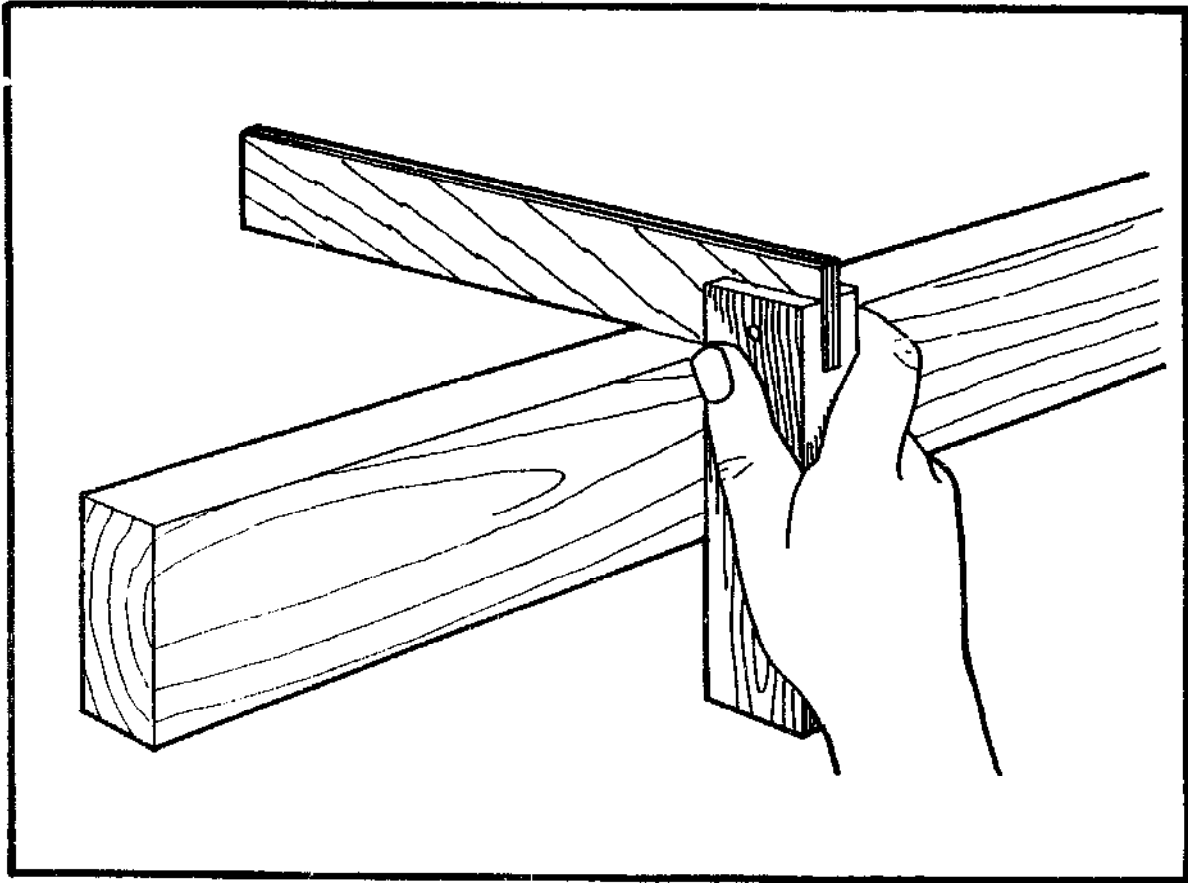

Try squares made of wood are very practical pieces of equipment, and are quick and easy to make. They can be made to any size up to a metre in length; use the dimensions given here only as a guide. When making this tool it is most important that the straight edge and the stock are glued up perfectly square, otherwise all the work done with it will be inaccurate.

A wooden square is not as strong as one with a metal straight edge, and it must be used with care. If the outside edge does become worn or chipped it can be trued up with a plane. A method of checking a square is shown on page 00. If the inside edge becomes damaged, it is better to make a new square than to try to repair the old one.

The outside edge of the straight edge should protrude from the end of the stock by about 5mm. If it does not, the pencil line may be thrown out by the top of the stock.

## LIST OF PARTS

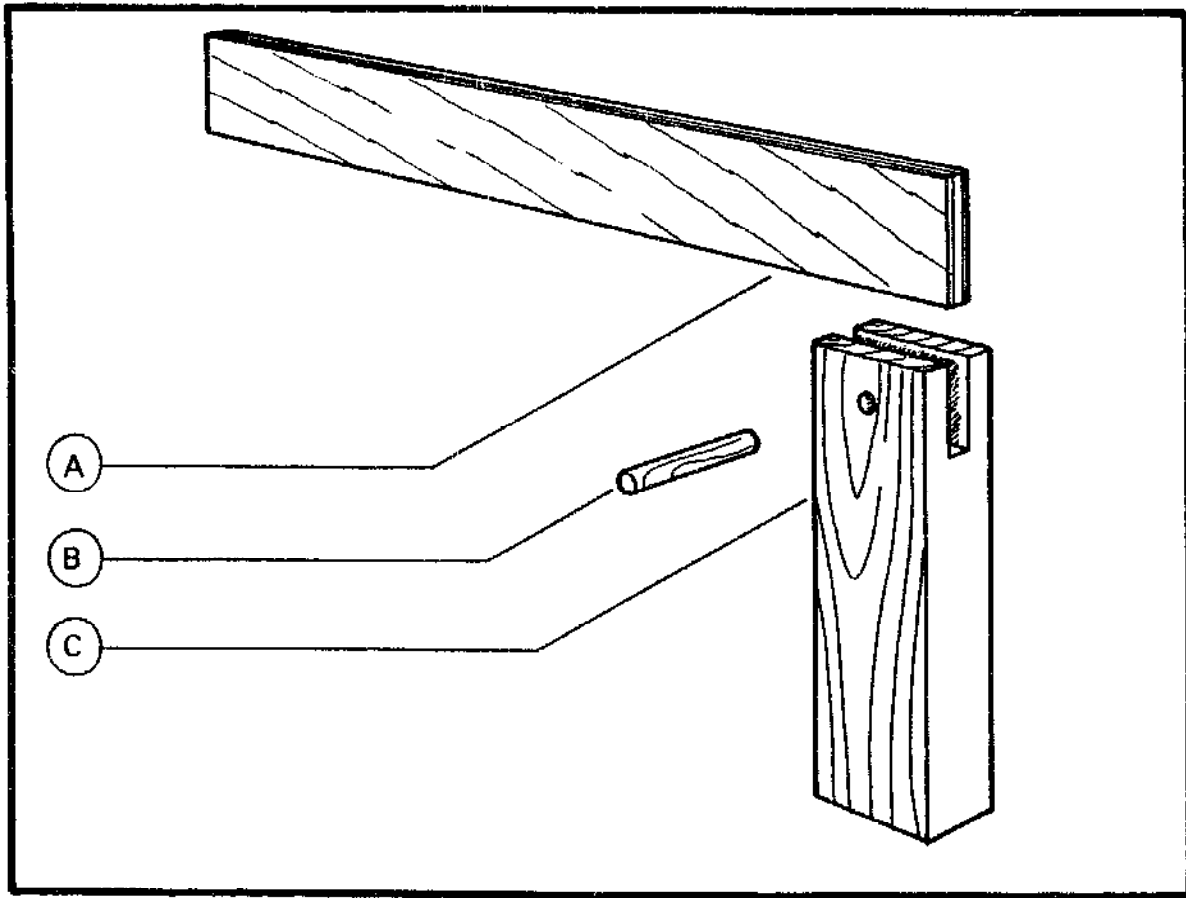

### Part

- A** *The straight edge* is best made from a piece of 6mm or 4mm plywood, but solid wood can be used as long as it is straight-grained and dry.
- B** *A dowel* can be used to secure the two parts together.
- C** *The stock* is made from one piece of timber with a socket for the straight-edge cut out of one end.

### Parts and Cutting List

Part	Name	Quantity, material and dimensions
<b>A</b>	Straight edge	1 pc. plywood 250mm × 50mm
<b>B</b>	Dowel	1 pc. 6mm timber dowel
<b>C</b>	Stock	1 pc. timber 200mm × 50mm × 20mm

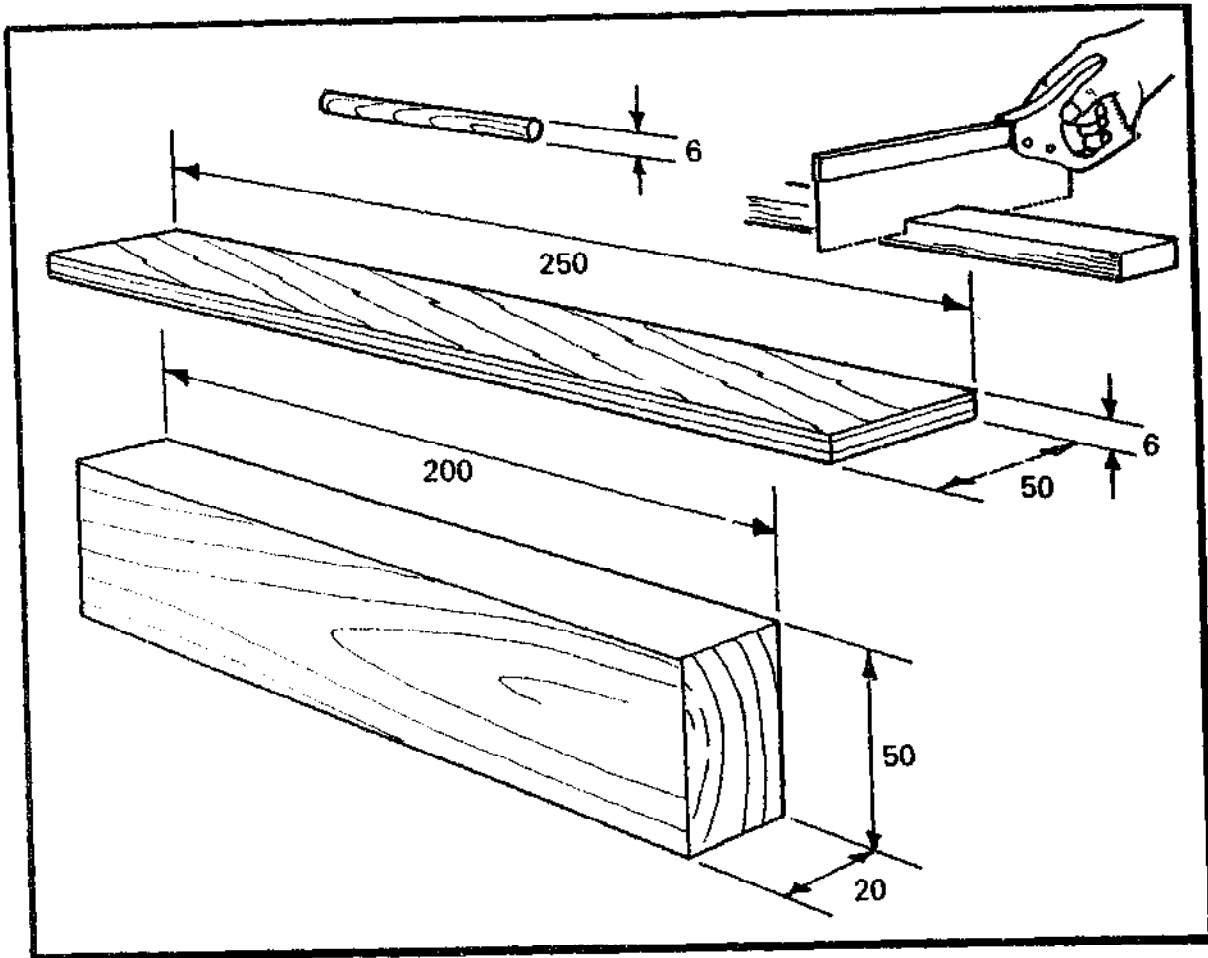
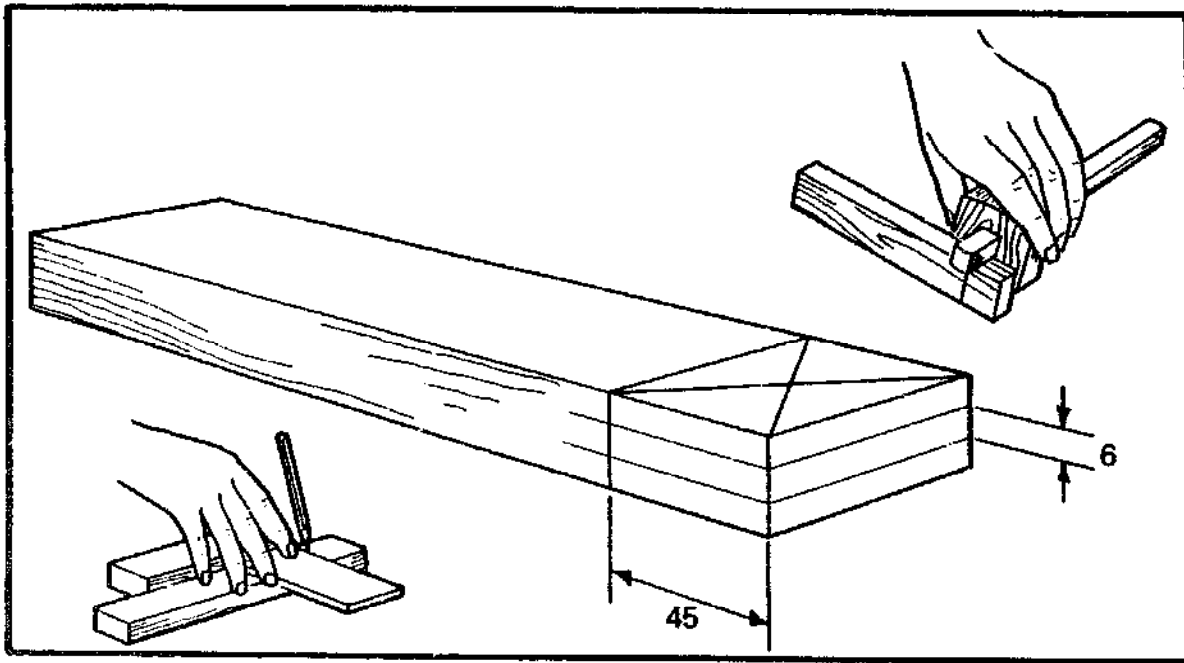
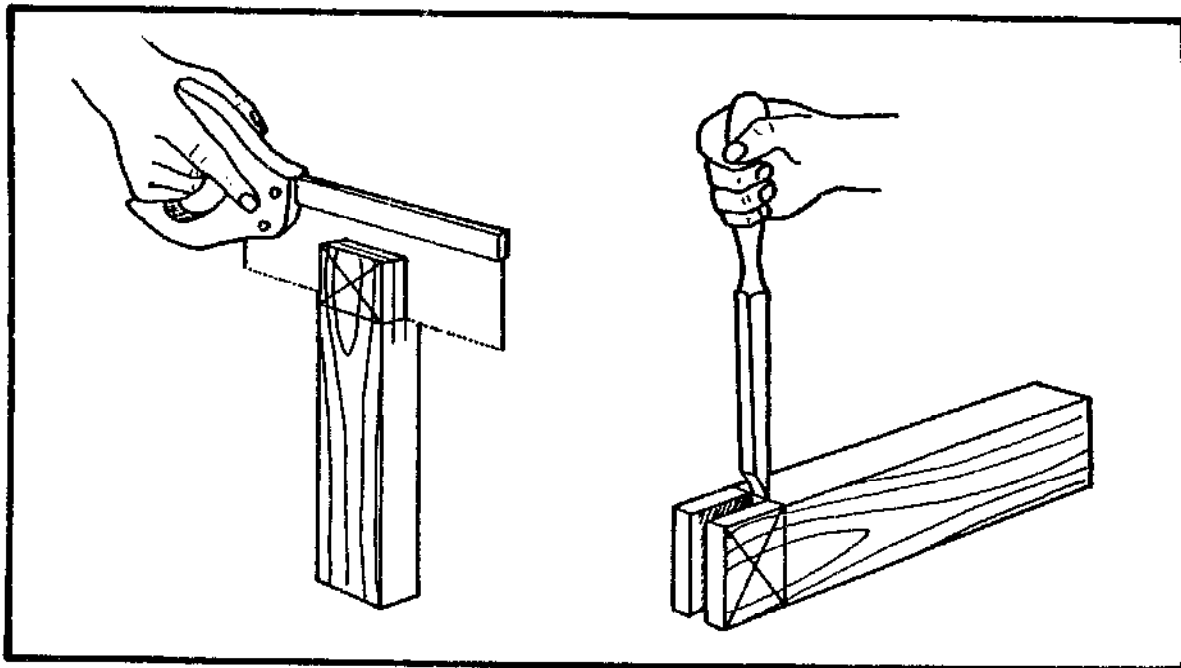

Diagram of Cutting List

## MAKING THE STOCK



Take the timber prepared for the stock and square a line all round 45mm from one end. Gauge two lines 6mm apart in the centre of the stock. Draw diagonals to find the centre of the joint.



Saw out the socket with a tenon saw and chisel out the waste.

## ASSEMBLY

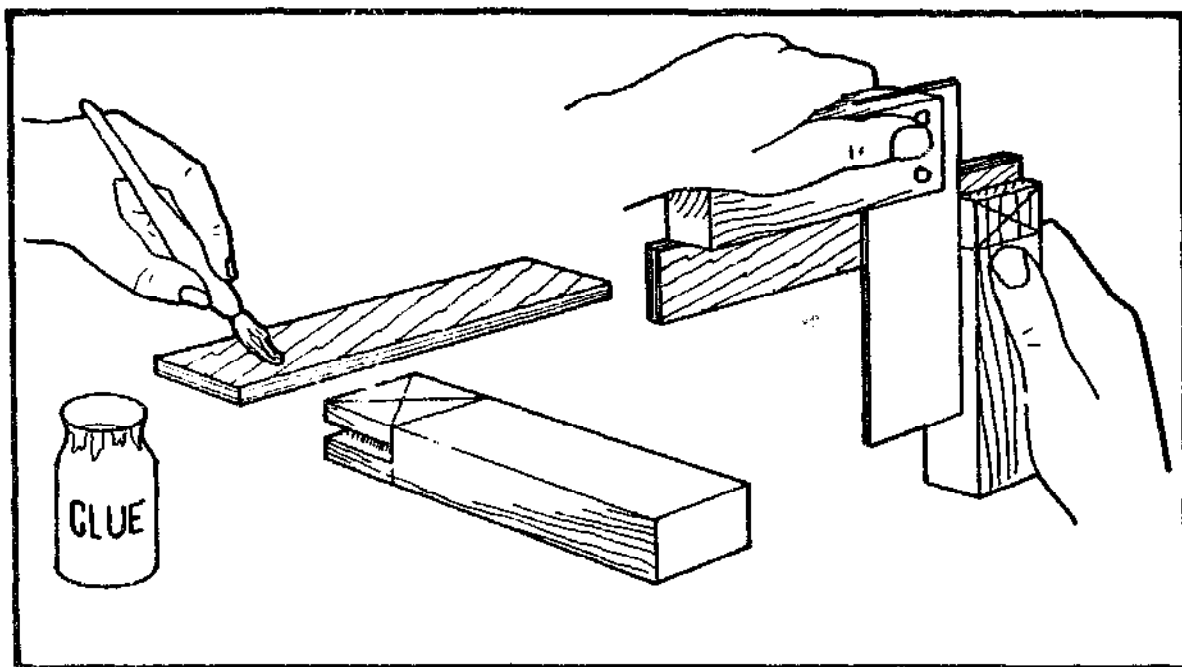

Glue the blade into the stock and, before the glue dries, make sure the blade and stock are square. Leave the assembly to dry.

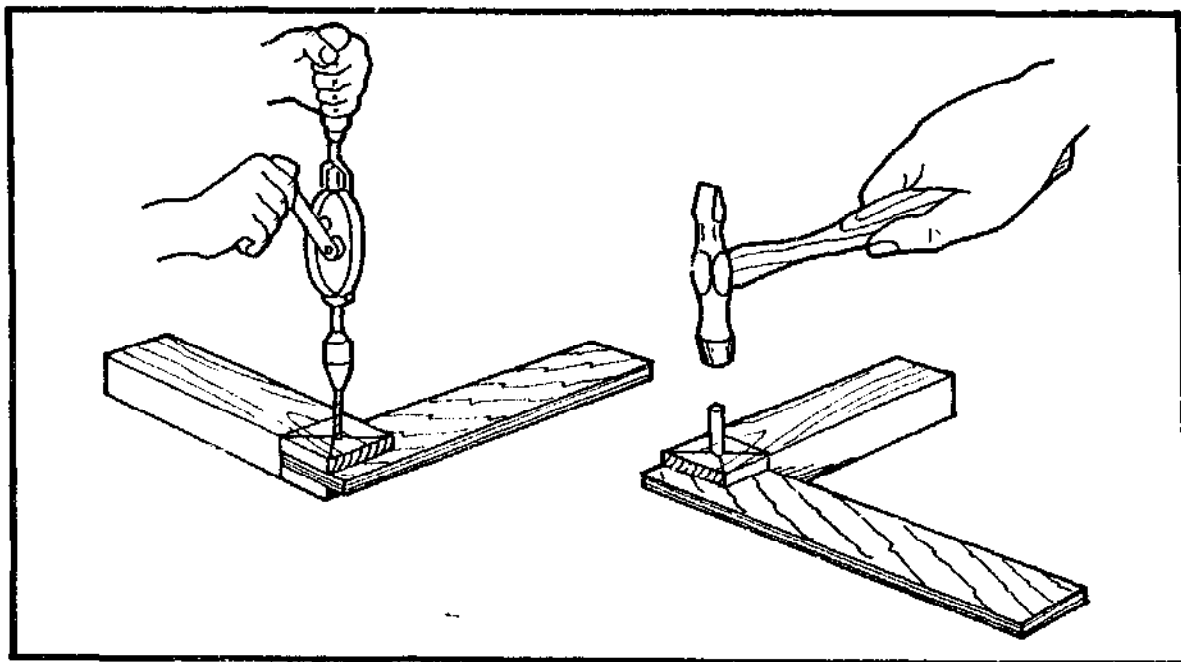

When the glue is dry drill a  $\text{Ø}6\text{mm}$  hole in the centre of the joint. Drive in a 6mm dowel. Plane the back of the blade flush with the stock and smooth up the ends of the dowel.

## TO CHECK A TRY SQUARE

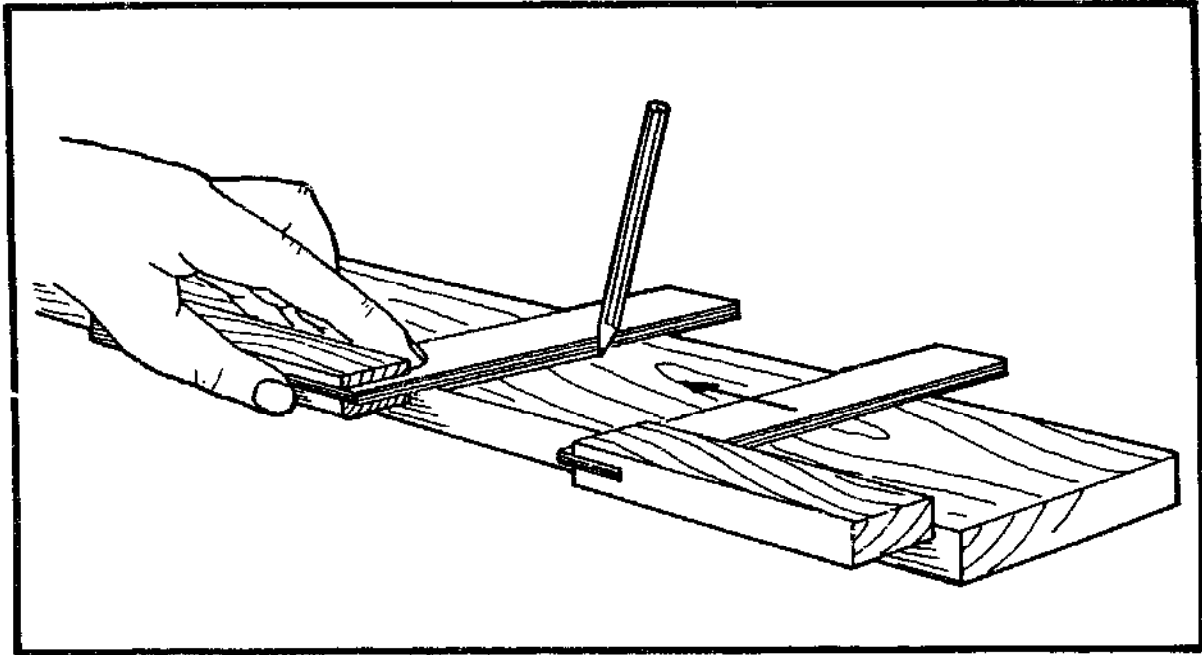

Take a piece of wood about 200mm wide, with face side and face edge planed straight and square. Place the try square on the timber and draw a line from the face edge. Turn the try square over to approach the line from the other side. If the square is true the pencil line and the straight edge will be parallel to each other.

## Bevel square

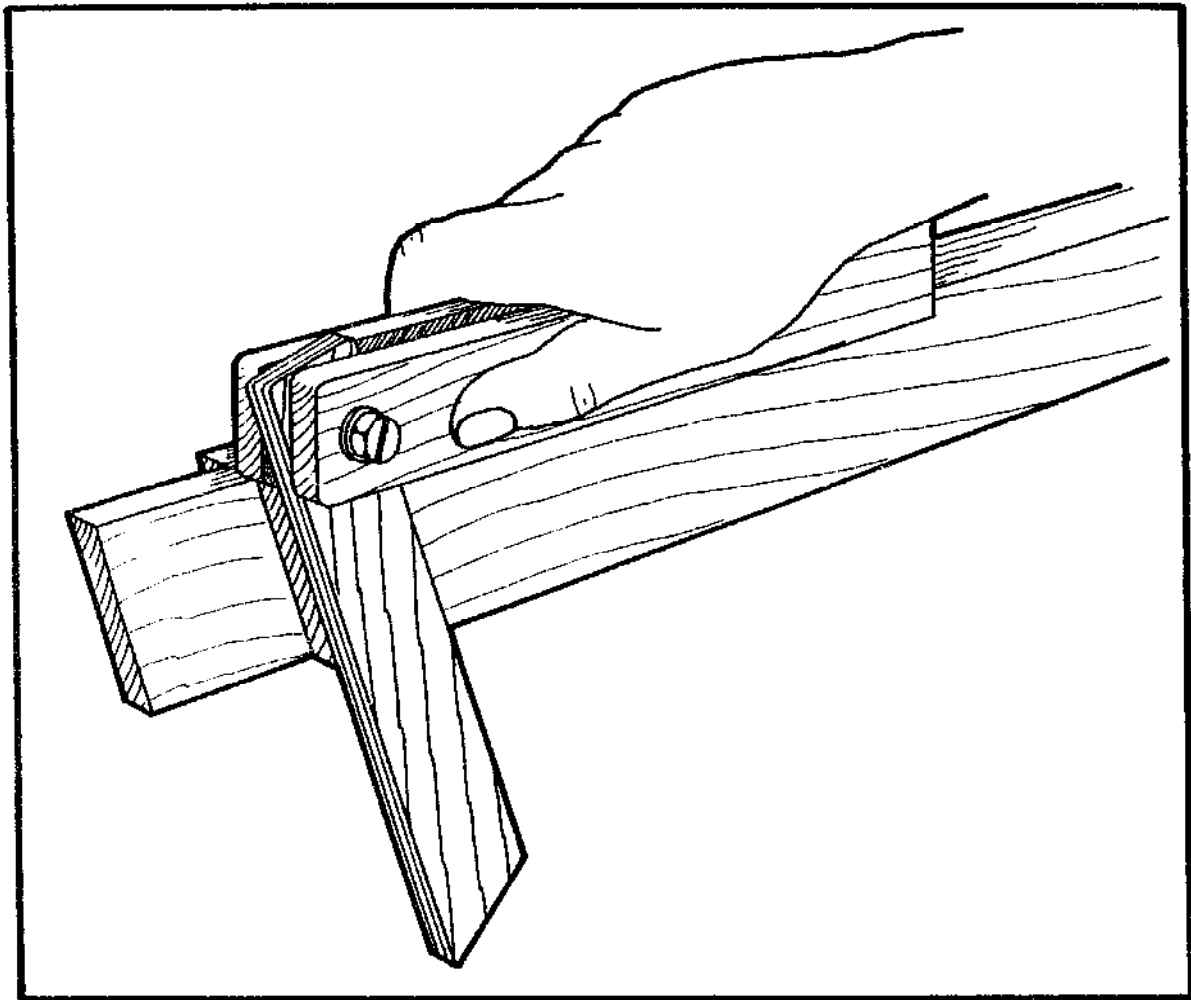

A bevel square, which is an essential tool for marking out dovetails and other joints with angles greater or smaller than 90 degrees, can be made on the same lines as the try square. Again the dimensions given are only for guidance.

In this case if either part of the tool becomes damaged, it can be taken apart and planed true again.

At the end of this section there is an alternative method of making the straight edge which improves the tool considerably.



## LIST OF PARTS

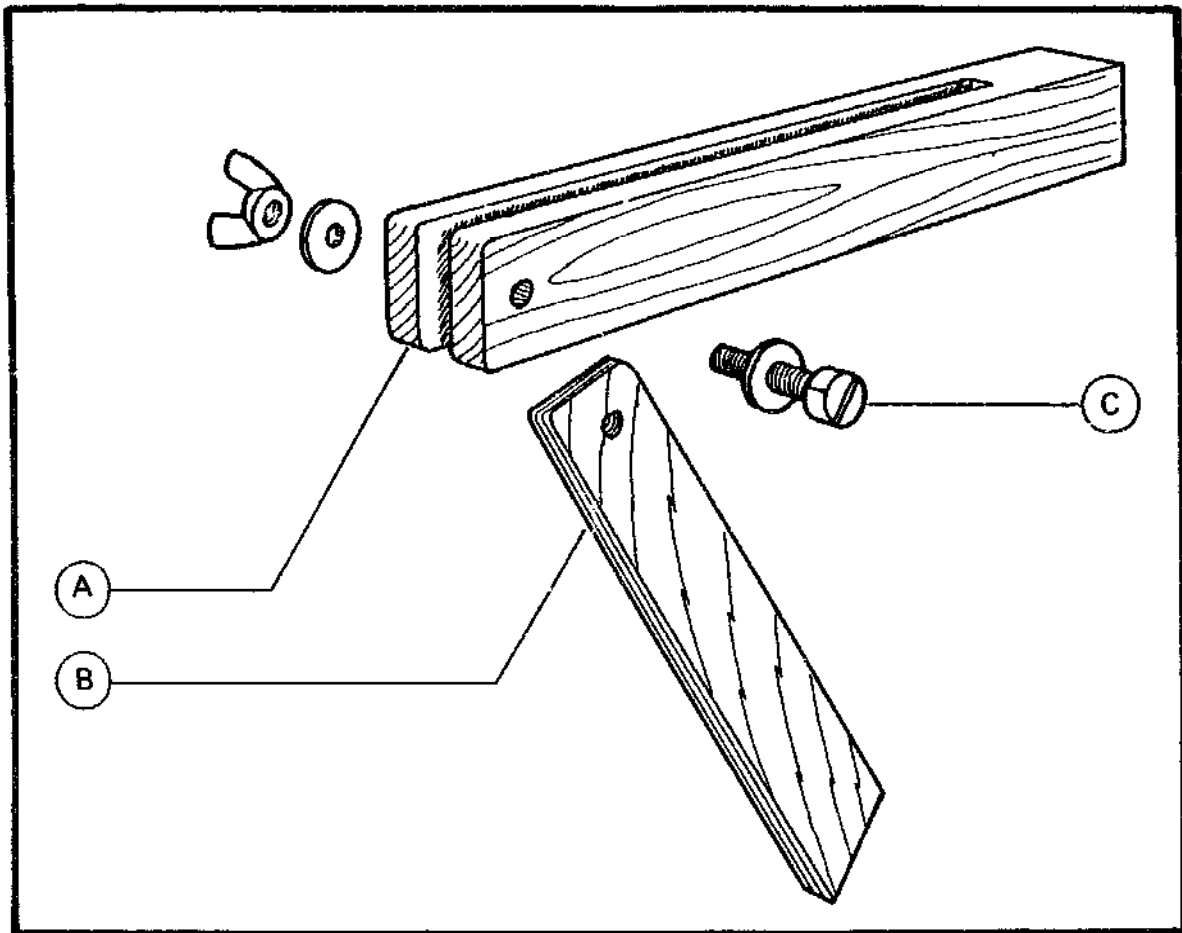

### Part

- A** *The stock* is made from one piece of wood, with a socket large enough to house the straight edge, cut out of one end.
- B** *The straight edge* is best made from a piece of 6mm plywood, but solid wood can be used as long as it straight-grained and dry.
- C** *The locking screw.* Use a wing nut and cut a slot in the head of the bolt for a screw driver. Washers are necessary to protect the stock from wear.

### Parts and Cutting List

Part	Name	Quantity, material and dimensions
A	Stock	1 pc. timber 175mm × 40mm × 20mm
B	Straight edge	1 pc. 6mm plywood 150mm × 40mm
C	Locking screw	1 pc. wing nut and bolt 25mm × 6mm 2 pcs. 6mm washers

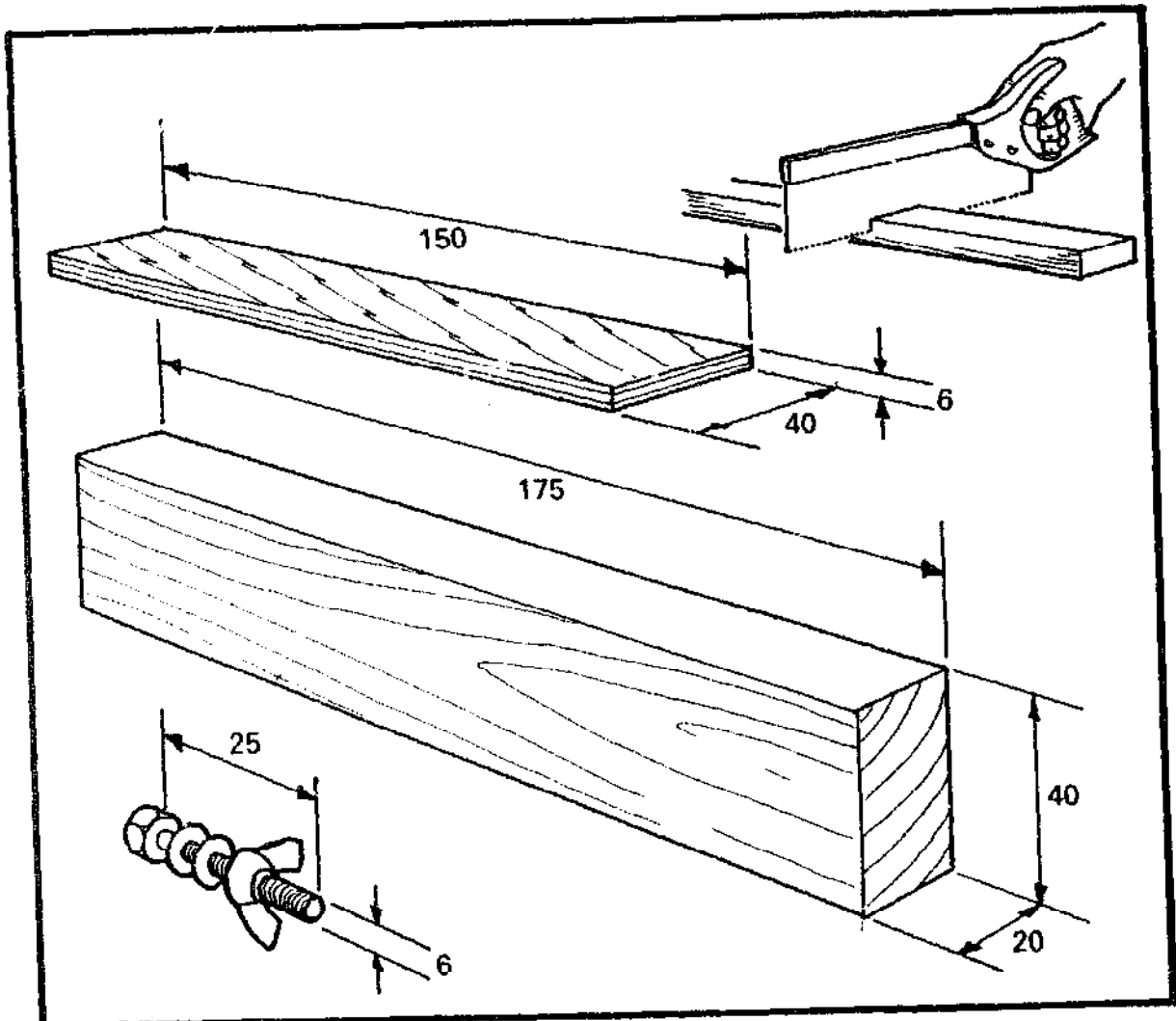
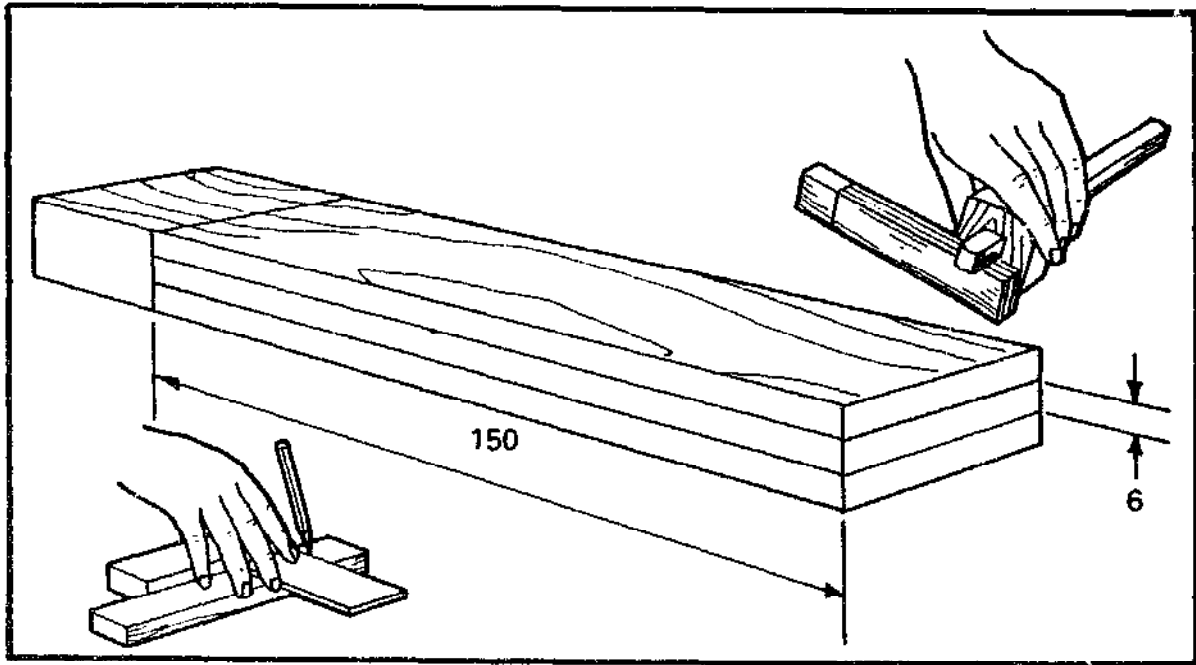

Diagram of Cutting List

## MAKING THE STOCK



Take the timber prepared for the stock and square a line round 150mm from one end.

Gauge two lines in the centre of the stock 6mm apart for the socket.

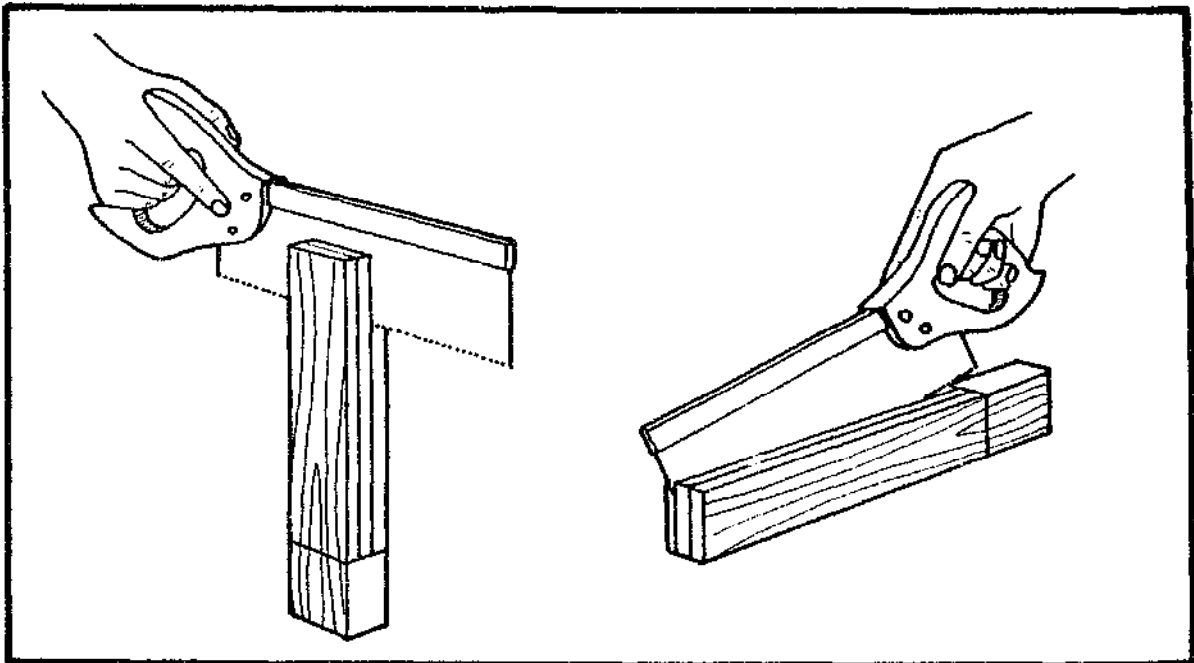

Use a tenon saw to saw out as much of the socket as possible.

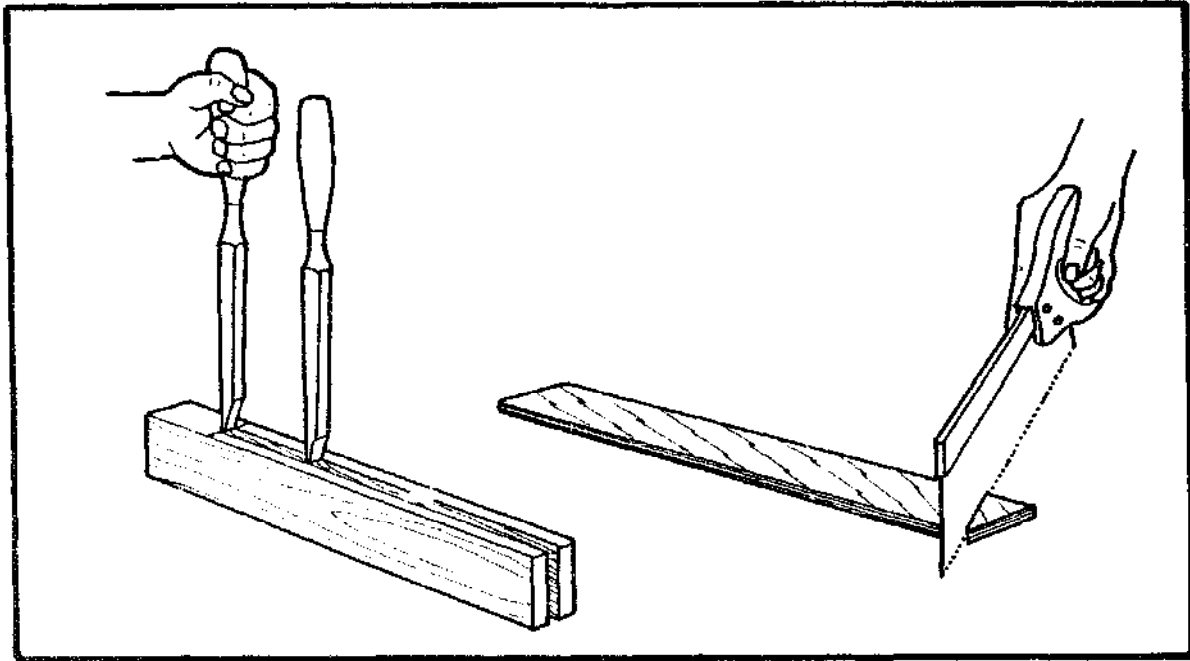

Use a 6mm chisel to cut out the waste wood in the stock.  
Take the plywood prepared for the straight edge and saw a 45 degree angle off one end.

### ASSEMBLY

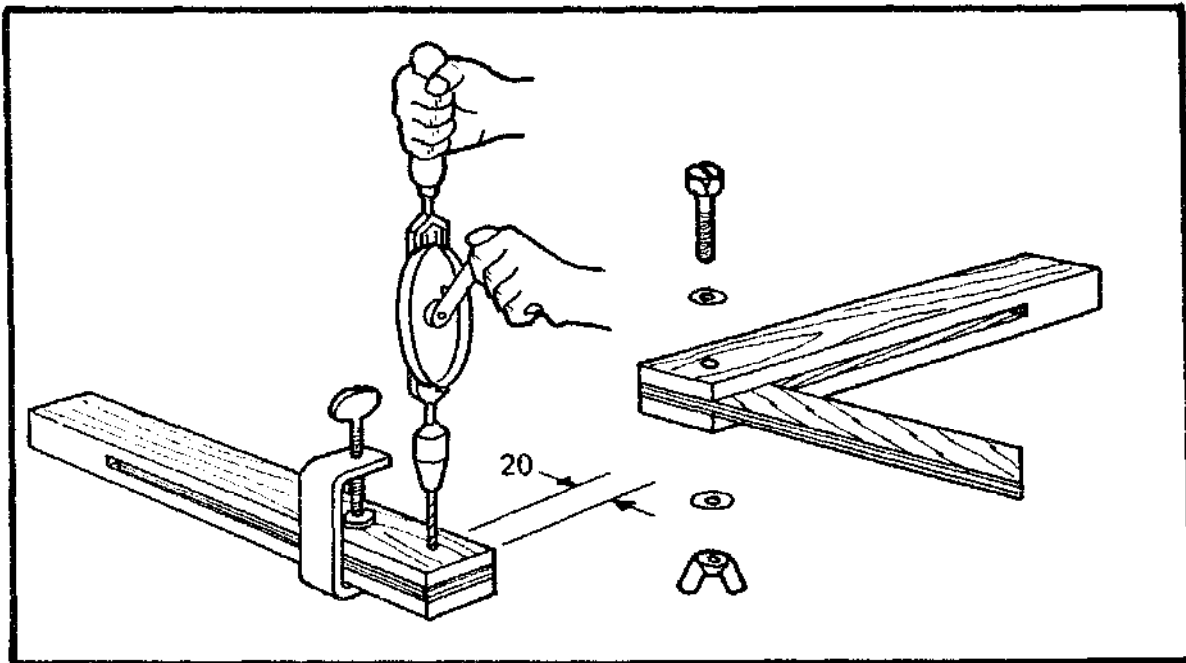

Fit the straight edge into the socket so there are no overlaps. Mark a central point 20mm from the end of the stock and drill a 6mm hole right through both pieces of wood.

Pass the bolt through this hole and the two washers and tighten the wing nut.

## SLIDING BEVEL SQUARE

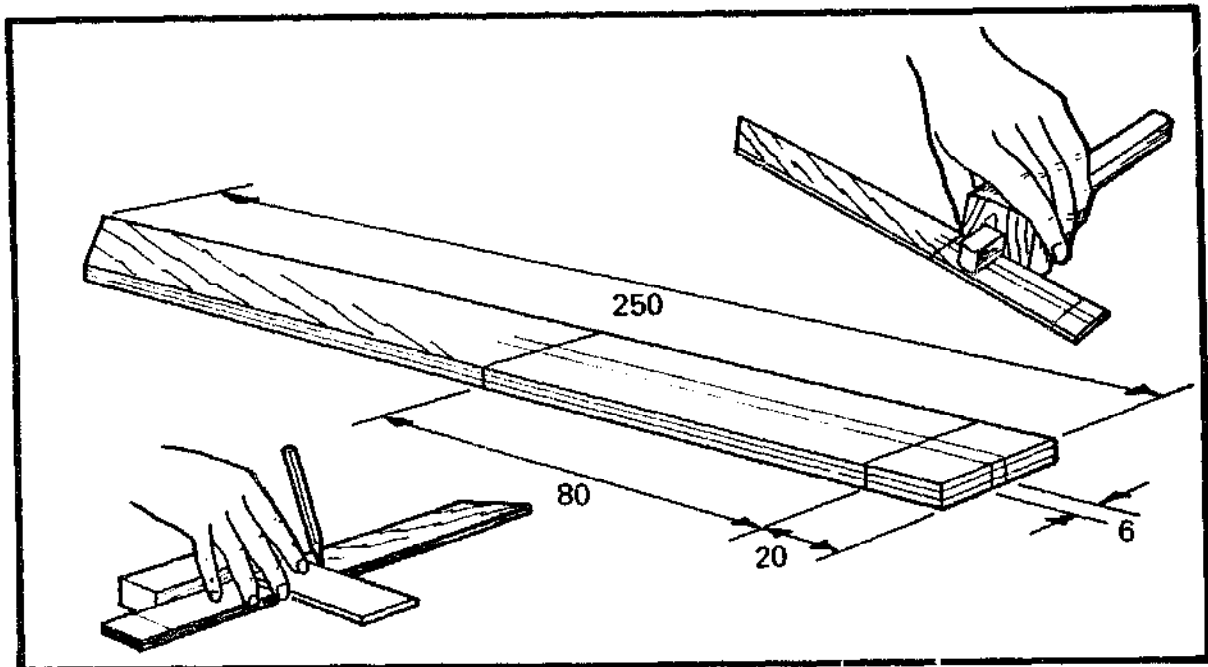

Prepare a piece of 6mm plywood 250mm × 40mm. Square a line 20mm from one end and another 100mm from the same end. Gauge a 6mm slot in the middle of the plywood between the two lines. Cut a 45 degree angle off the other end.

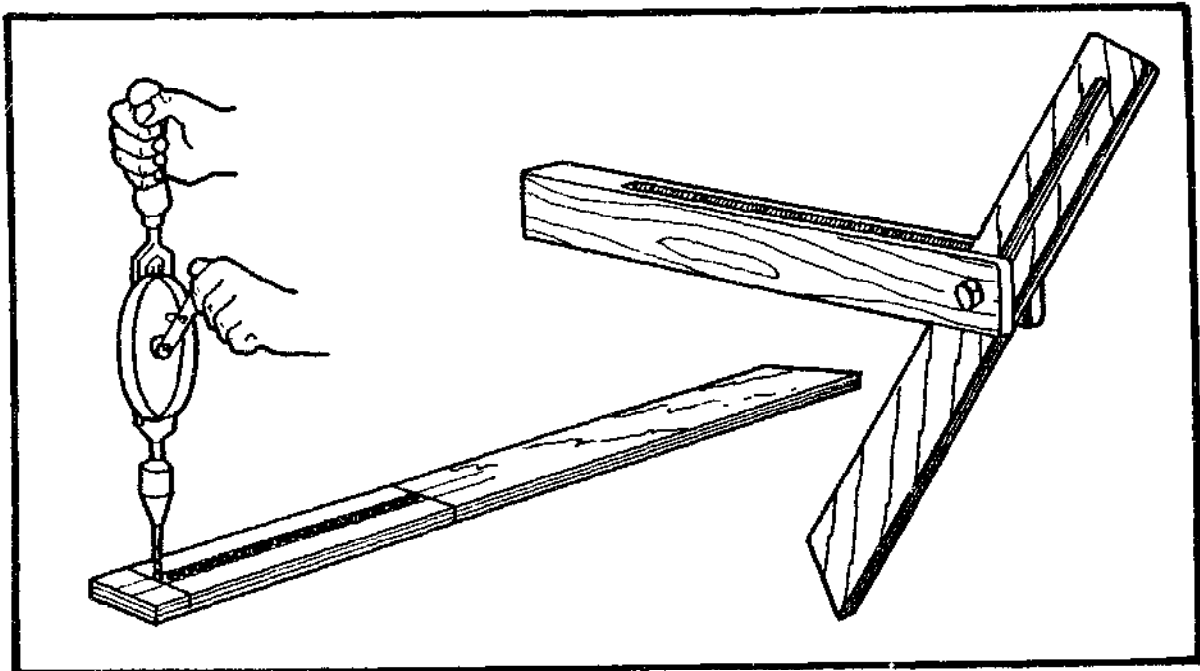

Drill a series of  $\varnothing 5$ mm holes between the gauge lines, clean out the waste with a chisel and file the slot smooth. Assemble the bevel square in the same way as shown on page 17.

## Marking gauge

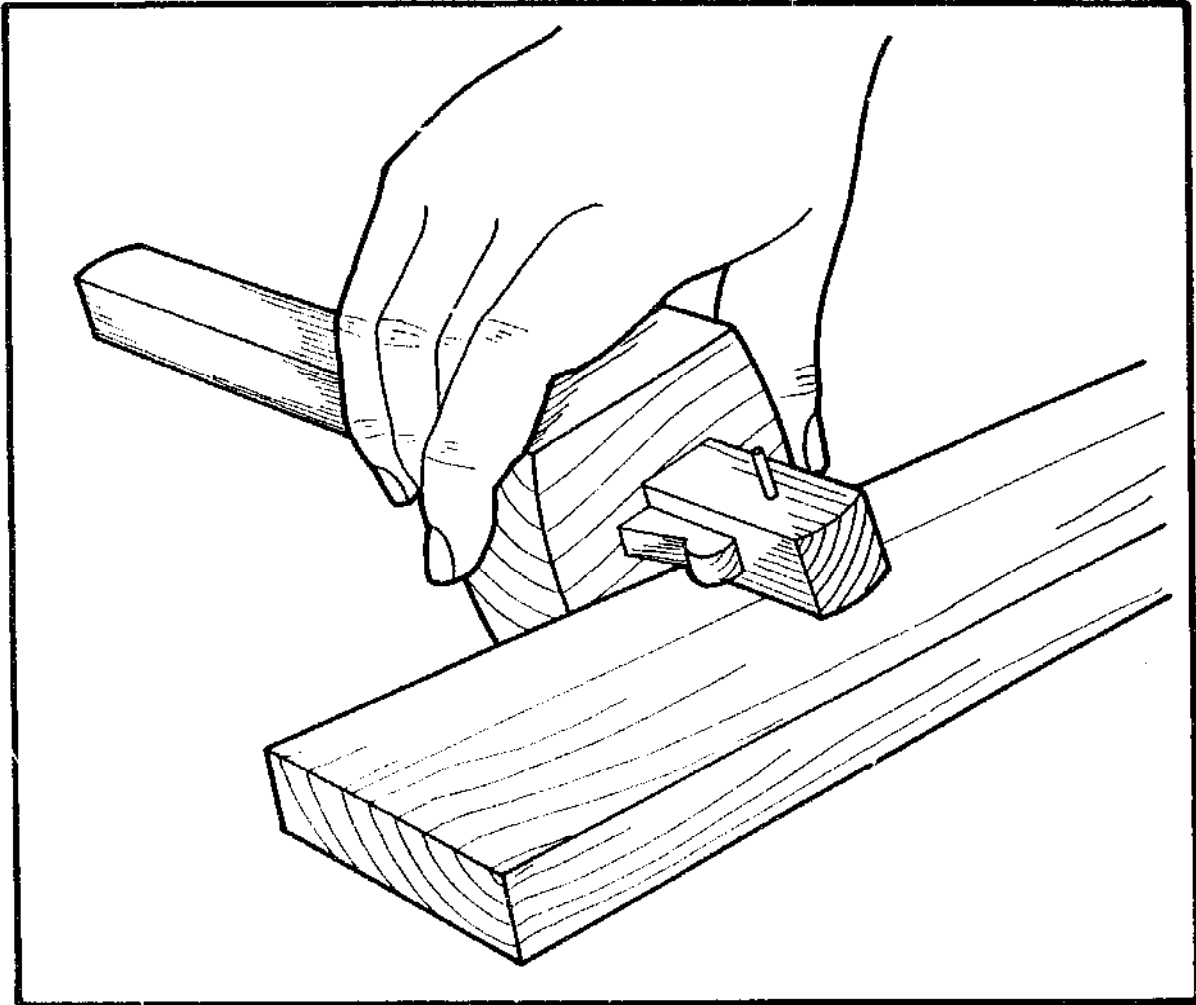

Marking gauges consist of two main parts, a fence and a stem. The stem carries a pointed metal spur at one end. The fence can be fixed to any position along the stem by a wedge as described here, or by a locking screw as shown on page 27 and page 41.

This type of gauge is the simplest to make because it has only one spur, but this limits the work it can do. For instance, it is not suitable for setting out relatively complicated joints such as mortise and tenon or bridle joints.

However, it is an essential tool for basic carpentry and joinery. It is used to score a single line parallel to the face side or face edge, when planning a piece of timber to size, and for marking out rebates and simple joints.

The fence is made from timber, and has a square mortise cut in the centre to take the stem. The wedge fits into a tapered groove also cut in the fence. The spur is simply a nail with its head cut off and hammered into the end of the stem.

## LIST OF PARTS

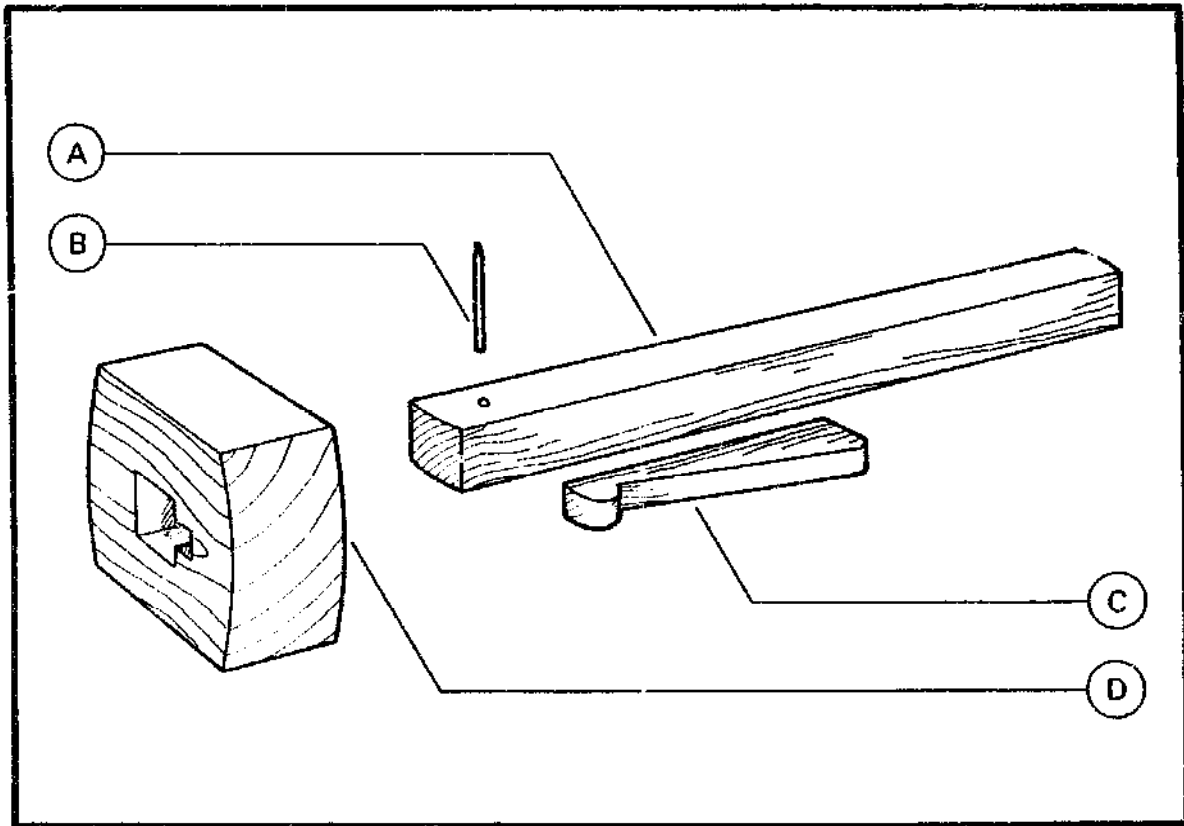

### Part

- A** *The stem*, made from timber, has a nail driven through one end to act as the spur.
- B** *The spur* is a 25mm nail cut down to 20mm.
- C** *The wedge* fits into a tapered slot in the fence. It has a small knob at the end to stop it falling out.
- D** *The fence* has a square mortise, and a tapered slot cut out of the centre.

### Parts and Cutting List

Part	Name	Quantity, material and dimensions
A	Stem	1 pc. timber 200mm × 20mm × 20mm
B	Spur	1 pc. 25mm nail cut down to 20mm
C	Wedge	1 pc. timber 70mm × 12mm × 6mm
D	Fence	1 pc. timber 100mm × 60mm × 30mm

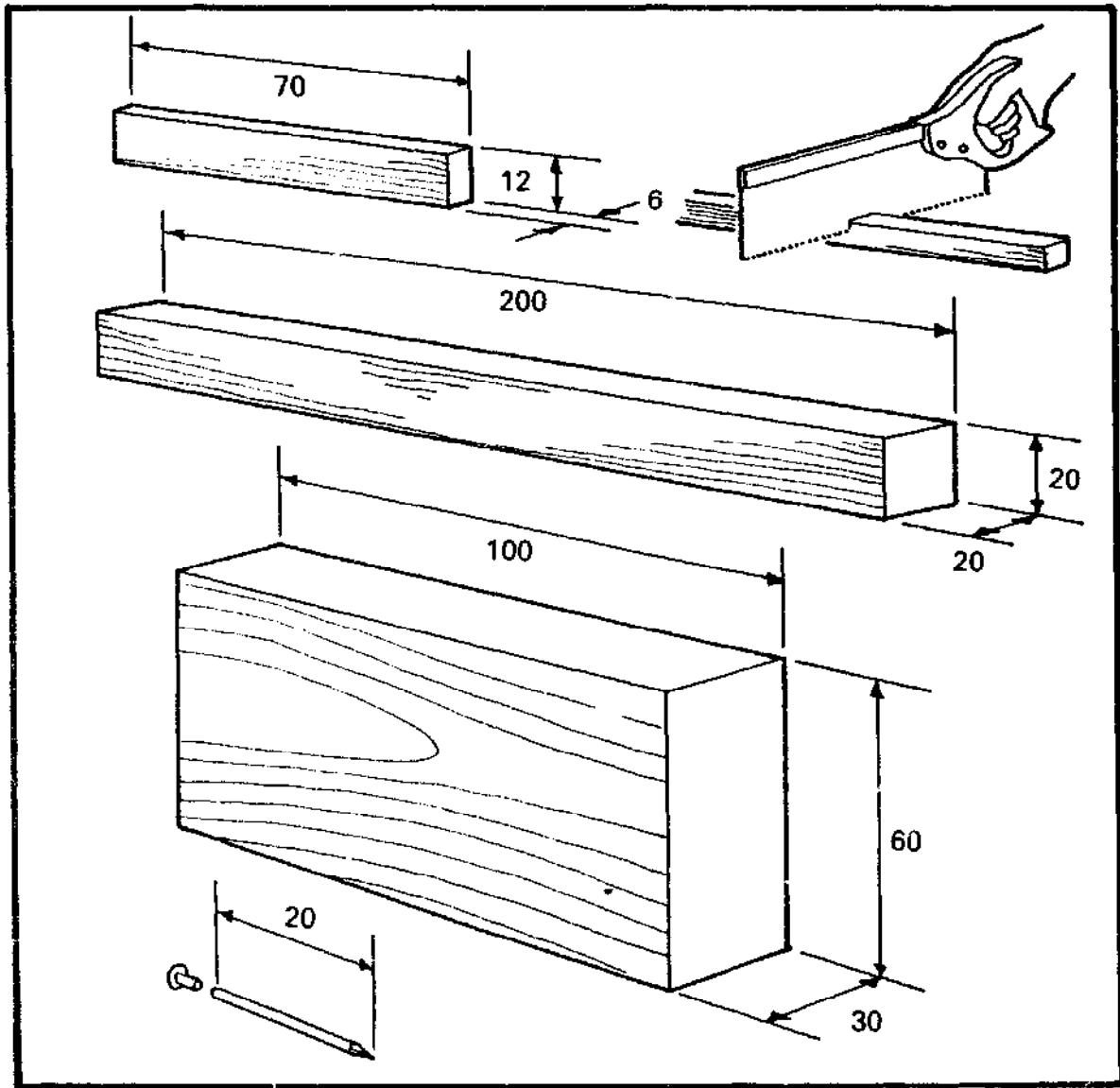
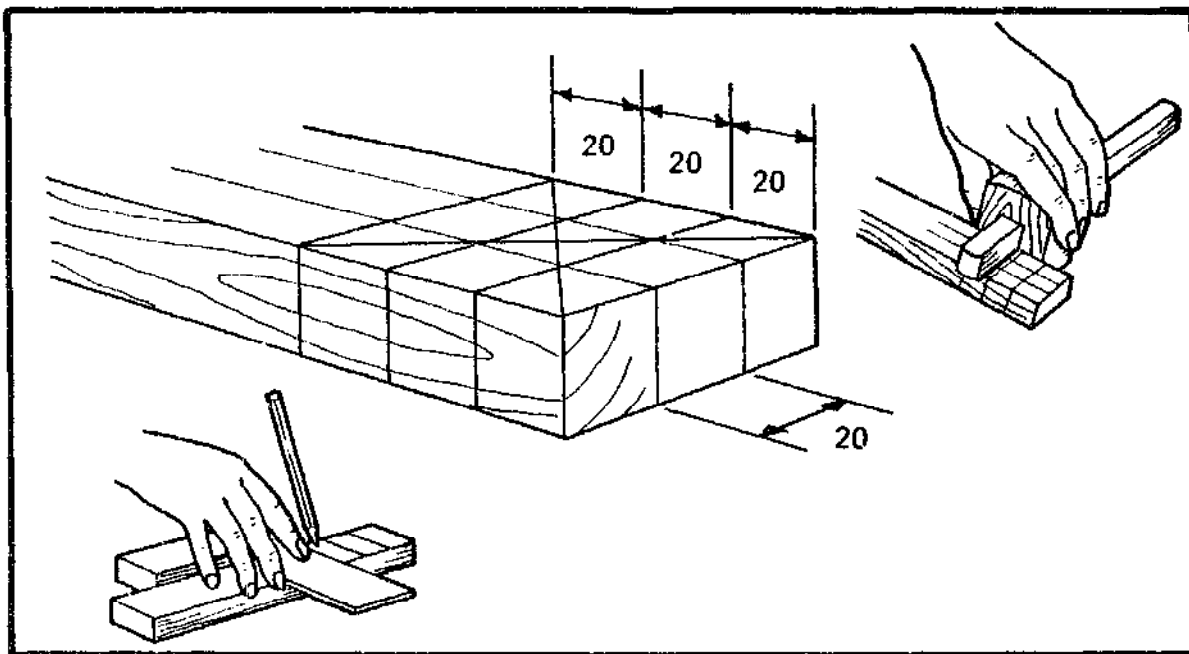

Diagram of Cutting List

The timber for the fence should be prepared over size because a small workpiece is difficult to plane accurately.



## MAKING THE FENCE



Take the timber prepared for the fence and square three pencil lines 20mm apart all round the timber; the first line should be 20mm from the end. Use a mortise gauge to mark two lines 20mm apart in the centre of the fence. Now mark the diagonals to find the centre of the mortise on both sides.

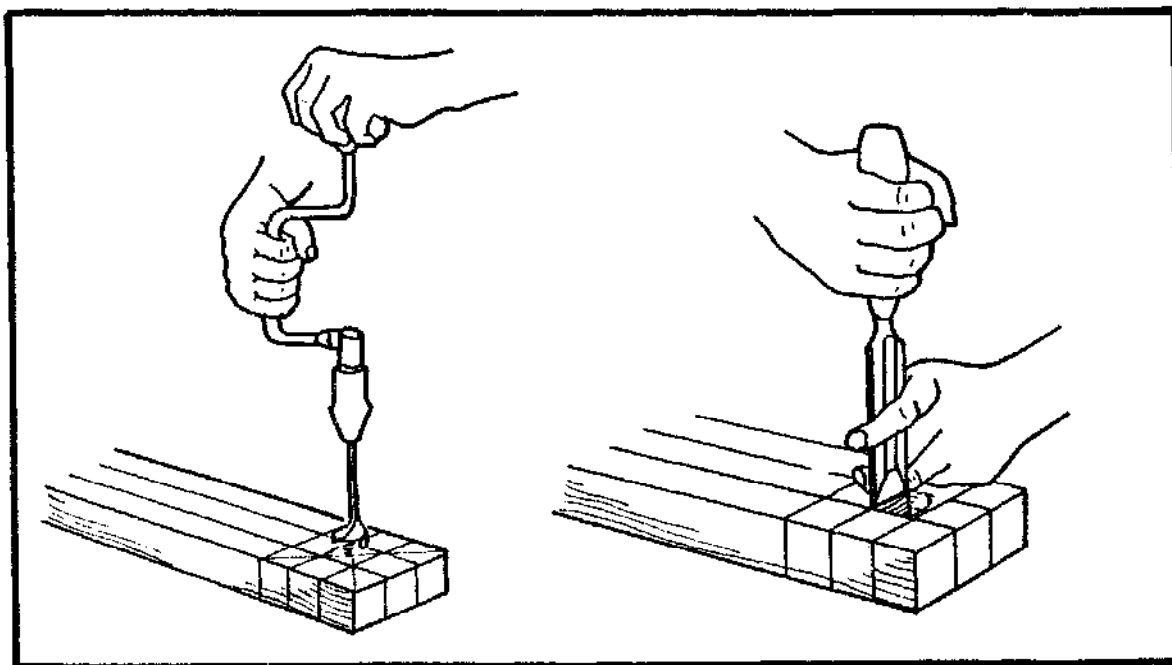

With a brace and bit, drill a  $\text{Ø}20\text{mm}$  hole exactly where the diagonals meet. Drill half way through, then turn the timber over to drill from the other side. Square the hole up to the gauge and pencil lines with a chisel.

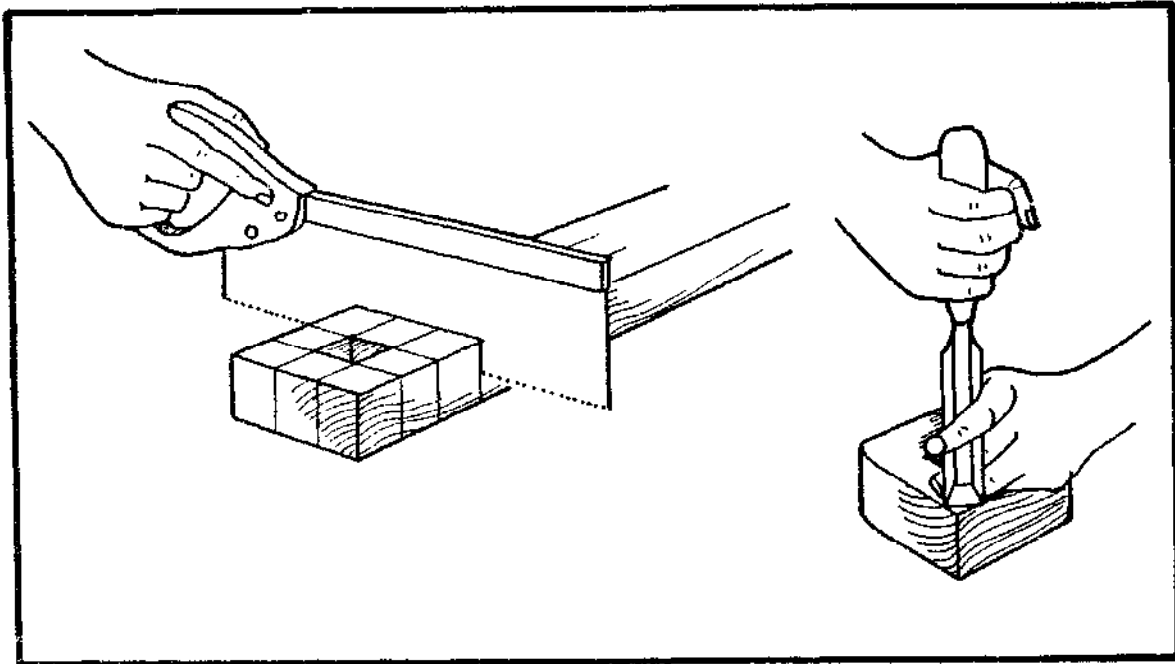

Saw the fence off on the pencil line 60mm from the end. You can round off the corners with a plane or chisel and smooth it with sandpaper.

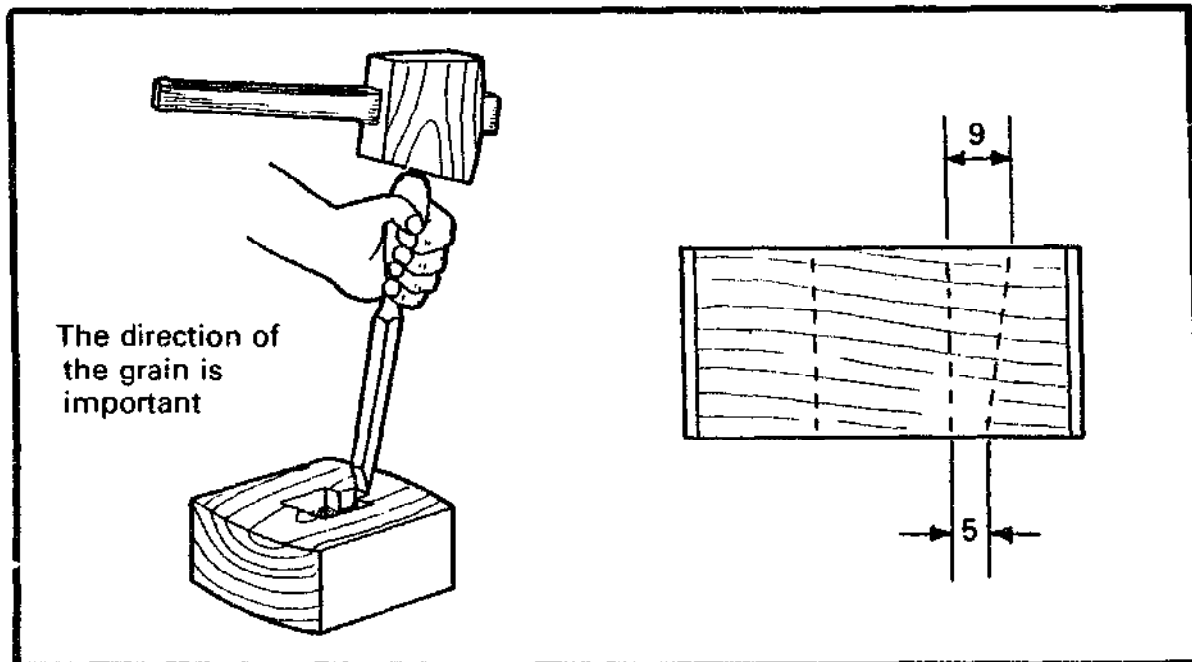

With a 6mm chisel and a mallet cut a sloping groove into the mortise of the fence. It should run from about 9mm at the big end to about 5mm at the small end.

The direction of the grain is very important, because if the sloping groove is not cut in the end grain, the fence may split.

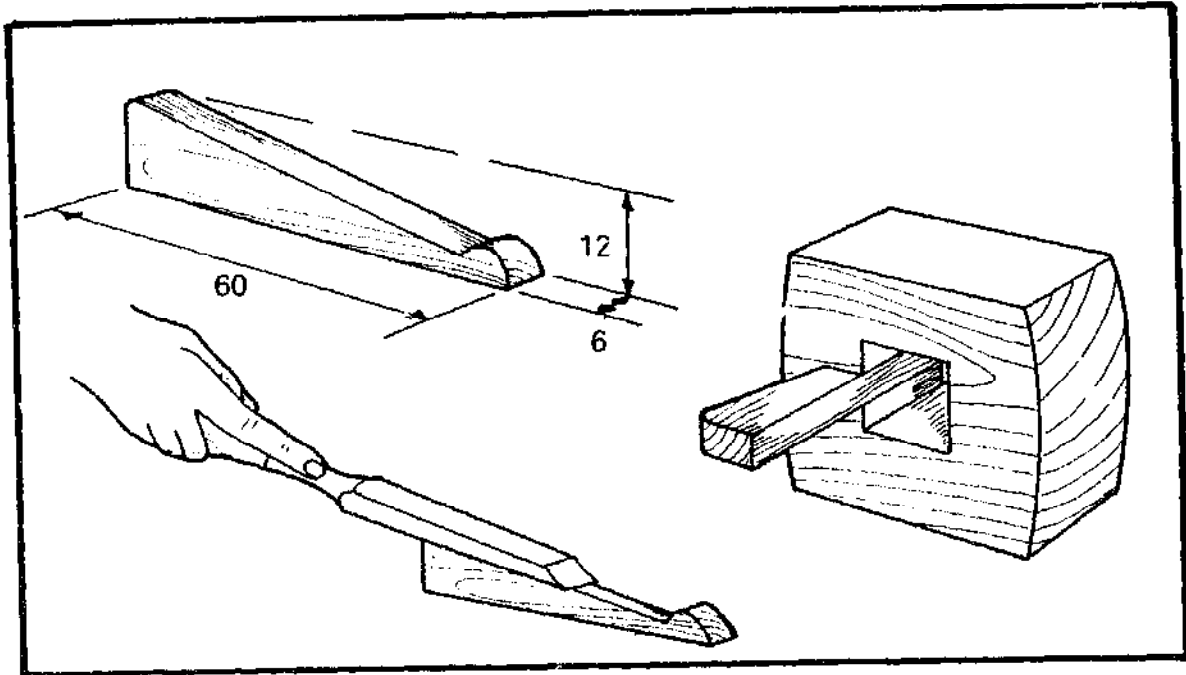

Cut the wedge to the dimensions shown; the knob at the end will stop it falling out and getting lost. Shape the wedge to fit into the groove in the fence.

### MAKING THE STEM

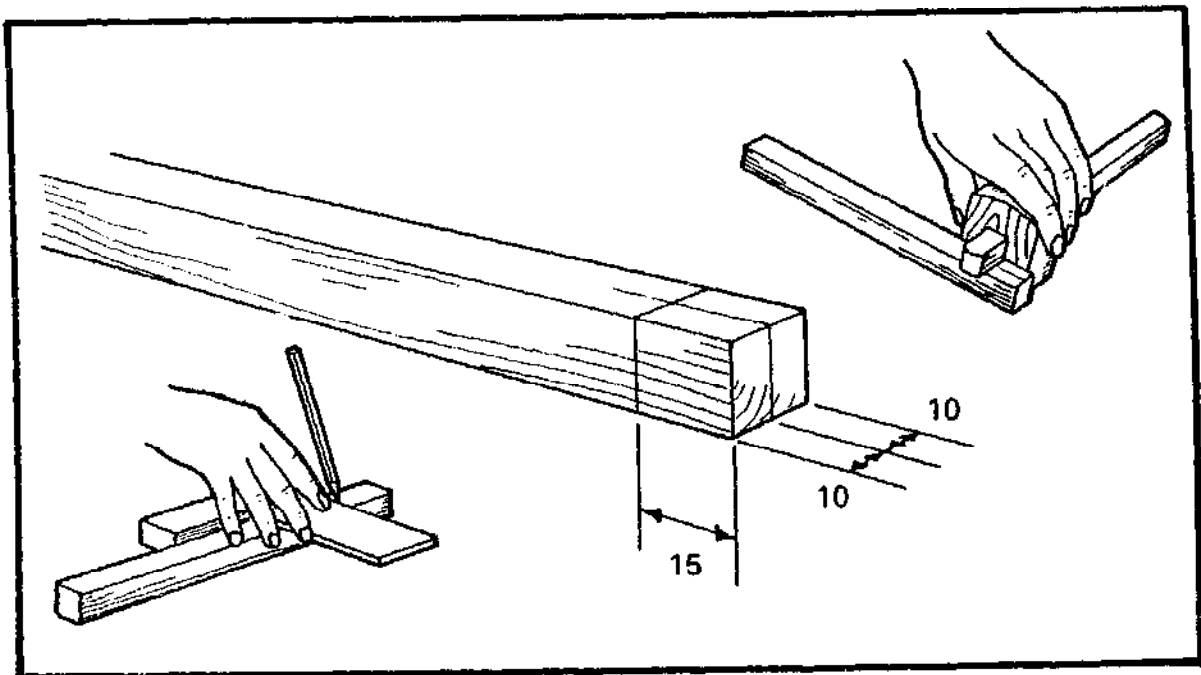

Take the timber prepared for the stem and square a line all round 15mm from the end. On two opposite sides of the stem gauge centre lines, crossing the pencil lines.

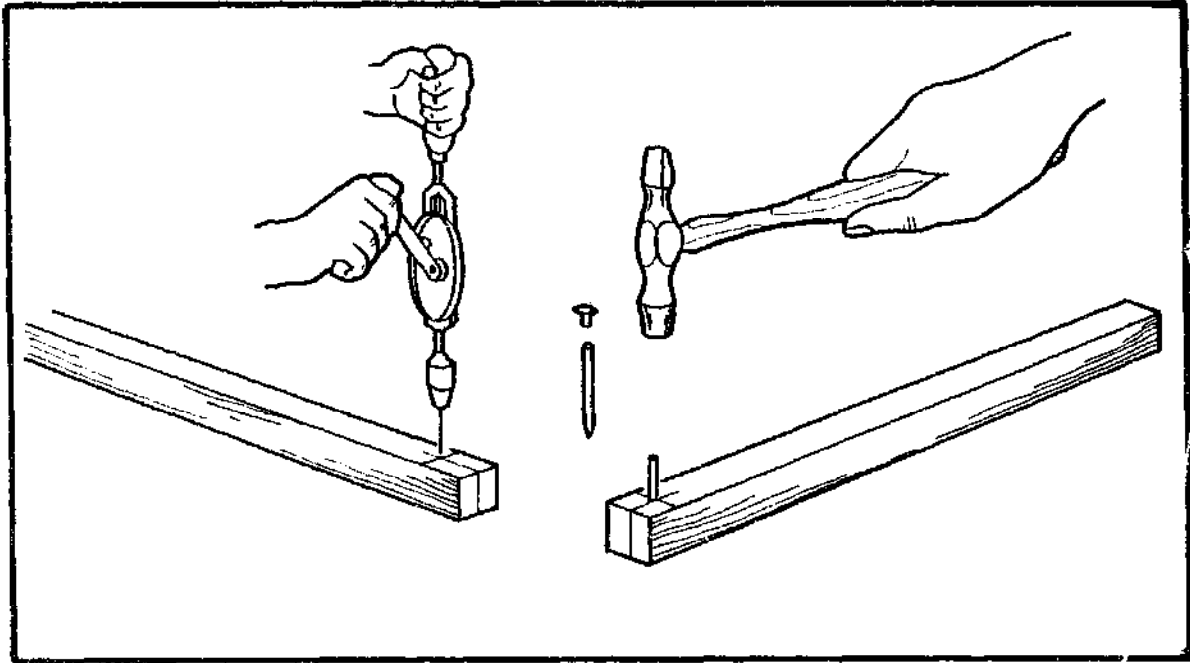

From both sides drill a hole with a bit slightly smaller than the diameter of the nail you will use as the spur. If you do not have a bit small enough, cut the head off a 20mm nail and use this to make the hole.

Now cut the head off a 25mm (1") nail and drive it right through the stem. The point should stick out about 5mm.

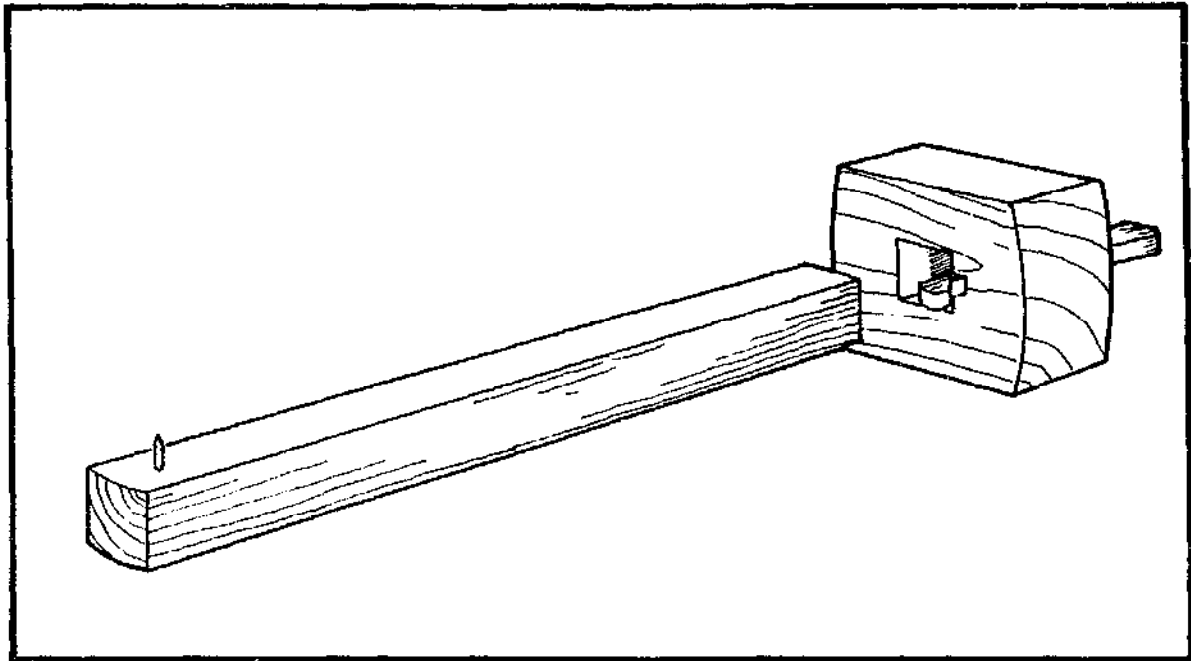

Assemble the marking gauge by fitting the wedge into its groove and sliding the stem through the fence. If it does not fit check that the sides of the mortise are straight, or plane the stem down very carefully.

## SETTING THE MARKING GAUGE

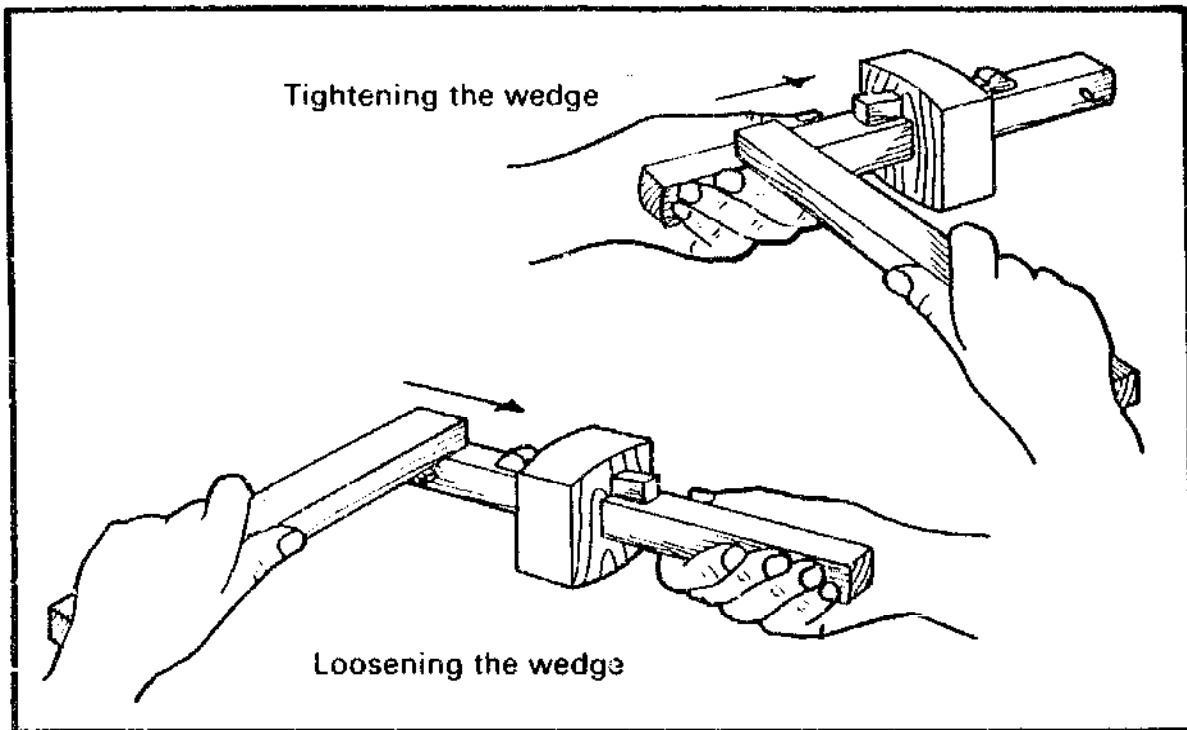

To use the gauge first set the distance from the spur to the fence. Tighten the fence to the stem by tapping the back of the wedge with a piece of wood. Check the setting and make final adjustments by tapping either end of the stem on the bench top.

To loosen the fence tap the front of the wedge.

## Cutting gauge

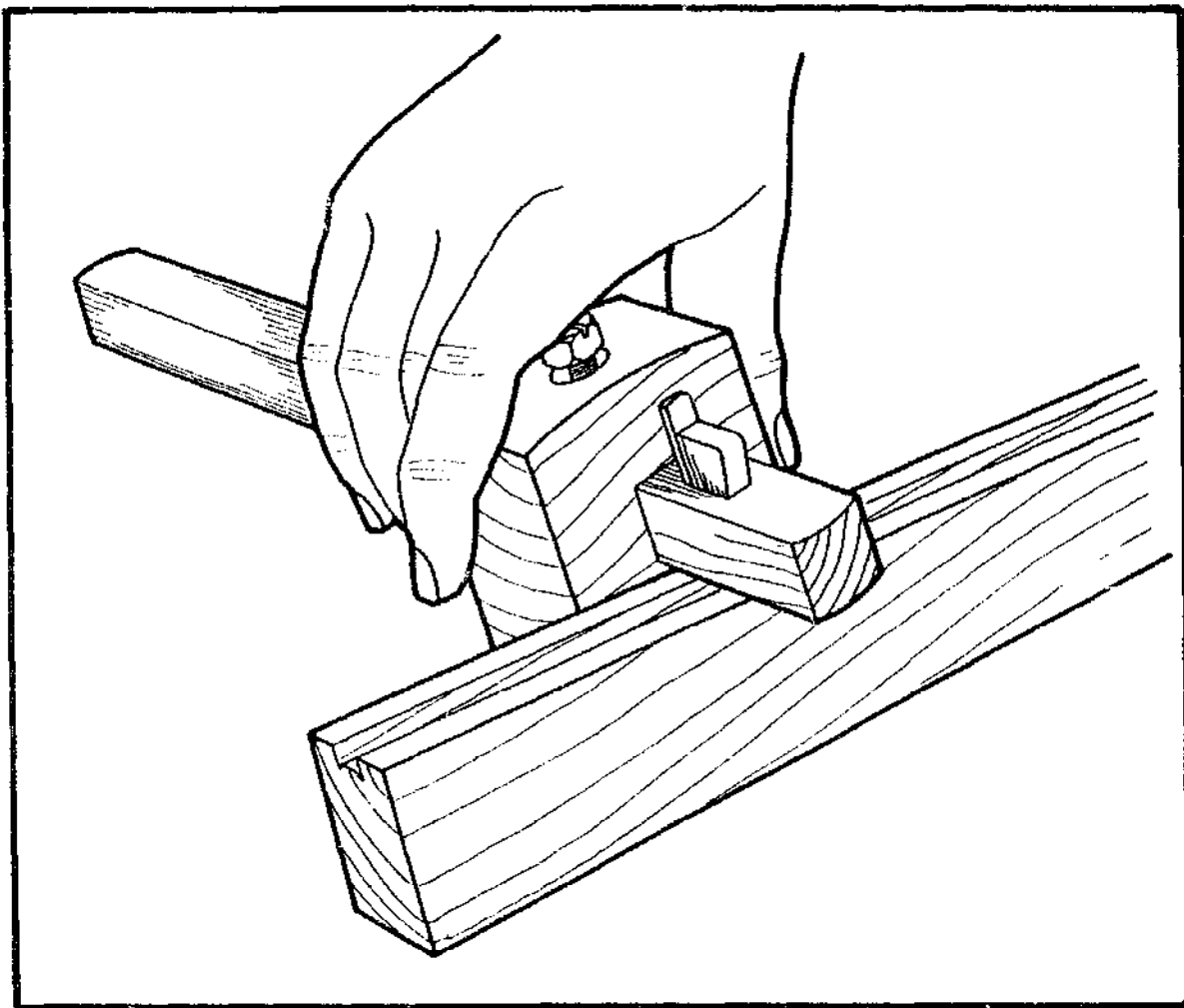

Cutting gauges are very similar to marking gauges, but instead of a metal spur, the stem carries a small knife blade held in position by a wedge. In the drawing the fence is fixed to the stem, using a 6mm bolt as a locking screw, but the wedge method could be just as effective.

The cutting gauge is used for scoring deep lines parallel to the edge, especially across the grain when marking long shoulders of joints. It can also be used for cutting the sides of small grooves, or for splitting thin wood into strips. It is not a very common tool to have in the workshop, but because it is so versatile and easy to make, it is well worth the time and effort for its construction.

Follow the directions on pages 22-3 to make the fence, but instead of cutting a slot for the wedge, a pilot hole is drilled through one side, and a small recess is cut inside the mortise for the shoe. The stem has a tapered mortise cut in the end to hold the wedge and the knife blade. A piece of hacksaw blade is used to make the knife blade, which can be removed from the stem and sharpened.

## LIST OF PARTS

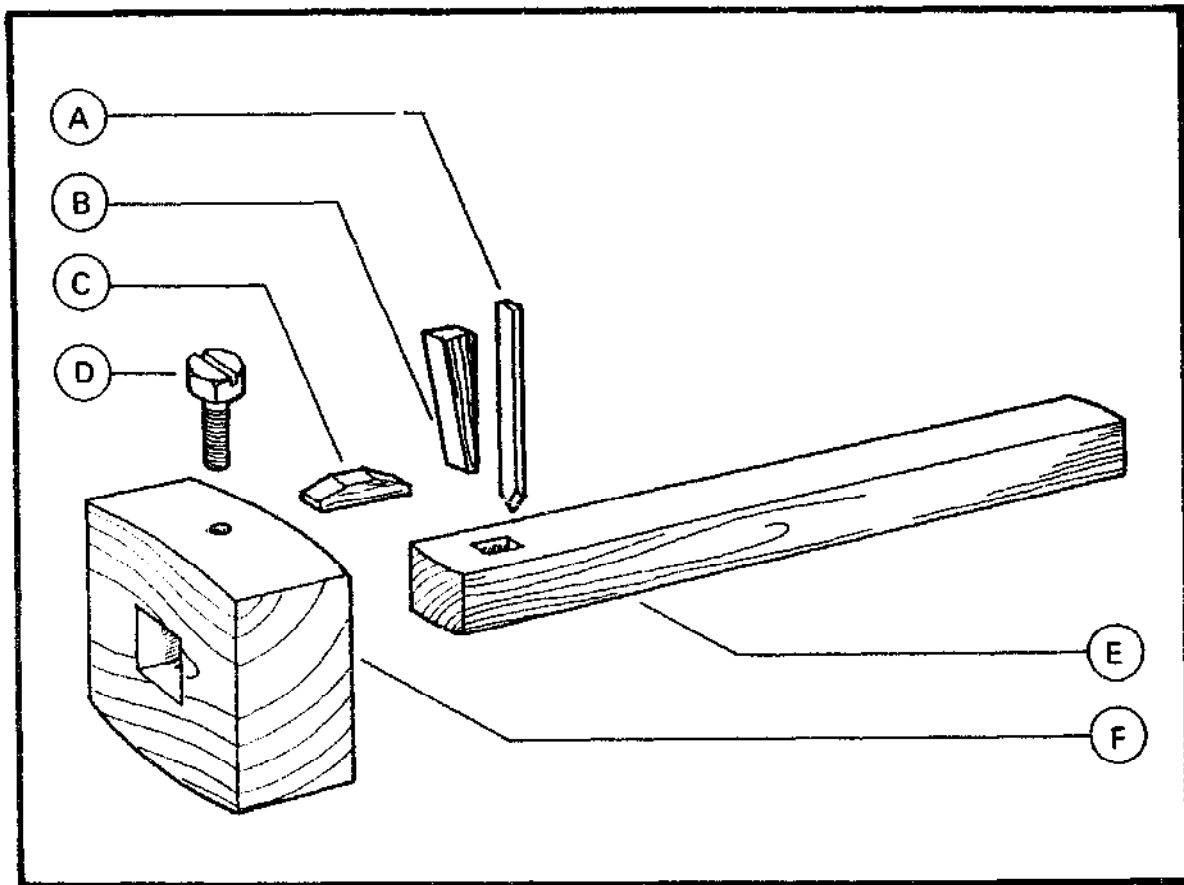

### Part

- A** *The knife blade* is ground or filed from a piece of hack saw blade.
- B** *The wedge* holds the knife blade in position.
- C** *The shoe* prevents the metal bolt bruising the stem.
- D** *The locking screw* is driven into a pilot hole in the top of the fence. When tightened, it locks the fence to the stem.
- E** *The stem* has a tapered mortise cut in the end to house the knife blade and wedge.
- F** *The fence*. To make the fence follow the directions on pages 22 and 23, but do not cut the slot for the wedge. Instead a pilot hole is drilled for the locking screw, and a small recess cut inside the mortise for the shoe.

# Parts and Cutting List

Part	Name	Quantity, material and dimensions
A	Knife blade	1 pc. hacksaw blade 50mm long
B	Wedge	
C	Shoe	1 pc. timber 80mm × 12mm × 6mm
D	Locking screw	1 pc. bolt 20mm × 6mm
E	Stem	1 pc. timber 200mm × 20mm × 20mm
F	Fence	1 pc. timber 100mm × 60mm × 30mm

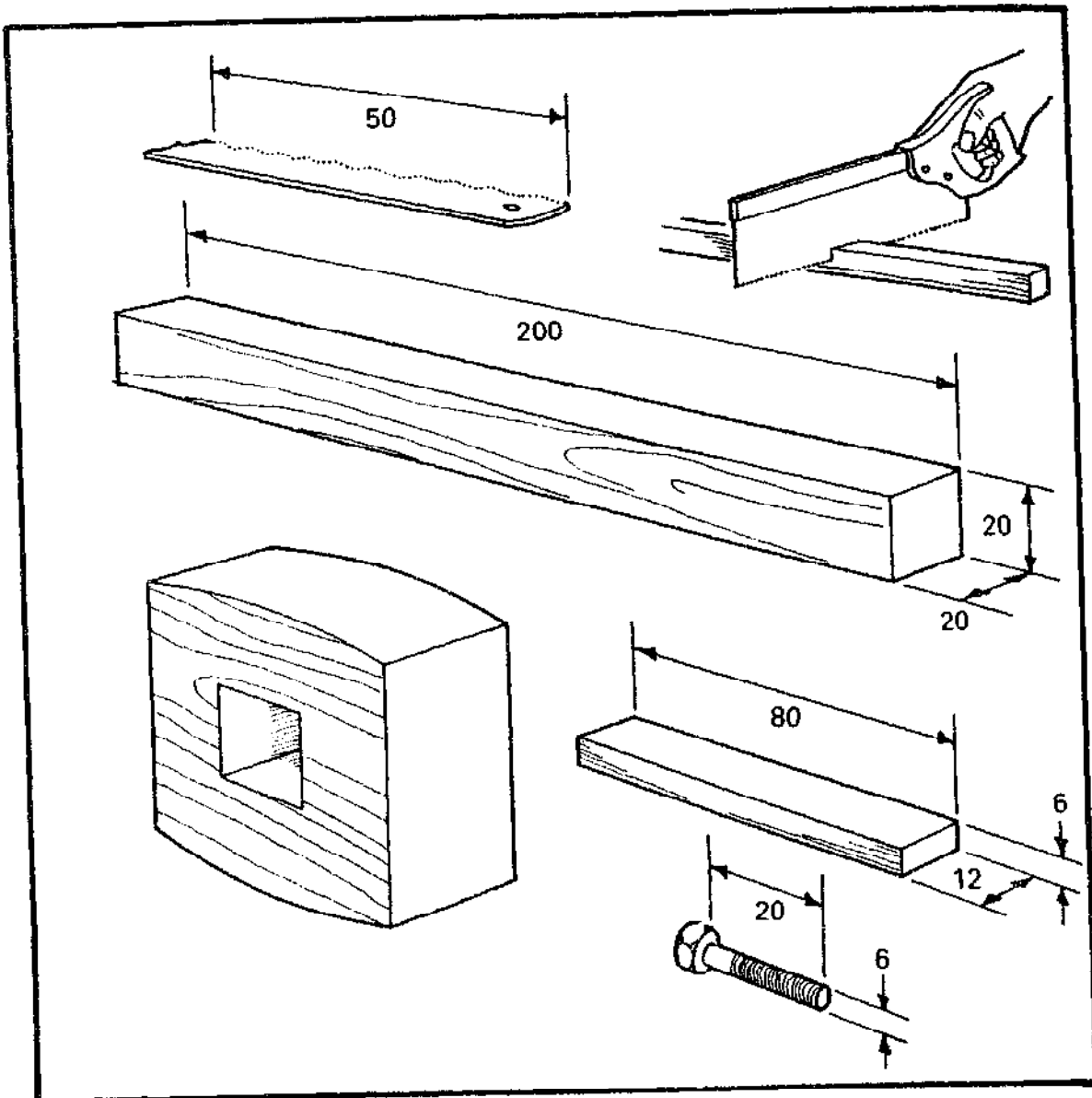
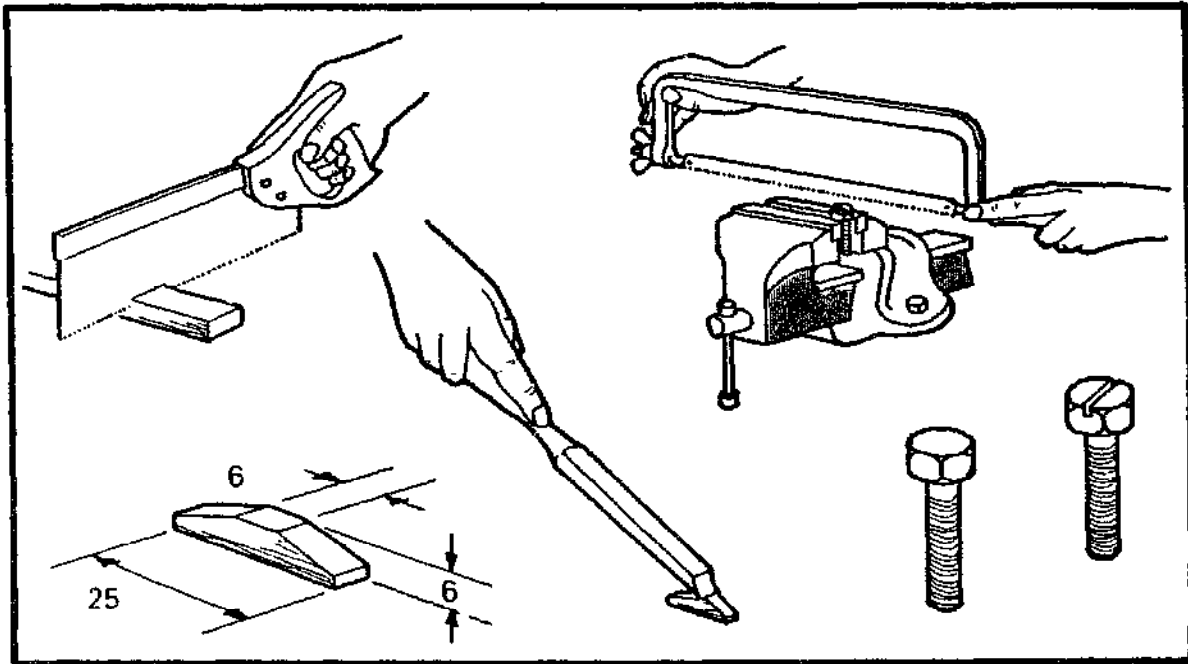

Diagram of Cutting List



## MAKING THE FENCE



Take the timber prepared to make the wedge and the shoe and cut a small piece off 25mm × 6mm × 6mm. Shape the shoe as shown with a chisel. Take the 20mm × 6mm bolt and saw a slot in the head for a screwdriver.

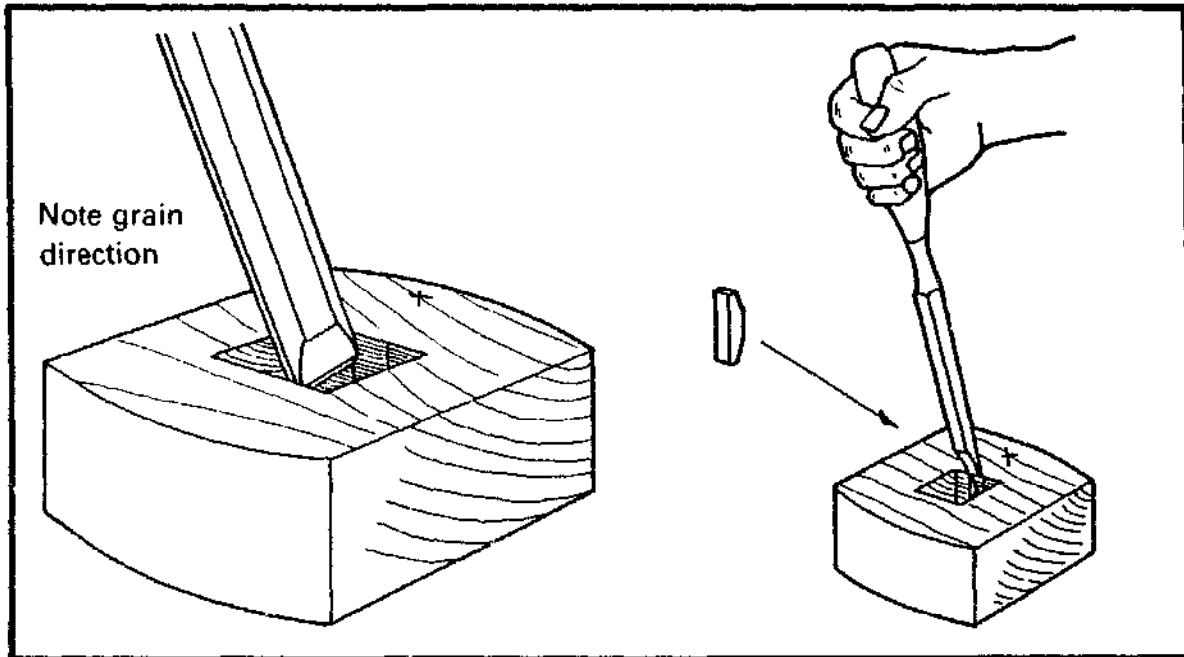

Make the fence as shown on pages 22 and 23, but do not cut the groove for the wedge. Instead carefully cut a recess in the centre of the mortise by first cutting the end grain with a chisel held at an angle. Then, with a 6mm chisel remove the waste.

Check that the shoe fits well into the hole.

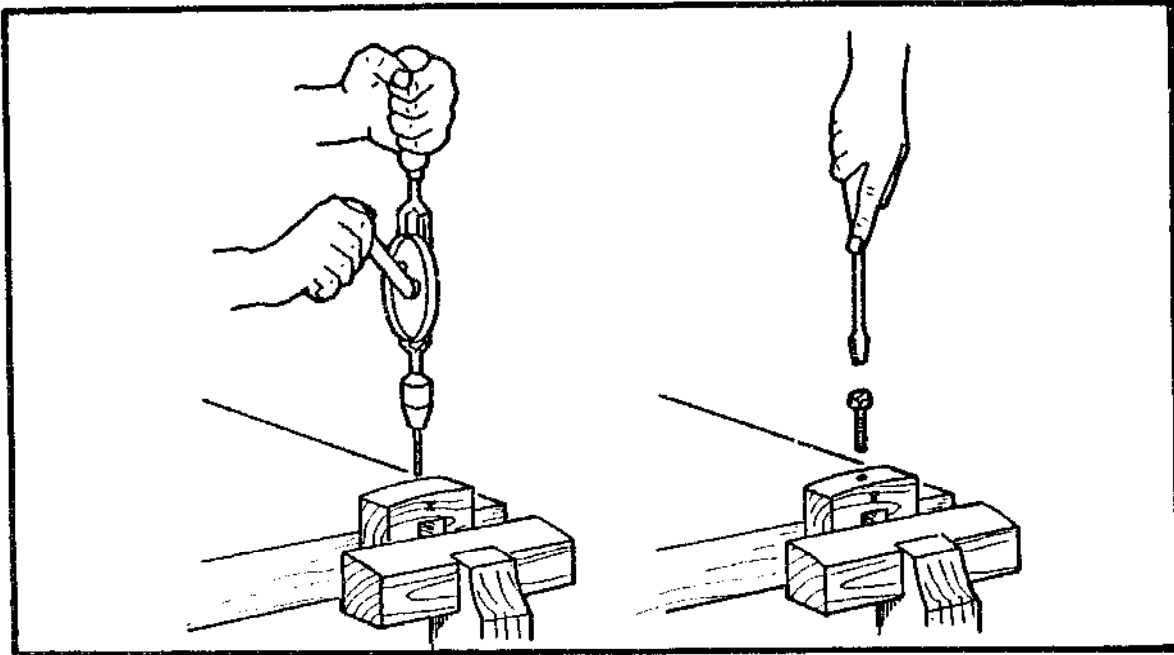

Mark the centre of the top of the fence, and drill a  $\text{Ø}5\text{mm}$  pilot hole right through into the recess for the shoe. The pilot hole must not be drilled through the end grain.

Use a screwdriver to screw the bolt into the pilot hole. It will cut its own thread in the same way as a wood screw.

### MAKING THE STEM

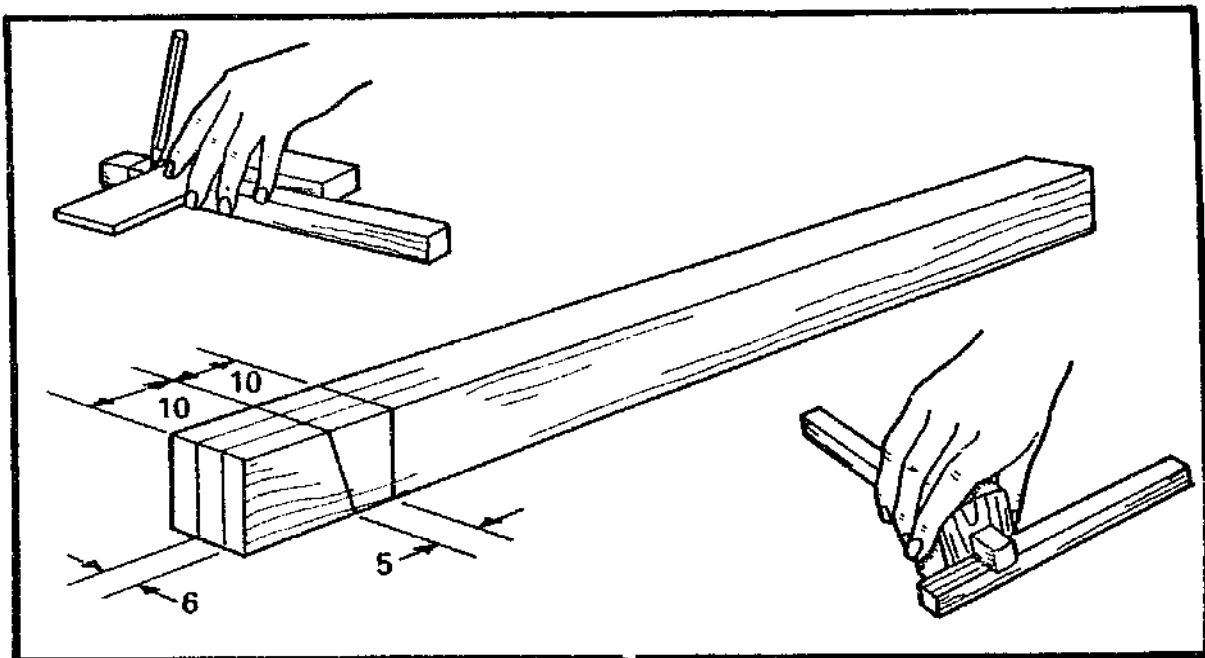

Take the timber prepared for the stem and square a line all round 20mm from the end. On the top square a line 10mm from the first line towards the end, and on the bottom 5mm from the first towards the end. When joined these lines mark the slope for the wedge. With a mortise gauge, gauge two lines in the centre 6mm apart to mark the mortise.

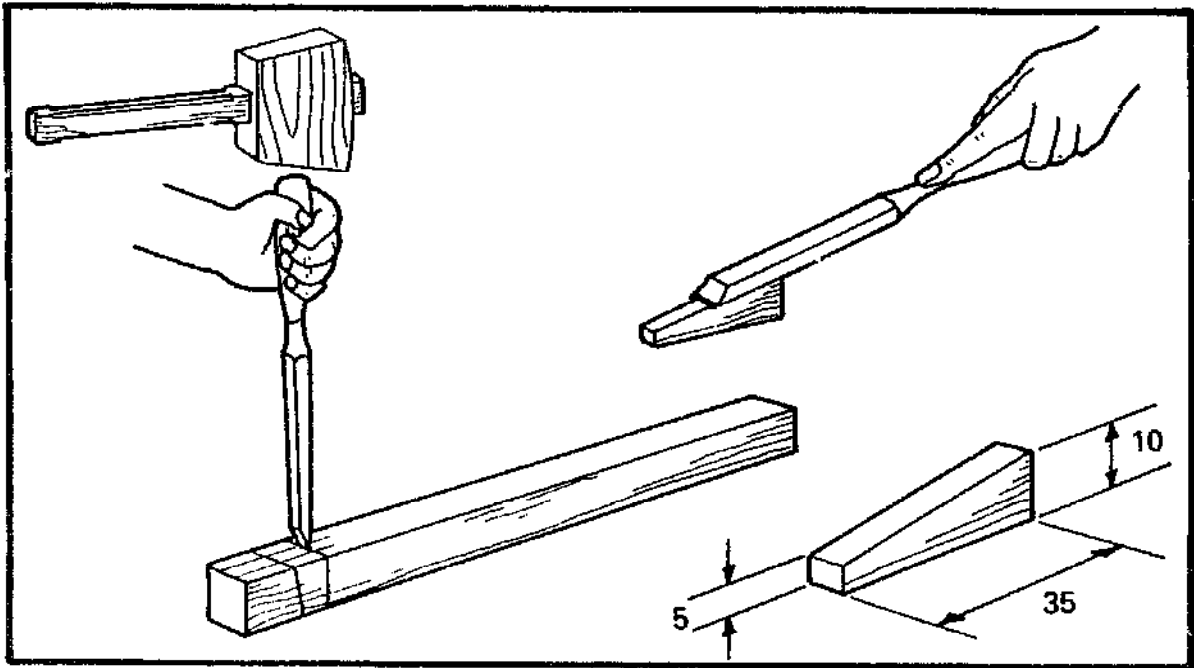

Cut the mortise between the pencil lines leaving a slope for the wedge. Make sure the ends of the mortise are straight.

Cut the wedge to the dimensions shown and fit it into the mortise, making final adjustments with a chisel.

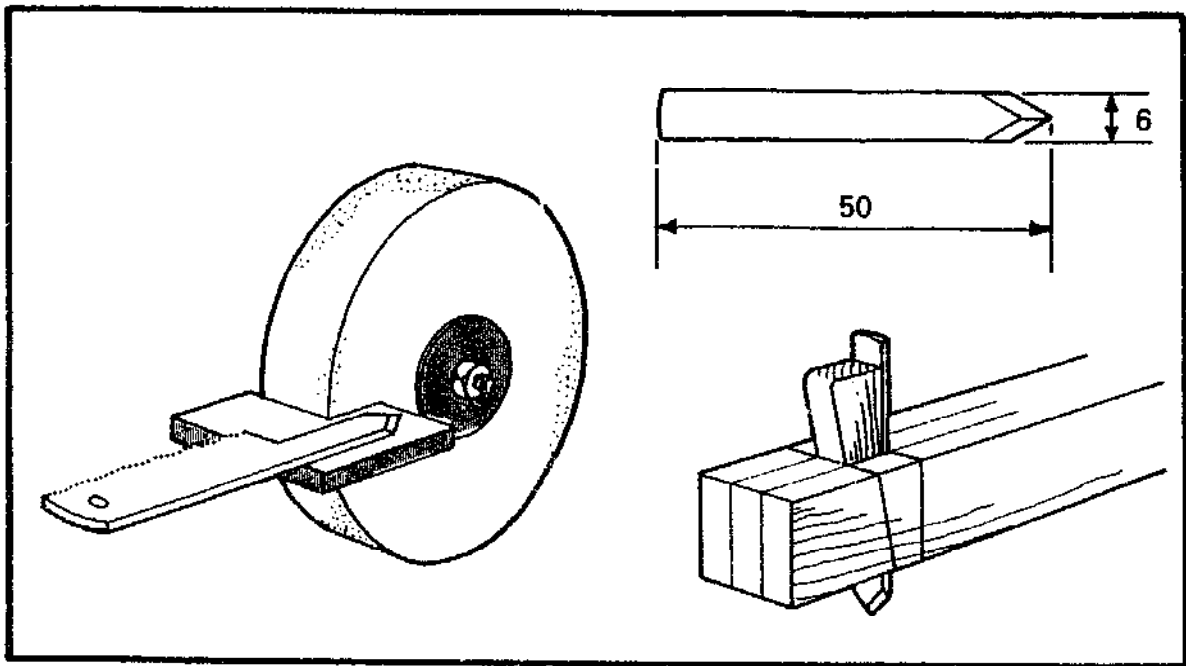

Grind a small piece of hacksaw blade to the dimensions shown, with a 'V' shaped bevel on the end. If you do not have a grinding wheel it can be filed, but first it must be heated until it is red hot, to soften the steel.

Fit the blade and the wedge into the mortise.

## USING THE CUTTING GAUGE

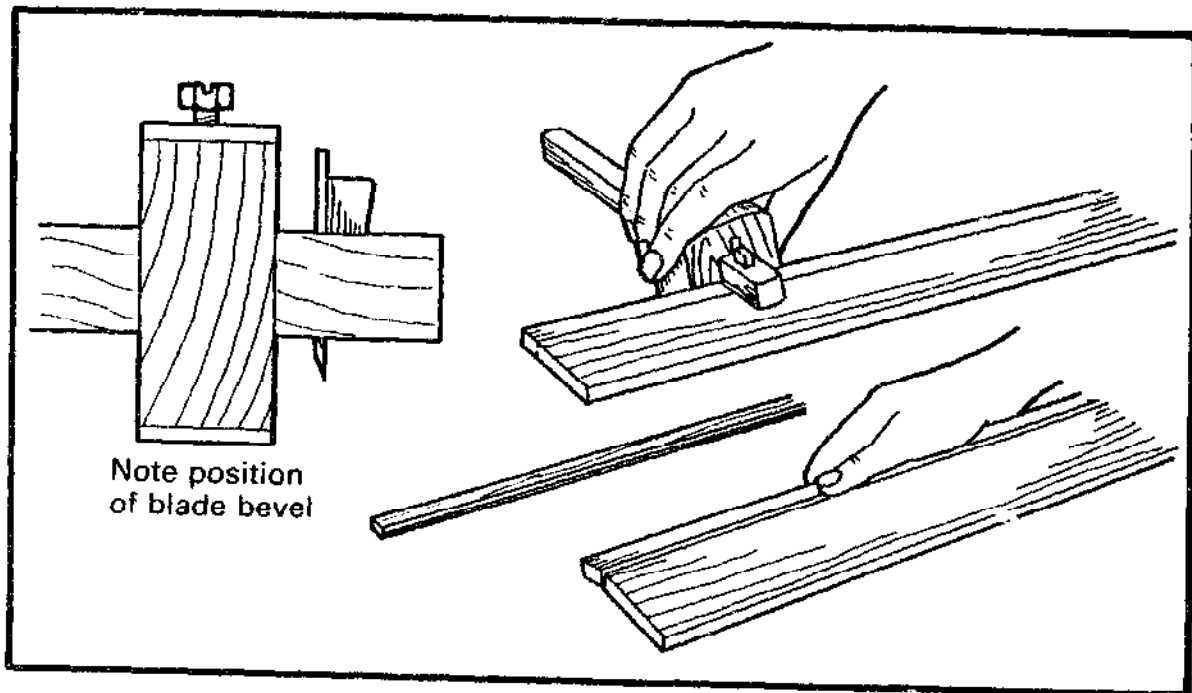

The bevel on the blade should face the fence, otherwise it will follow the grain. Cutting gauges can be used for cutting thin strips of wood for making small beadings or dowels. Score the timber on both sides and break the piece off with your hands.

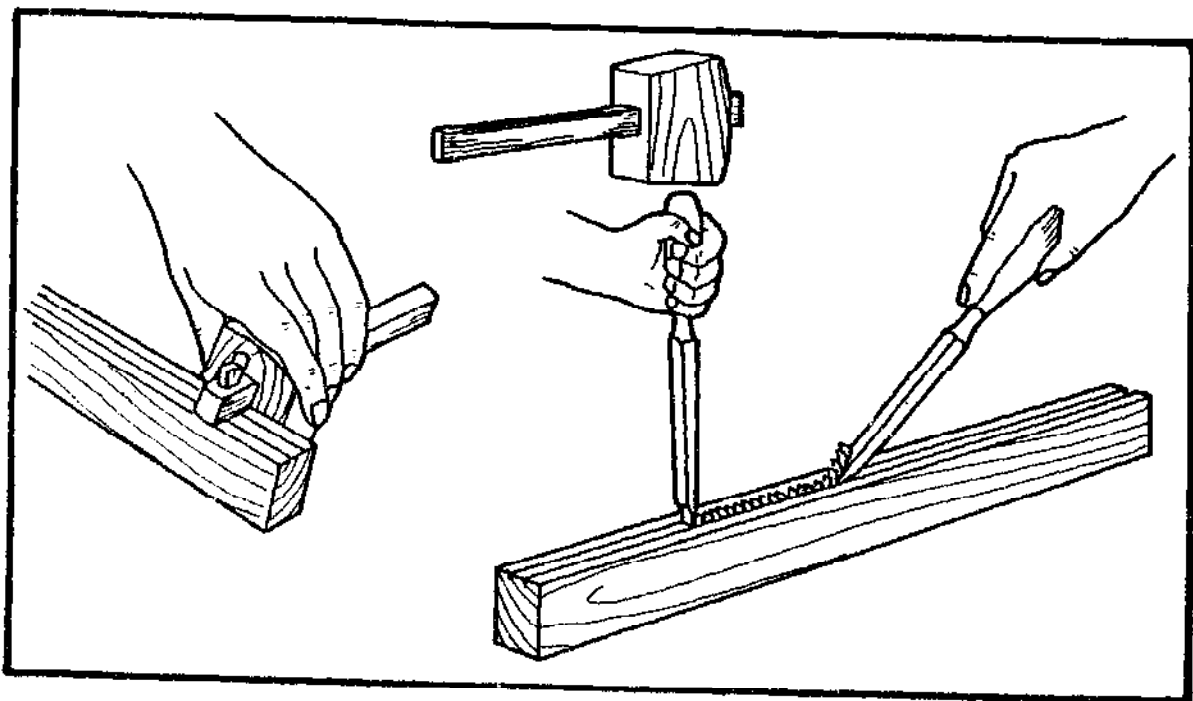

They can also be used for cutting the sides of grooves, with the grain or across it. Run the blade two or three times along the timber to make a deep cut. Remove the waste with a mallet and chisel.

## SETTING THE CUTTING GAUGE

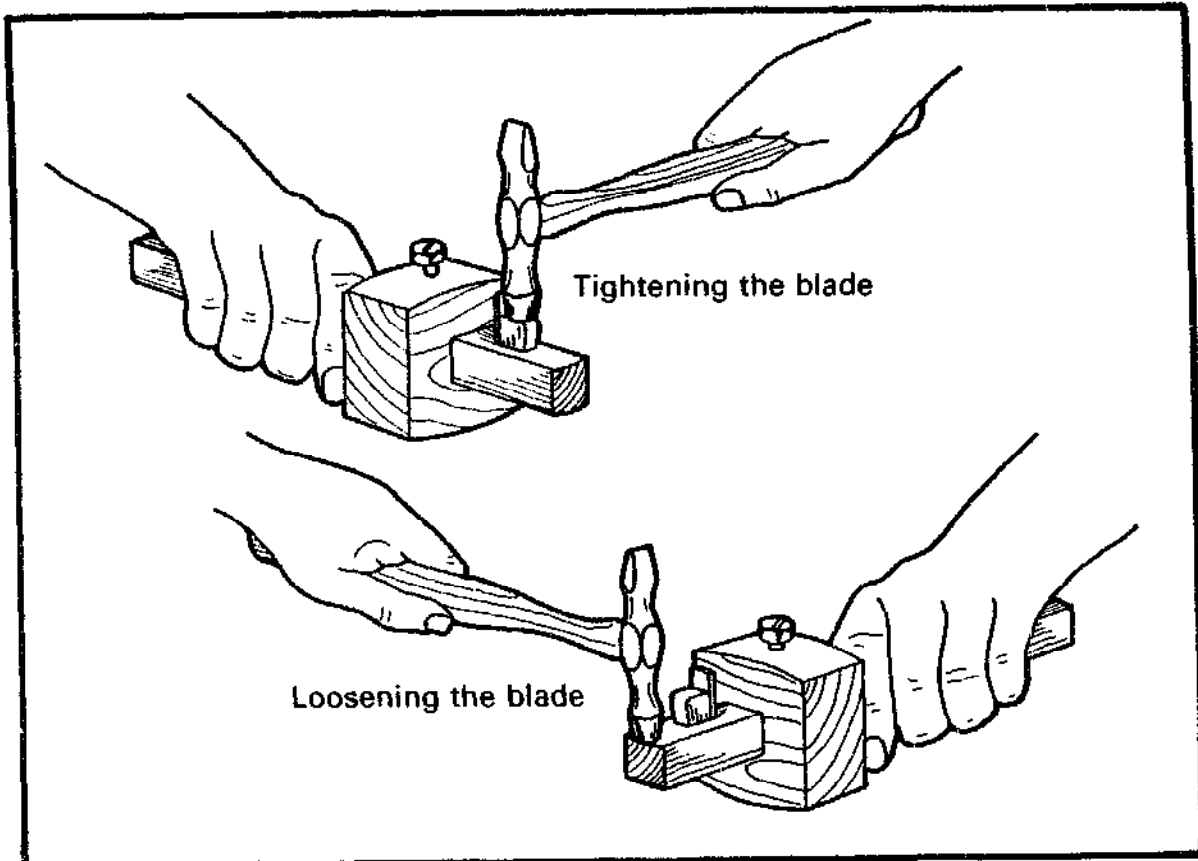

Set the distance from the blade to the fence, and tighten the locking screw with a screwdriver.

To tighten the blade tap the top of the wedge with a small hammer or a piece of wood.

To loosen the blade tap the end of the stem, and remove the blade with your fingers.

## Mortise gauge — wedge version

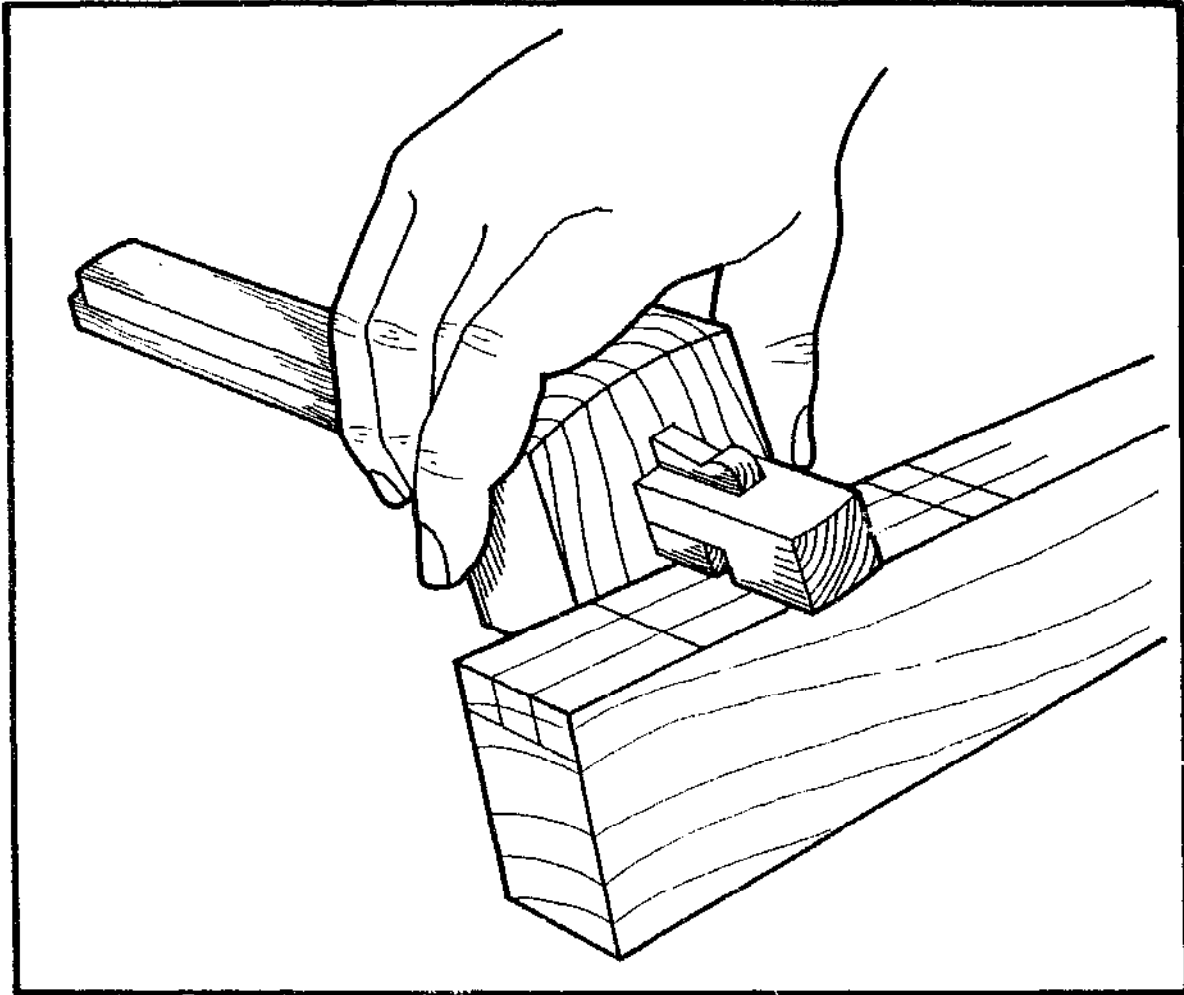

Mortise gauges are made with two spurs which mark two lines parallel to the edge of a workpiece, showing the position of a tenon or mortise or a similar joint. This avoids having to score two lines separately, and makes for greater accuracy. The spurs must be able to move independently, and be locked in any position by the fence. This makes it quite a difficult tool to construct.

There are two designs illustrated in this manual; this one is definitely the easiest to make. The stem is made up of two halves each carrying a spur. They are fixed together by a wedge seated in a slot in the fence.

Although the wedge is the simplest method of locking the tool, it takes practice to learn how to set the spurs accurately. You may decide to use the fences shown on page 19 or page 27, either of which would make setting the tool simpler.

The spurs are made from nails cut down and hammered into the ends of each half of the stem.

## LIST OF PARTS

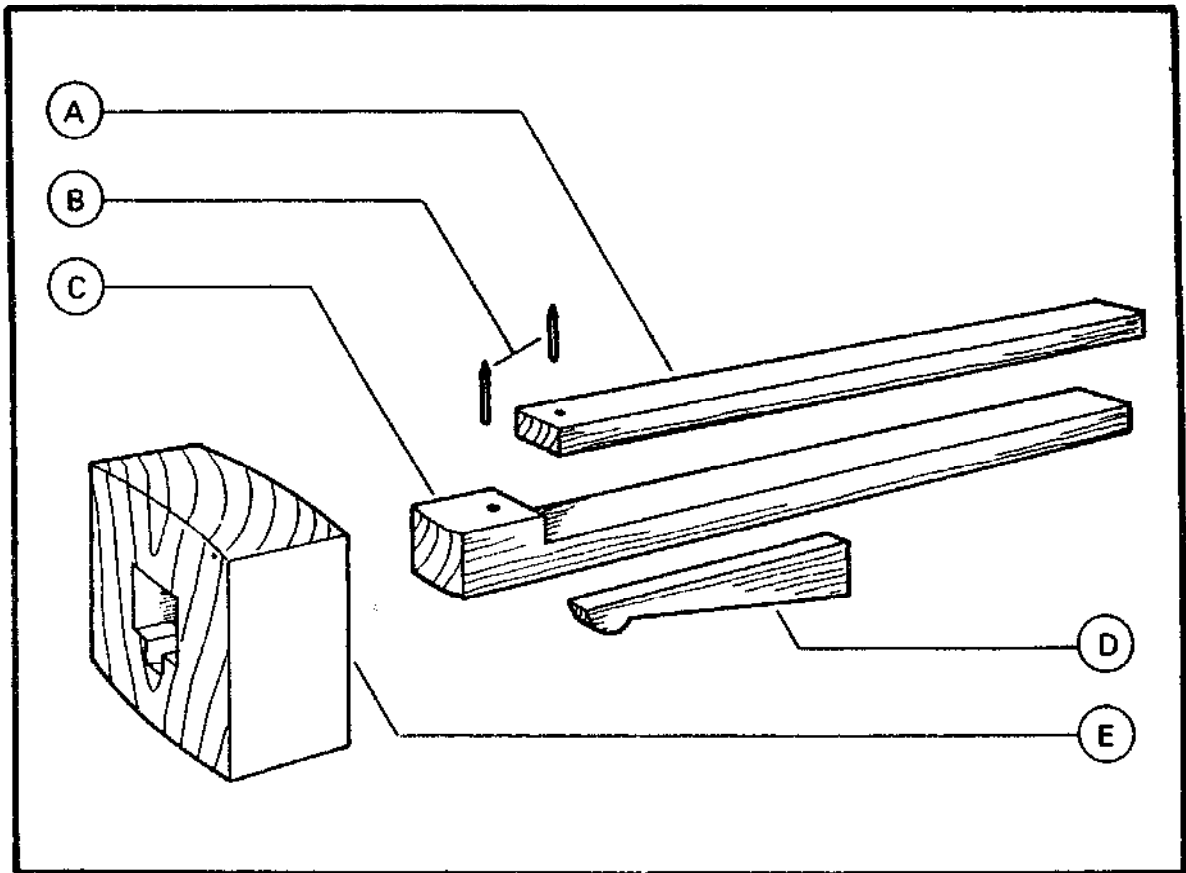

### Part

- A** *Stem A* is a straight piece of timber carrying a spur at one end.
- B** *The spurs* are made from two 25mm (1") nails cut down to 15mm.
- C** *Stem C* is made from two pieces of timber which are glued together to form a small step into which the second spur is hammered.
- D** *The wedge* locks the two halves of the stem together, and is held in place in the fence by a small knob at the end. Follow directions on page 00.
- E** *The fence*. To make the fence follow the directions on pages 22 and 23.

## Parts and Cutting List

Part	Name	Quantity, material and dimensions
A	Stem A	1 pc. timber 180mm × 20mm × 10mm
B	Spurs	2 pcs. 25mm (1") nails cut to 15mm
C	Stem C	1 pc. timber 200 mm × 20mm × 10mm
D	Wedge	1 pc. timber 30mm × 20mm × 10mm
E	Fence	1 pc. timber 100 mm 60mm × 30mm

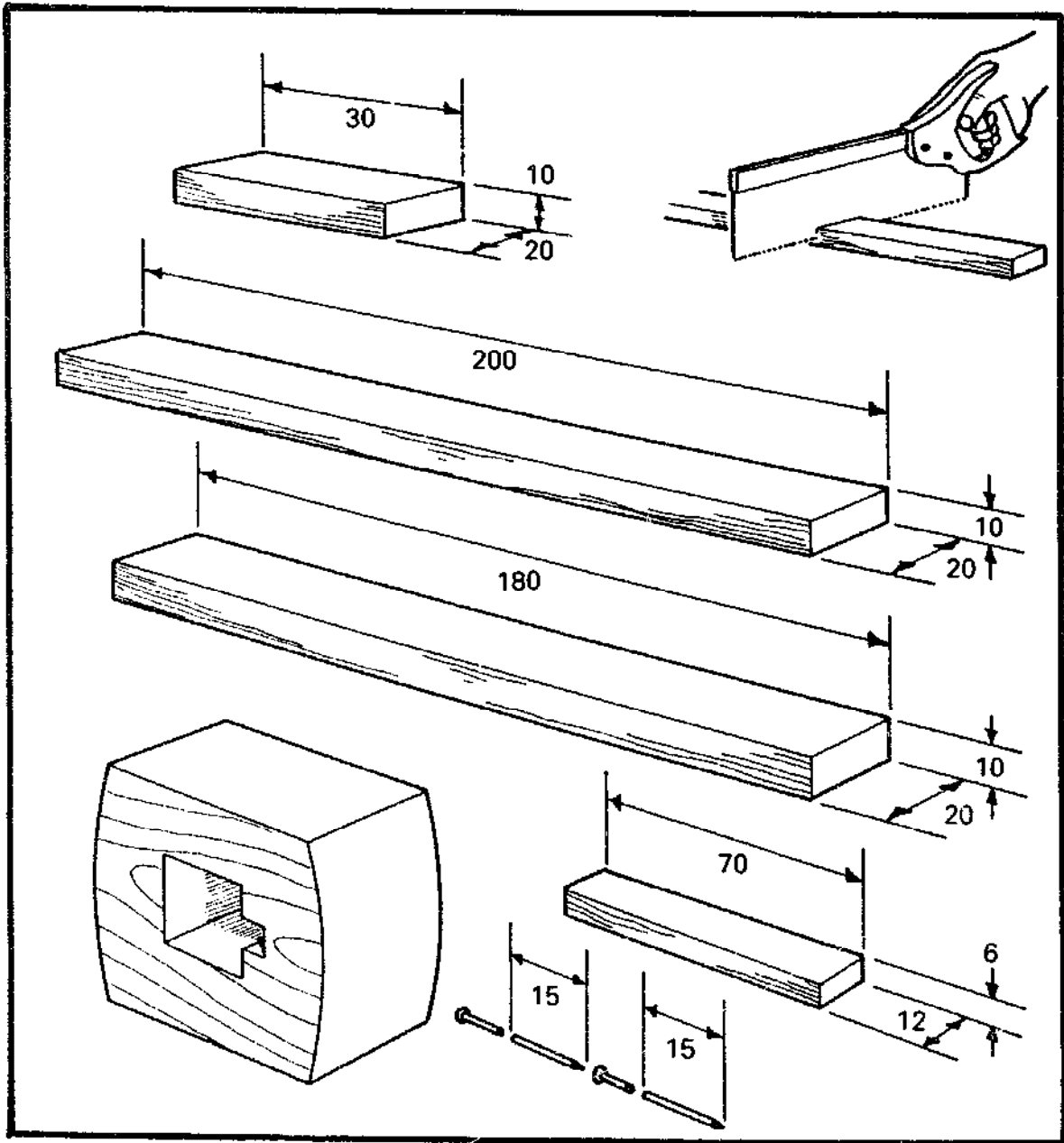
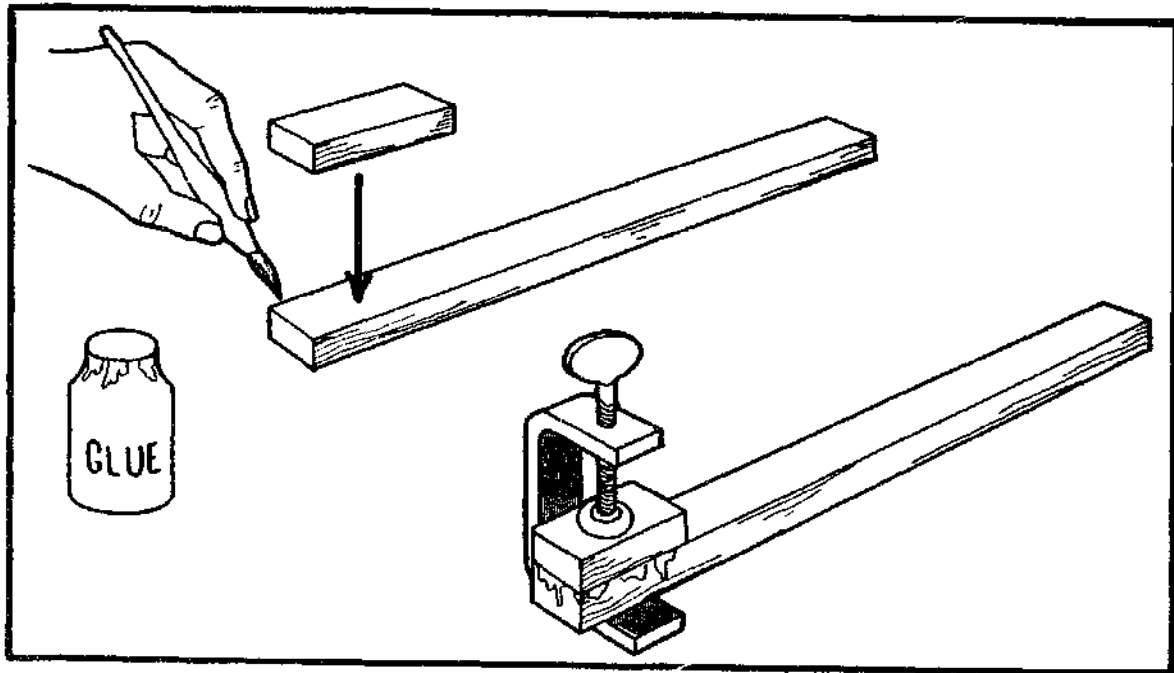

Diagram of Cutting List



## MAKING THE STEM



Take the pieces prepared to 200mm × 10mm × 20mm and 30mm × 10mm × 20mm. Glue and clamp the smaller one to the end of the larger one, and make sure there are no overhangs. Plane the glue off when it is dry.

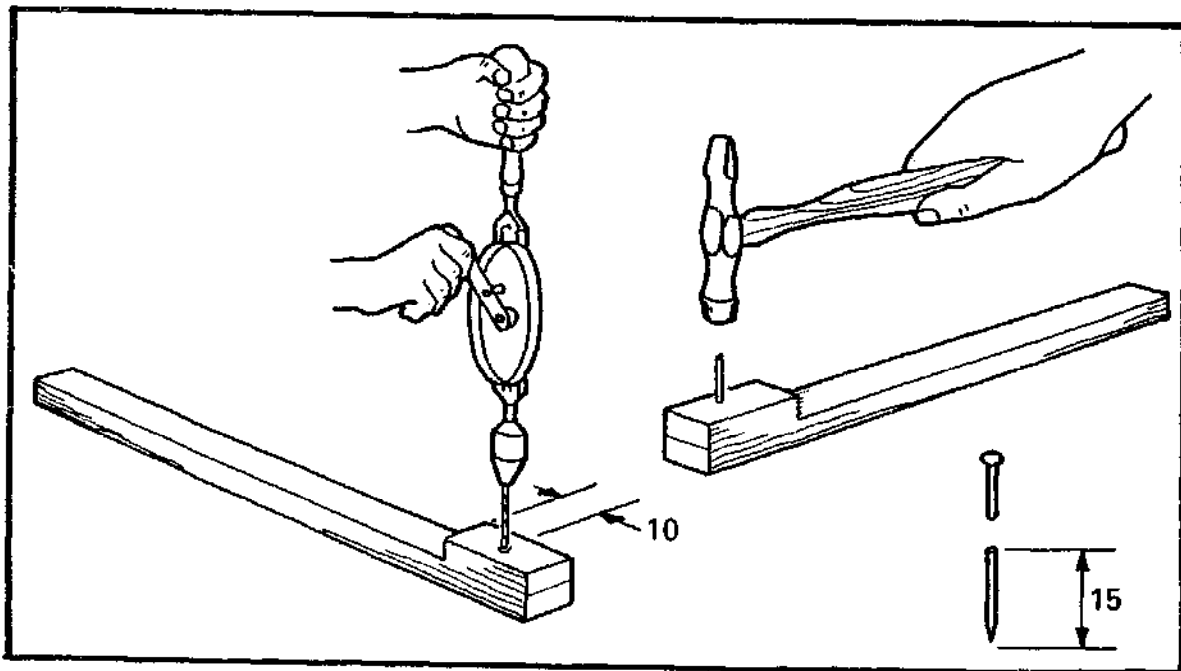

Take a 25mm (1") nail and cut off a piece 15mm long. Drill a hole, slightly smaller than the diameter of the nail. Use a small nail as a drill bit if you do not have one the right size.

Hammer the nail into the hole, leaving 5mm sticking out. Sharpen the end with a file.

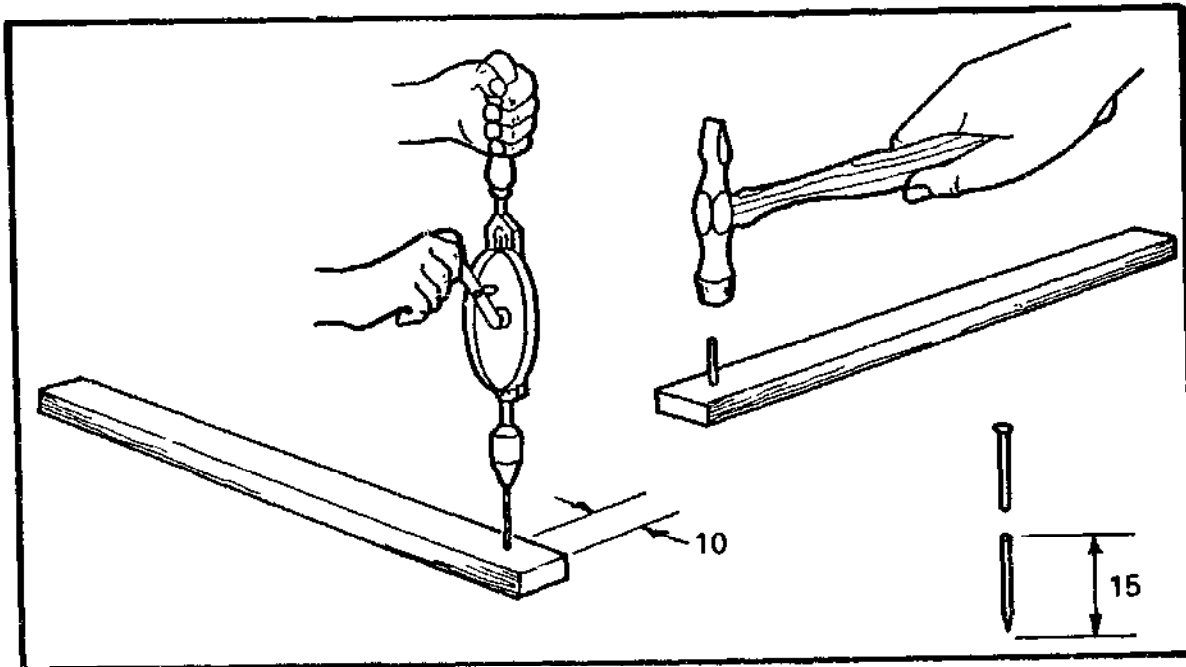

Take the timber prepared to 180mm × 10mm × 20mm, and using the same bit, drill a hole 10mm from the end of the timber. Cut a 25mm (1") nail down to 15mm.

Hammer the nail carefully into the hole. Drilling the hole first prevents the wood from splitting.

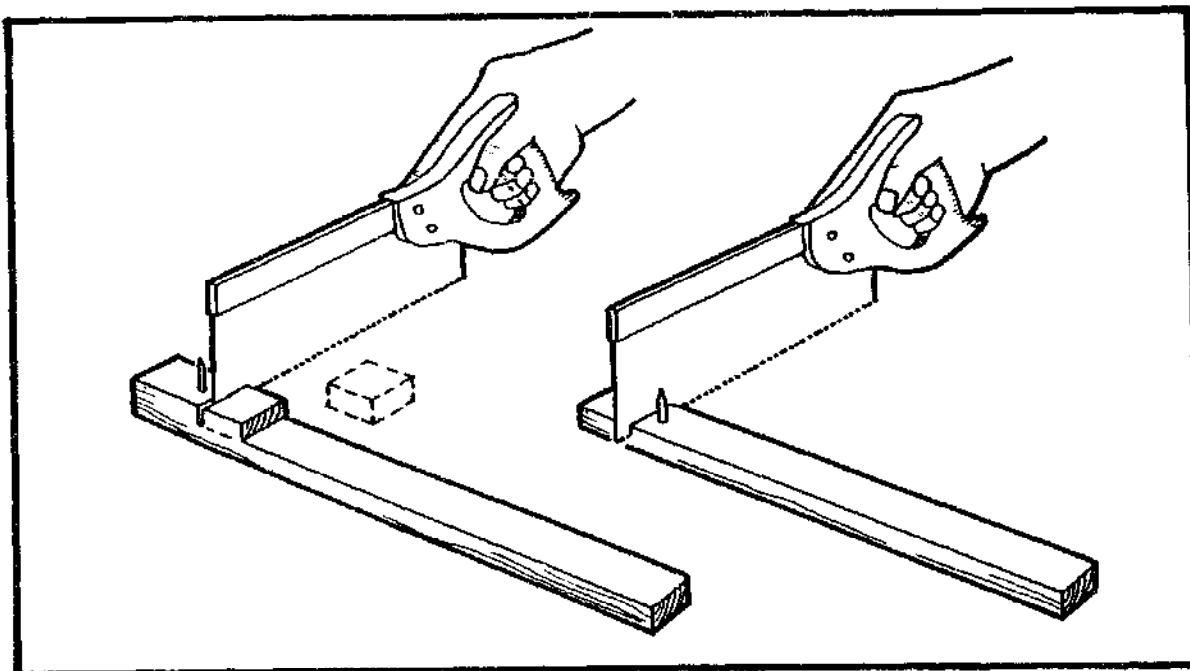

With a tenon saw, cut the step of stem A back to within 3mm of the spur. Also cut the end off stem C 3mm from the spur.

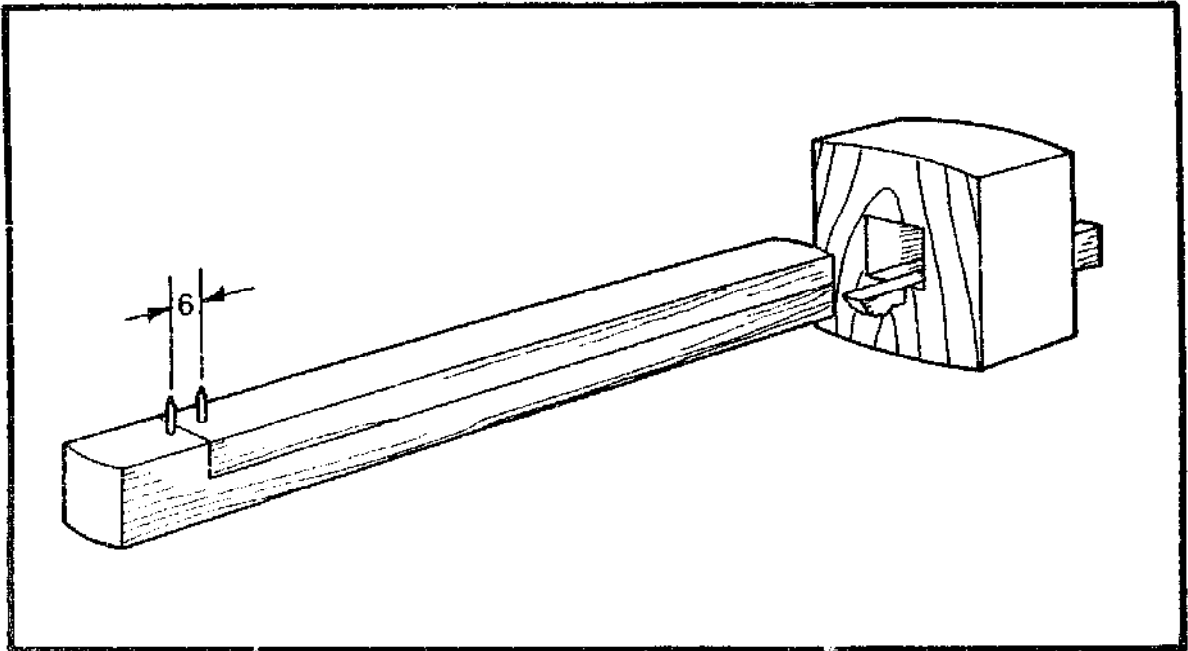

Fit the two parts of the stem together and if necessary trim the ends with a chisel or sharp knife so that the distance between the spurs is 6mm. Mark and cut the back end of stem **C** so that it is flush with the end of stem **A** and assemble the gauge.

See page 50 for setting the spurs.

See page 26 for adjusting the fence.

## Mortise gauge — locking screw version

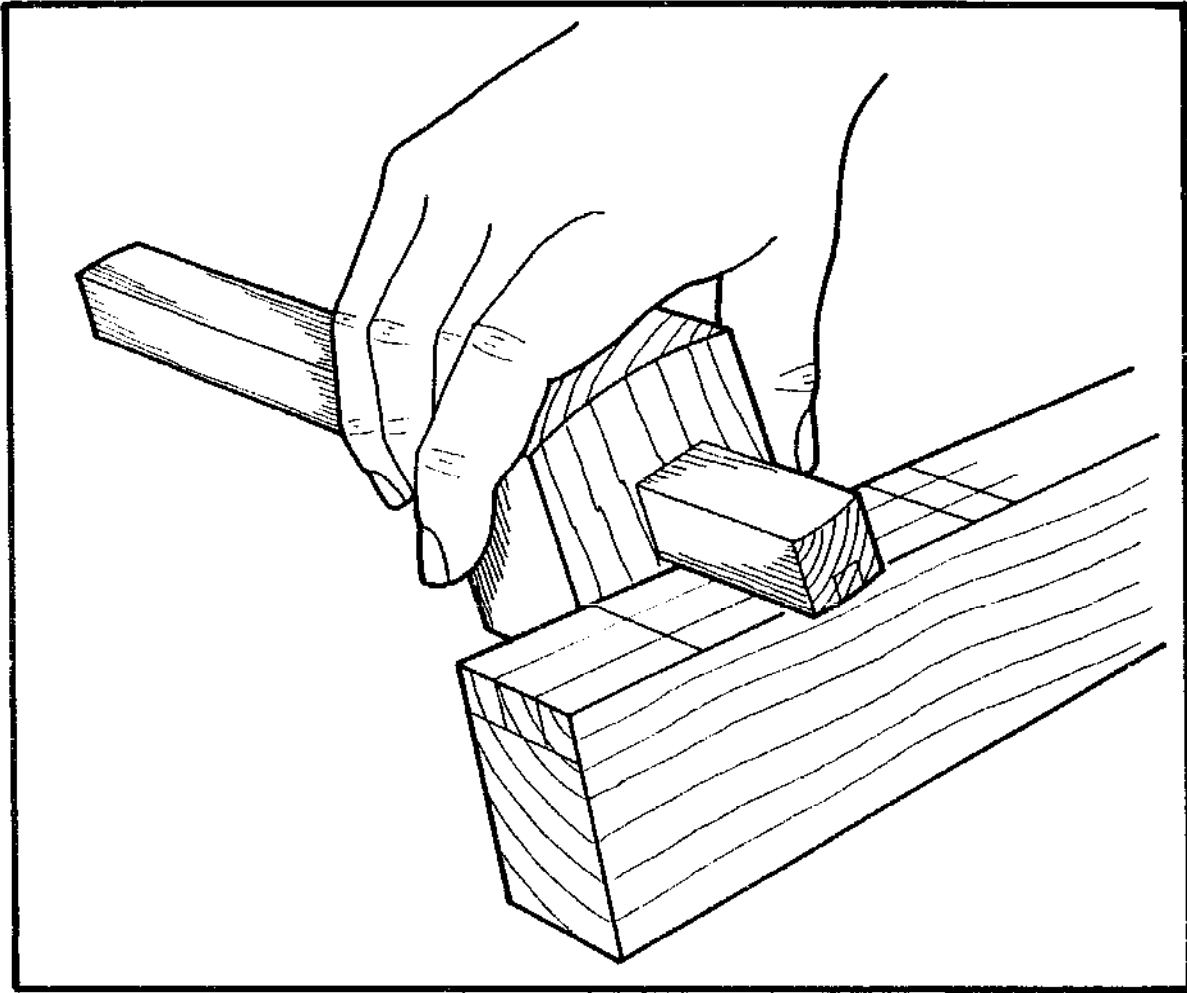

This design is based on the mortise gauges available in most tool shops. It is easy to use, but requires a higher degree of skill to construct.

It consists of a single stem which has a groove cut out of one side. A small wooden slider, carrying a spur, fits into the groove, and can be locked in any position along the length of the stem. The groove is filled in at one end by a small block of wood. The second spur is hammered through the block.

Only fences with locking screws are suitable for use with this type of stem. The wedge method cannot be used because it would have to be placed over the wooden slide, so preventing the spurs coming in contact with the workpiece.

You may find problems both in cutting a good smooth groove, and in fixing the spur into the wooden slide which is easily broken.

If you have difficulties, it may be a good idea to try the mortise gauge on page 35 instead.

## LIST OF PARTS

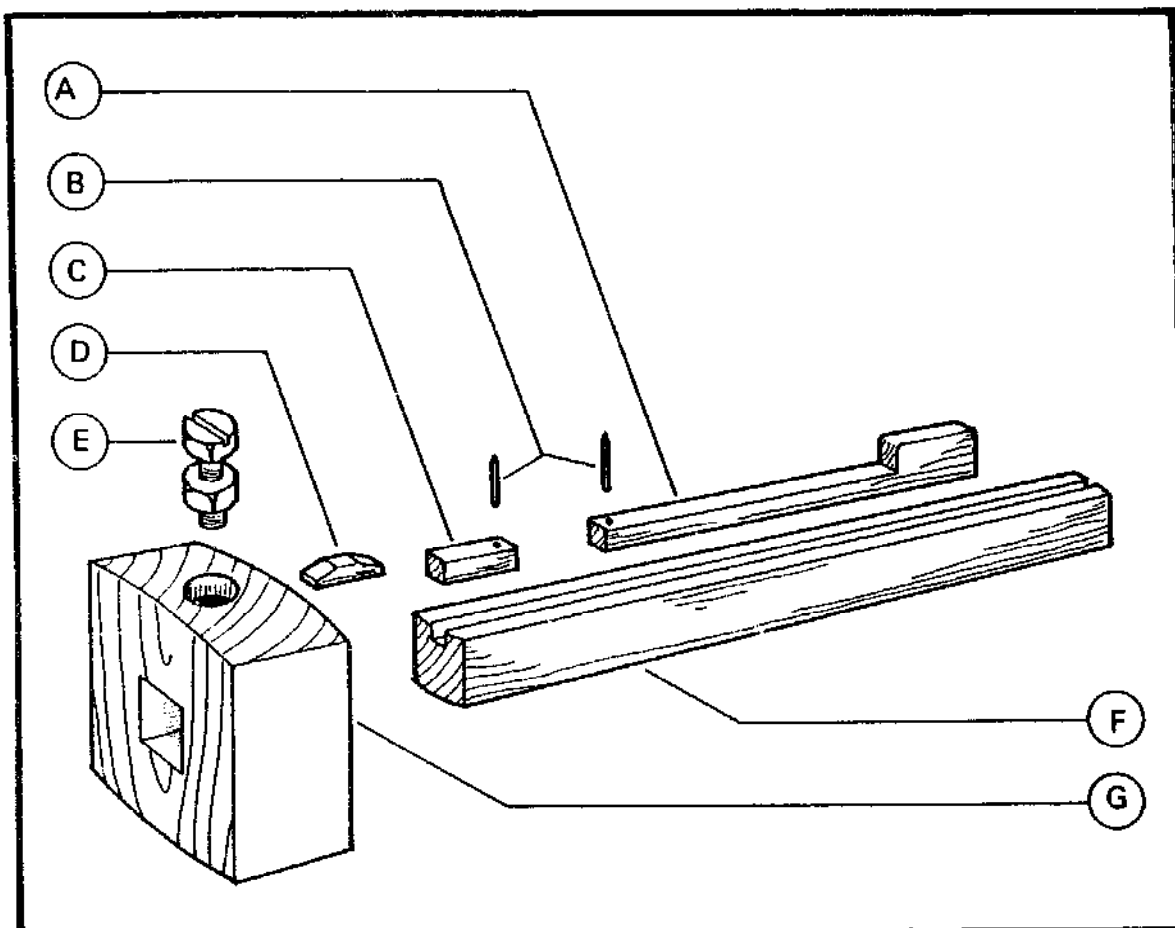

### Part

- A** *Wooden slider.* This is a small piece of wood with a knob at one end and a spur at the other.
- B** *The spurs* are made from two 25mm (1") nails.
- C** *End block.* This small piece of timber is glued into the groove at the end of the stem.
- D** *The shoe* protects the wooden slide from being damaged by the metal locking screw.
- E** *The locking screw* is a 20mm × 6mm nut and bolt, with a slot cut into the head.
- F** *The stem* has a groove for the wooden slide cut down the whole of one side.
- G** *The fence* is made following the directions on pages 22 and 23. Instead of cutting a slot for the wedge a hole is drilled in the top for the locking screw, and a small recess made for the shoe inside the mortise.

## Parts and Cutting List

Part	Name	Quantity, material and dimensions
A	Wooden slider	1 pc. timber 200m × 6mm × 12mm
C	End block	
D	Shoe	
B	Spurs	2 pcs. 25mm (1") nails cut down (one 15mm and one 10mm)
E	Locking screw	1 pc. 20mm × 6mm nut and bolt
F	Stem	1 pc. timber 20mm × 20mm × 20mm
G	Fence	1 pc. timber 100 × 60mm × 30mm

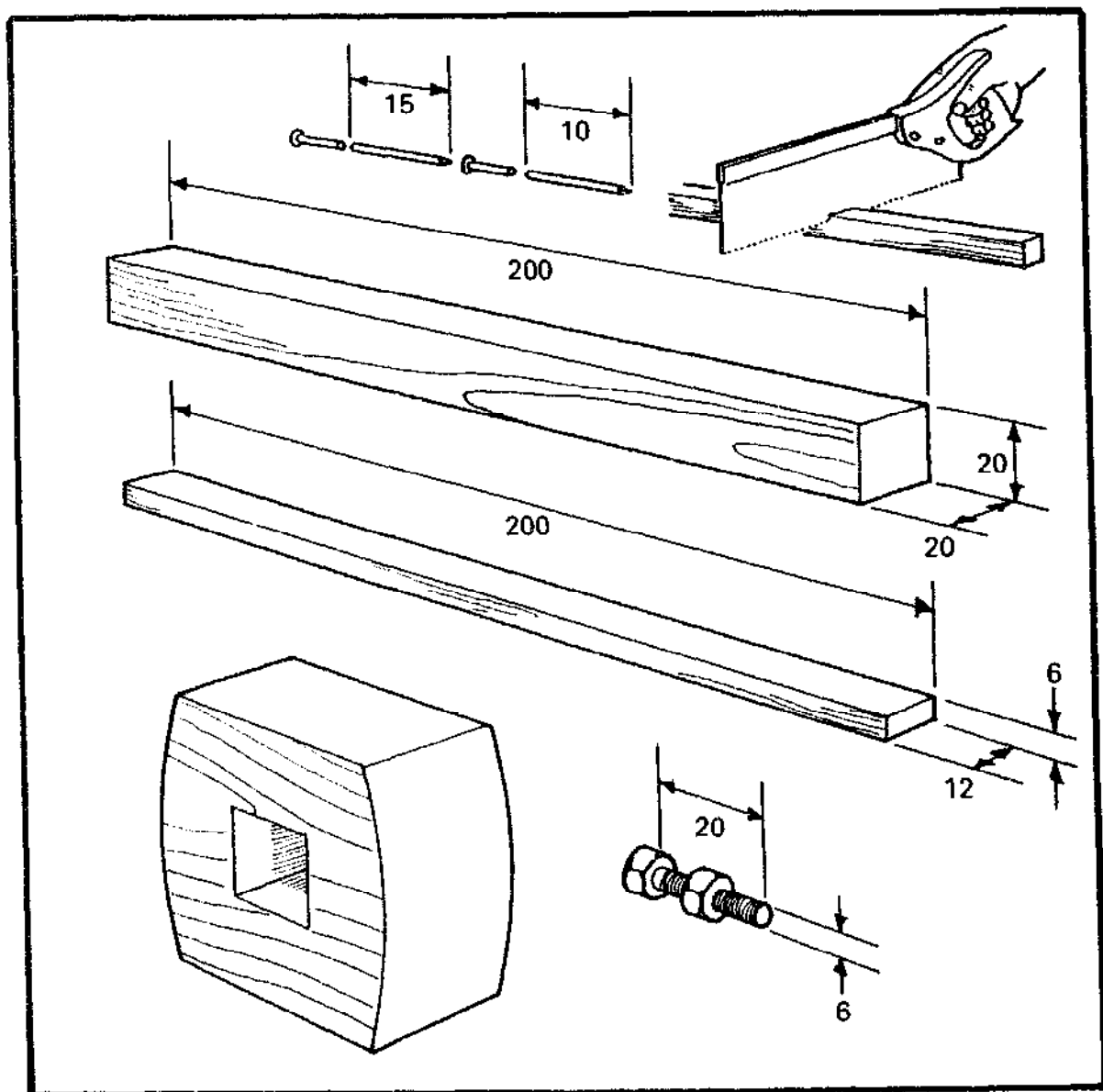
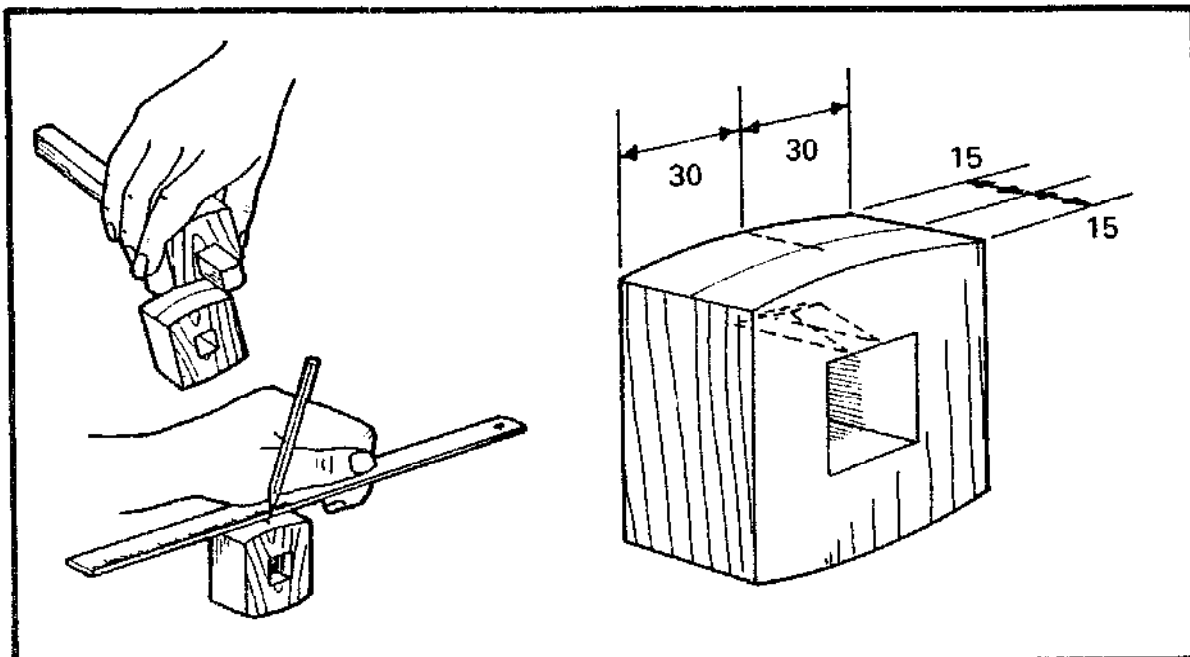

Diagram of Cutting List

## MAKING THE FENCE



To make the fence follow the directions on pages 22 and 23, but do not cut the groove for the wedge. Instead choose one edge of the fence with end grain and gauge a centre line, which should be 15mm from each side.

With a pencil and ruler, find the centre of this line and mark the hole for the locking screw.

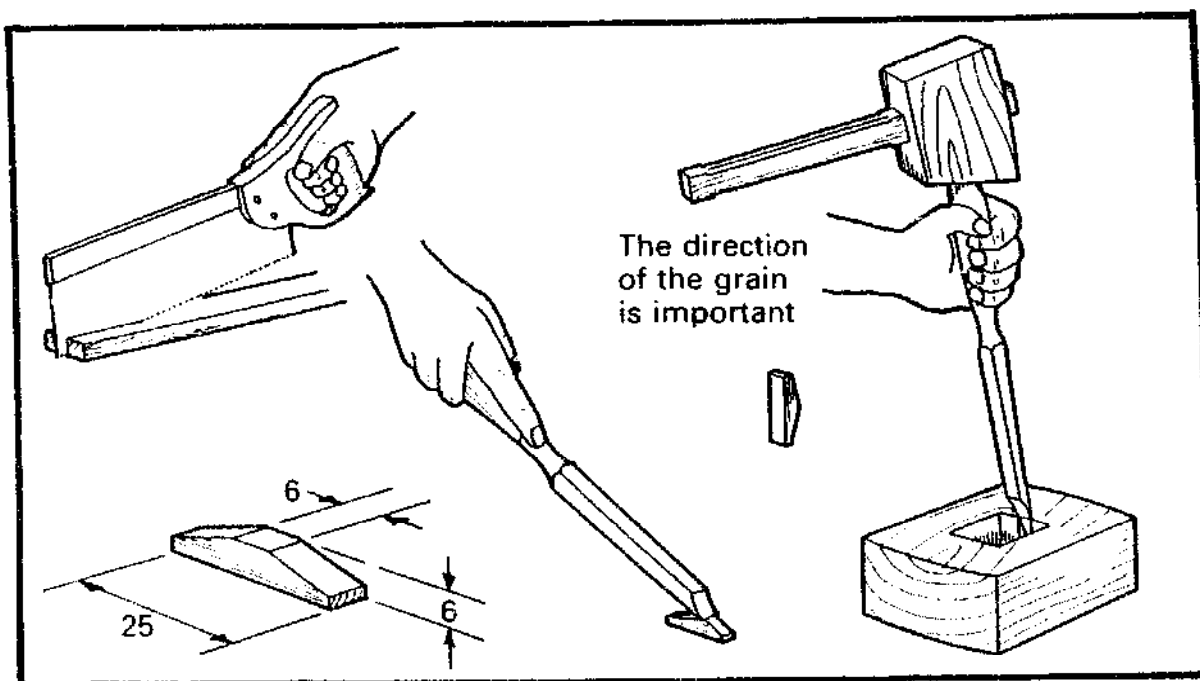

Cut and shape the shoe from the timber prepared to 200mm × 12mm × 6mm. With a mallet and 6mm chisel carefully cut a recess for the shoe in the end grain of the mortise, nearest the centre mark.

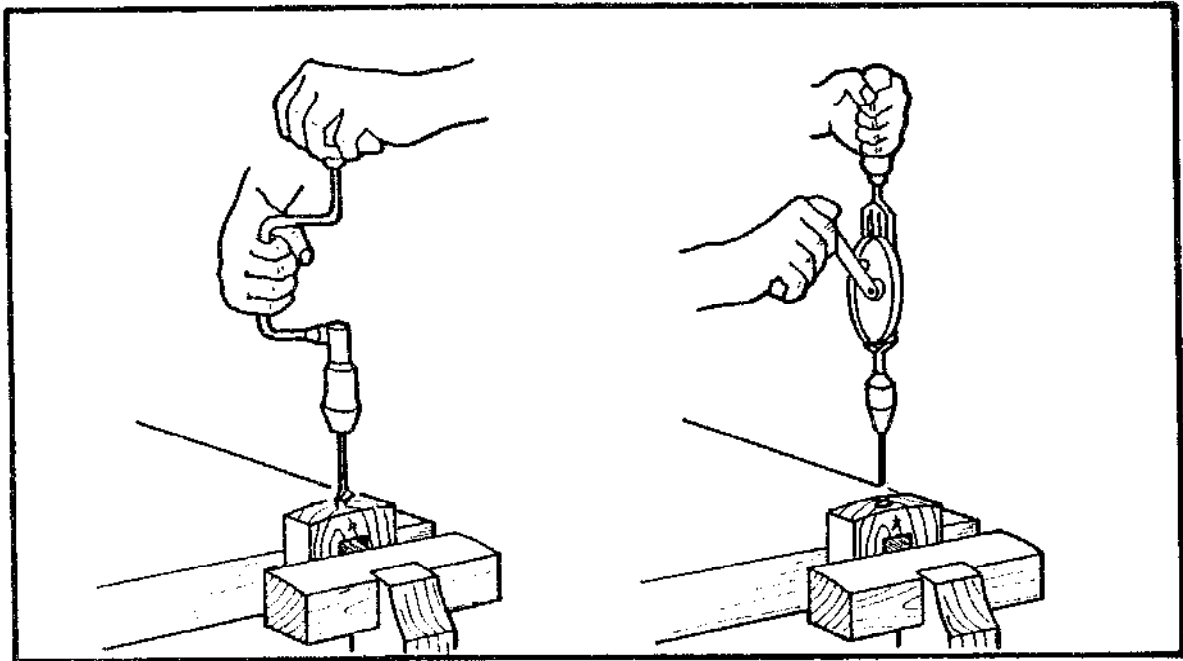

With a 12mm drill bit bore a hole on the centre mark to a depth of 6mm. Now drill a  $\varnothing 6\text{mm}$  hole right through, into the recess cut for the shoe.

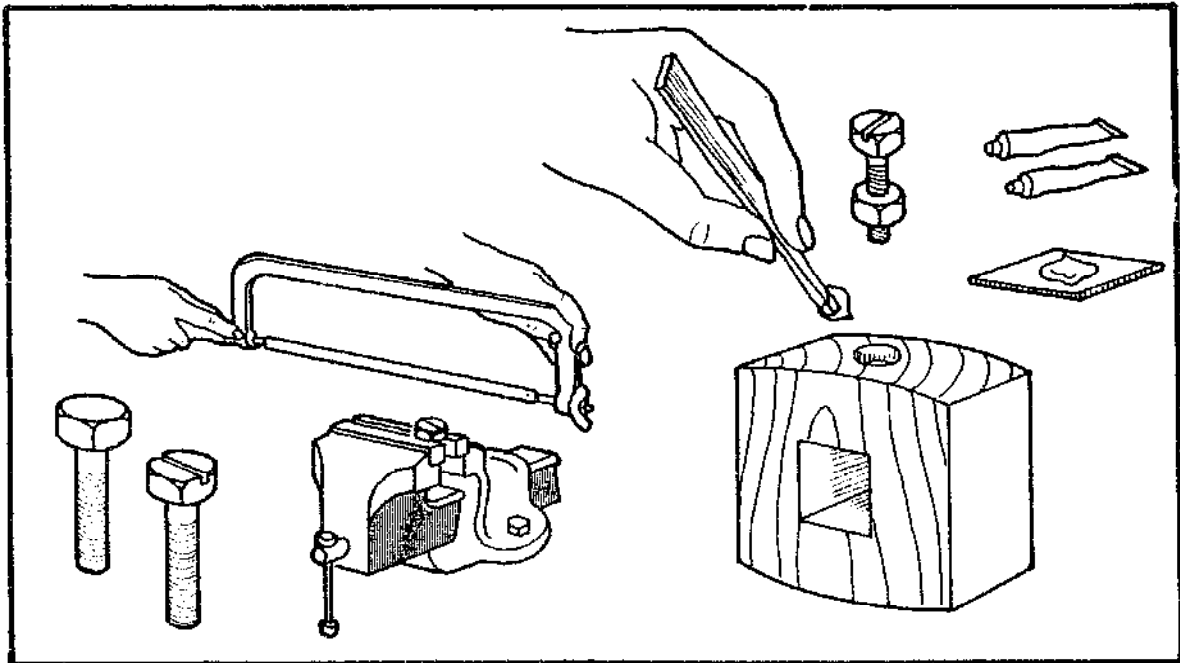

Take the 20mm  $\times$  6mm nut and bolt and saw a slot into the head for a screwdriver.

Wash the nut with turps to remove any grease. Mix some Araldite, or any epoxy resin glue, and glue the nut into the hole. Screw the bolt right into the hole, to position the nut properly, then remove it before the glue dries.



## MAKING THE STEM

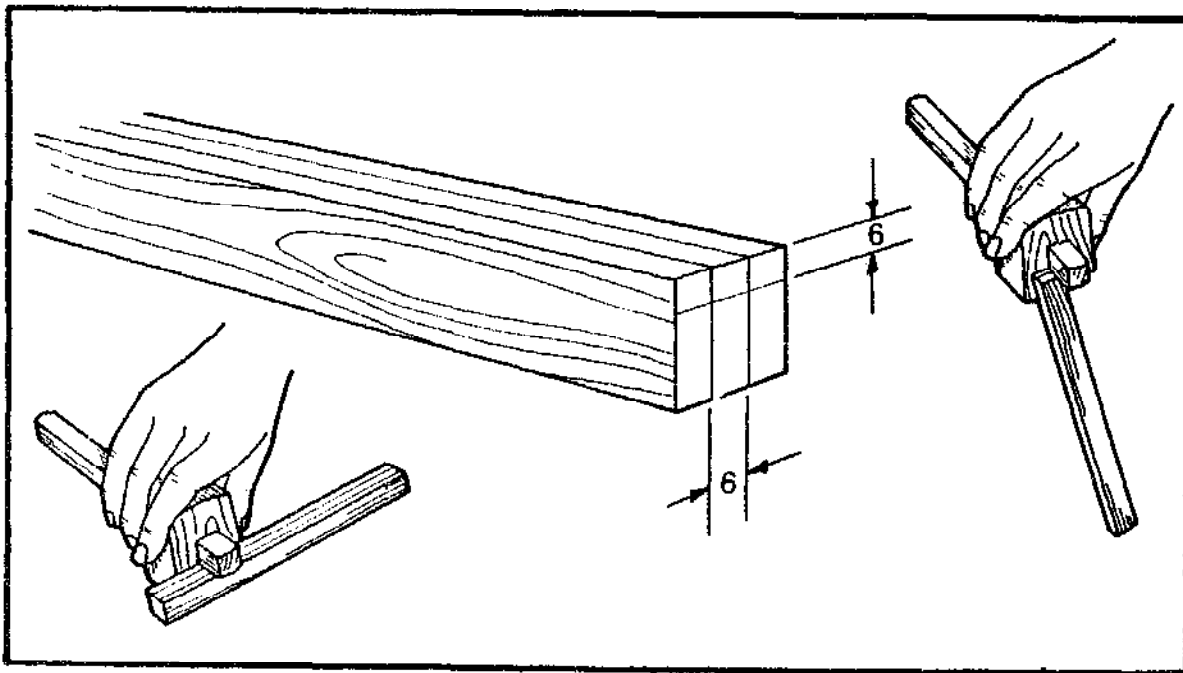

Take the timber prepared for the stem, and mark a 6mm groove down the centre of one side with a mortise gauge. Mark the depth at each end to 6mm.

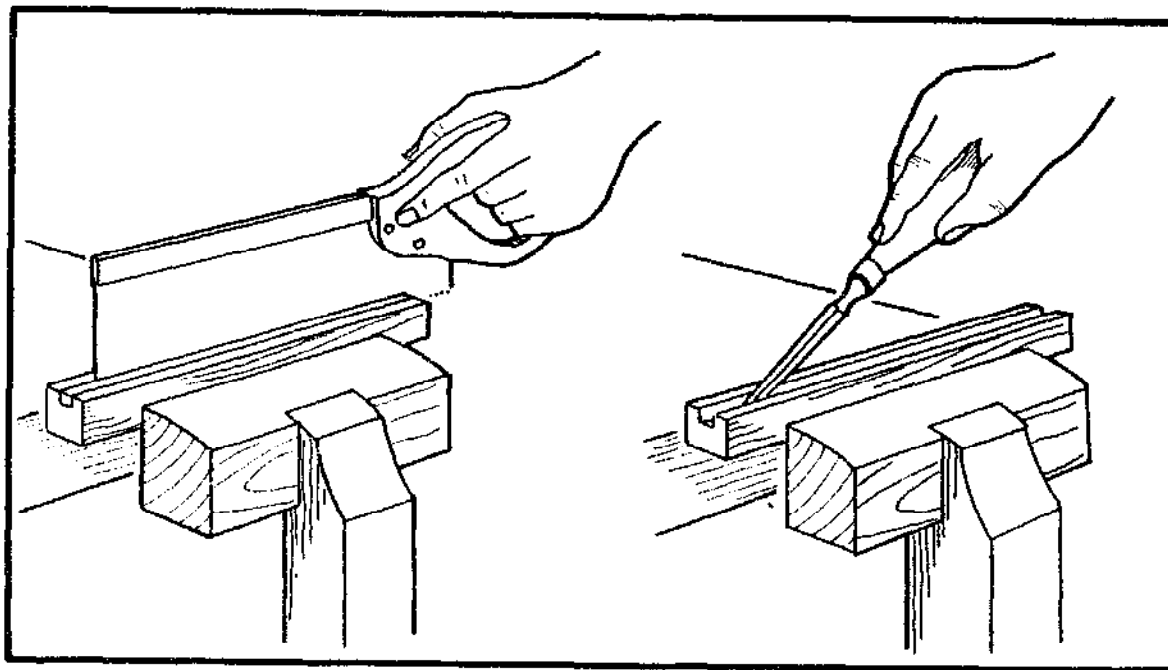

There are three ways to cut the groove:

- 1) Use a plough plane if one is available.
- 2) Use a cutting gauge as shown on page 27.
- 3) Use a tenon saw to cut the sides of the groove, then chisel out the waste.

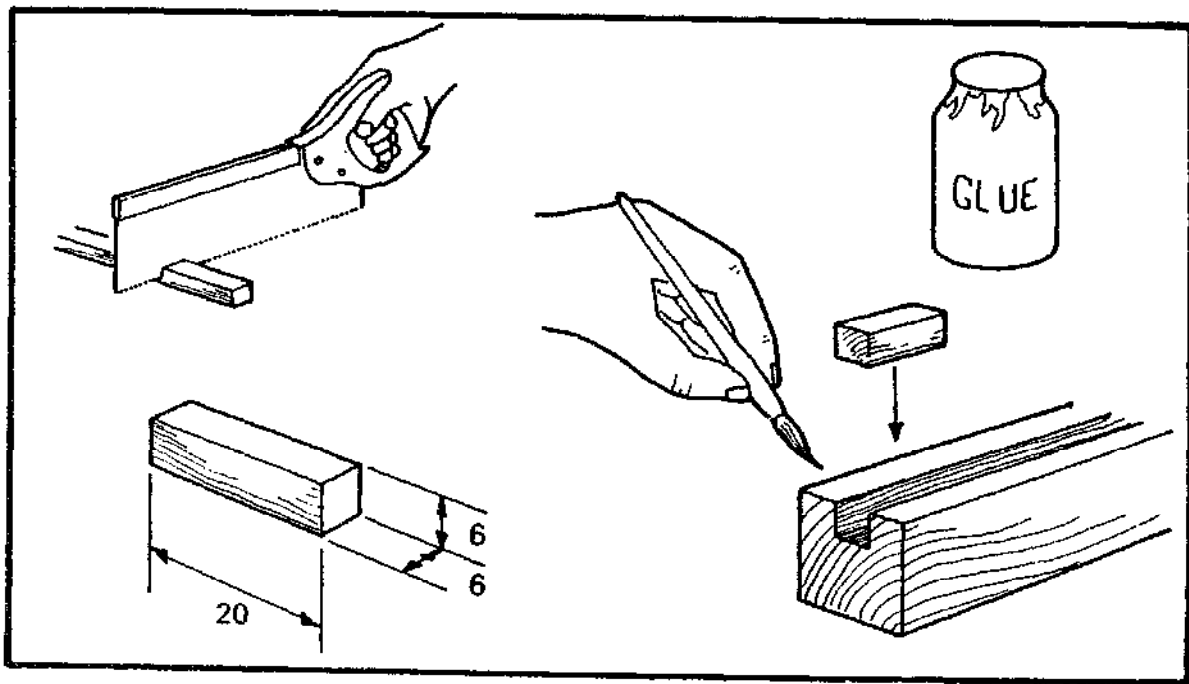

Cut a small block of wood from the piece prepared for the slider, 20mm × 6mm × 6mm. Fit and glue it into the groove at the end of the stem.

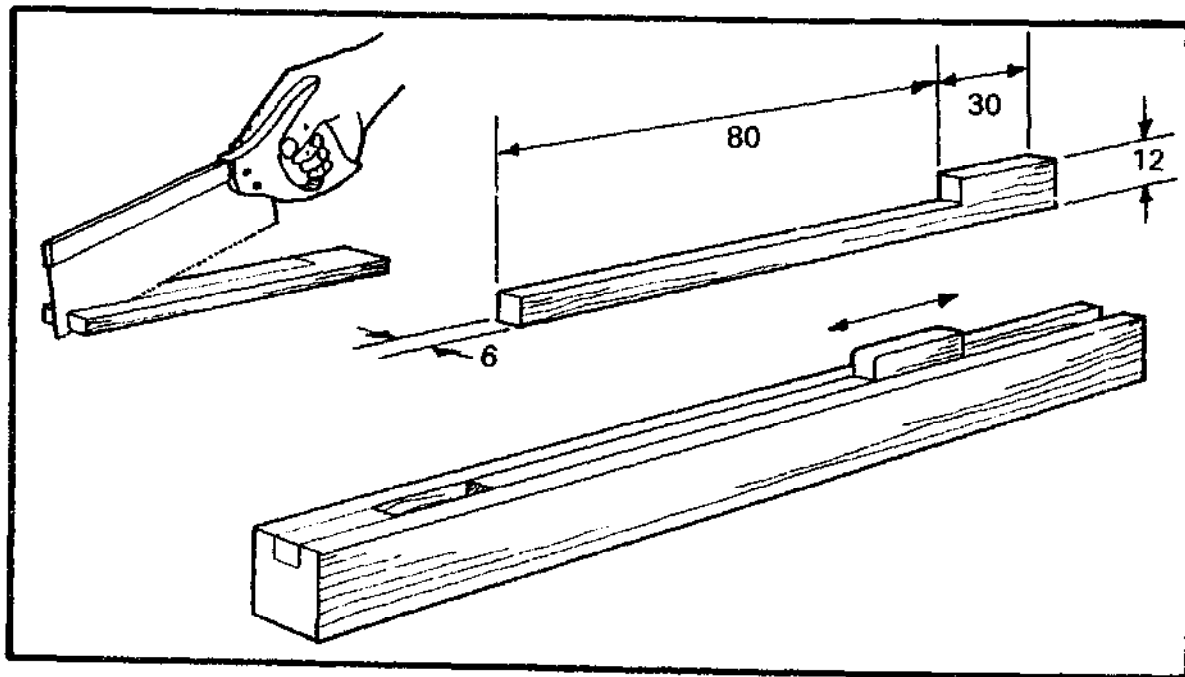

Cut the slider to the dimensions shown. Fit it into the groove. It should slide easily, but not wobble in the groove. The top of the slider can be scraped with a chisel so it is flush with the top of the stem.

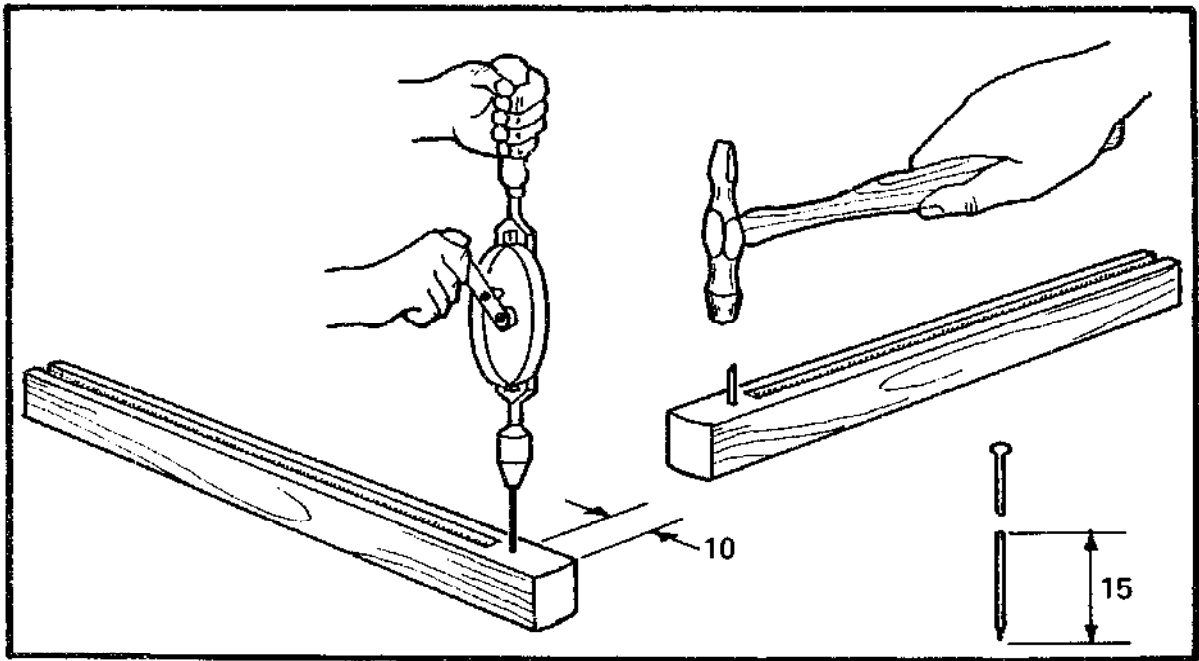

Take a 25mm (1") nail and cut it down to 15mm. Drill a hole slightly smaller than the diameter of the nail, 15mm from the end of the stem. If you do not have the right size bit, cut the head off a 20mm nail and use that to make the hole.

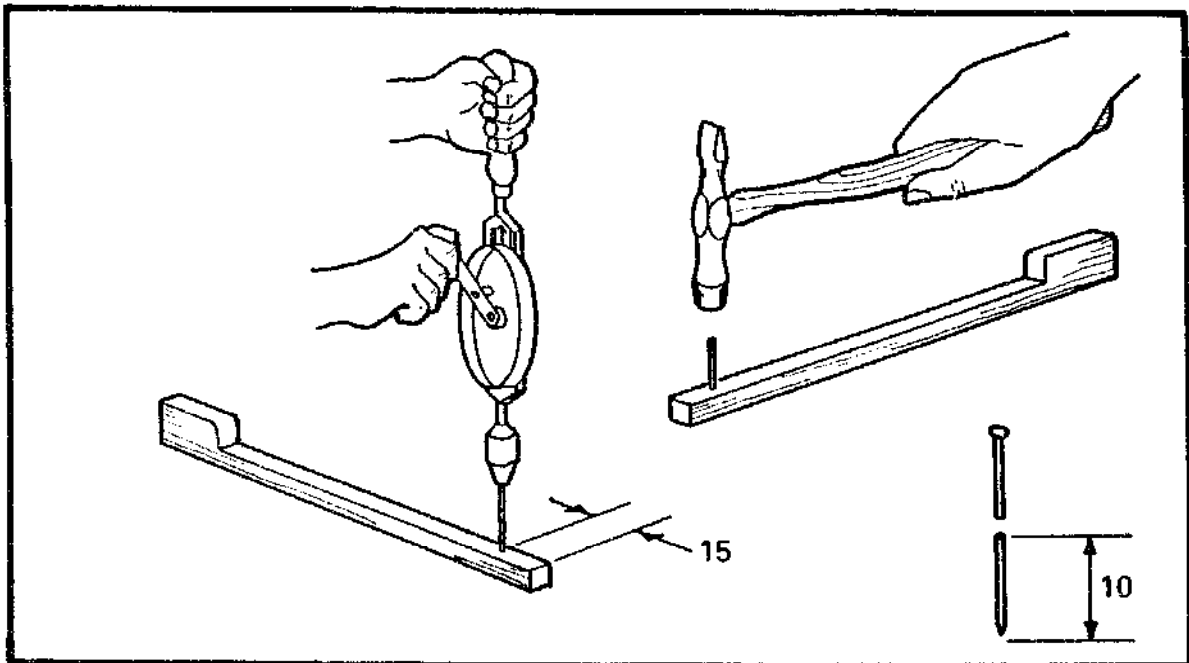

Use the same drill to bore a hole in the slider, 10mm from the end. Take another 25mm nail and cut it down to 10mm in length. Carefully hammer this into the slider, again leaving 5mm sticking out. Drilling the hole first should prevent the timber splitting.

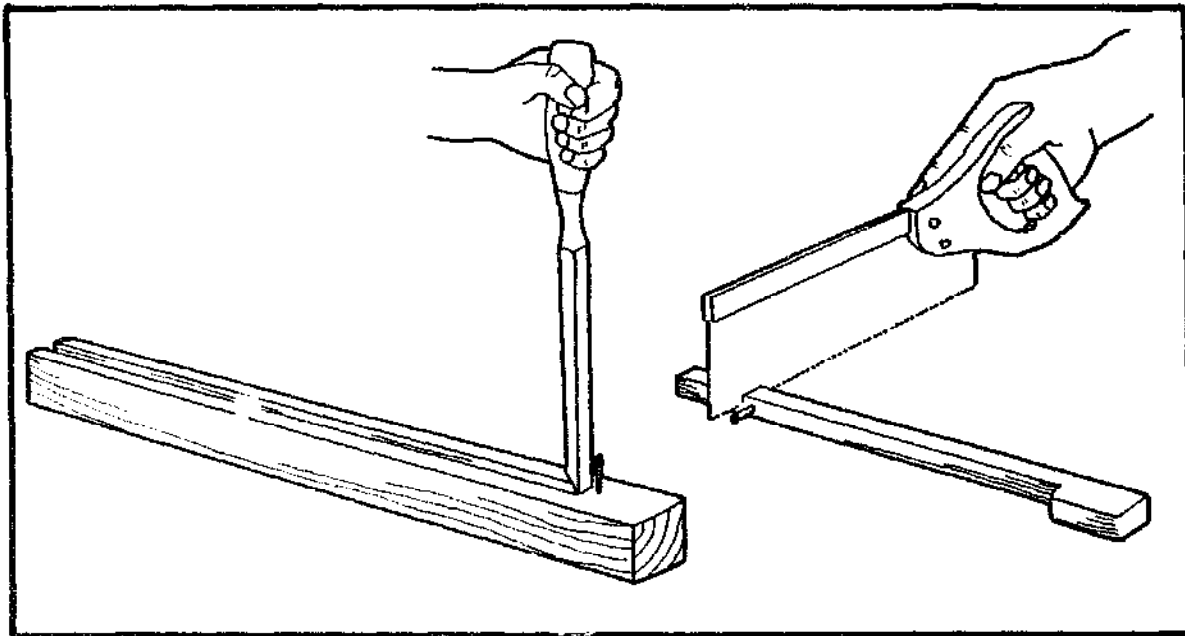

With a 6mm chisel, cut the groove back to within 3mm of the spur in the stem.

With a tenon saw, cut the end of the slider off 3mm from the spur.

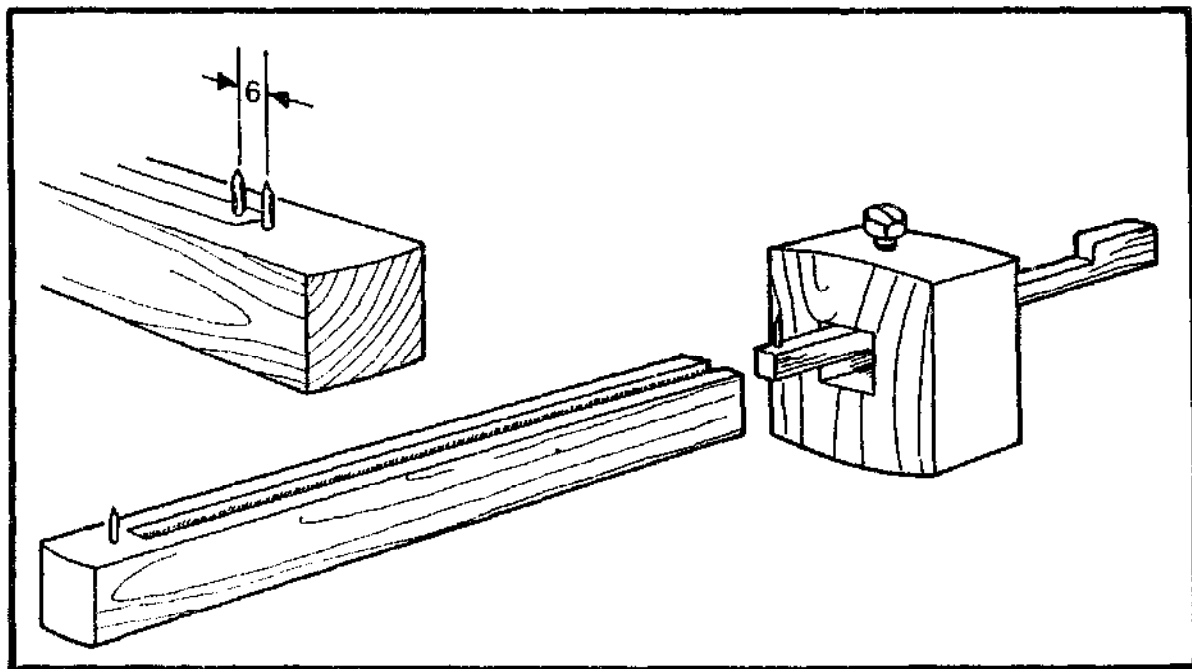

Fit the slider into the groove, so that the distance between the two spurs is 5mm. Sharpen the spurs with a file, and assemble the gauge.

## SETTING THE GAUGE

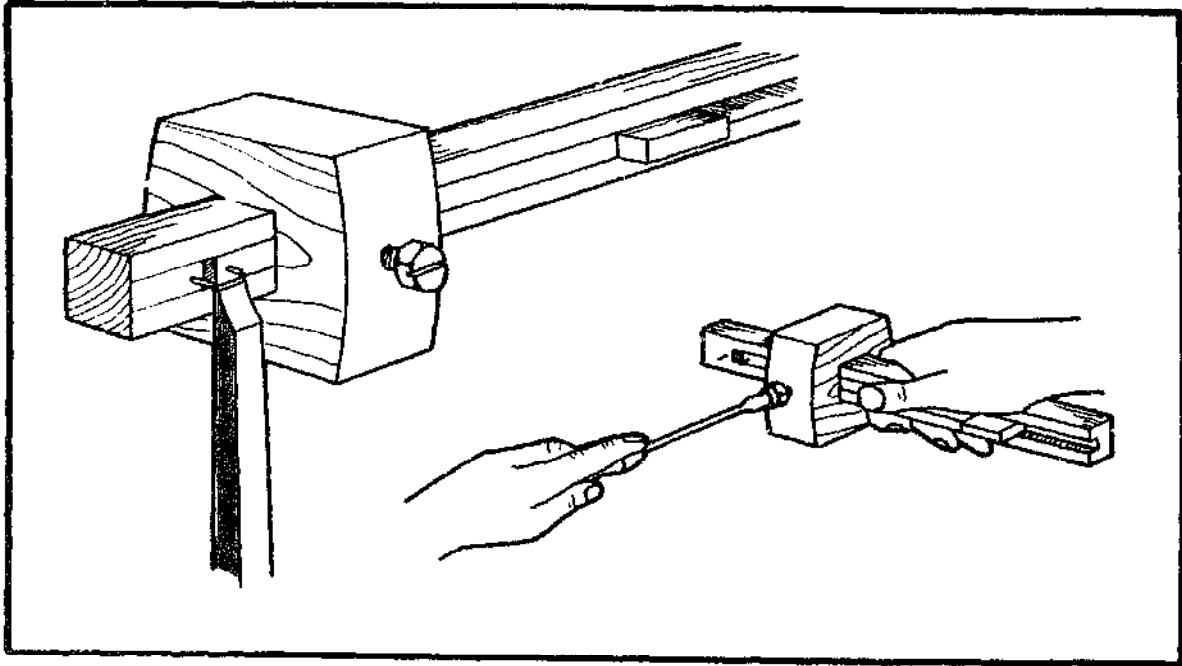

The gauge is set in the normal way by using a mortise chisel to determine the distance between the spurs.

Tighten the locking screw with a screwdriver.

## Panel gauge

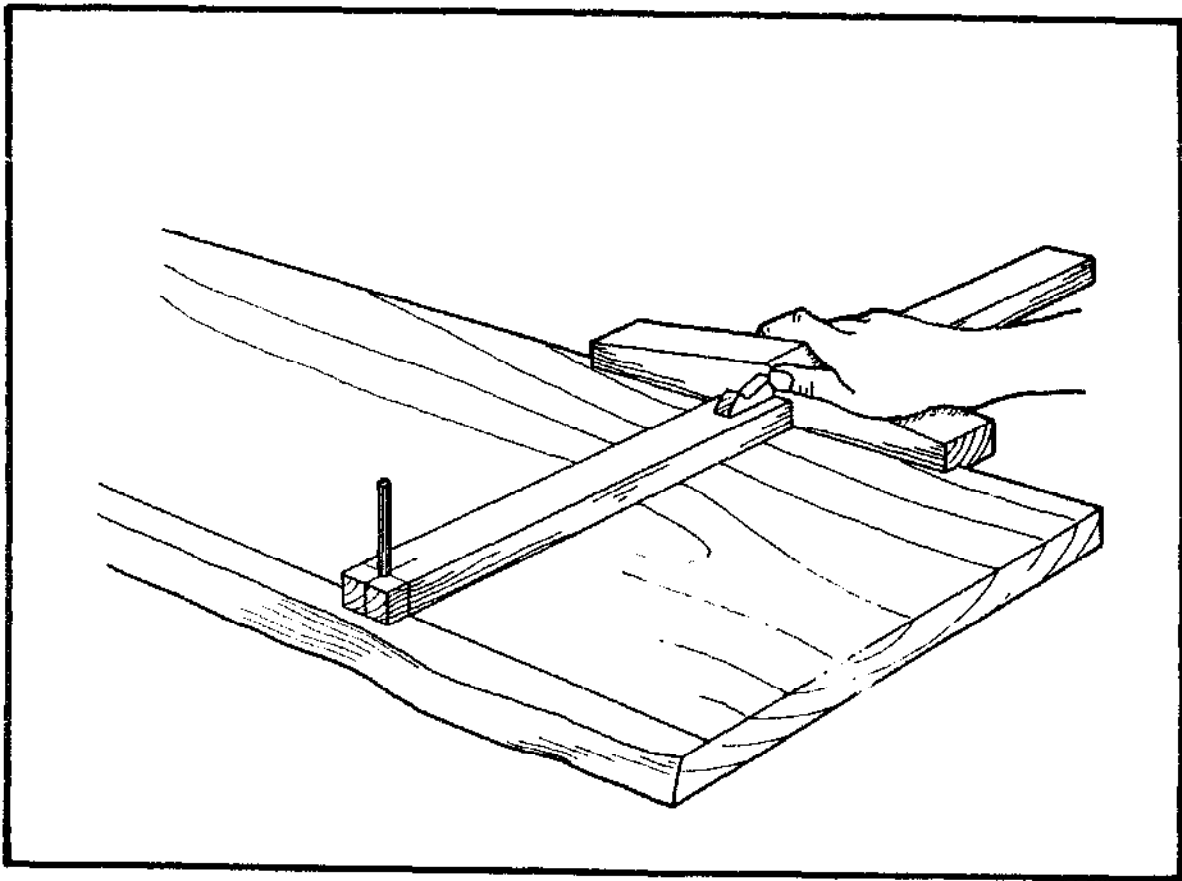

This is a large wooden gauge with a wide fence and a stem anything up to a metre long. Instead of the workpiece being marked with a metal spur, the stem carries a pencil, located in a hole at one end. The fence and the stem are locked together by a wedge.

This type of gauge is used for marking out wide panels of timber or plywood. The lower edge of the fence is rebated on one side, which helps to keep it firmly in contact with the edge of the board to be marked.

It is not an essential tool, but for repetitive work it may save time and prevent mistakes.

## LIST OF PARTS

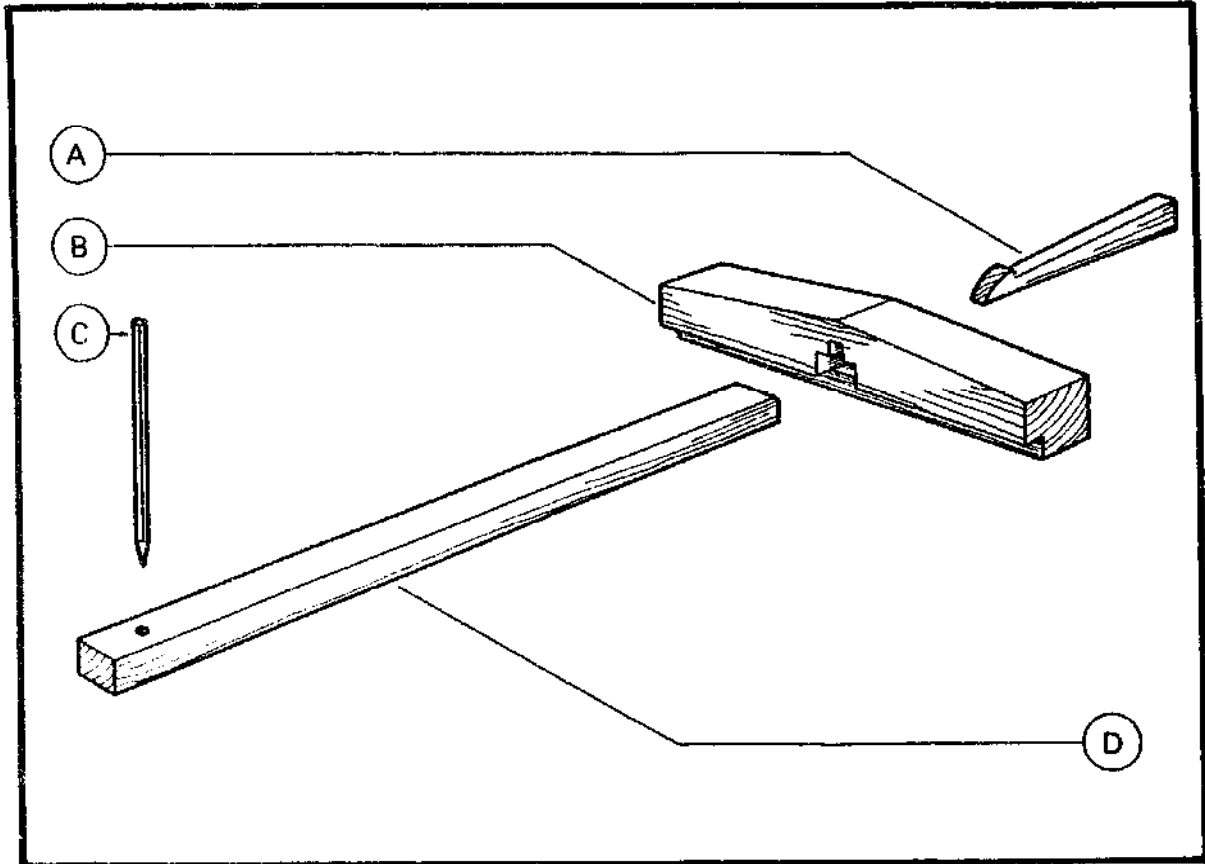

### Part

- A** *The wedge* locks the fence in any position along the stem.
- B** *The fence* has a rebate cut on the lower edge. In the centre there is a mortise for the stem, and a tapered slot for the wedge.
- C** *A pencil* is used to mark the work piece instead of a steel spur.
- D** *The stem* slides through the mortise in the fence, and has a hole in the end for the pencil.

### Parts and Cutting List

Part	Name	Quantity, material and dimensions
<b>A</b>	Wedge	1 pc. timber 100mm × 15mm × 6mm
<b>B</b>	Fence	1 pc. timber 350mm × 60mm × 60mm
<b>C</b>	Pencil	
<b>D</b>	Stem	1 pc. timber 1,000mm × 30mm × 20mm

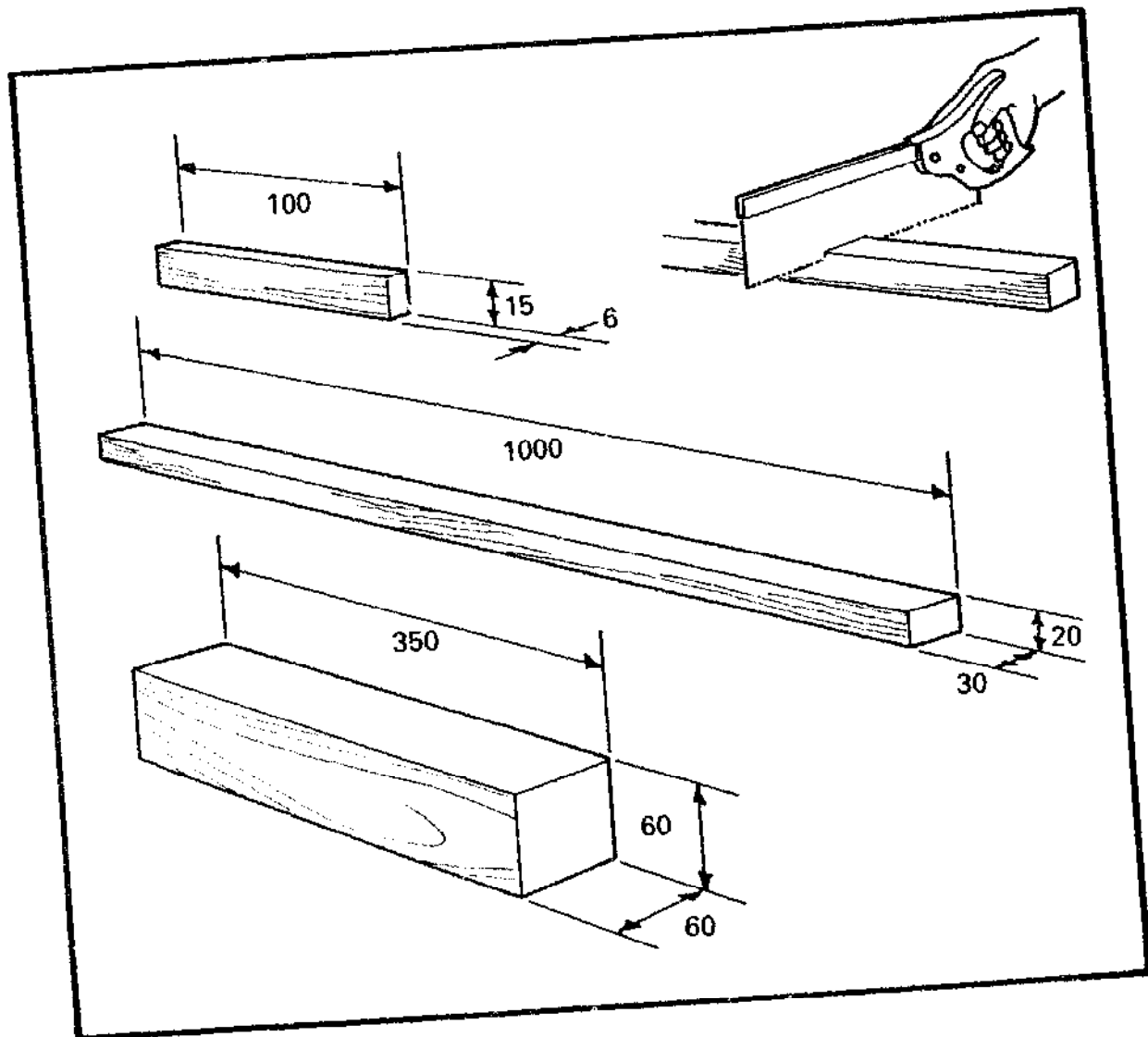
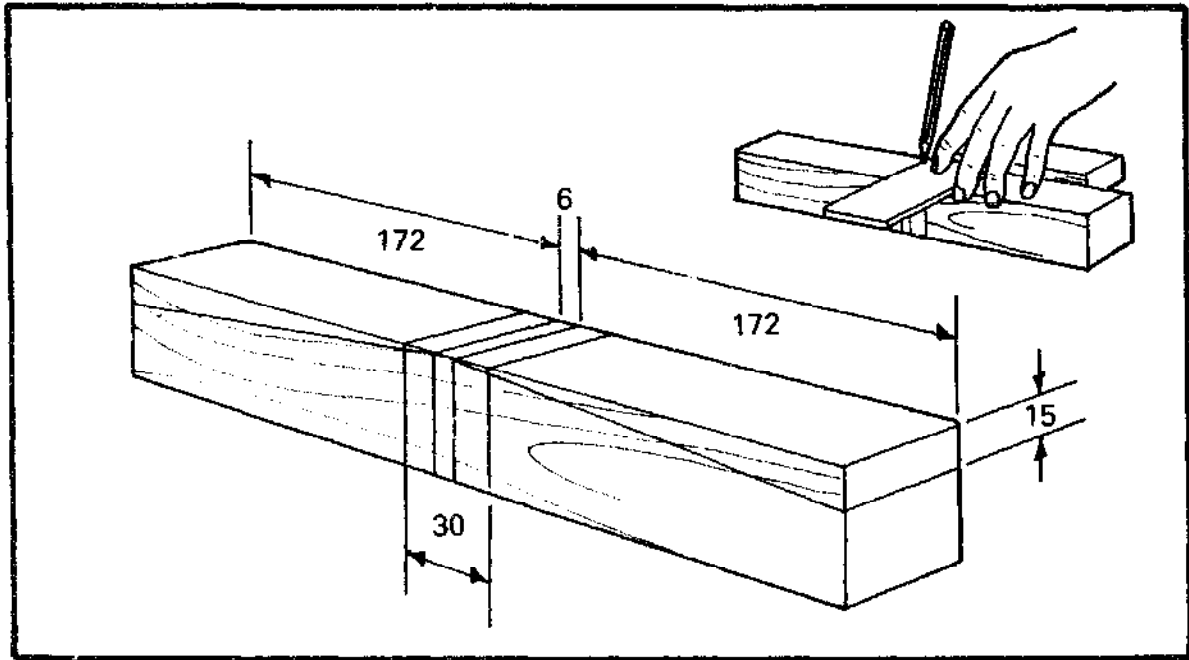

Diagram of Cutting List



## MAKING THE FENCE



Take the timber prepared for the fence, mark a point in the centre, and square two lines all round 3mm either side. Square two lines all round 15mm either side of the centre mark. On each end, square two lines 15mm below the top edge.

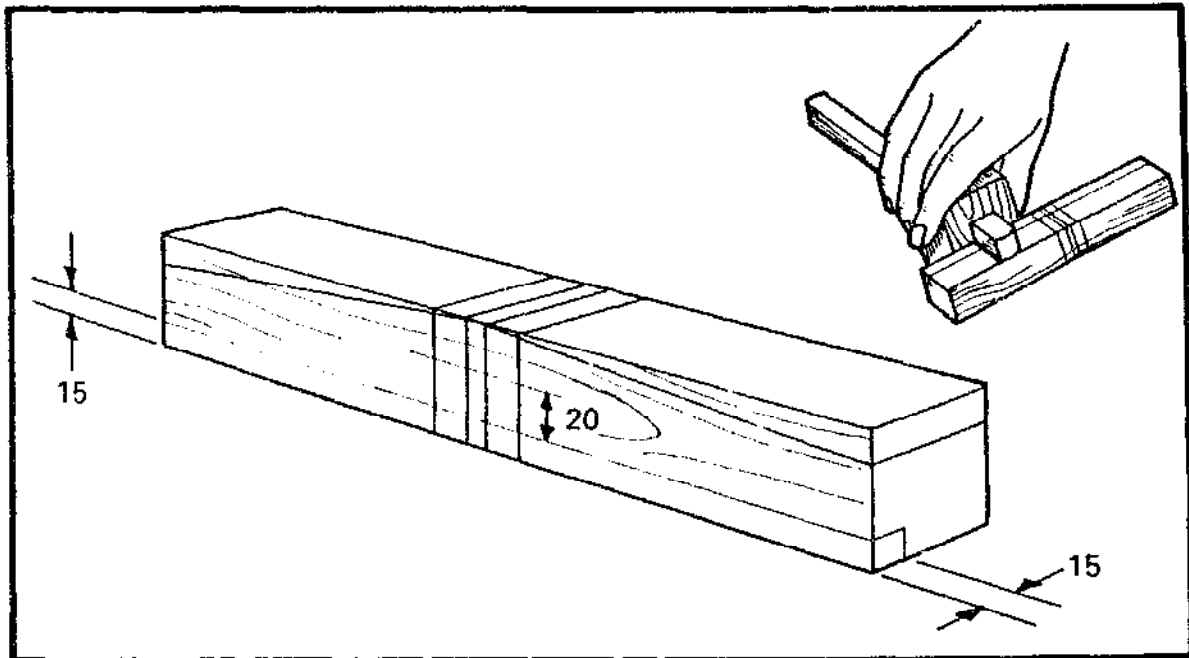

On one bottom edge gauge a 15mm × 15mm rebate. On the two sides gauge a line 35mm from the bottom edge, for the mortise.

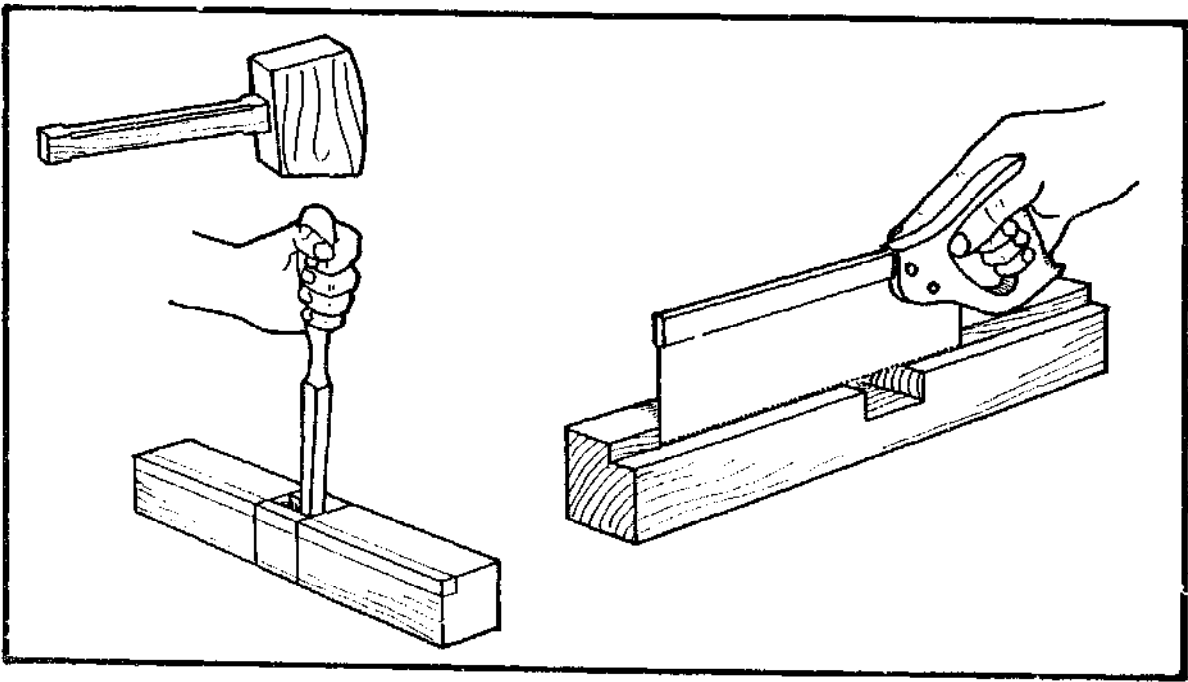

Chisel out the mortise. Cut the rebate with either a tenon saw, or a rebate plane.

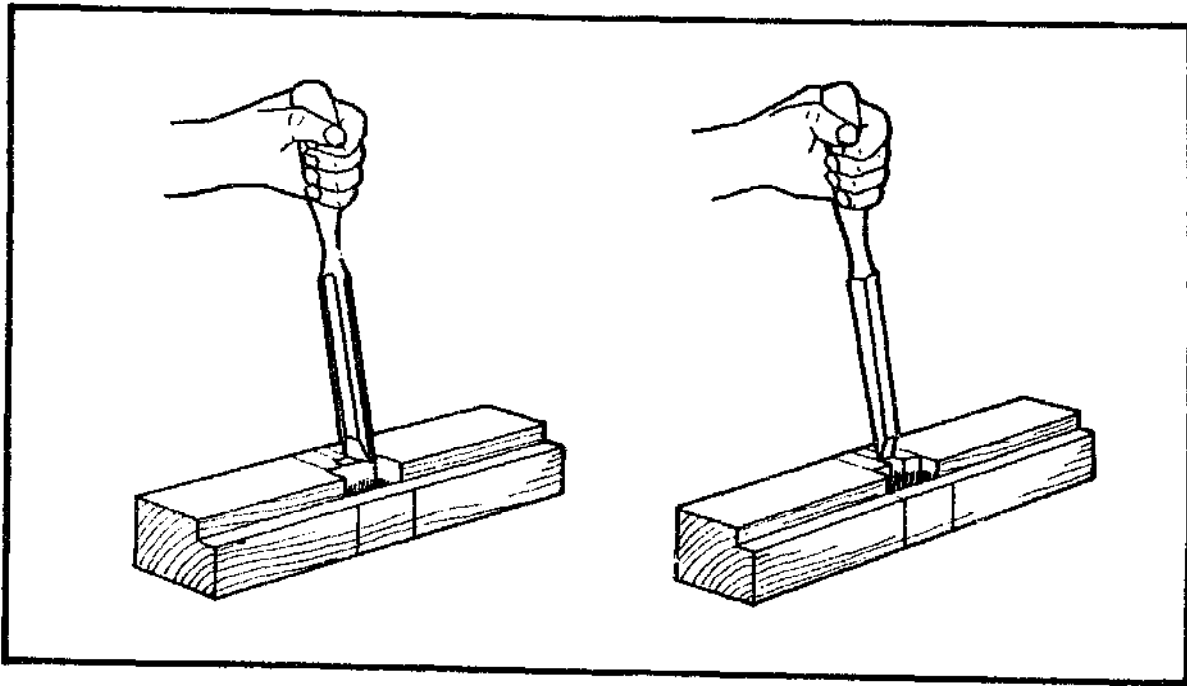

Carefully cut the groove for the wedge. First cut across the end grain on both sides with a mallet and chisel. Second, remove the waste with a 6mm chisel.

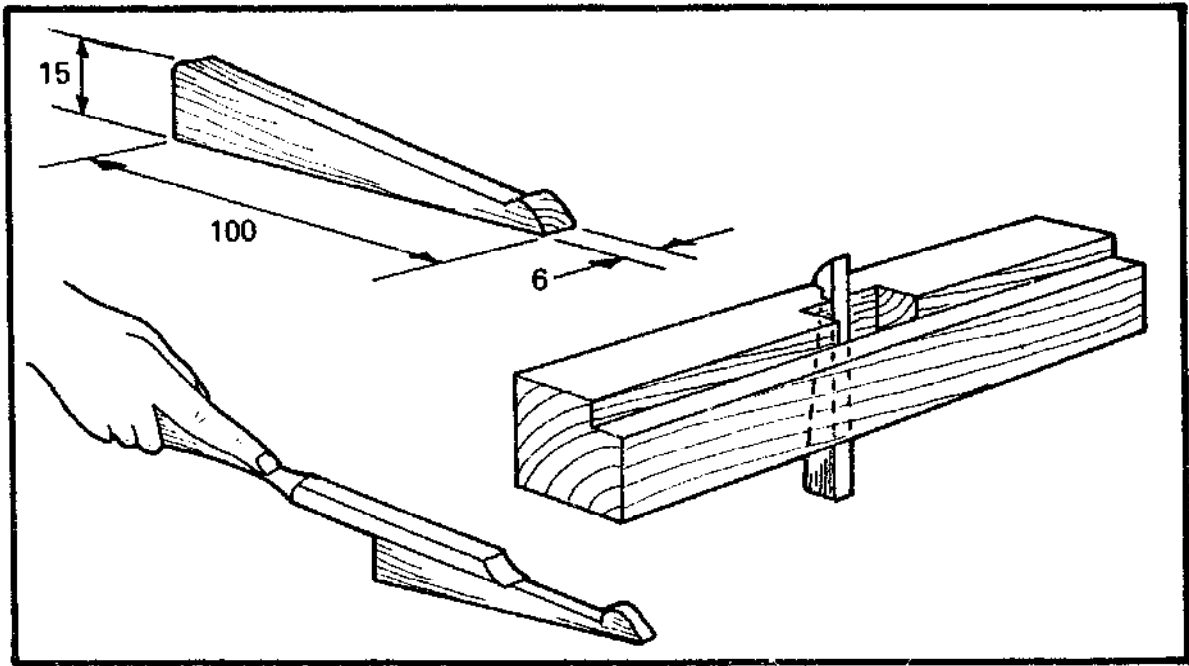

Cut the wedge to the dimensions shown, with a small knob at the end. This will stop the wedge falling out. Shape it so that it fits properly into the groove in the fence.

### MAKING THE STEM

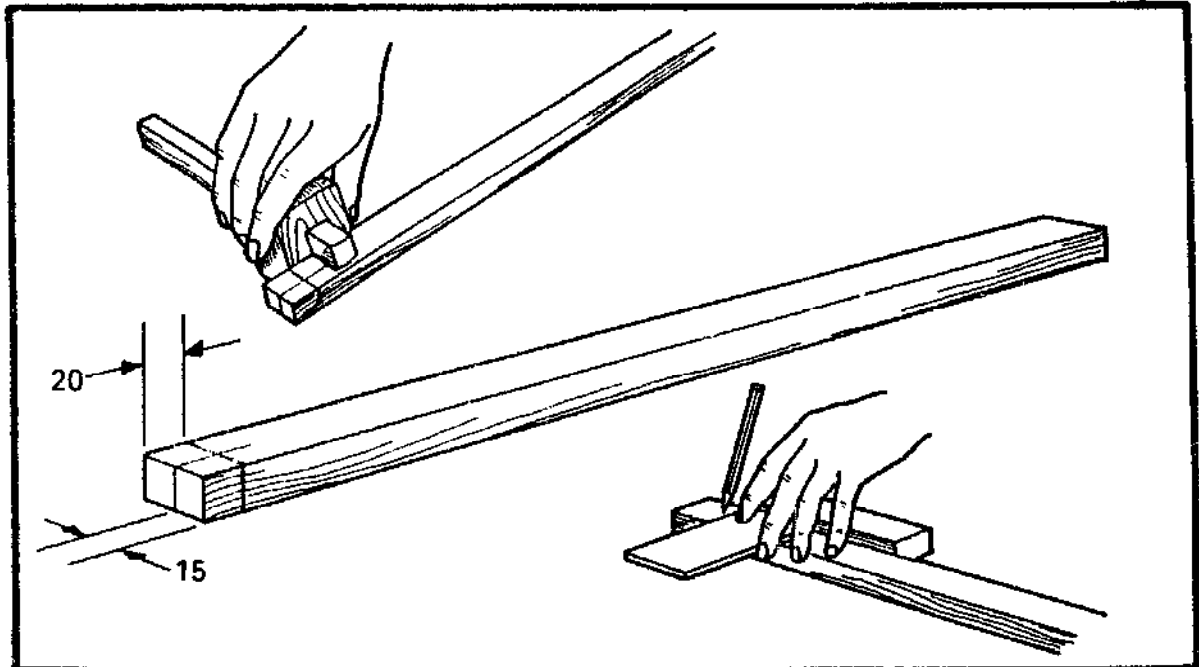

Take the timber prepared for the stem and square a line all round 20mm from the end. On top and bottom, gauge a centre line which should be 15mm from both sides.

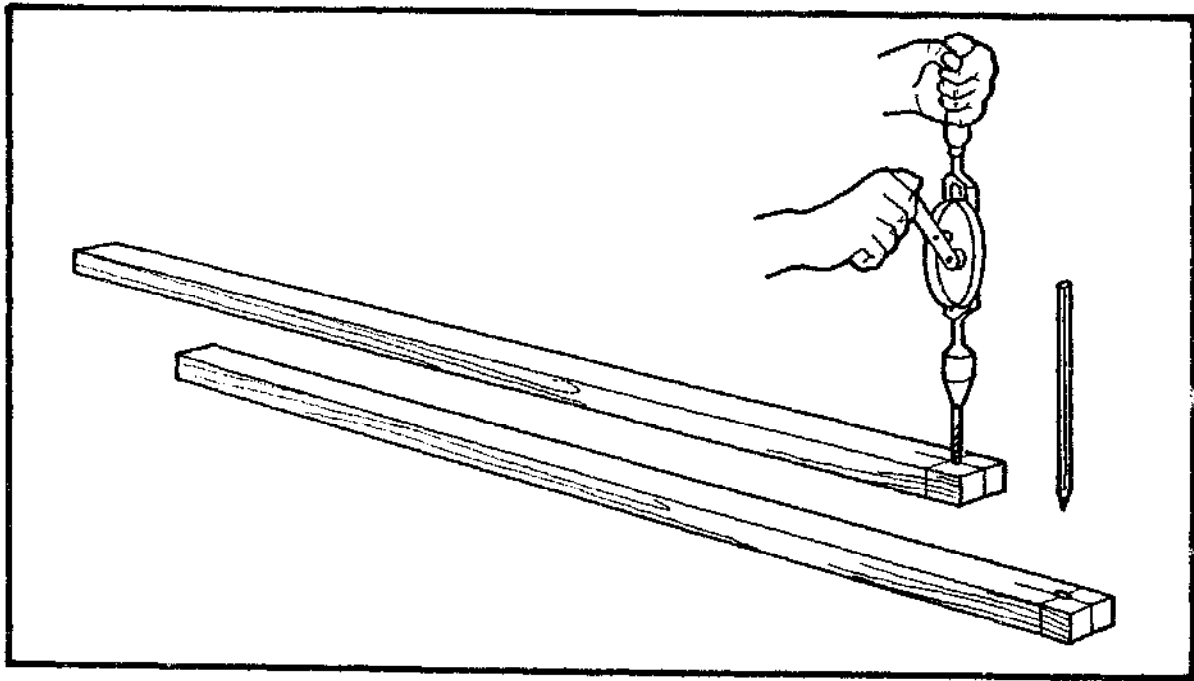

Drill a  $\varnothing 8\text{mm}$  hole from both sides of the stem. Fit a pencil into the hole

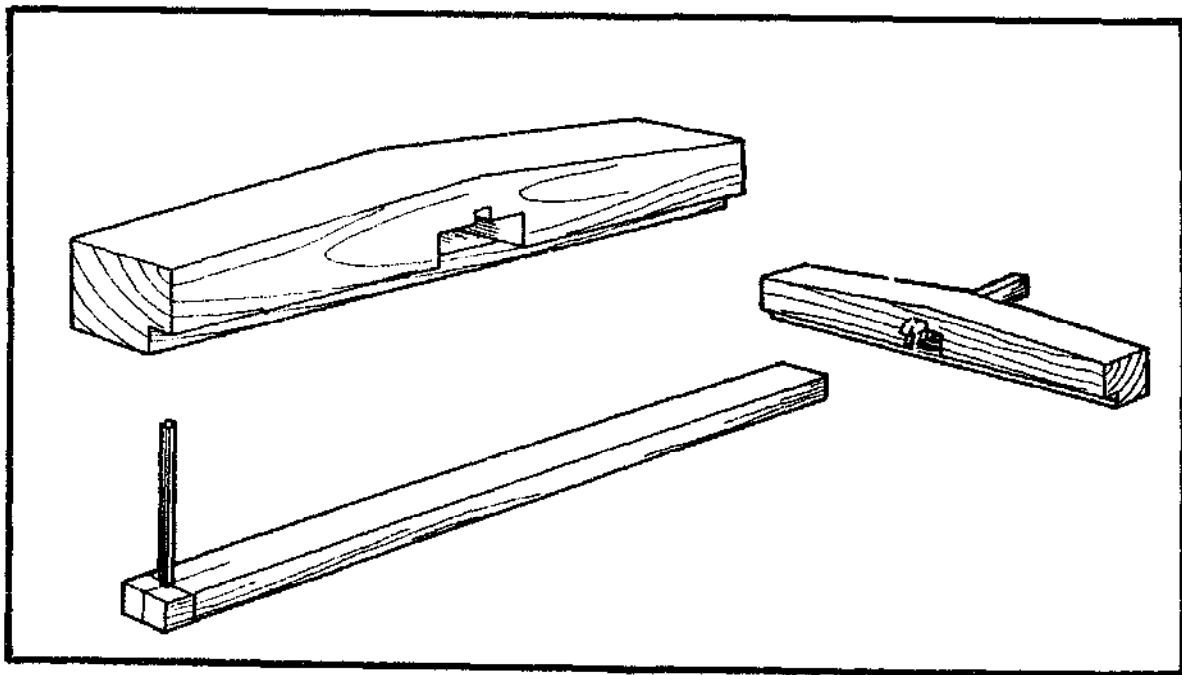

The fence can now be shaped by planing off the top down to the pencil lines on the end grain. This will make it a bit lighter.

Assemble the gauge by first inserting the wedge and then the stem into the mortise.

## ADJUSTING THE PANEL GAUGE

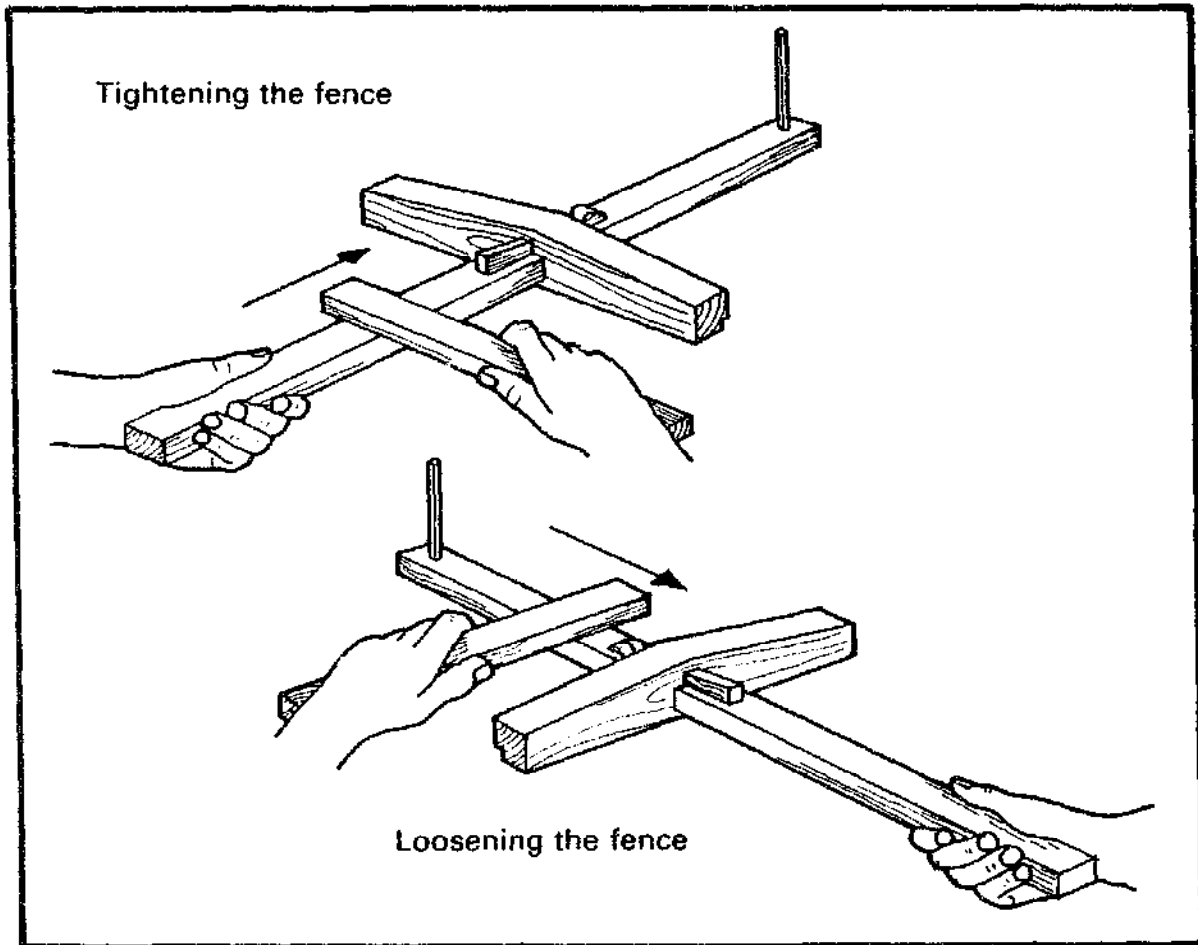

Set the distance between the pencil and the fence with a ruler.

Tighten the fence by hitting the back of the wedge with a piece of wood or a small hammer. Loosen the fence by hitting the front of the wedge.

# Mallet

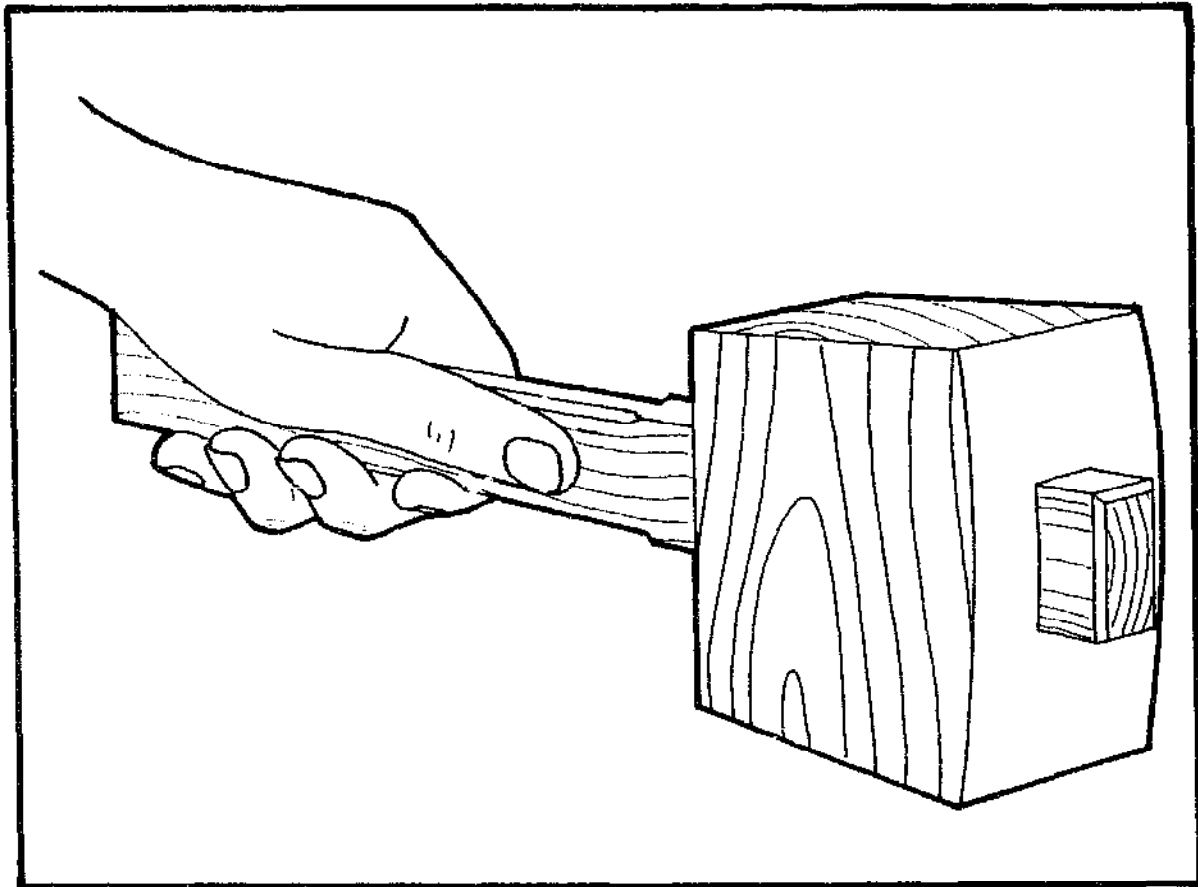

The wooden mallet is one of the easiest tools to make, and is essential for all joinery and furniture making.

Choose the hardest and heaviest timber available for the head. If it is a problem to find a piece the right thickness, glue two or three pieces together as shown on page 65. The handle can be made from any suitable hardwood.

The dimensions given are for a medium-sized mallet. If the tool is to be used by school children it should be smaller and lighter. On the other hand if it is to be used for making large joints the head can be slightly bigger. On page 66 there is a diagram showing the range of sizes.

## LIST OF PARTS

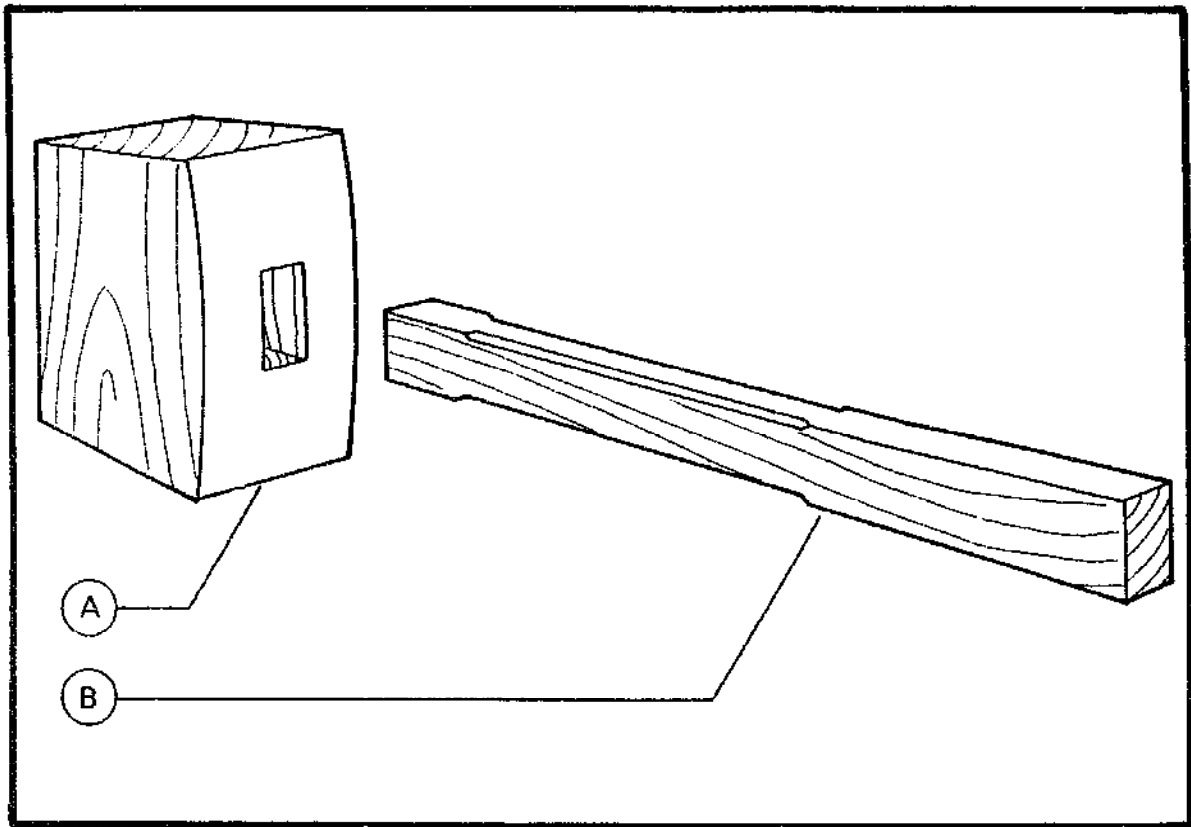

### Part

- A** *The head* is best made from one solid piece of timber. A tapered mortise is cut through the centre; the faces of the head are also tapered towards the handle.
- B** *The handle* is larger in cross-section at the top than the bottom, so it will not slide right through the head. As the mallet is used the two parts will become firmly wedged together.

### Parts and Cutting List

Part	Name	Quantity, material and dimensions
A	Head	1 pc. timber 130mm × 90mm × 60mm
B	Handle	1 pc. timber 350mm × 35mm × 20mm

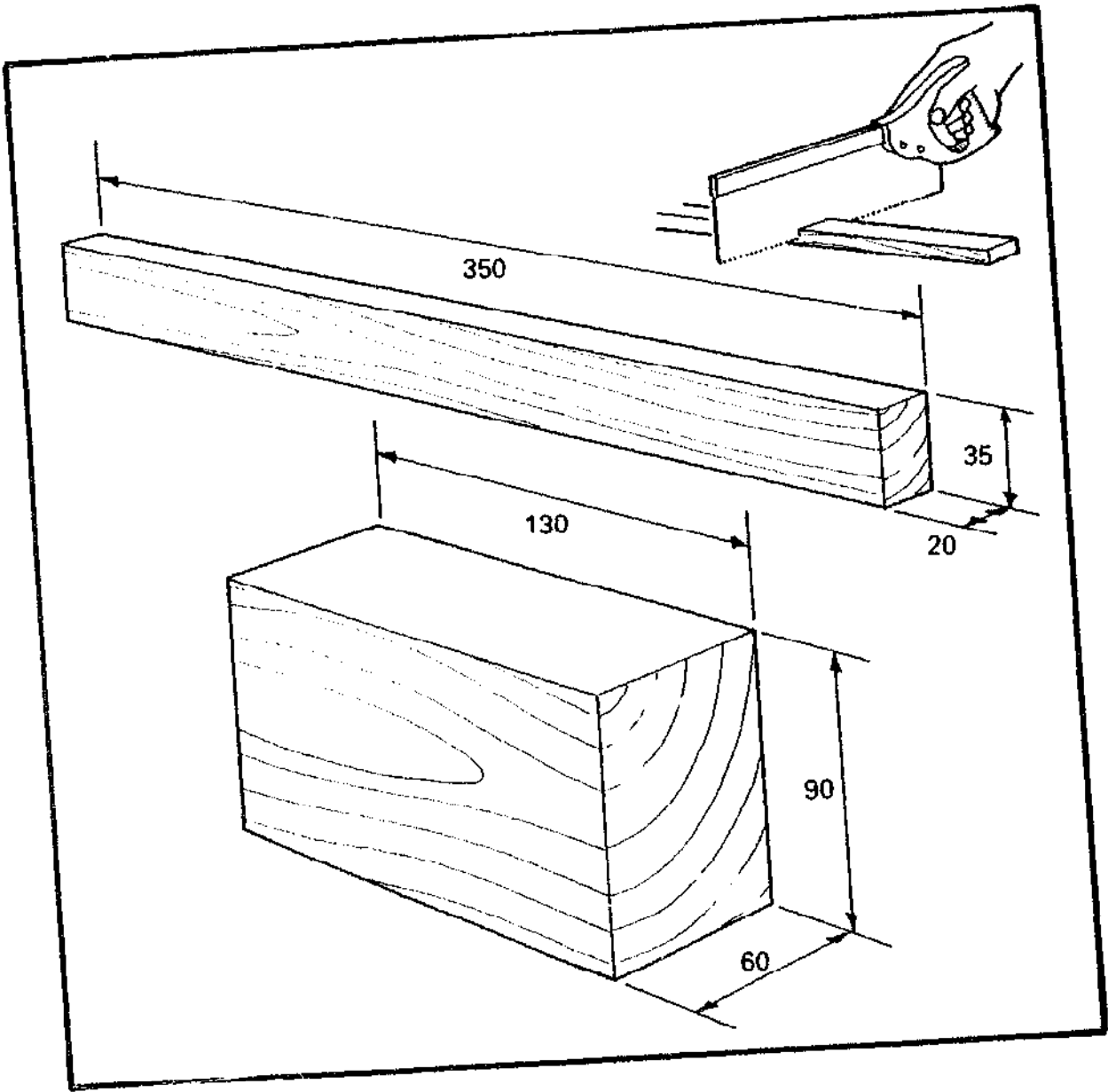
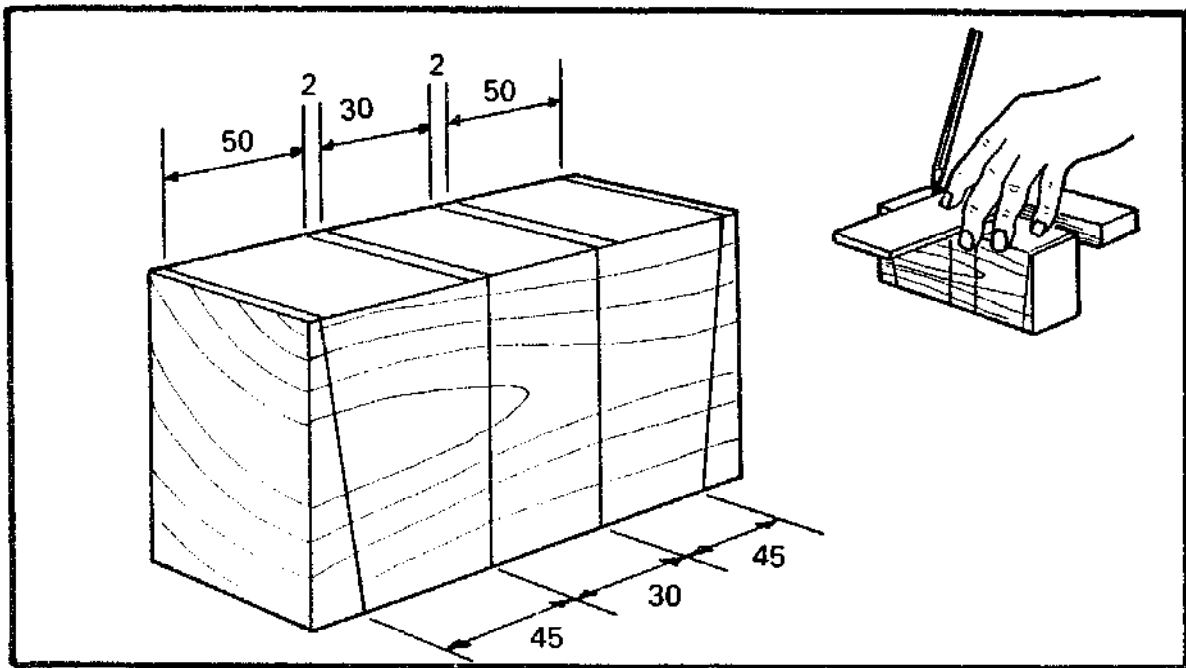

Diagram of Cutting List



## MAKING THE HEAD



Square two lines 30mm apart in the centre of the block. On the top mark two lines 2mm towards the end. Now mark the angled ends of the mallet head, by squaring two lines 50mm towards each end, on the top, and two lines 45mm towards the end, on the bottom.

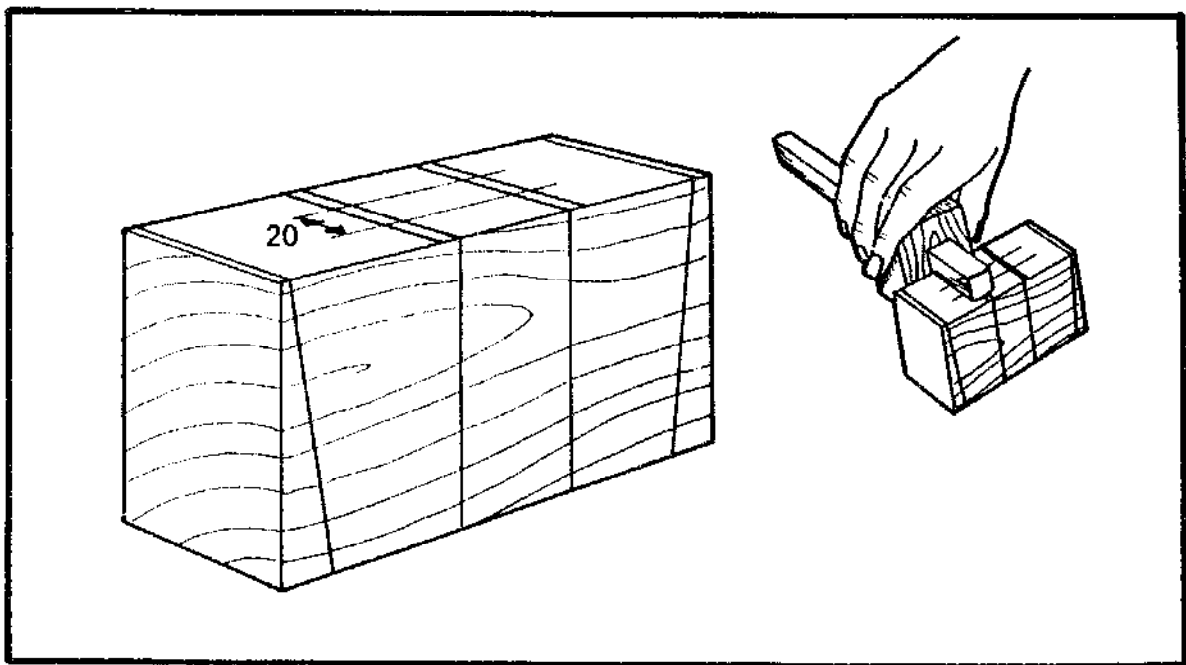

On the top and bottom of the head gauge two lines 20mm apart in the centre, with a mortise gauge.

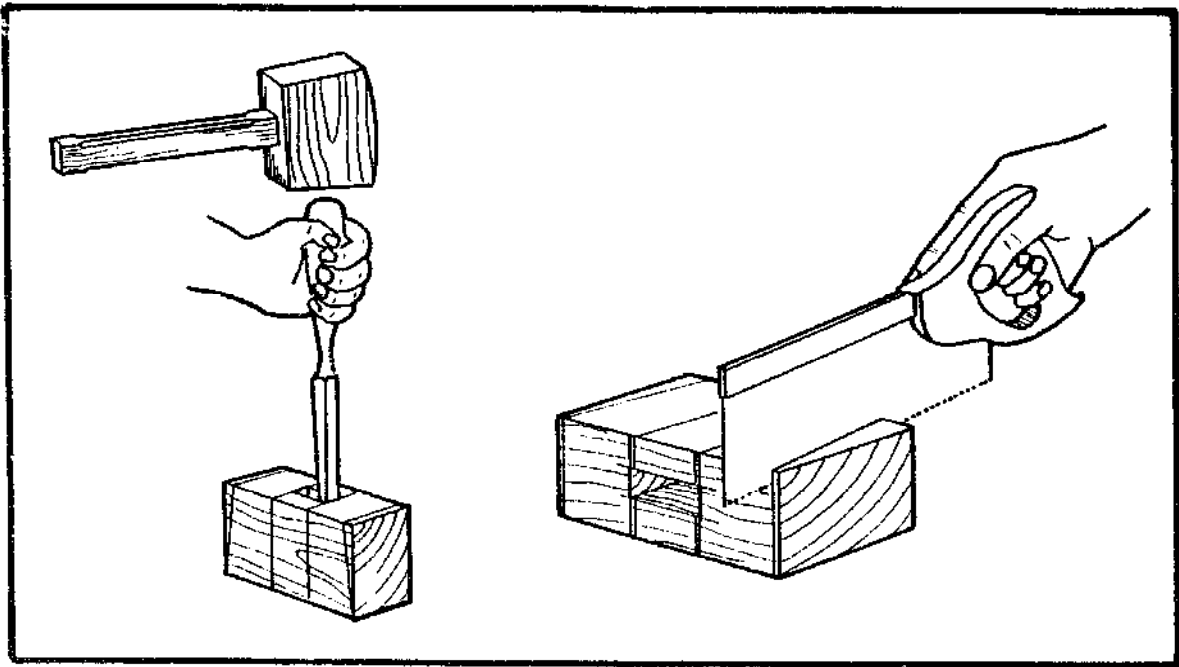

Cut the mortise with a mallet and chisel. Note how, at 34mm, the mortise is 4mm bigger at the top than the bottom. With a tenon saw cut the angled ends of the mallet head.

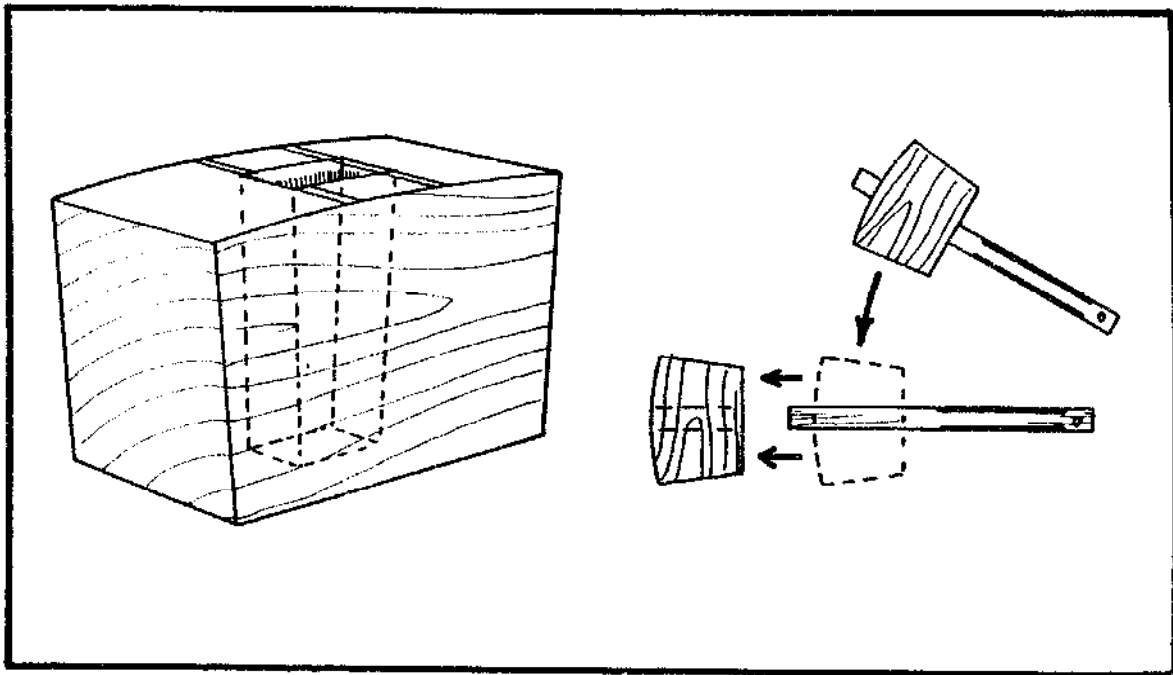

Shape the top of the mallet with a slight curve using a plane. The dotted lines in the drawing show the tapered mortise in the head. If the handle and the mortise was straight the head would soon fly off.

## MAKING THE HANDLE

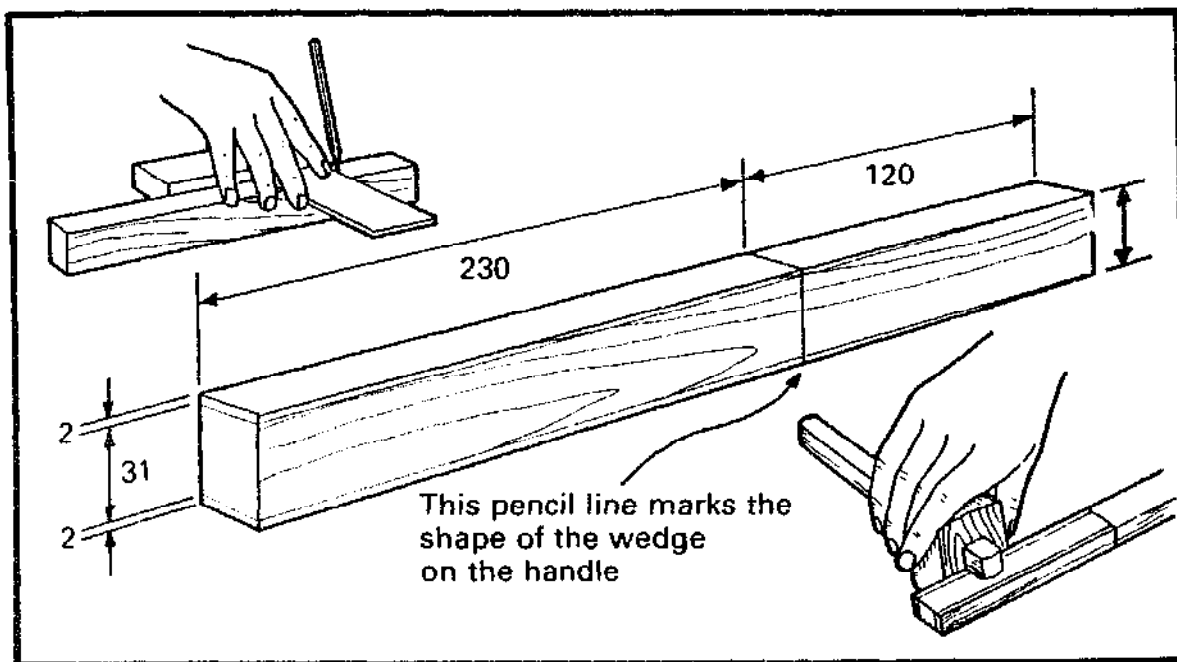

Square a line all round 120mm from the end of the handle. From this line gauge 2mm on both sides, to the other end. With a pencil mark the wedge shape at the top of the handle.

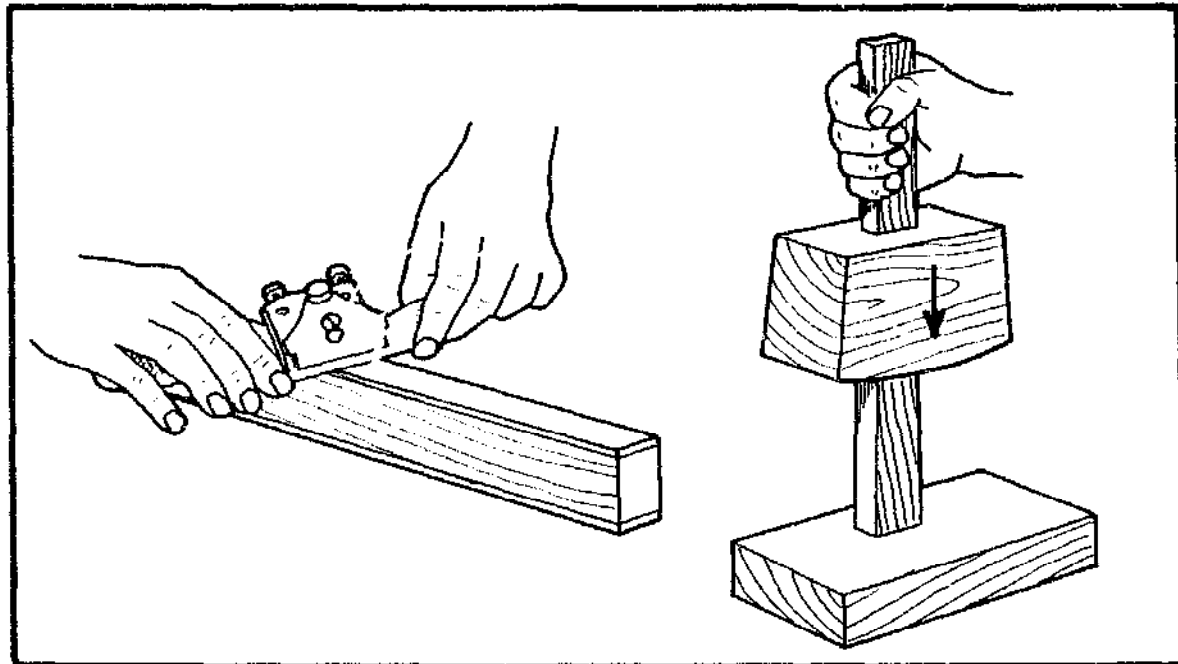

Shape the handle with a spokeshave or a plane down to the lines. To fit it, push the bottom of the handle through the top of the head and tap it down on a piece of wood.

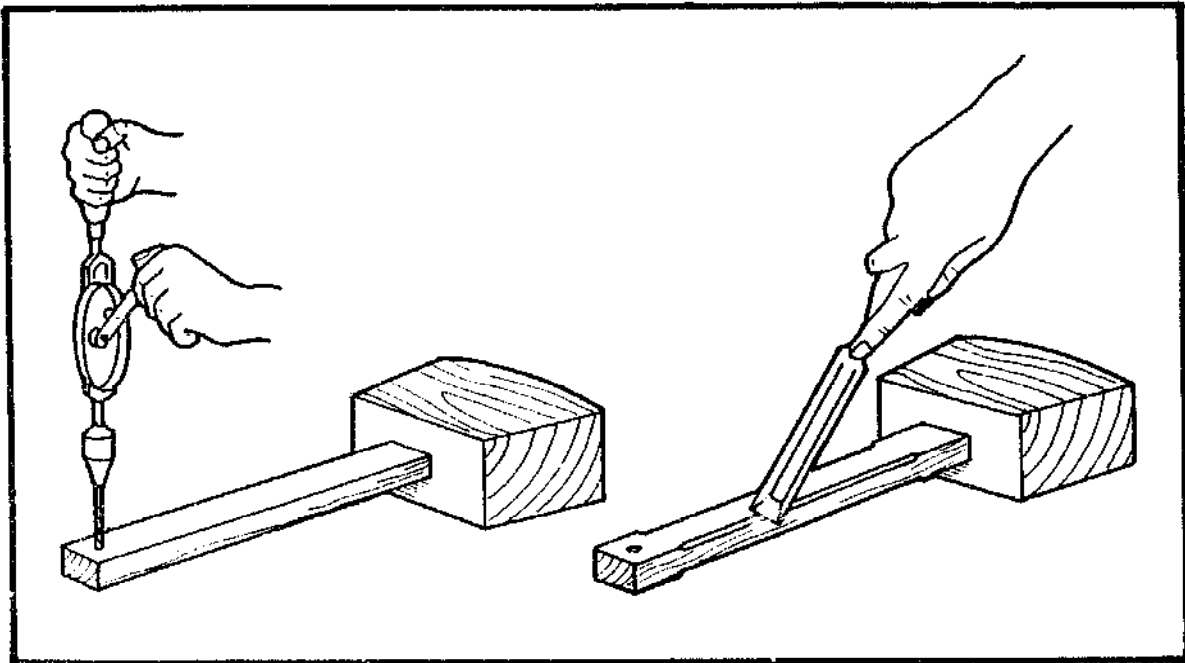

Drill a  $\varnothing 9\text{mm}$  hole in the end of the handle; this can be useful when storing the tool.

With a chisel, chamfer the edges of the handle to make the mallet comfortable to hold.

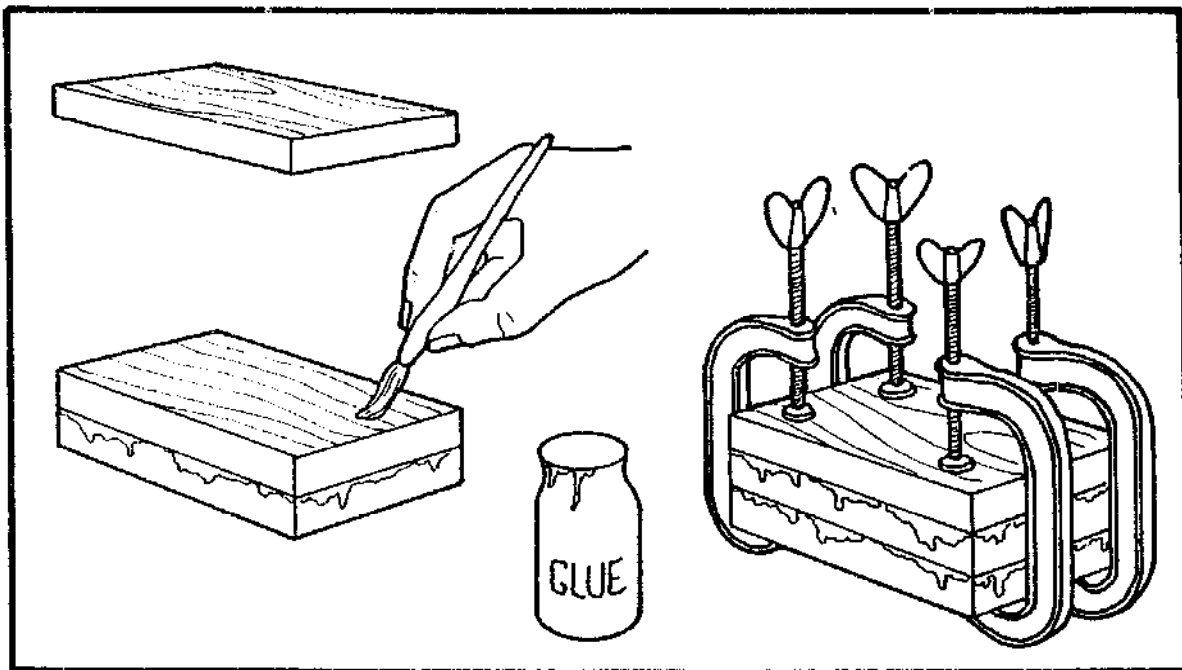

The mallet head can be made up of two or three pieces of timber, glued together. Make sure there are no gaps in the joints. Leave it clamped up for at least six hours.

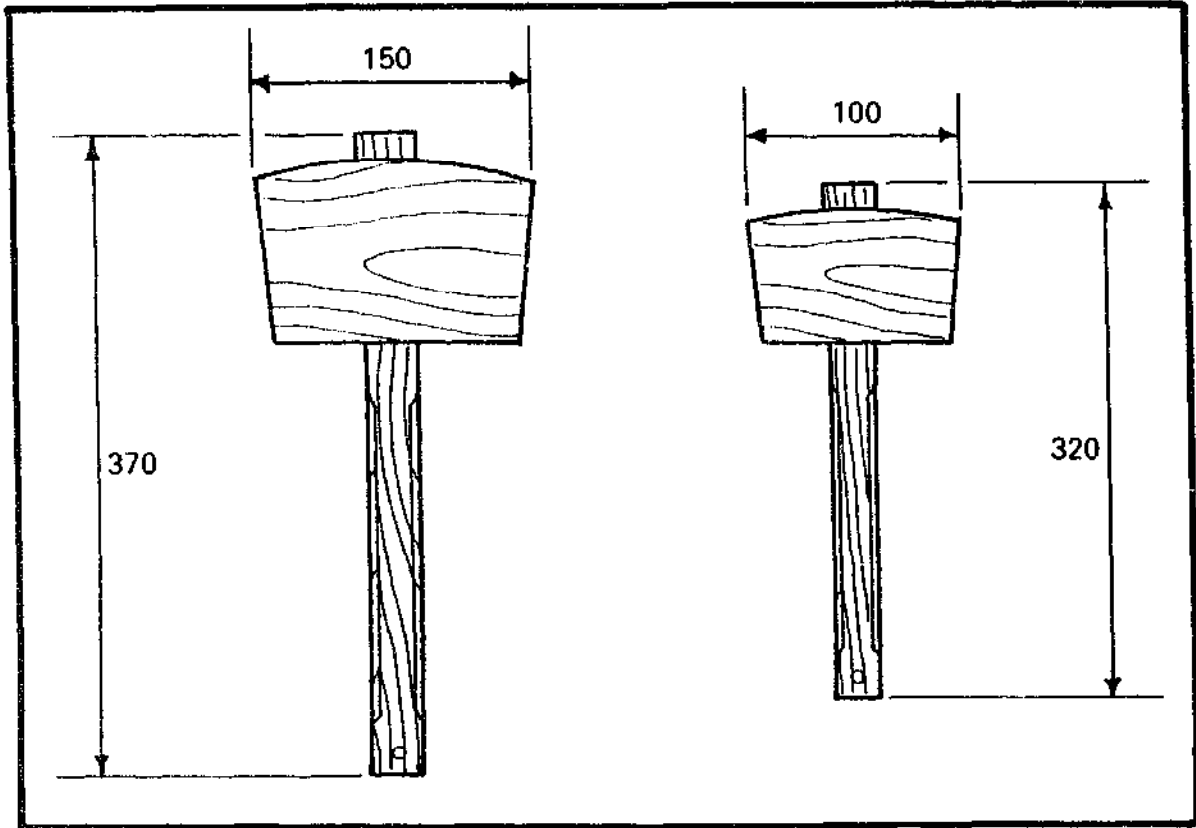

Drawing showing Size Range of Mallets

## Bow drill

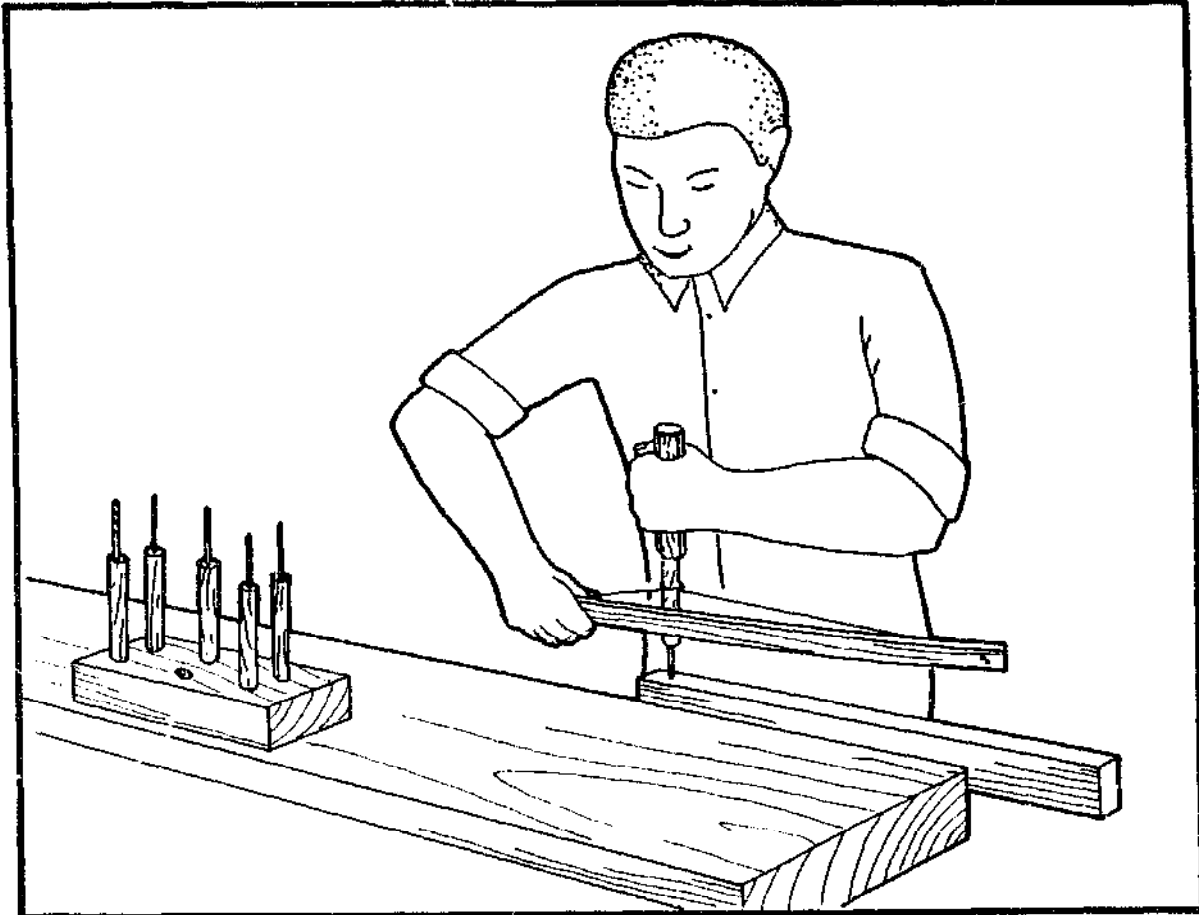

The bow drill has been in use for thousands of years and is still used in many parts of the world today. In the West it has been replaced by the wheel brace and carpenter's brace only quite recently. Although it seems a very basic tool it is in fact surprisingly efficient, and can be used for all the drilling operations in this manual that require a wheel brace. The drill bit is rotated back and forth by the string of a bow which is wound round the stock. It can be used for drilling holes in timber up to 10mm diameter and in metal up to 6mm.

The handle and stock are made from timber planed to an octagonal (eight-sided) cross-section, but they could be turned on a lathe if one is available. The bow should be made from a springy timber that will not break when you bend it, or a piece of bamboo, with a length of string tied to each end.

Each bit is fitted tightly into its own wooden stock. Bits for cutting wood can be made from nails of various sizes. For drilling metal twist bits have to be used and these must be bought from a shop.

Drilling metal is possible, but because the bit is only cutting on one stroke it takes a long time. Make sure the bit is sharp, do not put too much pressure on the handle, and if the string begins to slip bend the bow away from the stock.

## LIST OF PARTS

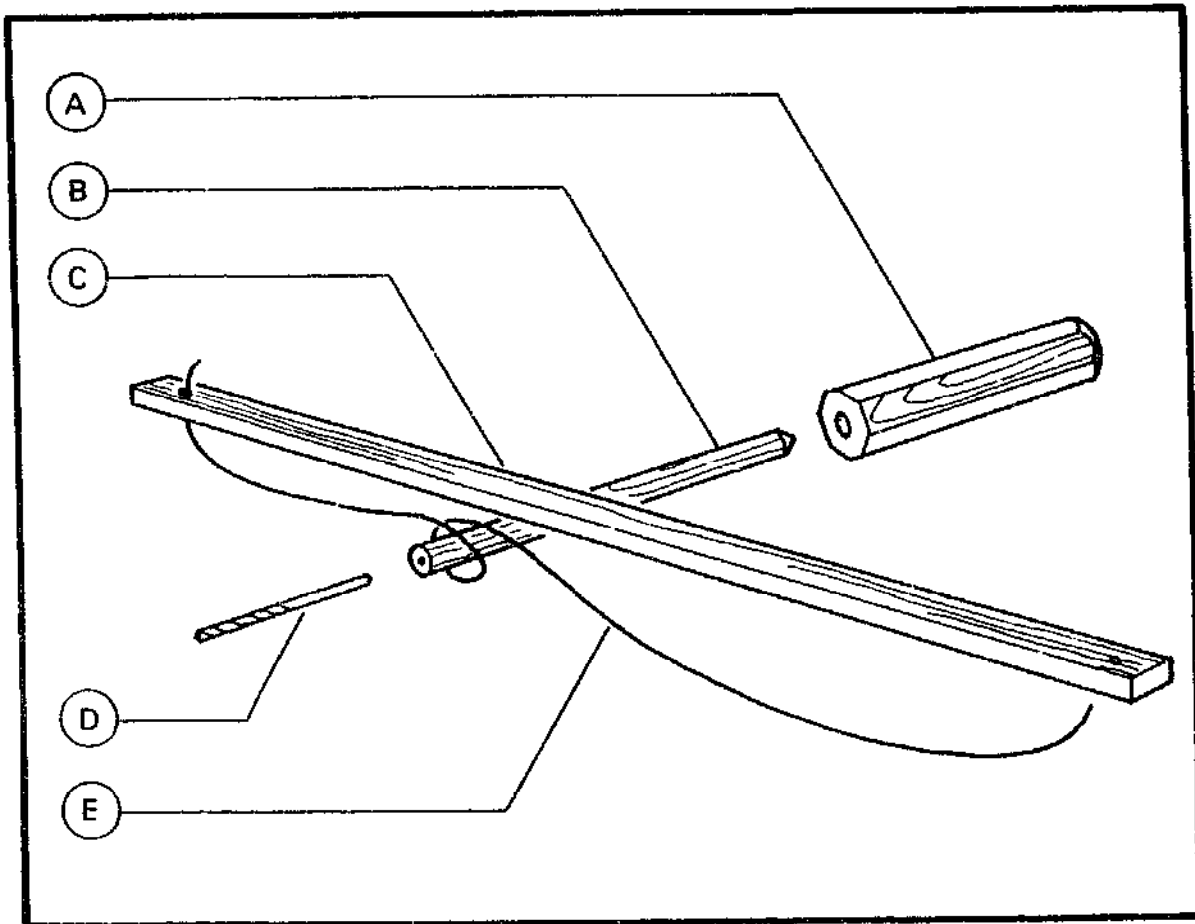

### Part

- A** *The handle.* Made from timber, planed to an octagonal cross section, it has a hole drilled into one end for the drill stock.
- B** *The drill stock.* Also planed to an octagonal cross section, it has a drill bit fixed at one end and a point shaped at the other. It fits into the handle.
- C** *The bow* should be made from flexible timber or a piece of bamboo.
- D** *The drill bit* is fitted tightly into the drill stock. Bits for cutting wood can be made from nails. Morse bits will cut wood and metal, but must be bought from a shop.
- E** *The bow string* is tied to both ends of the bow.

## Parts and Cutting List

Part	Name	Quantity, material and dimensions
A	Handle	1 pc. timber 100mm × 30mm × 30mm
B	Drill stock	1 pc. timber 150mm × 15mm × 15mm
C	Bow	1 pc. timber 700mm × 20mm × 10mm
D	Drill bit	1 nail or 1 Morse bit, between. 1mm and 6mm
E	Bow string	1 pc. string 800mm long

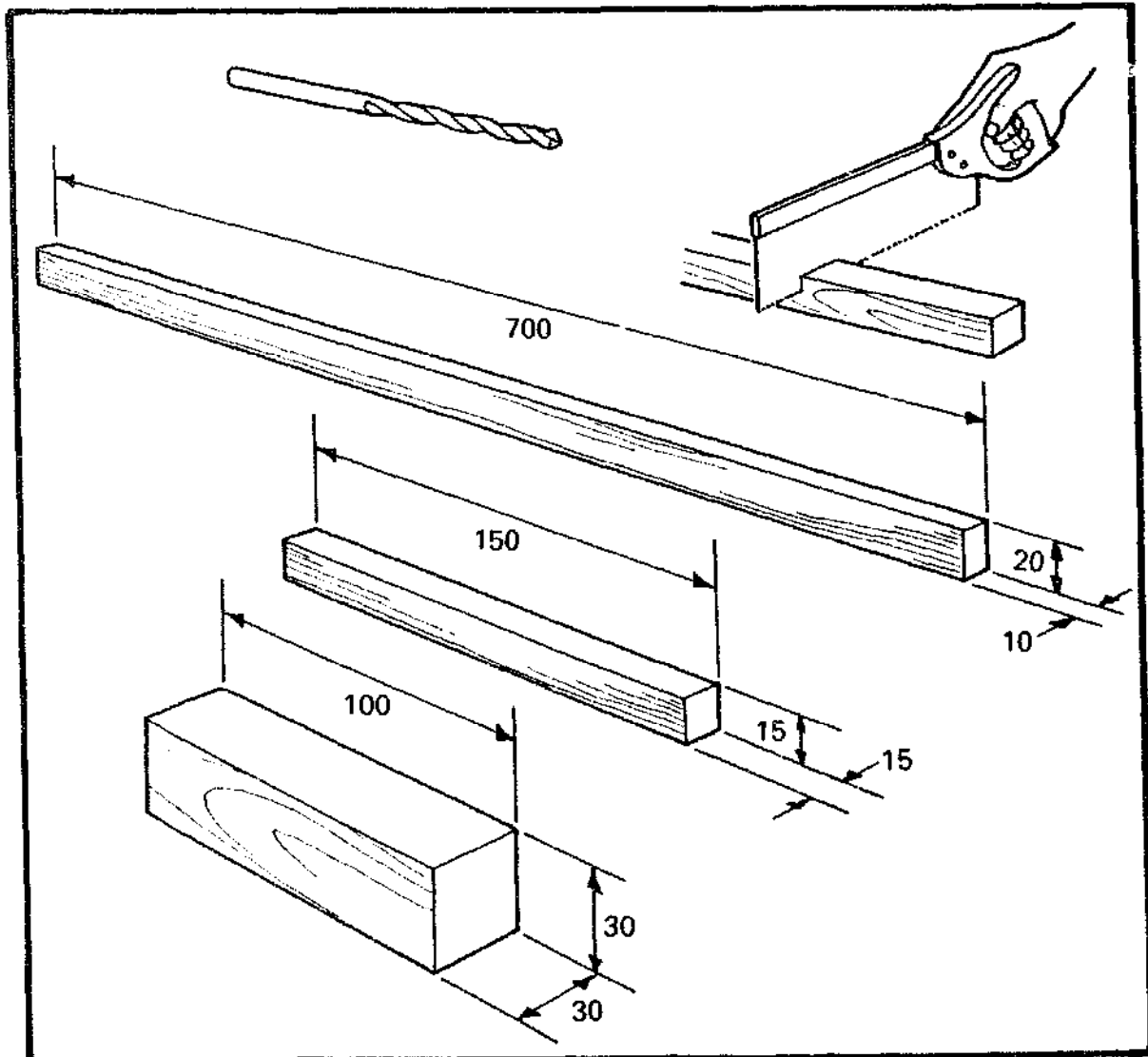
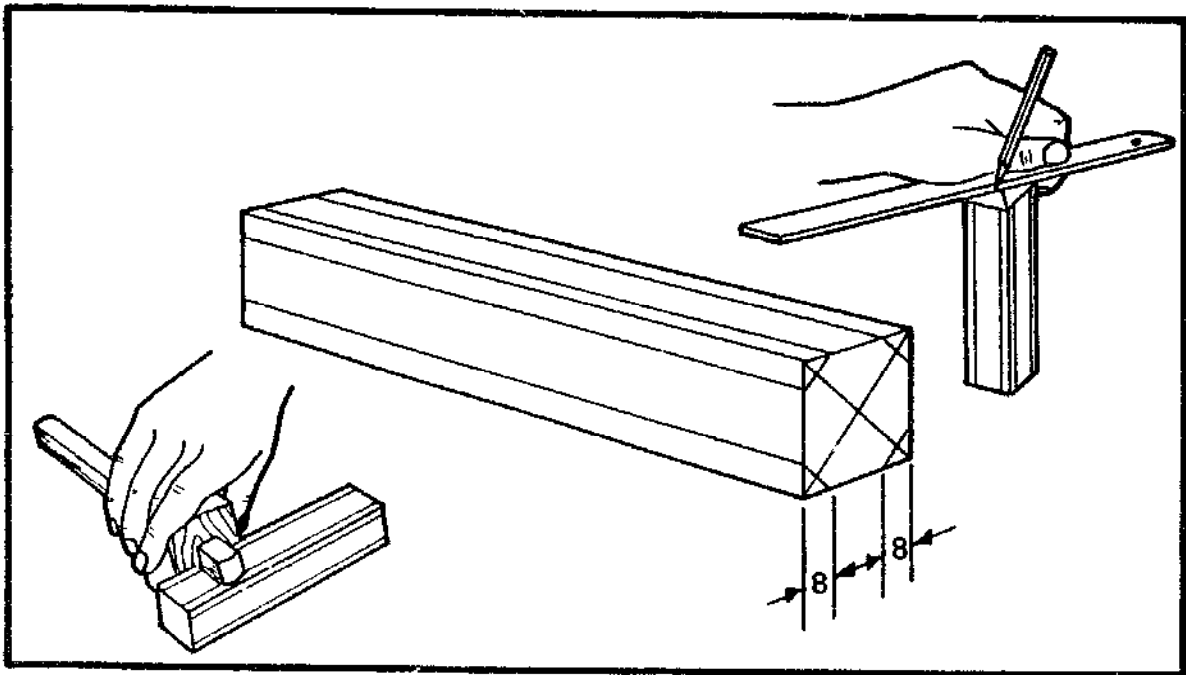

Diagram of Cutting List



## MAKING THE HANDLE



Take the timber prepared for the handle, and gauge eight lines 8mm in from each edge.

Find the centre of one end by marking the diagonals from corner to corner. Plane off the corners down to the gauge lines.

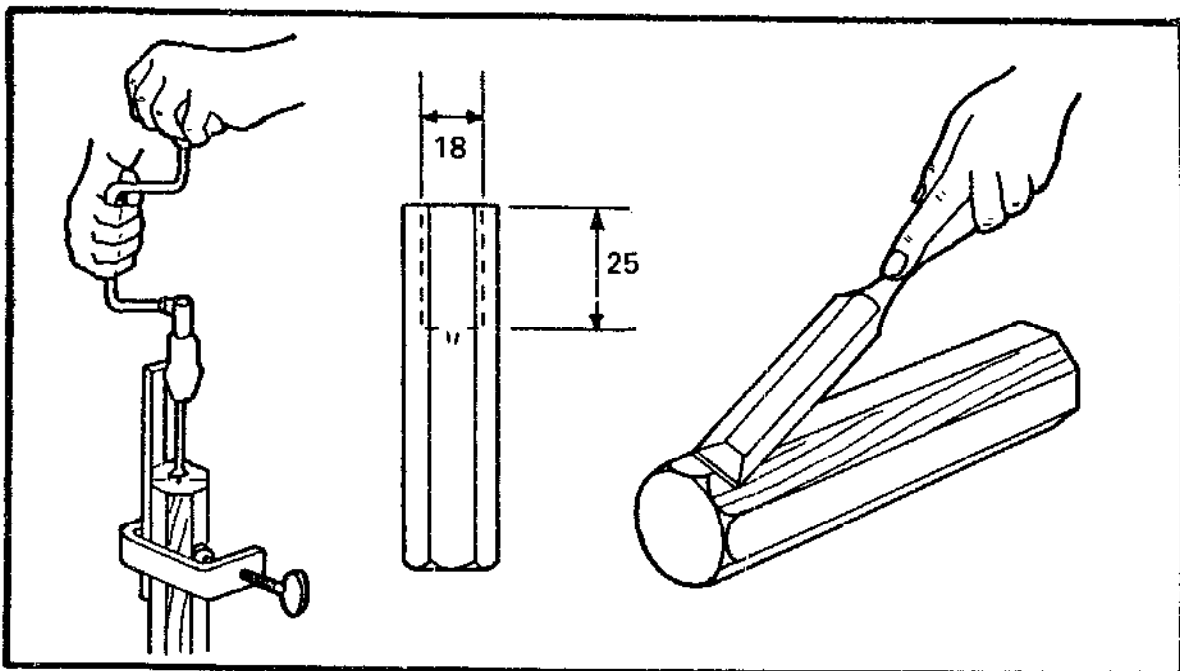

Where the diagonals meet, drill an  $\varnothing 18\text{mm}$  hole to a depth of 25mm.

At the other end of the handle, round off the corners with a chisel or sandpaper.

## MAKING THE STOCK

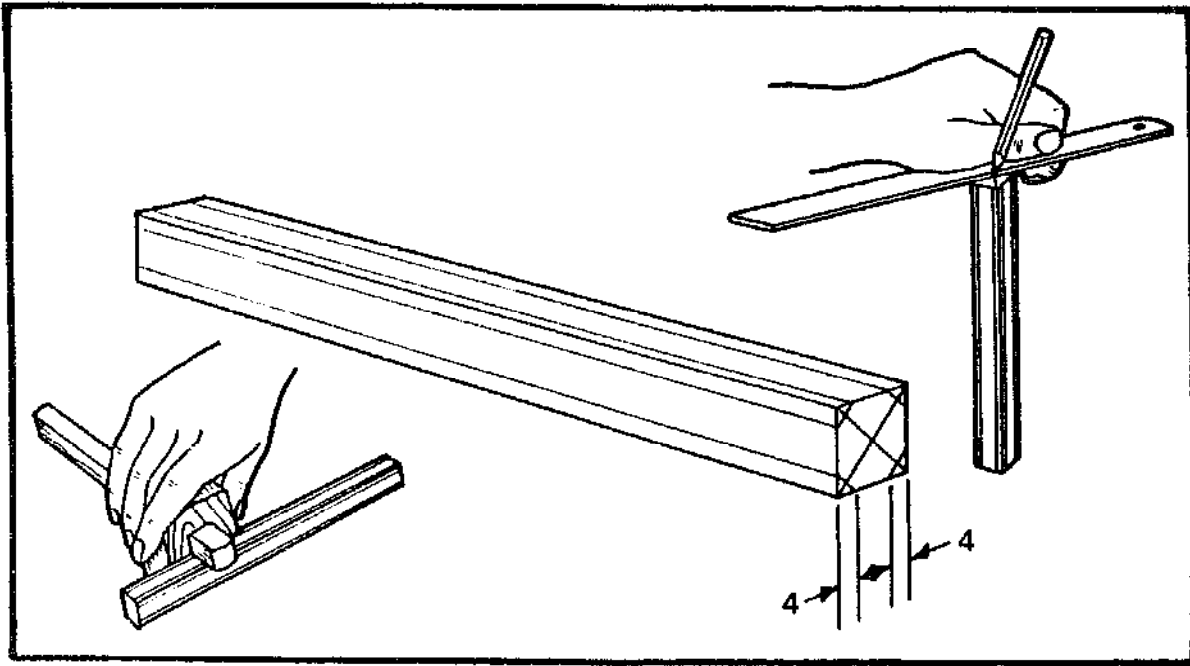

Take the timber prepared for the stock; find the centres of each end by marking the diagonals. Gauge eight lines, 4mm in from each end. Plane off the corners down to the gauge lines.

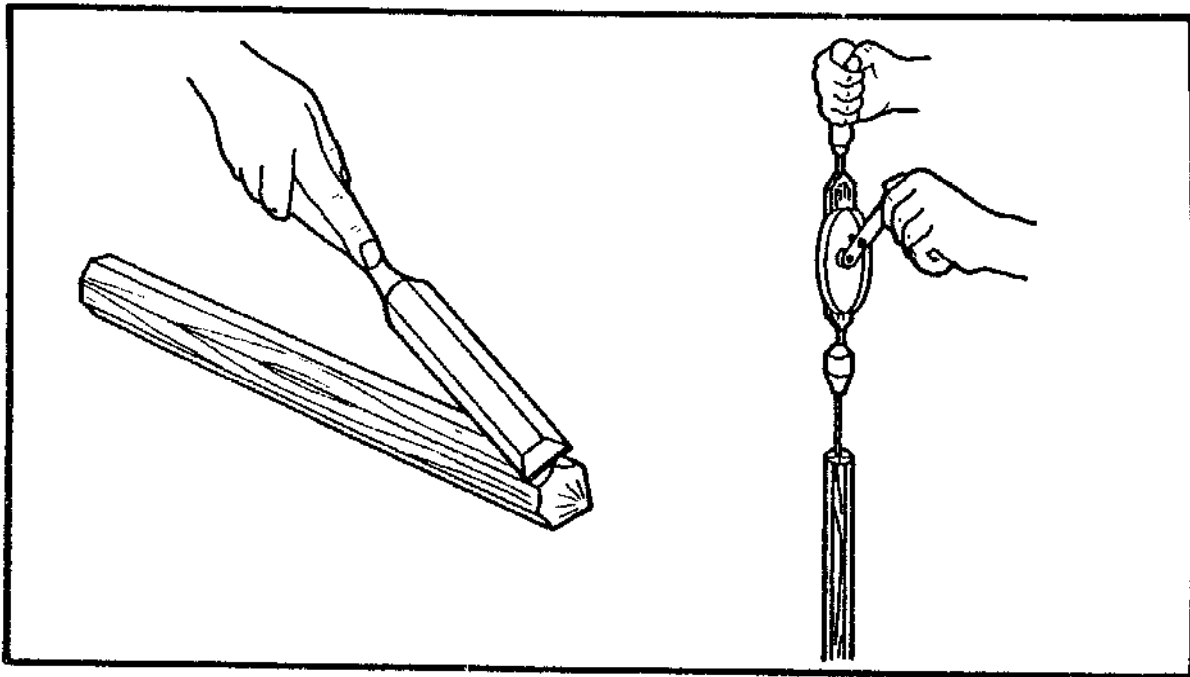

With a chisel or a sharp knife shape one end to a point. The tip of the point should be where the diagonals meet.

At the other end, drill a hole with a diameter 1mm smaller than the diameter of the drill you are going to fix into the stock.

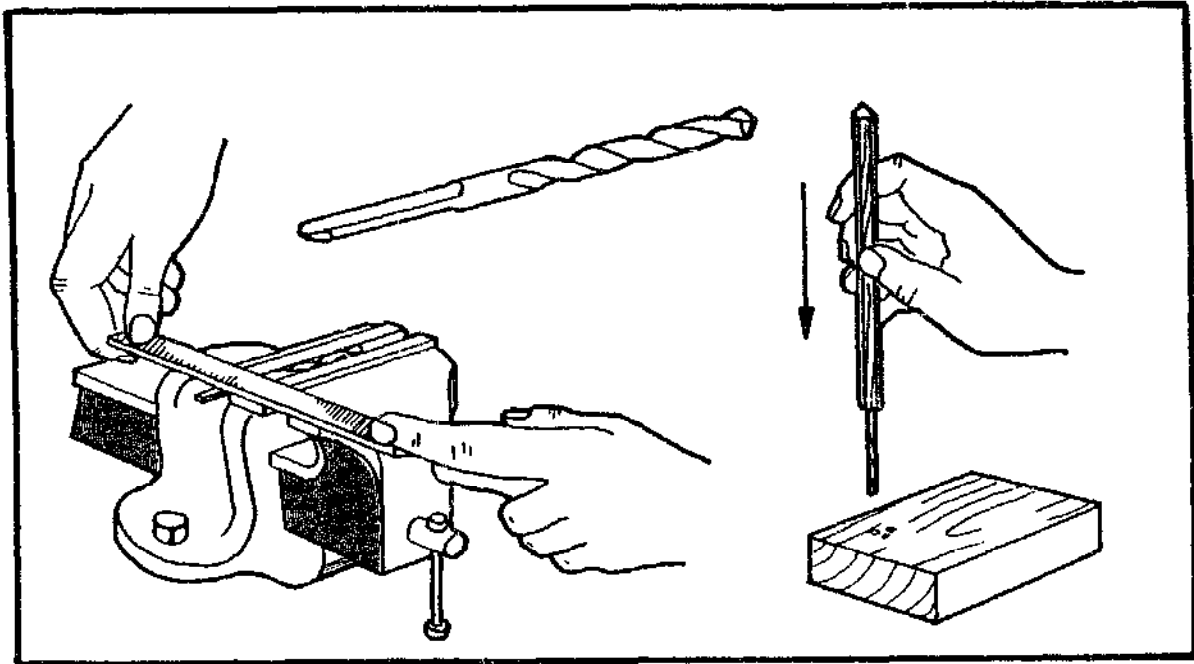

Take the drill bit and file two flats on the shank, and a point on the blunt end. Tap the bit into the stock, taking care not to blunt it. It may be necessary to use a hammer.

#### MAKING A WOOD-CUTTING BIT

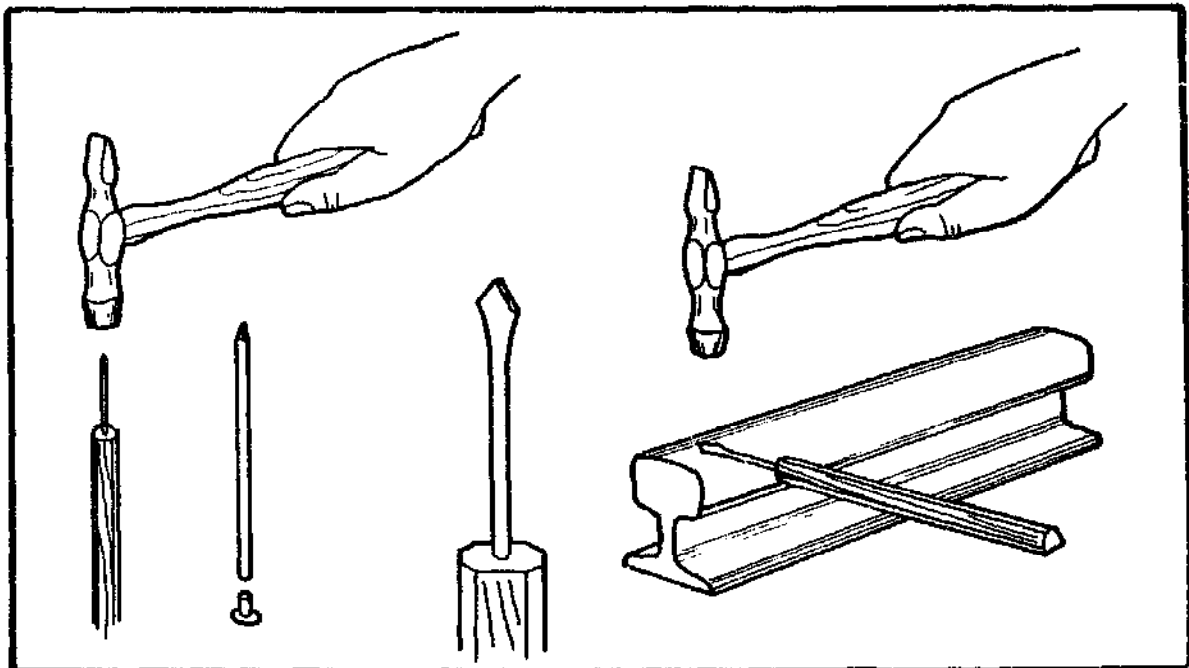

To make a wood-cutting bit from a nail. Take a suitably sized nail, cut the head off, and hammer the blunt end into the hole in the drill stock. Flatten the pointed end with a hammer on an anvil into a diamond shape. Sharpen the point with a file.

## MAKING THE BOW

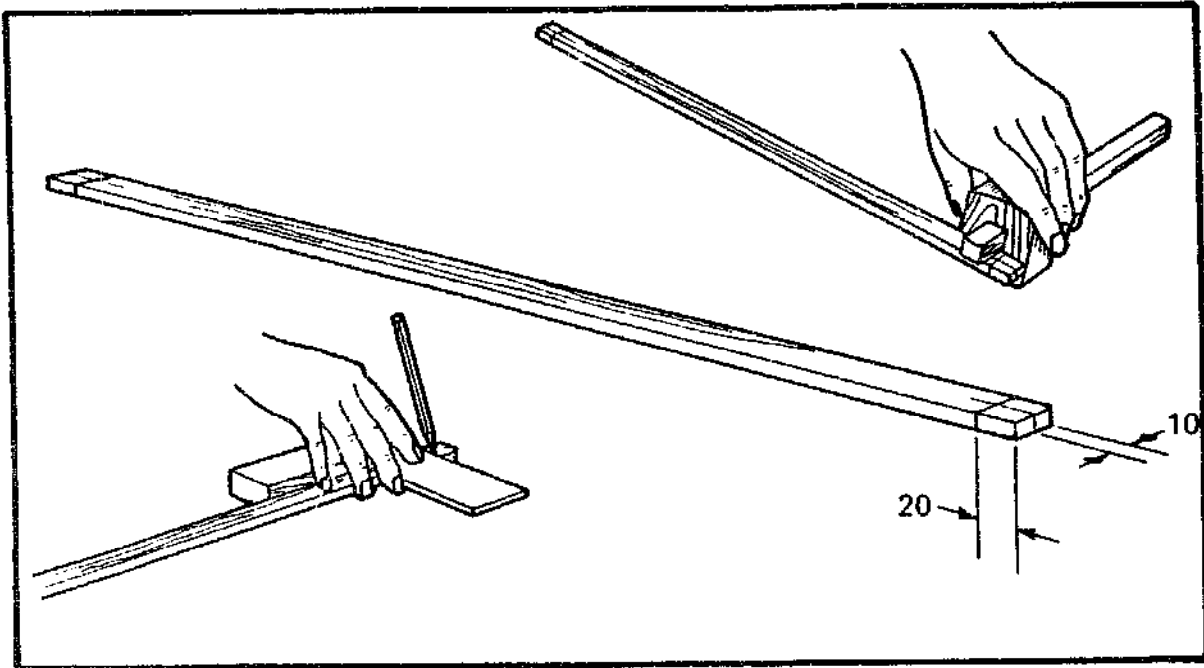

Take the timber prepared for the bow and square a line 20mm from both ends. Gauge a line in the centre of both ends to mark the holes for the bow string.

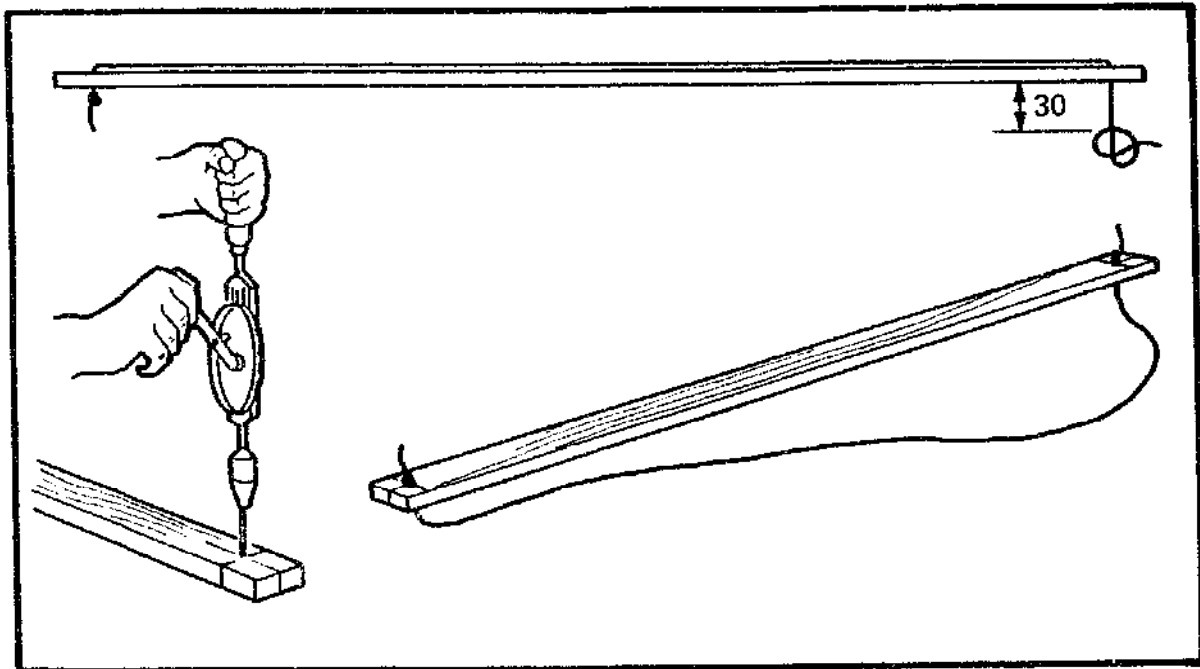

Drill two  $\varnothing 3\text{mm}$  diameter holes, one at each end of the bow. Thread the string through one hole and tie a knot. Thread the other end of the string through the other hole, and tie a knot 30mm from the hole.

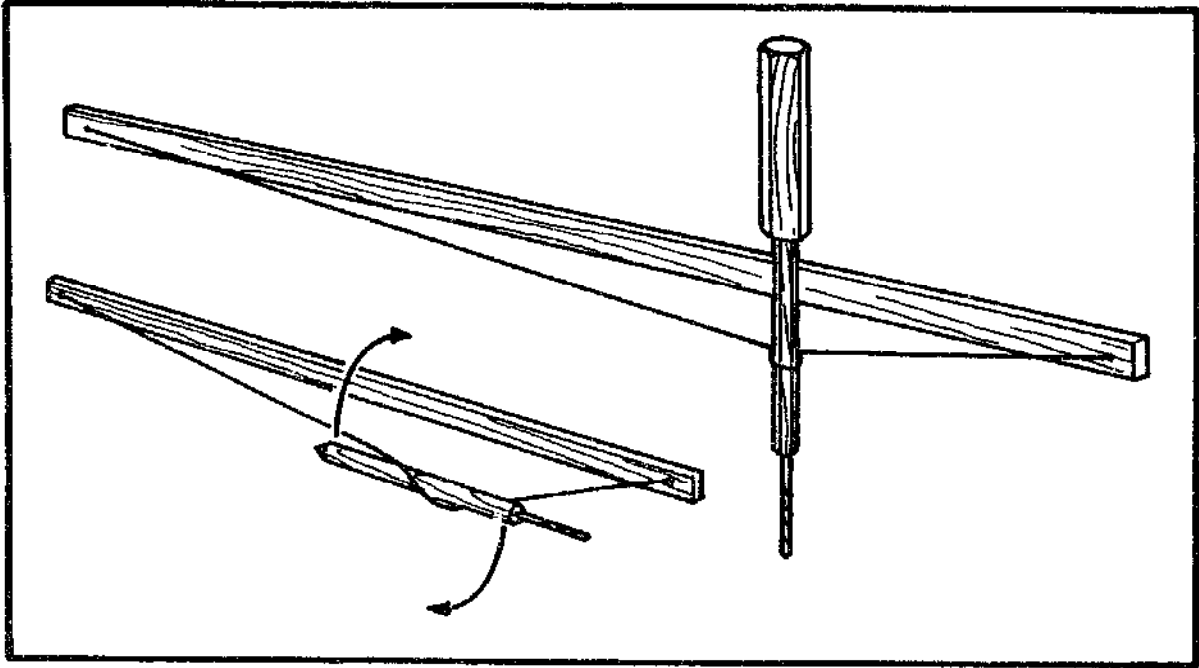

Twist the bow string once around the stock of the drill. Put some grease or cooking fat on the point, and push it into the hole in the handle.

## Bow saw

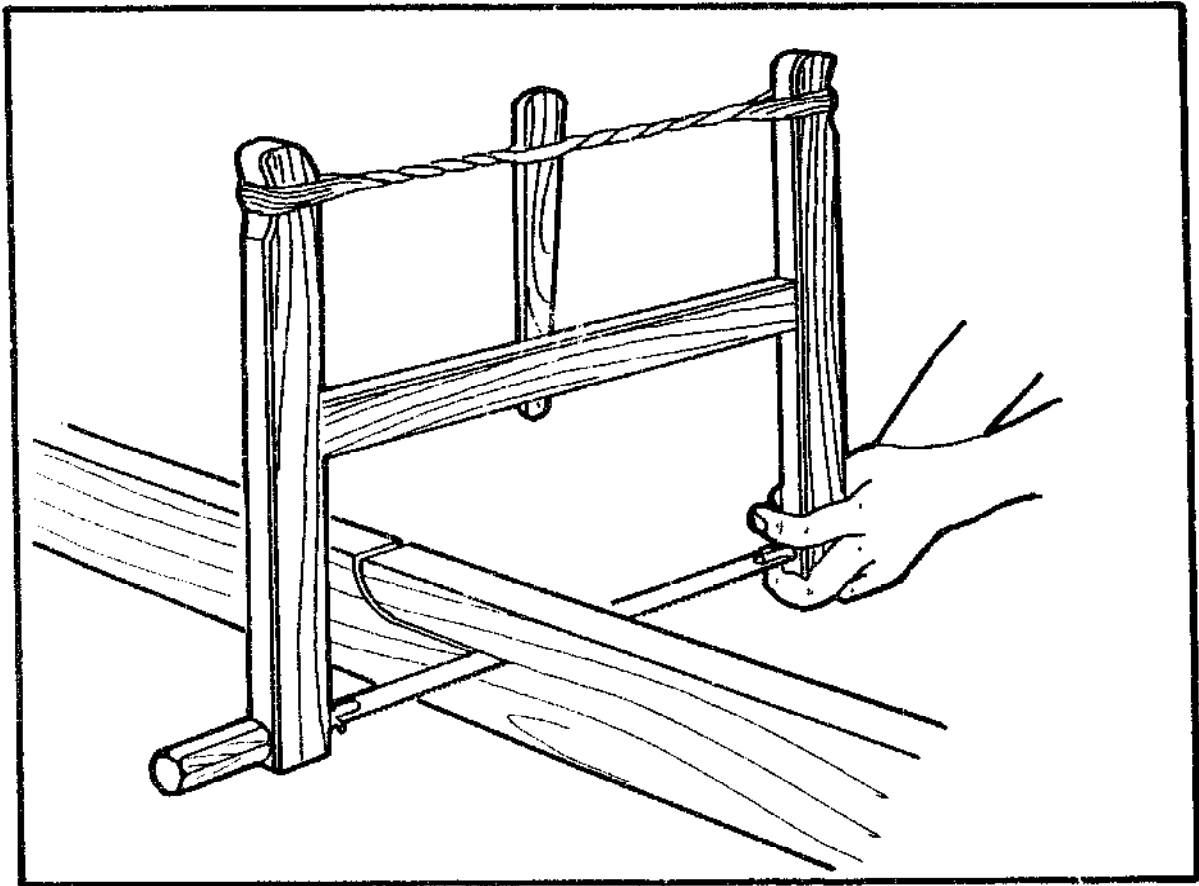

The bow saw is a difficult tool to make, involving metal work and wood work. Its advantage over the other types of saw in this manual is that the blades can be made from hack saw blades which are easily obtainable in most countries. This is not the case with fret saw and coping saw blades.

The bow saw is made to cut curves in timber up to about 50mm in thickness, giving a carpenter the ability to make fancy and decorative shapes, improving the style and range of his products. It is not a common tool, but anyone who takes the time to construct one will be surprised at the advantages it gives.

The frame of the saw is made from three pieces of wood, joined loosely together by mortise and tenon joints. The blade is held in tension by a loop of string at the top of the frame, twisted by the twisting slat. By turning the handles the blade can be adjusted to any angle. This means that the saw can cut parallel to the edge of the work.

When sawing you should keep checking that the blade is square to the workpiece. After cutting the shape it will need smoothing down with a spokeshave, or a plane.

## LIST OF PARTS

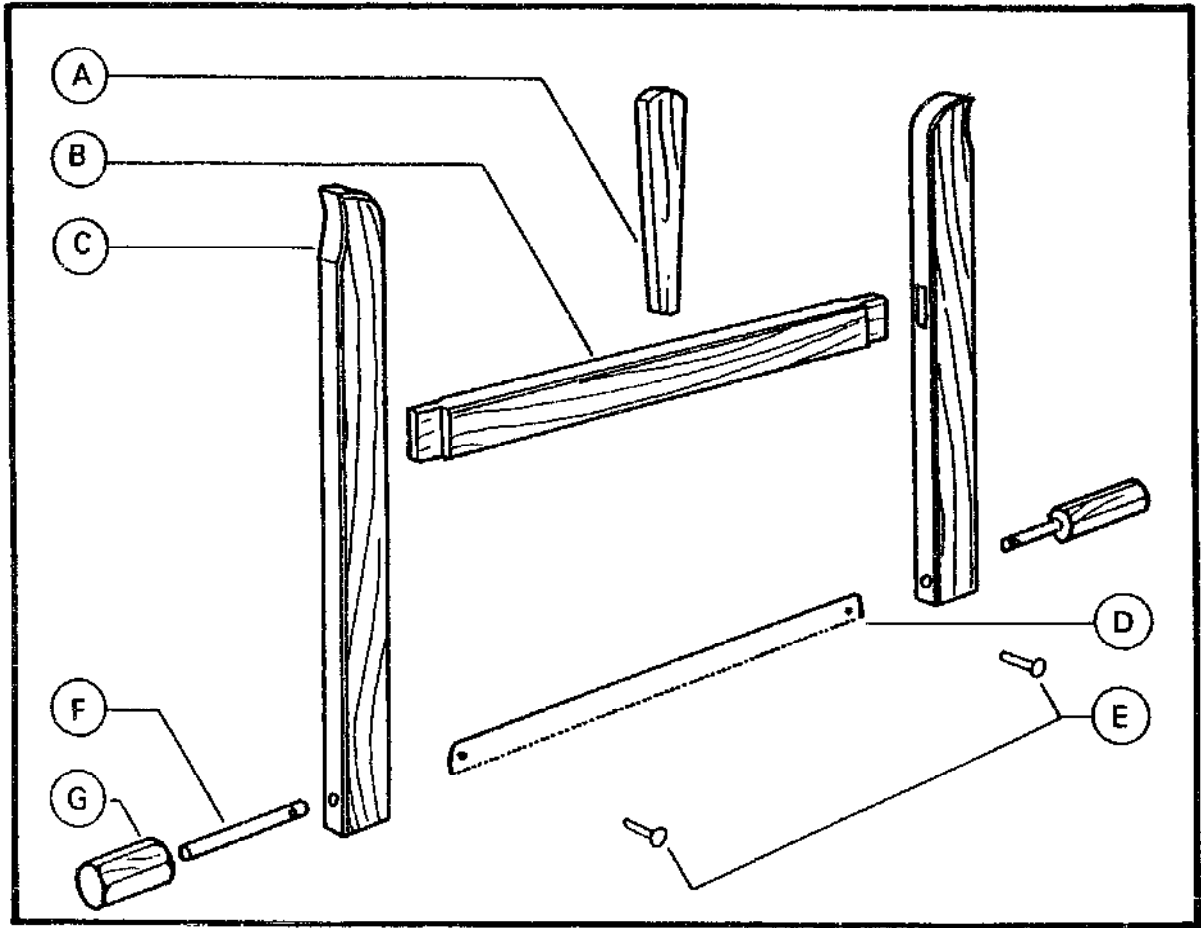

### Part

- A** *The twisting slat* tensions the blade by twisting a loop of string at the top of the frame.
- B & C** *The crossbar and side frames* make up the frame of the saw. The mortise and tenon joints at the end of the crossbar act as pivots so they must not be glued.
- D** *The blade sockets*, made of steel rod, are slotted and drilled to take the blade and blade holders.
- E** *The handles* are made of timber. If a lathe is available they can be turned, otherwise they can be shaped by hand. They are drilled in the centre of one end and the blade sockets are riveted into this hole.
- F** *The bow saw blade* is replaceable and can either be bought from a shop or made from a discarded hack saw blade. However, the teeth of a hack saw blade need to be made bigger to cut wood.
- G** *The blade holders* are made from two 50mm nails cut down to 20mm in length.

## Parts and Cutting List

Part	Name	Quantity, material and dimensions
A	Twisting slat	1 pc. timber 200mm × 40mm × 10mm
B	Cross bar	1 pc. timber 350mm × 45mm × 22mm
C	Side frames	2 pcs. timber 400mm × 45mm × 22mm
D	Blade sockets	2 pcs. 9mm steel rod 100mm long
E	Handles	1 pc. timber 160mm × 40mm × 40mm
F	Bow saw blade	1 pc hack saw blade
G	Blade holders	2 pcs. 50mm nails cut to 20mm

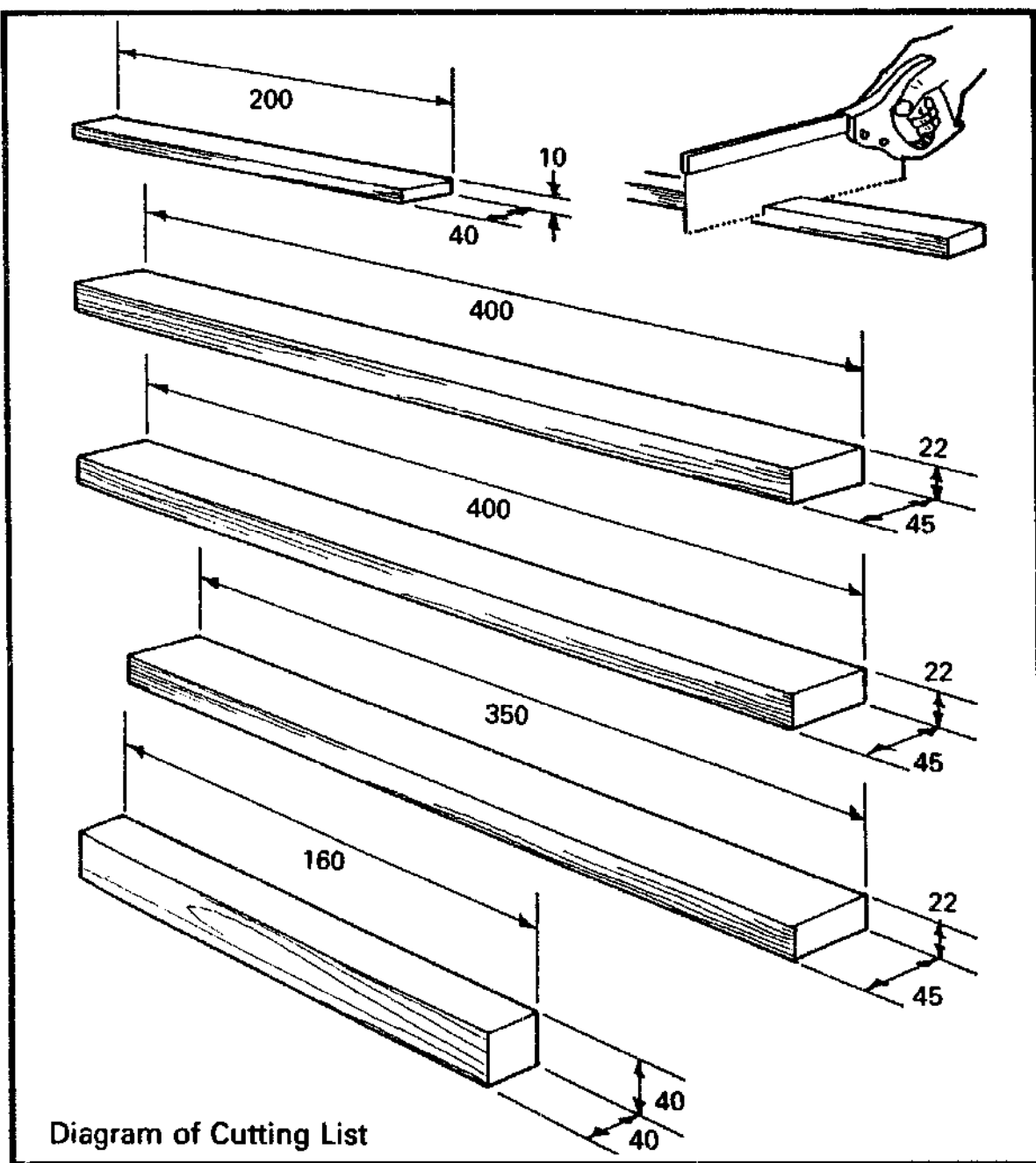

Diagram of Cutting List



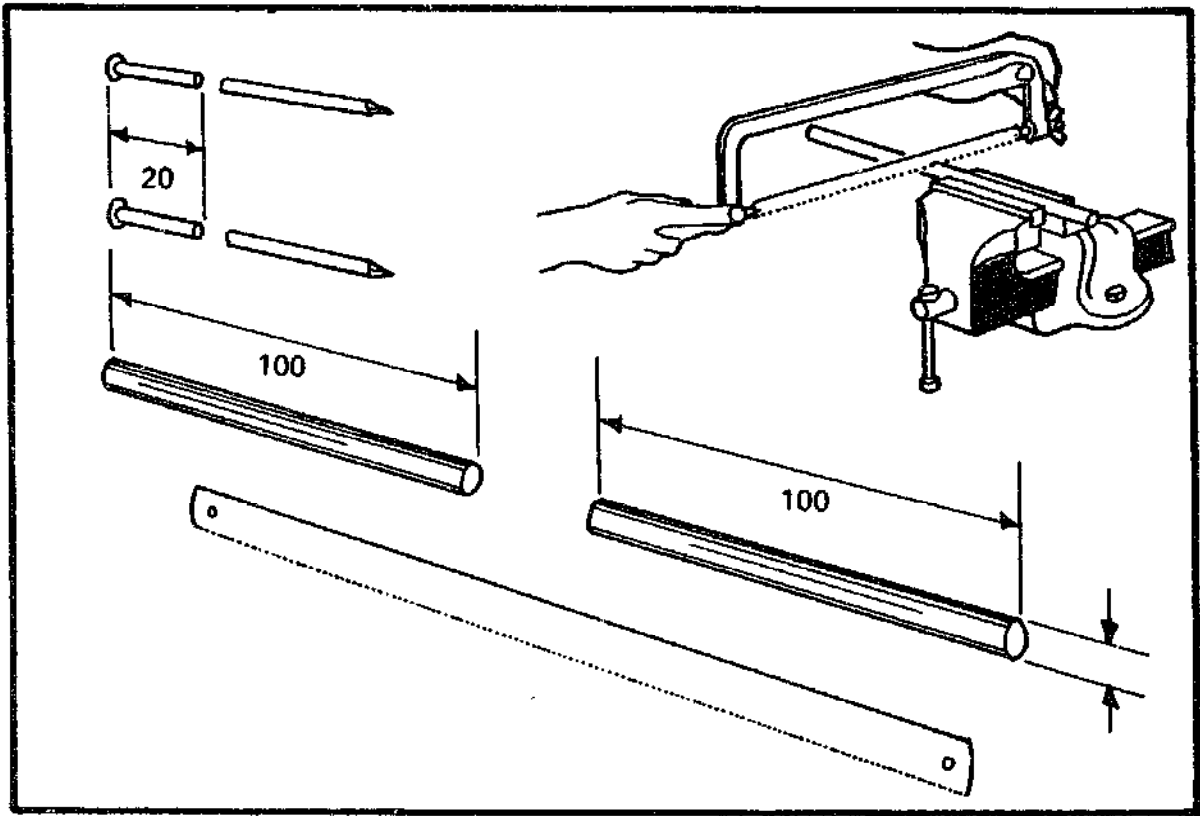
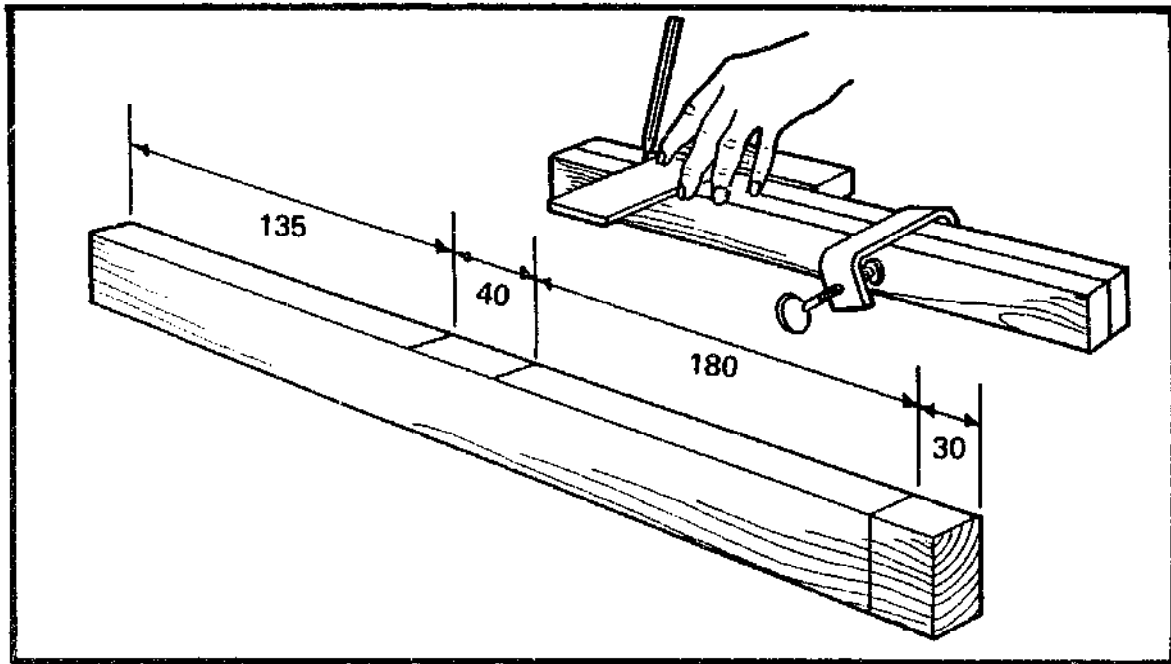
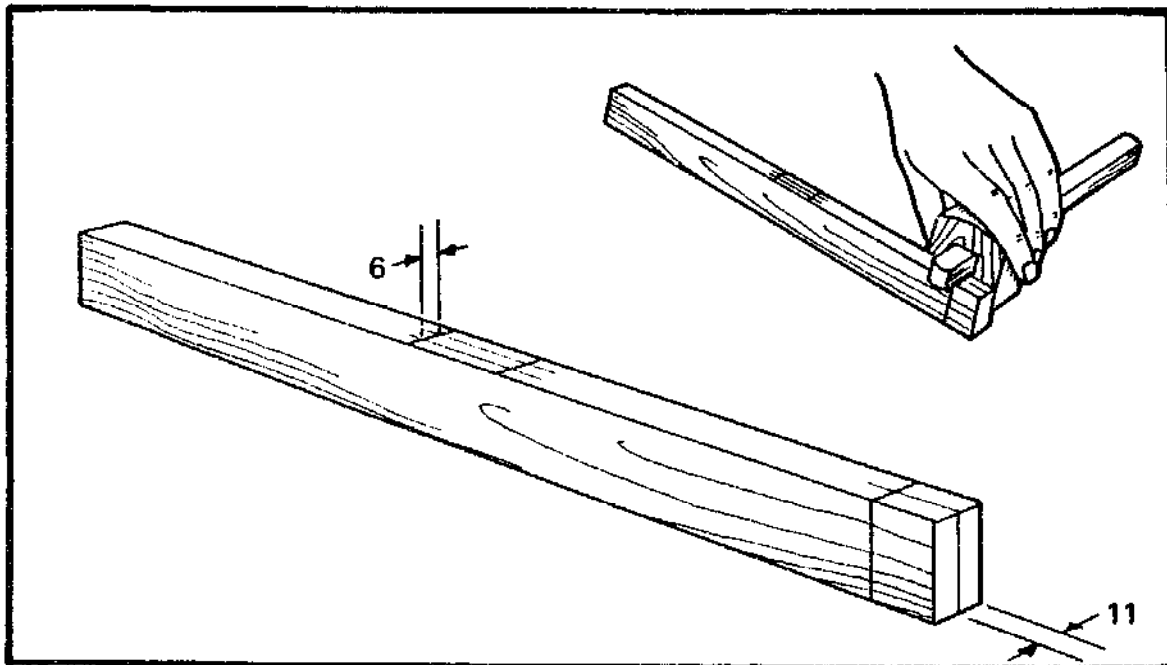

Diagram of Cutting List in Steel

## MAKING THE FRAME



Clamp the two side frames together and square two lines across, 40mm apart, for the mortise. Square one line across, 30mm from the bottom, to mark the hole for the blade socket. Square this line all round both frames.



Use a mortise gauge to mark a 6mm mortise, in each of the side frames, for the crossbar. Gauge a line in the middle of both edges of each frame, to mark the points for drilling the holes to take the blade sockets.

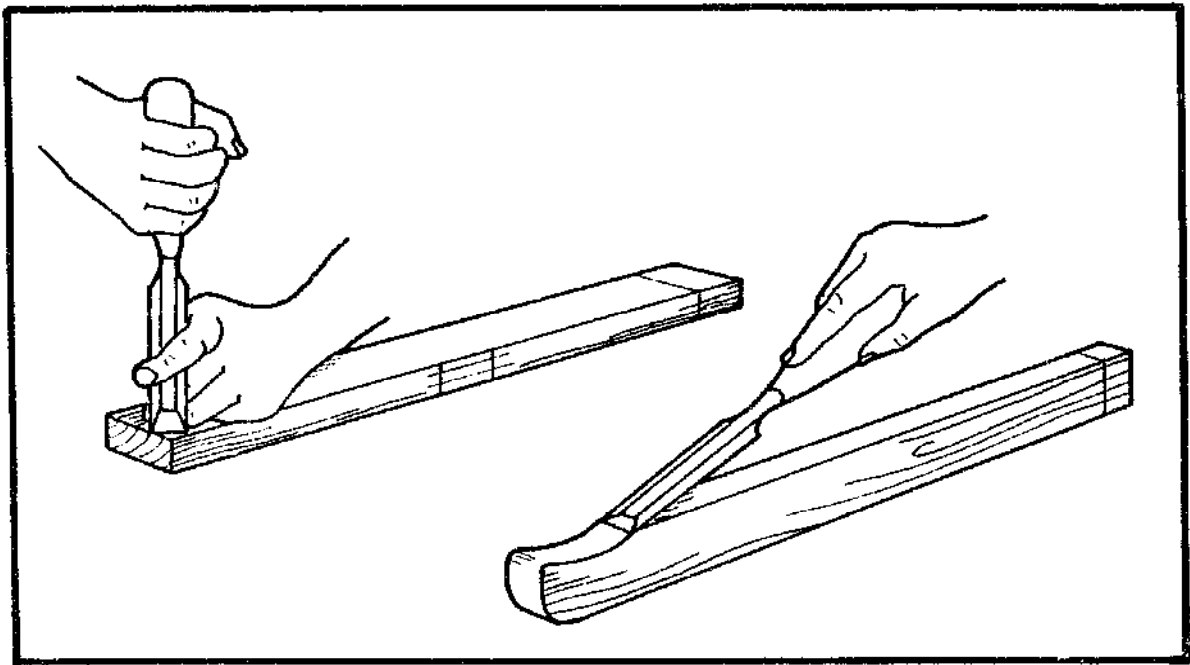

With a large chisel, shape the top of the side frames so that the string does not slip down. You can also round off the top inside corners.

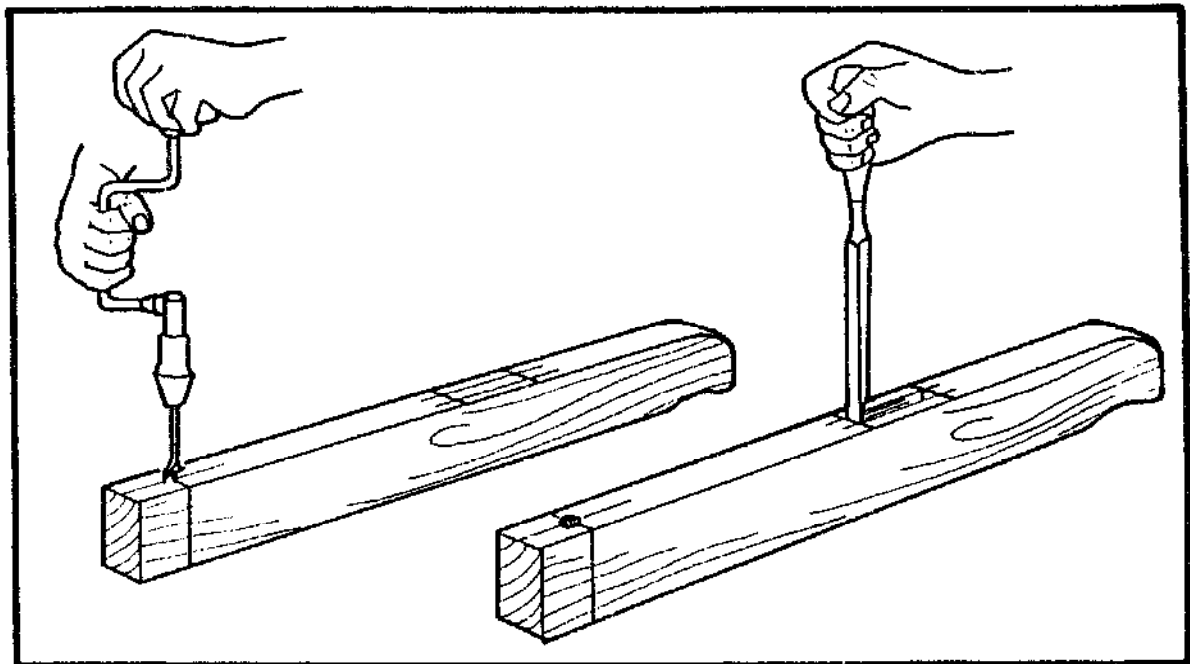

From both sides, drill a  $\varnothing 9\text{mm}$  hole, with a brace and bit. With a 6mm mortise chisel and a mallet, cut the mortise to a depth of 20mm.

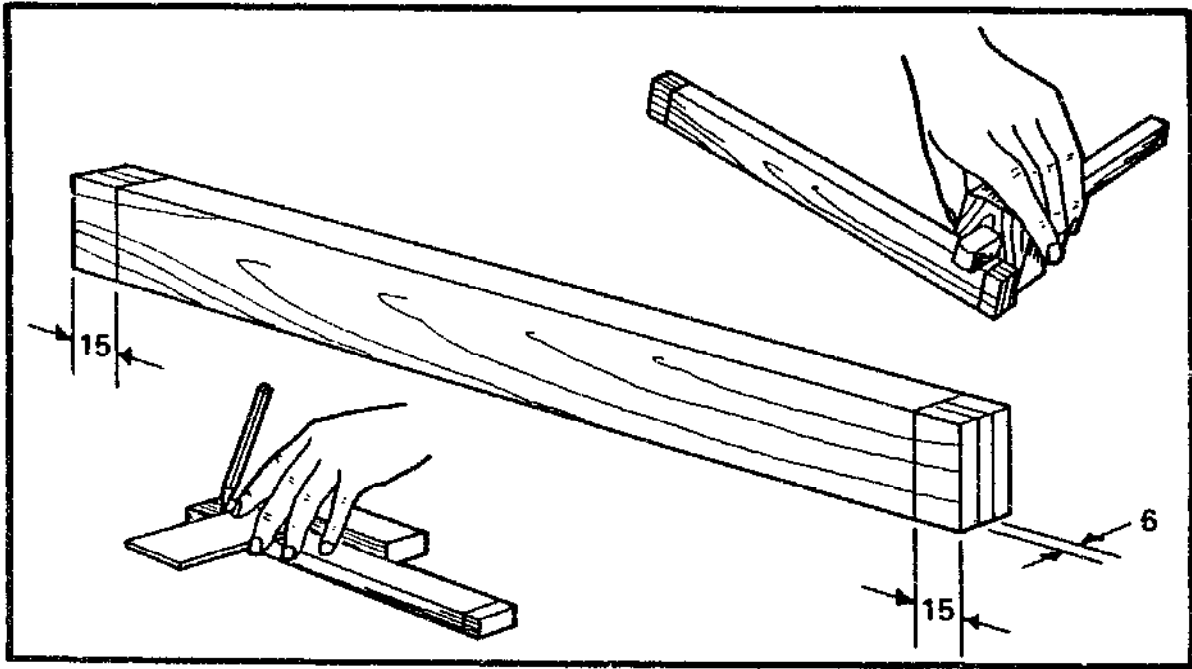

Take the crossbar and mark the shoulders of the tenons by squaring lines all round 15mm from both ends. With a mortise gauge, gauge a 6mm tenon on both ends of the crossbar.

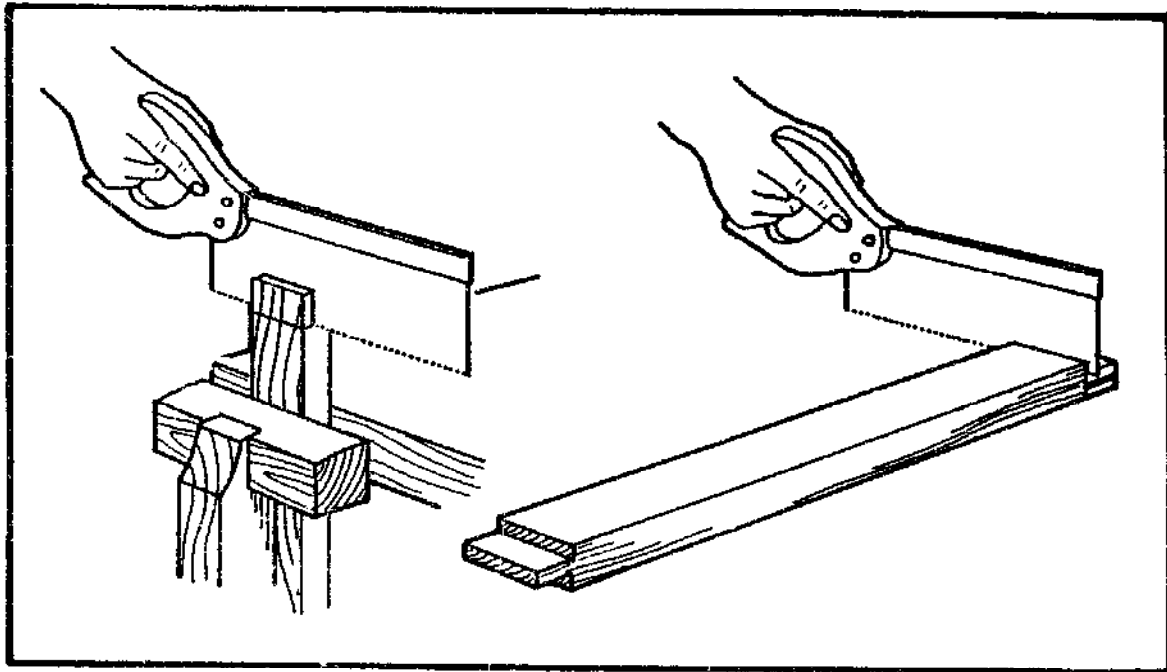

Cut the tenons on each end of the crossbar.

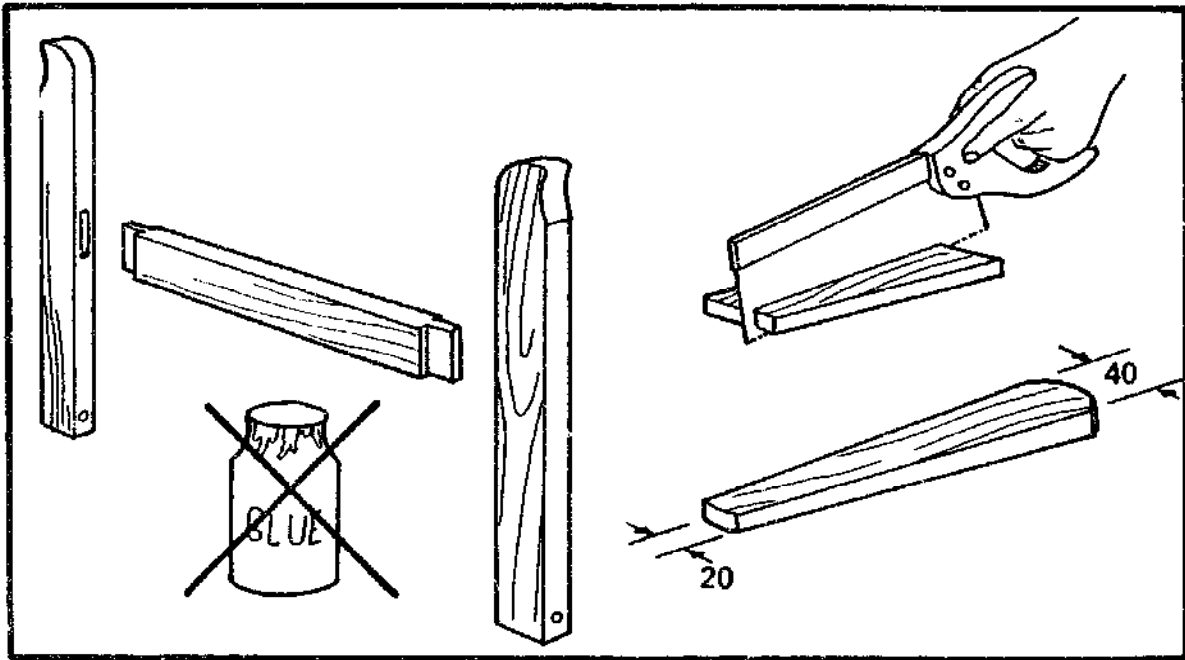

The joints should be a good tight fit, but they **MUST NOT BE GLUED**. Now cut and shape the twisting slat to the dimensions shown.

### MAKING THE HANDLES

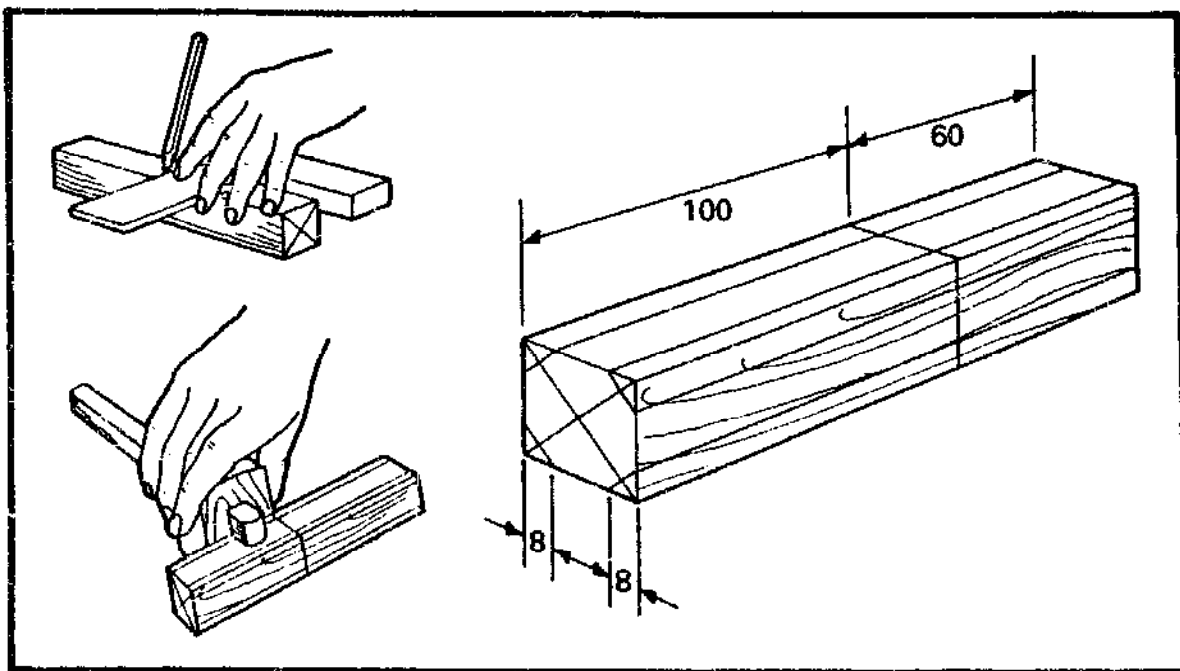

Take the timber prepared for the handles and mark the diagonals on each end to find the centres. Square a line all round 100mm from one end.

Gauge eight lines 8mm in from each edge and plane the timber to an octagonal cross-section.

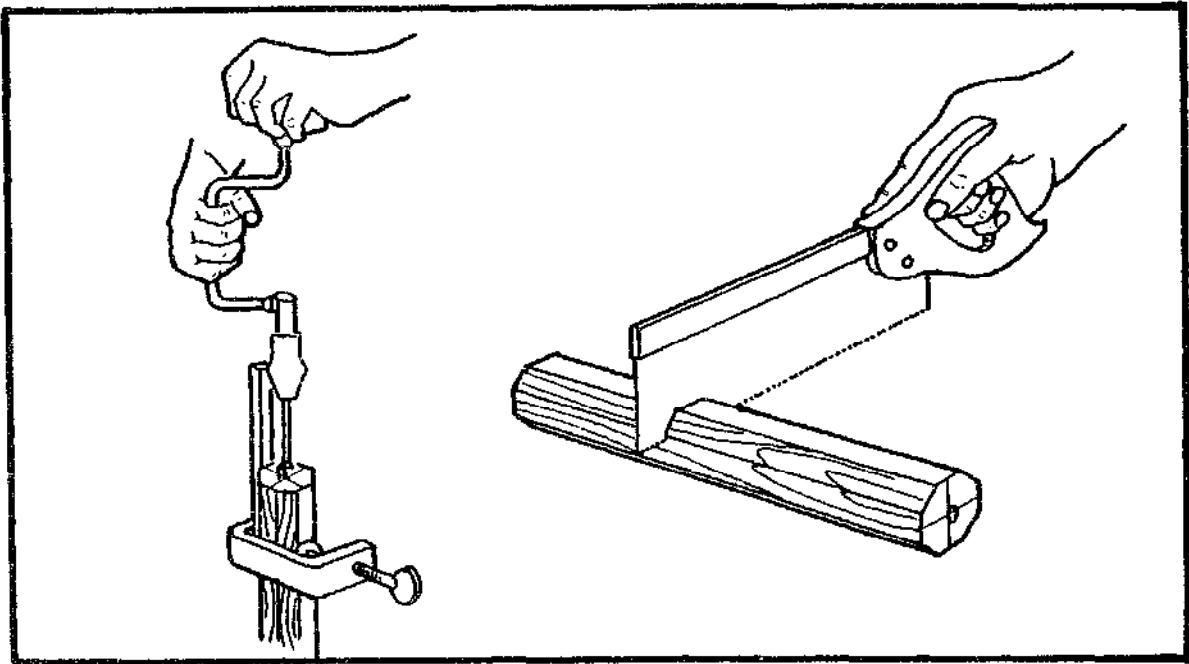

Drill a  $\text{Ø}9\text{mm}$  hole in both ends, 50mm deep. Clamp a small piece of timber to the handle to help you to drill the hole straight. Saw the handle into two pieces, one 60mm long, the other 100mm long.

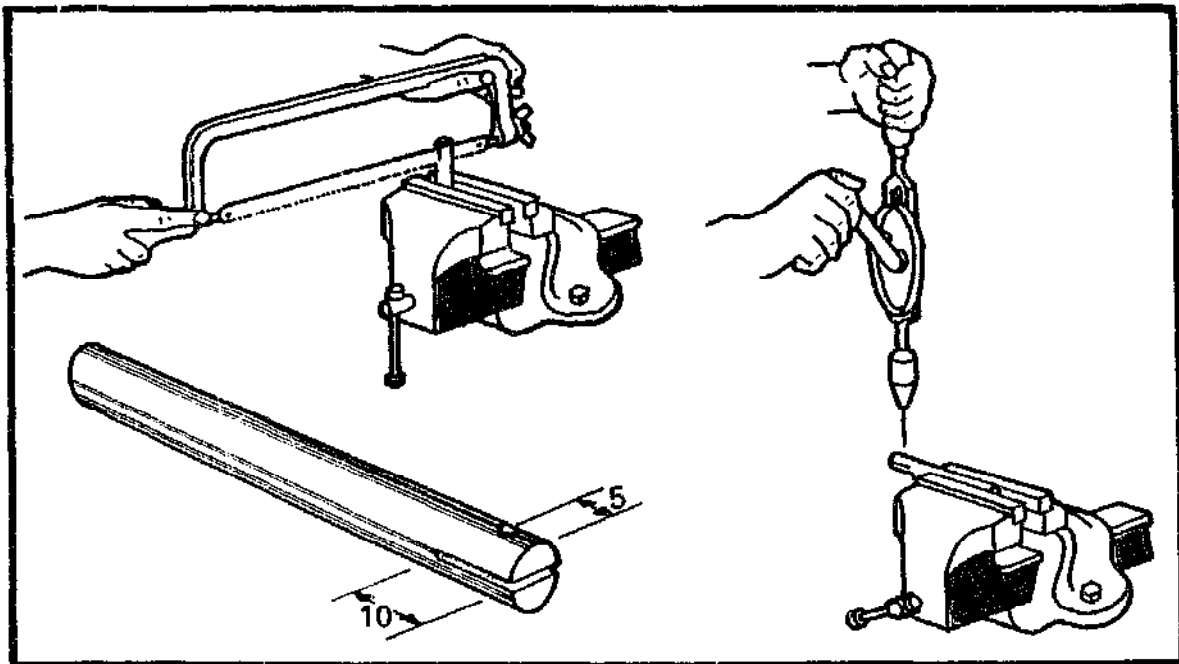

Take the two pieces of 9mm bar and saw a slot 10mm long in one end. 5mm in from the same end, punch and drill a  $\text{Ø}3\text{mm}$  hole right through.

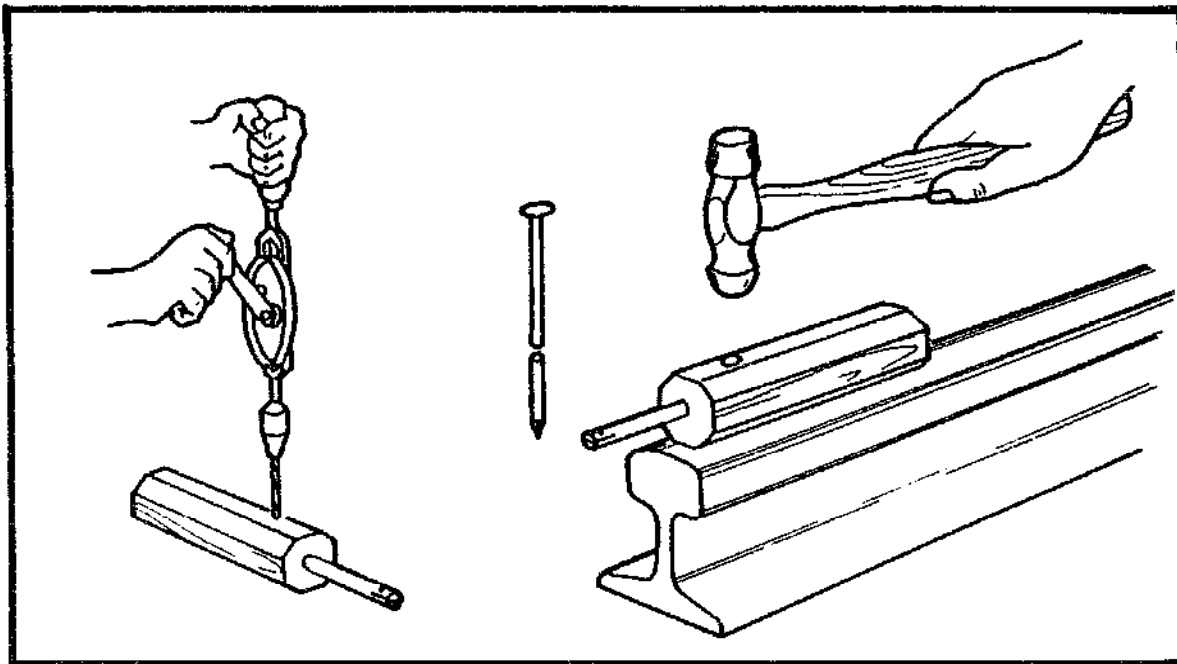

Push the 9mm bars into the handles, with the slot and the hole pointing out. 25mm in from the drilled end of the handle, drill a  $\text{Ø}3\text{mm}$  hole right through. Push a 50mm (2") nail through this hole. Cut the end off and rivet the cut end of it with a hammer to hold the two pieces firmly together.

### MAKING THE BLADE

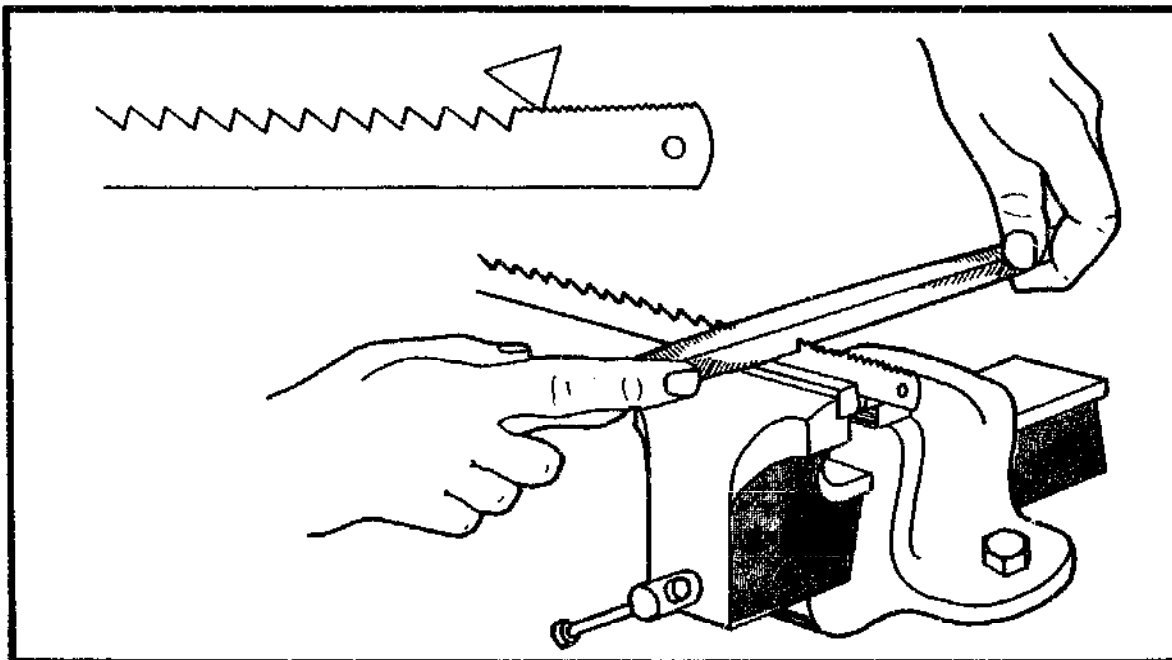

To make a blade for the Bow Saw, a hacksaw blade must be softened. Only the cheaper "low-speed" blades can be used. Put the blade into a fire until it is red hot. Take it out and let it cool down slowly beside the fire. With a saw file, file every third tooth until it is three times bigger. Take care to make each tooth the same size.

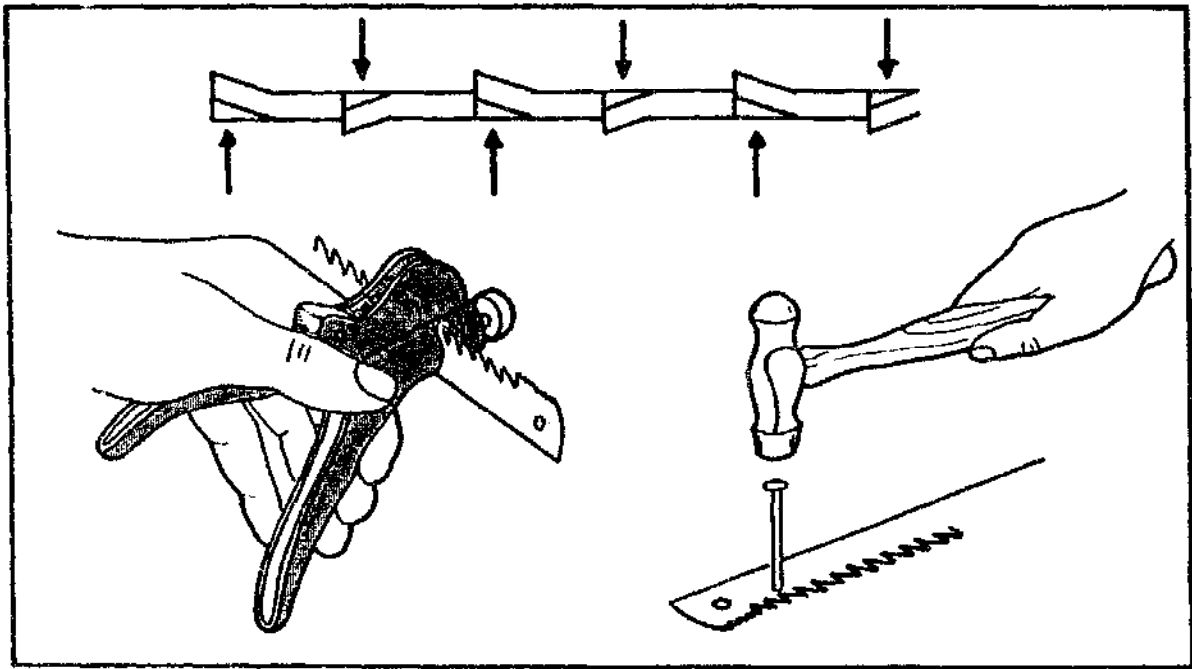

The teeth of the blade now have to be set. Use a saw set if one is available. If not a hammer and a blunt nail can be used to bend the first tooth to the left, the next to the right, and so on.

#### ASSEMBLY

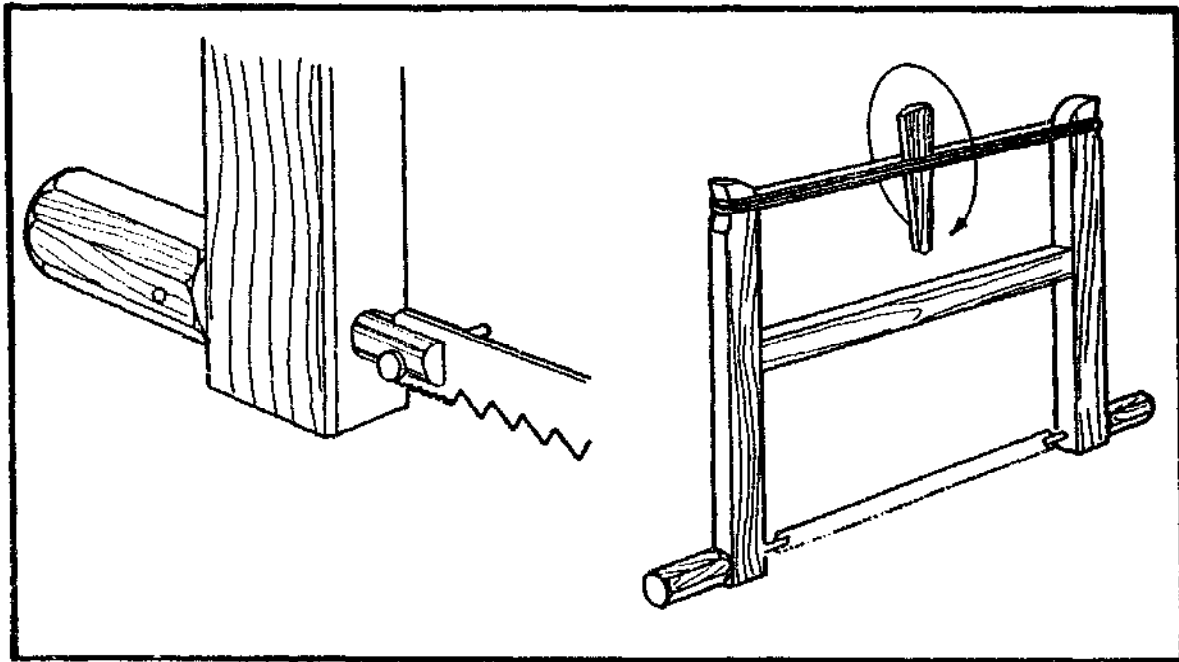

Now assemble the three parts of the frame. Push the blade sockets through the holes in the side frames and attach the blades with two 50mm nails cut down to about 20mm long. Wind some string three or four times around the top of the frame and tie the ends together. Slip the twisting slat through the string and twist it until the blade is tight, then slide it down until it rests on the crossbar.



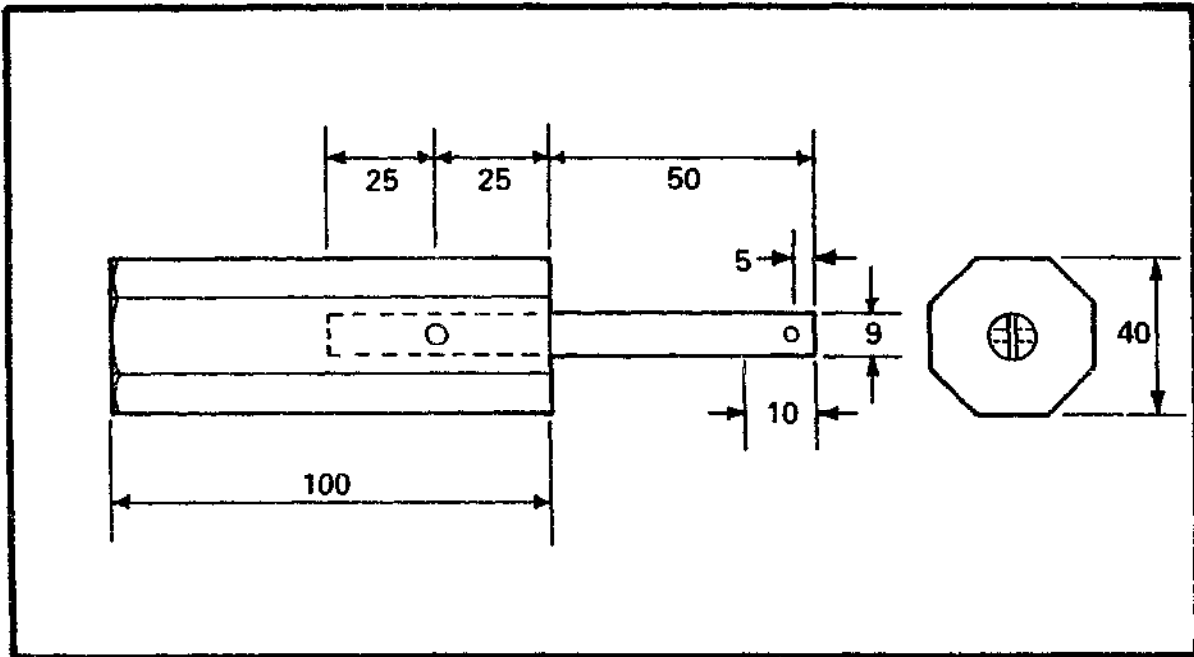

Half Size Drawing of the Handle

## Coping saw

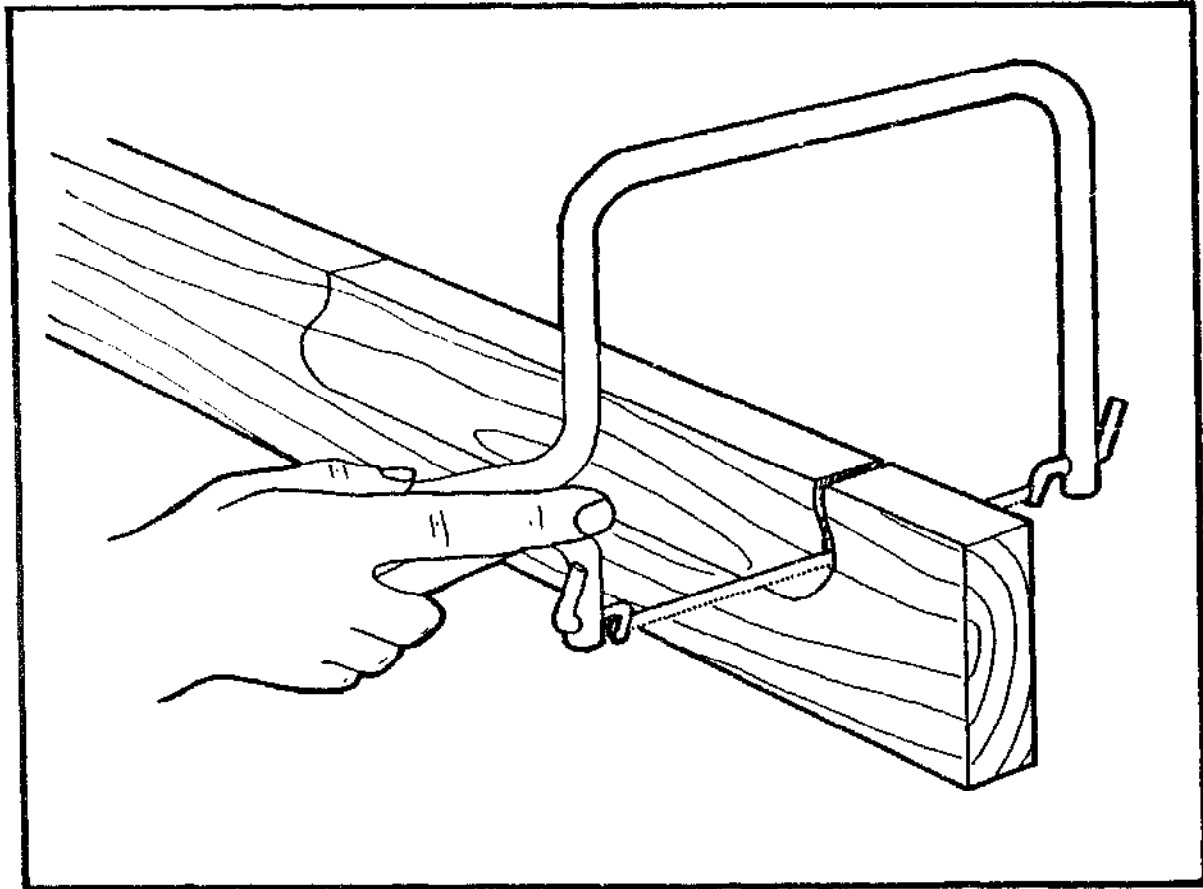

The coping saw is a small version of the bow saw. It has a very narrow blade, held in tension by the spring of a steel frame. The blades have to be replaced when they become blunt and must be bought from a shop.

Although it is not an essential carpentry tool, it is a very handy saw for cutting curves in timber up to 25mm thick. Its most common work is cutting the waste from dovetails and other joints, shaping handles and small decorative jobs.

The blade is about 150mm long with one very small pin fixed to each end, these fit over the blade holders. The coping saw can be used with the blade turned to any angle, and cutting a curve is often made easier by twisting the blade holders two or three times as the cut proceeds. Always make sure the blade holders are at the same angle, because if the blade is twisted it is very likely to break.

## LIST OF PARTS

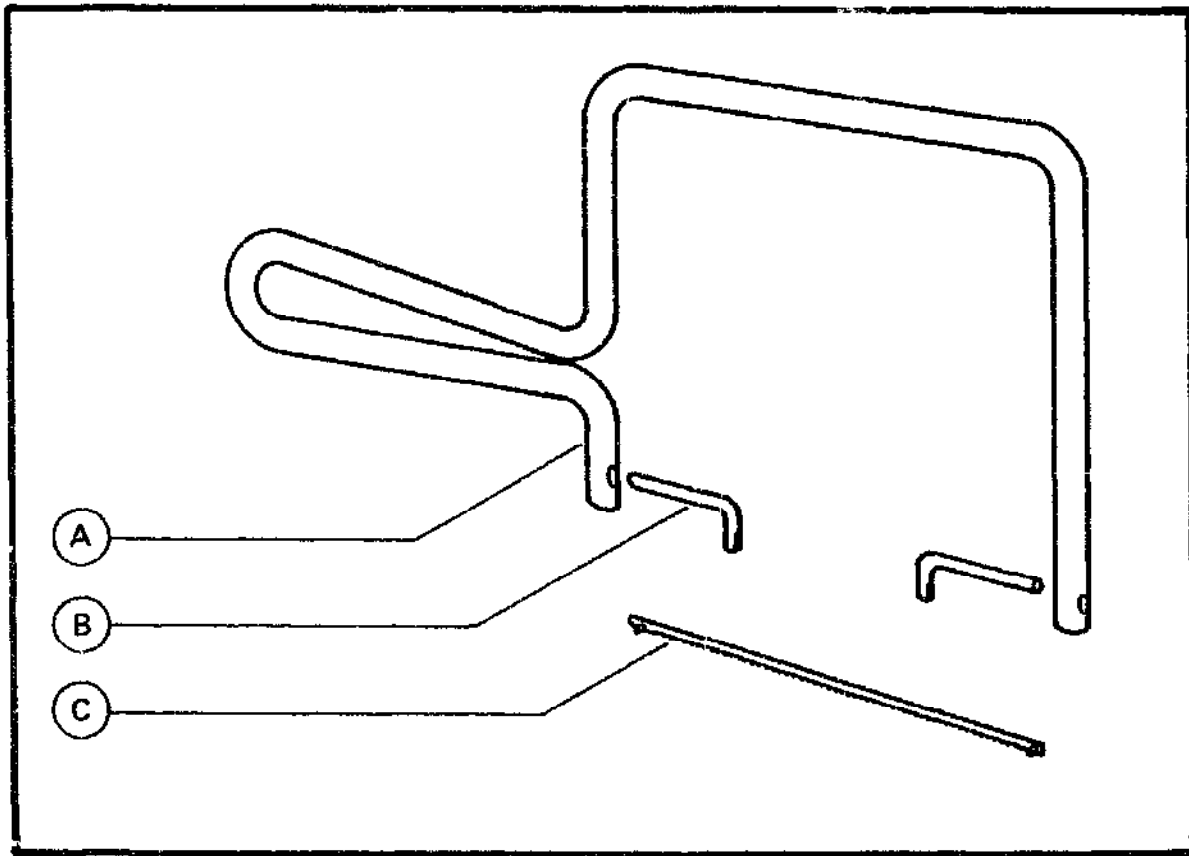

### Part

- A** *The frame is made from one piece of 9mm steel rod 900mm long.*
- B** *The blade holders are made from two 50mm nails cut down to about 45mm*
- C** *The coping saw blade is very thin and must be bought from a shop. It has two small pins, one fixed to each end which attach to the blade holders.*

### Parts and Cutting List

Part	Name	Quantity, material and dimensions
<b>A</b>	Frame	1 pc. 9mm steel rod 900mm long
<b>B</b>	Blade holders	2 pc. 50mm nail cut to 45mm
<b>C</b>	Coping saw blade	

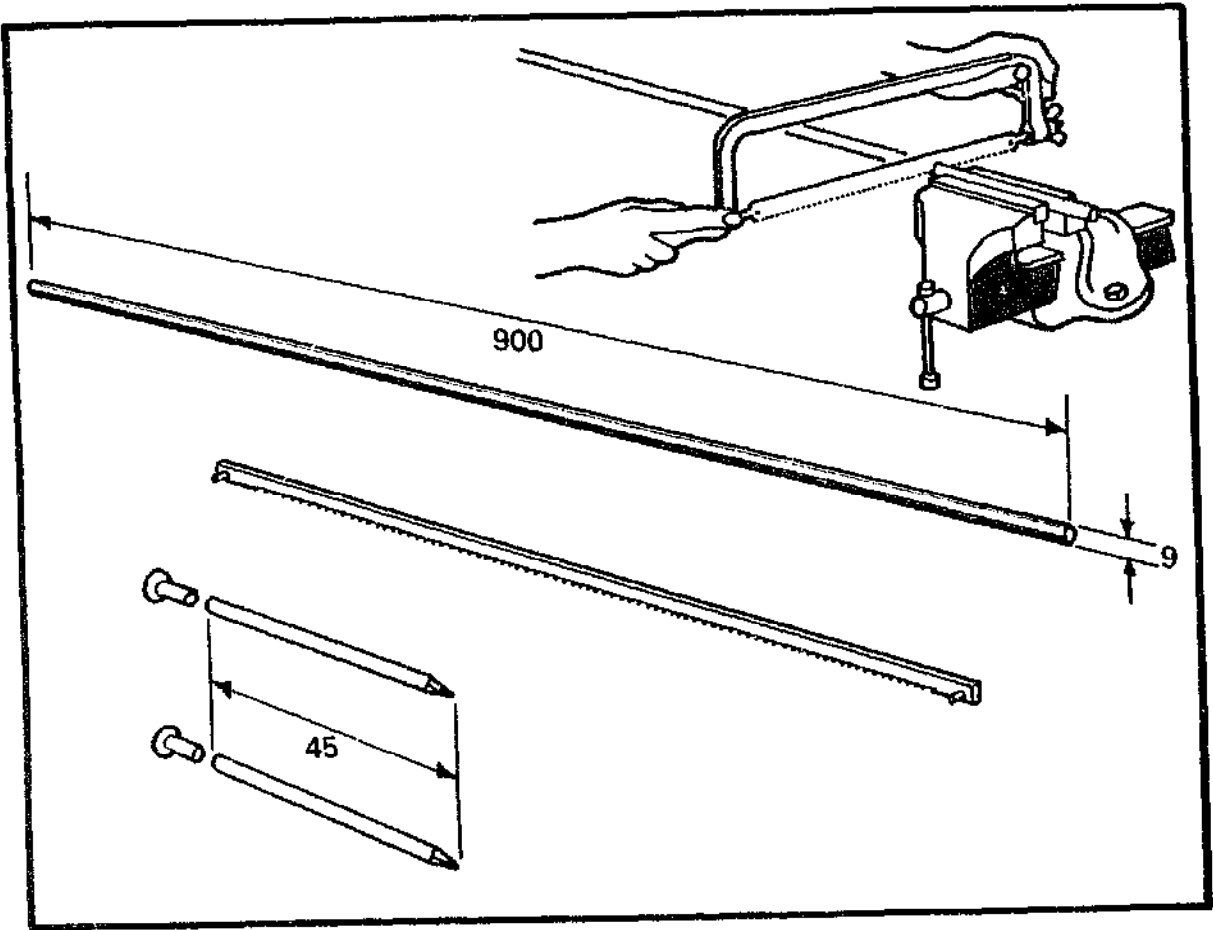
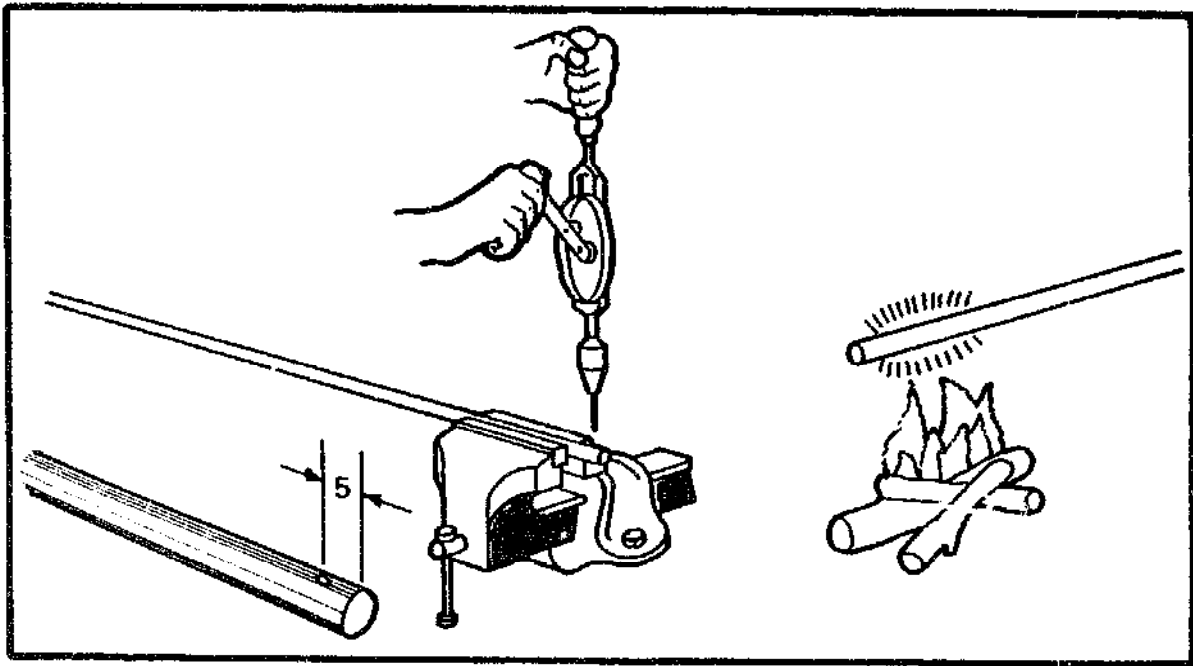
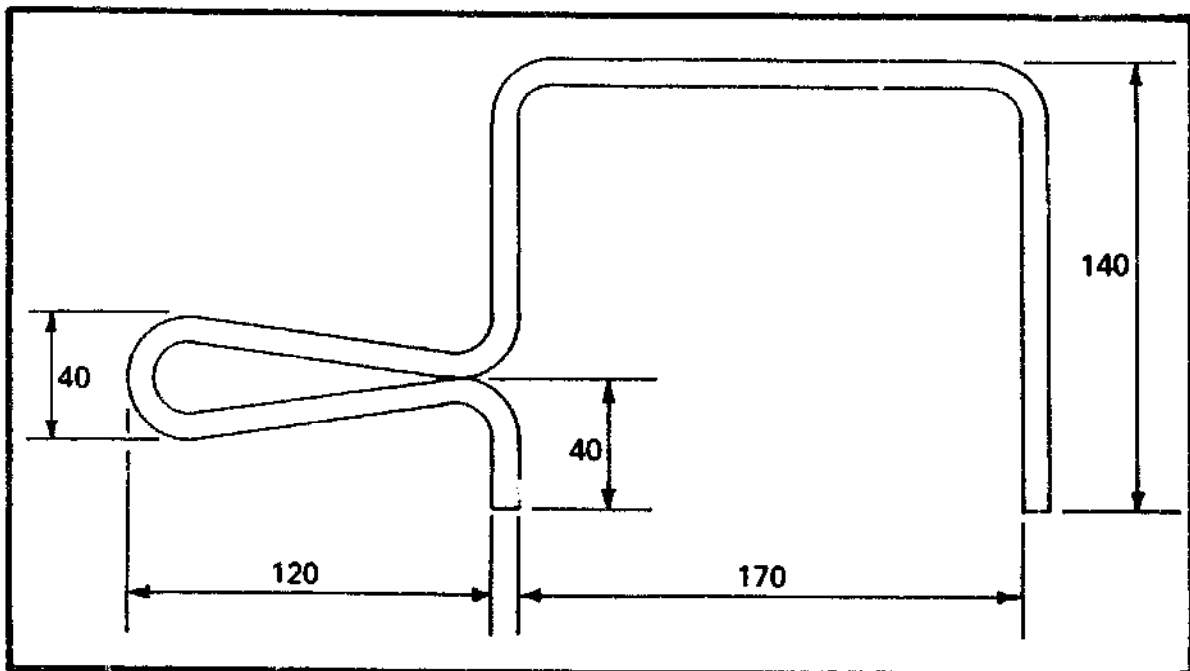

Diagram of Cutting List

## MAKING THE FRAME



Centre punch and drill a  $\text{Ø}3\text{mm}$  hole in one end of the steel rod (the hole should be slightly bigger than the nails to be used as blade holders). Build a fire from wood or charcoal. The frame can be bent easily if the rod is red hot.



Drawing of Frame showing Dimensions

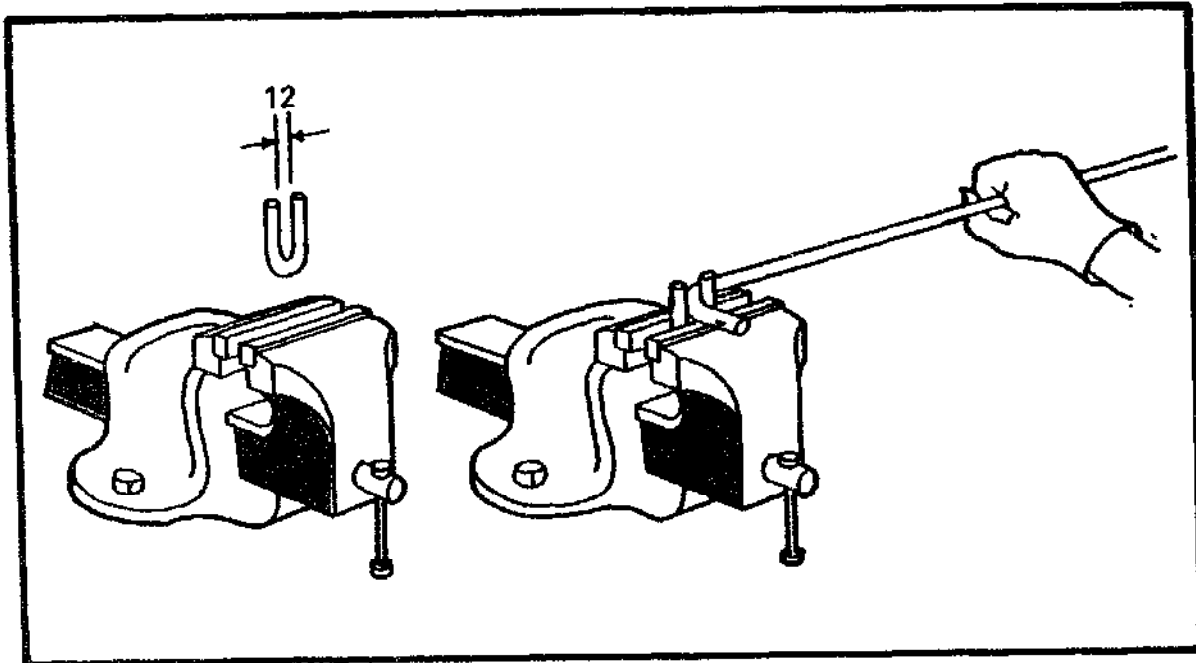

From a piece of 12mm rod make a 'U' shaped bending bar, with a 12mm gap between the uprights. Put this into a vice with about 20mm sticking out from the jaws. Heat up the end of the rod with the hole in and make a right angled bend 30mm from the end.

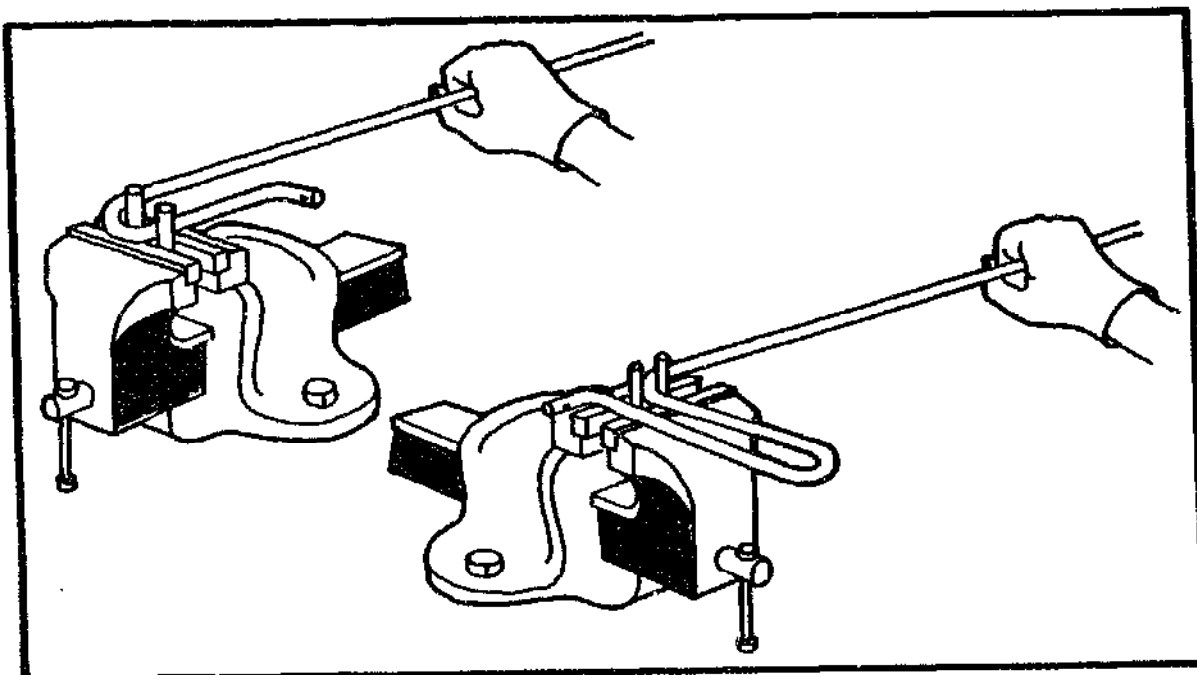

Heat up the rod 120mm from the first bend and make the handle by bending 180 degrees. Opposite the first bend make another 90 degree bend.

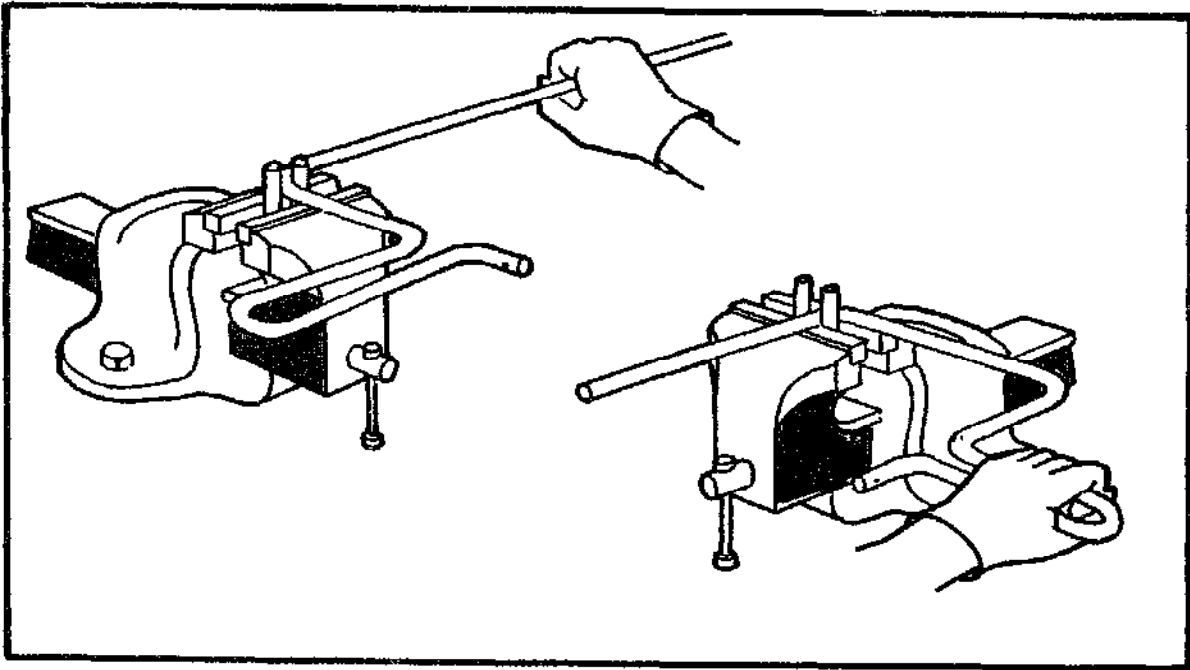

Measure 140mm from the end of the rod, heat it up until red hot, and make another 90 degree bend.

From the last bend measure 150mm, heat the rod up and make another 90 degree bend.

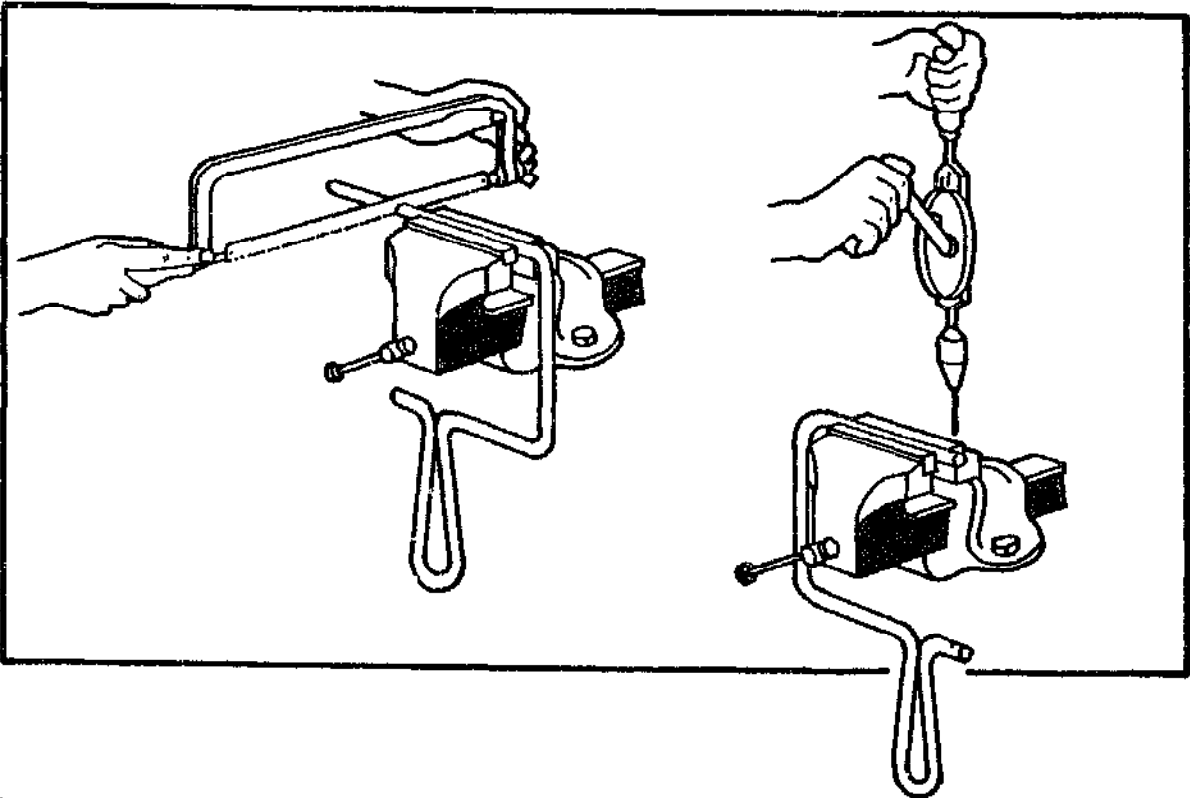

Measure and cut the front leg of the frame to be the same length as the leg at the handle. Punch and drill a hole the same size as the first, 10mm in from the end of the frame.

## MAKING THE BLADE HOLDERS

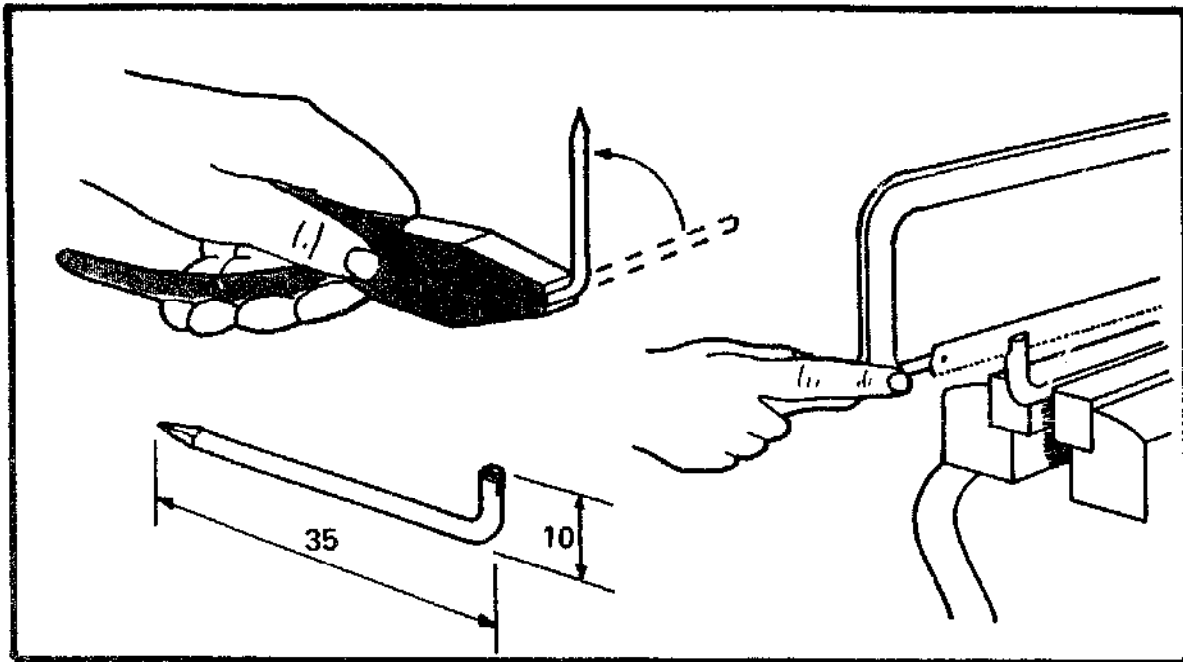

Saw the head off a 50mm nail leaving it 45mm long. Make a 90 degree bend 10mm from the sawn end. With a hack-saw carefully cut a slot about 4mm long down the centre of the nail.

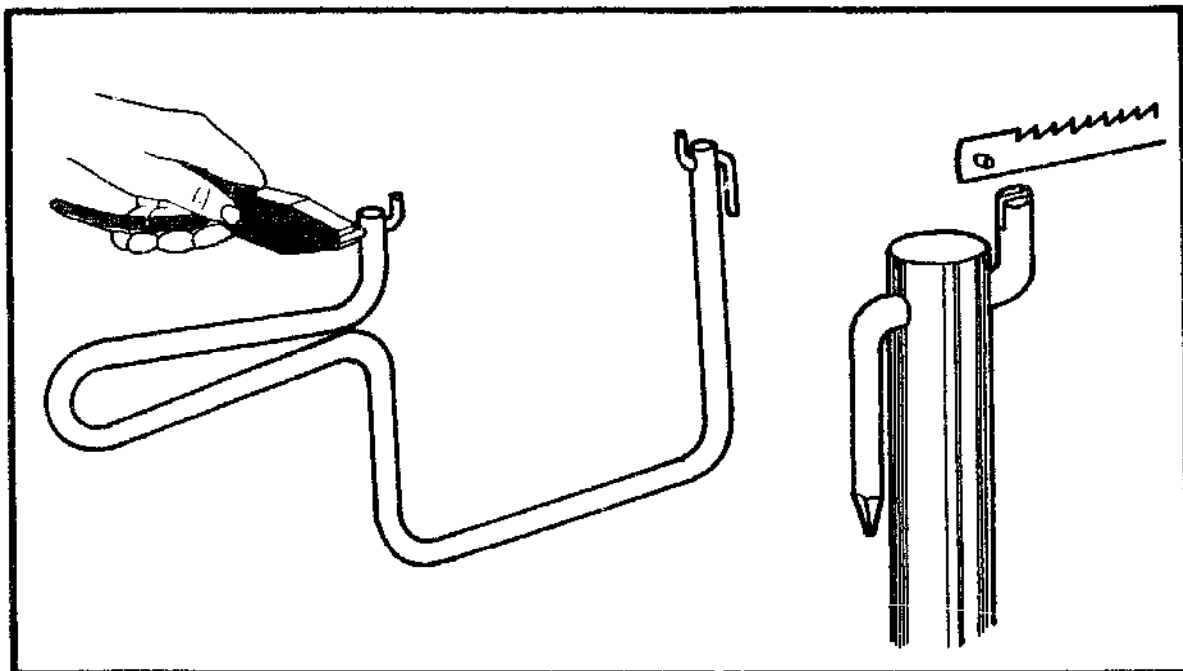

Push the sharp end of the nail through the hole and bend it 90 degrees in the same plane as the first bend. Do this at both ends of the frame.

The drawing on the right shows how the blade fits into the blade holder.



## FITTING THE BLADE

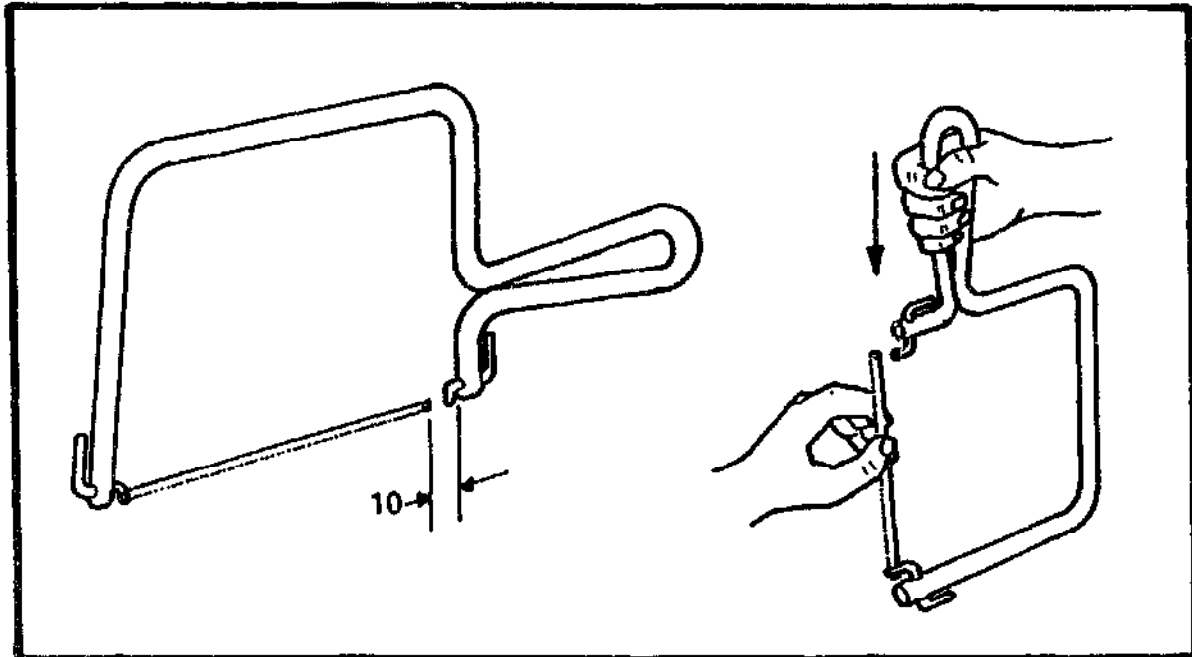

Bend the legs of the frame so that the gap between the two blade holders is 10-15mm bigger than the blade. This gives the right blade tension.

To fit the blade, attach it to one blade holder, push the two legs of the frame together and slip the other end of the blade onto the other blade holder.

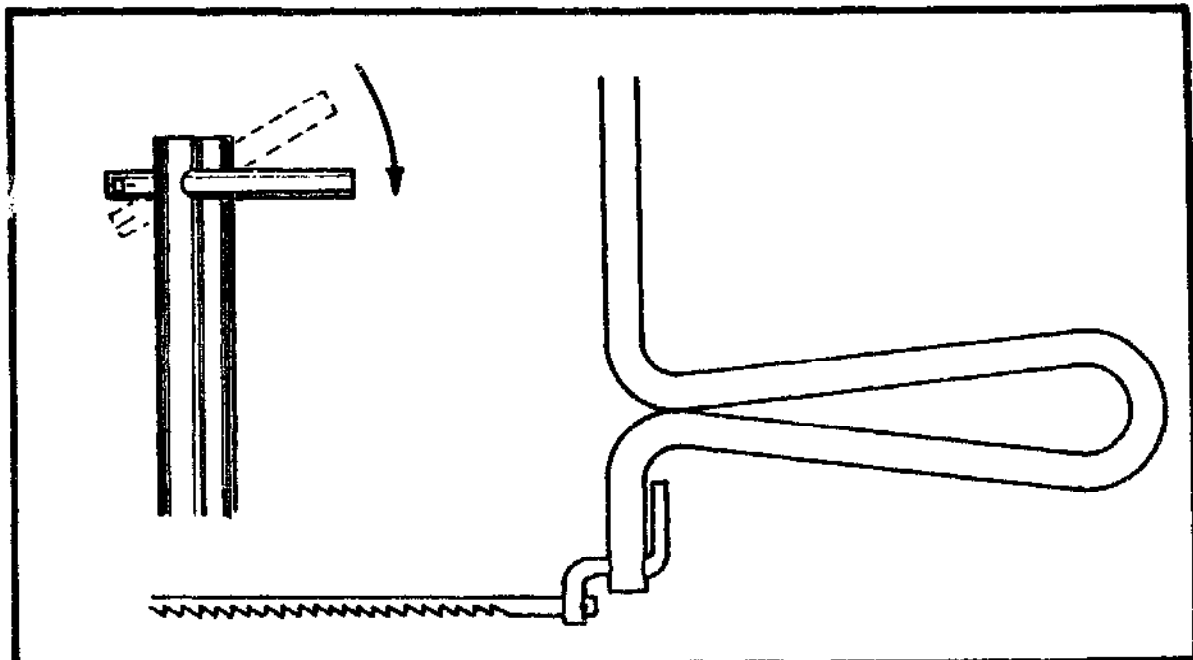

When using the coping saw make sure the blade is not twisted and the teeth point towards the handle. The blades are not strong so use the saw carefully.

## Fret saw

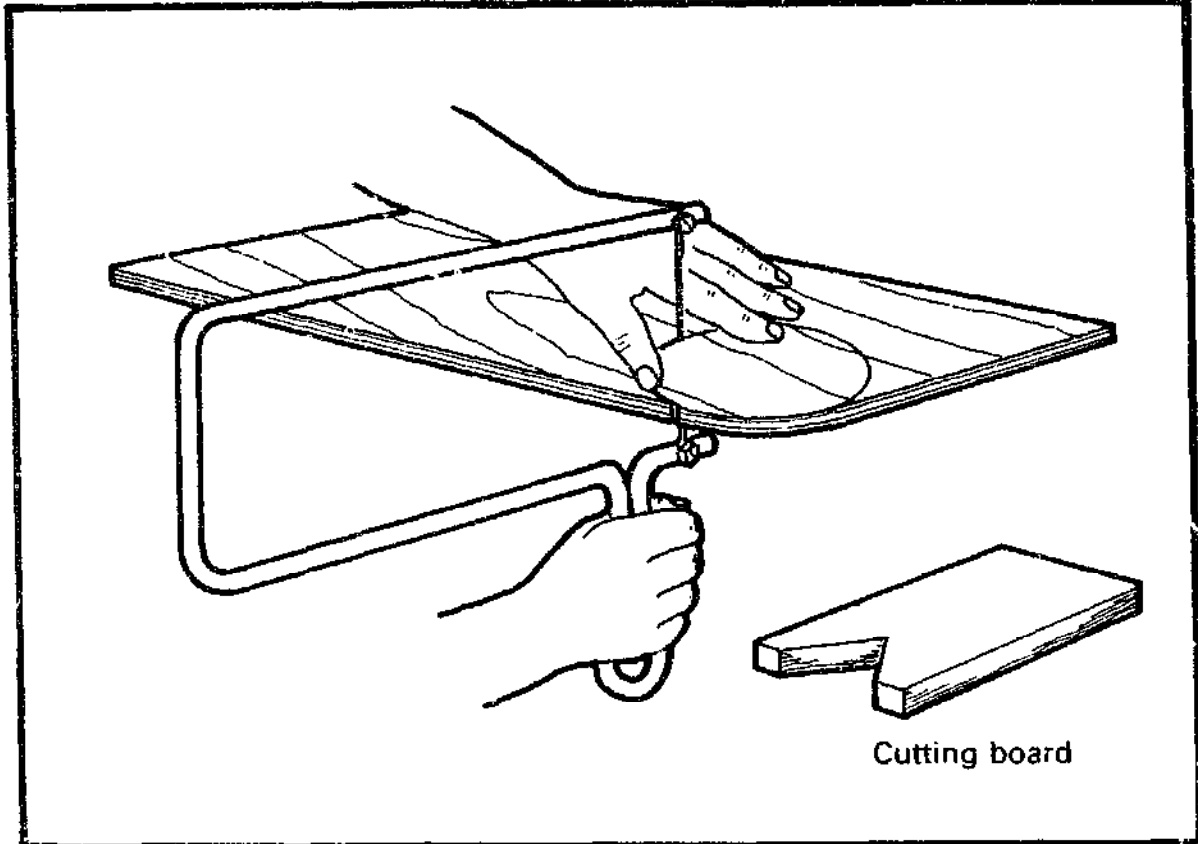

The fret saw is quite a specialized tool, not often used in carpentry workshops, but it is ideal for making childrens' toys and jig saw puzzles. The blade is very fine and is able to cut intricate shapes in thin timber and plywood, but it may be difficult to obtain. Unlike the coping saw, the blade cannot be adjusted, but this is overcome by the depth of the frame.

Support the work on a piece of wood with a 'v' cut out of one end fixed to the bench. It is not advisable to cut material above 12mm in thickness. Use the saw vertically and with care as it is easily broken.

The blade will give a very fine, smooth cut, so when using this tool saw down the middle of your line, and you will not need to sand the edges.

## LIST OF PARTS

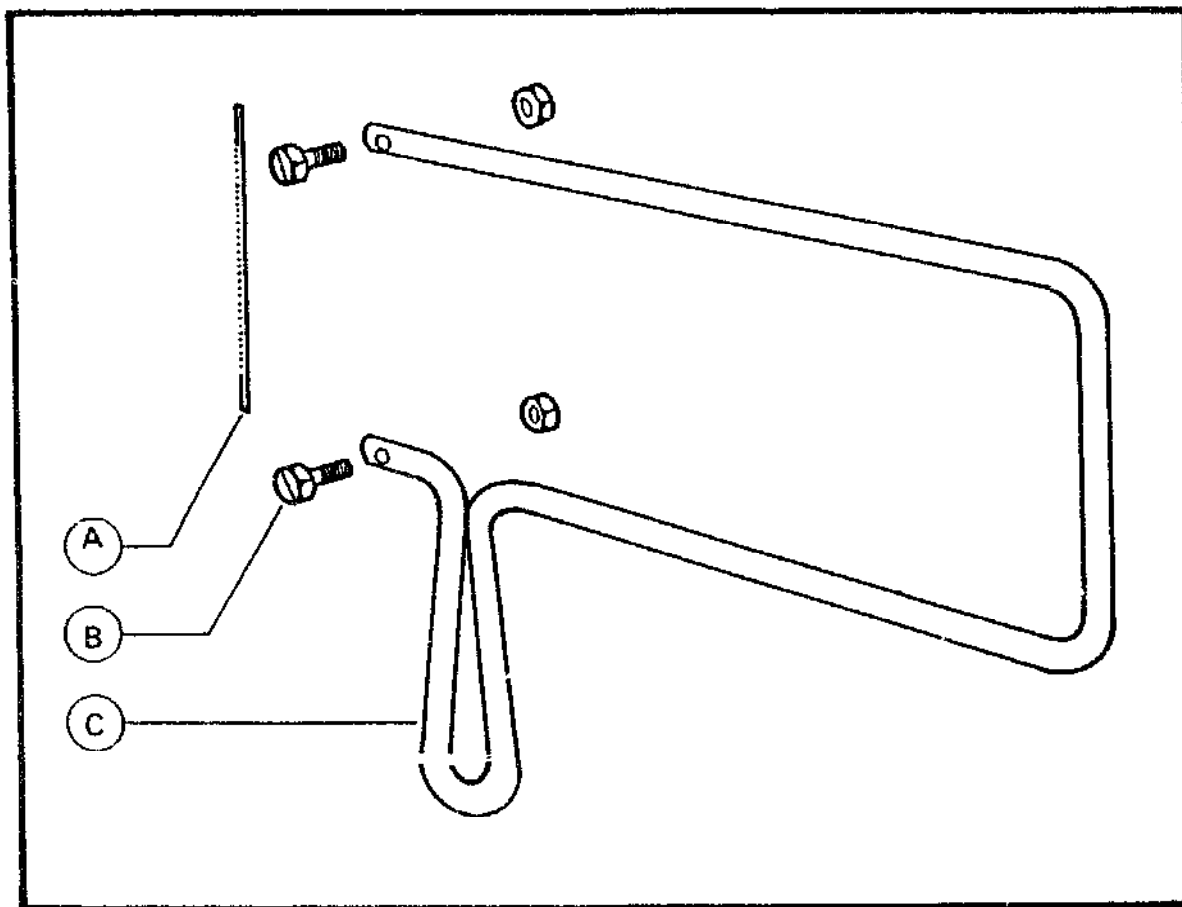

### Part

- A** *The fret saw blade is very thin, and must be bought from a shop. The only way of attaching it to the frame is by clamping it with two nuts and bolts.*
- B** *The blade holders are made from two 20mm × 6mm nuts and bolts; washers are not required.*
- C** *The frame is made from one piece of 9mm steel rod 1,200mm long.*

### Parts and Cutting List

Part	Name	Quantity, materials and dimensions
A	Fret saw blade	
B	Blade holders	2 pcs. 20mm × 6mm nuts and bolts
C	Frame	1 pc. 9mm steel rod 1,200mm long

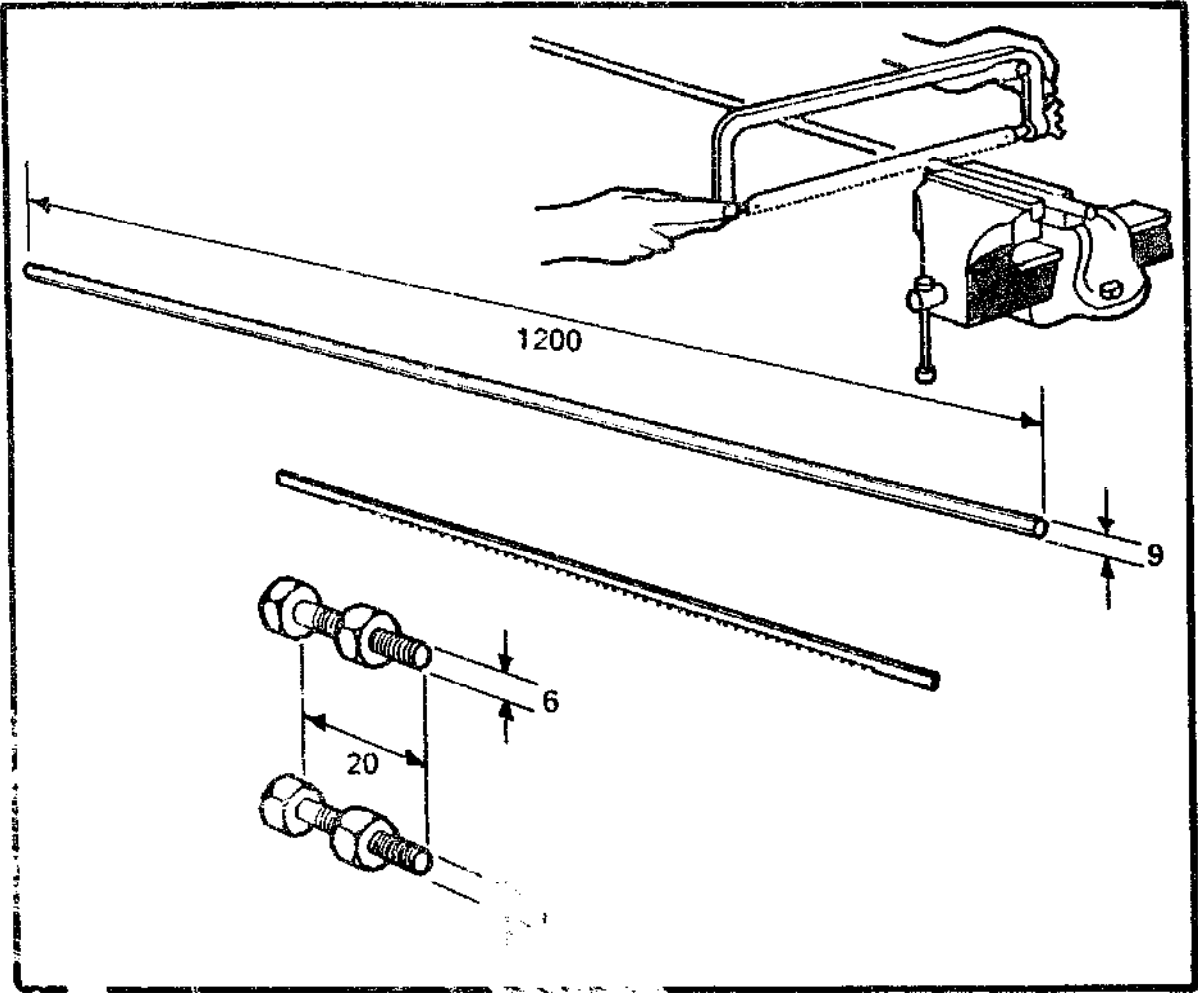
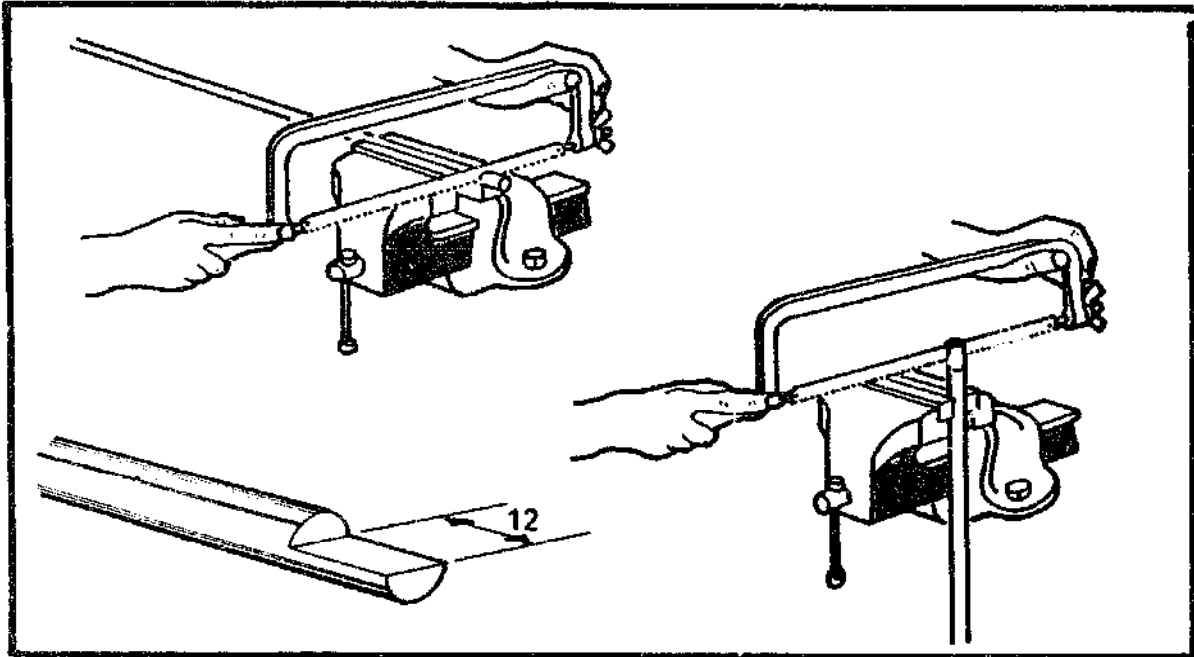
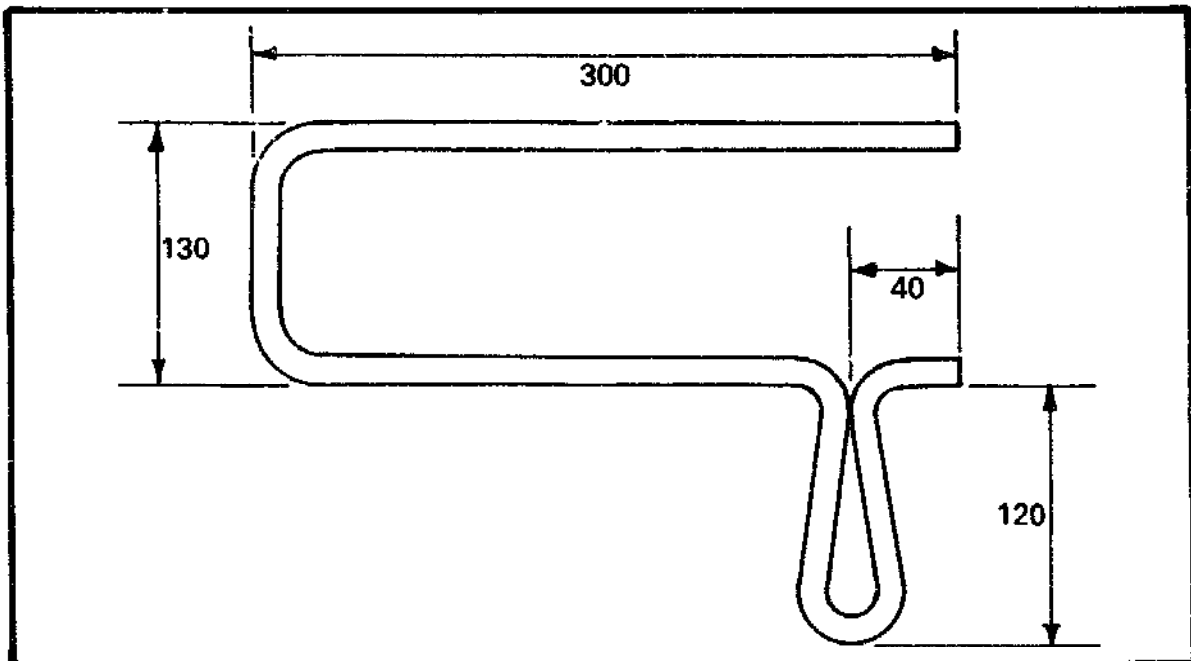

Diagram of Cutting List

## MAKING THE FRAME



Take the rod and saw out a semi-circular section 12mm long, using a hack saw.



Drawing showing Dimensions of Frame

To make the frame follow the directions for the coping saw on page 91, but remember the dimensions are different. Take care to bend the frame in the correct plane for the blade holder.

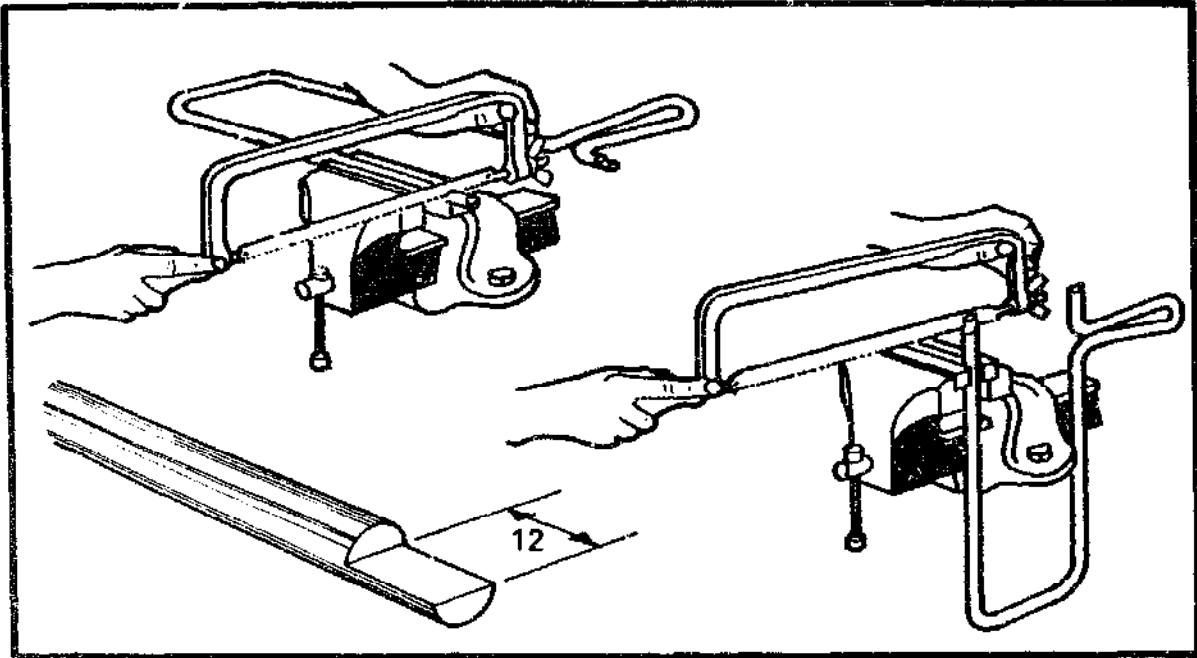

Cut another semi-circular piece from the front of the frame, the same size as the first.

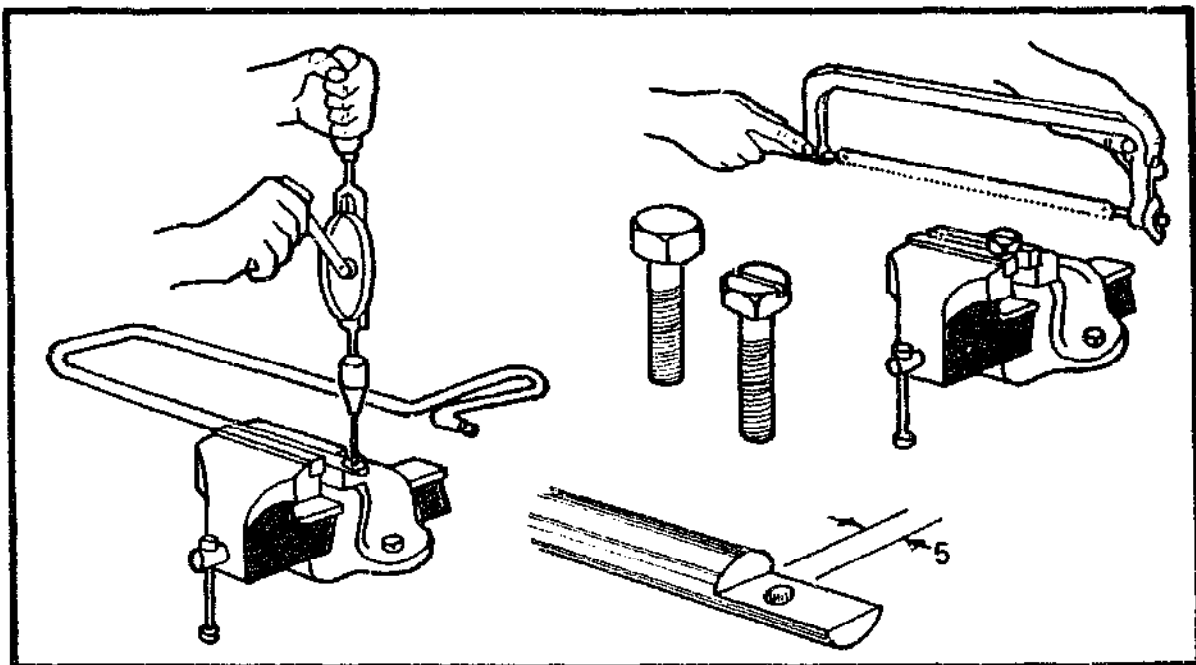

Punch and drill 6mm holes in the end of each leg of the frame. The centre of the holes should be exactly 5mm from the shoulder.

With a hack saw, saw a slot in the head of both bolts for a screwdriver.

## FIXING THE BLADE

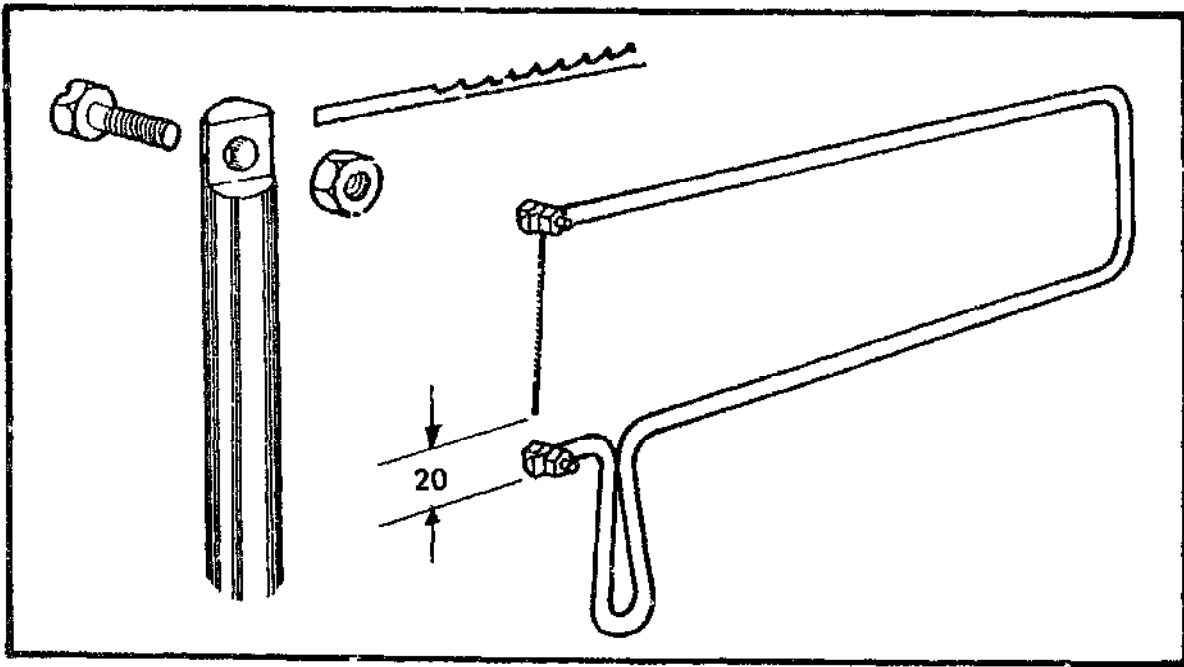

Place the bolts through from the round side of the frame and screw the nut on. The nut should not be able to turn because of the shoulder cut in the frame. Clamp the blade into one leg of the frame.

The gap between the legs of the frame should be 20mm bigger than the length of the blade.

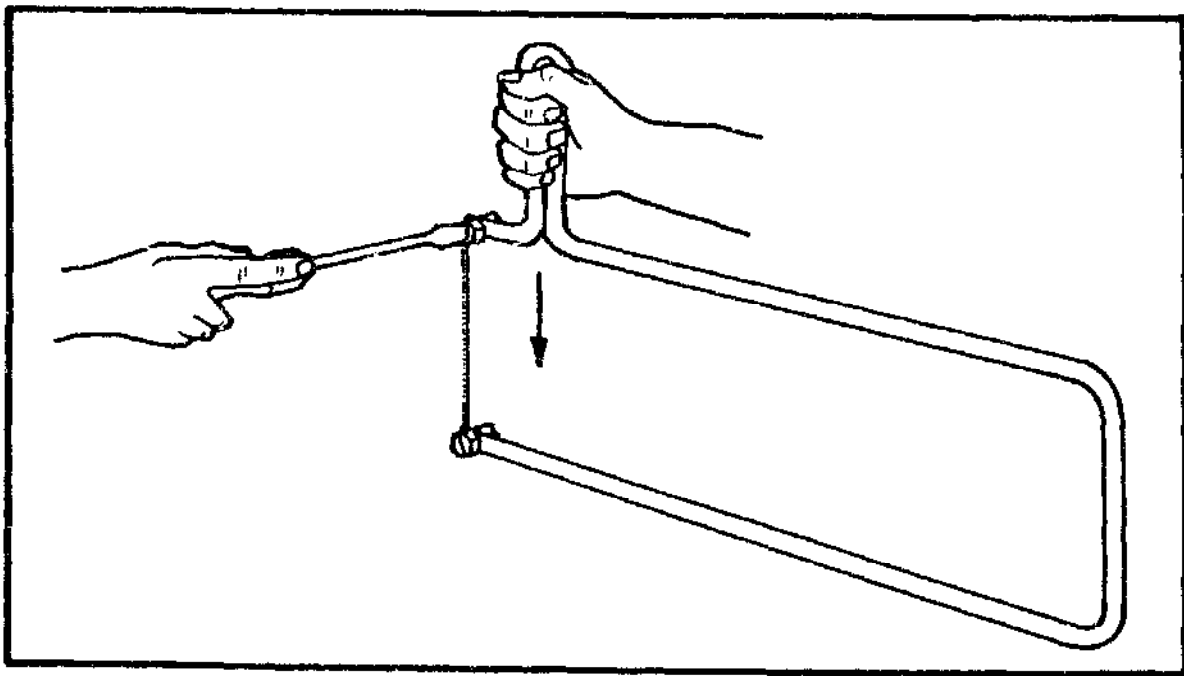

Push the frame together and fix the blade at the back (between the nut and the flat part of the frame).

## Hack saw

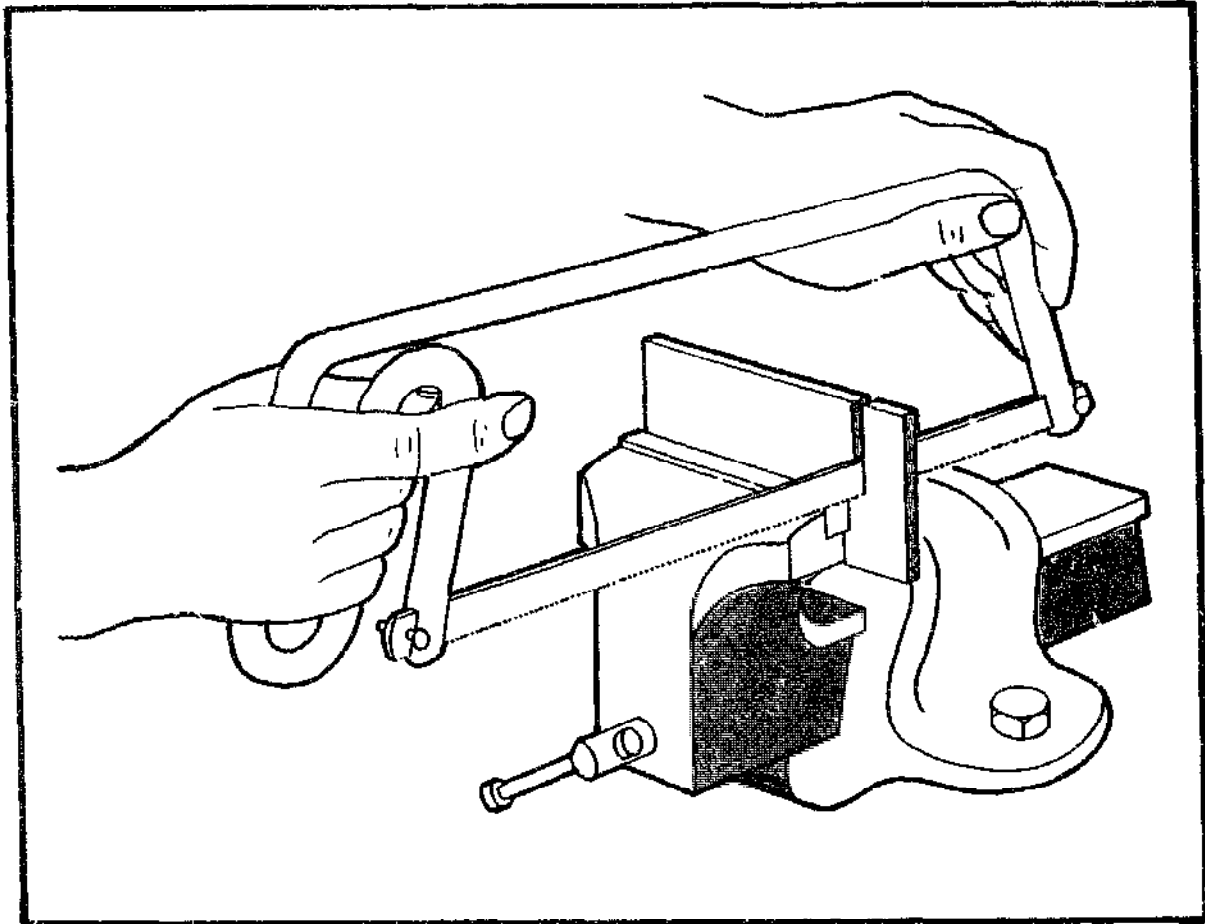

Although the hack saw is not a wood-working tool it is something every carpenter should have available, particularly when it comes to making tools.

The blade on this tool is replaceable and must be bought from a shop. If a 10" blade is to be used, reduce the size of the frame to fit.

The blade cannot be adjusted, which limits its length of cut, but this can be compensated for by giving the frame a deeper throat than found on shop-bought hack saws. 150mm is adequate; any bigger and the frame may not tension the blade enough.

When you buy the blade, take account of the thickness of material you are going to cut. For thin sheets of metal, choose a blade with 24 teeth per inch. For thicker sections a blade with 18 teeth per inch is better. As a general rule, three teeth should be in contact with the material at any one time.



## LIST OF PARTS

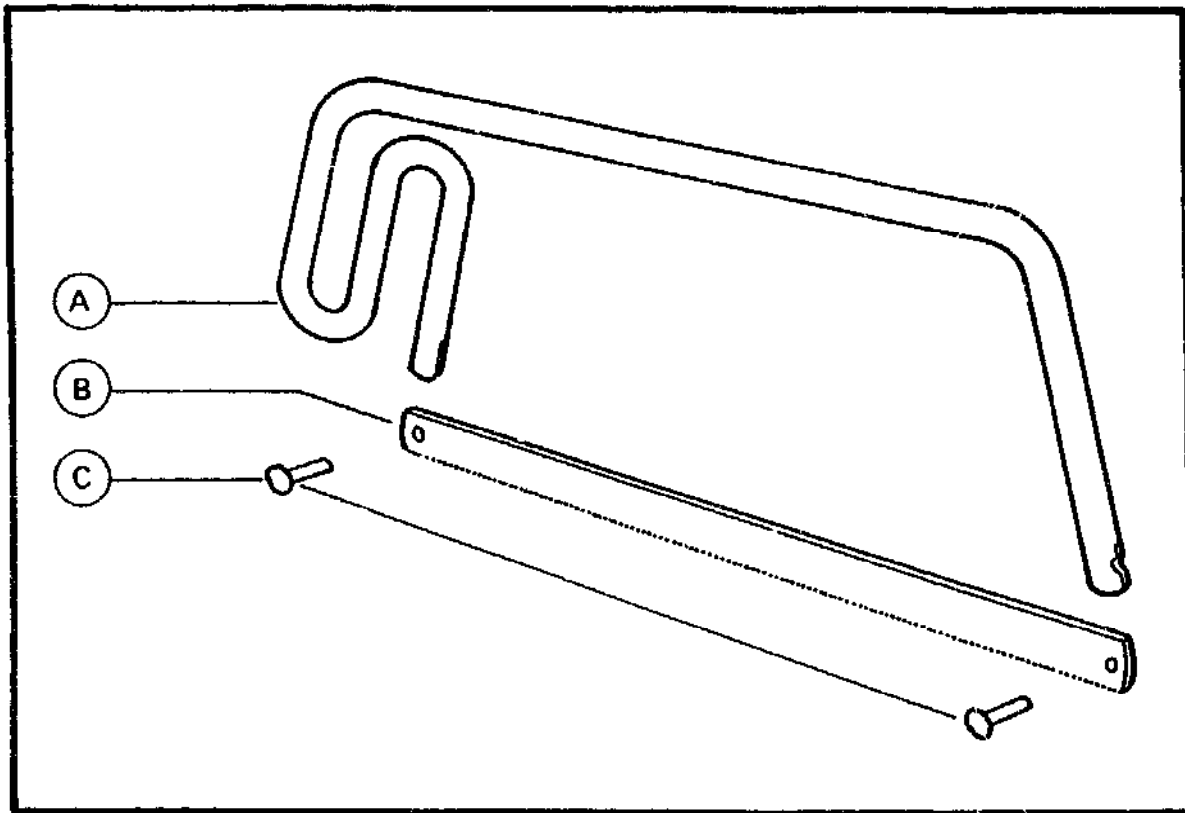

### Part

- A** *The frame* is made from one piece of 12mm steel rod 1m long, bent to form both the frame and the handle. A 12mm slot is cut at the end of each leg to hold the blade.
- B** *The hack saw blade* is replaceable and must be bought from a shop. It fits into the frame and is held under tension by two bladeholders.
- C** *The blade holders* are made from two 50mm nails cut down to about 20mm.

### Parts and Cutting List

Part	Name	Quantity, material and dimensions
A	Frame	1 pc. 12mm steel rod 1m long
B	Hack saw blade	
C	Blade holders	2 pcs. 50mm (2") nails cut to 20mm

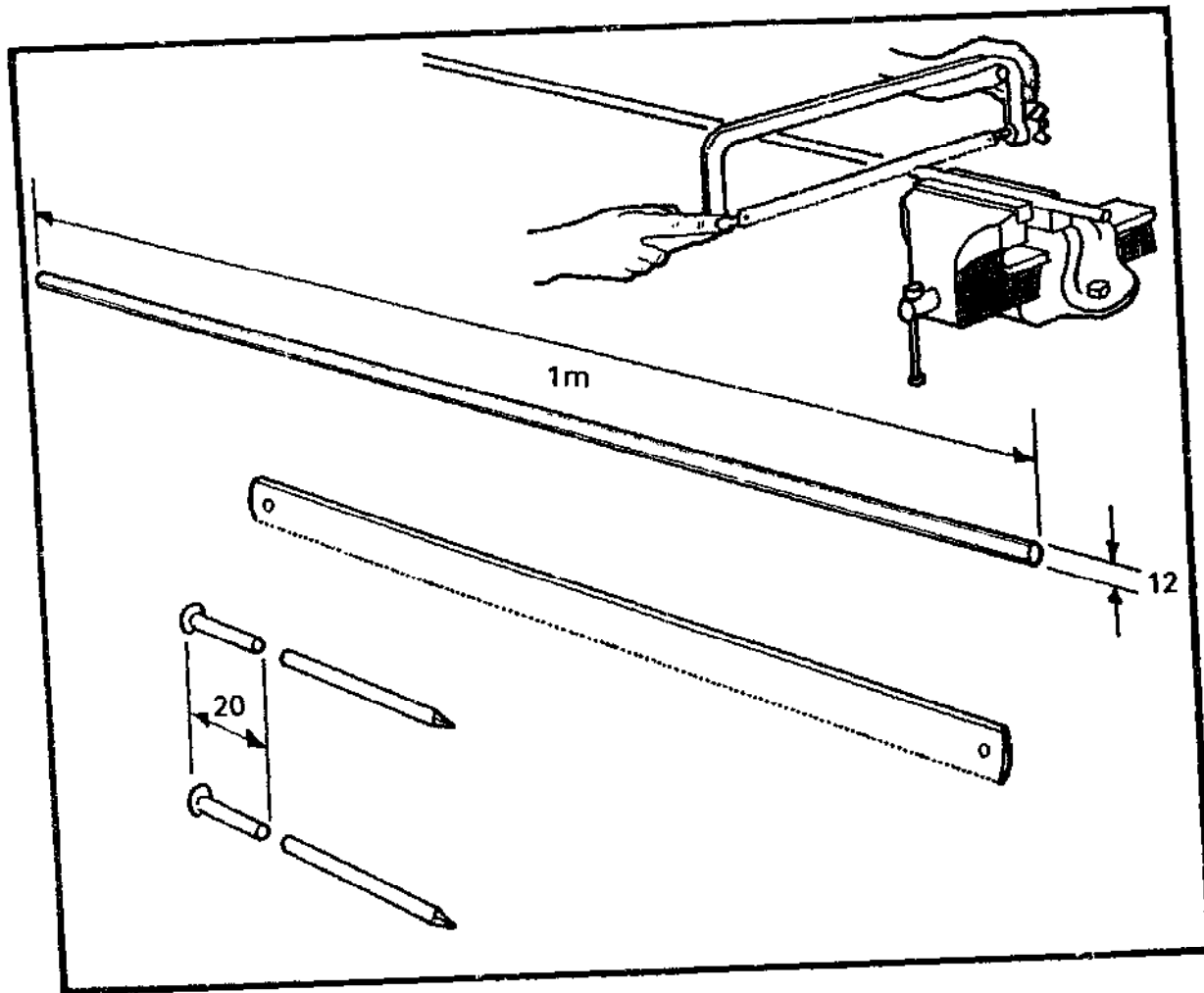
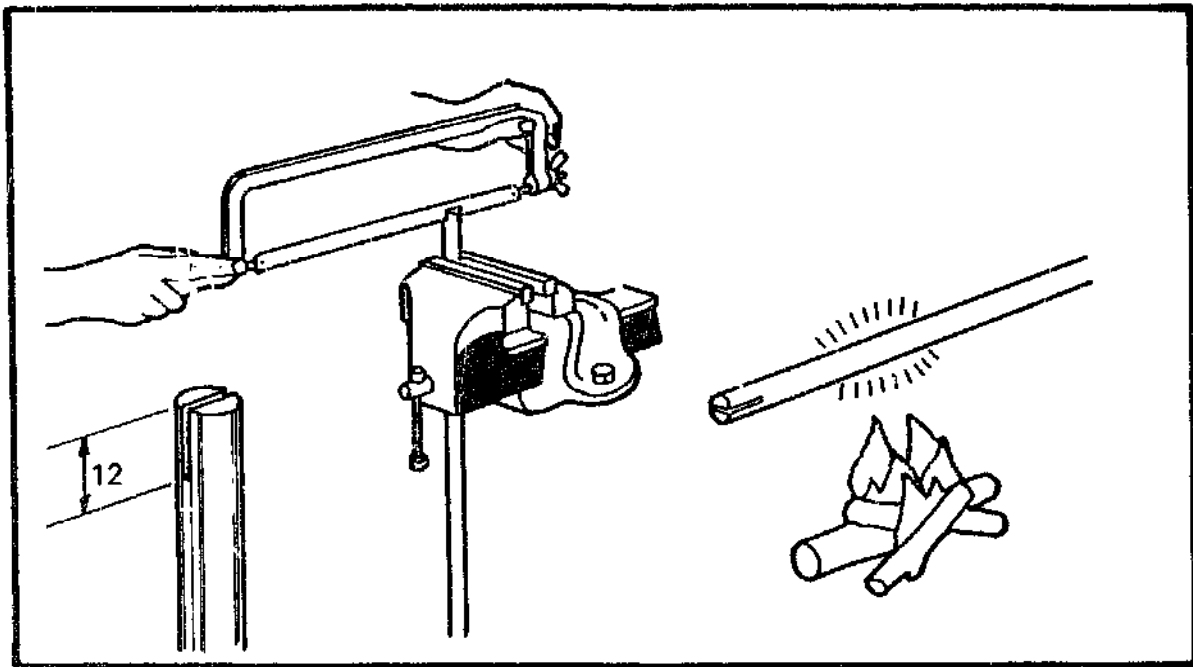

Diagram of Cutting List

## MAKING THE FRAME



Take the rod and cut a slit down the centre, 12mm long, in one end with a hack saw.

Build a fire from wood or charcoal. The frame can be bent very easily if the rod is red hot.

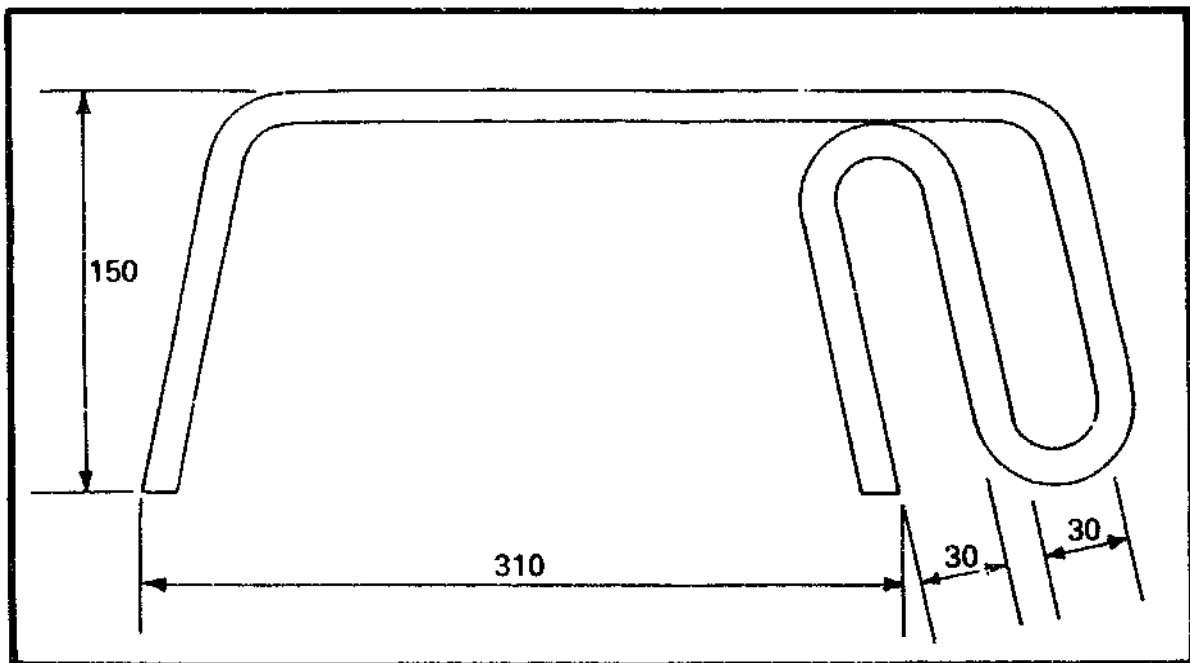

Drawing showing Dimensions of Frame

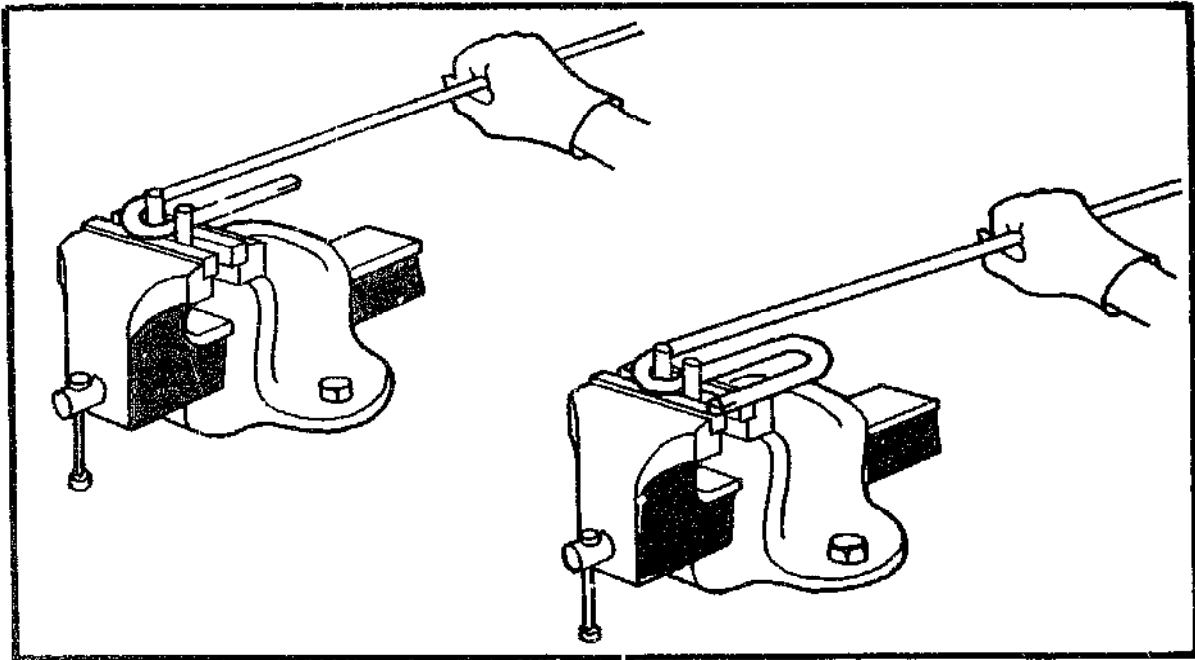

Make a 'U' shaped bending bar as shown on page 91. Heat the rod up and make the first bend 100mm from the end with the slit in. Heat the rod and make a second 180 degree bend opposite the end of the bar.

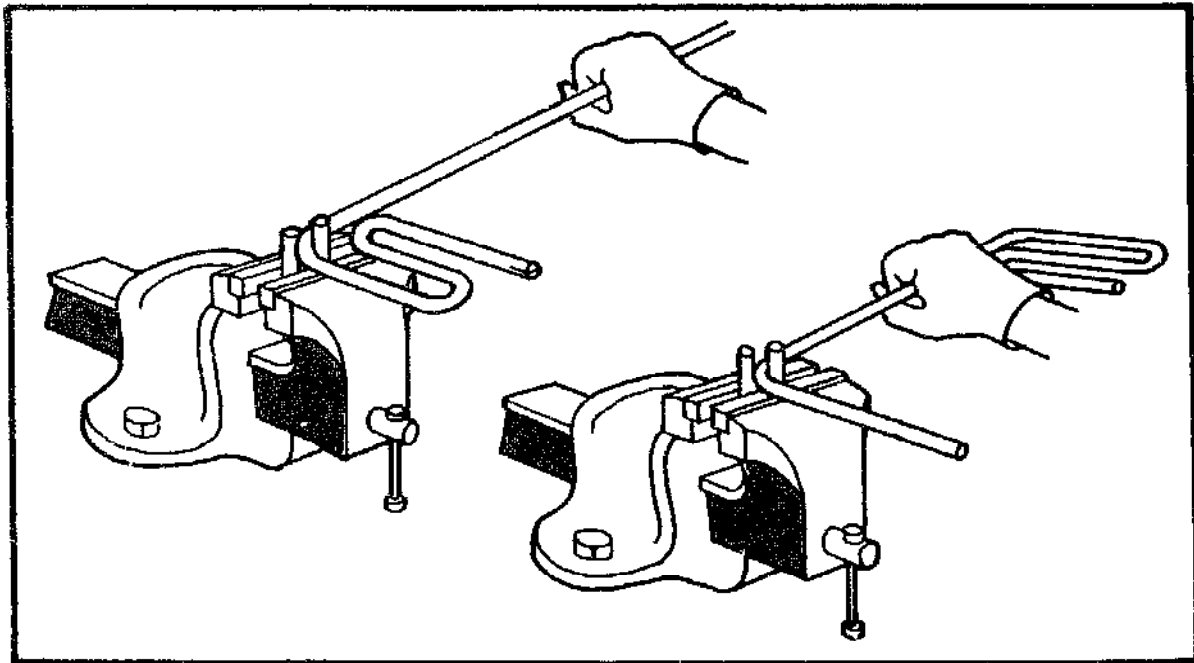

Heat the rod and make an 80 degree bend (see drawing of frame) so it just touches the first 180 degree bend. Heat the rod, measure 300m from the last bend and make one more 80 degree bend.

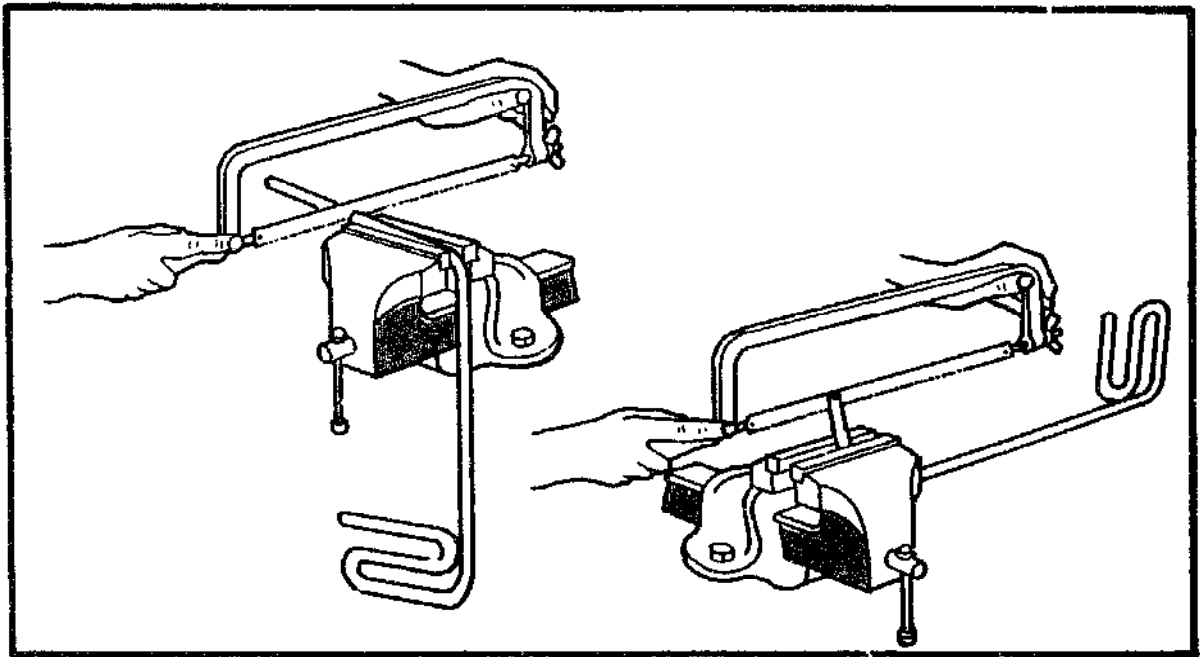

Measure and cut the front leg of the frame to the same length as the leg at the handle. Saw a slot down the middle of the front leg 12mm long with a hack saw.

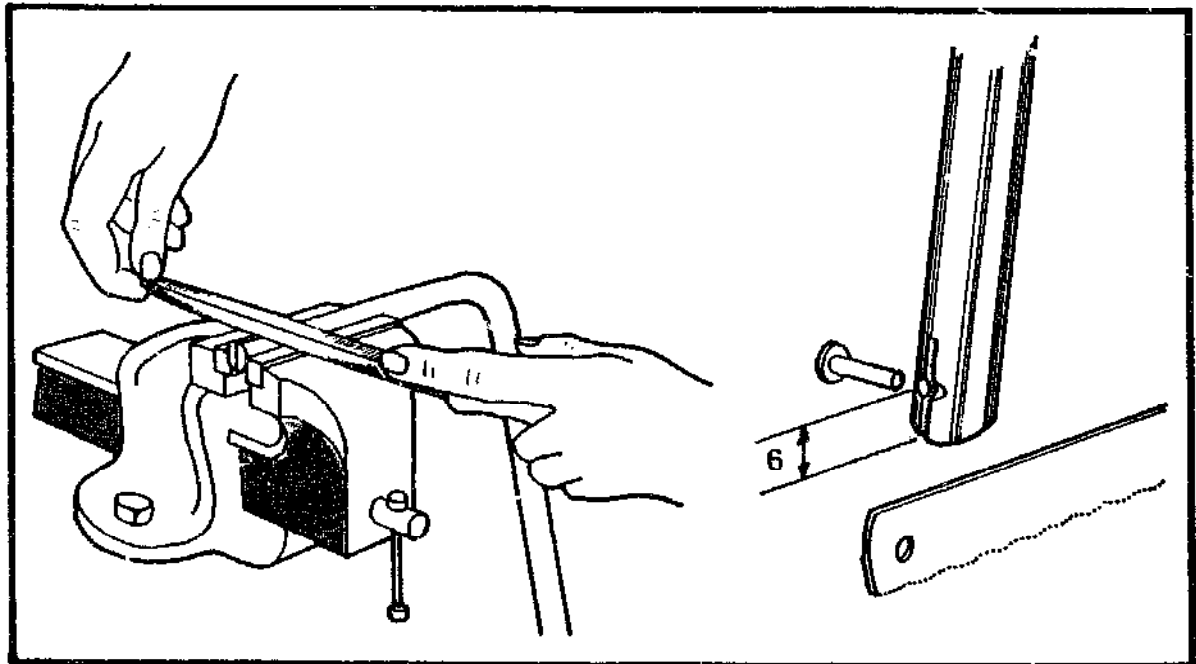

File a small nick, 6mm from the end of each leg, on the outside of the frame. This helps secure the blade holder. The blade holder is made from two cut-down 50mm nails.

## FITTING THE BLADE

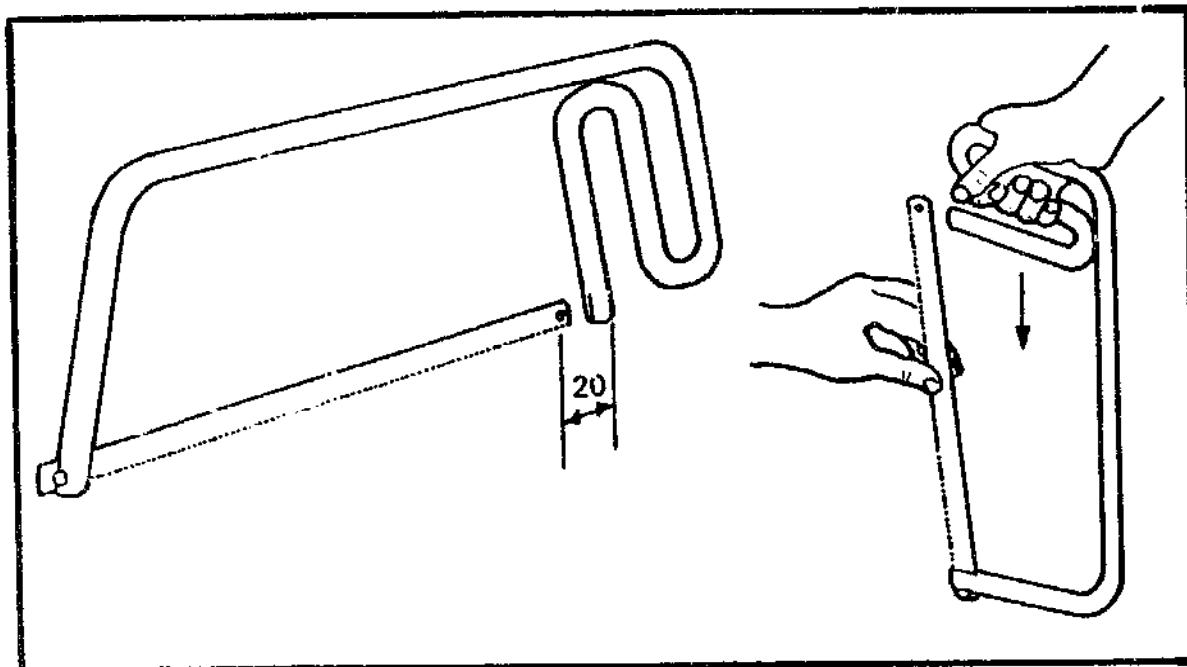

Bend the frame until the distance between the outside of the legs is 330mm. This gives the blade tension.

To insert the blade, push it into the slot on the front leg, put the blade holder through the hole in the blade, bend the legs of the frame together and insert the blade and holder into the back of the frame.