

AT MICROFICHE
REFERENCE
LIBRARY

A project of Volunteers in Asia

Low Cost Transportation

by Gert Thoma

Published by:

German Appropriate Technology Exchange (GTZ)
Dag Hammarskjold Weg 1
D-6236 Eschborn 1
FEDERAL REPUBLIC OF GERMANY

Available from:

same as above

Reproduced by permission.

Reproduction of this microfiche document in any form is subject to the same restrictions as those of the original document.



Deutsches Zentrum für Entwicklungstechnologien
Centre allemand d'inter-technologie appropriée
Centro Alemán para Tecnologías Apropriadas

German Appropriate Technology Exchange
in Deutsche Gesellschaft für Technische Zusammenarbeit (GTZ), GmbH

Deutsche Gesellschaft für Technische Zusammenarbeit (GTZ), GmbH
Postfach 5180, D-6236 Eschborn 1

LOW COST

TRANSPORTATION

M: 5/1

5/79

PREPARED BY

Gert Thoma

PUBLISHED BY

German Appropriate Technology Exchange (GATE)

in: Deutsche Gesellschaft für Technische
Zusammenarbeit (GTZ), GmbH
Postfach 5180, D-6236 Eschborn 1,
Federal Republic of Germany

CONTENTS:

REMARKS:

LOW COST TRANSPORTATION

Prepared by Gert Thoma,
Arbeitsgemeinschaft für
Entwicklungsplanung (AE)
München, Mai 1979

<u>CONTENTS</u>	page
Table of available solutions	2
1. Introduction	4
2. Transport needs and criteria for the choice of appropriate solutions	4
3. Description of technical solutions	7
3.1 Vehicle components	7
3.1.1 Wheels	7
3.1.2 Bearings	18
3.1.3 Brakes	22
3.2 Non motorised vehicles	26
3.2.1 Pedal driven vehicles	26
3.2.2 Wheelbarrows and handcarts	31
3.2.3 Animal drawn carts	40
4. Workshop equipment for the manufacture of low cost vehicles and components	61
Manufacture type a	61
Manufacture type b	62
Manufacture type c	62
Manufacture type d	62
5. Literature	63

Low cost transportation: Table of available solutions

Carriage and components	Institution and address	Kind of information
Wheels	-Tanzania Agricultural Machinery Testing Unit (TAMTU), Arusha, Tanzania	Drawings of wooden and steel wheels and rim bending jig
	-Deutsche Stiftung für internationale Entwicklung, Zentralstelle für gewerbliche Berufsförderung (DSE/ZGB), Käthe Kollwitzstr., D 68 Mannheim 1, FRG	Drawings of steel wheels
	-Intermediate Technology Development Group (ITDG), 9 King Str., London, U.K.	Drawings of metal bending device
	-Firestone Rubber Co., Haybunder Road, Bombay, India	Solid rubber tyres for wooden and steel wheels
Bearings	-TAMTU, DSE/ZGB, ITDG	Drawings of hardwood friction bearings
Brakes	- TAMTU, DSE/ZGB	Drawings of shoe brakes
Bicycles	-Dar es Salaam Liberation Support Group, Dar es Salaam, Tanzania	Description and drawings of transport bicycle
Tricycles	-Oxford University, Dep. of Engineering Science, Oxford, U.K.	Description and drawings of transport tricycle (Oxtrike)
	- T.J.Cycles of India Ltd., Madras, India	Indian rickshaw
	-Workman Trading Corp., 139 Banker Str., Brooklyn, New York, USA	Transport tricycles
Wheelbarrows and handcarts	-TAMTU	Drawings of wheelbarrows and handcarts
	-Agricultural Engineering Workshop, University of Ghana, Legon, Ghana	Drawings of wheelbarrows (Chinese type)
	-Appropriate Technology Development Association, Lucknow, U.P., India	Description and drawings of wheelbarrows and handcarts
	- Kumaon Nursery, Ramnagar, Nainital, U.P., India	Description of wheelbarrows
	-ITDG	Description of wheelbarrows, handcarts and hospital wheelchairs
	- Georgia Institute of Technology, Engineering Experiment Station, Atlanta, USA	Description of backpack device and wheelbarrow (improved "Chee-ke")
	-Regional Development Institute, Soong Jun University, Taejon, Korea	Description and drawings of "Chee-ke"

Low cost transportation: Table of available solutions (continued)

Carriage and components	Institution and address	Kind of information
Animal yokes and harnesses	-Food and Agricultural Organisation of the UN, Rome, Italy	Description of yokes, collar, breastband harnesses and swingle trees
	-Centre D'etudes et D'experimentation du Mechanisme Agricole Tropicale (CEEMAT), Antony, France	Description and drawings of yokes and harnesses
Animal drawn 2-wheel carts	-TAMTU	Description and drawings of 2-wheel carts
	-SISCOMA, Dakar, Senegal	2-wheel carts for donkeys, oxen and horses
	-Indian Institute of Science (ASTRA), Bangalore, India	Description of bullock carts
	-Indian Institute of Management, Bangalore, India	Description of bullock carts
	-Institute for Agricultural Research, Ahmadu Bello University, Zaria, Nigeria	Description of ox cart with pneumatic tyre wheels
	-ITDG	Description and drawings of 2-wheel carts
Animal drawn 4-wheel carts	-TAMTU	Description and pictures of 4-wheel carts
	-IMBERT Energietechnik, 5760 Arnsberg, FRG	Description and drawings of 4-wheel cart
All kind of low cost transportation	-German Appropriate Technology Exchange (GATE), POB 5180, D 6236 Eschborn, FRG	Description, pictures, drawings and manufacturers of non- and motorised vehicles
	-ITDG	"
	-DSE/ZGB	"
	-Regional Development Unit, Transportation Department, World Bank, Washington D.C., USA	"

1. Introduction

During the last decades the design, construction and manufacture of wheeled vehicles has been almost wholly confined to capitalintensive motorised means of transportation. But the farmers, traders, private households and manufacturers in developing countries have to deal with simple and low cost transport. In other words appropriate technologies which are necessary for the development of economically weak regions have been neglected carelessly with the result, that all people involved in low cost transport either suffer in burdensome and inefficient transport, do not find labourintensive jobs or have difficulties to market their products.

This study tries to collect the relevant information on low cost, wheeled and non motorised transportation. In many cases the designs of available solutions were weak. Thus some improved constructions are demonstrated according to the standards of technical designing. Generally all designs are to be understood as recommendations which have to be adapted to the local transport needs and conditions, production capacities, raw materials and purchasing power.

2. Transport needs and criteria for the choice of appropriate solutions

The theory, actual situation and development of transport needs in developing countries have been discussed in the literature concerned (see chapter 5). Table 1 shows different means of transportation in connection with the local terrain, transport distances and groups involved.

In order to select different means of transportation according to the local transport needs and conditions, production capacities, raw materials, purchasing power and other technical, economical, environmental and social aspects it is recommended to proceed in two steps:

Step 1 (general questions): What kind of transport is appropriate to

- LOAD (kind, weight, dimensions, volume, durability, solidity, smell etc.)
- UNDERGROUND (mountainous, hilly, plain, soft, hard, unprepared, prepared, metalled etc.)
- COSTS (first investment, running costs, maintenance and repair, spareparts, depreciation etc.)
- TRANSPORT RANGE (distance, time etc.)

Step 2 (specific questions): What are the technical, economical, socio-economical and environmental criteria and characteristics of available carriages with regard to

- LOAD ASPECTS
Kind of load (construction, height, weight, flexibility of frame, platform, body, means of fixing)

Weight, dimensions, volume of load (dimensions, height, weight, stability of frame, platform, body, kind of propulsion, wheels and suspension)

Durability, solidity of load (construction, flexibility of frame, platform, body, wheels and suspension)

- OPERATION ASPECTS

Transport efficiency (ratio of deadweight to payload)

Handling by operator (loading, unloading, simplicity and mobility of frame, platform, body, equipment, function of steering, brakes, propulsion and other devices)

Load flexibility (construction and equipment of platform, body and containers)

Driving comfort and security for operator, load and draught animal (kind, dimensions, weight, precision of carriage, wheels, brakes, suspension and other equipment, balance of body)

Frequency and range of transport (kind and size of platform, body, containers, wheels, suspension, brakes, propulsion, No. of wheels, max. speed, max. payload)

Maintenance and repair (stability, durability of whole carriage, simplicity, frequency and costs of m&r, availability of spareparts)

- PRODUCTION ASPECTS

Kind of local manufacture i.e. buildings, infrastructure, tools, equipment, labour force, raw materials, services etc. (technical standard, stability, durability, precision, price of whole carriage, kind of service, time of delivery)

Size of manufacture (technical standard, price)

- SOCIO-ECONOMIC ASPECTS

Kind of manufacture i.e. labour intensity, use of local labour and raw material, decentralisation (contribution to local development)

Size of manufacture i.e. small-scale (contribution to local development)

- ENVIRONMENT ASPECTS

Underground (construction, stability and flexibility of carriage, kind and size of wheels, brakes, suspension, propulsion, max. speed and payload)

Climate (kind and durability of carriage incl. platform, body and containers)

Ecology (emission of gases, dust, liquids, noise etc.)

Society (physical security of carriage for operator and other people, emission of gases, dust, liquids, noise, adequate stiling)

Tab. 1: Transport needs of low income groups

Load	Terrain	Group involved	Distance	Means of transportation
agricultural and manufacturing input, output, implements, market products, construction material, household utensils passengers etc.	mountaineous and narrow tracks, unprepared surface	farmers, craftsmen, vendors, porters, households	short	carrying poles, yokes with baskets, backpack panniers, pack animals
			long	backpack panniers, pack animals
	hilly and plain tracks and roads, unprepared surface	farmers, craftsmen, vendors, traders, goods and passenger carriers, households, health centres, public services	short	carrying poles, yokes with baskets, stretchers, human or animal backpack, headload, transport bi- and tricycles, wheelbarrows, handcarts
			long	human and animal backpack, transport bi- and tricycles, handcarts, 2-wheel animal drawn carts, pick-ups
	hilly and plain roads, prepared and metalled surface	farmers, craftsmen, vendors, traders, goods and passenger carriers, households, hospitals, public services	short	carrying poles, yokes with baskets, stretchers, headload, human or animal backpack, transport bi- and tricycles, wheelbarrows, handcarts, 2-wheel animal drawn carts, pick-ups, minibuses
			long	pack animals, bicycles, 2- and 4-wheel animal drawn carts, motorcycles, motorised tricycles, pick-ups, minibuses, trucks, buses

3. Description of technical solutions

3.1 Vehicle components

3.1.1 Wheels

Description: In order to transport loads beyond 50 kg weight which cannot be carried on human or animal back either disk wheels or spoke wheels are used. Generally wheels roll along the underground on the outer ring (rim) and rotate on an axle with the inner ring (hub) which is equipped with bearings. Both movements cause friction forces i.e. the rolling resistance (along the underground) and the bearing resistance (between hub and axle). These forces depend on the structure of underground, kind of rim and tyre, wheel width and diameter, bearing and axle width, diameter and material and the kind of lubricant.

As an example in figure 1 different friction forces of a hard wheel and a pneumatic tyre wheel on soft ground are shown, the first one having a 2.3 times higher resistance on the underground than the second (the bearing resistance is not

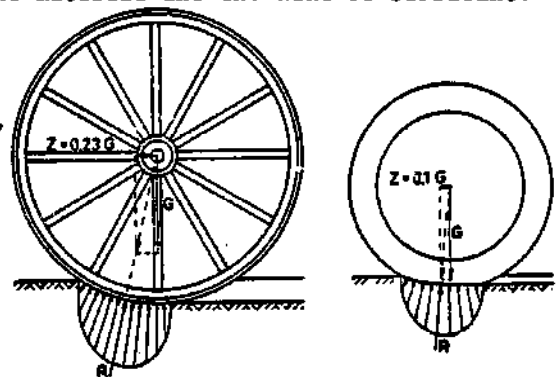

Fig.1: Friction forces on wheels

shown). If wheels with different rims (wood, steel, pneumatic tyre, caterpillar) and the same kind of bearings (ball bearings) are compared systematically the rolling resistances demonstrated in figure 2 come out (performed by "Landmaschineninstitut Berlin" 1933). Thus pneumatic tyres have an advantage if rolling on prepared roads but iron wheels should be favoured for transport on soft and wet underground. But the choice of appropriate wheels has to regard many other aspects such as the weight and kind of load, the riding comfort for load, driver and draught animal, the stability, durability and price of the wheel, range of road damage allowed, capacity of local manufacturers and others. A number of technical solutions for these requirements is given in figure 3.

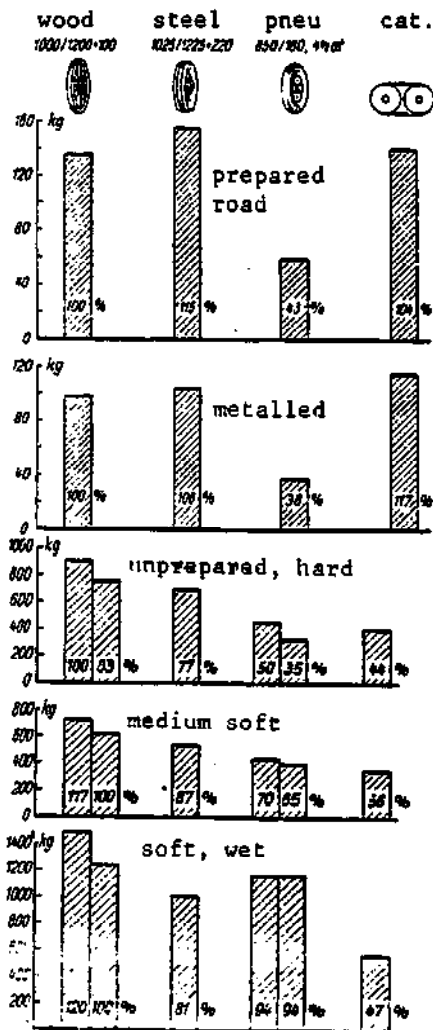

Fig.2: Rolling resistance of wheels on different terrain

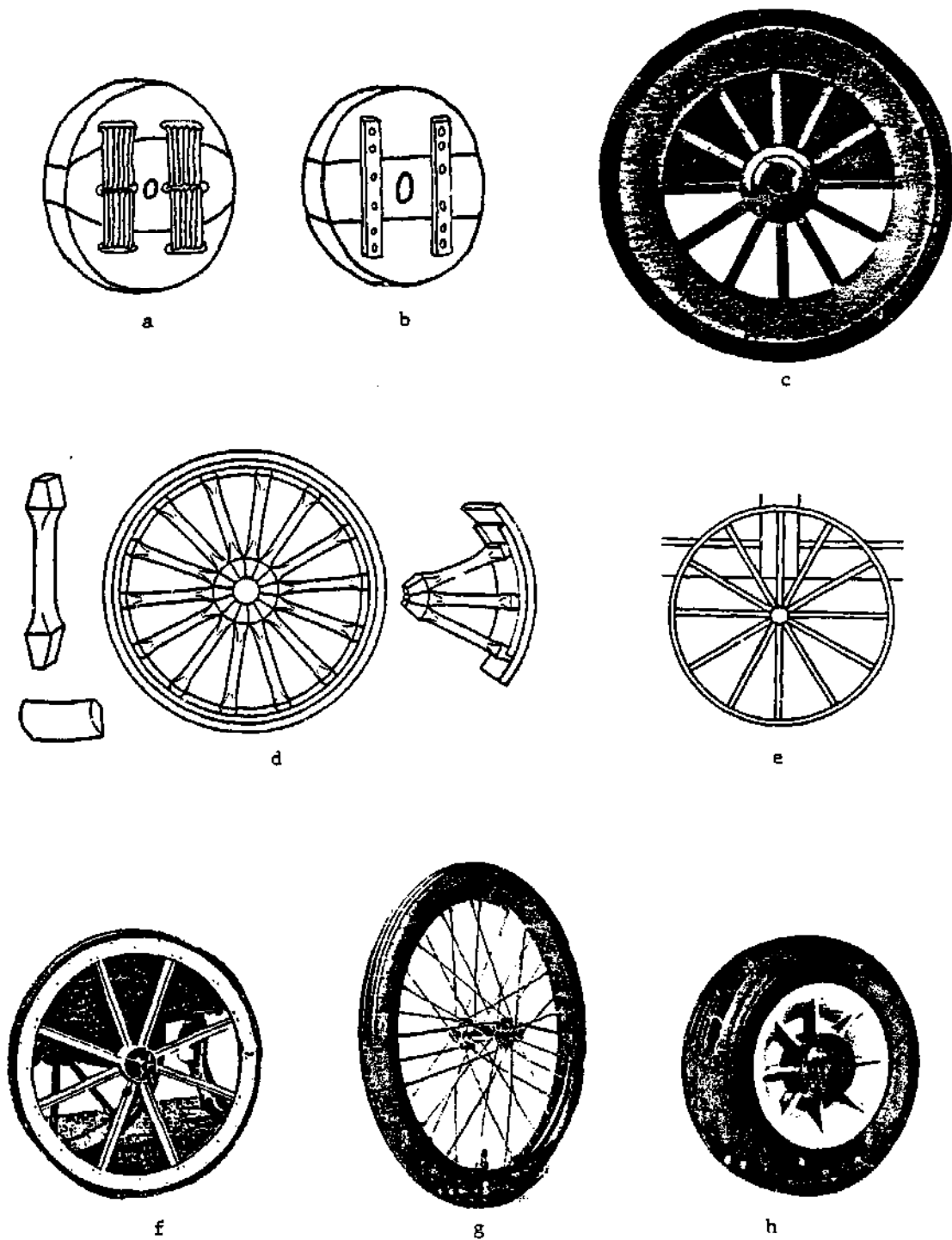

Fig.3: Different kinds of wheels, old Persian wood wheel (a), old German wood wheel (b), Indian wood wheel with solid rubber tyre (c), German-wood wheel with steel rim (d), iron spoke wheel (e), Indian iron spoke wheel with solid rubber tyre (f), pneumatic spoke wheel (g), pneumatic disc wheel with nylon hub (h)

From practical experience the following characteristics for the application of wheels can be derived:

- Wood wheels: high rolling resistance, transmit road shocks directly to vehicle, driver, load and draught animal, high tare weight, medium durability, carry loads up to 200 kg/wheel, big diameters favourable, iron tyres promote durability, solid rubber tyres absorb some shocks but can only be used on prepared roads, manufacture is relatively simple and cheap.
- Iron wheels: high rolling resistance, transmit shocks directly, medium tare weight, good durability, carry loads up to 350 kg/wheel, big diameters favourable, on metalled roads solid rubber tyres recommended, manufacture needs modern tools, devices and some know how, medium price.
- Pneumatic tyre wheels: low rolling resistance on prepared and unprepared hard underground, shock absorbing effect, medium (disc wheels) or low tare weight (spoke wheels), good durability, carry loads up to 700 kg per wheel (5.50 - 16 " wheel) and more, medium diameters sufficient, good maintenance and repair necessary (assembling, adequate air pressure, renewal in time etc.), manufacture with good know how, relatively high price.

As many problems for economically weak groups arise from transport on rough terrain it is recommended to manufacture simple, cheap but strong wood or iron wheels together with local wheelwrights. Thus the technical promotion has also positive socio-economic effects on the decentralised production which the large scale production of wheels with pneumatic tyres don't have:

In case of an actual demand for pneus the steel rim manufacturers must contact local tyre dealers in order to find out the diameters and widths of available tyres.

Design 1: Solid wood wheel

Wood wheel for wheelbarrows, handcarts, simple ox carts, max. payload about 150 kg, manufacture type a 1)

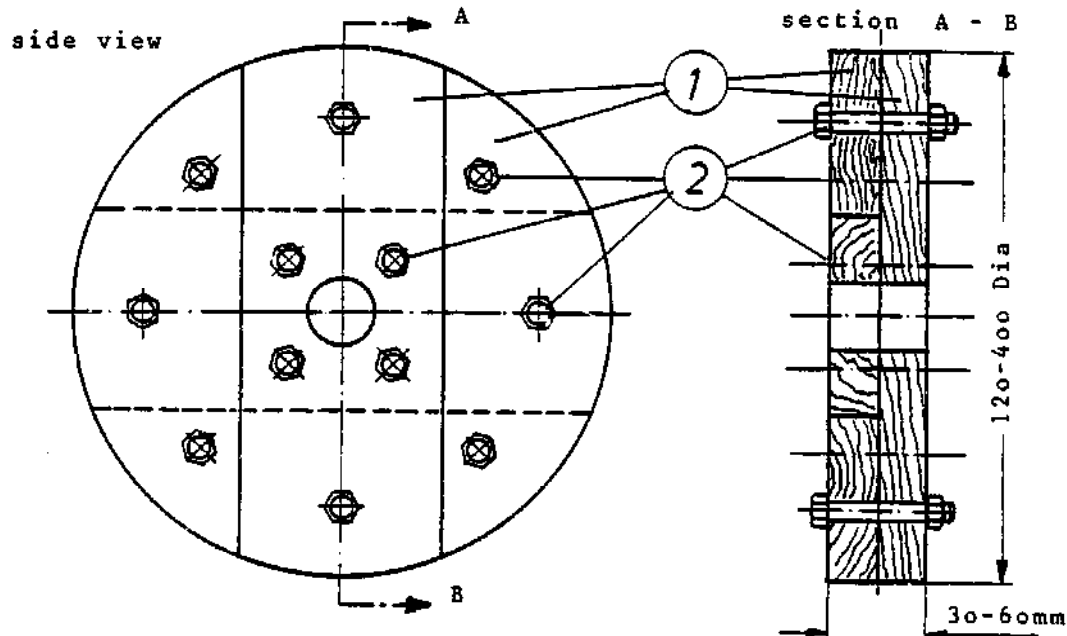

rim with steel tyre rim with rubber tyre rims with prefabricated rubber tyres of different forms

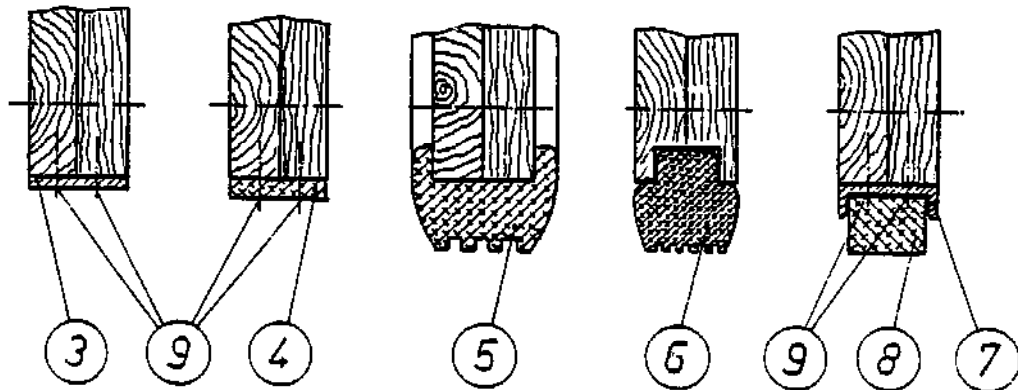

Specification design 1

Part No	Part name	Material	Dimensions of raw material
1	rim	hardwood	15x120 to 30x150 mm
2	screw, nut, washer	steel	M6x40 to 70 mm
3	tyre	MS flat steel	4x30 to 8x60 mm
4	tyre	rubber strip	30 to 60 mm broad, second hand
5	tyre	solid rubber	from local dealer
6	tyre	solid rubber	from local dealer
7	iron rim	MS U-profile	U 30x15 to U 60x30 mm
8	tyre	solid rubber	from local dealer
9	nail or screw	steel	3x60 to 4x80 mm

Remark 1): workshop equipment for different kind of manufacture is listed on page 61

Design 2: Solid wood wheel:

Wood wheel for wheelbarrows, handcarts, simple ox carts, max. payload about 150 kg, manufacture type a.

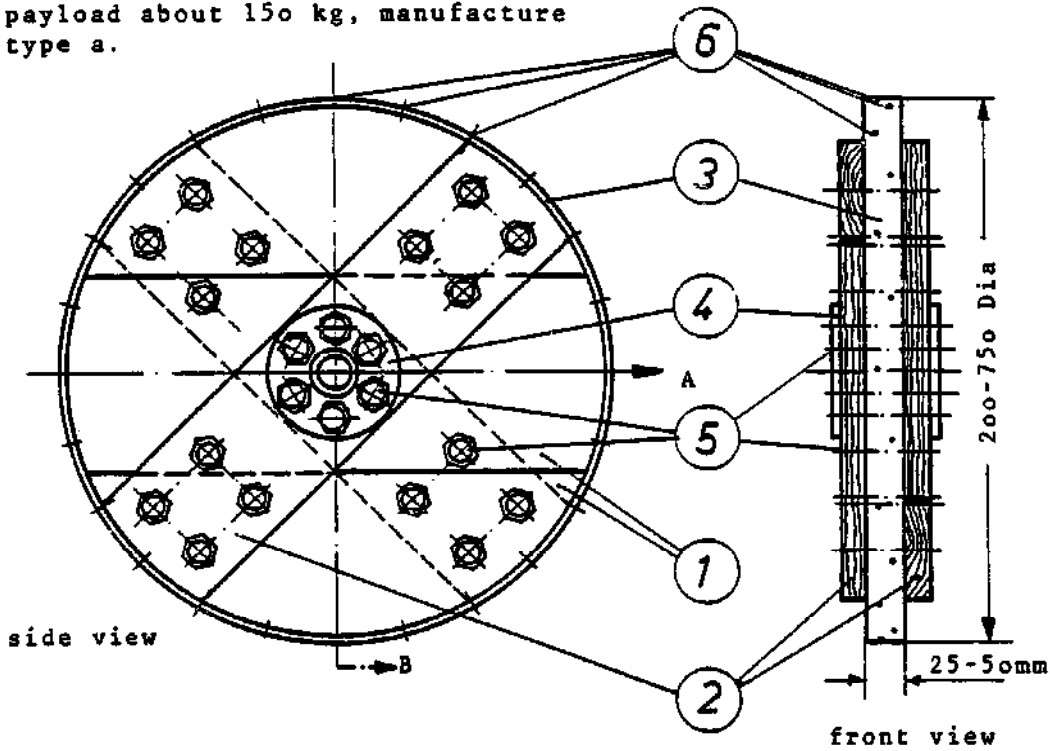

section A - B

oil impregnated borehole.
(25 to 40 mm Dia)

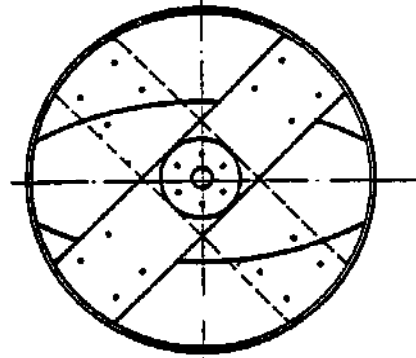
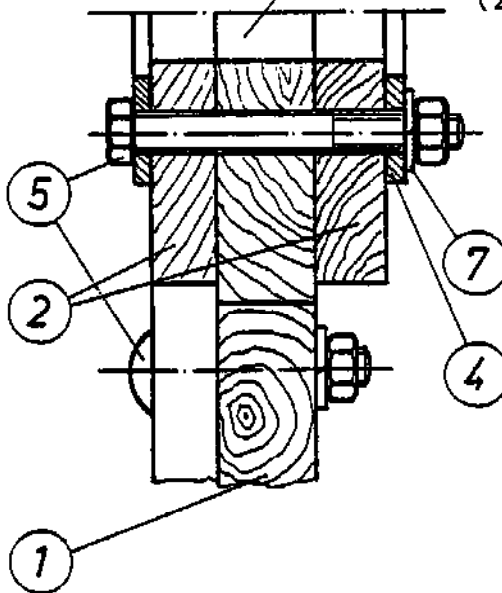

variant of wood wheel

Specification design 2

Part No	Part name	Material	Dimensions of raw material
1	rim	hardwood	25x150 to 50x200 mm
2	connecting board	hardwood	15x120 to 20x150 mm
3	tyre	rubber or steel	4x25 to 8x50 mm (steel)
4	hub disk	MS flat steel	5 mm
5	screw and nut	steel	M6x60 to M8x100 mm
6	nail or screw	steel	3x60 to 4x80 mm
7	washer	steel	for M6 to M8 screws

Design 3: Wood wheel with spokes for all kinds of carts, max. payload 100 to 200 kg, manufacture type b.

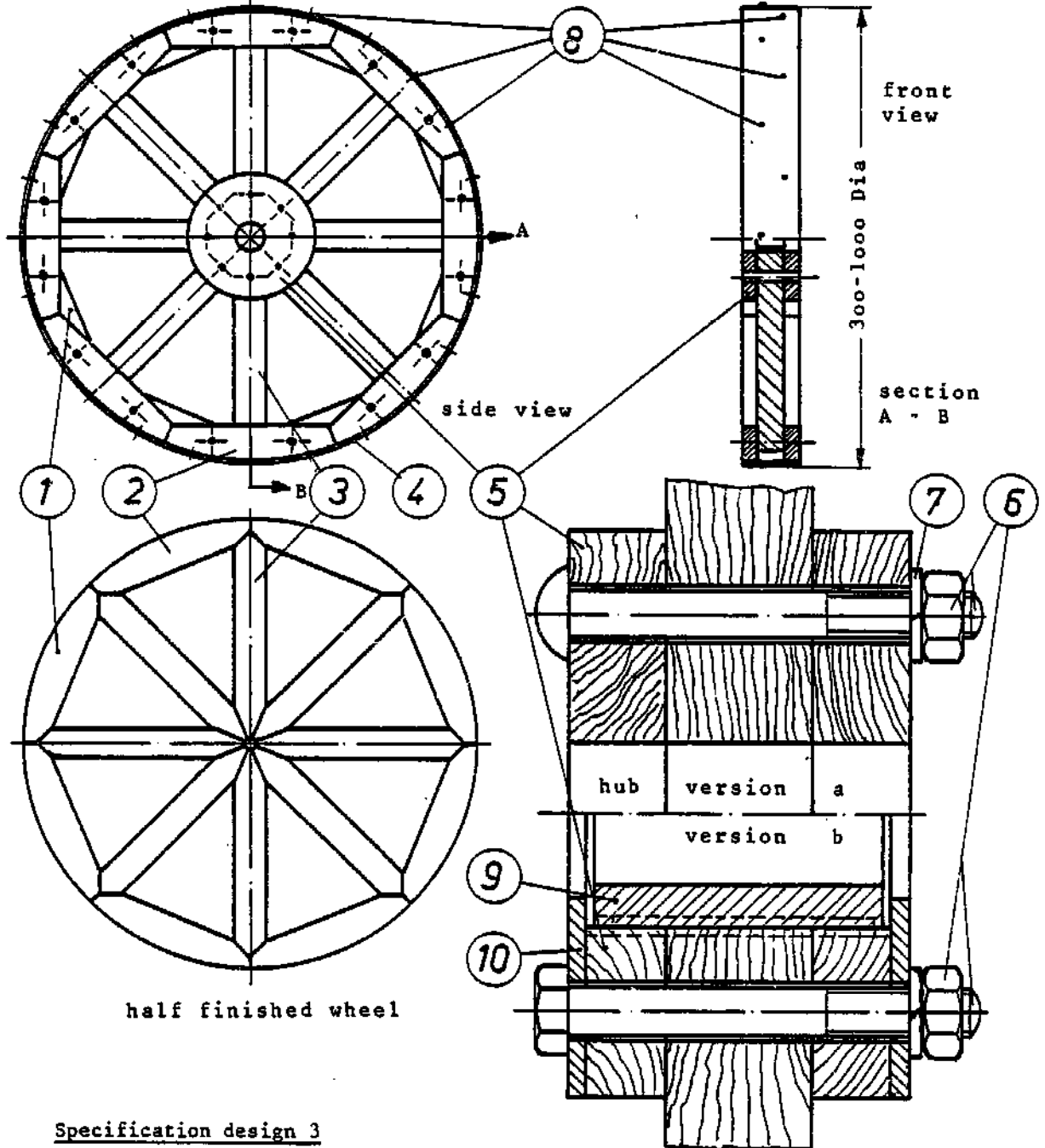

Specification design 3

Part No	Part name	Material	Dimensions of raw material
1	internal rim	hardwood	25 to 40 mm board
2	external rim	plywood	15 to 20 mm board
3	spoke	hardwood	25x25 to 40x40 mm
4	tyre	MS steel	4x25 to 8x80 mm
5	hub disk	plywood	20 to 40 mm board
6	screw and nut	steel	M6x75 to M8x130 mm
7	washer	steel	for M6 to M8 screws
8	nail or screw	steel	3x55 to 4x75 mm
9	bush	cast iron or bronze	25 to 40 mm inner Dia, 7 to 10 mm thick (version b)
10	hub disk	MS steel	3 to 4 mm thick (")

version a: oil impregnated hardwood bearing (300 to 600 mm Dia wheel)

version b: cast iron or bronze bearing (300 to 1000 mm Dia wheel)

Design 4: Wood wheel with spokes, 4 to 6 rim pieces, 8 to 12 spokes, for all kinds of carts, 150 to 250 kg payload, manufacture type b.

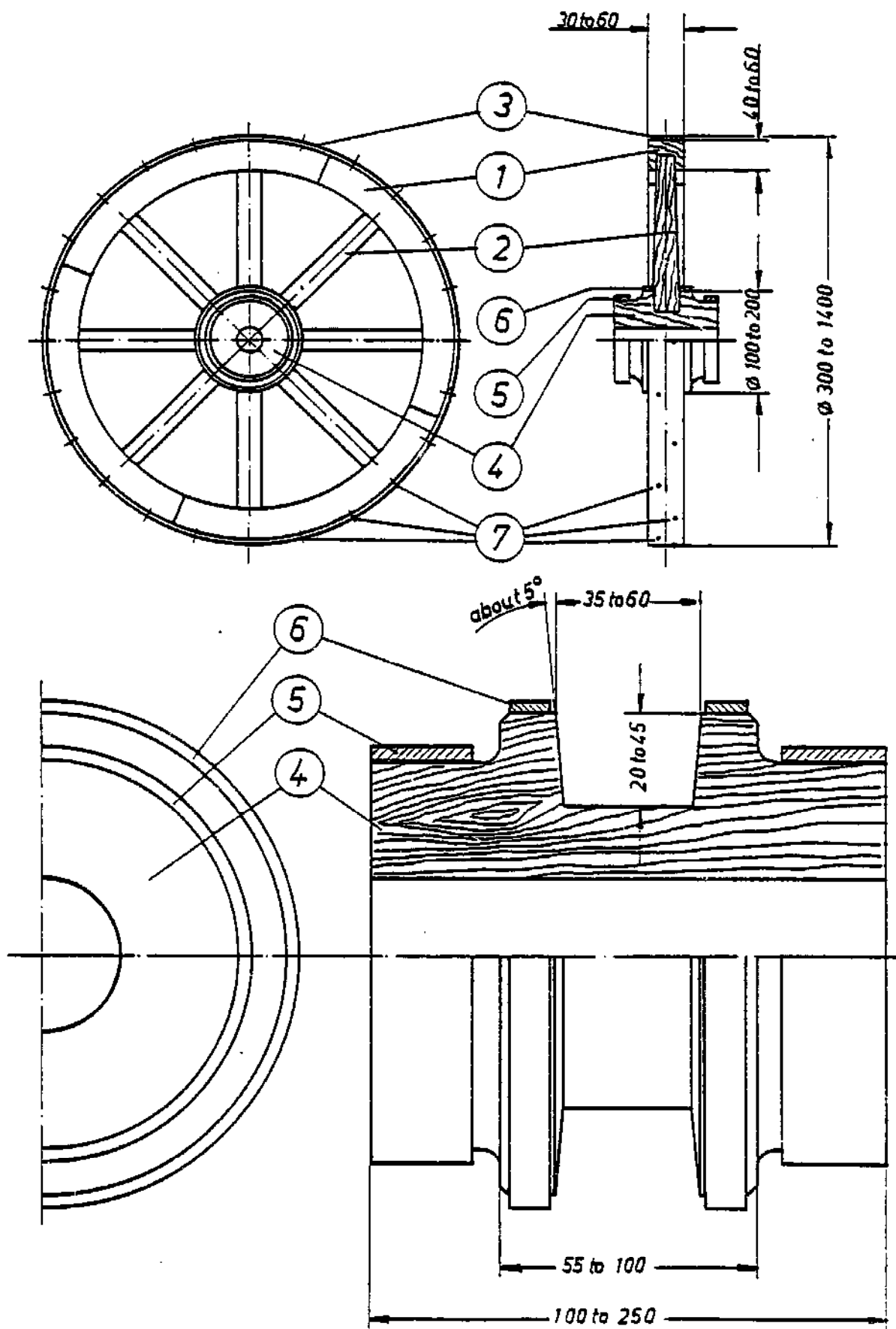

Specification design 4

Part No	Part name	Material	Dimensions of raw material
1	rim	hardwood	30x40 to 60x60 mm
2	spoke	hardwood	30x35x100 to 40x60x600 mm
3	tyre	MS steel	4x30 to 8x60 mm
4	hub	hardwood	110 to 220 Dia, 100 to 250 long
5	ring	MS steel/pipe	3" Dia x 20 to 6" Dia x 40 mm
6	ring	MS steel/pipe	4" Dia x 10 to 8" Dia x 20 mm
7	screw	steel	4x30 to 6x50 mm

Specification design 5

Part No	Part name	Material	Dimensions of raw material
	<u>version x</u>		
1	rim	MS	5x50 to 8x80 mm
2	spoke	MS	5x25 to 7x50 mm
3	axle	MS	1" to 1 1/4" Dia round steel
	<u>version y</u>		
4	spoke	MS	3/8" to 1/2" Dia round steel
5	hub	MS pipe	2 1/2" to 3" Dia
6	bush	hardwood	70 to 80 mm Dia
7	socket	MS pipe	1/4" Dia
8	grease cup		from local dealer
9	key spline	MS	1/8" Dia round steel

Design 5: Steel wheel with spokes for all kinds of carts, max. payload 350 kg, manufacture type c.

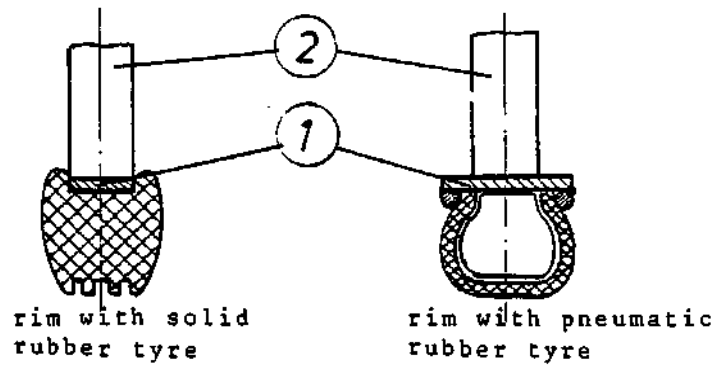
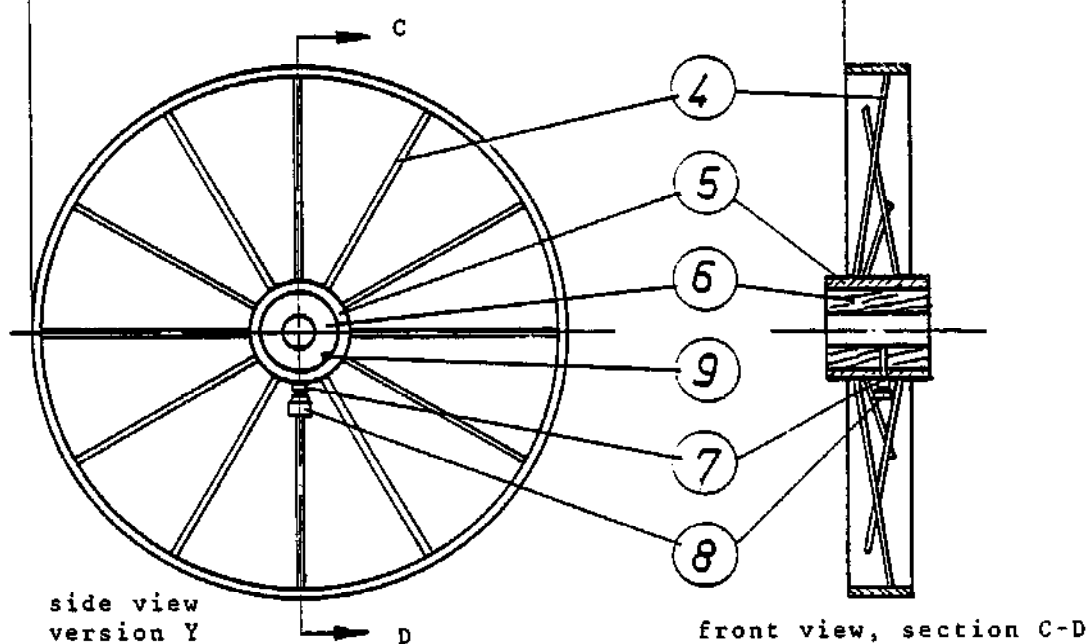
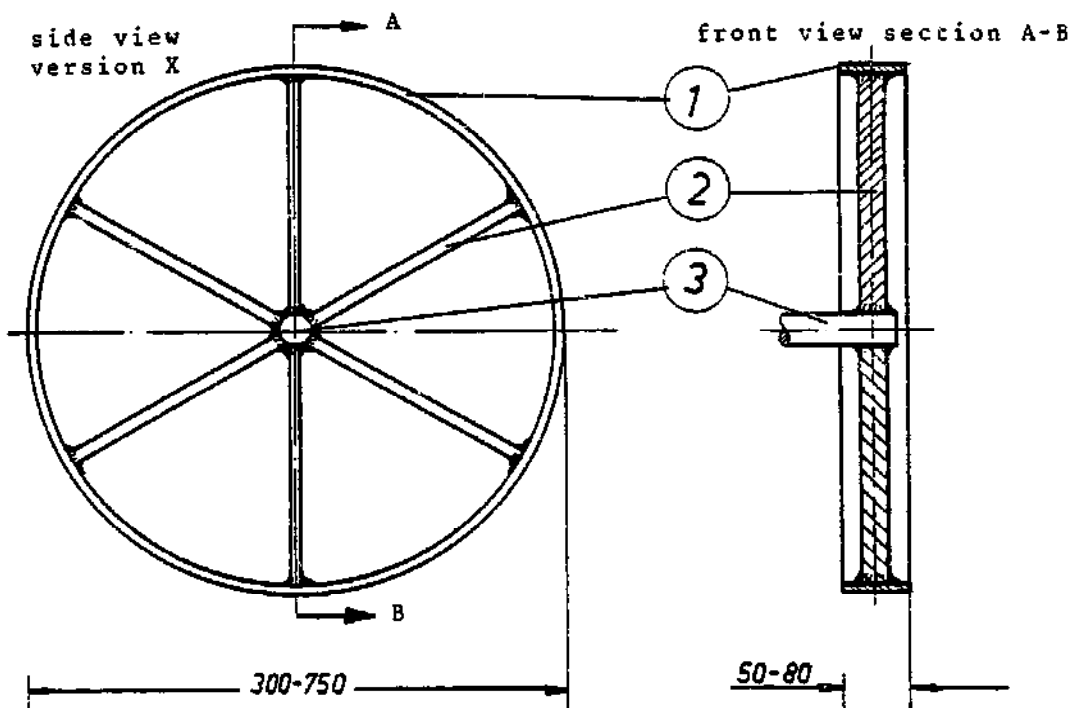

Design 6: Steel wheel with pneumatic tyre for animal and tractor drawn carts, max. payload about 600 kg, manufacture type c.

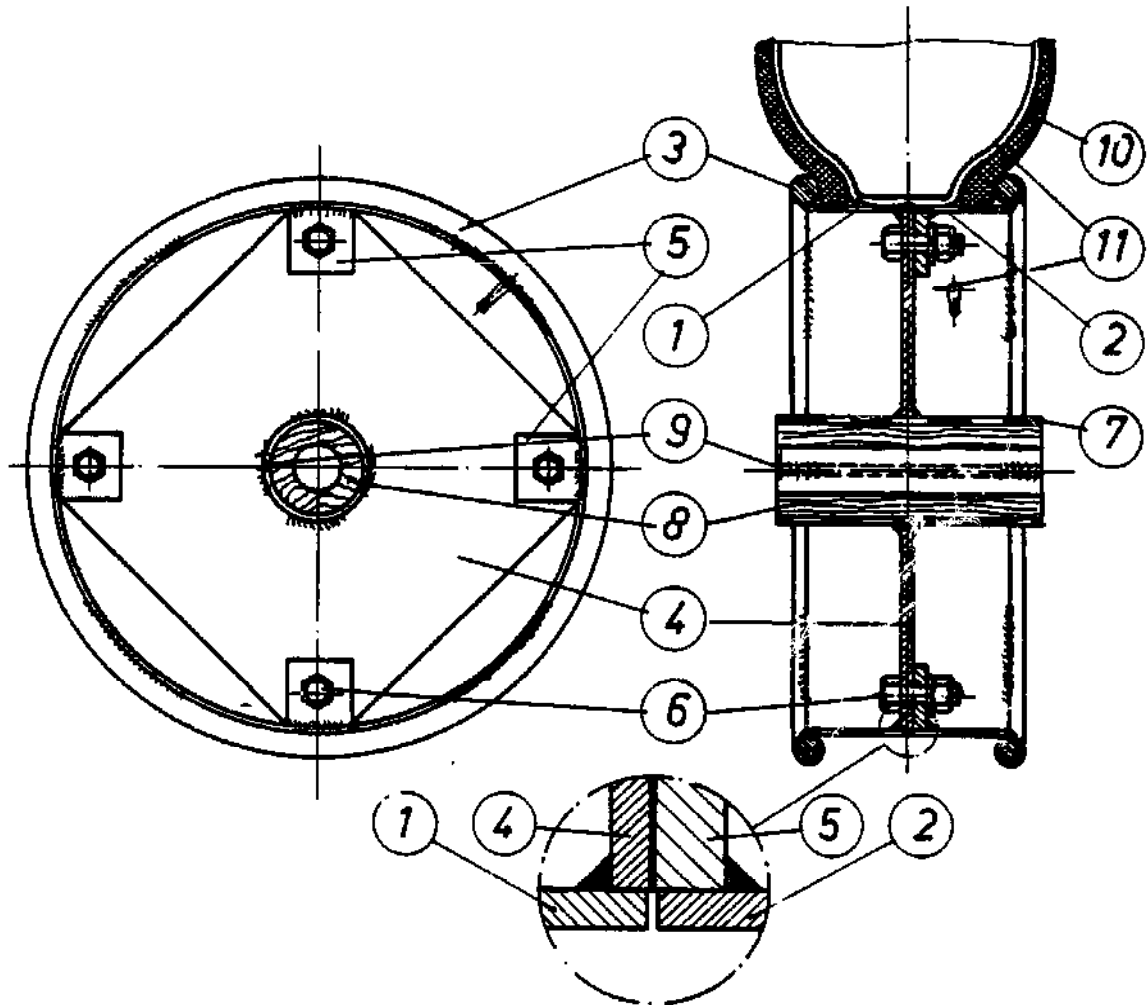

Specification design 6

Part No	Part name	Material	Dimensions of raw material
1	rim (back part)	MS flat steel	6x75 mm
2	rim (front part)	MS flat steel	6x75 mm
3	rim (adjustment ring)	MS round steel	3/4" Dia
4	wheel disk	MS sheet	6x310x310 mm
5	holding piece	MS flat steel	10x32x40 mm
6	bolt, nut, washer	steel	M12x30 mm
7	hub	MS pipe	2 1/2" Dia x 200 mm
8	bush	hardwood	70 mm Dia x 200 mm
9	key spline	MS round steel	1/8" Dia
10	pneumatic tyre	rubber	5.50-16 AW
11	tube	rubber	for 5.50-16 tyre

Source: TAMTU, Tanzania and DSE/ZGB, Federal Republic of Germany

Design 7: Steel wheel with spokes and pneumatic tyre for wheelbarrows handcarts, max. payload about 150 kg, manufacture type d

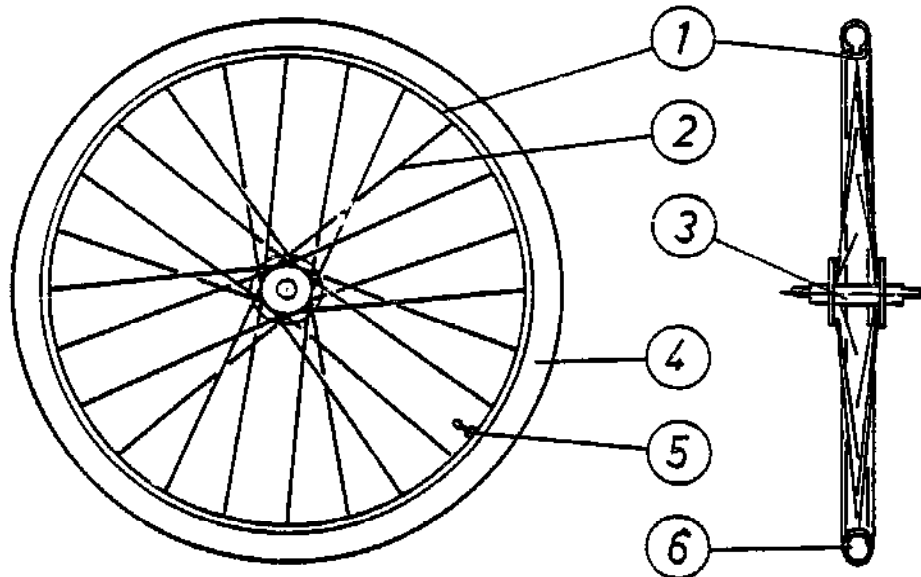

Specification design 7

Part No	Part name	Material	Dimensions of raw material
1	rim	steel sheet	2 mm, rolled and plated with chromium
2	spoke	tempered round steel	2 mm Dia
3	hub	steel	prefabricated (local market) with ball bearings
4	pneumatic tyre	rubber	from local market
5	tube	rubber	from local market
6	valve	steel	from local market

3.1.2 Bearings

Description: Bearings are necessary to support rotating shafts against a body or wheels against an axle. Generally two kinds of bearings are distinguished: friction and roller bearings. Table 2 gives some basic information on the characteristics of friction and roller bearings (hardwood, bronze, cast iron and ball-, cylinder-, needle-).

Table 2: Characteristics of friction and roller bearings

Criteria	Friction bearings		Roller bearings
	hardwood	cast iron/ally	
frictional resistance	high	medium	low
abrasion	high	medium	low
durability	low	medium	high
load capacity	low	low/medium	high
maintenance requirements	medium	medium	low
local inputs	high	medium	non
technological status	low	medium	high
price	low	medium	high

Friction bearings: For low speed and simple vehicles (less than 10 miles/h) friction bearings in dry and halfwet version are common. The surface of the rotating shaft and the bush of the wheel have direct contact with some grease in between. This causes abrasion and heating of the bearing. Bushes made of hardwood and cast iron have a relatively low load capacity, the ratio length to diameter should be at least $L/D = 3$ (cast iron) to 4 (hardwood). Bushes made of alloys like bronze (copper with tin, lead, aluminium), white metal (lead, tin and antimony mainly) or aluminium alloy (aluminium with copper and zinc) resist to higher loads and are qualified for very low shaft speeds and shocks as well. Their ratio L/D ranges from 1 to 2. Each version should be greased regularly not only to reduce friction but to keep off dirt and sand. Additional washers made of leather, felt, rubber or iron might help to reduce abrasion.

Friction bearings in wet version are applicable only for high rotations. In this case a film of oil is between the metal of the bush and the shaft. The frictional resistance is accordingly low. Special washers and devices for constant oiling must be installed.

Roller bearings: They are valid for low and high speed vehicles as well. Bush and shaft are supported by balls, cylindrical rolls or needles between an inner and outer ring all made of refined steel. Due to their high precision production is limited to specialised firms. They build roller bearings suitable for all purposes. The ratio L/D is less than 1. Roller bearings run in grease if low speeds prevail and in oil at high rotations. Shocks should be prevented.

Design 8: Hardwood friction bearing

(scale 1:3 and 1:4,5)

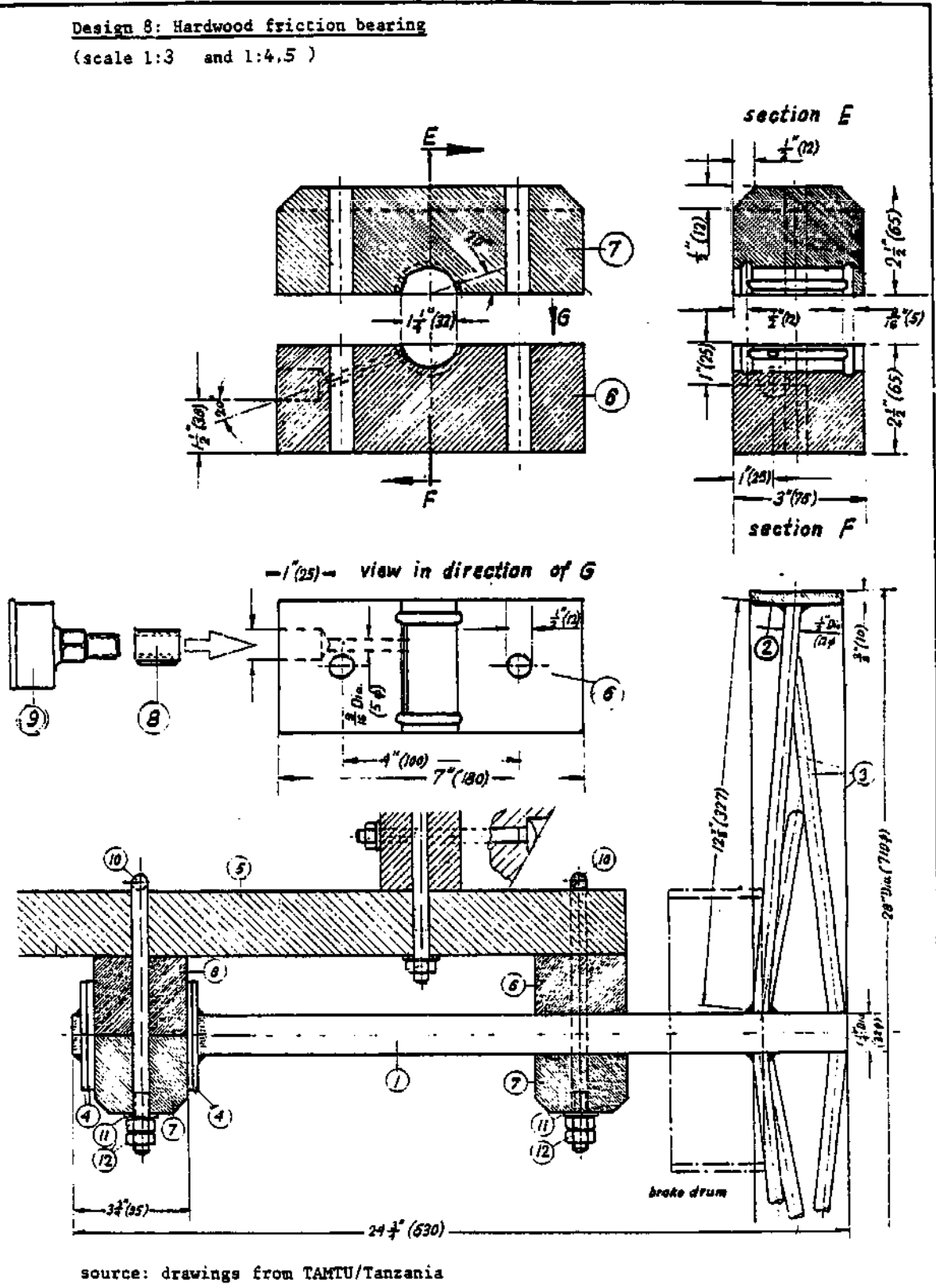

Specification design 8

- 20 -

Part No	Part name	Material	Dimensions of raw material
1	axle	MS round steel	1 1/4" Dia
2	tyre	MS flat steel	10x75 mm
3	spoke	MS round steel	10 mm Dia
4	washer and axle support	MS	1 1/4" inner Dia
5	cross beam	hardwood	50x180x1150 mm
6	bearing half	hardwood	65x75x180 mm
7	bearing half (top)	hardwood	65x75x180 mm
8	pipe socket	MS pipe	1/4" Dia
9	grease cup	steel	from local market
10	U-bolt	MS round steel	1/2" Dia
11	washer	steel	for M12 bolt
12	nut	steel	for M12 bolt

Design 9: Cast iron friction bearing (hub of a wood wheel with spokes)

(scale 1:1)

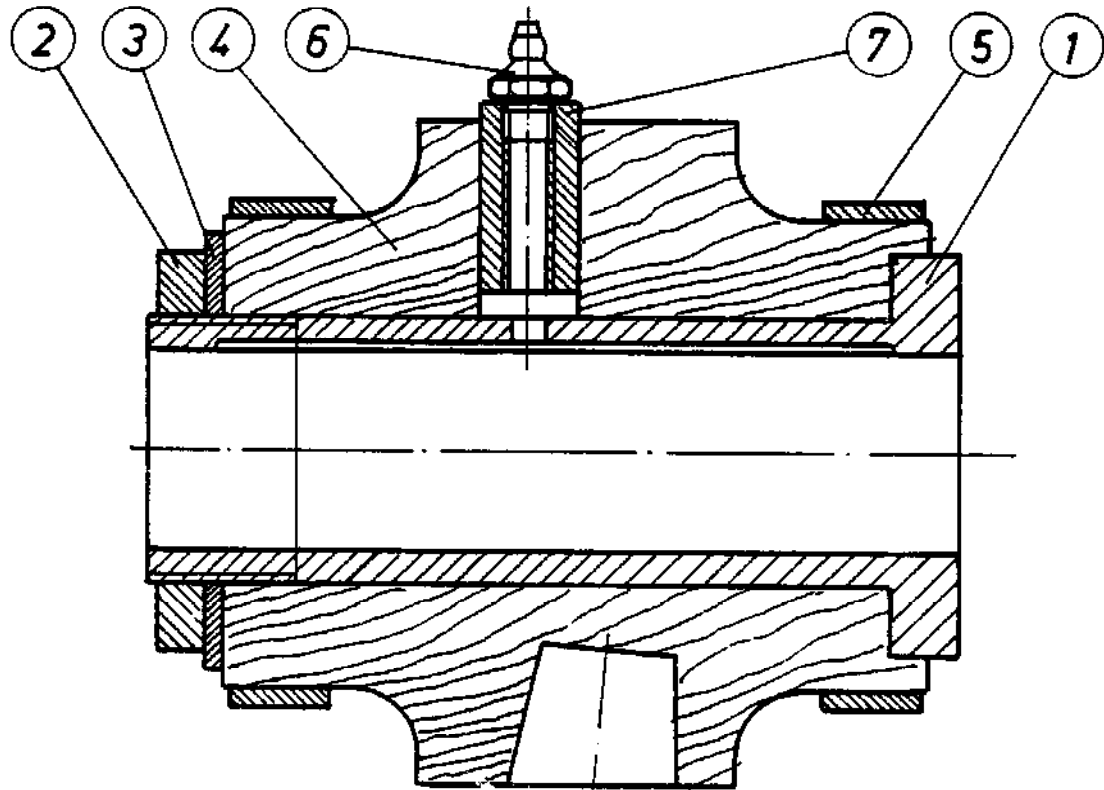

Specification design 9

Part No	Part name	Material	Dimensions of raw material
1	bearing bush	cast iron	from local foundry
2	nut	steel	
3	washer	steel	
4	hub	hardwood	
5	ring	MS pipe	
6	grease nipple	steel	from local market
7	socket	MS pipe	

Design 10: Alloy friction bearings

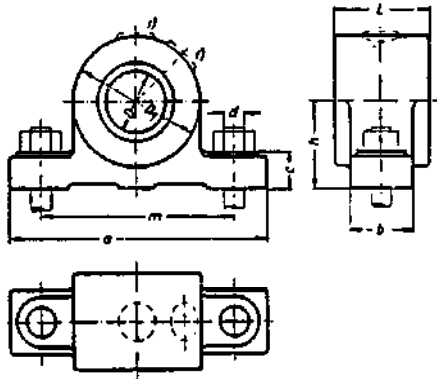

eye bearing with alloy bush

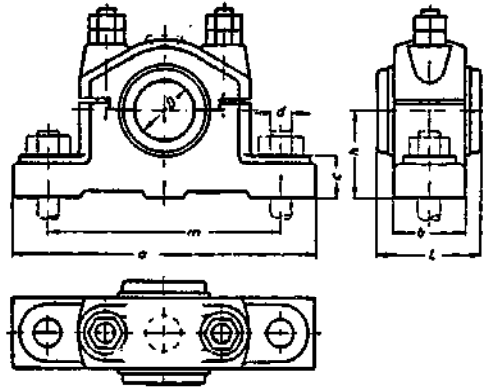

coverbearing with two half alloy bushes

Design 11: Roller bearings

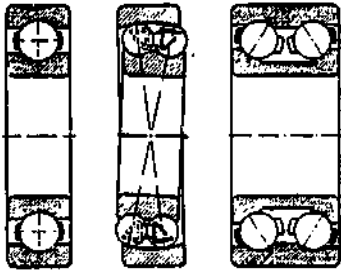

different ball bearings

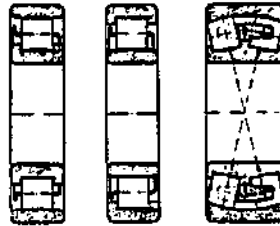

cylindrical roller bearings



tapered roller bearing

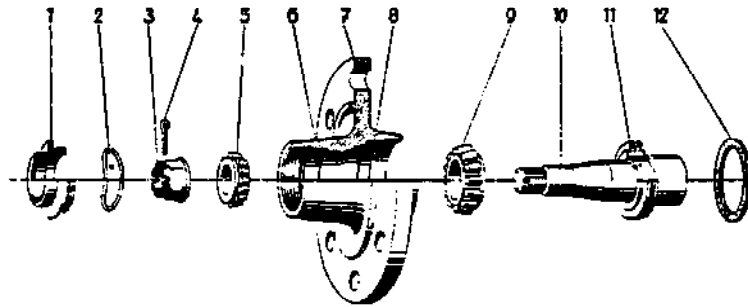
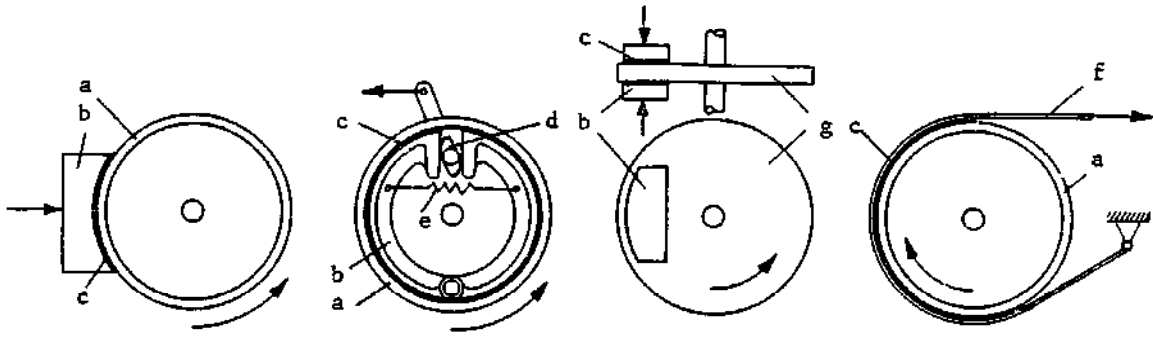

Fig.4: Installation of tapered roller bearings in a disk hub

Cover (1), packing ring (2), nut (3), pin (4), tapered roller bearing (5,6 and 8,9), disk hub (7), pivot (10), adjustment ring (11), packing ring (12)

3.1.3 Brakes

Description: The main brake systems are demonstrated in figure 5:



shoe brake (one shoe outside) shoe brake (two shoes inside) disk brake belt brake
 a = drum, b = shoe, c = lining, d = cam, e = spring, f = belt, g = disk

Fig. 5: Main brake systems

Brakes must be installed in vehicles which are operated on slopes or which are driving with speeds higher than 10 miles/hour. Concerning low cost vehicles it is recommended to provide

- handcarts with a total weight beyond 150 kg and operated at slopes with 10 % inclination and more
- animal drawn carts with a total weight beyond 250 kg and operated at slopes with 10 % inclination and more
- tractor drawn carts and trailers with a total weight beyond 500 kg and speeds higher than 10 miles/hour
- all kinds of cycles
- all kinds of motorised vehicles

with adequate brakes.

The capacity of shoe brakes has to be calculated

with the equation $F_f = F_s \times \mu > F_p$

with

- F_f = force of friction at the drum
- F_s = brake force at the shoe
- F_p = periphery force at the drum (or wheel)
- μ = coefficient of friction

- For brake shoes made from cast iron $\mu = 0.15$
- " " " " " hardwood $\mu = 0.25$
- For special brake lining (ferodofibre) $\mu = 0.40$

Figure 6 shows systematically the action and reaction of the different forces at the shoe brake

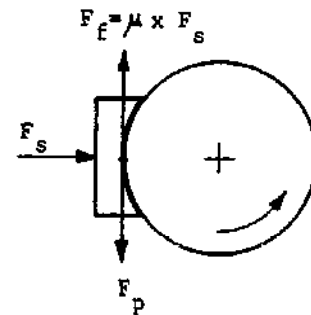

Fig.6: Forces at the shoe brake

The capacity of belt brakes has to be calculated according the formula $F_f = F_b \times (m - 1) > F_p$

with

F_f = force of friction at the drum

F_b = brake force at the belt (in direction of F_p)

F_p = periphery force at the drum

m = coefficient depending on α and μ

α = enclosing angle belt-drum

μ = coefficient of friction (see above)

Some data on m are given below

α	μ				
	0.1	0.2	0.25	0.3	0.4
180°	1.3	1.8	2.2	2.5	3.5
225°	1.5	2.2	2.7	3.3	4.8
270°	1.6	2.6	3.2	4.1	6.6

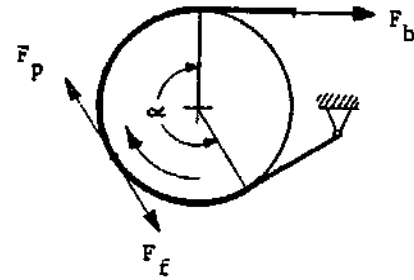

Fig.7: Forces at the belt brake

The periphery force F_p at the drum must be calculated from the forces at the wheel resulting from retardation of the fully loaded vehicle at a horizontal or inclined road. The necessary brake force F_b can be derived from hand or foot operated levers (max. manual force 25 kg) via transmission levers or wires to the brake. As regards belt brakes it is important to mention that F_b must pull in direction of F_p i.e. with the rotating wheel.

For low cost vehicles simple shoe brakes from hardwood or belt brakes with steel belts and leather lining are common. Double shoe brakes with two shoes outside or inside the drum and disk brakes are more efficient and cause only little opposing forces at the bearings of wheels and axles. But their manufacture needs fair workshop equipment and know how. They are more expensive than the simple shoe brake.

The following design 12 demonstrates a shoe brake of a 2-wheel ox cart working directly at the wheel (source: TAMTU, Tanzania, DSE/ZGB, FRG).

Design 12: Single shoe brake installed in an ox cart (scale 1:10)

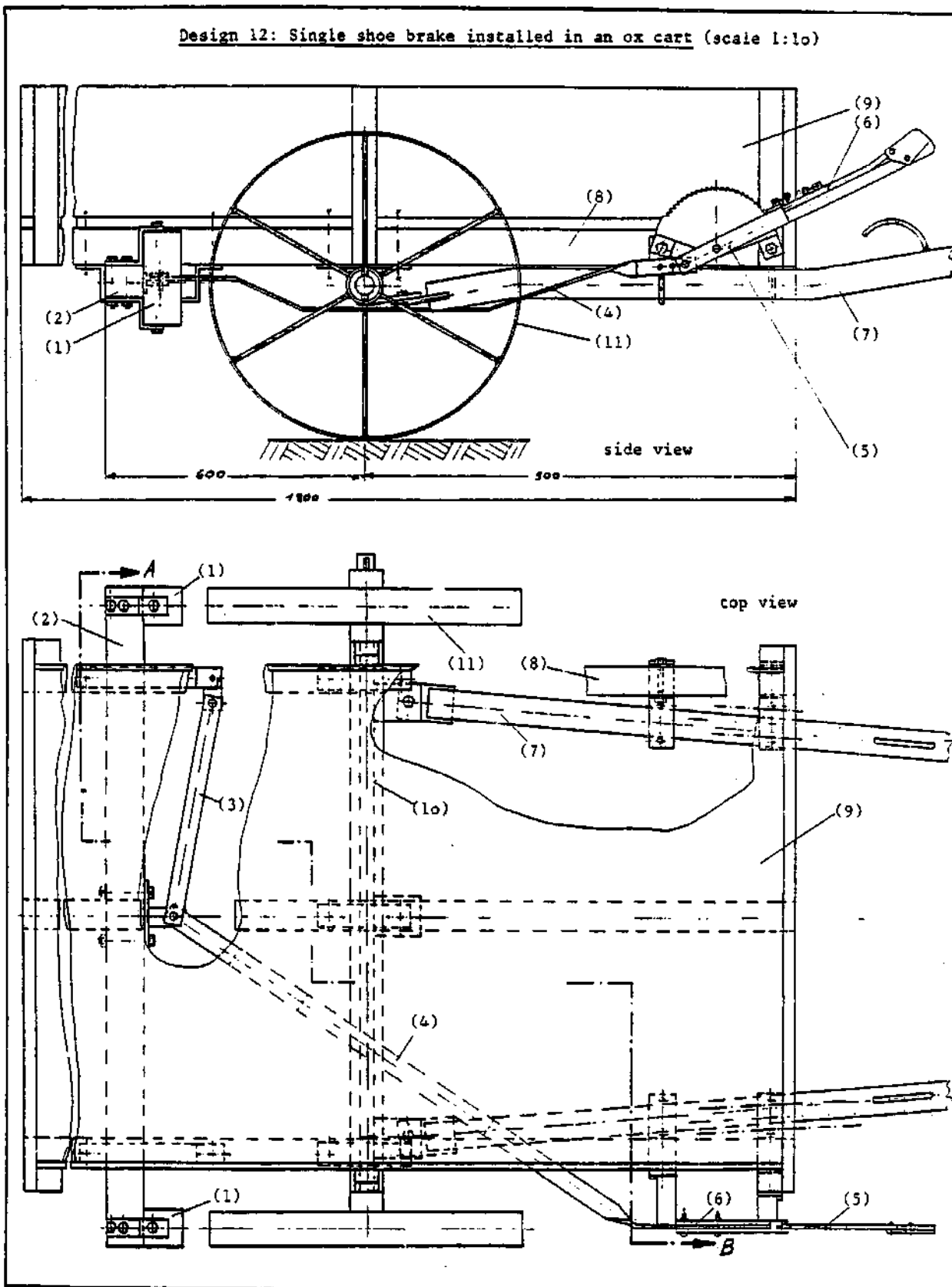

Design 12: Single shoe brake (continued)

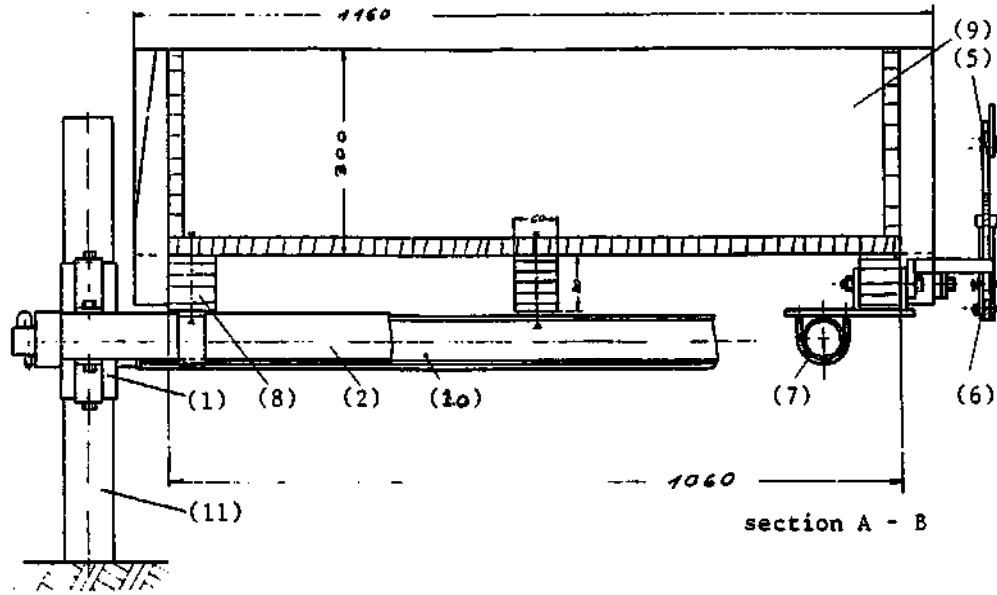

Source: TAMTU, Tanzania and DSE/ZGB, FRG

Specification design 12

Part No	Part name	Material	Dimensions of raw material
1	shoe	hardwood	specification available from TAMTU or DSE/ZGB
2	beam	wood	
3	transmission lever (short part)	MS flat steel	
4	transmission lever (long part)	MS flat steel	
5	hand operated brake lever	MS	
6	locking device	MS	
7	drawing shaft	MS or wood	
8	undercarriage	wood	
9	load container	wood	
10	axle	MS round steel	
11	wheel	MS	

3.2 Non motorised vehicles

3.2.1 Pedal driven vehicles

Main characteristics: Pedal driven vehicles are either 2-wheel (bicycles) or 3-wheel vehicles (tricycles). The wheels typically have a diameter of 28" or 710 mm. Transport by bicycle is about four times as efficient as walking. Its most popular type has a deadweight of about 30 kg and is mainly used to transport one person i.e. the driver himself. As the two wheels roll in one track the bicycle is qualified for paved and unpaved roads and narrow footpaths as well. Payloads up to 150 kg can easily be carried if adequate platforms or containers are fixed to the bicycleframe. In order to obtain stable driving conditions and a higher transport capacity the tricycle was constructed. Most widely used in Asia it allows to carry two or three passengers and even bulky cargo up to 250 kg. Its deadweight ranges between 40 and 80 kg and its track is more than 1 m. Thus its application depends on prepared and surfaced roads with enough width.

Construction and operation: The standard cycles which at present predominate in developing countries for transport of passengers and cargo are, by comparison, old fashioned. Their heavy frames are joined by lugs which are produced with highly mechanised methods in medium scale industries or imported. To meet the conditions of local small scale production and the specific transport needs some improved cycles have been designed. In figure 8 some conventional and improved cycles are illustrated.

For bicycles besides passenger transport different kind of carriers are used to move cargo: wood containers, steel hoops to insert water tanks, wicker panniers, steel platforms etc. In most cases these devices are fixed on both sides of the rear wheel to the frame (e.g. in China) but there are also sturdy containers to be found directly over the front wheel (e.g. in Europ or USA). In Tanzania a bicycle transporter has been developed where two platforms welded from anglebars are fixed to the conventional frame on both sides and a front carrier over the front wheel of the bicycle. Thus it is possible to push 150 to 200 kg load on narrow tracks while walking on the left side of the vehicle. Efficient operation is gained by a special pushbar, a broad steering bar and handbrakes on each of these bars (see design 13).

The widespread use of tricycles especially in Asian cities reveals a real need for low cost transportation. Nevertheless the existing designs cannot be regarded as satisfactory. Mostly rickshaws with passenger bodywork have to deal not only with persons but with bulky or loose cargo too which does not fit to the body construction. Besides this the vehicles are too heavy, the single-speed transmission imposes undue strain to the rider and brake systems are not valid for the existing traffic situation.

Answering to these disadvantages the so-called "Oxtrike" was constructed. It is light (40 kg), has a three-speed gearbox and foot-operated inboard band brakes in addition to the front handbrake. The chassis makes use of sheet steel which is cut, folded and welded without the use of expensive machinery. Furtheron the 20" diameter wheels of the Oxtrike give a longer load platform which can be provided with containers, tanks or passenger seats. While the Oxtrike is suited only for transport on prepared roads there is still a need for an improved tricycle on rough terrain. It is recommended to promote the construction of common tricycles according to the criteria mentioned above.

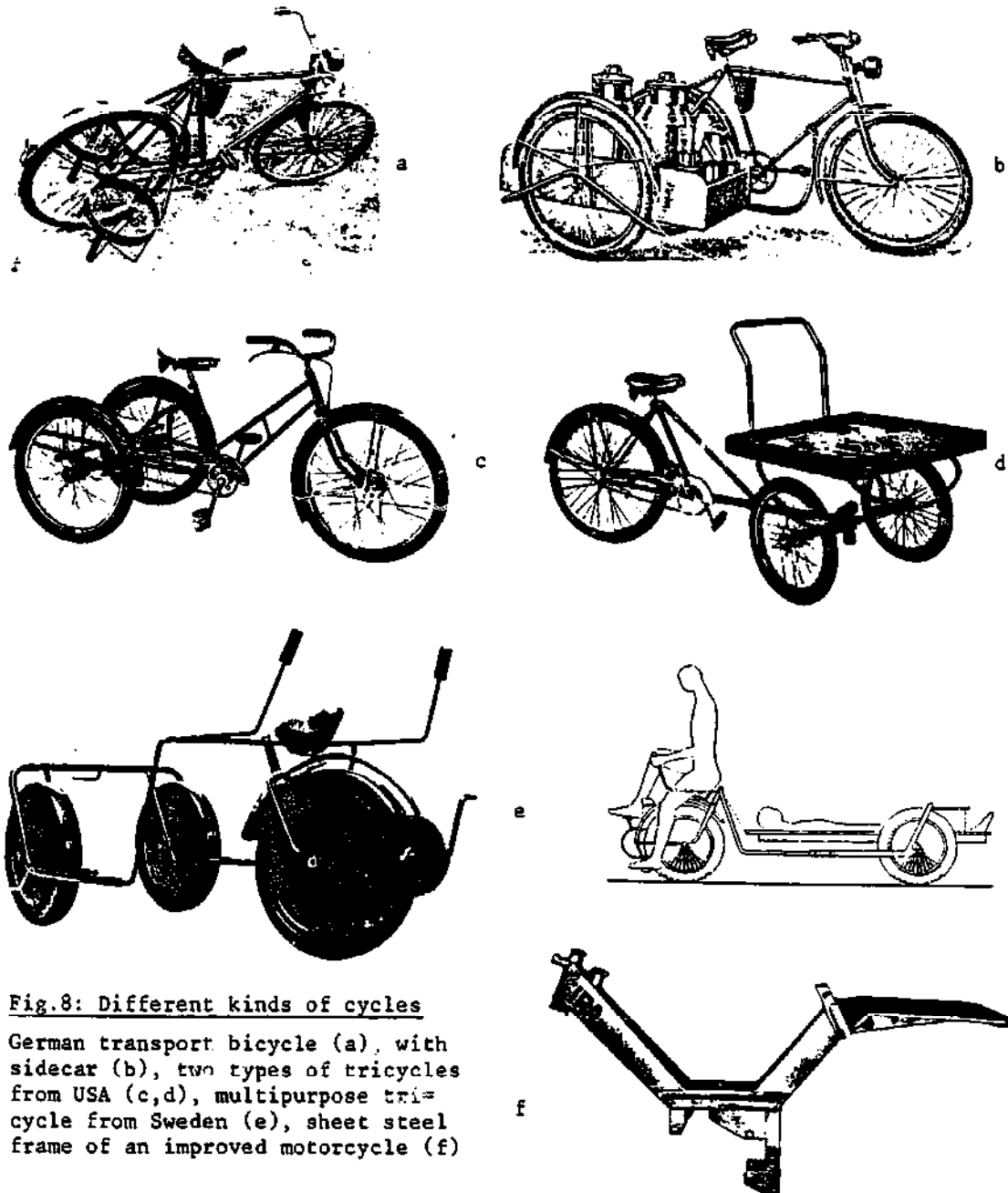
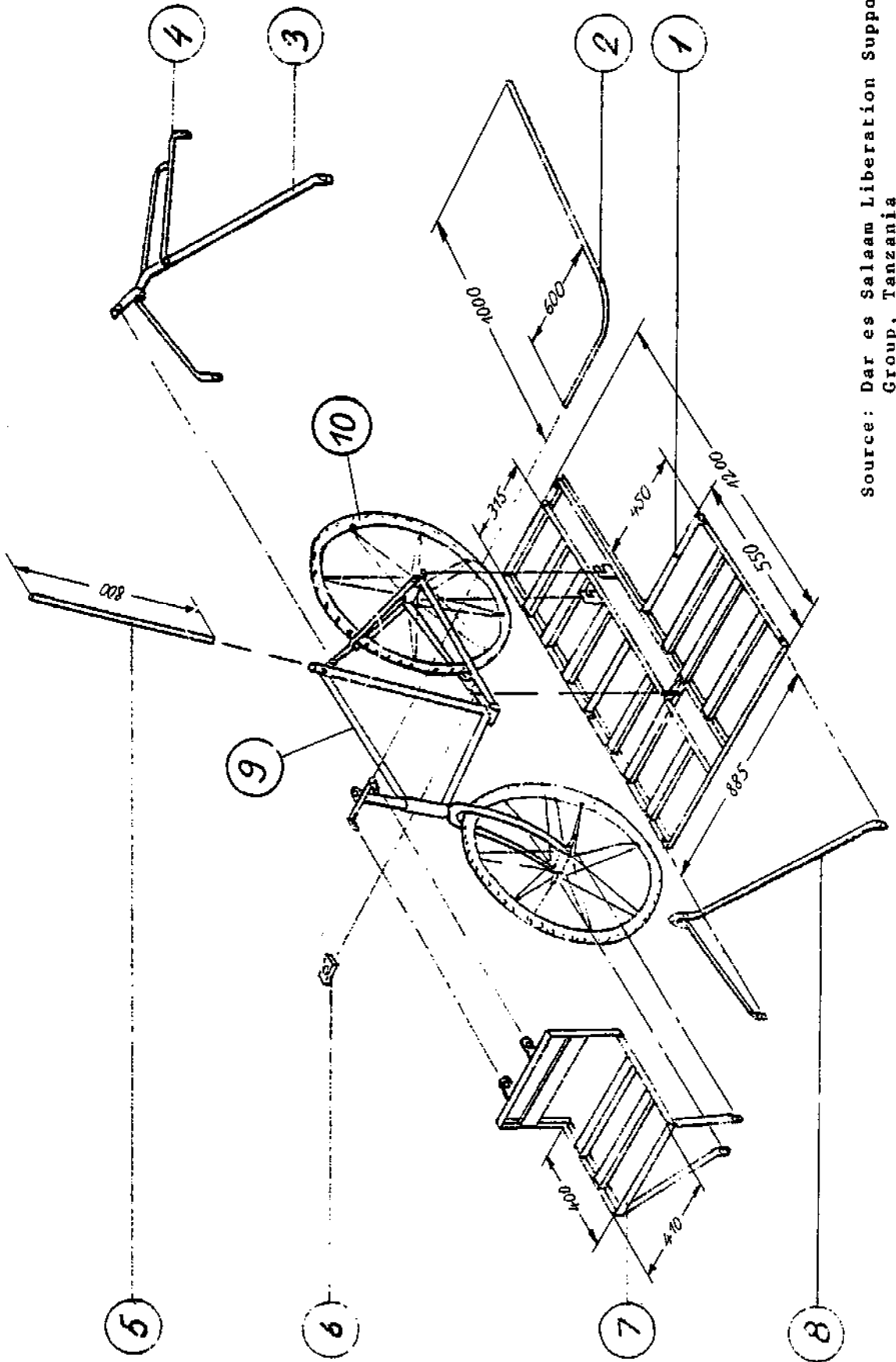

Fig.8: Different kinds of cycles
German transport bicycle (a), with sidecar (b), two types of tricycles from USA (c,d), multipurpose tri-cycle from Sweden (e), sheet steel frame of an improved motorcycle (f)

Design 13: Transport bicycle for on and off road transport, two pneumatic tyre wheels, one standard bicycle frame, about 200 kg max. payload, raw material mainly structural steel, manufacture type c.



Source: Dar es Salaam Liberation Support Group, Tanzania

Specification design 13

Part No	Part name	Material	Dimensions of raw material
1	platform	MS anglebar	L 20x20x3 mm
2	steering bar	MS pipe	1/2" Dia
3	rear truss	MS flat steel	6x20 mm
4	bar	MS flat steel	6x20 mm
5	push bar	MS pipe	3/4" Dia
6	washer	MS flat steel	6x20 mm
7	front carrier	MS anglebar	L 20x20x3 mm
8	front truss	MS flat steel	6x20 mm
9	frame	MS pipe	second hand or from local dealer
10	spoke wheel	steel with pneu	28" Dia

Specification design 14

Part No	Part name	Material	Dimensions of raw material
1	frame	MS sheet	2 mm
2	steering column	ERW tube	1 3/8" Dia
3	seat support	MS sheet	3 mm
4	strut	MS sheet	2 mm
5	fork	steel	standard bicycle part
6	handle bar	steel	" " "
7	saddle	steel, leather	" " "
8	pedal	steel, rubber	" " "
9	spoke wheel	steel with pneu	20" Dia
10	front brake		standard bicycle part
11	foot brake pedal	MS sheet	3 mm
12	load carrier	wood	20x150 mm planks

Design 14: Transport tricycle "Oxtrike" for transport on prepared roads, three pneumatic tyre wheels, frame folded from sheet steel, about 250 kg max. payload, manufacture type d.

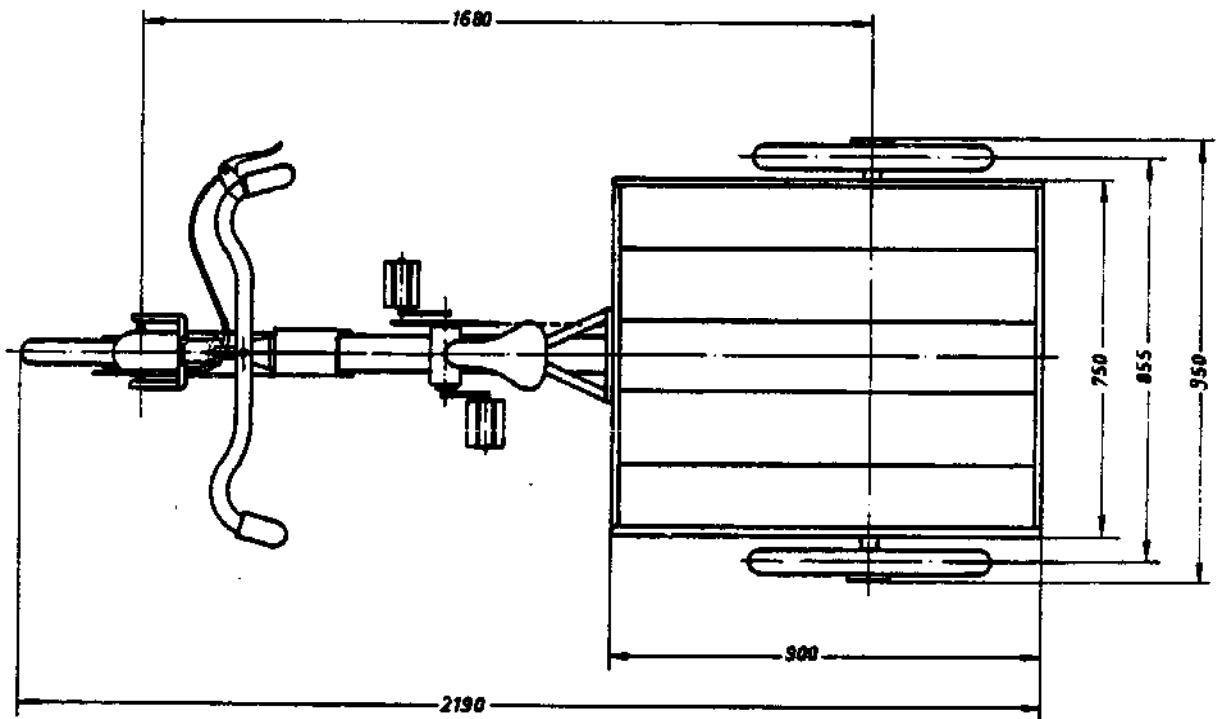
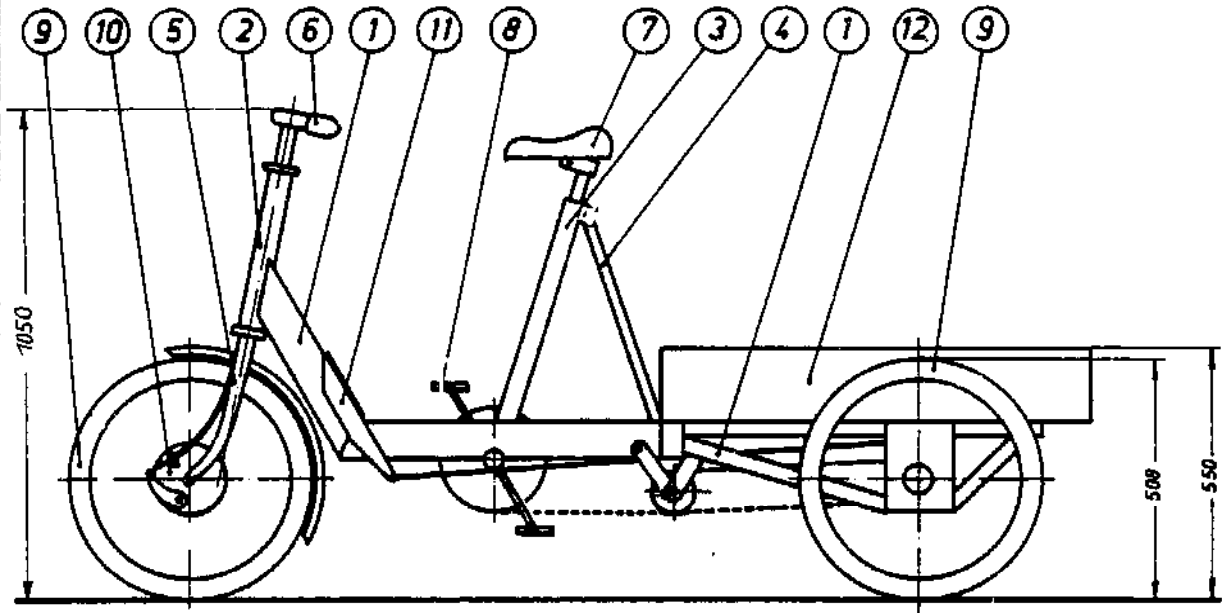

Source: Oxford University, U.K.

3.2.2 Wheelbarrows and handcarts

Main characteristics: Wheelbarrows and handcarts have one to four wheels and one or two handles to push or draw the vehicle by hand. The most common wheelbarrow has one wheel, two handles and a small load container in between.

All kinds of private, commercial and public sectors use wheelbarrows and handcarts to transport agricultural products, fertiliser, soil, stones building material etc. (high load flexibility). The maximum payload of wheelbarrows is relatively low (for standard types up to 100 kg, for improved versions up to 150 kg). The operator has to carry part of the load himself and must keep the vehicle in balance while driving. On the other hand wheelbarrows are very handy and qualified to roll on narrow and uneven footpaths and rough terrain. The max. payload of handcarts is generally higher. All vehicles of this kind have a small transport range and are not suitable for use in steep gradients.

Construction and operation: As wheelbarrows and handcarts are mainly operated by one person and sometimes off road their construction should fulfil some basic requirements:

- low centre of gravity (with regard to balanced driving)
- low rolling resistance
- low burden for the carrying person
- simple, cheap and strong design

The technical solution of these and other requirements meets some difficulties e.g. a low rolling resistance calls for big wheels which is in contradiction to a low centre of gravity. In adapting the technical possibilities to special transport demands a large variety of wheelbarrows and handcarts has been developed (see figure 9). From there it can be seen that wheelbarrows are either made from wooden or structural steel parts. Steel carriages, if manufactured properly, are generally lighter than those made of wood. Dependent on the kind of load flat or open, box-type or partly closed load platforms and containers are used. Appropriate wheels must be selected according to road surface, load, driving comfort, production capacity of wheelwrights, purchasing power of users etc. (further details on wheels see chapter "wheels").

If loads beyond 100 kg are to be transported modified wheelbarrows with the wheel directly under the platform or handcarts must be introduced. In this case the load is placed close to the wheels axle and the operator only has to support a small proportion of the load. Thus more of his energy can be devoted to propelling the vehicle forward. He wears a strap which passes across his shoulders and is attached to the handles of the barrow. Loads beyond 150 kg should be handled by handcarts or cycles.

A very special type of wheelbarrow has been developed in Korea. Its design was derived from the traditional backpack called "chee-ke" which is used by porters to carry loads up to 60 kg in hilly areas. In order to reduce the

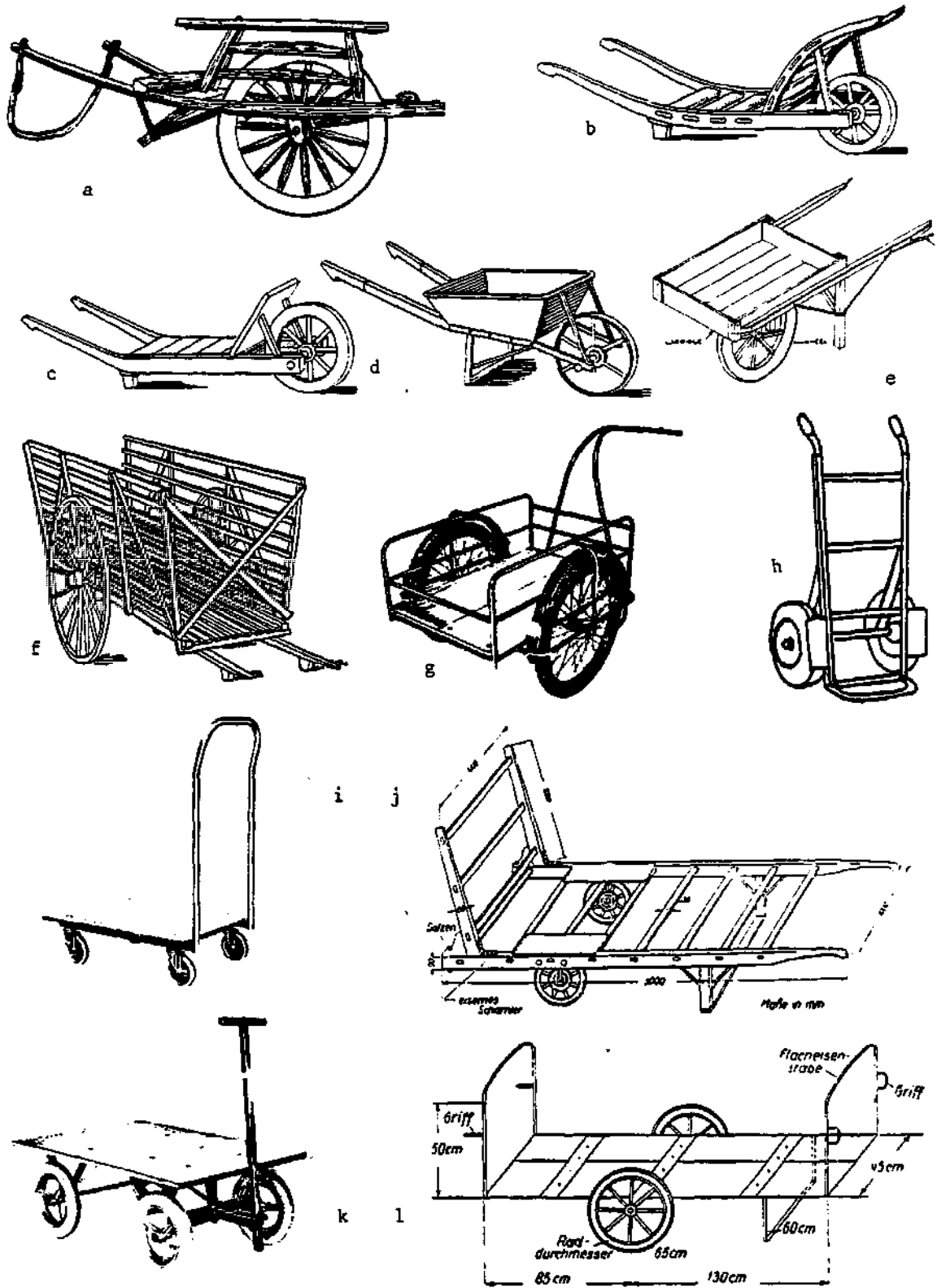

Fig. 9: Different kinds of wheelbarrows and handcarts, Chinese barrow (a,e), German stave-, platform- and box-wheelbarrow (b,c,d), sack-barrow (h), 2-wheel handcarts (f,j,l) bicycle trailer (g), 4-wheel handcarts (i,k)

physical effort required by the porter the chee-ke has been equipped with two pneumatic tyre wheels (see figure 10). Instead of the traditional wood frame a steel pipe frame was designed. Thus heavy loads can be carried either on human back along hilly terrain or rolled on even roads. As this construction has a deadweight of 12 kg or more a lighter version is shown in this study (compare design 18). Its frame is manufactured from aluminium pipes and it has only one wheel. Thus a deadweight of about 4 kg comes out. This construction has to be adapted and improved locally.



Fig. 10: The improved backpack device "chee-ke" from Korea

Design 15: Standard wheelbarrow for on and off road transport, one small wheel, about 100 kg payload, raw material wood, manufacture type 4.

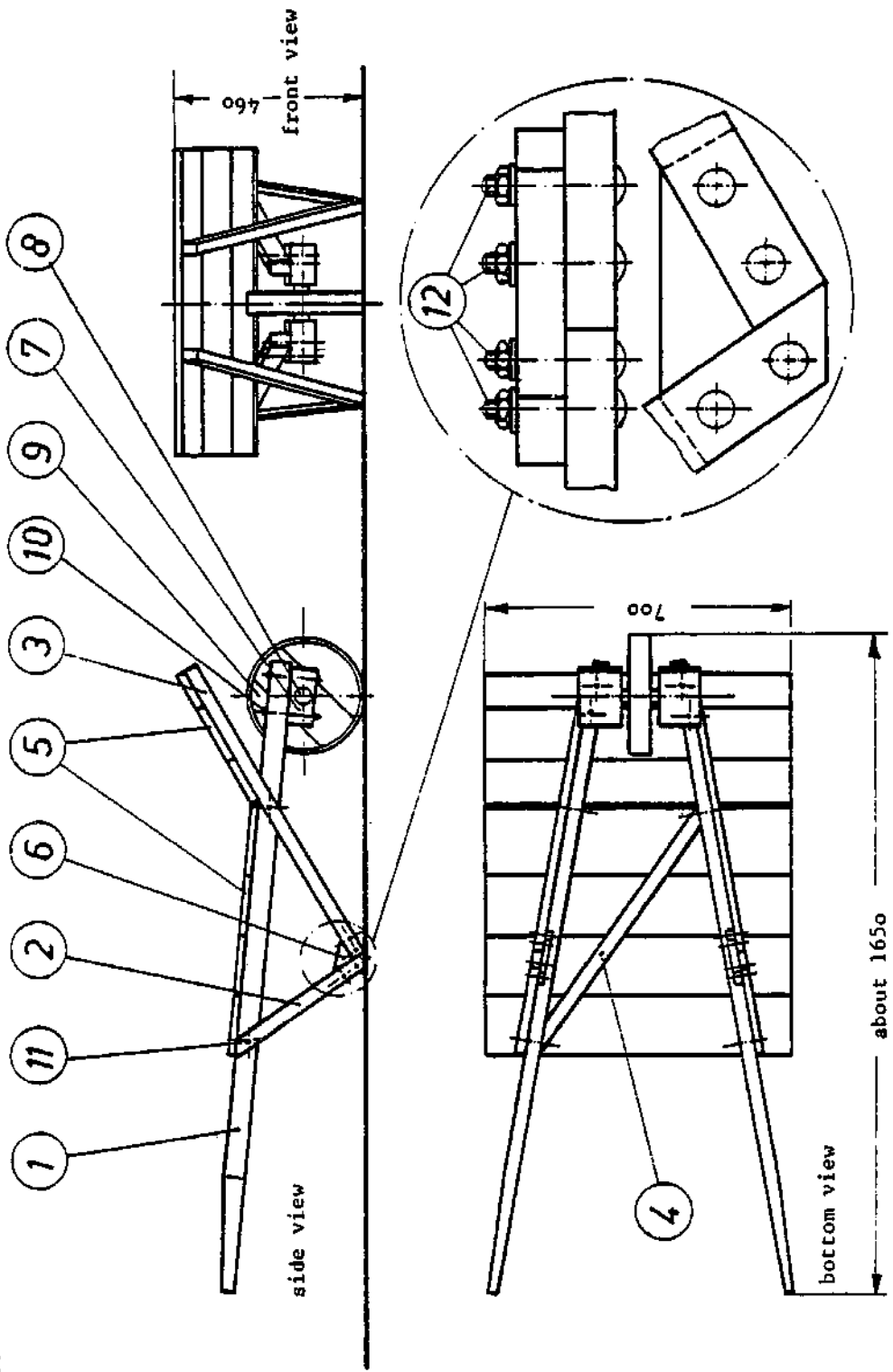

Specification design 15

- 35 -

Part No	Part name	Material	Dimensions of raw material
1	handle and frame	wood	25x50x1580 mm
2	leg	wood	20x30x450 mm
3	leg and front support	wood	20x30x850 mm
4	crosspiece	wood	20x30x750 mm
5	plank	wood	20x150x700 mm
6	bracket	plywood	20x70x150 mm
7	support and bearing	hardwood	60x100x150 mm
8	axle	MS pipe	1" to 2" Dia, 300 mm long
9	wheel	wood or steel	300 to 500 mm Dia
10	screw and washer	steel	M8 x 130 mm
11	screw and washer	steel	M6 x 55 mm
12	screw and washer	steel	M6 x 50 mm

Remark: the borehole for the wooden bearing must be drilled after assembly of the frame and the wooden bearing blocks.

Specification design 16

Part No	Part name	Material	Dimensions of raw material
1	handle and frame	MS pipe	1" Dia x 4000 mm
2	crosspiece	MS pipe	1/2" Dia x 650 mm
3	curved leg	MS pipe	1/2" Dia x 1000 mm
4	wheel support	MS pipe	1" Dia x 700 mm
5	box frame	MS pipe	1/2" Dia x 1400 mm
6	axle holder (fork)	MS flat steel	5x60x100 mm
7	spoke wheel	wood or steel	about 500 to 700 mm Dia
8	rear plank (fixed)	wood	20x150x580 mm
9	front plank (loose)	wood	20x150x580 mm
10	side plank (fixed)	wood	20x150x1000 mm
11	bottom plank (fixed)	wood	25x200x690 mm
12	connection piece	wood	40x40x150 mm
13	wood screw	steel	5x50 mm

Design 16: Wheelbarrow, Chinese type for on and off road transport, one big wheel, max. payload about 150 kg, raw material steel pipes and wood, manufacture type c.

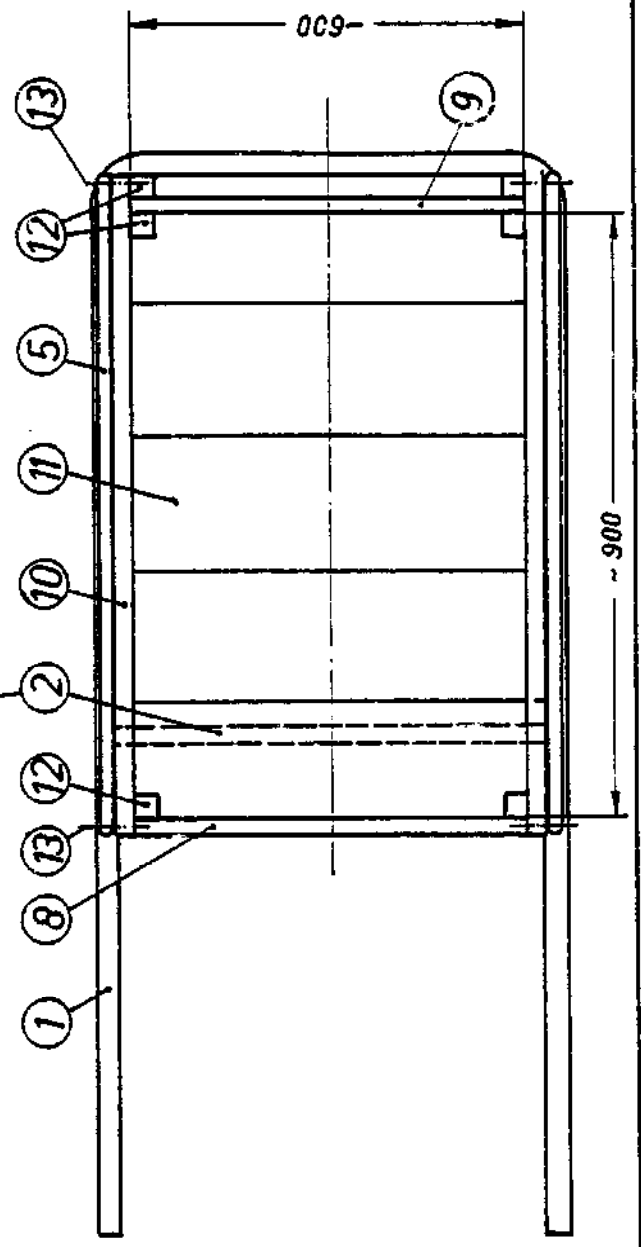
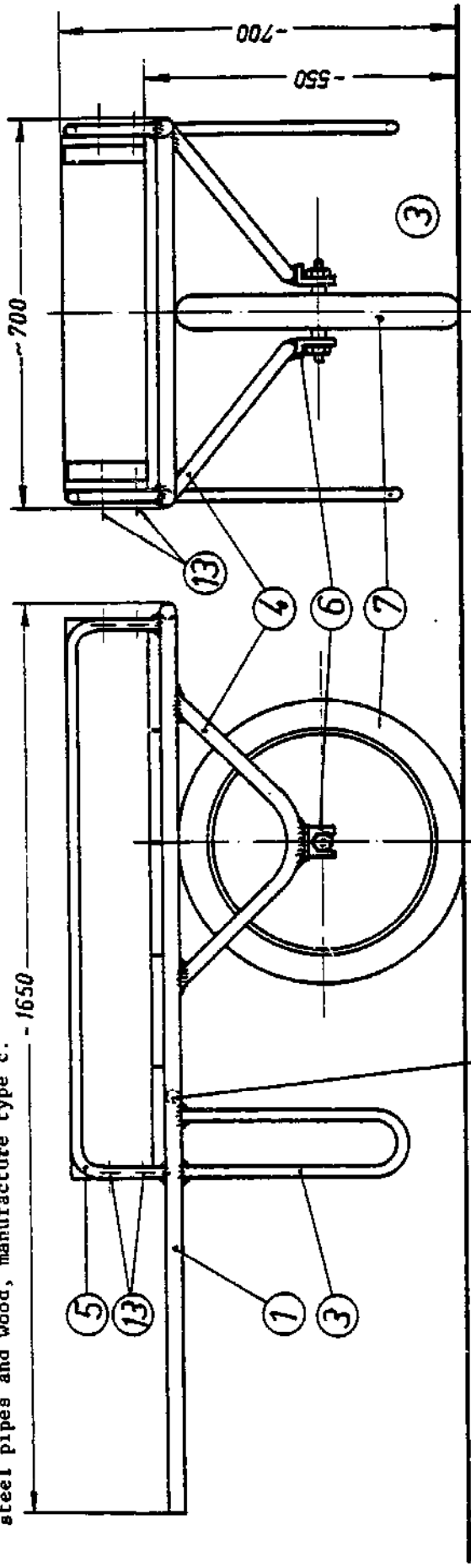

Design 17: Handcart for on and off road transport, two wheels, max. payload about 250 kg, raw material mainly steel pipes and sheet steel, manufacture type c.

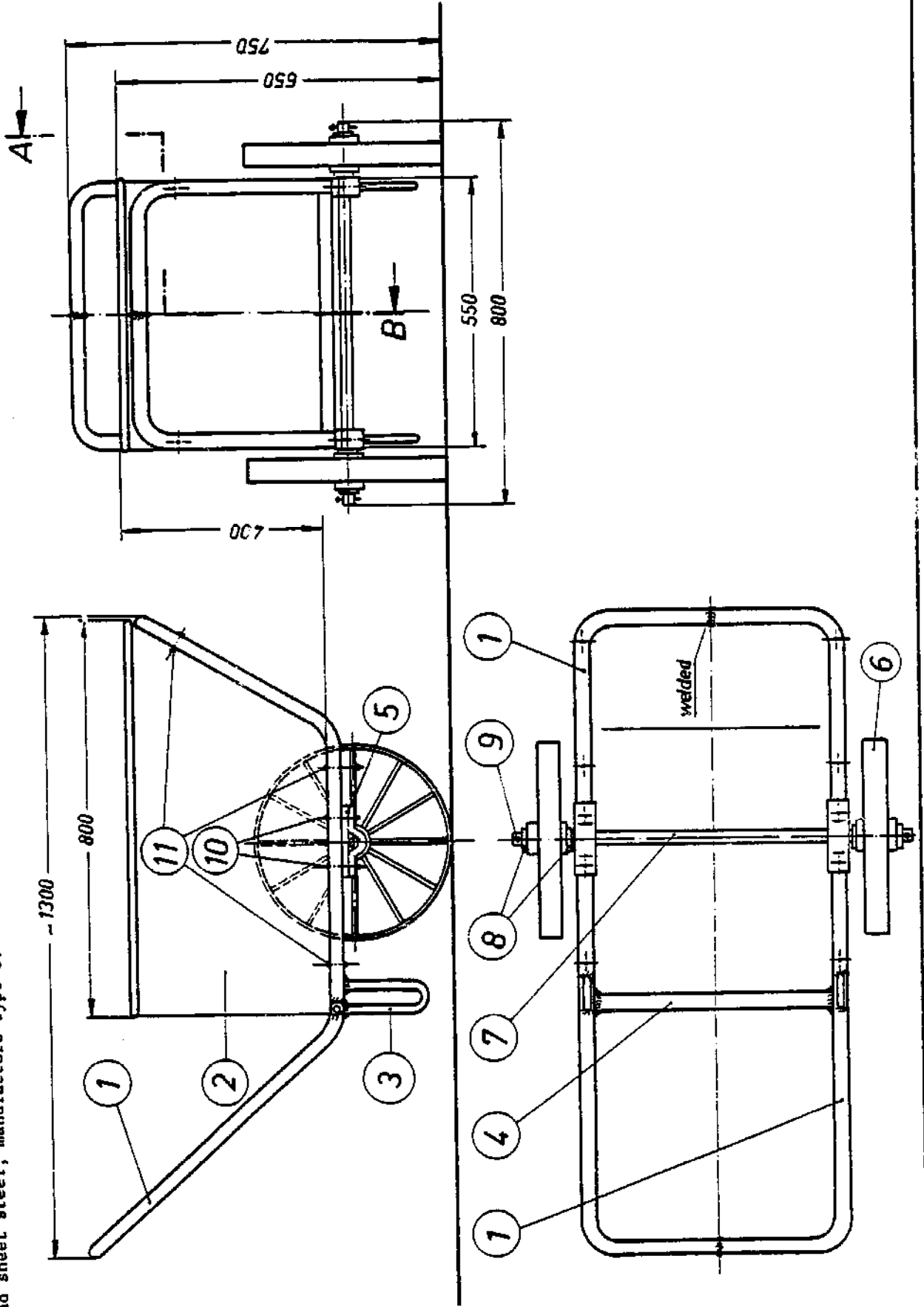

Specification design 17

Part No	Part name	Material	Dimensions of raw material
1	handle and frame	MS pipe	1" Dia x 2300 mm
2	load box	MS sheet	1.5 mm
3	curved leg	MS pipe	1/2" Dia x 400 mm
4	crosspiece	MS pipe	1" Dia x 480 mm
5	axle holder (top and bottom)	MS flat steel	8x30x150 (250) mm
6	spoke wheel	steel with pneu	about 16" Dia
7	axle	MS round steel	25 or 30 mm Dia
8	washer	MS	60 mm Dia x 4 mm
9	pin	steel	5 mm Dia x 70 mm
10	bolt and nut	steel	M8 welded to bottom of part 5
11	screw and nut	steel	M6 x 50 mm

Specification design 18

Part No	Part name	Material	Dimensions of raw material
1	outside frame (two equal pieces)	aluminium or steel pipe	1 1/4" (alu) or 1" Dia x 2400 mm
2	inside frame (two equal pieces)	alu or steel pipe	1 1/4" or 1" Dia x 1600 mm
3	connecting piece	alu or steel sheet	2x150x300 mm
4	crosspiece	alu or steel pipe	1 1/4" or 1" Dia x 700 mm
5	wheel support	alu or steel pipe	1 1/4" or 1" Dia x 800 mm
6	wheel with axle	steel with pneu	about 12" Dia
7	wheel holder	alu or steel sheet	4x40x250 mm
8	screw and nut	steel	M8 x 30 mm
9	back support	alu or steel sheet	2x100x450 mm
10	link	steel	10 mm Dia x 220 mm
11	shoulder strap	textile or leather	40 to 50 x 1000 mm
12	handle holder	alu or steel pipe	1 1/4" or 1" inner Dia x 100 mm
13	handle (adjustable)	alu or steel pipe	1 1/4" or 1" Dia x 1550 mm
14	splint	steel	standard part 6 mm Dia x 70 mm

Remark: While carrying the chee-ke on human back the handles (13) are to be used to balance and support the load. When changing the chee-ke to the wheelbarrow function the handles can be used as a set down support (handle position a) and as driving handles (position b).

Design 18: Backpack device and wheelbarrow (Chee-ke) for transport of loads in hilly terrain, one pneumatic tyre wheel, max. payload about 60 kg, raw material aluminium or steel pipe, manufacture type c.

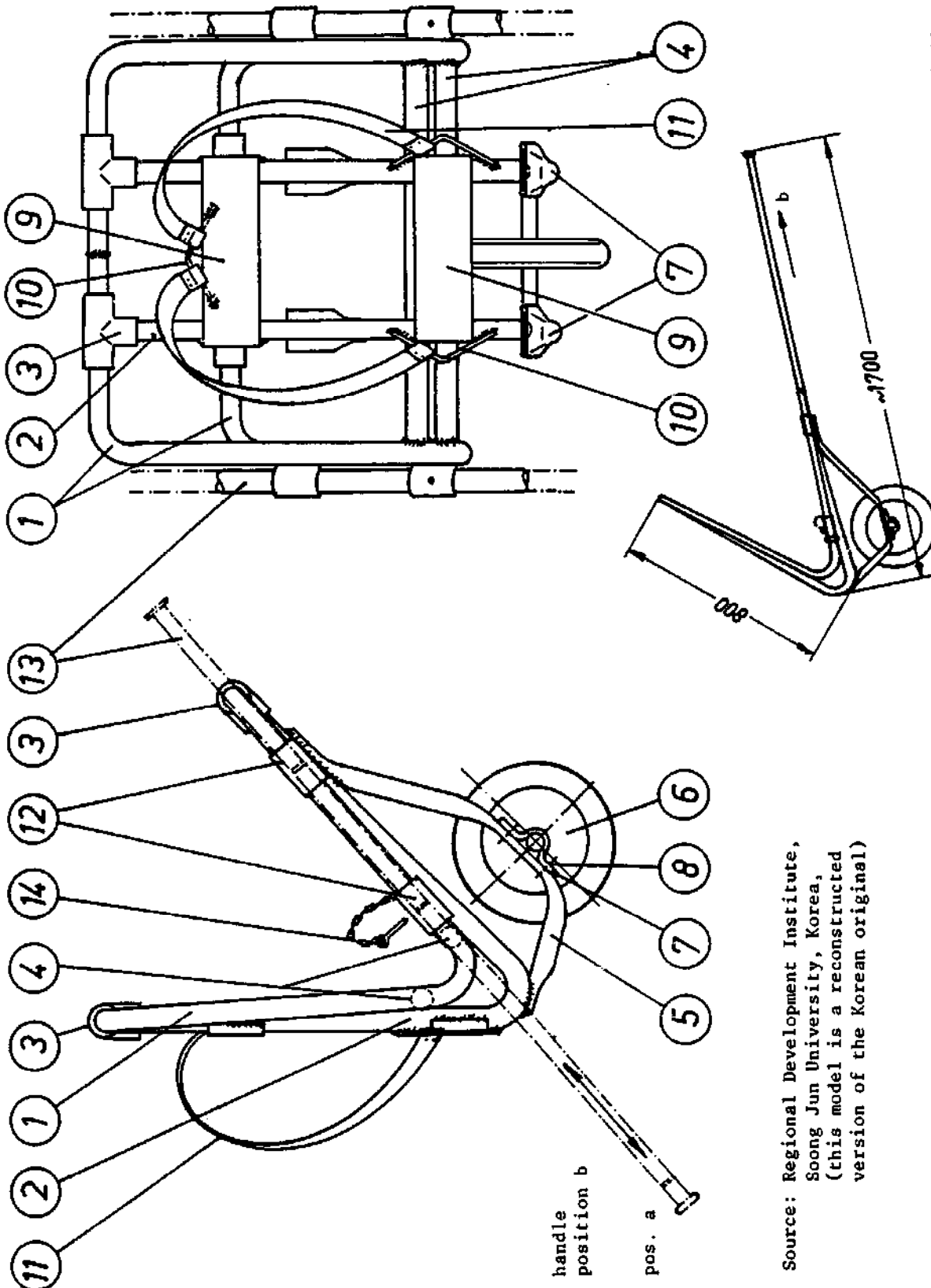

Source: Regional Development Institute,
Soong Jun University, Korea,
(this model is a reconstructed
version of the Korean original)

3.2.3 Animal drawn carts

Main characteristics: Animal drawn carts with two or four wheels are the major form of rural transport in many developing countries. Their transport efficiency depends on the condition of the cart, harness and draught animal. Provided that the animals are well tamed and trained they develop an average traction power of 250 (donkeys), 400 (mules), 500 (cows), 700 (buffaloes), 750 (bullocks) and 800 kg (horses). Thus it is enough to employ one animal for small carts on flat and prepared underground but two animals and more for bigger carts and rough conditions. The power of animals is frequently reduced as carts are badly balanced and a heavy burden presses the yoke on its neck. Besides this many yokes are inadequately shaped, too hard or wrongly situated.

The most common cart has two wheels, a flat and open platform and a long shaft to harness one draught animal. It is applicable for road and off road transport (high terrain flexibility) and has a turning circle not more than the total length of the cart. The max. payload of the 2-wheel type ranges between 0.4 tons (donkey cart with wood wheels) and 1.5 tons (bullock cart with pneus). Normally volumes close to 2 cubicmeters can be carried. The efficiency ratio (deadweight:payload) ranges between 1 : 1.5 (traditional wood construction) and 1 : 2.5 (advanced steel construction). 2-wheel carts must be balanced by the animal (low driving stability).

The 4-wheel cart is drawn mainly by two animals on fair roads or plain underground. If operated on uneven terrain the frame and platform of the 4-wheel cart is stressed by extreme forces due to torsion. They are suitable for loads up to 3 tons (two bullocks and pneumatic tyres) and volumes between 3 (container loaded with loose and heavy cargo to its upper brim) and 12 cubicmeters (load container with frame for hay). Traditional types have an efficiency ratio of 1 : 1.5, advanced steel constructions about 1 : 4. Its turning circle ranges between 6 m (cart with swivelling bolster steering) and 9 m (cart with axle pivot steering).

Generally animal drawn carts are used for long distance transport for all kinds of load. For each transport demand it must be decided whether flat or curved, open or closed, fixed or tipper-type load containers, wood, iron or pneumatic wheels, suspensions or brakes are adequate or not. Existing carts often use the animal power very inefficiently as they are too heavy loaded, badly balanced (so that a significant part of the load bears down on the neck of the animal), equipped with rough yokes and harness and carelessly maintained.

Construction and operation: Commonly there are used four types of harness: single yokes, double yokes, collar harness and breastband harness. The following figure 11 shall demonstrate some good examples for proper harness. It is recommended to reconstruct existing harnesses together with local animal drivers and harness makers. In particular the even and blank wood yokes must be shaped according to the form of the animals neck and cushioned with hair and leather. Three-pad collar harness should be introduced for cattle and horses as well.

Apart from the task to improve existing harness (suffering animals have no efficient tractive power) it is necessary to consider the common types of carts with regard to

- adequate mechanical and driving stability
- low rolling resistance
- good loading/unloading and transport performance
- high load and road flexibility
- high driving security and comfort
- simple, cheap and strong design

Because of these factors and the range of conditions under which animal carts are manufactured and operated the need is for a number of different constructions. Figure 12 shows some existing types with wide diffusion.

For relatively small farmers and traders the 2-wheel cart seems to be favourable. Even if employed on uneven terrain no major torsion forces appear at the frame of the carriage. Significant forces occur near the axle support as vertical movements of the wheels are transmitted directly to the platform. The mechanical structure of 2-wheel carts allows relatively simple details. Special attention must be given to the design of the shaft, yoke and harness as well as equal distribution of load and the position of the axle under the platform (less than 55 % of the load in front, 45 % behind the axle).

An appropriate construction of 4-wheel carts must be based on the following technical details. In order to obtain a high efficiency ratio the carriage must be light but strong. Though wooden carts generally are more heavy than steel carts it is possible to produce efficient wood vehicles which fulfil the requirements of uneven terrain. One of the axles must be attached to the frame by a flexible joint in order to keep peak torsion forces off the body. The same result can be obtained by wheel suspensions which is obviously more expensive. During the last years carts welded or srewed together from structural steelparts have proved true. They are more costly than wood carts of the same type but their tare weight, stability and durability are favourable. Since the introduction of pneumatic tyre wheels the diffusion of steel carts increased rapidly.

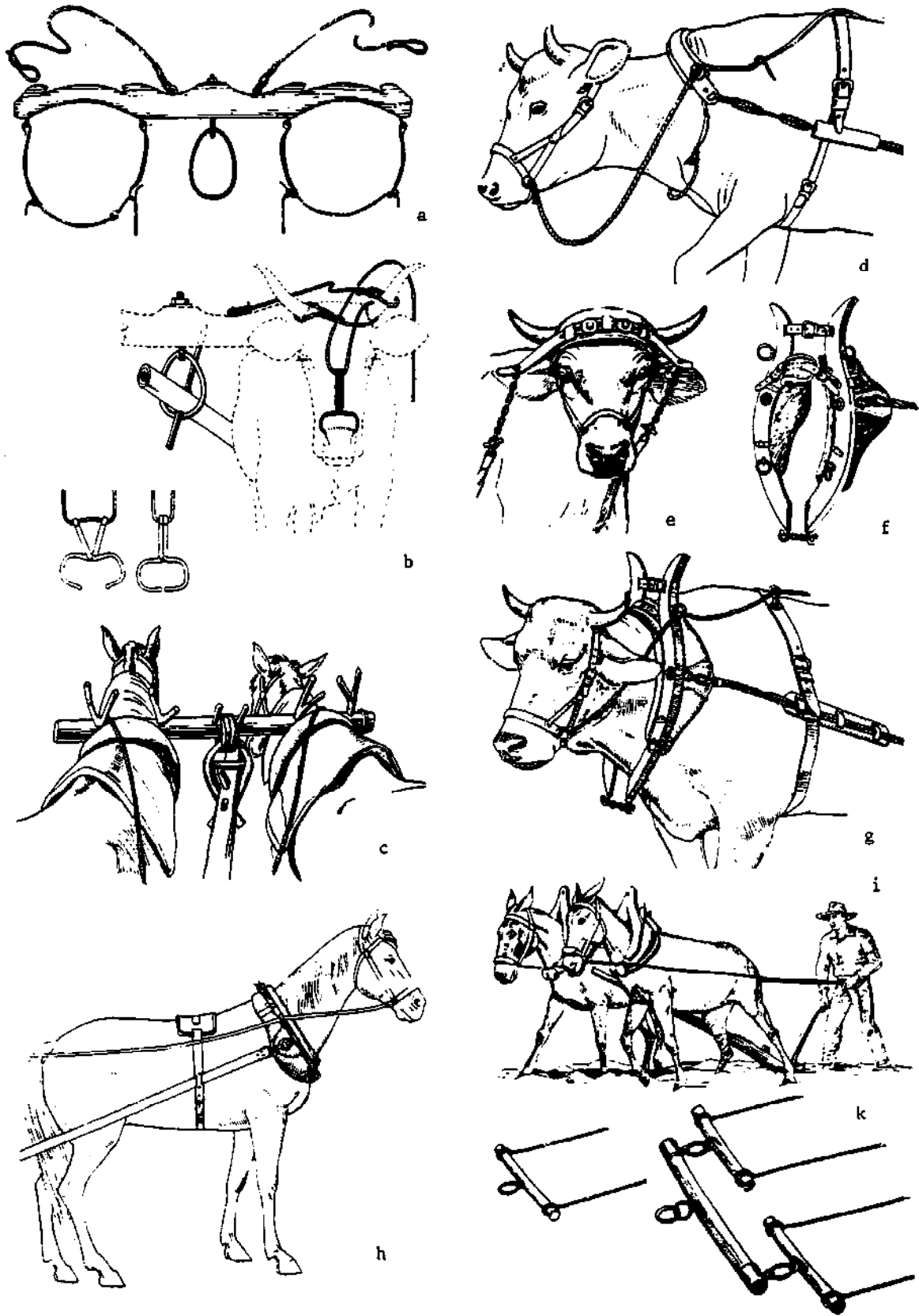

Fig.11: Various types of harness, double yoke for oxen (a,b) and with pads and collars for horses (c,i), single neck yoke (d) and head yoke (e), collar harness for cattle (f,g) and horses (h,i), swingletrees for one and two animals (k) (source: FAO Agricultural Development Paper No. 91)

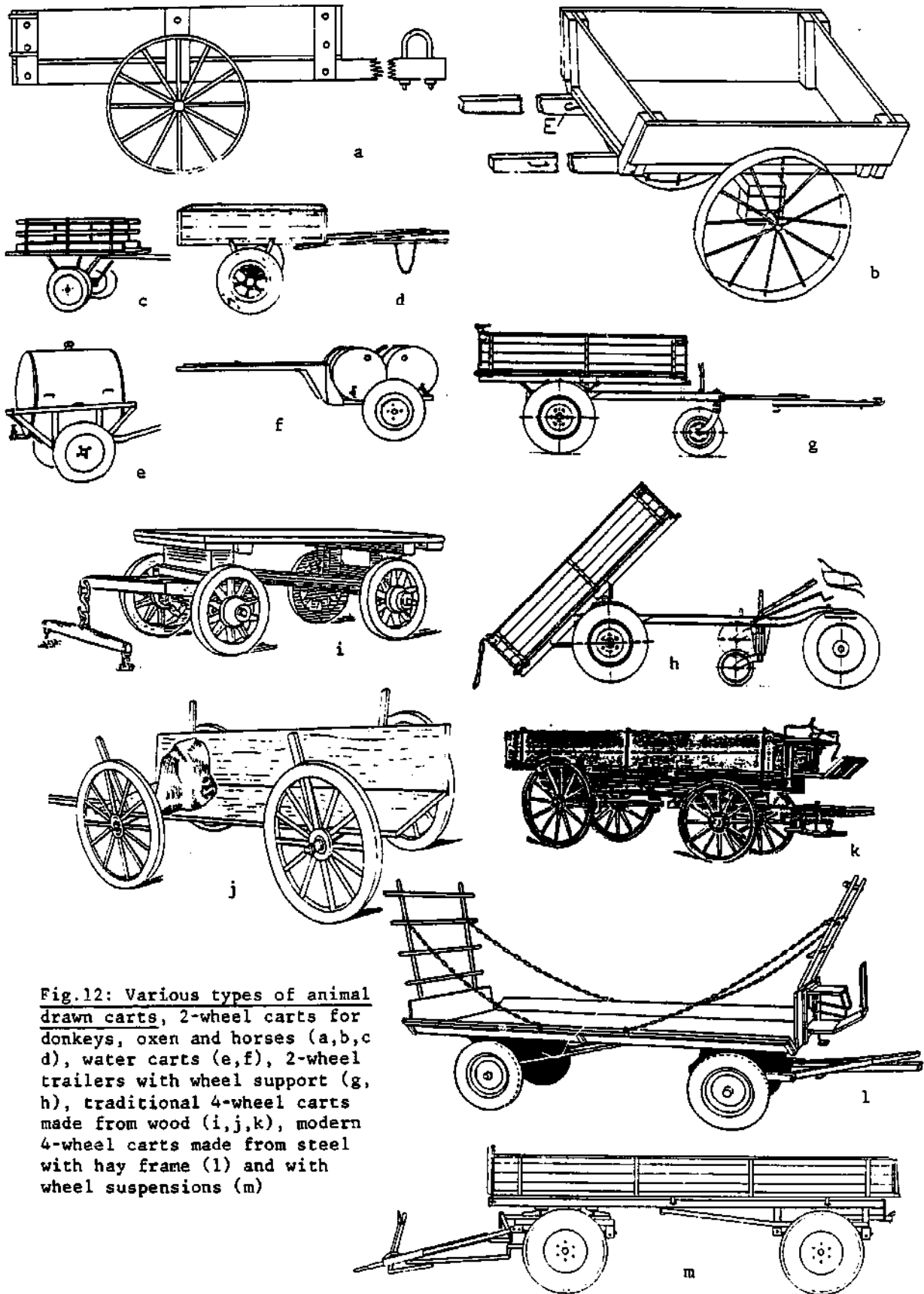

Fig.12: Various types of animal drawn carts, 2-wheel carts for donkeys, oxen and horses (a,b,c d), water carts (e,f), 2-wheel trailers with wheel support (g, h), traditional 4-wheel carts made from wood (i,j,k), modern 4-wheel carts made from steel with hay frame (l) and with wheel suspensions (m)

To prevent early tearing of vehicles while operating on uneven terrain (see fig. 13) rather flexible constructions have been developed. Body and frame are exposed to peak forces especially along the cornerpieces where longitudinal and crossbeams are connected.

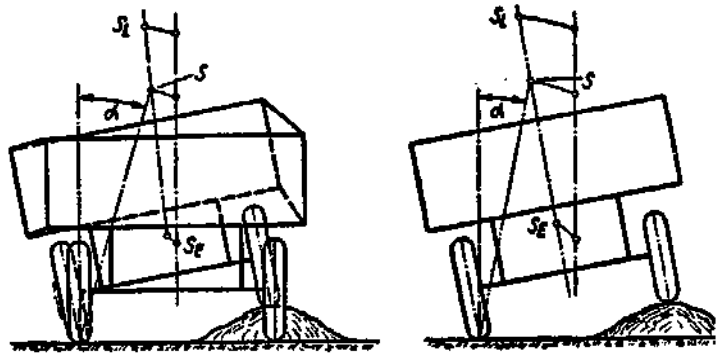

Fig.13: Scheme of a flexible and an inflexible coach on groundwaves

Figure 14 shows an example of a frame under torsion with a swivelling bolster steering and U-profile beams. It has two longitudinal beams which give a medium flexibility to the frame. The two diagonal crossbeams at the front part give a firm structure. More flexible are frames with one central beam. A comparison between the different frames and the respective crosspieces is given in figure 15. It has to be mentioned that in connection with central beam frames only the axle pivot steering should be applied.

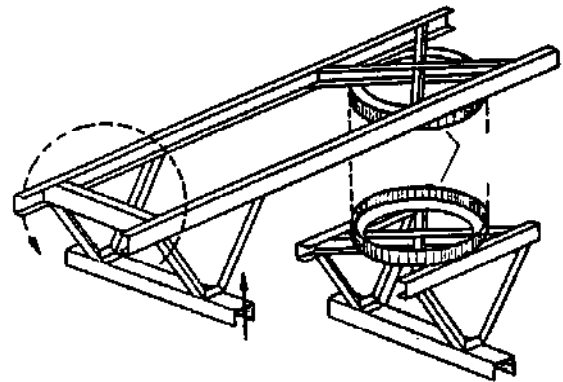
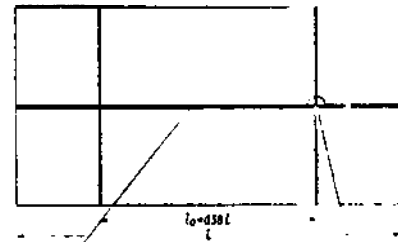
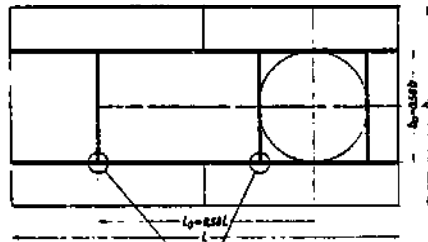

Fig.14: Cart frame from steel, inflexible front part to guarantee easy steering and flexible rear part



cornerpieces			central beam joint	cross connection joint
flexible	medium	inflexible	wrong	flexible
wrong			right	medium
better				inflex.
right				

Fig.15: 2-beam and 1-beam frames, cornerpieces and different kind of central beams

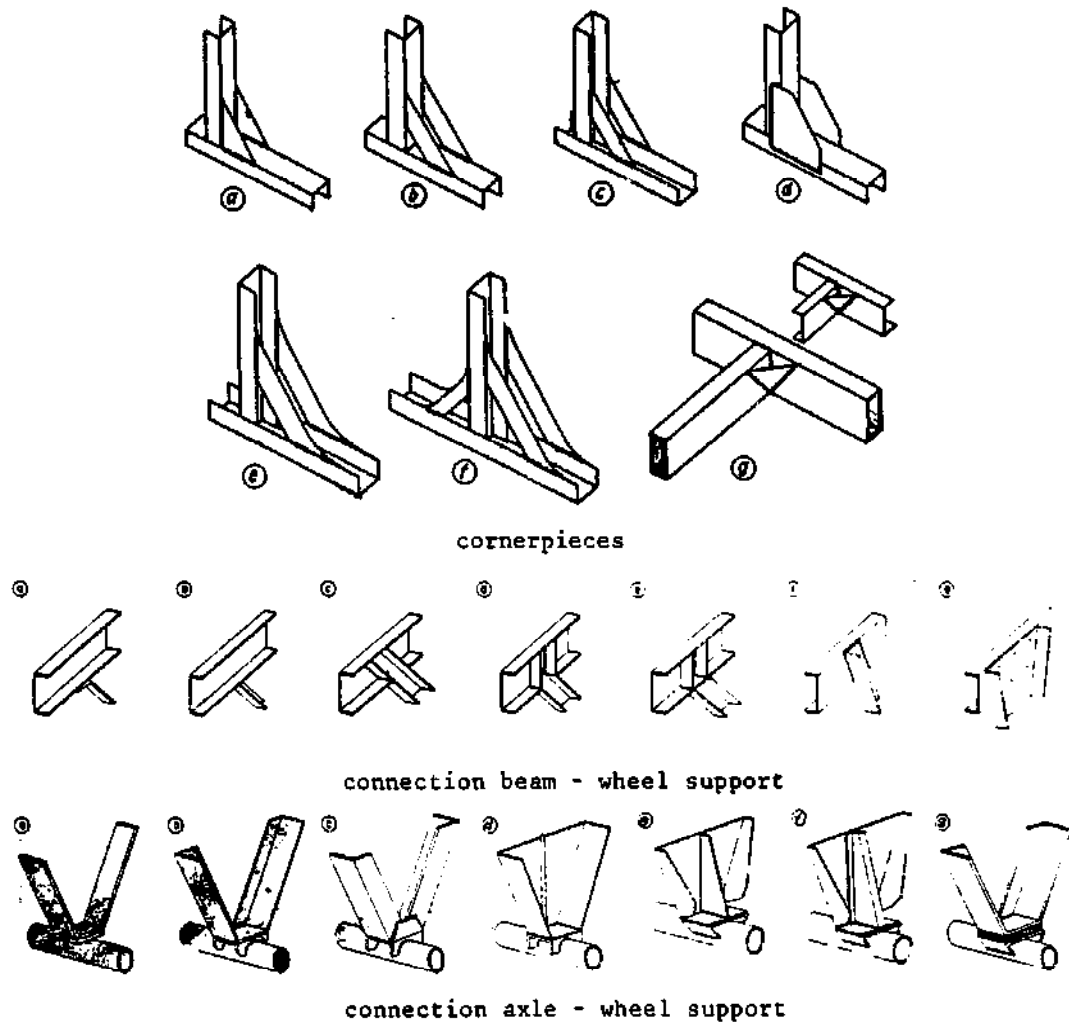

Fig.16: Different kinds of cornerpieces and connections between beam, axle and wheel support, welding connection is wrong (a,b,c), better (d,e) and good (f,g)

In order to produce strong cart frames in figure 16 some details on the kind of welded connections are recommended. Solutions a,b,c are wrong, those of d,e are better and solutions f,g are good. Frames assembled with screws must fulfil the same principles. In particular the strength of frames is determined by its design and the quality of raw material. Only little is contributed by the thickness of the material used.

Concerning the steering of 4-wheel carts two systems must be distinguished: the swivelling bolster steering and the axle pivot steering (see figure 17). The swivelling bolster steering allows narrow turning circles (about 6m), it is heavy, strong and cheap. In narrow curves its standing stability is highly reduced which gets quite dangerous on inclining terrain. Horizontal forces from the road are directly transmitted from the wheels to the shaft and harm the draught animal. This can be diminished by using pneumatic tyre wheels.

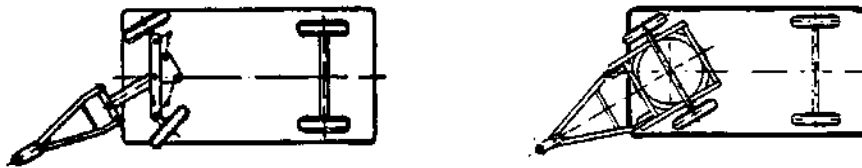

Fig.17: Axle pivot steering (left) and swivelling bolster steering (right)

Carts with axle pivot steering have a wider turning circle (about 9 m) but their standing stability is not reduced while riding through narrow curves. Shocks at the wheels don't come directly to the shaft and the neck of the draught animal. The axle pivot steering is relatively light but expensive and sensitive against twisting. Practical solutions of each steering system are shown in figure 18.

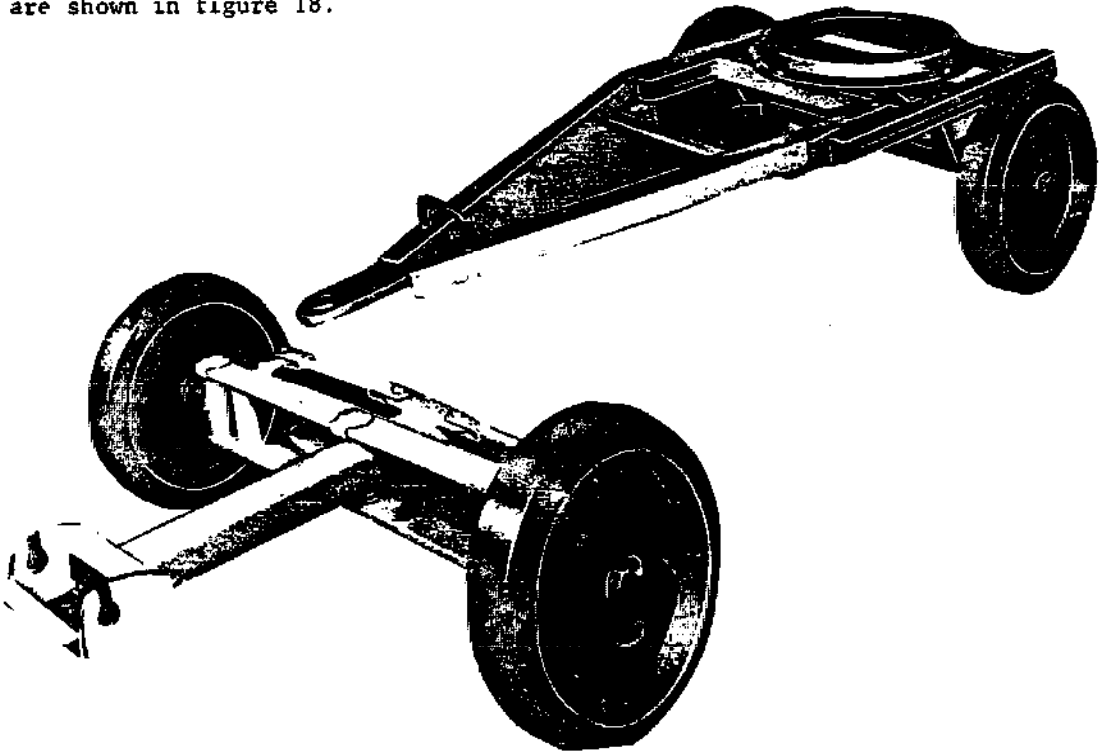

Fig.18: Axle pivot steering (left) and swivelling bolster steering (right)

With regard to an enhanced driving safety brakes must be installed in carts operating at inclining roads or/and with speeds beyond 10 miles/hour. Many bad accidents have occurred already as heavy carts were not equipped with adequate brakes (compare chapter "brakes"). The brakes can be set into function by foot- or handpedals. If the driver walks mainly aside the cart a handlever should be installed on this side. If he is sitting the most time on the coachseat either foot- or handoperated levers must be in front of the cart. When riding a tractor a handlever must be installed at the shaft (see figure 19).

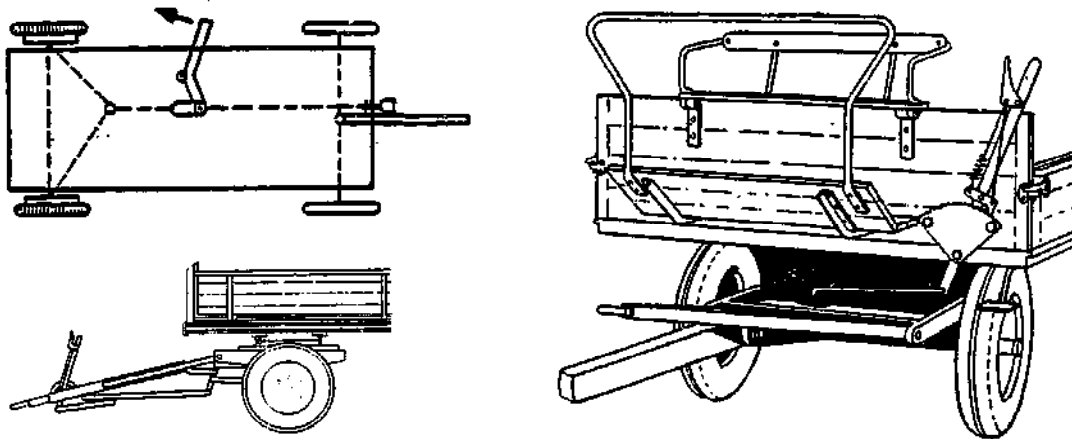

Fig. 19: Different kinds of brake lever installations in carts

Animal drawn carts riding with low speed do not need a suspension between wheels and body. But if the load is sensitive and must be protected against shocks or if extremely rough terrain will reduce the life span of the cart it is recommended to fit the vehicle with prefabricated leaf springs. This makes the cart more expensive and reduces its standing stability on inclining slopes. Figure 20 gives an example of a leaf spring and its installation in the front part of an animal drawn 4-wheel cart.

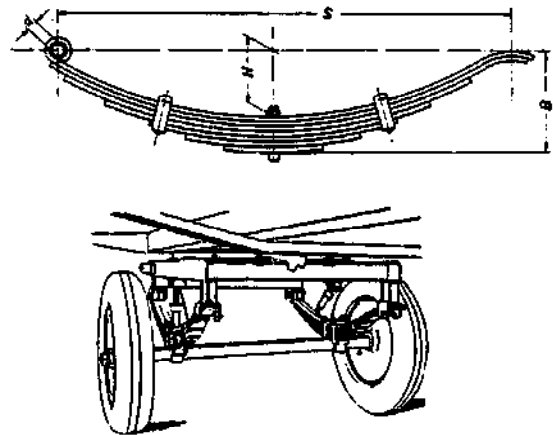
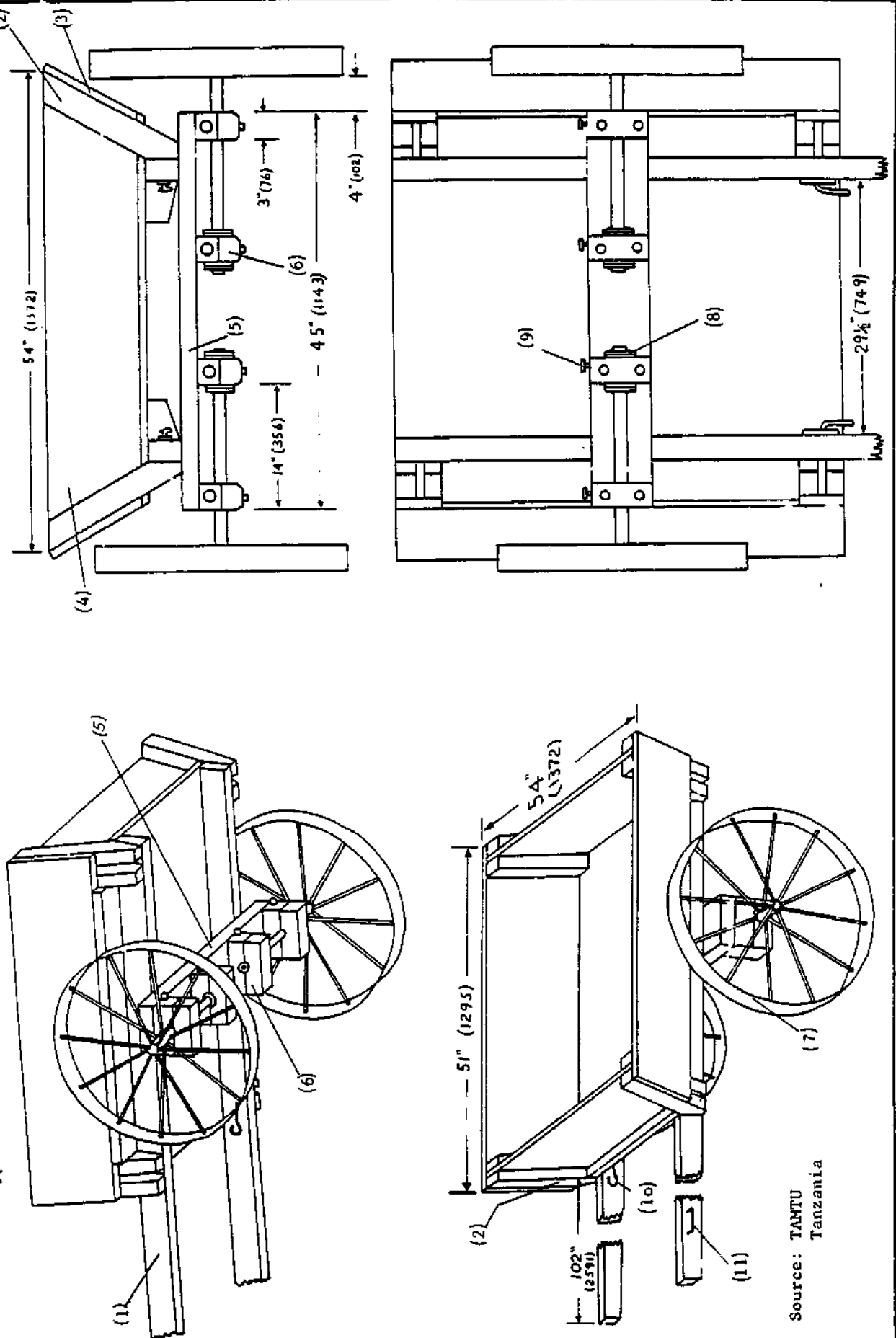

Fig. 20: Leaf spring and installation

The choice of appropriate wheels for carts influences its all over efficiency. E. g. the rolling resistance of hard wheels is about 50% higher than that of pneus. On rough terrain the difference is less or zero (see chapter "wheels"). It is recommended to continue the use of hard wheels for transport on unpre= pared terrain with low speeds while giving priority to big diameters. Some remarks on standardisation might be quite helpful : Typical for on-farm carts in Europe is the standard track (1.25 and 1.5 m). Other standards deal with the dimensions of the platform (e.g. 2-ton cart: length 3.5 m, width 1.6 m, height above ground 1 m), the max. payload (2,3,4,5 tons) and the size of rims and tyres (e.g. 5.50-16 or 6.00-16). Experience shows that the plat= form height of 1 m above ground is a good compromise for comfortable loading, unloading, adequate standing and driving stability and wheel size. These standards have proved to facilitate the work of designers, producers and users of vehicles.

Design 19: 2-wheel cart for single ox or donkey, on and off road transport, max. payload 320 kg, raw material mainly wood, manufacture type c.



Source: TAMTU
Tanzania

Specification design 19

Part No	Part name	Material	Dimensions of raw material
1	shaft/chassis	wood	65x90x3885 mm
2	corner support	hardwood	50x75x460 mm
3	side board	wood	25x305x1295 mm
4	front/back board	wood	25x265x1370 mm
5	axle bearing plate	hardwood	180x50x1140 mm
6	wood-block bearing	hardwood	65x75x180 mm
7	wheel and axle assembly	MS	rim 75x10 mm, 710 mm Dia 12 spokes, 1/2" Dia axle 1 1/4" Dia, 635 mm long
8	washer	steel	1 1/4" inner Dia
9	grease cup	steel	standard part
10	draught hook	MS round steel	1/2" Dia
11	harness eye	MS round steel	1/2" Dia

Specification design 20

Part No	Part name	Material	Dimensions of raw material
1	shaft	wood	100x100x4265 mm
2	chassis member	hardwood	50x100x1830 mm
3	side support	wood	50x100x430 mm
4	side board	wood	25x300x1780 mm
5	front/back board	wood	25x300x1320 mm
6	floor board	wood	25x300x1220 mm
7	axle bearing plate	hardwood	50x255x1220 mm
8	wood-block bearing	hardwood	75x100x255 mm
9	axle	MS round steel	1 1/2" Dia x 760 mm
10	wheel assembly	MS	rim 10x100 mm, 760 mm Dia 12 spokes, 3/4" Dia
11	shaft brace	MS flat steel	6x40x915 mm
12	washer	steel	1 1/2" inner Dia
13	grease cup	steel	standard part
14	bearing bolt	steel	M12, 255 mm long
15	yoke hitch	MS round steel	1/2" Dia

Design 20: 2-wheel cart for two oxen, off and on road transport, max. payload 650 kg, raw material mainly wood, manufacture type b.

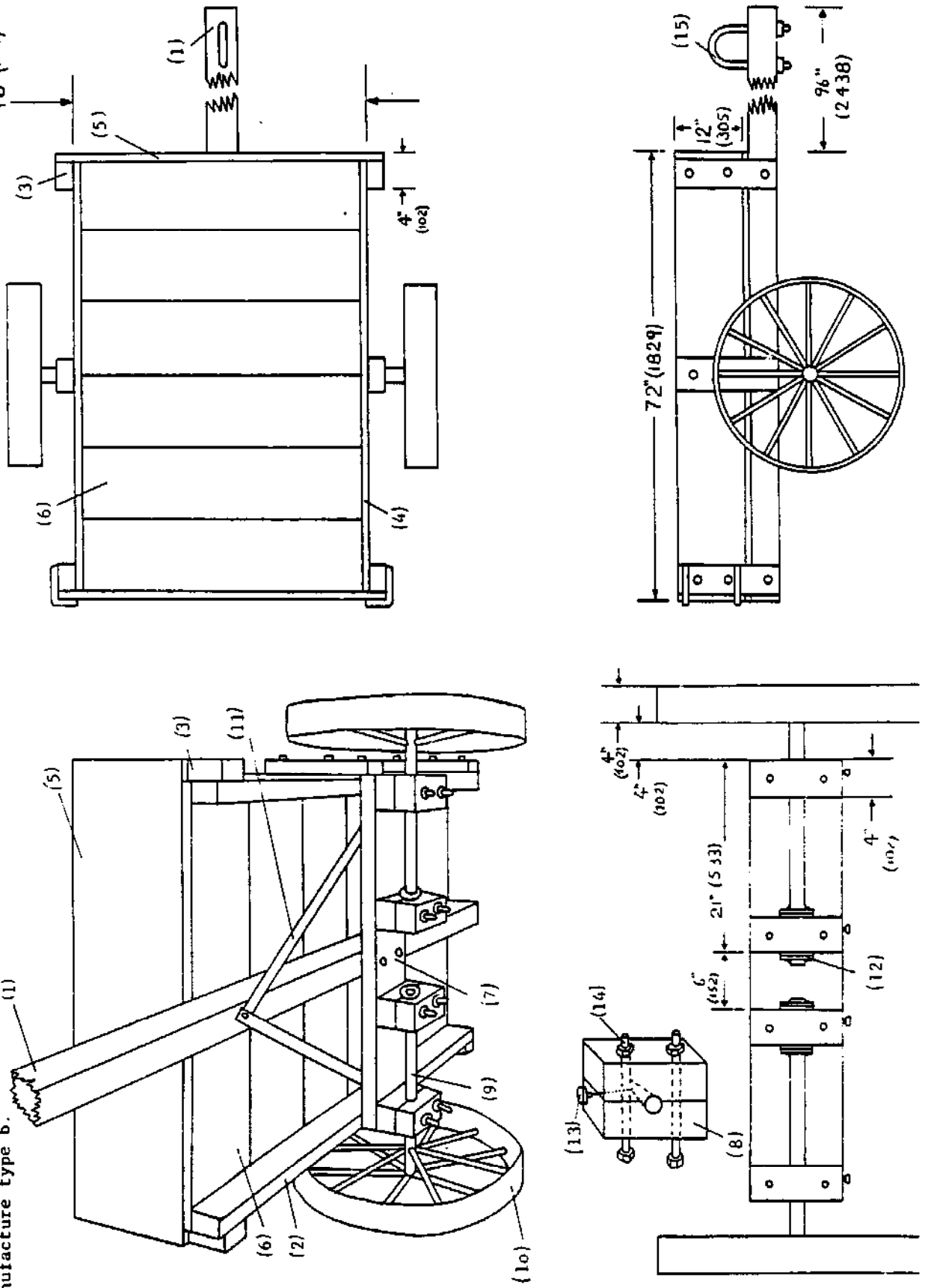

Specification design 21

Part No	Part name	Material	Dimensions of raw material
1	frame	MS	U 60x30x6, 2000 mm long
2	crosspiece	MS	U 60x30x6, 1060 mm long
3	shaft	MS pipe	2 1/2" Dia, 3940 mm long
4	diagonal crosspiece	MS	L 40x20x3, 1150 mm long
5	axle support	MS	L 60x30x5, 430 mm long
6	corner piece	MS flat steel	4x40x60 mm
7	support	MS flat steel	4x40x50 mm
8	axle	MS pipe	2" Dia, 1100 mm long
9	wheel	steel and pneu	about 600 to 700 mm Dia
10	shaft holder	MS flat steel	4x30x160 mm
11	sidewall leg	MS	U 40x20x5.5, 550 mm long
12	sidewall plank	wood	20x120x2000 mm
13	bottom plank	wood	30x275x2000 mm
14	screw	steel	M6 x 35 mm
15	screw	steel	M6 x 45 mm

Design 21: 2-wheel bullock cart for on and off road transport, max. payload 1000 kg, two pneumatic tyre wheels, raw material mainly structural steel, manufacture type c.

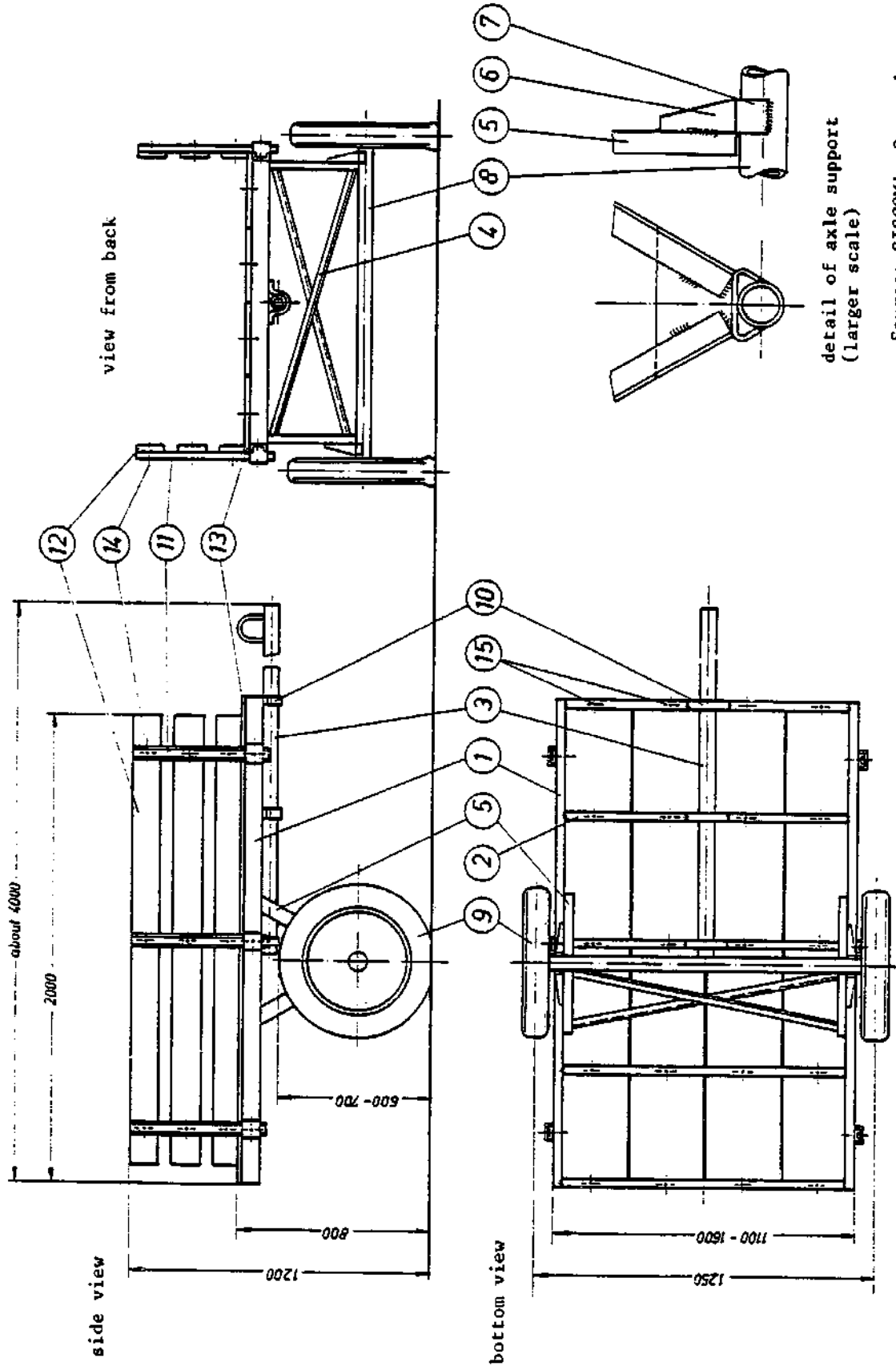

Source: SISCOMA, Senegal

Part No	Part name	Material	Dimensions of raw material
1	frame	MS	U 80x45x8, 3000 mm long
2	crosspiece	MS	U 60x30x6, 600 mm long
3	diagonal crosspiece	MS	U 60x30x6, 1000 mm long
4	rear axle support	MS	L 50x40x4, 520 mm long
5	rear corner piece	MS flat steel	4x110x260 mm
6	support	MS flat steel	4x40x200 mm
7	axle	MS pipe	1 3/4" Dia, 260 mm long
8	axle body	MS	U 80x45x8, 1100 mm long
9	upper steering ring (inner Dia 720 mm)	MS	L 40x40x3, 2390 mm long
10	lower steering ring (inner Dia 730 mm)	MS	L 40x40x3, 2450 mm long
11	steering frame	MS	U 60x30x6, 700 mm long
12	crosspiece	MS	U 60x30x6, 640 mm long
13	front axle support	MS	L 50x40x4, 500 mm long
14	front corner piece	MS flat steel	4x80x260 mm
15	support	MS flat steel	4x40x200 mm
16	shaft holder	MS	L 50x40x4, 240 mm long
17	shaft fork	MS	L 50x40x4, 800 mm long
18	shaft	MS pipe	2 1/2" Dia, 2500 to 3000 long
19	wheel	steel and pneu	about 500 to 700 mm Dia
20	crosspiece	wood	40x60x1520 mm
21	sidewall plank	wood	25x200x3000 mm
22	front/backwall plank	wood	25x200x1600 mm
23	frontwall holder (fixed)	MS flat steel	4x40x600 mm
24	side/backwall hinge	MS flat steel	4x40x600 mm
25	locking hook	MS	from local blacksmith
26	screw	steel	M6 x 40 mm
27	bolt and nut	steel	1" Dia x 30 mm with 20 mm thread

Design 22: 4-wheel ox cart for transport on roads, max. payload 2000 kg, four pneumatic tyre wheels, swivelling bolster steering, raw material mainly structural steel, manufacture type c.

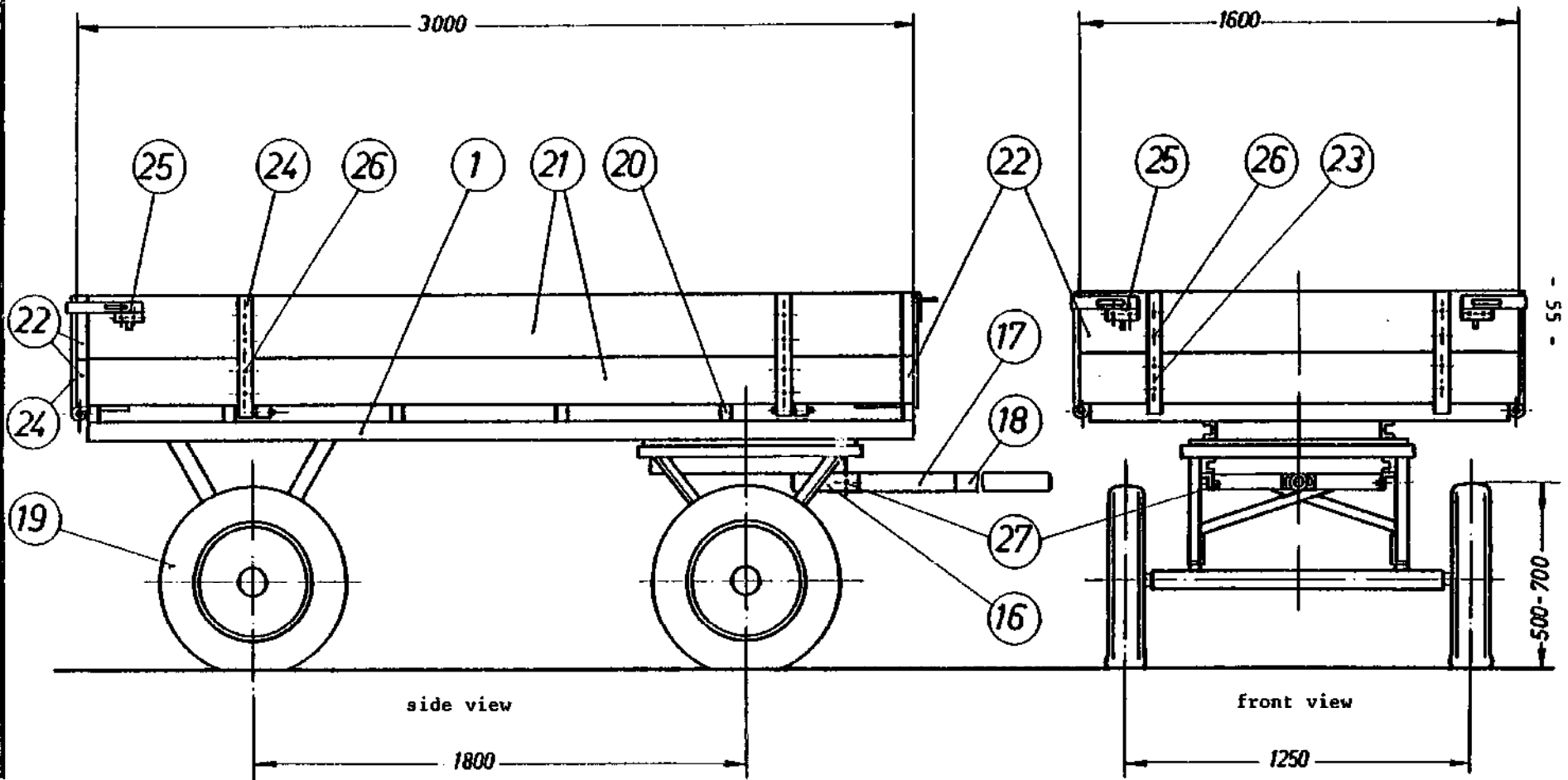

Design 22 continued: Frame of 4-wheel ox cart

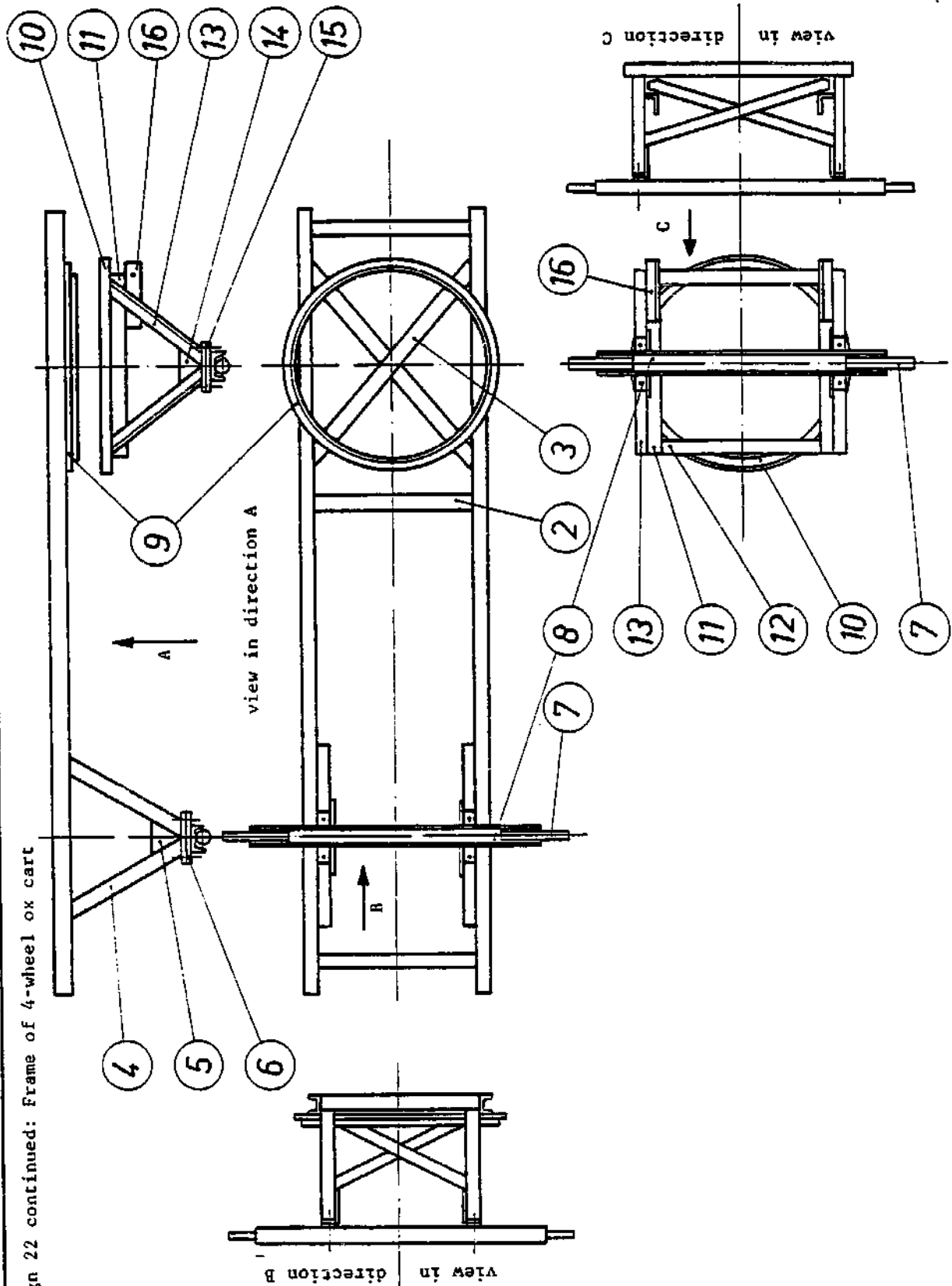

Design 23: 4-wheel trailer

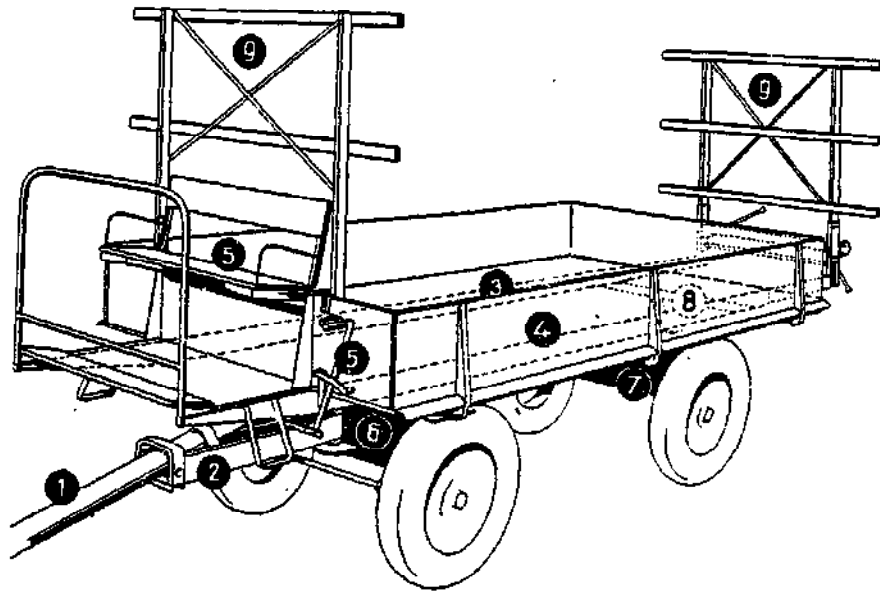

- Trailer components:
- ① shaft (not specified)
 - ② shaft joint
 - ③ frame
 - ④ platform with walls
 - ⑤ coachseat with brake
 - ⑥ front axle
 - ⑦ rear axle
 - ⑧ rear joint
 - ⑨ hay frame (not specified)

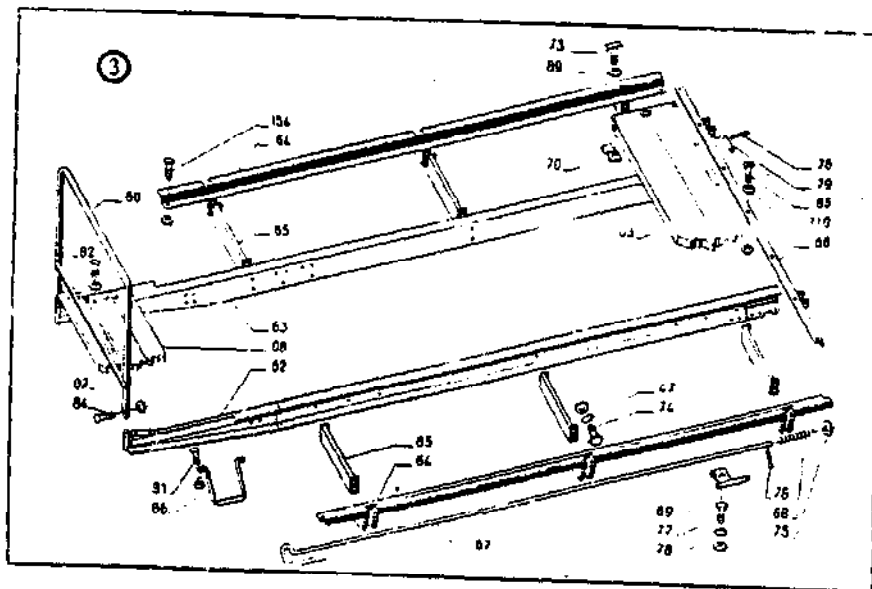

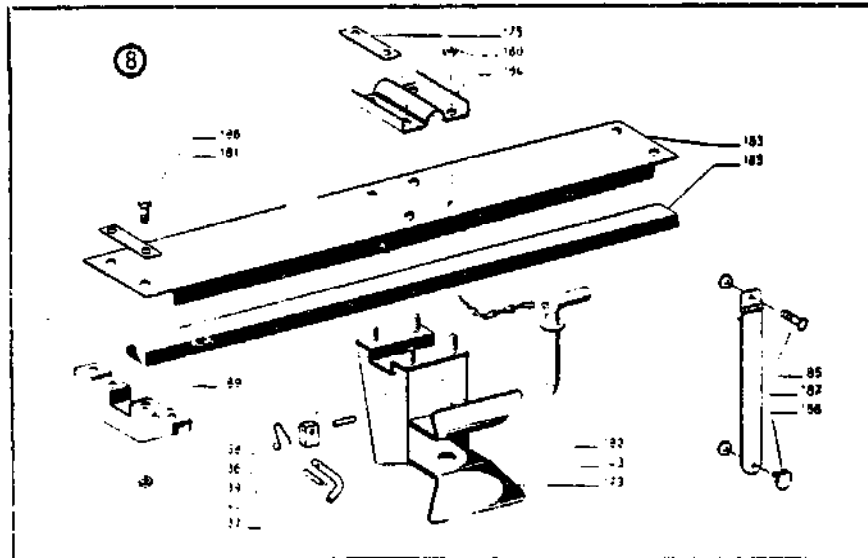
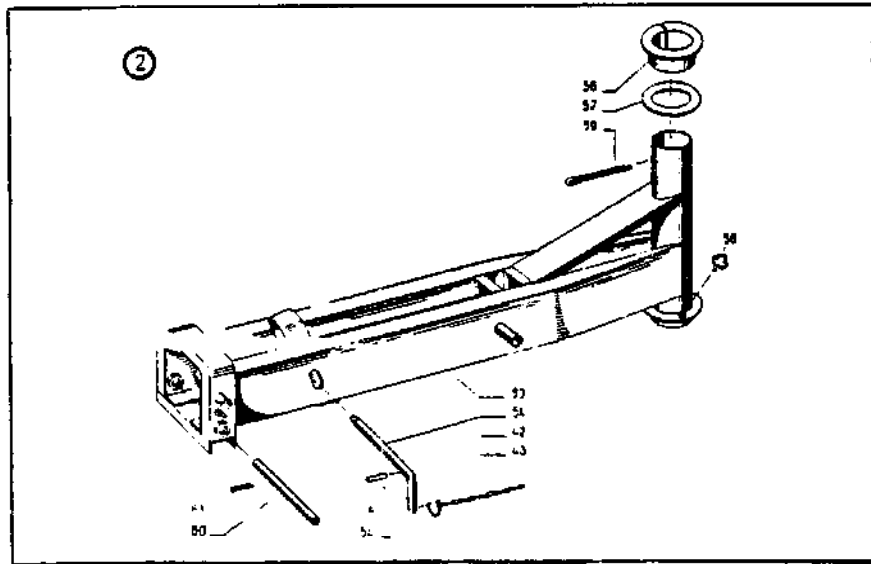

<u>Specification design 22</u>	
payload	: 2.5 to 3.0 tons
deadweight	: 0.7 tons
platform size	: 1.6 x 3.5 meters
platform height above ground	: 1.0 meter
track	: 1.25 meters
wheel base	: 2.35 meters
turning circle	: 5.5 meters diameter
steering	: axle pivot
wheels	: pneumatic tyres 5.50 - 16 "
operation terrain	: prepared roads
max. speed	: 10 miles/hour

(Further specification from Imbert / Arnsberg, FRG)

4. Workshop equipment for the manufacture of low cost vehicles and components

The vehicles and components described in the chapters before are constructed for small scale manufacture, i.e.

- application of basic and relatively cheap workshop tools, devices, machinery and other equipment
- low cost investment, working capital and infrastructure
- occupation of local labourers
- use of a high proportion of local raw material
- labour-intensive and decentralised manufacture

As the vehicles shown before have a different technological standard the following recommendations distinguish between

- manufacture type a : basic woodworking
- manufacture type b : advanced woodworking
- manufacture type c : basic metalworking
- manufacture type d : advanced metalworking

Regarding raw materials it is important to use

- dry wood (either stored under a roof for several months or dried in a special drying device)
- oil impregnated hardwood for friction bearings
- varnish after finishing wooden structures (in order to protect them against damage by moisture, rain etc.)
- strong screws instead of nails for assembling the wood parts
- structural steel profiles (sheet metal, flat steel, round bars, pipes, L-, T-, U-profiles etc.)

Type a : Basic woodworking equipment

- work bench (wood, 800 mm high, 650 wide, 2500 long, strong and accurate)
- woodworking vice (wood or cast iron)
- sawing horses (wood)
- crosscut handsaw (700 mm blade)
- compass saw (300 mm blade)
- claw hammer (0.5 to 1.0 kg)
- wood rasp (flat and half round blades, about 400 mm long)
- carpenters ratchet brace with auger bits (3, 5, 10, 15 mm)
- screw driver (250 mm long, 5 mm wide blade)
- open ended spanners (10, 13, 17 mm width)
- measuring tape (2 meters long)
- set square (400 mm)

Type b : Advanced woodworking equipment

like type a and in addition

- tenon saw (300 mm blade)
- wood files (flat, second cut; half round, second cut; 300 mm long)
- pincers (150 mm long)
- chisels (bevel-edged, square-edged, mortise chisel)
- wooden mallet
- jack plane (either wood or metal, 400 mm long)
- G-cramps (150 and 300 mm)
- spokes shave
- hand drill with set of bits (3, 5, 10 mm)
- expanding bits (15 to 30 mm)
- different kinds of assembling jigs (self made)
- hand or foot operated turning lathe for woodworking

Type c : Basic metalworking equipment

- work bench (wood or steel, 800 mm high, 650 wide, 2500 long, strong)
- metalworking vice (cast iron)
- standard hacksaw (300 mm blade)
- ball pein hammer (0.5 kg)
- files (flat, second cut; half round, bastard; 250 mm long)
- breast drill with set of bits (2,3,4,6,8,10 mm)
- screw driver (250 mm long, 5 mm wide blade)
- combination pliers (200 mm long)
- set of open ended spanners (7 to 24 mm width)
- centre punch
- measuring tape (2 meters long)
- engineers scribe and divider
- set square (300 mm)
- rim bending and wheel assembling jig
- welding apparatus

Type d : Advanced metalworking equipment

like type c and in addition

- wire frame hacksaw
- copper hammer (0.5 kg)
- files (flat, smooth; round, second cut; 250 mm long)
- hand operated post drill (with 12 mm capacity chuck)
- tin snip (straight blade 200 mm)
- adjustable spanner
- die stock and set of taps and dies (for 6 to 12 mm threads)
- simple bar and pipe bending equipment
- sheet metal folder and guillotine (250 mm long blades)

5. Literature

General

- UNIDO, "Appropriate technology for rural transport", International forum on appropriate industrial technology, New Delhi, India, Nov. 1978
- World Bank, "Appropriate technology in rural development: vehicles designed for on and off farm operations", Washington, D.C. 20433, USA, April 78
- Aian K. Meier, "Intermediate transport in Southeast Asia", Upton, N.Y., 76
- Alan K. Meier, "Superior technology in low technology transport", Part I, II, Berkeley, 94707, USA, 75
- ITDG, "Simple vehicles for developing countries", proceedings of an ITDG seminar, Coventry, G.B., June 76
- I.J. Barwell, "Notes on simple transport in some developing countries", University of Oxford, Oxford, G.B., 77
- Josef Lengsfeld, "Erleichterte Beförderung von Lasten", Band 30, Berlin, FRG., 1937

Pedal driven vehicles

- Jens Møller, "Report for development of a transport bicycle", Dar es Salaam Liberation Support Group, POB. 2099, Dar es Salaam, Tanzania
- S.S. Wilson, "The Indian cycle rickshaw", University of Oxford, Oxford, GB.
- ASTRA, "Development of bicycle makes", Indian Institute of Science, Bangalore, 560002, India
- I.J. Barwell, "The design of cycle trailers", University of Oxford, Oxford, GB., 77

Wheelbarrows, handcarts and animal drawn carts

- Appropriate Technology Development Association, "Appropriate technology", POB. 311, Gandhi Bhawan, Lucknow 226001, U.P., India, 77 (wheelbarrows)
- G.A. Macpherson, "First steps in village mechanisation", Dar es Salaam, Tanzania, 75 (wheelbarrows)
- S.S. Wilson, "The wheelbarrow", in Appropriate Technology, vol.2, No.2, 75, ITDG publication
- I.J. Barwell, "Chinese handcarts and wheelbarrows", in Appropriate Technology, vol.3, No.3, 76, ITDG publication
- FAO, "Farm implements for arid and tropical regions", Rome, 69, (harness)
- D.L. Prasanna Rao, "A study on bullock carts", ASTRA annual report, 1975-1976, Indian Institute of Science, Bangalore 560002, India
- N.S. Ramaswamy, "Modernisation of the bullock cart", Indian Institute of Management, Bangalore 56 0027, India
- CCPD, "Materiel à grand rendement pour traction bovine", World Council of Churches, Geneva, Switzerland
- R.M. Schneider, "The Samaru ox cart", Ahmadu Bello University, Samaru, Zaria, Nigeria, 67
- Th. Stoppel, "Der Entwicklungsstand im Ackerwagenbau", FAL, Braunschweig, FRG., in Landtechnik, 1952, p. 476
- Josef Lengsfeld, "Die landwirtschaftlichen Wirtschaftsfahrzeuge", Braunschweig, FRG., in Handbuch der Landtechnik, C.H. Dencker, Hamburg, 1961
- W. Kloth, "Ackerwagen mit Gummibereifung", Wofratshausen, FRG., 1948