

Ferro-Cement Jar

Instructions for manufacture

(Based on the construction of a Ferro-cement Jar at Kyera Farm, Mbarara, Uganda)



Prepared by Dai Rees and Vince Whitehead

Development Technology Unit
School of Engineering
University of Warwick
Coventry CV4 7AL
Tel: +44 (0)1203 522339
Fax: +44 (0)1203 418922
dgr@eng.warwick.ac.uk
www.eng.warwick.ac.uk/DTU/

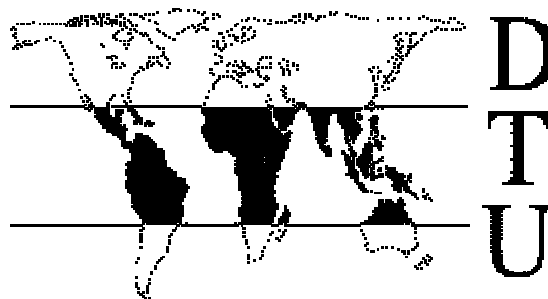

September 2000

Contents:

| | |
|---|-----------|
| 1. Introduction | 4 |
| 2. Merits and drawbacks of the Ferro-cement Jar | 4 |
| 3. Ferro-cement Jar specifications | 4 |
| 5. Tools and equipment required | 5 |
| 6. Jar Costing | 6 |
| 7. Site selection | 6 |
| 8. Manufacturing procedure for the jar | 7 |
| 9. Care of the jar on completion..... | 11 |
| Appendix 1: Low cost threading of PVC pipes using a standard galvanised iron (GI) pipe fitting | 12 |

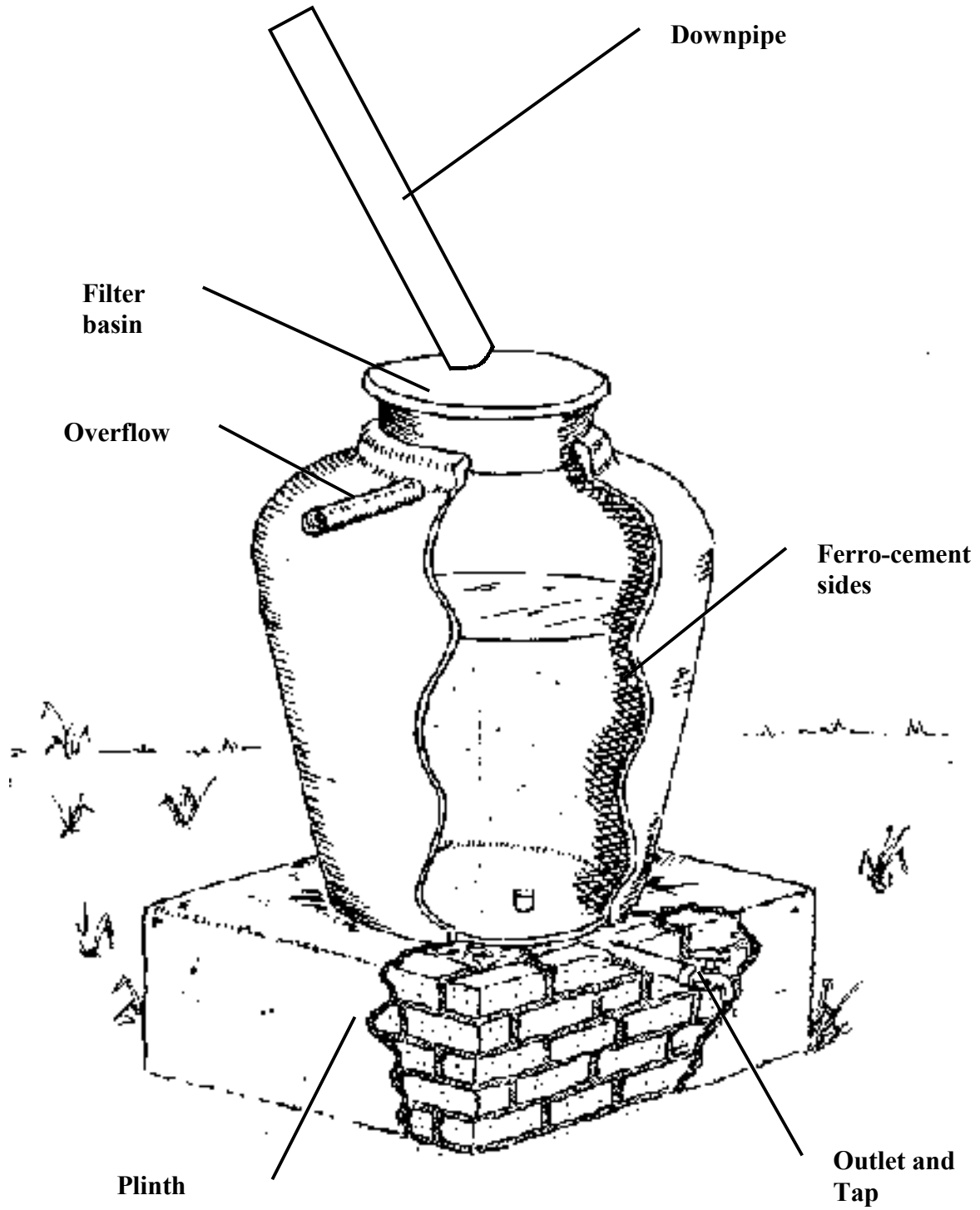

Cutaway drawing of a ferro-cement tank

1. Introduction

This manual gives guidelines for the manufacture of a 500 litre Ferro-cement Jar, which was based on a jar built at Kyera Farm, Mbarara, Uganda during June and July 2000.

The jar basically consists of a brick plinth, a Ferro-cement shell, and a filter basin.

This is a well proven technology that has been successful in Thailand, these were traditionally made from a rendered bamboo mould but now they use chicken mesh, 10 million jars were built in Thailand between 1985 and 1992.

2. Merits and drawbacks of the Ferro-cement Jar

Pros:

- Has the potential for small/large scale production by artisans.
- Very low maintenance.
- Repairs can be easily carried out.
- Low cost.
- Suitable for most ground conditions.
- Good protection against mosquitoes.

Cons:

- The level of skill required is quite high (based on recent experience in Kyenjojo, Uganda)

3. Ferro-cement Jar specifications

Table 1 gives the specifications for the jars main features:

Table 1 Ferro-cement Jar specification

| | |
|----------------------------|--|
| Jar external diameter | 0.84m (approx. at the widest point.) |
| Jar internal diameter | 0.80m (approx. at the widest point) |
| Jar height | 1.25m (approx.) |
| Jar capacity | Approximately 500 litres |
| Jar lining (inner surface) | Waterproof render |
| Wall thickness | 20mm |
| Wall composition | Chicken mesh sandwiched between inner and outer coat of render |
| Water extraction | Gravity via tap |
| Plinth | Brickwork 0.8 x 0.8 x 0.5m |
| Top | PVC filter basin |

N.B. See page 11 for Jar and plinth dimensions

4. Material and labour requirements

Table 2 Material and labour requirements for the jar.

| | Units | Ring beam | Base | Infill | 1st coat | 2nd coat | Water extraction | Totals |
|-------------------------------------|-------|-----------|------|--------|----------|----------|------------------|--------|
| Cement (OPC) | kg | 10 | 12.5 | 6 | 20 | 20 | | 68.5 |
| Sand | kg | 20 | 75 | 30 | 60 | 60 | | 245 |
| Aggregate <50mm | kg | 40 | | | | | | 40 |
| Bricks (household size) | no | | 100 | | | | | 100 |
| Rubble | kg | | | 75 | | | | 75 |
| Chicken mesh 0.5" x 0.9m roll width | m | | | | | 3.2 | | 3.2 |
| GI Pipe 1" | m | | | | | | 0.5 | 0.5 |
| GI Elbow 1" | no | | | | | | 1 | 1 |
| PVC Pipe 1.25" | m | | | | | | 0.5 | 0.5 |
| Tap 0.5" | no | | | | | | 1 | 1 |
| Reducer 1" - 0.5" | no | | | | | | 1 | 1 |
| Basin | no | | | | | | 1 | 1 |
| Labour (skilled) | days | | | | | | | 2 |
| Labour (unskilled) | days | | | | | | | 4 |

5. Tools and equipment required

- Spade or shovel
- Hoe
- Spirit level (600mm)
- Bucket
- Trowels
- Plasterers float
- Tape measure (3m)
- Tin snips or wire cutters (for mesh)
- Pipe wrench

6. Jar Costing

Table 3 gives a breakdown of the materials used for the jar and their costs

Table 3 Jar costing

| Item | Unit | No reqd | Unit cost | Total (UGS) | Total (US\$) | Total (£) |
|--|------|---------|-----------|-------------|--------------|-----------|
| Cement | kg | 68.5 | 300 | 20550 | 13.70 | 9.26 |
| Sand | kg | 245 | 20 | 4900 | 3.27 | 2.21 |
| Aggregate <50mm | kg | 40 | 25 | 1000 | 0.67 | 0.45 |
| Bricks | no | 100 | 42 | 4200 | 2.80 | 1.89 |
| Rubble | kg | 75 | 0 | 0 | 0.00 | 0.00 |
| Chicken mesh 0.5" | m | 3.2 | 1667 | 5334.4 | 3.56 | 2.40 |
| GI Pipe 1" | m | 0.5 | 4200 | 2100 | 1.40 | 0.95 |
| GI Elbow 1" | no | 1 | 1500 | 1500 | 1.00 | 0.68 |
| PVC Pipe 1.25" | m | 0.5 | 1667 | 833.5 | 0.56 | 0.38 |
| Tap 0.5" | no | 1 | 5000 | 5000 | 3.33 | 2.25 |
| Reducer 1" - 0.5" | no | 1 | 1500 | 1500 | 1.00 | 0.68 |
| Basin | no | 1 | 1000 | 1000 | 0.67 | 0.45 |
| Labour (skilled) | days | 2 | 5000 | 10000 | 6.67 | 4.50 |
| Labour (unskilled) | days | 4 | 3000 | 12000 | 8.00 | 5.41 |
| Material costs | | | | 47918 | 31.95 | 21.58 |
| Total cost (incl. labour) | | | | 69918 | 46.61 | 31.49 |
| Cost per litre stoarge | | | | 96 | 0.06 | 0.04 |
| Cost per litre storage (incl. labour) | | | | 140 | 0.09 | 0.06 |

Notes

- Mould cost not included - cost of mould is approx. 6000UGS (US\$3.38) and may last for up to 10 or 15 jars depending on care taken during manufacture
- Larger sizes of jar - say up to 1500 litres - can be achieved by experimenting with the mould size
- Sawdust can be obtained from local sawmills
- The volume is obtained by using a bucket of known volume and counting the appropriate number of buckets of sawdust
- Some transport costs included (i.e. for sand, aggregates and bricks)
- Cost of bucket slab not included

7. Site selection

It is important to select the right site for the jar so that it will remain a reliable source of water for years to come.

Some pointers for what constitutes a good site are given below:

- Good ground stability (i.e. not sandy soils).
- Jar should be close enough to the dwelling to avoid long lengths of guttering and downpipe (some suggest siting the jar mid way along the length of a building to reduce gutter size– this is fine if water from one side of the building only will be fed into the jar).
- Reasonably flat where possible – otherwise the ground will have to be levelled before marking out.
- Away from trees which may undermine the foundations and cause cracking.
- Away from areas where animals will wander – fence off if needed.
- Not so close to the dwelling that the foundations are undermined.
- Somewhere convenient for extracting water e.g. close to the kitchen area.
- It must be a suitable distance away from vehicle access as this may cause ground movement, fence off if necessary.

8. Manufacturing procedure for the jar

- Prepare a level piece of ground approximately 1.0m square.
- Mark out an inner and outer square with sides of 0.85m and 0.55m respectively as shown in Figure 1.

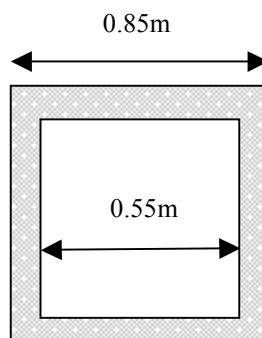

Figure 1 Inner and outer squares for the plinth foundations

- Carefully excavate between the two squares to a depth of 10cm. (NB if soil tends to be unstable excavate to 20 cm deep and fill with aggregate 10cm deep, alternatively make a larger deeper ring beam)
- Fill the excavation with a concrete mix of 4:2:1 (aggregate: sand: cement) and cover with damp grass/leaves and leave for two days. Start building the brickwork, with a plinth outer size of approximately 0.8m, on top of the concrete ring using a mortar mix of 5:1 (sand: cement) to a height of 0.55m as shown in Figure 1. Leave a gap in the top course of bricks for the outlet pipe.
- Fill the centre of the plinth with rubble/aggregate, compacting it well to prevent later settling.



Figure 1 Brickwork plinth

- Cut off a length of $\text{Ø}3/4''$ GI pipe and fit on a $\text{Ø}3/4''$ elbow at one end and a $\text{Ø}3/4''$ to $\text{Ø}1/2''$ reducer and a $\text{Ø}1/2''$ tap at the other. Local plumbers can thread the GI pipes, alternatively a low cost method of threading $\text{Ø}3/4''$ PVC pipe is explained in Appendix 1.
- Cut off a piece of pipe 25mm long pipe that has been threaded at one end and fit this to the elbow. This will give the jar a settling zone, but it can also be removed for washouts.
- Dig out a channel in the rubble and place the pipe in so that the tap and the elbow are vertical. N.B. make sure the top of the elbow is 3cm above the level of the rubble.
- Apply a 1cm layer of mortar to the top of the rubble and flush with the edges of the plinth, apply a layer of damp material and cover with plastic sheet, leave this to cure.
- Prepare a disc of mortar 0.6m diameter by 1cm deep on to the plinth base.
- Cut out a ring of chicken mesh to a diameter of 0.75m and turn up the edges 0.1m, so that it leaves a base diameter for the jar of 0.55m.
- While the disc of mortar is still damp lay the chicken mesh on to the top of this and then apply another layer 1cm deep to the mesh this should be level with the top of the elbow.

- Cut out and sew up a polypropylene or hessian sack to the dimensions shown in Appendix 2.



Figure 2 The filled polypropylene sack mould

- Fill the sack mould with sawdust (rice husk, coffee husks, sand or any other similar available material) and compact it as it is being filled. When full tie it up at the top and pat the sides to produce an even symmetrical shape then place this on the prepared base of Ferro-cement as shown in Figure 2. The capacity of the jar can be determined by filling the sack with buckets of known volume, simply count the number of buckets to until 500 litres is achieved.
- Place a medium sized basin centrally on top of the mould with a short length of PVC pipe for the overflow. Apply the first coat of mortar of 3:1 mix with a waterproof additive (quantity as per manufacturers instructions) to a thickness of 1cm as shown in Figure 3, (the thickness may vary as the irregularities of the mould shape is compensated for)



Figure 3 Overflow, filter basin and first coat application

- When the first coat has been applied cover with a damp cloth and a plastic sheet, leave for 24 hours, making sure the cloth is kept damp.
- Wrap around the jar a suitable length of chicken mesh to cover the whole area up to the filter basin pull the mesh tight and fix with short lengths of wire to secure in place as shown in Figure 4.
- Apply the second coat of mortar (make this layer smooth by rubbing over with a small wooden hand float) also apply mortar around the tap outlet to secure it to the base and jar side as shown in Figure 5.



Figure 4 Applying the mesh on top of first coat

- Cover the shell again with a damp cloth and a plastic sheet, leave for 48 hours.
- When the shell is firm carefully remove the filter basin and untie the mould bag, and carefully take out the contents.
- Fill the bottom of the jar with enough water to come up to the level of the outlet pipe and replace the damp cloth with the plastic sheet and leave for 7 days to cure.
- Make a series of about twenty holes in the bottom of the basin using a hot nail or a drill ($\text{\O}6\text{mm}$) for the rain to enter the jar. Fill the basin with aggregate (about 20mm) to about one third full.
- Cut out a section of clean cloth that will cover the basin and have sufficient to overhang down the sides, then tie around the sides of the basin with string or rubber inner tube strip to hold the cloth in place.



Figure 5 Detail of the outlet fixing

- Lower the basin on to the top of the jar.
- Fix the appropriate gutter to the roof and place the downpipe directly on to the cloth.
- Cut out a small piece of mosquito mesh and fit this on to the end of the overflow pipe with string/twine etc.

9. Care of the jar on completion

Once the jar is finished and has cured for 7 days, fill with 125mm (5”) of water each day so that the structure is gradually loaded rather than all at once.

It may be noticed that the jar will leak slightly somewhere around the sides, it is best if this is left for at least a week, as quite often the jar will eventually seal itself if the hole is small (based on masons personal experience in Uganda). However, if it shows no sign of sealing or the hole is quite visible, empty the jar and make the repair with a nil mix (i.e. purely a cement and water mix) from the inside of the jar.

It is important that there are no gaps around the filter and cover, or around the filter where light can enter as this will not only encourage the growth of algae but may be an entry point for mosquitoes both of which should be avoided. The water may have a cement taste at first so either rinse out well several times or use the jar for washing rather than cooking for the first few times.

Appendix 1: Low cost threading of PVC pipes using a standard galvanised iron (GI) pipe fitting

There are many occasions where threads are required on PVC pipes so that other fittings can be added to the pipe. This often involves the use of expensive threading equipment, which is not always available when needed and the charge for this service can become expensive when it is done repeatedly.

The method described here was tried out in Uganda after finding the problems mentioned above and was found to be a useful and successful solution that was very low cost. Though it requires some tools, a little bit of skill and some patience, once it has been made it will last for many threading operations and re-sharpening is simple to do.

The following example is for a $\text{Ø}1\frac{1}{2}$ " PVC pipe but the same procedure is carried out for other sizes:

Tools required:

One hacksaw blade (preferably with 24 teeth per inch)

A small (6" long) triangular file (the width across the faces should preferably be no more than about $\frac{3}{16}$ " or 4mm)

Pipe grips or a vice.

10" rough flat file.

The reliability of the threads for higher pressure applications has not been checked and care will be needed when trying this out.

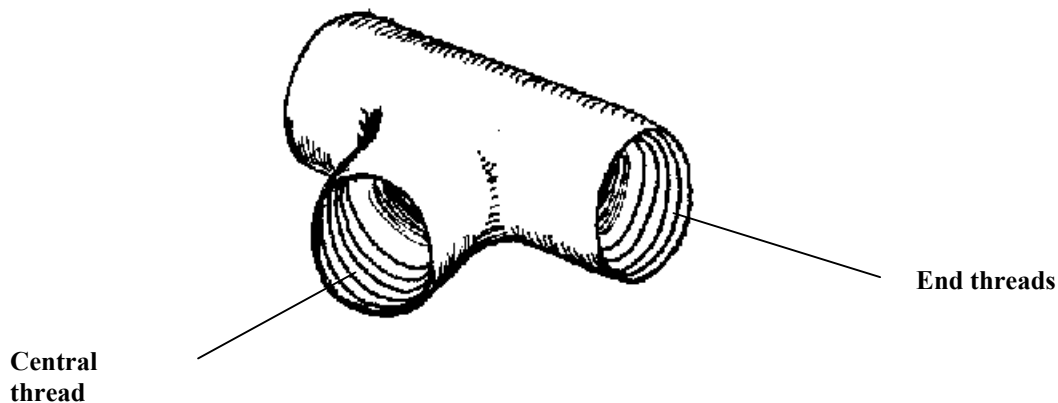

1. Take a normal GI $\text{Ø}1\frac{1}{2}$ " Tee fitting as shown in Figure 1 and make three equally spaced saw cuts with the hacksaw blade in the central part of the Tee to just beyond the roots of the thread as shown in Figure 2.

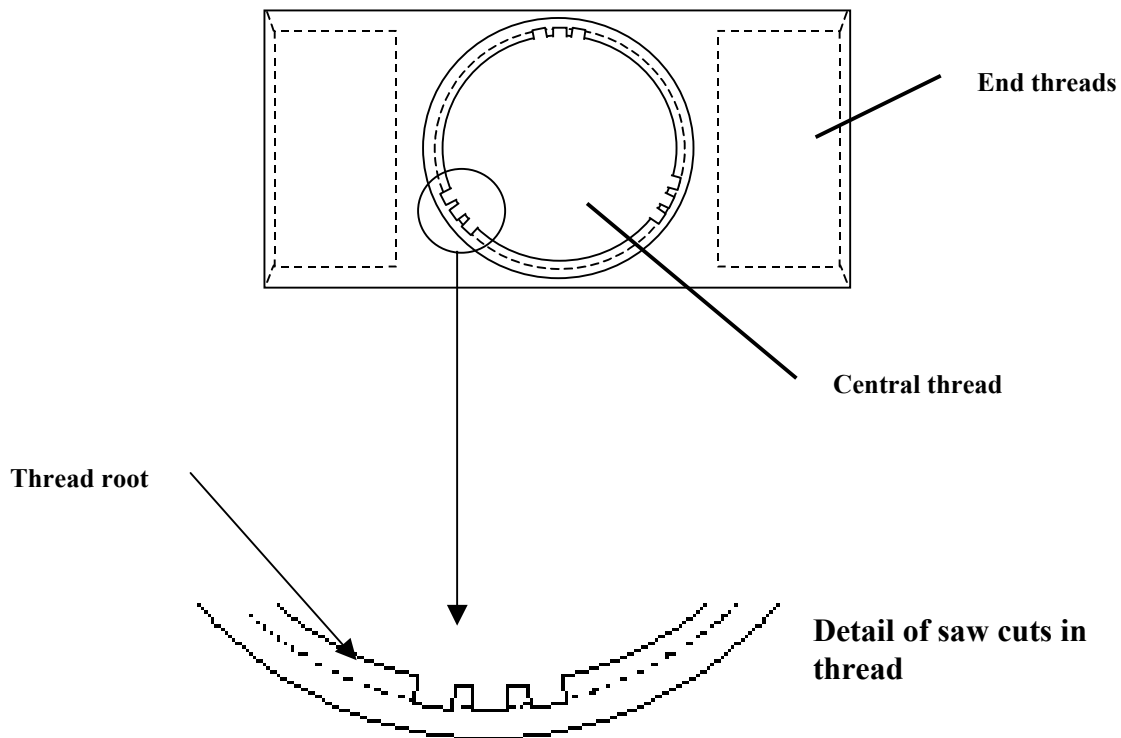

Figure 2 The GI Tee with the saw cuts equally spaced round the central thread

2. Make additional saw cuts as close as is practically possible to the first thread so that it is slightly wider than one of the faces of the triangular file, this is to ease the burden of filing.
3. Proceed to file each of the saw cuts so that the roots of the thread can no longer be seen.
4. File the left-hand side of the slot, as this will be the cutting edge, so that the profile is the same angle as the file i.e. 60° as shown in Figure 3.

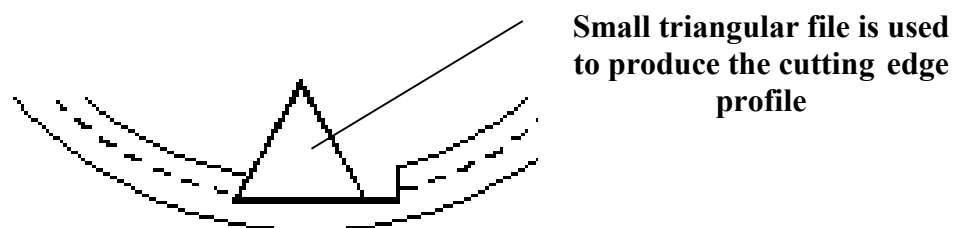

Figure 3 The GI Tee with detail of the cutting edge profile on thread

5. Using a rough file chamfer the end of the pipe to be threaded to the dimensions shown in Figure 4.

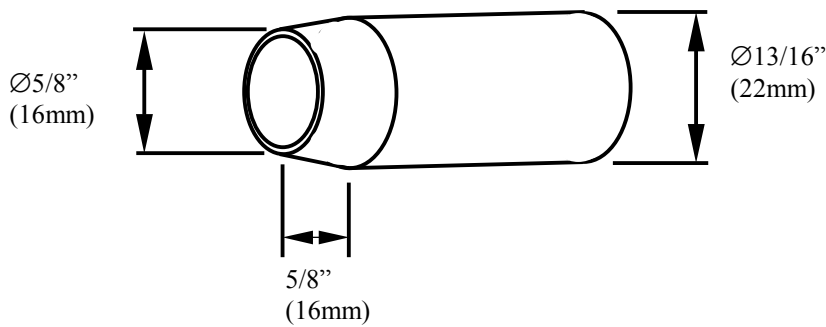

Figure 4 Chamfer dimensions for the Ø1/2" PVC pipe

6. Hold the pipe firmly in an upright position (using a vice or pipe grips) and apply a generous amount of grease or Vaseline to the thread cutter or to the pipe end. This will reduce the friction while thread cutting.
7. Place the thread cutter on top of the pipe and gently start to turn/thread it on to the prepared pipe, making sure that the top of the GI fitting is level as shown in Figure 5.

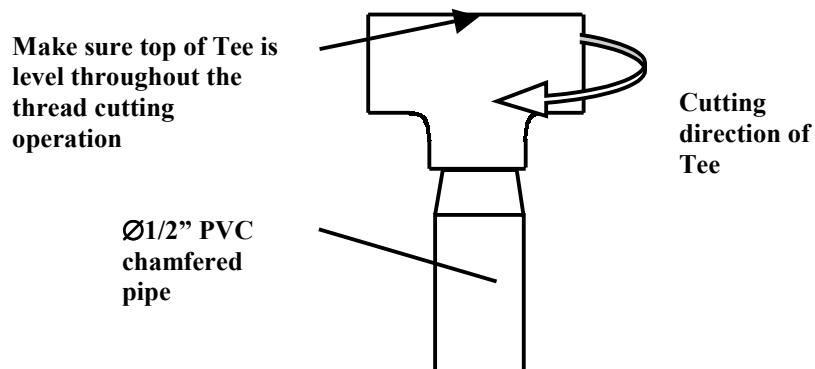

Figure 5 Starting the thread cutting

8. Turn several times (by inserting a screwdriver or steel rod through the Tee) then remove and clean out the thread of any plastic that has built up. For every revolution of the thread cutter turn back again half a revolution, this will break off the material being cut and avoid clogging of the cutting edge space.
9. Repeat the operation until a sufficient length of thread has been cut.

Re-sharpening the cutter is simply done by filing the cutting edge with the small triangular file until the blunt edge has been removed.

Polythene bags cut in to thin strips and wrapped round the thread is a good low cost substitute for PTFE tape.

Please note that it may take several attempts before a satisfactory thread has been made so practice on spare pieces of material until confidence and the quality is built up.