

AT **MICROFICHE
REFERENCE
LIBRARY**
A project of Volunteers in Asia

Rural Mechanics Course 1: General Metal Work, Sheet Metal
Work and Hand Pump Maintenance

By: John van Winden

Published by: **TOOL Foundation**
Sarphatistraat 650
1018 AV Amsterdam
The Netherlands

Available from: **TOOL Foundation**
Sarphatistraat 650
1018 AV Amsterdam
The Netherlands

Reproduced with permission.

Reproduction of this microfiche document in any form is subject to the same restrictions as those of the original document.

GENERAL METAL WORK, SHEET METAL WORK AND HAND PUMP MAINTENANCE

RURAL MECHANICS COURSE 1

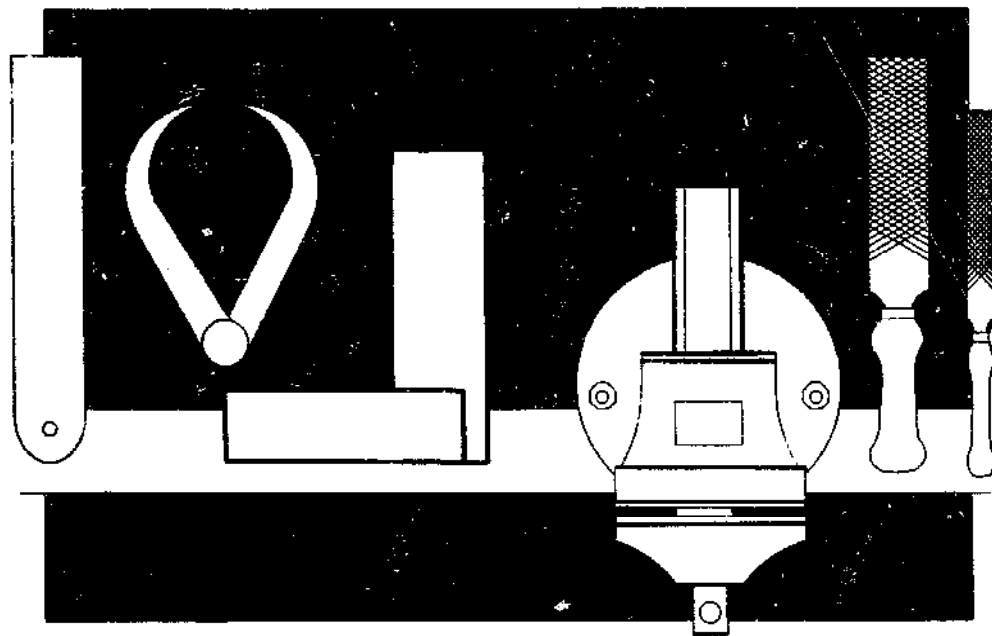

TOOL

John van Winden

General Metal Work, Sheet Metal Work and Hand Pump Maintenance

RURAL MECHANICS COURSE 1

TOOL

First impression 1990

Publisher TOOL foundation
Sarphatistraat 650
1018 AV Amsterdam
The Netherlands

Author Bro. J. van Winden
Drawings Bro. J. van Winden, J. Hovingh and
R. Cnossen

Translation Taalwerk textpers bv Soest
Typesetting
and lay-out Uitgeverij Jan van Arkel Utrecht
Printing Krips Repro Meppel

© Stichting Kongregatie F.I.C., Maastricht, 1990

No part of this publication may be reproduced in any form, by print, photography, micro film, or any other means without written permission from the publisher.

Whilst every care has been taken to ensure the accuracy of the information given in this publication, neither the publisher nor the author can be held responsible for any damage resulting from the application of the described methods. Any liability in this respect is excluded.

CIP-GEGEVENS KONINKLIJKE BIBLIOTHEEK,
DEN HAAG

Winden, John van

Rural mechanics course / [John van Winden : draw. by the author ... et al.]. – Amsterdam : Stichting TOOL
1: General metal work, sheet metal work and hand pump maintenance / [transl. by: Taalwerk Textpers bv]. – Ill., tek.
ISBN 90-70857-14-6
SISO 650.2 UDC 621.01(075.3)
Trefw.: leermiddelen ; mechanische techniek.

Preface

We have decided to publish this edition of the Rural Mechanics Course in response to the many requests from people involved in training for technical vocations and in general development work.

The main aim of this set of books is to provide technical training information in understandable language and with illustrations suited to the understanding of those involved.

The contents of these books reflect the rural development taking place in the agricultural sector in particular, where many urgent needs have to be looked after and solved in order to achieve sound development at all levels.

This Rural Mechanics Course has been compiled for teaching in Technical Vocation Centres in addition to a Rural Building Course, which deals with skills such as carpentry and masonry.

We are grateful to the Stichting Brothers F.I.C., Stichting TOOL for their technical assistance, Stichting Cebemo for their financial support and the German Volunteer Service for so many volunteers who have contributed in no small way to the compilation of these books.

It is our sincere wish that the contents of these books may be of assistance in stimulating the use of appropriate techniques to aid agriculture and general development.

Bro John van Winden F.I.C.

Introduction

In many situations radical and urgent changes are taking place in rural areas in order to restore land to agriculture, to bring about better living conditions and secure health and educational facilities - the basis for a healthy economy.

Needs arising from these changes are not always dealt with because many technical institutions do not provide appropriate technical training geared to solving problems which have gone unnoticed in the past.

It can also be noted that small co-operative workshops are being started these days in the interests of agriculture and these too may develop as they deal with the upkeep of small mechanized farm implements and diesel engines used for water supply or with making ploughs, handcars, gardening tools, etc.

Integrated and relevant technical training and grouping young people together into co-operative movements should be emphasized to ensure sound agricultural and general development. That is why an attempt has been made to achieve appropriate technical training for rural mechanics, who will contribute in no small way towards the necessary development.

Since the technical needs in rural areas are many but do not on the whole need highly specialised technicians to solve them, the rural mechanic - because his training covers a broad basis - will often be solving problems arising from the introduction of new implements or tools.

The course lasts four years, almost two years of which are set aside for so-called 'on-the-job training'. This is practical training provided in various workshops under the guidance of qualified technicians as well as a centre instructor who visits the workshop at intervals to see for himself how the trainees are progressing. During 'on-the-job training' the trainee is rewarded for his work which may help him later to buy the set of tools he has used during his training, so he can start working immediately after completing the course successfully.

Rural mechanics course

A set of four books has been compiled to accompany the four-year course for rural mechanics:

- 1 - General metal work, sheetmetal work and handpump maintenance
- 2 - Blacksmithing, welding and soldering
- 3 - Maintenance and repair of stationary diesel engines
- 4 - Technical drawing

While each of these books covers the full material of one course, a lot of additional information needed besides the contents of one particular book will be found in another book. So it is difficult to use just one of these books without consulting the others. The text on the properties of metals, for example, is to be found in the general metal work book. But this information is also needed when you are dealing with other subjects, such as diesel engines, blacksmithing etc.

As mentioned above, this course is made up in such a way that most of the practicals can be carried out with a limited set of tools. You will however notice that extra equipment or tools are needed sometimes and these must be available in the Vocational Centre's workshop.

It is believed and hoped that with the formation of co-operatives these additional tools and equipment will be available in the workshops because, though they are more expensive, they can be owned by the group.

The main aim of this course is that the trainee, besides acquiring a good formative background, will learn to master such skills as:

- working with and maintaining all the tools explained
- blacksmithing to such a degree that he will be able to shape different metals to the required implements, tools, etc.
- repairing, maintaining and installing hand waterpumps
- dismantling, repairing and assembling stationary diesel engines
- sketching or drawing simple items in orthographic, oblique and isometric form; reading engine or machine manuals.

This set of books can be used partly in the classroom but must also be used during workshop practice, where the reality of what can be seen will add greatly to the text and

illustrations in the books. Practical exercises recommended in the books can be varied since the practical nature of this course calls for articles to be made which can be used directly by people who may order them. But care should be taken that, though production may be necessary for one reason or another, all the skills which must be mastered are incorporated in each practical, so as to ensure sound training.

It is very important to study the proposed timetable given in each book to ensure that all skills are given the necessary attention. Apart from the progress made by each trainee, the time recommended for each skill may vary as well. Some skills take more time to master than others.

You will note the absence in this course of the science which may be important in explaining the diesel engine in particular. Providing this background theory is however beyond the scope of the course. But if the need arises, the relevant science should be included during part of the related subject time.

This Rural Mechanics Course is the result of many years' observation and experimentation with different techniques. The contents have frequently been revised to serve all those interested in rural development, and it is hoped this course will be used in many technical vocation centres and communities. It is also the sincere wish of the founders of this course that the trainees should feel on completion of their training that they are able to contribute personally to the development of the rural areas, which is of such importance to any general development.

Rural mechanics course lay-out and timetable

Four year training course

- a - Full Centre training: workshop practicals, trade theory, technical drawing and related subjects. Two years = 80 weeks
- b - Partly Centre training: trade theory, technical drawing, related subjects. Practicals take place outside the Vocational Centre. One year = 40 weeks
- c - On-the-job training: practicals take place outside the Vocational Centre. (Practicals are however controlled by Centre staff and marks are awarded for any progress made.) One year = 40 weeks

Total vocational training time
Four years = 160 weeks

Weekly timetable for related subjects and practicals

a - Trade theory	4	hours
b - Technical drawing	1½	hours
c - Mathematics	2	hours
d - Language	2	hours
e - Other related subjects	2½	hours

Total related subjects	12	hours
Total hours workshop practice	28	hours

Total training time in centre 40 hours

Four-year timetable, workshop practicals.

One full year reserved for Centre workshop practice:

a - General metal work	
b - Blacksmithing	
c - Welding and Soldering	
d - Sheetmetal work	1120 hours

One full year reserved for Centre workshop practice:

a - Stationary diesel engines	
b - Agricultural machinery	1000 hours
c - Water pumps and water supply	120 hours

Two full years reserved for on-the-job training:

a - One year partly practicals	1120 hours
b - One year full on-the-job training outside the Centre. (Care should be taken that the time is evenly divided for practical training in all skills.)	1760 hours

Three-year centre timetable for trade theory

a - General metal work	}	240 hours
b - Welding and soldering		
c - Blacksmithing		
d - Sheetmetal work		
e - Stationary diesel engines	}	220 hours
f - Waterpumps and supply		

Total theory time: 480 hours

General metal work and sheet metal work

General metal work and sheet metal work

The needs in rural areas which demand appropriate technical assistance are becoming a matter of urgency for sound development. Especially those people going into modern agriculture need help – provided by people who have undergone the appropriate technical training.

The Rural Mechanics Course, of which this book is a part, offers technical training which will answer some of the current needs. During the course the trainee will have a limited set of tools and equipment. That is why, during the practical exercises, imagination and creativity should be encouraged in the trainee, as well as sound judgement about when and how to repair with the means available and when to ask for assistance from specialist craftsmen.

As an introduction to the whole Rural Mechanics Course it is advisable to follow first the introductions offered in this book, which cover:

- Metallurgy
- Tools, equipment and their maintenance
- Working with tools and equipment
- Sheet metal work and tools
- Water supply and hand pump maintenance

Metallurgy

In metallurgy, a lot of attention and practical work should be devoted to the identification of metals, because extensive use is made of scrap metal and the original material used for equipment or machinery to be repaired or maintained is not always known.

For the practical tests on metal explained in this book it is advisable to have on hand original pieces of known identity and properties. The sound, sparks or appearance of the original pieces can then be compared with the pieces to be tested. The scope of this course does not extend to explaining many different metals, because special machine parts can never be made in the rural workshop.

Working with tools and equipment

In rural areas much of the work has to be done in difficult circumstances and on a wide range of articles. As a lot of the implements or equipment used are of complicated shape or construction, it is essential that the trainee receives thorough training on how to work with the tools and equipment available,

exploring all the possibilities of what can be done with one and the same tool and how to make additional tools to help get the job done. Though working with a limited range of tools must be encouraged, the Centre should have some additional tools or equipment. This is necessary to show the trainee how to work with them and thus encourage him to buy additional equipment at a later stage; this may be possible if he works in a co-operative workshop, because all the members may be in a position to raise enough capital between them.

Water supply and hand pumps

It is a recognised fact that the correct functioning of a water pump and supply system is essential for life and work in rural areas. Mechanics working in these areas should know how to maintain, repair and install a water pump and understand its operation.

Towards the end of this book the text and illustrations are geared to mastering the skill of installation, repair and maintenance of some of the most commonly used hand pumps.

Practical training should include work on a real borehole, because dropping the cylinder or pipe should be experienced in reality. It is advisable to have small groups working together at one time. One trainee should be appointed leader of the group and he alone gives instructions under supervision of the instructor in charge.

If the area where the Centre is located uses a different type of water pump from those explained in this book, it is a good idea to adapt the text and illustrations.

To ensure the supply of clean, uncontaminated water it is also a good idea to invite a medical practitioner to explain the advantages of clean water and show the effects of using water contaminated as a result of careless work on a well or a borehole.

Tools

Tools are aids for manufacturing products. A distinction can be made between:

- *Hand tools*

All possible tools meant for hand use are called hand tools. Hand tools are divided into reducing tools, assembly tools and auxiliary tools.

- *Measuring and marking tools*

Measuring and marking tools are used for measuring and marking sizes and angles.

We distinguish between readable and non-readable measuring tools. Also included in this group are tools which are needed for marking off the workpiece.

Maintenance of tools

Hand tools require little maintenance.

Measuring and marking tools are an exception to this. Clean them regularly with a little oil to prevent rust formation.

Never store measuring and marking tools among other tools. When working at the bench keep measuring tools apart from other tools.

Safety in tool use

Keep your tools clean and treat them with care.

Always ensure that the handles are properly fitted and are free from splits. Sharpen cutting tools regularly and remove burrs from the heads of chisels, drifts, centre punches etc.

This can prevent serious hand and eye injuries.

The rural workshop

Introduction

With the introduction of apprenticeship training and then of co-operative movements, many rural workshops are appearing in villages and medium sized towns to help people with their needs for household and farming equipment and also with the repair and maintenance of their tools.

Co-operatives are usually in a position to set up a good workshop and certain criteria have to be followed for a good lay-out of these workshops. You will find some of these criteria below, including workshop organisation, storage of materials and fuels and safety regulations.

Organisation

Organisation and cleanliness are the basis of good, efficient and safe work. All craftsmen should play an active role in achieving the aim of having work, tools and equipment well organised and keeping everything tidy and clean. Clear visible signs should make clients and visitors aware of the consequences involved in entering the workshop.

Workbench

A rural mechanic's workbench consists mostly of a steel frame and a wooden top which should be thick enough to withstand work pressure, see Fig. 1.

The height of the workbench is usually between 76 cm and 84 cm, but the ideal height is when the top of the vice (fitted on the bench) is level with the mechanic's elbow. See Fig. 2. The bench vice must be properly fixed to the workbench top with nuts and bolts. The vice should project far enough over the edge of the bench to allow vertical clamping of workpieces. See Fig. 3.

The front edge of the top has an angle iron fitted to protect the edge. See Figs. 3-A and 4-A.

Always place the tools on top of the bench in a neat way, easy to pick up and protected against damage. See Fig. 4.

Storage of tools

It is advisable to have a special store for tools. In this store there should be a toolboard on which the lay-out and shape of each tool is drawn or painted so that you can see immediately if a tool is missing. This toolboard should be checked after work. Make sure the toolstore is locked properly after leaving the workplace.

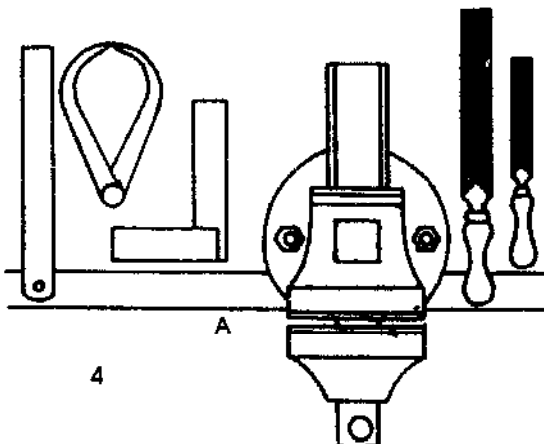
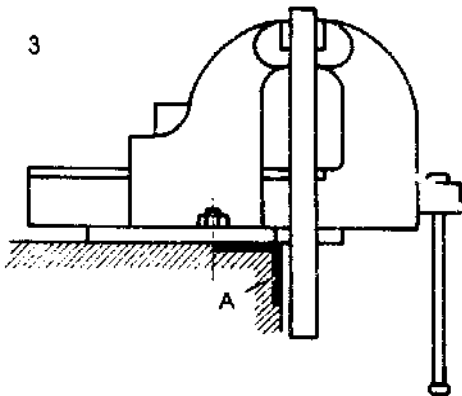
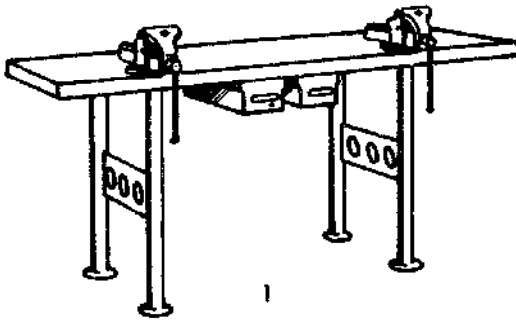

Storage of materials

Materials should be stored in a dry and secure place. All materials should be well arranged according to type, size and purpose. Nuts, bolts etc. should be kept in boxes and electrodes in a waterproof box.

Parts of equipment or machines should be kept in special cupboards together with the technical data about equipment and machinery. A record should be kept of all materials available. This record is valuable for ordering new materials in good time.

Storage of fuels

Fuel should be kept in a separate store some distance away from the actual workplace. As fuels are flammable and explosions are possible, it is important to have a well designed fuel store with enough ventilation located in a place which cannot be reached by bushfire. Fuels should be stored off the ground in solid containers.

Workshop lay-out

Before designing a workshop you should consider: durability, workability and safety.

The following are a few guidelines for designing a workshop.

- The workshop should be of a convenient length, width and height to be able to handle long pieces, based in general on a length of 600 cm.
- There should be adequate light and ventilation.
- Foundation, footing and floor should be made of lasting materials which are water and heat resistant.
- There should be ample room for the safe storage of tools and materials.
- There should be a separate store for fuel and gases.
- The workshop should be well sited with due regard for prevailing winds and rain. The length preferably in the East/West direction.
- The roof construction should be resistant to storms and rain. Thorough attachment of the roof construction to the walls or pillars is a must and deserves special attention.
- Ask for qualified advice when designing a workshop. The lay-out shown below may also help you.

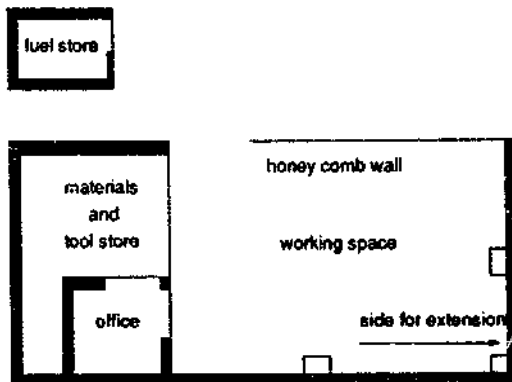

Metallurgy

Mined iron ore

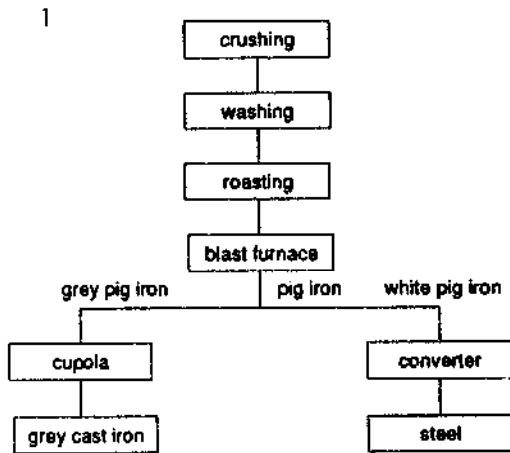

Iron ore is mined in various parts of the world. It contains iron oxide, stones, sand and clay. *Iron oxide* is a reaction of pure iron with *oxygen*.

To extract the pure iron from iron ore, the lumps are crushed, washed and heated to get rid of all components which can produce gases at a later stage. See Fig. 1 for the process flow.

Years ago, many blacksmiths in the north of Ghana mined their own iron ore, which is found in small quantities in laterite soil.

Blast furnace

The next phase in manufacturing iron is to extract the pure iron from the iron ore. This is done in the blast furnace, a cross-section of which you can see in Fig. 1. The approximate height of such a blast furnace is 30 metres. A mixture of iron, coke and limestone is dumped into the furnace at the top, see Fig. 1-A. The actual melting zone of the iron is in the shaded area 1-B.

The coke provides fuel to maintain the heat at approximately 2000 degrees Celsius. At the same time however the coke adds some carbon to the pure iron. The pig iron produced therefore contains some 4 to 4.5 percent carbon. Carbon is a component you find in coke, charcoal, pencil leads etc. It is black and has a major function in the production of steel, which is something you will learn about at a later stage.

The limestone combines all the dirt – such as sand, clay and stones – into a layer called slag. The slag floats on top of the liquid iron and can be removed from time to time through hole 1-C.

Hot air is blown into the furnace with blowers (shown in 1-D) mounted on the outside of the furnace. This air is needed to burn the coke and can leave the furnace together with all gases through the top of the furnace.

The liquid iron sinks down to the bottom of the furnace and is tapped out through hole 1-E. The liquid iron is tapped off and channelled into pig beds, see Fig. 2.

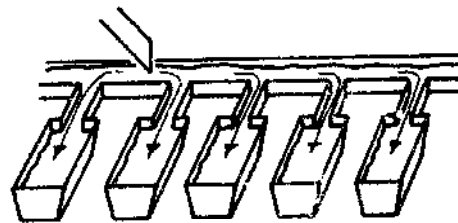
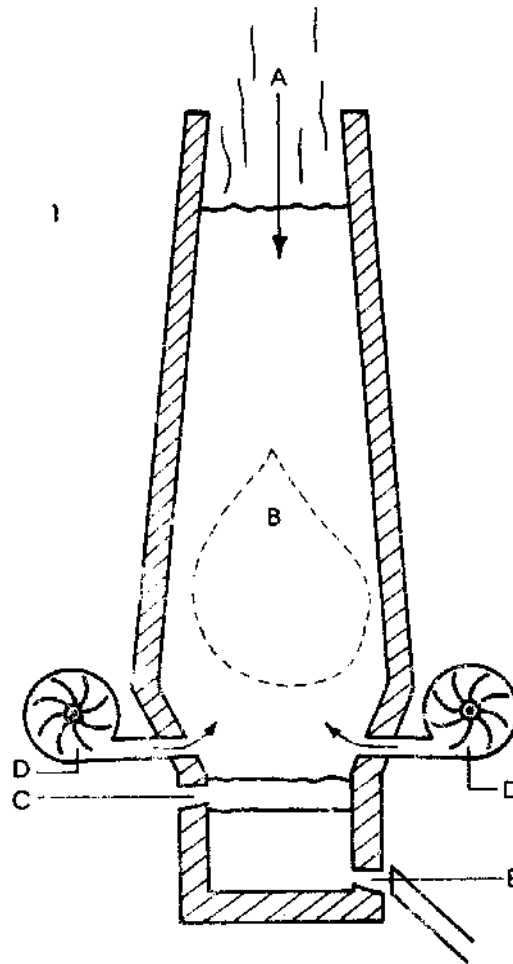

Nature of pig iron

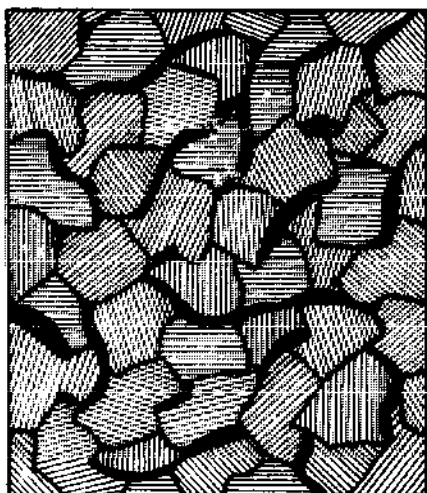

1

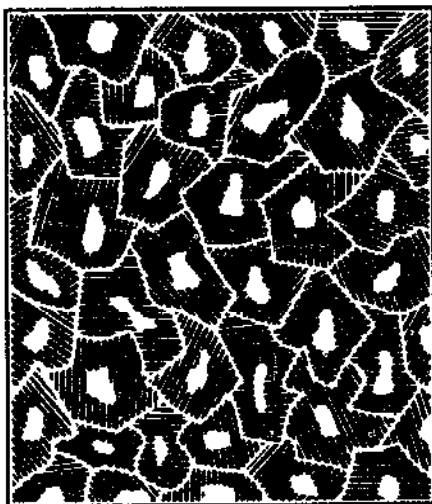

2

While in the blast furnace, the iron absorbs among other things an amount of carbon. Carbon is present in the coke just as it is in charcoal and in pencil leads etc. The carbon present in the iron after processing in the blast furnace may be in its natural state as *graphite* and is normally dispersed throughout the metal in the form of small flakes, see Fig. 1.

It may also be present in the form of a chemical composition of iron and carbon called *cementite*, see Fig. 2. This depends mainly on the cooling of the metal. If the cooling is slow, the carbon will settle between the crystals as graphite flakes. If the cooling is rapid, the carbon is trapped inside the crystals, so most of it is mixed up and present as cementite.

As you will understand, cementite is in a highly stressed condition when the carbon is trapped inside it and therefore makes the metal very hard and brittle.

When the metal is cooled normally, the fracture of the metal has a greyish-black appearance and the graphite carbon can easily be discerned. This metal is called *grey pig iron*, see Fig. 1.

When the metal is cooled rapidly, the fracture of the metal has a whiter appearance, showing that there is less free carbon and when all or nearly all the carbon is combined with the iron the metal is called *white pig iron*, see Fig. 2.

Cementite is a very hard substance and the greater the amount of combined carbon the harder the iron will be.

Observation

If you observe Fig. 1, you will understand that this piece of iron is not strong. A fracture can occur easily, following the line of the graphite flakes. Another problem is that the flakes and the iron are both very soft and weak.

Observing the white pig iron in Fig. 2, you see the carbon is trapped in each crystal. Cementite makes the crystal very hard.

Cupola/cast iron

Pig iron as produced in the blast furnace is the crude form of raw material from which different grades of cast iron and steel are made. Cast iron is made by a refining process of pig iron in a so-called *cupola*, similar to the blast furnace, see Fig. 1.

A cupola is approximately 8 to 10 metres high. At the top of the cupola there is a platform from which the cupola is filled, 1-A, with layers of broken pig iron, coke and limestone. Some scrap iron and old cast iron are added to the mixture to obtain the correct percentage of carbon required.

- Pig iron contains approx. 4.5% carbon
- Scrap metal contains approx. 0.2% carbon
- Old cast iron contains approx. 3.5% carbon
- The whole new mixture then produces an iron with approx. 3.5% carbon.

Coke and limestone have the same function as in the blast furnace. The hot air is blown in through the holes 1-B and the slag is removed through hole 1-C. After the whole mixture has melted down, the hot liquid enters the receiver 1-D, from where it can be tapped off through hole 1-E. A pilot hole 1-F in the receiver makes it possible to watch the process.

Properties and uses of white and grey cast iron

Cast iron is a very useful material used for castings. Its main advantages are that it is cheap to produce, has a low melting temperature of 1150 to 1200 °C and can easily be filed, cut and shaped.

The fluidity of the grey cast iron, when in molten condition, makes it possible to use it for castings of parts such as machine bodies and other components.

Grey pig iron can be converted into white or grey cast iron, the quality depending on the speed of cooling and the alloy used.

If for some reason a strong quality of cast iron is required, white cast iron can be used because, through its alloy, it is much stronger and harder than the grey cast iron.

Cast iron cannot be hardened or resist tension. You cannot use it, for example, as a beam for a bridge. The pressure on top will create so much tension underneath that the beam will crack. See Fig. 2.

Cast iron is brittle and may break when you hammer it or drop it. Cast iron is very useful for machine parts or components where there is compression or where vibration has to be absorbed.

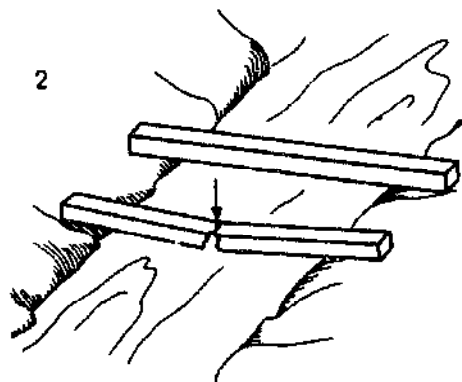
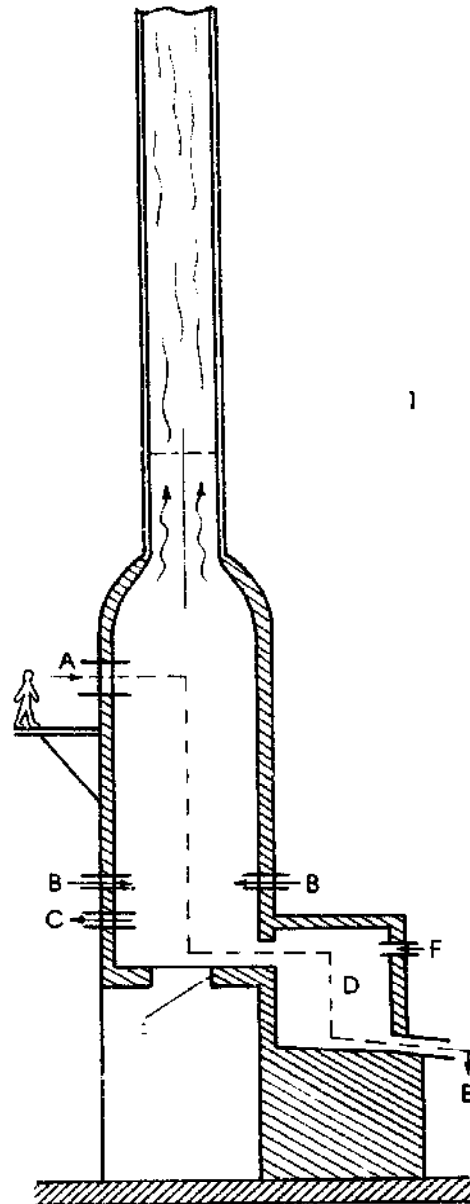

Castings

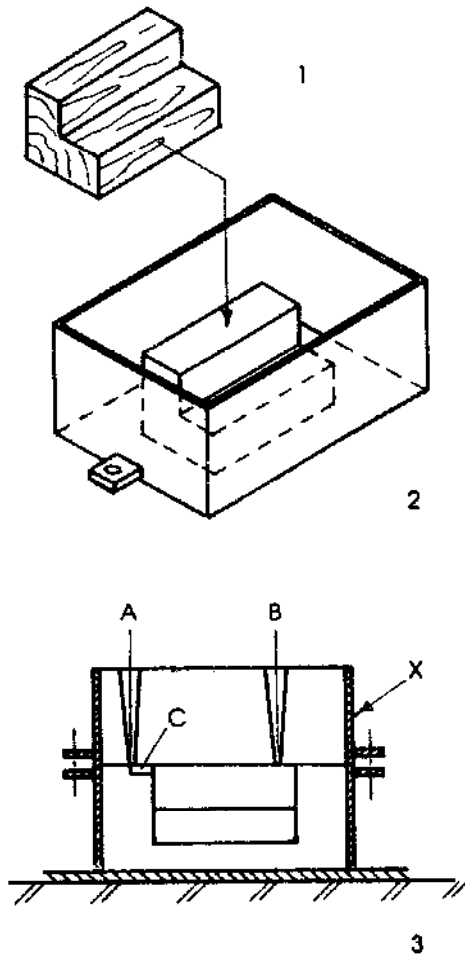

Castings can be made from steel, aluminium, cast iron, bronze etc.

Casting can be done in different ways; the most common is casting in sand.

For example, when you have to cast a product as shown in Fig. 1, you first have to make a wooden pattern of this product, that should be slightly larger than the actual product, because the metal shrinks during cooling.

The pattern is placed in a steel or wooden flask (the drag), see Fig. 2. The flask is then filled with sand and compacted and levelled at the top.

The flask is then carefully turned over and placed on a board. Another flask (the cope) filled with sand is placed on top of the first flask, see Fig. 3-X.

Two tapered holes are made as shown in Fig. 3. Hole 3-A is called the sprue and is used to pour the hot pig iron into the mould.

A second hole is made in the position shown in 3-B, which is called the open riser. This open riser is used to add some more metal to top up the mould and to let air and gases escape. After making the holes, the cope is taken off again and a connecting channel is made from the sprue to the mould; this hole is called the gate, see 3-C.

The wooden pattern is taken out carefully and the whole inside is cleaned. Then the cope is replaced and the hot metal poured in.

Wrought iron

Wrought iron was probably the first iron produced locally. It was produced for the blacksmith to enable him to make all kinds of tools needed for the farm and for hunting. Wrought iron is the nearest to pure iron and contains as much as 99.9% pure iron. Even when it is heated to a high temperature, wrought iron will not melt but only become pasty.

Puddling process

The main thing in the manufacture of wrought iron is the oxidation of nearly all carbon from the pig iron. This is done in a puddling furnace as shown in Fig. 1. As you see, the pig iron 1-A is not in direct contact with the fire 1-B, but is heated by reflection from the specially shaped furnace roof as shown in 1-C. During this process, the actual hearth is continuously filled with pieces of pig iron and a certain percentage iron oxide and mill scale. Mill scale is pieces of the outer layer of hot metal which has been in contact with the surrounding air (oxygen). These pieces peel off the metal as scale.

When the metal melts, the puddler stirs the mixture with a long rake, occasionally adding more pig iron, iron oxide or mill scale. Some of the slag will be removed but not all and some remains mixed with the metal. Through this melting and stirring process the carbon oxidizes and leaves the chimney as gases, see arrows in 1-D.

The process continues until the metal becomes pasty. This pasty metal is taken out in balls of 50 kg. The white hot balls are hammered to squeeze out portions of the slag, then rolled into rough bars with long fibres. During the rolling more slag is pressed out of the metal. The rough bars are then re-heated to a white welding heat and a number of bars are then bundled together and re-rolled, which welds the layers together.

A cross-section of a piece of wrought metal is shown in Fig. 2. Notice the layers and the stretched pieces of slag. See Fig. 2-A. The presence of slag gives a fracture of wrought iron a fibrous appearance. When it is filed or cut to the surface parallel to the direction of rolling, the slag can be seen as long lines running along the surface.

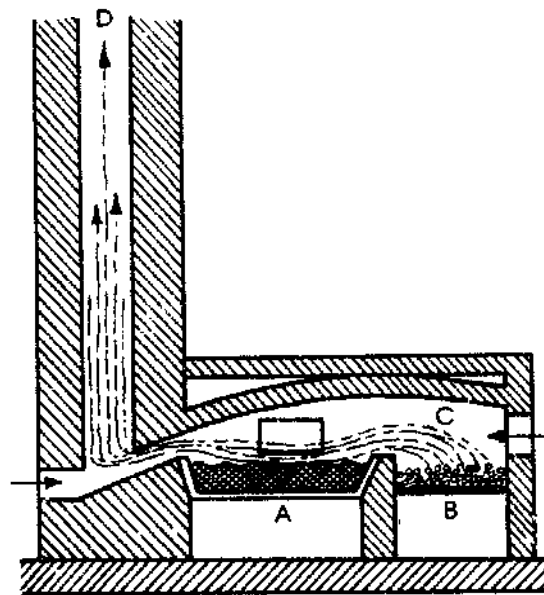

1



2

A

Steel converter

You remember that the first product of iron ore is pig iron, classified into grey pig iron and white pig iron. We have described the production of cast iron from grey pig iron. White pig iron is used in the making of steel.

The making of steel

Steel is made in a so-called *converter*. Such a converter is shown in Figs. 1, 2 and 3. The charging position of the converter is shown in Fig. 1. A certain amount is charged.

The actual process of conversion takes place when the converter is in an upright position as shown in Fig. 2. Pure oxygen is forced through a pipe 2-A over and into the liquid pig iron. This process develops so much heat that all carbon is burned out of the pig iron. Some scrap metal is added to cool the reaction and meet the required percentage of carbon.

After this process, the converter is turned sideways and the liquid steel is poured into moulds to make steel blocks. See Fig. 3. At a later stage these steel blocks are shaped into bars, rods, plates, strips, pipes etc.

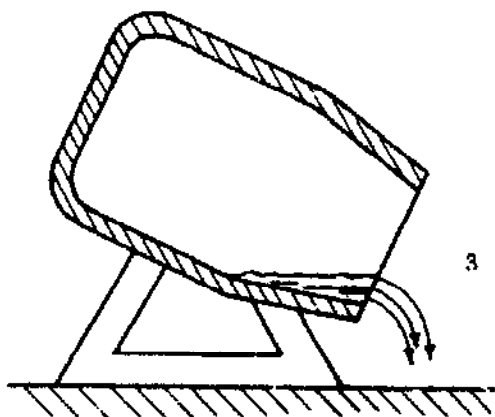
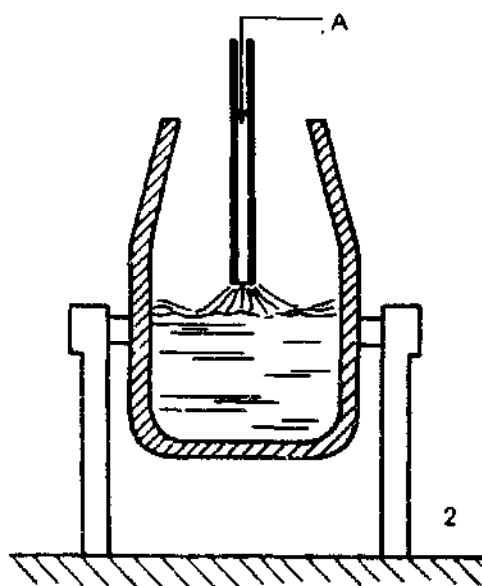
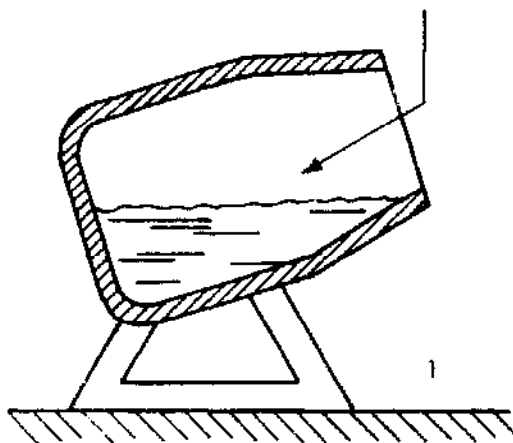

Properties of steel

In the previous lessons you have learned about some of the properties of steel. Something more, however, has to be said about certain properties to be able to understand at a later stage what actually happens during the heat treatment of steel.

Structure

The structure of pure iron is made up of crystals bonded together. Groups of crystals (1-A) are bonded together to form larger units called grains (1-B). In Fig. 1 you can see a group of grains enlarged about 100 times. You can compare the structure to a carton of sugar cubes in which the cubes are the grains and each cube is made up of crystals.

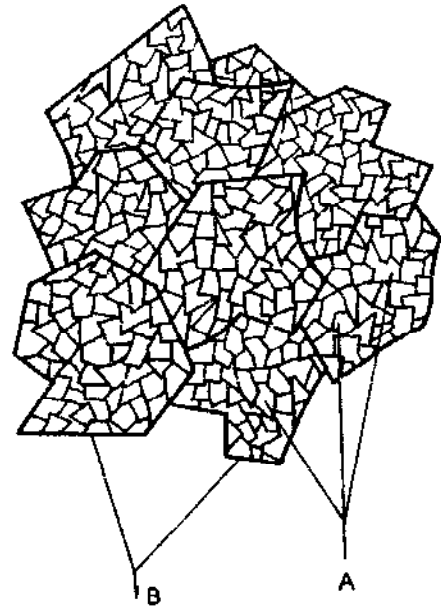

Strength

The strength of a metal lies in its resistance to the application of force to the metal - like compression (shown in Fig. 2-A), tension 2-B or shear force 2-C - without breaking it. When a metal has high strength, a great force is needed to break it. For example, drive chains and cylinder bolts for engines have high strength, otherwise they would break during performance.

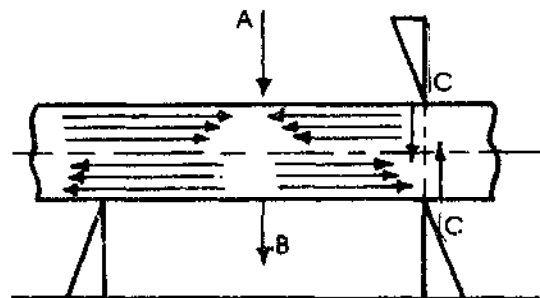

Hardness

The hardness of a metal can be tested for its ability to withstand wear, scratching, abrasion etc., if a body harder than the metal itself is used. See Fig. 3. Since a file itself is made of very hard metal, it is widely used to test the hardness of metals. Use the edge of a smooth file on the metal to be tested and see whether it is very easy to scratch the metal. This is of importance when you have to drill, cut or shape a metal with which you are not familiar.

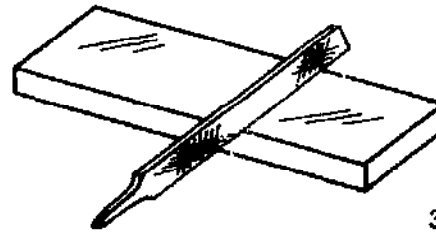

Brittleness

Brittle metal has the property of breaking by force without much permanent distortion. Brittleness may be due to the brittleness of the grain boundaries or the crystals (read first lessons). See Fig. 4.

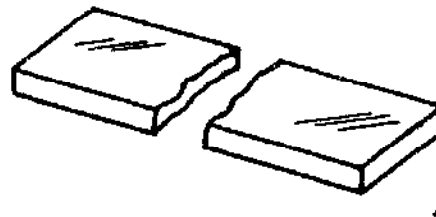

Plasticity/malleability



Plasticity is the property a metal possesses if permanently extending it in all directions and pressing, hammering, rolling or shaping it does not break it. See Fig. 1. Some metals which are heated to a bright red heat are very plastic and used for forging (lead, copper, aluminium).

Toughness

Toughness is the amount of energy a metal can absorb while, for instance, when clamped in a bench vice, the metal is hit at the end with a hammer on all sides without breaking it. See Fig. 2. Branches of a tree are very tough – not hard. They can bend in any direction during a storm without breaking.

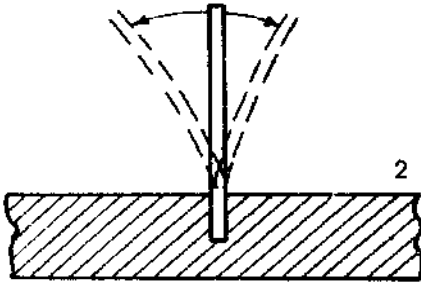

Identification of metals

All kinds of cast iron and steel are used in a rural workshop, including parts which are unidentified. Various methods can be used to identify these metals and discover their properties:

- sound, produced during a drop test,
- visual inspection of the metal,
- testing the metal with a file,
- bending or breaking the metal,
- a spark test on a grinding wheel.

Spark test

To carry out the spark test you need a grinding wheel with a speed of approximately 1500 rpm (revolutions per minute). The wheel should have a diameter of approximately 150 mm. The sparks produced during grinding will tell you approximately what kind of steel you are grinding.

While grinding you should:

- stand upright and in line with the stream of sparks,
- make sure the light is constant, so that the colours of the sparks can be judged correctly,
- use the same pressure on the workpiece during the test. If you increase the pressure, the temperature of the stream of sparks will rise, thereby changing the colour and length of the spark stream.

In general

When the carbon content is increased, the burst of sparks increases and the stream shortens. See Figs. 1, 2 and 3.

This happens because the carbon in the steel burns more rapidly and the stream of sparks changes from light yellow to a white yellow. Try this test first on various pieces of metal which have already been identified and labelled. You can then compare the sparks produced with the sparks produced from the test pieces.

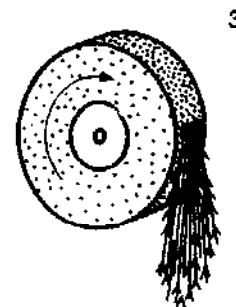
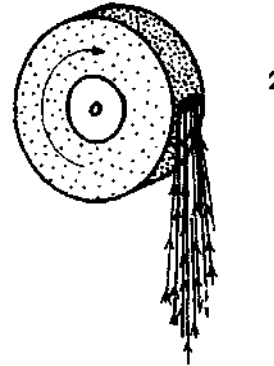
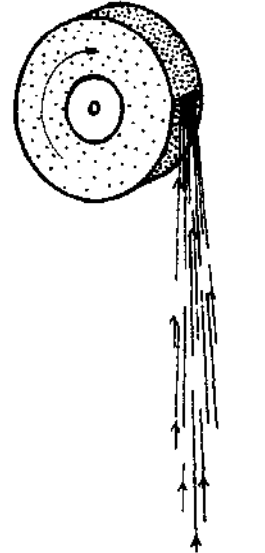

Carbon content

Steels are grouped into three different kinds, depending on the percentage of the carbon content:

- Mild steel
- Medium carbon steel
- High carbon steel

Properties

Some workpieces have to be made from steel which has a low carbon content and a tough structure. Many tools have to be made from steel which has a high carbon content and is fairly tough at the same time.

The following table gives an overview of different tests and indicators for the identification of different metals.

<i>Metal</i>	<i>Drop test</i>	<i>Visual inspection</i>	<i>Spark test</i>	<i>Filing test</i>	<i>Bending or breaking</i>
cast iron ± 3.5 % C	Dull sound on impact.	Dark grey. Rough finish.	Short stream of red sparks, not bright.	Hard skin, easy to file.	Breaks before bending.
mild steel 0.1 - 0.3 % C	A definite metallic ring.	Dark blue scale. Smooth finish.	Stream of long yellow sparks.	Easy to file.	Bend and then breaks.
medium carbon steel 0.3 - 0.9 % C	A clear and higher pitch ring than with mild steel.	Blue-black scale. Smooth finish.	Short wider stream of light yellow sparks.	Harder to file than mild steel.	Bends slightly before breaking.
high carbon steel 0.9 - 1.5 % C	Still higher pitch ring.	Polish black scale.	Short wide yellow stream of bright sparks.	Harder to file than medium carbon steel.	Resists bending and breaking.
high speed steel	A metallic ring not so clear as in carbon steel.	Rougher than cast steel. Often painted.	Stream of dull orange sparks.	Harder to file than medium carbon steel.	Resists bending and breaking.

<i>Percentage carbon</i>	<i>Quality</i>	<i>Application</i>
Mild steel		
0.125- 0.20	tough	structural steel, general forging work
0.20 - 0.30	quite tough	better grade for structural work, machine parts, agricultural implements, connecting rods
Medium carbon steel		
0.30 - 0.40	very tough	chain hooks, machine parts, gears, axles, shafts mould boards for agric implements
0.40 - 0.50	very tough to great, little hardness	heat treated machine parts, agric implements, some tools
0.50 - 0.60	great toughness some hardness	crow bars, garden tools, gears, shafts, machine parts
0.60 - 0.70	great toughness fair hardness	tools to be used for hot work, flatters, fullers hot swages
0.70 - 0.80	great toughness medium hardness	all general blacksmith tools, hammers, rivet sets, hot sets, gun barrels, screw drivers
0.80 - 0.90	very tough better than medium hardness	cold chisels, hammers, sledges, shear blades, large springs, scissors
High carbon steel		
0.90 - 1.00	fair toughness hard	wall chisels, knives, punches, taps, anvil faces, wrenches, wood working tools
1.00 - 1.10	little toughness	drifts, swages, springs, pliers
1.10 - 1.20	great hardness	planing tools, axes, saws, wood working tools
1.20 - 1.30	somewhat brittle	shear knives, cutting tools
1.30 - 1.50	very to extremely very brittle.	files, drills, tools to cut hard materials

Nonferrous metals

In the previous lessons you have learned about the chief metals: iron and steel. In addition to these, it is also important to know something about other metals such as copper, aluminium, tin, lead and zinc. These metals are called *nonferrous metals*. They can be pure or mixed with other metals or alloys.

Aluminium

Aluminium is widely used in the country in the form of roof sheeting, cooking pots etc. It is a white metal produced by an electrical process from bauxite (aluminium oxide), mined all over the world. Aluminium melts easily and can very well be used for castings.

Since pure aluminium is very soft and weak, it is mostly alloyed with other metals such as copper and zinc. Other special metals are sometimes added for the production of engine pistons, aeroplane parts etc.

Copper

Copper is a red coloured metal. The ore is mined and contains some 32 percent pure copper. The copper is extracted from the ore by a melting and refining process. Copper is a good conductor of heat and is therefore used for soldering bits. It is highly resistant to corrosion by liquids and a very good conductor for electricity as well, so it is used for making electric wire.

Lead

Lead has a blueish-grey colour and is very soft and plastic. It is easy to shape, cut and force cold into moulds or roll into thin sheets. Since it is highly resistant to corrosion, it is widely used for roofing and water supply.

Lead has a very low melting point, 330 °C, and can be joined together by heating with a blowlamp. Lead is mined as ore and purified by a melting and refining process. Lead alloyed with tin forms solders.

Tin

Tin is obtained from tin-stone by a roasting and refining process. Tin is silver-white in colour and its structure is crystalline. It is harder than lead and has a melting temperature of 232 °C.

To identify tin, you can bend a small piece and as it bends the metal will produce a crinkling sound called the *tin cry*. Tin is widely used for coating thin sheet metal to avoid corrosion. A tin-lead alloy forms the so-called solders. The proportion of tin in a solder can be estimated

by judging the *tin cry*. The louder the cry, the more tin there is in the solder.

Zinc

Zinc is made from ore which is roasted, mixed with some form of carbon and melted in a specially designed furnace. Zinc is a bluish-white metal, showing bright smooth crystals at its fracture. In its pure state zinc is used to cover sheets, called galvanized sheets. This galvanizing is done by dipping the steel sheets or other products into the molten zinc, thus protecting the steel against corrosion.

Bronze

Bronze is an alloy of 88% copper, 10% tin and 2% zinc. Or 85% copper, 5% zinc and 5% tin.

Brass

When copper is alloyed with zinc the alloy is called brass. Some types of brass are used for castings, hot and cold forging, cold rolling into sheets and drawing wires.

Heat treatment of steel

During and after the manufacture of a product made of steel, it may be necessary to change the properties of this steel to be able to work on it and give it a final property with a specific hardness. Ways of changing properties are:

- **Hardening**
Steel is hardened by heating it above 720 °C followed by a rapid cooling in water.
- **Tempering**
After hardening steel one can reduce its brittleness and give the steel any desired hardness by reheating it at a lower temperature and cooling it slowly.
- **Annealing**
Annealing metals consists in heating and subsequent gradual cooling, by which internal stresses are removed and the metals become tough and ductile.

Hardening steel

Steel with a carbon content of 0.70 and higher can be hardened by heating the steel to a temperature of approximately of 800 °C and then cooling it very quickly in water, oil or some other liquid.

The structure of the steel changes during hardening and this must be clearly understood to avoid mistakes and disappointments.

For example: the structure of the steel changes when you heat a piece of steel which has a carbon content of 0.70 to 800 °C and plunge this hot piece rapidly into cold water; the outer layer of the piece of steel cools very fast, with the result that the inner part of the steel cannot cool, so the outer layer cracks due to the tension of the shrinking taking place.

The faster the cooling, the harder the steel becomes, depending of course on the carbon content. Cooling should therefore be controlled.

Tempering

Tempering is controlled cooling of steel which has been hardened. When steel has been hardened, it may have become too hard for the purpose you need it for. Some of the hardness obtained may have to be taken away to ensure the correct hardness of the steel. A special process called tempering is used for this purpose.

Tempering means heating steel to a certain temperature – which is far below the hardening temperature – and then cooling it, not suddenly, but in a controlled way.

Since you cannot use a thermometer to measure the temperatures during the tempering process, it is important to observe the colours

which appear on the surface of the metal just after heating and before cooling. These are called tempering colours.

Tempering colours

All steel, whether it has been hardened or not, has a layer of oxide on its surface, caused by exposure of the steel to the surrounding air (oxygen). When this layer is thick it is called rust or, when the metal is hot, scale. Even after polishing the surface of the steel, this layer will form again and be visible.

The layer of rust on polished steel has the property of giving colour to hot metal. The colour changes when the temperature changes. Various temperatures with their colours are shown on the tempering and forging colour chart, see next page.

Before tempering, large workpieces can be heated in the blacksmith's forge. To avoid burning the steel, small workpieces can be heated by placing the material edge way over a piece of hot steel, from which it will take over the required heat. Tempering is one of the most important, but also very difficult skills in rural mechanics. It will take you a lot of time to master this skill. After tempering, you can use the spark test to find out the correct hardness of the steel you have tempered.

Annealing

To be able to cut, file or shape steel or change the properties of the steel permanently and relieve the internal stress in the crystals it may be necessary to anneal the steel. This is done by:

- Heating the steel slowly to the required temperature, see table.
- Leaving the steel long enough at this temperature to enable internal changes to take place.
- After this, letting the steel cool very slowly. The best method is to stop the forge in which the steel has been heated and leave the steel until its glow has disappeared.
- Burying the steel in sand or ashes to ensure a slow cooling process.

Tempering and forging colour chart

For a display of colours see page 20 of the Blacksmithing volume of the Rural Mechanics Course.

<i>Hardness</i>	<i>Temperature °C</i>	<i>Colour</i>	<i>Purpose</i>
Very hard	220	Light straw yellow	rasors, scapers
Very hard	230	Straw yellow	drills, plannig tools, cutting tools
Hard	240	Dark straw yellow	pen knives, drifts, rivetting tools
Hard	255	Brown yellow	wood drills, rock drills
Hard	265	Red brown	fullers, twist drills
Hard/tough	275	Purple	cold chisels, hammers, set hammers, table knives
Hard/tough	285	Purple-blue	wood chisels, axes, centre punches
Hard/tough	295	Full blue	cold chisels for steel, knives
Tough/hard	310	Light blue	drills, twin snips, screw drivers, hot chisels
Tough/hard	330	Steel grey	wood saws, punches, light springs
	600	Dark red	forging
	700	Dark cherry red	forging
	800	Cherry red	forging
	900	Light cherry red	forging
	1000	Orange	forging
	1100	Yellow	forging
	1250	Light yellow	forging
	1400	White	forging and welding

Shaping metals

Metals are sold in the form of sheets, bars, strips, wires and some other special shapes. You should know something about how these products have been hot or cold rolled in the rolling mill or drawn.

Hot rolling

You still remember that the final product of the blast furnace and the converter consists of lumps of steel, called ingots, with an approximate length of 1.50 m and 0.40 m in cross-section.

These ingots are still very hot when they leave the converter and are immediately rolled between rolls to the desired shapes. In Fig. 1 you can see how the hot steel is supported by small rollers and rolled between two rolls to a thinner size.

A pictorial view of a rolling mill is shown in Fig. 2. The space between the rolls differs in size so the steel can be reduced a little at each stage; see the shaded areas.

Sometimes, especially in the case of sheet making, more than one roll is used to speed up production, see Fig. 3.

Sometimes small sized rolls are used and they are supported by bigger rolls as shown in Fig. 4.

Cold rolling

The raw material for cold rolling comes from the hot rolling mill and the process of reducing the cross-sectional area is similar to hot rolling, except that the pressure between the rolls is much higher since cold steel gives more resistance.

Before cold rolling can be done, all scale must be removed to avoid the risk of the scale being rolled into the steel. Cold rolling improves the surface of the steel and gives a more accurate shape, which may be required particularly for products with a small cross-sectional area.

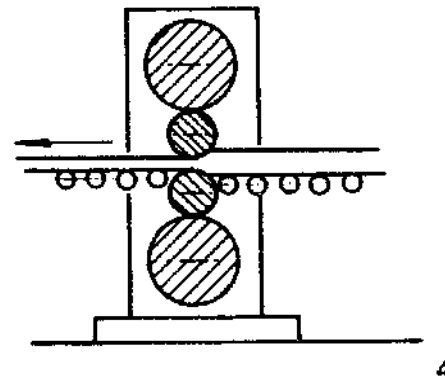
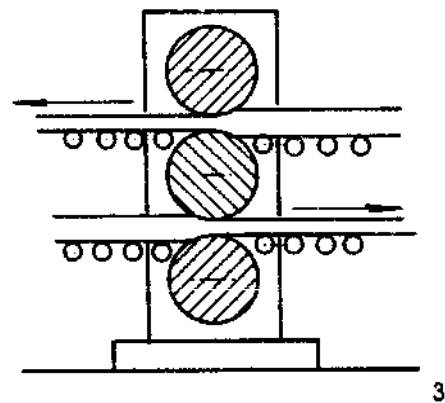
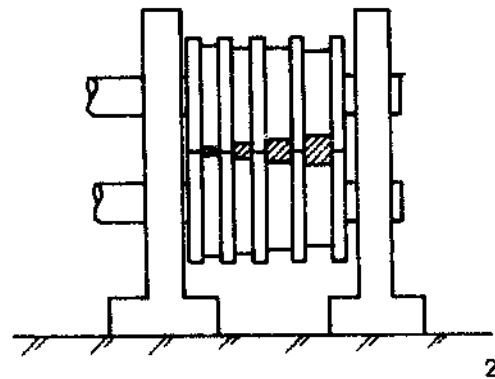
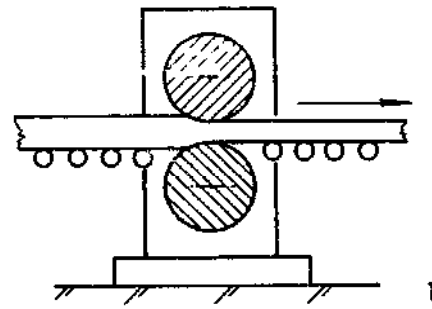

Tools and equipment

Clamping tools

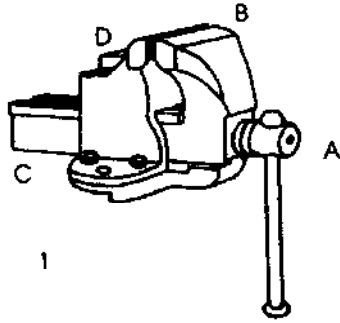

Bench vice

The bench vice shown in Fig. 1 has a spindle 1-A which, when turned around, moves the front jaw 1-B. The guide piece 1-C gives the front jaw of the parallel bench vice stability. Although it is covered, the spindle should be checked for dirt and should be greased regularly.

Vice jaws are made of hardened steel. They have serrations for a better grip on the workpiece. Some vices also have a small anvil 1-D at the back for light hammerwork.

Precautions

- Do not over-tighten the vice by using a hammer or a piece of pipe.
- Do not file, saw, drill or chisel into the vice jaws.
- Do not do heavy hammerwork on a bench vice; use an anvil or a blacksmith's vice instead.
- Clean the vice after use.
- Cover the vice if necessary.

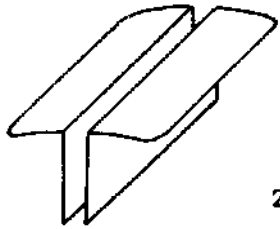

Vice Caps

Hardened vice jaws can damage the surface of a workpiece. When necessary, use vice caps to protect the workpiece. See Fig. 2. Vice caps are made of soft material such as aluminium, lead or of a hard material such as steel, when used for clamping parallel surfaces.

Vice caps which are made in the workshop may have different shapes according to the workpiece to be clamped.

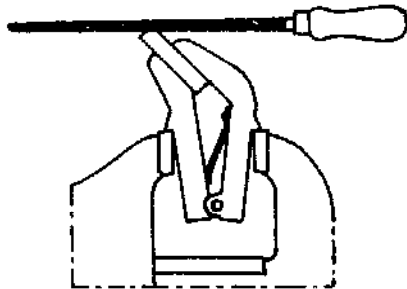

Saw sharpening vice

A special vice is shown in Fig. 3. This clamp can be used in the bench vice while special work is being done. The clamp is tightened by turning the spindle of the bench vice.



Hand vice

A hand vice is shown in Fig. 4. This vice is used to clamp several pieces of material together when they have to be moved or to hold small pieces during grinding. A vice grip can also be used for this purpose, see Fig. 5.

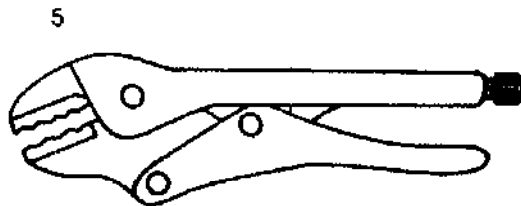

Clamping set

A clamping set is used for securing material or a workpiece. Particularly in a machining operation such as drilling the part to be machined must never rotate with the drill. See Fig. 1.

Fill out the clamp plate with a block (1-A). The height must be more or less equal to the thickness of the material to be processed and the base plate combined. Tighten the hammer head bolt which is enclosed in the table or work bench. This creates enough clamping force on the workpiece to prevent it from rotating.

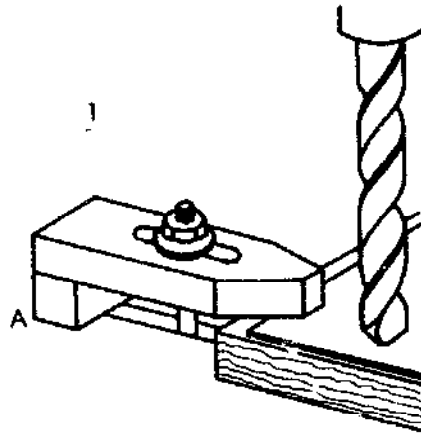

Clamping examples

Always clamp the workpiece in such a way that the cutting tool is close to the vice jaws, otherwise the workpiece will vibrate and then it can damage the cutting tool and accurate work will be impossible. See Fig. 2-A showing the right way and 2-B showing the wrong way.

Some workpieces will be distorted when you clamp them incorrectly in the bench vice. See Fig. 3. Clamp the piece as shown in Fig. 4.

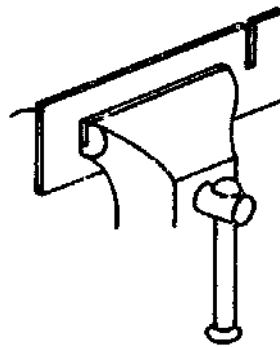

2A

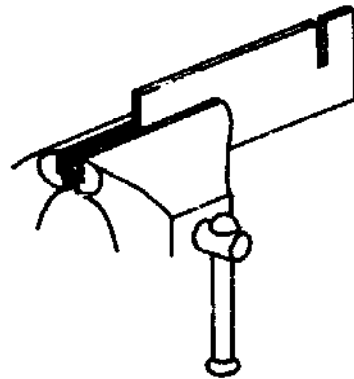

2B

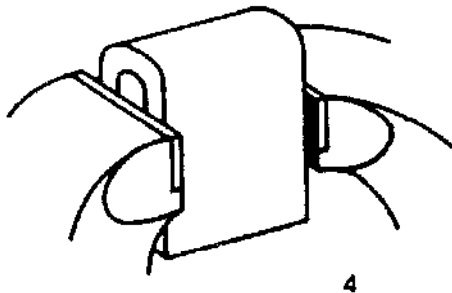

4

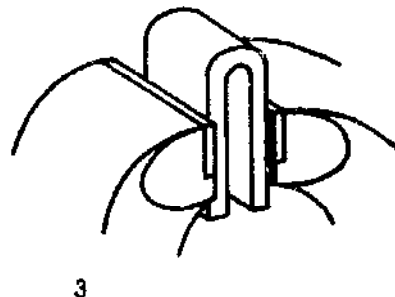

3

Sheetmetal clamp

A special device for clamping sheet metal is shown in Fig. 1.

The hand vice can also be used in combination with prolonged vice jaw caps, Fig. 2.

In Fig. 3-A you see an incorrect way of clamping a workpiece. This way the vice will be damaged. Instead, clamp the workpiece as seen in Fig. 3-B.

Pipes are distorted when you clamp them in the vice as shown in Fig. 4. For clamping pipes a pipe vice or a pipe clamp is used. See Figs. 5-A and 5-B.

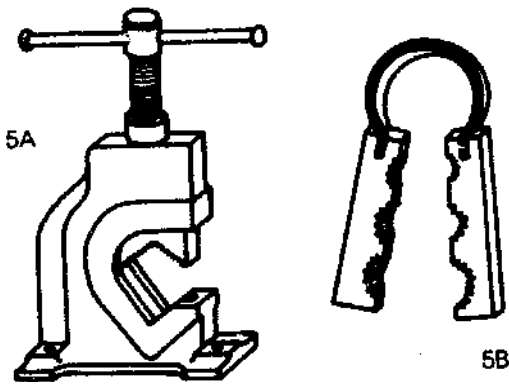
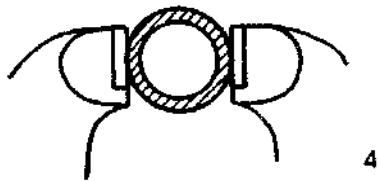
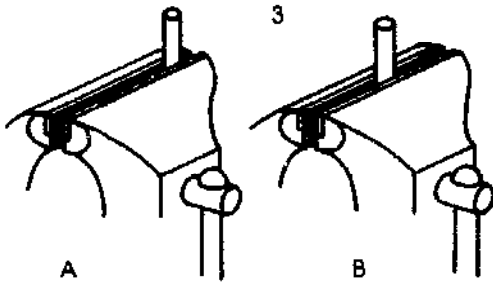
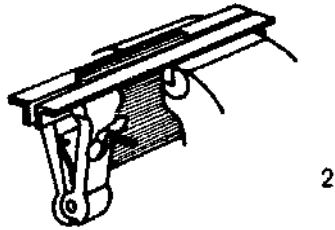
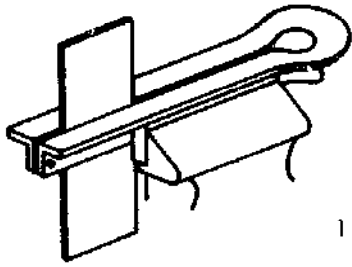

Measuring and measuring tools

Taking care of measuring tools

All measuring tools are precision tools. You must take good care of them to keep them in good shape to maintain their accuracy.

When working, get used to the following:

- Always wrap your measuring tools in a piece of oily cloth when you put them back in your toolbox after work.
- Keep these measuring tools in a good, safe place in your toolbox, otherwise they may get damaged.
- High precision instruments are always stored in their own boxes, because dust and dirt will spoil their mechanisms.
- Lubricate these instruments now and then with a clean light oil.
- Rub clean all your tools – such as try square, rule, caliper and feeler gauges – after work and oil them lightly. This will prevent corrosion.
- When you work with measuring tools, it is a good habit to put them on a piece of cloth in a safe place on the workbench so they cannot be dropped on the ground or damaged in some other way.
- Never have all your tools on the workbench but only those you need and keep tools and workpieces separate from each other.
- Use good, correct measuring tools and get to know which tools to use for a particular job.

Metric system

For some years now the official measuring system has been the metric system. All technicians should use this system. Once in a while, however, the Rural Mechanic will have to measure in inches. This is usually in the context of pipes, nuts and bolts, thread and repairing old machinery or implements.

Metric units are:

Metre, Centimetre, *Millimetre*.

Litre, Kilogram, *Gram*.

Imperial units are:

Yard, Foot, *Inch*.

Gallon, Pound.

inch	mm	mm	inch
1	25.40005	1	0.039370
2	50.80010	2	0.078740
3	76.20015	3	0.118110
4	101.60020	4	0.157480
5	127.00025	5	0.196850
6	152.40030	6	0.236220
7	177.80035	7	0.275590
8	203.20040	8	0.314960
9	228.60045	9	0.354330
10	254.00050	10	0.393700

In Fig. 1 a rule is shown with explanation of the metric division. The table can be helpful when inches have to be converted to millimetres or the opposite.

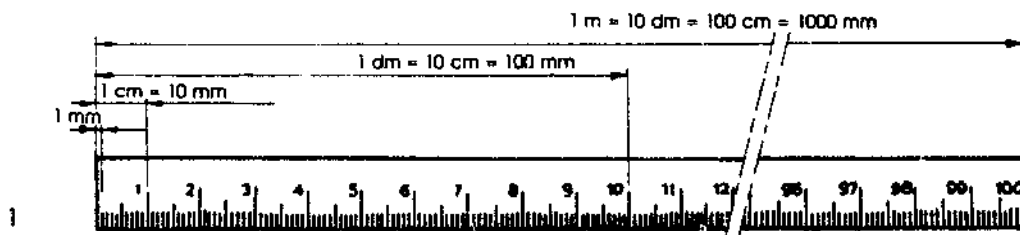

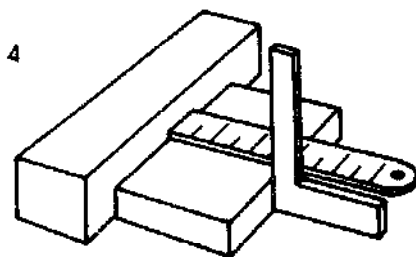
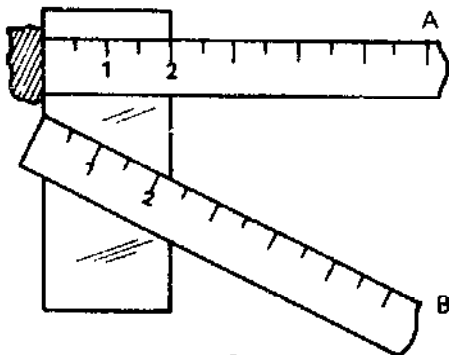
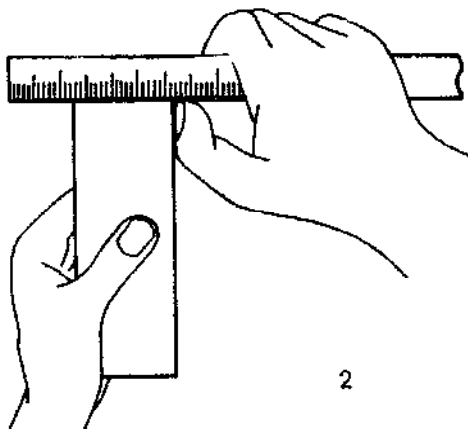
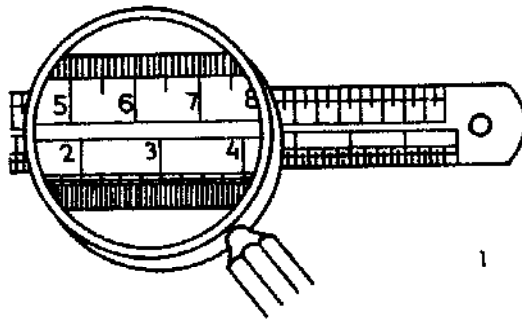

Measuring

Measuring is not only checking the length, width or thickness of an object but also checking of the shape – things like the straightness, flatness, roundness or squareness. Measuring is a very important skill for the Rural Mechanic.

Steel rule

The steel rule is a very important measuring tool in the workshop. Fig. 1 shows a steel rule for small work with a division in centimetres and inches. The edge of the rule is divided into parts of one centimetre (cm). Each centimetre is divided into millimetres (mm).

Questions

- How many cm are there in a metre?
- How many mm are there in a centimetre?
- How many mm are there in a metre?

How to use the steel rule

- Put the rule flat on the object and read the measurement from the rule. If you press your thumbnail against the rule, you can read the measurement more easily, see Fig. 2.
- Keep the rule at a rightangle to the object, see Fig. 3-A. What happens if you do not keep it square, as shown in 3-B?
- Read the measurement from directly above the rule. What happens when you read it from the side? A try square can be helpful, see Fig. 4.
- If the end of the rule is inaccurate, start measuring at the 1 cm mark, see Fig. 2. Of course, you have to subtract 10 mm from the total reading.

Folding rule

Fig. 1 shows a 1000 mm folding rule which is used for larger workpieces.

Tape measure

A thin flexible metal tape is called a tape measure. See Fig. 2. This tape can be pulled in and out of its housing and returns by means of a spring inside the housing. There is a hook at the starting end of the tape to hook the tape up against the object being measured.

This hook can only be used for measuring the length of an object; it cannot be used for any inside measurements unless it is differently designed.

This tape is specially handy when you have to measure curved objects. See Fig. 3.

Measuring with a spanner

Open-ended spanners are handy for measuring the outside diameters of round objects, especially if the objects are warm. See Fig. 4.

The number on the spanner gives the outside diameter of the object being measured. Use them only when no proper measuring tools are available.

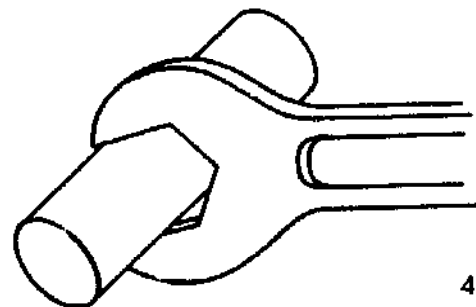
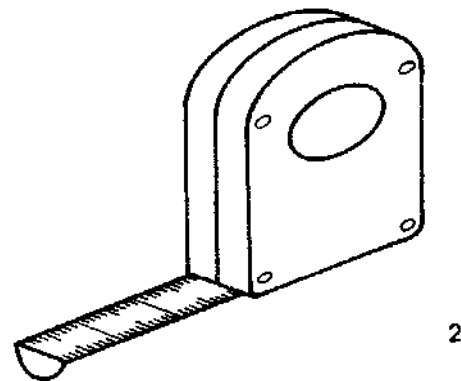
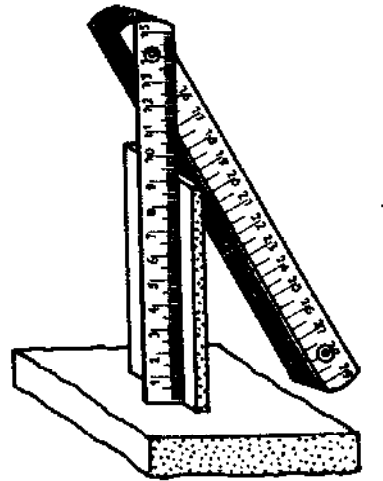

Vernier caliper

A vernier caliper is used for more accurate measuring than can be achieved with a measuring rule. See Fig. 1.

The parts of a vernier caliper are:

- Main scale (1-A): the main scale is graduated in millimetres. This is called the metric scale.
- Sliding jaw (1-B): this part slides over the main scale. There is also a scale on the sliding jaw; this is the vernier graduation or vernier scale.
- Jaws (1-C): you can measure inside dimensions with these jaws, see also Fig. 2.
- Jaws (1-D): you can measure outside dimensions with these jaws, see also Fig. 3.
- Depth gauge (1-E): you can measure the depths of grooves and holes with the depth gauge, see also Fig. 4.

When measuring outside dimensions, use an as large as possible part of the jaws. Apply only light pressure when measuring. Do not pull the vernier caliper from the workpiece. Take notice of the measurement and move the jaws apart, so that the vernier caliper can be removed easily and without excessive wear.

Scale

The vernier scale can have either 10 or 20 divisions.

- If the vernier scale has 10 divisions, the caliper can measure accurately up to 0.1 mm.
- If the vernier scale has 20 divisions, the caliper can measure accurately up to 0.05 mm.

*Be very careful with the vernier caliper.
Apply a little oil now and then.*

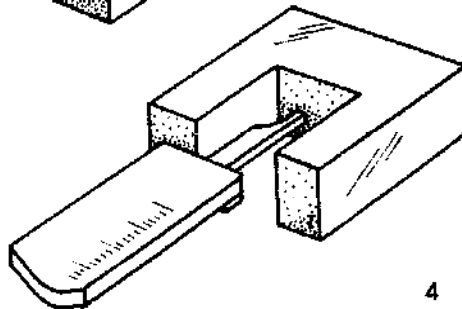
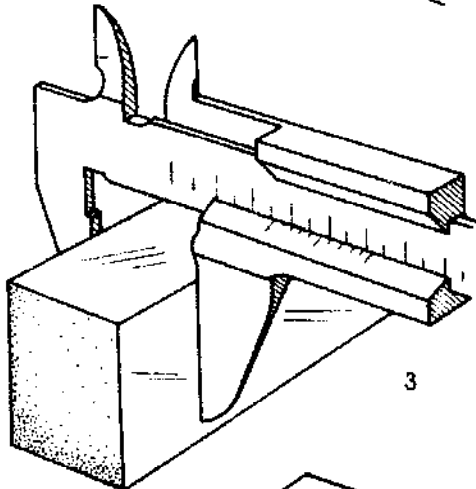
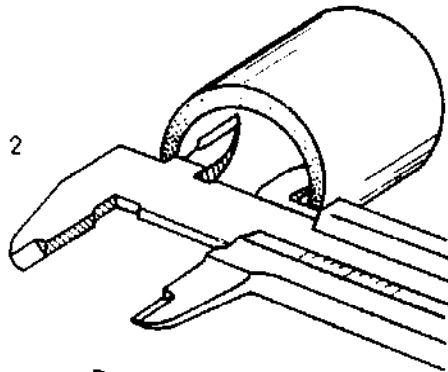
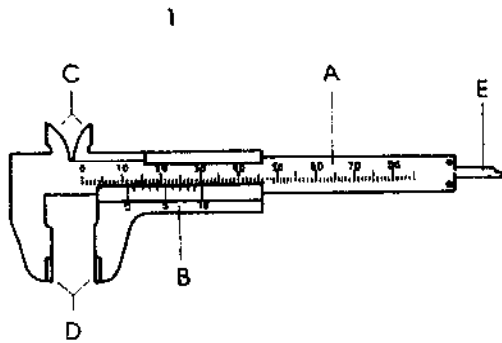

Using the vernier caliper

Fig. 1 shows how to adjust the vernier caliper with the thumb.

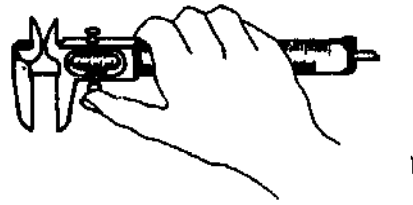

Measuring

Example A, see Fig. 2.

- Look where zero is on the vernier scale.
- Answer: it is just on the 20 mm mark.
- Write down: 20 mm.

- See which line on the vernier scale exactly coincides with a line on the mm scale.
- Answer: The 0 line on the vernier scale.
- Write down: 0.0 mm.

Total measurement is: $20 + 0.0 = 20.0$ mm

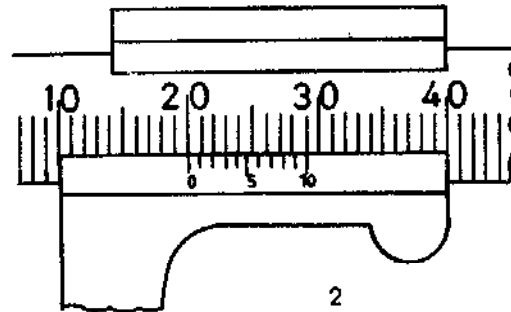

Example B, see Fig. 3.

- Where is zero on the vernier scale?
- Answer: it is just past the 12 mm mark.
- Write down: 12 mm.

- Which line on the vernier scale coincides exactly with a line on the main scale?
- Answer: the 5 line on the vernier scale.
- Write down: 0.5 mm.

Total measurement is: $12 + 0.5 = 12.5$ mm

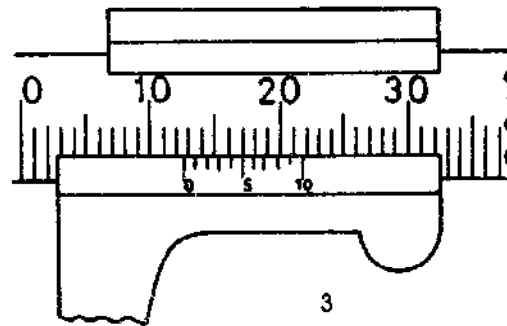

Exercise

Fill in the measured sizes.

A =

B =

C =

D =

E =

F =

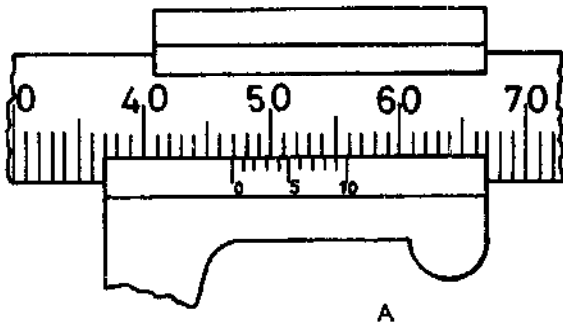

A

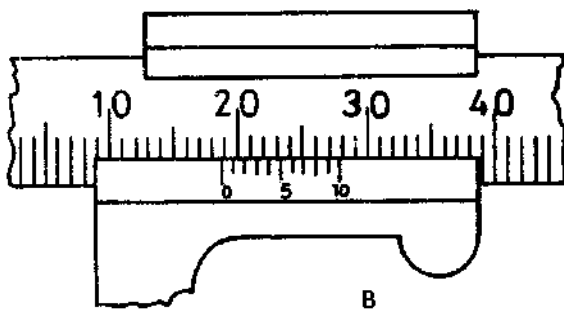

B

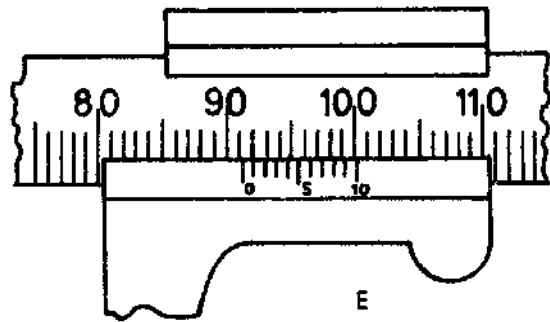

E

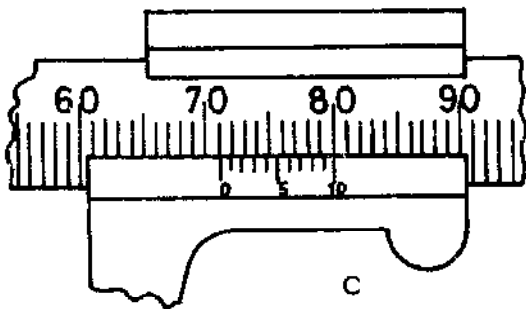

C

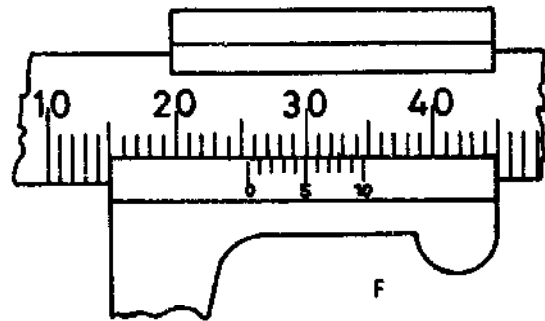

F

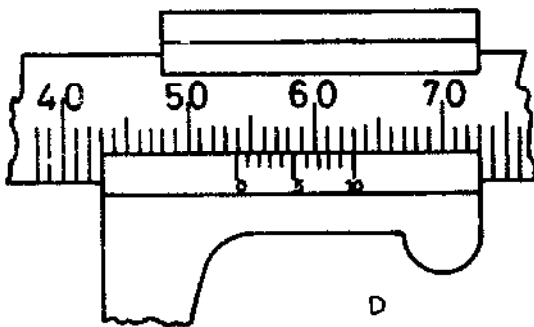

D

Micrometers

A micrometer has two scales. One scale is divided in millimeters, see Fig. 1-A. The outer diameter of the cylinder (1-B) is divided in 50 units. When the cylinder is turned twice (100 units), the plug (1-A) is transported 1 mm. The measurement accuracy therefore is $1/100 \text{ mm} = 0.01 \text{ mm}$. A slip clutch (1-C) assures a continuous measurement pressure.

Examples

- The micrometer in Fig. 2 measures a size of 14.27 mm.
- The micrometer in Fig. 3 measures a size of $61.5 + 0.34 = 61.85 \text{ mm}$.

Internal micrometer

These type of micrometers operate similar to the normal ones. The base length can be extended using an extension rod. See Fig. 4-A. The measured size = value read on micrometer + length extension rod.

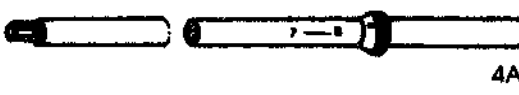
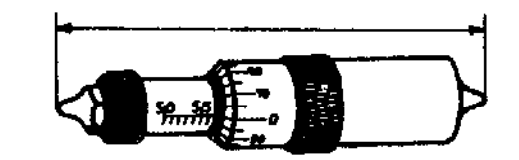
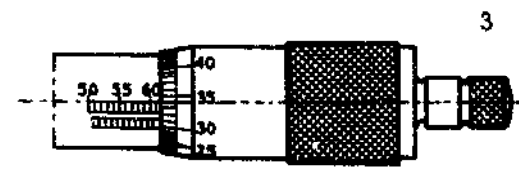
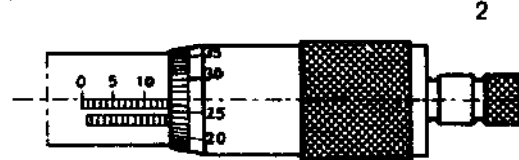
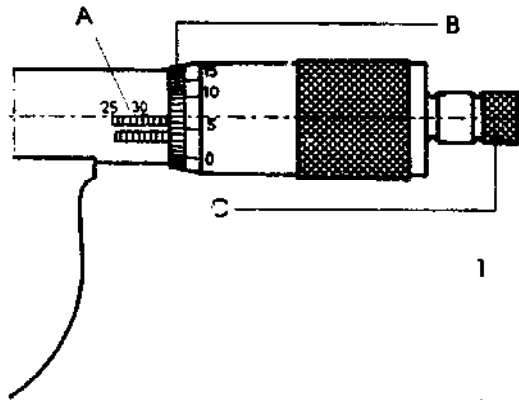
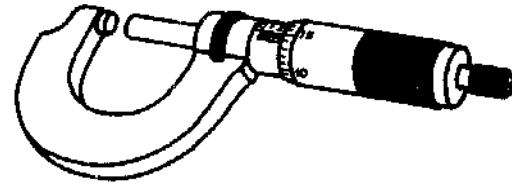

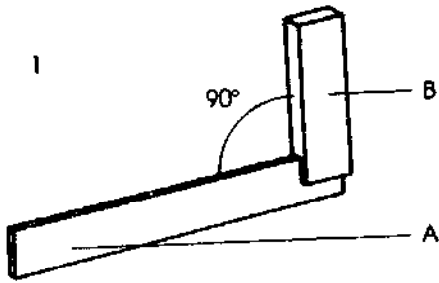

Try square

The try square as seen in Fig. 1 has a blade (1-A) and a stock (1-B) which are fixed together at exactly 90°. The edge of the blade and the stock are perfectly sharp and straight.

Outside corners

Outside corners are checked with the try square, see Fig. 2. The try square should be held firmly with the beam against one side of the object. Then it should be lowered until the blade touches the object. Between the blade and the object there should not be light anymore, to ensure the object is absolutely square.

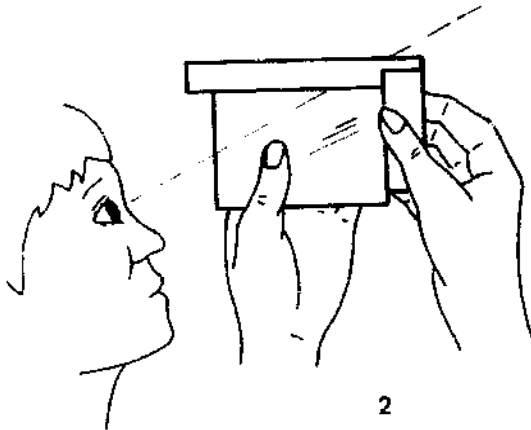

Inside corners

To check an inside corner, hold the stock of the try square firmly against one side of the workpiece and check whether there is any light to be seen between the blade and the other side of the object. If so, the second piece is not exactly square to the base piece. See Fig. 3.

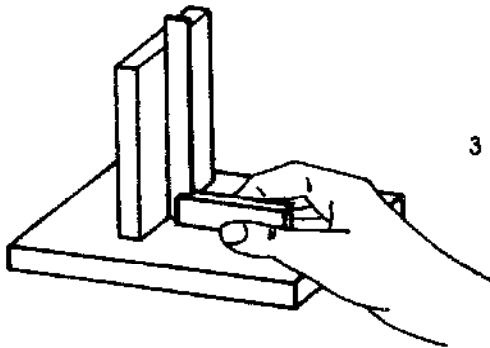

Flatness

As you see in Figs. 4 and 5, the flatness of an object can be checked with the aid of the try square. Hold the try square with the stock vertical and press the blade firmly against the object. Check against the light in the directions S-A-B-C-D-E-F.

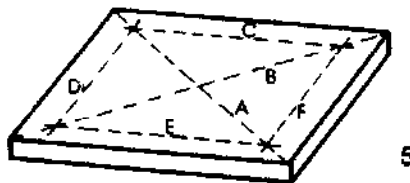
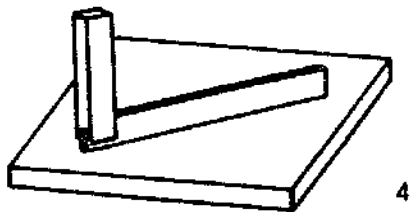

Try square and bevel

Testing the try square

You can use the following method to be sure the try square has an angle of 90° , see Fig. 1:

- Take a metal plate with a straight edge (1 A-A).
- Place the stock of the try square along the straight edge (1-B).
- Inscribe a line (1 C-C) along the blade over the metal plate.
- Turn the try square to position (1-D). The inscribed line should now coincide with the blade of the try square.

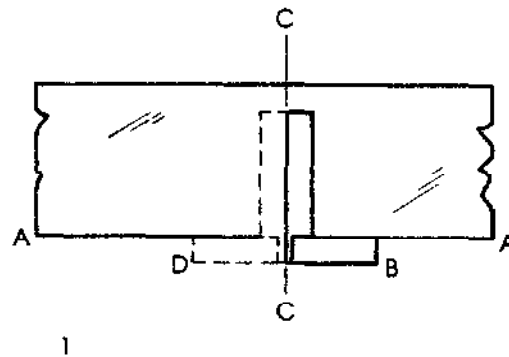

Sliding bevel

The sliding bevel looks a bit like the try square. It also has a blade and a stock. The blade can be adjusted to set the bevel at any angle. The bevel is used for checking any angle other than 90° , see Fig. 2. You can use it to mark out any angle.

If a piece of metal is shaped to an angle, it is checked with the sliding bevel. Move the sliding bevel along the object to check more than one place.

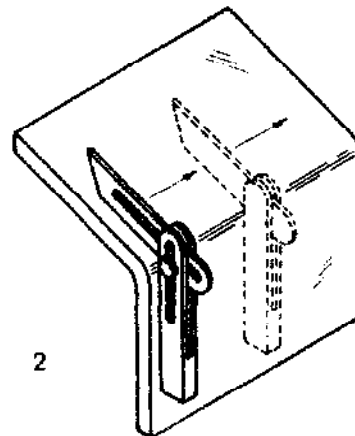

Fixed bevel

A fixed bevel can be made when a lot of workpieces have to be made with the same shape, see Fig. 3.

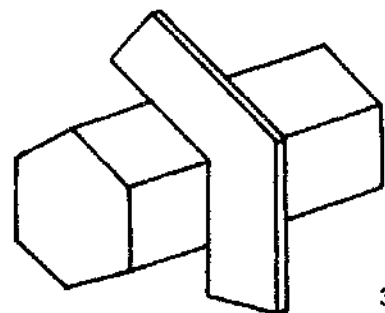

Protractor

You can draw any angle with the aid of a protractor, see Fig. 1. But make sure that you measure the angle from line 1 A-A and not from line 1 B-B. The protractor is also used to set the angle on a sliding bevel. Suppose you want to set the sliding bevel to an angle of 60° :

- Draw the angle with the aid of the protractor on a piece of paper.
- Copy this angle with the sliding bevel.

Some protractors have an arm which makes them easier to use. See Fig. 2.

Universal bevel protractor
Measuring, marking and checking of angles is done with an universal bevel protractor, see Fig. 3.

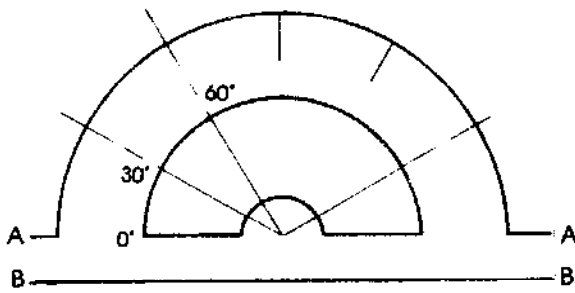

1

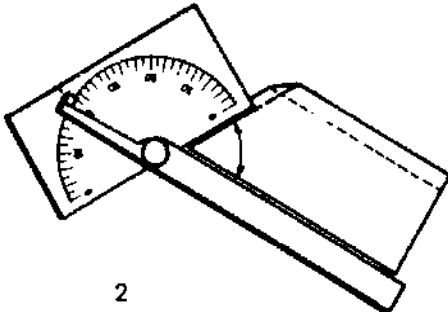

2

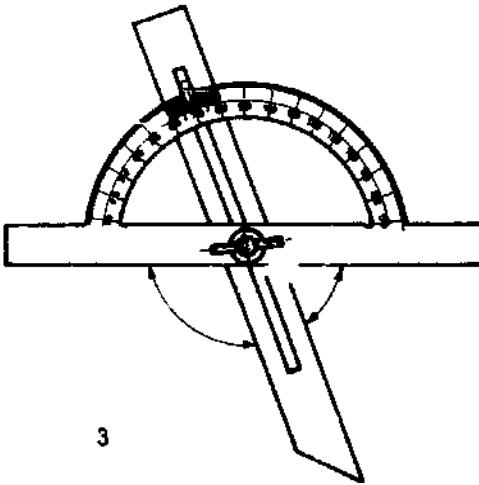

3

Feeler gauge

A feeler gauge is a set of thin steel blades. They fold into a handle, see Fig. 1. The thickness of each blade is marked on the blade. Blade .26 means this blade is 0.26 mm thick. Feeler gauges are used to measure the size of very small gaps between two pieces of metal. See Fig. 2. To measure the gap, find out which blade fits into it, hold the blade lightly between your fingers and move it in the gap. The blade should not move too tightly but it should not move too freely either. It takes a little practice to get the right feeling for measuring gaps. When using the very thin blades in particular, be careful not to push the blade too hard or it will bend and become crooked.

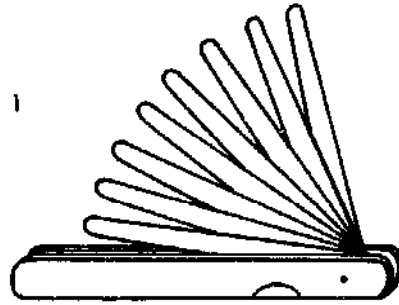

Screw pit gauge

A screw pit gauge is used to find out the correct pitch of a screw, bolt or nut. There are gauges for all kind of thread. Place the thread gauge over the thread and see which blade fits exactly over the thread. The numbers stamped on the blade tell you the correct pitch. See Fig. 3.

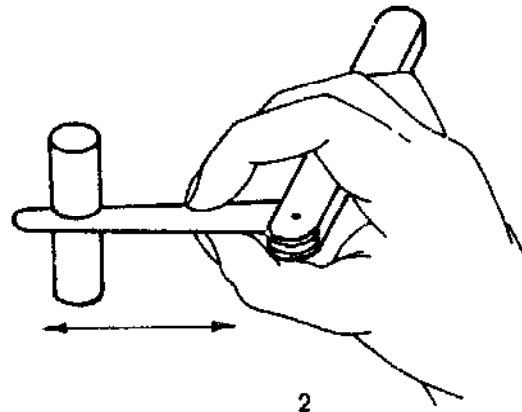

Spirit level

A spirit level is needed for instance when fitting up or installing machines, see Fig. 4. Check the surface in all directions.

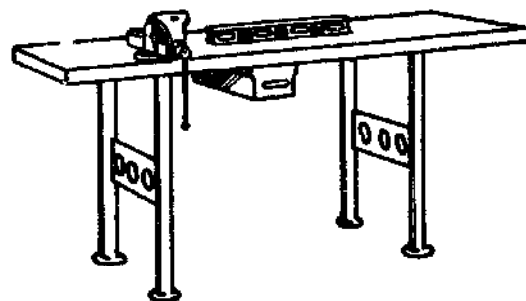
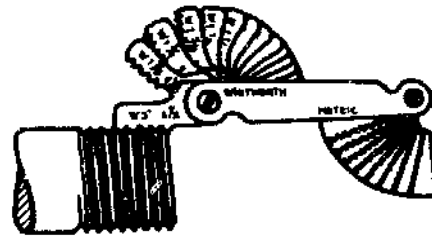

Marking out

Drawing

Marking out means: marking on the metal all the lines and points needed to make from it the workpiece required. These lines and points are called the *lay-out*. The shape and all the necessary dimensions are given on a drawing, see Fig. 1 which is drawn in scale 1:2 mm. The drawing can be made on the blackboard or on a piece of paper.

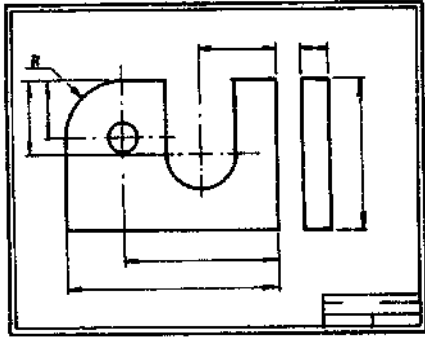

1

Marking on metal

Copy onto the metal (as shown in Fig. 2) the same shape as you see in the drawing. If it is too difficult to inscribe lines on metal that is bright and clean, rub the metal first with chalk or paint, then the inscribed lines are easier to see.

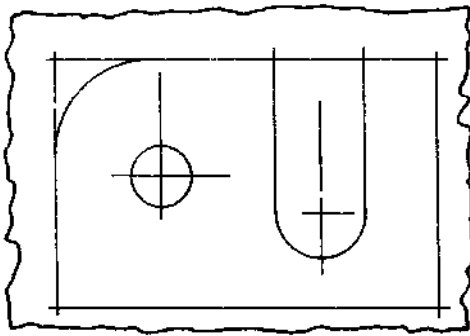

2

Before drawing a shape, like the one in Fig. 2, find out how the workpiece can be taken out of the piece of metal in the most economical way. Keep the straight side of a workpiece along a straight side of the metal. Be economical. After completing the lay-out, check all the dimensions once more. A small mistake in the lay-out means the actual shape of the workpiece will be incorrect.

Fig. 3 shows the actual shape of the workpiece drawn in Figs. 1 and 2.

Common marking tools

The most common marking tools are:

- Rule
- Try square
- Sliding bevel
- Protractor
- Scriber
- Centre punch
- Dividers

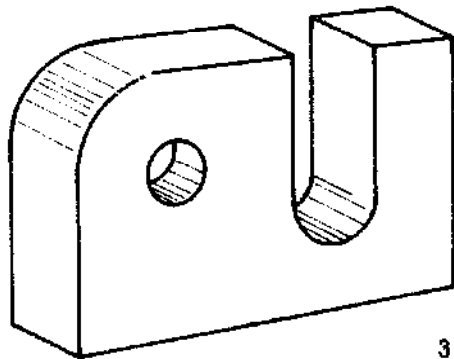

3

Scriber

You can use a pencil or a chalk stick to mark lines on metal, but these lines are not very sharp or clear and they wear off easily. For accurate work it is better to use a scriber, see Fig. 1. A scriber is a kind of steel pencil with a sharp point. It is used to scratch or inscribe lines on metal. A scriber can easily be made from an old round or triangular file.

Scribing lines

To inscribe a straight line, place the steel rule in the correct position and press the rule hard against the workpiece with the left hand, see Fig. 2. Hold the scriber with the right hand just as you hold a pencil and lean it to one side, so that the point will draw along the lower edge of the steel rule. Fig. 3-A shows the right way. Scratch one line. If necessary, sharpen the scriber on the oil stone.

Inscribe a V when you want to mark a point, because marking a point with a single dot is not very clear.

General rules for scribing lines

- Have a sharp conical point on the scriber.
- Press the try square or the steel rule very hard against the workpiece on the correct points. See Fig. 4.
- Watch very carefully that the point of the scriber is against the lower edge of the try square or rule, as shown in Fig. 3-A.
- Draw the line with the scriber in a slanting position. See Fig. 5.
- Scratch only one, firm line.
- If the metal is too hard or shiny, use some chalk or paint the surface.
- Mark points with a V.

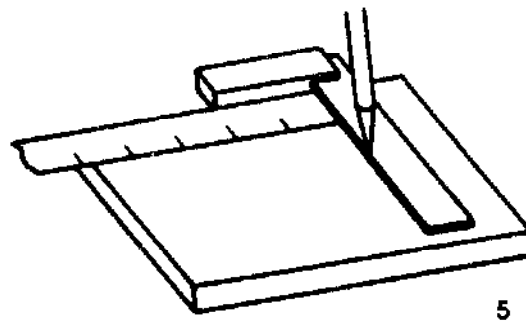
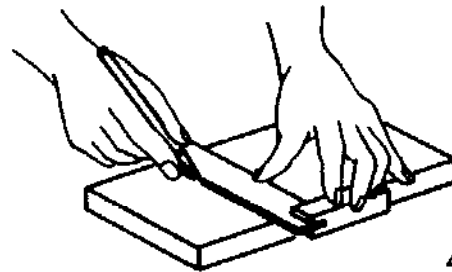
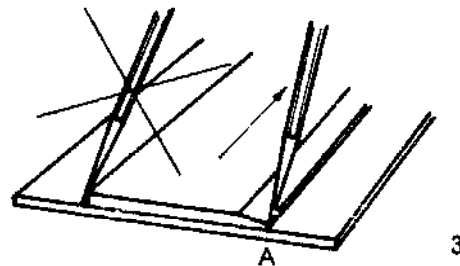
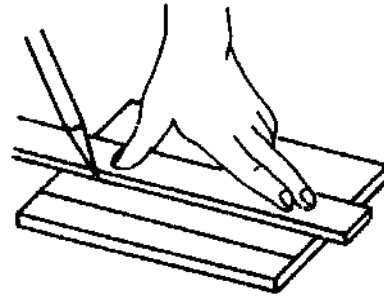
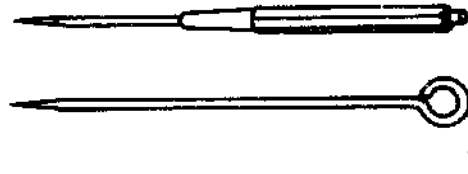

Marking off

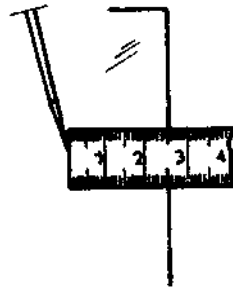

1A

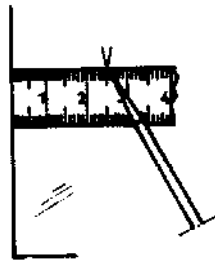

1B

A measurement can be marked off in two ways. You can measure from 25 to 0 mm. The rule is then placed on the workpiece in such a way that the desired measurement (in this case 25 mm) is on the same level as the edge of the workpiece. See Fig. 1-A. A line is then drawn along the front side of the rule with a scribe. The measurement can also be made from 0 to 25 mm. To do this the rule is placed on the workpiece in such a way that 0 is level with the side of the workpiece.

A V is then drawn at 25 mm. The point of the V indicates the correct measurement exactly. The marking off is therefore done by the point of the V. See Fig. 1-B.

Reference lines

What is a reference line?

A reference line on a workpiece is the line from which you are going to take all the measurements. If you have to make the workpiece shown in Fig. 1, you usually need two reference lines. These two reference lines are always at right angles to each other. The sides chosen for the reference lines are usually the sides which do not have many cuts etc. We have therefore chosen the sides 1-A and 1-B for the reference lines.

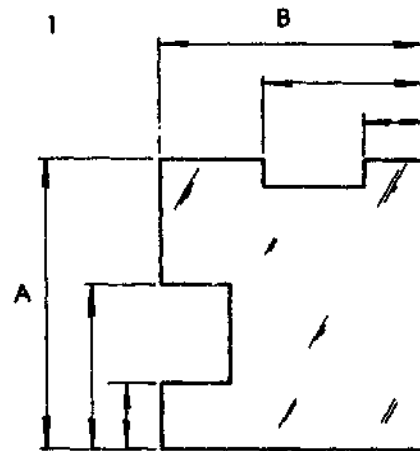

How to make reference lines

If the metal has a straight edge, you should use that side as a reference line. See Fig. 2. If the metal has no straight edge, you have to make a reference line yourself. Suppose you have to make a rectangle as shown in Fig. 3. This is the procedure you have to follow:

- File one edge straight; this is the first reference line (3-A).
- File the second edge straight and at 90° to the first edge. This is the second reference line (3-B).
- File the third and fourth edges according to the given dimensions (3-C).

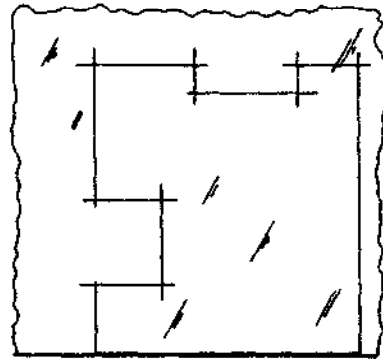

Symmetrical workpieces

Many workpieces are symmetrical, like the trowel blade shown in Fig. 4. The centre line is the first reference line for all symmetrical workpieces. Measurements have to be the same on both sides of the centre line.



4

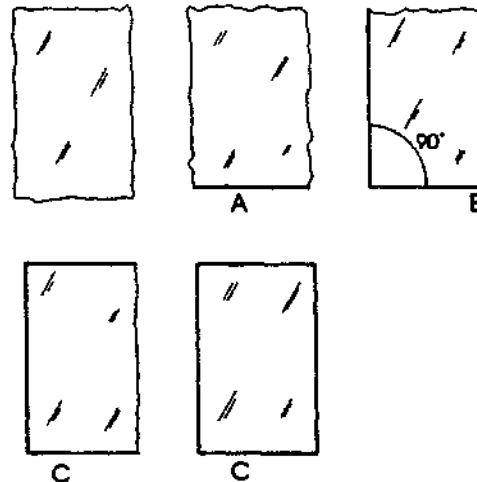

3

Centre lines

A centre line in a technical drawing marks the centre of a workpiece. See Fig. 1. A centre line is drawn only when the workpiece is symmetrical (the same shape on both sides).

Round holes

Round holes always have two centre lines to make it possible to locate the exact centre of a hole. See Fig. 2. The r on the drawing gives you the diameter of the hole to be drilled.

Marking out

The drawing in Fig. 2 shows you all the details. On the piece of metal in Fig. 3 you see only the centre lines. From the drawing you know the diameter of the drill to be used for the round hole and the slotted hole. All centre lines are marked from the reference lines 3-B.

Square or rectangular holes

Square or rectangular holes are drawn with four lines. See Fig. 4. To be able to make this rectangular hole you need to drill four holes at the corners of the large hole. The large rectangular hole is inscribed and four centre points drawn for the four holes. See Fig. 5. The four holes are then drilled and the large rectangle is cut out. See Fig. 6.

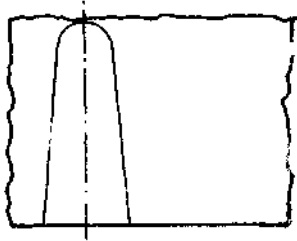

1

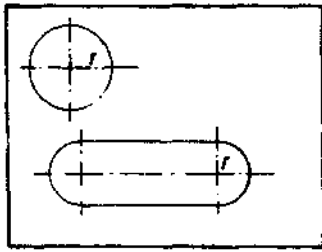

2

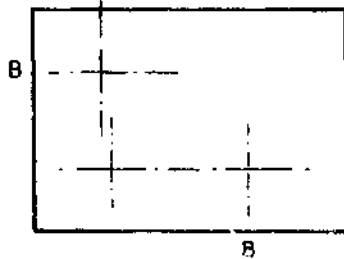

3

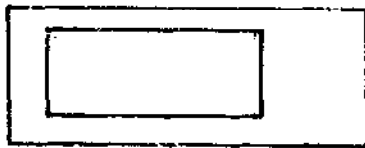

4

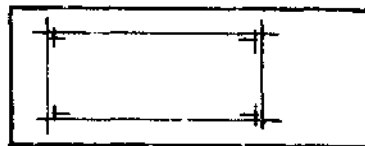

5

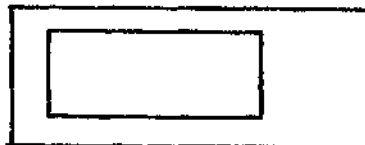

6

Centre punch

The centre punch is made of hardened steel and has a sharpened tip with a 30° to 60° cone. See fig. 1. The centre punch is used to mark the centre of a hole before drilling.

Exercise

- First measure out the centres of the holes. Inscribe a long line and some lines across where the holes should be.
- Place the centre punch on the intersections of the two lines. Carefully place the centre punch at an angle to ensure better vision. See Fig. 2.
- Move the centre punch into an upright position and strike it with a hammer, see Figs. 3 and 4. The blow must be delivered in the direction of the centre punch axis. When centre punching, always fix your eye on the tip of the centre punch.
- Strike the centre punch firmly so the mark can lodge the small drill, see Fig. 5.

Accuracy

The accuracy of the centre punch depends on:

- exact marking of the holes,
- the ground tip of the centre point,
- placement the centre punch in the exact position,
- correct use of the hammer.

Safety

Make sure that the head of the centre punch is free of grease and dirt. See to it that the head and the point have the correct shape.

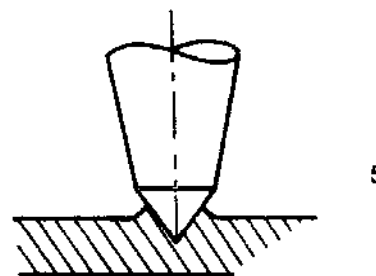
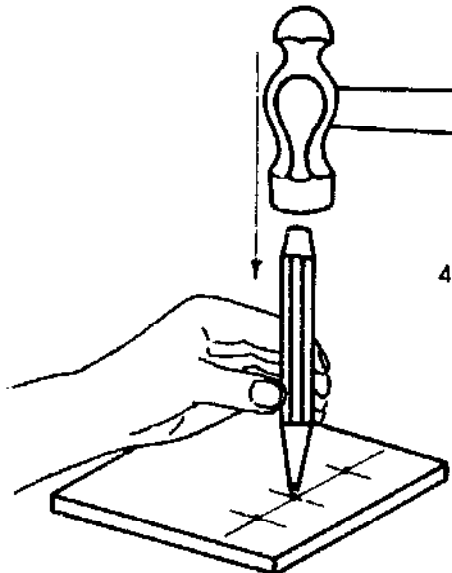
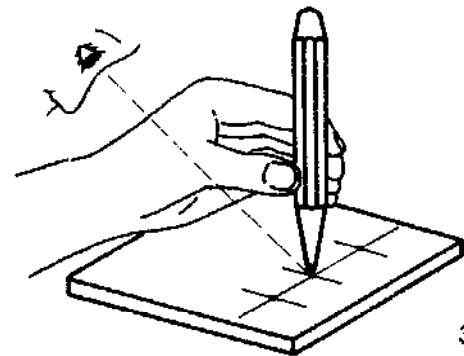
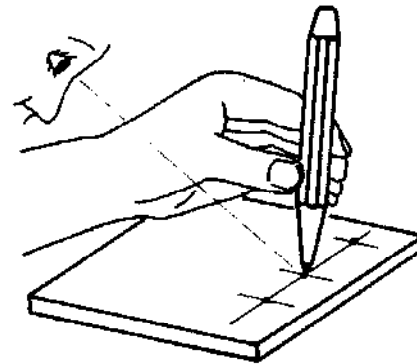
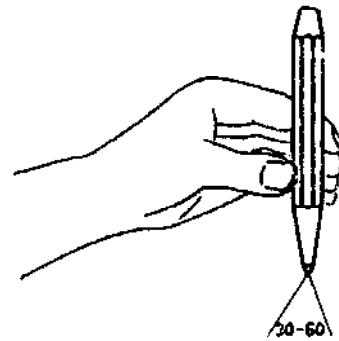

Lines on a cylinder

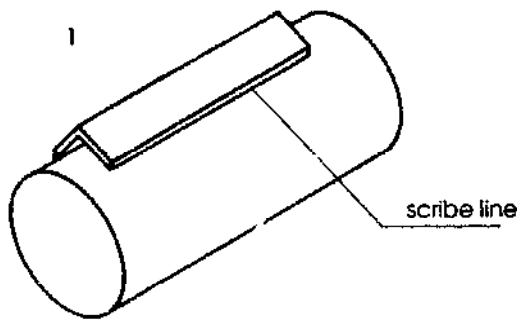

You can use an angle iron as shown in Fig. 1 to inscribe a line in the length of a cylinder. Press the angle iron firmly against the cylinder and inscribe the line. If V-blocks are available, the cylinder can be placed in the block and horizontal lines give the centre point as the cylinder is turned.

Centre point on a cylinder

Marking the centre point on a cylinder is possible with the aid of a *Centre square*. Press the square firmly against the side of the cylinder and inscribe several short lines, while turning the centre square in different directions, see Fig. 2.

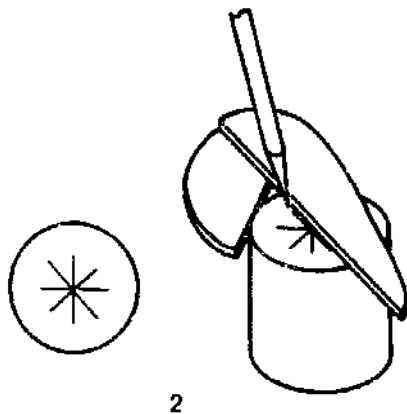

Template

It is more economical to make a *template* if a lot of workpieces have to be made of the same size and shape, see Fig. 3. A template can be made of sheet metal or any other material and should have exactly the shape of the pieces which have to be made. Mistakes are avoided by having one example because the same template is always used.

Round holes are made on the template as a small hole through which a centre point is passed to indicate a centre point on the rough material.

Square holes are marked at all four corners with a centre point. Lines can be inscribed around these points later.

When marking with the template, make sure there is ample space for the tool to cut the material. There should be enough space between curved lines in particular to allow the cutting tool to pass through.

A template makes it easy to make a good, economical lay-out without much waste of materials.

Use your right hand to mark lines with a scribe and with your left hand press the template firmly against the rough material, see Fig. 4.

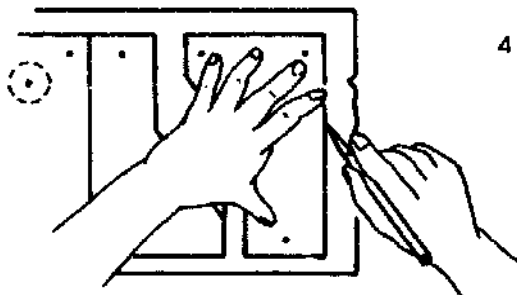
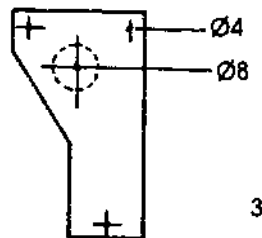

Dot punching

A centre punch can also be used to make dots along an inscribed line, see Fig. 1. This sort of marking is called *dot punching*. Dot punching is useful because inscribed lines can easily wear off while you are handling the work; dot punches make them last longer. Dot marks are smaller than centre marks and a light hammer is used for dot punching.

Exercise

- Inscribe a line with a scribe.
- Make dot punches at regular intervals.
- Cut the material.
- File the work to the exact shape, leaving half the dots visible. This is important because it shows that not too much material has been filed off.

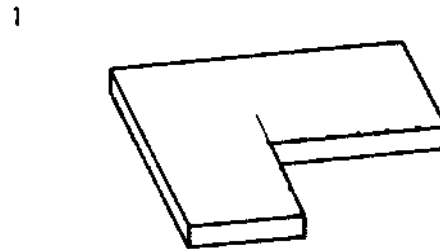
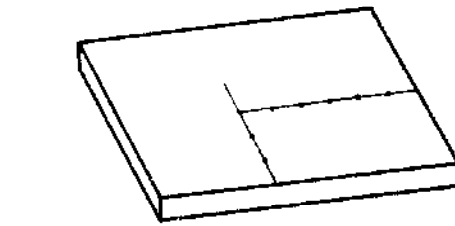

Dividers

A pair of dividers is a two-legged instrument with hardened tips; these legs are shaped as shown in Fig. 2.

Exercise

- *Inscribing circles or parts of circles*
Make a centre punch mark for the centre of the required circle. Put one leg of the divider in the centre punch mark, press this leg firmly in the small hole made by the centre punch. Inscribe the circle.
- *Marking equal distances*
Using the divider, scratch the first mark required. Mark this point again with the centre punch before you continue to the second mark, holding the leg of the divider in the centre punch hole you have just made, see Fig. 2.
- *Measuring distances*
Open the divider as far as necessary to reach from one mark to the second mark (Fig. 3). Place the divider carefully on a ruler and check the distance. See Fig. 4.

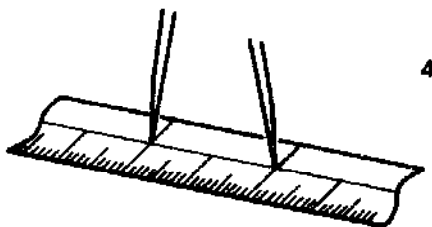
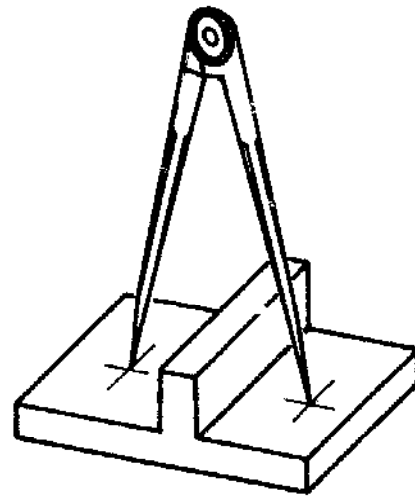
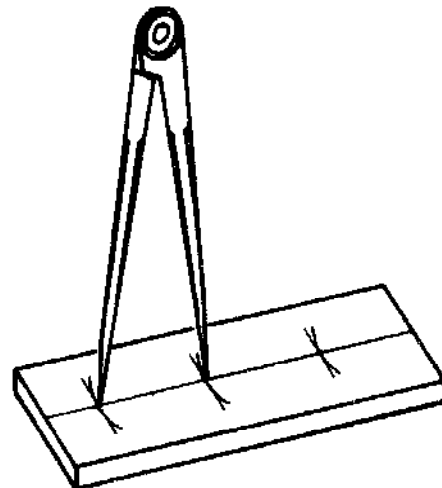

Dividers

Dividers are used to scribe circles on material to be used. The most commonly used dividers are shown in Fig. 1. During scribing the top of the dividers is held with the thumb and the forefinger as shown.

When made locally, make sure that the legs of the dividers are of the same length and shaped at the end as shown in Fig. 2.

Beam trammels

A beam trammel is used to scribe large circles, see Fig. 3.

Exercise

- Set the dividers at the correct radius of the required circle.
- Press one leg of the dividers into the punched hole.
- Hold the compass at the top between the thumb and the forefinger.
- Turn the compass around while scratching the circle into the material, as shown in Fig. 1.

Approximate large circles

Large circles with an approximate diameter may be made with the aid of a wire which is fixed at the other side to the scribe. The distance between the scribe and nail or screw is equal to the required radius. While scribing the circle hold the wire tight, so that the scribe produces the correct circle. See Fig. 4.

Chalk line

A very long rough cutting line may be made with the aid of a chalk line. This line is covered with chalk powder. Fix the line at two points onto the material. Lift the line in the middle and leave it at once so that it will jump to the material and so produce the required line, see Fig. 5.

As said before, this method produces a rough cutting line only.

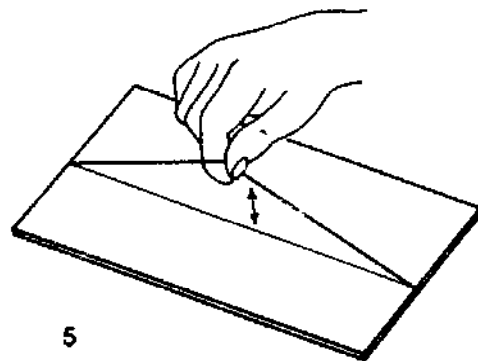
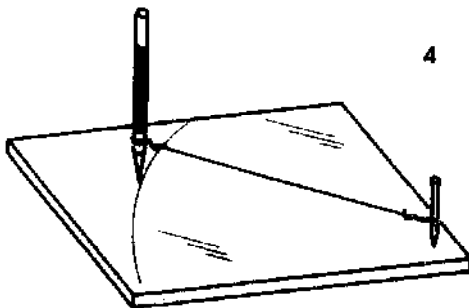
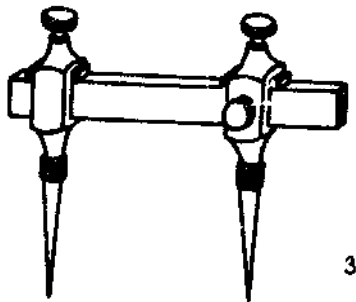
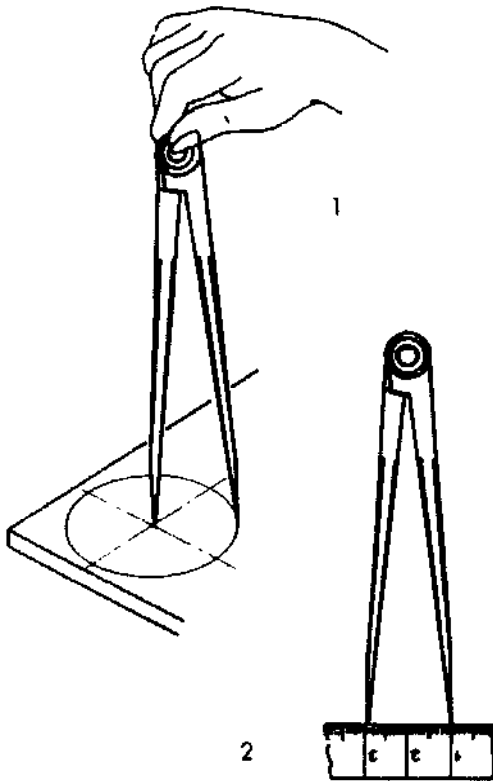

Callipers

External calliper



Internal calliper

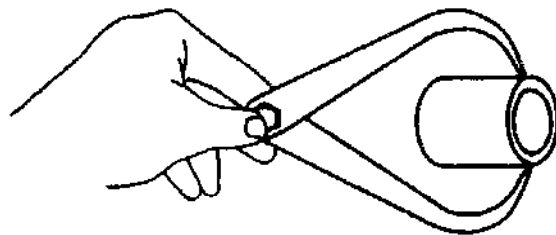
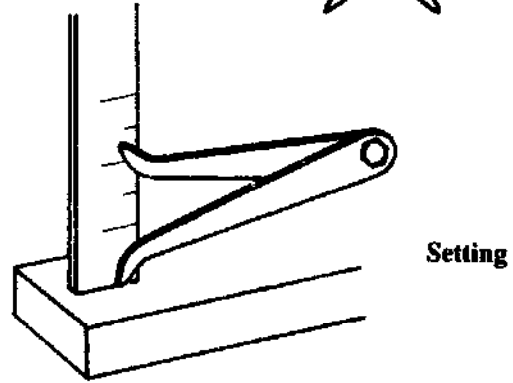
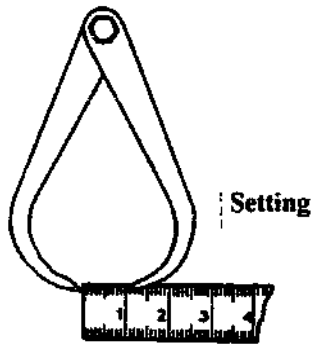

Measuring external

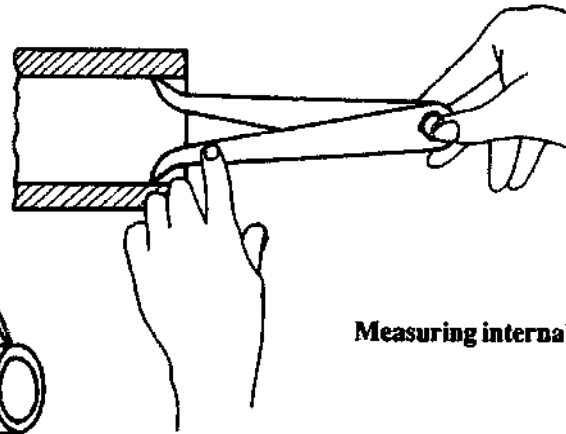

Measuring internal

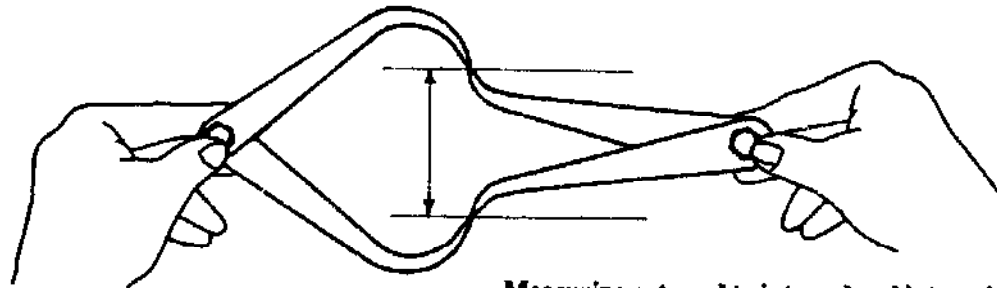

Measuring external to internal and internal to external

Cutting tools

Hack saw

The hack saw is one of the most useful tools used by the rural mechanic. It can cut different metals in a relatively fast way. See Fig. 1

Hack saw parts

- *Handle*, made of wood 1-A
- *Frame*, made of steel 1-B
- *Blade*, different sizes and shapes 1-C
- *Wing nut*, to adjust the spigot 1-D
- *Adjustable spigot*, to fix the saw blade 1-E

All metal hacksaws are shown in Fig. 2.

Hack saw blades

Saw blades are commonly available with the following shapes:

- *Coarse*: 14 teeth per 25 mm, for thick and soft metal, see Fig. 3-A.
- *Medium*: 22 teeth per 25 mm, for medium work, see Fig. 3-B.
- *Fine*: 32 teeth per 25 mm, for hard metal, see Fig. 3-C.

Quality

- *All hard*: the whole blade is tempered.
- *Flexible*: only the teeth are hardened.
- *High speed steel*: special steel.

Make sure you tighten the blade correctly in the hack saw frame with the correct tension and the teeth pointing forwards.

Cutting action

To ensure chip clearance, the teeth of the saw blade are set as shown in Fig. 4-A. Teeth are bent sideways to the left and to the right. Another way of ensuring chip clearance is to have saw blades which are wavy, as shown in Fig. 4-B. The space 4-C is the space for chip clearance.

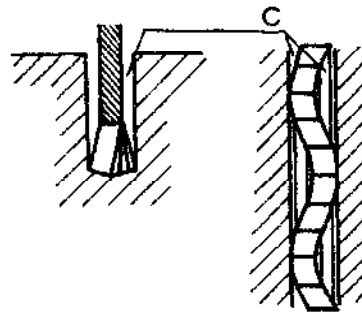
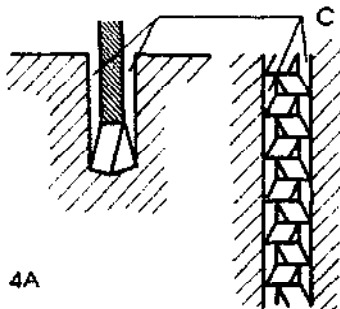
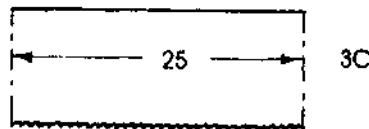
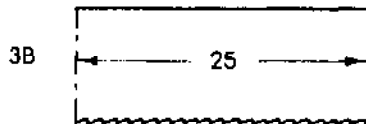
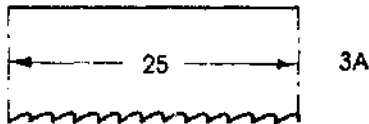
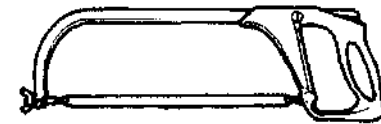
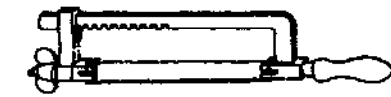
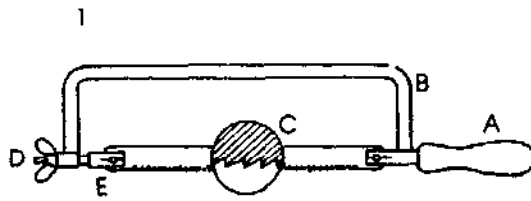

How to hold the hack saw

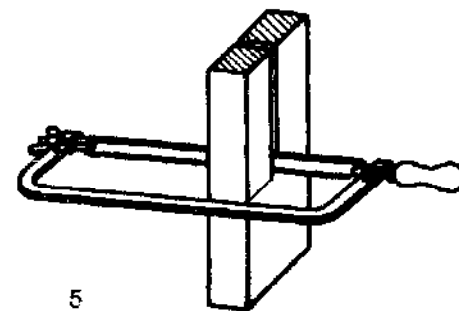
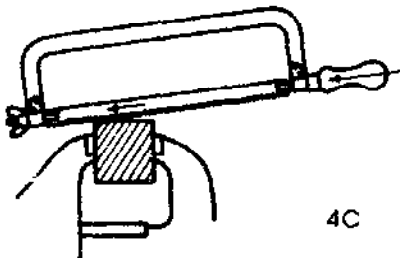
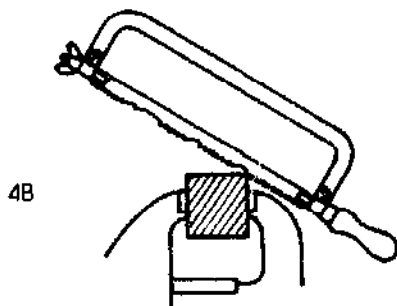
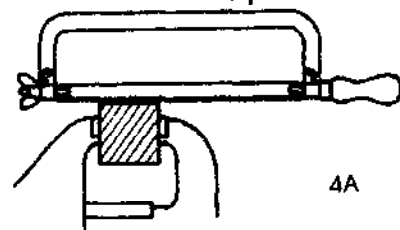
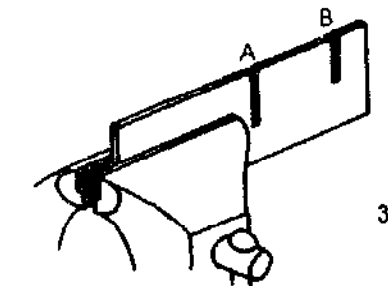
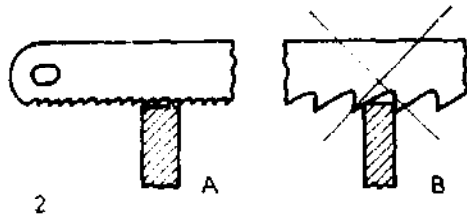
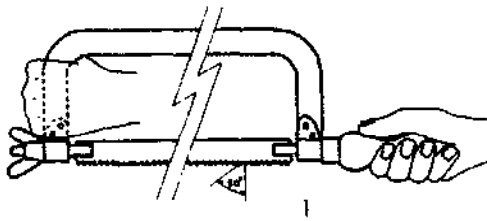

- Hold the handle with your right hand and hold the front of the frame with your left hand, see Fig. 1.
- Keep your feet 25 cm apart, the left foot pointing towards the workbench.
- Press the hack saw down on the forward strokes and lift it a little on the backward strokes.
- Use the full length of the blade, otherwise the middle part wears out instead of the whole blade.
- Do not make more than 50 strokes per minute. If you go faster, the blade becomes too hot and loses its hardness.

Always use a blade of such a shape that at least three teeth cut into the material. Otherwise the blade easily gets damaged. Fig. 2-A shows a blade easily gets damaged. Fig. 2-B shows a correctly shaped blade and Fig. 2-B shows an incorrectly shaped blade for this particular piece of metal.

Clamping the workpiece

Always clamp the workpiece in the vice so the cut is made near the vice jaws. See Fig. 3; 3-A is right, 3-B is wrong.

Starting a cut

Do not start cutting the metal as shown in Fig. 4-A. Working this way you cannot get hold of the metal and you may damage the surface. The method shown in Fig. 4-B is also wrong. The angle of the saw blade to the metal piece is too large, which may result in the teeth being broken.

The correct way to start is shown in Fig. 4-C. The angle between the metal and the blade is not too big. Start with a forward stroke. Cuts longer than the distance between the blade and the frame can be cut as shown in Fig. 5. Change the direction of the blade.

Filing a notch

It is a good habit to file a notch at the sharp edge of a workpiece. A notch makes it easy to start sawing exactly on the line and reduces the risk of breaking off teeth of the blade. See Fig. 1.

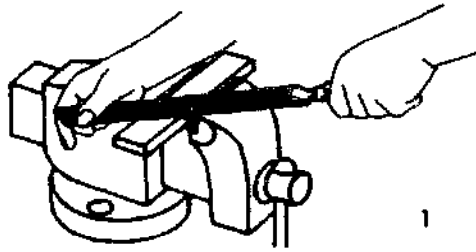

Sawing tool steel

Be sure that tool steel is annealed before sawing, otherwise the saw blade quickly becomes blunt. Although annealed tool steel can be sawn like ordinary steel, a good way is to saw only a deep notch all around the workpiece and then break the material by clamping it in the bench vice, but in such a way that the sharp blow falls in the direction of the fixed jaw. If you are not sure about the hardness of the material, first file a bit and this will tell you whether you can saw the metal.

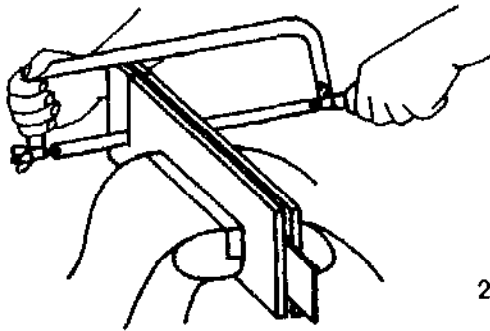

Sawing thin metal

A small piece of thin metal can easily be sawn by clamping it between two pieces of wood in a vice and sawing through both the metal and the wood. See Fig. 2. Larger pieces of thin metal cannot be held in the vice but can be clamped to the bench top with the part to be cut off projecting over the bench.

Thin pipes can be sawn by cutting through the metal while turning it round at the same time, see Fig. 3.

3

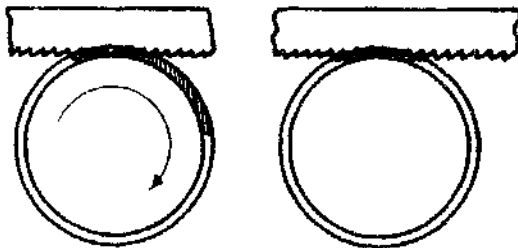

Sawing wide slots

Sometimes it is desirable to make a wide slot, in a bolt head for instance. Such a slot is easy to make, using two or more hack saw blades instead of one. See Fig. 4.

If for some reason a very small slot has to be made, an old hack saw blade can be used because the setting of the teeth is less than on a new blade. *

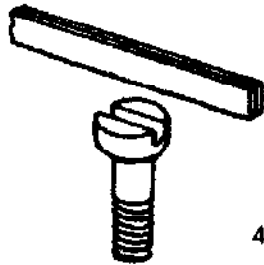

Files

A file is a most valuable cutting tool. Its real value is seldom fully appreciated by beginners. Unless a file is properly cared for and used, it will do only moderately satisfactory work and filing with it will be tedious and laborious. On the other hand when a file is properly cared for and used, a good rural mechanic can often do faster and better cutting with it than he can with a grinding wheel.

Files are made of tool steel and are covered with hardened teeth, see Fig. 1.

Parts of the file

- Handle

The handle is usually made of hardwood. See Fig. 2. But sometimes a handle is made of steel as shown in Fig. 3. This handle can fit onto most of the files. Notice how the handle holds the file.

- Ferrule

The ferrule is a metal ring which prevents the handle from splitting, see 1-A.

- Tang

The tang is the tapered shaped part of the file which fits into the handle, see 1-B.

- Heel

The length of the file is measured from the heel, see 1-C.

- Blade

The blade is the actual file. It is made of hardened steel. Teeth are placed at 70° and 52° , see Fig 2.

- Point

The point is the part to which the length of the file is measured from the heel, see 1-D.

How to hold the handle

Fig. 4 shows you how to hold the handle of a file. The forefinger should be on top of the handle to improve the pressure. The round part of the handle should be lodged in the hollow of your hand. Fig. 5 shows a wrong way to hold the handle.

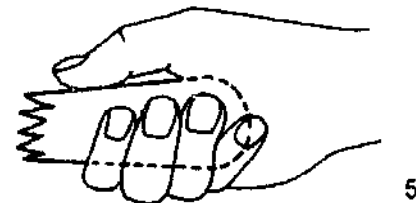
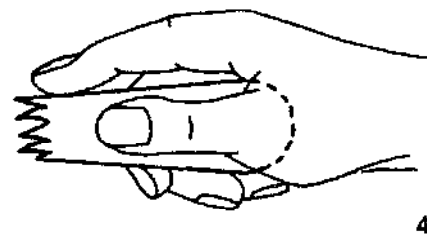
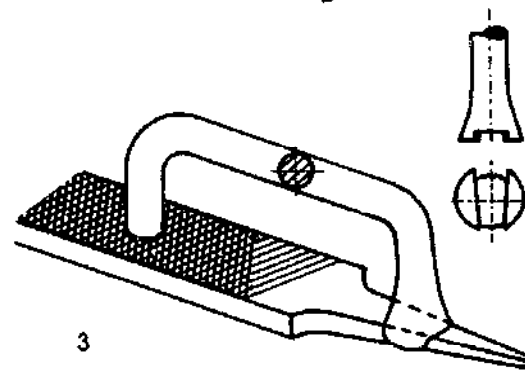
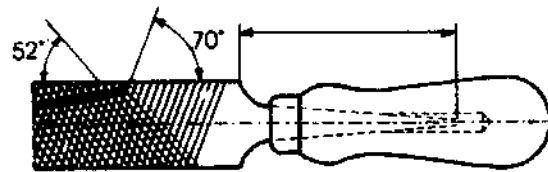
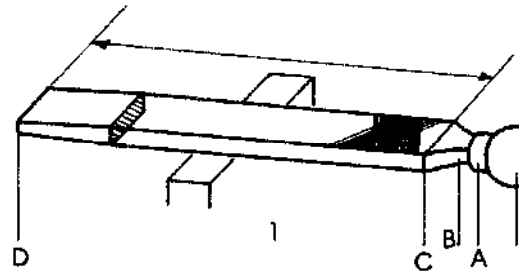

Classification of files

To identify any particular file it is essential to know (see Fig. 1):

- Length of file
- Shape of file
- Type of cut
- Grade of cut

Length of file

The length of a file is measured from the point to the heel of the file. The most commonly used files are of lengths from 150 to 300 mm.

Shape of file

The shape of the file is named after its cross-section, see Fig. 1.

- Flat file 1-A and 1-B
- Round file 1-C
- Square file 1-D
- Half round 1-E
- Triangular file 1-F

Type of cut

The *single cut* has one set of cuts. The teeth are like the edges of a chisel. See Fig. 2-A. The *double cut* has two sets of cuts crossing each other. This gives the teeth the shape of sharp points. See Fig. 2-B. The *rasp* has teeth which are not connected. The teeth are just sharp points. This rasp is used for woodwork, not for metal. See Fig. 2-C.

Grade of cut

Files are cut with teeth which are grooved at a certain angle, see Fig. 2-A and 2-B. Different grades of file produce finished surfaces with different qualities. Most file cuts are positioned at angles of 52° and 70°. The grade of cuts on files varies. The more cuts the smoother the file. Compare the grades shown in Fig. 2-B and Fig. 3.

Edge of file

One edge of the file has teeth, the other does not. The edge with cuts enables you to file inside corners of a square hole, see Fig. 3.

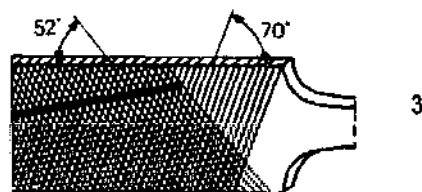
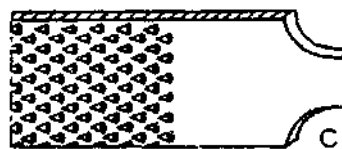
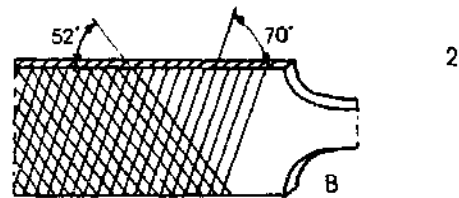
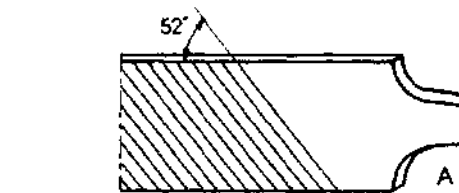
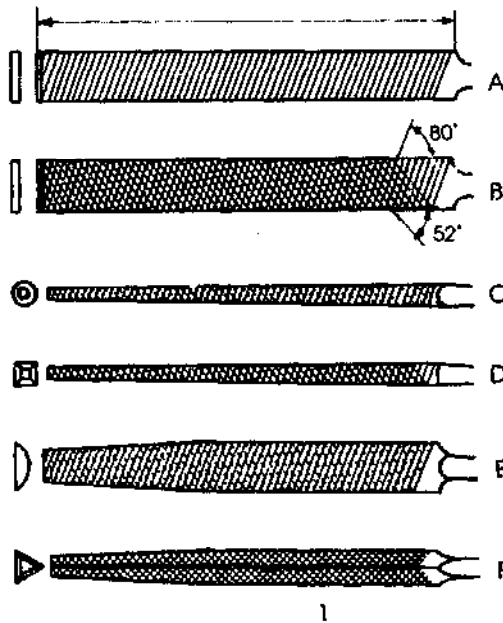

Holding the file

- When filing, stand with your left foot 15 to 25 cm in front, to the right, and your body leaning slightly forward from the hips.
- Hold the handle with your right hand, the point with your left hand, as shown in Fig. 1-A. For light filing, use the alternative positions as shown in Figs. 1-B and 1-C.

Filing

- Press the file firmly down on the forward stroke. Lift the file a little on the backward stroke. Use the full length of the blade.
- Make slow, even strokes. Do not make more than 40 cutting strokes per minute.
- When filing a narrow flat surface, use more pressure on the front end of the file than on the handle during the first part of the stroke. Then as the file is pushed forward, gradually ease the pressure on the front end and place more pressure on the handle.

Cross filing

Cross filing is shown in Fig. 2 and is used to produce a smooth, flat surface.

- Move the file forwards and at the same time sideways to the left and right.
- Change the direction of strokes regularly as shown in Fig. 2-A-B-C.

Draw filing

Draw filing is used to finish long narrow surfaces.

- Hold the file between your fingers as shown in Fig. 3.
- Use pressure on the forward and backward stroke when you use a double cut file. Press only on the forward stroke when you use a single cut file.

Draw filing wears out the file fast since only a small part of the file is used. Change the position now and then so that you use the whole file.

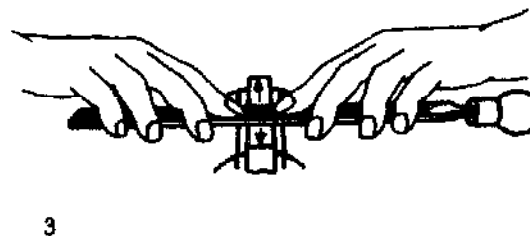
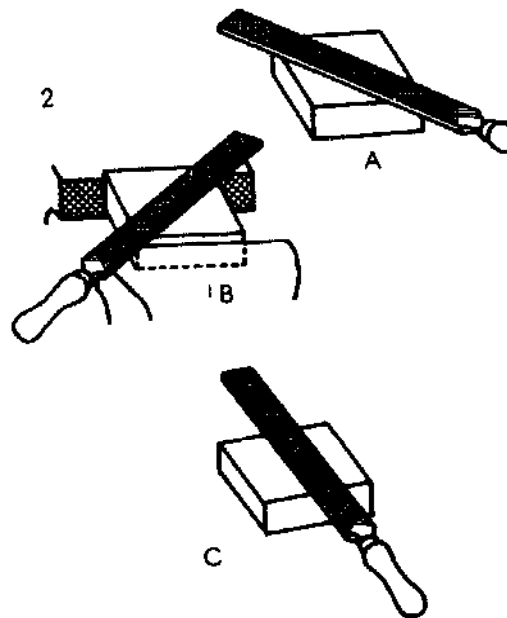
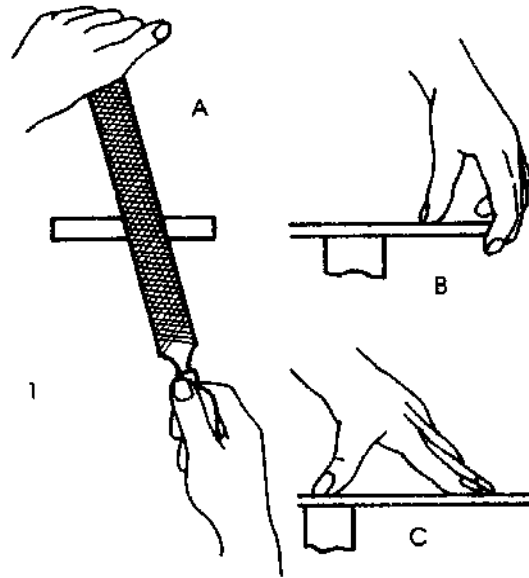

Round filing with radius

- Place the file with the tip in the position shown in Fig. 1-A. While moving the file to the positions 1-B, 1-C etc., push the file over its lateral axis to enable you to use the whole file.

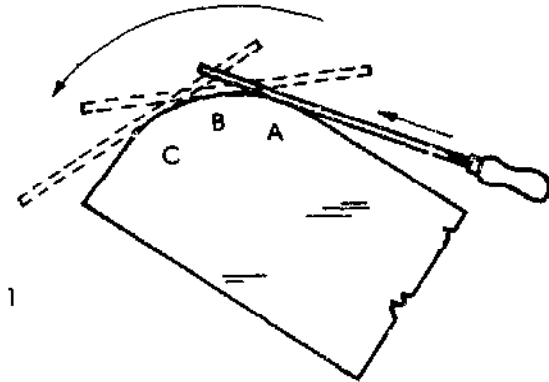

Round filing at right angle

- Place the file with its tip in the position shown in Fig. 2.
- Push the file forward while moving it in direction 2-A.
- Turn the file slightly as shown in 2-B.
- Move the file in direction 2-C as well.

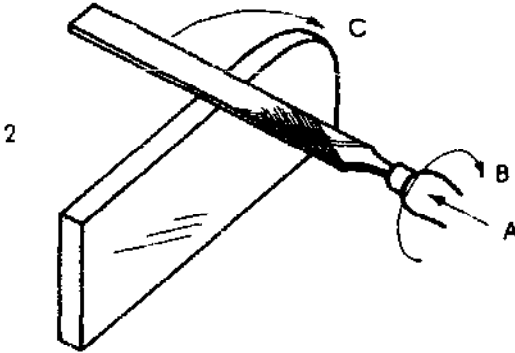

Internal round surfaces

- Guide the file as straight as for flat filing.
- Turn the file at the same time, as shown in Fig. 3.
- Draw one stroke 3-D-E at a time, as shown in 3-A-B-C.

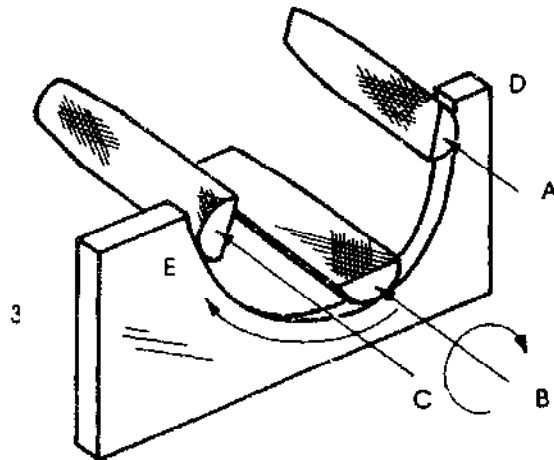

Internal round filing

- Use the same method as shown in Fig. 4.
- Change the position of the workpiece in the clamp as necessary.
- The rotation of the file is very important.

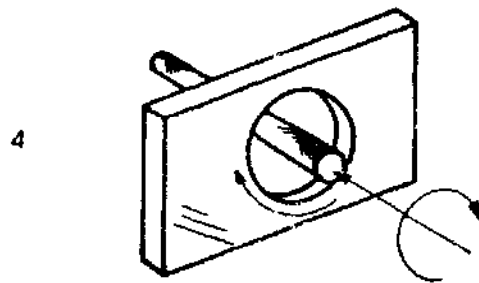

Clamping the workpiece

Clamp the workpiece in such a way that your file is close to the vice jaws, otherwise the workpiece starts to vibrate while you are filing, see Figs. 1-A (right) and 1-B (wrong). Obviously, you can never make a proper square edge on a workpiece if the piece is vibrating. An improperly clamped workpiece also makes a lot of noise and may damage the file.

Filing soft metals

The filings (dust) tend to stick between the teeth of a file – especially a double cut file – and make the file useless. So a single cut file is generally used on soft metals like aluminium, lead and copper.

Cleaning the file

Remove the filings with a wire brush, a piece of soft metal or a piece of hardwood. If you use hardwood, rub the file with the endgrain of the wood. Rub it in the direction the file cuts. See Fig. 2

Taking care of files

- Use your files correctly so they will last a long time.
- Do not allow a file to slip over the work as this makes the file dull. Lift the file on the backstroke.
- Never file hardened steel. Do not touch the vice jaws with your file.
- Do not allow files to touch each other, wrap them separately in a piece of cloth or store them in a file rack as shown in Fig. 3.
- Never use a file with a broken handle.

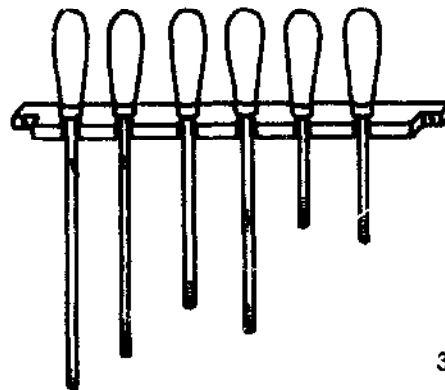
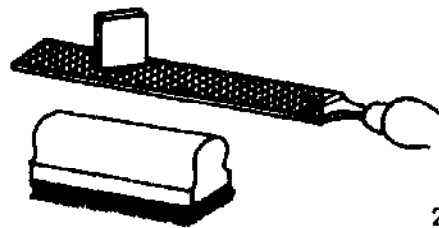
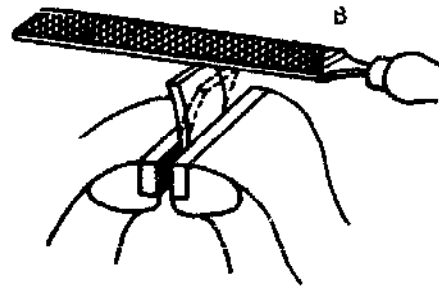
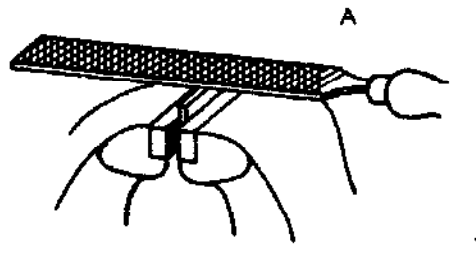

Steel hammers

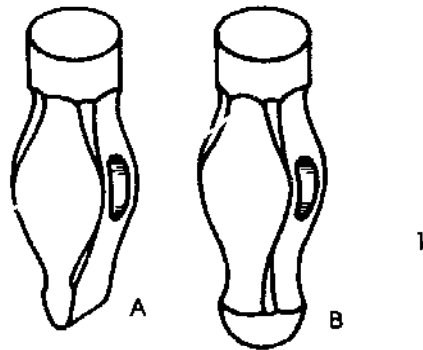

Hammers are very important for the rural mechanic. A lot of work is done with them in the workshop. Since our tool kit is limited, we deal here with only the most common hammers.

Hammers are made of hardened steel and are of different shapes and weights. The most suitable weight for hammers is 400 to 600 grammes.

Cross pein and ball pein hammer

The cross pein 1-A and the ball pein 1-B hammer are shown in Fig. 1. These hammers are used for all kinds of metal work which have to be done in the workshop. The ball pein hammer can be used for hammering out sheet metal.

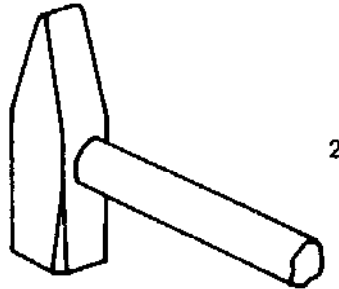

Hand hammer

A hand hammer is shown in Fig. 2. This hammer is commonly used for all kinds of work especially by the blacksmith. Light hand hammers are also used in sheet metal work.

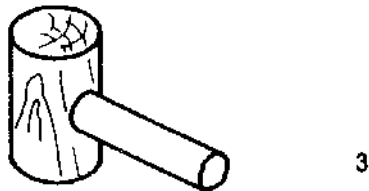

Mallet

A mallet is made of hardwood, plastic, rubber, lead or any other material, depending on the work to be done with it. A mallet (Fig. 3) is used when a steel hammer is likely to damage the workpiece.

Hammer shaft

The shaft of a hammer is made of straight grained wood. It is very important that it is straight grained, because tropical wood is mostly cross grained and this causes the shaft to break easily. The shaft is fitted into the hammer head. The hole in the hammer head has a special shape to ensure the shaft lodges well in the head and to allow room for expansion when the wedge is fixed. See Fig. 4. In dry areas it is better to wet the shaft now and then to make sure it will not break and to make it more flexible, which is necessary when there is heavy work to be done.

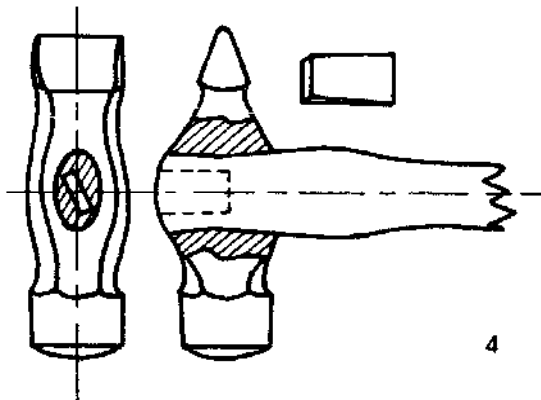

Hand chisel

Hand chisels are made of tool steel. They can have many different shapes and are sometimes specially made for special work. The most common shape of the chisel is shown in Fig. 1. This chisel is called a *flat chisel* and has the following parts:

- hammer anvil (1-A)
- shank (1-B)
- face (on each side) (1-C)
- cutting edge (1-D)

The cutting edge is ground to an angle of 60° . The cutting edge is hardened and tempered, that is why it can cut metals softer than the chisel itself.

How to hold the hand chisel

- The chisel is held in the left hand. Hold it lightly but with a full grip.
- The hammer is held in the right hand. Use a 1000 g hammer for heavy work.
- Cut thin chips. This is less tiresome and means you can work faster.
- Be very careful that the chips do not fly away.
- When chiselling, look at the cutting edge of the chisel and not at the anvil, see Fig. 2.

Light work

- When doing light work, hold the chisel with your fingertips. See Fig. 3.
- Use a light hammer for light work.

Safety

When the chisel is used a lot, the hammer anvil becomes *mushroom-shaped*. The hammer anvil should look like Fig. 4. When you are working, pieces of steel may break off the mushroomed anvil and injure your hand.

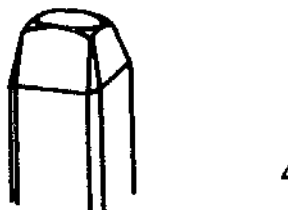
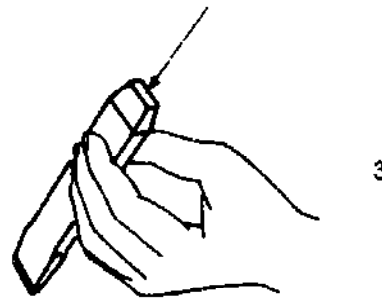
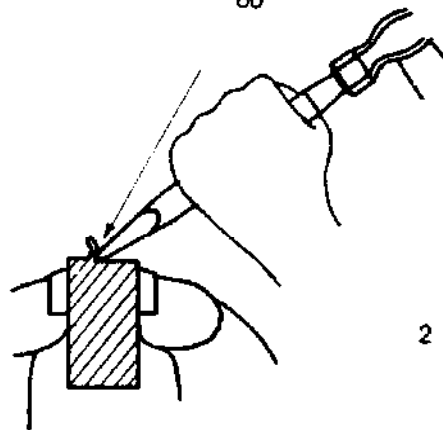
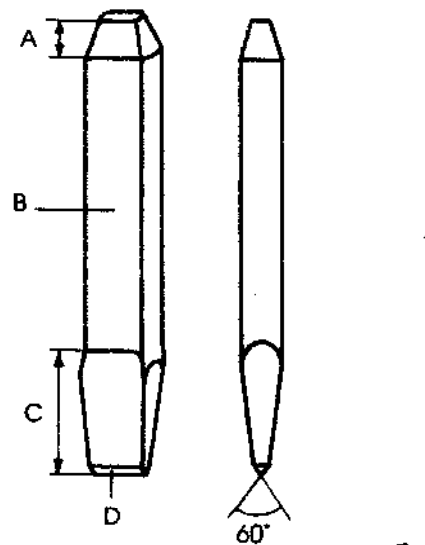

Cutting on the anvil

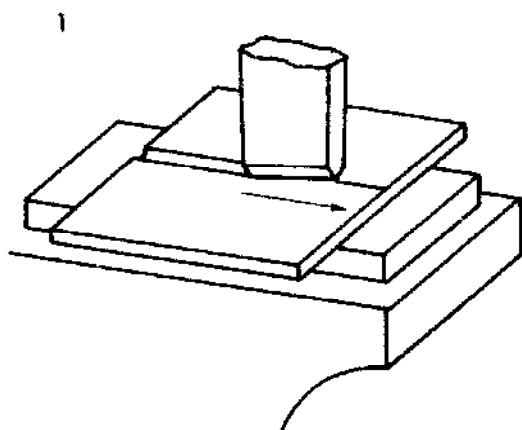

Thicker metal is cut with the hand chisel on top of the anvil. See Fig. 1. A chisel with a curved cutting edge gives the best results. If the cutting edge is straight, the corners of the chisel wear out or break off. Never use the surface plate as a packing block.

Exercise

- Mark the workpiece with the scribe.
- Before cutting, put a plate of mild steel (packing block) under the workpiece, otherwise the anvil will damage the chisel when going through the workpiece. See Fig. 1.
- Move the chisel in the direction of the arrow after each hammer blow.
- Keep the chisel a little tilted as shown in Fig. 2.



Shearing in the bench vice

The jaws of the bench vice and the flat chisel can be used together as a pair of scissors or shears. This method of cutting metal is called *shearing*, see Fig. 3.

Exercise

- Inscribe the cutting line on the workpiece.
- Clamp the workpiece in the bench vice. The cutting line should be just visible above the vice jaws.
- Take the hammer and chisel and cut the metal by shearing it off. Keep the chisel pointed in the cutting direction.
- Make sure during cutting that the face of the chisel is flat on the vice jaw, to avoid damaging the vice and to keep cutting along the cutting line. See Fig. 4.
- A clean cut should be made with a minimum of effort and without damaging the work.

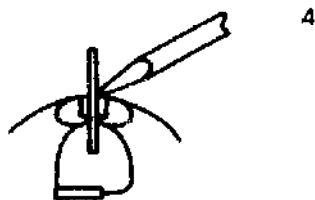
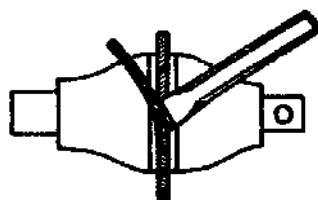
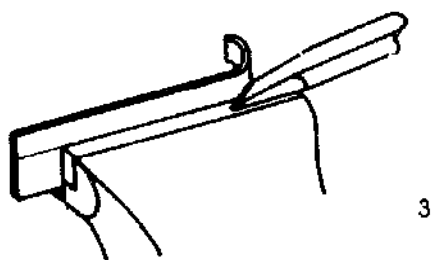

Cutting a steel rod

Bars and rods can generally be cut most easily by nicking them deeply on two or more sides and then breaking them by bending them back and forth. When cutting in the vice, always cut as close to the vice jaws as possible. Always strike so that the force of the blow is against the fixed jaw, not against the movable jaw. When cutting with the cold chisel at the anvil, always work over the packing block and not over the face of the anvil, see Fig. 1. Hold the chisel firmly, yet loosely enough to ease the shock of the hammer blows.

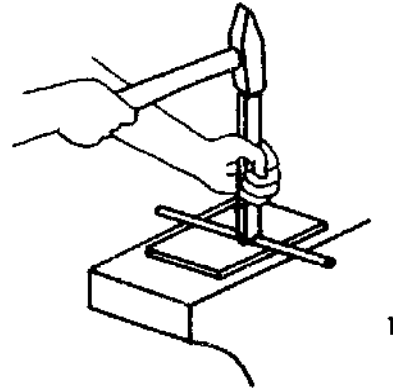

Removing rivet heads:

Small rivets can be cut at once, see Fig. 2. Bigger rivets may need some drilling before the head is cut. Hold the chisel in such a way that one side of the cutting edge is flush with the workpiece. See 2-X.

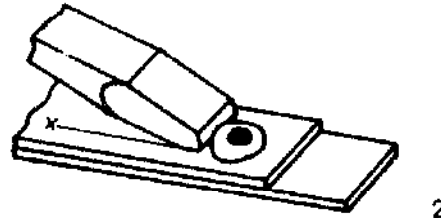

Cutting large holes

Large holes can be cut in a metal plate with a special chisel as shown in Fig. 3. This is called *web chiselling*.

Exercise

- Mark out the shape of the rectangular hole with the scribe.
- Punch three places where the holes are to be drilled.
- Drill the holes.
- Cut the holes through on both sides with the chisel.
- File the edges of the hole until they are smooth.

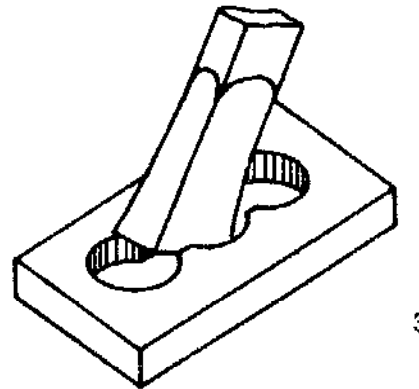

Cape chisel

Cape chisels can be used to cut sheet metal, oil drums, water tanks etc. The cape chisel is ground to a blunt square end, slightly thicker at the cutting end than a little further back. See Fig. 4. It shears out a ribbon of steel.

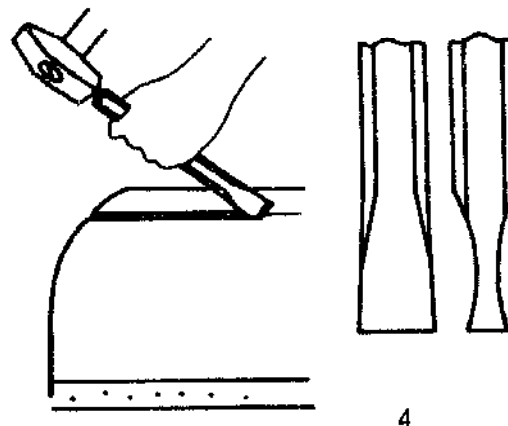

Hollow punch

The hollow punch shown in Fig. 1 is used to cut thin material such as leather, plastic, lead and thin sheet metal. The punch is made of tool steel and the cutting edge is hardened. The holes at 1-A should be able to push back the cut washers. The cutting edge of this punch is sharpened to approximately 60°, see Fig. 2-X. To protect the cutting edge from becoming dull or damaged, it is good practice to cut the washers or rings on top of the endgrains of a piece of wood which can be clamped into the bench vice.

Cutting gaskets

Before cutting, the shape of the object should be drawn on the gasket material. An example is shown in Fig. 3 of how a gasket should be made from a water pump part. Place a piece of paper on top of the object. With a small hammer or a piece of metal, tap over the edges of the object; this leaves a mark on the paper. Cut the paper gasket according to the marks on the paper. Place the paper gasket on the real gasket material and draw the actual shape. Cut the gasket to shape as shown in Fig. 4.

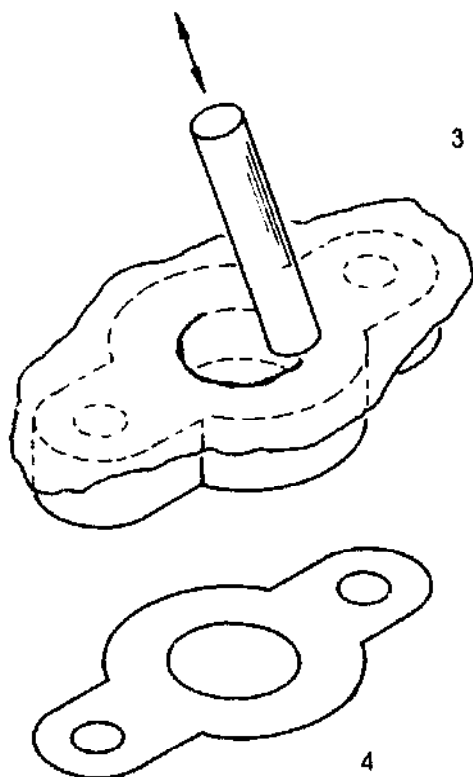
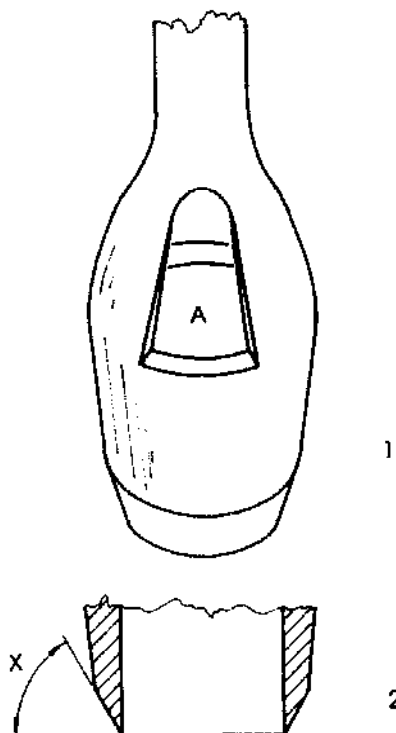

Drilling

Drilling

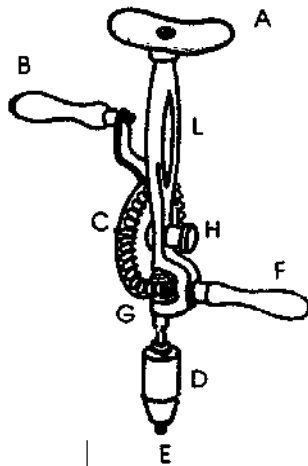

1

Drilling means cutting round holes with a hand drill and a twist drill. A hand drill is shown in Fig. 1 and has the following parts:

- Breast plate 1-A
- Crank 1-B
- Gear, sometimes more than one 1-C
- Chuck 1-D
- Jaws 1-E
- Side handle 1-F
- Pinion 1-G
- Bushing and nut 1-H
- Body 1-L

When tightening the twist drill, make sure the whole shank of the drill is between the jaws of the hand drill. The diameter of the twist drill is punched on the shank.

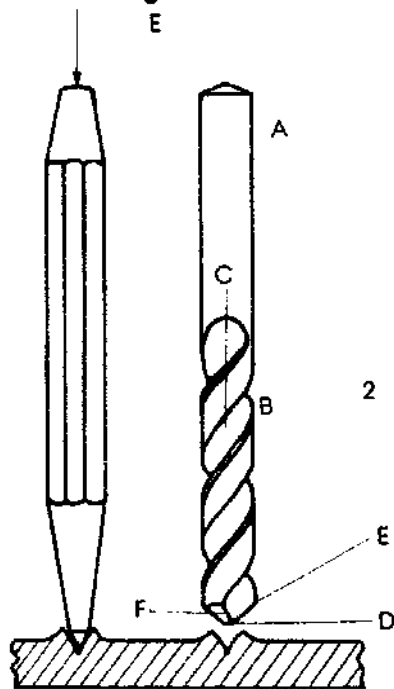

2

Twist drill

The drill shown in Fig. 2 is called a twist drill. The twist drill is the most common drill used for drilling metal. Parts of the twist drill are:

- Shank 2-A
- Flute 2-B
- Body 2-C
- Chisel edge/dead centre 2-D
- Cutting edge 2-E
- Margin 2-F

The cutting edges of the drill cut the material. To get an accurate hole the cutting edges should be equally long and should have the point exactly in the middle. The margin of the drill serves as a guide and ensures that the hole is smooth and exactly round. Chips are removed via the chip grooves.

The actual point of the twist drill is flat and is called the *dead centre*. This grinds but does not cut, see Fig. 3. It is therefore necessary to punch a mark in the metal with the centre punch so the punched hole will guide the twist drill. Always punch the metal to guide the drill.

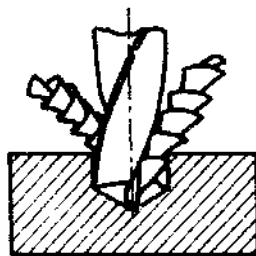

3

Drilling large holes

Drills with a large diameter have a large dead centre. A punched hole would be too small to take the dead centre. A pilot hole should therefore be drilled for holes with a diameter larger than 15 mm. The pilot drill should have a diameter at least $\frac{1}{8}$ of the diameter of the hole to be drilled. See Fig. 1.

Reamer

A drilled hole is usually not exactly cylindrical and completely smooth. If a perfect hole is needed, you should drill a hole only slightly smaller in diameter (0.1 – 0.5 mm) than the diameter required and widen with a reamer, see Fig. 2. An exactly cylindrical and very smooth hole will be the result. Use a tap wrench tightened on the square end of the reamer to facilitate the turning of this tool. Ensure that even pressure is applied on the reamer and turn it steadily in the cutting direction only. Reamers are fairly brittle and should therefore be handled very carefully. Lubricate the reamer while cutting.

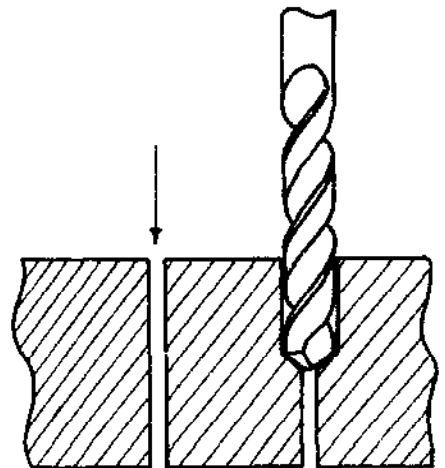

Drill sharpening

When a drill tip is blunt it must be sharpened. Drill sharpening is usually done by very experienced mechanics. Trainees should not attempt to sharpen their own drills, before it has been explained to them. You should practise a lot on old twist drills before you start sharpening your own drills.

Let us repeat the names of the twist drill tip, see Fig. 1:

- Cutting edges 1-A
- Bands 1-B
- Dead centre 1-C
- Heels 1-D

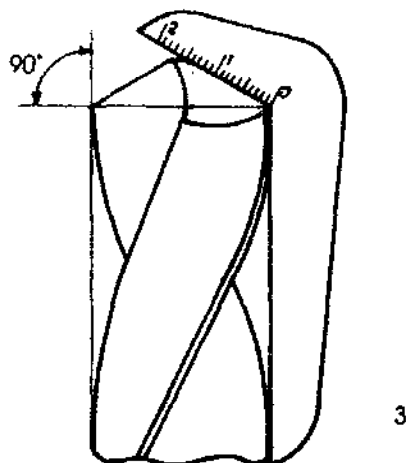
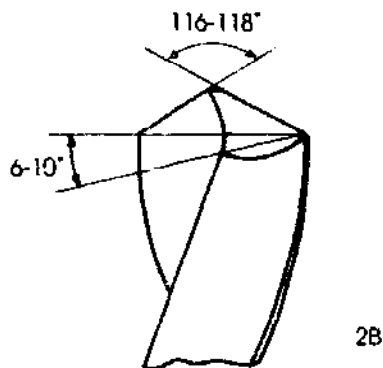
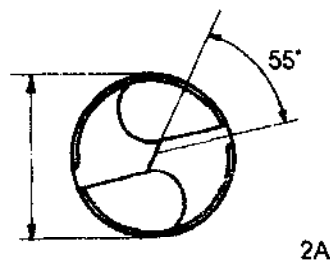
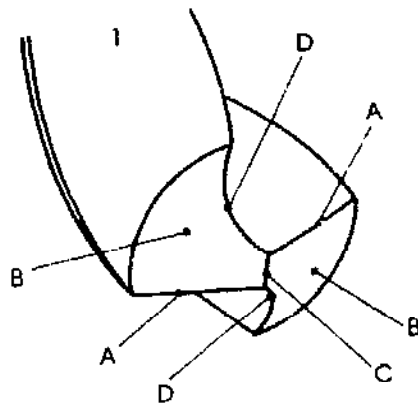

Sharpening

When sharpening a twist drill you have to consider the following:

- Sharpening the cutting edges is very important. It should be done very accurately. The line of the cutting edges should meet at an angle of 116° to each other: the *drill point angle*. See Fig. 2-B.
- The other angle of the cutting edge should be 55° to the dead centre, see Fig. 2-A.
- The heel should give a clearance of 6° to 10° to the cutting edge. The cutting edge should be sharp. By enlarging the angle to the heel the cutting edge becomes sharper. But do not exceed 6° to 10° . Clearance of the heel is also needed to prevent the heel from getting overheated. If the drill overheats, the steel of the drill burns and becomes useless and soft.
- The dead centre should be exactly in the centre of the drill and should not be too large.

Sharpening gauge

The drill point angle and the position of the dead centre can be measured with the aid of a sharpening gauge, see Fig. 3. The length of the cutting edges be measured with a try square.

Cutting edges with different angles

If a drill tip is not sharpened correctly and one cutting edge (1-A) is shorter than the other, see Fig.1, it is clear that only one cutting edge (1-B) has to do all the work. You will notice this because the drill produces only one shaving instead of two.

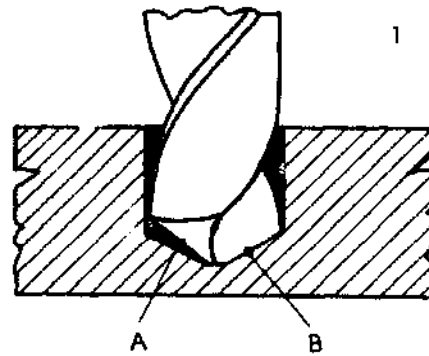

Cutting edges of unequal strength

A drill which is not correctly sharpened may produce a drill with an off-centre point. If you drill with such a drill, the workpiece shakes, the drill may break and the final result is that the hole produced is larger in diameter than the actual diameter of the drill. See Fig. 2. You can see that the centre of the hole will be at 2-A and the centre of the drill at 2-B. You can see in Fig. 3 that the hole is much larger than the drill diameter.

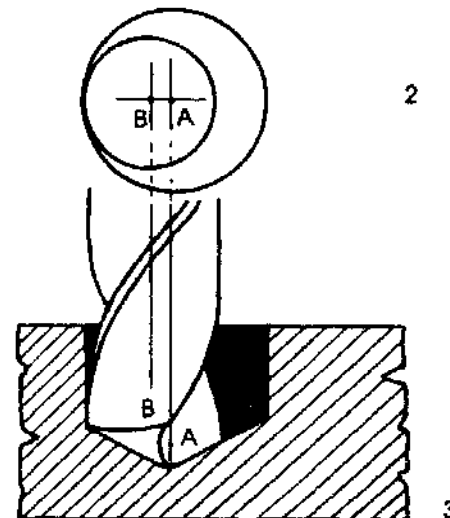

Drilling exercise

The drilling procedure is shown in Fig. 4.

- Mark the position of the hole on the metal and punch it.
- Inscribe a circle round the centre point equal to the diameter of the drill (4-A).
- Inscribe another circle with a diameter slightly larger than the circle (4-B).
- Place the drill in position, press the drill firmly and drill a point, spot drilled (4-C).
- Check whether this small hole is exactly in line with the centre point.
- Drill again and see whether the diameter of the drill coincides with the first circle (4-D).
- Drill through the metal and you will see that the hole exactly matches with the second circle (4-E).

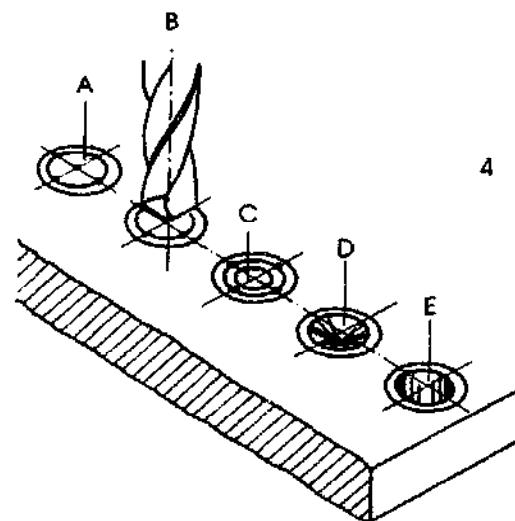

Post drill

Apart from all the other kinds of drilling equipment, the *post drill* is an excellent drilling machine, because electricity is not always available in the rural workshop. See Fig. 1. The whole drilling assembly of the post drill can be mounted to a wooden post (1-A) against the wall. Drills up to 13 mm can be fixed in the chuck with a special key (1-B). The workpiece is clamped on a table. When handle 1-C is turned, the drill turns round and at the same time moves downwards, regulated at the top by a ratchet construction 1-D. The whole axle and drill can be lowered with handle 1-E. Flywheel 1-F reduces the power needed to turn the drill round.

Drills with a diameter larger than 13 mm have a tapered shank with a flat end. See Fig. 2. The tapered shank fits into a tapered recess of the drill spindle (2-A). To remove the drill with the tapered shank, you have to hammer the drill drift (2-B), into the slot of the drill spindle.

Precautions

A drill shank must be clean and without burrs. Burrs can be removed with the sharpening stone. Do not use the grinding stone or you may damage the shank. If there is a burr or dirt on the drill shank, the drill will not fit straight into the chuck, it will start to wobble and may come out of the chuck.

The lower side of the drill drift is flat. Always use the drill drift with this side turned downwards, otherwise the post drill will be damaged. Use a piece of wood when removing a drill to prevent it from being damaged when hitting the table. A special reducing sleeve is available to make it possible for larger drills to fit in the recess of the drill spindle.

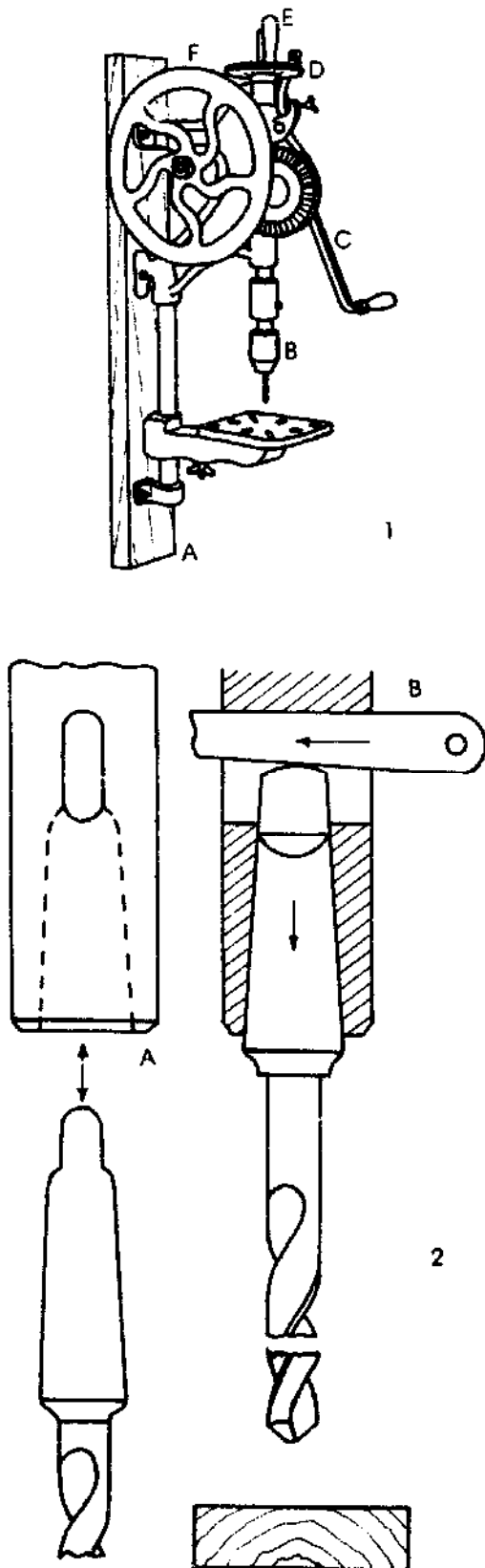

Drill chuck

A drill chuck is used for clamping a drill in position. See Fig. 1. This is necessary, for a loose drill will rotate, resulting in damage to the drill (burr formation) and the jaws of the drill chuck. Always use an appropriate chuck key. Ensure that the drill is exactly centred between the jaws. Keep the drill chuck thoroughly clean and see that no dirt gets between the clamping jaws.

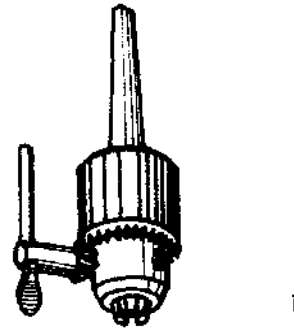

Drilling deep holes

When drilling deep holes, the drill tip easily gets overheated. To prevent this the drill has to be taken out of the hole from time to time to cool off. This also facilitates the removal of the chips.

Clamping the workpiece

When a hole is to be drilled the workpiece should be clamped onto the drilling table by means of a drill press vice (Fig. 2) or clamps (Fig. 3). These aids both have to be connected to the drilling table by means of T-slot bolts which fit into grooves on the table (2-A). To prevent the drilling table or the drill press vice from being damaged, packing pieces should be used, see 2-B. Steps should always be taken to prevent a workpiece from coming up or starting to turn with the drill.

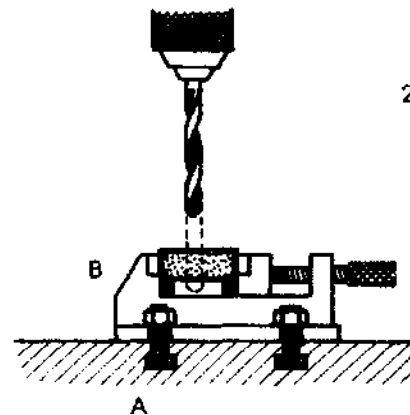

Lubrication

When you use an electric drill it is advisable to use a *lubricant* to cool down the drill, make cutting easier, make work smooth and make the drill last longer. A lubricant can be made locally by mixing soap and a little oil. Put the mixture in an oil can and shake it before use. No lubricant is needed when you cut cast iron: the carbon in the cast iron acts as a lubricant.

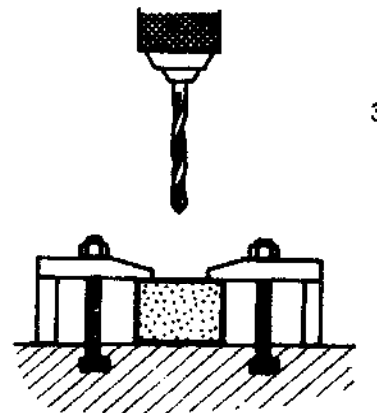

<i>Drill diameter (mm)</i>	<i>Drill speed (rpm)</i>
3	1000
4	750
5	600
6	500
7	425
8	375
9	325
10	300
11	275
12	250
13	225
15	200
16	170
18	165

Pillar drill

Drills can only operate efficiently up to a certain maximum cutting speed. If the cutting speed is too high the drill will heat up and consequently become dull. If the cutting speed is too low the electric drill operates below its capacity with poor quality performance.

The cutting speed varies with the diameter of the drill, but also with the changing of the spindle speed. The spindle speed can be changed by locating the V-belt on any of the three steps of the spindler. Driven and motor driven pulleys, see Fig. 1. The various spindle speeds are often indicated on the electric drill itself in rotations per minute (rpm).

It is not allowed to locate the V-belt out of level. The belt must be positioned at the same height on both pulleys.

The right combination of a certain drill diameter and a certain spindle speed (in rpm) is shown in the table.

Different materials need various spindle speeds. For mild steel the table on this page can be used. For tool steel a lower spindle speed is required and soft metals should be drilled with a higher spindle speed than indicated in the table.

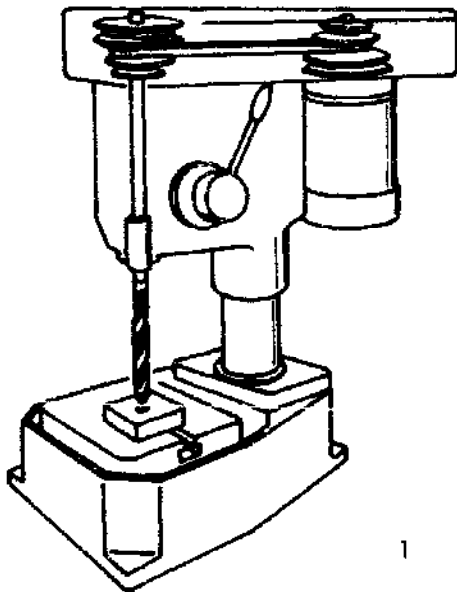

Assembly tools

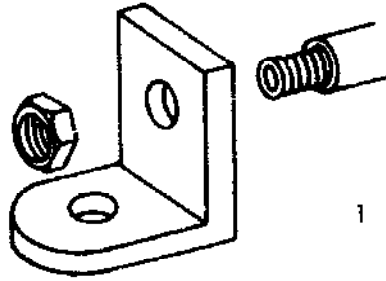

1

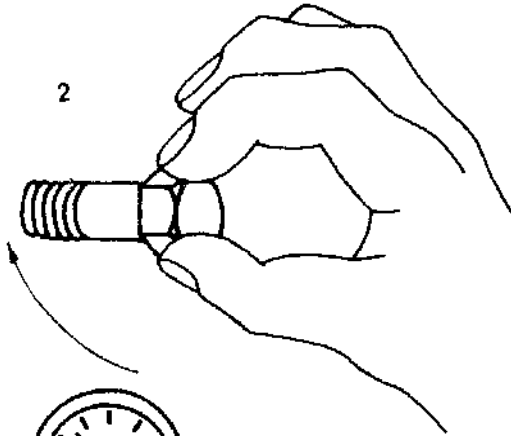

2

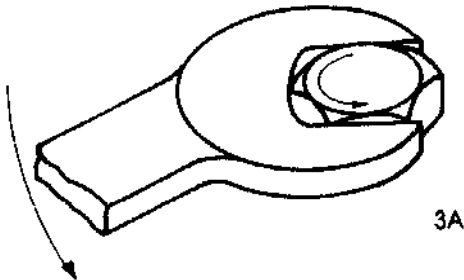

3A

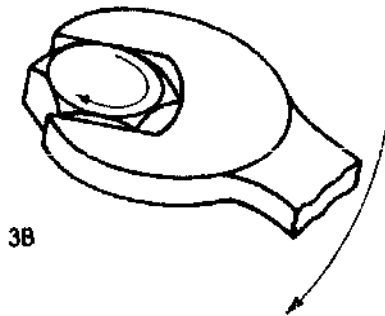

3B

Introduction

Assembly means putting parts together. Disassembly means taking parts apart. A rural mechanic has to assemble and disassemble engines, pumps, farming machinery, ploughs etc. Most important in any assembly or disassembly job is the loosening and tightening of nuts and bolts. See Fig. 1. Bolts can have a left or right thread. Most common is the right thread.

- A *right threaded* bolt is tightened: turn it *clockwise*, see Figs. 2 and 3-B.
- A *left threaded* bolt is tightened: turn it *anti-clockwise*, see Fig. 3-A.
- A *right threaded* bolt is loosened: turn it *anti-clockwise*.
- A *left threaded* bolt is loosened: turn it *clockwise*.

How to tighten nuts and bolts

This is difficult to describe. The correct tightening of nuts and bolts is a matter of experience. If a bolt is tightened too much, the thread is stripped off the bolt or the bolt breaks.

Small bolts: 6 to 8 mm are tightened *lightly*, using only one hand, because these bolts break easily – be careful!

Medium bolts: 10 to 12 mm are tightened *moderately* with one hand.

Large bolts: 16 to 20 mm or more are tightened a *lot*. It is almost impossible to break these bolts and you can use both hands.

Practice tightening bolts and check this with the torque wrench. Ask your instructor for guidance.

Spanners

Spanners are tools for tightening and loosening nuts and bolts. They are made of special steel. The length of the handle is such that no extra extension of the handle is needed or even allowed. Spanners are classified into three common ranges/sizes:

- *Metric spanners* for metric nuts and bolts. See Fig. 1.
- *Inch spanners* for British made nuts and bolts.
- *Inch spanners* for American made nuts and bolts.

Note: the size is always marked on the spanner. Special nuts and bolts are sometimes used and you may need special spanners to tighten or loosen them.

Shape of spanner

There are many differently shaped spanners. But the most common are:

- *Open ended spanner*: this spanner has two U-shaped openings to fit two sizes of nuts or bolt heads. See Fig. 1.
- *Combination spanner*: this spanner is a combination of an open ended and a ring spanner. These spanners are very useful for the rural mechanic. See Fig. 2.
- *Ring spanner*: a ring spanner grips a nut on six sides, so there is no risk that the spanner can slip round a nut or bolt head. See Fig. 3. A ring spanner is therefore better than an open ended spanner when you have to apply a lot of force. A ring spanner is usually of double hexagon shape, that means it has twelve corners. The double hexagon thus means you can use this spanner in narrow places where you can turn the spanner only a little. See Fig. 4.

Use of the spanner

When you apply force on an open ended spanner, make sure that the jaws, which are positioned at an angle to the handle, are pointing towards the force applied on the spanner. See Fig. 5-A (right) and 5-B (wrong).

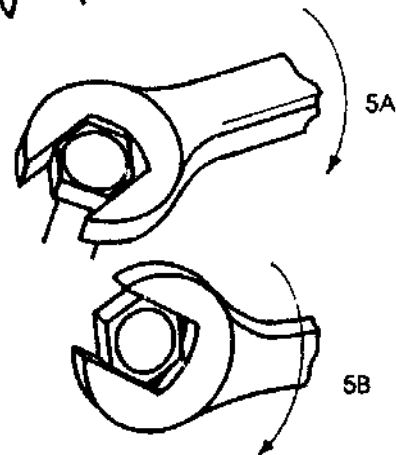
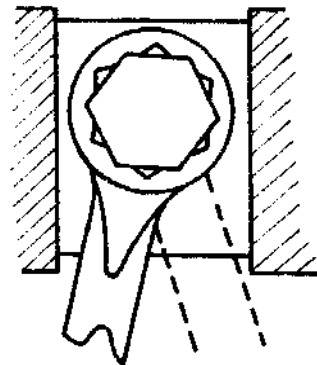
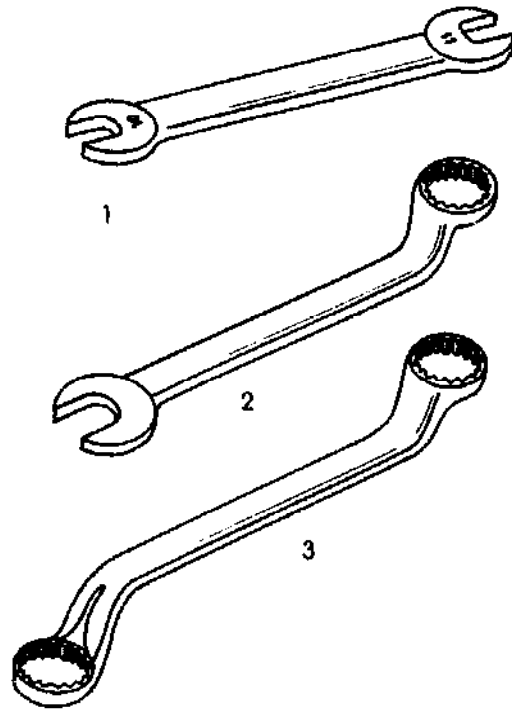

Set of socket spanners

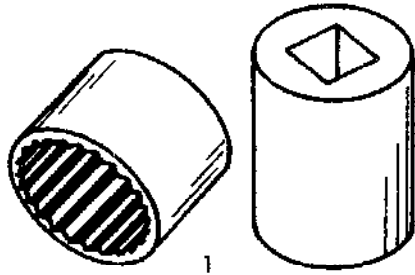

Socket spanners are short rigid steel tubes. On one end they have a hexagonal or double hexagonal recess to fit the nut or bolt. The other end has a square hole to fit the handle. This square hole is of the same size for all spanners. See Fig. 1. It is better to buy the hexagon shaped sockets because they are stronger and therefore last longer.

Handles

A set of socket spanners contains a variety of handles:

- Sliding T-handle (Fig. 2)
- Brace or speed handle (Fig. 3)
- Extension piece (Fig. 4)
- Universal joint (Fig. 5)
- Ratchet handle (Fig. 6)

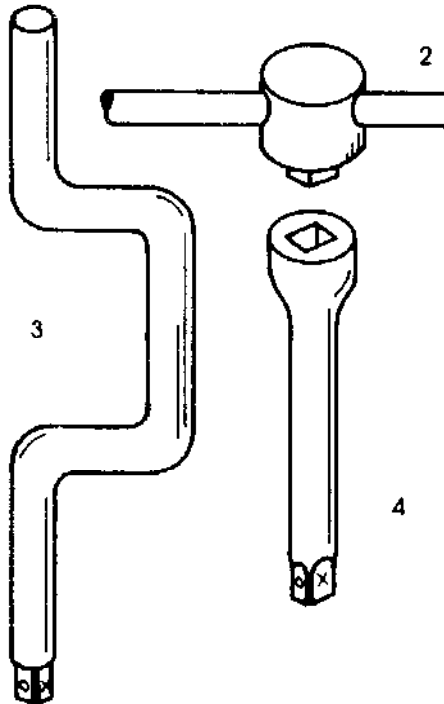

All handles have square ends which fit into the square hole in the sockets. On one side of the square end a *snap* is made to ensure the handle locks properly into the socket. This snap is a small ball locked into the metal which has a spring behind it to make sure the ball locks after the square end has been pushed into the socket.

Ratchet handle

The ratchet handle (Fig. 6) allows you to work fast with short movements. Especially when a construction does not leave you much space to move the spanner, it is advisable to use the ratchet handle because you can leave the socket on the nut or bolt.

Universal joint

The universal joint, shown in Fig. 5, is used when a construction is such that you cannot reach a nut or bolt either vertically or horizontally with the handle.

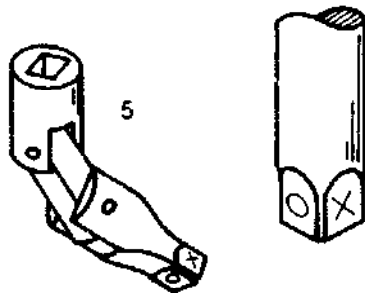

Precautions

Be very careful when you tighten small nuts or bolts. You can easily *over-tighten* a small nut.

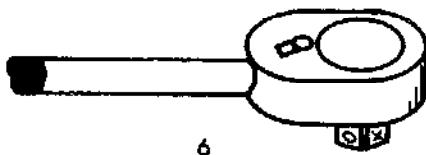

Box spanner

The box spanner is a piece of metal on which a hexagon head is pressed on one or two sides to allow a nut to enter. The pipe spanner is turned around with a handle called a *tommy bar*. See Fig. 1. With the box spanner you can reach nuts or bolts which are deeply recessed, like spark plugs etc.

Allen keys

Allen keys are L-shaped bars with a hexagon section. See Fig. 2. These bars fit into the recessed head of special bolts.

Adjustable spanners

This spanner has one fixed jaw and one sliding jaw, adjusted with a worm screw for different nut sizes. See Figs. 3 and 4. The sliding jaw is never rigid, especially when the spanner is used for a long time, so the spanner never fits snugly onto a nut or bolt. This spanner should only be used when no other spanner is available. When working, position the spanner as you would an open ended spanner.

Torque wrench

A torque wrench is a handle which can be used on a socket spanner. With this handle you can measure how much *torque* you apply to a nut or bolt. The parts of a torque wrench are (Fig. 5):

- Square head for socket spanner 5-A.
- Pointer to indicate the torque 5-B.
- Torque scale 5-C.
- Movable handle 5-D.
- Bar fixed to head and handle 5-E.

The torque is always indicated on machines, engines or drawings. See also the next page.

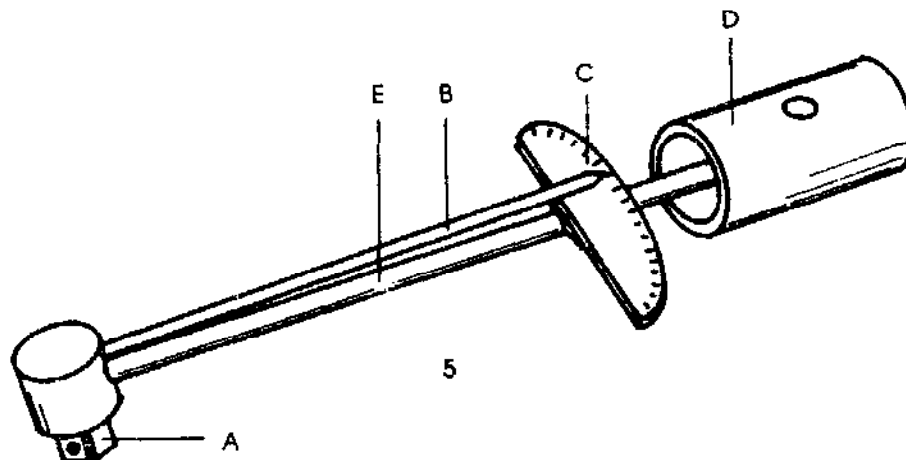
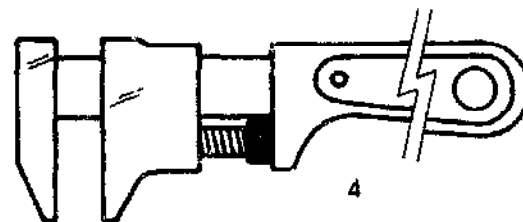
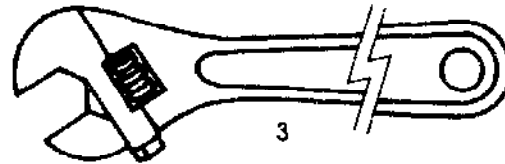
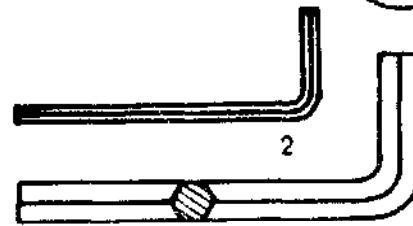
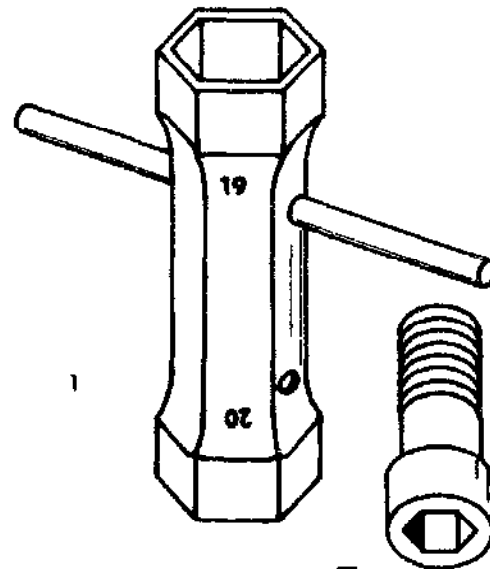

Torque indication

As mentioned before, all the important nuts and bolts in an engine or any piece of machinery have to be tightened to the correct torque. The torque can be measured in different units of measurement:

- Nm (newton metre)
- Kpm or Kgm (kilogram metre)
- Lbft (pound foot)

The torque wrench has different scales for different units of measurement. Be sure you read the torque on the correct scale. Not every rural mechanic has a torque wrench in his toolbox. But a Rural Mechanic Co-operative should have one in the tool store.

Records

Keep a record of torque values for various engines. Whenever you come across a workshop manual, copy the important torque figures in a note book.

Precautions

A good mechanic has the right 'feeling' for using spanners. Small nuts need little tightening, bigger nuts can be tightened more. This is why a larger spanner size is also longer and gives more leverage. Make sure that you turn the correct way. A bolt which is upside down can be very confusing. Remember the difference between clockwise and anti-clockwise.

Make sure the spanner is of the correct size and fits well, otherwise it will damage the head of the bolt.

Whenever possible you should *pull* on a spanner. If you have to push it, use the palm of your hand and keep your fingers out of the way. Never use a piece of pipe to increase the leverage of a spanner. The spanner or the bolt may break. Never use a hammer either.

A very stubborn nut can be loosened if you heat it. Use a blow torch or gas welding equipment or, if the piece is not too large, you can use the charcoal fire.

Re-adjust the adjustable spanner to tighten each nut or bolt. Use this spanner only if there is no other type of spanner available.

Remember that the jaws of the adjustable spanner or the open end spanner should point in the same direction as the force being applied.

Use a torque wrench whenever necessary. Check the torque loading in the workshop manual. Keep the torque wrench in the tool store, not in your toolbox because you may damage it.

Exercise

Take an old engine or a piece of machinery. Place this in position and loosen the nuts and bolts without turning the workpiece. Fasten all nuts and bolts and check with a torque wrench the torque you have given these nuts and bolts. Place all nuts and bolts properly. If necessary, place them in a certain sequence on the table or on a piece of wood. Clean rusty nuts and bolts with a wire brush and grease them a little if necessary.

Remember where you have placed washers, if any.

Screwdrivers

Screwdrivers are used to tighten and loosen screws. The screwdriver consists of different parts, see Fig. 1.

- *Handle*: the handle is made of wood or plastic. Along the handle some grooves are made to ensure a good grip on the handle (1-A).
- *Tang*: the tang is the part of the shank that goes through or partly through the handle. It is shaped in such a way that it cannot turn inside the handle (1-B).
- *Shank*: the shank is made of hardened steel and varies in length from 50 to 300 mm (1-C).
- *Blade*: the blade is a widened part of the shank to form the tip (1-D).
- *Tip*: the tip has a special shape and is less hardened than the shank and is therefore more flexible (1-E).

Holding the screwdriver

How to hold the screwdriver is shown in Fig. 2. Keep the handle in the hollow of your hand, so that you push the screwdriver forward. Place the forefinger on top of the handle or sometimes partly on the shank, to guide the screwdriver. Make sure the screwdriver is exactly in line with the screw.

Types of screwdrivers

- *Standard tip screwdriver*
This screwdriver has a flat tip. It is used for all kinds of ordinary work. An extra short screwdriver may be used for work in restricted places.
- *Phillips tip screwdriver*
This screwdriver has a cross-shaped tip. It is used for screws with a Phillips head. The advantage is that the screwdriver cannot slip out of the slot. See Fig. 3.
- *Offset screwdriver*
This screwdriver is used in places where you cannot work immediately above the screw. See Fig. 4.

Sharpening the tip

Fig. 5 shows different shapes of screwdriver tips:

- The correct tip shape 5-A
- Improved anti-slip shape 5-B
- Phillips screwdriver shape 5-C

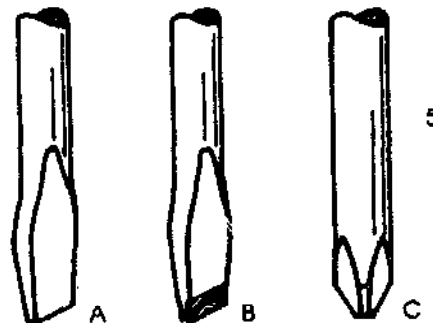
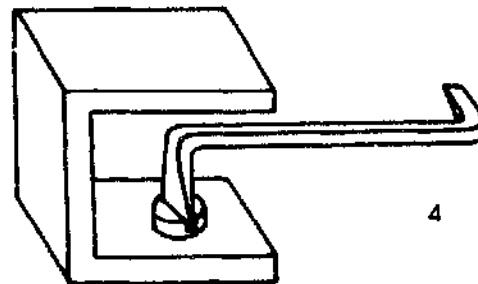
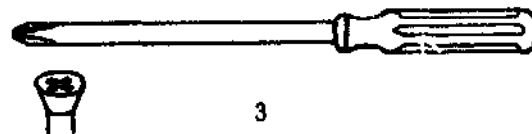
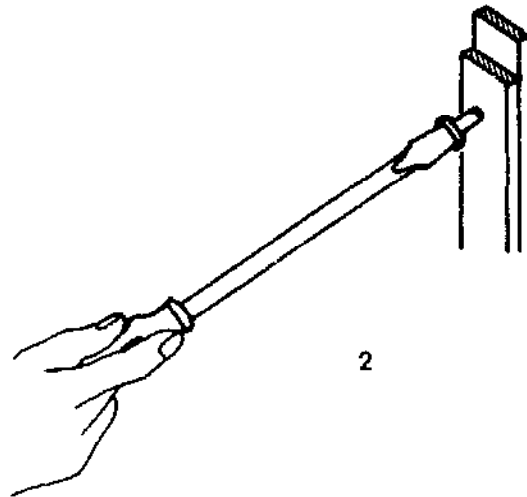
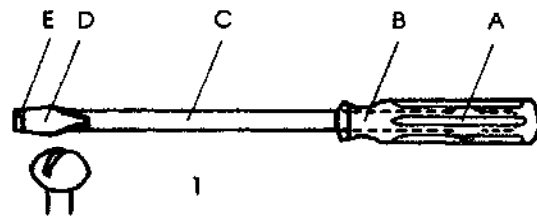

How to use screwdrivers

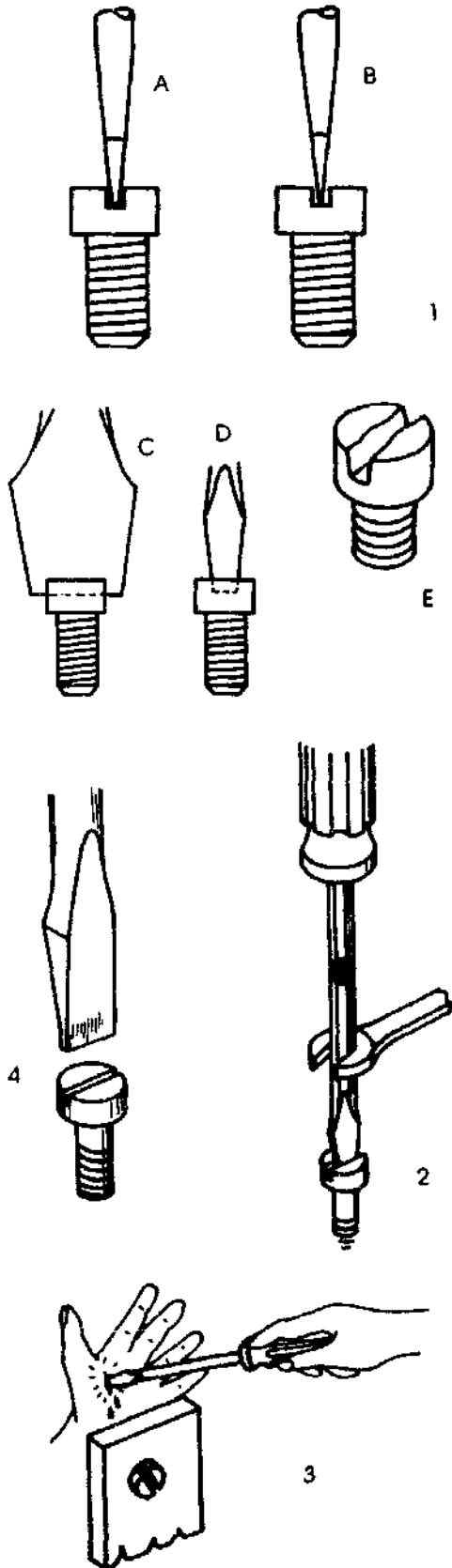

- A screwdriver is designed only to turn screws. Do not use the screwdriver as a *wedge* or a *lever*, because this will deform the shank and the tip may break.
- The *tip* of the screwdriver should fit correctly into the slot of the screw head. See Fig. 1-A.
- The tip of the screwdriver shown in Fig. 1-B is not correctly shaped, it is tapered and will slip out of the slot of the screw and therefore out of the head of the screws or will damage the head of the screw.
- Never use a flat tip screwdriver as a Phillips screwdriver.
- For heavy work you can use a screwdriver with a square shank. You can use a spanner to increase the turning force. See Fig. 2.
- Do not hold the workpiece loose in your hand while you turn a screw. Clamp it in the vice or put it down on the work bench, because a screwdriver can make wounds and the dirt on the tip of the screwdriver may cause infection. See Fig 3. For the same reason do not carry a screwdriver in your pocket.
- After some time you may have to re-shape the tip of the screwdriver. If you use a grinding wheel for this, do not press the tip too firmly onto the grinding wheel, because the tip may overheat and the correct properties of the steel may change. When sharpening, cool the tip regularly.
- When the tang in the handle of the screwdriver does not go through the handle, *do not hammer* on the handle of the screwdriver. The handle may break or it may be pushed over the shank.

Have different screwdrivers in your toolbox for different types of screws (Fig. 4). If not the screw head will be damaged (see Figs. 1-C to 1-E).

Bolts and thread

Bolts

Bolts are made in many different sizes and qualities. See Fig. 1. Important dimensions of a bolt are:

- *Length*: the head is not included in the length of a bolt, see 1-A.
- *Threaded length*: the threaded length is only measured on the actual threaded part of the bolt, see 1-X.
- *Size*: the size of the bolt is the same as the major thread diameter (the outside diameter of the thread), see 1-O.

Screw thread

The winding groove around a bolt or inside the nut is called a *screw thread*, or simply a *thread*.

- *Internal thread*: is on the inside of a round hole - for example, a nut. See Fig. 2-A.
- *External thread*: is on the outside of a round object for example, a bolt. See Fig. 2-B.

In a technical drawing a bolt is drawn as shown in Fig. 3. The slanting lines indicate the thread.

Bolts and screws

Bolts and screws are represented on a drawing as shown in Fig. 4. Contrary to the bolt 4-A, the countersunk screw length is measured including the head, see 4-B. The length of the round countersunk screw is measured including half the head, see 4-C.

Quality

As mentioned before, there are many different kinds of bolts and also different qualities. Special nuts and bolts are used for engines. Order the right kind of nuts and bolts from the factory. The tensile strength of a bolt is indicated on the head of the bolt.

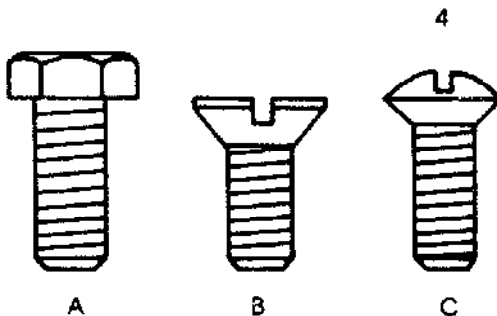
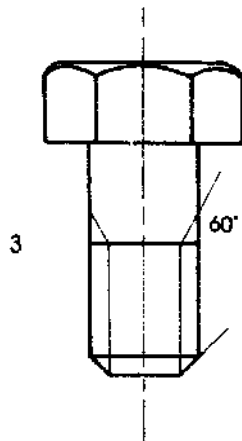
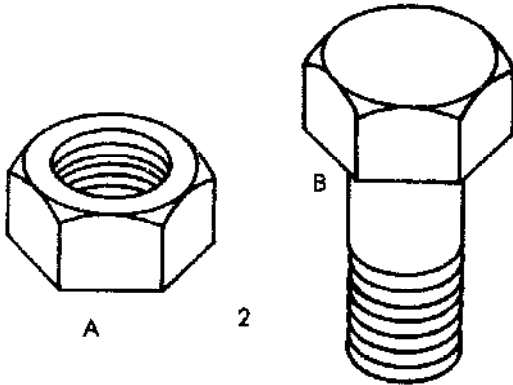
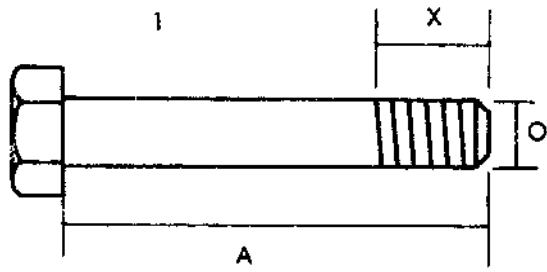

Various bolts

In Fig. 1-A you see a *machine bolt*. This bolt is used for common purposes. If this bolt is to be used, make sure the thickness of the material to be fastened is greater than the unthreaded part of the bolt.

In Fig. 1-B you see a *tap bolt*. This bolt is threaded over the full length and can be used to fasten thin material like sheet metal etc.

Fig. 2-A shows a *carriage bolt*. This bolt is used to fasten wood to wood or wood to steel. The head is round and has no slot or anything to hold the bolt while fastening the nut. This is why there is a square part under the head. This square part is hammered into the wood and thus prevents the bolt from turning when the nut is being tightened.

A *stud bolt* is shown in Fig. 2-B. This bolt is fixed on one side to a construction. Over the unthreaded part another piece of the construction can be mounted and a nut tightens the whole assembly.

Bolt heads

Bolt heads can be of different shapes, as shown in Fig. 3.

- Hexagon head 3-A
- Square head 3-B
- Socket head 3-C

Right and left hand thread

In Fig. 4-A you see a right hand threaded bolt. You can see this from the fact that the lines representing the thread go upwards to the right side. In Fig. 4-B you see a left hand threaded bolt. You can see this from the fact that the lines representing the thread go upwards to the left side and the head is marked in all corners.

- *Right hand thread* is tightened *clockwise*.
- *Left hand thread* is tightened *anti-clockwise*.

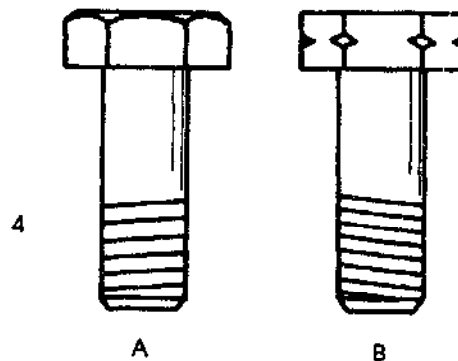
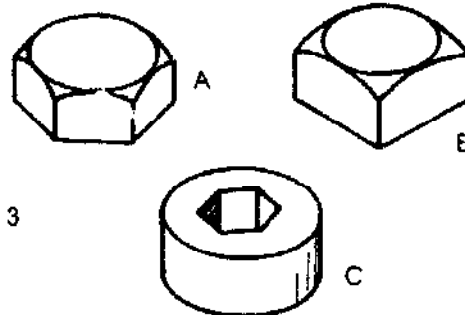
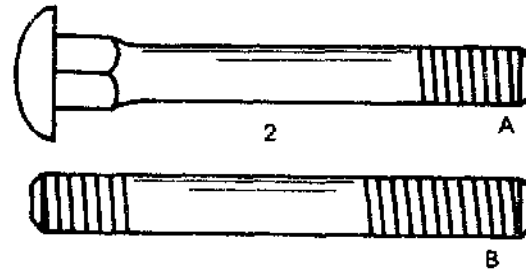
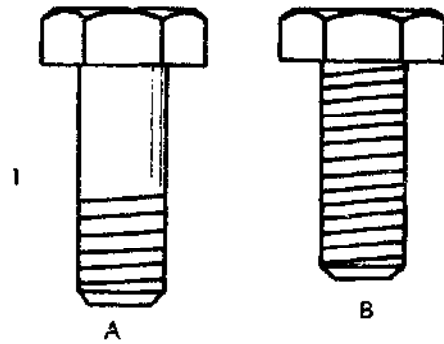

Bolts, nuts and screws

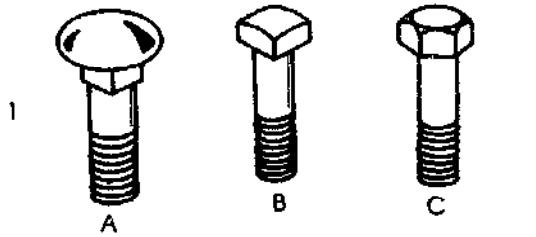

Bolts, see Fig. 1

- Carriage bolt 1-A
- Square head bolt 1-B
- Hexagon head bolt 1-C



Nuts, see Fig. 2

- Wing nut 2-A
- Square nut 2-B
- Hexagon nut 2-C

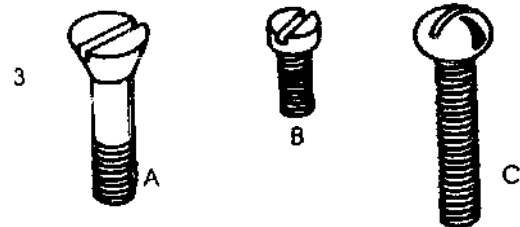

Screws, see Fig. 3

- Countersunk head 3-A
- Cheese head 3-B
- Metal screw 3-C

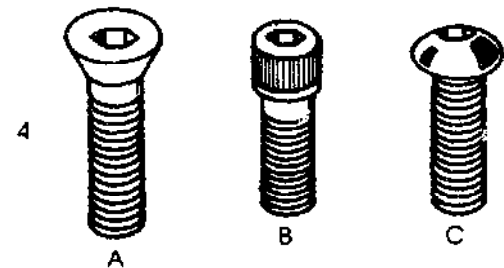

Socket heads, see Fig. 4

- Recessed countersunk 4-A
- Recessed socket head 4-B
- Recessed round head 4-C

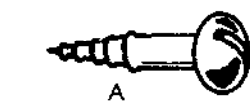

Wood screws, see Fig. 5

- Roundhead wood screw 5-A

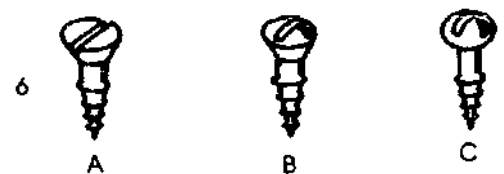

Self-tapping screws, see Fig. 6

- Counter sunk 6-A
- Round counter sunk 6-B
- Round head 6-C



Self-tapping phillips head, see Fig. 7

- Counter sunk 7-A
- Round counter sunk 7-B
- Round head 7-C

Thread dimensions

Types of thread

Four different types of thread are:

- External thread
- Internal thread
- Right hand thread
- Left hand thread

External thread

The bolt shown in Fig. 1 has an external thread. The thick line represents the major diameter (outside of thread). The thin lines represent the inside of the thread, the minor diameter.

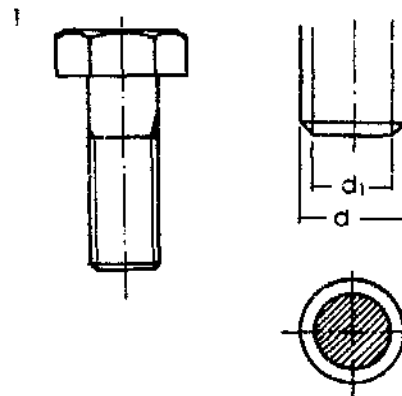

Internal thread

Fig. 2-A shows the top view of a subject with a threaded hole in it. This thread is an internal thread. The thick circle represents the minor diameter. The thin part circle represents the major diameter.

In the cross section, see Fig. 2-B, you see the same thick and thin lines representing the major and minor diameter.

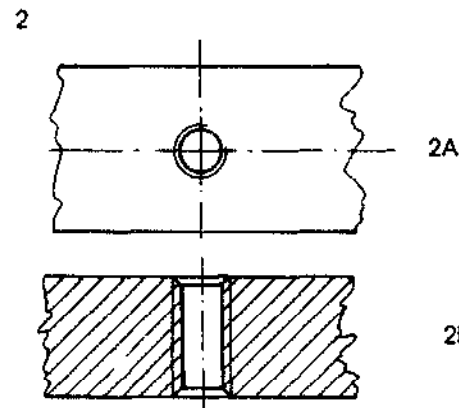

Metric ISO thread M

The metric thread which is measured in millimeters is widely used. The thread angle is 60° and the pitch (p) is measured in millimeters. See Fig. 3.

Thread profiles

Six thread profiles are shown in Figs. 3 and 4.

- *Angular thread* with a top angle of 60° (metric and American thread).
- *Angular thread* with a top angle of 55° (British thread, 4-A).
- *Trapezoidal thread* (used on lathe machines, 4-B).
- *Butress thread* (4-C).
- *Round thread* (lamp bulbs/threaded rod, 4-D).
- *rectangular thread* (on vice, 4-E).

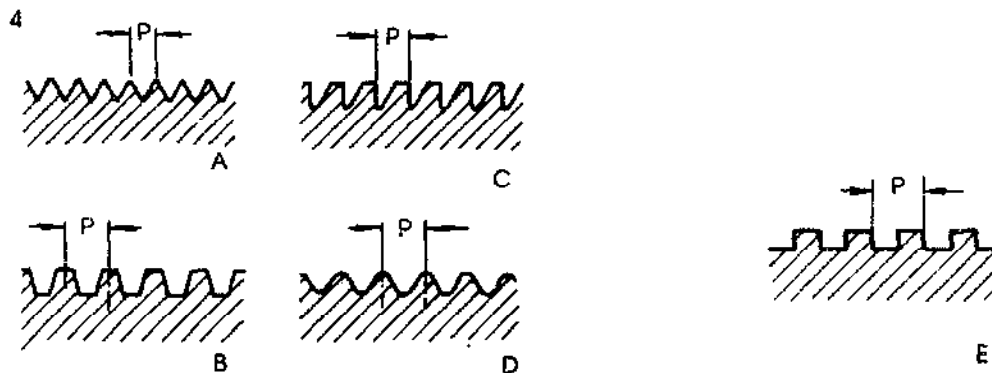
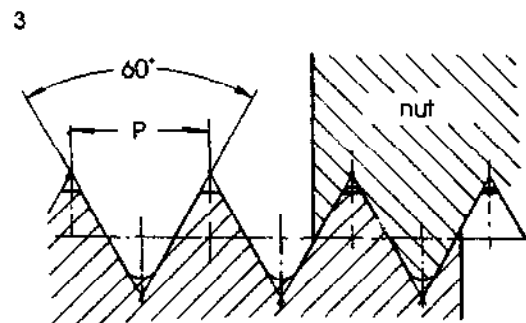

Thread dimensions

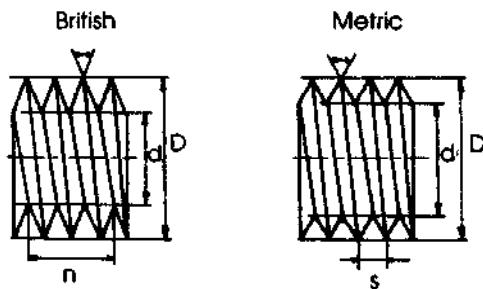
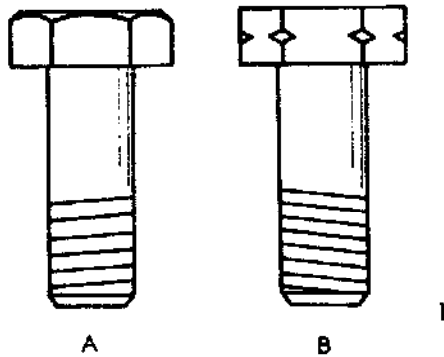

Right hand thread

In Fig. 1-A you see a drawing of a bolt with a right hand thread. The lines representing the slope of the thread are going down towards the left side as seen on the real thread.

Left hand thread

Fig. 1-B shows a bolt with a left hand thread. The side of the hexagon head is marked to show that the bolt has a left hand thread. It is seen also on the lines which represent the thread. They are pointing down to the right, as seen on the real thread. This bolt is tightened *anti-clock wise*.

Course thread

A course thread or bolt has less pitch than a bolt which has a fine thread. The course thread is used for general work. The advantage of course thread is that it can stand a rough handling well.

Fine thread

A fine threaded bolt has more pitch than a bolt with course thread. The fine thread is less common than the course thread. It is mostly used on strongly vibrating engine parts. A course bolt or nut will shake loose when it vibrates much, a fine thread stand these vibrations much better.

Types of thread

Three types of thread are used on bolts or nuts:

- *Metric thread*, measured in millimeters.
- *American or unified thread*, measured in inches.
- *British thread*, measured in inches.

British thread is indicated in the number of threads per inch, while metric thread is indicated by the pitch. Metric thread is stronger than British thread due to a larger minor diameter because of a larger top angle. See Fig. 2. Some major characteristics of thread are:

- Outer diameter of the screw thread in mm ($2-D$)
- Core diameter of the screw thread in mm ($2-d$)
- Number of threads per inch ($2-n$)
- Pitch of the thread in mm ($2-s$)

Although different threads might look just about the same, they should never be interchanged. After having studied the *thread charts*, you should take a variety of bolts and nuts and identify the thread.

Types of thread: metric thread

More and more manufacturers are using metric thread. In time the metric thread will probably become a worldwide standard.

Note

Metric thread can be either *fine* or *coarse*.
Major diameters commonly used range from 3 to 24 mm.
The thread has a 60° V-profile.
The sharp edges of the V are rounded off.

M8 × 40 means:

- bolt with a *major diameter* of 8 mm.
- *pitch* of 1.25 mm.
- *length* of 40 mm.

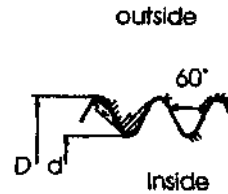

Bolt	Metric	Course	Metric	Fine
Diameter (mm)	Pitch (mm)	Tapdrill (mm)	Pitch (mm)	Tapdrill (mm)
6	1	5.0	0.75	5.2
7 *	1	6.0	0.75	6.2
8	1.25	6.7	1	7.0
9 *	1.25	7.7	1	8.0
10	1.5	8.4	1	9.0
11 *	1.5	9.4	1	10.0
12	1.75	10.0	1.5	10.5
14 *	2	11.8	1.5	12.5
16	2	13.8	1.5	14.5

Note: The thread sizes marked with * are *nonstandard*.
Normally these sizes are not used.

Types of thread: American or unified thread

American thread is mostly used on machinery etc. which is manufactured in America.
American thread is the same as unified thread.

Note

American thread can be either American National Course (A.N.C.) or American National Fine (A.N.F.)

- Major diameters are measured in inches.
- The thread has a 60° V-profile.
- The pitch is given in Thread per Inch (T.P.I.).

10 T.P.I. means:

- There are 10 threads per inch.
- The distance between two threads is $\frac{1}{10}$ inch.

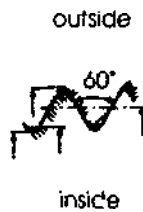

Bolt	American National Course		American National Fine		
	Diameter (inches)	Thread (per inch)	Tapdrill (mm)	Thread (per inch)	Tapdrill (mm)
$\frac{1}{4}$		20	5.3	28	5.5
$\frac{5}{16}$		18	6.7	24	7.0
$\frac{3}{8}$		16	8.1	24	8.5
$\frac{7}{16}$ *		14	9.4	20	10.5
$\frac{1}{2}$		13	10.9	20	11.5
$\frac{9}{16}$ *		12	12.3	18	13.0
$\frac{5}{8}$		11	13.7	18	14.5
$\frac{3}{4}$		10	16.6	16	17.5

*Note: The thread sizes marked with * are nonstandard. Normally these sizes are not used.*

Types of thread: British thread

The British thread is still commonly used. It looks similar to the American thread, but with the difference that the degree of the pitch is different.

Note

British thread can be either British Standard Whitworth (B.S.W.) British Standard Fine (B.S.F.).

- Major diameters are measured in inches
- The thread has a 55° V-profile
- The pitch is given in Thread per Inch (T.P.I.)

Questions

- Which bolts have a *finer* pitch, B.S.F. or A.N.F.?
- For which bolt size do B.S.W. and A.N.C. have a different pitch?

outside



inside

Bolt Diameter (inch)	British Standard Whitworth		British Standard Fine	
	Thread (per inch)	Tapdrill (mm)	Thread (per inch)	Tapdrill (mm)
1/4	20	5.1	26	5.3
5/16	18	6.5	22	6.8
3/8	16	7.9	20	8.3
7/16 *	14	9.25	18	9.7
1/2	12	10.5	16	11.0
9/16 *	12	12.1	16	12.7
5/8	11	13.5	14	14.0
11/16 *	11	15.1	14	15.5
3/4	10	16.5	12	17.0

*Note: The thread sizes marked with * are nonstandard. Normally these sizes are not used.*

Inside pipe diameter	Thread	Tapdrill diameter
(inch)	(per inch)	(mm)
1/8	28	8.9
1/4	19	11.8
3/8	19	15.3
1/2	14	19.1
5/8	14	21
3/4	14	24.6
7/8	14	28.3
1	11	30.8
1 1/8	11	35.5
1 1/4	11	39.4
1 3/8	11	41.8
1 1/2	11	45.4
1 3/4	11	51.3
2	11	57.2
2 1/4	11	63.3
2 1/2	11	72.8
2 3/4	11	79
3	11	85.5

Types of thread: Whitworth gas thread

The Whitworth gas thread is especially used for cutting thread on gas or water pipes. The Whitworth Gas thread has the same top angle as B.S.W. but a much higher pitch. This results in a larger minor diameter. This type of thread therefore gives good sealing and can be cut on thin-walled pipes.

- The thread has a 55° V-profile.
- The pitch is given in threads per inch (T.P.I.).
- G1" stands for thread on a pipe with an inside diameter of 1 inch. As the thread is cut on the outside surface the minor and major diameter of the thread will consequently be larger.

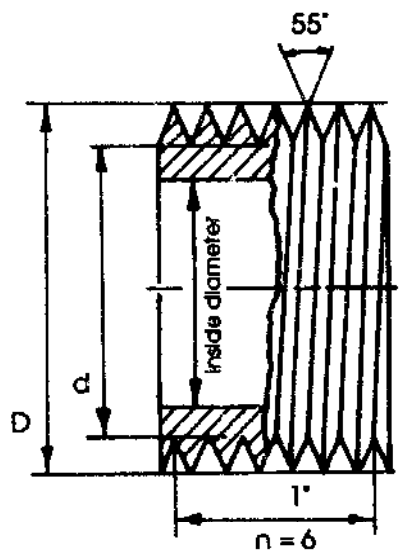

Threading

Tapping is cutting thread grooves in a workpiece with the aid of *taps*. *Threading* is cutting thread grooves around a workpiece with the aid of a *Die*.

Taps

Taps are cutting tools made of hardened tool steel. They are used to cut thread in holes, see Fig. 1. The top end of the tap is square and fits into the *tap wrench* (1-A and Fig. 3). The type of thread is stamped on the *shank* of the tap (1-B).

A tap has three or four *flutes* to break the chips produced and make room for withdrawal from the hole (1-C). On the cross section of the tap you can see the cutting edges are made at a certain angle and the heels are set slightly backwards (1-D).

Set of taps

Fig. 2 shows a set of three taps:

- *taper tap*, with one ring 2-A
- *plug tap*, with two rings 2-B
- *bottoming tap*, with three rings or no rings at all 2-C

Taper tap

This tap starts cutting the thread gradually. It is tapered for about the first eight threads.

Plug tap

This tap takes the second cut. It is tapered for the first three threads. If the hole goes through the material, this tap finishes the cutting.

Bottoming tap

When you cut thread in a *blind hole*, the bottoming tap should be used in addition to the two other taps, in order to cut the thread right down to the bottom of the hole. This tap is not tapered.

Tap wrench

A tap wrench is shown in Fig. 3. In the centre there are two jaws, one of which can be adjusted by turning one handle.

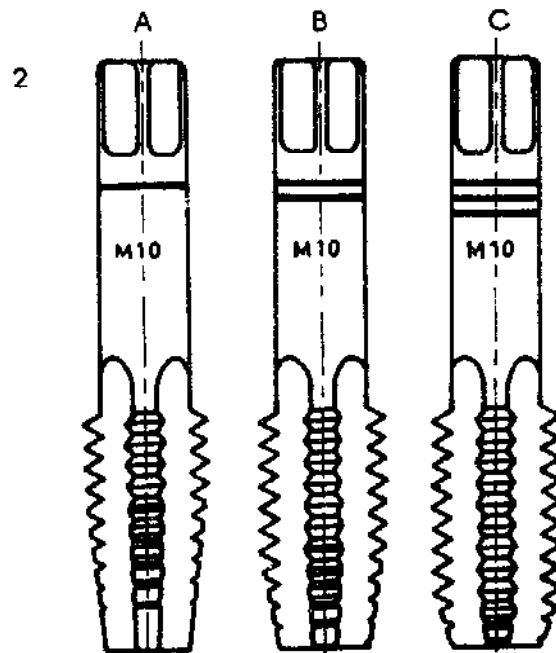
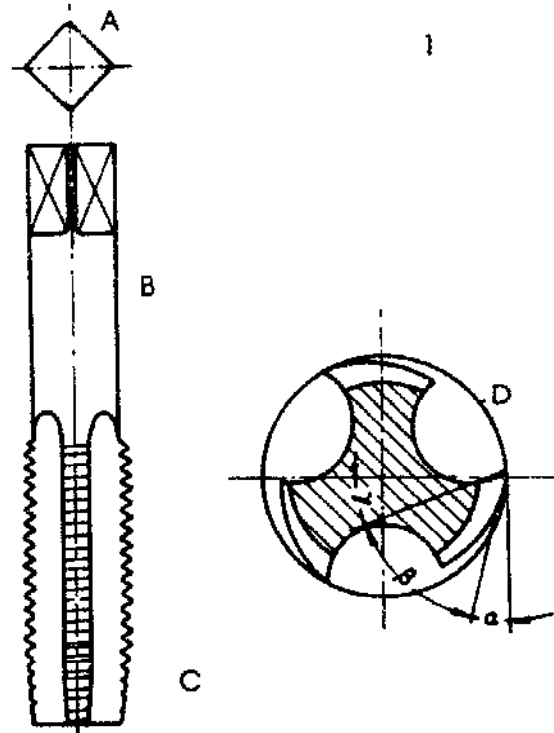

3

Dies

A die is a cutting tool made of hardened toolsteel. It is used to cut thread on bolts, see Fig. 1-A. The type of thread is stamped on the die. The hole in the die is for holding the screw that holds the die in place.

Another die is shown in Fig. 1-B. This die can be adjusted slightly by turning a screw in the stock. This makes it possible to cut a little over or under the size.

Die stock

As mentioned before, the die is fixed with a screw in the die stock. See Fig. 2. Make sure it is tightened well to prevent the die turning round in the die stock.

Thread gauge

If you have to make a nut for a ready-made bolt, or a bolt for a ready-made nut, then you have to use the thread gauge to find out the right pitch. A thread gauge is shown in Fig. 3-A. There are gauges for all kinds of thread.

Place the thread gauge over the ready-made thread and see which blade fits exactly over the thread (3-B). The number stamped on the blade tells you the correct pitch (3-C).

Threading tools

If possible, it is best to have different sets of taps and dies in the rural workshop to meet demand. Many nuts and bolts on old machinery have threads other than the metric, British or American thread.

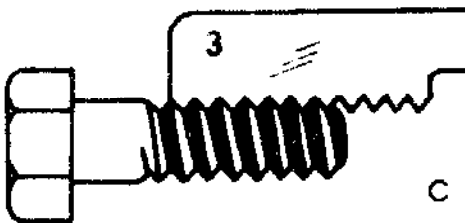
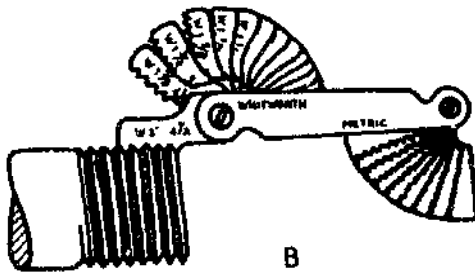
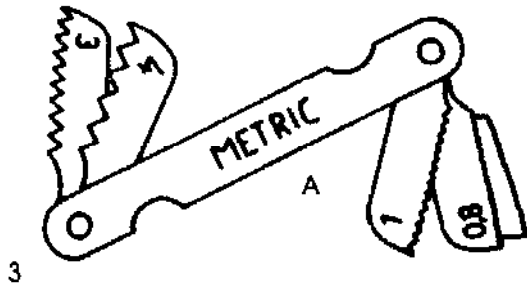
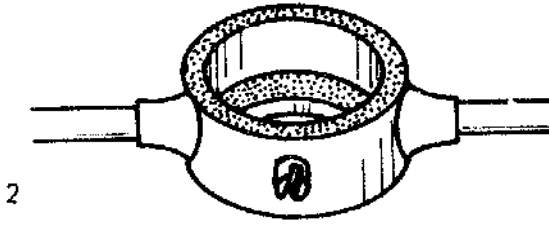
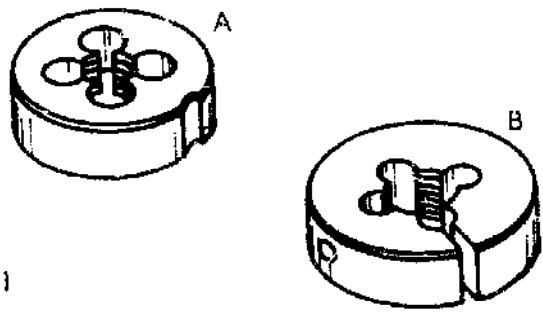

How to cut a thread

The procedure for threading a rod or bolt is:

- Cut the rod and check that it is the correct size and shape. The rod should be perfectly round and should have the same diameter as the major diameter of the thread to be made.
- Clamp the rod vertically in the bench vice. Check this with the try square, see Fig. 1.
- Chamfer the end of the rod with a file at 45°. See Fig. 2. Place the stock in the correct position on top of the rod. See Fig. 3.
- Place the stock in the correct horizontal position on top of the rod. Press it squarely on the end of the rod and turn it clockwise to get right-hand thread.
- Step back and carefully inspect whether the die is positioned square. Start again if the die is not square on the rod. Check this from all sides. See Figs. 4 and 5.
- After the die has been turned a few times, no more pressure is needed.
- Ease the die back at regular intervals to break the chips. Do this as soon as you feel resistance. Chips which clog in the die can be removed with a wire.
- Apply some oil after every few turns. This gives the die a longer life and cools down the heat produced by the friction. See Fig. 3.
- Never force a die. You can easily break the teeth of the die.
- After work is finished, clean the die and the wrench and put them back in the box.

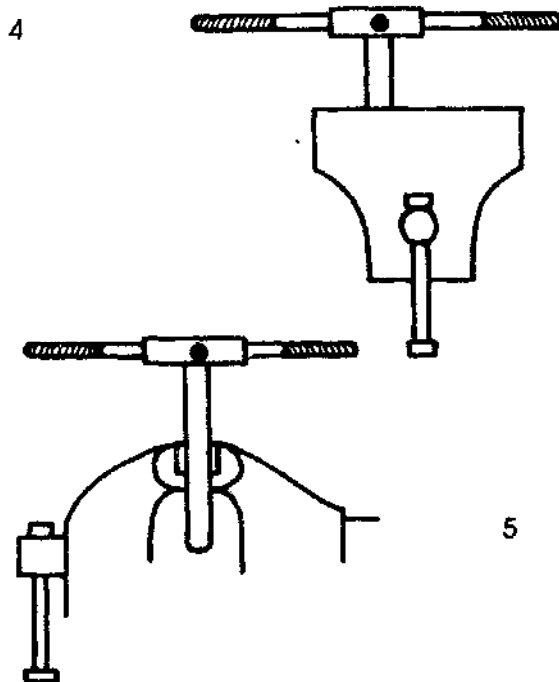
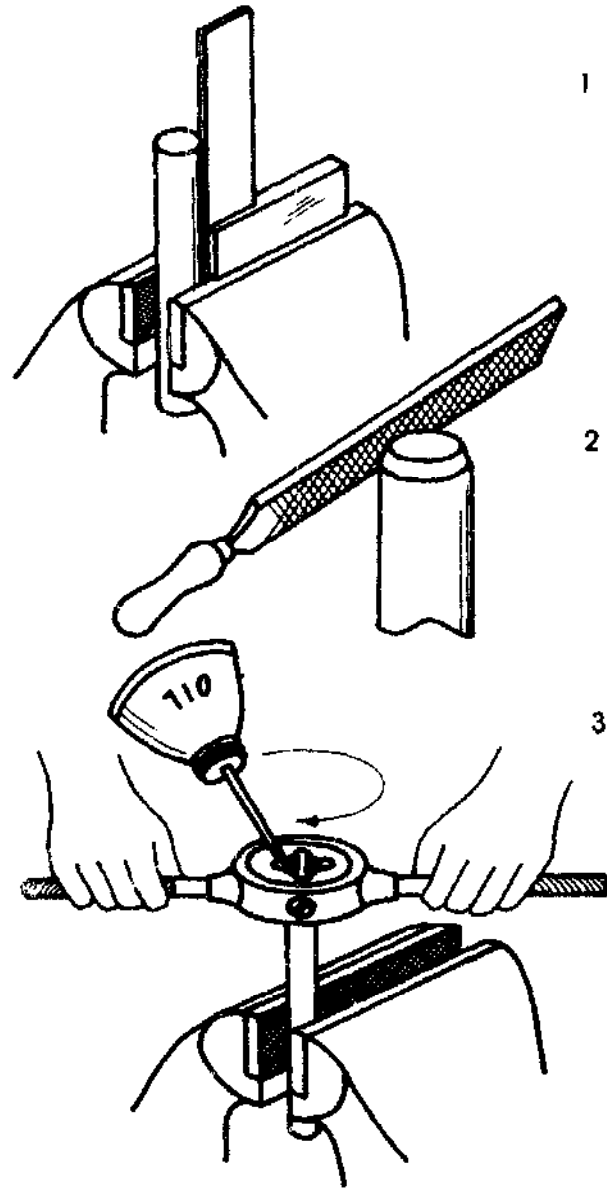

Cutting thread with a tap

The procedure for threading a hole with a tap is as follows:

- Make sure that the hole has the correct diameter for cutting thread. The following rule of thumb can be used for smaller diameters:
drill diameter = $0.8 \times$ bolt diameter
- Fix the taper tap in the tap wrench. Hold the tap wrench in your right hand and position it *squarely* on the work piece. See Fig. 1.
- Press the tap down and turn it clockwise to screw the tap into the hole.
- Check after a few turns whether the tap is square to the work, using the try square. See Fig. 2.
- Make a new start if the tap is not square. A tap which is not square at the start will *break* if you continue.
- Apply some oil regularly, see Fig. 3.
- After the tap has started to make thread, no more pressure is needed. You can turn the tap with both hands. See Fig. 4.
- For small taps and deep holes it is necessary to remove the tap several times to clear out the chips at the bottom of the hole.
- When threading a blind hole, use the bottom tap. Clean the hole in time.
- Never force a tap.
- Clean the tap and the stock before you put them back in the box.

To make the centre lines of the drilled hole and the tap come together you can clamp the workpiece on the drilling table and put a centre in the post drill. This centre gives guidance to the tap, see Fig. 5.

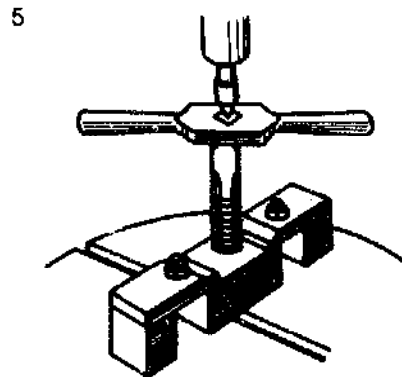
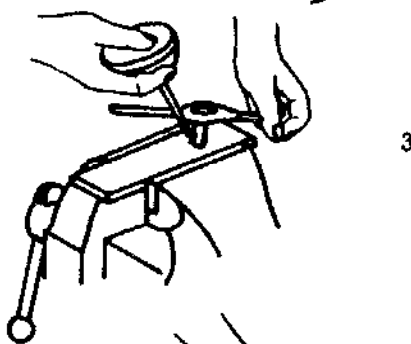
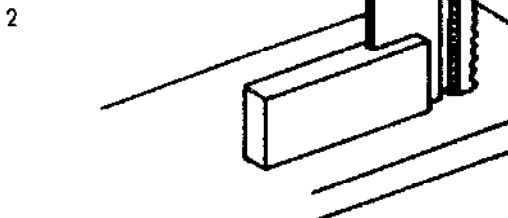
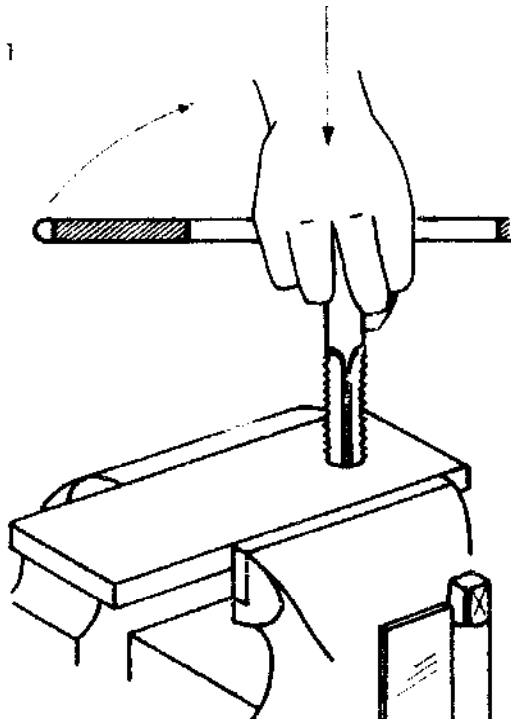

Tapping a thread

When you tap thin metal, it is best to hold a nut with the same thread over the hole. This nut guides the tap squarely through the thin metal.

Tapping blind holes

Take special care when you tap a blind hole. Remove the tap several times to clear out the chips. Be careful when the tap reaches the bottom of the hole. Do *not* turn any further or the tap will break. It is very difficult to remove a broken tap from a hole. The material used to make the tap is so hard that a drill cannot be used.

Tapping drill

A hole in which you want to tap thread should be of exactly the right diameter.

- *If the hole is too big:* It is impossible to cut a full thread.
- *If the hole is too small:* It is difficult to turn the tap; it may break.

The drill size used to drill a hole before tapping is called the *tapping drill*. The *thread charts* give the tapping drill sizes for the various types of thread. A set of twist drills in steps of half a millimetre is needed when threading holes. If the thread chart says a tapping drill of 9.3 mm is needed, you can try a drill of either 9.0 or 9.5 mm. A fairly good method to find the correct tap drill is to take a drill and pass it exactly through a new nut of the required thread.

Causes of broken taps

Taps and dies should be handled carefully. They are hard and brittle and therefore break easily. Small taps in particular are very delicate. A tap will break when:

- The diameter of the hole is too small
- The taps are not squarely in the hole
- No oil is used
- The tap is not eased back to break the chips
- The tap is turned after reaching the bottom of a blind hole
- The tap is dropped on the ground

Repairing thread in holes

Suppose the thread in a hole is damaged, the bolt now turns loosely in the hole. You can repair this by cutting an oversized thread. This oversized thread will be a *non-standard* thread. Non-standard threads are: M7, M9, M11 and M14.

An M7 tap can repair a damaged M6 thread. When the hole is cut oversized, you have to make an oversized bolt which will fit into the hole.

Locking devices

Locking devices

Some parts of engines, agricultural machinery or implements vibrate strongly. These vibrations will shake loose any bolt or nut, unless the bolt or nut is *locked* properly. Some methods to lock bolts and nuts in the correct way are as follows.

Washer

Washers are thin rings made of steel, plastic, lead, aluminium or copper. They are placed under the nut and make the nut fit flat on the workpiece. See Fig. 1.

Spring washer

A spring washer, also called lock washer, looks like the winding of a spring, see Fig. 2-A. A spring washer is made of spring steel. When a spring washer is used under a nut, the spring force of the washer locks the nut, see 2-B. A spring washer can also be used under the bolt head.

Castle nut

This is a nut with six slots on one end and is screwed on to a bolt. See Fig. 3-A. A small hole is drilled through two slots and the bolt and a cotter pin is pushed through this hole (3-B). Note how the cotter pin is spliced: one end is bent upwards, the other end is bent downwards (3-C). The head of the cotter pin is inserted in the slot and bent upwards.

Lock nut

A lock nut is a second nut screwed down on top of the first nut. See Fig. 4-A. The first nut is tightened in the normal way. Hold this nut in position with a spanner. Then screw the lock nut and tighten it with a second spanner (4-B). When you disassemble a lock nut, you also need two spanners. Keep the spanner on the lowest nut into position and loosen the first nut with another spanner. Make sure that you turn both nuts the correct way.

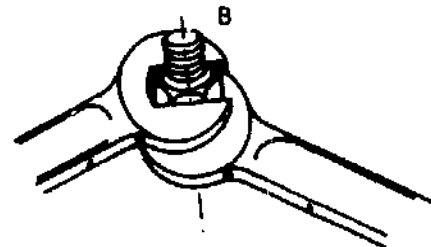
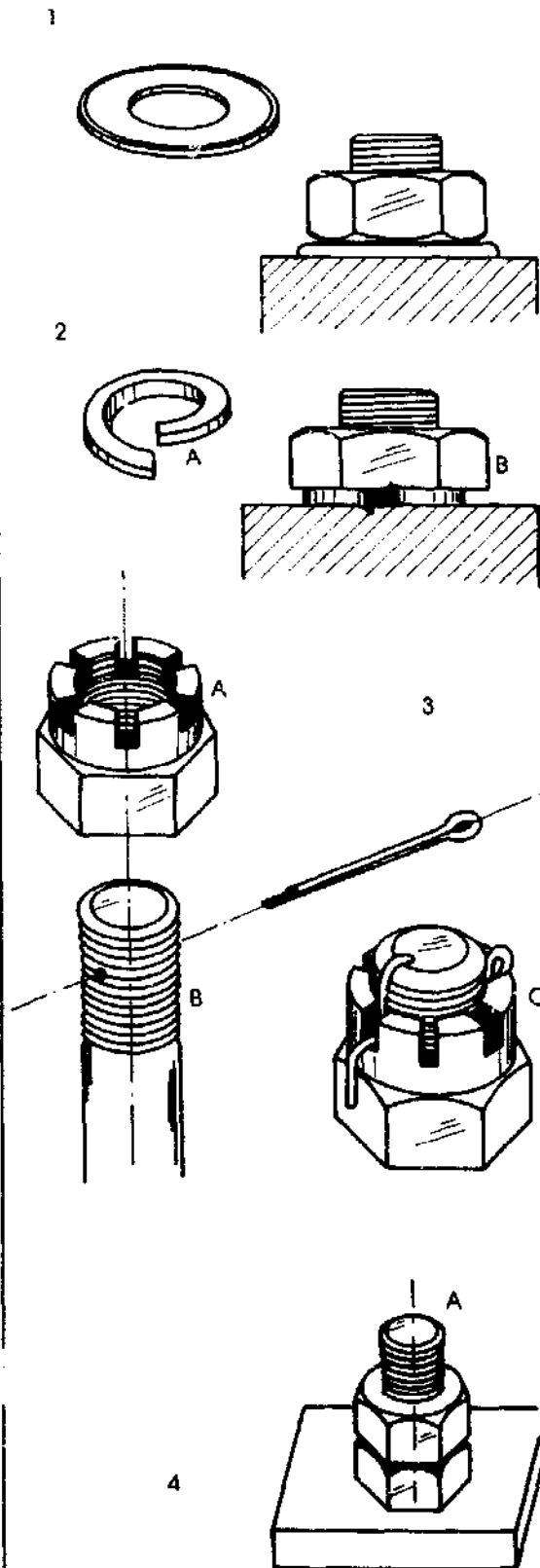

Nyloc nut

This is a nut with a nylon collar fitted inside the nut. This nut locks itself after being fit to the bolt, because the collar grips the thread of the bolt, see Fig. 1.



Locking wire

This method of using a locking wire is often used when a large number of small bolts have to be secured. Every bolt has a hole drilled in its head. The wire passes through all these holes and the ends are twisted together, see Fig. 2.



Locking plate

A locking plate is a piece of sheet metal with a hole in it, see Fig. 3. The bolt passes through this hole, and the plate is placed under the head of the bolt. After tightening the bolt, bend the plate against the side of the bolt head and at the other side passing over the workpiece. The locking plate must be secured to the work for otherwise it may turn round. There are two ways to secure the plate;

- By bending it over the workpiece, see Fig. 3.
- By using the locking plate for several bolts, so that the one bolt secures the other bolt, see Fig. 4.

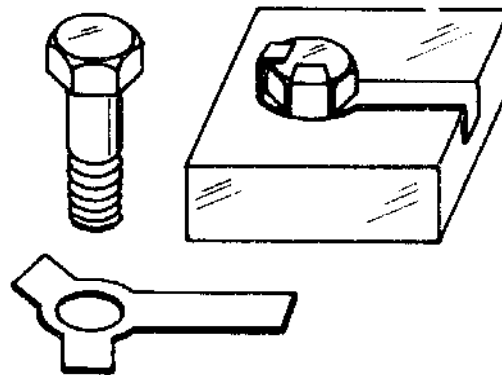

Screwed locking plate

Another type of locking plate is shown in Fig. 5. This plate has a shape which grips the bolt head. The locking plate is secured to the bolt with a small screw. This method is less advisable since the small screw may loosen, and the plate may fall off.

Nuts can also be locked with locking plates.

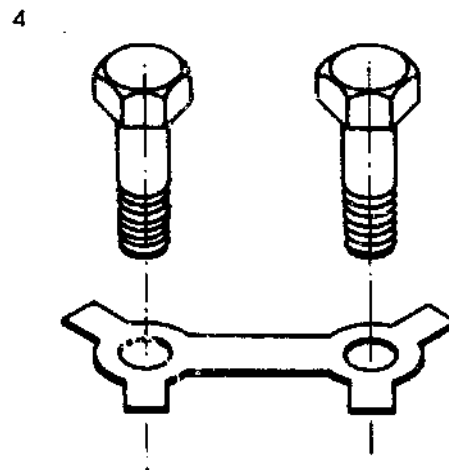
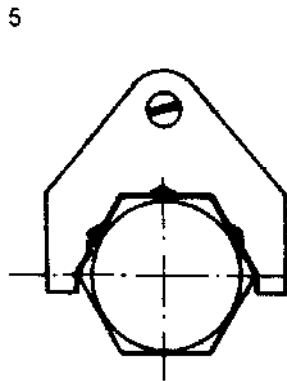

Pins

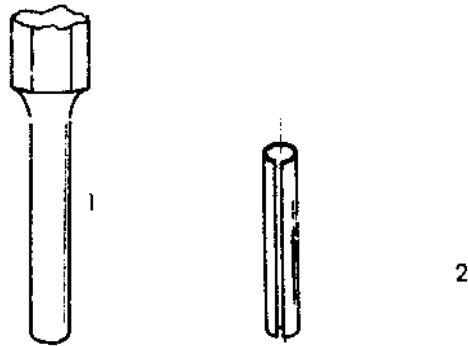

Pins are used to fasten various parts to axes. Pins are only used for relatively light connections. For very strong connections a key is used instead of a pin. Keys are explained on the next page.

To drive a pin out of a hole, you have to use a drift punch, see Fig. 1. Since most of the pins protrude slightly above the surface, make sure that you use the correct drift punch with the same diameter as the pin. If the drift punch is too small in diameter the head of the protruding pin may widen and it is then impossible to drive the pin through.

Before fixing the pin, push the drift punch through the holes to make sure that they are all in line with each other.

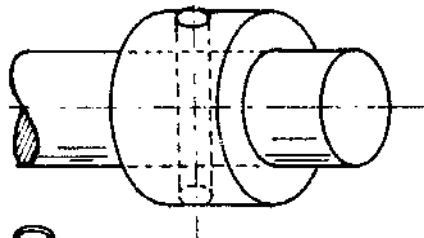

Roll pin

A roll pin is made of spring steel. It is hollow and has a slot along the side, see Fig. 2. The roll pin fits into a hole with a slightly smaller diameter, but the slot in the pin allows it to enter and so the pin will be fixed securely in the hole.

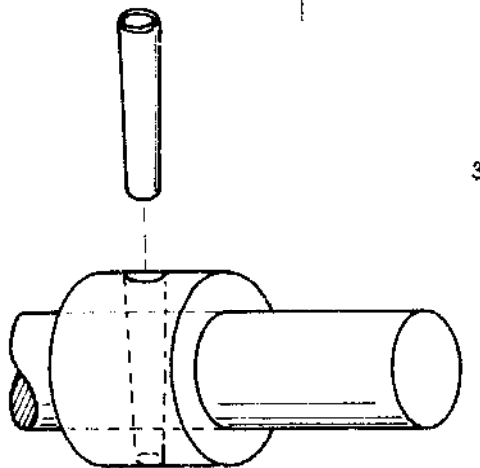

Tapered pin

The tapered pin is not as common as the roll pin. The hole where the pin fits is also taper shaped, see Fig. 3. When you assemble the construction, make sure that the tapered part of the axle is also positioned correctly. The pin should be wedged into position with a few light hammer strokes. If you have to drive this pin out, you should do this from the smallest diameter side.

Cotter pin

The cotter pin is used, for example, to secure a castle nut, but it can also be used for many other purposes. See Fig. 4. Sometimes a nail is used instead of a cotter pin. This is only allowed if it cannot cause accidents.

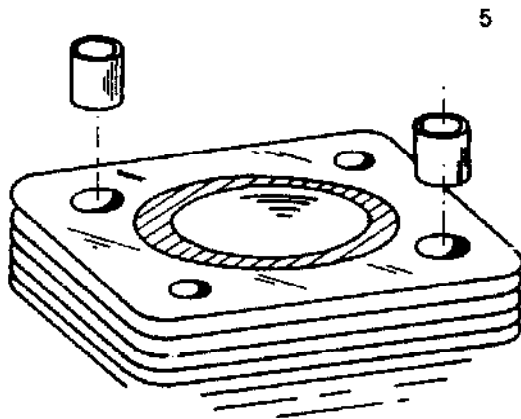

Dowel pin

Dowel pins are used to position two pieces of metal, see Fig. 5. Mostly two pins are used before tightening the workpiece with bolts.



Circlips

Circlips are thin rings made of spring steel. You can open or close them slightly with internal or external circlip pliers to fit them inside the groove made in the axle and the part which has to fit around the axle. Some circlips can be opened with long-nosed pliers.

There are two kinds of circlips:

- The *outside circlip*, which fits into a groove on an axle, see Fig 1.
- The *inside circlip*, which fits inside a hole, see Fig. 2.

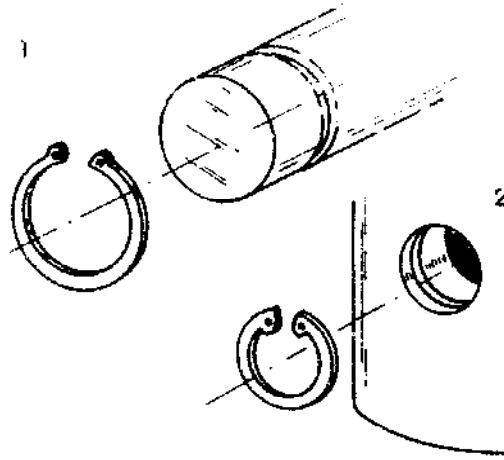

Keys

A key prevents the free rotation of a wheel on an axle. This wheel can be a gear, a pulley, a flywheel etc. The wheel and the axle both need a keyway in which the key is located, see Fig. 3. A key has to fit accurately into this keyway. If there is any play (if the keyway is too wide) the wheel can rotate slightly and very soon this will cause serious damage to the key and the keyway.

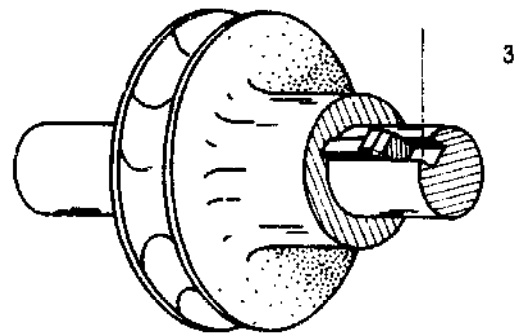

Types of keys

- Gibhead key

This key is slightly tapered. You have to wedge it in position with a hammer. When you have to take out a gibhead key use a tapered piece of steel and wedge this between the hook of the key and the pulley, to avoid damaging the hook. See Fig. 4.

- Woodruff key

This key is mostly used on tapered axes, see fig. 5.

- Feather key

The groove for this key can be located at any place along the axle. The key is placed in position first and the wheel is then moved over the axle and the key, see Fig. 6.

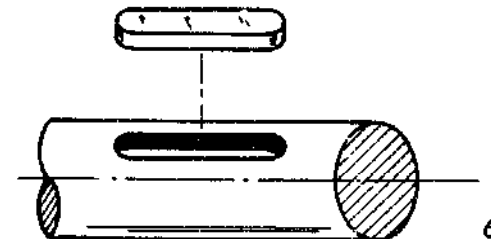
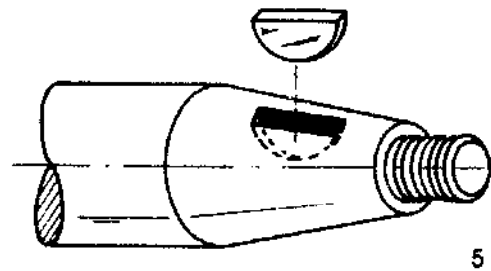
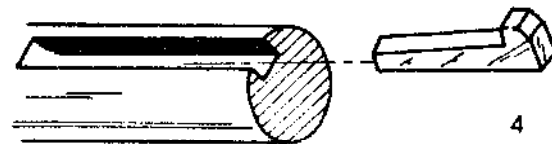

Removing a broken bolt

If a piece of the broken bolt is still protruding you can:

- Try to grip this piece with pliers or a wrench.
- Weld a nut onto it and use a spanner on the nut, see Fig. 1.

If the bolt is broken inside the hole, you can:

- Use a hammer and centre punch to knock out the bolt bit by bit.
- Drill a hole in the bolt and use a screw extractor, see fig. 2.

Removing stud bolts

A stud bolt has no head on which you can put a spanner. To get the stud bolt out you can:

- Grip it with pliers if it is an unthreaded protruding part of the stud bolt. See Fig. 3-A.
- Make a *lock nut*, see Fig. 3-B. If only the threaded part of the stud bolt is protruding. Tighten the two nuts with two spanners. Put a spanner on the lowest nut and unscrew the stud bolt in the same way as a normal bolt.

Removing worn nuts

Sometimes hexagon shaped nuts or a bolt head are worn round. The spanner has no grip on such a nut. You can use the following method to loosen this nut or bolt:

- Try to remove the damaged nut or bolt with the slip joint pliers or with a pipe wrench.
- Take a new nut or bolt when you assemble the workpiece again.
- If no new nut or bolt is available, you may take the damaged piece and file the shape to the next smaller size of the spanner. Keep checking with the spanner to see whether you have filed enough.

You are not allowed to use this method on engine bolts!

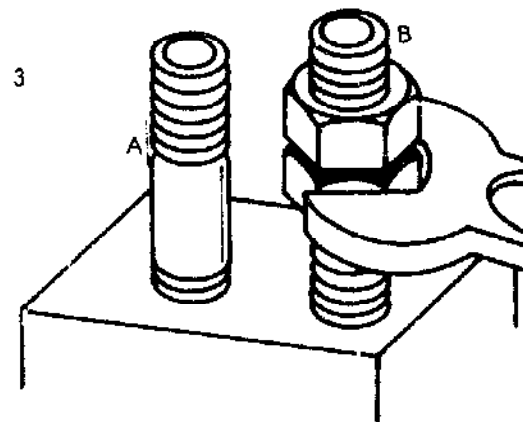
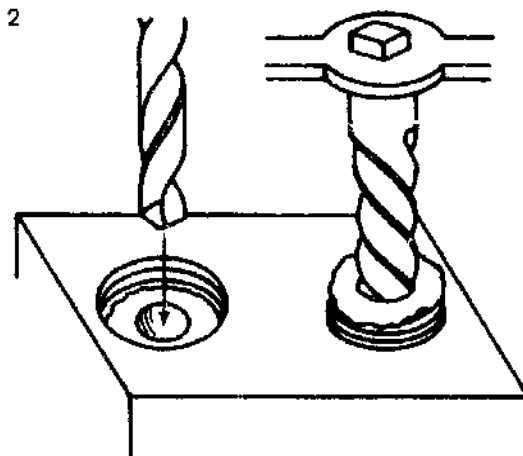
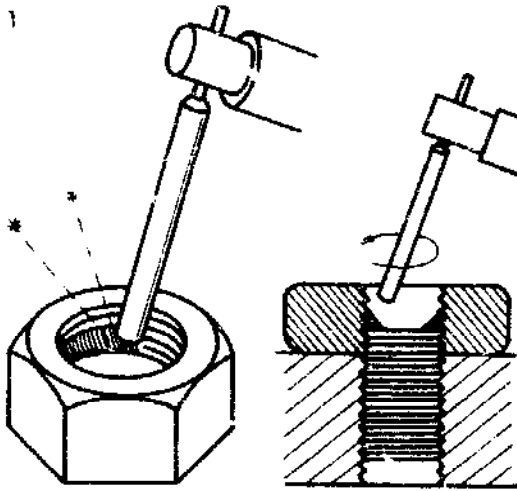

Sharpening tools

Introduction

Sharp tools are the mark of a good rural mechanic. Only a poor craftsman struggles along with a blunt tool instead of taking time to sharpen it. Blunt tools may cause accidents.

Tools can be sharpened with:

- Hand grinder
- Electric bench grinder
- Oil stone

Hand grinder

A hand grinder can easily be fixed on top of a work bench by means of a clamp, see Fig. 1-A. The grinder has a handle with gear wheels (1-B) and a toolrest (1-C). Two people are needed to do a good job. One has to turn the wheel towards the tool rest and the other does the actual grinding job, holding the tool against the tool rest in the correct position.

The wheel is fixed to the grinder over an axle and is tightened with a nut. Make sure that you place the washers in correct order.

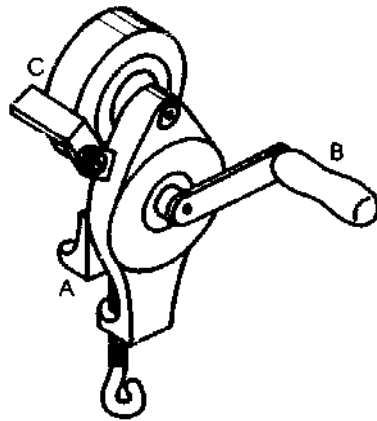

1

Electric bench grinder

If there is electricity in the rural workshop it is advisable to have an electric bench grinder which can be used for many jobs. Electric bench grinders are available in many different sizes. A grinder with two wheels of 150 x 20 mm will do an excellent job. See Fig. 2.

The two wheels on a grinder are usually of different texture. One has a coarse texture and is used for rough work and the other wheel is of fine texture for finishing work. A steel guard, 2-B, protects you from touching the wheel or from an accident if the wheel breaks. A tool rest, 2-C, is mounted to let the tool or the workpiece rest properly. The gap between the tool rest and the grinding wheel must be as small as possible, without the grinding wheel touching the rest.

If the guard is fitted with a slide, set it so that it is as close to the grinding wheel as possible without touching it. To check that the wheel can rotate freely after adjusting the tool rest and the slide, rotate the wheel a few times by hand. Check the gap between the tool rest and the grinding wheel at regular intervals.

It is essential to use the eye shield, see 2-D. Grains from the abrasive artificial stones fly around and are very dangerous.

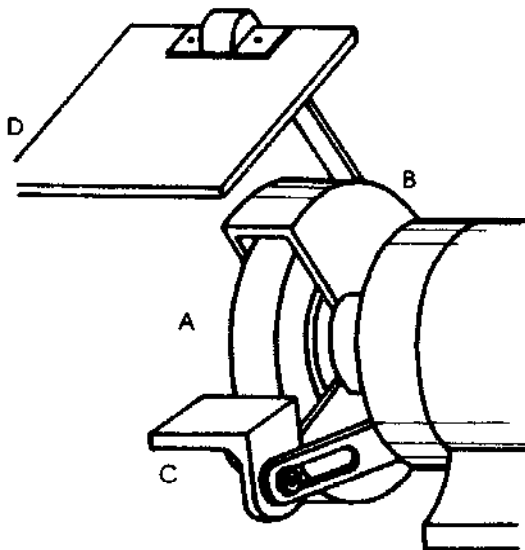

2

Grindstone dressers

While grinding an object one should take care to move the object gradually from left to right and back to avoid making grooves in the surface of the grinding stone. If for one reason or another a groove is made into the surface of the grinding stone it is advisable to have a wheel dresser at hand to smoothen the surface again.

Wheel dresser

A wheel dresser as shown in Fig. 1 may be used to flatten the surface of the grinding stone again. This wheel dresser consists of a handle with a wheel at its end. This wheel is made of very hard steel and specially shaped. It is moved over the surface of the grinding stone while it is rotating. Make sure that you move the dresser gradually left and right until the surface is smooth again. During dressing wear safety goggles because particles of the grinding stone may fly around.

Instead of a wheel dresser a diamond-point wheel dresser may be used. At the end of the bar, shown in Fig. 2, an industrial diamond is located. With the diamond, being harder than any material, the surface of the grinding stone can be smoothened.

Safety precautions when sharpening tools

- Before grinding adjust the tool rest very close to the grinding wheel and at the required angle. See Fig. 1. Make sure the gap between the tool rest (1-A) and the wheel is not so big that a workpiece can wedge between the tool rest and the wheel. This is very dangerous: the wheel may break.
- If necessary adjust the eye shield (1-B) so no abrasive grains can fly into your eyes.
- Put on safety glasses.
- Never wear gloves or use cotton waste to hold the workpiece when grinding.
- Never knock against the wheel, as this may cause breakage.
- Always stand aside when starting the grinding motor, until the operating speed is reached.
- Switch on the machine and wait until it has reached full speed.
- Secure all loose clothing and remove rings or other jewellery.
- Position the workpiece on the tool rest.
- Press the workpiece gently against the wheel and move it left and right over the top of the wheel to avoid wearing out the wheel in one place.

- See to it that the material does not get overheated. Remember that heat changes the properties of the steel.
- Cool the material regularly in water.
- Never use the side of the wheel.
- Switch off the machine after use.
- Never try to sharpen material thinner than 2 mm. It may be pulled between the wheel and the tool rest. This situation can be very dangerous.

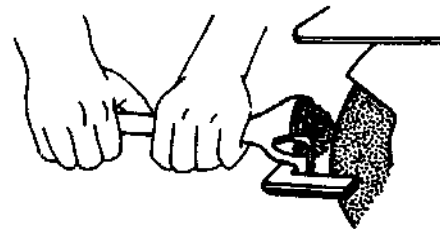
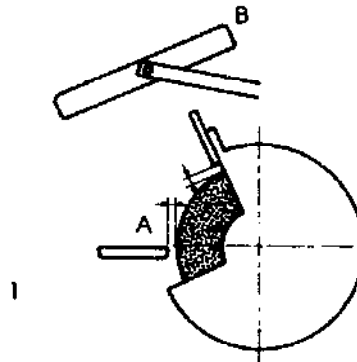

Mounting a new wheel

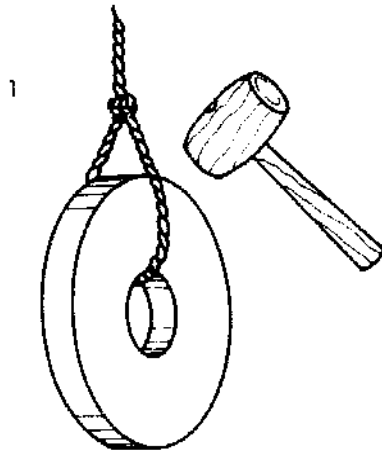

If the grinding wheel becomes too small in diameter it should be replaced by a new wheel. Before placing the new wheel on the spindle ensure that:

- The maximum number of revolutions of the spindle does not exceed the value stated on the wheel.
- The diameters of the spindle and the shaft hole of the wheel correspond.
- The wheel does not show any damage.

First test the new wheel for cracks. Hang the wheel freely on a rope. The wheel should make a clear sound when you tap it with a mallet, see Fig. 1. A cracked wheel makes a dull sound. Never use a cracked wheel.

If the grinding machine has two wheels, the wheel out on the left side will have a *left hand* thread. This is to prevent the nut loosening itself during grinding.

Use safety washers of heavy paper or leather between the mounting flanges of the wheel. Large safety washers prevent excessive stress on the wheel. See Fig. 2.

Tighten the wheel nut moderately.

When a new wheel is mounted give it a one minute test run. This prevents injury if the wheel falls apart due to a defect that has not been noticed.

Oil stone

An oil stone for sharpening keen-edged tools is indispensable in a good rural workshop. Two kinds of stones are available:

- natural stones
- artificial abrasive stones

The artificial stones are generally preferred, as they are more uniform in structure. A combination stone with one side made of coarse grained and the other side made of fine grained abrasive is recommended. The coarse side is used for fast cutting during the first part of the sharpening and the fine side for finishing to a keen smooth edge.

Use a light oil, such as kerosene and motor oil mixed in equal parts on an oilstone, to float off the small cuttings of steel and to prevent the surface from becoming clogged with dirt.

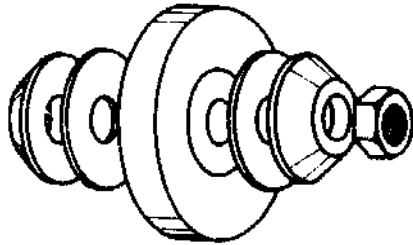

Sharpening the cold chisel

A cold chisel should have a cutting edge of 60°. Both faces should have the same length. To avoid accidents the hammer anvil should be re-shaped occasionally. See Fig. 1-A for a correct shape.

- Hold the chisel with the right hand. Place it on the tool rest. The forefinger should be against the front of the tool rest for guidance. Two fingers of the left hand should press the chisel towards the wheel.
- The chisel should rest at the correct angle against the wheel. A little experimenting may be necessary to find the correct position. Once it is found, *keep* this hold with your fingers, even when you dip the chisel in water or inspect it. The chisel can then easily be replaced on the tool rest.
- Press the chisel *gently* against the grinding wheel. Swing it from side to side, pivoting it over the tool rest. Fig. 2-A.
- Dip the chisel in water regularly.
- Check the correct angle of the cutting edge with a sheet metal gauge. See Fig. 2-B.
- A 60°-slot can be filed in the sheet metal with a triangular file.

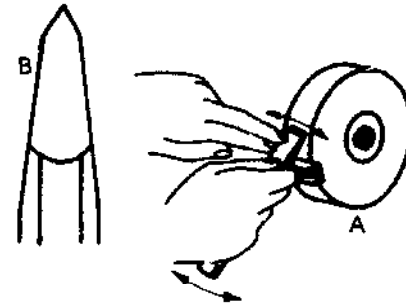
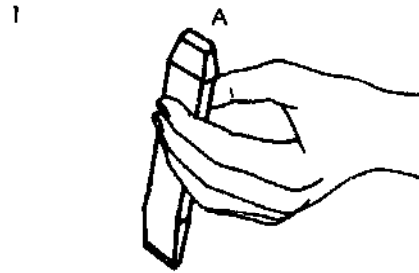

Re-shaping a screwdriver

The tip of a screwdriver should be flat. If the tip is round, it easily slips out of the screw slot. Figs. 3-A and 3-B show the correct shape of the screwdriver tip. Figs. 3-C and 3-D show the wrong way to re-shape.

To grind a screwdriver:

- Hold it on the grinding wheel as shown in Fig. 4.
- Move the blade endwise back and forth a little to grind the face a short distance back from the end.
- Turn the screwdriver over and grind the other face in the same way.
- Grind the edges and the end of the screwdriver bit.
- Remove the tool and inspect it.

2

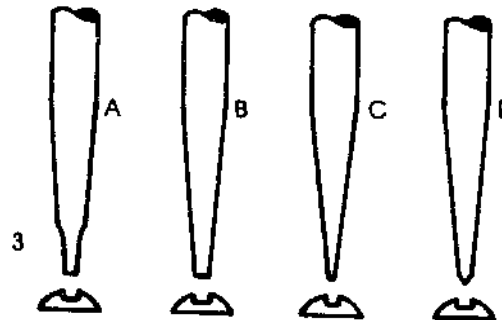

Watch out for overheating!

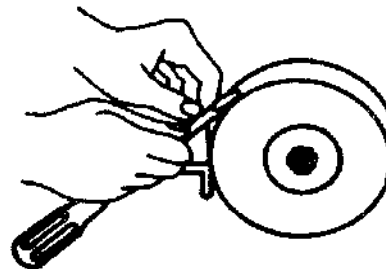

4

Sharpening the centre punch

The centre punch should be sharp and have a point sharpened to 60° . Hold the centre punch in the same way as the cold chisel. See Fig. 1. Press the centre punch against the grinding wheel and roll it between your fingers, left and right. Dip the point in water frequently to cool it. The grinding marks should run away from the point as shown in Fig. 2-B. If the grinding marks run across the point of the centre punch, the point is weakened. See Fig. 2-A.

Sharpening the scriber

The scriber is sharpened in much the same way as the centre punch. The point should have an angle of 30° . Be careful, because the thin point will burn easily during grinding. So use only light pressure and dip the point in water frequently.

Sharpening shear blades

When you sharpen the blades of the tin snip, see Fig. 3, or the blades of the lever shears, you have to grind only the cutting edges of the blades, see 3-A. The sharpening angle should be $10 - 15^\circ$, as shown in Fig. 4-A. If the sharpening angle is too great, the blades soon become blunt. Figs. 4-B and 5-A show you a set of wrongly sharpened blades. If you grind the steel side of the blades, the blades cannot cut and the material to be cut will wedge between the two blades as soon as they come together, see Fig. 5-B.

After sharpening, make sure that the rivet of the tin snips is tight enough. If there is too much space between the blades, the tin snips cannot cut and material will wedge between the blades. Some clearance is necessary, however, in order to be able to cut material of various thicknesses.

With lever shears it is sometimes necessary to add a piece of stiff paper between the frame and the blades, when adjusting them, to ensure that the blades pass each other correctly.

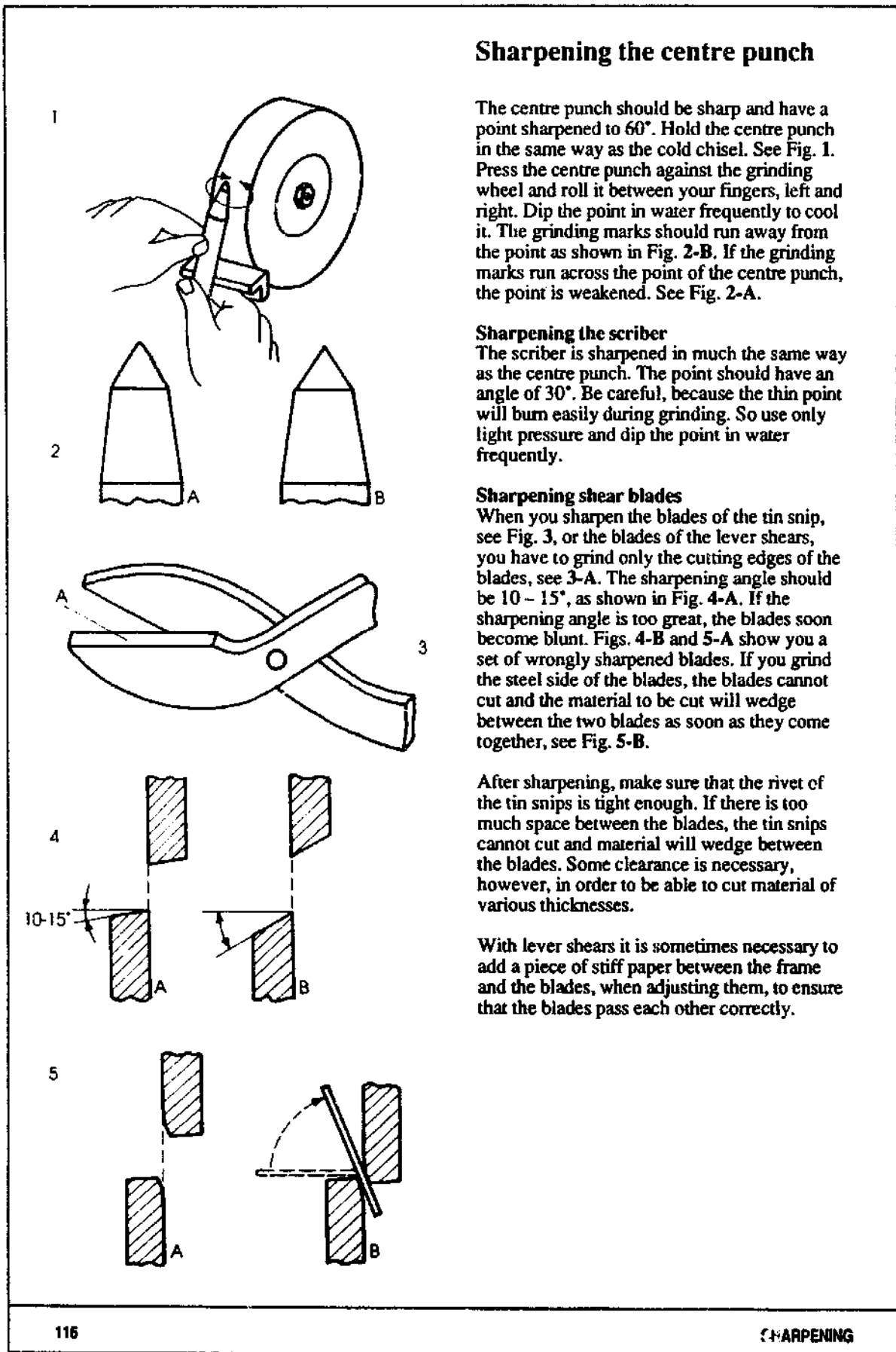

How to sharpen twist drills

Twist drills are sharpened on a medium coarse grinding wheel. As mentioned before, it is difficult to sharpen twist drills and it takes a lot of practice to master this skill. The procedure for sharpening a twist drill is:

- Study the drill tip and check the shape. If the drill is damaged, some rough sharpening can be done.
- Take the drill in your hand and place your finger on top of the tool rest on which the drill will be supported. See Fig. 1-A.
- Make sure the axis of the twist drill is at an angle of 59° degrees to the face of the grinding wheel. See Fig. 2. It is a good idea to file a 59° -guide on the tool rest.
- Hold one cutting edge exactly horizontal against the grinding wheel. See Fig. 1-B.
- Press the cutting edge gently against the grinding wheel and slowly lower your right hand while grinding.
- Do not stop while lowering your hand, but make one stroke.
- Repeat the grinding stroke as many times as necessary.
- Dip the drill in water frequently and at the same time inspect the shape of the cutting edge and the correct angles.
- Grind the other cutting edge, regularly check the gauge for the correct angles and the shape of the two cutting edges, including the dead centre.

Note: Study Fig. 3-A; you will see the shape of the cutting edge is somewhat rounded. This is necessary because if you sharpen it straight the clearance angle will be too wide, see Fig. 3-B.

1

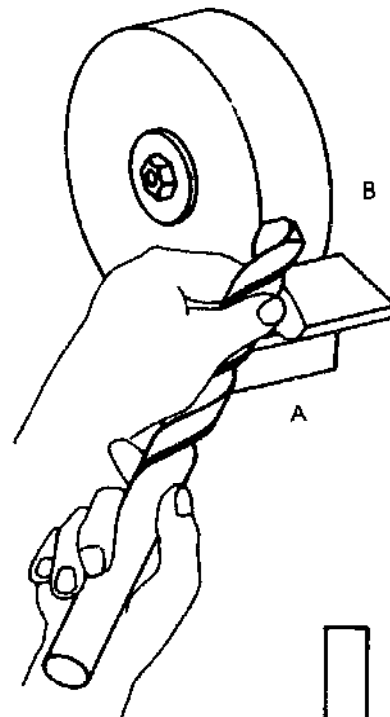

2

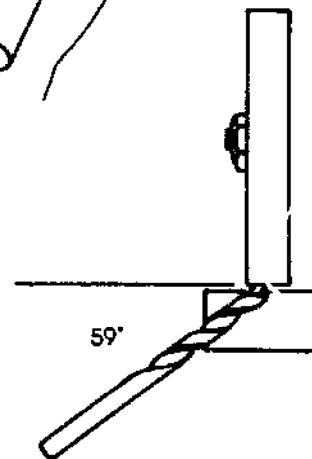

3

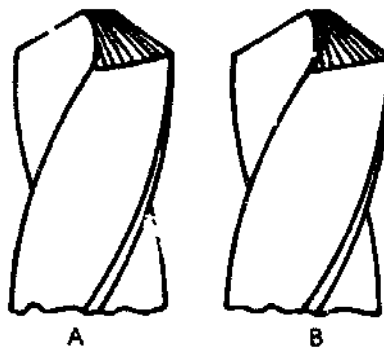

Twist drill sharpening gauge

It is advisable to make a sharpening gauge yourself for sharpening twist drills, see Fig. 1. The gauge shown is made of sheet metal with a thickness of 2 to 3 mm. The three sides of the gauge have different shapes, with the required angles for:

- An angle of 118° for both cutting edges of 59° , see 1-A.
- An angle of 6 to 8° for the clearance angle of the two cutting edges, see 1-B.
- The dead centre angle of 55° , see 1-C

Checking different angles

- Marks on the gauge shown in Fig. 2 make it possible to check the drill point angle and the lengths of the cutting edges. Spaces of 1 to 3 mm are marked on both sides to measure the length of each cutting edge. The length of the dead centre can also be measured.
- Fig. 3 shows the correct angle of the dead centre to the cutting edges, which is 55° . If the dead centre is not exactly in the centre of the drill, the drill wobbles during operation and produces a larger hole than the actual diameter.
- In Fig. 4 you can see the gauge in position to check the clearance angle, which may be between 6 and 8° .

Clearance angle

The harder the material to be drilled, the less the clearance angle of the drill tip should be. If the clearance angle is too wide, the drill will chop too much material at once, with the result that you cannot make a smooth hole, the drill vibrates and the cutting edges very soon become blunt.

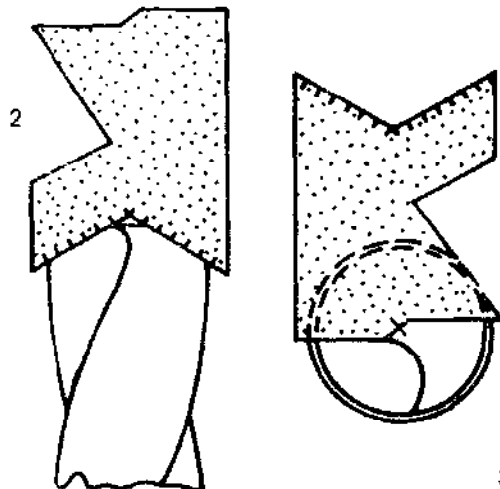
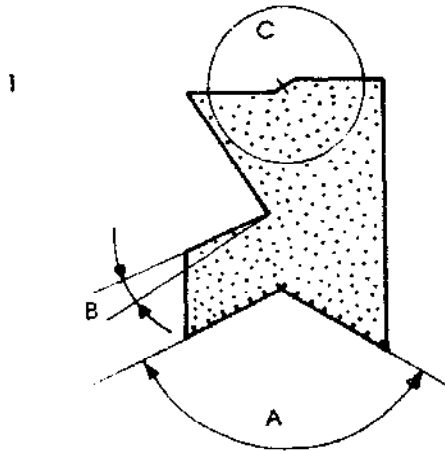

3

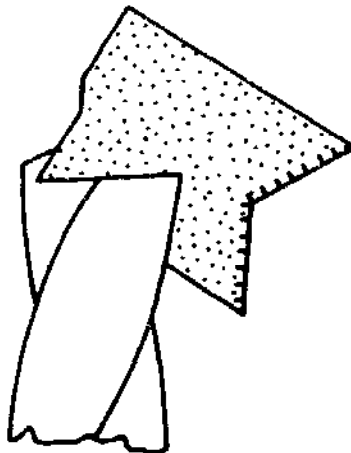

4

Sharpening scissors

A pair of scissors is very useful in the rural workshop, because washers made of leather, plastic, rubber or paper have to be cut. Many people outside the workshop may ask for your help by sharpening their scissors, because they do not have the means to do this themselves. To sharpen a pair of scissors you have to know the following procedure:

- Clamp the scissors between the bench vice and use a pair of soft vice clamps.
- File the bevelled edges carefully at the original angle - see also the procedure for sharpening tin snips and Fig. 1.
- If the material of the scissors is too hard to file, use the grinding stone.
- While grinding, hold the blade at an angle across the grinding face of the wheel, with the back of the blade tilted just enough to grind at the desired angle. See Fig. 2.
- Move the blade back and forth slowly across the wheel.
- After the bevelled edges are renewed, finish the sharpening by whetting on the fine side of the oil stone.

Note: If the scissors are not blunt, the bevelled edges may be renewed by first whetting on the coarse side of the oil stone and later on the fine side of the oil stone.

Be careful to keep the blades perfectly flat when whetting the flat side (Fig. 3) and at the correct angle when whetting the bevelled edges (Fig. 4). Study the drawings properly and observe the position of the hands and the fingers. This is very important for a good job.

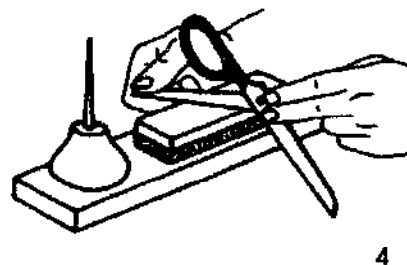
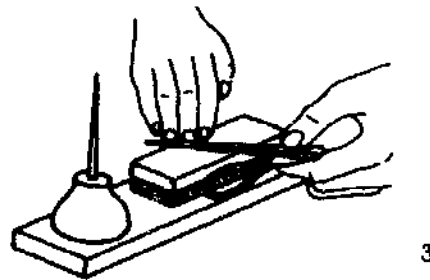
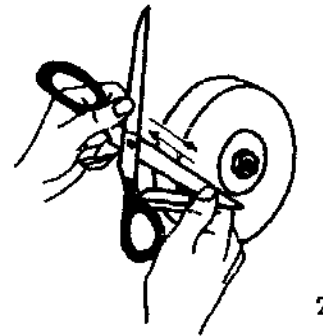
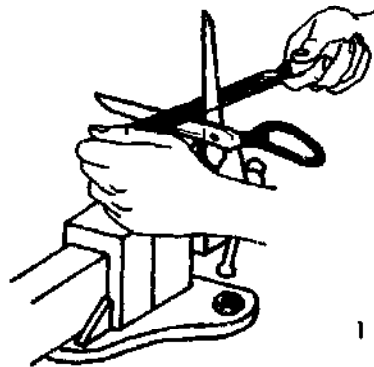

Testing the sharpness of a knife

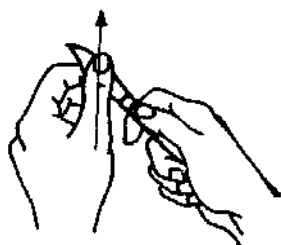

1

Probably the best way to tell whether or not a knife is sharp is to feel the blade with your thumb. Hold the blade with the cutting edge upwards in the open hand and, with very light pressure, move the thumb lengthwise along the edge. See Fig. 1. Be careful, do not press against the edge.

If the knife takes hold or pulls on the calloused skin of the thumb, it is sharp. If it does not take hold or feels slick and smooth, it is blunt.

2



A

B

Shape of cutting edges

Contrary to the cutting edge of the tin snip or lever shear blades, which have a keen edge on one side of the blade, the knife has the cutting edge in the middle of the blade. Fig. 2-A shows the cutting edge of the lever shear blade and 2-B the cutting edge of a knife.

3

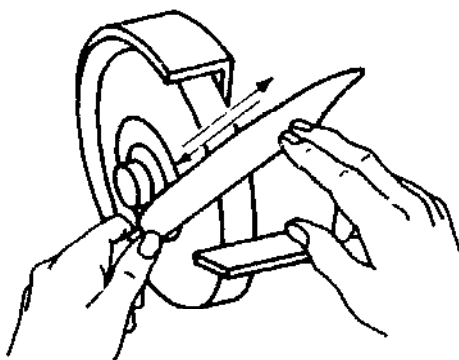

4

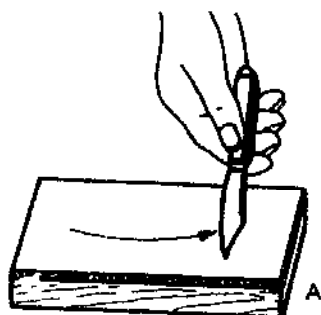

A

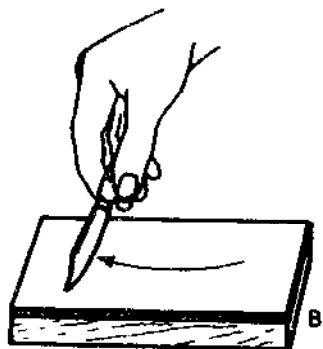

B

Sharpening a knife blade

- Use a medium or fine grinding wheel.
- Place the blade against the wheel at the required angle. The tip of the blade should be somewhat higher than the handle, see Fig. 3.
- Move the blade over the wheel, pressing it gently.
- Keep an eye on the tip of the blade; this will quickly overheat.
- Dip the blade in water regularly to cool it.
- If one side is sharpened, turn the blade and sharpen the other side of the cutting edge.
- Use the same pressure on both sides to make sure the cutting edge is exactly in the middle of the blade.
- To produce a keen edge, whet the blade on an oil stone, moving the blade as shown in Figs. 4-A and 4-B. Turn the blade after every stroke.

Fine keen edge

A very fine keen edge is produced with the aid of a piece of smooth leather. Move the blade over the leather, turning it after every stroke. Make sure you use pulling strokes with the cutting edge *ailing* not *leading*.

Axes

Some tools have specially shaped cutting edges. So it is always necessary to study the shape before sharpening a tool.

In the case of an axe, the cutting edge is slightly rounded off in the length and on both sides. See Fig. 1-A. After sharpening as shown in 1-B, a keen edge can be made with the aid of an oil stone, using first the coarse and then the fine side of the stone, see 1-C.

Thin metal tools

Thin metal tools which are not too hard can be sharpened with a file. Some tools, like the shovel, are sharpened on one side. Other tools, like the chopping knife, are sharpened on two sides. See Fig. 2.

If for some reason a file is not available, thin metal tools can be sharpened with the aid of a small rounded-off anvil and a hammer. See Fig. 3-A. Place the tool in a convenient position on top of the anvil. Hammer the metal towards the edge with the pein of the hammer so that it takes on the shape shown in 3-B. When you hammer, a burr is produced which should be taken off with the oil stone.

Keen edge

A keen edge on hammered-out tools is produced with an oil stone. Use:

- Coarse stone
- Medium stone
- Fine stone

Sharpening steel

The sharpening steel is a long round tool that is made of hardened steel. Along the length of the tool very tiny grooves are made which straighten the actual keen edge. See Fig. 4.

When using the sharpening steel, tilt the blade slightly so the cutting edge is in contact with the steel. Quickly draw it down with sweeping diagonal strokes. Stroke the other side in the same way and continue stroking, first one side and then the other side of the blade.

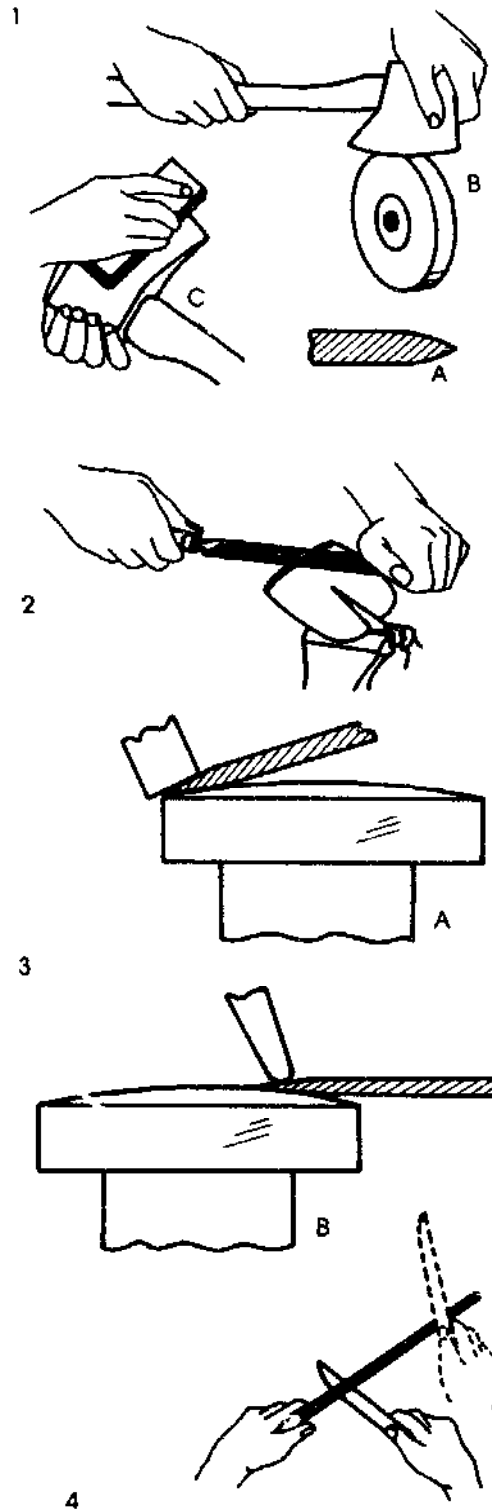

Pipe bending and fitting

How to bend a pipe

Steel pipes can be bent in the rural workshop while the pipe is hot. Hot-bending galvanised pipes must be avoided, because the heat burns the zinc coating which protects the pipe against rust. Before bending, remember that the bend must never be less than three times the diameter of the pipe to be bent.

Bending Procedure

- Mark the length of the bend on the side of the pipe where the welding seam is. The seam must always be on the inside of the bend.
- Close one end of the pipe with a wooden plug, hammering it in firmly.
- Fill the pipe with clean, dry sand to avoid flattening the pipe during bending. Make sure the sand is very dry and high-grade. Moist sand contains water that turns into steam when the pipe is heated – the steam may force out the wooden plug violently.
- While filling, shake the pipe and gently tap the pipe wall continuously to make sure no voids are left. See Fig. 1-A.
- After filling the pipe, close it with another wooden plug. See Fig. 1-B.
- Heat the inside of the bend a little more than the outside to avoid wrinkles on the inside of the pipe bend.
- Heat a short length of the pipe each time and bend it. Repeat this until the whole bend is made.
- Bending can be done over a jig or according to a template made of sheet metal.
- While bending, watch the cross-section of the pipe very carefully to see that it remains round. See Fig. 2.
- Bends can only be made 50 cm or further from the end of the pipe. Never attempt to make a bend at the end of a pipe, it is then impossible to keep the pipe round in shape.

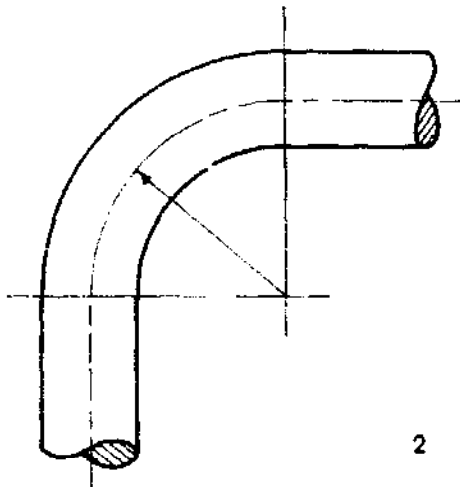
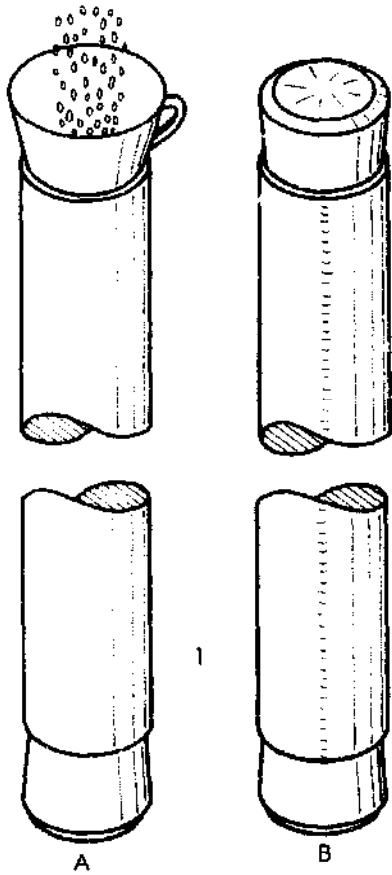

Pipe wrenches

A pipe wrench, shown in Fig. 1, can be adjusted with a screw 1-A. Pipe wrenches are sold in different lengths and are suitable for pipes with a diameter of $\frac{1}{2}$ to 1 inch and of 1 to 2 inches or larger, depending on the adjustments made. It is advisable to buy pipe wrenches in pairs because you always need one to hold the pipe in position and another to tighten or loosen the pipe.

Chain pipe wrenches, shown in Fig. 2, are used to tighten or loosen pipes with large diameters. When you want to tighten or loosen a pipe, turn the wrenches in the direction of the arrows in Figs. 1 and 2. While moving the wrenches in these directions, the jaws grip correctly over the pipe. While tightening or loosening, do not damage the galvanised surfaces.

Pipe vices

It is impossible to clamp a pipe securely in an ordinary bench vice. When you tighten the vice, the pipe is flattened. To avoid damaging the pipe, you can use a pipe vice as shown in Fig. 3. If you do not have a pipe vice, you can make a pipe clamp as shown in Fig. 4. With this pipe clamp you can clamp the pipe in the bench vice. Design a clamp vice for different common size pipes. If you do not have a pipe clamp or a pipe vice, you can clamp the pipe loosely in the bench vice - just hand tight.

To prevent rotation of the pipe, clamp a pipe wrench on the pipe as shown in Fig. 5. Make sure the handle of the wrench rests against the edge of the work bench. Positioning the pipe wrench takes some practice. Place this tool in such a way that it tightens by itself and the teeth do not damage the galvanised surface.

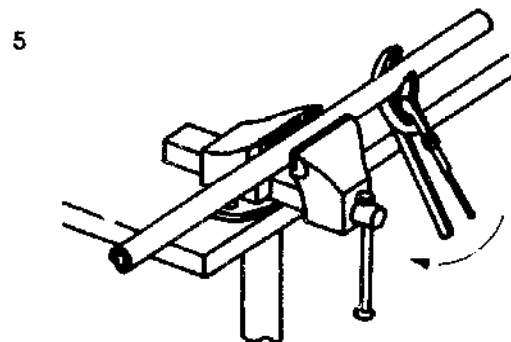
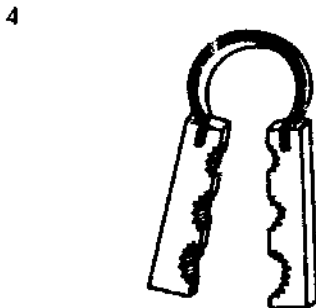
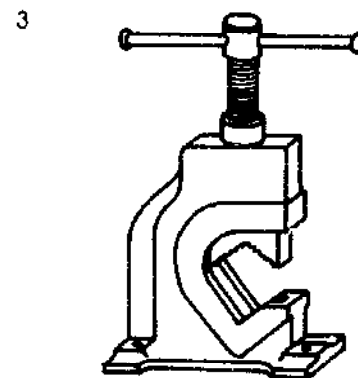
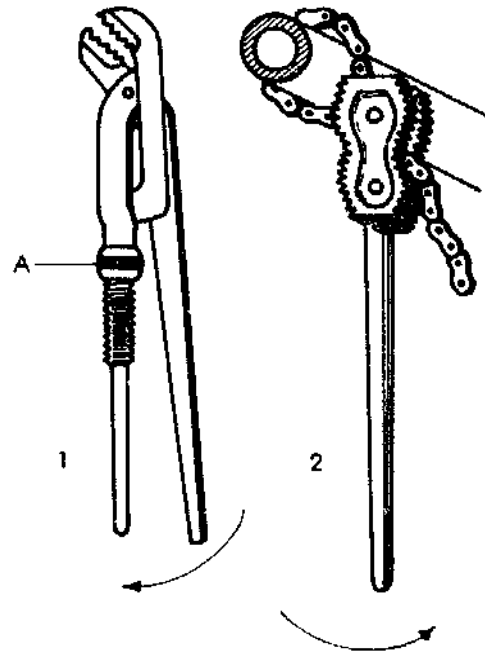

Pipe fitting

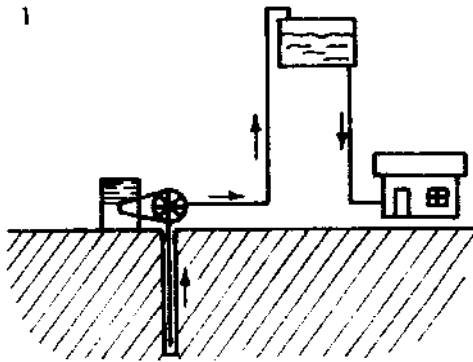

Large villages and institutions like schools and hospitals often have a drilled borehole with a diesel powered pump and a big overhead tank to provide storage and pressure. The water from the overhead tank is carried through pipes to the different buildings. It is important for the rural mechanic to know about pipe connections, pumps and stationary diesel engines, to be able to maintain and repair these installations which are of vital importance to the community. See Fig. 1.

Pipe

Besides copper tubing, galvanised steel pipe is also commonly used for water supply. Since galvanised steel pipes can stand more force, they are widely used in rural areas. *Galvanised* means the pipe is covered with a thin layer of zinc. This zinc protects the pipe against corrosion. You can recognize galvanised pipe from its bright greyish colour.

Pipe is sold in lengths of 6 metres and different pipe diameters are available. At present, pipe sizes are still measured in inches and the size of the pipe refers to the *inside* diameter of the pipe, see Fig. 2-A.

Make sure you get the correct size when you buy pipe of: $\frac{1}{2}$ " - $\frac{3}{4}$ " - 1" - $1\frac{1}{2}$ " - $1\frac{3}{4}$ " - 2".

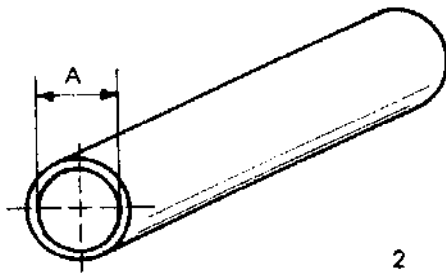

Pipe fittings

When there is thread on the end of a pipe, the pipe can be screwed into a pipe fitting. Pipe fittings are used to make connections between pipes. Pipe fittings have the same sizes as pipes. For example, a 1"-pipe is connected to a 1"-fitting. There are fittings for many purposes. Fig. 3 shows the most commonly used fittings in rural water supply systems:

- coupling 3-A
- reduced coupling 3-B
- tee 3-C
- elbow 3-D
- street elbow 3-E
- knee 3-F
- union 3-G
- nipple 3-H
- cap 3-I

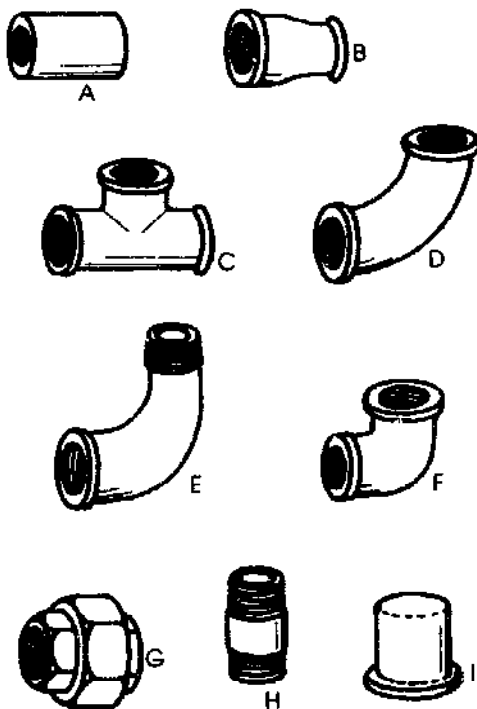

Pipe die

A pipe die is used to cut thread on a pipe. Fig. 1 shows a die stock 1-A with a set of pipe dies 1-B. For every size of pipe there is a die. The die stock has a ratchet mechanism which can be set to turn clockwise or anti-clockwise, see 1-D.

Since the pipe thread 2-C is tapered, the threads in the die are also tapered. See Fig. 2-A. Usually a pipe die has a collar. This collar, 2-B and 1-C, fits just around the pipe and guides the die squarely onto the pipe.

How to use the fixed pipe die

- Select the correct die and put it in the die stock.
- Place the die on the end of the pipe, at the same time turning the handle of the die stock. See Fig. 3.
- When the die starts to cut, it screws itself onto the pipe and no more pressure is needed.
- Apply some oil at regular intervals to the pipe near the die.
- Turn the die back a little at regular intervals to cut and remove the chips made by the die.
- Continue to turn the die until one thread projects through the die.
- Turn the die back.

When the threading is finished, get the metal chips from the die and clean the die and the stock with a cloth. Before you store the tools, oil all parts a little to prevent them from corrosion.

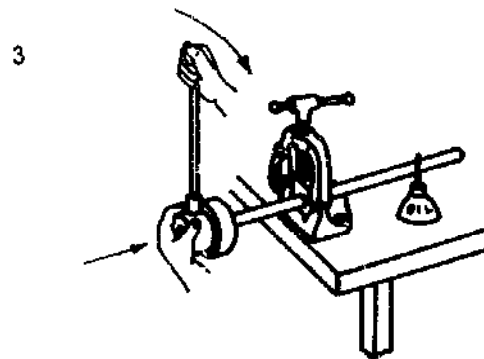
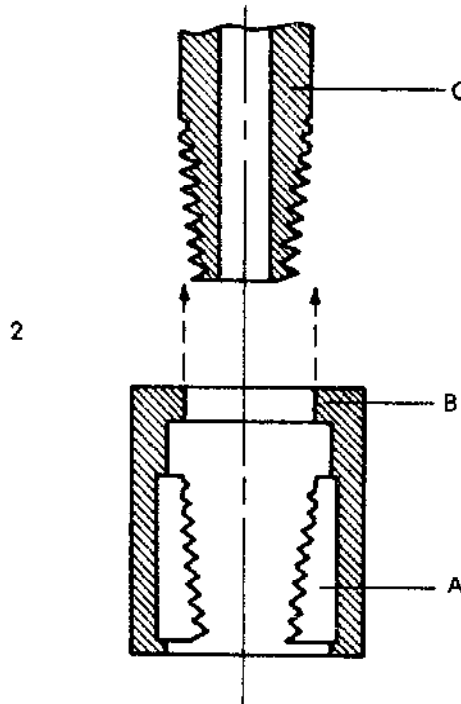
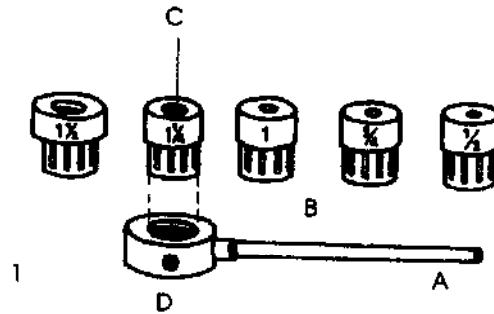

Adjustable pipe die

In the rural workshop the adjustable pipe die is more often used than the fixed pipe die. The advantage of the adjustable pipe die is that it can cut threads on pipes from $\frac{1}{2}$ to 2 inches.

Parts of an adjustable pipe die are shown in Fig. 1:

- die 1-A
- die plate 1-B
- flange ring 1-C
- knurled ring 1-D
- eccentric lever 1-E
- collar lever 1-F
- locking lever 1-G
- die block 1-H

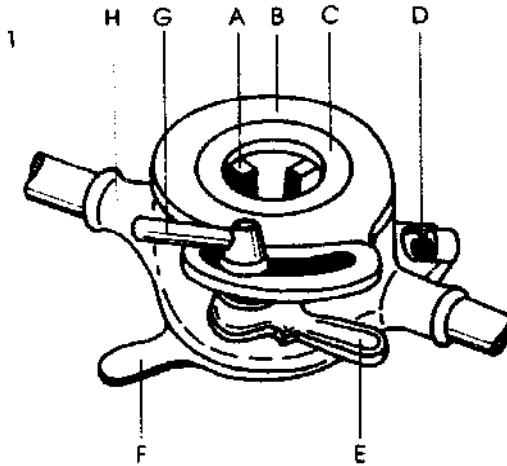

Note: There are three sets of dies for:

$\frac{1}{2}$ " to $\frac{3}{4}$ "-pipe

1" to $1\frac{1}{2}$ "-pipe

$1\frac{1}{2}$ " to 2"-pipe

Each set consists of 4 pieces which are numbered on top 1-2-3-4. Fig. 2-A shows piece no.4 of the die that cuts 1 to $1\frac{1}{4}$ "-thread.

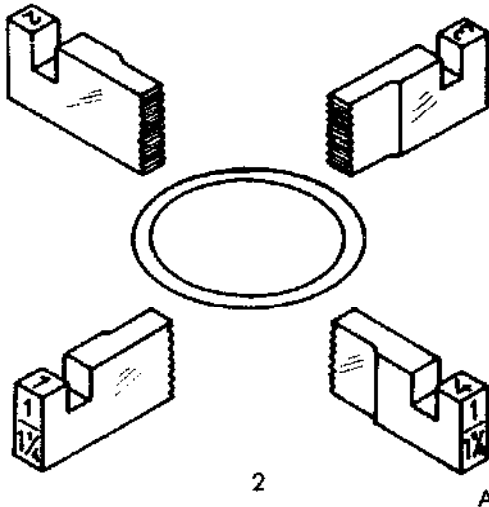

Mounting the die (Fig. 3)

- Turn the die plate so that lines 3-A coincide. Now the die can be exchanged.
- When you insert the dies, make sure you put every piece in the correct slot: the numbers are marked in circles on the die plate. See Fig. 3-C.
- The slots in the dies should face upwards.

Threading with the adjustable die

- Turn the die plate so the pipe size number 3-B coincides with line 3-O. Tighten the locking lever.
- Turn the eccentric lever clockwise. Place the die stock on the pipe and adjust the collar.
- Turn the eccentric lever anti-clockwise and start the threading. Do not forget to apply oil from time to time. Break the metal chips when necessary.
- Use the knurled ring to adjust the ratchet mechanism.
- Do the threading in two steps. First adjust the die plate to cut a bit oversize.

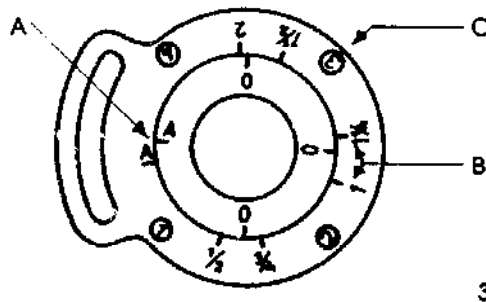

Cutting a pipe

A simple method of marking a pipe before cutting is shown in Fig. 1. Take a piece of paper with a straight edge. Fold the paper round the pipe, making sure the straight side coincides all over its length round the pipe. Mark the pipe with a pencil or chalk.

You can cut the pipe with a hack saw, see Fig. 2. Use a fine blade, because if the blade is too rough the teeth may break off during cutting. It is very important that you cut the pipe square and straight, otherwise it will be difficult to start threading the pipe at a later stage. After cutting, remove the burr on the inside of the pipe with a half round file.

Pipe thread

The thread on water pipe is known as *British Standard Pipe thread* (B.S.P.). Pipe thread is different from thread on bolts, because it is tapered, see Fig. 3.

Why is this pipe thread tapered (Fig. 4)?
Because this gives a watertight joint when the pipe is screwed as far as possible into the pipe fitting.

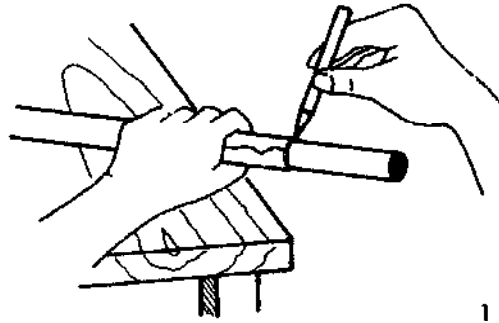

1

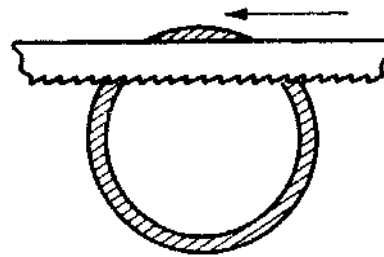

2

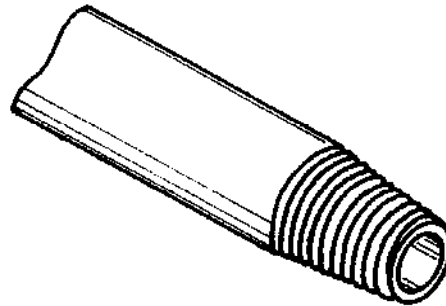

3

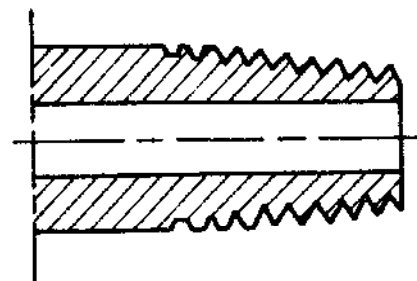

4

Cutting and threading

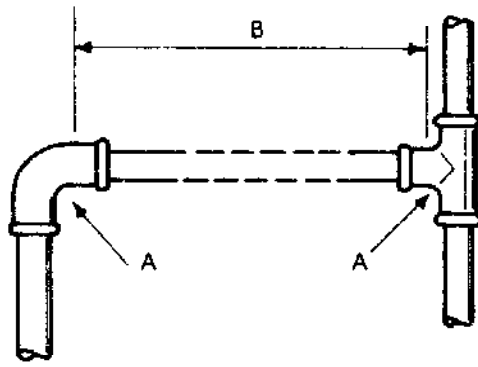

1

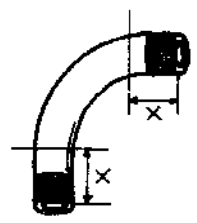

2



3



4

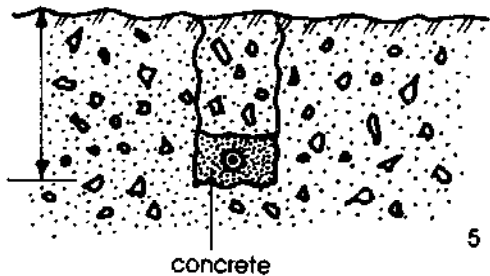

5

Pipe is often threaded in the workshop but assembly is done on the spot. When measuring pipes which must fit in a certain place, do not forget the length of the thread that is screwed into the fittings. See Fig. 1.

Sometimes the required pipe fittings are not available. You can make some yourself. A locally made elbow is shown in Fig. 2. When making this elbow, be sure there is enough length on both sides to make the thread $2 \cdot X$. A reducing coupling can be made by welding two pieces of pipe together. Apply some paint on the inside and the outside of the socket. See Fig. 3-A. Instead of using a cap, a piece of pipe can be hammered flat and welded together as shown in Fig. 4. Other parts can also be made locally. It is left to your imagination how to make them.

Since the galvanised layer which protects the pipe against rust may be damaged while these parts are being made, paint all parts inside and outside before assembling them.

Bury a pipeline deep enough to avoid damage by ploughing, hoeing etc. See Fig. 5. At road crossings pipes should be laid deep enough in the ground and covered with concrete. Before assembly, check all pipes for dirt and insects or animals. Put a plug in the open end of a pipe line when the work stops.

Assembling pipes and fittings

When you work with galvanised pipes you should be very careful not to damage the layer of zinc that protects the pipe against rust. But you cannot avoid taking off some of the zinc when cutting a thread on a pipe. This is why rust will appear first at the threaded joints. To protect pipe joints against corrosion and make them watertight, you can do the following:

- Wrap some sealing tape around the pipe thread, see Fig. 1.
- Apply some sealing compound – for instance bituminous paint on the pipe thread, then wind some hemp round the thread. Be careful not to use too much hemp or tightening will be very difficult and you may not be able to tighten the whole thread inside the pipe fitting. See Figs. 2 and 3.

When you screw a pipe joint, you need two pipe wrenches as shown in Fig. 4. Turn the pipe wrench only in the direction in which the jaws are pointing. If you turn it the other way, the wrench has no grip on the pipe. Keep a firm grip on the wrenches. If they slip too often they damage the layer of zinc on the pipe. The opening between the two legs of the pipe wrench should be just large enough to suit the size of your hand.

Installing valves and taps on a pipe

Valves and taps are made of soft brass and have hexagon ends, so it is possible to tighten them. Do not use a pipe wrench on these parts as this will damage the surface. Always use a spanner. When you screw a valve onto a pipe, put the spanner on the nut nearest to the pipe, see Fig. 5-A.

If you use the other nut 5-B, you will probably damage and distort the whole valve.



+



2

3

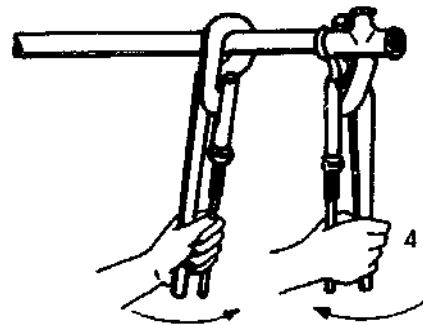

4

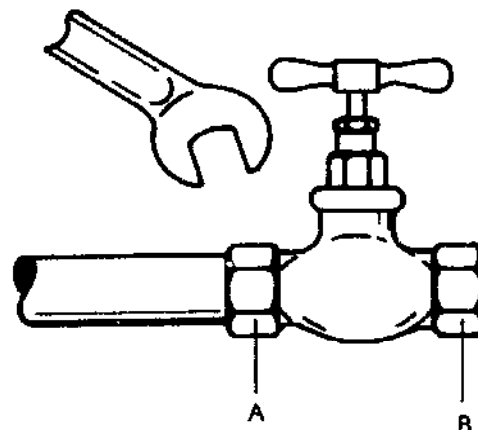

A

B

Repairing leaks

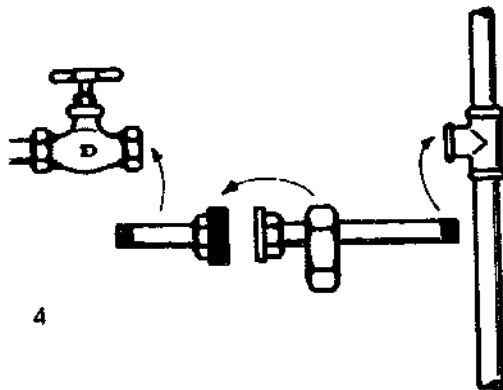
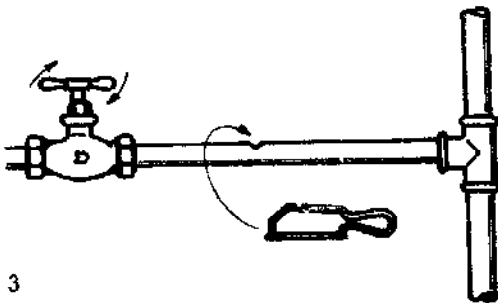
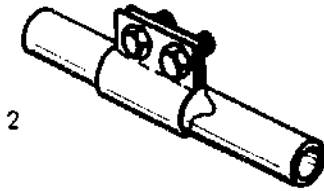
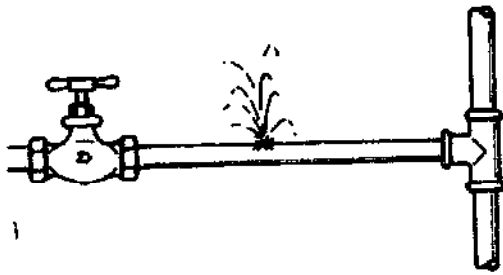

Small leaks in a pipe (Fig. 1) can be repaired with a piece of sheet metal. Prepare a piece as shown in Fig. 2. Apply some sealing compound around the leak. Clamp the sheet round the pipe and tighten the nuts. For larger leaks you have to replace the pipe.

- Close the valve to shut off the water pressure.
- Cut the pipe with a hack saw, see Fig. 3.
- Unscrew the two pipe sections.
- Cut new thread on the two pieces which have been cut a second time exactly to the required length, see Fig. 4.
- Fix a union with sealing tape.
- Fix the two pipe sections and tighten the union.

Before using the same pipe, make sure the leak is not the result of rust. If that is the case, you had better use a new piece of pipe.

Polyvinyl chloride pipes

Polyvinyl chloride (PVC) is a kind of plastic that can be used to make pipes for water supply. As you will understand, PVC pipes are cheaper to produce than galvanised steel or copper pipes. Pipes are made with the same inside diameters as the galvanised steel pipes. On request you can obtain a catalogue of all fittings made for the use of PVC pipes. Remember that PVC materials extremely pollute the environment when these are burnt.

Special fittings may be needed to connect PVC pipe to galvanised pipe. A threaded PVC coupling is shown in Fig. 1. A union with one end made of PVC and the other made of galvanised steel is shown in Fig. 2.

PVC fittings are glued instead of screwed. Special glue is used for this. Read the instructions on the tin very carefully before you start using this glue. PVC pipes can be bent easily over a charcoal fire. Like all pipes, they should be filled with very fine, dry sand. During heating, the flames should not touch the pipe, otherwise they burn the PVC. After heating, bend the pipe while rubbing it with a piece of cloth to smooth out the bend.

You do not need to use specially made connectors to connect pipes together. You can instead expand the end of each pipe and glue them together. To expand the end of a pipe, you can heat the end of the pipe. Carefully press a tapered wooden block, shown in Fig. 3, into the pipe and turn it around. See Fig. 4. Remove the block and glue the pipes together. A PVC pipeline should be buried at least 60 cm deep in the ground, otherwise the pipe becomes too hot during daytime and too cold during the night. This makes the pipe expand and shrink, which causes leakage at the joints. Do not expose the PVC directly to sunlight because it will become very brittle.

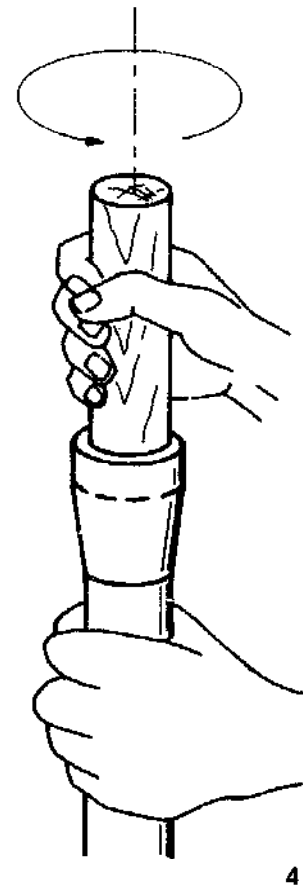
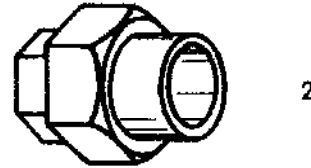

Main valves

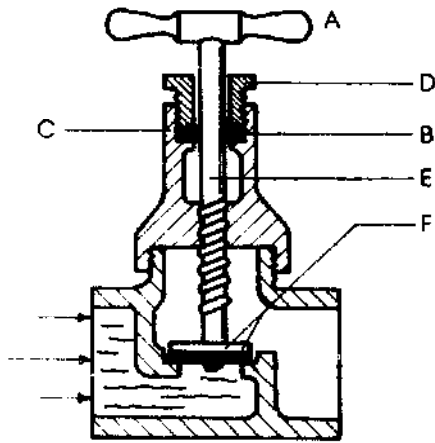

Fig. 1 shows a cross-section of a *gate valve*. Gate valves are mostly used in main pipelines, because in main pipelines the water should flow easily and the valves are rarely closed.

Parts of a gate valve are:

- Hand wheel 1-A
- Packing unit 1-B
- Packing ring 1-C
- Packing box 1-D
- Spindle 1-E
- Gate 1-F

When you turn the hand wheel, the spindle and the gate move up or down. When the gate is down, the water cannot flow and the gate is closed, see Fig. 2. When the gate is up, the water can pass and the valve is open, see Fig. 3.

1

Remember: Turn the wheel clockwise to close the valve. Turn the wheel anti-clockwise to open the valve.

2

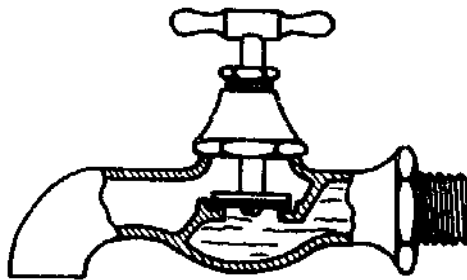

Disadvantage of gate valve

The disadvantage of the gate valve is that it cannot be repaired. When the gate is worn out the valve has to be replaced.

Packing box

The packing box, 1-D, is a very important part of the gate valve. Most valves and pumps have a packing box. The packing box prevents water leaking around the spindle. When you tighten the nut, the packing ring 1-B is pressed round the spindle on top of seat 1-C. Do not over-tighten the nut. It should be just tight enough so that no water can leak. Replace the packing ring when it is damaged.

3

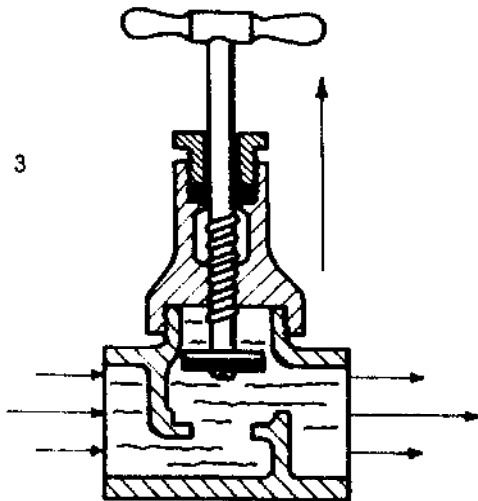

Globe valve

The globe valve in Fig. 1 is more common than the gate valve. Some parts are the same in both valves:

- Packing nut 1-A
- Packing ring 1-B
- Packing box 1-C
- Spindle 1-D

Other parts are:

- Rubber washer/metal washer 1-E
- Seat 1-F

The valve is closed when the rubber washer is pressed down. The valve is open when the rubber washer is positioned upwards. See Fig. 2.

On the outside of the globe valve you see an arrow pressed into the metal. Connect the valve so that the water flows in the direction of the arrow.

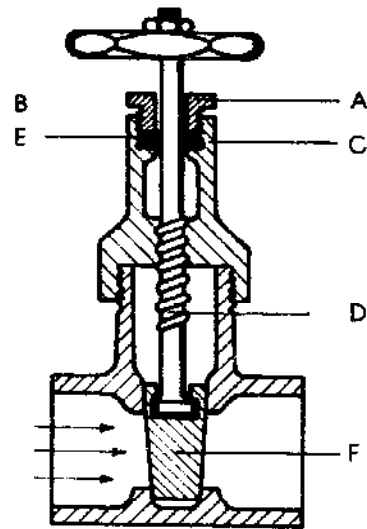

Tap

A tap is a water outlet. It works in the same way as a globe valve. Most taps have $\frac{1}{2}$ " or $\frac{3}{4}$ "-thread which can be screwed into a corresponding fitting.

Replacing the rubber washer

When a globe valve or a tap leaks, it usually means the rubber washer is worn out. If no washer is available, it may help to turn over the old rubber washer.

The correct shape of a seat is shown in Fig. 1-F. When the seat is rough or pitted, the tap or valve will leak. In that case smooth the seat with a special seat reamer or a piece of sandpaper.

Important: make sure the spindle is turned up when you assemble a valve or a tap. What can happen if you do not do this?

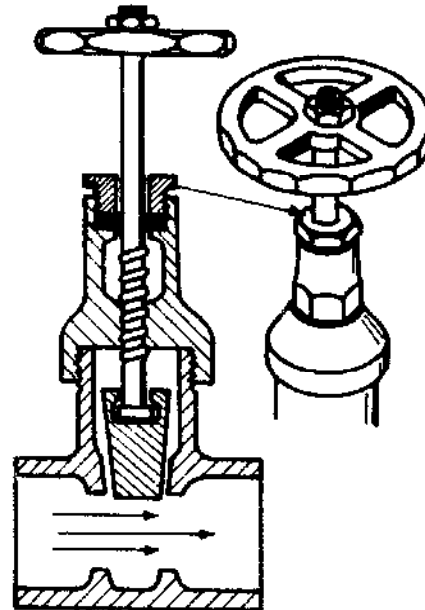

Hand pump maintenance

Introductions

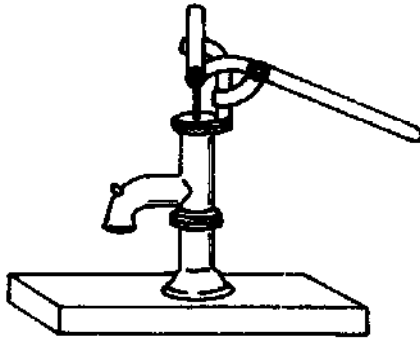

More water is needed every day for the growing human community. But we cannot increase the quantity of water on the earth. We can only conserve, protect and make better use of what we have (from *World Neighbours in Action*).

Water taken from ponds or rivers should not be used for human consumption. Many diseases are caused by dirty drinking water, so it is better to use clean water from a hand pump. Every rural mechanic should feel responsible for the water pumps in his area and maintain them regularly.

Pump valves

Every water pump has valves. These valves are very important parts of the pump. Before you can understand how a pump works, you first have to understand the purpose of the valves and how they work. A pump valve is a *one-way* passage for water. Water can flow through a valve in one direction. But as soon as the water wants to flow in the other direction, the valve shuts off the water flow, see Fig. 1.

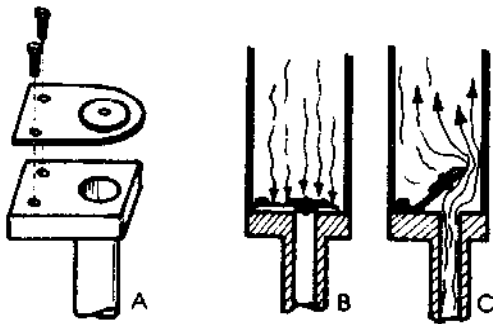

Types of pump valves

Three types of valves are commonly used:

- Flap valve, see Fig. 1
- Ball valve, see Fig. 2
- Poppet valve, see Fig. 3

Flap valve

This is a rubber or leather flap. A metal disk is attached to the flap to help close off the water passage. This type of valve can easily be made or repaired in the rural workshop. See Fig. 1-A.

Ball valve

This is a very simple valve. The water flow is shut off when the ball is pressed on the valve seat. Dirt or corrosion may cause this valve to leak. See Fig. 2-A.

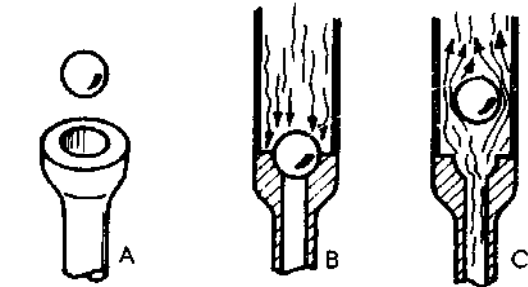

Poppet valve

Here the waterflow is controlled by a disk. The disk has a stem to guide its movement. This valve is very sensitive to dirt and corrosion which can block free movement of the stem. See Fig. 3-A.

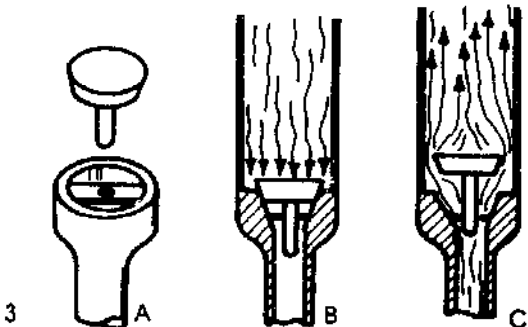

Types of pumps

Three types of water pumps are explained below:

- Suction pump
- Suction/pressure pump
- Lift pump

The suction pump

The suction pump got its name because it *sucks* the water out of a well or a borehole. It is important to remember that this type of pump cannot suck water if the water level is more than 8 metres below ground level. Fig. 1 shows a suction pump with a separate pump piston. Fig. 2 is a diagram of the suction pump and the pump piston.

Parts of the suction pump are:

- Pump cylinder 1-A.
- Suction pipe 1-B.
This pipe goes down into the well or the bore hole and reaches below water level.
- Pump handle 1-C.
- Pump rod 1-D.
The pump rod moves the piston up and down inside the cylinder.
- Piston 1-E.
In the middle of the piston is a hole with a valve.
- Piston seal 1-F.
Around the piston is a leather or rubber seal, sealing off the gap between the piston and the cylinder.
- Piston valve 1-G.
This is the valve in the hole of the piston.
- Foot valve 1-H. This is the valve at the bottom of the cylinder.

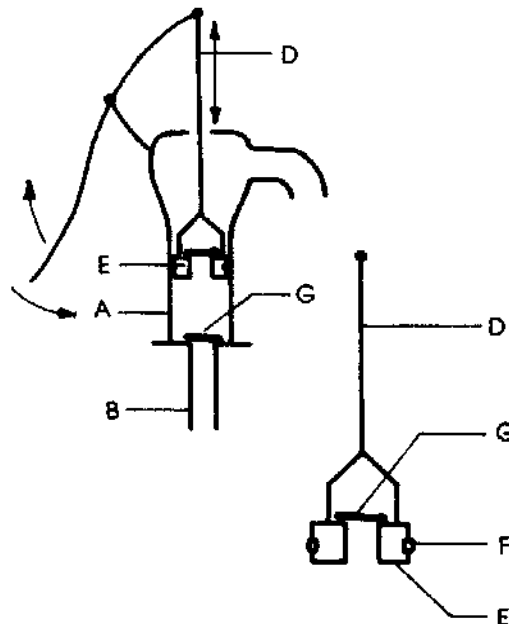
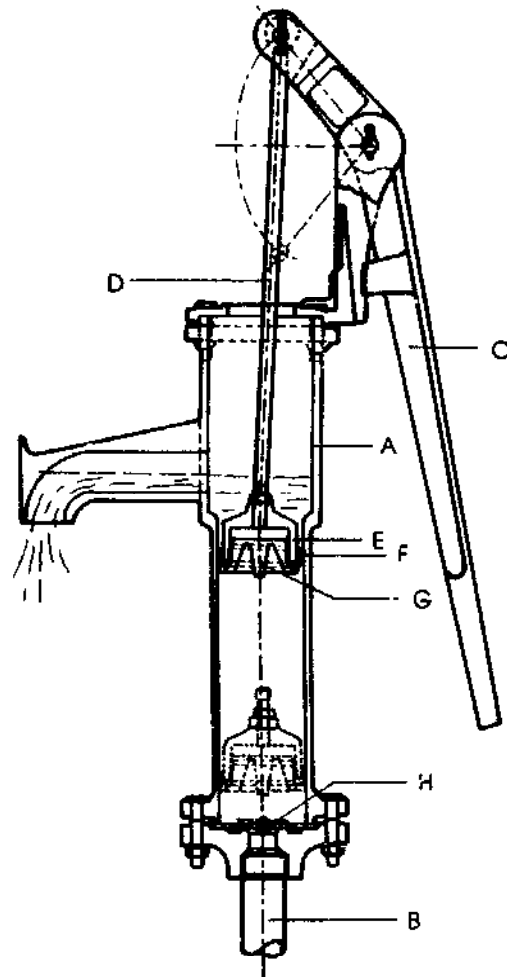

How the suction pump works

In Figs. 1 to 3 you can see again a diagram of the suction pump. When you pump water, you move the handle and thus also the piston up and down. The movements of the piston are called *strokes*.

Suction strokes

Pushing the handle down makes the piston move up and the cylinder volume 1-A becomes larger. Because of this, water is sucked into the cylinder through the footvalve 1-X. At the same time the water at 1-B is lifted by the piston and flows out of the cylinder through the water outlet.

Return strokes

Lifting the handle (Fig. 2) makes the piston move down and the cylinder volume 2-A gets smaller. Now the water is pressed out of the cylinder through the piston valve 2-Y. No water flows out of the water outlet (spout) of the pump during the return stroke.

Priming the pump

When the foot valve closes perfectly, there is always water in the pump and in the suction pipe. But in tropical countries there will be no water if the pump is not used regularly, because of evaporation through heat. In that case you have to pour some water on top of the piston to make the leather piston seal wet. This is called *priming* the pump.

Summary

Refer to Fig. 3.

- Primed suction stroke 3-A.
- Return stroke 3-B.
- Suction stroke 3-C.
- Return stroke (half) 3-D.
- Return stroke (full) 3-E.
- Suction stroke 3-F.

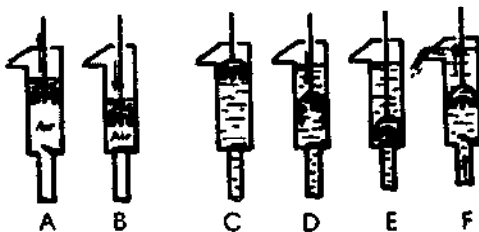
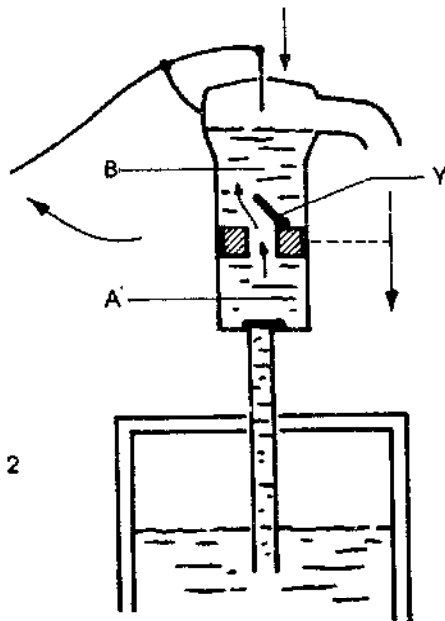
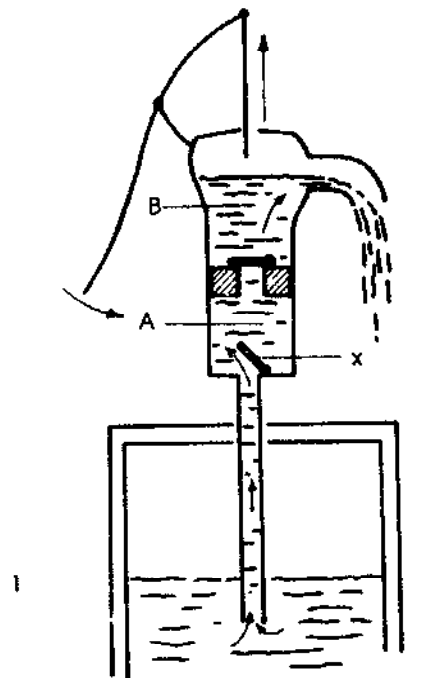

3

The suction/lift pump

Figure 1 shows a suction/lift pump. This pump got its name because:

- It sucks water out of a well or borehole which cannot be deeper than 8 metres below ground level.
- At the same time it can lift the water to a higher level, for example to an overhead tank.

Parts of the suction/lift pump

- Pump rod 1-A
- Packing box 1-B
- Pump handle 1-C
- Pump cylinder 1-D
- Suction pipe 1-E
- Riser pipe 1-F
- Priming cup 1-G
- Piston H
- Foot valve I

How the suction/lift pump works

There is only one important difference between the suction pump and the suction/lift pump – this is the packing box. The packing box is the same as in taps and valves. The suction/lift pump works in exactly the same way as the suction pump. It is possible to connect a riser pipe to the spout of the pump. With the riser pipe you can pump the water up to a higher level. If there were no packing box, the water could never be pumped up in the riser pipe. Instead it would leak along the pump rod.

Figure 2 shows a diagram of the suction/lift pump. Write all the correct letters in the correct circles.

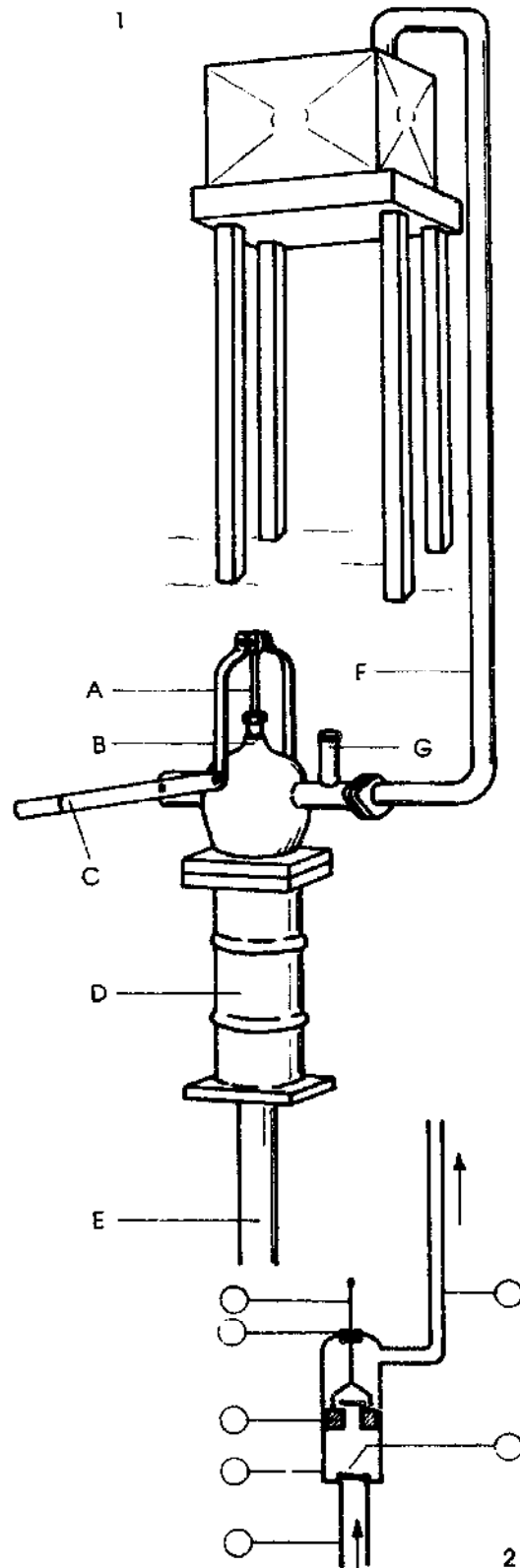

The lift pump

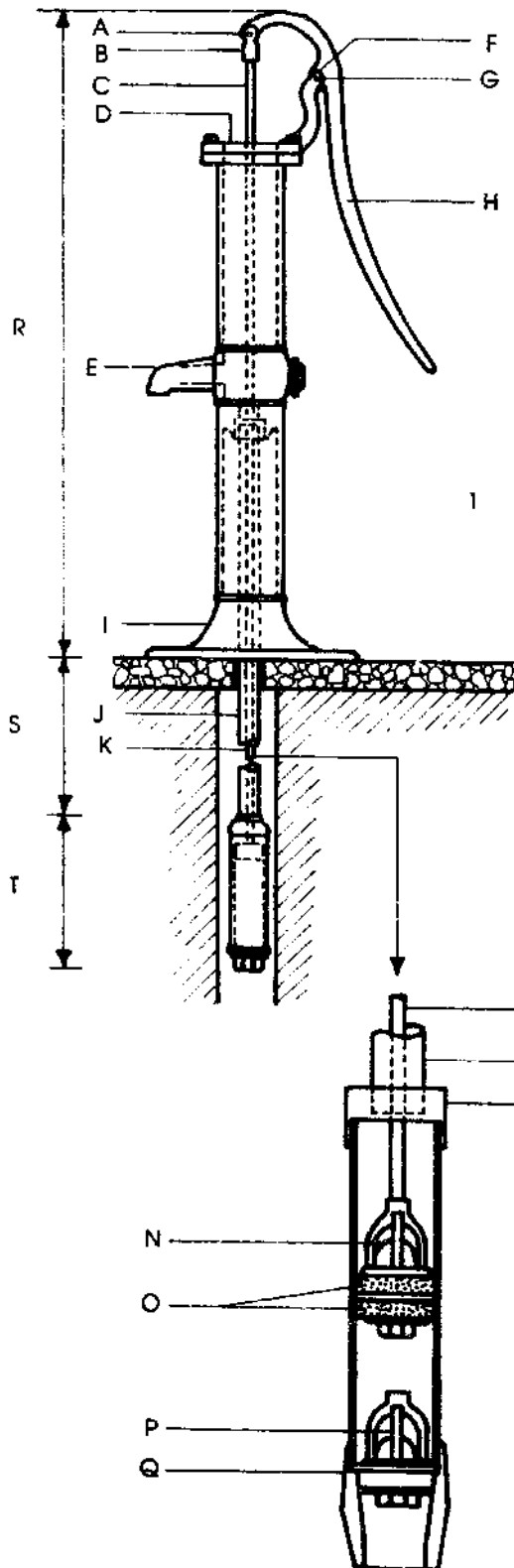

As we have seen before, the suction pump and the suction pressure pump are easy to repair because the pump cylinders are located above the ground. The disadvantage of these pumps is that they cannot suck water deeper than 8 metres below ground level. When the water level is deeper than 8 metres it is necessary to use a *lift pump*. This is the case with almost all boreholes, because the ground water level in these boreholes is deeper than in wells.

How a lift pump works

The working of a lift pump is similar to other pumps, but with the difference that the pump cylinder is lowered into the borehole as seen in Fig. 1. Because the cylinder is under water, it is not necessary to prime the lift pump. If there is trouble with the cylinder piston or valves, it is necessary to lift the riser pipe in order to bring the cylinder to the surface.

How to maintain and repair a lift pump

As mentioned above, it is sometimes necessary to raise each cylinder to the surface. In the next lessons you will learn how to do this.

Parts of pump stand assembly

Refer to Fig. 1-R.

- Pin 1-A
- Coupling 1-B
- Pump rod 1-C
- Cap 1-D
- Spout 1-E
- Fulcrum 1-F
- Pin 1-G
- Handle 1-H
- Stand base 1-I

Parts of connecting assembly

Refer to Fig. 1-S.

- Drop pipe 1-J
- Pump rod 1-K

Parts of cylinder assembly

Refer to Fig. 1-T and detail.

- Drop pipe 1-L
- Cylinder cap 1-M
- Discharge valve 1-N
- Cups 1-O
- Suction valve 1-P
- Cap 1-Q

Lifting the riser pipe

When you have to repair the pump cylinder of a lift pump, it is necessary to lift the riser pipe with the cylinder out of the borehole. A riser pipe is quite heavy because it is filled with water. Some firms in charge of repairing pumps use a hoisting winch, which is mounted on a vehicle. However with a few strong men it is possible to lift the riser pipe by hand. When a hoisting winch or a tripod with a wheel and rope is used to lift the pipe, you need an eye coupling to connect the winch to the pipe. See Fig. 4.

Equipment needed

The following equipment is needed to lift the riser pipe by hand:

- Two pipe wrenches, see Fig. 1
- Two vice grips, see Fig. 2
- Two pipe clamps
- Two pieces of timber, 3 metres long
- Pipe coupling

Lifting the riser pipe by hand

A rural mechanic should know how to lift a riser pipe by hand because some villages cannot be reached by car in the rainy season and the hoisting vehicles are not always on the road.

Procedure

- Fix a clamp as shown in Fig. 3.
- Insert the two pieces of wood on either side of the pipe under the clamp.
- Raise the riser pipe as far as possible.
- Fix a second clamp again.
- Repeat the procedure again until the whole riser pipe and the cylinder are out of the bore hole.
- For safety reasons, fix the eye coupling at the end of the pipe each time. Then the pipe can not slip through the clamp.

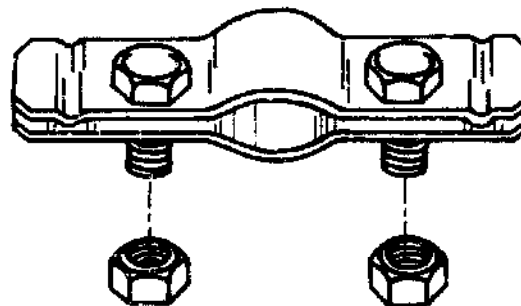
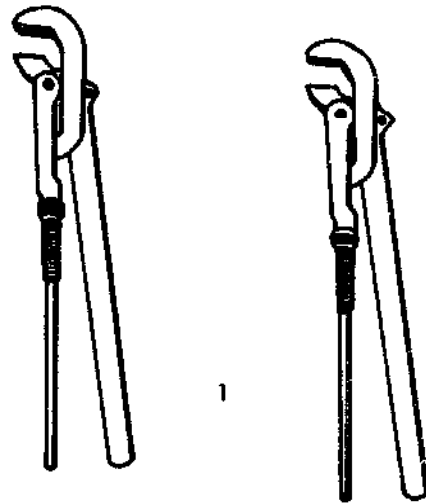

How to lift the riser pipe

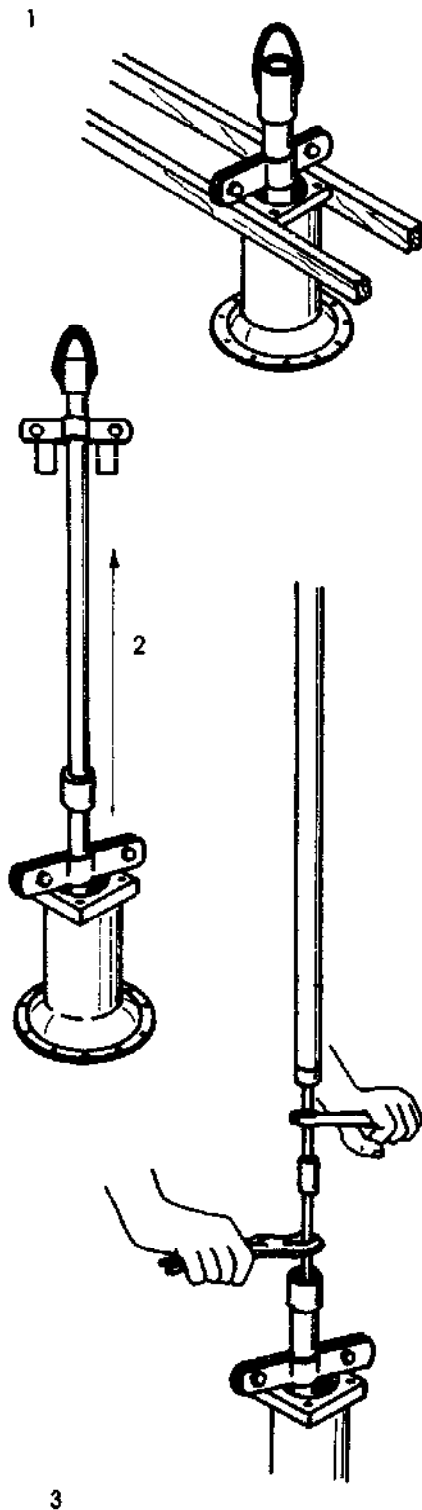

When the riser pipe is being lifted, it is clear that only one man should give the commands to avoid mistakes and accidents during this work. The first job is to remove the pump head. The pump base must remain bolted on the concrete base. How you have to remove the pump head will be explained later on.

As shown in Fig. 1, put a pipe clamp on the riser pipe. The pipe clamp is used to lift the riser pipe with the aid of two pieces of wood of about 3 m. Also fix a pipe coupling on top of the riser pipe. This coupling is for the sake of safety if the riser pipe slips through the clamp. With the two pieces of wood, lift the riser pipe as far as possible. Then fix a second clamp round the riser pipe. Lift the pipe again with the two pieces of wood until you reach the end of the first section. Fix a clamp as shown in Fig. 2. Use two pipe wrenches to disconnect the first pipe section. Lift the pipe section a little as shown in Fig. 3. Keep the pipe in a steady vertical position. If you do not keep the pipe vertical, you bend the pump rod.

Use two grip wrenches to disconnect the pump rod. Take care not to drop the pump rod into the riser pipe or into the bore hole after disconnection. Repeat the procedure until the whole pipe and cylinder are out of the borehole.

As mentioned above, one man gives the commands and the others follow his instructions. Make sure that all helpers know their position and their work.

Transporting pipes and rods

There is some risk that the threads of pipes and rods will be damaged while they are being transported. Couplings should therefore be left on the ends of the pipes and nuts on the ends of rods. In this way at least one end of each pipe and rod is protected. During transport, rods are kept inside pipes so that they cannot bend. See also Fig. 1.

Before installation

Before installing the riser pipe and the pump rod, make sure that:

- Every pipe has a coupling on one end.
- Every rod has a coupling on one end.
- There is one rod in every pipe.
- The coupling end of the pipe and the rod are at one and the same side.
- The length of each pipe plus coupling equals the length of the corresponding rod plus coupling.

Installation of the riser pipe

The procedure for installing the riser pipe is the reverse of the procedure for lifting the riser pipe. If the thread is damaged, you have to restore it at the work site. The thread of a pump rod can be restored with a *die* or a *die nut*, see Fig. 2.

British, American and Metric threads are used on pump rods, depending on where they come from. Note that $\frac{1}{2}$ " British and American thread do not have the same pitch! The pipe thread can be restored with a small triangular file, see Fig. 3.

Note: During installation, make sure that you apply some bituminous paint to each thread to protect them against corrosion.



1

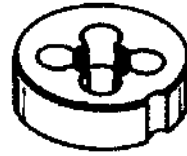

2



3

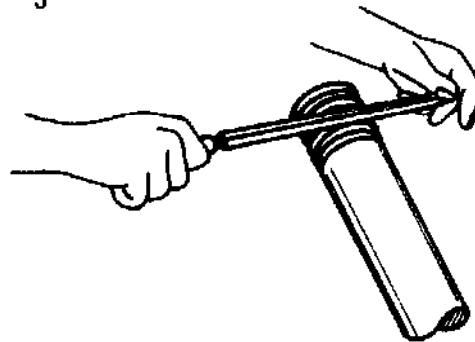

Pump maintenance

Refer to Fig. 1.

- Pump rod 1-A: lubricate every week.
- Stuffing box 1-B: check every month.
- Hinge pins 1-C: lubricate every week.
- Exposed iron work 1-D: paint.
- Concrete slab 1-E: clean every day.
- Pump rod 1-F.
- Pump rod coupling 1-G.
- Drop pipe 1-H.
- Brass cylinder 1-I: look for symptoms of wear from time to time.
- Leathers/Leather cup 1-J: look for symptoms of wear.
- Plunger valve 1-K: check now and then.
- Suction valve 1-L.

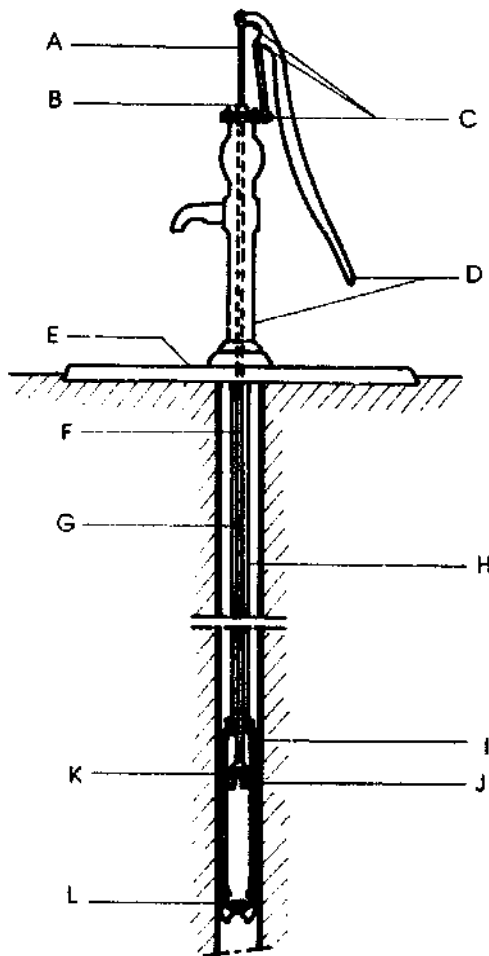

Pump trouble-shooting

In many cases, pump failures are caused by the breakage of hinge pins, bearings, bolts or levers at the pump head. Such breakages are easily detected and repaired, because they are above ground level. To prevent from breakage, the hinges and sliding parts of the pump should be greased every week. Bolts and other connections should be checked and tightened every month. Do not over-tighten the mounting bolts in the concrete slab, because the bolt may break.

If the pump delivers less water, this may be due to worn leathers, leaky valves, blockage of a foot valve, a leaky riser pipe or the well drying up.

If the pump handle moves without any resistance it means the pump rod is broken.

Spare parts for pumps

If you go to the Water and Sewage Corporation for spare parts, you have to state very clearly:

- Location of pump.
- Type of pump.
- Serial number of pump.
- Clear description with sketch or drawing of the broken or damaged part. If possible, bring the broken part along.

The monarch pump

The monarch pump is a lift pump with a cylinder and piston at the end of the riser pipe. This type of pump can be used when the water level is less than 20 metres below ground level. When the water level is deeper, this kind of pump should not be used because the lever system is not strong enough.

Parts of the monarch pump

Refer to Fig. 1 and cross section of detail.

- Flange bolts 1-A
- Pump rod 1-B
- Pump rod 1-C
- Pump rod coupling 1-D
- Riser pipe flange, screwed to the riser pipe 1-E
- Pump base 1-F
- Bore hole lining 1-G
- Concrete base 1-H

Dismantling the monarch pump

- Remove the four flange bolts at 1-A.
- Lift the pump head from the pump base.
- Use the vice grip wrenches to grip the pump rod at 1-B and 1-C.
- Unscrew coupling 1-D and remove the pump head.
- Lift the pipe flange 1-E which is connected to the riser pipe.

Assembling the monarch pump

Assembling the pump is the same as dismantling in reverse. Before assembly, check all parts, clean them and use bituminous paint for all connections.

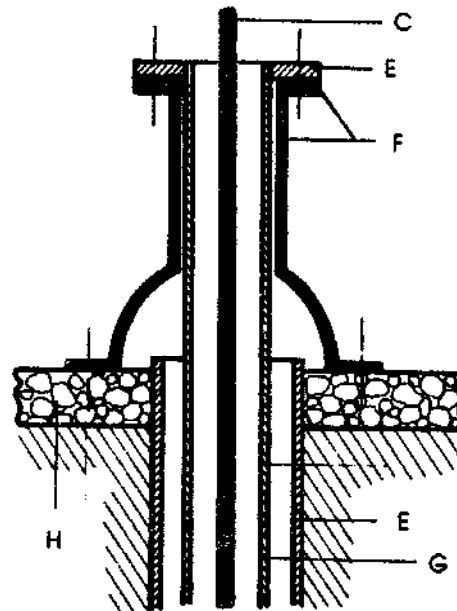
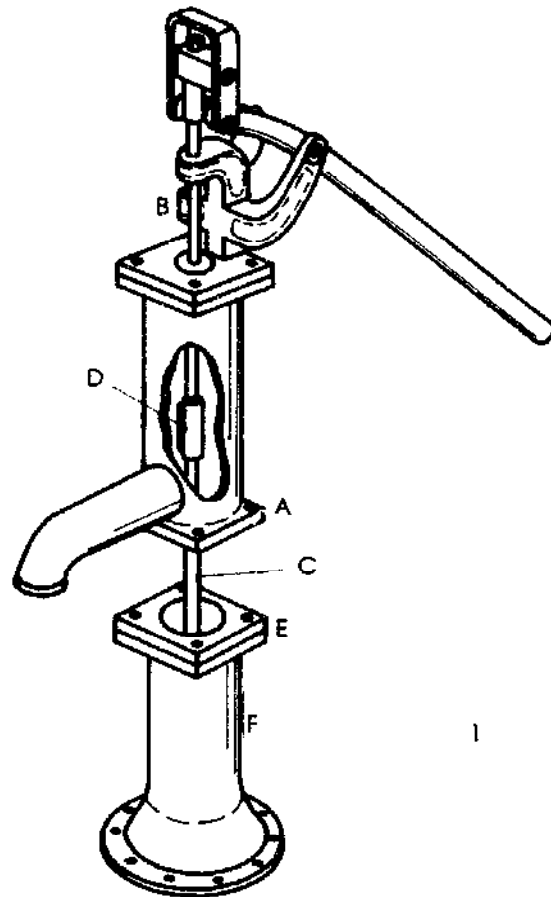

India Mk II pump

Refer to Figs. 1 to 3.

- Inspection cover 1-1
- Chain 1-2
- Handle 1-3
- Sealed bearing 1-4
- Connecting rod check nut 1-5
- Spout 1-6
- Pump stand 1-7
- Piston rod 1-8
- Front plate 2-9
- Chain 2-10
- Spout 2-11
- Pin 2-12
- Bracket 2-13
- Handle 2-14
- Chain, guide 2-15
- Chain 2-16
- Coupling 2-17
- Tee 2-18
- Nipple 2-19
- Reducer 2-20
- Pipe 2-21
- Rod 2-22
- Nut 2-23
- Side cover 3-24
- Grease nipple 3-25
- Base plate 3-26

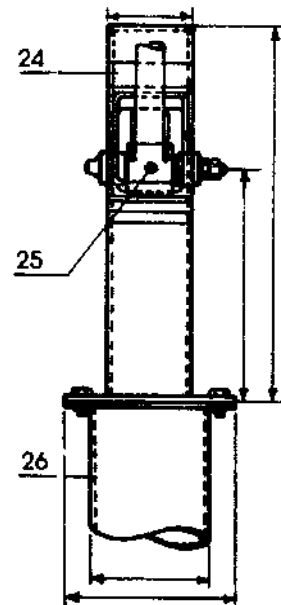
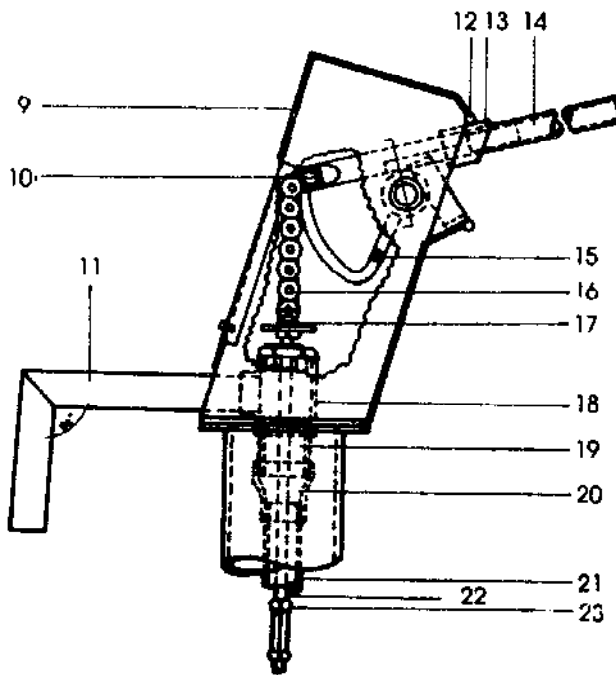
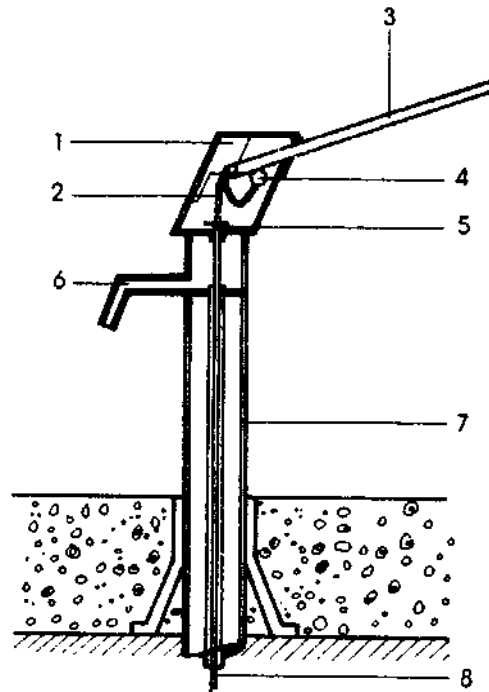

2

3

Robbins & Meyers pump

The R&M lift pump is a special design, see Fig. 1. The pump rod does not move up and down; it turns round. The pump rod is driven by a gearbox in the pump head. Look at Fig. 2. The pump rod 2-U turns the *rotor* 2-V inside a *rubber stator* 2-W. This rubber stator is bound to the inside of the pipe.

The rotor screws the water upwards as soon as the pump rod is turned round. As you can see, this pump has neither a piston nor a cylinder.

Maintenance

The R&M lift pump requires little or no maintenance. Every three years the grease in the grease box has to be replaced. Remove the four bolts at 1-A and pack the gearbox half full with the correct grease.

After several years of use, the pump capacity may fall. If that happens, the stator is worn out and has to be replaced.

How to dismantle the R&M pump

- Use an Allen key to remove the four socket bolts at 1-A.
- Lift the pump head from the base 1-B and fix a pipe clamp as seen at 1-C.
- In most cases the riser pipes are fitted into the pump head with an adaptor bushing 1-D.
- Remove the drive shaft coupling 1-E from the gearbox. This coupling is recessed in the pump head and is difficult to reach.
- Lift the riser pipe out of the borehole.

The last section is made of 2" -pipe.

Note: Do not attempt to repair the rubber in the stator. If the rubber stator is worn out or damaged, it must be replaced by a new one.

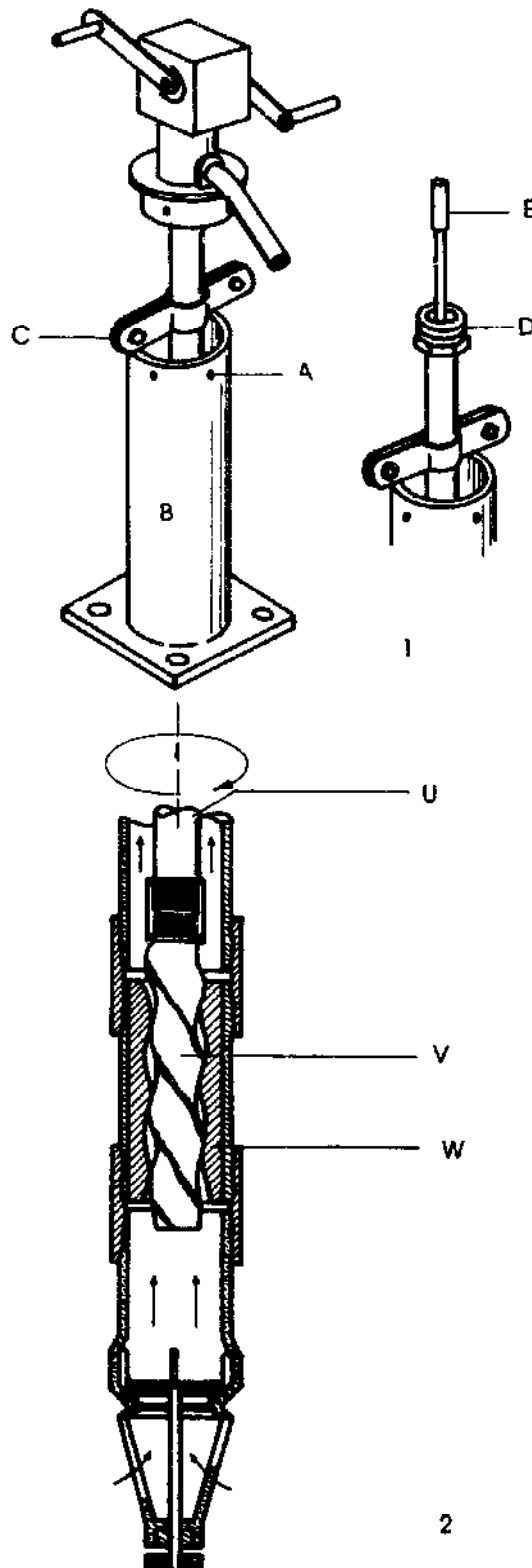

Making a leather cup

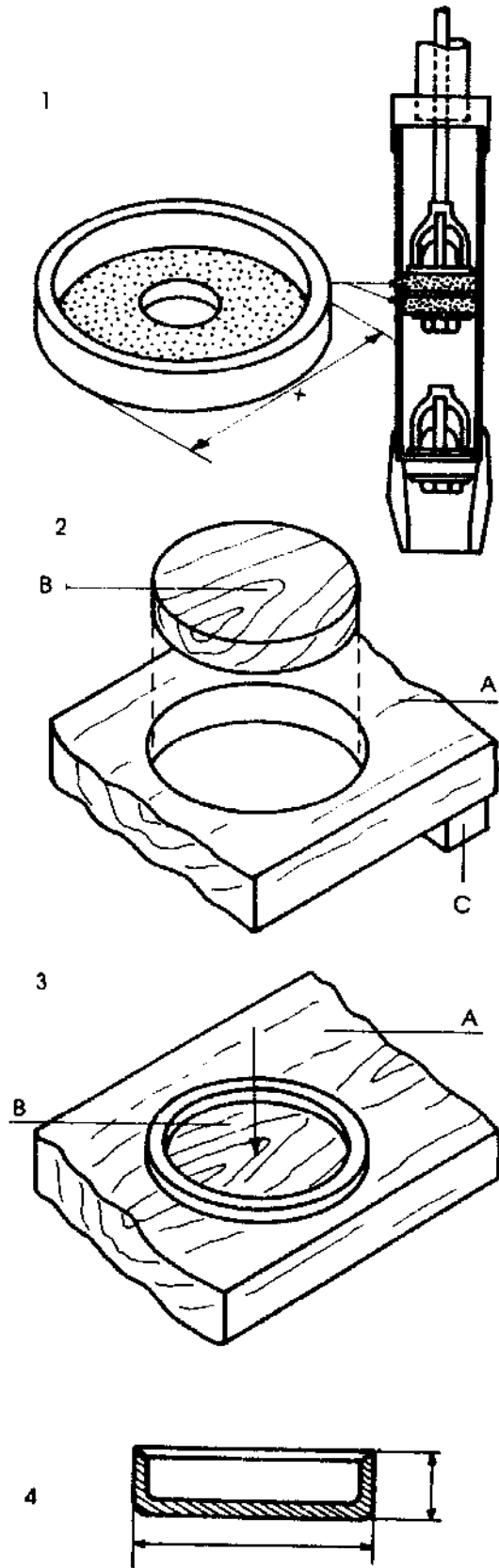

Before making a cup, study the shape of the old cup. Make a sketch with all dimensions and find a good piece of leather. See Fig. 1. Construct a wooden mould as shown in Fig. 2. Reinforce the wood with some clamps, see 2-C. The hole in the mould should be 1% greater in diameter due to shrinkage of the leather during the drying process.

Cut the leather to roughly the right shape. Place it in water to make it soft. Place the leather over the hole in the mould. Place disk 2-B exactly over the centre. Clamp the mould between the jaws of the bench vice. Tighten it gradually until the leather cup is formed. See Fig. 3.

Heat up stearine, a candle wax, to 90 °C. Take the cup out of the mould and place it in the hot stearine. Do not soak the leather too long in the stearine because you may burn it. Replace the cup at once in the mould and cool it rapidly in cold water. Take out the cup and finish the shaping with a sharp knife. See Fig. 4.

Sheet metal work

Sheet metal work

When you were a young boy, you made cars, lorries, etc. from old tins. This is a very nice example of sheet metal work. The metal of used tins can also be re-used to make household implements such as boxes, drinking mugs, funnels, measuring containers etc.

Sheet steel is light in weight and easy to form. It therefore occurs in many different shapes. Shaping and assembling sheet metal to finished products involves:

- Design
- Making developments
- Marking sheet metal
- Cutting/bending/shaping
- Joints and seams
- Riveting and soldering
- Finishing

Design

Before the actual design is made, you should know something about shaping sheet metal in such a way that it can stand and carry forces. A piece of sheet metal as shown in Fig. 1 cannot stand much force in the direction of the arrow and bends easily.

But if you take the same piece of sheet metal and shape it as shown in Fig. 2 it can stand more force in the direction of the arrow.

Look around and notice products made of sheet metal and you will see that most of the sheet metal is shaped to gain strength.

Roofing sheets as shown in Figs. 3-A and 3-B are corrugated to make them stronger.

Fuel or oil drums are not made square but round to avoid bulging. The side is sometimes shaped to gain strength. See Fig. 4.

Neither is the door of a car or lorry made flat but is designed with various curves to make the door stronger. See Fig. 5.

In general sheet metal products should be designed in such a way that the metal acquires more strength.

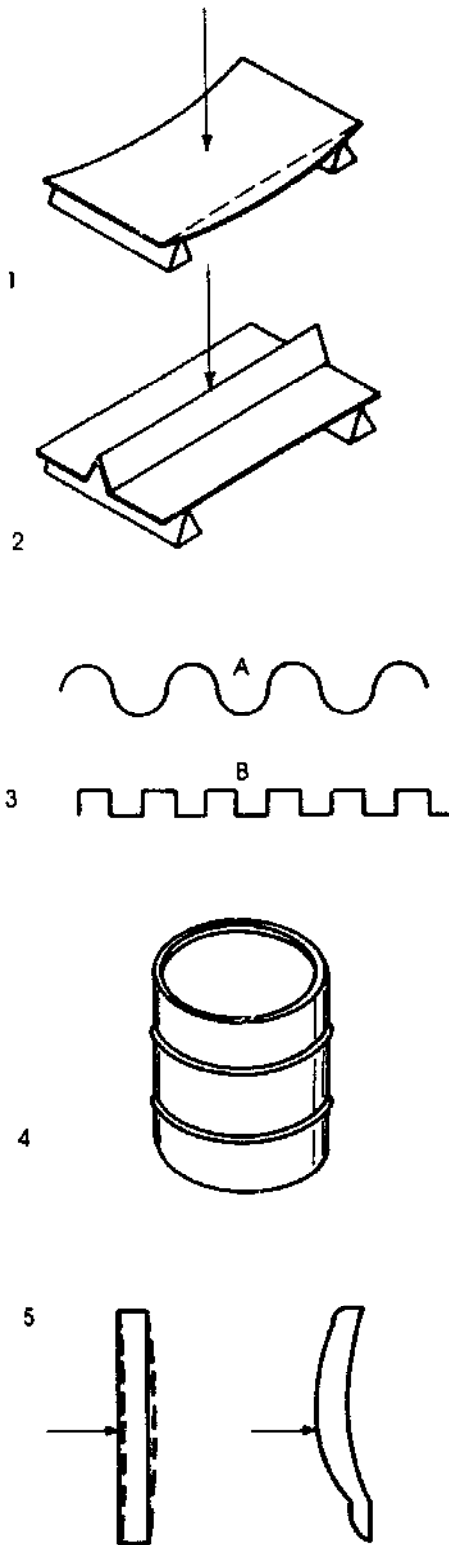

Sheet metal development

To make an object like the metal box shown in Fig. 1 you need a drawing showing all views if the material from which the box is to be made is heavy and cannot be bent. See Fig. 2. If the same box is to be made from thin sheet metal, a lay-out is drawn directly on the sheet metal or on a piece of paper first. This lay-out is called a development.

More information on developments can be found in the drawing book of the Rural Mechanics Course.

Template

If you have to make more than one of the same development, it is advisable to make a *template* first. A template can be made from any hard material, see Fig. 3.

A template must have exactly the same outside dimensions as the object to be made. If required, notches can be filed at the edges of the template or holes drilled in it to mark the folding lines. Then place the template on the sheet metal and scribe the outline firmly. When using the template, be sure to leave enough space between the objects to allow for cutting the material.

Fig. 4 illustrates incorrect marking. At X there is no room for you to cut with the tinsnip.

Fig. 5 shows a marking method where waste of material is minimal, see the shaded area.

Fig. 6 shows another marking method where a lot of material is wasted.

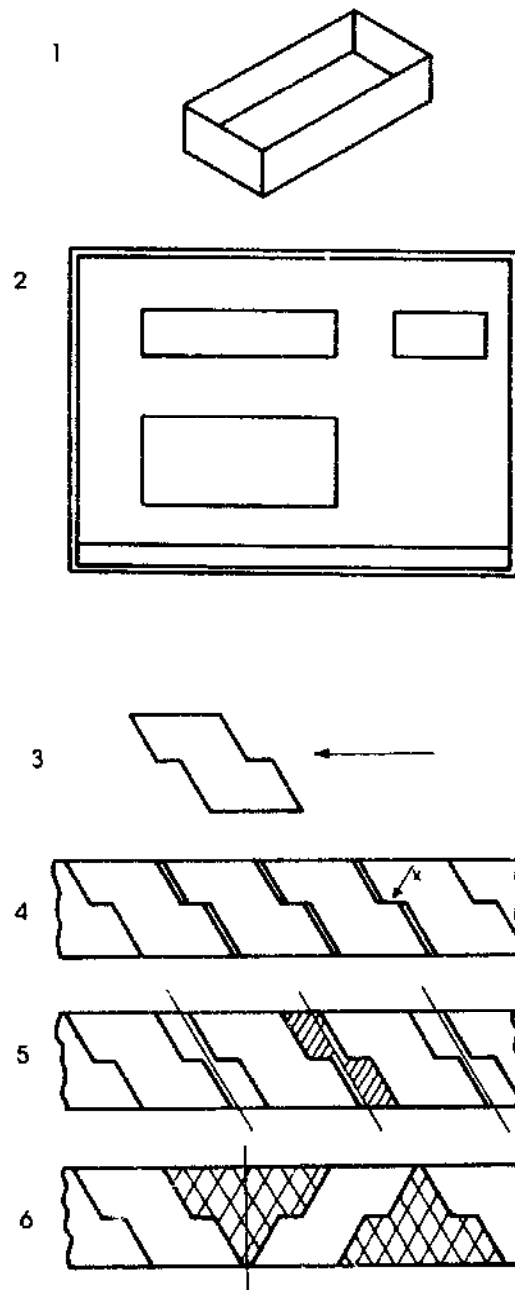

Marking

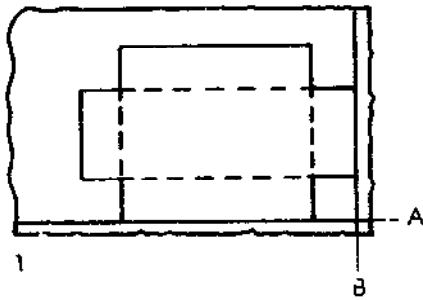

On a development cutting lines are scribed with a firm, full line. Folding lines are thinner and dotted in order to avoid mistakes in cutting the material. Before scribing the development on the sheet metal, draw a reference line 1-A as shown in Fig. 1. Scribe a second line 1-B perpendicular to this line. You can draw the development of the object between these lines.

Bending lines and cutting lines can be indicated by drawing them with a pencil (Fig. 2-A) or with a hard metal scriber (Fig. 2-B).

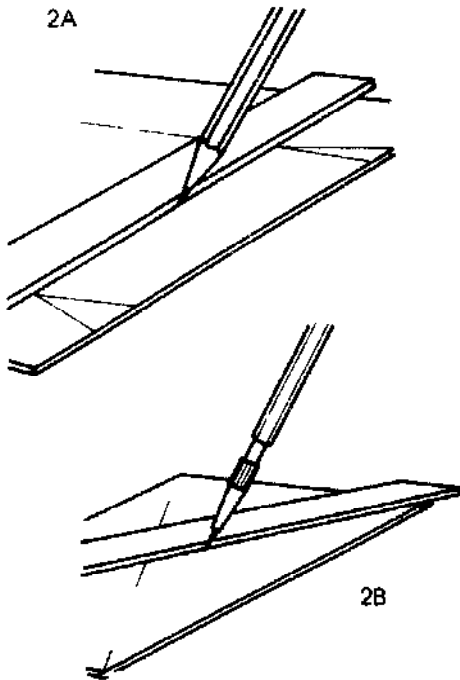

The indication of a middle point is called centring. This can be done with a centre punch. Ensure you have a strong, firm base and do not make the centre hole too deep, see Fig. 3.

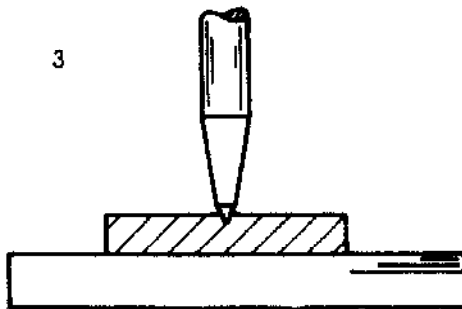

Reinforcement and joints

Before you are able to design the most common developments, you should know more about the way sheet metal can be joined together and reinforced. These joint seams and reinforcement require some additional material which must be shown on the development of each workpiece.

The metal box shown in Fig. 1 is not strong. The four sides of the box are liable to bulge out due to inside pressure and the soldered butt joints (see arrow) at the four corners, which do not give a strong structure. Fig. 2 shows a development of this box and it is good to compare this later with the developments in Figs. 3 and 4.

Flaps and notches

To reinforce the metal box at the four corners, *flaps* are added on the long or short sides of the box, see Fig. 3-A. To avoid sharp corners, the flaps are cut off at 45° on all sides, see 3-B. There is a risk of cutting too deep when you cut the edges on the flaps. So it is advisable to drill small holes of about 2 to 2.5 mm at the corners, see 3-C. These holes also help to give the material ample play when the flaps are folded.

Note again the *full cutting lines* and the *dotted folding lines*.

Safety edges

The top edge of the metal box is sharp and therefore dangerous. To avoid accidents, the top edge can be folded over to a *safe edge*, see Fig. 4-A. The material for the safety edge is added to the height of the box, see Fig. 4-B. Note also the way the notch and the safety edge are shaped at 4-C.

The safety edge also acts as reinforcement against side pressure on the sides of the box.

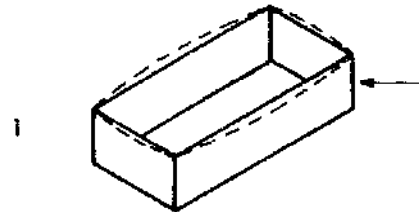

2

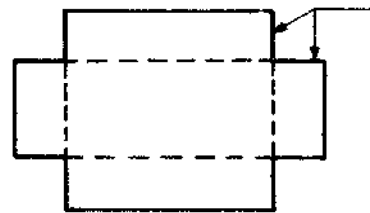

3

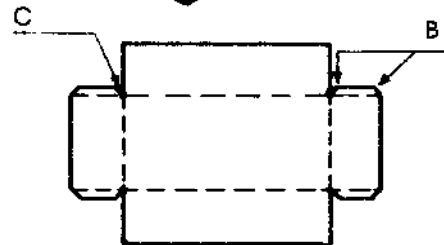
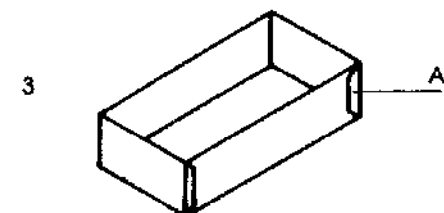

4

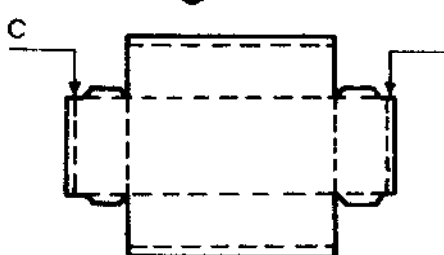
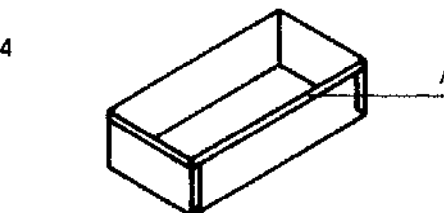

Cutting sheet metal

Tinsnip

A tinsnip is used to cut thin material such as sheet metal. Hold the tinsnip with your right hand, placing your little finger inside the lower handle so you can move the handle up and down. The tinsnip shown in Fig. 1 is used for cutting sheet metal in a straight line. The dotted lines 1-A and 1-B show how the metal finds its way during the cutting procedure.

Because the jaws of the tinsnip shown in Fig. 2 are at an angle, this tinsnip makes it possible to leave the metal flat during cutting. But a small space should be forged to lodge the lower jaw. It takes a lot of practice to find the space during cutting.

Specially shaped tinsnips are available for curved work. Tinsnips with an extra lever are shown in Fig. 3.

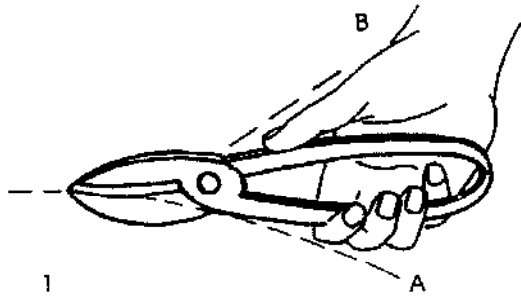

1

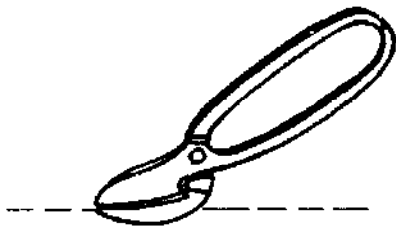

2

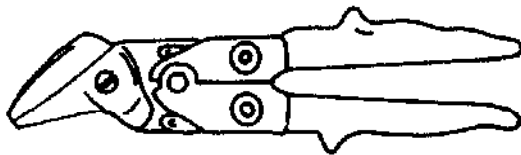

3

Cutting sheet metal

The best tool for cutting sheet metal is a pair of tinsnips as shown in Fig. 1. The two eyes at the end of the handles make it easy to open the tinsnip when needed, contrary to some other straight tinsnips which do not have these eyes and thus make opening more difficult.

Cutting is done along a scribed line, holding the tinsnip in your right hand and the metal in your left. Before cutting the whole line, first make a notch at the beginning of the line.

Open the blades wide and insert the metal all the way back in the throat, making sure the cutting edge of the upper blade is exactly over the scribed line. See Fig. 2. Then squeeze the handles together.

It is best not to cut all the way out to the tips of the blades but to stop towards the end and make a new cut, avoiding the small nicks and burrs made by the end of the blades if full-length cuts are made.

When cutting larger sheets, allow the right part to bend down over the edge of the workbench and pull the left part up to leave space for your hand to operate the tinsnip. See Fig. 3.

Heavy metal can be cut by clamping the sheet between two pieces of angle iron and shearing it with a cold chisel, see Fig. 4.

Fig. 5 shows how you can also use a straight tinsnip to cut outside curves. First cut away the excess material and then trim the curve, allowing the waste material to curl or roll up.

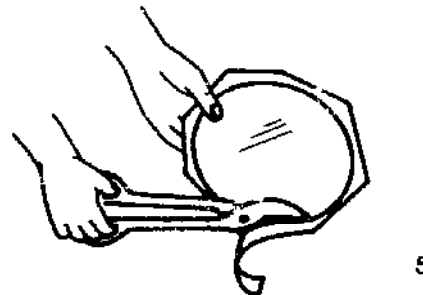
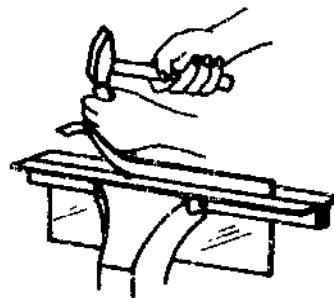
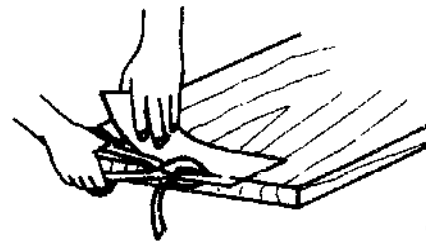
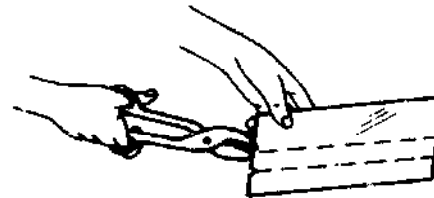
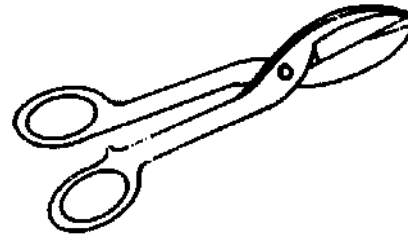

Cutting a large hole

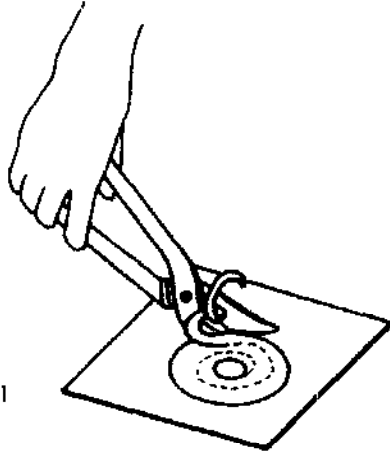

Cutting a large hole in sheet metal is done with a curved tinsnip. To be able to enter, pierce a hole through the centre of the hole, large enough for the tinsnip to pass through. See Fig. 1. Cut the material spirally, so that the waste comes out in narrow strips. When cutting with the curved tinsnip, place a finger on the inside of the lower handle making it possible to open the tinsnip while cutting.

Cutting action

In Fig. 2 you see a cross-section of a cutting action on sheet metal. You note that the blades have cutting edges 2-A with angles to the sheet metal 2-B. The real angle of the cutting edge is determined by 2-C. You note too that the blades have a clearance angle 2-D to each other.

If angle 2-B is too large, the blades are very sharp but quickly become blunt. If the angle is too small the blades cannot cut correctly. The correct angle for B is approximately 8°.

While cutting there is some friction between the blades, the clearance angle 2-D prevents this friction as far as possible and at the same time gives a better, keener edge.

If the blades do not pass each other correctly as shown in Fig. 3, the metal to be cut tilts and squeezes and a clean cut is not possible. See also Fig. 4.

Before using the tinsnip, check whether the rivet or bolt holding the blades in position is tight enough for the blades to pass each other correctly. If the blades have to be sharpened, take the tinsnip apart and shape it correctly as you have learned in a previous lesson. Do not attempt to cut heavier material than the tinsnip is designed for and do not use it to cut hardened steel wire.

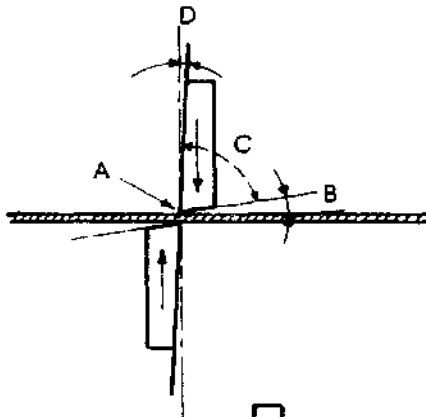

2

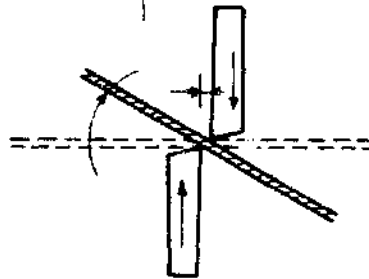

3

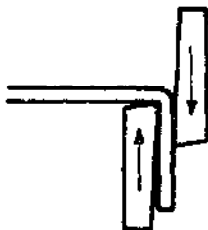

4

Lever Shears

Lever shears are shown in Fig. 1. These lever shears are very useful in the workshop because you can cut thicker material with them. The cutting action is similar to that of cutting with a tinsnip, the difference being that the jaws are moved by the lever 1-A.

Working with lever shears

Never cut material thicker than the permitted thickness. Sharpen the blade of the shears regularly so that they remain sharp and less force is required when cutting. Always use the hold-down, see Fig. 1-B. Then the blades will not twist away from each other and there will be no play between the blades.

Sharpen the blade so that it is slightly convex, see Fig. 2. A convex blade makes the cutting work a little easier.

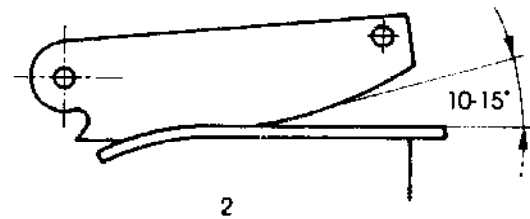
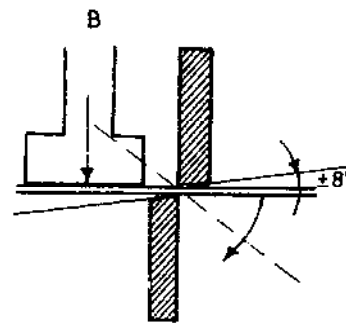
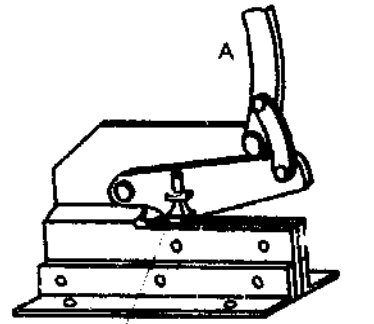

Folding bars

Sheet metal can be bent over the edge of the work bench or, if the workpiece is small, in the bench vice. Larger foldings can be made with a specially prepared angle iron, see Fig. 1. The bar is fixed in the bench vice.

If foldings with a round corner have to be made, a hardwood folding bar can be made to the shape required. See Fig. 2. It is advisable to construct the folding bars in such a way that the inside, over the length of the bar, is slightly hollow to ensure a good grip over the whole length.

Another way to obtain a round corner is by clamping the workpiece in the vice around a metal rod, see Fig. 3. Select the diameter of the rod smaller than the diameter to be given to the workpiece. The diameter will become larger in any case because of the springiness of the sheet material. The extent of this increase must be determined by trial and error.

Another folding bar is shown in Fig. 4. As you can see, one angle iron is fixed at the edge of the workbench and another angle iron can be attached to it with bolts. Make sure you bend the sheet metal towards the fixed angle iron to avoid over-straining the attached bar. Here it is also advisable to curve the angle iron slightly towards the inside to make sure the sheet metal workpiece is fixed well and firmly.

A device for clamping larger foldings is shown in Fig. 5. It consists of a hand vice in combination with two pieces of angle iron.

If a vulnerable workpiece is to be bent, as in Fig. 6, ensure that the workpiece is protected against damage. Place clamping plates in the bend vice. When striking hold a piece of hardwood between the hammer and the workpiece.

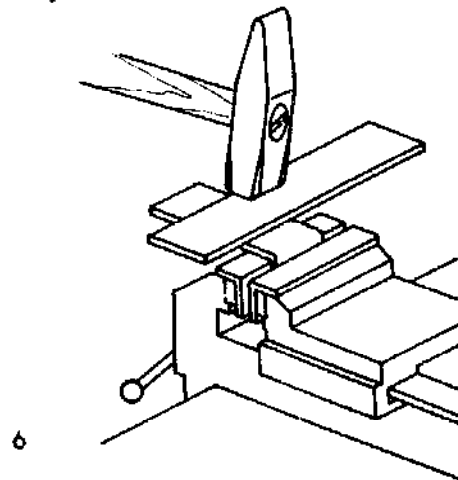
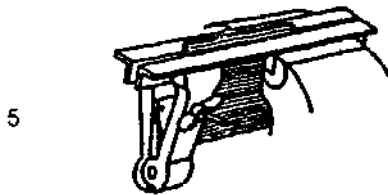
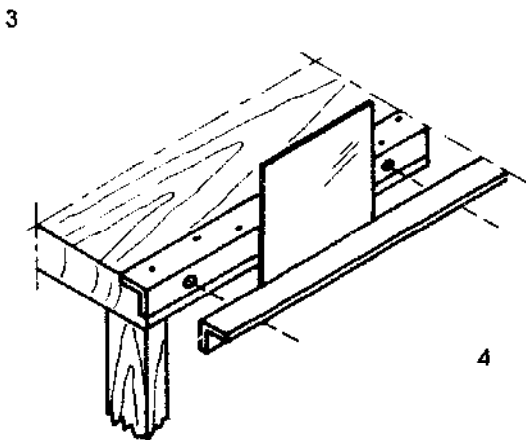
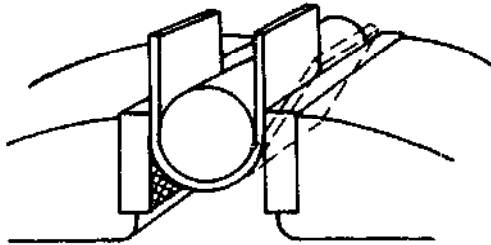
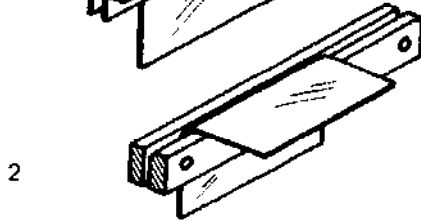
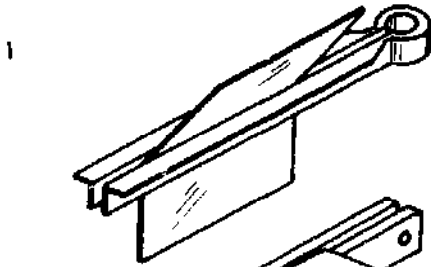

Hand hammer and mallet

To shape sheet metal it is advisable to use a small hand hammer or a wooden mallet. See Figs. 1-A and 1-B. When using the hand hammer, do not hammer too heavily as this makes the material spread and may give the wrong results.

Use a wooden or rubber mallet for bending sheet steel and for upsetting. A steel hammer is used for stretching material. It has greater penetrating power which enables the material to be extended easily.

The dolly

The dolly, with a square bottom end clamped in the bench vice, is used for support when processing thin sheet, see Fig. 2. Never strike the hardened top surface of the dolly with a steel hammer as dangerous splinters could fly off.

Pipe stake

A pipe stake is essential when making pipes bent from thin metal sheet (for example for stoves). See Fig. 3. A short pipe stake is clamped into the bench vice for use. Long stakes are pushed below steel brackets fitted to the workbench. The pipe is pushed over the stake which can act as a support during forming. The pipe stake can also be used as a dolly when making a riveted joint.

Edge stake

An edge stake can be used for flanging right-angled folded seams (as in the case of cans or pails). See Fig. 4. Either a straight or a round edge stake is used, depending on whether the folded seam to be flanged is straight or circular in shape.

Cylindrical objects are pre-rounded on both sides. See Fig. 5.

1

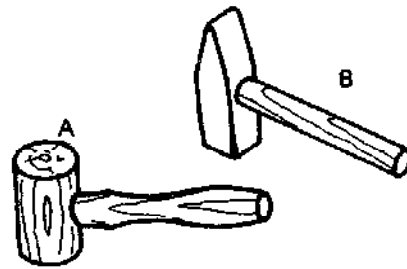

2

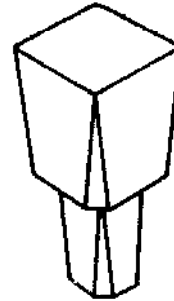

3

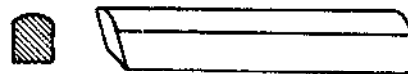

5

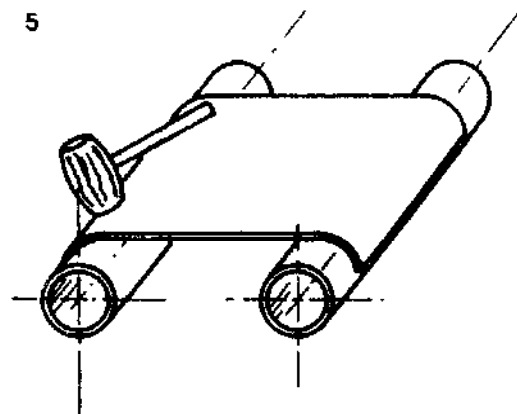

4

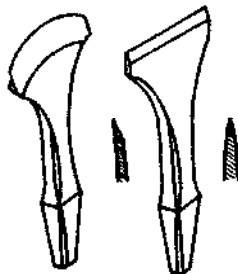

Folding machine

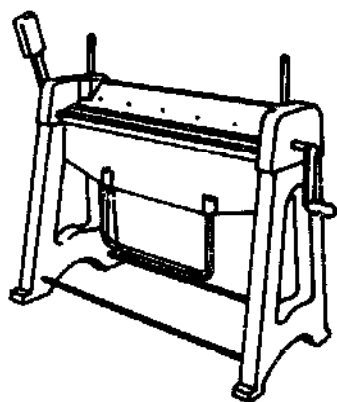

A folding machine is used for deforming sheet steel by bending it, see Fig. 1. It is generally not possible to bend an angle greater than 90° to 100° . It is however, possible to install cutting edges which permit the bending angle to be increased. Note that these special cutting edges are more easily damaged if not correctly used.

The cross-section in Fig. 2 shows the fixed top straight edge and the moving bottom straight edge. The distance between the top and bottom straight edges must be the same as the material thickness of the workpiece.

If the distance is taken too small the material will be cut off slightly and if the distance between the straight edges is too great the radius for the workpiece will be too large. Depending on the material used a spring-back of several degrees will occur. See Fig. 3.

2

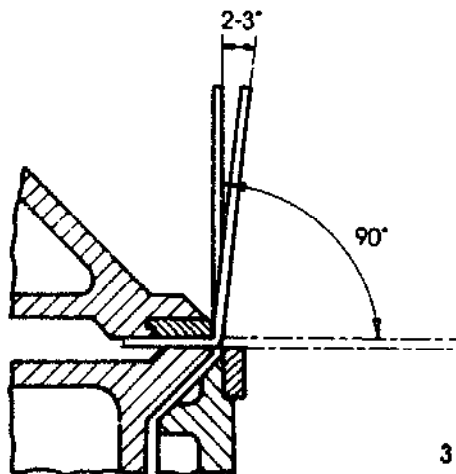
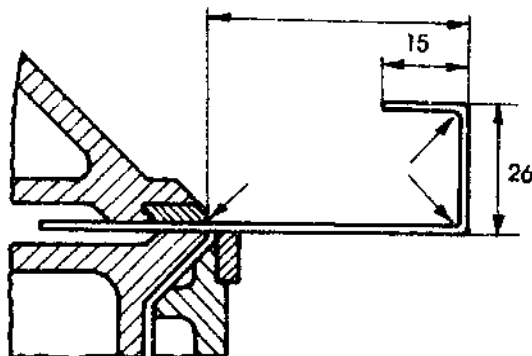
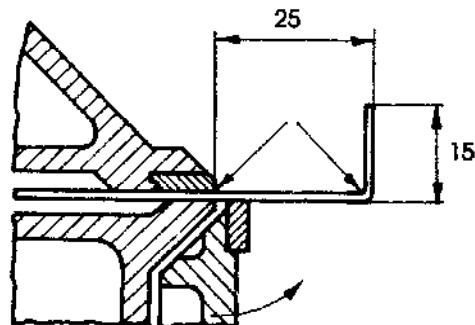
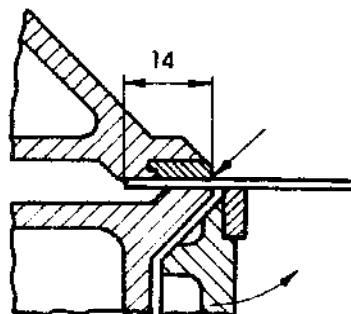

3

Sheet rolling mill

A sheet rolling mill is used for bending sheet material in such a way that cylindrical or cone-shaped objects are formed. See Fig. 1. To achieve this the sheet to be rolled is generally passed between the three rollers several times. After every pass the rollers are brought closer together until the desired result is achieved.

The cross-sections in Fig. 2 show how the sheet rolling mill works. Ensure that the ends of the sheet are rounded before feeding the sheet into the roller.

The top guide, roller makes it possible to roll workpieces until they are completely cylindrical and to remove them from the rolling mill without deformation, see Fig. 3.

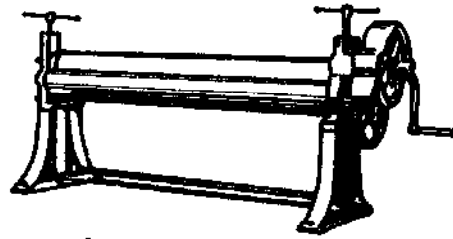

1

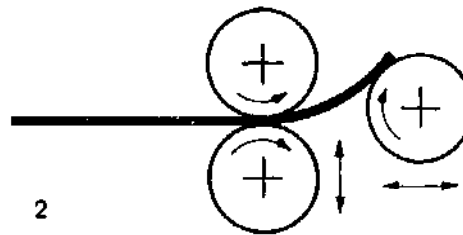

2

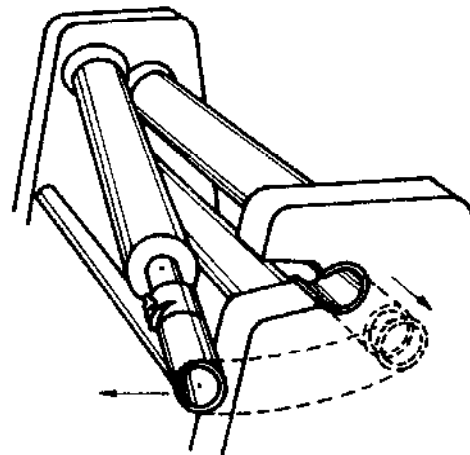

3

Stretching and upsetting material

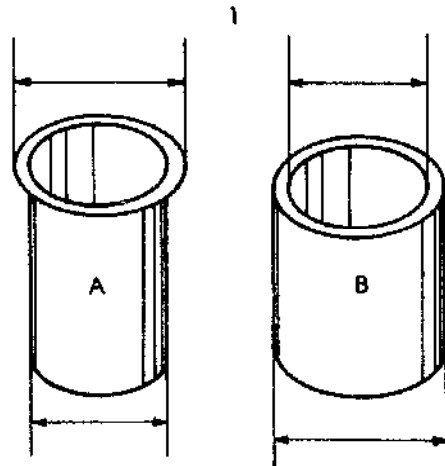

Generally speaking, the stretching and upsetting of sheet material are done on cylindrical objects. In stretching, we increase the diameter (see Fig. 1-A) and in upsetting (see Fig. 1-B) we reduce the diameter. In both stretching and upsetting it is advisable always to start opposite the seam and to work round on the left and right towards the seam from this starting point. Only in this way can a completely closed rim be obtained. See Fig. 2, 2-A is right and 2-B is wrong. Flange the rim in several stages, see Fig. 3.

To stretch rims we use the pein of a steel hammer. They must be beaten in such a way that the outside of the rim stretches more than the inside. Upsetting is done with a rubber or wooden mallet.

In this case beating must be done in such a way that the inside of the rim is upset more than the outside of the rim.

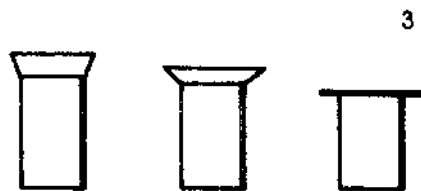
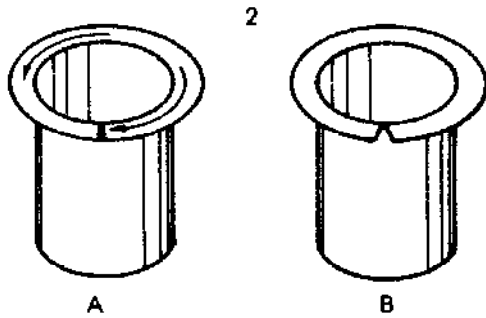

Safety edge

To achieve the effective height $1-H$ as seen in Fig. 1 for a box with a safety edge, you have to add $1-X$ to the height of the box on all sides. To make a safety edge, you need to fold the edge of the metal over to a square. Insert a piece of sheet metal as shown in Fig. 2-A and fold the sheet metal completely over. Finish off the edge with a hand hammer as shown in Fig. 2-B.

Wire edge

A wire edge is shown in Fig. 3. To cover the wire, you must add material to the sides, equal to $2 - 2.5$ times the diameter $3-A$ of the wire to be used, see $3-B$.

Prepare a piece of flat metal with a thickness equal to the thickness of the wire. Fold the metal over that piece of metal as shown in Fig. 4. Insert the wire and fold the metal over the wire as shown in Fig. 5, using a hand hammer. Sometimes a piece of wire should be left sticking out, see $5-X$, for possible connection at a later stage.

A beading iron can be used to obtain an absolutely round edge, see Fig. 6.

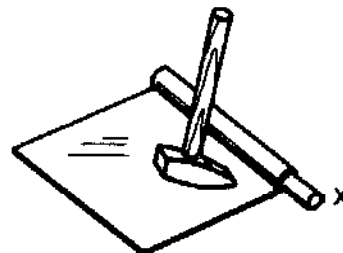
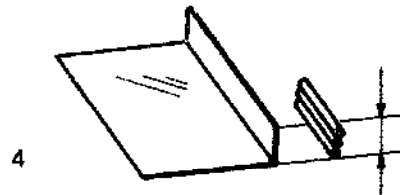
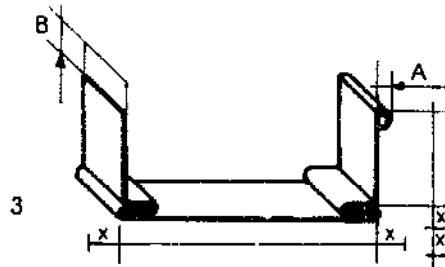
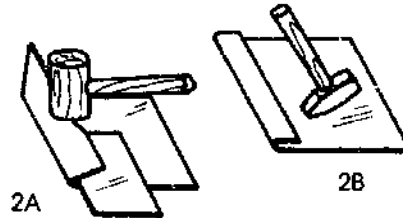
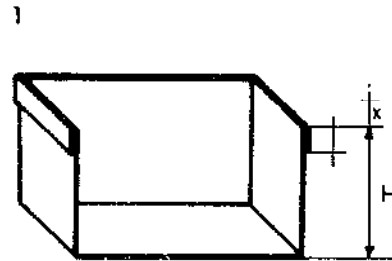

Hand-operated beading and corrugating machine

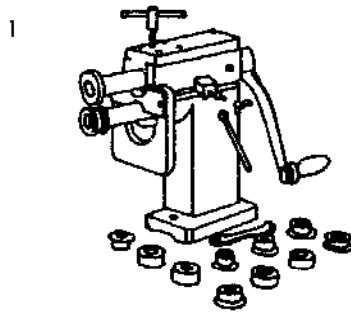

A beading and corrugating machine is used for reinforcing steel sheet. Fig. 1 shows the machine with attachments. The machine forms the steel sheet in accordance with the rollers installed, see Fig. 2-A. When the rollers of a beading machine are in the form of blades this apparatus can also be used to cut bottoms and circles out of steel sheet. The beading machine can also be used for making joints, for example for fixing bottoms into cans and similar products, see Fig. 2-B.

Beadings protect the edges of cans and pails, which are often sharp, and give the rim greater rigidity. See Fig. 2-C.

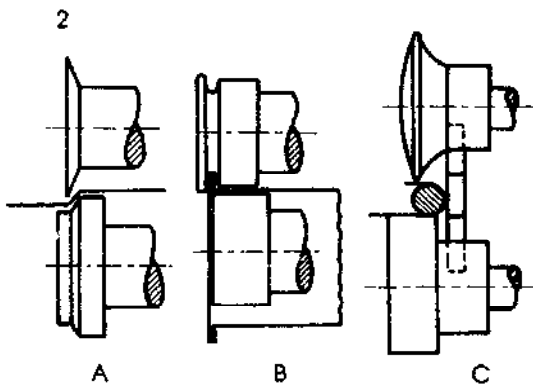

Corrugating gives the material greater rigidity. It is done in various steps. See Fig. 3. The corrugation can be made slightly deeper at each pass by tightening the top roller. The shape of the bottom roller determines the maximum depth of the corrugation.

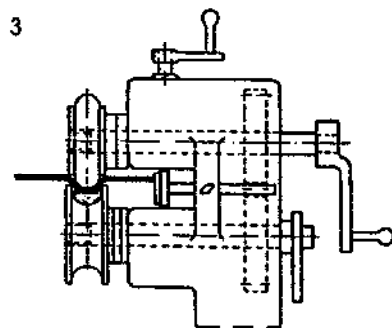

Drilling in sheet metal

To prevent drills from breaking in thin steel sheet special sheet metal drills are often used. These drills have a shorter body and a shorter shank than normal twist drills. See Fig. 1. There are also conical sheet drills with which holes of various diameters can be bored in sheet metal. The deeper you drill, the larger the diameter of the hole. A drill with a centring point can also be used. Always fix the material firmly in position, see Figs. 2, 3-A and 3-B.

When drilling out thin sheet a double centre punch is a very good aid when marking. The distance from point to point is equal to the centre-to-centre distance of two holes to be drilled in succession, see Fig. 4.

When drilling holes of a larger diameter in sheet it is advisable to place a bundle of paper (for instance a newspaper) or a thick piece of cloth between the drilling point and the material to be drilled. This permits an exactly round hole to be obtained.

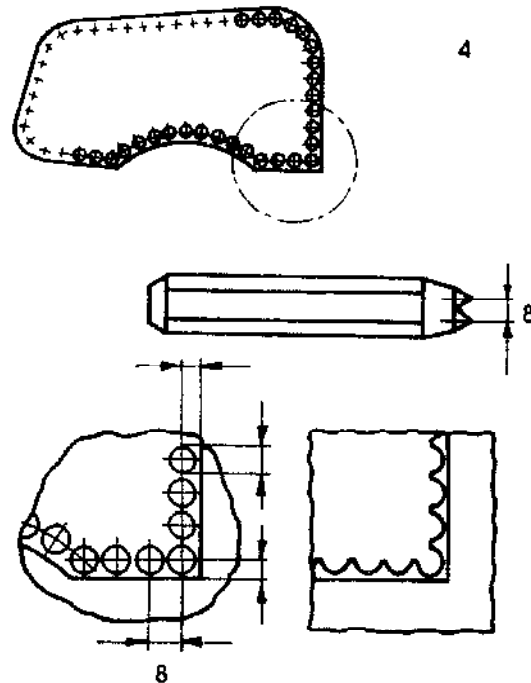
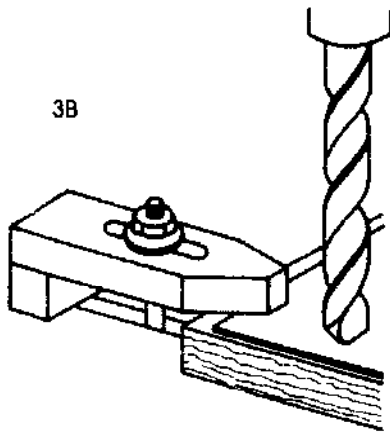
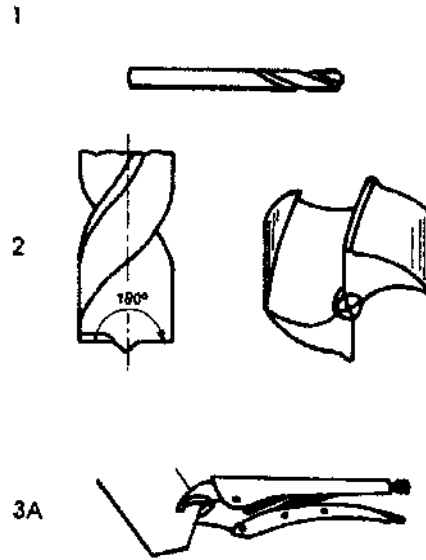

Sheet metal joints

Sheet metal can be jointed in many different ways. Frequently used methods are: folding, riveting, pop riveting, spot welding and, of course, welding and soldering.

Lap joint

A lap joint is shown in Fig. 1. If you look at the jointed pieces of metal in Fig. 1, you see that piece 1-A is equal in length to 1-Y and piece 1-B is equal to 1-O. All the same the total length, called the *effective length*, is equal to 1-L. The effective length is very important in the design of sheet metal work, because, to obtain the correct effective length you have to add to piece 1-B a length equal to 1-X.

Folding

Folding is used to join sheet steel or to make bottoms. A folded seam can be made as a single or as a double folded seam. A double folded seam is used when a thorough seal is required.

Folded seam

In Fig. 2 you see a folded seam. To obtain the effective length for this workpiece you must add to piece 2-A one times 2-X. And you must add to piece 2-B two times 2-X.

Double over-folded seam

A double over-folded seam is almost similar to the folded seam, with the difference at 3-O, see Fig. 3. When upsetting at 3-O, you do not have to allow additional material because the sheet metal is very thin.

To make this seam, fold the two pieces of sheet metal over as shown in Fig. 4. Hook them together, see arrow. A grooved stake is used to tighten an folded seam in such a way that a completely closed joint is obtained, see Fig. 5. Use the right grooved stake for the desired width of the folded seam.

Another way to finish this double overfolded seam is to use a mallet to shape the seam roughly. Use a hand hammer to finish the job. See Figs. 6-A and 6-B.

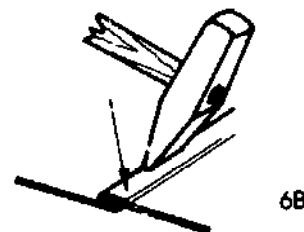
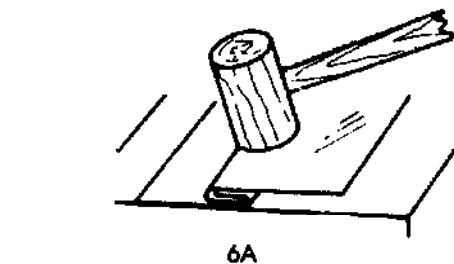
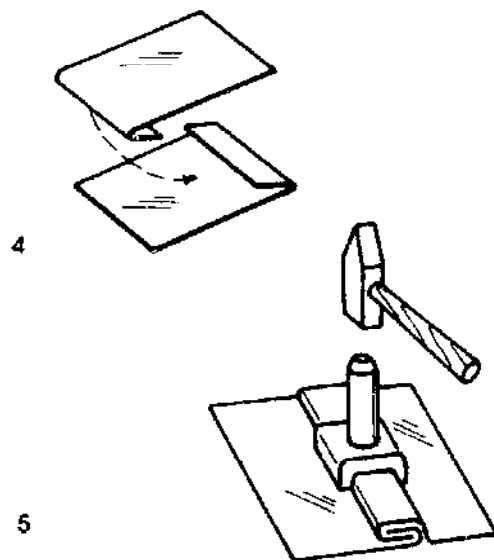
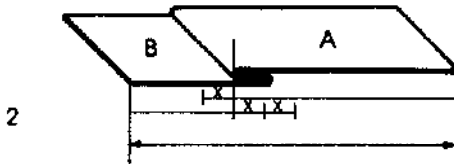
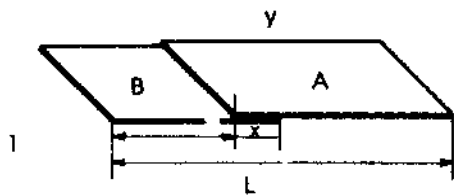

Box seam

For a box seam as shown in Fig. 1, you must add two times 1-X to the bottom part of the box. You must also add two times 1-X to the sides of the box.

Some examples of seams are shown in Fig. 2:

- Angle fold 2-A
- Upright fold 2-B
- Upright casing fold 2-C
- Upright top fold 2-D
- Upright bottom fold 2-E

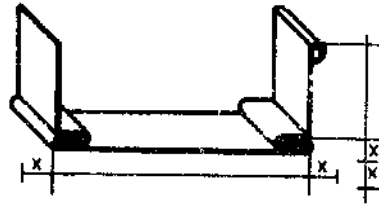

1

2

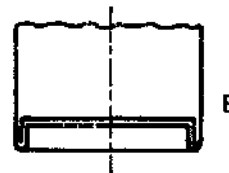
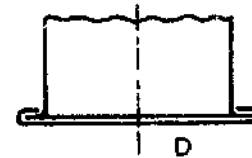
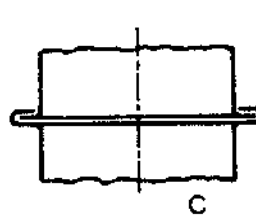
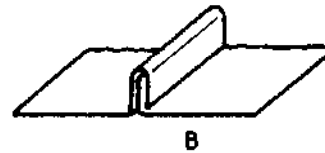

Riveting sheet metal

When sheet metal has to be jointed, rivets can be used instead of solder the sheets together. Since sheet metal is thin, it is advisable to use button head shaped rivets only. A rivet is a small piece of metal with a body and a head; the head is not included in the length, see Fig. 1. The length of the body 1-L should be equal to the thickness of the two sheets 1-X plus a length equal to the diameter of the head 1-D.

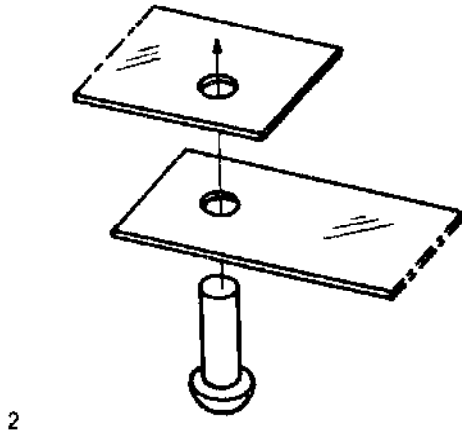
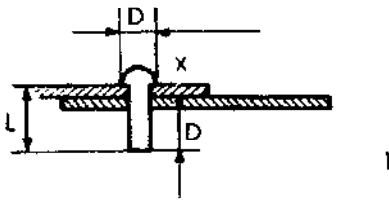

Riveting procedure

Drill or punch holes in the parts which have to be joined. The holes should fit exactly. It is best to clamp the parts together so that you can drill or punch them at the same time, see Fig. 2. Put a rivet through the holes and place it upside down on a *dolly*, see Fig. 3. Use the riser in the rivet set to knock the sheets tightly together. Make sure not to touch the workpiece with the edge of the dolly; leave a space. Use the flat pein of the hammer to spread the body of the rivet a little, see Fig. 4. Shape a rough round head with the ball pein of the hammer, while turning it round so that the head is shaped on all sides. See Fig. 5. Use the rivet snap as shown in Fig. 6 to finish off the rivet head.

Note: Heavy blows or too many blows will make the metal stretch and buckle round the rivet. If a rivet starts to bend, cut it off, remove it and insert a new rivet.

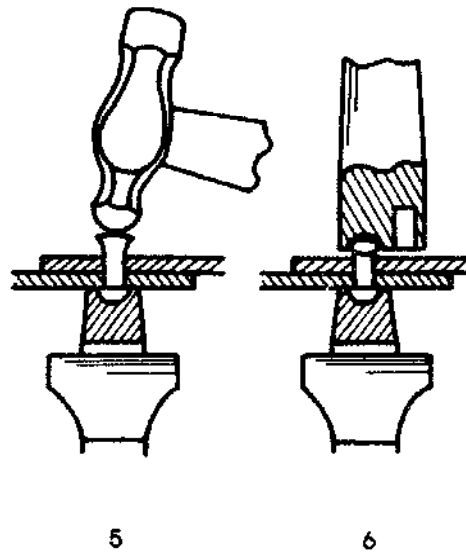
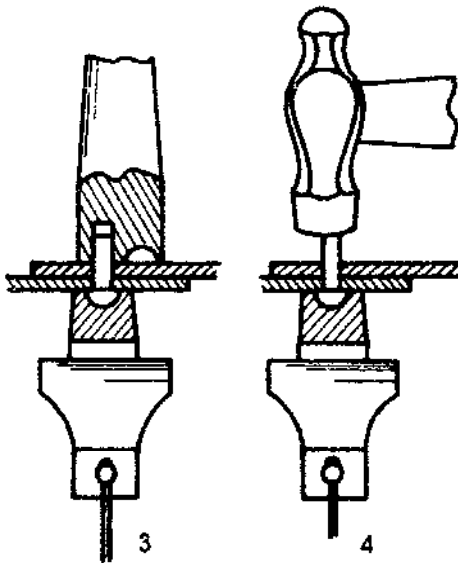

Riveting tools

Punched holes can be widened with the aid of a hand reamer, see Fig. 1. One tapered point of the hand reamer is square, the other side is hexagon shaped; the latter is for fine work. Figure 1 shows an enlarged detail of the hand reamer. The corners of the reamer: 1-A-B-C-D act as a file, scraping off some material and widening the hole.

After the metal has been punched or drilled through, the edges of the holes should be chamfered to allow correct connection between the metal and the rivet heads.

For the actual riveting a rivet set, see Fig. 2-A, is used in combination with a dolly shown in Fig. 2-B. The two tools can be combined to make one tool, as shown in Fig. 3. The hole in the tool 3-A is slightly greater in diameter than the shaft of the rivet and equal to the length of the rivet shaft.

The round shaped hole in the dolly 3-B is slightly less than half the diameter of the rivethead, to allow for a space between the rivethead and the metal to be joined.

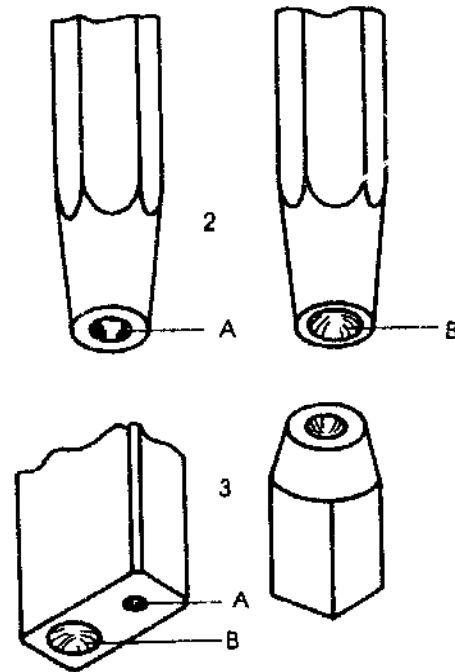
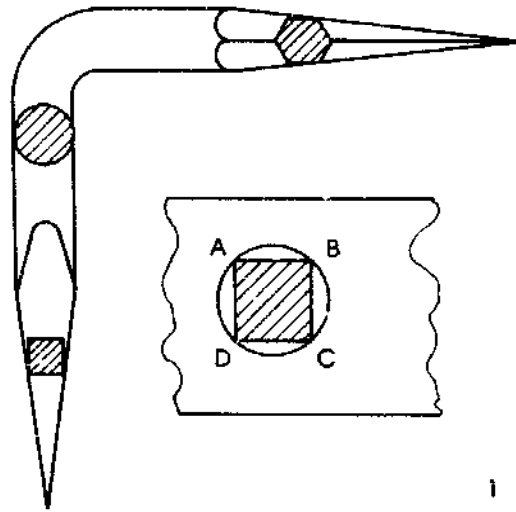

Cold riveting

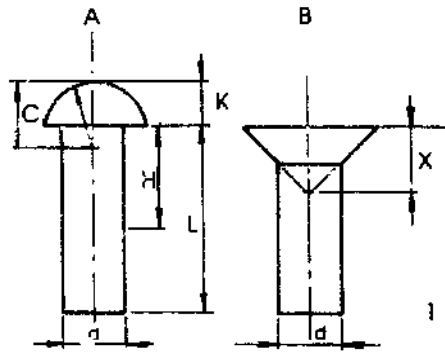

Rivets are sold with different shaped heads.

The most commonly used are:

- round head rivet (Fig. 1-A)
- countersunk rivet (Fig. 1-B)

The length of these rivets is measured as shown in Fig. 1.

1-L = length

1-K = face

1-H = grip (thickness of material to be joined)

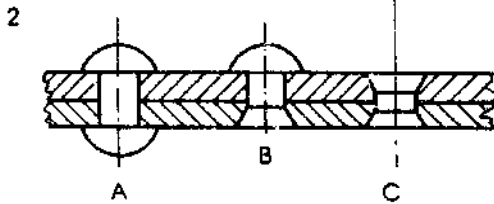

Rivets can be used in different ways as shown in Fig. 2:

- Round head to round head 2-A
- Round head to countersunk 2-B
- Countersunk to countersunk 2-C

Rivet holes in thick material should be drilled. Holes can be punched in thin sheet metal, as shown in Fig. 3. When punching, put a piece of lead or end grain wood underneath the workpiece so that the punch can go through the material. When it is being punched the material will bend downwards, which should be corrected at a later stage.

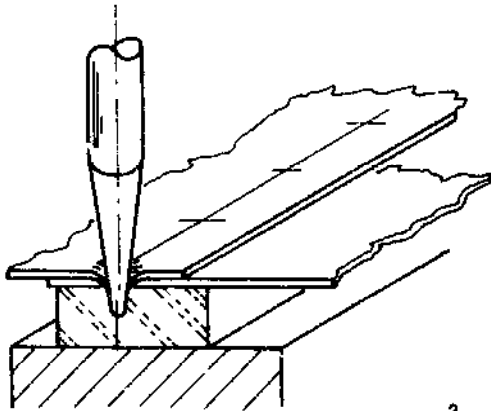

Rivet dimension: (in mm)

<i>Dia-meter</i>	<i>Length</i>	<i>Dia-meter</i>	<i>Length</i>
1.8	4	4.9	15.5
2	4.5	5.3	17.5
2.2	5	5.8	19.5
2.5	6	6.2	22
2.7	6.5	6.5	24
3	7.5	6.9	26
3.3	8.5	7.2	28
3.6	9.5	7.6	30
3.9	11	8	32
4.2	12	8.4	32
4.5	13.5	8.8	36

Pop riveting

Another way of riveting light sheet metal together is with the so-called pop rivet. This pop rivet is fixed with special pop rivet pliers, shown in Fig. 1. A special nozzle is fixed at 1-X. This nozzle has a hole with a diameter equal to the diameter of the pin 1-Y.

A specially shaped rivet – that can be made of aluminium, copper or steel – is placed over the pin.

Riveting procedure

Drill holes through the sheet metal, making sure the holes are exactly above each other, with the correct diameter. Place the correct rivet with pin into the nozzle and close the handles until you feel some resistance.

Place the rivet in the hole, pressing it down so that the sheets are close together, see Fig. 2.

While you close the handles gently, the head of the pin widens the rivet as shown in Fig. 3.

Continue closing the handles and, because of the resistance, the pin breaks off at once, as shown in Fig. 4. The final result is shown in Fig. 5. The head of the pin remains inside the rivet or falls off.

Note: Use the right nozzle for this work, close the handles gently and press the sheet metal and the rivet tightly together.

Welding and soldering

Welding and soldering of sheet metal are discussed in volume 2 of the Rural Mechanics Course: *Blacksmithing, welding and soldering.*

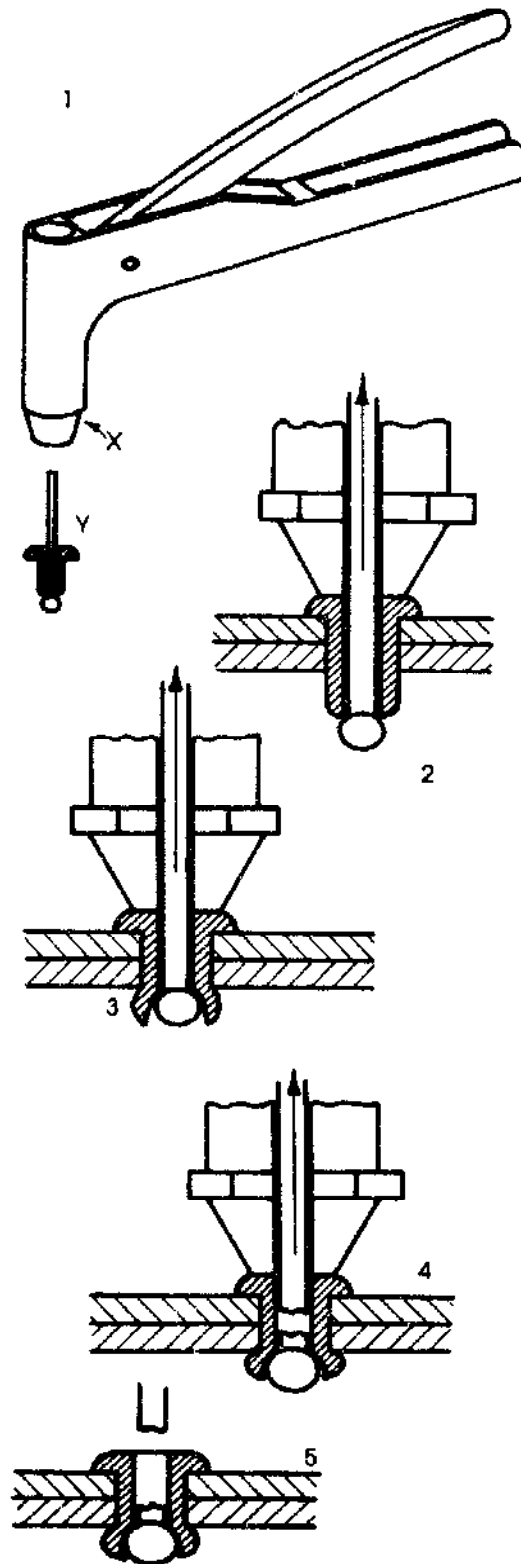

Metal box

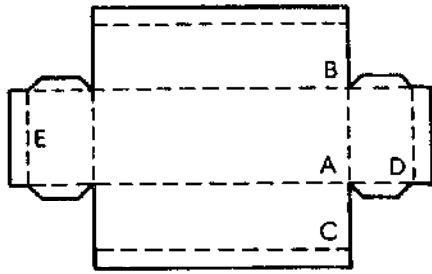

Fig. 1: Development

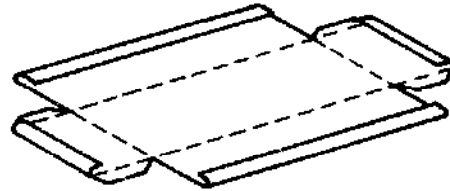

Fig. 2: Cutted and wire edge folding

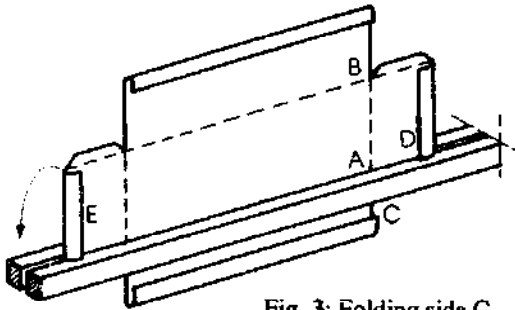

Fig. 3: Folding side C

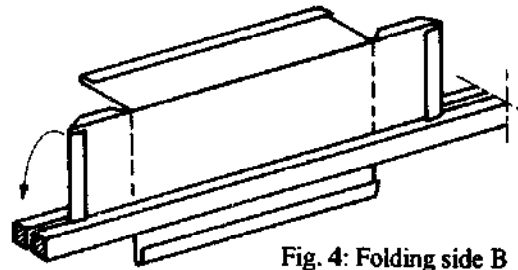

Fig. 4: Folding side B

Fig. 5: Folding sides with flaps

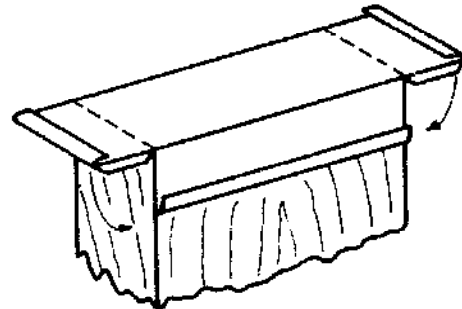
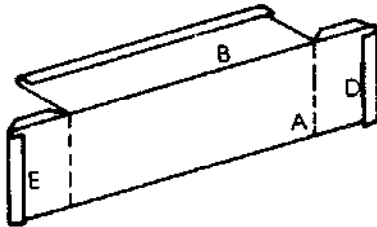

Fig. 6: Folding D and E over wooden block

Fig. 7: Inserting wire

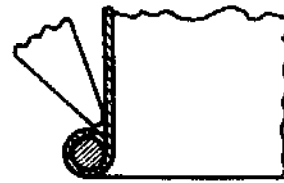
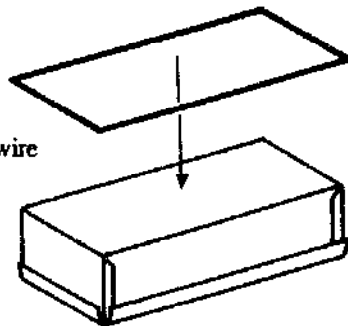

Fig. 8: Wire edge

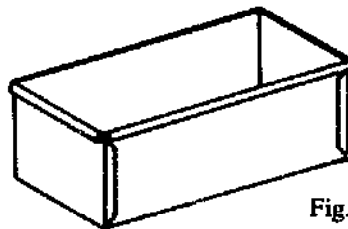
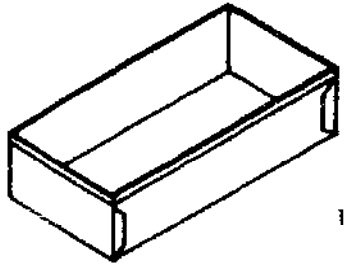

Fig. 9: Finishing off

More metal boxes



1

Metal box with safety edges and flaps

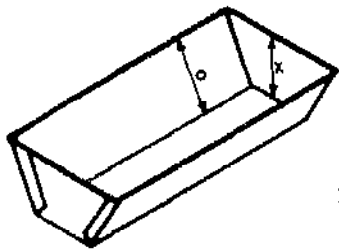
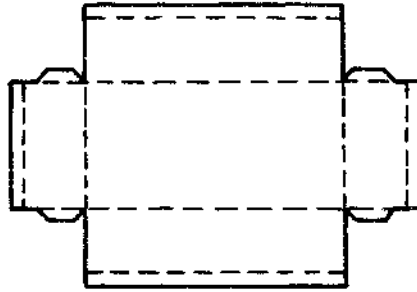

2

Bread tray with wire edges and flaps
X is the height of the tray, O is the width of the sides.

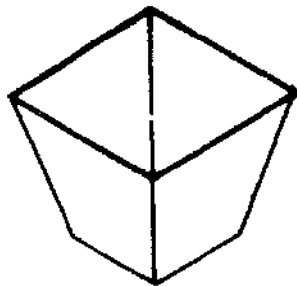
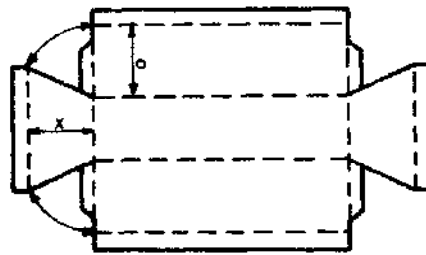

3

Paperbasket with wire edge and flaps
Fig. 3: Method A – paperbasket with sides from one piece.
Fig. 4: Method B – paperbasket with separate sides.

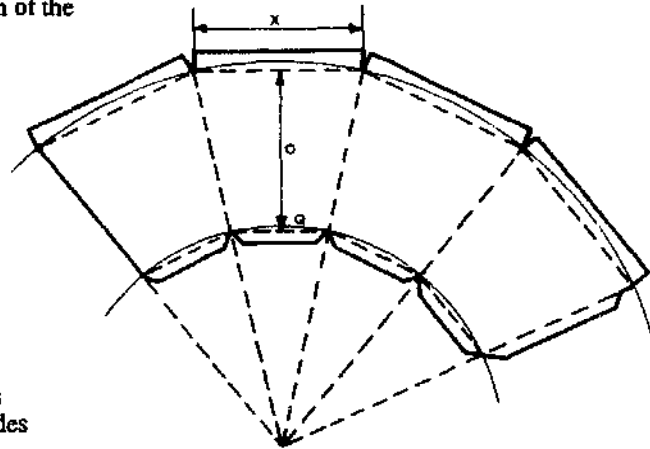

4

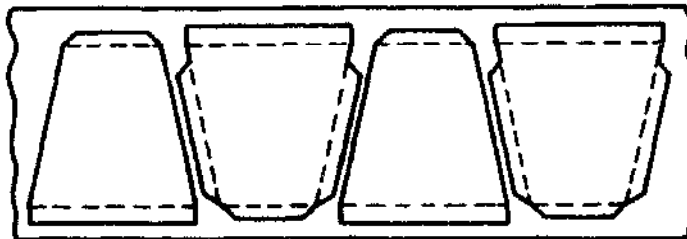
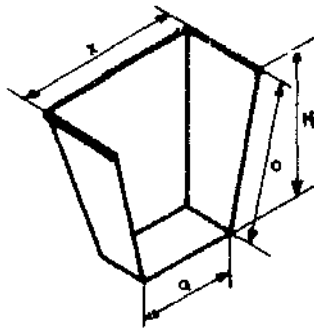

H is the height of the basket, O is the length of the sides.

Metal box with lid

The box (Fig. 1) is made out of sheet metal with a thickness of 0.5 mm. The hinge is a wire edge construction, see Fig. 2. The lid is 1 mm more in width and 2 mm more in length than the box is. Cut the hinge after shaping. See Fig. 3.

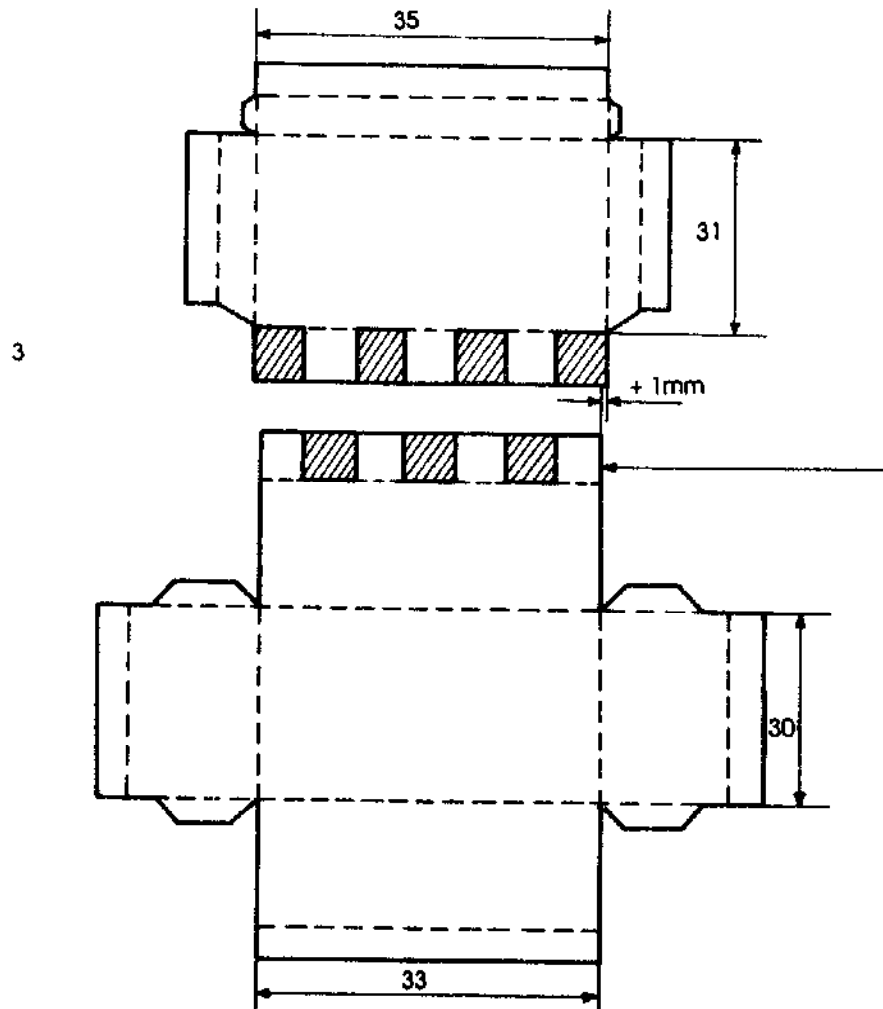
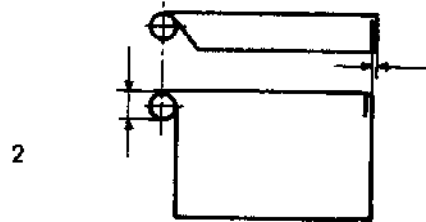
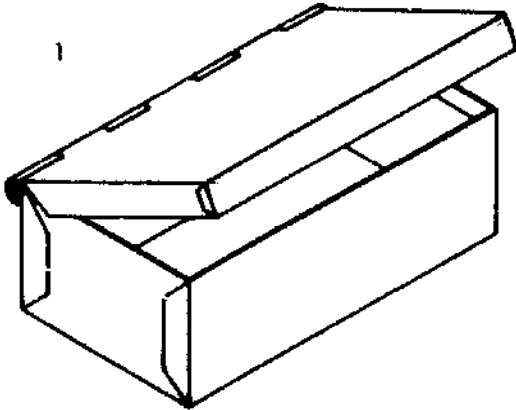

Charcoal pot

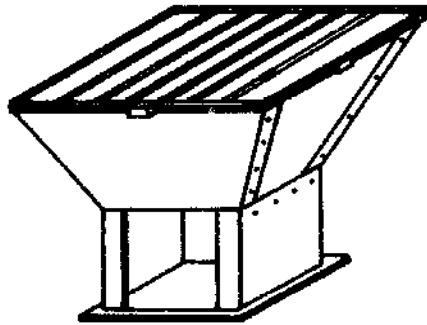

Fig. 1: Pictorial view

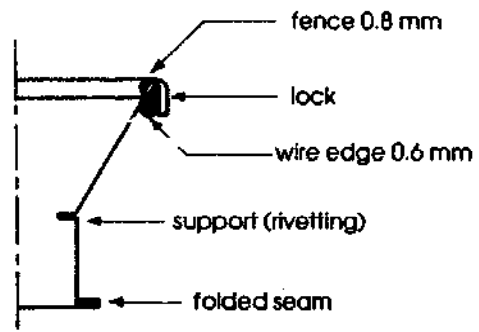

Fig. 2: Side construction

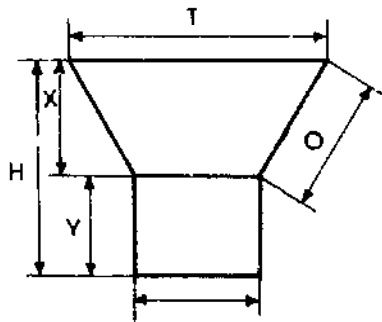

Fig. 3: Cross section

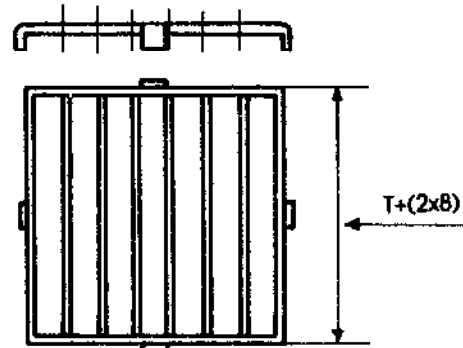

Fig. 4: Top fence

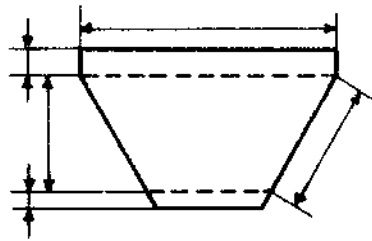
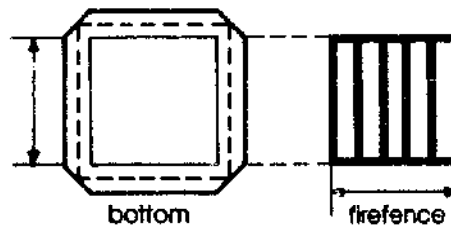
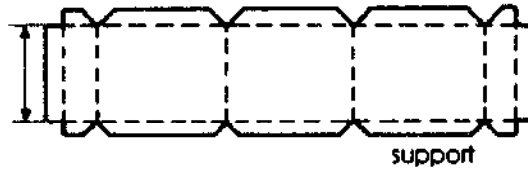

Fig. 5: Development



Upsetting

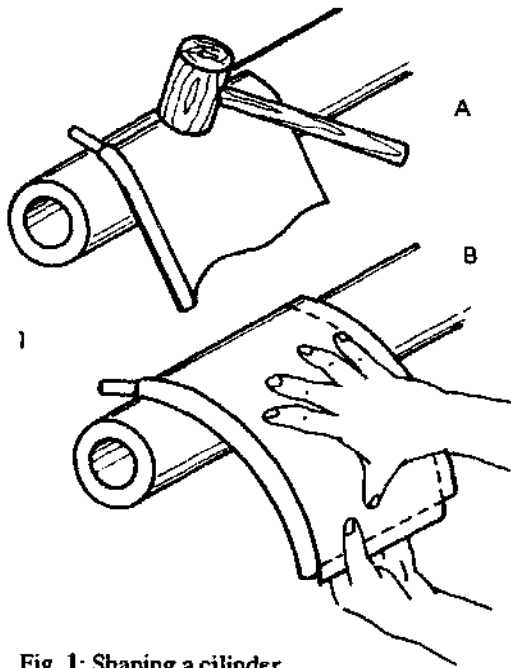

Fig. 1: Shaping a cylinder
A - bend both ends with a mallet
B - shape cylinder by hand

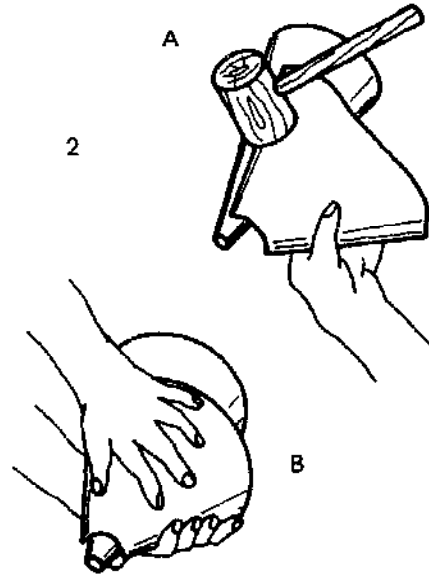

Fig. 2: Shape a cone
A - Bend both ends with a mallet
B - Shape cone by hand over round beak

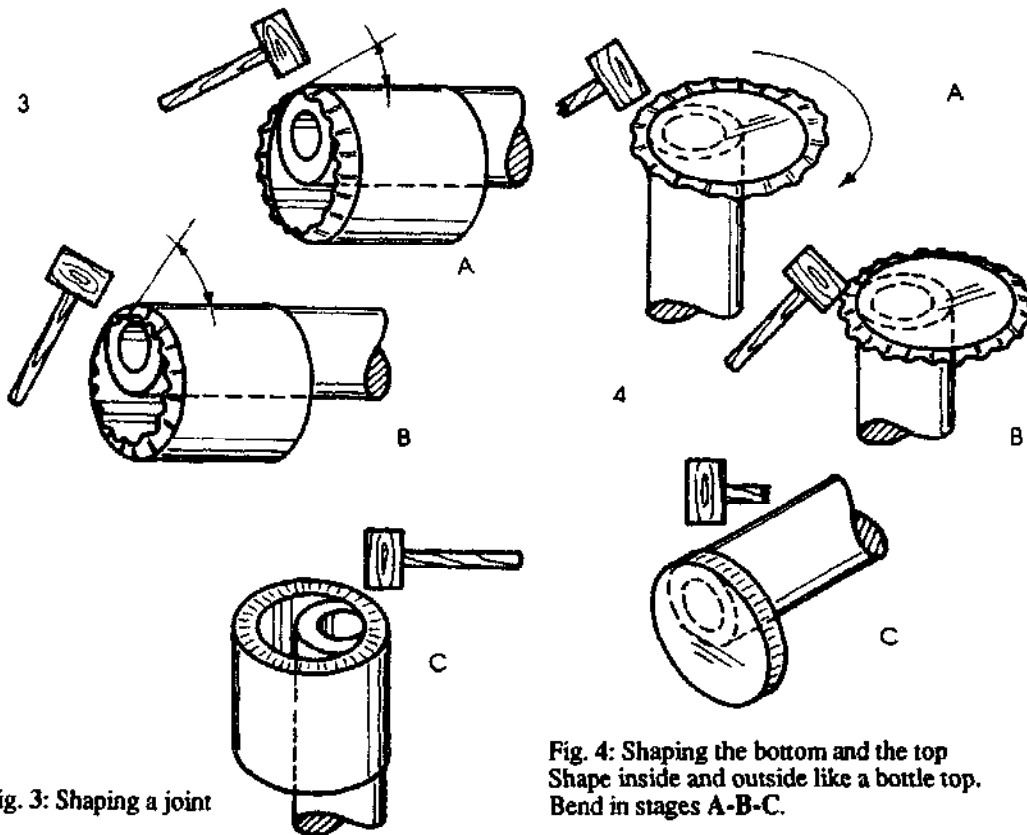

Fig. 3: Shaping a joint

Fig. 4: Shaping the bottom and the top
Shape inside and outside like a bottle top.
Bend in stages A-B-C.

Drinking mug

After designing the correct development for the mug shown in Fig. 1, the outline can be cut and the safety edge folded. To shape the cylindrical body you need a piece of pipe with an outside diameter slightly smaller than the diameter of the mug. Shape the first and the last part of the body with a mallet. See Fig. 2. This shaping cannot be done by hand, because the edge is very short.

The rest of the body can be shaped by hand. Move the metal over the pipe, as shown in Fig. 3, while pressing it gradually down until the right shape is obtained.

Shaping the bottom

To shape the bottom of the drinking mug the pipe is fixed upright in the bench vice. Place the bottom piece on top of the pipe, see Fig. 4, and gradually fold over the edge for the seam while turning it round. First hold the bottom sheet horizontal and hammer the edge slightly, shaping it like a bottle top. See Fig. 5. In Fig. 6 you see the edge is folded over a bit more, keep turning and hammering at the same time. Fig. 7 shows the edge folded 90° for the seam. For a tight soldered connection it is good to over-fold the edge slightly, as shown in Fig. 8. The other side of the pipe can be used for this.

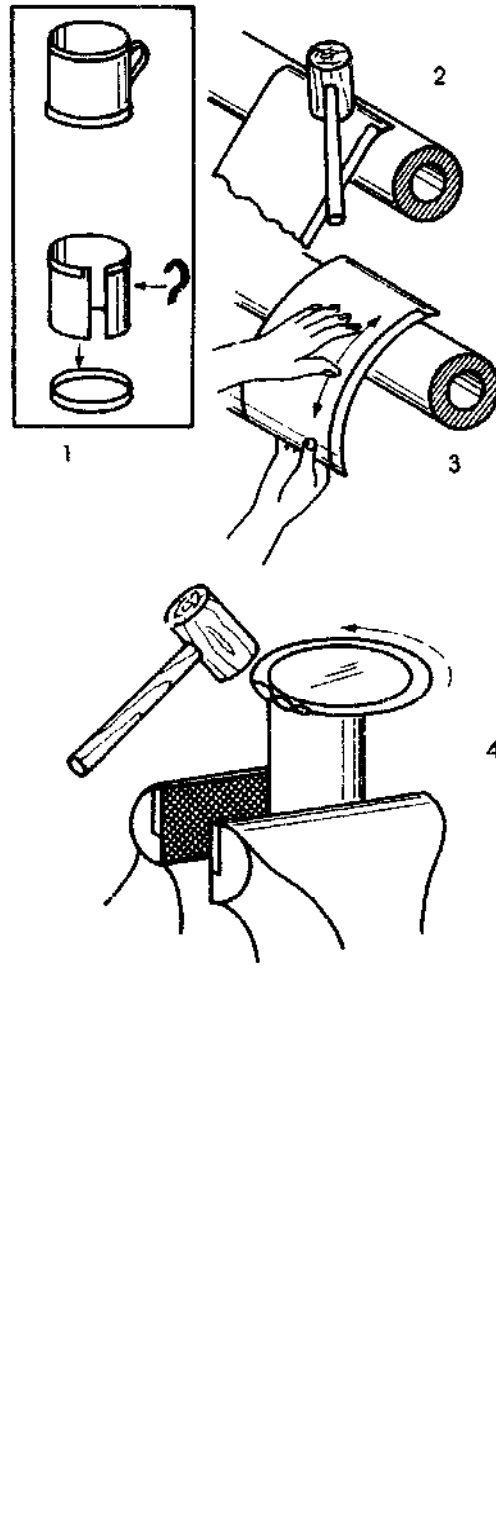

Stretching

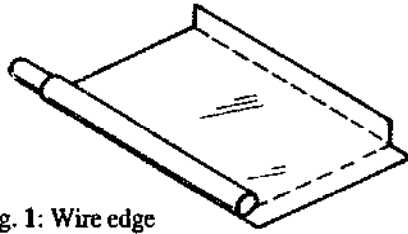

Fig. 1: Wire edge

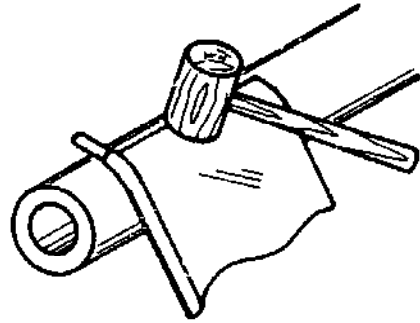

Fig. 2: First shaping with a hammer

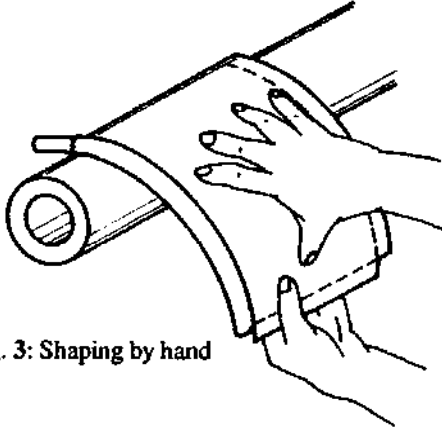

Fig. 3: Shaping by hand

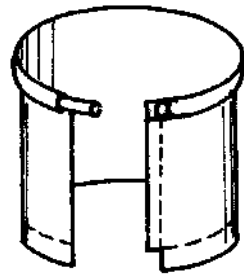

Fig. 4: Result of shaping

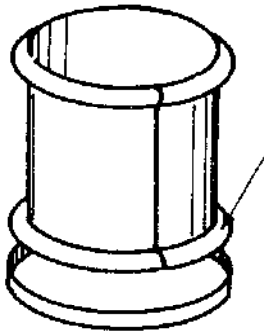
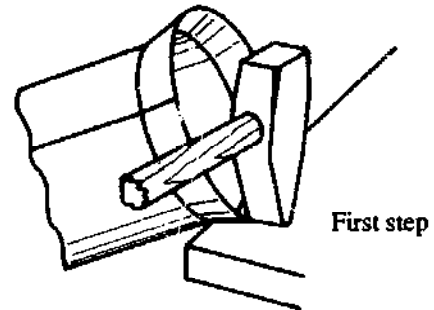
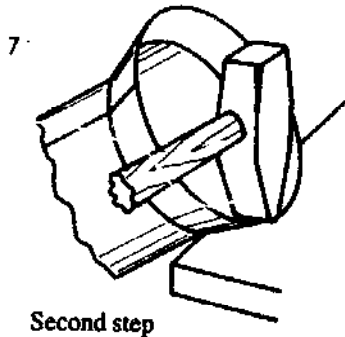

Fig. 5: Cilinder



First step

Fig. 6: Stretching – start shaping opposite to the joint to avoid cracks in the hammered part



Second step

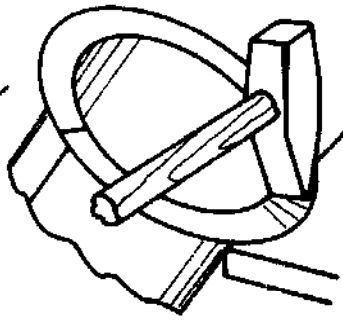

Third step

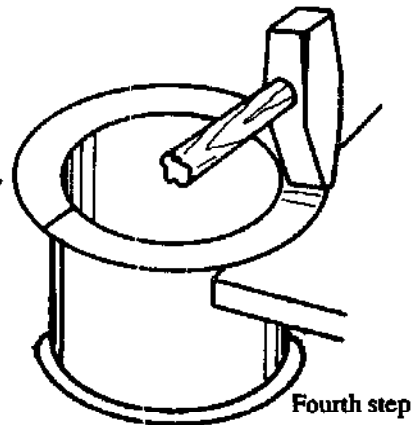

Fourth step

Upsetting

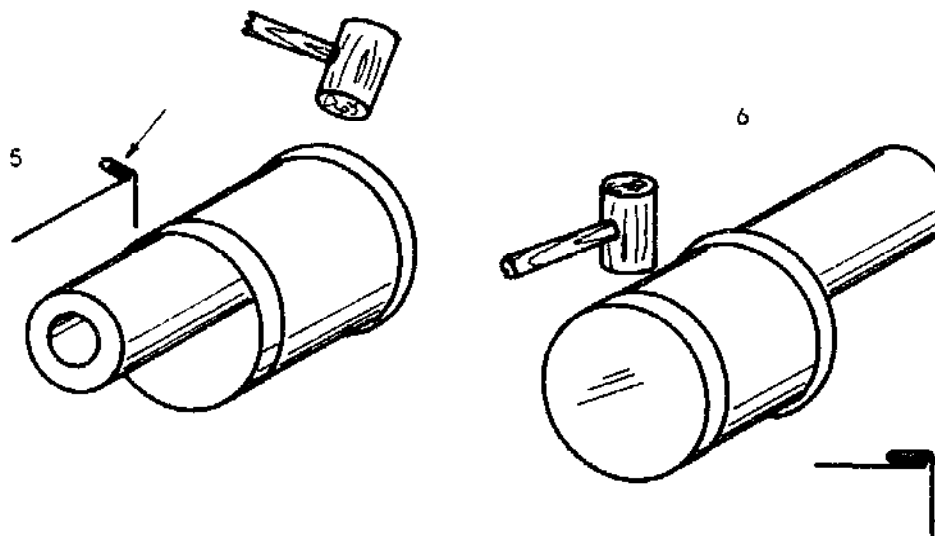
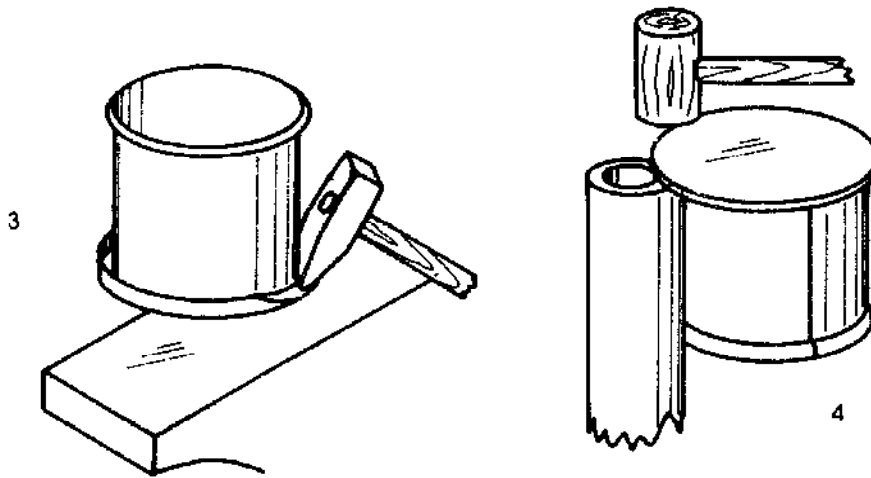
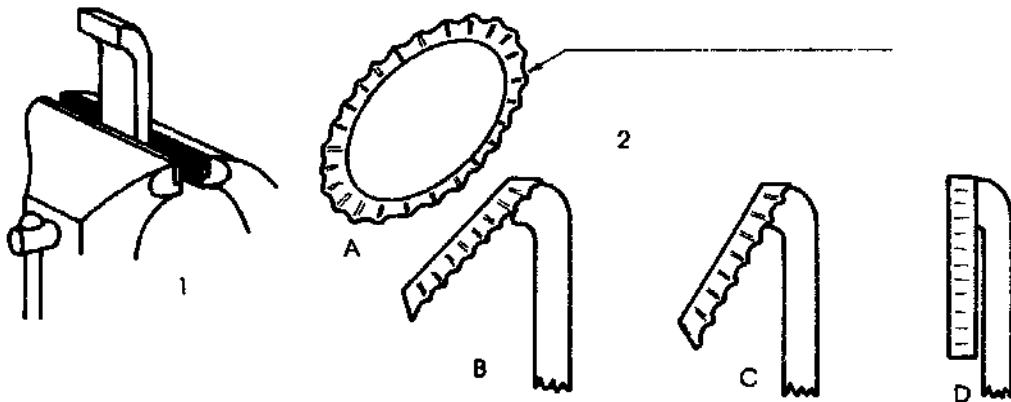

Developments

Note: $\pi \times D$ is calculated for thin material only.

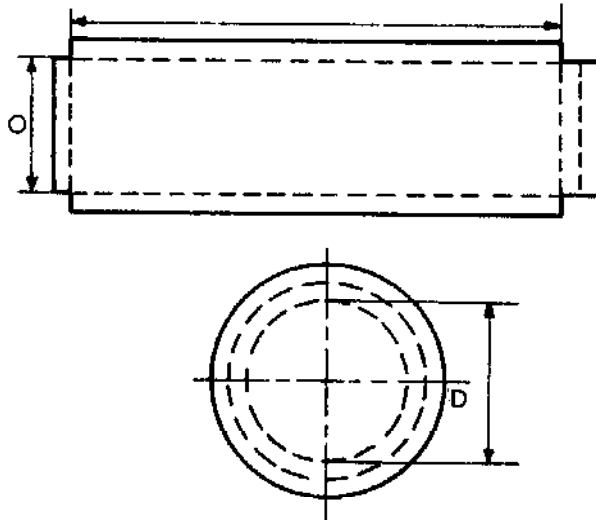
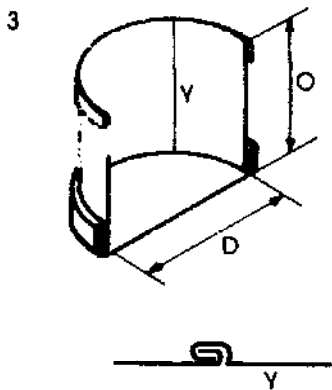
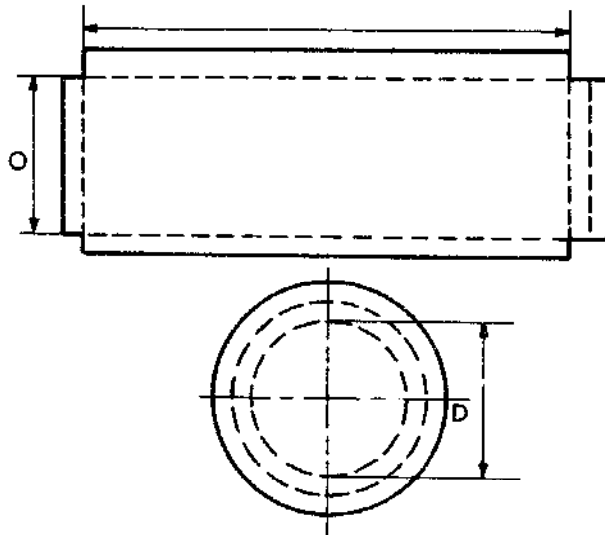
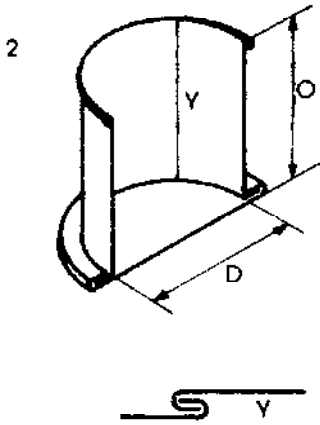
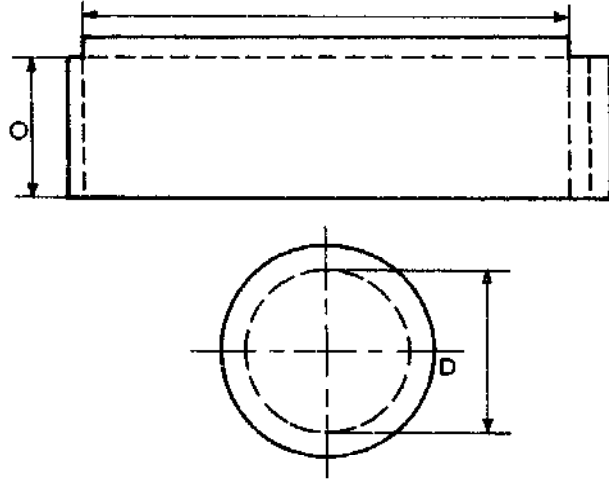
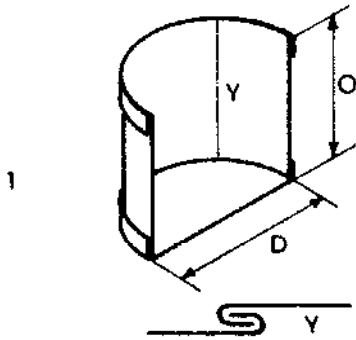

Bucket

Fig. 1: Dimensions

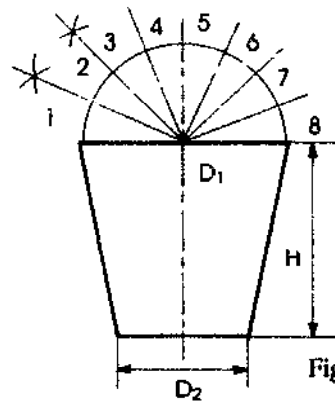
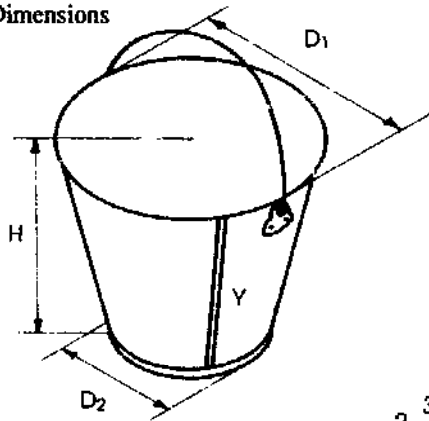

Fig. 2: Cross section

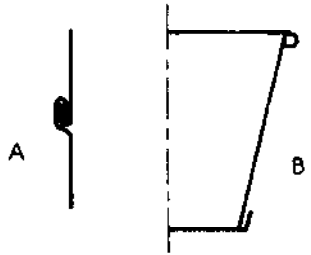

Fig. 3: Seam (3-A) and seam/wire edge (3-B)

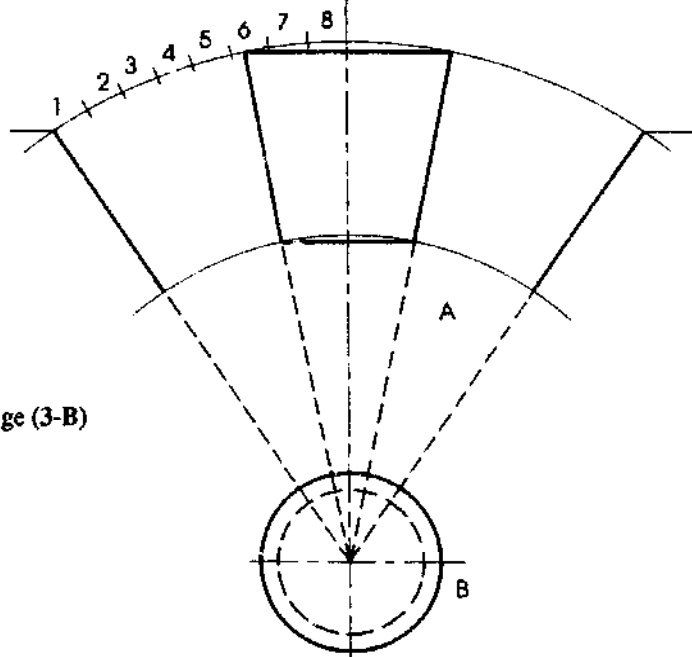

Fig. 4: Development circle (4-A) and bottom (4-B)

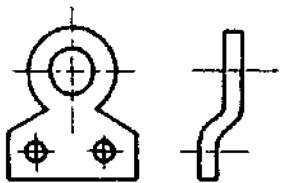

Fig. 5: Attachment for the handle - find stretched length

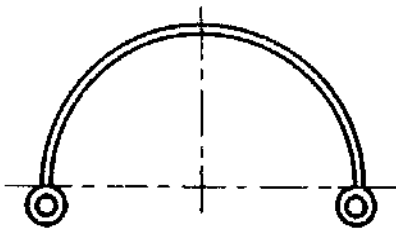

Fig. 6: Handle - find stretched length

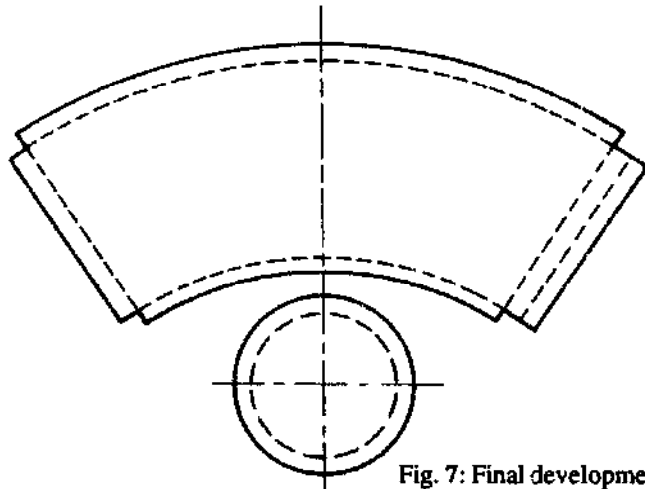
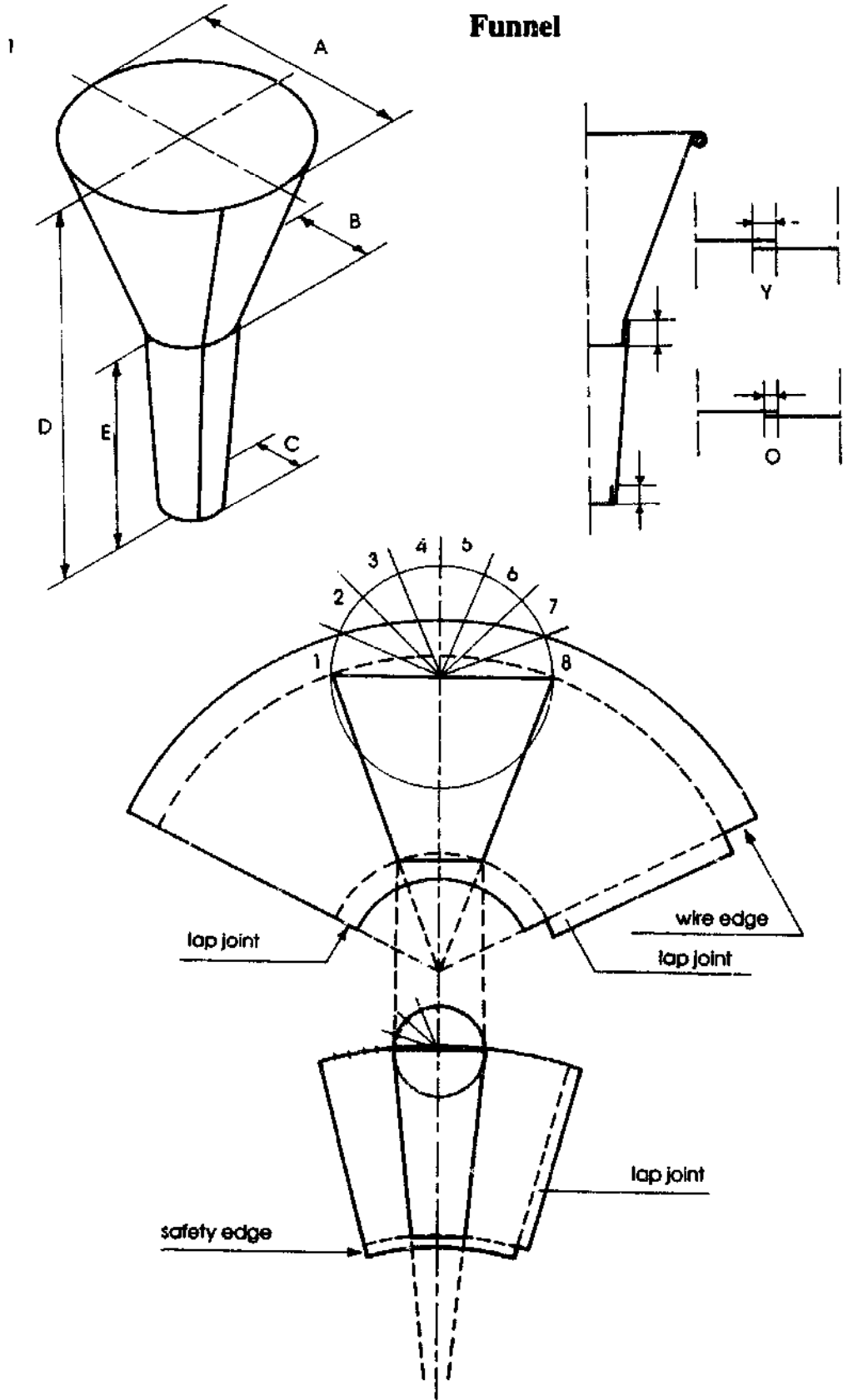

Fig. 7: Final development

Funnel



Charcoal pot

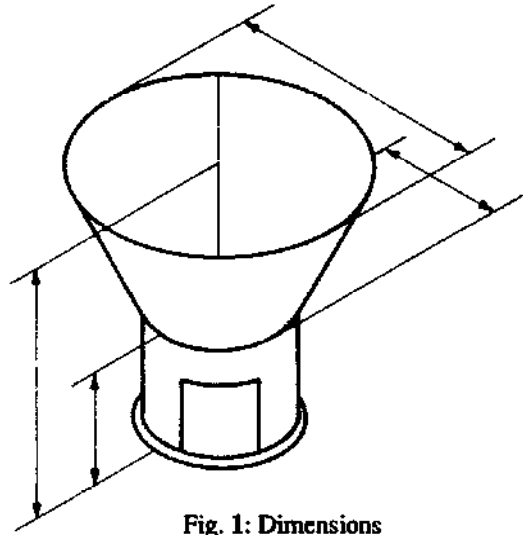

Fig. 1: Dimensions

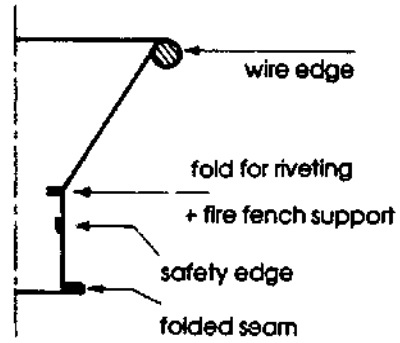

Fig. 2: Cross section

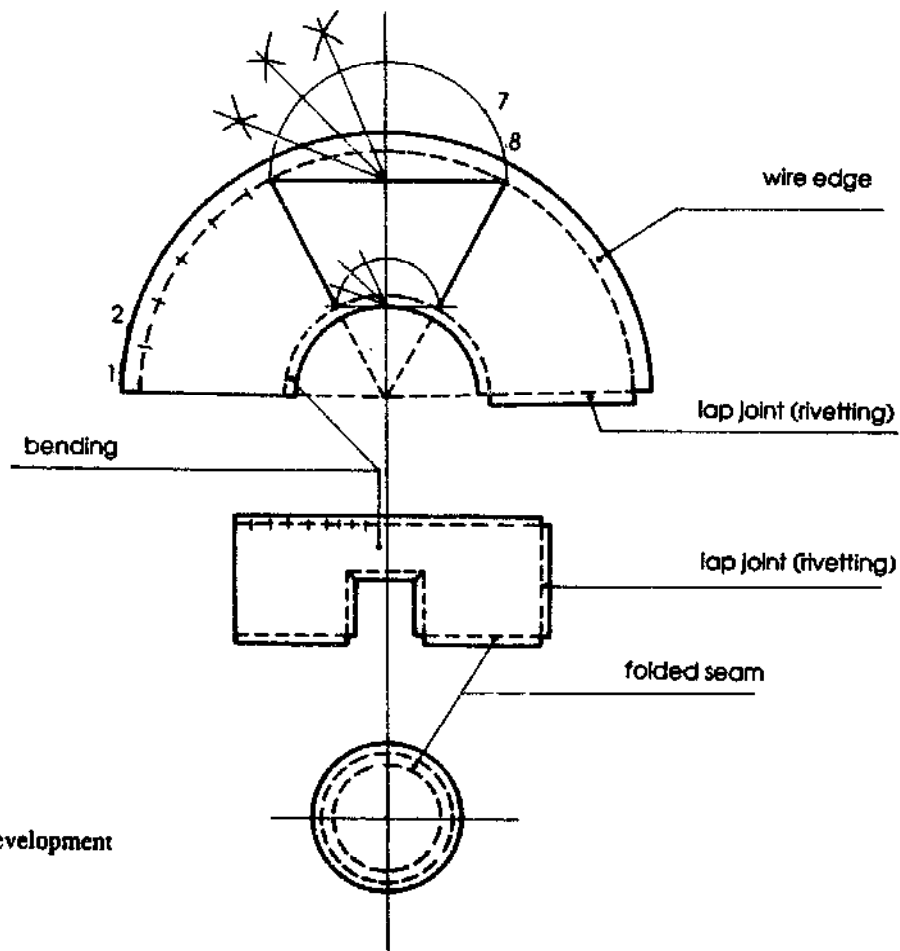
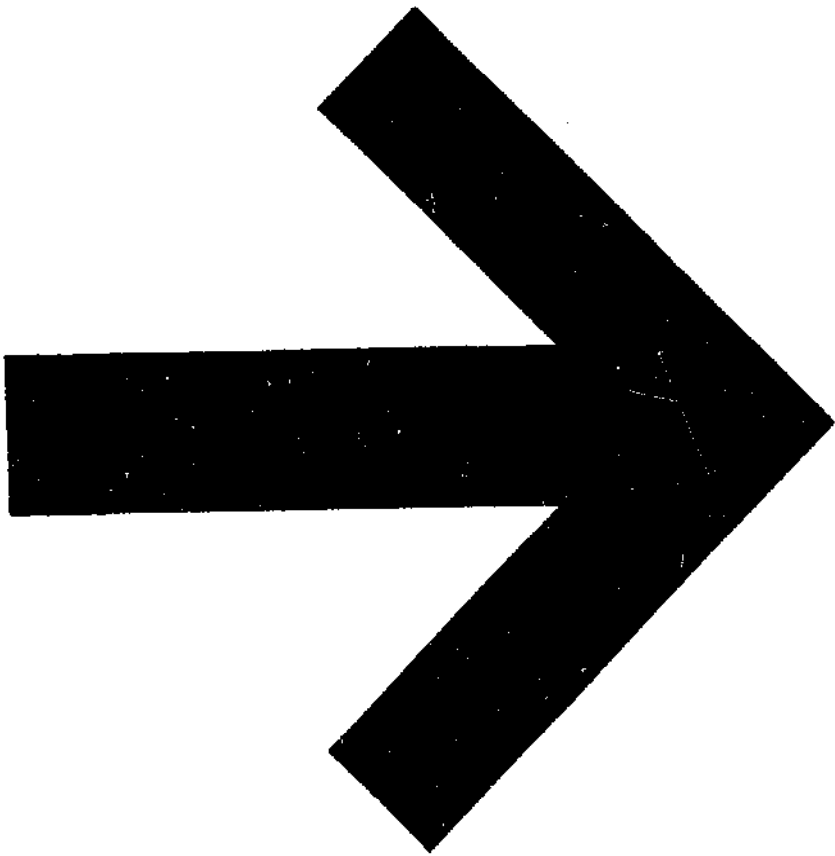

Fig. 3: Development



Contents

Rural Mechanics Course	3
Preface	3
Introduction	3
Rural Mechanics Course	4
Rural Mechanics Course Lay out and Timetable	5
General metal work and sheet metal work	7
General metal work and sheet metal work	8
Tools	9
The rural workshop	10
Storage of materials	11
Workshop lay-out	12
Metallurgy	13
Mined iron ore	14
Blast furnace	15
Nature of pig iron	16
Cupola/cast iron	17
Castings	18
Wrought iron	19
Steel converter	20
Properties of steel	21
Plasticity/malleability	22
Identification of metals	23
Carbon content	24
Nonferrous metals	26
Heat treatment of steel	27
Annealing	28
Shaping metals	29
Tools and equipment	31
Clamping tools	32
Clamping set	33
Sheetmetal clamp	34
Measuring and measuring tools	35
Measuring	36
Folding rule	37
Vernier caliper	38
Using the vernier caliper	39
Exercise	40
Micrometers	41
Try square	42
Try square and bevel	43
Protractor	44
Feeler gauge	45
Marking out	46
Scriber	47
Marking off	48
Reference lines	49
Centre lines	50
Centre punch	51
Lines on a cylinder	52
Dot punching	53
Dividers	54
Callipers	55

Cutting tools	57	Sharpening tools	111
Hack saw	58	Introduction	112
How to hold the hack saw	59	Grindstone dressers	113
Filing a notch	60	Mounting a new wheel	114
Files	61	Sharpening the cold chisel	115
Classification of files	62	Sharpening the centre punch	116
Holding the file	63	How to sharpen twist drills	117
Round filing with radius	64	Twist drill sharpening gauge	118
Clamping the workpiece	65	Sharpening scissors	119
Steel hammers	66	Testing the sharpness of a knife	120
Hand chisel	67	Axes	121
Cutting on the anvil	68		
Cutting a steel rod	69		
Hollow punch	70	Pipe bending and fitting	123
		How to bend a pipe	124
Drilling	71	Pipe wrenches	125
Drilling	72	Pipe fitting	126
Drilling large holes	73	Pipe die	127
Drill sharpening	74	Adjustable pipe die	128
Cutting edges with different angles	75	Cutting a pipe	129
Post drill	76	Cutting and threading	130
Drill chuck	77	Assembling pipes and fittings	131
Pillar drill	78	Repairing leaks	132
		Polyvinyl chloride pipes	133
Assembly tools	79	Main valves	134
Introduction	80	Globe valve	135
Spanners	81		
Set of socket spanners	82	Hand pump maintenance	137
Box spanner	83	Introductions	138
Torque indication	84	Types of pumps	139
Screwdrivers	85	How the suction pump works	140
How to use screwdrivers	86	The suction/lift pump	141
Pipe wrench	87	The lift pump	142
		Lifting the riser pipe	143
Bolts and thread	89	How to lift the riser pipe	144
Bolts	90	Transporting pipes and rods	145
Various bolts	91	Pump maintenance	146
Bolts, nuts and screws	92	The monarch pump	147
Thread dimensions	93	India Mk II pump	148
Thread dimensions	94	Robbins & Meyers pump	149
Types of thread: metric thread	95	Making a leather cup	150
Types of thread: American or unified thread	96		
Types of thread: British thread	97	Sheet metal work	151
Types of thread: Whitworth gas thread	98	Sheet metal work	152
Threading	99	Sheet metal development	153
Dies	100	Marking	154
How to cut a thread	101	Reinforcement and joints	155
Cutting thread with a tap	102	Cutting sheet metal	156
Tapping a thread	103	Cutting sheet metal	157
		Cutting a large hole	158
Locking devices	105	Lever Shears	159
Locking devices	106	Folding bars	160
Nyloc nut	107	Hand hammer and mallet	161
Pins	108	Folding machine	162
Circlips	109	Sheet rolling mill	163
Removing a broken bolt	110	Stretching and upsetting material	164
		Safety edge	165
		Hand-operated beading and corrugating machine	166
		Drilling in sheet metal	167

Sheet metal joints	168
Box seam	169
Riveting sheet metal	170
Riveting tools	171
Cold riveting	172
Pop riveting	173
Exercises	174
Metal box	174
More metal boxes	175
Metal box with lid	176
Charcoal pot	177
Upsetting	178
Drinking mug	179
Stretching	180
Upsetting	181
Developments	182
Bucket	183
Funnel	184
Charcoal pot	185

