

AT MICROFICHE
REFERENCE
LIBRARY

A project of Volunteers in Asia

Piston Water Pump
Publication No. T-114

Published by:
Brace Research Institute
MacDonald College
McGill University
Ste. Anne de Bellevue 800
Quebec, Canada H9X 1C0

Paper copies are \$ 5.00.

Available from:
Brace Research Institute
MacDonald College
McGill University
Ste. Anne de Bellevue 800
Quebec, Canada H9X 1C0

Reproduced by permission of the Brace Research
Institute, McGill University.

Reproduction of this microfiche document in any
form is subject to the same restrictions as those
of the original document.

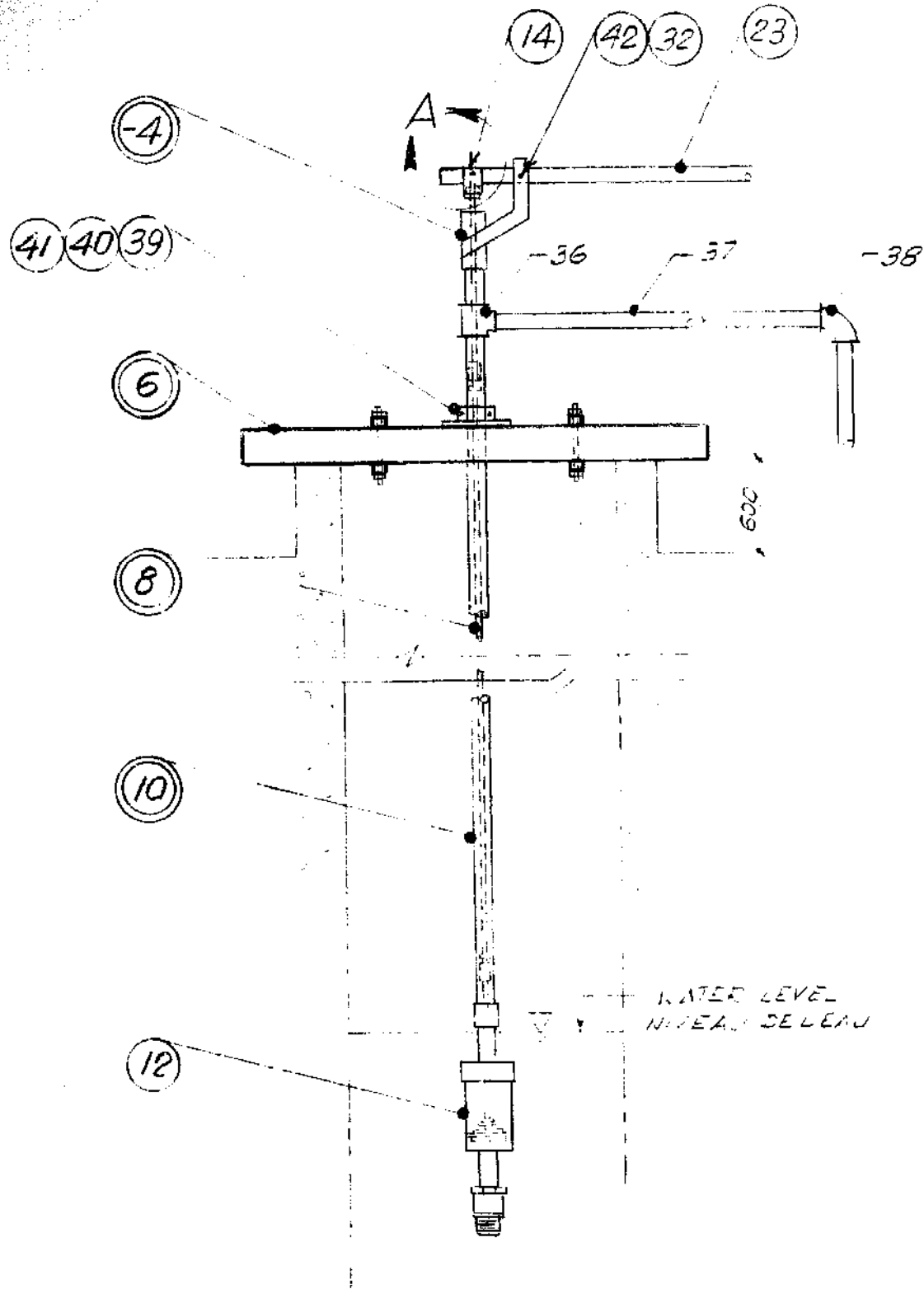

(-2) INSTALLATION

NOT TO SCALE

PAS D'ECHELLE

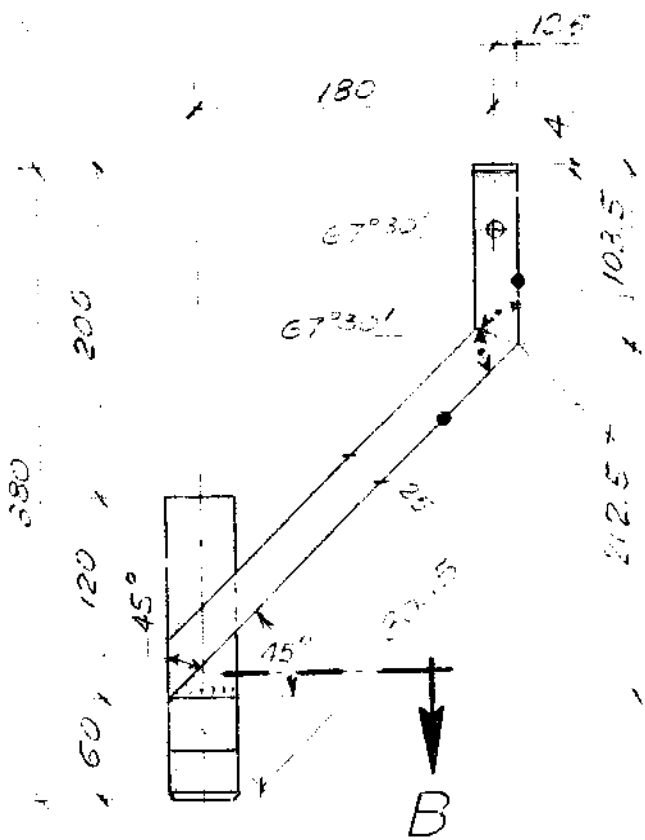

SECTION B

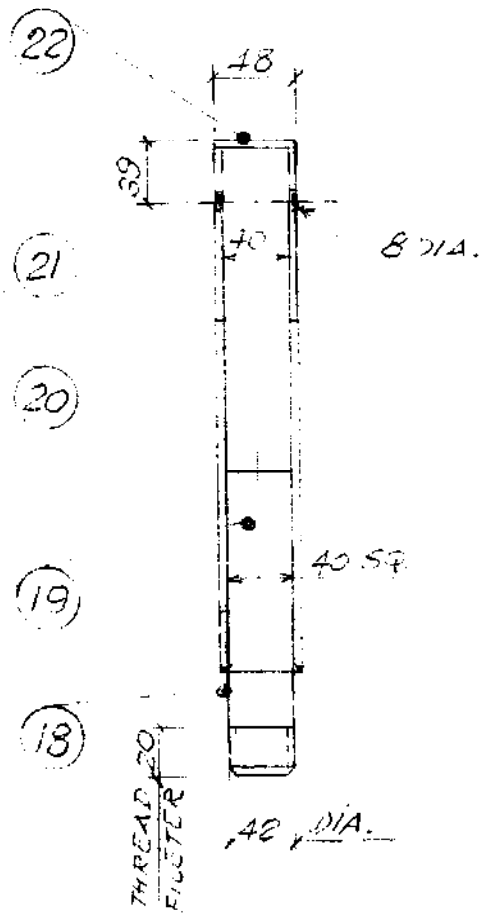

④ ASSY ASSEMBLAGE
1:40

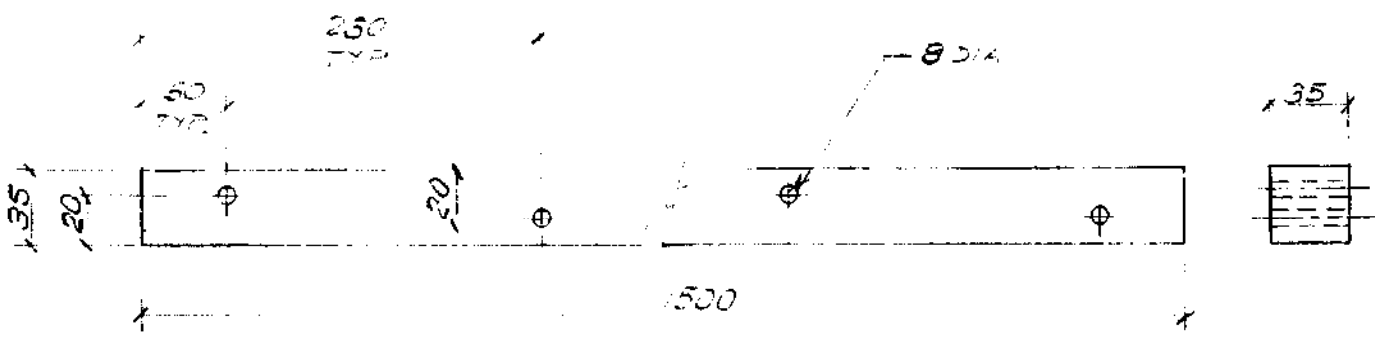

②③

NOT TO SCALE
PAS. SCHELLE

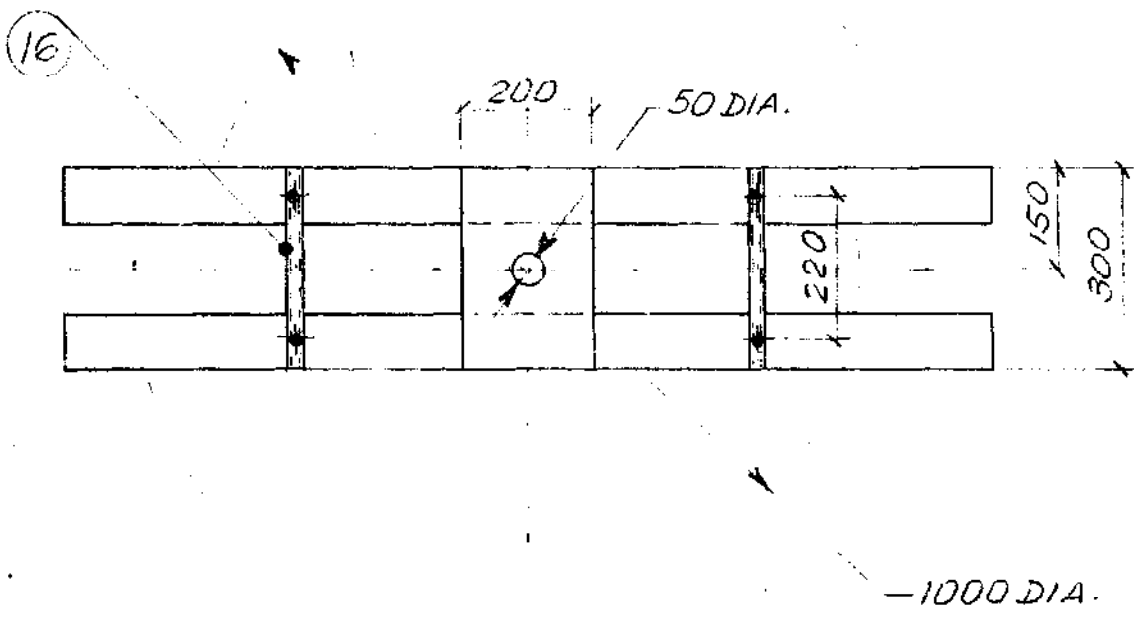
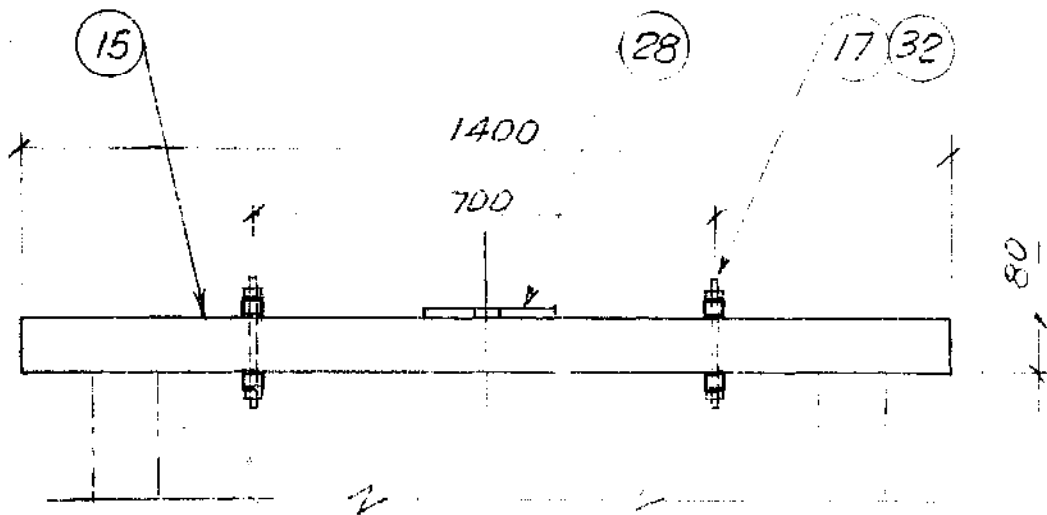

(-6) ASSY. ASSEMBLAGE
 1:10

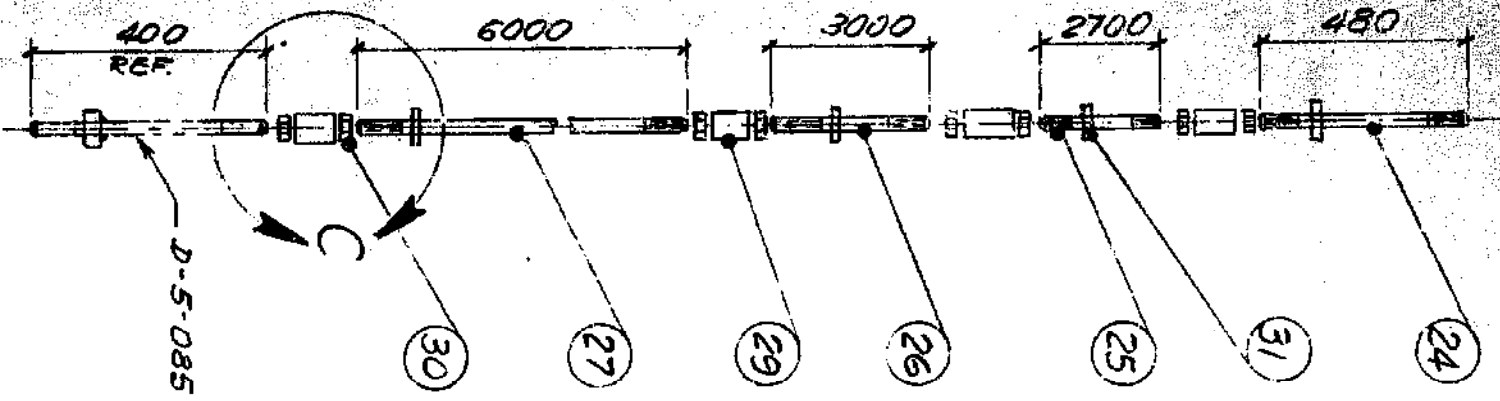

⑧ ASSY.

NOT TO SCALE
PAS D'ECHELLE

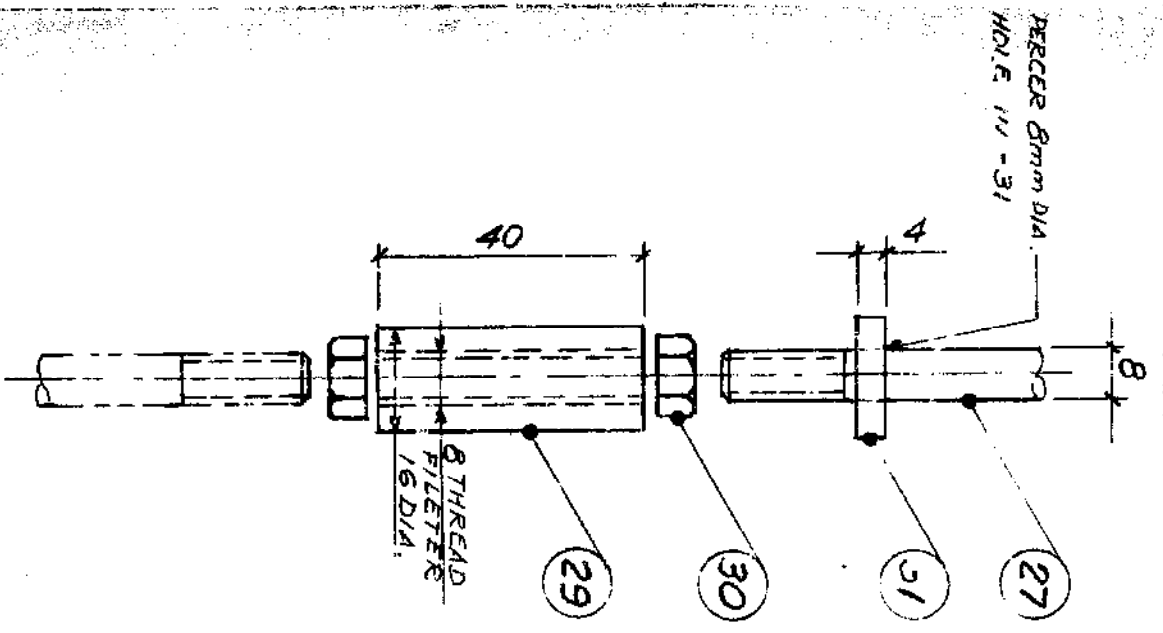

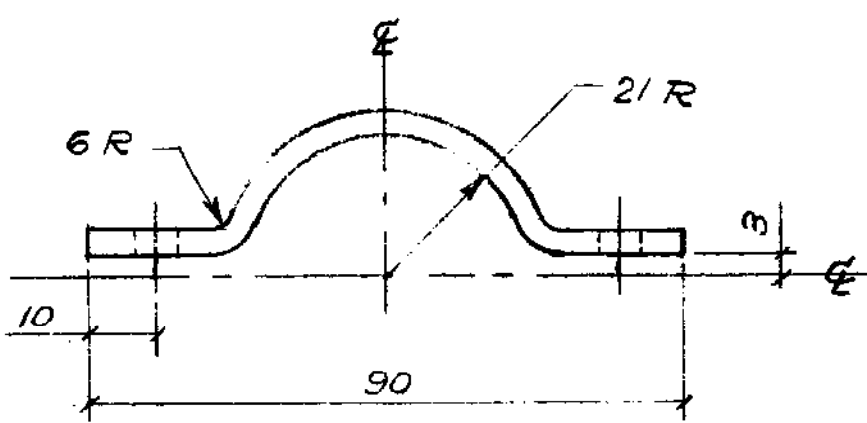
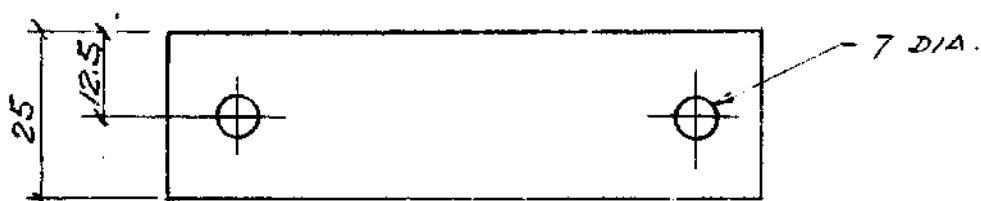
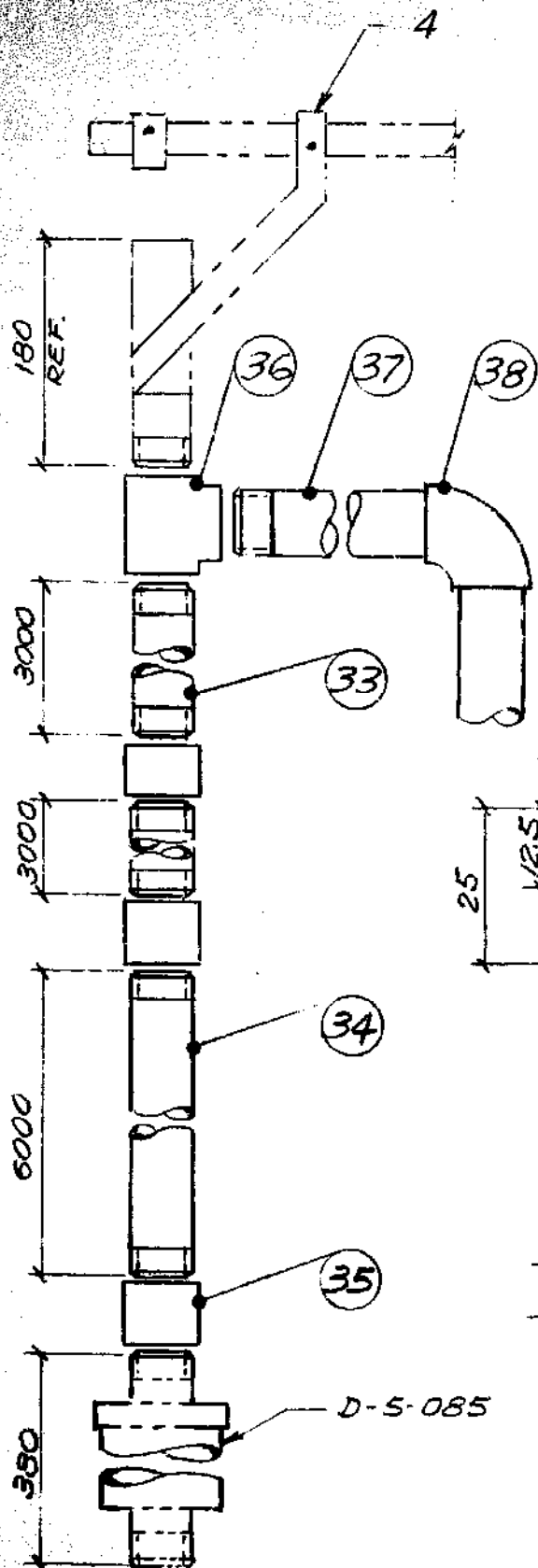

(39) 1:1

(-10) ASSY. - ASSEMBLAGE
NOT TO SCALE
PAS D'ECHELLE

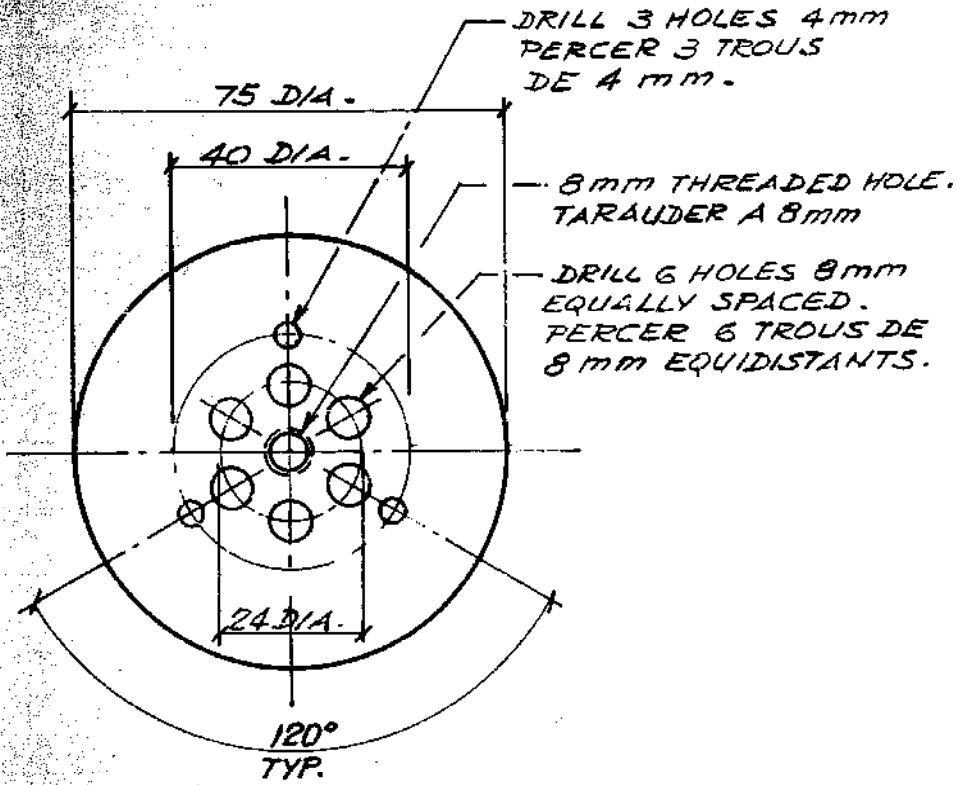

(26)

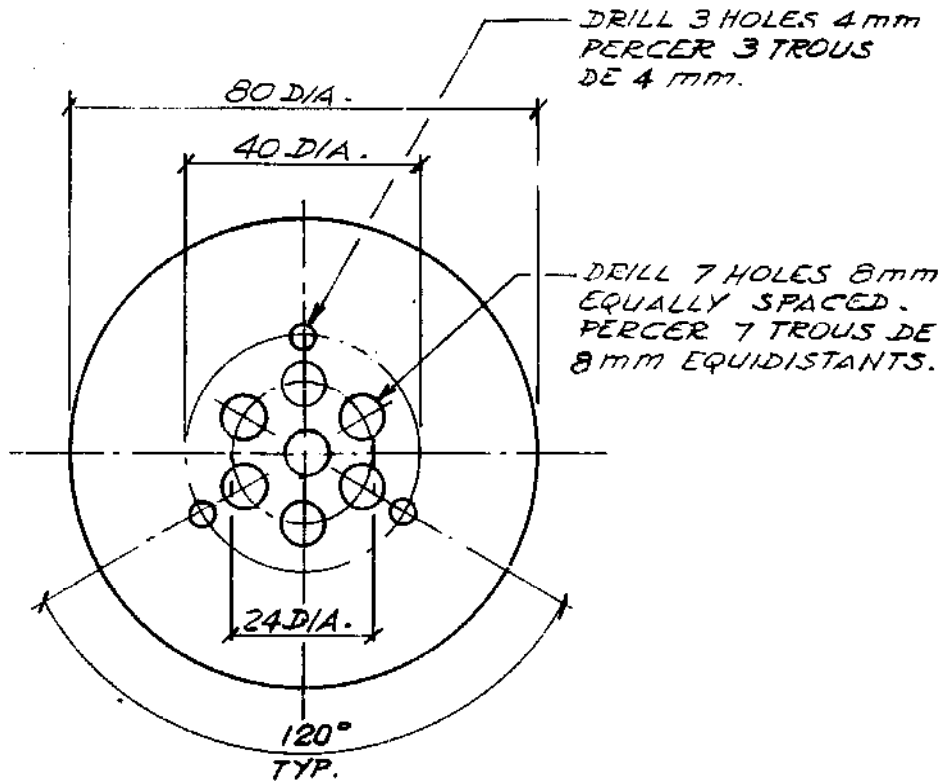

(24)

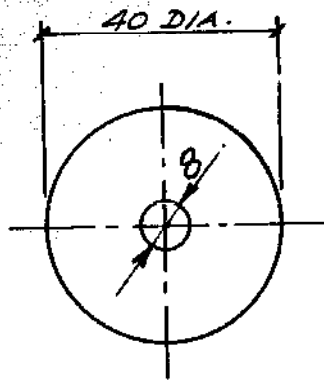

(22)

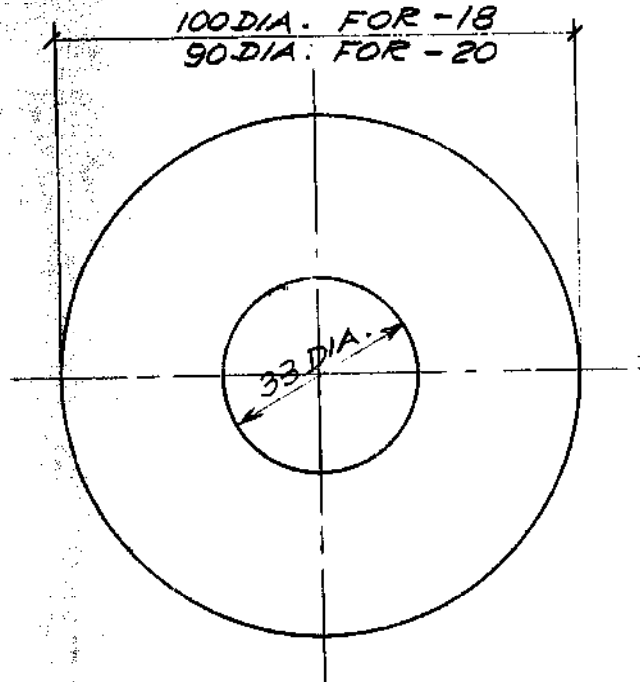

(18)

(20)

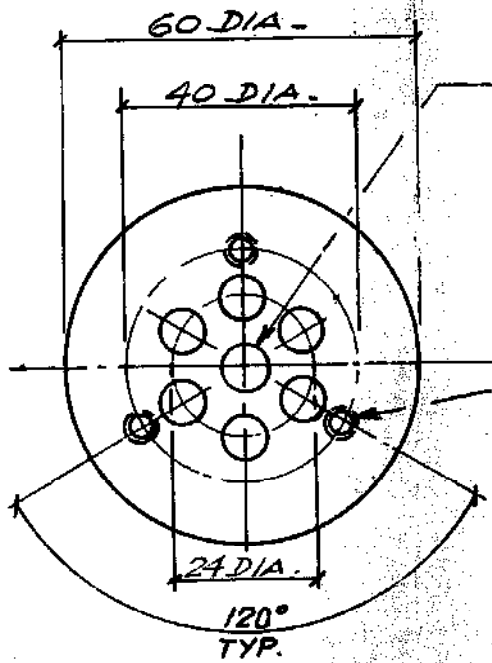

DRILL 7 HOLES 8mm
EQUALLY SPACED.
PERCER 7 TROUS DE
8 mm EQUIDISTANTS.

3 HOLES THREADED 4mm
TARAUDER 3 TROUS DE 4mm.

(28)

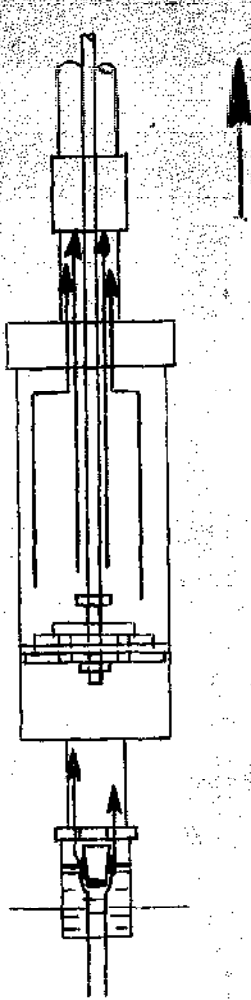

FIG. 1 A

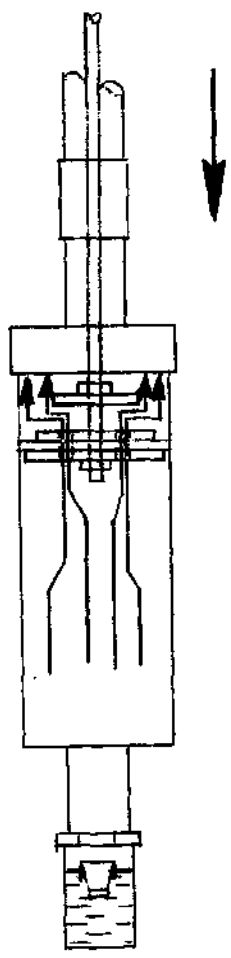

FIG. 1 B

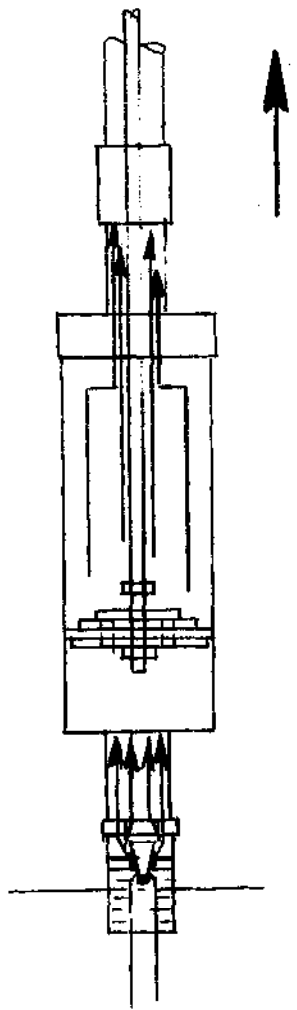
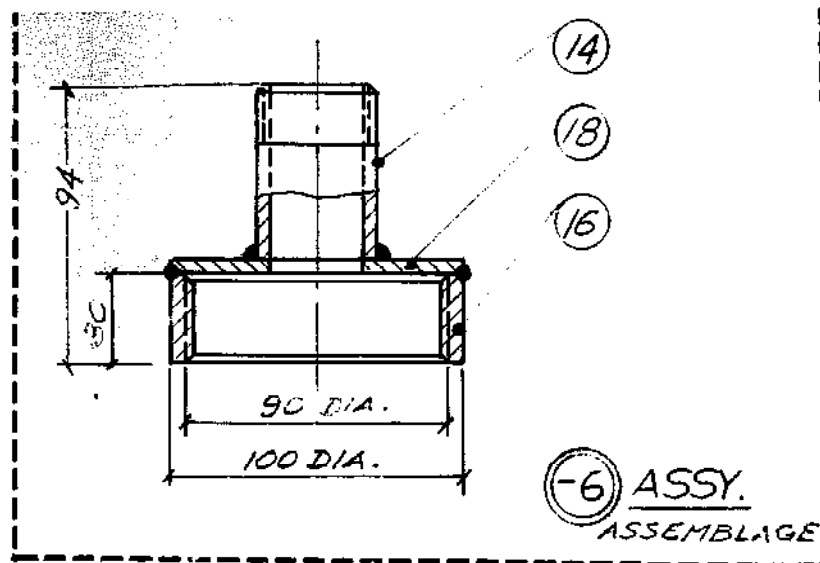

FIG. 1 C

PUMP OPERATIONAL STEPS
SCHÉMAS DE FONCTIONNEMENT DE LA POMPE



	1			36	ECROU DE 8mm ALÈSE / NUT BORED AT 8mm		
	3			34	ROUND HD. SCREW / VIS A TÊTE RONDE 4mm		
	1			32	NUT / ECROU DE 8mm		
	1			30	IRON ROD / TIGE DE FER ROND 8mm		
	1			28	STEEL PLATE / RONDELLE DE MÉTAL 4mm		
	1			26	STEEL PLATE / RONDELLE DE MÉTAL 4mm		
	1			24	RUBBER WASHER / RONDELLE DE CAOUTCHOUC 5mm		
	1			22	RUBBER WASHER / RONDELLE DE CAOUTCHOUC 5mm		
		1		20	BLACK STEEL PLATE / PLAQUE D'ACIER NOIRE 4mm		
		1		18	BLACK STEEL PLATE / PLAQUE D'ACIER NOIRE 4mm		
		1		16	COUPLING / MANCHON	90mm / 100mm	
		1	1	14	GALV. PIPE / TUYAU GALVANISÉ	33mm / 42mm	
		1		12	GALV. PIPE / TUYAU GALVANISÉ	80mm / 90mm	
		1		10	PISTON		
1			1	8	PISTON ROD / TIGE DU PISTON		
			1	6	ASSY. / ASSEMBLAGE		
			1	4	ASSY. / ASSEMBLAGE		
				2	ASSY. / ASSEMBLAGE		
10	8	6	4	2	ITEM	DESCRIPTION	MATERIAL MATERIEL
							SIZE DIMENSION

**BRACE RESEARCH INSTITUTE
OF MCGILL UNIVERSITY**

PISTON WATER PUMP
POMPE À EAU À PISTON

SCALE 1:1 & 1:2

MACDONALD CAMPUS
STE. ANNE DE BELLEVUE
P.O., CANADA

DRAWN	O. G.	Mar 77
CHECKED	Baldwin	Mar 77
ASSEMBLY		

DWG. No. D-5-085

T-114 \$5.00