

Brakedrum PM-Alternator Windmill Plans. UK 1998
Hugh Piggott 1998.

Brakedrum
permanent magnet
alternator
Windmill Plans

Hugh Piggott

1998

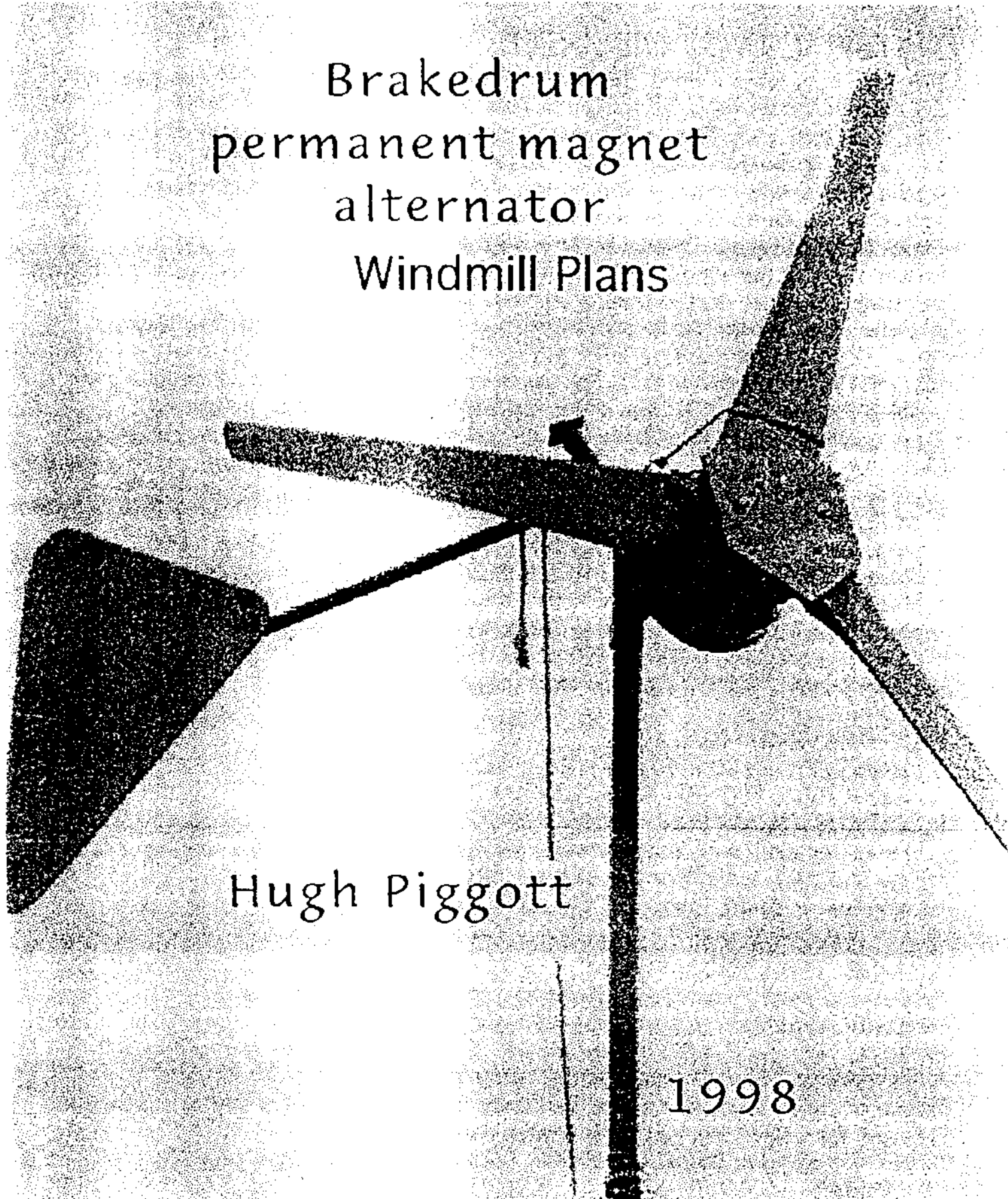

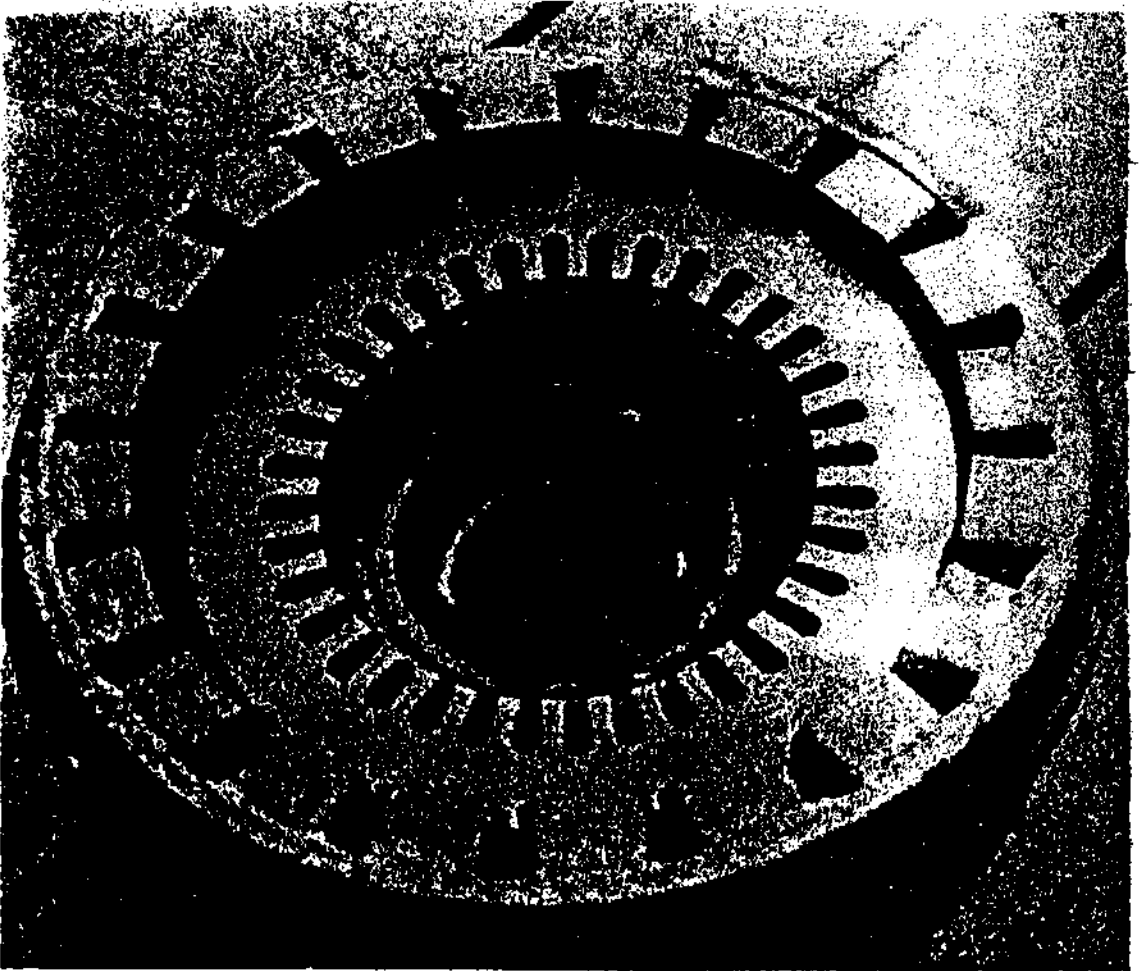
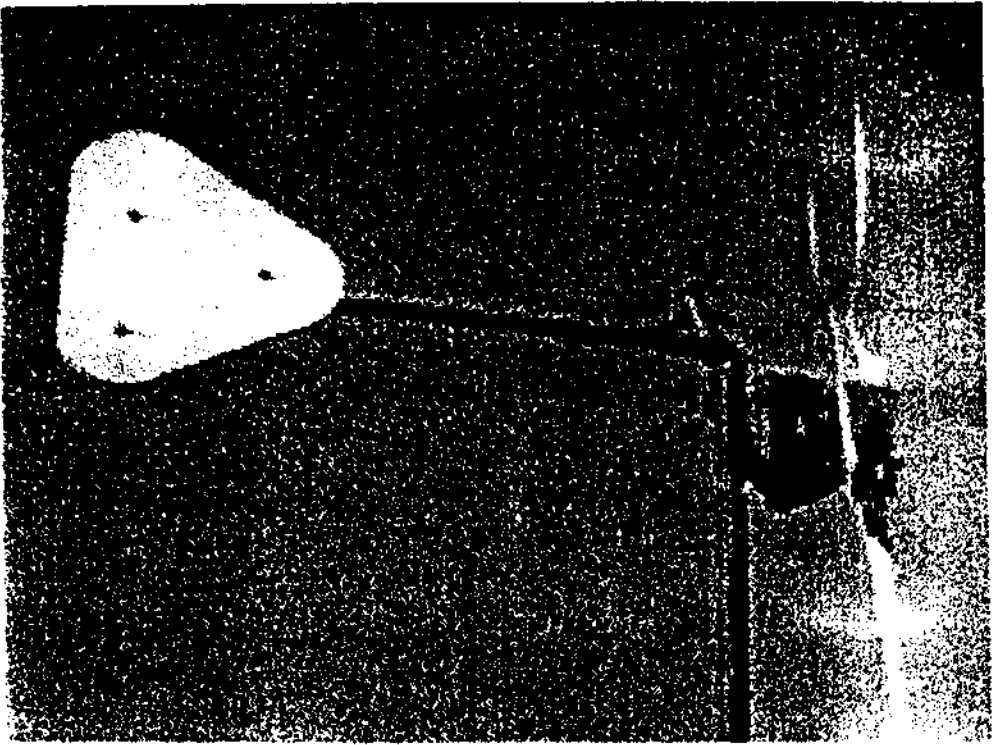

Ford Transit Brakedrum permanent magnet alternator wind turbine plans

first concocted in 1993

Contents:

PAGE

1. Why do it like this at all ? The story, how I got here.
5. General notes More preamble
6. Dismantling the back axle down to work
8. Dismantling the electric motor
9. Fitting Magnets to the brake drum
10. Winding the coils
12. Connecting up the coils
15. Making the propeller
22. Putting it together with a tail etc.
27. Resource list

Hugh Piggott . Scoraig Wind Electric

fourth edition

1998

Dundonnell
Ross shire, Scotland
IV23 2RE
TEL/FAX (01854) 633 286

USING A FORD TRANSIT HUB AND BRAKE DRUM TO BUILD A WIND TURBINE GENERATOR.

WHY DO IT?

I have been making windmills from scrap materials for twenty years. It cuts the cost and I like recycling. The biggest headache has always been to find a suitable generator. A generator for a windmill has to work at low speed, be efficient (not wasteful of power), and also be reliable and affordable. A tough spec.

Vehicle dynamos and alternators were the obvious first choice, but they need rather high speed (rpm) and are inefficient. I learned to rewind Lucas alternators, so they would work at low rpm, but the efficiency went from bad to worse, so most of the energy caught from the wind was wasted heating up the alternator.

The best bet turned out to be dynamos from buses or jeeps. A low speed 24 volt dynamo can be simply converted to a very low speed 12 volt dynamo, and these heavy old machines are rugged, efficient and cheap. I have described how to make them into windmills in my booklet "Scrapyard Windpower Realities", first published in 1982 (updated 1992). (now out of print)

There are many successful windmills in operation based on these dynamos, but I have become painfully aware of the shortcomings. The worst thing is the performance in light winds. Here is the reason why:

All generators require magnetism: they work by dragging coils of wire through a magnetic field. Vehicle dynamos and alternators use electromagnets, and these need about 40 watts of power AT ALL TIMES. So the first 40 watts of power you generate is used up energising the field coils, and only when the wind is stronger do you see an actual "profit", in terms of charging the battery.

Old dynamos are also harder and harder to obtain in good condition, and there are maintenance problems with the brushes.

The best type of generator for a small wind turbine is a purpose built, permanent magnet alternator (pma). This requires no field coils to energise, and has no brushes to cause problems. There are scrap permanent magnet machines which can be useful, such as computer tape drive motors, servos etc, but I have found no reliable source.

Buying permanent magnet machinery new is expensive, and I prefer to recycle, so I started making alternators built on wheel bearings. My first attempt is detailed in "Scrapyard Windpower". It was a rather laborious, welded fabrication of steel discs. Magnets glued on the faces of the steel discs rotated past coils set in a stationary disc sandwiched between, as in the design used by Marlec for their Rutland wind turbines. It worked very reliably, but I felt that it had been too much hassle to justify building another.

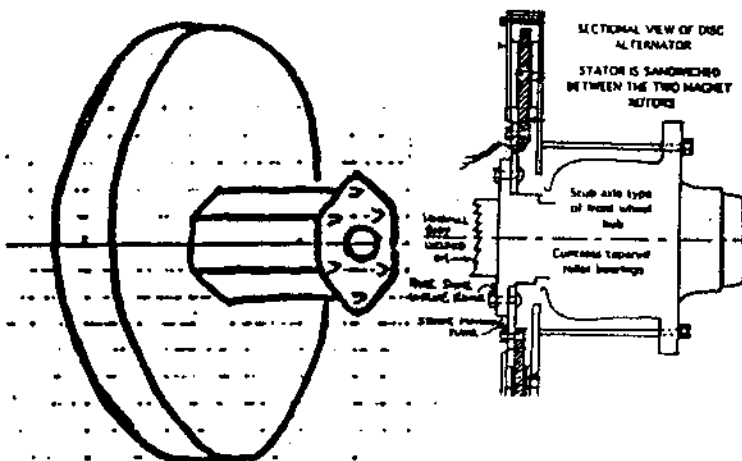

SIMPLIFIED SKETCH OF THE PERMANENT MAGNET ALTERNATOR BUILT FROM STEEL DISCS, MOUNTED ON A WHEEL HUB.

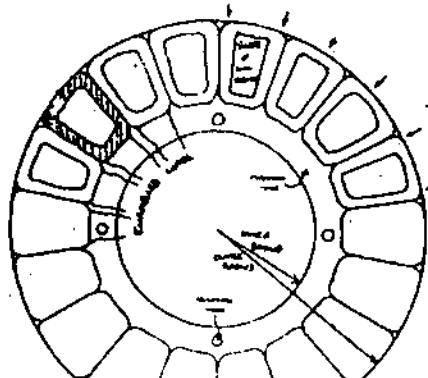

But over the years, quite a few people have built these, using the plans in 'Scrapyard' and I hope to produce a new, united set of plans for both approaches, one day.

Small american wind turbines such as the Whisper and Bergey machines use a different geometry for their pma. The magnets are glued to the inner surface of a cylinder (steel tube) which rotates. The coils which produce the output are wound on a stationary core of laminated iron material, with slots in its outer surface for the coils to fit into. (The stationary bit with the coils is called the stator.) It seemed to me that a much simpler wheel-hub pma could be built using a brake drum rather than steel discs, and following this american style. Long wheelbase Ford Transit vans have big brake drums on the back axle, and excellent bearings.

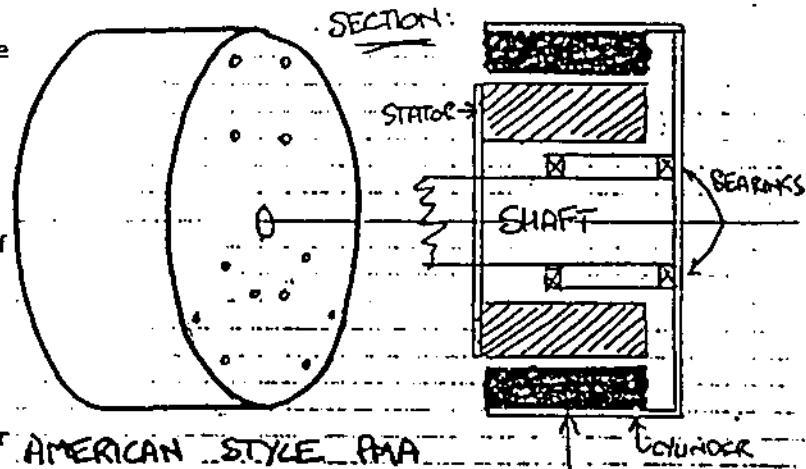

AMERICAN STYLE PMA
 BASED ON A ROTATING
 CYLINDER, WITH MAGNET
 BLOCKS GLUED INSIDE.

HOW I DID IT

Finding suitable magnets was not a problem. Hawnt Electronics in Birmingham gave the best quote, although I could have got smaller quantities from Magnet Applications, at twice the unit price. The internal diameter of the brake drum is 10 inches (254mm). The length is 2 1/4 inches (64mm). I chose magnet blocks 64 by 32 mm, with thickness 20mm, (magnetised through the thickness). Twenty magnets can be fitted around the inner face of the drum, bringing the internal bore down to about 212mm.

The big problem was finding laminate material for the core of the stator, to carry the coils. The core has to be made from thin laminates of soft iron stacked into a solid block. You can see them in transformer cores, or dynamo armatures. If you used solid iron, the changing magnetic fields would set up wasteful eddy currents in the iron, but the laquer between the laminates prevents this. I wanted a core which fitted close up to the magnets, with only a small air gap, and slots to carry the coils, as in the american design. A small air gap allows the maximum magnetic field strength. But the diameter of laminated material I needed was much bigger than standard sizes in scrap dynamos etc, and to have it purpose made would have added over a hundred pounds to the cost of each alternator.

IDEAL SHAPE FOR LAMINATES.
 SLOTS FOR COILS

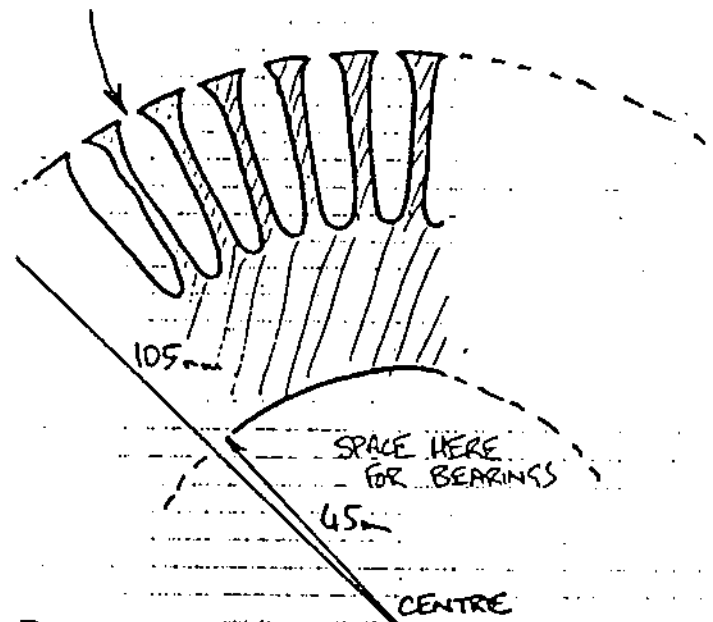

For a while I almost abandoned the whole idea. I could see no way to make the stator at low cost. Then Gordon Proven of Proven Wind Turbines encouraged me to try a different tack.

The way I did it in the end was using laminates from a very ordinary big 3-phase, 5 horse electric motor. The laminates are the "wrong way out", with slots on the inner bore, and an almost smooth out surface, diameter 8 inches (203mm). Rather than placing the coils in slots, I glued them on the outer face of the laminated core, in the 4.5mm gap between core and magnet faces. This gap is a rather large one for the magnetic field, and the field is weakened. Much of it also "leaks" straight from one magnet to its neighbour, to avoid jumping the gap. But the laminates were cheap (from a scrap motor), and the resulting alternator does work.

ACTUAL SHAPE USED:

COILS GLUED ON SURFACE

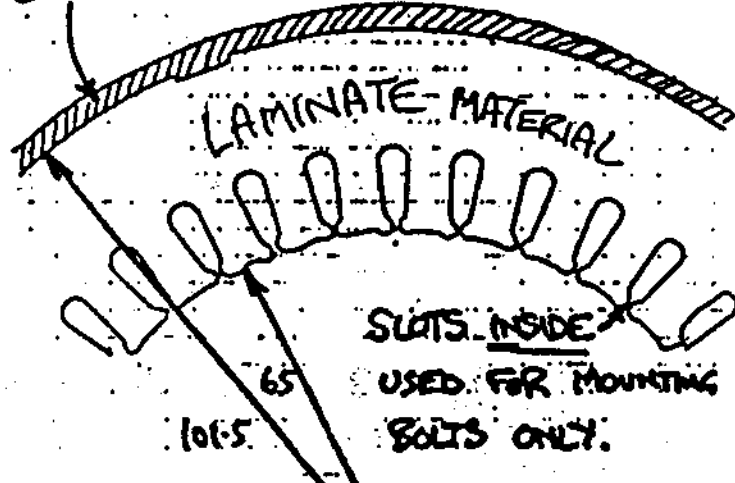

In fact the alternator was quite a success.

for its weight, it is not as efficient as an alternator with the right sort of laminations and a smaller airgap, but it does have some advantages.

For one thing, this sort of lamination is much easier to find.

Also, the alternator starts up more easily in light winds than it would if the airgap were narrow. Machines with small airgaps have much higher magnetic drag, which holds the windmill back from starting up in light winds.

I glued the coils to the outside of the laminations with epoxy resin. I needed a very thin layer of coils, so I used a g-clamp to press them down onto the lams. The wooden former shown is easily made by carving a hollow in the wood with an internal radius of 104mm.

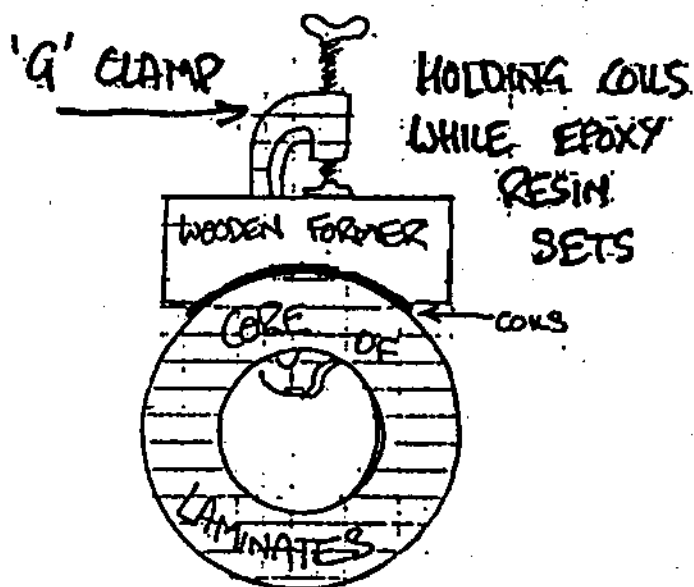

From past experience, the commonest problem with permanent magnet alternators is that the magnets start to rub the stator, so I allowed plenty of clearance (around 2mm). So only just over half of the 'airgap' is filled with coils. You could get more power by making the coils thicker, but at the cost of lower reliability. I have never had a problem with the magnets hitting this stator, even when the bearings were quite slack.

The resulting windmill has been one of the best I ever built, and I immediately set to work and prepared plans so others could do the same. I actually built it for the low windspeeds of the Glastonbury Festival site in 1993, where it proved to be as good as the Marlec fm1800 wind turbine in low winds.

After the Festival, I put it up on a hilltop site near my home, powering a neighbour's house. Here it had the chance to prove itself as a high windspeed survivor. The furling tail system protects it against overspeed. At first we set the tail up to limit the output to 300 watts, but after a couple of trouble free years I added more weight to it, so my neighbour gets 500 watts (well actually rather less, as nearly half is lost in the cable to the house).

Here is some data for the alternator (connected 'star', for 24 volts):

Cut-in rpm 200rpm Internal resistance 4 ohms.

3 amps at 30 volts (90 watts) at 320 rpm

9 amps at 42 volts (378watts) at 600 rpm.

See page 28 for more details on amps and volts.

The technically minded reader will have sussed out that there will be quite some heat generated in the windings when the alternator is putting out 9 amps. In fact the loss will be about 360watts, so the alternator is only about 50% efficient at this point.

This is not wonderful efficiency, but the important thing is to be efficient in light winds, when power is scarce (and this alternator certainly is that). In higher winds, there is often power to spare, and also plenty of cooling to prevent the windings from burning out!

To milk the best output from the alternator, you should ideally load it with only a small current and use higher voltage in higher winds. The Marlec fm1800 wind turbine has a special controller which does this, (part of the reason why this windmill is so expensive). One solution would be to use star connection in low winds, and change to delta in high winds. Resistive loads (heaters) will work with better efficiency from the alternator than battery loads because their voltage will vary.

But this is not a crucial issue, and in fact you will have a very good windmill even if you ignore the above considerations.

GENERAL NOTES

I should be very surprised if anyone follows these plans exactly, although this course of action would certainly give good results. In practice, it is most likely that

- a) the parts which are obtained will vary slightly in size and shape from those suggested
- b) individuals will have their own ideas for simpler or better ways to suit their own skills and resources.

For example, I have made much use of electric welding, but for some it will be easier to bolt pieces of steel together and so avoid welding.

BLADES

I prefer to make blades from wood, but they can also be made from glassfibre and resin, or even from metal. Metal blades will tend to suffer from fatigue, and this danger should be recognised. Gordon Proven has a very interesting technique for making blades from polypropylene sheets, but I am not qualified to describe this properly.

I have used a 3-bladed propeller for this windmill, because they run more smoothly than 2 blades and faster than 4 or more blades would. You could use a larger, 2-bladed propeller instead. The pitch of the blades would need to be finer (flatter) in this case. You could increase the diameter from 2.1m (7') to 2.7m(9') using a higher 'tip speed ratio' (see my book 'Windpower Workshop').

SPEEDING

The alternator can be run through a belt-drive to obtain higher speed, and so more power, from the same machine, if this is considered worthwhile. Belt drive or other gearing is not only more work to make, but will introduce friction, which may make starting difficult in light winds.

The windmill described here cuts in at a very low wind speed, for battery charging applications, where a reliable, slow charge is most desirable. It is at its most efficient when it cuts in, but is fairly inefficient by the time it delivers 300 watts, directly driven by a propeller, and wired as described here, for low speed cut-in.

Higher outputs could be obtained with good efficiency by running it at higher speed, and either rewiring the coils in parallel groups, or operating at higher voltage. There is a trade-off between speed and power which you can use: more speed allows the alternator to handle more power, but also brings more problems with noise, wear, fatigue and vibration. A better approach to getting more power would be to use a larger brakedrum or fabricate something with larger diameter. It's all up to you, but I am available to give advice on the phone or in answer to letter or fax enquiries.

GETTING BITS

There is a list of suppliers at the end of the document, to help you find the bits you need. If you find cheaper sources (I am sure they exist) perhaps you would let me know, and I shall pass the information on to others. If there is anything you really cannot get hold of (laminates may be a problem) then I may be able to help out.

The Ford 3/4 ton truck brakedrum can be used with inch thick mangets and 9.75 inch laminations.

DISMANTLING THE BACK AXLE

What you need is a big brake drum from a Ford transit long wheel base van or similar. There is a Bedford with the same size brake drum, and there will probably be other makes. Front wheel hubs usually have disc brakes these days and so are not suitable for this design of alternator. You need "fully floating" bearings on the hub, ie the hub must be supported by two bearing races, even after the half shaft is removed. In the case of the transit, there are two tapered-roller bearings.

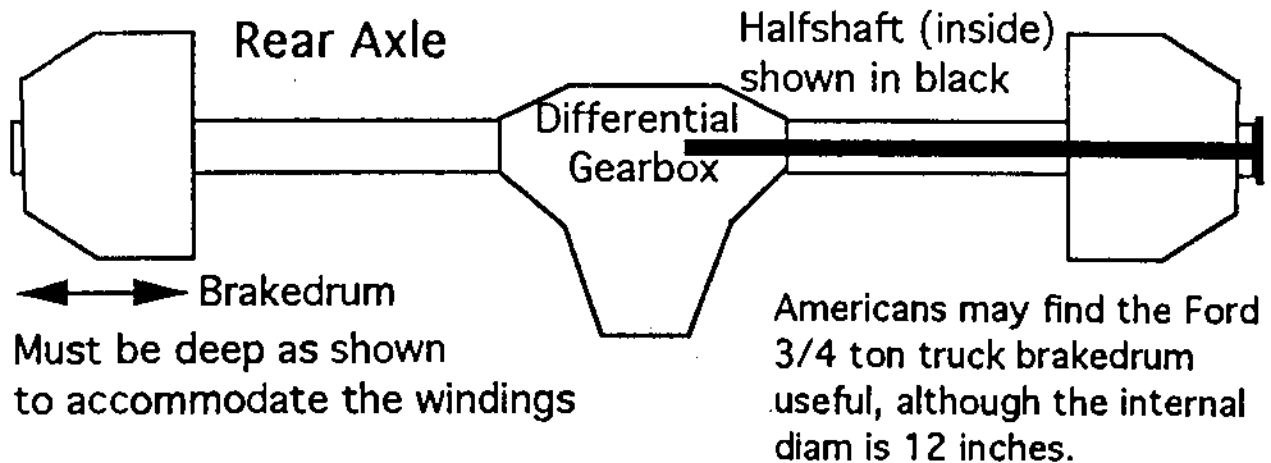

The first step is to remove the half shaft, which carries the drive from the gearbox out to the hub. This is done by removing the six small nuts near the centre of the hub; and simply pulling the circular flange which is actually the end of the shaft.

Next you need to remove the outer bearing race, which is retained by two large thin nuts. The outer nut (which has been revealed by removing the half shaft) is locked by a tab bent outward from a washer behind the nut. Knock this tab backwards with a screwdriver or punch, driven by a hammer, so that the nut can turn. The nut is undone (anticlockwise) by placing a chisel against a corner, and driving it around with a hammer. Lift out the washer, and remove the second nut in the same way. Now the bearing race is free to come out, but it may not wish to. The easiest way I know to persuade it is to refit the half shaft back-to-front (sticking out, not in) and tighten two or three nuts. Pulling and waggling the shaft should release the bearing. When it comes out, keep it clean. It will need to be washed in petrol and repacked with grease (in moderation) before refitting.

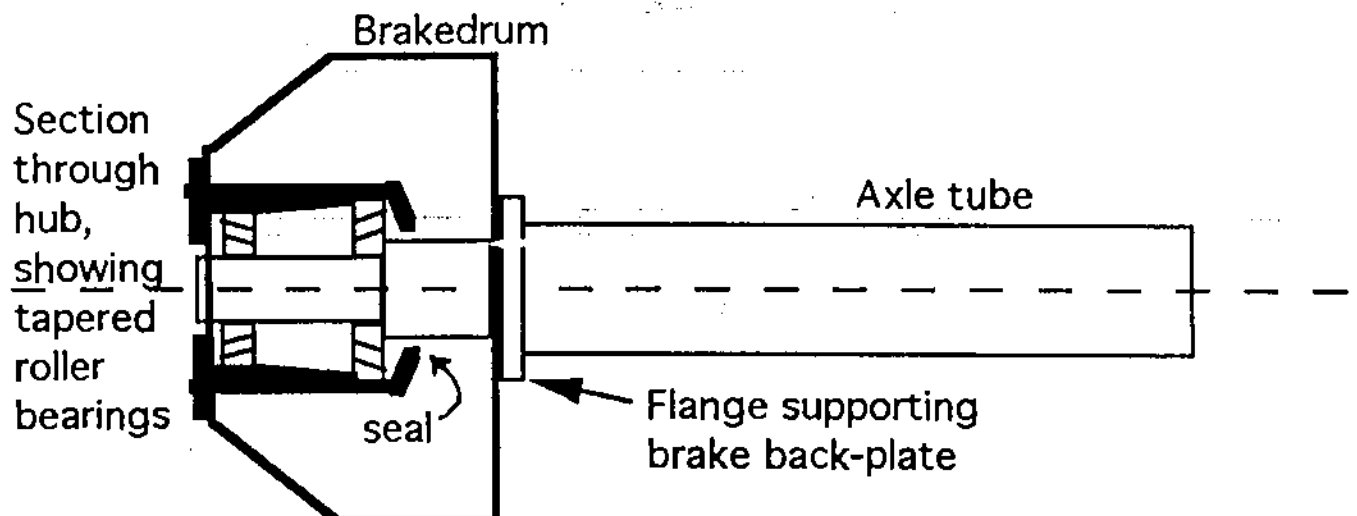

Now the whole hub and brakedrum can be removed from the axle, but it may still be retained by the brake shoes and the seals. Ensure that the handbrake cable is released. Keep waggling and pulling the half shaft. Some hammer blows may also be needed to release the brakes.

The brake parts can be removed as a whole by undoing the four nuts which retain the brake back plate to the axle. These may need penetrating oil, or even some heating, as they will probably be corroded. A piece of pipe on the end of the socket wrench will give you more leverage (and you may also bend your wrench!). Again, some hammer blows may help to crack the rust and let in the easing oil. Having removed the brake parts, knock out the screws which held them with a hammer.

The seal on the inner end of the hub can be removed from the hub using a hammer and screwdriver to prise it out. Maybe there is a more sophisticated method but this does work ok. Take care not to damage the inner bearing race. The purpose of this seal was to keep the oil (which comes from the gearbox to lubricate the bearings) out of the brakes. The seal causes a lot of friction, and you do not need it.

You can saw off the axle tube wherever you want, using a sharp hacksaw blade, in a few minutes. It is not that hard to do! Take it slowly, use the full length of the blade, and pay attention to keeping it square. I cut it off quite close to the end, but if you plan to bolt the windmill together rather than weld it you can leave the flat bracket (which normally meets the leaf springs) attached to the end you are using. For a small fee, the scrap merchant will probably cut it off with oxy-acetylene at the point of sale, and this would save you from transporting the incredibly heavy axle home at all.

EXPLODED
SCRIBBLE
OF ELECTRIC
MOTOR

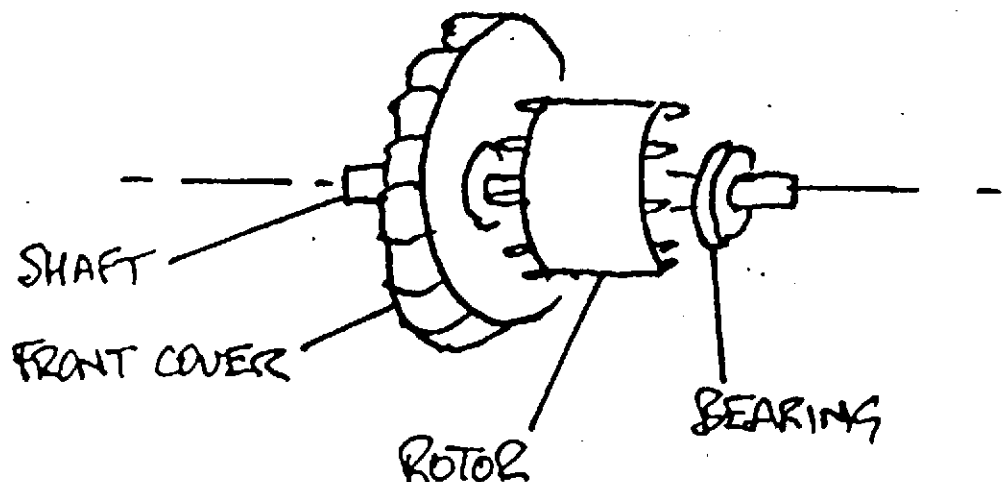

DISMANTLING THE ELECTRIC MOTOR

I have only done two of these, but in spite of some differences in age and general appearance, they had exactly the same kind of laminates in the core, so I think it is commonly used. You need a big (3 phase probably) motor, and the body is usually of cast iron/white metal, with fins. The quickest way to see the laminates is to remove the cover on the terminal box where the wires enter, and perhaps the whole box. You can then estimate the radius from the axis of the shaft to the outer face of the core. This radius should be about 4 inches (100mm).

Start by taking off the cover from the fan at the back, and remove the fan from the shaft. It may be held in place by a roll pin which can be driven out with a punch or a nail with the tip sawn off. Then remove the screws holding on both the ends. The ends should come away, bringing the rotor from inside, and leaving only the motor body. Now you can see the copper windings, fitted to the core within the body. You need to remove the outer frame from the core, or vice versa. The core is retained in the outer frame by a locking pin which is not easy to locate, so the simplest method I know is to destroy the outer frame (the bit with the fins on it). If you have an angle grinder, cut the frame from one end to the other, at the thinnest place, which is where the wiring comes through. Having split the frame, it may spring open or it may need to be levered open until it releases the core, or snaps. The casting is not strong.

To remove the copper windings from the core, first shear off the ends of the coils with a sharp wood chisel, working tangentially (around the circle rather than inwards, or the coils will move into the gap and jam up). When the ends are neatly cut off, you can punch out the copper wires from the slots with a piece of 1/4" rod, leaving the laminates ready for use.

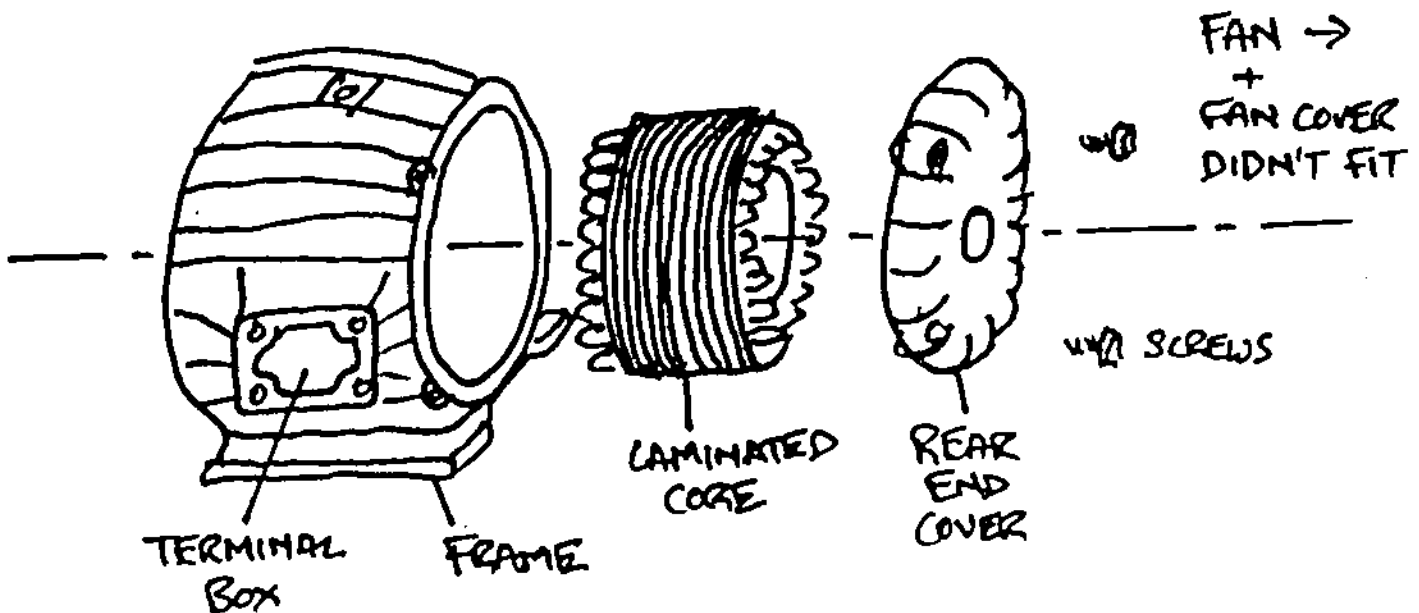

FITTING THE MAGNETS TO THE BRAKE DRUM

The hub and brakedrum will need to be cleaned up thoroughly, to remove all grease and grime, especially from the inner face where the shoes rubbed and the magnets are to be fitted. A rotary wirebrush in a drill chuck is good. Beware of asbestos dust from the brakes: this should not be inhaled.

Place the blocks around the inner face of the drum evenly and note the space between blocks. It should be around 1mm. You will need shims of some non-magnetic material to place between the blocks as you lay them or they will slip together (they are attracted). Aluminium sheet is ideal.

If you want to shape the magnets, this can be done with an angle grinder, using a stone-cutting disc. The magnets are flat, and the drum is curved, so they do not fit perfectly, but shaping is not essential.

The magnets must be clean (no magnetic debris attached). Sticky tape is good at removing rubbish, as is plasticine.

The magnets must be fitted alternating: first with north inside, then with south inside, and north against the drum. (Of course it does not matter which is north as such). The blocks will naturally stack with north against south. As you take them off the stack, TURN EVERY SECOND ONE OVER. As you place it on the drum it should be attracted sideways to its neighbour and not repelled. When the inner face of the drum is coated with resin the magnets slip around fairly easily, and they will slide together. Hence the need for shims. You actually only need about 4 shims because after a while you can start robbing shims which you used earlier and re-using them. Once there are magnets on each side of any given magnet, it will no longer tend to shift. When you get to the end you can adjust the spacing so that it is as even as you can get it. Performance will not be adversely affected by any error which you cannot easily see.

The epoxy resin I use is intended for boat building in wood (SP Systems 106). You mix it at the rate of five of resin to one of hardener, and it takes plenty of time to set (maybe an hour you can safely work in). Avoid mixing a large amount in a pot, or it may heat up and set too fast (going "exothermal"). It helps to add powder to the mix to thicken it, otherwise it will dribble away. "Colloidal silica" is good powder, but again, do not inhale this. There are other thickeners which will do just as well, such as microballoons, or aluminium powder. If you can get hold of iron filings in sufficient quantities then core material could be made in this way. But this is not relevant to the job in hand.

Clean resin from the fingers at once with a dry rag or paper. It can be removed from the skin with solvents such as meths, but this tends to carry it into the skin as well, and can cause an allergic reaction. (Resin is nasty stuff- do not touch.)

WINDING THE COILS

You will need about 800 grams of enamelled copper wire. The enamel prevents the wires from shorting out, and must not be damaged. I used 0.75mm wire, because that was what I had, and it gave a good result. I used 24 turns per coil. A smaller number of turns of thicker wire, or a larger number of turns of thinner wire would give more current or more volts per coil respectively. Power output (volts x current) is not affected by the size of wire chosen.

More power can be obtained by making the coils physically bigger (wider) and using more turns of wire. This is possible to do, since there is good clearance between the magnets and the coils. But if the magnets do touch the coils then you have problems, so I suggest you keep the coil size close to the 2.5mm which I used.

See the diagram of the coil winding machine. You need to build something like this. The tricky bit is getting the crank shaft (made of M10 threaded rod or similar) to drive the coil former and cheek pieces. Nuts are required on the shaft, which can be tightened against the pieces of ply. You start winding the coils by twisting the end of the wire around the retaining nut and passing it into the notch in the front cheek piece. Hold the wire in one hand, keeping a gentle tension on while you crank the machine with your other hand. The coil should be wound neatly in layers to get tight packing.

Before removing from the coil former, the coil has to be tied up. You can simply put a loop of wire around each end, but because the coil is wide and thin, it tends to be distorted this way. I suggest it is as follows:

- either: 1. Use a hot glue gun to solidify the ends of the coils, leaving enough flexibility to shape them later,
or 2. What I did was this:
- a) Wind 12 turns
 - b) Pass short pieces of wire inside the ends of the coil
 - c) cross them over outside the ends of the coils
 - d) wind the next 12 turns
 - e) twist the ends of the short pieces together outside the coil, so that it grips the coil in a figure of 8.

The core should be as thick as the magnet blocks are long (64mm). Simply split off as many laminates as you need to make 64mm thickness, from the core which you extracted from the electric motor. The core must be coated in a thin layer of resin and surfacing tissue or something to prevent sharp edges which might damage the enamel on the wires.

When you have wound six coils, you can glue them to the core. Mark the core in five places for accurate positioning of the coils around the circumference (five equal intervals of 72 degrees, easily found by dividing the 25 inch circumference into 5 equal 5 inch arcs). Place the coils in two heaps of three on the core, overlapping as shown. The ends of the coils need to be manipulated to pass each other without causing bumps which would foul the magnets.

When you are happy with the shape of the coils, mix some (thickened) resin and tip it onto the coil groups. Lay on some surfacing tissue, and press down the wooden former. The inner radius of the curve on

COIL WINDING MACHINE

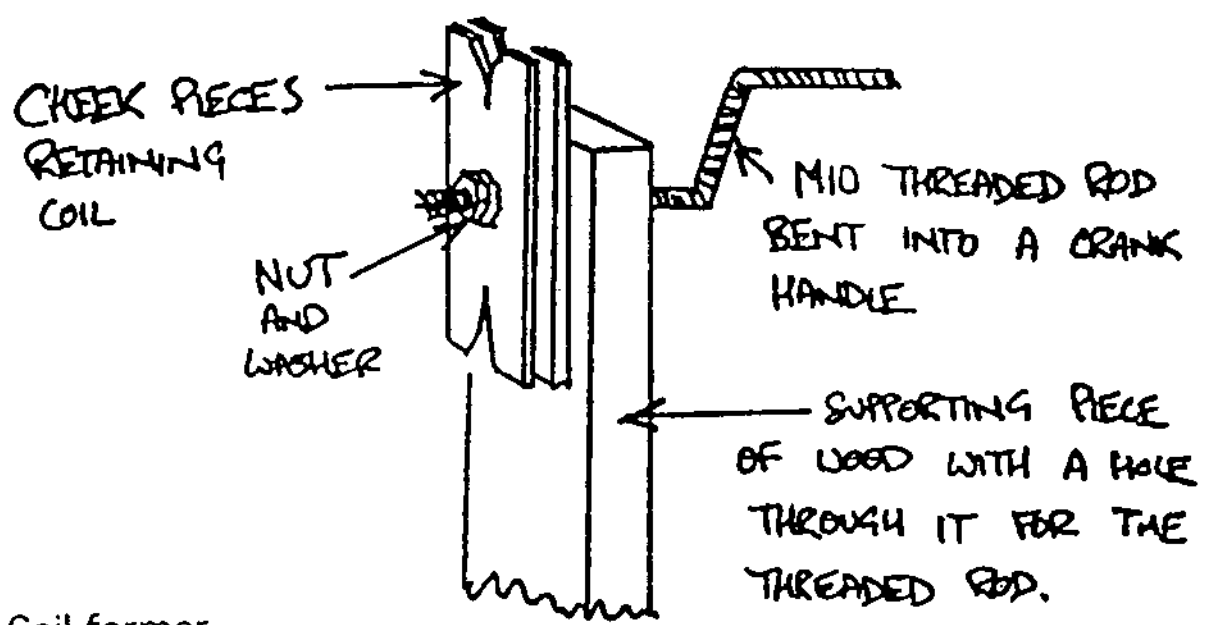

Coil former
(actual size) 70 x 16 mm

Thickness = 2.5mm

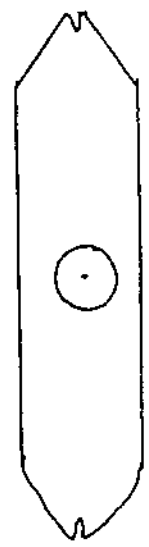

The former is attached to one cheek piece, which in turn is locked to the shaft.

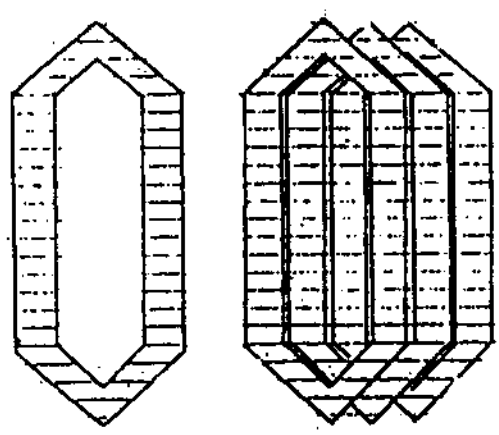
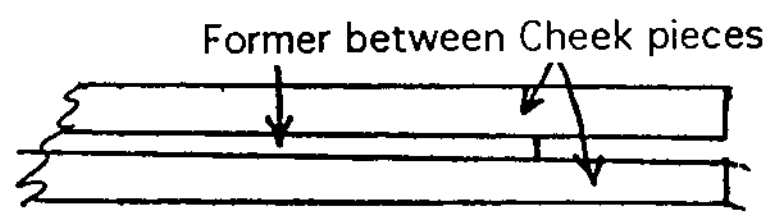

The coils are overlapped in groups of 3 like this.

There are ten groups of three coils each, in all.
 Glue them to the core in pairs. (six coils at a time).
 This makes five gluing sessions.
 Use a G-clamp and a wooden former as shown on page 3.
 Others have succeeded in gluing all thirty coils at once,
 using a band around the whole thing.

the former should be 104mm. The surface of the former needs to be greased to prevent it sticking to the job. Or maybe you could use polythene. Anyway, as the clamps tighten the former down onto the coils, resin squirts out the ends. This should be encouraged to soak into the end windings in such a way as to set them solid. But ensure that you can still see which end of the coil is which when you come to connect them up. You need to be able to see whether the coil runs clockwise from one end to the other (see below). Now wash your hands.

CONNECTING UP THE COILS

When I talk about the start and the finish of a coil, it does not matter which is which, provided you always follow the same rule. For example, looking at the coil from the outside (it is hard to look at it from the core side anyway!) the wire runs clockwise from the starting tail to the finishing tail. This rule defines the start and the finish. You can say anti-clockwise instead, provided you apply the same rule to all thirty coils.

The coils fall into three kinds according to the timing or "phase" of the AC power produced. There are ten of each kind. You will need to use take every third coil, and connect them in series (finish of one to start of the next) as shown below:

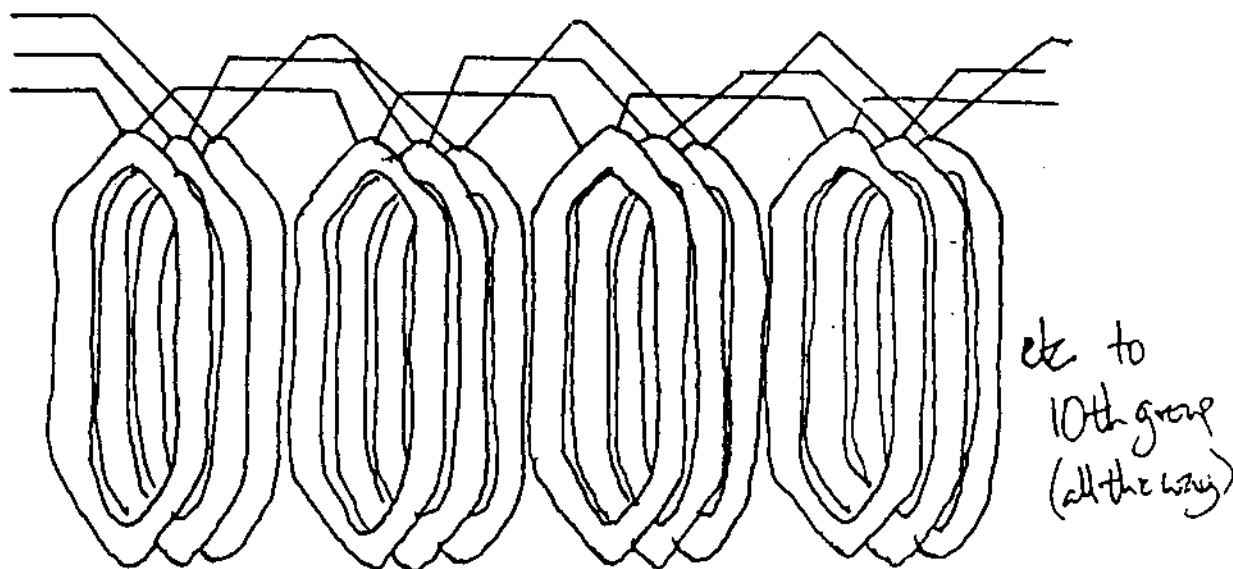

The tails of the coils must be meticulously cleaned with a sharp knife to remove ALL the enamel coating, then twisted together tightly and soldered with a hot soldering iron, and resin core solder. Insulate the joins with tape (self amalgamating tape is best) or heat-shrink sleeving.

You can crank the alternator around and measure the voltage from a set of coils using a multimeter. At 60 rpm (one rev/second), a set of ten coils produces around 3.5 volts AC. This tells us that at 240 rpm it will produce 14 volts AC. So the alternator will cut in and charge a 12 volt battery at just under 240 rpm.

Check the outputs of each group of coils: they should be the same voltage at the same speeds, or you have got some coils reversed. This will leave you with six ends: the starts and finishes of the three series groups of coils. To make a 12 volt machine, these three groups of coils should be connected in "delta" (start of one goes to

finish of the next and so on), whereas a 24 volt machine can be produced by connecting them in "star" (all the starts are joined together, and you take your output from the three finishes) In the diagram, each group of ten coils in series is shown as a single coil, for simplicity:



Just to make life more confusing, the second group of coils, which is made up of all the coils in the middle of the overlapping heaps of three, must be reversed. In other words the start of this group and the finish must be reversed. The actual wiring diagram which results from all this is shown next:

CONNECTING THE SIX ENDS OF THE GROUPS

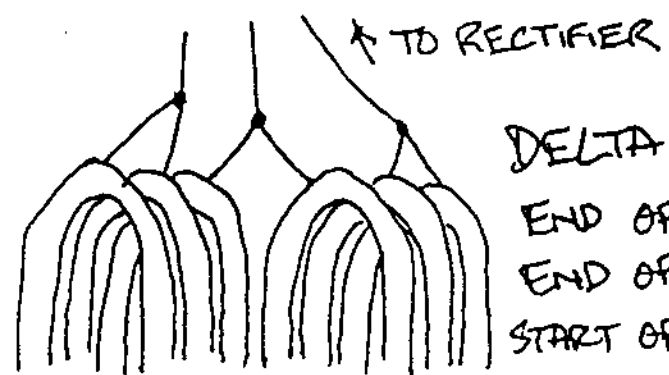

DELTA CONNECTION (12VOLT)
 END OF GROUP ① TO END OF ②
 END OF GROUP ③ TO START OF ①
 START OF GROUP ② TO START OF ③

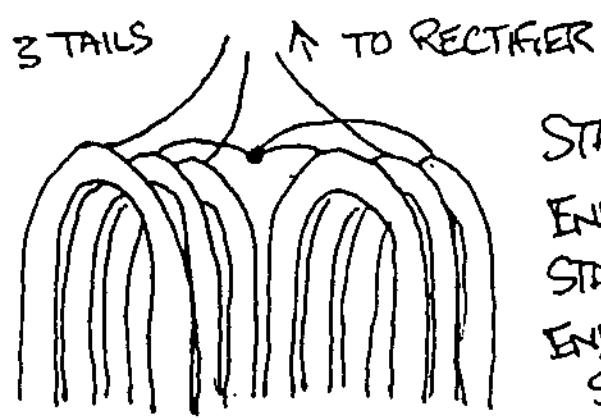

STAR CONNECTION (24 VOLT)
 ENDS OF GROUPS ① AND ③ TO OUTPUT
 START OF GROUP ② TO OUTPUT
 END OF GROUP ② JOINS
 STARTS OF GROUPS ① AND ③

PRACTICAL HINTS

The tails which go to the output should be flexible cable, leading to the bridge rectifier, probably through some sort of connectors and a cable to the house. If find that the blade and receptacle type of crimp connectors are very handy for this sort of situation.

You can connect wiring to the rectifiers with these same crimp-on receptacle connectors (or solder them). The rectifiers are square blocks which must be bolted to a piece of aluminium to dissipate the heat they produce. There are four terminals on each. One terminal is at right angles to the other three. This is connected to battery(+). The one diagonally opposite to it is connected to battery(-). The remaining connectors take the AC wires from the windmill. Since we have three wires (3 phases) we need two rectifier blocks, and there is one spare AC terminal: useful if damage occurs due to lightning or suchlike. It does not matter which AC wire goes to which AC terminal.

CONNECTING THE BRIDGE RECTIFIER

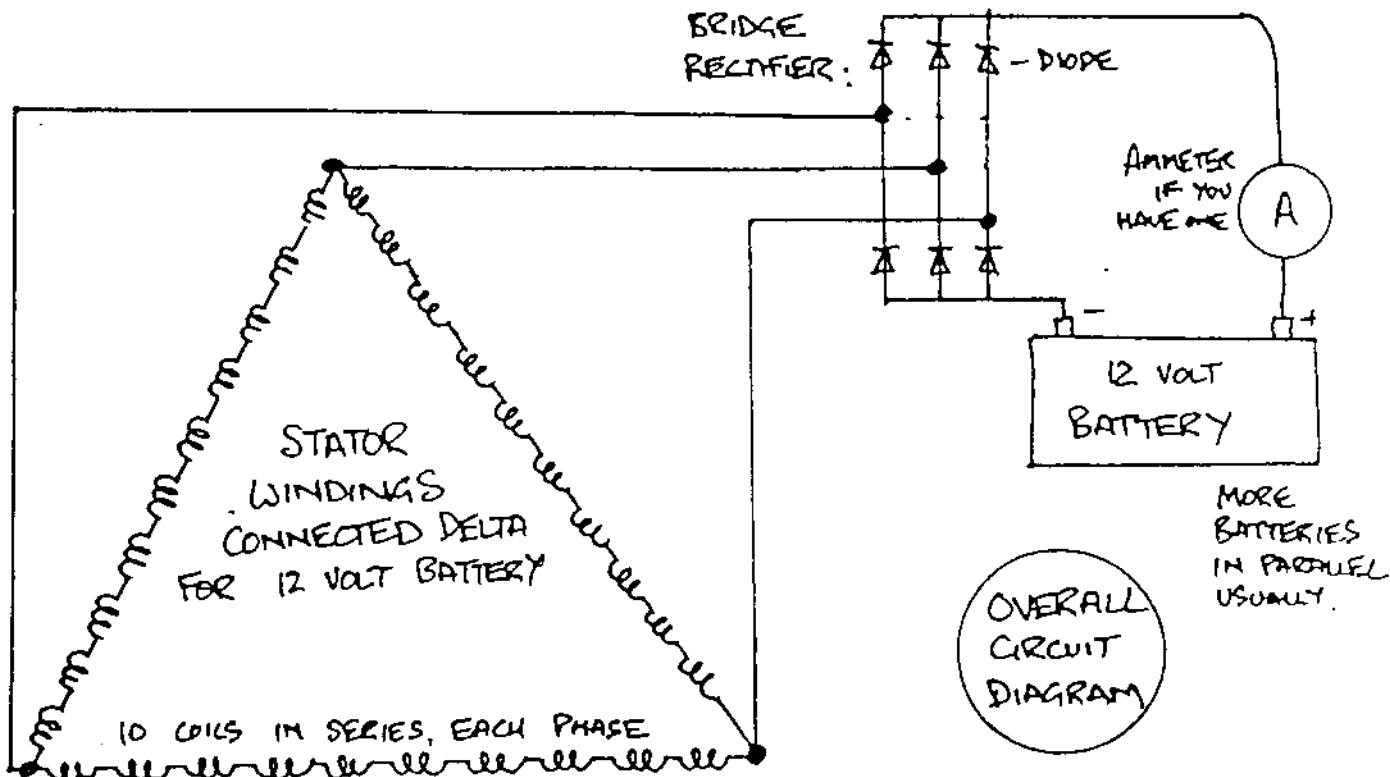
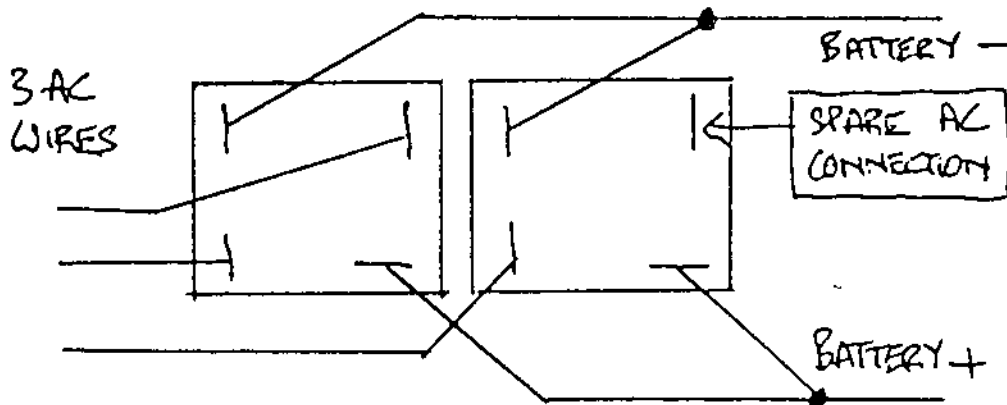

MAKING THE PROPELLER

Whilst I am aware that many people are apprehensive about carving their own propeller out of wood, I still strongly advocate that you try this method, as it yields much better results than bent bits of metal. Making moulded fibreglass blades is a tricky operation and very laborious for a one off job.

You will need some sharp tools: a plane, spokeshave, chisel, saw, and ideally, a drawknife, which is great fun for ripping out great hunks of wood. Sharpen the edges with an oilstone, at the correct angle (work up towards the edge rather than back from it), and remove any rag which may result, by stropping the edge to and fro until it breaks off.

I usually clamp the wood onto a bench with a G-clamp, or clamp it to a waste piece of wood, which in turn is firmly gripped in a vice. This allows me to turn it around to the best working angle with ease, and hold it rock steady. If it vibrates, and the tools judders, try cutting slightly crabwise, angling the blade diagonally to the direction of motion. Obviously you will need to cut with the grain for best results. Power tools may be useful but they create a lot of dust, and it is difficult not to cut too much off at once.

Reasonably knot free ("clear" is the technical term), straight grained wood is necessary for a satisfactory job: if you buy it new, then Oregon Pine is a good choice but very expensive. Old bedframes can be a good source of propeller wood, or even old building timber or church pews. In what follows I assume that you are using 4"x2" timber 100mm by 50mm, but you can piece the same shapes together with any starting size once you understand the principle.

You need a total of over 5 metres of 100x50 timber, cut into six pieces, 3 at 1000mm, 3 at 750mm. Each blade is then built up by gluing two pieces together, overlapping as shown in fig1:

FIG

1

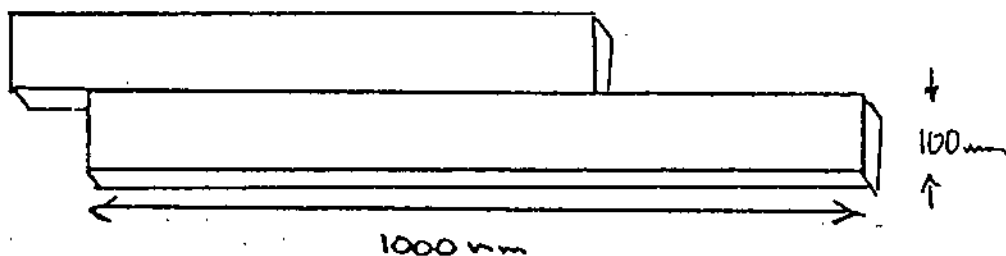

If you do not have enough wood, you may be able to work out a way of producing the final shape by cutting what you have into triangles. Use the same epoxy as for the alternator job. Other glues may be ok, but epoxy is definitely very suitable. Clamp the pieces together very firmly while the glue sets.

Each of the operations which follow will start by marking the correct measurements onto the work piece at each of a series of "stations". There are 7 stations including the tip, spaced equally at 150mm intervals from the centre of the propeller. Mark the stations on the work piece now, using a square to draw a line right around the piece, as shown in figure 2:

FIG
2

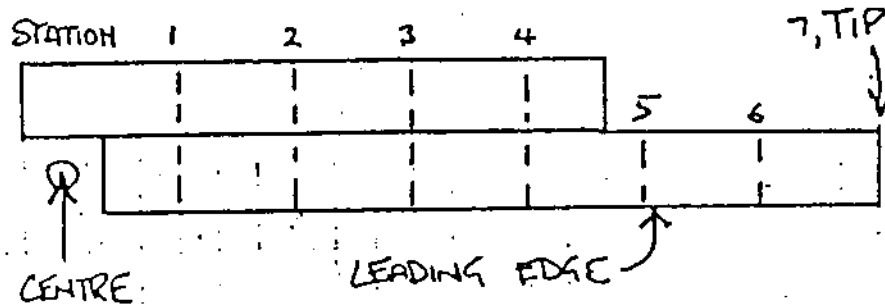

Next you need to produce the correct taper : ie get the blade "chord width" right at each station. In all that follows, the leading edge remains untouched, as a sort of reference line. Measure the width from the leading edge at each station, join the dots with a line, and cut away the surplus wood, as shown in fig 3:

FIG
3

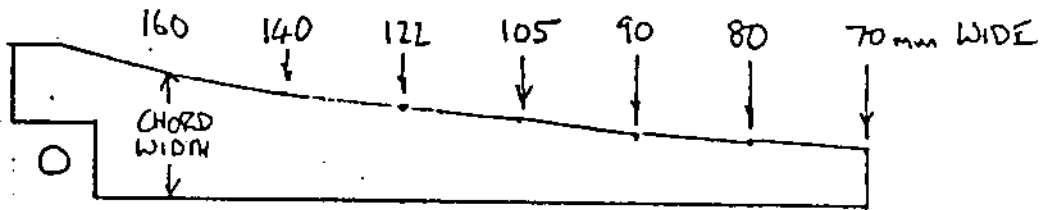

Turn the blade on edge, and work down to the line to an accuracy of plus/minus 1mm, and keep the cut face square to the "top" of the wood (see fig 4). Where there is more than 10mm of wood to remove, it may be easiest to cut through the waste across the grain with a saw and then chop out chunks with a chisel, along the grain. Or you can use a bandsaw if you have access.

The next job is to put the correct angle on the blade, so it will catch the wind and run at the right speed. This is variously known as the weather angle, setting angle or pitch of the blade. The angle is measured relative to the "top face" of the piece of wood: the one shown facing you in the above figures.

Before going any further, check for warp on this face, as this will affect the angle produced. You can check for warp by laying the work piece on a level surface, with the top face horizontal. Place a spirit level ACROSS this top face at each station in turn. At each station the bubble should sit at the middle of the glass. If there is a tilt at some of the stations then you will need to compensate, either by planing the top surface carefully level, or by measuring the error and compensating for it in what follows.

Turn the wood up on edge again. Draw your square lines at each station on the newly cut face, as shown in Fig 4.

FIG
4

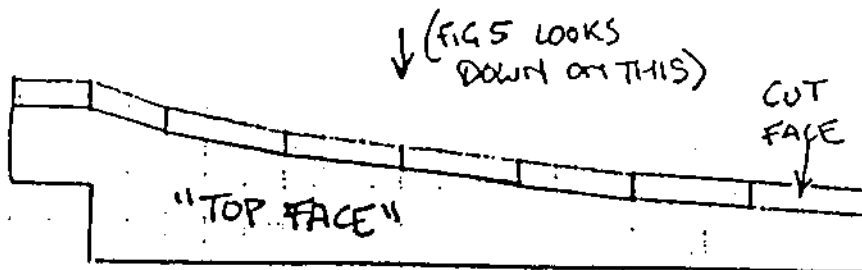

Now we need to draw a line to mark the position of the trailing edge of the blade on the newly cut face. At each station, measure the prescribed amount (figure 5) from the "top face" along the newly drawn lines on the cut face. Mark a dot on each line at the correct distance from the top face. Join the dots, to produce the trailing edge line of the blade, as shown in figure 5. The thickness of the wood is exaggerated to make it easier to see what is happening:

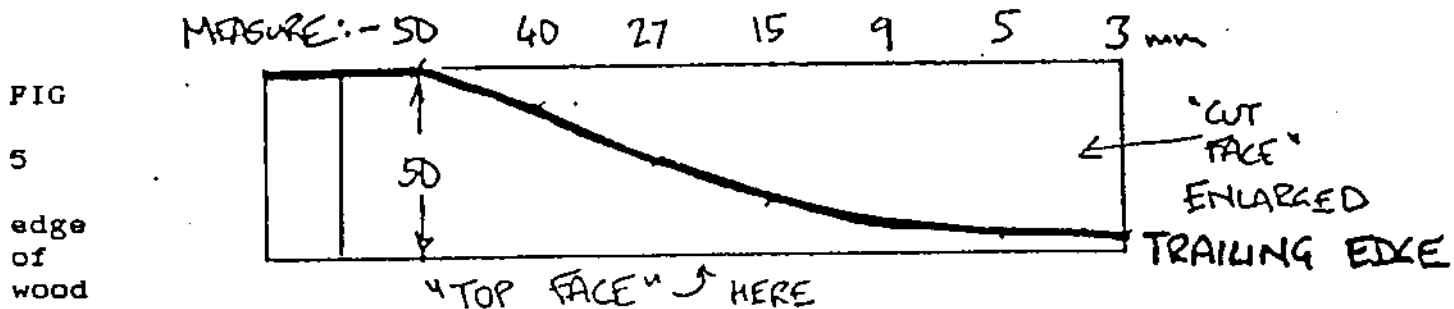

The trailing edge line is shown in bold in figure 5. This line is all that will remain of this face of the wood when you have finished the job. Now it is time to tackle the windward face (front) of the propeller blades. For simplicity, I recommend a flat front face, although some people cut them concave. When I say flat, I mean that the line between leading and trailing edges is straight. The face itself is not flat, but twisted, due to the strange curve of the trailing edge.

First mark the top face as shown in figure 6, which shows (hatched) the part of the top face which should be left alone:

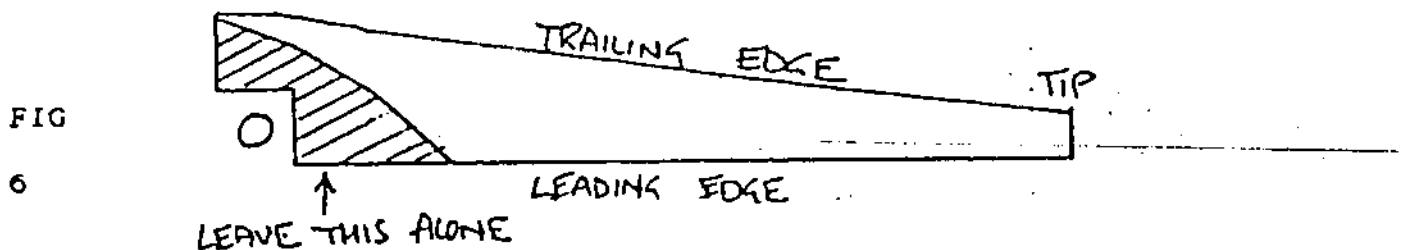

Now you have to cut away all the wood above a line between the leading and trailing edges, to produce the flat, twisted, front face referred to above. Figure 7 is a CROSS-SECTIONAL view of the fourth station, to show the part of the wood which must be removed (marked "CUT"):

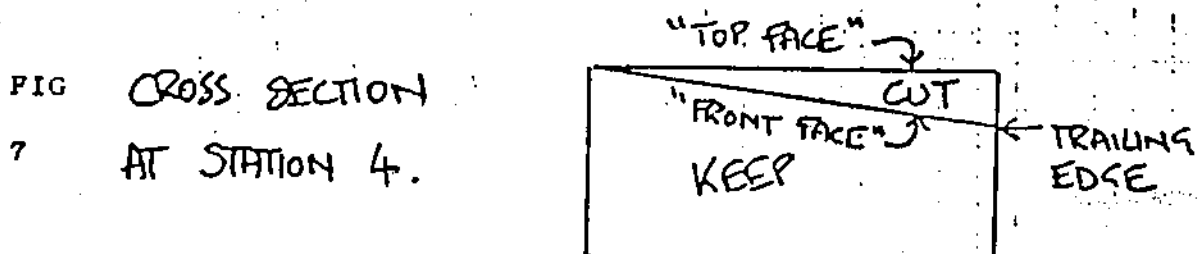

Having cut the front face, the next step is to make the blade the correct THICKNESS. Near the root, the thickness should be about 15% of the chord width. It drop to about 12% of the chord width at the tip. The actual thicknesses I recommend are shown in figure 8.

You must measure these thicknesses from the front face, in a way similar to marking out the trailing edge in figure 5. Do it at both, the leading and trailing edges, and make two lines running the length of the blade, on opposing faces as shown:

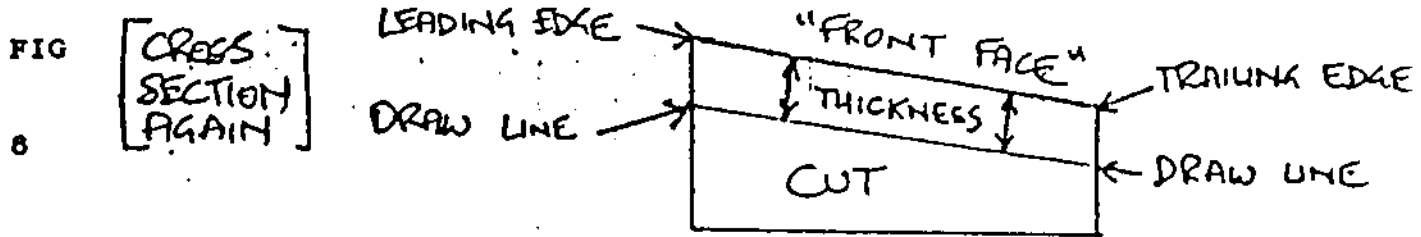

TABLE OF THICKNESSES:

Station :	1	2	3	4	5	6	7
Thickness:	(50)	20	18	16	14	12	9 mm

Turn the work piece upside down, with the front face downward. Now cut away the portion marked "CUT", working down to the two lines you have just drawn. It may be helpful to use callipers for accurate measurement of the remaining thickness, especially near the tip where precision is required.

You will be left with a blade which is the correct width and thickness, but has a crude rectangular/parallelogram cross-section. This now needs to be made into an aerodynamic shape. I normally leave the front face flat, but the back face (away from the wind) has to be convex (bulbous), and the trailing edge needs to be sharp, for minimum drag.

Shave wood away from one side of the most recently cut face to sharpen the trailing edge. The correct angle for the trailing edge is obtained by cutting away about 40% of the back face into a bevel down to the trailing edge as in figure 9:

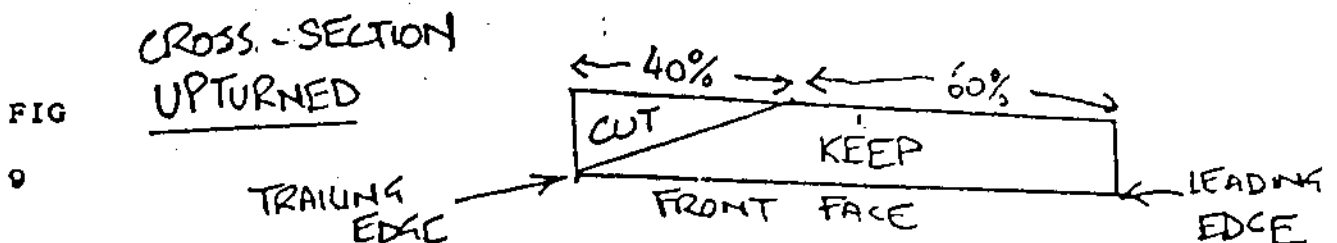

Finally you need to round off the sharp corners on the back of the blade, to produce a smoothly curved airfoil shape. I do this by eye really. Draw a line on the back face about 25% of the width back from the leading edge, and leave this line untouched, or you will lose your thickness. Figure 10 shows the general idea:

FIG

SAME SECTION

10

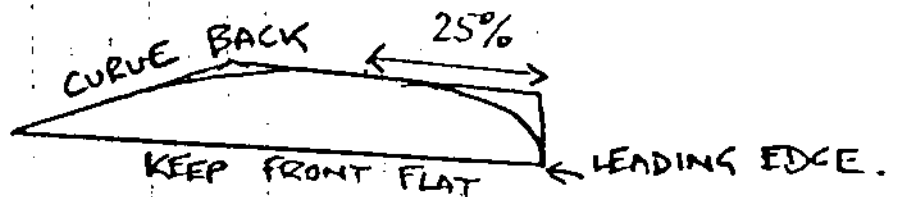

There is usually some debate about the best shape of the leading edge. I tend to keep it rather too sharp for some people's taste, maybe it should be more bulbous. In any case the wind generally wears this bit out of all recognition after a couple of years.

You should now have three lovely propeller blades. Normally I remove the leading edge with a plane to a depth of about 3mm and rebuild it with a mixture of epoxy and powder, to provide a tough setting paste. This has to be applied with a butter knife, and filed off when hard to make the original shape again. With this windmill, which turns much more slowly than my old dynamo ones, erosion is not such a problem, and even a bare wooden blade lasts a few months without serious damage. It's up to you.

However, I do recommend painting the blades thoroughly. I use Woolworths non drip gloss on primer, and coat them thickly, sanding smooth with waterproof abrasive paper after the fourth coat. Painting should follow the next bit: assembling the whole rotor at the hub.

The way the blades fit together is shown in fig 11. The centre of the prop is 50mm back from the line of each leading edge, and 50mm from the end of the longer piece of wood, in the original construction (see fig 2). Position the blades so that these centre points coincide, and the angle between any two leading edges is 120 degrees. Fitting them together will require the removal of some wood (a triangle at the root) from the pieces you glued on the sides (see fig1). I leave this *until last,* because these pieces are useful for clamping up during the carving phase of operations.

FIG

11

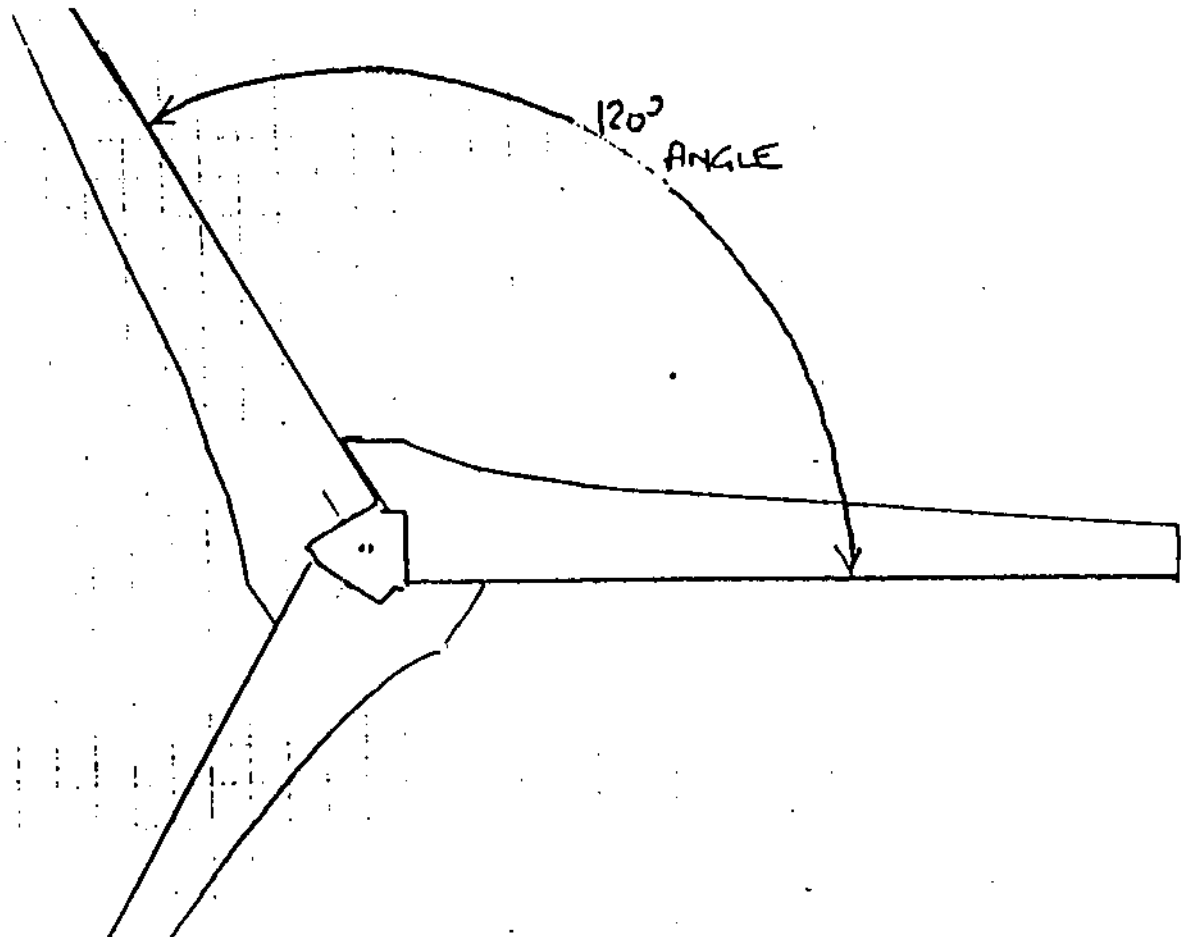

When you have the blades all fitting snugly as described, cut two hexagons out of sturdy plywood (minimum 9mm better 12mm) as shown in figure 12:

FIG
12

PLYWOOD
HEXAGONS

TWO
OFF

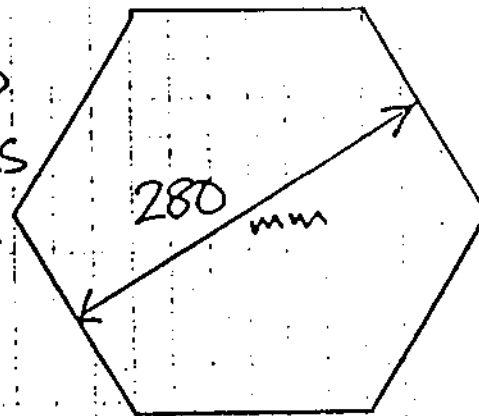

Sandwich the centre of the propeller between these two hexagons and fasten the whole together with a pattern of 2" woodscrews. I used 36 screws in all. Obviously you need to position the blades carefully before you start driving in screws.

If you will never need to take the propeller to bits again (for easy transport or painting for instance) then it may be an idea to use epoxy as well as screws in the assembly of the hub.

The propeller is now complete, but it still needs to be balanced and fitted to the brakedrum alternator. Balancing is just a matter of making sure that the centre of gravity of the propeller assembly lies exactly on the centre of the shaft of the alternator. First find the centre of gravity of the propeller as follows:

Mount a sharp "knife edge" about 300mm long, horizontally in the jaws of a vice or similar. Balance the back of the propeller hub on this knife edge. Sit the propeller dead level, and release it gently. If it tips, move it in the opposite direction a fraction and try again. Finally you should reach the point where it can hardly decide which way to tip. Press down firmly and slide it to and fro on the knife edge to mark this position. Rotate through 60 degrees or so and repeat the process. Rotate a second time and cut a third line on the underside of the hub. When you have three lines, all passing below the centre of gravity of the propeller, turn it over and check that all three scratches meet at one point. This is the centre you need to use. It may not be the exact geometrical centre of the prop, due to differences in density or whatever, but it is the centre you must use. If you do not like it, you can move the centre by attaching weights (eg bits of lead screwed on), and repeating the process. The back of the hub will get a bit messy and you will find the lines hard to interpret after a while.

Having found the centre, you can interface this with the mounting to the alternator. I mounted the prototype propeller by drilling and tapping two M10 holes in the front of the hub. One was in a hole previously used by a small screw which holds the brakedrum to the hub. The other hole I put exactly opposite. Precision is necessary for correct balance of the propeller. The holes are not flush with the surface of the alternator but I filled the gap with nuts and washers. See figure 13

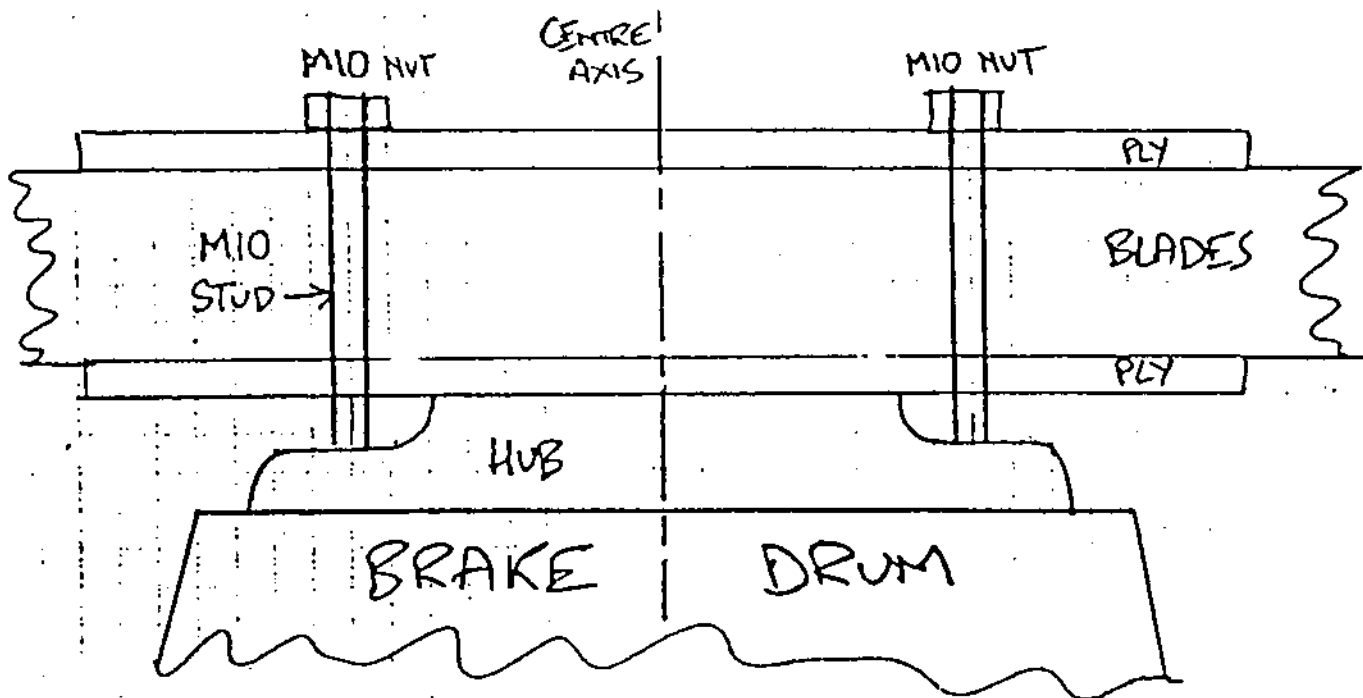

FIG 13

When drilling the two 10mm holes in the propeller hub assembly, use the centre of gravity as the mid point between holes. This will ensure correct balance.

The studs for securing the half-shaft need to be removed or ground off. I tried drilling them out at one point, but found them very hard indeed. You can seal the front end bearing against entry of moisture, using silicone sealant or mastic. Put a bead of sealant around the hexagonal face where the propeller sits on the alternator before applying the propeller.

When the propeller is correctly attached, the tips should follow each other exactly through space, as the blades rotate. If you find that the tips are more than 3mm in front of or behind each other, then it will be worth shimming the propeller slightly to correct the tracking.

PUTTING IT ALL TOGETHER

We now have an alternator and a propeller attached to it. It only remains to explain how I mounted it on a pole as a workable wind turbine. The mounting which is described in what follows has the following functions:

1. Holding the alternator up securely on the tower top.
2. Keeping it facing the wind when there is a breeze,
- and 3. Protecting it from overload when the wind is too strong.
(It allows it to turn away from the wind.)

I built this mounting from scrap steel, using an electric arc welder. It is no doubt possible to achieve a satisfactory result without welding, but it will look awkward, with bolts and bits sticking out, and it will probably be more work. Provided the important dimensions are the same, then a successful result can be achieved.

My first step was to cut through the axle tube with a hacksaw. I recommend the use of NEV, SANDVIK (or similar high quality) hacksaw blades, and this will be found to take only ten minutes or so work. If you are going to bolt it together, you may wish to leave the bracket on the axle tube, which took the leaf spring suspension. I cut through closer to the wheel end (in fact about 30mm from the back of the brake back-plate flange). To connect the alternator to the mounting, I welded four pieces of M10 stud to the axle tube, such that they project beyond it thus:

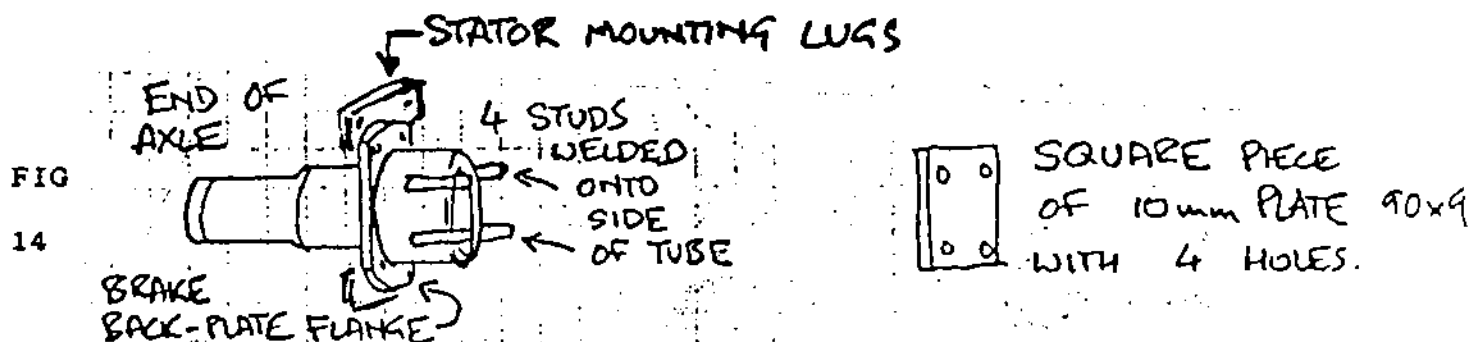

Actually, to be honest, before I welded them I found a piece of square 10mm plate with four holes in exactly the right places, and I used these holes to support the studs while welding. Lovely coincidences like this happen sometimes, but I expect you will need to drill your own holes in a piece of plate or piece(s) of heavy steel angle. Or you could simply weld the tube itself onto the mounting.

The tower is a piece of inch and 1/2 nominal bore waterpipe (48.3mm overall diameter). This is the standard size for scaffold tubing, and although it is rather smaller than Marlec use for their wind turbines it is strong enough, as I have used it for years on machines this size. It does need to be well guyed (or otherwise supported) at a point just below the propeller tips, so as to be stiff enough.

The bearing which supports the wind turbine and allows it to rotate and face the wind is simple in the extreme. I have used car front wheel bearings, which are very good, but lots of hassle. They tend to corrode up anyway unless you do a very good job of stopping the rain from running in. For this job, I just used a piece of 2" nominal bore (60.3mm OD) steel waterpipe, which can be a fairly neat fit over the

smaller pipe. I cut a 250mm length of the 2" pipe, and welded a small piece of plate over the end. I drilled a 12mm hole in the centre of the plate, for the flexible cable from the windmill to the ground. When well greased, this slips around quite nicely on the top of the smaller tube. Both tube ends have to be cut accurately square.

The piece of square plate to which the alternator bolts is in turn attached to this 2" steel pipe, at around the mid-point. It is set up such that the face of the plate is approximately tangential to the tube, and the centre of the alternator is 90mm away from the centre line of the tower. These dimensions are important, so I shall do another figure:

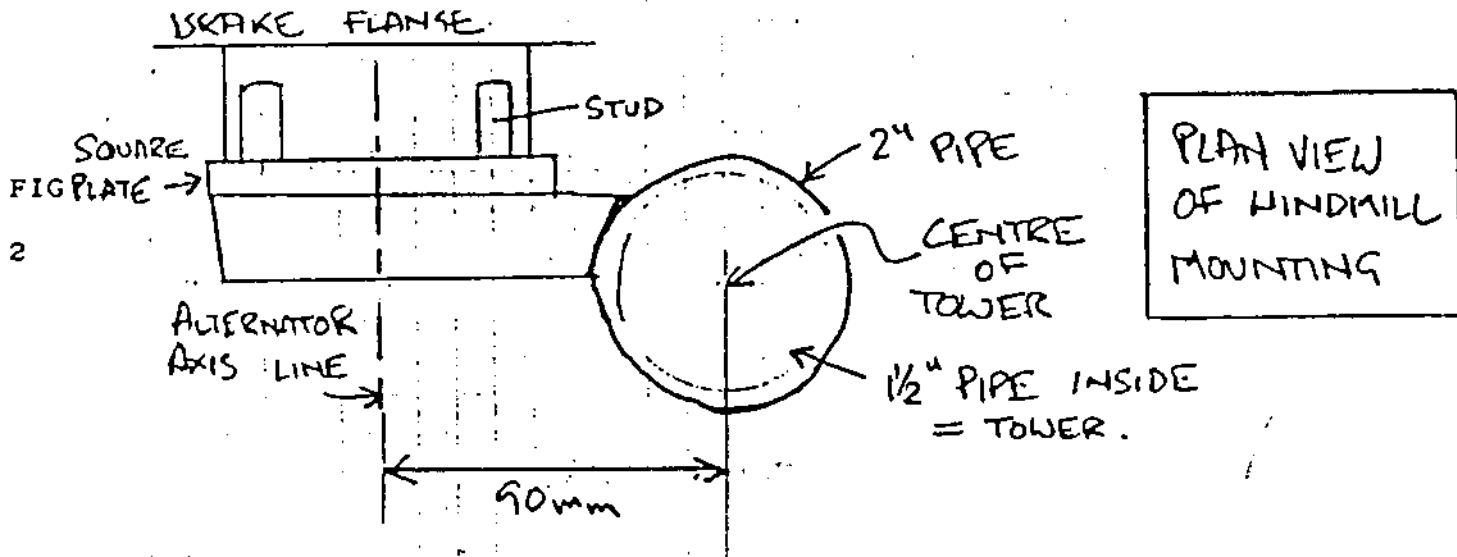

The square plate is connected to the pipe by three pieces of steel about 100x25x10mm in size, running horizontally. Care must be taken so they do not interfere with the operation of the spanner which you use to secure the nuts on the ends of the alternator mounting studs. Here is what they look like from behind:

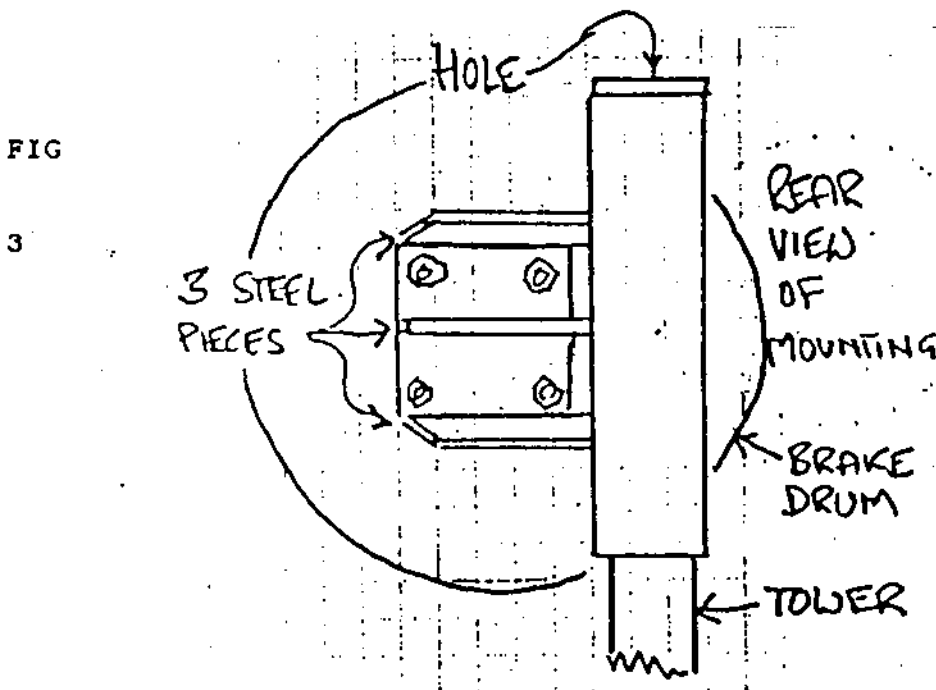

The alternator axis should be about 90mm away from the centre axis of the tower tube, so that wind pressure on the propeller will try to turn it away from the wind. If it is less, then this action will not be sufficiently positive. If it is more than 90mm then you will need a bigger tail.

Now we have a windmill which is supported and can rotate to face the wind. We need a tail to make it face the wind. We also need to allow it to face away when the wind gets too strong. This will prevent overspeed, with consequent erosion damage to the blades, overheating of the alternator, and vibration fatigue of the whole structure.

The tail must be designed to hold the windmill into the wind until the wind pressure exceeds a certain limit. After that, the tail must yield, allowing the windmill to turn away from the wind. The action needs to be proportional, so that we continue to generate power, but do not expose the windmill to undue stress. Here is another figure to show what is intended:

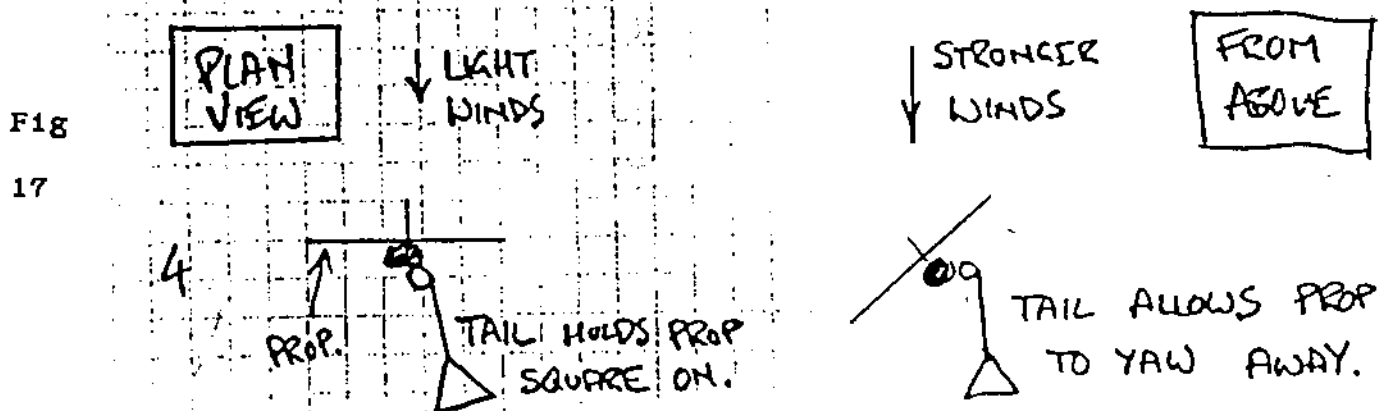

PS: TAIL VANE WOULD NOT LOOK LIKE THIS FROM ABOVE. I DREW A TRIANGLE BUT REALLY IT IS EDGE-ON.

I have a great deal of experience in the design of these tails, and the tail on this windmill, while it is not the absolutely optimal system for best energy production in all windspeeds, is simple and reliable, and will keep the machine working without falling apart.

The tail is a piece of plywood (aluminium sheet always fatigues) bolted onto a steel boom. I used a triangle of plywood, but the shape is not very critical provided it is large enough: at least 0.25 square meters (2.5 sq. feet). The overall length of the tail is 1250mm (just over 4 feet). Another important feature of the tail is its MOMENT OF WEIGHT. This is the weight of the tail, multiplied by the distance from its centre of gravity to the root. In this case, the weight was 4.4kg, and the distance was 0.6m, giving a moment of weight of 2.6kgm. (Engineers use a different unit of force: the Newton, but kg will do us fine.) I suggest you use the same moment of weight, plus or minus 10%. PS: MOMENT INCREASED TO 3.6kgm IN 1994. SEE PAGE 4.

The moment of weight is what makes the tail hard to hold up from the root. We can use this moment of weight to control the whole windmill, by mounting the tail on an inclined hinge, so that it falls down into place, but can be lifted away by strong winds, to allow the windmill to yaw out of the wind. Here is how you construct the inclined hinge:

Once again, a simple bearing is used: a piece of inch and 1/4 pipe (od 42.4mm) fits neatly over a piece of inch pipe (od 33.7mm). We start by attaching the smaller (one inch) pipe to the main windmill mount at the correct angle. And this is hard to describe.

Cut a piece of one inch pipe about 150mm long. It is to be welded to the small plate on the top of the 2" pipe used as a main bearing for the windmill.

It must not obstruct the hole for cable exit.
 It must be angled 27 degrees from the vertical.
 Viewed from ABOVE, it should make an angle of 45 degrees to the windmill propeller.

Here is another figure:

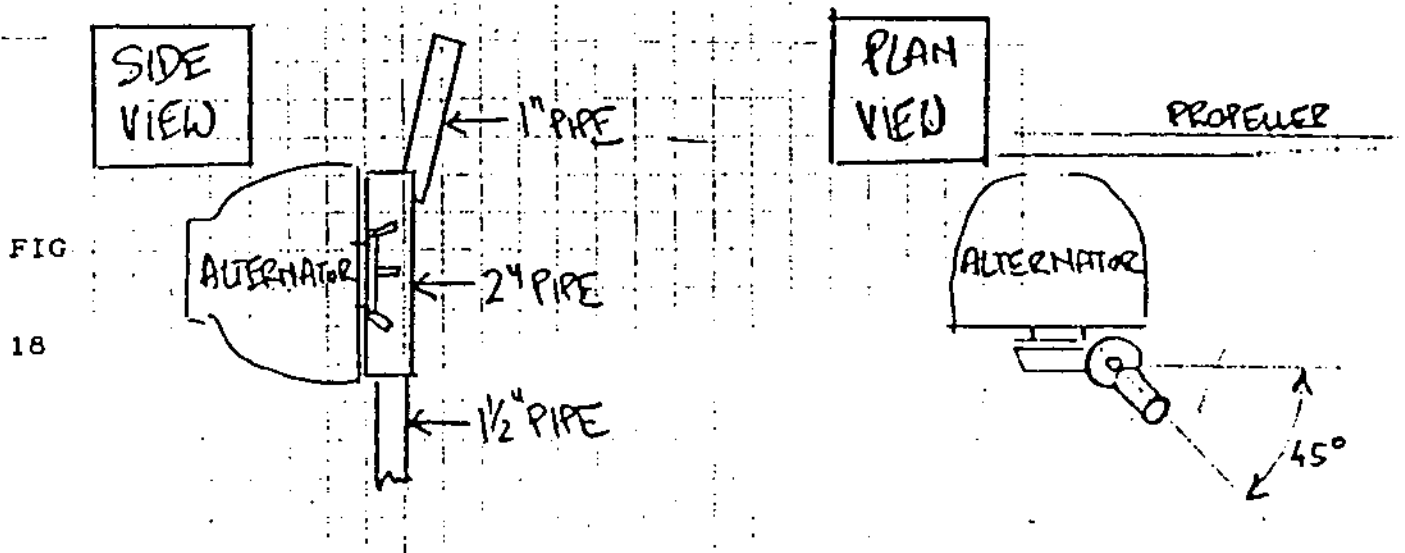

Now cut a shorter (125mm long) piece of the larger size pipe (inch and 1/4). Weld a small piece of plate across the top so it can be dropped onto the 1" pipe just described. We need to limit the range of movement of this outer pipe to about 100 degrees. This is done by welding a flange to the smaller pipe, and cutting a slot in the larger pipe, so it can only rotate by that much:

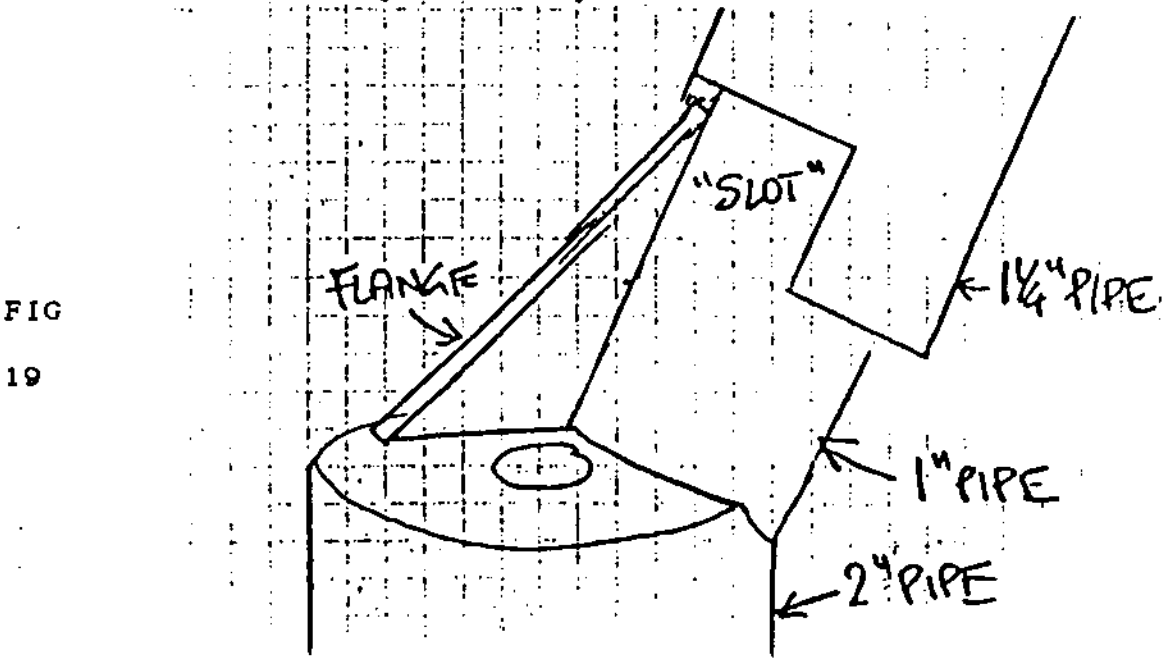

When all this is set up, you can weld the tail boom (could be another piece of the 1" pipe: I used some patent shelving support material) onto the larger, outer pipe so that it hangs horizontally outward when the outer pipe is rotated fully anticlockwise.

Conditions when you tack weld the tail boom on should be as follows:

boom horizontal
outer pipe fully anticlockwise rotated
tail boom seen from ABOVE
 should be almost square to propeller
 but cocked 10 degrees into wind as in fig. 17

This is a highly stressed point if there is vibration, and good welding is essential at the tail root. Next fix the plywood support brackets (bits of steel with holes in) such that the ply is neatly vertical on the horizontal boom. When you swing the tail around it should fall back into position under the action of its own weight. Check that it cannot swing as far as to hit the propeller blades, when at the top of its swing.

To increase the output in high winds
add weight to the tail.

To make it turn away sooner,
make the tail lighter

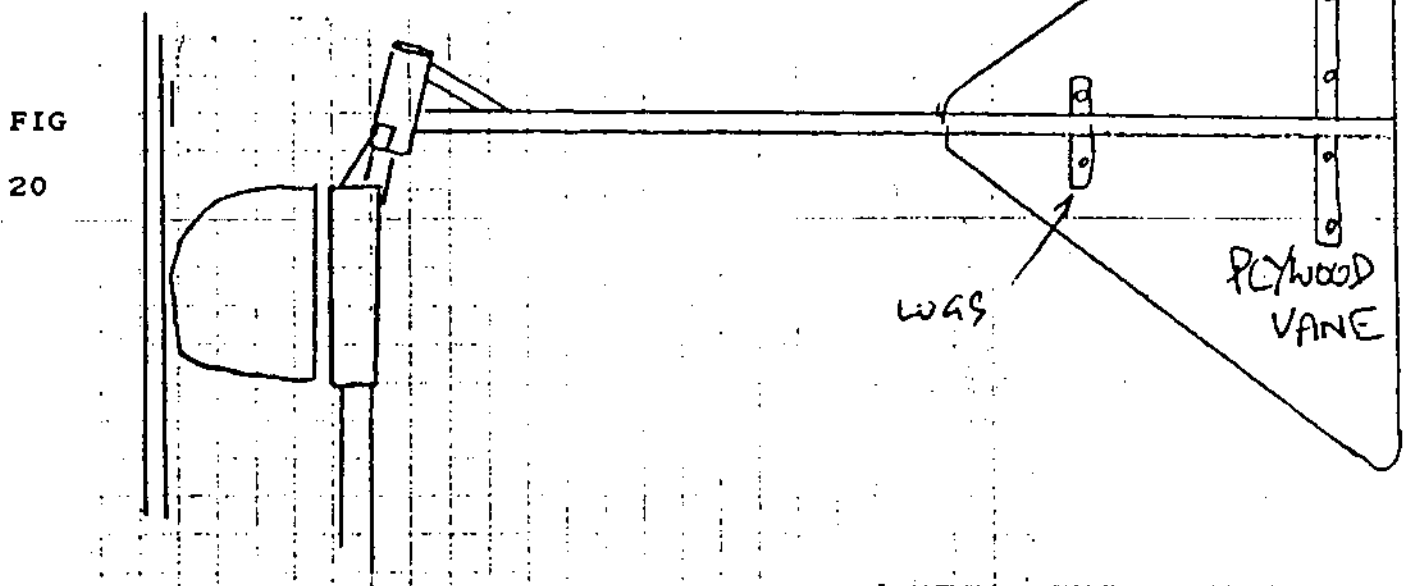

When you have finished, paint all the steelwork with Hamerite or similar paint, and the ply with suitable paint for wood.

I hope that covers everything. If not please give me a ring, and I shall try to explain some more.

Phew.

Hugh Regent

(0857) 633 286
01854

Brakedrum alternator output (approximate)

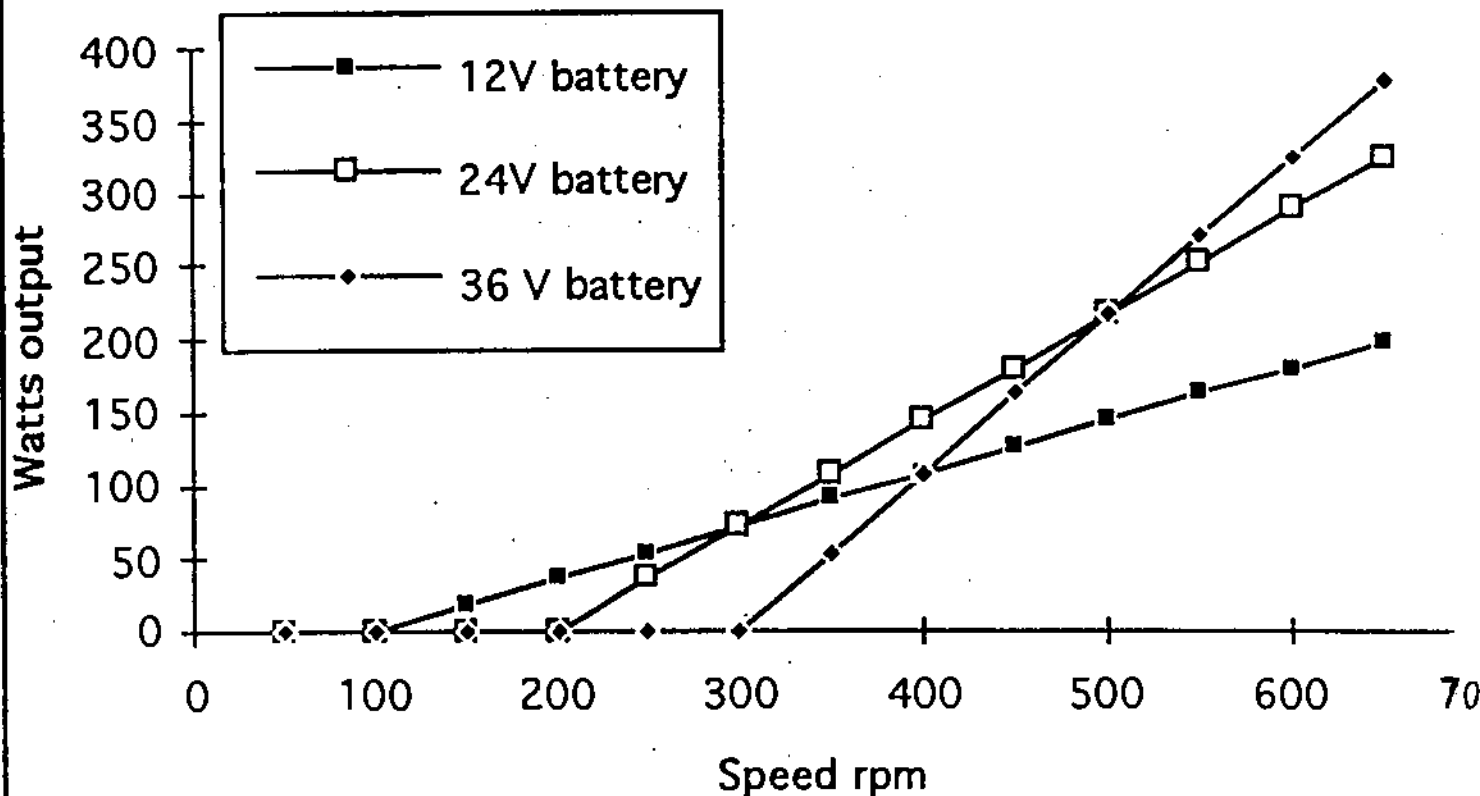

This chart shows the pros and cons of different battery voltages for a given alternator winding. It is approximately based on performance of the star connected, 24 turns/coil winding in this booklet. External cable volt-drop is ignored.

Connected to a 12 volt battery, the cut in rpm is lower, but the maximum power output is also lower. 24 volt operation does not start until the speed reaches 200 rpm, but after that, the power output soon exceeds the 12 volt performance curve. The higher the battery voltage, the less power you will lose in heating of the stator, too.

You could also change the performance by altering the number of turns per coil. Volts increase with turns, so by rewinding with from 100 turns (not 24 turns), for instance, you could get 100 volts output, with the same wattage as the 24 volt graph above. This might be useful for long cable runs and for powering heaters, but it could also be lethal, so take care!

MATERIALS YOU WILL NEED:

The rear hub, from a Ford Transit double wheel van (or similar, see page 6)
20 magnet blocks 64 x 32 x 20 mm (see list of suppliers at the end)

The laminated core from a 5 horsepower electric motor (8 inches diameter)
(This is the part made from a stack of thin sheets of steel.)

About 800 grams of enamelled copper wire for winding the coils (page 10)

Epoxy or similar resin (see list of suppliers at the back)

Glass fibre surfacing tissue, or thin fabric.

Bridge rectifier assemblies for converting AC to DC (from electronics suppliers, see page 14. I can supply the 2 you need for £5))

A piece of aluminium scrap (saucepan?) to act as 'heatsink' for the above.

MILD STEEL (sizes are nominal. Use common sense + substitute what you got):

1 piece flat 90 x 90 x 10 mm = 4 x 4 x 3/8 inch for mounting (page 22)

5 pieces flat, 125 x 25 x 6mm = 5 x 1 x 1/4 inches (for stator mounting lugs, and horizontals on page 23).

2 pieces flat 60 x 60 x 6 = 2.5" x 2.5 x 1/4, and 43 x 43 x 6 for bearing heads

2 odd pieces flat for tail boom lugs (page 26)

1 piece tube 6000 x 48 overall x 4mm thick = 20 feet by 2 inches (pole)

1 piece tube 250 x 60 overall x 4 mm thick = 10 x 2.5 inches (bearing page 22)

1 piece tube 150 x 43 overall x 4 mm thick = 6 x 1.75 ins (tail bearing p 25)

1 piece tube 1,000 x 34 x 4mm = 3 feet by 1.5 inches for tail (p 26)

1 piece threaded rod 500mm = 20 inches / 10mm = 3/8th plus nuts (pages 21, 22)

40 woodscrews, 50mm / 2 inches long (page 20)

KNOT-FREE WOOD FOR BLADES

3 pieces 1,000 x 100 x 50 mm = 40 x 4 x 2 inches

3 pieces 750 x 100 x 50 mm = 30 x 4 x 2 inches

PLYWOOD FOR BLADE HUB

2 pieces 300mm (one foot) diameter by 12mm (half inch) thick marine ply.

Primer and gloss paint for the wooden bits.

Hammerite or similar paint for the steel bits.

TOOLS YOU WILL NEED

Socket spanners (wrenches), Hammer, chisel, screwdriver, pliers
wirebrush, rags, petrol (gasoline) to clean autoparts

Hacksaw, with good quality, new blades (Sandvik blades are recommended)

Angle grinder, electric drill + sharp bits.

Pieces of 1mm aluminium sheet for shims between magnets during assembly

Plywood for coil-former + cheek pieces page 11

Former for clamping coils, made from 100x50mm timber (see page 3)

'G' clamps

Knife, soldering iron, multicore solder, tape.

Electric welder and steel welding rods size 2.5 or 3 mm (if possible)

Wood working tools : saw, plane and spokeshave, to carve blades.

RESOURCE LIST

SUPPLIER	MATERIAL	CODE
----------	----------	------

<p>Blake Marine Paints Ask for Loretta (0703) 636373 She will tell you your nearest supplier. 1kg costs £12.65 plus VAT.</p>	<p>Epoxy resin SP 103 colloidal silica powder</p>
--	--

<p>Glasplies 2, Crowland St. Southport Lancs. PR9 7RL (0704) 540626 Free information pack is worth asking for.</p>	<p>Polyester resin Surface tissue Aluminium powder</p>
--	--

<p>Maplin Electronics plc Freepost, PO box3, Rayleigh, Essex, SS6 2BR (0702) 554161</p>	<p>enamelled copper wire 250g 0.71mm YN83E crimp receptacles JH82D</p>
---	---

<p>Farnell Components Canal Rd, Leeds, W. Yorkshire LS12 2TU (0532) 636311</p>	<p>enamelled copper wire 500g 0.71mm 146-529 Bridge rectifiers 234-136</p>
---	---

<p>Centre for Alternative Technology Machynlleth, Powys, Wales, SY20 9AZ (01654) 703743</p>	<p>Windpower courses 2-4 days £125-250 March 13-17 November 6-10</p>
---	--

SCORAIG WIND ELECTRIC

<p>rectifiers for £2.50 each as seen on page 14. My book "WindpowerWorkshop" costs £7.95</p>	<p>Scoraig Dundonnell Ross shire IV23 2RE (01854) 633 286</p>
--	---

MAGNET BLOCKS

CERMAG offer a good service, cutting blocks to size.
CERMAG LTD. 94, Holywell RD, Sheffield, S4 8AS.
Tel: (0114) 244 6136

UNIMAG (01709) 829783

in the USA, try the magnet source tel. 1 800 525 3565

Edmund Scientific Company
101 East Gloucester Pike
Barrington, NJ 08007-1380
to order:

call 1-609-547-8880
Fax 1-609-573-6295

For customer Service: Dial 1-609-573-6260 .

Miami Magnet Co.
6073 N.W. 167th Street
Ste.C26
Miami, FL
tel. 1-305-823-0641

NOTES ON HANDLING MAGNET BLOCKS

the blocks are quite robust, but they can fracture if they are allowed to snap together abruptly. This tends to happen, and your fingers can also suffer. Use epoxy to repair broken magnets.

Keep magnets AWAY from floppy discs, and tapes!!