

**AT** **MICROFICHE  
REFERENCE  
LIBRARY**  
A project of Volunteers in Asia

Engineering applications:1: Installation and Maintenance  
of Engines in Small Fishing Vessels

By: Brian Mutton  
FAO Fisheries Technical Paper 196

Published by: Food and Agriculture Organization of the United Nations  
Publications Division  
Via delle Terme di Caracalla  
00100 Rome  
Italy

Available from: UNIPUB  
4611-F Assembly Drive  
Lanham MD 20706-4391  
U.S.A.

Reproduced with permission.

Reproduction of this microfiche document in any form is subject to the same restrictions as those of the original document.

# Engineering applications: 1 Installation and maintenance of engines in small fishing vessels

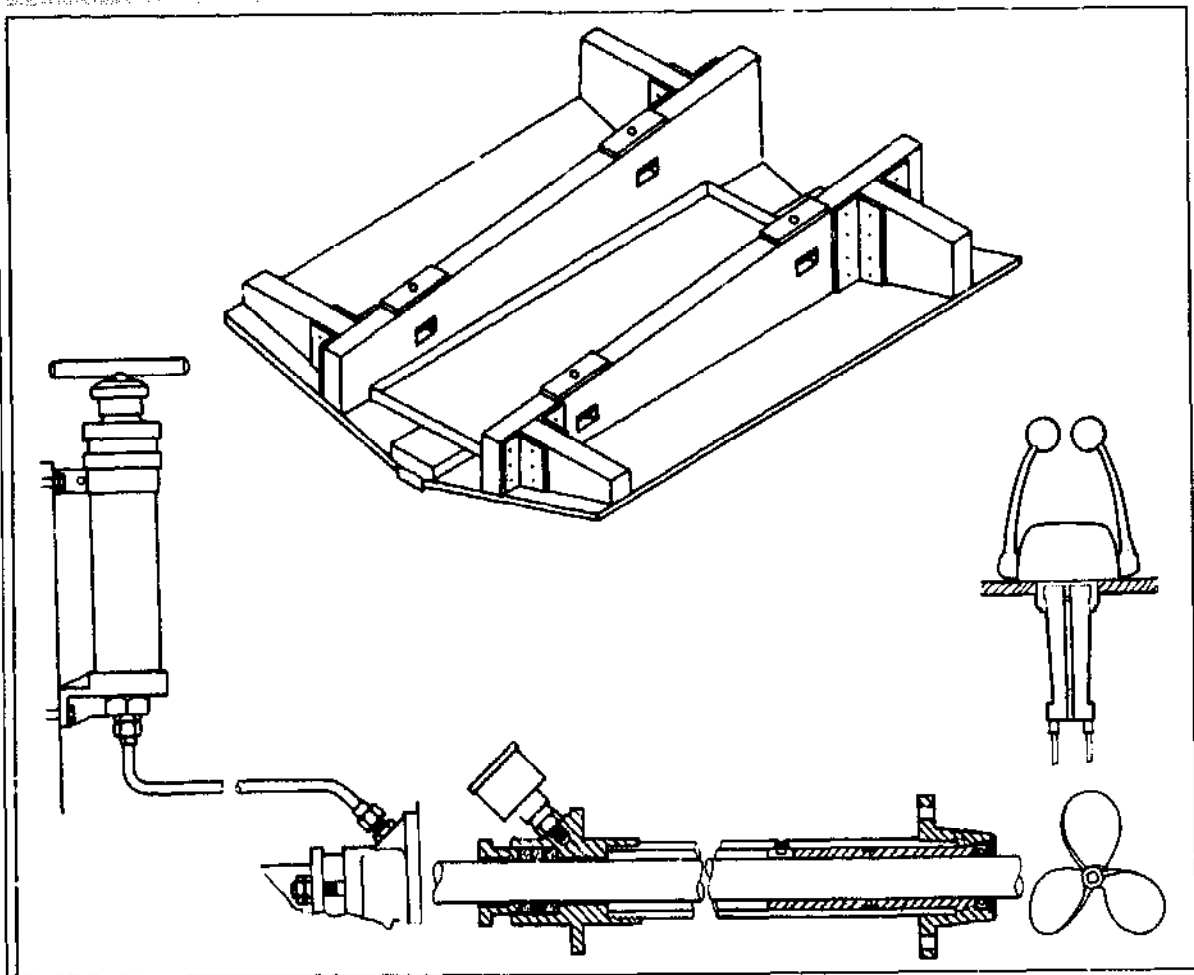

FAO  
FISHERIES  
TECHNICAL  
PAPER

196

# Engineering applications: 1 Installation and maintenance of engines in small fishing vessels

by  
**Brian Mutton\***  
FAO Consultant

Exclusively Distributed by:

~~BERTON~~ - UNIPUB

4611 - F Assembly Drive

Lanham, MD 20706-4391

(301) 459-7666

Price: \$ 9.50



FOOD  
AND  
AGRICULTURE

Reprinted 1984

The designations employed and the presentation of material in this publication do not imply the expression of any opinion whatsoever on the part of the Food and Agriculture Organization of the United Nations concerning the legal status of any country, territory, city or area or of its authorities, or concerning the delimitation of its frontiers or boundaries.

M-41

ISBN 92-5-100862-0

All rights reserved. No part of this publication may be reproduced, stored in a retrieval system, or transmitted in any form or by any means, electronic, mechanical, photocopying or otherwise, without the prior permission of the copyright owner. Applications for such permission, with a statement of the purpose and extent of the reproduction, should be addressed to the Director, Publications Division, Food and Agriculture Organization of the United Nations, Via delle Terme di Caracalla, 00100 Rome, Italy.

© FAO 1979

PREPARATION OF THIS DOCUMENT

Assistance is frequently required by boatyards in developing countries in the technical requirements for good engine installation in small fishing vessels. This paper has been prepared to provide a basic handbook covering all details of installation and the necessary maintenance procedures to be adopted for small boatyards, boat owners and fishermen.

The collaboration and advice of technical staff of the Fisheries Technology Service, Fishery Industries Division in the preparation of this publication is acknowledged by the author.

\* Mr. B. Mutton,  
Goldmartin Square,  
Mawnan Smith,  
Nr. Falmouth,  
Cornwall TR11 5EP  
England.

Distribution:

FAO Fisheries Department  
FAO Regional Fishery Officers  
FAO Fisheries Field Projects  
Selected Boatbuilders and Naval Architects  
and Marine Engineers

For bibliographic purposes this document  
should be cited as follows:

Mutton, B.,      Engineering applications: 1  
1979              Installation and maintenance of  
engines in small fishing  
vessels. FAO Fish.Tech.Pap.,  
(196): 127 p.

## INSTALLATION AND MAINTENANCE OF ENGINES IN SMALL FISHING VESSELS

### Contents

	<u>Page</u>
<b>PART ONE</b>	
<b><u>Section 1 - Principles of engine installation</u></b>	<b>1</b>
1.1 Planning	1
1.2 Engine installation angle	1
1.3 Engine bearers of engine beds	3
1.4 Drip tray	5
1.5 Engine mounting	5
1.6 Vee drives	6
<b><u>Section 2 - Stern gear</u></b>	<b>11</b>
2.1 Propeller shafts	11
2.2 Couplings	11
2.3 Propeller shaft bearings	15
2.4 Intermediate bearings	18
2.5 Underwater fittings	19
2.6 Propeller shaft glands	21
2.7 Shaft greasing arrangements	22
2.8 Propellers	24
2.9 Alignment	24
<b><u>Section 3 - Cooling systems</u></b>	<b>26</b>
3.1 Introduction	26
3.2 Planning	26
3.3 Direct cooling	27
3.4 Indirect cooling by heat exchanger	28
3.5 Keel cooling	30
3.6 Air cooling	31

	<u>Page</u>
<u>Section 4 - Exhaust systems</u>	32
4.1 Introduction	32
4.2 Planning	32
<u>Section 5 - Fuel systems</u>	36
5.1 System types	36
5.2 Fuel tanks	36
5.3 Water traps and filters (primary and secondary filter)	36
5.4 Pipework	37
<u>Section 6 - Electrical system</u>	39
6.1 Introduction	39
6.2 Batteries	39
6.3 Alternators	42
<u>Section 7 - Controls and instruments</u>	43
7.1 Controls	43
7.2 Instruments	44
<u>Section 8 - Starting systems</u>	
8.1 Hand starting	55
8.2 Electric starter motors	55
8.3 Spring starter motors	55
8.4 Hydraulic starter motors	55
8.5 Compressed air starting	55
8.6 Cold start systems	55
<u>Section 9 - Engine boxes</u>	58
9.1 Planning	58
9.2 Installation	58
9.3 Daily running	58
9.4 Servicing	58

	<u>Page</u>
<u>Section 10 - Noise</u>	60
<u>Section 11 - Bilge pump and bilge systems</u>	61
11.1 Hand pumps	61
11.2 Electric bilge pumps	61
11.3 Engine driven bilge pumps	61
11.4 Bilge system	62
<u>Section 12 - Power take-off</u>	63
 PART TWO	
<u>Section 13 - Installation details</u>	64
13.1 Establishing the shaft line (boat with stern tube, boat with shaft log and "P" bracket)	64
13.2 Planning the engine bearers	64
13.3 Making an engine template	65
13.4 Fitting engine bearers (wooden boats)	68
<u>Section 14 - Sterngear and alignment - installation</u>	
14.1 Cutting shaft to length	71
14.2 Installing shaft and shaft bearings	73
14.3 Fitting a propeller	73
14.4 Drilling holes in engine bearers	73
14.5 Alignment	76
<u>Section 15 - Cooling systems - installation</u>	80
15.1 Direct system	80
15.2 Indirect by heat exchanger	80
15.3 Keel cooling	80
15.4 Air cooling	81
<u>Section 16 - Exhaust systems - installation</u>	85
16.1 Installation - general	85
16.2 Wet exhaust system	85
16.3 Dry exhaust system	86



	<u>Page</u>
<u>Section 17 - Fuel tanks and fuel systems - installation</u>	89
17.1 Installation - general	89
17.2 Primary filter and pipework	89
<u>Section 18 - Electrical - installation system</u>	90
18.1 Battery care	90
18.2 Battery installation	90
18.3 Alternators	90
18.4 Wiring	91
18.5 Fuses and fuse boxes	92
<u>Section 19 - Instruments and controls - installation</u>	94
19.1 Installation - general	94
19.2 Typical instrument panel	94
19.3 Engine controls	95
<u>Section 20 - Starting systems - installation</u>	98
20.1 Hand starting	98
20.2 Electric starting	98
20.3 Spring and hydraulic starting motors	98
20.4 Cold starting systems	98
<u>Section 21 - Engine boxes - installation</u>	101
<u>Section 22 - Noise - installation</u>	102
<u>Section 23 - Bilge pumps and bilge systems - installation</u>	104
23.1 Hand pumps	104
23.2 Electric pumps	104
23.3 Engine driven pumps	104
23.4 Bilge systems	105
<u>Section 24 - Power take-off installation</u>	107
24.1 Bolt on unit	107
24.2 Bolt up to units	107

	<u>Page</u>
<b>PART THREE</b>	
<u>Section 25 - Engine selection</u>	108
25.1 General	108
25.2 Make of engine	108
25.3 Type of engine - long term costs	109
<u>Section 26 - Ordering equipment</u>	111
26.1 General guidance	111
26.2 Example	111
26.3 Spare-parts	112
26.4 Instruction books, service manuals, spare-parts lists	114
26.5 Service tools	115
26.6 Torque spanner	115
<u>Section 27 - Care and maintenance</u>	118
27.1 General	118
27.2 Major service	119

## INTRODUCTION

This handbook on the installation and maintenance of small marine diesel engines is intended for those working in developing countries who are employed either in boat building, or in the mechanized fishing industry.

Its aim is to give a basic introduction to the various principles employed in marine engineering which have been proved, over the years, to be the best for situations which may prevail in small boat yards all over the world.

The handbook is in three parts:

- Part One deals with a brief introduction to the various components and their functions.
- Part Two gives a guide in sequence (where possible) as would be done by the engineer or boat builder actually in the boat yard doing the installation.
- Part Three is concerned with servicing and maintenance of engines and installed equipment.

The author has tried to put himself in a teaching situation all the way through, and the emphasis is on being simple, practical and positive. It is not possible to foresee all the "snags" but many that the author has experienced personally have been included.

Some of the literature and illustrations have been based upon engine manufacturers' handbooks and installation guides, and the acknowledgements appear below.

### Acknowledgements

#### Engine

Lister - R.A. Lister & Co., Ltd., Dursley, Gloucestershire, England.

Sabb - Dainsgård Motorfabrik, Bergen, Norway.

Petter - Petters Ltd., Hamble, Southampton, England.

Perkins - Perkins Engines Ltd., Peterborough, England.

Caterpillar - Caterpillar Tractor Co., Peoria, Illinois, U.S.A.

#### Ancillary equipment

Volvo Penta - Volvo Penta S-405 08, Gotëborg, Sweden.

Yacht Chandlers of Great Britain, Abbotskerswell, Newton Abbot, South Devon, England.

Teleflex Morse Ltd., Basildon, Essex, England.

## PART ONE

### SECTION 1

#### Principles of engine installation

##### 1.1 Planning

When the design of a boat is planned decisions to be made right at the beginning are the type of boat, size, style, draft, the kind of work it will be doing, the speed required, etc.

In the early stages it will also be decided what size and type of engine is required, the type of propeller shaft and bearings to be fitted, the size of the propeller and the arrangement and position of the engine.

When all these points have been carefully considered, a clear picture will emerge giving the boatbuilder and engineer concerned with building the vessel all the facts they require.

Once orders have been placed for the equipment and work is to commence on the building of the boat and the installation of the 'machinery', it is important to have a plan or sequence of the work involved to follow.

This chapter is concerned with some of the basic options and a general introduction to the various standard methods to be considered prior to actually starting to install an engine.

##### 1.2 Engine installation angle

Most engines are designed to run from a 'level' position to a 'front-end up' position up to a maximum of 20°.

As the boat rises at the front when it is moving at full speed by about 3-5°, the normal maximum angle of installation when measured on a static or stationary boat is about 15°.

When a boat is being designed it is most important to work out the angle of installation to make sure the engine to be selected will operate safely at the angle concerned.

Never expect an engine to work at a greater angle than the manufacturers allow. If an engine is incorrectly angled, the level of oil in the sump may not come up to the inlet on the oil pump, and severe damage would result because of lubrication failure.

Similarly an engine should not be installed 'nose down' as pockets of air in the water-cooling system could be formed with the result that the engine would overheat.

The angle of the shaft, and therefore the installation of the engine to it, is governed by the shape and design of the craft, the size of the propeller selected to match the engine for the craft and the clearance necessary between the tips of the propeller and the bottom of the boat. Generally, the aim of the designer, when all other things are considered, is to keep the angle of the shaft as flat as possible, and the propeller as deep as possible in the water for the maximum efficiency of the propeller.

Once the line of the shaft has been established the engine bearers have to be considered.

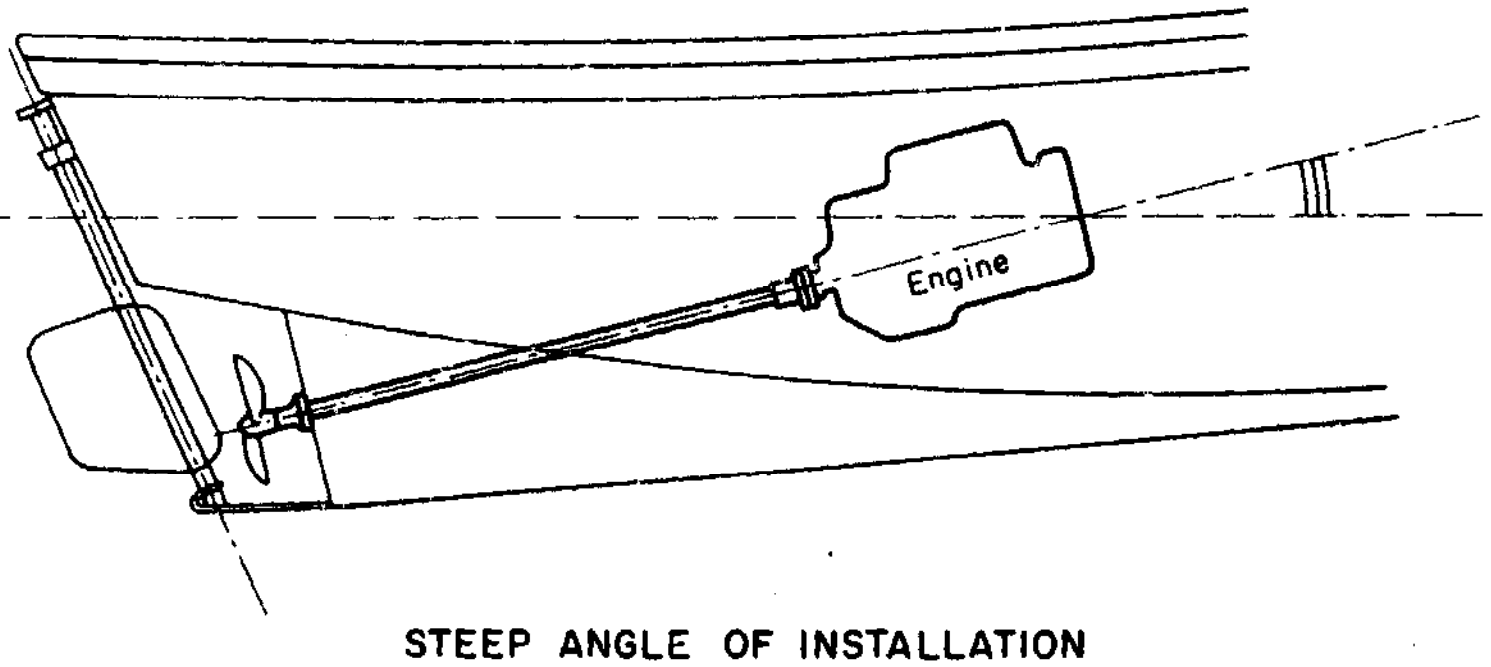
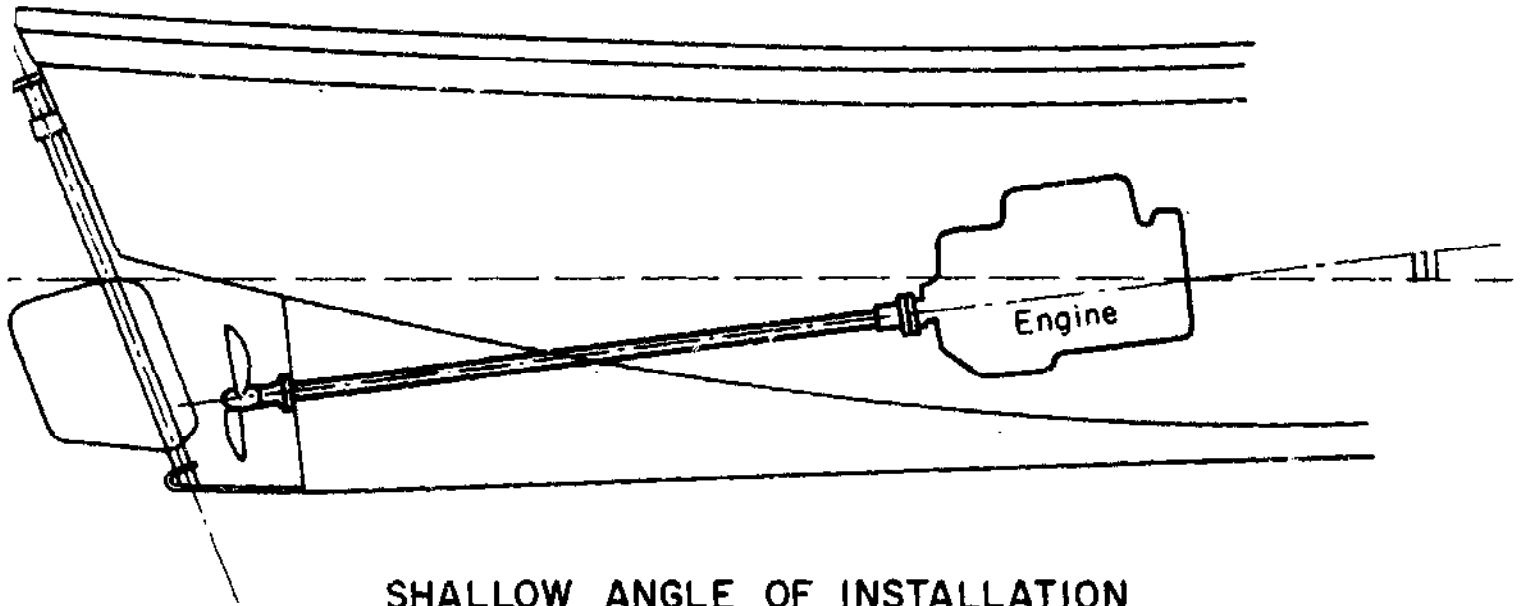

Fig. 1

### 1.3 Engine bearers of engine beds

The engine bearers are one of the most important parts of any installation, and in many cases are not given enough thought and consideration. In rough sea conditions the effect of the boat being lifted and dropped by the waves can produce forces as strong as 8 times the weight of the engine being felt by the engine bearers.

Therefore, the bearers have to be extremely strong to withstand this, as well as vibration, propeller thrust and engine torque whilst all the time maintaining the correct alignment of the engine to the propeller shaft.

Normally, the engine bearers should be:

- (i) at least one and a half to two and a half times the length of the engine;
- (ii) in wooden boats, the engine bearers should be of thick hardwood treated to prevent rot;
- (iii) a system of cross-bracing to spread the weight over as much of the hull as possible should be adopted;
- (iv) all fastenings should be through-bolted - wood and coach screws should not be used;
- (v) pressure pads between the engine feet and wooden engine bearers should be provided. In some cases full-length mild steel angles can be bolted on the bearers on which the engine feet sit.

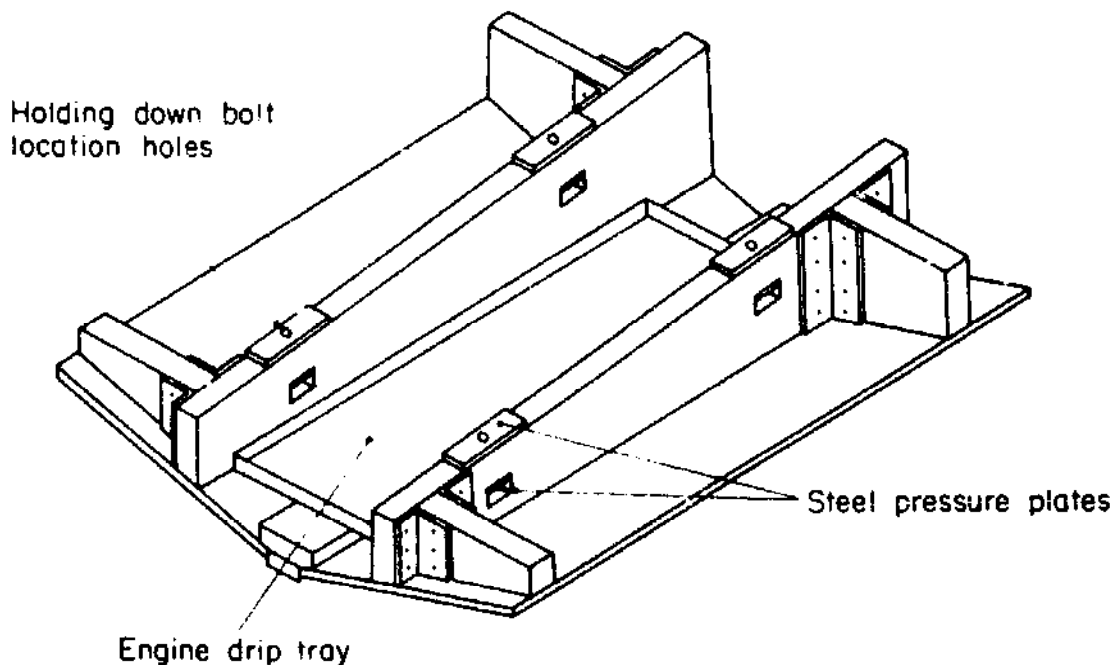

ENGINE BEARERS

Fig. 2

Most engine beds are made parallel and run "fore and aft" down the boat. Some engines are manufactured which need bearers which taper, e.g., Sabb, which are designed to fit double-ended vessels.

The following sketch shows typical Sabb engine installation.

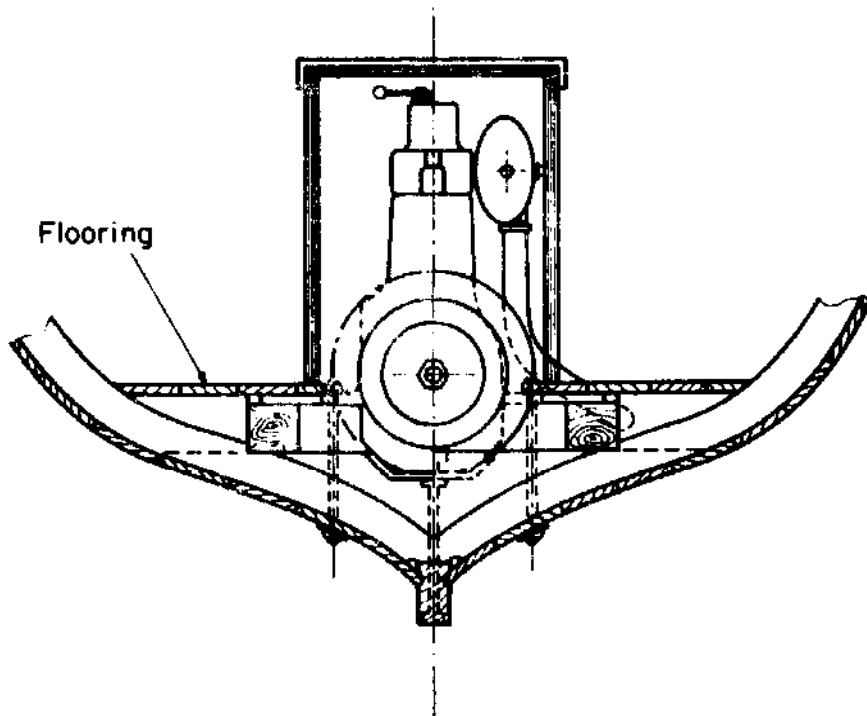
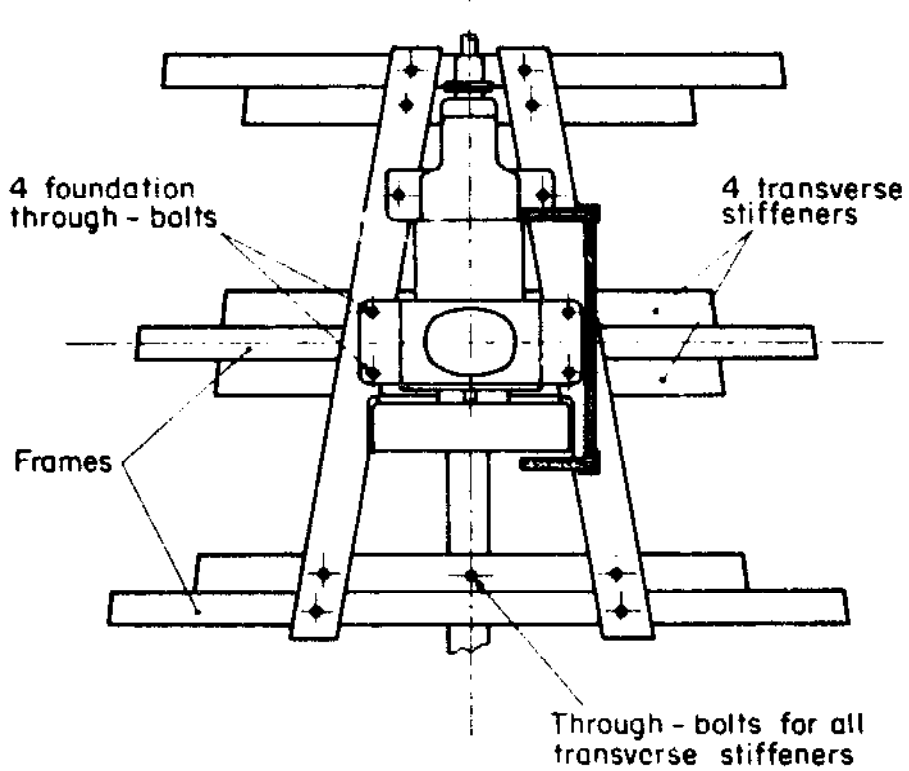

Fig. 3

#### 1.4 Drip tray

During the planning and construction of the engine bearers it is wise to make provision for a drip tray under the engine.

Made of fibreglass, galvanized mild steel sheet or mild steel sheet which has been thoroughly primed and painted to prevent corrosion, it should be fastened to the engine bearers before the installation of the engine. Careful planning of the drip tray is necessary to prevent the engine components, shaft, coupling, etc., from fouling the tray. Provision of a sump or well from which any oil, fuel or water leaks can be pumped out is also necessary.

The drip tray is an important item, and the provision of one under each engine will help preserve the cleanliness and hygiene of the craft especially to prevent contamination of fish in small boats by fuel and oil.

#### 1.5 Engine mounting

Engines may be mounted directly on to the engine bearers with solid and rigid engine mounting feet, or on flexible mountings to reduce noise and vibration, whichever is preferable and practical.

- (a) **Solid mountings** - Many workboats, barges and fishing boats where noise and vibration are not so important use engine mountings which bolt directly on to engine bearers. A typical solid mounting foot is shown in fig. 4.

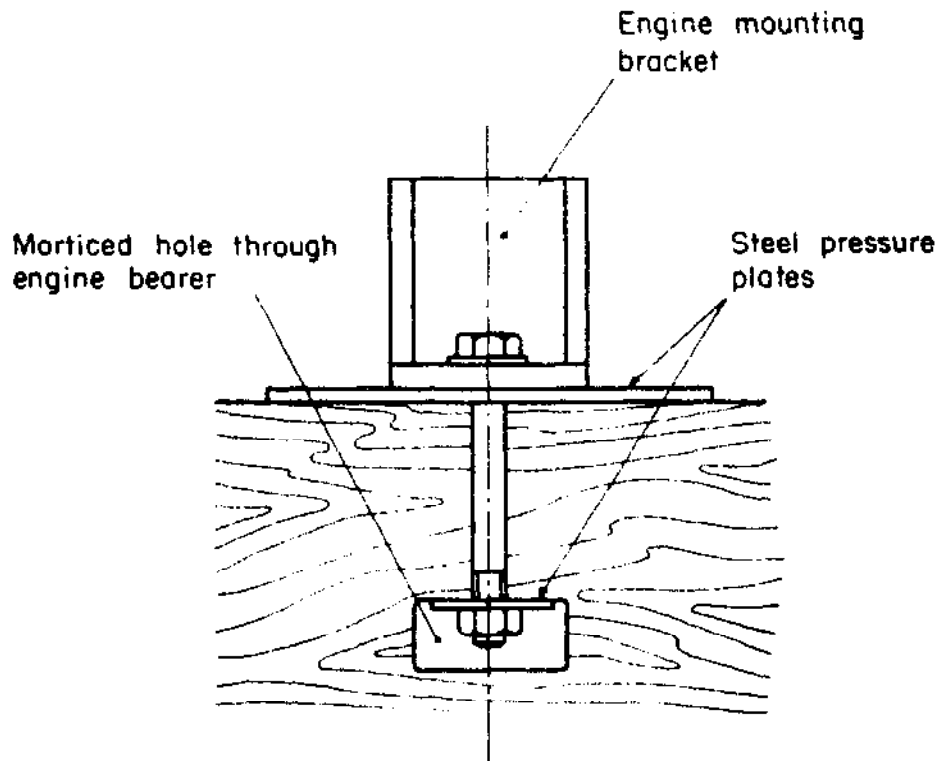

ARRANGEMENT OF ENGINE HOLDING  
DOWN BOLTS IN WOODEN BEARERS



- (b) Flexible mountings - permit a certain amount of movement by the engine to absorb vibration, especially noticeable when an engine is "idling". The connexion of the engine to the bearer is by way of a rubber block bonded between the two which is soft enough to flex.

Typical flexible mountings are shown in Figures 5 and 6.

It is obvious that as the engine is permitted to move by flexible mountings, all the connexions to the engine must also be flexible. For example, the following components have to be flexibly connected:

- (i) exhaust, from engine to hull fitting;
- (ii) fuel pipes to and from the engine;
- (iii) cooling water pipes to and from the engine;
- (iv) oil gauge and instrument connexions;
- (v) engine and gearbox controls;
- (vi) flexible shaft log connexion or flexible coupling to the propeller shaft;
- (vii) any drive to auxiliary equipment that is not mounted on the engine itself, e.g., bilge pump, power take-off;
- (viii) any part of the engine protruding through an engine box must be given space to move without hitting the box, e.g. starting handle shaft.

From the above it will be seen that for simple or small work-boat engine installations, it is often preferable to use solid engine mountings to avoid the additional cost and expertise required to flexibly mount an engine. This is particularly true where long, heavy solid engine bearers can be utilized to absorb vibration and noise.

### 1.6 Vee drives

A Vee-drive system is used on some craft where engine space is saved by positioning the engine over the shaft, instead of in line with the shaft, thus taking up less length.

The Vee-drive gearbox may be an integral part of the engine, or may be separated from it and driven by an intermediate shaft.

In the latter case, the Vee-drive gearbox is solidly mounted to the boat in line with the propeller shaft and the engine is mounted on flexible mounting feet, with a flexible coupling on the intermediate shaft.

The Vee-drive gearbox usually requires a cooling water supply.

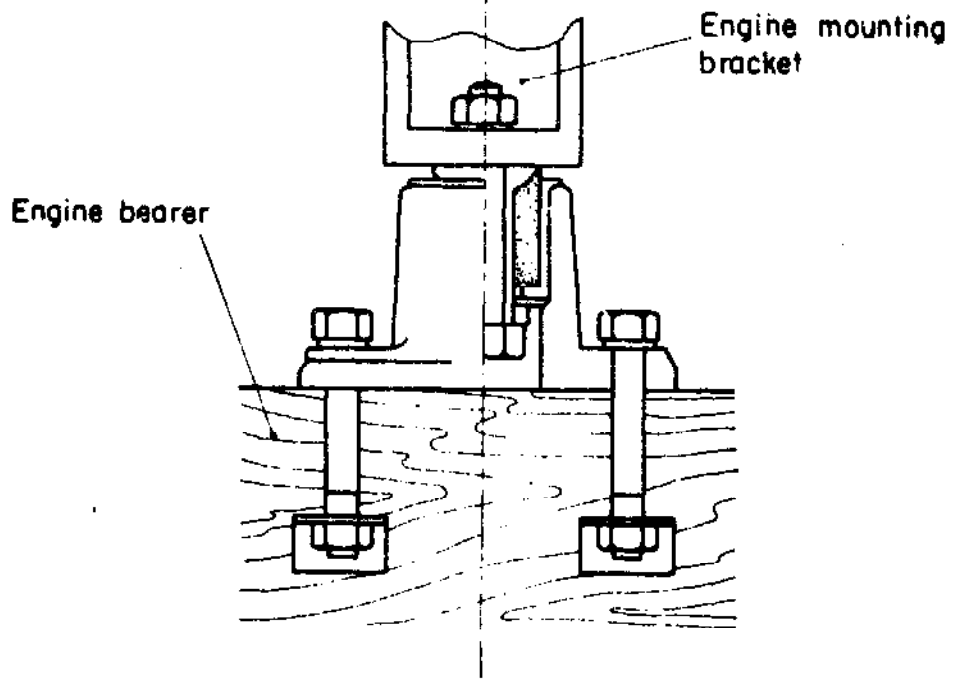

PEDESTAL TYPE FLEXIBLE MOUNTING

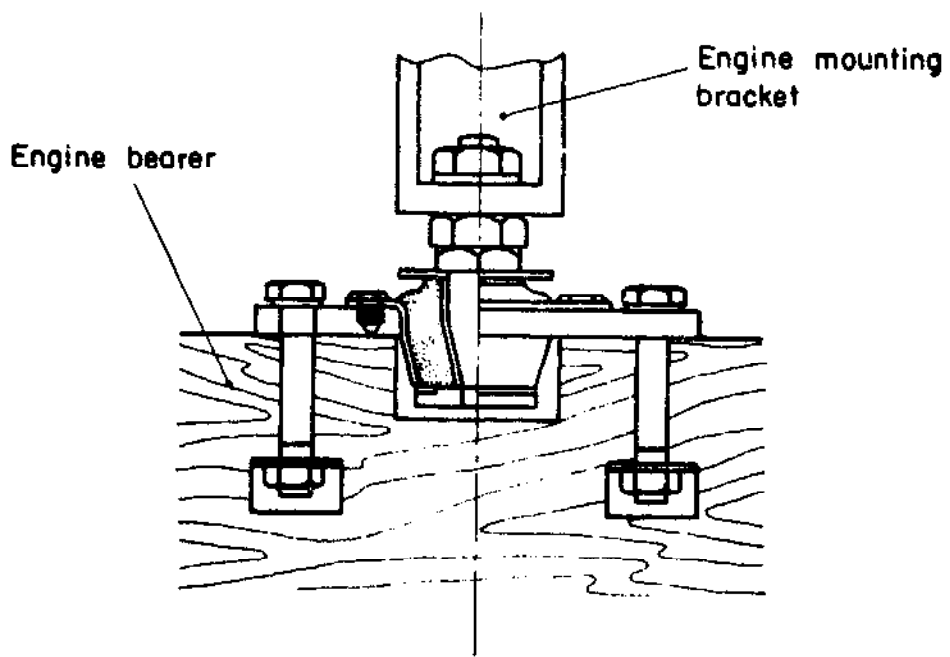
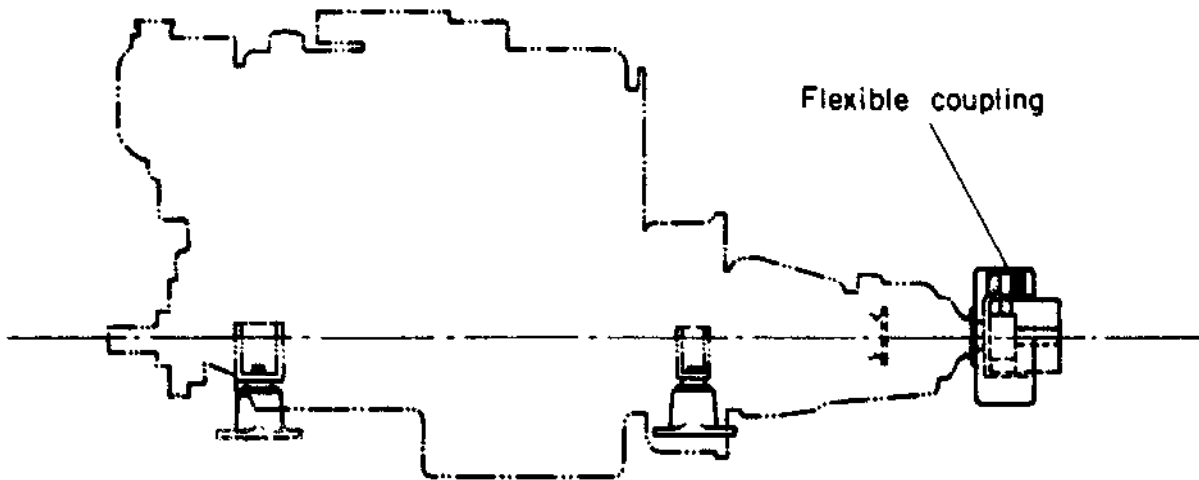
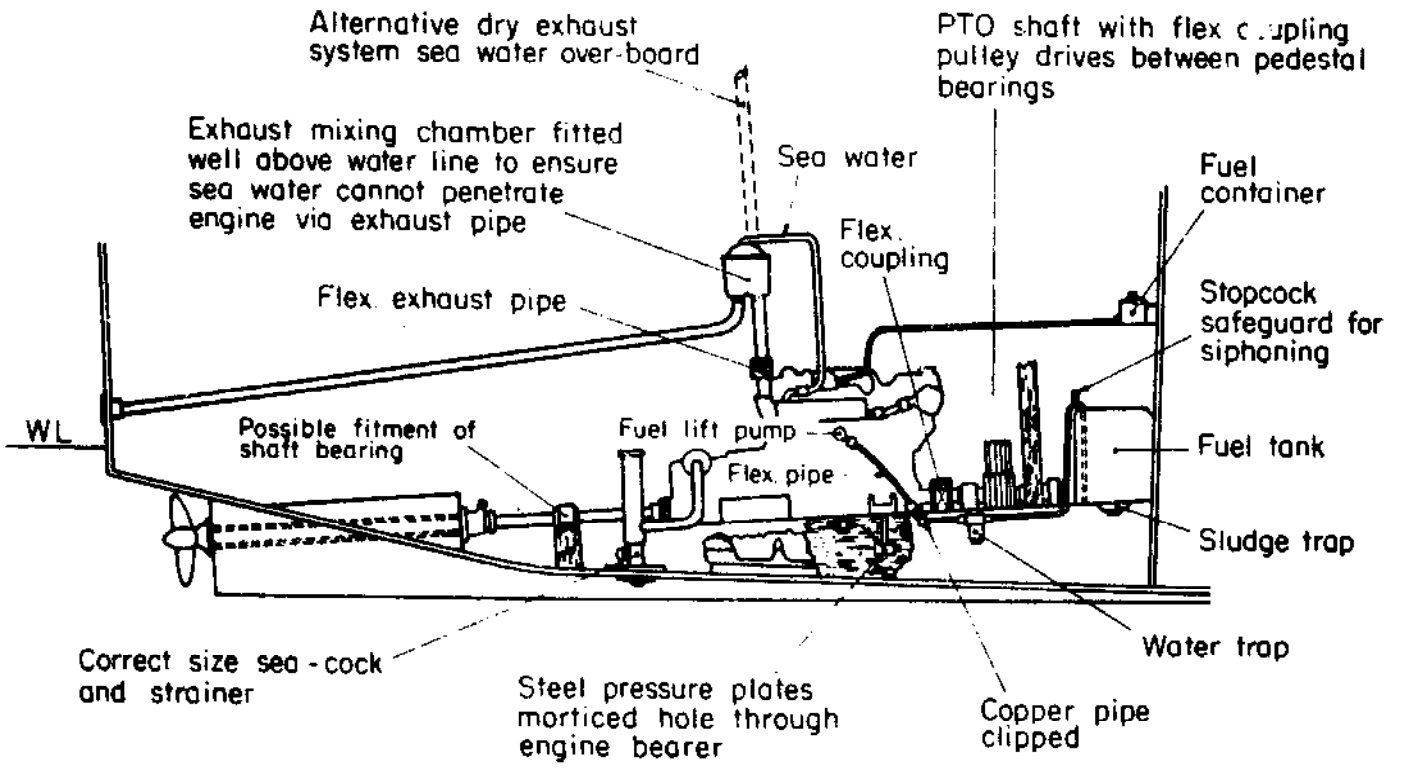

PLATE TYPE FLEXIBLE MOUNTING



4 POINT FLEXIBLE MOUNTING ARRANGEMENT

Fig. 6



TYPICAL WORK BOAT INSTALLATION

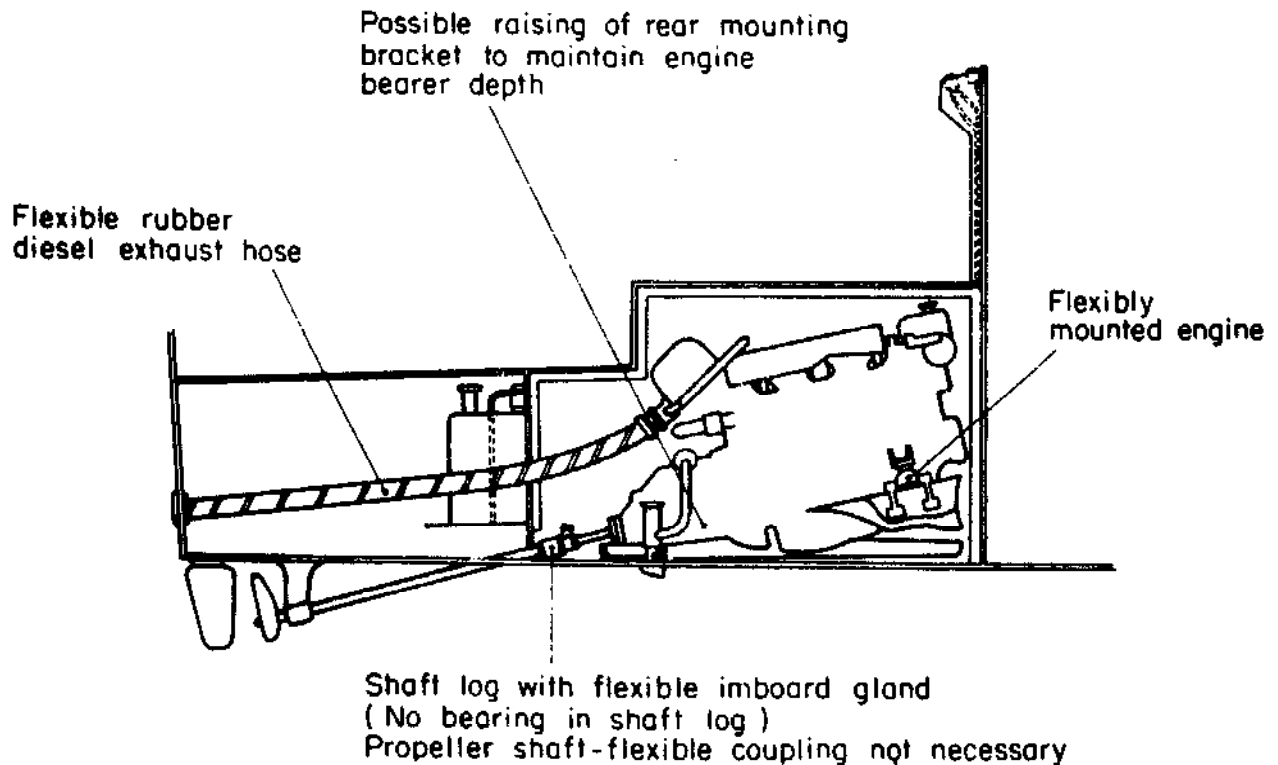
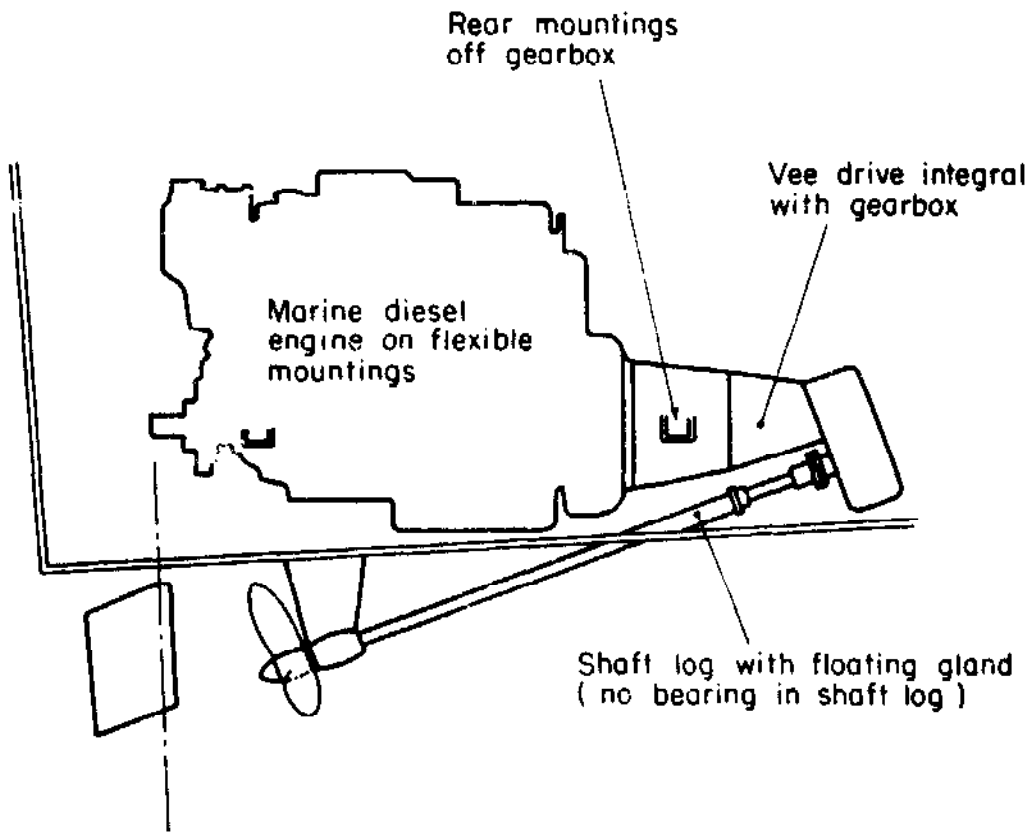
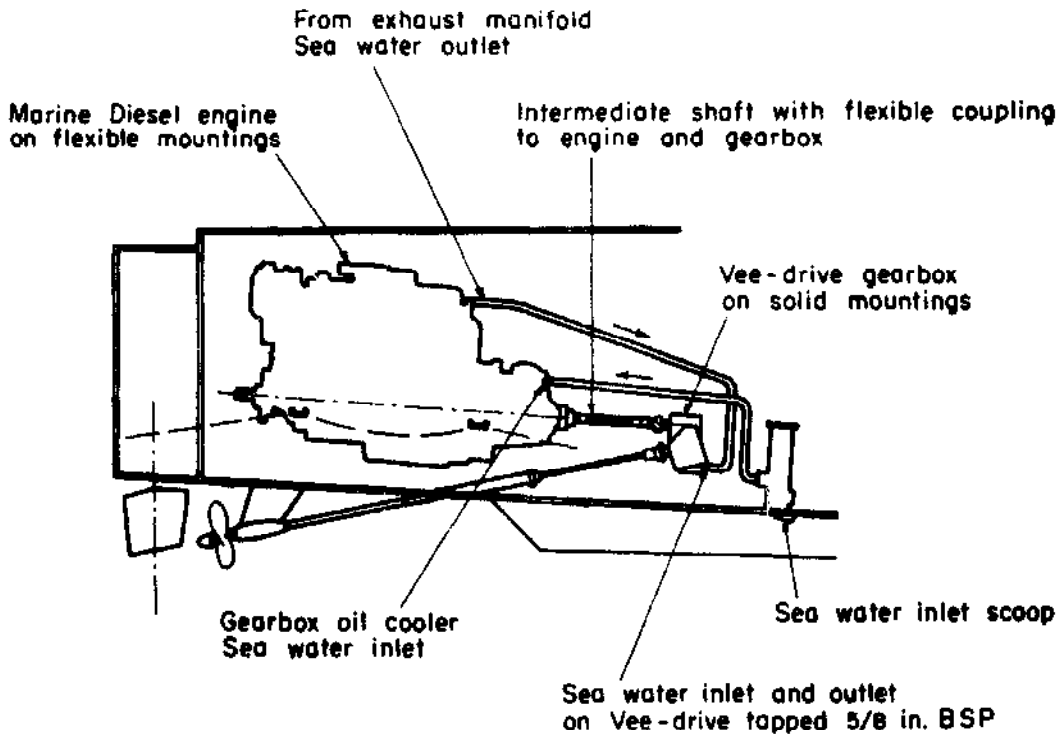

Fig. 7



### VEE - DRIVE ARRANGEMENT

Fig. 8



### TYPICAL VEE - DRIVE ARRANGEMENT

Fig. 9

## SECTION 2

### 2.1 Propeller shafts

Propeller shafts are made from mild steel (preferably with liners of non-ferrous material for corrosion protection), bronze, marine stainless steel or monel metal. The shaft is machined at the propeller end with a taper, keyway (with parallel key to fit) and a thread to take a split pin for locking the nut. There are also different methods of locking, where the spinner nut is locked to the propeller.

On very small engine installations (up to 10/12 hp) the half coupling at the engine end of the shaft may be clamped to the shaft, without the shaft having to be machined resulting in a simple installation and lower cost.

On others, the shaft is fitted with a keyway, and the coupling fitted by means of a key and held with set screws in the coupling.

The larger engines require a stronger method of fixing the coupling to the shaft, and the best way is to machine the shaft exactly the same at both ends and machine the coupling to fit, with a keyway and room for an internal nut. If this is done, it means the shaft can be reversed if it begins to show any sign of wear, thus saving a major expense.

### 2.2 Couplings

Methods of fitting the coupling to the shaft are shown in figures 10 and 11.

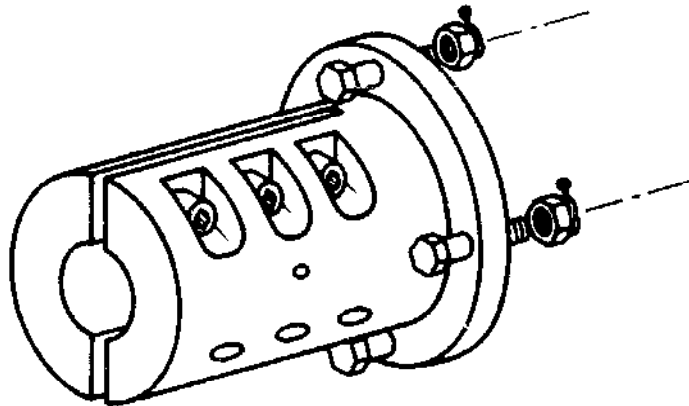

PROPELLER SHAFT  
COUPLING WITH CLAMPING

Fig. 10

(1) Solid couplings - On most small and medium horsepower engines the coupling connecting the shaft to the engine or gearbox is made up of 2 'matched' precision-made half couplings bolted together.

One half coupling is usually supplied and fitted to the engine, whilst the shaft half coupling is supplied loose, and has to be made to fit the shaft. It is normally "pilot-bored", i.e., provided with a small hole in the centre which has to be bored or turned out to the correct size of the shaft.

If the shaft is tapered at both ends (see previous section on shafts) then the half coupling has to be made with the corresponding taper and keyway and with a recess to take the threaded nut and locking device.

Care should be taken to ensure that the mating faces of the couplings are undamaged, as when the engine has to be aligned to the shaft the use of the feeler gauges is required, which can only be accurately used on precision faces (see alignment).

Never split couplings which have been bolted together, by the use of hammers and wedges.

(ii) Flexible couplings - There are several designs and types of flexible shaft couplings which usually consist of a rubber cushion either in one part or several elements. Sandwiched between two coupling halves, they are able to transmit the engine power (or thrust) both in ahead and astern, as well as permitting the movement of the flexibly mounted engine.

Couplings should be specified by the engine makers as there are many different sizes to suit various engines and gearboxes, reduction gear ratios and types of craft into which they are fitted.

Most flexible couplings can be dismantled, but care must be taken to mark the coupling parts first so that they will be reassembled exactly as they were.

As with solid couplings, flexible couplings are supplied pilot-bored only.

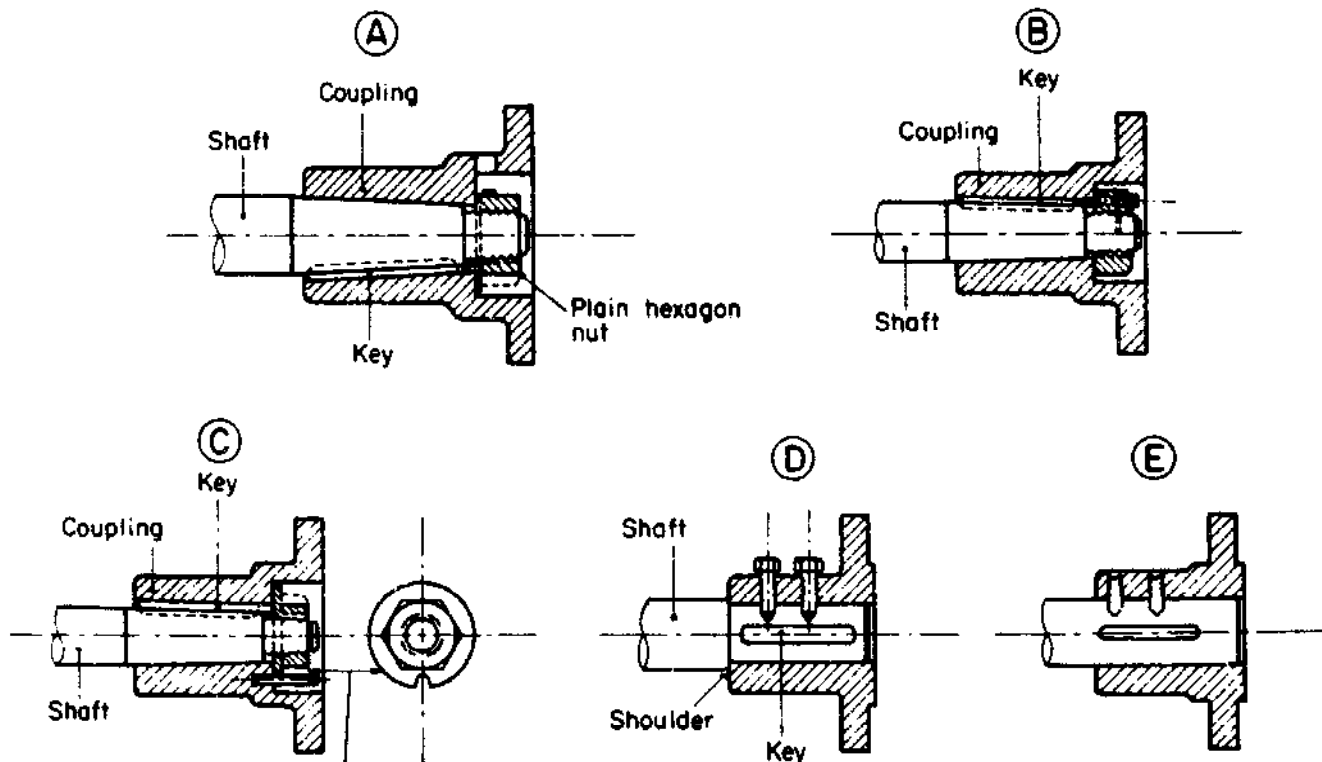

INBOARD COUPLING ARRANGEMENTS

Fig. 11

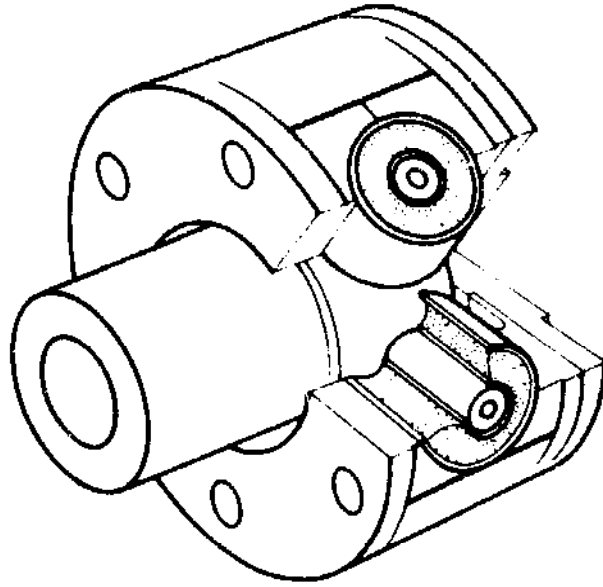

FLEXIBLE PROPELLER SHAFT COUPLING

Fig. 12

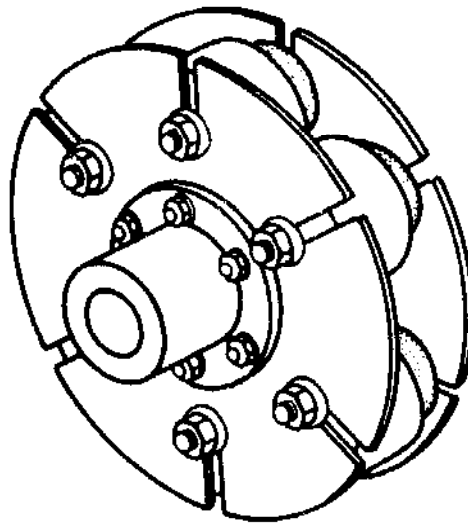

FLEXIBLE PROPELLER SHAFT COUPLING

Fig. 13



(iii) Universal coupling - Universal couplings are used when it is impossible to arrange the engine and the propeller shaft in the same line.

Although it looks relatively easy to achieve, the installation of an engine on a different line to the shaft can be quite difficult in practice, and advice from the engine manufacturers should be obtained as to the type of universal couplings to use and the degree of alignment to be accommodated.

Figure 14 shows a preferred universal coupling arrangement where the thrust is taken in the stern tube.

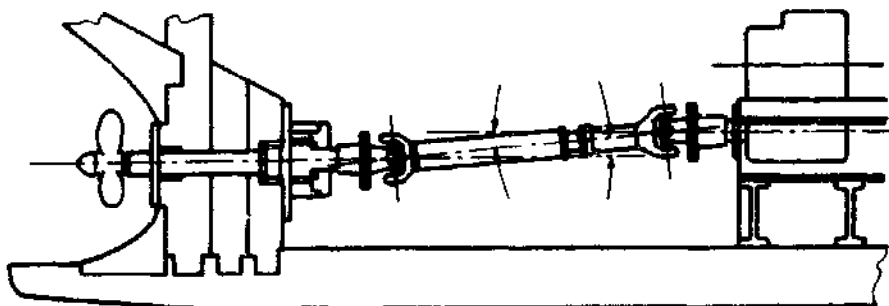

UNIVERSAL COUPLING

Fig. 14

### 2 3 Propeller shaft bearings

The propeller shaft has to be supported by bearings to maintain its correct position and to allow the shaft to turn freely without bending or whipping.

The type of bearings to be used and their position is normally decided upon by the designer of the craft; the choice of which system to use is dependant upon many factors including:

- (i) the length, diameter and material of the shaft;
- (ii) the speed of the propeller shaft;
- (iii) the shape of the hull and the materials with which it is built;
- (iv) whether the engine is mounted solidly or flexibly, etc.

There are two main designs, as follows:

a) Rigid stern tube - The system commonly used for working boats and fishing boats of small to medium horsepower. It usually consists of a solid metal tube threaded at both ends. The tube is fixed through the keel, skeg or shaft log and stern post of the vessel, with a threaded portion protruding through the hull both inside and outside.

On the outside of the hull is screwed the stern bearing which is fastened to the stern post, on the inside of the hull is fitted a water-tight gland (or 'stuffing' box) (which may or may not contain a bearing) with packing which is fastened to the inner face of the shaft log.

Figure 15 shows the component parts of a typical rigid stern tube containing white metal bearing. The bearing in this case is lubricated by grease in the grease cap.

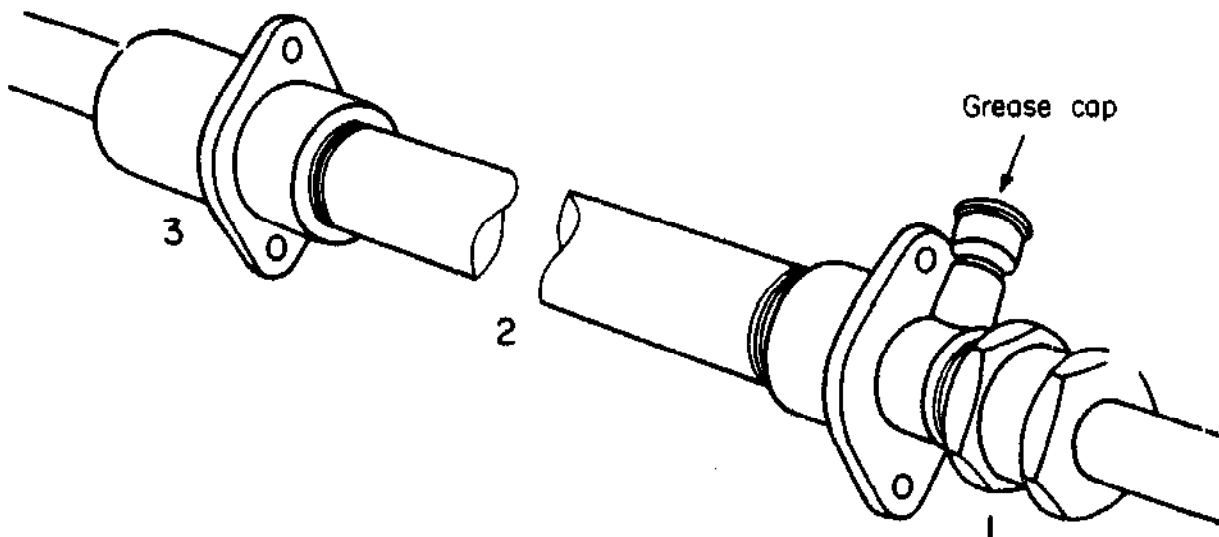

1. Gland packing box
2. Stern tube, threaded at both ends
3. Stern bearing (grease lubricated)

Fig. 15

In other cases, the bearings in the stern tube are made of rubber, which have to be lubricated by water. The water cooling system of the engine is tapped and a pipe carrying water is connected to the stern tube. Alternatively, water is scooped by a fitting on the outside of the craft and fed into the stern tube bearing to be lubricated.

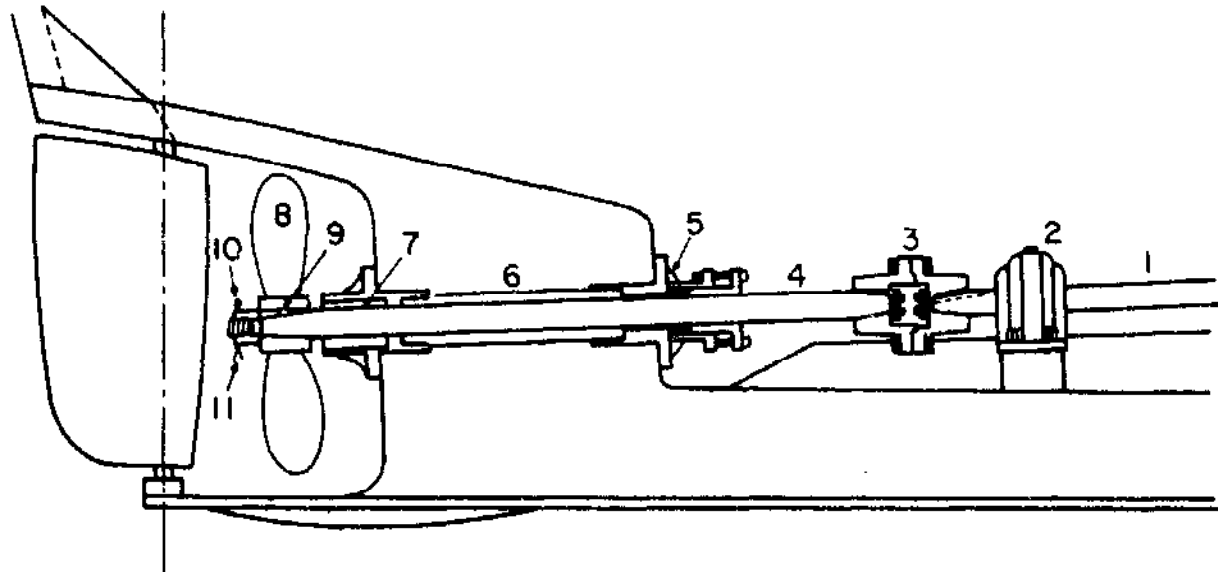

- |   |   |    |               |
|---|---|----|---------------|
| 1 | Intermediate shaft                            | 7  | Stern bearing |
| 2 | Shaft bearing                                 | 8  | Propeller     |
| 3 | Shaft coupling                                | 9  | Key           |
| 4 | Tail shaft                                    | 10 | Retaining nut |
| 5 | Packing gland. May or may not contain bearing | 11 | Split pin     |
| 6 | Stern tube                                    |    |               |

**PROPELLER SHAFT COMPONENTS  
TYPICAL ARRANGEMENT  
STERN TUBE TYPE**

Fig. 16

b) Flexible shaft log - A fitting shaped to the hull, with provision to bolt the fitting through the skin of the boat. The shaft tube or log is not fitted with a gland or bearing, but a heavy duty rubber hose is clipped to it. A gland packing box is in turn fitted into the rubber hose thus allowing it to be floating or self-aligning to absorb any engine movement.

## FLEXIBLE LOG

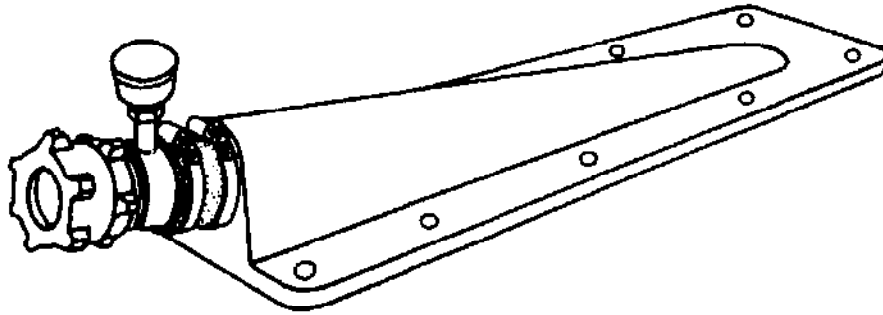

Fig. 17

For light duty use a combination of the floating gland fitted on to the rigid stern tube arrangement is sometimes found. An example is shown in figure 18, with the stern bearing incorporating a scoop for water lubricating the rubber bearing.

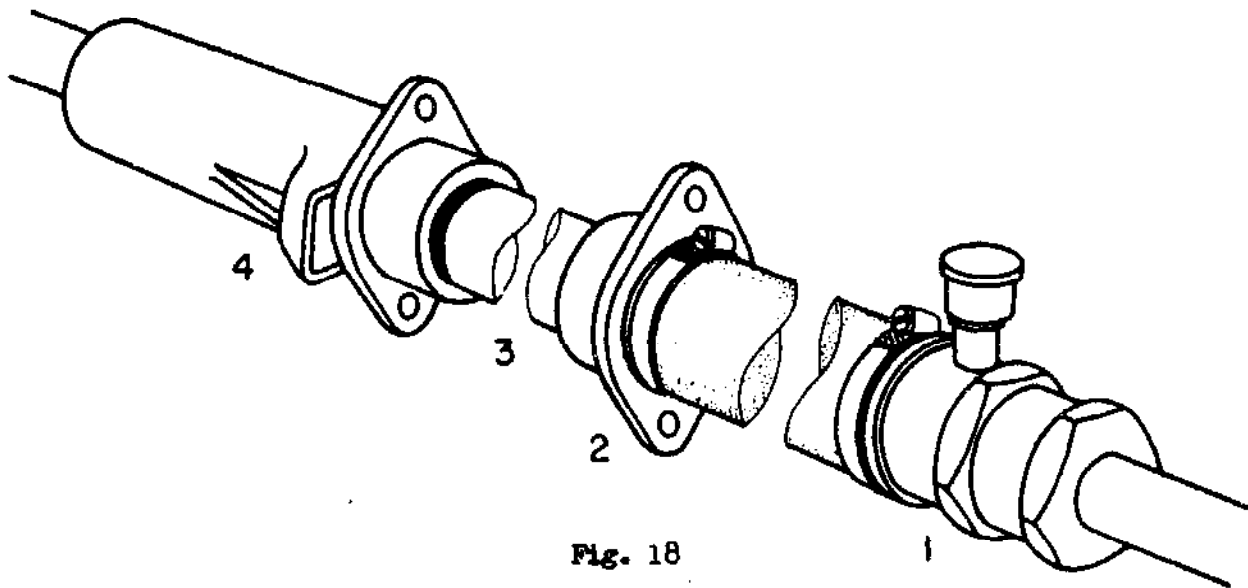

Fig. 18

1. Gland packing box
2. Hose attachment
3. Stern tube
4. Stern bearing with scoop

## 2.4 Intermediate bearings

If the propeller shaft is very long, because the engine is mounted a long way forward of the stern tube bearings, it may be necessary to fit an intermediate bearing.

Table 2.1 gives recommended maximum spacing of shaft bearings for different shaft diameters for propeller shafts of manganese bronze, monel metal or marine stainless steel with minimum tensile strength of 28 tons/sq. ins. The spacing given is for shaft revolutions of not more than 1000 rpm.

TABLE 2.1.

Diameter of Shaft (mm).	Maximum Shaft Bearing Spacing (c/s to c/s) (metres)
25	1.21
30	1.37
35	1.52
40	1.66
45	1.80
50	1.93
55	2.05
65	2.29
75	2.52

Minimum distance from gearbox flange to the first bearing

= 12 times the diameter of the shaft

e.g., 35 mm shaft - distance = 0.42 metres but,

Preferable distance

= 20 times the diameter of the shaft

e.g., 35 mm shaft - distance = 0.70 metres.

## 2.5 Underwater fittings

'P' bracket - In conjunction with the fitting of a shaft log, where the shaft actually goes through the hull, a bearing is required for the shaft close to the propeller. The most usual method is to fit a 'P' bracket containing a water lubricated bearing. Usually constructed of brass or bronze to prevent corrosion (wooden and fibreglass boats only) the 'P' bracket is through-bolted to the hull.

The 'P' bracket sometimes incorporates a 'fin' below, to protect the propeller if the boat grounds.

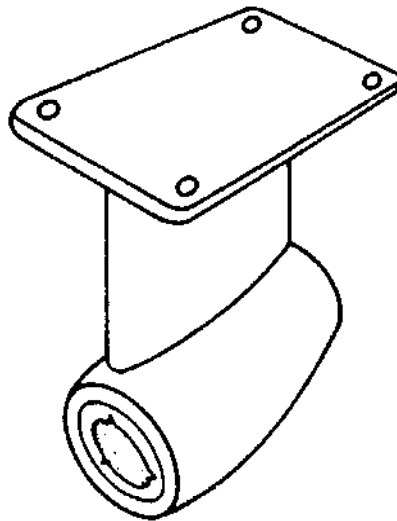

TYPICAL 'P' BRACKET

Fig. 19

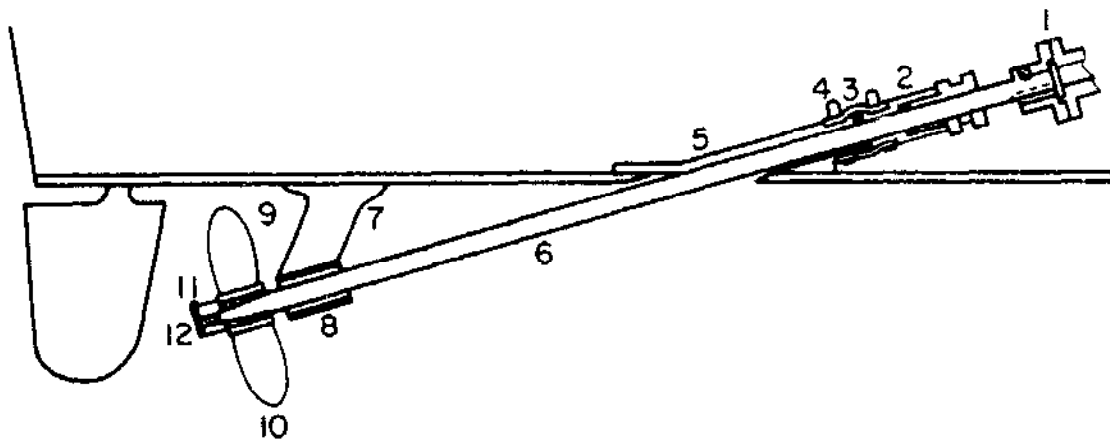

- |   |  |    |                           |
|---|--|----|---------------------------|
| 1 | Shaft coupling   | 7  | P. bracket                |
| 2 | Packing gland . May or may not contain bearing                             | 8  | Stern bearing             |
| 3 | Flexible coupling . Solid connection used for larger than motor boat sizes | 9  | Propeller key             |
| 4 | Retaining clamps for coupling  | 10 | Propeller                 |
| 5 | Shaft log  | 11 | Castellated retaining nut |
| 6 | Propeller tailshaft  | 12 | Split pin                 |

**PROPELLER SHAFT COMPONENTS**  
**TYPICAL ARRANGEMENT**  
**SHAFT LOG AND P. BRACKET**

Fig. 20

'P' bracket cutless rubber bearing - Contained in the 'P' bracket is a fluted rubber bearing bonded to a bronze tube and held in place by countersunk threaded screws.

The bearings are long lasting (if shaft alignment is correct) but can be replaced quite easily with new ones. Many sizes are available.

Similar bearings are used in water lubricated stern tube bearings.

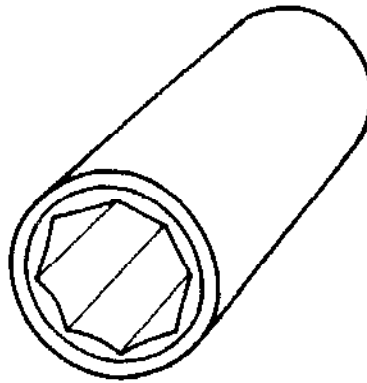

CUTLESS BEARING

Fig. 21

## 2.6 Propeller shaft glands

The purpose of the propeller shaft gland is to prevent water entering the boat through the propeller shaft tube or through the shaft log.

As we have seen, the gland may be rigidly fitted, by being screwed on the propeller shaft tube or flexibly fitted by means of heavy duty rubber hose, either to a shaft tube or to a shaft log.

It consists of an adjustable flange or adjusting nut which presses on to special gland packing material around the shaft.

Ideally the gland should be adjusted so that there is a very slight amount of water passing into the boat past the gland. If the gland is overtightened to stop all the water coming in the propeller shaft will overheat at the gland and damage will result.



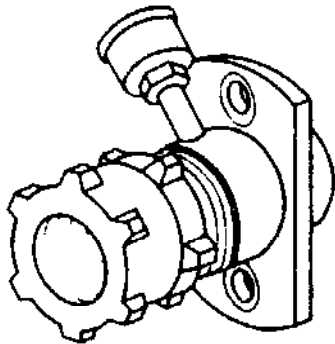

RIGID GREASE  
LUBRICATED

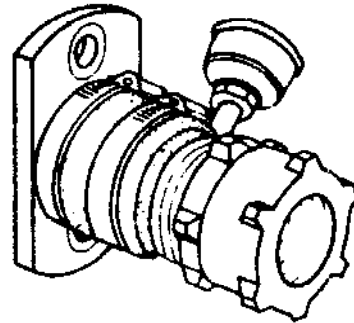

FLEXIBLE

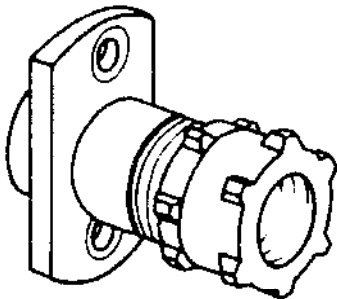

RIGID WATER  
LUBRICATED

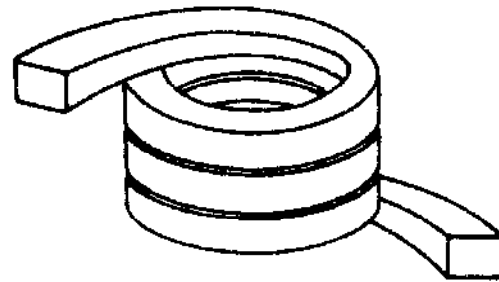

GLAND PACKING MATERIAL

Fig. 22

In some conditions engine makers recommend fitting a gland at the propeller end of the stern tube to keep water out, and grease within the stern tube, to lubricate metal bearings.

### 2.7 Shaft greasing arrangements

Shaft bearings made of metal, usually called 'white metal' require grease for lubrication.

One method for greasing these bearings is by a small grease cup on the inboard end of the shaft tube behind the gland. This cup has to be filled with a special water resistant grease and turned down at regular times whilst the boat is being run.

Another method is to use a larger container, like a grease gun, but with a threaded handle. By turning the handle, grease is forced into the stern tube.

Similar arrangements to the above are also used to grease variable pitch propellers.

Remember, shaft tubes fitted with rubber bearings must NEVER be greased.

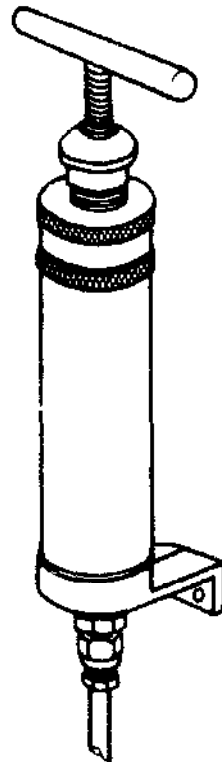

SHAFT  
GREASING  
ARRANGEMENTS

Fig. 23

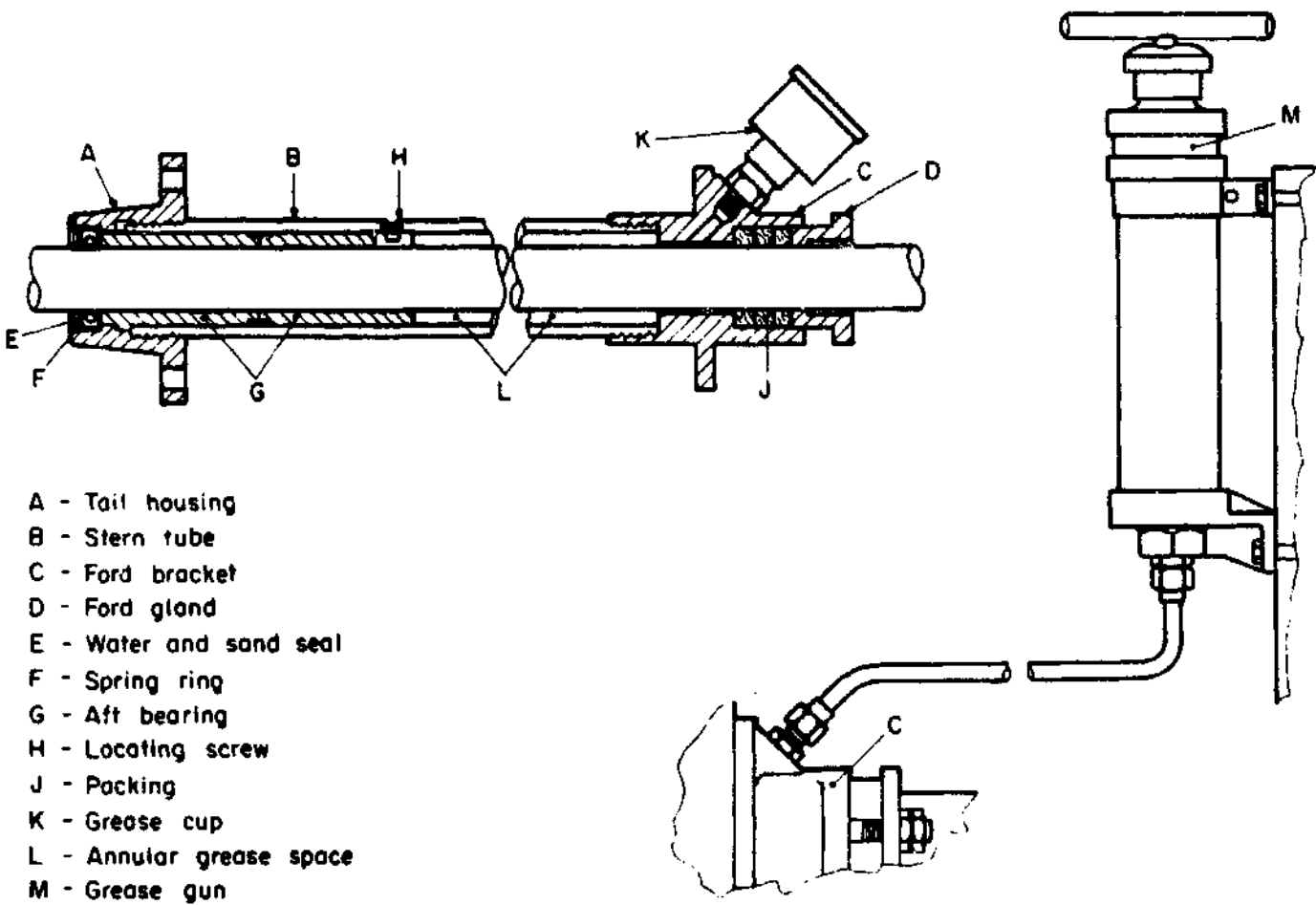

Fig. 24

## 2.8 Propellers

Usually made of bronze alloy, a propeller is a very carefully made precision part. They are of various designs, usually with 2, 3 or 4 blades and "handed", i.e., either made for right hand rotation - clockwise, or left hand rotation - anticlockwise when viewed from the aft end.

Propellers are made to fit a variety of shaft sizes and therefore if a new or replacement propeller is to be ordered, precise information must be given so that the correct one is sent.

The information needed by the manufacturer or agent is:

1. diameter of propeller;
2. diameter of shaft, length of taper and size of keyway;
3. number of blades;
4. direction of rotation (either LH or RH);
5. pitch of the blade (usually stamped on the propeller hub).

The pitch of blade may be hard to understand, but it is the distance the propeller would proceed axially (i.e. in direction boat is going) during one revolution if it did not "slip" in the water. It may be compared with the distance a screw tightens when turned one complete revolution (in theory only).

## 2.9 Alignment

Alignment means the careful and exact placing of the engine to the propeller shaft, so that the engine driven coupling (whether on the engine, gearbox or reduction gearbox) is perfectly in line with the propeller shaft coupling.

The engine is always lifted or lowered to make this possible. NEVER try to move the shaft tube.

On wooden boats the craft must be in the water and left for several days before trying to align the engine. This is because a wooden boat changes its shape as the wood becomes soaked, and it may take time to do that.

On boats made of other materials, e.g., fibreglass, the alignment may be done as soon as the boat is in the water.

The method used to align an engine is fully described in Part 2.

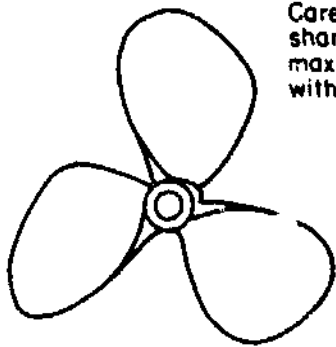

Carefully finished sharp sections for maximum performance with high-speed boats

HIGH - SPEED PROPELLER

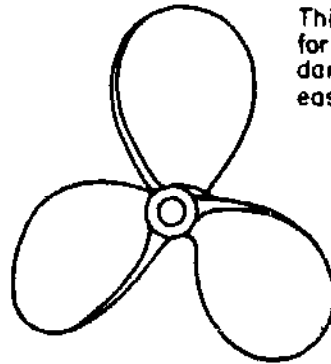

Thick blade section for resistance to damage in service and ease of manufacture

COMMERCIAL PROPELLER



TWO BLADE PROPELLER FOR AUXILIARY SAILING BOATS

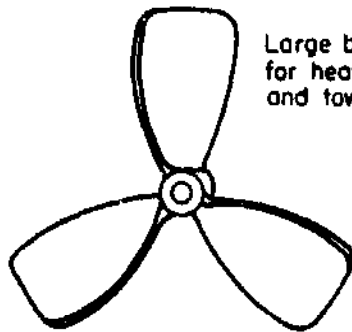

Large blade area for heavy duty and towing boats

LOW - SPEED COMMERCIAL PROPELLER

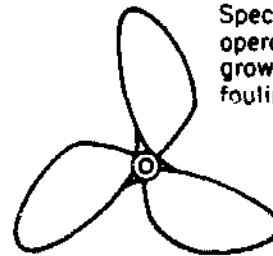

Special shape for operation in marine growth without fouling

WEEDLESS PROPELLER



FOLDING PROPELLER FOR AUXILIARY SAILING BOATS

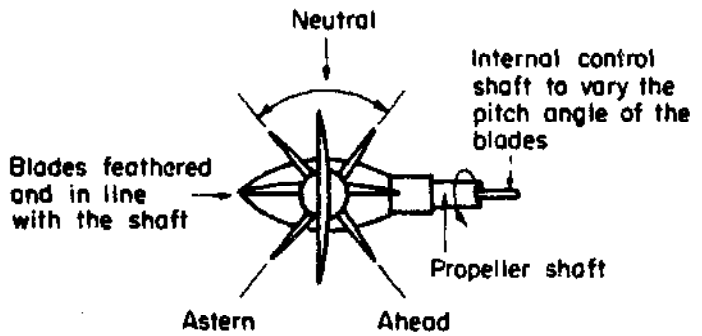
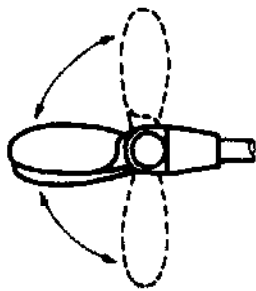

THE ACTION OF A CONTROLLABLE PITCH PROPELLER

SECTION 3Cooling systems3.1 Introduction

3.1.1 Water cooling - There are three different methods of water cooling a marine engine as follows:

- (a) Direct cooling where water is picked up from the sea or lake passed through the water jackets of the engine, and returned overboard, either with the exhaust or separately.
- (b) Indirect cooling by the heat exchanger. The engine water jacket is filled with fresh water in a closed circuit. Sea or lake water is picked up and passed through a special unit (called a heat exchanger) which cools the fresh water without mixing with it. The sea or lake water is returned overboard.
- (c) Keel cooling. The engine water jacket is filled with fresh water in a closed system. To cool the water in the system, water pipes containing the fresh water pass outside and underneath the hull of the boat. As the water around the outside of the pipes (in the sea or lake) is cold, the hot water in the pipes is cooled.

3.1.2 Air cooling - The engine drives a fan, which blows cold air around special cooling fins on the engine, taking away the hot air, by a system of ducts if necessary.

3.2 Planning

The variety of cooling systems available give the installation engineer a choice of which type is best suited to the conditions where the boat will be working. These points can be considered at the planning stage so that the engine type and extra equipment can then be ordered.

Direct water cooling -

Advantages - A cheap and easy installation, requiring only an inlet fitting on the hull (sea-cock and strainer) and the outlet connexion, either to the hull direct, or with the exhaust system.

Note: The engine must of course have its own water pump.

Disadvantages - The engine must be constantly checked to make sure cooling water is circulating. Weeds, grass, mud, etc., cause blockages in strainer causing lack of water and overheating.

Raw water (e.g., salt water) can cause corrosion problems in engine and low engine temperatures, causing dirty lubricating oil.

Indirect cooling by heat exchanger -

Advantages - Enables engine water jackets to be cooled by fresh water, reducing corrosion. An easy installation requiring only an inlet fitting on the hull (sea-cock and strainer) and outlet as in direct cooling system. Failure of raw water cooling not so quickly damaging. Higher engine running temperatures keep engine-oil cleaner.

Disadvantages - More expensive with heat exchanger/tank, pump (usually impeller type) for fresh water and second pump for raw water (ordered and bought as a complete set fitted to the engine).

### Keel cooling -

**Advantages -** Enables engine water jackets to be cooled by fresh water, as in indirect system. No possibility of overheating caused by weeds, mud, etc., as in other two systems.

**Disadvantages -** Slightly more difficult to fit. If keel cooling pipes become damaged, the craft has to be taken out of the water for repair. Some engines are not suitable for keel cooling so manufacturers must be consulted.

### Air cooling -

**Advantages -** Easy to install in open boat. Requires very little maintenance, other than cleaning.

**Disadvantages -** More noisy. Under-deck installations need careful planning of air-ducting to ensure enough air to and from the engine. Air ducting can take up a lot of room.

### 3.3 Direct cooling

A typical direct cooling system is shown in Fig. 26.

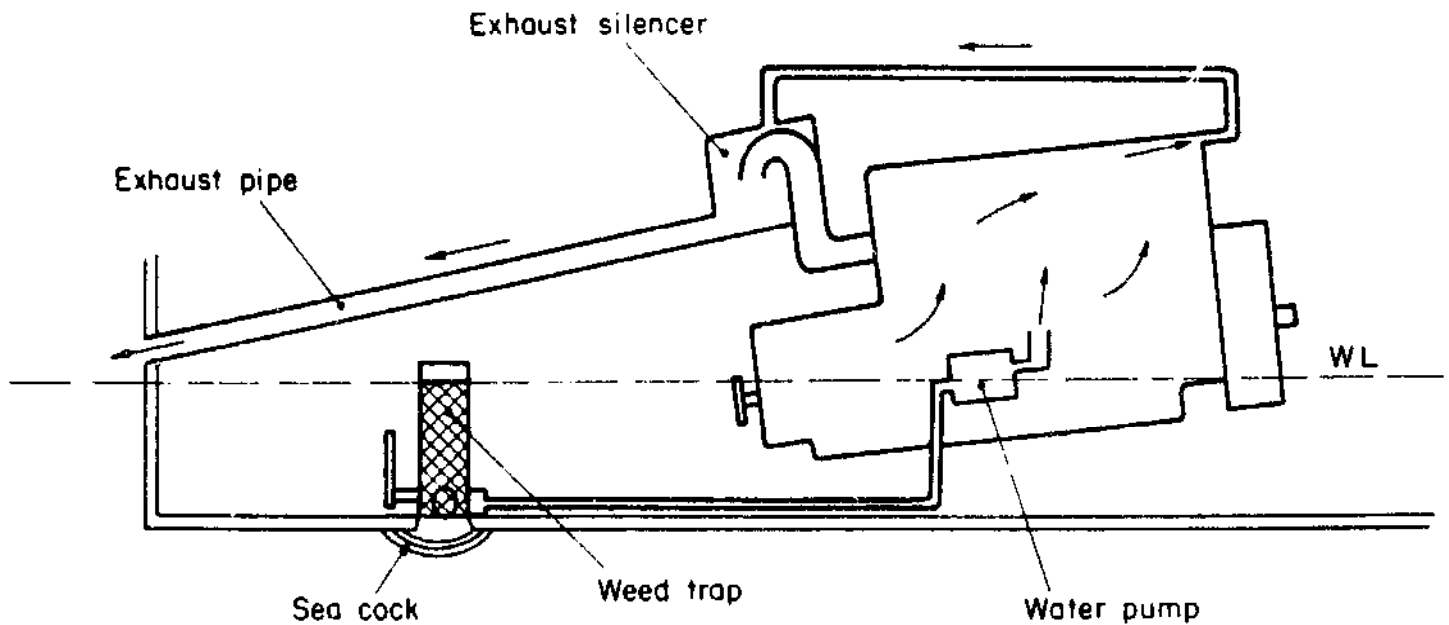

TYPICAL DIRECT COOLING SYSTEM

Raw water is picked up by the pump through the sea cock and weed trap. The water passes upward through the engine cooling water jacket to the highest point of the engine.

It is then lead by a pipe to the exhaust silencer where it cools the exhaust gases by mixing with them, and then flows back to the sea or lake.

Note: The exhaust water cooling is not a necessary part of the system. The water, after leaving the engine, can be directed straight overboard by a separate pipe. In practice though, it is often very simple to use the water for exhaust cooling as shown above.

### 3.4 Indirect cooling by heat exchanger

Raw water is picked up by the pump through the sea cock and weed trap. Then it passes through the heat exchanger to be pumped into the exhaust manifold cooling jackets and then overboard, either mixed with or separate from the exhaust gases (as in the direct cooling method).

The engine water jackets contain fresh water in a closed circuit which is circulated by a fresh water impeller around the system. The heat generated by the engine is absorbed by the fresh water, which is in turn taken (exchanged) by the raw water in the heat exchanger.

A thermostat controls the working temperature of the fresh water; to enable the engine to run at high operating temperatures the system is under a slight pressure controlled by a pressure valve in the fresh water filler cap.

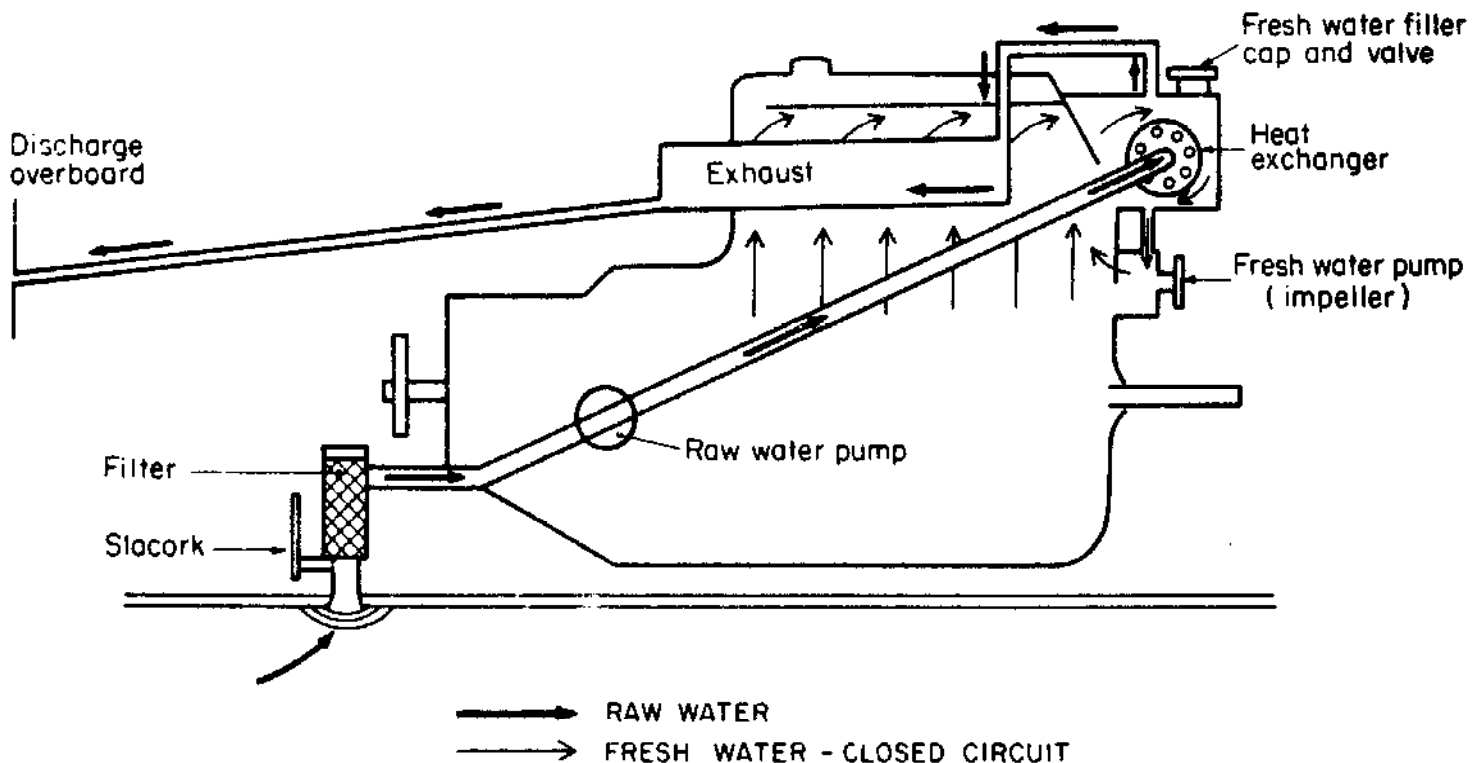

TYPICAL INDIRECT COOLING  
SYSTEM - BY HEATEXCHANGER

A sea-cock and strainer (or weed trap), see Fig. 28, is required in both the direct (raw water) cooling or the indirect (heat exchanger) cooling systems. This is a fitting whereby the water comes through the skin of the hull. It is then passed through a filter, which can be removed for cleaning.

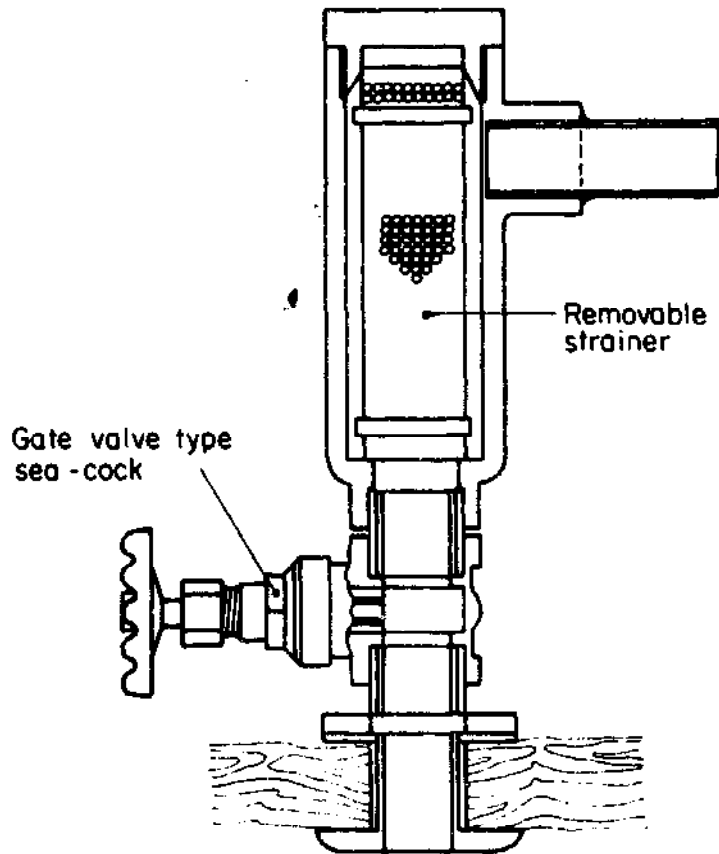

TYPICAL FULL FLOW SEA-COCK  
INCORPORATING A STRAINER

Fig. 28



### 3.5 Keel cooling

A closed circuit method of cooling using fresh water only, which gets rid of the heat produced by the engine by passing through tubes fitted to the outside of the hull.

A typical system is shown in Fig. 29.

Note: The amount of heat produced by the engine depends largely on the horse power and the length of the keel cooling pipes is calculated accordingly.

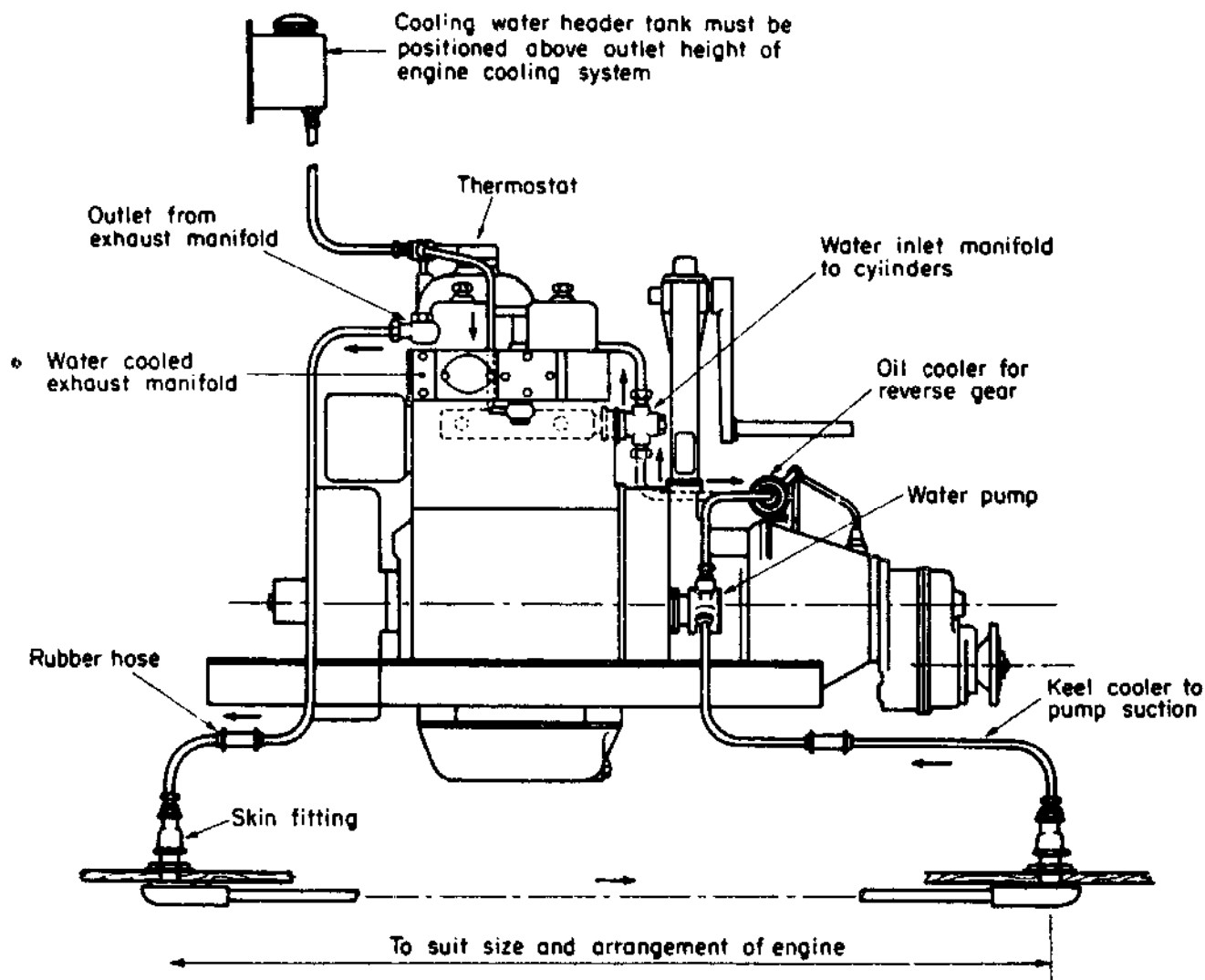

TYPICAL KEEL COOLING ARRANGEMENT

Fig. 29

### 3.6 Air cooling

Cooling air is drawn in by a fan driven by the engine. On small engines, the fan is often part of the flywheel, whilst on larger units it is driven by Vee belts from the crankshaft.

The air is directed around the engine, which is specially made with a large number of cooling fins at the cylinder head and cylinder - the hottest parts of the engine.

The air, after passing over the cooling fins, becomes hot, and is then directed away, by ducts on larger engines to the outside.

It is important to note that the hot air after cooling must not be allowed into the inlet side of the fan.

A typical installation is shown in Fig. 30.

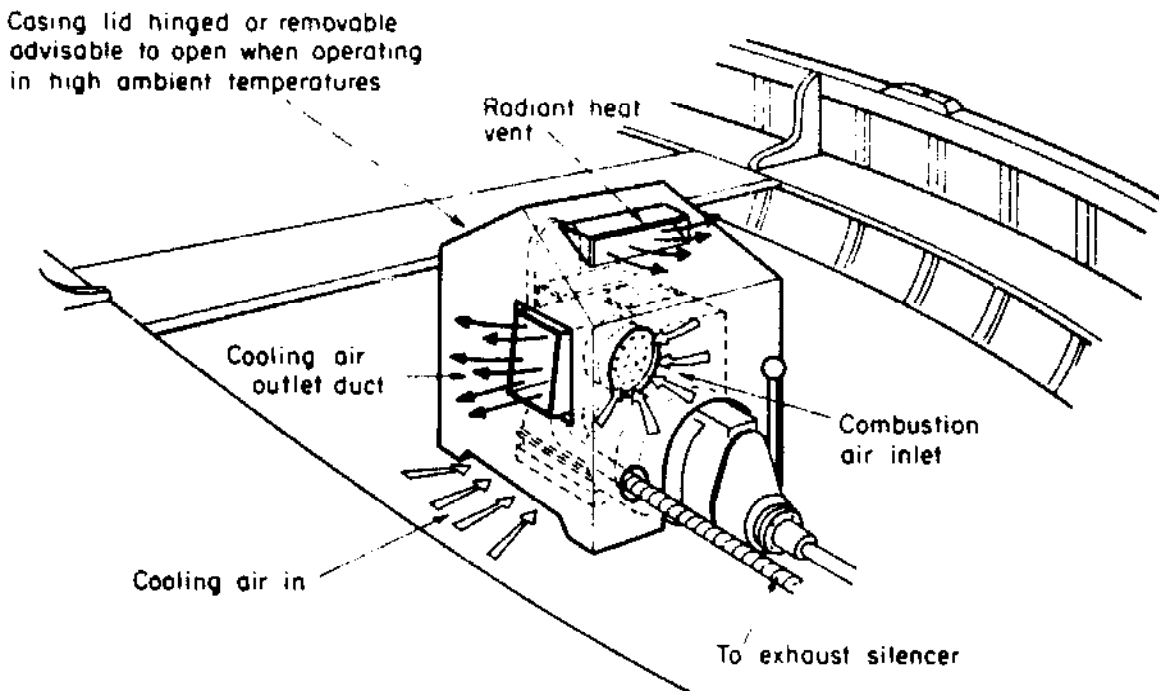

TYPICAL ENGINE HOUSING SHOWING  
COOLING AIR REQUIREMENTS

Fig. 30

SECTION 4Exhaust systems4.1 Introduction

There are two main types of exhaust system for marine engine installations. They are:

- (a) Wet exhaust - The exhaust gases are cooled by the addition of water from the engine cooling system at some point along the exhaust system. The exact point at which the water joins the gases depends upon whether the engine is mounted above or below the waterline.
- (b) Dry exhaust - The exhaust gases are not mixed with water, the exhaust system is completely dry and therefore very hot. All the pipe-work therefore has to be 'lagged', i.e., wrapped with a heat resistant material, usually asbestos tape.

4.2 Planning

With a choice of systems, the engineer can plan which system would be most suitable. The following points are to be considered:

## 4.2.1 Wet exhaust

**Advantages** - The system has less fire risk, the amount of heat given off is less and it is also quieter.

**Disadvantages** - Installation may be more expensive especially if engine is mounted below the waterline.

**Note:** It is important to make sure that water in the exhaust system cannot get back into the engine by suction when the engine is being started or stopped. There are three possible methods of wet exhaust systems.

- (a) Water injection exhaust system - The point at which water is injected into the exhaust pipe is just after the gases leave the manifold, which must be the highest point of the system. The gases and water then are blown out together "downhill". This system is only for engines mounted above the waterline (see Fig. 31).

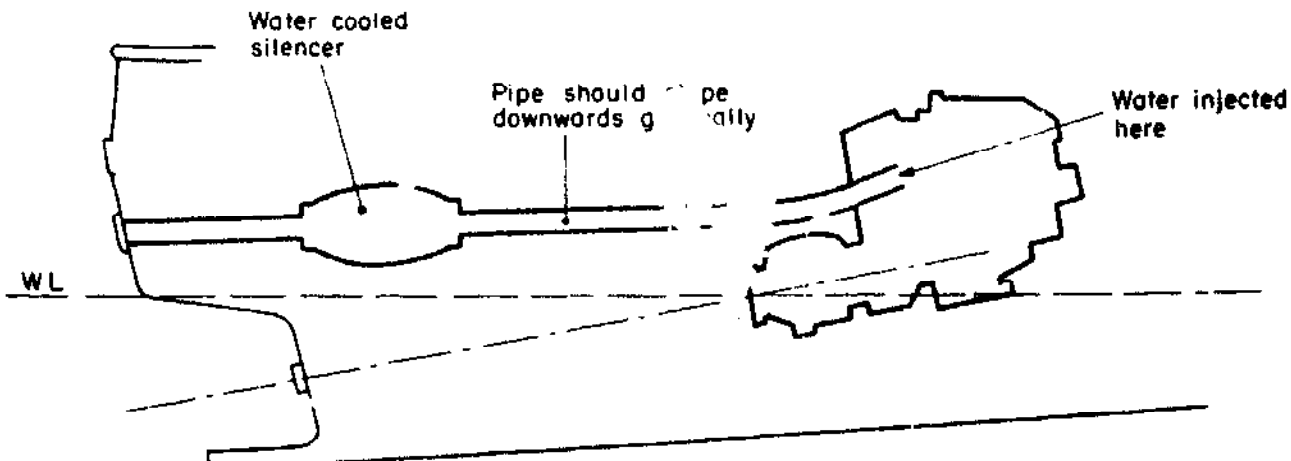
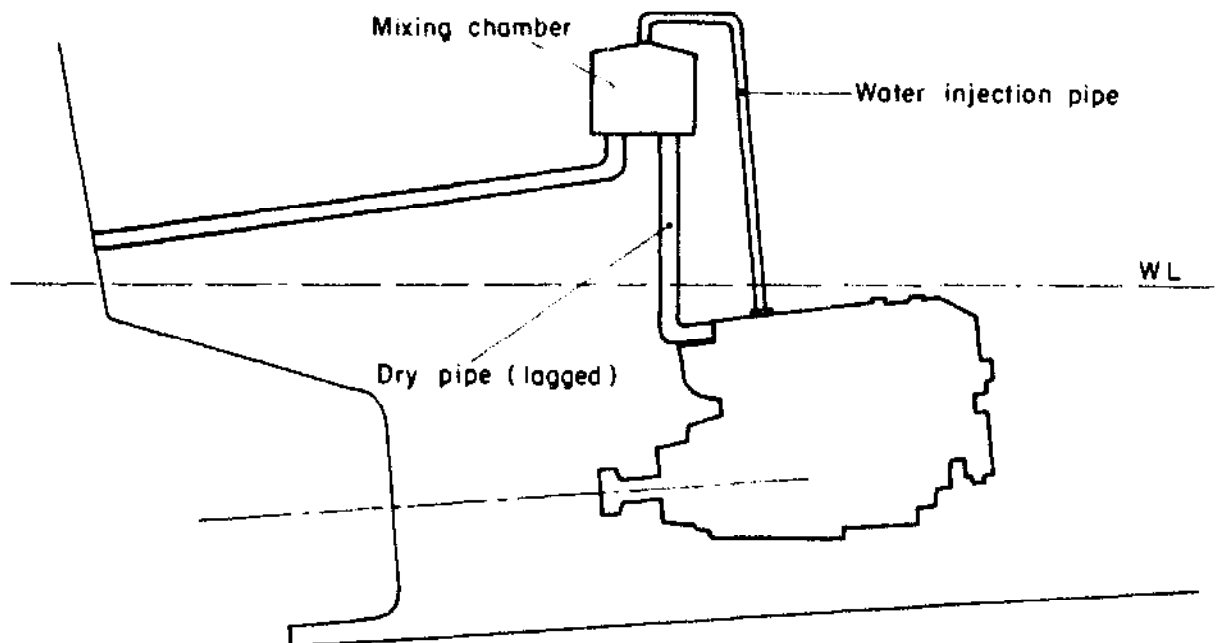

Fig. 31

**Note:** May or may not be fitted with a silencer, as preferred.

(b) **Watertrap exhaust system** A mixing chamber is mounted above the engine and waterline, with a dry exhaust connection to it, which is lagged. Raw water from the cooling system can be taken to the top of the mixing chamber and injected into the exhaust gases. The mixed gas and water then is blown out together as the pipe gradually slopes downward to the outside of the boat (see Fig. 32).



**WATERTRAP EXHAUST SYSTEM**

**Fig. 32**

This system is suitable for engines mounted below the waterline, as long as the mixing chamber can be fitted well above the waterline.

(c) **Water-lock exhaust system** - The water-lock exhaust system can be used if there is not enough room for a mixing chamber to be fitted above the waterline as in the previous paragraph.

Raw water is injected into the exhaust system just after the manifold. The water-lock chamber partly fills with water up to the bottom of the outlet pipe, then extra water blows out mixed with the exhaust. (See Fig. 33)

**Note:** (i) The water-lock chamber should be big enough to hold the water in the two pipes when the engine is stopped.

(ii) A bleed-off pipe should be fitted above the highest point of the exhaust system to prevent water coming in by "siphoning" and connected to the outside of the hull.

The above system is quite complicated and the engine manufacturers' advice should be obtained.

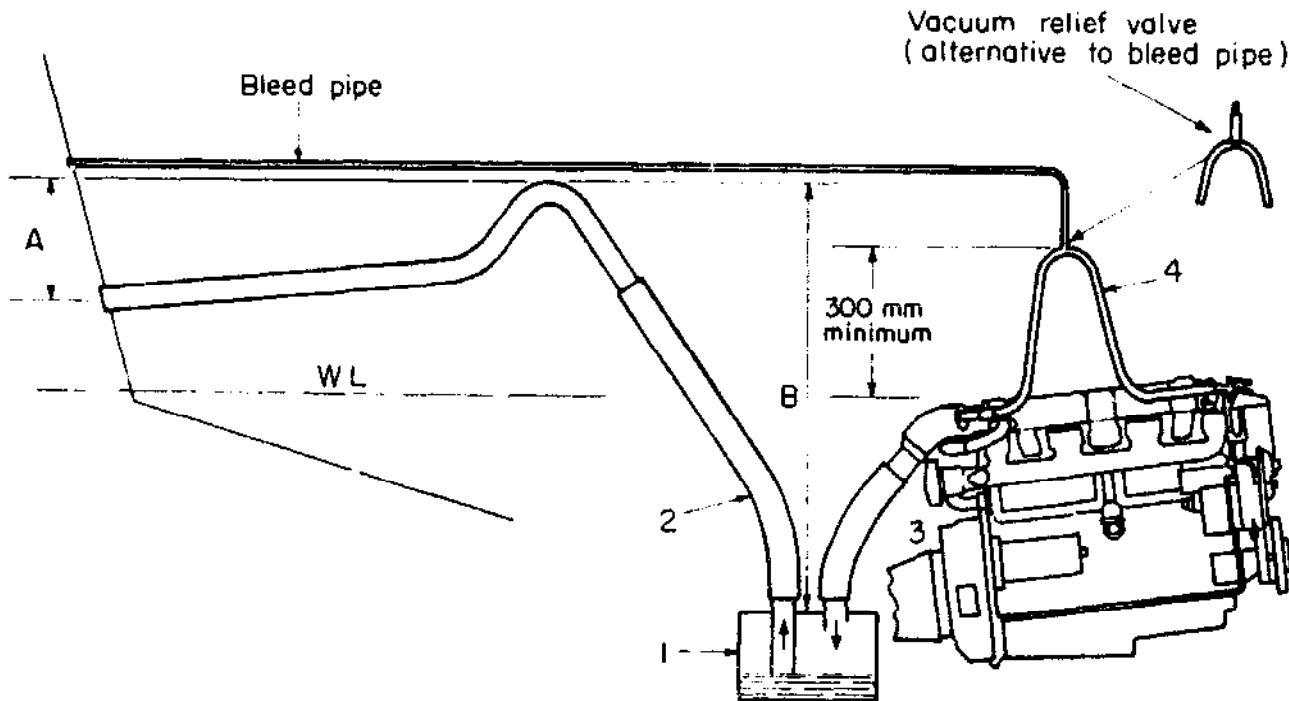

### WATER - LOCK EXHAUST SYSTEM

Fig. 33

#### 4.2.2 Dry exhaust system (horizontal and vertical)

**Advantages** - Simple low cost installation, which may be either for horizontal or vertical discharge to suit the installation.

**Disadvantages** - Noisy, also a great deal of heat can come from pipework, causing hot engine compartment and therefore cooling difficulties. Possible fire risk if incorrectly fitted, particularly in wooden boats.

Figs. 34 and 35 show both typical horizontal and vertical installations respectively.

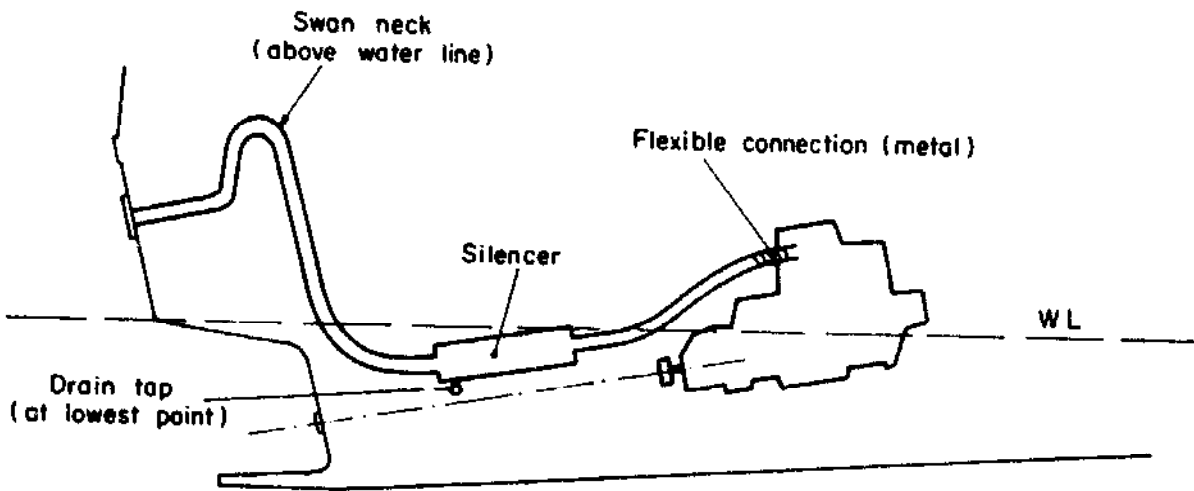

HORIZONTAL EXHAUST SYSTEM

Fig. 34

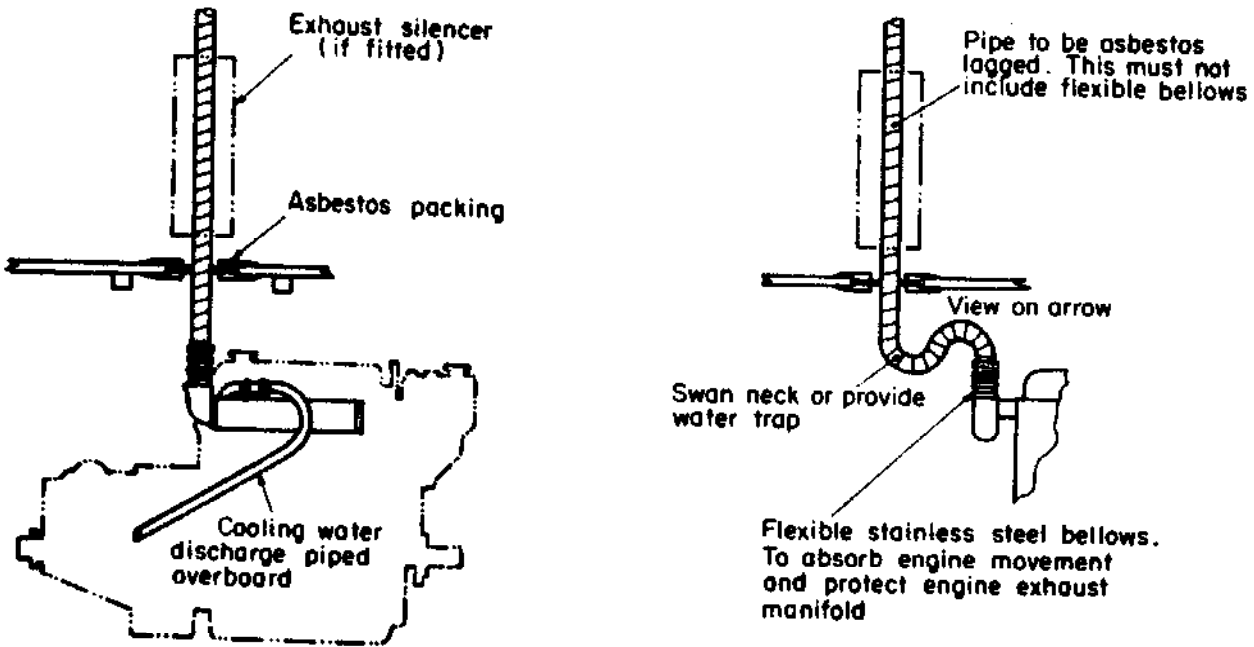

DRY EXHAUST SYSTEM

Fig. 35

SECTION 5Fuel systems5.1 System types

Fuel tanks may be fitted either above the engine, or below it, depending upon the design of the boat and the size of the engine in the following ways:

## 5.1.1 Gravity fed system

The fuel is fed to the engine by gravity, i.e., the tank level is above the engine. Often used in small boat engine installations where in some cases the tank is even mounted on the engine itself.

May also be used on larger craft where the engine is mounted low down in the boat, and the tanks can be fitted either side of the engine, in the engine compartment or across the transom, above the engine height.

## 5.2.2 Pressure fed system

The engine uses a fuel lift pump to feed the engine with fuel from a tank or tanks mounted lower than or in line with the engine.

## 5.2 Fuel tanks

For diesel fuel, the tanks may be made of steel (not galvanized) or glass fibre which is reinforced. Copper or galvanized steel should NEVER be used to hold diesel fuel.

Ready made tanks are available for small engines from the manufacturers. Other tanks to fit specific boat shapes may have to be specially made.

Careful planning of the fuel tank by a specialist may be necessary. Always obtain information from engine makers or their recommended agents.

It is also important to place the tank in the boat so that it will not adversely affect the stability or trim of the craft; the boat builder or designer should be consulted if there is any doubt.

The capacity of the tank should be sufficient for the type of work the boat will do, with enough reserve for emergencies.

For example, for a boat engaged in daily fishing which normally takes say, 10 hours, then the fuel capacity of the tank should be enough for about 15 engine running hours (minimum).

All fuel tanks must have a 'sludge trap' within the tank, so that water and heavy sludge will settle in the sludge trap, and may be drained off.

The fuel pipe inside the tank must be arranged so that it does not draw from the very bottom of the tank, thus ensuring that clean fuel only goes to the engine.

Clean fuel is very important.

## 5.3 Water traps and filters (primary and secondary filter)

A fuel installation must include a water trap and filter, sometimes called a primary filter, in the pipeline. This unit is designed to filter out water and heavy solid particles of dirt. It must be emptied and cleaned in service.

There is also a second filter or secondary filter, usually with a replaceable paper

element, fitted on the engine itself by the manufacturers.

It is not necessary to add more filters than this to the system - to do so would possibly cause difficulties by overloading the fuel pump.

#### 5.4 Pipework

Pipes should be of the correct diameter, as per the engine makers' recommendations. Annealed copper pipe is most often used, and this should be clipped to prevent damage caused by any movement.

Connections to the engine should be by flexible metal-covered pipe to allow for engine vibrations.

Plastic fuel lines should not be used.

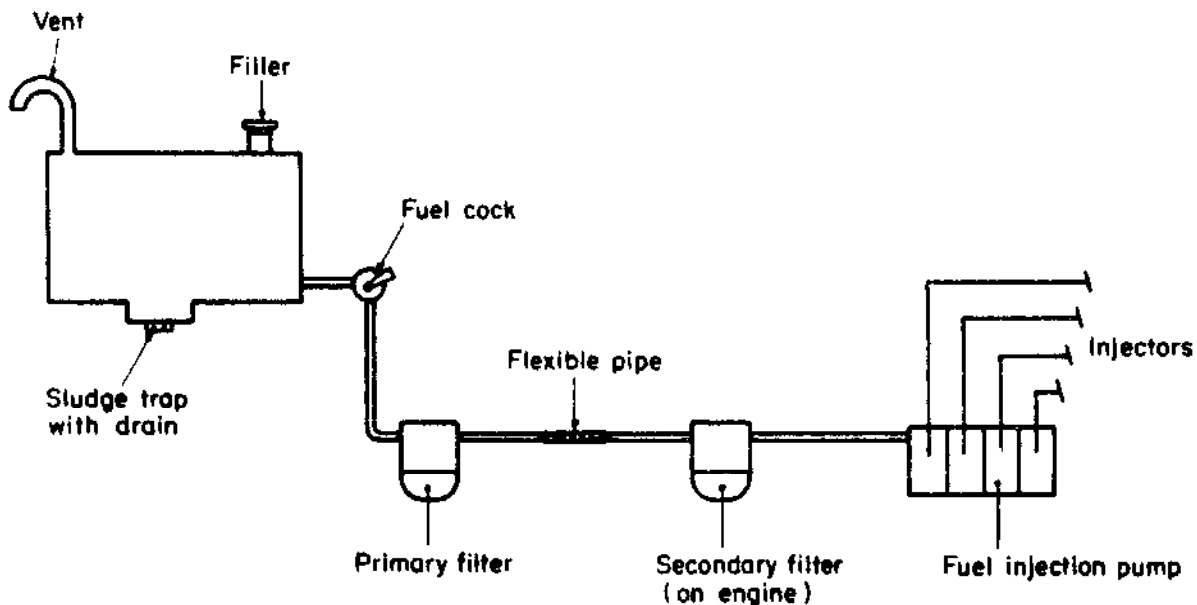

TYPICAL FUEL SYSTEM - GRAVITY FED

Fig. 36



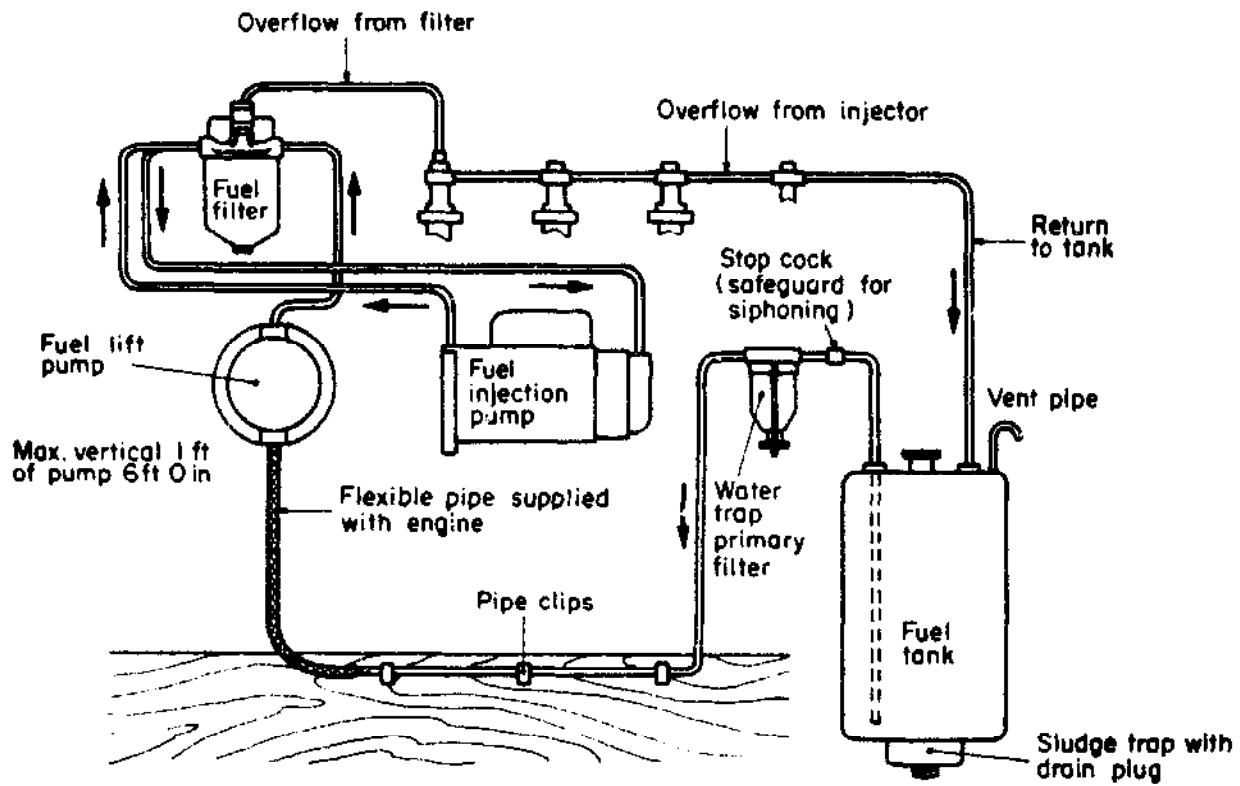

TYPICAL FUEL SYSTEM - PRESSURE FED

Fig. 37

## SECTION 6

### Electrical system

#### 6.1 Introduction

6.1.1 Small engines - On simple engines of small horse power there may only be a very simple electrical system for the purposes of starting the engine. This may consist of only a battery, starter motor and switch. When the battery becomes flat, the battery is removed for re-charging, or a separate battery charging unit, either engine driven or from "mains electricity", is used to re-charge the battery in position.

On this type of small installation there would be no other electrical equipment used.

6.1.2 - Small/medium engines - On most types of engines an electrical system is fitted which will start the engine by starter motor, re-charge the battery, and provide a supply of electrical power to run lights, and small navigational or fishing aids, e.g., echo sounder, radio, etc.

This requires a system consisting of battery, starter motor, switch, generator (dynamo) or alternator with regulator and cut-out and wiring to connect it into a complete system. In the system there is a fusebox where electrical power may be taken off for various other equipment; lights, instruments, radio, etc.

#### 6.2 Batteries

There are several kinds of batteries, but in most cases the type used is the LEAD-ACID battery. It consists of a plastic case divided into cells. Each cell contains lead plates coated with a chemical paste, which are immersed in a solution of sulphuric acid and water (Electrolyte) and sealed. The battery is first "charged" with electricity, when each cell can 'hold' about 2 volts. Once the battery is used, and electrical energy is required the chemicals begin to change and produce a steady flow of electricity. When the chemical change is complete, the energy becomes used up and the battery is said to be 'flat'.

The energy in the battery can be saved or stored by being continually connected to a generator, which replaces the energy as it is drawn off. In this way a battery can be used over and over again for many years, provided it is looked after properly.

Each cell of a battery has a "Positive" and a "Negative" connexion, and they are linked together in a battery so that the battery has a Positive (or +) and a Negative (or -) terminal.

In most cases the electrical system is of 6, 12 or 24 volts, which means that batteries used are either 6 volt (with 3 cells) or 12 volt (with 6 cells). A system may be made of 6 or 12 volt batteries connected up in various ways to give the required voltage.

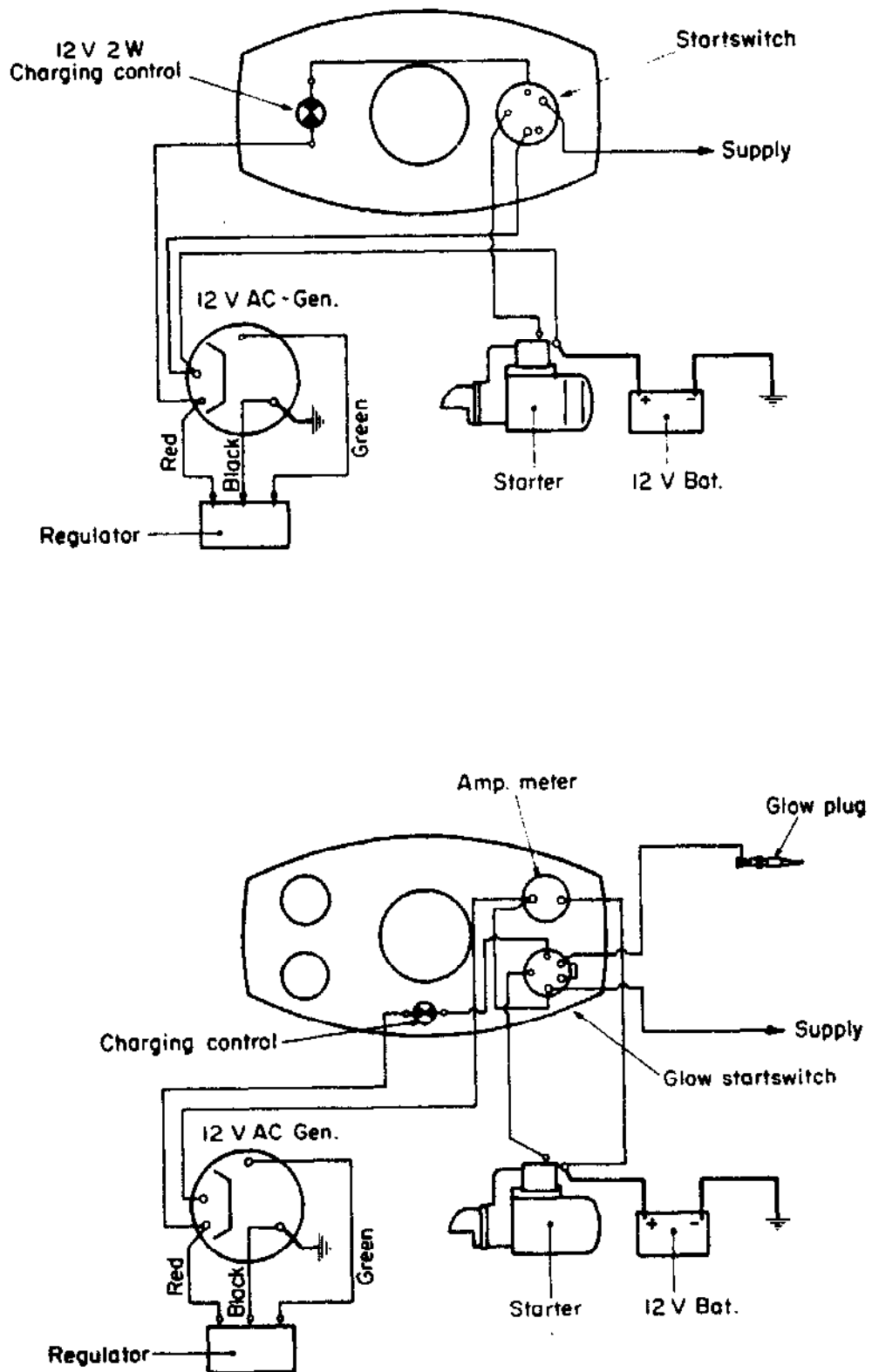

AC WIRING DIAGRAM - TYPICAL ARRANGEMENT

Fig. 38

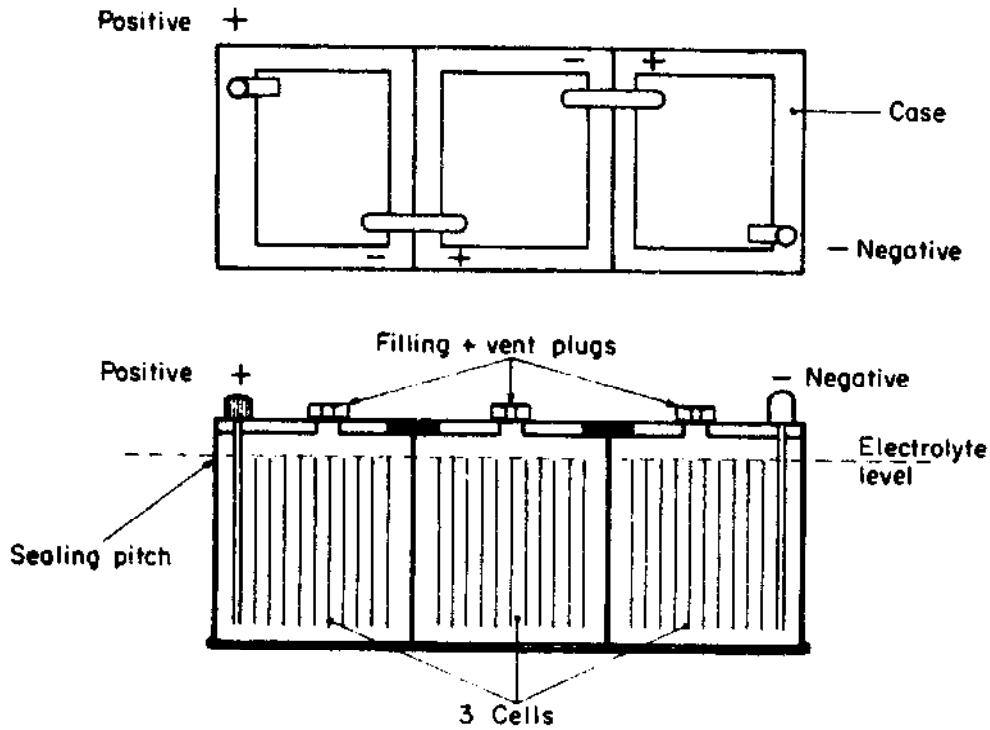

6 VOLT BATTERY

Fig. 39

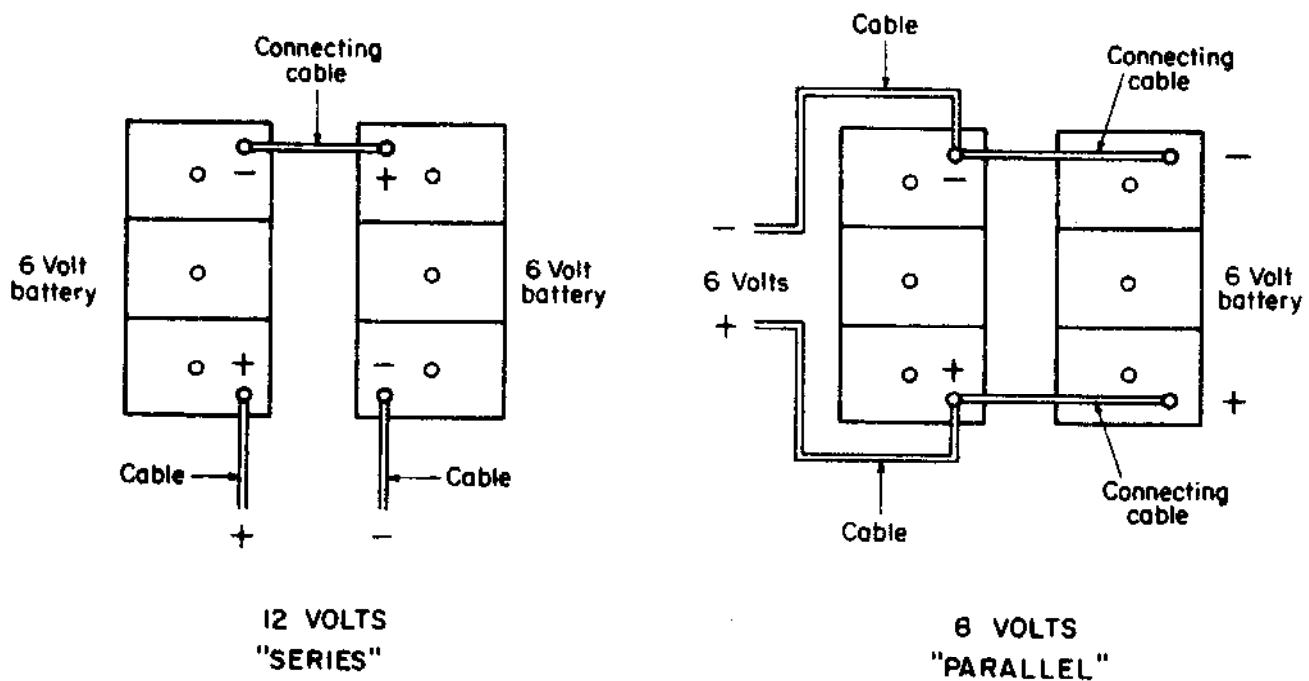

BATTERY CONNECTIONS

Fig. 40

NOTE: In Fig. 40 the voltage of 2 x 6 volts batteries in 'series' is made into 12 volts.  
In Fig. 41 2 x 6 volts batteries in 'parallel' gives a voltage of 6 volts, but the 'capacity' of the power is twice as much.

### 6.3 Alternators

Alternators are used on most modern marine engines to provide the power for battery charging and the electrical system, instead of dynamos (or generators) as in earlier years.

The advantages of the alternator are that it can produce a much higher charging rate than the dynamo, and especially at slow engine speeds, this makes the use of smaller batteries possible, instead of having to provide large storage of power by heavy batteries. Also, the alternator needs very little maintenance.

The disadvantages of the alternator are that it is easily damaged by misuse.

SECTION 7Controls and instruments7.1 Controls

Most marine engines have the following controls for the operation of the engine:

1. Engine starting switch or key
2. Throttle or engine speed lever
3. Gearbox control lever
4. Engine stop or fuel cut-off control

7.1.1 Engine starting switch

Usually a combined switch operated by a key which provides one or more of the following:

Position 1

Turns on the instruments

Position 2

Operates the cold starting electrical aid

Position 3

Turns the engine by starter motor

The use of a key is to prevent theft, or accidental turning of the starter motor while the engine is running.

7.1.2 Throttle lever

A mechanical connexion to the fuel pump which increases or decreases the speed of the engine. It is fitted within easy reach of the operator so that he can control the speed of the engine from the steering position.

On engines fitted with a hydraulic/oil operated gearbox the throttle is often combined with the gear lever so that the selection of engine speed and gearbox "ahead" or "astern" is done by one lever.

7.1.3 Gearbox control lever

A mechanical connexion to the gearbox, or clutch to allow the operator to select "ahead" or "astern" from the steering position.

Engines fitted in an open boat are often close to the operator, who can reach the lever which is fitted directly to the gearbox/clutch.

7.1.4 Remote controls

On boats with a forward steering position the throttle and gearbox control levers are by 'remote' controls, and connected to the engine by cables which have a flexible rod inside a flexible outer tube or conduit. The most common are Morse or Teleflex controls which may be either a 2 lever system, i.e., one for throttle and one for gearbox, or the combined single lever system as already mentioned. These are illustrated in Figs. 41 and 42.

### 7.1.5 Engine stop or fuel cut off control

This is a mechanical connexion, usually a Morse or Teleflex or similar, with a 'springy' wire (piano wire) inside a flexible outer tube, connected to the fuel cut off lever on the fuel pump. Typical Morse through bulkhead mounted engine stop, fuel cut off or choke controls are shown in Fig. 48.

When the lever is pulled, the engine stops because the fuel pump control is moved to the 'no-fuel' position.

### 7.1.6 Remote propeller control

On engines fitted with a variable pitch propeller, it is possible to vary the propeller either on the engine itself, or by remote control as shown in Fig. 48.

## 7.2 Instruments

Most small engines can be supplied with an instrument pack, consisting of an instrument panel with tachometer (rev counter) oil pressure ammeter and temperature gauges or warning lights.

Other instruments may include gearbox oil pressure gauge (on oil operated/hydraulic gearboxes), oil temperature gauge, cold-start warning lamps, etc., as used by certain engine makers.

Many modern instruments are electrically operated, for example, tachometer, or it may be mechanically driven by a flexible drive inside a flexible tube. Temperature gauges also may be either electrically operated, or by a hollow copper pipe linking the thermometer bulb in the engine to the gauge.

Where instruments are not supplied with the engine, they have to be purchased separately and made up to fit the engine and to an instrument panel. (See Part II, under Instruments).

Most instruments are quite delicate and should be handled with care, and installed in a position where they are not exposed to damage, water or strong sunlight, but where they can be easy to get to for removal, bulb replacement, etc.

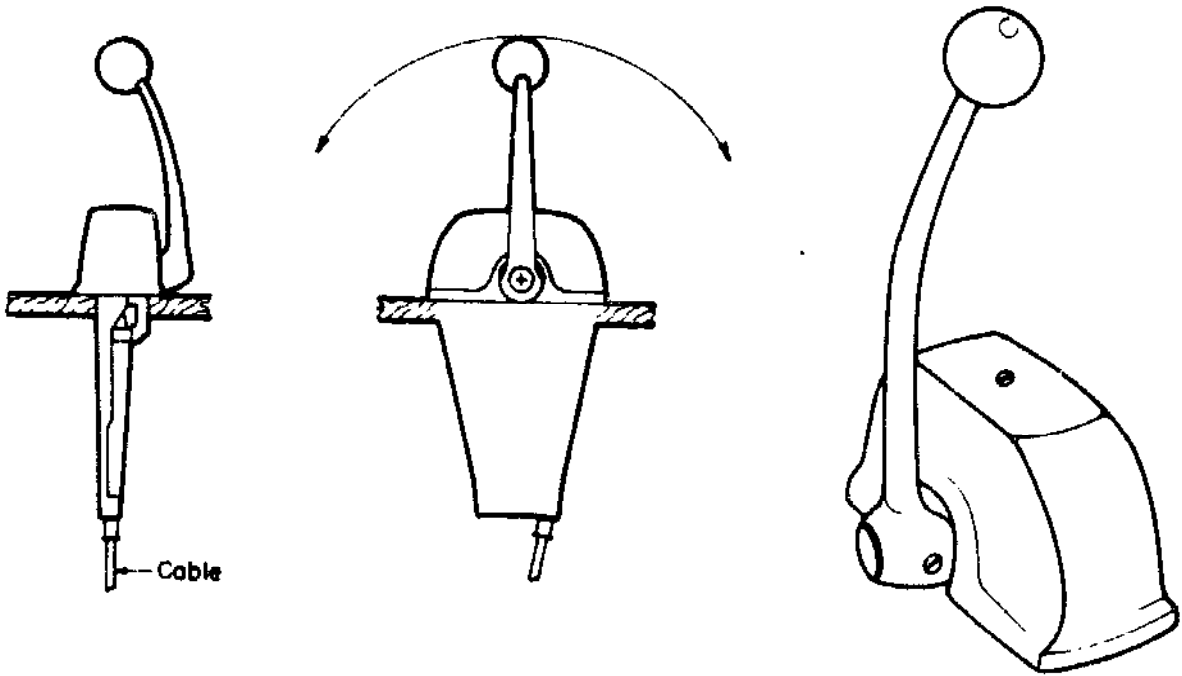

SINGLE LEVER MODEL

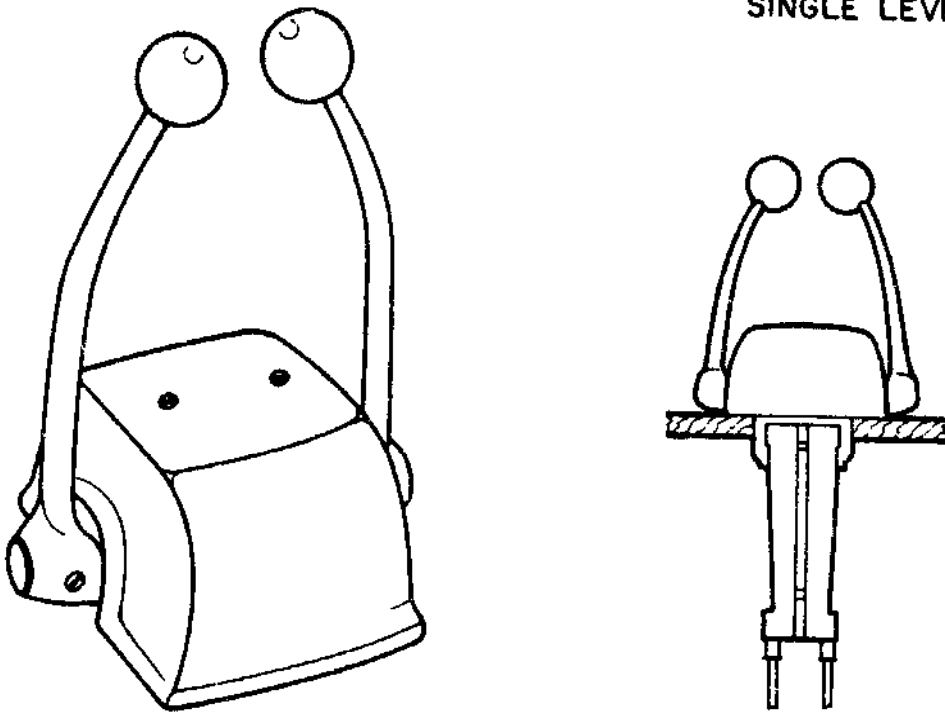

TWIN LEVER MODEL

Fig. 41  
REMOTE CONTROLS



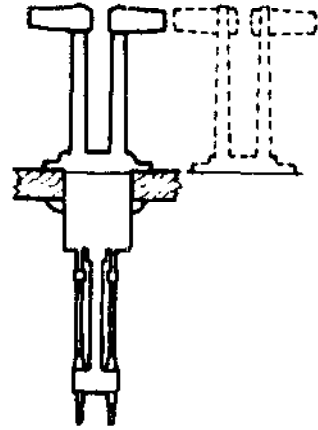
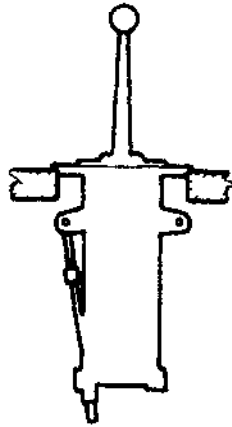
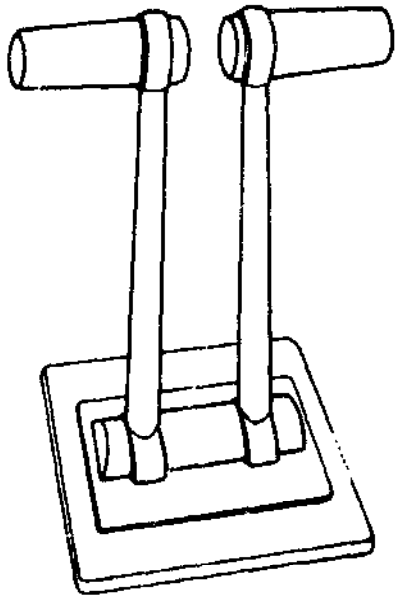

TWIN LEVER

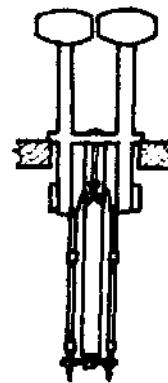
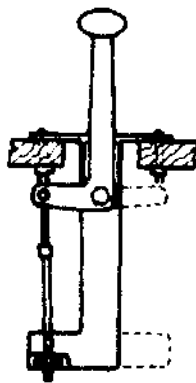
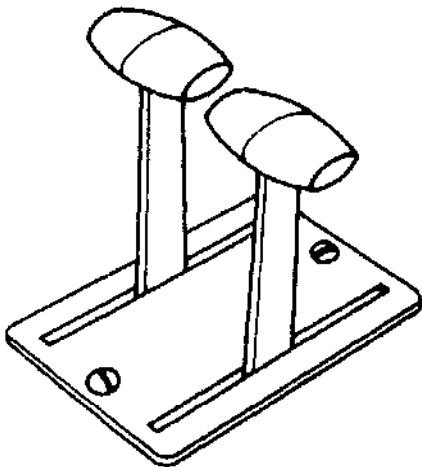

TWIN LEVER

Fig. 42  
REMOTE CONTROLS

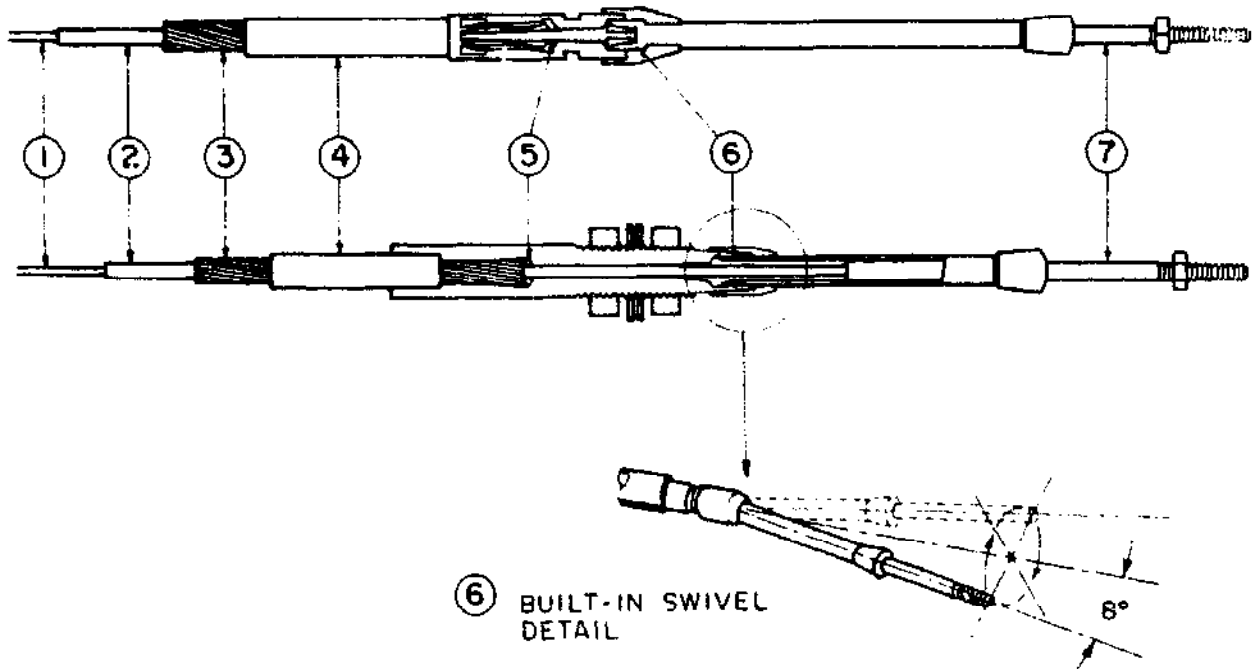

## FEATURES OF PATENT "MORSE CONTROL SYSTEM"

Fig. 43

### 1. Patented stainless steel cores

Patented armoured strand cores are double-wrapped with stainless steel for extra flexibility. Rotary swaged under high pressure for ultra smoothness, the stainless flat wire double wrap tends to stay straight for increased efficiency. Smaller sized cables have super-smooth, solid wire, stainless cores.

### 2. Low friction, high efficiency

Heavy-walled liner tube is an exclusive compound of high density polyethylene and lubricant with an extremely low coefficient of friction. Result - higher efficiency lower input load for a given output load and because the liner tube has extra heavy walls, the cables maintain that high efficiency longer.

### 3. Strong, long lay protective conduit

Made of non-preformed, oil tempered spring wire, the exclusive long pitch conduit construction gives good longitudinal compressive and tensile strength, reduces "sponginess", minimizes lost motion. Conduit strength increases proportionately with the load capacity of the cable. More and larger wires are used as the cable size increases. Result - additional strength, more protection for the core where it is needed.

#### 4. Heavy-duty jacket

The heavy duty extruded plastic jacket is especially formulated to resist abrasion, common solvents and temperatures ranging from - 60°F. to 225°F.

#### 5. Triple-sealed dependability

The heavy duty jacket is rotary swaged under the hub to form a tight, positive barrier against dust and moisture. An internal seal inside the hub keeps moisture and foreign materials out of the tube and conduit. A flexible, abrasion resistant sleeve seal protects the swivel and the rod seal is a specially designed seal that cleans the rod with every cycle, excluding dirt, moisture, and other foreign materials.

#### 6. Built-in swivel

Swivel joints built into both bulkhead and clamp end fittings allow 8° angular deflection of the rod end in any direction. This feature compensates for control arm arc movement and slight misalignment at the work end and control end of the cable.

#### 7. Corrosion resistant end fittings

Cadmium-plated steel hub (including nuts and washers on bulkhead cables). Nickel-plated brass sleeves and stainless steel rod resist the most severe corrosion conditions. For unusual corrosion resistant requirements custom end fittings can be provided, such as all stainless steel.

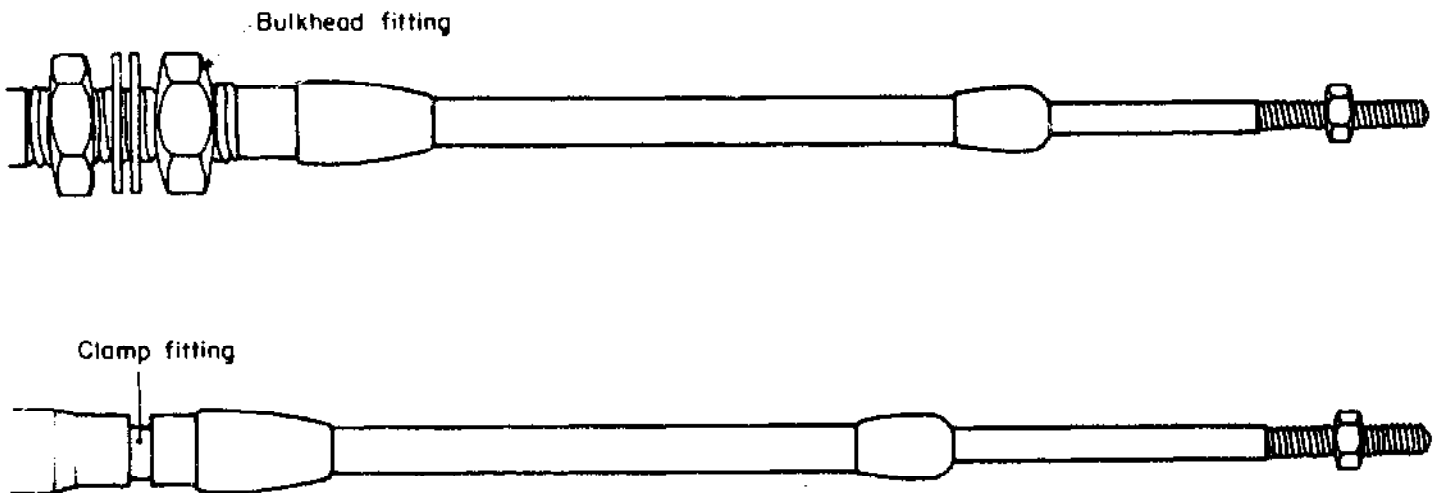

MORSE CONTROL CABLES

Fig. 44

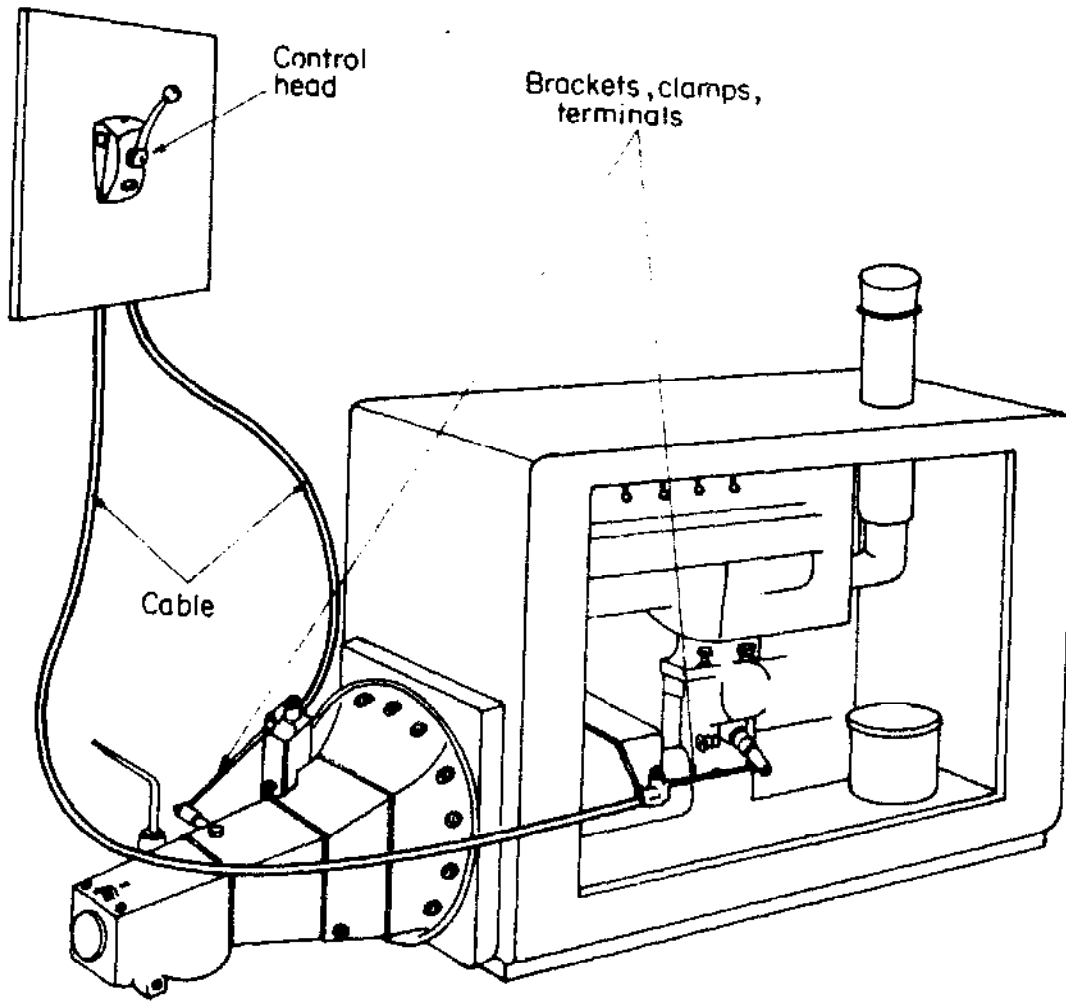

MORSE CONTROL SYSTEM

Fig. 45

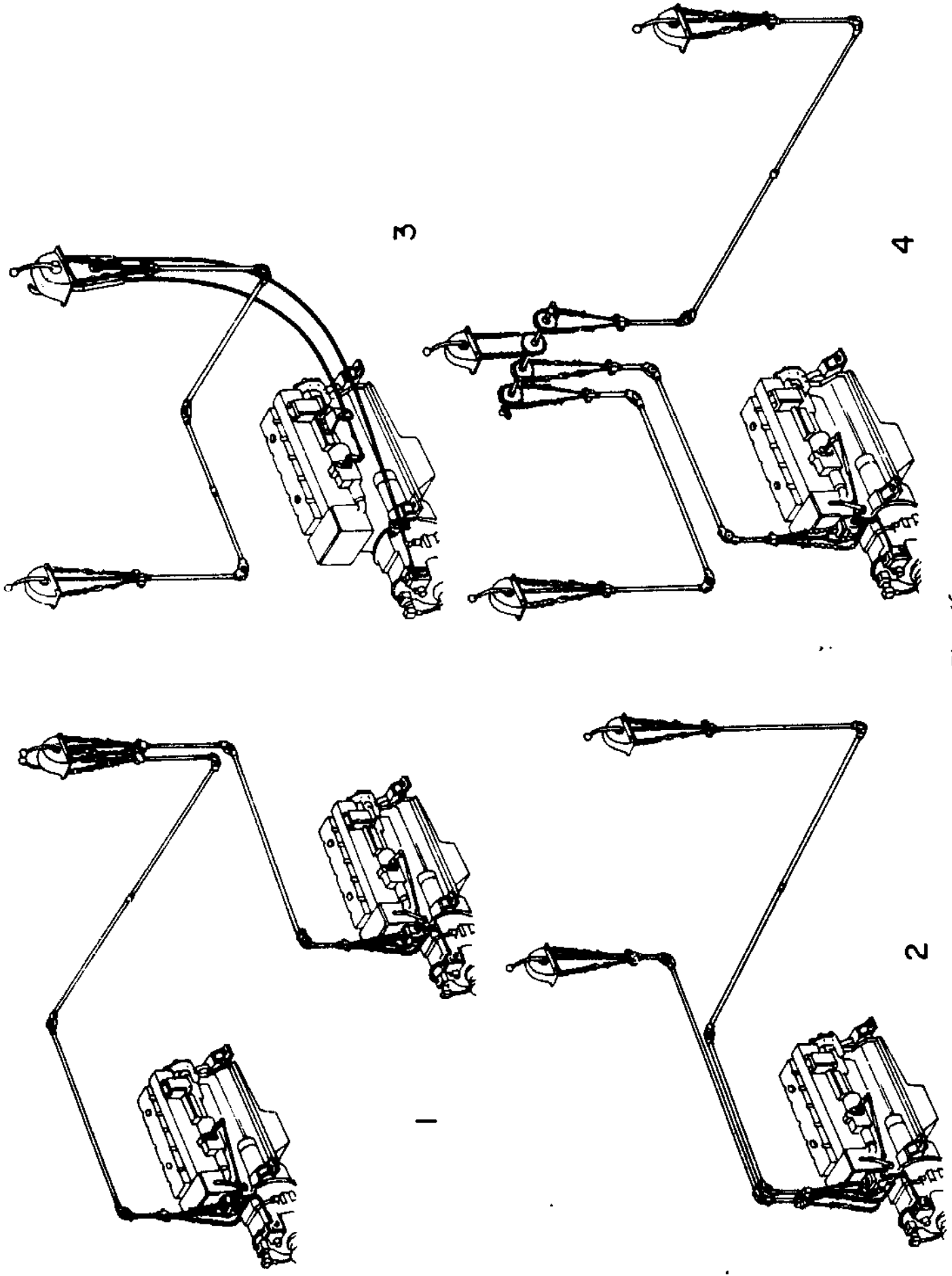
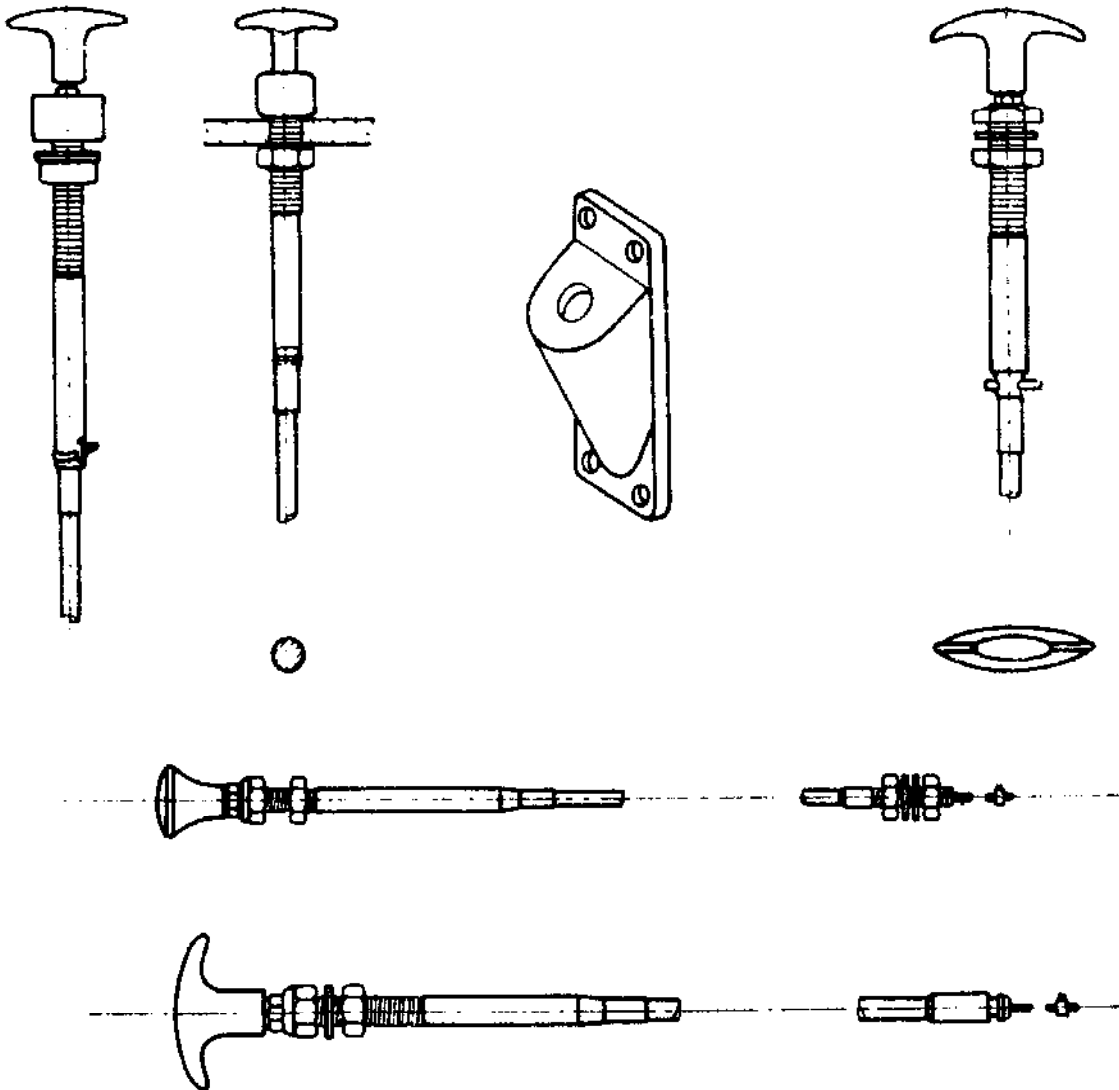

Fig. 46

Figure 46 illustrates various Morse remote control installations as follows:

1. A typical single station twin engine installation showing engine room disconnect for over-riding engine room control.
2. A typical dual station single engine installation showing engine room disconnect for over-riding engine room control.
3. A dual station single engine installation. The control is in the main station because of the separate throttle run-up facility on the control head.
4. A typical triple station single engine installation, using a common jack-shaft arrangement (these shafts not supplied by Morse)



FOR CHOKE AND STOP OPERATION

Fig. 47

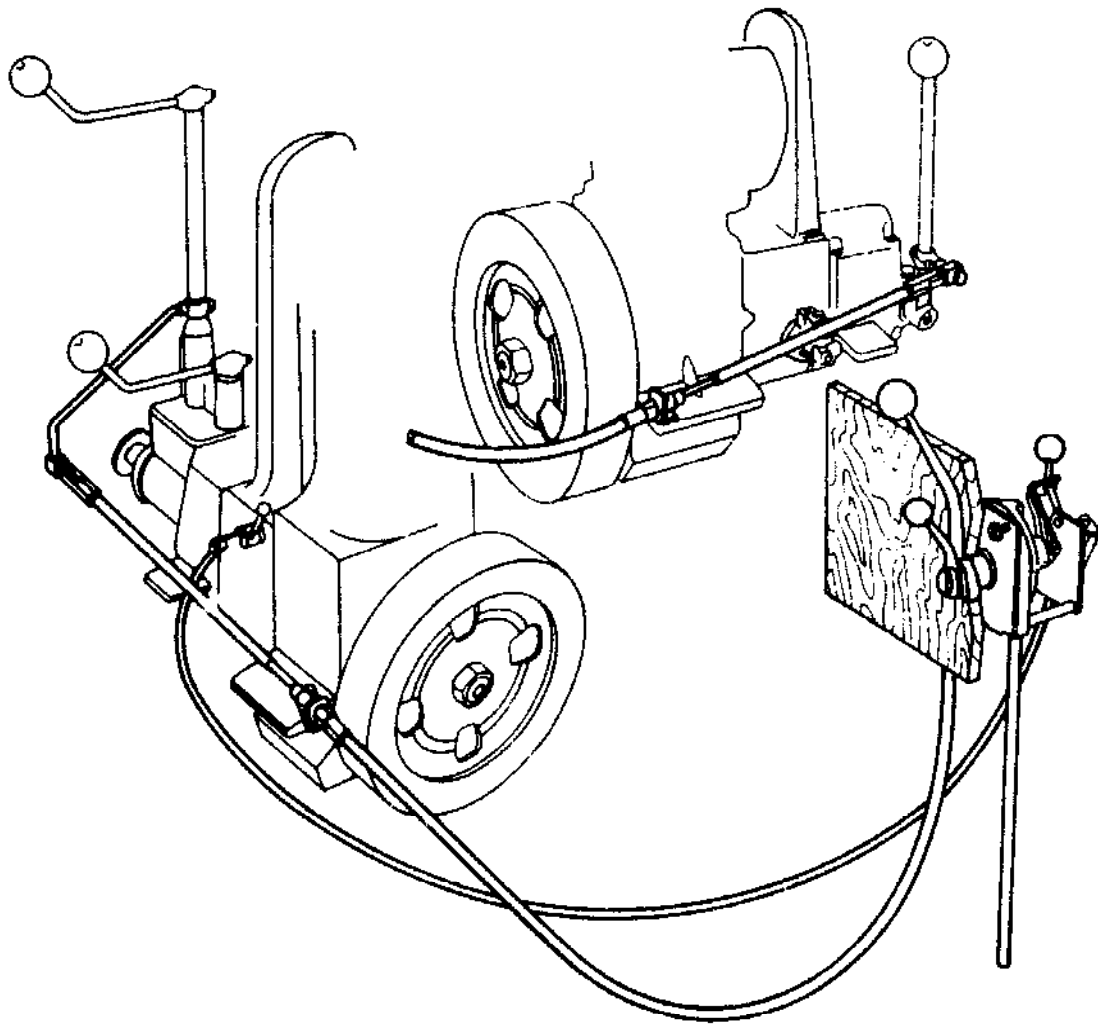

REMOTE PROPELLER CONTROL

Fig. 48

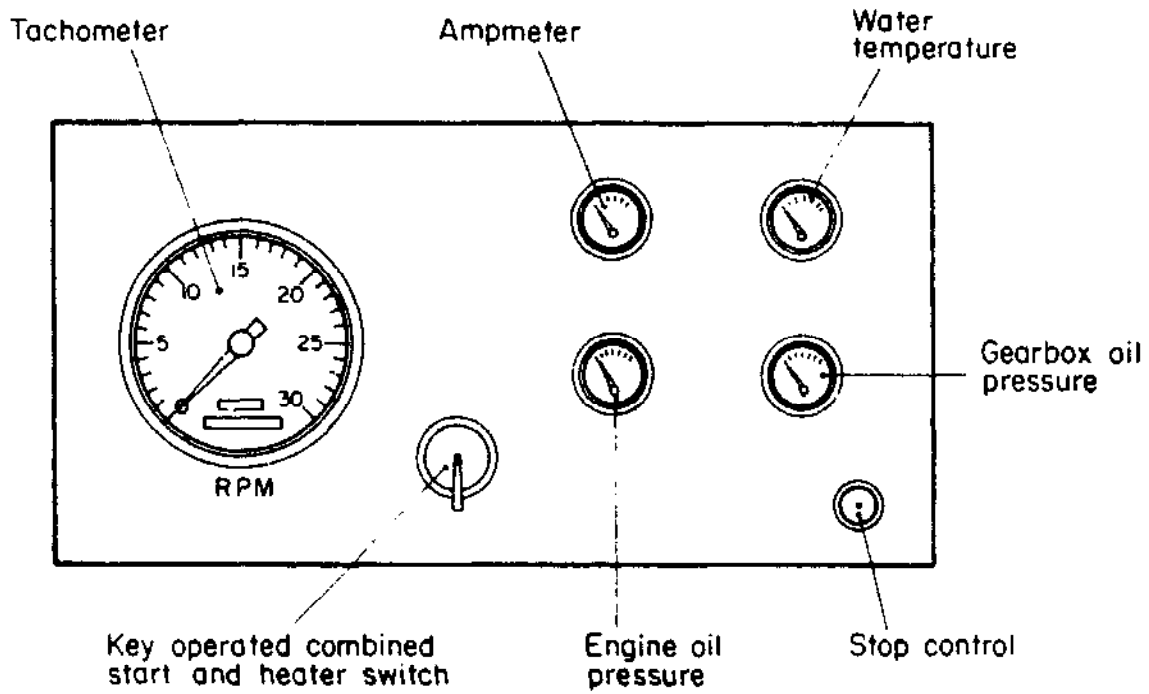

TYPICAL INSTRUMENT PANEL

Fig. 49



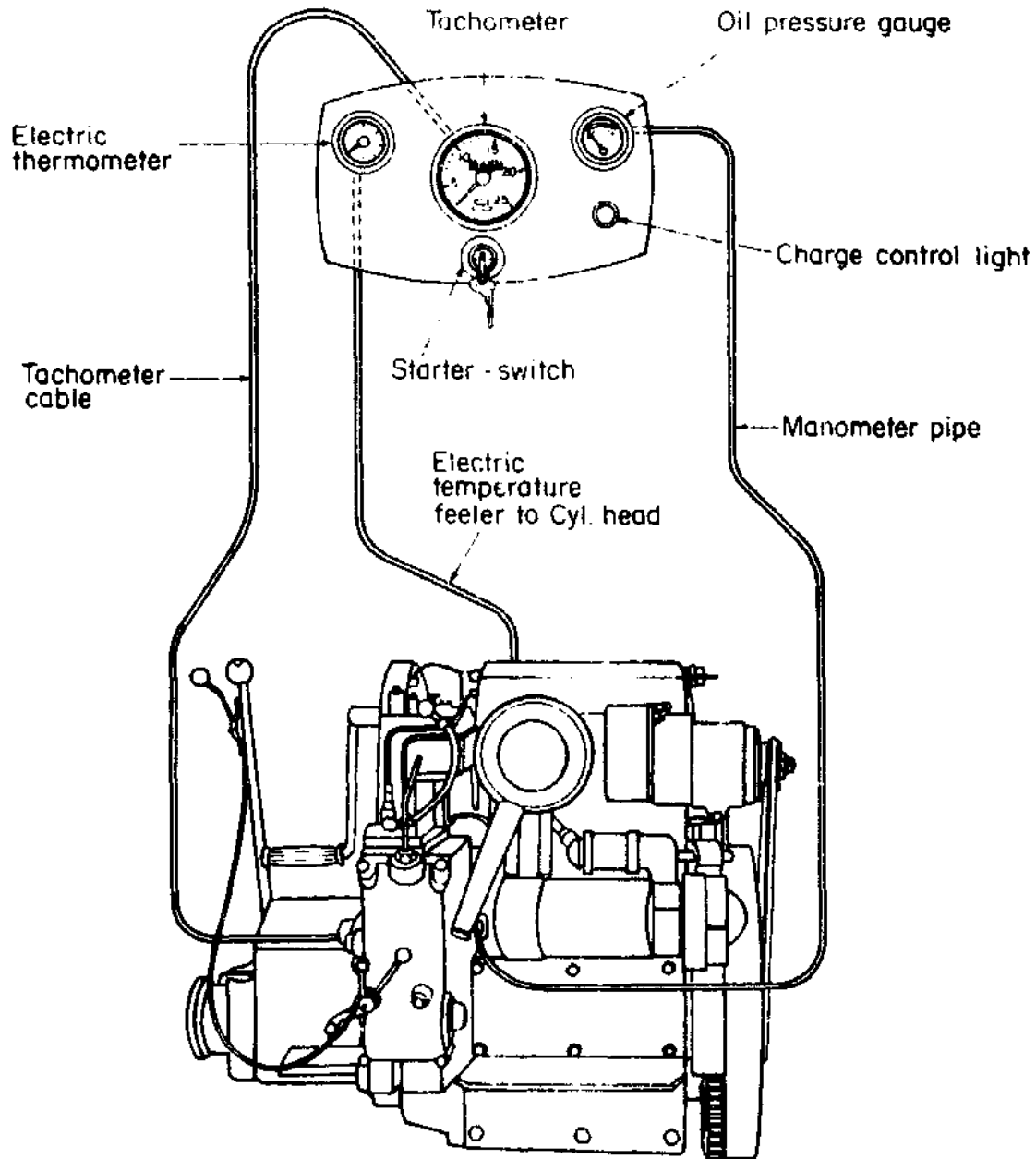

CONNECTIONS FOR TACHOMETER, WATER TEMPERATURE  
GAUGE AND OIL PRESSURE GAUGE

## SECTION 8

### Starting systems

#### 8.1 Hand starting

A simple system usually used on small engines, with the starting handle connected directly to the crankshaft or camshaft extension, or by a raised shaft turning the crankshaft by a chain and ratchet wheel.

A decompressor is fitted to allow the engine to be turned until fast enough to fire when decompressor is moved to 'off' position. A system with a grooved flywheel or starting handle shaft is sometimes used to drop decompressor in automatically.

#### 8.2 Electric starter motors

The most common starting system, used on high speed, multi-cylinder or larger engines.

An electric motor fitted with a pinion gear which meshes with the toothed ring on the engine flywheel and turns when the starter switch is operated.

#### 8.3 Spring starter motors

A unit containing a heavy coiled spring which can be wound up by hand until tight. When the starter is required, the heavy spring unwinds, turning the engine by rotating a gear driving the flywheel.

#### 8.4 Hydraulic starter motors

A similar method as 8.3 above, usually fitted on the crankshaft direct. Oil in the unit is pumped to a high pressure by a small hand operated lever. When the pressure is released by the operating lever, the engine is turned very quickly.

#### 8.5 Compressed air starting

Usually used on larger, particularly slow/medium speed engines in an 'engine room' installation. This system consists of a compressor, either driven by the engine itself or a separate auxiliary engine, storage bottles or reservoir of air under high pressure, and a compressed air starter motor.

When the system contains sufficient air under pressure, the air starter motor is operated by lever, and the motor turns the engine.

Another variation is that the compressed air is connected to the cylinders of the engine itself, so that the compressed air drives the piston down, thus turning the engine.

There are other starting systems, such as cartridge starting, donkey engine starting etc., but outside the scope of this publication.

#### 8.6 Cold start systems

In countries where temperatures fall to around 0°C or below, diesel engines are usually fitted with a 'cold start' system so that the engine can be started easily in cold weather.

As the diesel engine works by compressing air until it is hot enough to burn fuel sprayed into the combustion chamber, the cold start systems use either a method of

warming the air, adding extra fuel, or by improving the compression.

#### 8.6.1 Cylinder "Cigarettes"

Used on smaller engines, this system uses a "cigarette" of paper and a special chemical which will automatically burn and warm the air in the combustion chamber when the engine is turned.

A 'holder' is unscrewed and removed from the engine, 'the cigarette' placed in the holder and screwed back into the cylinder, so that the "cigarette" is actually in the combustion chamber. As the engine is turned, the air is compressed and heats up, causing the cigarette to burn, therefore heating the air still more and helping the engine to start. See Fig. 51.

#### 8.6.2 Heater plugs

On engines with an electrical system, there is a special heater plug (which looks something like a spark plug) screwed into the combustion chamber of each cylinder.

When the switch is used, the heater plugs heat up and glow, therefore heating the air in the cylinder and helping the engine to start. A warning light is often fitted which tells the operator when the plugs are hot enough to start the engine, and the engine is not turned over or cranked until then.

#### 8.6.3 Thermostart

A small reservoir of fuel is fitted to the engine or bulkhead, and connected to a heater unit in the inlet manifold. When the electric key operated combined heater/starter switch is operated, a small quantity of fuel is automatically allowed to the heater unit as it heats. The key is held in the heat position for about 10 - 15 seconds only before turning the engine.

#### 8.6.4 Oil plungers

On smaller, usually handstart engines, starting can be helped by adding a small quantity of lubricating oil to each cylinder of the engine, or to the inlet manifold through special oil plungers.

The addition of oil improves the compression of the air by stopping the air leaking past the piston and rings, therefore the air is compressed more and so becomes hotter.

Some manufacturers recommend a mixture of fuel and lubricating oil to be added to the plungers.

It is important to use as directed only, and never to use any other fuel or too much oil, as damage can be caused.

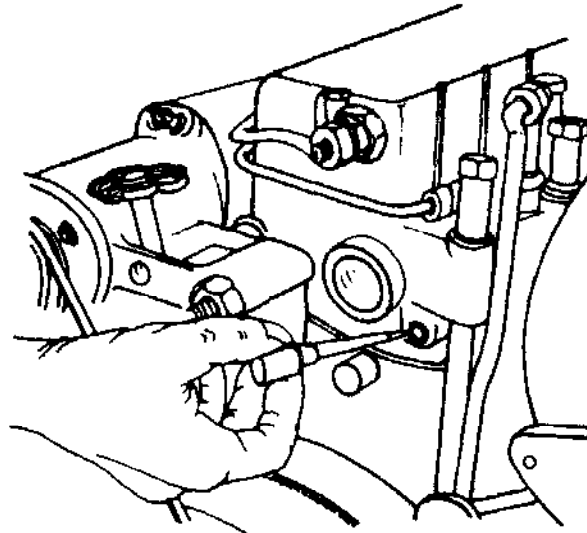

STARTING CIGARETTE

Fig. 51

SECTION 9Engine boxes9.1 Planning

In an open boat installation, it is necessary to fit a protective box over the engine to prevent damage by rain and spray, to reduce noise and to protect the operator, crew and passengers on board from being caught in the engine or burned by exhaust, etc.

The design of the engine box is important, as many factors should be carefully considered before it is made. A manufacturer's 'General Arrangement' drawing is helpful and gives the measurements of many parts, and clearances for various controls.

In some cases the lid of the engine box may need to be opened to get at various parts for starting and closed as soon as the engine is running.

In general, the box may be designed to be removed completely for servicing or with removable panels or sections in the case of larger engines.

On aircooled engines, the box must be made to allow for enough air to enter the cooling fan, and for the escape of the hot air. The most common fault with an air-cooled engine is that it is not given enough cooling air. This results in difficult starting when hot, loss of power, engine stalling at low rpm and engine seizure in extreme cases.

A list of things to check when planning the engine box follows, and it is broken down into 3 sections: Installation, Daily Running and Servicing.

9.2 Installation

Follow the manufacturer's general arrangements drawing to allow for:

1. Air cooling, intake to the cooling fan, and hot air exhaust.
2. Air intake into the engine.
3. Starting handle swing and decompressor access.
4. Placing controls, like throttle, gear lever and stop control. Give them sufficient movement.
5. Placing instruments.
6. The engine to be moved when aligning to shaft.
7. Engine movement on flexible mountings.
8. Movement of flexible exhaust pipework.
9. Fitting of noise insulation and baffles. See Section 10, Part 1.

9.3 Daily running

Consult the engine handbook for daily running tasks, and allow for easy access when:

1. Checking engine and gearbox dipsticks and filling points.
2. Checking water header tank, and weed trap on inlet sea cock.
3. Turning grease caps, if fitted, on raw water pump or gearbox (e.g. Sabb Variable Pitch propeller engines).
4. Fuel priming levers, or excess fuel button, if fitted.

9.4 Servicing

It must be easy to service the engine in position without removing major parts or frame of the engine box, unless the box is designed to lift off in one piece or in panels.

Points to consider on servicing are as follows:

1. Draining engine sump, gearbox and reduction gearbox.
2. Changing oil filter.
3. Changing fuel filter, and bleeding fuel system.
4. Checking water pump impeller.
5. Changing any drive belts (e.g. alternator)
6. Checking valve clearances and decompressor adjustments.
7. Changing injectors.
8. Checking and adjusting ahead clutch and astern brake band.
9. Checking propeller shaft coupling.
10. Cleaning out engine drip tray.

AIR  
COOLED  
DIESEL  
ENGINES



---

LET ME BREATHE !

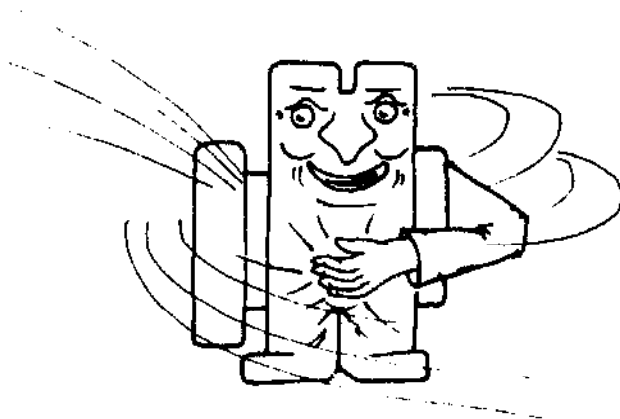

Fig. 52

SECTION 10Noise

Diesel engines are noisy anyway, and air cooled engines are worse than water cooled engines. The "thickness" of the water and the water cooling jacket around the cylinder helps to reduce the noise on water cooled engines.

Air cooled engines also "let out" the noise with the ducts needed for the air cooling, and are therefore harder to quieten.

Fibreglass boats are generally noisier than wooden boats, because the large panels vibrate with the engine, and also "reflect" noise.

In some work boat installations, especially open boats, the noise aspect is not always considered important. When it is, there are various ways of reducing noise, but it is better to consider the whole subject from the beginning and plan to reduce noise before installation, rather than as an after-thought.

If noise is to be reduced from the beginning, the following points should be considered, and the manufacturer's advice followed carefully:

1. Choice of construction of hull, whether wood, fibreglass, steel, aluminium, etc.
2. Choice of engine, either water or air cooled.
3. Type of engine bearers, and construction. Wooden engine bearers should be as long, wide and thick as practicable for quietness.
4. Engine mounting. Flexible mounting is quieter than solid mounting, with flexible coupling.
5. Propeller aperture. The propeller should turn in an unobstructed position for least noise.
6. Air intake (induction) noise. This can be reduced by fitting or the choice of an approved air silencer.
7. Exhaust system. Water injected system, with flexible joints, is the least noisy. Direct, dry exhaust or vertical exhaust, are both noisy.
8. Cooling air ducts can be made quieter by fitting sound absorbing linings as recommended by manufacturers, and similarly around engine compartment or box.
9. All gaps around the engine compartment or box should be sealed as completely as possible.
10. Where controls, pipes and cables leave the engine compartment, they should be fitted with seals or baffles, as illustrated in Fig. 53.

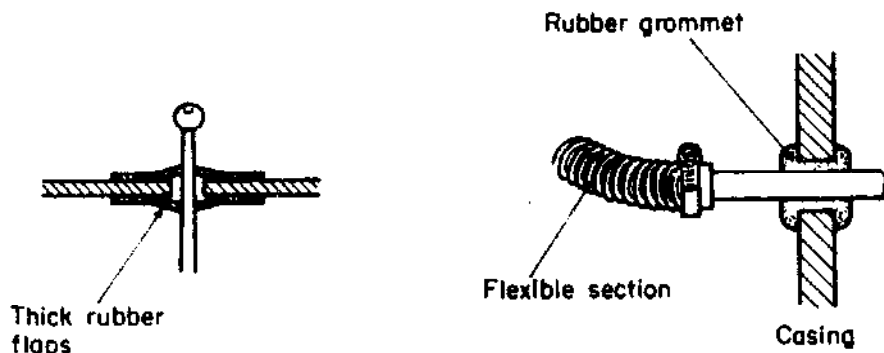

Fig. 53

## SECTION 11

### Bilge pumps and bilge systems

All small boats should have an efficient bilge pump which may be hand operated, engine driven, or electric. In some countries there are safety laws which apply to various sizes of boats, and which therefore must be followed. In the absence of laws or legislation about safety, any working boat should be fitted with an efficient engine driven or electric bilge pump, able to pump out most of the boat; additional hand bilge pumps should also be carried or fitted to be able to pump out the boat if the engine or electrical supply has failed.

#### 11.1 Hand pumps

The best pumps are those which are self-priming and which can be quickly and easily repaired if they stop pumping, with cheap and easy to find spare parts.

Diaphragm pumps are quite efficient, and on some models a replacement diaphragm can be made out of a car or lorry inner tube.

Semi-rotary pumps are not so widely used as before, as the valves can be troublesome, and some are not self-priming.

On small open boats it is convenient to place the hand pump on the gunwale, near the engine so that the pump collects bilge water near the stern or aft locker. Any hand pump should be fitted with a strainer or strum box to prevent solids entering the pump. The strainer should be easy to get to for cleaning.

#### 11.2 Electric bilge pumps

The trend towards submersible pumps has made electric bilge pumps more popular, as they have become more trouble-free in recent years.

Electric pumps are made in a variety of voltages, and capacities, i.e. the amount of water pumped per hour or minute, and therefore it is important to order the correct voltage motor, with a sensible capacity for the size of craft.

The electric bilge pump must be installed for easy access for cleaning and periodic servicing as recommended by the manufacturers.

#### 11.3 Engine driven bilge pumps

These may be driven by the main engine, or have a separate engine/pump unit, or engine generator/pump unit (sometimes called a "donkey" unit), all usually by Vee belt drive.

Most of the earlier bilge pumps were of the twin gear type, but the most popular type now found is of the single "impeller" kind, with a neoprene or plastic impeller fitted slightly "off-centre" in the pump housing. This creates suction as well as acting as an impeller and pushing the water through the pump.

One of the most successful manufacturers of these pumps is "Jabsco", and they are found on many makes of marine engines.

One of the most common faults on the plastic impeller type of pump is that it cannot run for long when dry, as the impeller is lubricated by the water passing through the pump. It will eventually overheat and damage the impeller if run in a dry state for more than a few minutes.

It is important that spare impellers are carried on board, and that someone in the crew knows how to change an impeller should the pump stop working.



#### 11.4 Bilge system

On larger craft, the bilge pump is usually connected to a system of pipes able to pump out each section or watertight compartment of the boat.

In this case there are valves to open and close off each compartment, and the valves have to be numbered or named, showing to which it refers. In each compartment there is a strainer or strum box which prevents solids entering the system, and the strainer should be positioned for easy cleaning, and usually at aft end or lowest point of each compartment.

SECTION 12Power take off

The engine fitted to drive the boat through the water, can also be used to power other equipment on the boat, depending upon the nature of the work that the boat is required to do.

For example, the main engine may be used to power one or more of the following:

Fishing winch, powerblocks, line hauler, anchor winch, derrick or cargo winch, extra electrical generator, water or bilge pump, compressor, etc.

On small working boats the most usual power take-off is for a small fishing winch or hydraulic oil pump for line hauler or power blocks, or bilge water/deckwash pump.

The power has to be taken from the engine either by a direct drive clutch from the end of the crankshaft or camshaft, or by Vee-belts from pulleys fitted to either crank or camshaft.

It is most important to follow the engine makers instructions on the maximum loads and power that can be taken from the engine without damage.

Any power take-off driven equipment must be positioned to allow for the realignment if necessary when the engine is aligned to the propeller shaft.

Belt driven equipment must allow for the adjustments of belts as they stretch and wear, and the replacement of belts. All belts should have belt guards to protect the crew and loose clothing from being caught up in moving belts, pulleys and shafts. This is very important in countries where flowing robes or long clothes are worn by tradition.

PART TWOSECTION 13Installation details

It is hoped that the text which follows will prove adaptable for the installation of shaft and engine into any small craft, whether built of wood, glass fibre, steel or ferro-cement. For this reason it has to be assumed that the starting point of the text is from the time that the shaft tube is fitted into the boat.

Obviously, if the boat is of glass fibre or ferro-cement construction, the shaft tube will have been moulded or cast into place by the boatbuilder.

### 13.1 Establishing the shaft line (boat with stern tube, boat with shaft log and 'P' bracket)

With the shaft tube in position, the first step is to find the position that the shaft will take called the "shaft line". This is done as follows:

- a) Make a plug which will fit into the shaft tube, with a hole in the centre and place it in the tube from the outside of the boat. (See Fig. 54)
- b) Thread a long thin nylon string or thin piano wire through the shaft tube so that it comes into the boat. The string/wire must be long enough to go to where the front of the engine will be. (See Fig. 54)
- c) Look carefully at the string/wire as it comes out of the shaft tube, and by moving the string/wire find out where it sits in the centre of the tube. (See Fig. 55)
- d) Fix bracket or suitable wooden strip and fasten string/wire securely to it. Make sure bracket cannot be knocked out of line or moved, and is well forward of engine position (see Fig. 55). This line will be the basis of the line for the engine bearers and should not be moved till bearers are made and fitted.

### 13.2 Planning the engine bearers

Before beginning to install the engine bearers it is important to obtain from the engine makers a "General Arrangements" drawing, similar to that shown in Fig. 56, which will give detailed information of measurements of the engine and the amount of space various items on the engine require. For example, if the engine is provided with hand starting or turning, there must be room to turn the handle once the engine is in place.

Similarly, it must be possible to service the engine once it is fitted, and details like "how much room it needs to drop the oil filter out and put in a new one" must be considered at the beginning.

A check list of items like this which need careful planning before the engine bearers and engine box, floor boards, etc., are made, is as follows:

- a) filling and draining the engine sump;
- b) filling and draining the gearbox;
- c) filling and draining the reduction gear or Vee drive;
- d) checking dipstick and oil pressure gauges;
- e) checking water header tank, if fitted, turning water pump grease caps;
- f) changing air, oil, fuel and raw water filters;
- g) allowing sufficient air into and out of the engine for cooling purposes (air cooled engines only);

- h) sufficient air for the engine to run properly;
- i) enough room to turn starting handle and decompressor lever if fitted;
- j) enough space for the gear lever and throttle linkage to move freely;
- k) space to get at the drip tray under the engine for cleaning;
- l) space for the engine to move (if on flexible mountings).

### 13.3 Making an engine template

Plan - An engine template is easily made from a piece of 10mm plywood, given the "General Arrangement" drawing of the engine - plan view:

- a) Select a piece of plywood that you know will be long and wide enough and draw a centre line down the middle. Mark the template "Front" and "Back".
- b) Along the centre line, mark the distance apart of the engine mounting feet - engines usually have 4, sometimes 6.
- c) Mark the width of the feet apart (the centre of the fixing hole) from the centre line by using a large T-square. Mark the position of the 4 (or 6) mounting holes.

#### ESTABLISHING SHAFT LINE

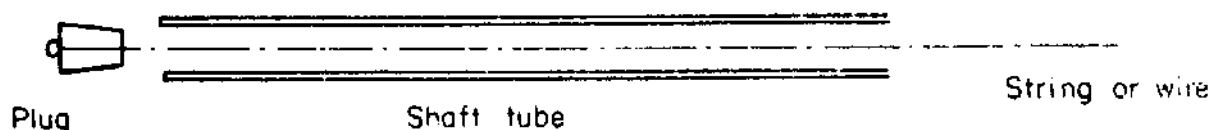

#### SKETCH 1

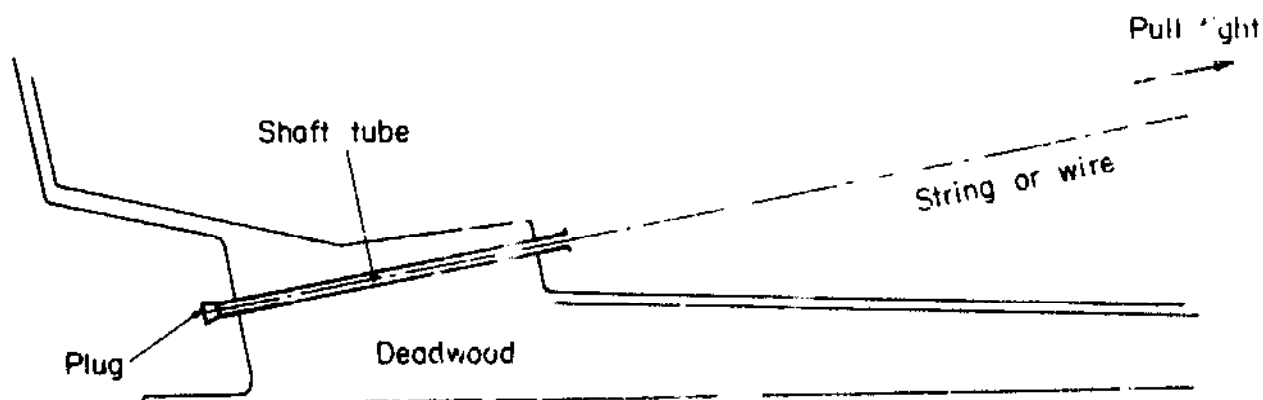

#### SKETCH 2

# ESTABLISHING SHAFT LINE

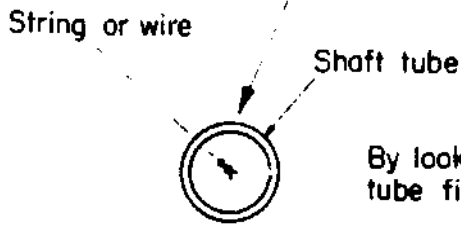
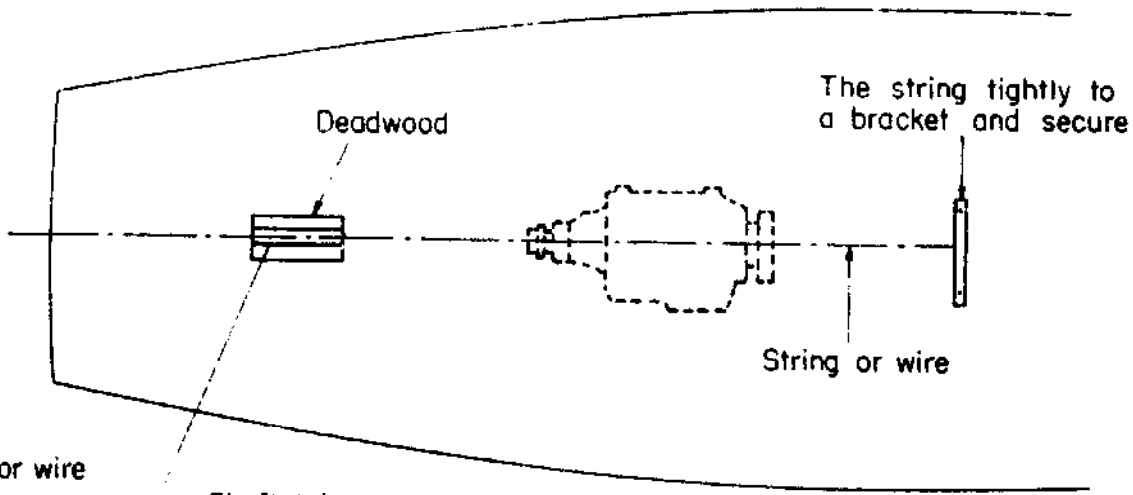
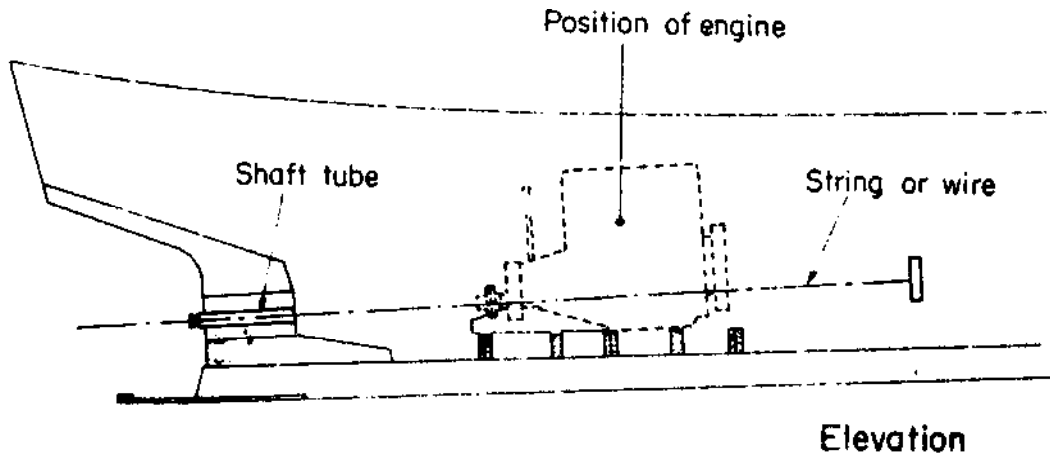

By looking at the inside of shaft tube find where string is in centre

Fig. 55

- d) Check by measuring from one corner foot to the other. Repeat, measuring the opposite pair. The measurements should be the same. You can also check by measuring the engine itself.
- e) Drill the holes carefully using a small "pilot" drill, and then drill out the holes the same size as the bolt holes on the drawing of the engine.
- f) Draw around the bolt holes the size of the engine feet, and cut out the shape.

You then have an accurate template, showing the 4 (or 6) engine feet.

**Profile** - If there is the possibility that the depth of the engine could foul the transverse frames or any timbers between the engine bearers, make a "profile" template instead of a "plan" template (as described in the previous section) from the "General Arrangement" drawing.

- a) Select a suitable piece of 10 mm plywood and accurately draw the full size profile on to it.
- b) Cut around the drawing with a jig-saw.
- c) Measure and mark the position of the engine bearers on to 75 mm x 25 mm battens and accurately slot them into the profile.

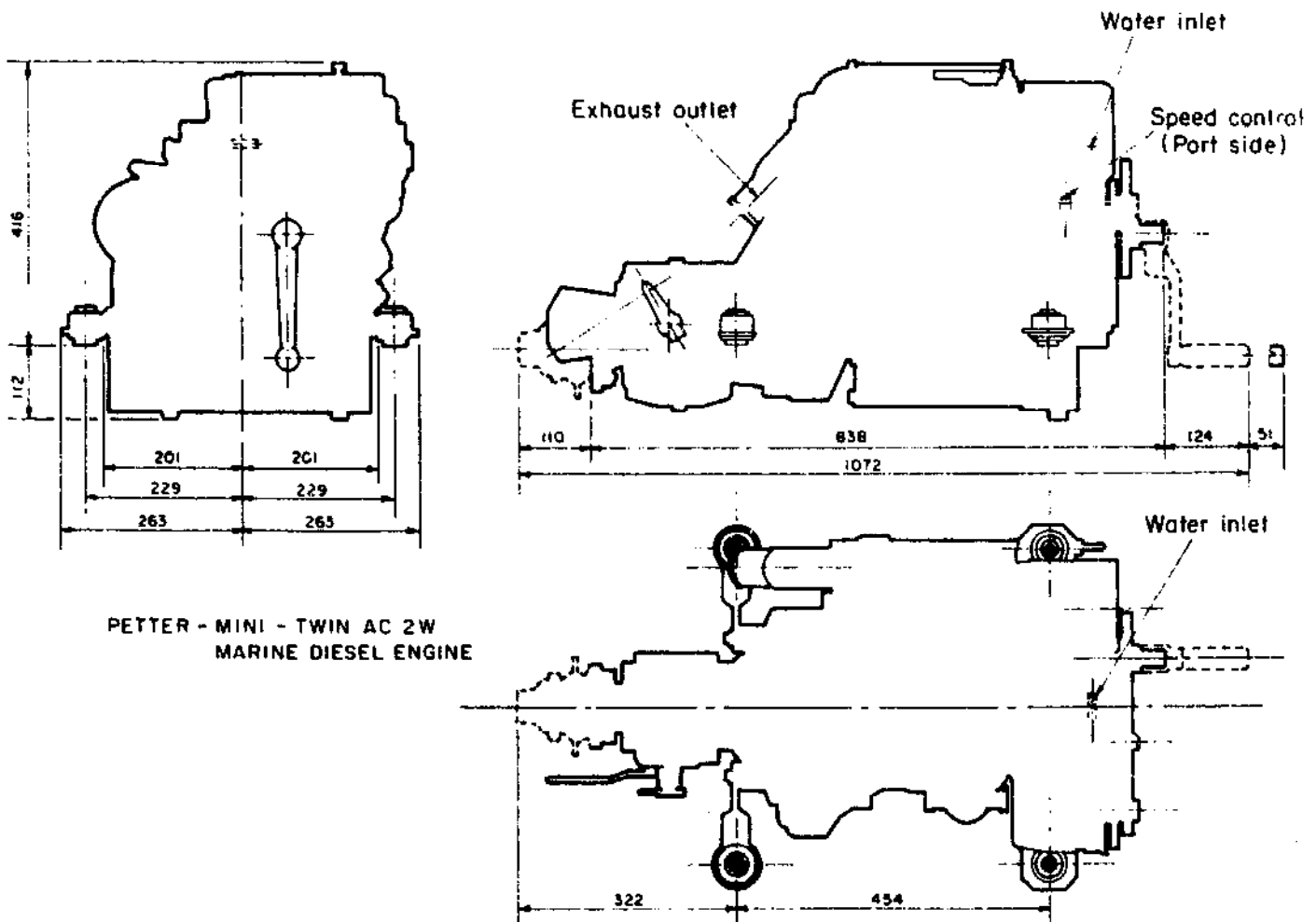

PETTER - MINI - TWIN AC 2W  
MARINE DIESEL ENGINE

TYPICAL GENERAL ARRANGEMENT DRAWING

- d) Fit supporting braces so that the vertical profile is at right angles to the cross pieces.
- e) The cross pieces should accurately represent the position of the engine feet.
- f) The completed profile template can now be used to check the position of the bearers and of clearances between the engine bearers and any frames.
- g) Any main components, e.g., exhaust outlet can also be marked on template to give an idea of how they will be arranged.

#### 13.4 Fitting engine bearers (wooden boats)

Having decided upon the shaft line and with wire or string marker in position, the next step is to put in the engine bearers, with the aid of an engine template.

Depending upon the design of the boat, the engine bearers may bolt directly to the stringers which run the length of the boat, or they may bolt on to transverse frames.

Transverse frames help to spread the weight of the engine across the boat, and usually bolt to the keel and possibly to the stringers also. They should be as heavy as possible, and can be further supported by "knees" (made from either metal or wood).

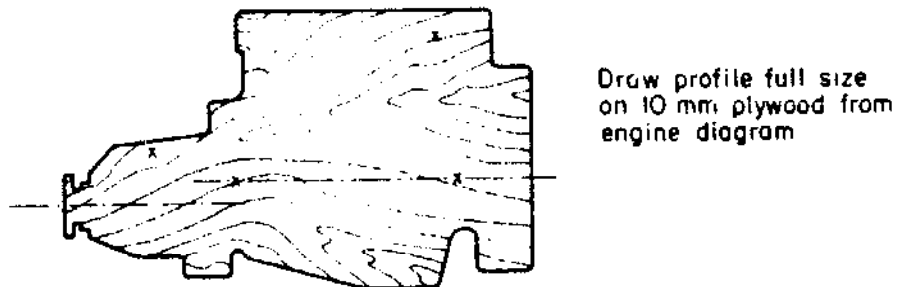

x Mark accurately for mounting lugs and main accessories

Cross arms through plywood and well braced

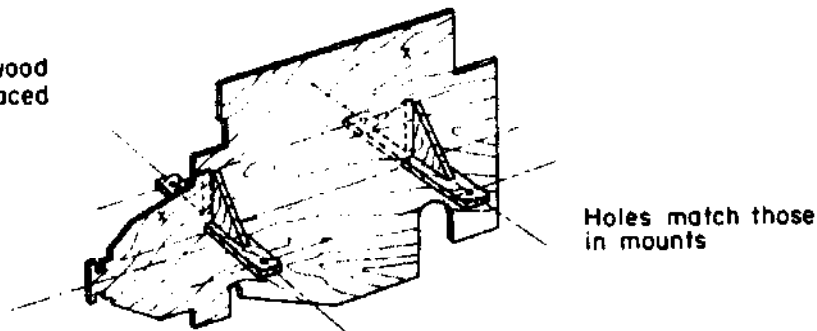

ENGINE TEMPLATE

It is important that the frames are shaped to fit the hull exactly, and that the weight of the engine is spread over the hull. An incorrectly made frame touching the hull in one or two places only could put "pressure" on those parts of the hull, which could cause trouble later on.

Once the preparation for the engine bearers is complete the next move is to place them in position as follows:

- a) Using the engine template as a guide, position the engine bearers exactly parallel to the shaft line, and the correct distance apart, so that the bolt holes for the engine come in the centre.
- b) Mark the position of the bearers in the boat and then check that the bearers are parallel to the shaft line in height.

Note: On many engines, especially with reduction gears, the output shaft (where the propeller shaft will bolt up to) is lower than the engine feet.

Make sure that the height difference between the engine feet and the shaft centre line is planned carefully, see Note i) below.

- c) When you are satisfied that the bearers are in the correct position, fasten them to the boat, by bolting. All fastenings should be either of bronze or galvanized steel, to prevent corrosion. Always use flat washers underneath nuts.
- d) Refer to the "General Arrangement" drawing, the profile template or, by measuring the engine itself, adjust any part of the bearers (by removing any wood necessary) to allow the engine to sit on the bearers without "jamming".

Note: i) If a steel angle or flat strip is to be fastened on top of wooden bearers, the thickness of the metal must be allowed for.



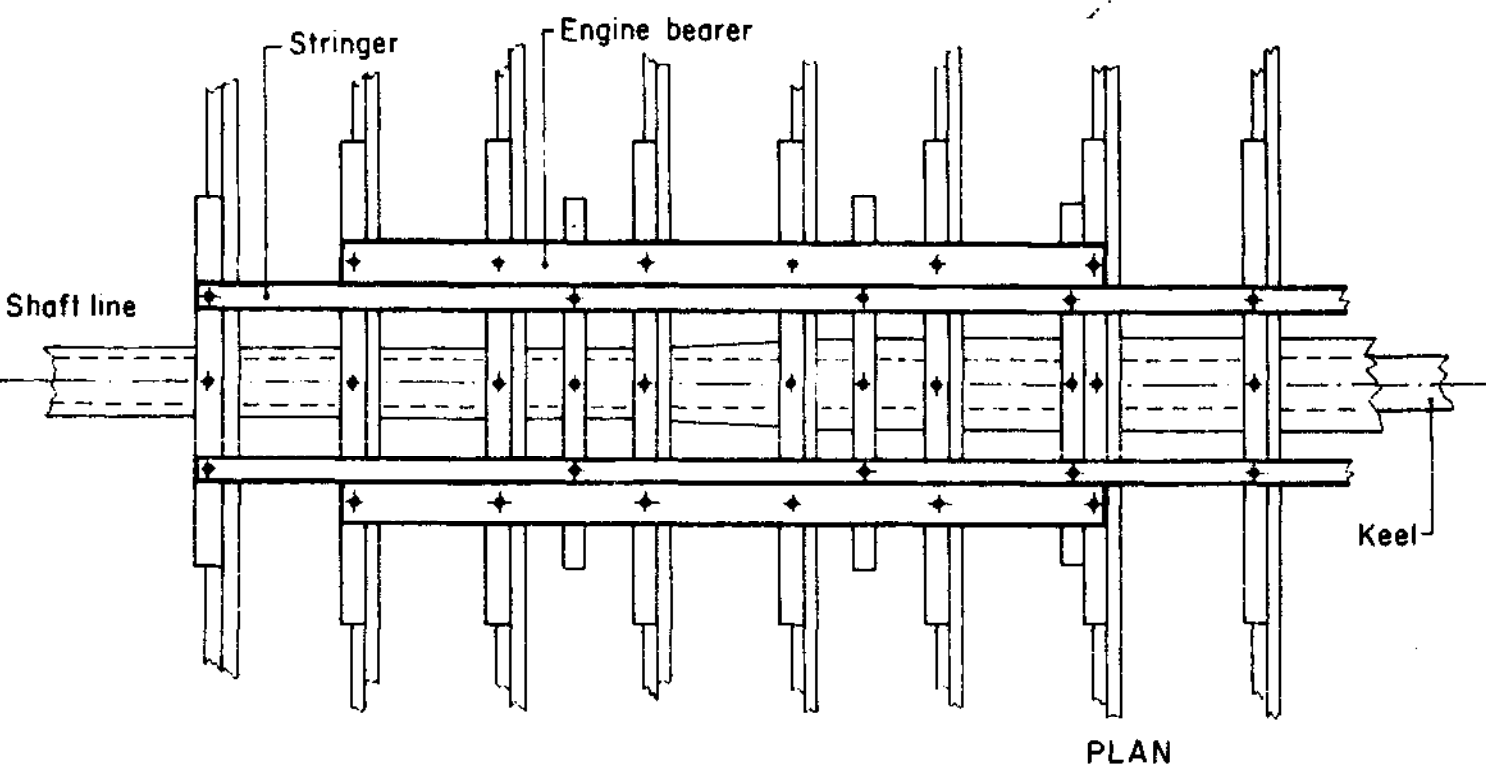
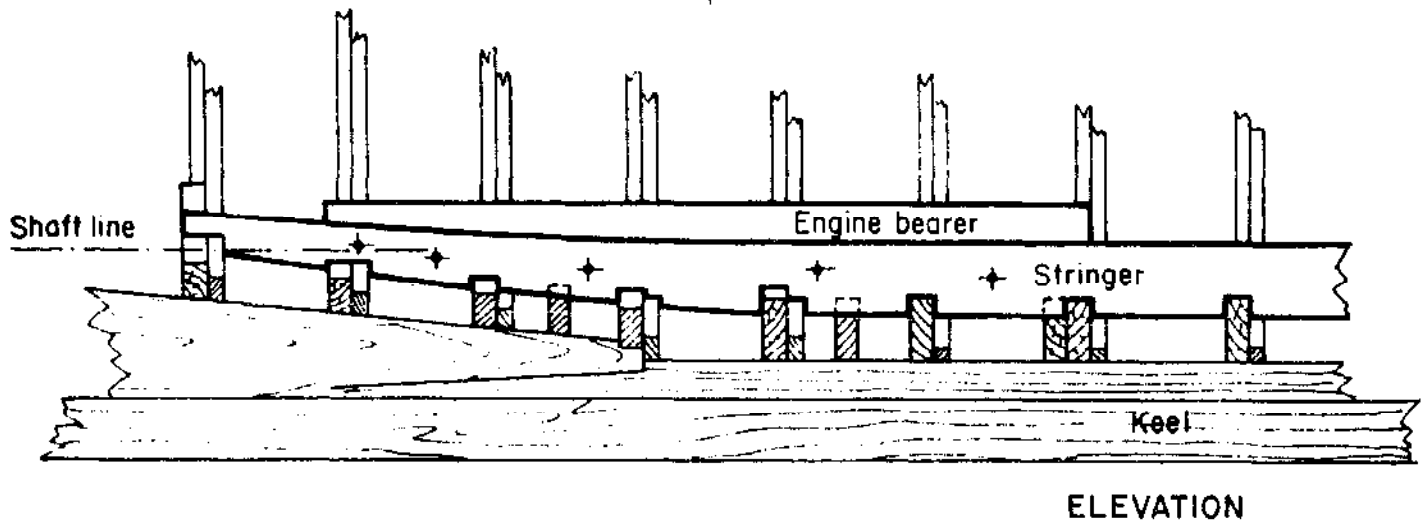
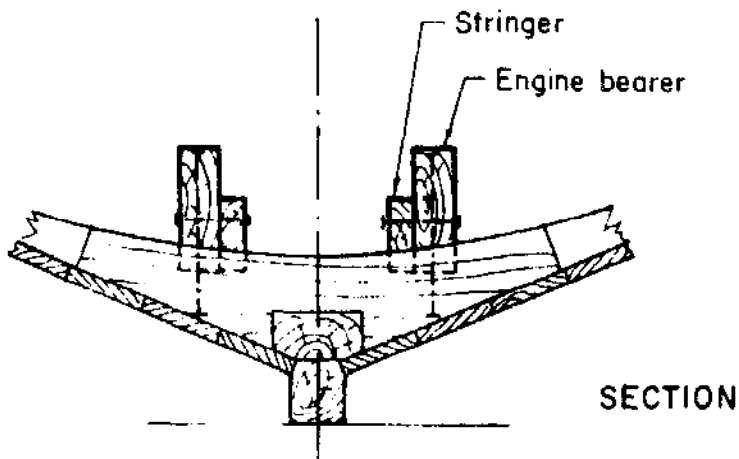

TYPICAL SMALL BOAT ENGINE BEARERS

Fig. 58

SECTION 14Stern gear and alignment - installation14.1 Cutting shaft to length

Careful planning of the engine position and the length of the shaft must be done.

If the shaft is supplied with the engine and has to be cut to length, the following should be noted:

## 1) Fixed propeller

On boats to be fitted with a fixed propeller, the shaft length must be sufficient for the half couplings to be bolted up while there is still a slight clearance between the stern bearing and the propeller hub, as follows:

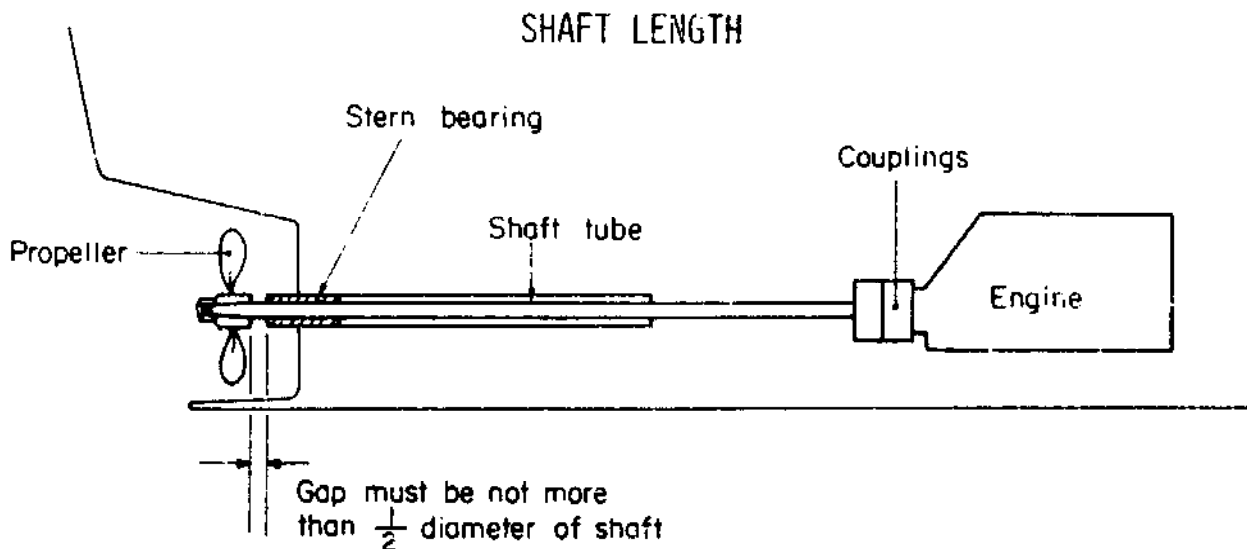

Fig. 59

The gap must not be more, or less than half the diameter of the shaft. For example, if the shaft is 30 mm in diameter, the gap between the end of the bearing and the propeller hub must be 15 mm approximately.

If it is too close, the propeller will not work so well, if it is too far apart, the shaft could become bent or even break off after being in use for a while.

## ii) Variable pitch propeller

The installation of the shaft and engine using certain types of variable pitch propeller is rather different.

Where the propeller pitch is varied by moving the shaft backward and forward, it is important to follow the maker's recommendations on how to set about cutting the shaft at the correct length so that full propeller pitch in ahead and astern is still possible.

With some makes, e.g., Sabb, firstly, the shaft is fitted into the shaft tube, and the stern bearing fitted to the boat.

The propeller is then assembled, as it consists of a propeller boss in two pieces, with three internal thrust rings, and 2 propeller blades with operating blocks.

When the propeller is correctly assembled and bolted (lightly) together it can be seen that the propeller blades can be twisted from ahead to astern, by pulling or pushing the shaft forward and backward.

The movement of the shaft in this way is done by a control on the gearbox of the engine.

When cutting the shaft to fit the installation it is important to set the gearbox control at full astern.

The blades of the propeller are also set at full astern (check you know which way the propeller shaft turns first).

The coupling on the shaft can then be slid along the shaft to meet the gearbox half coupling position. Mark the shaft, remove it from the boat and cut it off.

This operation is very important, as it is possible to cut the shaft too short, and then not be able to get the full ahead position of the propeller.

### CUTTING SHAFT TO LENGTH

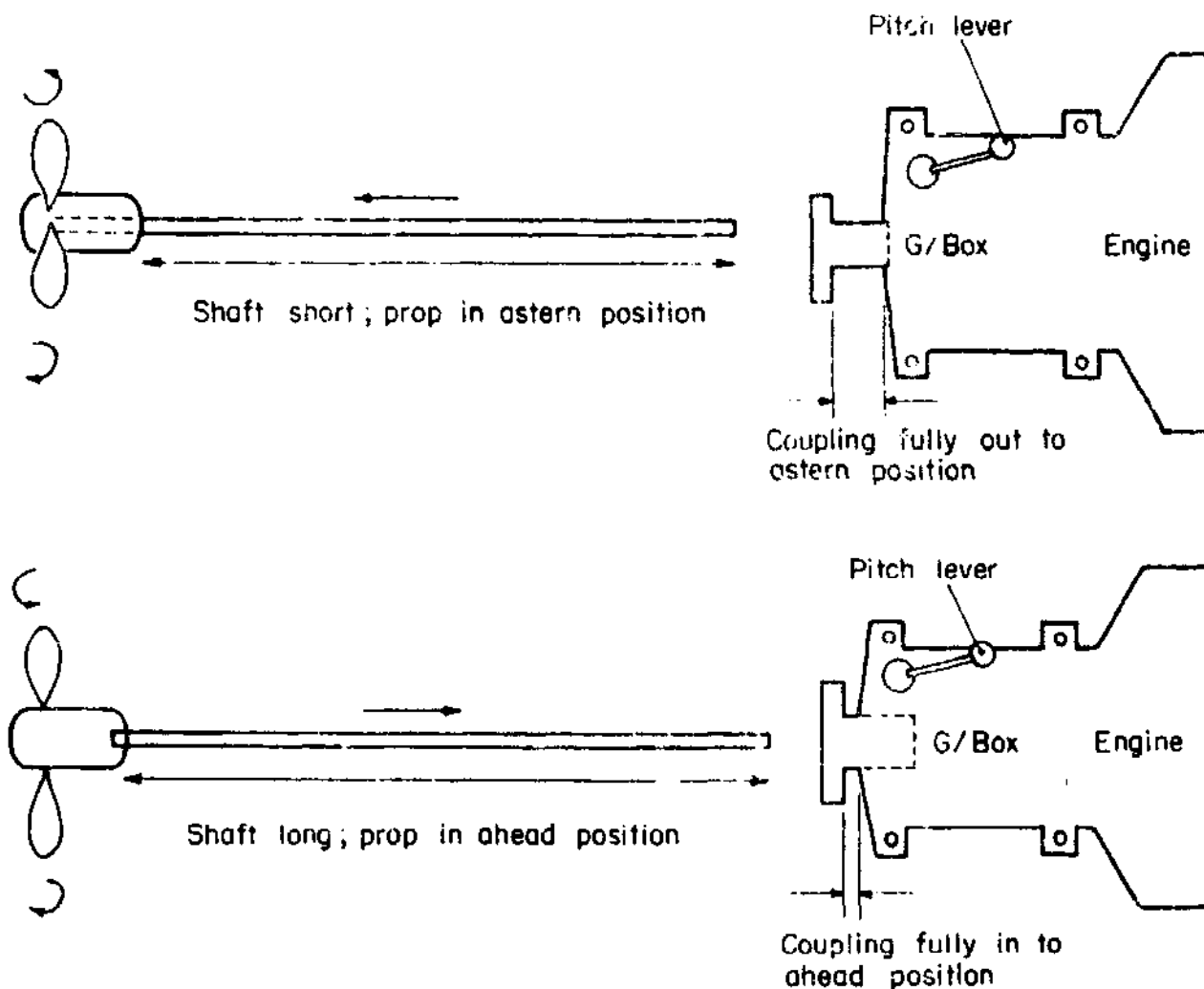

Fig. 60

#### 14.2 Installing shaft and shaft bearings

- a) Once the engine bearers are in position the shaft alignment marking string or wire can be removed.
- b) Check that shaft is clean and free from any damage, burrs, etc., which could make difficulties later. If necessary rub damaged areas with fine emery cloth or even a fine file on bad burrs.
- c) Slide shaft into shaft tube from outside the boat, then slide rear stern bearing on, and screw on to shaft tube. If fitted with 'P' bracket and rubber bearing instead of shaft tube, wet the rubber bearing with water (not oil or grease) to assist fitting shaft.
- d) Go inside the boat and fit the inboard gland (and bearing if fitted). Pack the gland but do not tighten adjusting nuts. (See gland packing note later).
- e) Fit shaft half coupling and tighten.
- f) Fit propeller and tighten (see following note).

Note: It is often necessary to fit half coupling and propeller at the same time, to tighten one against the other. Make sure all locking pins, tab washers, etc. are fitted.

- g) Fill grease cap or reservoir if fitted. Water lubricated bearings may need a connexion from the engine cooling system, when the engine is installed.

#### 14.3 Fitting a propeller

It is important when fitting a propeller to ensure that the shaft taper and propeller taper are in proper contact, so that the drive to the propeller is not just through the key.

It is very easy and quick to do the following checks:

- a) Place propeller on shaft without the key and push on.
- b) Make a line with a sharp scriber on the shaft at the front of the propeller.
- c) Remove the propeller, fit the key to the shaft.
- d) Push the propeller on. It should come up to the scribed mark.
- e) If it does not, the propeller is sitting on the key instead of on the taper.
- f) Remove the propeller, file the key on the top only.
- g) Refit the propeller to check.
- h) Continue to file the key and check by fitting the propeller until it reaches the mark as in d).
- i) The propeller nut can now be screwed on tight and locked with the locking device.

#### 14.4 Drilling holes in engine bearers

Where there are facilities for the easy lifting of the engine by chain blocks, crane, etc., it is always better to lift the engine and lower it on to the bearers when the shaft

## FITTING PROPELLER

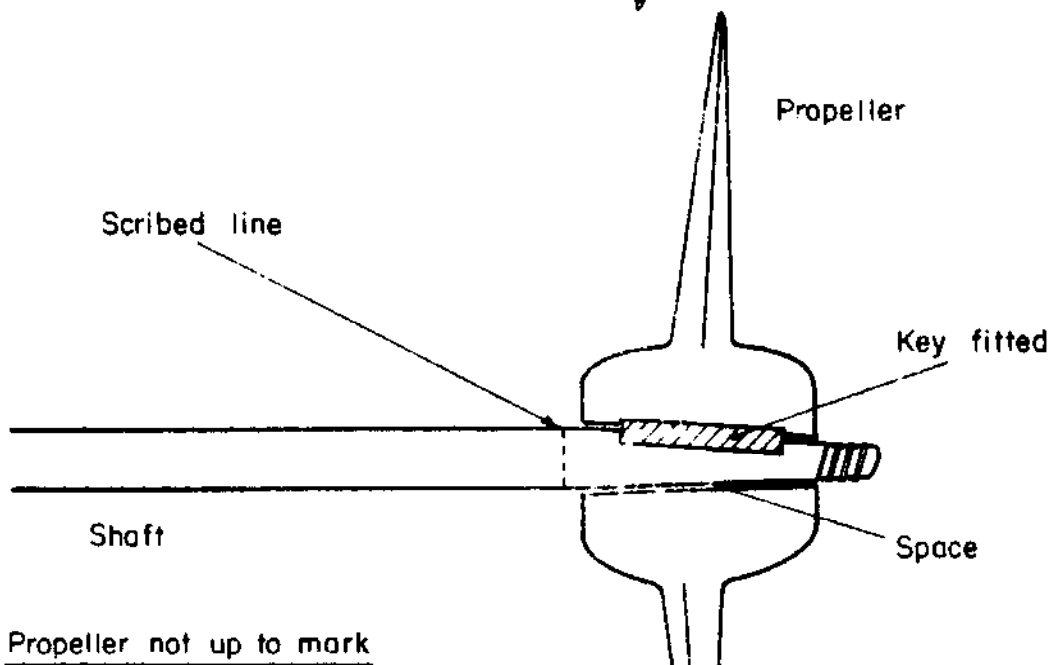
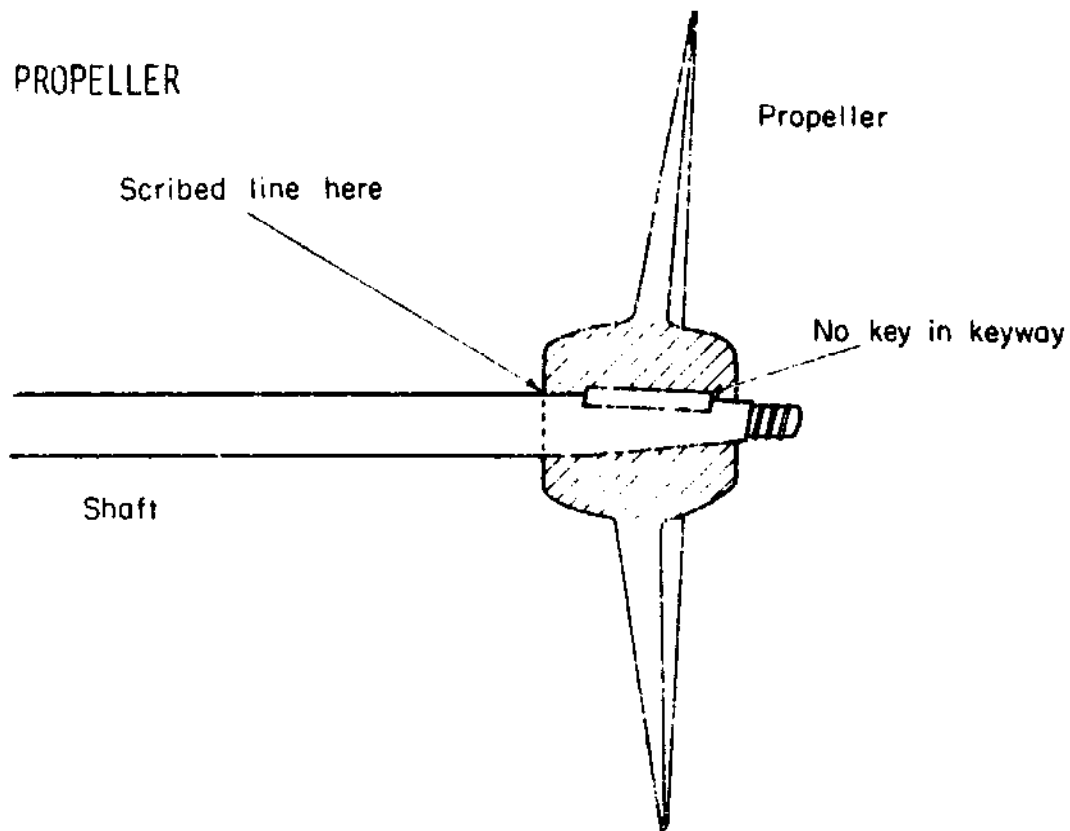

File top of key, and repeat until propeller comes up to mark with key fitted

Fig. 61

is in position before drilling the holding down bolt holes.

If this is done the engine position can be checked by offering it up to the shaft to see if the alignment is approximately correct.

The step-by-step method is as follows:

- a) Arrange lifting wire strop or chain to fix to the engine as recommended by the manufacturers. Be careful of pinching pipes or fragile parts of the engine with the wire strop or chain.
- b) Carefully lower engine down toward bearers, always checking that nothing is going to get damaged.

Note: Keep the engine forward of the shaft and coupling.

- c) When the engine is down (keep some weight of the engine on the chain blocks for easy moving) lever the engine to its correct place, using the shaft coupling to give the exact position.
- d) When correctly placed, lower the chain block until all the engine weight is on the bearers and check the alignment.

Checks before engine finally lowered:

Make sure that everything underneath where the engine will be is completed before lowering the engine to be finally positioned. A check list follows:

1. Engine
  - i) Make sure all bolts and nuts on the engine which cannot afterwards be reached, are tight, particularly around the engine sump, around clutch housing and reduction gearbox.
2. Boat
  - i) All bolts tightened around the engine bearers, and frames.
  - ii) All limber holes out out (to prevent pockets of water lying in one place).
  - iii) Any wood or steel is properly painted for protection.
  - iv) Engine drip tray painted and fitted.

The engine can now be lowered, tighten holding down bolts slightly to prevent engine moving when boat is moved.

Do not attempt to bolt the engine and shaft couplings together until the boat has been launched (see later under Alignment).

Note: It may be found that the engine has to be raised or lowered slightly. Carefully measure to see where alteration is required and mark.

- e) If all is correct, mark the engine bearers exactly where the engine mounting feet sit.
- f) Sometimes it is possible to drill some bolt holes with the engine in position, but usually it is not possible to get at them all.

- g) As long as everything is clearly marked, the engine may be lifted again and moved out of the way.
- h) When drilling, select a drill to give a clearance hole for the mounting bolts, i.e., slightly larger than bolts. If drilling into a steel angle, always use a small drill to make "pilot" holes first. When drilling, always make sure the drill is at right angles, i.e., side to side, and backward to forward to the engine bearer. DO NOT drill a vertical hole on sloping engine bearers.
- i) The holes should then be mortised out to take a pressure pad and nut, as in the next drawing. Make the mortised holes as low down in the bearer, keeping the maximum thickness of wood between the engine feet and the mortise.

#### 14.5 Alignment

Alignment must only be done when the boat is in the water - NEVER on land. A wooden boat must be left to soak for several days to take its "water-borne" shape.

Once it is sure that the boat is ready, the engine is aligned as follows:

- a) Release engine holding down bolts.
- b) Pull shaft and coupling up to meet the engine (driving) coupling.
- c) By the use of a straight edge, check to see if the coupling halves are "parallel", see Fig. 62.
- d) If the coupling halves are in line when viewed from side and top, the engine and shaft are "parallel". If not, the engine has to be raised or lowered, or moved from side to side until the above check shows it is correct.
- e) The next check is to see if the engine coupling is in line as shown in Fig. 63.

This must be checked, NOT BY LOOKING, but by THE USE OF FEELER GAUGES as shown in Fig. 64.

- f) Use feeler gauges to check that the couplings are in line as follows:

Take a fairly thick feeler gauge 0.4 mm or similar, and pull the coupling and propeller shaft up till it lightly grips the blade of the feeler gauge in position (A).

- g) Check in positions (B), (C) and (D). The same clearance (the same amount of gripping of the feeler blade) should be felt in all 4 places.
- h) If not correct, continue placing shims under the engine feet until it is exactly correct.

Note: Keep checking that the couplings are still parallel as in Note (c).

- i) When correct, tighten engine holding down bolts.
- j) Check again - MOST IMPORTANT, as tightening the bolts may alter it.
- k) When finally correct, put the coupling bolts in, tighten them and test the engine and boat under way (i.e., moving).
- l) When testing the boat, listen for any vibration and check the stern gland and bearing if fitted. Any heating of the gland or bearing may be caused by misalignment (see further note on Testing in Part 3).

**Note:** Flexible couplings must be aligned in exactly the same way as solid couplings. Do not think because it is a flexible coupling, it will be able to work if not exactly in line; this will only cause trouble in future.

The importance of careful alignment of the engine cannot be emphasised too strongly.

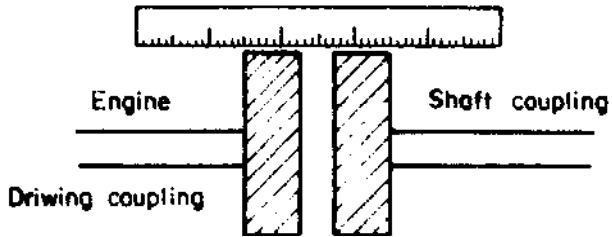

CORRECT

VIEWED FROM SIDE

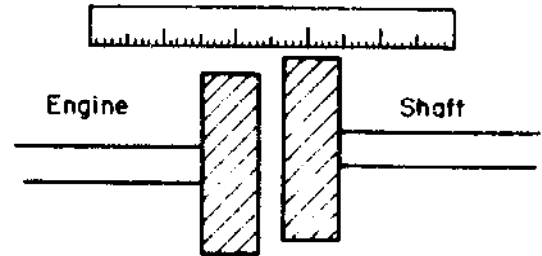

WRONG ENGINE TOO LOW

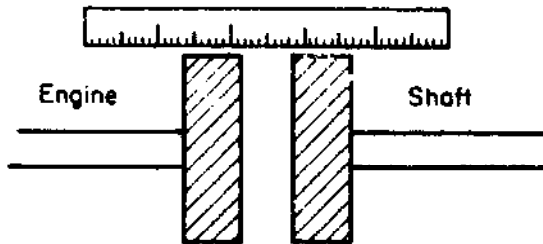

CORRECT

VIEWED FROM ABOVE

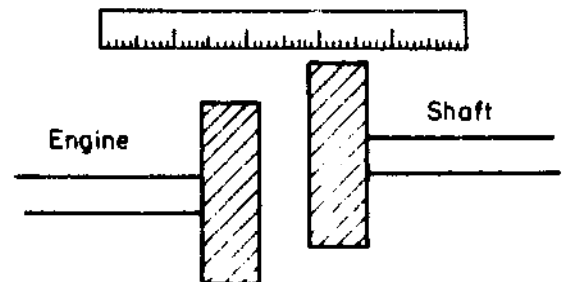

WRONG ENGINE TOO FAR TO ONE SIDE

Fig. 62

## SHAFT ALIGNMENT



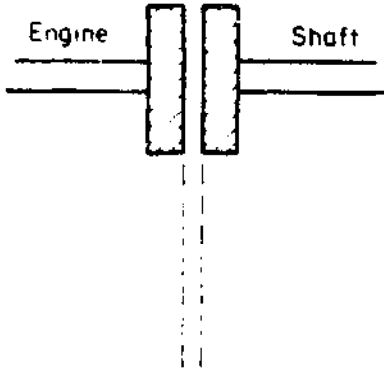

CORRECT

VIEWED FROM SIDE

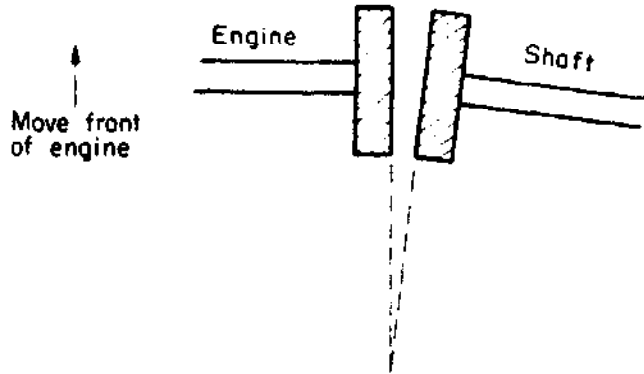

WRONG ENGINE TOO LOW AT FRONT

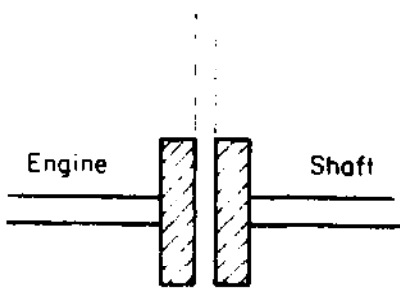

CORRECT

VIEWED FROM TOP

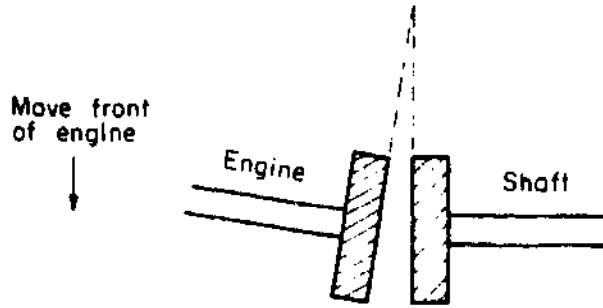

WRONG FRONT OF ENGINE  
TOO FAR TO ONE SIDE

Fig. 63  
SHAFT ALIGNMENT

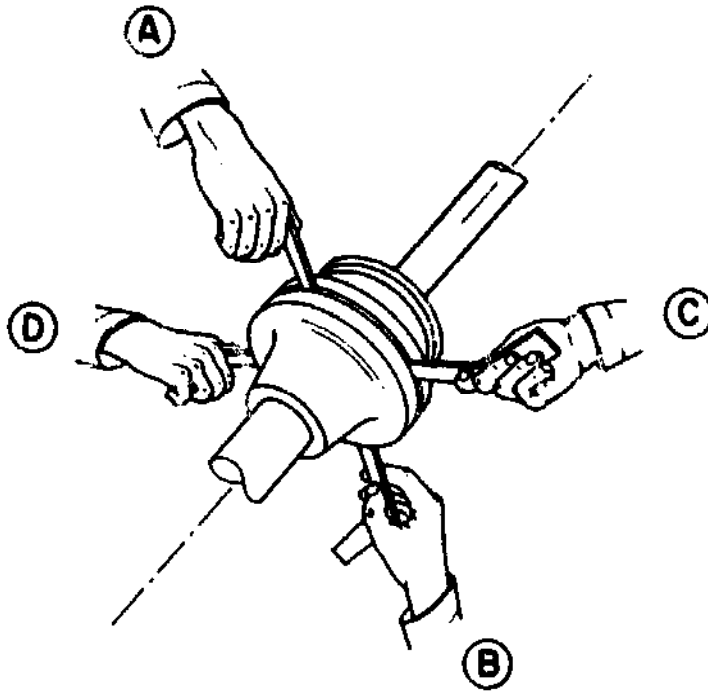

## USE OF FEELER GAUGES

Fig. 64

SECTION 15Cooling system - installation15.1 Direct system

- a) The sea-cock and strainer unit must be of the correct size for the engine. It must be positioned as close to the engine as possible, and easy to get at for turning on and off and for cleaning the filter. It must also be low down where it can draw water even if the boat rolls or pitches.
- b) The connexion between the sea-cock/strainer pipe and the engine must be by rubber hose, to allow for movement and vibration, etc.
- c) The discharge pipe must be connected by a rubber hose as in b) if water is piped directly overboard. If it discharges into the wet exhaust system it must be as per instructions on exhaust systems (see Section 16). The discharge pipe must always be above the waterline so that it can be seen that the pump is pumping water.
- d) It must be possible to drain the system dry in cold countries where it may freeze and burst the engine.

15.2 Indirect by heat exchanger

- a) Notes a), b) and c) relating to a direct cooling system also apply.
- b) The addition of anti-freeze into the fresh water system will prevent the engine from freezing. The raw water system must also be fitted with draining taps to empty the pipes and especially the pump.

15.3 Keel cooling

- a) With a keel cooling installation it is important to use the right type, diameter and length of pipe under the boat to maintain the correct running temperature of the engine. Some manufacturers produce a kit for their own engines, whilst some do not advise keel cooling. A general guide to the length and diameter of keel cooling pipes is about 150 mm of 25 mm pipe per hp of the engine. (These figures are for a guide only). For example, a 25 hp engine would require about 3.75 m of 25 mm keel cooling pipe.
- b) The pipes can be mounted on one or both sides of the craft, depending on the length of the pipes compared to the length of the boat.
- c) The fittings on the hull can either be factory made, or fabricated from standard galvanized iron water pipe fittings (fresh water only), copper pipe is better for the sea.
- d) It is common practice to fit a strong rubbing strake outside the hull, parallel and close to the pipes to give the maximum protection when beaching or grounding.
- e) The internal pipework should be as short as possible, with rubber hose connexions to prevent vibration. Avoid sharp bends in the pipework.
- f) A water header tank must be fitted above the highest point of the engine, to keep the system full of water. The connexion to the header tank must be of rubber hose, to permit movement.
- g) Anti-freeze may be added to the system to prevent the engine being frozen.

Note: Some engines cannot be keel cooled. Therefore, obtain information from the makers of the engine before installation.

#### 15.4 Air cooling

- a) The cold air inlet to the engine for cooling purposes is usually drawn from below the engine, and plenty of space must be left, with nothing in the way. Refer to engine handbook for size of opening to be made.
- b) The outlets must be arranged to lead the hot air away from the engine, so that it cannot get back into the inlet area.
- c) The inlet air to the engine air filter (for the engine's use) must be in a cool position. It can be removed from the engine and fitted away from the original place, for example, on top of the engine box, and connected by a pipe of the same diameter and rubber hoses.
- d) If the engine is in an open boat, the engine box must be drilled with large holes all round the top, usually 25 - 50 mm in diameter, and as many as possible. The box lid should be left off when the engine is running.
- e) If the engine is below decks, the engine must be fitted with ducts to lead the cold air in, and the hot air away, with the hot air duct higher than the cold (inlet) duct. These should be fitted so that they do not get in the way of engine controls, or interfere with the removal of the engine.
- f) Avoid sharp bends in ducting, and the use of wooden slats across the opening. If either are necessary open up the size to give about 25 per cent more area.

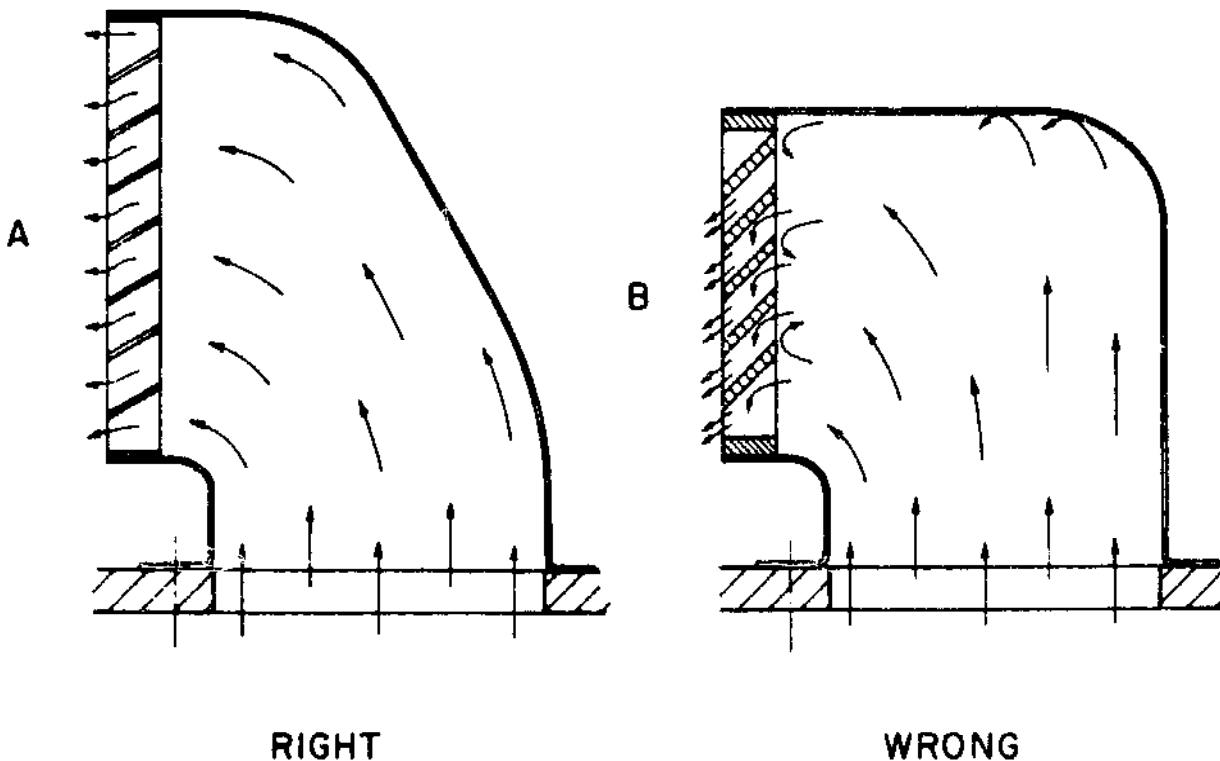
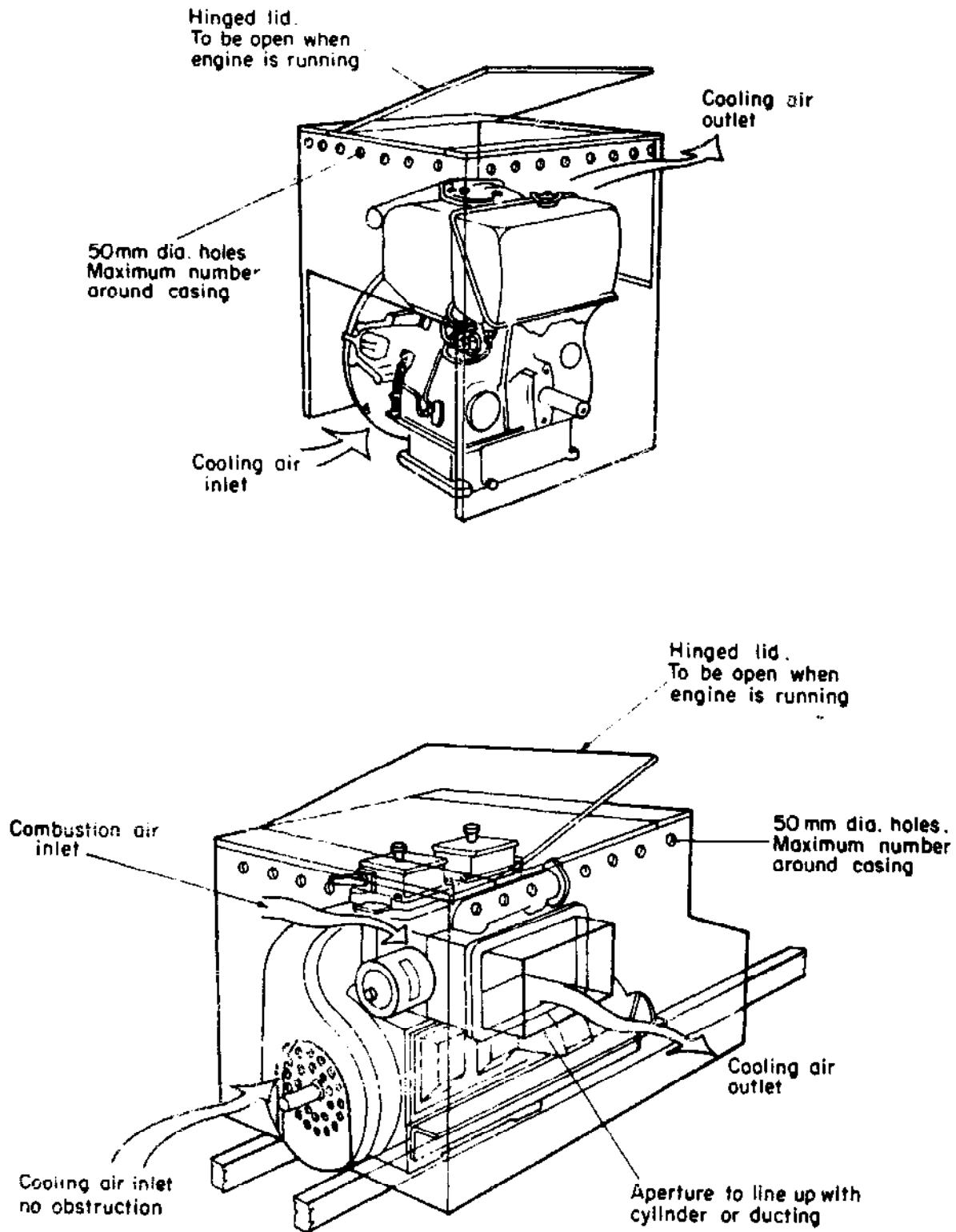
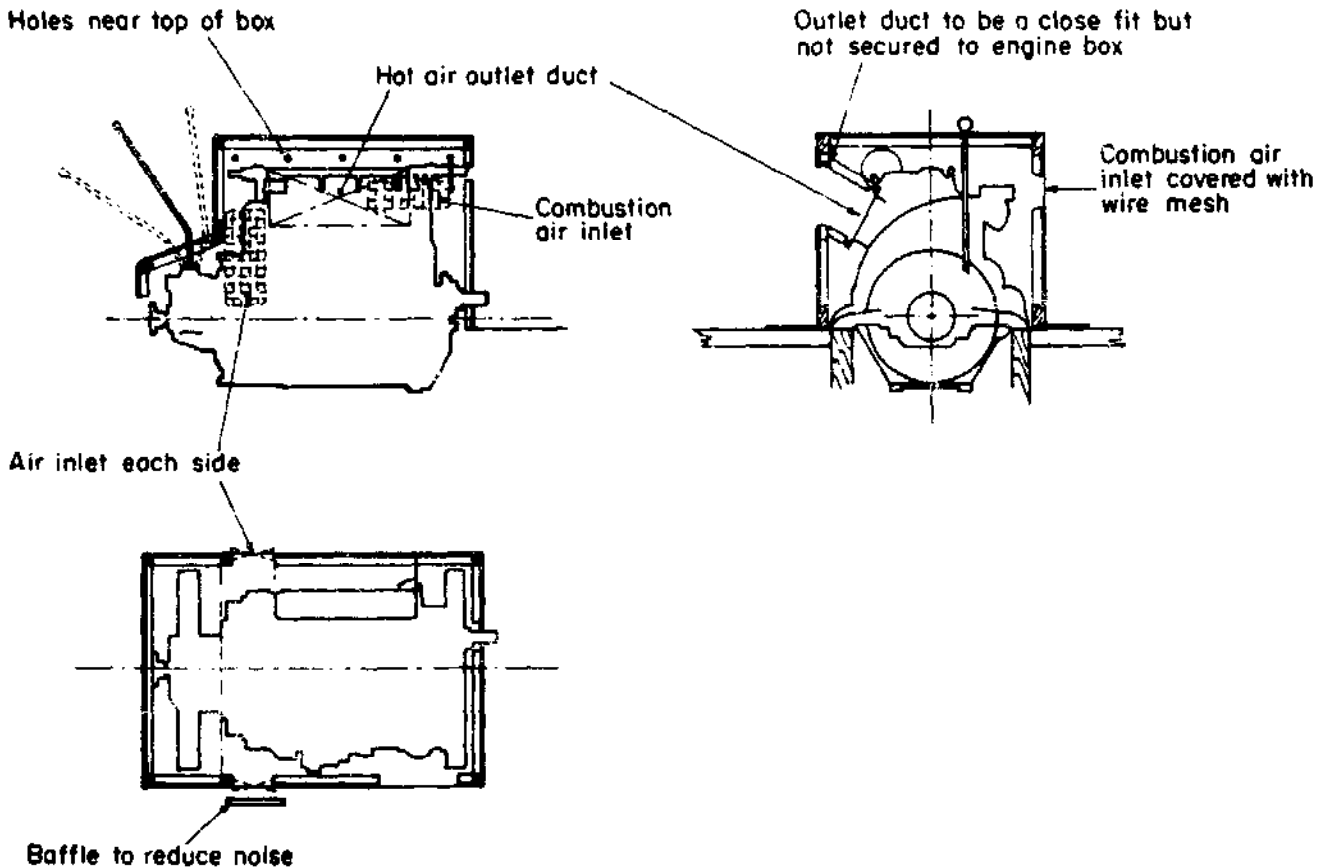
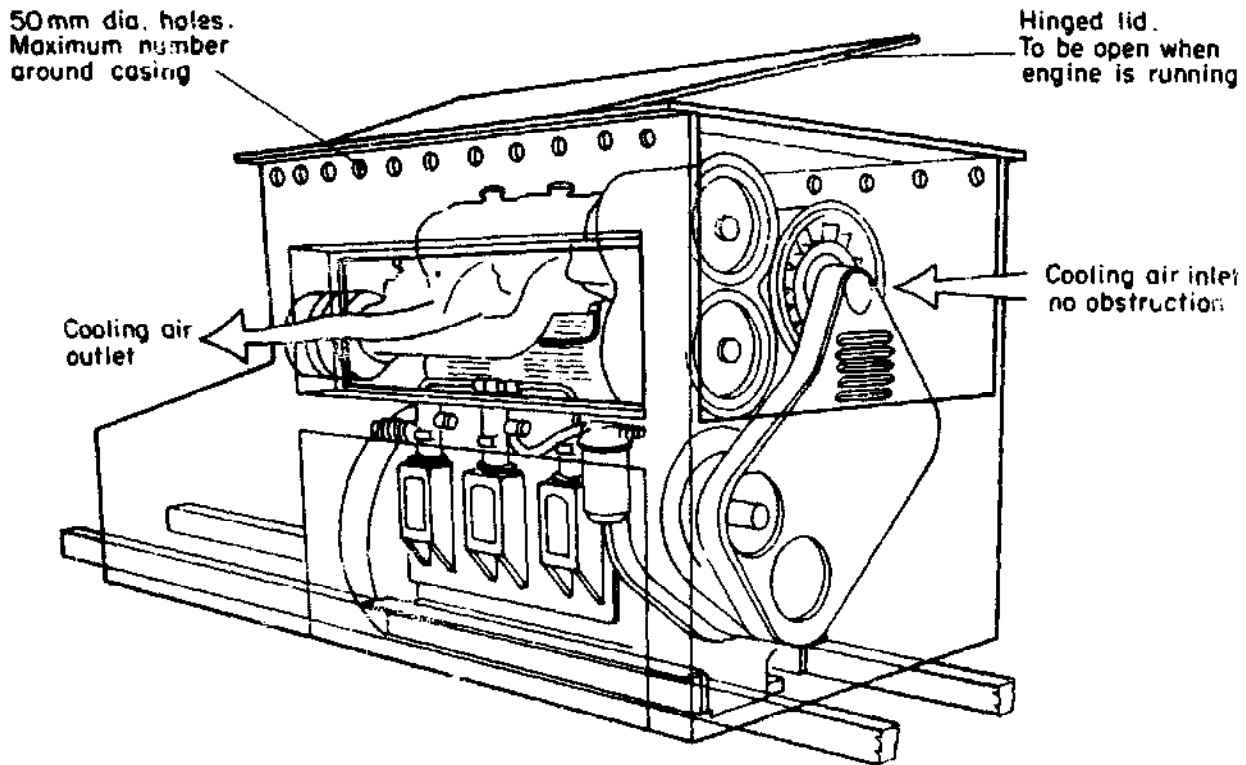

Fig. 65

Typical installations in open boat



ENGINE BOX INSTALLATION



ENGINE BOX INSTALLATION

Fig. 67

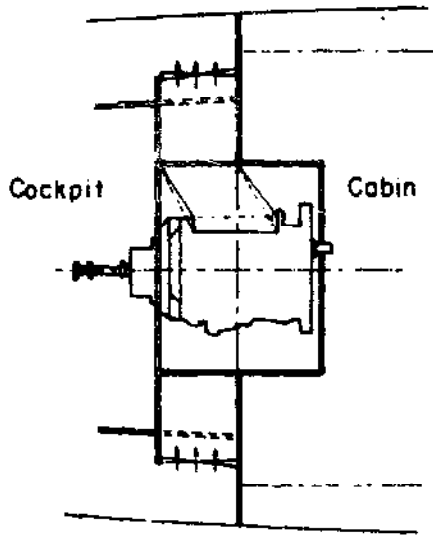

PLAN VIEW

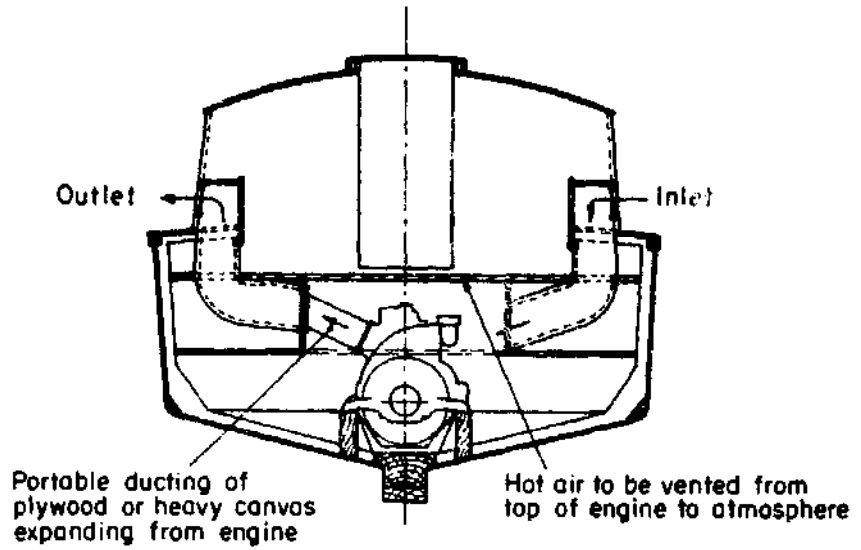

SECTION LOOKING FORWARD

TYPICAL INSTALLATION WITH ENGINE  
BELOW DECK

Fig. 68

SECTION 16Exhaust systems - installation16.1 Installation - general

The important points to note on the installation of exhaust systems are:

- 1) The exhaust system should not produce excessive back pressure. This can be caused by the following:
  - a) too small diameter;
  - b) too sharp bends or angles;
  - c) too long lengths of pipework. If a long system is necessary, increase the diameter of all the pipes;
  - d) too much water in the wet exhaust system. Fit an extra pipe to take some of the water before it enters the system. Do not reduce the water for engine cooling;
  - e) silencer in wrong place, or too small -
    - i) from manifold to silencer should be as short as possible;
    - ii) from silencer to tail pipe must be more than at i) above;
    - iii) volume of silencer too small, should be 3-5 times the swept volume of the engine;
    - iv) silencer diameter compared to exhaust pipe diameter must be as large as possible.
  - f) tail pipe from silencer to outlet too short. As a guide, the length of the tail pipe should be 10 times the diameter of the exhaust pipe (inside measurements).
- 2) Water must not be allowed to enter the system.
  - a) from outside when the engine is stopped;
  - b) from inside, by the engine sucking back water in the pipes when stopping or starting the engine.
- 3) No risk of fire - dry systems particularly.
- 4) Visible water outlet, so that it can be seen that the cooling water is flowing. Failure to stop an engine with no water through a wet exhaust can cause damage to rubber exhaust hoses.
- 5) The use of galvanized iron or mild steel exhaust pipes with diesel engines.
- 6) To fit drain taps on the exhaust system in cold countries, where there is a risk of freezing. Taps should be at the lowest position.

16.2 Wet exhaust system

16.2.1 Water injection system, using water injection bend (for engines mounted above the water line only).



- 1) The water injection bend should be fitted on to the exhaust manifold or as near as possible and should be at the highest point of the system.
- 2) The water injection bend should immediately be connected on to a rubber exhaust hose to allow the engine to move.
- 3) Make sure the water is injected so that it cannot be drawn back into the engine by suction (on stopping or starting).
- 4) The exhaust pipe should slope or fall gradually towards the outlet, with no sharp bends (see Note i) below).
- 5) The outlet for the exhaust should be above the water-line. Flaps of rubber on the outside of the outlet sometimes help to quieten the exhaust noise.
- 6) Galvanized pipe or mild steel is quite satisfactory.

Note: for engines mounted partly below the water-line:

i) This system can be used, but the exhaust pipework must include a swan-neck, i.e. the curve of the exhaust pipe must go above the water-line and fall to the outlet.

ii) If a silencer is fitted, it should be on the outlet side of the swan-neck.

#### 16.2.2 Water trap exhaust system - using mixing chamber.

- 1) Mixing chamber must be mounted well above water-line to allow remaining exhaust pipe to fall or slope gradually down to the outlet.
- 2) Raw water from the cooling system must be connected to mixing chamber at the top.
- 3) The exhaust pipe from the manifold to the mixing chamber must be dry and therefore lagged and flexible.
- 4) The exhaust pipe from the mixing chamber to the outlet can be connected with rubber exhaust hose.

#### 16.2.3 Water lock exhaust system - using water lock chamber.

- 1) Mixing chamber must be mounted as low as possible.
- 2) The mixing chamber must be big enough to hold all the water held in the pipes either side of the chamber when the engine is stopped without being able to suck the water into the engine.
- 3) A pipe to prevent a vacuum (and water entering the engine) must be fitted and looped 300 mm above the water-line.

Note: The water lock system can be quite complicated and advice should be obtained from the manufacturers if this system is to be used.

### 16.3 Dry exhaust system

16.3.1 Lagging - Dry exhaust pipework must be lagged to reduce heat radiating from it. Asbestos tape or cord is normally used, and covering the pipe to a thickness of 12 mm. Plaster of paris, or similar type material, e.g., Polyfilla, can be used to coat the asbestos for protection.

16.3.2 Horizontal exhaust - suitable for all engines, either above or below the water-line.

- 1) The system must include a silencer of the correct size.
- 2) It is necessary for all pipework to be lagged including the silencer, especially where pipes go through a wooden bulkhead.
- 3) A flexible metal section should be used to allow for expansion and vibration.

Note: Rubber exhaust hose cannot be used on a dry exhaust system.

- 4) A drain tap should be fitted at the lowest point of the system to drain off water formed by condensation.
- 5) The exhaust pipe should have a "swan-neck" if engine is below water-line (see Fig.69) to prevent water filling the system from outside.

See Notes i) and ii) below, at the end of 16.3.4<sup>3</sup> "Vertical exhaust".

16.3.3 Vertical exhaust

- 1) The system must include a silencer of the correct size (see Note i)).
- 2) All pipework to be lagged, including the silencer.
- 3) A flexible section should be used to allow expansion and for flexibility.
- 4) A water trap with a drain tap should be provided at the lowest point, to drain off rain-water and condensation.
- 5) A self-opening and closing rain-water flap should be fitted to prevent the weight breaking the exhaust pipework, especially the manifold.

Note:

- i) On both vertical and horizontal exhausts the size of the silencer is important. It should be ordered with the engine, or the dimensions given by the engine manufacturer.
- ii) Some manufacturers supply their own exhaust flexible piping which must not be lagged with asbestos tape. Refer to makers' instructions if in doubt.

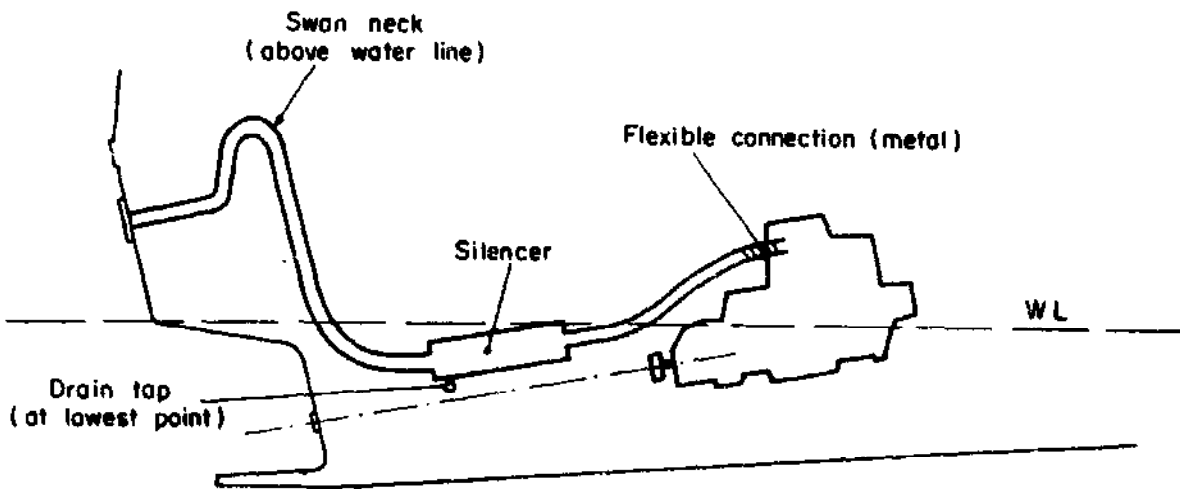

### HORIZONTAL EXHAUST SYSTEM

Fig. 69

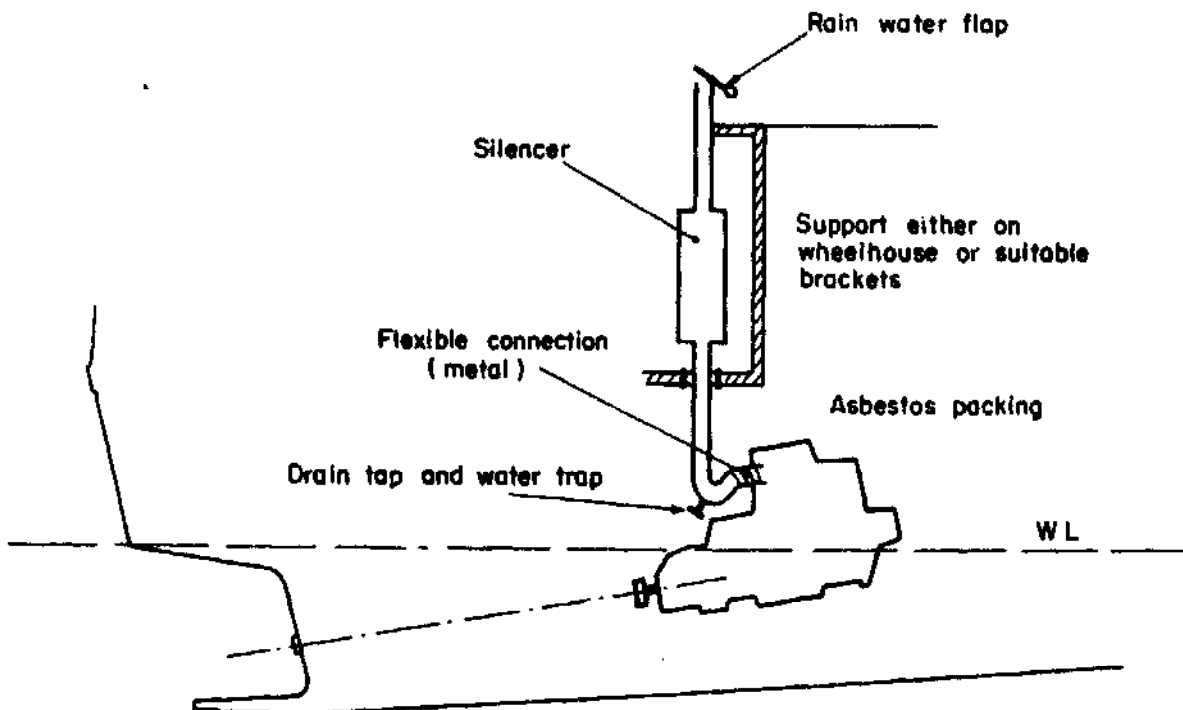

### VERTICAL EXHAUST

Fig. 70

SECTION 17Fuel tanks and fuel systems - installation17.1 Installation - general

- 1) It is important to install the fuel tanks in the correct position for craft stability and also to suit the engine.
- 2) Fuel tanks should be fully painted, externally only, before fitting in place.
- 3) The tanks must be fitted securely, in fittings strong enough to take the weight of the tank when full, with ample strength to stand shocks of rough weather.
- 4) Filling points should be arranged so that any fuel spilled goes "over the side" not into the bilge of the boat.
- 5) Filling pipes should be as short as possible and directly over the tanks, not a long system of pipes with bends, etc.
- 6) Fuel breather or vent pipes should be twice the diameter of the filling pipes.
- 7) Filling pipes and fuel tanks should be "bonded" to the earthing point of the craft - larger boats in particular.
- 8) It must be possible to get at the sludge trap drain.
- 9) A fuel cock or valve must be fitted as close to the tank as possible so that the fuel may be turned off in an emergency or while servicing or replacing parts of the fuel system.
- 10) Tanks must have a dipstick or gauge to show accurately how much fuel is in the tank.

17.2 Primary filter and pipework

- 1) The primary filter (water trap) should be fitted close to the tank but after the fuel valve, and in a position so that it can be cleaned easily.
- 2) Pipework should be of the correct size copper seamless tube and clipped to stop it moving and getting damaged.
- 3) A flexible pipe suitable for diesel fuel should be connected between the clipped copper pipe and the engine. (Some engine manufacturers supply this pipe).
- 4) Many engines need a return pipe to the tank to carry excess fuel from the fuel injection pump and the injector "leak-off". This pipe should be flexibly joined in the same way as the fuel supply pipe - see 3 above.
- 5) Pipes should be kept clear of hot parts of the engine, i.e., exhaust pipes, cylinder head, etc.
- 6) Pay particular attention to preventing leaks by using fittings, copper washers, etc., as recommended or supplied. Diesel fuel will leak out of any loose or poor quality joint.
- 7) Follow any instructions and specifications by the engine manufacturer.

Note: Never use plastic pipe for fuel lines.

## SECTION 18

Electrical - installation system18.1 Battery care

Batteries are very expensive, and can be easily damaged by being badly treated. Below is a list of things which should be done to look after the battery.

- 1) When carrying a battery do not drop it as the case will split.
- 2) Keep battery level. Do not spill the acid, it burns skin and clothes.
- 3) Keep battery charged when not in use. A flat battery will quickly spoil when not being used.
- 4) Keep battery connexions clean and tight, smear with grease or petroleum jelly.
- 5) Replace old worn connexions. Never hammer on connexions.
- 6) Keep electrolyte level correct. Add DISTILLED water only.
- 7) When charging, do not use a high current, the battery will heat up.
- 8) When charging, remove vent/filler caps to allow the gas to escape.
- 9) When discharging do not drain battery quickly, or "flash" a battery across the terminals, plates will spoil.
- 10) Do not use a flame or match near a battery. The gas will explode.

18.2 Battery installation

It is important that the battery is placed as near to the engine as possible, so that the cables from the battery to the starter motor are short. Long battery cables reduce the voltage available for the starter motor, which can cause starting difficulties. The battery must be protected from excess heat or cold, and should be covered to keep it dry. Salt water must be kept away from batteries.

It should also be firmly fixed so that it cannot move in rough weather. This is very important where there are several batteries connected together in a "bank".

There must be plenty of ventilation to the battery box. The gas given off a battery is explosive and the gas must not be allowed to build up in a confined space.

Batteries require frequent attention, topping up with distilled water and looking after the battery connexions, so the battery box must be made to be easily removable.

Batteries are heavy, in a small boat it is important that the batteries are positioned so that the trim and stability of the craft is not affected.

When connecting up batteries make sure the VOLTAGE is correct, particularly when connecting two batteries together.

When connecting the battery to the electrical system, make sure the POLARITY (Positive and negative connexion) is correct.

18.3 Alternators

Extreme care must be used when disconnecting and connecting batteries or carrying out

any servicing on engines fitted with alternators. They are easily damaged. The following check list gives a guide:

- 1) Never disconnect the battery while the engine is running.
- 2) Never "flash" the battery connexions.
- 3) Never connect the batteries the wrong way around, i.e. positive to negative.
- 4) Electric welding on the engine or on a metal boat with the engine in place will damage the alternator unless the alternator and the electrical system is disconnected.
- 5) Some electrical testing equipment will damage the alternator. Never use the type of hand-driven generator tester for testing the electrical system or the alternator.
- 6) Never try to adjust any parts of the electrical charging system without disconnecting the battery.
- 7) Only qualified electricians should adjust or service an electrical system with an alternator.
- 8) NEVER fit fuses in any wiring to the alternator.

#### 18.4 Wiring

It is important that the wiring system is followed carefully as per the makers' instructions. If the engine is supplied with an electrical wiring harness the installation should be straightforward, providing the harness is long enough to reach the proposed position of the instrument panel.

Where a harness is not supplied, care must be taken to select the correct type and thickness of wire to make up the electrical system. Many engine manufacturers supply a drawing, with the size and type of wire specified for each purpose. Stranded copper wire with PVC insulation is recommended

When an electrical wiring system or harness is installed, the following points must be followed:

- 1) All electrical joints should be by soldered terminal connexions, not twisted wire.
- 2) Keep all wires away from bilge water, oil and fuel.
- 3) Wires and cables should be clipped to prevent movement and damage to insulation. Protective conduit (plastic or metal) can be used to carry wires in exposed positions.
- 4) Keep wires away from exhaust pipes and silencers.
- 5) Allow for movement of the engine on wiring.
- 6) The instrument panel on an open boat should be fitted so that water and spray cannot run on to it, preferably in an upright rather than a flat position.
- 7) All lights and fittings should be wired up with 2 wire system. On metal boats the use of a one wire system (with earth return through the metal hull) must NOT be used.

- 8) All components and extra equipment wired into the system must be protected by a fuse in main fuse box.
- 9) An "isolation" switch, disconnecting the batteries from the electrical system, should be fitted.
- 10) Engines fitted with an alternator require very careful installation of the electrical system, as alternators are very easily damaged by incorrect polarity, or disconnection when running. See Section under ALTERNATORS.

#### 18.5 Fuses and fuse boxes

All boat electrical systems e.g., navigation lights, deck lights, echo sounders, etc., must be connected by a fuse or central fuse box. In the event of a fault in the system, the fuse blows instead of more serious damage. Without a fuse in the system, a wire in a harness can overheat and melt the insulation of the wires and others, which can cause a fire or other very serious trouble.

Fuses should be fitted in an easy position for access for changing fuses, and all fuses clearly labelled for each system or item on the circuit.

Note: NEVER use a fuse in wiring to an alternator - (See under 18.3 "Alternators").

TABLE 18.1

## CABLE SIZES AND RATINGS TO LLOYDS REQUIREMENTS

Number and diameter inches of strands comprising the conductor	Nominal cross-sectional area of stranded conductor		MAXIMUM CONTINUOUS RATING (Amperes)						Resistance for 1 foot of Conductor (Ohms)
			Rubber or PVC Insulation		Butyl Insulation		Mineral Insulation		
	inches <sup>2</sup>	mm <sup>2</sup>	1 Core	2 Core	1 Core	2 Core	1 Core	2 Core	
1/.044	0.0015	0.97	9	7	15	12	19	16	0.00547
3/.029	0.002	1.3	11	9	19	16	23	19	0.00428
3/.036	0.003	1.94	14	11	23	19	27	23	0.00275
7/.029	0.0045	2.9	18	16	29	24	34	29	0.00183
7/.036	0.007	4.5	25	21	38	32	44	37	0.00118
7/.044	0.01	6.5	31	26	48	40	56	47	0.00079
7/.052	0.0145	9.3	37	31	60	51	70	59	0.00056
7/.064	0.225	14.5	51	43	78	66	93	79	0.00037
19/.044	0.03	19.4	60	51	93	79	110	93	0.00029
19/.052	0.04	20.6	72	61	115	96	135	115	0.00021
19/.064	0.06	38.7	92	78	145	120	175	150	0.00014



SECTION 19Instruments and controls - installation19.1 Installation - general

- 1) Always make sure instruments are positioned so that the operator/driver can read them easily when using the boat. It is no good having warning lights which come on if something is wrong with the engine if they cannot be seen by the person steering the boat.
- 2) Always place the instruments in a panel which is protected from damage, water spray and strong sunlight. If in an open boat, install the panel nearly vertically and provide some protection for the panel.
- 3) If the instrument panel is supplied with the engine, and is also part of the electrical harness, make sure the wires and cables are long enough to reach the proposed position.
- 4) See also section 18.4 - Wiring.
- 5) An instrument panel will have to be serviced to replace bulbs, faulty gauges, etc. Make sure it can be easy to reach without other equipment in the way.

If instruments are not supplied with the engine, they have to be bought locally (or ordered) and fitted. Make sure that all instruments that are needed for the engine are fitted. Do not leave out vital items. Most engines need:

- i) A tachometer.
- ii) Oil pressure gauge or warning light.
- iii) Water temperature gauge or warning light (water cooled engines only).
- iv) Ammeter or warning light. (Alternators need either ammeter or battery state indicator).
- v) Gearbox oil pressure (Hydraulic/oil operated gearboxes only).

When mounting an instrument panel, it is better to fit rubber between the panel and the boat to absorb vibration. This gives a longer life to the bulbs and instruments.

19.2 Typical instrument panel

When installing temperature gauges and oil pressure gauges of the copper tube (capillary) type, do not bend the pipe too sharply or "kink" it as it will be damaged. The pipe should be coiled at each end to allow for vibration and movement, as shown in Fig. 71.

Tachometer drive cables must be treated carefully also, and tight turns and kinks must be avoided otherwise the inner drive cable will break after a short while.

All cables, pipes and wires must be carefully clipped away from bilge water, oil, fuel, exhaust pipes and moving shafts and chains on steering gear or deck machinery.

Wooden or metal battens fastened to the inside of the frames where all wires and instrument cables and pipes can be clipped are recommended.

TYPICAL  
PIPE COIL

Fig. 71

19.3 Engine controls19.3.1 Engine starting switch

Usually fitted so that it can be operated from the steering position on or close to the instrument panel, and near the throttle.

In open boats, the starter switch is usually fitted on or near the engine box, or inside. It should be protected from water and spray.

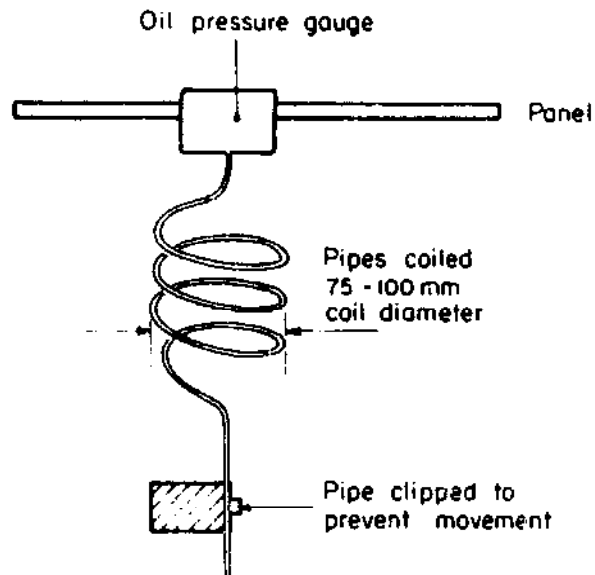
19.3.2 Throttle or engine speed lever

- i) Should be fitted close to the steering position so that the operator can reach it comfortably.
- ii) If fitted on vertical surface, the lever should increase the engine speed when lifted, and slow the engine when lowered. If fitted on horizontal surface, the engine speed should increase when the lever is pushed away from the operator, and decrease when lever is pulled back towards the operator.
- iii) Always install the throttle so that full speed can be reached without the lever striking any bulkhead, etc.
- iv) Make sure full movement of the throttle at the lever end also gives full movement of the fuel pump lever on the engine.
- v) If Morse/Teleflex type throttle units are fitted, there are adjustments which can be made inside the control lever box to match the movement of the lever with the movement needed on the fuel pump. Also it may be necessary to reverse the unit inside the control box so that the movement is in the right direction, e.g., "Pull" for Fast instead of "Push" for Fast (at the fuel pump end). Instructions are usually found inside the packing box of the control box and should be followed carefully.

### 19.3.3 Gearbox control lever

#### a) Mechanical gearbox/clutch - direct

On an open boat installation the clutch lever is fitted directly on to the gearbox and is usually supplied with the engine. Check that the fixing bolts or set screws are tight, and that there is nothing in the way of the movement needed for "ahead to astern".

#### b) Mechanical gearbox/clutch - indirect

Where the engine is fitted away from the steering position it will be necessary to fit a "Drop-arm" to the operating shaft of the clutch, and use a system of rods or tubes to a gear lever fitted close to the operator. The operating rods are usually fitted below the floor level (see Fig. 72).

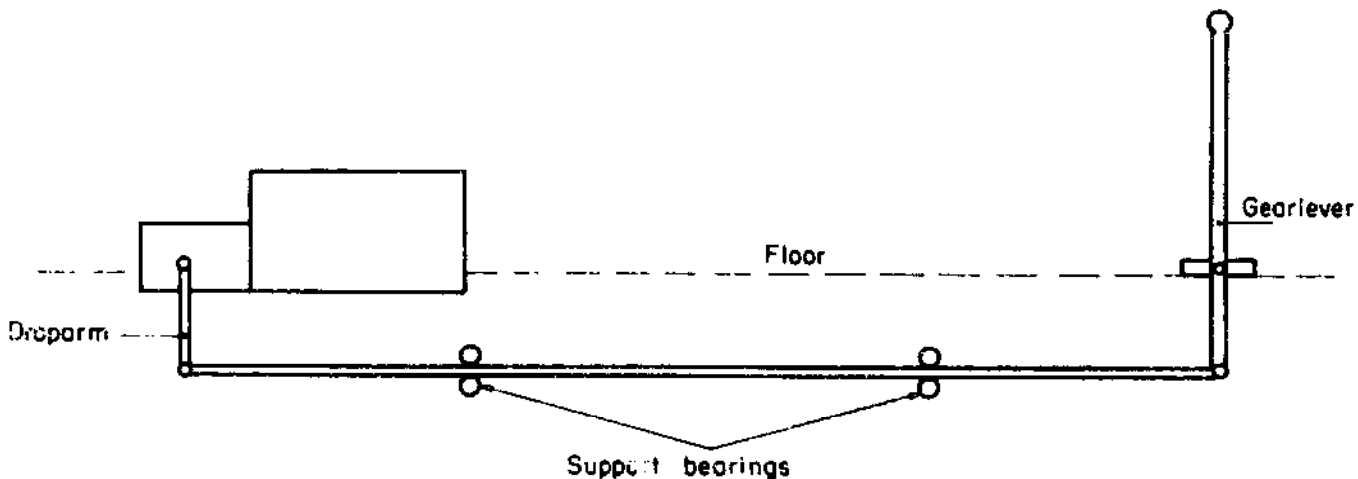

Fig. 72

It is most important that the materials used are strong enough to carry the force required to operate the gearbox. Some mechanical gearboxes are quite difficult to put in and out of ahead and astern, which puts a heavy strain on the operating rods.

In this case, supports or bearings have to be fitted on long lengths of rods or tubes to stop them from bending or deflecting.

Normal steel water pipes of 12 - 25 mm diameter can be used quite successfully for operating rods.

#### c) Oil operated/hydraulic gearboxes - remote control

The equipment needed to operate oil operated gearboxes can be much lighter in construction than for mechanical gearboxes and Morse/Teleflex type cables are often used, either as gear lever only or combined with the throttle to give single lever control of speed and gearbox.

In this case installation details are similar to those of throttle installation as in previous section.

It is most important that the direction and amount of movement of the hydraulic valve lever on the gearbox matches the direction and amount of movement on the operating cable, before they are connected together.

Cables should be installed with very gradual curves without kinks to make sure they work smoothly and for long service life.

Cables for both throttle and gear control have to be ordered or bought in the correct made-up length for the boat, and care when measuring for the order is essential.

#### 19.3.4 Engine stop or fuel cut-off control

- i) Must be fitted so that the operator can reach it easily from the steering position in case of emergency.
- ii) Usually fitted close to the throttle, or on instrument panel.
- iii) The most common remote control method is by "Bowden" cable, a flexible outer tube of wire with a stiff springy steel inner wire, or Morse/Teleflex cable.
- iv) Make sure the amount of movement at the control knob and matches the movement needed on the fuel pump lever to move it to "no fuel position".
- v) Also, when the control is pushed fully in, check the fuel pump lever is free to return to the normal "off" position. A partly closed position will prevent the engine from running at full speed.
- vi) The control is usually marked 'Pull to Stop', for easy identification.

## SECTION 20

### Starting systems - installation

#### 20.1 Hand starting

It is important that the engine can be turned easily, with nothing in the way of the starting handle and that it can be turned fast enough for an easy start.

Some engines can be turned by fitting the handle at either end of the engine, so there is a choice of starting positions.

It is important also to make sure that the decompressor can be easily operated for hand starting, and therefore the design of the engine box must allow for this.

#### 20.2 Electric starting

The battery or batteries should be installed as close to the engine starter motor as possible, and easy to get at for servicing (see note on Batteries, Section 18). The position of the starter switch should be on or near the instrument panel, close to the starting position (see also "Instruments", Section 19).

In an open boat installation, all the electrical fittings should be protected from rain and spray.

#### 20.3 Spring and hydraulic starting motors

The design of the installation and engine box should allow for the operator to have easy access to wind up the motors as the makers recommend.

#### 20.4 Cold starting systems

There is very little to note on cold starting systems on installation as in most cases the parts are included with the engine and engine instruments. It is important to note that the operator has to get to the cold starting devices easily and therefore engine boxes and fittings should allow for this.

The only cold starting aid which requires any installation is the "Thermostart" which needs a small fuel tank to be fitted, either to a bulkhead or fixed engine box. The tank should be fitted as per Fig. 73.

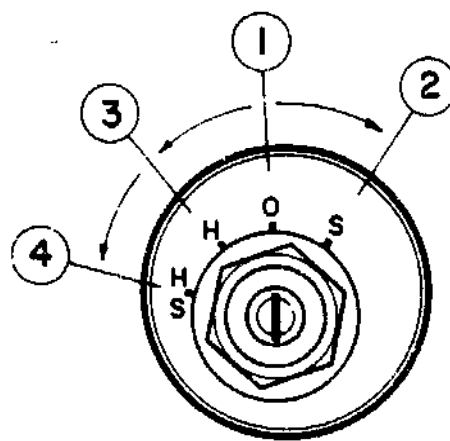
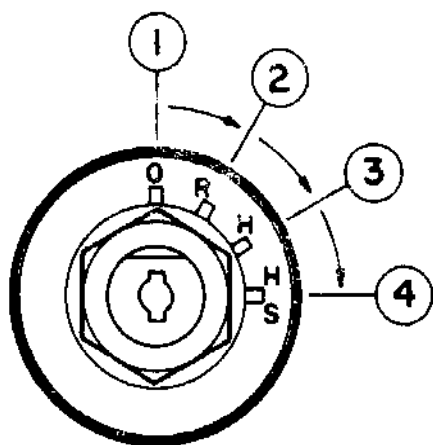
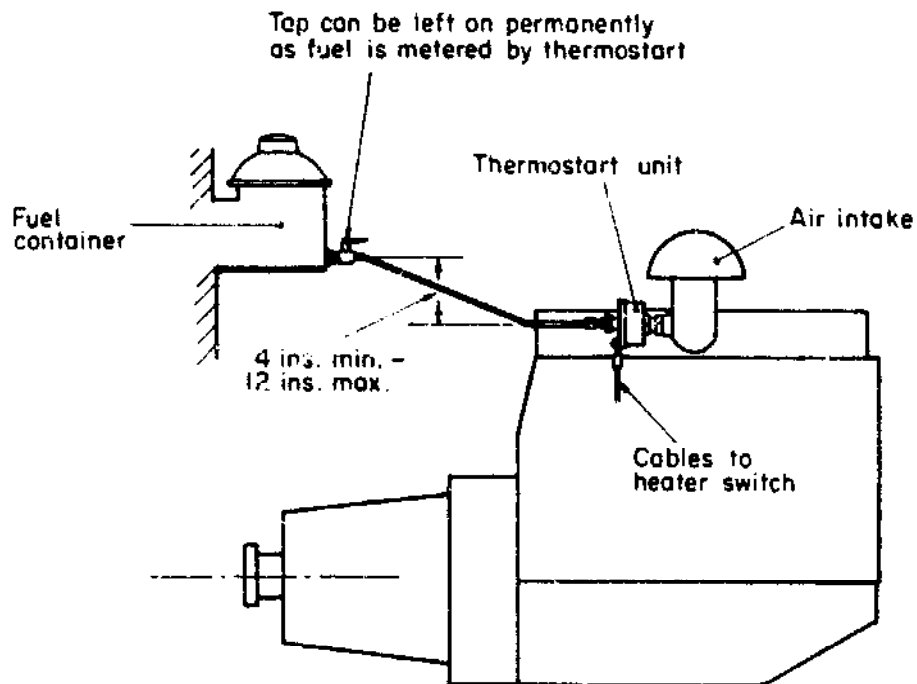

- 1 Off position
- 2 Run position
- 3 Heat position
- 4 Heat and start position

- 1 Off
- 2 Start
- 3 Heat
- 4 Heat and start

**THERMOSTART STARTING ARRANGEMENT**

**Fig. 73**

Sequence of operations to start engine with spring starting motor

- 1) Press reset button.
- 2) Fit winding handle, turn for about twelve revolutions, when fully energised a red indication appears in the inspection window. Remove winding handle.
- 3) Operate the trip lever.

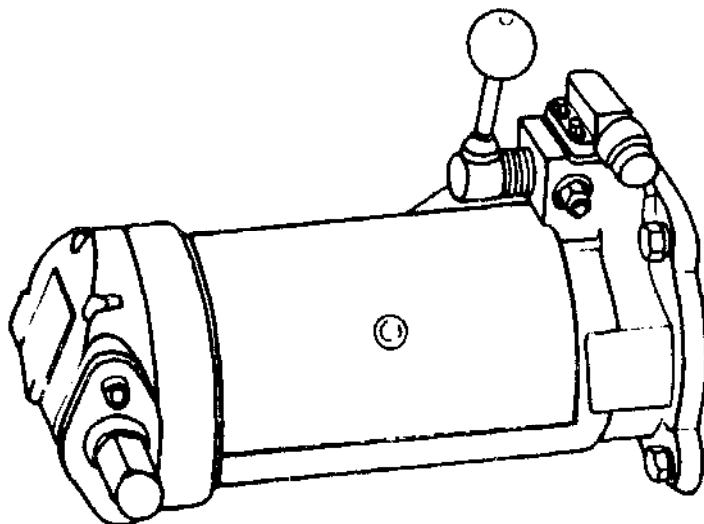

Fig. 74

SPRING STARTER MOTOR

SECTION 21Engine boxes

Most of the information on engine boxes is covered in Section 9, dealing with the planning of engine boxes and in Sections 10 and 22 under Noise.



SECTION 22Noise - installation

In general terms, the engine box should be made of heavy materials, heavier material (e.g. thick plywood) absorbs noise and deadens vibration better than flimsy material, (e.g. thin plywood).

The engine box can be lined with sound deadening material, for example, expanded polystyrene foam, "porolan" (a foam matting), "vermiculate" (a heat insulating material) and others specifically designed for noise insulation.

Care must be taken when insulating an engine to make sure the material cannot absorb FUEL. This could make a very dangerous situation where thick foam or polystyrene could become soaked in fuel, which could then lead to a serious FIRE risk.

The edges of the engine boxes must be sealed to prevent fuel being soaked up in this way. Similarly, water should not be allowed to soak into the sound insulating materials, as this could cause rot to the engine box.

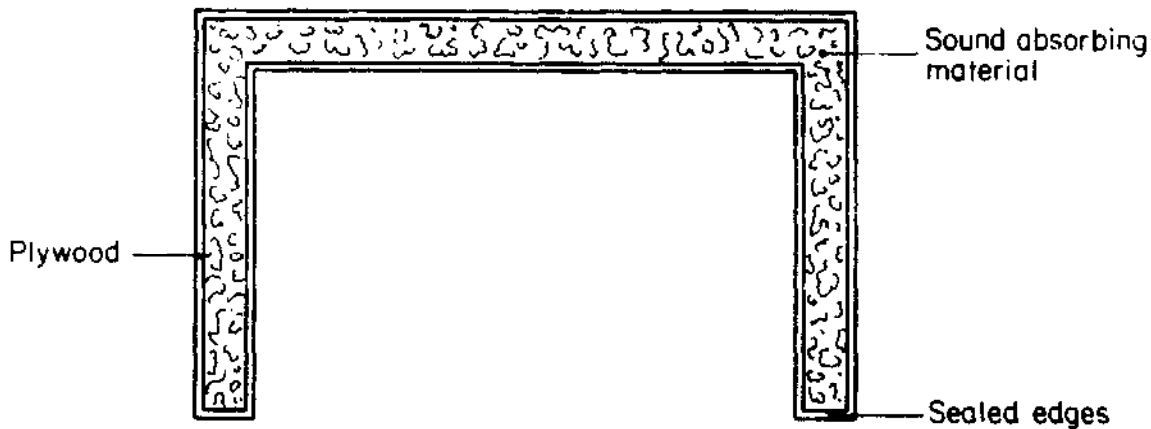

TYPICAL ENGINE BOX

Fig. 75

Fig. 76 covers some of the points mentioned.

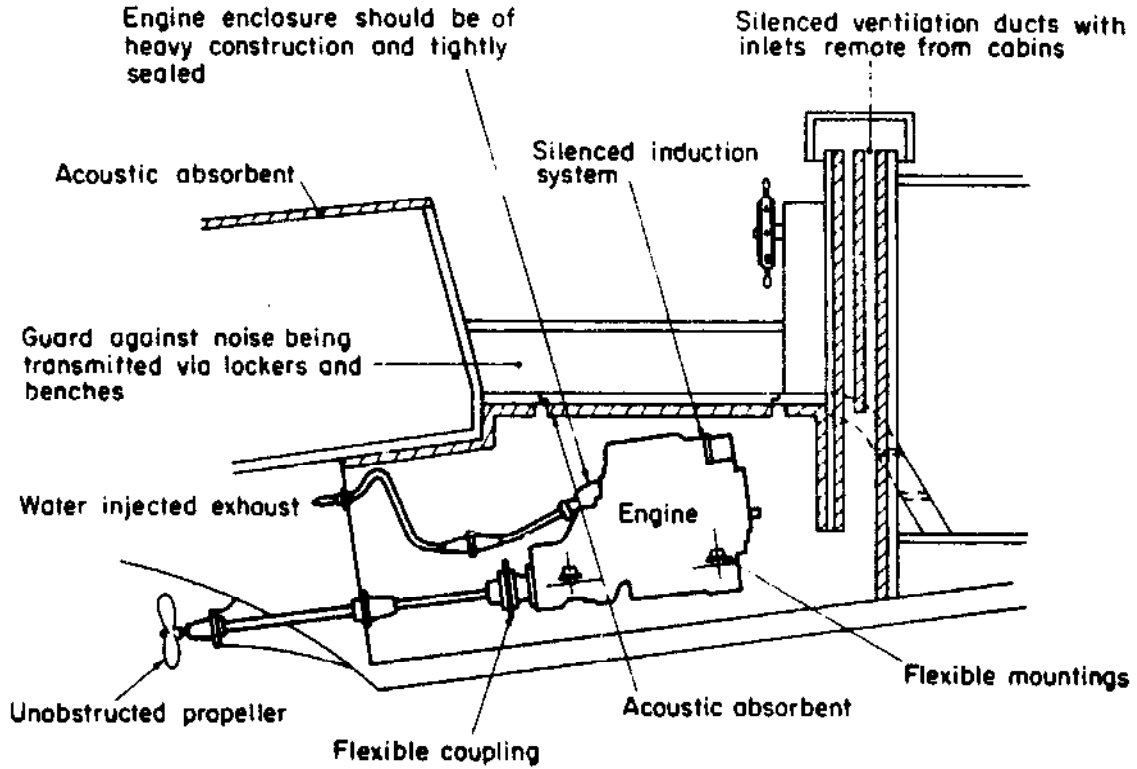

**A "QUIET" MARINE INSTALLATION**

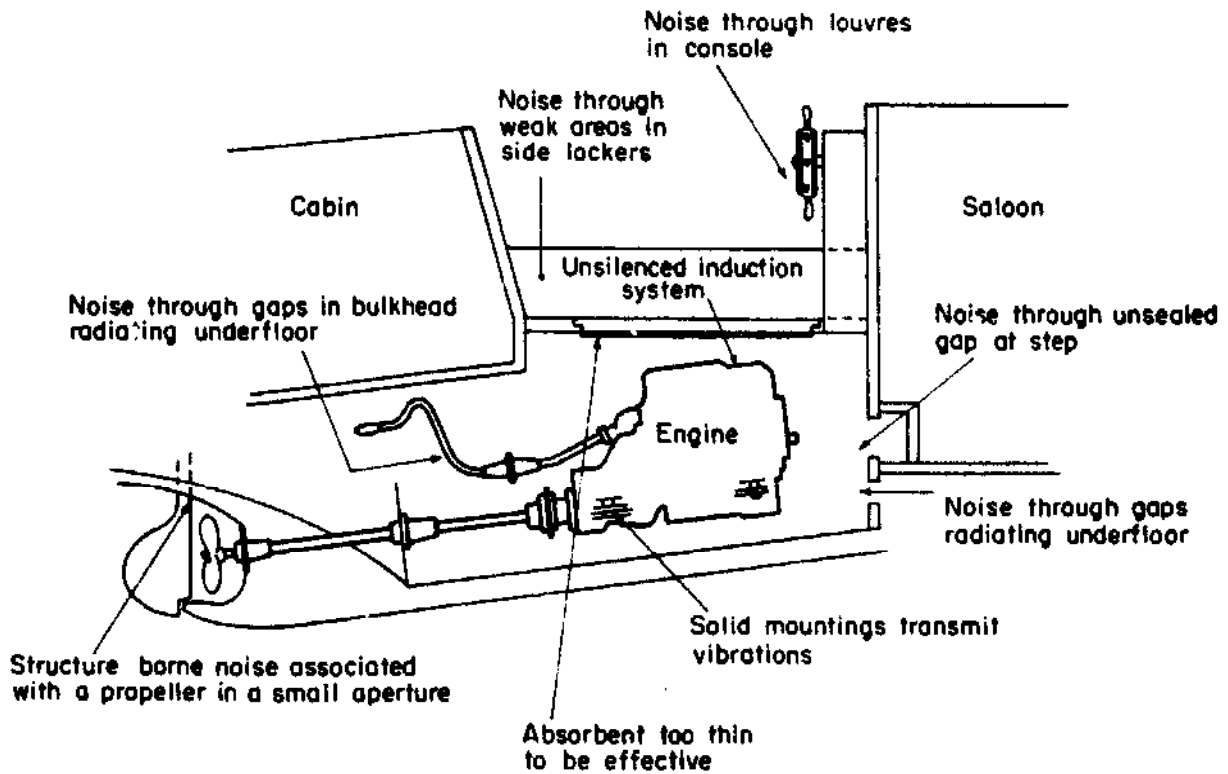

**WEAKNESSES IN A POTENTIALLY NOISY INSTALLATION**

Fig. 76

SECTION 23Bilge pumps and bilge systems - installation

It is most important that any water in the boat can drain back to the lowest point in the compartment, and the bilge pump can draw the water from there.

In the case of a boat with more than one watertight compartment, each compartment must have its own pick-up point for the bilge pump.

Limber holes should be drilled in all cross frames to allow the water to flow from one pocket to another, but not through watertight compartments. Limber holes should be at least 1" in diameter to prevent them being blocked by shavings, bits of wood, etc. and these should be checked and cleared out frequently.

23.1 Hand pumps

- 1) A hand pump should be fitted securely by bolts, not screws, through a strong frame member or gunwale of the boat, and where the pump can be operated easily and quickly.
- 2) The suction hose to the collection strainer should be of thick material which will not collapse when the pump is being used.
- 3) The strainer should be fitted so that it can draw water with the least air, so the holes through the strainer should be mostly at the bottom of the filter.
- 4) The diameter of the holes should be about 3 mm and sufficient to allow full capacity of the pump.
- 5) The filter should be fitted in a place which is easy to get at for cleaning.
- 6) The discharge of the pump should be fairly low down on the hull to prevent the water being pumped out being blown back into the boat. A flap or shield can be fitted to help this.

23.2 Electric pumps

The installation of electric pumps must be as the manufacturers recommend, as they all vary. General points to note are as follows:

- 1) The pump filter must be easily reached for cleaning.
- 2) Wiring to the pump must be fitted so that it cannot be damaged.
- 3) The switch for the pump must be fitted where it can be seen easily, and clearly labelled so that it cannot be left switched on. An indicator light which lights up when the pump is on, is recommended, if not part of the fitting kit.
- 4) Suction hose (if fitted) and discharge pipes should be installed as per "Hand pumps".

Note: if in doubt, ask the manufacturer, and follow their directions and recommendations on fitting and use.

23.3 Engine driven pumps

Most modern pumps are of the "Jawasco" neoprene/plastic impeller type of various sizes and capacities.

There is usually a clutch fitted to engage and disengage the pump, the clutch may either be an internal part of the pump, or a separate clutch unit outside the pump.

The pump may be driven directly by being bolted up to the engine as a specially designed unit, or driven by Vee-belt(s) and mounted as an auxiliary unit.

When installing an engine driven pump, especially the type driven by Vee-belts, the following should be noted:

- 1) There must be provision (an allowance) made for the belts to be adjusted to take up wear, and for the fitting and removal of new belts.
- 2) Vee-belt driven pumps must have a guard over the belt to stop accidents by getting fingers or clothing trapped.
- 3) The suction hose and filter must be fitted as per "Hand pumps".
- 4) The discharge pipe should be fitted low down on the hull to prevent spray.
- 5) The clutch lever should be easy to operate and clearly marked IN and OUT (of gear).
- 6) Neoprene/plastic impellers must not be allowed to run dry for long. If possible, a clear plastic pipe on the discharge of the pump will let the operator see when the water has stopped flowing and the pump can therefore be stopped at the right time.

#### 23.4 Bilge systems

When a boat has more than one watertight compartment, there is usually a bilge system, to allow for water to be pumped from each compartment by the bilge pump.

In most cases the bilge suction pipe is connected to a manifold, fitted with valves which may be opened and closed one at a time to pump out each compartment (see Fig. 77).

There is one discharge pipe in the normal way. It is most important that:

- 1) The manifold is fitted in such a way that the valves can be opened and closed easily.
- 2) Each valve must be marked to show which compartment it is controlling, e.g. engine room, crew's compartment, steering compartment, etc.
- 3) The strainers should be fitted so that they can be cleaned easily.

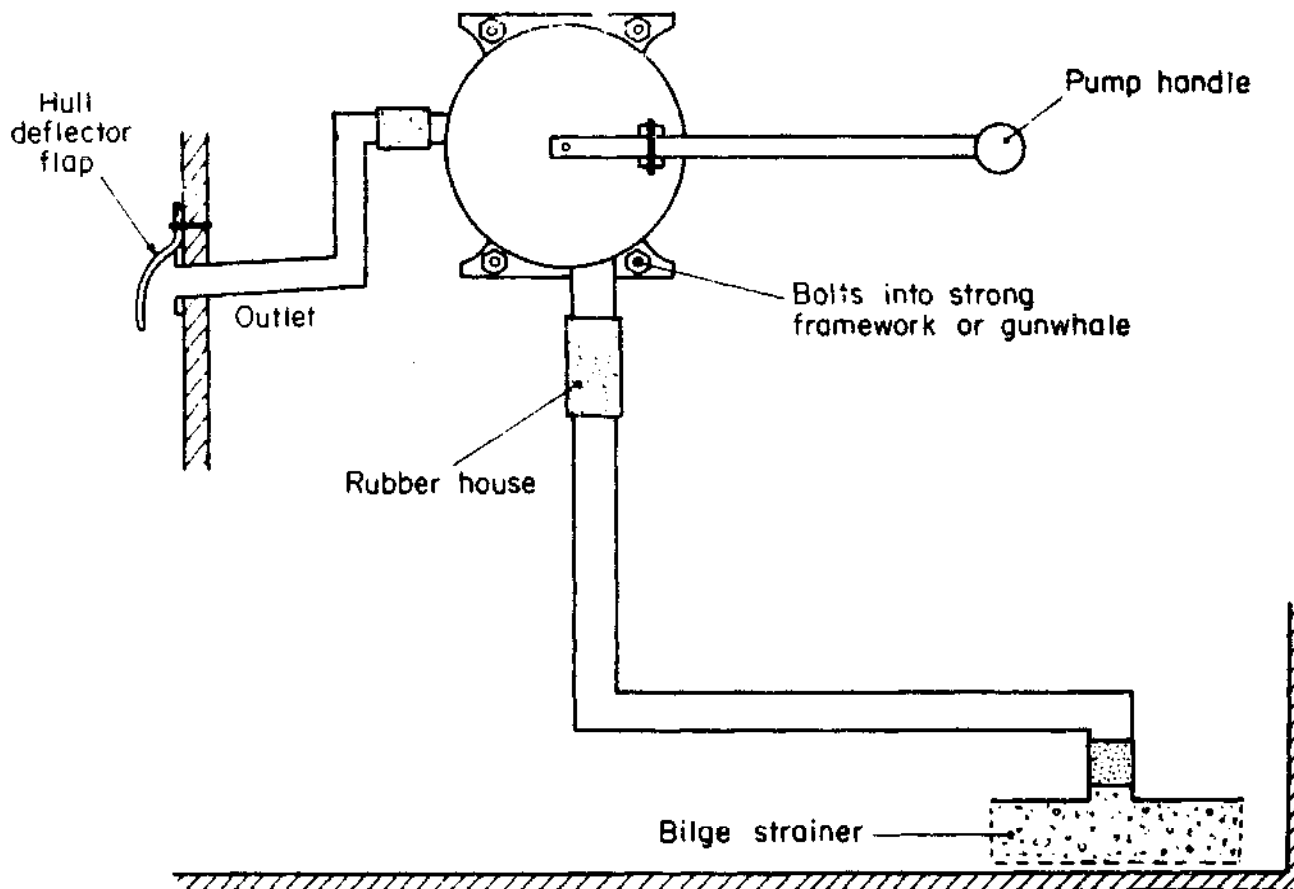

HAND PUMP LAYOUT

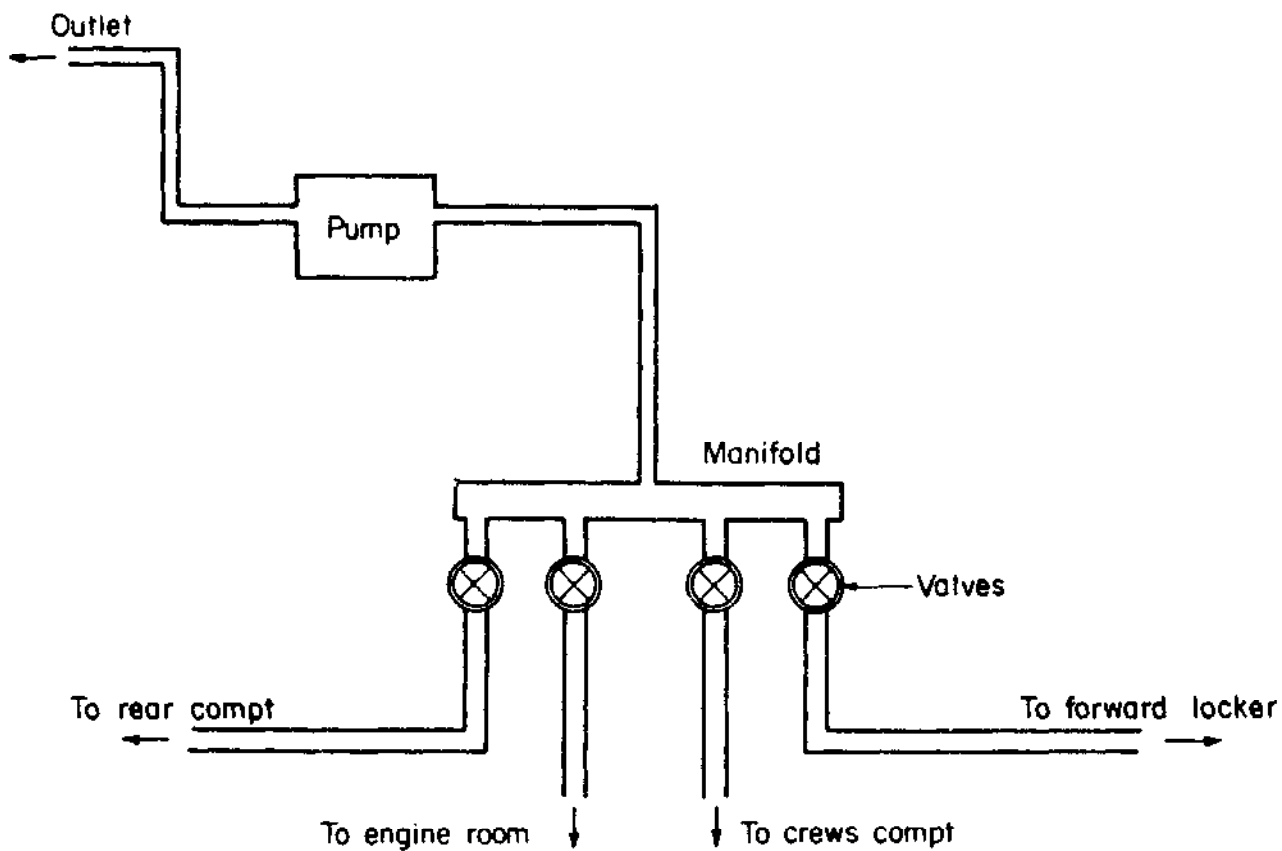

TYPICAL BILGE SYSTEM

Fig. 77

SECTION 24Power take-off - installation

The installation of a power take-off unit has to be done according to the maker's instructions and as per the engine manufacturer's recommendations.

Power may be taken off by either a direct driven unit bolted on or up to the engine, or by a belt driven unit, usually to the side of the engine.

24.1 Bolt on unit

This is quite easy to install as it is tailor-made to suit the engine and fitted on to a ready made mounting or flange. Fitting instructions are usually with the unit.

24.2 Bolt up to units

Usually fitted in front of the engine in line with and driven by the crankshaft, by direct coupling.

The most important points to note are:

- 1) If the unit is actually bolted to the boat and not the engine, it has to be aligned with the engine. This means that if the engine has to be re-aligned, there must be provision made to adjust the power take-off unit to suit the new alignment.
- 2) If the engine is flexibly mounted, the unit must be able to move with it. Care must be taken that the drive coupling will operate under those conditions, and that it can tolerate movement.
- 3) Make sure the clutch lever, if fitted, has enough room to be moved fully in and out of gear, and is easy to reach by the operator.
- 4) Any belts driven by the power take-off must be adjustable to take up wear. Belts must be able to be replaced when worn.
- 5) All belts must be guarded to prevent accidents to crew.
- 6) Shafting driven by the power take-off must be installed so that belts are in line with the power take-off, otherwise belts will wear quickly or throw off.

Note: always follow the engine maker's instructions about how much power can be taken by the power take-off. Always follow the power take-off maker's instructions on installation.

PART THREESECTION 25Engine selection25.1 General

It is important that the engine selected should match the hull. It is no good installing an engine which cannot do the job that the boat was designed for, because it is too small, or too heavy or inefficient.

The selection of an engine and propeller to match the hull is a complicated process and beyond the scope of this publication. In most cases, an engine and relative propeller, shafting, gearbox, etc. will have been calculated very carefully by the architect and matched to suit the vessel, and the job it will be doing, e.g. trawling.

The following list shows the points which have to be considered and matched to the engine and installation required:

- 1) Engine horse power.  
Engine rpm.  
Engine weight.  
Engine dimensions.
- 2) Direction of rotation of engine.  
Direction of rotation of gearbox.  
Direction of rotation of reduction gearbox (if fitted).  
Type of gearbox (manual or oil operated).  
Type of reduction gearbox (ratios).

Other considerations:

- 3) Position of engine in boat (open boat or engine compartment).  
Solid or flexible mounting of engine.  
Air or water cooled; type of water cooled system.  
Starting system required.  
Special electrics required.  
Power take-off required.
- 4) Shaft speed.  
Shaft diameter.  
Shaft material (i.e. brass, monel, etc.)  
Shaft length.
- 5) Number of shaft bearings.  
Type of stern gear (shaft log or stern tube).  
Type of coupling (flexible or solid).
- 6) Propeller diameter.  
Propeller pitch.  
Number of propeller blades.  
Size of propeller shaft it is to fit.  
Propeller locking method (nut, cone, etc.)

25.2 Make of engine

The make of the engine to be selected has also to be considered at an early stage, based on the factors in 1) and 2) in the previous paragraph 25.1.

When it is known that the engine to be chosen has to be of a certain horse power and type, the manufacturers who produce such an engine can be "short-listed".

It may be found that there are several manufacturers who produce similar size and types of engines within the required specification.

The choice may then be determined by one or more of the following:

1) Existing agents

If there is an existing agent for an engine manufacturer, offering a spares and service network with a good reputation, it is often wise to consider that make of engine.

The existing agent may carry engine parts and have contact with the manufacturer, though not necessarily on marine engines. Engines used in other fields, e.g. agricultural tractors, road vehicles, bulldozers, dumpers, lighting generators, or water pumps, etc., often use many spare parts found in their marine engines. They may also have mechanics who are used to working on such equipment, although not on marine engines.

2) Reputation

Where two or more engine manufacturers' products are known in an area, it is a question of finding out which make has the best reputation for:

- long engine life;
- low running costs;
- good performance;
- good spare-parts availability and service through the agents.

3) Price and delivery

Very often price is one of the main factors in choosing an engine, e.g., when a boat has to be built and equipped to a known budget.

Foreign exchange controls between certain countries, or the value of one country's money compared to another can also affect the price, depending on the country where the engine is manufactured.

Delivery is of major importance; engines produced in distant countries may take many months even years to arrive at the boatyard concerned, whereas often preference is given to a manufacturer who can deliver an engine in a relatively short time.

4) Spare parts/service costs

Wherever possible, where there is a choice of engines by different manufacturers, look very carefully at the comparative costs of spares, servicing, and the amount of servicing required, i.e., the frequency between servicing and overhaul (see 2) above).

Also some spares are available through allied engineering agents, and may be cheaper than through the main agents, although be cautious about fitting "non-approved" spare-parts.

25.3 Type of engine - long term costs

In smaller boats, the choice between one engine and another may be considered on their respective types of designs.



For example, it may be found that two 30 horse power engines may be of such different design that the choice is between a slow/medium speed engine of simple, robust construction, and a high speed marinized vehicle engine needing a complex installation and more frequent service and spare parts.

Although the initial difference in costs of the two types of engines concerned may be quite close, the advantages for a slow/medium engine could well be much greater when considering the long-term costs.

Therefore when selecting an engine, consider the short-term or initial costs, and the expected long-term costs over the life span of the engine.

SECTION 26Ordering equipment and spares26.1 General guidance

Ordering equipment, particularly all the machinery and parts necessary to install an engine in a boat requires a great deal of planning and thought. As will have been seen in Section 25 on "Engine Selection" there are a great many variations on engine selection alone.

The following points may help when faced with the task of ordering equipment when none or very little is available locally:

- 1) Always order as much from the engine manufacturer (or agent) as the factory offer with, or as "optional extras", to the engine. It is better to order such extra equipment with the engine, not as a separate order.
- 2) Always send as much information about the boat as possible and the work it will be doing.
- 3) A scale drawing or builders' plans of the craft are necessary if any advice is required on engine selection, suitability, components, etc.
- 4) Most engine manufacturers have an advisory service with staff very well qualified to offer any advice or assistance in the choice of engine, gearbox, shafting, propeller or auxiliary equipment.
- 5) When in doubt, ASK THE MANUFACTURER of the engine in question.

26.2 Example

Having decided upon a make of engine, model or type, horse power, etc. as per the previous text, and the various options on gearbox, reduction gears, cooling system, etc., the order to the factory has to be written out.

A suggested method is in the following example for a small boat installation:

Engine	
Make	- quote name of firm;
Model and hp	- quote model number from sales particulars and pamphlets;
Gearbox	- manual, ahead and astern;
Reduction gear	- not required;
Cooling system	- air cooled;
Starting system	- raised hand start, handle at "forward end" of engine;
Controls	- remote throttle and stop control units complete;
Exhaust	- vertical, dry exhaust. Supply standard silencer, plus 1 metre threaded pipe and fittings.

## Extras required:

- 1) Gearbox drop arm (for remote control) port side fitting.
- 2) Forward gear lever unit - floor mounted.
- 3) Tachometer and oil pressure gauges - cable and pipework, 5 m length.
- 4) Remote control cable - 5 m length.
- 5) Bilge pump unit, complete with strainer and 2 m suction hose, 3 m outlet hose, driving pulleys and 6 driving belts B.42 inch (107 cm) section or nearest.

6) Extra range fuel tank, approximately 200 litres required (see drawing attached).

Shaft sterngear propeller

Shaft material - Monel  
 Shaft diameter - 25 mm  
 Shaft length - 2.0 m  
 Stern tube length - 1.5 m  
 Propeller diameter - 260 mm  
 Propeller pitch - 210 mm  
 No. of blades - 3  
 Rotation - Left hand

Accessories - Please supply:

- 1) Sealed stern tube with gland packing at both ends - operating in silty water.
- 2) Propeller locking spinner nut.
- 3)  $\frac{1}{2}$  coupling bored to suit 25 mm shaft - not pilot bored.

Special instructions

- 1) Please quote delivery at the earliest, per air-freight, f.o.b. to ..... airport. Advise by cable.
- 2) Plans of the boat to be fitted are attached for your information.
- 3) Method of payment by International Bankers Order, payable in dollars (\$ US) on confirmation of acceptable delivery dates.
- 4) A spare-parts order will follow for the engine. Expected annual working = 2,000 hours.

### 26.3 Spare-parts

When an order for an engine is placed with a manufacturer, it is good practice and regarded as necessary, to order a quantity of spare-parts, any special service tools, instruction books and workshop manuals so that the engine can be looked after properly.

Many engines are left lying idle because of the simple mistake of not ordering spares, or the correct spares with an engine, or the service tools to fit them.

Most manufacturers work on the basis of 10% of the value of the engine should be taken up in spare-parts - in other words a \$5,000 engine should have \$500 of spares ordered with it. Whereas this is a guide, it should not be taken as a rule, but a more careful study of the engine and its spare-parts requirement should be made.

Some engine models have potential weak points, whilst others never use certain spare-parts that would be expected to be used. This is the difficulty in assessing which parts an engine is going to need.

Also it is unnecessary to buy spare-parts from overseas if they are already available in the country, perhaps on another machine, e.g., fuel and oil filters may be found on tractor engines used in the country, with a good supply in the local agent's stores.

The spare-parts order can be divided into three sections:

1) Fast moving spares

These include all items which the makers recommend to be fitted or changed on set servicing periods, e.g., oil filter elements every 250 hours, fuel filter element every 1,000 hours, gasket, injector nozzles, etc.

2) Slow moving spares

Spare-parts needed on major overhauls. These include crankshaft bearings, pistons, cylinder liners, cylinder head (certain models), etc.

3) Spares to replace breakages/damage

The most difficult to assess, as breakages and damage cannot be easily estimated, and depend on local conditions and usage. On boats operating in difficult conditions, e.g., man-made lakes with underwater obstructions, damage to stern-gear, propellers, etc., is likely.

Engines operated or serviced by inexperienced personnel will get damaged through misuse, by neglecting to do basic daily running checks, by incorrect adjustment or dismantling of parts.

Most manufacturers can reasonably estimate the spare-parts consumption of their engines knowing the annual hours expected running time, but only in Fast and Slow moving spares sections. A supervisor, or workshop manager may have some idea of the local conditions where the boat is operating and the extent of the training of operators and mechanics working with the engine, and this experience should be sought.

The following example shows how to find out where there are possible weak points on the engine, so that a spare-parts order can include those parts which may be expected to get broken. The engine is divided into its various sections, and by experience and with local knowledge, the most likely breakages can be listed.

Possible weak points where damage may occur1) Lubrication system

Filter body, external oil pipes, oil pressure gauge.

2) Fuel system

Fuel injectors, injector pipes, fuel lift pump body, fuel sediment bowl (especially glass), governor linkage and springs. Fuel feed pipes, especially unions. Fuel leak-off pipes, flexible pipes.

3) Valve gear

Valve covers (especially cast aluminium), valve cover gaskets, tappet adjusting screws.

4) Clutch/gearbox (Mechanical)

Astern brake band (where fitted), often broken by over adjustment and misuse. Rear drive bearings and oil seals, when engine misaligned.

5) Electrical systems

Most parts can be removed and repaired locally by electrical repair agents, e.g. car garages. The most difficult are alternator, voltage regulators and control boxes, which can be stocked as replacement parts.

6) Instruments

Instruments mounted in open boats and exposed to rain and spray will need replacement more frequently. Gauges (non-electric) e.g., oil pressure and temperature are often broken by vibration and misuse.

7) Cooling system

Neoprene/plastic impellers on "Jabsco" pumps, thermostats, water pump diaphragm (on certain engines only).

8) Propeller shaft and drive

Propeller shafts can be damaged by running out of line. Propeller shaft bearings also damaged by misalignment.

Propellers (hitting underwater objects). In silty conditions, shafts and shaft bearings more prone to wear.

9) Auxiliary equipment

Controls - morse/teleflex systems, damaged by incorrect installation or "heavy-handed" operator.

10) Difficult operating conditionsExtreme cold

Engines running in very cold countries need careful attention to prevent freezing up. Parts liable to damage by freezing should be stocked, e.g. core plugs, cylinder head, thermostat housing, etc.

11) General

It is a good idea to stock various studs, set screws, nuts and bolts of the type used on the engine, i.e., unified, metric, etc.

Commonly damaged are injector studs, cylinder head studs, generator or alternator belt adjusting bolts, rocker cover set screws, gearbox/clutch cover bolts, etc.

Generally the most prone to damage are the nuts and bolts which have to be undone most frequently to carry out regular servicing of the engine.

The use of a torque spanner will prevent a great deal of this kind of misuse and should be stocked, see Special Tools.

26.4 Instruction books, service manuals, spare-parts lists

Engine manufacturers usually include an operator's instruction book with each engine sold, which should be available to the operator or owner of the boat in which the engine is fitted.

It is good practice to order extra instruction books which can be used to instruct those using the engine. Depending upon the ownership of the boat and the organisation in which it operates (if any), it may be necessary for the handbook to be kept in the base, or harbour office for safety and reference.

In the case of the owner employing an operator, it is most important that the operator has sufficient knowledge to use and maintain the engine correctly. Where this is not the case, the operator should be given a course of instruction, either by a qualified mechanic

or someone with practical experience of the engine and boats.

The service manual is available from the manufacturers and should be ordered with the engine, together with a spare-parts manual/catalogue. These books should not be kept on board small boats, but again in a place of safety for easy reference.

The service manual is usually written giving a step-by-step description of the way in which the engine can be dismantled and reassembled. It may be included in the operator's instruction book, or as a separate book. Many manufacturers of small engines produce a combined book, giving engine installation details, operating instructions, full service instructions and spare-parts lists.

Note: always take a note of the engine model and serial number, usually stamped on a plate on the engine. This number should always be quoted when ordering parts for an engine from the agent or the manufacturer.

#### 26.5 Service tools

Service tools or special tools are sold by the manufacturers of the engine or their agents.

Some engines need several special service tools in order to carry out overhauls and repairs, and without these tools it is usually impossible to do the job, or damage to the engine results by trying to do it without the tools.

It is a good idea to find out from the manufacturers exactly which tools are considered necessary and order them at an early stage, either with the engine or shortly afterwards.

Very often a list of service tools required for an engine is given in the service manual, as per example in Table 26.1

Note: do not attempt to carry out an overhaul of an engine or component part without the correct service tools.

#### 26.6 Torque spanner

Most engine repair stations or workshops should carry at least one torque spanner, preferably more.

A torque spanner is essential so that the engine is correctly assembled and adjusted, without breaking off or stripping the threads on bolts, studs and nuts.

Torque settings for various sized nuts and bolts are often given in the instruction book or service manual, and these should always be used correctly. Examples are given in Tables 26.2 and 26.3

Table 26.1Approved Service Tools

PD1C Valve Guide Remover and Replacer Engine type: all With this tool all valve guides can be removed and replaced, provided puller bars are available.	PD 155B Small Adjustable Puller Engine type: all Can be used with suitable adaptors to remove water pump pulley, oil pump drive gears and camshaft gear.
PD 1C-1 Puller Bars Engine type: all Two bars are supplied for use with PD 1C to suit 5/16 in and 3/8 in i/d valve guide bores.	PD 155B-1 Small Adjustable Puller Adaptors Engine type: P3 144 3.152 4.192 4.203 Removes water pump pulley only on 6.305 L4 4.270 4.99 4.107 4.108. Removes water pump pulley and camshaft gear on 6.354 4.154 4.212 4.236 4.248.
PD 1C-2 Valve Guide Replacing Stop Engine type: 4.99 4.107 4.108 When the valve guide is replaced using one of these stops it will ensure that the guide protrudes the correct amount above the top face of the cylinder head.	PD 155B-2 Small Adjustable Puller Adaptors Engine type: P3 P4 P6 To remove low position water pump pulley.
PD 1C-4 Valve Guide Replacing Stop Engine type: P3 P3.144 3.152 4.192 4.203 P4 P6 6.288 6.305 Remarks: See PD 1C-2.	PD 155B-4 Small Adjustable Puller Adaptors Engine type: P3.144 3.152 4.192 4.203 Removal of oil pump gear
PD 1C-5 Valve Guide Replacing Stop Engine type: V8.510 Remarks: see PD 1C-2.	4RL Tension Wrench Engine type: all 3/4 in square drive 150-400 lbf ft.
PD 1C-6 Valve Guide Replacing Stop Engine type: 6.354 Remarks: See PD1C-2.	No.13 Tension Wrench Engine type: all 1/2 in square drive 50-170 lbf ft.
PD 1C-7 Valve Guide Replacing Stop Engine type: 4.154 Remarks: See PD 1C-2.	PD150 Cylinder Liner Remover and Replacer Engine type: 6.354 4.212 4.236 4.248 3.152 D3.152 4.203 D4.203 6.305
38 U3 Piston Assembly Ring Engine type: all This is an expandable piston assembly ring for Std. and oversize pistons.	PD150-1A Adaptors for PD 150 Engine type: 3.152 D3.152 4.203 4.212 4.236 6.305 6.354
PD 41B Piston Height and Valve Depth Gauge Engine type: all For checking piston heights and valve depths.	PD150-5 Adaptors for PD 150 Engine type: 4.107 4.108
	PD150-6 Adaptors for PD 150 Engine type: V8.510 The replacer pad to be used with PD150-8 when crankshaft is in position.
	PD150-7 Adaptors for PD150 Engine type 4.248.

Note: Engine types refer to Perkins Marine Engines.

Table 26.2

Recommended Torque Tensions

The following torque figures will apply with the components lightly oiled before assembly:

Component	Screw Size		
	U.N.F.	lbf ft	kgf m
Cylinder Head Nuts (or setscrews - 6.354.2 engine)	$\frac{1}{2}$ in	85	11.7
Cylinder Head Nuts	$\frac{7}{16}$ in	60	8.3
Big End Nuts (Cadmium Plated)	$\frac{1}{2}$ in	70	9.7
Big End Nuts (Plain)	$\frac{1}{2}$ in	90	12.4
Main Bearing Setscrews	$\frac{5}{8}$ in	150	20.7
Idler Gear Hub Nuts (early)	$\frac{7}{16}$ in	50	6.9
Idler Gear Hub Nuts (current)	$\frac{1}{2}$ in	65	9.0
Idler Gear Hub Nuts (heavy duty)	$\frac{3}{8}$ in	24	3.3
Scrap to Cylinder Block Setscrews	$\frac{5}{16}$ in	12	1.7
Flywheel Setscrews	$\frac{1}{2}$ in	80	11.1
Camshaft Gear Retaining Setscrew	$\frac{1}{2}$ in	50	6.9
Crankshaft Pulley Setscrew (with $\frac{3}{8}$ in washer)	$\frac{7}{8}$ in	300	41.5
Crankshaft Pulley Setscrew (with $\frac{1}{4}$ in washer)	$\frac{7}{8}$ in	250	34.5
Crankshaft Damper Setscrews	$\frac{5}{16}$ in	19	2.6
Atomiser Securing Nuts	$\frac{5}{16}$ in	12	1.7
Dynamo Pulley Nut	$\frac{7}{16}$ in	20	2.7
Alternator Pulley Nut	$\frac{7}{16}$ in	38	5.2

Note: 1) Connecting rod nuts should be replaced whenever the big ends are disturbed.  
 2) Engine number refers to Perkins marine engine.



Table 26.3  
Recommended Torque Tensions (Lister)  
Spanner Torques (Metric)

Thread Size	Torque		Engines	Location
	Kgf.m.	lbf.ft.		
M3 x 0.5	0.07	0.5	LT	Fuel hose clips
M4 x 0.7	0.30	2.2	LT LT	Governor link adjusting nuts Decompressor screw
M6 x 1.0	0.90	6.5	LT LT LT LT	Fuel filter to tank cap screw Valve rocker adjusting screw nuts Manifold lower nuts Fuel pump holding down bolts
M8 x 1.0	2.15	15.5	LT LT	Connecting rod nuts Injector clamp screw
M8 x 1.25	2.15	15.5	LT LT LT	Manifold higher nuts Main bearing housing screws Sump retaining screws
M8 x 1.25	0.8/1.5	5.8/10.6	LT	Oil starter adaptor taper thread
M10 x 1.25	4.20	30	LT	Cylinder head nuts
M10 x 1.5	3.50	25	J range	Valve rocker screw nuts
M12 x 1.5	3	21	ALL	Fuel injection pipe nuts
M12 x 1.75	8	58	J range	Shaft extension fan nuts
M12 x 1.75	5.50	40	J range	Injector clamp nuts
M12 x 1.75	3.50	25	J range	Fuel pump inlet union
M16 x 2.0	20	145	J range	Connecting rod nuts
M18 x 1.5	5.5	40	LT H range	Fuel pump delivery valve holder
M15 x 1.5	20	145	LT	Flywheel retaining screw
M18 x 1.5	19/21	140/150	JA	Cylinder head nuts
M18 x 1.5	25	180	JW	Cylinder head nuts
M20 x 1.25	2.8	20	LT	Injector top plug
M20 x 1.5	6.20	45	J range	Fuel pump delivery valve holder
M20 x 2.5	40	290	J range	Flywheel set screws
M21 x 1.5	9	65	ST, H & J ranges	Injector top cap and locknut
M24 x 3.0	44/47	320/340	J range	Main bearing cap nuts

Table 26.3 (continued)

## Spanner Torques (Unified)

Thread Size	Torque		Engines	Location
	Kgf.m.	lbf.ft.		
$\frac{1}{4}$ ins. 24 UNS	1.40	10	J range	Fuel pump inlet union nut
$\frac{5}{16}$ ins. UNF	2.1	15	ST.H range	Injector clamp nuts
$\frac{3}{8}$ ins. UNF	4.4	32	ST ST	Balance weight setscrew Connecting rod nuts
$\frac{7}{16}$ ins. UNF	6.9 6.9	50 50	ST H range	Cylinder head holding down nuts Dynamo shaft nuts
$\frac{1}{2}$ ins. UNF	9.4	68	H range	Connecting rod nuts
$\frac{7}{8}$ ins. UNF	41.4	300	ST	Flywheel crankshaft setscrew
$\frac{9}{16}$ ins. UNF	11.0 13.8 13.8	80 100 100	HR HRW H range (4 & 6)	Cylinder head nuts Cylinder head nuts Flywheel setscrews
$\frac{3}{4}$ ins. UNF	27.6	200	H range	Main bearing cap nuts
1 in. UNF	55.2	400	H range (2 & 3)	Flywheel crankshaft screw

SECTION 27Care and maintenance27.1 General

Any engine must be cared for and maintained correctly as recommended by the engine manufacturer. Failure to carry out normal maintenance will cause the engine to fail very early in its life with the result that expensive repairs will be necessary to put the engine back into service.

An engine which is looked after from its installation should give many years of fairly trouble-free running, with only the minimum of cost and expense.

Most servicing (care and maintenance) is carried out depending upon the number of hours the engine has worked. Some engines have an "hours-meter" or odometer fitted, which records the hours that an engine runs. Where no odometer is fitted, the operator should make a log-book, and write down the number of hours an engine is run and keep a "running total". In this way, servicing can be done at the correct intervals.

The servicing intervals can be split up as in the following list. This is outlined as a guide ONLY and not to be used in place of the engine maker's instructions.

Daily the engine should be checked before it is started, that is before the first start of the day.

- 1) Check engine oil level.
- 2) Check water cooling.

Weekly (or every 25 hours) certain engines require greasing, by turning greasecaps, e.g. on gearbox, propeller shaft, etc.

Every 100/150 hours

- 1) Most engines need the lubricating oil changed, some need the oil filter to be changed.
- 2) Air cleaners also may need cleaning.
- 3) Batteries need checking and topping up with distilled water.

250/300 hours

The first complete service, when most engines need the following:

- 1) Clean fuel filter and fuel feed filter.
- 2) Check valve clearances (some engines only).
- 3) Adjust all belts.
- 4) Adjust clutch if necessary.
- 5) Check oil in clutch and reduction gearbox.
- 6) Clean cooling fins and fan inlet (air-cooled engines).

500/600 hours

On working boats which do a great many hours a year, this service should be done at the correct time (i.e. at 500 or 600 hours as the makers suggest).

On boats which do not run many hours, the 500/600 hour service may be done once a year. In this case it may be when the boat is taken out of the water for its annual repaint, and therefore can be part of an ANNUAL SERVICE.

- 1) Check and adjust valve clearances (if not done earlier).
- 2) Check and adjust driving belts.
- 3) Check and adjust clutch and gearbox (e.g. brake band).
- 4) Change all filters, or clean as recommended.
- 5) Check injector nozzles. Renew if necessary and reset injectors.
- 6) Check and clean heater plugs (if fitted).

If boat is out of water

- 7) Draw propeller shaft out and check shaft for wear at bearing points.
- 8) Check underwater fittings, e.g., water inlet, keel cooling pipes.
- 9) Check propeller for damage.
- 10) Check and renew zinc pads on rudder or hull, if fitted.
- 11) Check rudder for damage and free movement.

27.2 Major Service

Many engine manufacturers suggest a major service at about 2,000/2,500 hours, when an engine should be stripped and examined thoroughly.

In most cases, where the engine has been running satisfactorily it may only need a top overhaul, and decarbonisation. This entails removing the cylinder head or heads, cleaning the carbon deposit from the combustion chamber, regrinding valves, etc.

This service may also include:

- 1) Cleaning out the crankcase and oil pump strainer.
- 2) Removing and servicing starter motor, generator, etc.
- 3) Drawing pistons and checking piston rings, oil return holes in scraper ring grooves.
- 4) Checking crankshaft bearings.
- 5) Checking injectors and nozzles, or fit serviced units.
- 6) Cleaning out gearbox, adjusting clutch and brake band, as necessary.
- 7) Reassemble the engine with new gaskets.

8) Adjust tappet clearances.

This service again depends upon the type of engine, the type of running it has had, e.g. short runs produce more carbon deposits than long periods of running.

Note: all manufacturers recommend the correct service intervals and the jobs which should be done then are carefully laid down (see Tables 27.1 and 27.2 and Fig. 78).

Some engines, especially slow/medium spec. engines, have much longer service intervals than high speed engines and therefore some of the jobs are done less frequently than may be recommended by other makers.

IT IS IMPORTANT TO FOLLOW THE MAKER'S INSTRUCTIONS AND SERVICE THE ENGINE AS RECOMMENDED.

Table 27.1Routine Maintenance (Lister)

When the engine is in daily use:

Daily: Check supply of fuel oil.  
 Check the level and condition of lubricating oil (also in gearbox if fitted).  
 Clean the air cleaner under very dusty conditions.  
 Drain the moisture trap in the exhaust pipe, if fitted.

Every 100 hours:

Clean the air cleaner under moderately dusty conditions. Renew the element if necessary.  
 Check for oil and fuel leaks - tighten nuts and fittings if necessary.  
 Wipe the engine and baseplate clean.  
 Clean the cylinder, cylinder head and injector finning under very dusty conditions.

Every 250 hours:

Drain the lubricating oil, renew filter element and refill with the correct grade and type.  
 Clean the fuel injector nozzle if the exhaust is dirty.

Every 500 hours:

Decarbonise if the engine shows loss of compression, or blow-by past the piston. Do not disturb otherwise.  
 Adjust valve clearances.  
 Wash the engine down with paraffin or fuel oil.  
 Clean the cylinder, cylinder head and injector finning under dusty conditions.

Every 1500 hours:

Decarbonise.  
 Clean the inlet manifold and exhaust system.  
 Examine the fan blades and clean.  
 Check for free working of the governor linkage.  
 Drain and clean the fuel tank.  
 Renew the fuel filter element.  
 Clean the fuel injector nozzle and adjust the pressure settings.  
 Check the fuel pump timing and balancing.  
 Clean the cylinder, cylinder head and injector finning under normal conditions.  
 Check the lubricating oil pump valve assemblies.

Every 5000 hours:

Check the big ends and main bearings.

A reasonable amount of time spent in checking over the details as described in the foregoing is the user's best insurance against loss of valuable time and costly repairs.

Table 27.2Preventive Maintenance (Perkins)Daily:

Check coolant level.  
 Check sump oil level.  
 Check oil pressures (where gauge fitted).  
 In extreme dust conditions, clean oil bath air cleaner and empty dust bowl on dry type air cleaner.

Every 5,000 Miles (7,500 km), 200 hours or 4 months (whichever occurs first):

Drain and renew engine lubricating oil (see approved Lubricating Oils).  
 Renew lubricating oil filter element.  
 Check drive belt tension.  
 Clean oil bath air cleaner.  
 Empty dust bowl on dry type air cleaner.  
 Clean compressor air cleaner (if fitted).  
 Clean water trap.  
 Check engine for leakage of oil and water.  
 Lubricate dynamo rear bush (where fitted).  
 Turbocharged Engines. Renew turbocharger lubricating oil filter element (where fitted).

Every 10,000 Miles (15,000 km), 400 hours or 12 months (whichever occurs first):

Clean lift pump gauze strainer.  
 Renew final fuel filter element - T.A. and industrial applications.  
 Check hoses and clips.

Every 20,000 Miles (30,000 km), 800 hours:

Renew final fuel filter element - vehicle engines.  
 Decarbonise compressor cylinder head.  
 Clean element of dry type air cleaner or renew.  
 Turbocharged Engines. Clean turbocharger impeller, diffuser and oil drain pipe.

Every 60,000 Miles (90,000 km), 2,400 hours:

Arrange for examination and service of proprietary equipment, i.e. compressor/exhauster, starter motor, dynamo, etc.  
 Service atomisers.  
 Check and adjust tappets.

Note: The "Periods" quoted are general in their application. The operator should compare the Routine Maintenance for his particular engine with the schedules as laid down by the manufacturer of the particular machine or vehicle into which his Perkins engine has been installed, and he should adopt the shorter period, where relevant.

The maintenance periods should be reduced to suit any exceptional operating conditions, such as stop-start, low mileage work, where the hours or engine running time are more applicable than the mileage run, or continuous sustained high speeds or temperatures.

The cleaning and replenishing of the oil bath air cleaner, or the replacement of the paper element filter should be done far more often than the periods quoted above if extremely dusty conditions are prevalent.

Post Delivery Checkover

After a customer has taken delivery of his Perkins Diesel engine, a general checkover of the engine must be carried out after the first 500/1000 miles (800/1600 km) or 25/50 hours in service.

The checkover should comprise the following points:

- 1) Drain lubricating oil sump and refill to full mark on dipstick with new oil. Remove and clean sump strainer where possible. Change lubricating oil filter element.
- 2) Remove rocker assembly and check cylinder head nuts are to correct torque.
- 3) Refit rocker assembly and set valve clearance to 0.010 in (0.25 mm) hot.
- 4) Check coolant level in radiator and inspect for leaks.
- 5) Check external nuts, setscrews, mountings, etc. for tightness.
- 6) Check belt tension.
- 7) Check electrical equipment & connexions.
- 8) Check for lubricating and fuel oil leaks.
- 9) Check general performance of engine.

RUNNING MAINTENANCE CHART



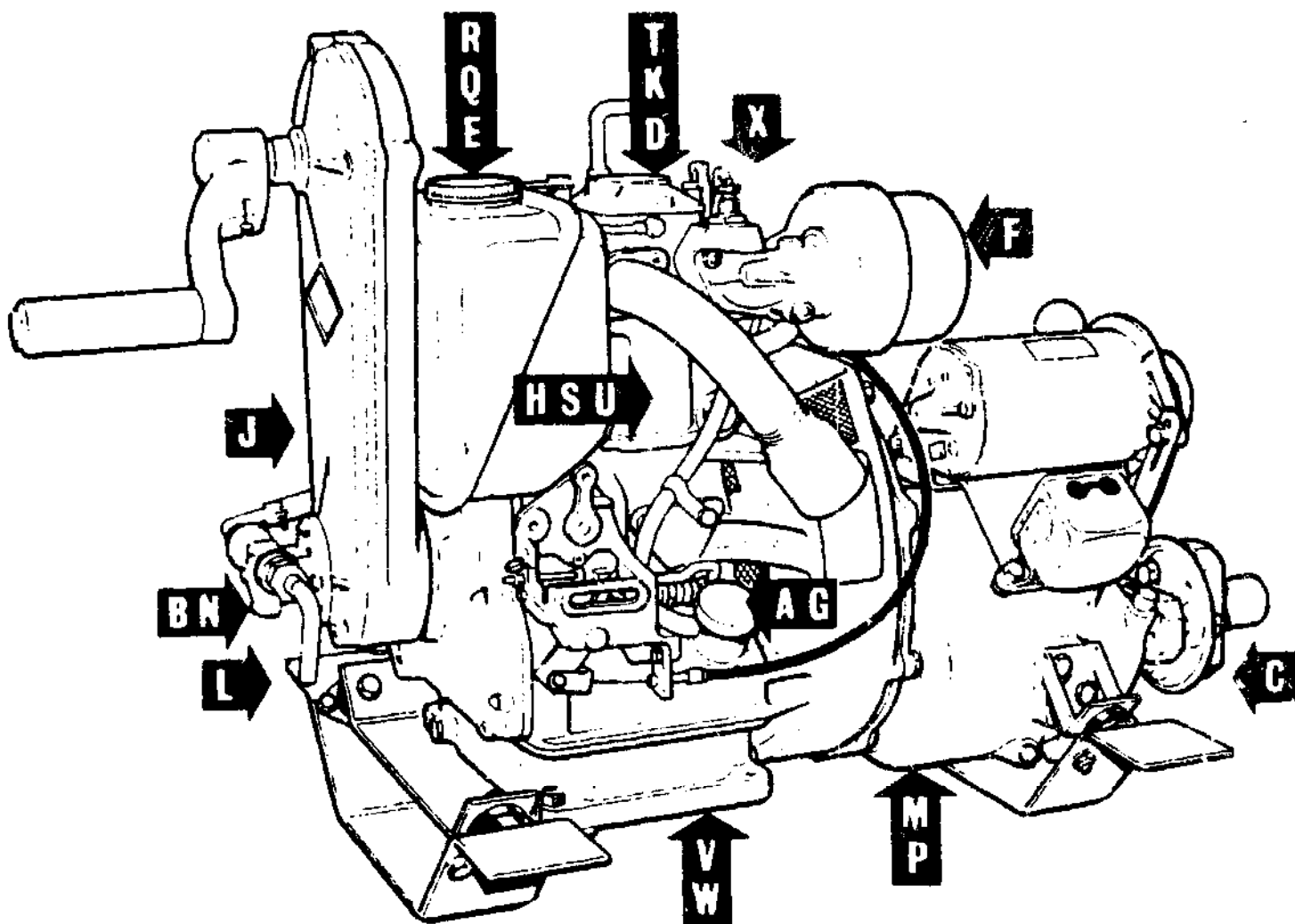

RUNNING MAINTENANCE CHART

FIG. 78