

# **AT** MICROFICHE REFERENCE LIBRARY

A project of Volunteers in Asia

Intercropping in Tropical Smallholder Agriculture  
with Special Reference to West Africa

by Kurt R. Steiner

Published by:

GTZ  
Dag-Hammarskjold-Weg 1-2  
D-6236 Eschborn 1  
WEST GERMANY

Available from:

same as above

Reproduced by permission.

Reproduction of this microfiche document in any form is subject to the same restrictions as those of the original document.



# Intercropping in Tropical Smallholder Agriculture with Special Reference to West Africa

Kurt G. Steiner

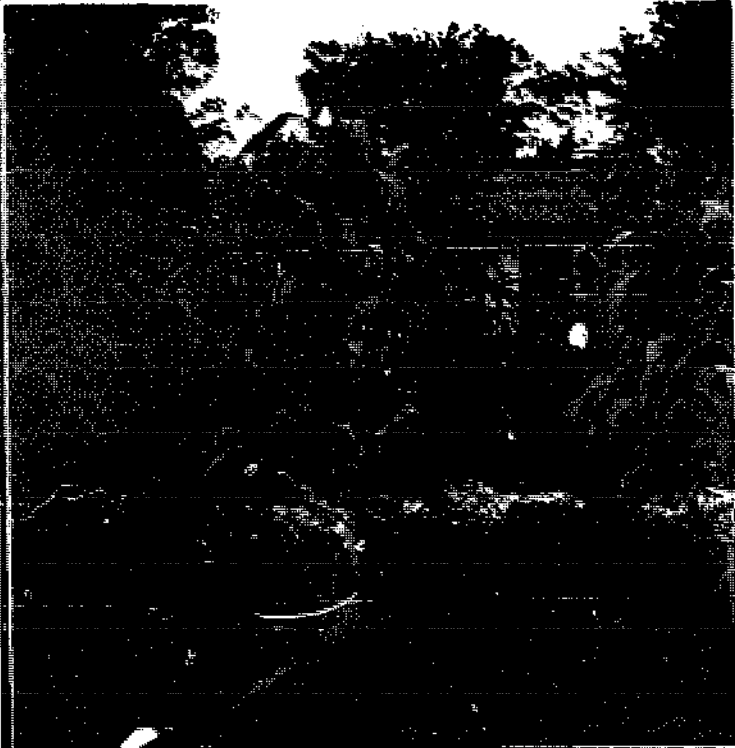

Intercropping maize with cowpea in the highlands of Cameroon

Sorghum fields with Parkia trees in northern Ghana

Intercrop experimentation with millet and groundnut at ICRICAT/Hyderabad

Alley cropping with Leucaena and cowpea at IITA/Ibadan

(Photos: Kurt G. Steiner)

Intercropping in  
Tropical Smallholder Agriculture  
with Special Reference  
to West Africa

by  
Kurt G. Steiner

2. Edition

Eschborn 1984

Published by  
Deutsche Gesellschaft für Technische Zusammenarbeit (GTZ) GmbH  
Postfach 5180, D-6236 Eschborn/Ts. 1

Graphic Work  
Stefan Amelung, Heidelberg

Distribution  
TZ-Verlagsgesellschaft mbH, Bruchwiesenweg 19, D-6101 Roßdorf 1

Production  
Druckerei Peter Schultz, Seehofstr. 17 H + 21, D-6000 Frankfurt/M 70

ISBN 3-88085-176-X

II/4801/1.

Printed in West Germany

## PREFACE

During the last ten years there has been an increasing awareness that the impact of the so-called green revolution on smallholder farming in developing countries has remained rather limited. Due to a lack of resources and increasing prices of commercial inputs the majority of small farmers in the tropics and especially in Africa were not able to benefit from the progress achieved by international agricultural research.

Hence, research gave more attention to the analysis and subsequent improvement of traditional cropping systems and a more efficient use of limited resources. Research results obtained so far made evident that traditional cropping systems are well adapted to the ecological, socio-cultural, and socio-economic conditions of tropical agriculture.

The intensification of traditional cropping systems and especially intercropping is a challenge to researchers and extension officers. These highly complex cropping systems require completely different approaches and new methods.

Even though research on intercropping systems has started only recently, a considerable amount of knowledge has already been accumulated and should be used when starting new or reorganizing existing extension programmes for smallholders in the tropics. It was the intention of the Federal Ministry of Cooperation, when requesting the present state-of-knowledge report, that the available information on intercropping was compiled and made available to development programmes.

Dr. Jürgen Friedrichsen

Head of Division 13 (Plant Production and Forestry)

## PREFACE

to the second edition

It is encouraging that a second edition of this publication is required so soon after the first. It met with great demand not only from policy makers, scientists, extension workers and journalists in all parts of the world, but also from the younger generation. We were interested to note the special attention accorded to the work by this group.

Traditional and improved intercropping systems are now broadly recognized as a feasible practice to optimize crop production in many developing countries. Intercropping systems promote the use of natural resources and at the same time constitute a most appropriate way of raising agricultural production in the tropics and subtropics, especially given the limited availability of external inputs based on fossil energy.

The author has received valuable suggestions which are being taken into consideration in a French edition currently being prepared.

In view of the rapid acceptance of the English version we felt it necessary to release a second edition to meet the demand at the present time.

Dr. Jürgen Friedrichsen,  
Head of Division 13  
(Plant Production, Plant Protection and Forestry)

## ACKNOWLEDGEMENTS

This report could not have been written without the assistance of many scientists and technical experts. In particular, I should like to express my gratitude to my colleague, Dr. J.E. TSCHERSCH, of the Research Centre for International Agrarian Development, Heidelberg, who participated in the farm surveys and gave me considerable help in formulating the economic aspects of intercropping.

Prof. Dr. W. HORST and Prof. Dr. B. OHNESORGE from the University of Hohenheim; Dr. R. MEAD, University of Reading; Dr. B.T. KANG and Mr. G.F. WILSON of IITA; Dr. D.E. LEIHNER of CIAT read earlier drafts and suggested corrections and improvements. Dr. PRINZ, University of Göttingen; Mr. E. BACHMANN, University of Hohenheim, helped by many fruitful discussions.

I should also like to thank all those who helped to conduct the farm surveys and supplied me with country-specific informations, especially Dr. P. MATLON, ICRISAT, Upper Volta; Dr. Y. BIGOT, GERDAT/IDESSA, Ivory Coast; Dr. D. HESSELBACH, GGADP, Ghana; Dr. P. AY, IITA, Nigeria; and M. SOFFO, UCCAO, Cameroon.

Nor must I forget all the persons from the agricultural research institutes, extension services, ministries of agriculture and German rural development projects in Cameroon, Nigeria, Benin, Togo, Ghana, Ivory Coast and Upper Volta who did not hesitate to supply me with information and ideas during my visit. I am also indebted to researchers of IRAT, ORSTOM and FAO who helped by information and fruitful discussions.



# C O N T E N T S

		<u>Page</u>
1.	<u>Introduction</u>	25
2.	<u>Intercropping in smallholder agriculture in tropical Africa</u>	29
2.1	Definition of related terms	30
2.2	Environmental and socio-economic constraints to agricultural production in West Africa	31
2.3	The importance of intercropping for food production in West Africa	38
2.4	Description of the principal cropping systems	50
2.4.1	Cassava-based cropping systems	52
2.4.2	Plantain-based cropping systems	53
2.4.3	Yam-based cropping systems	53
2.4.4	Rice-based cropping systems	55
2.4.5	Sorghum-based cropping systems	56
2.4.6	Millet-based cropping systems	57
2.4.7	Maize-based cropping systems	58
3.	<u>Agronomic aspects of intercropping</u>	59
3.1	Plant interactions in intercropping systems	59
3.1.1	Intercrop competition	59
3.1.2	Resource use in intercropping systems	63
3.1.2.1	Light	64
3.1.2.2	Water and nutrients	67
3.1.3	Nitrogen in legume/non-legume associations	73
3.1.4	Plant population and spatial arrangement	75
3.1.4.1	Plant population	75
3.1.4.2	Spatial arrangement	78
3.2	Evaluation of yield advantages	82
3.2.1	The land-equivalent ratio (LER)	83
3.2.2	Yield assessment on the basis of plant constituents	90

	<u>Page</u>	
3.2.3	Net income of intercropping systems	91
3.2.4	Yield stability	93
3.3	Adapting varieties to intercropping systems	99
3.3.1	Genotype by cropping systems interactions	100
3.3.2	Breeding and selection for intercropping systems	104
3.4	Soil fertility management	107
3.4.1	Soil related constraints to food production in the tropics	108
3.4.2	Maintenance of soil fertility under traditional cropping patterns	110
3.4.3	Possibilities of maintaining soil fertility under conditions of smallholder farming	111
3.5	Fertilizer use in intercropping systems	118
3.5.1	Nutrient requirements in intercropping systems	118
3.5.2	Fertilizer practices - rates, timing and placement of fertilizers	132
3.5.3	Economics of fertilizer use	134
3.6	Pest and weed management in intercropping systems	136
3.6.1	Influence of intercropping on population dynamics of pests	138
3.6.1.1	Mechanisms of pest control in heterogenous plant populations	139
	Crop colonisation	139
	Dispersal	142
	Mortality by natural enemies	143
	Associated resistance	144
3.6.1.2	Effects of intercropping on pest damage	145
3.6.1.3	Effects of weeds on insect populations	151
3.6.2	Influence of intercropping on epidemics of plant diseases	154
3.6.2.1	Mechanisms of disease control in heterogenous plant populations	154
3.6.2.2	Effects of intercropping on plant diseases	158
3.6.3	Effects of intercropping on nematodes	163
3.6.4	Effects of intercropping on growth of weeds	165

	<u>Page</u>	
3.7	Experimental designs for intercropping systems	169
3.7.1	Effects of plant population and spatial arrangement	172
3.7.2	Use of sole crop plots in intercropping experiments	174
3.7.3	Factorial experiments	175
3.7.4	Systematic designs	179
4.	<u>Socio-economic aspects of intercropping</u>	185
4.1	Farmers' motivations for intercropping	186
4.2	Maximising returns to the most limiting factor	190
4.2.1	Returns to land	191
4.2.2	Returns to labour	193
4.3	Risk minimization	197
4.4	Continuous and diversified food supply	203
4.5	Sexual division of labour	204
4.6	Influence of markets on intercropping systems	208
4.7	Flexibility of intercropping systems	209
5.	<u>Conclusions and recommendations</u>	212
5.1	Present state of research on intercropping	212
5.1.1	Summary of research findings	212
5.1.2	Research on intercropping in West Africa	221
5.2	Recommendations for agricultural research and extension	224
5.2.1	Research priorities	225
5.2.2	Extension programmes for smallholders	229
6.	BIBLIOGRAPHY	235
	Appendix	251
	1. Tables	253
	2. Figures	301

## Text Tables

	<u>Page</u>
Table 1: Definitions of the principal multiple cropping patterns	32
Table 2: Related terminology used in multiple cropping systems	33
Table 3: Percentage of total production of main food crops marketed by farms in eastern Cameroon	37
Table 4: Crop matrices on selected farms of a village in eastern Nigeria	40
Table 5: Crop combinations on yam mounds of various sizes in south-eastern Nigeria	41
Table 6: The seven most frequent crop mixtures in Zaria province, northern Nigeria (Percentage of cultivated land occupied by these mixtures)	43
Table 7: Plant densities of common mixtures found on outer fields in three villages in eastern Nigeria, June 1974	44
Table 8: Plant densities of major crops in a low and a highly populated area of southern Cameroon	45
Table 9: Important crop mixtures and percentage of land devoted to mixture of one to six crops in Zaria province of northern Nigeria	46
Table 10: Correlations between yields of cassava and associated legumes indicating degree of interaction between crops as a result of earliness of legumes	62
Table 11: Grain yield of maize and companion crops in an intercropping system	74
Table 12: Planting geometry at constant plant population on the grain yield of sorghum (kg/ha)	
Table 13: Seed yield and land equivalent ratio (LER) of maize/soyabean intercropping system	82
Table 14: Yield and LERs of 17 genotypes of pigeon pea intercropped with one of sorghum	87
Table 15: Variability (coefficient of variability) registered in different cropping systems during 3 years and three replicates each year	95
Table 16: Stability parameters, regression coefficient, and mean square deviation from regression $S_{d^2}$ of entries for yield	97

Table 17:	Yields of nine climbing bean collections associated with two contrasting maize types	101
Table 18:	Correlations of crop yields between two intercropping systems.	103
Table 19:	Effects of three years of cultivation after forest clearing on CEC, pH and exchangeable cations under different treatments	112
Table 20:	Soil losses and run-off under cassava monoculture and mixed cropping of cassava and maize	112
Table 21:	Yield reduction through shade of some major crops in farmers' fields	115
Table 22:	Results from analysis of soil samples taken at three different sites near Acacia albida trees	116
Table 23:	Yields of millet (grains and protein in kg/ha) at three different sites below Acacia albida trees	117
Table 24:	Dry matter production and nutrient uptake by maize and pigeon pea 16 weeks after planting (i.e. at time of maize harvest)	120
Table 25:	Grain yield of maize and soya bean intercropped at varying levels of nitrogen and corresponding LER values	125
Table 26:	Average relative yield totals for maize/groundnut intercrops	126
Table 27:	Effect of prior cropping pattern (all without added fertilizer nitrogen) on residual exchangeable soil nitrogen at 0 and at 19 weeks after sowing and uptake of nitrogen by following wheat crop	131
Table 28:	Value:cost ratios of fertilizers applied to sole crops and intercropping systems in the Savanna zone of Nigeria	135
Table 29:	Influence of field hue on stem borer oviposition in sole maize and a maize/groundnut intercrop	141
Table 30:	Dry seed yield of sole maize and sole cowpea compared with two forms of intercropping under minimum insecticide application	146
Table 31:	Effects of companion crops on maize stem borer incidence	147

	<u>Page</u>
Table 32: Predaceous, parasitic and phytophagous adult insect species and individuals taken in 600 sweeps of maize and sweet potato sole- and intercrop	149
Table 33: Examples of successful pest control by intercropping	152
Table 34: Incidence of pests and predators in different bean-weed systems	153
Table 35: Effects of a cassava-maize-melon association on cassava bacterial blight ( <i>Xanthomonas manihotis</i> ) incidence in Umudike, Nigeria	160
Table 36: Apparent infection rates (r) of cassava mildew ( <i>Oidium manihotis</i> ) in different cropping systems, Turrialba, Costa Rica	161
Table 37: Crop reaction to plant parasitic nematodes	164
Table 38: Effect on weed growth of various crops grown alone or in associations	166
Table 39: Estimates of returns to labour for traditional and recommended maize practices - Tamale, northern Ghana	186
Table 40: Reasons given by farmers in northern Nigeria (Sokoto) for the practice of growing crops in mixtures	187
Table 41: Reasons given by farmers for growing crops and crop mixtures	188
Table 42: Average gross and net returns from sole crops and crop mixtures	192
Table 43: Labour inputs and net returns of sole and mixed crops. Data of three villages in the Zaria region, northern Nigeria	194
Table 44: Rainfall distribution and yields of the main crops in the years 1967-1974 in the Southern Guinea Savanna of Ivory Coast	199
Table 45: Percentage of farmers reporting division of labour in farm operations for the production of food crops	206
Table 46: Division of fields by crops and sex of the main users	207

## Text Figures

	<u>Page</u>
Fig. 1: Size distribution of fields in the Bassa country of southern Cameroon	35
Fig. 2: Area of food crops cultivated per woman, Bassa country, southern Cameroon	36
Fig. 3: Area of food crops cultivated per head, Bassa country, southern Cameroon	36
Fig. 4: Spatial arrangement of some crop mixtures in northern Nigeria a. Three crop mixture: Millet/sorghum/cowpea b. Four crop mixture: Millet/sorghum/groundnut/cowpea	48
Fig. 5: Spatial distribution of crops on mounds in Abakaliki, Central East State, Nigeria	49
Fig. 6: Crop ecological zones of West Africa	51
Fig. 7: Cropping calendar of a plantain based cropping system in southern Cameroon	52
Fig. 8: Cropping calendar of a yam-based cropping system	55
Fig. 9: Cropping calendar of a rice-based cropping system in Sierra Leone	56
Fig. 10: Cropping calendar of a sorghum-based cropping system in the Sudan Savanna of Nigeria	57
Fig. 11: Maize-based cropping systems in the Cameroon Highlands	58
Fig. 12: 'Competition Gap', the period between the active growth of two crops	61
Fig. 13: Growth in height of millet mixed with other cereals	63
Fig. 14: Interception of light by cassava during its vegetative cycle and possible periods for intercropping	66
Fig. 15: Root systems of maize and lucernes.	69
Fig. 16: Summary diagram of the effect of wind barriers on micro-meteorological factors	72
Fig. 17: Response of intercropping to total population	77
Fig. 18: Population response of individual component crops in three intercropping experiments	79
Fig. 19: Response of cowpea yield (sole and intercropped cowpeas) to three spatial arrangements at three planting densities	81

Fig. 20:	Land equivalent ratio values and number of crops in different cropping systems tested at Turrialba, Costa Rica, 1974-78	85
Fig. 21:	Yields of a 50:50 resp. 25:75 soya bean/maize intercrop compared with the sole crops in terms of energy (kcal), fat, protein, lysine and methionine	92
Fig. 22:	Coefficient of variability of cassava, common bean, sweet potato, and maize in sole and different intercropping systems, Turrialba, Costa Rica, 1974-78	96
Fig. 23:	Probability of failure for sorghum and pigeon pea in different cropping systems at given 'disaster' levels of income	98
Fig. 24:	Effects of nitrogen application and tall crop row spacing on the land equivalent ratio of a maize/rice intercrop	122
Fig. 25:	Nitrogen response of a maize/bean intercrop on a Dystrandep in Turrialba, Costa Rica	123
Fig. 26:	Relative yields for maize and soya bean and relative yield totals (RYT) plotted against the relative planting frequencies	126
Fig. 27:	Response of cassava and cowpea yields to band-applied K in association as compared to sole crops	127
Fig. 28:	The response of cassava and cowpea yields to band-applied N in association as compared to sole crops	128
Fig. 29:	The response of cassava and cowpea yields to band-applied P in association as compared to sole crops	129
Fig. 30:	Effect of fertilizer nitrogen and cropping system on nitrogen uptake by wheat at anthesis - maize/groundnut, maize/soya bean, sole maize cropping patterns	132
Fig. 31:	Stages in pest population dynamics which may be affected by intercropping. Possible effects of intercropping are shown on the right.	140
Fig. 32:	Features of the population dynamics of pests affected by cropping patterns	145
Fig. 33:	<i>E. kraemeri</i> and <i>D. balteata</i> adult population dynamics in sole and intercropped (with maize) beans	148
Fig. 34:	Effect of selective attack by disease and pests	157



Fig. 35:	Apparent infection rates in 50:50 mixtures compared with those in sole stands of susceptible plants planted at the same overall densities	159
Fig. 36:	The effect of changing the proportions of two species in a mixture on apparent infection rates.	159
Fig. 37:	Intensity of damage of cassava dieback ( <i>Glomerella cingulata</i> ) under low and high levels of input in different cropping systems, Turrialba, Costa Rica, 1977	162
Fig. 38:	The effect of different inputs on yield of sole and intercropped cassava	167
Fig. 39:	The influence of a low level of plant resistance to pest attack on the effectiveness of natural enemies	168
Fig. 40:	Variation of intimacy and spatial arrangement of each crop for a two crop mixture	171
Fig. 41:	One replicate of a 3x2x2 factorial experiment with two sole crop treatments, and arranged in two blocks of 8 plots	177
Fig. 42:	WAHUA's and MILLER's fan design, modified from NELDER	180
Fig. 43:	Two-way systematic spacing design for two crops with densities varying in the perpendicular direction	181
Fig. 44:	Layout of two replicates showing chickpea and row-arrangement strips, position of sole plots, and direction of systematic change in safflower population	182
Fig. 45:	Comparison of harvested areas for randomized and systematic designs	183
Fig. 46:	Average labour input over time per activity and enterprise in Osara village of the Southern Guinea Savanna of Nigeria, 1977/78	195
Fig. 47:	Labour profile of AVB semi-motorized block fields and traditional fields in the central region of Ivory Coast	196
Fig. 48:	Probability of the appearance of a 12 days period with less than 20 mm rainfall in the Southern Guinea Savanna of Ivory Coast	198
Fig. 49:	Probability (%) of exceeding the sole crop medium return	201
Fig. 50:	Probability of net incomes at two levels in three cropping systems at several bean/maize price ratios	202

Fig. 50: Probability of net incomes at two levels in  
three cropping systems at several bean/maize  
price ratios

202

Appendix Tables

	<u>Page</u>
Table A 1: French terms related to cropping systems	253
Table A 2: General characteristics of holdings	254
a. Cameroon	254
b. Nigeria	255
c. Benin, Togo	256
d. Ghana	257
e. Ivory Coast	258
f. Upper Volta	259
Table A 3: Average cultivated area per farm worker in Cameroon, by region or zone, 1965 (in ares)	260
Table A 4: Importance of crop mixtures	261
a. Nigeria	261
b. Ghana	262
c. Ivory Coast	266
Table A 5: a. Crops and useful plants. Survey in selected farms of varying cropping intensities in compound and outlying farms located in the derived Savanna, transition and oil palm belt zones of eastern Nigeria	267
b. Species occurring in groundnut fields in the centre-south of Cameroon	273
Table A 6: Subregional crop combinations in Cameroon	274
Table A 7: Characteristics of the bioclimatic regions of West Africa	276
Table A 8: Intercropping systems in West African countries. Principal cropping systems within administrative resp. ecological regions	277
a. Cameroon	277
b. Nigeria	279
c. Benin	280
d. Togo	281
e. Ghana	282
f. Ivory Coast	283
g. Upper Volta	284
Table A 9: Principal cropping systems in Ivory Coast	285
a. Plantain-based cropping systems	285
b. Cassava-based cropping systems	286
c. Maize-based cropping systems	287
d. Yam-based cropping systems	288
e. Cropping systems including cocoyam	289
f. Rice-based cropping systems	290
g. Sorghum-based cropping systems	291
h. Cropping systems including millet	292
i. Cropping systems including groundnuts	293
k. Yam-based cropping patterns in eastern Nigeria	294
Table A 10: Maturity period of crops	295

	<u>Page</u>
Table A 11: List of botanical names of crops and the respective English and French common names used in West Africa	296
Table A 12: Consumption chart of a shifting cultivator's family in Manhaua, Mozambique	299
Table A 13: List of institutes and researchers working on intercropping in West Africa	300

Appendix Figures

	<u>Page</u>
Fig. A 1: Climates of West Africa	301
Fig. A 2: Annual rainfall of West Africa	302
Fig. A 3: Vegetation zones of West Africa	303
Fig. A 4: Two- and threedimensional cropping patterns	304

## 1. INTRODUCTION

In the countries of tropical Africa, the increase in food production in recent years has not been able to keep up with the rapid population growth. While the population has increased by nearly 3 % annually, food production has increased at only half that rate. Most countries are no longer self-sufficient and need to import food, at least in years with insufficient rainfall. The rapid population growth has caused land pressure in many areas. The traditional farming systems, relying on a restoration of soil fertility by means of a prolonged fallow period (bush fallow systems) which had evolved over centuries and had proved to be sufficient in the past, have not been adapted fast enough to the new situation. Shortening of the fallow period owing to land scarcity has provoked soil degradation resulting in decreased yields in many areas (GUILLEMIN, 1956; RUTHENBERG, 1980). Efforts made by the governments as well as by development projects of industrialized nations to increase food production by the introduction of new technologies relying on commercial inputs have not produced the expected results. The new methods have mainly been adopted by larger and better-off farmers but hardly by the majority of the small farmers (80-90 % of farms).

The steadily increasing prices of imported inputs that are based on non-renewable resources (mainly oil) are reducing even further the number of farmers who can afford to buy these goods.

It is evident that development policy in the past has neglected the individual goals of small farmers and has tried to superimpose societal goals (HARWOOD, 1979). However, these goals did not coincide, as most of those farmers are not commercially orientated.

The farmer values security and stability more than profit and hesitates to take unnecessary risks. Such risks include cash investments and new cropping systems that could lead to crop failure and thus famine.

Any efforts to develop small farms have to start with a proper analysis of existing farming systems. This analysis has to identify situations in which existing farm resources are insufficiently used. Changes in existing farming systems have to be planned in close collaboration with the farmer. The farmer contributes his intimate, often tacit, understanding of his own situation and the factors that influence his productivity. Planning of small farm development cannot be done by scientists of a single discipline only, but needs a team consisting of at least an economist, an agronomist and a soil scientist, allowing full understanding of the interactions between environmental and social factors.

Analyses of smallholder farming systems in West Africa (NORMAN, 1973; LAGEMANN, 1977) reveal mainly the following constraints: low productivity of soils, often combined with land shortage; labour shortage, caused in part by low productivity of labour; unpredictability of rainfall; lack of cash resources; and limited access to credit.

A change in farming systems has therefore to include measures to maintain or increase soil fertility, to increase labour productivity, to give stable yields even with uncertain growing conditions and to improve the efficiency of farm resources especially in the case of lacking commercial inputs.

A central part of traditional farming systems in most parts of tropical Africa is intercropping. In the following paragraphs this cropping system is analysed from various aspects to see if it can help to overcome production constraints. It was not considered necessary to include descriptions of the various cropping systems, as this would go beyond the scope of this report. The reader interested in cropping systems of specific regions is asked to consult the literature, where detailed descriptions of cropping systems down to the village level can be found (see, for example, OKIGBO, 1978; and the various volumes of the Atlas des structures agraires au Sud du Sahara, ORSTOM).

In the second chapter, therefore, only a general description of typical traditional cropping systems based on major food crops is given. Main emphasis in this chapter is placed on analysing the contribution of intercropping systems to food production.

In the third chapter agronomic aspects of intercropping systems are discussed. The central questions are whether intercropping systems make better use of limited natural resources, such as light, water, and nutrients, than sole crops and whether productivity of intercropping systems can be intensified sufficiently to meet the increasing demand for food. Therefore, a special paragraph is devoted to fertilizer use in intercropping systems, even though the author is aware of the restricted availability of fertilizers to smallholders in most parts of Africa. Furthermore, the contributions of intercropping systems to yield stability, soil fertility maintenance, and biological plant protection are evaluated.

Chapter 4 analyses the socio-economic aspects of intercropping, such as returns to land and labour, distribution of labour requirements and risk aversion.

The report is mainly a review of the international literature, including unpublished results on intercropping. Chapter 3, in particular, reflects the current state of knowledge on interactions and resource use in intercropping systems. This does not exclude existence of further interactions, such as allelopathy not mentioned here.

The last chapter gives an appraisal of intercropping in smallholder agriculture and ends with a recommendation for applied agricultural research and extension programmes for the promotion of intercropping.

The report is geographically limited to West Africa. In this region all ecological zones from the rainforest to the Sahel, including tropical highlands, are represented, and intercropping is rather common. However, the principles of intercropping are also



of value for other regions or continents. Specific for West Africa is probably the labour shortage in rural areas, due to migration to urban centres or regions with a strong plantation sector which certainly influences the cropping systems.

## 2. INTERCROPPING IN SMALLHOLDER AGRICULTURE OF TROPICAL AFRICA

Intercropping is a common feature of agriculture in tropical Africa as well as in the Asian and the American tropics (DALRYMPLE, 1971; PAPENDICK, SANCHEZ and TRIPLETT, 1976; OKIGBO, 1978). Specific intercropping systems have developed over the centuries in the different regions and they are closely adapted to the prevailing ecological and socio-economic conditions. Therefore intercropping systems differ frequently from one area to another with changes in soils and local climates. Social and cultural conditions may be superimposed on the ecological and economical ones, leading to different cropping systems in the same ecological zone. Ethnic groups differ, for example, in food preferences or their organisation of labour. The reason for these variations can sometimes be found in migration from other ecological zones. In southern Cameroon, for example, the principle staple crop of the Ewondo is cocoyam (Xanthosoma sp.), while the neighbouring Bassa prefer cassava (see also Paragraph 2.3).

Recent changes in socio-economic conditions have had a considerable influence on cropping systems. Thus increasing demand for cassava in the densely populated areas of southern Nigeria combined with the migration of the active male population to urban areas has caused a decline in yam cultivation in favour of cassava. The population pressure in south-eastern Nigeria has also led to an intensification of intercropping in order to increase the production per unit area (LAGEMANN, 1977).

In general, there is no indication of any decrease in the importance of intercropping. On the contrary, as efforts of extension services to introduce sole cropping have often failed, it has now sometimes become government policy to increase production by improving intercropping systems. For example, relay cropping of maize with cotton is now being tried in Togo and after the collapse of cassava production in the coastal region, intercropping of cassava with maize and groundnuts - the traditional system - is now being investigated by the agricultural research institute. As long as agriculture is dominated by smallholdings with low or no capital

inputs and the hoe is the only farm tool, there is no technical reason for sole cropping and intercropping will retain its importance.

## 2.1 Definition of Related Terms

Before going into details of intercropping it may be useful to give a definition of the different terms related to intercropping that are used in the literature. Terminology has been quite confusing in the past, but it seems that the definitions given by ANDREWS and KASSAM (1976) (Table 1) are now generally accepted. Multiple cropping is the general term for all cropping patterns where more than one crop is cultivated on a field in one year. (In the American literature the term "polyculture" is still in use).

The various patterns of multiple cropping reflect essentially two underlying principles: that of growing crops simultaneously on a given piece of land, i.e. intercropping, and that of growing individual crops in sequence during one growing season on the same piece of land, i.e. sequential cropping. In this context growing crops "simultaneously" means that crops are grown together for most of the growing period. This does not require that the crops are planted or harvested on the same date. However, when the overlap in time is too small, for example only 4 weeks out of a growing season of 3-4 months, the term relay crop is used.

Intercropping systems themselves can be distinguished by the spatial arrangement of the component crops, as the intimacy of the crop mixture has important effects on the interactions between the crop species. The term "row intercropping" is used when crops are planted in alternate rows, while "mixed intercropping" is used when no specific spatial arrangement can be distinguished. The term "mixed cropping" is normally used synonymously with intercropping. It is still common in agricultural practice and therefore sometimes used in this report too. Some authors, however, distinguish between "mixed cropping" and "intercropping" in the sense of mixed inter-

cropping and row intercropping. However, this distinction is not logical and may lead to misunderstanding. Strip intercropping is the growing of two or more crops simultaneously in strips. It allows the use of large field equipment, but still has some beneficial effects on crop development and especially on outbreaks of insect pest. Strip intercropping is only practised in highly mechanised agriculture, e.g. in the southern United States.

Multi-storey cropping is the association of tall perennial with shorter, mostly biannual and annual crops. The canopies of the crops have a multi-storey structure, allowing an efficient use of sunlight. This cropping system is common in the humid tropics, where arable (subsistence) crops are grown under perennial (cash) crops such as coffee, cocoa, oil palms, coconut palms or fruit trees. Often huge forest trees remain in the field, giving an additional storey.

Definitions of the related terminology used in multiple cropping systems are given in Table 2. Attention should be called only to the difference between "sole cropping" and "monoculture" as these terms are often used incorrectly in the literature. Sole cropping is the cultivation of a crop in pure stands in one season, while monoculture means the continuous cultivation of the same sole crop on the same field for several seasons. In the following we distinguish mainly between intercropping and sole cropping or intercrops and sole crops respectively (see also App. Table A 1).

## 2.2. Environmental and Socio-Economic Constraints in Agricultural Production in West Africa

Agriculture in tropical Africa is dominated by smallholders. Smallholdings are characterised by a limited production capacity caused by an almost complete lack of capital and often also by a restricted availability of labour. The productivity of labour is generally low, because the cutlass and hoe are the only farm tools used, the state of health of the rural population is often poor and long walking distances cause losses of time and energy.

Table 1: Definitions of the principle multiple cropping patterns  
(adapted from ANDREWS and KASSAM, 1976)

**MULTIPLE CROPPING:** The intensification of cropping in time and space dimensions. Growing two or more crops on the same field in a year.

1. **SEQUENTIAL CROPPING:** Growing two or more crops in sequence on the same field per year.\* The succeeding plant is planted after the preceding crop has been harvested. Crop intensification is only in the time dimension. There is no intercrop competition. Farmers manage only one crop at a time in the same field.
  - 1.1 Double cropping: Growing two crops a year in sequence.
  - 1.2 Triple cropping: Growing three crops a year in sequence.
  - 1.3 Quadruple cropping: Growing four crops a year in sequence.
  - 1.4 Ratoon cropping: The cultivation of crop regrowth after harvest, although not necessarily for grain.
2. **INTERCROPPING:** Growing two or more crops simultaneously on the same field. Crop intensification is in both time and space dimensions. There is intercrop competition during all or part of crop growth. Farmers manage more than one crop at a time in the same field.
  - 2.1 Mixed intercropping: Growing two or more crops simultaneously with no distinct row arrangement.
  - 2.2 Row intercropping: Growing two or more crops simultaneously where one or more crops are planted in rows.
  - 2.3 Strip intercropping: Growing two or more crops simultaneously in different strips wide enough to permit independent cultivation but narrow enough for the crops to interact agronomically.
  - 2.4 Relay intercropping: Growing two or more crops simultaneously during part of the life cycle of each. A second crop is planted after the first crop has reached its reproductive stage of growth but before it is ready for harvest.
  - 2.5 Multi-storey cropping: Association of tall perennials with shorter biannual and annual crops.

\* The farming year is 12 months except in aridic areas where only one crop can be grown every 2 years due to moisture limitations. In these areas sequential cropping involves growing two or more crops every 2 years.

Table 2: Related terminology used in multiple cropping systems (ANDREWS and KASSAM, 1976)

Sole cropping: One crop variety grown alone in pure stands at normal density. Synonymous with solid planting; opposite of intercropping.

Monoculture: The repetitive growing of the same sole crop on the same land.

Rotation: The repetitive cultivation of an ordered succession of crops (or crops and fallow) on the same land. One cycle often takes several years to complete.

Cropping pattern: The yearly sequence and spatial arrangement of crops or of crops and fallow on a given area.

Cropping system: The cropping patterns used on a farm and their interaction with farm resources, other farm enterprises, and available technology which determine their makeup.

Mixed farming: Cropping systems which involve the raising of crops, animals and/or trees.

Cropping index: The number of crops grown per annum on a given area of land X 100.

Land Equivalent Ratio (LER): The ratio of the area needed under sole cropping to one of intercropping at the same management level to give an equal amount of yield. LER is the sum of the fractions of the yields of the intercrops relative to their sole crop yields (relative yields).

Area Equivalent Ratio (AER): The ratio of the actually cultivated farm area to the sum of the equivalent sole crop areas of each crop involved.

Income Equivalent Ratio (IER): The ratio of the area needed under sole cropping to produce the same gross income as one hectare of intercropping at the same management level. IER is the conversion of LER into economic terms.

80-90 % of the farms are smallholdings, with an average size of 1-2 hectares. In Nigeria, for example, 90 % of the farms are smaller than 5 ha (OKIGBO and GREENLAND, 1976). In the Ivory Coast 64 % of the farms are smaller than 5 ha (Agric. Census 1973/74; the percentage is relatively low, since the coffee and cocoa plantations in the South are included). In Ghana 82 % of the farms are smaller than 4 ha, and the mean farm size is only 1.5 ha (Agric. Census, 1970). The situation is similar in other West African countries. (See App., Tables A 2 a-g)

Farm sizes depend mainly on the availability of labour at times of peak demand, such as for land clearing and weeding. Only in some areas of West Africa is the farm size limited by land shortage due to high population densities. This is the case, for example, in the Cameroon Highlands (average population density 150 persons/km<sup>2</sup>, maximum density 500 persons/km<sup>2</sup>), the Kano region of northern Nigeria, southern Benin or on the Mossi Plateau, Upper Volta.

Farms can be very small in the forest region. Thus in the Bassa country of southern Cameroon the mean size of farms cultivating only food crops was reported as 0.72 ha (CHAMPAUD, 1973) (Fig. 1-3). GUYER (1977) reports from the Lékié area of southern Cameroon that 0.3-0.4 ha are sufficient to feed a family of 4 people and that this area is cultivated by one woman. Similar conditions are reported from northern Ghana (HUNTER, 1972) where a farmer supports a family of 3-4 heads with only 0.4 ha (see also Appendix Table A 3).

On average a farm consists of 4-5 plots of 0.2 ha each. These may be located at a considerable distance from the village. Therefore, up to 30 % of the farmer's working time could be lost solely in walking to and from the fields (FLINN, JELLEMA and ROBINSON, 1975).

The average family size is 5-7 in the forest areas and slightly higher in some savanna areas, where the traditional family organisation still exists (for example in the northern parts of Togo and Benin the family size is greater than 10). The average family has 2-3 active members (3-4 in some savanna areas) cultivating an area of 0.5 ha each (see App., Tables A 2 a-g).

African farmers devote on the average only half of their time (1,200 hrs/year) to field work. The rest of the time is absorbed by construction works, off farm occupations and social obligations (NORMAN, 1978; NWEKE and WINCH, 1980).

Figure 1: Size distribution of fields in the Bassa country of southern Cameroon (CHAMPAUD, 1973)

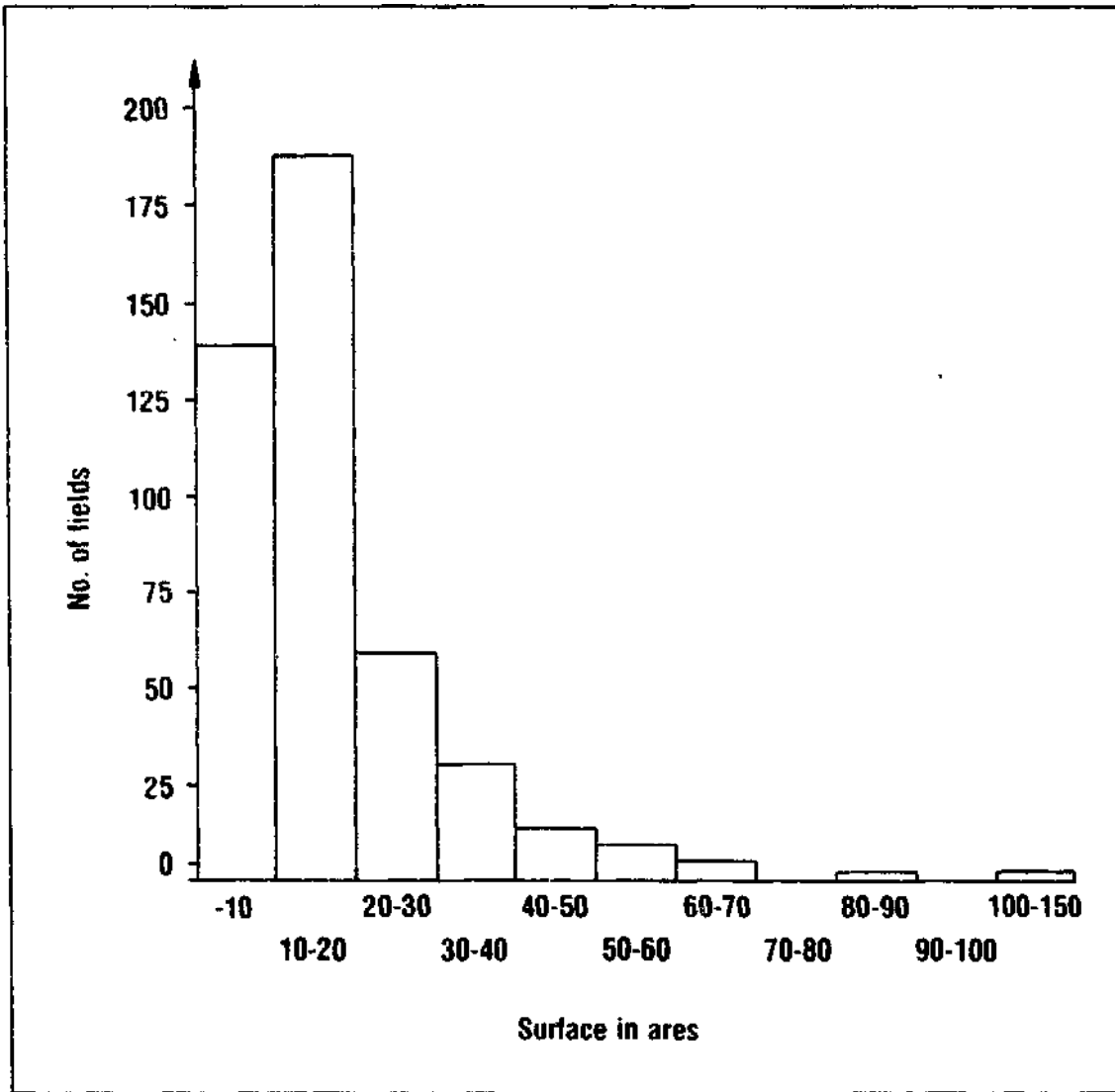



Figure 2: Area of food crops cultivated per head, Bassa country, southern Cameroon (CHAMPAUD, 1973)

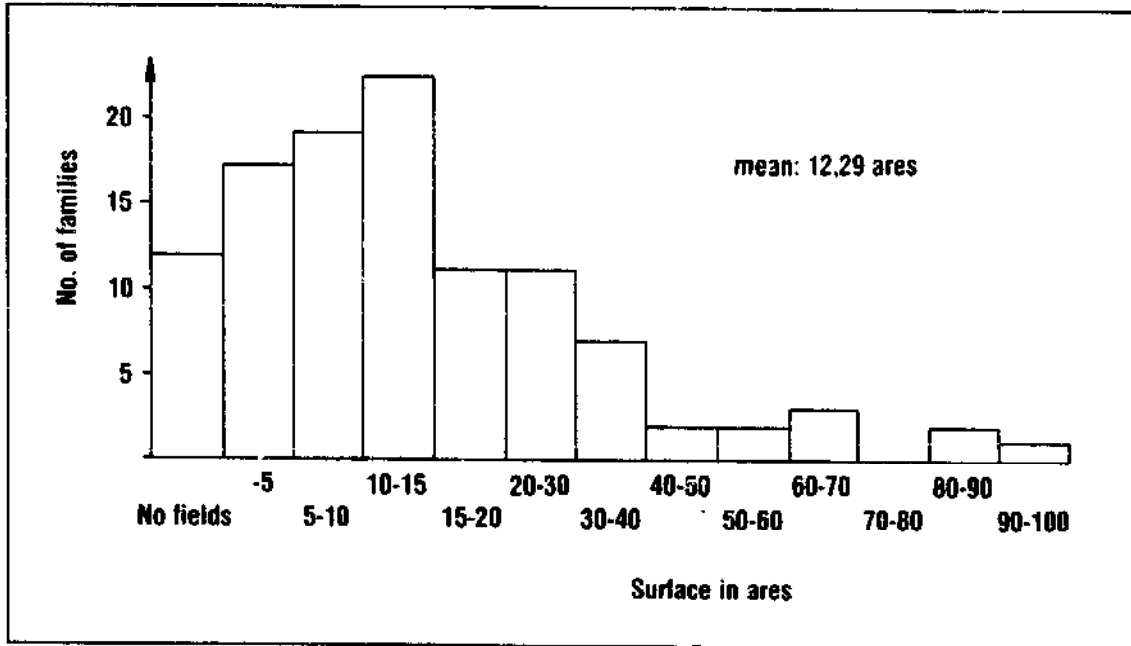
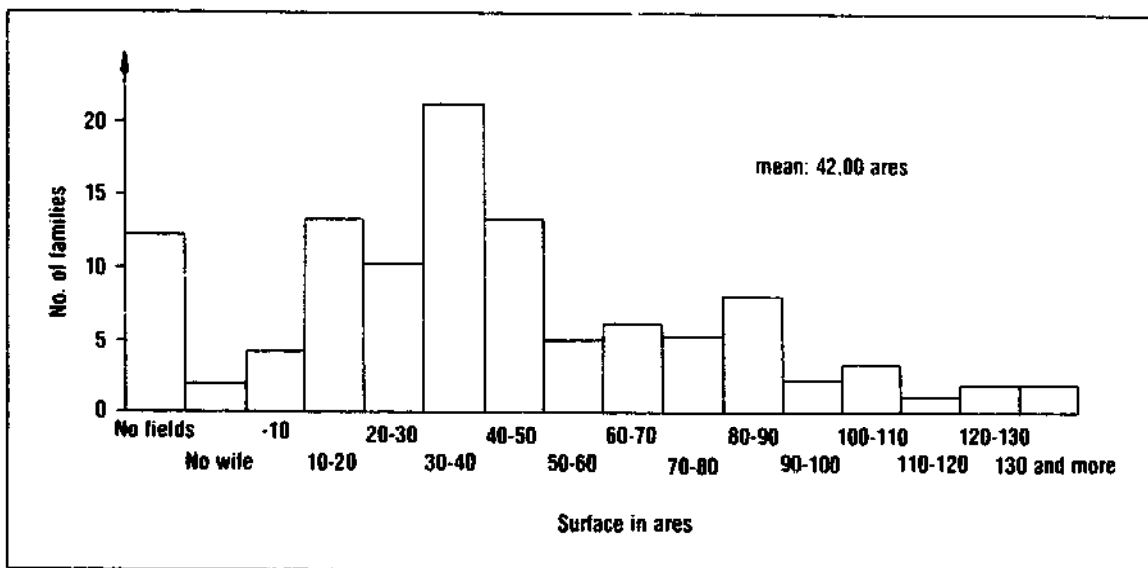

Figure 3: Area of food crops cultivated per woman, Bassa country, southern Cameroon (CHAMPAUD, 1973)



Smallholder agriculture is mainly subsistence agriculture. This is to say, the primary objective of production is to satisfy the food needs of the family, but not to produce for the market. Only surpluses are marketed (Table 3). (See also Chapter 4)

Table 3: Percentage of total production of main food crops marketed by farmers in Eastern Cameroon (adapted from ATAYI and KNIPSCHEER, 1980)

Crop	Total production <sup>1)</sup> kg	Consumption <sup>1)</sup> kg	Sale <sup>1)</sup> kg	Sale <sup>1)</sup> %
Maize	870	600	270	31
Groundnut	390	210	180	46
Plantain	1090	720	370	34
Melon (egusi)	560	400	160	29
Cassava	930	660	270	29
Cocoyam	860	630	230	27

1) Means of 216 holdings.

The rural exodus to urban centres and the plantation sector, motivated by different reasons, such as hard farm labour, attractiveness of urban life, and also education policies, has led to a scarcity of labour. In many areas only old men, women and children remain in the villages (e.g. Mossi Plateau (MARSHALL, 1977), parts of southern Nigeria). Besides causing a shortage of labour, the emigration of the male population has the secondary effect of making the introduction of innovations more difficult, because the older men are less interested in changes and the women are overburdened with field- and housework, and therefore not open to innovations.

The shortage of labour could be at least partially overcome by an increase in labour productivity, for example by introducing animal

traction. However, most farmers do not keep animals that could be used for cultivation, especially in the humid and semi-humid tropics. Efforts to integrate animals into farming systems have mostly failed because of disease problems and for sociological reasons.

### 2.3 The Importance of Intercropping for Food Production in West Africa

As stated in the previous paragraph, tropical African agriculture is dominated by smallholdings and smallholdings practise mainly intercropping (OKIGBO, 1978). The extent of intercropping, i.e. the ratio between areas under sole and under mixed crops depends on different factors such as the ecological zone, farm size and crop species, and so varies from region to region. On the average, however, 80 % of the cultivated area in West Africa is under mixed cropping. The percentage is higher in the anglophone than in francophone countries due to the influence of the former colonial administration and, after independence, of technical advisers. Figures from Nigeria, Ghana and the Ivory Coast reveal the predominance of intercropping and also demonstrate regional differences as well as differences between crops (see App., Tables A 4 a-c).

Yam, for example, is cultivated to a large extent as a pure crop in the main yam growing area of the Guinea Savanna (e.g. Brong-Ahafo in Ghana), while it is always mixed as a subsidiary crop in the forest areas. An exception is given by Nigeria where yam is a main crop in forest areas, too. The same is true of forest areas in south-western Cameroon in villages with Nigerian immigrants. In the Ivory Coast, too, Baoulé immigrants from the Southern Guinea Savanna have brought intensive cultivation of yam with them to cocoa growing forest areas.

Intercropping is generally more pronounced in forest than in savanna areas, as the holdings and fields are smaller in size and as there is a greater number of crop species. In the forest areas

perennial crops (cocoa, coffee, cola, oil palms, etc.) are an integral part of all cropping systems (multi-storey cropping), and the possibility of planting and harvesting nearly all the year round also favours intercropping. In eastern Nigeria, 62 different useful plant species were counted on a single field (a bush farm) (LAGEMANN, 1977), while in southern Cameroon 29 edible species and, in addition, tobacco, were counted (MUTSAERS, MBOUEMBOUE, and MOUZONG BOYOMA, 1978) (See also App., Tables A 5 and A 6). This number increases further if we take into account, that of the most important crop species several different varieties are always planted (e.g. in Cameroon mostly 4 cassava, 2-4 sweet potato, and 2-3 cocoyam (Xanthosoma sp.) varieties). The figures cited include all useful plant species cultivated on a farm. But even if we consider only the main food crops, quite a number (5-10) still remain.

The number of crops decreases as the distance from the house increases. The highest diversity is found on compound farms, while diversity is lowest on remote bush farms. (Farmers visit remote fields as little as possible, to avoid a loss of time for walking and therefore plant only a reduced number of crops.) Increasing field and farm sizes are also related to a decreasing number of crops (HOUYOUX, 1979). When studying the situation in a village in eastern Nigeria, IGBOZURIKE (1978) found 17.8 of 20 important crops on the compound farm, 12.2. crops on the second field, 11.8 on the third, 8.0 on the fourth and 5.6 on the fifth field. Crop matrices of several fields are shown in Table 4.

An example of high diversity is also given by OKIGBO (1978) who counted up to 11 different species on individual yam mounds in South eastern Nigeria (Table 5).

In the drier areas of the Northern Guinea and the Sudan Savanna the number of cultivated crops is of course reduced, because for example, no perennial crops are grown except tree crops such as Parkia sp. and Butyrospermum sp., but a considerable number of crop species still remain. In eastern Upper Volta, for example, 21 different crop species were counted in the fields (SWANSON, 1979).

Table 4: Crop matrices on selected farms of a village in eastern Nigeria (IGBOZURIKE, 1978)

F 133					F 102					F 99					F 42					F 12					Farm No.
1	2	3	4	5	1	2	3	4	5	1	2	3	4	5	1	2	3	4	5	1	2	3	4	5	Field No.*
x	x	x	x		x	x	x			x	x				x	x	x			x					Banana
x					x	x	x	x		x	x	x	x		x	x	x	x		x	x	x			Cassava
	x	x			x	x	x	x		x	x				x	x	x			x	x				Cocoyam
x	x				x					x	x	x	x		x	x	x	x		x	x				Cowpea
x										x	x	x										x	x		Groundnut
	x				x	x	x			x	x				x	x				x		x	x		Kola
x	x	x			x	x	x	x		x	x	x			x	x	x					x	x	x	Locust bean
x	x				x	x	x			x	x	x			x	x	x	x		x	x	x			Maize
x					x	x				x	x				x	x	x			x	x	x			Melon
	x	x	x	x	x					x	x				x	x				x	x	x	x		Oil bean
x	x	x	x		x	x	x	x		x	x	x	x		x	x	x	x		x	x	x	x	x	Oil palm
	x	x			x		x	x							x	x	x	x		x	x	x	x		Orange
x	x	x	x		x	x	x			x	x	x			x	x	x	x		x	x	x	x	x	Pepper
	x	x			x	x	x			x	x	x			x	x	x	x		x	x				Pigeon pea
x					x					x	x				x	x				x	x				Pineapple
	x				x	x	x			x	x				x					x	x	x	x		Plantain
x	x	x			x	x				x					x	x	x	x		x	x				Sweet potato
x					x					x					x	x				x					Tomato
x	x	x			x	x	x			x	x				x	x	x	x		x	x	x	x	x	Vegetables
x	x	x	x		x	x	x			x	x	x	x		x	x	x			x	x	x	x		Yam

\*Field No. 1 = compound farm. Distance of field from the compound increases from No's 1 to 5.

Within the same ecological zone cropping systems vary with the soil quality. Thus, when describing the cropping systems of the Bamiléké country in the Cameroon Highlands, VALET (1976) states that the crop associations change with soil fertility not only in quantity but also in quality. With increasing soil fertility the number of species in the associations rises from 7 to 14.

Table 5: Crop combinations on yam mounds of various sizes\* in south-eastern Nigeria (OKIGBO, 1978)

Crop	Locations and Mound Sizes															Percentage Frequency
	Emene			Nkalagu Junction			Ezillo			Abakaliki			Ikom			
	Mound Size 0.8x1.3m			Mound Size 1x3m			Mound Size 0.9x2m			Mound Size 1.3x3m			Mound Size 0.4x1.5m			
	No	No	No	No	No	No	No	No	No	No	No	No	No	No	No	
	1	2	3	1	2	3	1	2	3	1	2	3	1	2	3	
1. Dioscorea rotundata	x			x	x	x			x	x	x	x	x	x	x	80
2. D. alata	x	x	x	x	x			x		x			x			53
3. D. bulbifera	x	x	x	x				x	x							40
4. D. cayenensis		x						x	x							20
5. D. dumetorum											x	x	x			20
6. Cassava (Manihot sp)	x	x	x	x	x			x	x	x	x	x	x			73
7. Cocoyam (Xanthosoma sp)								x						x		13
8. " (Colocasia sp)		x	x	x	x					x						33
9. Maize (Zea mays)	x	x	x	x	x	x	x	x	x				x	x	x	80
10. Cowpea (Vigna sp)	x			x	x											33
11. Pigeonpea (Cajanus sp)	x	x														13
12. Bambara groundnut (Voandzeia subterranea)										x		x				13
13. Groundnut (Arachis sp)						x	x	x	x	x	x	x	x	x	x	67
14. Okra (Hibiscus sp)	x			x	x			x	x	x			x		x	53
15. Solanum sp									x							7
16. Pumpkin (Cucurbita spp)			x					x	x							33
17. Melon (Citrullus spp)									x	x	x		x	x	x	40
18. Telfairia sp		x														7
19. Talinum triangulare														x		7
20. Lagenaria sp	x		x	x	x					x	x					40
21. Capsicum spp							x	x	x							33
No. of species per sample	9	8	8	9	8	2	9	9	11	7	6	7	4	6	5	

\* First figure indicates height of mound, second figure the basal diameter.

Coffee (arabica), plantain, Irish potato and vegetables appear, while bambara nut, cowpea and sweet potato disappear and groundnut, cocoyam, and yam (D. dumetorum) decrease in number. On fertile soil there is a very high planting density and a nearly complete soil cover. The variations can take place within short distances.

Social and cultural conditions as well as ecological and economic conditions also influence cropping systems. Thus, in the Ewondo country of southern Cameroon, for example, 64 % of the fields are under 5 crops, whereas in the neighbouring Bassa country under the same environmental and economic conditions more than half of the fields are under only two crops (IRAT, 1977). Similar examples exist in other countries. Food preferences also play an important role, as can be observed when farmers having migrated from other areas continue to grow certain crops, even if they are not well adapted to local conditions.

The number of crop mixtures rises exponentially with the number of crops. While the number is nearly unlimited in forest areas, 156 crop combinations were still counted in northern Nigeria (NORMAN, 1974). There are some predominant crop combinations in every agro-ecological zone. In the forest areas of Cameroon and Ghana, the predominant cropping system consists of 5 crops (leaving tree crops aside): groundnut, maize, cassava, cocoyam (Xanthosoma sp.) and plantain (ATAYI and KNIPSCHEER, 1980; KARIKARI, 1977; BRUCE, 1980). In the Ewondo country of southern Cameroon, for example, 64 % of the plots were planted with this mixture (IRAT, 1977). Or in the Zaria region of northern Nigeria 7 crop mixtures accounted for about 51 % of the cultivated land, the most common sorghum/millet intercrop occupying already 26 % of the land (NORMAN, 1974) (Table 6).

As mentioned earlier, cropping patterns depend on farm and field size, and so they also depend on population density. In more densely populated areas the crop diversity is high and tree crops play an important role. This can be observed in the lowland tropics, e.g. eastern Nigeria (LAGEMANN, 1977), as well as in the

tropical highlands, e.g. in the Bamiléké country of Cameroon.

As the population density increases, however, not only the number of crop species per field, but also the plant density rises, leading to a general increase in intensity. In eastern Nigeria the maize population in a maize/cassava/yam intercrop rose from 400 stands/ha (4 plants/stand) in a low density area to 3,640 stands/ha (5 plants/stand) in a high density area. Simultaneously, the plant density of the component crops also increased (LAGEMANN, 1977) (Table 7). In southern Cameroon the plant density of all crops except groundnut rose in more highly populated areas. Plant density of plantain increased by nearly 50 % (IRAT, 1977) (Table 8). It is assumed that the optimum plant density is already exceeded in densely populated areas, because of low soil fertility resulting from short fallow periods.

Table 6: The seven most frequent crop mixtures in Zaria province, northern Nigeria (Percentage of cultivated land occupied by these mixtures) (NORMAN, 1974)

1. Millet/sorghum	25.8 %
2. Millet/sorghum/groundnut/cowpea	5.4 %
3. Millet/sorghum/groundnut	5.0 %
4. Cotton/cowpea/sweet potato	4.3 %
5. Millet/sorghum/cowpea	3.9 %
6. Cotton/cowpea	3.9 %
7. Sorghum/groundnut	2.8 %



Table 7: Plant densities of common crop mixtures found on outer fields in three villages in eastern Nigeria, June 1974 (LAGEMANN, 1977)

Crop mixtures	Stands per ha (plants per stand)						
	Cassava	Yam	Cocoyam	Maize	Melon	Groundnut	Telfairia Beans Vegetables Okra
a	Okwe <sup>1)</sup>	7800 (3-4)	300 (1)	400 (4)			
		7975 (3-4)		1456 (4)	1194 (1)		
	Umuckile <sup>2)</sup>	7400 (3)	1000 (1)	350 (4)			
b		8600 (3)		1158 (4)		13000 (1)	
	Owerre-Ebeiri <sup>3)</sup>	11200 (1)	12050 (1)	3640 (5)			
		19600 (1)		1100 (5)	1675 (1)		
c	Okwe	6100 (3-4)		1625 (4)	850 (1)		300 (1)
		8333 (3-4)	1133 (1)	2667 (4)	925 (1)		
	Umuckile	6600 (3)	1500 (1)	3000 (1)	250 (4)	9500 (1)	
d		6224 (3)	950 (1)	440 (4)			
	Owerre-Ebeiri	14500 (1)		24700 (1)	1820 (5)		900 (1)
		4800 (1)		30500 (1)	5040 (5)		6700 (1)
e	Okwe	5800 (3-4)	1100 (1)	2138 (4)	1263 (1)		700 (1)
		5733 (3)	4167 (1)	4967 (1)	467 (4)		933 (1)
	Umuckile	13700 (3)		3000 (1)	2175 (4)	2200 (1)	2300 (1)
f	Owerre-Ebeiri	19700 (1)		24600 (1)	5900 (5)		700 (1)
		23300 (1)	15400 (1)	3200 (1)	1480 (5)		1300 (1)

1) low density area 2) medium density area 3) high density area.

Table 8: Plant densities of major crops in a low and a highly populated area of southern Cameroon (IRAT, 1977)

Component crops	High population density (plants/ha)	Low population density (plants/ha)
Groundnut	94 000	103 000
Maize	2 600	2 000
Cassava	2 300	1 800
Cocoyam (Xanthosoma sp.)	3 300	2 600
Plantain (Musa paradisiaca)	472	319

Crop mixtures can be classified by the number of component crops. While in the forest areas 3- to 5-crop mixtures dominate, 2-crop mixtures are prevalent in the Northern Guinea and the Sudan Savanna. In northern Nigeria, for example, more than 40 % of the land is under 2-crop mixtures such as millet/sorghum, sorghum/groundnut, etc. (NORMAN, 1974) (Table 9). The same is true of Upper Volta (MATLON and BONKIAN, 1980; McINTIRE, 1981).

Mixed cropping patterns have a space and a time component. The space component is the spatial arrangement of the component crops, i.e. the cropping pattern. The cropping pattern influences competition, mainly for light, between the component crops.

Cropping patterns are determined by the environment. In forest areas, regular spacing is rarely found because it is difficult to achieve due to trees, fallen trees and stumps. Farmers make use of slight changes in soils and topography by planting, for example, cocoyam on concentrations of organic materials, and rice in depressions. This kind of planting is also called patchwork, as crops are not mixed regularly but planted in patches of different size and form.

Table 9: Important crop mixtures and percentage of land devoted to mixture of one to six crops in Zaria province in northern Nigeria (NORMAN, 1974)

No. of crops in the mixture	Crops	Percentage of cultivated area
Sole crops	sorghum, groundnut, cotton	16,6 %
2 crop mixtures	millet/sorghum, sorghum/groundnut, cotton/cowpea, other combinations	42,1 %
3 crop mixtures	millet/sorghum/cowpea, millet/sorghum/groundnut, cotton/cowpea/sweet potato, other combinations	23,7 %
4 crop mixtures	millet/sorghum/groundnut/cowpea, other combinations	12,1 %
5 and 6 crop mixtures		5,5 %

In some areas, however, and especially on older fields, planting is more regular, as in parts of south-western Nigeria where cassava and maize are planted on mounds, that are spaced approximately 1m x 1m apart. The same is true of yam in the Southern Guinea Savanna.

In savanna areas with ridge cultivation spacing is quite systematic. The crops are placed at regular intervals on the ridges (Fig. 4) Even without using a measure, the ridges are constructed at more or less equal distances apart. The introduction of animal traction is relatively easy under these conditions since no change of cropping patterns is required.

A special form of intercropping has developed in some areas with frequent waterlogging. In parts of Togo, Benin and Nigeria yam mounds can reach considerable dimensions and mounds of 1m height with a base diameter of 2-3 m can be found. The sides of the mounds are planted with different crop species (Table 5). Rice grows on

on the bottom between the mounds. An example from eastern Nigeria is given by OKIGBO and GREENLAND (1976) (Fig. 5).

Cropping patterns as defined above are twodimensional. However, with the integration of tall perennials, such as bananas and trees, they become threedimensional. As the canopies of the crops from different storeys, such cropping systems are called multi-storey systems (see App., Fig. A4).

Multi-storey systems are quite common in the humid tropics. The uppermost storey is often formed of giant forest trees, the second storey of coffee as well as cocoa trees mixed with plantains, and the lowest storey of annual, arable crops. From an ecological point of view, multi-storey cropping is regarded as the ideal form of crop production in rain forest areas, as it resembles the natural vegetation. In fact, multi-storey systems help to reduce erosion and to maintain soil fertility. On the other hand, radiation is already low in the lowland humid tropics and a limiting factor on crop production. Additional shading by trees can lead to further reduction in yields (see Paragraph 3.1.1, 3.4.1, Table 14). A multi-storey plant formation with perennial and annual crops is typical of compound farms in the humid tropics, but also quite common in the semi-arid tropics (SAT).

The following classification, based on village studies in eastern Nigeria, is cited from LAGEMANN (1977) who divided the crops into two different groups as a function of their height.

#### Tree crops

- Oil palms, coconuts (20-25 m);
- Breadfruit, raffia palm, oil beans, avocado (12-20 m);
- Colanut, mango (8-15 m);
- Orange, grapes, lime, paw-paw (5-10 m);
- Bananas, plantains (3-8 m).

#### Arable crops

- Yam (3-6 m);
- Maize (1.5-2.5 m);
- Cassava, cocoyam, pepper, telfairia (1-2 m);
- Groundnuts, melon, vegetables (0.1-0.3 m).

Figure 4: Spatial arrangement of some crop mixtures in northern Nigeria

- a. Three crop mixture: Millet/sorghum/cowpea
- b. Four crop mixture: Millet/sorghum/groundnut/cowpea

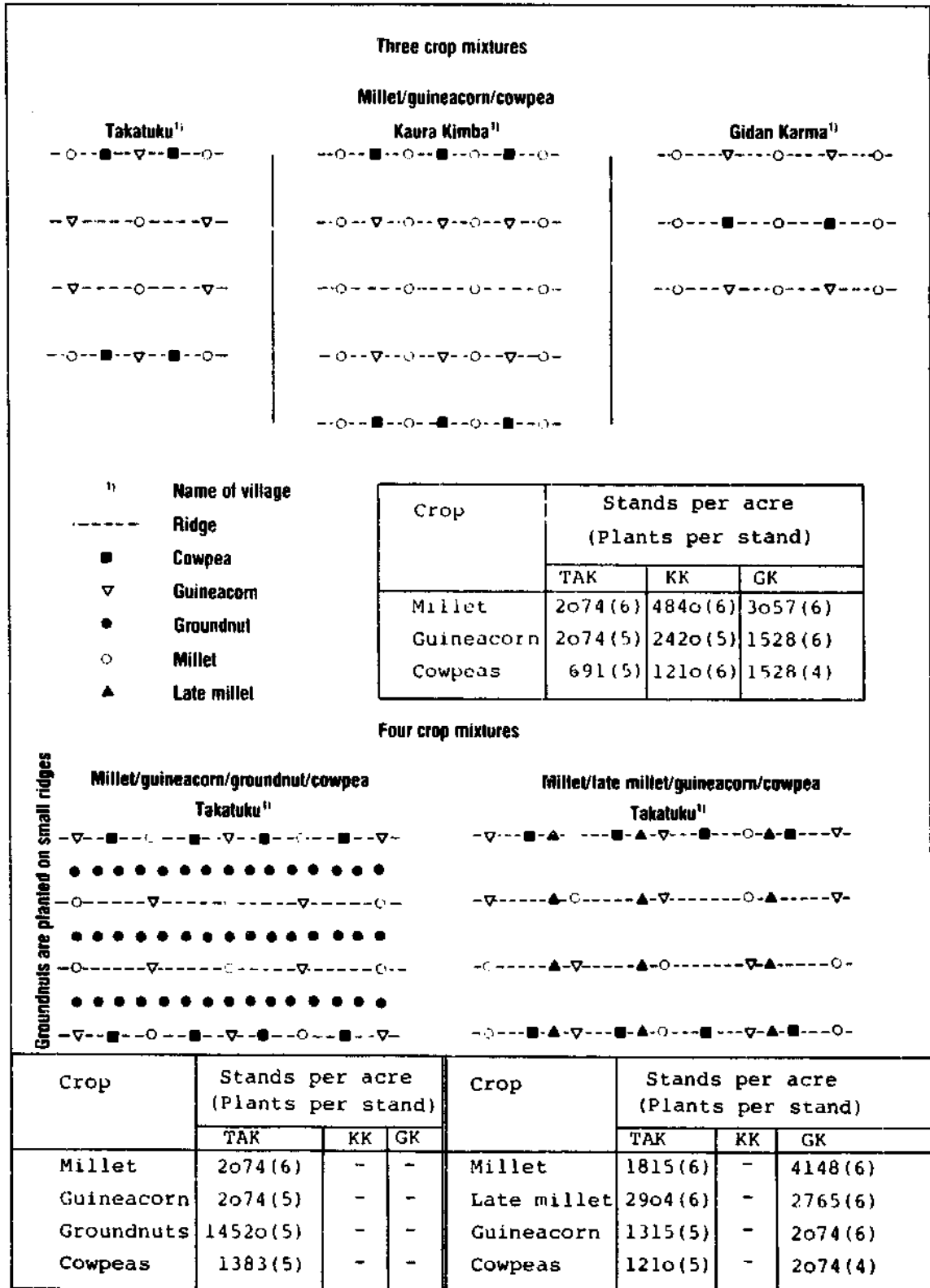
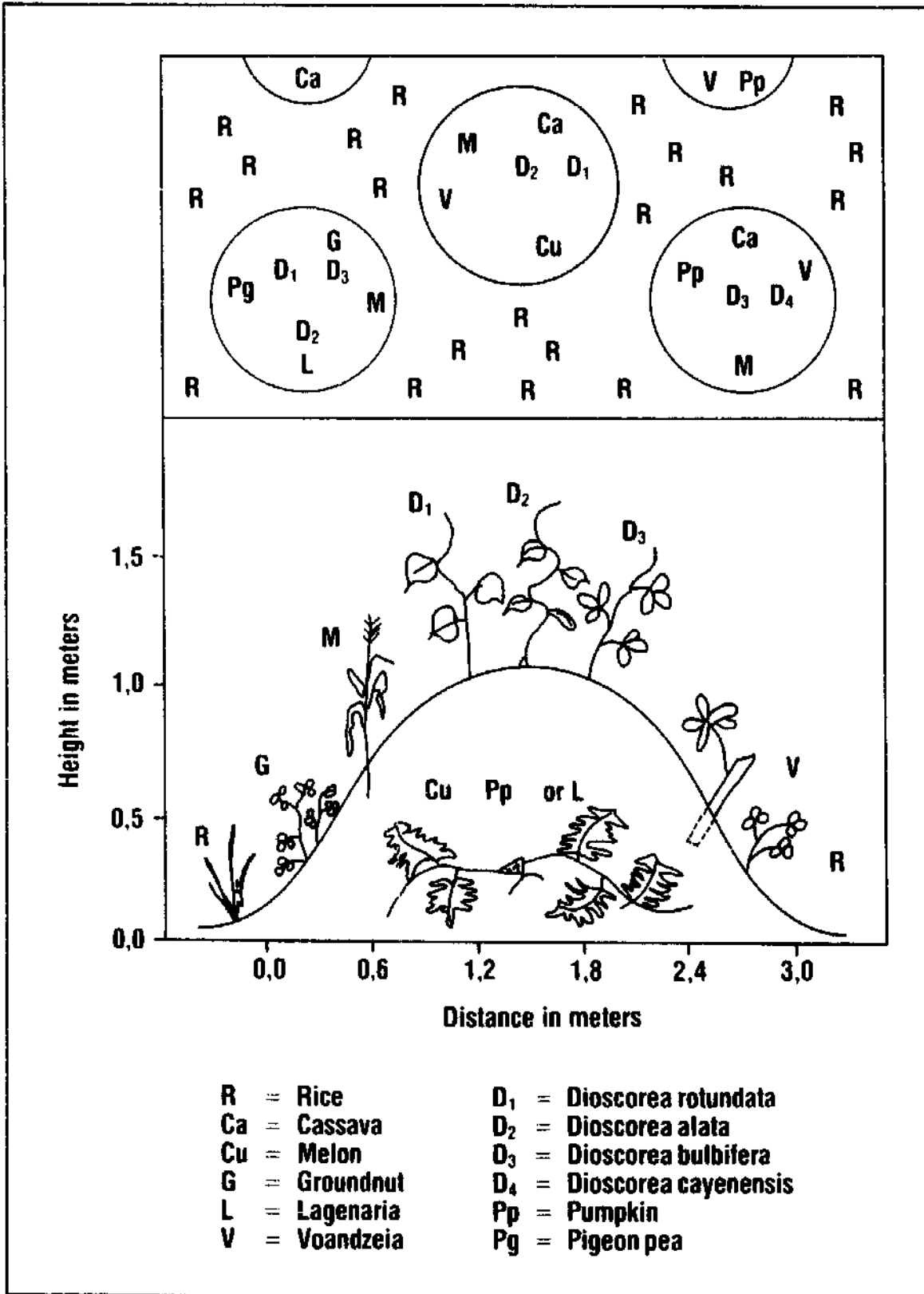

Figure 5: Spatial distribution of crops on mounds in Abakaliki, Central East State, Nigeria (OKIGBO and GREENLAND, 1976)



Time is introduced as an additional component by phased planting. Quite frequently not all crops are planted and harvested at the same time, due to differing maturity periods. Yam, for example, is planted before the onset of the rains, while maize, millet, etc. are planted only some months later, after the rainy season has begun. With cassava it is exactly the opposite. It is planted four weeks after maize, but not harvested until the following year (see Fig. 7-11). As will be discussed later (Paragraph 3.1.5), the time component significantly increases the yield advantages of intercropping systems.

The preceding paragraphs have given some idea of the importance of intercropping systems for food production in West Africa. While there are estimates of the acreage under mixed cropping, no figures are available for the percentage of food production originating from intercropped fields. However, it can be assumed, that the percentage is not much less than 80 % roughly corresponding to the acreage under mixed cropping. This means that intercropping provides the major part of the food supply of the population in West Africa and that a slight increase in productivity of these cropping systems will contribute more to the total food production than a higher increase in the output of the relatively few modern commercial farms.

#### 2.4 Description of the Principal Cropping Systems

West Africa is divided in climatic zones, forming belts of different diameters parallel to the degree of latitude (App., Fig. A 1). Rainfall is generally decreasing from South to North (App., Fig. A 2). While rainfall distribution is characterized by a single peak (monomodal) in the Sudan and Northern Guinea Savannas there are two rainy seasons (bimodal) in the Southern Guinea Savanna and Rain Forest. These climatic zones correspond to vegetation or agro-ecological zones (PAPADAKIS, 1965; FAO, 1978) (see App., Fig. A 3 and Table A 7). Thus we can find in each vegetation zone characteristic cropping systems based on one or more crops typical for that environment (Fig. 6).

Figure 6: Crop ecological zones of West Africa (Adapted from PAPADAKIS, 1965)

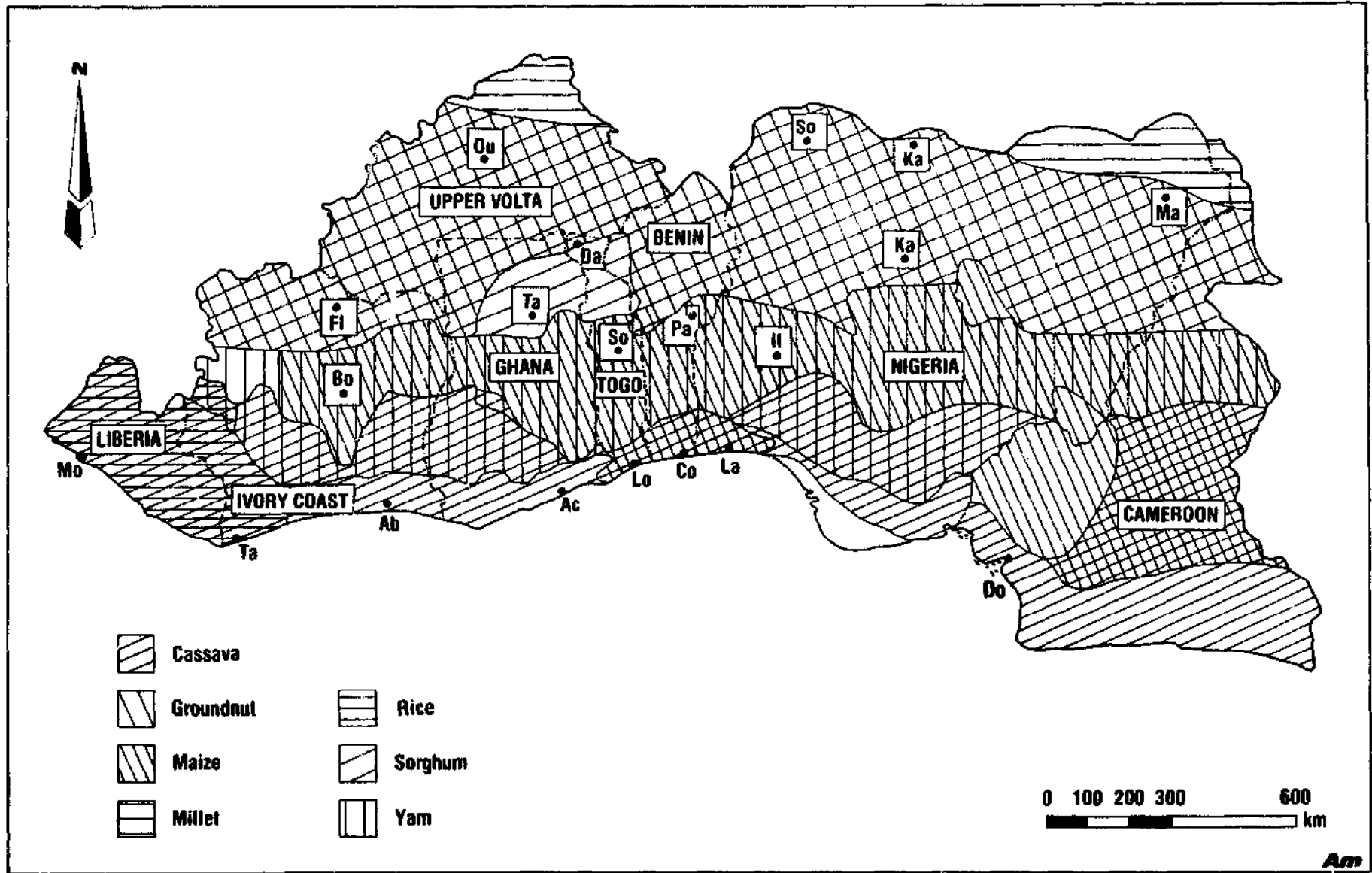



As there exists already an immense number of publications, describing traditional cropping systems of various parts of Africa, in the following only a simple classification of these cropping systems is given based on the most characteristic and/or most important food crop of the respective region. This crop is in most cases opening the rotation after a fallow period. But it is not necessarily the most important staple food, in respect to total production (see also App., Table A 9 a-g).

#### 2.4.1 Cassava-Based Cropping Systems

Even though cassava is most common in the forest region and in the Southern Guinea Savanna, really cassava-based cropping systems are mainly found on the poor sandy soils of the coastal belt. Here, food crops other than cassava hardly give satisfactory yields, except coconut or oil palms. Cassava is commonly associated with maize and cowpea (see App., Table A 9 b).

With increasing length of the cultivation period and decreasing soil fertility, cassava becomes the predominant staple crop in many regions of the rain forest and Southern Guinea Savanna, replacing especially other root and tuber crops like cocoyam and yam, and to some extent maize.

Figure 7: Cropping calendar of a plantain based cropping system in southern Cameroon

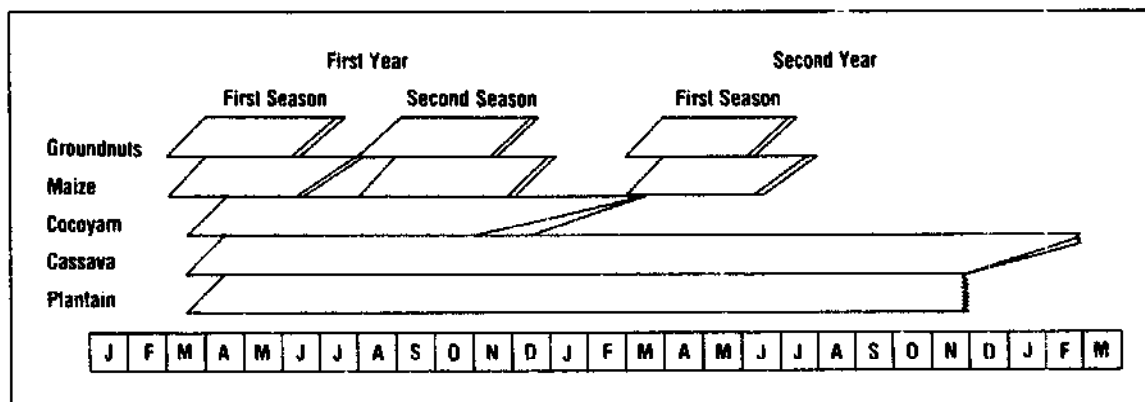

#### 2.4.2 Plantain-Based Cropping Systems

Plantain-based cropping systems are predominant in the forest areas from the Ivory Coast to Cameroon, the only exception being the eastern part of Nigeria where yam is the principle crop. Major food crops in this system are plantain, cocoyam, maize and cassava. The relative importance of each crop may vary, often even within short distances, so that maize or cassava may become the major staple food.

Plantain and cocoyam are planted after clearance at the beginning of the season; maize is planted after the onset of regular rains. Cassava closes the rotation being planted only in the second and third year and growing into the bush fallow.

Secondary crops are yam and groundnut (the first is a major crop in Nigeria and the latter is a major crop in southern Cameroon). Diverse crops, mainly vegetables and spices such as okra, red pepper, etc., are planted at a low density among the main crops (Fig. 7). Maize is generally gaining in importance since it requires relatively little labour and is in high demand, even though it is not well adapted to the environment and owing to low radiation and high night temperature (CHANG, 1981) yields do not exceed 3 t/ha. Cassava production is increasing, too, and often replaces yam and cocoyam, because it is easier to cultivate, gives higher yields, is better adapted to poor soils, and last but not least, is easier to process, transport and store. Tree crops, such as oil palm, kola, mango, orange and papaya often grow at random in the fields (see also App., Table A 9 a).

#### 2.4.3 Yam-Based Cropping Systems

In the Guinea Savanna (Middle Belt) cropping systems are traditionally based on yam. Here unpredictability of rainfall is high and yield stability of most crops is low due to periodical water stress

during the growing season. This is especially true for the Southern Guinea Savanna and the Transition Zone (Derived Savanna). In Ivory Coast (Bouaké region), for example, in 2 to 3 years out of ten there is a water deficit in the second and third decade of May (and similar deficits occur in July, August and October) (FRANQUIN, cited from JACOB, 1977) resulting in significant yield depressions of maize. Yam, even though it can also suffer from water stress, gives still the most stable yields under these conditions. This is probably the reason for its importance in this climatic zone.

Yam is normally planted after clearance in the first year. Early and late yam (*D. rotundata* and *D. alata*) are usually planted in the same field, either mixed or in separate plots. It is often interplanted with cowpea or low populations of maize, cassava, vegetables and plantain. Yam is a men's crop (see Paragraph 4), with men preparing the land, planting the yam and selling the harvest. Women help in weeding and interplant "their" crops at the foot or between the mounds (Fig. 8).

In the second year maize and/or rice are planted, also intercropped with various minor crops, and the cassava of the first year. Groundnut and cowpea are the main legumes. While cowpeas are always intercropped, groundnuts are for the major part cultivated on separate small plots, only occasionally being interplanted with very low populations of maize or cassava.

Maize and cassava are also gaining in importance in this climatic region, as they are easier to cultivate, store, process and transport than yam. Another reason is, that yam is exclusively a men's crop. When men migrate to urban areas, the women remaining switch over to maize and cassava (see also App., Table A 9 d).

Figure 8: Cropping calendar of a yam-based cropping system  
(OKIGBO and GREENLAND, 1976)

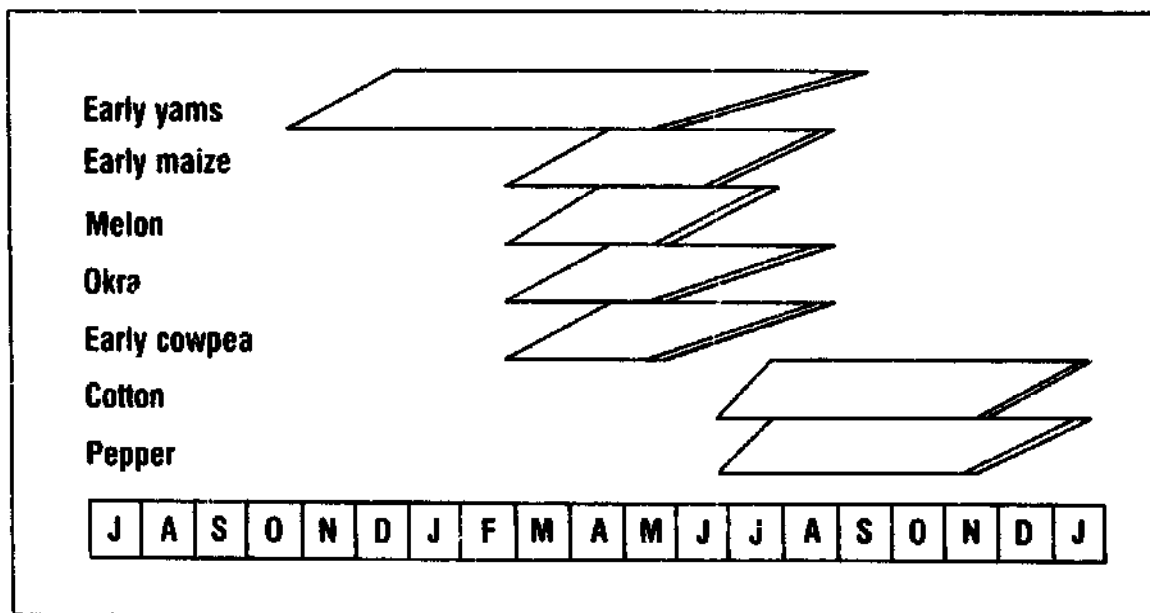

#### 2.4.4 Rice-Based Cropping Systems

Rice-based cropping systems (upland rice) are common in the high rainfall areas from the western Ivory Coast to Sierra Leone. Here the field is opened with rice, which is planted with the first rains and interplanted later with maize and cassava as well as vegetables and spices (Fig. 9).

As usual, the cassava is not harvested until the second and third year. Rice is planted mainly as upland rice, while in the other parts of West Africa it is usually planted as a pure crop (swamp rice) in valley bottoms (bas-fonds) (see also App., Table A 9 f).

Figure 9: Cropping calendar of a rice-based cropping system in Sierra Leone (OKIGBO and GREENLAND, 1976)

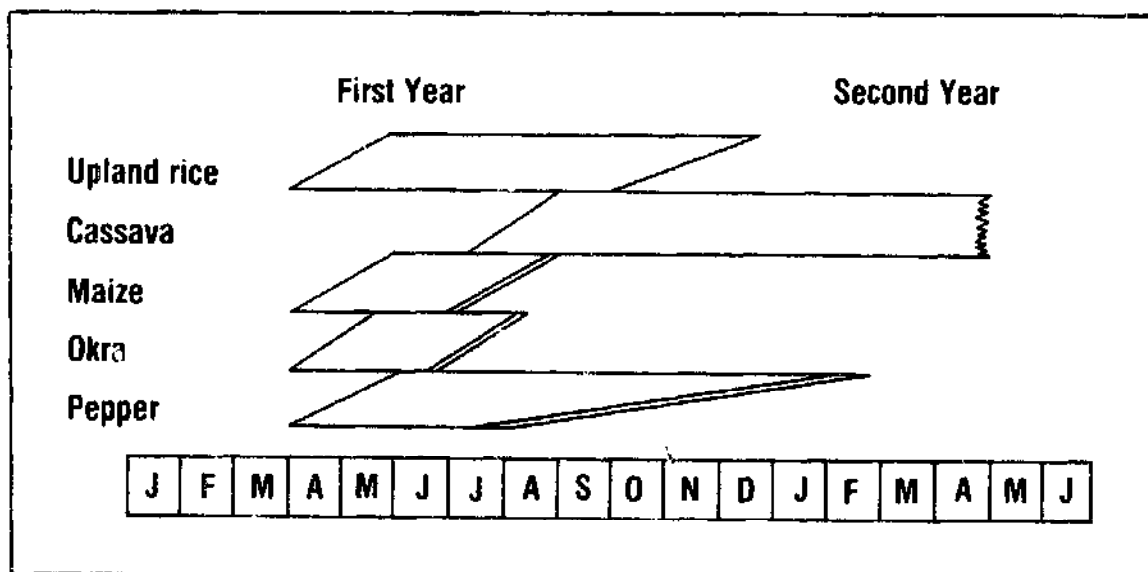

#### 2.4.5 Sorghum-Based Cropping Systems

Sorghum-based cropping systems are typical of the Northern Guinea and the Sudan Savanna. Major crops in the systems are millet, maize (only in the Guinea Savanna), groundnut and cowpea (Fig. 10). In most areas two different types of sorghum (red and white) are grown. Red sorghum is preferred for brewing beer and is normally planted on the more fertile soils.

In some parts of the Sudan Savanna, e.g. in Upper Volta, sorghum is often planted as a sole crop. Here groundnut and bambara nut (*Voandzeia subterranea*) are planted by the women on separate fields, while millet is planted on the poorer and more shallow soils of the catena (e.g. on top of hills) (see also App., Table A 9 g).

Figure 10: Cropping calendar of sorghum-based cropping systems in the Sudan Savanna of Nigeria (NORMAN, 1973)

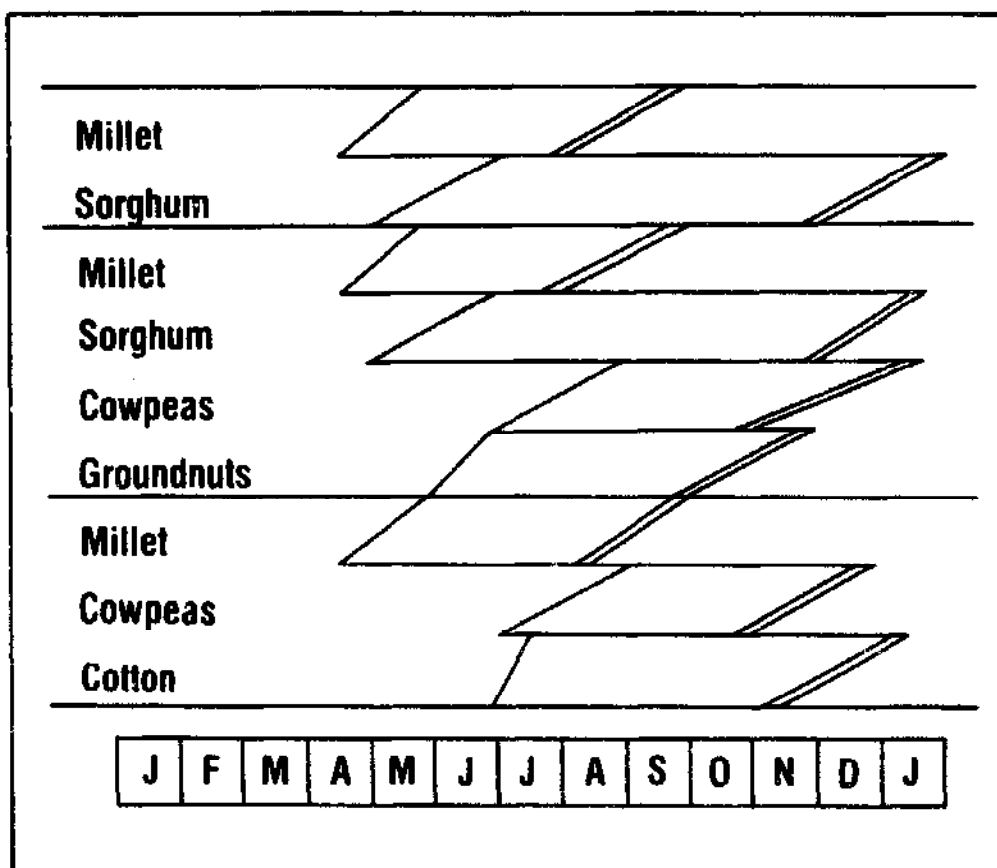

#### 2.4.6 Millet-Based Cropping Systems

With decreasing rainfall (less than 600 mm) millet becomes the pre-dominant food crop in the Northern Sudan Savanna and the Sahel. The choice of crops is rather limited because of uncertain rainfall distribution and the short duration of the growing season. Millet/groundnut and millet/cowpea are the most important cropping patterns of this region (see also App., Table A 9 h).

### 2.4.7 Maize-Based Cropping Systems

Even though maize is an important staple food in the rainforest and in the Guinea Savanna, it is best adapted to the tropical highlands where it has the highest production potential. Major food crops associated with maize are cocoyam, yam, bean and groundnut (Fig. 11). Because of the relative low rainfall variability in the highlands, yield stability of maize is rather high (see also App., Table A 9 c).

As already mentioned at the beginning of this chapter, traditional cropping systems are very flexible and well adapted to the local environment, physically as well as socially. As a consequence, the basic cropping systems described, vary under the influence of climate, soils, topography, land tenure, access to markets, food preferences, etc. Variations relate mainly to the choice of component crops as well as varieties, planting time, spatial arrangement, and planting density.

Figure 11: Maize-based cropping systems in the Cameroon Highlands

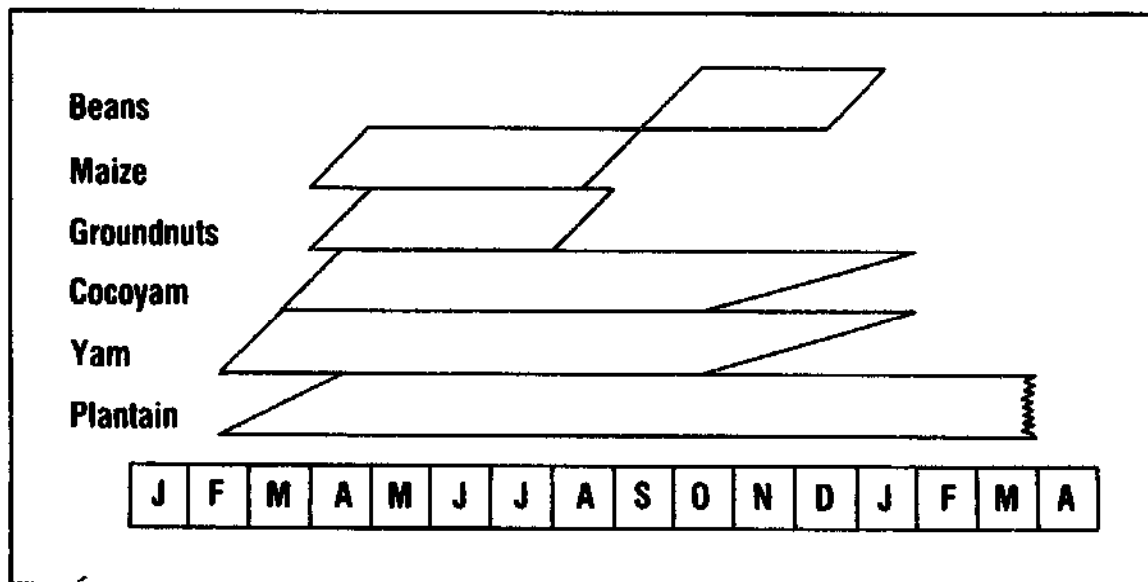

### 3. AGRONOMIC ASPECTS OF INTERCROPPING

In the previous chapter the predominance of intercropping in West African agriculture was pointed out. This is in striking contrast to the importance paid to intercropping in agricultural research in the past. Systematic research on intercropping has started only recently, about 10 years ago. Therefore it is not surprising that our understanding of intercropping systems and of methods for their improvement is still limited. It must be admitted, however, that considerable basic knowledge on interspecific competition among pasture plants had already existed (DE WIT, 1960; DONALD, 1963; DE WIT and VAN DEN BERGH, 1965).

In the following paragraphs a review is given of research results concerning different aspects of crop associations, such as plant interactions, breeding for intercropping systems, fertilizer use in intercropping systems, pests and diseases in intercrops, and, last not least, experimental designs for intercropping trials. As not enough results are available from African research institutes figures and examples from other regions had to be used, too. Even then many open questions remain in the different paragraphs. One aim of the review is therefore, to emphasize the need for more research on intercropping systems.

#### 3.1 Plant Interactions in Intercropping Systems

An examination of some concepts of how plants react in mixtures is an appropriate first step towards understanding intercropping.

##### 3.1.1 Intercrop Competition

Botanists define "plant interference" as the response of an individual plant or species to its environment as modified by the



presence of another plant or species (HALL, 1974, a, b; TRENBATH, 1974). Such interference can be noncompetitive, competitive or complementary. Noncompetitive interference occurs when different plants share a growth factor (light, water, nutrients) which is present in sufficient amounts so that it is not limiting. Plant yields are not affected by this type of interference. Competitive interference, or straightforward competition, occurs when one or more growth factors are limiting. In such cases the plant or species which is better equipped to utilize a growth factor (dominant species) increases its yield at the expense of the other plant or species which suffers a yield decrease (dominated species). Complementary interference, or simply complementarity, occurs when one plant helps another, as in the case of legumes supplying nitrogen to grasses (cereals) via symbiotic fixation.

Interference occurs among plants of the same species in single stands and among plants of the same and different species in intercropped systems. Noncompetitive interference is rare in agriculture. Competition or complementarity between plants and species is the normal situation on farmers' fields. Farmers, however, have obviously selected associations with reduced competition that thus give a yield advantage. In these associations the component crops are not competing for exactly the same overall growth factors and thus inter-crop competition is less than intra-crop competition. "Maximising intercropping advantages is therefore a matter of maximising the degree of complementarity between the components and minimising inter-crop competition. On this basis, intercropping advantages are more likely to occur where the component crops are very different" (WILLEY, 1979).

It is useful to distinguish between spatial and temporal differences. Spatial differences are differences in height and plant structure as well as differences in the depth and structure of the root system. They occur when, for example, cereals such as maize or sorghum are mixed with legumes such as groundnut or cowpea. Spatial differences mainly reduce the competition for light. Even more important than spatial differences are temporal differences. These occur in plant mixtures with different maturity periods. When the

growth patterns of the component crops differ with time, the crops make their major demands on resources at different times, thus decreasing competition (Fig. 12). Very important yield advantages have been reported when marked differences in maturity periods of component crops exist. ANDREWS (1972) reported an 80 % advantage with 85-day pearl millet/150-day sorghum; KRANTZ et al. (1976) gained advantages of up to 73 % with various 80- to 100-day crops and 180-day pigeon pea.

Figure 12: 'Competition gap', the period between the active growth of two crops (cited from BAKER, 1974)

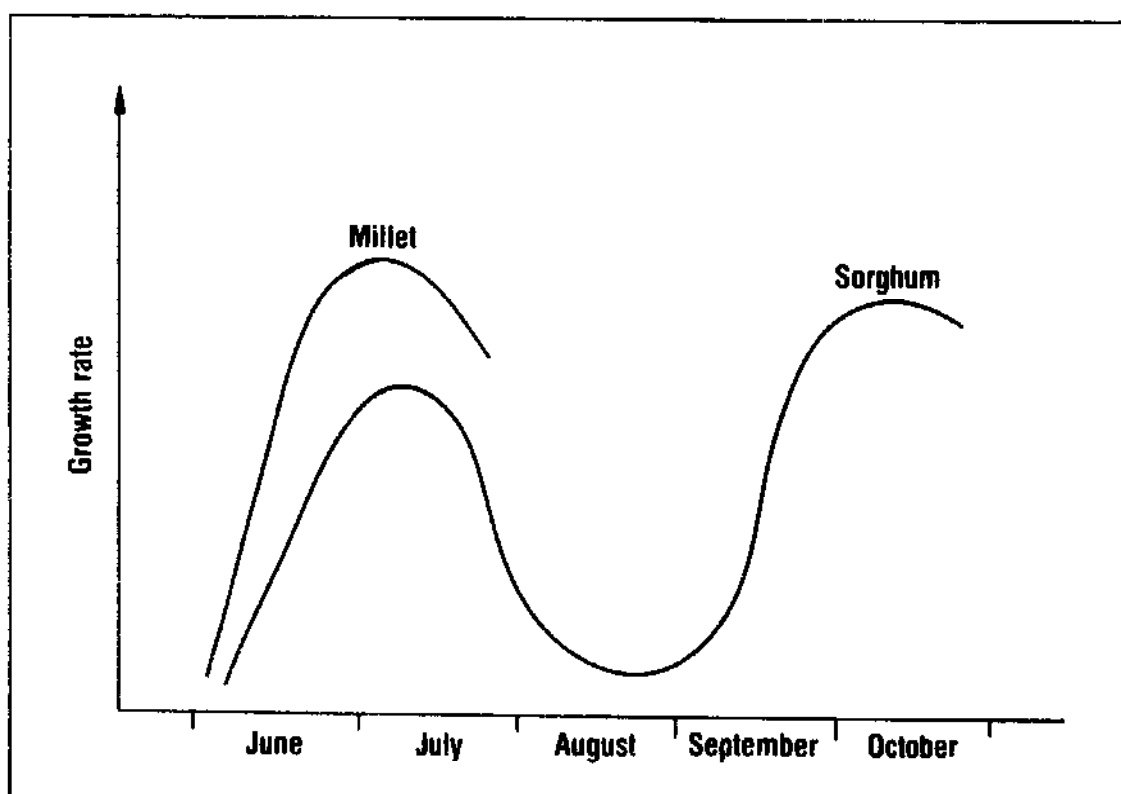

The same trend is to be observed in cassava interplanted with legumes. In trials at CIAT (LEIHNER, 1982) cassava yields were not influenced by early maturing species while yields were reduced by species with maturity periods exceeding 100 days. Interplanting of early maturing legumes, however, gave a full cassava yield plus an additional legume yield (Table 10).

Table 10: Correlations between yields of cassava and associated legumes indicating degree of interaction between crops as a result of earliness of legumes (LEIHNER, 1982)

Crop	Days to physiological maturity	Correlation coefficient cassava yield - legumes
Bean	80	$r = 0,01^{n.s.}$
Cowpea	90	$r = 0,05^{n.s.}$
Groundnut	106	$r = -0,14^{n.s.}$
Soya bean	125	$r = -0,35^*$

Using crop mixtures of maize, sorghum and millet, BAKER (1974) was able to demonstrate a clear trend towards a gain over sole crops as the harvest dates of crops in the mixtures diverged. In mixtures of cereals it is not only the difference in length of maturity that influences competition but also the difference in plant height. Thus in mixtures with sorghum, yield advantages could be obtained when varieties differed in height by more than 59 cm and in age of maturity by more than 51 days (BAKER, 1979) (Fig. 13). In practice, however, the influences of plant height and age of maturity, i.e. spatial and temporal effects, cannot be clearly separated.

A long growing period<sup>1)</sup> is the precondition for mixing crops of different maturity periods. Therefore, in the humid tropics, with a growing period exceeding 270 days, and also in the sub-humid tropics with a growing period between 210 and 270 days, mixtures of crops, especially those involving different length of maturity, are common (see App., Table A 11). Yield advantages can no longer be obtained in areas with a growing period of less than 120 days.

1) The growing period is defined as the period when both water and temperature permit crop growth. The growing period is longer than the rainy season, owing to residual soil moisture (FAO, 1978).

In these climates (Northern Sudan Savanna and Sahel) sole cropping of short duration crops is predominant (KASSAM, 1979). However, as will be demonstrated in the following chapters, farmers are practising intercropping not only because of yield advantages. While in areas with growing periods between 120 and 210 days intercropping is the best way of making use of the entire growing period, in the sub-humid and humid areas sequential cropping is another alternative.

Figure 13: Growth in height of millet mixed with other cereals: o — o ex Ghana millet; ● — ● (a) ex Borno millet, (b) Bomo local maize, (c) Samaru 123 maize, (d) 96 maize, and (e) Short Kaura sorghum (BAKER, 1979)

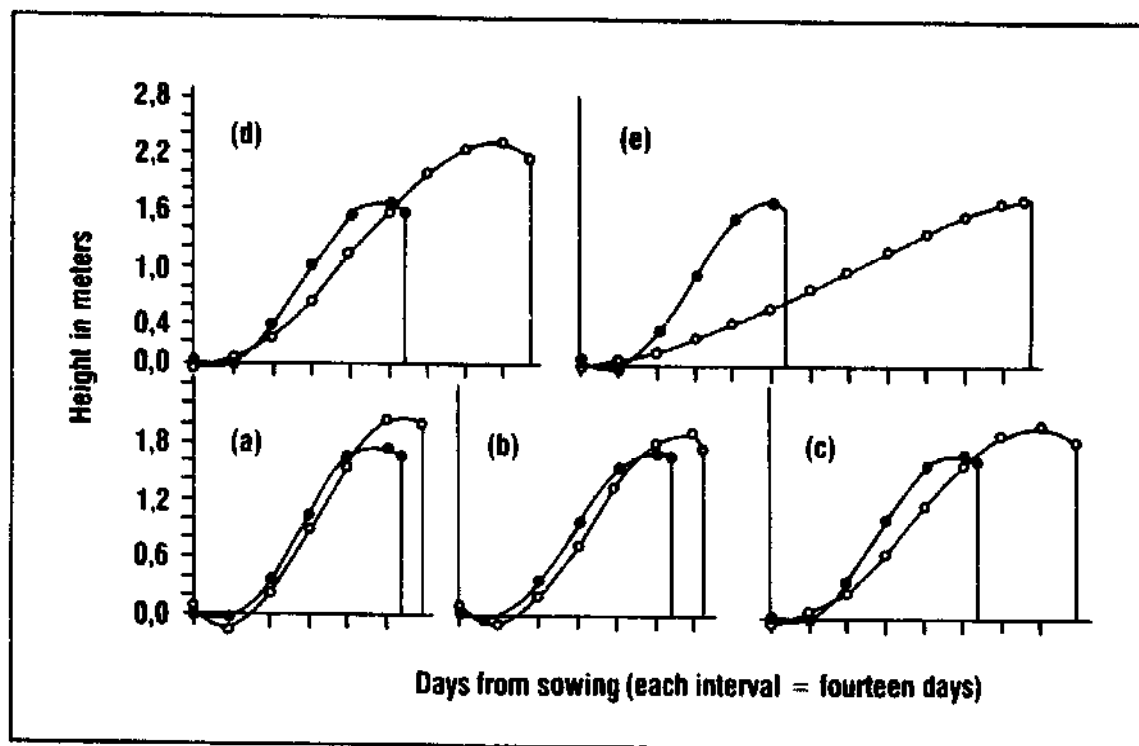

### 3.1.2 Resource Use in Intercropping Systems

As mentioned above crops compete for limited growth factors or resources such as light, water and nutrients. All work on the improvement of intercropping systems aims at better utilization of these resources.

### 3.1.2.1 Light

Light as a growth factor differs from the other growth factors (water and nutrients) in that it cannot be influenced directly by man. Consequently, in modern agriculture using inorganic fertilizers and irrigation, light often becomes the limiting factor. One aim of cropping systems (sole or mixed) is therefore to make optimal use of light. This includes not only high light interception but also an efficient use of light. Peak values of light interception can in fact be achieved by sole crops with optimum plant populations. WILLEY and NATARAJAN (1980 a, b) were able to demonstrate that the 90 % peak light interception of a sorghum/pigeon pea intercrop was nearly identical to sole sorghum, even though the intercrop gave a greater total dry matter yield and had a slightly greater leaf area index (LAI). In intercrops, however, the available light is more efficiently used, as the optimal LAI is more quickly obtained (BEETS, 1978), especially on low fertility soils.

In intercropping systems dominant plants are, usually associated with dominated plants. The taller plants are normally the dominant plants, intercepting the greater share of the light. The reduction of light intensity caused by interception within a leaf canopy is usually exponential (TRENATH, 1976). Consequently, the smaller dominated plant grows less than the dominant plant and slight differences in height even in early growth can occasion strong competition effects and increasing differences between dominant and dominated plants.

Successful intercropping systems aim at reducing the competition for light, i.e. the shading effects of the dominant plants, without reducing light interception. Various possibilities exist such as relay intercropping, planting the dominant crops in double rows (grouping of plants), orientation of rows in an east-west direction, increasing leaf inclination of dominant crops, and the growing of shade tolerant plants and multi-storey cropping systems.

The following example of a maize/groundnut intercrop, commonly planted in the humid tropics of West Africa is used here to illustrate this. As groundnut is very sensitive to shade, only low maize populations are used (approximately 5,000 pl./ha). This results in relatively high per plant yields of maize, as there is hardly any intra-specific competition (especially for light), and a nearly complete groundnut yield. If, in improved cropping systems, maize is planted in rows, the distance between the rows should not fall below 1.5 m, to ensure sufficient insolation of the groundnut. Thus the maize population and total yields of maize can be increased only minimally by this method. An increase of the maize population is possible only when maize and groundnuts are grouped, i.e. planted in double or quadruple rows with closer inter-row spacing. This allows good radiation of both crops and results in a considerable increase in the maize yield while the groundnut yield is only slightly reduced (see Paragraph 3.1.5).

An orientation of the rows in an east-west direction further reduces shading of groundnuts and leads to an additional yield increase (SCHILLING, 1965; PENDLETON, BOLEN and SEIF, 1963). It seems, however, that this is effective only in areas with high insolation. MUTSAERS (1978) was unable to obtain yield differences by different orientation of rows in his trials in the forest area of southern Cameroon.

More efficient use of light can be obtained, too, when the dominant species has inclined leaves (cited from TRENBATH, 1976). This not only allows a better use of light within the plant itself, but also increases the amount of light available to the dominated plants. In recent years plant breeders have therefore selected maize varieties with inclined leaves, especially for maize/cassava and maize/cocoyam intercropping systems (IITA resp. IRA, Cameroon).

Relay intercropping is another way of reducing competition for light by avoiding coincidence of maximum light interception of the component crops. Cassava, for example, with its slow initial development lends itself to relay cropping. Light interception is still low in the first three months, thus allowing the cultivation of a

short duration intercrop. Light interception decreases anew at the end of the growing cycle so that intercropping again becomes possible (Fig. 14).

Figure 14: Interception of light by cassava during its vegetative cycle and possible periods for intercropping (LEIHNER, 1982)

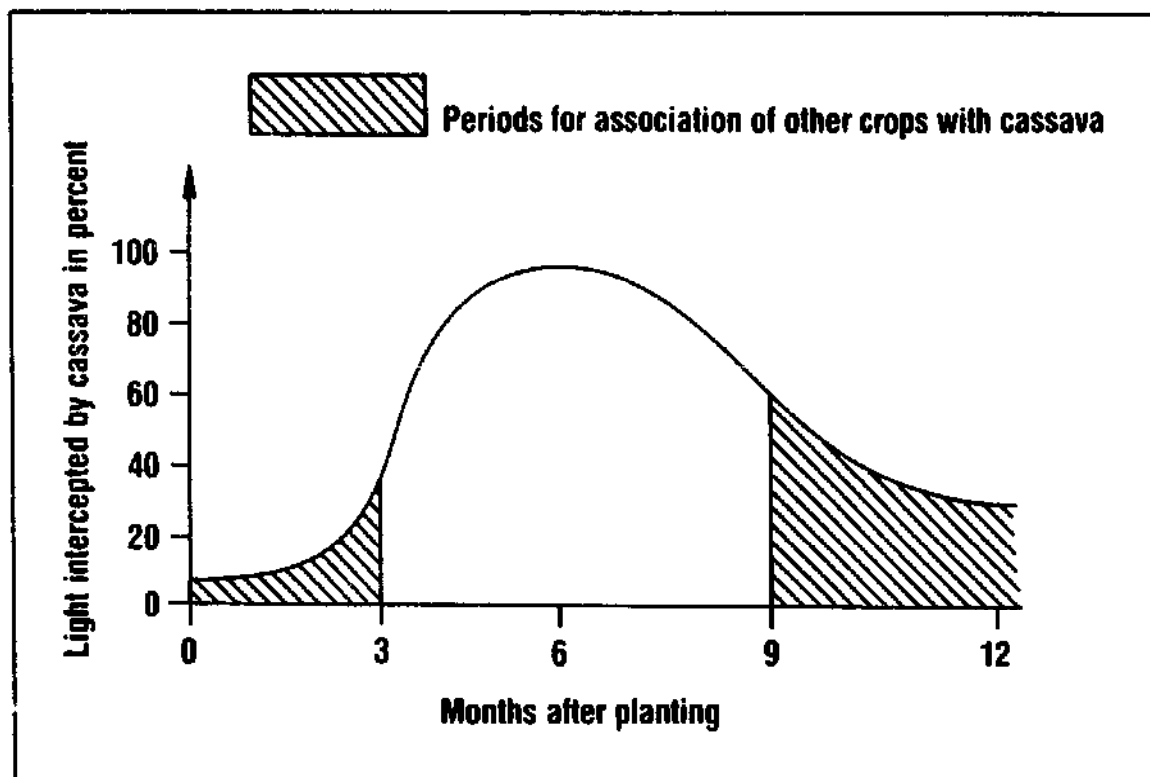

Plants have differing abilities to compete for light. Several plants can adapt themselves to low light intensities. Adaptations include reduced rate of dark respiration, lowered root/shoot ratio and greater leaf area/leaf weight ratio. Increased stem extension usually occurs in shaded plants and can sometimes prevent a shorter component from being overtopped (TRENATH, 1976). One example is cocoyam (*Xanthosoma sp.*) which has a high shade tolerance and is often cultivated under cocoa. The growth type of cocoyam varies considerably between shade and open light conditions. Plants growing under shade have longer petioles and much larger leaves than

those exposed to direct sunlight. Cowpea, too, has some shade tolerance and adapts itself to light conditions under tall cereals, such as sorghum and maize. Yam, too, as a forest plant is relatively shade-tolerant while cereals, such as maize, and cassava are very sensitive to shade, even though there might be varietal differences.

One cropping system which makes very efficient spatial use of light, is multi-storey cropping, where crops ranging from tall trees to low growing annuals form different canopy layers. Each crop appears well adapted to its particular light niche. NAIR (1979) gives an excellent description of a multi-storey system with coconut palms. In such a system the total optimum LAI is much higher than in a sole crop, i.e. light use efficiency is also higher.

#### 3.1.2.2 Water and Nutrients

Competition for soil factors between different component crops usually starts earlier than competition for light, because the root system develops faster than the shoots. As water and nitrate ions are more mobile in the soil than, for example, potassium and phosphate and as they are usually taken up at higher rates, the zones of their depletion around active roots will increase faster. Competition for soil factors (water and nutrients) will occur as soon as the depletion zones of roots of the component crops overlap. The depletion zone for water, for example, can extend up to 25 cm from a single root, just to give an idea of the distances involved.

Mobile ions such as nitrate are carried away passively in moving soil water. Their depletion zones correspond therefore to those for water, provided that the ions are taken up as fast as they arrive at the roots. Nutrients like phosphorus and cations like ammonium, calcium, and potassium are absorbed onto the surfaces of soil particles. Their concentration in soil water is low and



they move only by diffusion. Since diffusion is a relatively slow process, a phosphate depletion zone may extend up to 0.7 cm from the root surface after a week (cited from TRENBATH, 1976). This means that in the end competition for nutrients depends on the mobility of nutrients in the soil. Competition is high for mobile nutrients that are moved by mass flow to the roots ( $\text{NO}_3$ , Mg, Ca), and competition is low for immobile nutrients (K, P,  $\text{NH}_4$ ). For the latter, competition can be expected only when root densities are high.

Since the same principles apply to competition between individual roots as to competition between roots of different plants, the spatial distribution of individual roots in regions of root-system overlap can influence the intensity of the competition effects.

However, when discussing interspecific competition for soil factors, it is not only the spatial distribution and the density of root systems that is of importance, but also other characteristics as: early and fast penetration of the soil; high root/shoot ratio; high root length/root weight ratio; many and long root hairs; and an active root metabolism assuring a high rate of diffusion and uptake of nutrients. All these factors together contribute to success in competition. Earlier uptake, whatever the mechanisms, seems to be the key to success in competition for mobile nutrients (TRENBATH, 1976).

The assumption that intercropping systems make better use of soil resources is based mainly on the consideration that the root systems of component crops do not interfere with each other and exploit different soil layers (stratification of the root systems). Thus, in combination they may exploit a greater total volume of soil (WILLEY, 1979). When studying the uptake of solutes by root systems from the soil, BALDWIN, TINKER, and NYE (1972) found that the spatial distribution or pattern of strongly absorbing roots can greatly effect the uptake. The root pattern can decrease the uptake (of ions transported by diffusion) by at least 75 %, depending on the diffusion coefficient, time and root density. BALDY (1963) explains some of the yield advantages in a legume/cereal intercrop

by the different colonisation of the soil with legume and cereal roots. While the cereal roots colonize the soil nearest the surface, the legumes have a very deep-reaching root system (Fig. 15).

A greater uptake of main nutrients by intercrops compared to sole crops was shown by several authors. While some authors report an increase only for some nutrients (LIBOON and HARWOOD, 1975 and DE, 1980 for nitrogen; HALL, 1974 b for potassium), other authors report an increase for all main nutrients, including calcium and magnesium (DALAL, 1974; NATARAJAN and WILLEY, 1980; REDDY and WILLEY, 1981).

Figure 15: Root systems of maize (left) and lucerne (right). Maximum density of the maize root system is near the surface (0-30 cm), while the root system of lucerne has its maximum density in greater depth (40-90 cm) (BALDY, 1963)

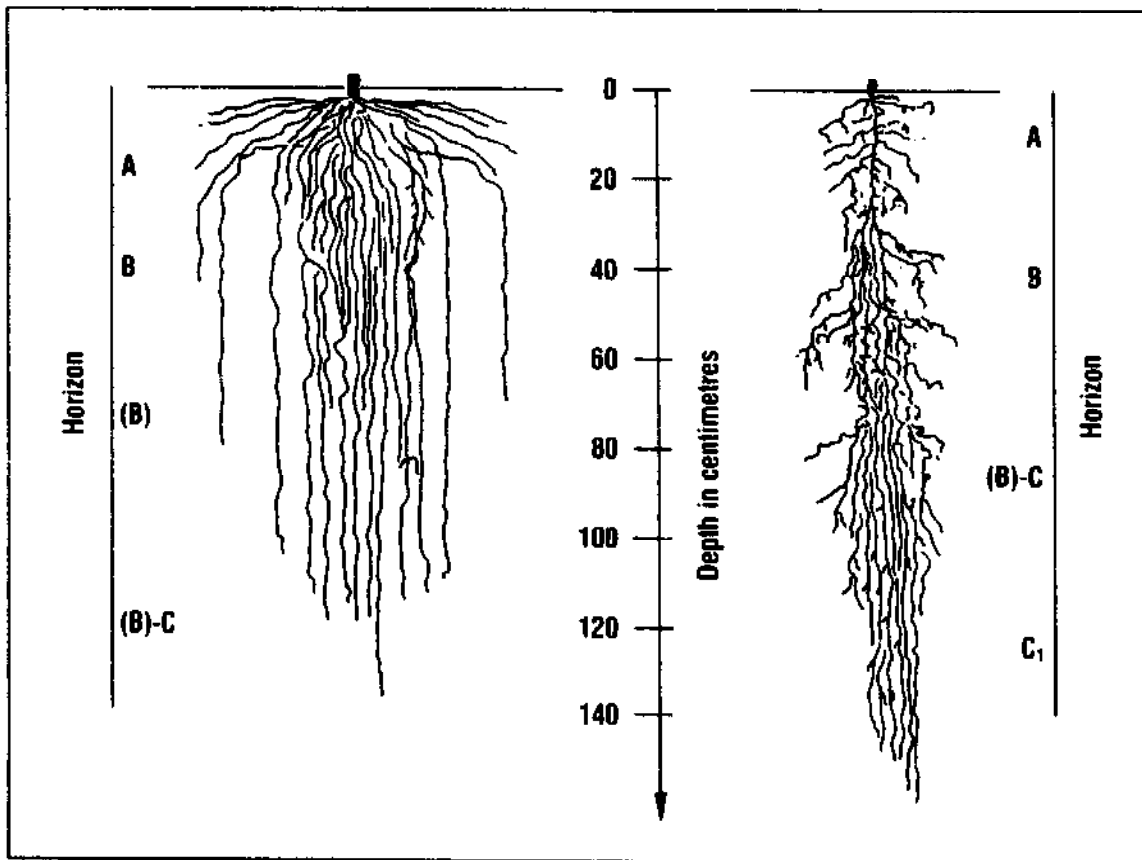

In a millet/groundnut intercrop the LER values for uptake of N, P, K at final harvest were 1.25, 1.28 and 1.26 respectively (for definition of LER see Table 2 and Paragraph 3.2.1). These values were similar to the LER of 1.28 for total dry matter, indicating that the greater yield from intercropping was associated with a greater and commensurate uptake of nutrients (REDDY and WILLEY, 1981).

Depending on the nutrient supply, there are different reasons which could lead to an increased uptake of nutrients by intercrops.

- (1) In the case of a fixed (limited) supply of nutrients (for example P and K) a high rooting density and differing root patterns will lead to a better penetration of the soil and thus a better extraction of nutrients. In addition, some crops may profit from the better disintegration abilities of the associated crop for some nutrients, especially phosphorus.
- (2) In situations of continuous gains (by mineralization) or continuous losses (by leaching, especially of nitrate ions) of nutrients intercrops make better use of the actual supply through a better distribution of demands over a prolonged period. Deep roots of associated crops can bring nitrate ions again to the surface.

(A rather different temporal effect could occur when nutrients released from one crop as a result of senescence of plant parts are then made more readily available to another crop; for example, there is evidence that shade trees above certain crops can have the beneficial effect of bringing to the surface, via leaf fall, nutrients which are normally unavailable to crops).

The effects of intercropping on water use have received less attention than the effects on nutrient uptake, but there is some evidence that the water-use efficiency (WUE) is higher in intercrops than in sole crops. BAKER and NORMAN (1975) suggested that better water use was probably a common cause of yield advantages in semi-arid tropical areas, because this was the most limiting resource. When studying a sorghum/pigeon pea intercropping system, NATARAJAN and WILLEY (1980) reported that the total water use was little affected by

the cropping system. Total water use till harvest by sole and intercropped pigeon pea was 584 and 585 mm. Thus the yield advantages of the intercropping system were not achieved at the expense of greater overall demand on soil moisture. The total water demand was dependent only on the length of the growing period and not on the growth pattern of the crop. DE (1980) reported an increased water-use efficiency of intercropping systems with maize. The WUE was 10.3 for sole maize increasing to 16.8 and 19.4 in intercropping systems with soya bean and mung respectively.

A possible reason for the increased WUE with intercropping is the windbreak effect when low growing plants such as legumes are interplanted with tall plants such as maize and sorghum. This leads to an increase in humidity and a reduction in transpiration. Crop associations allow a better net assimilation rate of each plant at a constant temperature per unit of consumed water (BALDY, 1963). The evapotranspiration can be reduced by certain crop mixtures. The advantages of mixed cropping are greater in a climate with high insolation (semi-arid tropics), as this improves the growing conditions of the dominated plants. The windbreak effect can be achieved even with only a small percentage of tall plants (< 5 %) that are at least 20-30 cm above the sheltered crop (HAGEN and SKIDMORE, 1974). Temporary windbreaks do not of course affect only the relative humidity and evapotranspiration but change the microclimate considerably, as can be seen from Fig. 16 (MARSHALL, 1967 in RADKE and HAGSTROM, 1976).

Since the sheltered crop produces more dry matter and higher yields (provided that no competition for light occurs), it is using the available water more efficiently. The transpiration to evaporation ratio is probably higher than that of unsheltered crops. A significant difference in the soil moisture for the sheltered versus the unsheltered areas under dryland conditions has never been found (RADKE and BURROWS, 1970; RADKE and HAGSTROM, 1976). This concurs with the findings of NATARAJAN and WILLEY (1980).

Figure 16: Summary diagram of the effect of wind barriers on micro-meteorological factors.  $h$  = height of barrier (MARSHALL, 1967)

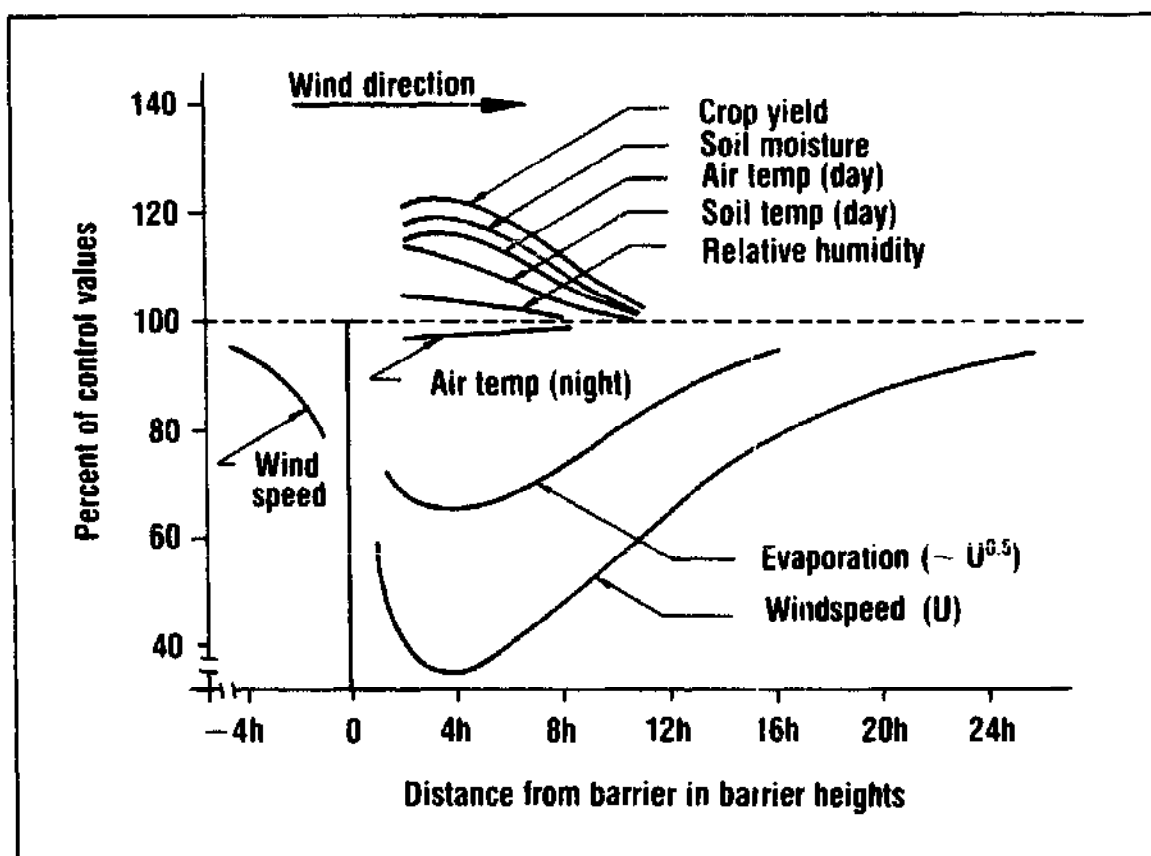

Yield advantages obtained by varietal mixtures of one crop (e.g. sorghum) using varieties of different heights, could be partially explained by the shelter effect which the higher varieties exert on the lower ones, and by more efficient use of light.

When discussing windbreak effects, the function of the trees as a permanent windbreak must also be mentioned. Especially in the semi-arid tropics, e.g. in the Northern Guinea Savanna, (fruitbearing) trees are often integrated into the fields. Besides other functions they also act as permanent windbreaks. A mere 15 trees/ha provide sufficient shade and wind protection to improve the growth of field crops (PROTHERO, 1971.).

### 3.1.3 Nitrogen in Legume/Non-Legume Associations

A special situation in resource use occurs when legumes are intercropped with non-legumes. Yield advantages (examples from Africa: EVANS, 1960; ANDREWS, 1972; SCHILLING, 1965; MUTSAERS, 1978) are more difficult to interpret as interspecific competition is complicated by the symbiotic nitrogen fixation of the legumes. As pointed out earlier, competition between cereals and legumes is often reduced because of great spatial and temporal differences. Therefore, yield advantages in legume/non-legume intercrops are only partially due to nitrogen fixation, but experimental designs often do not allow a specific nitrogen benefit to be distinguished. In general, there is no direct evidence of a quantitatively significant transfer of nitrogen from legumes to non-legumes while the legume plants are growing actively (HENZELL and VALLIS, 1977). Thus it is mainly the next crops in the rotation which profit from the residual effects (see also Paragraph 3.5).

In contrast to the findings of VIRTANEN and VON HAUSEN (1931) and VIRTANEN, VON HAUSEN and LAINE (1937) root nodules do not excrete nitrogen before the roots decompose. However, as in any case a certain amount of roots decays already during the growing season, there is always some nitrogen released that could be taken up by associated crops. This may help to explain why in many cases cereal yields are higher in association with legumes than in sole crops (HEGEWALD, 1978; DE, 1980) (Table 11).

Non-legume crops will profit of course most from associated legumes with a short maturity period, that release substantial amounts of fixed nitrogen during periods of high N-demands of the non-legume crops. Thus maize will profit more from intercropped green gram (Vigna radiata) than from cowpea (AGBOOLA and FAYEMI, 1972) or from Lathyrus sp. than from beans (P. vulgaris) (HEGEWALD, 1978).

Table 11: Grain yield of maize and companion crops in an intercropping system (DAS, S.K. and MATHUR, B.P., cited from DE, 1980)

Cropping system	Grain yield (kg/ha)		LER
	Maize	Companion crop	
Maize	3130	-	1.00
Maize/groundnut	3150	440	1.15
Maize/green gram ( <i>V. radiata</i> var. <i>aureus</i> )	3570	260	1.22
Maize/cowpea	3580	310	1.24
Maize/black gram ( <i>V. mungo</i> )	3690	480	1.33
C.D. (P=0.05)			

Yield advantages of cereal/legume intercrops are usually higher with low soil fertility than with high soil fertility. In trials with maize/soya bean and maize/groundnut intercrops LERs of 1.47-1.63 were obtained in unfertilized plots while LERs were reduced to 1.1-1.2 when nitrogen was applied (SURYATNA and HARWOOD, 1976; LIBOON and HARWOOD, 1975; MUTSAERS, 1978).

This is sometimes referred to an "N-saving effect". When legumes are substituted by non-legumes on a soil where the nitrogen supply is limited, the remaining non-legumes should be able to take up more mineral nitrogen per plant than they would in a pure stand (HENZELL and VALLIS, 1977). This explanation, however, is somewhat doubtful. It is more likely that LERs are decreasing with increasing soil fertility, because the non-legumes (especially maize) become more dominant and suppress growth of the legumes. In addition, high nitrogen rates reduce the symbiotic nitrogen fixation.

Nitrogen fixation by legumes can reach considerable amounts. Cowpeas can fix between 64 and 131 kg N/ha/year and soya beans between 64 and 104 kg N/ha/year (ALEXANDER, 1961 in KANG, NANGJU and AYANA-

BA, 1977). These amounts of fixed nitrogen may supply a major part or all of the nitrogen needed by the crop.

When studying residual effects of legume crops, NNADI (1978) found that residual nitrogen in intercropped plots (soya bean/maize; cowpea/maize) was significantly lower than in sole cropped legumes, indicating that farmers would get little or no benefit in terms of residual nitrogen when cowpea and soya bean are intercropped with maize (see also Paragraph 3.5). These findings would support the thesis of a direct N-transfer from legumes to non-legumes.

Even though the mechanisms of N-transfer from legumes to non-legumes in crop associations is not completely understood, there is no doubt that the yield advantages of intercrops compared to sole crops at low fertility levels is caused by an improved nitrogen supply of the non-legumes.

#### 3.1.4 Plant Population and Spatial Arrangement

Interactions in intercropping systems are considerably influenced by the plant population and spatial arrangement.

##### 3.1.4.1 Plant Population

Plant population defines the number of plants per unit area, which determines the size of the area available to the individual plant. Spatial arrangement, on the other hand, defines the distribution pattern of the plants over the ground which determines the shape of the area available to the individual plant. While this is relatively simple for a sole crop, it becomes complex in an intercrop situation where, with regard to plant number, both total population and component population have to be distinguished.



The main problem is that, in terms of plant population pressure on resources, a single plant of one crop is seldom directly comparable to a single plant of another crop (WILLEY and OSIRU, 1972). WILLEY (1979) proposes therefore to overcome this difficulty by regarding optimum plant populations of sole crops as comparable. If they are taken as 100, component populations can then be expressed on a simple relative basis, for example a simple intercrop treatment having half the sole crop optimum of each of the two components is expressed as a 50:50 component population.

From experiments in the last years it has emerged that the total population optimum of intercrops may be higher than that of either sole crop. Expressed on a relative basis, optimum component populations may be for example 60:70 (= 130). High total populations are likely to give yield advantages. WILLEY (1979) explains this by means of two sets of data taken from studies in Uganda (WILLEY and OSIRU, 1972). The data were produced from "replacement series" at different total population levels (Fig. 17). Comparisons are facilitated by presenting both the yield and the population on the relative basis mentioned above, i.e. optimum yield and optimum population for each sole crop are taken as 1 and 100 respectively. The figures clearly show that the optimum total population for the intercropping treatments was appreciably higher than that for sole crops.

The optimum population density can be increased in all intercropping systems where the interference between neighbouring plants is less than in sole crops, i.e. where intercrop competition is less than intracrop competition. This has been shown by other researchers such as ANDREWS (1972); BAKER (1978, 1979); ICRISAT (1977) and MUTSAERS (1978).

Population increases are most likely to cause increases in yield where there are large temporal differences in growth patterns of the components (see Paragraph 3.1.1). With mixtures of 75- and 85-day sorghum BAKER (1979) obtained yield increases owing to higher yields per plant. Millet, for example, increased from 0.151 kg/plant in sole millet to 0.218 kg/plant in a millet/maize intercrop

Figure 17: Response of intercropping to total population  
(WILLEY, 1979)

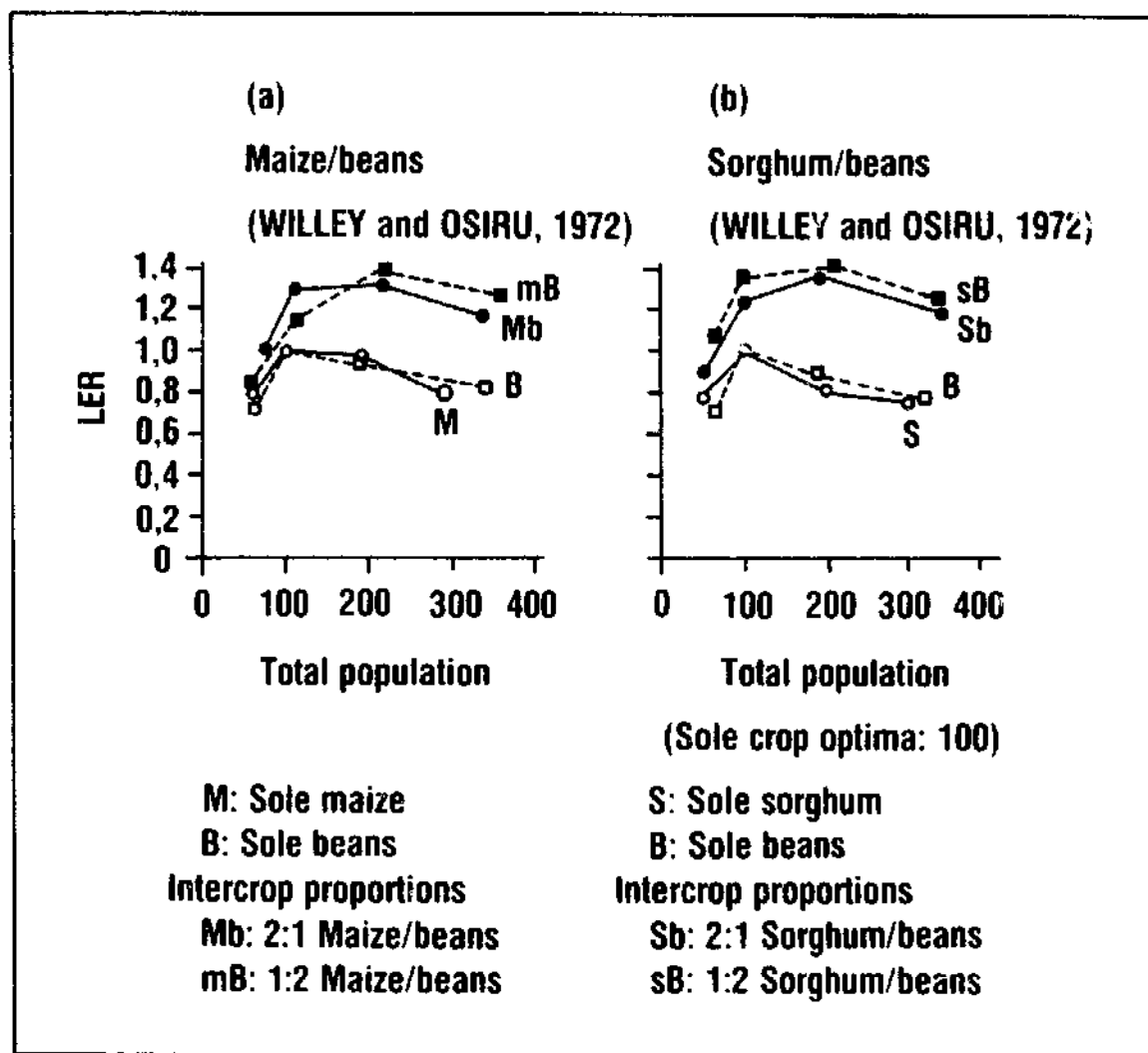

and to 0.314 kg/plant in a millet/sorghum/maize intercrop. Therefore, the overall gain can be increased by higher plant populations.

Results of intercropping trials in India with 80- to 90-day cereals and 150- to 180-day pigeon pea (ICRISAT, 1977; FREYMAN and VENKATESWARLU, 1977 and SHELKE, 1977 cited in WILLEY, 1979) suggest that the optimum plant population can be increased, in the extreme, up to full sole crop optimum of each crop. This is supported by results obtained from cassava/legume intercropping trials at CIAT (LEIHNER, 1982; THUNG and COCK, 1979). "The balance between maximising grain legume yields while minimizing cassava yield reduction again appears

to be the use of those planting densities for association which approach the optimum in monoculture" (LEIHNER, 1982). The total population in intercropping can reach therefore twice that of either sole crop optimum (i.e. 100:100 component population).

Because of these possible differences in population response calculations of yield advantages should be made between intercrop and sole crop at their respective optimum populations (HUXLEY and MAINGU, 1978). Only then it can be ascertained whether or not the farmer will benefit technically from a mixture or a sole crop.

Component populations mainly determine how much of the final yield is contributed by each crop. It is, however, impossible to predict yields for changing component populations, because there is not enough precise information on the competitive abilities of crops and the factors affecting them. Competitive ability is not a constant and quantifiable function of a given crop, but depends on the actual population situation. All component crops become relatively more competitive if they form a larger proportion of the total population; and dominant crops become even more dominant when the total population increases (WILLEY and OSIRU, 1972; WILLEY, 1979) (Fig. 18).

#### 3.1.4.2 Spatial arrangement

In crop associations importance attaches not only to the component populations but also to the distribution of the different species in the field, i.e. the planting pattern or spatial arrangement. The efficiency with which solar radiation is utilized by the component crops depends especially on the planting pattern.

It has been suggested sometimes that to obtain maximum benefit from any complementary effects, crops should be associated as intimately as possible and some experiments have supported this (ANDREWS, 1972). However, mixed intercropping is disadvantageous from the practical point of view, especially when planting is mechanized.

In addition, there are more examples where planting in alternate or multiple rows gives higher yields than mixed intercropping (DALAL, 1974, 1977; SANCHEZ, 1976). Especially where the shorter component crop is susceptible to shading, some "grouping" of the crops is advantageous as it ensures that the lower component receives a reasonable amount of light (WILLEY, 1979).

Figure 18: Population response of individual component crops in three intercropping experiments (WILLEY, 1979)

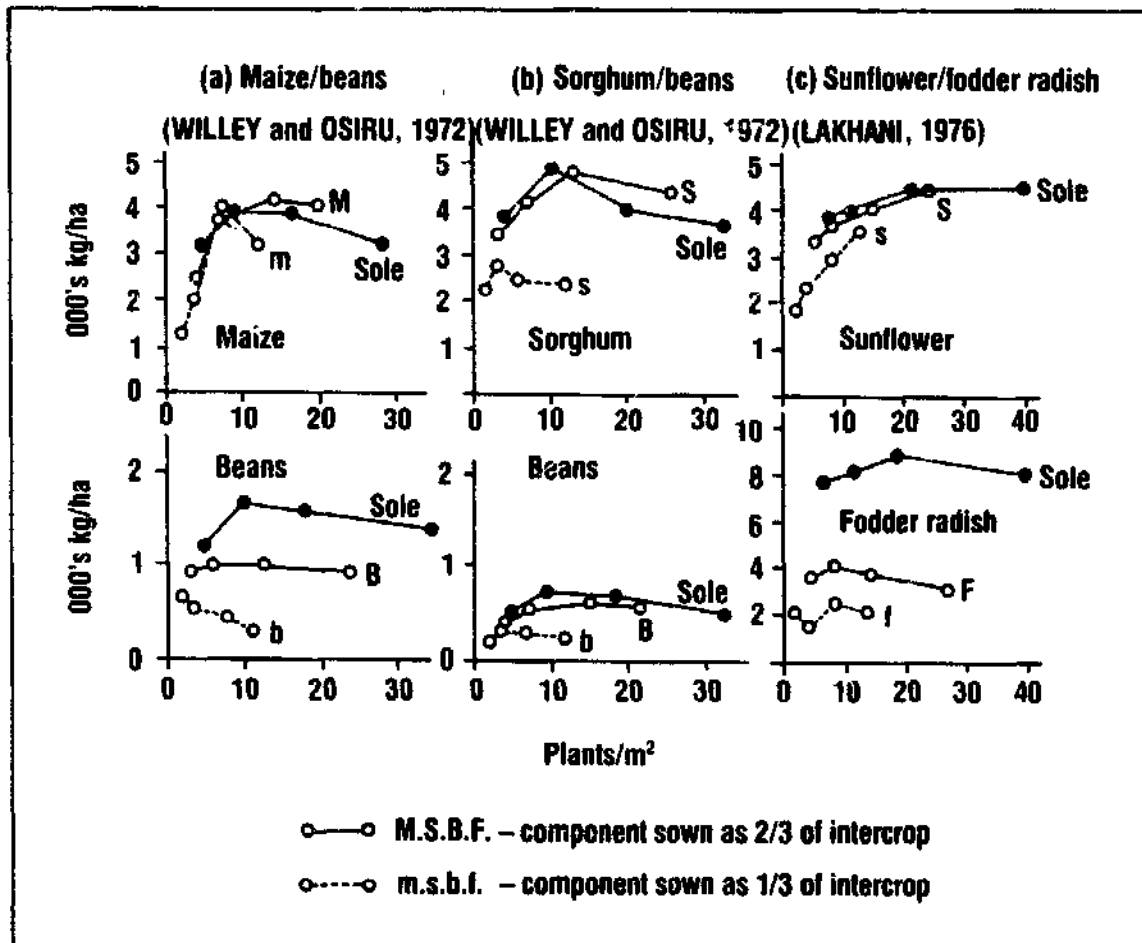

Planting in alternate rows is in itself a kind of grouping. In the case of combinations of tall crops with low growing, shade sensitive crops, better results are obtained, however, when the spatial arrangement is changed from a quadratic to a rectangular pattern, as this allows wider inter-row spacing. For example, planting

cassava in a 2 m x 0.5 m spacing gives the same results as the usual 1 m x 1 m spacing, the important fact being that the total plant population is not changed (CASTRO, in press, cited from LEIHNER, 1982). However, the rectangular pattern allows the interplanting of 2-3 lines of legumes, i.e., a much higher legume population than would be possible with the usual 1 m x 1 m arrangement.

At CIAT best results were obtained with a cassava spacing of 1.8 m x 0.6 m and interplanting of 3 rows of legumes (cowpea or groundnut). The highest cowpea yields were obtained and almost complete balance between the two species was achieved with this arrangement (THUNG, 1978 cited from LEIHNER, 1982) (Fig. 19).

In cereal based intercropping studies in India it has been found that rows of the dominant cereal can be grouped more closely together (while maintaining the optimum population) to increase the yield of the second component with virtually no loss in the cereals yield (DE, 1980) (Table 12). This is especially important when intercropping groundnuts which are very sensitive to shade and suffer high yield losses when planted in alternate rows with cereals (maize, sorghum, or millet). Here, double rows of the cereal and triple to quadruple rows of groundnuts give the highest LER and a balanced yield of the cereal and groundnuts.

Table 12: Planting geometry at constant plant population (180.000 pl./ha) on the grain yield of sorghum (kg/ha)<sup>1)</sup> (DE, 1980)

Planting pattern	Grain yield kg/ha
Uniform rows 45 cm	4410
Uniform rows 60 cm (1 row intercrop) <sup>2)</sup>	4220
Paired rows 30-30-60-30-30 cm (1 row intercrop)	4370
Paired row 30-30-60-30-30 cm (2 row intercrop)	4280
Paired row 30-30-90-30-30 cm (2 row intercrop)	4340

1) Average of 20 experiments 1974-1977.

2) Soya bean.

Figure 19: Response of cowpea yield (sole and intercropped cowpea) to three spatial arrangements at three planting densities (FONSECA, 1981, cited from LEIHER, 1982)

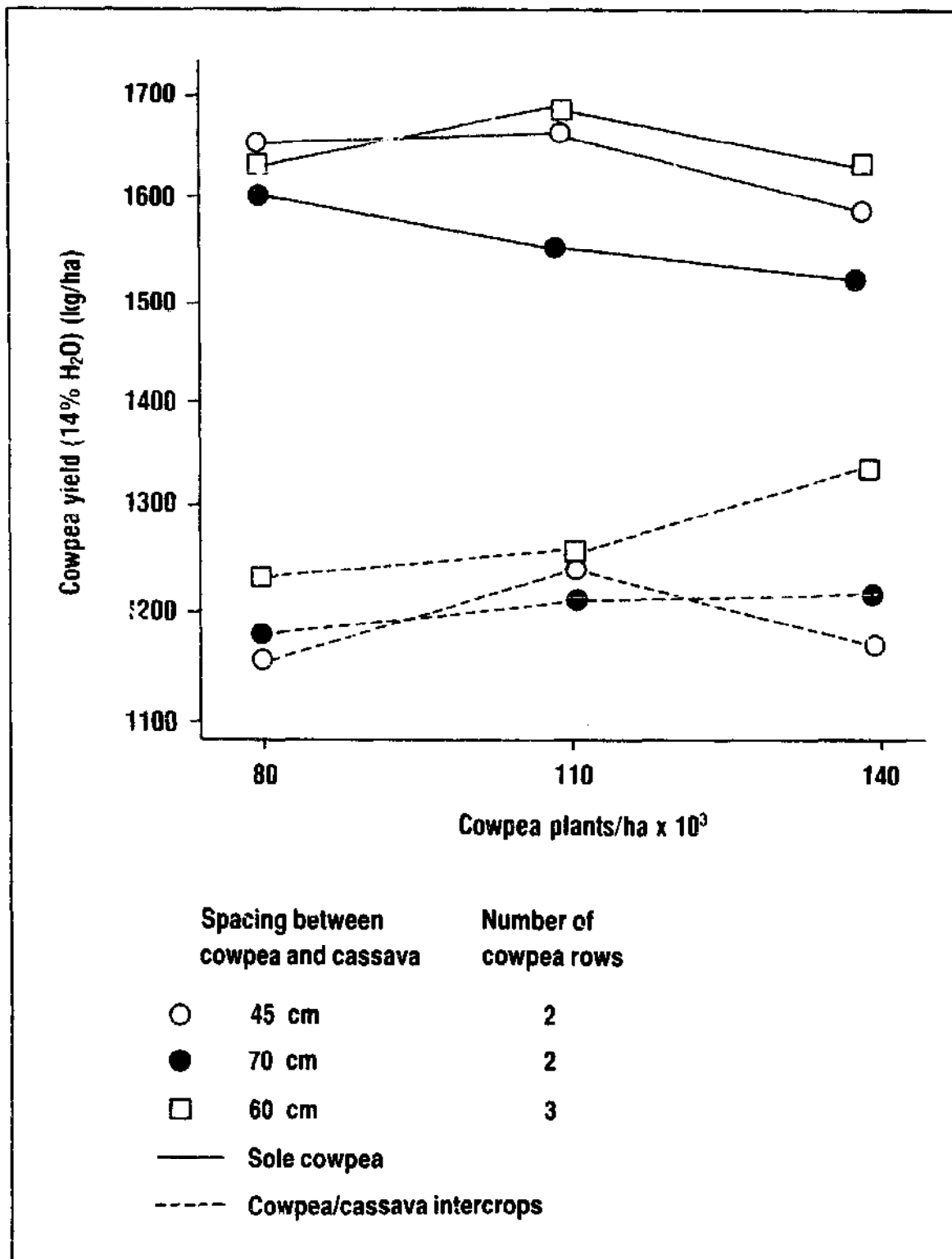

Another possibility is to decrease the planting distance within the rows of cereals, thus allowing wider inter-row spacing. By maintaining a plant population of 60,500 plants of maize/ha in a trial in India (DE, 1980), no difference occurred whether the rows were placed 60 cm or 120 cm apart. In the intervening spaces of 120 cm three rows of soya bean were planted which increased the LER by 54 per cent (Table 13).

Table 13: Seed yield and Land Equivalent Ratio (LER) of maize/soya bean intercropping system (DE, 1980)

Cropping system	Seed yield (kg/ha)		LER
	Maize	Soya bean	
Maize <sup>1)</sup> 60 cm rows	2370	-	1.00
Maize 120 cm rows	2410	-	1.02
Maize 120 cm rows + 3 rows of soya bean	2320	1310	1.54
Soya bean 45 cm rows	-	2340	1.00

1) Maize plant population 65,000 per hectare.

### 3.2 Evaluation of Yield Advantages

The preceding paragraph gave reasons for yield advantages in intercropping systems. This is the appropriate point to explain how yields of intercrops are compared to those of sole crops. As yields of different crops cannot be compared directly with each other and therefore not simply added together, special methods have to be used. Quite a number of different methods have been developed in the past, but the discussion here is limited to basic principles and the current methods. One possibility is to compare component yields with their sole crop yield for every crop in the mixture and add the ratios together. Another possibility is to compare the land area needed to obtain similar component yields in sole

and intercrops. Evaluations can be made on the basis of constituents such as calories, fat, crude protein, lysine, methionine (BEETS, 1977), or on the basis of net income. All these possibilities have their advantages and disadvantages and the method to be used depends on the objectives.

### 3.2.1 The Land-Equivalent-Ratio (LER)

Several different concepts have been developed to assess yields of intercrops: the relative coefficient (DE WIT, 1960), the competition index (DONALD, 1963), the relative yield total (RYT) (DE WIT and VAN DEN BERGH, 1965), the aggressivity (MCGILCHRIST, 1965) the relative replacement rate (VAN DEN BERGH, 1968) and the competitive ratio (CR) (WILLEY and RAO, 1980), but the use of the land equivalent ratio (LER) (IRRI, 1974, 1975) has become common practice in intercropping studies, because it is a relatively simple concept. The land equivalent ratio may be defined as the relative land area under sole crops that is required to produce the yields achieved by intercropping. It is usually stipulated that the "level of management" must be the same for intercropping and sole cropping. HUXLEY and MAINGU (1978) have pointed out that intercrop and sole crop have to be at their optimum populations, as differences in population responses are possible.

An important concept inherent in the use of LERs is that, whatever their type or level of yield, different crops are placed on a relative and directly comparable basis. Although based on land areas, LER also reflects relative yields (the relative yield total is numerical to LER), i.e. the LER can be taken as a measure of relative yield advantage (ICRISAT, 1978). The ratio is calculated in the following way:

$$LER = L_A + L_B + \dots L_N = \frac{Y_A}{S_A} + \frac{Y_B}{S_B} + \dots \frac{Y_N}{S_N} = \sum_{i=1}^N \frac{Y_i}{S_i}$$



where  $L_A, L_B \dots L_N$  are the LERs for the individual crops,  $Y_A, Y_B, \dots Y_N$  are the individual crop yields in intercropping, and  $S_A, S_B, \dots S_N$  are their yields as sole crops. A ratio  $> 1$  signals yield advantage, and a ratio  $< 1$  yield disadvantage. For example, a LER of 1.2 indicates a yield advantage of the intercrop over the sole crops of 20 %, i.e. sole crops would require 20 % more land to achieve the yield obtained by the intercrop.

In this way the LER represents the increased biological efficiency achieved by growing two crops together in the specific environment. The LER term is usually applied to combined intercrop yields but can equally be applied to the intercrop yield of each component crop ( $L_A + L_B = LER$ ). The following example (MUTSAERS, 1978) should help in better understanding of the concept and use of the land equivalent ratio. The trial was an addition series consisting of 4 treatments:

1. sole groundnut (250,000 pl./ha = 100)
2. groundnut + maize (100 : 33.3)
3. groundnut + maize (100 : 66.6)
4. sole maize (41,666 pl./ha = 100)

The following yields were obtained.

	Maize kg/ha	Groundnut kg/ha	$L_M f l_G = LER$
Treatment 1:	-	613.9	0 + 1.0 = 1.0
Treatment 2:	769.5	417.0	0.56 + 0.68 = 1.24
Treatment 3:	861.9	442.7	0.62 + 0.71 = 1.33
Treatment 4:	1,380.6	-	1.0 + 0 = 1.0

The LERs for treatment 2 and 3 are calculated in the following way:

$$\text{Treatment 2: } LER = \frac{769.5}{1,380.6} + \frac{417.0}{613.9} = 0.56 + 0.68 = 1.24$$

$$\text{Treatment 3: } LER = \frac{861.9}{1,380.6} + \frac{442.7}{613.9} = 0.62 + 0.71 = 1.33$$

As the LER is a relative figure, it does not reflect the absolute yields. Large values can be obtained because of high yields in intercropping but also because of small yields in corresponding sole crops. Therefore absolute yield figures have to be given together

with the LERs. This method alone allows comparison of different intercropping situations.

In the example used the intercrop consisted only of two crops. Yet intercrops on farmers' fields consist often of three or more crops. The biological efficiency of a cropping system increases with the number of crops, reaching its optimum at a certain number of crops. MORENO and HART (1979) found a positive linear relationship between the LER and number of crops up to 3 (Fig. 20). Therefore the optimum LER may perhaps be obtained by intercrops of three or more component crops. As field trials are normally carried out with only two to three crops, however, this question can not yet be answered. (RUTHENBERG (1980), referring to studies from northern Nigeria, suggests increased LERs only up to two crops.)

Figure 20: Land equivalent ratio values and number of crops in different cropping systems tested at Turrialba, Costa Rica, 1974-78 (MORENO and HART, 1979)

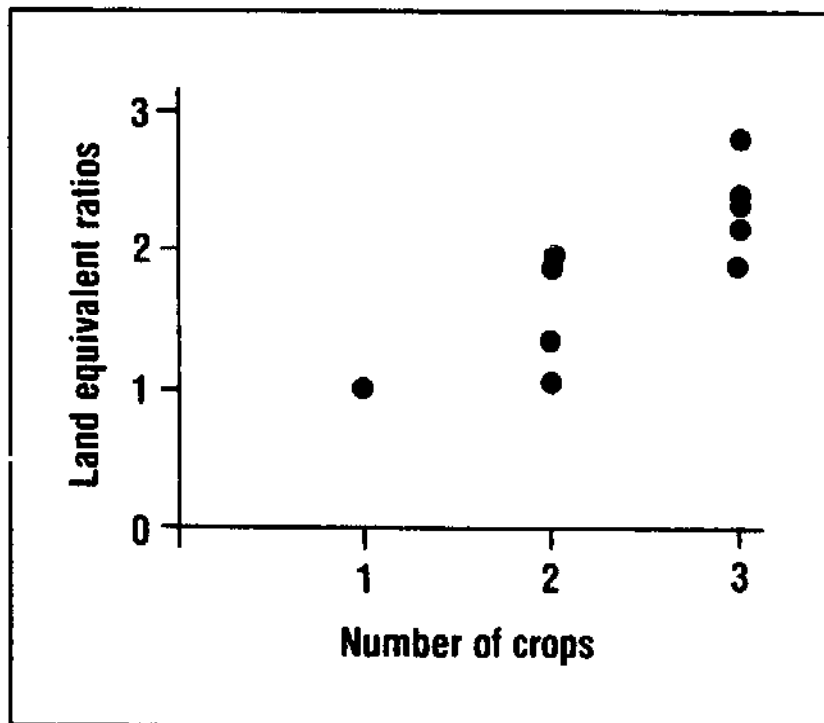

There are situations where it is not advisable, when calculating the LER, to use the sole crop yield of the same variety as that employed in the intercrop. When studying different genotypes for their suitability for intercropping, the intercrop yield should be compared with the sole crop yield of the best genotype (as sole crop).

The following example taken from MEAD and WILLEY (1979) may help to explain this. 17 genotypes of pigeon pea were intercropped with sorghum. LER values calculated for intercrop yields, using a constant sole crop yield for sorghum and sole crop yields of the appropriate pigeon pea genotypes (columns 4-6), show that quite large pigeon pea LERs (and thus quite large total LERs) occur where sole pigeon pea yields are poor (Table 14).

Thus a simple LER provides a measure of biological efficiency for each genotype combination but it is not always suitable for comparing combinations. For the purpose of comparing such genotype combinations as cited above it may be sensible to use the same standardizing factors for each combination, so that  $S_A$  and  $S_B$  are defined as maximum or "average" sole crop yields for the treatments used in the experiments. Columns 7-9 show LERs calculated in this way using the sole crop yield of the best pigeon pea genotype, thus indicating combinations which are genuinely more productive. The same approach may be used in experiments combining different genotypes for each crop. To determine the highest overall yielding combination, comparisons might be made with the highest yielding genotypes of each crop.

The method of standardization should be varied according to the form and objective of the experiment. A good example of when a single standardizing sole crop yield would be agronomically valid is where treatments consist of different plant populations and spacings because, as HUXLEY and MAINGU (1978) have emphasized, all intercrop yield should be compared with the sole crop at its optimum population and spacing. Populations and spacings are easily and cheaply adjusted (at least in theory) and intercropping should therefore be compared with sole plots which are at maximum produc-

Table 14: Yield and LERs of 17 genotypes of pigeonpea intercropped with one of sorghum, using constant sole crop yield for sorghum (3952 kg/ha) but (a) sole crop yield of appropriate individual genotypes for pigeonpea, and (b) sole crop yield of best pigeonpea genotype (MEAD and WILLEY, 1979)

Yield (kg/ha)			(b) LER using best pigeonpea genotype					
Sole pigeonpea	Intercrop		(a) LER using appropriate individual pigeonpea genotype			Sole pigeonpea	Intercrop pigeonpea	Sorghum/pigeonpea total
	Sorghum	Pigeonpea	Sorghum	Pigeonpea	Total			
(1)	(2)	(3)	(4)	(5)	(6)	(7)	(8)	(9)
1699	3804	850	0.96	0.50	1.47	1.00	0.50	1.46
1525	3931	842	0.99	0.55	1.56	0.90	0.50	1.49
1428	3640	740	0.92	0.52	1.44	0.84	0.44	1.36
1407	3630	815	0.92	0.58	1.50	0.83	0.48	1.40
1389	3386	757	0.86	0.54	1.43	0.82	0.45	1.31
1376	3344	885	0.85	0.64	1.48	0.81	0.52	1.37
1323	3899	799	0.99	0.60	1.62	0.78	0.47	1.46
1296	3381	619	0.86	0.48	1.45	0.76	0.36	1.22
1264	3973	585	1.01	0.46	1.44	0.74	0.34	1.35
1226	3757	619	0.95	0.50	1.45	0.72	0.36	1.31
1222	3232	512	0.82	0.42	1.24	0.72	0.30	1.12
1185	3500	463	0.89	0.39	1.25	0.70	0.27	1.16
1169	3323	503	0.84	0.43	1.27	0.69	0.30	1.14
1148	3930	661	0.99	0.58	1.58	0.68	0.39	1.38
1106	3198	718	0.81	0.65	1.47	0.65	0.42	1.23
1063	3645	530	0.92	0.50	1.42	0.63	0.31	1.23
1058	3677	720	0.93	0.68	1.66	0.62	0.42	1.35

tivity in this respect. There are other situations where it seems sensible to use more than one measure of the sole crop yield. In an experiment designed to examine the advantage of intercropping at different levels of fertility it could thus be appropriate to standardize any given intercrop yield against the sole crop yield at the same fertility level. Farmers may not be able to change their fertility level and it is pertinent to know how intercropping and sole cropping compare at any given level of fertility" (MEAD and WILLEY, 1979).

As already indicated, the LER represents the biological efficiency of an intercropping system and allows a comparison of one given intercropping combination with another one, or with sole cropping. In practice, however, the intercropping combination with the highest LER is not always the best one, as far as farmers' needs are concerned, because in most situations component crops are not equally acceptable and one crop is needed or preferred more than another one. When assessing the yield advantages of intercrop combinations, farmers' requirements should not be neglected; otherwise the research aimed at improving the intercropping situation is not based on sound objectives.

Three different situations can be distinguished (WILLEY, 1979):

1. Intercropping must give a full yield of a "main" crop and some yield of a second crop.

This situation is probably the most common one in smallholder agriculture, even though largely ignored in the literature. The primary requirement is a full yield of a staple crop, and a yield advantage occurs if there is any yield of a second crop. Farmers in the yam belt, for example, are aiming at a full yam harvest but try to obtain some maize, cassava, okra, etc. from the yam field. These crops are planted at low populations so as not to interfere with the yam. The same situation is found in the sorghum-based cropping system in the Northern Guinea Savanna, where farmers aim at a full yield of sorghum and some additional cowpea, roselle, etc. Intercropping work in India (ICRISAT) has mainly been aimed at maximising yields of pigeon pea without reducing sorghum yields.

2. The combined intercrop yield must exceed the higher sole crop yield.

This criterion has traditionally been used for assessing yield advantages in grassland mixtures (VAN DEN BERGH, 1968; DONALD, 1963). It is based on the assumption that the unit yield of each component crop is equally acceptable and therefore the requirement is simply the maximum yield, regardless of the crop from which it is obtained. But this criterion assumes, too, that growing only the higher yielding sole crop is a valid alternative to growing all of them. This is not, however, the case on smallholder farms where there is a need for different types of crops.

3. The combined intercrop yield must exceed a combined sole crop yield.

This criterion is based on the assumption that a farmer usually needs to grow more than one crop in order, for example, to satisfy dietary requirements, to spread labour peaks, to guard against market risks, etc. In this situation a yield advantage occurs if intercropping gives higher yields than growing the component crops separately. This is quite a common situation in smallholder agriculture, where yield surpluses are marketed. The land equivalent ratio (LER) is the most suitable concept for assessing yield advantages in such intercropping situations, because yields of the different crops are put on a comparable basis.

If the LER is taken as a measure of the available yield advantage, however, there is the implicit assumption that the yield proportions embodied in that LER are those required by the farmer. This raises particular difficulties when comparing LERs with different yield proportions, because a straight comparison implies that either yield proportion is equally acceptable (which is not the case in practice).

What is required is a method for comparing LERs which takes account of their different yield proportions and can relate these to farmers requirements. Such a method has been developed by WILLEY (1979)

The "effective LER" takes into account the fact that a farmer can obtain a required proportion of two crops by growing a certain type of intercrop on one part of his field and a sole crop on the rest of the field. This is in fact a strategy commonly used by farmers. In Cameroon, for example, farmers require a certain proportion of maize and groundnuts for their diet that could hardly be obtained by intercropping, because the shade-sensitive groundnuts tolerate only a certain amount of maize in the mixture. The additional maize required is cultivated either as a single crop or in other combinations, such as maize/cassava (if cassava is not already part of the maize/groundnut intercrop).

As the land equivalent ratio is not always suitable for comparing yields of different cropping systems, other methods are sometimes used.

### 3.2.2 Yield Assessment on the Basis of Plant Constituents

The land equivalent ratio compares yields of different cropping systems on the basis of the land required. As different crops have a different importance for human nutrition, however, there are situations where it is more appropriate to compare yields on the basis of constituents of crops, such as calories, fat, and crude protein. This is especially important for protein, because consumption of animal protein is very limited in rural areas and the main protein resources are pulses. For example, substitution of yam and cocoyam by higher yielding cassava or the displacement of groundnut or cowpea by maize, for whatever reason, lowers the quality of human nutrition in spite of increased LERs. All tropical staple crops, especially root crops and tubers such as cassava, sweet potato, yam and cocoyam or plantain provide a high yield in terms of carbohydrates but only small quantities of protein. Therefore, intercropping of root crops and tuber with legumes is essential to provide a balanced diet. This is possible without a substantial reduction in the yield of the main crop, or in the yield of carbohydrates.

In Latin America, for example (LEIHNER, 1982), one hectare of traditionally cultivated cassava intercropped with black beans can produce 10,000 kg of cassava and 600 kg of beans. This corresponds to 13,400 kcal and 168 kg of protein. Thus one hectare could supply enough food (balanced in terms of calories and protein) for 4.6 persons during one year, leaving a surplus of approximately 6 t of cassava for sale. The cassava yield in this example is not high and could be increased by changes in the cropping system but these should not reduce the bean yield in favour of cassava.

In the previous example only the crude protein yield was considered. In human nutrition, however, importance attaches not to the absolute protein content of the food but rather to the proportion of essential amino acids such as lysine and methionine. Thus maize protein with a low proportion of lysine (167 mg/g N) can be much better utilized when used concurrently with pulses, e.g. cowpea, which has a much higher lysine content (467 mg/g N). Not only does a maize/cowpea intercrop produce an approximately 10 % higher crude protein yield than sole cropped maize but this protein can be also better utilized in the human diet (AHMED and GUNASENA, 1979). Similar results can be obtained with maize/soya bean intercrops (BEETS, 1977). A maize/soya bean (50:50) intercrop, for example, gives a slightly reduced energy and lysine yield as compared to sole cropped maize or soya bean but the fat, protein and methionine yield is higher compared to both sole crops (Fig. 21). This example demonstrates that the maize/soya bean intercrop provides a well-balanced yield of constituents and thus the basis of a balanced diet.

### 3.2.3 Net Income of Intercropping Systems

The net income has served for a long time as the basis for comparing different cropping systems. It has the advantage that it compares not only the biological efficiency of cropping systems but also takes into account the fact that inputs, mainly labour in this context, are limited and have to be used in different amounts for



different cropping systems. This results in greatly varying production costs. There are, however, several disadvantages to this method and it is therefore being replaced more and more by the LER.

Figure 21: Yields of a 50:50 resp. 25:75 soya bean/maize intercrop compared with the sole crops in terms of energy (kcal), fat, protein, lysine and methionine (BEETS, 1977)

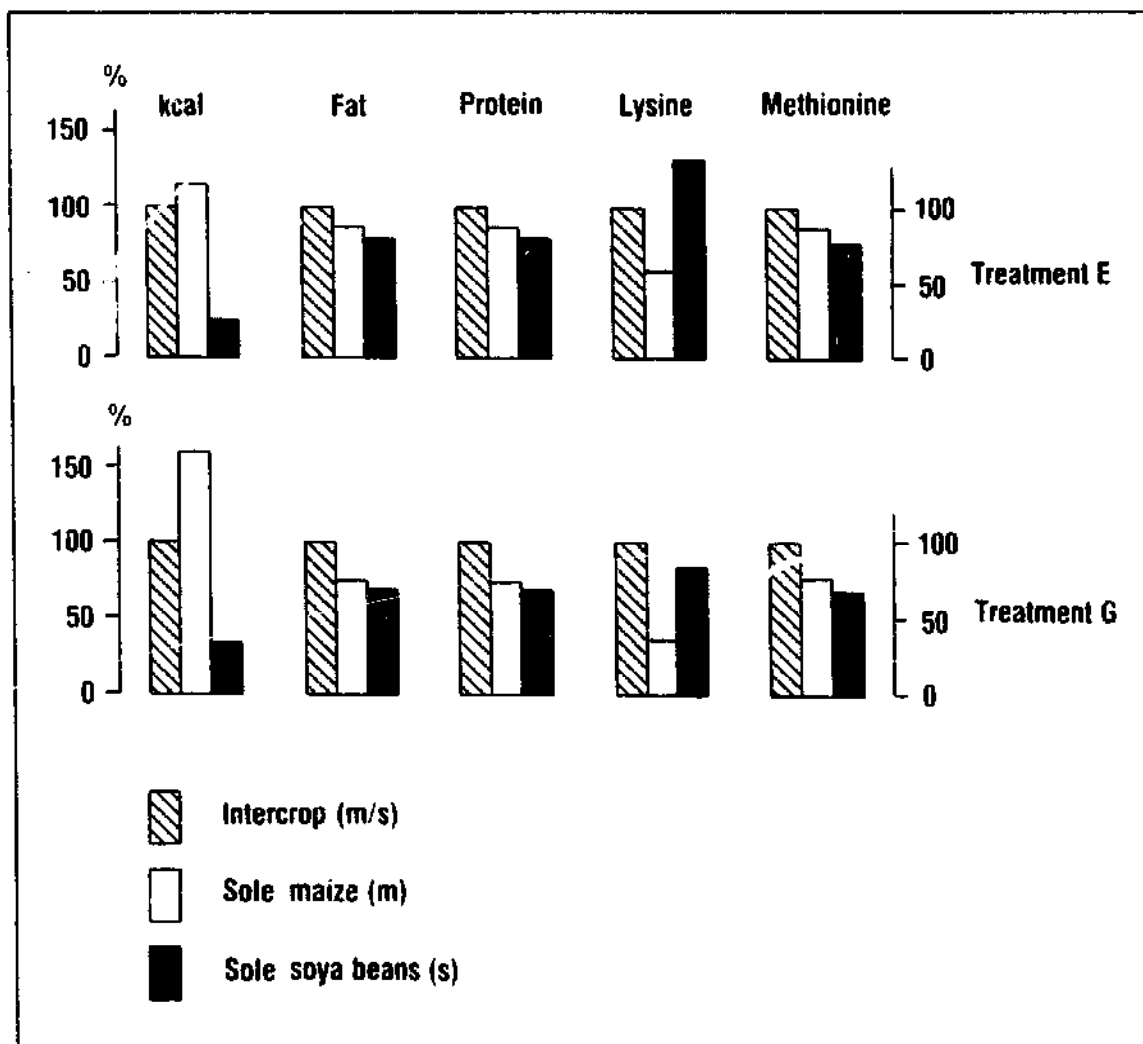

The calculation of net income assumes that the farmer is producing for the market and can change his cropping pattern with changing price relations. But this is not always correct because the multiple production goal of smallholders, and this is the majority

of farmers (approximately 90 %), is not only maximization of cash income, i.e. they do not produce mainly for the market, but at first they have to meet the subsistence needs of their families. Except for genuine cash crops, only surpluses are marketed (see Chapter 4). Another disadvantage is that market prices change with time and from region to region. Therefore, the use of the net income criterion allows the comparison of cropping systems only within limited areas and over limited periods.

The net incomes derived from intercropping systems are usually higher than that from sole crops. Increases reported in the literature range between 30 % and 60 % (WADE and SANCHEZ, 1975; NORMAN, 1977; NATARAJAN and WILLEY, 1980 a). The net incomes increase with the number of crops in the mixture (NORMAN, 1977).

#### 3.2.4 Yield Stability

When discussing yield advantages and explaining the concepts of the LER, the impression may be given that the only advantages of intercropping are higher yields or higher net incomes, and that research on intercropping is only concerned with increasing yields. Apart from the ecological and socio-economic aspects, to be discussed later, a major advantage of mixed cropping is yield stability, i.e. reliable food production over the years.

When improving cropping systems and especially in areas with climatic hazards such as unpredictable rainfalls, it is not the maximum yields under favourable conditions but acceptable yields over a number of years which are of interest. And in fact intercropping systems give more stable yields than sole cropping systems. This is one of the main reasons why farmers still prefer this system (see Chapter 4).

There are several reasons why intercrops give more stable yields than sole crops. One basic principle of intercropping is compensation. When one component crop suffers from drought, pests, or diseases, and does not develop properly, the loss of this crop is

compensated at least partially by the other component crop(s), since there is now less competition for resources. No compensation could be obtained, on the contrary, if a farmer had planted sole crops. He would obtain no yield or only a small yield from one field, while the yields of the other crops would remain unchanged.

Similar effects can also be obtained with mixtures of cultivars, as MERCER-QUARSHIE (1979) has proved with sorghum and ALLARD (1961) with beans.

Yield stability can be further increased with staggered planting. In northern Ghana, for example, where farmers plant maize and groundnut in June and 20 days later sorghum or millet and cowpea and sometimes also local short-cycle maize, a drought period is encountered by the different crops at different stages. Thus it is unlikely that all crops are hit by the drought just when they are most sensitive to a water deficit. This is confirmed by EVANS (1960) who obtained higher LERs in sorghum/groundnut and maize/groundnut intercrops when weather conditions were worse.

Yield stability is also increased by a reduction of pests, diseases and weeds in intercrops below the level of epidemics or outbreaks (see Paragraph 3.5). Perennial crops increase yield stability even more. This is one reason why cassava, which is also drought resistant, is a part of many cropping systems.

There are various statistical methods to express yield stability of cropping systems. A method, commonly used, is the coefficient of variation (C.V.). In an example given by MORENO and HART (1979) the C.V. is reduced by intercropping two species, while the introduction of a third component does not lead to a further reduction (Table 15, Fig. 22). Even though it can be assumed that appropriate associations of three or more crops are more stable than those of two components only, no examples can be found in the literature.

Table 15: Variability (coefficient of variability) registered in different cropping systems during 3 years and three replicates each year, Turrialba, Costa Rica, 1974-77 (MORENO and HART, 1979)

Cropping system	Average sole crops	Crop association
Sole cassava	39.93	-
Sole bean	18.78	-
Sole maize	13.46	-
Sole sweet potato	30.29	-
Sole sweet potato <sup>1)</sup>	65.78	-
Cassava/bean <sup>2)</sup>	33.04	27.54
Cassava/maize	28.76	18.09
Cassava/sweet potato	23.87	13.42
Cassava/sweet potato <sup>1)</sup>	41.14	27.45
Cassava/maize/sweet potato <sup>1)</sup>	31.05	21.44
Cassava/sweet potato → cassava/sweet potato	26.91	23.79
<u>Cassava/bean</u> → cassava/sweet potato <sup>3)</sup>	35.34	28.51
<u>Cassava/maize/bean</u>	25.04	14.95
<u>Cassava/maize/bean</u> → cassava/sweet potato	27.57	13.25

1) Sweet potato cultivated at the second planting season.

2) Association of crops

3) → = Sweet potato cultivated at the second planting season and intercropped in the cassava;        = same crop.

Using an analysis of variance, ALLARD (1961) found that genetically diverse populations were more stable than genetically uniform populations and also that even the limited genetic diversity obtained by mixing two pure lines was nearly as effective in stabilizing productivity as the presumably much greater genetic diversity in bulk population, i.e. the order of stability of production was: bulks  $\succ$  mixtures  $\succ$  pure lines.

MERCER-QUARSHIE (1979) used a regression coefficient to analyse yield stability of mixtures of sorghum varieties in northern Ghana (4 locations, 3 years). He was not able to find a clear relation between yield stability and number of varieties in the mixture, as in mixtures of 4 to 5 varieties one component was always as stable or more stable than the mixture. However, there was a trend that,

as the mixtures became more complex, the  $S_{d^2}$  (mean square deviation from regression) approached a value that was not significantly different from zero, suggesting that complex mixtures were more stable than simple ones (EBERHARD and RUSSEL (1966) defined a stable variety as one with a  $S_{d^2}$  of zero) (Table 16).

Figure 22: Coefficient of variability of cassava, common bean, sweet potato, and maize in sole and different intercropping systems, 1974-78 (MORENO and HART, 1979)

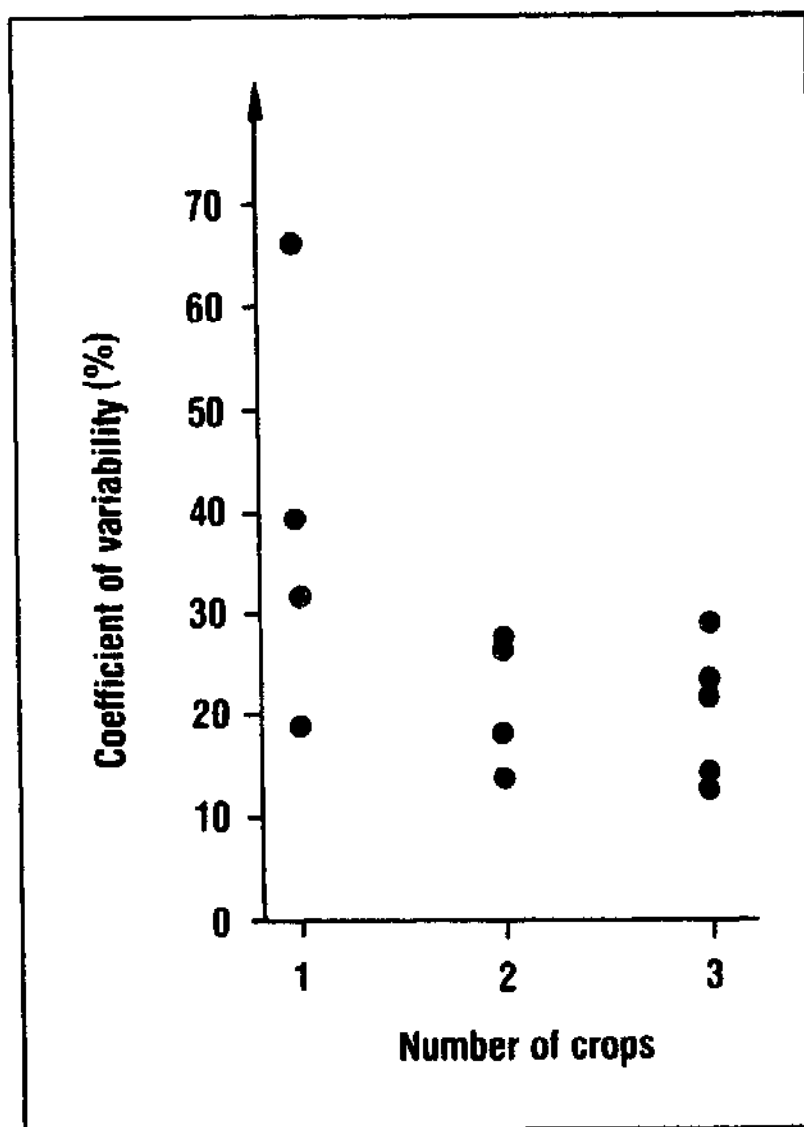

Table 16: Stability parameters, regression coefficient b and mean square deviation from regression  $S_d^2$  of entries for yield (MERCER-QUARSHIE, 1979)<sup>d</sup>

Entries	b	Mean b for entry group	$S_d^2$
A	0.52		506 ***
B	1.14		628 ***
C	0.42	0.794	454 ***
D	0.41		316 ***
E	1.48		1005 ***
A + B	1.22		16 NS
A + C	0.56		439 ***
A + E	1.06		187 ***
B + D	1.40	1.165	137 ***
B + E	1.60		778 ***
D + E	1.15		73 **
A + B + E	1.33		55 **
A + C + D	0.47		427 ***
B + C + D	1.07	0.963	147 ***
C + D + E	0.98		34 *
A + B + D + E	1.14		6 NS
A + B + C + E	0.73	0.990	92 ***
A + C + D + E	1.10		13 NS
A + B + C + D + E	1.18	1.180	14 NS

A, B, C, D, and E denote cvs 'Mankaraga', Bawku White', 'Ndim-larina', 'Kazee' and AA'226/3M respectively.

\*\*\*, \*\* and \* denote significantly different from zero at  $P = 0.001$ ,  $P = 0.01$  and  $P = 0.05$  respectively.

NS denotes not significantly different from zero at  $P = 0.05$ .

The use of the regression analysis to determine yield stability of intercrops is not always satisfactory. Studying yield stability of sorghum/pigeon pea intercrops in different environments of India, RAO and WILLEY (1980 b) always calculated a higher regression coefficient for the intercrops than for the sole crops. But they came to the conclusion that the different approaches leave much to be desired because they still do not indicate in common practical terms what a given level of "statistical" stability means to a farmer. On the assumption that a farmer's major concern is

to avoid a "disaster" situation, they tried an approach which estimated the probability of each cropping system failing to provide given "disaster" levels of monetary returns. At any given level of minimum income, probability of failure was lower for a sorghum/pigeon pea intercrop than for either sole crop. In the example given in Figure 23 sole pigeon pea would fail approximately once in five years to give an income of 1.000 Rupees/ha, sole sorghum once in eight years, shared sole crops (1/2 ha sorghum + 1/2 ha pigeon pea) once in thirteen years, but intercrops only once in thirty-six years. Thus, in these simple practical terms, intercropping showed a higher yield stability than any sole crop. Whether the reduced incidence of crop failure accrues from higher intercrop yields or whether it is caused by a reduction in variability of yields, cannot be followed from this calculation. For the farmer it will be of no interest, in any way (see also Paragraph 4.3).

Figure 23: Probability of failure for sorghum and pigeon pea in different cropping systems at given 'disaster' levels of income (RAO and WILLEY, 1980)

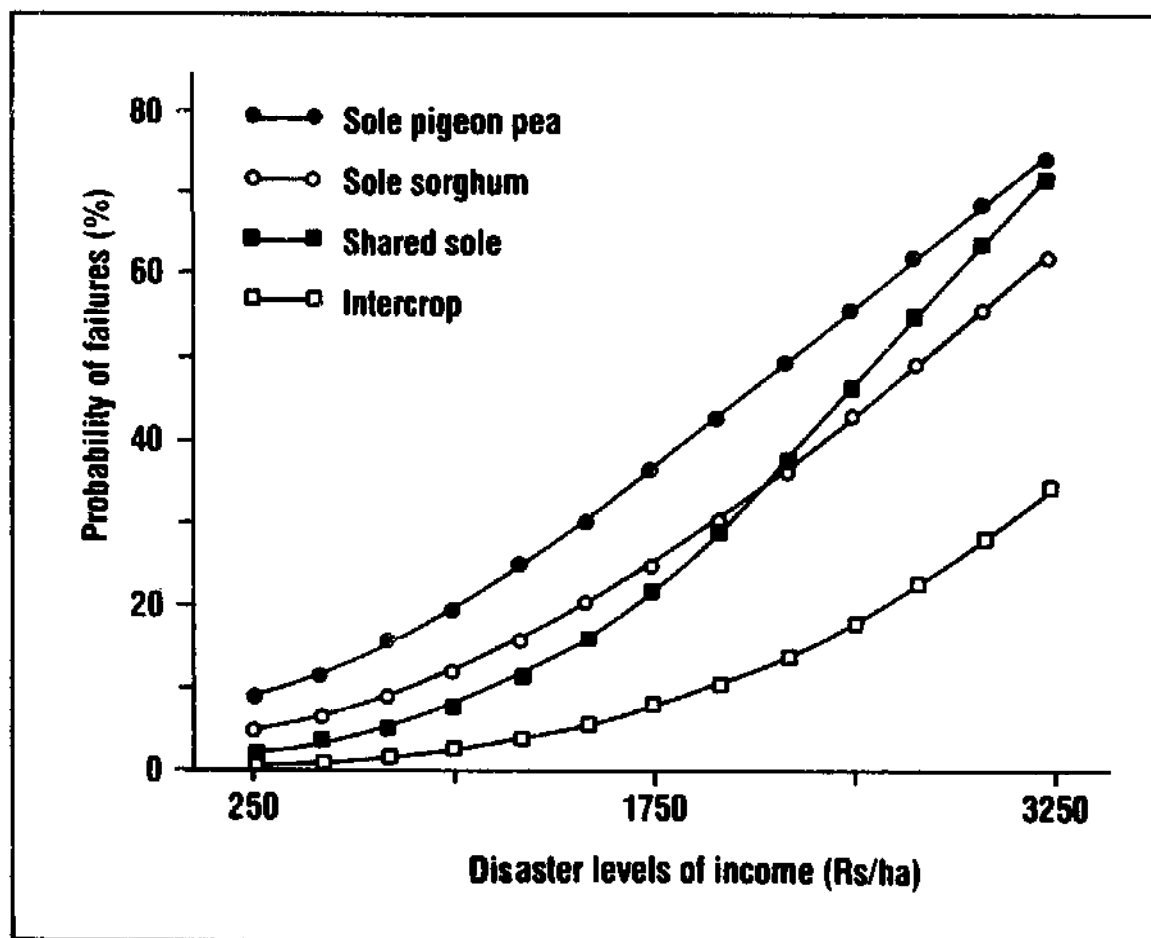

### 3.3 Adapting Varieties to Intercropping Systems

Crop varieties used in traditional cropping systems often represent years of natural selection for survival and selection by the farmer for production and quality. Though having a relatively low yield potential when compared to improved cultivars grown as sole crops with high levels of technology, these traditional cultivars generally compete well with weeds and other associated crop species, are relatively resistant to prevalent pests and diseases and possess a high level of genetic variability or heterozygosis, as in the case of cassava.

Attempts to increase the productivity of these cropping systems by introducing improved varieties have often been unsatisfactory because the new varieties did not produce the expected high yields. These varieties have been developed for commercial farming. Therefore, on farmers' fields with a low level of management the improved varieties could not exploit their potential because of low soil fertility, competition with weeds, etc. In addition, the varieties were selected for sole cropping conditions. Thus, they often have characteristics - mainly plant morphology and growth vigour which suppress the growth of associated crops - making them less suitable for intercropping.

In some cases, however, the best cultivars for sole cropping are also best for intercropping. This was found at CIAT for cassava, intercropped with beans, where plant types with medium vigour and late ramification gave highest yields in sole crops as well as in intercrops (LEIHNER, 1982). But in West Africa where cassava is mainly intercropped with maize, only very vigorous cultivars can compete with the associated crop. Under these conditions, the best types for sole cropping are not necessarily the best types for intercropping. In consequence, it seems necessary to select varieties specially for intercropping systems and perhaps also for situations of low or medium soil fertility.



Yet, most crop improvement programmes, national as well as international ones, are still breeding and selecting only for sole crop conditions. Since the development of varieties for sole cropping is regarded as a priority, there are normally not enough funds and personnel available to set up a second crop improvement programme. In addition, breeding and selection specially for intercropping systems are much more complicated, and this means that in the end it is more costly than breeding for sole cropping conditions.

Until recently there was a lack of knowledge about how such improvement programmes were to be organised to keep expenditure low. The question had to be answered as to whether there were some basic principles, e.g. an intercropping tolerance, whereby varieties could be selected or whether varieties had to be selected specifically for each crop combination. Another question is the heredity of such characteristics. Even though gaps in current knowledge still exist, research has advanced far enough to permit the design of future special breeding programmes for intercropping systems.

To give a better understanding of the problem, genotype by (cropping) system interactions will be discussed as well as possibilities of genetic improvement of varieties for intercropping systems.

### 3.3.1 Genotype by Cropping System Interactions

When discussing genotype by system interactions, the cropping system is considered as an important part of the environment of plants. Cropping systems have a direct influence on the performance of genotypes and cause considerable changes in the relative yields of genotypes.

The following examples should give a better understanding of the connection. In Ecuador, relative yields of nine climbing bean cultivars were determined by planting with contrasting normal and

brachytic maize. The data summarized in Table 17 show significant yield differences among the bean varieties tested. A comparison of bean yields in the two intercropping systems revealed non significant correlations for yield ( $r = 0.265$ ) and for rank order ( $r = 0.361$ ). Selection of a bean variety for one system would not therefore provide the best bean for a different system. Similar results were obtained when evaluating data from other trials, e.g. maize/soya bean intercrops in Tanzania (FRANCIS, FLOR and TEMPLE, 1976).

Table 17: Yields of nine climbing bean collections associated with two contrasting maize types, Boliche, Ecuador (BUESTAN, 1973, cited from FRANCIS, FLOR and TEMPLE, 1976)

Climbing bean variety	Beans associated with dwarf maize		Beans associated with normal maize	
	Rank	Yield	Yield	Rank
		kg/ha		
Panamito	1	1,343 a*	780 bc*	5
Puebla-421	2	1,025 b	695 cd	6
Aguascalientes-70	3	1,003 b	1,081 a	2
Pata de Paloma	4	954 b	991 ab	4
Guatemala-358	5	938 b	1,005 a	3
Puebla-163	6	882 bc	1,102 a	1
Guanajuato-113A	7	811 bc	669 cd	7
Puebla-151B	8	803 c	542 d	9
Aguascalientes-67	9	708 c	600 cd	8

\*Bean yields in same column followed by same letter do not differ significantly (5% level).

The only significant correlation between sole cropped and intercropped performance among varieties was found in a sorghum trial reported by BAKER (1974). Sole crop yields were significantly correlated with yields of sorghum intercropped with millet ( $r = 0.947$ , significant at 1 % level), although the trial included only 4 varieties.

While, in general, there is no correlation between the performances of cultivars in sole and intercropping systems, correlations among different intercropping systems are often high (FRANCIS, 1979). The examples in Table 18 indicate significant r-values for yields of maize, climbing bean and soya bean across several comparable systems. The differences in the environment of two intercropping systems may generally be less than between a sole crop and an intercropping system.

There are a number of statistical alternatives for evaluating the magnitude and nature of the genotype by systems interaction, such as the analysis of variance or a regression analysis (BREESE and HILL, 1973; ENGLAND, 1974). But this requires access to the original data on replications which are often not included in publications or annual reports where much of these data are found. Using original data from IRRI and CIAT of legume/cereal intercrop trials, FRANCIS (1979) found highly significant genotype by cropping system interactions in several trials. This led him to suggest that selection for specific genotypes in each cropping system could be indicated in those systems with a highly significant genotype by system interaction.

"In reaching a decision upon which system or systems to use in a breeding programme, one is faced with the circular problem inherent in the evaluation of genetic material in new systems. With a change in fertility, plant densities or cropping systems, selected material with superior performance under a previous system may no longer be superior. It will then be necessary to select germplasm under the new conditions" (FRANCIS, FLOR and TEMPLE, 1976).

As the testing of all germplasm for its suitability to certain cropping systems is an immense task, it would be valuable for a plant breeder to know whether there is a kind of hereditary "intercropping tolerance". Such a hereditary component would enable the breeder to concentrate on suitable parent materials and decrease the number of crosses that had to be evaluated. When testing local maize entries and their progenies for intercropping tolerance with soya bean, SAYAD GALAL, HINDI, IBRAHIM and EL-HINNAWY

Table 18: Correlations of crop yields between two intercropping systems.  
Average yield (kg/ha) (FRANCIS, 1979)

Crop	n	Association 1 (system)	Association 2 (system)	r <sub>yield</sub>	r <sub>rank</sub>	Reference
Maize	20	4681 (bush bean)	3479 (climbing bean)	0.93**	0.89**	Francis et al., 1979
Maize	20	5768 (bush bean)	3836 (climbing bean)	0.68**	0.58**	Francis et al., 1979
Bean, climbing	10	840 (maize H210)	847 (maize Suwan)	0.67*	0.60	CIAT, 1978
Bean, climbing	10	840 (maize H210)	649 (maize LaPosta)	0.90**	0.84**	CIAT, 1978
Bean, climbing	10	847 (maize Suwan)	649 (maize LaPosta)	0.89**	0.75**	CIAT, 1978
Bean, climbing	9	941 (dwarf maize)	829 (normal maize)	0.26	0.36	Buestan, 1973
Soya bean	12	560 (maize)	650 (sorghum)	0.60*	0.39	Finlay, 1974
Soya bean	12	560 (maize)	280 (millet)	0.44	0.34	Finlay, 1974
Soya bean	12	650 (sorghum)	280 (millet)	0.69**	0.60*	Finlay, 1974

\* and \*\* denote correlations significant at P = 0.05 and P = 0.01 resp.

(1974) found very high correlations ( $r = 0.91$  and  $0.98$  in 1967 and 1968 respectively) between the intercropping tolerance of varieties and their corresponding variety and tester crosses. They concluded that this indicated a heredity component to intercropping tolerance. It is, however, questionable whether a general "intercropping tolerance" exists. In the context of the reported trials this primarily means photosynthetic efficiency. The "intercropping tolerant" maize varieties competed more successfully with soya bean for light. As competition for light, on the other hand, is the major limiting factor in most intercropping systems, it would be helpful if a hereditary intercropping tolerance for this factor could be found in other crops, e.g. for cassava in cassava/maize, for groundnut and cowpea in legume/cereal intercrops, etc.

### 3.3.2 Breeding and Selection for Intercropping Systems

There is still a controversy as to whether or not a specific breeding programme for intercropping systems is needed or justified. Factors which should be considered include the magnitude and nature of correlations (significance of the genotype by system interactions), similarity of traits and breeding objectives between the two or more breeding schemes under consideration, relative importance of the two or more alternative cropping systems in the region into which improved genotypes are to be introduced, and the resources available for the total improvement programme.

Limited research facilities and budgets, however, make it normally necessary to focus entirely on one cropping system. In most cases sole cropping systems are preferred, as it is still believed that these systems will guarantee highest increases in production. There are only few examples of crop improvement programmes for intercropping systems. In West Africa some national and regional programmes (such as SAFGRAD) are selecting cowpeas for their suitability for intercropping with sorghum or maize. The same would be necessary for groundnut, bean and soya bean in legume/cereal intercropping systems and for maize and cassava in maize/cassava or

maize/cocoyam systems. In Cameroon, where maize/cocoyam intercropping is common practice in the humid areas of the country, maize is already bred for its suitability to intercropping with this tuber crop in a small programme.

The selection of large numbers of crosses of two or more species for their intercropping suitability is an ambitious venture, requiring much land and labour. Efforts have been undertaken, therefore, to develop an experimental design which is more efficient in land and labour use. One design, developed by HUMBLIN, ROWELL and REDDEN (1976), enables the study of segregating generations from parental varieties with  $N$  crosses (A, B, ... N) of one species and  $n$  crosses (a, b, ... n) of the other. In this design all combinations of the crosses are represented. The  $Nn$  combination constitute an  $N \times n$  factorial arrangement that makes it possible to study the following effects in an analysis of variance:

1. cross of test species
2. cross of associated species
3. interaction

Other screening methods have been developed at CIAT (FRANCIS, 1979).

When selecting for intercropping systems specific objectives have to be defined. In the following, the most important characteristics desirable for intercropped species are cited.

Photoperiod sensitivity: The genetic capacity to grow and mature in a given number of days, independent of day lengths, is a trait often associated with successful genotypes for intensive intercropping systems (DALRYMPLE, 1971). Photoperiod insensitivity is, for example, one of the most important breeding criteria for cowpea. This trait allows a cultivar to be planted on any convenient date, with flowering and maturity controlled by genotype reaction to prevailing temperature patterns and to some extent to other cultural and natural fertility factors. In some specific situations, on the other hand, photoperiod sensitivity may be important in one component crop to assure that its major growth flowering and filling period do not coincide with another component with a different seasonal duration (FRANCIS, 1979).

Appropriate crop maturity periods are important characteristics needed for specific cropping patterns, because the combination of an early and a late maturing crop is generally desirable in order to exploit better the available growth factors at different times (see Paragraph 3.1.1).

Plant morphology is a characteristic which directly influences the growth of the component crop, mainly through the shade effect of the dominant plant. Medium or short cereal crop plants provide less competition to an understorey legume or intercropped cereal of another species (ANDREWS, 1972). This effect is increased when the foliage of the variety is also reduced (PRAQUIN, 1980).

In cereal mixtures gains in yield depend on differences in height and age of maturity. When comparing combinations of sorghum varieties, BAKER (1979) found that overyielding occurred if the height of the varieties differed by more than 59 cm (and age at maturity by more than 51 days) (see Paragraph 3.1.1). The leaf angle and form or width of leaves or leaflets of the higher crop (e.g. maize or cassava) affects the amount of light transmitted to the lower components of a system and influences distribution of light to different levels of leaf area within the canopy (TRENATH and ANGUS, 1975; WIEN and NANGJU, 1976) (see Paragraph 3.1.2.1). For cowpea/cereal intercrops erect or semi-erect cowpea types are preferred which facilitate weeding. On the other hand, prostrate cultivars are less affected by shading of intercropped cereals (WIEN and NANGJU, 1976) and provide better protection against erosion. Cassava, used in maize/cassava intercrops should be high branching, while for some sole crop conditions bushy types which keep weeds down and resist lodging could be more suitable.

Other characteristics that are of importance when breeding for intercropping situations are:

Population density responsiveness: Component crops which respond to increased density give greater flexibility in the design of cropping systems with varied proportions of each crop in a mixture (FRANCIS, FLOR, PRAGER, and SANDERS, 1978).

Vigorous early seedling growth or vigorous early growth of cuttings (e.g. with root crops) leading to a rapid groundcover is highly

desirable to control weed growth. In addition it also increases the competitive abilities of a crop as an intercrop, which can be of importance for dominated components.

Resistance to pests and diseases: Even though this is not a specific trait for intercrops, being important for all cropping systems, it is mentioned here because resistance is most important for smallholder cropping systems (in the absence of commercial inputs).

### 3.4 Soil Fertility Management

The transition from traditional bush-fallow farming to intensive permanent agriculture is usually accompanied by a rapid deterioration of soil fertility in most cases. This is especially true for the humid tropics where maintenance of soil fertility is even more difficult than in the semi-arid tropics.

The rapid decline of soil fertility in the tropics is caused mainly by the following factors:

- a low inherent fertility of most soils (low effective CEC, low pH, low inherent nutrient status) (KANG and JUO, 1981);
- a rapid decomposition of organic matter due to high temperatures and humidity;
- soil erosion and loss of nutrients through leaching favoured by high intensity rains.

In the following paragraphs it will be analysed whether and to what extent, intercropping systems can contribute to soil fertility maintenance.



### 3.4.1 Soil Related Constraints to Food Production in the Tropics

Permanent agriculture in the tropics leads in most cases to a rapid loss of soil fertility indicated by decreasing yields. Large-scale mechanized agriculture in particular can cause heavy soil erosion and deterioration of the soil structure (compaction, surface sealing, etc.).

Almost the same effect is, however, obtained by traditional farming in densely populated areas where land pressure leads to a shortening of fallow periods so that soil fertility can no longer be restored. Thus in many parts of Africa thousands of hectares of arable land are destroyed irrevocably every year. This is true for both the humid and the semi-arid tropics. Well-known examples are the Lekie area in Cameroon, parts of Anambra State in south-eastern Nigeria, the "terre de barre dégradée" in Togo and Benin and parts of the Mossi Plateau in Upper Volta.

The difficulties of maintaining soil fertility under permanent agriculture are derived mainly from the following characteristics of tropical agro-ecosystems:

- a. Soils of the humid tropics are usually low in inherent fertility as they have been formed from material that has been reworked since the Precambium by processes of soil erosion and deposition which intensively weather the material. Exceptions are soils formed over basic volcanic rocks, calcareous rocks or limestone, and alluvial and valley bottom soils, where the degree of fertility depends on the parent material.
- b. Organic matter derived from fallow vegetation, green manure or crop residues is rapidly decomposed by the activities of micro-organisms, favoured by high temperatures and humidity. This is primarily true for the humid tropics but also for the semi-arid tropics during the rainy season. This process is accelerated by tillage, especially ploughing.
- c. Tropical rains are of high intensity, thus increasing soil erosion. Peak rainfall intensity of 75 to 100 mm/h is not un-

common and these rains are characterized by large drop sizes. Soil exposure to these high intensity rains results in progressive deterioration of the soil structure, causing crusting and low infiltration rates. Especially on Alfisols more than 50 % of the rainfall can be lost by run-off. This run-off causes sheet erosion that can remove 15 to 20 mm of surface layer per annum (at 1.000 to 1.500 mm rainfall) even on gentle slopes (10-15 %) (OKIGBO and LAL, 1979). This magnitude of soil erosion results in irreversible soil degradation.

- d. Except in soils derived from basic rocks, intensive weathering and high rainfall cause leaching of basic cations, thus resulting in low base saturation and low soil pH with all its harmful consequences for crop growth. Yearly losses due to leaching of 30 kg N/ha, 20 kg K<sub>2</sub>O/ha and 150 kg CaO/ha were measured (CHARREAU, 1970) in the Casamance. The mineral balance was negative under a range of crops including groundnuts. However, it can be assumed that at least the N-balance is positive under most legumes, e.g. cowpea.
- e. Accelerated soil erosion, decline in soil structure and a rapid rate of decay of soil organic matter decrease the soil's water-holding capacity (both surplus and deficit). Thus even short dry periods of only 7-10 days cause a moisture stress resulting in significant reductions in yield.
- f. In exposed soils of the lowland tropics, maximum soil temperature at the beginning of the growing period can reach 45-50° C at 5 cm depth, depending on the soil type and seed-bed preparation (LAL, 1974, cited from OKIGBO and LAL, 1979). This level of soil temperature can be supra-optimal for crops such as maize and soya beans. As high soil temperatures are usually combined with moisture stress, this can lead to significant yield reductions.

All these factors combined mean that food production does not increase as expected in spite of the progress made in agricultural research and especially in plant breeding. Yield stability is low on most soils and fertilizer use efficiency decreases with the deterioration of the soils.

### 3.4.2 Maintenance of Soil Fertility Under Traditional Cropping Patterns

The traditional African system of agriculture, south of the Sahara, is based on the practice of bush-fallow rotation. Common practices of this system are:

- a. Clearing of the natural vegetation mainly by using the axe, cutlass, and fire. This practice does not usually lead to bare soil because a layer of organic matter remains to cover the ground. Stumps of trees and bushes remain in the ground, enabling a quick regrowth at the end of the cultivation period. The stumps and roots stabilize the soil, thus reducing erosion hazards. Mechanical clearing, on the contrary, often leads to soil compaction, a removal of the O- and often, too, the A-horizon, together with the vegetation.
- b. Cultivation of the cleared land with hoe or planting stick only slightly disturbs the surface soil. Thus the organic matter in the soil is only slowly decomposed and erosion hardly occurs. Ploughing, on the contrary, leads to a deterioration of the soil structure and rapid decomposition of organic matter, thus increasing erosion.
- c. The practice of intercropping, and especially multi-storey cropping, provides a nearly continuous soil cover, thus preventing overheating of the soil and protecting it from the impact of the rains. Soil erosion is therefore rather limited. A dense and diversified root system reduces leaching of nutrients.
- d. A short cropping cycle (2-3 years) and a long fallow period allows a complete restoration of soil fertility, even on soils with low inherent fertility.

Socio-economic changes and more particularly demographic pressure on land (as mentioned earlier) do, however, reduce the traditional fallow period, although all the other practices involved in the bush-fallow rotation remain little changed. Thus, the equilibrium between the socio-ecological environment, vegetation and crops

which has been empirically evolved and maintained by traditional farmers is destroyed and leads to a progressive degradation on the fallow vegetation and of the land resources (MOUTAPPA, 1974).

### 3.4.3 Possibilities of Maintaining Soil Fertility Under Conditions of Smallholder Farming

Maintenance of soil fertility under permanent agriculture has been a research objective for many years. As the protection of the soil through permanent cover is a precondition, concepts of relay-cropped green manure, mulching, living mulches and no-tillage have been developed. While all these practices can considerably reduce the destruction of the soil structure and erosion, they are not suited to the conditions of smallholdings. Mulching, even though commonly employed for coffee, is too laborious for food production and farmers do not have enough material. Living mulch does not produce a yield - except perhaps fodder - and thus the farmer does not benefit from a direct return to his labour input. Moreover it is only suitable for the humid tropics, as the plants compete with the crops for the limited soil moisture. Green manure could be a solution only for mixed farms, which do not exist in the humid tropics and only to a limited extent in the semi-arid tropics of West Africa. No-tillage, lastly, requires a high input of herbicides, usually too costly and unavailable to smallholders.

Thus there remains only the possibility of maintaining a more or less permanent ground cover by methods of intercropping, relay-cropping, multi-storey cropping and some forms of agro-forestry. Of course, these cannot be as effective as no-tillage or mulching but they are at least methods known to farmers and can still be improved.

Even relatively simple intercropping systems as maize/cassava can alleviate the decrease of CEC and pH as well as the increase of Mn (Table 19). Soil losses and run-off can also be reduced by intercropping as shown in Table 20. When crops are included which

provide a quick ground cover, such as many legumes, sweet potatoes, or melon, intercropping will be more effective, of course.

Table 19: Effects of three years of cultivation after forest clearing on CEC, pH and exchangeable cations under different treatments (OKIGBO and LAL, 1979)

Treatment	pH-H <sub>2</sub> O	Effective CEC me/100 g	Exchangeable cations, me/100 g			
			Ca	Mg	K	Mn ppm
Bush fallow	6.5	4.94	3.34	0.89	0.42	3
Maize (without residue mulch)	5.3	3.95	3.01	0.46	0.13	28
Maize (with residue mulch)	6.0	6.38	4.58	0.92	0.68	11
Maize + cassava	6.2	5.24	3.92	0.67	0.39	10
LSD (0.05)	0.36	1.03	1.03	0.31	0.21	7

Table 20: Soil-losses and run-off under sole cassava and cassava intercropped with maize (OKIGBO and LAL, 1979)

Slope %	Soil losses (t/ha)		Runoff (% of rainfall)	
	Cassava	Cassava + maize	Cassava	Cassava + maize
1	3	3	18	24
5	87	50	43	33
10	125	86	20	18
15	221	137	30	19

The integration of trees into cropping systems is a further means of maintaining soil fertility by shading, by protecting the soil against the impact of rain, by reducing soil erosion and leaching with help of the root system, and by "pumping up" nutrients to the surface from layers beyond the root systems of annual crops.

In the lowland humid tropics radiation is, however, already low and a limiting factor to plant growth, especially during the rainy season. Additional shading by trees can lead to considerable reduction in the yields of crops such as maize, cassava or groundnut, thus neutralizing the beneficial effect on soil fertility (Table 21). Trees have therefore to be arranged in such a way as to minimize the detrimental effects of shading.

In the semi-arid tropics, on the other hand, where insolation is high, trees have a direct beneficial effect on many crops by shading, by reducing evapotranspiration and of course by producing litter. Here crops develop better under trees, provided that the shade is not too intense. Farmers in these areas protect trees primarily because of their direct economic value, especially Butyrospermum parkii (Shea butter or Karité) and Parkia clappertonia (Dawadawa or Néré), but they are also aware of the soil improving characteristics, especially of Parkia spp. and Acacia al-bida. A. al-bida is protected by farmers mainly for this reason. Populations may reach 40 to 50 trees/ha. A specific characteristic of A. al-bida which makes it very suitable for integration into cropping systems is that it retains its leaves during the dry season, shedding them during the rainy season and thus minimizing the competition for light.

Analytical results from soils under A. al-bida in Senegal (CHARREAU and VIDAL, 1965) indicate a remarkable fertility gradient from the external area covered by the foliage to the trunk; all soil properties are improved and rates of increase are highest for nitrogen, available phosphorus, exchangeable calcium and cation exchange capacity (CEC) (Table 22). Seed yields of millet increased by nearly 250 % from 52 kg to 179 kg/ha on average near the trees and protein yields were multiplied by 3 or 4 (Table 23). Thus the effect of

A. albida is not limited to an increase in grain yield; grain quality is also improved.

The integration of trees into cropping systems needs further study, but this is difficult because of the slow growth rate in the semi-arid tropics. A. albida, especially, is a very slow growing tree.

A further possibility of exploiting the soil improving potential of leguminous trees and shrubs in particular is "alley cropping" (IITA, 1979). This is a kind of systematic fallow where hedges are planted at intervals of 4-6 m directly in the field. They are pruned regularly during the growing period to prevent shading of the crops and to provide mulching material, rich in nitrogen. From the end of the growing season onwards, i.e. after harvest of the crop and throughout the dry season or fallow period, the hedges are no longer pruned providing shade to the ground as well as producing firewood or the stakes required for yam cultivation. Additional labour requirements for pruning in the rainy season are balanced by reduced labour demand for weeding, as weed growth is suppressed by the hedges (KANG, WILSON, and SIPKENS, 1981). Whether the system is feasible under farmers' conditions, however, still has to be studied.

Planted fallow, preferably with leguminous shrubs, is another means of restoring soil fertility. This has been practiced traditionally by several ethnical groups, e.g. the Bamiléké in Cameroon (DONGMO, 1980), but the method needs to be improved in view of the increasing land shortage which allows only short fallow periods, if at all.

One possibility for semi-arid regions is, for example, relay or intercropping of sorghum with pigeon pea. Pigeon pea remains in the field during the dry season and perhaps another year, thus protecting the soil against insolation and wind erosion and improving soil fertility by symbiotic N-fixation and by the effect of the deep rooting system (especially uptake of phosphate).

Table 21: Yield reduction through shade of some major crops in farmers' fields<sup>1)</sup>  
(OKIGBO and LAL, 1978)

Crop	No shade No fertilizer t/ha	Shade No fertilizer t/ha	Yield reduction %	No shade Fertilizer t/ha	Shade Fertilizer t/ha	Yield reduction %
Maize	0.5	0.4	20.0	1.5	0.7	53.3
Cassava	8.9	2.8	68.5	14.4	3.4	76.4
Yam	9.2	8.4	8.7	12.1	9.4	22.3

1) Means of 3 villages in southern Nigeria.



Table 22: Results (average) from analyses of soil samples taken at three different sites near Acacia albi-da trees (from CHARREAU and VIDAL, 1965)

Determinations	Gross results			Relative results (C = 100)		
	A <sup>1)</sup>	B <sup>2)</sup>	C <sup>3)</sup>	A	B	C
pH (water)	6.50	6.34	6.14	106	103	100
total carbon %	0.53	0.48	0.33	162	146	100
total nitrogen %	0.06	0.05	0.03	194	168	100
C/N ratio	8.9	9.2	10.6	84	87	100
exchangeable cations me/100 g						
Ca	2.94	2.33	1.47	200	158	100
Mg	1.12	1.00	0.63	178	158	100
K	0.10	0.08	0.07	143	114	100
Na	0.12	0.13	0.09	133	144	100
total exchange capacity me/100 g	4.13	3.69	2.25	147	131	100
P <sub>2</sub> O <sub>5</sub> ppm total	190	147	148	128	99	100
P <sub>2</sub> O <sub>5</sub> ppm available	35	19	15	234	127	100

1) A = near trunk. 2) B = edge of canopy. 3) C = outside of canopy.

Permanent cultivation is practiced traditionally in many regions of West Africa in compound farms. These are a sort of garden where soil fertility is restored by household wastes. In most cases, however, compound farms are of rather limited size and are primarily used for producing vegetables and spices, even though all kinds of crops, trees included, can be found. In areas with high population pressure and consequently reduced farm sizes the compound farms are enlarged and, in extreme cases, the entire farm becomes a compound farm (LAGEMANN, 1977). The promotion and improvement of compound farms could be a means of increasing food production and yield stability in smallholder agriculture. Besides intercropping in its broadest sense, incorporation of crop residues and the use of manure are further possibilities of maintaining soil fertility of small holdings.

Table 23: Yields<sup>1)</sup> of millet (grains and protein in kg/ha) at three different sites below *Acacia albida* trees (from CHARREAU and VIDAL, 1965)

Locations	Number of			Weight of grains (g)				Protein	
	pockets harvested	ears harvested	ears per plant	total	per pocket	per ear	(kg/ha) theoretical	% of grains	(kg/ha) theoretical
A. near trunk	3.6	19.3	5.4	593	166.8	29.8	1.668	10.68	179.9
B. edge of canopy	4.2	17.5	4.2	413	98.3	23.3	983	8.72	84.2
C. outside of canopy	4.0	11.6	2.9	255	66.0	22.6	660	8.10	52.2

1) means of 6 resp. 7 samples.

While maintenance of soil fertility by good management practices may perhaps keep yields stable in the long run, remarkable yield increases, as required by the high rate of population growth, can hardly be obtained without fertilizers. Rising fertilizer prices and the limited availability of fertilizers in developing countries, however, force the farmers to use fertilizers as efficiently as possible. In Chapter 3.1 it was pointed out that intercropping systems in general make more efficient use of limited natural resources. It would be of interest to know whether the same is true for fertilizers. In addition, the practical questions of the quantity and timing of fertilizer application in intercropping systems have to be studied. Knowledge of fertilizing intercropping systems with inorganic fertilizers is still rudimentary, as nearly all fertilizer experiments have been carried out in sole crops. Therefore data obtained from sole cropping systems are still used in intercropping systems.

Most fertilizer studies in intercropping systems have been limited to nitrogen, because many crops respond rapidly and significantly to this nutrient and also, because nitrogen plays an important role in the common legume/non-legume intercrops. To obtain substantial yields, however, the supply of the other elements cannot be neglected. This is especially true of phosphorus, since most tropical soils are poor in available phosphorus. Potassium, on the other hand, is rarely a limiting factor.

#### 3.5.1 Nutrient Requirements in Intercropping Systems

- a. Interactions between cropping systems and the requirements of individual crops

The main problem of fertilizer use in intercropping systems is that the component crops have different nutritional needs and that the period of maximum demand for one crop does not necessarily coincide

with that of the associated crop(s). It is therefore important to know as much as possible about the nutritional requirements and growth characteristics of the crops which are to be grown together in a specific cropping pattern.

Maize, for example, requires high amounts of N for a good yield, followed by P and K. Cassava removes large amounts of N, P, and K from the soil, because of high root yields. It requires, however, only little fertilizer-P, even on soils that are very poor in available phosphorus, because cassava roots absorb phosphorus very effectively (due to mycorrhiza). Grain legumes require large quantities of N but as they can satisfy most of their needs by symbiotic nitrogen fixation, they have to take up N from the soil only in the early stages of development. Sweet potatoes, on the other hand, respond to high N rates with luxurious growth of aerial parts but reduced formation of swollen roots.

When applying fertilizer to crop associations, account has to be taken of the different fertilizer responses of the component crops, in order to allow an efficient fertilizer use. The application of nitrogen to a cereal/legume intercrop, for example, will decrease the use efficiency of nitrogen, as it suppresses symbiotic nitrogen fixation of legumes. The same is true for a maize/sweet potato intercrop, where nitrogen reduces the root yields of sweet potato. Application of P to a maize/cassava intercrop will result in a low use efficiency of phosphorus since cassava hardly responds to P. So, fertilizers have to be applied in such a way that the nutrient requirements of the one component crop are met, without reducing yields of the other component crop or without wasting fertilizer by application to a non-responsive crop.

The different requirements of component crops, however, are not the only problem when applying fertilizer to intercrops. Growth patterns of crops change when the crops are grown in associations. For example, dry matter production by pigeon pea in a maize/pigeon pea intercrop was less than half that of sole cropped pigeon pea during the first 16 weeks. Once the maize matured, however, its competitive influence was reduced and the growth of the

interplanted pigeon pea between the 16th and 24th week was sufficient to produce seed yields comparable to the sole crop. The pattern of nutrient accumulation seemed to parallel growth (DALAL, 1974) (Table 24). This example clearly shows, that the nutrient requirements (in time and quantity) of crops differ when they are grown in association instead of being grown in pure stands.

Table 24: Yields of dry matter, grain and nutrients by sole and interplanted stands of maize and pigeon pea (DALAL, 1974)

Treatment	Maize grain yield	Total dry matter	Nutrient uptake		
			K	Ca	Mg
Maize	3130 a	6408 a	50.8 a	10.3 a	12.3 a
Pigeon pea		822 b	10.1 b	6.2 b	2.5 b
Mixed stand	2025 b	4225 (221) c	36.7 (2.1) c	9.8 (1.8) a	8.9 (0.9) c
Alternate rows	2606 c	5058 (340) d	46.5 (3.7) d	9.3 (2.5) a	8.6 (1.2) c
			Nutrient uptake		
			N	P	
Maize	3130 a	6408 a	66.2 a	13.2 a	
Pigeon pea		822 b	17.1 b	1.0 b	
Mixed stand	2025 b	4225 (221) c	48.3 (3.7) c	9.2 (0.2) c	
Alternate rows	2606 c	5058 (340) d	54.3 (5.7) d	11.2 (0.3) ac	

Means within each column not followed by letters in common are significantly different at  $P = 0.05$  according to DUNCAN's multiple range test (1955). Figures in parentheses for pigeon pea only.

Currently not enough is known of the actual fertilizer demands of crops grown in association. Therefore it can hardly be assumed that fertilizers are used very efficiently in intercrops. But it is at least obvious that increased optimum plant densities and increased production of intercropping systems lead to an increased total nutrient uptake and thus a greater depletion of the soil (see Paragraph 3.1.2.2). The increase in nutrient uptake corresponds to the increase in dry matter production. In a pearl millet/groundnut intercrop, for example, the LER values of the uptake of

N, P and K at final harvest were 1.25, 1.28 and 1.26, respectively, corresponding to an LER of 1.28 for total dry matter (REDDY and WILLEY, 1981). The increased removal of nutrients in intercropping systems has to be offset by increased fertilizer rates; otherwise a deterioration of the soil fertility would soon occur.

It should be mentioned here that plant population densities in traditional cropping systems, even in crop associations, are rather low. This is a way of avoiding over-rapid depletion of the soil.

b. Action of fertilizers in sole crops and in intercrops

The response to fertilization of intercrops as compared to sole crops can be measured by means of LERs. Should the LER increase with increasing fertilizer rates, this is a sign that the fertilizer use efficiency is higher in intercrops than in sole crops. In the same way, a decrease of the LER indicates a lower fertilizer use efficiency of intercrops compared to sole crops.

Quite a large amount of data is available concerning fertilizer response in intercropping systems. The results obtained differ greatly and an interpretation of the different effects is hardly possible without a description of the soils (mainly fertility status, previous crops, etc.) and general growing conditions. The response of the varieties used in the trials to fertilizers also have to be known as this has an influence on interspecific competition.

Dominant crops may become more dominant and suppress the dominated crop completely, e.g. maize after N application in a maize/groundnut intercrop. But there are also cases, where the relation between dominant and dominated plants is completely reversed.

The introduction of fertilizers into traditional cropping patterns is often accompanied by a change from the local to improved varieties. As these varieties have a different morphology, cropping patterns (population densities and spacings) have to be adjusted to the new situations, in order to reduce interspecific competition. Otherwise fertilizers cannot be used efficiently. Fertilizer

trials that do not take this into account may give misleading results. Trials carried out at the North Carolina State University (1976; and SANCHEZ, 1976) clearly show how the LER nitrogen curve depends on spacing configuration. While LER values are depressed in a maize/rice intercrop at a maize row spacing of 1 m, they remained almost constant at a maize row spacing of 2 m (Fig. 24).

Figure 24: Effects of nitrogen application and tall crop row spacing on the land equivalent ratio of a maize/rice intercrop (from North Carolina State University, 1976)

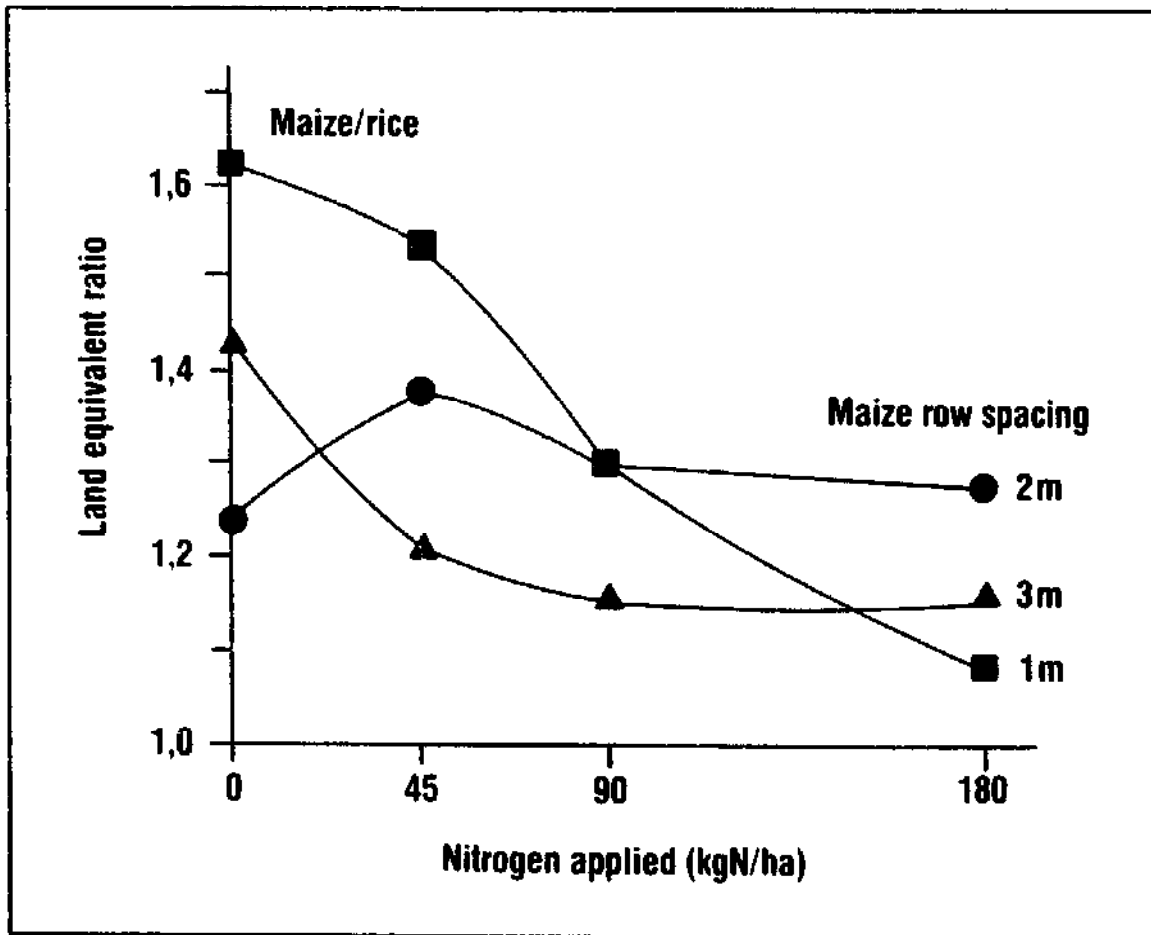

In a maize/bean intercrop the LER nitrogen curve differed completely between maize row spacings of 1 m and 2 m. Except for the 0-N level, the 1 m rows had higher LER values (Fig. 25).

Figure 25: Influence of nitrogen rate on grain yield and land equivalent ratio of maize/bean intercrop, Turrialba, Costa Rica (from SANCHEZ, 1976)

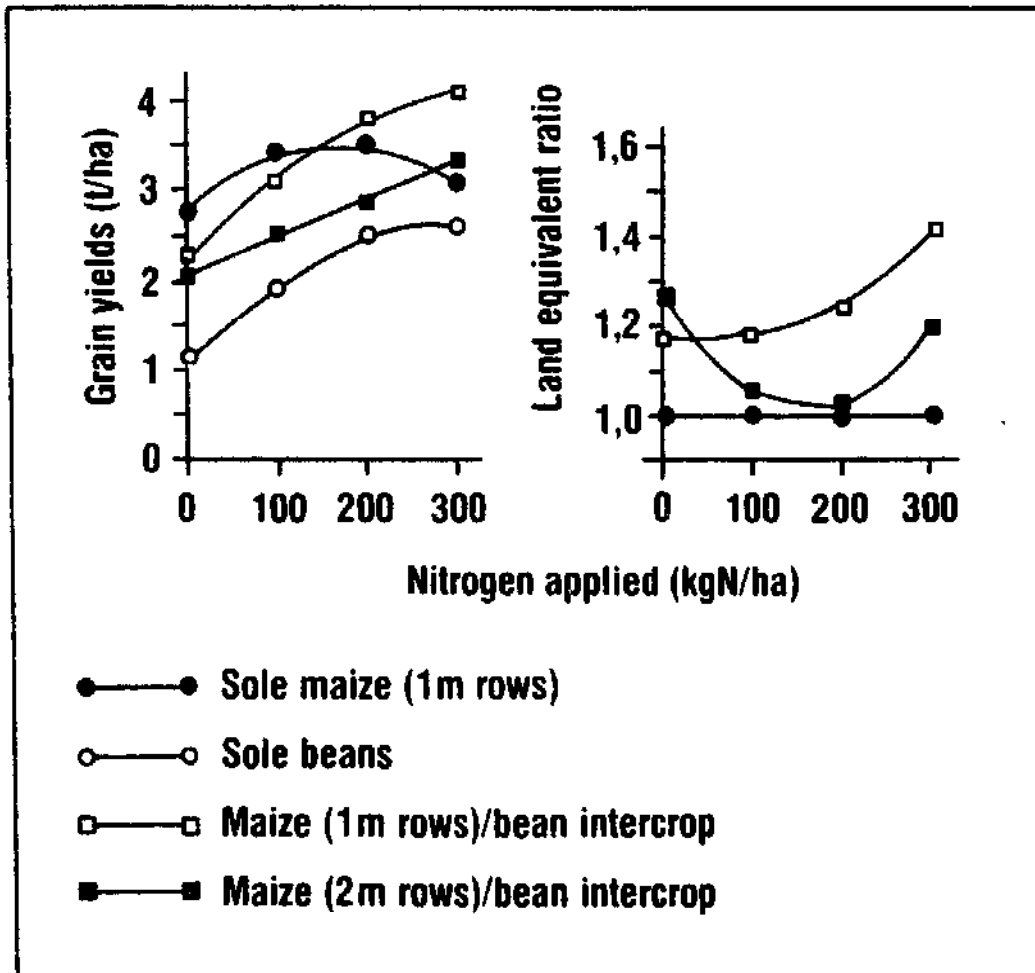

While local varieties may give the best relative yields at a low fertility level, improved varieties respond better to higher fertility rates. This necessitates the use of different varieties for different fertility levels and again an adaptation of cropping patterns to the varieties.

Thus some published data indicate decreasing LER values with increasing fertilizer rates, while others indicate increasing values. The available data do not make it possible to perceive a general trend in the effects of fertilizers in intercrops nor to give general recommendations for the application of fertilizers. An



exception is the response to nitrogen in legume/non-legume intercrops. LER values of these associations generally decrease as the N-rates increase, even though yields of the non-legume component rose significantly. But legume yields decrease sharply because of increased shading by the dominant non-legume crop and the negative influence of nitrogen fertilizers on symbiotic nitrogen fixation. Another reason for diminishing LER values is that initial yield increases due to N-fertilizer of cereals intercropped with legumes are much less than the increases in sole cropped cereals, because yields of intercropped cereals are already higher at 0-N than those of sole crops.

In a maize/soya bean intercropping trial in the Philippines, for example, the LER values fell from 1.47 at 0-N to 1.11 at 120 kg N/ha. Nitrogen uptake indicates that soya bean fixed about 125 kg N/ha when no nitrogen was added. A nitrogen application of 60 kg N/ha stopped the N-fixation, resulting in lower LER values (LIBOON and HARWOOD, 1975) (Table 25).

Similar responses to nitrogen application are reported from other countries (MUTSAERS, 1978; AHMED and GUNASENA, 1979; SEARLE, COMUDON, SHEDDEN and NANCE, 1981; DE, 1980) (Table 26).

In most cases LER values drop sharply at the first N increment from 0 to 40 or 60 kg N/ha, while there is only a slow decrease at higher N-rates. This drop in LER values is a clear indication of the greater relative advantage of intercropping under low fertility management compared with high fertility management. Therefore, for smallholders with limited access to fertilizers intercropping is undoubtedly the most suitable cropping system. This does, however, not imply that intercropping systems are bound to low fertility-low production situations. These systems can be intensified successfully.

BEETS (1977) could obtain, for example with appropriate cropping patterns (Fig. 26) in maize/soya bean intercrops even at a high fertility level (170 kg N/ha) LER values exceeding 1.2, with absolute yields of 2,400 kg/ha maize and 2,100 kg/ha soya bean.

Table 25: Grain yield of maize (DMR-2) and soya bean (Multivar 80) intercropped at varying levels of nitrogen and corresponding LER values (from LIBOON and HARWOOD, 1975)

Crop combination	Maize	Soya bean	Maize + soya bean	LER
<u>Control</u>				
Maize	1.3	-	-	-
Soya bean	-	2.0	-	-
Maize + Soya bean	0.8	1.7	2.5	1.47
<u>60 kg/ha N</u>				
Maize	3.9	-	-	-
Soya bean	-	2.0	-	-
Maize + soya bean	2.0	1.3	3.3	1.16
<u>120 kg/ha N</u>				
Maize	4.8	-	-	-
Soya bean	-	2.2	-	-
Maize + soya bean	2.7	1.2	3.9	1.11
<u>180 kg/ha N</u>				
Maize	5.0	-	-	-
Soya bean	-	2.3	-	-
Maize + soya bean	2.9	1.3	4.2	1.15
<u>240 kg/ha N</u>				
Maize	5.3	-	-	-
Soya bean	-	2.4	-	-
Maize + soya bean	3.3	1.1	4.4	1.12

LSD (5%) = 0.7 ton between crop means at the same N level for maize grain yield.

LSD (5%) = 0.2 ton between crop means at the same N level for soya bean grain yield.

There are no examples of mixtures of only non-leguminous crops, that could be cited here. The increased LER values reported for increasing N rates in a maize/rice intercrop (SANCHEZ, 1976) are mainly due to N rates above the optimum for single crops. In these cases intercrops with a higher population density make better use of the high fertilizer rate.

Table 26: Average relative yield totals for maize/  
groundnut intercrops (MUTSAERS, 1978)

Treatments	Sep. - Dec. 1975		Mar. - July 1976	
	F <sub>0</sub>	F <sub>1</sub>	F <sub>0</sub>	F <sub>1</sub>
groundnut/maize (66:33)	1.10	1.03	1.25	1.13
groundnut/maize (33:66)	1.08	1.03	1.17	1.09
average	1.09	1.03	1.21*	1.11**
SE <sub>av</sub>	0.061	0.037	0.077	0.033

\* Significantly different from 1.0 at the 95% probability level.

\*\* Significantly different from 1.0 at the 99% probability level.

F<sub>0</sub> = no fertilizer

F<sub>1</sub> = 110 kg/ha N (Urea) + 60 kg/ha P<sub>2</sub>O<sub>5</sub>.

Figure 26: Relative yields for maize (■) and soya bean (●) and relative yield totals (RYT) (▲) plotted against the relative planting frequencies (BEETS, 1977)

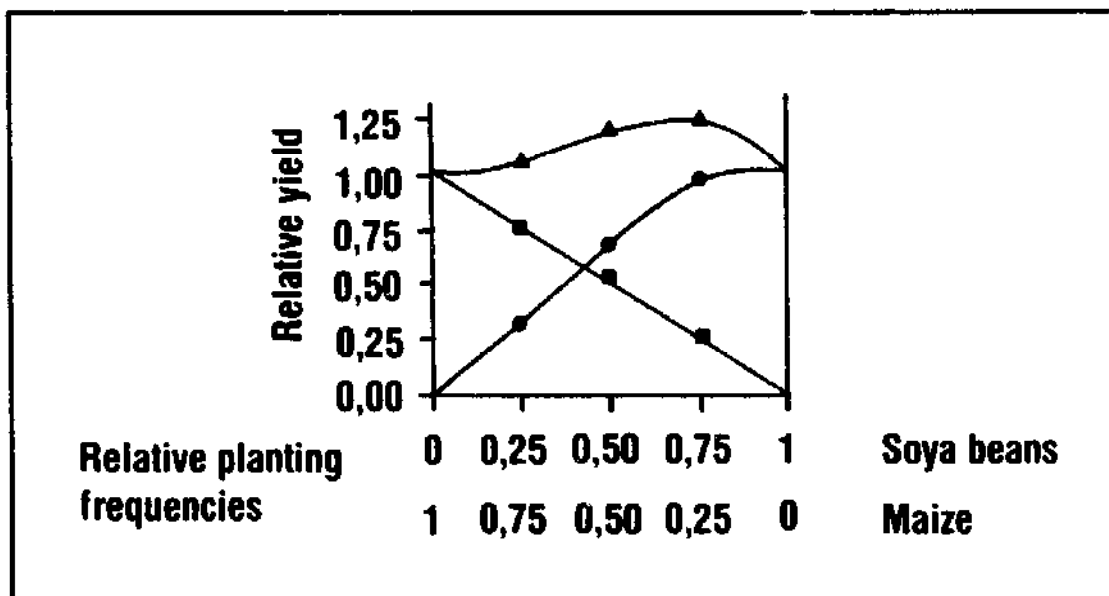

As already mentioned, the response to fertilizers from crops grown in association may be markedly different from the response observed in sole crops. This is demonstrated by the following example - even though the response to fertilization may not be typical - where fundamental differences in the response to N, P and K of cassava grown as a sole crop as compared to intercropped cassava are found (LEIHNER, 1982). In a sole crop fresh root yields showed a positive response to N and K application only up to the first increment and declined at high levels of these two elements (Fig. 27, 28).

Fig. 27: Response of cassava and cowpea yields to band-applied N in association as compared to sole crops (LEIHNER, 1982). (Kindly notice the high yield level of sole cassava)

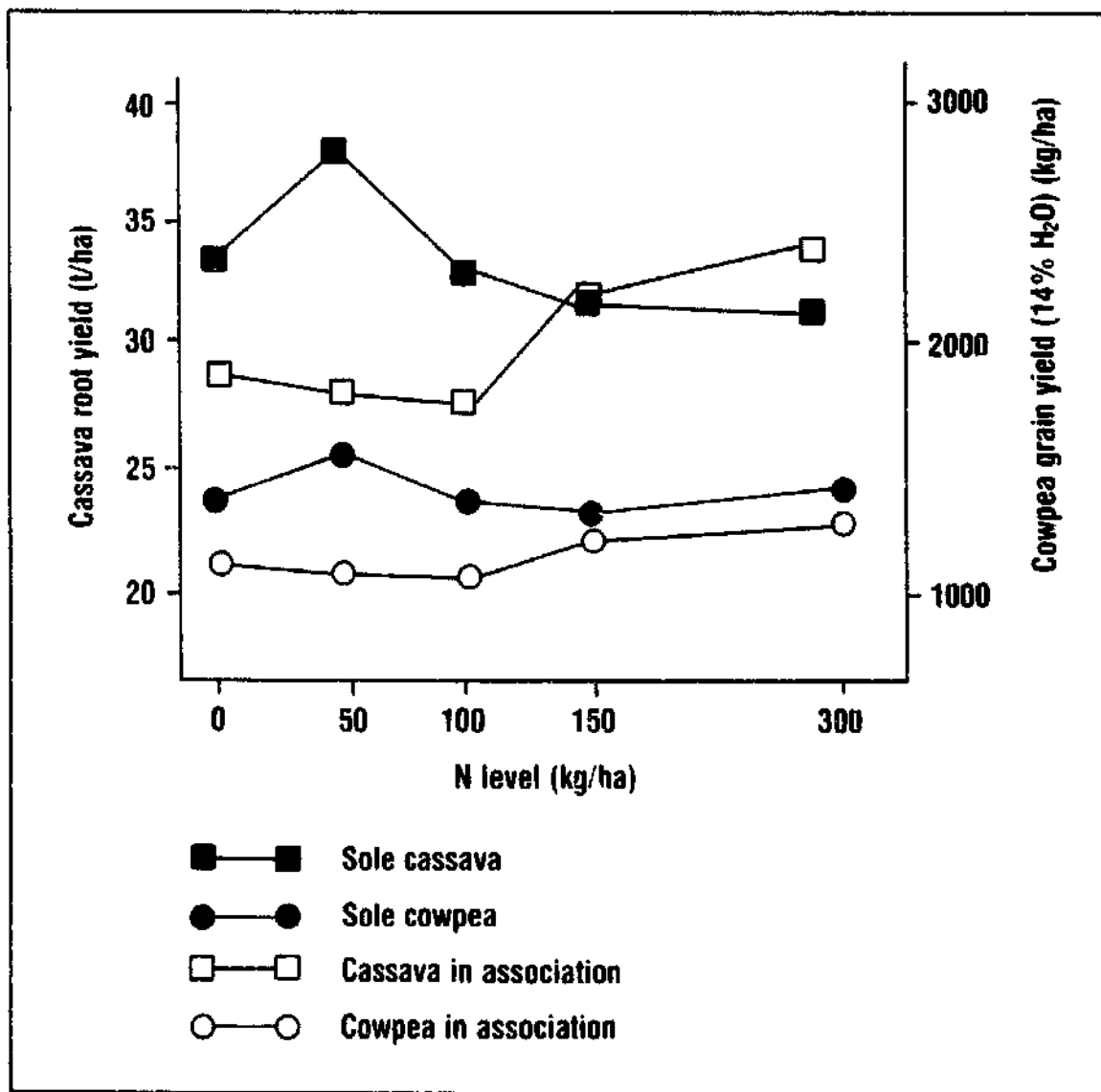
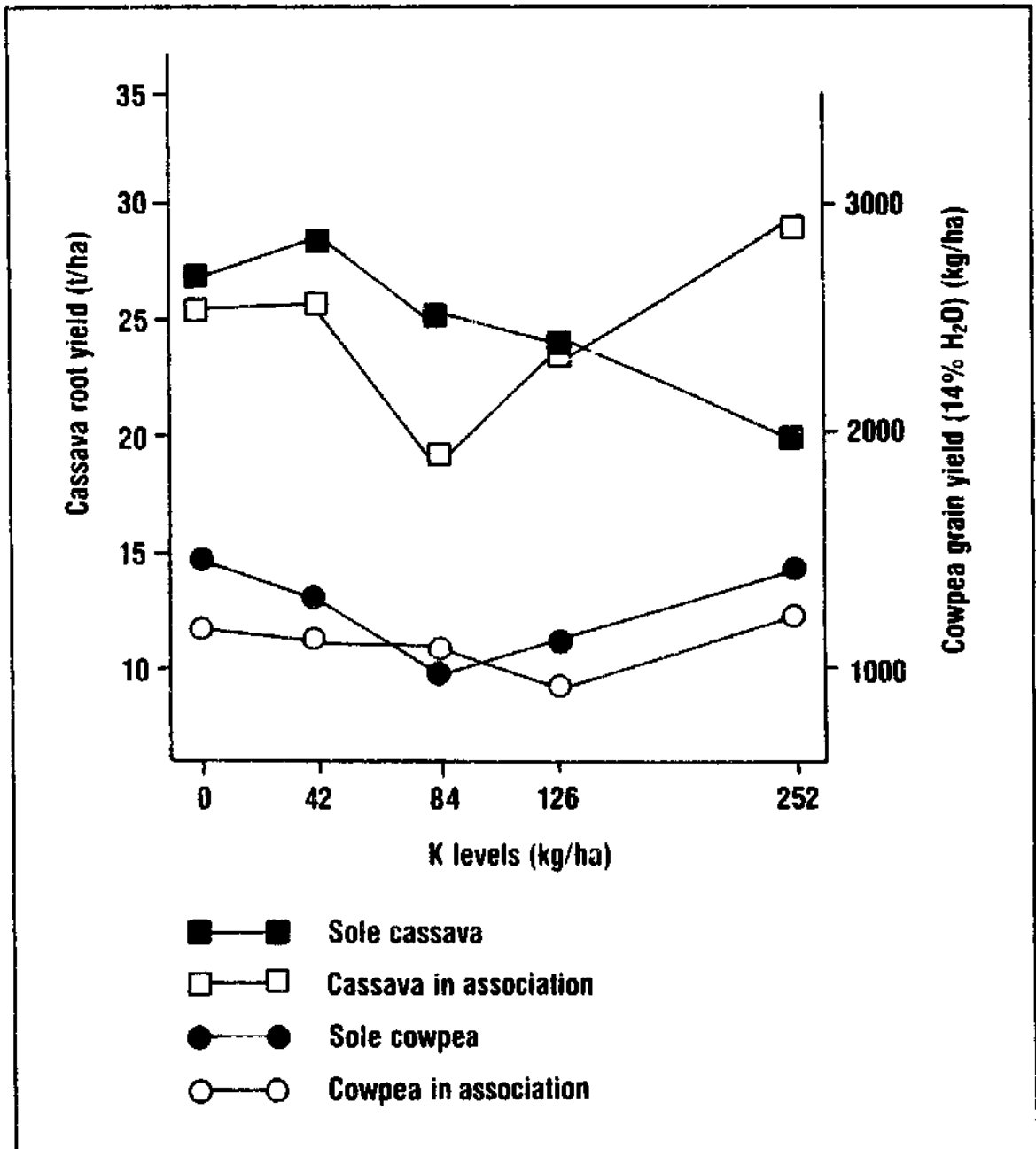

Figure 28: The response of cassava and cowpea yields to band-applied K in association as compared to sole crops (LEIHER, 1982)



In contrast, cassava intercropped with cowpea showed a positive root yield response up to the highest N and K rates. Cowpea, on the other hand, showed no difference in response to N and K when grown as a sole crop or intercropped with cassava.

On highly P-deficient and P-fixing soils both crops responded positively to increments of P. Sole-cropped cassava showed an almost linear response to P up to the highest P level (which is unusual), while intercropped cassava responded only up to the first increment of P (Fig. 29). Probably the demand for P was reduced because of the lower yield level.

Figure 29: The response of cassava and cowpea yields to hand-applied P in association as compared to sole crops (LEIHNER, 1982). (Kindly notice the yield level of cassava, being much lower than in figures 27 and 28).

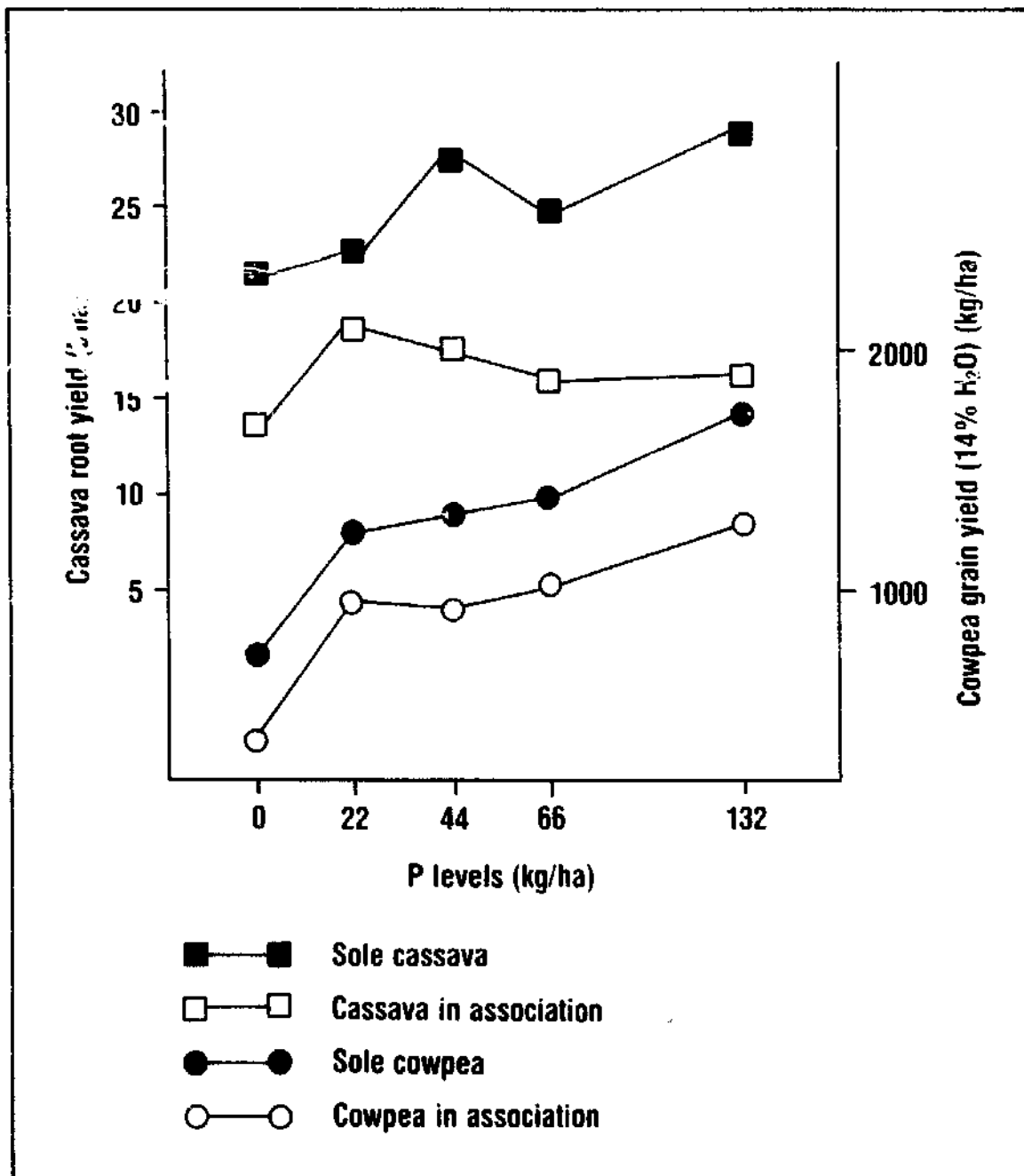

From this example it can at least be concluded that, in order to ensure an adequate and economic supply of nutrients for intercropping systems, it is important to know the response to these nutrients of each crop in association. This response can sometimes have the same tendency in both the sole crop and in association but on other occasions responses can be significantly different (as in the example of N and K application to cassava and cowpea). This means that no conclusion on the fertilization of intercropping systems can be derived solely from information on the fertilizer requirements and response to certain nutrients of their components in pure stands. The fertilizer requirements of intercropping systems have to be studied with particular attention to cropping pattern (spatial arrangement), varieties and soil conditions. Fertilizer trials have to take into account the fact that the competitive abilities of the crops in the association are changed with increasing fertilizer rates. This makes it necessary, at least in theory, to change the cropping pattern with each fertilizer increment or better to test every fertilizer rate in different spatial arrangements of the crop association.

c. Fertilizer needs of intercropping systems in comparison to crop rotations

In the example given above, the nutrient requirements and responses to fertilizers in sole crops and crop associations were always analysed for one season only. This approach does not, however, allow a comparison on the fertilizer use efficiency of sole crops and intercrops because it ignores the residual effects of applied fertilizers and of legumes. N-residues are, for example, considerably higher after a pure legume crop than after a legume/cereal intercrop (see Paragraph 3.1.4). It is therefore necessary to compare entire crop rotations or cropping sequences with intercropping systems.

Data from soil analyses (SEARLE, COMUDOM, SHEDDEN and NANCE, 1981) demonstrate that the residual exchangeable soil nitrogen of a legume/cereal intercrop was between that of a sole cereal crop (maize) and that of a sole legume crop (groundnut or soya bean) (Table 27).

This amount was still substantial and corresponded to the residual nitrogen of a sole maize crop to which 100 kg/ha N had been applied (Fig. 30).

Table 27: Effect of prior cropping pattern (all without added fertilizer nitrogen) on residual exchangeable soil nitrogen at 0 and at 19 weeks after sowing and uptake of nitrogen by following wheat crop (SEARLE et al., 1981)

Cropping system	Exchangeable nitrogen (ppm N)		Nitrogen uptake (kg N/ha)
	0 weeks <sup>1)</sup>	19 weeks <sup>2)</sup>	19 weeks <sup>2)</sup>
Maize	9.0 c	13.1 c	12 d
Soya bean	29.9 a	23.1 a	46 b
Groundnut	32.7 a	23.4 a	54 a
Maize + soya bean	16.7 b	14.8 bc	19 c
Maize + groundnut	15.3 b	17.9 ab	19 c

Figures in the same column are not significantly different at the 5 % level if followed by the same letter according to DUNCAN's multiple range test.

1) at sowing. 2) at anthesis.

The lower amount of residual soil nitrogen after a legume/non-legume intercrop compared to a pure legume crop is mainly caused by lower population densities of legumes in intercrops and by a reduced development of legumes due to competition from the companion crops. In some cases there might be also a direct N-transfer from legumes to cereals (see Paragraph 3.1.3).

Thus, from the available results intercropping shows few advantages in regard to fertilizer use efficiency and use of biologically fixed nitrogen, if intercropping systems are compared with crop rotations or cropping sequences. Some advantages might derive, however, from reduced N-losses due to run-off and leaching (see Paragraph 3.4).



Figure 30: Effect of fertilizer nitrogen and cropping system on nitrogen uptake by wheat at anthesis - ● maize/groundnut, ■ maize/soya bean, ▲ sole maize cropping patterns (SEARLE et al., 1981)

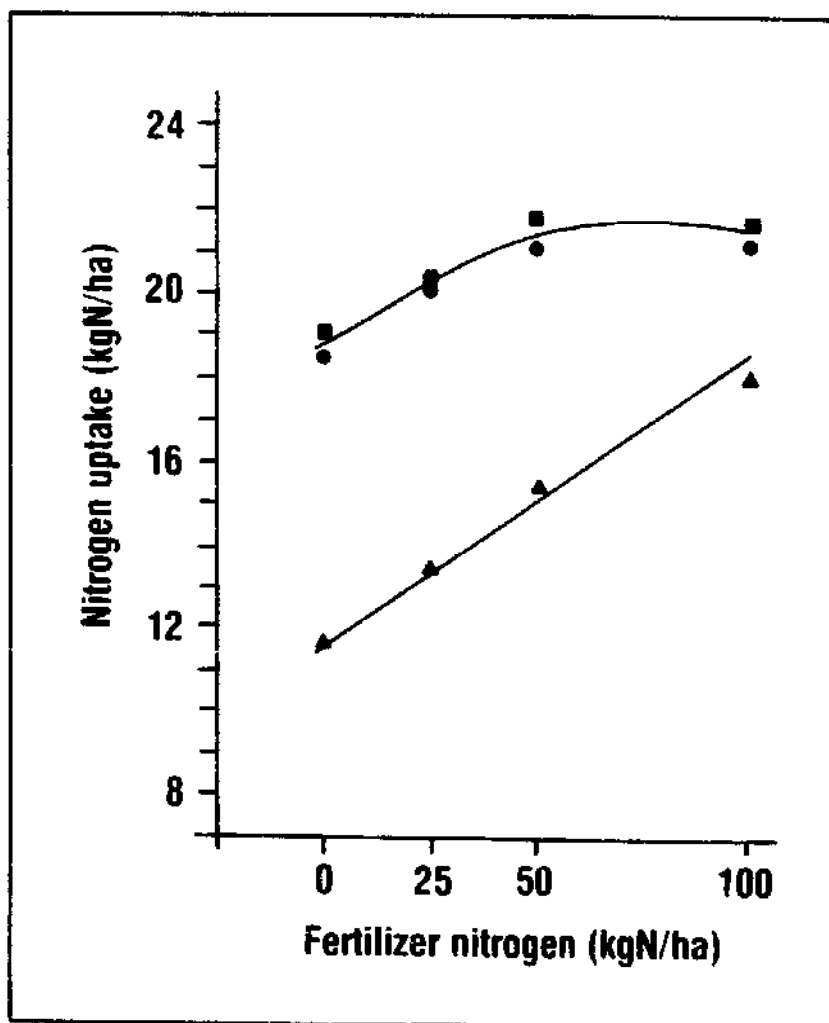

### 3.5.2 Fertilizer practices - rates, timing and placement of fertilizers

As mentioned in the preceding paragraphs, our knowledge of the nutrient requirements of intercropping systems is still rather limited. Therefore, no specific recommendations for fertilizer application to intercrops can be given in this report. Only general remarks can be made, as the actual demands depend too much on soils, climate, varieties, rotations, etc.

marks can be made, as the actual demands depend too much on soils, climate, varieties, rotations, etc.

Fertilizer applications have to be timed and placed in such a way that an adequate nutrient supply is available at periods of expected high demand. Since, however, in intercropping systems the nutrient demands of the component crops differ in quality, quantity and time, it will be difficult to find a general formula that satisfies these requirements. The use of cropping patterns (e.g. alternate rows) which still allow localized placement of a particular nutrient is therefore recommended. One possibility is to broadcast and incorporate a basic dressing of P and K before planting and to apply N directly to the component crops. On soils with a high rate of P-fixation, P has to be applied localized. It can be placed in bands under or near the crop in row intercropping or applied beside or below the seed pockets in mixed intercropping. P could also be applied (broadcasted) as rock phosphate, which is available in several West African countries. This is especially relevant for crops with a long growing period, such as cassava. An interesting method would be to band apply small amounts of a relatively soluble P source for the quick growing species and to broadcast a larger quantity of rock phosphate for the intercrop combination (OELSIGLE, McCOLLUM and KANG, 1976).

Localized placement is not, however, of value in every intercropping situation. The experiments of CHANG, CHANG and HO (1969, cited from SANCHEZ, 1976) with labelled P and K showed that in a sugarcane/groundnut system the placement of P and K under the groundnuts did not prevent the sugarcane from absorbing the greatest proportion of these nutrients. On the other hand, in a similar experiment with sugarcane and sweet potato the crop under which the fertilizer was placed also absorbed significantly more of the nutrients. Therefore, localized placement may be of value in fertilizing one crop in preference to another when the root systems are not competitive. But this method is not likely to work when one crop is able to use efficiently fertilizers placed directly under the companion crop (SANCHEZ, 1976).

Recommended medium fertilizer application rates in legume/cereal intercrops in West Africa are a basic dressing of 30-40 kg  $P_2O_5$  (as single or double superphosphate) and 20-30 kg  $K_2O$  (as muriate of potash) - if  $K_2O$  is given at all - plus 30-40 kg N/ha as starter nitrogen. The cereals receive a top dressing of another 30-40 N as urea (depending on the management levels) approximately 6 weeks after planting. The top dressing of nitrogen close to the cereals does not affect the productivity of the legume crop.

### 3.5.3 Economics of Fertilizer Use

As already mentioned earlier (Paragraph 3.5.1), fertilizer use efficiency cannot be measured solely in biological terms (LER) but also needs to be assessed in economic terms.

The farmer has to know whether it is more profitable to apply fertilizer to intercrops or to sole crops. This depends, of course, on the price ratios of the different crops. Legumes, for example, are normally more remunerative than cereals. A higher land equivalent ratio due to disproportionate increases in cereal yields does not therefore necessarily give greater monetary returns (see Chapter 4.). One method of comparing the profitability of fertilizer use in sole crops with that in intercrops is the value : cost ratio (VCR).

Figures published by the FAO Fertilizer Demonstration Programme in Plateau State, Nigeria (1979), show that the value : cost ratios are generally very high (Table 28). This means that a farmer is better off when he invests his fertilizer in intercrops. It is interesting to note in this context that the VCR for "farmers' practice + fertilizers" are often higher than those for "all improved practices + fertilizers". This is probably the reason why farmers are very interested in fertilizers but are reluctant to accept the other "improved practices".

Table 28: Value : cost ratios of fertilizers applied to sole crops and intercropping systems in the Savanna zone of Nigeria (FAO, 1979)

Crop	Plot	Yields in kg/ha	Increases of yields in kg/ha	Net profits ha	VCR
Millet	FP	350	-	-	-
	FP + F	720	370	115.3	9.1
	AIP - F	500	150	51.0	35.0
	AIP + F	940	590	183.7	9.1
Sorghum	FP	125	-	-	-
	FP + F	325	200	65.8	5.6
	AIP - F	150	25	4.7	1.9
	AIP + F	800	675	243.4	10.2
Maize/sorghum	FP	605	-	-	-
	FP + F	1 907	1 302	309.35	20.2
	AIP - F	1 021	416	98.7	19.6
	AIP + F	2 693	2 088	492.4	17.6
Yams/maize	FP	8 510	-	-	-
	FP + F	11 640	3 130	617.9	77.3
	AIP + F	14 336	5 826	1 117.8	24.6
Maize	FP	267	-	-	-
	FP + F	875	608	50.6	4.1
	AIP - F	408	141	29.95	6.7
	AIP + F	1 707	1 440	330.4	12.2
Maize/cowpea	FP	295	-	-	-
	FP + F	373	78	3.35	1.2
	AIP - F	254	-41	-19.05	<1
	AIP + F	590	295	40.65	2.2
Sorghum/cowpea	FP	563	-	-	-
	FP + F	1 041	478	177.0	13.5
	AIP - F	654	91	27.6	4.1
	AIP + F	1 193	630	221.9	8.4

F = Fertilizer ; FP = Farmers' practice ; AIP = All improved practices.

Traditional cropping systems, insofar as they are not degraded, are in an ecological balance with their environment. Yet, this balance is a "low-level equilibrium". Pest and disease incidence are relatively low, but yields are also low. The introduction of new cropping systems (e.g. sole cropping) and higher yielding varieties has in many cases created an ecological imbalance and has thus lowered stability (including yield stability), partially because of increased pest and disease incidence. This again prevents full exploitation of the increased yield potential.

It is therefore the task of agricultural research to stabilize yields at a higher level. This has been achieved partially by means of chemical plant protection which has become very efficient in temperate climates and in some cropping systems of the tropics. Yet the risk that the pests may develop resistance mechanisms - already high in temperate climates - is even higher in the tropics due to an increased number of generations per year. In addition, most farmers in the tropics are not able to apply chemicals because of the lack of infrastructure (distribution, availability, extension service) and the prevalent cropping systems (see also Chapter 4). Efforts have been made in the past to change traditional cropping systems so as to allow more efficient application of pesticides but these efforts have failed, for the reasons discussed in the preceding paragraphs and Chapter 4. Resistant varieties developed for some crops by national and international crop improvement programmes have suffered more or less the same fate. Apart from distribution problems, the new varieties were often not accepted by farmers because they did not fit into the prevalent cropping systems (different morphology or maturity periods) or because quality (taste, colour, texture, storability, etc.) did not satisfy consumers' demands.

So it seems expedient to try to exploit the biological factors inherent in traditional cropping patterns and to develop a cropping system stabilized, perhaps, at a medium yield level. This requires

the introduction of methods of integrated pest management, based on the assumption that it is possible to reduce yield losses due to pests, diseases, nematodes and weeds by the right match of crops species and cultivars, and by appropriate timing and spacing of each cultivar.

Several studies have been carried out in temperate as well as in tropical climates to examine the influence of the plant species' diversity and planting patterns on the population dynamics of insects. The fundamental question that has to be answered is whether species diversity increases stability by preventing insect population outbreaks. Species in this context include plant (crops and weeds) and insect species. Pest outbreaks are considered a symptom of a disturbed habitat. Ecologists (e.g. HOLRIDGE, 1959; IGBOZURIKE, 1971; and DICKINSON, 1972) believe that the most rational agricultural system for the tropics is that which most closely simulates natural tropical ecosystems, these being the most stable ecosystems due to a high degree of diversity.

Agro-ecosystems must, however, be much simpler than natural ecosystems and therefore systems should be designed which minimize pest damage while their agronomic characteristics remain acceptable for local conditions (PERRIN, 1977). The question as to whether species diversity increases stability, cannot be answered directly, but it can be said that diversity per se does not lead to stability (WAY, 1977b). On the contrary, most pests proliferate because there is too much diversity in the form of alternate food and refuges that are essential at some stages in their life cycle (WAY, 1977b). It is also doubtful whether the question is actually relevant, because even in stable ecosystems populations of certain pests may constantly remain at such high levels as to cause unacceptable yield losses. This is due to the fact that yield losses do not depend on the absolute number of pests individuals but on the damage caused by each individual. There are many low density pests which maintain relatively stable populations but cause serious damage, for example the rhinoceros beetle (Oryctes spp.), the coconut bug (Pseudotheraptus wayi) and various other insect pests of tropical trees.

Examples of stable sole cropping as well as stable intercropping systems do exist. Pest problems in general seem to be most acute at the interface between two kinds of habitats where diversity is greatest and where diverse elements of both habitats are exploited. There are serious pest problems in the Sudan Savanna, for example, where the main pests of sorghum - namely birds, grasshoppers, sorghum bug, shoot fly and midge - all originate from the wild trees and herbaceous vegetation of the natural savanna. The characteristic patchwork of "bush" and cropped land throughout much of the tropics also creates a diversity which exacerbates pest problems; thus many pests depend upon and originate from the bush, one example being the cotton stainers, Dysdercus spp., whose pest status in a particular region is entirely related to the presence and abundance of alternate hosts in the bush. The above evidence indicates that severe pest problems may be exacerbated at intermediate stages in the process of simplifying the ecosystem but can diminish in the ultimate simple system. In other words, the first stages in the breakdown of a delicate natural "climax" are sometimes deleterious. Further simplification can lead to another form of stability in which pest problems diminish, as in the wheat monocultures of Canada (WAY, 1977 b).

The above evidence implies that diversity within a region or group of ecosystems does not prevent pest problems; on the contrary, it more often seems to create them. Yet within smaller ecological units such as farm ecosystems, intricate relationships can be expected to evolve and it is at this level that diversity/stability relationships and their implications for pest and disease problems need to be examined (WAY, 1977 b).

### 3.6.1 Influence of Intercropping on the Population Dynamics of Pests

The great number of intercropping systems enables the farmer to spread the risk of crop losses due to insect attack even better than the risk of drought. Thus by crop management methods the

farmer can influence the attractiveness of the crops and can create an unsuitable habitat for pests and a favourable environment for predators; he can protect the main crop by means of diversionary hosts and build up barriers to the dispersal of pests (NORTON, 1975). To sum up, he can increase the associational resistance of a cropping system. The next two paragraphs outline some of these population effects and indicate how they may be strengthened as components of integrated pest management.

### 3.6.1.1 Mechanisms of Pest Control in Heterogenous Plant Populations

The population dynamics in most species can be simply represented as in Fig. 31 in order to highlight critical times at which control measures may be adopted. Mixed cropping may particularly affect crop colonisation as well as subsequent population development and survival.

#### Crop colonisation

Visual effects: a mixture of crop types may affect the visual stimuli which attract insect pests to their suitable host plants and, in extreme cases, one crop becomes totally camouflaged by another to flying insects, particularly young plants in a relay system. For most annual crops the number of exogenous insects invading at the beginning of the growing season, either from adjacent uncultivated areas or from great distances, is a vital factor in determining the final pest abundance (SOUTHWOOD and WAY, 1970). A solid green background appears to be less attractive to certain pests than a foliage/earth contrast, i.e. widely spaced crops (PERRIN, 1977; OHNESORGE, personal communication). Thus maize in a maize/groundnut intercrop is less attacked by maize borer (Ostrinia furnacalis) (Table 29) because the borer moths prefer a background with a brownish hue to a solid green background (RAROS, 1973).

Olfactory effects: Host plant orientation in insects often involves olfactory mechanisms and it is claimed that these are disturbed



by the presence of aromatic plants such as onions, garlic (AIYER, 1949) and lemon grass (Cymbopogon citratus). TAVAHNAINEN and ROOTS (1972) recorded reduced colonisation and subsequent reproduction of Phyllotreta cruciferae by interplanting collards with tomato and tobacco, resulting in only a quarter of the leaf damage found in pure stands.

Figure 31: Stages in pest population dynamics which may be affected by intercropping. Possible effects of intercropping are shown on the right (PERRIN and PHILLIPS, 1978)

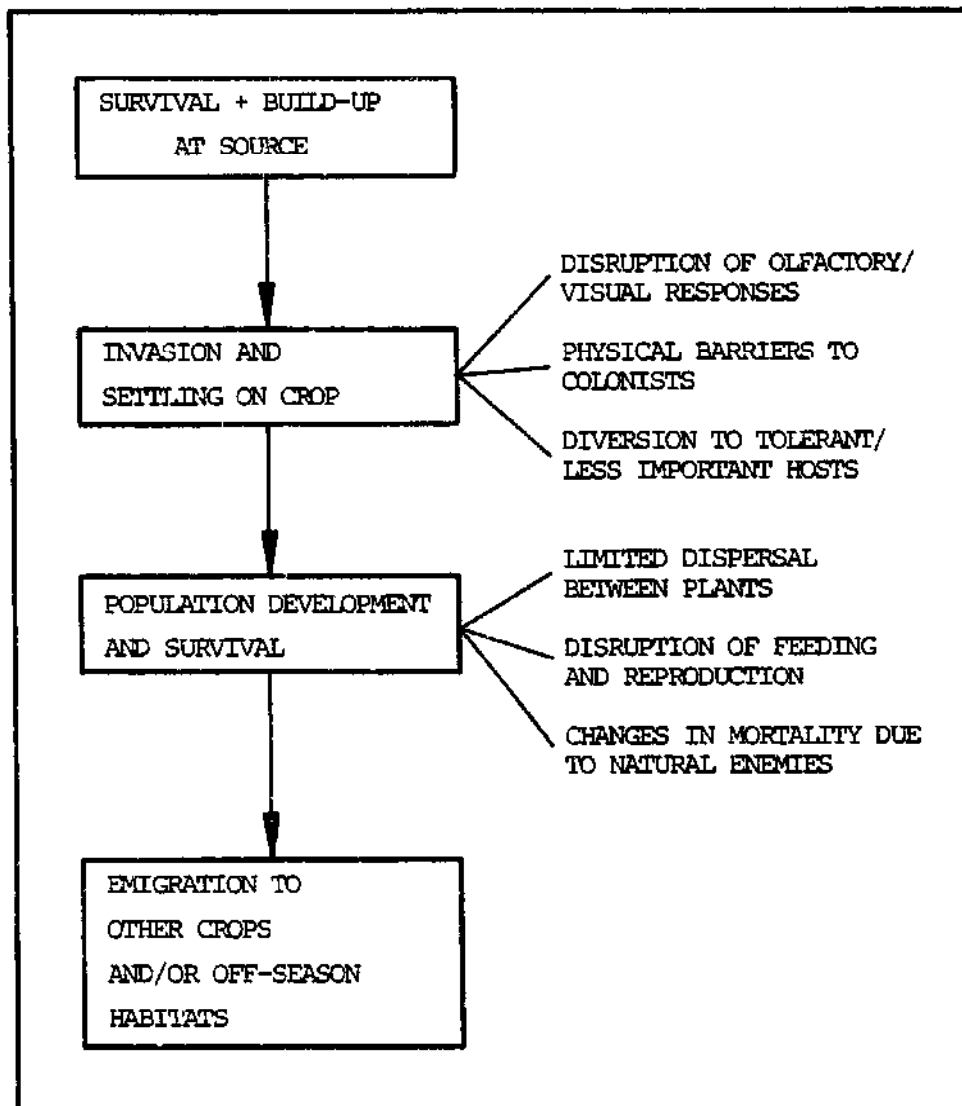

Table 29: Influence of field hue on stem borer oviposition in sole maize and a maize/groundnut intercrop (RAROS, 1973)

Cropping system	Days after seeding <sup>1)</sup>			
	29	35	42	51
<u>No cover</u>				
Sole maize	13	16	58	42
Maize/groundnut	6	2	26	42
% reduction	53.8	87.5	55.2	0
<u>Brown cover on soil and/or groundnut</u>				
Sole maize	14	27	44	38
Maize/groundnut	5	21	38	30
% reduction	64.3	22.2	13.6	21.0
<u>Green-brown cover on soil and/or groundnut</u>				
Sole maize	11	27	49	50
Maize/groundnut	6	22	43	51
% reduction	45.4	18.5	12.2	0
<u>Green cover on soil and/or groundnut</u>				
Sole maize	8	46	46	51
Maize/groundnut	6	19	42	45
% reduction	25.0	58.7	9.5	11.8

1) Planted June 11. Values are stem borer egg masses per 100 plants based on observation of 50 plants per 60 m<sup>2</sup> treatment plots, average of 2 replications.

In other cases polyphagous insects may be especially attracted by mixed odours and thrive in a habitat providing two or more essential host plants in close proximity, as with the coreid bug Acanthomia sp. which appears to be attracted to other legumes in high numbers by interplanted pigeon pea (KAYUMBO, 1976). Pigeon pea is also highly attractive to thrips (Megaluro-thrips sjoestedti), a major cowpea pest. Thrips damage to cowpea is therefore increased in the vicinity of pigeon pea (RÖSINGH, 1980).

Divisionary hosts: Pests sometimes colonize one particular crop in a mixture which thus serves as a divisionary host protecting

other, perhaps more susceptible or economically valuable crops from severe damage. Okra seems to be a useful divisionary crop for flea beetles, Podagria spp., attacking cotton. The preference of certain polyphagous pests for cereals may help to explain why cowpea is less subject to insect damage when intercropped with sorghum rather than sole cropped.

The particular growth stages of each crop present at the time of the pest invasion usually determine whether or not diversion from the main crop will occur. Thus, maize can protect cotton from H. armigera attack in certain situations, while in others it leads to severe infestation of cotton (PERRIN, 1977).

### Dispersal

The dispersal of both the adult and larval stages of insect pests may be impeded where host and non-host are growing together. The non-host plants may offer a barrier to dispersal. This appears to be true for pests of cowpea, where cowpea is intercropped with cereals. For example, the thrips attack on cowpea is reduced by interplanted maize (RÖSINGH, 1980). The degree of impedance may partly depend on the intercropping pattern, since TAYLOR (1977) has observed that cowpea flowers were less damaged by Maruca testulalis when cowpea was intra-row mixed with maize. In some cases the impedance of dispersal is more a result of wider spacing than of intercropping as wider spacing may result in increased larval mortality (PFAUE-VOGT, 1980). Thus, the reduction of stem borer infestation of maize intercropped with groundnut, as cited above, may be also a result of this effect. This strategy would not, however, be economic without interplanting groundnuts.

Interplanted non-host plants may exert a "fly-paper effect" (TREN-BATH, 1976) causing a loss of the dispersing individuals which settle on the non-host component of the intercrop. Even if the search for a suitable host is continued after a while, the mortality of the pest is increased leading to reduced infestation of host plants (PFAUE-VOGT, 1980).

Merely an outer "guard-row" of a highly preferred crop (trap crop) may prevent widespread dispersal of crawling insects which invade

from adjacent uncultivated areas. For example, in a soya bean/pigeon pea intercrop an outer row of the preferred soya bean may be just as efficient as a barrier to immigrating hairy caterpillars (Amsacta sp.) as a BHC-filled trench (KRANTZ, VIRMANI, SINGH, and RAO, 1976).

Therefore barriers and hazards to insect dispersal are regarded by WAY (1975, cited from PERRIN, 1977) as an "outstanding and fundamental component of insect pest control". An example of real hazards is given by FARREL (1976) who observed in Malawi that the hooked hairs of intercropped Phaseolus beans trapped dispersing individuals of Aphis craccivora and effectively reduced the rosette virus infection of groundnuts.

#### Mortality by natural enemies

In the more diverse environment created by intercropping, the numbers and/or diversity of natural enemies may be increased (RISCH, 1979) or, perhaps less commonly, decreased (PIMENTEL, 1961). More predatory wolf spiders were found in a maize/groundnut intercrop in the Philippines than in sole cropped maize (RAROS, 1973), which further contributed to the control of the stem borer achieved by wider spacing of maize in the intercrop (see above).

While most insect pests cause economic yield losses only when populations reach extreme densities, there are also some "low density" pests, whereby even a few individuals cause considerable damage. In this case, biological pest control is more difficult to achieve, but can nevertheless be successful. In the case of the coconut bug (Pseudotheraptus wayi) even 1.5 bugs per tree constitute an outbreak. The predaceous ant (Oecophylla smaragdina) can control the bug. But where coconuts are under clean culture the colonies of Oecophylla are eliminated by another ant, Pheidole megacephala. Only undergrowth provides a favourable habitat for Oecophylla as well as a means for it to avoid the Pheidole while moving from tree to tree. Thus in the Solomon Islands and Zanzibar a cover crop was recommended and this permitted effective control of the coconut bug (O'CONNOR, 1950 and WAY, 1953, cited from VAN DEN BOSCH and TELFORD, 1964).

Natural enemies may be one of the major hazards to which dispersing pests are increasingly exposed in an intercrop. But in situations where a complex of generalized predators is less important than one or two specific natural enemy species, intercropping may result in harmful interference and disruption of the pest/natural enemy balance (PERRIN and PHILLIPS, 1978).

Predators and parasites are not the only natural enemies of insect pests. Entomophagous fungi may also lead to an increased mortality of pests. These fungi generally benefit from high relative humidities beneath dense foliar canopies and this probably explains the reduction in the mite abundance on areca nut (A. catechu) grown beneath banana in India (KHADER and ANTHONY, 1968, cited from PERRIN, 1977).

#### Associated resistance

All factors which lower pest incidence in an intercrop operate in combination as "associated resistance" (ROOT, 1973, cited from PERRIN and PHILLIPS, 1978; ALTIERI, FRANCIS, VAN SCHOONHOVEN and DOLL, 1978). There is obviously still room to increase the associated resistance in intercrops and thus reduce the need for pesticides. Serious research will, however, be needed to better understand all the factors leading to "associated resistance" and to make full use of them in intercropping systems.

The effect of cropping patterns on the population dynamics of pests can be summarized as in Fig. 32. It has been emphasized that many factors influence a farmer's choice of crops and cropping patterns, but where a serious pest is regularly abundant, and intercropping is regarded as a potentially valuable control measure, opportunities clearly exist at several stages to prevent successful establishment and rapid increase of the pest population. In the following paragraph some examples of positive effects of intercropping on pest damage are given.

Figure 32: Features of the population dynamics of pests affected by cropping patterns (PERRIN, 1977)

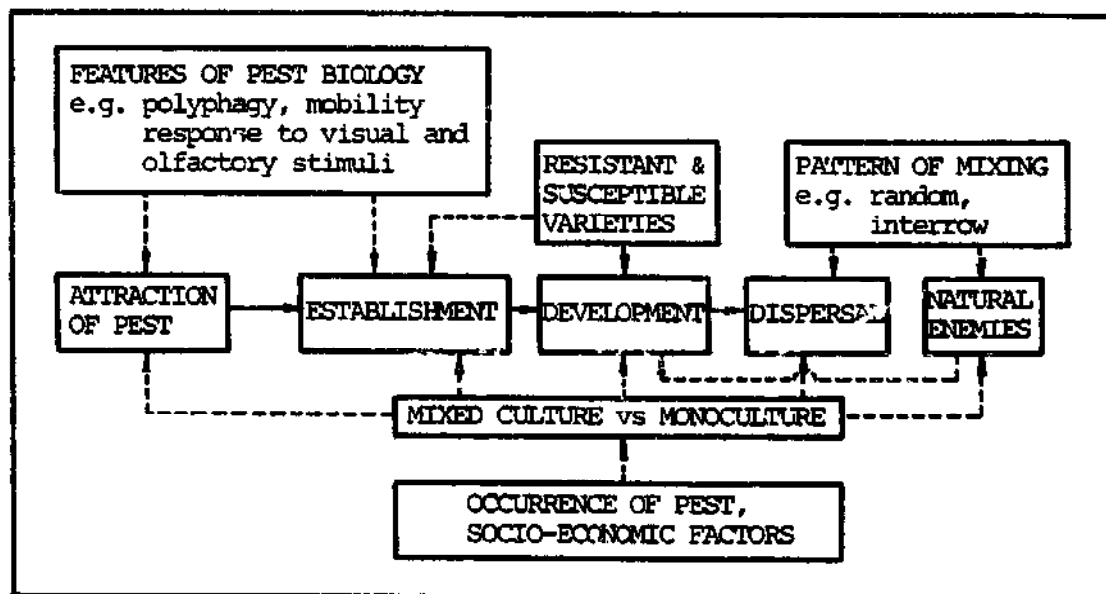

### 3.6.1.2 Effects of Intercropping on Pest Damage

There are quite a number of examples, where intercropping reduces pest damage. Even though this can never be as effective as chemical sprays or resistant varieties, the reduced yield losses can still be important for a small farmer for whom neither chemicals nor resistant varieties are available.

When intercropping maize with cowpea in south-western Nigeria, TAYLOR (1977) demonstrated that stem borer Busseola fusca and Sesamia calamitis damage to maize as well as Maruca (M. testulalis) damage to the flowers and pods of cowpea could be reduced significantly. It was possible to reduce the number of pesticide applications from 7-8 to 2. In this trial, mixed intercropping (intra-row mixing) resulted in less damage than row intercropping. With the variety "Ife-Brown" it proved possible to reduce the Maruca damage to pods from 19.4 % in sole cowpea to 9.9 % in intercropped cowpea, and maize stem borer damage from 16.2 % to 8.2 % (Table 30).

Table 30: Dry seed yield (kg/ha) of sole maize and sole cowpea compared with two forms of intercropping under minimum insecticide application (TAYLOR, 1977)

Sole and mixed crops	Maize	Cowpea	Total seed yield per ha	Mean percentage borer damage (maize)	Mean percentage Maruca damage (cowpea)		Mean percentage Laspeyresia damage (cowpea pods)
					Flowers	Pods	
A. Sole maize	2158.3 c	-	2158.3	15.6 a	-	-	-
Maize/cowpea (inter-rows)	2666.6 b	800.0 b	3466.6	10.2 b	18.8 a	16.4 a	17.3 b
Maize/cowpea (intra-rows)	3091.6 a	1200.0 a	4291.6	8.5 b	10.3 b	17.5 a	24.0 a
Sole cowpea	-	1250.0 a	1250.0	-	15.2 a	18.6 a	13.3 b
B. Sole maize	2631.0 b	-	263.1	16.2 a	-	-	-
Maize/cowpea (inter-rows)	2625.0 c	135.0 b	266.0	10.1 b	15.0 a	14.2 b	11.3 a
Maize/cowpea (intra-rows)	2675.0 a	155.0 a	283.0	8.2 b	8.3 b	9.9 c	11.0 a
Sole cowpea	-	85.0	8.5	-	15.9 a	19.4 a	11.0 a

A. = Cowpea cultivar TVU 4557; B. = Cowpea cultivar "Ife Brown".

\*Two applications of 0.1 % monocrotophos at 400 g ai/ha.

\*\* Figures followed by the same letters are not significantly different (P = 0.05) according to DUNCAN's multiple range (Test)

Similar results for maize were obtained in India (CHAND and SHARMA, 1977) where by intercropping with various legumes, it was possible to reduce stem borer (Chilo partellus) incidence significantly (Table 31).

Table 31: Effect of companion crops on maize stem borer incidence (Arcsin/percentage) (CHAND and SHARMA, 1977)

Crop associations	Mean percentage of plants showing borer attack					
	1st year		2nd year		Two years data	
	30 DAS <sup>1)</sup>	60 DAS	30 DAS	60 DAS	30 DAS	60 DAS
Sole maize	14.6 (6.8)	19.2 (11.1)	17.3 (9.4)	20.0 (12.6)	16.6 (8.1)	19.6 (11.9)
Maize/soya bean	11.9 (4.9)	14.2 (6.8)	11.2 (4.9)	15.3 (7.4)	11.5 (4.9)	14.8 (7.1)
Maize/black gram	11.5 (4.7)	14.8 (8.1)	13.1 (6.2)	16.0 (8.6)	12.3 (5.5)	15.4 (8.4)
Maize/velvet bean	13.0 (5.8)	14.5 (6.9)	10.4 (5.1)	14.4 (6.6)	11.7 (5.5)	14.5 (6.8)
C.D. 5 %	N.S.	N.S.	5.2	3.5	3.90	2.92

1) DAS = Days after sowing . Figures in parenthesis indicate original values.

In a maize/bean intercrop in Colombia (ALTIERI, FRANCIS, VAN SCHOONHOVEN and DOLL, 1978) the adult populations of the most important pests of beans, Empoasca kraemeri, a leaf hopper, and Diabrotica balteata, a polyphagous insect, were reduced by 26 % and 45 % respectively (Fig. 33). Spodoptera frugiperda incidence as cutworms in maize was reduced by 14 %. Also, intercrops had 23 % less infestation of fall army worms (S. frugiperda) as whorl feeder. These reductions in pest populations were obviously caused by an increased predator population, as the occurrence of natural predators was significantly higher in the intercrop after 40 days from planting.

Planting dates of maize and beans have an influence on the population dynamics of pests. Advanced planting of maize (30 days) reduced bean pests significantly and advanced planting of beans (30 days) reduced maize pests significantly. Unfortunately, no data are



available on the actual crop losses.

Fig. 33: *E. kraemeri* (a) und *D. balteata* (b) adult population dynamics in sole and intercropped beans (with maize) (ALTIERI et al., 1978)

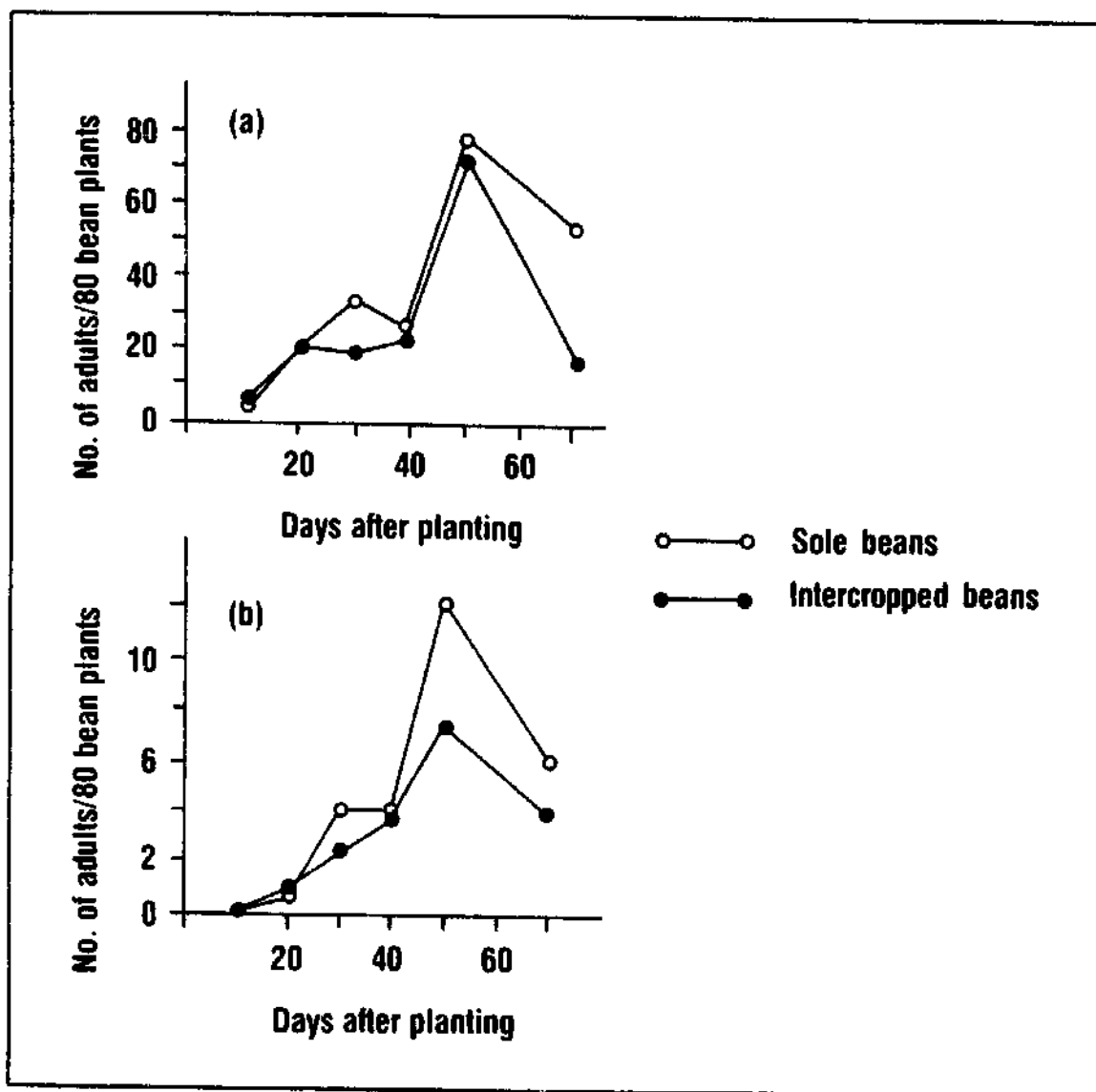

When comparing the insect fauna of 80-day old plots of sole and intercropped maize and sweet potato in Costa Rica, RISCH (1979) found 15 % more total species in the intercrop than in either sole crop, but approximately the same total number of individuals. There were 75 % more species and nearly 100 % more individuals of parasitic Hymenoptera in the intercrop than in sole crops. The proportion of phytophagous individuals was lowest in the intercrop

and highest in sole cropped sweet potato (Table 32). The differences in the number of species between the sole crops and the intercrop can mostly be attributed to the much larger number of parasitic Hymenoptera in the intercrop. It seems that the intercrop presents a more suitable habitat for many species of parasitic Hymenoptera and that it is not the particular insect host but the habitat (e.g. presence of nectar and pollen required as food by adult Hymenoptera, see Paragraph 3.6.1.3) which attracts these species and increases the probability of their remaining in the environment.

Table 32: Predaceous, parasitic and phytophagous adult insect species (sp.) and individuals (ind.) taken in 600 sweeps of maize and sweet potato sole- and intercrop (RISCH, 1979)

	Sole maize		Sole sweet potato		Intercrop maize/sweet potato	
	sp.	ind.	sp.	ind.	sp.	ind.
Hymenoptera	46	189	42	60	67	251
predaceous and parasitic	42	137	39	53	63	226
parasitic only	36	127	26	50	62	225
Formicidae	2	15	1	4	3	5
Hemiptera	18	54	12	25	2	5
predaceous	1	2	1	1	0	0
phytophagous	17	52	11	24	2	5
Coleoptera	52	242	35	503	60	401
predaceous	8	35	6	9	10	32
phytophagous	29	165	25	482	24	287
Homoptera	17	569	31	306	20	379
Orthoptera	2	2	9	69	4	5
Lepidoptera	7	9	11	19	7	11
Neuroptera	2	9	0	0	1	17
Trichoptera	0	0	3	3	1	2
Dermaptera	3	5	0	0	3	9
Total predaceous	17	56	10	13	14	50
Total predaceous and parasitic	53	183	46	63	74	275
Total phytophagous	72	797	87	900	57	687
<b>Total</b>	<b>142</b>	<b>1.036</b>	<b>143</b>	<b>976</b>	<b>145</b>	<b>1.012</b>

Intercropping does not necessarily favour only predators; there are also examples where it favours pests. The attack on cotton by the American Boll Worm (Heliothis armigera), for example, is increased by relay cropping maize with cotton. This was frequently observed in Tanzania, when the traditionally grown sorghum was replaced by maize in the cotton growing areas (REED, 1965). The effects of intercropping do, however, depend indirectly on the climate and may be thus different in the humid and semi-arid tropics. The permanence of crops is important, i.e. the presence of host plants all the year round favours an equilibrium between pest and predators and prevents rapid build-ups of insect populations. Thus many major pests of perennial crops have a limited tendency to dispersal and form relatively closed populations, together with their complex of natural enemies. The comparative stability of the plant habitat makes this possible and creates a situation where biological control by natural enemies can have an important stabilizing effect on pest species. In contrast, in annual crops of limited duration it is the natality rate which determines the population size (SOUTHWOOD and WAY, 1970). Thus in the equable humid climate of southern Uganda, Heliothis armigera breeds throughout the year on a wide range of crops and wild plants. Here the complex of small fields in a semi-wild environment apparently simulates "perennial" stability, ensuring that H. armigera remains a minor pest. In Tanzania, however, the dry season induces diapause, the effect of which is to produce an "annual crop" and this undoubtedly prohibits successful biological control. In these circumstances the planting of maize with cotton increases the abundance of H. armigera because the pest multiplies on maize and thus migrates to cotton without being checked by natural enemies. Thus the same cropping practices minimize the effect of the annual crop stability in some circumstances, but exaggerate it in others (SOUTHWOOD and WAY, 1970).

A decrease in the pest population does not, however, always lead to an equivalent reduction of yield losses. Several phytophagous insects, feeding on leaves, do not influence yields at all. For example, in sweet potato the leaf area index is above the optimum under good growing conditions. So a loss of leaves may just bring the LAI down to the optimum. Plants can also compensate for losses to a certain extent. Therefore, it is obvious that the final aim

of integrated pest management is to reduce the loss of crop yield and quality rather than the number of pests (PERRIN, 1977) (Table 33).

### 3.6.1.3 Effects of Weeds on Insect Populations

When discussing the influence of cropping patterns on the population dynamics of pests, the impression may be given that cropping patterns are defined only by arable crops and perhaps tree crops. Yet weeds are part of every cropping pattern and both the quantity and the quality of the weed population, are at least partially conditioned by the actual cropping pattern. Thus weeds in the field and, to some extent, around the field have an influence on the insect populations, whether pests or predators. While weeds are mainly considered as hosts for insect pests (more than 400 pest problems are caused by weeds (VAN EMDEN, 1965)), certain weed species play an important role in the biology of many beneficial insects.

Weeds are frequently the only source of flowers (pollen and nectar) which are vital for maintaining high populations of beneficial insects in agro-ecosystems (VAN EMDEN, 1965). Although insect prey provides the diet for most entomophageous species, the results of several studies demonstrate an additional need for aminoacids and carbohydrates from plants. Nectar sources appear to have a role in parasite survival during periods of lower host density (ALTIERI and WHITCOMB, 1979). Weeds are also the hosts for alternate prey. Non-pestiferous herbivorous insects on weeds may serve as hosts for entomophagous insects, thus improving the survival and reproduction of beneficial insects in the agro-ecosystem (VAN EMDEN, 1977; ALTIERI and WHITCOMB, 1979). At the moment, however, there is a lack of knowledge as to how the presence of specific weed species can be encouraged in a field for the purpose of increasing entomophageous insect populations.

Table 33: Examples of successful pest control by intercropping  
(adapted from ALTIERI et al., 1978)

Intercropping system	Pest regulated	Factor involved	Reference
1. Cotton/forage cowpea	<i>Anthonomus grandis</i>	Population increase of parasitoids ( <i>Eurytoma</i> sp.)	Marcovitch, 1935
2. Cotton alfalfa - strip cropping	<i>Lygus hesperus</i> and <i>L. elisus</i>	Prevention of emigration and synchrony in the relation between pests and natural enemies	Van den Bosch and Stern, 1969
3. Strip cropping of cotton and alfalfa on one side and maize and soya bean on the other	<i>Heliothis zea</i> and <i>Trichoplusia ni</i>	Increased abundance of predators ( <i>Orius insidiosus</i> , <i>Hippodamia convergens</i> and <i>Coleomegilla maculata</i> )	DeLoach, 1970
4. Cotton/sorghum or maize	<i>Heliothis zea</i>	Increased abundance of predators ( <i>Hippodamia</i> sp., <i>Nabis</i> sp., <i>Chrysopa</i> sp. and <i>Collops</i> sp.) due to the presence of alternative preys ( <i>Rhopalosiphum maidis</i> and <i>Schizaphis graminum</i> )	Fye, 1972; Burleigh, 1973
5. Tomato and tobacco/cabbage	<i>Phyllotreta cruciferae</i>	Feeding inhibition by odors from non-host plants	Tahvanainen and Root, 1972
6. Tomato/cabbage	<i>Plutella xylostella</i>	Chemical repellency or masking	Raros, 1973
7. Groundnut/maize	<i>Ostrinia furnacalis</i>	Abundance of predatory spiders ( <i>Lycosa</i> sp.)	Raros, 1973
8. Sorghum/cowpea	<i>Maruca testulalis</i> and others	Not reported	Raheja, 1973
9. Sesame/sorghum	<i>Antigostra</i> sp.	Shading by the taller companion crop	Litsinger and Moody, 1975
10. Maize/bean	<i>Empoasca kraemeri</i> and <i>Diabrotica balteata</i> on bean, and <i>Spodoptera frugiperda</i> on maize	Increased abundance of parasitoids and predators ( <i>Anagrus</i> sp., <i>Condylostylos</i> sp. and some Hemiptera → <i>E. kraemeri</i> ; <i>Meteorus</i> sp. → <i>S. frugiperda</i> )	Altieri et al., 1978
11. Maize/cowpea	<i>Maruca testulalis</i> on cowpea and <i>Busseola fusca</i> and <i>Sesamia calamistis</i> on maize	Not reported	Taylor, 1977
12. Maize/sweet potato	<i>Diabrotica balteata</i> and <i>D. adelpha</i>	Increased abundance of parasitic Hymenoptera	Risch, 1979

ALTIERI, VAN SCHOONHOVEN and DOLL (1977) carried out some field trials to determine the major crop-weed-insect interactions in a bean cropping system in Colombia. Adult and nymph populations of Empoasca kraemeri, a major bean pest, were significantly higher in weed-free than in weed-infested bean cultures. The population of Diabrotica balteata (another major bean pest), however, increased in weed-infested plots, while the predator population was not affected by habitat diversity (Table 34). The overall beneficial effect of weeds in reducing pest incidence was, however, mostly offset by the negative effect of weed competition.

The results are not surprising as VAN EMDEN (1970) had already stated that "any small beneficial contribution weeds may make to pest control is far outweighed by their harmful effect and the advantages to crop growth of their removal (see also VAN EMDEN and WILLIAMS, 1974).

Table 34: Incidence of pests and predators in different bean-weed systems (ALTIERI, VAN SCHOONHOVEN and DOLL, 1977)

% soil covered with weeds	<i>E. kraemeri</i>		<i>D. balteata</i>	Dolichopodidae	Reduviidae and Nabidae adults/
	Adults/ 80 bean plants	Nymphs/ 15 bean leaves	adults 80 bean plants	adults/80 bean plants	80 bean plants
0	52.8 c <sup>1)</sup>	22.4 b	2.3	0.98	1.48
25	37.7 b	13.8 a	3.6	0.60	2.60
50	29.7 a	10.5 a	6.7	1.40	2.60
75	28.4 a	11.8 a	5.6	0.95	3.30
100	30.1 a	6.7 a	4.5	0.83	3.70
				N.S.	N.S.

1) Figures followed by the same letter are not significantly different at P = 0.05.

When testing the effects of weed diversity on the dynamics of Spodoptera frugiperda and its associated predators on maize in Florida, ALTIERI (1980) found significantly higher predator populations and significantly lower damage to maize plants in the weed-infested

plots. Since, however, no yield figures are presented, it is doubtful whether reduction in plant damage really led to yield increases. Nevertheless, when discussing integrated pest control for smallholder agriculture, the beneficial effect of weeds should not be ignored (see also Paragraph 3.4, erosion control) and means of exploiting them should be investigated.

### 3.6.2 Influence of Intercropping on Epidemics of Plant Diseases

Cropping systems influence not only the population dynamics of insect pests but also epidemics of plant diseases. In the following two paragraphs mechanisms of disease control are discussed and some examples given.

#### 3.6.2.1 Mechanisms of Disease Control in Heterogenous Plant Populations

With a few exceptions intercrops suffer less disease than pure crops with the same overall density. This reduction in disease may occur, because mixed stands contain a greater proportion of plants with resistance to some of the pathogens present. Often, however, the level of disease in a mixed stand is less than that which would be predicted from a simple consideration of disease rates in pure stands of the component species (BURDON, 1978).

There are several mechanisms whereby disease reductions are achieved in mixed stands. Probably the four most important ones are (BURDON, 1978):

- a. In a pure stand of plants with uniform susceptibility to a particular pathogen, the replacement of a proportion of these plants by resistant ones reduces the amount of tissue which may become infected and this in turn reduces the amount of inoculum available for subsequent dispersal within the stand.

- b. Replacement of susceptible plants by resistant ones results in a decline in the density of the remaining susceptible plants and thus an increase in the average distance that inoculum has to travel between one susceptible plant and another; increased distance is often associated with factors which reduce the spread of inoculum.
- c. Resistant plants may interfere with the passage of inoculum between susceptible plants.
- d. Cross-protection phenomena may play some part.

Clearly these four mechanisms of disease control are utmost of importance when the majority of the pathogens present are host specific, because it is only under these circumstances that the development of each pathogen will separately be limited to one of the components of the mixture. Although a few studies have clearly shown a reduction in infection rates in mixed stands, when compared with pure stands (LEONHARD, 1969; BURDON and CHILVERS, 1975, 1976), little attempt has been made to determine the relative contributions which these four factors make towards reducing disease.

The relative importance of the reduced density of susceptible plants (through factors a and b) and the resistant plants which act as barriers to the spread of inoculum (factor c) as regards the reduction of disease rates in intercrops may be determined by comparing the effect on infection rates when susceptible plants are replaced by resistant ones which has the effect of simply reducing the density of susceptible pure stands under conditions in which cross-protection cannot occur. BURDON and CHILVERS (1975) used this approach to demonstrate that the rates of increase in a soil-borne patho-system were largely determined by the net density of susceptible plants present in any mixture. Similarly, in an air-borne system (BURDON and CHILVERS, 1976), most of the reduction in infection rates was attributable to the lower density of susceptible plants, although in mixtures containing high proportions of resistant plants, the rates were less than those recorded in susceptible pure stands of equivalent density. The interception of airborne inoculum was thus found to have a negligible effect on disease rates when the proportion of susceptible plants was high,



but the results suggested that this factor would make an increasingly significant contribution to disease control as the proportion of resistant plants rose (BURDON, 1978).

The final factor (d) to be discussed here, cross-protection, has been demonstrated in controlled conditions by many researchers but its occurrence in intercrops in the field has not really been proved.

When the proportion of resistant plants in a mixture is low, the density of susceptible plants does not differ greatly from that of a pure stand. In such circumstances infection rates will remain high because (a) there is an abundance of susceptible tissue for multiplication of the pathogen; (b) the distances between susceptible plants are small; (c) little inoculum is lost due to impaction on the relatively few resistant individuals present, and (d) the opportunities for cross-protection are limited. Conversely, when the proportion of resistant plants in a mixed stand is high, infection rates will be low. The relative effect of these factors in reducing infection rates (BURDON, 1978), and finally yield losses (Fig. 34) therefore depends upon the frequency of resistant plants.

The most effective mixture of crops from the point of view of disease control depends on the relative resistance of each crop species and on the prevalent diseases. When all crop species are equally susceptible in a certain environment, then the best disease control strategy is to keep all component crops in roughly equal proportions. The more susceptible crops should, however, be planted in smaller proportions. But this is only of value on the assumption that the total population densities of mixtures do not differ from those of sole crops.

Most times, however, the total plant density of intercrops is higher than that of either sole crop. This induces a change of microclimate, especially where low-growing crops are interplanted between tall species (shelter effect). In many cases the relative humidity is increased (see Paragraph 3.1.2), i.e. the microclimate becomes more favourable for fungal and bacterial diseases. The sus-

ceptibility of the crop species, primarily the dominated ones, might also increase due to reduced insolation.

Figure 34: Disease progress in a crop mixture with increasing frequencies ( $f = 0.125 - 1.05$ ) of susceptible plants in the mixture. (The lines represent logit lines in the exponential phase of the epidemic) (from ZADOKS and SCHEIN, 1979)

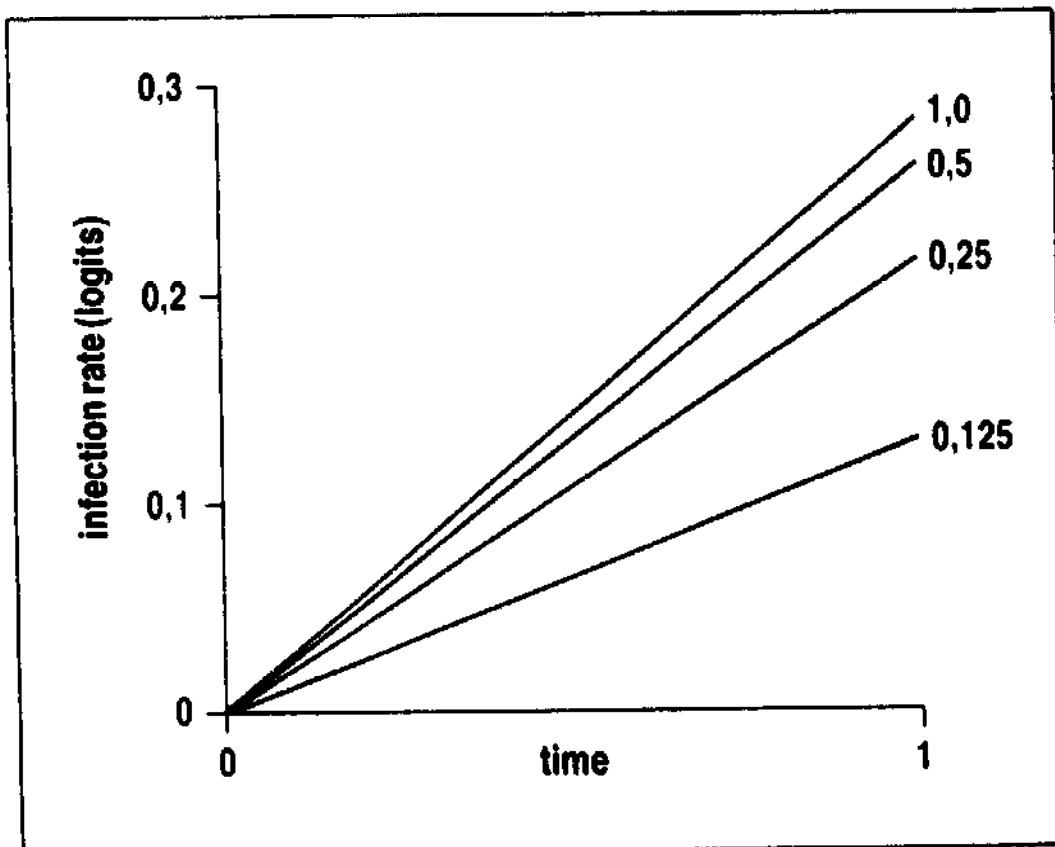

### 3.6.2.2 Effects of Intercropping on Plant Diseases

Beneficial effects of intercropping on plant diseases are most likely to occur with soil-borne diseases. In most soil-borne diseases, such as post-emergence damping-off caused by Pythium sp., disease transmission is reduced at lower plant densities and thus disease advance is slowed down. As the density needed to produce significant control is likely to be much lower than that required for efficient crop production, low planting density of a single species is unattractive as a disease control measure in agriculture or horticulture. An alternative is to fill the gaps with different disease resistant species. Thus a full plant population can be grown on a field and the same effect upon slowing down disease advance can be achieved by a low sole population of the susceptible crop.

That this can be a valuable practice was shown by experiments with Lepidium sativum (garden cress) susceptible to damping-off by Pythium irregulare and Lolium rigidum (a rye grass), resistant to the pathogen (BURDON and CHILVERS, 1976). In the experiments (with three different seedling populations) the apparent infection rates in the mixtures containing 50 % resistant plants were substantially less than those in sole crops of the same overall densities (Fig. 35).

At both densities tested in mixtures the apparent infection rate declined as the proportion of resistant plants increased and that of susceptible plants decreased (Fig. 36).

Even with soil-borne diseases, however, intercropping is not always the optimal solution. Root-rot of cocoyam (Xanthosoma sp.) in Cameroon, caused by Pythium myriotylum, was favoured by intercropping maize or cassava because this restricted the early development of the cocoyam plants, making them more susceptible to the disease (STEINER, 1981).

Figure 35: Apparent infection rates ( $r$ ) in 50:50 mixtures compared with those in sole stands of susceptible plants planted at the same overall densities. (a) (b), Separate experimental runs.  $\circ$ , sole stands of susceptible plants;  $\bullet$ , 50:50 mixtures (BURDON and CHILVERS, 1976)

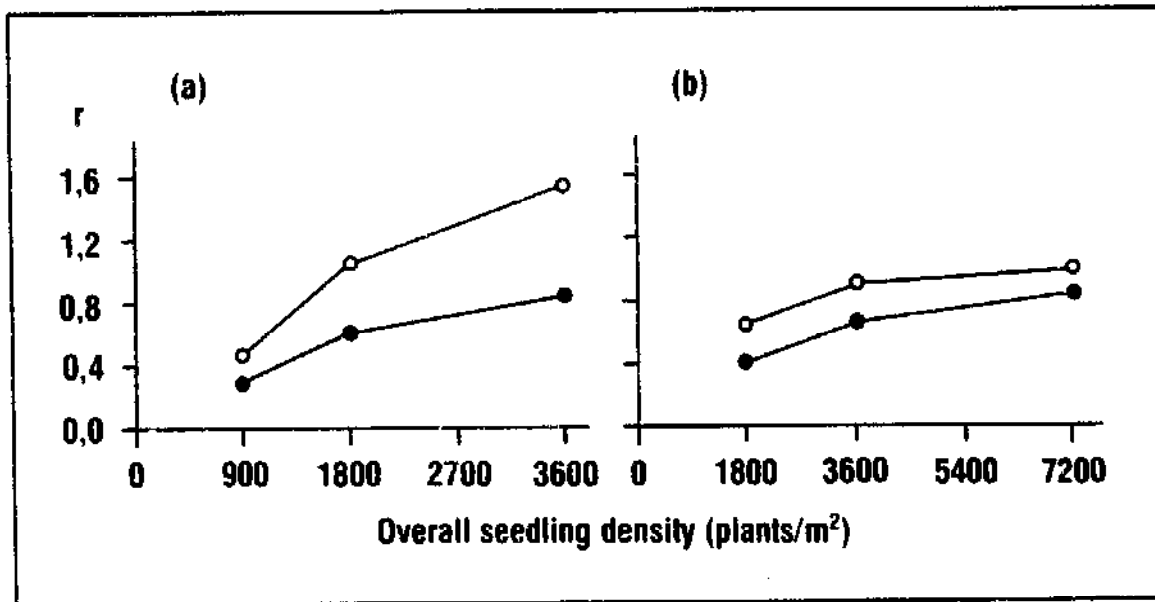
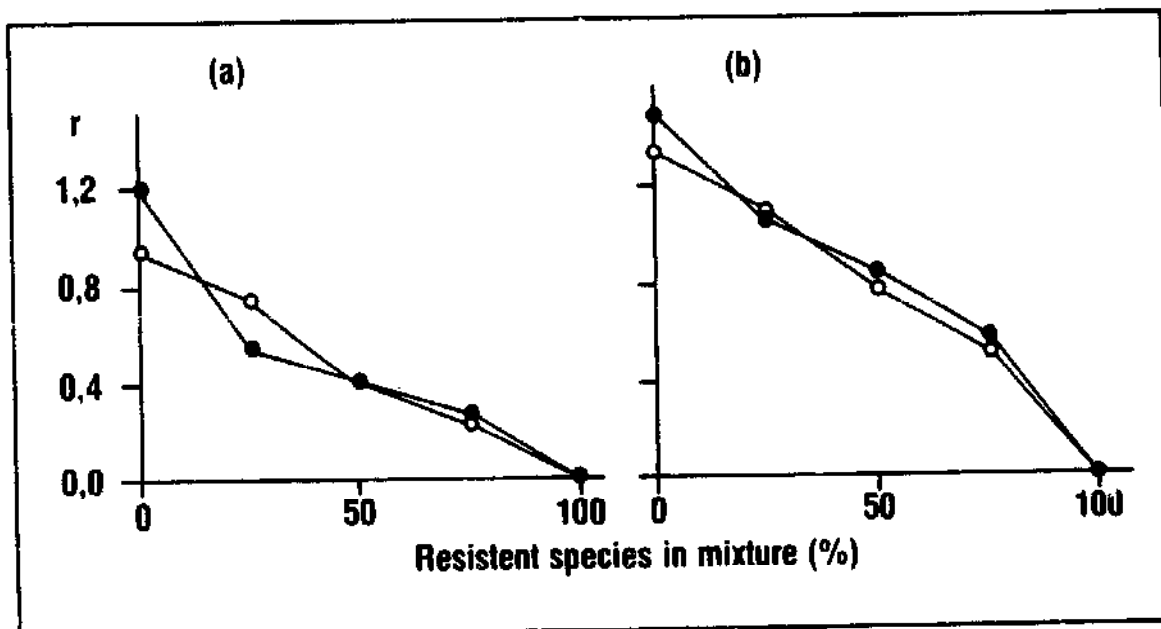

Figure 36: The effect of changing the proportions of two species in a mixture on apparent infection rates ( $r$ ). Overall densities of (a) 1800 plants/m<sup>2</sup>, (b) 3.600 plants/m<sup>2</sup> (results of two experimental runs,  $\circ$  and  $\bullet$ ) (BURDON and CHILVERS, 1976)



Intercropping also affects epidemics of airborne diseases. A significant reduction of cassava bacterial blight (Xanthomonas manihotis) by intercropping cassava with maize, melon or other crops is reported from Nigeria (ARENE, 1976; ENE, 1977). This is probably due to the earlier and better soil cover provided by the intercrops, which, at least to some extent, prevented the splashing of bacteria from the soil onto cassava leaves (Table 35).

Table 35: Effect of a cassava/maize/melon association on cassava bacterial blight (Xanthomonas manihotis) incidence in Umudike, Nigeria (ENE, 1977)

Cropping system	Average incidence %
Cassava	20.3 a <sup>1)</sup>
Cassava/maize	16.9 b
Cassava/melon	18.9 b
Cassava/maize/melon	14.1 b

1) Figures followed by the same letter are not significantly different at P = 0.05.

As only few data from West Africa are available in this respect, data from diseases in intercropping systems with cassava in Central America (MORENO, 1979) are presented in the following. While the apparent infection rate of cassava mildew (Oidium manihotis) is increased by interplanting maize, it is reduced by interplanting a low crop such as beans (Table 36). This is a surprising result, since one would assume that maize acted as a barrier, and reduced the spread of inoculum. At the same time, angular leaf spot (Isariopsis griseola) infection was reduced on intercropped beans.

Table 36: Apparent infection rates (r) of cassava mildew (*Oidium manihotis*) in different cropping systems, Turrialba, Costa Rica (cited from MORENO, 1979)

Cropping system	Infection rate <sup>1)</sup>	Maximum severity, %
Cassava	0.066	17.65
Cassava/sweet potato	0.055	12.50
Cassava/maize	0.071	27.34
Cassava/beans	0.038	10.20
Cassava/maize/beans	0.071	19.27

1) Units per day (r of Van der Plank (1963))

Intercropping cassava with maize significantly delays the onset of the cassava scab (*Spaceloma* sp.) epidemic. But, once the maize plants reached maturity and were doubled-over, the epidemic spread rapidly. There was less rust (*Uromyces manihotis*) on cassava cultivated in association with maize and common beans. Modification of the microclimate by intercropping has an influence on the development of *Daruca* spp. parasitizing rust uredospores earlier and more intensively.

No statistical differences in either the severity or incidence of *Cercospora* leaf spots were found between different cropping systems. This accords with findings from West Africa. Cassava die-back (*Glomerella cingulata*), on the other hand, always caused more losses under low management, regardless of the cropping pattern (Fig. 37).

As for the diseases of crops associated with cassava, beans growing between rows of either cassava or sweet potato were not as affected by *I. griseola* as beans grown as sole crops or in cropping patterns including maize. Common bean rust (*U. phaseoli*), on the

other hand, was lowest in cropping patterns involving maize. During the green pod stage of development, beans associated with cassava and with sweet potato had the highest severity values.

Figure 37: Intensity of cassava dieback (*Glomerella cingulata*) damage under low and high level of inputs in different cropping systems, Turrialba, Costa Rica, 1977 (MORENO, 1979).

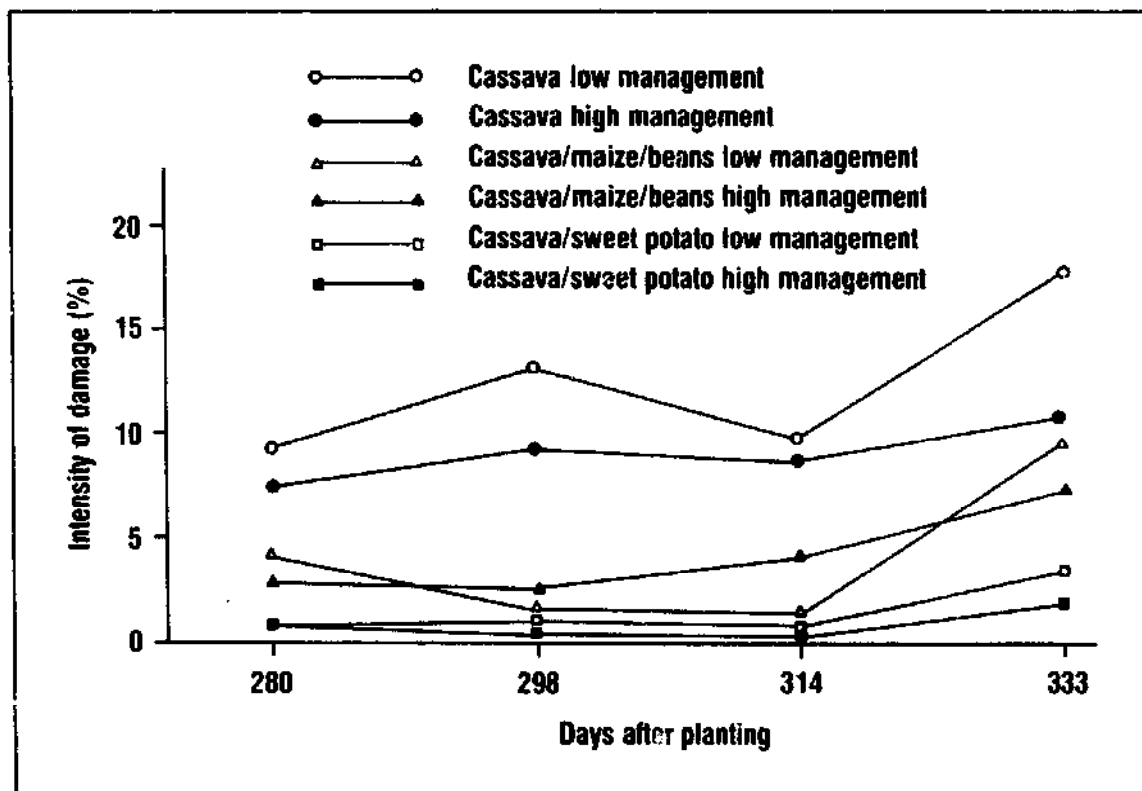

As for cowpeas, incidence of cowpea mosaic virus (MV) and cowpea chlorotic virus (CCMV) was not affected by associating cowpea with maize or cassava. Infection was lowest, however, in intercrops with plantain, due to the reduced activity of the vectors (*Diabrotica balteata* and *Ceratomyza ruficornis*). While intercropping had no effect on the frequency or severity of *Cercospora* leaf spots (*C. cruenta*), intercropping with plantain, cassava and maize significantly reduced the severity of *Ascochyta* leafspots (*A. phaseolorum*).

These examples demonstrate how intercropping influences the frequency and severity of diseases. This potential should be used when developing cropping systems for smallholders.

As the influence of cropping systems on epidemics of diseases depends on too many variables, it cannot be predicted. Therefore, experiments with different crop associations have to be carried out and appropriate cropping patterns have to be developed for different ecological zones.

### 3.6.3 Effect of Intercropping on Nematodes

Plant parasitic nematodes are of minor importance in traditional cropping systems because of the short duration of cultivation and the long fallow period. As the length of the cultivation period and the cropping intensity increase, however, large populations can develop, causing considerable damage. One means of keeping the population down is to rotate susceptible with resistant crops.

So far little information is available concerning the effect of intercropping systems on nematode populations but it can be assumed that the build-up of populations is prevented by suitable crop associations (see Fig. 34). When designing intercropping systems, care should be taken that no crops are associated which are good hosts for the same nematode species. And, of course, when intercropping is practised, a crop rotation has to be practised - at least among ridges - except perhaps in places where population density of suitable hosts is very low.

The following list (Table 37) of suitable and poor hosts of some major plant parasitic nematodes in cultivated soils should provide guidance when intercropping systems are planned.



Table 37: Crop reaction to plant parasitic nematodes (CLAYTON (1967) and GOOD (1972), cited from AMOSU, 1977)

Crop Reaction	Criconeimoides spp.			Heliotylenchus spp.			Hoplolaimus spp.			Pratylenchus spp.			Rotylenchus reniformis		
	H. glycine	H. sacchari					M. arenaria	M. incognita	M. javanica		Scutellonema spp.	Trichodorus spp.	Tylenchorhynchus spp.	Xiphinema spp.	
Cotton	2	1	-	3	3	1	3	2	2	3	2	2	2	2	
Maize	2	1	-	3	3	2	2	3	3	1	2	3	2	3	
Rice	2	-	-	3	2	1	2	2	3	-	-	-	2	2	
Millet	2	1	-	2	3	2	3	3	3	-	-	3	3	3	
Grain Sorghum	2	1	-	2	3	2	2	2	3	-	1	3	3	3	
Groundnut	3	1	-	2	1	3	1	1	2	1	2	1	1	1	
Soya Bean	2	3	-	-	3	3	3	3	3	3	-	2	2	3	
Cowpea	2	2	-	3	3	3	3	3	2	3	2	2	2	3	
Pigeon Pea	-	-	-	3	2	2	3	2	3	2	2	-	-	1	
Velvet Bean	-	1	-	2	-	2	2	2	2	2	-	2	-	-	
Lima Bean	3	1	-	2	3	3	3	3	3	3	-	3	3	3	
Yam	2	-	1	1	1	2	2	2	2	2	3	1	-	1	
Cassava	2	-	-	1	-	2	2	2	3	2	2	-	-	2	
Potato	2	1	-	2	3	3	3	3	3	3	2	2	3	3	
Sweet Potato	2	1	-	1	3	1	1	3	3	3	2	2	3	3	
Tobacco	2	1	-	-	2	3	3	3	3	3	-	2	2	1	
Tomato	2	1	-	3	3	3	3	3	3	3	1	3	2	3	
Pepper	2	1	-	2	3	3	3	1	3	1	2	2	1	3	
Okra	2	1	-	1	3	3	3	3	3	2	2	2	2	2	
Melon	-	-	2	2	-	-	2	2	-	-	-	-	-	-	
Egg Plant	-	-	-	2	-	3	3	3	-	2	1	-	-	-	
Onion	-	-	-	2	-	-	-	-	-	-	1	-	-	-	
Amaranthus spp.	-	-	-	3	1	-	2	2	1	-	2	-	-	-	
Celosia argentea	-	-	-	3	-	-	3	3	1	-	2	-	-	-	
Pineapple	2	-	-	1	-	-	3	-	3	-	-	-	-	-	
Sugarcane	2	1	3	3	3	3	3	3	3	1	2	3	3	3	
Banana	-	-	-	3	2	-	3	-	3	-	2	-	2	-	
Plantain	-	-	-	3	-	-	-	-	-	-	1	-	-	-	
Sunflower	-	-	1	3	-	-	3	3	-	3	2	-	-	1	
Marigolds	2	1	-	1	1	1	1	1	1	1	-	1	1	1	
Bahiagrass	2	1	-	2	3	2	2	2	2	-	-	2	2	2	
Bermudagrass	2	1	-	2	3	1	2	2	2	-	2	3	2	2	
Sugarweeds	1	1	-	-	-	1	1	1	1	2	-	2	2	2	
Crotalaria	2	1	-	2	1	1	1	1	3	1	2	1	1	1	
Hairy Indigo	2	2	-	3	2	2	2	2	2	3	-	2	2	2	
Pangolagrass	-	1	-	2	-	2	1	2	-	-	-	3	-	-	

#### 3.6.4 Effect of Intercropping on the Growth of Weeds

Yield losses due to weeds are considerable in the tropics and can exceed 50 %. Weed infestation increases with time from clearance onwards and after three years farmers are often forced to abandon a field and clear a new one, because the time needed for weeding is greater than the time needed for clearing forest or bush.

The time spent on weeding is the principal limiting factor as regards the size of a farm and therefore weed suppression is of major importance. In western Nigeria at least 50 % of a farmer's working time is spent on weeding (MOODY, 1975) and the situation is similar in other regions. As the use of herbicides cannot be recommended to smallholders for various reasons (availability, training, etc., see Chapter 4), an attempt has to be made to suppress weed growth with adequate cultivation practices and cropping patterns. Farmers are quite aware that intercropping reduces the time needed for weeding (see Chapter 4).

Most crop combinations suppress weed growth by providing an early ground cover, due to high plant populations or a fast growing component crop, e.g. melon. Even though yields of dominated crops are often considerably reduced, this is still more than weeds would produce in the same place (EVANS, 1972).

In many intercropping systems only one weeding is required to produce optimum yields instead of two or three in sole crops. Often this weeding is combined with planting another intercrop, thus further reducing the time required solely for weeding. A common practice in Nigeria, for example, is to sow cowpea into established sorghum, millet, or maize during weeding about one month after the weeds have emerged. Seed bed preparation and weeding are done at the same time and the emerging cowpea competes effectively with weeds, making another weeding unnecessary. Similar methods are common in most regions in West Africa.

In Asia crop associations of maize and groundnut, mungbean, or sweet potato are excellent for reducing weed growth, yield losses and weeding time. In maize/sweet potato and maize/groundnut combinations weed growth was less than in sole cropped groundnut or sweet potato but higher than in sole maize (MOODY, 1977) (Table 38).

Table 38: Effect on weed growth of various crops grown alone or in associations (BANTILAN and HARWOOD, cited from MOODY, 1977)

Cropping system	Weed wt (kg/ha)
Maize	1065
Mung bean	1172
Sweet potato	1793
Groundnut	2354
Maize/mung bean	617
Maize/sweet potato	1107
Maize/groundnut	1362

Intercropping cassava with beans proved to be an efficient means of reducing weed growth in Central America (CIAT). Frequent weeding of pure cassava was no more efficient in weed control than intercropping cassava with beans. At the early growth stages the intercropping system without additional inputs was just as efficient in reducing weed infestation as a pre-emergence herbicide in sole cassava. Fresh root weight of cassava showed a spectacular 44 % increase at the no-input level (zero weed control) when cassava was intercropped with beans instead of being sole cropped (Fig. 38). On the other hand, with intensive weed control, differences between yields from intercropped and sole cropped cassava were small (LEIHNER, 1979).

Figure 38: The effect of different inputs on yield of sole and intercropped cassava. Source: Cassava cultural practices program, CIAT 1978 (cited from LEIHNER, 1979)

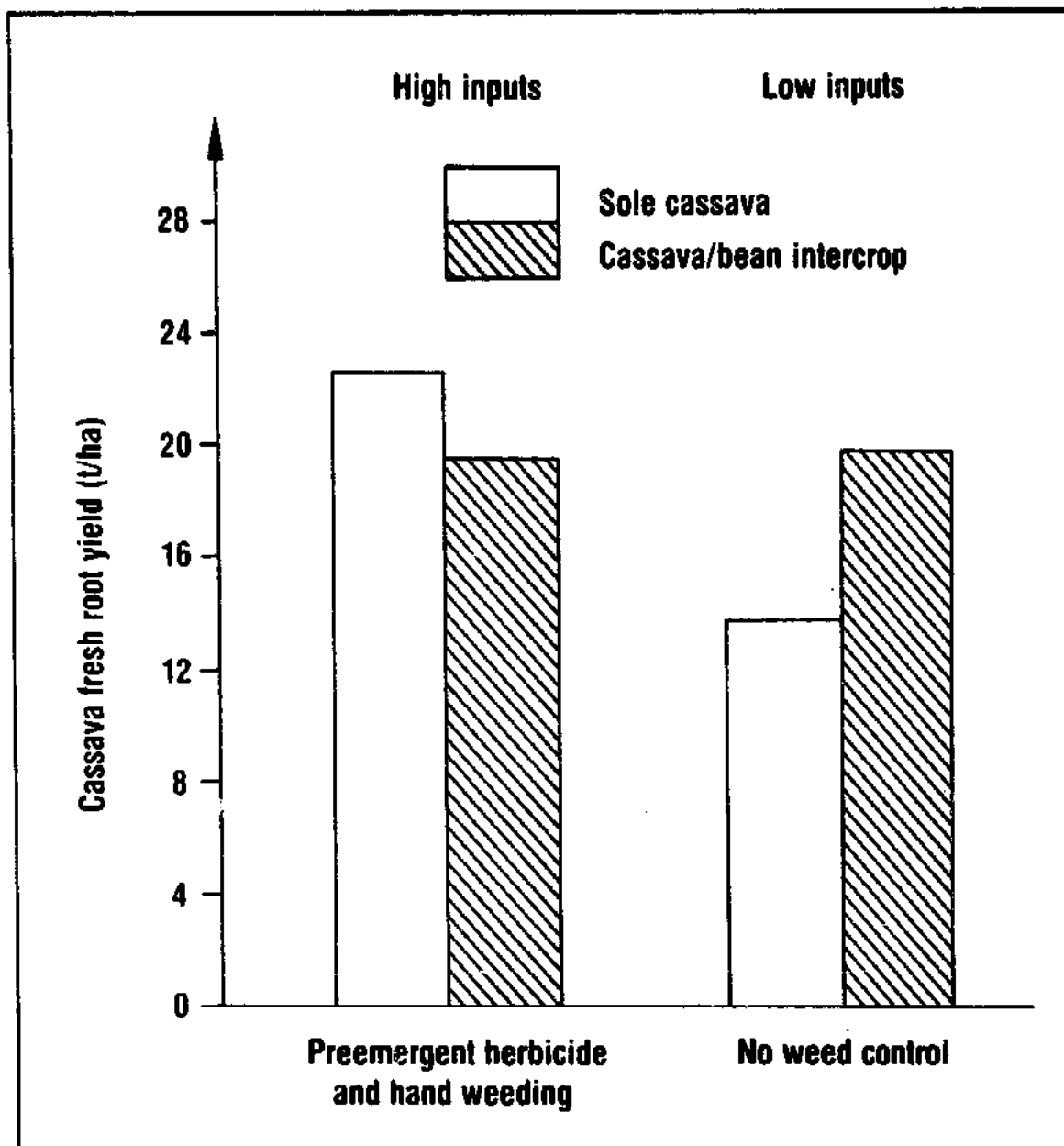

The success of an intercropping system in suppressing weed growth does, of course, depend on soil fertility and climate as well. Suppression is often higher with low fertility than with high fertility (HART, 1975) and the same is valid for low and high rainfall.

The preceding paragraphs clearly show that intercropping can serve as an input in integrated plant protection, together with resistant varieties. The use of this combination of control measures is illustrated in Fig. 39. (The left side of the figure exemplifies predator activity which fails to exert an economic control of pest numbers on a susceptible plant. The right side shows the same degree of predator activity which exerts economic control of the pest on a plant incorporating some measure of resistance. The resistance alone is insufficient to provide control).

Figure 39: The influence of a low level of plant resistance to pest attack on the effectiveness of natural enemies. A. Susceptible plant (log. pest multiplication rate : 2.25); B. Resistant plant (log. pest multiplication rate : 2.00); o, without predators; ●, with predators (VAN EMDEN and WEARING, 1965)

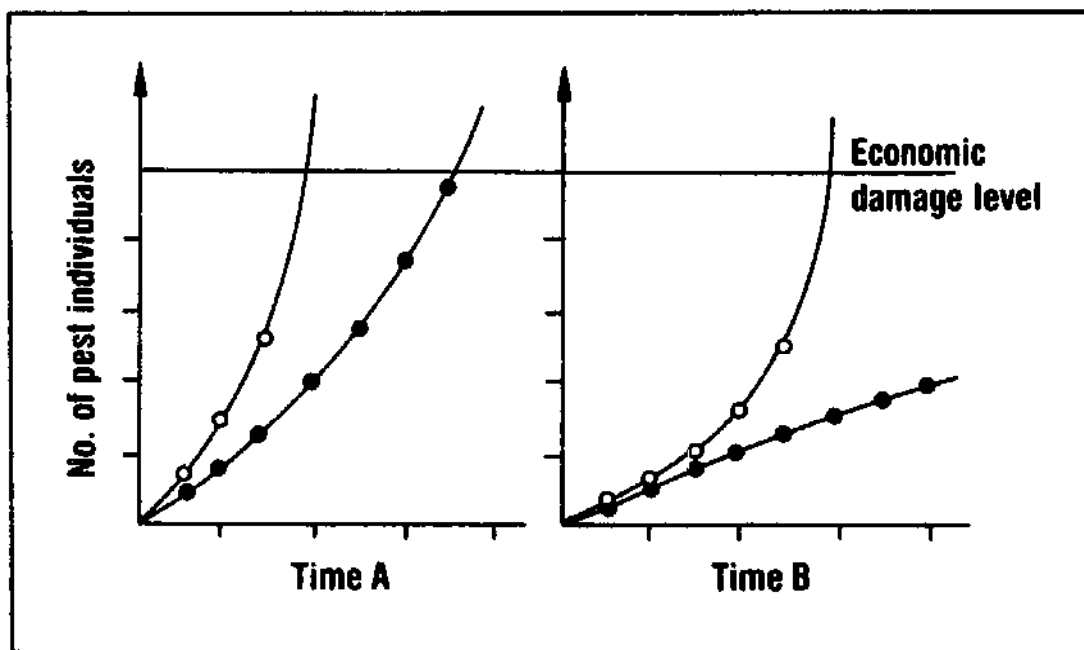

Yet it also becomes evident that little is known about the best means of exploiting the inherent capacities of traditional cropping systems. Hardly any research has been done in this respect in West Africa, except the work at the Institute of Agricultural Research and Training of the University of Ife (see TAYLOR, 1977).

It seems therefore to be important to intensify research on this aspect of intercropping.

### 3.7 Experimental Designs for Intercropping Systems

The following material is taken mainly from the paper published by MEAD and STERN (1980).

Experiments with intercropping systems are more complicated than those with sole crops. This is true for the experimental design as well as for the final statistical analysis. Probably, this has been a major reason why many researchers have been hesitant to start experiments with such cropping systems.

But although substantial experimental programmes of intercropping research have been initiated within the last decade, little thought seems to have been given for the problems of designing experiments specifically to investigate intercropping. Most researchers appear to have used very simple experimental designs similar to those they have used previously for monocrop experiments. The statistical understanding of experimental designs and the availability of computing facilities have, however, greatly improved since monocropping research was at the stage which intercropping research has currently reached, and a much wider range of experimental designs is therefore available to the researcher.

One reason why the range of experimental designs should be broader is that the involvement of two or more crops in an intercrop means that the set of possible experimental treatments is far larger than for a corresponding monocrop experiment. This point can be illustrated by an example of two sets of monocrop experiments, the objective of the first being to choose the best spatial arrangement. The selection of the best genotype may of course depend on the spatial arrangement, so that it would be important to include some experiments that investigate both factors at the same time.

In the corresponding intercropping experiment with two crops, there will be two sets of genotypes from which the optimal combination must be sought. Five factors need to be considered when studying the spatial arrangements of intercrops; the population density (plants/unit area) of each crop; the spatial arrangement within and between rows; and the intimacy, or relative arrangement of the two crops. To illustrate the complexity of the situation, Figure 40 shows how the two spatial arrangement and intimacy factors can be varied separately while keeping the overall densities of the two crops constant. The six arrangements are shown in pairs in which (a), (c), and (e) show more intimate arrangements (plants of different crops closer to each other) than (b), (d), and (f), which have the same spatial patterns of individual crops but arranged less intimately. Note that it is possible to construct an even more intimate arrangement for (a) but not for (c) or (e). In (a) and (b) the spatial pattern for each separate crop is approximately square, within-row and between-row distances are greater. In (e) and (f) one crop has the squarer pattern and the other crop the less square pattern.

Although investigations of both genotype and spatial arrangements are more complex in the intercropping situation, it remains just as important to investigate the combined effects of varying both genotypes and spatial arrangements simultaneously, which will inevitably involve experiments with a larger number of factors.

Among the particular aspects of intercropping experimentation which require thought are

1. the need to define the objectives of an experimental programme precisely, and to attempt to satisfy these objectives through a sequence of specific experiments;
2. the extent to which intercropping experiments should involve monocrop plots;
3. the need to investigate the effects of many factors and their interactions at an early stage of an experimental programme;

4. the large size of many intercropping experiments, which therefore require efficient use of available space and careful control of experimental error; and
5. problems of sampling within experimental plots, particularly in experiments examining the detailed growth patterns of intercrops.

Some of these aspects will be discussed on the following pages.

Figure 40: Variation of intimacy and spatial arrangement of each crop for a two crop mixture (MEAD and STERN, 1980)

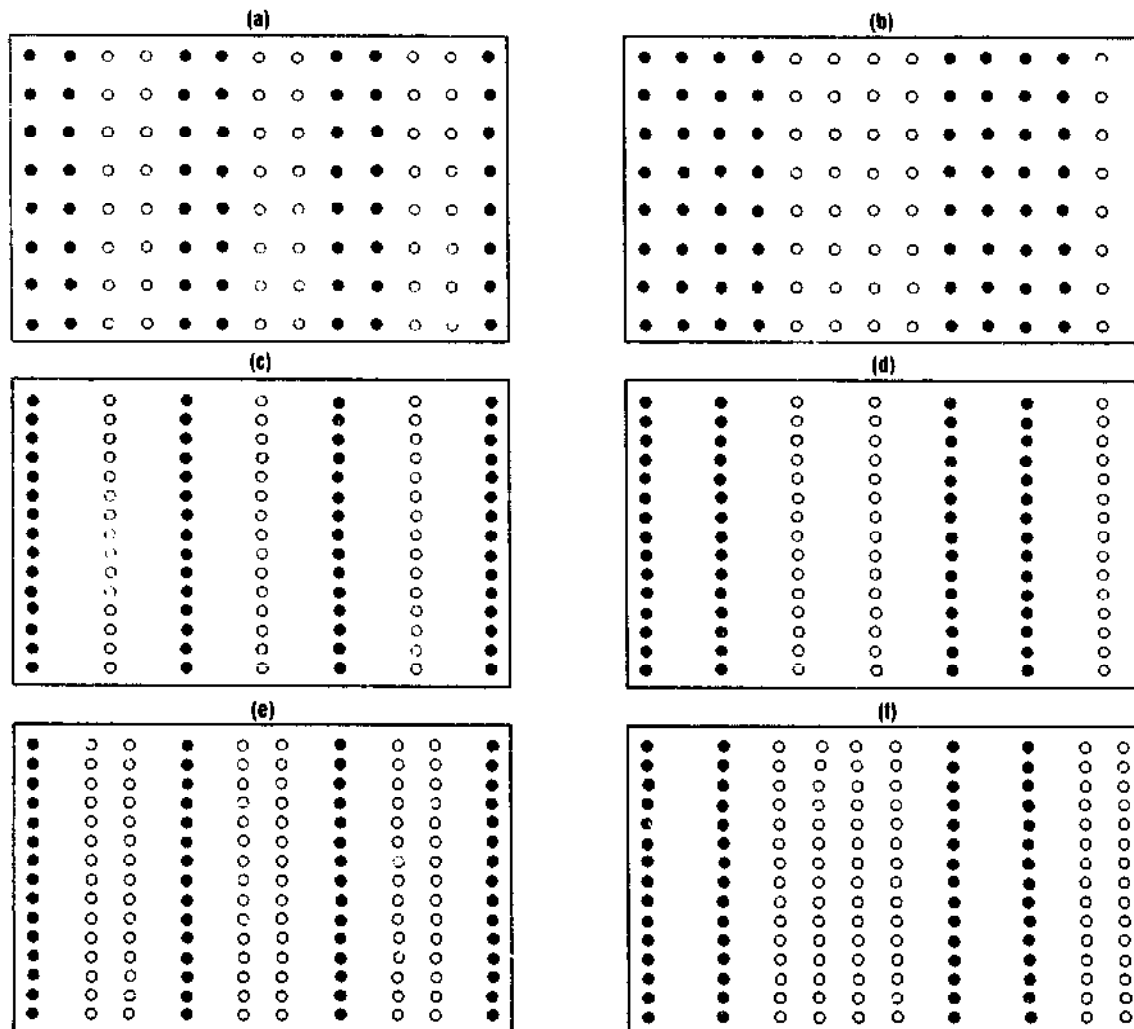



Until there is a better understanding of the interactions occurring between the different factors in intercropping situations, interpretation of the results obtained will be difficult. For example, at any one growth stage the exploitation of available (and possibly limiting) environmental resources by the components in a crop mixture will most decidedly be affected by the spatial relations between them. This may not necessarily always be in the same way, because at different stages of development a particular environmental factor may be more critical for one crop component in a mixture than for the others; furthermore, the time when a particular environmental resource begins to be depleted may well be brought forward or delayed, according to the plant population at which the mixture has been established.

When secondary variables, such as time of planting, level of crop protection and soil fertility are considered, the situation is very complex. Thus it is not surprising that some benefit from intercropping can be claimed under one range of plant populations in a particular environmental situation (OSIRU and WILLEY, 1972), whereas this has not been the case in similar experiments with different plant populations elsewhere (FISHER, 1977 a, b).

This situation is likely to continue unless sound crop physiological explanations can be obtained from each set of results, allowing some inductive conclusions to be drawn. To achieve this, experiments are needed which not only collect appropriate data on the growth and development of the various crop components, using standard crop physiological methodology but which do so over as wide a range of plant populations as possible. Systematic spacing designs are a possibility in this respect but data evaluation may be more difficult.

### 3.7.1 Effects of Plant Population and Spatial Arrangement

A change of plant population often involves a change of the spatial arrangement too. The individual effects of these two factors have seldom been distinguished because there has been insufficient iden-

tification of the various relations involved and little development of the experimental designs to examine them.

In sole crops, plant population can be defined as a number of plants per unit area, and spatial arrangement as the distribution of plants over the ground. In intercropping, plant population has to be defined both in terms of the total population (both crops combined), and the component populations (each crop individually); the spatial arrangement has to incorporate the space allocation of the two crops (the relative space initially allocated to each crop as defined by the planting pattern) (see Paragraph 3.1).

In many experiments the effects of component populations and spatial arrangement have been confounded, e.g. where different component populations have been achieved by varying the number of rows of each crop at constant within-row spacing. This has been the case with many 'replacement series' designs which have examined different 'proportions' of two crops at constant total population. Apart from the disadvantage of failing to distinguish between the different factors, this approach can severely limit the component population effect that can be examined because the population of one crop must decrease as the other increases. This disadvantage can be partly overcome by examining a given replacement series at different levels of total population (WILLEY and OSIRU, 1972). A simpler and more satisfactory approach, however, has been tried at the International Crops Research Institute for the Semi-Arid Tropics (ICRISAT) (WILLEY and RAO, 1981) to examine a range of populations of one crop in factorial combination with a range of populations of the other. All population combinations are examined at a constant row arrangement (or series of row arrangements), achieving the different populations by varying within-row spacing. This allows the individual effects, or interactions, of component populations, total population and row arrangement to be estimated independently.

### 3.7.2 Use of Sole Crop Plots in Intercropping Experiments

Most of the intercrop experiments reported in the literature have included a large proportion of sole crop plots, often up to 50 % of the total experiment and sometimes even more. The inclusion of many sole crop plots is probably largely due to force of habit and the extent to which sole crop plots should be included in an experiment is perhaps one of the major questions to be considered by a research worker when designing his experiment.

In considering this question it is necessary to be very clear about the aims of the experiment. If the primary aim is to assess the benefits of growing mixed crops as compared with sole crops, under a range of conditions, then it may be appropriate to have as many sole crop as intercrop plots. If, however, the main objective is to discover how best to grow intercrops then the requirement for sole crop information is simply to provide a good estimate of sole crop yields, to use in standardizing the intercrop yields (MEAD and WILLEY, 1980). The situation is analogous to that of "control" treatments in sole crop experiments, where the need is often not to have a control which can be compared statistically with the other experimental treatments (which are known a priori to differ from the control), but rather to have information about the background level of yield if no treatments are applied. In intercropping experiments the need to have information on sole crop yield, without the intention of making formal statistical comparisons of sole crop and intercrop yields, gives the researcher considerable flexibility in the size and positioning of the sole crop plots. For example, in some experiments it may be useful to grow the sole crop in fewer larger plots around or alongside the experimental intercrop plots. This would provide good estimates of sole crop yield for standardizing the intercrop yield, while allowing the blocks within which the intercrop treatments to be compared are grown to be smaller and therefore more homogeneous.

It is also worthwhile to examine which sole crop treatments are required. For example, in a genotype and spacing trial it may be sufficient to have sole crop plots for only one or two genotypes at the spacing recommended for sole crops.

### 3.7.3 Factorial Experiments

The area of experimental design which displays the greatest discrepancy between statistical theory and experimental practice is that of factorial treatment structure. The advantages of factorial experiments have been a major component of the statistical theory of experimental design for over forty years; they have been presented as such in standard texts such as COCHRAN and COX (1957) and were summarized concisely by COX (D.R.) (1958) who said that 'factorial experiments have, compared with the one factor at a time approach, the advantage of giving greater precision for estimating overall factor effects, of enabling the interactions between different factors to be exploited, and of allowing the range of validity of the conclusions to be extended by the insertion of additional factors'.

In contrast, most of the current experimentation on intercropping involves experiments with only a small number of treatments. Sole/mixed cropping is not usually a true factor, in the accepted sense, because either sole crop yields are included to provide standardization of mixed cropping yields or, if the aim is to estimate the intercropping advantage for different treatment combinations, then the yield variables of interest are essentially ratios of mixed to sole crop yields.

Several separate experiments are often carried out simultaneously, differing only in the level of what could have been one factor in a single experiment. The failure to use experiments with several factors is obviously a major weakness, particularly at the early stages of an intercropping research programme when it is desirable to consider the effects of many different factors and to obtain some idea of the importance of interactions.

Replacement series (see Paragraph 3.7.1), for example which are often used in experimentation on intercropping have precisely the disadvantage that they force the experiment into a particular and limited framework. This type of experiments can be carried out only in conventional randomized blocks with a limited number of plant populations, which is a considerable disadvantage because both crop combinations and plant populations are variables between which there is every reason to expect a high order of interaction. This type of experimentation does not allow the study of the individual effects and interactions of the main factors defining an intercropping situation, component populations (crop A, B, ... N), total population and spatial arrangement.

The following, relatively small example, provided by an ICRISAT experiment (NATARAJAN and WILLEY, 1980) is intended to help to demonstrate the use of the factorial treatment structure. The experiment involved two sorghum population densities ( $S_1 = 180,000$  and  $S_2 = 120,000$  plants/ha), three pigeon pea population densities ( $P_1 = 40,000$ ,  $P_2 = 80,000$  and  $P_3 = 120,000$  plants/ha) and two row proportions ( $A_1 = 2$  sorghum to 1 pigeon pea and  $A_2 = 1$  sorghum to 1 pigeon pea). Large plots were needed for the collection of both growth and yield data, and hence the A X S interaction was compounded with blocks, giving six treatment combinations plus two sole crop plots ( $S = 180,000$  plants/ha and  $P = 40,000$  plants/ha) in each block of 8 plots. Four blocks were used, comprising two complete replicates of the twelve factorial combinations, and the arrangement of one replicate (two blocks) is shown in Fig. 41. The original plan for this experiment included three complete replicates of a subset of the treatments shown in Fig. 41, which would have reduced the efficiency of many of the major treatment comparisons by factors of 3/2 or even 2.

There are two principle advantages of factorial experiments with at least three factors. One is that the experimenter is able to examine the extent to which the response to one factor is affected by different levels of a second factor (interaction). In the sorghum/pigeon pea experiment the yield response for the three pigeon pea densities can be assessed for the two sorghum densities, and also for the two row arrangements, whereas neither of these inter-

actions could have been assessed from the original non-factorial experiment because of its hidden replication. In the sorghum/pigeon pea experiment the average comparison of two pigeon pea densities is based on a total of 8 plots per density whereas, with the original non-factorial design, a comparison between two pigeon pea densities would have been based on only 6 plots (two from each replicate).

Figure 41: One replicate of a 3x2x2 factorial experiment with two sole crop treatments, arranged in two blocks of 8 plots (MEAD and STERN, 1980)

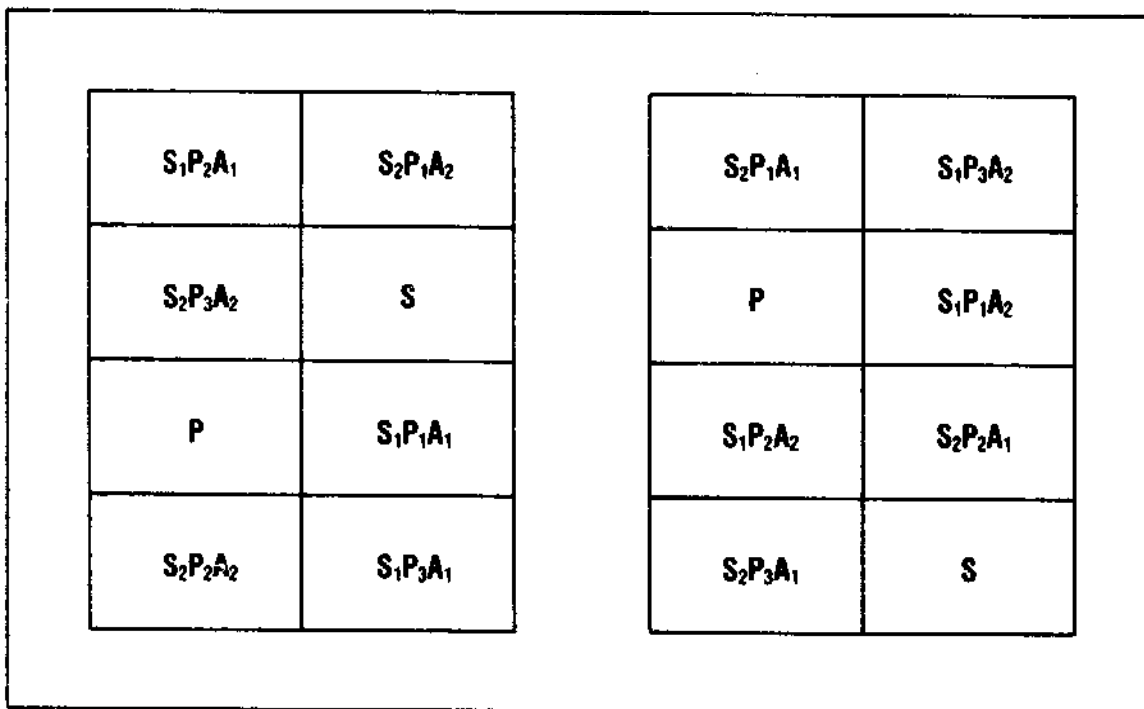

COCHRAN and COX (1957) is still the best reference book for helping to select an appropriate design if no statistician is available for advice, though the designs have to be adapted slightly if sole crop treatments are to be included. If there are only a few sole crop treatments it may be sensible to include them in each block, as in the sorghum/pigeon pea experiment. It is important to realize that in a factorial experiment with a large number of combinations of different factor levels it is not necessary

to have any replication in the sense of plots treated identically. Indeed for a large number of factors it is perfectly possible to draw sensible conclusions from an experiment having only a proportion of all the possible combinations of factor levels. These ideas (all of which appear in COCHRAN and COX) are very well-established and are in no sense new or radical. The crucial point, which seems not to have been widely appreciated by researchers is that the usual practice of having 3, 4 or even more replicates is only sensible if the number of treatment combinations is small. To use three or more replicates as a reason for avoiding large factorials is to misunderstand the purpose of replication.

In sole cropping as well as in intercropping experiments groups of plots which are likely to behave homogeneously are put together in a block. Researchers have traditionally sought to use their knowledge about the available land by dividing it into homogeneous blocks of equal size and by using randomized blocks or some other design for which the analysis was straightforward. As computer programmes are now available which can also analyze more complicated designs, it is no longer so important that the number of plots per block should equal the number of treatments, or even that the number of plots should be the same in each block.

Most intercropping experiments are conducted in the tropics, using land which has only recently been adapted for experimental work and which may not therefore be as homogeneous as in the well-established research institutes in temperate climates. Consequently, it will often be difficult to pick out areas of equal and sufficient size to serve as blocks in a randomized block experiment. Recognizing both the advantages offered by improved computing facilities, and the constraints imposed by the available experimental land, MEAD and STERN (1980) suggest that while careful identification of groups of plots likely to be homogeneous should be the overriding consideration in designing an experiment, there is now much less restriction on the size and shape of the blocks than has previously been assumed.

Many existing experiments on intercropping which include two or more factors use a split-plot design, but there are relatively few occasions when such a design is appropriate. The only good reason for using split plots is that some treatments (e.g. tillage) can only be applied to large plots whereas a large plot is not necessary or desirable for others. Split plot designs may often be used only for simplicity in allocating treatments, or from habit. Split plot designs are sometimes also advocated in principle if interaction effects are of primary interest. This reason is often specious, however, because the gain in the precision of the interaction effects is usually slight when compared with the loss in all comparisons involving treatments applied to different main plots, and also because the examination of the overall pattern of effects is hindered by the split level of some of the comparisons.

### 3.7.1 Systematic Design

A specific area of experimental design in which there has recently been increased interest is the use of systematic designs in experiments on the spatial arrangements of intercrops. The fundamental idea of the systematic design is that crop density (or spatial arrangement) changes consistently from row to row across a plot in such a way that each density change is small (usually 15 % or less). If many densities are used, a large overall range can be considered. Since each row is surrounded by others at nearly the same density, the usual requirement for guard or discard areas round each plot can be avoided. This reduction in guard area makes the systematic design potentially important to intercropping experimentation, where it will certainly be necessary to consider a wide range of spacing treatments combined factorially with many other factors. Thus systematic spacing designs are especially useful in the initial study of basic response patterns.

Several different designs have been tried in the last years. HUXLEY and MAINGU (1978), for example, used a systematic 'fan' design in



maize/cowpea intercropping to examine the effects of total population at constant 50 : 50 proportions of the two crops by arranging them in alternate radii and systematically varying the between-plant spacing along these radii. A more complex fan design was used by WAHUA and MILLER (1978), who maintained a constant population of one crop (sorghum) while varying the population of the other (soya bean) (Fig. 42). However, a limitation of fan designs is that harvest areas (usually one arc or at best 2-3 adjacent arcs) tend to be small and this could be a particular problem in intercropping experiments where the yield of each component is estimated from only a part of this harvest area.

Figure 42: WAHUA's and MILLER's fan design, modified from NELDER (cited from MEAD and STERN, 1980)

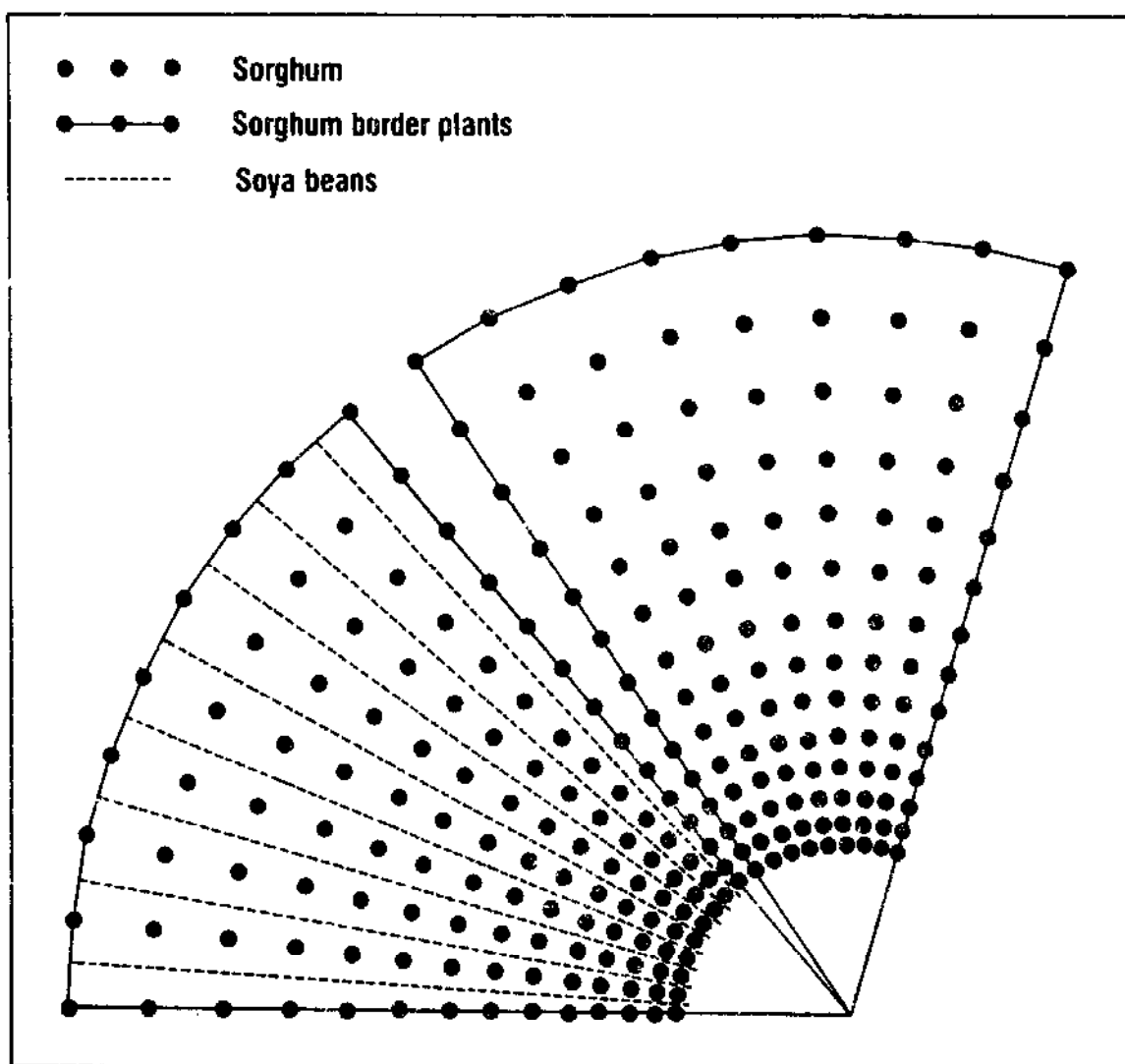

MEAD and STERN (1980) give an example of a row modification of the fan design which might be of considerable potential in intercropping experiments. This design makes it possible to vary the densities of the two component crops independently, as shown in Fig. 43. It has been used at Reading to investigate intercropping carrots and onions. However, it has the same disadvantage of small harvest areas.

In a chickpea/safflower experiment described by WILLEY and RAO (1981), this limitation was overcome by using a parallel row design in which row length can be adjusted to give any required harvest area. This arrangement is more easily laid out than fan designs and will usually give more efficient use of an experimental area because the experimental units fit together more conveniently; the parallel rows are also more closely related to normal cropping practice (Fig. 44).

Figure 43: Two-way systematic spacing design for two crops (x and o) with densities varying in the perpendicular direction (MEAD and STERN, 1980)

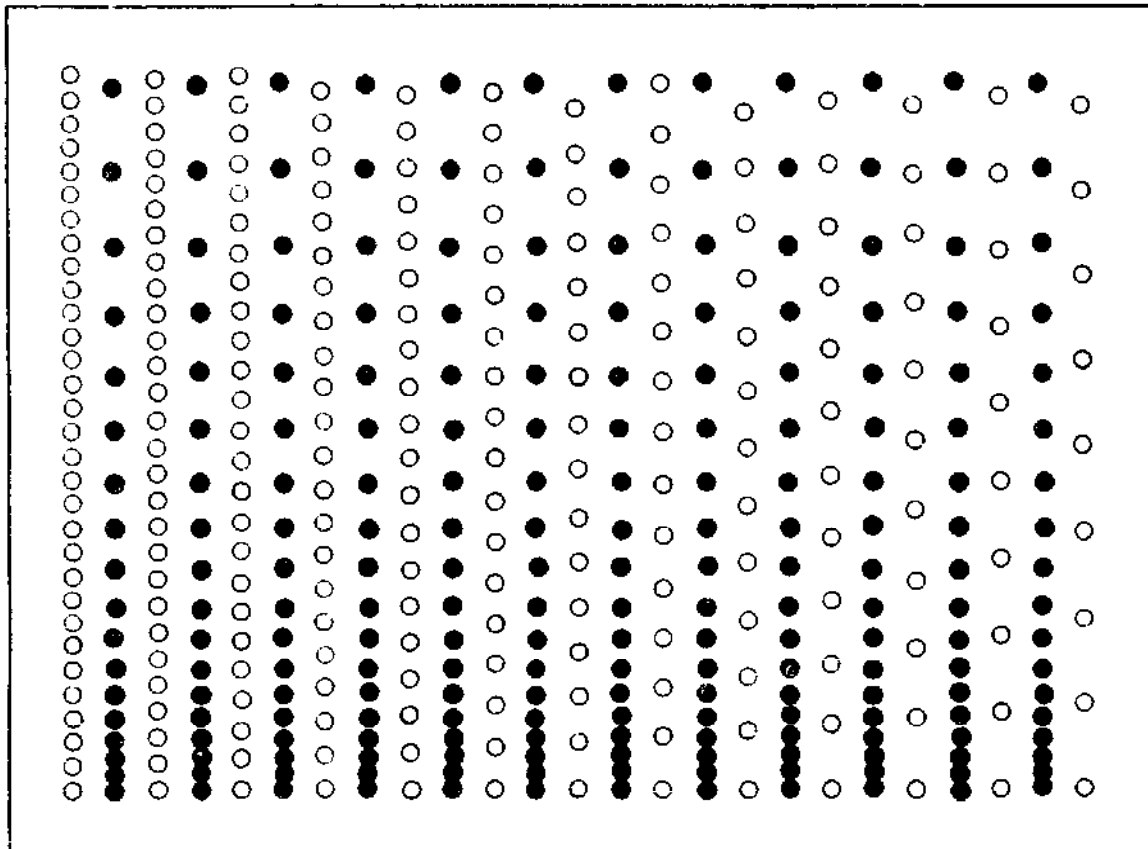
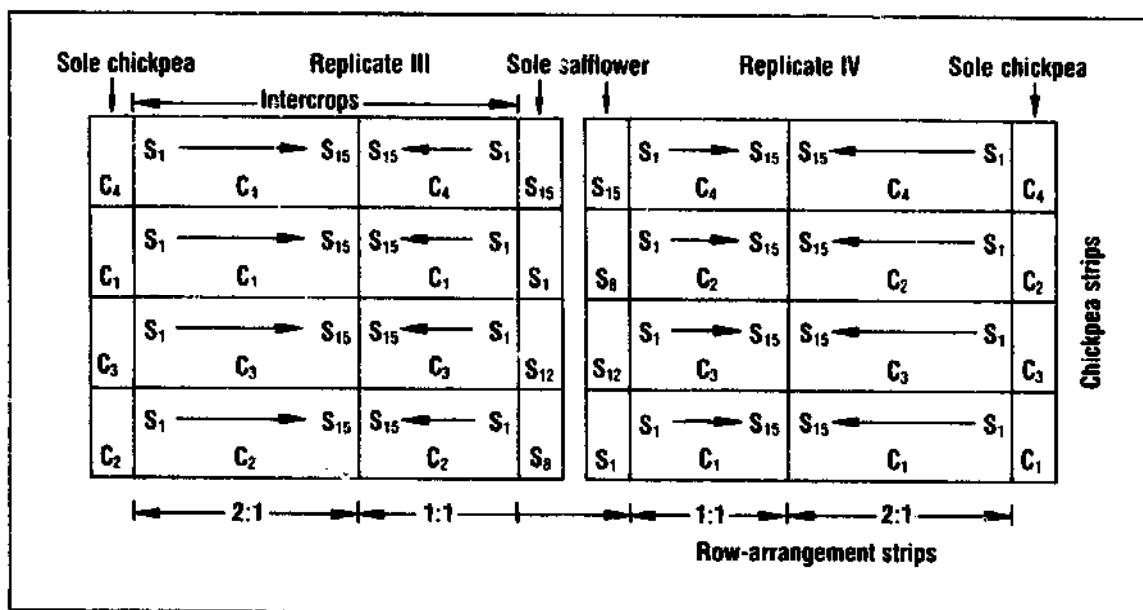

Figure 44: Layout of two replicates showing chickpea and row-arrangement strips, position of sole plots, and direction of systematic change in safflower population (WILLEY and RAO, 1981)



To demonstrate the greater efficiency of land use (in terms of harvested area) by systematic designs, two alternative designs are illustrated for investigating the effects of changing the density of one component crop. Fig. 45 (a) shows a randomized design with four densities and Fig. 45 (b) a systematic design with twelve densities. The harvested area indicated for each design is based on typical intercropping plot dimensions of 9 metres with 45 cm row widths, and the greater land use efficiency of the systematic design is clearly apparent.

When using systematic designs, it is important to check that the experiment is viable in terms of comparing the main plot treatments. Main plots within which a spatial factor is varied systematically will be larger than typical plots in a conventional randomized block design, usually about four times as large (as indicated in Fig. 45). Any trend across a systematic plot will bias the estimation of the response curve for that plot, thereby making the curves for different replicates less consistent, so it is particularly important to avoid such trends. Variation between main plots is "error variation"

in the usual randomized experiment sense, and within block homogeneity is desirable exactly as it would be for the rather large number of smaller plots in a fully randomized experiment.

Figure 45: Comparison of harvested areas for randomized and systematic designs (MEAD and STERN, 1980)

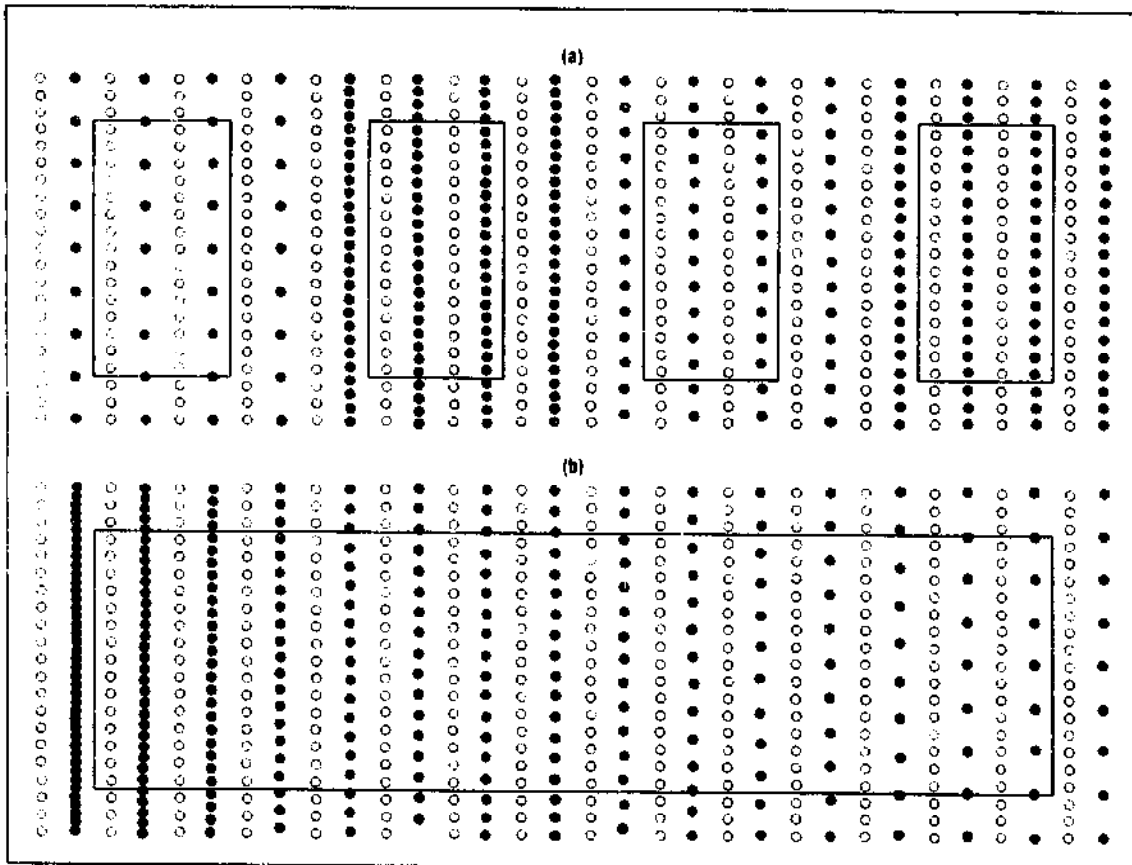

While there is no doubt that systematic designs have an important place in intercropping research, it is important to realize that they raise new problems which must be considered in the context of the complete experiment. Typically, systematic variation of a spatial factor will be only one component of an experiment which also includes other treatment factors (nutrients, genotypes) applied to whole systematic plots. The experiment thus resembles a split-plot design with spatial treatments as systematic split-plot treatments while the other treatments are randomized and replicated on the main plots in the usual way.

Regarding the analysis of systematic designs it must obviously be recognized that the data have different properties than for randomized designs. The conventional analysis of variance for split-plot designs is inappropriate for examining the differences between yields for different spacings because of the lack of randomization, and also because the null hypothesis of no yield variation over different spacings is usually of no interest since it is clearly untrue. In cases where the dominant source of error variation is plant variability an ordinary split-plot analysis of variance may have some value as a preliminary indicator of patterns of variation.

The use of a wide range of densities or spatial arrangements implies an interest in the response of yield to quantitative spacing factors, and the analysis of data from a systematic design should usually start by examining the relationship of yield to density (or other spatial factor). This should first be done graphically, followed by fitting a response function of yield on the factor that varies in each systematic plot. Subsequent analysis will involve comparison of the response curves for the different main plot treatments in what is essentially an analysis of variation of response curves. The replication of the other factors provides information on the consistency of the response curves for a particular main plot treatment in the same way that replication in a standard design provides the standard errors of treatment means.

#### 4. SOCIO-ECONOMIC ASPECTS OF INTERCROPPING

In the previous chapter the impression may have been given that farmers in the tropics practice intercropping mainly because of higher production per unit area. There are, however, many situations where intercropping is advantageous for the farmer even if the land equivalent ration (LER) does not exceed unit. Farmers have various reasons for practising intercropping. Higher yield is only one of the main reasons, because farmers are generally more interested in stable than in maximum yields. It should also be remembered that due to small field sizes and low yield levels yield increments of 20 % or even 30 % are relatively small in absolute terms.

For the farmer who often has to rely on hired labour, at least for the peak seasons, the net return per man-hour is more important than the return per unit area. This means that improvement of cropping systems has to aim primarily at increasing labour productivity. An example from Ghana (BRUCE, 1980) helps to explain this. The improved practice for growing maize recommended by the Grains and Legumes Development Board for the Northern Region leads to yield increments of 400 % over farmers' practices (1.8 t against 0.45 t/ha). The net return per man-day is, however, reduced from 48 to 47 Cedis because of increased labour input. Thus it is not surprising that farmers do not accept the recommendations in spite of high yields but still prefer their traditional practice which not only gives a nearly equal return to the invested labour but overall requires much less labour (28 against 193 hours) (Table 39).

Therefore, when trying to improve cropping systems, existing traditional systems and the motivations of the farmers have to be studied first. NORMAN (1974, 1977), who studied traditional cropping systems in northern Nigeria, came to the conclusion that farmers behave absolutely rationally when practising intercropping.

In the following paragraph reasons given by farmers for intercropping are presented and discussed in brief.

Table 39: Estimates of returns to labour for traditional and recommended maize practices - Tamale, northern Ghana (BRUCE, 1980)

	Traditional practice	Recommended practice
Yield (ton/ha)	0.45	1.8
Gross revenue (¢/ha)	1,350	5,400
Cost of fertilizer (¢/ha)	-	400
Gross income	1,350	5,000
Cost of capital on purchased inputs (¢/ha)	-	200
Returns to labour and land	1,350	4,800
Cost of land rental (¢/ha)	-	-
Returns to labour (¢/ha)	1,350	4,800
Total labour inputs (MD's/ha)	28	103
Returns to labour (¢/MD)	48	47

#### 4.1 Farmers' Motivations for Intercropping

In the past, most extension programmes started introducing new cropping systems without really knowing what they were trying to replace. Only when it became obvious that farmers were reluctant to accept innovations and adhered to their traditional systems, did researchers start to study farmers' motivations for practicing certain cropping systems. One of the first was NORMAN (1971, 1974, 1976) who as early as in the late 1960's began to study cropping systems in the Zaria and Sokoto regions of northern Nigeria. On the whole and taking into account local variations in physical, technological and socio-economic conditions, his findings proved to be valid for all of West Africa. Farmers have various reasons for practicing intercropping (Table 40) and, as he was able to prove later (NORMAN, 1977) they are acting absolutely rational when continuing their traditional cropping systems (see Paragraph 4.2 and 4.3).

Table 40: Reasons given by farmers in northern Nigeria (Sokoto) for the practice of growing crops in mixtures (NORMAN, 1976)

Reasons given by farmers	Percentage of answers	
	Primary reasons	Secondary reasons
1. Tradition	32.20	21.21
2. Higher output	28.82	27.27
3. Shortage of land	15.25	24.24
4. More efficient use of labour	10.17	9.09
5. More certain of yield	1.69	9.09
6. Best way to grow crops is in mixtures	6.79	3.03
7. Other reasons	5.08	6.06

Since the survey villages lie in the close-settled zone around Sokoto, shortage of land is a major reason given by farmers. In this respect, however, the results are hardly representative of West Africa in general where extended areas of similar population density are still confined to limited parts of the region. This is the case, for example, in parts of south-eastern Nigeria where farmers even gave land shortage as the primary reason for intercropping (LAGEMANN, 1977).

Whereas in NORMAN's survey the labour saving aspect of intercropping (Paragraph 4.2) ranks rather low among the reasons given by farmers, this aspect ranks first in surveys conducted several years later in other regions which were probably influenced by migration to urban areas (Table 41).

These findings accord with the results obtained by the author (STEINER and TSCHERSCH, unpublished) in the Ibadan region of south-west Nigeria, the Tamale region of northern Ghana, the Bouaké region of Ivory Coast and the Mossi Plateau of Upper Volta. Only in the closely populated highlands of Cameroon which are characterized by an absolute shortage of land, farmers interviewed by the author gave land shortage as a primary reason.



Table 41: Reasons given by farmers for growing crops in mixtures (OLUKOSI, 1976)

Reasons given by farmers	Number	Total number interviewed	Percent of total
1. More efficient use of labour, time & energy	17	21	81
2. More output, return and food per unit area	14	21	67
3. More certain of some yield	8	21	38
4. Tradition	6	21	29
5. Best way to make use of fertile land throughout the year	5	21	24
6. Beneficial effect of one crop on the other, e.g. protection	3	21	14

Although agro-ecological conditions differ widely between these regions, a remarkably high proportion of farmers interviewed in each of the first four regions gave lack of labour as the main reason for intercropping. Even in the rare cases where land shortage was mentioned as a reason the real constraint was not land availability as such but the labour available during the peak periods of farming activities which determines the amount of land a farmer can cultivate. Given the constraints imposed by the limited supply of family or hired labour to overcome labour bottlenecks, farmers consider intercropping a practice enabling them to obtain higher returns both per unit of land and per unit of labour.

Soil preparation including land clearing and weeding are the two labour peaks in traditional agriculture, followed by harvesting. So the farmers try to make as efficient use as possible of the limited area of land they can clear, especially in forest areas. They consider it a waste of land to plant only one crop which, moreover, occupies the land only for a limited period. The same is true for weeding, the main labour bottleneck in permanent and semi-permanent agriculture. Farmers think it a waste of time to weed a

field for one crop only. Furthermore, they know that they can keep weeds more effectively down by intercropping (see Paragraph 3.5). The time needed for weeding should be further reduced by planting crops in rows and mixing either within or between rows. But farmers are reluctant to spend too much time on planting since this activity depends very much on the rainfall pattern. They prefer, therefore, to devote more time to weeding as this does not have to be done within a specific time. As most farmers engage hired labour for land clearing and weeding, a typical reason given for intercropping is that they do not have the means to hire more labour. All the farmers interviewed by the author were aware of the fact that the yields of individual crops were depressed by intercropping, and they maintained that they would plant sole crops if they had more land and more labour available.

Diversified food supply (see Paragraph 4.4) throughout the year is another important reason, at least in the humid tropics. Theoretically, this would also be achieved by sole cropping on small plots. But, again, because of land and/or land shortage, farmers would not clear land especially for secondary crops. Land clearing is men's work and often men plant "their" own crops, as yam in the yam belt, on the newly cleared fields. Women can only interplant "their" crops in the men's fields (see Paragraph 4.2). The continuous food supply is mainly obtained by staggered planting. This has the advantage for the farmer that the land has to be prepared only once and that in several cases he can combine weeding and planting (see Appendix, Table A 12).

The motive of risk insurance (Paragraph 4.3), i.e. stable yields, is rarely mentioned by farmers even though it is commonly referred to in the literature on traditional cropping systems. It is certainly of minor importance in the humid tropics and the tropical highlands. Here the risk of drought or insect calamities is low and the farmer interviewed by the author never mentioned this motive, even when asked directly. On the other hand, intercropping is more pronounced (number of species, multi-storey cropping) in these areas than in savanna areas with unpredictable rainfall. Risk insurance is undoubtedly a motive in the Northern Guinea and Sudan Savanna where farmers can cultivate only one crop per year. And

here it was also cited as a reason in the author's interviews. Risk in this context is almost entirely the natural risk (crop failure) and rarely the economic risk (collapse of prices) (see Paragraph 4.3). Though risk insurance is certainly a clear advantage of intercropping, it does not seem to be a primary concern in the farmers' considerations.

Tradition is a reason frequently given by farmers but is hardly a primary motive. It is assumed by the author that tradition ("learned from my father"; "it was always done in this way") is mainly cited as a reason by those farmers who cannot express themselves well enough to identify the more fundamental reasons behind their attitude towards intercropping. "Tradition" was often indicated as a reason by young farmers. This is certainly a consequence of the process of rapid social change in rural areas, whereby much of the old knowledge is lost. Younger people often merely continue with certain practices without knowing the original purpose.

Tradition by itself, however, is certainly not a reason for farmers to continue such practices. This is often believed by extension workers who complain that farmers are too traditional to respond to innovations. It must be assumed that in these cases the farmers are convinced that their own practices are more rational under the prevailing conditions.

In the following paragraphs farmers' motivations will be analyzed in more detail to examine the economic rationality of intercropping.

#### 4.2 Maximising Returns to the Most Limiting Factor

As mentioned above, farmers frequently face labour and, to a lesser degree, land problems. The fact that the system of intercropping has evolved under conditions where labour rather than land has been the main constraint to farming clearly indicates that intercropping is consistent with a strategy which aims at maximising returns from labour as the most limiting factor. Even where farmers cite land

shortage as the main reason for intercropping, it is not always land availability as such but rather the labour needed to cultivate more land which is the real constraint. There are, however, situations where, due to high population pressure, access to farmland is extremely limited and in these cases farmers aim at maximising returns per land unit. (See Paragraph 2.2).

#### 4.2.1 Returns to Land

The more efficient use of land by intercropping has been analyzed already in Paragraph 3.1. This is the case when the land equivalent ratio (LER) exceeds 1 ( $LER > 1$ ). Farmers respond to land shortage with an intensification of cropping systems which, at least in areas with periodic rainfall and rainfed agriculture, means intercropping. Intercropping implies savings in land since farms can be smaller than those needed for sole cropping. In a study of land use systems in the Southern Guinea Savanna of Nigeria it was found (DIEHL, 1981) that the Area Equivalent Ratio (AER) was lowest in the stratum with the most pressing land availability problems. Here the AER had a value of 0.86 which means that with intercropping 14 % less land was needed than when the same crops were grown in pure stands. Thus the land use intensity of cropping patterns reflects the land availability situation and it demonstrates that farmers react to land shortage by simply planting more crops in their fields, thereby increasing the complexity of their cropping patterns. While in the cited study the planting density of individual crops did not change with increasing land shortage, this does often occur, as reported from south-eastern Nigeria (LAGEMANN, 1977) and southern Cameroon (IRAT, 1977) (see Paragraph 2.3).

In the humid tropics and the tropical highlands intensification is often obtained by multi-storey cropping. In densely populated areas the income from trees can exceed the income obtained from arable crops (LAGEMANN, 1977; AY, 1980). Further intensification is achieved by extending the compound farms (characterized by the use of manure and a high species diversity). In extreme cases, where the average farm size is below 0.4 ha, as in parts of south-eastern

Nigeria, the entire farm is a compound farm with a large number of different plant species (LAGEMANN, 1977) (see Paragraph 2.).

The more efficient use of land can be expressed by the gross and net returns on intercrops compared to sole crops. When studying cropping systems in the semi-arid parts of northern Nigeria, NORMAN (1977) found that the average gross return per acre was 62 % higher from crop mixtures than from sole crops. The gross return per acre increased with the number of crops and was highest for a four-crop mixture (Table 42).

Table 42: Average gross and net returns from sole crops and crop mixtures (in shillings) (NORMAN,1977)

Variable	Crop mixtures					Overall
	Sole crops	Two crops	Three crops	Four crops	All mixtures	
Gross return per acre	153.6	240.6	229.8	340.9	248.3	228.5
	+22	+19	+30	+80	+16	+13
Net return per acre						
Labour:						
Not costed	148.9	235.7	220.3	322.9	240.8	221.6
Hired costed	135.2	213.6	199.1	297.4	218.6	201.2
June-July costed	133.7	204.7	189.0	276.8	208.2	190.2
All costed	74.1	115.5	105.3	184.6	119.8	110.1

Note: June-July is a bottleneck period when land preparation, planting and weeding are taking place simultaneously.

Net return per acre increased at nearly the same rate. Profitability was generally 60 % higher for crop mixtures than for sole crops. The net return per acre increased with the number of crops in the mixtures. NORMAN came to the conclusion that growing crops in mixtures is consistent with the goal of income maximization. This was subsequently supported by ABALU and D'SILVA (1980). The findings of NORMAN and ABALU and D'SILVA are supported by experimental results of BAKER (1980) who tested different groundnut-based crop

associations in the Sudan Savanna of Nigeria. In no case was there any significant reduction in returns due to intercropping but many examples of considerable gains.

Similar results were obtained by an analysis of maize/bean intercrops in Latin America (FRANCIS and SANDERS, 1978). Production costs of maize/bean intercrops were lower than for sole crops while net incomes were higher and the standard deviation in income was lower. Thus "it is not surprising that farmers have chosen to maintain this traditional system under a range of conditions".

Unfortunately, no comparable data are available for cropping systems of the humid tropics.

#### 4.2.2 Returns to Labour

That intercropping is practiced because of labour shortage seems to be contradictory. It is still often believed that there is under-employment in rural areas and that labour-intensive cropping systems are needed to provide more employment. Intercropping is often recommended as an appropriate solution in this respect. While this may be true for land scarce, overpopulated farming areas in tropical Asia it does not apply to most of tropical Africa where there is generally a chronic shortage of labour in rural areas which, due to the seasonal nature of farming, is particularly acute during certain peak periods of labour demand.

While in most cases intercropping increases labour input per unit area, it reduces the overall labour input per holding as the necessary output is obtained from a smaller area. This means that less labour is required for land clearance, soil preparation and weeding.

In his study of the Zaria region NORMAN (1973) found that crop mixtures require on average 62 % more labour per acre than sole crops. But during the June-July labour bottleneck (with 50 % of the total labour demand) this is reduced to 29 % (Table 43). That means that

intercropping leads to a more even distribution of labour demand throughout the season and prevents the build-up of labour peaks. Thus intercropping serves the farmers' management objectives of achieving an even distribution of labour requirements throughout the year (RUTHENBERG, 1976).

Table 43: Labour inputs and net returns of sole and mixed crops  
 Datas from three villages in the Zaria region, northern  
 Nigeria (NORMAN, 1973)

Type of land	Number of crops in mixture	Man-hour input per acre		Net return per acre (dollars)		
		Annual	June July	Labour not costed	All labour costed	June/July labour costed
Upland	Average sole crop (a)	146.6	49.5	20.8	10.4	18.7
	Two-crop mixture (b)	235.6	60.7	33.0	16.2	28.7
	Three crop mixture (c)	225.3	61.1	30.8	14.7	26.5
	Four crop mixture (d)	271.1	90.3	45.2	25.8	38.8
	Average-mixed	237.3	63.9	33.7	16.8	29.1

- (a) includes sorghum, groundnut and cotton.
- (b) includes millet/sorghum, sorghum/groundnuts and cotton/cowpeas.
- (c) includes millet/sorghum/groundnuts, millet/sorghum/cowpeas and cotton/cowpeas/sweet potatoes.
- (d) includes millet/sorghum/groundnuts/cowpeas.

When studying yam-based cropping systems in the Southern Guinea Savanna of Nigeria DIEHL (1981) was able to show that farmers spread their labour requirements by practicing different mixed crop enterprises (Fig. 46).

The relatively balanced character of the labour profile in Figure 46 demonstrates very impressively the complementarity of the three mixed crop enterprises, particularly with respect to the soil preparation and harvesting activities. "A closer look at these harvesting activities reveals how skillfully farmers have staggered the planting of different crops. In the weeks 21 and 22 96 % of the harvesting hours are devoted to cowpea. In the following two weeks

cowpeas then again occupy 53 % followed by yam with 39 % of the harvesting labour. The sequence is then continued with groundnuts and yam for which the major harvesting period starts in September/October" (DIEHL, 1981).

Figure 46: Average labour input over time per activity and enterprise in Osara village of the Southern Guinea Savanna, 1977/78 (adapted from DIEHL, 1981)

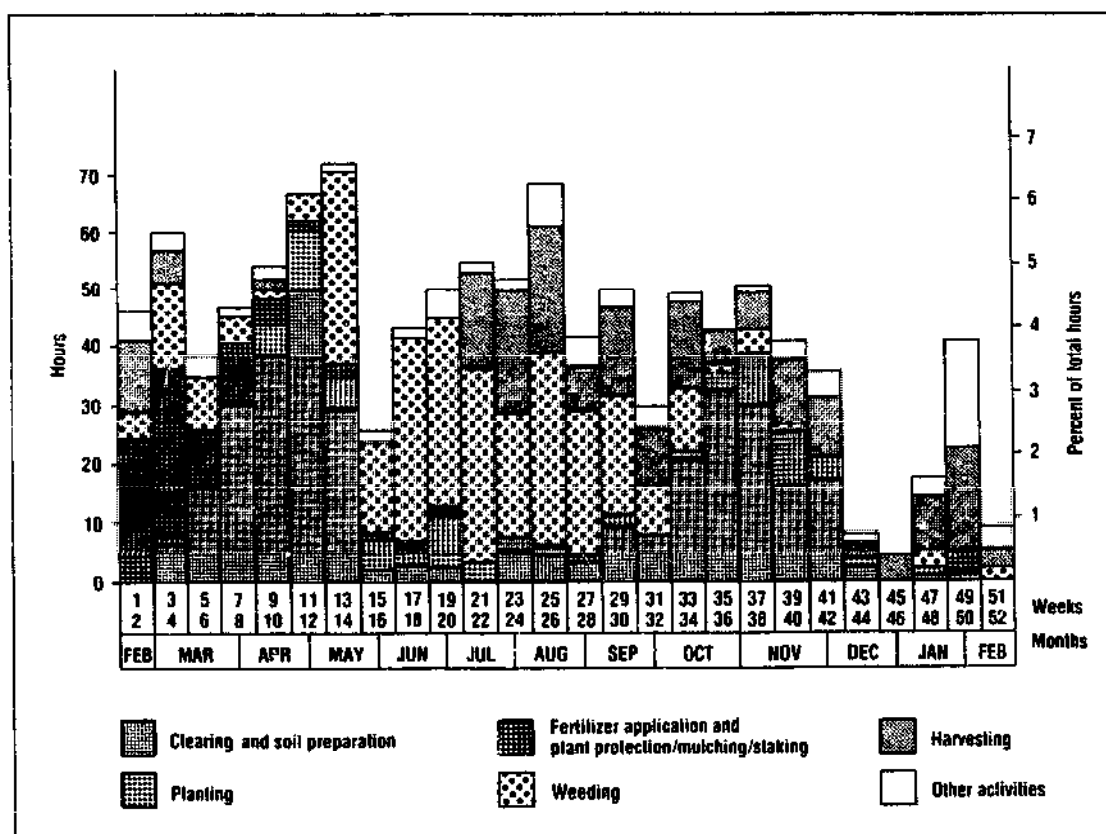

When new cropping systems, especially semi-mechanized ones, are introduced, the labour-saving aspect of intercropping and its equalizing effect on labour requirements throughout the year are often ignored. This leads to high labour peaks and farmers often cannot clear the weeds or harvest within the required time. This is illustrated by an example from the central Ivory Coast (Southern Guinea Savanna) where semi-motorized block fields were introduced by a development agency (Fig. 47).



Figure 47: Labour profile of AVB semi-motorized block fields and traditional fields in the central region of the Ivory Coast (from BIGOT, 1980)

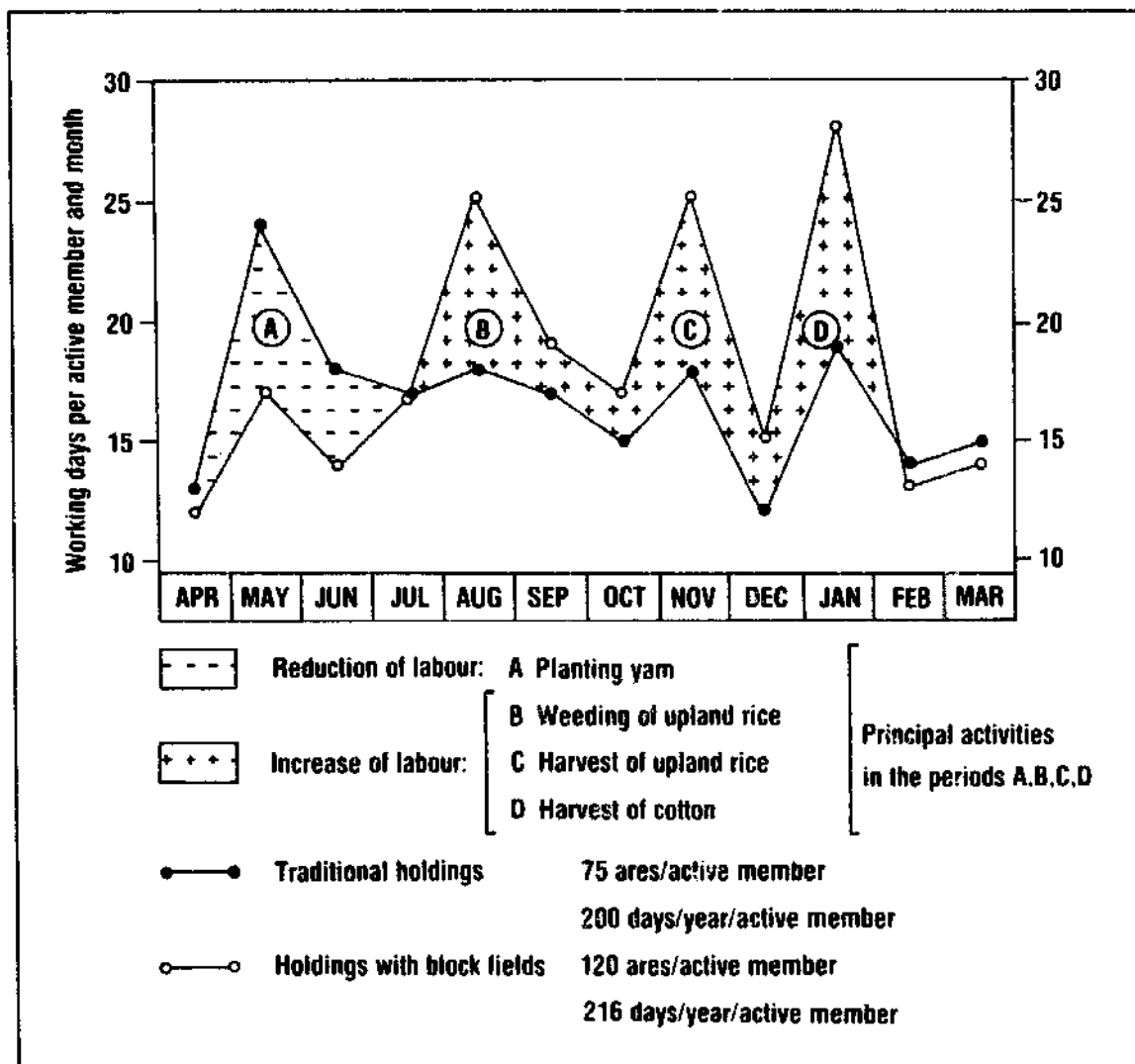

While NORMAN (1974) observed an increased labour input per unit area in northern Nigeria (see above), DIEHL (1981) was unable to find significant differences in labour inputs between sole crops and crop mixtures with different numbers of crops in southern Nigeria. This was observed not only for total labour input but also for single activities and even for highly crop-specific activities such as planting or harvesting. "Although this result is surprising, it can be explained by the fact that several crops are planted simultaneously." Either seeds are mixed before planting, e.g. maize/

cowpea or millet/cowpea, or are placed in the same pocket. "Therefore, planting two crops does not mean twice the labour input required to plant one crop." (DIEHL, 1981).

When comparing returns to labour in different cropping systems, NORMAN (1974) found that the average return per man-hour is 15 % lower for crop mixtures, but that the net return is 25 % higher during the peak demand in June-July.

Thus it can be concluded that, in general, labour is used more efficiently in intercropping than in sole cropping systems.

#### 4.3 Risk Minimization

As pointed out above, farmers are more interested in stable (sustained) than in maximum yields. In Paragraph 3.2.4 it was shown that intercropping increases yield stability. This aspect gains in importance as the rainfall becomes more unpredictable and the risk of insect calamities increases. In India, for example, intercropping is predominant in low rainfall/high risk areas (JODHA, 1976).

In West Africa rainfall predictability is not directly related to the total amount of rainfall. Thus in the Southern Guinea Savanna (the yam belt) rainfall is more unpredictable than in the Northern Guinea and Sudan Savanna and crop losses due to late onset of rains or drought periods are common (Fig. 48, Table 44).

In the village study of DIEHL (1981) in the Southern Guinea Savanna of Nigeria, only one of 34 reported crop failures was caused by pests and two by attack of Striga, while the majority of 26 was due to lack of rain. While farmers can adapt planting dates to the onset of the rains, dry periods - especially within the first four weeks after planting - are a great risk for most crops. This risk can be reduced only by mixing crops with different drought resistances. Thus cowpea, yam, melon and benniseed are classified by

farmers in southern Nigeria (DIEHL, 1981) as the most risky crops while maize and groundnut are less often reported to have failed because of lack of rain.

A typical example of a stable crop mixture is the maize/sorghum intercrop in the Northern Guinea Savanna while in the Sudan Savanna sorghum/millet intercrops are used to reduce the risk.

Figure 48: Probability of the appearance of a 12 day period with less than 20 mm rainfall in the Southern Guinea Savanna of the Ivory Coast (based on studies of GIGOU, 1973) (JACOB, 1977)

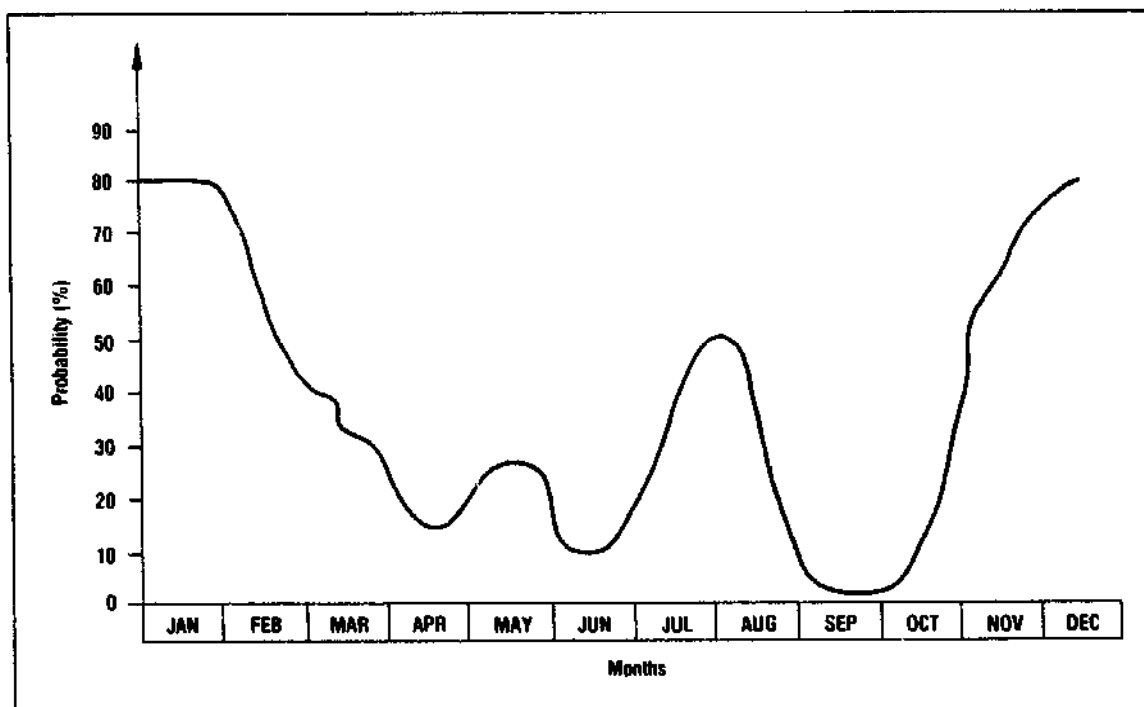

LOFT (1980) makes a distinction in this respect between "mixed cropping" and "contingency mixing". In the first case, where the weather is fairly stable farmers expect to harvest all crops of the mixture, while in the second case with extremely erratic and unpredictable rainfall farmers want to be sure of just one significant harvest. An example for the latter case is the association of maize and sorghum in the Sudan Savanna (Upper Volta) where maize fails completely in many years.

Table 44: Rainfall distribution and yields of the main crops in the years 1967-1974 in the Southern Guinea Savanna of the Ivory Coast (from BIGOT, 1977)

	1967	1968	1969	1970	1971	1972	1973	1974	Means 1973-74
<b>Rainfall</b>									
March-April (mm)	258	108	213	156	161	258	130	247	238
May-June (mm)	214	503	65	150	419	265	231	147	293
July-August (mm)	135	363	173	328	132	74	217	268	204
September (mm)	215	167	106	308	284	112	222	205	213
October (mm)	24	197	195	40	116	89	76	158	138
<b>Mean yields (kg/ha)</b>									
Yam	n.a. <sup>1)</sup>	10.270	11.330	18.925	13.860	5.740	12.680	13.700	-
Maize	997	2.340	0	1.897	2.445	3.350	2.270	2.196	-
Cotton	401	928	932	270	863	690	597	704	-
Upland rice	37	1.796	0	1.745	1.051	428	n.a. <sup>1)</sup>	2.020	-

1) n.a. = not available.

There are, however, also examples where drought sensitive crops are mixed, e.g. the maize/rice relay crop in the Southern Guinea Savanna of the Ivory Coast where both crops may fail in the same year.

When evaluating data collected by NORMAN, ABALU (1977) surmises that at least in the Northern Guinea and Sudan Savanna farmers use crop mixtures as a "diversification strategy as a precaution against biological and economic occurrences. As there is a marked seasonal distribution of rainfall in the region, the diversification strategy has tended to be pursued through intercropping rather than through sequential or relay cropping."

Economic occurrences (risks) in this context mean primarily that no surpluses are obtained for marketing to provide the necessary cash income. Economic risks due to a collapse of prices are of least importance in the mind of farmers. This is explained in part by the predominant subsistence orientation but also by the small transparency of markets to farmers, who can be guided only by the prices achieved in the last few years on their respective village markets (DIEHL, 1981).

Another aspect of intercropping is the fact that a great proportion of (sometimes hired) labour input is beneficial for a number of crops simultaneously and is therefore less likely to have been fruitless.

There are different methods for comparing the stability of intercrops with that of sole crops (see Paragraph 3.2.4). One approach suggested by RAO and WILLEY (1980) is to consider the probability of cropping systems giving a lower return than some specified "disaster" level of income. By using this approach BAKER (1980) clearly showed the advantage of mixtures over sole crops. In Fig. 49 the probability curves are shown for returns from mixtures and sole crops, selecting the level of the median return from sole crops, that is the return expected from sole crops 50 % of the time. In no case did a mixture show a higher probability of a return below the sole crop mean, and in the Northern Guinea Savanna mixtures showed a much reduced risk of falling below that level.

Thus, in the sense that probability of failure is less, mixtures in these trials must be considered more stable than sole crop groundnuts.

Figure 49: Probability (%) of exceeding the sole crop median return (BAKER, 1980)

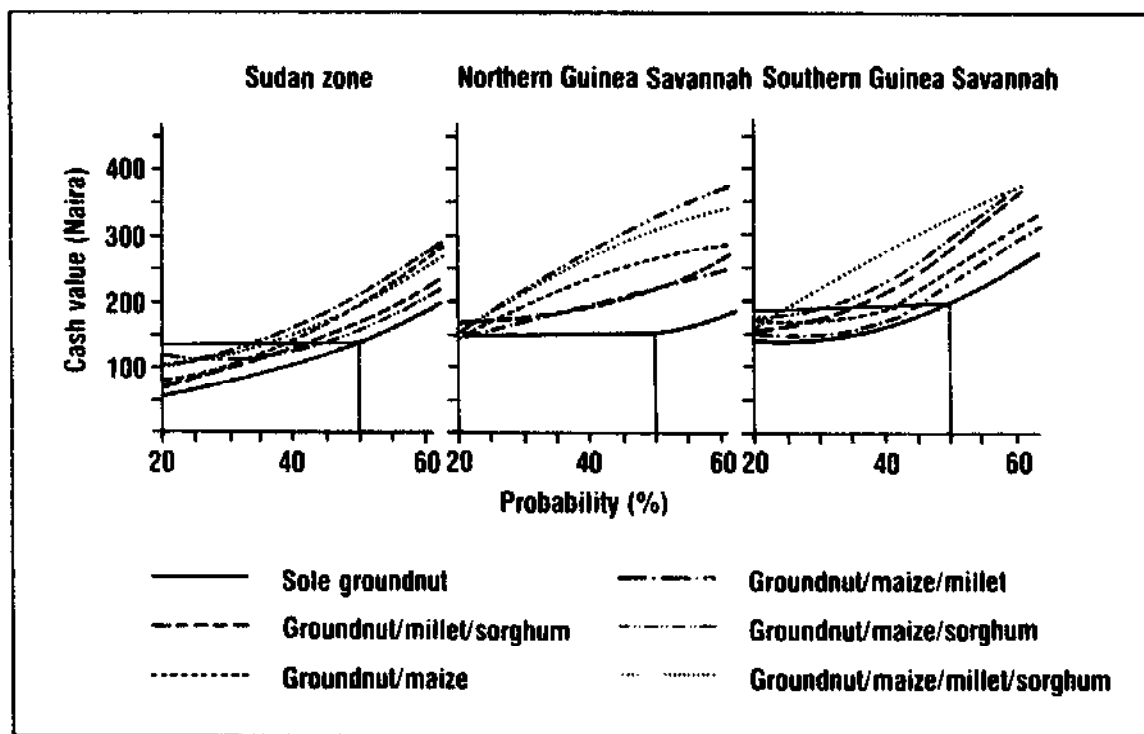

Similar results were obtained by an economic analysis of maize/bean intercrops, the most common crop association in Latin America (FRANCIS and SANDERS, 1978). At all price ratios between maize and beans (1:1 - 1:8) the probability of achieving a positive net income was higher for the crop mixture than for either sole crop (Fig. 50). At the average yield level of Latin America a maize/bean intercrop gives a higher net income and the standard deviation in income is lower than for sole crops. This result is especially interesting, because small farmers are not in a position to adjust the crop ratio in their mixtures to the current market situation.

Figure 50: Probability of net incomes at two levels in three cropping systems at several bean/maize price ratios. Each point represents the probability of receiving at least a net income of zero ( $X_{B,0}$ ,  $X_{M,0}$ ) or of CP \$ 10.000 ( $X_{B,10}$ ,  $X_{M,10}$ ) (FRANCIS and SANDERS, 1978)

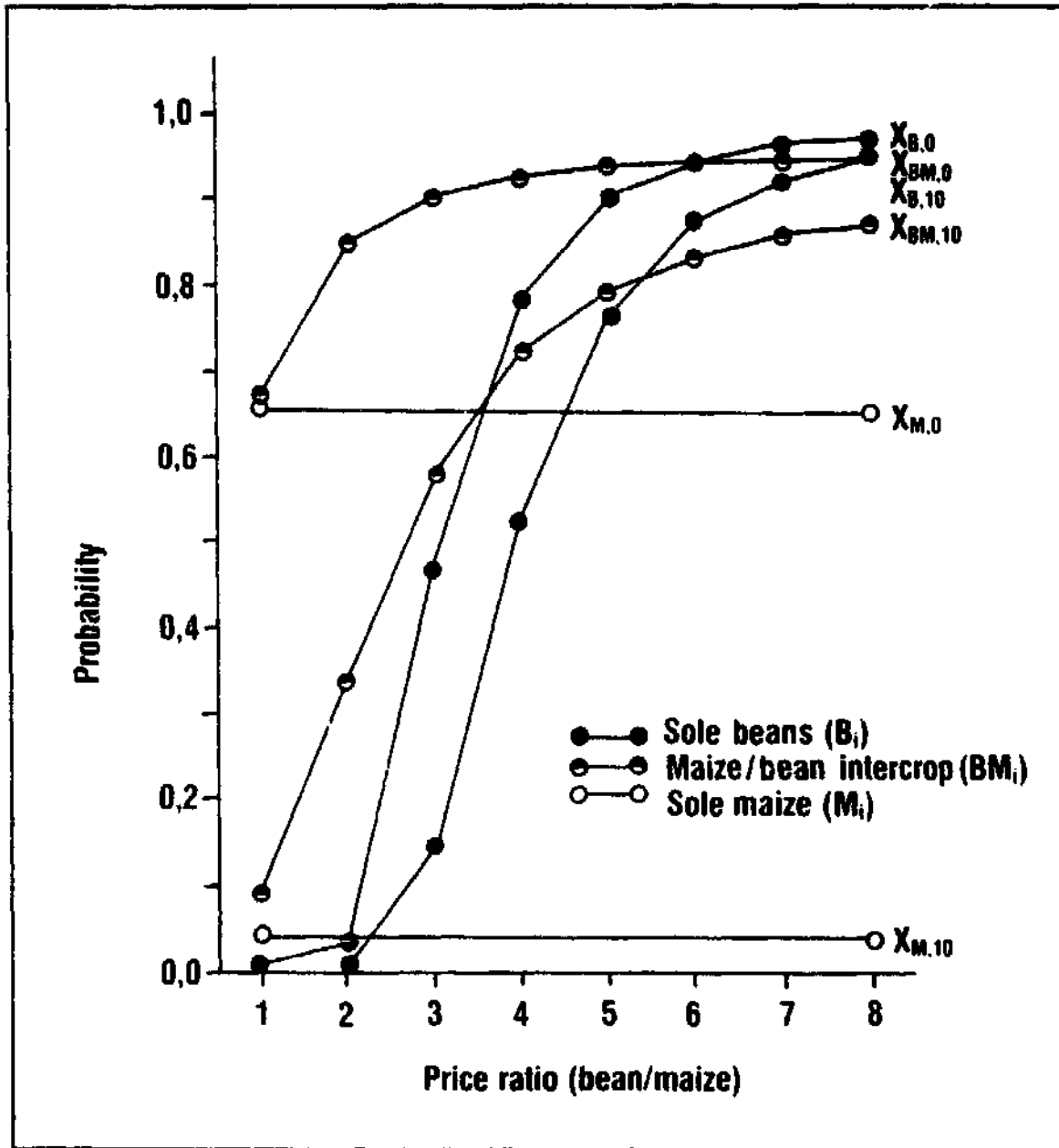

A further strategy employed by farmers to assure at least some income is a mixture of food crops and cash crops. While in the humid tropics cash crops are mainly permanent crops such as coffee and cocoa, in semi-arid tropics cash crops are cotton, groundnuts, and recently also maize. Even though the price level for cash crops is usually low, farmers recognize the advantage of a guaranteed cash income.

#### 4.4 Continuous and Diversified Food Supply

One reason for intercropping cited by the majority of farmers is a diversified and continuous food supply over a prolonged period (see Paragraph 4.2). This is an important aspect, at least for the humid tropics, because storage of harvested products is difficult in the tropics and post-harvest losses are high (RUTHENBERG, 1978). In the humid tropics with a long growing season ( $> 9$  months) crops can be planted and harvested nearly all the year round and harvested plants are often replaced immediately.

Generally speaking diversification is highest on the compound farms (see Paragraph 2.3) where quite a number of vegetables and spices are grown so that they seem more like a garden than a field. There are many regions, however, where compound farms do not exist and where minor crops are also cultivated in the fields (bush farms). The importance of this practice is sometimes ignored when intensification programmes are introduced to increase food production. This was observed, for example, in the central region of the Ivory Coast where a development agency had introduced block fields for yam, maize, rice and cotton. Even though the yields of yam were higher on the block fields, farmers continued to cultivate their traditional yam fields where yam was mixed with some cassava and different vegetables and spices. When asked for the reason, the farmers replied, that they needed all the diverse crops. Since they did not consider it worthwhile to clear a field especially for these crops, the only alternative was to clear a field for yam and interplant the yam with the other crops. The block fields were often neglected in favour of these traditional fields.



Intercropping also helps to bridge the time between planting and the new harvest, the "hungry season". Early-maturing crops are often planted at a low density and interplanted with a long-cycle crop. Or, as in the central Ivory Coast, farmers interplant yam with some cassava as a so-called "culture de soudure". This cassava, which is interplanted in the second year with maize and rice, is harvested only when there is an actual shortage of food.

#### 4.5 Sexual Division of Labour

As already mentioned in Paragraph 2.4.2, one reason for intercropping is the division of labour between sexes. While heavy work such as land clearance is always done by men, responsibility for the different farming operations and diverse crops depends upon the socio-economic (social, ethnic, religious) and ecological environment. Thus in the forest areas of Cameroon food crops are normally grown by women while men are cultivating permanent (cash) crops, including plantains (Table 45). Cash crops, which can also be food crops, such as maize and rice, are cultivated by men. In most parts of West Africa yam is a men's crop, cultivated exclusively by men. Where no cash crops are grown, men and women are each responsible for certain crops. In Upper Volta, for example, cereals are cultivated by men while women have their separate fields for groundnuts, okra, roselle, etc. (Table 46).

This specialisation by sexes is often a reason for mixed cropping, because women just plant "their" crops in their husbands' fields. This is, for example, the case with the yam fields in the Ivory Coast (see Paragraph 4.4) where women plant vegetables and spices between the yam, or with cereal fields in Upper Volta, where women interplant okra and roselle. The interplanting of coffee with food crops, quite common in the Cameroon Highlands, is also partly caused by this division of labour. As most men have additional off-farm employment, women weed their husband's coffee. To make this work more profitable, they interplant various food crops such as cocoyam, groundnuts, beans, maize and potatoes. In this way they also bene-

fit from the fertilizer applied to the coffee. Even though yields of these food crops are severely depressed by the dominating coffee, this practice is still rational for the women.

The division of labour between sexes and its implications have often been ignored by extension programmes. Either only the farmer was addressed even though he was not responsible for food crops at all, or in the case reported from the Ivory Coast (Paragraph 4.4) where block fields were introduced, the fact that men still had to prepare fields for their wives' diverse crops was not taken into account.

One example where account has been taken of present practices is the extension programme of the coffee cooperatives (UCCAO) in the highlands of Cameroon. Here, mixed cropping is now promoted and trials with intercropping systems are carried out in cooperation with the agricultural research institute (IRA).

Table 45: Percentage of farmers reporting division of labour in farm operations for the production of food crops (AFAYI and KNIPSCHEER, 1980)

Farm operations	Maize			Groundnut			Plantain			Cassava			Cocoyam			Melon		
	M	F	X	M	F	X	M	F	X	M	F	X	M	F	X	M	F	X
Land preparation	0.5	20.4	20.4	0.9	50.9	19.0	0.5	8.8	18.1	0.5	17.1	13.0	-	-	-	-	17.3	9.3
Planting	-	41.7	45.8	0.5	62.0	35.6	4.6	41.7	32.4	0.9	54.6	18.1	0.5	31.5	11.6	0.5	31.9	29.6
Weeding	3.7	42.6	19.4	6.0	35.2	12.0	5.6	34.3	20.4	6.0	45.4	10.6	-	-	-	1.9	31.9	11.6
Ridging	-	-	-	-	-	-	0.9	4.2	6.9	-	14.4	6.0	-	-	-	-	-	-
Harvesting	-	81.0	4.6	-	78.2	18.1	0.5	46.3	27.8	-	67.1	6.9	-	38.0	5.1	-	45.4	15.7

M = Male only      F = Female only      X = Mixed

Table 46: Division of fields by crops and sex of the main users (MATION and BONKIAN, 1980)

	Percentage of fields of each crop cultivated by		Total number of fields of each crop
	MEN	WOMEN	
<u>Sole crops</u>			
Pearl millet	86	14	14
Red sorghum	100	-	11
White sorghum	69	31	10
Maize	100	-	29
Groundnut	40	60	184
Bambara nuts	19	81	106
Cowpea	84	16	6
Okra	2	98	96
Roselle	2	98	44
Others (1)	100	-	16
<u>Intercrops</u>			
Pearl millet/cowpea	76	24	63
Pearl millet/roselle	68	32	37
Red sorghum/cowpea	87	13	31
Red sorghum/cowpea/roselle	79	21	5
White sorghum/cowpea	100	-	25
Others (2)	58	42	44
<b>Total</b>	<b>47</b>	<b>53</b>	<b>721</b>

(1) Not all sole crops taken into consideration.

(2) Not all intercrops taken into consideration.

#### 4.6 Influence of Markets on Intercropping Systems

In general, the influence of markets on intercropping is low. Except those situated near urban centres or main roads, farmers are hardly market-orientated (because of the low level of product prices). They produce primarily for their own needs and only small surpluses are marketed. Therefore, changes in the price ratios cause hardly any changes in the ratios of the associations and mixed cropping cannot be regarded as an insurance against price fluctuations. Farmers interviewed by the author in the different ecological zones of West Africa always denied that they would plant more of any specific crop if market prices had risen in the previous season.

Near urban centres or along major trunk roads, however, market influences may lead to a change of intercropping systems in favour of sole cropping. This is the case in some parts of southern Nigeria where the acreage of sole-cropped cassava and maize has increased in the last years. In southern Benin, too, under the influence of the strong Nigerian market the traditional maize/groundnut/cassava intercrop is being increasingly replaced by sole-cropped maize. Even though yields are extremely low, especially in the second season due to decreasing soil fertility and stemborer infestation, maize production still seems to be more profitable to farmers than the production of cassava and groundnuts. The relative superiority of maize to cassava is also caused, however, by the low productivity of cassava due to poor planting material. All the cassava is heavily infested with mosaic and in recent years outbreaks of bacterial blight and mealy bugs have also occurred. Together with other causes, the poor phytosanitary situation has already led to a collapse of the cassava industry in neighbouring Togo.

Newly introduced crops such as rice, cotton and maize in the Northern Guinea Savanna are normally regarded as cash crops. Thus they are not part of the traditional cropping pattern and are planted as pure crops on separate fields. However, where rice and cotton

are traditional crops, they are intercropped. Sole cropping of these crops is therefore not the result of market influences. On the contrary, where marketing boards pay low prices, farmers intercrop maize and cotton too.

#### 4.7 Flexibility of Intercropping Systems

There is a basic difference between the sole cropping systems of market-orientated holdings and the intercropping systems of predominantly subsistence-orientated smallholdings. While the former is a "fixed" system which is planned in advance and where the crops are planted entirely within a certain period, the latter is a "flexible" system. This means that the farmer does not know exactly what he will grow on his field in the middle or at the end of the season. The final cropping pattern depends on the time between the onset of the rains and the latest possible planting dates for individual crops, on intervening drought periods, and on the availability of labour:

- If the rains are late, there is often not enough time to plant all crops as it will be too late for some of them, e.g. photo-period-sensitive varieties (such as many cowpea varieties).
- Crops that have failed because of drought periods have to be replaced by others.
- The available labour depends on several factors, such as the number of active household members present during the planting period, the health of the farmer and his family and the money available for hired labour.

All these factors together determine the final cropping pattern. The pattern is "flexible", which means it can be adapted to the prevailing climatic and socio-economic conditions. Thus cropping patterns change from year to year and also between individual holdings. In 1977, for example, an unusually high proportion of sole crops (maize) was planted in southern Nigeria (HOUYOUX, 1979). This can be explained by the onset of the rains in that year which came

too late for the early crops (DIEHL, 1981).

Summarizing the socio-economic aspects of intercropping it can be concluded that intercropping systems are well-adapted to the socio-economic situation of smallholdings which account for the majority of farms in the tropics. Intercropping systems give farmers a greater return to their limited resources (land, labour, capital), they guarantee stable yields and thus stable incomes under uncertain climatic conditions, and they provide households with a secure diversified food supply over a prolonged period. On the whole, intercropping systems are consistent with the theoretical concept of traditional agriculture which assumes that traditional small farmers have reached an economic equilibrium characterized by allocative efficiency but low productivity (SCHULTZ, 1964). By practising intercropping, farmers allocate their resources in a way which enables them to achieve the goals of both profit maximization and security. Under the prevailing technological, economic and social conditions there is little opportunity for small farmers to increase agricultural productivity and income by reallocating their resources.

Since current levels of technology in traditional farming hardly permit more productive use of the limited resources available to small farmers, technological change is the major precondition for increased agricultural productivity. However, any changes in agricultural practices and inputs must be closely adapted to the resource constraints and socio-economic situation of the small farmer. Research and extension efforts to develop and introduce new technologies should therefore aim at improving rather than replacing intercropping systems. In particular, technical innovations should not only be more profitable but also take into account farmers' reluctance to accept additional risks.

Relationships between input prices and product prices can hardly be expected to change dramatically in favour of small farmers in the foreseeable future. This requires careful examination of the economics of the introduction of new or improved inputs which make farmers become more dependent on external sources of supply. Even

though the improvement of intercropping systems is likely to be a slow and difficult process, it appears to be a promising approach towards the development of smallholder agriculture in developing countries.



The review of research results in the previous chapters has revealed that there is already a considerable knowledge of intercropping systems, even though research has started only recently on a larger scale. There are many results that could already be used in extension programmes. As intercropping systems obviously have many advantages for smallholdings, and as there are possibilities of improving the traditional intercropping systems, rural development programmes in the tropics should no longer hesitate to promote intercropping.

### 5.1 Present State of Research on Intercropping

Even though the report is geographically limited to West Africa, it was not possible to restrict the review to findings obtained exclusively there. As will be discussed below, research on intercropping in West Africa is restricted to relatively few institutions. Therefore, many data from Asian or American researchers have also been included. However, since the basic principles of intercropping are universally valid, the origin of the data does not matter. It is only where socio-economic aspects have been discussed that findings exclusively from African research institutions have been referred to.

#### 5.1.1 Summary of Research Findings

The analysis of intercropping in the previous chapters has revealed that this cropping system is generally well adapted to the conditions of smallholder farming prevailing in the tropics.

There are only relatively few agro-ecological zones where intercropping is not appropriate. These are firstly the seasonally flooded lowlands, which are better suited for the cultivation of swamp rice, and, secondly, the (semi-)arid regions with growing periods of less than 120 days.

Even though well adapted to conditions of limited natural resources and restricted commercial inputs, intercropping systems cannot be classified as "low input-low productivity" systems. Intercropping systems can be intensified successfully and still maintain their advantages to smallholders even under conditions of high (commercial) input use. This presupposes that measures to increase labour productivity, i.e. mechanization, are not impeded by intercropping. In West Africa, for example, draught animals and even tractors are mainly used for land preparation. Planting, weeding and harvesting are still done by hand. But even sowing and weeding, the other labour bottlenecks, could easily be mechanized in intercropping systems. Appropriate farm implements for these operations have already been developed.

#### Advantages of intercropping systems

There are many advantages of intercropping for smallholdings, and this is obviously the reason why farmers have not abandoned their traditional systems in spite of the efforts of extension services to introduce sole cropping.

The main advantages of intercropping can be summarized as follows:

- better use of limited resources (light, water, nutrients) resulting in higher yields per unit area and unit of time.
- increased yield stability and reduced probability of incomes falling below the subsistence level;
- reduced crop losses due to weeds, pests and diseases;
- contribution towards soil fertility maintenance through reduced erosion and nutrient leaching;
- more balanced distribution of labour requirements throughout the season, as labour peaks for land preparation and weeding are reduced.

Higher yields per unit area: Intercropping systems produce higher yields per unit area compared to sole crops (expressed in terms of LERs). Yield advantages can range from 20 to 60 %, depending on the cropping systems and agro-ecological zones concerned. (It has to be borne in mind, however, that maximum LERs are often obtained with crop ratios that do not correspond to farmers' requirements). These yield advantages are mainly due to the fact that component crops do not compete for exactly the same overall growth factors and that intercrop competition is therefore lower than intra-crop competition. In successful intercropping systems the aim is to decrease competition by increasing the spatial and temporal differences between the component crops. This leads to a more efficient use of growth factors, such as light, water and nutrients, which is of special importance in situations of low inherent soil fertility and restricted availability of commercial inputs (mainly fertilizers).

Competition for light can be reduced successfully by using either appropriate species or certain variety combinations and spatial arrangements. Successful intercropping systems reach the optimal leaf area index (LAI) faster than sole crops, have a higher light interception, make more efficient use of light due to a larger photoactive surface (through inclined leaves, several storeys, etc.), and utilize the light for a longer overall period through the association of early and late maturing crops.

Intercrops have a better water-use efficiency (WUE) than sole crops. This is of special importance for the semi-arid tropics, where water is the main limiting factor. One reason for the increased WUE is the windbreak-effect when low-growing crops are interplanted with tall-growing ones, leading to reduced evapotranspiration. Adjusting plant populations to the available soil moisture, i.e. a low population at the onset of the rains, a high population in the humid phase of the season, and again a low population on the residual moisture at the end of the growing season, is another means of using the available soil moisture more efficiently by intercropping.

Under conditions of low soil fertility (limited supply of nutrients) intercropping - due to high root densities and differing root patterns - leads to a better extraction of nutrients. Component crops with differing growth patterns do not have their peak requirements at the same time, thus reducing competition and enabling the subsequent delivery of mobile nutrients. Crops may also benefit from the better disintegration abilities of the associated crops for some nutrients, especially phosphorus.

Increased yield stability: The increased yield stability of intercropping systems is obviously of more importance to smallholders than absolute yields. Especially in areas with uncertain rainfall, such as the Southern Guinea Savanna, but also in the Northern Guinea and the Sudan Savannas, yields of sole crops vary considerably from one year to another and certain crops may fail completely in some years.

Therefore, intercropping combined with staggered planting can be looked upon as a farmers' strategy to increase yield stability. The probability of incomes falling below the subsistence level is significantly lower in intercropping- than in sole cropping systems.

The improved yield stability in intercropping systems originates from a distribution of maximum demands for growth factors over a prolonged period and from a compensation effect. For example, if one crop fails because of drought or pest outbreaks, the associated crop, being at another growth stage and/or more resistant to the pest, will suffer less and, because of reduced competition, will be able to compensate the loss of the susceptible crop later on, at least partially.

The reduction of yield losses caused by pests, diseases and weeds contributes further to yield stability. In many intercropping systems the association of susceptible and resistant crops or varieties can prevent or at least postpone the outbreak of pests or diseases.

It is assumed that the "associated" resistance of intercropping systems was a selection criterion of traditional cropping systems. Introduction of new crops into traditional systems, for example the replacement of sorghum by maize, can reverse the situation and cause increased pest and disease incidence. The reduction of yield losses through intercropping cannot, of course, be compared to the effects obtained by the use of pesticides. As, for various reasons, an efficient application of pesticides is difficult to achieve in smallholder food production, advantage should at least be taken of the potential of biological pest control.

As to weeds, there is no doubt that appropriate crop associations can compete better than sole crops, mainly due to an early ground cover. This is of utmost importance in smallholder farming, since weeding - especially in the humid tropics - is the major labour bottleneck, restricting the size of holdings. Although in crop associations the yields of the dominated crops are sometimes considerably reduced, they still yield more than if weeds were to grow in their place.

Soil fertility maintenance: Intercropping contributes to soil fertility maintenance (thereby further increasing yield stability). The early ground cover achieved by intercropping protects the soil from the impact of rain and overheating. Surface sealing and runoff resulting in sheet erosion and decreased water retention can be reduced significantly by appropriate crop associations. Nutrient losses through leaching can be diminished by interplanting species with deep reaching root systems (such as pigeon pea or trees). These species can also "pump up" nutrients from beyond the root systems of the associated crops, making them available again after the decomposition of fallen leaves or prunings. Planted fallows, (e.g. of pigeon pea) established as relay crops, can protect the soil after the harvest of the main crop(s) and restore soil fertility in a shorter period of time than the traditional bush fallow. Systematic fallows such as alley cropping with Leucaena or other leguminous trees or shrubs also have to be considered in this context.

The advantages of intercropping in smallholder agriculture are not restricted merely to plant production. Farmers prefer intercropping mainly because it is well adapted to the socio-economic conditions of smallholdings.

Higher returns to land and labour: Intercropping is an intensification strategy used by farmers to increase the production from a limited amount of land. Farm sizes in traditional agriculture are limited (1-2 ha) either because of land shortage or, as in most cases in West Africa, because of (seasonal) labour shortage.

While labour requirements per unit area are higher in intercrops compared to sole crops, requirements per product unit, and eventually for the entire holding, are lower owing to the increased production. Net returns to land and to labour are consequently higher.

As interviews with farmers showed, the labour saving aspect is their principle reason for practising intercropping.

Distribution of labour requirements: Intercropping, in addition, leads to a better distribution of labour, i.e. labour peaks, mainly for land preparation and weeding, are less likely to occur than in sole crops. This results partially from reduced labour requirements but also from spreading the requirements through staggered planting.

Income stability: In smallholdings, producing primarily to meet subsistence needs and selling only surpluses, income stability is closely related to yield stability. As pointed out above, the increased yield stability of intercrops reduced the probability of incomes falling below the subsistence level.

Diversified food supply: Another advantage of intercropping is the continuous and diversified food supply to the farmer's family. This is especially pronounced in the humid tropics, where highly diversified compound farms exist producing staple food, vegetables, spices and fruits throughout the year.

The above summary shows that there are many advantages of intercropping in tropical smallholder agriculture. Therefore, as stated by NORMAN, farmers are acting in an absolutely rational way when continuing their traditional intercropping systems.

#### Possibilities of improving traditional intercropping systems

When discussing the advantages of (traditional) intercropping systems, the impression might be gained that these systems are already quite perfect and do not need any further improvements. This, of course, is not correct since the productivity of traditional cropping systems is low. Yields are stable but on a low level. To meet the increasing demand for food of a rapidly growing population, the productivity of traditional cropping systems must be increased significantly, but their advantages, especially the stability, should preferably be maintained.

Chapters 3 and 4 indicate a number of possibilities of increasing the productivity of intercropping systems, such as:

- optimized spatial and temporal arrangements
- optimal crop combinations
- specific breeding and selection for intercropping systems
- fertilizer application
- mechanization
- integration of trees, systematic fallows
- continuous ground cover as a protection against soil erosion
- crop combinations with a greater potential to reduce pests, diseases, and weeds.

In addition to these measures specific to intercropping systems, of course all the other methods generally employed in smallholder agriculture for maintaining soil fertility and increasing food production should also be used.

Spatial and temporal arrangements: To make full advantage of the potential of intercropping systems, the spatial and temporal arrangements of the component crops have to be optimized. This implies an increase of the plant populations, which, however, results

in an accelerated depletion of nutrients and thus the need of fertilization. The optimal crop arrangements are very site specific and have to be adapted to changes in soils and climate.

Crop combinations: In many cases it is possible to increase the productivity of traditional intercropping systems by introducing another component crop c varieties differing in morphology, maturity period, resistance, etc.

Breeding and selection for intercropping systems: The improved varieties developed in the past were selected for sole crop conditions. The assumption that these improved varieties would be superior in all cropping systems was not correct. For the intensification of intercropping systems, therefore, varieties are required that are well adapted to specific crop combinations primarily in respect to plant morphology, plant density, responsiveness, and vigorous early seedling growth.

When selecting for intercropping systems, it is of utmost importance that the selection is carried out at a fertility level representative of farmers' fields. This is normally much below the fertility level of experimental station fields.

Fertilizers: The application of mineral fertilizers is a relatively easy way to increase production. As mentioned above, intercropping does not present an obstacle to fertilizer application. Owing to changes in growth patterns caused by interspecific competition, fertilizer requirements of component crops differ from those of sole crops. Specific recommendations hardly existing to date are consequently required for the various crop associations.

The available research results do not reveal any differences in the fertilizer use efficiency between intercrops and sole crops. Losses of fertilizers due to leaching, run-off or sheet erosion can, however, be reduced by intercropping.

Economic evaluations of fertilizer use in intercrops, expressed in value:cost ratios, show that farmers are generally better off when applying fertilizer to intercrops than to sole crops.



Mechanization: The low labour productivity in traditional farming is an obstacle to increased food production. Therefore, at least seed-bed preparation and weeding should be mechanized. In this respect, intercropping is not an obstacle as mentioned at the beginning of this paragraph, provided the crops are planted in rows.

Integration of trees, systematic fallows: Another possibility of intensifying traditional intercropping systems is the integration of (fruit bearing) trees. This contributes to soil fertility maintenance as well as to the stabilization of incomes.

In this context, "alley-cropping" should be mentioned, although, strictly speaking, this is not intercropping, but an attempt to systematize the bush fallow. For this purpose, hedges of leguminous shrubs (e.g. Leucaena sp.) are planted in the fields at regular intervals (2-6 m). They are pruned during the growing season to reduce competition to growth factors with the interplanted food crops and to provide nitrogen-rich mulches. The fast regrowth of the hedges after the harvest of the food crops provides an efficient bush fallow that can be cleared easily for a new cropping period.

Continuous ground cover against soil erosion: When intensifying intercropping systems, major emphasis is placed on sustained and not on maximum yields. This presupposes maintenance of soil fertility. As mentioned above, intercrops contribute directly to this by providing an early ground cover. Increasing the proportion of legumes and using fast growing species of lowgrowing component crops can still improve the impact on soil fertility maintenance.

Biological pest control: To improve intercropping systems not only a higher productivity but also a reduction of crop losses due to pests, diseases, and weeds must be aimed at. Higher plant populations and an early ground cover contribute directly to weed control. The reduction of pests and diseases, however, depends much more on the species and varieties in the associations, crop ratios, relative planting time and also on the agro-ecological zone. Not enough is known yet to make full use of the potential of intercrops in this respect. But there is no doubt that the reduc-

tion of yield losses will be only small and not comparable to those achieved by means of chemical crop protection.

In spite of these limitations, the potential of intercrops for reducing yield losses must be regarded as one of the main advantages of these cropping systems; in particular, because chemical pest control is no real alternative in smallholder food production.

Summarizing the advantages of intercropping and the possibilities of intensification it can be said that these cropping systems are well adapted to the ecological and socio-economic conditions of tropical agriculture and that they can be intensified to meet the increasing demand for food.

#### 5.1.2 Research on Intercropping in West Africa

The previous chapters have outlined the importance of intercropping for food production in West Africa as well as the agronomic, ecological and socio-economic advantages of this cropping system. These facts are in striking contrast to the importance attached to intercropping in agricultural research and extension. Policy makers are still convinced that the food problem can be overcome by methods developed in industrialized countries with temperate climates. In nearly every West African country general policy is to increase food production exclusively on the basis of sole cropping combined with high yielding varieties and commercial inputs such as fertilizers, pesticides, and mechanization. Increasing farm sizes, is to facilitate mechanization and ensure a higher efficiency of inputs.

Generally speaking, however, this policy has achieved only poor results. A lack of off-farm employment and rapid population growth have led to decreasing farm sizes in many regions. Price increases for imported inputs have made them scarce and often unprofitable for food production. For small farmers there are consequently hardly any alternatives to their traditional cropping systems.

This makes many research workers rather dubious about continuing work on sole cropping, because the results are irrelevant to the majority of farmers.

As discussed in Chapter 3, however, research on intercropping - the alternative - is much more complicated and difficult than research on sole cropping. Combining crops is more than merely adding another crop species but introduces a completely new dimension. This is obviously the main reason why many research workers have so far hesitated to turn their attention to intercropping. Nevertheless, intercropping is slowly gaining importance in agricultural research, due not least to the influence of international agricultural research organizations such as IITA or ICRISAT. The high complexity of traditional farming systems, on the other hand, does not allow research to be restricted entirely to agronomical aspects, but necessitates a (farming) systems approach in research.

There is quite a difference between anglophone and francophone countries as regards research on intercropping. Francophone researchers have confined themselves to a description of traditional cropping systems and have done little work directly related to intercropping. But this situation is now changing.

Nigeria is the only West African country where intercropping research has gained real importance. Quite a number of researchers at Nigerian universities and national institutes are working on intercropping. Outstanding in this respect is the Institute of Agricultural Research at Samaru, Zaria, where research had already started in the late 1960s and where the socio-economic aspects of intercropping are also investigated.

The attached list (see App. Table A 13) which does not claim to be complete, gives the names of institutions where important work on intercropping has been or is still being done. Where research was mainly conducted by a single person, the name of the researcher and the subject of his work are also indicated.

So far, research on intercropping has produced practical results in only a few cases. This is mainly for two reasons. Firstly, research on intercropping is more difficult than research on sole crops since more factors are involved. This requires the development of a new methodology, beginning with experimental designs. Lack of systematic research is one of the reasons why results obtained at research stations often cannot be transferred to different environments. A large proportion of the experiments have been confined to the simulation of traditional cropping patterns. In the absence of adequate experimental designs, trials were often rather simple and mostly limited to spacing and/or population densities.

The other reason for the slow advance in intercropping research is the structure of agricultural research itself. In most cases, research on intercropping is carried out by researchers who are interested in the subject, but are given only limited support by their respective organisations. There is only little exchange of information between researchers working on related subjects in neighbouring countries and often even within the same country.

In addition, most research workers have limited access to professional journals. As research on intercropping is relatively new, a systematic exchange of ideas and information would be necessary to increase the efficiency of the work. With regard to the importance of intercropping for food production in West Africa, methods need to be developed to improve the flow of information and to facilitate communication between researchers. The proposed farming systems research network could be useful in this respect.

Despite the difficulties described above, considerable knowledge on intercropping has already been accumulated. The existing knowledge would at least allow extension agencies to formulate preliminary recommendations for subsequent implementation. Extension services are, however, sometimes reluctant to adopt new approaches and in many cases they are not showing any interest at all in propagating intercropping.

## 5.2 Recommendations for Agricultural Research and Extension

Analyses for traditional cropping systems and field trials have revealed the advantages of intercropping for tropical smallholder agriculture. The results make it necessary to reassess the relative importance of intercropping in agricultural research and extension. This does not only concern national policy makers but also international development agencies involved in agricultural research and rural development.

The urgently needed increase in food production can hardly be achieved solely by providing means (mainly commercial inputs) to a minority of farmers enabling them to intensify their production. The food problem will be solved only if the millions of smallholders increase their production. The experience of the past has shown that this cannot be achieved by introducing completely new cropping systems. Therefore, a more promising alternative seems to be the stepwise improvement of traditional cropping systems. This approach is, of course, much more difficult than the development of sole crop enterprises.

What is needed is an interdisciplinary approach comprising ecology, agronomy and economics, i.e., a farming systems approach. Only farming systems research in its widest sense will make possible the development of extension packages acceptable to farmers. A start in this direction has been undertaken by the international research institutions in West Africa, i.e. by IITA and ICRISAT. National research institutes will probably follow in the near future. During a recent reorganisation, the Crops Research Institute of Ghana, for example, has created a farming systems department comprising agronomy, soil science, agro-meteorology and economics. This department is in close contact with the extension service, as this is the only way to ensure a continuous feed-back and re-orientation of research programmes.

When discussing the improvement of intercropping systems, it must always be kept in mind that intercropping is only one element of improved smallholder farming systems, even though an essential one.

### 5.2.1 Research Priorities

Research on intercropping, if it is to serve the small farmer has to be organized along lines different from the approach used in the past. Besides investigating basic questions like competition for growth factors, more importance must be attached to adaptive research. Promising cropping systems have to be adapted to the specific agro-ecological zones and economic and socio-cultural conditions. This cannot be done entirely on stations, but requires on-farm experimentation. The farmer should participate actively at the stage of planning of experiments. Only continuous contact with the farmer will ensure that the methods developed are accepted by the majority of farmers in the end. On-farm experimentation passes through different phases with an increasing participation of the farmer, from researcher managed-research executed, through researcher managed-farmer executed, to farmer managed-farmer executed trials. On-farm experimentation must be much simpler than station experiments, i.e. with a reduced number of treatments and replications to enable the farmer to realize differences between treatments. Farmer managed trials should be nearly of field size, as only this will force the farmer to take real decisions as regards the timing and quantity of inputs (mainly labour). Methods of on-farm experimentation have been developed already in West Africa, especially by ICRISAT and SAFGRAD (Semi-Arid Food Grains Research and Development Programme). National research programmes should take advantage of this.

Besides adapting cropping patterns to regional conditions, continued research is necessary on a number of basic issues that have not been completely answered to date, as pointed out in the preceding chapters. In the following, five fields will be outlined where further research is regarded as most necessary.

### (1) Methodology of Intercropping Experimentation

As mentioned in Chapter 5., research on intercropping was hardly carried out systematically in the past; in most cases it was an attempt to arrive at a better understanding of traditional cropping patterns and to compare yields of sole and intercrops. Inadequate experimental designs have resulted in rather inefficient trials with too limited numbers of different cropping patterns (spatial arrangements and plant populations). Lack of methodology in experimentation makes it extremely difficult to draw general conclusions from most data obtained so that a transfer of results to other environments becomes impossible.

For the development of improved cropping systems it is therefore necessary to develop methodologies permitting more efficient experimentation. This includes experimental designs and statistical evaluation as well as a better knowledge of interspecific competition. At the international research centres, especially at ICRISAT, considerable progress has been made in this direction in the last years. However, more basic knowledge on interspecific competition is still needed.

### (2) Fertilizer Use

Fertilizer requirements of intercropping systems have not yet been fully understood. To increase the efficiency of fertilizer use, further research is required. Timing, placement and quantities of the main nutrients (plus perhaps Zn, S and Mg) have to be tested for different crop combinations. As outlined in Paragraph 3.4.2, trials have to be conducted on the same site for some years, to enable residual effects to be taken into account. Fertilizer rates should be low to medium, i.e. orientated to the possibilities of farmers. Criterion for determining rates of application should be the efficiency of fertilizer use and not maximization of yields.

### (3) Breeding and Selection for Intercropping Systems

It has been emphasized in Paragraph 3.3 that for growing crops in associations genotypes need to be identified and selected

within the actual intercrop situation, because genotype performance in intercropping may not be very closely related to genotype performance in sole cropping. That means, crop performance in intercropping could be improved by identifying suitable genotypes. Although this applies mainly to dominated crops as, for example, legumes (groundnut, cowpea) under cereals or cassava, dominant crops, too, need to be selected specifically for intercropping situations, since genotypes are required having a morphology which allows sufficient radiation of intercropped low-growing species.

Methods for selection have already been developed. Selection programme should be started for important intercropping systems such as: maize/groundnut; sorghum/groundnut; millet/groundnut; sorghum/millet; maize/cowpea; sorghum/cowpea.

#### (4) Pest Management

Intercropping can be used as an instrument for integrated pest management (see Paragraph 3.6). There are many cases where pests and especially weeds are suppressed by certain crop combinations. However, to make efficient use of this potential, the influence of specific cropping patterns on population dynamics of important pests as well as on epidemics of diseases and on growth of weeds have to be studied first. Since, for various reasons, the use of pesticides in smallholder agriculture will remain limited in the near future, it will be worth-while giving attention to the development of cropping systems which significantly reduce yield losses due to pests, diseases and weeds.

#### (5) Socio-Economic Analyses of Intercropping Enterprises

Although there is evidence that intercropping is labour saving and increases returns per hectare, more detailed studies in different agro-ecological zones are still needed. Total labour requirements as well as the distribution of labour requirements of sole crop and intercrop enterprises and net returns to labour and land need to be calculated and the contribution to risk minimization assessed.



Besides being needed for the development of more productive cropping systems, the above data should also serve to convince policy makers and extension agencies of the advantages of intercropping. When yields of crops grown traditionally and with improved practices are compared, the additional yields of the associated crops contributing to the gross return per unit area are usually neglected. This simplification can only be avoided through a careful analysis (labour requirements, net returns to land and labour) of traditional and improved intercropping systems.

From the above it is evident that much basic research is still required for which the necessary facilities do not exist at all national research institutes. Work in this direction has already started at some universities of industrialized countries and at international research centres. Progress in applied and adaptive research of national agricultural research institutes depends to quite some extent on the rapid flow of information and on the cooperation between international and national institutes.

It would be rewarding for international cooperation agencies to strengthen the national capacities in intercropping research. Support to national institutes must also include improving the flow of information as mentioned in Paragraph 5.1.2. This could be achieved by providing institutes with relevant literature (books, professional journals, annual reports, etc.) and by supporting personal contacts between researchers of institutions of neighbouring countries. This could be the responsibility of a central service to be established by an international cooperation agency. The establishment of a farming systems research network could, in addition, strengthen the contacts between national and international research institutes and accelerate the transfer of research results.

To create more interest in intercropping research, not only among researchers but also among policy makers at the ministries of agriculture and research, or in extension services ,

intercropping should be included as a subject in the curricula of agricultural faculties and colleges.

In Africa, the senior personnel in the agricultural sector were mostly trained in countries where intercropping is of no importance (Europe, North America). At African training institutes, the subject of intercrops is rather neglected, as curricula are generally adopted from foreign institutes. Therefore, it could be most appropriate for an organisation such as ISNAR (International Service for National and Agricultural Research) to make an effort to improve the situation by assisting countries to include intercropping in the curricula of their agricultural faculties.

### 5.2.2 Extension Programmes for Smallholders

Although intercropping is increasingly gaining importance in agricultural research, extension services and regional development programmes are still reluctant to promote this cropping system. This attitude does not, however, result from a lack of research results and knowledge on intercropping systems. As shown in Chapters 2 to 4, considerable knowledge has been accumulated during the last 15 years, sufficient to start advising farmers on the intensification of their traditional cropping systems. The advantage of intercropping for smallholders, summarized in Paragraph 5.1.1, should convince extension officers that intercropping has its place in smallholder farming and that sole cropping is superior only in specific situations. Due to the reduction of subsidies on fertilizers in most West African countries and increasing prices for pesticides and farm implements, commercial inputs become increasingly unavailable for smallholder food production. In this situation the improved high yielding varieties, developed for sole cropping, are no longer superior to the local varieties, which were selected over centuries under conditions of medium or low soil fertility and which have accumulated a certain resistance to several common pests and diseases. Extension programmes should, therefore, again emphasize the maintenance of soil fertility by

adequate tillage methods and organic recycling, and sustained yields. As shown above, these objectives can best be reached by practising intercropping. A precondition for a reorientation of extension practices is the sensibilisation and training of extension officers and the revision of the objectives of existing extension programmes. In this connection, rural development projects of technical cooperation agencies have a special responsibility, especially when setting up extension services. As these projects are generally more flexible than the established extension services they should pioneer new contents of extension.

A reorientation of extension programmes necessitates a close cooperation, presently non-existent, in most countries between extension services and agricultural research institutes. In many situations some short-term adaptive research, mainly in form of on-farm experimentation, will be necessary to define data for extension packages. Often the extension services themselves could start some demonstration trials, either on their own sites or on fields of farmers or cooperatives. While the demonstration of cropping systems with annual crops can be conducted without difficulties on appropriate farmers' fields, cropping systems including perennials, particularly trees and shrubs, should be established on special demonstration sites (because of the long duration of the trial).

The aim of extension programmes should be the improvement of existing cropping systems and not their replacement by entirely new systems. In this respect the intensification of intercropping systems is only one measure besides the improvement of soil fertility management, the increase of labour productivity, the integration of livestock (mixed farming), etc.. With the existing knowledge intercropping systems can be improved in at least four ways:

- choice of varieties: improved, higher yielding varieties with a morphology and growth pattern fitting into the cropping pattern should be used. For example, in legume/cereal associations cereals with a restricted vegetative growth and inclined leaves are to be preferred. In cassava-based systems, the cassava should be high-branching with short, compact swollen roots. Cowpeas should be erect (to facilitate weeding) and photoperiod-insensitive, etc.

- plant population and spatial arrangement: a full population (as for sole crops) of the component crops should be aimed at. In cereal/legume combinations, for example, this can be achieved by reducing the intra-row spacing and increasing the inter-row spacing of the cereals, thus allowing a nearly full population of legumes to be interplanted without reducing the cereal population.
- timing: in most cases the traditional planting dates of the component crops can still be used, till more precise data are available. In many situations it is advantageous to plant the dominated crops 2-4 weeks before the dominant component, for example beans in a maize/bean association or maize in a cassava/maize association.
- fertilizer applications: as long as no specific recommendations are available, fertilizers should be applied close to the plants at the rates recommended for sole crops. On soils with a high rate of P-fixation, P has to be applied in bands under or near the crop in row-intercropping, or applied besides or below the seed pockets in mixed intercropping. In countries with deposits of rock phosphate, this mineral should be used rather than water-soluble super- or triplephosphate. Nitrogen can also be applied individually to the component crops. In cereal/legume associations both component crops should be given a basic dressing of nitrogen, which serves as starter nitrogen for the legumes. The cereals receive later on an additional top dressing of nitrogen. When applied close to the plants and at reasonable rates, the fertilizer nitrogen does not affect the symbiotic nitrogen fixation of the associated legumes. All these general recommendations will have, of course, to be specified over the years by means of on-farm experimentation.

There is no doubt that the promotion of intercropping systems is much more difficult than promoting sole crops, because these systems are much more complex and, if full use is to be made of their potential, they have to be closely adapted to the specific environmental and socio-economic conditions. As mentioned above, these systems are relatively flexible, so that recommendations cannot be formulated as easily as for sole crops. Extension officers have to assess

on the spot, together with the farmers, how existing cropping systems can be intensified. Extension advice should no longer be confined to rigid standard recommendations as, for example, in a maize improvement programme (timing, spacing, fertilizer application, etc.). For such a task, however, extension officers need to be better qualified, which requires better training. Similar to training at universities mentioned above, much more attention has to be paid to traditional cropping systems and intercropping in the training courses for extension officers. This could lead to a better understanding of traditional practices and reduce the bias against these methods which are still used by the majority of farmers. As a consequence, the cooperation between extension services and farmers would undoubtedly be improved.

Rural development programmes are normally not only engaged in extension but also in other activities relevant to intercropping such as breeding programmes, draught animal projects and production of farm implements. All these diverse activities need to be reconsidered in view of their ability to contribute to the intensification of the present intercropping systems. This requires that the project personnel is more sensible to a better understanding of intercropping, and of farming systems in general.

In particular, the project personnel needs more guidance for carrying out farm surveys, which is a precondition for the understanding of local farming systems, and on-farm experimentation. At present, there is a lack of simple but appropriate methods to assess resource availability and resource use in traditional cropping systems such as intercropping. Therefore, too much valuable time is lost by gathering information on local farming systems and by establishing field demonstrations. A well prepared and organised approach could be much more efficient. To facilitate such an approach it would seem to be helpful to prepare a manual for use by personnel involved in planning and implementing agricultural activities in the smallholder sector. The main purpose of the manual would be to help promote awareness of the specific features and problems of traditional farming systems and to develop practical guidelines for improving such systems. In particular, it should provide simple

methods and procedures to collect data on intercropping (measuring of yields in intercropped fields, information on farmers' motivations for intercropping, etc.) and to undertake on-farm experimentation (selection of farms and farmers, lay-out and evaluation of trials, etc.).

## 6. BIBLIOGRAPHY

- ABALU, G.O.I 1977: A note on crop mixtures in northern Nigeria. Samaru Research Bulletin 296: 212-220.
- ABALU, G.O.I. and D'SILVA, B. 1980: Socioeconomic analysis of existing farming systems and practices in northern Nigeria. In: Proceedings, International Workshop on Socioeconomic Constraints to Development of Semi-Arid Tropical Agriculture. 19.-23. Febr. 1979. Hyderabad, India. ICRISAT. Hyderabad: 3-10.
- AGBOOLA, A.A. and FAYEMI, A.A.A. 1972: Fixation and excretion of nitrogen by tropical legumes. Agronomy Journal 64(4): 409-412.
- AGRICULTURAL CENSUS 1972: Ghana Sample Census of Agriculture, 1970. Accra, Ghana.
- AGRICULTURAL CENSUS 1981: Recensement National de l'Agriculture de 1973-74. Ministère de l'Agriculture Côte d'Ivoire. Abidjan, Ivory Coast.
- AHMED, S. and GUNASENA, H.P.M. 1979: N-utilisation and economics of some intercropped systems in tropical countries. Trop. Agric.(Trin.) 56(2): 115-123.
- AIYER, A.K.Y.N. 1949: Mixed cropping in India. Indian J. Agric. Sci. 19: 439-543.
- ALEXANDER, M. 1961: cited from KANG, B.T.; NANGJU, D.; AYANABA, A. 1977.
- ALLARD, R.W. 1961: Relationship between genetic diversity and consistency of performance in different environments. Crop Science 1: 127-133.
- ALTIERI, M.A. 1980: Diversification of corn agroecosystems as a means of regulating Fall Armyworm populations. The Florida Entomologist 63: 450-456.
- ALTIERI, M.A., FRANCIS, C.A., VAN SCHOONHOVEN, A. and DOLL, J.D. 1978: A review of insect prevalence in maize (Zea mays L.) and bean (Phaseolus vulgaris L.) polycultural systems. Field Crop Research 1: 33-49.
- ALTIERI, M.A., VAN SCHOONHOVEN, A. and DOLL, J.D. 1977: The ecological role of weeds in insect pest management systems: A review illustrated by bean (Phaseolus vulgaris) cropping systems. PANS 23: 195-205.
- ALTIERI, M.A. and WHITCOMB, W.H. 1979: The potential use of weeds in the manipulation of beneficial insects. Hort. Science 14: 12-18.

- AMOSU, J.O. 1977: Effect of cropping systems on the population densities of plant parasitic nematodes. In: Proceedings, Workshop on Cropping Systems in Africa. 1.-6. Dec. 1975. Morogoro, Tanzania. AAASA. Addis Abeba: 55-61.
- ANDREWS, D.J. 1972: Intercropping with sorghum in Nigeria. Expl. Agric. 8: 139-150.
- ANDREWS, D.J. and KASSAM, A.H. 1976: The importance of multiple cropping in increasing world food supplies. In: PAPENDICK, R.I., SANCHEZ, P.A. and TRIPLETT, G.B. (Eds.) 1976: Multiple cropping. ASA Special Publication 27. Madison: 1-10.
- ARENE, O.B. 1976: Influence of shade and intercropping on the incidence of Cassava Bacterial Blight. In: PERSLEY, G., TERRY, E.R. and McINTIRE, R. (Eds.) 1977: Workshop on Cassava Bacterial Blight. Ibadan, Nigeria. IDRC. Ottawa, Canada.
- ATAYI, E.A. and KNIPSCHER, H.C. 1980: Survey of food crop farming systems in the "ZAPI-Est", East Cameroon. IITA/ONAREST. Ibadan, Nigeria.
- AY, P. 1980: Agrarpolitik in Nigeria. Produktionssysteme der Bauern und die Hilflosigkeit von Entwicklungsexperten. Arbeiten aus dem Institut für Afrikakunde 24. Hamburg.
- BAKER, E.F.I. 1974: Research on mixed cropping with cereals in Nigerian farming systems - a system for improvement. In: International Workshop on Farming Systems. 18.-21. Nov. 1974. ICRISAT. Hyderabad, India: 287-301.
- BAKER, E.F.I. 1978: Mixed cropping in northern Nigeria. I. Cereals and groundnuts. Expl. Agric. 14: 293-298.
- BAKER, E.F.I. 1979: Mixed cropping in northern Nigeria. III. Mixtures of cereals. Expl. Agric. 15: 41-48.
- BAKER, E.F.I. 1980: Mixed cropping in northern Nigeria. IV. Extended trials with cereals and groundnuts. Expl. Agric. 16: 361-369.
- BAKER, E.F.I. and NORMAN, D.W. 1975: Cropping patterns in northern Nigeria. Invited paper for South and East Asia Cropping Systems Network Workshop to be held at IRRI. 18.-20. March 1975. Los Banos, Philippines. Samaru, Zaria, Nigeria.
- BALDWIN, J.P., TINKER, P.B. and NYE, P.H. 1972: Uptake of solutes by multiple root systems from soil. II. The theoretical effects of rooting density and pattern on uptake of nutrients from soil. Plant and Soil 36: 693-708.



- BALDY, C.H. 1963: Cultures associées et productivité de l'eau. Ann. agron. 14: 489-534.
- BANTILAN, R.T. and HARWOOD, R.R. 1977: cited from MOODY, K. 1977.
- BEETS, W.C. 1977: Multiple cropping of maize and soya beans under a high level of crop management. Neth. J. agric. Sci. 25: 95-102.
- BEETS, W.C. 1978: Multiple cropping systems reviewed. SPAN 21(3): 114-116.
- BERGH, J.P. VAN DEN 1968: An analysis of yields of grasses in mixed and pure stands. Versl. Landbouwk. Onderz. 714: 1-71.
- BIGOT, Y. 1977: Fertilisation, labour et espèce cultivée en situation de pluviosité incertaine du Centre de Côte d'Ivoire. Agron. Trop. 32(3): 242-247.
- BIGOT, Y. 1980: GERDAT/IDESSA, Bouaké, Ivory Coast.
- BOSCH, R. VAN DEN and TELFORD, A.D. 1964: Environmental modification and biological control. In: DE BACH, P.: Biological control of insect pests and weeds. Chapman and Hall. London.
- BREESE, E.L. and HILL, J. 1973: Regression analysis for interactions between competing species. Heredity 31: 181-200.
- BRUCE, K. 1980: Maize in the semi-arid zone of Ghana. Results of an exploratory survey in the Tamale area. Grains and Legume Development Board. Ghana Grains Development Project. Occasional Paper 3. Kumasi, Ghana.
- BUESTAN, H. 1973: cited from FRANCIS, C.A., FLOR, C.A., and TEMPLE, S.R. 1976.
- BURDON, J.J. 1978: Mechanisms of disease control in heterogeneous plant populations - an ecologist's view. In: SCOTT, P.R. and BRAINBRIDGE, A.: Plant disease epidemiology. Blackwell Scientific Publications. Oxford: 193-200.
- BURDON, J.J. and CHILVERS, G.A. 1975: Epidemiology of damping-off disease (Pythium irregulare) in relation to density of Lepidum sativum seedlings. Ann. appl. Biol. 81: 135-143.
- BURDON, J.J. and CHILVERS, G.A. 1976: Epidemiology of Pythium induced damping-off in mixed species seedling stands. Ann. appl. Biol. 82: 233-240.
- CASTRO, A. in press: cited from LEIHNER, D.E. 1982.
- CAVENESS, F.E. 1967: cited from AMOSU, J.O. 1977.

- CHAND, P. and SHARMA, N.N. 1977: Influence of crop associations on insect pest incidence. Proc. Indian nat. Sci. Acad. 43 (Part B): 108-114.
- CHANG, H., CHANG, C.H. and HO, F.W. 1969: cited from SAN-CHEZ, P.A. 1976.
- CHANG, Jen-Hu 1981: Corn yield in relation to photoperiod, night temperature, and solar radiation. Agricultural Meteorology 24: 253-262.
- CHAMPAUD, J. 1973: Mom. Terroir Bassa (Cameroun). Atlas des Structures Agraires au Sud du Sahara 9. ORSTOM. Paris.
- CHARREAU, C. 1970: Problèmes posés par la fixation et l'intensification de l'agriculture en zone tropicale sèche. Paper presented at Séminaire sur les Systèmes Traditionnels de l'Agriculture Africaine et leur Amélioration. 16.-20. Nov. 1970. IITA. Ibadan, Nigeria.
- CHARREAU, C. and VIDAL, P. 1965: Influence de l'Acacia al-bida Del. sur le sol, nutrition minérale et rendements des mils Pennisetum au Sénégal. Agron. Trop. 20: 600-626.
- CIAT 1978: cited from LEIHNER, D.E. 1979.
- COCHRAN, W.G. and COX, G.M. 1957: Experimental designs. Wiley and Sons. Chichester.
- COX, D.R. 1958: Planning of experiments. Wiley and Sons. Chichester.
- DALAL, R.C. 1974: Effects of intercropping maize with pigeon peas on grain yield and nutrient uptake. Expl. Agric. 10: 219-224.
- DALAL, R.C. 1977: Effect of intercropping of maize with soya bean on grain yield. Trop. Agric. (Trin.) 54(2): 189-191.
- DALRYMPLE, D.G. 1971: Survey of multiple cropping in less developed nations. Economic Research Service. US Department of Agriculture. Washington D.C.
- DE, R. 1980: Role of legumes in intercropping systems. In: Nuclear techniques in the development of management practices for multiple cropping systems. Proceedings: Advisory Group Meeting on Nuclear Techniques in Development of Fertilizer and Water Management Practices for Multiple Cropping Systems. 8.-12. Oct. 1979. Ankara, Turkey. IAEA. Wien: 73-84.
- DE WIT, C.T. 1960: On competition. Versl. Landbouwk. Onderz. 66(8): 1-82.
- DE WIT, C.T. and BERGH, J.P. VAN DEN 1965: Competition between herbage plants. Neth. J. agric. Sci. 13: 212-221.

- DICKINSON, J.C. 1972: Alternatives to monoculture in the humid tropics of Latin America. The Professional Geographer 24(3): 217-222.
- DIEHL, L. 1981: Smallholder farming systems with yam in the Southern Guinea Savanna of Nigeria. Diss. Univ. Hohenheim.
- DONALD, C.M. 1963: Competition among crop and pasture plants. Adv. Agron. 15(1): 1-118.
- DONGMO, J.L. 1980: Les efforts des Bamiléké de l'Ouest-Caméroun pour adapter leur agriculture à l'accumulation démographique et pour sauver leur équilibre alimentaire contre les "agressions" de l'économie marchande. In: Maîtrise de l'espace agraire et développement en Afrique Tropicale. Actes du Colloque de Ouagadougou. 4.-8. Déc. 1978. ORSTOM. Paris: 149-154.
- EMDEN, H.F. VAN 1965: The role of uncultivated land in the biology of crop pests and beneficial insects. Scientific Horticulture 17: 121-136.
- EMDEN, H.F. VAN 1970: Insects, weeds and plant health. Proceedings: 10th Br. Weed Control Conf. Brighton: 942-952.
- EMDEN, H.F. VAN 1977: Insect-pest management in multiple cropping systems - a strategy. Proceedings, Symposium on Cropping Systems Research and Development for the Asian Rice Farmer. IRRI. Los Banos, Philippines: 325-343.
- EMDEN, H.F. VAN and WEARING, C.H. 1965: The role of host plants in delaying economic damage levels in crops. Ann. Appl. Biology 56: 323-324.
- EMDEN, H.F. VAN and WILLIAMS, G.F. 1974: Insect stability and diversity in agroecosystems. Ann. Rev. Entomol. 19: 455-475.
- FAO 1978: Report on the agro-ecological zones project. Vol. 1. Methodology and results for Africa. World Soil Resources Report 48. FAO. Rome.
- FAO 1979: Fertilizer Demonstration and Distribution Programme. Plateau State, Nigeria. Interim Report 1.2.78 - 31.3.79. By KRIGGSMA, D.W. and DAMLA, J.D.
- FARREL, J.A.K. 1976: Studies in mixed cropping. I. Seasonal differences in relation productivity of crop mixtures and pure stands in the Kenya highlands. Expl. Agric. 13: 177-184.
- FISHER, N.M. 1977b: Studies in mixed cropping. II. Population pressures in maize-bean mixtures. Expl. Agric. 13: 185-191.

- FLINN, J.C., JELLEMA, B.M. and ROBINSON, K.L. 1975: Problems of increasing food production in the lowland humid tropics of Nigeria. *Zeitschr. Ausl. Landwirtschaft* 14: 37-48.
- EBERHARDT, S.A. and RUSSEL, W.A. 1966: Stability parameters for comparing varieties. *Crop Science* 6: 36-40.
- ENE, I.S.O. 1977: Control of Cassava Bacterial Blight (CBB). *Tropical Root and Tuber Crops Newsletter* 10: 30-31.
- ENGLAND, F. 1974: Genotype x environment interactions in mixtures of herbage grasses. *J. agric. Sci. (Camb.)* 82: 371-376.
- EVANS, A.C. 1960: Studies of intercropping: I. Maize or sorghum with groundnuts. *E. Afr. Agric. For. J.* 26: 1-10.
- FONSECA, D. 1981: cited from LEIHNER, D.E. 1982.
- FRANCIS, C.A. 1979: Development of plant genotypes for multiple cropping systems. In: *Plant Breeding Symposium II*. Iowa State University. 14. Mar. 1979. Ames, Iowa.
- FRANCIS, C.A., FLOR, C.A. and TEMPLE, S.R. 1976: Adapting varieties for intercropping systems in the tropics. In: PAPPENDICK, R.A., SANCHEZ, P.A. and TRIPLETT, G.B. (Eds.): *Multiple Cropping*. ASA Special Publication 27. Madison: 235-253.
- FRANCIS, C.A., FLOR, C.A., PRAGER, M. and SANDERS, J.H. 1978: Density response of climbing beans in two cropping systems. *Field Crops Research* 1: 225-267.
- FRANCIS, C.A. and SANDERS, J.H. 1978: Economic analysis of bean and maize systems: monoculture versus associated cropping. *Field Crops Research* 1: 319-335.
- FREYMAN, S. and VENKATESWARLU, J. 1977: cited from WILLEY, R.W. 1979.
- GIGOU 1973: cited from JACOB, B. 1977.
- GODDARD, A.D., FINE, J.C. and NORMAN, D.W. 1971: A socio-economic study of three villages in the Sokoto close-settled zone. 1. Land and people. *Samaru Miscellaneous Paper 33*. Inst. of Agric. Res. Samaru, Zaria, Nigeria.
- GOOD, J.M. 1972: cited from AMOSU, J.O. 1977.
- GUILLEMIN, R. 1956: Evolution de l'agriculture autochtone dans les Savannes de l'Oubangui. *Agron. trop.* 12(1,2,3).
- GUYER, J.I. 1977: The women's farming system. The Lekié, southern Cameroon. ENSA. Nkolbisson, Cameroon.

- HAGEN, L.J. and SKIDMORE, E.I. 1974: Reducing turbulent transfer to increase water-use efficiency. *Agricultural Meteorology* 14: 153-168.
- HALL, R.L. 1974a: Analysis of the nature of interference between plants of different species. I. Concepts and extension of the de Wit analysis to examine effects. *Aust. J. Agric. Res.* 25: 739-747.
- HALL, R.L. 1974b: Analysis of the nature of interference between plants of different species. II. Nutrient relations in a Nandi Setaria and Green-leaf Desmodium association with particular reference to potassium. *Aust. J. Agric. Res.* 25: 749-756.
- HAMBLIN, J., ROWELL, J.G. and REDDEN, R. 1976: Selection for mixed cropping. *Euphytica* 25: 97-106.
- HARRISON CHURCH, R.J. 1980: West Africa. 8th Edition. Longman, London.
- HART, R.D. 1975: A bean, corn and manioc polyculture cropping system. II. A comparison between the yield and economic return from monoculture and polyculture cropping systems. *Turrialba* 25(4): 377-384.
- HARWOOD, R.R. 1979: Small farm development. Westview Press. Boulder, Colorado.
- HEGEWALD, B. 1978: Eine Beitrag zum Mischkulturanbau (Körnermais, Futterrüben und Wirsingkohl mit Leguminosenuntersaat). Diss. Tech. Univ. Berlin.
- HENZELL, E.F. and VALLIS, I. 1977: Transfer of nitrogen between legumes and other crops. In: AYANABA, A. and DART, P. (Eds.): Biological nitrogen fixation in farming systems of the tropics. Wiley and Sons. Chichester: 73-88.
- HOLDRIDGE, L.R. 1959: Ecological indications of the need for a new approach to tropical land use. *Economic Botany* 13(4): 271-280.
- HOWELER, R.H. 1981: Nutrición mineral y fertilización de la yuca (Manihot esculenta Crantz). CIAT, Cali, Colombia.
- HOYOUX, Ir.J.M. 1979: Sole and mixed cropping patterns in a maize production area: Oyo State of Nigeria. Discussion Paper 5/79. Agricultural Economics. IITA. Ibadan, Nigeria.
- HUNTER, J.M. 1967: Population pressure in a part of the West African Savanna. A study of Nangodi, Northeast Ghana. In: PROTHERO, R.M. 1972: People and land in Africa south of the Sahara. Oxford University Press: London: 152-162.

- HUXLEY, P.A. and MAINGU, Z. 1978: Use of a systematic spacing design as an aid to the study of intercropping: some general considerations. *Expl. Agric.* 14: 49-56.
- ICRISAT 1977: Report on the Cropping Systems Research carried out during the Kharif(monsoon) and Rabi (postmonsoon) season of 1976. Hyderabad, India.
- IGBOZURIKE, M.U. 1971: Ecological balance in tropical agriculture. *Geographical Review* 61(4): 519-529.
- IGBOZURIKE, M.U. 1978: Polyculture and monoculture: Contrast and analysis. *Geo-Journal* 2(5): 443-449.
- IITA 1980: Annual Report for 1979. Farming systems program. Ibadan, Nigeria.
- IRAT 1977: Rapport annuel. Paris
- IRRI 1974: Annual Report for 1973. Los Baños, Philippines.
- IRRI 1975: Cropping systems. Los Baños, Philippines.
- JAKOB, B. 1977: Expérience de culture continue, intensive, motorisée en bandes alternées sur un bassin versant du Centre de la Côte d'Ivoire. IRAT. Bouaké, Ivory Coast.
- JODHA, N.S. 1977: Resource base as a determinate of cropping patterns. In: Proceedings, Symposium on Cropping Systems Research and Development for the Asian Rice Farmer. 21.-24. Sept. 1976. IRRI. Los Baños, Philippines: 101-126.
- JUO, A.S.R. and LAL, R. 1977: cited from OKIGBO, B.N. and LAL, R. 1979.
- KANG, B.T., NANGJU, D. and AYANABA, A. 1977: Effects of fertilizer use on cowpea and soybean nodulation and nitrogen fixation in the lowland tropics. In: AYANABA, A. and DART, P.J. (Eds.): Biological nitrogen fixation in farming systems in the tropics. Wiley and Sons. Chichester: 205-216.
- KANG, B.T., WILSON, G.F. and SIPKENS, L. 1981: Alley cropping maize (Zea mays L.) and leucaena (Leucaena leucocephala Lam.) in southern Nigeria. *Plant and Soil* 63: 165-179.
- KARIKARI, S.K. 1972: Plantain growing in Ghana. *World Crops* 24: 22-24.
- KASSAM, A.H. 1979: Multiple cropping and rainfed crop productivity in Africa. Consultants Working Paper 5. FAO/UNFPA Project on Land Resources for Populations of the Future. AGLS. Rome.
- KAYUMBO, H.Y. 1976: Crop protection in mixed-crop ecosystems. Paper presented at a Symposium on Intercropping in Semi-Arid Areas. 10.-12. May 1976. Morogoro, Tanzania.

- KHADER, K.B.A. and ANTHONY, K.J. 1968: cited from PERRIN, R.M. 1977.
- KRANTZ, B.A., VIRMANI, S.M., SINGH, S. and RAO, M.R. 1976: Intercropping for increased and more stable agricultural production in the semi-arid tropics. Paper presented at a Symposium on Intercropping in Semi-Arid Areas. 10.-12. May 1976. Morogoro, Tanzania.
- LAGEMANN, J. 1977: Traditional farming systems in eastern Nigeria. Weltforum-Verlag München.
- LAL, R. 1974: cited from OKIGBO, B.N. and LAL, R. 1979.
- LEIHNER, D.E. 1979: Agronomic implications of cassava legume intercropping systems. In: WEBER, E., NESTEL, B. and CAMPBELL, M. (Eds.): Intercropping with cassava. Proceedings, International Workshop. 27. Nov.-1. Dec. 1978. Trivandrum, India. IDRC. Ottawa: 103-112.
- LEIHNER, D.E. 1982: Cassava intercropping. Management and evaluation of cassava intercropping systems. Habilitationsschrift Göttingen.
- LEONARD, K.J. 1969: Factors affecting rates of stem rust increase in mixed plantings of susceptible and resistant oat varieties. *Phytopathology* 59: 1845-1850.
- LIBOON, S.P. and HARWOOD, R.R. 1975: Nitrogen response in corn soybean intercropping. Paper presented at 6th Annual Scientific Meeting of the Crop Science Society of the Philippines. 8.-10. May 1975. Bacolod City, Philippines.
- LOFT, M.V. 1980: The economics of mixed cropping. A case study from Kigoma region, Tanzania. 2. Symposium on Intercropping for Semi-Arid Areas. 4.-7. Aug. 1980. Morogoro, Tanzania.
- MARCHAL, J.Y. 1977: The evolution of agrarian systems: The example of Yatenga (Upper Volta). *African Environment* 2/3(4/1): 73-85.
- MARSHALL, J.K. 1967: cited from RADKE, J.K. and HAGSTROM, R.T. 1976.
- MATLON, P.J. and BONKIAN, A. 1980: Profile d'unité de production dans deux villages du centre de la Haute-Volta. Etudes villageoises. Rapport 1. ICRISAT. Ouagadougou. Upper Volta.
- MCGILCHRIST, C.A. 1965: Analysis of competition experiments. *Biometrics* 21: 975-985.
- MCINTIRE, J. 1981: Reconnaissance surveys in north and west Upper Volta. Village Studies Report No. 3. ICRISAT, Ouagadougou, Upper Volta.

- MEAD, R. and STERN, R.D. 1980: Designing experiments for intercropping research. *Expl. Agric.* 16: 329-342.
- MEAD, R. and WILLEY, R.W. 1980: The concept of a "Land Equivalent Ratio" and advantages in yields from intercropping. *Expl. Agric.* 16: 217-228.
- MERCER-QUARSHIE, H. 1979: Yield of local sorghum (*Sorghum vulgare*) cultivars and their mixture in northern Ghana. *Trop. Agric. (Trin.)* 56: 125-133.
- MOODY, K. 1975: Weeds and shifting cultivation. *PANS* 21: 188-194.
- MOODY, K. 1977: Weed control in multiple cropping. In: Proceedings, Symposium on Cropping System Research and Development for the Asian Rice Farmer. IRRI. Los Baños, Philippines: 281-308.
- MORENO, R.A. 1979: Crop protection implications of cassava intercropping. In: WEBER, E., NESTEL, B. and CAMPBELL, M. (Eds.): Intercropping with cassava. Proceedings, International Workshop. 27. Nov.-1. Dec. 1978. Trivandrum, India. IDRC. Ottawa: 113-127.
- MORENO, R.A. and HART, R.D. 1979: Intercropping with cassava in Central America. In: WEBER, E., NESTEL, B. and CAMPBELL, M. (Eds.): Intercropping with cassava. Proceedings, International Workshop. 27. Nov.-1. Dec. 1978. Trivandrum, India. IDRC. Ottawa: 17-24.
- MOUTAPPA, F. 1974: Soil aspects in the practice of shifting cultivation in Africa and the need for a common approach to soil and land resources evaluation. *FAO Soils Bulletin* 24/1974. Shifting cultivation and soil conservation in Africa. Rome.
- MUTSAERS, H.J.W. 1978: Mixed cropping experiments with maize and groundnuts. *Neth. J. agric. Sci.* 26: 344-353.
- MUTSAERS, H.J.W., MBOUEMBOUE, P. and MOUZONG BOYOMBO 1978: Shifting cultivation in transition. ENSA. Dépt. de l'Agriculture, Communication 6. Nkolbisson. Cameroon.
- NAIR, P.K.R. 1979: Intensive multiple cropping with coconuts in India. *Fortschritte im Acker- und Pflanzenbau* 6. P. Parey. Berlin/Hamburg.
- NATARAJAN, M. and WILLEY, R.W. 1980a: Sorghum-pigeonpea intercropping and the effects of plant population density. 1. Growth and yield. *J. agric. Sci. (Camb.)* 95: 51-58.



- NATARAJAN, M. and WILLEY, R.W. 1980b: Sorghum-pigeonpea intercropping and the effects of plant population density. 2. Resource use. J. agric. Sci. (Camb.) 95: 59-65.
- NNADI, L.A. 1978: Nitrogen economy in selected farming systems of the Savanna region. Paper presented at SCOPE/UNEP Workshop on Nitrogen Recycling in West African Ecosystems. 11.-15. Dec. 1978. IITA. Ibadan, Nigeria.
- NORMAN, D.W. 1970: Cultures mixtes. Séminaire sur les systèmes d'exploitations traditionnels et leur intensification. Fondation Ford. IITA/IRAT. 16.-20. Nov. 1970. Ibadan, Nigeria.
- NORMAN, D.W. 1973: Economic analysis of agricultural production and labour utilization among the Hausa in the north of Nigeria. African Rural Employment Paper 4. Dept. of Agric. Economics. Michigan State University. East Lansing, Michigan.
- NORMAN, D.W. 1974: Crop mixtures under indigenous conditions in the northern part of Nigeria. Samaru Research Bulletin 205. Inst. of Agric. Res. Samaru, Zaria, Nigeria.
- NORMAN, D.W. 1977: The rationalization of intercropping. African Environment 2/3(4/1): 97-109.
- NORMAN, D.W. 1978: Farming systems and problems of improving them. In: KOWAL, J.M. and KASSAM, A.H.: Agricultural ecology of savannah. Clarendon Press. Oxford: 318-347.
- NORMAN, D.W., FINE, J.C., GODDARD, A.D., KROEKER, W.J. and PRYOR, D.H. 1976: A socio-economic survey of three villages in the Sokoto close-settled zone. 3. Input-output-study. Samaru Miscellaneous Paper 64. Inst. of Agric. Res. Samaru, Zaria, Nigeria.
- NORTH CAROLINA STATE UNIVERSITY 1976: Tropical Soils Research Program. Annual Report for 1975. Raleigh, North Carolina: 181-187.
- NORTH CAROLINA STATE UNIVERSITY 1978: Research Program on Soils of the Tropics. Annual Report for 1976-77. Raleigh, North Carolina: 137-152.
- NORTON, G.H. 1975: Multiple cropping and pest control. An economic perspective. Meded. Fac. Landbouww. Rijks.Univ. Gent 40: 219-228.
- NWEKE, F.I. and WINCH, F.E. 1980: Bases for farm resource allocation in the smallholder cropping systems of south eastern Nigeria: A case study of Awka and Abakaliki villages. Discussion Paper 4/80. Agricultural Economics. IITA. Ibadan, Nigeria.

- O'CONNOR 1950: cited from VAN DEN BOSCH, R. and TELFORD, A.D. 1964.
- OELSLIGLE, D.D., McCOLLUM, R.E. and KANG, B.T. 1976: Soil fertility management in tropical multiple cropping. In: PAPENDICK, R.I., SANCHEZ, P.A. and TRIPLETT, G.B. (Eds.): Multiple cropping. ASA Special Publication 27. Madison: 275-292.
- OHNESORGE, B.: personal communication
- OKIGBO, B.N. 1978: Cropping systems and related research in Africa. AAASA Occasional Publications. Series OT-1.
- OKIGBO, B.N. and GREENLAND, D.J. 1976: Intercropping systems in tropical Africa. In: PAPENDICK, R.I., SANCHEZ, P.A. and TRIPLETT, G.B. (Eds.): Multiple cropping. ASA Special Publication 27. Madison: 63-101.
- OKIGBO, B.N. and LAL, R. 1978: Residue mulches and agri-silviculture in tropical African agriculture. Paper presented at International Conference on "Basic Techniques in Ecological Agriculture" 2.-5. Okt. 1978. Montreal, Canada.
- OKIGBO, B.N. and LAL, R. 1979: Soil fertility maintenance and conservation for improved agroforestry systems in the lowland humid tropics. In: MONGI, H.O. and HUXLEY, P.A. (Eds.): Soil research in agroforestry. Proceedings, Expert Consultation. 26.-30. March 1979. ICRAF. Nairobi, Kenya: 41-47.
- OLUKOSI, J.O. 1976: Decisions of farmers under risk and uncertainty. The case of Ipetu and Odo-Ore farmers in Kwara State. Samaru Agricultural Newsletters 10: 108-122.
- OSIRU, D.S.O. and WILLEY, R.W. 1972: Studies on mixtures of dwarf sorghum and beans (Phaseolus vulgaris) with particular reference to plant population. J. agric. Sci. (Camb.) 79: 531-539.
- PAPADAKIS, J. 1965: Crop ecological survey in West Africa. Vol. II. Atlas. FAO. Rome.
- PAPENDICK, R.I., SANCHEZ, P.A. and TRIPLETT, G.B. (Eds.) 1976: ASA Special Publication 27. Madison.
- PENDLETON, J.W., BOLEN, C.D. and SEIF, R.D. 1963: Alternating stripes of corn and soyabean vs. solid plantings. Agronomy Journal 55: 293-295.
- PERRIN, R.M. 1977: Pest management in multiple cropping systems. Agro-Ecosystems 3: 385-393.
- PERRIN, R.M. and PHILLIPS, M.L. 1978: Some effects of mixed cropping on the population dynamics of insect pests. Ent. exp. & appl. 24: 385-393.

- PFAUE-VOGT, J. 1980: Einfluß der Heterogenität von Pflanzenbeständen auf die Ausbreitung tierischer Schädlinge. Diss. Univ. Göttingen.
- PIMENTEL, D. 1961: The influence of plant special patterns on insect populations. *Annals of the Entomological Society of America* 54: 61-69.
- PRAQUIN, J.Y. 1980: Comparatif varietal maïs en cultures associées. IRA. Dschang, Cameroon. mimeo.
- PROTHERO, R.M. 1971: Land use at Zoba, Zaria Province, Northern Nigeria. *Economic Geography* 33: 72-85.
- RADKE, J.K. and HAGSTROM, R.T. 1976: Strip intercropping for wind protection. In: PAPENDICK, R.I., SANCHEZ, P.A. and TRIPLETT, G.B. (EDS.): Multiple cropping. ASA Special Publication 27. Madison: 201-223.
- RADKE, J.K. and BURROWS, W.C. 1970: Soybean plant response to temporary field windbreaks. *Agronomy Journal* 62: 424-429.
- RAO, M.R. and WILLEY, R.W. 1980a: Preliminary studies of intercropping combinations based on pigeonpea and sorghum. *Expl. Agric.* 16: 29-39.
- RAO, M.R. and WILLEY, R.W. 1980b: Evaluation of yield stability in intercropping: studies on sorghum/pigeonpea. *Expl. Agric.* 16: 105-116.
- RAROS, R.S. 1973: Prospects and problems of integrated pest control in multiple cropping. IRRI. Saturday Seminar. 4. Aug. 1973. Los Baños, Philippines.
- REDDY, M.S. and WILLEY, R.W. 1981: Growth and resource use studies in an intercrop of pearl millet/groundnut. *Field Crops Research* 4: 13-24.
- REED, W. 1965: Heliothis armigera (Hb.) (Noctuidae) in Western Tanganyika. II. Ecology and natural and chemical control. *Bull. ent. Res.* 56: 127-140.
- RISCH, S.J. 1979: A comparison by sweep sampling of the insect fauna from corn and sweet potato monocultures and dicultures in Costa Rica. *Oecologica* 42: 195-211.
- RÖSINGH, C. 1980: Untersuchungen über die Resistenz der Kuherbse, Vigna unguiculata (L.) Walp., gegen Megalurothrips sjostedti (Trybom) (Thysanoptera, Thripidae). Hochschulverlag Freiburg.
- ROOT, R.B. 1973: cited from PERRIN, R.M. and PHILLIPS, M.L., 1978.
- RUTHENBERG, H. 1976: Farm systems and farming systems. *Z. Ausländische Landwirtschaft* 15: 42-55.

- RUTHENBERG, H. 1980: Farming systems in the tropics. Third edition. Clarendon Press. Oxford.
- SANCHEZ, P.A. 1976: Properties and management of soils in the tropics. Wiley and Sons. Chichester.
- SAYED GALAL, Jr., HINDI, L.H., IBRAHIM, A.F. and EL-HINNAWY, H.H. 1974: Intercropping tolerance of soybean to different local corn stocks (*Zea mays* L.). *Z. Acker- und Pflanzenbau* 139: 133-145.
- SCHILLING, R. 1965: L'arachide en cultures associées avec les céréales. *Oléagineux* 20(11): 673-676.
- SCHULTZ, T.W. 1964: Transforming traditional agriculture. Yale University Press. New Haven.
- SEARLE, P.G.E., COMUDOM, Y., SHEDDEN, D.C. and NANCE, R.A. 1981: Effect of maize + legume intercropping systems and fertilizer nitrogen on crop yields and residual nitrogen. *Field Crops Research* 4: 133-145.
- SHELKE, V.B. 1979: cited from WILLEY, R.W. 1979.
- SOUTHWOOD, T.R.E. and WAY, M.J. 1970: Ecological background to pest management. In: RABB, L.R. and GUTHRIE, F.E. (Eds Concepts of Pest Management: Proceedings of a Conference held at North Carolina State University. 25.-27. March 1970. Raleigh, North Carolina.
- STEINER, K.G. 1981: A root rot of macabo (*Xanthosoma* sp.) in Cameroun, associated with *Pythium myriotylum*. *Z. Pfl.Krankh. Pfl. Schutz* 88(10): 608-613.
- STEINER, K.G. and TSCHIRSCH, J.E.: unpublished data.
- SURYATNA, E.S. and HARWOOD, R.R. 1976: Nutrient uptake of two traditional intercrop combinations and insect and disease incidence in three intercrop combinations. IRRI. Saturday Seminar. 28. Febr. 1976. Los Baños, Philippines.
- SWANSON, R.A. 1979: Gourmantche agriculture. Part II. Cultivated plant resources and field management. Integrated Rural Development Project. Eastern ORD, Upper Volta. Document 8. Fada N'Gourma, Upper Volta.
- TAHVANAINEN, J.O. and ROOT, R.B. 1972: The influence of vegetational diversity on the population ecology of a specialized herbivore, *Phyllotreta cruciferae* (Coleoptera, Chrysomelidae). *Oecologia* (Berl.) 10: 321-346.
- TAYLOR, T.A. 1977: Mixed cropping as an input in the management of crop pests in tropical Africa. *African Environment* 2/3(4/1): 111-126.
- THUNG, M. 1968: cited from LEIHNER, D.E. 1982.

- THUNG, M. and COCK, J.H. 1979: Multiple cropping cassava and field beans: status of present work at CIAT. In: WEBER, E., NESTEL, B. and CAMPBELL, M. (Eds.): Intercropping with cassava. Proceedings, International Workshop. 27.Nov.-1. Dec. 1978. Trivandrum, India. IRDC, Ottawa: 7-16.
- TRENBATH, B.R. 1974: Biomass productivity of mixtures. Adv. Agron. 26: 177-210.
- TRENBATH, B.R. 1975: Diversify or be damned? Ecologist 5: 76-83.
- TRENBATH, B.R. 1976: Plant interactions in mixed crop communities. In: PAPENDICK, R., SANCHEZ, P.A. and TRIPLETT, G.B. (Eds.): Multiple cropping. ASA Special Publication 27. Madison: 129-169.
- TRENBATH, B.R. and ANGUS, J.F. 1975: Leaf inclination and crop productivity. Field Crop Abstr. 28: 231-244.
- VALET, S. 1976: Observations et mesures sur les cultures associées traditionnelles en pays Bamiléké et Bamoum. IRAT. Paris.
- VIRTANEN, A.I. and VON HAUSEN, S. 1931: Untersuchungen über die Leguminosen-Bakterien und -Pflanzen. Z. Pflanzenernährung und Düngung, Teil A 21: 57-69.
- VIRTANEN, A.I., VON HAUSEN, S. and LAINE, T. 1937: Investigations on the root nodule bacteria of leguminous plants. XX. Excretion of nitrogen in associated cultures of legumes and non-legumes. J. agric. Sci. 27: 584-610.
- WADE, M.K. and SANCHEZ, P.A. 1975: North Carolina State University. Tropical Soils Research Program. Annual Report for 1975. Raleigh, North Carolina: 137-152.
- WAHUA, T.A.T. and MILLER, O.A. 1978: cited from MEAD, R. and STERN, R.D. 1980.
- WAY, M.J. 1953: cited from VAN DEN BOSCH, R. and TELFORD, A.D. 1964.
- WAY, M.J. 1975: cited from PERRIN, R.M. 1977.
- WAY, M.J. 1977: Pests and disease status in mixed stands vs. monocultures; the relevance of ecosystem stability. In: CHERRET, J.M. and SAGAR, G.R. (Eds.): Origins of pest, parasite, disease and weed problems. Blackwell Scientific Publications. Oxford: 127-138.
- WIEN, H.C. and NANGJU, D. 1976: The cowpea as an intercrop under cereals. Paper presented at a Symposium on Intercropping in Semi-Arid Areas. 10.-12. May 1976. Morogoro, Tanzania.

- WILLEY, R.W. 1979: Intercropping. Its importance and research needs. Part 1. Competition and yield advantages. *Field Crop Abstracts* 32(1): 1-10.
- WILLEY, R.W. 1979: Intercropping. Its importance and research needs. Part 2. Agronomy and research approaches. *Field Crop Abstracts* 32(2): 73-85.
- WILLEY, R.W. and NATARAJAN, M. 1980: Some aspects of resource use in sorghum/pigeonpea intercropping. *Indian J. Genet.* 40A: 16-26.
- WILLEY, R.W. and OSIRU, D.S.O. 1972: Studies on mixtures of maize and beans (*Phaseolus vulgaris*) with particular reference to plant population. *J. agric. Sci. (Camb.)* 79: 517-529.
- WILLEY, R.W. and RAO, M.R. 1980: A competitive ratio for quantifying competition between intercrops. *Expl. Agric.* 16: 117-125.
- WILLEY, R.W. and RAO, M.R. 1981: A systematic design to examine effects of plant population and spatial arrangement in intercropping, illustrated by an experiment on chickpea/safflower. *Expl. Agric.* 17: 63-73.
- ZADOKS, J.C. and SCHEIN, R.D. 1979: *Epidemiology and plant disease management*. Oxford University Press, New York, 1979.

Table A 1

French Terms Related to Cropping Systems  
(French terms from R. Tourte, IRAT)

1. Multiple cropping	- Culture multiple
Sequential cropping	- Cultures sequentielles
Double cropping	- Double culture
Triple cropping	- Triple culture
Quadruple cropping	- Quadruple culture
Ratoon cropping	- Repousse
Intercropping	- Cultures associées
Mixed cropping	- Cultures associées (ou en mélange)
Row intercropping	- Cultures intercalaires
Strip intercropping	- Cultures en bandes (alternées)
Relay intercropping	- Cultures dérobées
Multi-storey cropping	- Cultures en strates ou étages
2. Sole cropping	- Culture pure
Monoculture	- Monoculture
Rotation	- Rotation
Cropping pattern	- Modèle de culture
Cropping system	- Système de culture (combinaison de cultures au niveau d'une parcelle, d'un champs, d'un type de milieu)
Mixed farming	- Polyculture
Cropping index	- Index culture (mais contexte à voir)
Land Equivalent Ratio	- Surface équivalent relative

Table A 2 a

General Characteristics of Holdings

Country	Region	Farm size (ares)	No. of fields	Size of fields (ares)	No. of plots	Size of plots (ares)	Persons per holding	Active members
Camercon	Nord	164	2.8	60	3.2	51	4.5	2.6
	Est	182	3.9	47	5.2	35	5.0	2.8
	Centre-Sud	202	4.2	48	4.7	43	5.2	2.7
	Littoral	149	2.6	58	2.7	54	6.0	2.5
	Ouest	125	2.2	58	2.8	45	6.8	2.8
	Nord-Ouest	122	4.5	27	6.0	20	6.4	2.9
	Sud-Ouest	146	2.2	67	2.5	60	5.8	2.6
Average		160	3.2	50	3.8	42	5.4	2.7

Source: FAO, Enquête 1972/73



Table A 2 b

## General Characteristics of Holdings

Country	State	Farm size (ares)	No. of fields	Size of fields (ares)	No. of plots	Size of plots (ares)	Persons per holding	Active members
Nigeria	North Central	126	-	-	-	-	-	-
	Kwara	116	-	-	-	-	-	-
	North Western	172	-	-	-	-	-	-
	Benue Plateau	171	-	-	-	-	-	-
	North Eastern	192	-	-	-	-	-	-
	Kano	94	-	-	-	-	-	-
	Western	120	-	-	-	-	-	-
	Mid-Western	56	-	-	-	-	-	-
	Rivers	40	-	-	-	-	-	-
	South-Eastern	20	-	-	-	-	-	-
	East Central	30	-	-	-	-	-	-
	Lagos	35	-	-	-	-	-	-
	Average	98	-	-	-	-	-	-

Source: Nigeria Rural Economic Survey (1976/77)  
Fed. Office of Statistics, Lagos 1980

Table A 2 c

## General Characteristics of Holdings

Country	Region	Population density	Farm size (ares)	No. of fields	Size of fields (ares)	No. of plots	Size of plots (ares)	Persons per holding	Active members
Benin	Atacara	16	200	3	50	4	46	7.1	3.6
	Borgou	11	270	3	71	4	-	10.5	5.6
	Zou	30	210	2	71	3	-	7.4	3.7
	Mono	101	120	2	71	3	-	6.7	2.9
	Atlantique	76	160	2	71	3	71	6.2	2.6
	Ouémé	81	110	2	71	3	-	5.4	2.4
*)	Average	26	170	2.4	71	3.1	-	7.1	3.3
Togo	Savanes	29	384	3.8	101	-	-	10.0	4.6
	Kara	50	81	2.7	30	-	-	7.0	3.6
	Centrale	12	224	3.4	66	-	-	8.0	3.5
	Plateaux	22	172	3.3	53	-	-	6.9	2.9
	Maritime	75	152	3.1	49	-	-	7.7	4.9
Average		27	182	3.2	57	-	-	7.7	3.9

Source: Enquête Agricole, 1972/73 et 1973/74

\*) Source: Structure des exploitations agricoles traditionnelles de la Rep. Pop. du Benin, 1976/77

Table A 2 d

## General Characteristics of Holdings

Country	Region	Farm size ha	Size distribution % Farms < 1,6 ha (4 acres)	No. of fields	Size of fields	Persons per holding	Active members	
							full time	full or part time
Ghana	Western	2.2*)	40.9	2.6		5.4	1.9	3.5
	Central	1.0	68.4	2.6		5.0	1.8	3.5
	Eastern	1.2	62.6	2.9		4.8	1.3	3.4
	Volta	0.9	71.9	2.9		5.2	1.1	3.1
	Ashanti	1.8*)	48.4	3.1		5.5	1.5	3.7
	Brong-Ahafo	1.4*)	40.4	2.6		5.9	1.9	3.9
	Northern	1.7	47.5	1.9		7.1	2.6	4.8
	Upper	1.7	47.6	2.2		6.8	2.2	4.4
Average		1.5	54.7	2.7		4.4	1.7	3.7
*) considerable proportion of big cocoa plantations (>7 ha)								

Source: Ghana Sample Census of Agriculture, 1970

Table A 2 e

## General Characteristics of Holdings

Country	Region	Farm size (ares)	No. of fields	Size of fields (ares)*	No. of plots	Size of plots (ares)**	Persons per holding	Active members
Ivory Coast	Sud-Est	764	-	114	-	45	6.8	3.0
	Centre	412	-	72	-	37	6.1	2.7
	Centre-Ouest	443	-	101	-	53	6.2	2.9
	Sud-Ouest	522	-	110	-	84	6.3	2.9
	Centre Nord	346	-	72	-	70	7.0	3.5
	Grand Nord	408	-	82	-	82	8.6	4.4
Average		482.5	-	-	-	-	6.6	3.1

\*) Annual and perennial crops

\*\*\*) Annual crops only

Source: Recensement National de l'Agriculture 1973/74

Table A 2 f

## General Characteristics of Holdings

Country	Region	Farm size (ares)	No.of fields	Size of fields (ares)	No.of plots	Size of plots (ares)	Persons per holding	Active members
Upper Volta	East	417	-	-	-	-	9.2	4.2
	Centre	-	-	-	16.4	<24>	10.2	4.7
Average		526	-	-	-	-	9.7	-

Source: ORD de l'Est 1980  
West African Fertilizer Study, Vol.4, 1977  
ICRISAT, 1980

Table A 3

Average Cultivated Area Per Farm Worker in Cameroon,  
by Region or Zone, 1965 (In Ares)

Region or Zone	All crops	Food or mixed crops	Plantations
Coastal Lowland (Forest zone)			
Sanaga maritime .....	38	31	7
Nkam and Ndikinimeki.....	58	41	17
Kribi.....	100	50	50
Nyong and Kellé.....	60	37	23
Mungo.....	74	58	16
Central Region (Equatorial forest zone)			
Ntem .....	139	52	87
Dja and Lobo .....	98	38	60
Eastern forest.....	98	65	33
Central Region (Transitional forest zone)			
Forest-savanna: Nyong and Sanaga .....	91	31	60
Forest-savanna: eastern .....	68	50	19
Mbam plains .....	81	42	39
Guinea savanna lands .....	42	41	1
Western High Plateaux			
Bamileke plateau .....	38	37	1
Bamoun and Tikar plateau .....	51	39	12
Adamaoua High Plateau .....	44	44	-
Moslem pastoralists .....	(34)	(34)	-
Pagan cultivators .....	(55)	(55)	-
Northern Region			
Southern Bénoué plains .....	65	60	5
Farms with cotton .....	(95)	(80)	(15)
Farms without cotton .....	(50)	(50)	-
Northern Bénoué plains .....	73	64	9
Moslem pastoralists .....	(75)	(69)	(6)
Moslem cultivators: .....			
with cotton .....	(91)	(80)	(11)
without cotton .....	(79)	(77)	(2)
Pagan cultivators: .....			
with cotton .....	(109)	(86)	(25)
without cotton .....	(69)	(67)	(2)
Logone fishermen .....	(58)	(58)	-
"Town" farms .....	(83)	(76)	(7)
Mandara highlands .....	66	66	-

Table A 4 a

Importance of Crop Mixtures

NIGERIA

Percentage of areas of main crops grown in mixtures

Region	Maize		Sorghum		Millet		Rice		Yams	
	Total ha	% mixed	Total ha	% mixed	Total ha	% mixed	Total ha	% mixed	Total ha	% mixed
Forest and Derived Savanna areas	881.000	91.4	83.700	95.2	-	-	91.100	64.0	612.200	67.6
Middle Belt-Derived and Guinea Savanna	302.600	79.4	527.600	82.9	371.200	73.9	79.200	91.9	492.100	50.9
Northern Region Guinea and Sudan Savanna	408.300	73.4	5097.700	80.1	3662.400	91.8	76.900	42.5	132.600	73.6
Region	Cocoyam		Cassava		Groundnut		Cowpea			
	Total ha	% mixed	Total ha	% mixed	Total ha	% mixed	Total ha	% mixed		
Forest and Derived Savanna areas	177.610	89.1	350.600	23.2	55.400	46.0	132.300	82.5		
Middle Belt-Derived and Guinea Savanna	5.600	92.2	36.000	66.4	46.600	47.9	261.900	100.0		
Norther Region Guinea and Sudan Savanna	17.800	58.6	33.200	22.0	1767.800	91.4	3603.900	99.6		

\*) Source: Federal Office of Statistics, 1972

Table A 4 b - GHANA

## Importance of Crop Mixtures

Percentage of area of main crops grown in mixtures

Region	Maize <sup>1)</sup>				Sorghum				Millet			
	Total ha	% mixed		total	Total ha	% mixed		total	Total ha	% mixed		total
pred. <sup>2)</sup>	subs. <sup>3)</sup>	pred.	subs.		pred.	subs.	pred.		subs.			
Western Rainforest	29.565	58	38	96	-	-	-	-	-	-	-	-
Central S. Guinea Savanna	36.450	41	17	58	-	-	-	-	-	-	-	-
Eastern S. Guinea Savanna	65.205	71	6	77	-	-	-	-	-	-	-	-
Volta S. Guinea Savanna	43.740	56	15	71	2.430	17	83	100	-	-	-	-
Ashanti Rainforest	46.980	66	21	87	-	-	-	-	-	-	-	-
Brong-Ahafo S. Guinea Savanna	49.005	68	12	80	2.430	17	83	100	-	-	-	-
Northern Northern Guinea S.	60.345	58	39	97	70.000	33	59	92	42.000	85	89	98
Upper Northern Guinea S.	33.210	74	24	98	168.480	45	51	96	206.145	57	28	95
Total	364.500			84	243.000			95	249.075			87

1) Main season only

2) predominantly

3) subsidiary

cont. '-



Table A 4 b - GHANA cont.' -

## Importance of Crop Mixtures

-2-

Percentage of areas of main crops grown in mixtures

Region	Rice				Yam				Cocoyam			
	Total ha	% mixed		total	Total ha	% mixed		total	Total ha	% mixed		total
		pred.	subs.			pred.	subs.			pred.	subs.	
Western Rainforest	5.670	36	-	36	4.050	-	100	100	38.780	5	95	100
Central S. Guinea Savanna	810	-	-	-	6.480	6	94	100	19.035	6	94	100
Eastern S. Guinea Savanna	1.215	33	-	33	12.150	10	90	100	59.130	13	86	99
Volta S. Guinea Savanna	6.480	69	-	69	14.580	78	14	100	10.530	8	88	96
Ashanti Rainforest	4.050	30	-	30	20.655	10	90	100	167.670	11	89	100
Brong Ahafo S. Guinea Savanna	5.265	77	-	77	42.525	46	8	54	72.495	11	88	99
Northern Northern Guinea S.	14.580	-	-	-	51.435	76	13	90	-	-	-	-
Upper Northern Guinea S.	17.010	24	-	24	20.655	51	14	65	-	-	-	-
Total	55.080			29	172.530			80	359.640			99

cont.' -

Table A 4 b - GHANA cont.' - Importance of Crop Mixtures

-3-

Percentage of areas of main crops grown in mixtures

Region	Cassava				Groundnut				Cowpea			
	Total ha	% mixed		total	Total ha	% mixed		total	Total ha	% mixed		total
		pred.	subs.			pred.	subs.			pred.	subs.	
Western Rainforest	43.335	22	64	88	-	-	-	-	-	-	-	-
Central S. Guinea Savanna	38.070	22	55	77	-	-	-	-	-	-	-	-
Eastern S. Guinea Savanna	87.885	20	61	81	-	-	-	-	-	-	-	-
Volta S. Guinea Savanna	60.750	16	54	71	4.860	33	32	66	-	-	-	-
Ashanti Rainforest	53.055	28	62	90	2.025	20	60	80	-	-	-	-
Brong Ahafo S. Guinea Savanna	35.640	15	64	79	4.860	25	33	58	-	-	-	-
Northern Northern Guinea S.	5.265	-	85	85	21.060	37	56	93	8.900	5	95	100
Upper Northern Guinea S.	2.025	-	100	100	64.385	65	14	79	112.185	2	98	100
Total	326.025			82	98.010			80	121.055			80

cont.' -

Table A 4 b - GHANA cont.' - Importance of Crop Mixtures

-4-

Percentage of areas of main crops grown in mixtures

Region	Bambara Nut				Plantain				Oilpalm			
	Total ha	% mixed		total	Total ha	% mixed		total	Total ha	% mixed		total
pred.	subs.	pred.	subs.		pred.	subs.	pred.		subs.			
Western Rainforest	-	-	-	-	55.080	14	86	100	11.745	7	24	31
Central S. Guinea Savanna	-	-	-	-	34.020	14	86	100	7.290	6	83	89
Eastern S. Guinea Savanna	-	-	-	-	82.620	15	85	100	12.960	6	88	94
Volta S. Guinea Savanna	-	-	-	-	9.315	8	91	99	10.530	4	62	66
Ashanti Rainforest	-	-	-	-	299.295	11	89	100	52.245	2	98	100
Brong Ahafo S. Guinea Savanna	-	-	-	-	95.175	6	94	100	16.200	0	95	95
Northern Northern Guinea S.	-	-	-	-	-	-	-	-	-	-	-	-
Upper Northern Guinea S.	28.755	4	96	100	-	-	-	-	-	-	-	-
Total	31.590			96	575.505			97	110.970			87

Source: Ghana Sample Census of Agriculture, Accra 1970

Table A 4 c

## Importance of Crop Mixtures

IVORY COAST

Percentage of areas of main crops grown in mixtures

Region	Yam				Cocoyam				Cassava			
	Total ha	% mixed			Total ha	% mixed			Total ha	% mixed		
		pred.	subs.	tot.		pred.	subs.	tot.		pred.	subs.	tot.
Sud-Est	41.438	41.2	57.1	98.3	154.753	2.1	97.5	99.6	71.768	24.3	49.7	74.0
Centre	78.147	59.7	35.3	95.0	67.334	6.8	89.7	96.5	76.662	11.8	65.9	77.7
Centre-Ouest	35.019	42.3	50.8	93.1	158.827	0.8	99.0	99.8	46.649	16.7	55.2	71.9
Sud-Ouest	4.258	16.0	77.8	93.8	20.314	0.1	99.9	100.0	113.782	16.7	67.1	83.8
Centre-Nord	35.709	42.4	11.6	54.0	-	-	-	-	11.524	6.7	69.5	77.2
Grand-Nord	34.430	49.7	1.7	51.4	-	-	-	-	2.929	2.4	61.0	66.4
<b>Total</b>	<b>229.001</b>											
Region	Groundnut				Plantain				Oilpalm			
	Total ha	% mixed			Total ha	% mixed			Total ha	% mixed *)		
		pred.	subs.	tot.		pred.	subs.	tot.		pred.	subs. *)	tot.
Sud-Est	1.832	46.2	30.8	77.0	237.071	4.5	94.3	98.8	17.985	8.2	-	8.2
Centre	9.279	66.8	22.5	89.3	116.438	2.6	96.5	99.1	-	-	-	-
Centre-Ouest	4.949	49.0	40.3	89.3	405.269	3.6	95.1	98.7	-	-	-	-
Sud-Ouest	828	78.4	10.0	84.4	137.444	3.4	95.0	98.4	3.875	26.5	-	26.5
Centre-Nord	15.374	11.0	50.3	61.3	1.865	9.4	90.3	99.7	-	-	-	-
Grand-Nord	24.161	36.0	12.2	48.2	369	-	100.0	100.0	-	-	-	-
<b>Total</b>	<b>56.423</b>				<b>898.456</b>							

\*) These figures are misleading, as subsidiary associations are not enumerated. However, most oilpalms are grown in subsidiary associations. Figures presented here, reflect mainly commercial oilpalm plantation in the South.

Source: Recensement National de l'Agriculture 1973/74.

Table A 5 a Crops and Useful Plants Survey in Selected Farms of Varying Cropping Intensities in Compound and Out-lying Farms Located in the Derived Savanna, Transition and Oil Palm Belt Zones of Eastern Nigeria

-1-

Crops and Other Plants	AREA A		AREA B				AREA C				AREA D				AREA E				% of locations where observed
	1	2	3	4	5	6	7	8	9	10	11	12	13	14	15	16	17	18	
	Area of Land Sampled in Hectares																		
	0.45	0.003	0.014	0.04	0.04	0.04	0.04	0.3	0.4	0.04	0.25	0.5	0.04	0.04	0.1	0.5	0.5	0.04	
<u>ROOTS AND TUBERS</u>																			
Dioscorea rotundata (Aga)	x	x			x	x	x	x	x		x	x				x		x	61
Dioscorea rotundata (Abi)	x				x	x	x		x									x	39
Dioscorea rotundata (Okom)																			0
Dioscorea alata								x	x		x	x			x	x	x	x	50
Dioscorea cayenensis	x	x					x			x	x	x			x	x	x	x	56
Dioscorea bulbifera	x				x			x									x	x	33
Dioscorea dumetorum	x		x		x		x	x	x	x	x		x		x	x	x	x	72
Dioscorea esculenta	x	x		x					x	x								x	33
Manihot esculenta	x	x		x		x			x	x	x		x	x	x	x	x		67
Colocasia esculenta	x	x			x	x	x	x	x		x	x		x		x	x	x	67
Xanthosoma sagittifolium	x						x		x	x	x	x				x	x	x	50
Ipomoea batatas	x									x	x								17
<u>CEREALS AND OTHER</u>																			
<u>STARCHY STAPLES</u>																			
Zea mays	x			x	x	x	x	x	x	x	x		x		x			x	67
Sorghum vulgare					x							x							11
Oryza sativa																			0
Musa sapientum var. Gros Michel	x							x	x	x	x	x						x	47
Musa sapientum var. Cavendish											x	x				x	x		17
Musa paradisiaca	x								x		x	x				x	x		33
<u>LEAF AND FRUIT</u>																			
<u>VEGETABLES</u>																			
Amaranthus hybridus var. cruentus	x	x	x					x	x	x	x					x	x		50
Amaranthus viridis									x	x		x	x						22

267

cont.

Table A 5 a Crops and Useful Plants Survey in Selected Farms of Varying Cropping Intensities in Compound and Outlying Farms Located in the Derived Savanna, Transition and Oil Palm Belt Zones of Eastern Nigeria

-2-

Crops and Other Plants	AREA A		AREA B					AREA C				AREA D				AREA E				% of locations where observed
	1	2	3	4	5	6	7	8	9	10	11	12	13	14	15	16	17	18		
	Area of Land Sampled in Hectares																			
	0.45	0.003	0.014	0.04	0.04	0.04	0.04	0.3	0.4	0.04	0.25	0.5	0.04	0.04	0.1	0.5	0.5	0.04		
<i>Corchorus olitorius</i>	x	x	x		x		x	x	x		x	x					x	x	56	
<i>Solanum macrocarpon</i>	x	x	x		x		x	x	x										50	
<i>Solanum sp.</i>																			0	
<i>Telferia occidentalis</i>	x	x	x					x	x	x	x		x		x	x		x	61	
<i>Talinum triangulare</i>			x					x	x	x	x						x		22	
<i>Vernonia amygdalina</i>	x		x				x	x	x	x	x	x				x	x		56	
<i>Cucurbita pepo</i>	x	x	x			x		x	x	x	x	x					x	x	61	
<i>Hibiscus esculentus</i>	x	x	x	x				x	x	x						x	x	x	61	
<i>Justicia insularis</i>			x																6	
<i>Capsicum frutescens</i>	x		x						x		x	x				x	x		39	
<i>Lycopersicon esculentum</i>			x		x			x	x	x									33	
<i>Pterocarpus soyauxii</i>	x							x	x	x	x	x				x	x	x	50	
<i>Pterocarpus osun</i>									x		x	x					x		22	
<i>Pterocarpus santalinoides</i>											x					x			11	
<i>Vitex spp.</i>									x		x						x		17	
<i>Pennisetum purpureum</i>											x	x	x		x				22	
<i>Gnetum africanum</i>																	x		6	
<i>Abelmoschus sp.</i>												x							6	
<i>Sesamum indicum</i>											x								6	
<u>LEGUMES AND PULSES</u>																				
<i>Vigna unguiculata</i>	x		x	x	x		x	x	x	x									44	
<i>Arachis hypogaea</i>	x		x	x									x						22	
<i>Phaseolus lunatus</i>	x	x			x		x						x					x	39	
<i>Mucuna urens</i>	x						x		x		x		x			x	x		39	
<i>Sphenostylis stenocarpa</i>											x		x				x		17	
<i>Pentaclethra macrophylla</i>	x		x				x		x						x	x	x		39	
<u>OIL PLANTS, NUTS AND FRUITS</u>																				
<i>Dacryodes edulis</i>	x							x		x	x				x	x	x		39	
<i>Elaeis guineensis</i>	x	x						x	x	x	x	x		x		x	x	x	61	

Table A 5 a Crops and Useful Plants. Survey in Selected Farms of Varying Cropping Intensities in Compound and Outlying Farms Located in the Derived Savanna, Transition and Oil Palm Belt Zones of Eastern Nigeria

-3-

Crops and Other Plants	AREA A		AREA B				AREA C				AREA D				AREA E				% of locations where observed
	1	2	3	4	5	6	7	8	9	10	11	12	13	14	15	16	17	18	
	Area of Land Sampled in Hectares																		
	0.45	0.003	0.014	0.04	0.04	0.04	0.04	0.3	0.4	0.04	0.25	0.5	0.04	0.04	0.1	0.5	0.5	0.04	
Citrus sinensis	x							x	x		x	x				x	x		36
Citrus aurantifolia								x		x	x								17
Citrus reticulata												x						x	11
Carica papaya	x		x					x	x		x	x							38
Chrysophyllum albidum	x								x			x					x		22
Synsepalum dulcificum	x																		6
Treculia africana	x							x	x	x	x	x			x		x		44
Cucumeropsis edulis	x		x					x	x							x	x	x	30
Colocynthis vulgaris			x	x		x				x	x	x	x					x	44
Cocos nucifera	x							x	x		x	x				x			33
Ananas comosus	x										x	x			x	x	x		33
Mangifera indica								x	x			x					x		22
Tetracarpidium conophorum	x															x	x		17
Dioscoreophyllum communsii											x					x			11
Persea americana	x										x	x							17
Irvingia gabonensis									x							x			11
Spondias mombin	x								x		x	x				x	x		33
Dialium guineense													x	x					11
Eugenia sp												x							6
Syzigium cumini																		x	6
Cola lepidota												x							6
Cola pachycarpa																			6
Aframomum sceptrum								x								x			11
Psidium guajava	x							x		x						x			27
Brachystegia eurycoma										x									6
Annona muricata										x									6
Artocarpus incisa												x							6
<u>SPICES AND BEVERAGES</u>																			
Aframomum melegueta								x		x							x		17
Ricinus communis	x		x				x		x		x	x							33
Cola acuminata	x							x	x		x	x			x	x	x		44

cont. -

Table A 5 a Crops and Useful Plants. Survey in Selected Farms of Varying Cropping Intensities in Compound and Outlying Farms Located in the Derived Savanna, Transition and Oil Palm Belt Zones of Eastern Nigeria

-4-

Crops and Other Plants	AREA A		AREA B				AREA C				AREA D				AREA E				% of lo- cations where observed
	1	2	3	4	5	6	7	8	9	10	11	12	13	14	15	16	17	18	
	Area of Land Sampled in Hectares																		
	0.45	0.003	0.014	0.04	0.04	0.04	0.04	0.3	0.4	0.04	0.25	0.5	0.04	0.04	0.1	0.5	0.5	0.04	
<i>Cola nitida</i>											x	x					x		17
<i>Capsicum frutescens</i>								x				x							11
<i>Ocimum basilicum</i>					x												x		11
<i>Ocimum gratissimum</i>											x								6
<i>Curcuma longa</i>												x							6
<i>Zingiber officinale</i>																	x		6
<i>Raphia sp.</i>								x	x	x	x					x		x	33
<i>Monodora myristica</i>												x							6
<i>Coffea liberica</i>																	x		6
<i>Dennetia tripetala</i>								x			x	x			x	x	x		36
<i>Garcinia kola</i>	x							x	x			x			x				28
<i>Theobroma cacao</i>												x				x			
<u>MISCELLANEOUS USEFUL PLANTS</u>																			
<i>Newbouldia laevis</i>	x							x	x		x	x				x	x		39
<i>Rothmannia spp.</i>										x						x			6
<i>Chlorophora excelsa</i>										x		x				x	x	x	28
<i>Crescentia cujete</i>											x	x							11
<i>Saccharum officinarum</i>												x							6
<i>Lagenaria siceraria</i>																	x	x	11
<i>Ficus spp.</i>	x									x	x	x				x			28
<i>Baphia nitida</i>											x	x		x	x	x	x		33
<i>Ceiba pentandra</i>								x		x		x					x		22
<i>Albizia spp.</i>								x		x								x	17
<i>Berlinia grandiflora</i>									x								x		11
<i>Ricinedondron heudeloti</i>	x											x							11
<i>Glyphaea brevis</i>	x									x	x								17
<i>Dracaena arborea</i>	x											x							11
<i>Dracaena nanni</i>											x								6
<i>Marantochloa spp.</i>																			0

cont. 1-



Table A 5 a Crops and Useful Plants. Survey in Selected Farms of Varying Cropping Intensities in Compound and Outlying Farms Located in the Derived Savanna, Transition and Oil Palm Belt Zones of Eastern Nigeria

-5-

Crops and Other Plants	AREA A		AREA B			AREA C				AREA D				AREA E				% of locations where observed	
	1	2	3	4	5	6	7	8	9	10	11	12	13	14	15	16	17		18
	Area of Land Sampled in Hectares																		
	0.45	0.003	0.014	0.04	0.04	0.04	0.04	0.3	0.4	0.04	0.25	0.5	0.04	0.04	0.1	0.5	0.5	0.04	
<i>Cola milleni</i>								x			x	x					x		28
<i>Acioa bateri</i>													x	x					11
<i>Napoleona imperialis</i>								x						x					11
<i>Anthonotha macrophylla</i>																			0
<i>Spathodea campanulata</i>	x							x			x						x		22
<i>Musanga cecropicides</i>												x			x	x			17
<i>Azadirachta indica</i>												x							0
<i>Jatropha curcas</i>												x							6
<i>J. gossypiifolia</i>												x							6
<i>Sansevieria sp.</i>										x									6
<i>Cassia alata</i>							x		x										11
<i>Kigelia africana</i>								x											6
<i>Hibiscus sp.</i>										x							x		11
<i>Codiaeum variegatum</i>												x							11
<i>Amorphophallus sp.</i>										x									6
<i>Icacina mannii</i>																			0
<i>Lonchocarpus cyanescens</i>											x					x			11
<i>Hildegardia bateri</i>	x																		6
<i>Pedilanthus sp.</i>								x											6
<i>Hibiscus sp.</i>												x					x		11
<i>Schumanniophyton magnificum</i>																			0
<i>Casuarina equisetifolia</i>								x											6
<i>Ipomoea hederifolia</i>										x									6
<i>Erythrina spp.</i>										x									6
<i>Notopanax sp.</i>								x											6
<i>Momodica angustisepala</i>										x						x			11
<i>Rauvolfia vomitoria</i>												x				x	x		17

cont. '-

Table A 5 b

Species occurring in groundnut fields in the  
Centre-South of Cameroon

Scientific name	vernacular names			uses
	Ewondo	French	English	
1 <i>Allium cepa</i>		oignon	onion	vegetable
2 <i>Amaranthus</i> sp.	Folong	amaranthe	amaranth	leaf vegetable
3 <i>Ananas comosus</i>		ananas	pineapple	fruit
4 <i>Arachis hypogea</i>	Owondo	arachide	groundnut	grains
5 <i>Capsicum frutescens</i>		piment	chilly	spice
6 <i>Carica papaya</i>		papaye	pawpaw	fruit
7 <i>Citrus</i> spp.		agrumes	citrus	fruit
8 <i>Colocasia esculenta</i>	Mobuda	taro	cocoyam	tuber
9 <i>Corchorus olitorius</i>		corette potagère	jute	leaf vegetable
10 <i>Cucumeropsis mannii</i>	Ngôn			fruit vegetable
11 <i>Cucurbita</i> sp.	Mindzeng			leaf vegetable
12 <i>Cucumis sativus</i>	Ongbalag			leaf vegetable, grains
13 <i>Dioscorea</i> spp.		igname	yam	tuber
14 <i>Elaeis guineensis</i>		palmier	oilpalm	oil
15 <i>Hibiscus esculenta</i>		gombo	okra	fruit vegetable
16 <i>Ipomoea batatas</i>		patate douce	sweet potato	tuber
17 <i>Lycopersicon esculentum</i>		tomate	tomato	fruit vegetable
18 <i>Manihot esculenta</i>	Mbong	manioc	cassava	tuber
19 <i>Musa</i> (AAA) "Gros Michel"		bananier	banana	fruit
20 <i>Musa</i> (AAB), (Plantain)		plantain	plantain	fruit
21 <i>Nicotiana tabacum</i>		tabac	tobacco	tobacco
22 <i>Saccharum officinarum</i>		canne à sucre	sugar cane	sugary juice
23 <i>Solanum nigrum</i>	Zom			leaf vegetable
24 <i>Solanum tuberosum</i>	.	potte de terre	potato	tuber
25 <i>Solanum</i> sp.	Zom			leaf vegetable
26 <i>Solanum</i> sp.	Zong			fruit vegetable
27 <i>Talinum</i> sp.				leaf vegetable
28 <i>Xanthosoma sagittifolium</i>	Mecaba	macabo	cocoyam	tuber
29 <i>Zea mais</i>	Fon	mais	maize	grains



Rei and Touboro plains	x	x	x			x	x	x		y		x	x	⊗	
Bénoué valley and southern Garoua	x	x	x	x	x	x	x			y	y	y		⊗	x
Garoua plains and Guider	x		x	x	x	x	⊗	x	x	x			x	⊗	⊗
Diamaré plain: Maroua Kaélé	x		x	x			⊗	x	⊗				⊗	⊗	⊗
Eastern Diamaré sands: Bogu, Moulvoudaye							x	x	x	⊗			⊗	x	⊗
Mora plains and Koza							⊗	x		x			x	⊗	⊗
Mandara massif: Mokolo and Mora mountains		x					⊗			⊗	x		⊗		
Mandara massif: Mokolo plateau		x		x		x	x	⊗	x			x	⊗		
Mandara massif: Gawar plain and Zamey							x		⊗				⊗	x	
Southern Mandara massifs: west of Guider		x	x	x	x	x	x	x	⊗						
Logone plains and lake Fianga			x				x	x	x	x	x	x	x	x	x
Mayo Danay plains: north Yagoua	x						⊗	x		x	x		x	x	x
Lower Logone: Logone Birni							x	⊗	x						x
Chari and Serbewel: Fort-Foureaux, Makari	x						x	x		⊗	x			⊗	⊗
Lake Chad shores	x	x					x	x	x		x	x	x	⊗	⊗

x Characteristic crop

⊗ Crop of special significance locally

Source: DIZIAN, 1976

Table A 7 Characteristics of the Bioclimatic Regions of West Africa (Adopted From KOWAL and KASSAM, 1978)

Characteristics	Sahel		Sudan Savanna	Guinea Savanna		Rain forest
	Northern	Southern		Northern	Southern	
Range in annual precipitation (mm)	0-350	350-500/600	500/600-880	880-1200/1300	1200/1300-1500/1600	> 1500/1600
Length of the rainy period (days)	0-68	68-95/102	95/102-140	140-187/200	187/200-229/244	229/244- (270)
Length of the growing period (days) <sup>1)</sup>	0-75	75-89	90-179	180-239	240-269	270-365
Solar radiation during the rainy period (cal cm <sup>-1</sup> day <sup>-1</sup> )	523-478	478-464/460	464/460-439	439-416/408	416/408-394/386	< 394/386
Evaporation (E <sub>0</sub> ) during the rainy period (mm/day)	7.3-6.6	6.6-6.2/6.1	6.2/6.1-5.6	5.6-4.9/4.7	4.9/4.7-4.3/4.1	< 4.3/4.1
Main soil types	Sands-Arid brown	Arid brown	Non-leached, <sup>2)</sup> ferruginous	Leached ferruginous	Concretionary ferruginous, Ferrisols, Ferrallitic	Ferrallitic
Main food crops	--	Millet	Millet, Sorghum	Sorghum	Maize, Yams, Sorghum	Cassava, Plantain Maize
Main export crops	--		Groundnut	Cotton	Soya bean, Sesame	Coffee, Cocoa, Rubber
Physiognomy	Open thorn Savanna	Open thorn Savanna	Shrub woodland	Open Savanna woodland	Light forest, open woodland	High, dense, evergreen forest

1) FAO, 1978

2) French classification; Sols ferrugineux tropicaux  
Sols ferrallitiques

Table A 8 a - Cameroon

Intercropping Systems in West African Countries  
Principle Cropping Systems within Administrative Resp. Ecological Regions

Region Climatical Zone	No. of Growing Seasons	Perennial Crops in Mixtures	Basic Crops )	Major Crops	Minor Crops	Divers Crops
Nord SS + NG	1		Sorghum	Millet Groundnut	Maize Rice Cowpea 3) Bambara Beans	Sweet Potato Sesame Okra 4) Roselle 5) Pepper 6) Cassava
Est RF + T + SG	2	Coffee Cocoa Oilpalms Kola	Cassava	Maize Cocoyam 1)  Plantain	Yam Groundnut Cowpea (Tobacco)	Sweet Potato Melon Tomato Okra, Pepper Sugarcane
Centre-Sud RF + T + SG	2	Cocoa Coffee Oilpalm Kola	Cassava	Maize Cocoyam  Plantain Groundnut	Yam Sweet Potato Cowpea	Okra Pepper Tomato Melon
Littorale RF	1	Coffee Cocoa Oilpalms Kola	Cassava	Maize Cocoyam Plantain	Yam Sweet Potato Groundnut Cowpea	Okra Pepper Tomato Melon
Ouest TH	1	Coffee Avocado Kola Citrus	Maize	Yam Cocoyam Groundnut Beans 2)	Cassava Sweet Potato Plantain	Potato Okra, Pepper Tomato, Melon Vegetables
Nord-Ouest TH	1	Coffee Avocado	Maize	Cassava Cocoyam Yam	Groundnut Cowpea Rice Plantain	Potato, Beans Okra, Pepper Tomato Vegetables
Sud-Ouest RF	1	Coffee Cocoa Oilpalms Kola	Cassava	Maize Cocoyam Plantain	Yam Sweet Potato Cowpea	Okra, Pepper Tomato Melon

Legend: see Table 8g

\*) base of nutrition / base alimentaire

Table A 8 b - Nigeria

Region (State) Climatical Zone	No. of Growing Seasons	Perennial Crops in Mixtures	Basic Crops	Major Crops	Minor Crops	Divers Crops
North (Sokoto, Kano, Borno) NG + SS	1	Shea Butter <sup>1)</sup>	Sorghum/ Millet	Millet/ Sorghum Groundnut Cowpea	Maize  Rice Sesame Bambara Bean	Roselle  Tomato Pepper Sweet Potato Cassava
Centre (Kwara, Niger, Kaduna, Plateau, Bendel, Adamawa) SG + TH	2		Maize	Sorghum Millet Yam	Cowpea Groundnut Sesame Soya Bean Rice Cassava	Bambara Bean Sweet Potato Potato Okra Tomato Melon, Pepper
South West (Oyo, Ogun, Ondo) SG + T + RF	1/2	Cocoa Oilpalm Citrus Kola	Cassava	Maize Yam Cocoyam Plantain	Cowpea Melon Rice	Groundnut Okra Sweet Potato Pepper
South East (Cross River, Anambra, Imo) SG + T + R	1/2	Oilpalm Kola	Yam	Cassava Maize Cocoyam Plantain	Cowpea Melon Rice	Groundnut Okra Sweet Potato Pepper

Legend: see Table 8g

1)= *Butyrospermum parkii* (Karité)

Source: Agricultural Atlas of Nigeria

Table A 8 c - Benin

Region Climatical Zone	No. of Growing Seasons	Perennial Crops in Mixtures	Basic Crops	Major Crops	Minor Crops	Divers Crops
Atacora, Borgou NG	1	Shea Butter	Sorghum	Millet Groundnut Cowpea	Maize Yam Bambara Bean	Rice Cassava Roselle Okra, Tomato Pepper
Zou SG	2	Oilpalm	Yam	Maize Cassava	Groundnut Cowpea	Rice Okra, Pepper Tomato, Melon
Mono, Atlantique, Ouémé SG	2	Oilpalm Citrus	Maize	Cassava	Groundnut Cowpea Plantain	Rice Okra, Pepper Tomato

Legend: see Table 8g



Table A 8 d - Togo

Region Climatical Zone	No. of Growing Seasons	Perennial Crops in Mixtures	Basic Crops	Major Crops	Minor Crops	Divers Crops
Savanes NG	1	Shea Butter	Sorghum	Millet Groundnut Cowpea	Maize Bambara Bean Rice Yam	Roselle Okra Pepper Tomato
Kara, Centrale NG + SG	1 (2)	Shea Butter	Yam	Sorghum Maize Millet	Rice Bambara Bean Cassava	Okra Pepper Tomato Melon
Plateaux SG + TH	2	Coffee Cocoa Oilpalm Avocado Citrus	Maize	Yam Sorghum Cassava	Groundnut Cowpea Rice Plantain	Okra Pepper Tomato Melon
Maritime SG	2	Oilpalm Coconut palm	Cassava	Maize	Groundnut Cowpea Plantain	Okra Pepper Tomato Melon

Legend: see Table 8g

Table A 8 e - Ghana

Region Climatical Zone	No. of Growing Seasons	Perennial Crops in Mixtures	Basic Crops	Major Crops	Minor Crops	Divers Crops
Western, Central RF + SG	2	Cocoa Coffee Oilpalm Coconut	Cassava	Maize Plantain	Cocoyam Yam Rice	Groundnut Cowpea Okra, Pepper Tomato
Eastern SG	2	Cocoa Coffee Oilpalm	Cassava	Maize Plantain Cocoyam	Yam Rice	Groundnut Cowpea Okra, Pepper Tomato
Volta SG	2	Cocoa Coffee Oilpalm	Cassava	Maize	Plantain Yam Cocoyam Rice Groundnut	Cowpea Okra Sweet Potato Pepper Tomato
Ashanti RF	2	Cocoa Coffee Oilpalm Kola	Cassava	Maize Plantain Yam Cocoyam	Rice Groundnut	Cowpea Sweet Potato Okra, Pepper Tomato
Brong-Ahafo SG	2	Cocoa Coffee Oilpalm	Yam	Maize Cocoyam Plantain	Cassava Rice Groundnut	Cowpea Sweet Potato Tomato, Okra, Pepper
Northern	1	Shea Butter	Sorghum	Maize Yam Millet	Rice Groundnut Cowpea Bambara Bean Cassava Pepper *)	Okra, Tomato Pigeon Pea (Tobacco) Sweet Potato
Upper NG	1	Shea Butter	Sorghum	Millet Rice	Groundnut Cowpea Bambara Bean Maize	Okra, Pepper Pigeon Pea Sweet Potato (Tobacco)

\*) cash crop

Source: Ghana Sample Census of Agriculture, 1970.

Legend: see Table 8g

Table A 8 f - Ivory Coast

Region Climatical Zone	No. of Growing Seasons	Perennial Crops in Mixtures	Basic Crops	Major Crops	Minor Crops	Divers Crops
Nord-Ouest (Odienné-Boundiali) NG	1	Shea Butter	Maize	Sorghum Rice Groundnut	Yam Millet Cowpea	Okra Pepper Melon
Savane - 1 Saison (Korhogo-Ferkessedougou) NG	1	Shea Butter	Sorghum	Maize Millet Rice	Yam Sweet Potato Cowpea Groundnut	Roselle Okra Pepper
Nord-Est (Boua-Boundoukou) NG	1	Shea Butter	Yam	Sorghum Millet Maize Groundnut	Cassava Rice	Cowpea Okra Pepper Melon
Savane - 2 Saisons (Seguela-Katiola) SG	2		Yam	Maize Rice	Sorghum Millet Groundnut Sweet Potato	Cowpea Okra Pepper Melon
Ouest (Touba-Biankouma) SG	2	Coffee	Rice	Maize Yam	Groundnut Sweet Potato	Cowpea Okra Pepper
Centre-V Baoulé (Bouaké) SG + T	2	Coffee	Yam	Maize Cassava	Groundnut Rice	Cowpea Okra Pepper, Melon
Centre-Ouest (Daloa-Baouflé-Gagnoa) RF	2	Cocoa Coffee Oilpalm	Yam	Maize Rice Cassava	Groundnut Plantain Cocoyam	Cowpea Okra Pepper Melon
Sud-Ouest (Man-Sassandra-Divo) RF	2	Cocoa Coffee Oilpalm	Cassava	Rice Maize Plantain Cocoyam	Yam Cocoyam Groundnut	Cowpea Okra, Melon Pepper
Sud-Est (Dimbokro-Abengourou-Abidjan) RF	2	Cocoa Coffee Oilpalm	Plantain	Cassava Maize Cocoyam	Yam Groundnut	Cowpea Okra, Melon Pepper
Frangé-Côtière	2	Coconut	Cassava	Maize	Groundnut	Cowpea, Okra

Source: IRAT, 1979

Legend: see Table 8g

Table A 8 g - Upper Volta

Region Climatical Zone	No. of Growing Seasons	Perennial Crops in Mixtures	Basic Crop	Major Crops	Minor Crops	Divers Crops
Est SS	1	Shea Butter	Sorghum	Millet Cowpea	Groundnut Bambara beans Maize	Sweet Potato Yam Sesame Okra, Roselle
Centre (Centre-Ouest, Est, Centre-Est) SS	1	Shea Butter	Sorghum	Millet Cowpea	Groundnut Bambara Beans Rice Maize	Sweet Potato Sesame Okra, Roselle Vegetables
Nord (Centre-Nord, Nord, Sahel) SA	1		Millet	Sorghum Cowpea	Groundnut	Sesame
Ouest (Volta Noire) NG	1	Shea Butter	Sorghum	Millet Cowpea Maize	Groundnut Bambara Beans Rice Yam	Sweet Potato Sesame Fonio 1) Okra, Roselle (Tobacco)
Sud-Ouest (Sud-Ouest, Hauts-Bassin) NG	1	Shea Butter Citrus	Sorghum	Maize Millet Groundnut Cowpea	Yam Rice Bambara Beans	Sweet Potato Sesame Fonio Okra, Roselle Pepper, Sugar cane

1) *Digitaria exilis*

Source: LASSITER, 1980, Atlas de la Haute-Volta, Jeune Afrique

- cont.' -

Table 8 g - Legend

RF	=	Rainforest	1)	=	Colocasia sp. + Xanthosoma sp. ( Taro + Macabo)
T	=	Transition Zone	2)	=	Phaseolus vulgaris
SG	=	Southern Guinea Savanna	3)	=	Vigna unguiculata (Niébé)
NG	=	Northern Guinea Savanna	4)	=	Hibiscus esculentus (Gombo)
SS	=	Sudan Savanna	5)	=	Hibiscus sabdariffa (Oiselle)
TH	=	Tropical Highlands	6)	=	Capsicum spp. (Piment)
SA	=	Sahel			

Table A 9 a      Principle Cropping Systems in Ivory Coast  
Plantain-Based Cropping Systems

PRINCIPAL ASSOCIATIONS	% of total SURFACE
plantain, (sole)	1.3
coffee, plantain	12.8
coffee, cocoa, plantain	10.0
cocoa, plantain, cocoyam	8.6
cocoa, plantain	8.1
cocoa, coffee, plantain	7.4
coffee, plantain, cocoyam	7.0
coffee, plantain, pineapple	4.7
coffee, plantain, banana	4.5
cocoa, plantain, banana	2.7
cocoa, plantain, pineapple	1.7
coffee, pineapple, plantain	1.6
coffee, cocoyam, plantain	1.5
cassava, plantain	1.3
cocoa, cocoyam, plantain	1.3
coffee, plantain, cocoa	1.2
coffee, plantain, cassava	0.9
cocoa, plantain, coffee	0.8
coffee, banana, plantain	0.5
plantain, cocoyam	0.5
cassava, plantain, cocoyam	0.5
plantain, cocoyam, vegetables	0.4
other associations	20.8
TOTAL SURFACE:                      898 457 ha =	100.0

Source: Recensement National de l'Agriculture,  
 Abidjan, 1973/74

Table A 9 b

Cassava-Based Cropping Systems

PRINCIPAL ASSOCIATIONS	% of total SURFACE
cassava (sole)	22.1
rice, maize, cassava	7.6
rice, cassava, maize	7.4
yam, cassava	3.8
cassava, plantain	3.5
maize, cassava	3.1
coffee, plantain, cassava	2.4
yam, cassava, vegetables	2.2
cassava, vegetables	2.0
maize, cassava, vegetables	1.7
cassava, maize	1.7
cassava, cocoyam	1.4
cassava, plantain, cocoyam	1.3
plantain, cassava	1.3
rice, cassava	1.2
coffee, cassava, plantain	0.9
cassava, plantain, banana	0.8
coffee, cassava	0.8
other associations	34.6
TOTAL SURFACE: 323 314 ha =	100.0

PRINCIPAL ASSOCIATIONS	% of total SURFACE
maize (sole)	11.0
rice, maize	20.1
maize, millet	6.1
yam, maize	5.2
rice, maize, cassava	5.1
rice, cassava, maize	5.0
rice, maize, plantain	2.6
maize, rice	2.4
maize, cassava	2.1
groundnut, maize	1.7
yam, maize, vegetables	1.6
maize, sorghum	1.5
maize, cassava, vegetables	1.2
cassava, maize	1.2
sorghum, maize	0.8
yam, vegetables, maize	0.8
yam, rice, maize	0.7
yam, maize, rice	0.7
yam, maize, cassava	0.6
coffee, rice, maize	0.6
maize, vegetables	0.5
rice, maize, sorghum	0.5
millet, maize	0.4
groundnut, maize, cassava	0.4
other associations	27.1
TOTAL SURFACE: 481 076 ha =	100.0



PRINCIPAL ASSOCIATIONS	% of total SURFACE
yam (sole)	12.9
yam, maize	8.3
yam, vegetables	5.2
yam, cassava	4.1
yam, rice	3.4
yam, maize, vegetables	2.5
yam, cassava, vegetables	2.3
yam, vegetable, cassava	2.2
coffee, cocoa, yam	1.9
yam, millet	1.5
yam, vegetables	1.3
coffee, yam	1.3
yam, cocoyam	1.2
yam, rice, maize	1.1
yam, maize, rice	1.1
yam, maize, cassava	1.0
cocoa, yam, plantain	0.8
yam, millet, vegetables	0.7
yam, maize, millet	0.5
yam, sorghum	0.3
other associations	46.5
TOTAL SURFACE: 301 641 ha =	100.0

PRINCIPAL ASSOCIATIONS	% of total SURFACE
cocoyam (sole)	0.8
cocoa, plantain, cocoyam	19.3
coffee, plantain, cocoyam	15.7
coffee, cocoyam, plantain	3.3
coffee, cocoyam	3.0
cocoa, cocoyam, plantain	2.9
coffee, cocoa, cocoyam	2.5
cocoa, coffee, cocoyam	1.7
cocoa, cocoyam	1.6
plantain, cocoyam	1.1
cassava, cocoyam	1.1
cassava, plantain, cocoyam	1.0
yam, cocoyam	0.9
plantain, yam, vegetables	0.8
coffee, cocoyam, vegetables	0.6
plantain, cocoyam, cassava	0.4
maize, cassava, cocoyam	0.4
yam, vegetables, cocoyam	0.4
yam, maize, cocoyam	0.3
other associations	42.0
TOTAL SURFACE: 401 234 ha "	100.0

PRINCIPAL ASSOCIATIONS	% of total SURFACE
upland rice (sole)	20.6
lowland rice (sole)	2.8
irrigated rice (sole)	1.7
rice, maize	27.2
rice, maize, cassava	6.9
rice, cassava, maize	6.8
rice, maize, plantain	3.6
maize, rice	3.3
yam, rice	2.7
rice, maize, vegetables	2.1
yam, rice, maize	1.0
yam, maize, rice	0.9
rice, maize, sorghum	0.7
maize, rice, sorghum	0.4
rice, sorghum	0.4
maize, sorghum, rice	0.3
other associations	18.5
TOTAL SURFACE: 345 985 ha =	100.0

PRINCIPAL ASSOCIATIONS	% of total SURFACE
sorghum (sole)	27.7
maize, sorghum	14.9
sorghum, maize	8.0
rice, maize, sorghum	5.2
sorghum, beans	5.0
maize, sorghum, groundnut	3.3
maize, rice, sorghum	3.1
rice, sorghum	2.8
sorghum, groundnut, beans	2.7
maize, sorghum, rice	2.4
yam, sorghum	2.0
sorghum, maize, okra*	1.9
sorghum, millet, chilly pepper	1.7
sorghum, maize, beans	1.3
maize, millet, sorghum	1.3
sorghum, beans, maize	1.1
other associations	15.6
TOTAL SURFACE: 49 990 ha =	100.0

PRINCIPAL ASSOCIATIONS	% of total SURFACE
pearl millet (sole)	19.0
maize, millet	39.0
yam, millet	5.9
yam, millet, okra	2.7
millet, maize	2.7
groundnut, millet	2.5
millet, beans	2.2
yam, maize, millet	1.8
groundnut, maize, millet	1.8
maize, millet, beans	1.8
maize, groundnut, millet	1.4
sorghum, millet, chilly pepper	1.1
maize, millet, sorghum	0.9
maize, millet, groundnut	0.8
yam, millet, bambara nut	0.8
other associations	15.4
TOTAL SURFACE: 75 077 ha =	100.0

PRINCIPAL ASSOCIATIONS	% of total SURFACE
groundnut (sole)	36.4
groundnut, maize	14.3
groundnut, millet	3.4
groundnut, maize, cassava	3.3
maize, sorghum, groundnut	2.9
maize, groundnut	2.9
groundnut, maize, millet	2.4
sorghum, groundnut, beans	2.4
cassava, groundnut	2.3
groundnut, cassava	2.1
cassava, groundnut, millet	1.8
groundnut, maize, vegetables	1.2
maize, millet, groundnut	1.1
other associations	23.5
TOTAL SURFACE: 56 423 ha =	100.0

Table A 9 k

Yam Based Cropping Patterns in Eastern Nigeria  
Data of 30 Holdings in Amapu Village

Crop or Crop Mixture	Acreage
Water yam	0.80
Old cassava	0.89
New cassava	0.50
Yellow yam/new cassava	3.97
Gourd/new cassava	0.29
Yellow yam/groundnut	0.50
White yam/new cassava	0.58
White yam/okro	0.08
Water yam/new cassava	0.10
Yellow yam/cocoyam	0.06
Yellow yam/old cassava	1.20
White yam/cocoyam	0.14
White yam/trifoliolate yam	0.44
Yellow yam/new cassava/melon	1.17
Yellow yam/trifoliolate yam/fluted pumpkin	0.36
White yam/maize/fluted pumpkin	0.05
White yam/trifoliolate yam/maize	0.34
Water yam/new cassava/okro	0.11
Yellow yam/old cassava/maize	0.29
Yellow yam/groundnut/new cassava	1.06
White yam/old cassava/maize	0.13
White yam/new cassava/maize	0.32
Yellow yam/old cassava/melon	1.97
Yellow yam/water yam/trifoliolate yam	1.03
White yam/water yam/cocoyam/fluted pumpkin	0.30
Total	16.68
Average per farmer	0.55

Source: UZOZIE, 1971

Table A 10    Maturity Period of Crops

<u>Cereals</u>	<u>days</u>
Sorghum, in the Sudan Savanna	120 - 135
" , in the S.Guinea Savanna	<200
Millet, early	75 - 100
" , late	120 - 180
Maize	110 - 120
" , 2. season, short cycle types	80 - 90
Rice	120 - 160
Hungry rice (D. exilis)	90 - 120
<u>Legumes</u>	
Groundnut, runner type (Spanish or Valencia group)	90 - 105
" , bunch type (Virginia group)	120 - 145
Cowpea , spreading indeterminate	<100
" , erect, determinate	80 - 100
Bambara nut	120 - 150
Soya bean, improved, non-photoperiodic cultivars	90 - 110
Phaseolus bean, lowlands	90 - 120
Pigeon pea	<180
<u>Root and Tuber Crops</u>	<u>months</u>
Cassava	9 - 12
" , for processing	18 - 24
Yam , (D. rotundata)	8
" , (D. alata)	9 - 10
Cocoyam (Colocasia esculenta)	6 - 18
" (Xanthosoma sagittifolium)	9 - 12
Sweet potato	3 - 4
<u>Other crops</u>	
Banana/Plantain	<12 - 15
Sugar cane	14 - 18
" " , ratoon crop	12
Pepper	4 - 7
Okra	4 - 6
Sesame	4 - 6

Source: Kassam 1976, 1979



Table A 11 List of Botanical Names of Crops and the Respective English and French Common Names Used in West Africa

Botanical Name	English	French
<u>Perennials (Tree Crops)</u>		
<i>Butyrospermum parkii</i> (Don.) Kotschy	Sheabutter tree	Karité
<i>Carica papaya</i> L.	Pawpaw, papaya	Papayer
<i>Cocos nucifera</i> L.	Coconut palm	Cocotier
<i>Coffea arabica</i> L.	(Arabica) Coffee	Caféier (arabica)
<i>Coffea canephora</i> Pierre ex Froehner	(Robusta) Coffee	Caféier (robusta)
<i>Cola acuminata</i> Schott et Endl.	Kola	Kolatier
<i>Elaeis guineensis</i> Jacqu.	Oilpalm	Palmier à huile
<i>Mangifera indica</i> L.	Mango	Manguier
<i>Musa (sapientum</i> L.)	Banana	Bananier (douce)
<i>Musa (paradisiaca</i> L.)	Plantain	Banane plantain
<i>Parkia clappertonia</i> Benth.	Locust bean, dawadawa	Néré
<i>Parkia biglobosa</i> Benth.	" " "	"
<i>Pentaclethra macrophylla</i> Benth.	Oilbean	Ovala, mubala
<i>Persea americana</i> Mill.	Avocado	Avocatier
<i>Theobroma cacao</i> L.	Cocoa	Cacaoyer
<u>Cereals</u>		
<i>Digitaria exilis</i> Stapf.	Hungry millet (rice)	Fonio
<i>Oryza glaberrima</i> Steud.	African rice	Riz (locale)
<i>Oryza sativa</i> L.	Rice-lowland	Riz (bas-fonds)
" "	Rice-upland	Riz (pluviale)

cont.

Table A 11 cont.' -1-

Botanic Name	English	French
<i>Pennisetum typhoides</i> (Brum.) Stapf et Hubbard	Millet, pearl millet	Mil, petit mil
<i>Sorghum vulgare</i> Pers.	Sorghum, guinea corn	Sorgho
<u>Legumes</u>		
<i>Arachis hypogea</i> L.	Groundnut	Arachide
<i>Cajanus cajan</i> (L.) Millsp.	Pigeonpea	Pois d'Angole, ambrévade ou pois Congo
<i>Cajanus indicus</i> Spreng.	"	"
<i>Cicer arietinum</i> L.	Chickpea	Pois ciche
<i>Glycine max</i> (L.) Merr.	Soya bean	Soja
<i>Mucuna pruriens</i> D.C.var.utilis (Wall.ex Wight) Baker ex Burck.	Velvet bean, black Mauri- tius bean	Pois mascate, pois à gratter
<i>Vigna mungo</i> (L.) Hepper ( <i>Phaseolus mungo</i> (L.) Hepper)	Black gram, Urd	Ambérique, pois ou haricot mungo
<i>Vigna radiata</i> (L.) Wilczek ( <i>Phaseolus aureus</i> Roxb.)	Green gram, mung bean	Haricot velu, ambérique
<i>Phaseolus vulgaris</i> L.	(French) bean	Haricot (commun)
<i>Vigna unguiculata</i> (L.) Walp.	Cowpea	Niébé, haricot dolique
<i>Voandzeia subterranea</i> (L.) Thou.	Bambara groundnut, earth pea	Voandzou, pois bambara
<u>Root and Tuber Crops</u>		
<i>Colocasia esculenta</i> L.	(Old) Cocoyam	Taro
<i>Dioscorea</i> spp.	Yam	Igname
<i>Dioscorea alata</i> L.	Water yam, white yam	Igname ailée, igname tardive
<i>Dioscorea bulbifera</i> L.	Aerial yam	Igname bulbifère
<i>Dioscorea cayennensis</i> Lamk.	Yellow yam	Igname de Cayenne
<i>Dioscorea dumetorum</i> (Kunth.) Pax	Bitter yam, Trifoliate yam	Igname trifoliée
<i>Dioscorea rotundata</i> Poir.	White (early) yam	Igname de Guinée, i. précoce

cont.'

Table A 11 cont.'-2-

Botanic Name	English	French
<i>Ipomoea batatas</i> Poir.	Sweet potato	Patate douce
<i>Manihot esculenta</i> Crantz	Cassava	Manioc
<i>Solanum tuberosum</i> L.	Irish potato	Pomme de terre
<i>Xanthosoma sagittifolium</i> Schott.	(New) Cocoyam	Macabo (in Cameroon)
<u>Vegetables</u>		
<i>Amaranthus</i> spp. ( <i>A. thunbergii</i> Moq, Bondue)	African spinach	Epinaard africain, amarante
<i>Capsicum annum</i> L.	Red pepper, chilly	Piment (de Cayenne)
<i>Citrullus</i> spp.	Melon	Melon, pastèque
<i>Citrullus vulgaris</i> Schrad.	Melon	Melon
<i>Corchorus</i> spp. ( <i>C. olitorius</i> )	African spinach	Epinaard africain
<i>Cucurbita</i> spp. ( <i>C. pepo</i> L.)	Pumpkin, marrow	Courge, courgette, citrouille
<i>Hibiscus esculentus</i> L.	Okra, lady's finger	Gombo
<i>Hibiscus sabdariffa</i> L.	Roselle	Oiselle de Guinée
<i>Lagenaria vulgaris</i> Seringe	Calabash	Calebasse, gourde
<i>Lycopersicon esculentum</i> Mill.	Tomato	Tomate
<i>Solanum</i> spp. ( <i>S. nigrum</i> , var. <i>guineense</i> )	African spinach	Epinaard africain
<i>Talinum triangulare</i> Willd.	African spinach	Epinaard africain
<u>Divers Crops</u>		
<i>Ananas comosus</i> (L.) Merr.	Pineapple	Ananas
<i>Gossypium hirsutum</i> L.	Cotton	Coton
<i>Nicotiana tabacum</i> L.	Tobacco	Tabac
<i>Sesamum indicum</i> L.	Sesame, benniseed	Sésame
<i>Saccharum officinale</i> L.	Sugar cane	Canne à sucre

Table A 12

Consumption Chart of a Shifting Cultivator's Family  
in Manhaua, Mozambique

Product	1	2	3	4	5	6	7	8	9	10	11	12
Crops produced by the family												
(1) Staple foods containing starch												
Manioc	x	x							x	x	x	x
Maize in milk-ripeness			x	x								
Maize as ripe corn					x	x						
Rice					x	x						
Sweet potatoes							x	x	x			
Sorghum								x				
Sorghum-corn (ecununga)								x				
Sorghum-cane (maele)							x	x				
(2) Staple foods containing protein												
Beans (boer boer)									x	x		
Beans (jugo)						x						
Beans (manteiga)						x						
Green beans (boer boer)							x	x				
Green beans (nyemba)			x									
Green beans (jugo)					x	x						
Manioc leaves	x	x	x	x	x	x	x	x	x	x	x	x
Sweet potatoe leaves					x	x						
Bean leaves of all kinds		x	x	x	x	x	x					
(3) Additional foods and spices												
Onions											x	x
Tomatoes						x	x					
Gherkins			x									
Aubergine ( 2 kinds)										x	x	x
Quiabo (Hibiscus esculentus)	x											
Groundnuts						x	x	x	x	x	x	
Sugar-cane					x							
Pumpkins	x	x	x									
Sorghum-cane (ecununga)						x	x					

Source: PÖSSINGER, 1967 cited from RUTHENBERG, 1980

Table A 13

List of Institutes and Researchers working on  
Intercropping in West Africa

Country	Institute	Researcher	Subjects
Nigeria	Institute of Agric. Research Samaru, Zaria	Norman *	Economics
		Abalu D'Silva Andrews*, Baker*, Fisher, Kassam*	Economics Economics Agronomy Breeding
	IITA, Ibadan	Okigbo Wilson	Economics Agronomy
	Univ. of Ife IAR & T, Ibadan	Taylor Adelana	Plant Pathology Agronomy
	National Cereals Research Institute Ibadan	Remison*	Agronomy (Fertility)
	Univ. of Nigeria, Nsukka	Igbozurike	Ecology
	Nigerian Inst. for Oil Palm Research	Remison	Agronomy (Fertility)
Cameroon	ENSA, Yaoundé	Dogmo Mutsaers*	Economics Agronomy
		IRA	Praquin* Salez Lyonga
	SODECAO**	Miette	
	UCCAO**	Simon	
	Draught Cattle Program, Bamenda	German team	Agronomy
Benin	Unité de Recherche et de Production Niaouli	Djegui	Agronomy
	CARDER Atlantique**	German team	Agronomy
Togo	IRAT	Latrille	Agronomy
	SOTOCO	NN	Agronomy
Ghana	Crops Research Institute (Kumasi and Nyankpala)	Koli* German team	Agronomy " , Economics
	Univ. of Legon	Doku	Economics
Côte d'Ivoire			
Haute-Volta	ICRISAT	Matlon	Economics
	SAFGRAD	Brockman*, Cantrell	Agronomy
	IRAT	Morant	Agronomy
	Projet Phosphate de la Haute-Volta	Metzger (German team)	Agronomy

\* has left the institute / \*\* extension services or development agencies

Figure A 1 Climates of West Africa (From HARRISON CHURCH, 1980 and "Atlas de la République Unie du Cameroun")

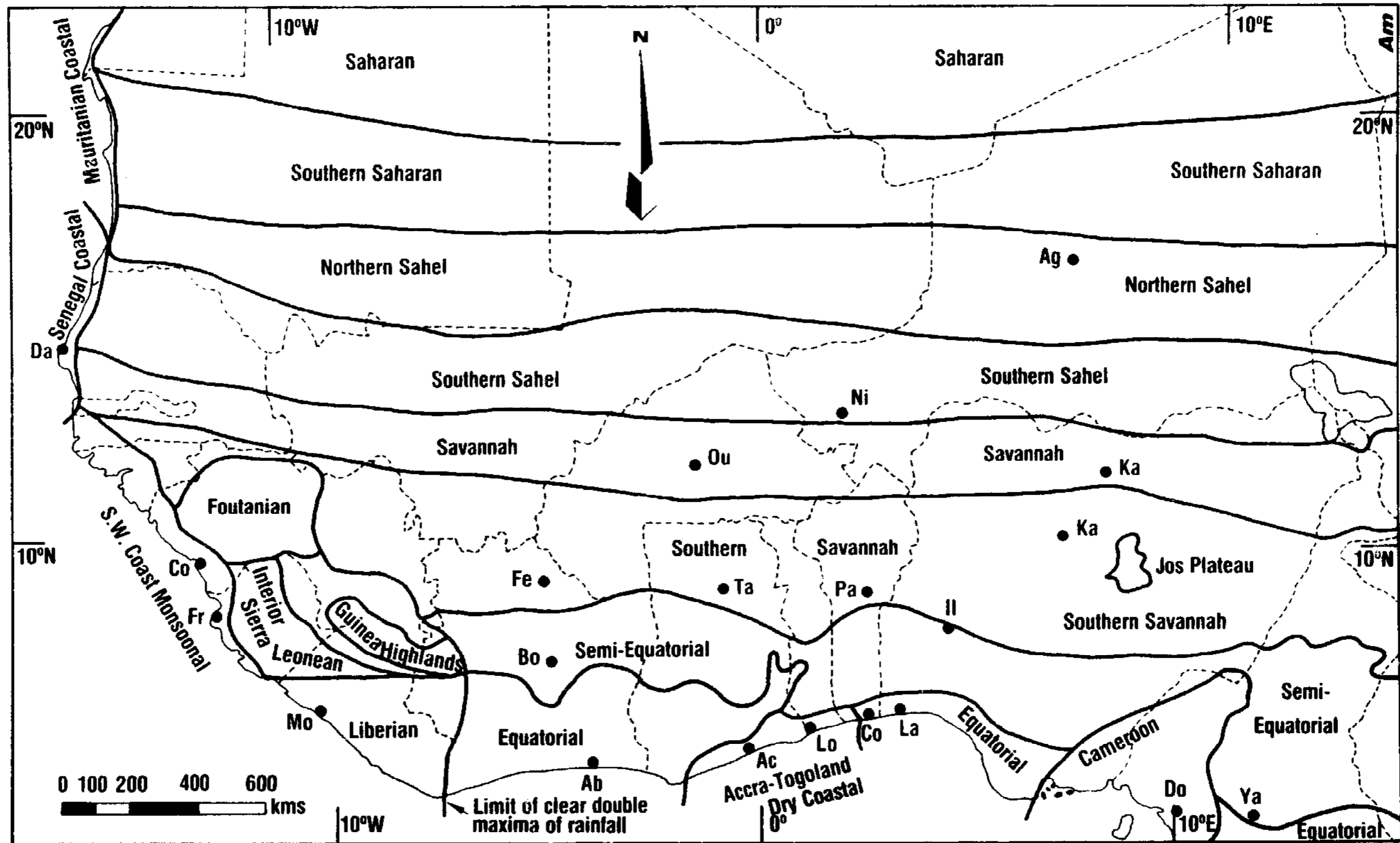

Figure A 2

Annual Rainfall of West Africa (Data of 95 Stations, Minimum Period of 10 Years) (HARRISON CHURCH, 1980)

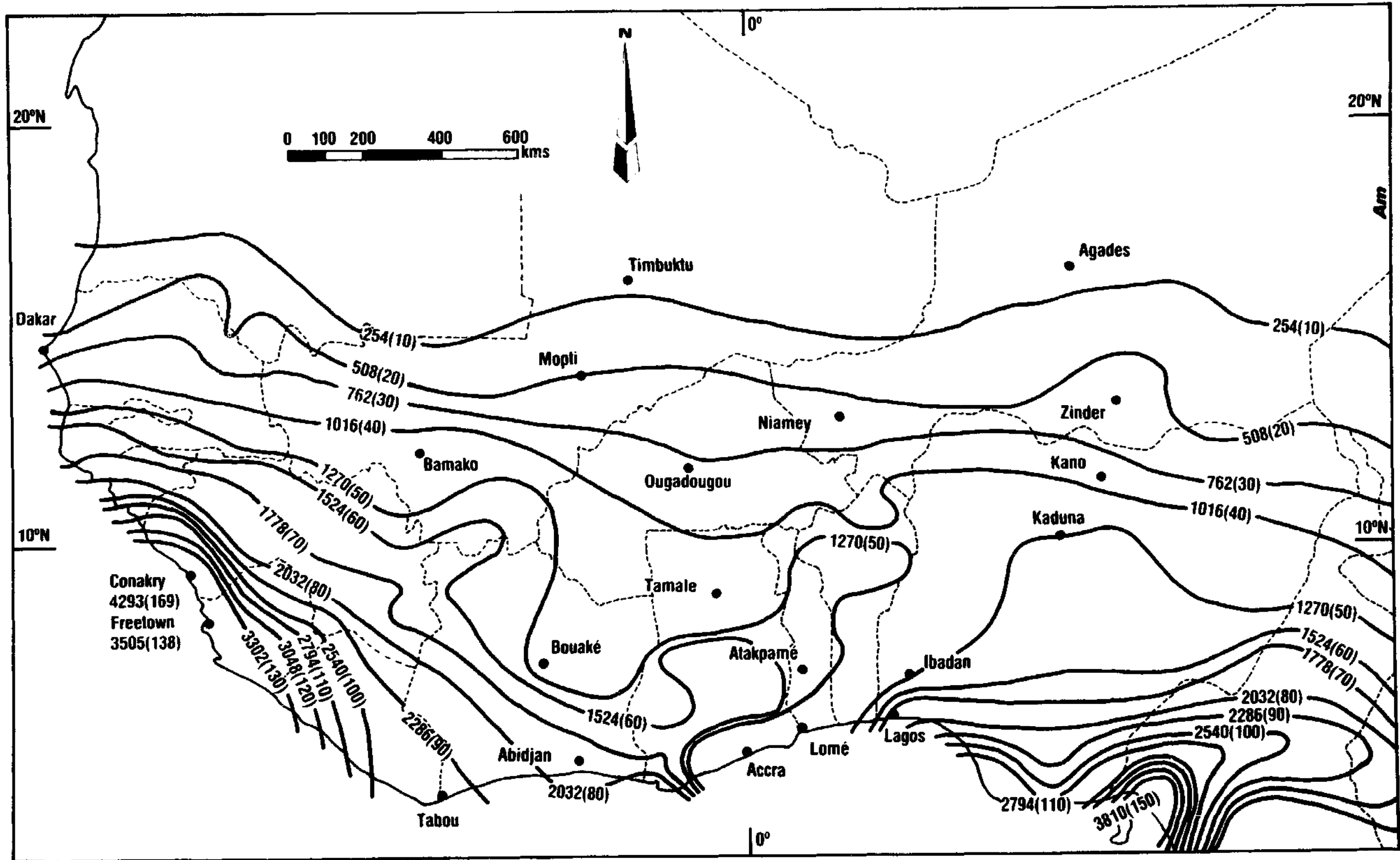

Figure A 3

Vegetation Zones of West Africa (From HARRISON CHURCH, 1980 and "Atlas de la République Unie du Cameroun")

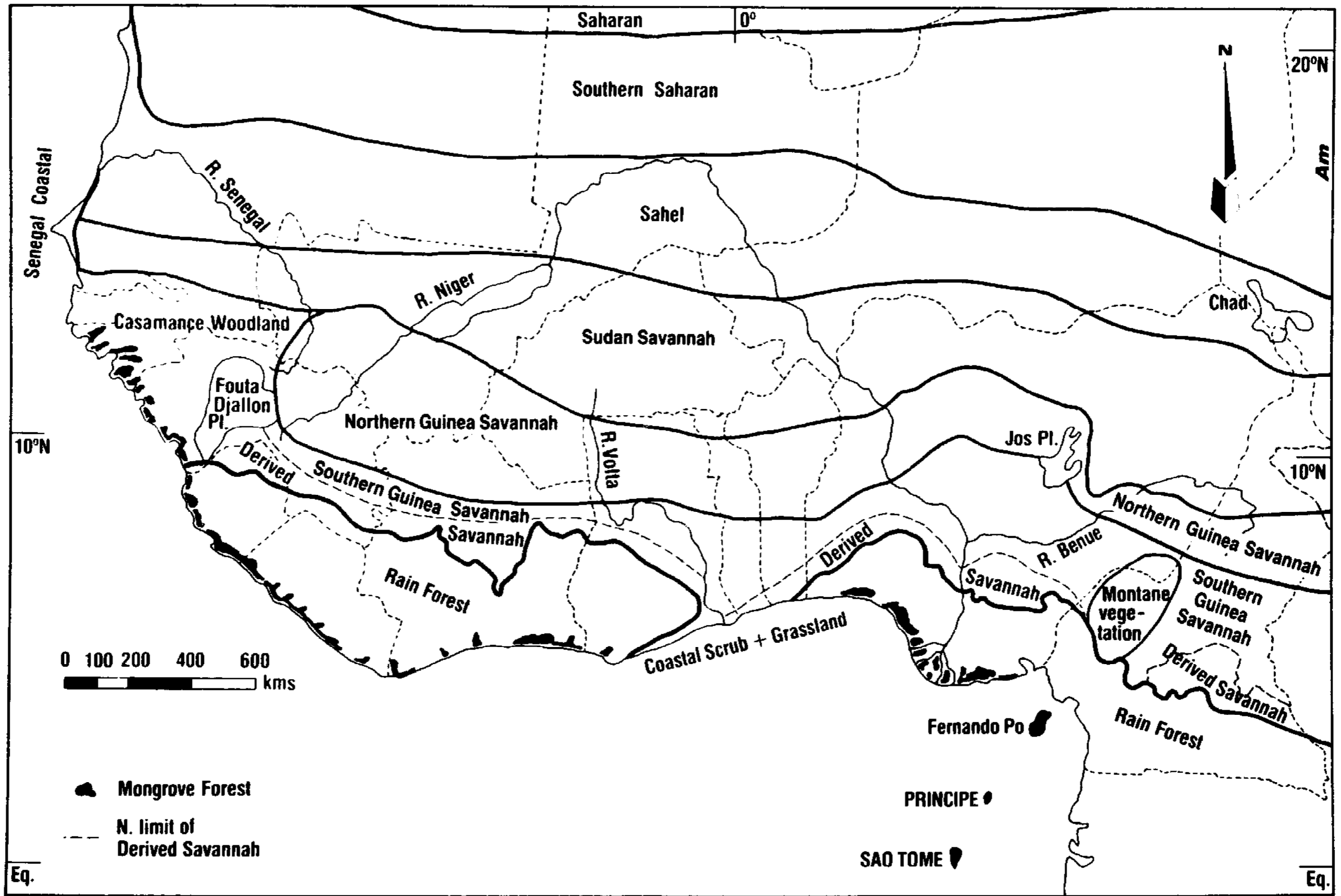
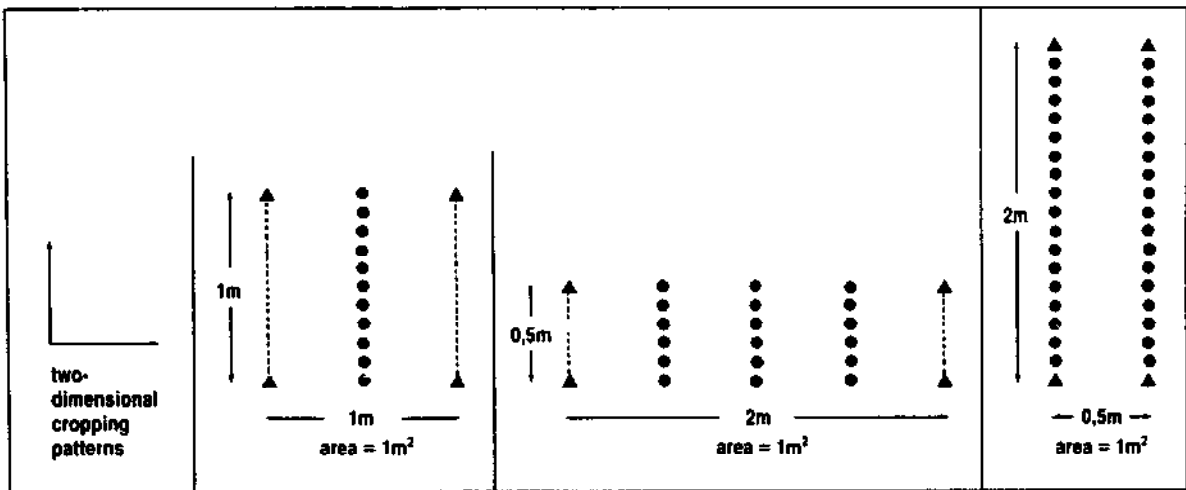
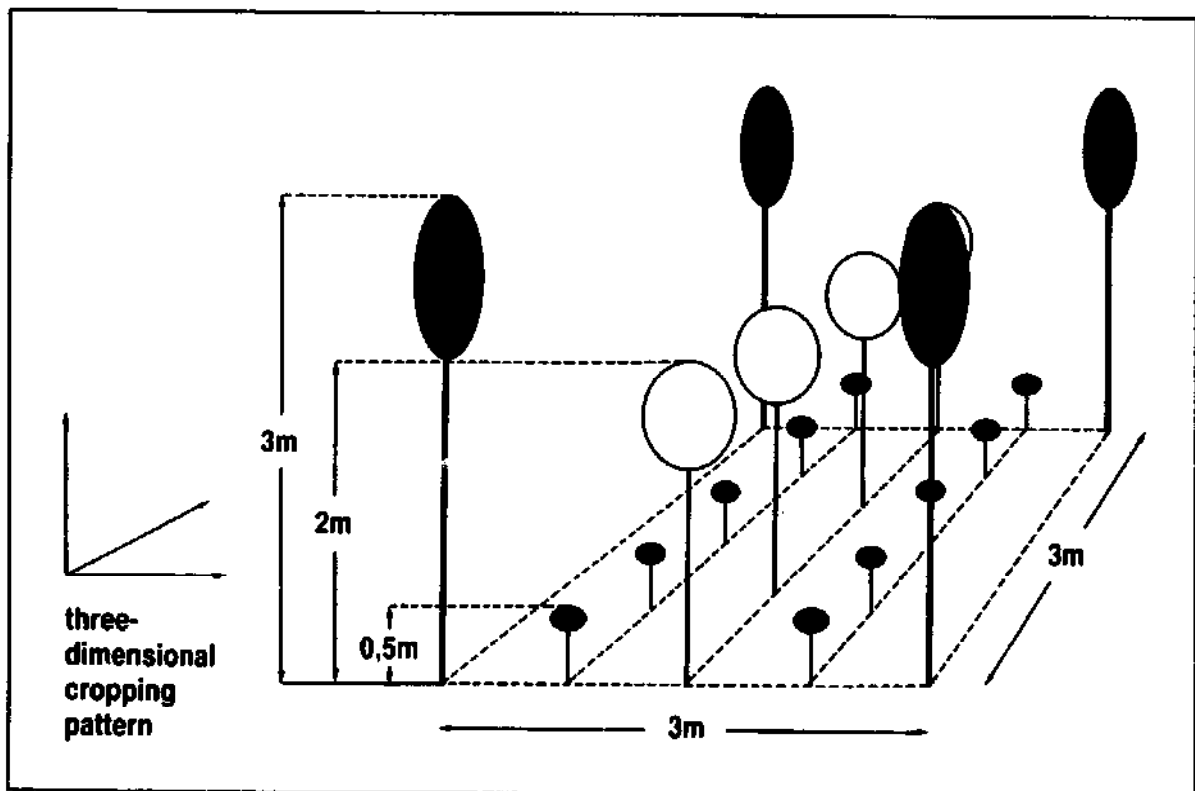



Figure A 4: Two- and threedimensional cropping patterns



Change of inter-row distance of the dominant crop ( $\blacktriangle$ ) without changing the plant population of the dominant crop, allows to interplant different populations of a dominated crop ( $\bullet$ ).



Multistorey cropping with three different storeys.

# GTZ-Publikationen

## Schriftenreihe Nr. 1

Gachet, Paul und Jaritz, Günther: „Situation und Perspektiven der Futterproduktion im Trockenanbau in Nordtunesien“. 1972. 30 Seiten. DM 5,-.

## Schriftenreihe Nr. 2

Jahn, Hans-Christoph und König, Siegfried: „Forst in Paktia/Alghanistan“. 1972. 56 Seiten. Englisch, Farsi und Deutsch. DM 5,-.

## Schriftenreihe Nr. 3

Jaritz, Günther: „Die Weidewirtschaft im australischen Winterregenklima und ihre Bedeutung für die Entwicklung der Landwirtschaft in den nordafrikanischen Maghrebländern“. 1973. 40 Seiten. DM 5,-.

## Schriftenreihe Nr. 4

Wienberg, Dieter; Weiler, Norbert und Seidel, Helmut: „Der Erdbeeranbau in Südspanien“. 1972. 92 Seiten. DM 5,-.

## Schriftenreihe Nr. 5

Neumaier, Thomas (Redaktion): „Beiträge deutscher Forschungsstätten zur Agrarentwicklung in der Dritten Welt“. 1973. 568 Seiten. DM 5,-.

## Schriftenreihe Nr. 6

Neumaier, Thomas (Redaktion): „Deutsche Agrarhilfe – Was, wo, wie 1973?“. 1973. 600 Seiten. DM 5,-.

## Schriftenreihe Nr. 7

Seidel, Helmut und Wienberg, Dieter: „Gemüsesortenversuche in Südspanien“. 1973. 102 Seiten. DM 5,-.

## Schriftenreihe Nr. 8

„Tsetse- und Trypanosomiasisbekämpfung“. 1973. 102 Seiten. DM 5,-.

## Schriftenreihe Nr. 9

Schieber, Eugenio: „Informe Sobre Algunos Estudios Fitopatológicos Efectuados en la República Dominicana“ (Bericht über einige phytopathologische Studien in der Dominikanischen Republik). 1973. 66 Seiten, 35 Abbildungen. Spanisch. DM 5,-.

## Schriftenreihe Nr. 10

Bautista, Juan Elias; Hansen del Orbe, Raymundo und Jürgens, Gerhard: „Control de Malezas en la República Dominicana“ (Unkrautbekämpfung in der Dominikanischen Republik). 1973. 40 Seiten. Spanisch. DM 5,-.

## Schriftenreihe Nr. 11

Neumaier, Thomas (Redaktion): „Internationale Agrarentwicklung zwischen Theorie und Praxis“ (Bericht über die vierte landwirtschaftliche Projektleitertagung Bonn 1973). 1974. 390 Seiten. ISBN 3-980030-1-9. DM 5,-.

## Schriftenreihe Nr. 12

Adelhelm, Rainer und Steck, Karl: „Agricultural Mechanisation – Costs and Profitability“ (Mechanisierung der Landwirtschaft – Kosten und Rentabilität). 1974. 70 Seiten. Englisch. ISBN 3-980030-2-7. DM 5,-.

## Schriftenreihe Nr. 13

„Mokwa Cattle Ranch“ (Modell eines Rindermastbetriebes für Westafrika). 1974. 44 Seiten. Englisch, Französisch und Deutsch. 35 Abbildungen. ISBN 3-980030-3-5. DM 5,-.

## Schriftenreihe Nr. 14

„La Lutte contre la Mouche Tse-Tse et la Trypanosomiase“ (Tse-tse- und Trypanosomiasisbekämpfung). 1973. 106 Seiten. Französisch. DM 5,-.

## Schriftenreihe Nr. 15

Zeuner, Tim: „Mandi – Projekt in einer indischen Bergregion“. 1974. 76 Seiten. 1 Karte. 41 Abbildungen. Englisch und Deutsch. ISBN 3-980030-5-1. DM 5,-.

## Schriftenreihe Nr. 16

Rüchel, Werner-Michael: „Chemoprophylaxe der bovinen Trypanosomiasis“. 1974. 252 Seiten. ISBN 3-980030-6-X. DM 5,-.

## Schriftenreihe Nr. 17

Lindau, Manfred: „El Koudia/Marokko – Futterbau und Tierhaltung – Culture fourragère et entretien du bétail“. 1974. 74 Seiten. Deutsch und Französisch. 4 Abbildungen. ISBN 3-980030-7-8. DM 5,-.

## Schriftenreihe Nr. 18

Kopp, Erwin: „Das Produktionspotential des semiariden tunesischen Oberen Medjerdatales bei Beregnung“. 1975. 332 Seiten. 28 Abbildungen. ISBN 3-88085-000-3. DM 5,-.

## Schriftenreihe Nr. 19

Grove, Dietrich: „Ambulante andrologische Diagnostik am Rind in warmen Ländern“. 1975. 288 Seiten. 40 Abbildungen. ISBN 3-88085-005-4. DM 5,-.

**Schriftenreihe Nr. 20**

Eisenhauer, Georg (Redaktion): „Forstliche Fakultät Valdivia/Chile – Facultad de Ingeniería Forestal Valdivia/Chile“. 1975. 245 Seiten. Deutsch und Spanisch. 4 Abbildungen. ISBN 3-88-085-015-1. DM 5,-.

**Schriftenreihe Nr. 21**

Burgemeister, Rainer: „Élevage de Chameaux en Afrique du Nord“ (Kameizucht in Nordafrika). 85 Seiten. ISBN 3-88085-010-0. DM 5,-.

**Schriftenreihe Nr. 22**

Agpaoa, A.; Endangan, D.; Festin, S.; Gumayagay, J.; Hoenninger, Th.; Seeber, G.; Unkel, K. und Weidelt, H. J. (Compiled by H. J. Weidelt): „Manual of Reforestation and Erosion Control for the Philippines“ (Handbuch der Aufforstung und Erosionskontrolle auf den Philippinen). 1975. 569 Seiten. Englisch. ISBN 3-88085-020-8. DM 5,-.

**Schriftenreihe Nr. 23**

Jurgens, Gerhard (Redaktion): „Curso Básico sobre Control de Malezas en la República Dominicana“ (Grundkurs zur Unkrautbekämpfung in der Dominikanischen Republik). Spanisch. ISBN 3-88085-010-0. DM 5,-.

**Schriftenreihe Nr. 24**

Schieber, Eugenio: „El Status Presente de la Herrumbre del Café en América del Sur“ (Der aktuelle Stand der Kaffeeroestbekämpfung in Südamerika). 1975. 22 Seiten. Spanisch. DM 5,-.

**Schriftenreihe Nr. 25**

Rohrmoser, Klaus: „Ölplanzenzüchtung in Marokko – Selection des Oleagineux au Maroc“. 1975. 278 Seiten. 8 Colorfotos, 1 Übersichtskarte. Deutsch und Französisch. ISBN 3-88085-035-6. DM 5,-.

**Schriftenreihe Nr. 26**

Bonarius, Helmut: „Physical Properties of Soils in the Kilombero Valley (Tanzania)“ (Physikalische Zusammensetzung der Böden im Kilombero-Tal/Tansania). 1975. 34 Seiten. Englisch. DM 5,-.

**Schriftenreihe Nr. 27**

„Mandi – A Project in a Mountainous Region of India“ (Mandi – Projekt in einer indischen Bergregion). 1975. Englisch – Hindi. ISBN 3-9800030-5-1. DM 5,-.

**Schriftenreihe Nr. 28**

Schmidt, Gerhard und Hesse, F.-W.: „Einführung der Zuckerrübe in Marokko – Introduction de la

betterave sucrière au Maroc“. 1975. 136 Seiten. 16 Tabellen. 17 Schwarzweißfotos. Mehrfarbige Standortkarte. Deutsch und Französisch. ISBN 3-88085-001-1. DM 8,-.

**Schriftenreihe Nr. 29**

„Landwirtschaftliche Entwicklung West-Sumatra“. 1976. 30 Seiten. 13 Schwarzweißfotos. 1 farbige Standortkarte. ISBN 3-88085-007-0. DM 5,-.

**Schriftenreihe Nr. 30**

Rüchel, Werner-Michael: „Chemoprophylaxis of Bovine Trypanosomiasis“. (Chemoprophylaxe der bovinen Trypanosomiasis). 1975. 252 Seiten. Englisch. ISBN 2-980030-6-X. DM 5,-.

**Schriftenreihe Nr. 31**

„Bildung und Wissenschaft in Entwicklungsländern“ (Die Maßnahmen der staatlichen deutschen Bildungs- und Wissenschaftsförderung). Zusammengestellt von Wolfgang Küper. 1976. 242 Seiten. ISBN 3-88085-004-6. DM 13,50.

**Schriftenreihe Nr. 32**

Wagener, Wilhelm Ernst: „Baukasten für die praktisch-pädagogische Counterpartausbildung“. 1976. 156 Seiten. ISBN 3-88085-006-2. DM 18,50.

**Schriftenreihe Nr. 33**

„Journées Agrostologie – Elevage des Ruminants“ (Erfahrungsaustausch über Weideverbesserung). 1976. 188 Seiten. ISBN 3-88085-009-7. DM 5,-.

**Schriftenreihe Nr. 34**

Neumaier, Thomas (Redaktion): „Internationale Zusammenarbeit im Agrarbereich – was, wo, wie 1976?“. 1976. 524 Seiten. ISBN 3-88085-012-7. DM 16,50.

**Schriftenreihe Nr. 35**

„Colheitas melhores para Minas Gerais – Bessere Ernten für Minas Gerais“ (Fünf Jahre brasilianisch-deutsche Zusammenarbeit in Minas Gerais). Zusammengestellt von Ernst Lamster und Thomas Neumaier. 1977. 54 Seiten. 52 Abbildungen. ISBN 3-88085-018-6. DM 7,50.

**Schriftenreihe Nr. 36**

Kassebeer, von Keyserlingk, Lange, Link, Pollehn, Zehrer und Bohlen: „La Défense des Cultures en Afrique du Nord – en considérant particulièrement la Tunisie et la Maroc“ (Pflanzenschutz in Nordafrika unter besonderer Berücksichtigung von Tunesien und Marokko). 1976. 272 Seiten, 375 Color-Abbildungen. DM 41,20.

**Schriftenreihe Nr. 37**

„Agricultural Development in West Sumatra“ (Landwirtschaftliche Entwicklung in Westsumatra). 1976. 30 Seiten. Englisch. 13 Schwarzweißfotos. 1 farbige Standortkarte. ISBN 3-88085-007-0. DM 5,-.

**Schriftenreihe Nr. 38**

Kopp, Erwin: „Le Potentiel de Production dans la Région semiaride de la Haute Vallée de la Medjerda tunisienne sous irrigation par aspersion“ (Das Produktionspotential des semiariden tunesischen Oberen Medjerdatales bei Beregnung). 1977. 360 Seiten. ISBN 3-88085-021-6. DM 26,-.

**Schriftenreihe Nr. 39**

Schmutterer, Heinz: „Plagas e Enfermedades de Algodon en Centro America“ (Krankheiten und Schädlinge bei Baumwolle in Zentralamerika). 1977. 104 Seiten. 50 Colorabbildungen. DM 22,-.

**Schriftenreihe Nr. 40**

„Dritte externe Veterinärtagung“ (Berichte und Arbeitsergebnisse). 1977. 370 Seiten. ISBN 3-88-85-022-4. DM 24,50.

**Schriftenreihe Nr. 41**

Becker, Günther: „Holzstörung durch Termiten im Zentralafrikanischen Kaiserreich - Destruction du bois par les termités dans l'Empire Centralafrican“. 1977. 96 Seiten. 16 Abbildungen. Deutsch und Französisch. DM 12,60.

**Schriftenreihe Nr. 42**

Furtmayr, Ludwig: „Besamungsstationen an tropischen und subtropischen Standorten“. 1977. 64 Seiten. ISBN 3-88085-031-3. DM 10,60.

**Schriftenreihe Nr. 43**

Wirth, Frigga: „Culture de plants à parfum en Tunisie - Parfumpflanzenanbau in Tunesien“. 1977. 196 Seiten. Französisch und Deutsch. DM 18,40.

**Schriftenreihe Nr. 44**

„Vikunjabewirtschaftung in Peru“. 1978.

**Schriftenreihe Nr. 45**

Grove, Dietrich: „Diagnostico Andrológico Ambulante en el Bovino en Países Cálidos“ (Ambulante andrologische Diagnostik am Rind in warmen Ländern). 1977. 280 Seiten. ISBN 3-88085-038-0. DM 24,50.

**Schriftenreihe Nr. 46**

Nägel, Ludwig. „Aquakultur in der Dritten Welt“. 1977. 110 Seiten, 21 Abbildungen. Deutsch. DM 14,50.

**Schriftenreihe Nr. 47**

Wagener, Wilhelm E.: „Model for Practical-Educational Counterpart Training“. 1977. 106 Seiten. DM 18,50.

**Schriftenreihe Nr. 48**

Metschies, Gerhard: „Technisch-wirtschaftliche Möglichkeiten und Grenzen des ländlichen Straßenbaus in Entwicklungsländern“. 1977. 219 Seiten. Deutsch. DM 25,-.

**Schriftenreihe Nr. 49**

Bischof, Friedrich: „Common Weeds from Iran, Turkey, the Near East and North Africa“. 1979. 234 Seiten, 204 Colorabbildungen. ISBN 3-88085-061-5. DM 56,-.

**Schriftenreihe Nr. 50**

Ballestrem, C. Graf und H.-J. Holler: „Potato Production in Kenya. Experiences and Recommendations for Improvement“. 1977. 88 Seiten. 69 Abbildungen. Englisch. DM 19,60.

**Schriftenreihe Nr. 51**

„Savar-Farm - The Central Breeding-Station of Bangladesch (Savar-Farm - Die zentrale Tierzuchtstation von Bangladesch). 1977. 44 Seiten. Englisch und Deutsch. DM 7,50.

**Schriftenreihe Nr. 52**

„Progress on Lake Malawi - The Central Region Lakeshore Development Project 1967 - 1977“. 1978. 54 Seiten. ISBN 3-88085-036-4. DM 7,50

**Schriftenreihe Nr. 53**

Kisselmann, E. (Redaktion): „Gutachten - Studien - Berichte“ (Beiträge aus 20 Jahren internationaler Zusammenarbeit im ländlichen Raum). 1977. 540 Seiten. DM 28,-.

**Schriftenreihe Nr. 54**

„Tierärztliche diagnostische Labors in Malaysia - Beispiel malayisch-deutscher Zusammenarbeit“. 1978. 32 Seiten. DM 8,60.

**Schriftenreihe Nr. 55**

Neumaier, Thomas (Redaktion): „Technische Zusammenarbeit im ländlichen Raum, was - wo - wie 1978“. 1978. 690 Seiten. ISBN 3-88085-044-5, DM 22,50.

**Schriftenreihe Nr. 56**

Leppack, Eberhardt und Roskamp, Robert: „Almacenamiento de Papas en Panama - un ejemplo para zonas tropicales y subtropicales (Kartoffellagerung in Panama - ein Beispiel für tropische und subtropische Zonen)“. 1978. 102 Seiten. 28 farbige Abb., 13 Skizzen, Spanisch. DM 26,50.

**Schriftenreihe Nr. 57**

Walker, J. B., D. Mehlitz und G. E. Jones: „Notes on the ticks of Botswana“. 1978. 83 Seiten. 32 Abbildungen. Englisch. DM 18,40.

**Schriftenreihe Nr. 58**

Kurt Hueck: „Los Bosques de Sudamérica – Ecología, composición e importancia económica“. (Die Wälder Südamerikas). 1978. 476 Seiten. Mit Vegetationskarte von Südamerika. ISBN 3-88085-053-4. DM 49,50.

**Schriftenreihe Nr. 59**

Dorow, Eberhard: „Hubschrauber in der Feldheuschreckenbekämpfung – Helicopter in Grasshopper Control – L'hélicoptère dans la lutte contre les criquets“. 1978. 66 Seiten. 13 Abbildungen. Deutsch, Englisch, Französisch. DM 8,20.

**Schriftenreihe Nr. 60**

Hubert, Klemens und Friedrich Sander: „The Rehabilitation of Rural Roads in Handeni District (Tanzania) – Project description and assessment of experiences –“. 1978. 81 Seiten. 3 Karten. Englisch. DM 8,60.

**Schriftenreihe Nr. 61**

German Agricultural Team (GAT) in Kenya: „Passion Fruit Growing in Kenya – A Recommendation for Smallholders“. 1978. 46 Seiten. 57 Abbildungen. Englisch. DM 11,50.

**Schriftenreihe Nr. 62**

Lippmann, Dieter: „Cultivation of Passiflora edulis D.“ (General Information on Passion Fruit Growing in Kenya). 1978. 88 Seiten. 88 Abbildungen. ISBN 3-88085-065-8. DM 18,-.

**Schriftenreihe Nr. 63**

„Rückstandsprobleme im Pflanzenschutz in der Dritten Welt.“ 1978. 62 Seiten. 35 Abbildungen. Deutsch. DM 14,50.

**Schriftenreihe Nr. 64**

Schmutterer, Heinz: „Cotton Pests in the Philippines“ 1978. 110 Seiten. 47 Abbildungen. Englisch. DM 21,-.

**Schriftenreihe Nr. 65**

„Dune Stabilization – A Survey of Literature on Dune Formation and Dune Stabilization“ (Dünenstabilisierung). 1977. 407 Seiten. Englisch. ISBN 3-88085-032-1. DM 18,50.

**Schriftenreihe Nr. 66**

Maier, Hermann (Redaktion): „51 x Ausbildung – Förderung der beruflichen Bildung in Entwick-

lungsländern“. 1977. 324 Seiten. ISBN 3-88085-034-8. DM 14,50.

**Schriftenreihe Nr. 67**

Becker, Silke: „La Propagación de la Roya del Cafeto“. 1979. 70 Seiten. 13 Abbildungen. Spanisch. Englisch. Deutsch. DM 7,50.

**Schriftenreihe Nr. 68**

Vollweiler, Berthold: „Escuela de Topografía y Catastro (ETC). Ausbildungsstätte für Vermessungswesen und Kataster – Costa Rica. College of Surveying and Cadastral Science.“ 1978. 29 Seiten. 13 Abbildungen. Spanisch. Deutsch. DM 7,50.

**Schriftenreihe Nr. 69**

A. Marouani, N. Kouki, M. Ghanmi und P.-H. Grell: „Gutes Saatgut – eine Voraussetzung für hohe Erträge.“ Dreisprachig (Deutsch, Französisch, Arabisch). 1979. 56 Seiten. ISBN 3-88085-066-6. DM 10,50

**Schriftenreihe Nr. 70**

Michels, Thomas: „Medical Laboratory Development in Tanzania.“ 1978. 30 Seiten. 22 Abbildungen. Englisch. DM 12,50.

**Schriftenreihe Nr. 71**

Korte, Rolf (Redaktion): „Nutrition in Developing Countries – A Seminar for German Technical Assistance Personnel.“ 1978. 394 Seiten. Englisch. DM 22,50.

**Schriftenreihe Nr. 72**

Brüning, Dietrich C.: „Population Planning in Pakistan – A Study of the Continuous Motivation System“ (Bevölkerungsplanung in Pakistan). 1977. 300 Seiten. ISBN 3-88085-043-7. DM 18,50.

**Schriftenreihe Nr. 73**

Seeber, G., H. J. Weidelt und V. S. Banaag. „Dendrological Characters of Important Forest Trees from Eastern Mindanao.“ 1979. 440 Seiten. ISBN 3-88 085-068-2. DM 22,60.

**Schriftenreihe Nr. 74**

Heidemann, C. und H. O. Ries: „Raumordnung, Regional- und Stadtentwicklung. Ein methodisches Konzept.“ 1979. 52 Seiten. Deutsch. DM 8,10.

**Schriftenreihe Nr. 75**

Goedicke, P. T., E. Reisch, G. Schnuer und A. Zülke: „Landtechnische Ausbildungs- und Beratungszentren als Mittel zur Förderung der Landwirtschaft in Entwicklungsländern.“ 1979. 96 Seiten. Deutsch. DM 16,50.

**Schriftenreihe Nr. 76**

Gassert, Werner L.: „Research on Coffee Berry Disease in Ethiopia“. 1979. 56 Seiten. ISBN 3-88 085-070-4. DM 12,60.

**Schriftenreihe Nr. 77**

Rosskamp, Robert; Eberhardt Leppack: „Potato storage in Panama“ (Kartoffellagerung in Panama). 1979. DM 26,50.

**Schriftenreihe Nr. 78**

Myntti, Cynthia: „Women and Development in Yemen Arab Republic“ (Frauen und Entwicklung in der Arabischen Republik Jemen). 1979. 170 Seiten. 28 Abbild. ISBN 3-88085-079-8. DM 24,50.

**Schriftenreihe Nr. 79**

Krause, R. und Lorenz, F.: Bodenbearbeitung in den Tropen und Subtropen. 1979. 252 Seiten. ISBN 3-88085-079-8. Deutsch. DM 24,50.

**Schriftenreihe Nr. 80**

Die Ökologie und Bekämpfung des Blutschnabelwebervogels (*Qudea quelea*) in Nordostnigeria. In Vorbereitung.

**Schriftenreihe Nr. 81**

„Orthopädie-technisches Versorgungszentrum und Ausbildungsstätte für Orthopädie-Techniker, Lomé/Togo“. 1979. 38 Seiten. Deutsch. DM 9,60.

**Schriftenreihe Nr. 82**

„Pesticide Residue Problems in the Third World“ (Rückstandsprobleme im Pflanzenschutz in der Dritten Welt). 1979. 64 Seiten. Englisch. ISBN 3-88085-074-7. DM 14,50. Übersetzung der Nr. 63.

**Schriftenreihe Nr. 83**

University of Dar es Salaam Faculty of Engineering. 48 Seiten. Englisch. DM 17,—.

**Schriftenreihe Nr. 84**

Die Bundesrepublik Deutschland und die Forstwirtschaft der 3. Welt. In Vorbereitung.

**Schriftenreihe Nr. 85**

„Sportförderung in Ländern der Dritten Welt“. 1979. 228 Seiten. Deutsch. ISBN 3-88085-078-X. DM 29,—.

**Schriftenreihe Nr. 86**

„Agricultural Engineering, Training and Advisory Centres as a means of promoting agriculture in developing countries“. 1980. Hierbei handelt es sich um die englische Übersetzung der Nr. 75. DM 16,50.

**Schriftenreihe Nr. 87**

Mielke, Gerd (Redaktion): „57 x Ausbildung – Förderung der beruflichen Bildung in Entwicklungsländern“. 1979. 358 Seiten. Deutsch. ISBN 3-88085-077-1. DM 16,50.

**Schriftenreihe Nr. 88**

„Technical Cooperation in Rural Areas – Facts and Figures 1979“ (Technische Zusammenarbeit im ländlichen Raum – Fakten und Daten 1979). 1979. 580 Seiten. Englisch. ISBN 3-88085-082-8. DM 22,—.

**Schriftenreihe Nr. 89**

„Bildung und Wissenschaft in der Technischen Zusammenarbeit mit Entwicklungsländern“. 1979 Deutsch. DM 29,—.

**Schriftenreihe Nr. 90**

„Gesundheit, Bevölkerungsentwicklung, Ernährung“. Deutsch. DM 13,50.

**Schriftenreihe Nr. 91**

„Masterplans for Electric Power Supply“ (Objectives and Methods). 1980. 277 Seiten. Englisch. ISBN 3-88085-093-3. DM 32,80.

**Schriftenreihe Nr. 92**

Rau, Norbert und Rau, Anke: „Commercial Marine Fishes of the Central Philippines.“ 1980. 608 Seiten. ISBN 3-88085-089-5. DM 38,—.

**Schriftenreihe Nr. 93**

Pflanzenschutz im Nordjemen (Arbeitstitel). In Vorbereitung.

**Schriftenreihe Nr. 94**

„Pollution of the waters of the Amman Zerka Area (Jordan) – A hydrochemical and hydrobiological study.“ In Vorbereitung.

**Schriftenreihe Nr. 95**

Rückstandsprobleme im Pflanzenschutz in der Dritten Welt. Spanisch. In Vorbereitung.

**Schriftenreihe Nr. 96**

Rückstandsprobleme im Pflanzenschutz in der Dritten Welt. Französisch. In Vorbereitung.

**Schriftenreihe Nr. 97**

Wasserhyazinthen. In Vorbereitung.

**Schriftenreihe Nr. 98**

Heidemann, G. und Ries, H. O.: „Regional and Urban Development“. A methodological framework. 1980. 48 Seiten. DM 11,25.

Übersetzung in der Nr. 74.

**Schriftenreihe Nr. 99**

Heidemann, C. und Ries, H. O.: „Ordenamiento Espacial, desarrollo regional y desarrollo urbano. 1980. 51 Seiten. DM 11,25.  
Übersetzung der Nr. 74.

**Schriftenreihe Nr. 100**

Hagenbrock, T., Pohl, H., Ries, H. O., Spanger, U., Springer, W.: *Aufgaben und Chancen von Regionalentwicklungsprojekten in Entwicklungsländern.* DM 39,50.

**Schriftenreihe Nr. 101**

CBE – College of Business Education Dar es Salam/Dodoma, Tanzania. DM 14,20.

**Schriftenreihe Nr. 102**

„Technical College Arusha – Training of Technicians in Tanzania.“ 1980. Englisch. 29 Seiten. ISBN 3-88085-090-9. DM 18,70.  
Eine Projekturkurzdarstellung.

**Schriftenreihe Nr. 103**

Centres de formation et de vulgarisation en génie agricole, un moyen de promotion de l'agriculture dans les pays en voie de développement. 1980. Französisch. DM 24,50.  
Übersetzung der Nr. 75.

**Schriftenreihe Nr. 104**

Das Verwaltungsinstitut Sana'a. Deutsch, Englisch, Arabisch. (Noch nicht erschienen)

**Schriftenreihe Nr. 105**

Doppler, Werner: „The Economics of Pasture Improvement and Beef Production in Semihumid West Africa.“ 1980. 195 Seiten. Englisch. ISBN 3-88085-101-8. DM 14,-.

**Schriftenreihe Nr. 106**

„Studien, Gutachten, Berichte – Beiträge internationaler Zusammenarbeit im ländlichen Raum. 1977-1980.“ 1981. 351 Seiten. Deutsch. ISBN 3-88085-102-6. DM 13,80.

**Schriftenreihe Nr. 107**

„Fischerei am Assad-See, Syrien“. 1981. 32 Seiten. Deutsch, Englisch, Französisch. ISBN 3-88085-100-X. DM 16,25.

**Schriftenreihe Nr. 108**

Schmidt, Gerhard; Hesse, Friedrich-Wilhelm und Trost, Karl: „Die Zuckerrohrkultur in Marokko“. 1981. 88 Seiten. Deutsch. ISBN 3-88085-105-0. DM 34,50.

**Schriftenreihe Nr. 109**

Nienhaus, Franz: „Virus- and similar diseases in tropical and subtropical areas“. 1981. 216 Seiten. Englisch. ISBN 3-88085-106-9.

**Schriftenreihe Nr. 110**

„Technische Zusammenarbeit im ländlichen Raum – was, wo, wie 1981“. 1981. 962 Seiten. Deutsch. ISBN 3-88085-107-7. DM 30,-.

**Schriftenreihe Nr. 111**

„Handbuch der Zugtiernutzung in Afrika“. 1981. 496 Seiten. Deutsch. ISBN 3-88085-103-4. DM 60,-.

**Schriftenreihe Nr. 112**

Schmidt, G.; Hesse, F.-W.; Trost, K.: „La culture de la canne à sucre au Maroc“. 1981. 88 Seiten. Französisch. ISBN 3-88085-105-0. DM 34,50.

**Schriftenreihe Nr. 113**

„Problèmes de post-récolte. Documentation sur un Séminaire OUA/GTZ“. 1980. 247 Seiten und 31 Seiten Anhang. Französisch. DM 15,40.

**Schriftenreihe Nr. 114**

Drescher, Wilhelm und Crane, Eva: „Technical Cooperation Activities: Beekeeping. A Directory and Guide“. 1982. 166 Seiten. Englisch. ISBN 3-88085-111-5. DM 39,50.

**Schriftenreihe Nr. 115**

„Post Harvest Problems. Documentation of a OAU/GTZ Seminar“. 1980. 258 Seiten und 33 Seiten Anhang. Englisch. DM 15,40.

**Schriftenreihe Nr. 116**

„Forst Sahel“. In Vorbereitung

**Schriftenreihe Nr. 117**

Jahn, Samia Al Azharia: „Traditional Water Purification in Tropical Developing Countries. – Existing Methods and Potential Application“. 1981. 284 Seiten. Englisch. ISBN 3-88085-116-6. DM 35,-.

**Schriftenreihe Nr. 118**

Kopp, E.: „Stickstoffproblematik in einem semiariden Raum“. 1981. 276 Seiten. Deutsch. Englische und französische Zusammenfassung im Anhang. ISBN 3-88085-117-4. DM 51,60.

**Schriftenreihe Nr. 119**

Jaritz, Günther: „Grünlandnutzung in Tunesien“. In Vorbereitung.

**Schriftenreihe Nr. 120**

„Animal Traction in Africa“. 1982. 490 Seiten. Englisch. ISBN 3-88085-133-6. DM 60,-.

**Schriftenreihe Nr. 121**

Munzinger, Peter: „La Traction Animale en Afrique“. (Handbuch der Zugtiernutzung in Afrika). 1982. 496 Seiten. Französisch. ISBN 3-88085-148-4. DM. 60,-.

Übersetzung der Nr. 111.

**Schriftenreihe Nr. 122**

Philipp, Ottmar; Koch, Werner und Köser, Heinz: „Utilization and Control of Water Hyacinth in Sudan.“ (Die Nutzung und Kontrolle der Wasserhyazinthe im Sudan). 1983. 224 Seiten. Englisch. ISBN 3-88085-184-0. DM 32,-.

**Schriftenreihe Nr. 123**

„Fleisch aus Ferké. Ein Feedlot am tropischen Standort.“ 1983. 112 Seiten. Deutsch. ISBN 3-88085-180-8. DM 14,60.

**Schriftenreihe Nr. 124**

Becker, E. W.: „Mikrologen. Ergebnisse aus drei Versuchsvorhaben.“ 1982. 118 Seiten. Deutsch. ISBN 3-88085-149-2. DM 24,50.

**Schriftenreihe Nr. 125**

Gross, Rainer und Bunting, E. S.: „Agricultural and Nutritional Aspects of Lupines.“ (Land- und ernährungswirtschaftliche Aspekte von Lupinen). Proceedings of the First International Lupine Workshop. 1982. 884 Seiten. Englisch. ISBN 3-88085-134-4. DM 39,-.

**Schriftenreihe Nr. 126**

Diehl, Lothar: „Smallholder Farming Systems with Yam in the Southern Guinea Savannah of Nigeria.“ 1982. 340 Seiten. Englisch. ISBN 3-88085-135-2. DM 36,-.

**Schriftenreihe Nr. 127**

„Mas Granos Basicos para Honduras.“ (Mehr Getreide für Honduras). 1982. 44 Seiten. 55 Farbabbildungen. Spanisch. DM 12,50.

**Schriftenreihe Nr. 128**

Kropp, E.: „Ländliche Regionalentwicklung – ein Orientierungsrahmen.“ 1983. ■ Seiten. Deutsch. ISBN 3-88085-221-9. DM ■.

**Schriftenreihe Nr. 130**

„Maschinengemeinschaften in Rio Grande do Sul“.

In Vorbereitung.

**Schriftenreihe Nr. 131**

Thal, J. M. Taoidi: „Bedeutung, Biologie und Bekämpfung der Kartoffelmotte in Marokko. Importance, Biology and Control of the Potato Moth in Morocco. Importance et biologie de la tergue de la pomme de terre, la lutte contre ce ravageur au Maroc.“ 1982. 144 Seiten. 19 Abbildungen. Deutsch-Englisch-Französisch. ISBN 3-88085-139-5. DM 23,-.

**Schriftenreihe Nr. 132**

Weidelt, Hans Joachim und Banaag S.: „Aspects of Management and Silviculture of Philippine Dipterocarp Forests.“ 1982. 308 Seiten. Englisch. ISBN 3-88085-157-3. DM 18,-.

**Schriftenreihe Nr. 133**

Finck, Horst und Oelert, Gerhard: „Investitionen im Energiebereich.“ Ein Leitfaden zur Berechnung der Wirtschaftlichkeit. 1983. 106 Seiten. Deutsch. ISBN 3-88085-210-3. DM 37,00.

**Schriftenreihe Nr. 134**

Schlögl, W.: „Kompendium der Kaninchenproduktion unter Berücksichtigung der Verhältnisse in der Dritten Welt.“ 1984. ■ Seiten. Deutsch. ISBN 3-88085-215-4. DM ■.

**Schriftenreihe Nr. 135**

Rüdenauer, Michael: „Production de viande de bovins trypanotolerants en savane guinée d'Afrique occidentale.“ Organisation, rentabilité et possibilités de développement compte tenu notamment des possibilités d'intégration en petites exploitations, à l'exemple du Togo. 1982. 344 Seiten. Französisch. ISBN 3-88085-144-1. DM 29,-.

**Schriftenreihe Nr. 136**

Merkle, Alfred: „The Cost of Health for All.“ A feasibility study from Upper Volta. (Der Preis für „Gesundheit für alle“ – eine Durchführbarkeitsstudie aus Obervolta). 1982. 101 Seiten. Tabeleinteil im Anhang. Englisch. ISBN 3-88085-145-X. DM 20,-.





*Deutsche Gesellschaft für Technische Zusammenarbeit (GTZ) GmbH*

*Dag-Hammarskjöld-Weg 1-2 · D 6236 Eschborn 1 · Telefon (0 6196) 79-0 · Telex 41523-0gtz d*

The government-owned GTZ operates in the field of Technical Cooperation. 2,200 German experts are working together with partners from about 100 countries of Africa, Asia and Latin America in projects covering practically every sector of agriculture, forestry, economic development, social services and institutional and material infrastructure. – The GTZ is commissioned to do this work both by the Government of the Federal Republic of Germany and by other government or semi-government authorities.

The GTZ activities encompass:

- appraisal, technical planning, control and supervision of technical cooperation projects commissioned by the Government of the Federal Republic or by other authorities
- providing an advisory service to other agencies also working on development projects
- the recruitment, selection, briefing, assignment, administration of expert personnel and their welfare and technical backstopping during their period of assignment
- provision of materials and equipment for projects, planning work, selection, purchasing and shipment to the developing countries
- management of all financial obligations to the partner-country.