



This is a digital copy of a book that was preserved for generations on library shelves before it was carefully scanned by Google as part of a project to make the world's books discoverable online.

It has survived long enough for the copyright to expire and the book to enter the public domain. A public domain book is one that was never subject to copyright or whose legal copyright term has expired. Whether a book is in the public domain may vary country to country. Public domain books are our gateways to the past, representing a wealth of history, culture and knowledge that's often difficult to discover.

Marks, notations and other marginalia present in the original volume will appear in this file - a reminder of this book's long journey from the publisher to a library and finally to you.

Usage guidelines

Google is proud to partner with libraries to digitize public domain materials and make them widely accessible. Public domain books belong to the public and we are merely their custodians. Nevertheless, this work is expensive, so in order to keep providing this resource, we have taken steps to prevent abuse by commercial parties, including placing technical restrictions on automated querying.

We also ask that you:

- + *Make non-commercial use of the files* We designed Google Book Search for use by individuals, and we request that you use these files for personal, non-commercial purposes.
- + *Refrain from automated querying* Do not send automated queries of any sort to Google's system: If you are conducting research on machine translation, optical character recognition or other areas where access to a large amount of text is helpful, please contact us. We encourage the use of public domain materials for these purposes and may be able to help.
- + *Maintain attribution* The Google "watermark" you see on each file is essential for informing people about this project and helping them find additional materials through Google Book Search. Please do not remove it.
- + *Keep it legal* Whatever your use, remember that you are responsible for ensuring that what you are doing is legal. Do not assume that just because we believe a book is in the public domain for users in the United States, that the work is also in the public domain for users in other countries. Whether a book is still in copyright varies from country to country, and we can't offer guidance on whether any specific use of any specific book is allowed. Please do not assume that a book's appearance in Google Book Search means it can be used in any manner anywhere in the world. Copyright infringement liability can be quite severe.

About Google Book Search

Google's mission is to organize the world's information and to make it universally accessible and useful. Google Book Search helps readers discover the world's books while helping authors and publishers reach new audiences. You can search through the full text of this book on the web at <http://books.google.com/>

NEDL TRANSFER



HN 1H2E V

ELEMENTARY
ELECTRICITY
AND
MAGNETISM
—
PAGE 108 AND BLANK

KD 145-80

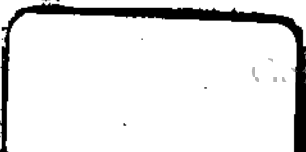
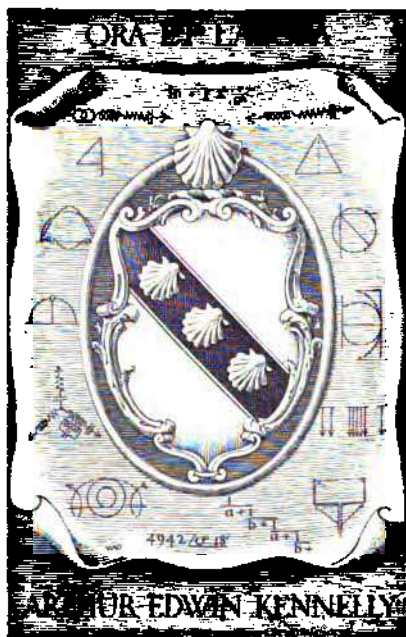

**ELEMENTARY ELECTRICITY AND MAGNETISM
AND THEIR APPLICATIONS**



THE MACMILLAN COMPANY
NEW YORK · BOSTON · CHICAGO · DALLAS
ATLANTA · SAN FRANCISCO

MACMILLAN & CO., LIMITED
LONDON · BOMBAY · CALCUTTA
MELBOURNE

THE MACMILLAN CO. OF CANADA, LTD.
TORONTO



BENJAMIN FRANKLIN (1706-1790).

Famous American statesman, scientist, and author; born in Boston; printer and publisher by occupation; made scientific studies in electricity as a diversion rather than as a profession. Introduced the terms positive and negative electricity; proved the identity of lightning and electricity by flying a kite in a thunderstorm; invented the lightning rod; originated the one-fluid theory of electricity.

AN ELEMENTARY BOOK
ON
ELECTRICITY AND MAGNETISM
AND THEIR APPLICATIONS

BY

DUGALD C. JACKSON, C.E.

PROFESSOR OF ELECTRICAL ENGINEERING
MASSACHUSETTS INSTITUTE OF TECHNOLOGY
MEMBER OF THE AMERICAN INSTITUTE OF ELECTRICAL ENGINEERS, ETC.

AND

JOHN PRICE JACKSON, M.E.

PROFESSOR OF ELECTRICAL ENGINEERING
PENNSYLVANIA STATE COLLEGE
MEMBER OF THE AMERICAN INSTITUTE OF ELECTRICAL ENGINEERS, ETC.

REVISED AND ENLARGED

BY

N. HENRY BLACK, A.M.

SCIENCE MASTER
ROXBURY LATIN SCHOOL, BOSTON
MEMBER OF THE AMERICAN INSTITUTE OF ELECTRICAL ENGINEERS, ETC.

New York

THE MACMILLAN COMPANY

1919

All rights reserved

60-55-

**HARVARD
COLLEGE
LIBRARY.**

**COPYRIGHT, 1902, 1919,
BY THE MACMILLAN COMPANY.**

Set up and electrotyped. Published April, 1919.

**Norwood Press
J. B. Cushing Co. — Berwick & Smith Co.
Norwood, Mass., U.S.A.**

PREFACE

THIS book is a new edition of Jackson and Jackson's **ELEMENTARY ELECTRICITY AND MAGNETISM**, which was first published in 1902. To meet present educational needs and to bring the subject matter up to date it has been rewritten and enlarged. Thus, much of the material on static electricity has been omitted, and the discussion of alternating currents and their applications has been greatly extended. The elementary style of the first edition has been retained, frequent use has been made of analogies, and the applications of principles have been shown at the points where the latter are discussed.

We have had in mind two types of readers: *first*, the student who has had one year's work in physics and who wants a course in Applied Electricity; and *second*, the general reader who is interested in or handles electrical machinery and who wants to know how and why it works. To-day there are great numbers of people who are in electrical businesses or are interested financially in electrical power plants and who need to have access to descriptive statements of the uses of various electrical machines. It is hoped that this book will in a measure bridge the gap between the electrical engineer and the general reading public.

To meet these various needs great effort has been made to state the fundamental principles so clearly that the reader will really know what the principle or law means in a practical sense. For this reason there are many illustrative examples worked out in the text and numerous groups of problems, not too difficult, based on electrical industries. At the end of each chapter we have placed a summary and a series of questions

which will greatly aid the student in reviewing and mastering the material therein. In these summaries we have aimed to make the phrasing brief and vivid so that it may be readily remembered and easily used.

We have endeavored to state the fundamental facts and theories relating to electricity and its present-day applications in such a way that any man who understands arithmetic and has had the elements of algebra and geometry can get the meat out of the book. Much time and thought have been expended in preparing the illustrations so that each one, as far as is feasible, tells its own story.

It is hardly necessary to state that suitable laboratory exercises should accompany the use of this book in schools. Such laboratory work should not only include the performance of the simpler electrical measurements but should aim to give the student some first-hand experience in running commercial electrical machines and a livelier conception of the phenomena treated of in the book. Small wooden or metal models as well as pictures, charts, and lantern slides of essential machine parts and instruments not used in the laboratory add an element of life and interest to classroom instruction as well as conduce to clearer conceptions on the part of the pupils. Every opportunity to extend one's acquaintance with electrical machinery should be taken by visiting power stations, repair shops, telephone exchanges, and various factories which use electrical machinery.

Abundant material has been supplied for a year's work in APPLIED ELECTRICITY, but, where the time for classroom instruction is limited, well-informed teachers may readily select the portions of the book which are most suitable for their purpose.

In a work of this sort it is quite impossible to mention all the books and men that have helped in its preparation. First of all the author of this edition acknowledges the great aid and

inspiration which the authors of the first edition have given him. To Professor W. H. Timbie of Wentworth Institute, Boston, both as a personal friend and as a maker of practical electrical textbooks, and to Mr. Elmer E. Burns of the Joseph Medill High School, Chicago, who through his books and apparatus has done much to make the teaching of alternating currents in high schools practicable, he is greatly indebted. The author is also under especial obligations to Mr. Charles O. Gibbon, assistant in Electrical Engineering at the Massachusetts Institute of Technology and instructor in the Franklin Union, Boston, for his correction of the manuscript, and to Dr. William Gallagher, Head Master of Thayer Academy, South Braintree, Massachusetts, for his untiring aid in the correction of the proof sheets and for his many helpful suggestions toward a clearer statement of the subject matter.

The author of this revised edition, however, is alone responsible for such errors as still remain, and will be sincerely grateful to any reader who will point out (1) *typographical errors*, (2) *matters which are not so clearly put as to be readily understood*, and (3) *subjects which should be added and those which might well have been omitted*.

Among the concerns and people that have coöperated in furnishing material for the illustrations are the following:

Allis-Chalmers Manufacturing Co., Milwaukee
American Telephone and Telegraph Co., New York
Boston Elevated Railway Co.
Boston Public Library
The J. G. Brill Co., Philadelphia
Edison Electric Appliance Co., Chicago
Edison Electric Illuminating Co. of Boston
Edison Storage Battery Co., Orange, N. J.
General Electric Co., Schenectady
Dr. Ariel W. George, Boston

Dr. James W. Hinckley, Boston
Hurley Machine Co., Chicago
Leeds & Northrup Co., Philadelphia
Lorain Steel Co., Johnstown, Pa.
Physical Laboratory, Harvard University
Simplex Electric Heating Co., Cambridge
Stone & Webster Engineering Co., Boston
Thomson Electric Welding Co., Lynn
Victor Electric Corporation, Cambridge
Wagner Electric Manufacturing Co., St. Louis
Walker Vehicle Co., Chicago
Westinghouse Electric & Manufacturing Co., East Pittsburg
Weston Electric Instrument Co., Newark, N. J.
Widener Library, Harvard University.

To Mr. James S. Conant of the Suffolk Engraving and Electrotyping Co., Boston, the author is greatly indebted for much patient care, ingenuity, and skill in preparing the illustrations.

N. HENRY BLACK.

January 1919.

TABLE OF CONTENTS

CHAPTER	PAGE
I. BATTERIES FOR PRODUCING ELECTRIC CURRENTS	1
II. ELECTRIC CIRCUITS AND THE FLOW OF ELECTRICITY. OHM'S LAW	31
III. ELECTRIC POWER AND HEATING EFFECTS OF ELECTRIC CURRENTS	66
IV. ELECTROMAGNETISM	84
V. NATURE AND PROPERTIES OF MAGNETISM	119
VI. ELECTROMAGNETIC INDUCTION	137
VII. ELECTRICAL MEASURING INSTRUMENTS	156
VIII. ELECTRIC MEASUREMENTS	181
IX. PRINCIPLES AND CONSTRUCTION OF DIRECT-CURRENT GENERATORS	199
X. DIRECT-CURRENT MOTORS	231
XI. ELECTROCHEMISTRY. STORAGE BATTERY	263
XII. PRINCIPLES OF ALTERNATING CURRENTS	302
XIII. INDUCTANCE AND CAPACITY IN ALTERNATING-CURRENT CIRCUITS	319
XIV. ALTERNATING-CURRENT GENERATORS	350
XV. TRANSFORMERS	371
XVI. ALTERNATING-CURRENT MOTORS	389
XVII. POWER STATIONS AND THE DISTRIBUTION OF POWER	411
XVIII. ELECTRIC LIGHTING	445
XIX. ELECTRIC HEATING	477
XX. ELECTRIC TRACTION	499
XXI. THE TELEPHONE	519
XXII. ELECTROMAGNETIC WAVES. RADIOTELEGRAPHY AND RADIOTELEPHONY	539
XXIII. ROENTGEN RAYS AND OTHER RAYS. MODERN THEORIES ABOUT ELECTRICITY	569

ELECTRICITY AND MAGNETISM

CHAPTER I

BATTERIES FOR PRODUCING ELECTRIC CURRENTS

Electricity at work — meaning of the word — fluid theory — difference of potential — electric current — voltaic cell — hydraulic analogy — units of current, resistance, and electromotive force: ampere, ohm, and volt — electric circuit, external and internal, open and closed — chemical action of cell — primary battery — voltage of cell — cells in series — defects, polarization, and local action — various types of commercial cells — source of energy in a battery.

1. **Electricity in the service of man.** Up to the beginning of the nineteenth century almost the only useful electrical invention was the lightning rod. Yet the people of the eighteenth century were fascinated by electricity and it was the most exciting topic with which scientific men dealt; but it was merely a plaything in laboratories. In the last half of the nineteenth century, as we shall see in the following chapters, electricity suddenly leaped into a commanding position in the arts and in engineering.

The electrical industries may be said to have had their birth and development within the last forty years — the telephone, electric light, electric motor, trolley cars, radiotelegraphy, electric transmission of power — all these have appeared and have become almost everyday affairs. Yet how few of us appreciate how these machines work. We are quite apt to dismiss the whole matter by saying that a machine runs by electricity.

2. Electricity. The exact nature of electricity, which makes itself evident in so many ways, has never been determined. Many surmises or theories have been advanced, but none has yet been able fully to stand the test of close examination. But by experimental evidence (which has been gathered for decades) we have been able to determine some of the laws which govern the action of electricity, although we do not know its constitution, very much as we have learned the laws of gravitation, although we do not know what "gravity" really is.

The meaning of the word "electricity" has developed parallel with the experimental growth of the science which bears its name. Springing from the Latin name for amber, *electricus* or *electrum*, the adjective **electrical** comes immediately from the word "electric," which was used in a book published in 1600 by Dr. Gilbert (a great scientist of Queen Elizabeth's reign) to designate the anciently observed attraction for light bodies like chaff and bits of paper which amber and similar substances exhibit when briskly rubbed.

From the word "electric" also comes the word **electricity**. Since the day Dr. Gilbert first applied the word "electric" to a particular phenomenon, our knowledge of all the sciences has widened, and the term "electricity" is now applied to cover a vast field of facts unknown either to the ancients or to Dr. Gilbert, but which are supposed to be based on the same underlying causes as the phenomenon exhibited by rubbed amber above referred to.

3. The nature of electricity. The action of electricity exhibited when amber or similar substances are rubbed led many experimenters who lived long after Gilbert to the belief that it was a **fluid** which was not perceptible to their senses. Our own great philosopher and statesman, Benjamin Franklin (Frontispiece), assumed it to be a fluid, and bodies which exhibited electrical manifestations were thought by him to con-

tain either more or less than a normal amount of the fluid. A Frenchman named Dufay and an Englishman named Symmer considered electricity to be composed of two fluids which were contained in neutral bodies in equal amounts. When by any means this equality was disturbed in a body, electrical manifestations occurred.

These theories, and a large number that were promulgated similar to them, are now discarded in the light of later scientific knowledge.* But *the conception of the fluid theory is very useful in giving a clear understanding of some of the phenomena of electricity*

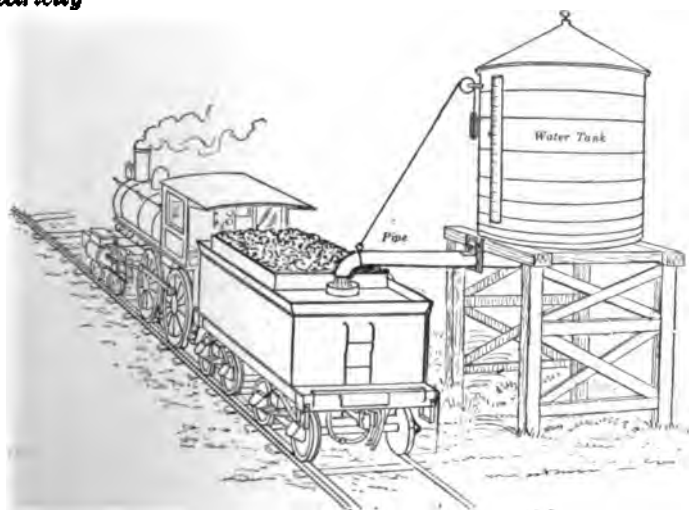

FIG. 1. — Difference of level tends to make water flow.

4. Difference of level or potential. Suppose we have a water tank mounted beside the railroad track for filling the tank of a locomotive tender, as shown in figure 1. It is evident at once from our ordinary experience that the water will flow

* Brief discussion of modern theories of electricity is given in Chapter XXIII.

from the tank down through the pipe and out into the tender. The water flows "downhill" on account of the difference in level, which causes a pressure or motive force. This hydraulic pressure or "head" is measured by the difference of level between the water in the tank and the water at the end of the pipe.

Similarly, if two pieces of metal, such as the binding posts or terminals of a dry cell, be maintained at different electrical states, this difference of condition causes a difference of electrical potential or **electromotive force** (e.m.f.), which in turn tends to make electricity flow. If a metal wire connects one binding post *A* in figure 2 with the other binding post *B*, electricity will flow through the wire, as is indicated by the ringing of the bell when the button is pushed. Such a flow of electricity is called an **electric current**. The means of setting up and maintaining such a current by chemical action will be described in this chapter.

Many of the simpler phenomena of electricity may be illustrated by the action of fluids, but the reader must carefully bear in mind that the comparison is merely for convenience, and that electricity is not a fluid, but *acts as if it were a weightless, invisible, noncompressible fluid permeating all space—saturating everything.* It must also be remembered that in using these comparisons we do not touch upon the true nature of electricity, which is not yet known, but only upon the laws of its action which have been experimentally determined. Also, that while water and gas may be directly perceived by our senses, electricity is absolutely impalpable,—that is, it

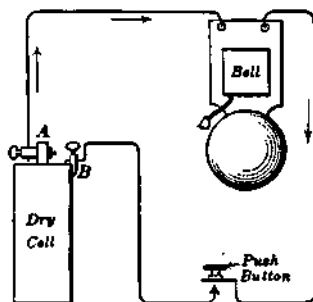

FIG. 2. — Difference of potential in the dry cell causes electricity to flow along the wire.

weightless, invisible, noncompressible fluid permeating all space—saturating everything. It must also be remembered that in using these comparisons we do not touch upon the true nature of electricity, which is not yet known, but only upon the laws of its action which have been experimentally determined. Also, that while water and gas may be directly perceived by our senses, electricity is absolutely impalpable,—that is, it



Alessandro Volta

1827

ALESSANDRO VOLTA (1745-1827).

Great Italian physicist, professor at Como and at Pavia; inventor of the first electric battery (voltaic pile) and various electrostatic instruments, such as the electroscope, the electrophorus, and the condenser; first one to measure the difference of potential arising from the contact of dissimilar substances; the volt, the unit of electromotive force, is named in his honor.



A. M. AMPÈRE.

ANDRÉ MARIE AMPÈRE (1775-1836).

French physicist and mathematician; professor at the Polytechnic School in Paris and later at the College of France; in 1820 began his experiments on the relations of electricity to magnetism; in 1823 published his great memoir on the magnetic effects of currents; first stated the rule for the relation between the direction of a current in a wire and the direction of the magnetic field about it. The ampere, the unit of intensity of current, is named in his honor.

cannot be directly perceived by our senses, — and the only way in which we may recognize it is by its various effects.

5. A simple electric cell. Suppose we take a tumbler and place in it a strip of zinc and a strip of copper so that they do not touch each other and then pour in some dilute sulphuric acid (Fig. 3). We observe that the copper plate is not affected by the acid while the zinc plate is soon covered with bubbles which rise to the top and the zinc plate is gradually eaten away.

Not only is there a difference in the chemical action of the acid on the two metal plates, but the two plates are maintained at different electrical states and an electromotive force exists between them which tends to cause a current to flow from one plate through a wire outside the liquid to the other. Therefore, if we connect the plates by wire containing an electric bell and push button as in figure 2, a current will flow through this wire from one plate to the other, as is indicated by the ringing of the bell.

It is customary to call the plate which is attacked the less readily by the liquid, in this case the copper, the **positive plate** (that is, the one of higher potential). Therefore in figure 3 the terminal attached to the copper plate is marked (+) and the zinc (-) and *the electric current is assumed to flow in the wire from the copper to the zinc.*

A little more than a hundred years ago an Italian scientist named Volta (Plate I, opposite page 4) discovered that an electromotive force may be set up through such an arrangement and so the latter is often called a **voltaic cell**. This discovery lies at the foundation of a great deal of our electrical work of to-day and is thus worthy of a little more study.

Almost any two electrical conductors might be used for

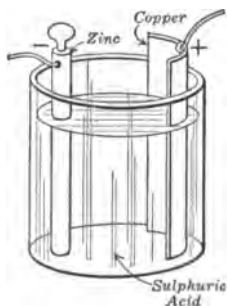

FIG. 3.—A simple electric cell.

the plates instead of zinc and copper, but the two plates must not be of the same material. Likewise, other liquids might be used in the place of the sulphuric acid, but it is necessary that the liquid should attack one of the metals chemically. In order to get a current of electricity it is necessary to furnish a complete conducting path or ring. Such a path through which the current flows is called an electric circuit. That portion of the circuit which is outside the cell, including the electric bell, push button, and connecting wires, is called the **external circuit**; that part which is within the cell itself, such as the plates and liquid, is called the **internal circuit**. The arrows show the direction of the current, and it will be noted that the current in the external circuit flows from the copper to the zinc through the metal wires and that its path is completed by the internal circuit from the zinc to the copper through the liquid. If we sever the wires outside the liquid, that is, **break the circuit**, the electromotive force will still remain but no current can then flow because the conducting path is broken. If we again join the wires, that is, **make or close the circuit**, the current again can and does flow.

6. Hydraulic analogy. The action of a voltaic cell, such as has just been described, may be compared, in a rough but handy analogy, to a pump for circulating water through a system of pipes. *A cell may be considered as a machine for pumping electricity.*

Suppose two deep tanks, *A* and *B* in figure 4, are placed at different levels with a pump *P* connected in a pipe leading from the bottom of one to the bottom of the other. If the tanks are partly full of water and the pump is started, water will be drawn from one tank *B* and sent into the other one *A*, thus raising the water level in the latter. If an overflow pipe is carried from the one tank to the other, the overflow will run back into the depleted tank, and the water will simply be circulated by the pump in a current flowing through the system of pipes and the two tanks.

This is similar to the conditions in an electric cell when the positive and negative terminals are connected by a wire, as illustrated in figure 2.

Now, if the overflow pipe is closed by a valve *V*, the pump will soon empty the tank *B*, after which it may continue to run, but it cannot pump any water, and no current of water will flow through the pipes.

In the same way, if the two terminals of an electric cell are not connected by a wire, the plates will be maintained in different electrical states (that is, their difference of electrical level or the electromotive force is maintained), but the action of the cell in circulating electricity must cease until a closed path is provided along which the current may flow.

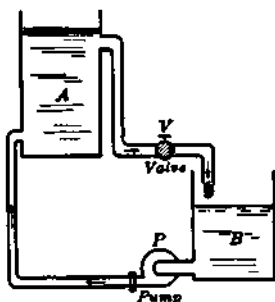

FIG. 4. — Hydraulic analogy of a voltaic cell.

7. Unit of current. The ampere. The quantity of water circulated by the pump in a unit of time depends upon the pressure which the pump produces and the size of the connecting pipes; and a similar rule holds for the circulation of electricity by an electric cell. The rate of the stream or current of water may be designated as a certain number of gallons or cubic feet per second. In the same way the rate of a current of electricity may be designated as one which conveys a certain quantity of electricity per second. The unit of quantity of electricity is called a coulomb in honor of the French scientist named Coulomb. The methods by which such a quantity of electricity may be measured are explained in Chapter VIII. *An electric current carrying one coulomb per second is called a current of one ampere*, and the intensity of an electric current or its rate of flow is generally given in *amperes*. This name was given in honor of a great French scientist who was called Ampère (Plate II, opposite p. 5).

In our study of electrical machinery we shall almost always be concerned with *electricity in motion*, for electricity at rest (static electricity) has few effects of practical value. Therefore we shall be studying not quantities of electricity but *currents of electricity* and shall constantly use the term *ampere*, and rarely the term *coulomb*.

FOR EXAMPLE, a new dry cell when short-circuited with a short stout wire causes about 20 amperes to flow through the wire. A 40-watt tungsten lamp takes less than half an ampere, while the arc lamps used for street lighting require from 5 to 10 amperes. A telephone receiver operates on less than 0.1 amperes, while the motor on a street car often takes as much as 40 or 50 amperes.

8. Electrical resistance. We are familiar with the fact that a stream of water flowing through a pipe is held back or retarded by the friction of the pipe. If the pipe is small and rough, we know that it offers a large resistance to the flow of water through it. In a similar way *electrical resistance is the opposition which is offered by electrical conductors to the flow of current*. We divide substances into two classes, conductors and nonconductors or insulators; but even the best conductors of electricity are not perfect. This means that all conductors offer some resistance to the flow of electricity and transform part of the energy which they carry into heat.

The electrical resistance of a conductor depends upon four factors:

(1) The *material* used; iron, for example, has nearly seven times as much resistance as copper;

(2) The *length*; a wire 10 feet long has twice as much resistance as a wire 5 feet long;

(3) The *size* of the wire, that is, the area of cross section; a wire 0.04 inches in diameter has four times the cross-sectional area, and hence one fourth the resistance of a wire 0.02 inches in diameter;

(4) The *temperature*; heating a copper wire from 0° to 100° C. increases its resistance about 40 per cent.

9. Unit of resistance. The ohm. The practical unit of resistance is the ohm, which is named after the German scientist, Dr. Ohm, who first set forth the law of electric currents, which will be discussed in the next chapter.

FOR EXAMPLE, 1000 feet of No. 10 copper wire has a resistance of almost precisely an ohm. About 157 feet of No. 18 copper wire (the size ordinarily used to connect electric bells) or 26 feet of iron wire or 6 feet of manganin wire of the same size has a resistance of 1 ohm. A 2½-inch vibrating bell will ordinarily have a resistance somewhere between 1.5 and 3 ohms, a telegraph sounder about 4 ohms, a relay 200 ohms, a telephone receiver 60 ohms, and a 40-watt Mazda lamp 300 ohms when hot.

10. Electromotive force. Voltage. In hydraulics we know that to get water to flow along a pipe it is essential to have some driving or motive force such as that furnished by a pump. In much the same way, to get electricity to flow along a wire we must have an electromotive force such as that furnished by a battery or dynamo. The unit of electromotive force is called the volt, after the Italian scientist Volta, who discovered the chemical means for producing electric current. *A volt may be defined as the electromotive force needed to drive a current of one ampere through a resistance of one ohm.*

FOR EXAMPLE, one volt is about the electromotive force of a simple cell made of zinc and copper plates and dilute sulphuric acid. A common dry cell gives about 1.5 volts and a storage cell about 2 volts. The current for lighting a building is usually delivered at 110 or 220 volts, and street cars operate on about 550 volts.

The term "electromotive force," abbreviated e.m.f., is sometimes called voltage or difference of potential. Each of these terms means the same thing and designates the "push" that moves or tends to move electricity.

11. Distinction between volts and amperes. The intensity of an electric current is measured in amperes, the electromotive force driving the current is measured in volts. In a given

circuit the greater the electromotive force is, the greater is the current. We know that we must have a certain "head" of water in order to get a given number of gallons of water to flow through a given pipe per second; so we must have a certain electromotive force to make a given current of electricity flow through a given wire. With both water and electricity we must have a motive force in order to have a current, but we may have the motive force and yet have no current. If the valve is closed in the water pipe or the switch is open in the electric circuit, we might have motive force (volts) but no current (amperes).

Throughout our study of electricity we shall have very much to do with the flow of electricity along a conductor and so it is of the utmost importance that we get a clear conception of these three things:

- (a) current (rate of flow of electricity),
- (b) resistance (opposition which regulates the flow),
- (c) voltage (moving force which causes current to flow).

The following table will help to fix the meaning of the units, ampere, ohm, and volt.

UNITS	WATER	ELECTRICITY
Quantity	Gallon	Coulomb
Current Quantity per second.	Gallon per second	Ampere Coulomb per second.
Resistance	(no unit)	Ohm
Motive force	"Feet of head"	Volt

12. Energy expended in continuous flow. When two insulated metal bodies at different electrical potentials are connected by a wire, a brief current flows; just as a current of water flows through the pipe connecting two tanks in which

water stands at different levels; but the current ceases as soon as the pressure is equalized. *In order that a continuous current may be produced a difference of electrical potential or voltage must be continuously maintained in a closed circuit.* If some method is used to maintain the difference of potential or electromotive force (as would be the case if we kept pumping the water from the lower to the higher vessel in our analogy of vessels of water connected by a pipe), the flow of electricity will be continuous. One method of accomplishing this is by means of the electric cells which have grown out of Volta's discovery and which may be considered for convenience as chemical engines for pumping electricity from a lower potential to a higher.

If we desire to have a continuous flow of water from one vessel to another at a lower level, it is necessary to keep refilling the higher vessel as water runs out of it. To do this the water must be raised from the lower level to the higher, which means that work must be performed to raise the water. There are various ways in which this work may be done: we may divert rain water or a flowing stream into the higher vessel, thus utilizing the effects of the energy from the heat of the sun, by means of which the water was raised from the earth to become clouds; we may pump the water directly from the lower vessel to the upper one by means of a pump driven by a steam engine, thus utilizing the energy of the steam, which was given to it from the heat of the burning coal.

We may then say that it requires a continuous expenditure of energy to keep water in circulation. Some of this energy may be recovered by putting water motors in the pipe through which the water flows from the higher to the lower vessel, but much of the energy is lost by friction in the pipes and pump.

In the same way, *it requires a continuous expenditure of energy to keep an electric current flowing, and this energy may be gained from the chemical action resulting from dissolving zinc or some other metal in an electric cell.*

13. Chemical action of an electric cell. We have already seen that a cell consists of two different electrical conductors, one the copper (or the carbon which often replaces it), called the **positive electrode** or **cathode**, and another the zinc, called the **negative electrode** or **anode**, and a solution of some acid or salt called the **electrolyte**. In general it can be said that the electric current depends on the difference in chemical action of the electrolyte on the two electrodes.

In chemistry we learn that sulphuric acid is made up of two atoms of hydrogen, one atom of sulphur, and four atoms of oxygen, as expressed by the formula, H_2SO_4 . When sulphuric acid is dissolved in water, some of it breaks up into positive and negative ions; thus $2H^+$ and \overline{SO}_4 .

When zinc (Zn) is placed in the acid, a little of it dissolves, becoming zinc ions (Zn^{++}), which unite with the sulphate ions (\overline{SO}_4) to form zinc sulphate ($ZnSO_4$). The displaced hydrogen ions ($2H^+$) give up their charge and rise to the surface as hydrogen (H_2) bubbles.

But when the circuit is closed by connecting the electrodes with a conducting wire, then the hydrogen ions migrate through the electrolyte to the copper plate and give up their charge to this plate and rise to the surface as gas bubbles. It will be noted that the *positively* charged part of the electrolyte ($2H^+$) goes with the current through the cell.

In this way an electric current will flow through the wire from the copper to the zinc as long as the chemical action is maintained. Thus we see that it is the energy of the chemical action which forces the electricity to run "uphill" inside the cell. In short, *an electric cell is merely a device for transforming chemical energy into electrical energy.*

In a good commercial cell the chemical action takes place only when the cell is delivering electrical energy. The rate at which this energy is delivered by the cell determines the rate at which the zinc is used up; just as the rate at which steam energy is delivered by a boiler determines the rate of coal consumption. *Zinc then is the fuel of the electric cell.*

14. What determines the voltage of a cell? The magnitude and direction of the electromotive force or voltage between the electrodes of a cell depend upon the materials in the plates and the character of the electrolyte. For instance, if zinc and copper compose the plates of a cell containing dilute sulphuric acid, the voltage of the cell is about nine tenths of a volt and the copper plate is the positive electrode. If two cells are made with dilute sulphuric acid as the liquid, using zinc and lead for the plates of one cell, and lead and copper for the plates of the other, the lead is the positive plate in the former and the negative plate in the latter. Also, the voltage developed in each of these is less than in the case of the zinc-sulphuric acid-copper cell.

In cells which are to be obtained from dealers, *the negative electrodes are nearly always of zinc, the positive electrodes are usually of carbon or copper.* The liquids, however, consist of various acids, or solutions of sal ammoniac, caustic soda, or blue vitriol in water.

The voltage of a cell depends only upon the nature of the plates and the liquid, and *is entirely independent of the size of the plates.*

If we connect a simple cell, such as the copper-sulphuric acid-zinc cell described in section 5, to a high-resistance galvanometer or the more convenient direct-reading voltmeter, we note the voltage of the cell. If we move the plates as far apart as possible in the jar and again note the voltage, we find that the distance between the plates does not seem to affect the electromotive force of the cell. Finally, if we lift one plate slowly until it is nearly out of the liquid, we find that the area of the plates immersed does not seem to affect the electromotive force of the cell.

In general then the size of a cell makes no difference in its voltage.

15. Electric battery. Cells in series. An electric battery is a group of two or more cells. Broadly speaking, a battery

is a group in which similar units are assembled to serve a common end; thus we speak of "a battery of boilers" or "a battery of artillery," but it is not correct to speak of one cell as a battery.

An electric battery may be composed of primary cells or secondary cells. A **primary cell**, such as a voltaic cell or dry cell, has a negative electrode or anode (zinc) and the electrolyte, which are consumed or used up in producing current. Often they can be replaced when they are exhausted and then the cell is as good as new. A **secondary cell** is a storage cell or accumulator. This will be described more fully in Chapter XI, but it may be stated here that in a storage cell, instead of replacing the worn-out negative plate, we send a current from an outside source through the cell in the reverse direction and thus restore the plates and the electrolyte to their original condition.

If a number of cells, such as the zinc-sulphuric acid-copper cell described above, are connected in a series so that the zinc

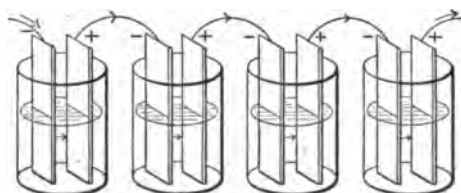

FIG. 5. — Four voltaic cells connected in series.

electrode of the one is connected with the copper electrode of the next, and so on (Fig. 5), then the total voltage measured between the free copper

plate at one end of the set and the free zinc plate at the other is equal to the *sum of the voltages developed by the individual cells*. When a battery is connected in this manner so that the voltages developed in the individual cells are all added together, the cells are said to be **connected in series**.

16. Polarization. It was soon found that Volta's simple cell has a great defect which shows itself whenever the terminals are connected by a wire; namely, the current does not remain

constant but rapidly becomes weaker. This is due to polarization.

Let us set up a zinc-sulphuric acid-copper cell and connect it to an electric bell. When the circuit is first closed, the bell rings loudly, but it soon weakens and after a time ceases to ring altogether. If we examine the cell, we find that the copper plate is coated with little hydrogen bubbles. We may restore the cell by lifting the copper plate out of the acid for a moment, or by brushing off the hydrogen bubbles. *This collecting of hydrogen bubbles on the positive plate is called polarization.*

In a similar way we may also show polarization in a carbon-sulphuric acid-zinc cell, but in this case we can easily restore the cell by pouring into the acid a solution of potassium bichromate, a substance rich in oxygen. This increases the current because the hydrogen is taken up chemically by the oxidizing agent.

The effect of the hydrogen bubbles is twofold: *first*, they form a gaseous coating on the copper or carbon plate. This layer of hydrogen is a poor conductor of electricity and therefore weakens the current. *Second*, the hydrogen layer has a slight battery action of its own, tending to send a current in the direction opposite to that desired, and this also weakens the current delivered by the cell.

17. Depolarization. In order that a cell may be capable of working continuously, some plan must be adopted to keep it from polarizing; or, as it is often called, to keep it depolarized. This may be effected in *three* different ways: *first*, by mechanical action, which removes the hydrogen from the positive plate; *second*, by direct chemical action, which absorbs the hydrogen; *third*, by electrochemical action, by which the hydrogen is exchanged for a metal which is deposited upon the positive plate.

In all cells that use a mechanical method of depolarization and in many that use a chemical depolarizer, the depolar-

izing is effected so slowly that the cells cannot give a long-continued steady flow of current, and for that reason they are called **open-circuit cells**. These cells are extensively used for ringing bells, for setting signals, for telephones, etc., where the work is intermittent and the cells have time to regain a proper working condition while resting between the periods of activity.

A majority of the cells making use of the electrochemical methods of depolarizing have no tendency to polarize, and

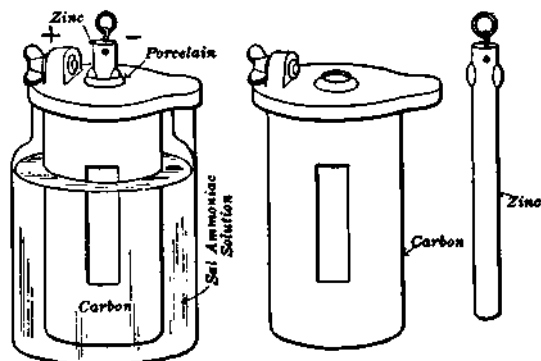

FIG. 6. — Carbon cell with zinc rod in sal ammoniac solution.

may therefore be used continuously. Such cells are called **constant or closed-circuit cells**.

The first method of depolarizing requires that the hydrogen bubbles be cleared off the positive plate as fast as they are deposited upon it. This may be done by continually stirring the liquid or by blowing air into it. If the positive plate is well roughened, the hydrogen bubbles will not adhere to it so closely, but many will float off to the surface of the liquid and escape. This plan was employed in a cell commonly called *Smee's cell*, which was used commercially many years ago, but it was not very successful.

There are also cells used for ringing bells, etc., which depend

entirely upon the use of a large positive plate surface to lessen the rapidity of polarization. It is evident that such cells can be used only intermittently. Figure 6 shows such a cell. It consists of zinc and carbon electrodes immersed in a solution of sal ammoniac (the scientific name is ammonium chloride). The carbons are made with very large surfaces.

18. **Chemical depolarization.** If some substance is added to the liquid of the cell which will combine with the hydrogen as quickly as it is formed, the polarization will evidently be avoided. This is the foundation of the second method of depolarizing. Various substances may be used for this purpose, such as manganese dioxide, potassium bichromate, and sodium bichromate. The *bichromate battery*, which is often used for experimental purposes in isolated places where no form of electric power is available, is a zinc-carbon battery with a liquid composed of sulphuric acid in which potassium bichromate or sodium bichromate has been dissolved. When this cell is in operation, polarization is prevented by the immediate combination with the potassium bichromate of the hydrogen which is liberated from the sulphuric acid. Carbon is used for the positive plate in this cell because the bichromate of potash will attack and

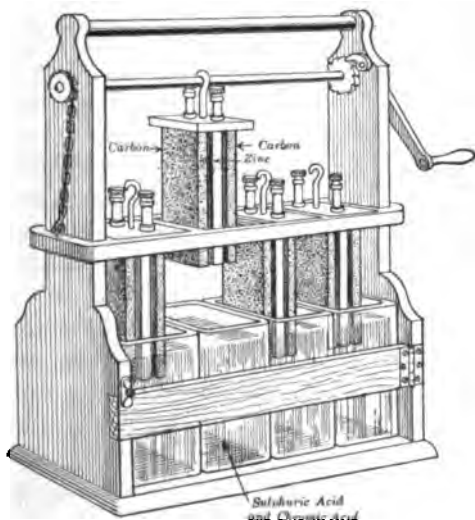

FIG. 7. — Plunge battery with four bichromate cells.

is available, is a zinc-carbon battery with a liquid composed of sulphuric acid in which potassium bichromate or sodium bichromate has been dissolved. When this cell is in operation, polarization is prevented by the immediate combination with the potassium bichromate of the hydrogen which is liberated from the sulphuric acid. Carbon is used for the positive plate in this cell because the bichromate of potash will attack and

destroy copper. In the bichromate battery the zincs are generally arranged so that they may be lifted out of the fluid when the cells are not in use, because the fluid eats up zinc when the circuit of the cell is open. From this comes the name *plunge battery* (Fig. 7).

The ordinary proportions in which the solution for this type of battery is made up are as follows, the parts being measured by weight :

180 parts of water

25 parts of commercial sulphuric acid

12 parts of bichromate of potash, or bichromate of soda.

The crushed bichromate should first be dissolved in the water at boiling temperature, after which the acid may be added slowly to the cooled solution. *Always* add the acid to the solution ; *never* add the solution to the acid, as serious burns are apt to result.

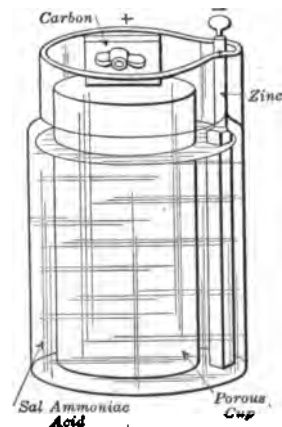

FIG. 8. — Leclanché cell with porous cup.

When manganese dioxide is used as a depolarizer, it is generally broken up into small lumps and put into a porous cup surrounding a positive plate of carbon. When sal ammoniac dissolved in water is used as the liquid in this form of cell, it makes the familiar Leclanché cell (Fig. 8), which is frequently used for ringing door bells and doing similar service. Sometimes the manganese dioxide is pulverized and placed inside of the carbon positive plate and the porous cup is

omitted (Fig. 9). In this case the zinc is bent into a cylinder around the carbon electrode. The depolarizing effect of the manganese dioxide is not, however, sufficiently powerful to prevent a cell from becoming polarized if used continuously. Consequently, Leclanché cells are satisfactory only in service which is intermittent, such as ringing door bells, where the circuit is open a large part of the time and the battery rests without

chemical action. Leclanché cells are called *open-circuit cells* on account of the small chemical action which goes on in them when the circuit is open, and because they are not satisfactory in continuous service.

19. Electrochemical depolarization. Daniell cell. The third method of depolarizing introduces more complicated chemical reactions, but concerning these we need not give much detail. By this method cells are constructed which give excellent results in continuous service, and which are, therefore, called *closed-circuit cells*. One of these is probably the most commonly used of any form of wet battery. This is the ordinary *gravity battery*, or copper sulphate battery, which is so much used in telegraphy.

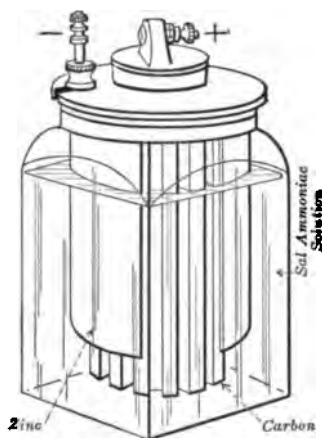

FIG. 9. — Sal ammoniac cell with depolarizer placed inside carbon and with zinc outside.

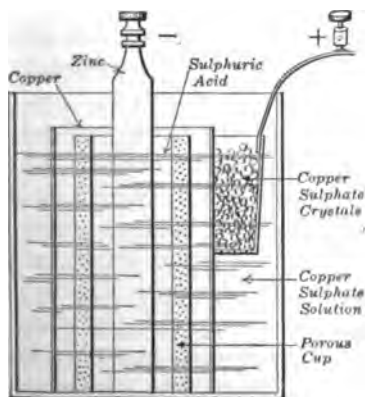

FIG. 10. — Daniell cell.

The original Daniell cell (Fig. 10), from which the gravity cell came, is still often used in experimental work when a constant voltage is needed in electrical measurements. The active liquid is dilute sulphuric acid in which is immersed the zinc or negative plate. The copper plate is immersed in a depolarizing solution of ordinary copper sulphate or blue vitriol (sometimes called bluestone). The

two solutions are separated by a porous cup made of unglazed porcelain. In general terms, the chemical action which occurs when the battery is working is as follows: the sulphuric acid attacks the zinc, and zinc sulphate is formed. At the same time hydrogen is liberated from the sulphuric acid and goes with the electric current toward the copper plate, where it would be deposited if it were not for the copper sulphate which surrounds the copper plate. When the hydrogen gets into the copper sulphate solution, it goes into chemical combination, and copper is separated from the solution and deposited upon the copper plate, which is accordingly kept bright and in good working condition.

During the operation of the cell the chemical action, which has been briefly explained, causes a change in the character of the solutions. The sulphuric acid in its action on the zinc changes to a solution of zinc sulphate, and the copper sulphate changes to sulphuric acid. If the sulphuric acid is replaced by a dilute or weak solution of zinc sulphate, a current is set up as before, and the chemical action is similar, but the copper sulphate is converted into zinc sulphate. In order that the depolarizing action may continue during the life of the cell, the strength of the copper sulphate solution must be kept up. This is done by putting crystals of copper sulphate or blue vitriol into the cell so that they may be dissolved.

20. Gravity or crowfoot cell. In the commercial modification of the Daniell cell the sulphuric acid or zinc sulphate solution is ordinarily much *diluted* or weakened by water, while the copper sulphate solution is kept quite concentrated or saturated. When in this condition, the solution of zinc sulphate is lighter than the other and will float upon it, just as oil floats on water. Consequently, if the copper plate, surrounded by the solution of copper sulphate, is placed in the bottom of a battery jar, a weak solution of zinc sulphate or dilute sulphuric acid may be carefully poured on top, and the

solutions will mix only very slowly. The zinc in the shape of a crowfoot is hung from the top of the jar in the upper solution (Fig. 11). This is called the gravity cell, because the solutions are separated by gravity through the difference of their densities instead of by a porous cup.

In setting up such a cell it is usual to put the copper in the bottom of the jar surrounded by crystals of copper sulphate. The jar is then filled with water nearly to its top, and the zinc is immersed in the upper part of the liquid. The cell may be placed on short circuit for a time by connecting the positive terminal directly with the negative terminal by a short piece of wire, and it will work itself into good operating condition; or a little sulphuric acid or zinc sulphate solution may be carefully poured into the water, and the cell will at once be in condition.



FIG. 11. — Gravity or crowfoot cell.

If a gravity cell is allowed to stand with the circuit open, the two solutions will slowly mix by diffusion. When any of the copper sulphate solution reaches the zinc, a black deposit of oxide of copper is made upon it. This puts the cell in such condition that it will not work satisfactorily until the zinc has been cleaned. When the cell is in operation, the copper sulphate is changed into zinc sulphate so rapidly that it gets no chance to mix with the latter. A gravity battery, therefore, is satisfactory only in service which keeps it constantly working. For this reason and also because it does not polarize in the least, it is called a closed-circuit battery. When not in use, the gravity cell should be short-circuited through a resistance of from 300 to 400 ohms.

21. Dry cell. During the last few years, what is called a "dry" cell has come into extensive use for open-circuit or intermittent work, like ringing bells, operating telephones, operating signal devices, flash lights, and for ignition on gas engines. This type of cell, which is really a modification of the Leclanché cell, has zinc and carbon electrodes, while the electrolyte is in the form of a paste instead of being liquid as in the ordinary cells. The zinc plate is commonly made in the form of a deep cup, which is also the containing vessel (Fig. 12). About 80 per cent of the dry cells manufactured in this

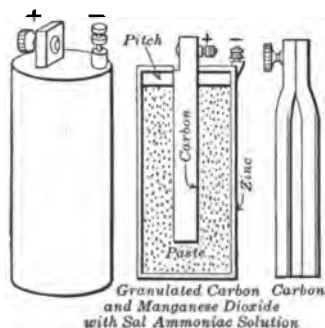

FIG. 12. — Dry cell, showing inside construction.

country are made with this zinc can 6 inches high and 2.5 inches in diameter. In the middle is the carbon electrode, which may be either cylindrical or fluted. The zinc can is lined with an absorbent layer of pulp board or blotting paper which is saturated with a solution of sal ammoniac and zinc chloride. The zinc chloride is necessary to reduce the rapid deterioration which would otherwise take place on open circuit. The

space between the lining and the carbon electrode is filled with a mixture of granulated carbon and manganese dioxide. This latter is used as the depolarizer. The top of the cell is generally sealed up with a pitch composition. This cell has a voltage of about 1.5 volts and will polarize rapidly if kept long on closed circuit.

There are a great many dry cells with pastes of various modified compositions now on the market, and they have proved themselves very convenient and effective.

22. How long will a dry cell last? The "life" of a dry cell is not a fixed quantity, but depends on the circuit in which

it is used. Oftentimes dry cells which are merely standing on a shelf for a year and not being used at all will dry up and become practically useless. Sometimes a battery of 5 dry cells, such as would be used for gas-engine ignition, which is in pretty constant use, will last a couple of months. The working life of a dry cell is extended by arranging the circuit so that the current drawn from any one cell will be small. The effective life of a dry cell also depends on the length of time that it is left on open circuit, which gives it a chance to depolarize.

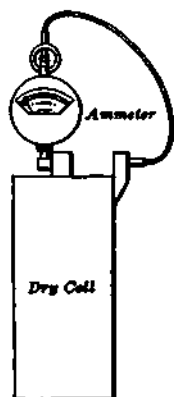

FIG. 13.—Testing a dry cell with pocket ammeter.

A new cell of good manufacture should, when tested, give a short-circuit current of at least 15 amperes and not more than 25 amperes (Fig. 13). A cell giving more than 25 amperes will probably polarize rapidly, and one giving less than 15 amperes is likely to be made of poor materials. Cells not in use should be stored in a cool place; this prevents rapid evaporation.

Recently there has been put on the market a modified form of dry cell called the Burn Boston Battery. This (Fig. 14) is built very much as the regular dry cell, except that it is made really dry, and when it is ready to be used, and not until then, the water is added through a pinhole in the top. It is claimed that such a cell will keep for any length of time and in any climate.

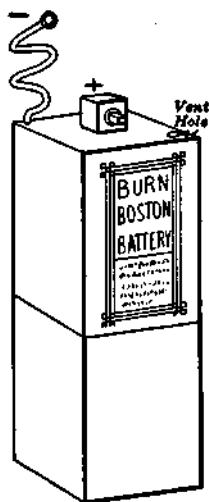

FIG. 14.—Burn Boston Battery.

23. Edison primary cell. The positive electrode in this cell (Fig. 15) is a plate of compressed copper oxide which has a

surface reduced to metallic copper. The negative electrode is zinc, and the electrolyte is a concentrated solution of sodium hydroxide (caustic soda). The hydrogen reduces the copper oxide to metallic copper and thus does not polarize the cell. To prevent the evaporation of the solution, as well as to stop the formation of "creeping" salts, a layer of heavy mineral oil is placed on the top of the electrolyte. The construction is made very rigid by fastening the positive and negative plates firmly to the top of the containing jar. This jar is made of enameled steel and the plates are separated by porcelain spacers.

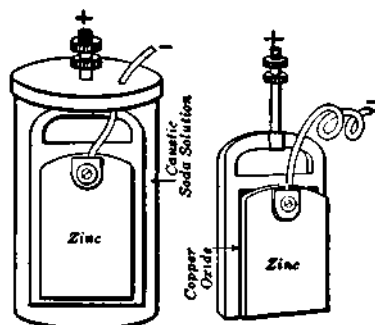

FIG. 15. — Edison primary cell.

This type of cell may be left set up for months without deterioration and is therefore suitable for open-circuit work. But it is also largely used on closed-circuit work such as in some systems of telegraphy and in alarm circuits, because it can be so designed that all the constituents are exhausted at the

same time. Although the voltage of this cell is low (about 0.75 volts), yet its resistance is also low and thus it is capable of producing large currents. For example, a battery designed to deliver 7 amperes for 85 hours (a 600-ampere-hour battery) would give over 40 amperes on short circuit.

24. Local action. In nearly all cells some chemical action by which the zinc is wasted goes on even when the main circuit is open. This may also proceed while the main circuit is closed without adding to the useful current in the cell. Such wasteful chemical action is called *local action*. It is usually caused by bits of impurity, such as carbon or iron, on the surface of the zinc, which form little local cells with the other

portions of the zinc (Fig. 16) and thus continually eat it away in spots. This action may be seen by placing a piece of ordinary commercial zinc in dilute sulphuric acid, when chemical action takes place which is similar to that described above in the case of a cell generating a current, and the zinc is dissolved; while, if the zinc is chemically pure (that is, does not contain any impurities), the action does not occur.

Local action is also caused in some cells by differences in the density of the liquid at various parts of the cell. In this case, the zinc near the top of the liquid is ordinarily wasted away, and it may be entirely eaten off. This will often be observed in cells with sal ammoniac solution which are used for ringing door bells.

25. Amalgamation. Local action caused by impurities may be largely avoided by **amalgamating** the zinc; that is, by *alloying its surface with mercury*. For this purpose the zinc is cleaned by dipping it into a dilute acid solution, and then it is rubbed with mercury, which makes a pasty alloy on its surface. The impurities in the zinc do not readily form an amalgam with the mercury and are therefore covered up, while pure zinc is brought to the surface. As the zinc is eaten away, the mercury remains and combines with the zinc below, thus keeping the zinc plate in good condition until it is practically all used up.

Zinc electrodes may be conveniently amalgamated by immersing them in a saturated solution of mercury in equal volumes of nitric and hydrochloric acids and water. The zinc is at the same time cleaned and evenly amalgamated. After removal from the solution the electrode should be rinsed in water.

Zinc plates, or zincs for batteries, are also sometimes cast with a small percentage of mercury in their composition,

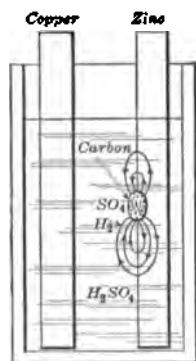

FIG. 16. — Local action in a cell.

which is intended to take the place of amalgamation. The mercury seems to cover all impurities and to present only pure zinc at the surface.

26. Amount of chemical action in a cell. The amount of metal, such as zinc, usefully consumed in a cell depends directly upon the quantity of electricity (coulombs) which is permitted to pass through the electrolyte. The amount of hydrogen gas, copper, or other metals liberated from the liquid also depends upon the number of coulombs of electricity which pass through the cell. This may be stated as a general law of electrochemical action: *the amount of chemical action in a cell depends directly upon the amount of electricity which passes through it, and therefore the chemical action is the same in all the cells of a number connected in series, since the same amount of current will flow through them all.*

The weight in grams (metric measure) of a metal which is dissolved or deposited when one coulomb of electricity passes through a cell, is called the **electrochemical equivalent** of the metal.

A table which shows the electrochemical equivalents of various chemical elements expressed in *grams per ampere hour* is included in Chapter XI.

27. Value of zinc as a fuel. One of the effects of chemical action is to give out heat. When wood or coal is burned, the carbon of the burning material combines with oxygen from the air, and heat is given out as the result of the chemical combination which we call combustion or burning. In the same way, if zinc is dissolved in sulphuric acid, the acid combines with the zinc, and heat is given off as the result of the chemical combination. This heat represents a certain **energy** or *capacity for doing work*. It has been found that, under the conditions already described, *the energy represented by chemical action may be converted into an electric current*, and, by taking advantage of this, we get *electric cells*.

In nearly all primary cells the metal which is consumed is zinc. The law of electrochemical action already stated shows that no current can be produced without an equivalent consumption of metal, just as no heat can be given out from an ordinary fire without an equivalent consumption of coal or wood.

The consuming of zinc in a primary cell to furnish electrical power in the form of an electric current is similar to the burning of coal under a boiler to furnish steam power. It can be readily seen that zinc makes an expensive fuel, even though the consumption of a pound of zinc in a battery produces several times as much energy as is produced by the combustion of a pound of coal in the furnace of a boiler; and, moreover, primary cells in which zinc is consumed cannot be used commercially to furnish electricity where currents of great magnitude are required, as on electric railways.

For such purposes the battery can never compete with the dynamo driven by a steam engine, unless a cell is invented in which coal may be economically consumed in the place of zinc and the heat due to the combustion of coal may be directly transferred into electrical energy; or, until a cyclic system is commercially developed in which the metal dissolved in the battery may be recovered through the action of electric currents generated by water power. If this is ever done, the electric battery will displace the steam boiler and engine; but *batteries in which zinc is consumed can never economically furnish current for light and power.*

On the other hand, there are many domestic operations such as ringing electric bells, regulating dampers, etc., in which primary batteries can continue to fill an important place. In telephony and telegraphy and in other commercial applications of electricity and magnetism on a large scale in which comparatively weak currents are required, they are also used in large numbers.

SUMMARY OF CHAPTER I

PRIMARY CELL transforms chemical energy into electrical energy. It consists of two unlike conductors (electrodes) immersed in a fluid (electrolyte) which attacks one of the electrodes (negative) chemically.

TYPICAL COMMERCIAL CELLS

TYPES OF CELLS	ELECTRODES		ELECTROLYTE	e.m.f., volts	INTERNAL RESISTANCE ohms
	Positive	Negative			
Gravity	Copper	Zinc	Zinc sulphate Copper sulphate	1.0	0.1-6
Leclanché	Carbon	Zinc	Ammonium chloride	1.5	1-6
Edison-Primary	Copper oxide	Zinc	Sodium hydroxide	0.76	0.02-0.1
Dry Cell	Carbon	Zinc	Ammonium chloride and zinc chloride	1.5	0.04-0.5

ZINC IS THE FUEL CONSUMED in batteries. Its cost is so high that it prevents the extensive use of batteries as a source of electric power.

POLARIZATION is the formation of hydrogen bubbles on the positive plate, which reduces the current. This is prevented by using a two-fluid cell, such as the Daniell cell, which is used for constant-current work. It is reduced by putting into the electrolyte oxidizing agents, such as manganese dioxide and copper oxide, but these act so slowly that cells can be used only on intermittent service.

BATTERIES FOR PRODUCING ELECTRIC CURRENTS 29

LOCAL ACTION is set up when there are impurities on the surface of the zinc. These impurities (with fluid and zinc) form little local cells, which use up zinc without furnishing useful energy. This defect is largely remedied by amalgamation of the zinc.

ELECTRICAL UNITS:

QUANTITY measured in **COULOMBS**

CURRENT measured in **AMPERES**

ELECTROMOTIVE FORCE measured in **VOLTS**

RESISTANCE measured in **OHMS**

USEFUL ANALOGY

UNITS	WATER	ELECTRICITY
Quantity	Gallon	Coulomb
Current (Quantity per second)	Gallon per second	Ampere (Coulomb per second)
Resistance	(No unit)	Ohm
Motive force	Pounds per sq. in. or "feet of head"	Volt

QUESTIONS

1. How does electricity manifest itself?
2. Give a reason for assuming that there is direction to an electric current.
3. What is the action of dilute sulphuric acid on commercial zinc?
What is the action on pure zinc?
4. What is an electrolyte?
5. Upon what does the e.m.f. of a cell depend?
6. Why are zinc and carbon commonly used as electrodes in a battery?
7. Distinguish between the internal and external circuit of a cell.

8. Explain the depolarization of the Daniell cell and of the Leclanché cell.

9. Why is a Leclanché cell better than a Daniell cell for ringing door bells?

10. Why and how are zinc plates amalgamated?

11. In what respect does a dry cell differ from a wet cell?

12. Why should the circuit of a dry battery which is not in use be kept open?

13. Why must the zinc of the bichromate battery be lifted out of the liquid when not in use?

14. Why is the solution of zinc sulphate diluted and the copper sulphate made concentrated in a gravity cell?

15. Why is a gravity battery short-circuited for a time when it is first set up?

16. Why must copper sulphate crystals (blue vitriol) be occasionally added to a Daniell cell?

17. Why are there so many different makes of cells on the market?

18. Draw a diagram to show how six dry cells are joined in series.

19. What effect does increasing the internal resistance of a cell produce upon the current? Why?

CHAPTER II

ELECTRIC CIRCUITS AND THE FLOW OF ELECTRICITY. OHM'S LAW

Conductors and insulators -- conductance and resistance -- Ohm's Law -- standards of resistance, current, and voltage -- effect of temperature on resistance -- computation of resistance -- series and parallel circuits -- fall of potential in a circuit -- Kirchhoff's Laws.

28. Conductors and insulators. Some materials readily conduct electricity and these are called **conductors**. Other materials either do not conduct it at all or conduct it only in a very small degree, and these are called **nonconductors** or **insulators**. Other materials have the conducting power in an intermediate degree and are often called **partial conductors**.

The cause of the difference in the conducting powers of the various materials is not known and will probably not be known until the exact constitution of electricity is more clearly understood. When science succeeds in unraveling that mystery, we shall probably also learn the exact nature of light, and the cause of the attraction of gravitation, together with the reasons for many other highly important laws, the explanations of which are now among the profound secrets of nature.

The following table gives a list of materials placed approximately in the order of their conducting powers:

- | | | |
|----------------------------------|-------------------|----------------|
| 1. Metals. | 6. Pure water. | 12. Shellac. |
| 2. Charcoal, coke, and graphite. | 7. Various oils. | 13. Vulcanite. |
| 3. Acids. | 8. Dry wood. | 14. Paraffin. |
| 4. Salt solutions. | 9. Silk. | 15. Porcelain. |
| 5. Plants and animals. | 10. India rubber. | 16. Glass. |
| | 11. Mica. | 17. Dry air. |

We ordinarily restrict the term "conductor" to the metals and to carbon in the forms of charcoal, coke, and graphite. The materials in the table numbered from 3 to 6 may be called "partial conductors," and the last eleven materials may be called "insulators." Of all the materials named, dry air may be said to be the only one which has absolutely no conducting power under ordinary conditions, although that of glass, porcelain, etc., is exceedingly small at ordinary temperatures.

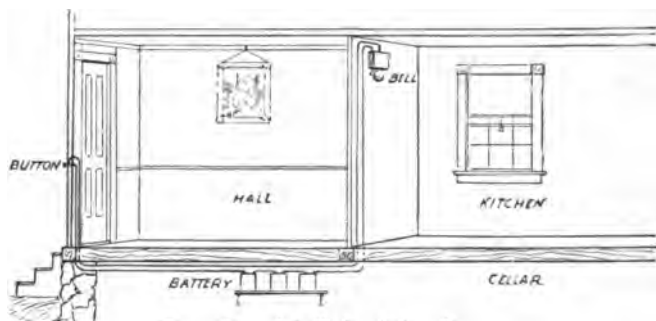

FIG. 17. — A bell circuit in a house.

But even dry air, when under the stress of very high voltages, becomes a partial conductor.

Chemically pure water and ice are practically nonconductors. The presence of a very slight percentage of impurities, however, renders water a partial conductor. Since water found in nature is never absolutely free from impurities, all natural water is a partial conductor. For this reason a film of moisture upon an insulator greatly reduces its insulating quality.

By means of the conducting property, or *conductance*, of metals, electric currents may be readily conducted from place to place. For instance, if a battery of several dry cells is located in the cellar of a house, a push button is located at the front door, and an electric bell is located in the kitchen, a metal wire may be led from one terminal of the battery to the push button, another wire may be led from the push button to the bell, and a third may be led from the bell to the

other terminal of the battery, in the manner illustrated in figure 17. Then if the button is pushed so as to close the break which it makes in the circuit, electricity flows through the battery, wires, push button, and bell, and the bell rings. The construction of the bell mechanism for this purpose is described in Chapter IV. The wires which form the circuit must be secured so that the current cannot escape from one wire to another by a short path (or short circuit) which does not include the bell. For this reason, wires which are intended to be used for bell circuits, electric-light circuits, and the like, are usually covered with a coating of cotton thread soaked in paraffin or gum, or with a coating of vulcanized India rubber. Such covered wires are commonly called *insulated wires*.

29. **Conductance and resistance.** We know by experience that the amount of energy required to drive water through a pipe depends upon the size of the pipe and its construction. Also, in the case of two pipes of the same size, we know that if one has a rough inner surface and the other a smooth one, the former is the poorer conductor of the water. Although electricity is not a fluid, the analogy between its flow and that of water is in many ways close. For instance, the flow of electricity is known by experience to be dependent upon the dimensions of the conductor through which it flows and the material of which the conductor is made. Electricity may be considered as flowing through the entire cross section of the conductor, so that any resisting action is uniform throughout the material instead of being a "skin" or friction effect, as in the case of water flowing in a pipe. The *resistance* of a circuit then is a measure of *how difficult* it is to force a given current through that circuit. If we *decrease the resistance* of a circuit, we *increase the ease* with which a given current may be forced through, or we increase the circuit's facility for conducting. *This facility for conducting an electric current we call the conductance of the circuit.* From this definition it is evident that the *conductance* of a circuit is the *reciprocal* of that circuit's *resistance*.

The table below shows the comparative order of the conducting powers of various materials. It is seen that the metals stand at the head of the list. Their conducting power is so much greater than that of other materials that we ordinarily speak of them alone as the conductors of electricity or as electrical conductors; but charcoal, coke, and graphite may also be included among the electrical conductors. Among the pure metals themselves there is considerable difference in conducting power; furthermore, mixing impurities in metals or mixing (alloying) them together generally decreases their conducting power. In the table the figures at the right hand of the names of the metals show the average relative conducting powers of pure metals and of alloys of fixed composition, in percentages of the conducting power of pure silver. Pure silver and pure copper are the best conductors known, and no other metals approach them very closely. Aluminum is so very light in weight that pure aluminum conductors have even less resistance than copper conductors of equal length and weight; but the relative conductances which are presented in the table refer to conductors of equal lengths and cross sections.

Silver	100	Zinc	27	Tin	14
Copper	92	Nickel	21	Lead	7
Gold	67	Platinum	13	Cast iron	2
Aluminum	56	Soft steel	12	Mercury	7
Brass (copper and zinc)					28-41
Nickel steel (4.35% nickel)					5
German silver (copper, zinc, and nickel)					3.5-7.5
Manganin (copper, manganese, and nickel)					3.5
Baker's Ia Ia soft (copper and nickel)					3.1

Pure graphite has a relative conducting power of 0.4 compared with pure silver.

The quality of a metal and the way in which it has been handled in the course of manufacture affect the conducting power to a considerable degree. Pure copper that comes from the ore of the Lake Superior copper mines or the Montana mines appears, as a rule, to

have a little higher conductance than that coming from the Arizona mines. Annealed metals (that is, metals which have been softened and toughened by properly cooling from a high temperature) generally have a slightly greater conductance than hardened metals, and wrought metals than cast metals.

30. Ohm's Law. When water is forced through a pipe by a pump, the stream which flows is directly proportional to the pressure exerted by the pump and inversely proportional to the frictional resistance of the pipe. In the same way, when a current of electricity is forced along a wire, the current increases as the electromotive force or voltage of the battery or other generator increases, and the current decreases as the resistance of the circuit increases. This relation between current, electromotive force, and resistance is called **Ohm's Law**, after the German scientist (Plate III, opposite page 36) who in 1827 formally announced it. The law is stated thus: *The intensity of the electric current along a conductor equals the electromotive force divided by the resistance.*

$$\text{Current} = \frac{\text{Electromotive force}}{\text{Resistance}}$$

In electrical units:

$$\text{Amperes} = \frac{\text{Volts}}{\text{Ohms}}$$

In symbols:

$$I = \frac{E}{R}$$

when I = Intensity of current in amperes,
 E = Electromotive force in volts,
 R = Resistance in ohms.

FOR EXAMPLE, suppose we want to find the intensity of the current sent through a resistance of 5 ohms by an electromotive force of 110 volts.

$$I = \frac{E}{R} = \frac{110}{5} = 22 \text{ amperes.}$$

If we want to find the electromotive force required to maintain a certain current in a circuit of known resistance, we have

$$E = IR.$$

FOR EXAMPLE, suppose we want to find the voltage required to send 10 amperes through an arc lamp if the resistance (hot) is 5.5 ohms.

$$E = IR = 10 \times 5.5 = 55 \text{ volts.}$$

If we need to find the resistance to be inserted in a circuit so that the current may not exceed a given intensity when a known voltage is applied, we use our fundamental equation in this form:

$$R = \frac{E}{I}.$$

FOR EXAMPLE, suppose an electric heater can safely carry 10 amperes. If the heater is used on a 115-volt circuit, what must be the value of its hot resistance?

$$R = \frac{E}{I} = \frac{115}{10} = 11.5 \text{ ohms.}$$

Since Ohm's Law is the foundation of all scientific knowledge of electricity, the student will do well to commit it to memory and will save himself much work if he learns the law in its *three forms*.

It may be well to remember here that the relation expressed in Ohm's Law is a GENERAL PRINCIPLE which is found to hold true throughout the workings of nature; namely, that *the result is proportional to the ratio of the force applied to the resistance*.

PROBLEMS

1. A wire of 10 ohms resistance has an e.m.f. of 24 volts impressed upon its terminals. What current will flow?
2. What is the hot resistance of a lamp filament which uses 0.4 of an ampere at 115 volts?
3. How much electromotive force is needed to send 2.5 amperes through (a) 2 ohms? (b) 50 ohms?



GEORG SIMON OHM (1787-1854).

German physicist and discoverer of the famous law in electricity bearing his name. In 1826, while teaching mathematics at a gymnasium in Cologne, he published his famous paper on the experimental proof of his law. At the time of his death he was professor of experimental physics in the university at Munich.

4. An electric heater of 30 ohms resistance can safely carry 4 amperes. How high can the voltage run?

5. An electromagnet takes 5 amperes from a 110-volt line. How much would it draw from a 220-volt line?

6. A dry cell which has an electromotive force of 1.5 volts gives 25 amperes when short-circuited. What is its internal resistance? What is the internal resistance of the same cell when, after much use, it will give only 9 amperes?

7. What voltage will produce a current of 0.09 amperes through a resistance of 1000 ohms?

8. The resistance of a telephone receiver is 80 ohms, and the current required is 0.007 amperes. What voltage must be impressed across the receiver?

9. A certain relay can safely carry 2 amperes. To determine whether it may be connected directly across the terminals of a 110-volt circuit, it is first connected with a battery; by measurement the current is found to be 0.14 amperes and the terminal voltage 7.0 volts. (a) May the relay safely be connected to the 110-volt circuit? (b) What is the maximum voltage to which the relay may be subjected?

10. The relay of problem 9 is known to be wound with 1000 feet of wire and it is necessary to add sufficient wire so that the relay may be directly connected with a battery supplying 120 volts. If the only available wire has but one half the cross section of the wire already on the coil, how many feet must be added before the reconstructed relay may be connected with the 120-volt line?

31. Application of Ohm's Law to partial circuits. It is very important to remember that *Ohm's Law applies not only to an entire circuit but also to any part of a circuit.* Thus, when applied to an entire circuit, it may be stated as follows:

(1) *The current in the entire circuit equals the voltage available in the entire circuit divided by the resistance of the entire circuit.*

When applying this law to only a part of a circuit, it may be stated as follows:

(2) *The current in a certain part of a circuit equals the voltage across that same part divided by the resistance of that same part.*

AN EXAMPLE will make plain the correct use of this law.

Suppose the electromotive force of a battery is 3 volts, the resistance of the bell (Fig. 18) is 3 ohms, the resistance of the wires and button is

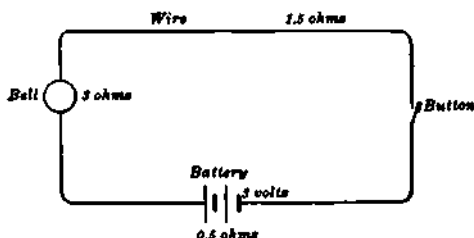

FIG. 18. — Diagram of a bell circuit.

1.5 ohms, and the internal resistance of the battery is 0.5 ohms. To find the intensity of the current, we have

$$I = \frac{E}{R} = \frac{3}{3+1.5+0.5} = 0.6 \text{ amperes.}$$

The current has the same intensity throughout the circuit. To find the voltage across the bell, we have

$$E = IR = 0.6 \times 3 = 1.8 \text{ volts.}$$

To find the voltage drop within the battery, we have

$$E = IR = 0.6 \times 0.5 = 0.3 \text{ volts.}$$

Since the total electromotive force of the battery is 3 volts, and since it takes 0.3 volts to send the current through the battery itself, the terminal voltage of the battery is 3 - 0.3, or 2.7 volts. Of this, 1.8 volts is needed to send the current through the bell, and the remainder, 0.9 volts, is used to send the current through the connecting wires and push button.

If a voltmeter were connected across the battery it would read 2.7 volts, or the terminal voltage. The total voltage or electromotive force (e.m.f.) is computed by multiplying the current in the circuit, 0.6 amperes, by the total resistance, 3 + 1.5 + 0.5 = 5 ohms:

$$\begin{aligned} E = IR &= 0.6 \times 5 = 3.0 \text{ volts, total voltage,} \\ 3.0 - 0.3 &= 2.7 \text{ volts, terminal voltage.} \end{aligned}$$

PROBLEMS

1. A cell with an e.m.f. of 2 volts sends a current through an electromagnet with a resistance of 0.4 ohms. If the internal resistance of the cell is 0.6 ohms, what is the intensity of the current?

2. The terminal voltage of a generator, when not delivering current, is 115 volts. Its internal resistance (armature) is 0.03 ohms. When it is giving out 120 amperes, what is the voltage drop in the machine? What is the terminal voltage at that load?

3. Five cells are connected in series; each has an e.m.f. of 1.4 volts and an internal resistance of 0.4 ohms. If the external resistance is 3 ohms, what is the current?

4. A lamp filament has a hot resistance of 6 ohms and requires 1 ampere. How many cells in series, each having an e.m.f. of 2 volts and internal resistance of 0.5 ohms, will be needed to operate the lamp?

5. If two cells which respectively give 1.8 volts and 1.08 volts are connected with a circuit in opposition (that is, with their poles connected so that they tend to send currents in opposite directions), and a current of 0.4 amperes flows, how much current will flow if the cells are connected properly to the same circuit in series?

6. A current of 1 ampere flowing through a silver solution will deposit 4.025 grams per hour. An electroplating apparatus when connected with a 10-volt generator is found to deposit 2 grams of silver per hour. What is the resistance of the apparatus?

7. An electric lamp when hot has a resistance of 10 ohms. The current is supplied through a line 750 feet long. The line wire has a resistance of 1 ohm per 1000 feet. At the supply end the potential is 110 volts. (a) What current will flow? (b) What is the voltage drop in the line? (c) What is the voltage at the lamp?

32. The standard of resistance. The resistance to the flow of water through a pipe, as we have said before, is a surface or "skin" friction effect, and depends upon the velocity with which the water flows, the number and form of bends in the pipe, the form of its cross section, and its length. The true electrical resistance of a conductor is quite different from this, since it simply depends upon the nature of the metal from which the conductor is made, the area of its cross section, its length, and its temperature.

The greater the cross section of a conductor the greater is the ease with which the current may pass through, and therefore the less is its resistance; and the longer the wire the greater is the total opposition to be overcome, and hence the greater its resistance. We may state this more briefly by saying that the resistance of a conductor varies directly as its length and inversely as its cross section. The cross sections of ordinary cylindrical wires are proportional to the squares of their diameters, and consequently the conductances of such wires of equal length are directly proportional to the squares of their diameters. This makes the resistances of similar wires vary inversely as the squares of their diameters. For instance, if a certain copper wire has a resistance of one ohm, the resistance of a copper wire of the same length but of twice the diameter is only one fourth of an ohm, since the square of two is four.

The adopted definition of the value of the ohm is based upon this property of **electrical resistance**, which depends simply upon the nature of the metal conductor, its temperature, its length, and the inverse of its cross section. The approved definitions of all the electrical units were adopted at the Electrical Congress held in Chicago in August, 1893. The definition of the unit of resistance makes one ohm equal to the resistance of a column of pure mercury which is 106.3 centimeters long, which has a uniform cross section, and which contains 14.4521 grams of mercury; the temperature being that of melting ice, 0° C. This gives to the column a uniform cross section of one square millimeter. The ohm as thus defined is called the **international ohm**, to distinguish it from units based on definitions adopted at previous electrical congresses. The definitions given by the Chicago Electrical Congress have been almost universally accepted, and it is generally believed that they will not be changed. The units by which electricity is measured are therefore the same in all countries. This is true of no other units which are used in common measurements.

Since a column of mercury is an inconvenient device to handle, standards of resistance made of mercury are not employed in ordinary measurements of electrical resistance, but coils of German silver wire, or other wires of high resistance, are used. These coils are carefully adjusted in resistance to a desirable number of ohms, and they can then be used in the measurement of the resistance of any conductor by methods explained on later pages.

33. The standard of current. Before the Chicago Electrical Congress was held, the fundamental definition of the ampere had usually been based upon the electromagnetic effects of currents; but at that Congress a definition was adopted which is based on the electrochemical effects of currents explained in Chapter XI. The international ampere as thus defined is the steady current which deposits silver at the rate of 0.001118 grams per second from a solution of silver nitrate in water, the solution being of a given fixed concentration to insure regular action.

Measurements of electrical currents in practical tests are made by means of instruments depending upon the magnetic effects of the currents described in Chapter IV, instead of according to the means indicated in the Chicago definition of the ampere. Methods of measurement based on the electrochemical effects of currents are valuable for determining whether the indications of electromagnetic instruments are correct.

34. The standard of voltage. In order that the fixed relation represented by Ohm's Law, $\text{Current} = \frac{\text{Voltage}}{\text{Resistance}}$, shall hold with these definitions, the international volt as defined by the Chicago Congress is the voltage which causes a current of one ampere to flow through a resistance of one ohm. This is practically equivalent to $\frac{1.0000}{1.0183}$ of the electromotive force of a Weston Normal Cell * at 20° C.

* See section 130.

35. Effect of temperature on the resistance of materials. The resistance of most materials is affected by temperature. That of most metals increases as the temperature rises, but in the case of a few alloys the resistance falls very slightly as the temperature increases. The resistance of carbon falls very rapidly as the temperature rises, and this fall is sufficiently great to reduce the working resistance, or *hot resistance*, of a carbon incandescent lamp filament to only about one half the resistance which it has at the usual atmospheric temperature. The resistances of liquids and of most insulating materials, as far as they are measurable, also decrease as the temperature rises. This decrease is so marked in some insulating materials (such as glass, for instance) that they actually become conductors when they are heated red hot or when they are melted.

The resistance of most pure metals seems to change at approximately the same rate; namely, beginning at a temperature of zero degrees on the centigrade scale, the change of resistance is about 0.4 of 1 per cent per degree of the centigrade scale. This change per degree of the centigrade scale is called the *temperature coefficient of the material*.

The temperature of melting ice is taken as the zero for the centigrade scale, while the temperature of boiling water under normal conditions is taken as 100 degrees. These two temperatures correspond to 32 degrees (32°) and 212 degrees (212°) respectively on the Fahrenheit scale. Between these two *fixed points* we therefore have 180 Fahrenheit divisions or 100 centigrade divisions. Hence one division centigrade is equivalent to $\frac{9}{5}$ divisions Fahrenheit.

To change a temperature expressed on the centigrade scale to the Fahrenheit scale, we have only to multiply by $\frac{9}{5}$ and add 32°. For example:

$$30^{\circ} \text{ C.} = \left(\frac{9}{5} \times 30\right) + 32 = 86^{\circ} \text{ F.}$$

To change a temperature expressed on the Fahrenheit scale to the centigrade scale, we must first subtract 32° and then multiply by $\frac{5}{9}$. For example:

$$98.6^{\circ} \text{ F.} = (98.6 - 32) \frac{5}{9} = 37^{\circ} \text{ C.}$$

It may be helpful in changing temperatures from one scale to the other, to remember the following equations:

$$\text{Temp. Fahr.} = \left(\frac{5}{9} \text{ Temp. Cent.}\right) + 32.$$

$$\text{Temp. Cent.} = \frac{5}{9} (\text{Temp. Fahr.} - 32).$$

A change of resistance of 0.4 of 1 per cent (0.004) per centigrade degree means a change of 1 per cent in resistance up or down for every $2\frac{1}{2}$ degrees centigrade when the temperature varies up or down. This is also nearly equivalent to 1 per cent (0.01) for every 4.5 degrees of the Fahrenheit or common thermometer scale.

As commercial copper contains but minute impurities, the temperature coefficient for pure metals applies with reasonable accuracy to commercial copper wire.

The temperature coefficient of alloys depends very much upon the composition of the mixture. In general, German silver may be taken to have a temperature coefficient about one tenth as great as that of copper.

36. The circular mil. In the practical measurement of wires it is usual to use feet in measuring the length, and circular mils in measuring the cross section. One thousandth of an inch is called a mil, and a round wire one mil in diameter is said to have a cross section of one circular mil. The cross sections, or areas,

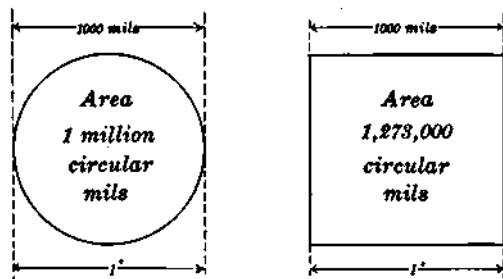

FIG. 19. — A circle and square in circular mils.

of wires are measured in this unit. And it is a very convenient unit for this reason: the areas of circles are proportional to the squares of their diameters, consequently, if the area of a wire one mil in diameter is called a circular mil, every other round wire has an area or cross section which, in circular mils, is nu-

merically equal to the square of its diameter measured in mils. A circle one inch in diameter (Fig. 19) is one thousand mils in diameter, and there are therefore one million circular mils in its area. As a square inch has an area $4/\pi$ times the area of such a circle, there must be $4/\pi \times 1,000,000$ or 1,273,000 circular mils in a square inch. The symbol π (Greek letter pi) is used to represent the constant value, 3.1416, which, in inches, equals the length of the circumference of a circle having a diameter of one inch.

37. Specific resistance. In order to calculate the resistance of a wire, it is necessary to know the resistance of a piece having a unit length and cross section; that is, the resistance of a wire one foot long which has a cross section of one circular mil. This may be called the **resistivity** or **specific resistance** of the material and is the resistance of a **mil foot**. The resistance of a mil foot of good commercial copper is very nearly 10.4 ohms at 20° C. In scientific writings, specific resistance is usually given on the basis of one centimeter as the unit of length, and one square centimeter as the unit of cross section, instead of on the basis of the mil foot, which is commonly used in practice.

On account of its low resistivity, copper is the metal most widely used for electrical conductors, although aluminum and even galvanized iron are sometimes used. The resistivity of aluminum is nearly twice that of copper, being 18.7 ohms per mil foot at 20° C. However, its specific gravity is less than one third that of copper. This means that a pound of aluminum made into wire will present slightly less resistance between two points than will a pound of copper, although the aluminum wire will have approximately twice the cross section of the copper wire. Since the resistivity of iron and steel is about seven times that of copper, these materials can be used only where a conductor of large cross section can be installed, as in a third rail, or where very small currents are to be transmitted, as in telegraphy.

PROBLEMS

1. Find the area of cross section in circular mils of a wire 0.015 inches in diameter.
2. What is the circular mil area of a circle 2.16 inches in diameter?
3. Find the cross-section area of a round wire $\frac{1}{4}$ inches in diameter.
4. A round wire has a cross-section area of 250,000 circular mils. What is its diameter in inches?
5. What is the diameter of a wire containing 22,500 circular mils?
6. What is the cross-sectional area in circular mils of a rectangular bar 1 inch by $1\frac{1}{4}$ inches?
7. What is the equivalent cross section (circular mils) of a cable composed of 10 strands of copper wire, each 0.2 inches in diameter?

38. Computation of the resistance of a wire. As has already been stated, the resistance of a wire or other piece of any particular conductor depends directly upon its length and inversely upon its cross section. So, *if the resistance of a mil foot of the wire (given in ohms) is multiplied by the total length in feet and divided by its cross section in circular mils, the result will be the resistance of the whole wire in ohms.*

This may be expressed, for convenience, as follows:

$$R = \frac{Kl}{d^2}$$

where R is the resistance in ohms, K the resistance of a mil foot (which is 10.4 ohms for copper at 20° C.), l the length in feet, and d^2 the circular mils in the cross section.

FOR EXAMPLE, to compute the resistance of 500 feet of No. 18 copper wire, we find from the wire tables on page 48 that No. 18 wire is 40.3 mils in diameter. Since the resistivity of copper at 20° C. is 10.4 ohms, we have

$$R = \frac{Kl}{d^2} = \frac{10.4 \times 500}{(40.3)^2} = 3.2 \text{ ohms.}$$

To compute the resistance at any other temperature it is convenient to know that the resistance of copper per mil foot at 0° C. is 9.6 ohms, and that taking the resistance at 0° C. as

a standard, copper increases 0.00426 ohms per degree for each ohm. This effect of temperature on the resistance of copper may be expressed in the form of an equation:

$$R_t = R_0 (1 + 0.00426t)$$

when R_t = resistance at t° C.

and t = temperature of wire in degrees centigrade.

If the temperature coefficient of resistance is based on the resistance at some other temperature than 0° C., the coefficient becomes smaller; thus, based on the resistance at 25° C., it is 0.0038. See *Electrical Engineer's Handbooks* for further details.

PROBLEMS

NOTE. — Unless otherwise stated, the temperature of wires in all problems is assumed to be 20° C.

1. Assuming the resistance of copper per mil foot at 20° C. to be 10.4 ohms, what is the resistance of 500 feet of copper wire, 0.032 inches in diameter?

2. What is the resistance of a mile of copper wire $\frac{1}{4}$ inches in diameter?

3. How long must a copper wire 0.064 inches in diameter be to have a resistance of 10 ohms?

4. What diameter will a copper wire have if 1000 feet has a resistance of one ohm?

5. It is necessary to transmit 40 amperes over a copper wire half a mile long with not more than 5 volts "line drop." What diameter wire must be used?

HINT. — Apply Ohm's Law to find the resistance required and then compute the size of wire.

6. What is the line drop in a 4-mile copper trolley wire carrying 200 amperes, if the wire is 0.325 inches in diameter?

7. Assuming the specific resistance of aluminum to be 18.7 ohms per mil foot, what is the resistance of a mile of aluminum wire 0.064 inches in diameter?

8. The resistance of a copper wire is 5.45 ohms at 0° C. What is it at 20° C.?

9. The resistance of the field coils of a motor is 210 ohms at 20° C. What will be the resistance when the coils become heated to 75° C.? (Hint. — Find resistance at 0° C.)

10. A coil at 0° C. has a resistance of 10.5 ohms. What will be the temperature when the resistance becomes 12.5 ohms?

11. A copper rod 1 inch in diameter and 10 feet long is drawn out into a wire 0.1 inches in diameter. What is the resistance (a) of the rod? (b) of the wire?

12. Copper weighs 0.32 pounds per cubic inch. A coil containing 1000 feet of wire weighs 38.4 pounds. (a) What is the area of the wire in circular mils? (b) What is the resistance of the coil?

13. An electric motor is guaranteed to have in continuous service a temperature rise of not more than 50 degrees centigrade above that of the surrounding air. Under test the following data were obtained: line voltage 110 volts, room temperature 22.5° C., resistance of field coils at first 58 ohms, current in field after continuous service 1.608 amperes. What is the actual temperature rise?

Copper wire is ordinarily manufactured only in certain standard sizes. In this country these sizes are arranged according to the Brown & Sharpe (B. & S.) Gauge. The table on page 48 gives a list of the standard sizes, of which only the even numbers are in general use except in the very small sizes. The second column shows the diameter of each gauge number in *mils* (0.001"). The third column gives the area of cross section in *circular mils*, which we have already learned is the square of the diameter in mils. The fourth column gives the resistance per thousand feet at 20° C. The use of this table greatly simplifies all wire computations.

It will be convenient to remember that No. 10 wire is about $\frac{1}{8}$ of an inch (100 mils) in diameter or about 10,000 circular mils in cross section (end area) and has a resistance of practically 1 ohm per 1000 feet. Further, it will be seen that the wires grow smaller as the numbers increase and that No. 13 wire is about half the size (cross section) of No. 10 wire and so has twice as much resistance. In the same way No. 16 wire is half the size of No. 13 and has double the resistance. As the

wires grow smaller, every third gauge number halves the area of cross section and doubles the resistance.

NOTE. — When the computation requires a wire of a size not in the table, always choose the size next larger.

RESISTANCE OF SOFT OR ANNEALED COPPER WIRE

B. & S. GAUGE No.	DIAMETER IN MILS, <i>d</i>	AREA IN CIRCULAR MILS, <i>A</i>	OHMS PER 1000 FT. AT 20° C. OR 68° F.	B. & S. GAUGE No.	DIAMETER IN MILS, <i>d</i>	AREA IN CIRCULAR MILS, <i>A</i>	OHMS PER 1000 FT. AT 20° C. OR 68° F.
0000	460.00	211,600	0.04893	21	28.462	810.10	12.78
000	409.64	167,810	0.06170	22	25.347	642.40	16.12
00	364.80	133,080	0.07780	23	22.571	509.45	20.32
0	324.86	105,530	0.09811	24	20.100	404.01	25.63
				25	17.900	320.40	32.31
1	289.30	83,694	0.1237	26	15.940	254.10	40.75
2	257.63	66,373	0.1560	27	14.195	201.50	51.38
3	229.42	52,634	0.1967	28	12.641	159.79	64.79
4	204.31	41,742	0.2480	29	11.257	126.72	81.70
5	181.94	33,102	0.3128	30	10.025	100.50	103.0
6	162.02	26,250	0.3944	31	8.928	79.70	129.9
7	144.28	20,816	0.4973	32	7.950	63.21	163.8
8	129.49	16,509	0.6271	33	7.080	50.13	206.6
9	114.43	13,094	0.7908	34	6.305	39.75	260.5
10	101.89	10,381	0.9972	35	5.615	31.52	328.4
11	90.742	8,234.0	1.257	36	5.000	25.00	414.2
12	80.808	6,529.9	1.586	37	4.453	19.82	522.2
13	71.961	5,178.4	1.999	38	3.965	15.72	658.6
14	64.084	4,106.8	2.521	39	3.531	12.47	830.4
15	57.068	3,256.7	3.179	40	3.145	9.89	1047.
16	50.820	2,582.9	4.000				
17	45.257	2,048.2	5.055				
18	40.303	1,624.3	6.374				
19	35.890	1,288.1	8.038				
20	31.961	1,021.5	10.14				

PROBLEMS

1. What is the resistance per mile of No. 10 wire, B. & S. gauge?
2. What size wire, B. & S., has about 2.5 ohms per mile?
3. How many miles of No. 00 will it take to make 5 ohms?
4. What size copper wire should be used to transmit 25 amperes from a generator to lamps, a distance of 500 feet, with 2 volts line drop?
5. A coil of No. 20 wire is found to have a resistance of 40 ohms. How many feet are there in the coil?
6. An electromagnet consists of a coil of 800 turns of No. 24 B. & S. copper wire. If the average length of a turn is 10 inches, what is the resistance of the coil?
7. Calculate the equivalent cross section of a cable made up of 91 wires, each No. 14 in size. What is the resistance of 1000 feet of this cable?
8. It is desired to build a coil whose resistance shall not exceed 300 ohms. The coil must have 200 turns of about 18 inches average length. What size wire should be used?

39. **Series circuits.** When the current passes around its circuit in a single path, the path is termed a **series circuit**.

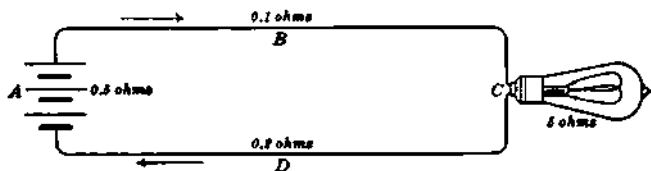

FIG. 20. — Series circuit composed of a battery, conducting wires, and an incandescent lamp.

The path may be made up of different materials which are of various dimensions, but *the resistance of the whole is the sum of the resistances of all the parts*. Thus, suppose we have a circuit like that shown in figure 20, where *A* is a battery of large cells having a resistance of 0.5 of an ohm for the battery, *C* is a small incandescent lamp having a filament of 5 ohms hot resistance, and *B* and *D* are connecting wires having re-

sistances of 0.1 and 0.2 ohms respectively. The total resistance of the circuit is the sum of these, or $0.5 + 5 + 0.1 + 0.2 = 5.8$ ohms.

The same condition exists when water flows through pipes. Thus, suppose in figure 21 that *A*, *B*, and *C* are three pipes of different sizes jointed together in series for drawing water from a tank. Evidently the separate resistances to the flow of the water introduced by these different pipes and joints must be added together to get the total frictional resistance from the tank to the valve. In the illustration, the tanks, valve, and pump also form parts of the circuit, and, therefore, if the total

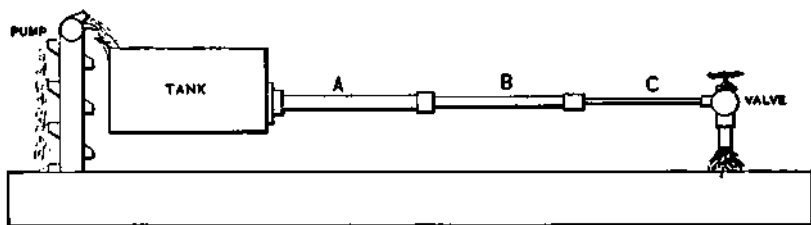

FIG. 21. — Hydraulic analogue of series circuit.

resistance of the circuit is desired, the resistances of these parts must be added to those of the pipes.

The laws governing series circuits are as follows:

The current in every part of a series circuit is the same.

The resistance of several resistances in series is the sum of the separate resistances.

The voltage across several resistances in series is equal to the sum of the voltages across the separate resistances.

Moreover, since the voltage is equal to the resistance times the current ($E = IR$), and since the current (I) in every part of a series circuit is the same, it follows that the *voltage across any part of a series circuit is proportional to the resistance of that part.*

FOR EXAMPLE, in figure 22, if the e.m.f. of each cell is 2 volts, the e.m.f. of the three cells in series is 3 times 2, or 6 volts.

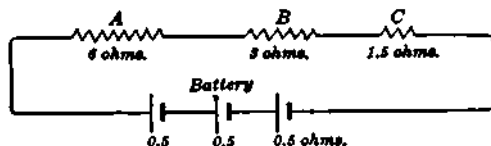

FIG. 22. — Three cells and three resistances in series.

If the resistance of A is 6 ohms, of B, 3 ohms, of C, 1.5 ohms, and of each cell, 0.5 ohms, the total resistance is $6+3+1.5+(3\times 0.5)=12$ ohms.

The current is $\frac{1}{12}$, or 0.5 amperes.

The voltage across A is 6 times 0.5, or 3 volts, across B, 3 times 0.5, or 1.5 volts, and across C, 1.5 times 0.5, or 0.75 volts.

The voltage "drop" in each cell is 0.5 times 0.5, or 0.25 volts, so that the terminal voltage of each cell is $2-0.25$, or 1.75 volts.

40. Parallel circuits. If two wires are connected in parallel (that is, so that a current divides between them, as shown in figure 23), the current flowing in each is equal to the voltage be-

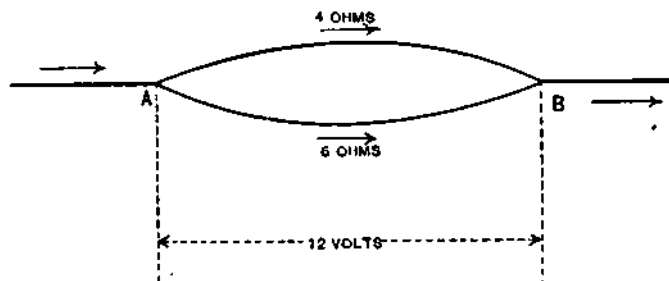

FIG. 23. — Branched or parallel circuit.

tween their common terminals divided by their individual resistances.

FOR EXAMPLE, if two wires (Fig. 23) have resistances of 4 ohms and 6 ohms respectively, and the voltage between their terminals (the points A and B) is 12 volts, the current flowing through the first

wire is $\frac{1}{4}$ = 3 amperes, and that through the second is $\frac{1}{2}$ = 2 amperes. It should be noted that the larger current, 3 amperes, flows through the smaller resistance, 4 ohms.

The total current flowing through the circuit containing the two wires in parallel is evidently 2 plus 3, or 5 amperes. Since the voltage causing these 5 amperes to flow through the wires is 12 volts, the resistance of the circuit between *A* and *B*, or the joint resistance of the two wires in parallel, must be $\frac{1}{5}$, or 2.4 ohms. This may be conveniently calculated directly from the conductances, which, it will be remembered, are reciprocal

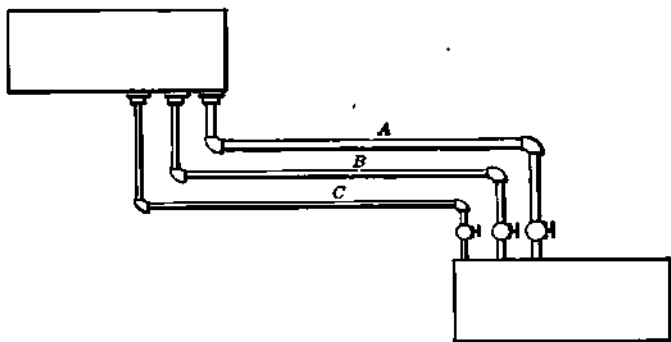

FIG. 24. — Hydraulic analogue of parallel circuit.

or inverse to the resistances. The name sometimes given to a unit of conductance is *mho*, which is the word "ohm" spelled backwards. The conductance of the first wire is therefore $\frac{1}{4}$ mhos and that of the second is $\frac{1}{2}$ mhos, and the joint conductance $\frac{1}{4} + \frac{1}{2}$, or $\frac{3}{4}$ mhos. Therefore the joint resistance is the reciprocal of $\frac{3}{4}$ mhos, or $\frac{4}{3}$ ohms.

The joint carrying capacity of two or more pipes which deliver water between two tanks is equal to the capacities of all the separate pipes added together. Thus, suppose in figure 24 that *A*, *B*, and *C* are three pipes connecting the two tanks. Evidently more water will flow through two pipes in a given

time than through one alone, and still more will flow through three pipes. Hence, as pipes are added between the tanks, the resistance to the flow of water is decreased; that is to say, the conductivity is increased. The capacities of the pipes for carrying water (that is, their conductivities) must therefore be added together to get the total conductivity for the flow of water from the higher tank to the lower one.

In the same way the joint conducting power or conductance of electric circuits which are connected in parallel (or multiple, as they are often called,) is equal to the conductance of the parts added together.

FOR EXAMPLE, suppose we have (Fig. 25) three resistances A , L , and M in parallel. $A = 8$ ohms, $L = 16$ ohms, and $M = 80$ ohms.

$$\begin{aligned} \text{Conductance of } A &= \frac{1}{8} = 0.125 \text{ mhos;} \\ L &= \frac{1}{16} = 0.0625 \text{ mhos;} \\ M &= \frac{1}{80} = 0.0125 \text{ mhos.} \end{aligned}$$

Conductance of the combination is:

$$\frac{1}{8} + \frac{1}{16} + \frac{1}{80} = 0.20 \text{ mhos.}$$

Since the resistance equals the reciprocal of the conductance, the resistance of the combination must be $\frac{1}{0.2}$, or 5 ohms.

This shows that simply adding together the resistances of the individual parts of a circuit will not always give the total resistance of the circuit. In fact, such an addition gives the total resistance only when all the individual resistances belong to parts of the circuit which are connected in series.

A little consideration of what precedes will show that when two wires of equal resistance are connected in parallel, their joint resistance is just half as great as the resistance of either wire. If three wires of equal resistance are connected in parallel,

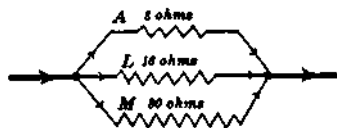

FIG. 25. — Three resistances in parallel.

their joint resistance is just one third as great as the resistance of one of the conductors, and so on. If the wires of equal resistance were connected in series instead of parallel, the resistances would be two, three, and so on, times as great as a single wire.

The laws governing parallel circuits are as follows:

The total current through the combination is the sum of the currents through the parts.

The conductance of the combination is the sum of the conductances of the parts.

The voltage across several resistances in parallel is the same for all.

41. Shunts. When one wire is connected in parallel with another, it is often called a **shunt**, because it switches off or **shunts** a part of the current from the other wire. The wire to which a shunt is attached is said to be **shunted**. Special shunts put up in boxes are frequently used to protect electrical instruments which are required for electrical measurements. Their purpose is to shunt a known part of the current around the instruments when the currents are so great that the instruments might be injured if the total current passed through them.

If the resistance of the instrument is 1 ohm and the resistance of the shunt is 1 ohm, then as much current will flow through the shunt as through the instrument; that is, the instrument's reading must be multiplied by 2 to obtain the total current. This value 2 is called the **multiplying power** of the shunt; that is, the amount by which the shunt multiplies the range of the instrument.

PROBLEMS

1. If a lamp having 45 ohms resistance is joined in series with a coil of 10 ohms across a 110-volt circuit, what is the resistance of the two pieces joined in series? What is the current?
2. Three resistances, 200, 200, and 40 ohms, are connected in

series across a 220-volt line. What is the resistance of the circuit? What current flows in this circuit?

3. If five lamps of 15 ohms each are inserted in series in a line whose resistance is 4 ohms, what is the total resistance? What voltage is needed to send 7 amperes through the lamps?

4. A lamp of 55 ohms, another lamp of 30 ohms, and a coil of 15 ohms are connected in series. There is a voltage of 120 volts across the 30-ohm lamp.

Find:

- (a) Current in the lamps and the coil.
- (b) Voltage across the 55-ohm lamp and the coil.
- (c) Total voltage.

5. Three resistances, one 30 ohms, another 40 ohms, and the third unknown, are connected in series with an ammeter which reads 2.5 amperes. Total voltage on the line is 225 volts.

Find:

- (a) Unknown resistance.
- (b) Voltage across 30 ohms.
- (c) Voltage across 40 ohms.

6. What is the joint resistance of three parallel branches each of which has a resistance of 120 ohms?

7. What is the joint resistance of two parallel branches which have respectively 40 and 60 ohms?

8. If the resistance of a wire is 4 ohms, what must be the resistance of another which when put in parallel with it makes the joint resistance 3 ohms?

9. What is the joint resistance of three circuits in parallel which have resistances of 1, 0.5, and 0.2 ohms?

10. If ten similar incandescent lamps, connected in parallel, have a joint resistance of 20 ohms, what is the resistance of each lamp?

11. An electromotive force of 150 volts is impressed on a parallel circuit which consists of four branches of 2, 4, 5, and 10 ohms respectively. (a) What current will flow in each branch? (b) What will be the total current through the combination?

12. What voltage is needed to send 9 amperes through a parallel combination consisting of a 4-ohm and a 12-ohm branch?

13. A circuit has three branches of 12, 6, and 4 ohms respectively. If the current in the 6-ohm branch is 4 amperes, what current will flow in each of the others?

14. The resistance of an ammeter shunt is 0.02 ohms and of the instrument 2.4 ohms. If 10 amperes flow through the joint resistance

of the ammeter and its shunt in parallel, how many amperes flow through the ammeter?

16. What is the multiplying power of the above shunt?

42. **Series and parallel circuits combined.** Circuits are sometimes spoken of as **simple circuits** when the parts are all

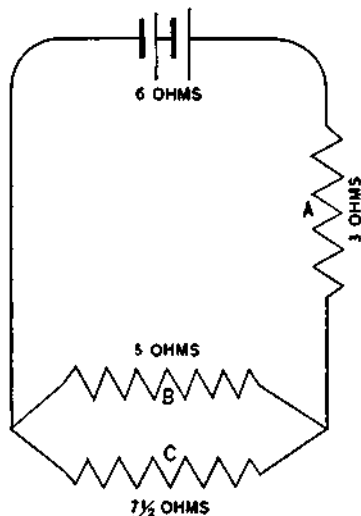

FIG. 26. — Compound circuit.

in series, and **branched, compound, or derived circuits**, when the parts are in parallel. Parallel connection is also sometimes called connection in **multiple or multiple arc**. The latter term was coined in the early days of arc lighting.

The total resistance of a circuit made up of parts connected in series is equal to the sum of the individual resistances of all the parts.

The total resistance of a circuit made up of parts connected in parallel is equal to the reciprocal of the total conductance of the circuit, and the total con-

ductance is equal to the sum of the individual conductances of the parts.

When part of the total circuit is made up of conductors in parallel and part of conductors in series, it is necessary to calculate the joint resistance of the first part and then add that to the resistance of the remainder of the circuit which is in series with the branched portion. It is easily seen that *the joint resistance of conductors in parallel is equal to the resistance of a single conductor by which the compound circuit might be replaced without changing the total resistance of the circuit.* Suppose that in the circuit shown in figure 26 the resistances

in ohms of the different parts are as marked; then the resistance of the complete circuit is

$$6+3+\frac{1}{\frac{1}{6}+\frac{1}{3}}, \text{ or } 12 \text{ ohms.}$$

If the voltage developed by each of the two cells, which are represented by the usual sign ($|$), is 1.2 volts, the current flowing through the circuit is $\frac{2.4}{12} = 0.2$ amperes.

This would be analogous to a system of water piping between two tanks, as seen in figure 27.

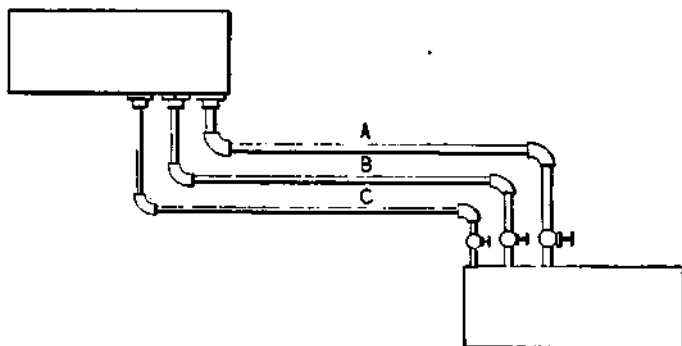

FIG. 27. — Hydraulic analogue of the compound circuit illustrated in figure 20 (omitting the pump, which in the analogy takes the place of the electric battery).

PROBLEMS

1. In figure 28, $A = 100$ ohms, $B = 120$ ohms, and $C = 150$ ohms.

Find:

- Resistance of parallel combination (A and B).
- Combined resistance of system.
- Voltage across each resistance when 115 volts is applied across the terminals.
- Current through each resistance when the voltage is 115 volts across the terminals.

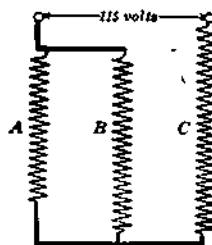

FIG. 28.

2. In figure 29, the voltage from *B* to *C* is 40 volts, the current in *X* is 3 amperes, the resistance *Y* is 4 ohms, and *Z* is 5 ohms.

Find:

Current through *Z*.

Resistance of *X*.

Current through *Y*.

Voltage from *A* to *C*.

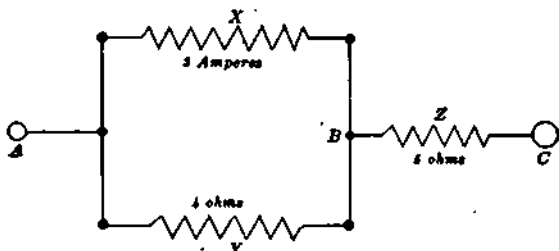

FIG. 29.

3. An electric car taking 20 amperes is 3 miles from the power house and another taking 25 amperes is 4 miles from the power house. If the trolley wire carrying the current has a resistance of 0.42 ohms per mile and the track through which the current returns has a resistance of 0.03 ohms per mile and the generator is delivering current to the line at 550 volts, what is the voltage across each car? What is the voltage drop in the line? (HINT. — The cars are in parallel.)

43. **Fall of voltage along a circuit.** Since Ohm's Law says that the voltage between two points in a circuit is equal to the current flowing in the circuit multiplied by the resistance of the part of the circuit between the points ($E=IR$), we may say that the voltage along a wire falls or "drops" in proportion to the resistance passed over. Thus, suppose the terminals of a copper wire of uniform cross section and 10 feet long are connected to the poles of an electric battery furnishing a voltage of two volts. Now, since equal lengths of the uniform wire may be considered as having equal resistances and since all parts of the wire carry the same current, the voltage measured between the middle of the wire and one end must be equal to the voltage measured between the middle and the other end,

and this must also be equal to one volt or one half the total voltage measured between the ends of the wire. In the same way, *the voltage measured across (that is, the "drop in voltage" in) any portion of the wire bears the same proportion to the total voltage as the length of the portion bears to the whole length of the wire.*

If the wire were not of a uniform cross section, or were composed in different parts of different metals, the resistances of equal lengths would no longer be the same. The voltages measured across the portions of the wire would no longer be directly proportional to the lengths of the portions, but would be *proportional to their resistances*, as before. This assumes that the current (I) is constant; that is, the same current is flowing through each part — there are no leakages or branches.

44. General law for fall of potential in a circuit. This general rule may therefore be written as a result of Ohm's Law: *the voltage along a conductor through which a given current flows falls directly as the resistance passed over; and the fall of potential between any two points measured in volts is equal to the resistance (ohms) between the points, multiplied by the current (amperes) flowing through that resistance.*

The same rule holds in the case of gas or water flowing through a pipe. Suppose it requires 10 pounds pressure to cause 500 gallons of water per minute to flow through a certain straight pipe 200 feet long. If the pipe is cut in half, 5 pounds pressure is sufficient to pass the same amount of water through either half. If pressure gauges are attached, with proper precautions, to the pipe at intervals of 20 feet, each gauge will show a pressure of one pound less than the preceding one, when taken in the direction of the current. This shows that the pressure falls directly as the resistance passed over, as in the case of the electric current.

The following experiment shows the same thing on a smaller scale. The tank or reservoir R in figure 30 is connected with a supply pipe

AB. The pressure along the pipe is indicated by the height of the water in the tubes C, D, and E. When the pipe is closed at B, the level is the same in R, C, D, and E; this is called the static condition.

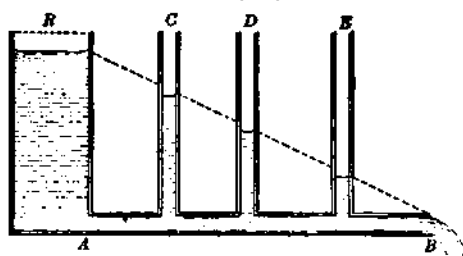

FIG. 30. — Hydraulic resistance causes drop in pressure.

But when the stopper is removed from B and water flows out, the pressure is no longer the same at all points along the pipe, but falls off as the distance from the reservoir R increases. This drop in pressure is

due to friction against the walls of the pipe through which the water has to run.

PROBLEMS

1. Three wires of 2, 6, and 8 ohms resistance are connected in series between the terminals of a battery which maintains 4 volts pressure when so connected. What is the voltage across each wire?

2. A cell with an internal resistance of 3 ohms gives 1.5 volts on open circuit. What will be the terminal voltage when a current of 0.2 amperes flows?

3. If the voltage across 5 feet of wire in which 3.5 amperes are flowing is 7 volts, what will be the voltage across 30 feet of the same wire?

4. What will be the voltage across 30 feet of the wire used in problem 3 when the current is 10.5 amperes?

5. What will be the voltage drop per mile of No. 3 copper wire (diameter 229 mils) when carrying 25 amperes?

45. **Kirchhoff's Laws.** These two laws are deductions from Ohm's Law and are especially useful in solving certain complex problems of electrical distribution. Although Kirchhoff's laws state no new facts, yet they regard electric circuits from a slightly different viewpoint.

They may be stated thus:

First Law. At any point in a circuit the sum of the currents flowing toward the point is equal to the sum of the currents flowing away from the point.

This law may be illustrated by figure 31. Take the point B where the total current from the battery I is equal to the sum of the currents in the branches $I_1 + I_2$. That is, 8 amperes = 5 + 3 amperes.

Second Law. In any closed circuit the sum of the IR (current \times resistance) drops around any one path is equal to the e.m.f.'s impressed on that path.

In applying this law care must be taken to get the algebraic signs of the e.m.f.'s correct. In any given circuit where there is no source of e.m.f., the sum of the IR drops in one direction equals the sum of the IR drops in the other direction.

Applying this second law to the circuit $ABEF$ (Fig. 31), we have the very obvious result that

the e.m.f. of the battery must equal the IR drop in $AB + BE + EF$ + the IR drop in the battery itself. Or, considering the circuit $BCDE$ which has no source of e.m.f., we have this result, that the IR drop in BE must be equal to the IR drop of $BC + CD + DE$ because the IR drop of BE is counter-clockwise in the circuit $BCDE$ and the IR drop of $BC + CD + DE$ is clockwise.

This same principle may also be stated as two separate rules: (1) the IR drop around any path in an electric circuit equals the sum of the impressed e.m.f.'s, and (2) the voltage drop along parallel paths between two points is the same.

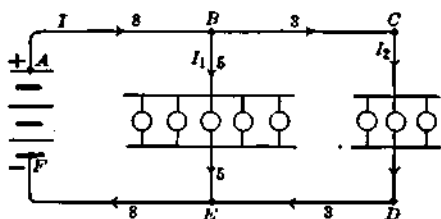

FIG. 31. — Illustrations of Kirchhoff's Laws.

46. **Application of Kirchhoff's Laws.** Suppose we have a trolley line with two cars on the line and a generator at each end, as shown in figure 32. Let generator G_1 feed the line at 600 volts and generator G_2 at 580 volts. Assume car No. 1 takes 100 amperes and car No. 2, 80 amperes, and that the resistances of the trolley line and track are as marked. Find the voltage across each car.

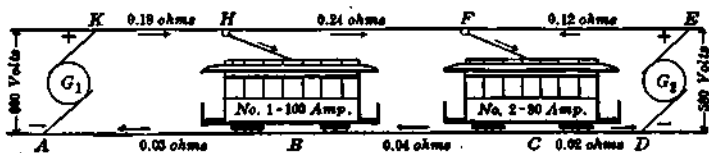

FIG. 32. — Trolley line with a generator at each end.

SOLUTION. Let x = current in KH and BA ,
 then $x - 100$ = current in HF and CB ,
 and $180 - x$ = current in EF and CD .
 This is according to Kirchhoff's First Law.

[Voltage across car 1 equals

$$600 - 0.21x.$$

Voltage across car 1 also equals

$$580 - 0.14(180 - x) + 0.28(x - 100).$$

Therefore (according to Second Law),

$$600 - 0.21x = 580 - 0.14(180 - x) + 0.28(x - 100).$$

Solving for x , we have

$$x = 116 \text{ amperes,}$$

and voltage across car 1 equals

$$600 - (0.21 \times 116) = 576 \text{ volts.}$$

Current in $EF = 180 - 116 = 64$ amperes,

and voltage across car 2 equals

$$580 - (0.14 \times 64) = 571 \text{ volts.}$$

PROBLEMS

1. A shunt generator of 125 volts and 0.2 ohms armature resistance is connected in parallel to another generator of 120 volts and 0.4 ohms armature resistance. This parallel combination (Fig. 33) is arranged to supply a load of 12 ohms resistance. Compute (a) the voltage across the line, (b) the current through each generator.

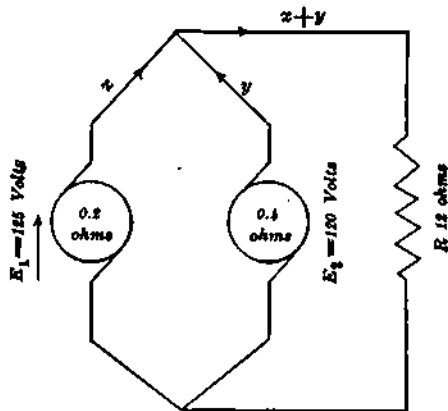

FIG. 33. — Unequal generators in parallel feeding line.

HINT. — Let x = current through 1st generator,

y = current through 2d generator,

and $x+y$ = current through line.

If the current value comes out negative, reverse the arrowhead.

2. A circuit is arranged as shown in figure 123. The resistance A equals 1000 ohms and B equals 100 ohms. X is an unknown resistance, and when R is equal to 252.5 ohms, the potential difference between the points e and f is zero, as is indicated by zero deflection of the galvanometer. What is the resistance of X ?

HINT. — The value of X is independent of the voltage impressed across c and d .

SUMMARY OF CHAPTER II

MATERIALS vary greatly in their power to conduct electricity: some, such as metals, conduct readily and are called *conductors*; others like porcelain and glass conduct it only to a very small degree and are called *insulators*; and still other materials have conducting power in an intermediate degree.

EVEN THE METALS vary greatly in their power to conduct; copper is a very *good* conductor and iron is a *poor* conductor.

$$\text{OHM'S LAW: } I \text{ (amperes)} = \frac{E \text{ (volts)}}{R \text{ (ohms)}}$$

This applies to a whole circuit, or to any part of a circuit. When applied to a whole circuit, the resistance (R) is the whole resistance; *i.e.*, internal resistance plus external resistance.

RESISTANCE of conductors varies *directly* as their lengths and *inversely* as their cross sections.

RESISTANCE of most metals *increases* as the *temperature* rises. Copper increases about 0.4 of 1% per degree centigrade. Certain alloys, such as German silver, have a much smaller temperature coefficient.

RESISTANCE OF A WIRE is equal to the resistance of a mil foot of the wire (ohms) times the length (feet) divided by the cross section (circular mils).

SERIES CIRCUIT. Resistance of the whole is the *sum* of resistances of the parts.

PARALLEL CIRCUIT. Conductance of the combination is the *sum* of conductances of the parts.

CONDUCTANCE is the reciprocal of resistance.

FALL OF POTENTIAL or voltage drop (volts) between any two points is equal to the resistance (ohms) between the points, multiplied by the current (amperes) flowing through that resistance.

KIRCHHOFF'S LAWS:

1. At any point in a circuit, the sum of the currents flowing *toward* the point is equal to the sum of the currents flowing *away* from the point.

2. In any closed circuit, the sum of the IR (current resistance) drops around any one path is equal to the e.m.f.'s impressed on that path.

QUESTIONS

1. A copper wire and an iron wire of the same cross section are found to have the same resistance. Which is the longer?

2. The conductivity of a porcelain rod is very low. What will be its insulating qualities?

3. Explain why some slate which has metallic veins running through it is useless for switchboards.

4. Why is cotton-covered wire improved by dipping it in paraffin?

5. Why is the resistance of wood increased by drying and covering it with shellac?

6. To test insulating materials, it is a common practice to determine the voltage necessary to puncture a sample by applying to the two sides of it a high electromotive force. Why is it necessary to specify the thickness of the sample?

7. On a constant-voltage line how must the resistance be changed in order to multiply the current by 2.5?

8. It is found that the intensity of the electric current entering a flatiron is 3.5 amperes. What will be the intensity of the current on leaving?

9. How does the resistance of a coil kept at constant temperature vary with the voltage? with the current?

10. Is it true that in a divided circuit an electric current "always takes the line of least resistance"?

11. How may the joint resistance of two parallel wires be found if the individual resistances are known?

12. How may the total current in a divided circuit be found if the voltage and individual resistances are known?

13. Why is the joint resistance of wires in parallel not equal to the average of the individual resistances?

14. If you have several equal resistances in parallel, how do you compute their joint resistance?

15. How does the "voltage drop" change along a uniform wire?

16. Upon what does the fall of potential depend in a wire made up of several pieces of different sizes and different materials?

17. Explain how the terminal voltage of a cell depends on the current which it is delivering.

CHAPTER III

ELECTRIC POWER AND HEATING EFFECTS OF ELECTRIC CURRENTS

Units of work and power — mechanical and electrical — watt, kilowatt, and kilowatt hours — conservation of energy — efficiency — line loss — heating effect — joules and calories — current-carrying capacity of wires — fuses — electric heaters.

47. Work and its units of measurement. The function of every machine is to do a certain amount of work. In the technical language of science, **work means the overcoming of resistance.** For example (Fig. 34), a man does work when

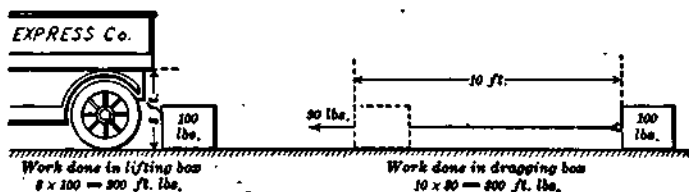

FIG. 34. — Examples of doing work.

he lifts a trunk from the sidewalk up into a wagon, or when he drags the trunk along the platform against friction. But the man does not do any work, in the scientific sense of the word, no matter how hard he pulls or pushes, if he does not lift or move the trunk.

If we lift one pound a vertical distance of one foot, we do *one foot pound* of work; if we lift 50 pounds 3 feet, we do 150 foot pounds of work; or if we pull hard enough on a trunk to

lift 50 pounds and thus drag it 3 feet, we still do 150 foot pounds of work. In other words,

$$\text{work (foot pounds)} = \text{force (pounds)} \times \text{distance (feet)}.$$

It should, however, not be forgotten that the distance must be measured in the *same direction* as that in which the force is exerted.

FOR EXAMPLE, if a machinist pushes down on a file with a force of 10 pounds and pushes forward 15 pounds, how much work does he do in 40 horizontal strokes, each 6 inches long?

According to our definition, since the downward push produces no motion, but merely serves to produce the friction between the file and the surface being filed, no work in the purely scientific sense is done by the machinist in maintaining that downward push of 10 pounds. Concerning the horizontal motion, evidently the total distance is 20 feet and the *horizontal* force is 15 pounds; therefore the work done is 300 foot pounds.

PROBLEMS

1. How much work is done in lifting one half pound 30 feet?
2. A man weighing 160 pounds walks upstairs, a 12-foot rise. How much work does he do?
3. A man carries a ton of coal in baskets up 20 steps, each 7 inches high. How much work does he do on the coal?
4. A load of 2 tons is drawn up a hill half a mile long by a traction engine. The hill is 275 feet high. How much work is done against gravity?
5. A thousand-gallon tank at a mean elevation of 50 feet is filled with water. How much work was done in filling it, assuming a gallon of water to weigh 8.34 pounds?

48. **Power and its units of measurement.** The terms "work" and "power" are often confused in colloquial use. For example, if we carry a pail of water weighing 50 pounds up a flight of stairs 12 feet high, we do 600 foot pounds of work. The amount of *work* done would be the same whether

we did this in one minute or one hour, but the amount of *power* required to do this job in one minute would be 60 times the power required to do it in one hour. The term "**power**" adds the notion of *time*. *Power means the speed or rate of doing work.*

Mechanical power is ordinarily measured in units called **horse power**. As the result of certain experiments James Watt found that a strong dray horse working for a short time could do work at the rate of *33,000 foot pounds per minute*. This rate is therefore called a **horse power**. To get the **horse power** of any machine, compute the number of foot pounds of work done per minute and divide by 33,000.

$$\text{Horse power (h.p.)} = \frac{\text{Foot pounds per minute}}{33,000}$$

FOR EXAMPLE, suppose it is desired to pump 120 gallons (1000 pounds) of water per minute to a tank 33 feet high. The work required to do this is 33,000 foot pounds per minute, and the power required is 1 horse power.

Again, suppose a stream discharges 480 gallons (4000 pounds) of water per minute over a fall 25 feet high; the power of the water is 4000×25 or 100,000 foot pounds per minute or a little over three horse power. It should be noted, however, that this is the power of the falling water, and only 80 to 90 per cent of it could be converted into mechanical power by an ordinary water wheel.

In a similar way the horse power of a steam engine is calculated. Suppose an engine is supplied with steam at an average pressure of 40 pounds per square inch, and that the piston is 100 square inches; then the total force against the piston is 4000 pounds. If the stroke of the engine is 1 foot, the piston moves 2 feet in every revolution, and consequently the steam does 4000×2 or 8000 foot pounds of work each revolution. If the engine runs at 250 revolutions per minute (r.p.m.), the work done by the steam is 250×8000 or 2,000,000 foot pounds per minute; therefore the engine is doing work at the rate of a little more than 60 horse power. This is called the **indicated horse power** of the engine.



JAMES WATT (1736-1819).

A Scotch instrument maker at the University of Glasgow, famous for his improvements on the steam engine, which were so important and fundamental that he is often called its inventor. The modern industrial age may be said to begin with Watt.

PROBLEMS

1. A horse draws a plow for 2 hours at an average rate of 2 miles an hour and exerts an average pull of 125 pounds. How much work does he do? What is the horse power?
2. What is the horse power of an engine that can raise 3 tons to a height of 22 feet in 2 minutes?
3. How many horse power are there in a waterfall 30 feet high over which 500 cubic feet of water pass each minute?
(1 cubic foot of water weighs 62.4 pounds.)
4. How much work can a 5-horse-power engine do in 15 minutes?
5. To what height could a 10-horse-power fire pump send 50 cubic feet of water per minute?
6. A fire engine is used to pump out a cellar 80 feet long, 40 feet wide, and 10 feet deep, in which the water stands to a depth of 6 feet. How long will it take a 10-horse-power engine? (HINT. — Average lift is 7 feet.)

49. **The watt.** We have just seen that to measure water power we must know two things, the rate of flow and the pressure; that is, we must know the quantity of water flowing per minute and the "head" of the water. The hydraulic engineer speaks of pressure as "head of water"; this means the pressure due to the weight of a column of water as high as the "head of water." Thus,

Water power = Quantity of water per minute \times Head

$$\text{Horse power (h.p.)} = \frac{\text{lb. per min.} \times \text{ft.}}{33,000}$$

To measure electrical power, we must multiply the quantity of electricity flowing per second — that is, the intensity of the electric current — by the voltage. Thus,

Electric power = Intensity of current \times Voltage.

The unit of electric power is called a watt, after James Watt (Plate IV, opposite p. 68), a great English engineer and the inventor of the modern steam engine. A watt may be defined as

the power required to keep a current of one ampere flowing under a drop or "head" of one volt. Thus,

$$\text{Watts} = \text{Amperes} \times \text{Volts.}$$

$$P = IE$$

when

P = power in watts,

I = current in amperes,

E = e.m.f. in volts.

Since the watt is a very small unit of power, we commonly use the kilowatt (kw.), which is 1000 watts.

$$\text{Kilowatts} = \frac{\text{Amperes} \times \text{Volts}}{1000}$$

Since mechanical power is usually reckoned in horse power (h.p.), it will be convenient to remember the relation of the unit of mechanical power to the unit of electrical power. Experiment shows that

$$1 \text{ horse power} = 746 \text{ watts.}$$

$$1 \text{ kilowatt (kw.)} = 1.34 \text{ horse power (h.p.).}$$

FOR EXAMPLE, if a lamp draws 0.5 amperes from a 110-volt circuit, it is using power at the rate of 0.5 times 110 or 55 watts.

Again, suppose the heaters of a street car have a resistance of 110 ohms. At what rate are they consuming electricity on a 550-volt line? The current is $\frac{550}{110}$ or 5 amperes, and the power is 5 times 550, or 2750 watts, or 2.75 kw.

50. Commercial units of electrical work. Power means the rate of doing work. *The total work done is equal to the product of the rate of doing work by the time.* Thus, if a steam engine is working at the rate of 15 horse power for 8 hours, it does 8 times 15, or 120 horse-power hours of work. In a similar way, if an electric generator is delivering electricity at the rate of 15 kilowatts for 8 hours, it does 8 times 15, or 120 kilowatt hours of work.

FOR EXAMPLE, we buy electricity by the kilowatt hour. In Boston the price is about 10 cents per kilowatt hour. If a store uses 100 lamps for 3 hours, each consuming electricity at the rate of 50 watts, it will cost

$$\frac{100 \times 3 \times 50 \times 0.10}{1000} = \$1.50.$$

51. Small units of electrical work. In the laboratory we often find it convenient to use a smaller unit of work, the watt second or joule.

Work (joules) = Current (amperes) \times e. m. f. (volts) \times Time (seconds).

Or $W = IEt.$

Since 1 kilowatt hour = 3,600,000 watt seconds or joules,

and 1 horse-power hour = 1,980,000 foot pounds,

$$1 \text{ joule} = 0.74 \text{ foot pounds.}$$

PROBLEMS

1. How much electrical power (watts) is required to light a room with 5 lamps, if each lamp draws 0.4 amperes from a 110-volt line?

2. A street-railway generator is delivering current to a trolley line at the rate of 1500 amperes and at 500 volts. At what rate (kilowatts) is it furnishing power?

3. How many horse power will be required to drive the generator in problem 2, if its efficiency is 90 per cent? (HINT. — Output = 0.9 input.)

4. A 10-kilowatt generator is working at full load. If the voltmeter reads 115 volts, how much does the ammeter read?

5. How many lamps, each of 120 ohms and requiring 1.1 amperes, can be lighted by a 25-kw. generator?

6. How much power is required by a laundry which uses 5 electric flatirons of 50 ohms each on a 110-volt line?

7. How much will it cost at 10 cents per kilowatt hour to run a 220-volt motor for 10 hours, if the motor draws 25 amperes?

8. Would it be cheaper to buy the power needed in problem 7 at 8 cents per horse-power hour?

9. How much energy is consumed in a line whose resistance is 0.5 ohms, and which carries a current of 150 amperes for 10 hours?

10. How many joules of energy are consumed when a 40-watt lamp burns 10 minutes?

11. What current will a 40-watt lamp take when burning on a 115-volt line?

52. Conservation of energy. When mechanical work is used in overcoming friction or other forms of resistance, *it is not lost, but is converted into an equivalent amount of heat, which is another form of energy.* A general law may be stated thus: *Energy* (that is, the capacity for doing work) *may be transformed from any of its forms into an equivalent amount of energy in any other of its forms.* This is called the Law of the Conservation of Energy.

When energy is transformed from one form to another, as when mechanical power is changed to electrical power or the reverse, there is always some loss in the amount of useful energy; unless the transformation is from some other form into heat. The seemingly lost energy has not been destroyed, however, but has been converted into heat. For instance, when the mechanical power conveyed by a running belt is changed by means of a dynamo of satisfactory size into electrical power, about 10 per cent of the available energy is lost. That is, the electrical energy (output) delivered by the dynamo is about 10 per cent less than the mechanical energy (input) which is given to the dynamo. Energy has not been destroyed, but the remainder has been converted into heat in the process of overcoming the friction of the dynamo bearings, through the resistance of the wire windings of the dynamo, and in other ways. A dynamo which is in operation is always found to be warmer than the surrounding air; this indicates that some of the energy delivered to the dynamo has been changed into heat, which goes to warm the machine. The practical usefulness of this portion of the energy which has been converted

into heat is lost, but the energy itself is not destroyed. This principle may be briefly stated as follows:

$$\text{Input} = \text{Output} + \text{Work done against friction.}$$

Thus we see that one can never get out of a dynamo an amount of electrical power that is quite as great as the mechanical power required to drive it; and, conversely, the amount of mechanical power which can be got out of any electric motor is not quite as great as the electrical power required to drive it. A different condition exists when the form of energy called heat is the desired result of the transformation, as in that case the transformation may be effected without loss. An electric heater is an example of such a transformation. In the ordinary electric heaters which are used on electric street cars, all of the electrical power transmitted to the heater is given out as heat.

53. Efficiency of electrical machinery. We have just seen that no electrical machine gives out all the power it receives. If we call the power which a machine receives the *input* and the power it gives out the *output*, the *ratio of the output to the input is called the efficiency*, or

$$\text{Efficiency} = \frac{\text{Output}}{\text{Input}}$$

Since the output is always smaller than the input, the fraction $\frac{\text{output}}{\text{input}}$ is always less than unity, and is usually expressed as a percentage. That is, the efficiency is always less than 100 per cent. In computation it must not be forgotten that the output and input must always be stated in the same units.

FOR EXAMPLE, a 5-horse-power motor takes 4.85 kw. to operate it. What is the efficiency of the motor?

$$4.85 \text{ kw.} = 4.85 \times 1.34 = 6.50 \text{ h.p.}$$

$$\text{Efficiency} = \frac{4.85}{6.50} = 75\%.$$

PROBLEMS

1. A motor under test was found to take 67 amperes at 113 volts and developed 8.5 h.p. Compute its efficiency.

2. What power in kilowatts is required to run a 15-horse-power motor which has an efficiency of 90 per cent?

3. If the motor of problem 2 is built for 110 volts, what current will it require?

4. A 115-volt motor takes 20 amperes and has an efficiency of 85 per cent. What horse power does it deliver?

5. What is the efficiency of a motor which does 425,000 foot pounds of work in 6 minutes if the input is 2 kw.?

6. A 20-h.p. motor which is 90 per cent efficient operates on a 500-volt line. What current does it draw?

7. The motor for an electric hoist draws 30 amperes from a 220-volt line. Of the power delivered by the motor 5 per cent is lost in the hoisting mechanism. The hoist will raise a load of half a ton 30 feet in 10 seconds. What is the efficiency of the motor alone?

54. Power used in overcoming electrical resistance. Whenever a current flows through a circuit, power is required to keep it flowing against the resistance of the circuit. The power thus used in overcoming the electrical resistance of the circuit is converted into heat, which warms the materials composing the circuit. The heat produced is proportional to the number of watts expended in causing the electric current to flow through the resistance of the circuit. This power is equal to the voltage measured between the terminals of the circuit multiplied by the current flowing in it, provided all the power expended in that part of the circuit is used in heating it.

$$P = IE.$$

According to Ohm's Law, voltage is equal to current times resistance, or

$$E = IR.$$

Consequently P is equal to $I \times IR$, or I^2R .

Hence, the power required to overcome the resistance of a circuit is equal to the square of the current multiplied by the resistance, or

$$\text{Watts} = (\text{Amperes})^2 \times \text{Ohms.}$$

$$P = I^2 R.$$

Power is in every case expressed in watts in the electric circuit, provided the current is given in amperes, the resistance in ohms, or the pressure in volts.

Since the line loss (*i.e.*, the portion of the available electrical power of a circuit which is lost in heating the conductors) is equal to the current squared times the resistance of the conductors, it is often spoken of as the *I squared R* loss.

FOR EXAMPLE, suppose the line wires connecting a motor with the generator have a total resistance of 4 ohms and the motor requires 5 amperes; then the power lost in the line is $I^2 R$, or 25×4 , or 100 watts.

PROBLEMS

1. If a generator is feeding 600 one-half ampere lamps at 110 volts, and if the voltage drop in the line is 5 volts, what is the line loss?

2. A generator is delivering 5 kw. to the line, and a motor is using 4.8 kw. Find watts lost in the line.

3. Suppose a generator *G* (Fig. 35) is delivering 25 amperes to the line at 115 volts, and the motor *M* is getting only 110 volts.

Find:

(a) Watts delivered by the generator.

(b) Watts received by the motor.

(c) Watts lost in the line.

(d) Resistance of the line.

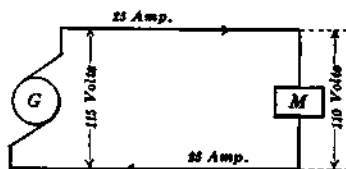

FIG. 35.

4. A 10-h.p. electric motor is supplied by a 500-volt generator over a line having a resistance of 2 ohms. At full load the motor has an efficiency of 90 per cent. (a) What current is supplied to the motor? (b) What is the terminal voltage of the motor? (c) What is the line loss? (d) What is the output (kw.) of the generator?

8. How much power does an electric flatiron use on a 115-volt circuit if its resistance is 50 ohms?

55. The calorie and its relation to the joule. It is possible to measure the heat produced by an electric current when it passes through a known resistance. This is usually done in an instrument called a calorimeter (Fig. 36), which is a vessel containing water or some other liquid in which the resistance

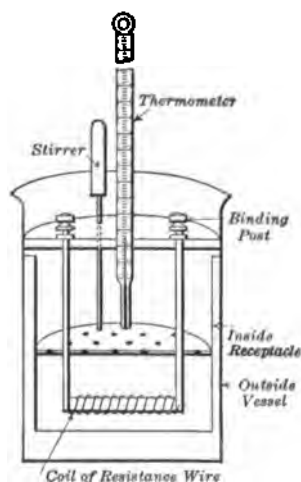

FIG. 36. — Simple form of electric calorimeter.

wire is immersed. The vessel ordinarily is double-walled or arranged in some other way so that it will not lose heat rapidly by radiation into the air. A thermometer is immersed in the liquid to determine its rise of temperature due to the heat given it from the wire. The amount of heat which is required to raise the temperature of a gram of water one degree centigrade is called a calorie. The number of calories given by the wire to the water in the calorimeter is determined from the amount of water and its rise in temperature, proper corrections being made for the effect of the vessel. The experiments of Joule,

of Rowland (an American scientist), and of others, have shown that the work represented by one joule (watt second) is equivalent to the heat represented by practically 0.24 of a calorie. Consequently, the total number of calories of heat produced in one second by the current passing through the wire in a calorimeter is equal to $0.24 I^2 R$. The total heat produced in the calorimeter in any time is also equal to $0.24 I^2 R$ multiplied by the number of seconds in the time. This may be written in the following form :

$$H = 0.24 I^2 R t$$

when

- H = Heat in calories,
 I = Current in amperes,
 R = Resistance in ohms,
 t = Time in seconds.

This experimental fact, or law of nature, is sometimes called Joule's Law.

By determining the total heat produced in the calorimeter in a fixed time when the current is passed through a wire of known resistance, the value of the current may be computed.

It will be seen from what precedes that *one ampere flowing through a resistance of one ohm expends continuously a power of one watt* (which is equivalent to the expenditure of one joule of work every second), *and that it will raise one gram of water 0.24° C. every second.*

In steam engineering the unit of heat is the British Thermal Unit (B.t.u.), which is defined as the amount of heat required to raise 1 pound of water 1° Fahrenheit.

It can be shown that

$$1 \text{ B.t.u.} = 1055 \text{ joules} = 778 \text{ foot pounds}$$

and that

$$H(\text{B.t.u.}) = 0.00095 I^2 R t$$

when $I^2 R t$ represents joules.

PROBLEMS

1. How many calories of heat are generated per hour in a 30-ohm electric flatiron using 4 amperes?
2. If the electricity costs 10 cents per kilowatt hour, what is the cost per calorie in problem 1?
3. How many calories per hour are given off by a car heater which takes 6 amperes at 550 volts?
4. How many joules of work will be done in raising the temperature of 500 grams of water 24° C.?

5. A calorimeter contains 600 grams of water. If the temperature is raised 10°C . in 10 minutes, and if $\frac{1}{4}$ of the heat is lost by radiation, how much power is supplied to the coil by the current?

6. A current of 10 amperes heated the water in a calorimeter 5°C . in 20 minutes. What current will be required to heat it an equal amount in 15 minutes? Radiation is negligible.

7. What current must be passed through a coil of iron wire, immersed in 2 pounds of water, so that it will be raised to boiling temperature in 45 minutes? The temperature of the water at the start is 60°F ., and the boiling point of water is 212°F . The coil is connected with a 110-volt line.

8. A 110-volt $\frac{1}{2}$ -ampere incandescent lamp is immersed in a vessel containing 1 pound of water at 60°F . Neglecting losses due to radiation and assuming that all the energy is transformed into heat, how long a time will be required to raise the water to the boiling point?

9. How many heat units (B.t.u.) are evolved in 5 hours from an arc lamp requiring 10 amperes and 45 volts?

10. Express the energy expended in problem 9 in foot pounds.

56. Temperature of wire carrying current. The actual rise of temperature on the part of a wire when a current passes through it depends upon several things in addition to the amount of heat produced in it. A long, thick wire and a short, thin wire of the same material and having the same resistance will, when stretched in the air, come to very different temperatures when equal currents are passed through them. If there is sufficient difference in their diameters, the thin wire may become red hot by the passage of a current which is only sufficient to make the thick wire appreciably warm, although each wire has the same amount of heat produced in it.

When a current passes through a wire, a certain amount of heat is produced during every second that the current flows. For a short time after the current is started, the wire rises in temperature, and finally reaches a certain fixed temperature. *When the temperature becomes fixed*, it is evident upon a little thought that *as much heat must leave the wire by*

radiation to surrounding objects, convection by air currents, or conduction to objects touching the wire as is produced by the flow of the current. That is, we have an equilibrium between the inflow and outflow of heat. If more heat is given to the wire than is carried off by these means, its temperature must rise; and if on account of a decrease in the current the amount of heat given to the wire is less for a time than the amount given off, the temperature must fall until the two are equal again.

The capacity of a wire to get rid of heat by radiation and convection depends upon the color and condition of its surface, and also roughly upon the extent of the surface. The amount of heat which leaves any surface in a second also depends upon the number of degrees by which its temperature is higher than that of the air and surrounding objects. The amount of heat which is required to bring a wire to a given temperature also depends upon the capacity of the material for holding heat, or its specific heat, as it is called. Consequently, the actual temperature to which any wire will rise when carrying a certain current can be exactly determined only by trying the experiment.

The explanation of why a short, thin wire will get hotter than a long, thick wire of equal resistance when equal currents are passed through them is now easy. The short, thin wire has a smaller surface exposed to the air than the long, thick one, and for that reason the radiation and convection of the heat from the former is more difficult, and the temperature rises until this difference is offset.

57. Effect of insulating coverings. The fact that the ability of a wire to emit heat is directly dependent upon the extent of its surface causes a wire with an ordinary insulating covering to remain cooler in the open air than a similar wire without the covering, although the two wires carry equal currents.

This seems at first sight to be exactly opposed to the facts

as observed in covered boiler pipes. There is no contradiction, however, because the thickness of the wall of insulation is entirely comparable with the diameter of the wire; and the outside surface of the insulation is therefore so much greater than that of the wire that the additional surface more than makes up for the difficulty which the heat experiences in getting through the insulation. The heat thus finds it easier to leave the wire which has the insulation on it when the wire is in the open air. This effect is most decidedly shown when the outer surface of the insulation is black.

When steam pipes are covered for the purpose of retaining their heat, the thickness of the covering is thin when compared with the diameter of the pipes, so that the outside surface of the covered pipes is not much greater than the surface of the pipes when bare. Consequently, the effect of the thickness of the covering which is placed in the path of the heat as it leaves a pipe is greater than the effect of the increased surface, and the heat finds it more difficult to leave a covered pipe. This is especially the case because the steam pipes are covered with the very best heat insulators.

On the other hand, when wires are closed up in moldings or placed under plaster, as is often the case with the electric-light wires in buildings, they become very much warmer than when exposed in such a way that they may be cooled by air currents. This is the case because the moldings and plaster do not afford an increase of radiating surface comparable with the hindrance which they put in the path of the escaping heat.

58. Fuses. We have already seen that the electrical power lost in the line depends directly on the resistance of the line; and furthermore, that if too small a wire is used to carry a certain current, then the temperature of the conductor rises. This not only increases the resistance and line loss but is likely so to heat the insulation that it will take fire. For this reason

the National Board of Fire Underwriters has issued a table giving the safe carrying capacity of copper wire of the sizes used in house wiring. Moreover, it requires that fuses be placed in the line to protect every electrical device. The fuse is a sort of "electrical safety valve" and is essentially a strip of an alloy (for example, lead and tin) which melts at so low a temperature that the melted metal can do no harm. The size of the fuse is such that if by accident too heavy a current is sent through the wires, the fuse melts and breaks the circuit. At the moment that the "link" fuse (Fig. 37 a) melts, there is an arc across the gap which might set things on fire. So the fuse is commonly inclosed in an asbestos tube, as in the "cartridge fuse" (Fig. 37 b); or in a porcelain cup which screws into a socket like a lamp, as in the "plug fuse" (Fig. 37 c). When the fuse wire melts because of excessive current, the fuse is said to "blow out."

59. Electric heaters. Advantage is taken of the heating effect which is produced when an electric current passes through a wire in the construction of electric heaters. These usually consist of bare metal wires of rather high specific resistance (such as an alloy composed of the metals nickel and chromium) wrapped on porcelain supports or embedded in an insulating enamel. By careful proportioning of the length and thickness of the wire and by giving due consideration to the way in which it is supported, the heater wire can be adapted to the conditions for which it is to be used. It will then absorb the correct amount of electrical power from the supply circuit and thereby produce the desired amount of heat, without so over-

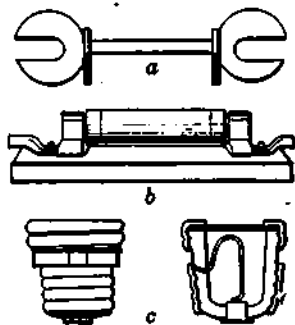

FIG. 37. — Different types of fuses: (a) link; (b) cartridge; (c) plug.

heating the wire that it deteriorates rapidly. Figure 38 shows an electric heater made for heating electric street cars. Such heaters are usually placed under the car seats.

The heating effects of electric currents flowing through conductors are also depended upon for the operation of incan-

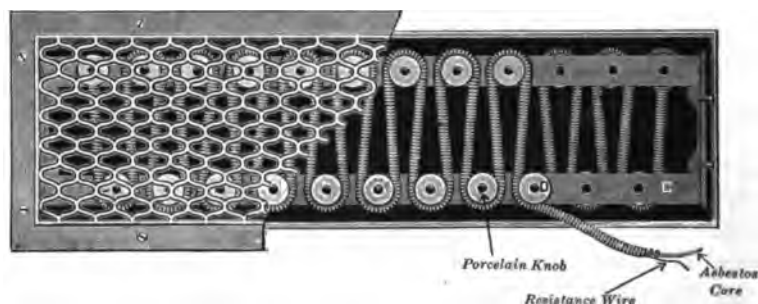

FIG. 38. — Street-car electric heater.

descent lamps and some other devices, which are described in later chapters.

SUMMARY OF CHAPTER III

WORK means the overcoming of resistance.

Work (foot pounds) = Force (pounds) \times distance (feet).

POWER means the rate of doing work.

1 horse power = 33,000 foot pounds per minute.

WATT is the unit of electric power.

Power delivered to circuit = Intensity of current \times voltage.

Watts = Amperes \times volts.

1 h.p. = 746 watts.

ELECTRICAL ENERGY is measured commercially in kilowatt hours: equals kilowatts \times hours.

ENERGY may be transformed but not destroyed.

Input = Output + losses.

EFFICIENCY = $\frac{\text{Output}}{\text{Input}}$.

POWER used to overcome resistance

= Current squared \times resistance.

Watts = (Amperes)² \times ohms.

JOULE is a watt second.

$$J = I^2 R t.$$

HEAT in calories = $0.24 I^2 R t$.

"**CARRYING CAPACITY**" of a wire is limited by the rate at which it can radiate the heat generated in it.

QUESTIONS

1. Distinguish between the popular use of the term "work" and its technical use in engineering. Give an example of "work" that is not technically "work."

2. What is the difference between force and work?

3. Arrange in tabular form the units of mechanical and electrical work and power.

4. What is the difference between a kilowatt and a kilowatt hour?

5. What unit is used in making out electric-light bills? Why?

6. What unit would be used in rating the capacity of a steam engine, of a gas engine, of an electric generator, of an electric motor, of an electric lamp?

7. To what three factors is the heat developed in a conductor proportional?

8. What electrical device has an efficiency of 100 per cent?

9. Equal lengths of small and large copper wire are connected in series to a cell. Compare the intensity of current through each wire and the heat evolved from each wire.

10. A chain made of alternate links of platinum and silver wire of the same size is connected with a storage battery. Why do the platinum links become red hot and the silver links remain comparatively cool?

11. Why is the safe carrying capacity of insulated aluminum wire about 84 per cent of that given for the same size copper wire with the same kind of insulation? (Sp. ht.: Al, 0.22 and Cu, 0.094.)

12. Why is electricity not more generally used for heating and cooking?

CHAPTER IV

ELECTROMAGNETISM

Magnetic effect of electric currents — magnetic field — lines of force — Oersted's discovery — direction of electromagnetic field. Solenoids — mutual action between current and magnet — electromagnets and applications to bells and telegraphy.

Magnetic and nonmagnetic materials — magnetic circuit — magnetomotive force — magnetic intensity and flux — density — permeability — curves of magnetization — Ohm's Law for magnetism — reluctance — hysteresis.

60. Effect of a current flowing near a magnetic needle. If an ordinary compass is placed above or below a wire which carries an electric current, *the magnetic needle will turn on its pivot so as to set itself as nearly at right angles to the wire as possible.*

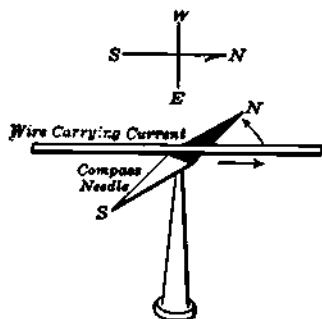

FIG. 39. — Wire held above magnetic needle.

This may be readily tried by connecting a short piece of copper wire to one or two dry cells and holding it above the needle (Fig. 39) while the current flows through the wire. The effect on the needle may be made most evident by making and breaking the electric circuit. The needle will swing back and forth, since it will be deflected every time the circuit is closed and will

return toward its position of natural rest when the circuit is broken. The current in the wire has the greatest effect in causing the needle to deflect from the north and south position when the wire also lies in a

north and south direction — that is, when the wire is parallel with the needle.

The earth itself is a great magnet, and it is the force of the earth's magnetism that causes the needle to turn into a north and south position and stay there when it is undisturbed by other magnetic effects. When the electric current is placed so as to flow near the magnetic needle, *the needle is affected by the force of magnetism which is set up by the current*, and this tends to make the needle set itself at right angles to the wire carrying the current. The needle takes an intermediate position, which is the result of the two magnetic forces (that due to the earth and that due to the current). Its new position, therefore, depends upon the magnitude of the force of the magnetism set up by the current as compared with the force of the earth's magnetism. Studies of the effect of electric currents on suspended magnets, and their attraction of iron filings, have proved that *electric currents are always surrounded by magnetic effects*.

61. Magnetic fields. Any open space in which there is magnetism, and consequently magnetic force, is called a **magnetic field** or a **magnetic field of force**. The magnitude or intensity of the magnetic force at any point is called the **strength of the field** at that point.

If an independent north magnetic pole could be placed in front of the north pole of a magnet, it would be repelled by the latter pole and be attracted by the south pole of the magnet. This would cause the independent pole to move away from the magnet's north pole and towards its south pole, but as it moved it would continually change its relative distance from the two poles, and the relative magnitude of the forces exerted upon it by the two poles would vary. The direction of the motion of the independent pole would depend upon the relative direction and magnitude of the forces which the two poles of the magnet exerted on it at every point. The actual path would

be a curved line very much like the line *AB* in figure 40. An independent south magnetic pole would move in an opposite direction, but over a similar path.



FIG. 40. — A line of force set up by the magnet NS.

It is, in fact, impossible to have an independent magnetic pole, but for this experiment the companion pole which is always found at the other end

of a magnet may be sufficiently far removed satisfactorily to show the action.

A shallow glass dish containing a little water may be placed over a magnet (Fig. 41). By properly sticking a magnetized sewing needle in a cork, it may be floated upon the water in a vertical position with one of its poles close to the bottom of the dish. Then the upper pole will be so much farther away from the magnet than the lower one that the latter will be affected by the force due to the magnet almost as would an independent pole. If the lower pole of the needle is a north pole, it will tend to move through the water, when placed in front of the north pole of the magnet, in a curved line away from the north pole and toward the south pole. If the lower pole of the needle is a south pole, it will tend to move from the south pole toward the north pole. This is the exact procedure which was explained above for an independent magnetic pole. The experiment here outlined may be readily tried; it is, however, more striking when the magnet beneath the dish is a strong electromagnet such as will be described later, because the force (acting on the floating needle to move it) is then greater.



FIG. 41. — Experiment to illustrate the movement of a free magnetic pole when near a bar magnet.

The two spots of a magnet which point one to the north and one to the south are called the poles: one is called the north-seeking pole (*N*) and the other the south-seeking pole (*S*).

If we bring the north-seeking or *N*-pole of a magnet near the *N*-pole of a suspended magnet, the poles repel each other (Fig. 42). If we bring the two *S*-poles together, they also repel each other. But if we bring an *N*-pole toward the *S*-pole of the moving magnet, or an *S*-pole to the *N*-pole, they attract each other.

That is,

Like poles repel each other,

Unlike poles attract each other.

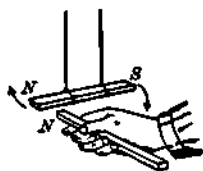

FIG. 42. — Magnetic repulsion.

Experiment shows that these attractive or repulsive forces vary inversely as the square of the distance between the poles.

62. Lines of magnetic force. A convenient way of looking upon a magnetic field is to consider it as a space which is more or less filled with *lines of magnetic force*. The strength of the field may be represented by the number of lines of force to the square centimeter (metric measure). Thus, if the strength of the field be such, for instance, that a unit pole when placed in it experiences a force of ten dynes,* or units of force, we may consider the field as having ten lines of force per square centimeter. These lines of force no more actually exist than do definite stream lines, or lines of flow, exist in water which is flowing around in a tub; but the idea based on this assumed existence is a very useful and practical one. The directions of the lines of force are traced out by iron filings as shown in figure 43, or by the path of travel of the supposed free magnet pole shown in figure 40. We shall find this conception of lines of magnetic force or *magnetic flux* a convenient way of remembering how a magnet will affect other magnets in its vicinity.

63. Lines of force like elastic fibers. Michael Faraday (Plate V, opposite p. 88) thought of these lines of force as having a much more real meaning than this. He thought of them

* One dyne = 0.00102 grams = 0.00000225 pounds.

as actually existing throughout the space around every magnet, even when there are no filings to show them. He believed that they represent a real state of strain in the ether in which all material bodies are immersed. Even now, however, we know very little about what the ether really is. We know simply that it is not a kind of matter, but something much more subtle and fundamental.

At any rate, these lines of force of Faraday's *act as if they were stretched fibers in the ether* which are continually trying

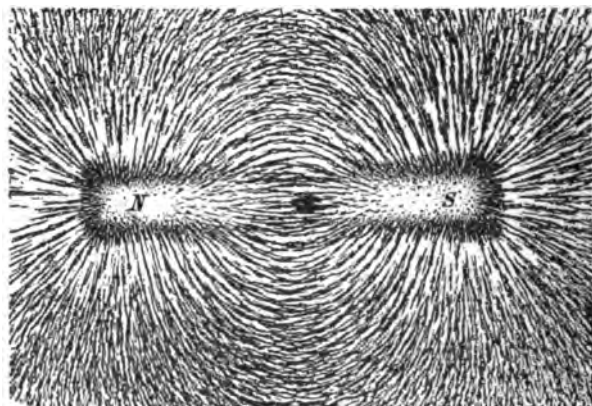

FIG. 43. — Lines of force traced by iron filings.

to contract and are thus pulling on the poles at their ends. They also *act as if they were trying to swell out sidewise as they contract*, and thus seem to crowd each other apart. It is not easy to see why lines of force have these properties, but once the properties are assumed it is easy to reason out from them *what will happen* in many practical cases.

64. Oersted's discovery. The real connection which exists between magnetism such as is exhibited by the steel magnets and currents of electricity was not generally known until 1820, when Oersted, a Danish scientist, published the fact



MICHAEL FARADAY (1791-1867).

A distinguished English physicist and chemist; one of the most gifted of experimenters. While apprenticed to a bookbinder he devoted his leisure time to science and later became a laboratory assistant to Sir Humphry Davy. In 1825 he was made director of the laboratory at the Royal Institution and in 1831 he discovered electromagnetic induction. His extraordinary power and ingenuity resulted in important discoveries in electrochemistry and in the relations of electricity to magnetism.

that a magnetic needle is disturbed by the presence of an electric current in its neighborhood. This discovery had really been made earlier, but its importance had not been recognized. It had also been known that under some conditions lightning discharges had magnetized steel needles, but the conditions had not been successfully reproduced by experimenters. The publication by Oersted of the results of his experiments led a number of scientists to turn their attention during the early part of the nineteenth century to a determination (as complete as was then possible) of the exact relation existing between electricity and magnetism. We are, therefore, entirely justified in crediting Oersted with the original discovery of the magnetic effect of the electric current — one of the epoch-making discoveries of the world.

65. Direction and strength of an electromagnetic field.

Magnetism set up by an electric current is called **electromagnetism**. But this term is merely a convenient indication of the immediate source of the magnetic force. For the magnetic force produced by a permanent magnet such as the earth or a magnetized piece of steel and that produced by an electric current are exactly alike. The direction of the magnetic force due to electromagnetism is always at right angles to the direction of the current which produces the magnetism. The lines of force in the magnetic field due to the current in a cylindrical wire must, therefore, be circles surrounding the wire. *The strength of the magnetic field at any point due to an electric current near by depends directly upon the strength of the current and inversely upon the average distance of the current from the point.* The reason why a magnetic field is set up by an electric current is entirely unknown; merely the experimental fact and its applications are known.

The magnetic field which surrounds a current may be graphically shown in a way that is interesting and instructive. A stout copper wire may be passed vertically through a hole in a horizontal sheet of



FIG. 44. — Iron filings showing the distribution of magnetism around a wire carrying an electric current. The black dot represents a cross section of the wire.

cardboard or stiff paper. If fine iron filings are sprinkled upon the paper, they will arrange themselves in circles (not spirals) around the wire when a current is passed through it (Fig. 44). If a small magnetic needle or compass is placed on the paper with its center over a line of filings, the needle will tend to stand at a tangent to the line (Fig. 45). An independent magnetic pole (if such a thing were physically possible) would tend to move continuously round and round the wire along any one of the lines of filings upon which it might be placed.

If the cardboard has been soaked in paraffin, the iron filings may be fixed in position for examination at leisure by passing the flame of a Bunsen gas burner quickly over the surface, thereby softening the paraffin for an instant and allowing the filings to become embedded in it.

The direction in which the magnetic needle points when near a wire carrying an electric current depends upon two things: (1) the side of the wire on which it stands and (2) the direction in which the current flows in the wire. In figure 45 it is evident from the positions of the magnetic needles (the black ends represent north poles) that the lines of force run counter to the

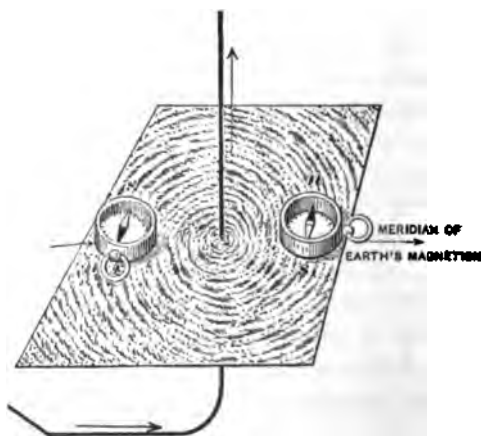

FIG. 45. — Magnetic lines of force which surround an electric current shown by small compass needles, *NS*.

motion of the hands of a clock. If the direction of the current is reversed by interchanging the connection of the wires leading to the battery or generator, the magnetic needles also reverse their directions. This shows that the direction of the lines of force has a fixed relation to the direction of the current.

66. Rules for determining the direction of a magnetic field around a current. There are various ways of remembering the relation between the positive direction of the lines of force and the direction of the current which produces them. One rule is to consider an ordinary right-handed screw which is being screwed into or out of a block (Fig. 46). *If an electric current is considered as flowing through the screw in the direction in which the screw moves through the block, then the direction of the lines of force is shown by the direction in which the screw turns.* Instead of a screw and nut, a corkscrew may be thought of as being screwed into or out of a cork.

Another rule for remembering the relation between the direction of the current in a wire and the direction of its lines of force is this:

grasp the wire with the right hand, the thumb being extended along the wire and the fingers being wrapped around the wire; then the fingers point in the direction of the lines of force while the thumb points in the direction of the flow of the current (Fig. 47).



FIG. 47. — Thumb rule for magnetic field around a wire.

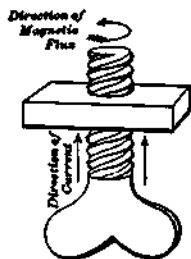

FIG. 46. — Illustration by screw and nut of the relation between the directions of current and the magnetism produced by it.

This relation between the direction of the current flow and the deflection of a magnetic needle gives a ready method for determining the direction of the current in a wire; the only indicator which is required is a small compass such as may be obtained of any optician

and in most hardware stores. The compass may be placed under the wire and the direction toward which its north pole turns noted. Then an application of one of the rules gives the direction of the current. This means is very commonly

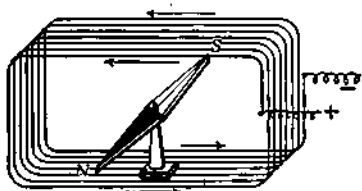

FIG. 48. — Magnetic needle placed at center of coil of wire.

used in electrical manufacturing establishments and in testing laboratories.

67. Solenoids. By applying one of the rules given in section 66, we see that if a wire carrying a current is passed above a magnetic needle, and then is turned back and passed below the needle, both the top and the bottom branches of the current tend to deflect the needle in the same direction, so that the effect on the needle is increased. (See Fig. 48.) If the two branches are equally near the needle, they act upon it with equal force, and thus the total force on the needle is doubled. By coiling the wire about the position of the needle, each additional turn will cause an additional deflecting force. In this way the magnetic effect of a current may be greatly multiplied. It has already been said that the magnetic force at a given point due to a current near it depends upon the strength of the current. We now see that *when a current is coiled around a point, the force depends upon the strength of the current multiplied by the number of turns in the coil. This product of the current by the turns is usually called "ampere turns."*



FIG. 49. — Loose solenoid with its lines of force.

When a wire carrying a current is coiled into a ring or helix, the lines of force which surround each turn seem to join to-

gether so that they belong to the coil or windings as a whole (Fig. 49). Such coils are often called **solenoids**, and, when a current is passed through them, they exhibit all the magnetic effects which are shown by steel magnets. They attract and repel magnets and other solenoids, and attract pieces of iron. If suspended so that they are free to swing, they turn into a north and south position exactly like magnets. Figure 50 shows an iron filing illustration of the magnetic field within a solenoid. The illustration is the longitudinal section taken along the axis of the solenoid, and the black dots represent the individual conductors of the coil.

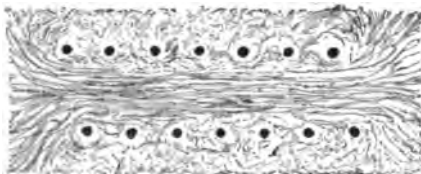

FIG. 50. — Iron filings showing the magnetism inside and outside of a solenoid.

Such an arrangement may be made by threading the turns of a solenoid like figure 50 through holes in a piece of glass or thick cardboard or celluloid and sprinkling iron filings on the surface when an electric current flows through the solenoid.

By applying either of the rules for finding the relation between the direction of a current and its magnetic field, the polarity of a solenoid may be readily found.

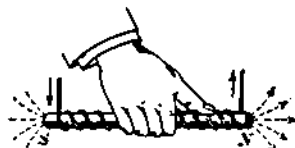

FIG. 51. — Rule for polarity of coil carrying current.

To determine its polarity, we shall find it convenient to express the thumb rule as used for a straight wire, in another way, as follows:

THUMB RULE FOR A COIL. Grasp the coil with the right hand so that the fingers point in the direction of the current in the coil, and the thumb will point to the north pole of the coil (Fig. 51).

68. Mutual force acting between a magnet and current. The experiments described in sections 60 and 61 show that a

steel magnet is caused to move when brought near a wire carrying an electric current. Then, since we know that a force acting between two bodies always affects them both, we may expect that a wire which carries a current will tend to move when brought near a fixed steel magnet.

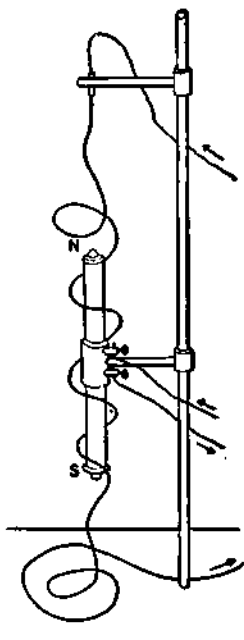

FIG. 52. — Effect of magnet on flexible wire carrying electric current.

This may be readily shown by suspending a very flexible conducting wire near a fixed magnet as in figure 52. When a current is passed through the wire, the wire winds itself around the magnet. If the current is reversed, the wire unwinds and then winds around the magnet again, but in the opposite direction.

The motions of the wire and the magnet are due to the apparent tendency of magnetic lines of force to move out of a position where they are not parallel with each other and into a position where they are parallel with each other and in the same direction.

The magnetic lines of force set up by the magnet in the air near it curve around from the north pole to the south pole (illustrated in figure 40) and therefore are more or less parallel with the body of the magnet, and they complete themselves by passing through the magnet itself. The lines of force set up in the air by the electric current in the wire are normally circles around the wire (illustrated by the iron filings in figures 44 and 45). When the wire winds itself around the magnet in the manner shown by the current, it forms a solenoid in which the lines of force are common to the turns of the solenoid (illustrated in figures 49 and 50). The wire winds itself around the magnet in such a way that these lines of force are parallel with and in the same general direction as the lines of force of the magnet. When the current in the wire is reversed, which also reverses the direction of the lines of force in the solenoid, the magnetic forces cause the wire

to unwind and then rewind around the magnet in the reverse manner, thus again bringing the two magnetic fields into parallelism.

Instead of the steel magnet, the fixed magnet in this experiment may be a solenoid intensified by the introduction of an iron coil around which the coils are wound. Such a magnet may be caused to give a very powerful effect, and for that reason figure 52 shows such an arrangement.

69. Electromagnets. When a coil of wire (*i.e.*, a solenoid) is wound around a piece of soft iron or steel for the purpose of getting a magnetic field, the combination is called an **electromagnet**. A piece of hard steel might be used instead of soft iron, but in this case the amount of magnetism created by a given current in the turns of the coil, or number of ampere turns, would be much less than is produced in soft iron; moreover, the steel would retain its magnetism and become a so-called permanent magnet. Soft iron or mild steel is universally used, therefore, in electromagnets.

The electromagnet is of the greatest value in electrical industries because it can be built in practically any desired size and form, and with enormous magnetic strength because *its magnetism is under the control of the current*: when the circuit is "made," it becomes a magnet; when the circuit is "broken," it ceases to act as a magnet. The magnets of commercial dynamos and electric motors are always electromagnets. Figure 53 shows two forms of electromagnets,

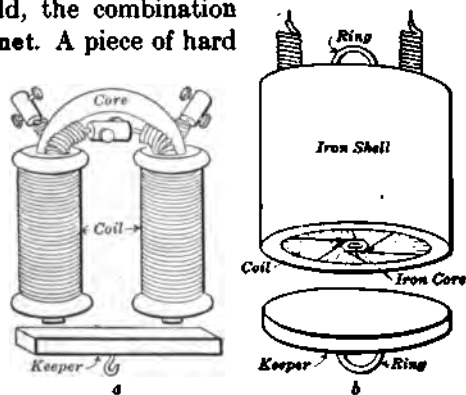

FIG. 53.—Two forms of electromagnets: (a) horse-shoe form and (b) ironclad magnet.

one the horseshoe form and the other the ironclad magnet. Electromagnets such as are shown in this figure are often provided with a movable piece of iron in front of the two poles, which is called an *armature* or *keeper*.

The property of soft iron through which it becomes strongly magnetized when placed within a solenoid carrying an electric current, and then loses its magnetism when the current is broken, was discovered by William Sturgeon of England in 1825. Very shortly after Oersted's discovery (section 64), Sir Humphry Davy, Arago, Ampère, and others had magnetized steel needles by placing them in solenoids. But it was reserved for Sturgeon, an otherwise little-known scientist, to make the discovery of that most important property of soft iron — the dependence of its magnetism upon the continued presence of the magnetizing force of the electric current and the controllability of its magnetism by varying the magnetizing force. Like Davy, Faraday, Henry, and others of the world's great discoverers in physical science, Sturgeon, as a boy, was an artisan apprentice and gained his knowledge of science through study and experiment in his unemployed hours.

At the time of the discovery of the electromagnet nothing was thought of its great commercial future; but it was welcomed with the highest scientific interest. In that day the laws of electric circuits were unknown, the common insulated wire of to-day was not yet made, and the manufacture of an electromagnet was a matter of much labor. Moreover, the only sources of current were at first plain zinc-copper cells, and later Bunsen, Daniell, or similar types of galvanic cells. Practical electromagnets were made in 1831 by Joseph Henry, a famous American schoolmaster and scientist then teaching in the Academy at Albany, N. Y. Henry's magnet was capable of supporting fifty times its own weight, which was considered very remarkable at that time. By the year 1845,

less than a century ago, the investigators had succeeded in overcoming their lack of experimental facilities and had mapped out the laws of magnetic circuits very much as we know them at the present time. Thus was laid the foundation of the profession of electrical engineering.

70. Electric bells. One of the earliest applications of electromagnets to domestic convenience was the electric bell. The mechanism of an ordinary vibrating electric bell consists of a stationary electromagnet *m* (Fig. 54), with a vibrating armature *A*, which is fastened at one end to a spring hinge *S*, and carries at the other end the bell clapper *H*. When an electric current is passed through the electromagnet of a bell, the armature is attracted and moves forward so that the clapper strikes the gong. At the same time the electric circuit is broken by a spring contact *C* at the back of the armature, the magnet loses its magnetism, and the armature flies back to its original position. When the armature flies back, the circuit is again completed at the spring contact *C*, the armature again flies forward, the clapper again strikes the gong, and the whole process is rapidly repeated over and over again as long as the electric circuit is complete at the push button. The back-and-forth motion of the armature causes the clapper to strike a succession of blows on the gong, and thus produces the ringing of the bell. When a bell gets out of order, the trouble is usually to be found in the spring contact, which may be dirty or out of adjustment, or the electromagnets may be short-circuited.

Figure 55 is a diagram of a push button, the simplicity of which is to be seen at a glance.

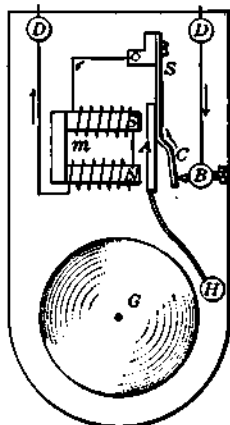

FIG. 54. — Electric bell with push button.

Sometimes it is not desirable to have an electric bell ring continuously while the push button is depressed, and in that case the spring contact *C* is omitted, and the conducting wires are connected directly with the electromagnet. Such a bell makes a single stroke for each push of the button, and it is therefore often called a "single-stroke bell."

71. Wiring bell circuits. The wire commonly used inside of buildings for bell circuits is called "annunciator wire." It is copper wire with an insulation consisting of two heavy cotton wrappings, wound in opposite directions and thoroughly waxed with paraffin. These wires are made in various sizes (No. 16 and No. 18) and are frequently striped in different colors. Sometimes what is known as "office wire" is used for telephone and messenger call connections. The insulation of "office wire" ordinarily consists of two braidings of cotton which are well soaked in paraffin.

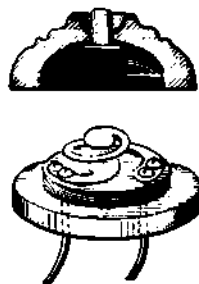

FIG. 55. — Ordinary push button.

While no danger can arise from the use of these poorly insulated wires for such circuits, provided they are not in a position to come in contact with electric light wires, yet a great deal of inconvenience is caused by their unsatisfactory and leaky character. This is the condition of numberless electric-bell circuits in houses all over the country where the front door bell fails to ring when the button is pushed. The trouble is caused by the battery's being run down through the constant flow of current leaking from poorly insulated wires where they come in contact with dampness or at some point where they are both placed under one metal staple. The difficulty, in a great majority of the cases, would never have appeared had wire with good rubber insulation been used. As No. 18 wire of the Brown and Sharpe gauge is usually taken for bell circuits, the extra expense caused by using rubber-covered or "weatherproof" wire is not very great, while the inconvenience avoided by its use may be considerable.

It must not be assumed, however, that all the troubles to which bell circuits and similar circuits are subject arise from poor insulation.

Battery zincs become used up or the water evaporates, and the battery may not work on that account. The mechanism of bells and push buttons is very simple and not likely to get out of order, but trouble may occur even in them. The contact parts in a push button gradually become corroded, and then when the button is pushed it does not complete the circuit. This fault is easily remedied by taking the cover off the button and scraping the contact points.

If a leak occurs from wire to wire, the battery remains in action all the time, the depolarizer (if the battery has one) soon becomes

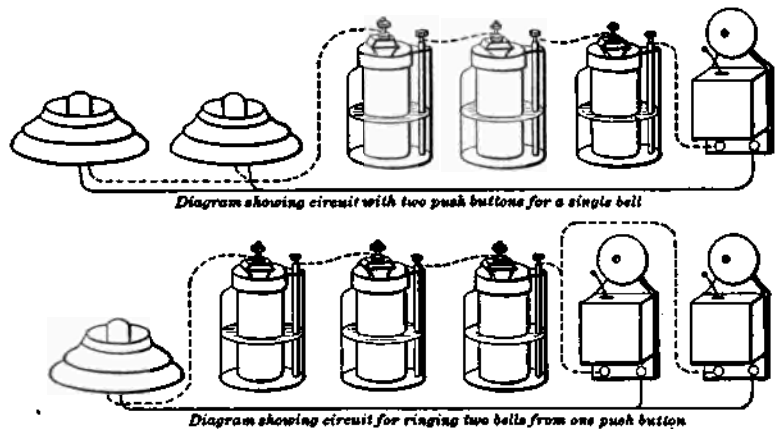

FIG. 56. — Diagram of electric-bell circuits.

exhausted, and the battery becomes polarized or "run down." The bell then fails to ring when the button is pushed. If the battery has no depolarizer, the process of running down occurs in exactly the same way, but it is more rapid.

Figure 56 is a diagram which shows two arrangements for electric-bell circuits. The battery consists of one or two open-circuit cells. These are connected in series with the bell and push button by wires which may run within the walls of a house. When the button is pushed, it closes the circuit and the bell rings. When the button is not being pushed, the circuit should be open and the battery at rest.

When one bell is operated from one push button, the circuit is exactly the same as though one push button were removed from the upper diagram in figure 56. The bell service in most houses is performed by several circuits, each of which includes a bell and its push button; but one battery is used in common for all circuits. This is illustrated in figure 57, from which it may be seen that the bell circuits are connected in parallel to the common battery.

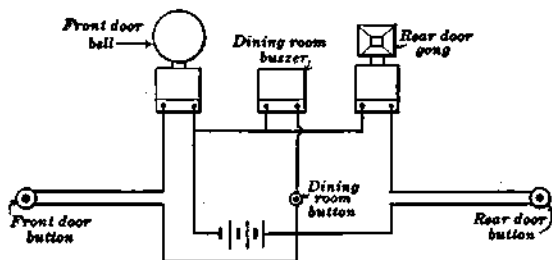

FIG. 57. — Diagram of household bell circuit.

72. Telegraph circuit. Another simple application of the electromagnet is in telegraph sounders, one of which is illustrated in figure 58. This consists of a stationary horseshoe electromagnet and a movable armature. The armature, which is of soft iron, is attached to a substantial brass bar. This bar is pivoted near one end, as shown in the figure, so that its other end may move up and down between adjustable stops. To the first end of the bar is attached a spring, which draws the bar against the upper stop when no current is flowing in the magnet. The large cylinders shown in about the center of figure 58 compose the electromagnet. This magnet consists of two cores of soft iron about three eighths of an inch in diameter and one inch and a half long, wound with a cotton-covered wire called "magnet wire" and covered with

black paper or a short piece of hard rubber tube over all. The cores are screwed fast to an iron base so as to make a horse-shoe electromagnet. The armature is shown at the top of the figure, above the magnet.

When a current flows in the magnet winding, the armature is attracted and the bar drawn against the lower stop. As the bar moves back and forth it makes a sharp click whenever it strikes one of the stops. The strength of the spring is adjustable by means of a screw, so that the sounder may be adjusted for use within a certain range of currents of different strengths.

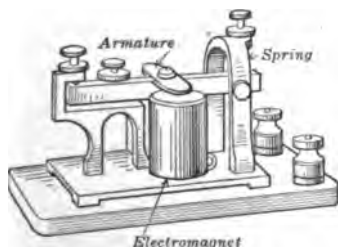

FIG. 58. — Telegraph sounder.

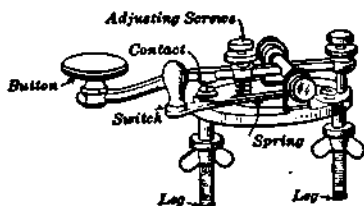

FIG. 59. — Telegraph key.

73. Telegraphic signals. Telegraphic signals are made up of a combination of long and short current impulses, which are made by pressing a sending key (Fig. 59) at proper intervals and for proper periods. A telegraph key of ordinary form is merely a quick-acting switch for opening and closing the circuit. Each combination of dots and dashes represents a letter of the alphabet or a certain much-used word or phrase.

To read successfully signals from a sounder much experience is necessary, but operators become very expert by long practice. It is necessary in reading to distinguish between the clicks of the armature against the top and bottom stops. A little reflection will show that the length of time between the clicks when the armature strikes the *bottom* and *top* stops causes the difference between dots and dashes, since the dots

and dashes represent intervals during which current is flowing through the magnet. The interval of time between the *top* click and the *bottom* click represents the spacing between the dots and dashes, because the spacing represents intervals during which no current flows, or during which the signal key is open.

The Morse Code (Fig. 60), as it is called, was arranged by Morse (Plate VI, opposite page 102), the inventor and promoter of the telegraph, between 1840 and 1850, and it is still used in

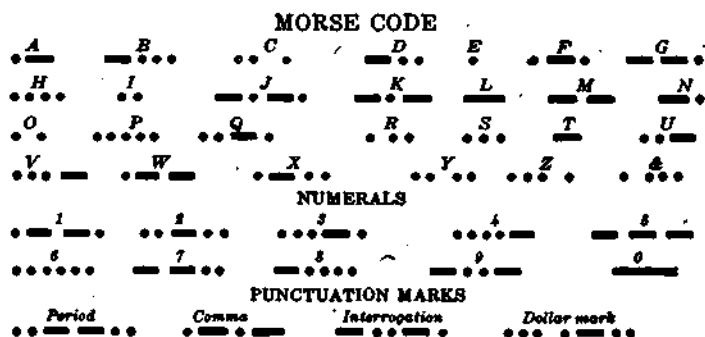

FIG. 60. — Morse code as used in America.

this country. The international code, which is used all over the world in radiotelegraphy and for submarine lines, and for land lines in nearly all countries except the United States, is given in Chapter XXII.

74. **Telegraph relays.** Telegraph sounders require only a fraction of an ampere to operate them; but to cause that fraction to flow through a long line, which necessarily has a high resistance, requires the use of a battery with a very large number of cells. This is undesirable because the cells are expensive to buy and to keep up. Long telegraph lines, therefore, are furnished with instruments which operate like sounders, but which are made very sensitive by placing a great



SAMUEL F. B. MORSE (1791-1872).

An American artist and inventor, was born at Charlestown (now part of Boston), Massachusetts, was graduated at Yale College in 1810, and in 1832 invented the commercial telegraph and the dot-and-dash alphabet known by his name. In 1844 by the aid of a \$30,000 grant from Congress he built the first commercially successful telegraph line between Washington and Baltimore.

many turns of fine wire on their magnets. Thus they may be satisfactorily operated on as little current as eight or ten milliamperes.* These instruments are called relays (Fig. 61).

Reading signals directly from a relay is not usually attempted, as the motion of its armature is so delicate that it makes very little sound, but the armature and one of its stops

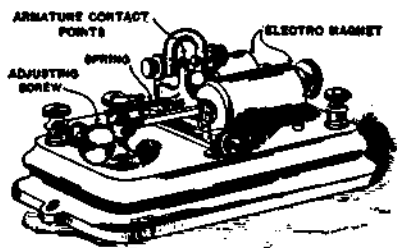

FIG. 61. — Telegraph relay.

are arranged as a part of a *local circuit* which contains a sounder and a couple of gravity cells (Fig. 62). As the relay armature

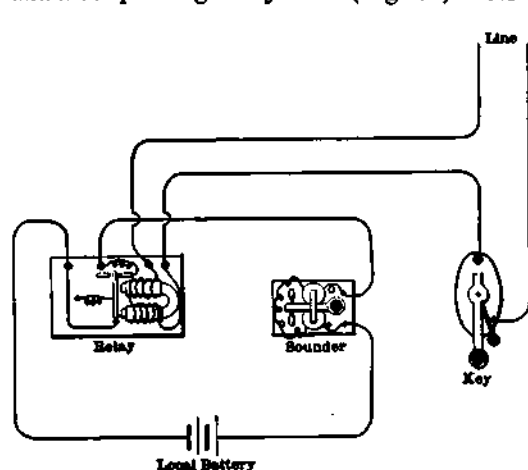

FIG. 62. — Apparatus at telegraph station, including key, relay, and local circuit, with battery and sounder.

moves back and forth it makes and breaks the local circuit and reproduces in it the signals which pass over the main line. The sounder in the local circuit gives the signals exactly as they pass over the line. The telegraph circuits used in this country are kept

closed when not in use. Therefore "closed-circuit cells," that is, cells with continuous depolarizing qualities, must be

* A milliampere is one one-thousandth of an ampere.

used to supply the current; and the key is provided with a short-circuited switch (Fig. 59), which keeps the circuit closed when the key is not in use. When telegraphing, the switch is open and the key makes and breaks the circuit as it is pressed and released by the fingers of the operator.

QUESTIONS

1. An electromagnet is found to be too weak for the purpose intended. How may its strength be increased?

2. In looking at the *N*-end of an electromagnet, in which direction does the current go around the core, clockwise or anti-clockwise?

3. If you find that the *N*-pole of a compass held under a north and south trolley wire points toward the east, what is the direction of the current in the wire?

4. A feed wire for an overhead trolley line is conducted up a vertical wooden pole from an underground duct. If one approaches the pole from the south, the *N*-pole of the compass needle is deflected eastward. Is the current flowing up or down the pole?

5. What limits the lifting power of an electromagnet?

6. In building an electromagnet, when would you use coarse wire and when fine wire? Give examples of each.

7. A coil wound in such a way that a current produces no magnetic effect is said to be noninductive. Show by diagram how such a coil is made.

75. Magnetic and nonmagnetic materials. Materials in which magnetism may be induced by a solenoid carrying a current and which thereby intensify the magnetic strength of the solenoid are called **magnetic materials**. Iron, in its various forms (such as wrought iron, cast iron, and steel), is the most strongly magnetic material known. There are only a few other materials that are known to be magnetic. Of these, the metals called nickel and cobalt are the commonest. Manganese, platinum, some of the salts of magnetic metals with their solutions, and oxygen are more or less magnetic, though usually to a very slight degree. All materials which

are not strongly magnetic are usually spoken of as nonmagnetic, since they are nearly neutral as regards magnetism. Magnetic materials are sometimes called paramagnetic, and nonmagnetic materials are sometimes called diamagnetic; but these terms have also additional scientific meanings which need not be discussed here.

Whenever magnetic material is needed in the useful arts, iron in its various forms (cast iron, wrought iron, and steel) is almost exclusively used on account of its great magnetic qualities. In fact, other materials, except nickel and cobalt, may be considered to be practically neutral when compared with iron.

Permanent magnets, such as are used in magnetos and electrical instruments, are made from the best grade of crucible tungsten steel, which contains about 5 per cent tungsten, a small percentage of chromium and manganese, and about 0.65 per cent carbon. After the steel has been hardened and magnetized it is artificially aged. One method of doing this (for watt-hour meters) is to pass them through a bath of boiling water or oil several times and then to demagnetize them to about 7 per cent of the original value by rotating a copper disk between the poles.

76. Magnetic circuit. Just as an electric current flows along a closed circuit, so we think of the magnetic lines of force or magnetic flux as flowing in a more or less fixed or definite circuit. Suppose we wind a very thin wire uniformly around a circular wooden ring (Fig. 63). We find by experiment that there is no magnetic field or flux outside the ring and that the field inside the coils represents a very simple magnetic circuit. The arrowheads in the diagram represent the direction of the magnetic flux along concentric circles.

If we now use an iron ring instead of the wooden ring and wind the same number of turns of insulated wire around it and magnetize it with the same strength of electric current,

we have a magnetic circuit made up entirely of iron. If we plunge such a magnetized ring into iron filings, we shall not observe any poles. This shows that the magnetic flux has a complete circuit within the iron.

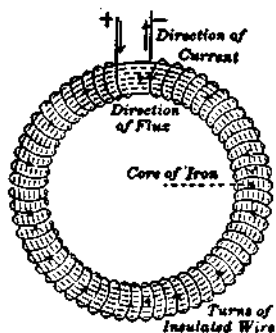

FIG. 63. — Magnetic circuit in the form of a ring wound with wire.

If we saw out a small section of the ring (Fig. 64), we introduce a short air gap into the magnetic circuit and the flux has to pass through this air gap to complete its circuit. If such a magnetized split ring is dipped into iron filings, we find that strong *N*- and *S*-poles have been produced where the cut was made and the gap or space is permeated with lines of force or magnetic flux. It can be shown that,

even though the split ring is magnetized with the same number of ampere turns, yet the flux through the iron is not nearly so dense as before, due to the increase in magnetic resistance introduced by the short air gap. Such a magnetic circuit made up partly of iron and partly of air is sometimes called a *compound circuit*, and a large proportion of the magnetic circuits in electrical machinery are of this kind. It should also be noted that the magnetic circuit is quite analogous to an electric circuit in that the introduction of resistance diminishes the magnetic flux. There is, however, this difference:

the introduction of an air gap into the ordinary electric circuit would, unless the voltage were exceedingly high, open the circuit and stop the flow of current; but in the magnetic circuit this cannot happen because *there is no magnetic insulator known*.

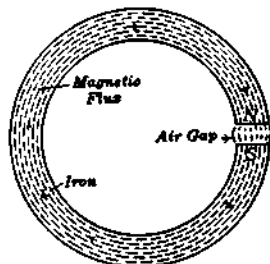

FIG. 64. — Iron ring with air gap in magnetic circuit.

77. Magnetomotive force. We have already said that the magnetizing force of a solenoid or any coil of wire depends upon the turns of wire as well as upon the intensity of the current. That is, magnetizing force is proportional to the product of the current expressed in amperes and the number of turns of wire, this product being called **ampere turns**.

FOR EXAMPLE, 500 turns of wire with a current of 2 amperes flowing in each will produce the same flux as 1000 turns with 1 ampere, or 200 turns with 5 amperes, because in each case the product is 1000 ampere turns.

The term **magnetomotive force** is applied to the total magnetizing force acting on the magnetic circuit. One may think of a difference of magnetic level between the two ends of a solenoid, which tends to set up lines of force between the two points. This difference of magnetic potential or magnetomotive force is analogous to the voltage or electromotive force of electric circuits, which has been explained in Chapter II.

In order to express the magnetomotive force in the conventional units, it is necessary to multiply the ampere turns by a constant factor which is nearly equal to $1\frac{1}{4}$. This factor is $\frac{4\pi}{10}$ or, more accurately, 1.26. This may be expressed in the form of an equation thus:

$$M = 1.26 NI^*$$

where M = magnetomotive force in a complete magnetic circuit,

N = total number of turns,

I = current in amperes.

FOR EXAMPLE, suppose we have a coil of 25 turns and 20 amperes flowing in it; the magnetomotive force would be $1.26 \times 25 \times 20$, or 632 units.

* In case inches instead of centimeters are used, the equation becomes

$$M = 3.2 NI.$$

In modern practice the ampere turns themselves are often taken as the magnetomotive force.

78. Magnetic intensity and flux density. It is often convenient to express the magnetomotive force as the magnetomotive force per unit length of the coil or solenoid. This intensity of the magnetic field is usually represented by the letter H .

Thus $M = 1.26 NI$,

and from this $H = \frac{M}{l} = \frac{1.26 NI}{l}$ *

where H = field strength,
 N = total number of turns on coil,
 I = strength of current,
 l = length of coil in centimeters.

Sometimes it is necessary to compute the number of lines of force per unit area of cross section (such as per square centimeter) of any part of a magnetic circuit; this is called the flux density. For any material except air the flux density is represented by the letter B .

FOR EXAMPLE, if the total flux in an iron circuit is 100,000 lines of force and the area of cross section is 25 square centimeters, then the flux density would be $\frac{100,000}{25}$ or 4000 lines per square centimeter.

79. Effect of magnetic materials in a magnetic circuit. We know that putting an iron core inside a solenoid increases the magnetic effect of the current. In other words, there are many more lines of force set up in iron than in air by the same magnetizing force H because the permeability of iron is much larger. Given a certain magnetizing force, then the flux density in an iron core B (the number of lines per square centimeter) is as many times the flux density when the coil has an air core H as the permeability of the iron is greater than the permeability of air, which is assumed to be 1. Thus we may define the permeability of a material as the ratio of the flux density B which would be set up in the material by the magnetizing force H , to that which would be set up in air by the same

* In practical work H is often expressed in amperes turns per centimeter.

magnetizing force. It is quite common to represent permeability by the Greek letter μ (pronounced mu), and to express this relation in the form of an equation:

$$\text{Permeability } (\mu) = \frac{\text{Flux density } (B)}{\text{Field intensity } (H)}$$

Permeability, though not constant (see next section), is a quality of the material which may be compared to electrical conductivity, and the reciprocal of permeability (μ) is the magnetic resistivity or reluctivity, which may be compared to the specific electrical resistance of the material.

Since the lines of magnetic flux pass through nonmagnetic bodies exactly as through air, the permeability of nonmagnetic substances is 1.

80. Permeability depends upon saturation. In comparing electric with magnetic circuits, magnetic permeability has been compared to electric conductivity. But there is this important difference: Given a piece of copper, its conductivity (that is, the reciprocal of its resistivity) is a definite fixed quantity, unless the temperature changes. In the case of a piece of iron which forms a part of a magnetic circuit, *its permeability is not a fixed quantity but depends upon the number of lines it already contains.* In other words, the value of μ depends upon B , the magnetic state of the iron.

In magnetizing iron there comes a point where, as the flux density increases, the permeability decreases and so it becomes more and more difficult to set up a greater number of lines. For this reason it is *impracticable* to magnetize a piece of iron beyond a certain flux density, which is called the **saturation point**. It is *possible*, but not usually practicable, to carry the magnetization beyond the saturation point.

81. Magnetization curves. In the following table will be found some interesting results of experiments in magnetizing various kinds of iron.

AMPERE TURNS PER CENTIMETER	LINES OF FORCE IN EMPTY COIL H	LINES PER SQUARE CENTIMETER B		
		Wrought Iron	Cast Steel	Cast Iron
5	6.3	9,000	11,000	—
10	12.6	12,000	13,500	2,300
15	18.9	13,300	14,500	3,900
20	25.2	14,400	15,000	5,000
25	31.5	14,900	15,500	5,600
30	37.8	15,300	15,800	6,200

It is evident from an inspection of this table that the flux density (B) is greater for cast steel than for wrought iron with the same magnetizing force (H), and that the flux density for

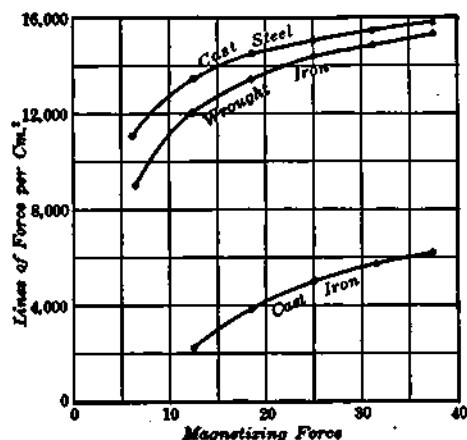

FIG. 65. — Magnetization curves of various kinds of iron.

both these varieties of iron is much greater than for cast iron. This relation of flux density to magnetizing force can be very clearly shown by what are called magnetization curves (Fig. 65) on which the magnetizing force H is represented horizontally and the flux density B vertically. One sees from these curves that the permeability of various sorts of iron is not a constant quantity but becomes less as the magnetizing force increases. It is also evident that the amount of magnetism which a piece of iron can take on does not increase directly as the magnetizing force, but increases more slowly and tends to approach a limit.

82. **Ohm's Law for magnetism.** We have already seen that the magnetic circuit is quite analogous to the electric circuit. We have magnetomotive force, which sets up lines of force or flux in the magnetic circuit, and we have a magnetic resistance, called *reluctance*, which retards or opposes the flow of the magnetic flux. Just as might be expected, we have a law for the magnetic circuit which much resembles the statement of Ohm's Law for an electric circuit. It may be stated thus: *the number of lines of force in a magnetic circuit is equal to the magnetomotive force divided by the reluctance.*

$$\text{Magnetic flux} = \frac{\text{Magnetomotive force}}{\text{Reluctance}}$$

83. **Computation of reluctance.** The magnetic reluctance of a simple ring (Fig. 63), just as the electric resistance of a wire, varies directly as the *length*, inversely as the *area of cross section*, and inversely as the magnetic conductivity or *permeability*, which in turn depends upon the flux density used.

$$\text{Reluctance} = \frac{\text{Length}}{\text{Cross section} \times \text{Permeability}}$$

This law is easily applicable to such a simple closed magnetic circuit as an iron ring, yet we can make a fair approximation for a nearly closed magnetic circuit such as the split iron ring (Fig. 64). If the air gap in the iron ring is short, we can assume that the lines of force are straight and run from the *N*- to the *S*-pole face and that only a few lines bend outside the gap. Now the reluctance of the magnetic circuit can be computed by adding the reluctance of the iron to the reluctance of the air gap — μ in the case of air being unity. In the case of more complicated magnetic circuits the reluctance of each part should be calculated separately. The combined reluctance of the entire magnetic circuit may thus be obtained by using the same rules as for series and parallel electrical circuits,

except that the magnetic reluctances are used instead of electrical resistances.

FOR EXAMPLE, given an iron ring whose cross section is 5 square centimeters and length 60 centimeters. The permeability of the iron is assumed to be 1000. Then the reluctance of the iron ring is equal to $\frac{60}{5 \times 1000}$, or 0.012.

If we suppose that a slit is cut making an air gap 1 centimeter long, the reluctance is equal to

$$\frac{59}{5 \times 1000} + \frac{1}{5} = 0.0118 + 0.2 = 0.212.$$

As the reluctance of the iron ring 0.0118 is in series in the circuit with the reluctance of the air gap 0.2, they are added together.

It will be seen that the reluctance of the ring with the air gap is about 17.7 times as much as that of the closed ring.

Again, suppose we make two very short air gaps of 0.1 centimeters each in the closed iron ring. Then the reluctance will be equal to

$$\frac{59.8}{5 \times 1000} + 2 \left(\frac{0.1}{5} \right) = 0.052.$$

This is more than 4 times the reluctance of the closed ring. In this case the iron and the two air gaps are all in series.

If we want to determine the number of *ampere turns* required in each of these three cases to produce, for example, 17,000 lines of force, we use Ohm's Law for magnetism.

$$\text{Magnetic flux} = \frac{\text{Magnetomotive force}}{\text{Reluctance}}$$

$$17,000 = \frac{M}{0.012},$$

then

$$M = 204,$$

and

$$NI = \frac{204}{1.26} = 165 \text{ ampere turns.}$$

In the second case, it would be 17.7×165 or about 2920 ampere turns; in the third case, it would be about 4 times 165 or about 660 ampere turns.

Thus one sees how much the number of ampere turns must be increased in order to force the same magnetic flux across an air gap.

Ohm's Law for magnetism is very generally used in the designing of dynamo machinery, although it is necessary to use great care in computing as nearly as possible the average lengths and cross sections of the various iron and air reluctances in the circuit, since they are usually irregular in form. Care must also be taken in finding the permeability of the metal parts of the circuit for the particular flux density which is to be used, since it varies with the flux. It is also necessary to take into account the leakage paths about the magnet. The flux in these paths passes through the cores under the coils and then leaks by outside paths from the iron of one pole to the other. These leakage paths may be considered to be in parallel with the main body of flux, which passes directly from pole face to pole face.

PROBLEMS

1. What is the reluctance of a piece of iron 40 centimeters long with a cross-section area of 20 square centimeters? Permeability = 1000.
2. A cast iron ring is 4.8 square centimeters in cross section and has a mean diameter of 20 centimeters ($\mu = 200$). What is the reluctance?
3. Suppose the iron ring in problem 2 has a section cut out, making an air gap 2 centimeters long. The permeability of air is assumed to be 1. What is the reluctance of the circuit?
4. What is the reluctance of a magnetic circuit made up of cast iron 30 centimeters long with a cross-section area of 2×4 centimeters, $\mu = 150$; and of annealed steel 25 centimeters long with a cross-section area of 3×3.5 centimeters, $\mu = 1500$?

(In the following problems use such values as you may require from the table in section 81.)

5. How many ampere turns are required to produce a flux density of 14,900 lines per square centimeter in a wrought iron ring 5 square centimeters in cross section and with a mean diameter of 25 centimeters?
6. How many ampere turns are necessary to produce a total flux of 150,000 lines through a cast steel ring having a cross section of

10 square centimeters and a mean diameter of 10 centimeters? Assume that the ring has a section cut out making an air gap 1 centimeter long.

84. Hysteresis. We have already seen that if we gradually increase the current which flows spirally around a piece of iron the iron gradually grows stronger magnetically. This is graphically represented by the magnetization curve (Fig. 66).

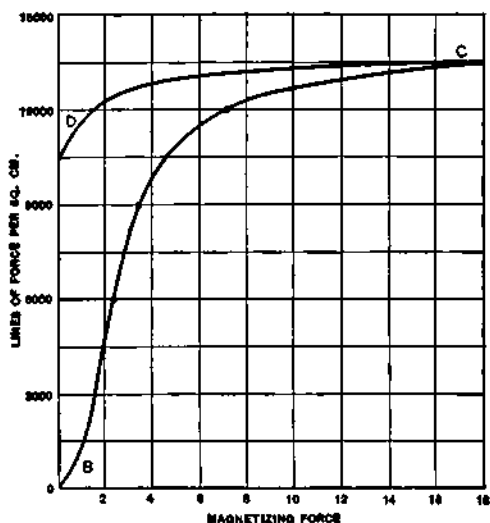

Fig. 66. — Curve of magnetization *BC* and curve of demagnetization *CD* of soft iron.

It will also be found that if we gradually decrease the electric current again, the iron becomes weaker magnetically. But (this is the new point) as we decrease the magnetizing force *H*, the flux density *B* does not decrease along the same line by which it had increased, but follows the curve *CD* as shown in figure 66. It will be seen that at the point *D* the magnetizing force is zero, but the flux density is still 10,500 lines: that is, we have a residual magnetism of 10,500 lines remaining in the iron. So we say the flux density *B* lags behind the magnetizing force *H*, and this lagging is called hysteresis.

One can form a sort of mental picture of this process, if one thinks of a piece of iron as being made up of very tiny particles called *molecules*; when the iron is magnetized, these molecules are oriented or turned about so as to lie in a regular

order. In the process of turning about, they rub against one another and so interfere with one another. This intermolecular friction produces heat. At any rate, it is an experimental fact that rapid magnetization and demagnetization does warm the iron. If the process is carried on rapidly and continuously, as in alternating-current machinery, the hysteresis produces considerable rise in temperature. The heat thus generated results in a loss of energy, as has been pointed out in section 52. This loss we call the **hysteresis loss**, and in the design of electrical machinery both this loss and the resulting rise in temperature must be given consideration.

In studying alternating-current machinery in later chapters we shall learn that the electric currents flowing through the coils are constantly changing and reverse their direction many times a second. Consequently the magnetic flux in the iron cores is reversed many times a second. It is, in fact, this rapid reversal of the magnetism of the core that causes the humming of a transformer.

We have just seen that magnetic hysteresis may be considered as caused by molecular friction. It is obvious that energy must be expended to shift the molecules around, that is, to overcome this molecular friction. Experiments show that the loss of power due to hysteresis is much greater in hard steel than in soft iron. It can be shown too that this hysteresis loss also depends on the frequency (that is, the number of times the magnetism is reversed per second) and the maximum density B of the flux. Steinmetz gives the following equation for computing the hysteresis loss:

$$P = KVfB^{1.6}$$

where P = hysteresis loss in watts; V = volume of iron in cubic centimeters; f = frequency, number of cycles per second; B = maximum flux density, lines per sq. cm.; and K = constant, depending on the material.

The hysteresis constant varies from 1×10^{-10} for the best annealed transformer sheet metal (silicon steel) up to 25×10^{-10} for hardened cast steel.

FOR EXAMPLE, what is the hysteresis loss in a machine that contains 2500 cu. cm. of iron, which is subjected to 60 cycles a second? Given $K = 3 \times 10^{-10}$ and maximum flux density = 12,000, then

$$P = 3 \times 10^{-10} \times 2500 \times 60 \times 12,000^{1.6} = 152 \text{ watts.}$$

SUMMARY OF CHAPTER IV

ELECTRIC CURRENTS are always surrounded by a *magnetic field*.

EVERY MAGNET has at least two *poles*, one the north-seeking pole (*N*) and the other the south-seeking pole (*S*).

Like poles repel each other.

Unlike poles attract each other.

LINES OF FORCE tend to contract endwise and to swell side-wise; that is, there is tension along them and compression at right angles to them.

LINES OF MAGNETIC FORCE about an electric current are at right angles to the direction of the current and form concentric circles about the wire.

If one looks along the wire in the direction in which the current is flowing, the lines of magnetic force circle around the wire in a clockwise direction.

An electric current flowing in a coil of wire makes a magnetic solenoid of the coil.

TO DETERMINE ITS POLARITY, grasp the coil with the right hand so that the fingers point in the direction of the current in the coil, and the thumb will point to the north-seeking pole of the coil.

The magnetic effect of a solenoid is enormously increased by a soft iron or steel core which makes an electromagnet.

ELECTROMAGNETS are used in nearly every electric machine; *e.g.*, bells, telegraphs, generators, and motors.

LINES OF FORCE OR MAGNETIC FLUX may be considered to flow along a closed path or magnetic circuit.

THE MAGNETOMOTIVE FORCE depends on the *ampere turns*.

$$M = 1.26NI.$$

MAGNETIC INTENSITY *H* is the magnetomotive force per unit length.

$$H = \frac{1.26NI}{l}.$$

FLUX DENSITY B equals field intensity per unit area of cross section, such as per square centimeter. In air flux density equals field intensity; that is, for air

$$B = H,$$

$$\text{Permeability } (\mu) = \frac{\text{Flux density } (B)}{\text{Field intensity } (H)}.$$

Permeability of air is 1; of iron, sometimes several thousand, depending on the degree of saturation.

RELUCTANCE of magnetic circuit corresponds to resistance in an electric circuit.

OHM'S LAW for a *Magnetic Circuit*:

$$\text{Magnetic flux} = \frac{\text{Magnetomotive force}}{\text{Reluctance}}.$$

To compute reluctance of magnetic circuit use the following equation:

$$\text{Reluctance} = \frac{\text{Length}}{\text{Cross section} \times \text{Permeability}}.$$

When we remove the magnetizing force the magnetic flux does not become zero, because there is a certain "lag" in the magnetic flux with respect to the magnetizing force. This "lagging" is called "*hysteresis*."

Soft iron and annealed silicon steel show little hysteresis and so are used in armature cores and alternating-current machines in order to make the "*hysteresis loss*" as small as possible.

QUESTIONS

1. If a magnetic needle lies parallel to a wire placed in a north and south direction, what two forces act upon it when a current is sent through the wire?
2. Is the magnetism created by an electric current in any way different from the magnetism of a magnetized steel bar?
3. How much stronger is the magnetic field set up by a current 1 inch from the straight wire carrying the current, than it is 2 inches away?
4. How can the direction of a current be determined by means of a compass?

5. If you are standing beside and facing a wire in which a current flows from left to right and you place a compass needle over the wire, will the north-seeking pole tend to turn toward you or away from you?

6. In what ways can a solenoid be compared to a permanent magnet?

7. If you wish to have a south-seeking pole at the bottom of a vertical solenoid, how must the current be made to flow?

8. How many ampere turns has a coil of twenty turns which carries one half of an ampere?

9. What happens to a bar of steel placed within a solenoid?

10. What happens to a bar of soft iron when it is placed in a solenoid?

11. What happens in Questions 9 and 10 if the current is shut off?

12. What is residual magnetism?

13. Which will become the more highly magnetized by the same magnetomotive force, hard steel or soft iron?

14. If the current in an electromagnet be increased 1 ampere at a time up to 50 amperes and if 25 amperes saturates the iron, will the magnetism increase proportionately to the current?

15. In Question 14 what would be the effect of the last 25 amperes?

16. If in Question 14 the current be decreased again, will the curve of magnetism be the same as for the rising current? Will it be higher or lower?

17. How many ampere turns are required to set up a unit of magnetomotive force?

18. How much magnetomotive force will be set up by one hundredth of an ampere in a coil of one hundred turns?

19. How much magnetomotive force will be set up by 1 ampere in a coil of ten turns?

20. What causes hysteresis? How?

21. In which will a solenoid set up lines of force most readily: air, soft iron, or hard steel? In which next most readily?

22. What is permeability?

23. Compare magnetic permeability to specific conductance of electric conductors.

24. What is the permeability of air, wood, brick, etc.?

25. If one magnetic circuit is twice as long and has twice the cross-section area of another made of the same material, will they be of equal reluctance?

26. If a certain ring of steel has one tenth the permeability of an equal ring of iron, how much greater will be the reluctance of the steel than that of the iron?

CHAPTER V

THE NATURE AND PROPERTIES OF MAGNETISM

Early history of magnetism — natural and artificial magnets — methods of making — test of magnetism — forms: bar, horseshoe, laminated — poles: location, number, kind — field and circuit — induced magnetism depends on permeability — reversed polarity and screens — coercive force — demagnetization — laws of attraction and repulsion, unit pole and unit field.

Theory of magnetism — experiments — molecular magnets — saturation.

Terrestrial magnetism — earth's polarity — equator — meridian — variation and dip — compasses — magnetic exploration.

85. Historical facts about magnetism. In the last chapter we saw that the electric current is always associated with magnetism. We must not forget, however, that some of the facts about magnetism were known long before the Christian era and therefore far antedate our knowledge of the electric current. It is even said that the Chinese used a device similar to the compass many centuries before the birth of Christ to guide them across the plains of Tartary; but this is not probable. In Europe the use of the compass did not become general until the thirteenth century of the Christian era. Many early Greek writers — Plato, Euripides, and Thales — speak of lodestone, which is an iron ore occurring in Magnesia and having the attractive power of a magnet. This magnetic iron ore (Fe_3O_4) is called magnetite and is valuable. It is found in Norway, Sweden, and in various parts of North America.

In about the year 1600 Dr. Gilbert published a large number of discoveries concerning magnetism in his famous work *De Magnete*.



FIG. 67. — Natural magnet or lodestone attracts iron.

86. Natural and artificial magnets. It was long ago found that any piece of hard iron when rubbed with a lodestone (Fig. 67) acquired the properties characteristic of the stone; that is, it would attract light bits of iron, and if hung up by a thread, would point north and south. When pieces of soft iron touch a magnet, they also become magnets and are magnetized while in contact with the magnet; but when separated from it, the magnetism of the soft iron disappears. It was Dr. Gilbert who

observed that the attractive power of a magnet appears to reside in two spots or regions; in a long-shaped magnet these spots or poles are usually near its ends. When a magnet is suspended on a pivot or a thread, it sets itself in a direction so as to point nearly north and south. A small elongated magnet thus suspended is called a *magnetic needle* or *compass* (Fig. 68).

The pole which points toward the north is called the *north-seeking* (*N*) pole and the other, the *south-seeking* (*S*) pole.

87. How to make a magnet. First the steel must be hardened. To do this, heat to brilliant red and then quickly plunge into cold

water, oil, or mercury. The steel then becomes intensely brittle and *glass-hard*. A very simple method of magnetizing the steel is by stroking it with another magnet. It is better to stroke one half with an *S*-pole, beginning at the center and repeating this several times on each side; then using the

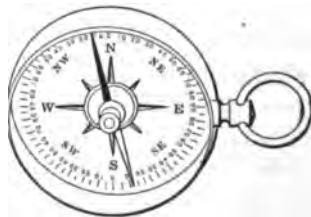

FIG. 68. — Magnetic needle in a compass. Black end is north-seeking.

N-pole, stroke the other half in the same way. In these days when electricity is so common, it is more usual to magnetize steel by making it a part in the magnetic circuit of an electro-magnet, as explained in Chapter IV. Tapping the end of the steel with a hammer while it is under the influence of the electric current will produce better results.

88. Forms of magnets. When steel bars, round or flat, are made into straight magnets, they are called bar magnets. When a straight bar of steel is bent into the form of a horseshoe (Fig. 69) and then properly magnetized, one end will be an *N*-pole and the other an *S*-pole. By thus bringing the poles close together, the magnet will lift much more because both poles act together. A piece of soft iron, called the *keeper* or *armature*, is placed across the ends of the poles when they are not in use, to retain the magnetism. This forms a closed magnetic circuit of iron.

Experiments also seem to show that a magnet made up of a number of thin pieces of steel, magnetized separately, and fastened with like poles together, will be stronger than one of solid steel of the same dimensions. Such magnets can be made in any form and are called laminated magnets. They are used in various electric measuring instruments and mag-neto-generators.

89. Two poles of a magnet inseparable. In magnetizing a piece of steel with only one pole of a magnet, it will have an *N*- and an *S*-pole. Even when a magnet is broken into two pieces, each piece will have an *N*- and an *S*-pole at the point of breaking. Hence it seems to be impossible to make a magnet with only one pole. A long steel bar may, however, have more than two poles (Fig. 70), but it always has at least two opposite poles. In cases where the bar has a number of intermediate

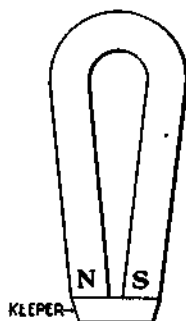

FIG. 69. — Horseshoe magnet with its keeper.

poles and neutral points, as can be readily shown by plunging its entire length into iron filings, the intermediate poles are called **consequent poles**.

90. Distribution of magnetism. Faraday was the first to see that a true understanding of the action of magnets could be had only by studying the empty space around them, as well as the magnets themselves. The familiar experiment of sprinkling iron filings on a cardboard placed over a magnet (Fig. 43) shows very quickly and clearly the magnetic field around a magnet. It is assumed, as already explained in Chapter IV, that the magnetic lines of force, the flux, emanate from the *N*-pole of a magnet and after passing through the surrounding medium,

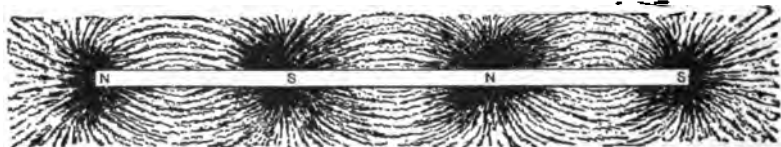

FIG. 70. — Bar magnet with two consequent poles.

reënter the *S*-pole and thus complete the circuit from the *S*-pole to the *N*-pole through the magnet itself. Every line must have a complete circuit; as we have said before, it is impossible, therefore, to have a magnet with only one pole. These magnetic lines of force complete their circuits independently and never cut or cross each other. That the magnetic field inside the iron is so much smaller in cross section than the external field, and that the flux density is therefore greater, is accounted for by the fact that the steel is so much more permeable than the surrounding space and that the lines in the air will distribute themselves over a large cross section in order to find the path or paths of lowest reluctance.

91. Iron magnetized by induction. When pieces of soft iron are placed in a magnetic field, we find that they themselves become magnetized (Fig. 71), and when the magnetic

field is removed, that the pieces of soft iron lose their magnetism. This process is called *induction*. For example, the iron filings near a magnet become magnetized by induction. Each little piece of iron, when tapped or jarred, turns itself in obedience to the attractions and repulsions in the field and tends to assume the direction of force jointly due to the simultaneous action of both poles.

The magnetization of iron in a magnetic field is directly due to the high permeability of the iron and the low reluctance of the path through it. A larger number of lines of force are set up in the iron than in the air, as if they left the air and crowded into the iron. For example, figure 72 shows a small piece of iron *A* in the field of a magnet *M*; it will be noted that the field is distorted because so much flux is apparently trying to crowd through the iron. The result is that the piece of iron *A* now has a north and south pole of its own because lines of force enter one end and leave the other. It is

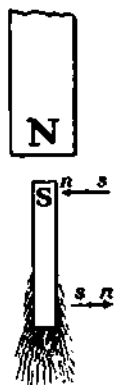

FIG. 71. — Iron becomes a temporary magnet by induction.

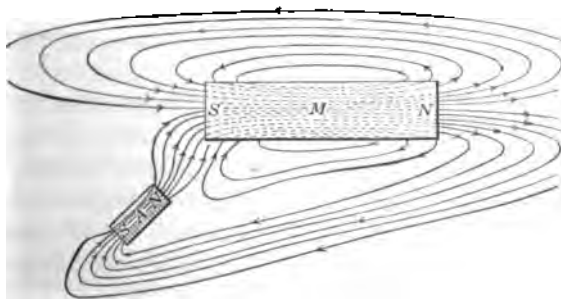

FIG. 72. — Concentration of magnetic flux in iron due to its high permeability.

easy to see then that the strength of the *induced magnet* depends on the permeability of the iron and the strength of the field in which it chances to be placed. In general, then, a *magnetic body*,

free to move under the influence of a magnetic field, tends to move so as to accommodate through itself the greatest number of lines of force of the field. If the movable body is a magnet, it moves in such a direction that its own internal magnetic lines will be in the same direction as those of the field in which it is placed.

92. Reversed polarity. When a compass needle is brought near a magnet, it turns so as to indicate the direction of the field at that point. But if the needle is held so that it is not free to rotate and is brought near a bar magnet so that two like poles approach each other, repulsion takes place between the like poles up to a certain distance, after which attraction occurs. This is due to the induction effect of the stronger magnet, which has demagnetized the weak magnet of the compass and

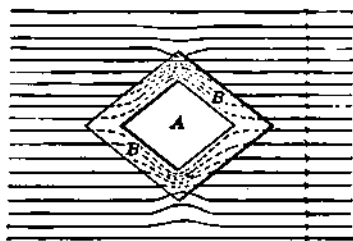

FIG. 73. — Soft iron can be used to shield an instrument A from magnetic flux.

remagnetized it again oppositely. This reversal of the polarity of a compass needle is quite common in laboratory testing and so it is necessary first to test the needle in the earth's field to make sure that its marked or N-end points north.

93. Magnetic screens.

Since we know of no magnetic insulator and since the magnetic flux passes through all non-magnetic materials such as wood, copper, liquids, and gases, or even a vacuum equally well, it would seem impossible to shield an instrument from a magnetic field. But when a very permeable material, such as soft iron, is interposed (Fig. 73), the instrument at A is almost entirely screened from external magnetism. Watches are sometimes inclosed in a soft iron case to protect the mainspring and balance wheel from becoming magnetized. They may be demagnetized by moving them

slowly near to and away from the pole of an electromagnet in the coils of which the current is rapidly reversing.

QUESTIONS

1. What is the probable derivation of the word "magnet"?
2. In what century did the use of the magnetic needle become usual?
3. How could you magnetize a steel pen, using a horseshoe magnet, so that the point would be a north pole? How could you test it to prove that you had magnetized it correctly? Make a sketch.
4. How would you magnetize a steel horseshoe by an electromagnet?
5. What kind of steel would you select to make a good permanent magnet?
6. What is the difference between magnets and magnetic material?
7. Six magnetized sewing needles are thrust vertically through six little floats of cork and are placed in a dish of water with their north poles downwards. How will they affect one another, and what will be the effect of holding over them the north pole of a magnet?
8. Describe a method of making a permanent picture of magnetic fields.
9. What is meant by the neutral point of a bar magnet? by the axis?
10. How does a jeweler demagnetize a watch?

94. Demagnetization. Experiments show that it is more difficult to get magnetism into steel than into soft iron of the same dimensions, and that it is also harder to get the magnetism out of steel than out of iron. In other words, the steel retains the magnetism once put into it. This power of resisting magnetization or demagnetization is sometimes called *coercive force*, or perhaps a better term is *retentivity*. The harder the steel, the greater is its retentivity.

Any steel magnet loses magnetism partially or wholly if subjected to rough usage, but a newly magnetized magnet loses more of its strength by such treatment than those which have become somewhat aged. Even slight shocks will destroy any magnetism remaining in soft iron. It was discovered

by Gilbert that a magnet loses its magnetism on being heated red hot; on the other hand it has been found that magnets have their strength increased when subjected to very low temperatures.

Electrical measuring instruments which have permanent steel magnets must be handled with care. The ease with which soft iron and steel can be magnetized and demagnetized is made use of in telegraph sounders and in armature cores of generators, where the magnetic flux surges through many hundred times in a minute.

95. Force exerted between two poles. We have already seen (section 61) that *unlike poles of a magnet attract and like poles repel each other*. We have also seen that a magnet attracts any piece of iron by induction (section 91); but we must always remember that this *magnetic attraction is a mutual action*; that is, the iron attracts the magnet just as much as the magnet attracts the iron because it has itself become a temporary magnet. In order to be able to estimate how much this force of attraction or repulsion of the magnetic poles in any given case will be, we must know three facts; namely, the strength of the poles and the distance between them. *The force exerted between two poles is equal to the product of the strengths of the poles divided by the square of their distance apart.*

$$\text{Thus } F = \frac{mm'}{d^2}$$

when F = force in dynes,

m = strength of one pole,

m' = strength of other pole,

d = distance between poles in centimeters.

A unit pole is a pole of such strength that if placed a centimeter away in the air from a like pole it will repel it with the force of one dyne (1 dyne = 0.00102 grams = 0.0000225 pounds). It should, however, be noted that an *isolated N-pole* is a physical impossibility, because every magnet must have a south pole corresponding to every

north pole. Moreover, this assumes that a pole is in effect concentrated in a mathematical point, whereas this cannot be physically produced.

The condition required for this law of force can be gained only by using two very long, thin magnets; and even then the force between two actual magnets, as it is usually measured, does not follow this law directly, because the poles are of considerable size as compared with their distance apart. Every small portion of the pole of one magnet exerts a force on every small portion of the pole of the other magnet in accordance with the law, and when all these small forces are added together, the law is apparently changed, although it is based on the fundamental one.

When a magnetic field exerts a force of one dyne on a unit pole, the intensity or strength of that part of the field is said to be 1 line per square centimeter. So the intensity of the field is theoretically measured by the number of lines passing through a square centimeter of it. Thus the force on a magnetic pole in a magnetic field may be stated as

$$F = mH$$

when F = action of the field on the magnet in dynes,
 m = strength of the magnet in unit poles,
 H = strength of the field in lines.

It should be remembered that these ideas are purely theoretical conceptions, but they form a correct basis upon which practical conceptions can be built up.

QUESTIONS AND PROBLEMS

1. If a magnet pole is brought near a piece of iron, will the pole exert a pull on the iron? Will the iron exert a pull on the pole? Will the two pulls be equal?
2. Describe an experiment that will show that the force of attraction or repulsion between two bodies is mutual.
3. Suppose two long magnets with their poles concentrated into points of 20 units strength each have their unlike poles 2 centimeters apart. Then what force is exerted between their two poles?
4. Suppose two poles as in Question 3 are separated 1 centimeter, one of them being of one unit strength. If the force between them is 10 dynes, what is the strength of the second pole?

5. Suppose two poles of the same strength as in Question 3. If the force exerted between the poles is 25 dynes, how far are they apart?

6. If a portion of a field is of 10 units strength, how can you represent it?

7. How many lines of force per square centimeter cross section are there conceived to exist in a field of 25 units strength?

8. If a pole of 10 units strength is placed in a field of 5 units strength, with what force will it be acted upon?

9. If a pole of 5 units strength is acted upon by a force of 20 dynes, how strong is the field?

10. If a field having 10 lines of force per square centimeter cross section acts upon a pole with a force of 2 dynes, how strong is the pole?

11. How could you prove two magnets to be of equal strength?

96. What is magnetism? Although we do not know what magnetism really is, yet we have a very useful theory, called the **molecular theory of magnetism**, which has proved helpful as a partial explanation of the phenomenon arising from the magnetism of steel and iron.

If we fill a glass tube with coarse steel filings (Fig. 74) and cork up the ends and test the tube for magnetism, we find that either end



FIG. 74. — Glass tube of steel filings before magnetization.

attracts the same end of a suspended magnetic needle. Now, if we treat the tube like a steel bar and magnetize it in a solenoid, being careful not to shake it, and test it again, we find that one end repels

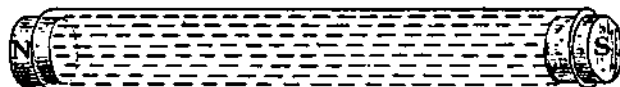

FIG. 75. — Glass tube of steel filings after magnetization.

one end of a needle and attracts the other (Fig. 75). When we shake the tube thoroughly so as to jar the filings, and repeat the test, we find it has been demagnetized.

Again, suppose we magnetize a long, thin piece of hard-tempered steel and mark the *N*-pole. If we break it in halves and test each piece separately, we find that we have two magnets. The *N*-pole in one piece remains an *N*-pole but a new *S*-pole is developed, and in the other piece the *S*-pole remains as before, but a new *N*-pole is developed. If we break these pieces again, as shown in figure 76, each piece becomes a perfect magnet.

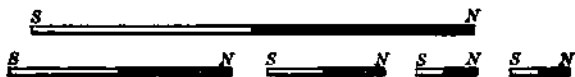

FIG. 76. — A broken magnet shows poles at the break.

All these facts point to a molecular theory of magnetism, which was suggested by a Frenchman, Ampère, and elaborated by a German, Weber, and an Englishman, Ewing. Every molecule of a bar of iron is supposed to be itself a tiny permanent magnet — why, no one yet knows. Ordinarily these molecular magnets are turned helter-skelter throughout the bar (Fig. 77 a) and have no cumulative effect that can be noticed outside the bar. When the bar is magnetized, however, they get lined up more or less parallel (Fig. 77 b), like soldiers,

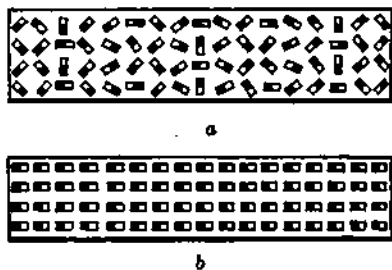

FIG. 77. — Model of (a) unmagnetized bar and (b) magnetized bar.

all facing the same way. Near the middle of the bar the front ends of one row are neutralized by the back ends of the row in front; but at the ends of the bar a lot of unneutralized poles are exposed, north-seeking at one end and south-seeking at the other. These free poles make up the active spots which we have called the poles of the magnet.

On this theory it is easy to see that when a magnet is broken in two without disturbing the alignment of the molecular magnets the new poles which appear at the break are simply

collections of molecular poles that have been there all the time, but are now for the first time in an independent, recognizable position.

It will also be evident that, if this theory is true, there is a perfectly definite limit to the amount of magnetism a given piece of iron can have. For when all the molecular magnets are lined up in perfect order, there is nothing more that can be done, no matter how strong the magnetizing force may be. Such a magnet is said to be saturated.

TERRESTRIAL MAGNETISM

97. The earth is a huge magnet. We have already seen that a compass needle points north and south. To explain this

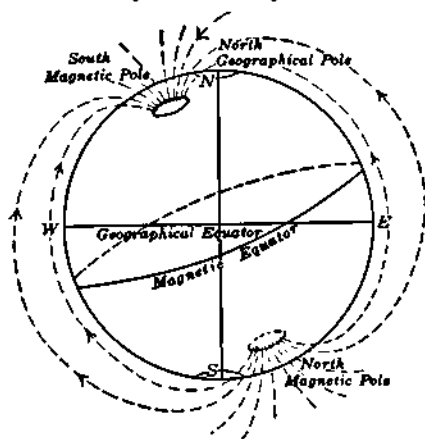

FIG. 78. — The earth is a huge magnet with poles.

and many other facts about magnetism we consider the earth itself as a huge magnet with two magnetic poles (Fig. 78). But according to the law of attraction and repulsion between magnetic poles, the north-seeking pole of a compass must be attracted by the *S*-magnetic pole of the earth. Thus it is that the *S*-magnetic pole of the earth is near the geographical north pole and the *N*-magnetic pole is nearly opposite in the southern hemisphere.

98. Variation and dip. Not long after the compass was invented, it was noticed that it did not point exactly north and south. For a long time it was supposed that this variation

was everywhere the same, until Columbus, on his way to America in 1492, discovered near the Azores a place of no variation. An exact knowledge of the variation at different places is evidently of the greatest importance to mariners and surveyors, and so careful maps are published by the different governments giving lines of equal variation. Figure 79 shows such a map. It will be observed from this map that in the extreme eastern section of the United States the variation is as much as 20° W.

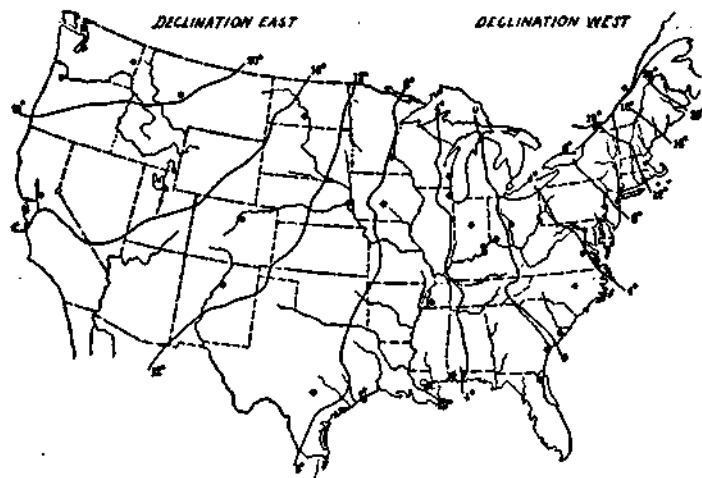

FIG. 79. — Map showing variation of the compass in the United States.

This decreases to zero at a place near Cincinnati, O., and becomes an easterly variation amounting to 20° E. in the northwest.

It was discovered nearly a hundred years after Columbus' time that if a compass needle is perfectly balanced so that it can swing up and down as well as sidewise, its north-seeking pole in the northern hemisphere will dip down to a considerable angle (Fig. 80). As one goes farther north this angle increases and as one goes south it decreases. Along a line near the

equator there is no dip. The points at which the dip is 90° are the magnetic poles. The magnetic pole in the northern hemisphere was reached by Sir James Ross in 1831 and found to be in longitude $96^\circ 48'$ W., latitude $73^\circ 31'$ N., or about 1400 miles from the geographical north pole.

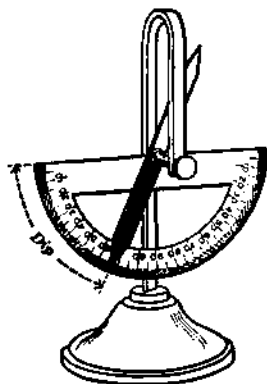

FIG. 80. — Compass needle to show magnetic dip.

In 1909 Shackleton's South Polar Expedition located the other magnetic pole in latitude $72^\circ 25'$ S., longitude $155^\circ 16'$ E. Thus it will be seen that the magnetic poles are not quite at opposite ends of a diameter of the earth and that this approximate magnetic axis of the earth makes an angle of about 17° with the axis of rotation.

99. Changes in the earth's magnetism. Careful measurements of the intensity of the earth's magnetic field and of the variation and dip at any locality show that these do not remain fixed but change from time to time. It has been found that there is a secular change which occurs once a century, another which is annual, and that there are still others which occur daily. Besides all these, there are erratic disturbances which occur simultaneously over the whole earth and are called *magnetic storms*. Thus it is necessary to erect at certain observatories recording instruments or magnetographs, which give a permanent record of the slight changes in the terrestrial magnetic field.

It is of such great importance to determine the exact direction of the earth's magnetic lines of force or **magnetic meridians**, not only on land but particularly on the oceans, that the Carnegie Institute has had a special ship built, the "Carnegie," almost entirely from nonmagnetic materials. This vessel with its delicate instruments is making an accu-



WILLIAM THOMSON, LORD KELVIN (1824-1907).

A British physicist and electrical engineer; born in Belfast, Ireland; for more than fifty years professor of physics in Glasgow University, Scotland; invented the mirror galvanometer used in cable signaling; developed an improved form of mariners' compass. His work in thermodynamics is of the greatest value. He was one of the first to appreciate the principle of CONSERVATION OF ENERGY.

rate magnetic survey of the important portions of the earth's surface.

100. A ship's compass. The form of ship's compass which is now quite generally used was introduced by Lord Kelvin (Plate VII, opposite p. 133). It has a ten-inch card consisting of a thin sheet of aluminum or paper on which a scale is pasted, or drawn, and varnished. The middle portion is cut out for the sake



FIG. 81. — Kelvin's compass card.

of lightness. In this middle area six magnets are slung on to radial threads, as shown in figure 81. In this way the oscillations of the magnets are small and are quickly damped out. In some forms the card is floated on liquid, which takes most of the weight off the needle point and also serves to stop the vibrations. Thus it is seen that in the ship's compass the *N*-point on the scale is always pointing approximately toward the north. To steer in any particular course, as northeast, the ship's helm is turned until the northeast on the movable scale is opposite a

fixed vertical black line, which is drawn on the inside of the bowl. Of course, it must always be remembered that the compass needle tends to point in the direction of the magnetic meridian and this

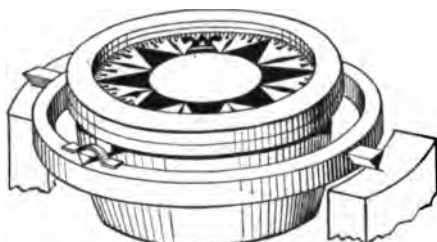

FIG. 82. — Ship's compass bowl mounted on gimbals.

is seldom exactly the same as the geographical meridian. It will also be noticed that the compass bowl (Fig. 82) is supported on gimbal bearings, so that, no matter how much the ship may pitch and roll, the card will always be level.

The navigator not only has to take account of the earth's magnetic variations but also of disturbances caused by the magnetization of the iron of the ship itself, the cargo, and the electric-light wires in the vicinity. This necessitates a frequent determination of all these deviations for every ship.

SUMMARY OF CHAPTER V

Dr. Gilbert in 1600 published the famous book *De Magnete* describing a great many discoveries about magnets.

ALL MAGNETS have three properties :

- (1) Attraction for steel and iron ;
- (2) Pointing in a nearly north and south direction ;
- (3) Inducing magnetism in another piece of iron.

HARDENED STEEL can be magnetized by stroking with another magnet or by being placed in the field of an electromagnet.

LAMINATED MAGNETS of horseshoe form make the strongest permanent magnets.

Every magnet has at least *two unlike poles*.

MAGNETIC FLUX consists of lines of force which are assumed

to leave at the *N*-pole and passing through the surrounding medium to enter at the *S*-pole, making a complete circuit.

MAGNETIC INDUCTION is the setting up in a magnetic substance of a greater number of lines than would be set up in air by the same cause.

ANY MAGNETIC BODY, free to move under the influence of a magnetic field, tends to move so as to accommodate through itself the greatest number of lines of force of the field.

There is no material which will stop the lines, but a shield of soft iron, because of its high permeability, will take up nearly all the magnetic flux.

Heat and rough treatment will ruin the best of magnets.

FORCE exerted by one pole on another :

$$F = \frac{mm'}{d^2}.$$

FORCE OF MAGNETIC FIELD on pole placed in it :

$$F = mH.$$

THE MOLECULAR THEORY of magnetism assumes a magnet to be made up of molecules, each in itself a tiny magnet.

THE EARTH is a magnet with its *S*-magnetic pole at Peary's end, about 1400 miles from the geographical north pole.

The angle between the magnetic meridian and the geographical meridian is the *variation*.

The angle which a magnetic needle makes with the horizontal is the angle of *dip*.

The use of the compass in surveying and navigation makes it necessary to make frequent magnetic surveys.

QUESTIONS

1. Sketch a long magnet and assume it to be broken into several pieces. Then sketch the pieces of a broken bar magnet and indicate their resultant polarity in the order in which they were supposed to be broken.

2. Why is magnetism supposed to be molecular in nature?

3. If a magnetic needle is attracted by a certain body, does that prove that the body is a permanent magnet?
4. If a piece of soft iron is brought near the positive pole of a magnet, what kind of pole is induced in the iron nearest the magnet pole?
5. Why will either pole of a magnetic needle be attracted to a soft piece of iron?
6. If a magnet is struck by a hammer, what is likely to happen?
7. Will a magnetic needle be attracted by a piece of red-hot iron?
8. If two bar magnets are to be kept side by side in a box, how should they be arranged? Why?
9. If a very short magnet is placed in a magnetic field, will it tend to move bodily along the lines of force? State your reasons.
10. Would a magnet floating on a cork in a dish of water float toward the north, as well as turn north and south?
11. Will a magnet attract a tin can? Explain.
12. What is meant by the "aging" of magnets?
13. A compass needle is deflected from the magnetic meridian by a bar magnet placed six inches away. What will be the effect of interposing an electric-light bulb containing a vacuum?
14. A piece of wrought iron is interposed in Question 13. How is the deflection affected?
15. How could you with a bar magnet diminish the earth's attractive force on a magnetic needle?
16. Would a hard-rubber case serve as a magnetic shield for a watch?
17. What position does a magnetic needle take in America when allowed to swing freely in all directions?
18. How could you determine whether a compass had had its polarity reversed?
19. Why are the hulls of most iron ships permanently magnetized? What determines the direction in which they are magnetized?
20. How can the compass on an iron ship be "compensated" for the induced magnetism in the ship?
21. A long soft-iron bar is standing upright. Why does its lower end repel the north pole of a compass needle?
22. Does hammering the bar while it is in the position described in problem 21 increase or decrease the effect? Why?
23. What effect does the angle of dip have on the horizontal intensity of the earth's magnetism at any point?

CHAPTER VI

ELECTROMAGNETIC INDUCTION

Induction by moving a wire in a magnetic field — direction and magnitude of induced current — induced currents in a revolving loop — other methods of inducing currents — mutual induction — Lenz's law — induction coils and their uses — self-induction and its application — mutual attraction or repulsion of electric currents.

101. Electromotive force induced by moving a conductor across a magnetic field. The experiments of Oersted (section 64) and others have shown us that an electric current always produces magnetism. It remained, however, for the brilliant experimental studies of Michael Faraday of the Royal Institution, London, and of Joseph Henry (Plate VIII, opposite p. 138), then a schoolmaster at Albany Academy, Albany, N. Y., to make the most important additions to our knowledge of the mutual action between electric currents and magnetism; namely, *how magnetism can produce electricity*. Shortly after the publication by Oersted of the discovery that a magnetic needle may be deflected by bringing near it a wire carrying an electric current (section 60), Faraday produced continuous motion by means of the effect of an electric current upon a permanent magnet. It was soon after learned that a wire hung over the pole of a magnet and with one end in a mercury trough, as shown in figure 83, would continuously revolve around the pole on account

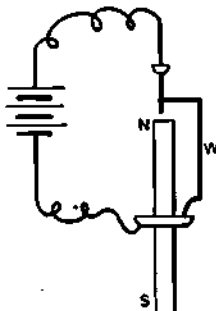

FIG. 83. — Wire *W* rotates around magnetic pole *NS*.

of the mutual attraction between the lines of force belonging to the magnet and to the current in the wire. In the motion thus produced lies the principle of the electric motor and of many of the present-day electrical instruments.

It must not be forgotten that the best method of generating an electric current at that time was by means of an electric battery, and the usefulness of the electric motor could be but small as long as it depended for its power upon the consumption of zinc in a battery. To the vigorous minds of Faraday and Henry, the production of motion when an electric current was brought under the influence of a magnet suggested the possibility of a reverse action, through which an electric current might be produced by the motion of a wire in a magnetic field. Shortly after 1830 this thought led to the magnificent discovery by Faraday that *a tendency for electric currents to flow is produced in a conductor when it is moved in a magnetic field so as to cut through the lines of force of the field.* That is, *voltage is set up in the conductor when it cuts the lines of force.* The two great experimenters also independently discovered the fact that *any change in the magnetic field around a wire tends to set up an electric current in the wire;* exactly as any change in an electric current which flows in a wire causes a corresponding change in the magnetic field about it.

In this great discovery lies the principle of the operation of **dynamo electric generators or generators**, as they are usually called.

It must not be forgotten, however, that there is a vast difference between *discovering* a new principle, such as that of electromagnetic induction, and building a commercially efficient machine, such as the electric generator, which *utilizes* the principle. It takes a genius to develop a new principle, but it often requires years of patient experimenting by a multitude of inventors to perfect the machine. Sometimes it takes so long to apply the principle that the public has quite forgotten who discovered it and rewards only the inventor who has made the machine "go."



JOSEPH HENRY (1790-1878).

An American physicist, born in Albany, New York; was for six years a school-master at Albany Academy, for fourteen years a professor at Princeton, and for the rest of his life the head of the Smithsonian Institution in Washington. Made the first careful study of the electromagnet and in 1842 discovered the oscillatory nature of the electric spark. Shares with Faraday the honor of having discovered the laws of electromagnetic induction.

102. **Direction of induced voltage in the moving wire.** Suppose the straight wire AB is pushed down across the magnetic field, as shown in figure 84. An induced voltage is set up in AB , which makes B of higher potential than A . This can be shown by connecting B and A with a sensitive galvanometer or millivoltmeter. It will also be observed that as long as the wire remains stationary no current flows, and even if the wire does move, there will be no current if it moves in a direction parallel to the lines of force.

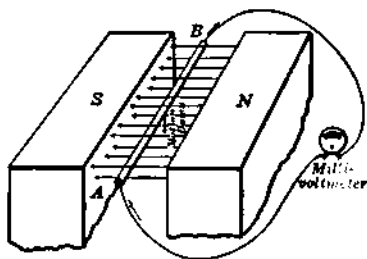

FIG. 84. — Induced e.m.f. in a wire cutting lines of force.

If the wire were moved up, the induced current would be from B to A ; or if the field were reversed without changing the direction of the motion of the wire, the current would reverse.

It will be seen that the current flows in the external circuit through the voltmeter from the positive or high-pressure end B to the negative or low-pressure end A of the wire; and within the moving wire the current flows from the low-pressure end to the high-pressure end. The motion of the wire across the lines of force causes it to act like a pump which lifts the electric current from its low-pressure or suction end to its high-pressure or discharge end. In this respect the moving wire acts exactly like a primary battery, such as is described in Chapter I.

In short, if a wire is to have an e.m.f. induced in it, it must move so as to cut lines of force. Furthermore, it will be seen that the direction of the induced e.m.f. depends upon two factors, (a) the direction of the motion of the wire and (b) the direction of the flux or magnetic lines of force. The relation of these three directions may be kept in mind by Fleming's rule of three fingers (Fig. 85).

FLEMING'S RULE. *Extend the thumb, forefinger, and center finger of the right hand so as to form right angles with each other. If the thumb points in the direction of the motion of the wire, and the forefinger in the direction of the magnetic flux, the center finger will point in the direction of the induced current.*

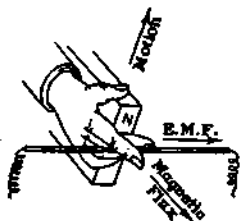

FIG. 85. — Right-hand rule for induced e.m.f.

As an aid to remembering this rule, notice the corresponding initial letters in the words "fore" and "flux," "center" and "current."

103. Magnitude of the voltage set up in a moving wire. The magnitude of the voltage depends upon the *rate at which the wire cuts lines of force*; that is, upon the total number of lines of force cut by the wire in a second of time. *When the wire cuts one hundred million (100,000,000 or 10^8) lines of force in every second during its motion, the voltage set up is one volt.*

FOR EXAMPLE, if a wire cuts through lines of force at the rate of two hundred millions (200,000,000) per second, the induced voltage is equal to two volts, and if a wire cuts only seventy-five million (75,000,000) lines each second, a voltage of only three fourths ($\frac{3}{4}$) volts is set up, and so on, which is according to the rule given in italics above.

The number of lines of force which are cut in a second by a wire moving in a magnetic field depends upon *four* factors:

- (1) Upon the *strength* of the field, or the number of lines of force which it contains in each square centimeter.
- (2) Upon the *length* of the wire which is in the field.
- (3) Upon the *speed* with which the wire moves.
- (4) Upon the *angle* at which the wire moves across the lines of force. If the wire moves diagonally across the lines of force, it does not cut through so many lines in a given time as when it moves equally fast at right angles to the lines.

104. Experimental demonstration. If we have a large electromagnet with flat-faced pole pieces (Fig. 86), we can demonstrate the various laws about induced voltage in a conductor. If we move a wire down through the gap between the pole pieces, a millivoltmeter will show the induced voltage. If we hold the wire at rest in the gap,

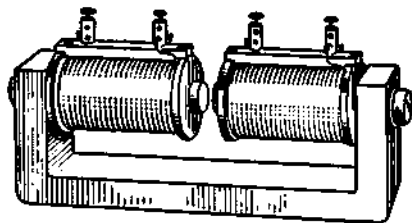

FIG. 86. — Electromagnet for demonstrating induced e.m.f.

we observe no voltage. If we move the wire horizontally parallel to the lines of magnetic flux, we get no voltage. If we move the wire up through the gap, we observe a voltage in the opposite direction, as predicted by Fleming's rule. If we increase the magnetic field by increasing the current through the electromagnet,

we increase the induced voltage. If we move the wire more quickly through the gap, we increase the induced voltage. Finally, if we bend the wire into a loop of several turns, and move the loop down over one pole so that all the wires on one side of the loop pass through the gap, we find that the voltage is increased.

In this experiment we see that the induced e.m.f. is increased by moving the wire faster across the magnetic field, by making the magnetic field stronger, and by using more turns of wire. In short, *the amount of induced e.m.f. depends on three factors: (1) the speed of cutting; (2) the magnetic field; (3) the number of turns.*

Experiments show that

Induced e.m.f. varies as speed \times flux \times turns.

FOR EXAMPLE, a wire passes 40 times a second across the pole face of an electromagnet which has a flux density of 15,000 lines. If the pole face is 30 by 20 centimeters, what is the induced e.m.f.?

$$\text{Flux} = 30 \times 20 \times 15,000 = 9,000,000 = 9 \times 10^6$$

$$\text{Lines cut per second} = 9 \times 10^6 \times 40 = 3.6 \times 10^8$$

$$\text{Induced e.m.f.} = \frac{3.6 \times 10^8}{10^8} = 3.6 \text{ volts.}$$

PROBLEMS

1. What voltage is induced across the ends of a wire which cuts 6×10^8 lines in 2.5 seconds?

2. A wire cuts through a field of 4,000,000 lines at an average rate of 18,000 times per minute. What is the average voltage set up across the wire?

3. A wire 100 centimeters long passes through a magnetic field which has a flux density of 8000 lines per square centimeter. If it moves 1200 centimeters per second at right angles to the lines, what voltage is induced in the wire?

4. Twenty conductors, connected in series, cut through 6×10^8 lines of force at the constant rate of 3000 times per minute. What is the average voltage set up by the set of conductors?

5. If a wire which is cutting across a magnetic field at the rate of 150 feet per minute induces 5 volts across its terminals, how fast must it move to generate 8 volts?

105. Current in a revolving loop of wire. If we rotate a rectangular coil between the poles of an electromagnet (Fig. 88), we can detect an electric current in the revolving coil by connecting it by means of flexible leads with a galvanometer or millivoltmeter. As

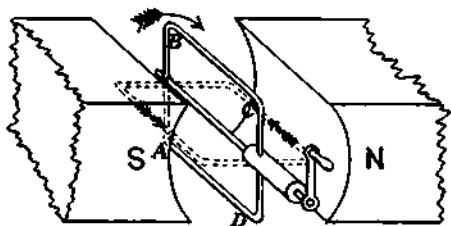

FIG. 87. — Single loop of wire turning in a magnetic field.

we turn the coil, the current is reversed every half revolution.

It will help us to understand just what is happening in the revolving coil if we first consider what would happen in a single

loop of wire which is rotated in a magnetic field (Fig. 87). If we start with the plane of the loop vertical and turn the handle in a clockwise direction, the wire *BC* moves *down* during the first half turn, and thus, by Fleming's rule, the induced e.m.f. tends to send the current from *C* to *B*. At the same time the

wire AD is moving *up*, and the current tends to flow from A to D . The result is that during the first half turn the current goes around the loop in the direction $ADCB$. During the second half turn the current is reversed and goes around in the direction $ABCD$.

To show that this really does happen in the loop, we can cut the wire and connect the ends to *slip rings* x and y (Fig. 88).

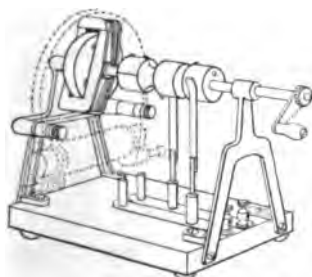

The brushes B' and B'' , which rest on the rings, are connected to a galvanometer. In this way it can be shown that there

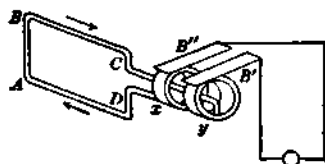

FIG. 88. — Coil rotating between poles of electromagnet and a single loop connected to slip rings.

is generated in the coil an **alternating current**, which reverses its direction twice in every revolution. Moreover, it will be seen that the induced e.m.f. starting at zero goes up to a maximum and then back to zero in the first half turn; then it reverses, goes to a maximum in the opposite direction and finally back to zero. The induced e.m.f. reaches its maxi-

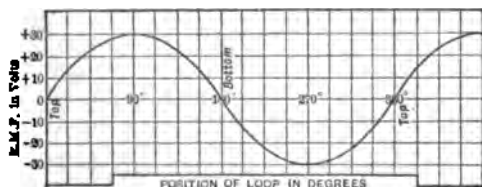

FIG. 89. — Curve to show relation of induced e.m.f. to position of loop.

imum when the coil is horizontal, because in this position the wires AD and BC are cutting lines of force most rapidly. This is illustrated by the curve shown in figure 89. Machines which

are built to deliver alternating currents are called **alternators** or **alternating-current (a-c.) generators**.

PROBLEMS

1. A coil of one turn includes 5,000,000 lines of force within its area when the plane of its face is at right angles to the lines. If it is turned over at the rate of 1200 revolutions per minute, what will be the average of the voltage induced during each half revolution? (HINT. — Each side of the coil cuts all the lines twice in a revolution.)

2. If the coil in problem 1 had 25 turns, what would be the average voltage induced?

3. One side of a large coil of wire having 100 turns cuts through a field of 10,000,000 lines of force at an average rate of 2400 times per minute. What is the average voltage developed? (HINT. — The turns are in series.)

4. A coil of fifty turns with two active sides cuts through 5,000,000 lines of force at a speed, during the moment considered, of 2400 times per minute. The resistance of the coil is 0.2 of an ohm and the resistance of the external circuit to which it is attached is 1.8 ohms. How much current flows?

5. How many horse power are required to drive the coil in problem 4?

6. How much e.m.f. is used in the coil and how much in the external circuit of problem 4?

7. What is the voltage across the terminals of the coil in problem 4?

8. How many watts are used in the coil and how many in the external circuit of problem 4?

9. How many Daniell cells, each of 2 ohms internal resistance and an e.m.f. of 1 volt, must be used to supply to the same external circuit an amount of power equal to the arrangement in problem 4, supposing that the internal resistance of the battery equals the resistance of the coil? How should they be arranged?

106. Other methods by which voltages may be induced. It has been experimentally shown that any change in the magnetic field around an electric conductor which causes the lines of force to cut the conductor tends to cause an electric current to flow in the conductor. We are now sufficiently acquainted with the mutual effects of electric currents and magnetism not to be surprised to learn that there are many conditions

under which the effects of magnetism may result in an electric current. One of these conditions is seen when the motion of a conductor across magnetic lines of force causes, as already described, a current to flow in the electric circuit of which the conductor is a part. But it is not necessary that the conductor move; for the magnetic field itself may move so that its lines of force cut across stationary conductors. In fact, *voltage is set up in a conductor when it cuts lines of force, whether the cutting is caused by the motion of the conductor or by the motion of the lines of force.*

Moreover, the magnetic lines of force which are cut by a conductor and so cause voltage in the conductor may not come from a magnet, but may belong to an electric current in a neighboring wire. When a conductor is moved toward or away from a wire carrying a current, the lines of force belonging to the current are cut by the moving conductor, and voltage is induced in the moving conductor. If the wire carrying the current is moved toward or away from the other conductor, the lines of force belonging to the current cut the conductor, which is now stationary, and voltage is set up as before.

We may demonstrate these principles by connecting the coil *S*, shown in figure 90, to a galvanometer and connecting another coil *P* to a battery. When we move the current-carrying primary coil *P* either into or out of the other secondary coil *S*, an e.m.f. is induced in *S*, just as when we move a magnet in and out of a coil. We find that after the primary coil *P* is pushed into the secondary coil *S* and its movement is stopped, the e.m.f. in the secondary is zero. Moreover, we observe that if the primary coil is *drawn out* from the secondary coil the resulting e.m.f. in the secondary is opposite to that set up when the primary coil was pushed into the secondary.

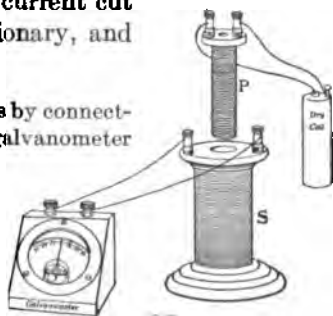

FIG. 90. — E.m.f. induced by moving current.

We may increase the induced e.m.f. by increasing the intensity of the current in coil *P* or by inserting an iron coil inside the primary coil.

Finally, we may put the primary coil with its iron coil inside the secondary coil, and then generate an induced e.m.f. by merely opening and closing a switch in the primary circuit. When the switch is opened and closed, the deflections are in opposite directions.

In general, we see that *an induced electromotive force is set up in a coil whenever there is a change in the number of lines of magnetic force passing through the coil.*

107. Mutual induction. The effects described in section 106 may be produced by fixing the coil *P* in a stationary position inside of the coil *S*, and then varying the current which flows through the coil *P*. When the current increases in the primary coil, the lines of force belonging to the growing magnetic field of the growing current cut, as they are produced, the conductors of the secondary coil, and thus set up voltage in the secondary coil *during the time the magnetic field is increasing*. If the primary current is reduced or shut off entirely, voltage is set up in the secondary coil in the opposite direction *during the time that the magnetic field is decreasing*.

Electric currents which are set up in circuits by means of cutting lines of force are said to be caused by **electromagnetic induction**, and they are sometimes spoken of as **induction currents** or **induced currents**. The currents produced by dynamos are examples of currents induced by electromagnetic action. When the coils act upon each other by variation of currents and not by mechanical motion, the effect is called **mutual induction**.

108. General rules for the direction of induced voltage.

1. *When a primary coil is pushed into a secondary coil, the induced current is opposite in direction to the primary current.*
2. *When a primary coil is drawn out of a secondary coil, the induced secondary current is in the same direction as the primary current.*

When the primary and secondary coils are fixed relative to one another and current is induced in the secondary by making and breaking the primary current, we have the following rules:

3. *When a current is made (started) in the primary coil, a momentary opposite or inverse current is induced in the secondary coil.*

4. *When a current is broken (stopped) in the primary coil, a momentary current of the same direction is induced in the secondary coil.*

These rules relate to the flow of current when the secondary circuit is closed. If the secondary circuit is open, the voltage which is set up is in such a direction that the current would flow in the direction indicated, were the circuit closed.

109. Lenz's Law. A careful examination of these rules shows a very important fact which may be stated in this way: *The direction of an induced current is always such that the magnetic field belonging to it tends to oppose the change in the strength of the magnetic field belonging to the primary current.* For instance, when the primary current of an induction coil is "made," an inverse current is induced in the secondary coil, whose magnetic field opposes the growth of the magnetic field of the primary current. When the primary circuit is broken, the magnetic field of the induced current opposes the decay of the magnetic field belonging to the primary current. Another illustration may be taken from the primary coil which is pushed into a secondary coil. When the primary coil carrying a current is pushed into the secondary, an *inverse current* is induced which sets up a magnetic field which tends to repel the primary coil and, therefore, *opposes its motion*. When the primary coil is drawn out of the secondary, the *direct induced current* sets up a magnetic field which tends to attract the primary coil and, therefore, again *opposes its motion*.

The above facts may be briefly stated in one sentence: *When electric currents are induced by a changing magnetic field,*

the magnetic field belonging to the induced currents tends to stop the change in the original field. We have also the following statement which results directly from the former. When electric currents are induced by the motion of a conductor, the induced currents have such a direction that their magnetic effect tends to stop the motion. This is called Lenz's Law, after a German scientist who first formally stated the principle.

The principles stated in the preceding paragraph are the electrical corollaries of the general law of the conservation of energy, which tells us in effect that we can *transform mechanical energy into electrical energy or vice versa*; or, we can transform the energy of electrical currents flowing under one voltage into the energy of electrical currents flowing under another voltage. But in every case, as much energy must be put into the transforming apparatus — whether it be dynamo, motor, or Ruhmkorff coil, — as is taken out; although the useful "output" of electrical apparatus is usually smaller than the "input" by a certain percentage of the total energy, which has been changed into useless heat. In short, then, *the total quantity of energy in the universe is always the same and is changed only in form and distribution.*

110. Induction coils. In the commercial induction coil (Fig. 91) the core *C* is made of soft iron wires; the primary coil *P* consists of a few turns of large copper wire, and the secondary coil *S*, which is carefully insulated from the primary, consists of many turns of very small silk-covered copper wire. This division of the iron core is necessary for the same reason that it is necessary to laminate the iron cores of dynamo armatures. It will be described further in Chapter IX. To make and break the primary current very rapidly, an interrupter *H* is commonly made to operate on the end of the coil. This automatic interrupter works exactly like the electric bell described in section 70.

When the primary circuit to such a coil is broken, the current tends to keep on as if it had inertia, and may jump the interrupted gap at *A* even after it has opened slightly. This slows up the "break" and weakens the induced e.m.f. in the secondary. So a condenser *J* is connected across the gap, as shown in the cross section in figure 91. Such a condenser is usually made of sheets of tin foil insulated by paraffin paper.

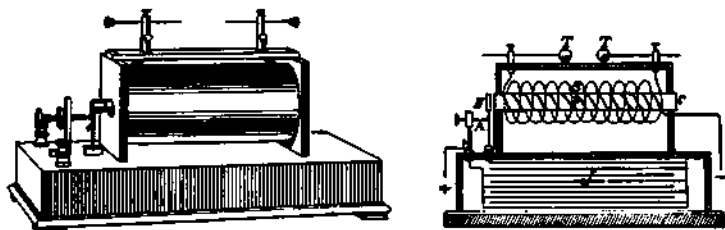

FIG. 91. — Induction coil and its cross section.

It furnishes a storage place into which the current can surge when broken and it diminishes the sparking at the interrupter. Even with a condenser there is some sparking, and so the contact points have to be tipped with silver, platinum, or tungsten and kept clean. By shunting a condenser across the interrupter, the energy of what would otherwise be an arc is absorbed. This prevents the contacts from being burned away rapidly and increases the induced voltage of the secondary by making a sharper break. This type of coil is sometimes called the *Ruhmkorff* coil, and is the one in general use for the jump-spark ignition on gas engines.

111. Uses of induction coils. Very small induction coils, which are called *medical* or *household* coils, are sold as toys and are sometimes used to stimulate the nerves in paralysis and other affections. These are usually so made that the strength of the induced current in the secondary can be varied either by varying the number of primary cells used to excite

the primary coil or by moving in and out a brass tube which fits around the core.

Very large and powerful induction coils have been built for exciting X-ray tubes and for setting up electric waves for wireless telegraphy. But in recent years more efficient apparatus has been devised for these purposes, which will be described in Chapters XXII and XXIII.

A very large number of induction coils are used in the ignition system of the Ford automobile engines. Each cylinder has its own induction coil, which acts as a transformer to raise the voltage of the dry cells, storage battery, or low-tension magneto-generator to the several thousand volts required to

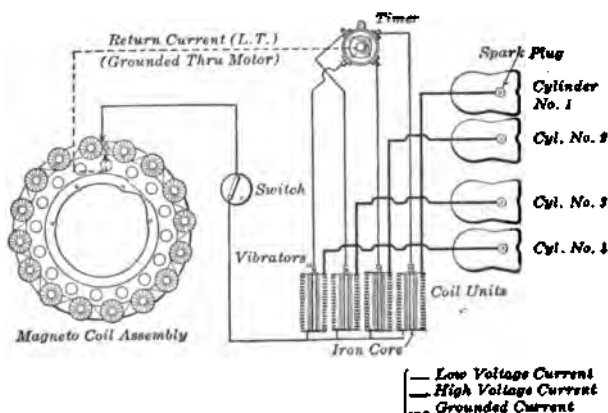

FIG. 92. — Ignition system for the Ford automobile engine.

leap the air gap which exists between the points of the spark plug in the cylinder. In the wiring diagram shown in figure 92, the primary circuit includes a timer for closing the circuit at just the right time; a magneto to supply the energizing current; and a vibrator or make-and-break mechanism on the coil. The secondary circuit includes the spark plug and the secondary winding of the coil. The voltage induced in the

secondary coil is great enough to cause the current to jump over the gap between the ends of the circuit in the plug, thereby causing the spark which ignites the mixture of gasolene vapor and air in the cylinder and makes the engine run.

112. Self-induction. A varying current may have an inductive effect upon the coil in which it itself flows, in addition to its inductive effect upon adjacent conductors. When a current is started in a coil, it sets up a magnetic field, which quickly grows from zero to its full value. As the field grows, its lines of force cut the turns of the coil itself and induce in them a voltage which opposes the growth of the current. On stopping the original current, its magnetic field quickly dies away and the lines of force again cut the turns of the coil, but this time in such a direction that the self-induced voltage upholds the original current. Thus we see that Lenz's Law applies also to self-induced voltages. If the coil has a great many turns wound on an iron core, its self-induction may be of sufficient magnitude to make a brilliant spark or give a severe shock when the circuit is broken. The spark at breaking a circuit is often spoken of as caused by the *extra current of self-induction*.

This self-induction of a circuit is sometimes considered as the electromagnetic inertia of the circuit. In mechanics it is a familiar fact that bodies act as if disinclined to change their state, whether of rest or motion, and we call this tendency inertia. Self-induction seems to be a similar electrical phenomenon. It should be remembered that *self-induction occurs only while the current is changing*.

The effects of self-induction in a straight wire carrying a current are exceedingly small; but when it is coiled up so that the magnetic field of every turn cuts many adjacent turns, and especially when the coil contains an iron core, the effects of self-induction are very much greater. For example, if the circuit of a coil wound around an iron core is broken at some point, we see a bright spark, and if the terminals at this point

of break are held, one in each hand, and then separated, the body will receive a shock. The intensity of this extra current due to self-induction depends upon the size of the coil and the current used.

113. Applications of self-induction. The effect of self-induction is made use of in the so-called **spark coils**, which are

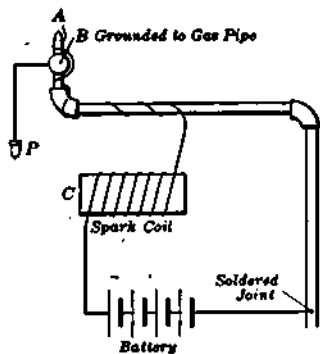

FIG. 93. — Connections for electric gas lighting by spark coil.

used with devices for lighting gas by electricity, and which consist simply of a single coil containing a few layers of coarse insulated wire wound on a core of soft iron wire. This spark coil *C* is included in a circuit with a battery and wires leading to spark points at the gas jet (Fig. 93). These spark points may be touched together by pulling a chain, whereupon current flows through the circuit, and when the spark points are again separated so as to interrupt the current,

the large self-induction of the spark coil raises the voltage so that a bright spark is maintained for an instant between the separated points, and the gas issuing from the jet is ignited by it.

This principle of self-induction is also employed in the **make-and-break** ignition system which is sometimes used on gas engines. The spark coil is connected in series with a battery or magneto and some kind of make-and-break contact in the cylinder of the engine, such as is shown in figure 94. The terminals consist of one stationary point *A* and a mov-

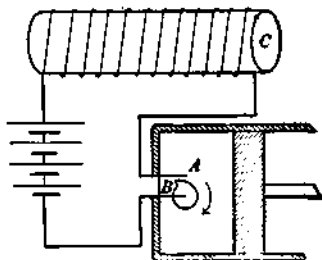

FIG. 94. — Make-and-break spark coil used for ignition.

ing point *B*. When *A* and *B* separate, the self-induction of the coil causes enough induced e.m.f. to make a spark jump across the gap between them.

114. Mutual attraction or repulsion of electric circuits. The fact that a conductor carrying an electric current is always surrounded by a magnetic field should lead us to expect that conductors carrying electric currents will attract and repel each other. This is indeed the fact. We have already seen that solenoids act toward each other exactly as though they were magnets. It has also been learned by experiment that wherever magnets or solenoids are brought into the sphere of each other's influence, they tend to move so that their lines of force shall be placed parallel to each other and in the same direction. Exactly the same is true of straight or curved wires which are brought into each other's influence. Remembering this, we can see that *two wires lying side by side must attract each other if they carry currents flowing in the same direction*. This is the case because the lines of force can become parallel and of the same direction only when the two conductors are very close together. *When the currents flow in opposite directions, the wires repel each other*. In the same way, if the wires are inclined toward each other, they tend to turn around into such a position that the wires are parallel and the currents flow in the same direction (Fig. 95). This principle is used in the design of electrical measuring instruments, such as are described among others in Chapter VII.

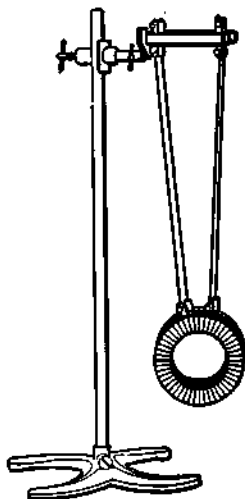

FIG. 95. — Parallel wires carrying currents. Attract when in same direction and repel when in opposite direction.

SUMMARY OF CHAPTER VI

VOLTAGE is set up in a conductor when it moves so as to cut across magnetic lines of force.

To get **DIRECTION** of induced current use *right hand* :

Thumb indicates *motion*.

Forefinger indicates *flux*.

Center finger indicates *direction of current*.

MAGNITUDE of e.m.f. depends on *rate* at which a wire cuts lines of force.

CUTTING 10^8 lines of force per second gives 1 volt.

Revolving a loop of wire in a magnetic field produces an *alternating* current.

INDUCED CURRENT is set up in a coil whenever there is a change in the number of lines of magnetic force passing through the coil.

INDUCED CURRENT has such a direction as to *oppose* the motion that causes it.

INDUCTION COILS are used to *increase* the e.m.f., but do not produce *energy*.

SELF-INDUCTION appears *only* while the current is changing.

THE EFFECT OF SELF-INDUCTION is always to *oppose* the *change* of the current.

TWO WIRES lying side by side and carrying current flowing in the *same* direction *attract* each other.

When the currents flow in *opposite* directions, the wires *repel* each other.

QUESTIONS

1. Can we have induced electromotive force and not have an induced current?
2. In producing an induced current by moving a magnet in and out of a coil, why is it necessary to use a coil of many turns?

3. Show how a coil of wire should be rotated in the earth's magnetic field in order to get the maximum induced current.
4. Show how a coil of wire can be rotated in the earth's magnetic field so as to get no induced current.
5. Why is it dangerous to touch the terminals of the secondary of a large Ruhmkorff coil?
6. What is likely to happen to an induction coil if you short-circuit the secondary while the coil is running?
7. Why is the induced e.m.f. in the secondary of an induction coil so much greater at the break of the primary than at the make?
8. How can a coil be moved in a uniform magnetic field and not have an induced e.m.f. within it?
9. Is it necessary that a conductor shall move to have e.m.f. induced within it?
10. Why is an iron core used in an induction coil?
11. Will more energy be put into the primary coil of an induction coil when the secondary is closed than when it is open? Why?
12. Does it take more work to thrust one coil carrying a current into another when the latter is connected with a closed circuit than if its circuit is open?
13. Does Lenz's Law apply to cases of self-induction?
14. What is the difference between the current flowing from a battery and that from the secondary of an induction coil?
15. If an alternating current were used in the primary of an induction coil, what sort of current would be induced in the secondary?
16. Given primary and secondary coils such as are described in section 106, describe five different methods of inducing a current in the secondary circuit.
17. Why is the core of a spark coil not made of solid iron?
18. How could you wind a coil so as to neutralize the effects of self-induction; that is, to be noninductive?
19. What will be the mutual action of two portions of circuits crossing one another obliquely?
20. Is there any case of a conductor which tends to move in the direction of its own length?

CHAPTER VII

ELECTRICAL MEASURING INSTRUMENTS

Galvanometers: tangent and Thomson astatic, d'Arsonval — constants: sensibility, resistance, and period — shunts — **ammeters:** construction and uses — **voltmeters** — other types of ammeters: moving-soft-iron fixed coil, hot-wire — **electrodynamometer** — **electrostatic voltmeter** — **indicating wattmeter** and **watt-hour meter**.

115. Galvanometers. Instruments which are made to measure or detect small currents of electricity are called galvanometers. The portable form of galvanometer, which indicates directly the strength of the current passing through the instrument, is called an ammeter. Practically all galvanometers depend for their operation on the force exerted between one or more wires carrying a current and a magnetic field. It is convenient to divide galvanometers into two main types according to whether the magnet or the coil is the moving part.

In the older type of instrument we have a moving magnet which is acted upon by a current flowing along one or more stationary coils of wire. The **tangent galvanometer** is of this type and consists of a compass needle pivoted or hung at the center of a large ring-shaped coil. This coil must be set facing east and west so that the compass needle lies parallel to its plane. When a current is sent through the wire, an east and west magnetic field is set up at the center of the coil and the compass is deflected more or less according as the current is stronger or weaker. In such an instrument the current is proportional to the tangent of the angle through which the

needle is deflected. Although such an instrument is useful for measuring a current absolutely in terms of the angle of deflection, the dimensions of the instrument, and the strength of the earth's magnetic field, yet it is now very seldom used. This is because it is not very sensitive, and the moving part keeps swinging back and forth; that is, it is not deadbeat. Besides the fact that it cannot be made in a convenient portable form, there is this disadvantage, that it is subject to very slight changes in the magnetic field around it, such as are produced by railway circuits, even though a mile away.

116. Thomson astatic galvanometer. Lord Kelvin, then Sir William Thomson, while working on submarine cables, devised an exceedingly sensitive moving-magnet type of galvanometer. He did this by using two coils wound in opposite directions, and two sets of magnets arranged in what is called the astatic position. Figure 96 shows the two coils *A* and *B* which consist of many turns of very fine wire and two sets of needles within the coils. These needles are joined together by a stiff wire so that their poles are reversed and thus neutralize one another. Since a very light mirror is attached rigidly to one of the needles in order to reflect a beam of light on to a scale, it is possible to detect a very slight motion of the magnet, and thus an exceedingly minute current even down to one fifty-billionth part of an ampere (2×10^{-11}) can be observed.

But the Thomson galvanometer cannot be made to return quickly to its zero position, nor can it be made deadbeat. In fact, such a delicate instrument is suitable only for research work in a special laboratory.

117. D'Arsonval galvanometer. Nearly all the modern galvanometers are built with a moving coil and strong fixed

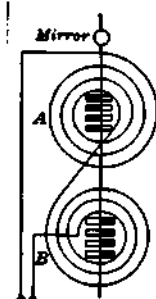

FIG. 96.—Thomson astatic galvanometer.

magnet; such an instrument is called the *d'Arsonval* type. This contains the essential principles of most of our modern commercial ammeters and voltmeters and is constructed on just the reverse principle of the Thomson type. The instrument consists essentially of a coil of fine wire pivoted or suspended in a powerful magnetic field. In the most sensitive instruments the coil is suspended by a very fine wire or ribbon, usually of phosphor bronze, which also serves to lead the current into the coil, the current leaving the coil by a spiral wire or ribbon below. Figure 97 shows one form of galva-

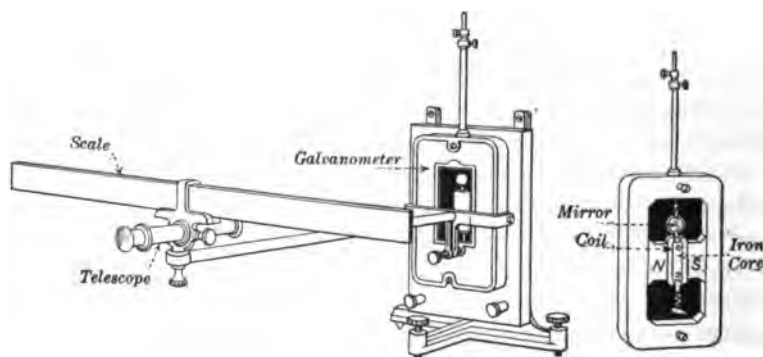

FIG. 97. — *D'Arsonval* galvanometer. *N* and *S*, poles of fixed magnet.

nometer which is convenient for use in the laboratory. A soft iron core is supported rigidly between the poles in order to concentrate the magnetic lines of force. The rotation of the moving coil of such a sensitive galvanometer is usually measured by means of a telescope and scale. The observer views the image of the stationary scale reflected in a small mirror attached to the coil of the instrument. Since the force tending to turn the coil is proportional to the current, to the number of windings, and to the intensity of the magnetic field, it is possible to make a very sensitive instrument by making the magnet very powerful. The elasticity of the suspending wires controls

the position of the coil and tends to bring it back to its zero position. This type of galvanometer is quite independent of the earth's magnetic field and of changes in the magnetic field around it. Perhaps its most useful characteristic is that it is remarkably deadbeat. This damping is not done mechanically but is effected by means of the induced currents set up in the metal rectangular frame on which the moving coil is wound. The production of these "eddy currents," as they are called, will be explained in Chapter IX. The sensitiveness of an inexpensive form of d'Arsonval galvanometer is such that 1 volt through 70 million ohms (70 megohms) will cause a deflection of 1 millimeter with the scale at 1 meter distance; in other words, it is sensitive to 1.4×10^{-8} amperes. Very highly sensitive galvanometers of this sort are made which will measure 1×10^{-10} amperes. Thus it will be seen that the d'Arsonval galvanometer has been made almost as sensitive as the Thomson type and yet has practically none of the disadvantages which characterize the older form of instrument.

118. Characteristic constants of a galvanometer. The first characteristic of any galvanometer is its sensibility. There are several ways of expressing this quality. When we are intending to use the instrument for current measurements, we express the sensibility as a certain fraction of an ampere which will cause a deflection of 1 millimeter at a distance of 1 meter.

FOR EXAMPLE, a certain galvanometer is specified to have a sensibility of 5×10^{-10} amperes; which simply means that a current of 0.000,000,000,5 amperes will give a deflection of 1 millimeter at a distance of 1 meter. This is also called its figure of merit. It is evident that the *smaller* the current needed to produce a deflection of one scale division, the *greater* the sensibility.

A more common way of expressing this same quality is to state the number of megohms (million ohms) which must be connected in series with the instrument in order to have 1 volt produce 1 millimeter deflection at a distance of 1 meter.

For example, the same galvanometer mentioned above has a sensibility of 2000 megohms. In this case it will be seen that the *greater* the number of megohms through which 1 volt will produce the standard deflection, the *greater* the sensibility.

In purchasing a galvanometer another characteristic to be considered is its resistance. For general laboratory work an instrument may have a resistance of from 100 to 500 ohms and a sensibility of from 70 to 200 megohms; but when it is used to measure insulation or very high resistances, as described in section 137, then its resistance may be 1000 ohms and its sensibility 1000 megohms. Still another factor to be

considered is the period or time of one swing of the coil. For example, it may take 10 seconds for the coil to swing from its zero position to one side and back again, and so its period is stated as 10 seconds. Of course, it is in general desirable to have an instrument of high sensibility, low resistance, and short period, and at the same time to have it mechanically strong and convenient to manipulate.

119. Galvanometer shunts. It will be obvious that strong currents must not be passed through such sensitive instruments because of the danger of burning out the coil. Therefore, in order to extend the use of a galvanometer over a wide range of current measurements, shunts (Fig. 98) are connected across the

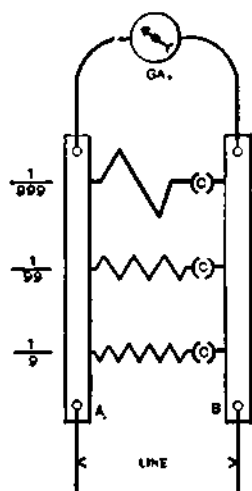

FIG. 98. — Diagram of a galvanometer and shunts.

terminals of the instrument so that only a small fraction — say $\frac{1}{10}$ or $\frac{1}{100}$ or $\frac{1}{1000}$ — of the current actually passes through the moving coil. Suppose that it is desired to divide the current so that $\frac{1}{10}$ goes through the galvanometer coil and $\frac{9}{10}$

goes through the shunt. Since the shunt carries 9 times as much current as the moving coil of the instrument, the resistance of the shunt must be $\frac{1}{9}$ of the resistance of the galvanometer. In the same way we see that the resistance of the shunt is $\frac{1}{99}$ of the resistance of the galvanometer in order that $\frac{1}{100}$ of the current may flow through the instrument; and when the shunt is $\frac{1}{999}$ of the galvanometer resistance, then $\frac{1}{1000}$ of the current will flow through the galvanometer, according to the principles of parallel circuits given in section 40.

FOR EXAMPLE, suppose a galvanometer has a resistance of 550 ohms and is shunted by a 50-ohm coil. What fraction of the main current goes through the galvanometer?

Since the galvanometer has 11 times the resistance of the shunt, the shunt must carry 11 times as much current, and therefore the galvanometer carries only $\frac{1}{12}$ of the main current in the line.

PROBLEMS

1. A galvanometer of 100 ohms resistance has a shunt of 10 ohms resistance. What part of the main current flows through the galvanometer?

2. If it is desired to shunt the galvanometer in problem 1 so that but $\frac{1}{10}$ of the main current goes through it, what must be the resistance of the shunt?

3. A galvanometer is so made that a current of 0.000,005 amperes gives a deflection of 1 millimeter. When the instrument is shunted by a $\frac{1}{10}$ shunt box and shows a reading of 20 centimeters, what is the current in the main line?

4. If the galvanometer in problem 3 has a resistance of 1000 ohms, what must be the resistance of the shunt to be used in order to get a deflection of 25 centimeters with the same current in the main line?

5. Suppose a galvanometer has a resistance of 100 ohms, a sensibility of 70 megohms, and a centimeter scale at a distance of 1 meter. What resistance must the shunt have to make the instrument a direct-reading ampere meter? (1 centimeter deflection on the scale corresponds to 1 ampere in the main circuit.)

120. Construction of an ammeter. A shunted galvanometer which is graduated so that it reads directly on the scale the

number of amperes flowing through the line is called an ampere meter or ammeter. The ammeters most commonly used on switchboards and in the laboratory are merely a more or less portable form of the d'Arsonval galvanometer. Instead of supporting the moving coil by a delicate suspension wire or ribbon, it is mounted on pivots, which are as accurately fitted into jeweled bearings as the balance wheel of a watch. The control of this moving coil is effected by means of two spiral springs which act against each other and at the same time serve to lead the current into and away from the coil.

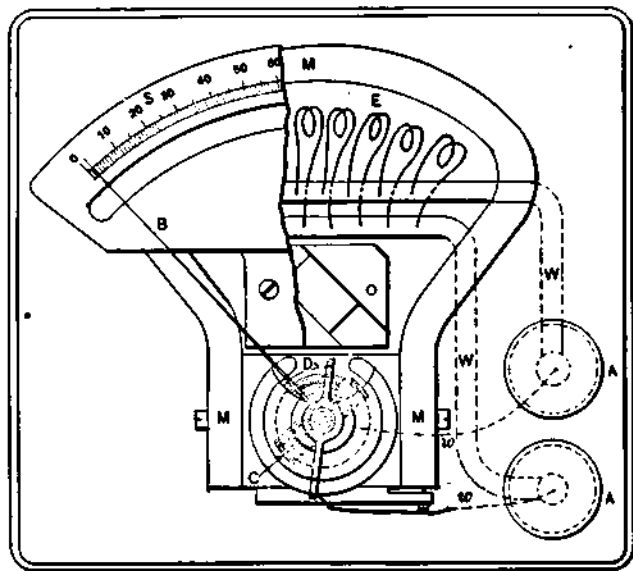

FIG. 99. — Plan of Weston ammeter.

Figure 99 shows a Weston ammeter with the moving coil mounted on pivots and arranged with a pointer to play over a scale; and the whole is arranged in a very convenient, portable form in a self-contained case (not shown in the figure).

AA, in the figure, are the binding posts of the instrument, by means of which wires may be connected to the instrument. Large wires *WW* run from these to the shunt *E*, and small wires *ww* to the armature coil *C*. This coil is mounted on pivots so that it may move between the pole pieces of the permanent magnet *MMM*. When a current flows through the coil, it tends to turn so that its magnetism may be parallel to the lines of force of the permanent magnet. The motion is opposed by the springs *DD*, so that it is proportional to the current. The pointer *B* is attached to the coil and moves over the scale *S* so as to indicate the amount of current flowing through the instrument. The object of the shunt *E* is explained in section 119. Figure 100 shows an end view of one of these instruments with a portion of the construction cut away so as to show the works. The movable coil and permanent magnet are clearly visible in both of the illustrations. Similar letters in figures 99 and 100 refer to the same parts. The soft iron cylinder, which is so plainly seen in figure 100, is used to improve the magnetic circuit of the magnet, and to produce a uniform field in which the coil swings, thus making the scale divisions of the Weston ammeter uniform throughout. The core is stationary, and the conductors of the coil move between it and the pole pieces of the magnet. A cylindrical soft iron core of the same character is shown in the d'Arsonval galvanometer of figure 97. The instrument is made deadbeat by the damping effect of the eddy currents set up in the aluminum bobbin on which the moving coil is wound.

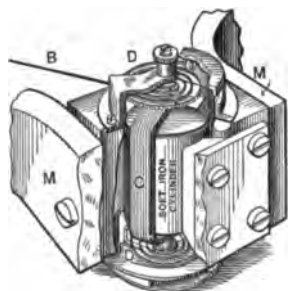

FIG. 100. — Sectional end view of Weston ammeter.

It must not be forgotten that the moving coil of an ammeter is made of such fine wire that it can carry but a very small

fraction of an ampere (not more than 0.05 amperes). In order, therefore, to make the ammeter a measuring instrument of moderately large currents, a shunt must be placed across the coil. This shunt should be made of such a material that it does not change appreciably in resistance when its temperature varies. For currents up to 30 amperes this shunt can safely be placed inside the ammeter case, as shown in

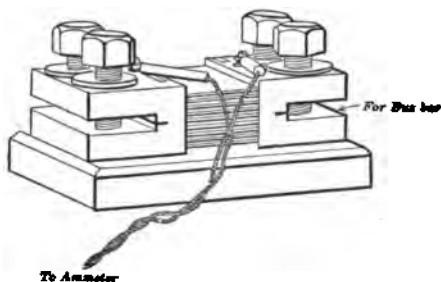

FIG. 101. — Separate shunt used for large currents on switchboards.

figure 99. But for larger currents this cannot be done on account of the heat generated; hence separate shunts are used (Fig. 101). The instrument (often a millivoltmeter) with its shunt and connecting leads is so calibrated that the deflections indicate

directly the number of amperes flowing through the line in which the instrument and its shunt are placed.

121. Uses of the ammeter. Almost every manufacturer of dynamos or other electrical machinery manufactures ammeters for use with his machines. Ammeters are universally used wherever electricity is used, and they are made to measure currents consisting of only a few thousandths of an ampere (called *milliamperes*, *milli-* comes from a Latin word meaning thousand), as well as the enormous currents reaching to thousands of amperes which are generated by some of the larger electric-lighting plants. In such works many ammeters may be seen mounted on a slate board among the switches for controlling the current. They show the attendants how much current is being generated by the plant at any moment, and what proportion is furnished by each generator.

Ammeters are used in laboratories to determine the amount

of current used in experiments; also in testing the operation of electric lamps, electric motors, or other electric devices. Physicians use ammeters to measure the currents used in the electrical treatment of their patients. For the latter purpose the currents are generally measured in milliamperes. This is also true of the currents used in telegraphy. The currents used in operating telephones are often measured in microamperes, or millionths of amperes (*micro-* comes from a Greek word meaning small). Ammeters that are especially made to measure thousandths of amperes, or milliamperes, are called **milliammeters**. Externally, milliammeters look like ordinary ammeters, to which they bear the same relation that a very sensitive galvanometer bears to a similar but less sensitive instrument.

When we need to know how many amperes are flowing through a given part of a circuit, we must first *break the circuit* and insert the ammeter in such a way that the current flows through it; in other words, the *ammeter is always connected in series in the circuits*. Care, of course, must be taken to use an instrument of sufficient range to carry the current and to get the + side of the instrument connected to the + side of the line. Since an ammeter has a very low resistance, *it must never be connected across the line*.

NOTE.— We have already seen that the shunt for an ammeter must be of such material or combination of materials that it does not change appreciably in resistance as its temperature changes; in other words, it must have a low temperature coefficient of resistance. Besides this property it must have low thermoelectric power (section 338) where soldered to copper. Dr. Edward Weston has invented such a substance called "manganin." It is an alloy of copper, nickel, and ferromanganese. There are several other alloys which have nearly as low a temperature coefficient but which do not also have a low thermoelectric power. The invention and use of this alloy in shunts is one of the reasons for the success of the Weston instruments.

PROBLEMS

1. The resistance of a millivoltmeter and its connecting leads is 1.000 ohms, and its maximum reading is 0.050 volts. What resistance must its shunt have in order to be able to use it as an ammeter to measure 100 amperes?

2. If the same millivoltmeter used in problem 1 is used to measure 5 amperes, what must be the resistance of its shunt?

3. The millivoltmeter of problem 1 is connected with a shunt whose resistance is 0.01 ohms. What is the intensity of the current in the main line when the instrument shows its maximum deflection?

4. Suppose a 30-ampere ammeter whose resistance is 0.002 ohms were by mistake connected directly across a 6-volt storage battery. How many amperes of current would rush through the instrument for an instant before it was burned out?

5. If the current required to obtain a full-scale deflection on a certain ammeter is 0.01 amperes and its resistance is 6 ohms, what e.m.f. will be required to give full deflection?

122. Voltmeters or potential galvanometers. Any high-resistance galvanometer, or any galvanometer with a high resistance coil included in its circuit, may be used to measure the difference of potential or voltage which is applied to the two ends of its circuit. Such a galvanometer allows but very little current to flow through it; but what does flow is directly proportional to the voltage applied and so the instrument may be arranged to read volts directly on its scale. The commercial voltmeter is simply a high-resistance galvanometer. The instrument (Fig. 102) is generally built on the same plan as the ammeter except that it does not have a shunt between its terminals, but does have a *high-resistance coil inserted in series*. Only a very small current passes through the instrument, but all of it goes through the moving coil. In fact, such a voltmeter gives correct values only when the current used is so small as not to affect appreciably the voltage to be measured.

The voltmeter that is shown in figure 102 has three binding posts. The instrument is connected to a circuit by binding

posts AA' for ordinary use. Then, when the key K is closed, current flows through the high-resistance coil E and the movable coil C , and the pointer is deflected a distance proportional to the voltage of the circuit. When the instrument is connected to the circuit by means of the binding posts Aa , and the key is closed, the current flows through the coil e and

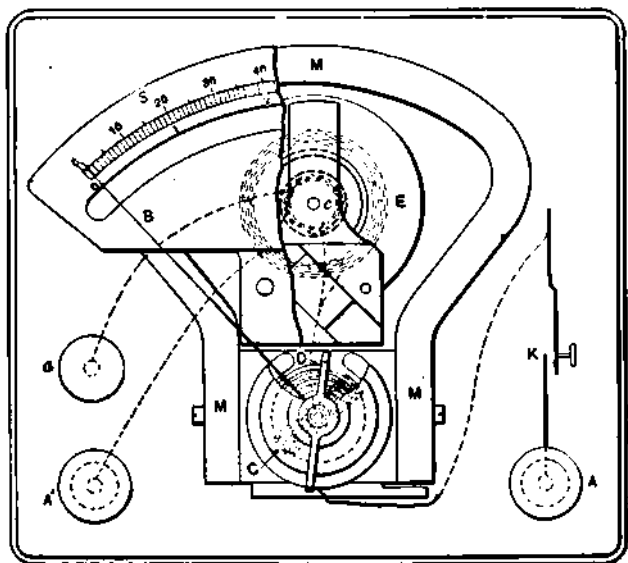

FIG. 102. — Plan of Weston voltmeter.

thence through the movable coil C . The coil e is adjusted so that the resistance between binding posts Aa is just one twentieth of the resistance between binding posts AA' , and the instrument is therefore twenty times more sensitive when the binding posts Aa are used. If two volts cause a movement of the pointer a certain distance across the scale in one case, it requires forty volts to cause an equal movement in the other case. Many voltmeters are made with only one resistance

coil and only one scale. The letters in this figure refer to the same parts as the similar letters in figures 98 and 99.

All voltmeters are placed across the line between the two points the difference of potential of which is to be measured.

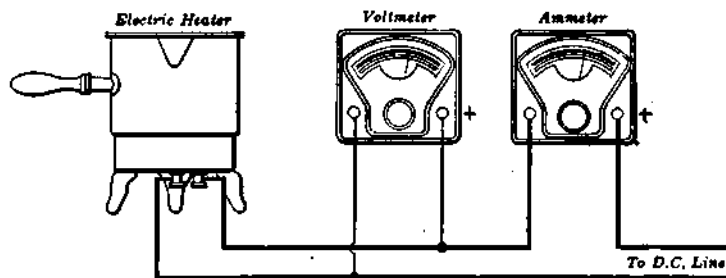

FIG. 103. — How to connect a voltmeter and ammeter.

They are never connected in series with the main line as are ammeters. The proper connections for both ammeter and voltmeter are shown in figure 103.

PROBLEMS

1. If the resistance of the moving coil of an instrument is 6 ohms and it takes 0.01 amperes to give a full-scale reading, how much resistance must be put in series to make it a 100-volt instrument?

2. Suppose a millivoltmeter having a resistance of 1 ohm is to be used as a 150-volt instrument. If it takes 0.0075 amperes to give the maximum reading, what resistance must be placed in series with the coil?

NOTE. — A series resistance to be used with a millivoltmeter to get various ranges is called a multiplier.

3. What resistance multiplier must be placed in series with the instrument of problem 2 to give 15 volts as the maximum range?

4. Suppose the ammeter used in figure 103 has a resistance of 0.05 ohms and the voltmeter 15,000 ohms, and that the instruments read 2.500 amperes and 110 volts and are correct.

(a) How much current does the voltmeter take?

(b) How much current then really flows through the heater?

123. **Other types of ammeters.** Currents which rapidly alternate in direction, as do the currents of many electric-light plants, cannot be measured by magnetic instruments having permanent magnets, since the tendency of such currents is first to deflect the moving parts in one direction and then in the other, and the pointer accordingly stands still or nearly so. But there is another type of instrument which can be

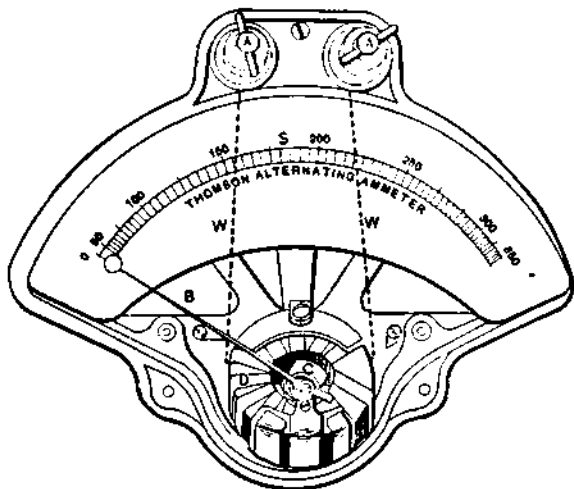

FIG. 104. — Thomson inclined coil meter.

used on either *direct-current* (d-c.) or *alternating-current* (a-c.) circuits and this is the moving-iron and fixed-coil type of ammeter. One form, known as the **Thomson inclined coil meter** because designed by Mr. Elihu Thomson, is shown in figure 104. In this meter the moving element is a light soft-iron vane (C) set at an angle on a shaft, which is carefully pivoted. The shaft itself is set at an angle to the axis of the stationary coil (D). When a current flows through the coil, the vane tends to turn into such a position that the lines of magnetic force passing through it shall be parallel to the lines

within the coil. This moves a pointer (*B*) across a graduated scale. It should be noted, however, that the deflecting force is not proportional to the current and therefore the scale divisions are not uniform throughout.

In the **Weston soft-iron type** of meter (Fig. 105) the reaction which causes the deflection takes place between two

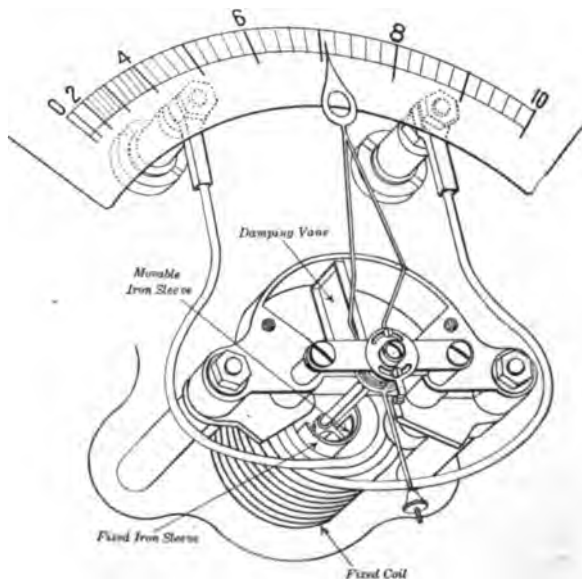

FIG. 105. — Diagram of Weston soft-iron meter.

pieces of soft iron bent in the form of an arc of a circle and placed concentrically; one of these is movable, and the other is stationary. When the surrounding fixed coil has a current flowing through it, the movable and fixed iron sleeves become magnetized in like manner and so repel each other. The only resultant motion possible is the rotation of the movable sleeve. The stationary sleeve is made triangular in shape with the pointed end in the direction of rotation so as to make

the scale more uniform. The control is by means of spiral springs and is very delicate. The damping is done by a light aluminum vane moving in an inclosing air chamber.

Such instruments can be used on *either* d-c. or a-c. circuits and have the advantage of low price, rugged construction, and small weight. When the instrument is designed for current measurement (that is, as an ammeter), it is made so that all the current goes through the fixed coil, which consists of a few turns of large wire. But when it is designed to measure voltage, the coil is made of many turns of small wire and besides has a carefully adjusted resistance coil in series.

Another type of instrument which is suitable for current measurement on both d-c. and a-c. circuits is the **hot-wire ammeter**. Figure 106 shows the essential parts of a modern hot-

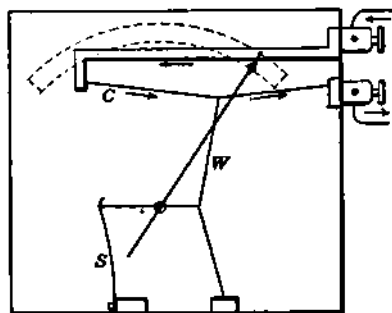

FIG. 106. — Hot-wire ammeter.

wire ammeter. The current to be measured flows along a fine wire *C*, which is stretched horizontally and is pulled downwards by a second wire *W*; this in turn is stretched sideways by a spring *S* and by means of a fine thread passing around a small roller. When a current passes through the fine wire *C*, the wire is heated, causing it to expand slightly. As the spring pulls it down through the second wire, the roller turns and moves a pointer over a scale. The scale must be calibrated by finding experimentally the points to which the pointer turns when 1 ampere, 2 amperes, etc., are passed through the instrument. Instruments of this sort are now quite commonly employed to measure the small alternating currents of high frequency used in wireless telegraphy.

One of the oldest forms of ammeters is the two-coil type, which is usually called an **electrodynamometer**. Figure 107 shows the ordinary form of the Siemens' electro-dynamometer when arranged for use as an ammeter.

One coil *F* in this instrument is fastened to the frame of the instrument, and the other coil *M*, which stands at right angles to the

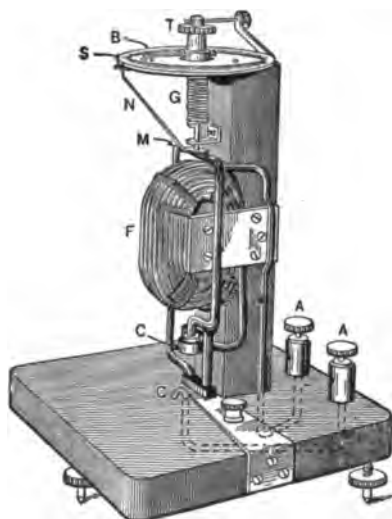

FIG. 107. — Siemens' electro-dynamometer.

first, is suspended by a heavy silk fiber so that it is free to move. The ends of the wire composing the movable coil dip into little cups *CC*, containing mercury, which are connected with a circuit so that the current can enter and leave the coil. The movable coil is attached to a spring *G*, the other end of which is connected to a thumbscrew *T*, called a **torsion head**, by means of which this spring may be twisted. When a current flows in the coils, the magnetic force tends to turn the movable coil around so as to place it parallel with the fixed coil (section 114). This force is balanced by twisting the spring by means of the thumbscrew. The amount of twist, as shown by a pointer *B* attached to the

screw, is proportional to the force exerted by the coils on each other; and *this deflecting force is proportional to the square of the current flowing in the coils*, since the magnetism set up by each coil is proportional to the current, and they act on each other mutually. So the angle of deflection is proportional to the current squared. The pointer *N* indicates whether the movable coil is at its zero position. The "binding posts" for connecting the instrument into the circuit are shown at *AA*.

This instrument can be used on a-c. as well as on d-c. circuits, and when calibrated for direct current its indications

are correct for alternating currents. It can be made very sensitive and accurate, but it does require considerable skill to manipulate it and so its use is largely confined to testing laboratories. If the coils are made of very high resistance, this type of instrument may be used as a voltmeter.

124. Electrostatic voltmeter. Another entirely distinct method of measuring voltage is by means of electrometers. These are instruments for determining the quantity of electricity on a charged body by measuring its attraction for another charged body. Electricity at rest at a high potential or pressure constitutes a positive charge, and electricity at rest at low potential or pressure constitutes a negative charge. These terms, positive and negative charge, must be taken as relative terms, exactly as are the terms high and low potential. An electrometer is an instrument for measuring the attraction between two charges.

Electrometers made for commercial use in the measurement of voltage are usually called **electrostatic voltmeters**. Figure 108 shows the construction of one example of this type of voltmeter which is commonly used to measure differences of potential of 1000 volts or more. The vane *AA* is a paddle-shaped plate of aluminum supported by knife edges at its center. The quadrants *II* are both behind and in front of it and so placed that, when a difference of potential exists between the movable vane and the stationary quadrants, the vane is attracted from its normal position and moves its pointer over a graduated scale. The movable vane is connected to one side

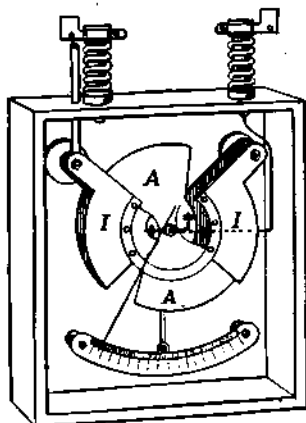

FIG. 108. — Construction of electrostatic voltmeter.

of the line and the stationary quadrants to the other side. The position of the pointer is controlled by gravity, little weights being hung on a projection of the axis of the movable vane. It does not matter whether the vane is positively charged and the quadrants negatively charged, or vice versa; an attraction between the two will always take place and therefore the instrument can be used equally well on d-c. and a-c. circuits. It should also be remembered that this type draws an inappreciable amount of current from the line and consequently does not waste any power.

125: Indicating wattmeter. The electric power which is used in any part of a direct-current circuit may be determined

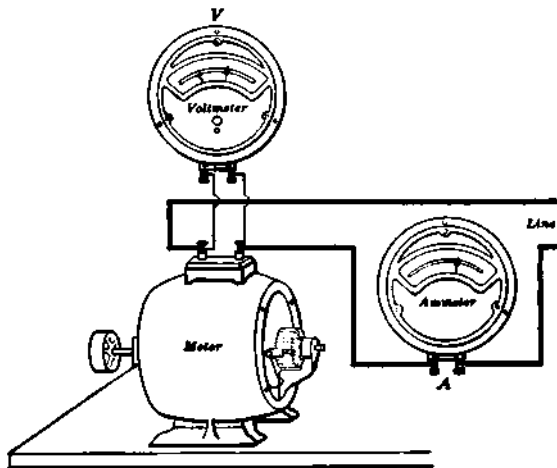

FIG. 109. — Measurement of power supplied to a motor by ammeter and voltmeter.

by measuring the current flowing by an ammeter, and the voltage at the terminals of that portion of the circuit by a voltmeter (Fig. 109). The values of these multiplied together give the power in watts. Instruments are made in which the double measurement and multiplication are all made together,

so that their indications are directly proportional to the power. Such instruments are called **wattmeters** because they measure watts.

The simplest wattmeter is a form of electro-dynamometer (section 123), in which one coil is wound with many turns of fine wire exactly as though it were to be used as a voltmeter coil, and the other coil is wound with a few turns of coarse wire as though it were to be used in an ammeter. For convenience we shall call the two coils respectively the **voltage coil** and the **current coil**. The action of such a wattmeter is best explained by an illustration (Fig. 110). Suppose it is desired to measure the power used by an electric motor. The current coil of the wattmeter is connected in series with the motor, and the voltage coil is connected across the terminals of the motor. The magnetic effect of the current coil is

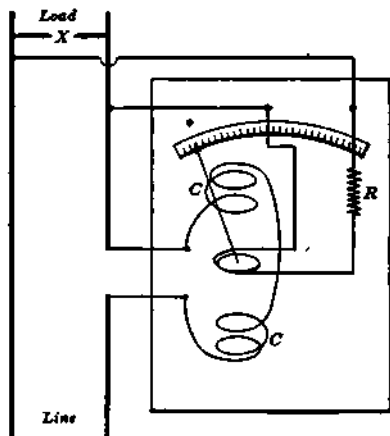

FIG. 110. — Measurement of power by wattmeter.

then proportional to the current which flows through the motor, and the magnetic effect of the voltage coil is proportional to the voltage at which the current is supplied to the motor. The indications of an electro-dynamometer are proportional to the product of the magnetic effects of the two coils. Consequently, in this case the indications are proportional to current times voltage, or watts, instead of current times current (*i.e.*, current squared) as in the Siemens' electro-dynamometer. It should also be remembered that a wattmeter, unless compensated, indicates the power consumed by the load plus the power

consumed by one of its coils. When the power to be used is small, this error is appreciable and must be corrected.

These direct-reading wattmeters can be used for alternating as well as direct currents and may be made in a portable form to test the efficiency of generators, motors, lamps, or any other electrical device. The accuracy of a wattmeter may be tested by comparing its readings when connected with a d-c. circuit with the indications of standard voltmeters and ammeters.

126. Watt-hour meter. Watt-hour meters are used to show the amount of energy used each month by the customers of

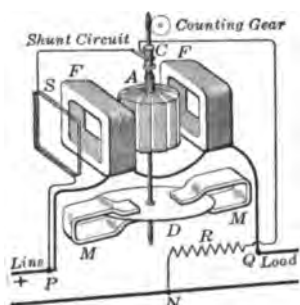

FIG. 111.—Interior of Thomson watt-hour meter.

electric plants. A common form of meter used for this purpose is that shown in figure 111, known as the Thomson watt-hour meter, or integrating meter, after its inventor, Elihu Thomson. This is built like a little electric motor but without any iron in its working parts. It is arranged with its revolving part or armature *A* as a voltage coil, and its magnetizing windings *FF* as a current coil. The magnetic pull

which tends to make the armature rotate is proportional to the product of the two magnetizing effects, and this is proportional to the watts in the circuit, exactly as in an electro-dynamometer.

If the speed of such an armature is made to be proportional to the magnetic pull, every revolution of the armature means a certain number of watts used for a fixed length of time. Such instruments usually have a set of dials attached to the spindle of the armature (Fig. 112) like those of a gas meter, which record the revolutions and are so marked that the consumption of electric energy may be recorded in kilowatt hours. *Kilowatt hours are the product of the number of kilowatts by the number*

of hours during which the power is used. Since the dials record a total number of kilowatt hours which are added together, or "integrated," by a meter during the period that it operates, these meters are sometimes called **integrating wattmeters**.

If no external retarding force were applied to the armature of such

an instrument, it would run away as soon as placed in service, and in order that its speed may be proportional to the watts, the retarding force must be in proportion to the speed. This is ingeniously arranged for by placing at the bottom of the spindle a flat disk *D* of copper or aluminum, on either side of which are placed the poles of permanent magnets *M*. The rotation of the disk between the magnet poles generates electric currents in it, which according to Lenz's Law are attracted by the magnets and retard the motion of the disk.



FIG. 112. — Dials of a watt-hour meter reading 538 kilowatt hours.

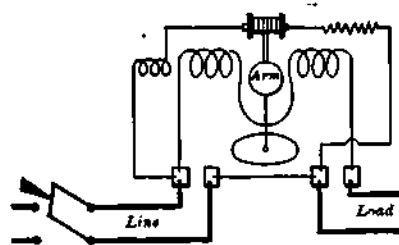

FIG. 113. — Connections of a watt-hour meter in service.

To compensate for inevitable friction of the pivots, a small auxiliary field coil *S* is inserted into the shunt circuit of the armature. Figure 113 shows how such a watt-hour meter is connected to a circuit.

Such a watt-hour meter as we have just described will operate on either a d-c. or a-c. circuit, even though the relations which exist between current, voltage, and power in a-c. circuits are not so simple as in d-c. circuits. The special measuring instruments for use in a-c. circuits are described in succeeding chapters, which treat of the important and interesting features of alternating currents.

PROBLEMS

1. In using an electro-dynamometer as an ammeter it is found that 2 amperes cause a deflection of 10° . What deflection would a current of 5 amperes give?
2. If the instrument of problem 1 gives a deflection of 45° , what current does that indicate?
3. An arc lamp operates on 5 amperes at 85 volts. At what rate in kilowatts is it using power?
4. If the electric energy in problem 3 is furnished at 10 cents per kilowatt hour, what will it cost to run this lamp 6 hours?
5. An electric flat iron is found to consume electricity at the rate of 530 watts, and electricity costs 10 cents per kilowatt hour. What will it cost to do an ironing which takes 2 hours and 15 minutes?
6. A wattmeter, connected as shown in figure 110, reads 250 watts. The voltage across the load is known to be 500 volts. The resistance of the current coil is 0.003 ohms and of the potential coil 5000 ohms. (a) What is the correct power taken by the load? (b) What is the per cent error in the uncorrected reading?

SUMMARY OF CHAPTER VII

GALVANOMETERS:

- (1) Tangent: now obsolete.
- (2) Thomson astatic: very sensitive, but not deadbeat, slow.
- (3) D'Arsonval: moving coil and fixed magnet, sensitive and deadbeat.

With *shunts*, used to measure currents; with *series coil*, to measure voltage.

Equation for shunts:

$$\frac{\text{Current in galvanometer}}{\text{Current in line (galv. + shunt)}} = \frac{\text{Resistance of shunt}}{\text{Resistance of shunt + galv.}}$$

Sensibility: (1) Fraction of ampere needed to give 1 mm. deflection at 1 meter distance, or (2) number of megohms which may be placed in series with galvanometer so that 1 volt will give unit deflection.

AMMETER — low resistance — put in series — carries whole current.

VOLTMETER — high resistance — put across circuit — diverts small current.

AMMETERS AND VOLTMETERS:

- (1) Permanent magnet and moving coil: extremely accurate, deadbeat, uniform scale, used on d-c. only.
- (2) Solenoid instruments with movable soft iron: simple, cheap, used on both d-c. and a-c., fairly accurate.
- (3) Hot wire: simple, cheap, slow, used for d-c. and for a-c., especially with very small currents of high frequency.
- (4) Electrodynamometer: simple, difficult to manipulate, accurate, used on d-c. and a-c.
- (5) Electrostatic: only as voltmeter, takes no power, used on d-c. and a-c., good for high voltage.

WATTMETER. Used for power measurement instead of ammeter and voltmeter. Built on electro-dynamometer principle, — *fixed coil in series, moving coil and resistance coil in shunt.*

WATT-HOUR METER. A *small shunt motor* with speed in proportion to rate of electric power consumed.

Armature connected across line — voltage.

Field coils connected in series — current.

Revolving disk between permanent magnets acts as electric brake.

QUESTIONS

1. What would happen if an ammeter were connected across a 110-volt line? (Don't try it!)
2. What would happen if a voltmeter were put in series with an electric lamp on a 110-volt line?
3. Why is the moving-magnet type of galvanometer inconvenient?
4. Why is a shunt used with the permanent-magnet and moving-coil type of ammeter?
5. Why is a separate shunt used for large current ammeters?
6. Why can the solenoid in a soft-iron type of ammeter carry 200 amperes without shunt?

7. Why are shunts not made of copper or iron?
8. What advantage is there in having an instrument with uniform scale throughout?
9. How would you calibrate an electro-dynamometer?
10. How would you test the accuracy of a watt-hour meter?
11. What especial advantages have electro-dynamometers and hot-wire instruments over the other types?
12. What types of voltmeter are really amperemeters calibrated to read volts?
13. Can an electrostatic voltmeter be used to measure currents?
14. Why do we test a dry cell with a 30-ampere ammeter but do not so test a storage battery?
15. Why cannot instruments containing a permanent magnet be used to measure alternating currents?
16. Why can instruments with soft-iron cores be used for both a-c. and d-c.?

CHAPTER VIII

ELECTRIC MEASUREMENTS

Calibration of instruments — coulombmeter — potentiometer — standard cell — methods of measuring resistance: voltmeter-ammeter, Wheatstone bridge (slide-wire and box form) — locating faults in cables — insulation resistance of electric machines and covered wire.

127. Calibration of instruments. In all electrical measuring it is essential not only that we use the right kind of instrument and in the right way, but also that we know how accurate the instrument itself is. It is quite natural to regard any direct-reading instrument, whether it is a watch, a thermometer, an ammeter, or a voltmeter, as correct simply because the scale is marked off to read minutes, degrees, amperes, or volts. Experience in careful measurement, however, gradually teaches us to regard any graduated instrument with suspicion, and so it becomes necessary from time to time to test the accuracy of electric instruments. This process is called **calibration**. Generally this is done by comparing the ordinary working instrument with a very accurate semi-portable instrument, which is used as a standard. The errors at various points on its scale are determined and then plotted as a curve, which is used to correct the readings of the instrument.

128. Coulombmeter test of ammeter. The so-called standard instruments are occasionally compared with the legal standards at the National Bureau of Standards in Washington, D. C. *By international agreement the quantity of electricity which deposits 0.001118 grams of silver is one coulomb, and the current which deposits silver at the rate of 0.001118 grams per second is one ampere.* The apparatus used in the accurate

measurement of current by this method is called a coulombmeter (sometimes called voltameter) and is shown in figure 114. The anode is a silver disk *S* at the left, and the cathode

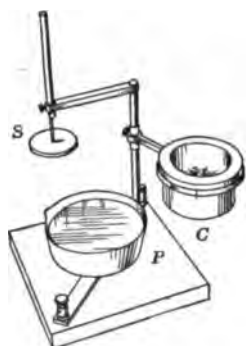

FIG. 114. — Silver coulombmeter.

P is the platinum cup at the bottom. A porous cup *C* at the right is put between the anode and the cathode in the solution like the cup in a Daniell cell. The object of this cup, however, is to keep bits of silver from dropping on the cathode. Before a determination is made, the cathode cup is very accurately weighed; then the solution of silver nitrate is poured into it and the porous cup, and finally the anode is put in place. The current is turned on and continued for a desirable number of seconds. It is then

stopped, the cathode is carefully washed and dried, and finally again weighed with great care. We may thus compute the average current in amperes from the following equation:

$$I = \frac{W}{0.001118t}$$

where *I* = current in amperes, *W* = weight in grams of silver deposited, *t* = total time of run in seconds, and 0.001118 = electrochemical equivalent of silver.

On account of the expense of the silver consumed and the care required in using a silver coulombmeter, it is not satisfactory for measuring currents exceeding about one ampere. For larger currents the copper coulombmeter is generally used. This usually has two anode plates of copper and between them a copper cathode plate with a solution of copper sulphate

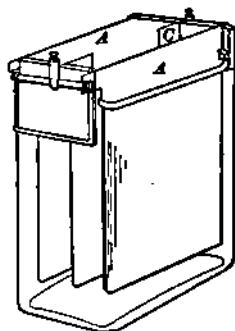

FIG. 115. — Copper coulombmeter. AA, anodes and C, cathode.

as the electrolyte (Fig. 115). The electrochemical equivalent of copper is 0.000329 grams per second.

129. Comparison of voltages by potentiometer. The usual method of measuring voltage is by the use of a voltmeter, which is simply a high-resistance galvanometer, but this instrument is often calibrated by means of the much more accurate potential measuring device called the potentiometer. With this apparatus we may determine an unknown voltage in terms of the voltage of a standard cell such as the Weston normal cell, which has been adopted as a legal standard.

In its simplest form, the potentiometer consists of a large known resistance connected between the points whose voltage is to be measured,

such as *A* and *B* in figure 116.

This causes a small steady current to flow through the resistance from *A* to *B*, and the voltage will drop along the path of the current in proportion to the resistance passed over. This is simply Ohm's Law :

$$\text{Voltage} = \text{Current} \times \text{Resistance.}$$

Now, suppose the terminals of a standard cell *S* are connected in series with a sensitive galvanometer *G* and a key *K* to the points *C* and *B* on the resistance, in such a way that the voltage of the cell is opposed to the potential drop between the points. Suppose further that the contact point *C* touches the wire *AB* at such a point that the voltage drop (*IR*) along *CB* is greater than the e.m.f. of the standard cell; then a current will be forced in the reverse direction through the standard cell and

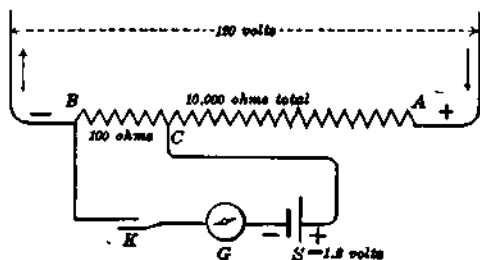

FIG. 116. — Measuring voltage by comparison.

the galvanometer, as will be indicated by the deflection of the galvanometer. On the other hand, suppose the contact point C touches the wire AB at such a point that the voltage drop (IR) along CB is less than the e.m.f. of the standard cell; then a current will flow and the galvanometer will be deflected in the opposite direction, showing that the current is in the direction from CB so that the standard cell increases the current I and thus raises the voltage drop. Finally, suppose that the portion of the resistance CB which is between the terminal connections of the cell is so adjusted that no current flows through the galvanometer; then the voltage drop (IR) through that part of the resistance exactly equals the e.m.f. produced by the cell. *The total voltage to be measured is to the voltage of the standard cell as the total resistance AB is to the balancing resistance CB .*

FOR EXAMPLE, in the figure the e.m.f. of the cell is marked 1.2 volts, the total resistance is 10,000 ohms, and the balancing resistance is 100 ohms. Then the proportion would be

$$x : 1.2 :: 10,000 : 100 \text{ and } x = 120 \text{ volts.}$$

130. Standard cells. On January 1, 1911 the U. S. Bureau of Standards adopted the **Weston normal cell** as the standard of electromotive force. This cell at 20°C . gives 1.0183 volts but is not intended to give a current of more than 0.0001 amperes.

It is made up in the H -pattern shown in figure 117. One limb contains cadmium amalgam, which serves as the negative electrode, and the other, the positive electrode, contains mercury which is covered with a paste of mercurous sulphate. The whole is filled with a solution of cadmium sulphate kept saturated by crystals of cadmium sulphate. This cell is intended only for purposes of standardization and testing, and for these purposes it is remarkably constant and independent of all local conditions.



FIG. 117. — Weston normal cell.

Exceedingly accurate potentiometers which make use of the standard cell are used to calibrate voltmeters and, with standard resistance, to calibrate ammeters. These are all rather complicated in their construction; hence a detailed description of the various forms is left to the descriptive circulars which are furnished by the manufacturers.

PROBLEMS

1. The cathode of a copper coulombmeter has gained in weight 1.818 grams in 30 minutes. What was the average value of the current?
2. How long will it take to deposit 5.933 grams of silver on the cathode of a silver coulombmeter with a current of 2 amperes?
3. In the very simple form of potentiometer shown in figure 116 the Weston cell of 1.0183 volts e.m.f. is used as the standard cell. The resistance between *B* and *C* when a balance is obtained is 88.5 ohms. What is the voltage across *AB*?
4. A dry cell was used instead of a standard cell (Fig. 116) and balanced when its terminals were 125 ohms across. What was the e.m.f. of the dry cell?

131. Measurement of resistance by voltmeter-ammeter. The commonest method of measuring resistance, wherever extreme accuracy is not required, makes use of the common instruments, voltmeter and ammeter. Suppose a lamp is the unknown resistance to be measured (Fig. 118). It is connected in series with the ammeter. The voltmeter is placed across the lamp. Then, according to Ohm's Law, the resistance is equal to the voltage divided by the current; that is,

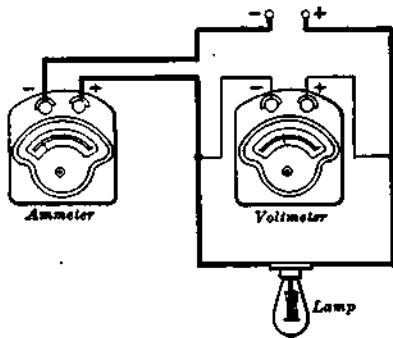

FIG. 118. — Connections for measuring resistance of a lamp by voltmeter and ammeter.

$$R = \frac{E}{I}$$

This method not only requires that the instruments be of suitable range and be accurately calibrated, but also that the voltmeter be of high resistance. In case there is not much current in the circuit, the voltmeter is generally connected around *both* the resistance and the ammeter, because the voltage across the ammeter is a smaller fraction of the whole voltage than the current through the voltmeter is of the whole current.

132. Measurement of resistance by Wheatstone bridge.

A more accurate method of measuring resistance is the Wheatstone bridge, which is an apparatus for balancing resistances. It consists essentially of a loop of four resistances R , X , m , and n , arranged as in figure 119. When the key is closed the current from the cell flows into the loop at A and there divides so that one part I_1 goes through AC and the other I_2 through AD . A sensitive galvanometer is connected between C

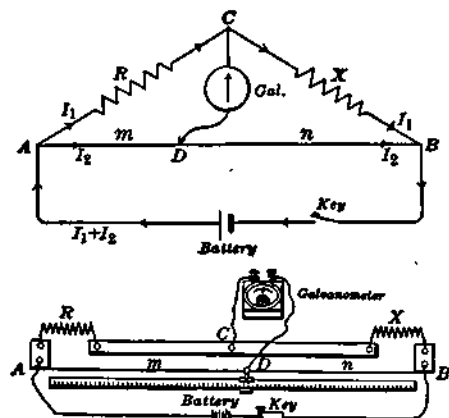

FIG. 119. — Wheatstone bridge to balance resistances. Slide-wire form.

and D . Then the resistances R , m , and n are so adjusted that no current flows through the galvanometer, which means that all of I_1 has to go on through CB and all of I_2 through DB , and also that C and D are "equipotential" points. When this adjustment has been made, the voltage drop across AC is $I_1 R$, and the voltage drop across AD is $I_2 m$. But since C and D are at the same potential, these voltage drops are equal, and

$$I_1 R = I_2 m. \quad (1)$$

For similar reasons

$$I_1 X = I_2 n. \quad (2)$$

Dividing equation (1) by equation (2), we have

$$\frac{R}{X} = \frac{m}{n}$$

From this fundamental equation of the Wheatstone bridge, if we know R , m , and n , we can compute X .

In one form of this apparatus, called the slide-wire bridge, the resistance ADB consists of a wire of uniform cross section one meter long. Since the resistances m and n are then directly proportional to the distances AD and DB , the equation becomes

$$\frac{R}{X} = \frac{\text{Distance } AD}{\text{Distance } DB}$$

where R is a known resistance, such as a resistance box, and the distances AD and DB are read off on a meter stick. It may help one to remember this equation to observe that

$$\frac{\text{Left resistance}}{\text{Right resistance}} = \frac{\text{Left distance}}{\text{Right distance}}$$

FOR EXAMPLE, suppose R is 5 ohms and AD is 45.5 centimeters; then DB is 54.5 centimeters, and

$$\frac{5}{X} = \frac{45.5}{54.5}$$

$$X = 6.05 \text{ ohms.}$$

PROBLEMS

A student in using the slide-wire form of Wheatstone bridge (Fig. 119) to measure the resistance of several coils records his data as follows:

Coil	R	m
1	6.3 ohms.	48.3 cm.
2	8.5 "	55.6 "
3	20.3 "	53.8 "
4	40.8 "	46.2 "

Find the resistance of each coil.

133. **Resistance boxes.** A resistance box (Fig. 120) corresponds for electrical measurements to a set of weights used

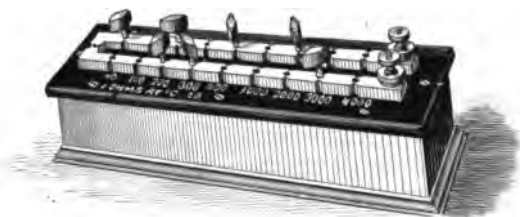

FIG. 120. — Box of known resistances.*

in weighing. Such boxes contain spools of silk-covered wire, each of known resistance, which may be needed in electrical measurements. Manganin or some similar alloy, having a comparatively low conductivity and a small temperature

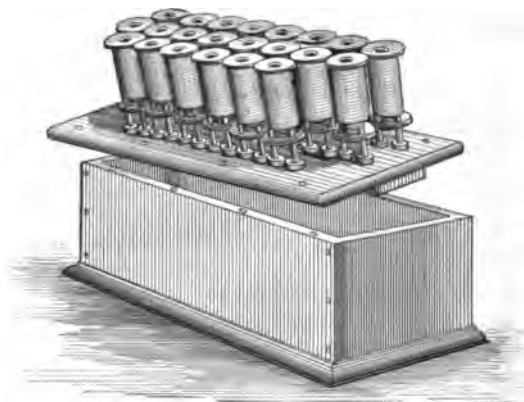

FIG. 121. — Spools of wire fastened to under side of cover of resistance box.

coefficient, is generally used in making the spools or coils for resistance boxes. In making the coils the proper length of wire for each is taken and doubled at the middle, and it is then wound double upon a spool. The object of doubling

the wire is to avoid the effects due to self-induction. After the spools are wound they are dipped in paraffin, placed inside the box, and fastened to the under side of the top of the box by brass bolts, which also fasten a series of brass blocks to the upper side of the top (Fig. 121). The individual ends of each coil are connected with adjoining brass blocks, so that all the coils are in series when the blocks are not directly connected together. This is shown in figure 122 where the ends *a* and *b* of one of the resistance coils are fastened to the brass blocks *L* and *M*, while the ends *c* and *d* of the next coil are fastened to the blocks *M* and *N*. The brass blocks are so arranged that they may be connected together by plugs which fit in tapering holes, as shown in the figure, thus "short-circuiting" the coils.

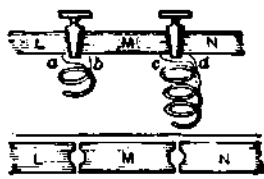

FIG. 122. — Arrangement of brass blocks and plugs for resistance box.

If such a resistance box is connected in a circuit when all the plugs are removed, the current flows through all the resistance coils in series. If one of the plugs is inserted in a hole, the corresponding resistance coil is short-circuited; that is, a negligibly small resistance (that of the plug) is connected in parallel with it, and no appreciable current flows through the coil. Since the resistance of the plug is practically negligible, the resistance of the circuit is reduced, when the plug is inserted, by the amount of the resistance of the corresponding coil. The resistance of a box may, therefore, be varied at will by simply inserting or removing plugs. Resistance boxes generally have a series of coils of different resistances, usually given in tenths, units, tens, hundreds, etc., of ohms.

134. Box form of Wheatstone bridge. The box form of apparatus is commonly used in commercial work because it is much more convenient and sufficiently accurate for most purposes. The principle of operation is, however, just the same

whatever the form. When four resistances are grouped as in figure 123, and a battery and galvanometer form part of the circuit as shown, the combination is called a Wheatstone bridge. Such a bridge is said to be balanced when the resistances have the relations to each

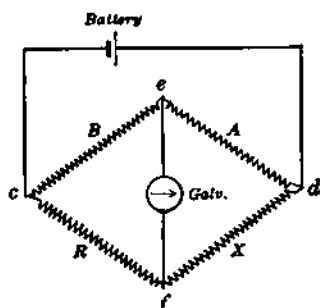

FIG. 123. — Diagram of Wheatstone bridge.

other $\frac{A}{B} = \frac{X}{R}$, because under this condition no current will flow through the galvanometer. It should also be noted that a balance can be obtained if the positions of the galvanometer and the battery are interchanged, the battery being between *e* and *f* while the galvanometer is joined from *c* to *d*. The resistance coils

which represent *A* and *B* are often called the balancing or ratio coils and bear a decimal relation to each other, such as 1 : 10, 1 : 100, or 1 : 1000.

Figure 124 shows a box form of bridge which is often called the Post-office pattern because its arrangement is similar to the bridge used by the British department of postal tele-

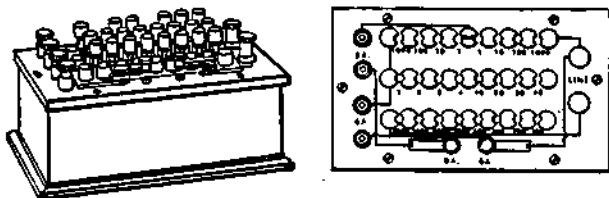

FIG. 124. — Post-office form and diagram of connections.

graphs. The box contains, besides the resistance coils and ratio coils, the necessary keys for the galvanometer and battery circuits, and binding posts marked *BA.*, *GA.*, and *LINE*, which are all connected so as to form a bridge.

135. Portable testing sets. The demand for some instrument with which to measure resistances rapidly and with considerable precision has led to the portable form of Wheatstone bridge, such as is shown in figure 125, which contains in one box the galvanometer, resistance coils, battery, and keys. To save time, use is made of the "dial" control of resistances, which is much more convenient than the older method of plug control. The ratio coils are all operated by one dial. By means of such an instrument one can easily



FIG. 125. — Portable testing set.

measure resistances with an accuracy probably greater than $\frac{1}{4}$ per cent; that is, the error is less than 2.5 in one thousand.

PROBLEMS

1. Suppose a resistance is connected in series with an ammeter of 0.00090 ohms resistance, and a voltmeter of 300 ohms resistance is connected across *both* the unknown resistance and the ammeter. Assume the voltmeter reads 2.00 volts and the ammeter 50.0 amperes. Compute the percentage error made in the voltage when thus connected.

2. Suppose the instruments in problem 1 are connected so that the voltmeter reads the voltage across the unknown resistance, but the ammeter records the current flowing through *both* the unknown resistance and voltmeter. Compute the percentage error made in the ammeter as thus connected.

3. In the slide-wire form of Wheatstone bridge shown in figure 119 suppose $R = 10.0$ ohms, $AB = 100.0$ cm., and $m = 37.5$ cm. Compute the value of X .

4. In testing a Wheatstone bridge, 4-ohm and 5-ohm coils are inserted in the loop AC and CB . Find the position which D should have on the meter wire ADB .

5. If the resistance coils of a box form of bridge range from 1 to 10,000 ohms, and the ratio coils are 1, 10, 100, and 1000 ohms, what ratio would you use to measure 1,000,000 ohms?

6. If the same box used in problem 5 were used to measure an unknown resistance of 0.01 ohms, what must be the ratio?

136. Locating faults in cables. There are two common methods of locating a "ground" in a cable, such as an underground telephone wire, and these are called the Murray loop and the Varley loop. Since both methods are simply modifica-

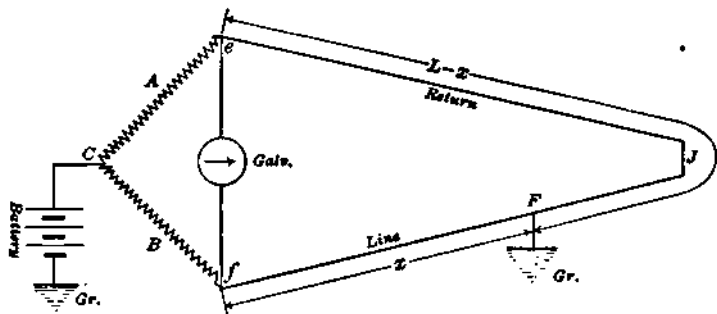

FIG. 126. — Connections for the Murray loop.

tions of the Wheatstone bridge, the same underlying principles apply to them.

These tests are called the loop tests, because the faulty wire is always connected at its distant end with a good wire and the two in combination make a loop. The loop is divided into two parts by the fault, which here is assumed to be a ground.

In the Murray loop arrangement (Fig. 126) these two parts, z and $L-x$, are two arms of the Wheatstone bridge, and the other two arms, A and B , are made up in the testing apparatus. The bridge is balanced by moving C or varying the ratio of A and B until there is no deflection of the galvanometer. The regular equation of the bridge gives

$$\frac{A}{B} = \frac{L-x}{x}$$

when L is the entire length of the loop which is known, and x is the distance out to the fault. From this we find

$$x = \left(\frac{B}{A+B} \right) L.$$

The Varley loop differs from the Murray in having a portion of the loop made up of resistance in the testing set, as shown in figure 127. This test is most useful when the bridge will permit of making only

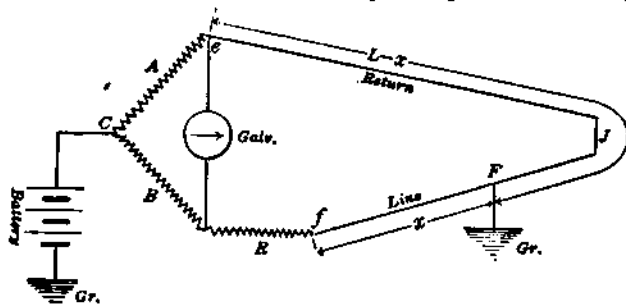

FIG. 127. — Connections for Varley loop.

decimal ratios of A to B , such as 1 to 10, 100, 1000. In this test the balance is effected by varying the resistance R . The fundamental equation for the bridge gives

$$\frac{A}{B} = \frac{L-x}{R+x}$$

when L is the total resistance of good and bad cables and x is the resistance out to the fault. From this we obtain

$$x = \frac{BL - AR}{A+B}.$$

PROBLEMS

1. The total resistance of a loop one wire of which was grounded was found to be 290 ohms. When connected as a Murray loop with $A = 1000$ ohms and $B = 450$ ohms, a balance was obtained. Find the resistance to the fault.

2. In the above example the length of one of the two wires making up the loop is 8990 feet. Find the distance to the ground.

3. Check the results of problems 1 and 2 by the fact that the above circuit consists of No. 22 B. & S. copper wire, which has a resistance of 0.0161 ohms per foot.

4. When the circuit of problem 1 was connected as a Varley loop, $A = 100$ ohms, $B = 1000$ ohms, and a balance was obtained when $R = 1910$ ohms. Find the resistance and distance to the fault.

5. A Varley loop is connected, as in figure 127, with a loop which has a resistance of 44.9 ohms and is made of No. 14 B. & S. copper wire. If $A = B$ and $R = 4.25$ ohms, how far is the fault from the instrument? (No. 14 B. & S. copper wire has a resistance of 2.521 ohms per 1000 ft.)

137. **Insulation resistance by voltmeter.** The insulation resistance of an electric machine such as a generator or motor means the resistance of the insulation like that between the commutator and the frame. It is necessary that this resistance

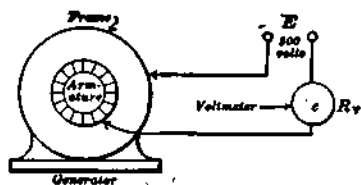

FIG. 128. — Connections for voltmeter test of insulation resistance.

should exceed a certain minimum number of ohms. For instance, a 100-kw. generator at 110 volts should have an insulation resistance of at least one tenth of a megohm or 100,000 ohms. To measure this insulation resistance, connect a voltmeter across a

110-volt or, better, a 500-volt d-c. line and call this line voltage E and the resistance of the instrument R_v . Then connect the frame of the machine with one side of the line and the commutator in series with the voltmeter to the other side of the line, as shown in figure 128. Call e the reading of the voltmeter in this position, which shows the voltage across the resistance of the instrument itself. It is evident, then, that $(E - e)$ is the voltage drop across the insulation of the machine. Since these two resistances are in series, it follows that

the resistances are proportional to the voltages across each. That is,

$$\frac{\text{Insulation resistance}}{\text{Voltmeter resistance}} = \frac{\text{Voltage across insulation}}{\text{Voltage across voltmeter}}$$

Let X = insulation resistance, then we have

$$\frac{X}{R_v} = \frac{E - e}{e}$$

and

$$X = R_v \left(\frac{E}{e} - 1 \right).$$

FOR EXAMPLE, a voltmeter has a resistance of 15,000 ohms and is used on a 113-volt line. When connected as in figure 128, the voltmeter reads 4 volts. Then the insulation resistance between the frame and the armature coils is

$$X = 15,000 \left(\frac{113}{4} - 1 \right) = 405,000 \text{ ohms (about).}$$

138. Testing the insulation of covered wire. The insulation resistance of a covered wire is usually expressed in megohms for a given length, such as a kilometer or a mile or one thousand feet. To determine this resistance, a known length of the wire is soaked in salt water and then connected through a sensitive galvanometer with some source of constant voltage, as shown in figure 129. First the galvanometer is shunted and connected

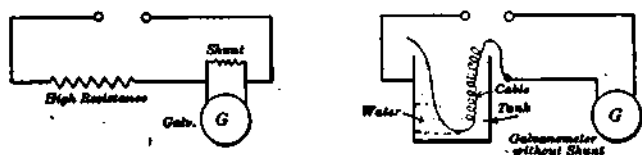

FIG. 129. — Testing the insulation resistance of a cable.

in series with some very large known resistance, and the deflection of the galvanometer is read. Then the known resistance is removed from the circuit, and in its place is inserted the resistance to be measured. One connection is made to one end of the coil of wire, and the other connection is made to the metal

tub. The deflection of the galvanometer *without shunt* is read and the insulation resistance computed as follows:

Suppose that the known resistance is one half of a megohm (500,000 ohms) and that when connected with a galvanometer shunted by the $\frac{1}{10}$ shunt it gives a deflection of 80 scale divisions. This means that there would have to be $80 \times 1000 \times \frac{1}{2}$ or 40,000 megohms in the circuit in order to give one scale division with the unshunted galvanometer. If now with the unknown resistance, that is, the insulation of a covered wire, the reading of the galvanometer without shunt is, for illustration, 25 divisions, then the insulation resistance of the wire or cable is $\frac{40,000}{25}$ or 1600 megohms.

If the sample used were $\frac{1}{2}$ mile long, the insulation resistance per mile would be only $\frac{1}{2}$ as great, or 800 megohms. This is because the current would have twice as much area to leak through in a mile as in half a mile.

PROBLEMS

1. In testing the insulation resistance of a motor the line voltage is found to be 111 volts with a voltmeter of 15,000 ohms resistance, but when connected in series with the unknown resistance it reads 1 volt. What is the insulation resistance?

2. Suppose a galvanometer of negligible resistance without a shunt gives a deflection of 100 when connected in series with a standard resistance of 100,000 ohms. If the deflection becomes 25 when an unknown resistance is substituted, what is the unknown resistance?

3. If in place of the terminals of the standard resistance of problem 2 one end of an insulated telegraph line and a connection to the ground is substituted and the deflection becomes 45, what is the insulation resistance of the line?

4. Suppose a galvanometer shunted with the $\frac{1}{10}$ shunt gives a deflection of 80 using a standard resistance of 50,000 ohms in series; then suppose the deflection is 120 with the $\frac{1}{2}$ shunt and with a certain resistance substituted for the standard. What is the value of the resistance?

5. If the galvanometer of problem 4 is connected with another unknown resistance and the deflection becomes 60 when the $\frac{1}{10}$ shunt is used, what is the unknown resistance?

6. In testing the insulation of a certain coil of wire the following measurements were recorded:

Resistance of galvanometer = 2000 ohms.

Resistance of shunt = 20 ohms.

Deflection of shunted galvanometer with 250,000 ohms in series (Fig. 129) = 54.5.

Deflection of galvanometer without shunt and with unknown resistance in series = 6.4.

Length of coil = 750 ft.

What is the insulation resistance per mile?

SUMMARY OF CHAPTER VIII

Every *ammeter*, *voltmeter*, and *wattmeter* must be frequently tested or calibrated.

One AMPERE is a current which deposits silver at the rate of 0.001118 grams per second.

One VOLT is $\frac{1}{1.0182}$ of the e.m.f. of a Weston normal cell at 20° C.

A POTENTIOMETER is a very accurate device for measuring voltage or e.m.f.; takes no current from source the voltage of which it measures; it balances e.m.f. against voltage drop (IR) along a wire.

RESISTANCE measurement by *voltmeter* and *ammeter* much used for low resistances; instruments must be calibrated.

RESISTANCE measurement by Wheatstone bridge consists in balancing four resistances; requires a sensitive galvanometer to determine just when balanced. A slide wire may take the place of two of the resistances.

FAULTS IN CABLES may be located by modifications of this bridge as used in Murray and Varley loops.

VOLTMETER may be used to determine *high* resistance; that is, to find whether the insulation on a machine exceeds a certain minimum.

INSULATION RESISTANCE of a covered wire is determined by comparing deflections of a shunted galvanometer in series with a very large known resistance, with that of the same galvanometer unshunted in series with the insulation resistance.

QUESTIONS

1. Why is an ammeter more likely to be injured than a voltmeter?
2. What advantage is it to have a voltmeter with a very high resistance coil?
3. What objection is there to the more general use of the copper coulombmeter in the calibration of ammeters?
4. Why is a standard cell used only in connection with potentiometers?
5. Why is the potentiometer a more accurate method of measuring voltage than the direct-reading voltmeter?
6. Why is it necessary to use a galvanometer of extreme sensibility with a potentiometer?
7. What objections are there to the voltmeter-ammeter method of measuring resistance?
8. What are the difficulties in measuring resistance with a slide-wire form of Wheatstone bridge?
9. Why is manganin wire better than German silver wire for use in resistance boxes?
10. Why is the wire on a resistance-box spool wound double?
11. Why should the battery key of a bridge be depressed before the galvanometer key?
12. When the ratio arms A and B are equal in a bridge, what is the relation of R to X ? Why?
13. In the use of the slide-wire form of bridge it is desirable to have A as nearly equal to B as convenient. Why?
14. What is meant by the plug resistance in a resistance box?
15. A special form of the slide-wire bridge is often used in the Murray-loop method of detecting faults. What advantage has this over the portable testing set?
16. Show how one can locate the point where two wires are crossed by means of a portable testing set.
17. What would be the effect of dampness on the insulation resistance of an electrical machine?
18. How would you measure the insulation resistance of a lead-covered telephone cable?

CHAPTER IX

PRINCIPLES AND CONSTRUCTION OF DIRECT-CURRENT GENERATORS

Dynamo — generator and motor — simple form — commutator — ring and drum armature — field magnets — multipolar generators — factors determining e.m.f. — series-, shunt-, and compound-wound fields — characteristic curves — regulation — field rheostats — efficiency and losses in generators — hysteresis and eddy currents — rating of generators — position of brushes — interpoles — operation of small power station — generators in parallel.

139. Dynamos. A dynamo consists essentially of a machine for transforming mechanical energy into electrical energy, or *vice versa*, by means of electromagnetic induction. If the machine derives its mechanical power from some source outside of itself, such as a water wheel or steam engine, and delivers electric power, it is called a **generator**. If, on the other hand, the electricity is generated outside the machine and is brought to it, and if this power puts the machine in motion and so runs other machinery, such as a sewing machine or street car, the machine is called a **motor**. The term "dynamo" includes both generator and motor. In short, the dynamo is a reversible machine, and the same machine may be driven part of the time as a generator and the rest of the time used as a motor to drive another machine; this is sometimes done in shops and often on self-starting automobiles which have but a single unit.

As already stated in Chapter VI, Faraday discovered about 1830 that a conductor cutting lines of force, when part of a

closed circuit, will produce a current. He then constructed crude machines for utilizing this phenomenon; he may, therefore, be fairly considered to be the primary inventor of the dynamo. During the following years many investigators, some of whom bear famous names, entered this fascinating field of discovery. In the fifties, Siemens, Gramme, and Pacinotti appeared with improvements which developed the dynamo into nearly its present form; since their time many improve-

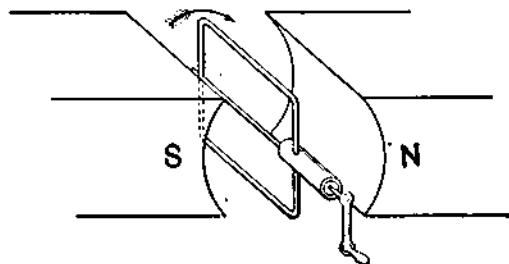

FIG. 130. — Coil arranged to be rotated in magnetic field.

ments have been made and it is continually being perfected.

140. A simple generator. If a closed coil of wire mounted on an axis or shaft is revolved as in figure 130, an alternating

current is produced, which has been described in section 105.

If, instead of being short-circuited on itself, the coil is connected with an external circuit by means of such sliding contacts as are shown in figure 131, the alternating current may be led off to be used for any desired purpose. The rings *AA*, to which the ends of the coils are attached, are in this case called **collecting rings**, and the parts *BB*, which bear on the collecting rings, are called **brushes**. In an actual machine made up for the purpose of generating electricity by a coil revolving in a magnetic field, the revolving part is called an **armature**. Telephone magnetos, which

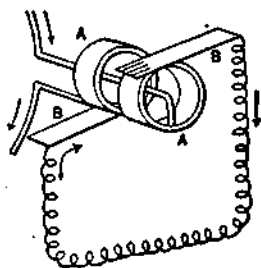

FIG. 131. — Ends of coil attached to sliding rings *AA*, with brushes *BB* making connection with external circuit.

are used for ringing telephone call bells, are small alternating-current generators; each consists of a coil of wire wound on an iron core which is revolved in the magnetic field between the poles of a permanent horse-shoe magnet. In the Ford magneto we have a series of horse-shoe steel magnets attached to the flywheel so that their poles move rapidly past stationary coils (Fig. 92) in which the alternating electric current is generated. Here we have a moving magnetic field and stationary armature coils.

141. Commutator. To get a direct current or continuous current, that is, one which flows always in the same direction, we have to use a commutator. To understand how this works let us study a very simple case. If the ends of the loop in section 140 are connected with a split ring, as shown in figure 132, we may set the brushes $B+$ and $B-$ on opposite sides of the ring so that each brush will connect first with one end of the loop and then with the other. By properly adjusting the brushes so that they shift sections on the commutator just when the current reverses in the loop (that is, when the loop is in a vertical position), we may get the current to flow *out* only at one brush $B+$, and *in* only at the other brush $B-$. The direction of the current in the external circuit is always the same, even though the current in the loop itself reverses twice in every revolution.

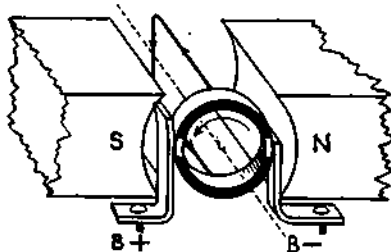

FIG. 132. — Split-ring commutation.

The voltage delivered by such a machine can be represented by the curve in figure 133. Although it is always flowing in the same direction, it is pulsating. This is easy to understand after a little consideration. When the coil stands up and down

between the pole pieces as in figure 132, it is in such a position that when it is revolved a small amount the conductors move

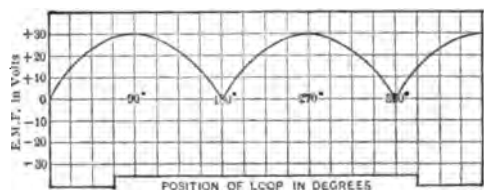

FIG. 133. — Pulsating e.m.f. delivered by loop fitted with commutator.

practically parallel to the lines of force and no lines are cut. When the coil is in continuous revolution, no voltage is induced at the instant that it is in this position,

which corresponds with the points 0° , 180° , and 360° on the curve in figure 133.

When the coil stands as shown in figure 134, it is in such a position that the conductors cut squarely across the lines of force as they move, and the largest possible number of lines of force are cut for a given amount of motion. The position of the coil shown in the figure and the position 180° therefrom correspond with the points 90° and 270° on the curve in figure 133.

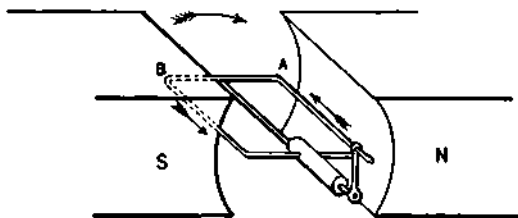

FIG. 134. — Coil rotated in magnetic field.

A machine with a commutator for delivering direct current continuously in the same direction is called a **direct-current (d-c.) or continuous-current (c-c.) generator**.

142. Armatures having more than one coil. Gramme ring. Direct-current generators having armatures with one coil are not satisfactory for general use, for two reasons:

(1) The wavy character of the current is a disadvantage for some purposes.

(2) The commutation of large currents at the full voltage which is required for most commercial uses is not practicable. To overcome these difficulties coils must be uniformly distributed over the surface of the armature, and the windings must be connected at equal intervals to commutator segments. The first armature of this kind that was put into commercial service was invented in 1870 by a Frenchman named Gramme.

The Gramme-ring armature is now very seldom used, but it is worth studying carefully because the fundamental principles of its action can be understood from very simple diagrams; whereas most armatures of the common or drum type, although based on exactly the same principles, cannot be represented by simple diagrams.

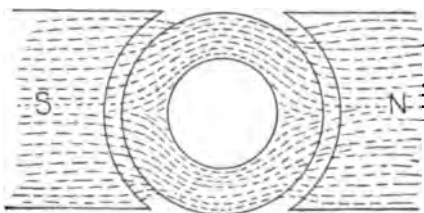

FIG. 135. — Magnetic field in a Gramme ring.

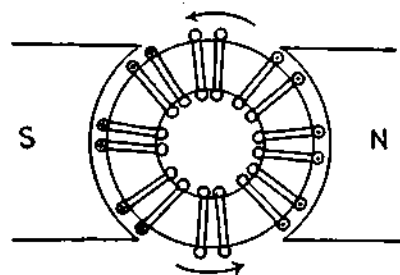

FIG. 136. — Gramme ring rotating in a magnetic field.

A rotating soft-iron ring or hollow cylinder is mounted between the poles of an electromagnet, as in figure 135. The ring serves to carry the flux across from one pole to the other. There are scarcely any lines of force in the space inside the ring. A continuous coil of insulated copper wire is wound on the ring, threading through the hole at every turn. When the ring rotates, as in figure 136, the wires on the *outside* are cutting lines of force, but those inside are not. Furthermore, according to the **RIGHT-HAND RULE**, the outside wires on the right-hand side

are moving in such a direction that the induced current tends to flow toward us. The wires lying on the other side of the ring

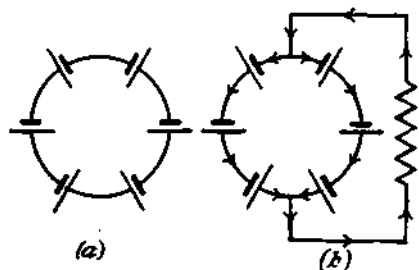

FIG. 137. — Batteries (a) without and (b) with an external circuit.

to the first group (Fig. 137 (a)); obviously no current would flow.

But if we imagine the copper wires on the outer surface of the ring to be scraped bare, and if two metal or carbon blocks or brushes at the top and bottom rub on the wires as they pass, a current could be led out of the armature at one brush and, after passing through an external resistance, such as a lamp, could be led back to the armature again at the other brush. In this case the armature circuit is *double*, consisting of its two halves in parallel. The adding of brushes and the external resistance to the Gramme

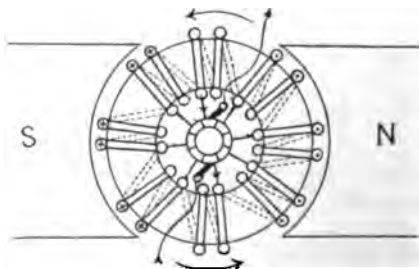

FIG. 138. — Ring armature with commutator.

ring is like adding an external circuit to the arrangement of cells described above. This battery analogue for a Gramme-ring armature is shown in figure 137 (b).

In the Gramme-ring arrangement there are at every instant

the same number of active conductors in each half of the armature circuit, and so the current delivered by the armature is not only *direct* but also *steady*.

In practice, however, it would be difficult to make a good contact directly with the wires of the armature, because the wires must be carefully insulated from each other and from the iron core, and so the various turns of wire, or groups of turns, have branch wires which lead off to the commutator segments, as in figure 138.

The commutator consists of copper bars or segments which are arranged around the shaft and insulated from each other by thin plates of mica (Fig. 139). To get a satisfactorily steady current there should be many segments in a commutator, so that the brushes may always be connected with the armature circuit in the most favorable way. The brush itself is generally a block of carbon or graphite held in position by a brass holder which has an adjustable spring resting on the brush. The carbon block is also electrically connected by a short piece of copper cable. When the current is heavy, several brushes are set side by side.

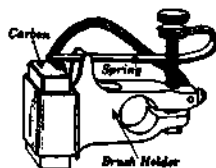

FIG. 139.—Commutator and brush with its holder.

143. Drum armature. Since very little flux passes across the air space in the center of a Gramme-ring armature, the wires on the inner surface of the ring do not cut lines of magnetic force and are useless, except to connect the adjoining wires on the outer surface. Furthermore, it is very inconvenient to wind the wire on an armature of the ring form. For these reasons most armatures are now of the **drum** type. In this form the core is made with slots along the circumference, in

which the wires lie (Fig. 140). Since the active wires in one slot are connected across the end with active wires in another slot, there are no idle wires inside the core.

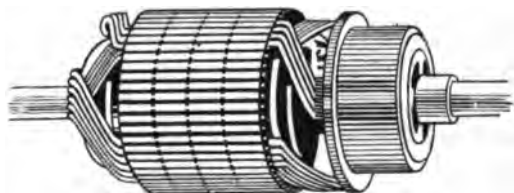

FIG. 140. — Slotted armature core, drum type. Partly wound.

144. Field magnets. The magnetic field in which the armature revolves is ordinarily produced by a great electromagnet. The frame of this electromagnet (Figs. 141 and 142) is so arranged that it can hold the windings required to set up the lines of force; and in order that the lines may be caused to pass

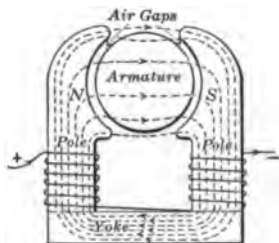

FIG. 141. — Field magnet of a small old-style two-pole machine.

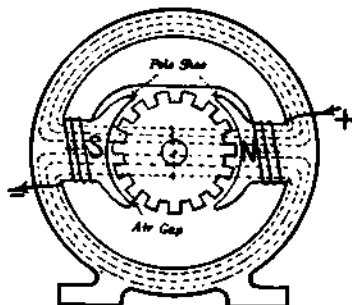

FIG. 142. — Field magnet of small modern two-pole machine.

through the armature, the poles are arranged to embrace the armature. These expanded pole pieces are called **pole shoes** and the whole of the magnet frame is called the **field** of the machine. The parts of the field upon which the windings are placed are often called the **field cores**. The portion of the magnet that connects the cores is called the **yoke**.

145. Reluctance of magnetic circuit. It is always necessary to allow a certain amount of space or clearance between the poles and the surface of the armature. This space is usually called the **air gap**. The number of ampere turns which are required to give the magnetomotive force that is needed to set up the lines of force necessary to induce a given electrical voltage in the armature windings depends upon the reluctance of the armature core, of the air gap, and of the magnet frame.

The reluctance of the air gap constitutes the principal reluctance of the magnetic circuit. For example, the following computations for ampere turns were made for two machines :

MACHINE	I	II
Yoke	420	250
Poles	228	340
Air gap	2038	3987
Armature	37	60
Total ampere turns	2723	4637

Since there is no insulator of magnetism, some of the lines of force which are set up in the field magnet will leak around the armature instead of passing through it, and the cross section of iron in the path of the lines of force through the field magnet must be sufficiently large to hold these leakage lines as well as the useful ones which pass through the armature. It is the **leakage**, or stray lines of force, which sometimes magnetizes watches when they are carried near a dynamo.

146. Multipolar generators. The machines which have been described have two poles and are called bipolar machines. For commercial purposes, especially in machines above 10 kw. capacity, it is common practice to use four, six, eight, or even more poles. Such machines are called **multipolar**. Figure

143(a) gives the external view and figure 143(b) gives a diagram of the electric and magnetic circuits of a four-pole generator. By increasing the number of poles we can get the commercial voltages (110, 220, or 500 volts) at much slower speeds than would be necessary in bipolar machines. Since the voltage depends on the rate at which the wires of the armature cut the lines of magnetic force, in a four-pole machine each wire

on the armature cuts a complete set of lines of force four times in each revolution instead of twice as in a two-pole

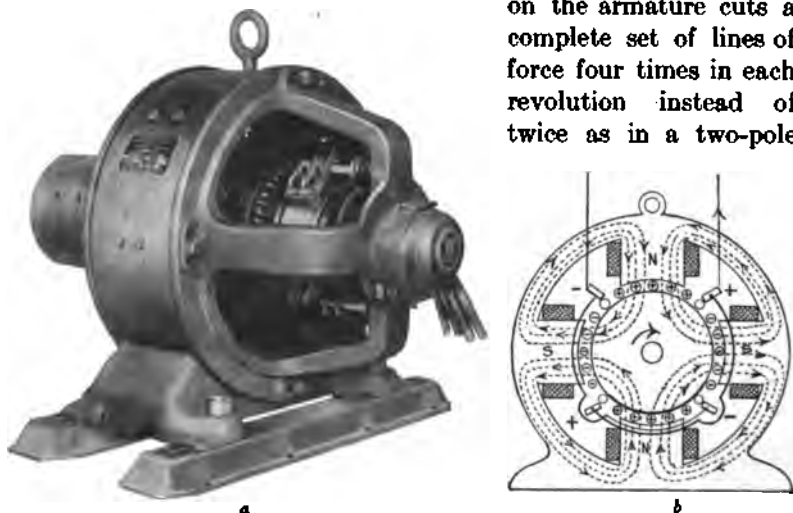

FIG. 143. — Four-pole generator (a) and its diagrammatic cross section (b).

machine. For this reason the speed of a four-pole machine is one half the speed required in a two-pole machine for the same voltage. Furthermore, the multipolar machine is more economical to build, because it requires less iron to carry the magnetic flux.

The same principles govern the winding of the armatures for multipolar machines as those already described for bipolar machines, but each coil reaches around a chord of the armature instead of across the diameter. The chord must always be

such that when one conductor of a coil is under one pole the return conductor of the same coil must be under a pole of opposite sign; and the chord is usually the same as the chord from the center of one pole face to the center of the next pole face, although it may be an odd multiple of the same.

It will be observed from the diagram (Fig. 143(b)) that every other brush is positive and is connected to the positive terminal of the machine.

147. What determines the voltage of a generator? In Chapter VI it has been shown that when a wire is moving across a magnetic field *the amount of induced e.m.f. depends on three factors: (1) the speed, (2) the magnetic field, and (3) the number of turns.* For the same reasons it follows that

voltage of a generator varies as speed \times flux \times turns.

The fundamental equation which expresses mathematically the relation between the generated e.m.f. in volts, the total magnetic flux cut by the armature conductors, the speed in revolutions per second, and the number of armature conductors in series between the brushes is

$$E = \frac{\Phi N C p}{10^8}$$

when E = volts generated in armature,

Φ = field flux measured in lines per pole,

N = speed of armature in revolutions per second,

C = number of armature conductors in series between the brushes,

p = number of field poles.

We have to divide by 10^8 because the units in which the magnetic flux and the e.m.f. are measured have been so chosen that, when 100,000,000 (10^8) lines of magnetic force are cut per second, the e.m.f. induced is one volt.

The direction of the voltage induced in the conductors of an armature may be determined by applying FLEMING'S RULE of Chapter VI. If we place the right hand alongside of a pole

piece so that the first finger points with the lines of force (i.e., in the direction which would be given by drawing a line through the armature from a north pole to a south pole) and the thumb points in the direction of rotation of the armature, then the middle finger points in the direction of the current which should flow as a result of the induced voltage.

This rule, however, will not show which brush is positive, because the connections of the conductors with each other affect that. If a diagram showing the connections of the conductors is available, the polarity of the brushes may be determined by means of the foregoing rule.

PROBLEMS

1. How many revolutions per minute (r.p.m.) would a single-coil bipolar generator have to make in order that the current might have 120 alternations per second?
2. How many revolutions per minute would an eight-pole generator have to make to have the current alternate 120 times a second?
3. An armature with 100 conductors in series rotates so that these conductors cut across a field of 5,000,000 lines 800 times a minute. What is the average e.m.f. induced?
4. If the armature resistance in problem 3 is 20 ohms and the external resistance is 80 ohms, (a) how much power is consumed in the armature circuit? (b) how much in the complete circuit?
5. Find the voltage of a four-pole generator with four brushes; speed 1800 r.p.m.; number of active conductors 416; flux per pole 4×10^6 lines.
6. How fast must the armature of a bipolar generator revolve to generate 120 volts? Given 460 conductors and flux per pole $= 6 \times 10^6$ lines.
7. A six-pole generator has six brushes. The armature has 1200 active conductors and a speed of 900 r.p.m. Flux per pole 6×10^6 lines. What is the voltage?
8. A bipolar generator's field magnet gives a flux of 9,000,000 lines. How many conductors must there be on the armature in order that the generator may give 110 volts at 600 r.p.m.?

148. **Excitation of the field of generators.** The exciting current for the field magnet of a d-c. generator is almost universally generated by the machine itself, the voltage at starting being obtained by the slight residual magnetism that remains in the magnet. The conductors in cutting through this residual flux have induced in them a small e.m.f., the direction of which, according to Fleming's right-hand rule, depends upon the relative direction of the residual flux and the direction of rotation. Due to the small induced e.m.f., a slight current flows through the field coils. If the field connection is correct for the given direction of rotation, this slight current increases the flux. This increase in the flux increases the induced e.m.f., which in turn causes an increase in the current, etc. until full voltage is reached. When this action occurs the generator is said to build up. But if the current which flows as a result of the e.m.f. induced by the residual flux passes through the field coils in such a direction as to reduce the field flux, the generator cannot build up. From the above it is evident that a d-c. generator will build up only if the field connection is proper for the given direction of rotation; and that if it is desired to reverse the direction of rotation the connections must likewise be reversed.

In order to distinguish the several methods of winding the field, generators may be divided into three classes. These are:

1. *Series-wound* (Fig. 144), in which the field winding is connected in series with the external circuit and all the current generated by the machine passes through a thick wire, which is wound a comparatively few times around the field cores.

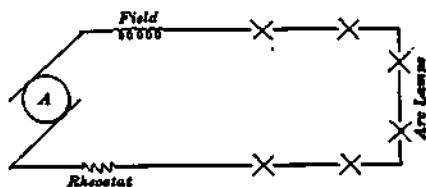

FIG. 144. — Diagram of series-wound generator.

2. *Shunt-wound* (Fig. 145), in which a field winding of high resistance is connected in parallel, or as a shunt, with the external circuit, and only a portion of the current generated by the machine passes around the field cores through a great many turns of fine wire.

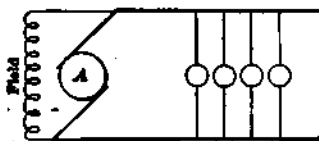

FIG. 145. — Diagram of shunt-wound generator.

3. *Compound-wound* (Fig. 146), which is a combination of the first two, so that the field magnet is magnetized in the same direction by both a shunt and a series winding.

If three generators of the same size and shape have their field magnets wound in the three different ways, the number of ampere turns in the magnetizing coils must be the same

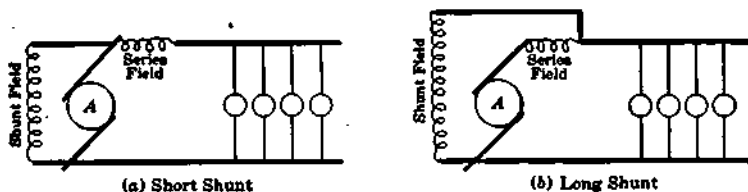

FIG. 146. — Diagrams of compound-wound generators. (a) short shunt, (b) long shunt.

in each, if the armatures are alike and the same voltage is to be produced. Since the series winding carries a large current, the number of times the current must pass around the magnet core to make a given number of ampere turns is comparatively small, and the winding has relatively few turns. The shunt winding carries a comparatively small current, and this current must, therefore, pass many times around the core in order that it may have the same magnetizing effect as the large current passing a few times around the core. In the compound winding the number of series turns and of shunt turns must be so proportioned that the number of ampere

turns made up by both together shall be approximately the same as in the other cases.

149. Characteristics of field windings. The purpose for which a generator is to be used almost always fixes the style

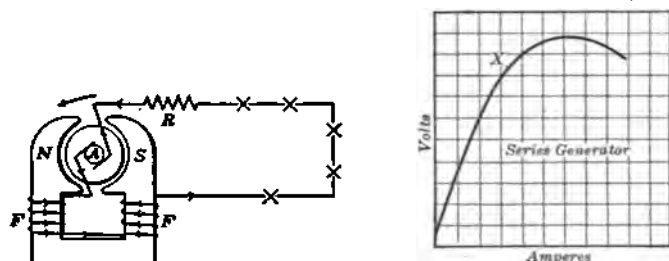

FIG. 147. — Connections of a series arc-light machine and its characteristic curve.

of its field windings. Series-wound generators are sometimes used for furnishing a current of constant strength to arc lamps which are connected in series (Fig. 147).

Shunt- or compound-wound generators are used to furnish the current for incandescent lamps or electric motors,

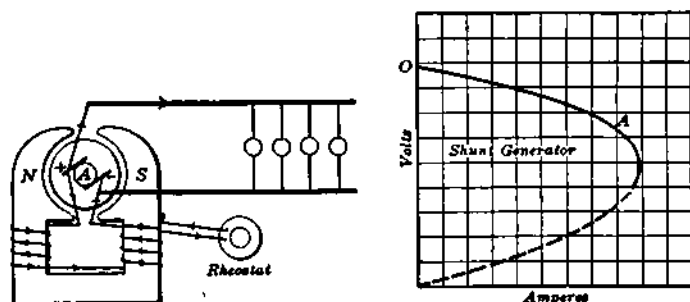

FIG. 148. — Connections for shunt generator and its characteristic curve.

which are all connected in parallel (Fig. 148) and require constant voltage for their satisfactory operation.

It will be noticed that the characteristic curves which show the relation between load current and terminal voltage, as given in figures 147 and 148, are quite different for the series- and shunt-wound generators. In the first case the curve does not start from the origin because of the slight residual magnetism left in the field magnet. It will also be noticed that from this curve the voltage increases very rapidly with increasing load until the point *X* is reached. At that point the field magnets are saturated so that an increase in current through the field coils does not thereafter give a corresponding increase in magnetization and so no great increase in voltage.

In fact, the voltage reaches a maximum and falls off if too much current is taken from the generator. This is due partly to the great magnetic reaction produced by excessive currents in the armature, and partly to the increased voltage drop in the armature.

From the characteristic curve for the shunt generator it will be seen that this machine maintains fairly constant terminal voltage at all loads. But as more current is drawn from the machine the terminal voltage falls, until at point *A* the generator commences to "break down." Any further attempts to increase the load result in an abrupt decrease of both voltage and current. Therefore *OA* is the operating portion of the curve. In large machines the break-down point is many times their normal load. With a field rheostat to control the field current, a constant terminal voltage may be maintained throughout the normal operating range of the machine.

Compound-wound generators have quite an advantage for furnishing current to be used by electric motors, that is, for *power distribution*, because they automatically keep the voltage constant through the combined action of the shunt and series field windings. The voltage supplied by shunt-wound generators decreases to a certain degree as the current furnished by the armature increases on account of the resistance of the armature and because the magnetism set up by the current

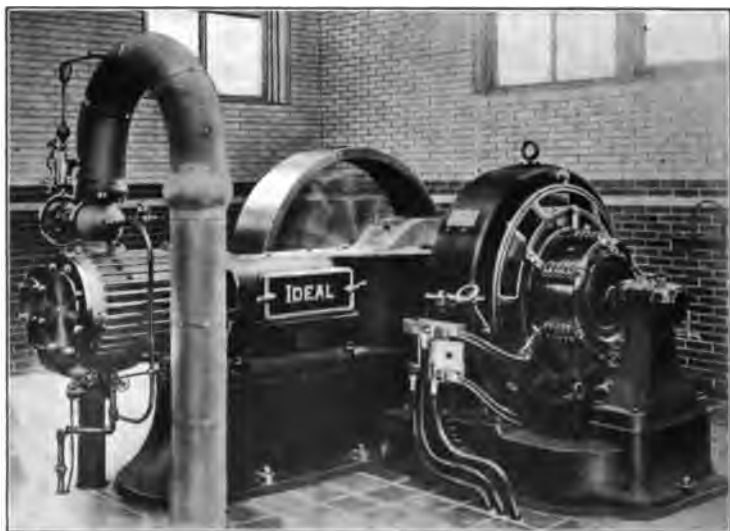

FIG. 149 a. — Direct-current generator connected directly to a steam engine.

in the armature coils interferes with the field magnetism. The magnetizing power of a series winding (Fig. 149) increases with the current which is furnished by the machine, and the natural fall of voltage in a shunt generator may be entirely overcome, or even reversed, by the addition of series turns.

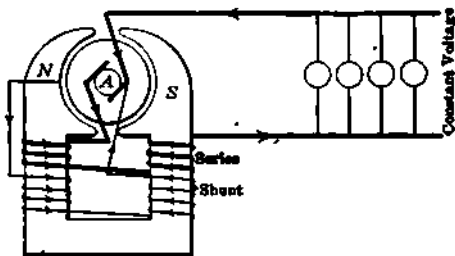

FIG. 149. — Connections for compound-wound d-c. generator.

150. Voltage regulation. A shunt-wound generator is very generally used to supply a circuit where only fair voltage regulation is required. Regulation is expressed as the percentage of "full-load" voltage that the voltage falls as the load rises from "no-load" to "full-load"; or

$$\text{Voltage regulation} = \frac{\text{No-load voltage} - \text{full-load voltage}}{\text{Full-load voltage}}$$

It is, of course, desirable to keep the voltage constant; that is, to have the voltage regulation a small percentage. Sometimes

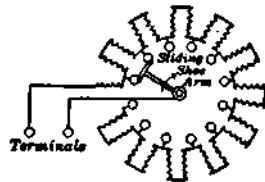

FIG. 150. — View of field rheostat with its connections.

this is accomplished by automatic devices for controlling the speed of the "prime mover"; that is, the water wheel or steam engine. More generally with small generators this is done by a hand regulator or field rheostat. This (Fig. 150) consists of an adjustable resistance mounted on an iron frame with the resistance wire

embedded in enamel, and is placed in the field coil circuit. As the load on the machine increases and the voltage drops, some

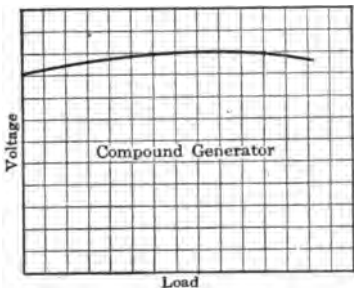

FIG. 151. — Regulation curve of a compound generator.

of this resistance may be cut out so as to increase the excitation. Still another method of keeping the voltage constant is by adding series coils to the field; that is, by making the machine compound-wound. By the use of a larger number of series turns the total excitation may increase so much with the load that the terminal voltage will rise as shown in the curve in figure 151; then the machine is said to be *over-compounded*. For street-railway service the generators are usually wound for 600 volts at full load and are over-compounded so as to maintain the trolley voltage at some distance from the power house. If the compounding effect of the series coils is too large, it is customary to reduce the current through these turns. This is done by placing a shunt in parallel with the series coils, as shown in figure 152, so that only a fixed portion of the total current passes through the series field coils.

As the load on the machine increases and the voltage drops, some of this resistance may be cut out so as to increase the excitation. Still another method of keeping the voltage constant is by adding series coils to the field; that is, by making the machine compound-wound. By the use of a larger number of series turns the total excitation may increase so much with the load that the terminal voltage will rise as

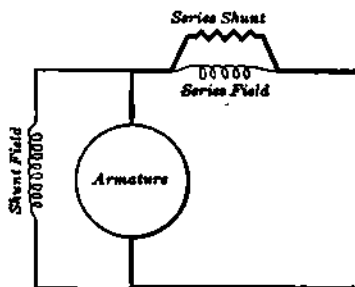

FIG. 152. — Series shunt to vary the series excitation.

151. Efficiency of generators. The following table gives some average values of the efficiencies of modern compound-wound d-c. generators of various capacities under varying loads.

CAPACITY kw.	EFFICIENCY		
	$\frac{1}{2}$ LOAD	$\frac{1}{2}$ LOAD	FULL LOAD
5	77	81	83
25	85	88	89
100	89	90	91
500	92	92	93
1000	93	93	94

It will be noted that the efficiency is greater at full load than at half load, especially with small machines, and that machines of large capacity are in general more efficient than those of small capacity.

Just as with any machine, the efficiency of a generator is the ratio of the OUTPUT to the INPUT. Stated as an equation it is written:

$$\text{Efficiency} = \frac{\text{Output}}{\text{Input}}$$

Since it is difficult to measure the input of a generator, we measure the output and losses. The input equals the output plus the losses. The equation for the efficiency of a generator becomes:

$$\text{Efficiency} = \frac{\text{Output}}{\text{Input}} = \frac{\text{Output}}{\text{Output} + \text{losses}}$$

152. Losses in a generator. There are three sources of loss in generators:

1. Copper losses (I^2R in armature and field),
2. Iron losses (hysteresis and eddy currents),
3. Mechanical losses (bearing friction and windage).

Since the iron losses and mechanical losses are difficult to measure separately, they are usually included under one term, **stray-power loss**.

The copper losses consist of the watts lost in excitation due to the resistance of field coils (equal I_f^2R , where I_f =

field current and R_f = field resistance), and of the watts lost in the copper of the armature due to the resistance of the armature windings (equal to $I_a^2 R_a$, where I_a = armature current and R_a = armature resistance). It will be seen that the copper loss in the armature is proportional to the square of the load.

The watts lost in the iron of the armature are caused by hysteresis and eddy currents.

Hysteresis seems to be due to a sort of friction between the iron molecules as they are caused to turn around by the attraction of the magnetic field while the armature revolves. Every time the molecules are caused to turn around under the influence of a magnetic field, a certain amount of power is used, which is converted into heat; consequently, for every revolution of the armature a certain amount of power is used and converted into heat. This is an effect of magnetism which has been described in Chapter V.

The amount of power wasted and heat produced in a core on account of hysteresis depends upon the amount of iron

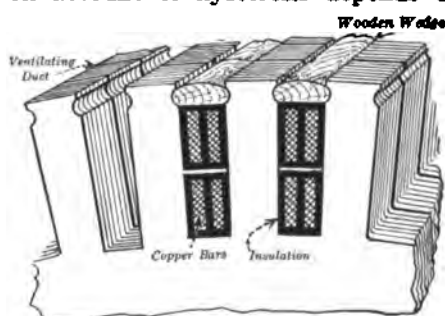

FIG. 153. — Portion of laminated armature core with air ducts and insulated conductors.

in the core, the number of reversals per second made by the magnetism in it, the density of magnetism in the iron, and the quality of the iron. It may be said that, in general, the softer the iron the less is the loss due to hysteresis; consequently, the iron used in armature cores is very soft wrought iron or steel which has been carefully annealed.

In modern machines the cores for armatures are built up of disks which are punched out of sheet iron (Fig. 153). These

disks are sometimes insulated from each other by thin tissue paper, or by thin coverings of varnish or nonconducting oxide. The object of dividing the cores into disks, or laminating them, and of insulating the disks from each other is to prevent eddy currents from being set up in the core itself when it is revolved in the magnetic field. The rule that electric currents are set up when a conductor cuts lines of force applies just as much to the core of the armature as to the windings. Currents tend to flow in armature cores from one end to the other near the surface under one magnet pole, and to return under the opposite pole. By properly laminating the cores these currents are nearly all prevented, and at the same time the passage of lines of magnetic force through the iron from one side of the core to the other is not interfered with.

The great objection to permitting currents to circulate in the armature core is the fact that it takes power to keep them circulating and that all this power is converted into heat in the armature core and is wasted. The heating of the core has another disadvantage; namely, that a high temperature is likely to injure the cotton and shellac insulation which is used between the coils themselves and between the coils and core. Even with the best of lamination a certain amount of power is lost and heating is caused by currents circulating in the core disks.

The mechanical losses are made up of the friction of the bearings, the friction of the brushes rubbing on the commutator, and the friction of the air, which is called "windage."

The efficiency curve (Fig. 154) of a generator is drawn by plotting the percentage of efficiency against the kilowatt output.

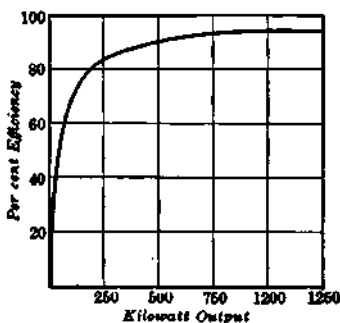

FIG. 154. — Efficiency curve of a 1000-kw., 600-volt d-c. generator.

153. **The rating of a generator.** A generator is rated as a 5-, 50-, or 500-kw. machine according as it delivers 5, 50, or 500 kilowatts of electrical power. But in any particular machine the principal factor which limits the amount of electricity that it can deliver is the **safe temperature rise**. The losses in an electrical machine are transformed into heat, which causes the temperature of the machine to rise above that of the surrounding air. But insulating materials lose their mechanical and dielectric strengths at high temperatures, so that, in general, it is not permissible to let the temperature of any part of a machine run more than 50 degrees centigrade above the temperature of the surrounding air, which may be 35° C. It is customary for manufacturers to guarantee that the machine will operate under full rated load continuously with a temperature rise of any part not exceeding 40 degrees centigrade above the surrounding air, and that it will carry 25 per cent overload for two hours without a temperature rise of more than 55 degrees centigrade. The rise in temperature is based on a temperature of the surrounding atmosphere of 25° C. Such temperatures are measured with thermometers wherever convenient, but in the case of the armature the temperature is computed on the basis of the increase of the resistance of the copper wire.

PROBLEMS

1. If 25 horse power are used in driving a 15-kw. generator at its full capacity, what is its full-load efficiency?
2. If the efficiency of a 7.5-kw. generator is 75 per cent, how many horse power will be required to drive it?
3. The e.m.f. of a shunt generator drops from 110 to 93 volts when the speed is reduced from 1000 to 900 r.p.m. If the flux at the higher speed is 1,000,000 lines, what is the flux at the lower speed?
4. Suppose the flux in problem 3 were kept constant. What would be the voltage at the lower speed?

5. What causes the flux to decrease with the speed?

6. If the resistance of a generator armature is 0.15 ohms and the total e.m.f. induced is 120 volts, what will be the terminal voltage when the armature current is 75 amperes?

7. What is the voltage regulation in problem 6?

8. What is the e.m.f. of the compound-wound generator shown in figure 146 (b)? Given

resistance of armature = 0.04 ohms,

resistance of shunt field = 550 ohms,

resistance of series field = 0.03 ohms,

current in line 60 amperes, and voltage in line 550 volts.

9. What is the full-load efficiency of a d-c. compound generator rated at 1000 kw. and 600 volts? Given

resistance of armature and series coils = 0.006 ohms,

resistance of shunt field coils = 20 ohms,

stray-power loss = 30 kw.

Assume the machine is long compound.

10. In a similar manner, assuming that the mechanical and iron losses and shunt-field copper loss remain constant at various loads, compute the efficiency at $\frac{1}{4}$, $\frac{1}{2}$, $\frac{3}{4}$ loads and $\frac{1}{4}$ overload and plot the efficiency curve. Assume a constant voltage of 600.

154. Position of dynamo brushes.

It might be supposed from the previous discussion that the brushes would be set on the commutator in such a position that they would connect with the coil just as its wires were passing the neutral line, as in figure 155. For it is evident that as the coil crosses this line its current reverses and its induced e.m.f. drops to zero

because the wires are not cutting lines of force. Unfortunately the situation is not so simple because of the cross-magnetizing effect of the armature itself. In figure 156, diagram A, will be

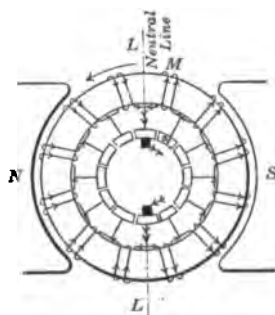

FIG. 155. — Diagram showing reversal of current at the neutral line.

seen the distribution of magnetic flux in a two-pole machine when only the field coils are excited, and in diagram *B* the distribution of magnetic flux when only the armature is carrying current and the brushes are in neutral position. It will

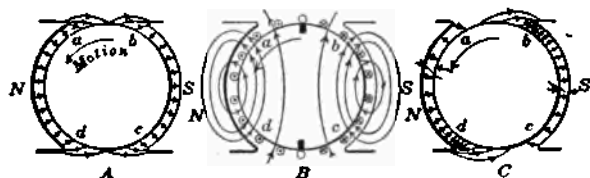

FIG. 156. — Armature reaction: *A*, flux due to field coils; *B*, flux due to armature windings; *C*, resultant flux distribution.

be noted that the armature magnetic field is at right angles to that produced by the field magnets. It will also be observed in diagram *C* that the resultant distribution of magnetic flux has shifted the neutral line in the direction of the rotation of the armature. Therefore, as the load in a d-c. generator increases, the brushes are shifted from the no-load neutral position in the direction of motion in order to prevent sparking

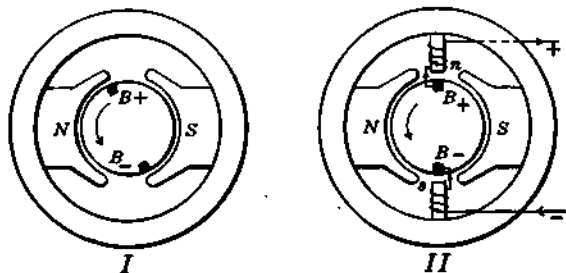

FIG. 157. — Diagrams to illustrate the principle of the interpole generator.

at the brushes. This shifting of the brushes, however, is not necessary in modern machines because of the use of interpoles. These small interpoles or commutating poles (Fig. 157) are placed between the main poles and are supplied with series

field coils so that their strength depends upon the armature current. They are not there to generate power in the armature, but are merely to keep the brushes, which are set on the neutral line, from sparking on heavy loads or high speeds.

155. Operation of a small power station. At the present time it has been estimated that probably ninety-five per cent of the electric power generated in this country is generated as alternating current in the large size a-c. generators or alternators which are described in Chapter XIV. The principal use of d-c. generators is for small plants and as exciters for furnishing current for the field coils of alternators. In decid-

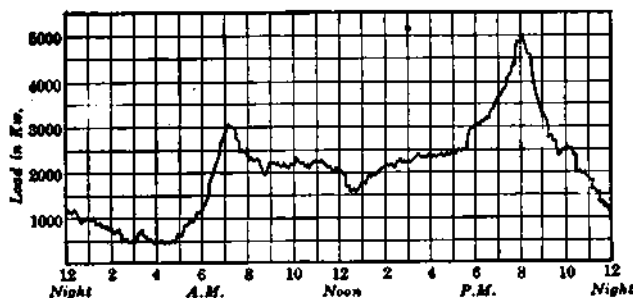

FIG. 158. — Load curve for a small power station. Railway, lighting, and factory loads.

ing upon the equipment for a small power station it is first necessary to study the probable load curve. Figure 158 shows such a curve. It might at first appear that we needed a 5000-kw. generator to carry the load at 8 P.M. But a 4000-kw. generator would be able to run at overload long enough to carry the peak. However, in case of an accident to this single machine the station would be without power until repaired, and for most of the day the machine would be operating on less than fifty per cent of its full-load rating, which is not a very efficient method of operation.

The proper installation to supply such a load as that in-

dictated by the curve would consist of two 2500-kw. generators and one 1000-kw. machine. From midnight until 6 A.M. the 1000-kw. unit would take the load, during most of the day one 2500-kw. unit would do the work, and during the two hours of peak load the two 2500-kw. machines would carry the load. With such an equipment it will be noted that the generators are practically always operating at full load, which is the condition of maximum efficiency, and that any two generators can carry the load, which guarantees continuity of service. It must, however, be stated that the first cost of installation would be considerably more than that of a one-unit station.

156. Parallel operation. Since it is often desirable to have two or more direct-current generators supply current to the

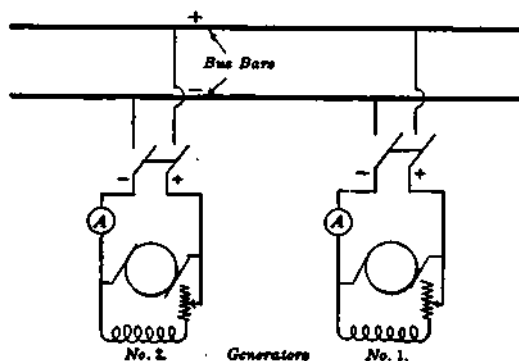

FIG. 159. — Diagram of station connections for shunt generators.

same constant-voltage circuit, the connections must be carefully made in order to get the total load properly divided between the machines. The current from each generator is led to a switchboard by conducting cables of the proper size which are con-

nected with the main switchboard conductors, called bus bars, through switches and measuring instruments (Fig. 159).

If two shunt generators are operating in parallel, supplying current to the same circuits, it is evident, since they are both connected with the same bus bars, that the terminal voltages of the two machines must be equal. Suppose we have two

machines in parallel supplying current to a 110-volt circuit and that one machine has an armature resistance of 0.1 ohms and supplies 20 amperes and that the other has an armature resistance of 0.08 ohms and supplies 40 amperes. Then the generated e.m.f. of the first machine will be $110 + (20 \times 0.1)$ or 112 volts, and the generated e.m.f. of the second will be $110 + (40 \times 0.08)$ or 113.2 volts. From this it is evident that the current carried by any machine operating in parallel with others will always be such that the generated e.m.f. (E) minus the drop through the armature (IR) is equal to the terminal voltage (V). This may be expressed thus:

$$E - IR = V$$

or

$$I = \frac{E - V}{R}$$

Since the armature resistance and the terminal voltage are fixed quantities, it is evident that we may control the current supplied by a machine by means of a field rheostat. Thus, if we strengthen the field by cutting out resistance in the field rheostat, thereby increasing the generated e.m.f., we shall in this way increase the current supplied by the machine. Or if, on the other hand, we cut in resistance in the field rheostat, we shall reduce the current supplied by the machine.

FOR EXAMPLE, a small power house contains two 110-volt shunt generators. No. 1 has a rating of 200 kw. and No. 2 a rating of 500 kw. During the day No. 2 carries the load, but in the early evening a "peak" in the load curve requires the addition of No. 1. From 10 P.M. to 6 A.M. No. 1 alone carries the load.

Let us follow the attendant in his manipulation of the two machines. He first starts No. 1 and then by closing its field switch and adjusting its field rheostat "builds up" its voltage to 110 volts, which is the voltage of the bus bars. A single voltmeter is so arranged that by transferring a plug the voltage either of the busses or of the oncoming machine may be read. This at the same time insures that the polarity of the oncoming machines is the same as that of the busses. If it were reversed, the voltmeter would try to read backward.

Having assured himself that the two voltages are equal and the relative polarities correct, the attendant closes the switch connecting No. 1 in parallel with No. 2 on the bus bars. But even yet No. 1 is carrying none of the load, for its generated e.m.f. was adjusted to 110 volts, exactly the terminal voltage. The attendant now simultaneously reduces the field resistance of No. 1 and increases the field resistance of No. 2, keeping his eye upon the voltmeter so that he may change each by just the proper steps to shift the load and at the same time keep the bus voltage constant. The load is thus transferred from No. 2 to No. 1 until each is carrying a share of the load in proportion to its rating. The machines are now properly paralleled and operate together until 10 p.m., when No. 2 is to be taken off.

To take No. 2 out of operation, the attendant increases the field resistance of No. 2 and at the same time decreases the field resistance of No. 1, keeping the voltage constant. When its ammeter shows that No. 2 is supplying no current, the switch is opened, disconnecting No. 2 from the bus bars. The entire field resistance of No. 2 is then cut in, after which its field switch is opened and the machine stopped.

In the case of compound generators the conditions are not so simple, because manipulations such as those described are

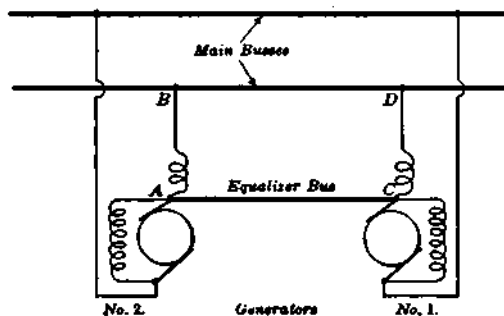

FIG. 160. — Station connection for two compound generators in parallel.

sure to result in current flowing backward through the series field winding and armature, and the magnetizing effect of the series field winding is then reversed. It is necessary to prevent this contingency, and to do so an

additional connection, called an equalizer bus bar (Fig. 160), is made between the generators. The terminals of the machine are connected with the bus bars through a main switch for

each machine, as in the case of shunt generators; but the equalizer connection serves like a third bus bar to connect the respective points where each series field circuit joins a brush. This has the effect of putting all the field windings directly in parallel with each other, and the current carried by any series winding remains unaffected by variations in the proportions of the total current which the different armatures produce. To obtain the effect in full it is necessary that the resistance of the equalizer connections be negligible, even as compared with the low resistance of the series field windings.

When two compound generators are to be paralleled, the following sequence of operations should be carried out. (1) Build up the field until the voltage of the oncoming machine is practically that of the bus bars, and close the equalizer switches. (2) Close the switch connecting the free end of the series field to the bus bar. As soon as this second switch is closed, the total current divides equally between the two series fields. This causes an increase in the voltage of the oncoming machine and a decrease in the voltage of the busses. Hence, increase the shunt-field excitation of the loaded machine until the standard operating voltage of the busses is recovered. (3) Having returned the bus voltage to its correct value, adjust the voltage of the oncoming machine to the same value and close the remaining switch. The machines will now be in parallel, but the new machine will be carrying no load. Transfer the load exactly as in the case of shunt generators.

To take a compound generator out of service proceed exactly as with a shunt machine until the load supplied is zero. Then open the three switches in the reverse order to which they were closed. *The equalizer switch should always be the first to be closed and the last to be opened unless all are arranged to be thrown simultaneously.*

CAUTION. Sometimes there is a switch in the shunt-field circuit of a generator and then great care must be taken not to open this switch until the machine stops. The reason for this is that a shunt field always has a great many turns through which a large magnetic flux goes. If a switch is opened in this circuit, a large and sudden change in flux occurs through every one of these turns. A tremendous voltage may thus be generated in the field coils, enough to break down the insulation.

SUMMARY OF CHAPTER IX

DYNAMO includes both generator and motor. **GENERATOR** does not make energy; it *transforms* mechanical into electrical energy. **MOTOR** transforms electrical energy into mechanical energy.

When a wire cuts lines of force, an induced e.m.f. is set up in the wire. When 10^9 magnetic lines are cut per second, one volt of e.m.f. is induced.

GENERATORS are essentially loops of wire revolved so as to cut through a strong magnetic field. An alternating e.m.f. is induced in these loops.

SLIP RINGS give alternating current.

COMMUTATOR gives direct or continuous current.

VOLTAGE induced in d-c. armature equals $\frac{1}{10^8}$ of the number of lines cut per second by the conductors in series between two adjacent brushes.

Field magnets generally self-excited and may be series-, shunt-, or compound-wound.

SERIES. Full-load current flows through a few turns of heavy wire. Voltage rises as load increases. Used on constant-current line.

SHUNT. Field consists of many turns of small wire, connected in parallel with line; takes small fraction of current. Voltage nearly constant, regulated by field rheostat.

COMPOUND. Field consists of both series and shunt coils. Gives constant voltage and is much used.

$$\text{EFFICIENCY of generator} = \frac{\text{Output}}{\text{Output} + \text{losses}}$$

LOSSES in a generator are

- (1) Copper losses (I^2R in armature and field),
- (2) Iron losses (hysteresis and eddy currents),
- (3) Mechanical losses (friction and windage).

CAPACITY of a generator limited by permissible temperature rise.

INTERPOLES or **COMMUTATING POLES** are small poles between the main pole pieces to prevent sparking at the brushes. Coils consist of a few turns of heavy wire in series with armature.

SEVERAL SMALL UNITS generally to be preferred to one large unit for small power stations.

SHUNT AND COMPOUND GENERATORS MAY BE OPERATED IN PARALLEL. The latter require an equalizer bus bar.

QUESTIONS

1. The electric generator is said to have revolutionized modern industry by furnishing cheap electricity. Explain.
2. Why is the price of electricity dependent on the price of coal or the availability of water power?
3. Why are not one-coil armatures used commercially?
4. Why is the Gramme armature so seldom used to-day?
5. Why are armature cores laminated?
6. What kind of iron or steel is used in the construction of the armature core, pole pieces, and yoke?
7. What effect has the quality of iron and length of air gap on the magnetic reluctance?
8. What advantages have the slotted or toothed armatures?
9. What is magnetic leakage?
10. Why must the power applied to a dynamo armature be increased if the current generated is increased?
11. Tell how the law of CONSERVATION OF ENERGY applies to the work put into and obtained from a generator.
12. What is meant by the efficiency of a generator?
13. What becomes of the energy lost in a generator?
14. Of what use is residual magnetism when a generator is started?
15. What is meant by "building up" the field of a generator?
16. Why are many turns of small wire used on a shunt field?
17. Why does a compound generator give constant voltage?
18. What is "over-compounding"? When is it used?

19. Why is the resistance wire on a field rheostat tapered?
20. Why must a generator be kept clean and dry?
21. What advantages has carbon over copper for brushes?
22. Why do interpoles help commutation?
23. Why must the field-coil terminals be reversed when the direction of rotation is reversed?
24. What harm does sparking at brushes do to the commutator?
25. Why do manufacturers advise strongly against using emery to smooth up a rough commutator?
26. Why is it sometimes desirable to have the fields of a d-c. generator separately excited?
27. How does the angle of lead of the brushes change with the load?
28. If the generator has commutating poles or interpoles, is it necessary to shift the brushes with the load?
29. A generator is found to be making an unusual noise. Make a list of the possible causes for the "trouble" and state how you would test for each.
30. A generator fails to build up. Make a list of the possible causes and show how you would trace up each one.
31. The voltage of a generator is found to be too high. How would you proceed to test for the cause of this fault?
32. The voltage of a generator is too low. What are the possible causes? In what order would you proceed to test for these causes?

CHAPTER X

DIRECT-CURRENT MOTORS

Dynamo as a motor — side push on wire carrying current — motor rule for direction of motion — forms of motors — position of brushes and use of interpoles — back e.m.f. — armature resistance — starting rheostat — automatic release for overload and no-voltage — starting and stopping — reversing — torque and speed of series-, shunt-, and compound-wound motors — efficiency — uses of stationary motors.

157. The dynamo as a motor. We have already seen that a dynamo, when driven by a steam engine, gas engine, or water wheel, may supply electricity. Now we shall see how this electric current can be supplied to a second machine, exactly like a generator but called a motor, which may be used to drive an electric car, a printing press, a sewing machine, or any other machine requiring mechanical energy. *The dynamo is a reversible machine.* Structurally, the motor is exactly like the generator and consists of an electromagnet, an armature, and a commutator with its brushes. To understand how these act in the motor, however, we must get a clear idea of the behavior of a wire carrying an electric current in a magnetic field. We shall see that the motion of a motor is due to the reaction between (1) *the current flowing in a set of conductors mounted on an armature*, and (2) *a magnetic field in which the conductors and their armature rotate.* The motor exerts its mechanical effort or torque as a pull on a belt, or thrust on a gear, or as a twisting force on a shaft. The input of an electric motor is electric power and the output is mechanical power.

158. Side push of a magnetic field on a wire carrying a current. Suppose we stretch a flexible wire loosely between two binding posts *A* and *B*, so that a section of the wire lies between the poles of an electromagnet, as shown in figure 161. Let the exciting current be so connected with the electromagnet that the poles

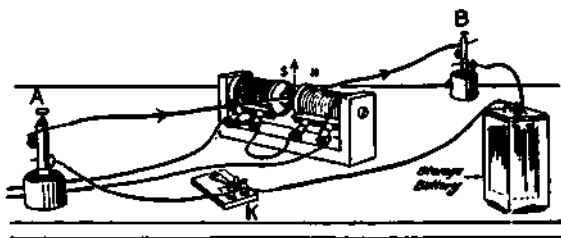

FIG. 161. — Side push on wire carrying a current.

are *N* and *S* as shown. Then, if a strong current from a storage battery is sent through the wire from *A* to *B* by closing the switch, it will be seen that the wire between the magnet's poles is instantly thrown *upward*. If the current is sent from *B* to *A*, the motion of the wire is reversed, and it is thrown *downward*.



FIG. 162. — Magnetic field about a wire with current going in.

To understand this side push exerted on a current-carrying wire in a magnetic field, let us recall that every current generates a magnetic field of its own, the lines of which are concentric circles. Figure 162 shows a wire carrying a current *into*, that is, at right angles to, the paper and away from us. The lines of force are going around the wire in clockwise direction.

The magnetic field between the poles of a strong magnet is practically uniform and is represented by parallel lines of force (Fig. 163).

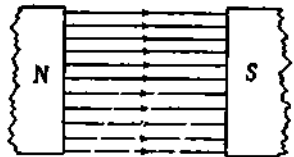

FIG. 163. — Uniform magnetic field.

If we put a wire with its circular field in the uniform field between the *N* and *S* poles of the magnet, the lines of force are very much more crowded above the wire (Fig. 164) than below. But we have seen in section 63 that we can think of magnetic lines of force as acting like rubber bands, which would, in this case, push the wire down. If the current in the wire is reversed, the crowding of the lines of force comes below the wire, and it is pushed up.

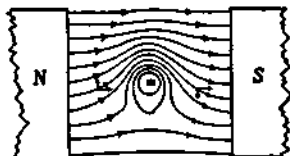

FIG. 164. — Lines of force about a wire carrying current in a magnetic field.

The force with which the wire tends to move sideways across the magnetic field depends upon the strength of the electromagnet and the amount of current flowing through the wire. The powerful forces exerted by motors are obtained by using many wires carrying large currents placed near strong electromagnets.

The direction of this sideways push on a wire in a magnetic field can be easily remembered by FLEMING'S RULE for the generator, except that the left hand instead of the right is used.

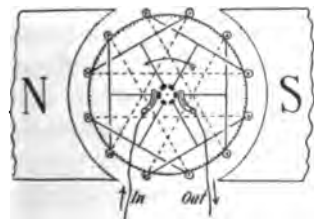

FIG. 165. — Drum-wound motor.

159. The action of a motor. In motors, as in generators, the drum type of armature is almost exclusively used. In this type the active wires lie in slots along the outside of the drum, as in figure 165, and the wiring connections

across the ends of the armature are such that when the current is coming *out* on one side — say the right — it will be going *in* on the other side — the left. Just how these wiring connections are made is not important for the present purpose, and indeed there are many different ways in which they can be arranged. In any case, from what has just been said it will be clear that

the wires (\odot) on the right side of the armature will be pushed upward, and those (\oplus) on the left side of the armature will be pushed *downward* by the magnetic field. In other words, there will be a turning effort or torque tending to rotate the armature counter-clockwise. The amount of this torque depends on the number and length of the active wires on the armature, on the current in the armature, and on the strength of the magnetic field.

Another way of looking at this action is to notice that the effect of these armature currents is such as to make the armature core a magnet, with its north pole at the bottom and its south pole at the top. The attractions and repulsions between these poles and those of the field magnet cause the armature to rotate as indicated by the arrows.

The function of the commutator and brushes is, as in the generator, to reverse the current in certain coils while the armature rotates, in order that the current may be kept circulating as shown in figure 165.

160. Forms of motors. Direct-current generators and motors are often of identical construction. Thus we have **series** motors, such as are used on street cars and automobiles, and **shunt** motors, such as are used to drive machinery in shops. So also we have **bipolar** and **multipolar** motors. When it is desirable that a motor shall run at a slow speed, it is built with a large number of poles.

Since the cooling of a motor depends largely on the circulation of air through the core and windings, the frame should be as open as possible. But if chips and flying particles are liable to get into the windings, then the openings in the frame are covered with perforated sheet metal, and such a motor is said to be **semi-enclosed**. When a motor is to be used out of doors, as for street-car work, it must be **totally enclosed** to protect it against water. The output of a machine thus enclosed is considerably reduced because the supply of air for cooling is

throttled. For example, a 10-horse-power motor as an open machine can be used to deliver 9 horse power when semi-inclosed and only about 6 horse power when totally inclosed.

161. Brushes and interpoles. In a d-c. generator we have already seen (section 154) that as the load increases the brushes have to be shifted forward; that is, in the direction of the motion of the commutator. The same machine operating as a motor, with the direction of rotation and the polarity of the poles unchanged, will have the direction of the current in the armature coils just reversed. This means that *the neutral line in a motor, and therefore the brushes, must be shifted backward* (Fig. 166); that is, against the direction of rotation.

The problem of sparkless commutation with varying loads is just as difficult to solve for the motor as for the generator, and perhaps more so, because motors have frequently to be quickly reversed, as in elevator service. We have already seen (section 154) that interpoles or commutating poles are very important for the successful operation of a generator. These interpoles are even more important in motor operation, because the load variations are more sudden and violent. Practically all modern motors are fitted with interpoles. *The brushes of such machines are carefully set before the machine leaves the factory and should not be shifted from this position.*

162. Back e.m.f. in a motor. Suppose we connect an incandescent lamp in series with a small motor. If we hold the armature stationary and throw on the current from a battery, the lamp will glow with full brilliancy, but, when the armature is running, the lamp grows dim.

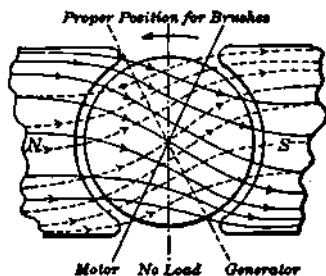

FIG. 166. — Shifting of brushes in a generator and in a motor.

This shows that *a motor uses less current when running than when the armature is held fast.* The electromotive force of the battery and the resistance of the circuit are not changed by running the motor. Therefore, the current must be diminished by the development of a **back electromotive force**, which acts against the driving e.m.f. When a motor armature is caused to rotate by the interaction of the magnetism of the field magnet and the current in the armature conductors, its conductors cut the flux of the magnetic field, precisely as though the armature rotation were caused, as in a generator, by the external application of mechanical power; and an electromotive force is therefore induced in the motor-armature conductors just as it is in the conductors on a generator armature. The direction of this e.m.f., however, is of especial interest in the motor, for it is always in opposition to (*i.e.*, contrary or counter to) the electromotive force of the external source which sends the current through the motor armature. This follows directly from Lenz's Law. On account of this relative direction of the induced e.m.f. in the motor-armature conductors it is called the **back e.m.f. or counter-electromotive force of the motor.**

Just as in the generator, when the armature revolves faster the back e.m.f. is greater, and the difference between the impressed e.m.f. and the back e.m.f. is therefore smaller. This difference is what drives the current through the resistance of the armature. So a motor will draw more current when running slowly than when running fast, and much more when starting than when up to speed.

FOR EXAMPLE, suppose the impressed or line voltage on a motor is 110 volts and the back e.m.f. is 105 volts. Then the net voltage which will force current through the armature is $110 - 105$, or 5 volts. If the armature resistance is 0.50 ohms, the armature current is $5.0/0.5$, or 10 amperes. But if the whole voltage (110 volts) were thrown on the armature while at rest, the current would be $110/0.5$, or 220 amperes.

163. Effect of armature resistance. The back e.m.f. of the motor armature can never become equal to the voltage of the supply circuit, because a certain voltage is required to push the current through the resistance of the armature conductors. In shunt-wound motors the sum of the back e.m.f. and this drop of voltage (IR) through the armature resistance is equal to the circuit voltage. When the current flowing through the motor is multiplied by the circuit voltage, the product gives input or the amount of power (in watts) which is put into the motor by the circuit.

The product of the armature current by the net voltage which is required to push the current through the armature conductors of the motor gives the watts wasted in the heating of the armature conductors. This is called the I^2R loss of the armature and should be quite small in order that the motor may be reasonably efficient and regulate well.

The product of the armature current and the back e.m.f. is equal to the power that is exerted in causing the armature to rotate; and the more nearly the back e.m.f. approaches the circuit voltage when the motor is running, the better is the efficiency of the motor and the better will it regulate. We sometimes hear of an attempt to build an improved motor which produces no counter-voltage; but all such attempts are doomed to failure, *since the success of the motor depends upon its producing this counter-electromotive force.*

164. Starting box or rheostat. As the resistance of the armature of an electric motor is usually quite small, some special means must be provided for avoiding too great a rush of current at the start, when a motor is connected with a circuit.

The resistance of the armature of a 10-horse-power motor, which is designed to be operated in connection with a 220-volt circuit, may be about 0.3 ohms or even less. The current that such an armature may be expected to carry at full load

is nearly 40 amperes. Now, if this armature is connected across the 220-volt circuit while it is at rest, the only opposition which the current meets is that caused by the resistance, since no back e.m.f. is induced while the armature is standing still; and the current that instantly tends to flow through the armature is, in accordance with Ohm's Law,

$$\frac{220}{0.3} = 733 \text{ amperes}$$

—a sufficient current to overheat and ruin the armature, unless the circuit is instantly broken.

It is necessary, therefore, to insert a certain amount of extra resistance in series with the armature, when the motor is to be started, so that the current may be choked back until the rotation of the armature has reached a speed which causes it

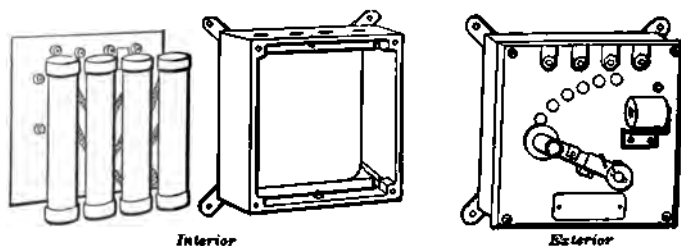

FIG. 167. — Exterior and interior of motor starting box.

to produce sufficient back e.m.f. to prevent an excessive rush of current through the windings. A rheostat made up for this purpose is called a starting box or starting rheostat. A usual form is illustrated in figure 167. It consists of an iron box containing resistance coils, wound on asbestos tubes or some similar incombustible material. These are all connected in series, and one end of the series is connected to one binding post. The resistance coils are connected at intervals to contact buttons that are shown on the front of the box. The

lever arm shown in the figure is connected with another binding post by a short wire behind the box cover.

When the starting box is connected in the circuit with a shunt-wound motor, as in the illustration (Fig. 168), the motor may be safely started by the following procedure. When the main switch is closed, the current flows through the field winding and sets up the field magnetism. The handle of the box lever *L* is then moved slowly toward the right, from button to button.

When the lever contact spring is on the button marked *A*, all the resistance of the starting box is connected in series with the motor armature. As the lever contact spring is moved toward the right, the resistance included in the circuit is gradually reduced; and when the contact spring stands on the button marked "on," all of the resistance has been cut out, and the motor armature is connected directly with the circuit.

In the meantime the armature has been given an opportunity to come up to its regular speed, so that the counter-voltage is sufficient to prevent the current from becoming excessive.

The resistance of the coils in the starting box must be sufficient to prevent much more than the normal current of full load from flowing through the armature when it is stationary. In the case of the 10-horse-power motor referred to above, the starting box should contain not less than 4 or 5 ohms, and the rheostat coils should be capable of carrying the full-load current for several minutes without becoming dangerously hot.

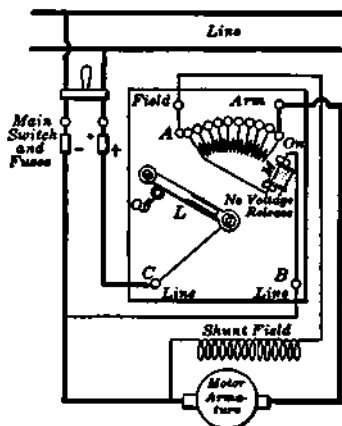

FIG. 168. — Diagram of starting box connected with shunt-wound motor.

165. Automatic release. Most starting boxes nowadays are fitted with an automatic arrangement called a "no-voltage" release that allows the contact lever to return to its "off" position in case the main switch is opened or the current supply fails for any reason. This is very desirable since it disconnects the motor from the circuit and prevents it from being injured in case the current supply is renewed while the armature is at rest. This construction also makes it impossible, after the motor is started, to leave the contact lever permanently in a mid-position, which might result in dangerously overheating the resistance coils. Such starting boxes are recommended in the rules of the Underwriters and are required for many locations. Figure 168 shows the circuit connections of a box of this character. In the arrangement illustrated, the contact lever of the starting box is provided with a spring at its pivot which always carries the lever to the left-hand or "off" position unless it is forcibly held. The magnet *M* has its winding in shunt with the motor and it holds the lever in the right-hand or "on" position when it has been moved to that position, provided current is flowing through the magnet circuit. If the lever is in the "on" position (the motor being in operation) and the current supply fails, the magnet *M* loses its magnetism and the lever returns to the "off" position by the compulsion of the spring.

Frequently, as in figure 168, the same magnet *M* serves for a no-voltage and a no-field release. In case the motor field becomes weak, the armature rotates at a speed much above that for which it was designed and it may have its windings torn off by centrifugal forces. With no field at all the armature stops and, since there is no counter e.m.f., an excessive current will be forced through it. For this reason the holding magnet *M* (Fig. 168) is connected in the shunt-field circuit.

Some starting boxes also have an "overload" release or cut-off arrangement which stops the motor if it is overloaded. In figure 169 the overload release consists of a low-resistance

coil L which is connected in series with the motor. When the current becomes excessive, the coil is so strongly magnetized that it pulls up the armature A and thus short-circuits the magnet coil M . The arm is released and moves back to the "off" position and so stops the motor.

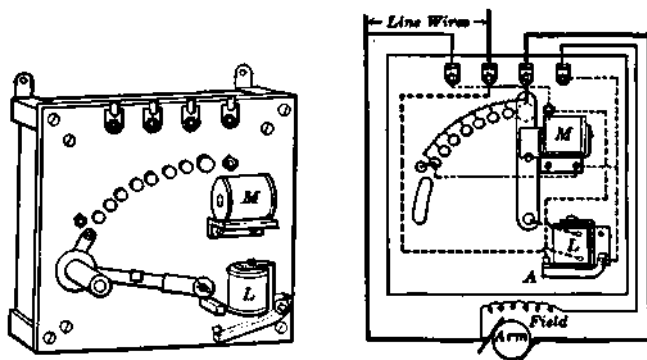

FIG. 169. — Starting box with overload release and diagram of connections.

166. Starting and stopping motors. When a shunt-wound motor is to be started, the first thing is to see that the contact lever of the starting box is in the "off" position. Then the main switch may be closed. The contact lever of the starting box is thereupon moved to the first button, the field magnets become excited, and the motor armature begins to move. The contact lever is then slowly moved toward the "on" button, while the motor gathers speed. Care must be taken to avoid cutting the resistance of the starting box out of the circuit *too rapidly*, in order that the starting current may not be too great; but the lever must not be permitted to stand more than a short time (perhaps half a minute) on any one intermediate button, because the resistance coils are intended to carry a large current for only a short time.

In stopping a motor the main switch should be opened. After the armature has nearly stopped, the contact lever of

an automatic starting box returns to its "off" position. If the starting box is not automatic, the lever should be returned by hand before the attendant leaves the motor. If only the field circuit were open and not the armature at the same time, a shunt motor would race. **Don't stop a motor by pulling back the arm of a starting box**, because a bad arc is formed between the first button and the contact arm.

The starting and stopping of compound-wound motors is effected in the same manner as shunt-wound motors. Series-wound motors, which race in speed and "run away" when lightly loaded, are used only for situations where the load increases with the speed, as, for example, motors driving ventilating fans, in which case they are started and stopped in the same way as shunt motors; and, furthermore, for situations where the load varies, as on cranes and street cars, an attendant must always be present at the controller. It is very important in experimental work *to remember never to start an unloaded series motor and never to remove all the load from a series motor while it is running*. To do so will result in such excessive speeds that the armature will fly to pieces, thus wrecking the machine and perhaps seriously injuring or even killing any one in the path of the flying pieces of metal.

167. Reversing the direction of rotation. To reverse the direction of the rotation of a motor armature, it is necessary to reverse either the current in the armature coils while the field magnets retain their original polarity, or the polarity of the field magnets without changing the direction of the current in the armature. A simple exchange of the positive and negative terminal connections of the main circuit to the motor has no effect on the direction of the rotation of the armature, since the polarity of the fields is reversed by this exchange at the same time that the direction of the current in the armature coils is reversed. This exchange, therefore, does not change the *relative* conditions. Consequently, *to effect a reversal of*

rotation, change either the direction of the current in the field coils, or the direction of the current in the armature, but not both. Reversing the direction of the current in the armature coils is the commoner method of effecting the reversal of rotation. If a motor is to be reversed often, as in elevator work, it is usual to provide it with a relatively powerful field magnet, so that the positions of the brushes on the commutator need not be changed during its ordinary operation.

PROBLEMS

1. A motor is connected with a 110-volt line and draws 7.5 amperes in the armature. If the resistance of the armature is 0.33 ohms, what back electromotive force is being generated?

2. If the impressed voltage is 220 volts, the back e.m.f. is 212 volts, and the armature current is 16 amperes, what must the armature resistance be?

3. A shunt motor is connected with a 115-volt circuit. The field windings have a resistance of 200 ohms and the armature has a resistance of 2 ohms. When the machine is at rest, what current will it take from the line?

4. If a starting box made up of five 2-ohm coils in series is used in problem 3, what is the starting current of the motor?

5. If the motor in problem 3 takes 3.2 amperes when up to speed, what is its back e.m.f.?

6. The total current taken from a 110-volt line by a shunt motor is 60 amperes. The resistance of the field is 50 ohms and the resistance of the armature is 0.04 ohms. How many watts are used up in heating the field and armature?

7. A 4-h.p. shunt motor takes 20 amperes when running at full load on a 200-volt line. The resistance of the field is 400 ohms and the resistance of the armature is 1.5 ohms. What starting resistance must be used in order that the starting current may not exceed one and one quarter times the full-load current?

8. A small series automobile motor is used on a 75-volt battery and under full load draws 37 amperes. The armature resistance is 0.13 ohms and the field resistance is 0.062 ohms. Find the input of the machine, the watts used in heating the field windings, and the watts used in heating the armature.

168. Torque. When a generator armature is revolved in a magnetic field so as to produce a current, the lines of force belonging to the current in the armature windings are attracted by the lines of force belonging to the field. This attraction tends to stop the motion, so that power has to be exerted to keep the armature moving. The greater the current the greater must be the pull or torque given to the shaft of the generator armature to make it rotate. Likewise in a motor the current flowing in the armature must be sufficient to give the necessary pull to keep the armature going, whatever the load upon the motor pulley. By Ohm's Law the amount of current that will flow through the resistance of the armature will be proportional to the *net voltage* acting to overcome the resistance. In a motor the net voltage sending currents through the armature windings is the difference between the voltage applied to the armature by the external circuit and back electromotive forces. Evidently, then, when a load is put on the pulley, the motor armature must either slacken a little in speed, or the field magnet must be weakened, to reduce the counter-voltage so that sufficient current will flow through the armature windings and give the proper torque.

Motor torque may be defined as the turning tendency or moment of the motor armature. The armature produces torque (*i.e.*, effort to rotate) whenever the field magnet is excited and current flows in the usual manner through the armature conductors. This is true whether the armature is running or is forcibly held stationary.

It is a principle of nature that a force acting between two bodies always reacts on one at the same time that it acts on the other, and that the action and reaction are equal and opposite. This is true of a dynamo. The armature torque is an exhibition of electromagnetic force acting between the armature current and the field-magnet flux. When the motor torque tends to rotate the armature in one direction, it also tends to

rotate the field magnet in the other direction; and the field magnet instead of the armature would rotate if the magnet were rotatably mounted and the armature were held stationary. The fact is that relative motion between the armature conductors and excited field magnet is all that is required for the motor (or generator), and the armature is usually designed to be the rotating part in direct-current machines, because it is simpler to have the commutator rotate in contact with stationary brushes than to have moving brushes rotating around a stationary commutator with which they are in contact.

The function of a motor is to produce torque. The unit of torque is the pound-foot or the turning effect of one pound acting at one foot radius.

FOR EXAMPLE, if a man cranks an automobile by pulling up with a force of 45 pounds on a crank of 8-inch radius, he exerts the same turning effect as if he were pulling with a force of 30 pounds on a crank of 1-foot radius; that is, he exerts a torque of 30 pound-feet. If he substitutes for his own right arm an electric motor, the machine must be designed to exert an equal or greater torque.

The amount of torque produced by a motor is proportional to the product of (1) the field flux, (2) the number of armature conductors, and (3) the current flowing through the conductors.

Torque varies as flux \times turns \times armature current.

In a series motor, increasing the current in the armature increases the current in the field exactly as much and therefore increases the flux nearly as much. Hence, for a series motor the torque varies nearly as the square of the current. In other words, if we *double* the current in a series motor we have increased the torque *four* times.

In the shunt motor, however, the field current remains nearly constant; therefore *doubling* the current means *doubling* only the torque. Accordingly, the torque is directly proportional to the armature current.

These facts and many other interesting features about the torque of motors can be shown in the current-torque curves

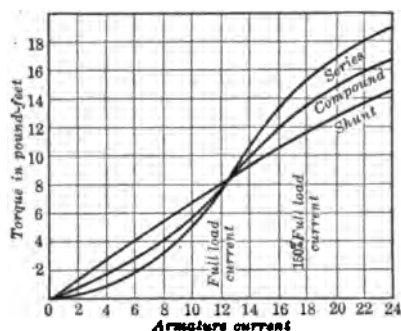

FIG. 170. — Current-torque curves for series, shunt, and compound motors.

for various types of motors, such as are shown in figure 170. It will be noticed that the curve for the compound motor is a compromise between the curves of the other two types of motors. It will also be seen why the series motor is used for traction work. In starting a heavy train the necessary starting torque is excessive. But for large overloads the

series motor requires less current than the shunt motor.

169. Speed regulation. In a generator the induced voltage is directly proportional to the product of (1) total field flux, (2) speed of armature, and (3) number of armature conductors; and the terminal voltage is equal to the induced voltage less the IR drop through armature resistance. In a motor the induced voltage (back e.m.f.) is also directly proportional to the product of total field flux, speed of armature, and number of armature conductors, but the terminal voltage (*i.e.*, the voltage of the supply circuit which is impressed on the machine) is equal to the induced voltage *plus* the IR drop through the armature resistance.

This may be shown in the form of the following equations:

$$E = e + I_a R_a$$

where

E = impressed voltage on motor,

e = induced voltage in motor (back e.m.f.),

and

$I_a R_a$ = voltage drop in armature.

Since

$$e = E - I_a R_a$$

and

$$e = \text{a constant} \times \text{flux} \times \text{speed},$$

we get

$$\text{Speed} = \frac{(E - I_a R_a)}{\text{a constant} \times \text{flux}}$$

In general, then, we see that the speed of a motor varies directly as the difference between the impressed voltage and the voltage drop in the armature, and inversely as the strength of the field. This means that with a fixed line voltage *we may increase the speed of a motor by decreasing the strength of the field.*

It seems at first a bit strange that weakening the field of a shunt motor should increase its speed. Increasing the resistance in series with the field coils decreases the current through them, and so decreases the magnetic field of the motor. If the motor were to continue at its original speed, the wires on the armature would cut fewer lines of force and generate less back e.m.f. Therefore the armature takes more current from the line; and since under ordinary circumstances the current increases much more in proportion than the field decreases, the motor delivers more power and speeds up under a constant load. That is, putting in resistance in the shunt field speeds up the motor. It should be noticed that if the increase in current were merely proportional to the decrease in field there would be no change in speed.

FOR EXAMPLE, decreasing the flux per pole to eighty per cent makes the armature current 4.5 times its normal value and the torque 3.6 times its normal value.

CAUTION. When starting a shunt or compound motor which is provided with a field rheostat, always be sure this resistance is all cut out before moving the handle on the starting box. Never for any reason open the field circuit of a shunt or compound motor while it is running. A study of the above speed equation shows that to do so will reduce the denominator of the right-hand member to zero, whereupon, theoretically, the speed will become infinite. Practically the result will be an excessive speed which will cause the armature to fly to pieces, thus destroying the machine and perhaps causing serious injuries.

The way in which the speed of a shunt, series, or compound motor of the same rating varies as the load changes will now be discussed.

170. Shunt-wound motor. Since the field current and therefore the field flux does not change with the current, the only internal change which occurs when the load on the motor and therefore the armature current changes, is the IR drop in the armature. This is small, being at full load usually not more than three to five per cent as large as the impressed (*i.e.*, supply-circuit) voltage; and the change of speed, from the condition when the motor runs without load and the IR drop is negligible to the condition of full load, is correspondingly small (compared with the speed at no load).

The drop of speed which occurs when a light-running motor has been loaded to its normal full load, measured in percentage of the no-load speed, is called the **regulation** of the motor.

$$\text{Speed regulation} = \frac{\text{No-load speed} - \text{Full-load speed}}{\text{No-load speed}}$$

The variation of speed from no-load to full-load for a shunt motor is illustrated by the curve shown in figure 171.

171. Series-wound motor. The field flux changes with the load on this motor because the armature and field windings are in series, and the excitation of the field magnet therefore varies with the load. If the load is small, the current through the field winding is small and the field flux is therefore small. Consequently the required counter-voltage is produced only when the armature rotates very rapidly. A series motor therefore races and "runs away" when lightly loaded. When the

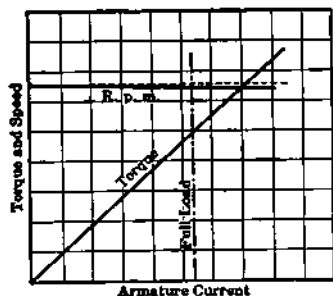

FIG. 171. — Characteristic curves of a shunt motor.

load of the motor is increased, the excitation of the field magnet and the flux increase, and the speed therefore decreases if the impressed voltage remains the same.

The relation between load and speed for a series motor is illustrated in figure 172. The inflection of the curve in its lower part is caused by the gradual saturation of the field-magnet iron as the flux increases.

172. Compound-wound motor.

When a compound dynamo is connected with a circuit, the direction of current through the shunt winding is the same whether the machine runs as a generator or motor; but the direction of current through the armature and series field winding for the motor is the reverse of the direction for the generator. Consequently, if the generator is arranged so that the series winding

aids the excitation produced by the shunt winding (*i.e.*, the two are **cumulative**), then the machine running as a motor has the ampere turns of the series winding opposing the ampere turns of the shunt winding (*i.e.*, the two are **differential**).

In this latter case, with increasing load on the motor (Fig. 173), the series winding decreases the excitation and field flux and therefore may be used to overcome the tendency of a shunt motor to fall off a few per cent in speed as it is loaded up. A motor giving almost a uniform speed, or even increasing

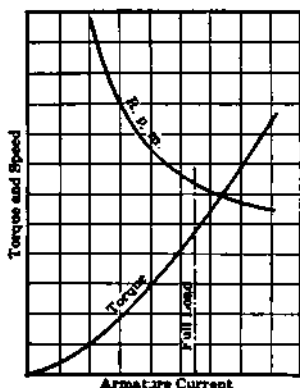

FIG. 172. — Characteristic curves of a series motor.

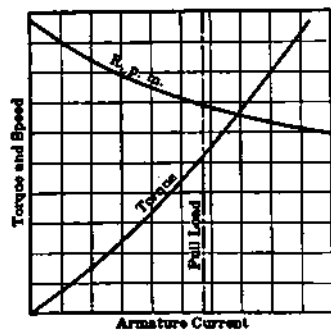

FIG. 173. — Characteristic curves of a compound motor.

a shunt motor to fall off a few per cent in speed as it is loaded up. A motor giving almost a uniform speed, or even increasing

in speed somewhat as it is loaded up, may thus be constructed. The differential motor is used to drive certain textile machines. When such a motor is being started, however, the armature current is likely to be quite large, and so, the differential effect of the series winding being also large, the field flux and therefore the torque are likely to be small. For this reason differential compound motors are not much used.

For elevator service, where it is desired to have motors with especially strong starting torque, cumulative compound motors are used. These are like differential compound motors, except that the connection of the series field winding is reversed compared with the regular connection. These motors give a strong starting torque, but they do not regulate so well as do shunt motors. Cumulatively compound motors are also often used to drive ventilating fans, and are suitable for driving such machines as rock crushers, which may have to be started up full of rock.

173. Efficiency of the electric motor. One reason for the extensive use of electric motors is their great efficiency, which is sometimes as high as ninety or ninety-five per cent. The efficiency of a motor, just as of any machine, means the ratio of output to input. We can easily

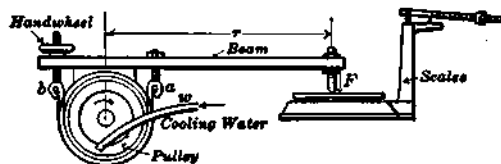

FIG. 174. — Prony brake used to measure output of a motor.

measure the number of amperes and the number of volts supplied to the motor and thus compute the watts put in.

To get the output of mechanical work, engineers usually make a "brake test." One simple form of brake is the Prony brake illustrated in figure 174. It consists of a steel band lined with canvas which embraces the pulley of the motor and is fastened to a lever; the other end rests on platform scales.

When the motor revolves, friction is developed between the lining of the brake and the pulley, which thus converts the power of the motor into heat. The brake pressure is controlled by a small handwheel, and thus any desired load is obtained.

From the force (F) exerted at the end of the lever and length of the arm (r), we may compute the turning moment or *torque* (T).

Torque = Force \times radius.

$$T = Fr.$$

This torque gives us the equivalent force acting at 1 foot radius. In one revolution, then, the *work* done (foot pounds) is equal to the product of the *distance* (the circumference of a circle 1 foot in radius) and the *force* (the torque T), and in one minute, if the motor makes N revolutions, the work done is equal to $2\pi NT$ foot pounds. Since one horse power is equal to 33,000 foot pounds per minute, the general equation for computing the horse power from the Prony-brake test becomes:

$$\text{H.P.} = \frac{2\pi NFr}{33,000}$$

Finally, to get the efficiency we must express the output and the input of the motor in some common unit of power and then divide the output by the input. The result is usually expressed as per cent.

FOR EXAMPLE, in testing a 3-h.p. 75-volt series automobile motor with a Prony brake the following data were obtained: length of brake lever = 2 ft.; force at end of lever = 12.6 lb.; speed = 770 r.p.m.; current = 45.2 amperes; voltage = 75.0 volts.

$$\text{Output h.p.} = \frac{2 \times 3.14 \times 770 \times 2 \times 12.6}{33,000} = 3.70$$

$$\text{Input h.p.} = \frac{45.2 \times 75}{746} = 4.54$$

$$\text{Efficiency} = \frac{3.70}{4.54} = 0.815 \text{ or } 81.5\%$$

We often wish to know the efficiency of a motor when it is either inconvenient or impossible to absorb the energy output.

This is done by the **method of losses**. The efficiency of a motor may be expressed as the ratio of the input minus the losses to the input. That is,

$$\text{Efficiency} = \frac{\text{Output}}{\text{Input}} = \frac{\text{Input} - \text{losses}}{\text{Input}}$$

The various losses in a motor are the I^2R losses in the field and armature windings, core losses (due to hysteresis and eddy currents) in the armature core and pole faces, bearing friction, and wind friction.

If we measure the input of a shunt motor by ammeter and voltmeter without load, this gives us approximately the sum of the I^2R loss in the shunt field, core loss, bearing friction, and wind friction. Then we measure the input again, but with the motor under full load. Finally we measure the resistance of the armature when it is blocked so as to remain stationary. Then, by computing the I^2R loss in watts for the armature carrying the current shown by the ammeters when the motor is loaded and by adding this to the watts obtained by the first measurement, we get approximately the total losses in the loaded motor; and by subtracting these from the input of the loaded motor, we get approximately the output. The ratio of output to input is the efficiency. This approximate test is more accurate if separate and simultaneous readings are made of the currents in field and armature circuits. Then the only inaccuracy which can occur in the calculated efficiency is caused by errors in the ammeter and voltmeter readings, and by small changes of the stray losses when the load is put on the motor. It is important that the supply-circuit voltage impressed on the motor shall remain the same throughout the duration of such a test.

The simplest way of measuring the efficiency of a direct-current generator is to operate it as a motor and to test it in the second manner above stated.

FOR EXAMPLE, in testing a 10-h.p. motor, the following data were obtained:

No-load current = 15.0 amperes; voltage = 115 volts;

full-load current = 65.0 amperes; voltage = 115 volts;

resistance of armature = 0.09 ohms.

Losses in field, core, friction = $15 \times 115 = 1725$ watts.

I^2R loss in armature = $65^2 \times 0.09 = 380$ watts.

Total losses = 2105 watts.

Input of loaded motor = $65 \times 115 = 7475$ watts.

Output of loaded motor = $7475 - 2105 = 5370$ watts.

$$\text{Efficiency} = \frac{5370}{7475} = 72\%$$

PROBLEMS

1. Find the efficiency of a certain motor from these data as given on the name plate: 110 volts, 38.5 amperes, and 5 h.p.

2. If a 25-h.p. motor has an efficiency of 90 per cent, what is the input in kilowatts?

3. If the motor of problem 2 is run 8 hours a day and 24 days in a month in a place where electricity costs 5 cents per kilowatt hour, what does it cost per month to run it?

4. A shunt motor is tested at full load with a Prony brake and the following data are obtained:

Speed = 1200 r.p.m.;

Force at end of lever = 20.5 pounds;

Length of arm = 24 inches;

Impressed voltage = 112 volts;

Current intake = 80.4 amperes.

Calculate (a) the torque in pound feet; (b) output in horse power; (c) output in watts; and (d) efficiency of the motor.

5. A shunt motor which has an armature resistance of 0.2 ohms and a field resistance of 220 ohms draws 2.8 amperes from a 110-volt line, and runs at 1000 r.p.m. If 55 ohms are added in series with the field, 1 ohm in series with the armature, and the motor is loaded until it draws 20.4 amperes from the line, at what speed will the motor run? Assume that the field flux is proportional to the field current.

6. A shunt motor has an armature resistance of 0.9 ohms. When connected across a 110-volt line, it draws 10.5 amperes and runs at 1200 r.p.m. The field resistance is 220 ohms. What is the back e.m.f. generated?

7. If the motor in problem 6 is mechanically driven as a generator at a speed of 1500 r.p.m. and its field flux increased 20 per cent, what would be its terminal voltage when delivering 8 amperes? The field is separately excited.

8. If the speed of the motor in problem 6 is held at 1200 r.p.m. and the field is increased 2 per cent, what is (a) the efficiency, (b) the horse-power output, and (c) the torque? Assume a stray-power loss of 6 per cent and that the field flux is proportional to the field current.

9. A 10-h.p. motor is fed from a switchboard at 115 volts. The motor is located at a distance of 500 feet from the switchboard, and it is desired to have a voltage of 110 at the motor terminals when the motor is carrying its full load of 10 horse power. What must be the diameter (mils) of the copper wire used to connect the motor to the switchboard? Assume a temperature of 50° C. and that the efficiency of the motor is 86 per cent.

10. Repeat the computation of problem 9 for a switchboard-voltage of 550 and for the same per cent voltage drop to the motor.

174. A few of the uses of stationary electric motors. The uses to which electric motors are put are almost endless. They have become a practical necessity for small manufacturing establishments in cities, and a welcome convenience and comfort in the household. Only a few of the commoner household applications are illustrated

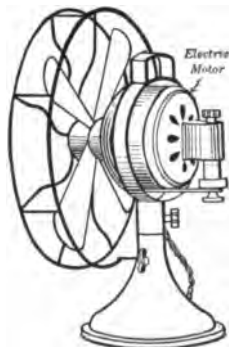

FIG. 175. — Portable fan operated by a series motor.

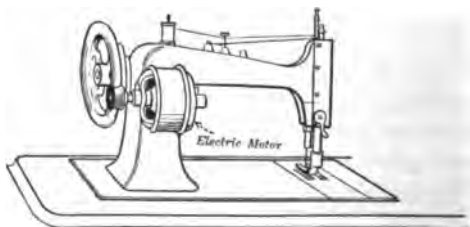

FIG. 176. — Sewing machine run by a shunt motor.

here. Figure 175 shows an ordinary portable electric fan; figure 176 a sewing machine with a motor; and figure 177 a small refrigerating machine with a cooling coil to put in the refrigerator in the place of ice, the compressor pump being driven by a small motor. Figure 178 shows a washing machine and wringer driven by a motor.

Other common applications outside of manufacturing establishments are: driving the bellows

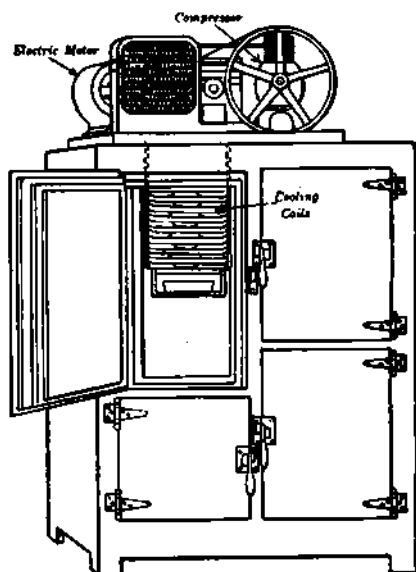

FIG. 177. — Motor-driven compressor for small refrigerator.

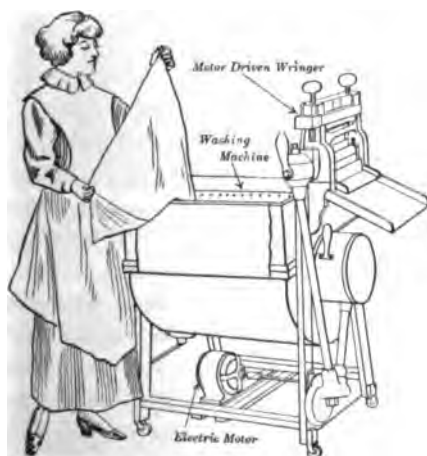

FIG. 178. — Motor-driven washing machine and wringer.

of church organs, driving ventilating fans in large buildings, driving pumps used in a great variety of service, operating contractor's hoists used in the construction of large buildings, operating mining machinery, and starting automobile engines.

This list might be extended indefinitely without exhausting the uses of electric motors.

Figure 179 shows a motor-generator for a Dodge automobile. The dynamo is connected with the gasoline engine by means of a chain. When the engine is running, the dynamo acts as a generator and furnishes current for charging the storage battery and operating the lights. When the engine is standing still and is to be started, the dynamo serves as a motor, which receives current from the storage battery and starts the engine.

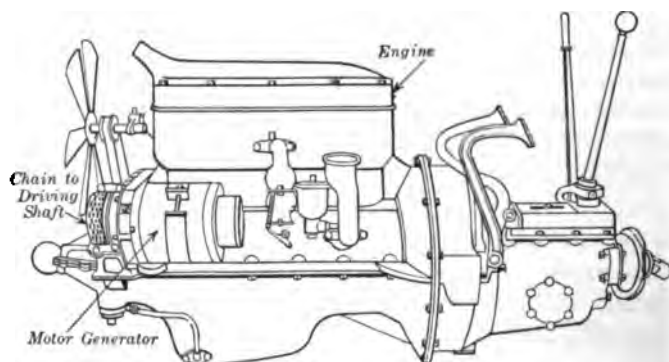

FIG. 179. — Self-starter on a Dodge automobile.

175. Motors and manufactories. The place above others, perhaps, in which electric motors have come to be very much appreciated and widely used is in large manufactories. The ordinary method of carrying power through shops by means of great belts and heavy shafts is very wasteful of power. The attached table, taken from one in Professor Flather's book on power measurements, shows the amount of power lost in belting and shafting, and the amount actually delivered where it is required for use, for every hundred horse power developed by the engine. The table shows that *from one fourth to four fifths of the power of the engines was actually wasted, simply in making shafting revolve and in causing the belts and gears to run where the old-fashioned main belts and shafts were used to distribute the shop power.*

NAME OF WORKS	POWER LOST, PER CENT	POWER USED, PER CENT
Union Iron Works	23	77
Frontier Iron and Brass Works	32	68
Baldwin Locomotive Works	80	20
Wm. Sellers and Company	40	60
Pond Machine Tool Company	41	59
Bridgeport Forge Company	50	50
Yale and Towne Company	49	51
Ferracute Machine Company	31	69

Shafts and belts are a menace as well as a great nuisance in shops, and any convenient arrangement which can take their place would be useful even if it did not save power. It is in this field of usefulness that the electric motor shows one of its finest characteristics. Figure 180 represents a large



FIG. 180. — Machine shop in which the machinery is driven by belts.

FIG. 181. — Machine shop in which the machinery is driven by electric motors.

machine shop where the power is distributed by shafts and belts, which give the shop somewhat the appearance of a forest; while figure 181 shows a similar shop after the lathes, planers, and other machines are arranged to be driven by electric motors. The motors are on the machines, and the electric wires leading to them are put out of the way so that the shop presents a much improved appearance.

The improvement is as great in fact as in appearance, because the removal of shafting and belts disposes of a source of danger to the workmen and of inconvenience in the manufacturing; moreover, electrical distribution of the power is much less wasteful than distribution by shafts and belts. A properly arranged system of electrical distribution of power also makes it possible to place every lathe, planer, or other machine at the position in the shop where it may be used most conveniently; and the speed of each machine may be adjusted by the turn of a hand to suit best any work that is being done. These conditions

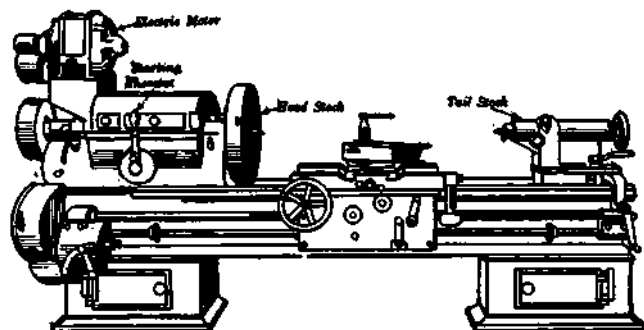

FIG. 182. — Machinist's lathe arranged to be driven by electric motor.

enable an electrically driven factory to execute more work than a similar establishment where belt driving is used. Figure 182 shows the way in which a motor may be applied to drive a lathe or drill or other machine, while figure 183 shows a large traveling crane which is driven by electric motors. Such cranes are used in nearly all large machine shops.

The disposition of electric motors which will give the best results in any shop depends upon a great many things, and can be arrived at only by good judgment. The ideal method would be to have one or more motors built as a part of every machine in the establishment; but this arrangement would make the machinery too costly and consequently could not be carried

out. The next best arrangement, and the one which is usually adopted, is to have all large machines which require considerable power each furnished with an individual motor. These may be built into the machines, thus doing away with all un-

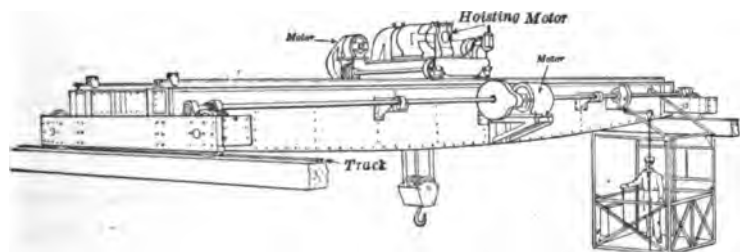

FIG. 183. — Traveling crane with electric motors.

necessary belting or gearing; or they may be directly belted or geared to the usual driving pulleys of the machines. Smaller machinery may be arranged in groups of from two to six machines with a motor to supply power to the machines of each group through a light shaft.

Finally there remains the problem of determining the type and size of the electric motor required to drive a certain machine or group of machines. First it is desirable but often very difficult to get complete information about the machines to be driven so as to determine the actual power required. There is a tendency for machine-tool builders and motor manufacturers to overestimate the horse power required of a motor in order "to be on the safe side." Much useful information on this subject has been collected in the various engineering handbooks,* but probably the best method is to arrange a temporary test motor to drive the machine by belt and then to measure the input to this motor. From the efficiency horse-power curve of the motor its actual horse-power output can be computed.

* *Mechanical Engineers' Handbook* — *Lionel S. Marks, Editor*; McGraw-Hill Book Co.

Standard Handbook for Electrical Engineers — *Frank P. Fowle, Editor*; McGraw-Hill Book Co.

American Handbook for Electrical Engineers — *Harold Pender, Editor*; John Wiley and Sons, Inc.

SUMMARY OF CHAPTER X

MOTOR transforms electrical energy into mechanical energy.

A wire carrying a current, when set at right angles to a magnetic field, is pushed sideways by the field.

To get direction of motion use *left hand*; let

Thumb indicate Motion,

Forefinger indicate Flux,

Center finger indicate Current.

INTERPOLES prevent sparking at the brushes, so that brushes need not be shifted with the load.

Every motor, when running, is acting at the same time as a generator. The e.m.f. thus induced opposes the impressed voltage and is the *back* e.m.f.

NET E.M.F. equals impressed voltage minus back e.m.f. Net e.m.f. drives the current through the armature.

Ohm's Law applies to a motor armature *only* if *net* e.m.f. is used.

IN STARTING A MOTOR a resistance must be placed in series with the armature until it produces sufficient back e.m.f.

A **NO-VOLTAGE** release throws the motor off the circuit if the voltage of the line drops below a certain point.

An **OVERLOAD** release throws the motor from the line when the armature is carrying too much current.

TO REVERSE the direction of rotation of a motor, reverse the direction of the current in *either* the field or the armature, *not in both*.

TORQUE means turning tendency or turning moment, and is measured in pounds at one foot radius (pound-foot).

MOTOR TORQUE varies as flux \times turns \times current in armature.

DIRECT-CURRENT MOTORS

KINDS	CHARACTERISTICS		USES
	SPEED	TORQUE	
Shunt	Nearly constant Increased by weakening field	Varies as current	Line shafts Wood-working machines
Series	High speed on light load, races	Big starting torque, good for overloads	Small fans, cranes, auto- mobiles, all traction work
Compound	Constant speed Does not race	Good starting torque	Rock crushers Express ele- vators

$$\text{EFFICIENCY} = \frac{\text{Output}}{\text{Input}} = \frac{\text{Input} - \text{losses}}{\text{Input}}$$

Electric motor is used to drive industrial machinery, either individually or in groups. Saves power lost in friction in line shafting, increases output of production, gives freedom in placing machines, eliminates danger and nuisance of belting. Question of installation is a financial one.

QUESTIONS

1. A belt-driven shunt dynamo is used to charge a storage battery. The belt breaks but the dynamo keeps on running. Explain.
2. Why does an electric truck take more current going up hill than on the level?
3. Upon what factors does the back e.m.f. depend?
4. Why is it impossible for the back e.m.f. of a motor to attain a value equal to the impressed e.m.f.?

5. A 10-kw. shunt motor is to be used as a generator. Will its output be more or less than 15 kw.? Why?
6. A shunt motor is called a *constant-speed* motor. If constant speed means constant back e.m.f., why does it take current from the line in proportion to the load?
7. How does the law of the CONSERVATION OF ENERGY apply to the input and output of a motor?
8. What is the difference in the construction and use of a field rheostat and a starting rheostat?
9. What will happen if the brushes of a motor are not placed in the right position?
10. How can one tell whether the brushes are set correctly?
11. What special features must be considered in the design of crane motors?
12. Make a list of the "Don'ts" for starting and stopping a motor.
13. Why are not electric motors universally used to drive the machinery of manufactories?
14. What advantage has the compressed-air drill over the electrically driven drill for tunnel work?
15. Why is a high-speed motor always cheaper than a low-speed motor of the same capacity?
16. What type of motor would you recommend for driving a press for punching sheet metal?

CHAPTER XI

ELECTROCHEMISTRY. STORAGE BATTERY

Liquid conductors — chemical action in electrolytic cell — theory of ions — electrolysis of water — electrochemical equivalents — Faraday's Laws — industrial applications of electrolysis: nickel and silver plating; electroplating with other metals; electrotyping; refining of copper — reduction of aluminum — electrolytic destruction of water mains.

Storage battery — construction of lead cells — chemistry of charge and discharge — care and testing of storage battery — uses of storage battery — Edison storage battery, its chemical changes — comparison of lead and Edison cells.

176. Importance of electrochemistry. The rapid improvement in the machinery used to generate and transmit electricity has led to a great extension in the uses of electricity. The recent development of water-power plants for generating electricity has been followed by the development of the electrochemical processes for the manufacture of materials which were formerly made in other ways. Electrical methods are now used extensively in the extraction and refining of such metals as aluminum and copper, and in the manufacture of other valuable substances such as chlorine, caustic soda, caustic potash, calcium carbide, and the nitrates. A few of these important relations between electricity and chemistry as well as the more familiar examples, such as electroplating and storage cells, will be discussed in this chapter.

177. Liquid conductors. Electrolytes. When an electric current flows along a copper wire, the wire becomes warm and is surrounded by a magnetic field. When an electric current

flows through a solution of salt and water, the solution is warmed and is surrounded by a magnetic field, and it is at the same time *decomposed* or broken up. For example, under certain conditions an electric current will decompose brine into a metal, sodium, and a gas, chlorine, which are the two elements composing common salt. Not all liquids, however, conduct electricity; thus alcohol and kerosene are nonconductors. But all solutions which do conduct electricity are more or less decomposed in the process.

Substances which act as conductors of electricity may be divided into two classes. The first class includes **metallic conductors**, such as copper, aluminum, brass, iron, and mercury, and some solid nonmetallic substances of which carbon is the most important. The second class, known as **electrolytes**, includes water solutions of acids, bases, and salts of metals as well as some melted compounds. When a current of electricity passes through an electrolyte, two different substances are always liberated. One of these appears at the terminal where the current enters the solution, called the **anode**, and the other at the terminal at which the current leaves, called the **cathode**.

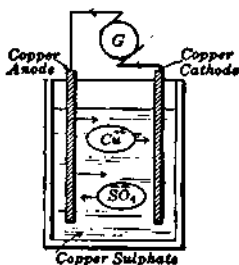

FIG. 184. — Electrolytic cell with copper electrodes and electrolyte of copper sulphate.

178. Chemical action in an electrolytic cell. Suppose an electrolytic cell is made by placing copper (Cu) plates in a vessel containing a solution of copper sulphate (CuSO_4) in water (Fig. 184), and an electric current from a battery or other generator is sent through the cell. It will be seen that the anode plate is gradually eaten away or dissolved in solution, while the cathode grows from the deposited copper. The solution itself appears to

remain practically unchanged. This is the way copper plating is done, except that the cathode to be plated is not usually

made of copper and in fact may be of any conducting material. The weight of copper deposited depends, as we have seen in section 128, on the intensity of the current and the length of time it is allowed to flow through the cell.

To explain this result it will be useful to state very briefly the theory of electrolytic dissociation. When an electrolyte is dissolved in water, a part at least of its molecules (little particles) break up into two parts, one charged with positive electricity and the other with an equal amount of negative electricity. The charged portions of the molecule are called respectively positive and negative ions. For example, when common salt (sodium chloride) is dissolved in water, an equal amount of positive sodium (Na^+) ions and of negative chlorine (Cl^-) ions are produced. This may be indicated in an equation, thus:

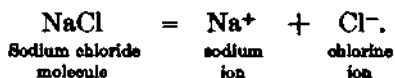

When we dissolve the blue crystals of copper sulphate (blue vitriol) in water, there are copper (Cu^{++}) ions and sulphate (SO_4^{--}) ions formed.

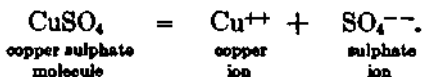

It will be noticed that a double charge is here indicated on each ion.

Molecules of the dissolved substance in an electrolyte dissociate on dissolving into positive metallic ions and negative nonmetallic ions.

When the copper electrodes are dipped into the copper sulphate (CuSO_4) solution and the circuit is closed, the copper (Cu^{++}) ions, which have been wandering around in the solution, are immediately attracted toward the cathode or negative electrode. The sulphate (SO_4^{--}) ions begin to move

toward the anode or positive electrode. As soon as a copper ion reaches the cathode, the opposite charges on ion and electrode neutralize each other, and metallic copper is deposited. When a sulphate ion reaches the anode, the opposite charges neutralize each other and a bit of metallic copper on the anode goes into solution as a copper ion. Thus *the ions serve to conduct the electricity through the solution.*

Many soluble substances, especially organic compounds such as sugar, alcohol, and glycerin, do not dissociate on dissolving, and such solutions are called **nonelectrolytes**. These are nonconductors of electricity. Pure water is a very poor conductor, and so its molecules are only very slightly dissociated.

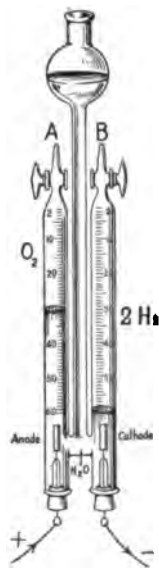

FIG. 185. — Water is broken up into oxygen and hydrogen.

179. Electrolysis of water. Water (made slightly acid with sulphuric acid) can be decomposed by an electric current in the apparatus shown in figure 185. The platinum electrodes are connected with a battery or generator giving at least 5 or 6 volts. The electrode in tube *A*, which is connected to the positive (+) pole, is called the *anode*, and the other electrode in *B* is the *cathode*. The current passes through the solution from the anode *A* to the cathode *B*. Small bubbles of gas are seen to rise from both electrodes, and the gas collects in tube *B* twice as fast as in tube *A*. When tube *B* is full, we open the switch and test the collected gases. To test the gas in tube *B*, we open the stopcock at the top and carefully apply a lighted match. This gas burns with a pale blue flame, which shows it to be *hydrogen*. If we open the stopcock in tube *A* and bring a glowing pine stick near, it bursts into a flame, which shows the gas to be *oxygen*.

Thus we see that water is decomposed by electricity into its constituent elements, hydrogen and oxygen. This process of decomposing a compound by means of an electric current is called **electrolysis**.

The theory of this process may be stated as follows: The small quantity of sulphuric acid (H_2SO_4), when put into the water, breaks up into hydrogen ions (2H^+) and sulphate ions (SO_4^{--}), which have positive and negative charges of electricity respectively. When the current is sent through the solution, the positive hydrogen ions (2H^+) wander toward the cathode and the negative sulphate ions (SO_4^{--}) toward the anode. At the cathode the hydrogen ions give up their positive charges and rise to the surface as bubbles of hydrogen. At the anode the sulphate ions give up their negative charges of electricity and react with the water (H_2O) to form sulphuric acid (H_2SO_4) and to set free oxygen (O_2). In this way the sulphuric acid, which is added to conduct the electricity, is not used up, while the water ($2\text{H}_2\text{O}$) is broken into hydrogen (2H_2) and oxygen (O_2).

180. Electrolytic cells in series. Suppose two electrolytic cells, one with copper plates in copper sulphate solution and the other with silver plates in silver nitrate solution, are connected in series, as shown in figure 186, so that the same current will pass through each of them. On weighing the cathode plates in each cell before and after the current has been allowed to flow through, we find that the weight of silver deposited is a little over three times as great as that of copper.

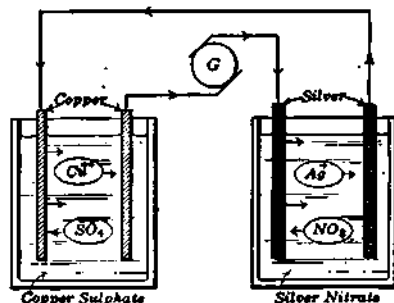

FIG. 186. — A current produces equivalent decomposition in cells containing different electrolytes joined in series.

To explain this constant ratio between the weights of silver and copper deposited by the same current in the same time, we shall need the idea of "chemical equivalent." The chemists have analyzed substances into about seventy simple

substances, called the **elements**. For example, we have just seen that water may be decomposed into the two elements, oxygen and hydrogen. They also have assigned to each element a number, called its **atomic weight**, which expresses the relative weights of the atoms* of the different elements. Thus the atomic weight of oxygen (O) is 16 and that of hydrogen (H) is approximately 1. In our discussion of ions (section 178), we assumed that some ions, such as sodium (Na^+), carried one unit charge of electricity, and others, such as copper (Cu^{++}), two charges. *An element which forms an ion with one unit charge of electricity is said to be univalent and one which forms an ion with two is said to be bivalent.*

In electrolytes the **valence** of each ion is numerically equal to the number of charges of electricity carried by it. Thus silver (Ag^+) is univalent and copper (Cu^{++}) is bivalent.

The ratio of the atomic weight of an element to its valence is generally known as its *chemical equivalent*.

Thus the chemical equivalent of silver is equal to its atomic weight, 107.88, divided by its valence, 1, and that of copper is equal to its atomic weight, 63.57, divided by its valence, 2, or 31.79. Accordingly we see that the weights of silver and copper deposited in two electrolytic cells are directly proportional to their chemical equivalents; that is, as 107.88 to 31.79, or 3.394 : 1.

When chemical elements combine with each other to form compounds, experiments show that they join the combinations in certain fixed proportions, which are characteristic of the individual elements. These combining weights are the chemical equivalents. Many of the elements are not, however, confined to a single relation in all of their compounds, but possess two or more combining proportions which are simple multiples of each other. This is true, for instance, of copper, whose chemical

* An atom is the smallest particle of an element which takes part in a chemical change.

equivalent in the usual compounds (cupric) is 31.79, but also in other compounds (cuprous) is 63.57.

181. Faraday's laws. During the years 1833 and 1834 Faraday made a very careful study of many phenomena, such as we have just been considering, and he summarized his results as follows:

1. *The weight of an electrolyte which is decomposed by an electric current is proportional to the current flowing and to the time during which it flows.*

In other words, the amount of chemical action under such circumstances is an exact measure of the number of coulombs (ampere seconds) of electricity passed through the electrolyte. This law may be stated in the form of an equation, thus:

$$W = Zit$$

where W = gain in weight of cathode in grams,
 I = current in amperes,
 t = time in seconds,
 Z = electrochemical equivalent of the element;
i.e., grams deposited per coulomb.

FOR EXAMPLE, how many grams of silver are deposited in 8 hours from a silver nitrate solution by a current of 5 amperes? We know (section 128) that 1 ampere deposits 0.001118 grams each second. Then

$$\begin{aligned} W &= 0.001118 \times 5 \times 8 \times 3600 \\ &= 161 \text{ grams.} \end{aligned}$$

2. *When equal quantities of electricity are passed through different electrolytes, equivalent weights of the electrolytes are decomposed.*

This second law was stated by Faraday thus: "If the same quantity of electricity passes through different electrolytes, the masses of different ions liberated at the electrodes are proportional to their chemical equivalents."

This means that the electrochemical equivalents of elements are directly proportional to the chemical equivalents; that

is, the atomic weights of the elements divided by their respective valences. This is shown in the following table of electrochemical equivalents.

ELEMENT	ATOMIC WEIGHT	VALENCE	CHEMICAL EQUIVALENT	GRAMS PER COULOMB (Ampere Second)
Aluminum . . .	27.1	III	9.03	0.0000936
Chlorine . . .	35.46	I	35.46	0.0003679
Copper (ous) . .	63.57	I	63.57	0.0006588
Copper (ic) . . .	63.57	II	31.79	0.0003294
Hydrogen . . .	1.008	I	1.008	0.0000104
Iron (ous) . . .	55.85	II	27.93	0.0002894
Iron (ic) . . .	55.85	III	18.62	0.0001930
Nickel . . .	58.68	II	29.34	0.0003039
Oxygen . . .	16.00	II	8.00	0.0000829
Silver . . .	107.88	I	107.88	0.001118

The gram-equivalent of silver is the same number of grams as its atomic weight; that is, 107.88 grams. The number of coulombs of electricity required to deposit this weight of silver is then

$$\frac{107.88}{0.001118} = 96,500 \text{ coulombs.}$$

This same number of coulombs will deposit the equivalent weight of any other metal which can be electroplated in the same way, and it is the electrochemist's unit quantity of electricity.

PROBLEMS

1. How many ounces of silver will be deposited by 100,000 coulombs of electricity? (1 ounce = 28.35 grams.)
2. How many ounces of aluminum will be deposited from a suitable electrolyte by 100 amperes flowing for one hour?
3. How many liters of hydrogen will be generated by a current of 10 amperes in 4 hours? (A liter of hydrogen weighs 0.09 grams under standard conditions.)

4. How many amperes will be needed to deposit 2.5 pounds of copper per day of 24 hours?
5. How long will it take a current of 500 amperes to refine a ton of copper?
6. If the atomic weight of zinc is 65.37 and its valence is 2, what is the electrochemical equivalent of zinc?

182. Industrial applications of electrolysis. The electrochemical operations which result in depositing metals from solutions of their metallic salts are very widespread in the industries, and are of great usefulness. The ordinary electrolytic operations do not appeal to the casual observer as do the applications of electricity to transmitting messages, driving street cars, or furnishing light or power. Nevertheless, we owe to electrochemical operations many of the commonest necessities of life. The commercial applications of electrolysis cover an extensive range, from nickel and silver plating to electroplating for use in printing; from methods of bronzing and gilding to methods of smelting certain ores and refining metals. Electrolysis is also becoming a most important factor in chemical manufactories. At Niagara Falls alone several hundred thousand kilowatts are utilized in manufacturing bleaching powders and other commercial chemical products, and much more is utilized elsewhere for the same purpose. Nearly all these processes depend upon the laws of chemical action which have just been described; but the solutions used are frequently quite complex and the conditions of successful operation have to be carefully regulated. Even to-day the chemical action is so complicated that it is not always fully understood. Therefore, in this chapter we shall attempt to give only a brief account of certain electrochemical processes.

183. Electroplating. The electrical deposition of a coating of one expensive metal on another cheaper one is one of the most important applications of electrolysis. The process of

copper plating may be taken as a typical example. The electroplating vat (Fig. 187) contains a solution of some salt of the metal to be deposited. The anode consists of plates or rods of the same metal as that which is plated out on the cathode. The positive terminal of a low-voltage d-c. generator is connected to the anode, while the negative terminal of the generator is connected to the cathode, which consists of the object to be plated. The anode dissolves approximately to the same extent that the cathode gains, so that the amount of the metal ions in the bath remains nearly constant. The cathodes are always

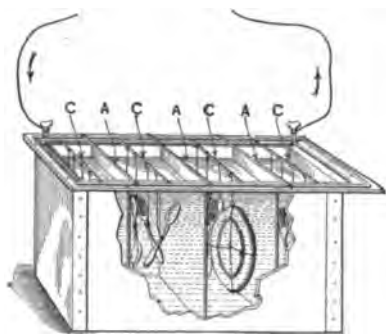

FIG. 187. — Electroplating vat with one side cut away so as to show the articles in the solution. *A, A, A*, supports for anodes. *C, C, C*, supports for cathodes.

suspended in the vat between two rows of anodes so that they will be plated uniformly on both sides. In fact, when the cathode is large or of irregular shape, it has to be turned frequently during the plating in order to get a uniform deposit. Both cathodes and anodes are suspended from horizontal metal tubes, whose ends rest on the edge of the plating vat. Small objects, such as screws, are

suspended in the vat in a wire basket, which of course is plated at the same time. To get a uniformly plated surface the objects have to be well shaken during electrolysis. Large vats are made of wood lined with lead or some especially prepared substance resembling pitch, and small tanks for gold and silver plating are often porcelain lined. Special low-voltage generators giving about 5 or 6 volts are used for electroplating. The proper current density (amperes per square inch) is carefully controlled by a rheostat.

Washing and pickling is the first step in electroplating, for the object must be smooth and perfectly clean in order to make the metal adhere well. Grease is removed by dipping it into a hot alkaline solution, about 10 per cent by weight, of sodium carbonate or caustic soda. After washing off the alkali, the object is pickled in order to remove any oxide which may have been produced by the alkali and to give it a bright surface. Finally, the pickle is washed off with water, and the object is at once suspended in the electroplating vat. The pickling solution varies with the nature of the metal. With iron a dilute solution of sulphuric acid is used, with zinc dilute hydrochloric acid, and with copper and brass dilute nitric acid.

184. Plating by dipping. There is a method of *plating* by *simply dipping* the article into a solution of a salt of a metal; for example, by dipping iron into a copper sulphate solution. A small amount of iron dissolves and an equivalent amount of copper is deposited on the remaining iron. It is evident that only a very thin film can be produced in this way, for as soon as the iron is covered with copper the action stops. In this process no external electric current is needed, for it is simply a chemical replacement, the more active metal replacing the less active metal in solution.

185. Nickel plating. A solution which is much used in nickel plating is made by dissolving 50 parts by weight of the double nickel-ammonium sulphate, $\text{NiSO}_4 \cdot (\text{NH}_4)_2 \text{SO}_4 \cdot 6\text{H}_2\text{O}$, with from 25 to 50 parts of ammonium sulphate in 1000 parts of water. The solution is made slightly acid by adding a small amount of sulphuric acid or citric acid. The proper current density is about 5.5 amperes per square foot of exposed surface on the cathode.

Sometimes iron is copper plated before it is nickel plated to insure the nickel's adhering well to the metal.

186. Silver plating. If a solution of silver nitrate is used in silver plating, the deposit is in the form of isolated crystals,

which do not entirely cover the surface. So the double cyanide of potassium and silver is used because of the smooth deposit obtained with the solution. One formula for making a silver plating bath is as follows:

20 parts by weight potassium silver cyanide, $KAg(CN)_2$,
10 parts by weight potassium cyanide, KCN,
1000 parts by weight distilled water.

The proper current density is about 2.7 amperes per square foot.

Silver is deposited only on a surface of copper or some alloy of copper. Other metals must be copper plated before silvering. To make the silver adhere well, the copper surface must be amalgamated; that is, coated with a very thin layer of mercury. This is done by dipping the cleaned surface into a "quicking bath," which consists of a solution of some mercury salt, such as potassium-mercury cyanide. After removal from the quicking bath, the articles are washed and placed immediately in the silvering bath.

During the operations of dipping and washing the articles should be supported upon wires or in wire baskets and *must not be touched with the fingers*, for the points so touched are made greasy and the deposit will not take. It must also be remembered that all cyanide solutions are extremely poisonous, and must therefore be handled with care. On account of the value of the silver which they contain these solutions must be handled without waste.

187. Finishing processes. After the metal has been deposited in the electrolytic bath, the articles must be put through a series of operations to give the plated surface the proper finish. This is largely done by polishing and buffing on rapidly revolving wheels made of brass wires, leather, and canvas. The same tools are used for polishing the articles before plating. In the case of some articles the polishing is done by

means of hand burnishers (Fig. 188), which are smooth tools made of steel, agate, or similar hard materials.

Burnishing a silver-plated article hardens and toughens the layer of silver very materially. Therefore, a thin coat of silver is put on and burnished, then a second thin coat, and then a third, the result being a layer of silver that wears better than if it had been put on all at once. Such an article is said to be triple-plated.

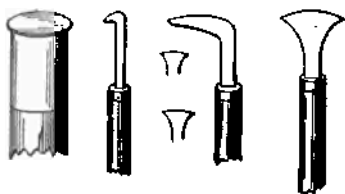

FIG. 188. — Several forms of steel burnishers.

188. Gold plating. Plating with gold is carried on in very much the same way as plating with silver. The commonest solution is of a double cyanide of gold and potassium made up in a manner quite similar to that used in making up the cyanide of silver solution. The solution is generally used when hot, and great care to have all the details exactly right is necessary to get a deposit of satisfactory color. It is particularly important that all the materials used in making the solution shall be pure.

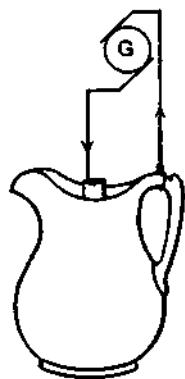

FIG. 189. — Arrangement of circuit for gilding inside of metal cream pitcher.

Gilding the inside of silver cups, sugar bowls, and cream pitchers is commonly done by filling the article to be gilded with the hot solution, hanging a gold anode in the shape of a cylinder in the center of the solution, and finally connecting up a generator so that the article to be gilded is the cathode (Fig. 189). The cleaning of articles for gold plating is usually not so

important as in silver plating, since the hot solution helps in the cleaning.

189. Plating with other metals. Zinc plating has come into considerable vogue of late years as a substitute for the process of galvanizing, which consists in merely dipping the articles in a bath of melted zinc. However, the zinc deposited electrolytically (called "cold galvanizing") is of a dull color and is not so pleasing in appearance as the layer obtained by "hot galvanizing"; but it has been shown that electrolytic zinc does protect iron better for a given thickness of deposit than a coating made of melted zinc.

It is even possible to deposit electrolytically brass, German silver, or other alloys. These require extreme care, however, in the management of the solutions and the regulation of the voltage and current supplied to the vats. Sometimes plating with platinum, tin, lead, and iron is carried out for special purposes.

It is also interesting to note that the electrolytic process is one method of detinning scrap tin and old tin cans. This is just the reverse of the usual electroplating and is generally carried out as an anode reaction. The object of this process is to recover both the tin and iron separate and pure.

190. Electrotyping. The object of electrotyping is to make a copper plate which shall be an exact duplicate of the printer's set-up type, engravings, and other illustrations. This copper plate is then used for printing in place of the original type. The great advantages of this procedure are, first, that it saves the wear on the type and, second, that it enables a relatively small amount of type to be distributed and used over and over again. Most books which are made in large numbers are printed from electrotype "plates."

A wax impression of the page as set up in type is first made in such a way that every letter leaves its imprint on the wax mold. Since the wax is itself a nonconductor, it has to be coated with a thin layer of graphite. The plumbagoing, as it is called, consists in dusting the fine powder over the surface

with soft brushes. A very thin layer of copper is then formed by sprinkling the surface with iron filings and pouring over the surface a solution of copper sulphate. The iron goes into solution, depositing copper on itself and on the graphite. The wax plate is then washed in water and suspended as the cathode in an acid bath of copper sulphate; the anode plate is pure copper. The current density ranges from 0.9 to 1.8 amperes per square foot. After the current has deposited copper on the wax mold to the thickness of a visiting card, this shell of copper is separated from the mold and "backed up" with type metal to give the necessary strength for use in printing.

191. Refining copper. Copper as it comes from the smelting works is not pure enough for certain purposes, such as making wires and cables for carrying electricity. So the copper for electrical machinery is refined by electricity and is known as **electrolytic copper**. The crude copper which comes from ordinary smelting works with from two to five per cent of impurities is refined by electrolysis so that it is about 99.95 per cent pure copper.

In electrolytic refining the crude copper is cast into heavy plates, which are used as anodes in depositing vats (Fig. 190). The solution in these vats is copper sulphate with a little sulphuric acid. The cathodes at first are thin sheets of pure copper, but they grow by deposition into thick plates of copper, which may be worked into bars and drawn into wires as desired. The action in the depositing vats is quite similar to that which goes on in a copper electrolytic cell.

Enormous d-c. generators are used in copper refining works, and a great number of tanks or vats, each containing a number of anodes and cathodes, which are arranged in alternate rows, are provided. The vats are ordinarily connected in series; or sets of a number of vats connected in series are connected in parallel with each other. The several rows of anodes in

each vat are connected in parallel, as are also the cathodes. The voltage required to pass the current through each vat is quite small, and consequently a number of vats may be connected in series without causing the total voltage to exceed 100 volts.

It is desirable that the voltage required at each vat be as small as possible, in order to avoid the deposition of impuri-



From *Brownlee and Others' Chemistry*.

FIG. 190. — View of vats in tank house for copper refining.

ties on the cathodes, and also to save power. The power used in each vat is equal to the voltage from an anode to a cathode multiplied by the current flowing through the vat.

It is desirable, furthermore, to have as great a current flow as will give a fairly smooth deposit, in order that the time required for depositing each pound of copper may be as small as possible. Any reduction made in the current without changing the voltage simply reduces in a proportional rate the amount of copper deposited per hour, so that the power re-

quired to deposit a pound of copper is not materially changed. If the voltage required to pass the current through the vats is reduced without changing the current, it at once reduces the power required to deposit a pound of copper, and a saving in the cost of manufacture is effected. In order to reduce the voltage, the anodes and cathodes are set as closely together as possible without interfering with the circulation of the solution. There is an old saying, that for electrolytic work electrical energy consists of two factors, one of which, the volts, *costs* money, and the other, the ampere hours, *brings* money.

During the process of refining copper by this means, the impurities of the crude copper, usually some silver and gold, are mostly dissolved in the solution or are thrown to the bottom of the vats as mud. Sometimes there is enough of these precious metals recovered from the mud to pay for this final step in the refining of copper.

192. Commercial extraction of aluminum. Although aluminum compounds in the form of clay, marl, slate, feldspar, mica, and many other minerals compose an amazing proportion of the material of the earth's crust, yet it was not until 1836 that a commercially satisfactory method of extracting it from the compounds was discovered by Hall in the United States and Heroult in France. Before this time aluminum sold for \$4 a pound, while at present the price of aluminum is about 20 cents a pound in ingot form. This discovery has made aluminum one of the common metals and it is extensively used in making cooking utensils, electric cables, parts of automobiles, and valuable alloys.

Aluminum cannot be electrolytically deposited from solutions of its salts in water, as the metal at once becomes oxidized at the cathode, and hence some other solvent must be used. In the process of Hall and Heroult this solvent is a melted "bath" of the mineral *cryolite* ($3\text{NaF} \cdot \text{AlF}_3$), and the aluminum compound which composes the electrolyte in

this bath is an oxide of aluminum (Al_2O_3), or *alumina*. Fortunately for the process, beds of a reasonably pure natural aluminum oxide, called bauxite, are found in several parts of the world. Alumina is also a "by-product" of certain chemical manufacturing processes.

In the operation of the process, melted cryolite is put into large iron pots, which are lined with a hard, baked carbon mixture, and carbon anodes are dipped into the bath. The carbon lining of each pot serves as the cathode. An electric current of about 10,000 amperes is passed through each bath, with a pressure between the terminals of each pot of 5.5 volts. This represents sufficient power to heat the bath and to keep the cryolite in a molten condition. The temperature is about $900^{\circ}C$.

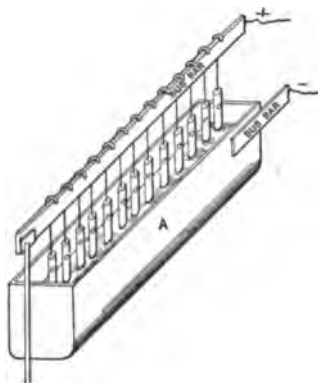

FIG. 191. — Vats used in extraction of aluminum from alumina. CC, carbon anodes suspended in bath of molten cryolite; A, iron crucible which contains bath and serves as cathode.

The aluminum oxide is dissolved in this bath (Fig. 191) of molten cryolite, and the electric current causes it to separate into its constituents — aluminum and oxygen. The aluminum goes

with the current to the cathode and lies in a melted condition in the bottom of the pot until tapped off. The oxygen goes to the positive pole or anode and combines with the carbon, which is gradually consumed. After the melted aluminum has been drawn off from the pot, it is cast into ingots, from which it may be made into sheets, rods, wires, or other forms, as may be desired.

Many thousands of horse power are used in the manufacture of aluminum at Niagara Falls, and equally great powers

are utilized elsewhere in the world; and the demand for the metal is growing with a truly wonderful rapidity as the price becomes more reasonable.

ELECTROCHEMICAL EQUIVALENTS		
ELEMENT	SYMBOL	GRAMS PER AMPERE HOUR
Aluminum	Al	0.337
Copper	Cu	1.186
Gold	Au	3.677
Hydrogen	H	0.0376
Nickel	Ni	1.094
Oxygen	O	0.298
Silver	Ag	4.025

PROBLEMS

1. An iron casting is to be copper plated and then nickel plated. If the current used in each case is 5 amperes, how long must it remain in each vat to have 8 ounces of each metal deposited on it? (1 ounce = 28.35 grams.)

2. What weight of water will be decomposed by a current of 10 amperes flowing for 1 hour?

3. If the production of 1 kilogram of aluminum requires 22 kilowatt hours, what is the cost for electricity in extracting 1 pound of aluminum? Given 1 kg. = 2.2 pounds and electricity costing 1.5 cents per kilowatt hour.

4. A certain plant for the reduction of aluminum found that the average yield was 1.75 pounds of aluminum per horse-power day. Compare this result with the data given in problem 3.

5. A plant for refining copper uses 1000 amperes 23 hours per day for 300 days in the year through 60 electrolytic cells arranged in series. How many tons of copper are refined each year?

193. **Electrolytic action on water mains.** In the usual arrangement of electric railways, the tracks serve as return conductors; that is, the rails are connected to the negative ter-

terminal of the generator in the power station. Since the rails are in contact with the ground, part of this current will shunt off through the earth and will follow any low-resistance conductor, such as a water or a gas main. Under ordinary conditions soils contain considerable water with various salts in solution, which make the soil an electrolytic conductor. Figure 192 illustrates a very simple case where such electrolytic action might be expected. Where the current enters the pipe at *B*, no destructive action takes place, but at *A* where the current leaves the pipe, usually near the power station,

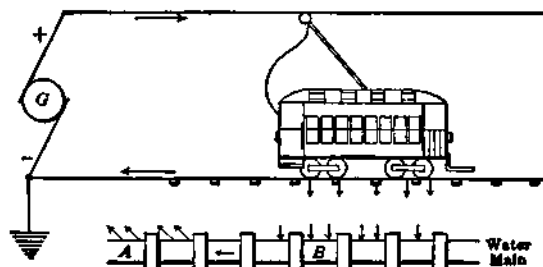

FIG. 192. — Conditions for electrolysis of water mains at *A*.

we have corrosion due to electrolysis produced. The pipe in moist ground serves as the anode plate in an electrolytic cell. Where these stray electric currents leave an iron pipe for the soil, there we find corrosion, which forms oxide of iron, eventually going entirely through the wall of the pipe. This electrochemical action has led to various city and state regulations which are designed to reduce to a minimum the stray electric currents from electric railways using a grounded return circuit.

STORAGE BATTERIES

194. What is a storage battery? When the zinc in a primary cell, such as the gravity cell, is nearly consumed, we usually replace it by another piece. But if instead of replacing the

worn-out negative plate we send a current in the reverse direction through the cell from some outside source of electromotive force, so as to deposit the zinc back on the negative plate, then the cell would be called a **storage cell**. Since a storage cell does not differ fundamentally from a primary cell, any primary cell might be used as a storage cell by restoring its negative plate by electrolysis, just as in the ordinary storage cell. This, however, is not yet a feasible proposition, except in the case of two types of cells which will presently be described.

Some people think a storage battery is a sort of condenser (Chapter XIII) where electricity is stored, but it is not that. In the storage battery, as in any other battery, the electrical energy comes from the chemical energy in the cells. The **charging process** consists in forming certain chemical substances by passing electricity through a solution, just as hydrogen and oxygen are formed in the electrolysis of water. In the **discharging process**, electricity is produced by the chemical action of the substances which have been formed in the charging process.

195. Construction of a lead storage battery. We may make a small lead storage cell by putting two sheets of ordinary lead in a glass battery jar with a very dilute solution of sulphuric acid. To charge it or "form" the plates quickly, we connect this cell and an ammeter in series with a primary battery of three or more cells, or better, a d-c. generator of about 6 volts (Fig. 193). While the current is passing, bubbles of gas rise from each plate. If, after a few minutes, we disconnect the generator and touch the wires of a voltmeter to

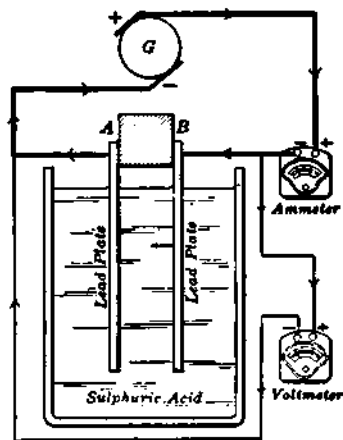

FIG. 193. — Forming a lead storage cell.

the lead terminals, it shows an e.m.f. of about 2 volts. If we then connect an electric bell in series with the ammeter and the lead cell, the bell rings. This indicates that a current is produced, and the ammeter shows, furthermore, that the current on discharge is opposite to that used in charging the cell. When the plates are lifted out of the solution after charging, plate *B*, the anode, is brown, due to a coating of lead peroxide (PbO_2), and plate *A*, the cathode, is the usual gray of pure lead (Pb).

In the commercial lead storage battery, the negative plates are pure spongy lead (Pb), the positive are lead peroxide

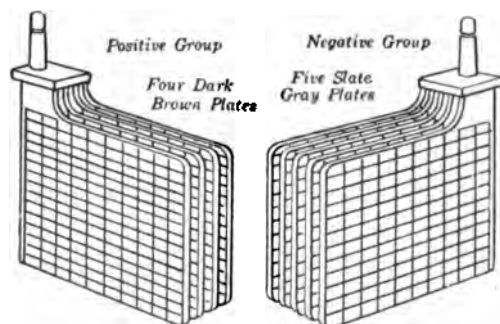

FIG. 194. — Positive and negative group of pasted plates.

and the electrolyte is dilute sulphuric acid. Inasmuch as the active materials, lead peroxide and spongy lead, are poor conductors of electricity and not hard enough to be made into plates, it is necessary to attach them to frames,

called grids, which are made of an alloy of lead and antimony.

Sometimes the plates are made up for use by filling the perforations in the grids with a paste consisting of lead oxide moistened with sulphuric acid. This process is called **pasting** and plates made up thus are often called **pasted plates**, or **Faure plates** (Fig. 194), after the inventor of the method. Sometimes the oxide is formed by frequent charging and discharging of the cell. This process is called **forming**, and plates of this kind are called **Planté plates** (Fig. 195), after the original inventor of the lead-plate storage battery, who used this method.

Planté plates (Fig. 195), which are formed electrochemically out of the lead plate itself, are used largely for stationary

batteries; they are heavier and more expensive than pasted plates, but are also more durable and less liable to lose active material by rapid charging and discharging. For automobile and motor-truck service pasted plates are commonly used, because they are lighter than Planté plates.

To get a battery of large ampere-hour capacity, it is necessary to have an extensive surface of active materials exposed to the electrolyte. This is obtained by putting in one jar alternately a number of positive and negative plates, which are connected in parallel, positive with positive and negative with negative. In this way we make the current capacity of the cell equal to the sum of the capacities of the various plates; but the voltage

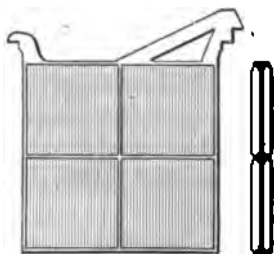

FIG. 195. — Planté plate, showing cross section.

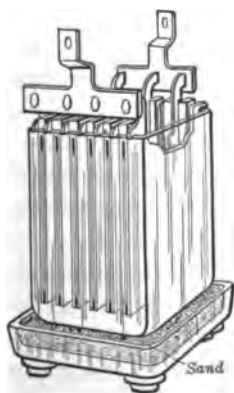

FIG. 196. — Storage-battery jar supported on sand.

of the cell (about 2 volts) is the same as that of a cell made up of a single pair of plates. *There is always one more plate in the negative (gray) than in the positive (brown) group of plates.* The two sets of plates are sandwiched together, with the adjoining plates separated from one another by glass rods in large cells or by wooden or rubber separators in small cells.

The plates are assembled in an acid-proof tank, usually glass, hard rubber, or wood lined with lead, in such a way as to leave ample space at the bottom for the accumulation of sediment, which must not be allowed to short-circuit the plates. To

prevent leakage of electricity, the stationary jars or tanks are mounted on trays filled with sand and supported on glass insulators, as shown in figure 196.

196. Chemistry of charge and discharge. The electrolyte of the lead storage battery is a solution of chemically pure sulphuric acid and distilled water. This mixture is made by adding the acid to the water slowly in the proportion of about 1 part of acid to 3 parts of water by volume. The specific gravity of the electrolyte, when the battery is fully charged, varies from about 1.210 for stationary batteries to 1.300 for automobile ignition batteries. The proper specific gravity to be used with any particular type of battery is carefully specified by the manufacturers.

The exact nature of the chemical changes which take place in a lead cell during its charge and discharge seems to vary with the conditions and there are many theories to explain the facts. The probable chemical reaction that takes place when the cell is furnishing current (*discharging*) is as follows:



That is, each of the plates tends to become coated on the surface with lead sulphate. As the action proceeds, the electrolyte becomes more dilute and the electromotive force of the cell, which remains almost constant for a considerable time, gradually diminishes, because the solution is becoming more dilute and the two plates are becoming alike.

The cell is then charged by connecting it to some other electric generator and forcing a current to flow in the reverse direction through the cell. NOTE: *the dark brown plate, marked +, is connected with the positive terminal of the generator.* This current causes electrolysis, just as in the case of acidulated water, described in section 179. The final result is a reversal of the reaction for discharging given above. This is expressed as follows:

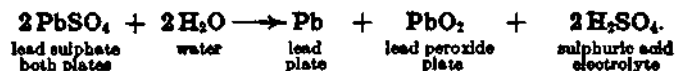

In this charging process the positive plate becomes coated with lead peroxide, which is of a chocolate-brown color, and the negative is made into gray lead. The acid solution becomes more concentrated and the electromotive force gradually rises. When a battery is being strongly charged or overcharged, bubbles of oxygen and hydrogen are given off. Since these gases, if sufficiently concentrated, form an explosive mixture, no open flames or fires should be allowed in the vicinity. Evaporation of the electrolyte should be made good by the addition of distilled water; the acid itself does not evaporate, and, unless there is excessive spraying due to the gases given off, the quantity of acid in the cell will not change. A storage battery inevitably gives off a certain amount of acid fumes, which necessitate a special, well-ventilated room with all metal surfaces protected.

197. Care and testing of a battery. As yet no one has invented a "fool-proof" storage battery. It requires continual, intelligent oversight, just as any other delicate piece of machinery. We may test a dry cell very easily with a pocket ammeter; but if we try the same method with a storage battery, we instantly burn out the instrument. This happens because the internal resistance of the battery is exceedingly small and accordingly the current which flows through the ammeter is enormous. Therefore, don't try to test your storage battery with an ammeter.

The voltage of a storage cell is about 2 volts. Nevertheless it should always be remembered that the voltage of a cell on open circuit tells us absolutely nothing about its condition as to charge and discharge. The e.m.f. generated by lead and lead peroxide plates in sulphuric acid of specific gravity 1.2 is about 2.2 volts; hence, as long as there are any active materials left on the plates, the e.m.f. will be approximately 2.2 volts. The voltage, then, of a storage cell must always be measured during the process of charging or discharging

at its normal rate. Figure 197 shows the change of voltage of a lead storage cell during charge and discharge.

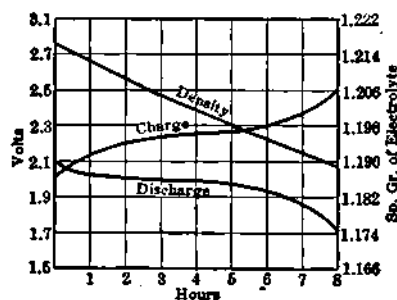

FIG. 197. — Change of voltage and specific gravity of electrolyte in lead storage cells.

The terminal voltage of a battery

$= E + IR$ while the battery is charging,

$= E - IR$ while the battery is discharging;

when

E = e.m.f. generated by the battery,

I = current in amperes,

R = internal resistance in ohms.

Thus it will be seen that the difference between the terminal voltages on charge and discharge will be greater, the larger the current. Cells may be fully charged up to about 2.5 volts. The discharge of a storage cell should be stopped when the terminal voltage has dropped to about 1.8 volts at the normal rate of discharge.

The amount of charge in a battery is best determined by measuring the specific gravity of the electrolyte, as this gives a measure of the amount of acid which has gone to form sulphate on the plates. The specific gravity of a liquid may be readily measured by a hydrometer. This instrument (Fig. 198) consists of a weighted glass bulb with a graduated stem. In concentrated solutions the stem protrudes farther above the surface of the solution than in dilute solutions. The point at which the surface of the liquid touches the scale indicates its specific gravity. For testing vehicle batteries, where the space between the plates is very



FIG. 198. — Hydrometer used to measure specific gravity of a liquid.

small, it is convenient to use the syringe hydrometer. In this form the hydrometer floats within the enlarged portion of a glass cylinder, when acid is sucked up into it by means of the rubber bulb.

The specific gravity of the acid used depends on the type of battery and its intended service. For automobile work, such as starting, lighting, and ignition, when the battery is fully charged, the solution in the cells should have a specific gravity of 1.27 to 1.29, and as the battery discharges, the specific gravity becomes lower, until when completely discharged it will be from 1.15 to 1.17 or about twelve points less than when fully charged. For other service a range of from 1.23 to 1.15 is more usual. It is assumed that the temperature of the solution is 70° F.

198. Capacity and efficiency. The rate at which a storage battery can safely deliver current depends mainly on the area of the plates. Storage cells are sold according to their capacity in ampere hours, but this does not tell the whole story because this capacity depends on the rate of discharge. For example, an 80-ampere-hour battery would maintain a current of 10 amperes for 8 hours, but would not give a current of 80 amperes for 1 hour. In fact, it would probably give only 40 amperes or half that current. Lead cells are usually rated on the basis of a steady discharge for 8 hours.

When we speak of the real efficiency of a storage battery, we mean the ratio of the electrical energy (watt hours) gotten out to the electrical energy (watts hours) put in.

$$\begin{aligned} \text{Efficiency} &= \frac{\text{Watt hours output}}{\text{Watt hours input to recharge}} \\ &= \frac{\text{Amp. hours output} \times \text{av. discharge voltage}}{\text{Amp. hours input} \times \text{av. charging voltage}} \end{aligned}$$

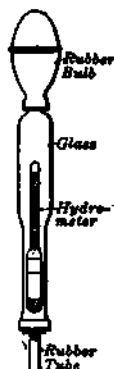

FIG. 199.—Syringe hydrometer for testing portable batteries.

Good lead storage cells have an average efficiency of about 75 per cent at normal load.

199. Uses of the storage battery. The most important services performed by storage batteries are, perhaps, not those with which we are most familiar. Very large storage batteries are used in connection with central power stations, first, to regulate the load by helping to carry the peak loads, and second, for "stand-by" or insurance service. For the first service, which is very hard on the battery, the Planté plates are used. For the second service, which is merely a reserve of power to be used only in case of emergency, the paste plates are used. Next in order of the size of installations come those used in submarine boats. Here the design is most exacting, as both space and weight are sharply limited and a very large amount of power must be furnished over a considerable time. While the boat is submerged, it is wholly dependent for power on its batteries, which are usually of the paste type. For train-lighting, storage batteries of the Planté type are commonly used in conjunction with an axle-driven generator. There is a rapidly growing field of usefulness for the storage battery in vehicle service, both for pleasure carriages and for heavy trucks. Paste plates are now almost universally used the world over for electric automobiles.

Probably there are more people who are somewhat familiar with the storage battery as used on automobiles for starting, lighting, or ignition work, than in any other service. The battery (Fig. 200) usually consists of 3 cells (6 volts) or 6 cells (12 volts) and has a capacity of from 60 to 80 ampere hours. These have to be built for abuse as well as for use. The majority of car owners are careless about giving the battery, which is the heart and center of the starting and lighting system, the attention it should have. Such batteries should be inspected once every two weeks, and if the electrolyte is below the bottom of the filling tubes distilled water should be added. If a

battery is kept fully charged and properly supplied with pure water, it will give uninterrupted service for at least a year.

There are many other important uses of the storage battery, such as for emergency purposes in wireless telegraphy, for

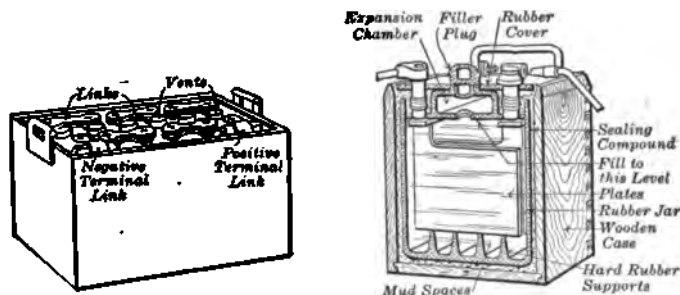

FIG. 200. — Automobile starting and lighting battery and section of one cell.

private lighting plants where the service of a central station is not available, for telephone exchanges and telegraph, for fire-alarm and signal systems, and in testing laboratories where a constant voltage is necessary.

PROBLEMS

1. A lead cell has an e.m.f. of 2.00 volts and its internal resistance is 0.004 ohms. What will be its terminal voltage when discharging 25 amperes?
2. What would be the impressed voltage needed to charge the cell of problem 1 at the rate of 25 amperes?
3. What would be the terminal voltage of the cell in problem 1 when discharging at the rate of 50 amperes?
4. When a lead cell with an internal resistance of 0.002 ohms is discharging at the rate of 30 amperes, its terminal voltage is 1.98 volts. What is the e.m.f. of the cell?
5. In a trolley system the generator maintains 565 volts on the line. How many lead storage cells, each of 2.1 volts, will be needed to help the generator carry the peak of the load?

6. Most manufacturers of lead cells allow about 55 ampere hours for each square foot of positive plate area. How large a plate area will be required in a cell which delivers 10 amperes for 8 hours?

7. If the e.m.f. of a lead cell is 2.3 volts on open circuit, while the terminal voltage when the cell is delivering 10 amperes is only 2 volts, what is the internal resistance of the cell?

8. A battery of 24 lead storage cells in series, each having an e.m.f. of 2.1 volts, a normal charging rate of 15 amperes, and an internal resistance of 0.005 ohms, is to be charged by a generator. What must be the terminal voltage of the generator?

9. A storage battery is used to light 20 incandescent lamps, each requiring 0.4 amperes at 112 volts. How many cells, each having an e.m.f. of 2 volts and an internal resistance of 0.004 ohms, will be needed?

10. The regulation battery used in conjunction with a 500-volt power circuit is capable of delivering 2000 amperes for 8 hours or 32,000 amperes at about 400 volts for 5 minutes. What is the total quantity of energy (in kilowatt hours) furnished at the 8-hour rate, and what at the 5-minute rate?

11. A submarine boat is equipped with 60 cells. When discharging at the 3-hour rate, its voltage is 110 volts and its capacity is 5000 ampere hours. How much horse power does it furnish?

12. A pleasure vehicle equipped with a storage battery of 32 cells requires about 25 amperes at an average voltage of 60 volts. A single charge will carry it continuously for 5 hours. How much power expressed in kilowatts has the battery?

13. If the average efficiency of the motor is 80 per cent, what horse power does the motor deliver?

14. A battery of 15 lead cells is to be charged in series from a 115-volt line. Each cell has an e.m.f. of 2.10 volts and an internal resistance of 0.005 ohms. How many ohms resistance must be placed in series with the cells in order that the current may not exceed 25 amperes?

15. In problem 14 what per cent of the power delivered by the line is lost in the series resistance?

16. A Christmas tree is to be lighted by 18 miniature electric lamps, each taking 0.8 amperes at 6 volts. Each cell has an e.m.f. of 2.10 volts, an internal resistance of 0.008 ohms, and a normal current rate of 0.75 amperes. Assuming the resistance of the line wire to be 0.03 ohms, how many cells would you use to light the tree for one hour? How would you arrange the lamps and the cells?

200. Edison storage battery. The great objections to the lead storage battery are its weight, its expense, and its demand for close supervision. There is another entirely different type of storage battery which is known as the Edison battery. The active materials are nickel peroxide (NiO_2) for the positive plate and fine divided iron (Fe) for the negative plate and the electrolyte is a 21 per cent solution of caustic potash (KOH).

If a current is drawn from this battery, the nickel peroxide is reduced to a lower oxide (Ni_2O_3), while the iron is oxidized to form FeO . The reaction for discharging is essentially:

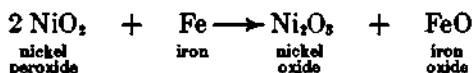

Now if a current from some external source is forced through the cell in the opposite direction so as to cause electrolysis, the action is completely reversed. The reaction for charging is as follows:

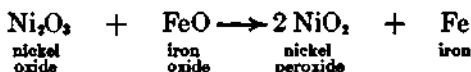

It will be noticed in the above equations that the electrolyte does not appear at all. This is because the change in the density of the electrolyte is so slight that it is insufficient to indicate the condition of the battery. The result of charge and discharge is merely to transfer oxygen from one plate to the other. After the battery is fully charged, oxygen and hydrogen appear as gases, which bubble up through the solution, just as in the lead cell.

201. Mechanical construction. The Edison storage cell is surely a very clever contrivance to get light weight and at the same time great mechanical strength. The tank is made of steel welded at the joints, corrugated for strength, and heavily nickel plated as protection against rust. The positive

plates (Fig. 201) consist of a nickel-plated steel grid with perforated steel tubes, which are filled with alternate layers of nickel hydroxide and flaked metallic nickel. The hydroxide is changed by electrochemical action to nickel peroxide. The flaked nickel is added to reduce the internal resistance of the cell. The negative plate (Fig. 201) consists also of a nickel-

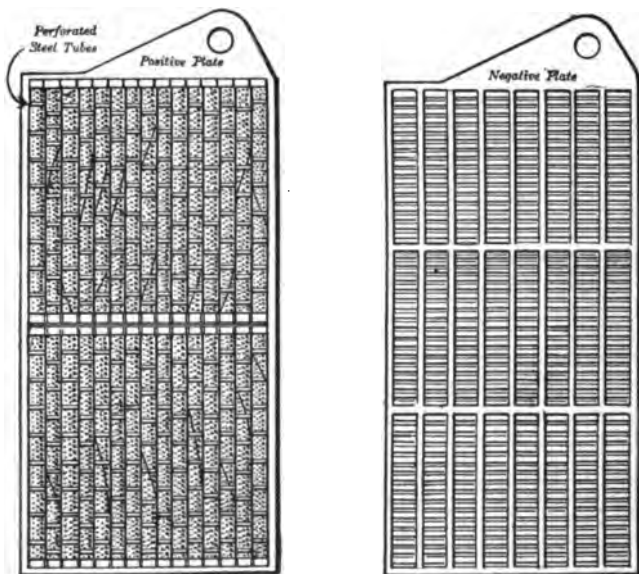

FIG. 201. — Positive and negative plates of an Edison storage cell.

plated steel grid holding a number of perforated rectangular pockets, which are filled with powdered iron oxide. These boxes are assembled in the grid and subjected to pressure to weld the joints and to corrugate their surfaces. In forming the plates the iron oxide is converted electrolytically to metallic iron. The two sets of plates are sandwiched together with the adjoining plates separated by strips of hard rubber. The

whole thing (Fig. 202) is very compact, and rugged in its construction.

202. Characteristics of an Edison battery. The voltage of the Edison cell at its normal discharge rate is only 1.2 volts.

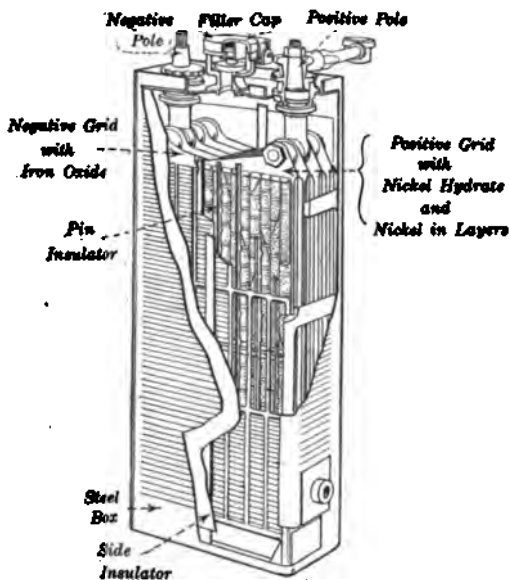

FIG. 202. — Edison cell assembled.

These cells are easy to take care of, as they may be left standing either charged or discharged for long periods without injury, provided the electrolyte remains in the cells. They may be charged at a very rapid rate and also discharged very quickly or even short-circuited without injury, provided the temperature of the electrolyte does not exceed 115° F. At the normal charging rate it takes seven hours to give a full charge, and smaller charging currents should not be used. The charging voltage is from 1.5 volts to about 1.85 volts per

cell during the charging process. The usual discharging rate for commercial use gives a fairly complete discharge in five hours.

On account of its comparatively high internal resistance, the watt-hour efficiency of the Edison battery is only about 60 per cent. Another disadvantage of this cell is its high cost. The following table from Morse's book on Storage Batteries gives a comparison between the lead cell and the Edison cell:

COMPARISON OF STORAGE BATTERIES

	LEAD		EDISON
	Standard American	Light European	
Watt hours per pound .	8	12	12.5
Life	1	0.75	3
Cost	1	0.5	2.25
Watt-hour efficiency .	75%	80%	60%

203. Battery charging. It has already been pointed out that the positive (+) terminal of the battery must be connected to the positive (+) terminal of the generator and the negative (-) terminal of the battery to the negative (-) terminal of the generator. To determine which is the positive and which the negative wire, a voltmeter can be used to test, or if no instrument is at hand dip the ends of the two wires into a glass of water which contains a teaspoonful of common salt. Hold the immersed ends about one quarter of an inch apart. The wire from which the small bubbles rise is the *negative* wire and therefore should be connected to the *negative* battery post, marked *Neg.* or (-). The other wire, which is positive (+), should be connected to the positive battery post, marked *Pos.* or (+), *but not until the proper*

amount of resistance has been determined. For example, if the direct current is 110 volts and the charging rate is 4 amperes, it would serve the purpose to use four 100-watt lamps arranged in parallel (Fig. 203). For any particular battery the manufacturers furnish definite information as to the charging rate and time of charging.

If only alternating current is available, it is necessary to use some rectifying device for changing alternating to direct current, such as a motor generator or a mercury-arc rectifier, which will be described in Chapter XVII.

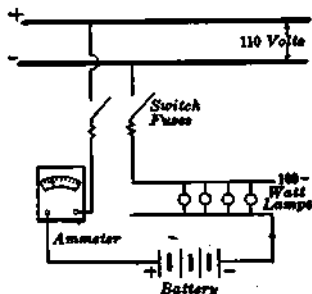

FIG. 203. — Connections for charging battery from 110-volt mains.

PROBLEMS

1. A storage battery of 60 cells, connected in series, is used to light 10 incandescent lamps, which are connected in parallel. Each lamp has a hot resistance of 220 ohms, each cell of the battery a resistance of 0.01 ohms, and the mains have a resistance of 0.4 ohms. If the e.m.f. of each cell is 2 volts, what is the current flowing (a) from the battery? (b) through each lamp?

2. How many Edison storage cells of type B-2 would be needed to light the lamps in the above problem? This type has a capacity of 40 ampere hours when discharging at its normal rate of 7.5 amperes and gives 1.2 volts per cell at this discharge rate.

3. A storage battery consists of 60 cells, each with an internal resistance of 0.003 ohms. In charging, the cells are connected up in 2 sets in multiple, each set of 30 cells in series. The generator has an internal resistance of 0.15 ohms and the line 0.02 ohms. At the time of beginning the charge the battery gives a back e.m.f. of 1.95 volts per cell. What e.m.f. must be induced in the generator to give a charging current of 40 amperes?

SUMMARY OF CHAPTER XI

ELECTROLYTES are liquids which conduct electricity and are somewhat decomposed in the process.

SOLUTIONS of metallic salts, bases, and acids contain **POSITIVE IONS** (hydrogen or a metal) and **NEGATIVE IONS** (non-metals or nonmetallic radicals).

Ions conduct electricity through a solution.

ELECTROLYSIS is the process of decomposing a compound by an electric current. The solution usually contains a metallic salt.

The electric current deposits the metal on the negative plate, while the positive plate is consumed.

$$\text{CHEMICAL EQUIVALENT} = \frac{\text{Atomic weight}}{\text{Valence}}$$

FARADAY'S LAWS OF ELECTROLYSIS:

- I. Weight of electrolyte decomposed by electric current is proportional to current and time of flow.
- II. Equal quantities of electricity passed through different electrolytes decompose equivalent weights.

ELECTROCHEMICAL EQUIVALENT of a metal is the weight deposited by one ampere in unit time, one second or one hour.

INDUSTRIAL ELECTROLYSIS is used in electroplating with nickel, silver, and other metals, in electrotyping, and in the refining and extraction of metals.

DESTRUCTIVE ELECTROLYSIS is caused by stray currents from the return circuits of electric railways. These currents travel along iron pipes and often eat away portions of the iron where they leave the pipe to return to the generator through the ground.

STORAGE BATTERY does not store electricity, but chemical energy.

LEAD CELLS contain lead peroxide (+) plate — sulphuric acid — spongy lead (-) plate. Action on charge and discharge:

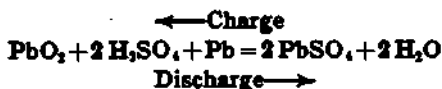

CARE OF LEAD BATTERY: when possible, charge and discharge at 8-hour rate. Never discharge faster than twice the 1-hour rate and then only for half a minute or less. Test condition of cell frequently with hydrometer. Replace evaporated electrolyte with distilled water. In testing voltage, take readings while cell is discharging at normal rate. If plates turn white ("sulphation"), give cell long overcharge. When a battery stands unused for a long time, give it an hour or two of freshening charge about once a month.

CAPACITY means *ampere hours* at normal rate of discharge.

$$\text{EFFICIENCY} = \frac{\text{Watt hours output}}{\text{Watt hours input to recharge}}$$

APPLICATIONS: in central stations, to level the load peaks and as a stand-by; electric vehicles; automobiles, ignition, lighting, and starting; submarines; wireless emergency; private lighting plants; telephones, telegraphs, fire-alarm and signal systems; and as a constant potential source in testing laboratories.

EDISON STORAGE CELLS. Positive plate, nickel peroxide; electrolyte, 21 per cent solution of potassium hydroxide; negative plate, iron.

Action on charge and discharge:

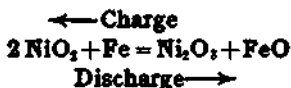

Mechanically is very rugged; *lighter* per watt hour than most lead cells, but has *lower voltage* per cell. Can stand charged or discharged indefinitely without harm. Efficient temperature range is limited. Costs more.

QUESTIONS

1. In making a water rheostat why is it necessary to add salt?
2. Which of the following substances are electrolytes and which are nonelectrolytes: kerosene, sea water, rain water, vinegar, gasolene, zinc sulphate solution, caustic potash solution, muriatic acid, and alcohol?
3. Indicate the anions (-) and the cations (+) of the electrolytes given above.
4. What other material might have been added to the water to make it conducting in the electrolysis of water experiment?
5. Why were the electrodes made of platinum in the apparatus for the electrolysis of water?
6. Describe just what would happen if the plates in the electrolysis of copper sulphate had been platinum.
7. Suppose two electrolytic cells, containing nickel plates and a nickel salt solution in one, and silver plates and a silver salt solution in the other, are joined in series. Compare the weights of silver and nickel deposited.
8. When is the chemical equivalent of a metal equal to its atomic weight?
9. Just what is the relation between the electrochemical equivalent and the chemical equivalent of a metal?
10. Why has there been such a rapid development in the industrial applications of electrochemistry in recent years?
11. Why is electrolytic copper so generally used in electrical construction?
12. Name ten common objects which are electroplated.
13. What are the necessary operations in getting an object ready to be electroplated?
14. Why is not plating by simply dipping more generally used?
15. What are the necessary operations in finishing an object which has been electroplated?
16. Are newspapers printed from electrotype?
17. Why has aluminum not replaced copper more generally in electrical construction?
18. What great advantage has Niagara Falls for the electrochemical manufactures?
19. Do alternating currents produce electrolytic destruction of water and gas pipes?

20. What are the disadvantages of the lead storage battery?
21. Make a list of ten "Don'ts" in the use and care of a lead storage battery.
22. Account for the comparatively low efficiency of storage batteries.
23. Compare the "life" of lead cells and Edison cells.
24. Why are street cars not generally operated by storage batteries?
25. How can one test the condition as to charge and discharge of an Edison storage battery?
26. What would happen if one tried to charge a storage battery directly from a-c. mains?
27. How could one charge a 6-volt battery from a 110-volt d-c. line?

CHAPTER XII

PRINCIPLES OF ALTERNATING CURRENTS

Direct currents, including continuous and pulsating — alternating currents — water analogies and graphical representation. Phase of flow — difference in phase. Mathematical and actual alternating-current curves — oscillograph.

Heating effect of alternating current — effective value — maximum value — instantaneous values.

Definitions: cycle, frequency, period. Phase relations: current in phase, lagging current, and leading current.

Ohm's Law in a-c. circuits for resistance only.

204. Importance of alternating currents. A very large per cent of all the electrical power generated in this country today in central stations is generated as alternating current. The reasons for this fact are not hard to find. In the first place, the generators for alternating currents can be built bigger and more cheaply than those for direct currents. For example, a-c. generators have been built of 35,000 kw. capacity and the largest d-c. generators have about 2000 kw. capacity. Another important fact is that alternating current can be transmitted much more cheaply than direct current due to that very simple and efficient machine known as the transformer. Moreover, the a-c. system is much more flexible and adaptable to various kinds of service. Finally, the a-c. motor is a very simple, strong, compact, and almost "fool-proof" machine.

It should also be recalled that even in a direct-current generator the current is generated in the armature coils as alternating current and then is rectified by means of a commutator. Thus

we see that one cannot really understand the fundamental principles of a direct-current generator without also understanding the principles of alternating currents.

205. Direct and alternating currents obey the same laws.

A deeply rooted belief seems to have been cultivated in the minds of many that phenomena connected with the flow of direct currents and of alternating currents are almost entirely unrelated. This popular idea, however, is erroneous; the principles which relate to the flow of electric currents, whether direct or alternating, and which are applied to the design and construction of machines and circuits, are one and the same. It is desirable, therefore, before taking up the subject of this chapter in detail, to give a few simple illustrations for the purpose of showing how the fundamental laws which have been treated in previous chapters apply equally to electric currents of all kinds.

When Oersted in 1820 made known his signal discovery that an electric current exerts a magnetic influence in the space around it, the foundation was laid for our knowledge of the laws of the flow of electric currents, whether direct or alternating. Within a dozen or fifteen years thereafter much knowledge of the electric current was threshed out experimentally by men like Ampère, Arago, Faraday, and Henry. And the last two laid the finishing stone on the foundation by searching out and making known the laws of electromagnetic induction, which are treated in Chapter VI.

The apparent flow of electric current may be likened to the flow of a fluid, and it may be continuous, pulsating, or alternating. The term "direct current" includes both continuous and pulsating currents.

206. Continuous, pulsating, and alternating currents of water.

In an unbranched river channel the water flows continuously onward without pause or hesitation, provided it is a season of uniform flow. The velocity of the stream is affected by the

character of the banks and the contour of the country traversed; but the onward motion of the volume of water never ceases, and the quantity of water flowing past any cross section of the channel is always the same in a given time, though its width, depth, and velocity may change with the character of the channel.

We may represent this flow of water in a graphic manner in this way: Suppose we let distances measured up from a zero or horizontal line (Fig. 204) represent the quantity of water which each minute flows past some point along the river.

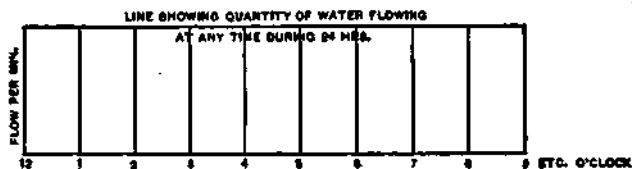

FIG. 204. — Graphical record of constant current.

Further, let us represent the time when the measurements are made along the horizontal base line. If these measurements are taken every hour through the day and night and the flow of water is constant, then we may erect a number of vertical lines at the proper time intervals on the horizontal base line. Since the flow is continuous, all the verticals are of equal height, and we complete the chart by drawing a line through the tops of the verticals. In this case, the line drawn through the ends of the verticals is a horizontal line which graphically represents a continuous flow of water at uniform rate.

The flow of arterial blood furnishes a good example of a pulsating current. With each heart beat the blood rushes forward and then slackens in velocity, and then again rushes forward as the heart beats again. If we plot on a chart the quantity of blood flowing through the artery at each instant, we get a wavy line which never crosses the zero line (Fig. 205).

Here since the blood pulsates many times per minute, the horizontal scale more conveniently represents seconds or fractions of a second than hours; and because of the limited amount of blood that flows in an artery, the vertical scale may represent the flow in fractions of a fluid ounce per second instead of gallons per second. The vertical height of the wavy line above the horizontal zero line shows the amount of blood flowing at each instant. The frequency of heart beats is the number of pulsations made per minute, which is not far from 70 in the average human adult, and the duration or period of each pulsation is, therefore, about $\frac{1}{70}$ of a minute. The period is represented on the chart by the time that has elapsed between two like points, such as the two points of greatest flow, *a* and *b*.

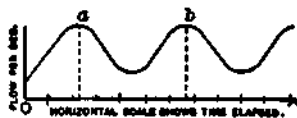

FIG. 205. — Graphical record of pulsating current.

Finally, we may consider the flow of water in a narrow tidal way as an alternating current. As the tide rises, the water rushes up the channel until nearly high tide, when the flow gradually ceases; it then turns, and with increasing flow the

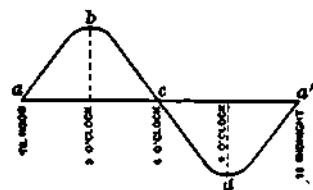

FIG. 206. — Curve showing one cycle of an alternating current of tidal flow.

water rushes down the channel until nearly low tide, when its outward flow gradually ceases; again it turns, and with increasing flow once more the water begins to rush up the channel. This action is repeated again and again as the days pass by. The period of the complete action or cycle is a little

over 12 hours, and the frequency is, therefore, nearly two cycles per day. We may also represent this alternating flow or current by a curve, as in figure 206. In this figure it is to be borne in mind that the vertical height of the curve shows the amount of water, measured in gallons per second, passing through the

channel at the instant considered, and that it does not represent the height of the tide. For example, the flow of water continues up the channel after 3 o'clock but at a decreasing rate, until high tide is reached at 6 P.M. Then, for an instant, at the point C where the curve crosses the line of zero flow, there is no flow of the water. After 6 o'clock the tide turns and the amount of outward flow increases for a time up to the maximum d , and then decreases as low tide is approached. Thus one complete cycle of tidal flow has been represented.

207. Phase of flow. It is well known that the character of the tidal flow is greatly affected by the character of the

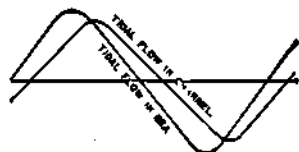

FIG. 207.— Graphical record of two alternating currents which differ in phase.

channel. For instance, in a narrow, crooked channel the phase of the flow is retarded as one proceeds along its length, through the buffeting action of the banks; and the times of high and low tides, when the flow in the channel is zero, may not correspond with the times of

similar tidal phases in some other channel or in the open sea. In this case we may say that the tide in one channel differs in phase from that in the other or from that in the sea; and a chart may be drawn, as in figure 207, to represent the respective cycles of sea and channel tides at certain selected points. In this figure the tidal cycle in the channel is shown to be retarded or behind the tidal cycle of the sea.

Alternating currents of electricity, flowing in branch circuits, may be at different phases and they may be represented on a chart entirely similar to that of figure 207. The currents are said to be out of phase, and may be said to be in advance of or behind each other, depending upon which is regarded as the datum for comparison; exactly, for instance, as we may with equal propriety and with the same meaning say of the illustration shown in figure 207, either that the channel tide is behind

the tide of the open sea, or that the tide of the open sea is in advance of the channel tide.

208. Electric current compared with the water current from pumps. We may give another set of analogies so as to emphasize these important relations still more decidedly.

1. A *continuous current* is like the uniform current of water set in motion by means of a centrifugal pump operated at a constant speed (Fig. 208).

2. A *pulsating current* is like the current of water set in motion by a piston pump. As the piston moves forward in the water cylinder, the water therein is forced to flow through the delivery pipe. When the piston reaches the end of its stroke, the flow slackens or ceases; as the piston returns on the stroke, the flow again proceeds as before through the delivery pipe and slackens as the piston reaches its initial position (Fig. 209). This is repeated as the stroke is repeated, and the action causes a succession of impulses in the water, with intervening pauses or slackening of the current.

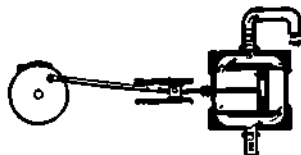

FIG. 209. — Piston pump setting up pulsating current of water.

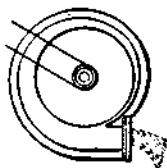

FIG. 208. — Centrifugal pump setting up continuous current of water.

3. An *alternating current* is like the current of water which would be set up if the delivery and suction pipes of the piston pump were directly connected and the valves removed. Now, as the piston moves back and forth, the water flows alternately back and forth, first from one end of the cylinder to the other and then the reverse, as long as the pump is operated. Thus the piston exerts on the water a pressure which gradually increases to a certain maximum and then gradually dies down to zero again; then the operation is repeated in the opposite direction.

Figure 210 shows clearly that a complete cycle of the alternating current is produced with each revolution of the pump-

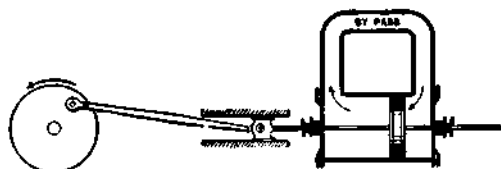

FIG. 210. — Piston pump with by-pass setting up alternating current of water.

driving shaft; that is, with each 360 degrees of angular motion of the shaft. We may, therefore, for the sake of convenience, divide the horizontal axis or zero line in our charts into 360 parts for each cycle of the flow, and call the parts *degrees* instead of fractions of time. This is illustrated in figure 211, which shows two alternating currents of different phases. We may speak of these as having 30 degrees difference of phase, or they are 30 degrees apart, since they are similar in form and cross

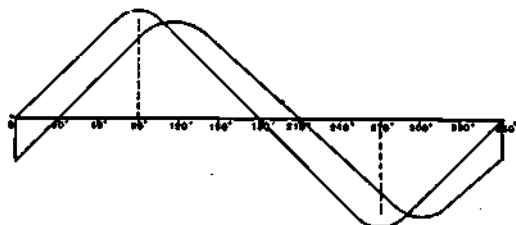

FIG. 211. — Two alternating currents with 30 degrees difference of phase.

the horizontal axis at points which are 30 divisions or degrees apart.

209. Curve of electric current made by a bipolar generator. We have already seen (section 140) that each armature coil of a d-c. generator tends to generate an e.m.f. which rises from zero to a certain maximum value and falls to zero again, then reverses in direction, rising to a maximum value and returning again to zero.

In figure 212 let us suppose that an armature coil is revolving around the axis O between the poles N and S ; in making one complete revolution of 360° suppose it makes 12 equal steps of 30° each. Let us plot also the instantaneous values of the voltage generated in the coil at these 12 positions in one revolution or cycle. On the horizontal line we lay off 12 equal spaces of convenient size, which will represent equal time intervals.

When the coil is in position A , it is cutting no lines of magnetic force and hence no voltage is induced in it; therefore we start the e.m.f. curve at the base line B . When the coil has moved 30° it is cutting flux and there is an e.m.f. induced *out* at 1. We may lay off a vertical line e_1 , upward to represent the instantaneous voltage

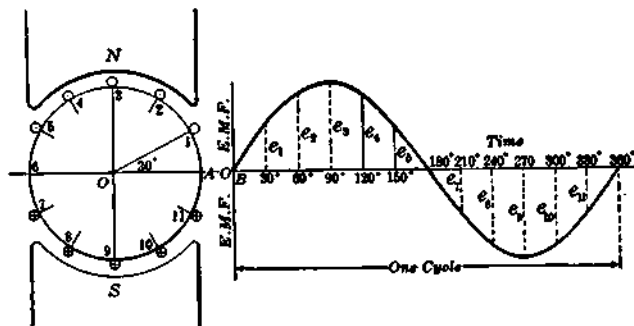

FIG. 212. — Alternating-current curve of bipolar generator.

when the coil is at 30° and another line e_2 to represent the instantaneous e.m.f. when the coil has moved 60° to position 2. When the coil has moved 90° from the zero position, it is at that instant cutting flux at the maximum rate, since it is moving directly across the lines of force, and the line e_3 represents the instantaneously induced voltage. As the coil moves on from this point the induced voltage begins to decrease and at length becomes zero again as the coil reaches a point 180° from the zero position. Lines e_4 and e_5 show the instantaneous value of the e.m.f. at 120° and 150° respectively. As soon as the coil passes the 180° point, it begins to cut flux in the opposite direction and so the induced e.m.f. is now *in*. Therefore the instantaneous value of this induced e.m.f. is represented by a vertical line e_7 downward. The value of this induced voltage continues to increase in this reverse direction until a position 270° from zero is reached. Here the voltage

becomes a maximum and is represented by the line $-e_2$. From here on, it gradually decreases until it becomes zero again as it reaches 360° (which is really the zero point of the next cycle). The curve plotted from these values, which is known as a *sine curve*, represents the various instantaneous values of the e.m.f. at all times during one complete cycle. It will be seen that the e.m.f. is continually changing. The sine curve, shown in figure 212, which has been drawn to represent the instantaneous values of the voltage, serves just as well to represent the instantaneous values of the alternating current generated in the coil. We may put i_1, i_2, i_3 , etc., in the place of e_1, e_2, e_3 , etc., and the curve will show alternating current instead of voltage values.

NOTE. Lines e_1, e_2 , etc., equal the vertical distances of 1, 2, etc., above OA .

210. Forms of current and voltage curves. The sine curve, which has just been mathematically constructed in the preceding



FIG. 213. — Actual curve of alternating electric current.

section, is a smooth curve, but the actual curves of alternating current and voltage produced by commercial machines are usually more or less irregular in outline, and sometimes they are very irregular; but successive loops are ordinarily

similar. Figure 213 shows the actual curve of an alternating electric current which was determined by experimental means. It is also a fact worth remembering that whenever any iron is magnetized by the currents, which is usually the case, the alternating-current curves do not have the same shape as the voltages which are applied to the circuits to produce the currents. For example, the curve in figure 213 was set up by a smooth voltage wave with a form quite like the mathematical sine curve shown in figure 212. Changing the iron or other conditions of the circuit would produce changes in these current curves, though the voltage curves remained unchanged.

211. How to make a-c. curves. It will be shown later (section 248) that it is very important to make the actual alternating-current curves approximate very closely the mathematical

sine curve. For that reason, apparatus, known as an oscillograph, has been designed to trace the actual alternating current and voltage produced by a commercial generator under working conditions, very much as an engineer may obtain with the aid of the steam-engine indicator a curve showing how the pressure of the steam in the cylinder changes with the movement of the piston.

The principle of the oscillograph is quite simple. It consists essentially of a loop of wire placed between the poles of an electromagnet (*NS* in figure 214) and on this loop of wire is cemented a tiny mirror *M*. The electromagnet is energized by some suitable source of direct current such as a storage battery. The alternating current to be studied is led through the loop of wire *AB*. It will be noted that at any instant the current in one side of the loop flows in the opposite direction to that returning on the other side, and so, just as

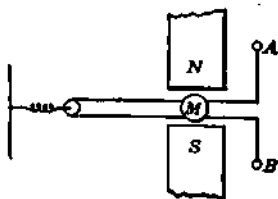

FIG. 214.—Diagram of essential parts of oscillograph.

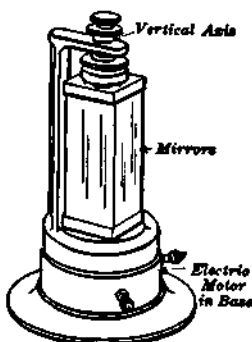

FIG. 215.—Rotating mirror with electric motor in the base.

in the electric motor, there is a sidewise push exerted by the magnetic field, which is just opposite in direction in the two sides of the loop. But the next instant the current reverses in the loop, and so the sidewise thrust on the sides of the loop is reversed. The result is that the tiny mirror *M* is continually being tilted back and forth around a horizontal axis.

If a beam of light is projected on this mirror, it will be reflected back and produce a bright vertical band on a suitable screen. But if a rotating mirror like the one shown in figure 215 is placed between the oscillograph and the screen in the proper position, it is possible to stretch

out horizontally these spots of light so as to get a curve such as that shown in figure 213.

By using suitable shunts and resistances it is possible in this way

to make alternating-current and alternating-voltage curves which are of great use to the operating as well as to the designing electrical engineer.

212. Heating effect of an alternating current. An alternating current has no special unit of its own, but is measured in terms of the direct-current unit, the ampere. It will be remembered that the ampere is defined as that steady current which will deposit a standard amount of silver from a standard silver nitrate solution in one hour. An alternating current, however, is not steady and will not deposit any silver from a solution, since whatever it deposits during one half of a cycle it takes off the next half. Hence we must use some other property such as the heating effect in order to compare an alternating with a direct current.

An alternating current is said to be equivalent to a direct current when it produces the same average heating effect under exactly similar conditions. This value is called the **effective value** of an alternating current and is measured in amperes.

We have already seen that the heating effect (I^2R) of a steady current in a circuit of given resistance (R) varies as the square of the current (I^2). It also is easy to see that the *simple heating effect of a current is entirely independent of its direction.* Therefore the heating effect of a current depends upon the *average of the squares of each instantaneous value of the current.* So, to get the heating effect of an alternating current such as that shown by the curve in figure 216, we must square a large number of the instantaneous values in a cycle and plot these squares, as indicated by the dotted lines in figure 216. We then find the average of these squares, which is

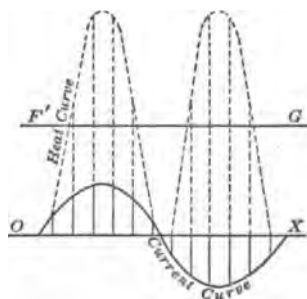

FIG. 216. — Heat curve and alternating-current curve.

represented by the height of the line $F'G$ above OX , and finally we extract the square root of this average and obtain the effective value of the alternating current. Thus

Effective value = $\sqrt{\text{Average of squares of instantaneous values.}}$

NOTE. It should be remembered that the effective value of an alternating current is not equal to the average value, which is 0.636 times the maximum value.

213. Effective current and voltage. It can be proved mathematically as well as experimentally that the effective value of an alternating current when the curve is sinusoid bears a definite relation to its maximum value. This can be expressed for all practical purposes by the following equation :

$$\text{Effective current} = \frac{\text{Maximum current}}{\sqrt{2}}$$

or **Effective current** = 0.707 maximum current.

When we measure the value of an alternating current, we desire to find the effective value, and so this is always assumed unless some special value is designated.

In measuring an alternating voltage or electromotive force we likewise desire to find the value which, when multiplied by the effective current that it causes to flow through a circuit without self-induction, will give the power expended in the circuit. This is called the **effective voltage** and is somewhat larger than the average voltage. The effective voltage bears the same relation to the maximum voltage that the effective current does to the maximum current. Thus the effective value of an alternating current or an alternating voltage is often spoken of as the "*square root of the mean (average) squares.*"

The power in a circuit without self-induction, such as incandescent lamps, is equal to the product of the effective current and the

effective voltage. In other words, when the current is in phase with the voltage,

$$P = IE$$

where

P = power in watts,

I = effective current in amperes,

E = effective e.m.f. in volts.

PROBLEMS

1. What is the effective value of an alternating current whose maximum value is 50 amperes?
2. If the effective value of an alternating current is 10 amperes, what is the greatest instantaneous value of this current?
3. If a voltmeter placed across an a-c. line reads 110 volts (the effective voltage), what is the greatest instantaneous voltage on the line?
4. In a noninductive circuit 5 amperes are flowing under a pressure of 110 volts. If the current is in phase with the voltage, what is the power consumed in the circuit?
5. A 115-volt a-c. circuit contains a noninductive resistance of 40 ohms. Assuming the current to be in phase with the voltage, what is the power consumed in the circuit?

214. Frequency of an alternating current. The number of complete cycles which an alternating current makes in one second is called its *frequency*. Thus a current which rises to a maximum in each direction 60 times a second is said to make 60 cycles per second, or to have a frequency of 60. The fraction of a second during which an alternating current makes one cycle is called its *period*. Thus the period of an alternating current whose frequency is 60 cycles is $\frac{1}{60}$ of a second.

The commonest frequency used in this country is now 60 cycles per second, although a frequency of 25 cycles per second is used in many of the great transmission plants. In European countries frequencies of 50 and 25 cycles per second are common, and 15 cycles are used on certain a-c. electric railways.

215. Phase relations of current and voltage. Wherever an alternating e.m.f. sends a current through a circuit, the current is also alternating, and the curve representing the current will have the same general form as the curve for the voltage. These two curves will have the same frequency and period for any particular circuit and may

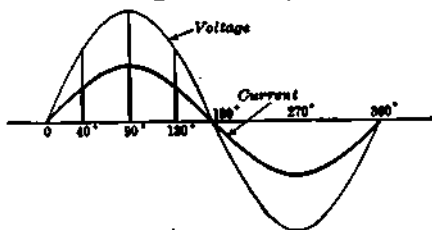

FIG. 217. — Curves of e.m.f. and current in phase.

both be drawn on the same horizontal base line. Figure 217 shows an e.m.f. and also a curve of current "in phase." It will be noticed that the current and voltage are both at zero at the same instant, both pass through their maximum values at the same instant, and in fact keep in step throughout their entire cycles. This is the condition of an alternating-current circuit which contains resistance only.

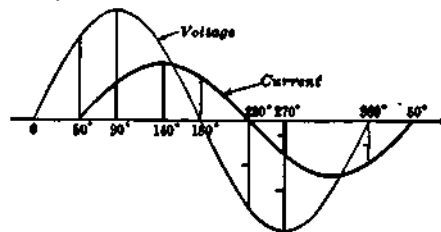

FIG. 218. — Current lagging 50° behind the e.m.f.

We shall see that in alternating-current circuits we very often have to consider other factors besides resistance, such as inductance and capacity, which may cause the current to "lag" behind the voltage (Fig. 218) or even to "lead" the voltage (Fig. 219). The discussion of the causes and effects of lagging and leading currents will be the subject of the next chapter.

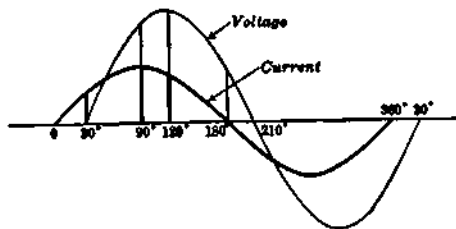

FIG. 219. — Current leading e.m.f. by 30°.

216. Ohm's Law in noninductive a-c. circuits. Sometimes there is doubt about how to use Ohm's Law (section 30) in a-c. circuits; hence it will perhaps be well to recall again that *this law states the relation of voltage, current, and resistance only*, and always holds true as far as the relative values of these alone are concerned. It will be seen that *this law does not deal with inductance or capacity*. Therefore, when we are dealing with resistance alone, we may be sure that *the voltage needed to drive a certain current through a certain resistance is always the product of the current times the resistance, whether the voltage is direct or alternating*.

PROBLEMS

1. How many volts are needed to force 25 amperes alternating current through 8 ohms resistance?
2. Compute the number of watts consumed in the resistance of problem 1.
3. How much direct current would be required to cause the same heating effect as the alternating current in problem 2?
4. What would be the maximum instantaneous value of the voltage in problem 1?
5. Experiment shows that 15 amperes of direct current passing through a certain fuse will just melt it. How many amperes of alternating current will just melt it? What would be the maximum value of this current?

SUMMARY OF CHAPTER XII

A **DIRECT CURRENT** flows always in the same direction. It may be *continuous* and have constant value, or it may be *pulsating* and have varying value.

An **ALTERNATING CURRENT** is an electric current which flows back and forth.

A **CYCLE** consists of one complete flow back and forth. It is completed when an alternating current has passed through one complete set of values in both directions.

The **FREQUENCY** is the number of cycles completed in one second.

The **SINE CURVE** is the standard wave form which an alternating current should be made to follow.

An **ALTERNATING ELECTRIC CURRENT** is generated by an alternating e.m.f. The current and voltage curves usually approximate the standard wave form.

The **EFFECTIVE VALUE OF AN ALTERNATING CURRENT** is that value in amperes which will produce the same heating effect as a direct current of the same number of amperes. It equals the square root of the average of the squares of all the instantaneous values.

$$\text{Effective current} = \frac{\text{Maximum current}}{\sqrt{2}}$$

$$I = \frac{I_m}{\sqrt{2}} = 0.707 I_m$$

where

I = effective current in amperes,

I_m = maximum current in amperes.

Similarly

$$E = 0.707 E_m$$

where

E = effective e.m.f. in volts.

A-C. VOLTMETERS AND AMMETERS indicate the effective values.

When current is *in phase* with voltage, the **POWER IN AN A-C. CIRCUIT** is equal to the product of the effective current and the effective voltage.

OHM'S LAW applies in a-c. circuits *only* when we have *non-inductive resistance and current in phase with voltage*.

QUESTIONS

1. How does an alternating current differ from a continuous current?
2. How does an alternating current differ from a pulsating current?
3. What advantages has the alternating current over the direct current?

4. For what purposes is the alternating current not adapted?
5. Why do we not use a 15-cycle alternating current for lighting purposes?
6. In the voltage curve for an armature coil, what does the horizontal distance of any point on the curve, from the beginning of the curve, represent?
7. What is meant when the curve drops below the zero line?
8. How can we determine when an alternating current and a direct current are equal?
9. Draw two a-c. curves with 45° difference in phase.
10. Why should we ever need to know the maximum instantaneous voltage?
11. Under what conditions in an a-c. circuit are watts equal to the volt amperes?
12. When does Ohm's Law apply to an a-c. circuit?
13. What is meant by the angle of lag?
14. What is the phase relation between the current and the impressed voltage in a circuit containing resistance only?
15. A certain current lags 50° behind the impressed voltage (Fig. 218). If the frequency is 60 cycles, what is the time lag (fraction of a second)?
16. If an a-c. voltmeter reads 110 volts, does this indicate the effective or average value?
17. Why cannot alternating-current intensity be defined by its electrolytic effect, as is direct-current intensity?
18. What would happen if the moving-coil, permanent-magnet type of instrument were connected into an alternating-current circuit? Why?

CHAPTER XIII

INDUCTANCE AND CAPACITY IN ALTERNATING-CURRENT CIRCUITS

Inductance — effects on direct currents and alternating currents — choke coils, operation — unit of inductance, the henry — computation of self-inductance — inductive reactance, impedance — power in a-c. circuit — power factor.

Capacity — effects on alternating currents — condensers — dielectric constants — mechanical analogue of condenser — capacity of condenser, farad and microfarad — computation of capacity reactance.

Comparison of effects of inductance and capacity in a-c. circuits — resonance — Ohm's Law for a-c. circuits.

217. What do we mean by inductance? We have already seen (section 112) that when a varying current flows through

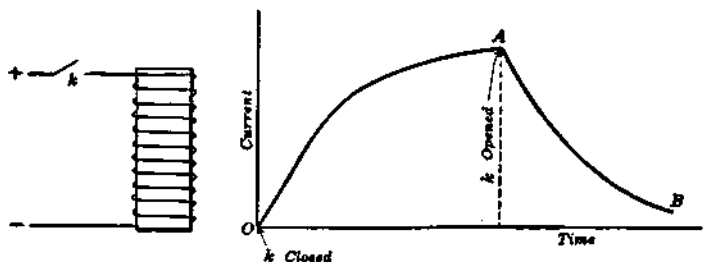

FIG. 220. — Growth and decay of current in an inductive circuit.

a coil it produces an inductive effect upon the coil itself. For example, when a current is started in a coil by closing the switch (*k* in Fig. 220), it does not instantly attain its full value as determined by Ohm's Law. If we plot as a curve the value

of the current at each instant from the time the switch is closed until the ultimate or steady value is reached, we find the **growth** of the current to be something like that shown as *OA* in figure 220. The reason for this is seen when we remember that the current itself is building up a magnetic field and that as this field grows, its lines of force cut the turns of the coil and *induce in them a voltage which opposes the growth of the current.*

On opening the switch *k*, the original current does not drop to zero *instantly*, but requires an appreciable time. The curve *AB* in figure 220 shows the **decay** of the current in a coil. As the current's own magnetic field dies away, the lines of force again cut the turns of the coil, but this time in such a direction that the *self-induced voltage upholds the current.* Of course, this whole process takes place very quickly indeed, and the current may reach its steady value in one hundredth of a second, the time depending in any case upon the size and shape of the coil and the character of its core.

This property of an electric circuit is called its **self-induction** or **inductance**. Sometimes it is spoken of as the electromagnetic **inertia** of the circuit because it is quite like the property of inertia, which we find in all machines. For example, an automobile or *anything else at rest tends to remain at rest*; it takes time and force to get the machine up to speed; or in other words, **energy** must be supplied to set it in motion. We also know that *anything in motion tends to keep moving in a straight line unless acted upon by some force.* It takes time and force (brakes) to stop a machine; that is, the energy stored in the moving machine must be absorbed as it is brought to rest. So it is with electricity when flowing through a coil, especially when the latter has an iron core.

That property of an electric circuit whereby it opposes a change in the current flowing is called the self-induction or the inductance of the circuit. These two terms have the same meaning, but the term "inductance" is generally used in engineering work.

218. Alternating currents in inductive circuits. We have already in the preceding chapter seen that *an alternating current is always changing*. We shall also see that most alternating-current machines consist of coils of wire with iron cores, and therefore it is very important that we get a clear idea of just what the effect is of inductance on an alternating current. In a straight wire carrying an alternating current the effects of inductance are exceedingly small, but when the wire is coiled up so that the magnetic field of every turn cuts many adjacent turns and especially when the coil contains an iron core, the effects of inductance are surprisingly great.

219. Experiment to show effect of inductance. Let an incandescent lamp be connected in series with a coil which has a removable iron core, as shown in figure 221.

Remove the core and let a direct current be passed through the coil and the lamp. We see that the lamp burns brightly. If we insert the iron core inside the coil, the brilliancy of the lamp is not in the least diminished. Now remove the core and connect the coil and lamp to an alternating-current supply of the same voltage as the direct current. The lamp is now *dim* and if the iron core is again inserted in the coil, the dimming effect is still more strikingly shown.

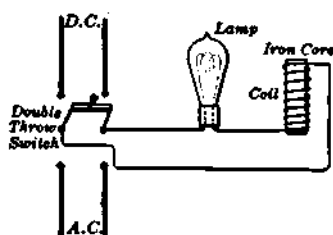

FIG. 221. — Lamp connected in series with inductance on d-c. or a-c. circuits.

Thus we see that, although the ohmic resistance of the circuit remains constant and the voltage is also constant, yet the current produced by the a-c. voltage is less than that produced by an equal d-c. voltage and the iron core inside the coil still further reduces the current produced by the a-c. voltage. In other words, *an alternating current is weakened by the inductance of a coil*.

One important effect, then, of inductance upon an alternating current flowing through a coil is to weaken the current more than would be expected from Ohm's Law by considering its ohmic resistance alone. This is because *the counter-electromotive force of self-induction has at every instant a direction opposed to the change of current, and a magnitude proportional to the rate at which the current is at that instant changing.* That is, the more rapidly the current is increasing (or decreasing) the greater is the e.m.f. of self-induction opposing that increase (or decrease).

FOR EXAMPLE, if we consider the usual a-o. curve (Fig. 212) we note at the points 0° , 180° , and 360° (where it crosses the horizontal axis) the value of the current is changing most rapidly, and hence at these points the counter e.m.f. of self-induction has its maximum positive (+) and negative (-) values. At the points 90° , 270° , and 0° the current ceases to increase and begins to decrease; that is, for an instant at these points the current is not changing at all, and hence at these points the e.m.f. of self-induction passes through zero, or is said to reverse.

HINT. — If the reader will draw an alternating current curve (sine curve) similar to figure 212, and then draw on the same axis an a-c. voltage curve which lags 90° behind the current, he will find that it will greatly clarify his ideas in regard to the counter e.m.f. of self-induction.

We have seen that, due to the alternating current flowing through a circuit, there is set up an electromotive force opposing that current, as just explained. Hence, to force the current through we must impress upon the circuit an electromotive force which is at every instant exactly *equal in magnitude and opposite in direction* to this inductive electromotive force. This means that the impressed electromotive-force curve reaches its maximum *positive* value just when the counter e.m.f. of self-induction has reached its maximum *negative* value; that is, the *crests* of the impressed electromotive-force curve coincide exactly with the *troughs* of the counter e.m.f.

curve. These two electromotive-force curves differ in phase by one half a cycle or 180 degrees. In other words, the impressed electromotive force reaches its maximum positive value ninety electrical degrees before the resulting current reaches its positive maximum, or the impressed voltage *leads* the resulting current by 90 degrees.

In a purely inductive circuit (that is, a circuit in which the effects of resistance and capacity are negligibly small) the impressed electromotive force always leads the resulting current by ninety electrical degrees; or, to reverse the statement, *the current lags 90° behind the impressed electromotive force.*

HINT. — The reader is urged to draw these curves to show the phase relation between impressed e.m.f., resulting current, and the counter e.m.f. of self-induction in a purely inductive circuit.

220. Hydraulic analogy of inductance. This action of self-induction or inductance of an electric circuit can be compared to the action of water flowing through a pipe. When the pipe is opened, the water holds back for an instant. It takes a little time, a small fraction of a second, for the water to get to going and for the stream to come up to its full strength. If the pipe is suddenly closed, the water tries to flow on

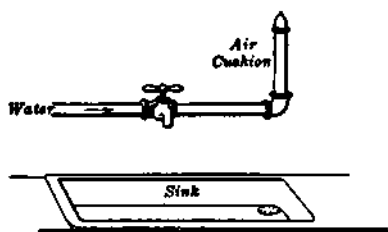

FIG. 222. — Air cushion takes the bump due to the inertia of the water when the faucet is quickly closed.

and bumps the pipe, or causes what is known as a "water hammer." This hammer may be sufficiently violent to burst the pipe and it is for this reason that an air cushion is provided by means of a short extension of the pipe above a faucet (Fig. 222). This inertia of the water is in some ways like self-induction.

221. Noninductive circuit. Such mechanical comparisons are often useful in trying to visualize certain invisible electrical

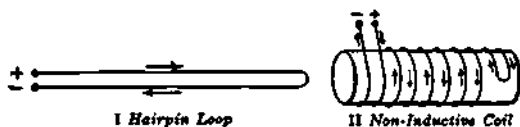

FIG. 223. — Noninductive circuits formed by a wire doubling back on itself.

phenomena, but there is one point where we have no mechanical analogy and that is the noninductive circuit. Why

is it that when a wire doubles back on itself, as shown in figure 223, there is no inductance?

In this, as in all such electrical problems, it is necessary only to return to the first principles of the magnetic action of an electric current. It is easy to see that the magnetic flux circulating around one wire will be neutralized by the flux about another carrying a current in the opposite direction.

Thus we shall have only the ohmic resistance of the wire to consider. The resistance coils used with a Wheatstone bridge (section 132) are wound noninductively. The filament of an incandescent lamp is practically noninductive. A straight wire is also practically noninductive, although if the wire is of large size, there is a slight inductive effect.

222. Choke coils. A choke coil is merely a coil having considerable reactance. Figure 224 shows one form of choke coil such as is used on transmission lines in connection with lightning arresters, which will be described in Chapter XVII.

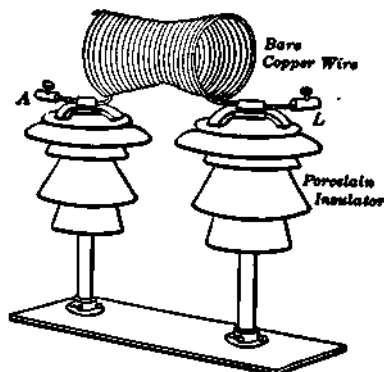

FIG. 224. — "Hour glass" form of choke coil used in connection with lightning arresters.

The apparatus to be protected is connected at *A* and the line at *L*. If a surge (or big electrical wave due to lightning) travels along the transmission line, a very high voltage is induced in the reactance coil. The coil thereby tends to force the "high-frequency" lightning current to the ground through the lightning protector.

223. How to calculate inductance. In the first place it is necessary to keep in mind that inductance is not a *material thing* but merely *the name of a certain algebraic expression* relating to the shape, size, and dimensions of an electric circuit. The expression given below, though exactly true only for a long solenoid, may be used as an approximation in calculating the inductance of ordinary coils. The proof of this algebraic expression will be found in the more advanced books on alternating currents.*

$$L = \frac{4\pi^2 N^2 r^2 \mu}{10^9 l}$$

where

- L* = inductance in henrys,
 π = 3.14
N = number of turns,
r = average radius of coil,
 μ = permeability of core,
l = length of core.

If the coil is a solenoid with an air core, then $\mu = 1$; but we are generally dealing with the inductance of transformer coils and other electrical machinery containing more or less iron in the circuit. This equation is one of great practical importance.

In general it will be found that inductance depends upon the dimensions of the coil, the number of turns of wire, the

* *Jackson & Jackson's Alternating Currents and Alternating-Current Machines.* The Macmillan Company.

magnetic permeability of the various parts of the path through which the flux must pass, and the distribution of the winding.

FOR EXAMPLE, what is the inductance of a coil formed of 2000 turns of wire wound upon an iron ring having a constant permeability of 1000? The mean circumference of the ring is 150 centimeters and the radius of the coil 8 centimeters.

SOLUTION. —
$$L = \frac{4\pi^2 N^2 r^2 \mu}{10^9 l}$$

$\pi = 3.14$
 $N = 2000$ turns,
 $r = 8$ cm.,
 $\mu = 1000$,
 $l = 150$ cm.,

therefore
$$L = \frac{4 \times (3.14)^2 \times (2000)^2 \times 8^2 \times 1000}{10^9 \times 150}$$

= 66.3 henrys.

224. The unit of inductance. It will be noticed that in this equation the inductance is represented by the letter L and is expressed in henrys. A circuit has an inductance of one henry when a current changing at the rate of 1 ampere per second induces an e.m.f. of 1 volt in the circuit. Since the "henry" is a large unit, the one thousandth part of it, or the millihenry, is frequently used. The real significance of this unit of inductance can best be understood by learning the inductances in henrys of some familiar objects.

The inductance of an ordinary electric vibrating call bell is about 0.012 henrys, that of a Bell telephone receiver with diaphragm is from 0.075 to 0.100 henrys, that of a complete telegraph sounder is about 0.440 henrys.

PROBLEMS

1. A coil of 800 turns is wound on an iron ring whose average permeability is 1200. The mean diameter of the ring is 12 centimeters and the radius of the coil is 2.5 centimeters. What is the inductance of the coil?

2. Find the inductance of a solenoid 50 centimeters long, 4 centimeters in diameter, containing 2000 turns.

3. What is the inductance of the primary coil of a transformer having 1000 turns, the mean length of whose magnetic circuit (core) is 100 centimeters and its area of cross section 75 square centimeters? Assume $\mu = 1500$.

HINT. — The inductance equation may be expressed as

$$L = \frac{4\pi N^2 \mu A}{10^9 l}$$

when A = cross section of the core in square centimeters.

4. It is desired to determine the permeability of a sample of iron. A round test piece 4 centimeters in diameter and 60 centimeters long is formed into a ring about which are wound 1000 turns of wire. The inductance is then measured and found to be 3.68 henrys. What is the permeability?

225. Reactance. We have already seen (Chapter XII) that an alternating current changes constantly, so that it never has a steady value, and the effect of inductance is therefore felt by it all the time. The result is, as was shown in section 219, that in a circuit having inductance an alternating current

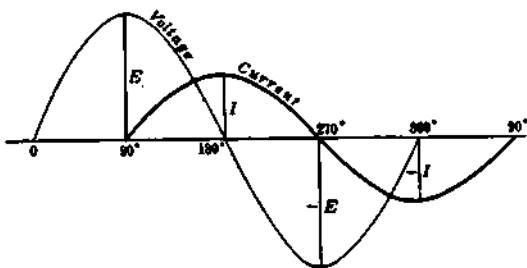

FIG. 225. — Current lags behind voltage in inductive circuit.

is always retarded a certain amount behind the alternating voltage which sets it up. In short, inductance makes an alternating current lag behind its voltage (Fig. 225). This same retardation makes the maximum value of the current smaller than it would be were there no inductance.

This effect of inductance in decreasing the amount of alternating current which flows in a circuit depends, as we have

seen, upon the magnetic effect which the different parts of the circuit have on each other, and also upon the frequency of the current.

FOR EXAMPLE, if we have a certain coil whose inductance is 1 henry, and use it on an a-c. circuit whose frequency is 60 cycles, we have a certain magnetic effect. But if we change the frequency to 120 cycles, we double our frequency; that is, we double the rapidity with which the current changes in value from instant to instant, and thereby double the speed with which the magnetic flux set up by that current cuts through the conductors in the coil. This doubling of the rate at which the flux changes doubles the e.m.f. of self-induction, which means that twice the impressed electromotive force is required at 120 cycles to maintain a given current through the coil as is required to maintain that same current at 60 cycles. In other words, though the inductance of the coil is still 1 henry, the reactive effect at 120 cycles is twice as great as at 60 cycles.

Reactance, or inductive resistance due to inductance, depends on the frequency and on the number of henrys of inductance.

The equation for reactance is :

$$X_L = 2\pi fL$$

where X_L = reactance in ohms,

$$\pi = 3.14$$

f = frequency in cycles per second,

L = inductance in henrys.

FOR EXAMPLE, suppose a reactance coil has an inductance of 0.12 henrys and is used on a 25-cycle line, what is its reactance?

$$\begin{aligned} X_L &= 2\pi fL \\ &= 2 \times 3.14 \times 25 \times 0.12 \\ &= 18.8 \text{ ohms.} \end{aligned}$$

The inductive reactance (X) of a circuit may also be defined as the ratio of the volts applied to the amperes produced, *pro-*

vided the circuit has inductance only (that is, where resistance and condenser effects can be neglected). Thus

$$X = \frac{E \text{ (effective)}}{I \text{ (effective)}}$$

FOR EXAMPLE, if the voltage in the preceding example is 11,000 volts and if the reactance coil were put across the line, then the current through it would be

$$I = \frac{E}{X} = \frac{11,000}{18.8} = 585 \text{ amperes.}$$

PROBLEMS

1. Given an iron ring whose inside diameter is 5 inches wound with 730 turns of wire. If the iron core is $1\frac{1}{4}$ inches in diameter and the average permeability is 1700, calculate the inductance. (1 inch = 2.54 centimeters.)

2. If the coil in problem 1 is put across a 110-volt 60-cycle line, compute the current, neglecting the resistance of the wire.

226. Impedance. Thus far we have been considering circuits where the opposition to the flow of an alternating current consisted entirely of reactance and where the resistance was too small to be taken into account. Such is the case, however, only in such apparatus as the reactance coils used with lightning arresters. In most electrical devices we have to consider a combination of resistance and reactance, and therefore we speak of the **apparent resistance** or **impedance** of a circuit through which an alternating current flows.

The effective current in an alternating-current circuit is equal to the effective voltage applied to the circuit divided by the impedance of the circuit.

$$\text{Current} = \frac{\text{Voltage}}{\text{Impedance}}$$

It might be assumed that if we had a resistance of 3 ohms and a reactance of 4 ohms the impedance would be the arithmetical sum; but experiment shows that the impedance is 5 ohms.

This is because we are dealing with a *geometrical* relation between the ohmic resistance and the inductive resistance. These two resistances are acting at right angles (90°) to each other. This is shown graphically in figure 228, in which the ohmic resistance is represented by the horizontal line AC and the inductive resistance by the vertical line BC . The resultant resistance or the impedance can be shown mathematically to be represented by the hypotenuse AB of the right triangle. But we know in a right triangle the square of the hypotenuse equals the sum of the squares of the other two sides. That is,

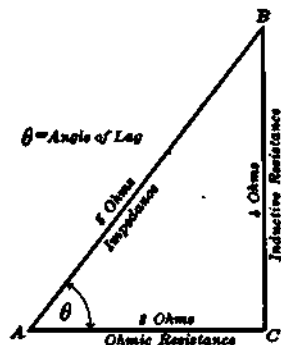

FIG. 228. — Ohmic resistance and inductive resistance act at right angles.

$$\overline{AB}^2 = \overline{AC}^2 + \overline{BC}^2.$$

In general *the square of the impedance equals the sum of the squares of the reactance and the resistance.*

$$\text{Impedance} = \sqrt{\text{Resistance}^2 + \text{reactance}^2}.$$

$$Z = \sqrt{R^2 + X_L^2}$$

or,

$$Z = \sqrt{R^2 + (2\pi fL)^2}.$$

Therefore for alternating currents in circuits containing resistance and inductance Ohm's Law takes the form

$$\text{Current} = \frac{\text{Voltage}}{\sqrt{\text{Resistance}^2 + \text{reactance}^2}}.$$

$$I = \frac{E}{\sqrt{R^2 + X_L^2}} = \frac{E}{\sqrt{R^2 + (2\pi fL)^2}}.$$

PROBLEMS

1. A certain type of choke coil for use on a 6600-volt line for protection against lightning is 12 inches long, 15 inches in diameter, and consists of 15 turns of aluminum wire 0.4 inches in diameter. (a) What is the inductance of the coil? (b) If used on a 60-cycle circuit, what is the reactance? (c) What is the impedance?

2. If the lightning discharges an oscillating current of 1,000,000 cycles per second, what is the reactance of the coil in problem 1?

3. How much current will flow through a coil of 0.075 henrys inductance and 20 ohms resistance when 220 volts at 60 cycles are applied to its terminals?

4. In a given circuit the resistance is 1 ohm and an e.m.f. of 220 volts at 60 cycles per second causes 110 amperes to flow through the circuit. Find (a) the impedance, (b) the reactance, and (c) the inductance.

5. What is the impedance in a transmission line having a resistance of 0.05 ohms and 0.03 ohms reactance?

227. Power in a-c. circuits. The power taken at any instant by an alternating-current circuit equals the product of the voltage at that instant times the current at that instant. Let figure 227 represent an alternating current and voltage *in phase* and also the power curve, which is so drawn that each point on it shall be the product of the value of the current times the value of the voltage at that instant. It will be seen that all the power loops are positive (above the axis), even when the current and voltage are negative. This is because the signs of the current and voltage values change at the same instant, and thus the product is always a product of *two positive values* or of *two negative values*.

Therefore, when the current and voltage are in phase, the power is all positive. The average power expended in such a circuit is represented by the height of the line *FG*, which cuts off the tops of the loops so that they will exactly fill up the intervening valleys. *The power in such a circuit is equal to the product of the effective voltage times the effective current.*

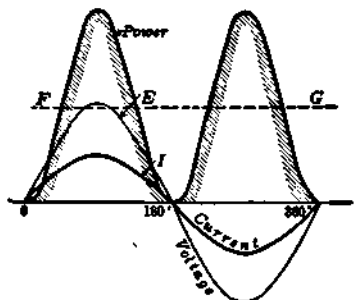

FIG. 227. — Power curve when current and voltage are in phase.

228. Power in an inductive circuit. In an inductive circuit the current lags behind the voltage, and the power curve for

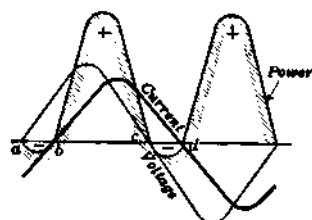

FIG. 228. — Power curve when current lags behind voltage.

such a case is represented in figure 228. The instantaneous power equals the product of the current value times the voltage value at the same instant. Any point in the power curve is equal to the product of the instantaneous values of current and voltage. But here it will be seen that there are large positive loops and small negative loops.

The negative loops are located at places *ab* and *cd*, where the current and voltage curves are on opposite sides of the axis.

This means that during part of each half-period work is being *absorbed* by the circuit as represented by the positive loop, and during another part of the time work is being *returned* by the circuit to the source of electric power. The average work absorbed by the circuit is now the difference between the average values of the positive and negative loops and so is less than that which would be produced by an equal current which flowed in phase with the voltage.

If the current happens to lag 90° behind the voltage, as shown in figure 229, then the negative loops just equal the positive loops, and all the power absorbed by the circuit during one quarter-period is returned during the next. This curve could be possible only when there was no resistance but just inductance. Of course in practice there is always some resistance in the circuit.

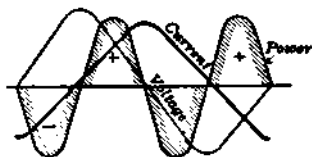

FIG. 229. — Power loops when current lags 90° .

229. Power factor in an inductive circuit. We have already seen that the power taken in a noninductive circuit (resistance

only) is always equal to the product of the volts times the amperes (whether the current is alternating or direct). In this case the alternating current is in phase with the voltage. But in a circuit containing both resistance and inductance the alternating current lags behind the voltage and so the apparent power (which is the name given to the product of volts \times amperes or *volt amperes*) is greater than the true power. The relation between the true power as determined by a wattmeter and the apparent power in an alternating-current circuit is expressed by the power factor. Thus

$$\text{Power factor} = \frac{\text{True power}}{\text{Apparent power}} = \frac{\text{Watts}}{\text{Volt amperes}}$$

Therefore

$$\text{Watts} = \text{Volt amperes} \times \text{power factor.}$$

Power factor * is the name given to that quantity by which the product of volts and amperes must be multiplied to obtain the true power in watts.

The greater the amount of inductance in a circuit, the lower will be the power factor. Power factor is usually expressed as a percentage. If a circuit contains resistance only, its power factor will be 100 per cent. In practice the average values of power factors for circuits with different kinds of loads are about as follows:

Incandescent lighting — no motors	95 per cent
Lighting and motors	85 per cent
Motors only	80 per cent

* It can be shown that the power factor is equal to the cosine of the angle by which the current lags behind the voltage.

That is, *power factor* = $\cos \theta$. (See figure 226.) Cosine is the ratio between the adjacent side and the hypotenuse of a right triangle. Thus, in figure 226,

$$\cos \theta = \frac{AC}{AB}$$

or,

$$\text{Power factor} = \frac{\text{Resistance}}{\text{Impedance}}$$

230. Computation of a-c. power. **EXAMPLE.** What is the power taken by a multiple-arc-lighting circuit where the voltage is 115 volts, the current is 85 amperes, and the power factor is 87 per cent?

SOLUTION. — Power = $115 \times 85 \times 0.87 = 8500$ watts = 8.5 kw.

EXAMPLE. — Again, suppose a generator is delivering 2 kilowatts at a voltage of 220 volts and the power factor of the circuit is 70 per cent. What is the current?

SOLUTION. — $2000 = 220 \times I \times 0.70$,

$$I = \frac{2000}{220 \times 0.70} = 13.0 \text{ amperes.}$$

EXAMPLE. — In testing an a-c. motor the wattmeter indicated 42 kw. when the voltage was 220 volts and the current was 230 amperes. What is the power factor?

SOLUTION. — $42,000 = 220 \times 230 \times \text{p.f.}$

$$\text{p.f.} = \frac{42,000}{220 \times 230} = 0.83 = 83 \text{ per cent.}$$

231. The effect of low power factor. If the power factor in a constant-voltage circuit is low, the current necessary to transmit a given amount of power is greater than that required to transmit the same power in a circuit of unity power factor (a noninductive circuit). This excess of current does not in itself represent an additional expenditure of energy and therefore does not require more coal burned under the boilers. But a low power factor and its larger current do involve a small increase in energy expended because of the increase in the I^2R loss in the conductors. Furthermore, it cuts down the effective capacity of the generators because it increases the heat (I^2R) losses.

In practice, a low power factor is frequently due to under-loaded induction motors on the line and this may be corrected, as we shall see in Chapter XVI, by the installation of synchronous motors. When such a motor (which is built like an alternator) has its field magnets over-excited, it causes a leading current to flow.

PROBLEMS

1. The ammeter shows that an a-c. generator is delivering 21 amperes and the voltmeter reads 220 volts. A wattmeter shows that 4 kw. are being delivered. What is the power factor of the load?

2. A single-phase induction motor takes 25 amperes, which lags behind the impressed voltage of 220 volts so that the power factor is 87 per cent. How much power does it take?

3. In a 24-hour day the ammeter connected in a small motor circuit indicates steadily 11 amperes and the voltmeter reads 220 volts. The reading of the watt-hour meter increases by 44 kilowatt hours during this time. Compute the power factor at which the motor operates.

4. What size generator in kv-a. (kilovolt amperes) is required to supply a group of induction motors taking 65 kilowatts at 80 per cent power factor? Neglect losses and reactions in transmission system.

5. In a certain circuit the resistance is 10 ohms, the inductance 0.03 henrys, and the frequency 60 cycles per second. What current will flow if the e.m.f. is 125 volts?

6. A 200-kv-a. alternator is delivering power to a number of induction motors at 80 per cent power factor. What is its kilowatt capacity at full load?

7. A 110-volt a-c. circuit contains 10 ohms resistance and 7.2 ohms reactance. Calculate the power factor. What is the average power consumed in the circuit?

8. An ammeter inserted in a 110-volt a-c. circuit reads 140 amperes. The wattmeter reads 14 kw. (a) What is the power factor? (b) What is the kv-a. capacity of the generator furnishing the current?

9. An alternator generating 1100 volts at 60 cycles per second supplies a system which has a resistance of 125 ohms and an inductance of 0.5 henrys. (a) Find the current supplied. (b) Find the kv-a. rating of the alternator. (c) What is the power factor of the circuit? (d) How many kw. are supplied by the generator? (e) How many kw. could the generator supply to a noninductive load?

10. A 200-kv-a. alternator is supplying current to a system of 40-watt Mazda lamps at unity power factor. Assuming the line losses to be 10 per cent, how many lamps can be used?

11. If the alternator of problem 10 supplies current to a group of one-horse-power induction motors at 80 per cent power factor, how many motors can be used? Assume the line losses to be 10 per cent.

232. Capacity in a-c. circuits. There is another factor besides the resistance and inductance of a circuit which must sometimes be considered in determining what current a given a-c. voltage will send through the circuit and that is its *capacity* or capacitance. In order to see just what we mean by the capacity of a circuit let us describe a rather striking case. In a certain long-distance transmission line in California it was found that, when an alternating e.m.f. of 90,000 volts was impressed across the terminals of the line at the power station, an ammeter inserted in the line wire showed that a current of 48 amperes flowed into the line, *even when the line was open* or absolutely unloaded. In other words, an electric transmission line possesses a sort of *elasticity* to electricity and this electric elasticity is called the capacity of the line.

233. A laboratory experiment with capacity. We may show the effect of capacity in a circuit very conveniently by substituting for the long-distance transmission wire a condenser. In general, a condenser consists of any two conductors separated by a nonconductor, such as air, mica, glass, etc.

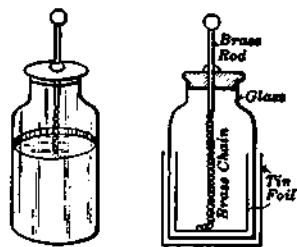

FIG. 230.—Condenser made in form of Leyden jar.

For certain experimental purposes a condenser is sometimes made by coating the inside and outside of a glass jar with tin foil. Such an arrangement is called a Leyden jar and is shown in figure 230. The form of condenser used in telephone practice is, however, usually more convenient in laboratory experiments.

These commercial condensers are commonly made by putting thin strips of mica or oiled paper between sheets of tin or lead foil. The sheets of metallic foil constitute the conductors and the mica acts as an insulator, sometimes called the dielectric. It will be noticed in figure 231 that the alternate metal plates are joined to one side of the line and the remaining plates to the other terminal, and the two sets of plates are thus insulated by the dielectric, which is not represented in the diagram.

If we connect an incandescent lamp in series with a condenser (Fig. 231) to a direct-current generator, the lamp is not lighted because the circuit is open between the two sets of plates of the condenser.

But when we connect the same circuit to an alternator producing alternating current, the lamp glows even though the circuit is open between the plates of the condenser. If we remove the condenser, however, and place the ends of the wire near together, thus leaving the circuit open, the lamp is not lighted. We say that the lamp glows because there is capacity in the circuit.

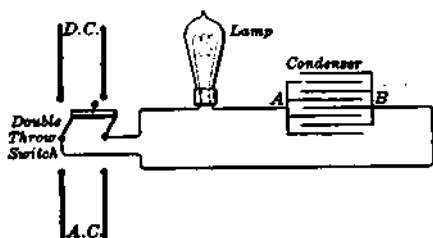

FIG. 231. — Lamp connected in series with condenser on d-c. or a-c. circuits.

234. What is the action of a condenser? Perhaps we can picture the action of a condenser by comparing it to a box in a pipe line, as shown in figure 232. This box is divided into two compartments *C* and *C* by means of a rubber diaphragm *D*, and the two compartments are connected to a pump *P*.

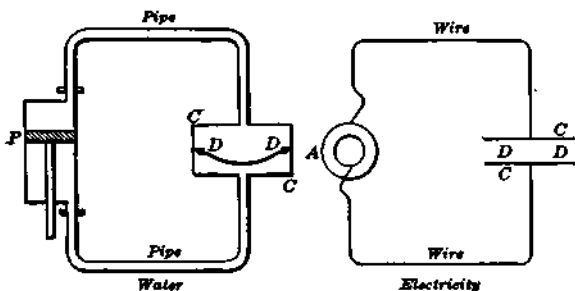

FIG. 232. — Mechanical analogue of a condenser in circuit.

This reciprocating pump displaces the fluid, first in one direction, as the piston travels upward, then in the other, as it travels downward. Thus the surging of the fluid back and forth subjects the rubber diaphragm to a mechanical stress.

The pump corresponds to an alternating-current generator *A*, the water to the electricity, the two compartments of the box to the two sets of plates *CC* in the condenser, and the diaphragm to the dielectric *D* of the condenser. The alternator generates an alternating electromotive force which produces an electrical stress in the insulating material *DD* between the metal plates *CC* as these plates are charged electrically first in one direction and then in the reverse direction.

Now let us study just what happens when we apply to the condenser an alternating voltage, such as is represented in the curve *E* (Fig. 233). During the *first* quarter-cycle (90°)

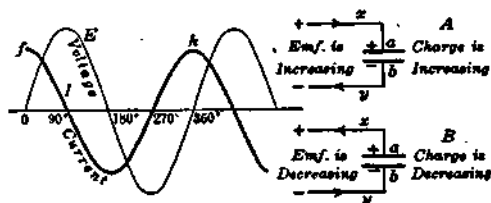

FIG. 233. — Voltage and current curves in a capacity circuit.

the voltage rises and the electricity is flowing into the condenser until it is *charged*, as shown in *A*. During the *second* quarter-cycle the voltage drops gradually to zero and the electricity flows out of the condenser or in negative direction, as shown in *B*. During the next half-cycle the voltage is reversed and so the condenser is charged and discharged in the opposite direction. If the current curve is plotted on the same sheet with the voltage, it can be proved that the *current leads the voltage by 90 degrees*.

Of course, in this study we have assumed that the current has already been flowing for a few seconds, for it is quite evident that at the instant the switch in the circuit is closed, the current must start at zero, no matter what value the e.m.f. may have. So it happens that the current waves are generally

abnormal for a few cycles after closing the switch, but they usually change and become regular waves leading the voltage waves by 90 degrees.

235. Capacity of a condenser. Experiments show that the capacity of a condenser is increased by bringing the plates near together and by increasing the area of the plates. *The capacity is directly proportional to the area of the plates and inversely as the thickness of the dielectric.* It can also be shown that the capacity of a condenser depends very much on the nature of the dielectric.

The quantity of electricity stored in a condenser is called its **charge**. In any condenser this charge is found to be directly proportional to the applied voltage. This is expressed by the equation

$$Q = CE$$

where

Q = charge in coulombs (amperes \times seconds),

E = voltage applied,

C = constant, called the **capacity** of the condenser, expressed in farads.

A condenser of 1 farad capacity will hold a charge of 1 coulomb if a difference of potential of 1 volt is applied between the plates. In practice such a condenser would be too enormous to be constructed and so the practical unit of capacity is the **microfarad**, which is one millionth of a farad. For example, one mile of ocean cable is equal to about $\frac{1}{2}$ of a microfarad.

To show how the capacity of a condenser depends on the nature of the dielectric, we shall suppose that a condenser with air as the dielectric has a capacity of F farads; then the capacity becomes equal to kF farads when another dielectric is used. This constant k , called the **dielectric constant** or the **specific inductive capacity** of the material, is given in the following table for some of the materials commonly used in commercial condensers.

MATERIAL	SPECIFIC INDUCTIVE CAPACITY	DIELECTRIC STRENGTH (Volts per Millimeter)
Air	1.00	about 790 (using points)
Glass	2.8 to 9.9	5,500 to 8,000
Mica	4.6 to 8.0	17,000 to 28,000
Paraffined paper	2.8 to 3.8	4,200 to 30,000

It is very important not to confuse the *specific inductive capacity* or dielectric constant of the dielectric material with the "strength of the dielectric." The first term refers to its *power to convey* the influence of the charges through it, while the second term refers to its *strength as an insulator* so that the voltage across it will not rupture it and cause a charge to pass through it in the form of an arc.

Furthermore, it should be kept clearly in mind that the capacity of a condenser or circuit is a quality of the circuit and is not dependent upon the current flowing or the voltage applied, — just as the capacity of a vessel to hold a liquid is a quality of the vessel, dependent upon the size and shape of the vessel, and irrespective of the amount of liquid that may be in the vessel or the rate at which it is running in or out.

236. Capacity and inductance compared. We have already seen that inductance in a circuit causes an alternating current to "lag" behind the voltage, and that capacity causes the current to "lead" the voltage. Thus the effect of capacity is just the opposite of that of inductance. In the same way we have to consider *capacity reactance*, which is the opposite of inductive reactance. Generally the capacity reactance is too small to be taken into account, but where it is large enough to affect the transmission of power, it must be deducted from the inductive reactance to get the *net* reactance. We have already seen that the reactance of inductance has much the same effect as increasing the resistance. In fact, inductive

reactance is measured in ohms, and since capacity reactance has the effect of neutralizing inductive reactance it is also measured in ohms. *But it is not true that adding capacity reactance is like reducing the ohmic resistance of a circuit.*

Reducing the ohmic resistance of a circuit would, of course, allow more power to be transmitted, but capacity reactance hinders the transmission of power just as effectively as inductive reactance does, only in a different way. Inductance makes the current lag and so puts it out of phase with the voltage and thus reduces the amount of power transmitted. Capacity makes the current lead and so puts it out of phase with the voltage and thus also reduces the amount of power transmitted. It makes no difference in the amount of power held back and returned to the generator whether we introduce into the circuit 100 ohms of inductive reactance *or* 100 ohms of capacity reactance. But suppose we introduce 100 ohms of inductive reactance *and* 100 ohms of capacity reactance, then the two will neutralize each other and power will be transmitted as though there were no reactance at all. The only loss will be that due to ohmic resistance. However, it should be remembered that capacity and inductance neutralize each other only when both are distributed along the whole length of the circuit. This has been done on long-distance telephone lines, as will be described in Chapter XXI. When the inductive reactance and capacity reactance neutralize each other, the resulting condition is called "*resonance*" (Chapter XXII).

The effect of frequency on capacity reactance is just the opposite of that on inductive reactance. The greater the frequency, the less is the capacity reactance. For example, doubling the frequency makes *the capacity reactance one half as great.*

237. How to compute capacity reactance. Although the effects of capacity on circuits operating at voltages lower than 6000 are of little consequence, yet they are present nevertheless.

Every electrical conductor has capacity and when an insulated wire is laid in the earth or is strung overhead it becomes one plate of a condenser. The other plate of the condenser is the earth, and the dielectric is the insulating covering of the wire, or the air which is between it and the earth. The capacity of a wire has a great effect on its usefulness in telephone service. The capacity of ocean cables is also a matter of much importance and the capacity effects are of great moment in the long-distance transmission of power by electricity. But perhaps the greatest field for condensers is radiotelegraphy.

Although the computation of the effects of capacity in all these fields of application would be quite beyond the scope of this book, yet we may give a few fundamental equations which will be useful.

It can be shown that a condenser connected in series with an alternating current acts as an effective resistance and exerts a back pressure on the impressed e.m.f., and also that this back pressure opposes that set up by inductance. To distinguish these counter e.m.f.'s, the reactance caused by inductance is expressed as *positive reactance*, and that by a condenser as *negative reactance*.

The equation for computing the capacity reactance of a condenser is as follows:

$$X_c = \frac{1}{2\pi fC}$$

where

X_c = capacity reactance in ohms,

π = 3.14

f = frequency, cycles per second,

C = capacity in farads.

This equation resembles the expression for inductive reactance ($2\pi fL$), except that it will be noticed that the capacity reactance is a reciprocal and so varies *inversely* as the frequency and size of the condenser.

Usually, however, we are more interested in the current used to charge the condenser, which can be expressed in this form :

$$I = \frac{E}{\frac{1}{2\pi fC}}$$

that is,

$$I = 2\pi fC E.$$

FOR EXAMPLE, what is the charging current needed for a line having a capacity of 3 microfarads, when the voltage is 40,000 volts and the frequency is 60 cycles per second ?

$$\begin{aligned} \text{SOLUTION. — } I &= 2 \times 3.14 \times 60 \times 0.000003 \times 40,000 \\ &= 45.2 \text{ amperes.} \end{aligned}$$

When we have *both* inductive and capacity reactance combined in series, then they tend to neutralize each other, and the combined effect is the *difference* between them. This is expressed in the equation

$$X = X_L - X_C$$

where X = combined reactance in *ohms*,
 X_L = inductive reactance in *ohms*,
 X_C = capacity reactance in *ohms*.

But when $X_L = X_C$

or $2\pi fL = \frac{1}{2\pi fC}$

and $f = \frac{1}{2\pi\sqrt{LC}}$

then the circuit is said to be in *resonance* and the current has its maximum value and is equal to E/R .

FOR EXAMPLE, suppose a circuit contains an inductance of 1.5 henrys in series with a capacity of 30 microfarads. What is the reactance when the frequency is 60 cycles per second?

$$\begin{aligned} \text{SOLUTION. — } X_L &= 2 \times 3.14 \times 60 \times 1.5 \\ &= 565 \text{ ohms.} \end{aligned}$$

$$\begin{aligned} X_C &= \frac{1}{2 \times 3.14 \times 60 \times 0.00003} \\ &= 88.5 \text{ ohms.} \end{aligned}$$

$$\begin{aligned} X &= 565 - 88.5 \\ &= 476.5 \text{ ohms.} \end{aligned}$$

If the circuit contains both inductance and capacity in series with resistance, then the impedance can be calculated by first

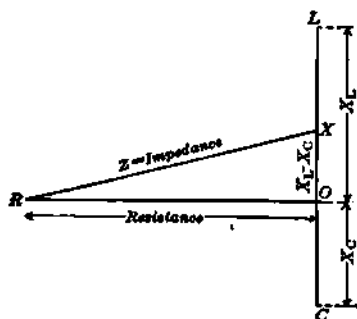

FIG. 234.—Diagram to show how to compute impedance in a circuit containing resistance, inductance, and capacity.

subtracting the capacity reactance (X_C) from the inductive reactance (X_L) and then combining the resulting reactance X with the resistance, as described in section 225. This is illustrated by the diagram in figure 234, where the resistance is represented by the horizontal line OR , the capacity reactance by OC , drawn vertically downward, and the inductive reactance by OL , drawn upward.

Then by subtraction, the resulting reactance is OX and by combining this with the resistance OR in a right triangle, the hypotenuse RX is the impedance Z . The equation would be as follows:

$$Z = \sqrt{R^2 + (X_L - X_C)^2}$$

where Z represents the impedance in ohms.

FOR EXAMPLE, suppose a circuit contains 25 ohms inductive reactance in series with 70 ohms capacity reactance and 40 ohms resistance. What is the impedance?

$$\text{SOLUTION. — } Z = \sqrt{40^2 + (25 - 70)^2} = \sqrt{40^2 + (-45)^2} = \sqrt{1600 + 2025} \\ = 60.2 \text{ ohms.}$$

Ohm's Law for a-c. circuits may be now stated as follows:

The current flowing in an alternating-current circuit equals the quotient of the voltage divided by the impedance. This is represented by the equation

$$I = \frac{E}{Z}$$

where I = effective current in amperes, E = effective e.m.f. in volts, Z = impedance in ohms.

FOR EXAMPLE, what would be the current in the preceding example if the voltage were 110 volts?

$$\text{SOLUTION. — } I = \frac{110}{60.2} = 1.83 \text{ amperes.}$$

Regardless of whether the circuit contains inductive reactance, capacity reactance, or both, the power factor is always equal to the ratio of the resistance to the impedance; that is,

$$\text{power factor} = \frac{R}{Z}$$

PROBLEMS

1. What is the capacity reactance of an a-c. circuit containing 25 microfarads capacity if the frequency is 60 cycles per second?
2. What would be the capacity reactance in problem 1 if the frequency were 25 cycles per second?
3. If 500 volts were applied to the circuit in problem 1, what would be the current?
4. Find the voltage across a condenser of 15 microfarads capacity if a current of 2 amperes flows when the frequency is 133 cycles.
5. What is the combined reactance of a 60-cycle a-c. circuit which has 25 microfarads capacity in series with 5 henrys inductance?
6. If the voltage in problem 5 is 600 volts what is the current?

7. What current will flow in problem 6 if the frequency drops to 25 cycles per second and everything else remains unchanged?

8. A 60-cycle 110-volt circuit has 10 ohms resistance in series with 0.2 henrys inductance and 20 microfarads capacity. What is the impedance of the circuit?

9. What would be the impedance in problem 8 if the frequency changed to 25 cycles per second?

10. What would be the current in problem 8?

SUMMARY OF CHAPTER XIII

INDUCTANCE means the magnetic effect of the different turns of a coil tending to stop any change in the current. The inductance of a coil is greatly increased when the coil is wound on an iron core. A straight wire or a wire bent in the shape of a hairpin has very little inductance.

An **ALTERNATING CURRENT** in a circuit having inductance always "lags" behind the alternating voltage.

Self-inductance in a-c. circuits reduces the value of the current because it sets up in the same circuit a counter e.m.f.

UNIT OF INDUCTANCE: HENRY. When a change of one ampere per second sets up an induced e.m.f. of one volt, the circuit is said to possess an inductance of one henry.

EQUATION FOR INDUCTANCE

$$L = \frac{4\pi^2 N^2 r^2 \mu}{10^9 l}$$

REACTANCE OR INDUCTIVE RESISTANCE (X_L) depends on the frequency and on the number of henrys of inductance:

$$X_L = 2\pi f L.$$

IMPEDANCE is the combination of reactance and resistance.

$$\text{Impedance} = \sqrt{\text{Resistance}^2 + \text{reactance}^2}.$$

$$\text{POWER FACTOR} = \frac{\text{True power}}{\text{Apparent power}} = \frac{\text{Watts}}{\text{Volt amperes}}$$

$$\text{POWER FACTOR} = \frac{\text{Resistance}}{\text{Impedance}}$$

A-C. POWER:

$$\text{Watts} = \text{volts} \times \text{amperes} \times \text{power factor.}$$

CAPACITY is that property which gives an electric circuit elasticity.

A **CONDENSER** consists usually of thin sheets of lead or tin foil, separated by thin sheets of insulating material called the dielectric. Capacity of a condenser varies directly as the area of the plates, inversely as the thickness of the dielectric, and depends on the nature of the dielectric. The charge of a condenser is directly proportional to the applied voltage.

FARAD: unit of capacity. A condenser would have a farad capacity if it held one coulomb of electricity for every volt pressure across its terminals. The practical unit of capacity is one millionth of a farad and is called the **MICROFARAD**.

$$\text{CAPACITY (farads)} = \frac{\text{Charge (coulombs)}}{\text{Voltage (volts)}}$$

CAPACITY tends to make an alternating current *lead* the voltage.

CAPACITY REACTANCE is the opposition offered by capacity to the flow of an alternating current and is measured in ohms; symbol X_c .

$$X_c = \frac{1}{2\pi fC}$$

REACTANCE (X) in a circuit containing inductive and capacity reactance in series is equal to the difference

$$X = X_L - X_c$$

IMPEDANCE (Z) in a circuit containing resistance and reactance is found from the following equation:

$$Z = \sqrt{R^2 + (X_L - X_c)^2}$$

OHM'S LAW FOR A-C. CIRCUITS

$$\text{Current} = \frac{\text{Voltage}}{\text{Impedance}}$$

QUESTIONS

1. Will essentially the same current flow through a straight wire under a given voltage whether it be continuous or alternating?
2. Will essentially the same current flow through a coil with an iron core under a given voltage whether it be continuous or alternating?
3. What causes the effects of self-inductance?
4. Why are these effects noticed in a circuit only when the current is changing?
5. Name three practical cases where the circuits are essentially noninductive.
6. What advantages has a choke coil over a rheostat for current control?
7. Compare the power consumed in a choke coil and an equally effective rheostat.
8. How does the inductance of a coil vary with (a) its number of turns, (b) its radius, (c) its length, and (d) the permeability of its iron core?
9. How does inductive reactance depend upon the frequency of an alternating current?
10. Under what conditions will an alternating current lag 90 degrees behind the voltage?
11. Is the equation, watts = volts \times amperes, ever true of an alternating current?
12. How is the equation affected by inductance?
13. How would you state Ohm's Law for circuits containing inductance?
14. Under what conditions is the power factor unity?
15. What is the relation between kv-a. and kw.?
16. Why is it undesirable for electric power companies to have a low power factor?
17. What is the hydraulic analogue for a condenser?
18. Under what conditions may a circuit have capacity, even if there are no condensers connected to the line?
19. What effect does capacity have on the phase relation between current and voltage?
20. If an alternating current leads the voltage by 90 degrees, what do we know about the circuit?
21. Name three practical uses for condensers.

22. What is the distinction between the "power" of a dielectric and the "strength" of a dielectric?

23. What would be the effect on the value of the current of separating the plates of a condenser placed in the circuit?

24. Under what conditions will the inductive reactance of a circuit just balance the capacity reactance?

25. What is meant by a resonant circuit?

26. If a circuit is adjusted so as to be resonant for some particular frequency, will it be resonant for any other frequency?

27. If a circuit contains resistance, capacity, and inductance, under what conditions will a given alternating electromotive force produce the maximum current?

28. At this point it is suggested that the reader write out a carefully worded definition of each of the following electrical units which have been explained in this and the preceding chapters:

Ampere	= unit of current.
Milliampere	= one thousandth of an ampere.
Microampere	= one millionth of an ampere.
Volt	= unit of pressure.
Millivolt	= one thousandth of a volt.
Microvolt	= one millionth of a volt.
Ohm	= unit of resistance.
Megohm	= 1,000,000 ohms.
Coulomb	= unit of quantity.
Farad	= unit of capacity.
Microfarad	= one millionth of a farad.
Watt	= unit of power.
Kilowatt	= 1000 watts.
Horse power	= 746 watts.
Joule	= unit of work = one watt second.
Watt hour	= unit of work = 3600 watt seconds.
Kilowatt hour	= 1000 watt hours.
Horse-power hour	= 746 watt hours.

The prefixes micro, milli, kilo, and meg (or mega), which respectively mean one millionth, one thousandth, one thousand, and one million, may be applied to any of the electrical units. For instance, one kilovolt means one thousand volts, one microhm means one millionth of an ohm, etc.

CHAPTER XIV

ALTERNATING-CURRENT GENERATORS

Comparison of d-c. and a-c. generators — types of revolving fields: cylindrical and salient forms, horizontal and vertical shafts — exciters — single and three-phase generators — frequency — voltage and power — commercial rating — operating alternators in synchronism — importance of wave form — efficiency.

238. A-c. generators much like d-c. generators. Practically all machines for generating an electric current depend upon the fundamental idea of moving conductors so as to cut lines of magnetic force. We have already seen (section 141) that even in the direct-current generator the current induced in the armature windings is an alternating current and requires a special device, called a commutator, to deliver to the external circuit unidirectional or continuous current. Therefore, all we have to do to convert a direct-current generator into an alternating-current generator is to omit this rectifying device and to lead the current out by means of collecting rings. In short, we substitute the collecting rings for the commutator in order to convert a d-c. generator into an a-c. generator. Indeed, we shall see that the alternating-current generator, or alternator, is a simpler machine to build and to understand than the direct- or continuous-current generator.

239. Revolving-field alternator. Since it is the relative motion between conductors and magnetic flux which generates the electric current, we can easily see that it is merely a matter of convenience in construction whether the conductors move through a stationary magnetic field (that is, the armature



FIG. 236. — Cylindrical form of partly wound revolving field used with steam turbines. It has 4 poles.



FIG. 237. — Stationary armature of figure 236 for high-speed alternator.

revolves) or the magnetic flux moves across stationary conductors (that is, the field revolves, as shown in figure 235). As a matter of fact, the revolving-armature type is rarely used even in very small sizes, so that practically all alternators are built with a rotating field and stationary armature. The reasons for this construction are that it offers better opportunity for insulation of the armature windings and it is not necessary to have such a high voltage on the collecting rings.

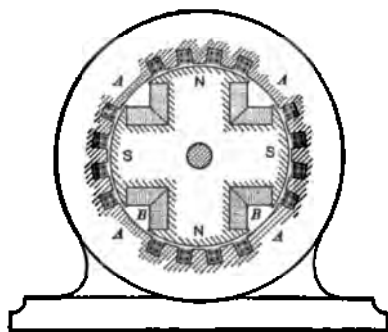

FIG. 235. — Diagram of revolving field and stationary armature.

Figure 236 shows the cylindrical type of revolving field, which is merely a steel drum with slots cut in its periphery and with heavily insulated copper conductors set in so as to form two or four magnetic poles. This rotates at very high speed within a shell made up of laminated steel with slots cut in its inner surface for the armature windings, as shown in figure 237. The whole machine is inclosed so that it can be cooled by a forced draft of air. Such machines are built in sizes ranging from about 500 kv-a. up to the giant 45,000-kv-a. turboalternators, and run at speeds of 750, 1500, 1800, and 3600 r.p.m., depending upon whether the field has two or four poles, and whether the machine is intended to operate at 25 cycles or 60 cycles.

Figure 238 shows a salient-pole type of revolving field which looks and acts very much like a great flywheel. The poles are alternately north and south and are fitted with a curved shoe for the better distribution of magnetic flux. The necessary current for exciting these poles is, of course, direct current and is introduced through two collecting rings fastened to the shaft. This slow-speed, revolving field rotates inside a large ring made up of steel stampings with the armature windings placed in slots on the inside surface. Such a fixed armature is shown in figure 239. This type of alternator is generally placed on the same shaft with a reciprocating steam engine or water wheel, although there is still some demand for this type of generator built with a pulley for belt drive.

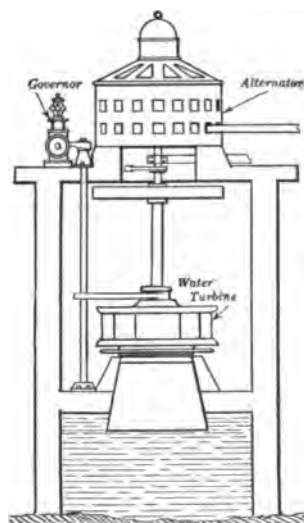

FIG. 240.—Vertical water-wheel generator installation.

The machines just described have a horizontal shaft, but this is not always the case. For example, the generator shown in figure 240 has a vertical shaft and is driven by a water turbine placed directly underneath. Some of these revolve very slowly; for instance, the generators at Keokuk, Iowa, run at 58 r.p.m. Others turn at a much higher speed; for example, some of the generators at Niagara run at 250 r.p.m. Some of the older steam turbogenerators (Curtis type) also have a vertical shaft. But in recent years the speed of steam turboalternators has greatly increased (in some cases doubled) and this involved smaller diameters, greater lengths, and greater vibration difficulties, so that the horizontal type has become more desirable.

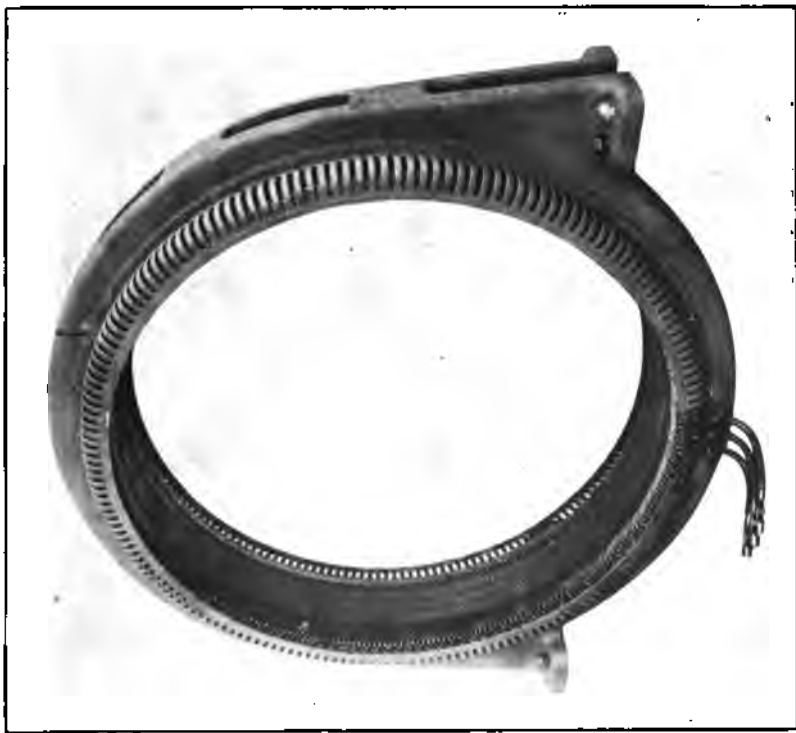

FIG. 239. — Stationary armature for the rotating field shown in figure 238.



FIG. 238. — Revolving field with 60 poles used with reciprocating steam engines and water wheels.



FIG. 241 a. — Shaft with rotating field and exciter armature. Note grids across pole faces.

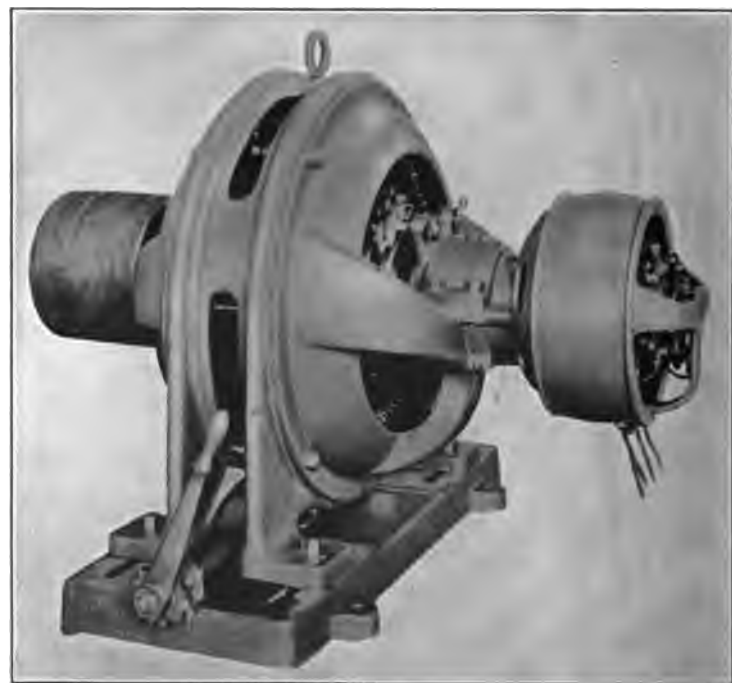

FIG. 241 b. — Small alternator with exciter (right) coupled to the shaft.

240. Exciters. In the earlier types of alternators the direct current for exciting the field coils was furnished by a little d-c. generator connected with the alternator by a belt. But in recent years the exciter has been either directly connected on the same shaft, as shown in figure 241, or has been driven independently. Separately-driven exciters are more common, because of the fact that this system is much more flexible, since any drop in the speed of the alternator does not cause a corresponding drop in the exciter voltage. Then, too, if the exciter is not direct-connected, an accident to it will not necessitate shutting down the alternator, provided there is a duplicate exciter set. Sometimes a storage battery is installed in connection with the exciting generators, so that current may be furnished to the field circuits of the alternators even though all other rotating apparatus is at a standstill. Unless a storage battery is available for excitation, it is necessary to provide independent prime movers (steam-, water-, or gas-driven units) for the exciters when the plant is first starting up. With the plant going, motor-driven exciters are often used.

241. How an alternator works. Perhaps it will help us to understand how these alternators work if we study a very simple diagram in figure 242. The rotating field consists of eight poles, which are so wound that the N- and S-poles alternate.

The direct current for exciting these poles is led in through slip rings from some outside source. The ring outside, which represents the armature frame, has also eight sets of

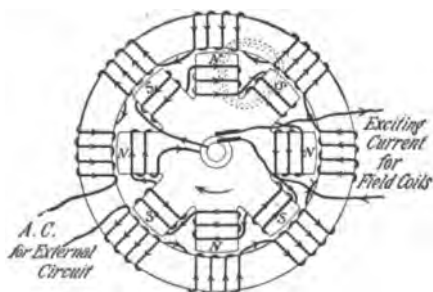

FIG. 242.—Diagram to represent the revolving field and stationary armature of an alternator.

windings, which are so connected that the induced e.m.f. tends to circulate the current around the ring. But it will be seen that when the field poles have rotated through an angle of 45° the south poles will be where the north poles are at the instant represented, and the current will be induced in the armature in the *opposite direction*. When the field rotates another 45° , the situation will again be exactly as shown in the figure. So the current alternates eight times in a complete revolution or makes four complete cycles in one revolution. To determine, then, the frequency of an alternator (that is, the number of cycles per second), we have only to *multiply the number of revolutions per second of the field by the number of pairs of poles*. But since the speed of the alternator is usually expressed in revolutions per minute (r.p.m.), we may express this relation thus:

$$\text{Frequency (cycles per sec.)} = \frac{\text{Poles} \times \text{r.p.m.}}{120}$$

FOR EXAMPLE, if a two-pole alternator is driven at 3600 r.p.m., what will be the frequency?

$$\text{SOLUTION. — Frequency} = \frac{2 \times 3600}{120} = 60 \text{ cycles.}$$

To make use of the alternating current for any purpose such as electric lighting, we have simply to cut the armature circuit at any convenient point and connect the ends directly to the mains. Such a machine would be a *single-phase* alternator. Of course, in the commercial machine the armature coils are not wound *around* the frame as shown in the diagram, but are made up in rectangular shape so that two sides may be slipped into slots, very much as in the case of the drum-wound armature of a d-c. generator.

242. Single-phase and polyphase currents. It has been found more economical of space to have more than one coil for each pole of the field, and so we have **two-phase** and **three-phase** machines, in which there are two or three sets of coils

on the armature. In the three-phase alternator, which is the type most used to-day, the three sets of armature coils may be used separately to furnish electricity for three separate lighting circuits, as shown in figure 243.

The currents in the three circuits differ in phase by one third of a cycle or 120 electrical degrees, as shown in figure 244. It will be seen that the currents are such that at any instant their sum is zero.

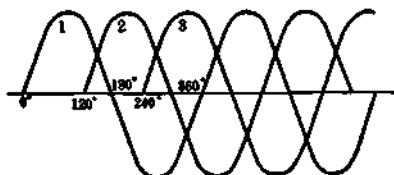

FIG. 244. — Curves of currents in a three-phase machine.

in figure 245 (I), and (2) the delta or Δ -connection shown in figure 245 (II). Most generators have their coils Y-connected, but it is ordinarily impossible to determine from an external inspection of a machine whether it is Y- or delta-connected.

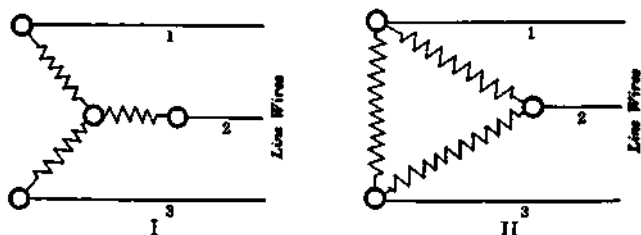

FIG. 245. — Three-phase system connected in (I) star or Y, and (II) delta or Δ .

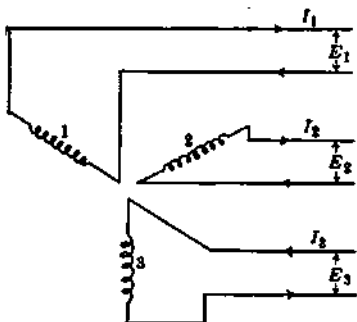

FIG. 243. — Diagram of three-phase generator with six line wires.

To save wire electrical engineers have invented *two methods of connecting devices of any sort to a three-phase circuit*, so as to have only three line wires instead of six. They are (1) the star or Y-connection shown

It will be well to remember that in a three-phase circuit one wire serves as a return circuit for the other two and that each wire in turn carries the return current. At any instant the current is going out from the generator through two wires and returning through one, or it is going out through one wire and returning through the other two. For *instantaneous* currents, then, Kirchoff's law holds, which states that the algebraic sum of all currents flowing to a point is zero.

243. Single-phase and three-phase alternators. Nearly all of the alternators in use to-day are three-phase machines. In fact, single-phase generators are seldom manufactured now, because the three-phase machines are more economical in the utilization of their constructive materials. When it is necessary to supply a single-phase circuit such as is sometimes used for railways and electrochemical work, then it is the practice to use a three-phase machine connected up in Y and to leave one leg idle. Experience has shown that single-phase machines are in general about 30 per cent heavier and more expensive than the three-phase machine of the same capacity.

Figure 246 shows a diagram of a three-phase Y-connected alternator, which is the type most often met with in practice. In this diagram it should be remembered that the circumferential distance from the center of one pole to that of the next pole of the same polarity is reckoned as 360 magnetic degrees. Each conductor, as the flux passes through 360 magnetic degrees, has an induced electromotive force which can be represented by the regular sine curve. The three sets of coils are so distributed on the stationary armature that the phase displacement between the e.m.f.'s is 120 electrical degrees, and figure 244 may also be used to show the curves of the instantaneous electromotive forces.

244. Frequencies of alternators. The time required for the alternating e.m.f. or current to pass through a complete "cycle" is called the **period**. Evidently the period of the e.m.f. in-

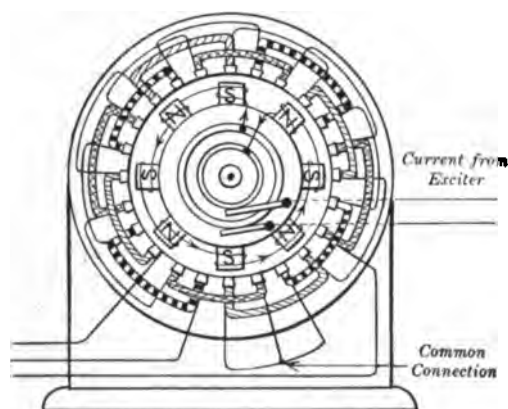

FIG. 246. — Diagram of three-phase Y-connected alternator.

duced in any single conductor is the time required for it to pass a pair of poles (i.e., 360 magnetic degrees) and the number of cycles per second or frequency is equal to the number of poles passed per second.

In the United States the frequencies most commonly used commercially are 60 and 25 cycles per second. For electric lighting and small-power purposes the 60-cycle system is generally used on account of the freedom from flickering; but there is a tendency toward the lower frequency because of lower iron losses in a-c. machines, greater economy in transmission, and lower speed for alternators of the same number of poles. It is very important in ordering a-c. machinery to specify the frequency of the system.

PROBLEMS

1. At what speed (r.p.m.) must the field revolve in the alternator shown in figure 246 in order to deliver a 60-cycle e.m.f.? A 25-cycle e.m.f.?
2. At what speed must the field in the turbogenerator shown in figure 235 revolve in order to give a 60-cycle e.m.f.? A 25-cycle e.m.f.?

3. What is the frequency developed by a two-pole alternator when running at 3600 r.p.m.?

4. How many poles must a 25-cycle alternator have, if its speed is 100 revolutions per minute?

245. Voltage and power of alternators. We have already learned that one volt is induced in a single conductor when it cuts 100,000,000 (or 10^8) lines of magnetic force per second. Actually, a conductor never cuts lines of force at a uniform rate for anything like a whole second, for although the rotor is turned at practically constant speed yet the flux is not uniformly distributed. Thus the e.m.f. in each conductor is not steady. It is, however, often necessary to *compute* the instantaneous e.m.f. The instantaneous e.m.f. in any conductor may be computed from the following equation:

$$E = \frac{BLV}{10^8}$$

where E = e.m.f. at any instant,

B = density of flux where the conductor is at that instant,

L = cutting length of the conductor,

V = relative speed of field and conductor at given instant.

NOTE. — B , L , and V must all be expressed in the same units of length.

Since the standard form for an alternating e.m.f. wave is the sine curve, it can be demonstrated that the effective value of the e.m.f. is 0.707 of the maximum value. That is,

$$E = \frac{E_m}{\sqrt{2}} = 0.707 E_m$$

where E = effective value of e.m.f.,

and E_m = maximum value of e.m.f.

In general, when we speak of an alternating e.m.f. of so many volts, it is understood to be the **effective voltage**, and so instruments are graduated to read in terms of effective values.

In a three-phase alternator the phases are often internally connected so that only three terminals are brought out. Figure 247 represents diagrammatically these connections in a Y-armature. If E and I represent the volts and amperes per armature phase in a Y-connected machine, and E_l and I_l represent the line volts and amperes, then it can be demonstrated that

$$E_l = \sqrt{3}E = 1.73E$$

and $I_l = I.$

While a-c. generators are Y-connected, yet among other a-c. machines it is quite common to find the Δ -connection. Therefore we shall introduce at this point the relation between phase and line current and volts in a delta-connection.

In a delta-connection, if E and I represent the volts and amperes per phase, and E_l and I_l the line volts and amperes, it can be demonstrated that

$$E_l = E$$

and $I_l = \sqrt{3}I = 1.73I.$

Let us now consider the power delivered by a three-phase alternator. If the power is supplied over six wires forming three independent single-phase circuits, then it is evident that, if the load on the machine is balanced, the total power of all three phases will be three times the power of a single phase. That is,

$$P = 3EI \times \text{power factor}$$

where

P = total power in watts,

E = volts per phase,

I = amperes per phase.

Connecting the three separate phases, either by means of the Y- or the Δ -connection, to form a three-phase circuit

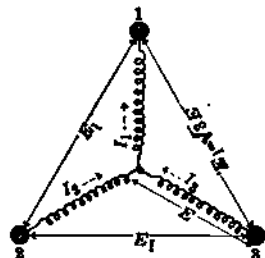

FIG. 247. — Diagram indicating voltage relations in a three-phase Y-connected alternator.

will not change the total power. Therefore the same equation holds true. It has just been shown that in the Y-connection the line voltage differs from the phase voltages, and in the Δ -connection the line amperes differ from the amperes per phase. In a three-phase circuit we usually measure the line voltage (E_l) and the line current (I_l) and so it is desirable to express the power in terms of these values.

For the Y-connection, then, we have

$$\text{since} \quad E = \frac{E_l}{\sqrt{3}}$$

$$\text{and} \quad I = I_l$$

$$\text{then} \quad P = 3 \frac{E_l}{\sqrt{3}} I_l \times \text{p.f.} = \sqrt{3} E_l I_l \times \text{p.f.}$$

For the delta-connection we have

$$\text{since} \quad E = E_l$$

$$\text{and} \quad I = \frac{I_l}{\sqrt{3}}$$

$$\text{then} \quad P = 3 E_l \frac{I_l}{\sqrt{3}} \times \text{p.f.} = \sqrt{3} E_l I_l \times \text{p.f.}$$

These two expressions are seen to be identical. We may therefore state the rule that the power for a balanced load delivered by a three-phase alternator, regardless of whether Y- or Δ -connected, is the product of $\sqrt{3}$ by the effective volts between the line wires, by the effective current in each line wire, and by the power factor.

$$P = \sqrt{3} E_l I_l \times \text{power factor.}$$

NOTE. — The power factor is the cosine of the angle of phase difference between the current and voltage.

The commercial voltages for d-c. generators are 125 volts, 250 volts, and 600 volts, and for alternators we have the same

voltages and in addition machines at 2300 volts, 6600 volts, and 11,000 volts. These higher voltages for a-c. machines can be used because the armature windings are usually stationary and so can be safely insulated. The highest voltages are employed only on the slow-speed alternators.

PROBLEMS

1. Assume the maximum value of an alternating e.m.f. is 100 volts. Plot on fine coordinate paper a sine curve (Fig. 212) of this e.m.f. and find the instantaneous values for every 20° . Square these instantaneous values and find the average of the squares. Extract the square root. This is called the effective voltage.

2. What is the greatest instantaneous value of an e.m.f. when the voltmeter reads 110?

3. What power does a balanced three-phase system with 90 per cent power factor deliver, when each line wire carries 45 amperes, and the voltage between the line wires is 6000 volts?

4. An alternator with 85 per cent power factor is rated as 100 kv-a. and 2300 volts, and has a three-phase star-connected armature. What is the current in each part of the armature at the rated full-load output?

5. What would be the kilowatt capacity of a three-phase Y-connected alternator, built for 6600 volts and 88 amperes in each phase, on the basis of a load with 80 per cent power factor?

6. A 125-volt, 100-kilovolt-ampere star-connected alternator is re-connected in delta. What will be the voltage? What will its kilovolt-ampere capacity be?

HINT. — Make a diagram similar to figure 247 for delta-connection.

246. Rating of alternators. We have already seen that d-c. generators are rated according to their capacity to deliver kilowatts continuously without undue heating. But alternators are commonly rated according to the kilovolt-amperes which they can deliver without undue heating. This is because the power capacity of an alternator depends upon the current it must deliver to supply that power, and it is this armature current which in turn determines the armature-

copper loss irrespective of the power factor. Therefore the output of a three-phase alternator can be computed thus:

$$Kv-a. = \frac{\sqrt{3}EI}{1000} = 0.00173EI$$

where $Kv-a.$ = kilovolt-amperes,

E = effective voltage between phase wires on external circuit,

I = current in amperes in each of the line wires.

It is assumed that the load on the three phases is balanced.

There are numerous turbogenerators as large as 25,000 kv-a. rated capacity; but there are also numerous power stations requiring over 1,000,000 kv-a., which means the installation of several alternators of the largest size that have yet been built.

PROBLEMS

1. What would be the kilowatt capacity of an alternator if, operating at 70 per cent power factor, it is rated at 250 kv-a.?
2. What size alternator (kv-a.) would be required to supply a load of 800 kw. at 80 per cent power factor?
3. What would be the output in horse power of the steam engine required to drive this generator at this load if the efficiency of the latter at this load is 95 per cent?
4. How many kilowatts in incandescent lamps may be added to a 500-kv-a. alternator which is already delivering 300 kv-a. to induction motors at 75 per cent power factor?
5. A 500-kv-a. generating plant is already supplying 300 kw. at 82 per cent power factor. How many kw. can still be supplied at 78 per cent power factor without exceeding the rated full load of the plant?

247. Operation of alternators. Just as with d-c. generators, it is the general practice to operate alternators in parallel. But in order to do this successfully, three conditions must be

fulfilled: (1) their voltages as registered by a voltmeter must be the same; (2) their frequencies must be the same; and (3) their voltages must be "in step" or in phase. When two or more alternators satisfy these three conditions, they are in **synchronism**. If two machines are not in synchronism, there will be an interchange of current between the machines. In the case of three-phase alternators which are to be operated in parallel it is also necessary to "phase out" the circuits; that is, to arrange the leads so that each lead from one alternator will, when the switch is thrown, connect to the corresponding lead of the other alternator.

In order to determine whether the induced e.m.f.'s of two alternators are equal at every instant, and whether similar terminals are connected, some form of **synchronoscope** must be used in addition to a voltmeter. One of the simplest forms of this device consists of a number of lamps which may be connected to indicate synchronism. There are other instruments that indicate the difference in phase between two electromotive forces at every instant. Special books on the management of a-c. machinery should be consulted for complete descriptions and circuit diagrams.

To operate alternators in parallel successfully involves a correct division of the load among the machines. This is really a problem of how to control or regulate the prime mover; hence the prime movers of parallel generators must have nearly the same speed regulation. It is important to remember that increasing the field of a generator in order to raise its voltage will *not*, as in the case of a d-c. generator, cause the generator to take a greater share of the load. Any variation of the field, within certain limits, merely results in changing the power factor at which that generator is supplying its share of the power. If the field is varied so that the power factor is decreased, the current $\left(I = \frac{P}{\sqrt{3} E \times \text{p.f.}} \right)$ will increase, while,

if the power factor is increased, the current will decrease; but in either case the power will remain unchanged. To cause a certain alternator to take a greater share of the load, the governor on the prime mover is adjusted by hand in a way that would make it run at a greater speed if it were running alone. In this way the machine forges ahead and slightly advances the phase of its e.m.f., which causes it to take a greater share of the load. If the bus-bar frequency is low, it is necessary to adjust the field excitation of every alternator.

248. Why wave form is important. We have assumed that both the current and the terminal e.m.f. have a sine wave form, and indeed it is very desirable that they should have. In fact, in all of our calculations of the generator and for the alternating-current circuit we assume a sine wave. It has been found that machines with unlike wave forms, operating in parallel, exchange local currents, and this reduces their output. If the curves are too peaked, the machines require better insulation than those with sine curves. On the other hand, if the wave is flat-topped, the hysteresis loss is increased, which may greatly increase the cost of operating transformers.

Figure 248 is an oscillogram which shows the actual curve of the terminal voltage of a 6600-volt generator, and it will be seen to follow very closely the form of a sine wave. Experiments show that the wave form of e.m.f. depends on the way in which the magnetic flux is distributed around the poles and also on the way in which the inductors are distributed over the surface of the armature. Besides these factors, it is necessary to consider the shape and length of the air gap, the relative strength of field magnets and armature winding, the power factor of the load, and the method of connecting the phases of a three-phase machine. Usually, therefore, *the first and most necessary consideration about an alternator is that it shall generate very nearly a sine wave of e.m.f.*



FIG. 248. — Actual voltage curve at no load. 150 kv-a. and 60 cycles.

249. Efficiency of alternators. The efficiency of any machine means the ratio of the power delivered by the machine to the power received by it.

$$\text{Efficiency} = \frac{\text{Output}}{\text{Input}}$$

In the case of a large alternator it is generally impracticable to measure directly the input and so we determine the output and the losses and calculate the efficiency thus :

$$\text{Efficiency} = \frac{\text{Output}}{\text{Output} + \text{total losses}}$$

The results of tests on alternators of varying sizes from 100 kv-a. to 10,000 kv-a. show that the efficiencies run from about 91 per cent to 97 per cent. It is, of course, possible to get very high efficiency by increasing the first cost of the machine. But experience has shown that sometimes it does not "pay" to build machines for the highest possible efficiency. Hence we must distinguish between efficiency and economy.

If we know the efficiency of an alternator, we can compute the size of the engine required to drive it.

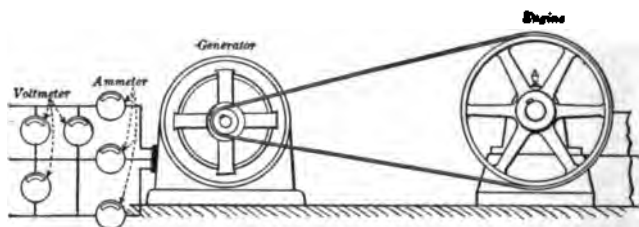

FIG. 249. — Size of engine required to drive three-phase alternator.

FOR EXAMPLE, what horse power would be required at the pulley in figure 249 when the alternator is impressing 2300 volts on the external circuit and delivering a current of 25 amperes, it being assumed that the power factor of the load is 80% and the efficiency of the generator is 92%?

SOLUTION. — Let x = horse power supplied at pulley,

$$746 x = \text{input in watts,}$$

$$\sqrt{3} \times 2300 \times 25 \times 0.80 = \text{output in watts,}$$

$$0.92 \times 746 x = 1.73 \times 2300 \times 25 \times 0.80,$$

$$x = \frac{1.73 \times 2300 \times 25 \times 0.80}{0.92 \times 746} = 116 \text{ h.p.}$$

PROBLEMS

1. What is the kilovolt-ampere output of a three-phase alternator when it is delivering 54 amperes in each of the three-phase wires and impressing on the external circuit a voltage of 2200?

2. Find the kilowatt capacity of the machine in problem 1 when delivering a load at 80% power factor.

3. If it requires 715 horse power to drive a three-phase generator delivering 600 kv-a. at 80% power factor, what is the efficiency of the alternator?

4. What horse power is needed to drive a single-phase generator under such conditions that its efficiency is 85%, the e.m.f. impressed

on the external circuit is 600 volts, the current is 145 amperes, and the power factor is 82%?

5. What is the efficiency of a single-phase generator which is delivering 625 kv-a. at 80% power factor and is driven by a 745-horse-power engine working at its rated capacity?

6. An alternator, operating at 68% power factor, receives 250 horse power from the engine and delivers 250 kv-a. from its terminals. What is its efficiency?

7. An alternator is delivering 200 kv-a. at 85 per cent power factor, and its efficiency at this load is 92 per cent. How many horse power must the direct-connected engine deliver at the shaft to drive this alternator?

8. The following table gives the results of a shop test for losses and efficiency on an alternator.

LOAD, PER CENT OF RATED	OUTPUT kw.	CORE LOSS kw.	FRICION AND WINDAGE kw.	FIELD COPPER LOSS kw.	ARMATURE COPPER LOSS kw.
0	0	39.4	30.3	4.7	0.0
25	427	39.5	30.3	5.2	0.4
50	857	39.6	30.3	5.9	1.7
75	1283	39.7	30.3	7.0	3.8
100	1712	39.8	30.3	8.1	6.7
125	2137	39.9	30.3	9.9	10.5
200	3424	40.2	30.3	20.7	26.9

Draw three curves,* using the per cents of rated output as abscissas (horizontal distances), and as ordinates (vertical distances) the following:

- constant losses; that is, core plus friction and windage;
- variable losses; that is, copper losses in field and armature;
- efficiency.

NOTE. — The ordinates of the loss curves are to be plotted to a scale of kilowatts and of the efficiency curve to a scale of percentage.

* For a fuller discussion of these results the reader is advised to consult *Alternating-Current Electricity (second course)* by *Timbie and Higbie*. John Wiley & Sons, Inc.

SUMMARY OF CHAPTER XIV

ELECTROMOTIVE FORCE is generated whenever there is relative motion between a conductor and a magnetic field so that one cuts the other.

In **D-C. GENERATORS** the conductors move (revolving armature).

In **A-C. GENERATORS** usually the field moves (revolving field).

FIELD COILS ARE EXCITED by a direct current from an outside source.

COLLECTING OR SLIP RINGS are used to lead the exciting current to revolving field coils.

HIGH-SPEED ALTERNATORS have two- or four-pole cylindrical form of revolving fields driven by steam turbines.

LOW-SPEED ALTERNATORS have a salient form of revolving field of many poles driven by reciprocating steam engines or water wheels.

EXCITERS are d-c. generators driven directly by belt or on the same shaft, or else separately by an independent prime mover or by a motor which is itself driven with storage battery for starting.

THREE-PHASE ALTERNATORS having armature windings Y-connected are the most common type of a-c. generator. A single-phase circuit may be supplied by leaving one leg idle. The alternating currents in the three wires differ in phase by 120° .

COMMERCIAL FREQUENCIES in the United States are 60 cycles for lighting and 25 cycles for railway and power work.

VOLTAGE OF AN ALTERNATOR is controlled by regulating the exciters.

OUTPUT of a three-phase alternator = $\sqrt{3} \times$ voltage between the lines \times current in each line \times power factor; or,

$$P = \sqrt{3}EI \times \text{power factor.}$$

RATING OF ALTERNATORS in kilovolt-amperes (kv-a.):

$$\text{kv-a.} = \frac{\sqrt{3}EI}{1000} = 0.00173EI \text{ (for three-phase generator).}$$

ALTERNATORS OPERATE IN PARALLEL when

- (1) Terminal e.m.f.'s are at every instant equal to one another,
- (2) Similar terminals are connected together.

WAVE FORM should approximate very closely to a sine curve.

EFFICIENCY of an alternator is generally computed on the basis of output and total losses in the machine; thus:

$$\text{Efficiency} = \frac{\text{Output}}{\text{Output} + \text{total losses}}$$

QUESTIONS

1. How could a generator be constructed so as to deliver both direct current and alternating current?
2. Why are alternators usually built with a revolving rather than a stationary field?
3. What advantages has the cylindrical form of rotor (revolving field) for high-speed alternators?
4. Why is the single-phase circuit generally used in railway work instead of the three-phase?
5. How is the vertical shaft in that form of generator supported?
6. What is the method of lubrication for the horizontal shaft of alternators?
7. What advantage is there in using forced-draft ventilation for turbogenerators?
8. What are the disadvantages in directly connecting the exciter to the alternator?
9. What is the difference between magnetic degrees and circular degrees? Are they ever equal?
10. What is the difficulty in using 25 cycles for lighting purposes?
11. Why are 60 cycles not generally used in long-distance transmission of power?
12. Why are alternators built for higher voltages than direct-current generators?

13. What is the relation between the effective value of e.m.f. and the maximum value of e.m.f. in an alternating current?
14. What value of e.m.f. does the voltmeter indicate?
15. Under what conditions would the power factor be unity?
16. Why are a-c. generators rated in kilovolt-amperes while d-c. generators are rated in kilowatts?
17. What constant is in the power equation for three-phase alternators which is not in the equation for single-phase alternators?
18. What precautions must one take in operating alternators in parallel that one does not take in operating d-c. generators? Why?
19. Give three reasons why the wave form of an alternator should not differ much from a sine curve.
20. What are some of the important factors in the construction of an alternator which determine the wave form of its terminal e.m.f.?
21. When is the highest efficiency in an alternator not desirable?
22. How may one compute the input of an alternator?

CHAPTER XV

TRANSFORMERS

Purpose and practical importance — fundamental principle — essential parts of distributing transformer — commercial forms: core type, shell type, and H-type — voltage ratio — approximate current ratio.

Some mistaken ideas about transformers and some common questions.

Losses: core and copper. Losses produce heat. Cooling by oil, by water-cooled oil, and by air blast. Ordinary efficiency and all-day efficiency.

Special types: constant-current, auto-transformer, welding transformer, and instrument transformers.

250. Why use transformers? We shall see that the real advantage in the use of alternating currents is in the economy of transmission, and that this is made possible by a simple and efficient machine known as a transformer. It must be kept in mind that a transformer is primarily a **voltage changer** and that it does not change the frequency of the alternating current, nor does it change the alternating to direct current. In construction it is the simplest, most rugged, and durable piece of electrical machinery; it requires less space and attention and involves less investment per kilowatt than either generators or motors. The step-up transformer takes the electric power of the generator at from 2300 to 11,000 volts and steps it up to from 50,000 to 150,000 volts for the transmission lines. Then this *high-tension electric power is stepped down in two steps* or stages; first, in large transformers at *substations* down to 2300 volts, and second, in *small distributing trans-*

formers located near the consumer to 110, 220, or 550 volts. Thus we see (Fig. 250) that the transformer is a very necessary link in every alternating-current system, for the alternators cannot generate directly the high voltages needed for long-

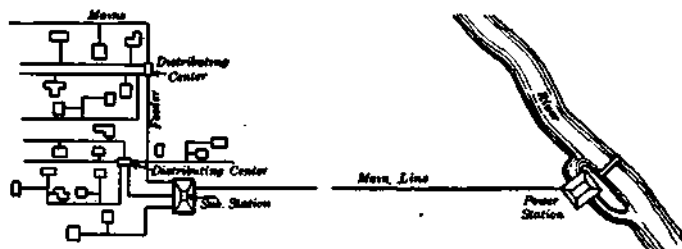

FIG. 250.—Diagram of power-transmission system showing service performed by transformer.

distance transmission and the consumer cannot utilize power at this voltage. In short, it is the remarkably high efficiency of transformers which has made possible the transmission of electricity for long distances.

251. Fundamental principle. As long ago as 1831, Faraday wound two coils of wire on a soft iron ring, as shown in figure 251. When coil *A* was connected with a battery and coil *B* with a galvanometer, he found that the needle of the galva-

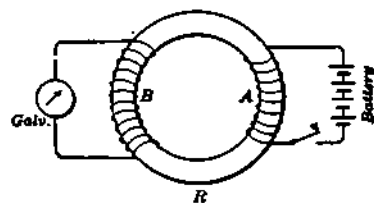

FIG. 251.—Faraday's ring transformer.

nometer was disturbed every time the battery circuit was made and every time it was broken.

The modern transformer consists of two coils on a common iron core not unlike Faraday's ring. When an alternating current is set up in one coil, called the **primary**, it magnetizes the iron core, causing surges of magnetic flux first in one direction and then in the opposite direction. Since this magnetic flux passes through the second coil, called the **sec-**

ondary, as well as the first, it induces an alternating current in the secondary. Since the same number of lines of force pass through both coils, *the volts per turn are the same.*

In short, then, we see that a transformer consists of two coils or sets of coils and an iron core. *The alternating-current power is transferred from the primary to the secondary by means of the magnetic flux in the iron core.*

252. Ordinary distributing transformer. Since the voltage of the transmission lines in the street is usually about 2200 volts, it is necessary to transform it or "step it down" to 110 volts in order to use it safely in private houses. In such a transformer the high-tension coil, consisting of many turns of small wire, would be connected to the 2200-volt circuit, and the low-tension coil, consisting of a few turns of large wire, would be connected with the lamp circuit of the house. In this case the high-tension or primary coil must have 20 times as many turns as the low-tension or secondary. But the secondary coil must be made of larger wire than the primary coil, because the secondary current is about twenty times the current taken by the primary. Thus the transformer delivers the same amount of energy which it receives, except for a small amount (from 2 to 5 per cent) which is lost as heat in the transformer. The efficiency of a transformer is therefore very high, from 95 to 98 per cent.

For the sake of interchangeability and standardization it is customary to split up the windings into groups or sections, which may be connected either in series or parallel. In this way the low-voltage winding of the same transformer may be connected for 110 or 220 volts as shown in the following table:

HIGH-VOLTAGE	LOW-VOLTAGE		RATIO
	Connection	Voltage	
2200	Parallel	110	20:1
2200	Series	220	10:1

253. Commercial forms of transformers. Transformers are built in two general types: (a) the **core type** (Fig. 252, A), in

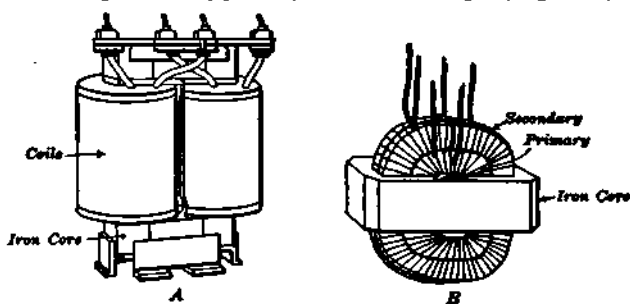

FIG. 252. — Two types of transformer. A, Core type; B, Shell type.

which the coils are wound around two sides of a rectangular iron core, and (b) the **shell type** (Fig. 252, B), in which the iron core is built around the laminated coils. In both these types the cores are built up of thin sheets of annealed silicon

steel having a thickness of about 0.014 inches.

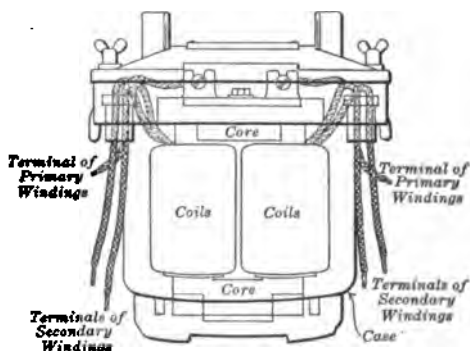

FIG. 253. — Small core-type transformer, assembled in case.

steel having a thickness of about 0.014 inches. The core type resembles very closely the Faraday ring shown in figure 251; however, the shape of the core is rectangular and its cross section is nearly square. The two coils are placed one over the other and each coil is divided into two sections, which are placed on opposite legs of the core. Figure 253 shows a core-type transformer, assembled and placed in the containing case.

In the shell-type transformer the coils are commonly built

up in thin sections (called "pancake" coils) and these sections of the high-tension and low-tension coils are sandwiched together. Figure 254 shows a small shell-type transformer.

The iron core in each type of transformer forms a continuous iron circuit around the coil, and yet the laminations are not built in one piece, since this would involve winding the coil upon the core by hand instead of its being built up independently of the core. Each lamination is made of two or more pieces (Fig. 255), and these are so stacked that every other one is reversed. Thus, by this alternation of the joints, the core, when built up and clamped together, has but little more reluctance than it would have if each lamination were in one piece.

The most modern type is really a modification of the core type, with which are combined many of the advantages of the shell type. It has the windings or coils on one leg of the core, while the other leg is divided into four parts, symmetrically placed around the center leg, on which the coils are placed, as shown in figure 256. In this type it is possible to

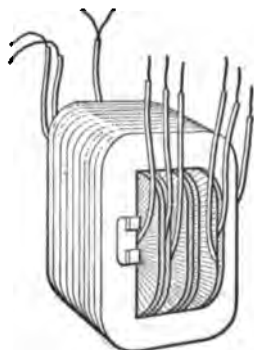

FIG. 254. — A small shell-type transformer. Iron laminations vertical.



FIG. 255. — Laminations of iron core built of pieces.

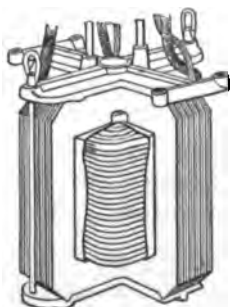
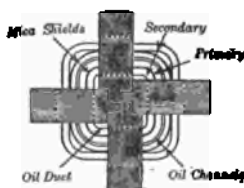

FIG. 256. — View of the General Electric Company's H-type of transformer; assembled, and plan.



use concentric cylindrical coils, which are the easiest to manufacture. This arrangement is compact and more easily cooled than either of the other forms.

254. Transformer ratio. We have already seen that, since the same number of lines of magnetic force pass through both coils, the total voltage in the primary coil is to the total voltage in the secondary coil as the number of turns in the primary is to the number of turns in the secondary. This may be expressed in the following equation :

$$\frac{E_p}{E_s} = \frac{\text{No. turns on primary}}{\text{No. turns on secondary}}$$

This ratio is known as the **ratio of transformation**. It should be remembered, however, that the equation is strictly correct only when there is no magnetic leakage. This is very nearly the case in modern transformers.

It can also be shown that at loads near or above full load the transformer currents vary *inversely* as the number of turns, which is expressed in the equation :

$$\frac{I_p}{I_s} = \frac{\text{No. of turns on secondary}}{\text{No. of turns on primary}} \quad (\text{Notice the inverse proportion.})$$

This equation neglects the magnetizing current, which at full load may be about 5 per cent. When the secondary current (I_s) is zero, then the primary current (I_p) is the exciting current and the above equation is absolutely wrong.

This fundamental relation between the currents in the primary and secondary may be stated in words thus: *The primary ampere turns are equal to the secondary ampere turns (neglecting the magnetizing current).* The approximate equation is

$$N_p I_p = N_s I_s.$$

255. Some mistakes about transformers. Many people somehow get the idea that a transformer changes an alternat-

ing current into a direct current. The fact is, of course, that the current which comes out is alternating. Another question which is often asked in regard to a transformer is, "Do we gain power in a step-up transformer?" No. Power depends on the product of voltage and current. The approximate equation for apparent power in the two coils is

$$E_p I_p = E_s I_s.$$

In a step-up transformer we may *multiply* the voltage perhaps ten times, but at the same time we *divide* the current by a little more than ten, so that we always lose some power.

Another question which often perplexes the beginner in electrical matters is, "Does the primary coil of a transformer always draw the same amount of current from the line?" No. The power put into the primary depends directly upon the amount of power being supplied by the secondary. Even when there is no power being taken from the secondary, there is a small current going into the primary which is called the magnetizing or exciting current and is perhaps 5 per cent of the full-load current. In a step-up transformer the primary coil has low resistance. Why does it not short-circuit the system when there is no load on the secondary? This is on account of the back e.m.f. of the self-induction or inductance of the primary coil.

256. Transformer losses. The losses of energy in a transformer due to heating vary from 2 to 5 per cent of the input. These are about equally divided at full load between the **copper loss** and the **core loss**. Since the copper loss is simply the IR loss in the windings, it increases with the square of the load current, and this is true for both transformer coils, because we have previously seen that the primary current increases with any increase in the secondary current. Therefore the copper loss may be computed from the equation:

$$\text{Copper loss} = I_p^2 R_p + I_s^2 R_s.$$

The core loss in a transformer is caused by hysteresis and also by the eddy currents that are set up in the steel laminations.

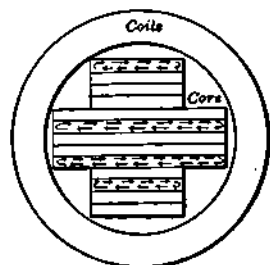

FIG. 257.— Eddy currents in transformer core. Thickness of laminations much enlarged.

Energy is required to cause the changes in magnetic flux in the core; how much, depends a great deal on the quality of the steel and on its treatment before it is assembled. For a given transformer the *hysteresis loss has been found to vary directly with the frequency and with the 1.6 power of the maximum flux density.*

are useless; they heat the iron and so represent loss in the transformer. But this loss can be kept low by using thin laminations. For a given transformer the *eddy-current loss varies with the square of the frequency and with the square of the maximum flux density.*

257. Ways of cooling transformers. The losses in the core and coils of a transformer produce heat, just as in any other piece of electrical machinery. Therefore, to prevent injury to the insulation, since there are no moving parts to set up air currents, special means have to be provided to keep down the temperature. The method most generally used for small transformers is oil cooling. Figure 258 shows a small transformer

The eddy currents circulate in the laminations of the core, somewhat as indicated in figure 257. These currents

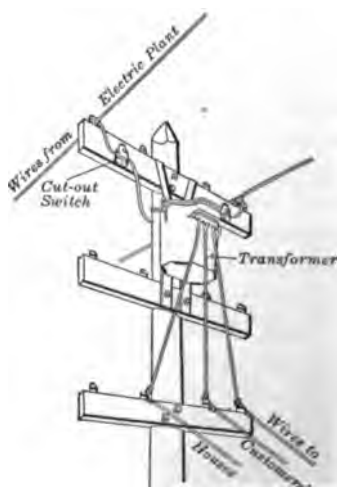

FIG. 258.— Small transformer case fastened to a pole.

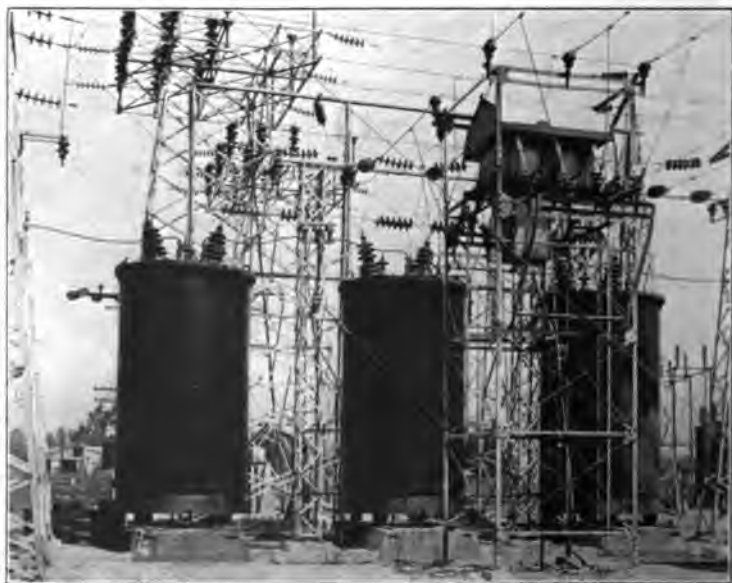

FIG. 259 a. — Outdoor substation with three 150,000-volt water-cooled transformers at San Bernardino, California.

case fastened to a pole, which would contain a transformer of probably less than 15 kv-a. capacity, such as might supply perhaps 25 to 50 customers. The case is filled with oil, which serves both as an insulator and as a cooling medium, and it has a corrugated surface so that the radiating surface is much increased.

In very large station transformers the heat cannot be radiated fast enough even with a corrugated case, so that the oil has to be water-cooled. Coils of

copper pipes are placed in the top of the case immersed in the oil and through these pipes cold water is kept circulating.

Figure 259 shows a large water-cooled transformer such as is frequently used in power stations and substations. The water pipes are placed near the top of the transformer case where the oil is hottest. The water piping must be carefully constructed of seamless tubing so as not to leak, because a trace of water in the oil would greatly reduce its insulating power. Where climatic conditions are not too severe the

out-of-doors type of transformer (Fig. 259 a) is largely superseding the indoor type, particularly for high voltage installations.

Sometimes transformers in power stations are air-cooled. In this method a fan forces cool air up from the bottom of the transformer, past the coils and core, so as to carry off the excess heat from the top of the transformer. Such transformers are not immersed in oil and have several disadvantages.

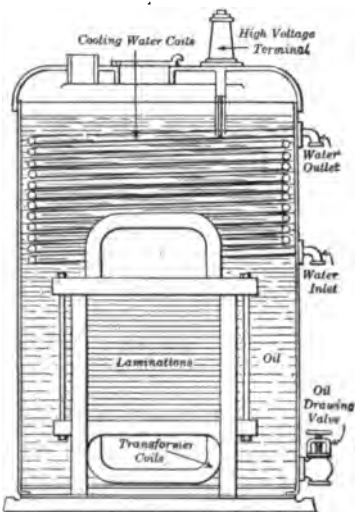

FIG. 259. — Water-cooled transformer in its case.

If the insulation breaks down and an arc is formed, it is fanned into flame by the air currents instead of being quenched by the oil. Unless great pains be taken to filter the air, the transformer gets dirty, which injures the insulation. If anything stops the blowers, the temperature rises very rapidly. Finally, for a given capacity the air-blast transformer is more bulky than the other types and does not seem to be satisfactory for high voltages, say above 35,000 volts.

Some of the largest transformers are cooled by a forced circulation of the oil. The oil may be cooled outside the transformer case by water currents, and in this way much greater amounts of heat may be carried away from the surfaces of the coils and core than by any natural circulation of oil.

258. Efficiency. In general, transformers have a remarkably high efficiency, which varies from 94 to 98 per cent, the larger sizes having the higher efficiency. But the efficiency of a given transformer depends somewhat on the load, and the reason for this can be seen from the equation :

$$\text{Efficiency} = \frac{\text{Output}}{\text{Input}} = \frac{\text{Output}}{\text{Output} + \text{losses}}$$

Losses = core losses (constant at all loads) + copper losses. The copper losses vary as the square of the load current. Therefore the efficiency of a transformer drops off a little at less than full load. For example, a certain 10-kv-a. transformer used for lighting purposes showed an efficiency of 96.9 per cent at $\frac{1}{4}$ load and 97.9 per cent at full load. Such a transformer would be called a "high-efficiency type," which should be used when the cost of energy is high and when it must be operated all day at underload. In the so-called "low-efficiency type" we have a higher core loss and lower efficiency, but this is due to the fact that less material was used and so we have a cheaper transformer. For example, such a 10-kv-a. transformer showed an efficiency of 94.3 per

cent at quarter load and 96.8 per cent at full load. This type of transformer is justifiable where the cost of energy is low and where it is not so essential to have a high operating efficiency.

259. All-day efficiency. We have already learned that efficiency is the ratio between the output and the input of a given machine. The all-day efficiency is the ratio of energy output during one day to the energy input during the same time. Suppose a 5-kv-a. transformer is used for lighting and operates at full load $1\frac{1}{2}$ hours and at half load $1\frac{1}{2}$ hours and during the rest of the day has no load. Suppose the core (iron) loss is 200 watts and full-load copper loss (I^2R) is 200 watts and half-load copper loss is 50 watts.

Then core loss for all day	= $24 \times 200 = 4800$ watt hours,
Copper loss at full load	= $1\frac{1}{2} \times 200 = 300$ watt hours,
Copper loss at half load	= $1\frac{1}{2} \times 50 = 75$ watt hours,
Total loss for 24 hours	= $4800 + 300 + 75 = 5175$ watt hours,
Energy output for one day	= $1\frac{1}{2} \times 5000 + 1\frac{1}{2} \times 2500$ = 11,250 watt hours,
Energy input for one day	= $11,250 + 5175 = 16,425$ watt hours,
Therefore all-day efficiency	= $\frac{11,250}{16,425} = 68.5$ per cent.

This same transformer would have an efficiency in the ordinary sense (that is, an instantaneous efficiency at full load) of about 93 per cent.

Since it is the "all-day" efficiency of a transformer which is most important to the central-station manager, it is better to design transformers to be used at full load for only a short time so that the core loss is low, even if copper losses are increased. For example, if the above transformer were built with core loss 100 watts and copper loss 300 watts at full load, it would have an all-day efficiency of 79.3 per cent.

260. Constant-current transformers. Certain types of arc lamps operate on a constant current and therefore require a

transformer which furnishes a constant secondary current. In this system the lamps are connected in series, and, as it often happens that some of the lamps go out, the high voltage required to give a constant current must vary with the number of lamps in circuit.

The constant-current transformer is an ingenious machine for transforming the constant voltage and variable current into constant current and variable voltage. This is done by varying the leakage of magnetic flux between the primary and secondary coils. Figure 260 shows this type of transformer,

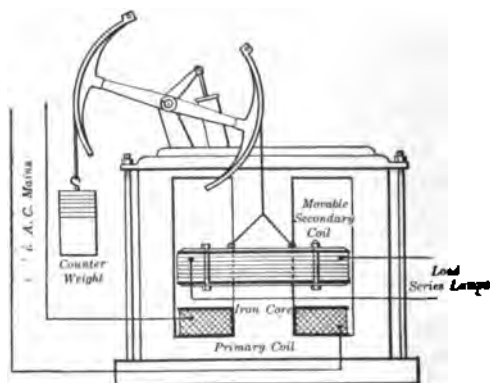

FIG. 260. — Constant-current transformer with movable secondary coil and series lamp circuit.

in which the secondary coil is suspended and so nearly counter-balanced that very little force is needed to lift it up and separate it from the primary. When the secondary coil is carrying current, the leakage flux repels the coil and so helps to lift the coil. If more than the rated current flows through the secondary coil, it is lifted farther from the primary, so that more leakage flux is produced. But the greater the leakage, the lower is the secondary voltage, and so the current in the secondary coil is reduced to its proper value. Thus this type of

transformer gives a constant current as long as the secondary coil is floating freely on the leakage flux.

261. Auto-transformer or single-circuit transformer. When the same coil is used for both primary and secondary windings, the machine is termed an auto-transformer. Figure 261 shows the connections for such a transformer coil, where the primary voltage is 440 volts and the primary current is 5 amperes. If we tap off one quarter of the whole number of turns, as shown in the figure, we get approximately a secondary voltage of 110 volts and a secondary current of 20 amperes. Since the currents in primary and secondary circuits are opposite in phase, the current flowing in those windings which are common to both coils will be equal to the difference between the secondary and primary currents, or in this case 15 amperes.

In actual practice the single circuit may consist of the coils of an ordinary transformer connected together electrically. When the secondary and primary voltages are nearly the same, that is, when the ratio is nearly unity, the auto-transformer is very economical in the use of copper because of the neutralization of currents. The advantage of auto-transformers lies in the greater efficiency and lower cost for the same capacity, and these advantages become more marked as the ratio approaches unity.

Since the low-tension coil is connected electrically to the high-tension coil, there is great danger to life and property if used for high voltage.

An auto-transformer differs from the regular transformer only in that the primary and secondary coils are joined in series, or rather, that one of these is a portion of the other.

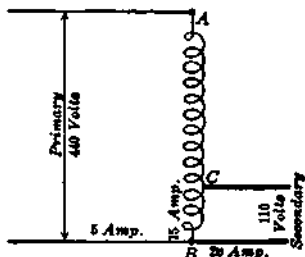

FIG. 261. — Diagram of an auto-transformer. Ratio 1 : 4.

When the voltage is low and is to be changed only slightly, the auto-transformer is very much cheaper than the ordinary transformer.

262. Special types of transformers. The step-down transformer is often used to supply at very low voltage the larger currents needed for electric furnaces and electric welding. The adjoining rails of a car track may be electrically welded together as shown in figure 262.

The two rails to be joined are clamped tightly together between two splice bars. The welding transformer consists of 44 turns on the primary side, and of a single loop of heavy copper on the secondary. The parts of the rail and splice bars to be welded complete the secondary circuit. Since the contact between the rail and the bars on each side is the point of greatest resistance in the secondary circuit, it becomes intensely hot. The current in the welding circuit is about 28,000 amperes, and so, after a very short time, the pieces of steel fuse together. An enormous force of about 34 tons is applied to the weld by means of the pressure levers and the ram at the top.

Since it is not easy to build ammeters to carry thousands of amperes, or voltmeters to measure the high voltages now used

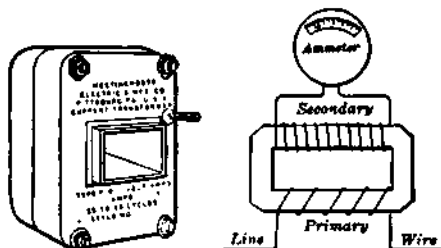

FIG. 263. — Current transformer for mounting on bus bar and plan of connections.

in long-distance transmission, we use instrument transformers.

By means of a potential transformer, which is merely a step-down transformer with a capacity of only a few watts, we may measure the voltage on a 22,000-volt line with a

voltmeter having a range of 125 volts. Such a transformer cannot be used as a step-up transformer and must not be overloaded. A current transformer (Fig. 263), such as would be



Courtesy of The Lorain Steel Co.

FIG. 262.—Welding track electrically. The equipment consists of an inverted rotary converter to change the direct current of the trolley to an alternating current, a regulator to keep the voltage practically constant, and the welding transformer.

mounted on the station bus bar, may be used to measure very heavy alternating currents. The primary circuit passes once through the hole in the core and so is equivalent to a single turn. Since the current transformer is always connected in series with the high-tension conductors, it is often called a series transformer. The ammeter is connected to the secondary winding of the transformer. Such a transformer is designed expressly to keep the ratio between the two currents constant. For example, if the ratio is 300:1, then a five-ampere ammeter would really indicate 1500 amperes in the bus bar.

Since all electrical apparatus must have its insulation tested before it is put into use, it becomes necessary to build testing transformers which can furnish between 500,000 and 1,000,000 volts. As these machines are used for test purposes only, they do not have much capacity but are very bulky.

PROBLEMS

1. The high-tension coil of a transformer has 1860 turns and the low-tension coil has 93 turns. If 2300 volts are impressed on the high-tension coil, what will be the voltage across the low-tension coil?

2. A step-down transformer is used to change 2200 volts to 225 volts. If the primary winding has 1180 turns, how many turns will be needed for the secondary?

3. A transformer has 1000 turns on the primary and 50 turns on the secondary and the primary current is 20 amperes. Neglecting the magnetizing current, how much is the secondary current?

4. If the transformer in problem 3 is built for a 2200-volt line, what would be its kv-a. capacity?

5. A 10-kv-a. transformer is used to step 2200 volts down to 220 volts. The resistance of the primary is 5.0 ohms and that of the secondary is 0.05 ohms. Assume the core loss to be 150 watts. Calculate the efficiency at full load. (Assume power factor to be 100%.)

6. If the transformer in problem 5 were used for 5 hours at full load and for 19 hours with no load, calculate the all-day efficiency.

SUMMARY OF CHAPTER XV

A TRANSFORMER is an a-c. voltage changer. It does not change the frequency.

It consists essentially of *two coils* and an *iron core*. The a-c. power is transferred from the primary coil to the secondary coil by *magnetic flux* in the iron core.

HIGH VOLTAGE IS NECESSARY for the economical transmission of electric power for long distances. But alternators cannot generate these high voltages directly, and the consumer cannot utilize power at this voltage. Hence step-up transformers at central stations and step-down transformers at substations and near the consumer.

FORMS OF TRANSFORMERS:

- (a) Core type: divided coils on two legs of rectangular iron core.
- (b) Shell type: laminated coils surrounded by laminated iron shell.
- (c) G. E. H-type: coils on one leg of core, other core leg divided into four parts.

TRANSFORMER RATIO:

$$\frac{E_p}{E_s} = \frac{\text{No. turns on primary}}{\text{No. turns on secondary}} \quad (\text{Assuming no magnetic leakage.})$$

At loads near or above full load, neglecting magnetizing current,

$$\frac{I_p}{I_s} = \frac{N_s}{N_p} \quad (\text{Note inverse proportion.})$$

Therefore, *approximate* equation for apparent power is

$$E_p I_p = E_s I_s.$$

Step-up transformer does not increase the power. There is always some loss.

TRANSFORMER LOSSES:

- (a) Copper losses: I^2R losses in the windings.
- (b) Iron losses: hysteresis and eddy currents.

CAPACITY OF A TRANSFORMER is the load that it will carry without developing an injuriously high temperature at any spot.

COOLING OF TRANSFORMERS is done in one of the following ways:

- (1) Case filled with oil, which carries the heat from the coils to the case, which in turn radiates it into the surrounding air. Cooling surface often increased by means of corrugated surface and auxiliary pipes.
- (2) By circulating water through pipes installed in the oil-filled cases.
- (3) By blowing air through the coils by means of a fan.
- (4) By forced circulation of oil, which is cooled outside the transformer case.

EFFICIENCY of transformers is very high. Highest efficiency is reached in large sizes at full load.

$$\text{Efficiency} = \frac{\text{Output}}{\text{Output} + \text{copper loss} + \text{core loss}}$$

(Core loss is constant at all loads.)

ALL-DAY EFFICIENCY means the ratio of energy in kilowatt hours used by the consumer in 24 hours to the total energy put into the transformer for the same time.

CONSTANT-CURRENT TRANSFORMERS furnish constant alternating current for series arc lamps. The voltage is varied by moving one of the coils so as to vary the magnetic leakage.

AUTO-TRANSFORMERS have but a single coil. In a step-down auto-transformer the *secondary* coil is a *portion* of the *primary*. The current flowing in those windings common to both coils is equal to the difference between the secondary and primary currents. Cheaper when transformer ratio is nearly unity, but dangerous to life and property for high voltage circuits.

SPECIAL TYPES OF TRANSFORMERS:

Step-down transformers are used for electric furnaces and for welding. Instrument transformers are used on high-tension circuits so as to be able to use ordinary a-c. voltmeters and ammeters. Testing transformers of small capacity but very high voltage are used to test insulation.

QUESTIONS

1. Why cannot a transformer be used on d-c. lines?
2. Why are the ordinary distributing transformers not placed inside of buildings or even attached to the outside of buildings?
3. What special precautions must be taken in locating a transformer in a manhole?
4. What is the difference between a step-up transformer and an induction coil?
5. What are the essential differences between the modern transformer and Faraday's ring?
6. Is it true that the "volts per turn are the same" in the constant-current transformer?
7. What would happen if the core of a transformer were made of one solid piece of iron?
8. Why is it necessary to provide a transformer with a closed magnetic circuit?
9. Why is it only approximately true to state that *the primary ampere turns are equal to the secondary ampere turns*?
10. How nearly correct is it to assume that the volt amperes in the primary equal the volt amperes in the secondary?
11. When no current is being taken from the secondary coil, what prevents the impressed e.m.f. from sending an excessive current through the primary coil?
12. What losses in a transformer may be reckoned as fixed losses?
13. Why do big transformers require some special means of carrying away heat in order to avoid excessive temperatures?
14. How can the input of a transformer be calculated?
15. What makes the all-day efficiency so much lower than the instantaneous efficiency?
16. What is the essential difference between a constant-voltage transformer and a constant-current transformer?
17. Why are auto-transformers not more generally used in distributing systems?
18. What advantages has electric welding over other methods of welding?
19. What precaution should be taken in using a current transformer?
20. What makes testing transformers so bulky?
21. What apparatus would you use to change the voltage on a direct-current system?

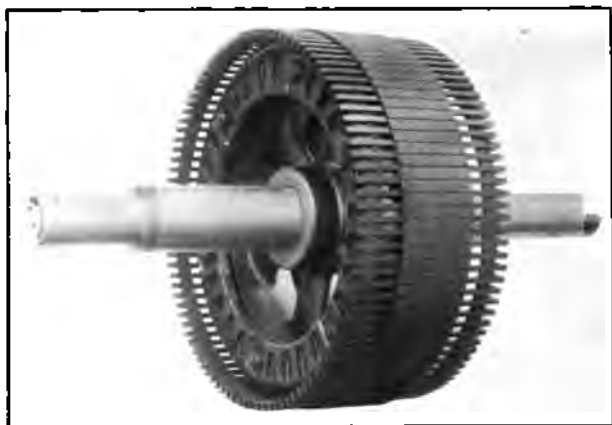

a

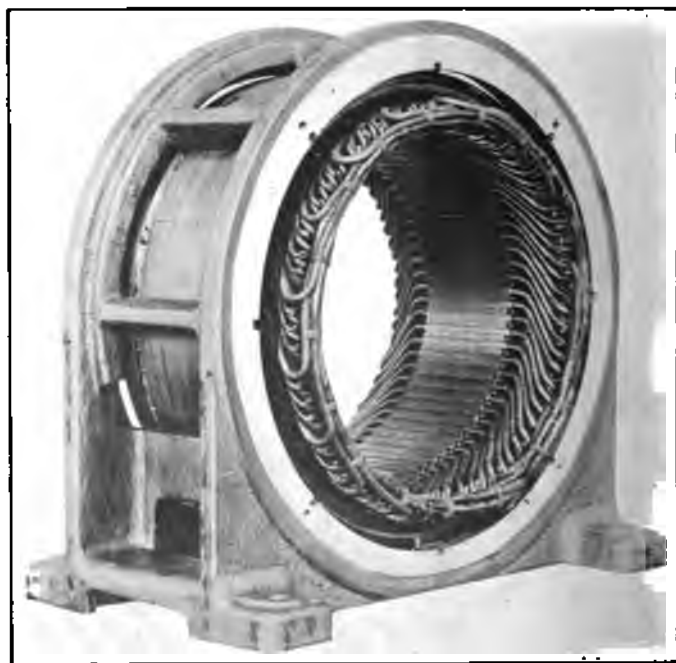

b

FIG. 264. — An induction motor, (a) rotor and (b) stator.

CHAPTER XVI

ALTERNATING-CURRENT MOTORS

Induction motor, its place and essential parts — rotating magnetic fields produced by two-phase currents and three-phase currents — rotor, squirrel-cage and wound types — starting and running characteristics — speed and slip — its commercial uses. Single-phase induction motor, methods of starting and its use.

Synchronous motor, ways of starting and special uses.

Series motor with commutator, special features and use for railways. Wagner motor starts as repulsion motor and runs as induction motor.

263. Place of the induction motor. We have seen (Chapter XIV) that the alternating-current generator can be built bigger and more cheaply than the direct-current generator and that the alternating current is much cheaper for transmission and gives a system of greater flexibility for varying needs. Naturally these advantages of the a-c. system called for an efficient a-c. motor. The motor which is most extensively used with alternating currents is undoubtedly the **induction motor**. The ruggedness and simplicity of its construction and its nearly uniform speed under varying loads make it a very satisfactory machine. This motor is especially adapted to polyphase currents, and in fact the three-phase a-c. system is installed mainly so that induction motors can be made use of.

264. Parts of induction motor. This motor consists essentially of two parts, the stationary or **stator** and the rotating or **rotor**. These are pictured in figure 264. The line wires are connected directly to the stator windings in order to set

up a rotating magnetic field, as will be explained later. *The windings on the rotor are not in any way connected electrically with the primary stator windings and so may be called secondary windings.* The currents which flow in these rotor windings are induced by the rotating magnetic field produced by the stator. It is the reaction of these induced currents in the rotor on the magnetic field of the stator, just as in a d-c. motor, which

drags the rotor after it.

265. Rotating magnetic field.

The first thing to get very clearly fixed in one's mind is the rotating magnetic field. How can poly-phase currents in a stationary iron

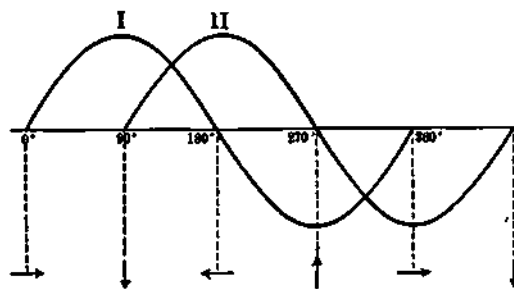

FIG. 265. — Curves of two alternating currents which differ in phase by 90° .

frame produce a magnetic field which rotates round and round? We shall suppose that we have two alternating currents of the same frequency but differing in phase by 90 degrees as shown in the curves of figure 265. These currents are connected to the two windings of the stator (Fig. 266). In the actual machine, of course, the end connections are bent back so that the rotor may be inserted. When the current in line I is at a maximum, it will be seen from the curves (Fig. 265) that the current in line II is zero. The top of the stator frame is therefore a north pole *N* and the bottom is a south pole *S*. Figure 267 *A* shows the distribution of magnetic flux at this instant. But one

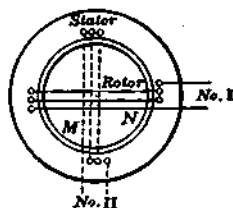

FIG. 266. — Diagram of a stator with two windings.

quarter of a cycle (90°) later, we see from the current curves that current I has dropped to zero and current II is at a maximum. This brings the north pole of the stator to the right side (Fig. 267 B). Again, a quarter of a cycle (90°) later, we

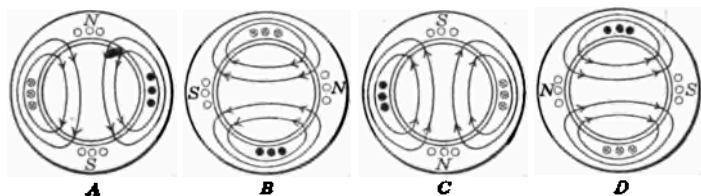

FIG. 267. — Revolving magnetic field of a two-pole two-phase induction motor.

find that current I has reached a maximum in the opposite direction and current II has dropped to zero, which brings the north pole of the stator around to the bottom, as shown in figure 267 C. Finally, a quarter of a cycle (90°) later, we find the north pole on the left side of the stator, as shown in figure 267 D. Evidently the north pole is traveling around the stator and will make a complete circuit for each complete cycle of the current. From this study it may be seen that, although the windings are stationary, a revolving magnetic field is produced, which by more careful analysis can be proved to be constant and which makes one revolution while the current in one line wire passes through one cycle.

In the case of a three-phase motor we have three currents which differ in phase by one

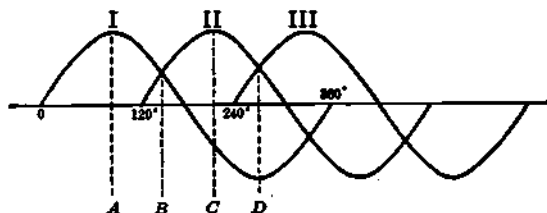

FIG. 268. — Curves of three-phase system.

third of a cycle or 120 degrees, as shown in the curves in figure 268. The diagram of the windings for a two-pole three-phase

motor is shown in figure 269. These windings may be connected either Y or delta (section 242) to the three-phase mains; in either case the currents which flow at any instant in the three coils are given by the curves in figure 268. The resultant magnetic field produced by these windings at instants A, B, C, and D, is shown in figure 270. It may be seen that, just as in the two-phase motor, a revolving field is produced, which is of constant

FIG. 269. — Diagram of stator with three windings.

strength and makes one revolution while the current in one phase passes through one cycle.

In actual machines these coils are embedded in slots exactly as in the stationary armature of an alternator and very often the machine is built not with two poles but with several pairs of poles so as to reduce the speed.

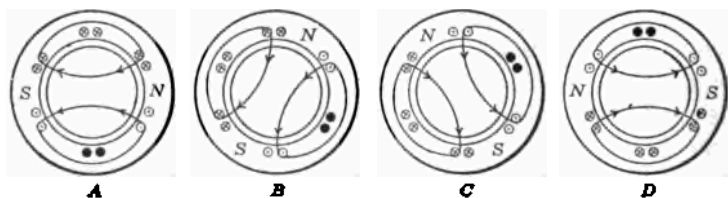

FIG. 270. — Revolving field of a two-pole three-phase induction motor.

266. Rotor of an induction motor. Any piece of metal which is free to rotate will rotate when placed within this revolving magnetic field. But the rotor can never spin quite so fast as the magnetic field. This difference between the speed of the field and the rotor is called the slip. The rotor of a commercial induction motor consists of an iron core, much like the core of a drum armature, with copper conductors placed in slots around the circumference. When it is placed in a rotating field, the conductors on the opposite sides of the core,



FIG. 271. — Various types of rotors for same stator. *A*, wound rotor with slip rings; *B*, wound rotor with internal resistance controlled by lever from end of shaft; and *C*, squirrel-cage rotor with ventilating vanes.

which are connected across the ends, act like a closed loop of wire and a large current is induced, *even though the rotor has no electrical connection with any outside circuit.* This large induced current makes a magnet of the iron core, and the rotating field, acting on this magnet, drags it around.

The strength of the induced current which is set up in the rotor depends on the slip. If there were no slip, there would be no cutting of lines of force, no currents would be induced, and there would be no power available to drive the rotor against its load.

267. Squirrel-cage and wound rotors. The simplest form of construction for the rotor of an induction motor is that known as a squirrel-cage. This consists of a laminated iron core around which is built a sort of squirrel cage of copper rods joined together at their ends into a closed circuit. The copper rods are inserted in slots just below the surface of the core and have no electrical connection with the stator, have no slip rings and no commutator.

The wound rotor has an iron core wound with coils like an ordinary d-c. armature and these coils are grouped to form a Y-connected three-phase winding and the three ends are connected to three slip rings. The purpose of this construction is to enable resistance to be inserted in the circuits of these windings at starting. When the rotor gets up to its speed, this starting resistance is cut out and the rotor operates just like a squirrel-cage rotor.

Sometimes the resistance is placed inside the rotor itself on the spider. In this design no slip rings are needed, as the ends of the rotor windings are connected to sliding fingers, which are connected with the resistance. A lever operates a sliding sleeve mounted on the rotor shaft and so regulates the amount of resistance in the rotor circuit by the position of the fingers.

Figure 271 shows the different types of rotor which can be used in the same stator. For small motors, say less than 5

horse power, the squirrel-cage rotor is generally used, but it may also be used for motors even up to 200 horse power; but for the reasons given in section 270, large induction motors generally use the wound rotor with external resistance.

268. Starting an induction motor. In the squirrel-cage type of motor the starting current is large. For example,

such a motor requires 5 times the full-load current in order to give a starting torque equal to 1.5 times the full-load torque. It is easy to understand this if we remember that an induction motor standing at rest with a short-circuited rotor is essentially a short-circuited transformer, in that the rotor corresponds to the secondary and the stator to the primary winding. It is, therefore, necessary for motors of more than 5 horse

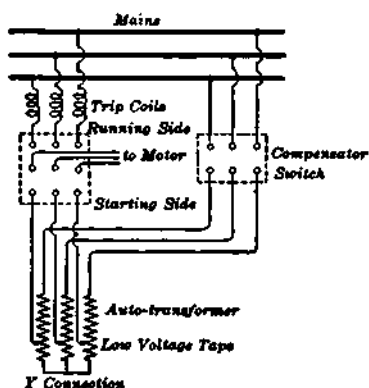

FIG. 272.—Connections for a three-phase starting compensator.

power to use an auto-transformer or compensator for starting. This device (Fig. 272) consists essentially of three auto-transformers connected in Y. A switch connects the motor terminals to taps on the auto-transformers for starting the motor at a lower voltage, and then changes it over directly to the line after the motor has reached its full speed. At the top are the fuses which protect the motor when running but not when starting.

Another method of getting a lower voltage for starting a three-phase induction motor is the triple-pole double-throw switch, which is connected as in figure 273. In the starting position the three windings of the motor are connected in star

or Y, and in the running position they are connected in delta. This means that in starting a motor on a 220-volt line the windings would each receive only $\frac{220}{1.73}$, or 127 volts; in other

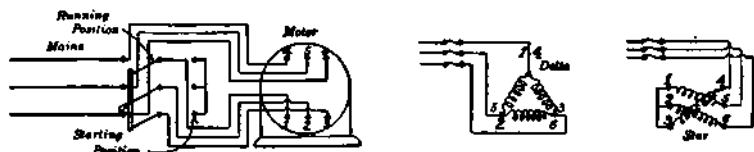

FIG. 273. — Three-pole double-throw switch used as star-delta switch to start induction motor.

words, the star connection gives the motor only 58 per cent of the line voltage.

With a wound rotor the method of starting is simply to insert resistance in the rotor circuit. Since the rotor windings are connected in star or Y and attached to three slip rings, connections are made to the starting box (Fig. 274). The rotor circuit is never open and at the position shown all the resistance of the box is in use. As the handle is moved to the right, resistance is cut out and finally the rotor winding is short-circuited.

269. Speed and slip of induction motor. We have already seen that the rotor follows the rotating magnetic field but it never quite "catches up" with the field. Since there is always some friction for the rotor to overcome, it can never run at synchronous speed; that is, at the speed of the rotating field. For example, in a certain motor the synchronous speed is 900 r.p.m. and the rotor makes

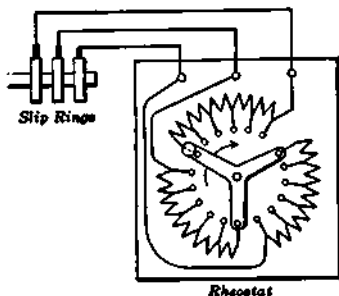

FIG. 274. — Connections for starting with resistance in rotor circuit.

898 r.p.m. at no load; hence the rotor is said to slip 2 r.p.m. or about 0.2 per cent. In other words,

Slip = Difference between rotor speed and field speed;
or, expressed in percentage,

$$\text{Slip (\%)} = \frac{\text{Synchronous speed} - \text{rotor speed}}{\text{Synchronous speed}} \times 100.$$

Although several methods have been used to vary the speed of an induction motor, none is yet quite satisfactory because *the induction motor is essentially a constant-speed motor.*

The speed of the induction motor (that is, the synchronous speed) is determined by the frequency and the number of poles. Commercially the frequency most used for lighting systems is 60 cycles and for power work alone it is 25 cycles.

The following table shows the possible speeds for induction motors with various poles at these frequencies.

POSSIBLE SPEEDS FOR INDUCTION MOTORS

POLES	60 CYCLES	25 CYCLES
2	3600	1500
4	1800	750
6	1200	500
8	900	375
10	720	300

270. Running characteristics. In order to show how a motor behaves under various conditions it is customary to plot curves somewhat like those shown in figure 275.

From these curves it will be seen that the no-load current is about 40 per cent of the full-load current and increases more rapidly for the overloads. The speed drops about 10 per cent as the load increases to full load. This slip increases rapidly

with overloads, and if the motor is loaded too much it stops altogether and is said to be "stalled." This maximum load point or overload capacity varies with different motors but is generally 75 or 100 per cent greater than the rated load of the motor. The efficiency curve reaches its highest point when the output is a little above the full-load capacity.

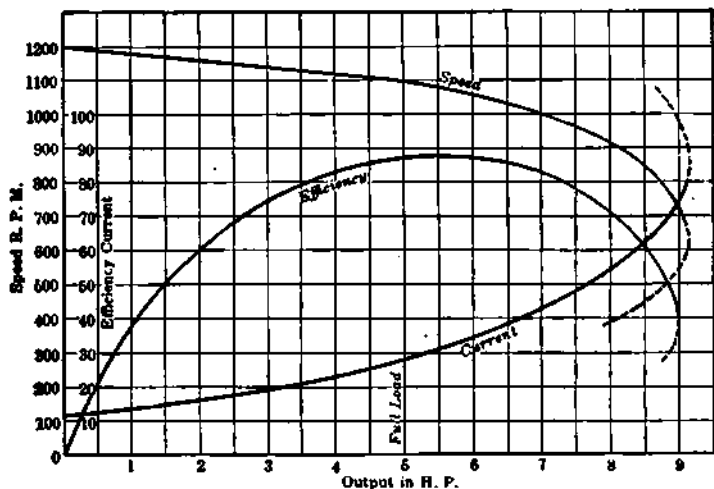

FIG. 275. — Running characteristics of a small induction motor.

If similar curves were made for this motor with resistance in the rotor circuit, it would be found that for any given load there is an increased slip, decreased efficiency, and an increase in current. It would also be noted that the maximum load has dropped from 10 horse power to 6 horse power. It is possible to obtain good starting characteristics, such as low current and high torque, by using a motor with a wound rotor and inserting external resistance, and then, as it speeds up, gradually to cut out the external resistance and thus to obtain the running characteristics of the squirrel-cage motor.

We have already seen that in transformers it is very desirable to have the magnetic leakage as small as possible; so in the induction motor the air gap is made very short in order that the magnetic reluctance may be low. In fact, it may be said that the air gap is usually reduced to a comfortable mechanical clearance.

As for the efficiency of the induction motor, it is about equal to that of the d-c. motor of the same size, because there are heat losses in the windings, iron losses in the cores, as well as bearing friction and windage. It must not be forgotten that *the electrical power represented by the flow of current in the rotor all comes from the electrical energy supplied to the stator.*

271. Uses of the induction motor. Where only alternating current is available, the polyphase induction motor is used for practically all power work. For example, a line shaft must run at practically constant speed under all loads and may well be driven by a squirrel-cage motor, but, if the starting torque needed exceeds the full-load torque, then a motor with a wound rotor must be used. Thus, **woodworking machinery**, such as planers and saws, is often driven by induction motors. Since this type of motor has no sliding contacts, such as a commutator, it is especially useful in **cement mills**. Also in the **textile industry** the quality of the product of the loom depends very largely on constancy of speed, and the induction motor is therefore used for this service. Induction motors are also used for **crane work**, but in order to obtain sufficient starting torque it is necessary to insert resistance in the rotor circuit; for this kind of work, however, the induction motor is not so efficient as the direct-current series motor. For driving machine tools such as lathes we need an adjustable speed motor. The a-c. induction motor with a wound rotor is at present available, but this is not so efficient as the d-c. shunt motor. There is also a brush-shifting repulsion type of induction motor whose

speed may be varied from standstill to full speed in either direction by simply moving the brush-shifting lever.

QUESTIONS AND PROBLEMS

1. Why is the induction motor often compared with a transformer?
2. Why is it impossible for an induction motor to run without "slip"?
3. A 60-cycle induction motor has 3 pairs of poles. How many r.p.m. does the rotor make, allowing for a 10% slip?
4. Why does the slip of an induction motor increase as the load is increased?
5. Why is the "air gap" in an induction motor so small?
6. What advantages has the squirrel-cage rotor over the wound rotor?
7. What effect on the power factor of a line do induction motors have?
8. Calculate the synchronous speeds for polyphase induction motors having 2, 4, 6, 8, 10, and 12 poles when the frequency is 15 cycles; when it is 50 cycles.
9. In what kind of service is it essential for an electric motor to have a large starting torque?
10. What difficulties arise when a motor draws a large current in starting?
11. What advantages has the induction motor over other motors for driving line shafting in a machine shop?
12. Why is it necessary to use a wound rotor for operations requiring adjustable speed?
13. What is meant by the "pull-out torque" or "breakdown-point"?
14. What information does one get from the performance curves of an induction motor?
15. What methods or devices are used to keep an induction motor from overheating?
16. Why is it sufficient to insulate the copper bars in the squirrel-cage rotor only lightly?

272. Single-phase induction motor. If a polyphase induction motor is running and if one terminal is disconnected, it

will continue to run and carry its load. Why use a polyphase induction motor then instead of a single-phase motor? First, it costs less to build a polyphase motor of a given output than it does to build a single-phase motor of the same capacity. Second, the polyphase machines are more efficient. Finally, the single-phase motor has of itself no starting torque and hence will not start from a standstill unless provided with special starting devices, which make its construction more complicated and expensive than a polyphase machine of the same rating.

There are several devices which are used to start the single-phase motor, since there is a real field for the single-phase

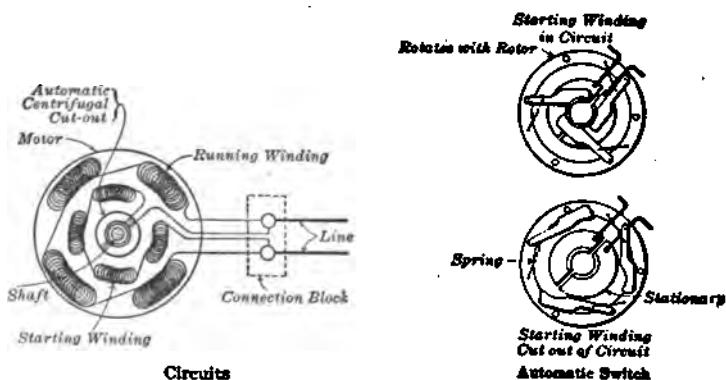

FIG. 276. — Diagram of split-phase method of starting single-phase induction motor.

motor. (1) If the motor is small it can be given a pull by hand; then the switch is thrown in and it goes whichever way it is started. (2) It is also possible to start a single-phase motor by starting it as a two-phase motor. This is done by splitting the alternating current into two currents differing in phase, a result which may be accomplished by dividing the circuit into two parallel circuits (Fig. 276) with different reactances.

For example, the starting winding ordinarily consists of fine wire and thus gives this winding high resistance, or a choking coil in one branch offers inductance and so retards the current. When the rotor is up to speed, the extra circuit is cut out by an automatic centrifugal switch. This method of starting is called the **split-phase** method. The combining of these two currents produces a rotating field for starting and when once the motor is going the alternating current continues to drive it even though the impulse is now only oscillating. (3) Still a third method is to start up the motor as a series motor with a commutator and then, when up to speed, to short-circuit the commutator bars and to operate it as a **repulsion motor**, which will be described more fully in section 278.

The single-phase motor is used mainly in small sizes where polyphase circuits are not available, as on certain lighting circuits. So we find such motors used for fans, sewing machines, and washing machines.

273. The synchronous motor. We have already learned that a direct-current generator is a reversible machine and can be operated as a motor. The same is true of an alternating-current generator, provided it is first brought up to the exact speed of the alternator which is supplying current to it, and put in step with the alternations of the current supplied. Such a machine is called a **synchronous motor**. But this machine has two disadvantages and so is not very generally used except in substations to drive d-c. generators. First, it is not self-starting and so must be brought up to speed before the current is applied, and second, it has field magnets which must be excited by direct current.

When a synchronous motor is running on no load, it takes from the line practically no current or just enough to overcome the friction of the machine. The rotating-field poles of the alternator and motor will then rotate together, as shown in

figure 277. But as the motor is loaded, it will slow down for an instant and the rotating field will swing back relative to the position of the alternator. There is now a current sent through the motor and a torque developed due to this current, which

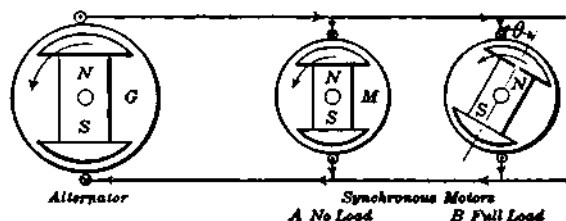

FIG. 277. — Alternator driving synchronous motors; A without load and B with load.

keeps the motor running at synchronous speed but always with a lag behind the generator. So the motor automatically draws from the generator a current which corresponds to its load. This is somewhat like the mechanical transmission of power through a flexible spring coupling, such as is shown in figure 278. If the load on the side M is increased, the spring stretches and M drops back through a small angle relative to G, but both continue thereafter to rotate together.

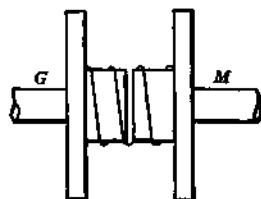

FIG. 278. — Mechanical analogy of a synchronous motor.

274. Ways of starting a synchronous motor. One way of bringing a synchronous motor up to speed for starting is by an auxiliary induction motor which is directly connected on the same shaft. This is a small motor having a capacity of from 5 to

10 per cent of the rating of the machine to be started. Because of the slip in the induction motor, it must be built with at least one pair of poles less than the synchronous motor, otherwise the motor could not be brought up to synchronous

speed. For example, suppose a 10-pole synchronous motor is to be started. Then the induction motor attached to it would have only 8 poles. If the power is supplied at 60 cycles, then the synchronous speed is 720 r.p.m. for a 10-pole machine and 900 r.p.m. for an 8-pole machine. So the induction motor would be designed to run at a speed 20 per cent less than the synchronous speed when it is carrying the necessary load.

Another way of starting a synchronous motor is by making the synchronous motor itself act as an induction motor. In this method no extra starting motor is necessary. We have already seen that the stationary polyphase currents generate a rotating magnetic field. This rotating magnetic field produces eddy currents in the pole faces and damping grids which are set in the pole faces (Fig. 279).

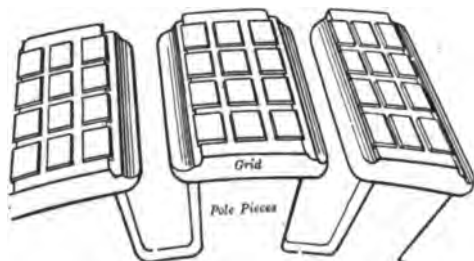

FIG. 279. — Field structure of synchronous motor showing damping grids.

These grids form low-resistance paths for the eddy currents, and so, just as in the squirrel-cage rotor of an induction motor, help to produce a good starting torque. They also tend to damp out oscillations, called "hunting," and from this action get their name. In starting a motor, however, by this method it is not practicable to connect it at rest directly to the line, because the starting current would be excessive, perhaps 5 to 10 times the normal current. So the motor is supplied with current from transformers fitted with half-voltage taps.

275. Uses of synchronous motor. Small motors of this type are not used because of the difficulty of starting them and the need of always starting without load and the necessity of supplying the motor with direct current for exciting its field

coils. But large synchronous motors are used on long-distance power-transmission lines, because they have an absolutely constant speed. Then, too, they can be operated on a line with a voltage of 6600 volts.

Sometimes this type of motor is used to improve the power factor of a transmission line. The power-carrying capacity of any electrical circuit depends upon the power factor of the receiving circuit. For example, suppose a line is rated to carry 200 amperes at 60,000 volts and therefore has a power-carrying capacity of 12,000 kw., *provided* the power factor is one; that is, provided the current and voltage are in phase with each other. But if the load consists of induction motors and lightly loaded transformers, the current may lag behind the voltage as much as 45° , which means a power factor of 0.707, and therefore the power-carrying capacity of the line is $0.707 \times 12,000$ kw. The customer pays only for the *actual* power in kw. hours which he uses and not for the *apparent* power in kv-a. hours.

Therefore it is advantageous to the owner of the transmission line to bring the power factor up as high as possible. Sometimes it pays to install at the end of the transmission line a synchronous motor which will not supply any mechanical power but will just "float" on the line with its field considerably overexcited. Such a machine (Fig. 280) is called a **synchronous condenser**, since its effect on the line is exactly equivalent to that of a condenser.

276. An a-c. series motor. Experience shows that a d-c. series motor, if the current is reversed, continues to rotate in the same direction. In fact, almost any small d-c. series motor will operate on "no load" if connected to an a-c. line of the same voltage, but, when a load is put on, it is quite likely to spark badly at the brushes. However, such motors of small size are used commercially to operate small vacuum cleaners, office appliances, dental engines, and the like. In recent years



FIG. 280.— Synchronous condenser in substation at Eagle Rock, California, used to improve power factor on a very long transmission line. The exciter is in the foreground.

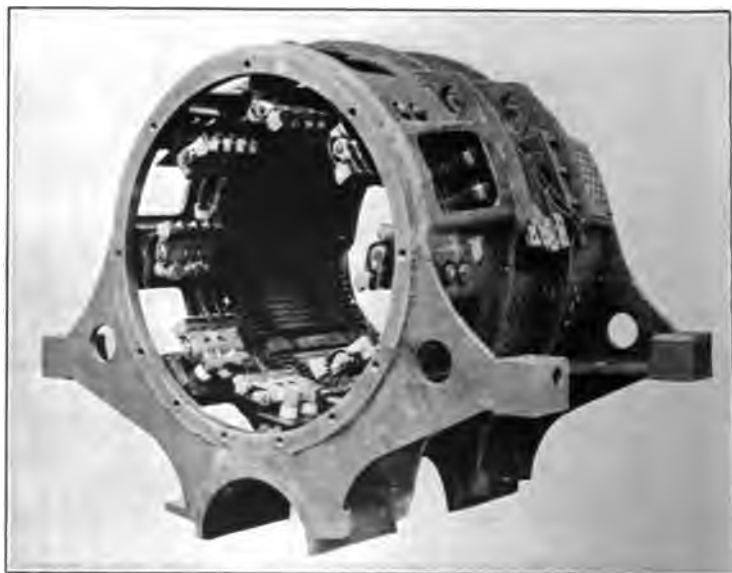

FIG. 281. — **Field structure of a single-phase series railway motor.**

a single-phase series motor with commutator has been developed for railway service to operate on either d-c. or a-c. lines.

In railway work there is need for a motor with large starting torque so that the motor will start under heavy load. But the synchronous motor and the induction motor have very little starting torque. The series motor is the only alternating-current motor which does have this large starting torque. In order to secure the best results from a series motor operated on alternating current, it is necessary to introduce some special features. *First*, since the field coils are excited by an alternating current, it is necessary to have the whole magnetic circuit, including the core and yoke of the field magnets, made of laminated iron to keep the eddy-current loss small. This means a larger and more expensive machine for the same capacity. *Second*, in the a-c. series motor there is self-induction in both field and armature coils. This self-induction produces an opposing e.m.f., which hinders the current. Therefore, on account of this self-induction, an a-c. series motor requires a higher voltage than a d-c. series motor with the same winding to cause the same current to flow through the coils. This means lower efficiency. *Third*, the reactance of the field coils of an a-c. series motor is reduced by operating the motor on low frequency and by using as few turns as possible in the field windings, as shown in figure 281. It will also be observed in the figure that there are windings laid in slots across the pole face. These are called *compensating windings*. Their purpose is to set up a magneto-motive force which will be just equal and opposite to that of the armature coils and thus reduce the self-induction of the armature almost to zero. Finally, resistance is usually introduced into the leads connecting the commutator segments to the tapping points (Fig. 282) in order to prevent excessive sparking at the brushes (which is caused when the coils short-circuited by the brushes are cut by the

constantly alternating flux, and have as a result of this "transformer action" a short-circuited current set up in them).

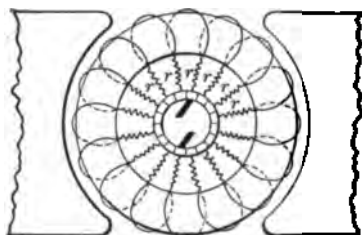

FIG. 282. — Diagram of a-c. series motor with resistance (r) between coils and commutating bar.

277. Uses of the a-c. series motor. Since the starting and running characteristics of the single-phase series motor are very similar to those of the d-c. series motor, it is very well adapted to railway work. It has the advantage, however, over the direct-current machine of being easily and economically controlled as to

speed. This is done by regulating the voltage from the taps of an auto-transformer instead of by inserting series resistances with the necessary I^2R loss. For several years the New York, New Haven, and Hartford R.R. has been using locomotives driven by single-phase series motors. Although this type of motor seems to be fairly successful, it is inferior to the direct-current series motor, and so is not likely to come into extensive use.

It must, however, be remembered that, although the a-c. series motor is not so efficient and reliable as the d-c. series motor, yet the losses in the distributing system for the a-c. motor are much less than those of a d-c. system. It has been estimated that probably not more than 45 per cent of the power generated in the main station is delivered to the ordinary street-car wheels.

278. Another commutator type of motor. There is a form of induction motor, called the *Wagner single-phase motor* (Fig. 283), which uses a rotor fitted with a commutator and brushes quite similar to a direct-current motor. After the motor reaches the proper speed, all of the commutator bars are automatically short-circuited and the brushes lifted from



a

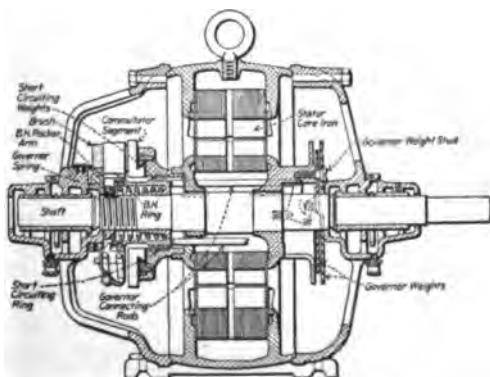

b

FIG. 283. — Wagner motor starts as repulsion motor and runs as induction motor, (a) general view and (b) cross section.

the commutator. This turns the rotor into an ordinary squirrel-cage rotor. The motor is started on the principle of the repulsion motor, which was first developed by Elihu Thomson in 1887. The idea of this motor was to use a wound armature with commutator and brushes, *but the armature circuit is not connected electrically to the power-supply line.* The circuits of a simple repulsion motor are shown diagrammatically in figure 284, in which it will be seen that *the brushes are short-circuited.*

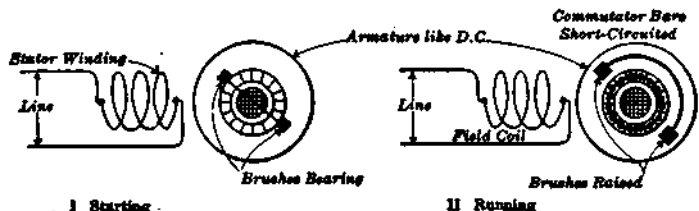

FIG. 284. — Circuits of a simple repulsion motor.

The operating characteristics of the repulsion motor are quite similar to those of the a-c. series motor, but on account of its poor commutation the single-phase repulsion motor has not come into extensive use in this country except in small sizes.

PROBLEMS

1. What is the slip at full load of a 4-pole, 60-cycle induction motor which has a full-load speed of 1700 r.p.m.?
2. What will be the horse-power output of a single-phase motor when the impressed voltage is 220 and the current is 10 amperes? Assume the power factor is 84% and the efficiency is 80%.
3. What will be the full-load current taken by a 10-horse-power, 220-volt, single-phase induction motor? At full load the power factor is 80% and the efficiency is 85%.
4. What will be the horse-power output of a 220-volt three-phase induction motor, if its full-load efficiency is 87%, its power factor is 85%, and its current is 88 amperes?

NOTE. — Power in three-phase balanced systems equals $\sqrt{3} \times$ voltage between any two wires \times current in each wire \times power factor.

SUMMARY OF CHAPTER XVI

INDUCTION MOTORS consist of two essential parts, the *stator*, which sets up a rotating magnetic field, and the *rotor*, in which currents are induced by the magnetic action of the currents in the stator windings. These motors are inherently nearly constant-speed motors. The speed of the rotating magnetic flux is called the *synchronous speed*, and is equal to 60 times the frequency divided by the number of pairs of poles. Rotor of loaded motor "slips" so that the revolving stator flux cuts the rotor windings and produces the necessary e.m.f. current and torque to carry the load. Stated as per cent,

$$\text{Slip (\%)} = \frac{\text{Synchronous speed} - \text{rotor speed}}{\text{Synchronous speed}} \times 100.$$

ROTATING MAGNETIC FIELD in polyphase motor is formed by the combined fluxes of the several phases. The dying flux of some phase is always combined with the given fluxes of the others, so that the total flux remains the same value and sweeps around the axis of the rotor.

ROTORS may be of the "squirrel-cage" type, consisting of insulated copper bars with short-circuited ends; or may be of the "wound" type, consisting of insulated windings laid in slots and brought out to slip rings. A wound rotor can be connected with extra external starting resistance, but this resistance is cut out when the rotor is running at full-load speed so as to increase the efficiency.

STARTING CURRENT of squirrel-cage motor is large and power factor is low and starting torque is low.

SPEED OF INDUCTION MOTOR falls a little as load is increased until a maximum load is reached and the motor comes rapidly to a standstill.

SINGLE-PHASE induction motors will run if started and brought nearly up to full speed, but with less torque than polyphase motors of the same size. Single-phase induction motors are started:

(1) By hand, in very small sizes. (2) By supplying split-phase or starting coils on the stator. Starting coils are cut out when rotor attains full speed. (3) By repulsion-motor action, in which the rotor is much like a d-c. armature and the brushes are short-circuited.

SYNCHRONOUS MOTOR has same construction as an a-c. generator and is usually of revolving-field type. Such motors are not self-starting but may be started by a small auxiliary induction motor, or the motor may itself act as an induction motor if equipped with damping grids and started on low voltage.

SYNCHRONOUS MOTORS are not used much as *small* motors but are used to modify the phase relation between the current and voltage of transmission lines. Such a motor is called a *synchronous condenser* and will produce a power factor of nearly unity.

A-C. SERIES MOTORS must be designed somewhat differently from d-c. series motors to operate satisfactorily. They are generally used on low-frequency circuits and have very few turns on field windings. Air gap is made small. Armature inductance is decreased by using compensating windings on the poles. Iron cores and yoke of the field as well as the core of the armature must be laminated. To avoid excessive sparking at the brushes resistance is introduced into the leads from the tapping points and commutator segments. These things make the a-c. series motor heavier and more expensive than a d-c. series motor of the same capacity. Since it has nearly the same characteristics as the d-c. series motor, it is well adapted for railway work.

QUESTIONS

1. Why is the magnetic circuit of all alternating-current motors made of laminated steel?
2. What advantages have polyphase motors over single-phase motors?
3. Why is the synchronous motor not commonly built in small sizes?

4. Make a list of the methods of starting a synchronous motor.
5. What is the function of a synchronous condenser on a transmission line?
6. Why can a small series motor be used on either a d-c. or an a-c. system?
7. Why cannot a large series motor be used on either a d-c. or an a-c. system?
8. For what kind of service is the a-c. series motor better adapted than the induction motor? Why?
9. Why is the a-c. series motor not more generally used for street-car work?
10. What are the distinctive features of the so-called Wagner motor?
11. Why is the straight repulsion motor not more generally used?
12. The polyphase induction motor is often spoken of as almost "fool-proof." Why?

CHAPTER XVII

POWER STATIONS AND THE DISTRIBUTION OF POWER

Electricity as a transmitting agent — small power plants — central power stations — prime movers — steam and gas engines — hydroelectric power — high pressure and low pressure.

Generators — exciters — switchboard — lightning protectors — feeders, overhead and underground — substations — transformers — rotary converters — methods of starting — inverted converter — small rectifiers, mercury arc and vacuum valve.

Local distribution — constant current and constant voltage — three-wire system. House wiring — national code of rules — various methods — plans.

279. Electricity for power transmission. When we read the big illuminated signs telling us to do nearly everything "electrically," we may easily lose sight of the fact that *electricity is not a source of power, but only a very convenient method for transmitting power.* Our real sources of power are of three kinds: first, coal, which can be burned under a boiler, thus making steam with which to drive steam engines; second, oil and gas, which we can burn inside the cylinders of oil and gas engines; and third, water, which we can dam up and then cause to turn various kinds of water wheels. Thereupon the electric generator transforms the mechanical energy into electricity. The electricity from these generators is distributed through a switchboard over a network of large conductors or feeders and the current in these main lines is often further subdivided and distributed over small wires to the numerous points where power is needed.

Electricity has many advantages over the other methods of power transmission, such as belts, shafting, or compressed air. Especially for long-distance transmission of power, electricity is much more convenient and economical. Electricity travels swiftly and silently along wires which do not move and which may be bent in any direction. Moreover, electric power may be started and stopped as well as controlled by devices which are compact, accurate, durable, and rapid. Finally, electricity is suited to a great variety of uses, not only for motors, big and little, but also for lamps, heating devices, and chemical apparatus.

280. The small isolated power plant. Before describing the generation and distribution of electricity on a large scale, we shall first study these processes on a small scale. Take, for example, the case of a small hotel or farmhouse or ranch which is located far from the regular lines of electric-power transmission. The most convenient form of *prime mover* is doubtless the oil or gas engine. In some countries, such as Denmark and Germany, even windmills have been utilized. In order that the engine and generator may not have to be operated continuously, a storage battery is used, which can be charged from time to time and then it is always ready to supply current for lamps or motors. Such systems (Fig. 285) are generally

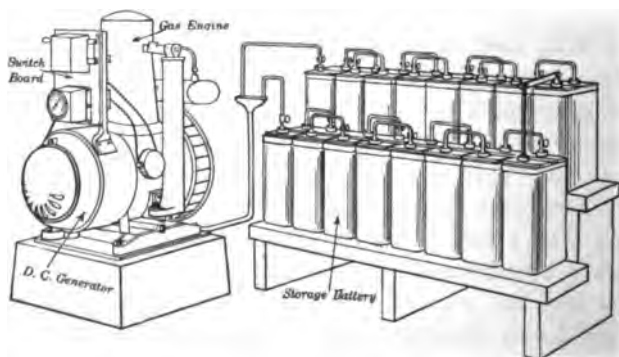
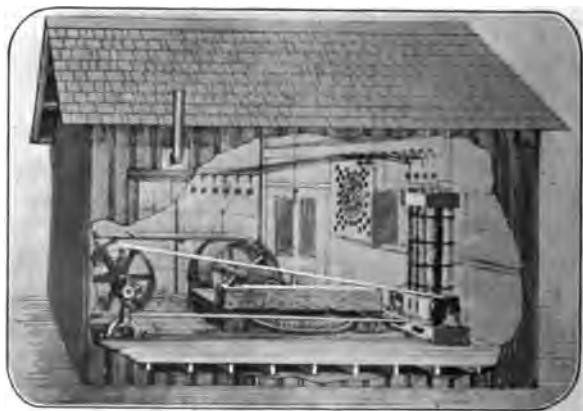

FIG. 285. — Delco system of small electric-power plant.



a



b

FIG. 286. — Early Edison electric-light station, (a) exterior view and (b) interior view of first hydroelectric central station in U. S. Capacity 250 lights.

operated on a low voltage so as to economize on the number of cells required for the storage battery. If used only for lighting, the installation may be very small, but a considerably larger plant is required if electricity is to be used also for running the motors which are so convenient for operating washing machines, churns, separators, pumps, fans, sewing machines, ensilage cutters, and the various threshing, shelling, and grinding machines.

In recent years such plants have been so much simplified that it does not require a skilled engineer to operate them, and the first cost has been so reduced that they need not be considered as a luxury when convenience and safety are considered.

281. Development of central power stations. It would be instructive and interesting to trace the development of electric-power stations since 1881, when the first Edison central station for the public supply of electrical current was built at Appleton, Wis. In figure 286*a* is shown the exterior of the small frame shanty in which this plant was located, while in figure 286*b* the shanty is shown with one side removed, so that the plant with its dynamo, pulleys, and belts is exposed to view. This plant was operated by water power, and the gears on the water-wheel shaft, used to drive the countershafts to which the dynamo was belted, are shown in the center of the figure. The plant was put in operation before the day of the three-wire system, and it therefore had only one dynamo. Behind the dynamo in the picture the regulating and indicating apparatus are vaguely seen.

In these early days of electrical power there were many independent plants even in our large cities, but with the rapid development of more efficient large generating units and with the greater economy of transmitting electricity at high voltage the large central power station has very considerably displaced the small independent plant.

Figure 287 shows a picture of the Edison power house located at South Boston, which supplies most of the electricity used in Greater Boston within a radius of twenty-five miles. Here one finds the coal conveyed by endless belts to hoppers above the boilers. Figure 288 shows a battery of boilers, into which the coal is fed to the grates by automatic stokers. The steam is led in great pipes to a large adjoining room, where one can see a group of steam turbogenerators. Each unit consists of a steam turbine at the bottom and an alternating-current generator at the top.

Such large plants can be operated more efficiently than small plants, not only because big units are more efficient than small ones, but also because a large plant has a great diversity of service and so can operate each unit under a fairly steady load. Then, too, such a plant can be located advantageously so as to get its coal directly from boats and also an abundant water supply for cooling the condensers.

282. Prime movers. The reciprocating steam engine is the oldest form of prime mover and is still used where conditions are favorable. Figure 290 is a horizontal type of compound Corliss steam engine with its big flywheel, and on the same shaft the revolving field of the alternator. The exciter is driven by a belt from the main shaft. Such machines are common in power stations, but in many of the more recent installations the turbogenerator unit has taken its place. This is because steam turbines require less floor space, lighter foundations, and less attendance. Where there is an ample supply of water for the condensers and when conditions as regards steam pressure and superheat are favorable, turbines of moderate size are as efficient as the best multiple-expansion steam engines and for larger sizes are more economical. Where it is necessary to increase the capacity or improve the efficiency of existing engine plants, it is coming to be the practice to combine low-pressure turbines with the existing high-pressure re-



FIG. 287. — A modern power plant, the Edison power station at South Boston.



FIG. 288. — A battery of Babcock and Wilcox water-tube boilers. Coal bins above.



FIG. 289.—Compound Corliss engine connected directly to an a-c. generator. Belt-driven exciter in front, switchboard in rear.



FIG. 290.—Engines using blast-furnace gas. Each engine has two cylinders set end to end, the two pistons being on one long piston rod running through both ends of each cylinder.

reciprocating engines and so to get an efficiency superior to that of either type alone.

To gain greater stability, steam-turbine units, whether of the **Parsons type** built by the Westinghouse Machine Co. and by the Allis-Chalmers Co. or of the **Curtis type** built by the General Electric Co., are now manufactured with the axis horizontal. This means more floor space, but on the other hand it is more economical of head room.

The **gas engine** has come in recent years to be a real rival of the steam engine as a prime mover. This is especially the case in places where there is an abundant supply of natural gas. In localities which do not have cheap natural gas but do have cheap coal, producer gas is commonly made. One advantage of the internal combustion engine is that it can be made to use a great variety of fuels, such as alcohol, kerosene, gasoline, crude oil, coke-oven gas, illuminating gas, water gas, and blast-furnace gas. Some of the largest gas engines yet manufactured have been built for the U. S. Steel Corporation to use blast-furnace gas. Figure 292 shows three 500-horse-power Westinghouse horizontal gas engines driving 60-cycle alternators in parallel.

In many sections of the country where water power is available or can be developed by constructing dams, hydroelectric power plants of enormous capacity have been built. Where the head of water is not great but the volume is large, such as the Mississippi River at Keokuk, Iowa, the water turbine is the prime mover; while in places where there is a great head but small volume, such as in the Sierra Nevada Mountains at Big Creek, California, the Pelton or impulse water wheel is used. (Figures 291 and 292.)

Since these two plants represent two quite different types of hydroelectric developments, it will be well to describe each a little further. At **Keokuk** we have a concrete dam nearly a mile long built across the Mississippi River. This dam, which consists of 119 arched spans,

gives a head of about 32 feet. The power house is constructed at right angles to the dam near the Iowa bank and contains space for thirty units, each consisting of a turbine and generator on the same vertical shaft. The water for each turbine enters at four intakes, which converge into a scroll chamber so shaped that the water strikes every point on the circumference of the wheel with equal velocity and impulse. The turbine is direct-connected with the generator on a vertical shaft 25 inches in diameter. Each unit has a capacity of 7500 kilowatts, so that the total capacity of the plant is 225,000 kilowatts. The generators have a revolving field about 25 feet in diameter and furnish three-phase alternating current at 25 cycles. The current is generated at 11,000 volts and stepped up by transformers to 110,000 volts for transmission. One of the important transmission lines runs to St. Louis, 144 miles away. It consists of six copper cables about five eighths of an inch in diameter and carries 60,000 horse power. Besides the dam and power house, the development company has constructed a big lock and dry dock, which have been ceded gratis to the government.

The Big Creek development in California is especially interesting, because it is the largest high-head development in this country, with the most powerful impulse water wheels, used to drive the largest electric generators of their type. Moreover, its transmission line operates at the highest voltage (150,000 volts) ever used commercially and carries power from a remote spot in the Sierra Nevada Mountains, halfway between San Francisco and Los Angeles, to the latter city, a distance of 240 miles. This development required the making of a reservoir 7000 feet above the sea; the erection of four concrete dams; the construction of two power houses and a substation; the boring of five miles of tunnel through granite; the setting of over 3000 steel towers over the mountains and across the desert, and the stringing of 5,000,000 pounds of aluminum wire. A fall of 4000 feet has been utilized by diverting the water from its natural channel, holding it in a big storage reservoir, leading it through a tunnel and steel pipes to the first power house halfway down, and then through another series of conduits to a second power house. The water comes from the six-inch nozzles at the terrific velocity of 350 feet per second (about 3½ miles per minute) and strikes the buckets of the water wheels. Each unit consists of two Pelton water wheels, 94 inches in diameter, with the electric generator placed in between on the same horizontal shaft. In each power house there are two units, each of 17,500 kilowatts capacity. Current is generated at 50 cycles and at 6600 volts and



FIG. 291. — Mississippi River Power Company (largest in the world) with fifteen 9000-kv-a. 11,000-volt generators. The ultimate installation will have double its present capacity.



FIG. 292.— Big Creek Development. Power station No. 1. Hydraulic head 1900 feet. Two 17,500-kv-a. 6600-volt generators, each having a momentary peak capacity of 25,000 kv-a. Apparatus controlling Pelton water wheel in foreground.

then stepped up to 150,000 volts for its 240-mile journey to Los Angeles. The transmission line consists of two lines of steel towers, which carry six cables nearly one inch in diameter, made of aluminum with a steel core. A substation at Eagle Rock, just outside of Los Angeles, receives the energy at 150,000 volts and delivers it to the distributing lines at 72,000 and 18,000 volts.

Thus we have at Keokuk a small head of water operating water wheels at slow speed (57.7 r.p.m.), while at Big Creek we have a high head of water driving wheels at a high speed (375 r.p.m.). In the former plant we have the Francis type of vertical turbine water wheel, while at the latter we have the Pelton type of horizontal impulse wheel. In each case we have the hydroelectric development of vast quantities of power for long-distance transmission at high voltage.

283. Generators. Of all the electrical power now generated in the central stations in this country a very large percentage is generated as alternating current. Nevertheless, many applications, such as the electrolytic refining of metals, require direct current, and many others, such as railway motors and arc lights, operate better on direct current. So we find in most small stations and in some large power stations, such as that of the Ford Motor Company in Detroit, direct-current generators. These generators are the regular, compound-wound, stationary field machine with a revolving armature directly connected to a reciprocating steam engine.

Large alternators, as we have already seen in Chapter XIV, are usually built with a revolving field and stationary armature. When driven at high speed by a turbine engine or impulse water wheel, the field has only a few poles, two or four; but when run at slow speed by reciprocating engines or turbine water wheels, the number of poles may be as high as 72 or more.

With any type of alternator we must have an exciter to furnish direct current for the field. These little generators are sometimes placed on the same shaft with the alternator's

revolving field and sometimes, as in small plants, they are driven by a belt from the generator. But in the more modern installations the old practice of having a separate exciter for each alternator has been abandoned. The excitation is supplied from two or more d-c. generators, which are driven either by independent induction motors or, in the case of hydroelectric plants, by independent water wheels. To make sure that the plant shall never be without a source of direct current, it is quite common to keep a storage battery all ready to be connected, to build up or maintain the voltage of the alternators.

284. Switchboards. In the early days of power stations the switchboard was a very crude wooden rack, on the front of which were mounted the switches and fuses necessary for the operation of the plant. In a modern power station the switchboard is doubtless the most important part of the generating plant, for, if an accident happens at the switchboard, the whole plant may be put out of business. It is here that the electric power from the generators is brought, metered, and then distributed to the outside system through a group of feeders. Here are placed all the switches, meters, and protective devices of the plant and from it the operation of the whole plant is controlled.

It is the modern practice to construct switchboards in panels, which may be from 18 inches to 24 inches wide and perhaps 6 feet high. They are usually made of slate or high-grade marble slabs, which are supported by a framework of structural steel anchored to the floor and wall of the building. Figure 293 shows the front and side views of a single-panel switchboard and figure 294 is the back view, showing the leads and bus bars. Each vertical section or panel serves for the control either of one generator or of a feeder or a group of feeders. In addition, there may be separate panels for exciters, recording meters, etc. Behind the whole length of the switchboard run two or three heavy copper bars called bus bars.

Since the generator panels are on one side and the feeder panels on the other, the bus bars must be made of very heavy cross section so as to carry the total current of the station along

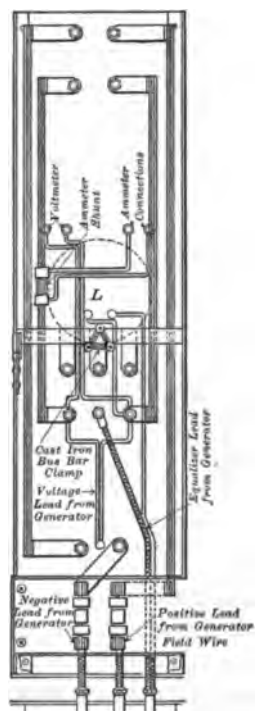
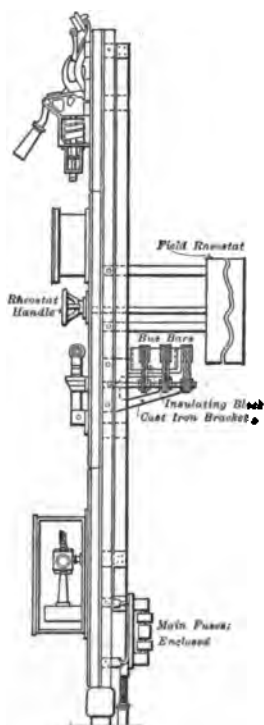
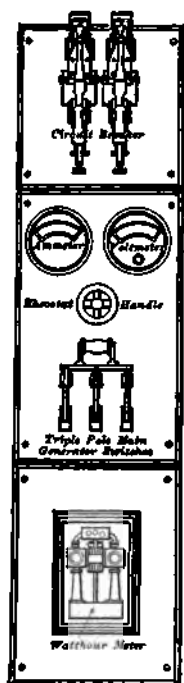

FIG. 293. — Front and side views of single-panel switchboard.

FIG. 294. — Back view of panel shown in figure 293.

the board. This arrangement of the panels makes it easy to add more generators or feeders without disturbing the arrangement of the board, by merely adding the proper number of panels at either end of the board. At the center of the board it is a very common practice to place the station-output

panel where the recording and watt-hour meters show the total power output of the station.

Another instrument which is usually found on modern switchboards is the **circuit breaker**. It is simply a large switch which is automatically opened by an electromagnet when the current is excessive. There are various forms used but the type shown in figure 295 is interesting, because the electromagnet that operates the trip which opens it consists of but one "turn."

For large alternating-current stations the switchboards are quite different from the type just described, because the voltage

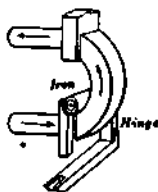
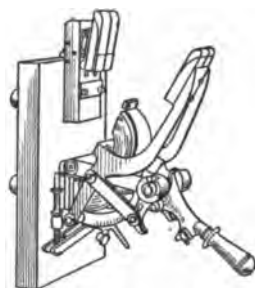

FIG. 295. — Circuit breaker and plan of its construction.

on the bus bars is generally high, that is, 11,000 volts. The circuit breakers and switches must be of the oil-immersed type and are generally operated by motors so that it would be difficult to arrange them on the back of a switchboard. Consequently, we find the master switchboard with

remote control, which enables the chief operator to manipulate all the machines and switches in the station. The oil switches are located out of the way in fireproof recesses, and the master control board is located in a quiet part of the station, but so placed that the operator has full view of all the machines he controls. By small signal lamps of different colors the operator can see at a glance what machines are running, what feeders are alive, and what switches are open. A control desk or benchboard switchboard is frequently used in large installations. On vertical panels in front are mounted the instruments, and on the bench are arranged the remote-control switches and indicating lamps together with a miniature bus-bar system.

285. Lightning protection. Doubtless the earliest electrical invention made in America was Benjamin Franklin's lightning rod. We have still much to learn about atmospheric lightning, but it seems clear that it is due to the equalization of a difference of potential between two oppositely electrified clouds or between a cloud and the earth. The lightning rod was designed to conduct the electricity safely from the clouds to the earth. Nowadays, in cities where houses are built in blocks with frameworks, tops, and cornices of metal, the lightning rod is not much used. But tall chimneys, church steeples, and isolated houses are often provided with lightning rods.

It should, however, be remembered that, unless a lightning rod is put up with great care, it is a menace rather than a protection. Its lower end must be well grounded by soldering it to a large copper plate buried in *damp* soil, and no part of the rod should turn a sharp corner. If these and other precautions are not observed, a lightning rod will often discharge into the house itself, rather than into the ground, the electricity which it has attracted.

Lightning may disturb an electrical system in either of two ways — by a *direct stroke* or by an *induced stroke*. In a direct stroke the lightning-discharge current between a cloud and the earth selects for a portion of its path some part of the electrical system, such as an aerial pole line. For protection against this disturbance an overhead wire is often strung above the pole line and connected with the earth at frequent intervals.

An induced stroke is simply an abnormally high potential which is developed in the electrical system, due to induction by the lightning discharge. Since induced strokes are much more common than direct strokes, suitable lightning-protective apparatus is usually installed in power stations. There are a great many kinds of such apparatus in use, but the fundamental principle of all these devices is shown in figure 296. Assume

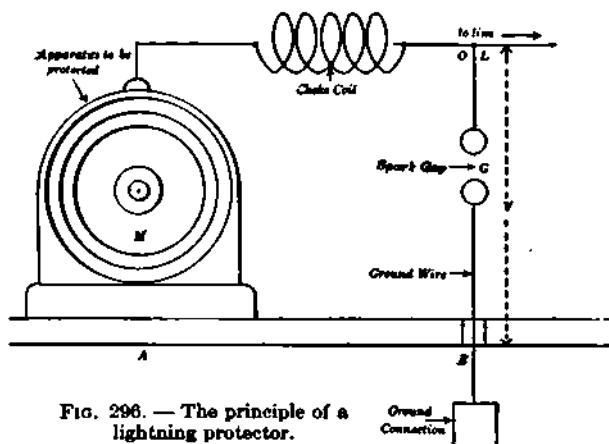

FIG. 296. — The principle of a lightning protector.

the high-voltage wave due to lightning comes along the line L . It has a tendency to force a current to the earth along the path of least resistance. If no protective apparatus is afforded, this path would doubtless be through the windings of the machine M to the frame, and thence to the ground. This would probably "burn it out." But if we connect a choke or reactance coil, such as has already been described in section 222, in the line and also connect a spark gap G in a branch line OE to the ground, then the high-frequency currents produced by the lightning discharge will find that

the path containing inductance offers greater opposition than the branch line across the air gap to the ground. The form of air gap commonly used on a-c. lines is the "horn-gap" shown in figure 297. When an electric arc is once established across such a gap, it tends to extinguish

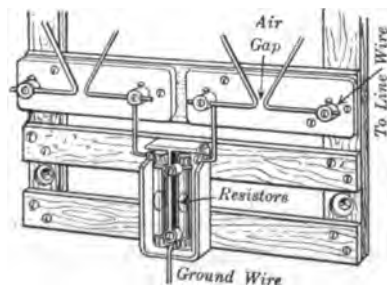

FIG. 297. — Horn-gap lightning protector on a-c. circuits.

itself, for the arc rises on the horns, due to the upward flow of the column of hot gases, and so finally attains a length of gap which it cannot maintain. Thus we see that a choke coil with a ground connection across a spark gap acts as an electrical safety valve for the electrical system.

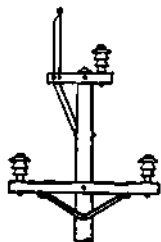

FIG. 298. — Wooden pole with pin insulators, ground wire at top.

strength of conductor is required. For voltages up to 50,000 wooden poles are used. These are usually of white cedar or chestnut, though in some parts of the country they are made of pine, cypress, and tamarack, or other woods. Figure 298 shows the top of a wooden pole with pin insulators. For higher voltages, pin insulators become very large so that the suspension type of insulator has to be used and these are suspended from steel towers, as shown in figure 299. To protect the line against lightning, it is usual to run a steel wire along parallel to the power wires, and to ground this wire at every tower.

In large cities more and more electric conductors are being placed underground. This method is of course expensive because it requires a stranded copper cable

296. Feeders. The material used for the conductors which carry the electric power from the central stations to the substations or other points for retail distribution is usually copper or aluminum. Sometimes conductors consisting of a steel center with copper or aluminum outside are used where long spans are desirable and mechanical

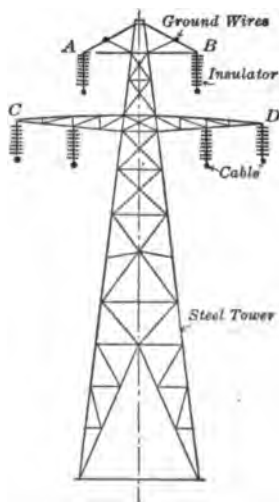

FIG. 299. — Steel tower with suspension insulator.

which is insulated with rubber or with paper impregnated with a compound such as resin oil and then sheathed with lead to keep out the moisture and to protect the cable against mechanical injury. The cable must be flexible enough to bend around corners, for it is drawn into tile ducts through manholes such as are shown in figure 300. These electric conduits are made of glazed tile, wood, or paper fiber, and sometimes of wrought-iron pipe. The ducts are sometimes laid singly, but usually they are laid in sets surrounded by concrete, as shown in figure 301, which is

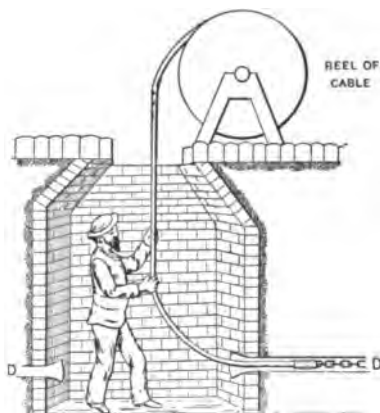

FIG. 300. — Cable manhole, showing cable fed into duct from reel.

an end view of a conduit containing twelve ducts. Each duct is about three or four inches across.

Manholes are placed at intervals of three or four hundred feet in straight parts of a conduit and also at turns. These are usually brick vaults six or seven feet deep and several feet in diameter which are covered at the street surface by cast-iron covers.

When a conduit with its manholes is completed, the cables are drawn into the ducts, one section at a time. The sections of each cable must be joined together in the manholes. To do this, the conductors are first joined in the usual manner, and their joints are separately insulated. Finally, a short piece of lead pipe is placed over the bunch of joints and

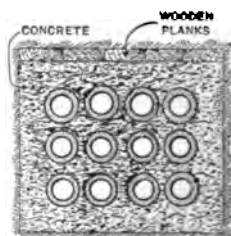

FIG. 301. — End view of conduit containing twelve ducts.

is soldered at both ends to the lead covering by a plumber's "wiped joint." This makes the joint moisture-proof if the work is properly done. Making cable joints requires the greatest care in order to avoid the entrance of moisture into the cable, and it is always necessary to handle open cable ends with extreme caution. The ends should always remain sealed, except when work is to be done on them.

When a cable is to be pulled into a duct, a strong rope must first be passed through the duct so that it may be used in drawing through the cable. Several plans are in use for getting the rope through. A light runner which nearly fills the end of the duct may be attached to a cord, and the runner, with the cord trailing after it, may be sucked or blown through the duct by a mechanical blower. The cord may then serve to draw the rope after it. But the commonest plan for getting the rope through a duct is called "rodding" the duct. A large number of rods made of hickory, bamboo, or the like, about a yard long, are provided with metal ferrules and couplings at each end. One of these rods is slipped into one end of a duct by a man standing in a manhole and another rod is then coupled to the end of the first. The second rod is then pushed into the duct (while it pushes the first before it), and a third rod is coupled to the end of the second. This process is continued until the first rod is pushed through the duct into the next manhole. A rope is then attached to the end rod, the rods are withdrawn (while they are uncoupled, one by one), and the rope is drawn into the duct after the rods. When the last rod is withdrawn, the rope lies extended from end to end in the duct and may be used to draw in a cable.

287. Substations. Transformer substations are built wherever it is necessary to step down the transmission voltage of between 22,000 and 150,000 volts to a city circuit, which is usually about 2300 volts. This is required for the sake of greater safety to human life. In recent years the outdoor type of substation (Fig. 259 a) has been introduced and put into successful operation. In such installations the transformers, high-voltage switches, and lightning arresters are located outdoors, which means economy in building construction and the

saving of one set of expensive high-voltage bushings, used to carry the high-tension leads into the building.

Another type of substation is the **converter substation**, which is located along the transmission line at points where larger quantities of direct-current power are needed, such as for street-railway work. Here the synchronous converter or motor generator is installed to change the alternating current to direct current. The motor-generator converter consists of two separate machines, an a-c. motor and a d-c. generator, usually direct-connected to each other, as shown in figure 302. In the sets of large capacity, say over 100 kv-a., the synchronous motor is used on account of its constant speed and adjustable power factor. For smaller sets an induction motor is generally used, because it can be started more easily than the synchronous motor. The generator is a regular compound d-c. generator.

Instead of using two separate machines for motor and generator, it is common practice to build one machine, called a synchronous converter, to perform the function of both motor and generator. It is made with a revolving armature, which receives the alternating current at collecting rings on one side and delivers direct current at the brushes bearing on the commutator on the other side. Thus the same armature, fitted with both collecting rings and a commutator, revolving in a field separately excited from a source of direct current, receives alternating current and delivers direct current. This is not so strange as it may at first appear, for we have already learned (section 140) that every direct-current generator carries alternating currents in its armature windings, and that, if we tap these windings at the proper points and connect to the proper segments of a commutator, we get direct current delivered to a set of brushes bearing on the commutator. Such a machine is shown in figure 303 and is called a **synchronous converter** or **rotary converter**.

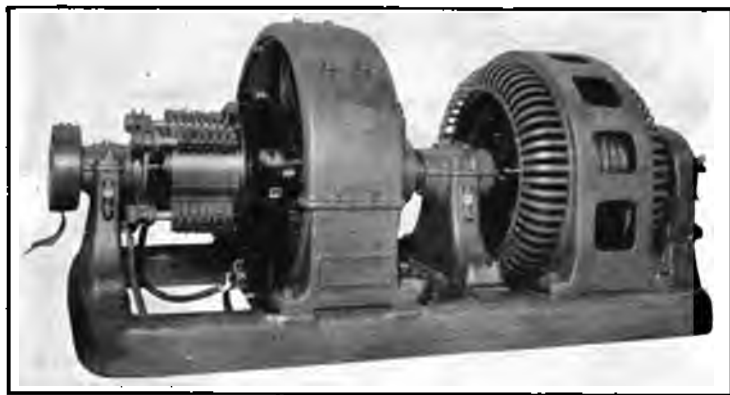

FIG. 302. — Motor-generator converter. The motor on the right is a 300-kv-a. synchronous motor operating on 2300 volts. The d-c. generator on the left furnishes 275 kw. at 550 volts.

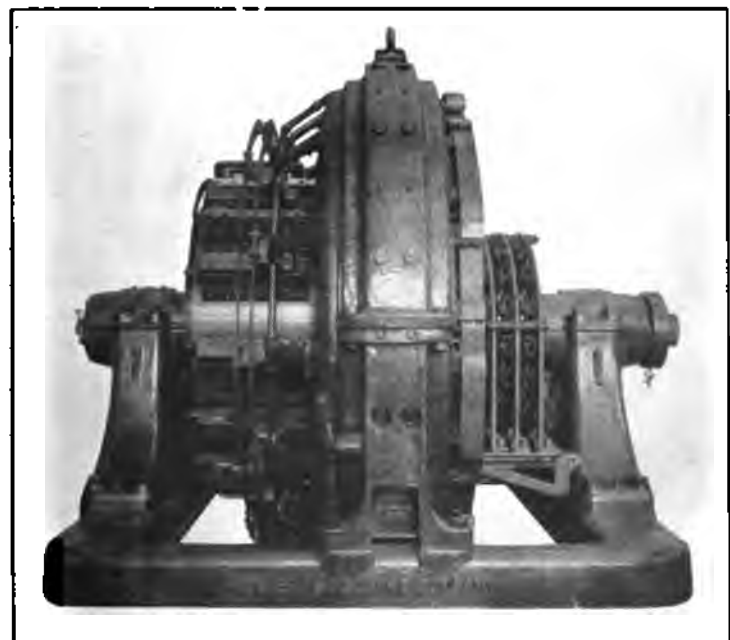

FIG. 303. — Synchronous converter. Alternating current received at the right and direct current delivered at the left.

288. A comparison of the synchronous converter and motor generator. If we compare these two types of machines, we find that in the large sizes the synchronous converter is more efficient, because there is but one field and but one armature and so the various losses are much smaller. Then, too, the synchronous converter weighs less and occupies less space and costs less, provided that no large amount of auxiliary apparatus is required to control the voltage. On the other hand, the synchronous converter in smaller sizes is hard to start and is unstable on lines where sudden changes in load or voltage occur. In fact, direct voltage cannot be regulated separately from the power factor and it is impossible to improve the power factor or the regulation of the line without great loss in capacity.

It should be noted, however, that the capacity of a polyphase converter is greater than the capacity of the same machine if operated as a direct-current generator. This is the case because the alternating currents and the direct currents in the armature windings partly neutralize each other and so the heating of the armature coils is less in a converter than in the same machine run as a direct-current generator and delivering the same power. For example, a three-ring converter with unity power factor which has a capacity of 100 kw. as a d-c. generator, would have a capacity of 134 kw. In general, the output marked on the name plates of synchronous converters is based on the maximum load which they can safely deliver under standard conditions of test. But converters for railway service are built so as to deliver twice their normal load for one minute and a 50 per cent overload for two hours without exceeding the specified standard temperature rise and without serious sparking at the brushes.

289. Points about the construction of synchronous converters. Many converters have commutating poles like those in direct-current generators, which have already been described

(section 154). This enables the converters to run at higher speeds and yet to commute without too much sparking at the brushes. Another result is that with fewer poles there is less weight and less cost. Many converters have laminated field cores and poles, in the faces of which are slots, parallel to the armature slots, and containing copper bars joined at their ends to form a low-resistance grid. These squirrel-cage windings on the pole faces act as dampers to prevent hunting (Fig. 279). This term is applied to an oscillating or pulsating motion of the rotor back and forth across the synchronous position when any sudden change in the load or in the line voltage takes place. In converters this hunting is liable to make the machine drop out of step and to cause destructive sparking at the direct-current brushes and even a "flashing over" from brush to brush.

290. Method of starting converters. Since a synchronous motor is not naturally self-starting, there are several methods used to start converters. (a) **By means of a small induction motor** which is mounted on the same shaft. When the converter is brought up to synchronous speed and has built up its own field and is at the proper voltage, it is thrown on to the a-c. line. (b) **As a direct-current motor.** The field is excited from d-c. bus bars and then, after using proper resistance for starting, the armature is put on the line and brought up to speed and when synchronized is connected to the a-c. supply. (c) **As an induction motor.** It has already been explained that the armature winding is like that of a d-c. machine, but when an alternating current is applied through the slip rings a rotating magnetic field is produced exactly like that in any induction motor. The copper grids in the pole faces take the place of the squirrel-cage secondary winding. At first, half-voltage is applied by means of special taps brought out from the secondary of the transformer, and the converter turns over and speeds up. At some speed near regular running

speed, the switches are thrown over so as to give full voltage to the machine and it is ready for service. There are also numerous important details about starting a machine by this method, such as opening the shunt-field circuit at several points by means of the field-break-up switch. This prevents the voltage induced in the field coils by the rotating-armature flux from becoming great enough to puncture the insulation. Another device which prevents short circuits in those armature coils immediately under the commutating poles is the brush-raising switch. Since the rotating field set up while the armature is running below synchronism induces voltage in the armature coils as well as in the field coils, and since the commutating poles furnish paths of low reluctance, destructively large currents would flow in these coils if they were short-circuited by the brushes remaining on the commutator. Another precaution which must be taken is to make sure that the d-c. side of the machine has "come up" with the right brush polarity before putting the machine into service.

291. Inverted converter. It is well to remember that the synchronous converter is a reversible machine and so can be used to convert direct current into alternating current. When it is so used, it is called an inverted converter. For example, suppose a power station supplies direct current for local uses and alternating current for the distant load. Sometimes a converter will be used straight to help the d-c. generators and at other times it will be used inverted to help the alternators. Again, suppose a direct-current power house must supply power to a district at a distance from the central plant. It would use an inverted converter to change the power to alternating current for high-voltage transmission and at the distant point use another converter to change the power back to direct current for use.

SMALL RECTIFIERS

292. Mercury-arc rectifiers. When it is necessary to change small quantities of alternating-current power into direct-current power, the mercury-arc rectifier is very commonly used because it is cheaper than the motor-generator or synchronous converter.

Figure 304 shows in diagram the connections of the type of single-phase mercury-arc rectifier used for charging storage batteries and for operating arc lights. The glass tube has four terminals, which pass through the glass and terminate in graphite electrodes. Over each of the two lower ones *A* and *B* there is a pool of mercury. The air is exhausted from the tube so that it contains only mercury vapor. The two positive electrodes *C* and *D* are generally called the anodes. The operation of this device depends on the fact that the mercury-vapor rectifier acts as an electrical valve, which permits current to flow only from a positive terminal (*C* or *D*) to the pool of mercury (*B*), depending on whether *C* or *D* happens to be positive at this instant. Suppose *C* is positive, then a current is at once carried by the vapor to *B* and through the battery to *E* and through coil *S*₁ (which has high reactance but low resistance) to the other side of the transformer. At the next instant *D* becomes positive and the current flows from *D* to *B* through the vapor, then through the battery to *E*, through the reactance coil *S*₂ to the other side of the transformer. In this way the current through the battery is always in one direction.

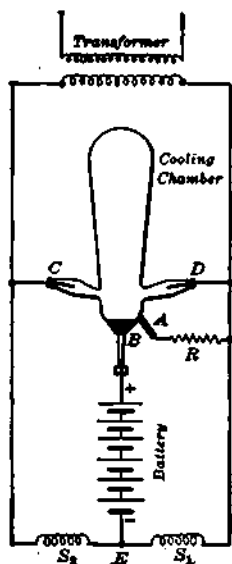

FIG. 304. — Diagram of connections for a single-phase mercury-arc rectifier.

To start this action of the rectifier, the tube is tilted until a bridge of mercury connects *A* and *B*, and, as the tube is tilted back into a vertical position, an arc is formed between *B* and *A*, which vaporizes some of the mercury and charges it with electricity so that the resistance between *C* and *B* or between *D* and *B* is out down.

But the mercury arc requires voltage to keep it going, and in reversing the direction of the alternating current through the transformer there is an instant when the voltage drops to zero, and at this instant the arc tends to go out. So the reactance coils S_1 and S_2 are used to preserve the arc. In operation, the mercury pool is violently agitated by the boiling of the mercury and the vapor condenses in the upper part of the tube.

In the most common size used for charging storage batteries the glass tube will carry a current of from 5 to 30 amperes. The voltage drop across the tube is always about 14 volts. The combined efficiency of the transformer and tubes ranges from 80 to 92 per cent with a power factor of about 90 per cent. The life of the tube depends upon the temperature at which the bulb is run; with low currents and low temperatures it has an indefinitely long life.

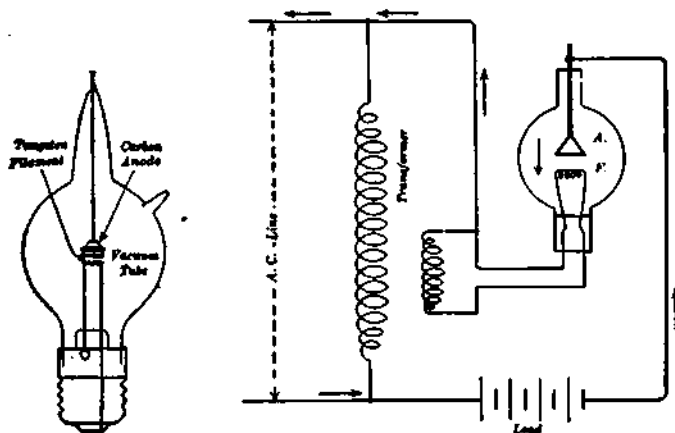

FIG. 305. —Vacuum tube and the principle of its use as a rectifier.

293. **Vacuum-valve rectifier.** Another type of rectifier has recently been developed on the principle of Fleming's vacuum valve (Fig. 305). It is designed for charging automobile

batteries and the construction is shown in figure 306. While this type of rectifier gives a unidirectional current, yet it does not give an absolutely steady current.

It consists of an evacuated glass bulb containing a tungsten filament F heated to incandescence by the alternating current and has a carbon electrode C introduced through the top of the bulb. The bulb itself is filled with inert gas at low pressure. The tungsten filament is connected in the secondary circuit of a transformer, which is part of the outfit, and when heated to incandescence, emits electrons (Chapter XXIII) and ionizes the rarefied gas in the bulb, which thus becomes a conductor of electricity. The filament is also connected

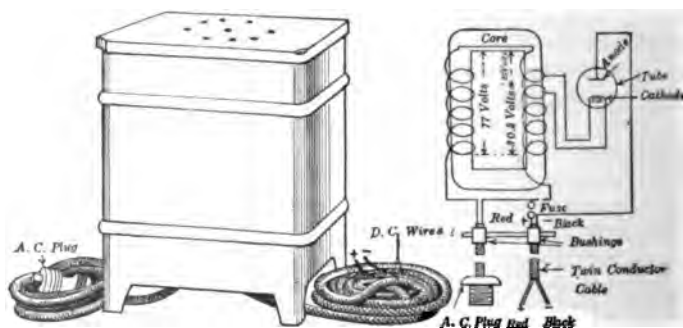

FIG. 306. — Vacuum-valve or "Tungar" Rectifier and diagram of connections.

to one terminal of the a-c. line and the graphite (carbon) electrode C is connected to the other terminal. During the half-cycle in which the graphite electrode is positive and the filament is negative, current passes through the bulb, due to the ionizing action of the electrons. During the other half-cycle when the graphite electrode is negative, the gas remains nonconducting, due to the absence of electrons. Thus the current passes through the valve during each alternate half-cycle from the graphite to the tungsten filament. We have, then, in the circuit of the bulb a pulsating unidirectional current, which is suitable for charging storage batteries. While the efficiency is not high yet this form of rectifier is extremely handy about the laboratory or garage.

LOCAL DISTRIBUTION OF ELECTRIC POWER

294. Different systems used. Just what electrical system is used in a particular locality depends, of course, on the history of the electrical development there, as well as upon various local conditions. If the distances are small and there is much variable-speed machinery, then direct or continuous current is used. If the distances are greater and the density of load is small and the power is used for lighting as well as for small-power service, then alternating current is better adapted for this work.

A constant-current or series system is used only in street lighting where the arc lights are all in use at the same time. Such a system is essentially high-voltage and so is not suitable for general distribution. It is the American practice to use a constant current of from 5 to 10 amperes. For general purposes a constant-voltage or parallel system is used almost exclusively. The normal voltage on d-c. lines is 110, 220, or 550, the last being used only for power distribution. When alternating current is used, the primary mains for distribution are operated at about 2200 volts. The frequency is usually 25 or 60 cycles. For lighting and small-power service, the single-phase circuit at 60 cycles is the standard. For larger power loads, two-phase and three-phase circuits are used. The 25-cycle system is employed where most of the energy is converted into direct current for lighting and railway service. Various combinations of alternating-current and direct-current, or 25-cycle and 60-cycle systems, are necessary in the larger cities.

In general, then, parallel distributing circuits are used for the distribution of both d-c. and a-c. electricity for lighting, power, and heating. Such circuits are so designed that the voltage between the two sides will remain approximately constant under all conditions of load. Some sort of voltage regulator is often used to keep voltage constant.

295. Constant-voltage network. The arrangement most commonly used in city distribution of electricity for lighting and power service takes the form of a network. Figure 307 shows such a network of distributing conductors, which run along the streets and are cross-connected to each other at each intersection, such as *A*, *B*, and *C*. The customers are supplied through service connections, such as *J*, *K*, and *L*. From the central station run out feeders which end at different selected centers of the network, such as *E* and *F*. The resistance of

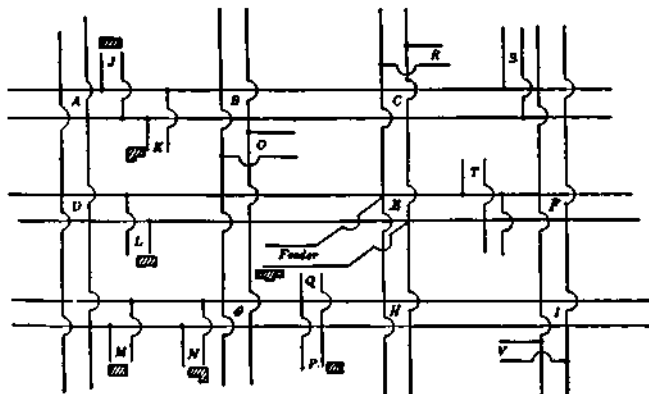

FIG. 307. — Feeders and mains in a d-c. network.

the mains is made very low so that without regard to the amount of the load or the place where it is heaviest the customers will all have constant voltages within narrow limits, say 2 per cent. In order to insure this constant voltage at the network voltmeter connections are oftentimes brought back to the station from the centers where the feeders enter the network, so that the volts there can be read at the switch-board.

296. The three-wire system. For a long time the Edison three-wire system of distribution of direct current has been in

use for distributing current over central-station mains. In it only **three wires** are required (Fig. 308). *A* and *B* are two generators; the positive terminal of *A* is connected to the positive line wire, the negative terminal of *A* is connected to the positive of *B*, and the negative terminal of *B* is connected to the negative line wire. A third wire, called the **neutral wire**, is connected to a point between the two generators and runs out along the line with the positive and negative wires. Some of the lamps are connected in parallel between the positive and neutral wires, and the others are connected in parallel between

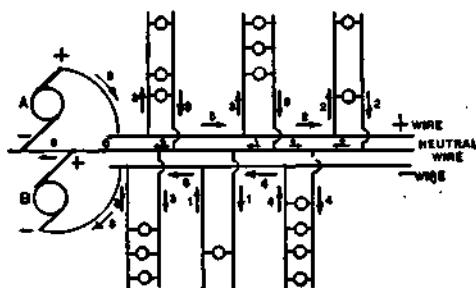

FIG. 308. — Diagram of balanced three-wire system.

the negative and neutral wires, the lamps being arranged so that the numbers on the two sides of the system are as nearly equal as possible. When this condition is fulfilled, as shown in the figure, the system is said to be **balanced**. In this case no current returns to the generators through the neutral wire, and the generators operate exactly as though they were simply connected in series. The function of the neutral wire is then to distribute the current from the lamps on the positive side of the system to those on the negative side. But if there are more lamps in use on one side of the system than on the other and so the system is unbalanced, the extra current is delivered by or returned to the generators through the neutral wire.

Figure 309 is a diagram of a three-wire system with more lights connected to the positive than to the negative side of the system. In this condition generator *A* carries more of the load than *B*.

When it is desired to change from a two-wire to a three-wire d-c. system, a special type of motor-generator set, called a **balancer set**, is used. This consists of two shunt-wound d-c.

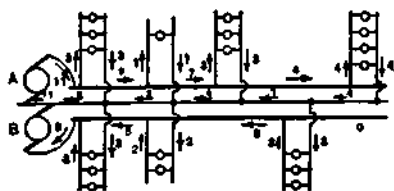

FIG. 309.—Unbalanced three-wire system. Numerals indicate the proportional currents flowing in different parts of circuit.

machines with their armatures on the same shaft connected in series across the line. The neutral wire is attached to the connecting wire between the two machines. The purpose of this apparatus is not only to supply the usual three-wire

d-c. system, but also to keep the voltages across the two sides of the system very nearly the same, even when the load is considerably unbalanced.

We may eliminate the balancer set by using the **three-wire generator**, which consists of a standard two-wire d-c. generator with a coil of high reactance and low resistance connected permanently across diametrically opposite points on the armature. The voltage across this coil is alternating, and therefore the current, even with no external load, is also alternating. But this current is extremely small since the reactance of the coil is large. The center point of this coil is connected to the neutral wire of the three-wire system.

Motors, except in the smallest sizes, are connected between positive and negative wires and if the voltage on each side is 110 volts, then the voltage between the positive and negative wires is 220 volts.

The reason for using this system is the fact that there is a considerable saving in the cost of the copper required in the

mains, much smaller conductors being needed than in a two-wire system. So the three-wire system is used in nearly all large installations for lighting or for lighting and power all over the world.

HOUSE WIRING

297. National code of rules. In 1897 a conference was held which was comprised of delegates from the various insurance, electrical, architectural, and allied interests of the United States. The object of this conference was to draw up a set of rules for the construction and installation of electrical apparatus *in a manner free from fire hazard.* The **National Electrical Code** was the result of their work and is accepted as a standard and adopted by the National Board of Fire Underwriters. This code is revised every two years and copies can be obtained on application to any of the Underwriters' Association offices or to any local inspection bureau. This code has placed electric lighting on a safe basis and has been of great economic value in regard to fire insurance and fire hazard. It is very important that all electrical installations be inspected whenever an experienced inspector is available, to insure that they comply with either the local ordinances or the Code Rules.

298. Wiring buildings. The importance of the parts of electric-lighting circuits which are inside of buildings cannot be overestimated. A central station may be built upon the best plan to supply current through a perfect distributing system, but a safe and satisfactory light will not be given if the **inside wiring** is poorly planned and badly put in place. Fires which occur on account of the electric-light wires in houses are always caused by the use of poor material, careless planning, or bad workmanship when the inside wiring was put in.

On account of the danger which may be caused by unscrupulous or untrustworthy wiremen, it is usual in large cities to

have official inspectors who examine and test all electric-light work placed within buildings. It is the duty of these inspectors to see that work is safely and properly done in accordance with rules fixed by the city authorities and approved by the fire underwriters. Even with such inspection the work is not always done in the best manner; yet comparatively few important fires have been caused by electric wires, and those have usually been the result of dense ignorance, or worse, — carelessness. A great majority of the accidents laid at the door of electricity are due to some other cause.

299. Various methods of wiring. In industrial plants and in mercantile establishments where appearance is of small moment, open wiring on knobs and cleats is a cheap and satisfactory method, if installed according to Code requirements. The cheapest method of installing concealed wiring in frame



FIG. 310. — National metal molding.

buildings is to carry the insulated wires within the floors and walls on knobs and to use porcelain tubes where passing through timbers. Although this method has given fair satisfaction, it is being superseded by the rigid conduit. In fact, in some cities only rigid iron or flexible conduit or flexible steel-armored cable is approved for concealed work. Metal molding (Fig. 310), which can be used only for exposed circuits, is now largely employed in the place of wooden molding. Undoubtedly the safest and most satisfactory method of electric wiring yet devised is the rigid iron conduit for both exposed and concealed work. Although the first cost is the highest of all of the methods, yet it is probably the most economical for permanent installations.

300. Planning the wiring of a house. The plan of the wiring of a house depends a great deal upon the size and construction of the building, but in its details it should always fulfill not only the letter but the spirit of the underwriters' requirements. Heavy service wires are led from the street mains of the electric-light company to a cut-out switch and fuse block and meter, which are often placed in the cellar. If the wires enter between

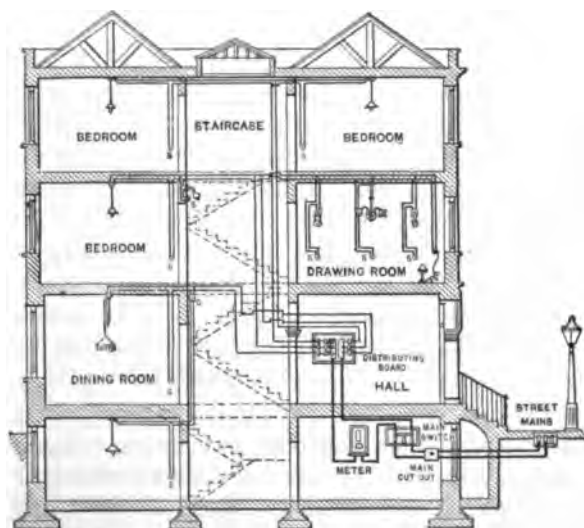

FIG. 311. — Diagram of wiring for a residence.

the first and second floors, the meter may be installed in the rear hall. At some central point in the building the distribution center is located in a cabinet or panel box. Next, the outlets are divided into groups which will absorb less than 660 watts and the wiring is so arranged that each group is fed by one branch circuit from the distributing center. Figure 311 shows such a plan of wiring, which is so plainly labeled that an extended description is not necessary. In the figure, *S, S, S*

are switches for turning the lights on and off. By this arrangement any trouble which occurs on one branch causes the fuses at the distributing center which belong to that branch to melt or blow. This disconnects the defective branch from the service wires without interfering with the other branches. The location of all the fuse blocks at a central point makes it convenient to replace fuses, and the fuse blocks can be so protected that a fire cannot possibly be caused by the arc which sometimes occurs when a fuse melts.

Motor circuits are subject to many special Code requirements, which should be consulted before installing motor wiring. In first-class installation it is always desirable to install separate circuits for the heating devices extending from the entrance switch. This permits individual metering (often at special rates) and insures that the heavy currents drawn by the heating appliances will not interfere materially with the voltage of the interior lighting circuits.

Besides the regular insulated wires used to conduct electricity to lamps, motors, and heating devices in a building, there are frequently numerous other wires which have to be installed for telephone and telegraph service, for call-bell circuits, fire and burglar alarms, door-opening devices, gas lighters, and electric clocks. Since all of these devices are operated at low voltage, it is unnecessary to use the same care in installing the wires as in higher voltage systems. Some care, however, must be taken even in a low-voltage system in order that the wires may not come in contact with light and power circuits. Much trouble will be saved if all the low-voltage wiring is carefully planned and well done.

Many buildings which are supplied with alternating current for lighting use a small step-down transformer in place of batteries and so save in the cost of the installation and avoid the possibility of run-down batteries. Such transformers are also used to obtain a low voltage for the lamps employed in electric

signs. A great deal of valuable information in regard to the details of electric wiring indoors and outdoors will be found in the convenient handbooks * used by electricians.

PROBLEMS

1. A 220-volt, 25-horse-power motor is located a thousand feet from the generator. If the efficiency of the motor is 90 per cent and the copper wire is 0.460 inches in diameter, what must be the voltage of the generator?

2. A 125-volt generator is located 500 feet from a 10-horse-power motor which operates on 110 volts at 85 per cent efficiency. What size copper wire is required?

3. A 125-volt generator is a quarter of a mile from 250 lamps which are connected in multiple and each lamp draws 0.45 amperes. Allowing 4 per cent line drop, what size copper wire must be used?

4. A 5-horse-power motor operates at 110 volts and at 85 per cent efficiency and is located 1000 feet from the generator. If the line wires are No. 8, what must be (a) the voltage of the generator and (b) its kilowatt capacity?

5. A 2-horse-power motor is 200 feet from a group of 10 incandescent lamps which are 3000 feet from the generator. The motor runs on 110 volts and is rated at 75 per cent efficiency. Each lamp takes 0.45 amperes at 112 volts. No. 4 copper wire is used between the generator and the lamps; what size wire should be used between the motor and the lamps?

6. What is the voltage of the generator in problem 5?

7. What power is lost along the line in problem 5?

8. A generator maintains a terminal voltage of 118 volts and supplies current to 250 lamps which are 500 feet distant. Each lamp is rated at 110 volts and 40 watts. What size copper wire should be used?

9. It is necessary to deliver 200 horse power at 550 volts to a place 3 miles from the generator. If the line loss must not exceed 8 per cent of the power delivered, what size copper wire should be used?

10. If aluminum is used for the line wires in problem 9, what size should be used?

* American Electricians' Handbook, by Terrell Craft. McGraw-Hill Book Co. Inc.

SUMMARY OF CHAPTER XVII

ELECTRICITY is a very *efficient means of transmitting the power* which is generated by steam engines, gas engines, or water wheels. Small isolated power plants as well as very large central stations are now used.

PRIME MOVERS include reciprocating steam engines, steam turbines, and gas engines. In hydroelectric power plants the prime mover is a water turbine for low head and impulse water wheels for high head.

GENERATORS for large plants are alternators with revolving fields. High-speed machines driven by steam turbines or impulse water wheels have only a few poles; slow-speed machines driven by reciprocating engines or water turbines have many poles.

At **SWITCHBOARDS** are placed switches, meters, and protective devices so that the operation of the whole power plant can be controlled at one place. In large a-c. power stations we have at the switchboard remote control of the oil switches and circuit breakers, which must be located in fireproof recesses.

TRANSMISSION SYSTEM consists of overhead or underground conductors, according to whether it is across country or through city streets. Substations contain transformers to step down the voltage and sometimes also rotary converters to rectify the alternating current.

SMALL RECTIFIERS may be of the mercury-arc type or of the vacuum-valve type.

ELECTRICITY is usually *distributed* to customers at constant voltage, 110, 220, or 550 volts, the last being used only for power distribution. The primary mains are commonly operated at about 2200 volts and at a frequency of 60 cycles. The 25-cycle system is used where energy is changed to direct current for lighting and railway service.

The **THREE-WIRE SYSTEM** is used for transmitting three-phase alternating current and in the Edison method of distribution of direct current.

HOUSE WIRING may be done on knobs and cleats, in wooden or metallic molding, or in rigid iron conduits, but must be done according to *National Electrical Code*.

QUESTIONS

1. What other means besides electricity are used for transmitting power?
2. What are some of the factors that determine which prime mover to use in a power plant?
3. What is the chief competitor of the small independent power plant?
4. What are the special advantages claimed for the small power plant?
5. Why have power plants in cities become more centralized in the last decade?
6. Describe the development of electric power from the coal to the customer.
7. What advantages have steam turbines over reciprocating engines?
8. What advantages have steam turbines with a horizontal shaft over those mounted on a vertical shaft?
9. What type of engine and generator would you expect to find in the power house of a railway company in a small city?
10. Under what conditions is it worth while to develop a hydro-electric power plant?
11. Under what conditions are Pelton impulse water wheels used?
12. What type of generator is used with Pelton water wheels?
13. What type of generator is used with reciprocating steam engines?
14. What advantages, is it claimed, follow from making the exciter direct-connected to the alternator?
15. What is the best position for a switchboard in a power station?
16. Why are not long-distance high-tension cables laid underground?
17. What advantages has the steel tower over the wooden pole for holding up high-tension wires?

18. What advantages has aluminum as a material for transmission lines?
19. What is the function of the transformer placed in a substation?
20. What is the function of a rotary converter?
21. What are the methods sometimes used in starting synchronous converters?
22. What is the purpose of an inverted converter?
23. Upon what principle does the mercury-arc rectifier operate?
24. Upon what principle does the vacuum-valve rectifier operate?
25. What advantages has the three-wire Edison system for distributing electricity?
26. What advantages has the three-wire three-phase system for transmitting alternating current?
27. Under what conditions can electric wires cause a fire in a house?
28. Why are the cut-out switch, fuse block, and meter often placed in the cellar near a window?
29. What advantages has electricity over gas for heating and lighting a residence?
30. What are some of the methods used in wiring a finished building for electricity?

CHAPTER XVIII

ELECTRIC LIGHTING

Early experiments — carbon filament — metal filament, tungsten — process of manufacture — testing with photometer — life of lamp — gas-filled lamp — commercial rating, efficiency.

Arc lights — carbons, mechanism — inclosed arc — flame arc — metallic electrode, magnetite — mercury-vapor lamps.

Distribution of light — measurement of illumination — foot candle — methods of illumination for interiors and streets.

301. Early history. Arc lights, which are so much of a necessity to-day in illuminating the streets of cities and all large spaces which require a high degree of illumination whether indoors or out, are the direct commercial outgrowth of an important discovery, which was announced shortly after 1800. This discovery was, indeed, nothing less than the possibility of producing the common electric arc. The discoverer of the electric arc, Sir Humphry Davy, the great English scientist, exhibited it on a large scale in 1808 in a lecture before the Royal Institution in London, when he connected the electric circuit from a battery of two thousand or more cells through two pieces of charcoal and then gradually separated them. The result was an arch or "arc" of dazzling light between the charcoal tips such as had never before been artificially produced. Sir Humphry Davy's experiments created a great deal of interest, but the real usefulness of the electric arc was not seen

until Faraday's later discoveries had laid the foundation for the development of the dynamo and the economical production of electricity.

The intense brilliancy of the arc light causes it to cast dense shadows, which, in general, quite unfit it for satisfactory use in indoor lighting. Its unavoidable flickering and occasional hissing also make it unsatisfactory for general use in small rooms. By 1880 the arc lamp had begun to prove its commercial value for outdoor lighting, but its disadvantages for general illumination had become known by that time, and inventors were using every effort to find some substitute.

Many years earlier, inventors had made electric lamps which consisted of a loop of wire made of platinum or iridium (two metals which melt only at exceedingly high temperatures) and in which the light was produced by heating the wire white-hot, or to incandescence, by means of a current. The light was, therefore, produced by means of the great heat caused in the wire when a current flowed through the high resistance of the wire. This is a case where the I^2R loss was turned to a useful account, but the lamps were not successful, though the same principle is used in the incandescent lamps of to-day.

Just previous to 1880 many prominent inventors, including Edison, Maxim, Farmer, Sawyer, and Man in this country and Swan in England, were making every effort to construct a satisfactory lamp which would operate by the incandescence of some material. It was found that loops of platinum and iridium were unsatisfactory because they soon melted or gave out when continuously subjected to the high temperature which is necessary to produce a satisfactory light. The only conducting material which would stand the high temperature of incandescence was found to be carbon. Unfortunately, carbon burns away when heated to a high temperature in the air, and therefore it could not be used in a lamp in the same way that metallic wires had been used.

302. The carbon-filament lamp. As early as 1845 a lamp had been made in which a thin stick of carbon was inclosed in a glass globe from which the air had been exhausted. This lamp produced an excellent light, since the carbon, however hot it became, could not burn away in a vacuum; but no satisfactory arrangements then existed for making proper carbon sticks or for exhausting the air from the glass globes. It was about 1880 that the inventors turned from their efforts to make a satisfactory loop of metal wire to make another attempt to use carbon, this time in the form of a thin strip or filament.

One of Edison's early lamps is shown in figure 312. The globe or bulb of the lamp contained a filament of carbonized paper in an arched or horseshoe form. The ends of the carbon horseshoe were connected to short pieces of platinum wire which passed through the glass of the bulb. By means of these wires a current could be led to the filament. The bulb was exhausted (that is, the air was removed) by means of a form of mercury air pump, which is capable of producing a very perfect vacuum.

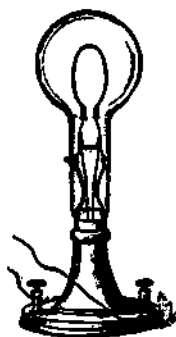

FIG. 312. — Early Edison incandescent lamp.

303. Improvements in the carbon filament. The long, slender filament in the early lamps was the carbon skeleton of a cotton thread. Later, liquid cellulose (wood fiber) was squirted into alcohol to form a thread, and after being bent into the right shape was carbonized by baking for many hours. Then it was found that a more uniform filament could be produced by treating the filament so that a coating of graphitic carbon was deposited; this was done by immersing the red-hot filament in gasolene vapor. Finally came the "metallized" carbon filament which was prepared by subjecting the base carbon to a very high temperature in an electric furnace and,

after "flashing in" gasolene vapor, by baking again at the furnace temperature. The ordinary carbon filament has less resistance when hot than when cold, but the so-called metalized carbon filament behaves like a metal and increases in resistance as the temperature rises.

304. Metal filaments. The early experimenters who used metallic filaments gave them up, because those which had a sufficiently high melting point, such as platinum, iridium, tantalum, and tungsten, were all either very expensive or very hard to draw into wires.

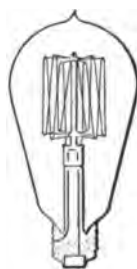

FIG. 313.—"Mazda" lamp with drawn-tungsten filament.

In recent years we have learned to draw tungsten out into very fine wires of great strength so that drawn tungsten has now come into very general use for the filament of incandescent lamps and seems likely to supersede all other material. The modern drawn-tungsten lamp (Fig. 313), known under the trade name of "Mazda," uses about one fifth as much energy as the old carbon-filament lamp and has a much longer life and gives a more nearly white light.

Since the production of drawn-tungsten filaments is one of the great triumphs of modern scientific research, it will be well to outline the steps in the process. From the concentrated ore of tungsten, pure tungstic oxide, a fine-grained yellow powder, is obtained. The metallic oxide is reduced with hydrogen in an electric furnace and comes out pure tungsten in rather coarse-grained powder form, gray in color and very heavy. This powder is pressed into ingots about 6 inches long and one quarter of an inch square and then heated to a white heat in an electric furnace in an atmosphere of hydrogen. The ingot now goes to the swaging machine. It is reheated and swaged several times before the square ingot becomes round and is changed into a thin rod 0.03 inches (thirty mils) in diameter and thirty

feet long. This rod or wire is still further reduced by drawing it red-hot through diamond dies. This process is continued until the wire is only three mils in diameter, which is about the size of the filament used in a 100-watt lamp for a 100-volt circuit.

To draw still smaller wires, the temperature is reduced and the wire is lubricated with graphite, which forms a coating and prevents oxidation of the wire. The filament in a regular 10-watt lamp is about three quarters of a mil in diameter, which is probably the finest wire ever produced by straight drawing.

305. Putting together an electric lamp. The raw materials used in a lamp factory are bulbs, tubing, filaments, and bases. The first operation on the bulb is "tubulating," by which a

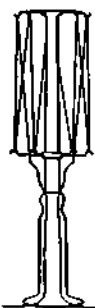

FIG. 315.—Filament wound on supporting stem with lead-in wires.

small tube is joined to the center of the round end of the bulb (Fig. 314). The filament-supporting stem is next made out of a short piece of glass tube, two leading-in wires, and a glass hub. The glass tube is melted

down upon the lead-in wires and squeezed together so as to make a seal about the wires which is air-tight. Wire hooks made of tungsten are then stuck in the glass hubs to support the filament. To make a lamp of a certain desired voltage, candle power, and efficiency, the filament must be of exactly the right diameter and must be cut just the right length.

The filament is wound on the supports by hand, and then the supports are bent so as to space them properly and to put the right tension on the filament (Fig. 315).

The assembling of the tubulated bulbs and the mounted



FIG. 314.—Lamp bulb with tube attached.

filament is done on a sealing-in machine, which has three sets of gas fires; the first *gently* heats the neck of the bulb and the flare at the bottom of the mount; the second heats these parts until the neck of the bulb *softens* and the glass sinks downward and inward until the neck of the bulb touches the flare and the two are sealed together; and the third set, which are thin sharp fires, melts the neck of the bulb below the seal, thus cutting off the surplus glass. Finally, while the glass is still soft, the operator centers the mount in the bulb.

The exhaustion of the lamp is done by slipping the tube, which has been joined to the round end of the bulb, into a rubber connection, which is in turn attached to a mechanical vacuum pump. This pump really consists of a preliminary vacuum pump and a final vacuum pump. During exhaustion the lamps are heated so as to free the glass of absorbed gases and vapors. The final step in the perfection of the vacuum is got by a chemical process. After a test with an induction coil which shows that the vacuum is good, the lamp is sealed off by melting the glass tube close

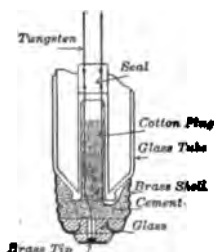

FIG. 316. — Cross section of Edison base of lamp bulb.

to the bulb. The last step consists in putting on the brass collar around the base and attaching the lead-in wires, as shown in figure 316.

306. Testing the lamps. In comparing the illuminating power of lamps, it is obvious that we must have a **standard lamp** and some instrument for making a comparison of lamps; that is, a **photometer**. Although many standard lamps have been proposed, none is altogether satisfactory. The oldest standard lamp, which is still used in calculation but seldom in actual practice, is the English standard candle, which is a sperm candle made according to certain specifications. The

illuminating power of a horizontal beam from this candle is called a candle power.

The present value of the candle power as used in the United States is that established by a set of standard incandescent lamps maintained at the Bureau of Standards in Washington, D. C. This unit of intensity is called the international candle and has been accepted by England and France. In Germany the legal unit of intensity is the *Hefner*, which is equal to 0.9 international candles.

307. The Bunsen photometer. This is an instrument (Fig. 317) for comparing the illuminating power of a beam from a

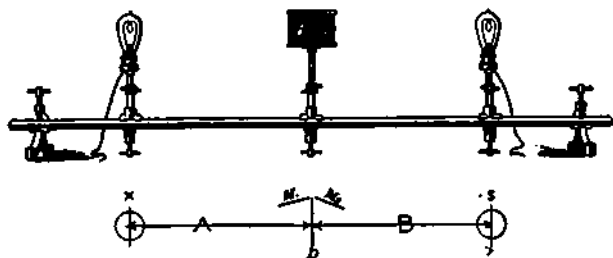

FIG. 317. — Bunsen photometer with grease-spot screen.

given lamp with the illuminating power of a horizontal beam from a standard lamp. This "grease-spot" photometer was invented by the great German chemist, Robert Bunsen. It consists essentially of a white paper screen with a translucent spot in the center, which transmits light freely. The screen is placed between the lamps to be compared, so that one side is lighted by one lamp and one by the other. If the screen is lighted more on one side, that side appears bright with a dark spot in the center, while the other side is darker with a bright spot in the center. If the two sides are equally illuminated, the spot disappears, or at least looks equally bright on each side. The arrangement of the Bunsen photometer is shown in

figure 317. The grease-spot screen is inclosed in a box, shown in figure 318, which is open at the ends *A* and *B* toward the lamps to be compared. The eye is held in front at *E*. Two mirrors *m*₁ and *m*₂ are placed on either side of the screen, as indicated in the figure, so that the two sides of the screen can be seen at the same time.

The photometer must be used in a dark room or else in a light-tight box. The lamp *X* to be tested is placed at one end of the photometer bar and the standard lamp *S* at the opposite end. The screen is then moved back and forth until a position is found where it is equally illuminated on both sides, and the distances *A* and *B* are measured.

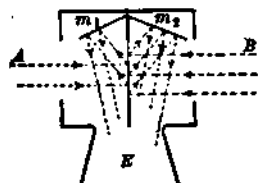

FIG. 318. — Photometer box with mirrors.

It is evident that, if the distances *A* and *B* are equal, the candle powers of the two lamps are the same. If the distances are not equal, the lamp which is farther from the screen has the greater candle power. Furthermore, since the intensity of illumination decreases as the square of the distance, the candle powers of the two lamps are directly proportional to the squares of their distances from the screen.

FOR EXAMPLE, let 16 = candle power of lamp *S*,
 and X = candle power of lamp *X*.
 Let 80 cm. = distance of screen from lamp *S*,
 and 100 cm. = distance of screen from lamp *X*.
 Then $\frac{X}{16} = \frac{(100)^2}{(80)^2}$,
 and $X = 25$ candle power.

NOTE. — The lamp *X* is frequently mounted so as to rotate approximately 120 revolutions per minute and thus its mean horizontal candle power can be determined from one setting of the screen.

PROBLEMS

1. A 4-candle-power lamp is 120 centimeters from a screen. How far away must a 16-candle-power lamp be to illuminate the screen equally?

2. In measuring the candle power of a lamp, a Hefner standard lamp (0.90 candle power) is 50 centimeters from the grease spot of a Bunsen photometer, and the lamp to be tested balances it when 150 centimeters from the grease spot. How many candle power has the lamp?

3. Two lamps are 16 and 32 candle power respectively, and are 200 centimeters apart. Where between the lamps may a grease-spot photometer screen be placed for its two sides to be equally illuminated?

4. The ordinary carbon-filament lamp, rated as 16 candle power, took about 0.5 amperes on a 110-volt line. How many watts per candle power?

5. The modern Mazda lamp rated at 40 watts gives 34.5 candle power. How many watts per candle power?

308. Life of a lamp. The average life of a 110-volt Mazda lamp is usually guaranteed to be 1000 hours, although in the laboratory tests the actual life is often considerably longer. The useful life of a lamp usually means the number of hours it will burn before it drops to 80 per cent of its initial candle power or the filament breaks. The life of a lamp depends on the voltage; for example, if a 110-volt lamp is used on a 105-volt line, it will probably last twice as long, but will give only 80 per cent as much light. If a lamp is operated at a higher voltage than its rating, more light will be produced at a higher efficiency but with a decrease in the life of the lamp. For example, if a 110-volt lamp is used on a 113-volt line, it gives about 18 per cent more light, but it will last only half as long. So it is very desirable to use lamps on the voltage for which they are intended. This means *we must have good regulation on the electric lighting service; that is, constant voltage at all loads.*

309. Gas-filled lamps. One of the factors which limits the life of a lamp, especially of a large lamp, is the blackening of the bulb. Very careful investigations have been made into the causes of this defect, and it has been found that of all the residual gases left in the bulb water vapor is the only one that produces perceptible blackening of the bulbs. But the attempts to improve materially the life of lamps by the more complete removal of water vapor have resulted in failure. The real cause of blackening in well-made lamps has been proved to be the evaporation of the filament, due to its temperature alone. Therefore, to improve the efficiency of tungsten lamps, either the rate of evaporation of the filament must be reduced or the evaporated tungsten must be prevented from blackening the bulb.

Experiments show that the introduction of gases such as nitrogen, mercury vapor, or argon into the bulb at atmospheric pressure reduces the rate of evaporation of the filament, but also produces a cooling effect, which is detrimental. In order, therefore, to obtain the same efficiency as in a vacuum, it is necessary to increase the watts so as to operate the filament at a higher temperature. In the gas-filled lamp the convection currents set up within the bulb deposit such tungsten as may be evaporated in the upper part of the bulb. By making use of these discoveries it has been possible to make gas-filled tungsten lamps which have run over 2000 hours and which have used less than 0.5 watts per candle power. But it must be pointed out that such high efficiency has been reached only in lamps taking large currents.

This new type of lamp seems to be especially adapted for large units, such as series street lighting, furnishing 600 to 1000 candle power and taking a large current of 20 amperes; also for small units such as stereopticon lamps and automobile headlights working on low voltage but furnishing a source of high intrinsic brilliancy and great steadiness.

The filament in this type of lamp (Fig. 319) is a closely coiled helix of drawn-tungsten wire. The coiling of the filament increases its effective diameter and simplifies the problem of its support, for it is distinctly soft when incandescent. Besides its higher efficiency this new lamp gives a light which is very much whiter and so comes very close to daylight.

310. Commercial rating of lamps. Carbon-filament lamps used to be rated according to candle power; thus a 16-candle-power lamp meant a lamp which gave a mean horizontal candle power of 16 at a definite voltage. At present lamps are usually rated in watts, because

it is the practice now in this country to maintain the wattages of the various types of lamps and to increase the candle power whenever improvements in the manufacture of lamps warrant efficiency increase. Thus we have tungsten ("Mazda") lamps from 10 to 1000 watts. The so-called *commercial efficiency* of lamps has long been given as *watts per mean horizontal candle power*, although this rating is really a measure of inefficiency because the larger the number the worse the lamp.

FOR EXAMPLE, an ordinary 50-watt carbon lamp gives 16.8 candle power or nearly 3 watts per candle power; a 50-watt metallized carbon (gem) lamp gives 20 candle power or 2.5 watts per candle power; a 40-watt tungsten (Mazda) lamp gives 38.8 candle power or 1.03 watts per candle power; and a gas-filled 20-ampere type of lamp uses 200 watts and gives 400 candle power or 0.50 watts per candle power.

Lamps intended to be used in series are rated according to the current, which is supposed to be kept constant, while in the case of constant potential the voltage is always prescribed.

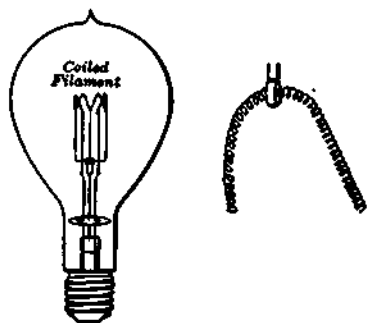

FIG. 319. — Gas-filled lamp with coiled tungsten filament.

PROBLEMS

1. If a 110-volt 16 c-p. old-type carbon lamp requires 55 watts, compute the following: (a) hot resistance of lamp; (b) efficiency, i.e., watts per candle power; (c) cost of burning the lamp for 1000 hours if electricity costs 10 cents per kw. hour.

2. A 25-watt Mazda lamp has an efficiency of 1.17 watts per candle power. Compute the following: (a) the candle power; (b) cost of burning the lamp for 1000 hours if electricity costs 10 cents per kw. hour.

3. A 40-watt gem carbon lamp costs 20 cents and has a life of 600 hours. What is the total cost per hour when electricity costs 10 cents per kw. hour?

4. A 25-watt Mazda lamp costs 27 cents and has a life of 1000 hours. What is the total cost per hour when electricity costs 10 cents per kw. hour?

5. If the lamp in problem 3 has an efficiency of 2.56 watts per candle power in all directions, and the lamp in problem 4 has an efficiency of 1.37 watts per candle power in all directions, find the mean candle power in all directions of each lamp.

6. If the carbon lamp in problem 1 costs 16 cents and has a life of 1000 hours, and if the Mazda lamp in problem 2 costs 27 cents and has a life of 1000 hours, find the price of electricity in cents per kw. hour which will make it cheaper to use carbon lamps.

7. Compare the cost of illumination with gas and electricity. A gas jet burning 5 cubic feet of gas per hour gives a flame of 18 candle power. The gas costs 95 cents per 1000 cubic feet. A 16-candle-power lamp consumes 40 watts. Electricity is 10 cents per kw. hour.

ARC LAMPS

311. Open arcs. The means for producing an arc of light are comparatively simple. When two pointed pieces of carbon (made of charcoal, coke, etc.) are joined to opposite poles of a circuit from a powerful generator of electricity and are touched together, a current flows between them. A considerable resistance exists where their points are in contact, and the points are heated by the current unless they are pressed very tightly together. If the contact is quite loose, the points become so

hot as to cause the carbon to pass off as vapor. Now, if the carbon points are separated, the current continues to flow across the space between the points, which is filled with carbon vapor, forming the electric arc. Carbon vapor is a much better conductor of electricity than air, and the current can, therefore, be made to flow across a space filled with it, though it could not readily be caused to flow continuously through the same space filled with air.

It seems strange to speak of the vapor of carbon, but the temperature of the electric arc is so great that it boils and vaporizes the most refractory materials. The vaporizing of any material is merely a question of temperature, and the vaporization of carbon, platinum, gold, iron, copper, etc., in the electric arc is just as simple as the conversion of water into steam (the vaporization of water) over a common coal fire. The vaporization of "refractory" materials like carbon, platinum, etc., simply requires a much higher temperature than that at which water boils over a coal fire.

After a direct-current arc has existed for a little time between the carbon points, they come to look very much as they do in figure 320. Both points become very hot and give off light, but the positive point (which is the upper point in the figure) becomes much hotter than the negative, and from it comes the greater part of the light of the arc. In an arc which is set up with a continuous current, carbon is carried off by the current from the positive point but not from the negative



FIG. 320. — Electric arc produced by direct current.

point. The positive point, therefore, becomes a little hollowed out on the end, as shown in the figure. This hollow is called the crater of the arc.

As the greater part of the light of the direct-current arc comes from this positive end or crater, the positive carbon in an arc lamp is almost always put at the top, in order that the light may be thrown downward. When an arc is set up with an alternating current (Fig. 321), both points become somewhat crater-like and light is given off about equally from the two points.



FIG. 321. — Open arc produced by alternating current.

Since the arc is surrounded by air, the carbon of which the points are composed is gradually burned up, and if the carbons are fixed in position the arc grows longer and longer until its resistance becomes so great that the current cannot pass through it; the current then stops and the arc goes out. Since carbon is carried away from

the positive point but not from the negative point, the former wastes away in a direct-current arc at a rate which is just about double that of the latter. The two carbons of an alternating-current arc waste away at approximately equal rates. The expenditure of carbon grows larger with the current and is approximately independent of the size of the carbons, so that carbons of large diameters have a "longer life" than smaller carbons.

312. Arc-lamp mechanism. In order that the electric arc may be used for commercial lighting, an automatic device must be used to keep the carbons fed toward each other as they waste away, so that the arc shall always have the proper length. This is included in the mechanism of what is known

as an arc lamp. It consists of a case which contains the feeding mechanism, below which is a frame to support the lower or negative carbon, and a glass shade. The feeding mechanism has two duties to perform:

1. To separate the carbons, or strike the arc, when the lamp is thrown into circuit.
2. To regulate the movement of the upper or positive carbon downward toward the negative one as the carbons wear away.

The lower carbon is usually clamped solidly at the bottom of the lamp frame, and the upper one is clamped at the end of a polished brass "carbon rod," the motion of which is controlled by the mechanism.

Besides this feeding mechanism every arc lamp must have a ballasting resistance to control the current. The reason for this will be evident when we consider the characteristics of the electric arc. Suppose the voltage to decrease slightly, then the current would also decrease and the conducting path of carbon vapor would become less dense and so increase the resistance; this would continue until the arc went out. On the other hand, if the voltage increased slightly, then the current would increase, causing more carbon vapor and decreasing the resistance of the arc, and so on until the arc would be practically short-circuited.

This instability of the electric arc is corrected by inserting in series with the arc a ballasting resistance coil. Figure 322 shows the connections of an electric arc with its regulating coil and ballasting resistance.

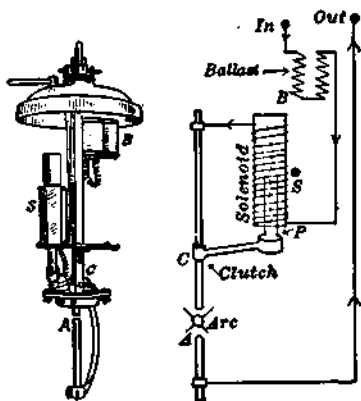

FIG. 322.—Arc lamp with diagram of its regulating coil and ballasting resistance.

When arc lamps are operated in parallel on a constant-voltage line, the regulating device is very simple. The plunger inside the regulating coil is attached to a friction clutch. When there is no current on, the upper carbon drops down until it touches the lower carbon, but when the current is turned on, the regulating coil sucks up the plunger and the friction clutch grips the upper carbon and lifts it up. Thus the arc is formed.

As the carbons burn away and the resistance of the arc increases, the current decreases and the regulating coil allows the plunger to drop. This releases the friction clutch on the upper carbon so that it drops down till it touches the lower carbon. Thus the process is repeated.

When arc lamps are operated in series, a much more complicated regulating device is used, but the ballasting resistance need not be inserted in each lamp as the generator automatically furnishes a constant current.

313. Inclosed arc lamps. About 1895-1896 it was found that an arc can be successfully maintained in a fairly tight globe; and that by so excluding the air a pair of ordinary carbons can be made to burn 60 to 125 hours. The inclosed lamp (Fig. 323) also burns with a steadier light than the open arc, so that it is more desirable for indoor lighting.



FIG. 323. — Inclosed arc lamp.

This lamp uses about the same power per candle power, but about twice the voltage and one half the current required by the open arc. The inclosed lamps are largely used on constant-voltage systems and the mechanism may be like that described above. The inclosing globe must not be absolutely air-tight or it will explode, and indeed it would be difficult to make it air-tight, since the upper carbon must be fed through an opening in the top plate.

314. The flame arc lamp. In the flame arc the light comes mainly from the arc itself rather than from the electrode ends, as in ordinary arc lamps. The carbons are impregnated with

chemicals, which when vaporized in the arc become highly luminous. Calcium compounds give a yellow light; barium and titanium a white light; and strontium a reddish light. In one type of this lamp, called the "long-burning" flame, the electrodes are vertical, and in another type, called the "short-burning" flame, the electrodes are inclined and converging. In both types the regulating mechanism is such that the arc is kept at a fixed level beneath a vitreous canopy or economizer (Fig. 324), which serves to conserve the heat of the arc, to deflect the fumes, and to help reflect the light downward.

In this country the flame arc lamp is used chiefly for display lighting. Although the efficiency of these lamps runs high (for example, one type requires 8 amperes, 45 volts, total watts 440, and gives 1025 candle power, or 0.43 watts per candle), yet the high cost of maintenance and of electrodes has greatly handicapped it.

315. Metallic-electrode arc lamp.

This lamp differs radically from the other arc lamps in that the positive electrode is a block of copper and the cathode consists of a thin iron tube closely packed with powdered magnetite (magnetic oxide of iron) and oxides of titanium and chromium. The copper anode is not consumed and requires infrequent renewal. The cathode has a life of from 100 to 250 hours, depending on the current. There are two types of commercial lamps which differ principally in the electrode arrangement. In one (the General Electric type) the copper is the upper, while in the other (the Westinghouse type) the copper is the lower electrode.

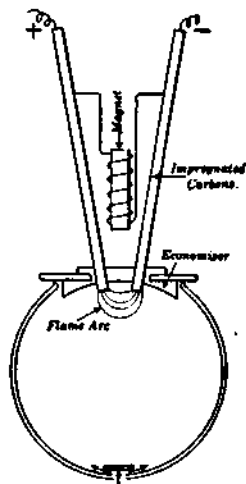

FIG. 324. — Flame arc made with impregnated carbons beneath a vitreous canopy.

Unlike other arc lamps, this luminous arc lamp (Fig. 325), as it is sometimes called, is not adapted to interior use on constant-

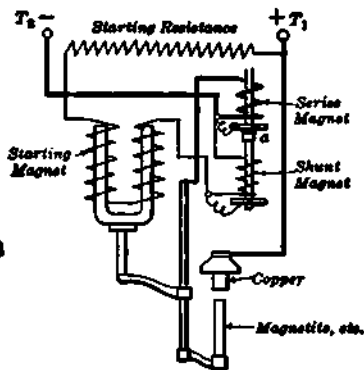
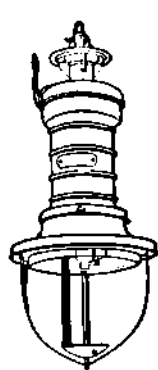

FIG. 325. — Luminous arc lamp with copper electrode and diagram of connections.

voltage circuits, but is used for street lighting on constant-current circuits. Since this magnetite arc is a d-c. lamp, it is usually supplied from a-c. lines by mercury-arc rectifiers (described in section 292), or in some cases by Brush arc machines.

316. Mercury-vapor lamps. The commonest form of mercury-vapor lamp, known as the Cooper Hewitt lamp, consists of a glass tube about 1 inch in diameter and 2 or 4 feet long, with mercury at the lower end and an iron or graphite electrode at the upper end. The tube is exhausted so that the pressure is only 1 or 2 mm. The current will not flow through the tube from B to A (Fig. 326) unless there is a stream of mercury vapor to carry it.

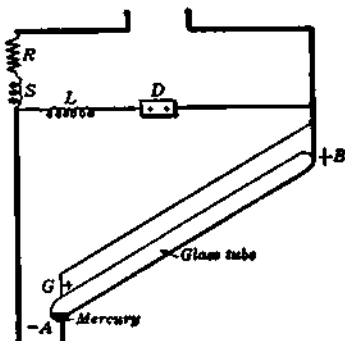

FIG. 326. — Diagram of mercury-vapor lamp.

The simplest way to start the lamp is to tilt the tube until a thin stream of mercury connects the two electrodes. When the tube is brought back to its normal position, the breaking

of this stream starts the arc. Generally an automatic starting device is used, which consists in causing a momentary high voltage discharge across G to A by means of an induction coil L . This spark sets up enough vapor in the tube so that the current passes from B to A . To keep the arc stable, a ballasting resistance R and an inductance S are connected in series with the tube.

The light given by this low-pressure mercury-vapor lamp is greenish blue and is without red rays. It produces a peculiar color effect on most objects, especially those which are red; that is, those that reflect red light. It has, however, been found well adapted for uses where color values are of little importance, as in warehouses, drafting rooms, and some factories. The light has a peculiar value in work where fine detail discrimination is needed.

In order to get higher efficiency by working the tube at higher temperature and pressure, a short quartz tube has been substituted for the long glass tube. This gives a light which is much more nearly white. The lamp has to be surrounded by a glass globe in order to cut out the harmful ultra-violet rays that penetrate through the quartz. The use of the reflector and the globe causes a certain loss of light flux, and there is also a certain amount of energy lost in the resistance in series with the arc, and yet in spite of these losses such a lamp uses less than 0.5 watts per candle. Since the mercury-vapor lamp is rich in blue, violet, and ultraviolet rays (which are especially active chemically) and since the light source is large and offers wide diffusion, this electric lamp is especially adapted for photographic purposes.

317. Distribution of light. In discussing incandescent lamps it has long been customary to measure the mean horizontal candle power. But as soon as one begins to consider the proper distribution of light for any particular purpose, then it becomes necessary to plot distribution curves, which show

the candle power in various directions. In figure 327 we have in curve *A* the distribution of light from a 600-candle-power lamp, and in curve *B* we have the distribution of the light from the same lamp, modified by proper devices, into the lower hemisphere.

In discussing the efficiency of arc lamps it is frequently useful to know the mean spherical candle power. Conse-

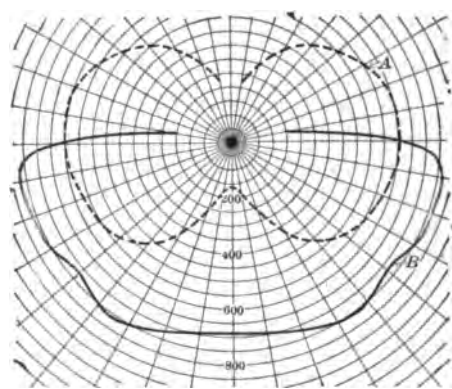

FIG. 327. — Distribution of light. Curve *A* without shade, curve *B* with shade.

quently lamp manufacturers often give the mean horizontal candle power and the reduction factor, which when multiplied by the mean horizontal candle power gives the mean spherical candle power. Thus, in the curve *A* (shown in figure 327) the spherical reduction factor would be 0.85 and consequently the

mean spherical candle power is 0.85×600 , or 510.

Since for street lighting it is the distribution of light in the lower hemisphere which is important, the manufacturers often state the mean hemispherical candle power and in discussing efficiency state the watts per mean hemispherical candle power. For example, a certain 300-watt luminous or magnetite arc lamp, when tested, shows the distribution curves which are given in figure 328. In curve *A* the mean spherical candle power is 763 and the mean hemispherical candle power is 711, while in curve *B* the mean spherical candle power is 607 and the mean hemispherical candle power is 1035. This shows an efficiency of 0.30 watts per mean hemispherical candle power.

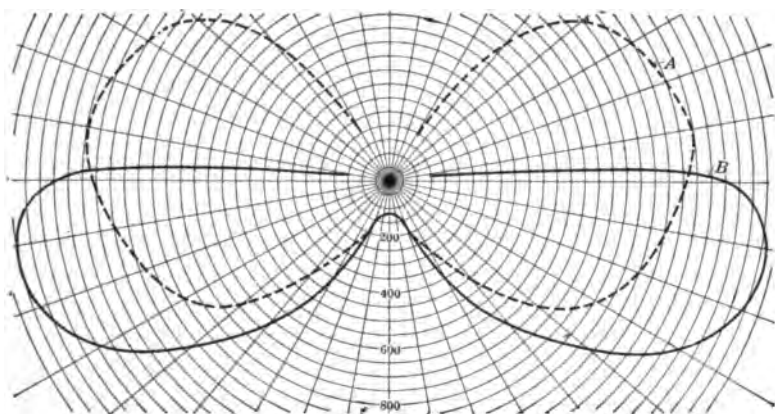

FIG. 328. — Distribution curves for a magnetite arc; *A*, lamp alone, *B*, with proper devices.

§18. Measurement of illumination. In these days when we do so much of our work and play by lamplight the problem of illumination is a very vital one. In the first place, it is essential to have enough light to see things distinctly, but, furthermore, experience shows that we may have enough light and yet not be able to distinguish the position and shape of objects well, because the lamps are not properly distributed to cast such shadows as we are accustomed to. Then there is the very difficult problem of getting lamplight which will give colored objects the same appearance which they have in daylight. Finally, we have to protect our eyes from the glare of the modern powerful electric lamps, which are likely to give us too much light in spots. Besides these purely physical aspects of the problem of illumination we have the economic question of its cost.

We have already seen that the unit of intensity for a source of light is the international candle. The illumination which such a standard candle throws upon a surface placed one foot

away and at right angles to the rays of light is called a foot candle. It is the unit of intensity of illumination.

FOR EXAMPLE, a 16-candle-power lamp would illuminate a surface placed 1 foot from it with an intensity of 16 foot candles. Again, if the lamp were a 32-candle-power lamp and the object were 4 feet away, the intensity of illumination would be 32 divided by (4)² or 2 foot candles.

319. Light varies inversely as the square of the distance.

The reason that the squares of the distances come into consideration in the comparison of candle powers is illustrated in figure 329. If we suppose a screen *AB* to be placed at a

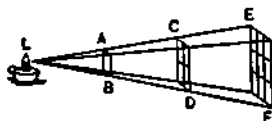

FIG. 329. — Illustration of the variation of illumination in inverse proportion to the square of the distance from a lamp.

distance of one foot from the lamp *L*, we may consider that the screen is illuminated by a certain number of rays of light falling upon it. Now, if the screen is moved to a distance of two feet from the lamp, the same rays of light will illuminate an area *CD*, which is four times as large as *AB*, and consequently the intensity

of the illumination of the screen is only one fourth as great as when the screen was at a distance of one foot from the lamp. If the screen is moved to a point three feet from the lamp, the same rays will cover the area *EF*, which is nine times as large as *AB*, and the intensity of the illumination is only one ninth as great as when the screen was within a foot of the lamp.

Since four and nine are respectively equal to the squares of two and three, we see that *the intensity of the illumination given to a surface by a fixed light is inversely proportional to the square of the distance from the light to the surface.*

Therefore the intensity of illumination on any surface at right angles to the rays of light can be expressed as follows:

$$\text{Illumination (foot candles)} = \frac{\text{Intensity of light (candle power)}}{\text{Distance (ft.) squared}}$$

Thus far we have assumed that there is only one source of illumination and that the surface is perpendicular to the rays of light. In practice this is almost never the case, so that the problem of computing or measuring the intensity of illumination on any given surface is somewhat difficult.

320. Illuminometer. There have been invented several forms of instruments with which to measure illumination, but most

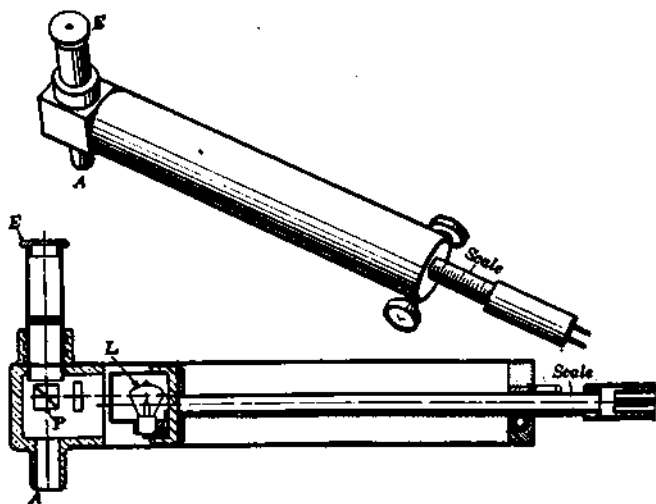

FIG. 330. — Macbeth illuminometer showing cross section.

of them are really semiportable photometers with a scale calibrated to read in foot candles.

Figure 330 shows the Macbeth illuminometer. The cross section shows a tube with a sliding carriage for the standard lamp *L* and a glass prism *P*, which serves as a photometer screen such as Bunsen's grease spot. A short telescope placed at right angles to the tube enables the observer at *E* to determine when the light coming in at the aperture opposite the telescope just balances the light from the standard lamp. By means of a rack and pinion at the end of the tube the standard lamp can be moved up and down the tube. The square

rod projecting from the bottom of the tube has a direct reading scale calibrated from 1 to 25 foot candles.

This standard lamp is supplied with current from a dry battery inclosed in a box and provided with a mil-ammeter and regulating rheostat, all of which is carried on a shoulder strap. Another standard lamp is provided for checking up the working standard and eliminating the personal error, which is quite likely to play an important part in photometry work.

To measure the illumination at any particular spot a test plate of depolished milk glass is placed in position (Fig. 331) and the instrument's aperture *A* is pointed at it.

Then the current through the standard lamp is checked up by the aid of the controller and the balance obtained by sliding the lamp up and down the tube. The intensity of illumination is read off directly from the scale. To increase the range of measurement, absorbing screens can be used so that the total range runs from 0.02 to 1200 foot candles.

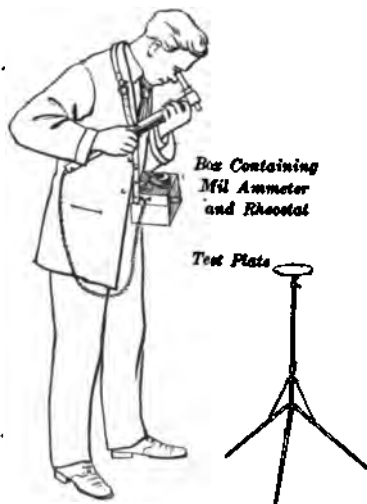

FIG. 331.— Measuring illumination on a test plate directly in foot candles.

To measure the candle power of a lamp, the *test plate* is set up perpendicular to the rays of light and at a measured distance away from the unknown source. It is also necessary to cut off all light from the test plate except that coming directly from the lamp under test.

After the illumination upon the test plate, as previously described, has been determined, the *value in foot candles is multiplied by the square of the distance in feet from the test plate to the lamp, and this will give the candle power in that particular direction.*

321. How much illumination is needed. The amount of illumination needed to furnish "good light to see by" varies

greatly with conditions. In drafting rooms, theater stages, stores with dark merchandise, and in work with machinery requiring delicate adjustment, bright illumination is required, which means 4 foot candles or more. In ordinary stores, offices, libraries, churches, schoolrooms, and residences, medium illumination is required, which means from 1 to 4 foot candles. In warerooms and shops where adequate local lighting is provided, low illumination of less than 1 foot candle suffices. Of course, these classes are only very roughly drawn to help in estimating installations.

Another way of making a preliminary estimate is based upon the *square feet of floor space per mean spherical candle power*; thus:

Bright illumination	2.0 sq. ft. or less per m.s.c.p.
Medium illumination	2 to 4 sq. ft. per m.s.c.p.
Low illumination	4 to 6 sq. ft. per m.s.c.p.

Such an empirical estimate assumes the rooms to be of medium height with walls and ceiling of fair reflecting power, and the lamps to be arranged to the best advantage for direct lighting.

PROBLEMS

1. A small arc lamp needs a current of 4 amperes and a voltage of 45. What is the resistance of the lamp?
2. If the lamp of problem 1 is used on a 115-volt line, what resistance must be put in series with it?
3. A certain searchlight requires 100 amperes and a difference of potential of 60 volts. What resistance must be placed in series with it on a 110-volt circuit?
4. The arc of problem 3 gives 128,000,000 candle power. Calculate how many candle power it gives per watt.
5. What is the illumination in foot candles on a surface 5 feet from an 80-candle-power lamp?
6. The necessary illumination for reading is about 2 foot candles. How far away may a 16-candle-power lamp be placed?

7. How high should a lamp fitted with a special shade be hung above a reading table? How high should it be hung if not provided with a shade? (Figure 332 shows the vertical distribution of light.)

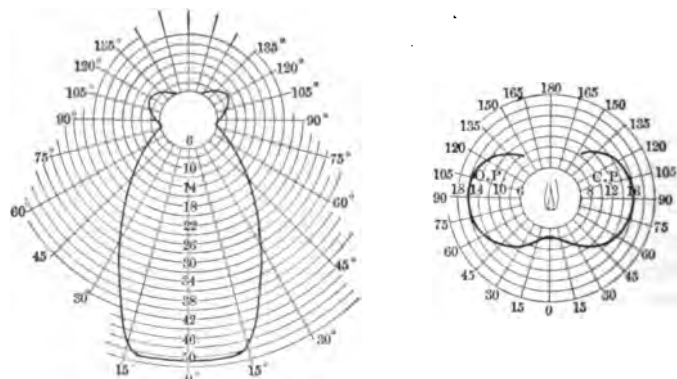

FIG. 332.—Vertical distribution for a lamp when fitted with a shade and without a shade.

NOTE.—A one-candle-power lamp placed in the center of a sphere of one foot radius shines on $12.56 (4\pi)$ square feet of surface. The light which shines on one square foot at a distance of one foot from a lamp of one mean spherical candle power and at right angles to the rays is called a lumen. Hence in general

$$\text{Lumens} = 12.56 \times \text{mean spherical candle power.}$$

8. If an ordinary lamp is rated as 4 watts per mean spherical candle power, calculate the efficiency in lumens per watt.

9. Compute the efficiency (lumens per watt) of a gas-filled tungsten lamp rated at one half watt per mean spherical candle power.

10. A parkway 2 miles long is to be lighted by 5.5-ampere series incandescent lamps 175 feet apart. The voltage across each lamp is 55 volts and the line wire is No. 7. If an extra mile of wire is needed to complete the circuit through all the lamps, compute (a) the volts needed when all the lamps are burning; (b) kilowatts.

11. If 4-ampere luminous arc lamps are used in problem 6 and are spaced 250 feet apart, make the same computations. Assume each lamp consumes 300 watts and that the line wire is No. 8.

322. Three methods of lighting interiors. The choice of the proper shades or reflectors is quite as important for good lighting as the lamp itself. Reflectors serve three purposes: (1) redirection of light; (2) concealment (more or less complete) of the light source; (3) decoration. Since the maximum candle power of the tungsten-filament lamp is in the horizontal direction and is about six times the candle power downward (see distribution curve, figure 332), it is evident that most of the light of the bare lamp is thrown to the side walls and not on a working plane where it is desired. There have been devised forms of shades or reflectors which serve to give a diffused light on the side walls and ceiling and sufficient illumination on the working plane, and at the same time to protect the eyes from the brilliancy of the filament.

The methods of proper distribution of light by means of shades and reflectors may be classified as the direct, indirect, and semi-indirect systems of lighting. In the direct system the light is received directly from the lamps and their accessory shades and reflectors. This gives the highest efficiency in the utilization of electrical energy. The indirect system conceals all the lamps and distributes light from large diffusing surfaces, usually white ceilings and upper walls. In this way shadows are either eliminated or greatly reduced in intensity and the glare of the visible filament is avoided. This is the most expensive method of lighting.

The semi-indirect system shields the lamps from direct vision by inverted-bowl reflectors of translucent glass (Fig. 333), which transmit downward a moderate amount of direct light and reflect to the ceiling the remainder. There is still

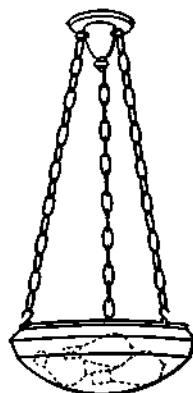

FIG. 333.—Semi-indirect system uses inverted-bowl reflectors of translucent glass.

doubt as to the most favorable ratio of direct to indirect light, but certain experiments indicate that very satisfactory results are secured by making the direct component about 15 per cent.

323. Some important don'ts about lighting :

1. Don't judge illumination by the brightness of the lamps. A glaring lamp may be giving too much light in the wrong place.

2. Don't expose the eyes to an unshaded light. It is best to have the light come from above and somewhat sidewise.

3. Don't waste light by using the wrong reflectors. No reflector ever increases the total light that streams out of a lamp; it only puts the light where it is needed instead of letting it go unguided.

4. Don't let lamps and globes get dirty. In this country millions of dollars are wasted by letting lamps become dust-laden. Promptly renew blackened bulbs.

5. Don't save light at the expense of your eyes.

324. Street lighting. Except for advertising or decorative purposes, such as shown in figure 334, the object of street lighting is to promote public safety and to facilitate travel and business at night. In this country there has been an enormous improvement in the standards of street lighting, but there is still great diversity between theory and practice. Municipal lighting has too often in the past been considered as a political job rather than as an important public service requiring the highest engineering skill.

Both arc lamps and incandescent lamps are now used extensively in street lighting. Large units, such as the electric arcs of carbon, flame, and metallic oxide, are most effective when suspended at a height of from 20 to 30 feet above the center of the street. Small units, such as the gas-filled incandescent lamp, are usually mounted on standards or brackets from 7 to 10 feet high upon the curb line. The spacing on



FIG. 334. — Statue of Liberty illuminated at night by means of 15 batteries of flood-lighting projectors using 250-watt tungsten lamps.

the two sides of the street is staggered to give greatest uniformity. Undoubtedly the most important improvement in street lighting in recent years has been the rapid development of a pole and lamp which is really ornamental as well as useful. Figure 335 shows the type of diffusing globe and pole used in Washington, D. C.

The required illumination (foot candles) for streets depends on traffic density and real-estate development. On important avenues and heavy-traffic streets the average illumination is from 0.5 to 1.0 foot candles. On suburban highways it may average from 0.01 to 0.02 foot candles. Wide departures from these general averages are the **display lighting** for advertising purposes based on the principle that "trade follows the light," and the **white ways** where the illumination, in addition to that produced by show windows and sign lights, may be 1.5 or even 2.0 foot candles.

In short, then, it may be stated that important streets require enough light for direct and detail vision so as clearly to reveal vehicles, persons, obstructions, irregularities of the pavement, and to permit the easy reading of a watch. This means uniform illumination without deep shadows and is usually obtained by well-diffused light sources with fairly close spacing. On secondary streets with only moderate traffic and orderly conditions, greater illumination is required at the intersections than at intermediate points. The silhouette aspect of vision is very important in such streets and emphasizes the need of fairly good and even roadway illumination without spots of deep shade from trees.



FIG. 335. — Ornamental type of diffusing globe and pole used in Washington, D. C.

SUMMARY OF CHAPTER XVIII

Electric arc discovered by Davy about a hundred years ago; incandescent carbon-filament lamps invented by Edison and others about 1880.

INCANDESCENT LAMPS. Carbon filament gives yellowish light of convenient candle power and sturdy but relatively low efficiency. About 3 to 4 watts per candle power. Candle power and life of lamp depend on voltage regulation. Filament must be in vacuum.

Drawn tungsten ("Mazda") gives whiter light and much higher efficiency. About 1 to 1.5 watts per candle power. Filament now made very tough and strong.

TESTING LAMPS. International candle determined by a set of standard incandescent lamps kept at Bureau of Standards. Illuminating power of a horizontal beam from this candle is a candle power.

BUNSEN PHOTOMETER compares illuminating power of a beam from a given lamp with illuminating power of a horizontal beam from a standard lamp.

RULE: *The candle powers of the two lights are to each other as the squares of their respective distances from the screen.*

GAS-FILLED LAMPS. Drawn-tungsten lamps filled with nitrogen, mercury vapor, or argon at atmospheric pressure reduce the evaporation of filament and can be operated at higher temperatures and higher efficiency. About 0.5 watts per candle power. Used in large units for street lighting and in small units for headlights and projection apparatus.

ARC LAMP. In the d-c. arc, light comes mostly from the crater in upper (+) carbon, except in flame arc made by carbons impregnated with metallic salts, where the arc itself is luminous. On constant-voltage line a ballasting resistance is needed. A regulating coil strikes the arc and feeds the upper carbon downward as the carbons wear away.

Luminous arc lamps (magnetite) use block of copper for positive electrode and tube packed with powdered metallic oxides as negative electrode. Due to pure white light and high efficiency (about 0.3 watts per mean hemispherical candle power), they are especially adapted for street lighting.

MERCURY-VAPOR LAMP. Luminous mercury vapor in vacuum tube lacks red rays, but has penetrating effect and is highly efficient (about 0.6 watts per mean hemispherical candle power). With a short quartz tube the mercury arc gives a light much more nearly white, and has a high efficiency (about 0.35 watts per mean hemispherical candle power).

ILLUMINATION. Unit is *foot candle*, which is the illumination that a standard candle throws on a surface one foot away and at right angles to the rays of light.

Illumination on a given surface at right angles to light rays varies inversely as the square of the distance from the source of light.

$$\text{Illumination (foot candles)} = \frac{\text{Intensity of light (candle power)}}{\text{Distance (ft.) squared}}$$

Illuminometer is a semi-portable photometer with a scale calibrated to read in foot candles.

Necessary illumination varies greatly with conditions from more than 4 foot candles for drafting rooms, theater stages, and stores down to less than 1 foot candle for churches, residences, and public corridors.

THREE SYSTEMS OF INTERIOR LIGHTING: direct, indirect, and semi-indirect.

Shades and reflectors should redirect the light, conceal more or less completely the light source to prevent glare, and be themselves decorative.

STREET LIGHTING. Largely an economic question. Standard of street lighting in this country rapidly improving.

Both arc lamps and incandescent gas-filled lamps now used. Ornamental poles and lamps are coming into general use.

QUESTIONS

1. Why did it take so long a time as seventy-five years to develop the experimental arc lamp into a commercial arc lamp?
2. What reasons led the early experimenters to give up the metal filament for the carbon filament?
3. Why is a high vacuum essential for a carbon-filament lamp?
4. What advantages has drawn tungsten over carbon as a material for filaments?
5. Why is the tungsten filament longer and smaller than the carbon filament?
6. Explain why platinum is so generally used for the lead-in wire in a lamp bulb.
7. What factors determine the life of a lamp?
8. The commercial rating of a lamp is not its true efficiency. Explain.
9. What advantages have gas-filled lamps over vacuum lamps?
10. Why must the gas introduced into the lamp bulb be inert?
11. What is the source of light in the direct-current open arc?
12. In what direction is this light at its maximum intensity?
13. What functions must be performed by the mechanism of an arc lamp?
14. What are the advantages and disadvantages of the inclosed arc?
15. Why has the flame arc lamp not come into more universal use?
16. What are the advantages claimed for the magnetite arc lamp?
17. What is the peculiarity of the mercury-vapor arc?
18. How can the distribution of light in various directions about a lamp be measured and graphically represented?
19. What is the difference between 16 candle power and 16 foot candles?
20. What are the purposes of shades and reflectors?
21. What are the advantages of the semi-indirect system of lighting interiors?
22. Under what conditions is it advantageous to use arc lamps for street lighting?
23. Under what conditions is it advantageous to use gas-filled incandescent lamps for street lighting?
24. What are the arguments in favor of ornamental lamp poles and fixtures?

CHAPTER XIX

ELECTRIC HEATING

Resistance and friction — power wasted in heating conductors — safe carrying capacity of wires — voltage drop in line. Heating of coils — ventilation of machines — protection by fuses and circuit breakers.

Applications: household appliances — blasting and exploding mines — furnaces, resistance and arc — electric welding. Thermoelectric currents — thermopile — thermogalvanometer — pyrometer.

325. Resistance and friction. We have already (Chapter III) seen that resistance in an electrical machine corresponds to friction in a mechanical contrivance. Just as we decrease friction in a machine by using smooth surfaces of suitable metals and by applying proper lubrication so that the temperature will not rise enough to do damage, similarly we decrease the resistance of an electric conductor by using a metal of low resistance and sufficient cross section so that the rise in temperature will not be enough to injure the insulation. In both cases it will be seen that the energy lost in friction or resistance is converted into heat, which may be useful or may be detrimental.

326. Power wasted in heating conductors. The amount of heat generated in any electric conductor depends on the power which is used in overcoming the resistance of the wire and is equal to the voltage at the terminals of the wire multiplied by the current flowing in it ($P = EI$), provided all the power

expended in that part of the circuit is used in heating the wire. Since the voltage is equal to current times resistance ($E = IR$), we have the result that the power required to overcome the resistance of a wire equals the square of the current multiplied by the resistance; that is,

$$P = EI = I^2R$$

when

P = power in watts,

E = voltage,

I = current in amperes,

R = resistance in ohms.

Therefore, that portion of the available electrical power of a circuit which is lost in heating the conductors is called the *I squared R loss*.

In transmitting power electrically there is, then, some loss of power due to the heat produced in the line wires. To obtain higher efficiency it is desirable to reduce the resistance of the line to a minimum by using wires of large cross section. But a large wire involves not only a big expense for metal but also more interest on the money invested in the line as well as the taxes and depreciation in the value of the line. In order to determine just what size wire will be most economical to use in a given case, one must take into consideration the cost of electrical energy and the market price of copper or aluminum. In general, by making the fixed charges (interest, taxes, and depreciation) equal the cost of lost energy, we get the most economical size of wire.

327. Safe carrying capacity of wires. In ordinary house wiring the size of wire to be used is fixed by the National Board of Fire Underwriters. The following table gives the allowable carrying capacities of various sizes of copper wire with rubber insulation and with other insulations.

SIZE OF WIRE B. & S. GAUGE	CURRENTS IN AMPERES WHICH IT IS SAFE FOR INTERIOR WIRES TO CARRY CONTINUOUSLY	
	Rubber Insulation	Other Insulation
18	3	5
16	6	10
14	15	20
12	20	25
10	25	30
8	35	50
6	50	70
5	55	80
4	70	90
3	80	100
2	90	125
1	100	150
0	125	200
00	150	225
000	175	275
0000	225	325

For aluminum wire the safe carrying capacity is 84 per cent of that given in this table for copper wire.

The capacities of these wires have been determined by the currents which these wires will carry for an indefinite period without becoming so hot as to injure their insulations or the materials near them. These currents must not, however, be taken as those which *cannot* be exceeded; but rather as safe values which *ought* not to be exceeded. For example, No. 14 wire with rubber insulation carries safely 15 amperes; if 20 amperes is forced through the wire, it gets warmer; and if the process is continued, it injures the insulation. If, however, 180 amperes were used with No. 14 wire, it would probably fuse or melt the copper. A current three times the safe value given in the table will cause the rubber insulation to smoke. Frequently, for temporary exposed work, twice the allowable capacity of a wire is taken.

Although the table gives the carrying capacity of wires as small as No. 18, yet it should be remembered that the underwriters do not allow conductors smaller than No. 14 to be used in electric light and power wiring, except for wiring fixtures and for flexible cords.

Stranded cables, on account of their greater flexibility, are often used instead of a solid wire. This is practically always done when a wire larger than No. 0000 is required. Even smaller sizes in the stranded form are very common because they are much easier to handle.

FOR EXAMPLE, No. 4 wire has a cross section of 41,700 circular mils; but if a cable made up of 7 strands is used, each strand must have an area of cross section of 5960 circular mils or a diameter of 0.077 inches.

328. Voltage drop in the line. Another factor, besides the power loss and the safe carrying capacity of wires, which must be considered in determining the size of wire to be used is the *voltage drop in the line*. The voltage at the receiving end of any line is always less than the generator voltage by the product of current times the resistance of the line (IR). This voltage drop in ordinary practice for house wiring should not exceed 2 per cent. This means that voltage variation at the receiving end of the line between a no-load condition and a full-load condition should not exceed 2 per cent of the full-load voltage. This difference in the voltages is called the *regulation of the line*.

PROBLEMS

1. A No. 0 solid conductor is to be replaced by an equivalent cable of 19 strands. What should be the size of the strands?
2. A cable is made up of 83 strands of No. 19 wire. To what size solid wire is the cable equivalent?
3. A two-mile aluminum wire is 0.25 inches in diameter. What is its resistance? (Assume one mil-foot of aluminum has a resistance of 18.7 ohms.)

4. A projection lantern requires 40 amperes. What size rubber-covered copper wire should be used?
5. What would be the size of weather-proof copper wire necessary to carry 15 amperes?
6. Calculate the voltage drop in 150 feet of the wire used in problem 5 at full load.
7. If the generator used in problem 6 furnished 125 volts, what was the regulation of the line at full load?
8. Compute the line loss in problem 6.
9. What is the diameter of a solid conductor which is 50,000 circular mils in area of cross section?
10. How many strands of No. 18 wire will it take to make a cable equivalent to the conductor in problem 9?
11. What will be the safe carrying capacity of the cable in problem 10?

329. Capacity of electrical machinery. Every machine, whether it is a generator, motor, or transformer, is designed and built for a certain load, which is definitely specified on the name plate (Fig. 336). Besides the kilowatt capacity, volts, amperes, speed, etc., the manufacturer puts on this name plate the style and serial numbers, which it is necessary to give when requesting information in regard to any machine or in ordering repair parts. If more load is put on the machine than it is designed to carry continuously, it becomes overheated, and if this is continued the insulation is set on fire and the machine breaks down. This heat is produced by the I^2R losses in the windings of copper wire and by the iron losses, hysteresis, and eddy currents, due to the changing flux in the iron. Great care has to be taken in designing electrical

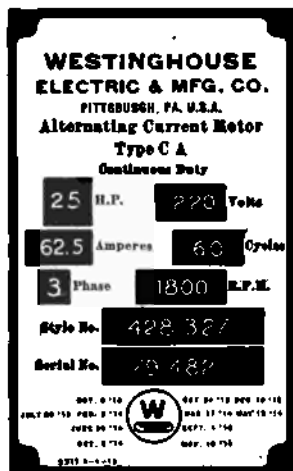

FIG. 336.—Name plate on a-c. motor.

machinery to reduce these losses as much as is practicable and then to dissipate the heat generated by ventilation or special devices.

Just as every attendant of a lathe or engine must occasionally inspect the bearings to see that the lubricating system is working properly, so an attendant who looks after a generator or motor must see that the machine does not get too hot.

330. Protection against too much current. We have already seen (Chapter III) that it is necessary to protect electrical

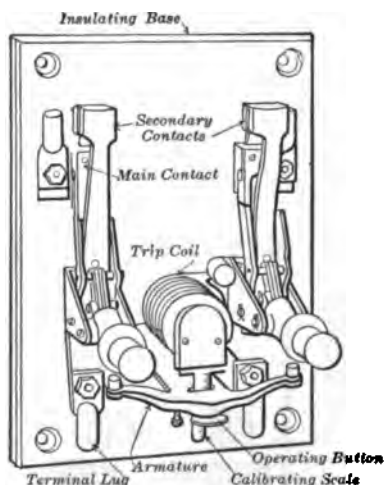

FIG. 337.—A medium-capacity double-pole circuit breaker (250 volts, 200 amperes).

machines from excessive currents by inserting some sort of automatic cut-out in the circuit. Fuses are used for the small currents in house lights and small motors, and circuit breakers for the larger currents handled on switchboards of power stations. A circuit breaker such as that shown in figure 337 is simply a large switch which is automatically opened by an electromagnet when the current is excessive. The advantage of the circuit breaker over the fuse as a safety device is that it is very prompt in action, and when once adjusted it is opened by a current of a perfectly definite value. Furthermore, the circuit can at once be closed after it has been opened by an excess of current. It should be stated, however, that the first cost of the circuit-breaker equipment is more than that for fuses.

machines from excessive currents by inserting some sort of automatic cut-out in the circuit. Fuses are used for the small currents in house lights and small motors, and circuit breakers for the larger currents handled on switchboards of power stations. A circuit breaker such as that shown in figure 337 is simply a large switch which is automatically opened by an electromagnet when the current is excessive. The advantage of the circuit breaker over the fuse as a safety device is that it is very prompt in action, and when once ad-

There are many forms of circuit breakers now on the market, but in practically all of them the closing of the switch puts in action a strong spring which tends to open it. The switch is kept closed by a latch, which is controlled by a trigger, and this trigger is released by an electromagnet carrying the main current.

It is also necessary to protect the main metal contacts of the circuit breaker from the destructive action of the intense arc across the break when the circuit breaker opens. For this purpose a secondary pair of contacts faced with carbon blocks at the extreme end of the movable arms are arranged in parallel with the main contacts, so that in operation the main contacts open first without an arc and then a moment later the secondary contacts open with an intense arc. But these carbon blocks are separated so widely as to put out the arc. Nearly all breakers are provided with a calibrated scale so as to operate at from 50 to 150 per cent of the normal load.

331. Household appliances. Thus far we have been considering the heating effects of an electric current as a necessary loss of energy which must be reckoned with and controlled. But in the numerous household appliances, such as toasters, flatirons, coffeepots, radiators, and ranges, we utilize to the full this heating effect of an electric current. In nearly all of these appliances the "resistor" — the conductor in which the heat is developed — is wound in a spiral or similar form so that the maximum length (resistance) can be put in a minimum space. The manufacturers of heating devices at the present time use an alloy of nickel and chromium for the resistors. This is because the alloy will withstand oxidation and has a high specific resistance (about 700 ohms per mil-foot) and can be safely operated at high temperatures without danger of fusion. This resistor is arranged in different forms according to the purpose of the device. For

example, in toasters (Fig. 338) and grills the resistor consists of exposed coils of wire or ribbon, open to the air and supported on

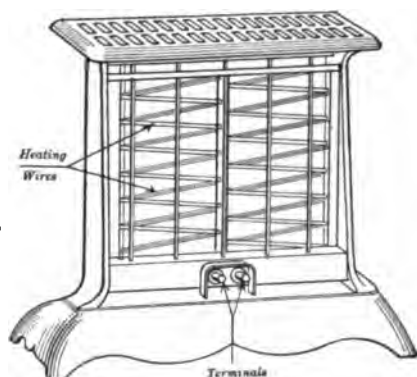

FIG. 338. — Electric toaster with exposed heater wires.

insulating material. In flatirons (Fig. 339), hot-plates, etc., the wire or ribbon is in the form of coils or flat layers embedded in enamel, asbestos, mica, or other nonconductors.

With the exception of the electric lamp and the electric flatiron, there is probably no electrical contrivance which has been more satisfactory to the housewife than the electric range. This is on account of its comfort, convenience, and cleanliness. In the range shown in figure 340 the heating units are made of "sheathed wire," which consists of special resistance wire only 0.01 inches in diameter surrounded by an insu-



FIG. 339. — Electric flatiron showing embedded heating coils.

lating powder in a steel tube or sheath about 0.125 inches in diameter. When the electric current passes through the core wire, the latter becomes red hot and the heat immediately passes through the insulating material to the outside sheath. The sheathed wire is formed into rectangular coils for the broiler

and oven units and into circular coils for the hotplates. Each unit is so connected that one can obtain three heats; for example, an 8-inch hotplate may use 1000, 500, or 250 watts, and a 12-inch square oven unit may use 1500, 750, or 375 watts.

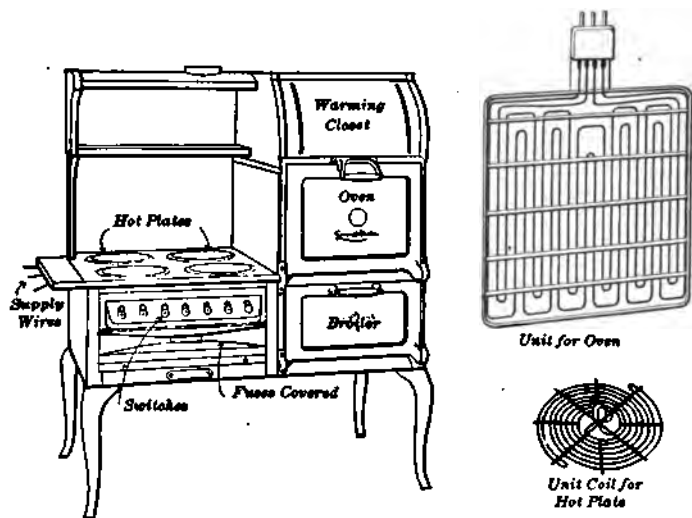

FIG. 340. — Electric range, showing heating units for oven, broiler, and hotplate.

332. Advantages of electric heating. It is obvious that the general advantages to be gained from electric heating are: (a) elimination of danger of explosion and fire, (b) absence of smoke and fumes, (c) exact control of the temperature, and (d) the localization of heat where it is desired. Thus far the great difficulty about introducing electric heating more generally into the household has been the cost of electric energy. It has to compete with gas. But when electricity costs from 3 to 5 cents per kilowatt hour, experience shows that it can compete with gas at from \$1.00 to \$1.50 per 1000 cubic feet. It is not uncommon for electric companies nowadays to put in separate meters and make a special price

on the electricity used for heating purposes. It is frequently desirable and often necessary to install special heating circuits in residences.

Even electric heating appliances are not absolutely "fool-proof." For example, a number of fires have been started by carelessly leaving on a wooden ironing board an electric

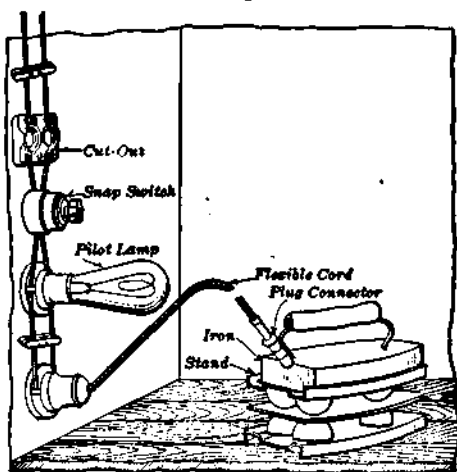

FIG. 341. — Flatiron on stand and connected with pilot lamp.

flatiron with the current on. It has been found that the ironing surface of the ordinary electrically heated iron should be operated at about 500° F., if it is to be used for ironing damp cloth. But if the ironing surface is not used and its heat thereby dissipated, it will often get red hot in less than 15 minutes. This makes it desirable to use an indicating or pilot

lamp connected in multiple in a heater circuit, as shown in figure 341, so that, when the current is switched on, the lamp will be lighted.

While electric cooking may be said to be satisfactory on account of its convenience, cleanliness, and adaptability, electric heating for general purposes can never replace the direct use of coal or the use of steam heating, until electricity is directly generated from the fuel or its equivalent without the intervention of steam engines. For in these there are enormous losses of heat, which cannot be prevented. The nature of steam engines makes it impossible, even with the best of

them, to convert into useful power more than 10 or 15 per cent of the heat energy contained in the coal which is shoveled into the boiler furnace. When the steam generated by the boiler is directly used for heating, a very much greater proportion of the heat in the coal is converted to a useful purpose; in fact, this proportion may be so great as to lie between 60 and 80 per cent.

333. Blasting and exploding mines by electricity. The heating effect of an electric current can also be used to ignite the charges in blasting and mining. The current is carried by a long cable from the battery or magneto to a special fuse (Fig. 342). This consists of a pair of insulated copper wires, the ends of which project into the detonating cap and are connected by a fine platinum wire. This wire becomes hot when the current flows; and being embedded in guncotton, which serves as priming on top of the fulminating mixture, it ignites this and sets fire to the charge. In this way submarine mines may be exploded beneath the water and at any desired distance from the battery.

334. Electric furnaces. These furnaces are coming into extensive use commercially, not because the electricity plays any peculiar part in the process, but simply because they furnish a convenient means of obtaining very high temperatures which can be easily controlled. For example, in the ordinary chemical and metallurgical furnaces temperatures up to 2000° C. are obtainable, but in the electric furnaces temperatures up to 3500° C. can be produced without special difficulty. In most places, however, when chemical or metallurgical processes are now carried out, heat produced electrically is much more expensive than heat produced from fuel.

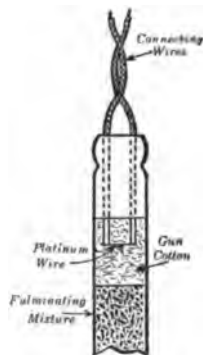

FIG. 342. — Electric fuse used in igniting the charge in blasting and exploding mines.

In general, it is convenient to divide electric furnaces into two classes: the resistance furnace, such as that used by Acheson in making carborundum, and the arc furnace, such as that used by Heroult for making high-grade steel.

It was in 1891, while trying to impregnate clay with carbon, that Acheson obtained a beautiful crystalline substance almost as hard as diamond. He thought this new substance was derived from carbon and clay and so called it carborundum, but it has since been found to be a compound of carbon (C)

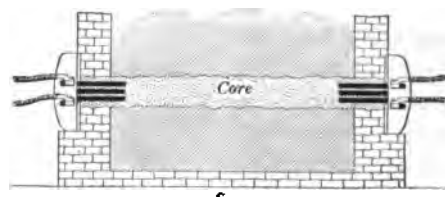
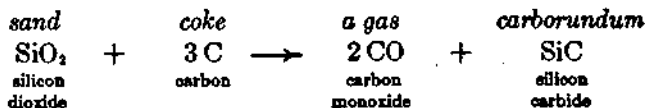

FIG. 343. — Section through carborundum furnace.

and sand (SiO_2) and is silicon carbide (SiC). To-day carborundum or silicon carbide is doubtless the most important abrasive on the market.

The carborundum furnace is shown in

cross section in figure 343. The core is granular carbon, around which the charge consisting of sand, coke, sawdust, and salt is packed. The electric current produces such a high temperature that the sand and coke react as shown in the equation:



The sawdust, when heated, liberates gases and thus helps to keep the mass porous so that the carbon monoxide gas can escape and burn in little flames around the surface of the mixture. The latest furnaces are about 30 feet long and 12 feet wide and use a current of 20,000 amperes and absorb 1600 kilowatts.

The use of this furnace has led to the discovery of a method of making artificial graphite, which seems to be formed in the

hottest part of the furnace by the decomposition of silicon carbide. The silicon is volatilized and the carbon is deposited in the form of graphite. To-day much artificial graphite is made by heating to a high temperature in such a furnace anthracite coal mixed with sand. This graphite is extensively used in the manufacture of electrodes and lubricants.

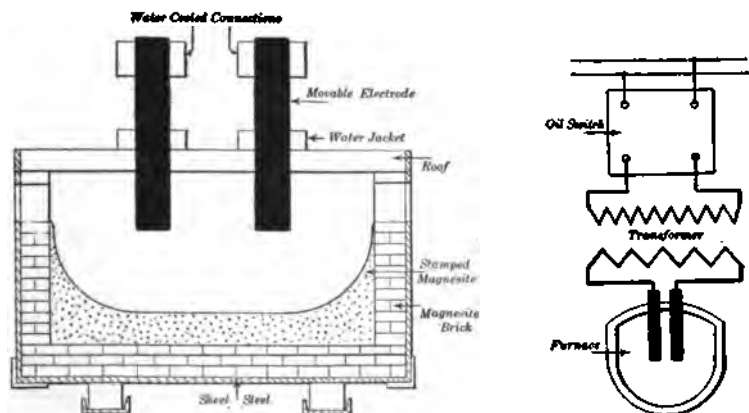

FIG. 344. — Cross section of Heroult furnace and plan of connections.

As an example of the arc furnace, we shall describe very briefly the furnace invented by Heroult, which is used in this country for the production of high-grade steel. Figure 344 shows a huge steel crucible or box made in two parts, the bed and the roof, and mounted so that it can be tipped to let the charge run out. The box is lined with fire brick and on this is a layer of dolomite (calcium magnesium carbonate). Carbon electrodes project into it through the roof. An arc is formed where the current passes from each electrode into the slag, which floats on top of the molten steel. As iron readily unites with carbon at high temperature, the electrodes are automatically regulated so that their ends remain about 18 inches above the steel. The current arcs from one electrode to the

slag and from the slag to the steel underneath and leaves the furnace by arcing from the steel to the slag and from the slag to the other electrode. An alternating current is used, and in large furnaces, taking 20 tons of steel at one time, three electrodes are used as shown in figure 344 a.

The advantages of the electric furnace for steel refining are that it gives steel ingots of 8 tons free from segregation and almost completely removes undesirable elements such as oxygen, sulphur, and phosphorus from the low-grade Bessemer steel.

335. Electric welding. Electrical methods are now used for welding, brazing, heating, shaping, and tempering metals. For most of these purposes the method in common use is to pass an electrical current of very great volume through the metal to be worked. This great current generates sufficient heat as it passes through the resistance of the metal to raise the temperature quickly to a welding or bending heat, or even to melt the metal. The electrical method of heating has this advantage over the ordinary method by forge fire: the latter heats a piece of metal from the outside, while the former heats all parts of the metal equally and at the same time the metal remains perfectly clean.

Electric welding, as ordinarily carried on, consists of heating the pieces of metal to be welded while they are firmly butted against each other. When the metals have been heated until they are soft at the points in contact, they are squeezed together a certain amount, the current is shut off, and the weld is complete. This is the process developed by Professor Elihu Thomson. The apparatus which is generally used in the Thomson welding process is: (1) an alternator, usually giving a frequency of from 40 to 60 cycles per second; (2) a welding transformer with clamps and arrangements for automatically making the welds; (3) apparatus for controlling the amount of current supplied to the transformer.



FIG. 344 a. — A 20-ton, 3-phase Heroult electric steel furnace fitted with three 12-inch graphite electrodes.



FIG. 345. — Thomson automatic electric welder with step-down transformer in case beneath. The secondary winding is but a single turn. The regulator switch is on the outside of case at left. On top is a stationary head (left) and a movable head (right) to hold the pieces to be welded. The compression lever with switch handle are at the extreme right.

Figure 345 shows a complete Thomson welder. The transformer is seen in the center of the case, the clamps are on top. The lever at the right is for squeezing together the heated rods held in the clamps. In welding heavy work hydraulic pressure is used to squeeze the weld.

336. Arc welding. Another process of utilizing the heating effect of electricity for the purpose of welding and working metals is that known as the arc process. This was developed by a Russian named Bernados and is particularly suitable for repairing broken pieces of cast and wrought iron. In this process a continuous current is used of from 200 amperes up, depending on the type of work being done, and the voltage across the arc is from 35 to 50 volts. The positive terminal of the electric generator is connected to the metal which it is desired to heat, and the other terminal is attached by a flexible conductor to a portable electrode. This electrode may be carbon or it may be a piece of the same metal which is being welded. When the carbon or metallic electrode is brought against the work, an electric arc is set up and the metal is heated.

This device has been used in the process of filling with metal the blowholes which sometimes occur in valuable castings. It has been found useful in welding the seams in small iron boilers, receivers for compressed air, and other iron vessels. It is of special advantage for the latter work, since the arc can be slowly drawn along the edges of the plates which are to be welded, thus bringing them to a welding heat, and the weld is then completed by pressing or hammering the edges together.

Recently the extension of electric welding to the building and repair of ships has been phenomenal. In the near future we may expect an entirely electric-welded ship, although at present there are many problems to be solved before the art is on a sound scientific and commercial basis.

In all of these processes protective coverings (Fig. 346) must be provided for the operator, as the light from the arc produces

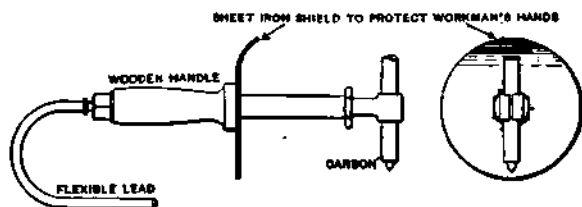

FIG. 346. — Carbon rod mounted on handle with protecting shield for use in arc welding.

severe burns on exposed skin and is peculiarly injurious to the eyes.

337. Pail welding. In all of the methods of electric welding it is to be noticed that the electric current is used only for the purpose of heating the product previous to welding, and that the mechanical pressure required to complete the weld is applied by external means of some kind. There is another striking method of electrically heating metals for the purpose of working them. If a pail of water in which is dissolved some common washing soda has immersed in it a lead plate which is connected to the positive terminal of a 150- or 200-volt electric circuit, it gives all the apparatus necessary for quickly heating iron. The metal to be heated is grasped in tongs which are electrically connected to the negative terminal of the electric circuit, the handles of the tongs being insulated.

When the metal is plunged into the pail of water, it is quickly brought to a white heat and may then be withdrawn and worked on the anvil or welded to another piece of heated iron by the ordinary blacksmith's method. Any metal may be heated by this process, but welding can be performed only on those metals which, like wrought iron, can be welded by the blacksmith. The heating of the metal when it is plunged into the water is apparently caused by an electric arc which is set up

around the submerged metal on account of its becoming surrounded by a coating of hydrogen gas. The amount of current used varies from a few amperes to many hundreds, depending upon the size of the metal to be heated. It is a remarkable sensation to see a *piece of metal which is dipped into a pail of water come quickly to a blinding white heat*; and, when held in another pair of tongs (not connected to the electric circuit), to see the same piece of metal again dipped into the same water for the purpose of cooling it.

338. Thermoelectric currents. In 1821 Seebeck, a Russian by birth and a German by education, found, when he held in his hand one of the junctions of a circuit composed of antimony and copper strips, that the needle of the galvanometer in the circuit was deflected. This he ascribed to the heating of the junction, since if he held his hand at any other place than a junction there was no deflection. He also found that cooling one of the junctions also caused a deflection. The manifestations of this phenomenon, and those allied to it, are called **thermoelectric effects**.

It has been found that electricity may be generated by heating or cooling a junction in a circuit composed of any two dissimilar materials, but if the joints in the circuit of unlike metals are heated equally no electromotive force is set up, and no thermoelectric current flows. *A difference in the temperatures of the junction is essential to the exhibition of the effect.*

Thirteen years after Seebeck's discovery, Peltier, a Paris watchmaker, made an allied discovery: that an electric current, when it flows across the junctions of unlike metals in a circuit, may either heat or cool the junction. This **Peltier effect** is the reverse of the thermoelectric effect discovered by Seebeck. Some years later, Lenz actually succeeded in cooling a junction by the Peltier effect to so low a temperature as to cause water to freeze.

Lord Kelvin, somewhat later, made additional discoveries

and with others added to the sum of experimental knowledge regarding thermoelectric effects, but the cause of the phenomena has never been discovered.

339. The thermopile. Different materials set up very different thermoelectric voltages, but the voltage of a single junction of any pair of metals is so small that it is desirable to measure it in microvolts (millionths of a volt). Antimony and bismuth furnish the highest voltage of any of the metals that can be used satisfactorily. Since the voltage which one

joint, or couple as it is called, sets up is very small, a number of couples are often connected in series. When these are laid up side by side so that alternating junctions may be heated and cooled, the arrangement is called a thermopile.

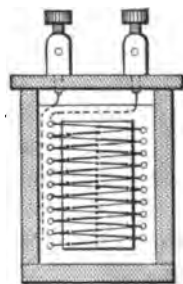

FIG. 347. — Rubens thermopile.

A thermopile (Fig. 347) has been devised by Rubens of Berlin which has a small thermal capacity and so is quick in its action. It consists of a series of junctions of iron and constantan wires, and generates 53 microvolts per degree centigrade

for each couple. The junctions are arranged in a zigzag form so that the alternate junctions are in a vertical straight line and the other junctions are half on one side and half on the other. This arrangement of the working junctions in a vertical line with a sensitive galvanometer makes an excellent electrical thermometer for detecting excessively small differences of temperature and has been successfully used in the examination of the heat spectrum.

340. Thermogalvanometer. An even more sensitive device for detecting small heating due to radiation consists in suspending by a delicate quartz fiber a loop of silver wire between the poles of a powerful magnet. This loop forms a closed circuit at its lower end by a piece of antimony and a piece of bis-

mith soldered to a minute disk of copper foil (Fig. 348). A rise of temperature of one millionth of a degree will generate current enough in the loop to cause a deflection of one scale division. This instrument is called the Boys radiomicrometer and will detect the radiant heat of a candle two miles away.

341. Pyrometer. To measure the temperature of a furnace the thermoelectric couple or pyrometer is used. This instrument was devised by Le Chatelier and consists of a pair of wires, one platinum and the other of a platinum-rhodium alloy,

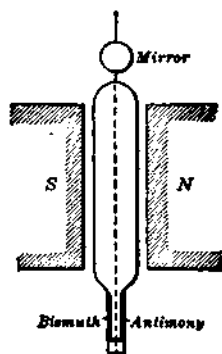

FIG. 348. — Boys radiomicrometer.

joined together at a junction, which can be put into a furnace. The wires are connected to a sensitive galvanometer or millivoltmeter, which is usually graduated to read degrees of temperature directly. For lower temperatures a thermocouple of nickel and an alloy of nickel and chromium and sometimes nickel-steel and copper are used. To protect the wires against breakage they are inclosed inside a porcelain or iron tube (Fig. 349). Such an instrument furnishes

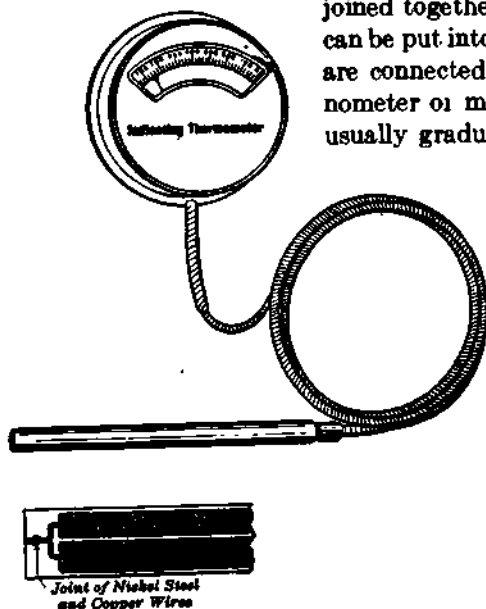

FIG. 349. — Thermoelectric pyrometer showing a cross section of joint.

a means of indicating temperatures up to 1500° C. and of objects at some distance from the observer.

SUMMARY OF CHAPTER XIX

RESISTANCE is electrical friction.

POWER required to overcome the resistance of a wire equals the square of the current times the resistance. $P = I^2 R$.

Underwriters will not insure a house in which the wires carry more current than that indicated in the table showing "Safe Carrying Capacity of Copper Wires." This is due to heating effect of the current.

Generator voltage – voltage at receiving end of line
= voltage drop of line (IR).

CAPACITY OF ELECTRICAL MACHINES limited by heating.

Heating comes from three sources:

- (1) Copper loss ($I^2 R$ in windings),
- (2) Iron loss (Hysteresis and eddy currents),
- (3) Mechanical losses (Friction, etc.).

FUSES AND CIRCUIT BREAKERS are automatic cut-outs, which serve as "electrical safety valves" to protect electrical machines from too much heat caused by excessive currents.

HEATING EFFECT of electric currents is utilized in many household appliances, such as toasters, flatirons, ranges, and radiators, but their use is limited by the expense of electricity.

Charges used in blasting and mines may be ignited by the heating effect of an electric current passing through a fine platinum wire.

ELECTRIC FURNACES are of two general types:

- (1) Resistance furnace, used in making carborundum, graphite, etc.
- (2) Arc furnace, used in making steel and in fixation of nitrogen.

ELECTRIC WELDING may be done by passing a very large current through the metal to be worked. Such currents are usually produced by a step-down transformer.

Arc welding uses an arc formed between the metal to be heated as one electrode and a bar of carbon or piece of the same kind of metal as the other.

THERMOELECTRIC CURRENTS are produced by heating one of the junctions of a circuit composed of two dissimilar materials such as antimony and copper.

THE THERMOPILE makes use of thermoelectric currents to measure slight differences in temperature.

A PYROMETER consists of a thermocouple and voltmeter and is used to measure temperatures of furnaces.

QUESTIONS

1. Apply the law of conservation of energy to the transmission of electric power.

2. If we double the load (current) on a given line, how is power loss due to heat increased?

3. How can we increase the power transmitted by a given line without increasing the current?

4. How does the price of copper enter into the computation of the size of wire to be used on a given line?

5. Why is the safe carrying capacity of rubber-covered wire rated at less than that of other weather-proof coverings?

6. No. 3 wire has double the cross section of No. 6 wire. Why is the carrying capacity of No. 3 not double that of No. 6?

7. In case the current to be carried lies between two values given in the table, which size wire should be used?

8. What advantages has stranded cable over a solid wire of equivalent cross section?

9. What are the difficulties which come from operating a line with a big voltage drop?

10. What are the various losses which make the output of an electrical machine less than the input?

11. What advantages have circuit breakers over fuses as protective devices?
12. What properties has nickel-chromium which make it excellent material for the resistors in heating appliances?
13. How does an electric fireless cooker operate?
14. What precautions must be taken in using an electric flatiron?
15. In what places does electric heating find its biggest field of application?
16. In what industries have electrically heated devices been found useful on a large scale?
17. Name a dozen household appliances which use electric heating.
18. What advantages has the electric fuse for exploding submarine mines?
19. Why are so many industries which use electric furnaces located at Niagara Falls?
20. What advantages has electric welding over the oxyacetylene process?

CHAPTER XX

ELECTRIC TRACTION

Electric railways — early history — fundamental principle — feeders, overhead, underground, and third-rail — railway motors, construction and characteristics — speed control, series-parallel — air brakes — rapid transit, elevated and subways; interurban systems of distribution of power.

Electric locomotives — when used — a-c. and d-c. systems.

Electric automobiles — pleasure car and truck.

Electric boats — launches, submarines, and electric ship propulsion.

342. Early history of electric railways. Soon after the invention of electric motors many suggestions were made to propel vehicles by electricity, but the great cost and trouble entailed in the use of primary batteries (Chapter I) prevented any success. When the first large electric railway enterprise was undertaken in the year 1887 in Richmond, Virginia, prophecies of failure were numerous, and the discouragement met by the promoters of the enterprise were at times sufficient to dishearten almost any one. Before the equipment of that electric railway was undertaken, various experimental electric railways had been laid and operated, and several had been actually constructed for the regular carrying of passengers, but none of them were of such magnitude as the railway at Richmond, and none served to prove the adaptability of electric motors to the purpose of driving cars as did the equipment which was operated there.

The first electric railway that was really built on a commercial scale was a short line laid in Berlin, Germany, in 1879, by the firm of Siemens and Halske. In 1883 the first electric railway open to the public in the United States was operated in the gallery of the Chicago Railway Exposition on a track about 1500 feet long and of 3 feet gauge. This electric line caused a great stir in the country and carried as passengers many who visited the Exposition. The motor car which ran on the line weighed three tons, and was capable of running at a speed of nine miles an hour. It was therefore very small compared even with the smallest electric street cars of to-day, which weigh from eight to twenty-five tons and are capable of running at speeds of eighteen to twenty miles an hour.

Even though the striking but modest early attempts at electric railroading made in Berlin and Chicago did little to bring electric cars into general use, they did serve to stir up the interest of the people. The construction of the early motors, as viewed to-day, was unmechanical and inefficient, so that great improvements were required before electric cars could replace horse cars or cable cars. Since 1883 the electric car has passed through a period of marked development both in this country and in Europe. From the beginning of 1883 until 1888 several small electric railways were put into operation in this country under the direction of Daft, Van Depoele, Sprague, and others, but until the latter date, by which time Mr. Sprague had made the Richmond road a success, the electric car cannot be said to have proved itself commercially successful.

343. The principle of the electric railway. The principle of the electric railway is very well illustrated by figure 350. In this diagram *G* is the d-c. generator, one terminal of which is connected to the street railway track, and the other to the feeder, which supplies the trolley wire, which is supported over the track. The motor which drives the car is placed underneath the floor (*M* in the figure), and is so geared to the axes

that the car is moved along by the revolutions of its armature. In order that current may be supplied to the motor, a movable arm extends above the car and presses a small wheel against the trolley wire. This arm is called the trolley, and the current is conveyed along it and thence down to the motor. After the current has passed through the motor, it completes its circuit by returning to the generator through the rails and earth.

344. Feeders. There are several ways of conveying the electric current to the moving car: (1) Current (usually direct or continuous current at about 600 volts) is supplied from the power house or from a substation through cables

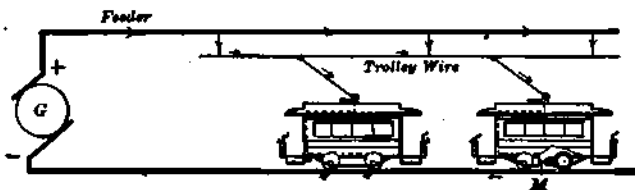

FIG. 360. — Diagram showing the fundamental features of the electric railway.

called **feeders** (Fig. 350) to an overhead line, with which the car makes contact as it runs by means of a trolley wheel (or a metal bow) fixed at the end of a pole above the car. The current passes down from the trolley wheel through the controller (which is a complicated barrel-type of switch at the end of the car) and the motors to the car wheels and so to the rails, which serve as the return conductor; the rails are either welded together or bonded together by copper bonds to insure good conductance. In some cases there are also return feeders from the rails to the power house (or substation).

(2) In some cities, such as Washington and New York, the overhead line is replaced by an **underground line**. The current is picked up by the car from conductors laid in a slot-

conduit in the road between the rails (Fig. 351), by means of a contact-piece, or "plough," let down into the slot. This

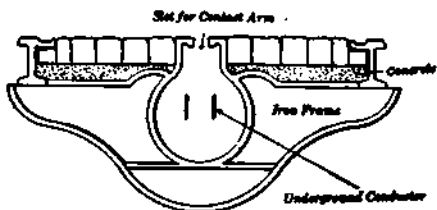

FIG. 351. — Underground line carried in slot-conduit.

system is expensive to install and cannot be operated where snow is abundant in winter.

(3) The third-rail system is the usual method of supplying current to electric railways operating in subways or on elevated structures, or where the electric railway controls its own right of way. The overrunning-contact type of third rail was first introduced and is more generally used. The construction consists essentially in supporting a steel rail upon insulators (Fig. 352), and contact is made with the rail by means of a third-rail shoe suspended from the trucks of the car.



FIG. 352. — Third rail protected by a wooden shield.

345. Railway motors. The motors which are generally used on electric cars are series-wound (because they have a large starting torque) and are mounted on the truck and drive the wheels through a single-reduction gear. The motor is usually built in a box-like steel case so that the armature is protected from mechanical injury, or from being splashed by water from the track.

Figure 353 shows a street-car motor with its case opened to show the inside arrangement. The field consists of *four* short poles projecting from the case, which serves as a path for the magnetic flux. The armature revolves so rapidly that its speed has to be reduced by a pair of cogwheels, the larger of which is on the axle of the driving wheels and is not shown in the picture. These gears reduce the speed of the driving wheels to about one third or one fourth that of the motor.

Street-railway motors are so designed that the top and bottom halves of the steel box frame may be easily separated to enable repairs to be made on the armature or on the field coils. This is very important because railway service is very hard on electric motors. The machines are exposed to dust and dirt, and are often forced to do more work than that for which they were designed. On account of the cramped space under a street car the motors must be as compact and at the same time as light as possible.

To prevent sparks at the brushes modern street-railway motors are built with *commutating poles*, as described in section 161. Moreover, the output of these motors has been increased by very effective ventilation. The air is drawn in at the commutator end of the frame and forced out at the other end by a fan mounted on the armature shaft. A 25-horse-power motor operating on 600 volts will draw about 35 amperes at full load, while a 50-horse-power motor on the same line will take about 74 amperes. The characteristic curves seen

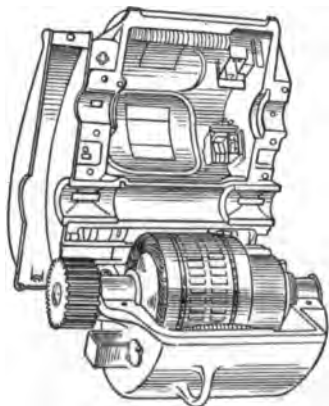

FIG. 353. — Street-car motor with top of case lifted up.

in figure 354 show in a graphic way the relation between the current used and the tractive effort, speed, and efficiency of a modern railway motor.

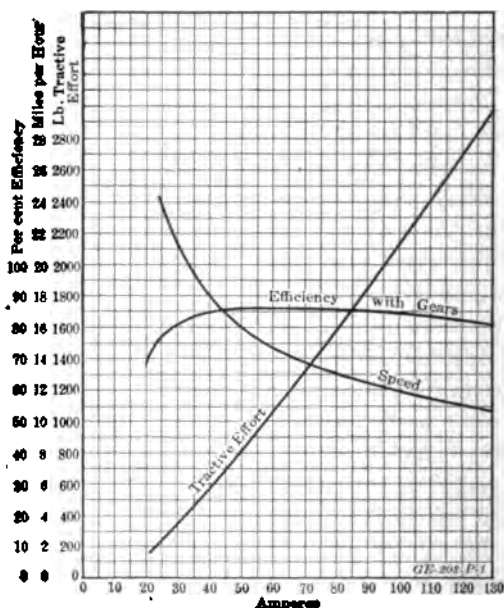

FIG. 354. — Characteristic curves of a ventilated railway motor with commutating poles.

346. Speed control. In the old days of small cars equipped with a single motor the speed was controlled by a rheostat and the old-fashioned hand brakes which had been used on horse cars. But modern cars are provided with two or four motors mounted on trucks, as shown in figure 355.

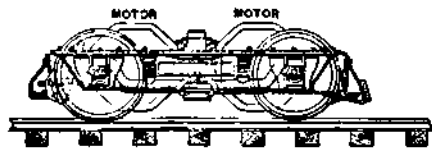

FIG. 355. — Electric-railway truck supporting a motor on each axle.

The method of control now used is the "series-parallel" (Fig. 356). By turning the handle of the controller (Fig. 357), the motorman is able to perform step by step the following operations: (1) in starting, the current is switched on to the two motors in *series*, with additional resistance in circuit, so that each motor at starting gets less than half the voltage; (2) as the speed increases, the controller cuts out the added resistance in stages; (3) then puts the two motors in *parallel*, with resistance in series; (4) cuts out the resistance in stages; and (5) at highest speed shunts part of the current from the field coils so as to weaken the magnets. The controller also contains devices for reversing the direction of the rotation of the motors.

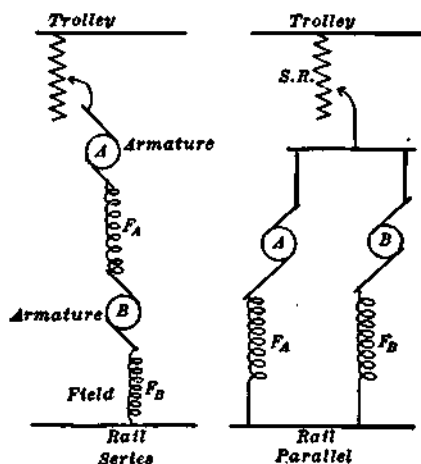

FIG. 356. — Diagram of series-parallel control of electric cars.

It should always be remembered that the resistance grids used for starting the motors are not designed to be left continuously in the circuit. Hence the controller should not be left for any length of time upon any but the "full series" and "full parallel" notches.

We have already seen that the pull or torque with which a series-wound motor tends to start depends only upon the current flowing through it. If two motors are connected in parallel, and enough current is passed through them to start a street car, the total amount of current may be as much as 100 amperes. The starting effort in this case is caused by 50

amperes flowing through each motor. Now, if the same two motors are connected in series with each other, and a current of 50 amperes is permitted to flow through them, each will exert the same starting effort as before, and the car *will start with the expenditure of only half the current.* Having started the car, the motors must be connected in parallel in order that they may run at a reasonably high speed, because when the motors are in series the total e.m.f. of 600 volts is divided between them, and each, therefore, gets only about 300 volts. The speed of a motor depends directly upon the voltage at its armature terminals, and therefore, when connected in series, the motors will run at only half speed.

It is equally important in controlling the speed of an electric car to have adequate braking facilities. The only force available is the friction which exists between the wheels and the rails. This is a variable and a more or less uncertain quantity. For instance, the adhesion or friction between a dry rail and wheel may be equal to 30 per cent of the pressure between wheel and rail, whereas if the rail is wet it may be only half that amount. The addition of sand will increase the friction from about 15 per cent to about 25 per cent. This force, however, is available only when the wheels are rolling on the rails; as soon as slipping occurs the friction rapidly decreases. So the force which opposes the revolution of the wheels, namely, the brake-shoe friction, must never exceed that which is keeping the wheels turning, namely, the friction between the wheels and rails. The force which is applied to the brake shoes is now very generally furnished by compressed air. There are several systems of air brakes which are adapted to various conditions and kinds of service. All of these systems require a motor-driven air compressor, a reservoir tank, brake cylinder, governor, valves, pressure gauges, and much piping. Such appliances make the modern electric street car a very complicated and expensive vehicle.

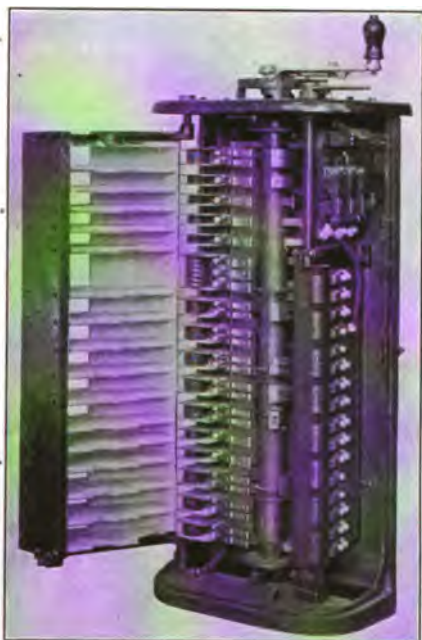

FIG. 357. — Street-car controller with the door open.



FIG. 358. — Large semi-convertible prepayment car with powerful motors. The center entrance makes this car also convenient to use as a trailer.

347. Rapid transit. In recent years there has been a demand on the part of the public not only for larger and more commodious street cars (Fig. 358), but for more rapid transit. It was soon found there was a limit to the speed at which it was safe to run cars through our crowded city streets and also a limit to the frequency at which cars can be operated on a given line without getting blocked. The first effort at relieving the congested traffic was to build steel elevated structures in our streets. But these proved to be very objectionable on account of their unsightly appearance and also because of the noise.



FIG. 359. — City streets showing elevated structure and entrance to subway.

Then the street cars were put underground in subways (Fig. 359). Such a system is expensive to construct, but does provide astonishingly quick transportation in congested districts.

348. Interurban railways. To handle the huge suburban traffic about our American cities larger and faster cars have been built and they are often run in groups or trains with the stops farther apart than in the cities. Out of this grew the practice of building electric railways on their own rights of way, very much as the steam railroads are built. It was soon found that the real problem in interurban service was the

economical transmission of the electrical energy. In some places the direct current has been used at a high voltage, such as 1200 or 2400 volts. On these lines 1200-volt d-c. motors have been used. Another method is to generate three-phase alternating current and then by transformers to raise the voltage for the transmission lines. At substations along the line are transformers to lower the voltage and synchronous converters to change the alternating current to direct current at 600 volts. This system, which is shown in outline in figure 360, is being

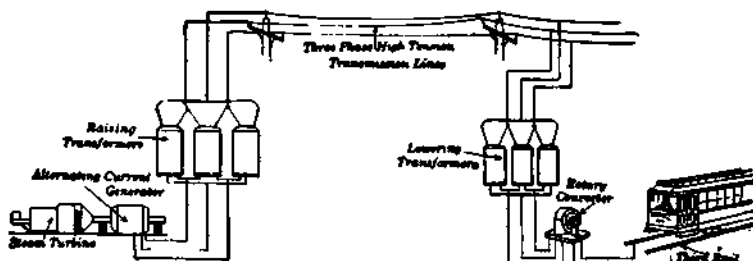

FIG. 360. — Three-phase transmission and direct-current railway.

used in and about some of our larger municipalities. Still another method is the **single-phase** alternating-current system, which has the advantage that voltages as high as 11,000 volts may be used on the trolley line so that the current in the trolley wire is small. This means that power may be transmitted for long distances before the voltage drop becomes too large. The substations, if used, will be few in number and will contain merely the necessary step-down transformers. But on the other hand the principal disadvantages of the alternating-current system (Fig. 361) are that the alternating-current motors are heavier and generally less satisfactory than direct-current motors of the same horse power, and the alternating magnetic flux of the line causes interference with adjoining telephone systems.

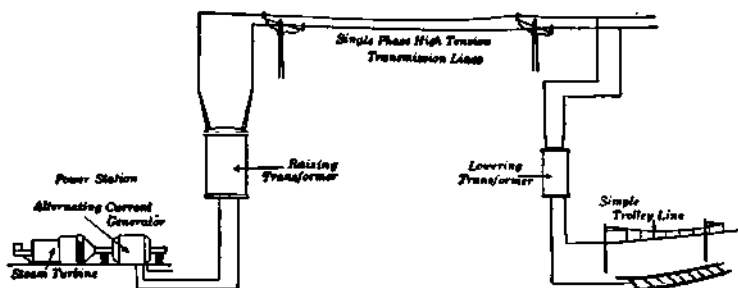

FIG. 361. — Single-phase transmission and railway system.

349. Electric locomotive. In 1896 the Baltimore and Ohio Railroad first used electric locomotives (Fig. 362) to haul their trains through the great tunnel under the city of Baltimore. Ten years later the New York Central Railroad electrified their New York terminal, and soon all the railroads running into or under New York City were electrified. Here the local conditions of tunnels and congested traffic prohibited

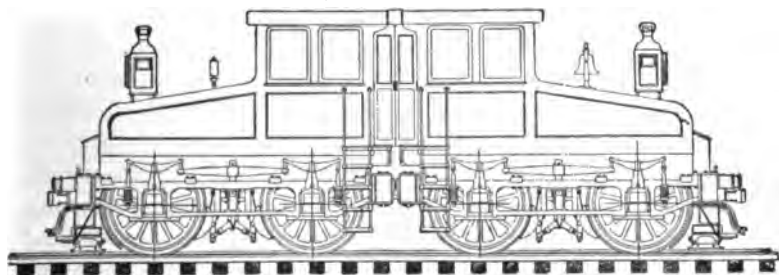

FIG. 362. — Electric locomotive for hauling heavy trains.

the nuisance of smoke, exhaust gases, and the noise of steam locomotives. Moreover, the electric locomotives greatly facilitated the rapid handling of the trains at the terminal stations.

There are three systems of distributing power for these electric locomotives, as follows: (a) *Single-phase* alternating current where the trolley voltages (third rails are not used)

are from 3000 to 11,000 volts and the frequency is 15 or 25 cycles. The New Haven Railroad is the largest installation of this type. (b) *Three-phase* alternating current, which is used at about 3300 volts with two overhead trolley wires. The Cascade Tunnel of the Great Northern Railway has the only three-phase locomotives in operation in this country. (c) *Direct-current system*, which is the same as that used so generally for city service. In recent years it has been possible to use as high as 3000 volts on these large direct-current locomotives, such as the Chicago, Milwaukee and St. Paul Railway has introduced.

The electrification of the Rocky Mountain district of this railroad, about 440 miles, is especially interesting: first, because the electric locomotives haul about 50 per cent more tons per train and at about twice the speed of the steam locomotives; second, because the system of *regenerative braking*, which means that the motors act as generators on the down grades, has eliminated air braking except for stopping; third, because the distributing system includes the generation of electricity from several water-power plants, its transmission at 100,000 volts, three-phase, 60 cycles, its conversion in substations to 3000 volts direct current, which is supplied to the locomotives by an overhead catenary; and lastly, because of the type of electric locomotive used (Fig. 363). This great locomotive, which is built in two units, is 112 feet long and weighs 288 tons. It is driven by 8 motors, each rated at 450 horse power and operating on 1500 volts. Each motor has four main poles and four commutating poles. About 2500 cubic feet of air are forced into each motor every minute by an external blower. The armature shaft has pinions at each end, which fit into gears on the driving-wheel shaft. A single locomotive, when working at full load, takes about 840 amperes. This current is collected from two overhead copper wires by a *pantograph* on each unit with sliding contacts.



FIG. 363. — Electric freight locomotive used on C. M. & St. P. Ry. hauling a freight train of 40 cars, 1640 tons.

For electric locomotives in general it has been found that the motors which are placed between the driving wheels (as are all street-car motors) are restricted in size. This limitation is most keenly felt in the design of large-horse-power slow-speed motors for freight service. One method of providing increased space for the motors is that adopted by the Pennsylvania Railroad for their tunnel work, shown in figure 364, where two motors, each of 2000 horse power, are mounted in the car and are connected to the driving wheels through side rods.

It has long been the dream of some engineers that the electric motor will some day as completely displace steam locomotives

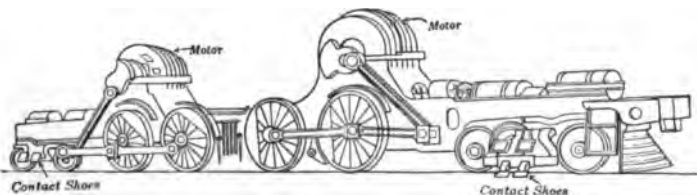

FIG. 364. — Electric locomotive driven through side rods.

as it has already displaced horse cars and cable cars for surface transportation in our cities. At present, however, the electric locomotive is mainly used to haul trains into cities, through tunnels, and over mountain grades. Experience shows that they can develop very large torque for starting and accelerating and can generally give 50 per cent more drawbar pull than a steam locomotive of the same weight.

350. The electric automobile. An electric automobile must necessarily carry a storage battery to drive its motors, and this battery must be systematically recharged. We have already discussed in Chapter XI the two types of storage batteries, the lead cells and the Edison nickel-iron cells. The problem of the electric automobile is fundamentally the problem of getting a cheap, durable, efficient storage battery. Only in large cities

where electric current may readily be obtained for charging the storage batteries do we see electric automobiles.

As a *pleasure* vehicle the electric automobile has to compete with the gasoline car. The advantages to be claimed for it are its ease of operation and the simplicity of its construction, and its disadvantages are its relatively slow speed, its limited range of operation, and its greater first cost. As a *commercial* vehicle the electric truck has found its widest field of application in city service where the hauls are of moderate length, say from two to ten miles.

All electric passenger cars and most electric trucks are now equipped with a single motor, which is of the series-type with

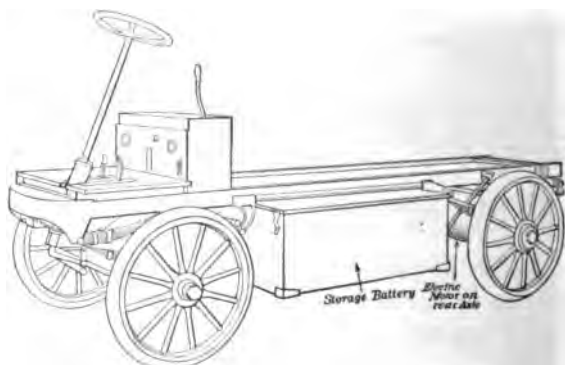

FIG. 365.—Side view of chassis of electric truck with underslung battery and motor built into rear axle.

four poles usually arranged in two groups which may be connected first in series and then in parallel. It is quite common to build these motors for 80 or 85 volts and to install a battery of from 40 to 44 lead cells or a 60-cell Edison battery. As in other automobiles the power may be transmitted from the motor to the wheels either by chains or by shaft and gears. The battery compartment is usually hung beneath the chassis frame, as shown in figure 365, although some makers place the

battery beneath the driver's seat. Improvements in the design and operation of electric vehicles in recent years have been so numerous that where electricity can be bought at 3 cents per kilowatt hour for charging the storage batteries the cost of energy for a five-ton truck constitutes less than 10 per cent of the entire operating expense. The comparative costs of maintenance of electric and gasoline vehicles show the greater economy of the electric vehicle due to the smaller number of wearing parts and the lower operating speed of the machine itself.

351. Electric boats. Before leaving the subject of vehicles propelled by electric motors, we must just touch on the sub-

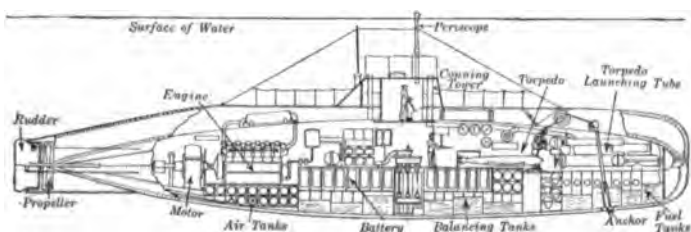

FIG. 366. — Section through a submarine with large storage battery in the center of the boat.

ject of boats propelled by electric motors. **Electric launches** are very much like small steam or gasoline launches, but instead of the hot steam boiler and engine or the disagreeable gasoline engine we have an electric motor, which may be put out of sight under the floor and operated by an electric current from a storage battery, the cells of which are placed under the seats and floor to act as ballast. The boat is not so independent as a steam or gasoline launch, for the battery must be charged every day to keep it in good order for operating. Electric launches are, however, convenient for use wherever current can be obtained for charging the batteries.

In recent years we have all been reading a good deal about submarines (Fig. 366), but we may have forgotten that these

boats when submerged depend on storage batteries and motors to drive their propellers. When on the surface they are generally driven by oil-burning gas engines (such as the Diesel) and at the same time the motors act as generators and charge the storage batteries. The most difficult part as well as the weakest part of the whole equipment is probably the storage battery. In a recent model the battery consisted of two sets or units of 60 cells each. The space occupied by each unit was 12 feet by 12 feet, it stood 50 inches high and weighed between 60 and 70 tons. Such a battery has a capacity of 3000 ampere hours. The one most commonly used is the lead type of cell with special construction to take care of the escaping gases and to prevent material from settling to the bottom and short-circuiting the cell. Also special plugs have been devised to prevent the acid from overflowing and at the same time to prevent the sea water, in case of a leak, from getting inside the cell and forming chlorine gas.

Another subject which has recently been of interest to marine as well as to electrical engineers is that of electric ship propulsion. For many years our large ships have been propelled by multiple-expansion reciprocating steam engines, and then more recently by steam turbines. But it has been found that the steam turbine works at its highest efficiency when at full speed, which is much higher than the desirable speed for propellers. Then, too, the turbine is not itself a reversible machine, which necessitates small turbines for astern work. To get rid of these two difficulties there have been suggested two solutions. One is to use high-speed turbines connected by mechanical gearing of the double helical type (Fig. 367). By the use of suitable gearing the turbine and propeller may be designed for the speeds at which each works most advantageously. For example, a 4000-horse-power turbine running at 1250 r.p.m. drives a propeller shaft at 130 r.p.m. through a gear and pinion of the double-helical type. This gearing has been

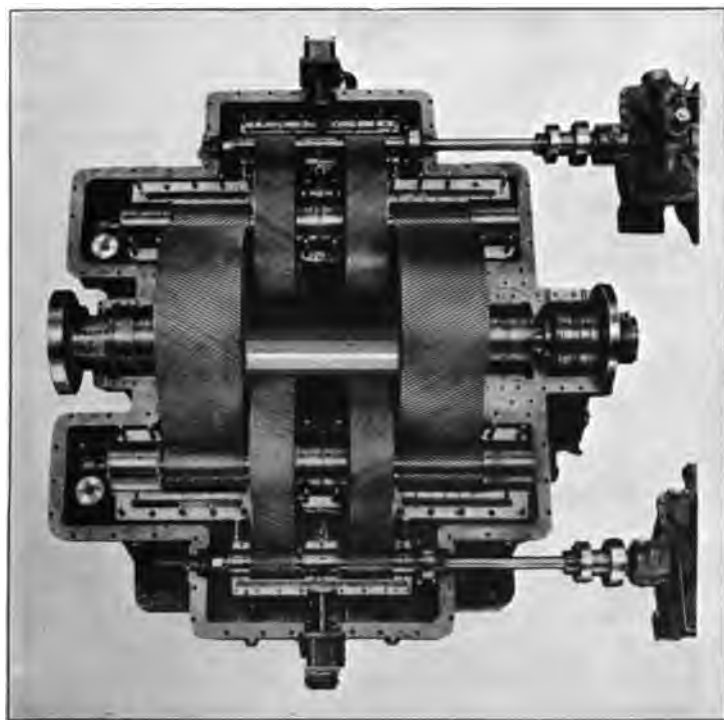

FIG. 367. — Double helical gears for reducing speed of two steam turbines (right) and transmitting 3000 h. p. to propeller shaft (left).

so designed in its case as to give an elastic support for the pinion shaft in a floating frame, which is carried on hydraulic rams. This support renders the gearing practically noiseless and insures nearly perfect alignment between gear and pinion under all conditions. The transmission efficiency of reduction gearing may exceed 98 per cent.

The other plan is to use between the prime mover and the propeller electrical transmission (Fig. 368). In this method the propeller is driven by an electric motor mounted directly

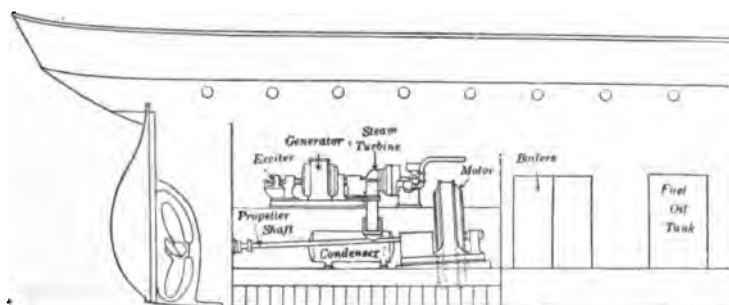

FIG. 368. — Plan of ship with electrical transmission.

on its shaft and furnished with current from a high-speed turbo-generator set located in any convenient part of the ship. For example, a 5000-kw. steam turbine driving a bipolar 2200-volt, 2000-r.p.m., 3-phase alternator supplies current to two induction motors, each of which drives a propeller shaft at 110 r.p.m. The advantages of the electrical plan are (1) obtaining the desired speed reduction, and (2) dispensing with any additional turbines for running astern.

Both solutions have been tried out, and the general tendency seems to be in favor of mechanical gearing for small ships of low power, making long journeys at full speed, and the electrical transmission for large ships requiring different speeds and excellent manœuvring ability.

PROBLEMS

1. A trolley wire shown in figure 369 is No. 0 hard drawn copper (0.53 ohms per mile) and the feeder is No. 0000 annealed copper cable (0.25 ohms per mile). The track resistance is 0.04 ohms per mile.

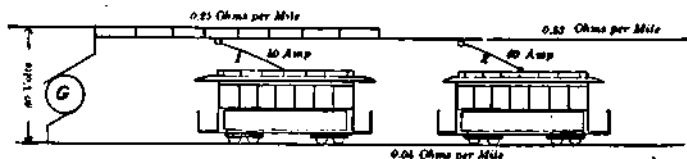

FIG. 369. — Trolley line with feeder and two cars.

Assume car I, which is 2 miles from generator, draws 40 amperes, and car II, which is 5 miles from generator, draws 60 amperes. Find voltage across each car, assuming the feeder extends 4 miles from the power house and is tied to the trolley wire every half mile. Voltage of generator is 600 volts.

2. Suppose the feeder were not used in problem 1, what would be the voltage across each car?

3. A street car has 33-inch wheels and the gear ratio between the motor and axle is 14:68. What is the speed of the motor in r.p.m. when the car is running 20 miles per hour?

4. The armature of an automobile motor has a resistance of 0.0625 ohms at 15 C. After running for several hours the resistance is found to be 0.0775 ohms. Assuming the temperature coefficient to be 0.004, calculate the rise in temperature of the armature.

5. The storage battery of an electric automobile consists of 40 cells in series; each cell has a positive plate area of 4.2 square feet, 2.2 volts and 0.003 ohms internal resistance. Allowing a charging current of 6.5 amperes per square foot of positive plate area, compute the terminal voltage of the generator.

6. A set of 44 vehicle lead cells is to be charged by direct connection to a 110-volt line. At the beginning of the charge each cell has an e.m.f. of 1.9 volts and at the end 2.2 volts. Assuming the internal resistance is 0.001 ohms for each cell, find the charging current (a) at the beginning of the charge and (b) near the end of the charge.

SUMMARY OF CHAPTER XX

ELECTRIC RAILWAYS began in the United States about 1890. They are generally operated on direct current from 550 to 600 volts. Overhead trolley system commonly used in city streets, third rail used for elevated, subways, and private rights of way. Feeders used to keep up voltage along the line.

ELECTRIC CAR is provided with two or more *series* motors, each with four poles. Modern ones also have *interpoles*. Speed controlled by connecting motors in series for starting and in parallel for running and by air brakes.

POWER for electric railways may be distributed directly from power stations for short distances, but for longer distances higher voltages on either d-c. or a-c. system must be used. High-tension three-phase transmission system requires transformers and synchronous converters at substations to furnish direct current at 600 volts. High-tension single-phase system also used for transmission and a-c. series motors.

ELECTRIC LOCOMOTIVES are used for hauling trains through city tunnels and over heavy grades in mountains.

ELECTRIC AUTOMOBILES for pleasure are convenient, simple, and expensive. Used mainly in larger cities where charging facilities are afforded. Electric trucks have proved to be practical and economical for work between two and ten miles. Speed is slow and storage battery requires constant expert care.

ELECTRIC BOATS. Small launches are convenient for short distances. Submarines operate on storage battery when under water. Electric transmission is being used to connect up high-speed steam turbines with slow-speed propellers. Excellent for speed control and for reversing.

QUESTIONS

1. Why was it found impracticable to operate street cars with a primary battery?
2. Why are certain cross-town street cars in New York City being operated with storage batteries?
3. Why is a feeder necessary in a trolley-line system?
4. What is the purpose in bonding the rails together?
5. Why is the shunt motor not used for traction purposes?
6. What is the purpose of interpoles in a railway motor?
7. Why is the armature of a railway motor not usually placed directly on the axle of the driving wheel?
8. What is meant by the "running points" of a controller?
9. In reversing a motor, just where in the motor (field or armature) is the current reversed? Why?
10. What are the advantages of air braking over hand braking?
11. What is regenerative braking?
12. What are the methods of getting more rapid transit in our cities?
13. How do we obtain rapid transit in interurban service?
14. Discuss the advantages of the various systems of transmitting electricity for railway work.
15. Why are steam railroads not more generally electrified?
16. What special advantages has the electric locomotive over the steam locomotive?
17. Why are electric locomotives built so heavy?
18. What are the disadvantages of the electric automobile as a pleasure vehicle?
19. Why is the horse-drawn truck more economical than any other for very short hauls?
20. Why don't the manufacturers of electric automobiles build faster cars?
21. What is the difficulty about running submarines, when submerged, by gasoline or oil engines?
22. What are the drawbacks about electric ship propulsion?

CHAPTER XXI

THE TELEPHONE

Early telephones — bipolar receiver — microphones — carbon transmitter — induction coil — local battery set. Telephone bells — exchanges — central battery system — switchboards. Simultaneous telephony and telegraphy — long-distance telephone. How to use the telephone.

352. Early telephones. Unlike telegraphy, which is nearly the oldest commercial application of electricity, the telephone is one of the modern commercial applications. The word "telegraph" comes from two Greek words which mean, when combined, to write at a distance, while "telephone" comes from two Greek words which mean to speak at a distance. The first telephone that can be given the credit of commercial success was invented by Alexander Graham Bell, and was privately exhibited by him at the Centennial Exposition at Philadelphia in 1876. Dr. Elisha Gray applied for patents on a telephone mechanism at the same time, and the nearly simultaneous invention of the instrument by the two noted men gave rise to a famous patent lawsuit.

Since that time the usefulness of the telephone has been increased by other inventions, which make its service much more perfect. In its improved form it has added wonderfully to the ease and quickness with which many kinds of business may be transacted, and it may be said to have revolutionized many of the processes of doing business. In the country as

well as in the city the telephone has quickly grown from a household luxury to well-nigh a necessity.

The telephone originally exhibited by Bell consisted of two instruments very similar to the ear pieces or receivers which are now used. One of these instruments was used as a receiver and the other was used to talk into, or as a transmitter, and the two were connected by wires (Fig. 370).

The operation of this system now seems quite simple. When one of the instruments was brought close to a speaker's mouth, the sound waves in the air set the diaphragm *D* in vibration. This diaphragm was a disk of thin varnished iron and was

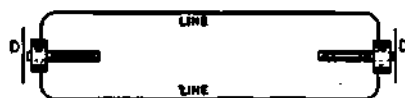

FIG. 370. — Diagram of Bell's early telephone system.

firmly clamped all around its edges to a hard rubber case, in such a position that its center was very close to the pole of the magnet *NS*. A spool of

very fine wire *W* was slipped over the tip of the magnet and connected to the line wires.

Most of the magnetic lines of force belonging to the magnet pass through the coil of wire *W* and some of them enter the iron diaphragm on their path to the opposite pole. As the diaphragm vibrates from the effect of a voice, it moves back and forth in front of the magnet. These vibrations are very, very small, — entirely too small to be seen by the eye, — but they are of sufficient extent to cause the number of lines of force which enter the disk to increase considerably as it approaches the magnet, and to decrease as it moves away from the magnet. In this way the distribution of the lines of force around the end of the magnet is altered with each movement of the disk, and the number of lines of force which pass through the coil of wire *W* on the magnet is increased or decreased at the same time.

It is a fact determined by experiment that, when a change occurs in the number of lines of force passing through a coil,

an electromotive force is set up in the coil. This voltage tends to send a current in one direction when the number of lines of force passing through the coil is increased, and in the opposite direction when the number is decreased. Consequently the movements of the Bell telephone diaphragm set up electric currents in the telephone coil, and when this coil is connected by wire to the coil of another telephone, as in figure 370, waves of current flow through the circuit, which correspond in a general way to the waves of sound set up in front of the diaphragm of the first telephone. As these current waves flow through the coil of the second telephone, they increase and decrease the strength of its magnet. This alters the amount of the attraction which the magnet exerts on its diaphragm, and the diaphragm is, therefore, thrown into vibrations which correspond with the current waves. The result of these vibrations of the second diaphragm is to send out waves of sound like those which set the diaphragm of the first telephone to vibrating.

363. Bipolar receiver. Bell's original telephone utilized one instrument as both transmitter and receiver. It still survives as a receiver in very much its original form, but as a transmitter it has been supplanted by more powerful devices.

The bipolar receiver shown in figure 371 is the standard form at present. The principle of the bipolar receiver is shown in figure 372, where *M* is a U-shaped permanent magnet, *cc* are soft iron pole pieces, each carrying a bobbin wound with fine silk-covered or enameled wire, and *d* is the diaphragm. The magnet, winding, and diaphragm of the receiver are assembled

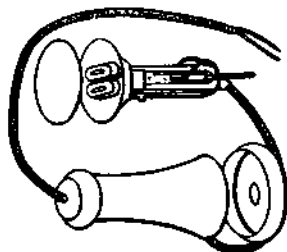

FIG. 371.—Parts of bipolar receiver.

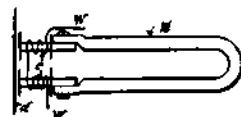

FIG. 372.—Principle of bipolar receiver.

in a case of hard rubber or an imitation thereof, which has one end adapted to fit the ear and the other end to hang on a switch hook. In modern receivers the whole mechanical arrangement of parts is supported from the ear end of the shell in order to keep the factory adjustment of the distance between the diaphragm and the pole faces.

The resistance of ordinary receivers varies from 25 to 100 ohms; some operators' head-receivers, which have very short magnets, have about 600 ohms, while those used in radio signaling sometimes have 1000 ohms or even higher resistance. The telephone receiver is almost incredibly sensitive. Kennelly has reported that in his experiments a sound could be heard from a receiver when actuated by a current as small as 0.000000044 amperes.

364. Microphones. The original Bell telephone is not sufficiently powerful as a transmitter to give satisfactory serv-

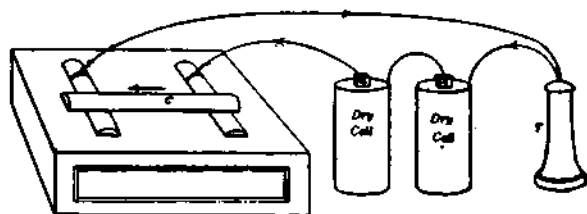

FIG. 373. — Simple form of microphone.

ice, and therefore the transmitters which are now generally used are based on an entirely different principle. When two bits of carbon are permitted to lie loosely against each other, the electrical resistance of their contact is very much changed when changes occur in the pressure of the contact. Such a carbon contact is called a **microphone**. Figure 373 shows a simple form of microphone which consists of a small thin pencil of carbon supported on two small blocks of the same substance fixed to a sounding board of thin pine wood, the blocks being connected with two dry cells and a Bell receiver.

The amplitude of the vibrations emitted by the receiver is much greater than those of the original sounds, and therefore the microphone may serve, as its name indicates, to magnify minute sounds, such as the ticking of a watch or the footfalls of a fly, so as to render them audible.

355. Carbon transmitter. In the modern telephone microphones under the name of carbon transmitters are in general use. Although these transmitters are made in many forms, yet the purpose in all is to produce current fluctuation as a consequence of diaphragm vibration caused by sound.

The essential elements of such a transmitter are two parallel circular electrodes, usually of carbon, one of which is attached to the diaphragm, the other being rigidly mounted. Between the electrodes is a loose mass of finely granulated carbon. Figure 374 illustrates these elements; *d* is the diaphragm, *m* the movable and *f* the fixed electrode, and *c* the carbon granules. Vibration of the diaphragm causes simultaneous variations of pressure on the carbon granules with accompanying changes in resistance from electrode to electrode. Increase of pressure on the granular carbon means increase of current through the transmitter.



FIG. 374. — Principle of carbon transmitter.

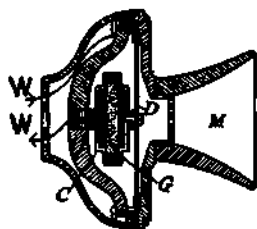

FIG. 375. — Cross section of solid-back transmitter.

Figure 375 shows a cross section of the solid-back transmitter, which was invented by A. C. White of the American Bell Telephone Company and which is in almost universal use in this country to-day. In this section *M* is the mouthpiece, *C* the carbon electrodes between which are the carbon granules *G*, and *D* is the diaphragm, which responds to the vibrations of the voice communicated to the mouthpiece *M*.

356. Induction coil. The current taken by the ordinary carbon transmitter averages from 0.14 to 0.32 amperes. Therefore for all long-distance work the transmitter is included in a small local circuit with a battery of one or two dry cells. In this circuit is inserted the primary winding of a small step-up

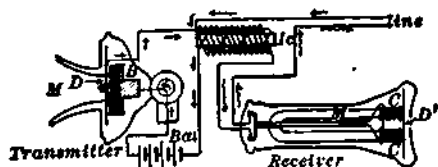

FIG. 376. — Induction coil in local battery telephone set.

transformer or induction coil. The secondary winding of this transformer is a coil of fine wire of many turns, which transmits through the line and receives smaller currents at a higher voltage. Figure 376 shows the use of such a transformer *Ic* in a local battery set. The battery is connected in series with the transmitter and the primary winding; the secondary is connected in series with the line and receiver. Figure 377 shows very clearly the construction of the telephone coil. *The function of the induction coil is to convert the local variations of*

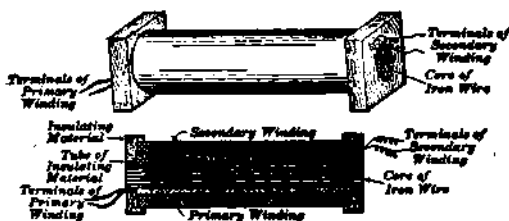

FIG. 377. — Perspective view and cross section of telephone induction coil.

direct current of low voltage into alternating currents of higher voltage so that the line loss may be less. The induction coil also has the advantage of shutting out a scratchy sound which is caused by the transmitter.

357. Local battery telephone set. The commercial telephone set consists of much more than the transmitter and receiver

with their accompanying battery and line. When telephones are used simply to connect two points, there must be located at each point a transmitter, a receiver, a battery cell, a means of operating an electric call bell at the other point, and a local call bell. This outfit is usually put up in a set like the familiar form shown in figure 378. Here *A* represents the transmitter, *B* the receiver, *C* a box containing the battery, *DD* the electric call bells, and

E a box containing a small magneto, which may be operated by a crank. The magneto is used for operating the call bells. When the receiver is not in use, it hangs on a hook (as shown), which is depressed by the weight of the receiver and moves the electrical contacts which connect the bells and magneto into the circuit and disconnect the telephone instruments. When the receiver is taken from the hook, the latter rises so that the contacts cut the bells and magneto out of circuit and the telephone instruments into the circuit.



FIG. 378. — Telephone set.

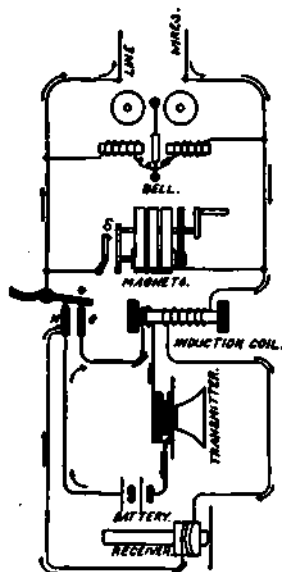

FIG. 379. — Diagram of the electrical connections in local battery telephone set.

Figure 379 shows a diagram of the circuits in an ordinary commercial set with the bell and magneto connected across the line, that is, in the bridged arrangement, as it is often called. The bell and magneto generator are connected in bridges across the line, the generator being provided with an automatic

switch that closes when the crank is turned. When the receiver is off the hook, as illustrated in the figure, a spring lifts the hook and brings the lever into contact with *N* and *O*, thus closing the battery circuit through the transmitter and connecting the receiver and the secondary winding of the induction coil into the line circuit.

358. Telephone ringers or bells. The standard telephone signal at present is a two-gong bell which is operated by an alternating current. Its construction is shown in figure 380. An iron armature *aa* is pivoted at its center and carries a light rod *b* with a clapper at its outer end arranged to strike the gongs when set in vibration.

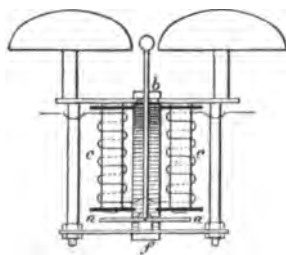

FIG. 380. — Alternating-current telephone bell.

The two coils *cc* of the electromagnet are arranged to attract the ends of the armature *a*. A permanent magnet *f* serves to polarize the armature *a*. Thus we have a permanently magnetized armature, which plays between the soft-iron pole pieces of an alternating-current electromagnet. The ends of the armature, being, for example, north magnetic poles, will be alternately tipped first to one side and then to the other as the alternating current reverses the polarity of the electromagnet. The greater the frequency of the alternating current, the more rapidly the bell rings.

359. Telephone exchanges. The use of telephones simply to connect two points is only a small part of their field of usefulness. The great majority of telephones are used in connection with a central exchange. This is a place where many telephone lines center and are brought to a switchboard so that they may be readily connected with each other. By this arrangement every telephone user in a great city may have his telephone quickly connected with that of any other person.

Every telephone user or subscriber is supplied with a set of instruments, and his line is run from the telephone set to a section on the switchboard at the exchange which bears the subscriber's individual number. When one subscriber wishes to speak with another, he turns the crank of his magneto, thus causing a signal at the switchboard. He then takes his telephone receiver from its hook, and when the switchboard attendant speaks, he asks her to connect him with the number of the second subscriber. This being done, the attendant rings the telephone bell of the second subscriber by means of a magneto, and this calls him to the telephone. When the conversation between the two subscribers is completed, one of them notifies the switchboard attendant by means of his magneto.

360. Central battery system. In recent years it has been found more economical to supply all the energy for a telephone system from large storage batteries at the ex-

changes, and so the local batteries and bell-ringing magnetos are practically eliminated except for small exchanges or on long party lines. There are many different types of circuits for telephones operated by a central or common battery. Figure 381 shows the connections of a desk telephone instrument as used by the Associated Bell Telephone Companies. In this diagram *r* is the ringer, *S* and *p* are the secondary and primary windings. The transmitter *t* and the hook and receiver are connected by a flexible cord of three strands (as indicated by the dotted lines) to the fixed portion of the set.

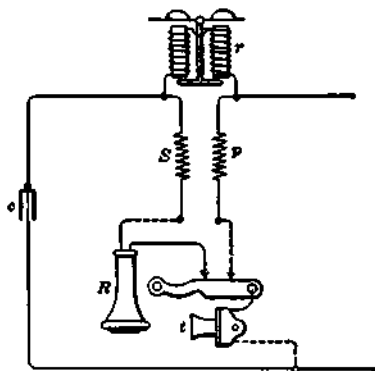

FIG. 381. — Connections for Bell desk set to be used with common battery.

Figure 382 shows the familiar desk set of telephone instruments. The portable part is the transmitter t and the receiver R hung on a hook switch. The fixed part of the set consists of a box mounted on the wall, and in this box is the ringer r , the induction coil, the condenser, and often a hand-magneto.

Since the condenser is "opaque" to direct current and "translucent" to alternating current, no direct current from the central office will flow through the set when the hook switch is down, but an alternating current from the central office can

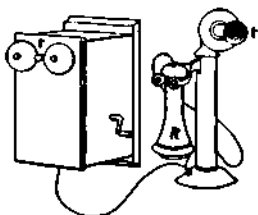

FIG. 382. — Fixed and portable parts of desk set of telephone instruments.

operate the ringer. When the bell rings and the subscriber takes the receiver off the hook, the hook switch goes up and then direct current from the central office flows through the transmitter and the primary winding of the induction coil. The sound of the subscriber's voice as he says "Hello" into the transmitter causes a pulsating current in the primary

winding, which in turn induces an alternating current in the secondary, which is superposed on the line.

361. Telephone switchboards. Telephone switchboards vary in style and are, as a rule, quite complicated, since an exchange is always connected to a large number of wires and since the connections of the telephone wires must be arranged so that the operators and the subscribers are able to signal and talk to each other and so that the subscribers' lines may be quickly connected together.

In the earlier and the simpler forms of telephone switchboards still used for small exchanges, the subscribers' wires on entering the exchange are each connected to a switchboard circuit which contains a spring jack and an electromagnet, which controls a drop or shutter. The circuit terminates at a ground plate. One form of the electromagnet with its *drop*

is illustrated in figure 383. The armature *A* of the electromagnet *M* has a hook *D*, which ordinarily supports the shutter or drop *P*, which is hinged at the bottom in a vertical position. When the subscriber sends a current over the line from his magneto, the armature *A* is attracted, the drop is released and falls into the horizontal position illustrated in figure 383 and thereby discloses the subscriber's number, which is painted at its back.

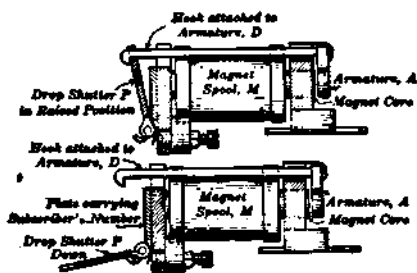

FIG. 383. — Electromagnet and shutter for telephone switchboard.

A "spring jack" is an arrangement by means of which an electrical connection may be made by inserting a metallic plug into a hole so that it touches a spring which is in electrical connection with the circuit. Figure 384 illustrates one form of a spring jack.

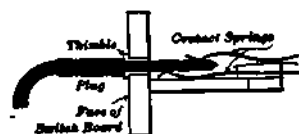

FIG. 384. — Telephone spring jack.

When a subscriber calls by working his magneto, the fact is indicated at the exchange by the fall of the drop belonging to his line. The exchange operator inserts in this subscriber's spring jack a plug, which is at one end of a conducting cord, and at the same time moves a switch, which connects her telephone to his line. She inquires what connection is desired, makes it by inserting the plug at the other end of the conducting cord in the spring jack belonging to the line of the desired subscriber, and calls him by pushing a button, which causes his telephone bell to ring. This completes the operator's duty in connecting the two subscribers. When the subscribers have finished talking, one of them turns his

magneto crank, which causes a special "drop" to fall in the exchange and calls the operator's attention to the fact that the lines may be disconnected.

Boards of this general type (Fig. 385) are used *only* in small exchanges. On large boards tiny electric lamps are used for signals instead of "drops."



FIG. 385. — Simple form of switchboard for small exchanges.

A storage battery is installed in the exchange for operating them. Lifting a subscriber's telephone receiver from its hook completes a circuit through the central battery so that the signal lamp on the board for his line is lighted, and no battery or magneto is needed at the subscriber's station. The same central battery supplies current for the subscriber's transmitter.

362. Multiple boards. As one operator can take care of the calls from only a limited number of subscribers (50 to 100 is the usual number per operator), a great many boards of the kind described would be required in the

larger exchanges, and much difficulty and waste of time would be experienced in making connections between the line of a subscriber connected to one board and the line of a subscriber connected to another board in another part of the room. Hence, what are known as multiple switchboards are used in exchanges having many subscribers.

The multiple board with its numerous details can be explained

here only in the briefest outline. The principle upon which it is based is to divide the total number of subscribers' lines into sets, each of which is brought to a different section of the switchboard where the lines belonging to one particular set may be looked after by one operator. The lines are connected to a drop and a spring jack in their proper sections so that the operator may communicate with the subscribers by means of her telephone set.

In addition to entering its own section through a drop and spring jack, each subscriber's line is also connected to a spring jack in every other section. Consequently, each operator attends to the calls of a limited number of subscribers whose lines are connected to drops in her section, and, since all other lines have spring jacks in her section, she can connect any of her subscribers' lines to the line of any other subscriber which enters the exchange.

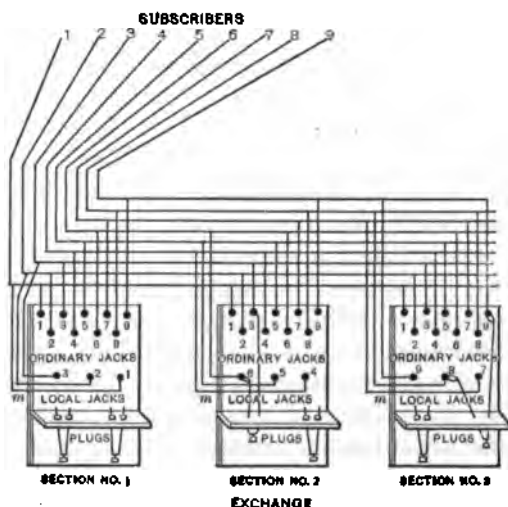

Fig. 386. — Diagram of multiple switchboard.

Figure 386 shows the principle of the multiple board. The dots marked "local jacks" in each section represent the spring jacks belonging to the lines which are looked after by the operator at the section. The drops, the keys for ringing up subscribers, the operator's telephone set, etc., are omitted from

the figure for the sake of simplicity. The dots marked "ordinary jacks" represent the multiple spring jacks, by means of which the operator may connect any one of her subscribers with any other that is connected with the exchange. It will be seen, for instance, that subscribers' lines, Numbers 1, 2, and 3, enter the local jacks of section Number 1, but they also enter the ordinary jacks of the other sections. If an operator in the second section wishes to connect one of her wires, say Number 6, with one of those belonging to the first section, say Number 3, she is able to do so at once on her part of the board, as shown in the figure.

An ingenious arrangement by which the operator can tell when a line is "busy" prevents switching three subscribers together. Exchanges with multiple switchboards have been planned to give telephone service from one board to the enormous number of ten thousand subscribers. However, the telephone service in any one place has never yet risen to such magnitude that any one exchange has reached the number of ten thousand subscribers, since it is customary to divide the service among sub-exchanges. This is done in the large cities for the purpose of economizing in the construction of lines, and several sub-exchanges are therefore located to serve the districts outside of the area immediately around the main exchange. This practice causes the number of subscribers' lines attached to any one exchange to be smaller than might otherwise be expected.

When it is necessary to establish more than one exchange in a given district, trunk lines or transfer circuits must be established to interconnect the lines of each exchange. Calls *originating* in one exchange for other lines in the *same* exchange are the only ones which can be completed in the same switchboard. Calls for subscribers in all the other exchanges must be trunked.

Operators who answer subscribers are called A operators; and those who serve trunk lines incoming from other offices

are called **B operators**. The operations involved in a call for a line not in the exchange first called are as follows:

The subscriber lifts his receiver and his line lamp lights; the **A operator** answers and asks the number; learning by the prefix to the number that the call is for a subscriber in another exchange, the operator presses a key marked with that prefix, thus connecting her telephone set with a line leading directly to a receiver of a **B operator** in the other exchange; the **A operator** speaks the number desired, following with the *prefix of her own exchange*; the **B operator** in the other exchange names back a trunk number; the **A operator** inserts the *calling plug* in a multiple jack of that trunk and simultaneously the **B operator** in the other exchange inserts the plug of that trunk in the *called line*; at the close of the conversation the **A operator** disconnects, which act lights a disconnect lamp in front of the **B operator**, who disconnects in response and thus extinguishes the signal lamp.

If an exchange requires more than three operators, there will be lines beyond the reach of each operator and then **local trunks** are sometimes provided to interconnect lines which cannot be reached directly. In large cities where the majority of calls have to be completed through another exchange, multiple jacks are provided only for the trunks, the subscriber's line is furnished with but a single jack, and practically all calls are trunked irrespective of their designations.

363. Simultaneous telephony and telegraphy. The rapid variations of the telephone current, which are caused by the vibrations of the diaphragm under the influence of voice waves, transmit themselves by induction through a condenser, while the slow make-and-break signals of the Morse telegraph do not. Utilizing these characteristics makes it possible to adapt a circuit for telephoning and telegraphing at the same time. This double use of telephone conductors is extensively adopted on the long-distance telephone lines in this country.

A diagrammatic sketch illustrating one arrangement of the

apparatus is shown in figure 387. The rapidly varying telephone currents are effectively choked back by the high self-induction of the telegraph instruments, so that they do not dribble off through them; and the condensers in circuit with

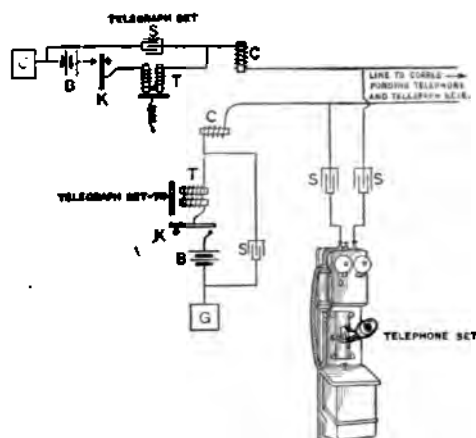

FIG. 387. — Diagram of circuits for telegraphing and telephoning simultaneously.

the telephones keep the telegraph signals from interfering with the talking currents. It represents the sum of improvements in the various parts which go to form the complete connection — transmitter, receiver, switchboard, cords, relays, open-wire lines, cables, in fact, every link in the chain.

The greatest gain has been made in the line itself. Telephone currents are alternating currents of great and varying frequencies, from 100 to 2000 per second being the usual range. In long-distance telephone lines (much longer than power lines) the line losses consume most of the power. To understand what these losses are we must consider *four fundamental properties of the line which affect transmission*: (1) *resistance*, (2) *inductance*, (3) *leakage to the ground*, and (4) *capacity*.

the telephones keep the telegraph signals from interfering with the talking currents.

364. Long-distance telephony. In January, 1915, a trans-continental telephone line between Boston and San Francisco, a distance of 3500 miles, was opened up for commercial use. This astonishing engineering feat is the culmination of a great variety of electrical

Most lines have very little inductance so that the line losses are due mainly to resistance, capacity, and leakage. The capacity is more important on cable lines, owing to the small separation between the wires, and the leakage is of special importance on open wire or aerial lines, owing to exposure to wet weather.

About 1899 Professor Pupin worked out a method of loading the line by adding suitable inductance coils at regular intervals so as to balance up the capacity and give approximately a uniform line electrically. In mechanical analogy it is like putting weights on a rope. One separate weight simply acts as a drag interfering with the vibrations, but if a number of weights are put on close enough together it acts like a heavy rope and the range of vibration is extended. In electric loading for telephone currents on open wire these coils are eight miles apart. They are inclosed in small iron boxes (Fig. 388) and mounted on poles similar to small electric-light trans-

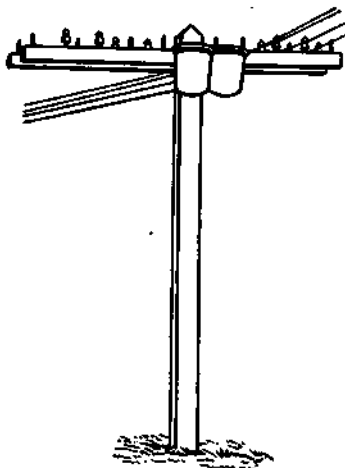

FIG. 388. — Loading pot on the line.

formers. The coils themselves consist of fine insulated wire about 4 mils in diameter wound on cores made up of fine enameled iron wire. The loading coils on the transcontinental line required a total of 13,600 miles of iron wire in the cores.

The lines consist of four hard-drawn copper wires (about No. 6 B. & S.) making two circuits. By a very interesting electrical scheme, called the "phantom," which cannot be described here, these four wires furnish three talking circuits. This is mainly a matter of economy in wires, although there is some gain in transmission.

It seems little short of miraculous that these wires should carry this tiny bit of energy across the continent and do it in $\frac{1}{18}$ of a second. If a voice were loud enough to be heard from Boston to San Francisco, it would take four hours to travel that distance through the air. In fact, due to a difference in the standard time of the two cities, a man speaking into a long-distance telephone in Boston is heard in San Francisco about three hours earlier by the clock.

365. The telephone and the people. Although only comparatively few people are directly concerned in the telephone business, yet we are practically all of us telephone users. It is therefore important to add *a few hints about using it correctly.*

1. Be sure to get the correct number and to speak it *distinctly* into the mouthpiece with a moderate tone of voice.

2. Avoid "line busy" reports by refraining from unnecessarily long and inconsequential conversations.

3. Remember that a party line is a single circuit shared in common by two or more subscribers. Use it on the share-and-share alike basis.

4. Don't "jiggle" the hook. When you want to get the operator's attention, the receiver hook must be moved up and down slowly.

5. Always remember that the telephone is a public-service institution, which requires the coöperation of the person calling, the person called, and the operator who connects them.

PROBLEMS

1. If the transcontinental telephone line is 3500 miles long and consists of 4 hard-drawn copper wires 0.165 inches in diameter (about No. 6 B.&S.), how many tons of copper wire were used in the line? Assume that copper weighs about 0.32 pounds per cubic inch.

2. If the total number of poles used is 130,000, what is the average distance in yards between poles?

3. The speed of transmission is 56,000 miles per second. What decimal part of a second is required to transmit sound across the continent by telephone?

4. If the telephone rate from New York to San Francisco is \$20.70 for three minutes' conversation and \$6.75 for each succeeding minute, what would it cost to talk for ten minutes?

SUMMARY OF CHAPTER XXI

The telephone transmits speech electrically by means of the transmitter, the line, and the receiver.

TRANSMITTER is a microphone of the granular carbon type. It consists of a diaphragm, two polished carbon electrodes, and carbon granules in between. The varying resistance of the transmitter causes a pulsating current.

RECEIVER consists essentially of a permanent horseshoe magnet, a sheet-iron diaphragm, and coils on the polar extremities of the magnet. Alternating current through the coils increases and decreases the strength of the magnet so that the normal tension on the diaphragm varies with the current.

INDUCTION COILS are used as little step-up transformers in order to transmit to the line impulses of higher voltage.

POLARIZED BELL OR RINGER is used as a signal to announce incoming calls. It consists of two coils and a permanent magnet, which polarizes the armature. The armature is pivoted at its center and carries a light rod with clapper so arranged as to strike the gongs.

In **LOCAL BATTERY TELEPHONE** system each subscriber's set contains a few dry cells, which are connected in series with the transmitter and the primary winding of the induction coil.

In the **COMMON BATTERY SYSTEM** a storage battery or generator at the exchange supplies all the energy.

EXCHANGES with switchboards and operators serve to connect quickly the line of one subscriber with another.

LONG-DISTANCE TELEPHONY has been made possible by improvements in all the instruments, line, etc., and especially by introducing inductance (loading coils) so as to balance the capacity of the line.

THE TELEPHONE TO-DAY is not only a business and household necessity, but it renders a public service which requires close *coöperation* between the *company* and its *subscribers*.

QUESTIONS

1. What is the essential difference between Bell's original telephone and the modern bipolar receiver?
2. Why was the original telephone abandoned as a transmitter?
3. What is the fundamental principle of the microphone?
4. Does the transmitter generate an electric current?
5. What are the essential differences between the current in the primary winding of the induction coil and that in the secondary winding?
6. What are the differences between the alternating currents transmitted in telephony and those used in power transmission?
7. What is the function of a condenser as used in a telephone set?
8. How does a condenser behave with direct currents?
9. What are the disadvantages of the local battery system?
10. What is the function of the magneto in a local battery system?
11. Why is a polarized bell generally used in telephone sets instead of the ordinary electric bell?
12. How does or should a subscriber on a common battery system signal to the exchange operator?
13. How can the same line be used simultaneously for telephony and telegraphy?
14. What is the function of the Pupin loading coil?
15. What are the four sources of line losses in long-distance telephony?
16. Why is a high-pitched voice poor for telephone transmission?
17. What is the objection to "jiggling" the hook in trying to call the attention of central?
18. What arrangements are made in a central battery system to keep the battery from sending current all the time through telephone lines not in use?

CHAPTER XXII

ELECTROMAGNETIC WAVES

RADIOTELEGRAPHY AND RADIOTELEPHONY

Electromagnetic waves — water waves, wave length, amplitude, and frequency — transverse and longitudinal waves — ether waves, oscillator, and resonator — oscillatory discharge of condenser — electrical resonance — wave detectors.

Radiotelegraphy — simple sending and receiving stations — commercial circuits — apparatus: aerial, helix, spark gap, key, condenser, and generator; detectors, tuning coil, variable condenser, and telephone receivers — radio service.

Radiotelephony — principles and apparatus — application.

386. Water waves. When a pebble is thrown into a pond waves of water ripple away in ever-widening circles, and the waves travel outward in all directions along the surface of the water from the place where the pebble strikes. The crest of each wave travels onward until it is either broken upon some obstruction, like the banks of the pond, or is dissipated by the friction of the water itself, when its height becomes so small as to be no longer discernible. The distance between the crests of two adjacent waves is called the **wave length**, while half the difference in level between the crest and trough is called the **amplitude** of the wave (Fig. 389).



FIG. 389. — Illustration of amplitude and wave length of waves on the surface of water.

If a log lies in the pond, the waves will break upon it and leave comparatively still water on its farther side (thus creating what may be called a water-wave shadow), although the waves which pass the ends of the log will tend to spread out and fill the shadow space.

If a second set of waves is created, they may interfere with the motion of the waves of the first set by striking against them, and the waves of the two sets then become entangled and broken up. This is called **interference** of the waves. However, if the water is struck at regular intervals by a rod or a paddle, a certain rate of strokes may be found which will produce a series of waves which do not interfere, but which move off regularly and strongly. It will also be found that the wave length is dependent upon the force and character of the stroke.

Although these water waves move out rapidly from the center of disturbance, the particles of water merely move up and down and do not flow away from their position in the pond. That is, the water is set **vibrating** (or swinging up and down), but not flowing. This may be proved by observing a chip or leaf which has been thrown into the pond; it will be seen that the float merely vibrates up and down as the waves pass it, and (if the wind does not interfere with it) it does not change its position in the pond as it necessarily would if the water actually flowed along with the waves.

367. Relation between velocity, wave length, and frequency. In the case of the waves started by throwing a stone into a quiet pool, we know that while the circular waves grow larger and larger, any particular crest seems to move out radially until it reaches the bank or dies away. The distance which a crest travels in one second is called its **velocity**. The number of crests passing a fixed point in one second is called the **frequency**. The time it takes one wave to pass a given point, that is, the time between crests, is called the **period** of the wave motion.

If n is the number of waves passing a given point in one second, that is, the *frequency*, and if p is the time required for one wave to pass a given point, that is, the *period*, then

$$p = \frac{1}{n}$$

Again, if l is the length of one wave in feet and n is the number of waves passing any point in one second, the distance traveled by a wave in one second, that is, its velocity v in feet per second, is equal to n times l ; that is,

$$v = nl.$$

It should be remembered that *it is only the wave form that travels over the surface of the water, not the water particles themselves*. Thus, if we float a cork or a toy boat on a pool over whose surface waves are passing, the cork or boat merely bobs up and down as a wave passes, but is not carried along with it.

368. Transverse and longitudinal waves. When the vibration of the particles of a body is at right angles to or across the direction of the movement of the waves, as is the case with the water waves, it is called **transverse vibration**. If, on the other hand, the particles vibrate along the line of the waves instead of across it, the vibration is said to be **longitudinal**. The vibrations of a stiff spiral spring which has been compressed endwise and then released are longitudinal vibrations. Figure 390 illustrates a spring which is designed to be struck by a hammer. When the spring is struck waves of compression pass very rapidly from the top to the bottom of the spring, while any part of the spring will merely vibrate back and forth. In the waves in the air which we call **sound waves** the vibration of the particles is longitudinal. When one utters a sound spherical-shaped waves of alternately

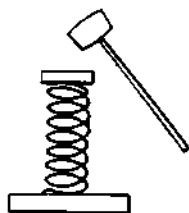

FIG. 390. — Spiral spring, which may be struck by hammer to illustrate longitudinal vibration.

compressed and rarefied air radiate away from the speaker (as the waves of water radiate from a point of disturbance); but the air particles vibrate back and forth, longitudinally, in lines of the direction of propagation or advance of the wave.

369. Ether waves or radiation. Waves that can be seen and heard in the ordinary way have the same wave characteristics as those that are supposed to be set up in the ether when light, electrical energy, or magnetic disturbances are transmitted. We cannot conceive of light and heat coming from the sun without some medium for transmitting them. The air is supposed to extend only a few miles beyond the earth's surface, and the sun is millions of miles away, so that the air cannot be the required medium. It is believed, therefore, that there is some other substance which serves as the transmitting medium. This substance is called ether, but must not be confused with the anæsthetic.

The ether is not supposed to be matter, as we usually consider it, but is assumed to have the capability of being set into vibrations or wave motions, much as a plate of jelly may be caused to vibrate by gently striking it at any point. The ether is thought to pervade everything and to be everywhere. Ordinary matter, such as our bodies, is supposed to be made up of separated molecules or atoms, and the ether is all about, between, and perhaps through these particles. When we move about in ether we do not disturb it. We move through it, as the ghost of the story-books is supposed to pass through walls and other obstructions that are impervious to us.

Although materials can be moved from one place to another without disturbing the ether, yet it may be set vibrating if an object is heated. When a body is heated its particles are thought to be set into rapid vibration, and this sets up corresponding waves in the surrounding air and ether. When you hold your hand toward a hot object, your hand feels the warmth. This feeling is caused by the mechanical heat waves

in the air striking against your hand. If the body is heated until it is white-hot, ether waves of shorter lengths are generated by the vibrating particles, and these cause the sensation of light when they strike against the retina of the eye.

Ether waves can also be generated by electrical or magnetic disturbances. When these waves strike conductors at a distance, electrical activity is set up in them. This is now believed to be the medium of electromagnetic induction.

A very crude mechanical analogy of electromagnetic induction may be constructed by sticking two pins in a plate of jelly (Fig. 391). Now, if one pin is struck and caused to vibrate, a wave is set up in the jelly, which starts the other pin to vibrating in the same way. In this way mechanical energy is transmitted by the jelly waves from one pin to the other.

The ether waves vary in frequency from several thousand trillion periods per second to, possibly, one hundred million periods per second, or less; and the wave lengths vary from a few millionths of an inch in length (from crest to crest) to several feet or yards in length. The waves all travel, so far as is known from experimental investigation, at a speed of about 186,000 miles per second (300,000 kilometers per second). This distance is almost seven and a half times the circumference of the earth. The ether waves of shortest known wave length can be detected only by the chemical action they produce when they strike upon certain substances; some longer waves are perceived by the eye, as light; still longer ones become apparent from their heating effect; and the longest create the electromagnetic phenomena with which we are to deal in the following sections.

370. Electromagnetic waves. In 1864 Clerk Maxwell, one of the most gifted mathematicians in the world's history,



FIG. 391. — Jelly analogue of electromagnetic induction.

showed by a brilliant mathematical demonstration that it ought to be possible to create ether waves by electrical disturbances. The experimental proof of Maxwell's mathematics was not forthcoming until 1888, when Heinrich Hertz (PLATE IX, opposite page 544),

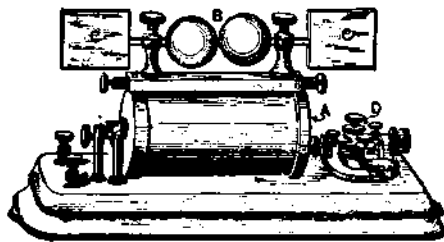

FIG. 392. — Oscillator. *A*, induction coil; *B*, spark gap; *CC*, condensers; *D*, telegraph key.

actually produced such waves by an equally brilliant investigation, but this time carried on in the laboratory. He created electromagnetic waves by passing sparks from an induction coil through a gap between two polished knobs. An apparatus for this purpose, which is called an oscillator, is illustrated in figure 392. In this figure *A* is an induction coil for getting a high voltage and *B* is the spark gap.

When a spark passes across the gap *B*, it looks like a single flash, but in reality the electric discharge flies back and forth across the gap many times with inconceivable rapidity (possibly at the rate of one hundred million times per second, or even more). This makes a rapidly vibrating or alternating current, which gradually dies out, as illustrated in figure 393. The effect is analogous to the mechanical action of a spiral spring which has been compressed and then released. When the balls are charged to a high difference of potential, we may consider that the medium surrounding the balls, which is called the dielectric, is under an electrical stress; the passing of the rapidly vibrat-

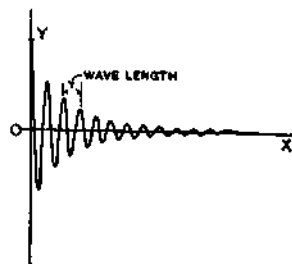

FIG. 393. — Curve of oscillatory electric discharge.



HEINRICH RUDOLF HERTZ (1857-1894).

One of the most brilliant of German physicists; died at the age of thirty-seven and yet had made notable contributions to theoretical physics. Made the highly important experimental discovery of the electromagnetic waves predicted by Maxwell. The application of this discovery was later made in radiotelegraphy.

ing spark occurs when the dielectric is relieved by the spark breaking through, and then the electric current surges back and forth like the spiral spring when it is released.

Now these vibrations of electricity, which really pass through the entire apparatus, are capable of setting up waves in the ether which pass out in all directions, but more strongly in a direction at right angles to the spark gap and the wings *CC* (Fig. 392). The ether waves which are created in this manner are called **electromagnetic waves**. To detect these waves

Hertz used a ring of wire containing a small spark gap, such as is shown in figure 394. When this resonator, as it is called, is held so that the ether waves pass through the ring, electrical vibrations are set up in the ring and are indicated by small sparks passing across the air gap. The effect of the oscillator on the resonator may be compared to two tuning forks of the same pitch which are placed at a distance apart. When one fork is set vibrating, the air or sound waves beat upon the other fork and set it also vibrating. This may be perceived by carefully examining the second fork a short time after the first fork is set vibrating, when it may be readily noticed that the second fork is also vibrating.

It is necessary to have the two forks of the same tone or musical note to get this effect in its fullest power. The second fork vibrates because the sound waves beat upon it at a rate which is equal to the natural rate of vibration of the fork, and each impulse from the sound waves adds to the preceding impulses. And just so it is necessary to have the electric oscillator and resonator tuned together so that the resonator

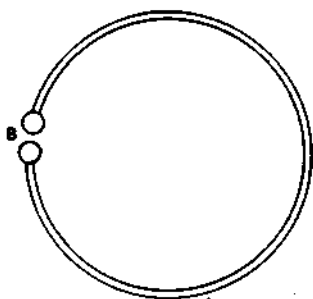

FIG. 394. — Hertzian resonator or ether-wave indicator. *B*, spark gap.

may naturally respond to the *ether waves* projected upon it by the oscillator in a manner that is analogous to that with which the second tuning fork responds to the *sound waves* projected upon it by the first fork. When one swings in a hammock, it is desirable to give the pushes which cause the hammock to swing (vibrate) at the same rate at which the hammock is going back and forth. If the pushes are given at any other rate, they tend at intervals to stop the motion and at other intervals to help it; that is, there is *interference*.

The natural rate of electrical vibration of the resonator or oscillator is dependent upon the dimensions of the conductor composing the instrument, and an adjustment may be effected by changing the sizes of the wings *CC* on the oscillator (Fig. 392), or the size of the resonator ring (Fig. 394), until their rates or frequency are the same.

It has been learned by experiment that the electromagnetic ether waves can be reflected, refracted, polarized, etc., just as light waves or heat waves, which clearly indicates the close alliance between the different kinds of radiation.

371. Discharge of Leyden jar is oscillatory. In 1842 Joseph Henry discovered that when a Leyden jar was discharged through a coil of wire surrounding a steel needle (Fig. 395) the needle was magnetized. Not only that, but he was astonished to find that sometimes one end was made the north pole and sometimes the other, even though the jar was always charged the same way.

He accounted for this fact by supposing that the discharge current kept reversing back and forth, that these oscillations gradually died away, and that the direction in which the needle was magnetized depended on which way the last perceptible oscillation happened to go.

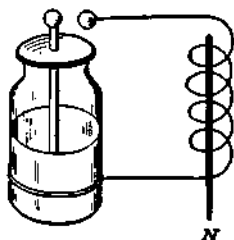

FIG. 395. — Leyden jar with coil in discharge circuit.

A few years later Lord Kelvin, the great English physicist and engineer, proved mathematically that the discharge must be oscillatory. Finally, in 1859 Peddersen succeeded in photographing an electric spark by means of a rapidly rotating mirror. The oscillatory discharge is drawn out into a band (Fig. 396) by the rotating mirror, and thus makes a zigzag trace on the camera plate. From this experiment it is possible to calculate the time of one oscillation. It is exceedingly short, varying from one one-thousandth to one ten-millionth of a second.



FIG. 396.—Photograph of oscillations of electric spark.

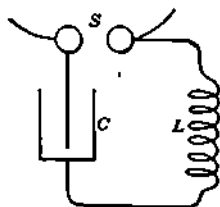

FIG. 397.—Connections for an oscillatory circuit.

Figure 397 shows one form of an oscillating circuit, in which the resistance is very small and the three essentials are (1) *capacity, C*, (2) *self-inductance, L*, and (3) *a spark gap, S*.

It can be shown that the discharge of a circuit is oscillatory only when

$$R^2 < 4 \frac{L}{C} *$$

where

R = resistance of the circuit in *ohms*,

L = self-inductance in *henrys*,

C = capacity in *farads*.

When the resistance R is very small, the period T (in seconds) of a complete oscillation of the current can be expressed by the approximate equation, which is usually sufficiently accurate,

$$T = 2\pi\sqrt{LC}$$

where $\pi = 3.14$ and L and C are measured in henrys and farads respectively.

* The symbol $<$ means "is less than."

A slight tap causes the resistance of the coherer to return to its original high value; that is, to decohere.

The microphone, described in section 354, is an excellent wave detector. Another form, called a crystal detector (Fig.

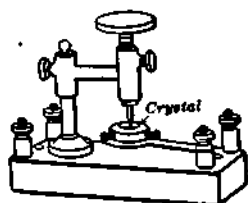

FIG. 401. — Silicon detector.

401), consists of a piece of silicon, or of any one of several crystalline substances, such as galena, embedded in soft metal on one side and touched on the other by a metal point. In the electrolytic detector a fine metal point just touches the surface of a conducting solution or electrolyte. The operation of crystal and electrolytic detectors seems to depend on

some mysterious property whereby they let electricity flow through them in one direction much more easily than in the other; in short, they act as rectifiers. They also automatically decohere when the wave stops.

A more recent and far more sensitive detector is the vacuum detector. This was invented by Fleming and has been adapted to use with a telephone. It consists of an electric-lamp bulb pumped to a high degree of exhaustion with a tungsten filament *F* made incandescent by the current from a battery. The bulb also contains a disk-shaped electrode *P* of copper or nickel. This electrode is connected up to the secondary of the receiving circuit and to the telephone receiver *T.R.*, as shown in figure 402.

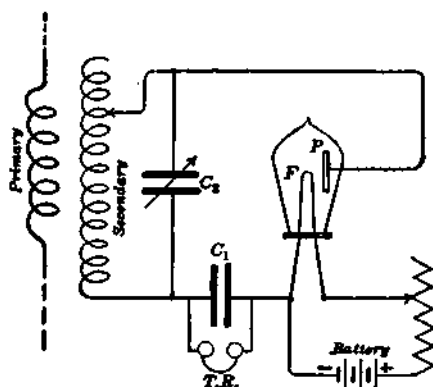

FIG. 402. — Connections for Fleming's vacuum detector.

The bulb also contains a disk-shaped electrode *P* of copper or nickel. This electrode is connected up to the secondary of the receiving circuit and to the telephone receiver *T.R.*, as shown in figure 402.

A fixed condenser C_1 bridges the telephone, and a variable condenser C_2 is joined across the receiving circuit.

When the filament is brought to a state of incandescence by the battery, electrons are sent off and the electric current can flow from the electrode P to F , as has been explained in section 293. The alternating current of radio frequency received by tuning coils will be changed into a unidirectional current, which affects a telephone receiver.

RADIOTELEGRAPHY

374. A simple sending station. Through the efforts of the Italian inventor, Marconi, and many others, electric waves are now being extensively used commercially for radiotelegraphy.

A simple sending station, such as Marconi used in his earliest experiments, is shown in figure 403. The essential part is a conductor called the *aërial* or *antenna*, extending to a considerable height above the ground. Powerful electrical oscillations are set up in this conductor like the oscillations in the spark discharge shown in figure 396.

These send waves out through the ether just as a stick laid on water and shaken up and down sends out ripples over the surface of the water. One way to set up oscillations in an *aërial* is to put a spark gap in it and to send sparks across this gap by means of an induction coil fed by batteries or by means of an alternator and step-up transformer, as shown in figure 403.

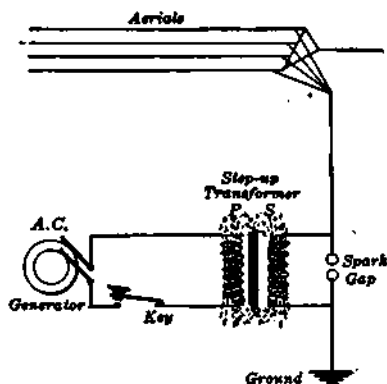

FIG. 403.— Simple sending station.

375. A simple receiving station. The simplest kind of receiving station is represented in figure 404. There is an aerial like that at the sending station, except that instead of a spark gap it contains a detector of some sort. In parallel with this detector is a telephone receiver. Every time a train of waves reaches such a receiving station, some of the energy is absorbed by the aerial and electrical oscillations are set up in it. These cannot get through the telephone because of its self-induction, and so they have to pass through the detector. But since a crystal detector lets more electricity through one way than the other, an excess of electricity accumulates in the antenna. This excess then discharges through the telephone, and the diaphragm moves over and back once.

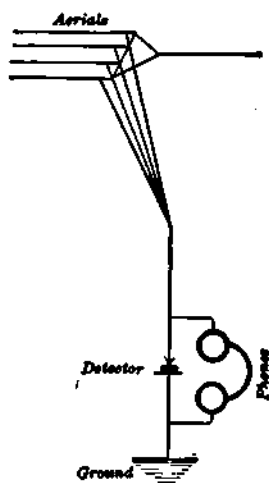

FIG. 404. — A simple receiving station.

Since this happens every time a train of waves comes in, which is many times every second, the telephone diaphragm is kept vibrating and emits a steady musical note as long as the key of the sending station is closed. The duration of this note can be made shorter or longer by holding the sending key down a shorter or a longer time, and so the dots and dashes of the International Morse Code can be transmitted.

The circuits used in commercial wireless telegraphy are of course much more complicated than these, because it is necessary to "tune" the sending and receiving stations accurately to the same frequency and to make them insensitive to waves of any other frequency, so that one pair of stations may not interfere with another.

INTERNATIONAL MORSE CODE SIGNALS

(To be used exclusively for all radio communications)

SPACING AND LENGTH OF SIGNALS

1. A dash is equal to 3 dots.
2. The space between the signals which form the same letter is equal to one dot.
3. The space between two letters is equal to 3 dots.
4. The space between two words is equal to 5 dots.

LETTERS

A • -
 B - • • •
 C - • - •
 D - • •
 E •
 F • • - •
 G - - •
 H • • • •
 I • •
 J • - - -
 K - • -
 L • • • •
 M - -
 N - •
 O - - -
 P • - - •
 Q - - • -
 R • - •
 S • • •
 T -

U • • -
 V • • • -
 W • - -
 X - • • -
 Y - • - -
 Z - - • •

š (German)

• - - -

š or š (Spanish—Scandinavian)

• - - • -

ch (German)

- - - -

ç (French)

• • - • •

ñ (Spanish)

- - • - -

ö (German)

- - - - •

ü (German)

• • - - -

NUMERALS

1 • - - - -
 2 • • - - -
 3 • • • - -
 4 • • • • -
 5 • • • • •

6 - • • • •
 7 - - • • •
 8 - - - • •
 9 - - - - •
 0 - - - - -

PUNCTUATION AND OTHER SIGNS

Full stop (.) • • • • •
 Semicolon (;) - • - • - •
 Comma (,) • - • - • -
 Colon (:) - - - • • •

376. Sending circuits. In commercial radiotelegraphy coupled circuits are now quite generally employed. These

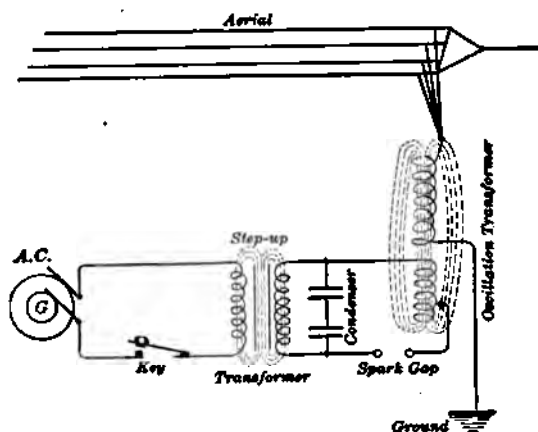

FIG. 405. — Inductive-coupled transmitting station.

are of two general types: the *inductive coupling*, which is illustrated in figure 405, and the *direct coupling*, which is illustrated in figure 406. The principle involved in each case is that of the high-frequency transformer invented

by Tesla and Thomson. This step-up transformer differs from the ordinary transformer in that it has no iron core. The primary, which consists of a few turns of heavy wire, is connected in series with a spark gap and a condenser. When the spark gap is connected across the secondary of an induction coil, or better, with the secondary of a step-up transformer, the condenser is repeatedly charged and discharged across the gap with oscillations of extremely high frequency. A group of these oscillations comes during each spark at the gap. These high-frequency oscillations in the

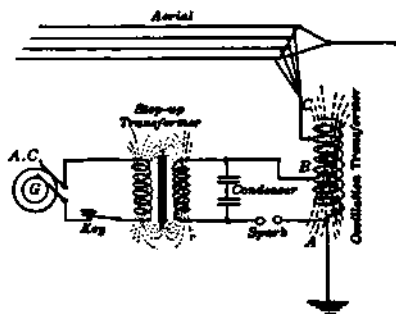

FIG. 406. — Direct-coupled transmitting station.

primary coil act inductively on the secondary coil. On account of the extreme rapidity of change of current in the primary the electromotive force induced in the secondary is very high.

In the direct-coupled system an autotransformer is used; that is, instead of having separate primary and secondary coils in the high-frequency transformer, the primary coil is a part of the secondary coil.

It should also be noted that in either case the primary circuit has a period of its own, and the secondary with its antenna and ground, which form the "plates" of a big condenser, has also its own period. Hence it is necessary, in order to get the best results, to tune the two circuits by adjusting the condenser and the number of turns on either the primary or secondary.

377. Receiving circuits. By means of switches it is customary to use the same antenna and ground connection for

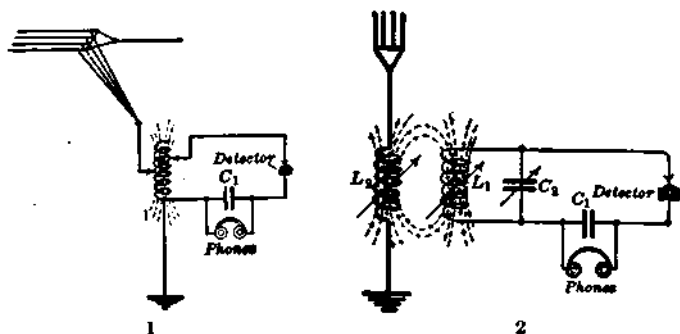

FIG. 407. — Typical receiving circuits. (1) direct-coupled, (2) loose-coupled.

both receiving and sending. It also is quite essential that the receiving circuit be tuned to resonance with the incoming waves. Inasmuch as most detectors used in radiotelegraphy are of high resistance, they are generally placed in separate circuits coupled directly or inductively to the antenna. Among the many types of receiving circuits used those shown in figure 407 will represent some of those most frequently found

in practice. The direct-coupled receiving circuit is shown in (1) and the inductive or loose-coupled type is shown in (2). In the latter type the number of turns on both coils L_1 and L_2 can be varied, as well as their distance apart; there is also a variable condenser C_1 bridged across the coil L_1 . It will be noticed that in each type a fixed condenser C_1 , called a "stoppage condenser," is bridged across the telephone so as to permit the oscillatory currents to pass freely through it and to store up the direct-current pulses and discharge them through the telephone.

378. Wireless apparatus. The development of radio-telegraphy has been so rapid that the apparatus has not as

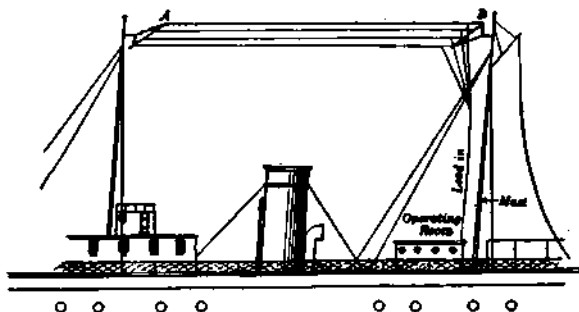

FIG. 408. — Inverted L aerial, which is almost universally used for ship service.

yet become standardized. Nevertheless, there are certain pieces of apparatus which are easily recognized in any radio station. The most striking feature of the equipment is doubtless the aerial or antenna, which is the elevated wire used to emit or intercept electric waves. The aerial usually consists of four or more parallel wires running up nearly vertically into the air and usually connected to a set of horizontal wires, as shown in figure 408. These wires are carefully insulated from the supporting masts and separated by spreaders. For example, on the U. S. S. *Dolphin* there are 6 wires 2 feet apart

with a flat top 140 feet in length and 136 feet above the operating room; this gives a total length of 276 feet and a natural wave length of 330 meters.

The oscillation transformer commonly consists of a large helix made of copper ribbon mounted on an insulating framework such as is shown in figure 409. The spark gap for small amateur sets is usually made of two zinc rods mounted as in figure 410. In the larger sets used for commercial work the rotating spark gap, which is

attached to the shaft of the alternator, or the quenched spark gap (Fig. 411) is now commonly employed. This so-called "quenched gap" is made up of a number of accurately turned copper disks, which are separated by annular rings of mica or oiled silk about 0.01 inches thick. The spark is confined to the air-tight space inside the mica rings. By using the proper number of disks in series this gap gives one discharge for each alternation of the current and thus produces a pure musical note. Furthermore, it is almost noiseless and quickly stops the oscillations of the closed circuit so that the open circuit (aërial, oscillation-

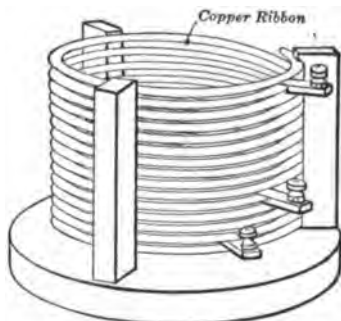

FIG. 409. — Helix of oscillation transformer.

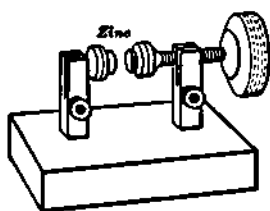

FIG. 410. — Spark gap for 0.25 and 0.5 kw.

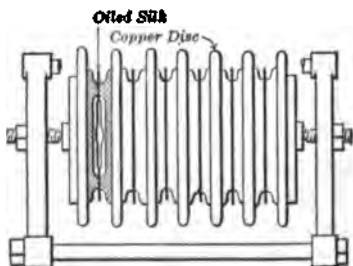

FIG. 411. — Diagram of quenched spark gap.

transformer secondary, and ground) is left free to vibrate in its own period and so radiates waves of but one length.

The wireless key (Fig. 412) is much like the ordinary Morse telegraph key except that it is made heavier and has large silver contacts instead of platinum points. Many different forms of transmitting condensers are in use. Some are made up of Leyden jars copper plated inside and out, but the glass plate type is much more convenient to handle.

As for generators, there are still a great variety in use. For small amateur sets as well as for portable sets induction

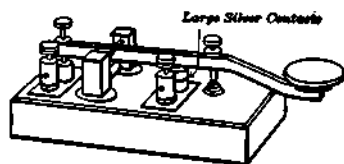

FIG. 412. — The "Boston" wireless key.

coils with hammer breaks, which are supplied with current from a storage battery, are still employed, but for large sets the hammer break has been discarded for some form of break regulated by rotary motion.

One very successful form is the mercury turbine interrupter. But on ships or at navy yards the induction coil has been largely replaced by alternating-current generators driven by motors, and at isolated shore stations, by oil engines. At first these alternators were the regular 60-cycle form, but now they have been replaced by 500-cycle generators. It was found that the higher frequency gave a pitch to which both the telephone diaphragm and the operator's ear are more sensitive. Besides the alternator it is necessary to have a step-up transformer to raise the voltage to about 25,000 volts. The transformer, usually of the closed-core type, must be designed for the frequency to be used.

In the receiving apparatus the most important instrument is the detector. Among all the various forms which have been invented about the only ones now in use are the crystal detector and the vacuum-tube detector. Both these detectors act as

rectifying or valve devices, which have the property of producing a direct current when an alternating current or electrical oscillations are sent through them. The cause of this action in the crystal detector is not yet known, but in the vacuum valve when used as the so-called "audion" detector (Fig. 413) it seems clear that the lamp filament when glowing

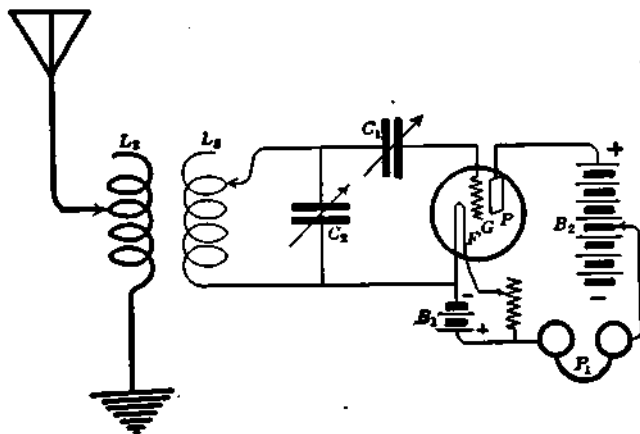

FIG. 413. — Vacuum tube used as "audion" detector.

emits electrons which carry away part of the filament, cause the darkening of the bulb, and also render the vacuum a conductor in one direction only.

In one type of vacuum valve, shown in figure 413, we have three elements: the tungsten filament F , the plate P , and between these two the grid G . This grid may be made up of a zigzag-shaped platinum wire or a plate perforated with holes. It will be noted in the diagram that there is a variable condenser C_1 , which is the so-called grid condenser and which has small capacity, varying between 0.00003 and 0.0005 microfarads. In addition to the lighting battery B_1 there is another battery B_2 of 35 or more volts, which has its positive terminal connected to the plate P and the negative to the telephones.

According to one explanation that has been advanced to account

for the action of this form of detector, the *grid*, which is placed in the path of the electrons (negative electricity), receives a *negative charge* which decreases the local battery current flowing between the plate and filament. An external positive charge (from the aerial) applied to the grid will to some extent neutralize the negative charge and thus increase the local battery current, but an external negative charge

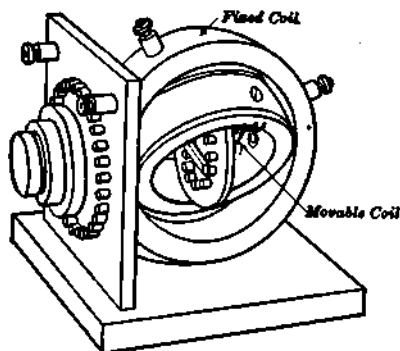

FIG. 414. — A receiving transformer.

will cause greater absorption of electrons and reduce the battery current still more. Hence, if an alternating e.m.f. be impressed between the grid and filament, the *positive alternation* increases the local battery current and the *negative alternation* decreases it.

The receiving transformer usually consists of two coils of fine wire so arranged that the number of turns used can be varied, and also the

relative positions of the two coils. One form of tuning coils is shown in figure 414. There is also in nearly every receiving circuit a small variable receiving condenser (Fig. 415). This usually consists of semicircular metal plates separated by air as the dielectric and having the alternate plates fixed. The other plates rotate about an axis so that by turning the knob on top any desired amount of the movable plates can be included between the fixed plates. Finally, the receiving telephones used in wireless telegraphy must be double-head telephones (Fig. 416) with a

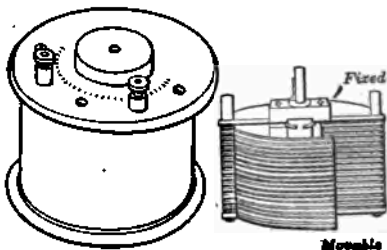

FIG. 415. — Variable receiving condenser.

resistance of from 1000 to 2500 ohms. Besides these important instruments one usually finds in a modern installation numerous switches, rheostats, and meters to measure current, voltage, and wave length.

379. The service of radiotelegraphy.

The ocean seems to be the peculiar field of service for radiotelegraphy, and it has already come into extended commercial use on the water. Of course wire telegraphy has for a long time been extensively used on land, but a moving ship cannot keep up wire communication with the land and so the ether waves have been seized upon as a medium for sending messages.

By sending out daily time signals, weather reports, and storm warnings, as well as by responding to calls for aid from ships in distress, radiotelegraphy has been of inestimable service to mariners and already has saved thousands of human lives.

In a certain sense radiotelegraphy has removed the sea and destroyed distance. For example, radio stations have been erected by the various governments so that each nation can communicate with the ships of its own navy and with other nations. In Paris the Eiffel Tower has been utilized to support an aerial, and a large radio station has been erected at Arlington near Washington. In fact, signals are occasionally received at the Marconi Station in Ireland from stations several thousand miles away, even from Darien, San Francisco, and Honolulu.

One of the difficulties with which long-distance radiotelegraphy has to deal is the atmospheric disturbance due to thunderstorms in the vicinity of a station. Another difficulty is the effect of sunlight upon the atmosphere, for messages can

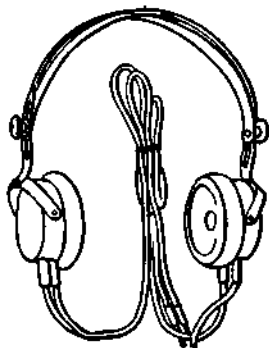

FIG. 416. — Double-head telephone receivers.

be sent much farther by night than by day. This effect of daylight fluctuates in an erratic manner from day to day, and the absorption of radio energy seems to occur more powerfully in the tropical zone than in the north temperate zone. It has also been found that, while the transmission of radio signals by day is fairly regular, yet at night the transmission is subject to very great fluctuations. In general, for short distances stronger signals may be obtained by the use of short wave lengths, say under 1000 meters, and for great distances longer wave lengths from 3000 to 10,000 meters are used. Perhaps the greatest problem now to be solved in this field of electricity is that of **directive** signaling so that the transmitter would radiate energy almost entirely in a single direction and so that the receiver could determine the direction in which the transmitter was located.

RADIOTELEPHONY

380. General principles. Not long after the first successful experiments in radiotelegraphy attempts were made to transmit speech by means of electromagnetic waves. Experiments seem to show that *undamped continuous oscillations of very high frequency are necessary for radiotelephone work.* The frequency of this alternating current must be above the limit of audibility and is often about 100,000 cycles per second. If such a persistent series of oscillations passes through a microphone transmitter at the sending station and if the resistance of this microphone is made to vary by the voice, then the sequence of the waves is modified in intensity and the amplitude of these high-frequency waves carries with it a series of modifications which correspond to the voice. These modifications also persist in the rectified current through the telephone at the receiving station and are heard as spoken words.

Perhaps this will be made clearer by studying the diagrams

in figure 417. The rapid oscillations $O A B C D E F$ represent the high-frequency alternating currents steadily supplied to the sending antenna when no telephonic transmission occurs. But when a microphone transmitter is put in the sending circuit, the amplitude of these outgoing waves is altered according to the diagram $O' A' B' C' D' E' F'$, and the telephone connected to the receiving antenna may be regarded as giving vibrations to its diaphragm corresponding to the wave $a b c d e$.

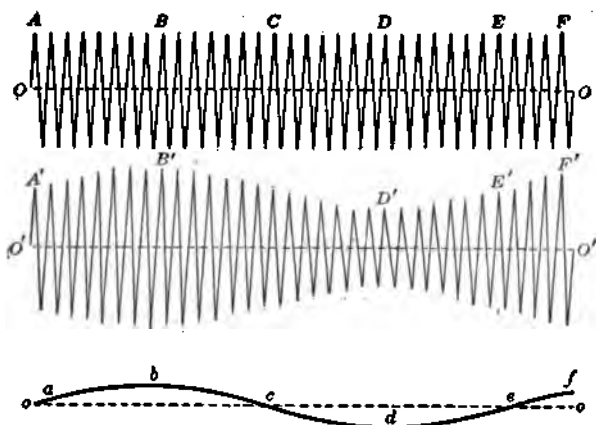

FIG. 417. — Diagram illustrating the production of sound by the modification in the amplitude of very high frequency currents.

381. Apparatus needed. Since the receiving circuits are identical for radiotelephony and for radiotelegraphy, we shall consider only the sending apparatus. In fact, the main problem of wireless telephony seems to be the production of persistent sequences of high-frequency oscillations at the sending stations. We shall very briefly describe three types of generators which are in use for this purpose: (1) the high-frequency alternator, (2) the Poulsen arc, and (3) the Chaffee gap.

(1) The General Electric Company has built an alternator (Fig. 418) capable of giving 100,000 cycles per second. It is driven by a 10-horse-power electric motor geared to the alternator by a DeLaval turbine gear so that the inductor makes 20,000 revolutions per minute. The machine has a stationary field and a stationary armature. The air gap of the machine may be varied by means of a micrometer screw attached to the frame of the machine.



FIG. 419. — Transmitter in main sending circuit.

(2) The Poulsen arc is used not only to get high-frequency currents for radiotelephony, but is also used in long-distance radiotelegraphy. This device is shown in figure 420, in which we have a copper-carbon arc in an atmosphere of coal gas. The positive terminal is copper, which is hollow and water-cooled. The negative *A* is carbon and is slowly rotated. The poles *N* and *S* of a powerful electromagnet are inserted into the arc chamber and are so placed as to give a magnetic field at right angles to the arc. The gas receptacle surrounding the arc is provided with a copper pipe carrying water for cooling the walls. Such an arc can deliver several kilowatts of high-frequency power.

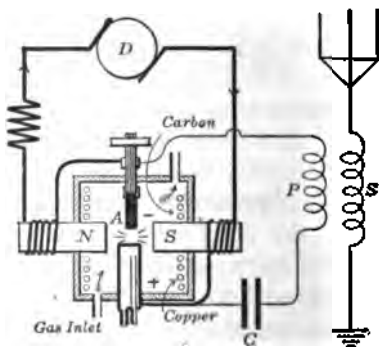

FIG. 420. — Poulsen-arc generator.



FIG. 418. — General Electric's high-frequency alternator. A d-c. motor (right) at 2000 r.p.m. drives through gears (middle) a 100,000-cycle alternator (left) at 20,000 r.p.m. The alternator is built with a stationary armature and a stationary field but with a rotating element which causes a pulsating field to cut the armature conductors.

The circuits are shown in figure 421, in which the leads from a d-c. generator of from 200 to 500 volts are brought through a suitable rheostat around the coils of the electromagnet and connected to the terminals of the arc. There is also about the arc a shunt circuit, which consists of a condenser C and self-inductance P . The oscillations set up in this circuit act inductively upon the secondary coil S , which is attached to the aërial and ground.

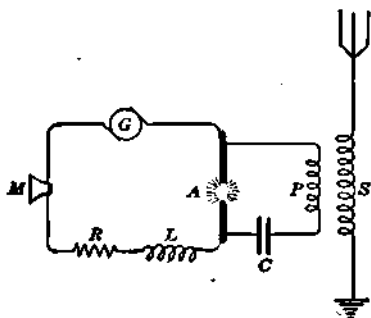

FIG. 421. — One way of connecting the arc into a wireless telephone circuit.

(3) The Chaffee gap consists of a minute gap in hydrogen or alcohol vapor between a copper anode and an aluminum cathode, as shown in figure 422. Except for the difference in the metal of the two terminals, the halves of the gap are symmetrical. Each terminal is inserted in a heat-radiating support.

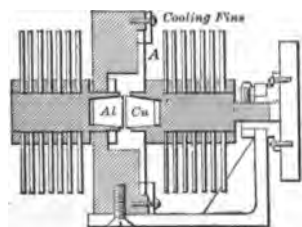

FIG. 422. — Section of Chaffee gap.

The form of gap shown is made air-tight by the use of a flexible phosphor bronze diaphragm. Such a diaphragm permits the necessary adjustment of the electrode. A condenser and inductance are shunted about the gap and this constitutes the primary circuit just as in the Poulsen circuit; but with the Chaffee gap the primary circuit is not an oscillatory circuit, for the gap acts as a rectifier and permits only

direct-current impulses to flow from the copper to the aluminum. One of these impulses starts oscillations in the secondary current. The frequency of these impulses is controlled by the condenser, inductance, and main supply of current. Such

a gap may be used to get any frequency up to 30,000,000 cycles per second.

Whatever the generator of the high-frequency oscillating current, the microphone transmitter must be of large current-carrying capacity and so sometimes a water-cooled transmitter is used.

362. Use of radiotelephony. Although the radiotelephone is not yet in commercial use, it is practicable to employ it up to 200 miles. In its present form, however, there seems to be little demand for such a device. On account of its delicate and complicated apparatus it obviously cannot take the place of the ordinary telephone, and its limitations in regard to power unfit it for long-distance service. Undoubtedly it would find a use in the navy if the apparatus could be simplified. It is only reasonable to expect, however, that the range of possible wireless telephony will be less than, but will gradually increase toward, the range of possible radiotelegraphy.

SUMMARY OF CHAPTER XXII

WAVE LENGTH of water waves means the distance between the crests of two adjacent waves (l).

AMPLITUDE is half the difference in level between the crest and trough.

VELOCITY is distance a crest travels in one second (v).

FREQUENCY is the number of crests passing a fixed point in one second (n).

WAVE EQUATION is $v = nl$.

ETHER is supposed to be the medium for transmitting light, heat, electrical energy, and magnetic disturbances.

ELECTROMAGNETIC WAVES are ether waves set up by an electric spark and were first detected by Hertz with a resonator.

DISCHARGE OF A CONDENSER through circuit of small resistance is *oscillatory*.

TWO CIRCUITS so tuned as to have the same frequency are said to be in *resonance*.

CRYSTAL DETECTORS and **VACUUM-TUBE DETECTORS** act as *rectifiers*.

RADIOTELEGRAPHY sends out electric waves from an aerial, which are transmitted through the ether and received by another aerial connected with a detector and telephone.

RADIOTELEPHONY uses undamped continuous oscillations of very high frequency. These oscillatory currents are modified in intensity by the varying resistance of the transmitter. Receiving station is identical with that used for radiotelegraphy.

HIGH-FREQUENCY OSCILLATORY CURRENTS may be generated by (1) special alternator, (2) by the Poulsen arc, and (3) by the Chaffee gap.

QUESTIONS

1. What is the difference between the motion of a water wave and the motion of the particles of water in the wave?
2. Under what conditions do two water waves reinforce each other and under what conditions do they interfere with each other?
3. What is the relation between the frequency of a wave and its period?
4. Are ether waves supposed to be transverse or longitudinal vibrations?
5. Why do we think ether is not matter?
6. What are essential properties of ether?
7. What evidence have we for thinking an electric spark starts a series of ether waves?
8. What is the difference between heat waves, light waves, and electromagnetic waves?
9. How can it be experimentally shown that the discharge of a condenser through a circuit is oscillatory?
10. What are the necessary conditions of two electrical circuits that they may be in resonance?

11. On what principle do the modern detectors of electric waves operate?
12. What is the function of the aerial wires used in radio stations?
13. How may you establish a good ground connection?
14. Why is a high-resistance telephone receiver necessary in radio work?
15. What advantages has the international Morse code over the ordinary Morse code?
16. In commercial radiotelegraphy how may two stations prevent interference by the other stations?
17. What advantages has the quenched spark over the ordinary spark?
18. What are the advantages of the modern detectors over the coherer formerly used by Marconi?
19. Why are such extensive aerial systems necessary for long-distance radiotelegraphy?
20. Why does it require so much more electrical energy to transmit signals across the Atlantic ocean by radiotelegraphy than under the ocean by cable?
21. What are some of the principal difficulties in long-distance radio transmission?
22. Why is radiotelephony not yet a commercial success?
23. What are some of the difficulties in building a high-frequency alternator?
24. What is the function of the magnetic field used in the Poulsen arc?
25. What are some of the limitations of the Chaffee gap?
26. Why is the ordinary telephone transmitter not adapted to heavy currents?

CHAPTER XXIII

ROENTGEN RAYS AND OTHER RAYS

MODERN THEORIES ABOUT ELECTRICITY

Spark voltage — discharges in partial vacua and high vacua. Cathode and canal rays — Roentgen or X rays; apparatus, applications, and nature.

Radioactivity — radium — alpha, beta, and gamma rays. Modern theories of electricity — electron theory of ionization, conductors, insulators, condensers, and magnetic field.

Pure and Applied Science as applied to electricity and magnetism.

383. Sparking voltage. The voltage needed to make a spark jump between two knobs depends on several factors, such as the size of the knobs, the distance between them, the frequency of an alternating current, and the atmospheric pressure. It takes less voltage as a rule to cause a spark to jump between two sharp points than between two round balls. For example, the sparking voltage for two sharp points 1 centimeter apart is about 7500 volts, and for two round balls 1 centimeter in diameter and 1 centimeter apart is about 27,000 volts. The sparking voltage between two sharp points varies so nearly as the distance that this is a method used to measure very high voltage.

To show the effect of atmospheric pressure we may connect a glass tube 2 or 3 feet long with an induction coil, as shown in figure

423. The tube is connected with a vacuum pump by a side tube. When the coil is first started the discharge takes place between x

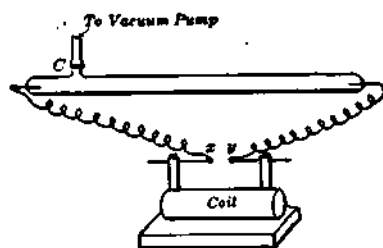

FIG. 423.—Discharge in partial vacuum.

and y , the terminals of the coil, which are only a few millimeters apart, but as the air is pumped out of the tube the discharge goes through the long tube instead of across the short gap xy . This shows that the sparking voltage decreases when the pressure is diminished.

384. Discharges in partial vacua. Reducing the atmospheric pressure between two points makes it easier for an electric discharge to pass, until a certain point in the exhaustion is reached. Then it begins to be more difficult. At the very highest degree of exhaustion yet attainable it is hardly possible to make a spark pass through a vacuum tube.

The changes in the appearance of such a tube as the exhaustion proceeds are very interesting. At first the discharge is along narrow, flickering lines, but as the pressure is lowered the lines of the discharge widen out and fill the whole tube until it glows with a steady light. With still higher exhaustion, a soft, velvety glow covers the surface of the negative electrode or cathode, while most of the tube is filled with the so-called positive column, which is luminous and stratified and reaches to the anode. The so-called Geissler tubes (Fig. 424) are little tubes of this sort which are usually made in fantastic shapes and serve as pretty toys. The color of the light from a Geissler tube depends on the gas which is in the tube and on the kind of glass used.



FIG. 424.—Geissler tube, made to study spectra of hydrogen.

385. Phenomena in high vacua. Sir William Crookes found that when the exhaustion of a tube is carried to a very high degree the dark space separating the negative glow from the cathode increases in width; and that electrified particles are projected in straight paths in directions nearly at right angles to the surface of the cathode and independent of the position of the anode. If the exhaustion is carried to such a high degree that only about one-millionth part of the air remains (*i.e.*, the pressure is about 0.0001 of a millimeter of mercury), the dark space fills the entire tube and the glass walls become beautifully phosphorescent. If a body

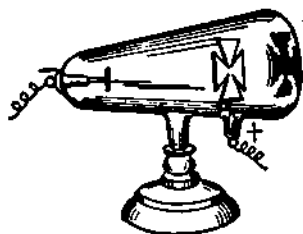

FIG. 425. — Shadow formed by cathode rays.

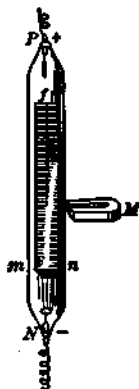

FIG. 426. — Bending of cathode rays by a magnet.

(whether opaque or transparent) is placed in front of the cathode, a sharply defined *shadow* of the body is cast upon the opposite wall of the tube. Figure 425 shows a Crookes tube in which is set a cross cut out of mica and its shadow appears on the end of the tube.

386. Cathode rays and canal rays. This invisible radiation from the cathode is called **cathode rays** and shows itself in several ways: *first*, by the yellowish green fluorescence wherever it strikes the glass of the tube; *second*, by the sharply defined shadows which a body interposed in its path produces in the fluorescence on the end of the tube; and *third*, by the fact that it can be brought to a focus where it produces intense heat.

A Crookes tube, made as in figure 426, sends a narrow band of cathode rays through the slit *s* in the aluminum screen *mn* against a fluorescent screen *f* slightly inclined toward them. When a strong magnet *M* is

held near the side of this tube, it is found that the stream of cathode rays is deflected in the direction which would be expected if they were a stream of negatively charged particles.

From this and other experiments we believe that *cathode rays are negatively charged particles projected at very high velocity from the cathode.*

J. J. Thomson, the English physicist, has estimated from various experiments on cathode rays that the negatively charged particles, which he calls *electrons*, have each a mass about sixteen hundred times smaller than that of a hydrogen atom, and move with a velocity of from one tenth to one third that of light. It is supposed that each particle carries a negative charge of electricity equal to that of the hydrogen atom in electrolysis.

Goldstein has shown that if the cathode is perforated with holes, "rays" of another kind, called *canal rays*, are observed to pass in pale blue lines through the apertures, as shown in figure 427. These rays, which excite a different kind of fluorescence, are very slightly affected by a magnet; but the deflection indicates

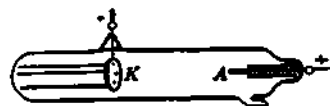

FIG. 427. — Vacuum tube showing canal rays.

that they are positively charged. Their speed is at least a thousand times slower than that of the electrons, and they probably consist of actual atoms of gas *positively* charged.

If we bring together our ideas in regard to the positive and negative electrons, we arrive at this conception: *The electrons result from the splitting or "dissociation" of uncharged atoms. The negative electron weighs almost nothing, the positive electron on the other hand weighs almost as much as the atom to which it is attached.*

387. Roentgen or X rays. William Konrad Roentgen took up the study of cathode rays in the fall of the year 1895. He was at that time occupying the chair of physics in the University of Würzburg in Bavaria and was well known in Ger-

many as an original experimenter in physical science. On November eighth he was experimenting with a well-exhausted Crookes tube (Fig. 428) which was covered by black cardboard so that no ordinary light could pass from it to the room. Near by lay a sheet of paper covered with a chemical compound which shines when struck by ether waves of high frequency. Crystals of tungstate of calcium possess this property, which is called *fluorescence*. Professor Roentgen noticed a peculiar line appearing on this paper while the tube was working, which indicated that something like light proceeded from the tube

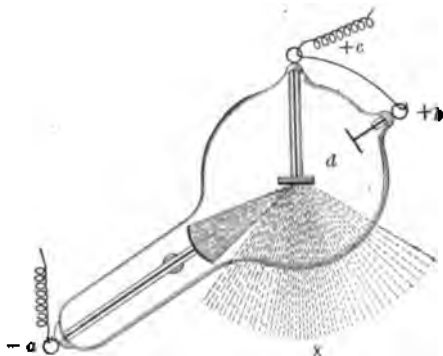

FIG. 428.—Typical X-ray tube; a, cathode; b, c, anodes; d, anticathode, source of X rays; x, X rays.

and cast a shadow upon the paper. An investigation showed that the effect was due to an hitherto unknown radiation proceeding from the tube, and **Roentgen** or **X rays** were discovered.

These rays or waves of Roentgen are apparently created where the cathode rays of a Crookes tube strike a solid object like the glass walls of the tube. If the cathode rays are focused upon a bit of metal by a concave cathode, the Roentgen waves may radiate from the surface of the metal. Figure 428 shows diagrammatically the cathode rays focused upon such a metal piece, called *anticathode*, and the X rays (x) passing downward.

The tube shown in the figure is of typical form, although it is now made of various sizes and shapes.

Roentgen found that different materials held between the working tube and a fluorescent screen — now called a fluoroscope (Fig. 429) — greatly differ in their transparency to X rays. Heavy (that is, dense) metals or materials, such as zinc or iron, in general cut off the X rays to a large extent and thus cast a shadow on the fluoroscope, while light materials, like wood and aluminum, seem to be transparent to the rays and to cast almost no shadow.

When a hand is held between a fluoroscope and a tube the denser bones cast a shadow and the flesh casts scarcely any.

Having investigated the rays by the use of a screen, Roentgen tried a photographic plate and found that the rays affected it in the same manner as light. Therefore, when the hand is placed between the tube and the plate a "radiograph" is taken

FIG. 429. — Fluoroscope, a light-tight box with fluorescent screen.

of the bones, the less dense flesh parts showing very indistinctly while the bones are clearly outlined. Figure 430 shows a "radiograph" of a hand. The rays are nearly all stopped in their progress from the X-ray tube to the photographic plate by the denser bones, but the flesh is nearly transparent to the rays. Consequently, the photographic negative almost gives the appearance of a negative which shows a skeleton hand or other body. If the sensitive photographic plate is bought in paper wrappings, it is not necessary to remove them, as they are easily pierced by the rays. Figure 431 shows the complete apparatus for taking X-ray pictures which is used in hospitals, with its step-up transformer, meters, tube,

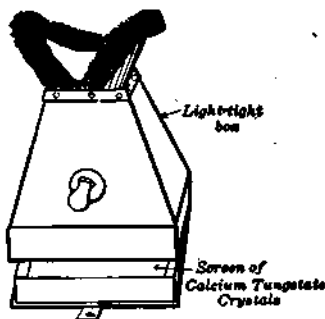



FIG. 430. — Radiograph of hand with gold ring on third finger.



FIG. 431. — Radiographic apparatus arranged for use in a dental hospital.
(Photographic film inside patient's mouth.)

and operating chair. The patient is about to have a radiograph taken of the interior of his jaw. Such photographs (Fig. 432) are taken for the purpose of locating abscesses on teeth, fractures in the bones, extraneous metal objects like bullets or needles in the flesh, and for other similar purposes.

388. X-ray apparatus. The high-tension generator used for X-ray tubes is either an induction coil or the more modern step-up interrupterless transformer. The induction coil is used exclusively for field-hospital outfits. For most

purposes a 12-inch coil will suffice, but the coil should give a "fat" flaming discharge well up to its maximum sparking

distance, and not a thin crackling spark. One form of interrupter sometimes employed is the mercury-jet break working in an atmosphere of coal gas. Such interrupters are motor-driven, and in the more modern types a jet of mercury is pumped against a series of rapidly revolving metal vanes. For instantaneous work an electrolytic break is often used. This device (invented by Wehnelt) consists of two electrodes immersed in dilute sulphuric acid; the cathode is a large lead plate (Fig. 433) and the anode is a platinum point. The amount of the anode exposed to the liquid can be adjusted by means of a porcelain sleeve.

There is still considerable difference of opinion as to the mode of action of this break, but the interruptions are conceded to be extremely rapid.



FIG. 432. — Radiograph of teeth showing an abscess (dark spot) on root of tooth. White areas in lower part of picture show fillings.

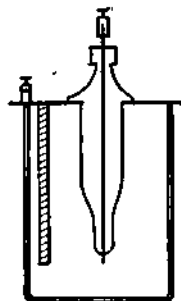

FIG. 433. — Wehnelt electrolytic interrupter with platinum anode.

For permanent installations the high-tension transformer (Fig. 434) is pretty generally used now in X-ray work. The machine is essentially an oil-immersed step-up transformer which is supplied with alternating current from an alternator. A rotating pole-changing switch rectifies the high-potential alternat-

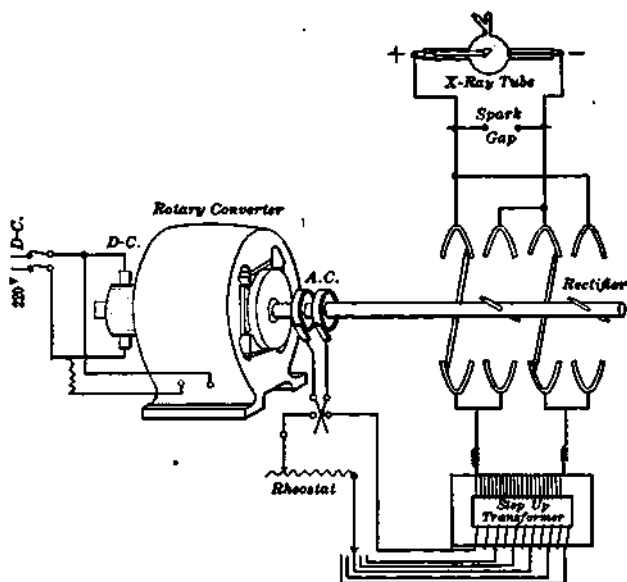

FIG. 434. — Connections of a modern X-ray apparatus.

ing current from the secondary of the transformer. To secure the perfect synchronism which is essential for rectification, the commutator is mounted on the same shaft as the alternator. The resulting current is not steady but pulsating, and can be carried as needed from 0.5 to 100 milliamperes.

Numerous varieties of X-ray tubes have been invented, but the tube (Fig. 435) invented by Dr. W. Coolidge (of the General Electric Company's Research Laboratory at Scheneo-



FIG. 436. — Radiograph showing the alimentary canal. *A*, adhesion; *B*, appendix.

tady, New York) marks an important step in the progress of the science. The chief novelty about it is the fact that the gas pressure is so low that it is impossible to send a discharge through the tube. In fact, the vacuum within the tube is about 1000 times that of an ordinary X-ray tube. To get the necessary electrons an incandescent cathode is employed. This consists of a small flat spiral of tungsten wire surrounded by a molybdenum tube. The tungsten spiral is heated by a subsidiary electric current (a 12-volt storage battery) and so becomes the source of the cathode ray (electrons). The molybdenum tube serves to focus this stream of electrons on the anticathode, which is made of tungsten and is unusually heavy.

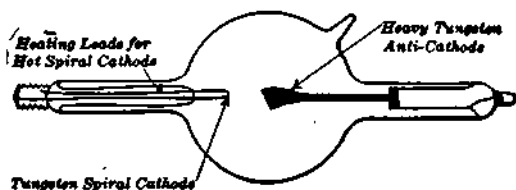

FIG. 435. — Coolidge X-ray tube.

The intensity of the X rays is precisely and readily controlled by adjusting the temperature of the cathode. The tube is remarkable in showing no fluorescence of the glass as in the ordinary X-ray tube.

389. Applications of X rays. In the early days of X rays it required prolonged exposure to make a radiograph, but nowadays it is possible with modern apparatus to take single-flash radiographs with exposures of the order of $\frac{1}{100}$ second. Even the alimentary system may be radiographed (Fig. 436) by rendering the required part temporarily opaque through the administration of bismuth salts or emulsions with the food. The great improvements in the technique of this subject have given to physicians and surgeons easy and exact diagnostic methods, which were never dreamed of a few years ago. For

instance, we can detect and determine the position of tumors in the cranial cavity even in its deepest parts, diseases of the pelvic organs, and tubercles in the lungs.

Besides these immensely important applications of X rays in medicine and surgery there are other uses such as: (1) the detection of pearls in pearl-bearing mollusks; (2) the examination of baggage by custom officers for the detection of smuggled articles; (3) the sterilization of tobacco and foodstuffs to prevent hatching of eggs of worms or other parasites; (4) the detection of flaws in metals; and (5) distinguishing real diamonds from imitations.

390. Nature of X rays. There has been long discussion as to the exact nature of the X ray. It is only within the last few years that the controversy has been settled by the experiments of the Braggs and Moseley, which show that X rays can be reflected and diffracted by crystals. There can scarcely be any doubt now that X rays are identical with ultra-violet light of extremely short wave lengths; wave lengths, in fact, of the order of the diameter of the atom.

With the addition of X rays to the list of electromagnetic waves already known, the following table of wave lengths is greatly extended in one direction. At the upper end of the

KIND OF WAVE	WAVE LENGTH IN CENTIMETERS
Hertzian waves (wireless)	10^8 to 0.4
Infra-red rays	0.031 to 7.7×10^{-5}
Visible light rays	7.7×10^{-5} to 3.6×10^{-6}
Ultra-violet rays	3.6×10^{-6} to 6.0×10^{-8}
X rays	1.2×10^{-7} to 1.7×10^{-9}
γ rays.	1.4×10^{-8} to 7.0×10^{-10}

From *Kaye's X RAYS*.

scale are the waves discovered by Hertz and now used in radiotelegraphy. The longest of these waves generated up to the

present time are about 15,000 meters or a little over nine miles. Next to the Hertzian waves, in order of magnitude, come the infra-red or heat rays, and the longest of these yet observed is 0.3 millimeters. Next we pass down through the visible spectrum to the ultra-violet rays which have been explored by Lyman as far as the wave length 6×10^{-6} centimeters. Here comes practically the only gap in the sequence, and doubtless some of the very "soft" X rays fill this gap. The X rays have wave lengths which are of the order of 10^{-8} centimeters, and beyond them the most penetrating of all, the γ rays (after the Greek letter γ).

391. Radioactive substances. In order to understand something about the X rays we must consider very briefly some of the radioactive substances. In 1896, shortly after the discovery of Roentgen rays, Henri Becquerel in Paris and Silvanus P. Thompson in England discovered that *uranium possesses the property of spontaneously emitting rays of some sort which have the power of penetrating opaque objects and of affecting photographic plates just as X rays do.* It was also found that these rays are emitted by all uranium compounds and that they are like X rays in that they discharge electrically charged bodies on which they fall.

Shortly after this Madame Curie found in uranium minerals a constituent more active than uranium itself, and succeeded in isolating this highly radioactive substance, which she named **radium**. Another radioactive element is thorium, which is the chief constituent of Welsbach mantles. In connection with this investigation it is interesting to note how Madame Curie discovered radium. She noticed that pitchblende, the crude ore from which uranium is extracted and which is largely uranium oxide, would discharge her electroscope about four times as fast as pure uranium. Therefore she inferred that the radioactivity of pitchblende must be due not alone to the uranium contained in it but to some hitherto unknown element which

had the property of emitting these Becquerel rays more powerfully than uranium. After a long and difficult search she succeeded in separating from several tons of pitchblende a few hundredths of a gram of a new element, which was capable of discharging an electroscope more than a million times as rapidly as uranium.

In 1899 Rutherford, then of McGill University, Montreal, showed that Becquerel rays are complex and that radium and its compounds emit *three* kinds of "rays," which can be separated by passing them through a strong magnetic field. These rays, known as **alpha** (α), **beta** (β), and **gamma** (γ) rays, are shown in the diagram (Fig. 437), which represents the action of a magnetic field, perpendicular to the plane of the figure, upon the rays emitted from a piece of radium placed in the bottom of a small lead cylinder. The *alpha* rays have small penetrating power and are only slightly deflected in a direction which shows them to be *positively* electrified. From the amount

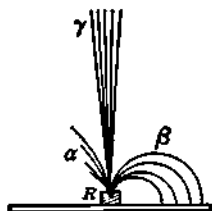

FIG. 437. — Emission of three kinds of rays from radium.

of their deflectability their mass has been calculated to be about four times that of the hydrogen atom or about 7000 times the mass of the electron, and their velocity to be about 20,000 miles per second. Rutherford and Boltwood have collected the alpha particles in sufficient amount to identify them definitely as *positively charged atoms of helium*.

The *beta* rays are found to be identical in all respects with cathode rays; that is, they are *streams of electrons*, corpuscular, negatively electrified, and highly penetrative. The *gamma* rays are not deflected at all by the magnet, but are of exceedingly high penetrating power, highly ionizing, and are in fact identical in their properties with the Roentgen or X rays. The gamma rays travel with the speed of light; the beta rays at varying speeds, but at less than the speed of light down to

about one tenth as great; while the alpha particles travel at a speed only about one twentieth as great. Finally, it has been shown that the radioactive substances are unstable, giving off emanations and emitting atoms of helium (alpha rays), and thus degenerating through a series of transformations in which they have different chemical properties. Radium itself is a degeneration product of uranium; and it finally seems to degenerate into an inactive product resembling lead. Since radioactivity has been found to be independent of all physical as well as chemical conditions, we must conclude that radioactivity is as unalterable a property of the atoms of radioactive substances as is weight itself.

392. Modern theories about electricity. The electron theory of electricity, which in one form or another is now pretty generally held by scientists, assumes that *the atoms of all substances contain as constituents both positive and negative electricity, the latter existing in the form of minute corpuscles or electrons.* These electrons are perhaps grouped in some way about the positive electricity as a nucleus. The sum of the negative charges of these electrons is supposed to be just equal to the positive charge of the nucleus, so that in its normal condition the whole atom is neutral. The electron is the atomic quantum of electricity, the smallest quantity which can be transferred from one atom of matter to another, and the smallest quantity of electricity that is capable of existing alone. The positive unit of electricity is unknown in the free state and apparently exists only as combined or associated with atoms of matter.

According to this theory the ions of electrolysis are atoms or groups of atoms carrying electrons. A monovalent positive ion (such as sodium Na^+ in salt water) is one which on being split off from a neutral molecule has one electron too few to neutralize its positive electricity and so is positive.

A "current" of electricity is regarded as a stream of electrons flowing along the conductor. Thus, metal wires must be thought

of as permitting and guiding the electrons as they pass freely between their molecules. No part of the conductance of a metal is due to positive atoms. Any electromotive force applied to a metal will tend to drive the electrons in the direction from negative to positive; that is, the ordinary positive current is simply to be considered as an electronic current or procession in the other direction.

Insulators or dielectrics are thought of as bodies which do not have free ions and no free electrons in them. Thus, pure water does not sensibly conduct; there are no ions in it. Such substances as glass and paraffin consist of large complex molecules which imprison their electrons so that they cannot conduct. A perfect vacuum does not conduct because there are no electrons in it to act as carriers. If a plate of glass or mica is placed in an electric field between two charged metal plates as in a condenser, the electric forces will tend to electrolyze the molecules and will produce molecular strains, but there will be no transfer of electrons and discharges in the mass. When the electric stress is removed the strain is released. The only actual locomotions of electrons in these operations of charge and discharge of a condenser will be *at the surface* of the dielectric.

Since we may think of an electric current as moving electrons, we must also consider them as exercising magnetic forces. Thus, an electron in traveling around a circular orbit will act like a minute magnet. Then a uniform magnetic field may be considered as equivalent to a continuous procession of electrons in a cylindrical sheet around it. The action of "cutting" a magnetic field by a moving conductor in a generator is equivalent to starting a procession of electrons along that conductor. From the motion of the electron its apparent mass has been calculated as about 6.5×10^{-28} grams. It seems fairly certain that *electrons constitute a definite primordial substance.*

393. Pure and applied science. In this book we have been studying some of the fundamental principles of electricity and magnetism together with some of their more important practical applications. It may seem that in this chapter we have been dealing with pure science unrelated to the great commercial applications. But we need to recall to ourselves again and again that discoveries of the utmost material importance are built upon and often follow close upon the labor of scientists in fields of pure research.

The men whose names have appeared most frequently in this book — Gilbert, Franklin, Ohm, Ampère, Volta, Faraday, Oersted, Davy, Henry, Maxwell, Crookes, Hertz, Roentgen, Kelvin, Siemens, Gramme — and many others, have each added a portion to the ever growing sum of man's knowledge of physical facts and laws. The advancement is steadily proceeding and will surely continue to proceed. New discoveries based upon those grown old are continually recorded by the great band of investigators of the world. We know little of the laws of the universe, and much less of its fundamental structure. The study of electromagnetic phenomena seems to lead toward an unraveling of the unknown in nature. If we ever learn the true constitution of electric and magnetic phenomena, we may expect at the same instant to know the constitution of matter and the truth regarding the hypothetical ether. With such knowledge the character of man's life may enter a condition of satisfaction and convenience exceeding our richest dreams. Many of our common mechanical necessities (the telegraph, the telephone, the electric light, the electric car, and the automobile) not long ago were almost inconceivable, and the adaptation of present known forces to man's use has only just begun. New discoveries are also gradually bringing to us the possibility of new utilities of which we do not now conceive. And the twentieth century may be expected to exert the most beneficent influence on civilization through

man's more intelligent and perfect application of nature's laws.

SUMMARY OF CHAPTER XXIII

SPARKING VOLTAGE between two sharp points varies very nearly as the distance.

DECREASING THE PRESSURE inside a tube decreases the sparking voltage, but in the very highest vacua a spark will not pass.

CATHODE RAYS are streams of negatively electrified particles, *electrons*, projected at right angles from cathode surface. These rays cause fluorescence, cast shadows, and produce intense heat.

CANAL RAYS pass through holes in cathode as if coming from anode. They consist probably of actual atoms of residual gas positively charged.

ROENTGEN OR X RAYS are created where cathode rays strike a solid object or target. They pass through the glass of the tube. They illuminate a fluorescent screen and affect a photographic plate. They pass through materials opaque to ordinary light. They penetrate different materials approximately *inversely* as the densities of the materials.

HIGH-TENSION GENERATOR giving a unidirectional discharge is used to excite X-ray tubes.

COOLIDGE TUBE has extremely high vacuum, electrons furnished by hot tungsten wire which serves as cathode. Thus the penetrating power of the rays emitted can be controlled.

X RAYS are indispensable to the physician and surgeon for accurate and quick diagnosis.

RECENT EXPERIMENTS WITH CRYSTALS show that X rays are identical with ultra-violet light of extremely short wave lengths.

RADIUM COMPOUNDS as well as uranium and thorium compounds emit spontaneously rays similar to X rays. In fact, they emit three kinds of rays: *alpha rays*, which are positively charged atoms of helium; *beta rays*, which are negatively charged corpuscles or electrons; and *gamma rays*, which are similar to X rays.

ACCORDING TO MODERN THEORIES an electric "current" is a stream of electrons flowing along the conductor, only in the *opposite* direction from that of the ordinary (positive) current.

INDEX

Numbers refer to pages. Blackface numerals indicate the principal reference.

A-C., <i>see</i> Alternating current		Arc	448, 457
Aerial	551, 558	crater of	458
Air gap, between armature and poles	207	furnace	488
of induction motor	398	lamp	456
Alpha rays	580	ballasting resistance of	459
Alternating current	143, 302	constant current	381
circuit, capacity in	335	flame	460
inductance in	319	inclosed	460
Ohm's Law for	345	luminous	462
power in	331	mechanism of	458
reactance in	327	metallic-electrode	461
curve of	308	light	445
effective value of	312	open	456
frequency of	314	welding	491
generator (<i>see also</i> Alternator)	350	Armature	200
motor	389	drum	206
period of	314	of magnet	121
series motor	404, 406	reaction	222
Alternator	144, 350, 417	stationary	351
efficiency of	365	Astatic galvanometer	157
exciter for	353	Atomic weight	268
high-frequency	564	Audion detector	559
power of	359	Automobile, electric	511
rating of	361	storage battery	291
revolving-field	350	Auto-transformer	383
voltage of	368	efficiency of	383
Aluminum, extraction of	279	Auxiliary induction motor	402
Amalgamation	25	Back electromotive force	236
Ammeter	161	Balanced system	435
hot-wire	171	Balancer set	436
Thomson inclined-coil	169	Ballasting resistance of arc lamp	459
Weston soft-iron	170	Battery	13
Ampere	7	Burn Boston	23
international	41	charging	296
turns	92	gravity	20
Anode	13, 264	lead storage	284
Antenna	551, 556	chemistry of	286
Anticathode	573	plunge	17

References are to pages.

Battery — Continued		
storage	282	of storage battery 289
automobile 285, 289, 290		of transformer 386
capacity of 289		Carbon-filament lamp 447
care of 287		Carbon transmitter 523
charging 283		Carborundum furnace 468
discharging 283		Care of storage battery 287
efficiency of 289		Carrying capacity of wire 78, 478
specific gravity of acid in 288		Cathode 12, 264, 570
testing 287		rays 571
uses of 290		Cell 13
Bell 97		closed-circuit 16
circuit 98		Daniell 19
telephone 526		dry 22
Beta rays 580		Edison primary 24
Blasting 487		Leclanché 18
Boats 513		local action in 24
Boys radiomicrometer 495		open-circuit 16
Brake, air 506		primary 14
on electric car 506		secondary 14
Braking, regenerative 510		standard 184
Bridged arrangement of tele-		storage 282
phone bell and magneto 525		Weston normal 184
British thermal unit (B. t. u.) 77		Central battery system 527
Brown and Sharpe (B. & S.)		Central exchange 526
gauge 47		Central power station, develop-
Brushes 200		ment of 413
position of 235		Chaffee gap 565
Brush-raising switch 429		Characteristic curves of field
Brush-shifting repulsion-type in-		windings 213
duction motor 398		of generators 213
Build up voltage 211		Charging storage battery 283, 296
Bunsen photometer 451		Chemical equivalent 267
Burn Boston battery 23		Chemistry of lead storage battery 286
Burnishing 275		Choke coil 324, 422
Bus bar 418		Circuit 6
equaliser 226		bell 98
Calibration 181		breaker 480, 482
Calorie 76		coupled 554
Calorimeter 76		magnetic 105
Canal rays 572		mutual attraction of 153
Candle, international 451		noninductive 324
Candle power 451		Ohm's Law for A-C 345
mean spherical 464		oscillating 547
Capacity, in a-c. circuits 335		parallel 51
of condenser 339		receiving 550
of electrical machinery 481		sending 554
reactance 340		series 49
how to compute 342		short 33
		Circular mil 43
		Code, Morse 102, 552

References are to pages.

Coherer	549	Crystal detector	550
Coil, choke	324, 422	Current, alternating	143, 302, 329
induction	148, 524, 575	direct or continuous	201
primary	145, 373, 377	eddy	219, 378
reactance	422	lagging	315
secondary	145, 373	leading	315
thumb rule for	93	polyphase	354
Commutator	201	protection against excessive	482
type of motor	406	single-phase	354
Commulating poles	223, 503	three-phase	355
Compass	120	transformer	385
ship's	133	Curtis-type steam turbines	415
Compensator	394	Curve, of alternating current	308
compensating windings	405	of oscillatory electric discharge	544
Compound-wound generator	212	sine	309
motor	249	Curves, distribution	463
Condenser	336	magnetization	110
capacity of	339	of ventilated railway motor	504
mechanical analogue of	337	Daniell cell	19
synchronous	404	D'Arsonval galvanometer	157
variable receiving	560	Davy, Sir Humphry	445
Conductance	33	Delta (Δ) connection	355
Conductor	31	Demagnetization	125
heating of	477	Density, flux	108
Conduits, electric	424	Depolarization	15
Consequent poles	122	Detector	558
Conservation of energy	72	crystal	550
Constant-current transformer	381	electric wave	549
Constant-speed induction motor	396	electrolytic	550
Constant-voltage network	434	vacuum	550
Controller	501	Dielectric	336
Converter, inverted	429	strength	340
method of starting	428	Differential compound-wound	
rotary	426	motor	249
substation	426	Dip, magnetic	131
synchronous	426	Dipping, plating by	273
construction of	427	Direct current (d-c.)	201
Coolidge tube	576	Direct system of lighting	471
Cooper Hewitt lamp	462	Discharging storage battery	283
Core-type transformer	374	Dissociation, electrolytic	265
Cortiss steam engine as prime		Distribution curves of light	463
mover	414	Distribution of light	463
Cosine	333	of power	411
Coulombmeter	181	for electric locomotives	509
Counter-electromotive force of		constant-voltage network	434
self-induction	322	three-wire system	434
Coupled circuits	554	Dodge automobile	256
Crane with electric motors	259	Drawn-tungsten lamp	448
Crater of arc	458	Drop, telephone	528
Crookes tube	571, 573		

References are to pages.

Drum armature	205	medium of electromagnetic in-	
Dry cell	22	duction	543
Dynamo	199	radiation	542
Dyne	126	waves	542
Earth as magnet	130	Excessive current, protection	
Eddy currents	218	against	482
in transformer	378	Exchange, telephone	526
Edison incandescent lamp	447	Excitation of the field	211
primary cell	24	Exciter	417
storage battery	293	for alternator	353
characteristics of	295	Exploding mines	487
construction of	293	Fall of voltage	58
Effective value of alternating cur-		Farad	339
rent	312	Faraday, Michael	87, 138
Efficiency	73	Faraday's Laws	269
of alternator	365	Faure plates	284
of auto-transformer	383	Feeders	411, 423, 501
of generator	216	Field-break-up switch	429
of induction motor	398	Field, excitation of	211
of storage battery	289	magnets	206
of transformer	380, 381	revolving	350
Electricity, modern theories about	581	windings, characteristic curves	
for power transmission	411	of	213
Electrochemical equivalent	28, 270	Filament, metal	448
Electrochemistry	263	Flame arc lamp	460
Electrodynamometer	172	Fleming's Rule	140
Electrolysis of water	266	Flow, phase of	306
of water mains	281	Fluorescence	573
Electrolyte	12, 263	Fluoroscope	574
Electrolytic copper	277	Flux, density	108
detector	550	magnetic	87
dissociation	265	Foot candle	466
Electromagnet	95	Force, lines of	87
Electromagnetic induction	146, 543	electromotive	9
Electromagnetic waves	539, 543, 545	magnetomotive	107
Electromagnetism	89	Ford automobile, ignition system	150
Electromotive force	9	Formed plates	284
back or counter	236	Franklin, Benjamin	421
Electron	572, 581	Frequency	354
Electroplating	271	of alternating current	314
Electrostatic voltmeter	173	Friction	477
Electrotyping	276	Furnace	384, 487
Elevated railway	507	arc	488
Energy	11	carborundum	488
conservation of	72	resistance	488
Equalizer bus bar	226	Fuses	80, 439, 482
Equivalent, chemical	267	Galvanizing	276
electrochemical	26, 270	Galvanometer	156
Ether	88, 542		

References are to pages.

Galvanometer — Continued		Hysteresis	114, 218
astatic	157	in transformer	378
D'Arsonval	157	Ignition, jump-spark	149
Gamma rays	580	make-and-break	152
Gap, air	207	system Ford automobile	150
Gas engine as prime mover	415	Illumination, amount needed	468
Gas-filled lamp	454	measurement of	465
Gears, double helical	514	Illuminometer, Macbeth	467
Geissler tube	570	Impedance	329
Generator 138, 199, 417, 558		Incandescence	446
alternating-current	350	Inclosed arc lamps	460
characteristic curves of	213	Inclosed motors	234
compound-wound	212	Indicating wattmeter	174
efficiency of	216	Indirect system of lighting	471
losses in	217	Induced voltage	139
motor	427	Inductance, in a-c. circuits	319
multipolar	207	how to calculate	325
rating of	220	hydraulic analogy	323
series-wound	211	unit of	326
shunt-wound	212	Induction coil 148, 524, 575	
three-wire	436	Induction, electromagnetic 146, 543	
Gilbert, Dr. William	120	magnetic	123
Gold plating	275	motor	389
Gramme ring	202	air gap of	398
Gravity battery	20	auxiliary	402
Grids in synchronous motor	403	brush-shifting repulsion type	398
Heating, advantages of electric	485	constant-speed	396
appliances in household	483	efficiency of	398
of conductors	477	parts of	389
electric	477	polyphase 391, 398, 400	
sources of	496	rotor of	392
Hefner, unit	451	running characteristics of	396
Henry, Joseph	137	single-phase	399
Henry, unit of inductance	326	starting	394
Hertz, Heinrich	544	starting characteristics of	397
Hertzian waves	549	starting single-phase	400
High-frequency alternator	564	slip of 392, 396	
High vacua, phenomena in	571	speed of	396
Horn-gap	422	uses of	398
Horse power	70	self- 151, 390	
Hot-wire ammeter	171	Instrument transformers	384
House wiring	437	Insulation resistance	194
national code of rules for	437	Insulators	31
H-type of transformer	375	Intensity of illumination, unit of	466
Hunting	428	Interference of waves	540
Hydraulic analogy of induc-		International ampere	41
 tance	323	International candle	451
Hydroelectric power plants	415	International Morse Code	552
Hydrometer	288	International Morse Code Signals	553

References are to pages.

International ohm	40	trunk	532
International volt	41	underground	501
Interpoles	222	Lines of force	87
Interrupter	575	Load curve of small power sta- tion	223
Interurban railways	507	Loading telephone line	535
Inverted converter	429	Local action in cell	24
Ions	12, 681	Local battery telephone set	524
Joule, unit	71	Local trunks	533
Jump-spark ignition	149	Locomotive	509
Kennelly, A. E.	522	Long-distance telephony	534
Key, telegraph	101	Longitudinal waves	541
Kilovolt amperes (kv-a.)	361	Loop, Murray	192
Kilowatt	70	Varley	193
hour	70	Losses, in generator	217
Kirchhoff's Laws	60	in transformer	377, 390
Lagging current	315	Luminous arc lamp	462
Lamp, arc	456, 469	Macbeth illuminometer	467
commercial rating of	455	Magnet, armature of	121
Cooper Hewitt	462	earth as a	130
gas-filled	454	field of	206
life of	453	Magnetic circuit	105
mercury-vapor	462	field	85
putting together	449	rotating	390
standard	450	flux	87
testing	450	induction	123
Lathe, driven by motor	258	meridian	132
Launches	513	needle	84
Leading current	315	pole, unit	126
Lead storage battery	284	screens	124
chemistry of	286	Magnetism, Molecular Theory of	129
Leakage, paths	113	Ohm's Law for	111
Leclanché cell	18	Magnetite	119
Lenz's Law	147	Magnetization curves	110
Leyden jar	336	Magneto	200
oscillatory discharge of	546	Magnetomotive force	107
Light, distribution of	463	Make-and-break ignition	162
Lighting	445	Manholes	424
early history of	445	Mazda lamp	448
interior	471	Mean spherical candle power	464
street	472	Measurement of resistance	185
Lightning	421	Mechanical analogue of con- denser	337
protection	421	Megohms	159
lightning rod	421	Mercury-arc rectifier	430
reactance coil	422	Mercury-vapor lamp	462
spark gap	422	Meridian, magnetic	132
Line, loading the	535	Metal filament	448
regulation of the	480	Metallic-electrode arc lamp	461

References are to pages.

Metal molding for wiring	438	starting	241
Microampere	165	squirrel-cage	394
Microfarad	339	stopping	241
Microphone	522, 550	synchronous	401, 404
Mil	43	grids in	403
circular	43	starting	402
foot	44	uses of	403
Milliamperes	164	three-phase	391
Mines, exploding	487	uses of	254
Molecular Theory of Magnetism	129	ventilation of	503
Morse code	102	Wagner single-phase	406
Morse, Samuel F. B.	102	Multiple switchboard	530
Motor	199, 231	Multiplier	168
a-c.	389	Multipolar generator	207
a-c. series	404	Murray loop	192
uses of	406	Mutual attraction of electric cir- cuits	153
commutator type of	406	Name plate	481
compound-wound	249	National Electrical Code	437
on crane	259	Neutral wire	435
differential compound-wound	249	Nickel plating	273
in factories	256	Noninductive circuit	324
generator, compared with synchronous converter	427	No-voltage release	240
inclosed	234	Orsted	88
induction	389	Ohm, Georg S.	35
air gap of	398	Ohm	9
auxiliary	402	international	40
brush-shifting repulsion type	398	Ohm's Law	35
constant-speed	396	for a-c. circuits	345
curves of	396	for magnetism	111
efficiency of	398	Opaque to current	528
parts of	389	Open arc	456
polyphase	391, 398, 400	Open wiring	438
rotor	392	Oscillating circuit	547
running characteristics of	396	Oscillator	544
single-phase	399	Oscillatory discharge of Leyden jar	546
slip of	395	Oscillograph	311
speed of	395	Overload release	240
starting	394	Pall welding	492
starting characteristics of	397	Panels	418
starting single-phase	400	Parallel circuits	51
uses of	398	Parallel operation	224
lath driven by	258	Parsons type steam turbines	415
railway	502	Partial vacuum, discharges in	570
repulsion	407	Pasted plates	284
reversing	242	Peak of load	223
series-wound	248		
shunt-wound	248		
single-phase series	405		
speed regulation of	246		

References are to pages.

Peltier effect	493	most convenient	412
Period	356	turbines	414
of alternating current	314	Prony brake test	250
of wave motion	540	Pupin, M. I.	535
Permeability	108	Pyrometer	495
Phase of flow	306	Quenched spark gap	557
Photometer	450	Radiation, ether	542
Bunsen	451	Radioactive substances	579
Platé plates	284	Radiograph	574
Plates, formed or Platé	284	Radiomicrometer, Boys	495
pasted or Faure	284	Radiotelegraphy	551
Plating, by dipping	273	apparatus	556
gold	275	service of	561
nickel	273	Radiotelephony	562
silver	273	apparatus	563
Polarization	14	Radium	579
Poles	86	Railway electric, early history of	499
commutating	222, 503	interurban	507
consequent	122	motor	502
unit magnetic	127	curves of	504
Polyphase currents	354	principle of	500
Polyphase induction		single-phase a-c. system for	508
motor	391, 398, 400	Rapid transit	507
Post-office form of Wheatstone		Rating of alternator	361
bridge	190	of generator	220
Potential transformer	384	Ratio of transformation	376
Potentiometer	183	Rays, alpha	580
Poulsen arc	564	beta	580
Pound-foot	245	canal	572
Power, in a-c. circuit	331	cathode	571
of alternator	359	gamma	580
distribution of	411, 434	Roentgen	572
for electric locomotive	509	X	572
factor	333	Reactance, in a-c. circuit	327
effect of low	334	capacity	340, 342
local distribution of	433	coil	422
losses in transmission	478	Receiver, bipolar	521
plant, hydroelectric	415	telephone	520
small isolated	412	Receiving radio circuits	550
station	411	Receiving radio station	552
central	413	Receiving telephone	560
small	223	Receiving transformer	560
transmission	411	Rectifier, high-potential	576
electricity for	411	mercury-arc	430
unit of	67	vacuum-valve	431
waste of	477	Regenerative braking	510
Primary coil	145, 372	Regulation, of the line	480
Prime mover	414	of voltage	215
Corliss steam engine	414		
gas engine	415		

References are to pages.

Relay, telegraph	103	Series-wound generator	211
Reluctance	111	Series-wound motor	248
Reluctivity	109	Shell-type transformer	374
Remote control	420	Ship's compass	133
Repulsion motor	407	propulsion	514
Resistance	8, 33, 477	Shops with electric drive	257
boxes	188	Short circuit	33
furnace	488	Shunts	54
insulation	194	Shunt-wound generator	212
measurement of	185	Shunt-wound motor	248
Resistivity	44	Silver plating	273
Resistor	483	Simultaneous telephony and telegraphy	533
Resonance	341, 648	Sine curve	309
Resonator	545	Single-circuit transformer	383
Retentivity	125	Single-phase a-c. system for rail- ways	508
Reversing a motor	242	Single-phase currents	354
Revolving field	350	Single-phase induction motor	399
Revolving-field alternator	350	Single-phase series motor	405
Rheostat	237	Single-phase Wagner motor	406
Rigid iron conduit for wiring	438	Slip of induction motor 392, 395, 396	396
Roentgen rays	572	Slip rings	143
apparatus	575	Small power station	223
Roentgen, William Konrad	572	Solenoid	92
Rotary converter	426	Sounder, telegraph	101
Rotating magnetic field	390	Sound waves	541
Rotating spark gap	557	Spark gap	423, 557
Rotor	389	Sparking voltage	569
hunting	428	Specific gravity of acid in storage battery	288
of an induction motor	392	Specific inductive capacity	340
squirrel-cage	393	Speed control	504
starting a wound	395	Speed of induction motor	395
wound	393	Speed regulation of motor	246
Running characteristics of induc- tion motor	396	Speed, synchronous	395
Saturation, magnetic	109	Spring jack	528
Science, pure and applied	583	Squirrel-cage motor, starting a	394
Screens, magnetic	124	Squirrel-cage rotor	393
Secondary coil	145, 373	Standard cell	184
Self-induction	151, 320	Standard lamp	450
counter-electromotive force of	322	Star (Y) connection	355
Semi-indirect system of lighting	471	Starting box	237
Sending radio circuits	554	Starting characteristics of induc- tion motor	397
Sending radio station	551	Starting, induction motor	394
Sensibility	159	motors	241
Series	14	single-phase induction motor	400
circuit	49	squirrel-cage motor	394
motor, a-c.	404	synchronous motor	402
single-phase	405		
transformer	385		

References are to pages.

Starting — Continued		grids in	403
wound rotor	395	starting	402
Stationary armature	351	uses of	403
Stator	389	Synchronous speed	395
Steam turbine, Curtis type	415	Telegraph	100
Parsons type	415	key	101
Steinmetz, C. P.	115	relay	103
Step-down transformer	384	sounder	101
Step-up transformer	558	Telephone	519
Step-up interrupterless trans-		bell	526
former	575	early	519
Stopping motor	241	exchange	526
Storage battery, automobile	291	and the people	536
capacity of	289	receiver	520
care of	287	bipolar	521
charging	283, 296	receiving	560
chemistry of lead	286	set, local battery	524
discharging	283	transmitter	520
Edison	293	Telephony, long-distance	534
characteristics of	295	and telegraphy, simultaneous	533
construction of	293	Temperature coefficient of re-	
efficiency of	289	sistance	42
lead	284	Terminal voltage	38
chemistry of	286	Testing set	191
specific gravity of acid in	288	Testing, storage battery	287
testing	287	transformer	385
uses of	290	Theories about electricity,	
Storage cell	282	modern	581
Street lighting	472	Thermal unit, British	77
Submarine	513	Thermoelectric effects	493
Substation	425	Thermogalvanometer	494
converter	426	Thermopile	494
converter type	426	Third rail	502
outdoor type	425	Thomson, inclined-coil ammeter	169
Subway	507	welding process	490
Switch, brush-raising	429	Three-phase current	365
field-break-up	429	Three-phase motor	391
three-pole double-throw	394	Three-pole double-throw switch	394
Switchboard	411, 418, 526, 528	Three-wire generator	436
circuit breaker	420	Thumb rule	91
multiple	530	for coil	93
panels	418	Torque	234, 244
remote control	420	Traction	499
station-output panel	419	Transformation, ratio of	376
Synchronism	363	Transformer, air-cooled	379
Synchronous condenser	404	all-day efficiency of	381
Synchronous converter	426	auto-	383
construction of	427	efficiency of	383
compared with motor generator	427	capacity of	386
Synchronous motor	401, 404		

References are to pages.

Transformer — Continued		Ventilation of motor	503
constant-current	381	Vertical water wheels	352
core type	374	Volt	9
current	385	international	41
eddy currents in	378	Voltage, of alternator	358
efficiency of	380	build up	211
H-type	375	drop in line	480
hysteresis in	378	fall of	58
instrument	384	induced	139
losses	377, 380	network of constant- regulation of	434
mistakes about	376	release, no-	240
oil-cooled	378, 380	sparking	569
potential	384	terminal	38
primary coil of	377	Voltmeter	186
ratio	378	electrostatic	173
receiving radio	560	Weston soft-iron	170
secondary coil of	377		
series	385	Wagner single-phase motor	406
shell type	374	Water mains, electrolysis of	281
single-circuit	383	Water waves	539
step-down	384	Water wheels, vertical	352
step-up radio	558	Watt-hour meter	176
step-up, interrupterless	575	Watt, James	69
testing	385	Wattmeter, indicating	174
uses of	371	Watt, unit of power	70
water-cooled	379	Wave, amplitude	539
welding	384	detector	549
Translucent, to current	528	electromagnetic	539, 543, 545
Transmitter, carbon	523	ether	542
telephone	520	form	364
Transverse waves	541	frequency	540
Trolley wire	500	relation to length and ve- locity	540
Trunk line	532	Hertzian	549
Tungsten lamp	448	interference	540
Turbine as prime mover	414	length	539
Turns, ampere	92	relation to velocity and fre- quency	540
		table of	578
Underground line	501	longitudinal	541
Unit magnetic pole	126	motion, period of	540
		sound	541
Vacua, high	571	transverse	541
partial	570	velocity	540
Vacuum detector	550	water	539
Vacuum-valve rectifier	431	Ways of cooling transformers	378
Valence	268	Wehnelt electrolytic interrupter	575
Variable receiving condenser	560	Welding	384
Variation of compass	130	arc process	491
Varley loop	193		
Velocity, wave length and fre- quency, relation between	540		

References are to pages.

Welding — Continued		Wiring, buildings	437
pail process	492	house	437
Thomson process	490	methods of	438
transformer	384	open	438
Weston, Dr. E.	165	Work, units of	66
Weston normal cell	184	Wound rotor	393
Weston soft-iron ammeter and		starting a	395
voltmeter	170		
Wheatstone bridge	186	X rays	572
post-office form of	190	apparatus	575
Windings, compensating	405	connections of	576
Wire, carrying capacity of	78	applications of	577
neutral	435	nature of	578
safe carrying capacity of (table)	479, 480	tube	577
size of	48	Y-connection	355
table	48		
Wireless, apparatus	556	Zinc, as fuel	26
key	558		

THE following pages contain advertisements of a few of the Macmillan books on kindred subjects.

PRACTICAL PHYSICS

By N. HENRY BLACK

Science Master in the Roxbury Latin School, Boston

AND

PROFESSOR HARVEY N. DAVIS

Of Harvard University

Cloth, 12mo, Illustrated, ix and 487 pages, \$1.25

The remarkable record that this text has made in the short period it has been on the market is sufficient testimony as to its adaptability to high school needs. And it is not difficult to sum up the features of the book that give it preëminence in its field.

It is written by experts in the field who are, moreover, thoroughly acquainted with the needs and limitations of the high school course.

It is practical in fact as well as in name. It connects the fundamental principles of physics with the everyday affairs of life, by introducing each subject through some familiar experience, by using the appliances of modern industrial and commercial life as illustrations of the principles studied, and by suggesting research questions at ends of chapters that send pupils afield for information.

The rate of progress is adjusted to the ability of the average class to proceed. The pace is slow in the early part of the book, more rapid later. Topics under any one subject are arranged in what experience has shown to be the most teachable order.

The manner of presentation shows exceptional skill in the actual work of teaching. The method is inductive and pedagogically sound — first, the familiar facts, then the underlying principles, then the application to less familiar facts. New subjects are introduced by illustrations from daily life — *not* by definitions. Principles are introduced by illustrative experiments or by appeal to familiar experience — *not* stated first and illustrated afterwards.

THE MACMILLAN COMPANY

64-66 FIFTH AVENUE

CHICAGO
SAN FRANCISCO

NEW YORK CITY
ATLANTA

DALLAS
BOSTON

**JACKSON AND JACKSON: Alternating Currents and
Alternating Current Machinery**

New Edition, \$5.50

Chapter I sets forth the fundamental formula for the generation of alternating currents and their resolution into component sinusoids. This is followed by a brief description of some of the fundamental instruments used for alternating current measurements and the basic reactions in a transformer. The next chapter deals with alternator armatures and methods of excitation. The following six chapters consider the subject of self-inductance, capacity, and resistance singly and in combination; the use of complex quantities; power and power factor; and the varying magnetic field with special reference to its effect in alternating current machinery. Chapter X deals with the constant potential and constant current transformers, reactance coils, auto transformers, etc., and includes many locus diagrams. Chapters XI and XII discuss synchronous machinery. Chapter XIII is a discussion of the effects of self-inductance, capacity, mutual inductance, and skin effect as met in problems relating to line transmission.

FERGUSON: The Elements of Electrical Transmission

A Text-book for Colleges and Technical Schools

\$3.50

An elemental study of the broad subject of the generation, transmission, distribution, and utilization of power by electrical processes, together with discussions not elsewhere available on matters of self-induction and capacity of polyphase circuits as derived from single-phase circuits, line calculations, standing waves, travelling waves, curve calculations, etc.

HADLEY: Magnetism and Electricity

\$2.00

A text-book for students who have made a beginning in the subject. The theoretical considerations are carefully explained and illustrated by the workings of practical instruments wherever possible; and the book is very well designed for students intending to pursue a course in Engineering.

THE MACMILLAN COMPANY

NEW YORK
CHICAGO

BOSTON
SAN FRANCISCO

ATLANTA
DALLAS

FORD AND AMMERMAN: Plane and Solid Geometry

This text-book presents logical proofs, both formal and informal, of a carefully selected group of theorems and corollaries and it includes also numerous problems, many of them constructive in character, that are designed to show applications of geometric science to the affairs of common life.

KENYON AND INGOLD: Elements of Plane Trigonometry

A brief treatment which deals with the essential topics in more than usual detail. Topics seldom used except in special lines of work are omitted. The solution of the triangle is the principal motive and other practical problems are introduced based on the general angle, the addition theorems, radian measure, the composition and resolution of forces, projections, and angular speed. The text is issued in two editions, one with brief and one with complete tables.

YOUNG AND MORGAN: Elementary Mathematical Analysis

A combined course in the elementary principles of trigonometry, college algebra, and analytic geometry, the fundamental mathematical principles which are of widest application and the greatest cultural value.

THE MACMILLAN COMPANY

**NEW YORK
CHICAGO**

**BOSTON
SAN FRANCISCO**

**ATLANTA
DALLAS**

A Laboratory Course of Practical Electricity

By MAURICE J. ARCHBOLD
Wendell Phillips High School, Chicago, Illinois

A manual of practical testing for use with shop work and apprentice classes, and in vocational courses in electricity.

The book is made up in slip-sheet form and note-book size. The graphical method of recording results is provided for in the exercises where it applies and blank pages are left facing each exercise for use in gathering and tabulating the data of the exercise.

There are ninety-eight experiments covering every practical application of electricity. To mention a few :

FIRST PART

Magnets and magnetic fields.
Electro-magnet, Galvanometer, Voltmeter, Ammeter.
The voltaic cell, Leclanché cell and others.
Fall of potential.
Ohm's law.
Resistances.
Meter bridge.

SECOND PART

Mil-foot resistances.
Comparison of wires.
Voltage.
Fuses.
Energy costs.
Reading dials, and meter testing.
Electroplating.
Arc lamp.
Induced currents and induction coil.
Motion by electricity.

THIRD PART

D. C. motor starting boxes.
Shunt motor.
Commutation.
Series motor.
Compound motor.
Prony brake tests.
Armature testing.
Load characteristics of dynamos.
Dynamos in parallel.
Dynamo efficiency.
Loading back method of dynamo testing.

FOURTH PART

Voltage curves.
Effective E. M. F.
Frequency.
Inductance.
Resistance and impedance.
Power factors.
Transformer tests for loss and efficiency.
Auto transformer.
Connecting and testing A. C. watt-hour meter.

THE MACMILLAN COMPANY

NEW YORK
CHICAGO

BOSTON
SAN FRANCISCO

ATLANTA
DALLAS

