

**AT** MICROFICHE  
REFERENCE  
LIBRARY

A project of Volunteers in Asia

Soil Tillage in the Tropics and Subtropics

by R. Krause, F. Lorenz, and W.B. Hoogmoed

Published by:

GTZ  
Dag-Hammarskjold-Weg 1-2  
D-6236 Eschborn 1  
WEST GERMANY

Available from:

same as above

Reproduced by permission.

Reproduction of this microfiche document in any form is subject to the same restrictions as those of the original document.

**gtz**

# Soil Tillage in the Tropics and Subtropics

R. Krause, F. Lorenz, W. B. Hoogmoed



Schriftenreihe der GTZ No. 150

---

Soil Tillage in the Tropics and Subtropics

# **Soil Tillage**

in the Tropics  
and Subtropics

by

R. Krause and F. Lorenz  
revised and translated by  
W. B. Hoogmoed

Eschborn 1984



Published by  
Deutsche Gesellschaft für Technische Zusammenarbeit (GTZ) GmbH,  
Dag-Hammarskjöld-Weg 1-2, D 6236 Eschborn 1

Compiled and prepared by  
Rüdiger Krause and Franz Lorenz

Revised and translated by  
Willem Hoogmoed

Layout / Technical Editing  
Anna Krafczyk

Printed by  
Hoehl-Druck GmbH + Co., Bad Hersfeld

Distribution  
TZ-Verlagsgesellschaft, Bruchwiesenweg 19, D 6101 Rossdorf 1

ISBN 3-88085-200-6

ISSN 0723-9637

I/4840/2

Printed in Germany

All rights of reproduction (in whole or in part)  
e.g. in print or by film, radio, television,  
or any photo-copying methods, are reserved

## TABLE OF CONTENTS

### PART I

1.0	INTRODUCTION . . . . .	13
2.0	THE OBJECTIVES OF SOIL TILLAGE . . . . .	15
2.1	Some General Comments On Soil Tillage . . . . .	16
2.2	General Tillage Objectives . . . . .	16
2.3	The Objectives Of Groups Of Tillage Operations . . . . .	19
2.4	Some Mechanical Aspects Of Soil Tillage . . . . .	21
2.5	Compaction Of The Field By Traffic . . . . .	23
2.6	A Note On Energy . . . . .	25
3.0	CLIMATE AND SOIL TILLAGE . . . . .	33
3.1	Soil Tillage In Temperate Humid Climates . . . . .	36
3.2	Soil Tillage In Arid Climates . . . . .	38
3.2.1	Soil Tillage In Winter-Rainfall Areas . . . . .	39
3.2.2	Soil Tillage In Summer-Rainfall Areas . . . . .	42
3.3	Soil Tillage In Humid And Semi-humid Tropical Climates . . . . .	45
4.0	SOIL EROSION . . . . .	47
4.1	Erosion By Wind . . . . .	48
4.2	Erosion By Water . . . . .	49
5.0	FARMING SYSTEMS AND SOIL TILLAGE . . . . .	55
5.1	Dry (Rainfed) Farming . . . . .	56
5.2	Irrigated Farming . . . . .	57
5.3	Cultivation And Harvest Practices . . . . .	59

PART II

1.0	THE CHOICE OF IMPLEMENTS . . . . .	67
1.1	Implements For Soil Tillage . . . . .	68
1.2	Practical Soil Tillage . . . . .	68
1.3	The Terminology Of Soil Tillage . . . . .	69
2.0	IMPLEMENTS FOR PRIMARY TILLAGE . . . . .	73
2.1	The Mouldboard Plough . . . . .	77
2.2	The Disc Plough . . . . .	91
2.3	The Chisel Plough And Cultivator . . . . .	101
2.4	The Rotary Tiller . . . . .	115
3.0	IMPLEMENTS FOR SECONDARY TILLAGE . . . . .	127
3.1	The Disc Harrow . . . . .	131
3.2	The Rotary Harrow . . . . .	139
3.3	The Rotary Hoe . . . . .	145
4.0	IMPLEMENTS FOR SEEDBED PREPARATION . . . . .	151
4.1	The Spike Tooth Harrow . . . . .	153
4.2	The Field Cultivator . . . . .	161
4.3	Pto-Driven Implements For Seedbed Preparation . . . . .	169
4.3.1	The Rotating Hoe . . . . .	173
4.3.2	The Reciprocating Hoe . . . . .	179
4.4	The Leveller . . . . .	183
4.5	The Roller . . . . .	189
4.6	The Weeder . . . . .	195
4.7	The Ridger . . . . .	201
5.0	SPECIAL IMPLEMENTS FOR IRRIGATED AGRICULTURE . . . . .	209
5.1	The Landplane, Leveller . . . . .	211
5.2	The Ridger (Furrower) . . . . .	215
5.3	The Bed Shaper . . . . .	223
6.0	SPECIAL IMPLEMENTS FOR PADDY RICE PRODUCTION . . . . .	227
6.1	Special Implements For Puddling . . . . .	231
6.2	Motor Hoes And Two-Wheeled Tractors . . . . .	235
7.0	SPECIAL IMPLEMENTS FOR DRYLAND FARMING . . . . .	239
7.1	The One-Way Or Disk Tiller . . . . .	241
7.2	The Sweep Plough . . . . .	247
7.3	The Rod Weeder . . . . .	255
8.0	IMPLEMENT COMBINATIONS . . . . .	261
8.1	Seedbed Preparation In One Operation . . . . .	263
8.2	Combinations For Seedbed Preparation . . . . .	267
9.0	SPECIAL IMPLEMENTS FOR ANIMAL TRACTION . . . . .	273
9.1	The Draught Animals . . . . .	275
9.2	Tillage Equipment . . . . .	277
10.0	ZERO TILLAGE - DIRECT DRILLING . . . . .	283
11.0	TRENDS AND NEW DEVELOPMENTS . . . . .	289
11.1	The Diamond Plough . . . . .	295
11.2	Sweep Combined With A Pto-Driven Rotary Hoe . . . . .	299
11.3	The Clod Breaker . . . . .	303
11.4	The Soil Loosener . . . . .	307
11.5	The Spade Plough . . . . .	309

## PREFACE TO THE FIRST EDITION

More than ever before, an increase in the production of food crops is the main aim of the developing countries, nearly all of which are located in tropical and subtropical zones. The ideas and proposals as to how this increase can be achieved cover a wide range. On the one hand, we find a highly capital-intensive production system aimed at obtaining maximum yields and employing every available means, including intensive soil tillage, similar to the system applied in the industrial countries; on the other hand, we have a suitable crop production system requiring minimum inputs and taking account of the employment and skills of the indigenous population, the availability of energy, the agricultural structure and the infrastructure.

In every case soil tillage forms a serious bottleneck in all the plant production operations. As the basis for more intensive cropping, correctly timed tillage can often be achieved only by a higher standard of mechanization in the form of tractors and large implements. The preservation of the productivity of the sensitive tropical and subtropical soils depends principally upon the correct choice and use of tillage equipment and tillage systems.

This book is intended primarily for agricultural specialists and their colleagues, extension workers and farmers and also for teachers and students of agricultural engineering and agronomy in the tropics and subtropics. Part I deals with the objectives, principles and problems of soil tillage in different climatic zones while Part II examines the main implements and systems from the point of view of their purpose, limitations, method of operation and technical data, such as linkage and drive systems, adjustments.

The implements discussed here are not chosen on the basis of any specific standard of mechanization, nor are they restricted to a specific farm-size or farming structure; instead, this book examines primarily the equipment available in countries with a fairly high standard of mechanization and the essential criteria for assessing its suitability for various locations in developing countries. Hand tools and animal draught implements are not examined; a special work in this series is devoted to the last-named group. Tools classified as "intermediate technology" are not examined separately because the principles of soil tillage also apply to them and any special problems concerning their design and manufacture are too site-specific. Special implements and tillage systems for wet (paddy) rice-growing are not considered. Nor does this work deal with systems and implements for land clearance, levelling, subsoiling and drainage since these operations are usually performed by contractors or government authorities and not by the individual farmer. This is also true of systems and machinery for removing stones and rocks from land.

Two major subjects are given only cursory consideration - if at all - because they are so important that they deserve a book of their own. These are:

- Zero-tillage (direct drilling), a valuable alternative for sites where there is a danger of erosion and where rainfed farming systems are used.
- Systems and equipment for mechanized weed control and the way in which they can be combined with herbicides.

We should like to express our gratitude to the Deutsche Gesellschaft fuer Technische Zusammenarbeit (GTZ), GmbH for its support and funds. We also wish to thank all contributors and especially Prof. Dr. Ing. E.E. Schilling, Ing.grad. D. Trenker, Ing.grad. R. Vetterlein and Ing.grad. W. Winter for their valuable suggestions and are also grateful to everyone who helped with the typing, preparation of drawings and proof-reading.

This first edition appears only in German; it is hoped that a second revised edition will soon be published in English, incorporating any suggestions and additional material by practical experience in the climatic zones under discussion.

In view of the wide diversity in the design, technical details and sizes of implements only typical characteristics and ranges can be given but we invite manufacturers to inform us of any corrections required or send us any additional material. In particular, any major new developments could be included in Section 3.1.

\*1974

THE AUTHORS\*

## PREFACE TO THE REVISED ENGLISH EDITION

A large number of reactions with additional information and suggestions was received after publication of the first edition. These contributions, which are gratefully acknowledged, encouraged the revision and translation into English of the original issue. Ir. Willem Hoogmoed of the Tillage Laboratory of the Wageningen Agricultural University, The Netherlands, carried out this laborious job, where his experience in tillage research in various tropical countries was most helpful.

We fully realise that again this second edition cannot be more than an aid to become acquainted with, to choose and to use properly tillage implements. It is not within the scope of this publication to treat the complex subject of "soil tillage" exhaustively, nor is it possible to present all available equipment.

The layout of the book has remained unchanged. Part I deals with the fundamentals of soil cultivation in tropical and subtropical climates and Part II discusses soil tillage methods in those climatic zones and the equipment employed for them.

The chapters on "The Objectives of Soil Tillage" and "Erosion" in Part I have been expanded to permit a better appreciation of the complexity of the processes affected by soil tillage operations.

Special equipment for animal traction (as a link with the publication on this matter by P. Munzinger, Nr. 120 of this series) is now also examined in Part II. Tillage equipment for paddy rice production, including the "powertiller" as the standard implement for soil tillage in large parts of southeast Asia is briefly discussed. The chapter on zero-tillage has been expanded. Some recent developments are mentioned.

One major improvement is the considerable increase in the number of references cited. A search of the literature was carried out by the Centre for Agricultural Publishing and Documentation (PUDOC) in Wageningen, The Netherlands. We have tried to include relevant literature for every implement or group of implements in case more detailed literature - practical rather than theoretical - is needed.

A number of figures and tables have been revised and corrected.

We should like to thank all those who have kindly sent us comments on the original edition; many of their suggestions have been incorporated in this text. Special thanks are due to Professor H. Kuipers, Head of the Tillage Laboratory of the Wageningen Agricultural University, for his encouragement and support, including use of the scientific and technical facilities of his laboratory. The authors are particularly grateful to Mr. Rolf Derpsch, GTZ/IAPAR, Londrina, Brasil for his substantial contribution to the chapters on erosion and zero-tillage. Dr. Chris Dirksen of the Laboratory for Soil Physics, Wageningen Agricultural University, undertook the correction of the English text.

We would like to thank, not in the last place, the GTZ for the appropriation of funds for the preparation of this issue and in particular Dipl. Ing. agr. Rudolf Holtkamp for his encouragement and enthusiasm in the realisation of this publication.

Finally, the reader is encouraged again to give comments and suggestions to help improving the quality of possible future editions.

## FOREWORD

The professional quality of project staff is a determining factor for the quality of rural development projects planned and implemented by the GTZ on behalf of the German Federal Ministry for Economic Cooperation (BMZ). A supply of appropriate, up-to-date, specialised information during their studies when preparing for a project and particularly during their project assignments can play a major role in maintaining high know-how levels. To this end the GTZ is collecting and processing available know-how on specific subject areas and disseminating it as publications.

Soil tillage -one of the basic tasks in crop production- has a very old tradition. Climate and production systems determine the work input. In addition, practical farming demands continuous updating to take account of progress in the biological (breeding), chemical (fertilizers and plant protection), organisational and technical sectors. Impacts on the ecology and on the socio-economic environment must be considered. The availability and cost of energy demand not only that it be used economically, particularly for energy-intensive tilling systems, but also that appropriate mechanisation strategies be developed which account for the risks of supply-bottlenecks.

The present publication is a second, revised and completed edition. We hope that the English version will be widely read by our non-German co-workers in the projects and particularly by extension workers and students in tropical and sub-tropical countries.

The 3500 year old, Mesopotamian farmers' almanac found in Nippur contains observations on soil cultivation, some of which could have been written in our times.

- Before you till your fields, open the sluices of the irrigation ditches but take care not to inundate the fields too much!
- When you water the land, make sure that the surface remains even, it should be as flat as a board.
- Do not allow the wandering oxen to churn up the soil!
- Then prepare the fields for sowing.
- Clear the weeds with a pick and tear out the stubble by hand!
- If the ground scorches in the sun, divide it into four parts.
- Then water them one at a time, so that you are not held up in your work.
- Before you begin to plough break up the earth twice with the mattock, and once with the hoe.
- If need be, take a hammer too, in order to demolish the toughest clods.
- Roll the field flat and fence it round!

What could better substantiate the expert's "lore":  
Advising means first of all: Learning how to listen!

Klaus J. Lampe

# **PART I**

## **Principles of Soil Tillage**



## 1.0 INTRODUCTION



Soil tillage is an integral part of crop production. The aim of these farming operations should be to influence the biological, chemical and physical characteristics of the soil in such a way as to create the optimum conditions for the germination and development of the plants.

These operations should also take account of the conservation and improvement of soils as an environment for the plants' growth to ensure high yields in the long term.

The second objective is equally important but is often difficult to achieve in both humid and dry tropical regions. Soil tillage consists of mechanical manipulation of the complex and sensitive "system" soil. The effects of this manipulation may be particularly pronounced in tropical and subtropical climates. The risks involved should be suitably recognized when planning and carrying out tillage operations: a greater danger of soil erosion by wind and water, increased destruction of organic matter and more evaporation losses, especially in areas with summer rains. High levels of salinity - often linked with high pH values - and the constant input of salts with the irrigation water cause further problems in the soil in these climatic zones.

The delicate balance of the soils - often characterized by a high degree of weathering - can easily be disturbed and produce serious and usually irreparable damage. Many steppe and desert regions have not been created by nature but by man and provide examples of incorrect land-use and soil tillage. Crop production is more problematic in tropical and subtropical climatic conditions than in temperate humid climates. In the latter zones mistakes in soil tillage can - to some extent at least - be remedied by the action of frost, low evaporation and reduced plant activity in the cold season.

Many cultivated plants derive from regions which are ecologically different from their present region of production. Breeding aimed principally at high yields results in plant varieties which make heavy demands upon their environment. When competing with weeds which have become properly adapted to their habitat, these crops cannot survive without protection and assistance from the farmer.

In this book we can present only a general framework within which the soil system is constantly protected in order to obtain an optimum environment for plant growth. We also describe technical equipment and systems for use in solving the complex problems.

For further reading, literature is given at the end of each chapter. It is obvious that soil tillage is a multi-disciplinary science, closely linked with soil science (physics), agronomy, economics as well as agricultural engineering.

## 2.0 THE OBJECTIVES OF SOIL TILLAGE



## 2.1 Some General Comments On Soil Tillage

Plants require an environment in which nutrients, water and air are available for their development, growth and reproduction. Leaving special cases aside (hydrocultures, greenhouses, etc.), the large majority of farmers has to cope with annual plants, growing in a natural soil in the open.

A soil can be regarded as a system, in which solids with certain textures (the soil minerals, i.e. clay, silt, sand, gravel and rocks), water (with dissolved solutes), air and organic matter are arranged in a specific form, known as structure. Plants develop best when they are able to extract the necessary elements - water, nutrients and air - from this soil system through their roots. Unless the temperature of the soil is a restrictive factor (excessively high temperatures may occur in tropical climates), the only important factor in the initial phase is the availability of water, enabling the seeds to germinate.

If the above conditions obtain, there is no reason for any manipulation of the soil. In their natural environment, plant species were able to survive in a balanced ecological system (competition) without any human interference. The introduction of a specific plant or crop does, however, inevitably disturb the balance; planting or sowing becomes necessary and the soil has to be opened up and even in the most primitive stage, be trodden. If one species is grown for production, all the others can generally be considered as weeds and will have to be eradicated (owing to their competition for light, water and nutrients). This too is an operation during which the soil has to be trodden and sometimes disturbed. The same applies to the harvesting operations.

Needless to say, this represents a typical example showing where certain manipulations in agricultural systems may cause adverse effects to the agricultural soil. Shifting cultivation inspite of certain advantages also can be detrimental to the agricultural development. Introduction of animal draught and motor traction does have advantages, such as faster and easier work, but also disadvantages, such as the risk of deterioration of the soil. In Modern Agriculture the soil has to serve, firstly, as an environment for nurturing young sensitive seeds and seedlings, and secondly, as a surface for carrying many tons of weight in the form of tractors, trailers and other implements.

The above paragraphs should clearly show that many of the objectives of soil tillage mentioned in the following pages are "self-induced".

## 2.2 General Tillage Objectives

Although tillage has been practised for millenia all over the world, the reasons for applying it merit some discussion. Soil tillage is one of the operations performed in arable crop production whose objectives form part of the production process, but where the direct results differ from these objectives.

The aim of arable cropping may be to produce the maximum yield of certain crops, a special quality of a crop or the highest possible financial return. When the crop is not sold and labour is not paid - as in subsistence farming

- we have to weigh up the benefits obtained from the crop against the amount of work required rather than discuss the process in terms of costs and returns.

The financial benefit obtained from crop production is obviously the final outcome of a complicated process depending upon many variables, such as the type of crop, soil-type, climatic conditions, type of farming, standard of mechanization, prices of crops, implements and inputs, interest rates and tax, and soil tillage is one of these variables.

Two aspects need to be emphasized in this connection:

1. A change in the proportion of tillage costs usually leads to a considerably smaller change in the proportion of total production costs.
2. Tillage may influence other production costs.

Both aspects may be very important. For example, a 20% reduction in tillage costs saves only 2% of the total production costs when tillage accounts for 10% of the total input. The actual proportion of tillage costs in the total costs depends upon the input of each production factor, such as water (irrigation), fertilizers, chemicals, etc. A mere 2% saving is insufficient to persuade farmers to adopt a new soil tillage system, especially if no higher yields can be expected or an increased risk is possible. As regards the second aspect, tillage operations are in fact often intended to facilitate other field-work by changing the structure of the soil. For instance, it is usually easier to sow in a seedbed than on untilled soil, or the construction of a ridge with a very small number of clods may considerably reduce the work required for harvesting tuber crops.

So, when analysing the ways in which tillage may influence crop growth, we should distinguish between its effect upon the soil structure and weed population and the effect of the soil structure and weed population upon crop growth.

As far as the soil structure is concerned, it should in theory be possible to predict the tillage effect of any specific implement if the soil and performance parameters are adequately described. This would permit a description of the soil structure in terms of its bulk density, structural homogeneity and strength (see Fig. 1). When describing the relationship between soil structure and crop growth, other aspects of the soil structure, such as air, water, temperature and mechanical resistance, are relevant. The relationship between these two groups of structural features should be established if the connection between tillage and crop growth is to be understood. The farmer generally knows from his experience what the effect of a certain soil structure (as a result of tillage) will be on the growth and development of the crop.

The relationship between tillage prior to crop growth and the yield at a much later date is generally so complex that a clear connection between tillage and yield can be expected only when a specific restrictive growth factor is affected by tillage. The relations within a production system are shown in diagram form in Fig. 2.

The influence of tillage upon other field-operations is not necessarily restricted to one growth period. In tropical regions in particular, the long-term effects of tillage must be given consideration. For example, if a tillage operation for optimizing the sowing conditions increases soil erosion by creating a soil structure susceptible to erosion, this damage is

an indirect result of the tillage operation. Since the effect may continue for many years, that operation is likely to have a detrimental effect upon economic yield.

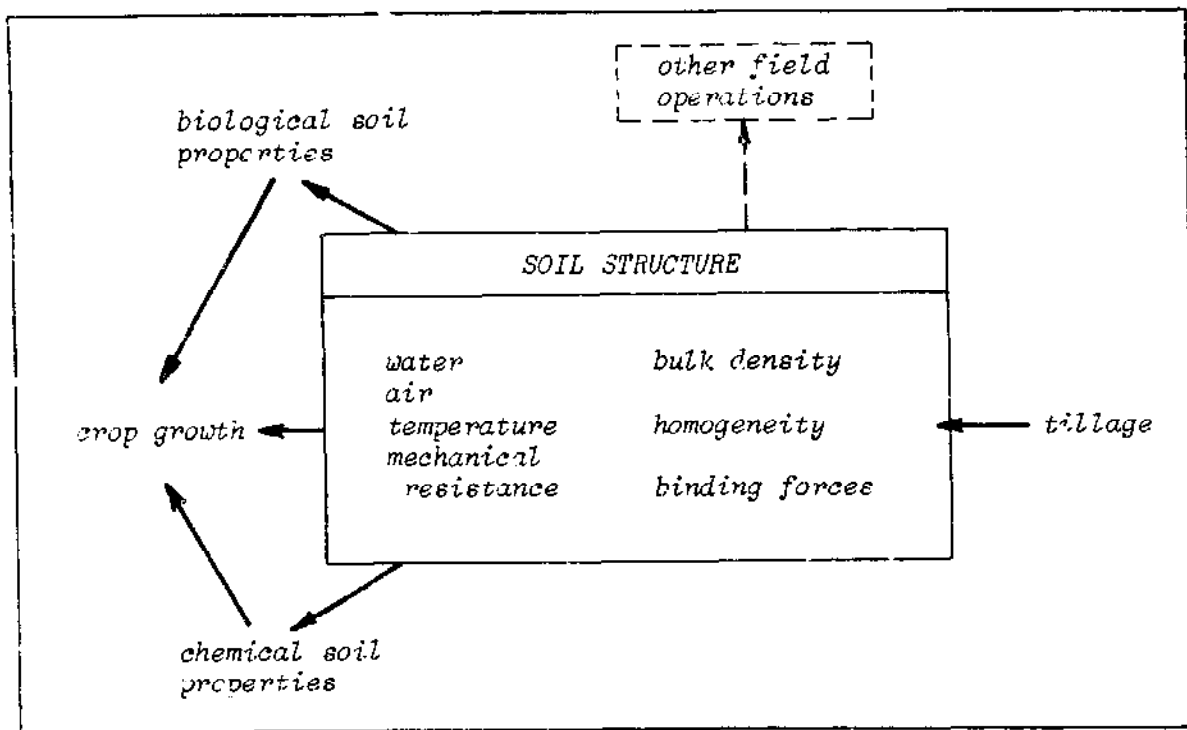

Fig. 1. Soil tillage and its sphere of influence on soil structure. - Source: Curf's.

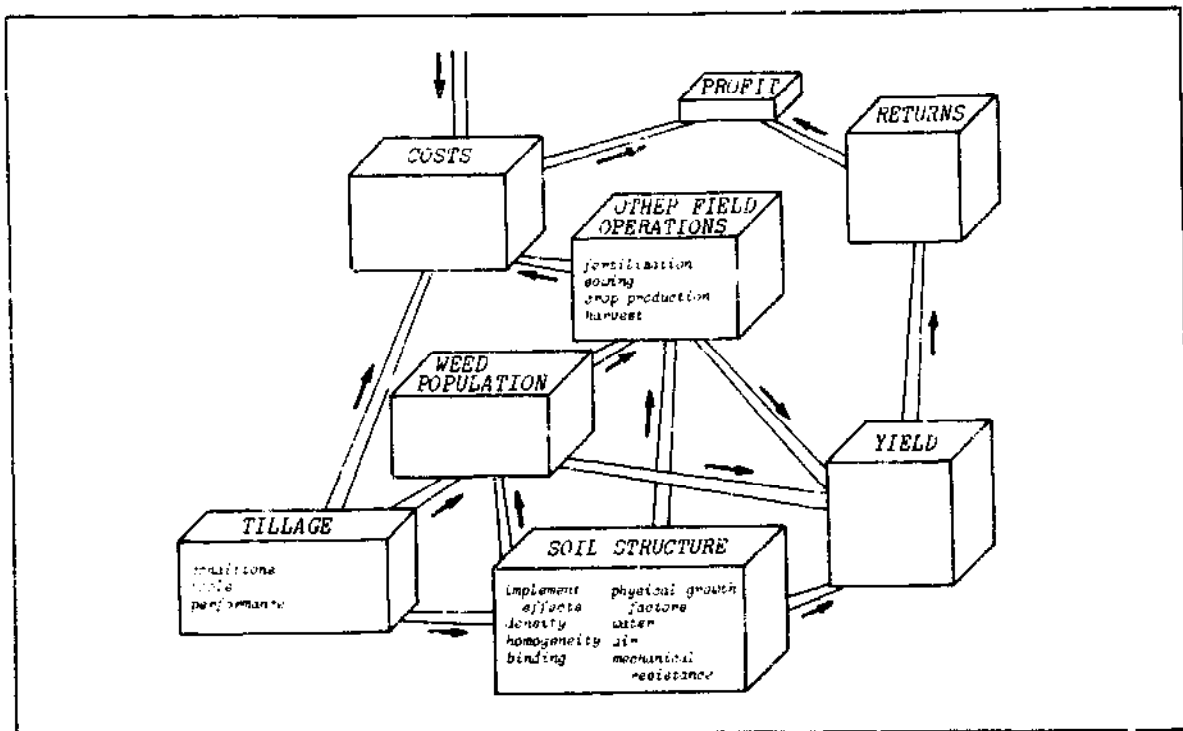

Fig. 2. Scheme of soil tillage objectives. - Source: Kuipers.

### 2.3 The Objectives Of Groups Of Tillage Operations

Different tillage operations have different purposes. Generally speaking, there are four groups of tillage operations which, in a complete system, are performed in the following sequence (see Fig. 3):

- a. Stubble or post-harvest cultivation. This consists of shallow operations carried out shortly after the harvest to clear the field of weeds and crop residue and to restore the soil structure. This group also includes tillage during fallow periods (for water conservation, weed control and improvement of the soil structure and fertility).
- b. Main (primary) tillage. This is normally the deepest operation which is performed during the period between two crops to control weeds, restore the soil structure in the arable layer where most of the roots will develop and to prepare the land for seedbed preparation.
- c. Seedbed preparation. These shallow operations are intended to prepare a seedbed or make the soil suitable for (trans)planting. They include weed control and structural improvement for germination and early growth.
- d. Crop management tillage operations. These are very shallow operations controlling weeds, breaking up surface crusts to improve water infiltration and crop emergence and for forming ridges which encourage early growth and facilitate the harvesting of root crops.

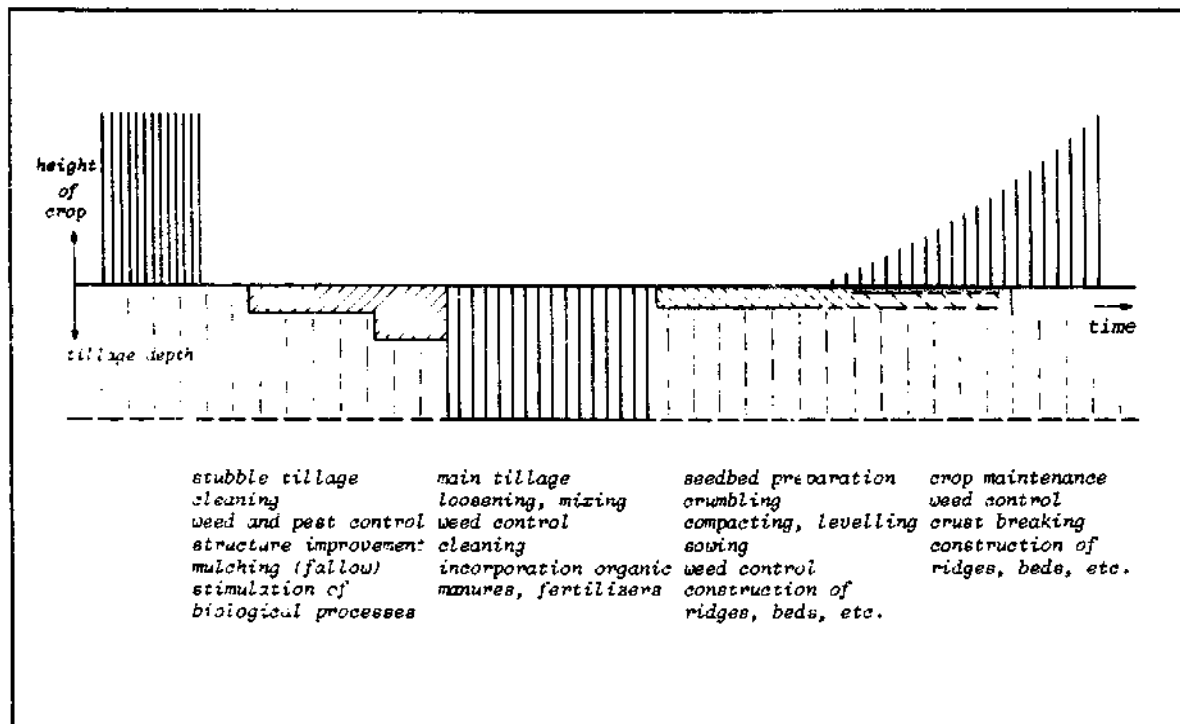

Fig. 3. Soil tillage practices during a cropping season. - Source: Kuipers.

A complete sequence of tillage operations may not be necessary or not possible because the interval between the two crops is too short or the circumstances unfavourable; in such cases the system is simplified while still achieving maximum efficiency.

"Incomplete" systems are very common in tropical regions. In particular, groups (a) and (b) are often combined to form one "stubble tillage" operation. In the case of rice production on flooded fields, groups (a), (b) and (c) may be performed as one set of (puddling) operations while the crop management tillage operations may be omitted.

Although soil tillage generally has the same aims irrespective of the climatic conditions, the priority of the various objectives differs. High and stable crop yields can be achieved only if the soil tillage system employed is suitable for the region and adapted to the cropping and production system.

Soil tillage can be defined as a sequence of mechanical manipulations of the topsoil in which all the operations are dovetailed and adapted to the overall production technology. Three principal objectives can be mentioned:

- Elimination and permanent control of the original vegetation (often considered as weeds);
- Creation of conditions favouring the germination, emergence and growth of the cultivated plants;
- Conservation and improvement of the soil as the growth medium for cultivated crops.



## 2.4 Some Mechanical Aspects Of Soil Tillage

From the physical point of view tillage is exerting a pressure on the soil system. This pressure is sometimes applied merely to create tensions elsewhere in the soil matrix. The pressures vary widely in magnitude and direction and depend upon the dimensions of the soil/tool contact area. These processes rarely last more than one or two seconds and may be so brief that they can be defined as an impact.

The soil moisture content has a major influence on its strength or consistency, and thus on how the soil will react to a certain (type of) pressure. Fig. 4 summarizes the various consistencies as the moisture content changes.

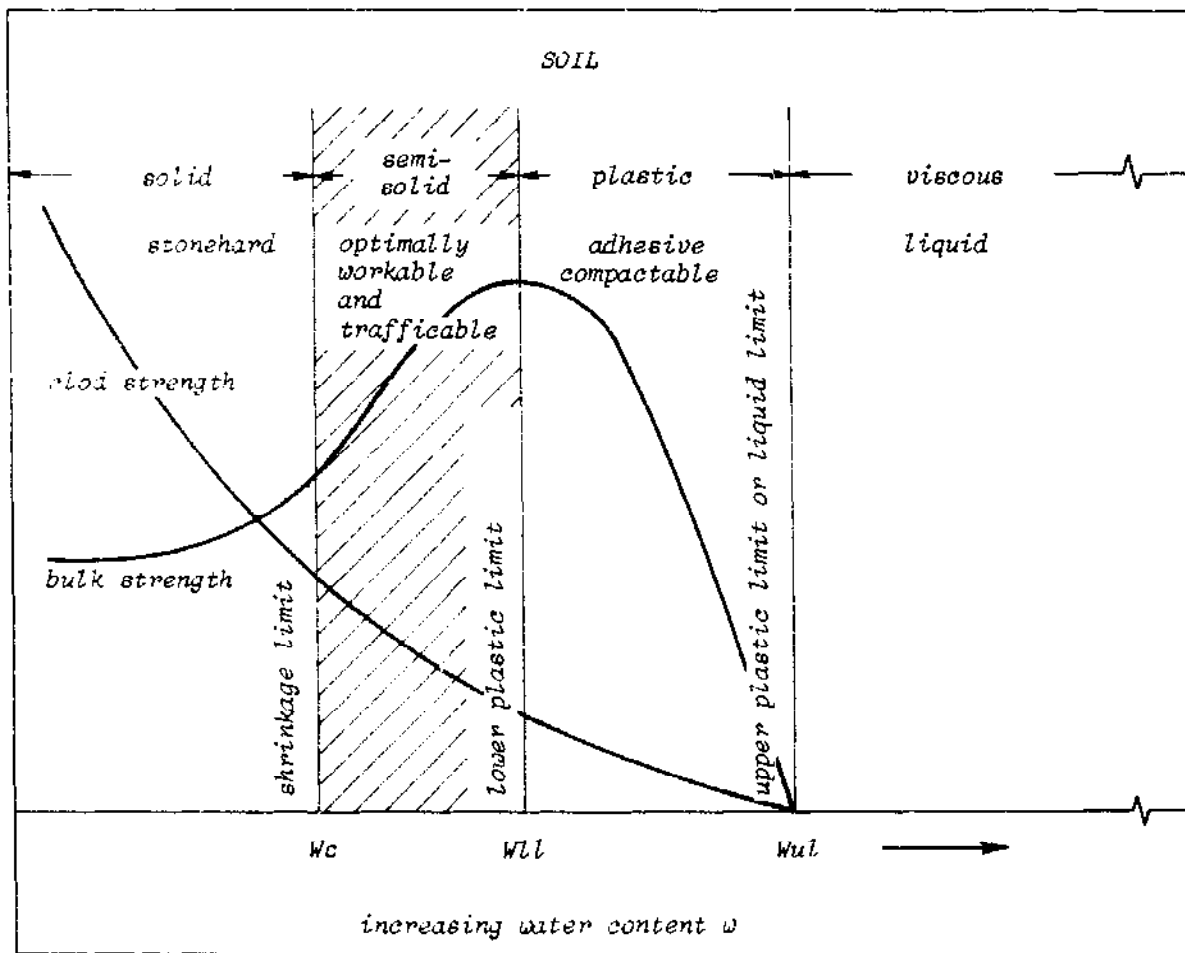

Fig. 4. Effect of moisture content on the consistency and workability of the soil.

The way in which the soil reacts to pressure determines the effect of the tillage operation. The following types of basic reactions can be distinguished:

- reduction of volume (compaction),
- cutting,
- shear plane formation (crumbling, pulverization),
- transport,
- deformation.

Compaction will occur when soil is subjected to pressure and the resistance to volume reduction is less than the energy required for plastic flow or other reactions. A cohesive soil (e.g. clay) is compacted by stress (depending upon the duration of the stress), while a friction soil (e.g. sand) is compacted by vibration (packing of particles). Compaction occurs, for example, when the soil is loaded by rollers or tractor wheels. Rollers are intended to produce compaction while, on the other hand, compaction caused by traffic is usually undesirable. Compaction caused by traffic is one of the more serious problems of highly mechanized agriculture. Some aspects of this problem are examined in the following chapter.

The shape of the roller is important for efficient compaction of the soil. Rollers with small diameters and large surface areas compact the soil more shallowly than narrow wheels with large diameters. Spike rollers cause high pressures over small areas and are effective for compacting at greater depths, especially when moving at slow speeds.

Cutting often occurs during tillage and is part of operations such as ploughing, rotary tillage and weeding. The determinant factors are the speed (impact) and the cutting angle of the knife or tool. When the angle is too large ("blunt"), damaging side-effects, such as smearing and compaction, may result.

Transport. Soil is transported in some way during each tillage operation. This process is most evident during ploughing but some movement of the soil occurs during rolling, weeding, etc. Soil transport may be intentional and desirable to produce a specific surface configuration (e.g. levelling or the formation of ridges), mixing (e.g. harrowing causes selected downward transportation of smaller aggregates) or inverting (e.g. mouldboard or disc ploughing). In some cases soil transport has damaging effects: when the soil is very hard, clods or aggregates will not be broken up under the pressure of an implement but will be moved forward or sideways, an unnecessary useless movement of the soil which reduces the efficiency of the implement (bulldozing effect).

The formation of "back" and "dead" furrows when using two-way ploughs is also harmful when a level field is required.

Shear plane formation. When the soil moisture content is favourable, pressure may cause the formation of cracks and the subsequent breaking-up of clods or aggregates. Soil will break up along natural planes of weakness. Depending upon the tillage intensity - the number of pressure points in the specific volume of soil at any particular moment - the result will be the formation of large clods (when ploughing dry soils, low intensity) or fine material (rotary tillage, high intensity).

Deformation of the soil should usually be avoided since it destroys the (micro)aggregate structure of the soil. The only exception is the complete destruction of the soil structure caused when puddling wet rice fields by applying intensive tillage under saturated conditions. In every other case deformation has detrimental consequences. The soil becomes denser and harder after drying, which causes serious problems with regard to its permeability for water and air and its resistance to root growth. Deformation will occur when the soil is in the plastic consistency phase (see Fig. 4). As examples, we can cite the ruts formed by traffic in fields which are too wet and the "sausages" brought up by chisel ploughs when the (sub)soil is too wet.

The above clearly shows that the soil consistency, which depends upon its moisture content, is a major factor in determining the effect of tillage operations. The term "workability" is used in this connection to indicate two characteristics:

- A. The soil's suitability for tillage or for facilitating tillage operations. The optimum workability range (expressed in moisture content) is given in Fig. 4. Workability is good when this range is wide but when it is narrow or commences at a level where the moisture content is much lower than the field capacity (the soil condition a few days after rain), the workability is poor because tillage cannot start until the soil has dried for a considerable period after the rains.
- B. The condition of the soil at any given time, determining whether or not it can be tilled without serious damage. A decision for or against tillage depends not only upon the soil workability but also upon the "trafficability", that is to say the soil's capacity to carry the weight of a tractor (animal) and machine. When drying conditions are strong, the topsoil may be dry enough for seedbed preparation but the subsoil may still be too wet and unable to bear traffic. The optimum workability or trafficability depends very much upon the type of tillage and the machinery used. For ploughing, for example, the soil will have a much wider workability range than for seedbed preparation.

A very broad rule of thumb is that for optimum workability the moisture content should be around 60% of field capacity, where field capacity is the moisture content of an initially saturated soil, allowed to drain freely for 24 - 48 hours. The soil may not reach this level of moisture during the rainy period in humid or semi-arid regions, but certain types of tillage operations may still be required. In such cases, methods should be chosen which cause as little damage as possible to the soil.

The moisture content can be considered optimum when:

- the effort (power) required to perform a certain operation is least, or
- the desired effect is greatest.

In practice, these two points will not coincide and so a compromise must be sought with due allowance for the basic input: the minimum requirements for cultivation and for overcoming the rolling resistance of tractor and implement.

## 2.5 Compaction Of The Field By Traffic

A few general rules regarding the compaction process are given below:

- The greater the soil moisture content, the easier it is to compact the soil (lower pressures required). This rule is valid up to the point where soils start flowing under pressure, which implies that the greatest compaction can occur under high pressures with relatively low moisture contents. Saturated soils cannot be compacted.
- The pressure distribution in the soil under a tyre depends upon the size and shape of the tyre (Fig. 5).
- Pressures extend to greater depths in loose soils than in hard soils.
- The first pass of a wheel over a soil produces more compaction than later ones (in the order of 90% for the first pass and 10% for the following ones).

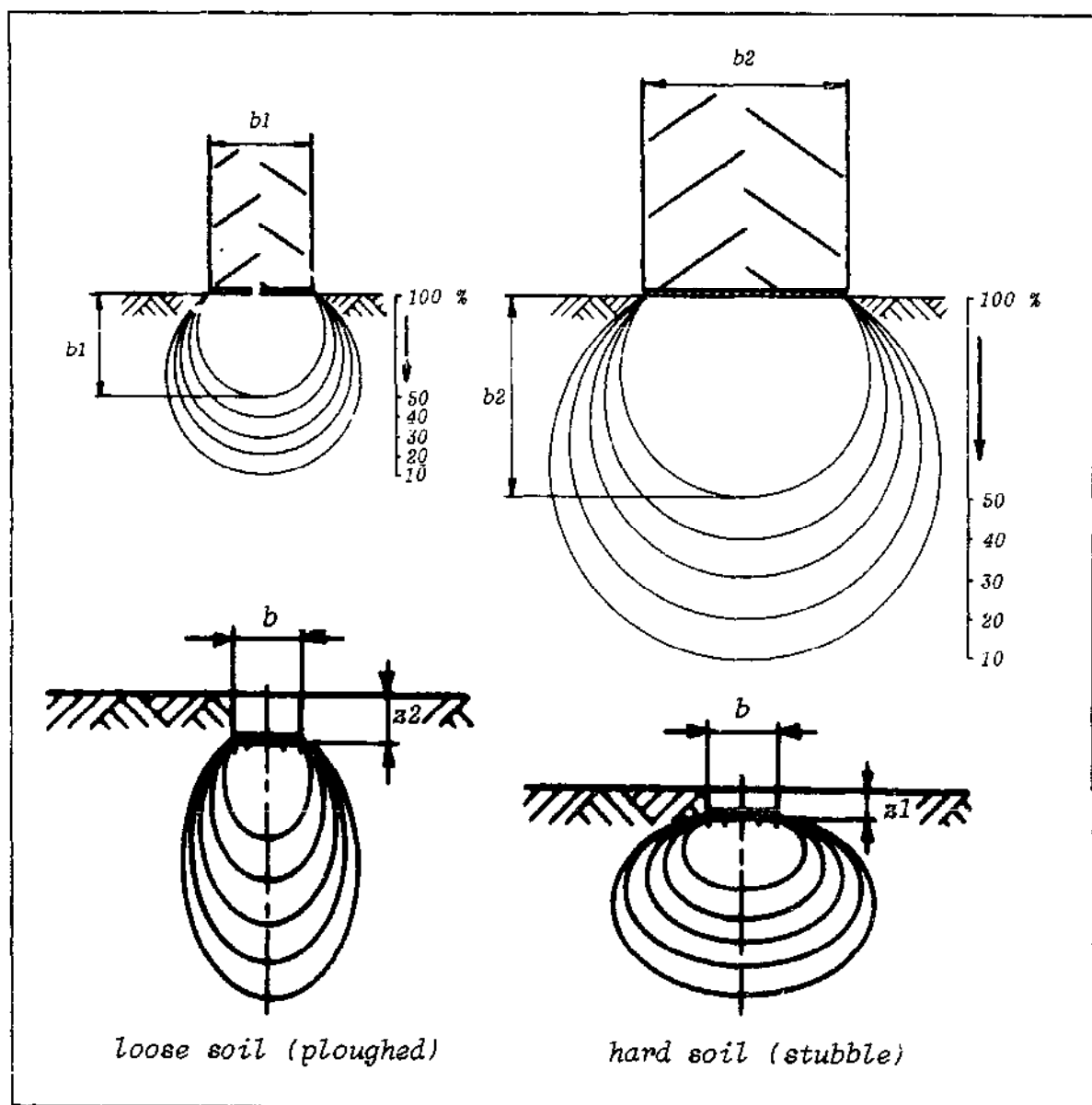

Fig. 5. Pressure distribution under agricultural tyres. - Source: Perdok and Terpstra.

Consequently, it is mainly during secondary tillage operations that compaction will produce the greatest effect. Particularly in cases where several passes are needed to achieve the required tilth of the seedbed, the bulk density of the soil may be reduced again to its level before primary tillage.

The most obvious harmful effects caused by traffic compaction are:

1. Irregular sowing depths and emergence of seedlings when plant rows are located both in and between wheeltracks.
2. An increased risk of erosion due to markedly reduced infiltration rates in the wheeltracks. Runoff followed by erosion often starts in wheeltracks.
3. Waterlogging in the surface layers (aeration problems).

These problems can be avoided by:

- Reducing the number of passes over a primary-tilled field to a minimum and by avoiding turns on tilled land during the primary tillage operations;
- Lowering the air-pressures in the tyres of the tractors and implements and using dual or cage wheels;
- Tilling and sowing, as far as possible, along the contour in sloping fields;
- Loosening the tracks after each pass, using chisel or tine-type tools behind the tractorwheels.

Fixed traffic lanes (wide permanent beds or cropping strips) do not yet offer a practical or economic solution, but a system of permanent beds separated by furrows with a slight gradient (controlled runoff) has produced promising results with animal draught operations on difficult black cotton soils in India.

Needless to say, no standard system or equipment can be suggested as the ideal solution to any particular tillage problem over a broad range of geographical conditions. The technologies and tools available for the operations depend very much upon local factors. Continuous testing and, where necessary, adaptation of the commonly-used equipment and system are required.

## 2.6 A Note On Energy

Crop production is one of the few processes whereby solar energy is collected and conserved in the form of organic material for use as food or fuel.

There are many reasons why actual crop yields are lower than the yields which could be obtained from solar radiation. The main constraints are limited supplies of water, a deficiency of plant nutrients, competition from weeds, in some cases low temperatures, the detrimental effects of pests and unfavourable timing (synchronizing the vegetation period with the season).

This implies that any attempts to improve crop yields must be based on an increase in, or modification, of the farmer's (energy) input. The agricultural energy balance is a complex subject and lies outside the scope of this book. Some data and literature will, however, be given at this point to indicate the position of soil tillage within the general energy pattern.

Studies show that, in the industrialized nations, agricultural production usually accounts for less than 5% of the total energy consumption. Unfortunately, very little information is available concerning the developing countries. A different situation obtains in those countries with regard to their total consumption: subsistence farming usually represents a much larger proportion of their total output while the on-farm energy input is not much lower than in the industrialized nations. In particular, the amount of energy required to feed the draught animals is very high and the input may actually be greater than with the highly mechanized methods employed in developed nations.

By comparing the energy balances of the agricultural systems applied in various countries, it becomes obvious that the developed countries' input consists mainly of fuel, fertilizer, irrigation, machinery, drying and on-farm processing. The energy input of subsistence farming or

small-holders in developing countries is mainly associated with human and animal labour and only a very small proportion is expended on fertilizers, machinery and fuel.

The output (in terms of energy of the agricultural product) from the high-input system is much greater but the output:input ratio is generally much lower than for low-input systems. Calculations show output:input ratios ranging from 1.5 to 6 for high-input systems and from 15 to 60 for low-input systems (care should be taken when comparing figures from various sources because of the different calculation methods).

Soil tillage accounts for a proportion of the total input side of the energy balance, a proportion which depends upon a number of factors. The overall production system determines the magnitude of the inputs for irrigation, fertilizers, pesticides, harvesting, crop drying, transport, etc. and for the type of tillage or cultivation system employed. In high-input systems using conventional tillage methods tillage accounts for approximately 5% for irrigated and up to 15% for dryland systems (all factors are expressed in energy units). Fertilizers, mechanization and irrigation are the greatest energy consumers. Reduced tillage or direct drilling systems may reduce the proportion used for tillage but, generally speaking (and certainly in the tropics), reduced-tillage systems are not applied only because of energy savings (see Chapter 11.10).

Machinery and fuel are usually available for tillage in high input systems but their cost and the labour are the prime concern while in low-energy systems the available energy and machinery are usually restrictive factors. When only a certain number of animal-hours or man-hours are available for each hectare, the area which can be used for crop production is limited to the number of hectares which can be coped with during peak labour periods. The bottlenecks are tillage, weed control and, to a lesser extent, harvesting. In many cases it may even be physically impossible to carry out some farming operations; for example, human or animal labour cannot till the dry hard soil in semi-arid regions.

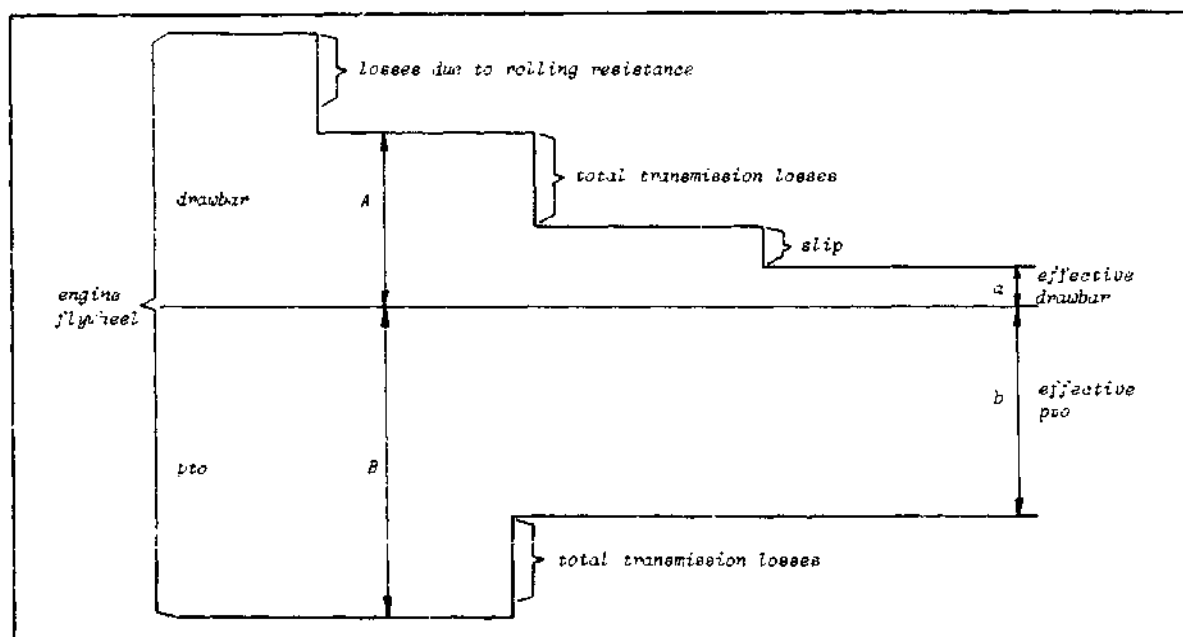

Fig. 6. Energy flow of a tractor as a power unit. Source: Meiborg and Perdok.

Only approximate figures can be given for the actual energy requirements for various tillage operations. The figures for each operation or implement depend on many factors, such as:

- soil type;
- condition of the soil (moisture content, bulk density, structure);
- shape, working depth and speed of the tool;
- climatic conditions;
- the extent to which the power source and implement or tool match;
- correct adjustment or use of the implement.
- plant cover

The relationship between draught and pto drive requirement and the required tractor power is shown in the energy flow chart in Fig. 6.

Figs. 7 and 8 provide rough guidelines for the required tractor power and draught for various tillage implements on a range of soils. The values are only for one speed and working depth; any increase in speed or in depth results in a disproportionate increase in the required draught.

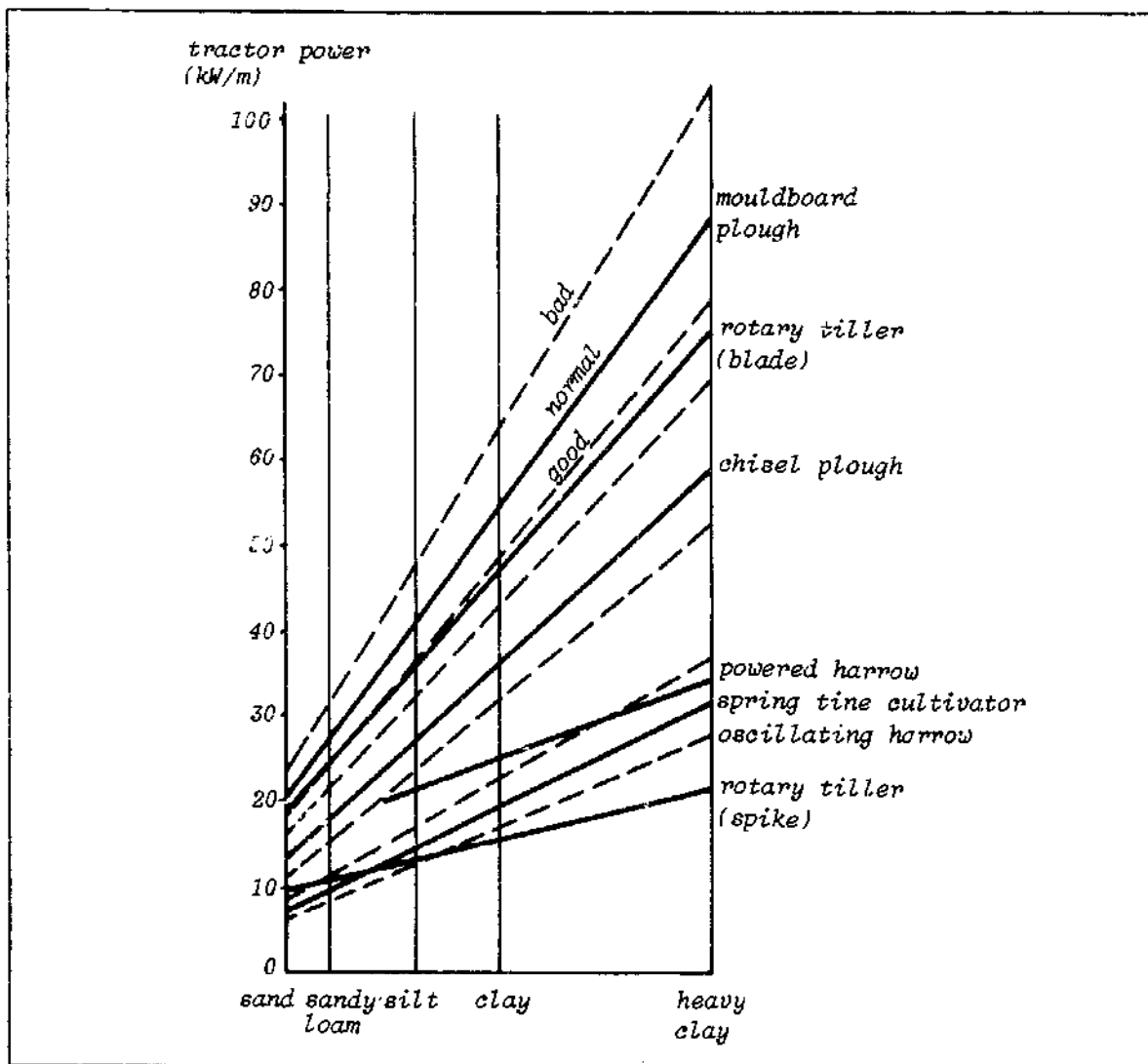

Fig. 7. Tractor power requirement per metre of working width for various tillage implements related to soil type. - Source: Perdok and van de Werken.

These data are approximate and attempt to provide information on the range of draught- or tractor power required for each implement type described in part II. It should be noted that considerable variations may occur even within one field.

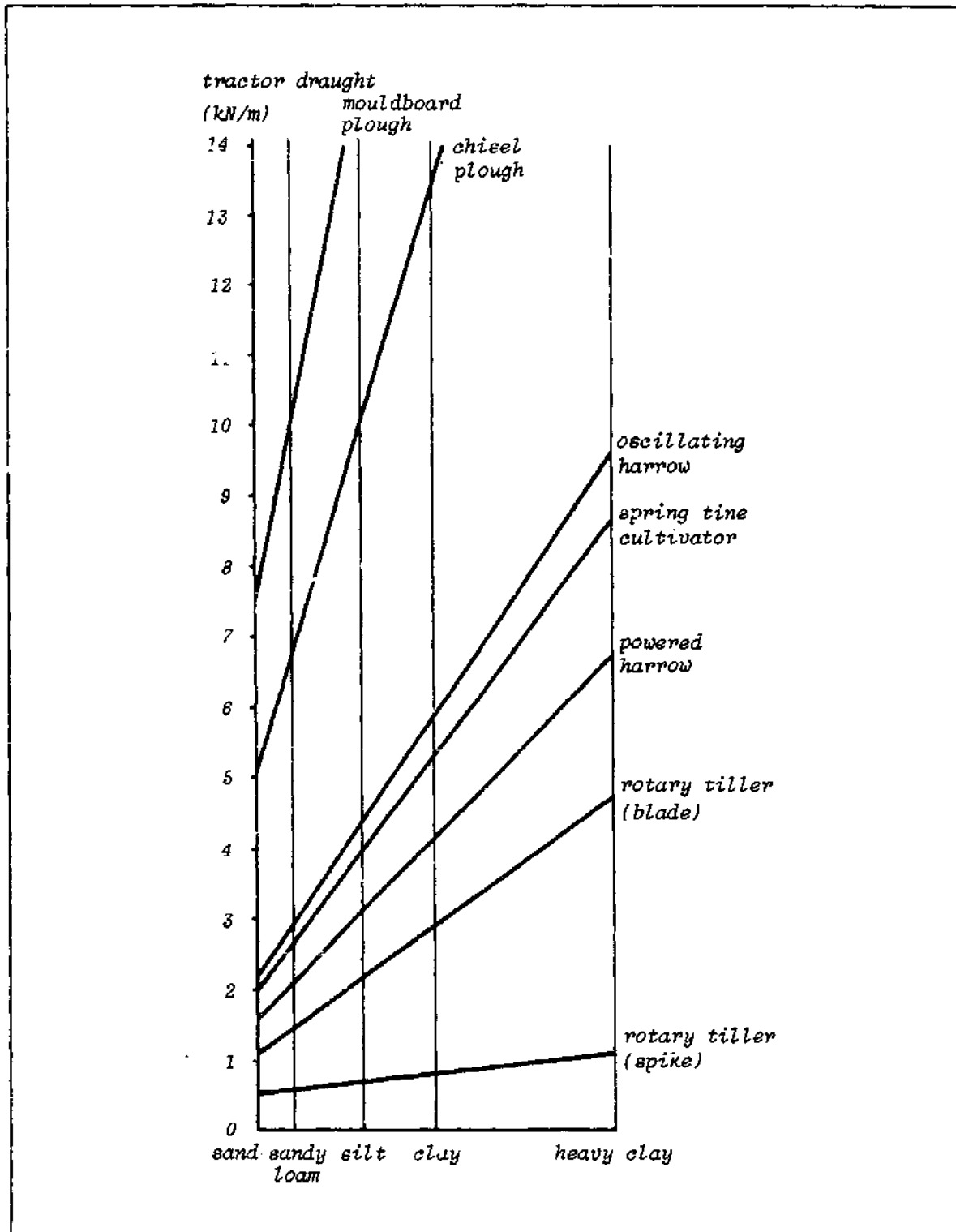

Fig. 8. Tractor draught requirement per metre and working width for various tillage implements related to soil type. - Source: Perdok and van de Werken.



## 2.7 Literature

- Allen, R.R., J.T. Musick and D.A. Dusek, 1980. Limited tillage and energy use with furrow-irrigated grain sorghum. Transactions of the ASAE, 23(2): 346-350.
- Baker, M. (Ed.), 1978. Energy conservation for crop production. Proceedings of an International Conference on Energy Conservation in Crop Production. Massey University, Palmerston North, New Zealand, pp. 240.
- Barnes, K.K. et al (Eds.), 1971. Compaction of agricultural soils. ASAE Monograph, St. Joseph, Mich, pp. 471.
- Bell, R.D. and T.J. Willcocks, 1982. Energy conservation in mechanisation of agriculture in developing countries. In: F. Vogt (Ed.), Energy conservation and use of renewable energies in the bio-industries 2; Oxford, pp. 88-99.
- Cheze, B., 1978. Materiel de desherbage adapte aux niveau de mecanisation de certains pais tropicaux. 3e Symposium sur le desherbage des Cultures Tropicales, Dakar, 1978. Vol. II: 507-513. CEEMAT, Antony, France.
- Davies, B., D. Eagle and B. Finney, 1977. Soil Management. Farming Press Ltd., Ipswich U.K., pp. 268.
- Eimer, M., 1982. Energiebilanzen in der tropischen Landwirtschaft bei unterschiedlichen Mechanisierungsstufen. Grundlagen der Landtechnik, 32(6): 200-208.
- Feuerlein, W., 1969. Bodenbearbeitung in den Tropen. Landtechnik 24(11): 362-365.
- Garner, T.H. and D. Wolf, 1981. Tillage energy versus hardpan configuration and tillage depth. ASAE Paper, No. 81-1572, pp. 15.
- Gill, W.R. and G.E. VandenBerg, 1967. Soil dynamics in tillage and traction. USDA-ARS, Agriculture Handbook No. 316.
- Hadas, A., D. Wolf and I. Meirson, 1978. Tillage implements - soil structure relationships and their effects on crop stands. Soil Sci. Soc. of Amer. Journal, 42(4): 632-637.
- Heinonen, R., 1979. Soil management and crop water supply; 3rd Ed. Swed. Univ. Agric. Sci., Uppsala, Sweden, pp. 106.
- Hudson, N.W., 1975. Field engineering for agricultural development. Clarendon Press, Oxford, pp. 225.
- ISTRO, 1976. Proceedings of the 7th conference, Uppsala, Sweden, pp. 288.
- ISTRO, 1979. Proceedings of the 8th conference, Hohenheim, Fed. Rep. of Germany, pp. 439 (2 Vols.)
- ISTRO, 1982. Proceedings of the 9th conference, Osijek, Yougoslavia, pp. 697.

- Krause, R., F. Lorentz and F. Wieneke, 1978. Bodenbearbeitung in den Tropen und Subtropen. Berichte ueber Landwirtschaft 56(2-3): 308-328.
- Kuipers, H., (undated). Lecture notes. Soil Tillage Laboratory, Agricultural University, Wageningen.
- Kutzbach, H.D., 1982. Ein Beitrag zur Fahrmechanik des Ackerschleppers - Reifenschlupf, Schleppermasse und Flaechenleistung. Grundlagen der Landtechnik, 32(2): 41-48.
- Lal, R. (Ed.), 1979. Soil tillage and crop production. Proceedings Series, No. 2, IITA, Ibadan, Nigeria, pp. 361.
- Low, A.J. and F.J. Piper, 1973. Some examples of the effect of soil physical conditions on the tractive effort required during ploughing. Journal of the Science of Food and Agriculture, 24(9): 1011-1020.
- Makhijani, A., 1975. Energy and agriculture in the third world. Ballinger Publishing Company, Cambridge, Mass., USA, pp. 168.
- Mante, E.F.G, 1979. The effect of tillage depth and other farming practices on some physical properties of a vertisol and on the yield of sorghum. Proceedings of the Appropriate Tillage Workshop, IAR, Zaria, Nigeria. Commonwealth Secretariat, London, U.K.: 95-106.
- Matho, D.N. and M.P. Sinha, 1980. Effect of tillage practices on weed control and yield of maize. Indian Journal of Agronomy, 25(1): 146-148.
- Matthews, J., 1979. The power requirement for tillage in the next decade. The Agricultural Engineer, 34(4): 99-104.
- Meiborg, R.H. and U.D. Perdok, 1979. Grondbewerking en vermogensbehoefte. IMAG (Wageningen) Report Nr. 11, pp. 43.
- Naravani, N.B. and B.S. Sirohi, 1978. Effect of tillage tools on soil structure. Journal of Agricultural Engineering, 15(3): 144-147.
- NN (Various authors), 1977. Les hommes et leur sols; Les techniques de preparation du champ dans le fonctionnement et dans l'histoire des systemes de culture. Journal d'Agriculture Traditionnelle et de Botanique Appliquee, XXIV(2-3): 67-281.
- NN (Various authors), 1981. Bodenbearbeitung. Spezialheft, DLG Mitteilungen, Frankfurt, pp. 48.
- NN (Various authors), 1982. Predicting tillage effects on soil physical properties and processes. ASA (American Society of Agronomy) Special Publication No. 44, pp. 198.
- Page1, H., 1976. Pedological aspects of mechanised cultivation of the soil in developing countries. Studien ueber Asien, Afrika und Latein Amerika, Band 22, Akademie Verlag, Berlin: 179-190.
- Pascal, J.A., A. Langley, B.W. Sheppard and A.J. Hamilton, 1983. Energy requirements for the reduction of clod populations during potato land preparation. The Agricultural Engineer, 38(1): 2-6.

- Perdok, U.D. and J. Terpstra, 1983. *Berijdbaarheid van landbouwgrond. Bandspanning en grondverdichting. Landbouwmechanisatie*, 34(4): 363-366.
- Perdok, U.D. and G. van de Werken, 1983. *Power and labour requirements in soil tillage- a theoretical approach. Soil & Tillage Research*, 3(1): 3-25.
- Pothecary, B.D., 1970. *Mechanised weed control in the tropics. World Crops*, Sept/Oct. issue.
- Sanchez, P.A., 1976. *Properties and management of soils in the tropics. John Wiley and Sons, New York*, pp. 618.
- Sieg, R., 1982. *Bodenbearbeitung mit weniger Sprit. Die Landtechnische Zeitschrift*, 33(1): 20-22.
- Singh, G. and T.T. Pedersen, 1979. *Effect of speed on specific draught of mouldboard and disc plows in Bangkok clay. AMA*, 10(3): 33-38.
- Soane, B.D., P.S. Blackwell, J.W. Dickson and D.J. Painter, 1981. *Compaction by agricultural vehicles: A review. I. Soil and wheel characteristics. Soil & Tillage Research*, 1(3): 207-237.
- Soane, B.D., P.S. Blackwell, J.W. Dickson and D.J. Painter, 1981. *Compaction by agricultural vehicles: A review. II. Compaction under tyres and other running gear. Soil & Tillage research*, 1(4): 373-400.
- Soane, B.D., J.W. Dickson and D.J. Campbell, 1982. *Compaction by agricultural vehicles: A review. III. Incidence and control of compaction in crop production. Soil & Tillage Research*, 2(1): 3-36.
- Soehne, W. and H. Stubenbock, 1978. *Theoretische Grundlagen der Mechanik der Bodenbearbeitung. Berichte ueber Landwirtschaft*, 56(2-3): 390-414.
- Stout, B.A., et al, 1979. *Energy for world agriculture. FAO Agriculture Series No. 7*, pp. 286.
- Stroppe, A. and W. Schafer, 1981. *Arbeitszeit- und Energiebedarf beim Pflugen in Abhaengigkeit von Getriebegang, der Arbeitsbreite des Pfluges und der Schlepperterasse. Grundlagen der Landtechnik*, 31(5): 165-171.
- Taylor, J.H., A.C. Trowse, E.C. Burt and A.C. Bailey, 1982. *Multipass behavior of a pneumatic tire in tilled soils. Transactions of the ASAE* 25(5): 1229-1231, 1236.
- Voorhees, W.B., 1983. *Relative effectiveness of tillage and natural forces in alleviating wheel-induced soil compaction. Soil Sci. Soc. Am. J.*, 47(1): 129-133.
- Wevers, J.D.A. and H. Kuipers, 1976. *Tillage as a weed control measure in the tropics. Proceedings of the 7th conference of ISTR0, Uppsala, Sweden*: 47:1-47:6.
- Willcocks, T.J., 1981. *Reducing the energy required for mechanised cultivations in developing countries. In: R.A. Fazzolare and B.S. Smith (Eds.) Beyond the energy crisis, opportunity and challenge.*

Pergamon Press, Oxford, pp. 1945-1955.

Wolf, D., T.H. Garner and J.W. Davis, 1981. Tillage mechanical energy input and soil-crop response (cotton, soybeans). Transactions of the ASAE, 24(6): 1412-1419, 1425.

### 3.0 CLIMATE AND SOIL TILLAGE

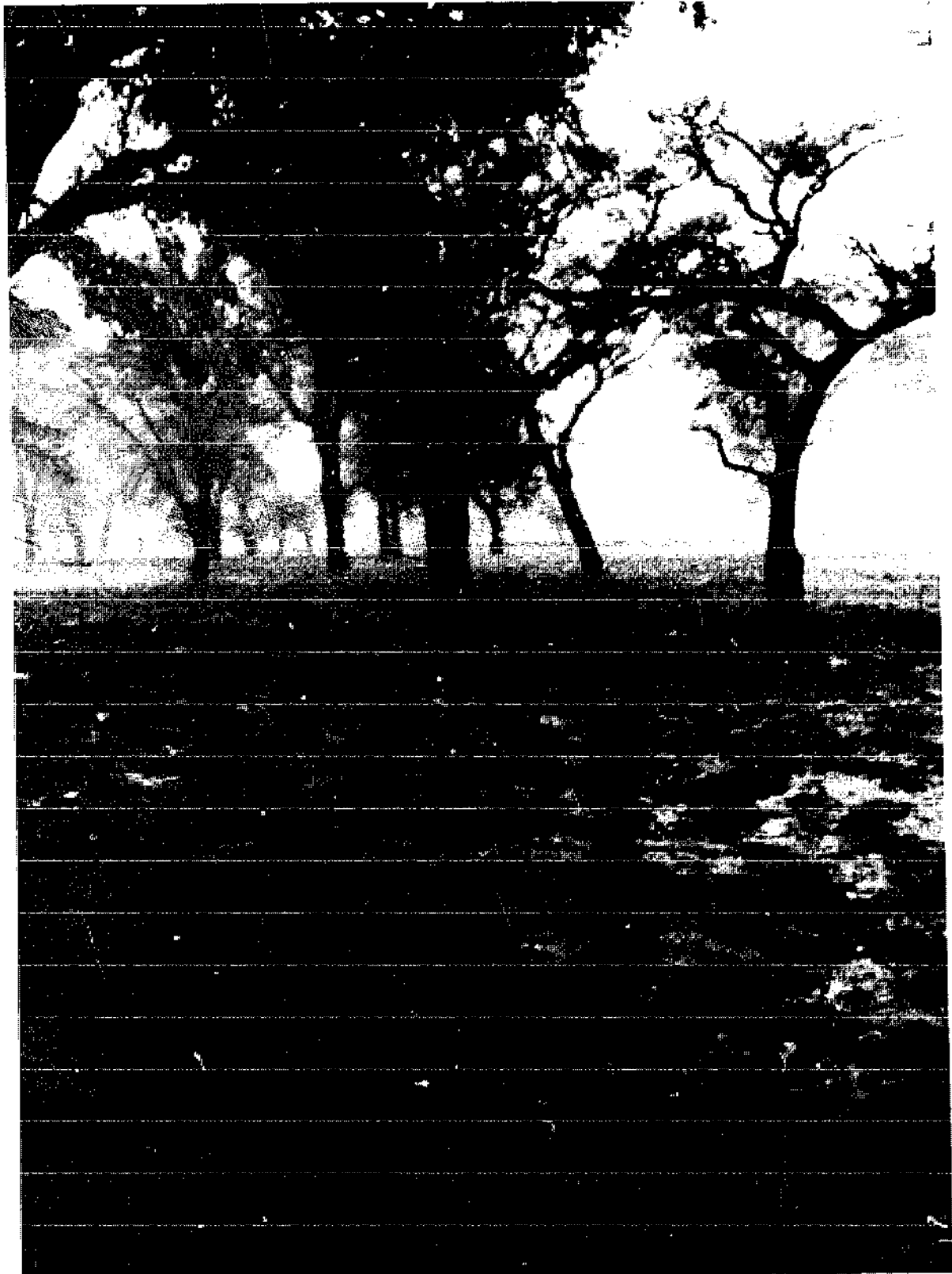

Climate and weather have a considerable effect not only on the cultivation of plants but also on the necessary or possible technologies and techniques.

Climate and weather particularly affect:

- the soil water balance throughout the year, both during and between vegetation periods;
- the duration of the vegetation period which is limited by water deficits and/or low temperatures;
- the soil temperature;
- the soil (micro)biological and chemical (conversion) processes.

In view of these effects of climate and weather it seems expedient to apply the following division into climatic zones:

- Soil tillage in temperate humid climates;
- Soil tillage in arid (tropical) regions
  - with winter rainfall,
  - with summer rainfall;
- Soil tillage in humid and subhumid tropical regions.

No clear definition of the climatic zones is possible since the site's position in relation to the sea and its height above sea-level may cause considerable deviations from the average characteristics. Figs. 9 and 10 give only a general idea. The aspects of soil tillage when there is a risk of soil erosion will be examined in a separate chapter because this subject is not limited to specific climatic zones.

### 3.0.1 Literature

Andrae, B., 1983. Agrargeographie (2nd Edition). De Gruyter, Berlin, New York, pp. 504.

Buringh, P., 1979. Introduction to the study of soils in tropical and subtropical regions. Pudoc, Wageningen, pp. 130.

Webster, C.C. and P.N. Wilson, 1980. Agriculture in the tropics; 2nd Ed. Longman, London, pp. 640.

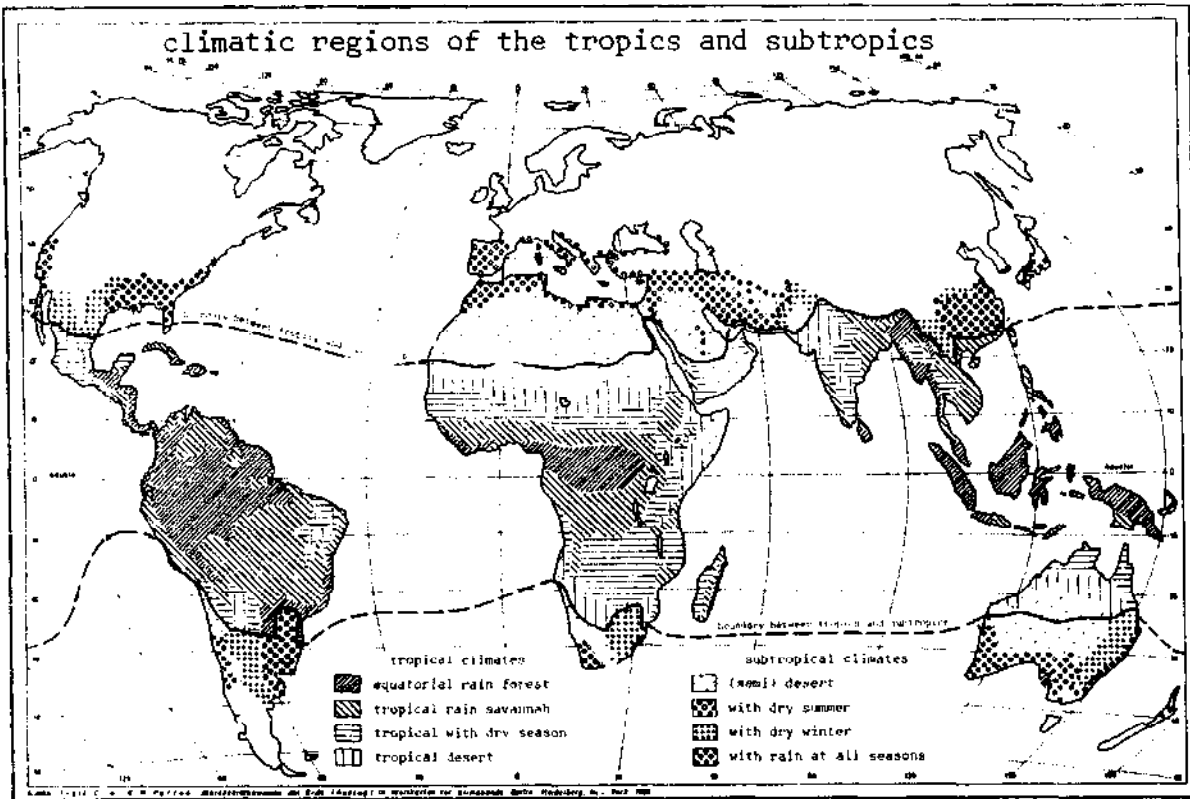

Fig. 9. Seasonal climates in the tropics and subtropics. - Source: Andreae.

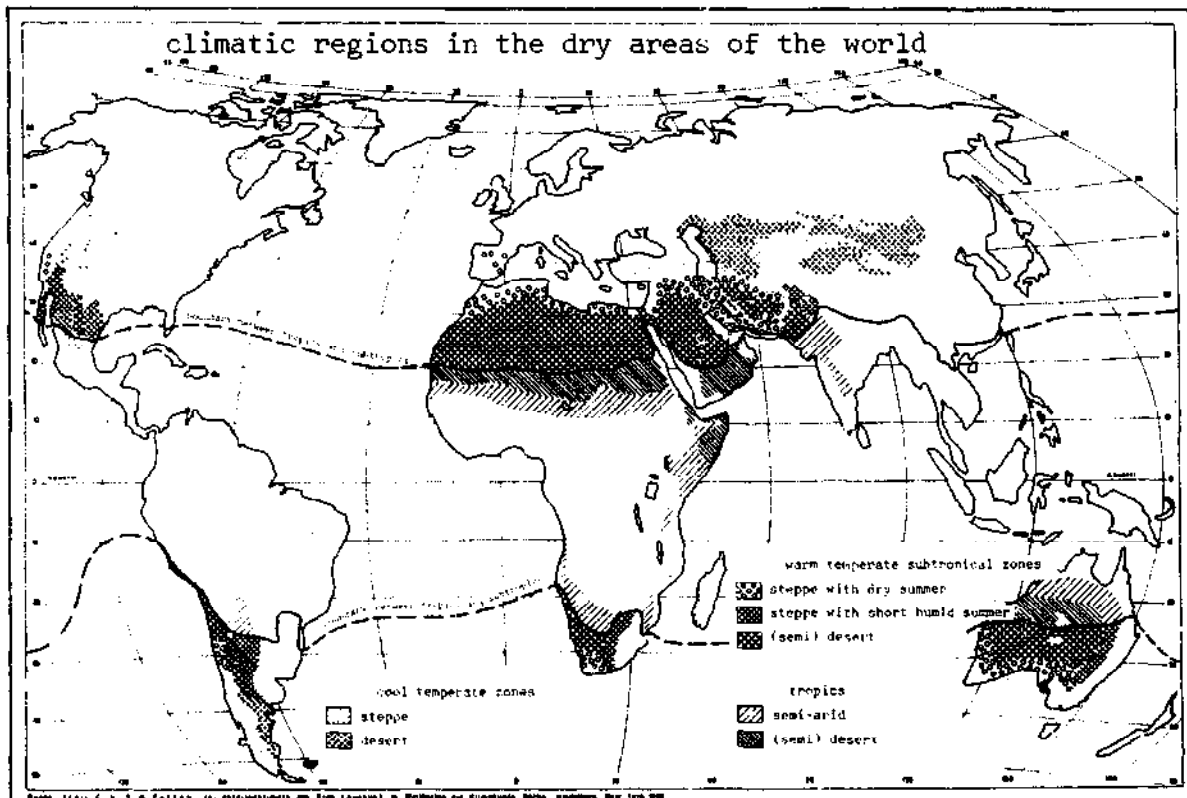

Fig. 10. Seasonal climates in the dry regions of the world. - Source: Andreae.

### 3.1 Soil Tillage In Temperate Humid Climates

In the temperate zones the vegetation period is restricted by low temperatures and, in some cases, also by insufficient light. During the cooler season the evaporation rate is low and the decomposition rate of organic matter is greatly reduced owing to the relative inactivity of the soil organisms. Frost improves the soil structure to a certain extent.

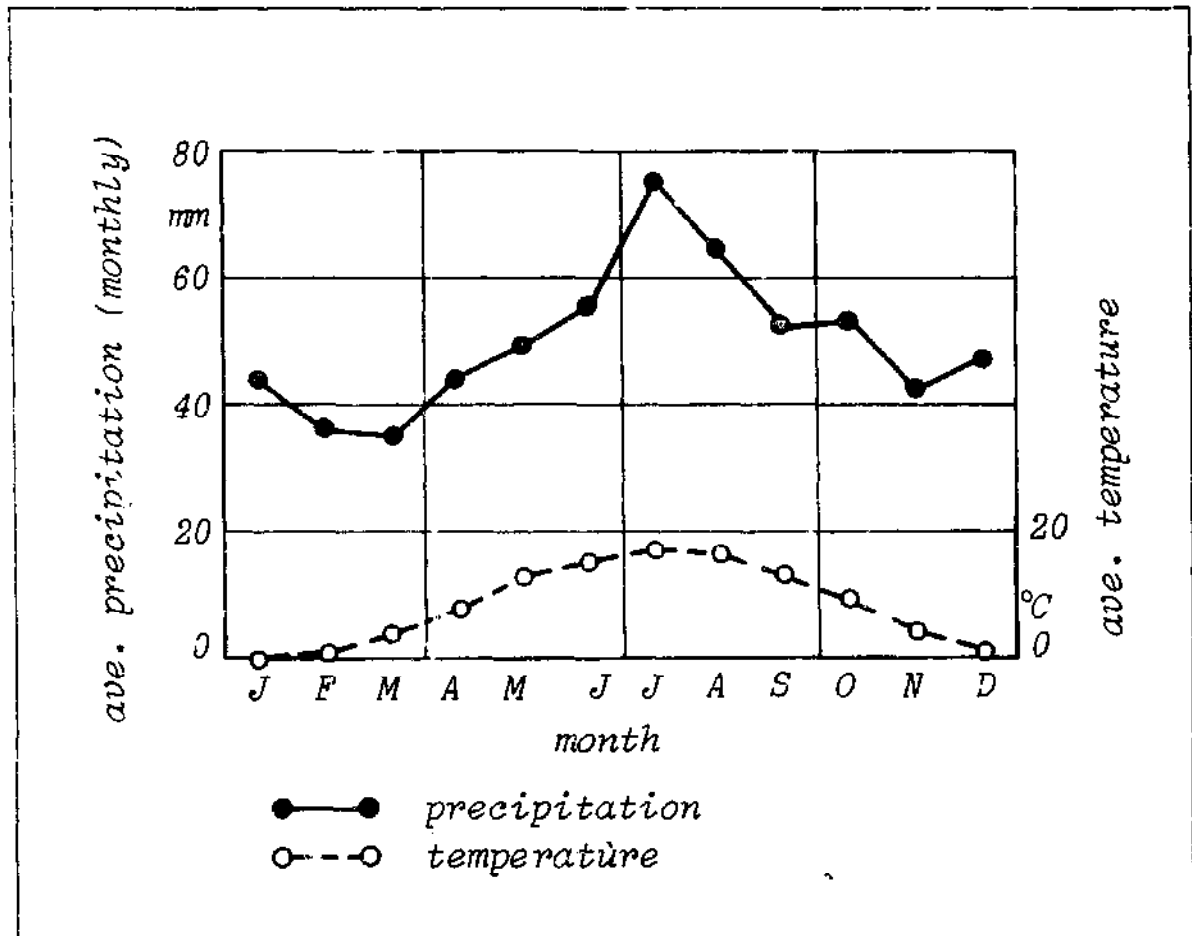

Fig. 11. Temperature and rainfall (monthly averages for Kassel, Fed. Rep. of Germany). - Source: Schreiber.

Temperate zones (Fig. 11) are usually humid in the sense that the annual precipitation exceeds evaporation. So during a large part of the year the soil water descends into the subsoil carrying with it dissolved salts and small soil particles. These particles often form dense layers which are impermeable to water and which plant roots find it difficult or impossible to penetrate. The greater the precipitation and the coarser the soil texture (particle size distribution), the more pronounced this phenomenon will be, especially near the natural boundaries between layers.

The soil tends to have a low pH value under these climatic conditions (acid).



The following soil tillage conditions may exist:

- The time available for tillage operations depends upon the crop rotation but in most cases is comparatively long. Very cohesive soils are an exception. They absorb so much water (low evaporation) that moisture contents suitable for soil tillage occur only very short periods.
- Deep (primary) tillage operations can be performed during and at the beginning of the period of vegetative rest. Owing to the low temperatures the decomposition of organic matter is not markedly increased by loosening the soil and making the oxygen available.
- Damage to the soil structure which may have occurred during the vegetation period and harvesting can to a large extent be remedied by deep tillage and frost action.
- Mechanical inversion is necessary to bring the leached small soil particles (clay minerals) and nutrients back to the topsoil. This operation should be performed more frequently when leaching is more pronounced. It is not required so often on cohesive ("heavy") soils.
- Inverting the soil with a mouldboard plough still seems to be the best mechanical means of controlling weeds.
- The extent to which soil tillage can be reduced to save energy and costs and the conditions required for this are still uncertain but are being intensively studied (see Chapter II.10).

#### 3.1.1 Literature

Cannell, R.Q., 1979. Cultivation and soil/plant relationships. Soil and Water, 7(2): 2-8.

Westmaas Research Group on New Tillage Systems, 1980. Experiences with three tillage systems on a marine loam soil I: 1972-1975. Agric. Res. Reports, No. 899, Pudoc, Wageningen, pp. 100.

### 3.2 Soil Tillage In Arid Climates

Arid climates are characterized by a deficit water balance. The annual evaporation exceeds precipitation as a result of low relative humidities, high temperatures and wind. Most of the infiltrated water may be lost as a result of evaporation.

Rain occurs during limited defined periods in these zones. Humid climatic conditions may temporarily obtain during these rainy seasons. The intensity of the rainfall, the infiltration capacity and hydraulic conductivity of the soil determine whether any excess rainwater will be stored in the subsoil during these brief periods.

Some of the soil water eventually reaches the surface again as a result of evaporation. Dissolved salts are also transported by this water and crystallize on the surface. These climatic conditions may result in the formation of alkaline soils which have a high concentration of salts in the upper layers or on the surface.

The length, intensity and timing of the rainy season or seasons depend upon the geographical location. Considerable deviations from the long-term mean may occur with regard to the incidence and amount of the rains.

Water is the principal restrictive growth factor in arid regions and fallowing is often the only way of producing some kind of water storage system. The yields in these regions are largely determined by the amount of precipitation (Fig. 12); below-average rainfall may result in complete crop failures which not only cause a complete loss of the input of soil tillage, seed and fertilizer but also leave the bare soil virtually without protection against wind and sun, making it extremely susceptible to erosion. Soils in arid climatic zones should be considered for agricultural use only after long-range weather records have been analysed with special attention to the extent and frequency of deviations from the mean.

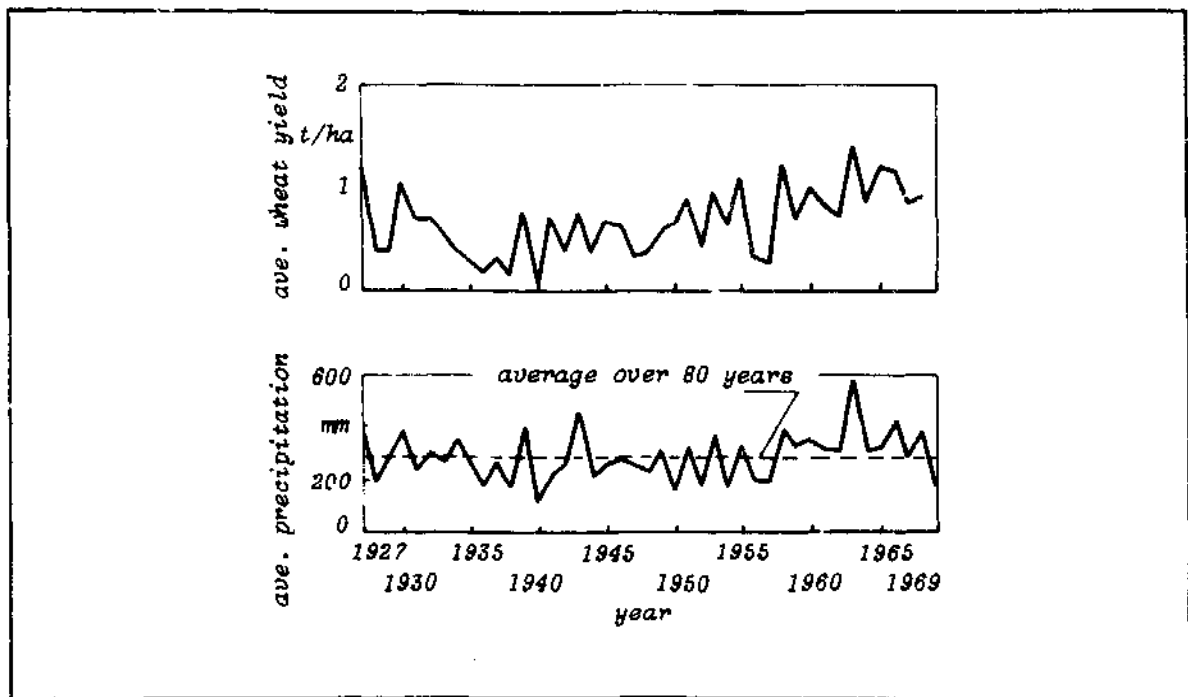

Fig. 12. Annual rainfall and yield of wheat in Western Australia (Yilgarn Shire).

One problem in every arid region is the short time available for soil tillage. Seed should be sown as soon as possible after the rainy season begins to obtain the full benefit of the vegetation period. Every delay shortens the growth period of the crop, because ripening begins anyhow with the dry season, resulting in yield losses and lower qualities. Soil tillage cannot, however, begin until the rainy season starts. If tillage is carried out too early, the soil surface may slake, reducing rain infiltration and causing surface runoff. In addition, the soil can be worked with a relatively low input of energy only during a short period after the first rains because the water content of the topsoil changes very rapidly; when the soil is too dry, it may become "rock hard" and, when it is too wet, it may not be workable or trafficable.

It is frequently difficult to predict the effects of soil tillage because the mechanical manipulations affect not only the physical but also the biological and chemical characteristics. For example, loosening the soil also increases the air and oxygen supply and, with high temperatures, this increases the decomposition of organic matter by organisms living in the water and soil. This will, in turn, cause rapid deterioration of the soil's capacity to retain nutrients and water. If the organic matter content is reduced, the soil's mechanical properties will also diminish.

For optimum results, the short period of time available for tillage requires a high standard of efficiency. When draught animals are used, they are particularly weakened by malnutrition at this period and cannot produce the necessary strength. Generally speaking, therefore, if plant production is to be increased and stabilized in these regions, motorized traction should be available.

Soil tillage in semi-arid climates should have the following objectives:

- total intake of the rainwater by the soil (high infiltration and water holding capacities);
- reduction of evaporation;
- weed control (weeds compete for water with cultivated plants);
- reduction in the decomposition rate of organic matter;
- control of soil erosion.

The methods required for achieving these objectives differ to some extent for regions with winter and summer rainfall.

### 3.2.1 Soil Tillage In Winter-Rainfall Areas

Winter rainfall areas are those in which the rainy season and thus the main vegetation period occurs during the cooler winter months (Fig. 13). Typical examples of this climate are found in the Mediterranean region. There<sup>e</sup> is less evaporation and weed growth during the cool period than in the summer-rainfall region. In some parts of this region (southern Europe, North Africa) the temperatures may be so low that they affect the development of cultivated plants.

The intensity of the rainfall in the winter-rainfall areas is comparatively low and the risk of soil erosion by water is less than in summer rainfall areas. Lengthy dry spells - not uncommon at the beginning of the rainy season - are less dangerous than in the summer-rainfall region owing to the lower evaporation rate.

In view of the mean precipitation of 250 mm during the vegetation period cereals can be grown with suitable cultivars and water-saving farming systems. These require a sufficiently long vegetation period and deviations of less than 100 mm from the mean precipitation.

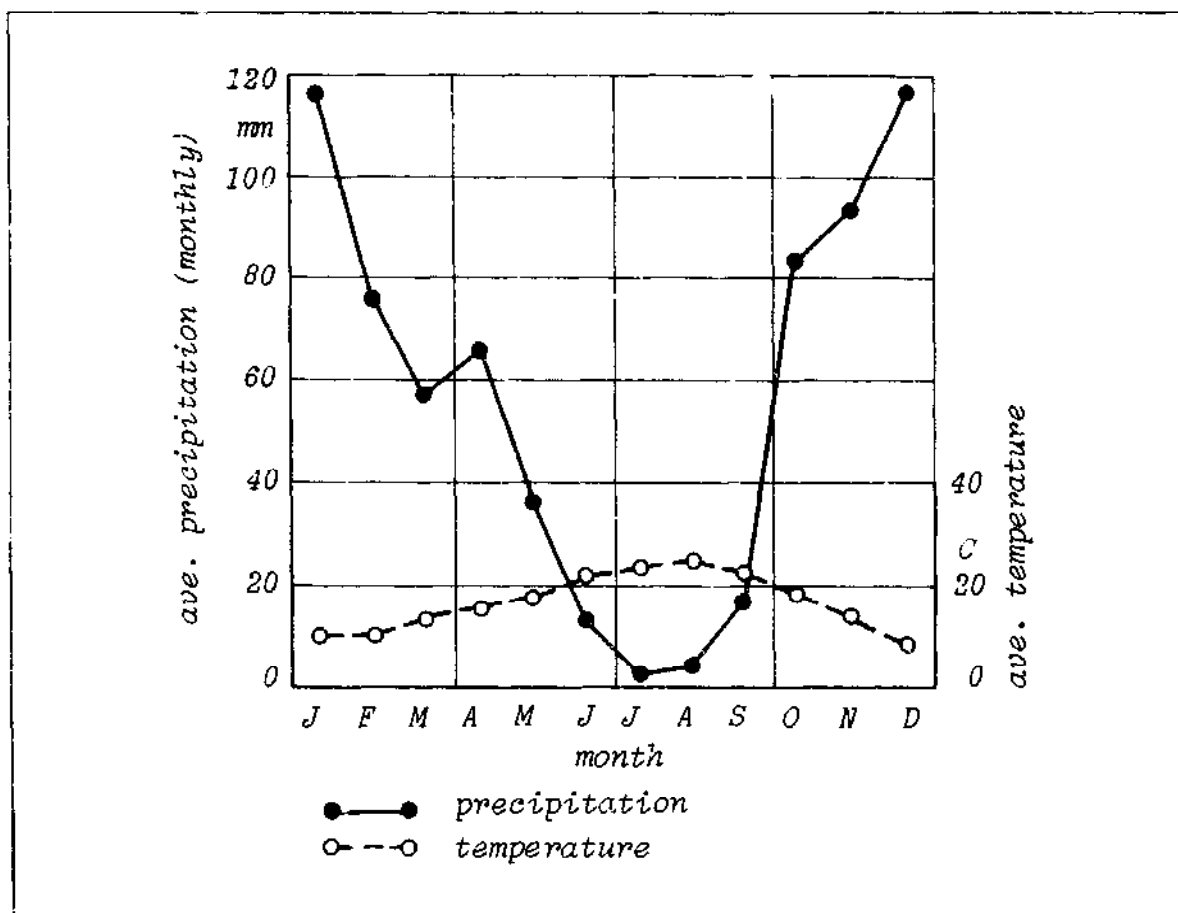

Fig. 13. Winter rainfall area; Monthly averages of temperature and rainfall in Algeria, Algeria. - Source: Schreiber.

With low rainfalls the soil is rarely moistened to depths of more than 30 cm and so shallow soil tillage is recommended. The soil surface must be sufficiently loosened to absorb the rainwater.

Soil tillage in regions with greater rainfall and heavy soils causes problems. These soils are subject to considerable hardening during dry periods. After the rains have started, they are still difficult to till and are almost impassable. Under these conditions the period during which they can be worked is extremely brief.

Primary tillage should be carried out shortly before or at the beginning of the rainy season. Harvest residues can thus provide at least some protection for the soil. Loosening the soil at the beginning of the dry season could increase the risk of wind erosion. Tillage should aim at creating a coarse aggregated surface. It is hardly necessary to invert the soil since this could cause water losses when the soil is already moist. Implements with discs, heavy tines or steep mouldboards with a limited inverting effect are suitable for primary tillage. Mouldboard ploughs should be moved slowly to avoid excessive pulverization. If conditions are favourable, a second tillage operation before sowing may be unnecessary or

combined with the sowing, in which case weed control by herbicides will very probably be required.

With the traditional method seeds (of winter cereals) are broadcast when the soil is moist enough for tillage; ploughing is then also carried out to cover the seeds. Weed control is poor.

Deep tillage during the dry season using mouldboard or chisel ploughs or subsoilers has become customary in many regions with high-input agriculture. This system has the advantages of timeliness, better weed control and improved soil structures. Deep tillage (50 - 70 cm deep) forms large clods which are resistant to wind erosion. Weed-roots, soil pathogens, etc. will die when these clods dry out completely. The clods will disintegrate slowly by natural weathering and under the effect of the first rains. Seedbed preparation causes no difficulties if the weather pattern is favourable; special equipment is used when clods have to be broken up. This system requires a high energy input and special equipment. The tractive power needed for ploughing operations in clod-forming soils may be 2 to 3 times more than for soils in temperate regions. Consequently, intervals of 4 to 5 years are normal, with shallow tillage in intermediate years.

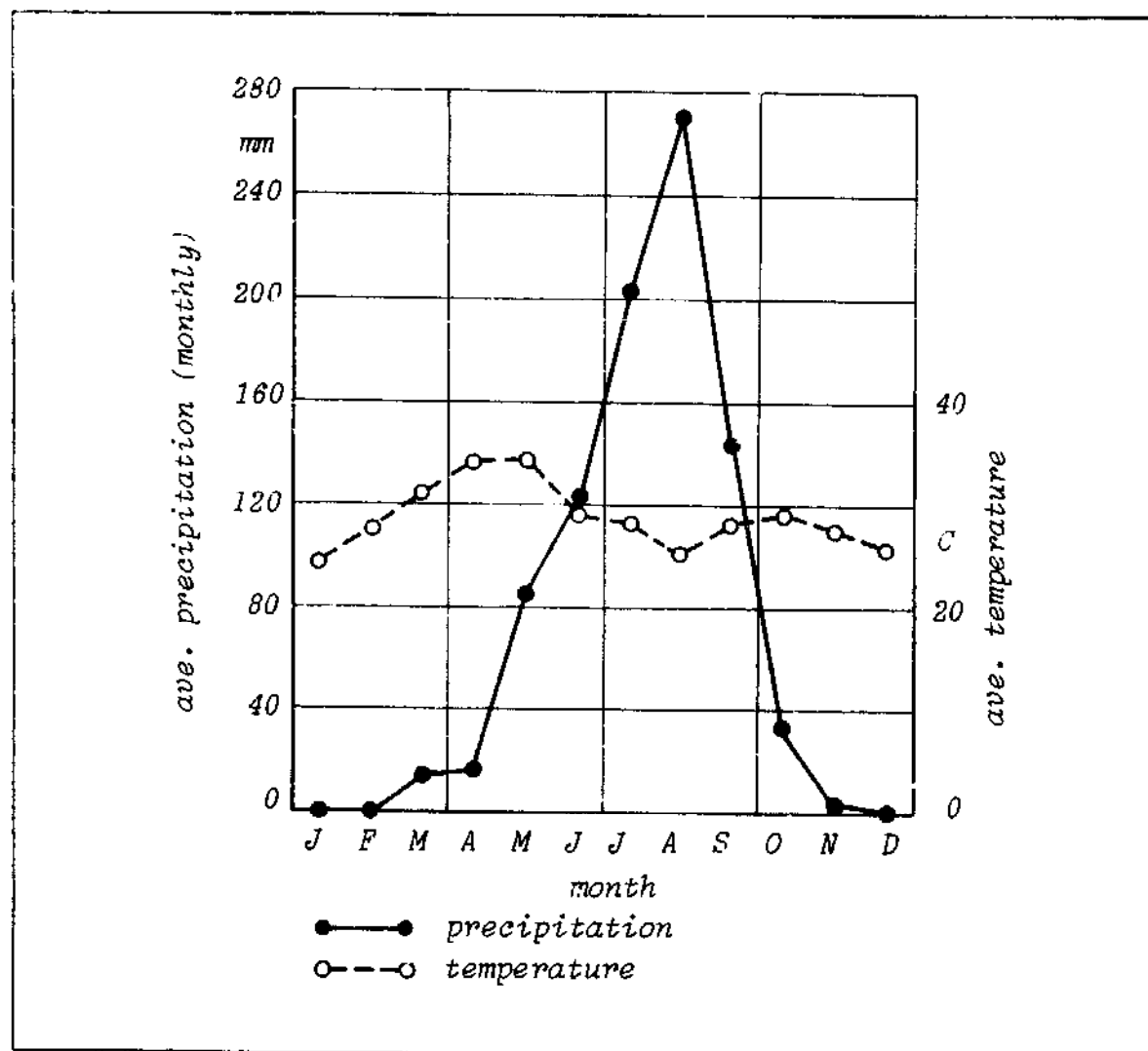

Fig. 14. Summer rainfall area; Monthly averages of temperature and rainfall in Ouagadougou, Upper Volta. - Source: Schreiber.

### 3.2.2 Soil Tillage In Summer-Rainfall Areas

The precipitation in summer-rainfall areas occurs during the hot season (Fig. 14), mainly in the form of thunderstorms. The rainfall intensity is very high during those storms. The largest raindrops have a high kinetic energy (impact). On uncovered soils this causes the destruction of the aggregates and compaction or crusting of the surface which prevents absorption of the large volumes of water, producing a serious risk of surface runoff and soil erosion. In the case of loamy sands in the Sahel region it is estimated that 25% or more of the annual precipitation may be lost as runoff.

Strong weed growth can be expected owing to the high temperatures which occur right at the beginning of the vegetation period. The potential evaporation is also high. Dry spells may be very critical for newly-sown fields or young crops.

The total annual precipitation is usually greater than in the winter-rainfall areas; 500 mm is considered the minimum requirement for growing millet, one of the cereals with the greatest drought-tolerance.

So in these regions the objectives of tillage should be:

- Water conservation,
- To permit sowing as early as possible in the rainy season. It has been demonstrated that the yields in these climates are closely related to the time of sowing. Delays of a few days or a week can reduce yields by 10 - 100%. An early soil cover also helps to prevent erosion;
- To create stable soil aggregates on the surface which can withstand the impact of raindrops;
- To form mulch from the plant residue which acts as a mechanical barrier to soil movement and slows down runoff water. The soil should be turned carefully, perhaps at longer intervals, because plant residue may be buried too deep so that it can no longer act as a mechanical stabilization agent for the soil surface. Inverting the soil also increases aeration in the tilled layer, which may accelerate the decomposition of the organic matter and cause water losses. On the other hand, the deeper the material is placed, the slower the decomposition rate;
- To improve infiltration and reduce evaporation losses by means of a second operation (opening-up the sealed soil surface) before the soil is entirely covered by crops;
- To preserve or, possibly, increase the amount of organic matter by combined farming operations. In view of the rapid mineralization process, plant residue should be worked in shortly before sowing.

While a tillage system should preserve organic matter, the amounts actually produced by crops are very small, especially in regions with annual rainfall of less than 1000 mm. The decomposed quantities are usually equal to or more than the volumes produced.

Disc implements which mulch in the plant residue without disturbing or inverting much of the soil may be suitable for primary tillage in low-density soils, but only under conditions where there is no erosion risk. Disc implements may produce less permeable layers in soils which are susceptible to erosion. Implements with tines or chisels are recommended when the soil has to be loosened. The operation will be satisfactorily carried out only if the soil is not too moist and below the lower plastic limit (see Fig. 4) because it should be broken up and not deformed. The

surface can be tilled with shallow-working weeder blades, duck-feet or rotary hoes. The rotary hoe is particularly suitable when there are large amounts of plant residue.

Water conservation - the principal objective of tillage in these regions - can be achieved by preventing runoff losses and by reducing evaporation. Preventing runoff is usually more effective than reducing the evaporation. In particular, there is less risk of crop failure when losses can be prevented at the beginning of the growing season. The surface storage capacity can be increased even with animal traction, possibly by tied or contour ridging. The main drawback of surface tillage as a way of reducing evaporation losses is that the loosened layer will dry out completely and so this operation is effective only when more than 5 - 10 cm of soil has been moistened.

Soil tillage in summer-rainfall areas causes problems because of the conflicting individual requirements and optimum solutions cannot be achieved because of technical limitations. For example, the need to loosen the surface in order to increase the water infiltration capacity is difficult to combine with the need to prevent decomposition of organic matter by reducing the aeration. A compromise must be found. Crop production in summer-rainfall areas generally causes more problems and requires more effort than in winter rainfall areas.

### 3.2.3 Literature

- Arakeri, H.R., G.V. Chalam, P. Satyanarayana and R.L. Donahue, 1967. Soil management in India. Asia Publ. House, Bombay etc. India, pp. 609.
- Arnon, I., 1972. Crop production in dry regions.  
Volume I. Background & Principles, pp. 650.  
Volume II. Systematic treatment of the principal crops, pp. 683.  
Leonard Hill, London, U.K.
- Bigot, Y., 1977. Fertilization, labour et espece cultivee en situation de pluviosite incertaine du centre de Cote d'Ivoire. Synthese des principaux resultats d'un test de differents systemes cultureaux de 1967 a 1974. *Agronomie Tropicale*, 32(3): 242-247.
- Dregne, H., 1976. Soils of arid regions. Elsevier, Amsterdam, *Developments in Soil Science* 6, pp. 237.
- FAO, 1973. Agricultural mechanization research in West Africa: country reports. AGS:MISC/73/11, Rome, pp. 160.
- Hadas, A. and D. Wolf, 1983. Energy efficiency in tilling dry clod-forming soils. *Soil & Tillage Research*, 3(1): 47-59.
- Hall, A.E., G.H. Cannell and H.W. Lawton (Eds.), 1979. Agriculture in semi-arid environments. *Ecological Studies* 34, Springer Verlag, Berlin, pp. 340.
- Henderson, H.D., M. Almassi, A.A. Malik and Z. Mojaddadi, 1981. Deep tillage in the Beqa'a Valley, Lebanon. *Transactions of the ASAE*, 24(6): 1466-1470.

- Hillel, D. et al, 1969. Soil-crop-tillage interactions in dryland and irrigated farming. The Hebrew university of Jerusalem, Dept. of soils and water, Rehovot, pp. 300.
- Jarvis, R.J., 1982. Cultivation research update (wheat). Journal of Agriculture, Western Antralia, 23(2): 41-45.
- Klaij, M.C., 1983. Analysis and evaluation of tillage on an alfisol in a semi-arid tropical region of India. Thesis, Soil Tillage Laboratory, Agricultural University, Wageningen.
- Macartney, J.C. and J.P. Northwood, 1971. The effect of different cultivation techniques on soil moisture conservation and the establishment and yield of maize at Kongwa, Central Tanzania. Trop. Agric. (Trinidad), 46: 13-23.
- Mallick, S. and Y. Nagarajarao, 1973. Effect of tillage on soil structure and plant growth under rain-fed conditions. Indian Journal of Agricultural Sciences, 42(9): 827-831.
- Northwood, J.P. and J.C. Macartney, 1971. The effect of different amounts of cultivation on the growth of maize on some soil types in Tanzania. Trop. Agric. (Trinidad), 48: 25-33.
- Nicou, R., 1981. Les techniques culturales du maïs en Afrique de l'Ouest. Agronomie Tropicale, 36(4): 356-363.
- Rawitz, E., W.B. Hoogmoed and Y. Morin, 1981. Final Report of the project: Development of criteria and methods for improving the efficiency of soil management and tillage operations, with special reference to arid and semi-arid zones. Tillage Laboratory, Agricultural University, Wageningen and Department of Soil & Water, Hebrew University, Rehovot, Israel (with 5 Appendices), pp. 260.
- Salmon, D.J., 1979. A review of EFSAIP - the evaluation of farming systems and agricultural implements project in Botswana. Proceedings of the Appropriate Tillage Workshop, IAR, Zaria, Nigeria. Commonwealth Secretariat, London, U.K.: 147-152.
- Wey, J. and M. Obaton, 1978. Incidence de quelques techniques culturales sur l'activite fixatrice d'azote et le rendement de l'arachide. Agronomie Tropicale, 33(2): 129-135.
- Willcocks, T.J., 1981. Tillage of clod forming sandy loam soils in the semi-arid climate of Botswana. Soil & Tillage Research, 1(4): 323-350.
- Wolf, D. and H.J. Luth, 1979. Tillage equipment for clod-forming soils. Transactions of the ASAE, 22(5): 1029-1032.
- Wolf, D., E. Stibbe and A. Hadas, 1979. Seedbed preparation for arid and semi-arid conditions - problems and solutions. Proceedings of the 8th. Conference of ISTRO, Hohenheim, Fed. Rep. of Germany: 143-146.



### 3.3 Soil Tillage In Humid And Semi-humid Tropical Climates

The semi-humid tropics are located around the world in a belt between 6 - 8 deg north and 6 - 8 deg south of the equator. Temperatures are high in these regions and deviations from the annual mean are less than the daily fluctuations. The semi-humid tropics are characterized by a principal and a secondary rainy season. The relative air humidity is high from the beginning of the first to the end of the second rainy period and is often not much lower during the main dry period (see Fig. 15). Rain-forests are the natural vegetation of these regions. These protect the soil from direct solar radiation and water erosion.

In a low-input land-use system (shifting cultivation) the plant cover is cleared and burnt in the dry season. The soil is then worked manually with a hoe. Food crops are planted in scattered plots between the tree-stumps, usually as a mixed crop. The yields show a marked decline after 2 or 3 years, mainly because the organic matter in the soil has almost entirely decomposed. The cycle recommences with the clearance of a new plot in the forest. The abandoned plots require at least 10 to 15 years to recover. High temperatures and large volumes of rainfall cause a very rapid degeneration of the soil. The pH value may be as low as 4 to 5. Soils with a high silt content become latosols. These tropical soils are often very shallow.

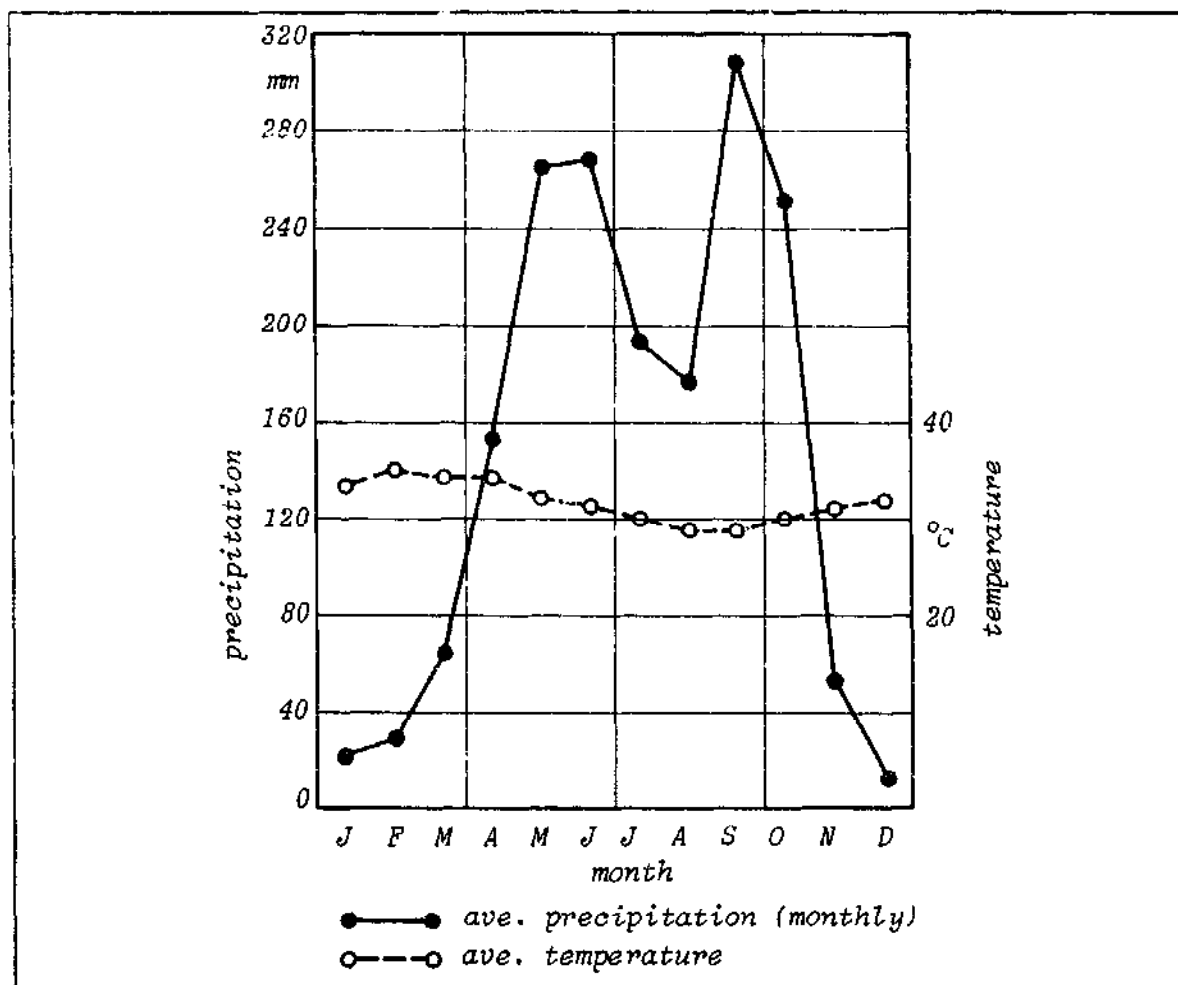

Fig. 15. Humid tropics; Monthly averages of maximum temperature and rainfall in Enugu, Nigeria. - Source: Schreiber.

Arable crops can be successfully and permanently grown on these soils only when the pH value and the organic matter content can be increased and kept at acceptable levels. Many of the fields have to be drained. The latosols - typical soils in these regions - are difficult to cultivate. Since they tend to dry out considerably after being tilled, they are susceptible to erosion and have limited nutrient absorption capacity. So they should be kept under cover as long as possible. Tillage should be reduced to a minimum; "no-tillage" systems may perhaps be intermittently employed. When sufficient organic matter is available - as is often the case in these regions - the stability of the yields can be improved by an appropriate crop rotation combined with a gradual incorporation of adequately pulverized organic material.

The climate usually allows crops to be grown throughout the year. This often means that harvesting and tillage operations for the next crop have to be carried out under adverse conditions. The soil will often be too wet; harvesting operations may compact or destroy the soil structure (puddling, creation of ruts).

It is essential to limit the number of operations. In addition to preventing erosion, weed control must be a primary objective of the tillage operations. Minimum-tillage methods which use plant residue as a protective mulch are beneficial as regards the soil structure and erosion control but usually fail because of (perennial) weed infestation.

#### 3.4 Literature

- Curfs, H.P.F., 1976. Systems development in agricultural mechanization with special reference to soil tillage and weed control. Mededelingen Landbouwhogeschool Wageningen 76-5, pp. 179.
- Greenland, D.J. and R. Lal (Eds.), 1977. Soil conservation and management in the humid tropics. John Wiley and Sons, London, pp. 283.
- Kowal, J. and K. Stockinger, 1973. Usefulness of ridge cultivation in Nigerian agriculture. Soil Water Cons. J., 28: 136-137.
- Lal, R., 1975. Role of mulching techniques in tropical soil and water management. IITA Technical Bulletin, No. 1, pp. 37.
- Leyenaar, P. and R.B. Hunter, 1977. Effect of seedbed preparation on maize production in the coastal savanna zone of Ghana. Ghana Journal of Agricultural Science, 10(1): 47-51.
- Muzilli, O., 1979. Evaluation of tillage systems and crop rotations in the State of Parana, Brasil. Proceedings of the 8th. Conference of ISTR0, Hohenheim, Fed. Rep. of Germany: 1-5.
- Ofori, C.S., 1973. The effect of ploughing and fertilizer application on yield of cassava. Ghana Journal of Agricultural Science, 6(1): 21-24.
- Uichanco, E.A., 1977. Mechanizing the sugar industry in the Philippines. AMA, 8(2): 17-20.
- Wijewardene, R., 1981. Matériels et méthodes de travail minimum et de non-travail du sol pour l'agriculture paysannaise en zone tropicale humide. Machinisme Agricole Tropical, 76: 3-24.

## 4.0 SOIL EROSION



Soil erosion can be defined as detachment and removal of soil particles by wind and water, especially the fine particles. The significance of soil erosion throughout the world should not be under-estimated: at least 15% of the world's total area of agricultural soils is (severely) damaged by erosion. Apart from a very small proportion of the damage which is caused by "natural" geophysical erosion processes, soil erosion is now the result of human influence. After the natural plant cover has been cleared, soil erosion can be induced by leaving the soil uncovered, by working the soil or by pulverizing the surface aggregates, to name only some of the causes. Even when improvement measures are applied, such as fertilization, irrigation or plant protection, negative results are produced if soil is lost by erosion.

There is no need to cite examples of the spectacular and disastrous effects erosion has caused, especially in tropical regions.

The damage resulting from erosion is serious from the agricultural point of view: losses of soil from fields with a shallow layer of fertile or cultivable soil may completely destroy the production potential. In Parana, Brazil, annual losses of up to 700 tonnes per ha have been reported. The damage is not confined to the loss of soil but includes losses of seeds and fertilizers and consequential losses, such as extra expense on resowing, more difficult farming operations, etc. In addition to the losses at the farm level, serious environmental problems arise, particularly pollution of rivers, harbours and reservoirs.

The two principal agents of soil erosion are wind and water; both will be briefly examined in this chapter before we formulate some general principles. Reference should be made to a recent FAO publication by Unger (1984) for a comprehensive examination of soil tillage systems from the point of view of erosion control.

#### 4.1 Erosion By Wind

Wind erosion can be expected under the following conditions:

- a fine, loose and dry topsoil;
- a flat smooth surface with little or no vegetation or plant residue;
- a high windspeed (in case of fine sand, a minimum of 15 km/h at 30 cm above the surface).

The windspeed is virtually zero along the surface but increases logarithmically with height. At low speeds the wind flow is laminar but as speeds increase it becomes turbulent. Severe erosion can be expected when turbulence occurs because soil particles can then be carried up to higher wind layers. Three types of soil movement by wind can be distinguished:

- a. SALTATION - This is a jumping motion which, in the case of certain light sandy soils, accounts for 50 - 70% of the soil transported by wind erosion. Saltation occurs mainly with particles having diameters of between 0.05 and 0.5 mm. The particles are lifted almost vertically, start to spin and are carried by the wind over a distance of approximately 10 - 15 times the height of the "jump". When they return to the surface, the impact can cause loosening and erosion of other particles. 90% of these particles do not "jump" higher than 30 cm and very few reach 1 m.

- b. **SUSPENSION** - This occurs when, after being lifted by the saltation process, soil particles are raised by the wind-stream, possibly to heights of 2 - 3 km! This may cause a duststorm when large amounts of material are transported. Soil can be carried over long distances (loess deposits). It is estimated that of all the small particles (< 0.05 mm) transported 40% are moved by suspension.
- c. **CREEP** - With this process particles (mainly 0.5 - 1 mm) are displaced by a rolling and sliding motion ("surface creep"). Extreme winds may take up particles larger than 1 mm but particles of more than 5 mm are rarely moved by wind.

There are two ways of preventing wind erosion:

- by increasing the resistance of particles to erosive forces,
- by reducing the wind-speed.

A vegetation cover is the most effective means but is difficult to establish in arid regions. Between the harvesting of annual crops and the emergence of the next crop a period will occur during which the soil surface is bare. A very young crop is also extremely sensitive to the impact of blowing sand particles (sand blasting). A layer of mulch provides some protection (stubble or plant residue worked into the surface). Tillage should aim at producing a coarse surface with large stable aggregates. The soil should be left uncovered for as short a time as possible. Tillage operations in moist (wet) conditions may form clods which are more resistant to wind erosion. Essentially, the line of direction of all the tilling, planting and sowing operations should transverse the prevailing wind direction. This alone may reduce the soil losses to as little as one-third of those which can be expected when the operations are carried out along the wind direction.

Soil losses or damage can also be prevented by "strip cropping". With this system alternate strips of erosion-resistant and erosion-susceptible crops are formed, again transversing the prevailing wind direction. The widths of these strips depend upon the soil type and range from 6 - 8 m on (loamy sand), 30 - 70 m on (sandy) loam to 130 m on silty loam. For practical reasons strips of less than 15 m should not be used for mechanized farming.

The implements suitable for tilling soils susceptible to wind erosion are the sweep (Chapter II.7.2), possibly fitted with a rod weeder, and the chisel plough (Chapter II.2.3). Ridges transversing the wind direction are also an effective means of controlling erosion; ridges 10 - 15 cm high are best (see Chapters II.4.7 and II.5.2).

Mechanical weed-control operations generally leave a fine surface; when use of herbicides can eliminate this operation, this is an effective erosion control measure.

## 4.2 Erosion By Water

Erosion by water occurs on sloping land with very intensive rainfall when it has no protection against the weather.

Two processes of water erosion can be distinguished:

- a. The destruction or disintegration of larger soil aggregates to form smaller particles, often accompanied by separation of the particles into their size categories;

- b. The detachment and removal of small particles by water falling on or flowing over the surface.

The soil particles are detached from the soil surface by the impact of the raindrops or by water flowing over the surface (when the speed of flow exceeds a specific minimum). The size and impact of the large raindrops are very important factors in this process of destruction and detachment (splash). The kinetic energy of the falling raindrops is generally employed as a parameter for determining the erosivity of the rainfall. This kinetic energy may be very high in the humid and semi-arid regions; in Africa, for example, it is at least twice and may even be six times as high as in the temperate zones. The very fine soil particles detached from the surface by the impact of heavy raindrops may obstruct the pores in the surface layer and considerably reduce the infiltration rate. This increases surface run-off and the risk of erosion. Silty soils are particularly susceptible to this process.

Even slight gradients (1 - 2%) or depressions are capable of producing surface run-off with high flow velocities and thus cause damage by erosion.

Generally speaking, three types of erosion by water can be distinguished:

- a. SHEET erosion. Soil is removed uniformly from the entire surface. This type of erosion is not obvious to the eye but may nonetheless cause considerable damage.
- b. RILL erosion. Water run-off very soon starts to concentrate in small depressions (wheel tracks!) and removes the soil in the bottom of rills, sometimes right down to the bottom of the tilled layer. The rills can generally be restored by tillage (levelling) but the damage is considerable. If rill erosion occurs repeatedly, the topsoil of a field may be removed in a few years or seasons.
- c. GULLY erosion. This is a more extreme form of rill erosion. Large concentrations of water running over a slope cut channels which are impassable to agricultural machinery and cannot be restored by tillage. In their extreme form, gullies may be several tens of metres deep, making the land almost unusable.

The damage caused by erosion:

- Loss of soil fertility owing to the removal of topsoil which contains nutrients, organic matter, soil organisms, etc.;
- Removal of seeds, seedlings or young plants, causing bare patches and usually reduced yields;
- Young plants are covered with eroded soil material, which also causes bare patches;
- Increased production costs when resowing is necessary (as is often the case in regions with a high risk of erosion). The extra costs are required for tillage, fertilizers, pre-emergence chemicals, seeds, and the actual resowing operation;
- Increasing wear and tear of the machine when rills and gullies have to be crossed;
- Deposits of eroded soil material in valleys;
- Streams are polluted and reservoirs become filled with soil.

The basic measures required for reducing or preventing water erosion are:

- Reducing the impact of the raindrops on the soil surface;
- Preventing the separation and destruction of soil aggregates;
- Increasing the infiltration rate of water into the soil;
- Reducing the flow velocity of the water running off over the surface.

The aim of every farming and crop production operation connected with water erosion should be to produce a dense plant cover and maintain that cover for as long as possible. A plant canopy can virtually eliminate the kinetic energy of raindrops. The degree of protection provided varies from crop to crop: for example, cotton is not very effective while cereals and soybeans give a good cover. A suitable type of crop rotation, mixed cropping systems or a system with intermediate cover crops can be very effective. The most suitable system does, however, depend upon many factors and must be tested on the site. Plant residue should not be buried but worked into the surface as mulch. Burning is very damaging from the point of view of protection against erosion and should be carried out only when essential for phytosanitary reasons.

Strip cropping has proved to be an effective way of preventing water erosion. Different crops are grown in alternate strips which follow the contour lines. The choice of crops ensures that some part of the field has plant cover at all times. When one strip is susceptible to erosion (especially around sowing time), the adjoining strip with its vegetation cover acts as a buffer and blocks surface flow.

The construction of contour dams or terraces is an engineering rather than an agricultural operation for controlling erosion. Dams can be built along the contour lines either by ploughing or by employing earth-moving equipment. The distance between the dams or the width of the strips depends upon the gradient, soil type and climate. Strips are not usually parallel and this arouses practical difficulties when they are cultivated. Special effort is required to work the entire surface area of long narrow fields. It is impossible to work crosswise when performing successive tillage operations. On slight gradients the strips may deviate a little from the contour in order to form parallel borders.

One system which can be incorporated in normal farming operations is the "tied ridging" system whereby furrows between ridges which do not run along the contour line are blocked by cross-dams at regular intervals (depending upon the size of the ridge, the gradient, rainfall and soil type). This is a very effective system for preventing run-off and erosion but requires special equipment for constructing the cross-dams (Chapter II.4.7). The "ties" also impede other farming operations (they are usually knocked down and rebuilt in each operation).

Broad-based dams can be constructed on slopes with gradients of up to 6%. These dams form part of the field, are also used to grow crops and can be crossed and worked by machinery.

The actual distance between contour dams depends upon many factors: soil type, climate (rainfall intensity), gradient, etc. The recommended intervals may range from more than 100 m on soils with good drainage and a gradient of only 1% right down to 10 or 12 m on unstable soils on 15% gradients. Arable cropping should not be carried out on slopes with gradients of more than 15%.

Tillage implements which cause pronounced crumbling or pulverization of the soil should not be used. All operations should be carried out across the slope, following the contour lines. Conventional tillage operations for annual crops may particularly increase the risk of erosion. The usual sequence - ploughing and disc harrowing for seedbed preparation - buries plant residue and leaves a bare fine-grained topsoil. The structural stability of the aggregates may also be reduced, causing drying-out in the top layer and crust formation. The infiltration capacity of the soil is

reduced and run-off begins more quickly. The infiltration capacity may also be reduced by the formation of less permeable layers in the profile by traffic or some tillage operations. A thin ploughsole may be formed by the smearing effect of blunt or incorrectly adjusted ploughshares and the weight of tractorwheels in the bottom or of heavy disc implements may produce a thicker compacted zone. In such cases the layer above that zone will soon become saturated under heavy rainfall and this "mud" layer can easily be eroded.

There are a number of ways in which suitable tillage operations can help to control erosion:

- An adapted tillage system where as much crop residue as possible is kept near or on the soil surface as a mulch. This can be achieved by using implements such as chisel ploughs, sweeps, etc. The factors favouring this system are the large proportion of crop residue left on the surface and the ability of the implements to break up hard impermeable layers (pans), thus improving the infiltration capacity.

The practical difficulties of this system are the amounts of plant material (which block the implements) and the sowing of the next crop (suitably adapted sowing equipment is necessary). Sufficient amounts of crop residue must also be available: at least 3 to 4 ton of material per ha to ensure reasonable protection.

- Very careful consideration must be given to the use of subsoilers for erosion control. They can be employed to break up compact impermeable layers but require considerably more power when working at depths of over 20 - 25 cm. A single subsoiling operation sufficient to destroy existing (natural) layers may be economical but repeated use as a primary tillage operation is questionable not only because of the high energy consumption but also in view of the possibility of recompaction. A subsoiling operation is not effective when the subsoil is moist.

- Suitably adapted tillage systems may also be useful for cutting the time required for the operations. The period during which the soil is exposed to the weather can be shortened if the number of passes with tillage equipment is reduced. For example, the time during which the soil remains bare is shortened by combining primary and secondary tillage into one pass (or possibly even combining with sowing: see Chapter II.8) although the tillage intensity is maintained.

- The extreme form of adapted "tillage" is the no-tillage or direct drilling system whereby the surface is opened only for the purpose of placing the seed. This system is highly effective for controlling erosion and has received a great deal of attention throughout the world. It will be discussed in chapter II.10.

#### 4.3 Literature

ASAE, 1977. Wind erosion; series of articles in Transactions of the ASAE, 20(5): 873-918.

Chepil, W.S. and N.P. Woodruff, 1963. The physics of wind erosion and its control. Advances in Agronomy, 15: 211-302.

Crosson, P., 1981. Conservation tillage and conventional tillage: a comparative assessment. SCS, Ankeny, Iowa, pp. 35.

FAO, 1978. Soil erosion by wind and measures for its control on agricultural lands. FAO Agricultural Development Paper, No. 71,



pp. 88.

- FAO, 1978. Soil erosion by water: some measures for its control on cultivated lands. FAO Agricultural development paper, No. 81, pp. 284.
- Fenster, C.R. and G.A. Wicks, 1977. Minimum tillage fallow systems for reducing wind erosion. Transactions of the ASAE, 20(5): 906-910.
- Hughes, H.A., 1980. Conservation Farming. John Deere & Co., Moline, Ill., pp. 150.
- Johnson, C.B. and W.C. Moldenhauer, 1979. Effect of chisel versus moldboard plowing on soil erosion by water. Soil Sci. Soc. of Amer. Journal, 43(1): 177-179.
- Johnson, C.E., C.B. Elkins and R.L. Schafer, 1981. Teaming with nature for conservation tillage: a concept. ASAE Paper, no. 81-1019, pp. 11.
- Lal, R., 1975. Role of mulching techniques in tropical soil and water management. IITA Technical Bulletin, No. 1, pp. 37.
- Lal, R., 1976. Soil erosion problems on an Alfisol in Western Nigeria and their control. IITA Monograph No. 1, pp. 160.
- Lyles, L. and J. Tatarko, 1982. Emergency tillage to control wind erosion: influences on winter wheat yields. J. of Soil and Water Conservation, 37(6): 344-347.
- Marelli, H., A. Lattanzi, J. Arce, B. Maseiro and E. Weir, 1980. Soil losses in wheat-soya rotation with direct drilling. Actas, IX Reunion Argentina de la Ciencia del Suelo, Tomo II: 823-827.
- McGregor, K.C. and J.D. Grear, 1982. Erosion control with no-till and reduced till corn for silage and grain. Transactions of the ASAE, 25(1): 154-159.
- Menet, M. and C. Juste, 1978. Interet du semis direct du mais pour le controle de l'erosion enlienue dans les sols sableux des Landes de Gascoigne. Comptes Rendus des Seances de l'Academie d'Agriculture de France, 64(8): 608-615.
- Newman, J.C. (Ed.), 1978. Stubble, trash or treasure? Special issue on conservation tillage. J. Soil Cons. N.S.W.: 185-236.
- NN (Various authors), 1982. Soil Erosion and Conservation in the Tropics. ASA (American Society of Agronomy) Special Publication No. 43, pp. 149.
- Unger, P.W., 1984. Tillage systems for soil and water conservation. FAO Soils Bull. (In press)
- Woodruff, N.P., L. Lyles, F.H. Siddoway and D.W. Fryrear, 1977. How to control wind erosion. Agricultural Information Bulletin, No. 354 (Revised Edition), ARS,USDA Washington, pp. 22.
- Young, R.A. and W.B. Voorhees, 1982. Soil erosion and runoff from planting to canopy development as influenced by tractor wheel traffic. Transactions of the ASAE, 25(3): 708-712.

## 5.0 FARMING SYSTEMS AND SOIL TILLAGE



## 5.1 Dry (Rainfed) Farming

Rainfed farming is a crop production system employed in both temperate and tropical regions whereby the water required for the growth of the plants is supplied only by natural precipitation. Dryland farming is a special form of rainfed farming under arid conditions.

All the cultivation operations should be aimed at making optimum use of the (sometimes sparse) precipitation. As regards soil tillage this means that only those operations should be carried out which ensure that:

- as much precipitation as possible is absorbed by the soil. This also prevents or reduces surface run-off which causes erosion and water loss;
- the water holding capacity of the soil is increased (in particular in summer-rainfall areas);
- the organic matter content of the soil is preserved and, possibly, increased;
- productive evaporation is reduced;
- intensive weed control is achieved (since they are serious competitors for water).

The maximum amount of rainwater can be absorbed only if the soil surface is neither crusted nor compacted. This means that an erosion-resistant coarse cloddy surface covered with plant residue must be created - preferably before the rainy season begins. When a surface crust has been formed by intensive rainfall, it must be broken up by means of a superficial loosening operation; only methods which leave trash on the surface should be employed and not soil-inverting operations.

These operations can also reduce the water-loss caused by evaporation. The sweep, cultivator and crust-breaking rollers are suitable implements. These operations are also usually effective in controlling weeds. The tillage operations may be carried out in fixed patterns or rows, thus forming contour ridges to prevent erosion.

The water holding capacity of the soil can be improved only by increasing the soil pore volume. Losses caused by deep drainage through cracks in heavy soils should, however, be prevented. A deep (non-inverting) loosening operation may be considered but this also facilitates aeration and thus evaporation and accelerated decomposition of organic matter. A compromise must be found allowing for the fact that the possibilities of increasing the pore volume by tillage are limited and the water intake is a much more important factor.

The preservation and augmentation of the soil's organic matter causes problems in semi-arid regions because the decomposition rate is rapid under the high temperatures, particularly when moisture is available. This objective can be achieved by:

- Keeping the plant residue in the soil when possible (there may be a risk of pests, etc.), instead of burning it, as is often the case with crops such as cotton, sugarcane and wheat;
- Leaving the plant residue on the surface during the dry season and mulching it only at the start of the next rainy season. In this way the trash acts as a protective cover against soil erosion and dries out, thus retarding decomposition. When it is worked in immediately after the harvest, a small amount of moisture is sufficient to initiate decomposition. This method also provides better erosion control. Weeds and pests have to be controlled by chemicals.

- Introduction of a suitably adapted crop rotation. Basically, two types of dryland farming may be distinguished:
  - a. Rotation between natural pastures, to collect water and improve fertility, and cultivation of plants with low water demands and correspondingly low yields. This system of shifting cultivation has a long cycle (in the order of 10 or more years, depending on climate) with low capital input and low production costs.
  - b. Production of crops in a system demanding higher input without fallow, or with one or more fallow years to collect water and/or store surface water in small ponds to be used for supplemental irrigation. The soil under fallow may be kept bare by repeated tillage; the resulting "dust mulch" is very susceptible to erosion. Growth of water-use efficient (cover) crops can combine a high production of root mass (organic matter) with surface protection. This latter system is used with success in Australia; in between cropping periods (cereals), there is a period with "grazed fallow". Sheep are allowed to graze on the fields which are sown with subterranean clover and other water-use efficient legumes or grasses. Main benefits involved in this "ley farming" system are accumulation of organic matter and nutrients and a better structure, rather than an improved water supply.

## 5.2 Irrigated Farming

In areas where water is the restrictive growth factor during (part of) the growing period, it should be possible to supply water at the correct time and in sufficient amounts by means of a properly-designed irrigation system.

Crop production conditions can be completely changed by irrigation (different types of crops, a more closely integrated rotation, higher yields, stronger weed growth and a need for additional operations).

Three types of irrigation can be distinguished, depending upon the method by which water is conveyed and supplied to the plant:

- SURFACE irrigation. Water is transported by (open) canals from the source to the fields (either entirely by gravity or with the help of water-lifting units). The water is applied to the field by an open furrow system of flooding.
- SPRINKLER irrigation. Water is pumped from the source to the field in a pressurized (closed) system. Water is applied to the field by aerial spraying through sprinklers.
- TRICKLE irrigation. Here again, water is transported to the field in a pressurized system but is fed very slowly to the soil adjoining the plant through (rubber) tubes or hoses.

All these irrigation systems have a considerable influence upon the soil tillage system, an influence which is most pronounced in the case of surface irrigation in which the soil becomes a component of the irrigation system. Special tillage operations may be needed to:

- level the fields to ensure uniform water distribution;
- construct dams, furrows or rills to convey water;
- supply and distribute water on the field and remove excess water.

There are, however, a three other essential processes of irrigated farming which require special soil manipulation operations:

1. Irrigation water usually contains salts in solution which remain in the soil after the water has evaporated (very quickly in arid regions). These

- salts accumulate in the soil, crystallize on the surface or reach the groundwater.
2. The repeated wetting and drying cycles (which often increase the soil moisture content to levels above field capacity) may cause considerable swelling and shrinkage of the soil.
  3. The application of water may cause slaking (erosion, crust formation) and consolidation (compaction) of the soil.

So soil tillage should produce soil with a high infiltration capacity, good internal drainage and good capacities for removing surplus water. These objectives can be achieved by creating large stable soil aggregates and a continuous macropore system and by preventing or destroying dense layers.

When layering is caused by the combined effect of tillage and irrigation (e.g. puddling), the top layer can again be made homogeneous again by inverting ploughing operations. In hot climates the tillage - and especially deep tillage - should be carried out shortly before the growing period. The aeration of the soil resulting from the tillage causes pronounced mineralization and nitrification of the organic matter; in particular, nitrogen may be leached away. More attention should be given to spreading the fertilizer applications over the entire season in order to reduce leaching losses. One main advantage of irrigation is that it makes it possible to supply water to the soil irrespective of the weather; the soil consistency, which depends upon the moisture content, can be altered to create optimum conditions for soil tillage (energy and time saving, better results from the tillage operations). On the other hand, the timing of the irrigation should take account of the fact that soil is impassable and/or unworkable for some time after a water input, not only in the pre-sowing period but also during the growing period (maintenance tillage).

Although, as regards soil tillage, sprinkler and trickle irrigation cause less problems than surface irrigation, some important aspects should be considered. For example:

- the layout of the water distribution system is usually permanently fixed in the field. The locations of the water outlets restrict the choice of different patterns of plant rows, beds, etc. On sloping fields in particular, this restricts the flexibility of the tillage system;
- the freedom of manoeuvre on the field may be restricted when tubes or pipes are laid down.
- a trickle irrigation system cannot be used for pre-tillage conditioning of the soil.

The installation of irrigation systems involves a high capital investment which can be amortized only by higher yields. Measures for increasing production should include in particular properly-adapted tillage methods.

### 5.3 Cultivation And Harvest Practices

A large number of crops, such as potatoes, groundnuts, maize, sunflowers, sugarbeet, cotton and many types of vegetables, are grown on beds or ridges. The ridges (and furrows) are usually formed immediately before sowing or planting but can also be constructed after the previous crop has been harvested. Small ridges may even be created during the growing period, e.g. as part of the weeding operation.

The tillage operation employed to construct the ridges may be carried out for various reasons:

- water and temperature control in the soil;
- furrow irrigation;
- erosion control;
- to improve the efficiency of the harvesting methods.

With furrow irrigation the plants stand on the top or shoulder of the ridges and the furrows are used for supplying water to the crop. The aim of the tillage should be to wet the ridges uniformly over their entire length (slight but constant gradient). The machinery used has to fulfil different functions depending upon the conditions of the field and soil; sometimes a low infiltration rate in a clean furrow is better (long gentle slopes) while completely opposite requirements may obtain in other cases (short steeper slopes). On very permeable soils the bottoms of the furrows may even have to be compacted to prevent too much water infiltration at the beginning of the furrow near the water inlet.

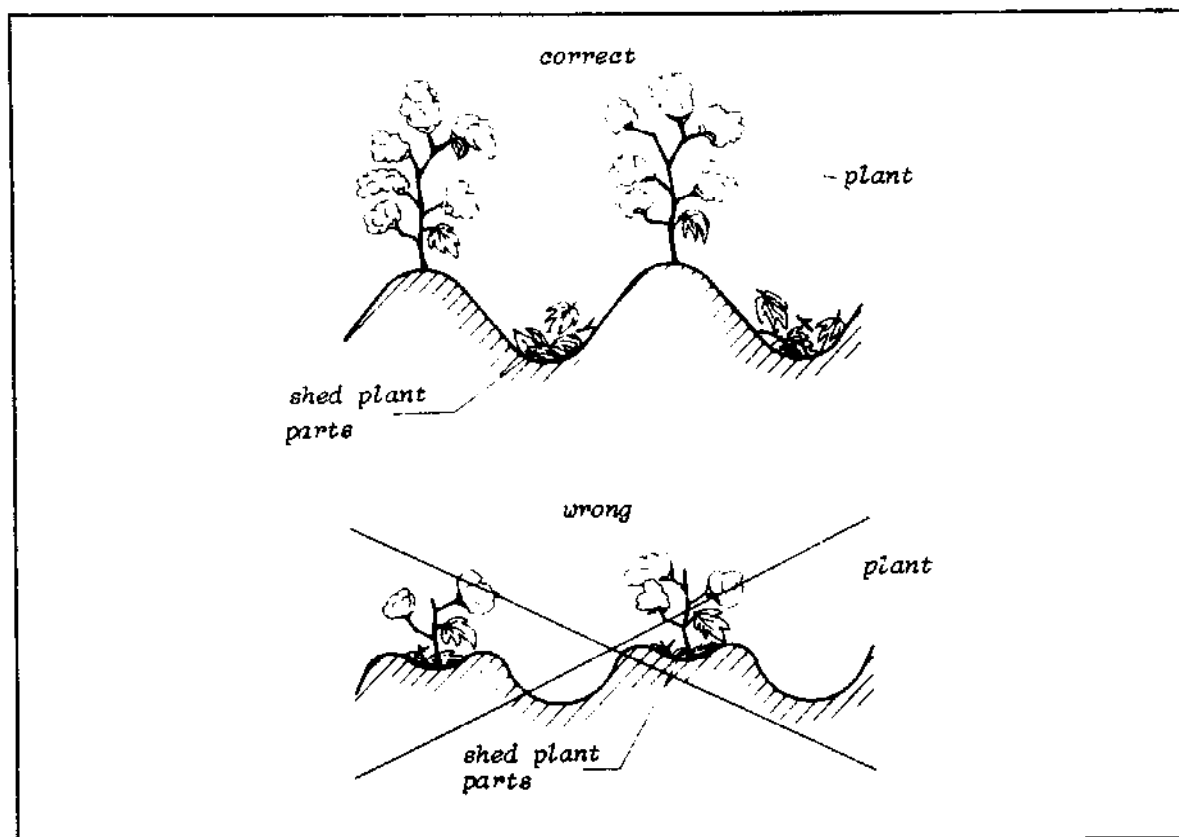

Fig. 16. Ridge shapes for cotton; Dead leaves should drop in the furrow (top fig.) and not on the top of the ridge (bottom fig.).

Erosion can be reduced and gully formation prevented by measures which decelerate the flow in the furrows or by growing crops in ridges which follow the contours. The latter method may be particularly effective in summer-rainfall regions but the ridges must be large enough not to collapse. If they do, the damage caused by "crossflow" can be very serious. All the rainwater should infiltrate in the furrows and so the soil should be kept loose in case the infiltration capacity is too low.

When rainfall distribution and intensity are such that the risk of crossflow is too great, the furrows may be formed with a slight gradient (about 0.5%) so that surface drainage can be controlled.

Some harvesting methods require that the crops are grown in ridges (e.g. minimum movement of the soil when digging potatoes or groundnuts). When cotton-picking machines are used the crop is best grown on ridges. The ridges should have the shape shown in Fig. 16 with the plants sited on the crest. In this way all the leaves shed before the harvest are deposited at the bottom of the furrow and cannot be caught up by the picking machine and foul the cotton. Cotton is also grown in beds with the same widths as the picking machine (this is approx. 2 m for dual-row machines).

For various reasons mechanized harvesting often cuts sugarcane directly below the surface of the soil. This is facilitated if the cane is grown on (small) ridges.

Maize is often sown in the furrows while the ridges are used to bury the residue of the previous crop. Ridges can also be split open after the harvest to cover the residue lying in the former furrows and to form new furrows under the previous ridges. This system makes it possible to prepare a new surface configuration and seedbed in one pass while permitting thorough movement of the soil (loosening).

Under some climatic conditions slow warming and/or drying of the soils (especially heavy soils) in spring can cause problems. The preparation of the seedbed may be delayed because the soil is unsuitable for traffic while sowing should be as early as possible. These conditions obtain, for example, in the northern part of the US Corn Belt (wet and cold in spring) and in Israel's Mediterranean climate (wet or moist conditions in spring). In the Corn Belt, advantage should be taken of the short hot summer while in Israel optimum use should be made of the rainwater stored in the soil during the winter. Consequently, ridges and beds can be prepared in the autumn so that sowing can take place as early as possible in the spring without the need for further preparation. This method can save at least one and possibly two weeks. The speed at which the soil is warmed is also increased by aligning the ridges along an east-west axis.

#### 5.4 Literature

- Ali, M. and R. Prasad, 1974. Effects of mulches and type of seedbed on pearl millet (*Pennisetum typhoides*) under semi-arid conditions. *Experimental Agriculture*, 10(4): 263-272.

- Anderson, R., 1980. The land imprinter. *World Farming*, 22(1): 20-22.
- Batchelder, D.G., and G. McLaughlin, 1978. Seedbed preparation for dryland narrow-row cotton production. *Transactions of the ASAE*, 21(3): 451-454,459.
- Batchelder, D.G., J.G. Porterfield and G. McLaughlin, 1974. Zone seedbed preparation for cotton production. *Transactions of the ASAE*, 17(3): 461-462.
- Bauer, A. and T.J. Conlon, 1978. Influence of tillage interval of fallow on soil water storage. *North Dakota Farm Research*, 35(4): 11.
- Beye, G., 1977. Etude de l'action de doses croissantes d'azote en presence ou en absence de paille de riz enfouie sur le developpement et les rendements du riz en Basse-Casamance. *Agronomie Tropicale*, 32(1): 41-50.
- Booher, L.J., 1976. Surface irrigation. *FAO Agricultural Development Paper No. 95*, pp. 160.
- Burrows, W.C., R.E. Reynolds, F.C. Stickler and G.E. van Riper (Eds.), 1970. *Proceedings of an international conference on mechanized dryland farming (August 1969)*. John Deere & Co., Moline, Ill., pp. 343.
- Carreker, J.R., S.R. Wilkinson, A.P. Barnett and J.E. Box, 1977. Soil and water management systems for sloping land. *USDA-ARS Report No. ARS-S-160*, pp. 76.
- Fornstrom, K.J. and C.F. Becker, 1977. Comparison of energy requirements and machinery performance for four summer fallow methods. *Transactions of the ASAE*, 20(4): 640-642.
- Gaury, F., P.A. Roger and Y. Dommergues, 1978. A propos de l'enfouissement de pailles dans les sols sableux tropicaux du Senegal. *Comptes Rendus des Seances de l'Academie d'Agriculture de France*, No. 6: 445-453.
- Hakimi, A.M. and S.M. Chakrabarti, 1976. The profitability of selected cultivations and their influence on growth and yield of silage corn (Iran). *Journal of Agric. Engineering Research* 21(1): 15-19.
- Hudson, N.W., 1975. *Field engineering for agricultural development*. Clarendon Press, Oxford, pp. 225.
- Hughes, H.A., 1980. *Conservation Farming*. John Deere & Co., Moline, Ill., pp. 150.
- Karimi, H. and F. Tabesch, 1979. Ergebnisse zweijaehriger Feldversuche zur Wirkung verschiedener Bodenbearbeitungsmethoden und Sorten beim Trockenfeldebau des Weizens in Trockenwaermen Landbaugebieten Irans. *Bodenkultur*, 30(2): 144-150.
- Lorenz, F., 1978. *Bodenbearbeitung im Trockenfeldebau*. Entw. und Zusammenarbeit, 12(5): 18-19.
- Moomaw, R.S. and O.C. Burnside, 1979. Corn residue management and weed control in close-drilled soybeans. *Agronomy Journal*, 71(1): 78-80.



- Musick, J.T., A.F. Wiese and R. Allen, 1977. Management of bed-furrow irrigated soil with limited- and no-tillage systems. Transactions of the ASAE, 20(4): 666-672.
- Reddy, D.S., D.R. Reddy and G.V. Chary, 1977. A note on the effect of deep ploughing on basic infiltration rate of soils, root growth and grain yield under rainfed agriculture at Anantapur. Annals of Arid Zone, 16(1): 149-152.
- Reddy, S.R. and S.B. Hukkeri, 1979. Soil, water and weed management for direct-seeded rice grown on irrigated soils in north-western India. Indian Journal of Agricultural Sciences, 49(6): 427-433.
- Siemens, J.C. and W.R. Oschwald, 1973. Corn-soybean tillage systems: erosion control, effects on crop production, costs. Transactions of the ASAE, 21(2): 293-302.
- Smith, J.A. and K.J. Fornstrom, 1980. Energy requirements of selected dryland wheat cropping systems. Transactions of the ASAE, 23(4): 822-825, 830.
- Soil Conservation Soc. of America, 1973. Conservation tillage. Proceedings of a national conference, March 1973. SCS, Ankeny, Iowa, pp. 241.
- Soil Conservation Soc. of America, 1979. Effects of tillage and crop residue removal on erosion, runoff and plant nutrients. SCS Special publication No. 25, Journal of Soil and Water Conservation, 34(2):74-98.
- Stibbe, E. and A. Hadas, 1977. Response of dryland cotton plant growth, soil water uptake and lint yield to two extreme types of tillage. Agronomy Journal, 69(3): 447-451.
- Tydens, N.M., 1981. Conservation tillage using Roundup. Australian Weeds, 1(1): 29-30.
- Unger, P.W., 1979. Effects of deep tillage and profile modification on soil properties, root growth and crop yields in the United States and Canada. Geoderma, 22(4): 275-295.
- Unger, P.W. and T.M. Mc Calla, 1980. Conservation tillage systems. Advances in Agronomy 33: 1-58.
- Wambeke, A. van, 1974. Management properties of Ferrasols. FAO Soils Bulletin 23.

## **PART II**

### **Tillage Equipment and Operations**

## 1.0 THE CHOICE OF IMPLEMENTS



effect implement	loosen		crumble	mix	incorporate mulch	invert	break crusts	comp
	shallow	deep						
mouldboard plough	X	X	X		X	X		
disc plough	X	X	X	(X)	(X)	(X)		
chisel plough	X	X	X	X	X			
rotary tiller	X		X	X	X			
skim plough	X		X		X	(X)		
disc harrow	X		X	(X)	X		X	X
rotary harrow	X		X	(X)	X		X	
rotary hoe	X		X				X	
rigid tine harrow	X		X	(X)				
light/flex. tine cultivator	X		X				X	
roller harrow	X		X					(X)
reciprocating hoe	X		X	(X)			X	
rotating hoe	X		X	(X)			X	
leveller/drag			X				X	X
roller							X	
subsurface packer		(X)					X	
weeder	X		X				X	
mouldboard ridger	X		X				X	
disc ridger	X		X				X	
leveller bed shaper								X
one-way tiller	X		X		X		X	
sweep	X	X	X					
rod weeder	X							
diamond plough	X	X	X		X	X		
combination *	X	X	X	X	X			
clod breaker	(X)		X	(X)				X
spade plough	X	X	X	X	X	(X)		

\*: sweep with rear mounted tine rotor

X: suited

(X): suited under certain conditions only

Table 1. Possible use of various tillage implements.

ridge mech.    stubble prim.    second.    remarks  
 weed    till    tili    till  
 control

	X	X	X		losses of water and organic matter; erosion danger function comparable to wedge plough; two operations necessary erosion danger!
	X	X	X		
	X	X	X		
	(X)	X	(X)	X	

	X	X			universal and versatile implement two operations at high speeds; not suitable for dry, hard soils
	(X)	X		X	
	X	X		X	
X	X				

	X				only on loose soil (after (chisel) plough)
	X			X	
	X			X	
	X	X		X	
				X	
				X	
	X				
X	X				

X					

	X	X	X	X	
			(X)	X	
				X	

	X	X	X		
	X	X	X	X	
	X	X	(X)	X	
	X	X	X		

## 1.1 Implements For Soil Tillage

The objectives of soil tillage and the basic tillage processes have been discussed in Part I of this book. A large number of implements are available (Table 1) to achieve the various objectives under a wide range of conditions (before, during and after the vegetation period: see Fig. 3).

The following criteria should be considered when choosing the correct implement:

- The implement's trouble-free performance under the given conditions (implement effect) taking the entire sequence of implements into consideration (possible combination of different operations);
- Potential (detrimental or beneficial) side-effects which may be expected, such as weed control, soil compaction, erosion, salinization, mineralization, decomposition of humus, loss or conservation of water;
- Sufficient capacity to cover the entire area in the time available, allowing for the size, shape and accessibility of the fields;
- Compatibility with the available tractor(s), the implement power requirements, available p.t.o. power, lifting and carrying capacities, standards of mounting systems;
- Maintenance requirements, supplies of spare parts, standardization;
- Labour requirements (and for subsequent operations);
- Need to instruct the operators in using and servicing the equipment;
- Available results of internationally recognized testing methods and practical tests.

## 1.2 Practical Soil Tillage

A soil tillage operation can never be assessed in isolation because all the subsequent operations are influenced. For example, irrigation requires very level fields (one-way instead of two-way ploughs); the accuracy (uniformity) required for a seedbed ranges from low when large amounts of cereal seeds are broadcast, to very high for precision drilling for the final stand of row crops, such as sugarbeet; mechanized harvesting methods may call for very level surfaces so that the crops can be cut close to the ground.

The interactions between soil/climate/plant/machine should always be viewed as a whole. With increasing equipment (and labour) costs and the need for higher productivity per area unit (by operating at the optimum times with a closely integrated crop rotation) high capacity and utilization should be the aims but they must not be achieved at the expense of the quality of the work. This objective must be attained by means of adequate training and attractive working conditions (possibly shift-work) for the personnel, sufficient maintenance, servicing and spare parts for the implements and optimum operating conditions (field shape, trafficability, etc.).

The number of tillage operations, the working depth and the intensity should all be kept to a minimum. Passes with some tillage implements may be combined with others or omitted (savings in energy and time and reduction of the number of wheel-tracks). The following points must be considered when tillage operations are combined:

- The optimum travelling speed of the various implements;
- The lifting capacity and power required from the tractor and the danger of taking the load off the front axle;
- Time required for preparing the implement;

- Control of the various functions (too many demands must not be placed on the operator);
  - Manoeuverability of the entire unit, transport.
- A number of implement combinations or trains have proved feasible, mainly with well-developed and highly-mechanized farming, and their success depends upon the soil and crops (Chapter 8).

Although self-propelled equipment is now available for nearly every harvesting operation, most tillage implements still have to be drawn or driven by a tractor. Owing to the severe demands on the power transmission, the lifting capacity and the degree of integration with the implement, tractors are still to a large extent constructed and designed to suit tillage implements. So correct matching of the tractor with the implements is essential for effective tillage.

Standardization of the 3-point hitch system and p.t.o. drive system and the development of suitable quick-coupling devices can simplify the mounting of the implements and reduce the risk of accidents.

The number of tractor wheel-tracks and the structural damage to the soil should be reduced to a minimum (avoiding slippage, filling the tyres with water, dual mounting of rear wheels, cage wheels, lower air pressures).

### 1.3 The Terminology Of Soil Tillage

The wide range of conditions under which tillage equipment is used inevitably means that the terminology for tillage equipment is not standardized.

The most common names and terms for implements, tools and systems are employed in this book. Anyone using or buying equipment will find that in many cases the manufacturer or importer markets equipment under trade-names which are not entirely specific as regards their function or potential field of application (components such as "rota-" or "-tiller" are very popular). The difference between USA and UK terminology may be confusing; for mouldboard ploughs (moldboard plows, USA) a reversible plough, equipped with opposite sets of plough bodies, is called "one-way" in the UK and "two-way" in the USA, the type with fixed bodies "two-way" in the UK and "one-way" in the USA. In this book, the UK terminology will be used.

A summary of the terminology for dryland tillage equipment is given in FAO (1971) while the American Society of Agricultural Engineers and the Soil Science Society of America issue glossaries of soil tillage terms (ASAE 1979, 1982, SSSA, 1978).

### 1.4 Literature

ASAE, 1979. Terminology and definitions for soil tillage and soil-tool relationships. Agricultural Engineers' Yearbook: 263-265.

ASAE, 1982. Terminology and definitions for agricultural tillage implements. ASAE Standard: ASAE S414. In: Agricultural Engineers Yearbook 1982: 232-241.

- Bernacki, H. et al, 1972. Agricultural machines, theory and construction. Vol. 1. USDA, Washington, pp. 883.
- Blight, D.P., 1979. Research into powered cultivations. *Agricultural Engineer*, 34(4): 96-98.
- Boehm, E. and J.A. Hansen, 1977. Agrartechnische Lehrbriefe, Landmaschinen 212-1 (Annex to Agrartechnik International). Vogel, pp. ??.
- Boyd, J., 1976. Tools for agriculture; a buyer's guide to low-cost agricultural implements. Intermediate Technology Publications Ltd. London, pp. 173.
- Buckingham, F., 1976. Fundamentals of machine operation: Tillage. John Deere & Co., Moline, Ill., pp. 368.
- CNEEMA, 1973. Tracteurs et machines agricoles, Livre de Maitre; Tome 2: Principales machines agricole de culture et de recolte. CNEEMA, Antony, France, pp. ??.
- Culpin, C., 1978. Farm machinery (9th Edition). Crosby, Lockwood, Staples, London, pp. 410.
- Dalleine, E., 1979. Les facons en travail du sol - choix des outils pour corriger au mieux un profil cultural. *Etudes du CNEEMA*, No. 455, pp. 75.
- Dwyer, M.J., 1982. Agricultural engineering state-of-the-art report. *J. Terramech.*, 19(1): 9-29.
- Esmay, M.L. and C.W. Hall, 1973. Agricultural Mechanization in Developing Countries. Shin-Norinsha Co., Tokyo, Japan, pp. 221.
- FAO, 1971. Tillage and seeding practices and machines for crop production in semi-arid areas. *FAO Agricultural Development Paper No. 92*, pp. 53.
- Feuerlein, W., 1971. Geraete zur Bodenbearbeitung. Ulmer, Stuttgart, pp. 161.
- IMAG, 1977. Trade Mark Guide of agricultural and forestry equipment in The Netherlands, Instituut voor Mechanisatie, Arbeid en Gebouwen, Wageningen, The Netherlands, pp. 442.
- IMAG, (undated). Equipment for vegetable production. Instituut voor Mechanisatie, Arbeid en Gebouwen, Wageningen, The Netherlands, pp. 185.
- Kepner, R.A., R. Bainer and E.L. Barger, 1978. Principles of Farm Machinery. AVI Publishing Company, Westport, Conn., USA, pp. 527.
- NN (Various authors), 1978. Bodenbearbeitung und Bestelltechnik. *Berichte ueber Landwirtschaft*, Bd. 56, Heft 2-3.
- Renaud, J., 1980. Les outils de travail du sol animes par la prise de force. *Motorisation et Technique Agricole*, 19/20: 6-23.
- Schafer, W., 1979. Ein Rechenmodell zur vergleichenden Beurteilung der Verfahrenskosten bei Bodenbearbeitungsgeraeten. *Grundlagen der*



Landtechnik, 29(5): 162-166.

Sheikh, G.S., S.I. Ahmed and A.D. Chaudhry, 1978. Comparative performance of tillage implements. AMA, 9(4): 57-60.

SSSA, 1978. Tillage Terminology. In: Glossary of soil science terms, Appendix 5. Soil Science Society of America, Madison, Wisc.: 31-34.

Stroppel, A., 1977. Eine Methode zur Beurteilung von Bodenbearbeitungsverfahren im Hinblick auf die Schlagkraft. Grundlagen der Landtechnik 27(4): 108-114.

Wieneke, F. and Th. Friedrich, 1982. Agrartechnik in den Tropen. DLG Verlag, Frankfurt, pp. 299.

Wilkinson, R.H. and O.A. Braunbeck, 1977. Elements of agricultural machinery. Volume 1. FAO Agricultural Services Bulletin No. 12, Suppl. 1, pp. 241.

## 2.0 IMPLEMENTS FOR PRIMARY TILLAGE

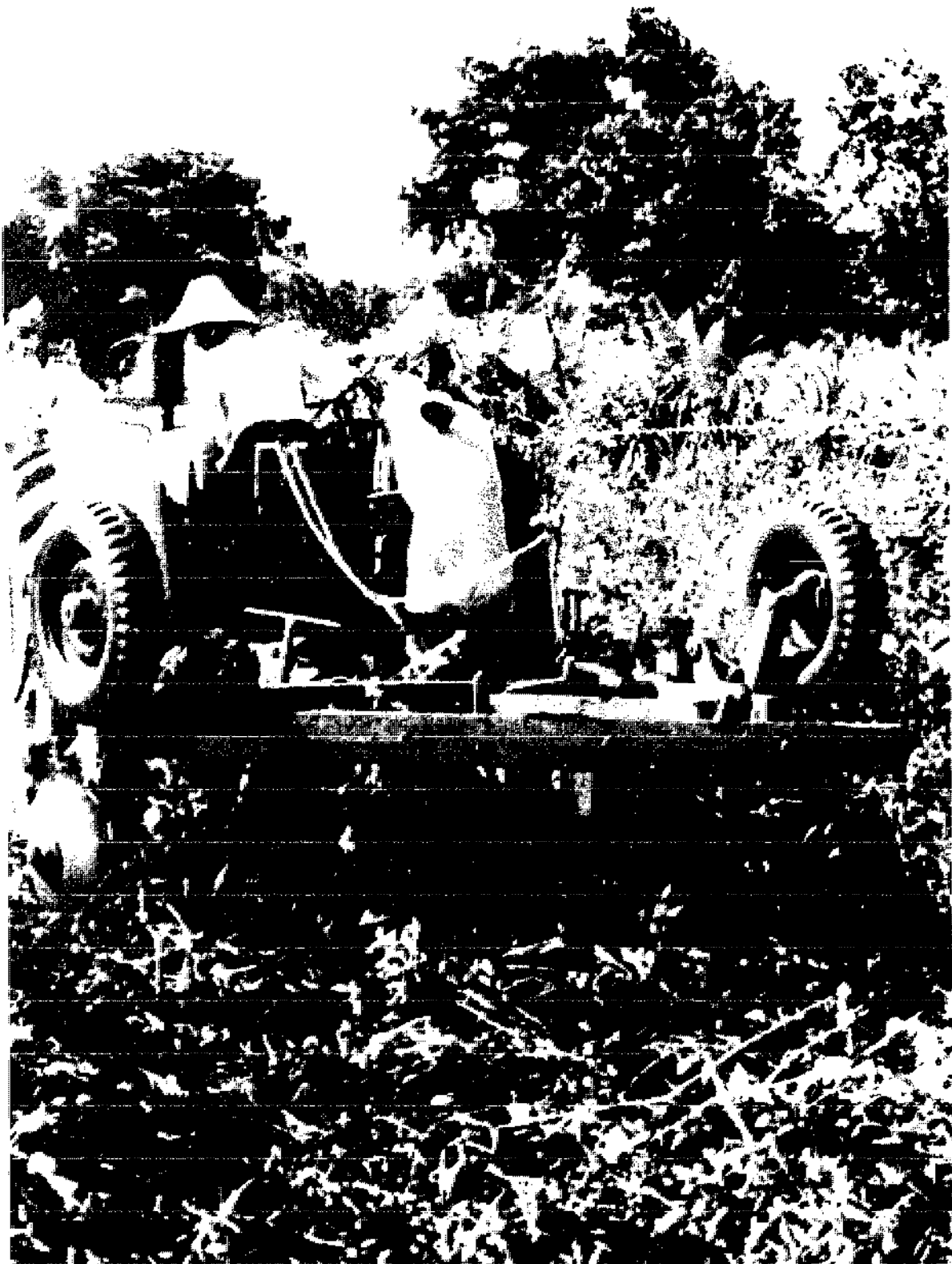

The main purpose of primary tillage is to create sufficient pore volume for absorbing water and air and to allow easy penetration of plant roots by loosening the soil down to the bottom of the arable layer. If the soil is inverted organic matter is deposited at deep levels, weeds are controlled and, under certain conditions, leached fine soil material and nutrients are restored to the surface. Crumbling and mixing are important, especially in areas where the following crop has to be sown shortly afterwards and many (secondary) tillage operations cannot be carried out.

Essentially, the following implements are available:

- mouldboard plough,
- disc plough,
- chisel plough,
- rotary tiller.

The functions of these implements are compared in Fig. 17.











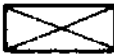
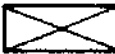



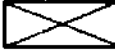
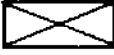

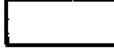
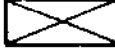
<i>implement</i> <i>effect</i>	<i>mouldboard</i> <i>plough</i>	<i>disc</i> <i>plough</i>	<i>rotary</i> <i>tiller</i>	<i>chisel</i> <i>plough</i>	
<i>pulverizing</i>					
<i>loosening</i>					
<i>mixing</i>					
<i>inverting</i>					
<i>big</i>		<i>medium</i>		<i>small</i>	

Fig. 17. Some effects of primary tillage implements after Heege.

Less common or specialized implements, such as the spading machine, will not be discussed in this chapter. Primary or main tillage operations are required on all soils for each crop or each year.

A benchmark in the history of mankind's development was achieved when the Sumarians invented the sowing technique and the hoe for loosening the soil in Mesopotamia more than 5000 years ago. Some 4000 years ago the Sumarians were able to introduce new forms of livelihood and settlement by using wedge (or ard) ploughs in a regular crop production system. This occurred after the domestication of animals (sheep and cattle) and the training of those animals for draught work.

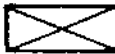
The first hoe was simply a branch used to scratch the soil. With relatively minor improvements this implement has survived in numerous countries (some 70% of all the world's farmers are still using wedge ploughs). This implement, together with a simple wooden leveller, is employed as a standard tool for primary tillage, preparing seedbeds and forming furrows and ridges for sowing and irrigation.

The wedge plough is the most typical and widely-used primary tillage tool in the arid tropics and subtropics. The implement loosens the soil without inverting it, leaves a rough structure and does not completely bury plant residue. Consequently, the tilled surface is less susceptible to erosion. The relatively low draught required is adapted to the prevalent conditions. The heavy seedbed preparation operations usually have to be performed before the rainy season when the draught animals are often weakened by inadequate food supplies during the dry season.

The inverting plough was developed around the early Christian era in the north-western European regions, i.e. in a cool humid climatic zone. The principal advantage of this implement is that it definitely improves weed control. The tillage intensity is also higher. In an experiment 50% of the surface was covered with clods > 50 mm after being tilled with a wedge plough whereas only 15 - 20% of the surface was covered by such clods after being tilled with a mouldboard plough.

The disc plough generally produces less intense and a different quality of tillage than the mouldboard plough but it is more suitable for rougher conditions (soils with roots, boulders or gravel).

The chisel plough may be used instead of the disc or mouldboard plough in many cases. In terms of performance, it is a direct descendant of the hoe.

In contrast, the rotary tiller makes the most of the tractor's power take-off device and is particularly suitable for intensive mixing of soil and organic matter, as well as for intensive tillage (churning) of the soil itself.

When combined with other operations for increasing production, deep primary tillage usually leads to higher yields with little risk of crop failures. From the economic point of view, however, trials are needed to determine whether maximum yields also provide maximum (cash) returns. The ecological and sociological aspects should also be taken into account.

#### A note on Subsoiling

The following pages do not examine subsoiling equipment in detail because subsoiling should not be considered as a regular operation but as a special treatment for improving the soil (profile). This operation may be carried out only once or at intervals of several years.

Subsoiling is "Any treatment to loosen soil with narrow tools below the depth of normal tillage without inversion and with a minimum mixing of the soil. This loosening is usually performed by lifting action or other displacement of soil dry enough so that shattering occurs" (SSSA Tillage Terminology, 1978).

In practice, it is difficult to make a clear distinction between chisel ploughing and subsoiling and subsoiling is too often adopted as a regular farming technique. Soil compaction caused by bigger and heavier tractors and equipment is usually given to justify subsoiling operations.

Unfortunately, the very fact that heavy tractors are used may tempt a farmer to buy and use subsoiling equipment.

In many cases the results of subsoiling are scarcely positive and may even be detrimental as regards not only the soil structure but also the financial benefits. The operation requires a high energy consumption and is effective only when there is a genuine hardpan which can be shattered under dry soil conditions. A correctly performed subsoiling operation will have longer-lasting results on heavier soils than on light sandy soils.

Subsoiling operations must be given careful consideration, especially in developing countries where only limited energy and equipment are available. "Under-the-row" subsoiling methods which build a ridge on top of the furrow made by the subsoiler shank have produced positive results in the USA but only under specific weather conditions.

### 2.0.1 Literature

Cote, D. and G. Dupuis, 1980. Effets du sous-solage et du labour profond sur les propriétés physiques du sol et le rendement de la luzerne et du maïs sur loam sableux Chaloupe. *Canadian Journal of Soil Science*, 60(2): 345-353.

Dalleine, E., 1982. De l'air pour le sous-sol. *Tracteurs et Machines Agricoles*, No. 790: 3-7.

Davies, D.B., 1982. Subsoil management. *The Agricultural Engineer*, 37(1): 20-23.

Garner, T.H. and D. Wolf, 1981. Tillage energy versus hardpan configuration and tillage depth. *ASAE Paper*, No. 81-1572, pp. 15.

Goyal, M.R. and L.O. Drew, 1979. Chisel plowing vs. moldboard plowing. *AMA*, 10(4): 51-56.

Grant, P.M., G.J. Meikle and W.R. Mills, 1979. A comparison of plough types and depths of annual ploughing for maize monoculture with varied manuring. *Rhodesian Journal of Agricultural Research*, 17(2): 99-123.

Hammond, C., J.T. Reid and W.E. Seigler, 1981. Seedbed preparation behind row subsoilers. *Transactions of the ASAE*, 24(4): 897-901,904.

Hoogmoed, W.B., 1982. Final report of a consultancy to IAPAR, Londrina (Erosionsbekaempfung Parana, Brasilien). *GTZ*, Eschborn, Proj. No. 76.2014.9, pp. 174.

NN, 1979. Tieflockerer. *Landtechnische Zeitschrift*, 30(7): 986-987,990.

NN, 1981. Ploughs and ploughing: tractors and traction. *Publication Scottish Agricultural Colleges*, No. 80, pp. 38.

Trouse Jr., A.C., 1983. Observations on under-the-row subsoiling after conventional tillage. *Soil & Tillage Research*, 3(1): 69-81.

# 2.1 The Mouldboard Plough



### 2.1.1 Use And Assessment

The mouldboard plough can be used for the following purposes:

- stubble tillage,
- deep inverting tillage,
- mechanical weed control,
- working in organic matter (plant residue, green or cattle manure),
- seedbed preparation,
- wasteland cultivation (reclamation).

The mouldboard plough (Fig. 18) is a typical soil tillage implement in the temperate latitudes; it is not really suitable for the arid tropics and only partially suitable for the humid tropics. Fields tilled with a mouldboard plough are susceptible to wind and water erosion. Much water will be lost by evaporation and the decomposition of organic matter will be accelerated because of the increased aeration and heating of the soil. Even in a temperate climate the decomposition of organic matter resulting from ploughing is estimated at approx. 2 tons/ha/year. A further disadvantage of this plough is its high draught requirement. The risk of smearing the furrow bottom by tractor-wheel slippage is high, specially on wet soils. With irrigated agriculture nutrients may be leached down in the profile by water gifts. A short-body mouldboard plough drawn at low speed is often used when such conditions obtain and weed control is particularly important.

Use of the mouldboard plough is justified only under conditions where - combined with other measures - it will lead to higher yields, without increasing the risk of erosion and where the resultant accelerated decomposition of organic matter can be offset by additional biomass left on the field (roots, plant residue).

Use of the mouldboard plough may also be warranted by the need to control weeds. Factors militating against the use of the mouldboard plough in the tropics and on heavy soils in the subtropics are its limited capacity (ha/hour) and the intensive secondary tillage needed to break up the large hard clods after primary tillage to prepare a seedbed.

When the soil is to be tilled shortly after the rainy period, more efficient equipment is required, such as the chisel plough, disc implements or p.t.o.-driven implements. Fig. 17 compares the functions performed by these implements.

Nevertheless, the plough is a strong simple implement and only a few of its parts are subject to wear and tear.

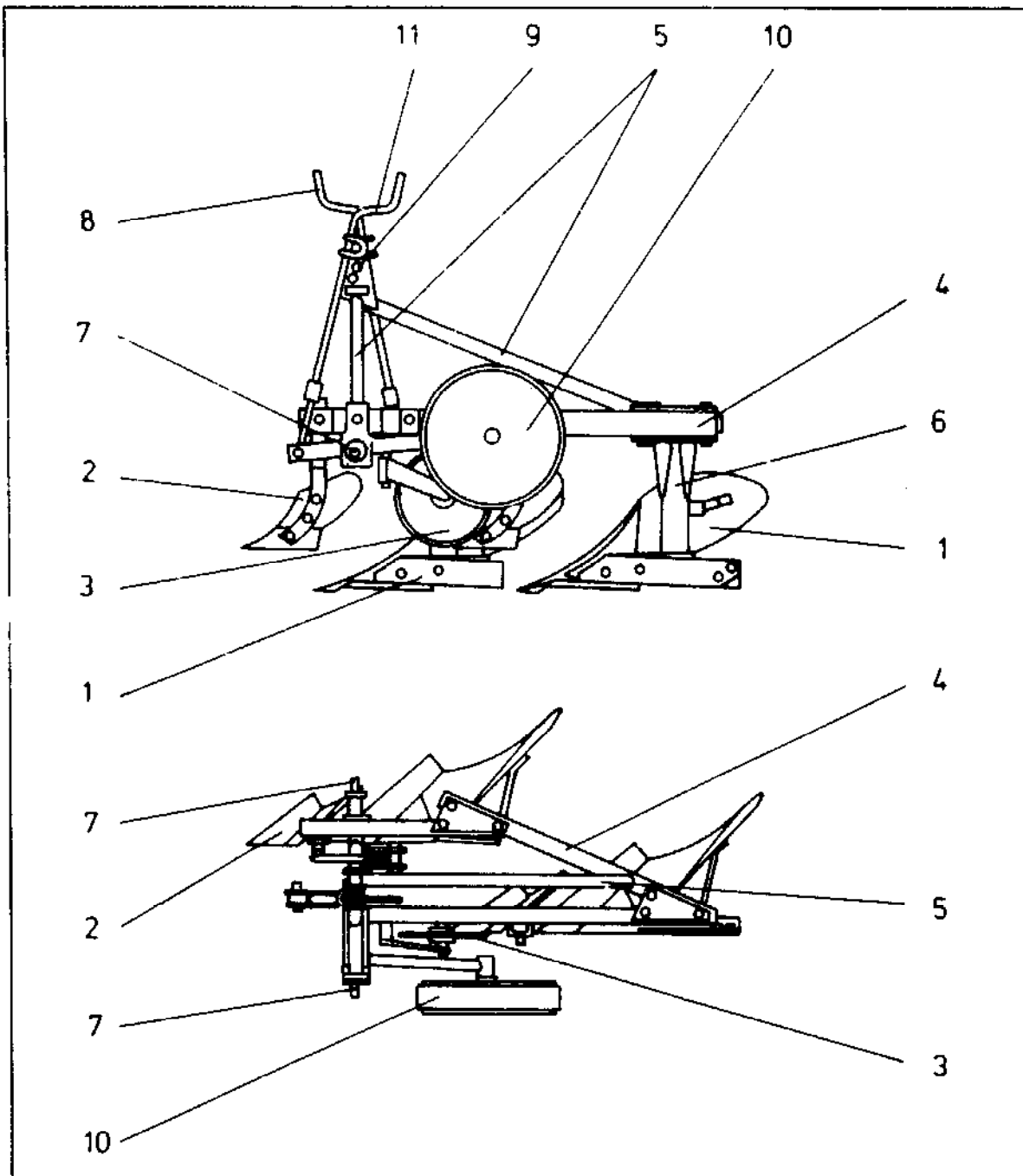

Fig. 18. Mouldboard plough (two-way, mounted) after Bernacki.

Soil engaging tools:

- 1. Body,
- 2. Jointer,
- 3. Disc coultter,

Supporting parts:

- 4. Frame,
- 5. Headstock (column) with brace,
- 6. Shank,
- 7. Hitch bar with linking pivots,
- 8. Spindle to adjust width,
- 9. Hitchpoint for upper link,
- 10. Support wheel,
- 11. Spindle to adjust supportwheel.



### 2.1.2 Functioning

The plough body cuts a slice of soil whose height and width are in the ratio of about 1:1.5 to 1:1. The share makes the horizontal cut while the edge of the share and mouldboard (shin) produces the vertical cut (often with the help of a coulter). The furrow slice is lifted, moved upwards along the mouldboard and turned over an angle of 120 - 150 degrees, depending upon the shape of the mouldboard. When this operation is performed at a correct speed the soil is transported laterally over the width of the furrow (Fig. 19). The lifting, compacting, bending and turning processes will cause the slice to rupture both lengthwise and laterally. The free fall which follows these processes breaks up the soil even more. A tailpiece extends the function of the mouldboard and prevents the slice from falling back into the furrow.

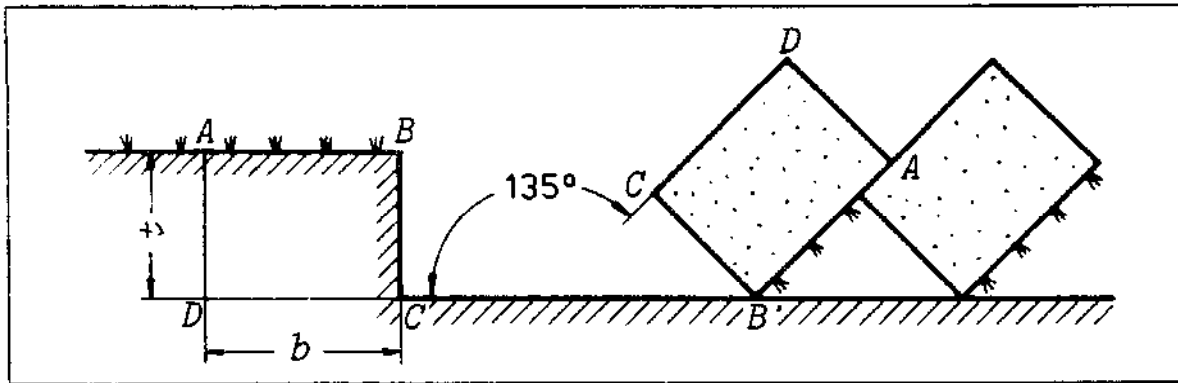

Fig. 19. Inversion and lateral transport of the soil slice during ploughing.

The degree of pulverization and loosening of the soil slice depends upon the shape of the plough body, the working speed, soil-type and the soil moisture content. The actual slice is not mixed. Material on the surface or the soil (plant residue, weeds, manure) is deposited in strips or "mats" on the bottom of the furrow and on the sides of the slice.

Attachments mounted in front of and on the mouldboard assist the functioning of the plough body. Knife, disc and mouldboard-mounted coulters cut the soil vertically in front of share or shin. The knife coulter has a sword-shaped cutting edge. The disc coulter is more expensive but less likely to become choked and requires less draught. Ripple-edged and notched (cut-out) coulters are particularly useful when the surface is covered with loose plant material.

The skim coulter (jointer, USA) is a small plough body. This attachment skims off the surface of the soil in front of the share over approximately half the working width. It moves the material from this strip into the main furrow.

The manure burying coulter (manure feeder, USA) is a steep curved and rounded plough body with a narrow cutting width designed to take the farmyard and green manure off from the side of the furrow, ensuring that this material is covered after the slice has been turned.

The extension on the mouldboard helps to turn the trash-covered surfaces and reduces the risk of choking. When large amounts of plant material have to be coped with, the clearance between two successive plough bodies and the height of the frame are vital factors for ensuring uninterrupted functioning.

Many types (standard and special-purpose) ploughs are available but only the main ones will be mentioned here:

Two-way ploughs are equipped with plough bodies which turn the furrow slices to one side only - usually to the right. This requires two specific methods: "face to face" and "back to back" ploughing. When a field is more than some 60 m wide it is advisable to arrange it in strips (lands) which are to be tilled separately. The "back furrows" (two furrow slices thrown back to back) and "dead furrows" (two open furrows together) will remain on the field after tillage.

One-way or reversible ploughs have two sets of bodies mounted symmetrically on a shared frame which can be rotated over 180 degrees (sometimes 90 degrees) along the longitudinal axis. This arrangement makes it possible to turn the furrows towards the same side of the field even though the plough travels in opposite directions. The bodies can be rotated or swivelled mechanically or hydraulically. If the plough is correctly adjusted, the surface of the soil is left almost level, which is important for irrigation and drainage purposes. The two-way and one-way ploughs are compared in Table 2.

Type	Advantages	Disadvantages
Two-way	<ol style="list-style-type: none"> <li>1. Cheaper to buy,</li> <li>2. Relatively simple to adjust,</li> <li>3. Wear only on (replaceable) tools,</li> <li>4. Large forces transferred via upper link (to activate hydr. control system),</li> <li>5. More ploughs can work (offset) behind each other,</li> <li>6. Simple way of mounting tools at the rear.</li> </ol>	<ol style="list-style-type: none"> <li>1. Dead- and back furrows unavoidable,</li> <li>2. Careful layout of field necessary,</li> <li>3. Width of individual lands no more than 60 m,</li> <li>4. More attention is necessary during secondary tillage,</li> <li>5. Large headlands necessary,</li> <li>6. Plough does not easily penetrate in dry soils,</li> <li>7. Contour-line ploughing on slopes is seldom possible.</li> </ol>
One-way	<ol style="list-style-type: none"> <li>1. Big savings in time on small fields,</li> <li>2. Laying out of the fields in lands not necessary,</li> <li>3. A level surface can be created,</li> <li>4. Contour ploughing on slopes is possible.</li> </ol>	<ol style="list-style-type: none"> <li>1. More expensive as the two-way plough (2-3 times),</li> <li>2. Heavy construction, causing a strong relief of the front axle load of the tractor,</li> <li>3. Swivelling mechanism is subject to wear,</li> <li>4. Symmetrical adjustment (of both sets of bodies) is difficult,</li> <li>5. Weight limits the total number of bodies.</li> </ol>

Table 2. Comparison between one- and two-way ploughs.

### 2.1.3 Linkage And Drive Systems

Drawn or trailer ploughs are fitted with wheels to control their depth. These ploughs are not linked to the tractor's hydraulic system - the only link is the hitchbar. They produce only a small additional load on the tractor's rear axle. Hitching and unhitching are quick and easy but they can be transported (to and from the field) only at low speeds. They may cause problems on small fields (e.g. in irrigated farming) because of the limited area for manoeuvring.

Semi-mounted ploughs are hitched at the front to the 3-point hitch system (or to the lower links) of the tractor. The plough is supported at the rear by a furrow wheel which is often hydraulically operated. This type of plough usually has 4 or more bodies. This mounting method prevents too much weight being taken from the tractor's front axle, as occurs in the case of heavy ploughs with a wide clearance between the bodies. The design of the semi-mounted plough allows more bodies than the mounted plough.

Mounted ploughs with up to 5 bodies are usually mounted to the tractor's 3-point hitch system. Quick-coupling systems can be fitted. Tractors with free-link operation of the hitch system can carry the plough during transport and support it by a gauge wheel when it is in operation. With automatic depth or draught control the plough is never supported by wheels. During operation a large part of the forces acting on the plough (including its own weight) are transferred to the rear axle of the tractor (less slippage). Care should be taken to ensure that the steering of the tractor is not over-affected by the considerable lessening of the load on its front axle.

The draught sensor for the automatic control system can be attached to the upper or the lower links. The control system does not guarantee a uniform depth but a more or less constant draught, i.e. a uniform pull load for the tractor. Strong power (about three times the weight of the plough) is needed to lift the plough from the soil and so the number of bodies is limited.

Large ploughs whose working width is wider than the tractor are sometimes mounted to the tractor in such a way that it does not have to travel with one wheel in the furrow. This system prevents the furrow bottom and the loosened soil from being compacted by the wide tyres. There must be no side draught on the tractor. The driver must be much more attentive when driving parallel to but clear of the furrow ("on land").

The latest development is a front-mounted plough combined with a rear-mounted unit. This combination makes maximal use of the drawbar power provided by very heavy tractors but which, until now, has been technically limited to a specific size of rear-mounted ploughs. A favourable distribution of the load is obtained, especially in the case of 4-wheel drive tractors. This development is not, however, within the means of small tropical farms.

Reversible ploughs require one or two extra hydraulic connections, depending upon the type of hydraulic cylinder used in the swivel mechanism. To achieve perfect operation the plough and tractor must be correctly matched. The power requirement depends upon the specific soil resistance, the dimensions of the furrow, the shape of the mouldboard and the speed. One basic disadvantage of the plough is that the total power requirement has to be transferred to the soil through the driving wheels.

When operated at an average speed of 6 km/h and at an average depth of 25 cm, tractor ploughs require 15-22.5 kW (20-30 hp) per body on a medium heavy soil. The power requirement may rise to 30 kW per body under very heavy conditions.

#### 2.1.4 Description Of The Implement And Tools

The mouldboard plough can be divided into two main sections (see Fig. 18):

- the soil engaging tools (plough body and extra attachments)
- the supporting parts (frog, frame, column for 3-point hitch, swivel system for one-way ploughs)

##### The soil engaging tools

The plough body (Fig. 20) consists of the share, mouldboard (with tailpiece), landside and frog.

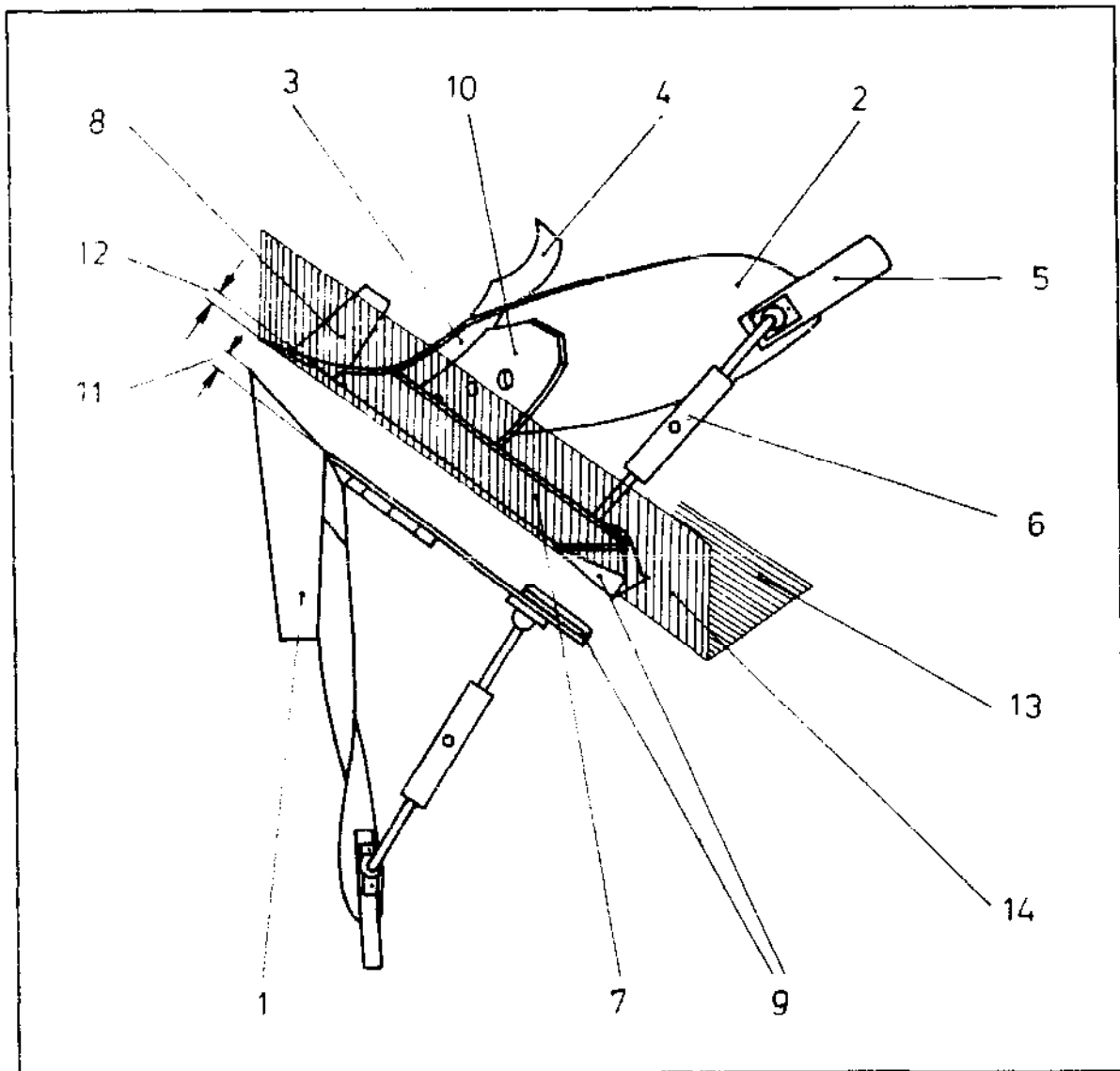

Fig. 20. Parts of a plough body:

- |                             |                           |
|-----------------------------|---------------------------|
| 1. Share,                   | 8. Mounted knife coulter, |
| 2. Mouldboard,              | 9. Heel,                  |
| 3. Shin,                    | 10. Frog,                 |
| 4. Trash board,             | 11. Side suction,         |
| 5. Tail piece,              | 12. Down suction,         |
| 6. Adjustable support stay, | 13. Furrow sole,          |
| 7. Landside,                | 14. Furrow wall.          |

The share:

The share is attached to the frog. It is subject to heavy loads and serious wear and tear and so it must be manufactured from soft-centre steel. This is a three-ply steel with outer layers of high carbon steel and a central layer of low carbon steel (0.5-0.9% carbon). Various shapes are available (Fig. 21):

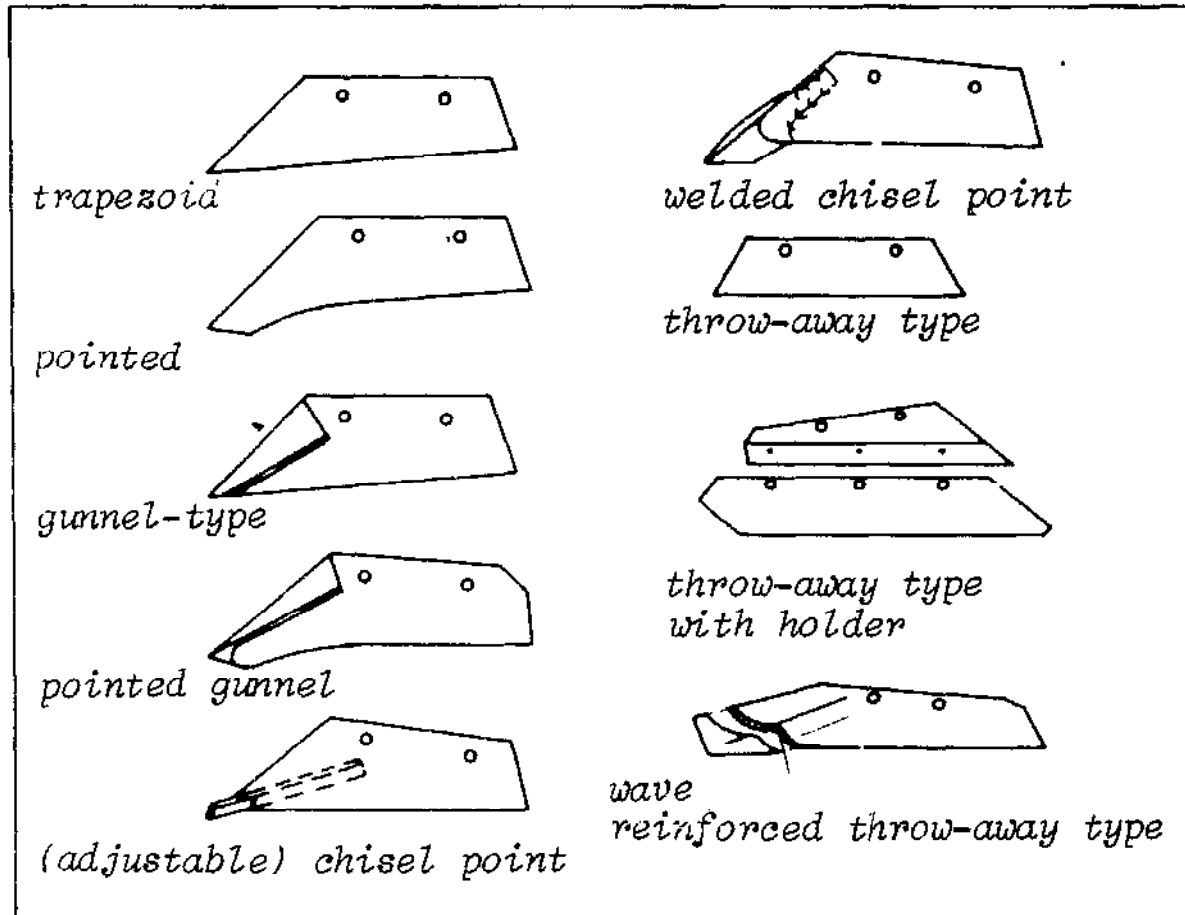

Fig. 21. Various share shapes.

- trapezoidal. For light soils and straight cuts; The point is reinforced to allow resharpening and reforging.
- pointed. For medium to heavy soils. This share is better than the trapezoidal shape for breaking up the soil, penetration, support, resistance to wear and susceptibility to damage from stones. It can be resharpened and reforged.
- gunnel-type. The share point and cutting edge are supported by a vertical, V-shaped flange. This flange is also used to provide extra material for forging. This share is very rigid and resistant to wear and suitable for difficult conditions.
- chisel point. For very heavy or stony soils, this share is similar to the pointed one except that, instead of the forgable point, it has a chisel which can be adjusted and used on both sides.
- disposable (razor blade) type. This self-sharpening share is suitable for light to medium heavy stoneless soils. It can be used for a considerable period but is not forgeable because it is narrow and thin. Wear may destroy the downwards suction effect.

Only general instructions for adjusting the share can be given. A sideways (share point extending approx. 10 mm into the furrow wall) and a downwards (share point approx. 10-15 mm deeper than the landside) suction effect should be created so that the share acquires stability and a good penetration capacity. Other important parameters (see Fig. 22) are the share point angle (the angle between the share edge and the direction of travel, usually 20-35 degrees) and the share lift angle (between the furrow bottom and share, perpendicular to the edge, usually 35-50 degrees).

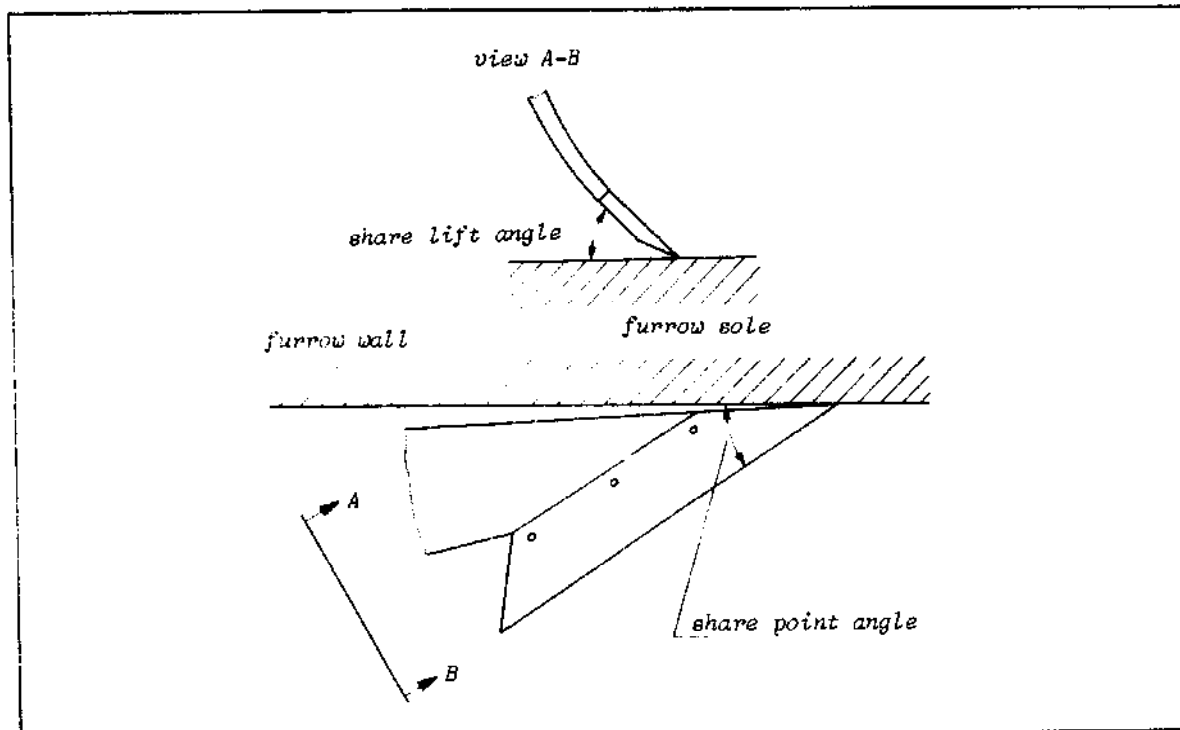

Fig. 22. Share angles of mouldboard ploughs.  
bottom: top view, top: along cross section A-B (=rear view).

Wide angles are suitable for light soils or low speeds (animal draught) but narrow angles are more useful for heavy soils or high speeds. The different share shapes and angles should always be compatible with the shape of the mouldboard.

#### The mouldboard:

The mouldboard is mounted on the frog with countersunk bolts and often has a further link in the form of an angle strut. It should be stable, resistant to wear and elastic with, possibly, a small friction angle at the (soil/steel) surface. All these requirements are best fulfilled by three-layered steel. Both of the outer layers are very hard resistant steel while the central soft layer is made of low carbon steel and protects the outer layers against breakage.

The curvature of the mouldboard combined with the various positions of the share gives the following basic shapes of plough bodies (Fig. 23):

- steep - for light, sandy soils, little inversion, low speed.
- steep, short - for light, sticky soils, little inversion, low speed.
- medium steep - for medium soils, average inversion, average speed.
- inclined - for medium and heavy soils, average to pronounced inversion, average to high speeds.

- helical - for heavy slaked soils, almost complete inversion, average to high speeds.
- universal - for all soil types (except extremes), average inversion, average speed.
- spiral - for the heaviest soils, complete turning of the sod, high speed - also suitable for sloping soils.
- slatted - for very sticky soils.

Another system divides plough bodies into:

Continental body (cylindrical): for light to average soils.

General purpose body (semi-helical): for nearly every soil type.

Semi-digger body (helical, extended): for heavy soils and on slopes.

Grassland body (helical, flat, extended); for clearing grassland.

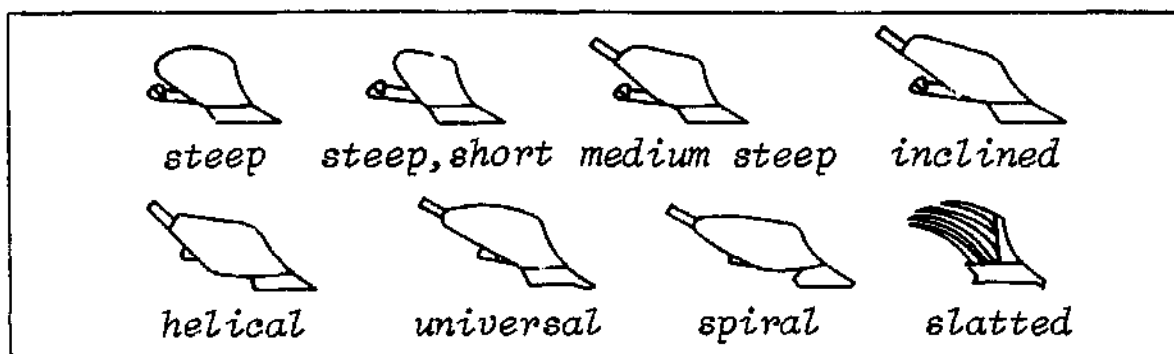

Fig. 23. Various mouldboard shapes.

The choice of plough bodies depends on the soil type, topography, the required inversion and the speed. Working widths of up to 42 cm and working depths of up to 35 cm per plough body can be achieved (excluding special "deep digger" ploughs). Plough bodies with a replaceable shin (the part suffering most wear) are widely used at present.

The tailpiece:

The tailpiece is used to improve the inversion and crumbling of the soil. It is mounted on the upper section of the mouldboard and can be adjusted to the ploughing depth.

The landside:

The landside is mounted on the frog and supports the horizontal forces exerted by the wall of the furrow and the vertical forces from the furrow bottom, especially when the tractor hydraulic system is in free-floating mode. The rear part is replaceable after it is worn out. The landside is sometimes spring-mounted on ploughs designed for tractors with automatic hydraulic control. A roller is better than a rigid landside on slopes and for skim ploughing. This roller is a rear furrow-wheel mounted at an angle of approx. 45 degrees to the furrow wall. Some makes allow a coulter to be mounted on the front part of the landside; this is cheaper than a knife-coulter and prevents choking.

The frog:

The frog must be strong resistant to bending and torsion. The share, mouldboard and landside are attached to the frog. The parts of the plough which enter the soil convey the draught forces to the frame through the frog.

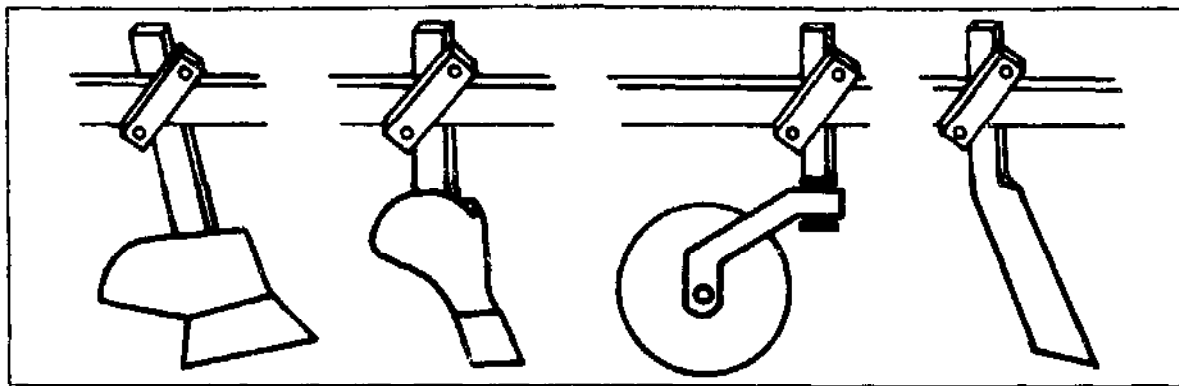

Fig. 24. Front-mounted tools.  
From left to right: jointer, manure feeder, disc coultter, knife coultter.

**Front- or body-mounted tools:**

Front-mounted tools are fitted in front of the plough body on the shank or frame and are adjustable. These tools improve the quality of the tillage (see Fig. 24), as do the body-mounted tools (see Fig. 25).

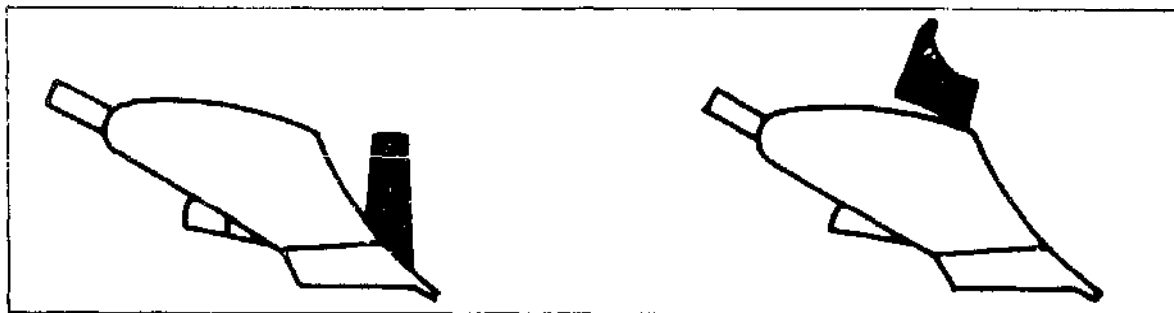

Fig. 25. Body-mounted tools. left: coultter, right: trash board.

Knives, discs or mounted coultters separate the furrow slice vertically from the undisturbed soil. The skim coultter, manure-burying coultter and trash board are used to cleanly bury plant residue or manure.

**Supporting parts**

The supporting parts of a plough are the frame and shanks. The shanks are either fixed rigidly to the frame or protected against overload (rocks, roots). The technical solutions used to provide protection against overload range from shearbolts to fully automatic mechanic, hydraulic or pneumatic systems. These "stump-jump" systems effectively prevent the plough body or shank from breaking and permit uninterrupted operation. As shown in Fig. 26, the plough body moves away from the obstacle and automatically returns to its original position.



Fig. 26. Safety devices (protection against rocks and stumps) on a mouldboard plough.



A flat-frame design using spring steel with lengthwise and crossways bars makes the entire plough suitably elastic. A beam design with profiled steel (hollow bars are most commonly used at present) allows the number of plough bodies to be changed more easily (modular design principle). Depending upon the type, the frame is supported by the plough head or by wheels (partly or entirely; mounted, semi-mounted or trailer plough). The frame height and the clearance between the bodies should be large enough to avoid choking when plant residue is being ploughed under. The trailer plough can be transported by using a lifting device.

The ploughhead:

The ploughhead of mounted ploughs consists of the column. Its dimensions (coupling pins for lower and upper links) have a definite influence on the plough's behaviour. DIN and ISO standards are applied. The swivel system (semi- or fully automatic) is also part of the head on reversible ploughs.

### 2.1.5 Adjustment, Operation

The plough frame should be completely level during ploughing to ensure that all the plough bodies work at the same depth. A 3-point hitch system is adjusted by changing the upper link and one of the lift arms for the lower links.

2.1.5.1 Working Depth - The depth for trailer ploughs is adjusted by the depth wheels; for semi-mounted ploughs, by the lower links and depth wheel (draught control). In the case of mounted ploughs, adjustments are made either to the upper link (free-floating action) or the hydraulic system. The lateral levelling is controlled by the tractor's lift arms for two-way ploughs and, for mounted reversible ploughs, by a spindle on the plough column (headstock).

2.1.5.2 Working Width - The plough's working width is determined principally by the number of bodies and the cutting width of each body. On many new ploughs (both one- and two-way models) the location of the bodies in relation to the tractor can be changed. The total working width on some ploughs can be varied by adding or removing plough bodies.

2.1.5.3 Tillage Intensity - The tillage intensity depends upon the speed, the shape of the plough body and the working depth. The intensity can be increased by using front-mounted or rear-mounted (crumbling, packing) tools.

#### 2.1.5.4 Adjusting Front-Mounted Tools -

Knife coulter: 0-30 mm in front of, 10-30 mm beside of and approx. 25 mm above the point of the share.

Disc coulter: as deep as possible (axis 50 mm above the soil surface), approx. 10-20 mm beside the share point (towards the unploughed land).

Skim coulter: small angle of attack, 40-80 mm deep, 10-20 mm beside and approx. 250 mm in front of the point of the share. The width is generally 0.3-0.7 times the width of the plough body and the depth is 0.3-0.5 times the depth of the plough body.

2.1.5.5 Handling - Ploughs can be mounted and dismounted by one man but not easily. Adjustment requires some technical knowledge. Ploughing in particular requires a high standard of skill and knowledge on the part of the driver. Frequent re-adjustments of the plough are needed if the soil conditions are irregular.

#### 2.1.6 Technical Data

Working width per body	up to 42 cm
Working depth	up to 35 cm (more for special ploughs)
Number of bodies	up to 12 (up to 24 in case of reversible ploughs)
Frame height	up to 90 cm
Clearance between bodies	up to 110 cm
Weight	up to 310 kg per body
Overload devices	protection against rocks by means of shearbolts, helical springs, hydraulic and pneumatic cylinders, overload protection on mountings.
Power requirements	15-25 kW per body (20-35 hp/body)

#### 2.1.7 Literature

See literature of chapters 1 and 2.0.

Koeller, K., 1978. Möglichkeiten des Pflugeinsatzes in der Primaerbodenbearbeitung. Berichte ueber Landwirtschaft 56(2-3): 415-430.

Krause, R., 1966. Die Zuordnung von Schlepper und Pflug. Grundlagen der Landtechnik 16(6): 229-235.

NN, 1983. Pflug einstellen - aber wie? Agrartechnik International 62(1): 12-14.

Traulsen, H., 1982. The role of the mouldboard plough? The Agricultural Engineer, 37(1): 12-14.

Traulsen, H. and W. Holtz, 1982. Streifenpfluege in der Praxis. Landtechnik, 37(6): 288-290.

Zumbach, W., 1980. Tests comparatifs de charrues portees. Technique Agricole, 42(11): 518-528.

## 2.2 The Disc Plough

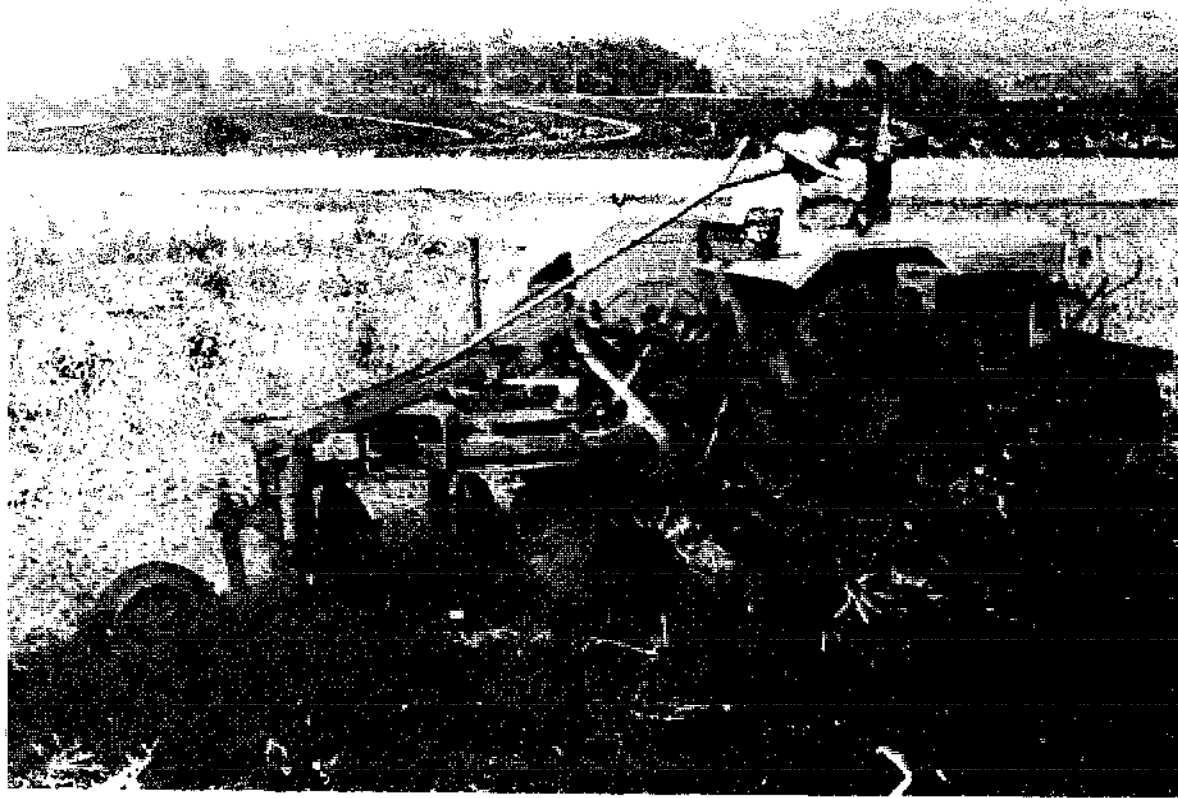

### 2.2.1 Use And Assessment

The disc plough (Fig. 27) is used mainly in tropical and subtropical regions for the following jobs:

- land clearance,
- primary tillage,
- ploughing land containing stones and roots,
- seedbed preparation,
- deep tillage between rows of trees,
- working in large amounts of plant residue,
- ploughing in regions with a high risk of erosion,
- ploughing on sticky waxy soils and soils which tend to form plough soles.

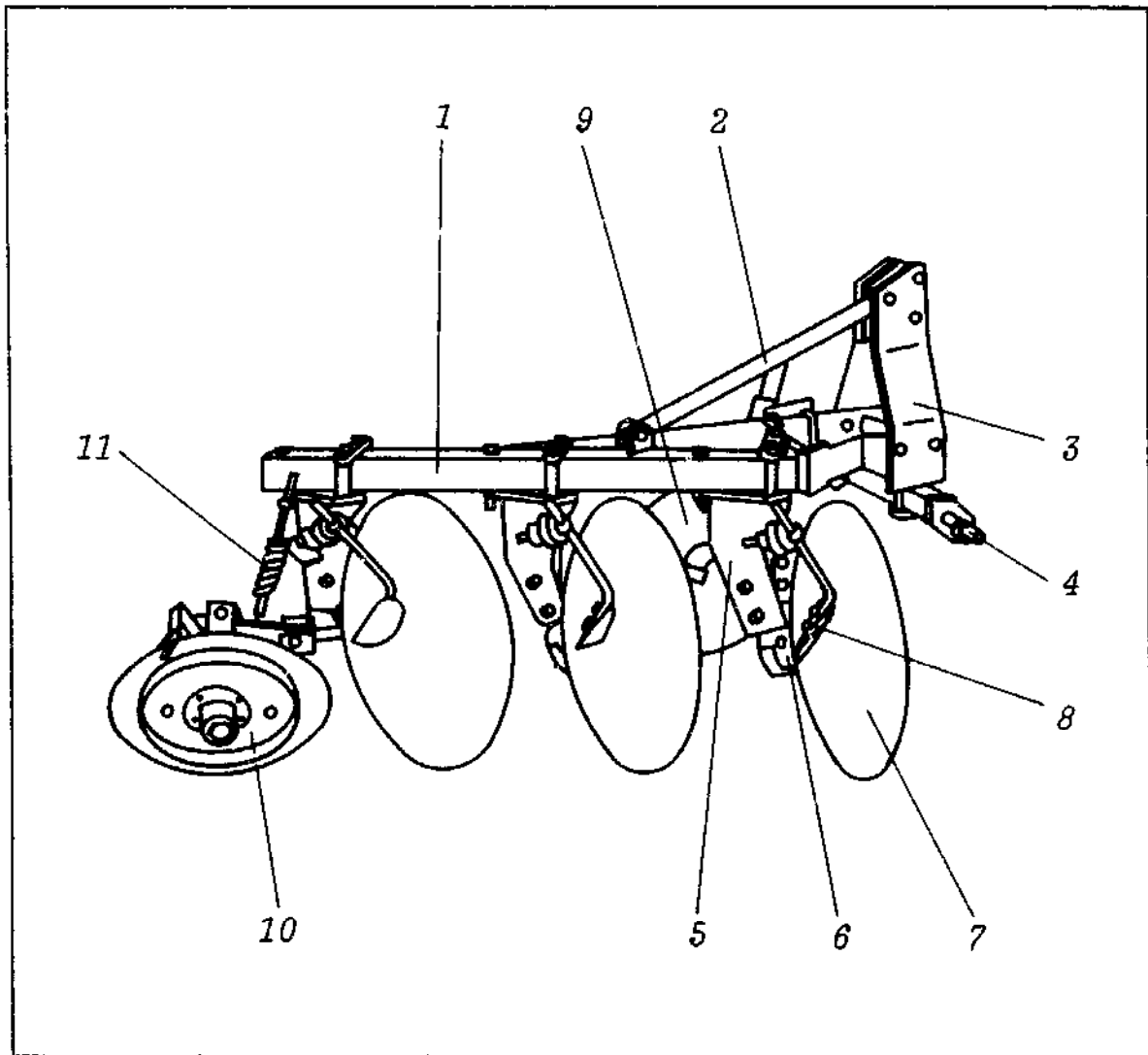

Fig. 27. Disc plough:

- |               |                               |
|---------------|-------------------------------|
| 1. Frame,     | 7. Disc,                      |
| 2. Brace,     | 8. Scraper,                   |
| 3. Headstock, | 9. Support (land) wheel,      |
| 4. Hitch bar, | 10. Furrow wheel with collar, |
| 5. Shank,     | 11. Spring.                   |
| 6. Bearing,   |                               |

There is little difference between mouldboard and disc ploughs as regards (Fig. 28):

- effect,
- maintenance,
- reliability,
- power requirements,
- total tillage costs.



<i>implement type</i>		
<i>criteria</i>		
<i>inverting</i>	<i>medium</i>	<i>good</i>
<i>mixing</i>	<i>medium</i>	<i>hardly</i>
<i>crumbling</i>	<i>medium/good</i>	<i>medium</i>
<i>burying of long stubble</i>	<i>not completely</i>	<i>completely</i>
<i>plough sole compaction</i>	<i>little</i>	<i>by landside (heel) less by share</i>
<i>susceptibility for damage by roots and stones</i>	<i>little</i>	<i>more</i>
<i>possible fields of use</i>	<i>heavy, dry, stony soils forest soils</i>	<i>clean fields</i>
<i>durability</i>	<i>high</i>	<i>medium</i>
<i>weight</i>	<i>high</i>	<i>lower</i>
<i>draught requirement</i>	<i>high</i>	<i>high</i>

Fig. 28. Differences between mouldboard and disc ploughs after Wieneke.

Penetration by disc ploughs presents problems on dry heavy soils. Penetration can be achieved only with a suitable high load (up to 500 kg per disc by adding weights). Unlike mouldboard ploughs which have to be protected by special mechanisms and suitable shares, however, disc ploughs roll over roots and stones, thus preventing damage. A constant working depth is very hard to maintain. It is also difficult to keep to a straight line of travel. Generally speaking, the soil is tilled less intensively and with less inversion than with a mouldboard plough.

Sticky soils cause fewer problems. The discs rarely have to be sharpened or replaced since their rotation produces a long cutting edge.

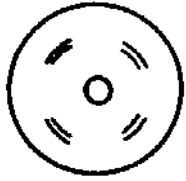
The disc plough's advantages over the mouldboard plough are:

- only partial inversion of the soil so that plant residue is left on the surface, thus reducing the erosion risk and water losses by evaporation,
- mixing action on loose soils,
- rolls over obstacles so that hardly any breakage occurs,
- lower risk of choking (sugarcane, cotton, maize),
- fewer problems with sticky soils,
- hardly any smearing of the furrow bottom (plough sole),
- the wear is spread over the entire circumference of the disc (2 m of cutting edge on discs with a diameter of 65 cm),
- the discs are self-sharpening,
- easier adjustment.

The disadvantages of the disc plough are:

- penetration is difficult in hard soils,
- heavy weight (and consequently, high prices),
- greater lifting capacity required from the tractor's hydraulic system,
- furrow wheel is needed for controlling for depth and lateral movement,
- not usually suitable for slopes owing to the strong lateral forces,
- the plough's weight may cause compaction of the furrow bottom,
- less efficient weed control,
- soil surface is not so level after ploughing (irrigated fields).

### 2.2.2 Functioning

Unlike the mouldboard plough, a disc plough will not penetrate into the soil of its own accord but needs a heavy load. The soil is not carried over the surface of the disc (as with a passive share) and so there is less scouring. The disc is rotated by the soil reaction; it lifts and deposits the soil not with a winding but with a pouring tumbling movement. When combined with the differences in the acceleration forces exerted on the soil while it is on the disc - those forces increase from the centre towards the edge -, this movement causes the disintegration, mixing and loosening of an aggregated soil. In the case of cohesive soils this movement may produce deposits of clods along a lateral axis, thus forming the unwelcome "rabbit holes". The furrow slices which form in these soils are difficult to crumble by secondary tillage operations. Consequently, the standard of the tillage depends to a large extent upon the type and condition of the soil. Like the mouldboard plough, the disc plough leaves an open furrow.

There is less likelihood of forming a plough sole with a disc plough because:

- a. The disc plough tears rather than cuts and so no cutting surface can develop (the tillage horizon is corrugated);
- b. There are no landsides and heels which, on the mouldboard plough produce further smearing and compaction.

In the case of compactible soils, however, the total weight of the heavy plough may cause compaction over a thicker layer (5 - 10 cm) below the furrow bottom.

Large discs require less draught and cut through plant residue more satisfactorily.

### 2.2.3 Linkage And Drive System

Disc ploughs are designed in the form of trailer, semi-mounted and mounted ploughs. Heavier larger units can be lifted hydraulically on support wheels. The discs are driven by the soil resistance and movement. Owing to its heavy weight the draught required (per volume unit of soil moved) for a disc plough is more or less the same as for a mouldboard plough despite the rolling action. For successful operation the hitch point for trailer ploughs should be as low as possible on the tractor; in the case of mounted ploughs the upper link should be only slightly inclined forward. When more concave discs are used to obtain better crumbling the draught requirement will increase with the degree of curvature. This requirement does, of course, depend to a large extent upon the soil conditions and is generally 15-20 kW per plough body. At 5.5 km/h a capacity of 0.4 ha/h can be expected for each metre of working width.

### 2.2.4 Description Of Implement And Tools

Disc ploughs (see Fig. 27) are very heavy implements equipped with between one and eight concave discs. The working depth is 25-40 cm. Each disc is mounted on its own shank with a bearing (frog). The shanks are mounted on a sturdy steel frame diagonally to the direction of travel. The disc angle and tilt angle (Fig. 29) are adjusted on the frog bearing and can be adapted to the field conditions. The diameter of the discs ranges from 560 to 810 mm. The discs' concavity - defined as the depth of the centre in relation to the edge - is between 60 and 120 mm.

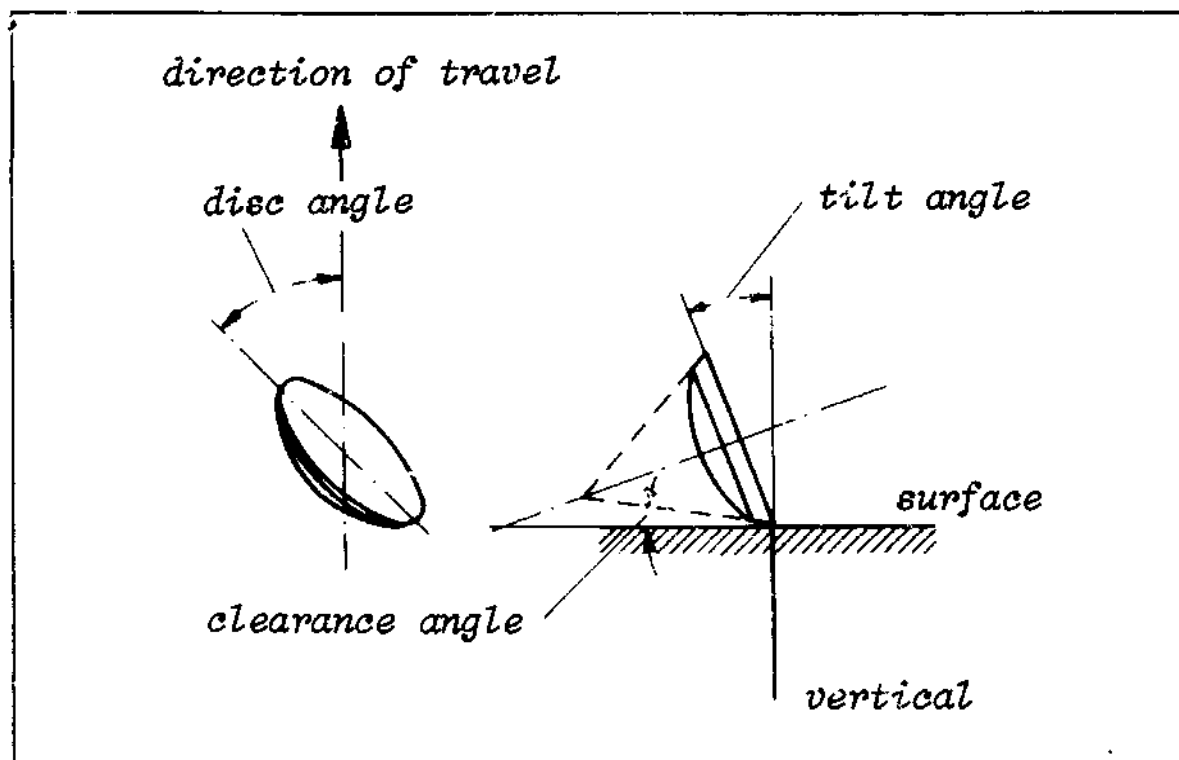

Fig. 29. Angle definitions on disc ploughs  
left: top view, right: side view.

A neat solution was found for one-way or reversible disc ploughs to avoid the need for a double set of soil-engaging tools, as is the case with reversible mouldboard ploughs. The discs are mounted on a sub-frame, usually one heavy beam, which is attached to the main frame by a pivot near its centre and can be rotated through an angle of 30-40 degrees. To keep the same disc angle for both ploughing directions a lever system is employed to rotate the shanks of the individual discs through a small angle when the sub-frame is rotated. At the same time a second system of levers reverses the rear furrow wheel (see Fig. 30). This rotation from left-hand to right-hand plough and vice versa can be performed manually or hydraulically. The main (or sub-)frame should have a clearance of at least a few centimetres from the discs.

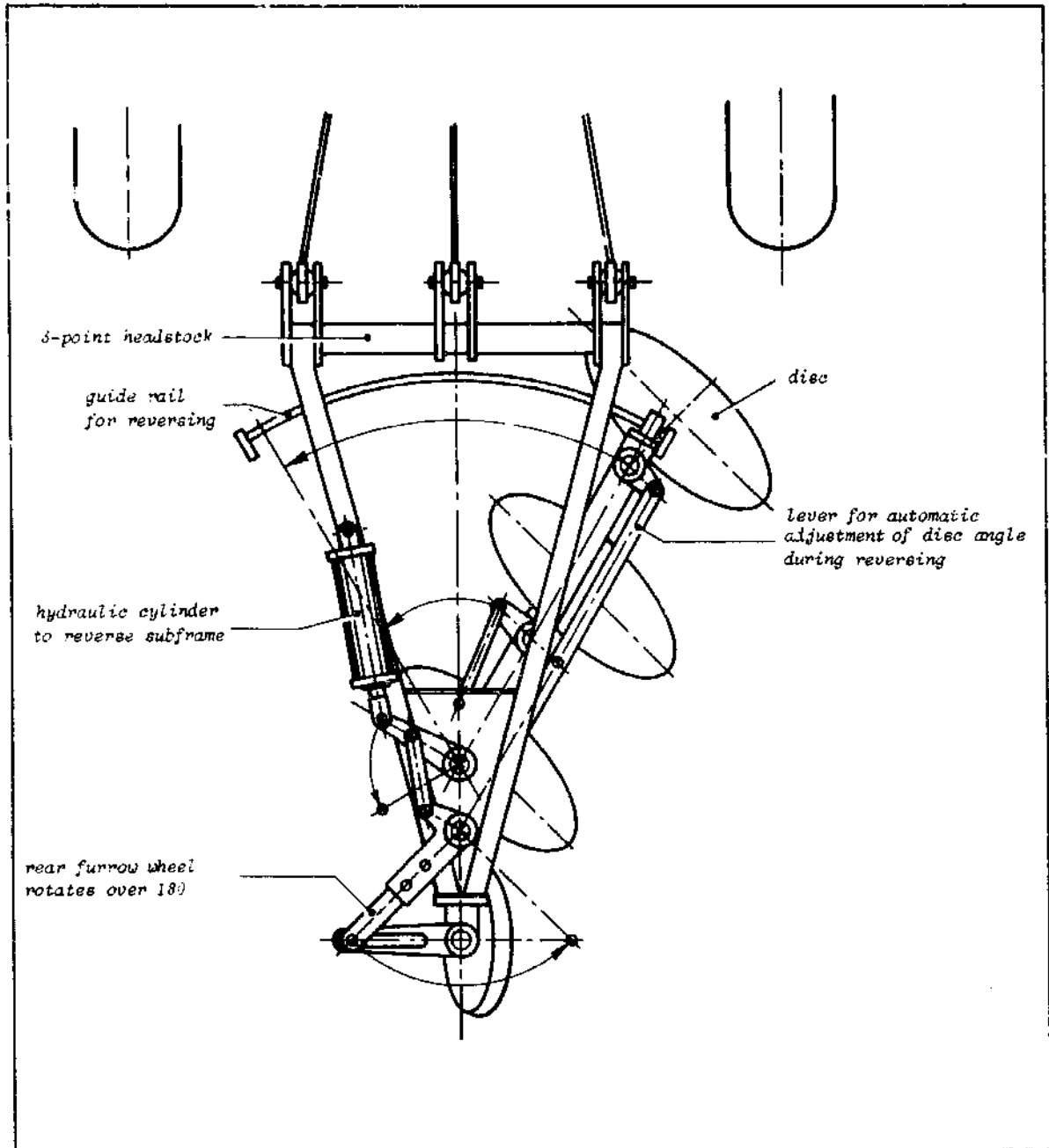

Fig. 30. Three-furrow reversible disc plough.



An opening in the center of the discs is used to mount a tapered roller bearing which can be adjusted by a castle nut to prevent too much play. The dimensions (diameter, thickness) of the discs are usually given in inches and are inter-related on the basis of a specific ratio.

disc diameter	thickness disc	depth of work	use
660 mm (26 in)	5.0-6.5 mm	10-30 cm	skim ploughing
710 mm (28 in)	6.5-7.5 mm	10-35 cm	skim- and deep ploughing
810 mm (32 in)	8.0 mm	10-45 cm	deep ploughing

The discs are made of specially treated manganese silicium steel which is very resistant to wear. The hardness is comparable to that of plough shares and may be as much as 600 HV (Vickers Hardness). Triple-layer types of steel do not have any advantages in this respect because, after the circumference of the disc has been worn down, the various layers will be exposed and may break. The direction of the disc rotation is always in the direction of travel since they are driven by the slice of soil moving along the concave inner side of the disc. Scrapers shaped like hoes or small mouldboards (Fig. 31) remove the soil from the disc and improve the inversion. Mounted ploughs are usually equipped with a rear furrow wheel.

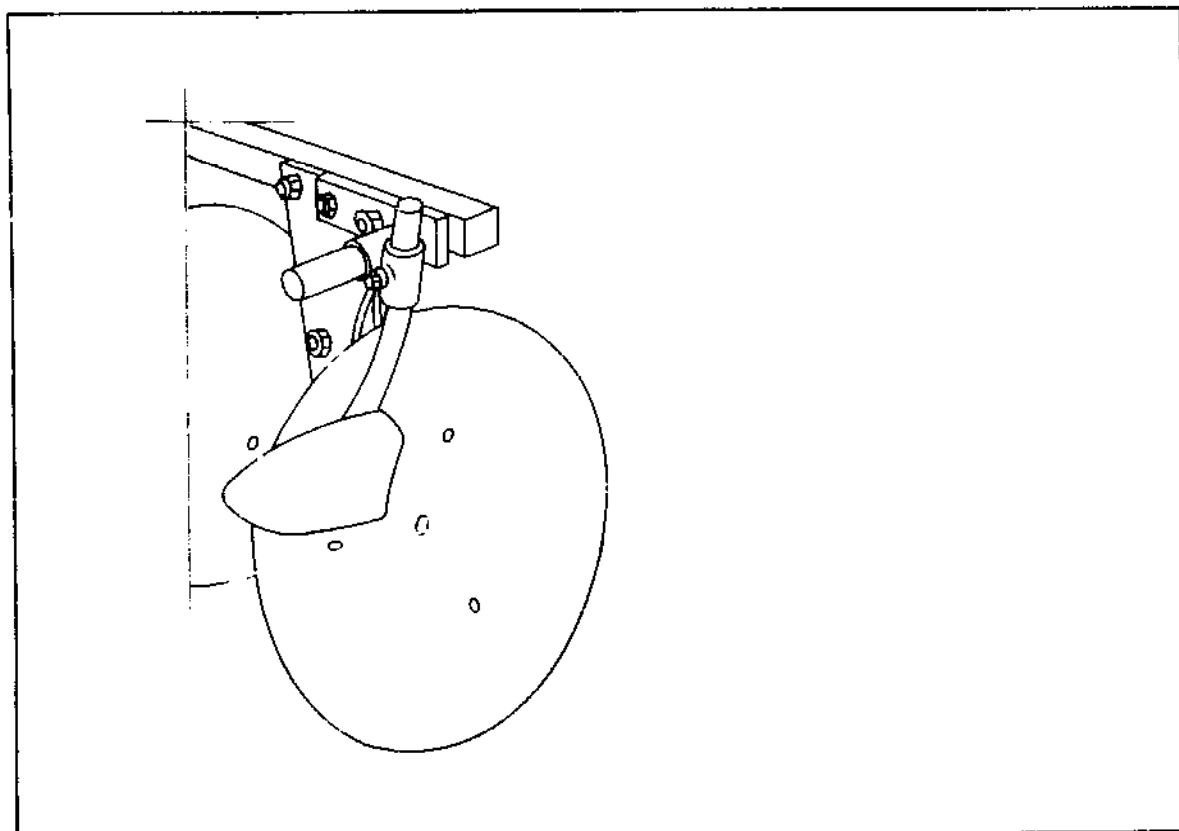

Fig. 31. Disc with scraper.

Every trailer disc plough has a land wheel attached to the rear lifting mechanism and a front and rear furrow wheel. The rear furrow wheel and the rear gauge wheel with their adjustment mechanisms form the rear bridge. The furrow wheels are angled at anything up to 45 degrees from the surface and are equipped with a collar. These wheels absorb at least part of the lateral forces exerted by the soil. With this wheel arrangement, however, a trailer plough will always tip over when making a right-hand turn. So the plough should always be turned to the left.

## 2.2.5 Adjustments, Operation

2.2.5.1 Working Depth - The working depth is maintained mainly by the weight of the plough. The disc and tilt angle which must be adapted to the soil conditions also strongly influence the depth control (see Fig. 29). The following settings may be used:

soil	tilt angle (vertical)	disc angle (in deg) (horizontal)
hard	3-20	45-50
cohesive	10-25	43-48
loose	15-30	40-45

The disc angle can be adjusted (often in gradations) on every plough, as can the tilt angle on many of them. When the disc is tilted, an angle of clearance should be allowed to prevent constraint upon the disc's tearing action and possible smearing of moist soil (see Fig. 29). The wider the tilt angle, the less freedom is left for the disc angle because, otherwise, the back of the disc may scour against the furrow wall (more power required and more wear caused).

2.2.5.2 Working Width - There are only limited possibilities of changing the working width. It can be adjusted by:

- Changing the angle between main cross-bar and rear bridge and the angle between main cross-bar and front bridge or 3-point hitch headstock,
- Adjusting the gauge wheels,
- Adjusting the disc-mounting clamps on the frame.

The cutting width of each disc can be changed by altering the disc angle. On reversible ploughs this can be achieved by adjusting the degree of the subframe rotation. Horizontal lateral forces must be absorbed by the slanting furrow wheels. For trailer ploughs these forces should also be absorbed by the gauge wheels running on the undisturbed soil; as little as possible should be absorbed by the tractor (to avoid side draught).

Collars on the furrow wheels improve the guidance of the plough. With the elimination of the horizontal forces the friction between the discs and the furrow wall is also reduced, causing less wear. Moreover, the theoretical centre of gravity is shifted towards the furrow, eliminating the need for counter-steering. Adjustment of the axle and spring tension can often

produce the penetrative forces of the furrow wheels which are required for guiding the plough. The crossbar with mounting pivots can be shifted laterally and rotated (mounting pivots are off-centre) in order to align the disc plough behind the tractor.

Correct setting of the tractor's front and rear track widths is most important for guiding the plough and for determining the cutting width of the front discs. This is particularly important in the case of reversible ploughs.

#### 2.2.6 Technical Data

Number of discs	2 - 8
Diameter of discs	560 - 810 mm
Working width	50 - 200 cm
Working depth	20 - 40 cm
Frame height	65 - 80 cm
Clearance between discs	50 - 75 cm (partly variable)
Weight per disc	150 - 250 kg
Power requirement per disc	15 - 20 kW (20-30 hp)

#### 2.2.7 Literature

See literature of chapters 1 and 2.0.

Finney, B., 1982. The role of discs in primary cultivation. *The Agricultural Engineer*, 37(1): 15-19.

Gill, W.R., C.A. Reaves and A.C. Bailey, 1980. The effect of geometric parameters on disk forces. *Transactions of the ASAE*, 23(2): 266-269.

Harrison, H.P., 1977. Soil reacting forces for disks from field measurements. *Transactions of the ASAE*, 20(5): 836-838.

Reaves, C.A., W.R. Gill and A.C. Bailey, 1980. Influence of width and depth of cut on disk forces. *Transactions of the ASAE*, 24(3): 572-578.

## 2.3 The Chisel Plough and Cultivator

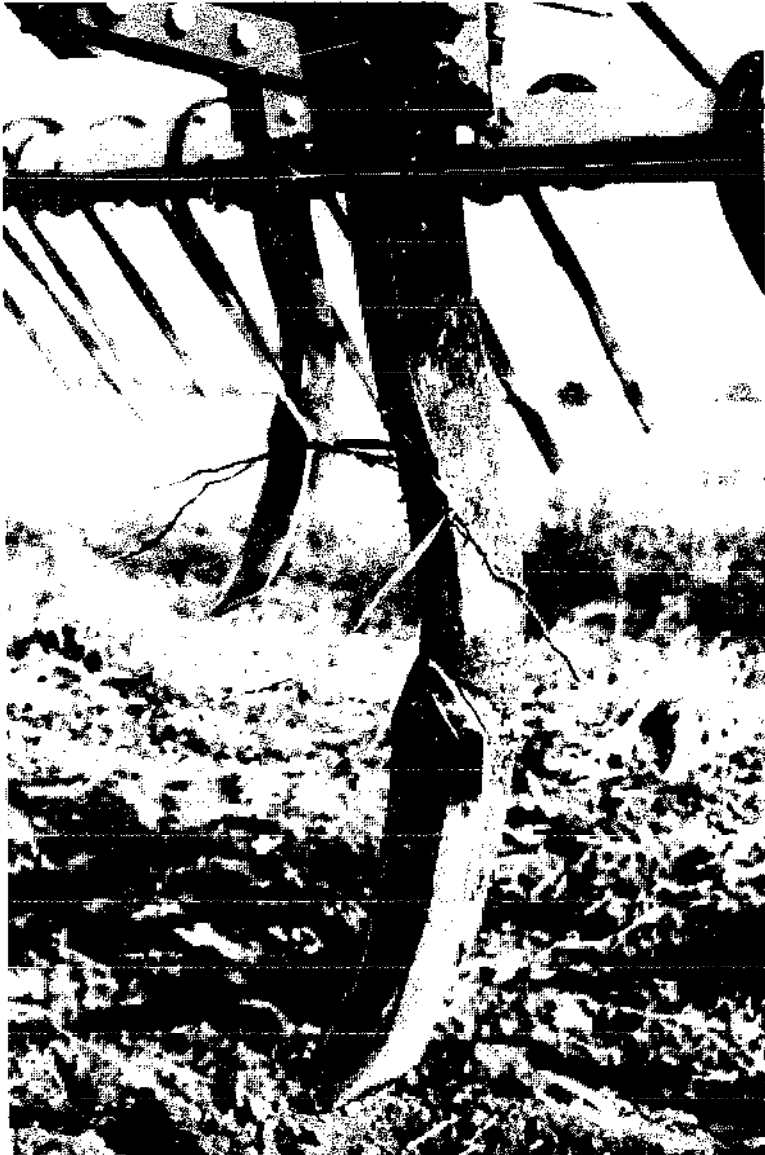

### 2.3.1 Use And Assessment

The chisel plough and cultivator are generally used for the following purposes:

- stubble tillage,
- working in straw and harvest residue,
- mechanical weed control (especially root-propagating weeds),
- deep tillage (alternative to ploughing),
- loosening hard dry soil before ploughing,
- breaking up hard layers below the normal ploughing depth (hardpans, plough soles),
- ploughing-in manure.

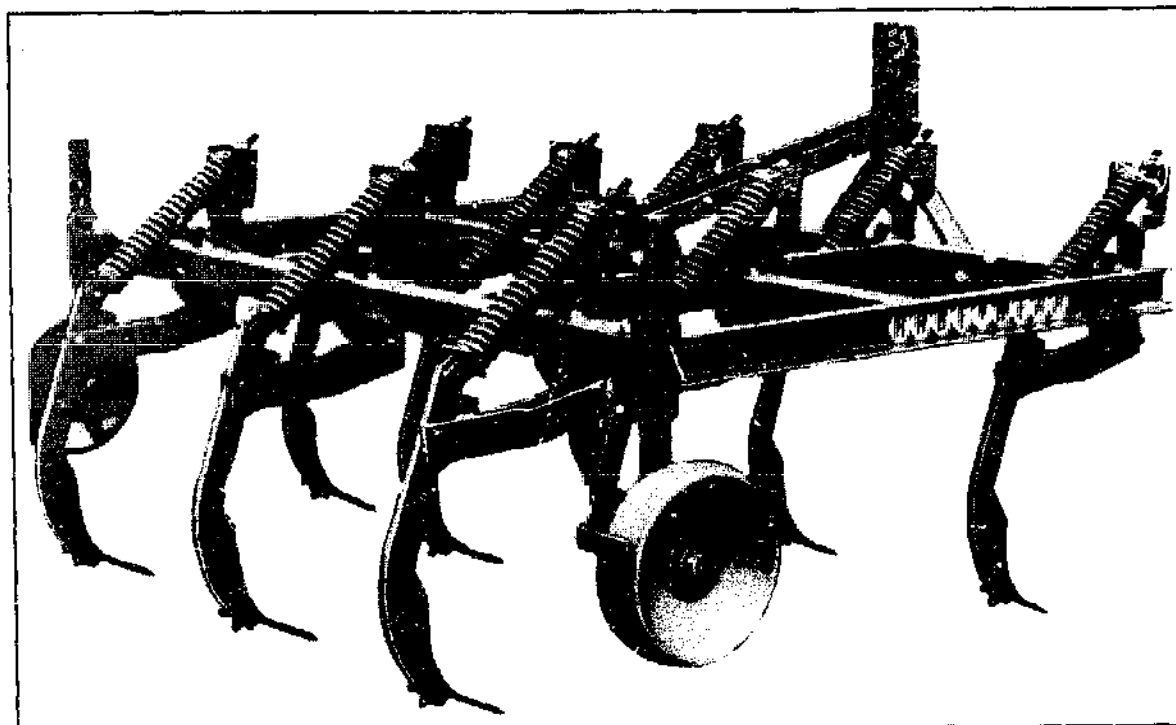

*Fig. 32. Chisel plough with three cross bars and rock protection device per tine.*

It may be appropriate at this point to explain the names used to head this chapter. The term "chisel plough" is generally used for a heavier type of implement designed for heavy duty, i.e. primary tillage. Essentially, this implement is equipped with rigid shanks. The term "cultivator" is applied mainly to lighter implements and, in the USA, often to crop maintenance implements. They may be equipped with both rigid and spring tines or shanks.

Chisel ploughs or cultivators (Fig. 32) are suitable for primary tillage in the tropics and subtropics because of their non-inverting action: the soil is sufficiently loosened and mixed without too much crumbling. In addition, after stubble tillage and the ploughing-in of straw the soil surface still retains a high percentage of plant material to contrc' wind and water erosion. Tillage operations should not be carried out when the soil is too wet. Fig. 33 and Table 3 give some criteria for choosing and using the chisel plough. Special mention should be made of the combination of chisel plough and rear-mounted tools (Chapter 8).

Chisel ploughs have the following advantages:

- wide range of possible uses (stubble tillage, mulching, primary tillage for seedbed preparation, deep loosening, breaking up plough soles);
- they may replace disc or mouldboard ploughs under certain conditions;
- suitable for use in the tropics; they loosen soil without inversion so that organic material decomposes more slowly; moist soil is not transported upwards; the soil surface retains an adequate cover of plant material (wind and water erosion);
- they can be used on extremely heavy soils where the quality and capacity of other types of ploughing are unsatisfactory;
- a high capacity with brief preparation time, making their operation very efficient;
- substantially less time required than for mouldboard ploughs;
- the power requirement per tilled cross-section is less than for the mouldboard and disc ploughs;
- the tractor needs only a comparatively small lifting power; they can be combined with rear attachments and sowing equipment;
- effective against root-propagating weeds;
- highly reliable.

Their disadvantages are:

- they require high speeds (8-10 km/h) when harvest residue is to be worked in; so greater demands are made on the driver and tractor, especially when working across crop rows;
- very often primary tillage needs to be repeated (usually at increased depth and, if possible, crosswise);
- the working width and speed must exceed minimum values if a good performance is to be achieved and so large tractors are required (at least 45 kW); this is possible for small farms only on a cooperative basis;
- the chisel plough can replace the inverting plough only to a small extent and so both implements are needed;
- the mixing action is often inadequate for working in straw on light soils.







tillage shallow                      deep	criteria
	number of tines
	distance between tines furrow distance
	angle of chisels width of chisels
	part of soil not loosened
	suitability in moist soil
	specific soil resistance
	incorporation of organic matter, weeds
	power requirement per tine

Fig. 33. Criteria for the choice and assessment of a chisel plough.

### 2.3.2 Functioning

Chisel tines cut vertically through the soil. The soil moves upwards along the curve of the chisel and is broken up by the flexing forces. The lateral shattering effect (becoming more pronounced towards the surface) results in complete loosening of the soil down to a specific depth. The cross-section of the soil tilled by a chisel tine can be represented as a triangle (Fig. 34). Consequently, the bottom of the tilled layer left by the chisel plough is shaped like a washboard. When wide duckfoot chisels are used, the ridges left between the chisels are obviously smaller.

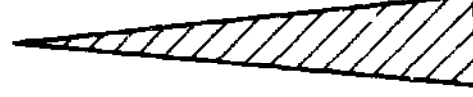
Very satisfactory mixing and loosening is ensured in relatively dry soil;

the soil is broken up perpendicularly to the direction of travel at an angle of approx. 50 degrees from the surface. As the soil moisture content increases, this angle becomes wider and the tilled area smaller. In very moist soils it may be as much as 90 degrees in which case the tine cuts only a very narrow groove in the soil and brings up "sausages" of smeared soil. These harden very quickly as they dry in the air and are very difficult to crumble by means of later tillage operations. These narrow furrows may also be cut in drier soils when the operating speed is too low, i.e. less than 6 km/h.

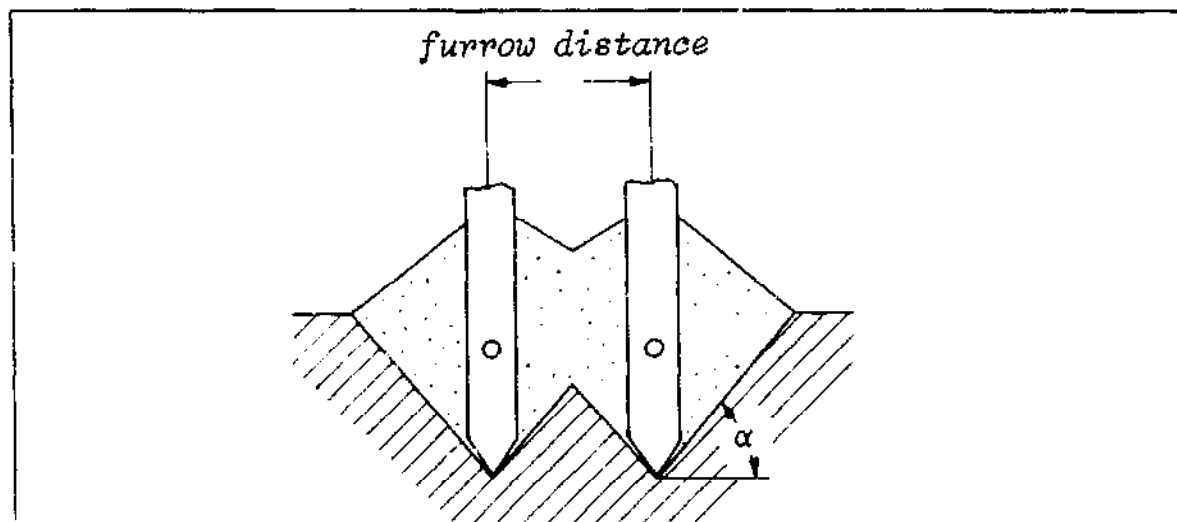

Fig. 34. Cross section of the soil actually loosened; two tines, relatively dry soil.

The advantages of spring tines over rigid tines are the possibility of diverting around obstacles, the better self-cleaning action and, under some conditions, the more effective crumbling of hard clods. The main disadvantage is that during the diversionary movement the tine moves not only backwards and sideways but also upwards; the angle of attack and working depth are changed and the lateral dispersal is decreased, leaving unworked strips. Spring tines raise more "sausages" when the soil is too wet. The spring tine is less suitable for deep tillage. Spring-loaded tines have proved a valuable compromise between rigid and spring tines. The standard chisel plough may be equipped with various sizes of single or dual-pointed shovels or chisels. Dual-pointed chisels can be used on both sides. A twisted chisel turns the soil more efficiently. Alternate right- and left-hand chisels are used to eliminate the lateral forces.

Various sizes of reversible ("diamond point", see Fig. 41) or duckfoot chisels are often used for shallow tillage (stubble tillage and weed control). In order to cut every root duckfoot chisels should be mounted so closely together that their cutting widths overlap. Chisels are mounted in rows one behind the other, applying a staggered configuration to ensure free flow. Some interval between the tines, furrows and crossbars (Fig. 35) and the frame clearance are essential for effective use and for uninterrupted working.

The cutting widths of pointed chisels do not overlap but all the soil near the surface is nonetheless loosened owing to the triangular shape of the dispersed soil mass. As the lift angle of the tine (angle of attack) is



increased, less soil will be pushed upwards. The angle of the cultivator chisels should be sufficient (up to 60 degrees) to bring weeds (especially root-propagating weeds) to the surface and to plough-in straw and weed seeds. If it is to be satisfactorily ploughed-in, the stubble should be short (< 10 cm) and straw should be spread evenly. The shorter the chopped straw, the deeper it will be ploughed-in. A good part of the material will, however, always remain on the surface.

When chisel ploughs are used on slopes (following the contour lines) the effect of the side draught must be taken into account. In particular, trailer implements may no longer follow the tractor in a straight line but at a slight angle. This may cause fluctuations in the intervals between furrows, depending upon the arrangement of the tines.

	cultivator	chisel plough	subsoiler
intended use	shallow stubble tillage	loosening at ploughing depth	loosening and breaking up of plough sole
chisel type	wide to normal	normal to narrow	narrow to normal
tine type	spring, spring loaded or rigid	spring loaded or rigid	rigid
angle of attack	up to 60 deg.	30 deg.	30 deg.
distance between tines	at least 55-60 cm	at least 70 cm	at least 75 cm
furrow distance	about 20 cm	25-30 cm	30-50 cm
required frame height	70 cm	70-80 cm	70-90 cm
rear mounted tools	necessary	desirable	desirable
working depth	5-15 cm	15-30 cm	30-50 cm

*Table 3. Criteria for the choice of a chisel plough/cultivator/subsoiler.*

When used for "stubble mulch tillage" in dryland farming systems chisel ploughs should have disc gangs in front. The discs can cut through (large amounts of) thrash, preventing the plough from becoming choked. Pointed or twisted chisel ploughs can be used for primary tillage while sweeps are usually fitted for fallowing operations or secondary tillage.

It must be emphasized that, basically, the distance between the tines, the frame clearance and the speed have more influence on the quality of the work than the implement shape and adjustment.

Table 4 shows the crumbling effect of a special type of chisel plough (Fig. 36) in heavy, hard and dry soils compared with the crumbling effect of a mouldboard plough.

Primary tillage using a chisel plough should generally be repeated, possibly crosswise with extra depth. On sloping land, however, operations along the slope should be avoided, if possible, because of the risk of erosion. The efficiency of chisel ploughs is considerably improved by rear-mounted tools for loosening, crumbling, levelling, mixing, packing, etc. In many cases the chisel plough's working depth is controlled by these attachments (see Chapter 8.1, Fig. 127).

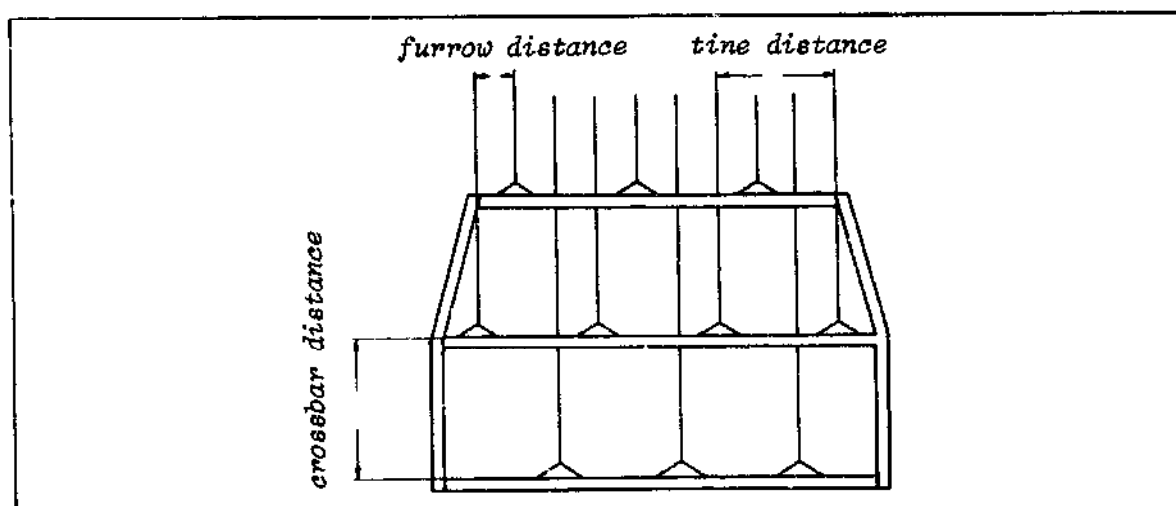
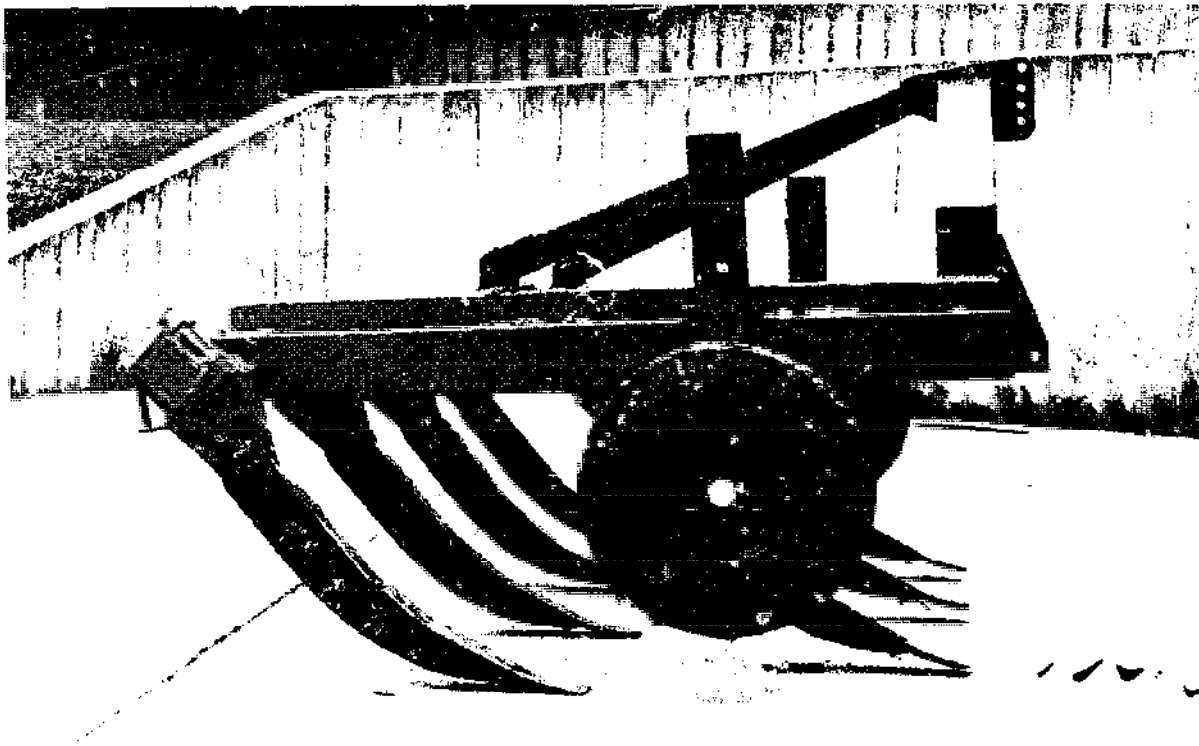

Fig. 35. Frame of a chisel plough with three crossbars, indicating distances between tines, furrows and cross bars.

implement	speed	percentage (weight) of size class				
		> 80 mm	40-80 mm	20-40 mm	2-20 mm	< 2 mm
	km/h	%	%	%	%	%
chisel plough VICON Jumbo buster	6.7	18.1	19.2	19.3	34.7	8.7
mouldboard plough (control)	6.1	48.4	17.6	12.2	18.3	3.5

Table 4. Distribution (by weight) of the various size fractions.



*Fig. 36. Chisel plough with tines at a small angle of attack.*

### 2.3.3 Linkage And Drive System

Chisel ploughs with a working width of up to 6.5 m are usually equipped for the 3-point hitch system, often with quick-coupling devices. The larger implements (with working widths of up to 20 m) are semi-mounted or trailed.

The comparatively light weight of the mounted chisel plough and its short length (centre of gravity is close to the tractor) mean that the tractor's hydraulic system needs only a comparatively low lifting capacity. So the mounted chisel plough offers favourable possibilities for combinations of implements.

Larger chisel ploughs require one or two extra hydraulic outlets on the tractor so that they can be lifted and folded to transport width.

The power required by a chisel plough depends upon the number of tines, the distance between them, the working depth, speed, type of chisel, type of tines (rigid, spring-loaded, springs), the tines' lift angle, the soil condition and type.

Some basic factors are given in Fig. 37. In theory, vertical tine A requires the most draught traction. Moreover, it is difficult to pull a tine of this shape through the soil and keep it implanted there. Tine C has the best draught requirement but will only lift the soil without adequately

loosening it. While tine B requires rather more draught power, it does scatter and crumble the soil more satisfactorily.

A chisel plough should cover the entire width of the tractor, i.e. working at least both of the tractor's wheel-tracks. "Strip" chisel ploughs have recently become available; these leave a strip in the centre of the implement untouched and so require less draught power. The left-over strip has to be tilled by the return pass. This involves a practical problem as it is difficult for the driver precisely to follow the (narrow) strip which has to be tilled.

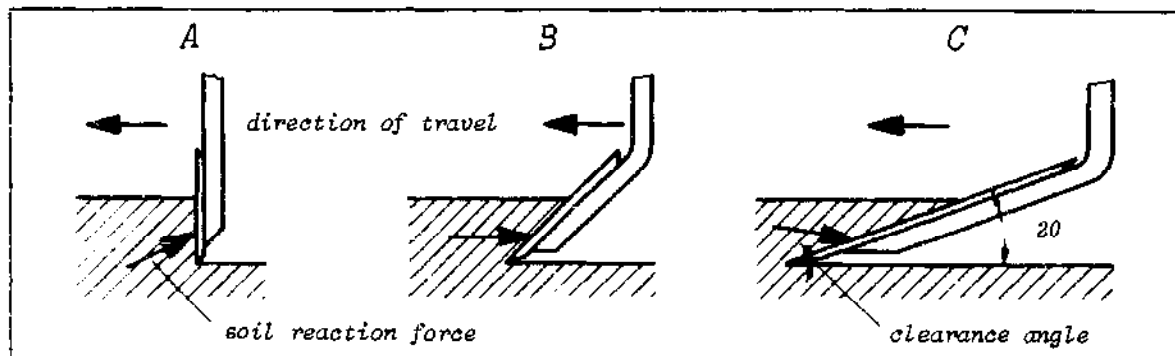

Fig. 37. Various angles of model tines, direction of the soil reaction forces: A: Vertical placement, B: Steep, C: Flat.

Under average conditions and with a speed of approx. 8 km/h the tractor power required for stubble tillage with a cultivator is around 26 kW per metre of width (30-35 kW with attachments). This increases to around 40 kW per metre (and occasionally to 60 kW/m) for deep tillage at 6 km/h. At the same speed the specific draught required for chisel ploughs is about half the power needed for mouldboard ploughs (about 5 N/m on heavy soil).

The appropriate lift angles are around 30 degrees for heavy chisel ploughs and up to 60 degrees for cultivators.

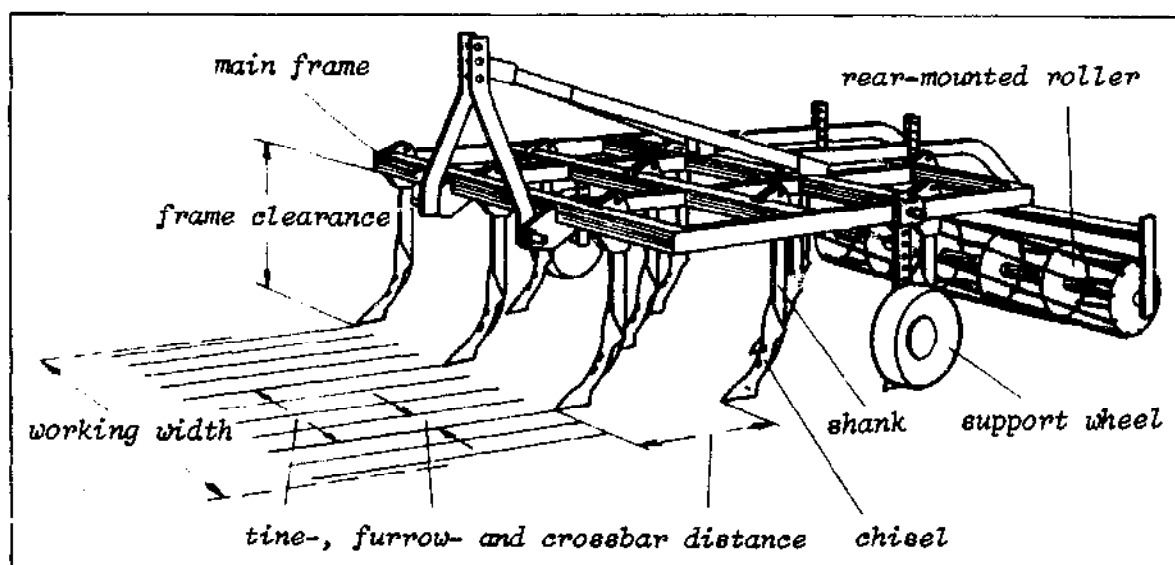

Fig. 38. Parts of a chisel plough.

### 2.3.4 Description Of The Implement And Tools

The basic frame (Fig. 38) is made of steel (flat, profiled or square tubes). The rigid, spring loaded or spring tines are mounted on this frame. They are placed in 2 to 4 staggered rows on fixed welded steel clamps or adjustable flanges. The depth is controlled by the supporting wheels or rear-mounted tools.

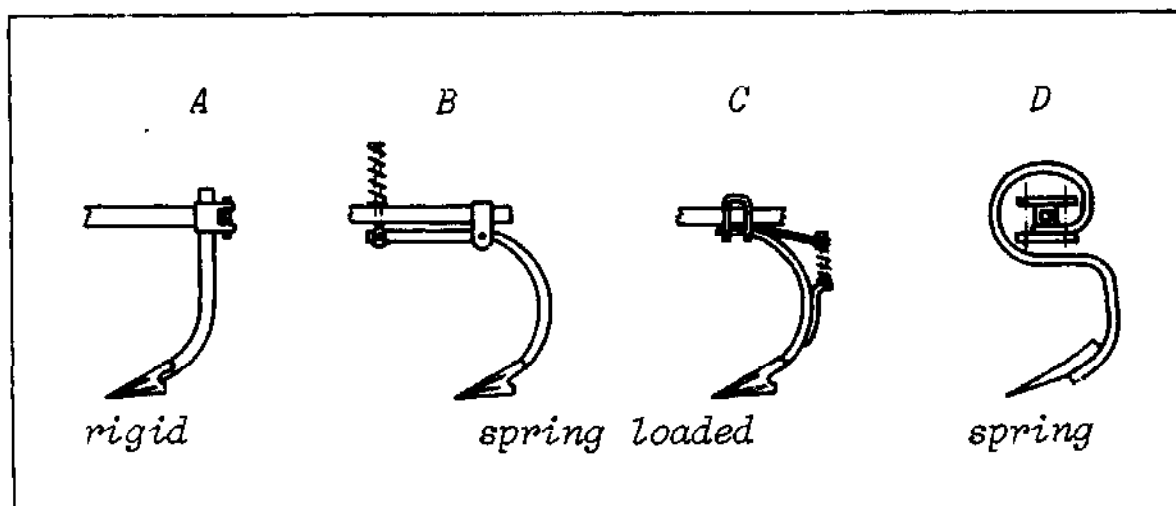

Fig. 39. Chisel tine shapes.

Rigid tines (Fig. 39A) - often fitted with a shearbolt for protection against stones - are made of high-carbon steel and are straight or slightly curved and angular to produce a chopping action. Rigid tines mounted at a smaller angle are particularly suitable for deep tillage.

Flexible tines (Fig. 39D), manufactured mainly from a heat-treated steel-nickel alloy, are flattened and slightly curved to allow diversion around obstacles. They are usually less suitable for deep tillage.

Spring loaded tines (Figs. 39B and C) are hinge-mounted on the frame and cushioned by spiral springs.

The main technical data of chisel ploughs are:

Number of tines, number of rows of tines (=number of crossbars), distance between tines, distance between furrows, distance between crossbars, working width, frame clearance (height) and the consequent working depth.

In practice, 25 cm is often used as the furrow distance (the greater the working depth, the wider the distance between furrows).

The minimum distance between tines on one bar should be 60 cm because of the risk of choking (deep tillage). Correct matching of the number of tines, working width, distance between furrows, number of rows of tines and the distance between tines is essential for good performance (see Figs. 35 and 38). The number of tines, rows of tines and effective distance between tines are determined for a given distance between furrows (25 cm), working width and minimum tine clearance (60 cm). For a 25 cm gap between furrows a chisel plough should have 3 rows of tines so that clogging caused

by too narrow clearance of the tines cannot occur. This means, for instance, that 13 tines are required for a working width of 3.25 m. It is essential for the tines to be placed symmetrically on the frame to prevent the implement from being pulled to one side. The distance between the rows of tines should be at least 70 cm to ensure a free flow of soil and plant material.

A simpler form of chisel plough is the single-bar, two-row type (Fig. 40). Its frame (for 3-point linkage) consists of one heavy hollow bar with a headstock. Two alternating types of tines are attached to that bar: straight tines pointing forwards and tines with the same angle of attack but with a wide loop at the top, curving backwards. The resulting distance between rows is about 40 cm.

A similar type of toolbar, equipped with one row of tines, is suitable for rear-mounting of p.t.o. driven equipment. Like the rotating or oscillating hoe, this type is also used in a special combination with rotary tillers (see Chapter 11.2).



*Fig. 40. One-bar, two-row chisel plough.*

The height of the frame should not be less than 70 cm. Supporting wheels may cause choking when they are placed between tines and so they should be mounted on the outside of the frame or run in front of the tines (with sufficient clearance) on the untouched soil.

Tines are equipped with various types of chisels according to the intended use (Fig. 41). Stone protection devices, as shown in Fig. 42, should

prevent breakage on soils containing many rocks or on extremely hard soils. These devices also help to keep the implement at the desired depth because only the individual tools will be diverted from obstacles, and not the entire frame.

Depending upon their size, chisel ploughs are designed as trailer, semi-mounted or mounted implements. The working width of mounted implements is between 2 and 6.5 m. Trailer (lighter) implements can cover up to 12 m. The heavier implements have an articulated frame with wings (outriggers) and supporting wheels which can be folded hydraulically for transport. Depths between 35 cm and 60 cm can be reached depending upon the type of implement.

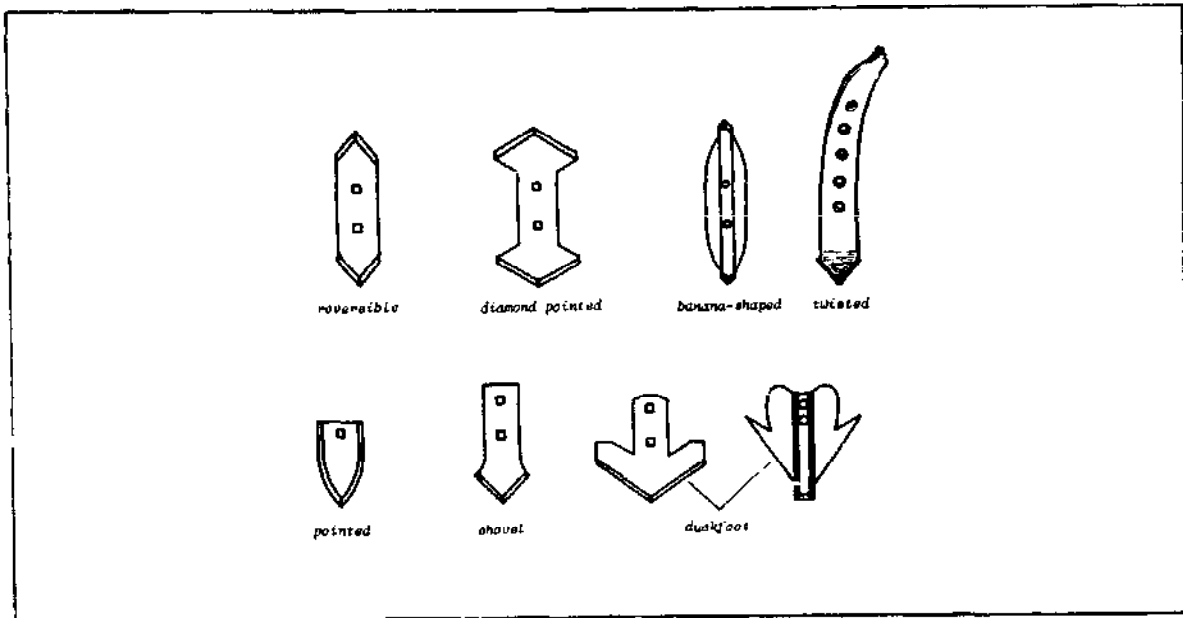

Fig. 41. Chisel shapes.

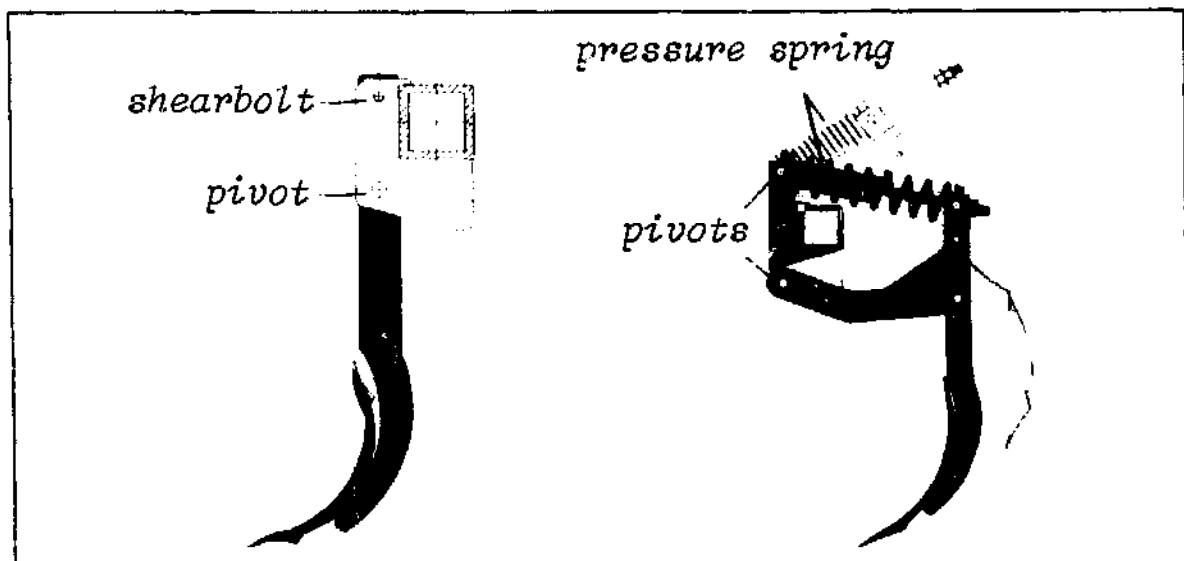

Fig. 42. Overload protection devices.  
left: shear bolt, right: compression spring.

### 2.3.5 Adjustments, Operation

2.3.5.1 Chisels - On most implements the chisels can be changed in keeping with the operating conditions. They can often be reversed after one side has worn out.

2.3.5.2 Distance Between Tines And Furrows - On some types the tines are mounted by adjustable flanges on the main frame, allowing adjustment of the tine and furrow distance.

2.3.5.3 Working Depth - The working depth is usually controlled by the supporting wheels (by changing bolts on light implements and hydraulically on the larger types) or by rear-mounted tools. The use of the depth control setting of the tractor's hydraulic system (when no supporting wheels are used) has not proved successful. The maximum depth is limited by the height of the frame (sufficient clearance).

2.3.5.4 Tillage Intensity - The tillage intensity depends upon the speed, the ratio between the distance and depth of the furrows, the type of tines, the angle of attack and the shape of the chisels. The intensity can be considerably increased by repeat working (crosswise) and by using rear-mounted attachments. Under favourable conditions the chisel plough can also be used for direct drilling when combined with rear-mounted tools (levelling, crumbling and even p.t.o. tools) and a sowing machine. A rod weeder can be mounted on the last row of tines on some types of chisel ploughs for better weed control.

2.3.5.5 Maintenance - Mounted implements can be fitted with quick-coupling devices. The operation is simple and can be performed by one man. The driver has to get off the tractor to make any adjustment on the actual chisel plough. Chisel ploughs for deep tillage and also standard cultivators are very sturdy and do not need much repair. Wear will occur not only on the chisels but also on the overload protection devices. Servicing is limited mainly to lubrication of the supporting wheels and the adjustment devices for rear-mounted tools.

### 2.3.6 Technical Data

#### Heavy chisel ploughs

Frame height	60-90 cm
Working width	up to 14 m



Working depth	up to 60 cm
Power required	20-60 kW/m (27-82 hp/m)
	5-10 kW/tine
Distance between furrows	20-37.5 cm
Distance between tines	55-90 cm
Number of tines	5-39
Number of rows (crossbars)	1-4
Distance between crossbars	up to 90 cm
Overload protection devices	shearbolts, spiral springs
Weight	120-450 kg/m

#### Light cultivators

Frame height	from 30 cm
Working width	up to 20 m
Working depth	15-20 cm
Power required	7.5-11.5 kW/m (10-15 hp/m)

#### 2.3.7 Literature

See literature of chapters 1 and 2.0.

Allmaras, R.R., R.W. Rickman, L.G. Ekin and B.A. Kimball, 1977. Chiseling influences on soil hydraulic properties. *Soil Sci. Soc. Amer. J.*, 41(4): 796-803.

Doty, C.W. and D.C. Reicosky, 1978. Chiseling to minimize the effects of drought. *Transactions of the ASAE*, 21(3): 495-499.

Erbach, D.C. and R.M. Cruse, 1981. Chisel plow induced changes in soil conditions. *ASAE Paper*, No. 81-1508, pp. 10.

Estler, M., 1978. *Schwergrubber, Universal- oder Spezialgeraet.* *Agrartechnik International*, Jan. 78: 10-11.

Herblot, G. (Ed.), 1980. *Travail du sol avec outils a dents. Applications possible dans les pays chauds* (Reunion technique, SIMA, Mars 1980). *Machinisme Agricole Tropical*, 71: 32-59.

Kiss, G.C. and Bellow, D.G., 1981. An analysis of forces on cultivator sweeps and spikes. *Canadian Agricultural Engineering*, 23(2): 77-83.

Koeller, K., 1981. *Bodenbearbeitung ohne Pflug.* Thesis Univ. Hohenheim. *Hohenheimer Arbeiten*, Heft 112, Ulmer, Stuttgart, pp. 320.

Spoor, G. and R.J. Godwin, 1978. An experimental investigation into the deep loosening of soil by rigid tines. *Journal of Agric. Engineering Research*, 23: 243-258.

Spoor, G. and R.J. Godwin, 1979. Effect of tine position on the performance of multi-tined implements. *Proceedings of the 8th. Conference of ISTRO, Hohenheim, Fed. Rep. of Germany*: 353-358.

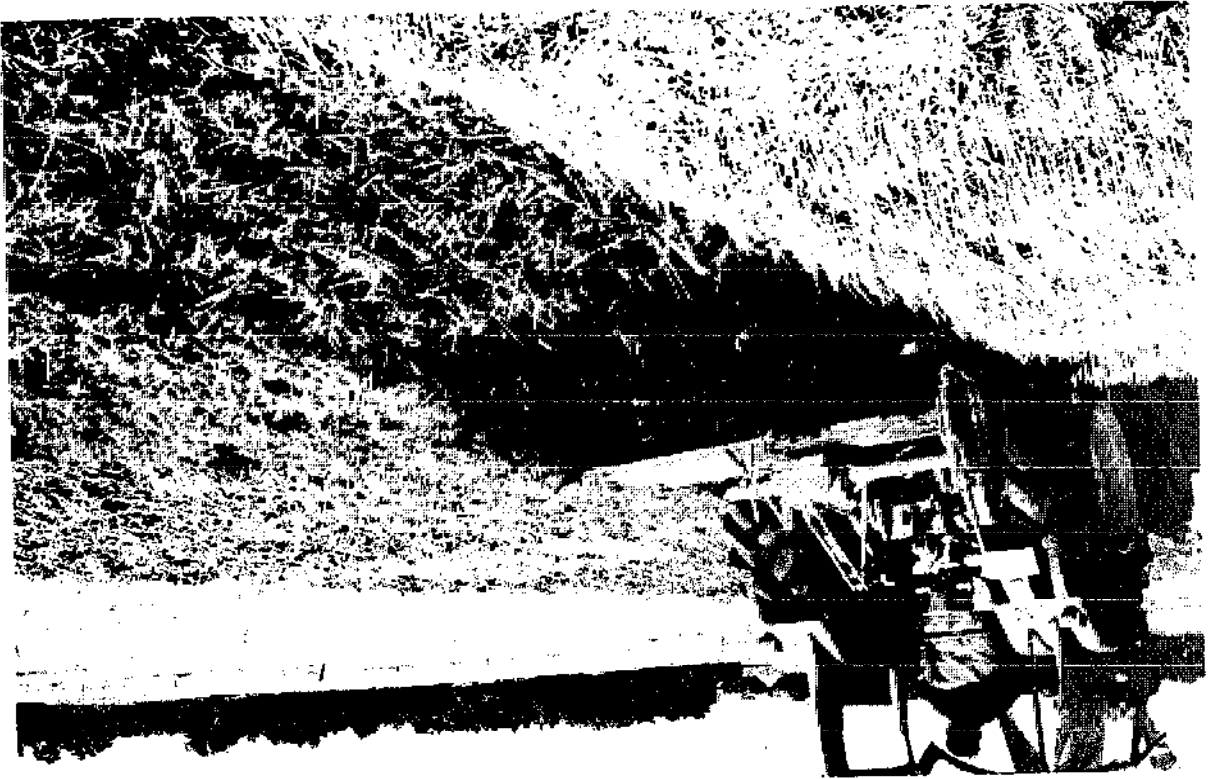

2.4 The Rotary Tiller

### 2.4.1 Use And Assessment

The rotary tiller (Fig. 43) is used for:

- stubble tillage (especially for intermediate crops) including working in straw (mulching),
- working in organic material,
- working in cattle manure,
- mechanical weed control,
- seedbed preparation,
- puddling in paddy rice production systems,
- sowing in one operation when combined with sowing equipment,
- strip cultivation in row crops (also in combination with ridgers),
- grassland and wasteland clearing,
- road reconditioning.

In principle, extreme caution is required when using the rotary tiller in the tropics and subtropics. On sloping land in particular the pronounced pulverization effect may lead to slaking of the surface, erosion, rapid decomposition of organic matter and, possibly, more rapid drying-out of the soil.

There are far fewer objections to the use of the rotary tiller in irrigated farming (especially in the case of surface irrigation). The special merits of this implement when used for paddy rice-growing will be given more attention in Chapter 6.

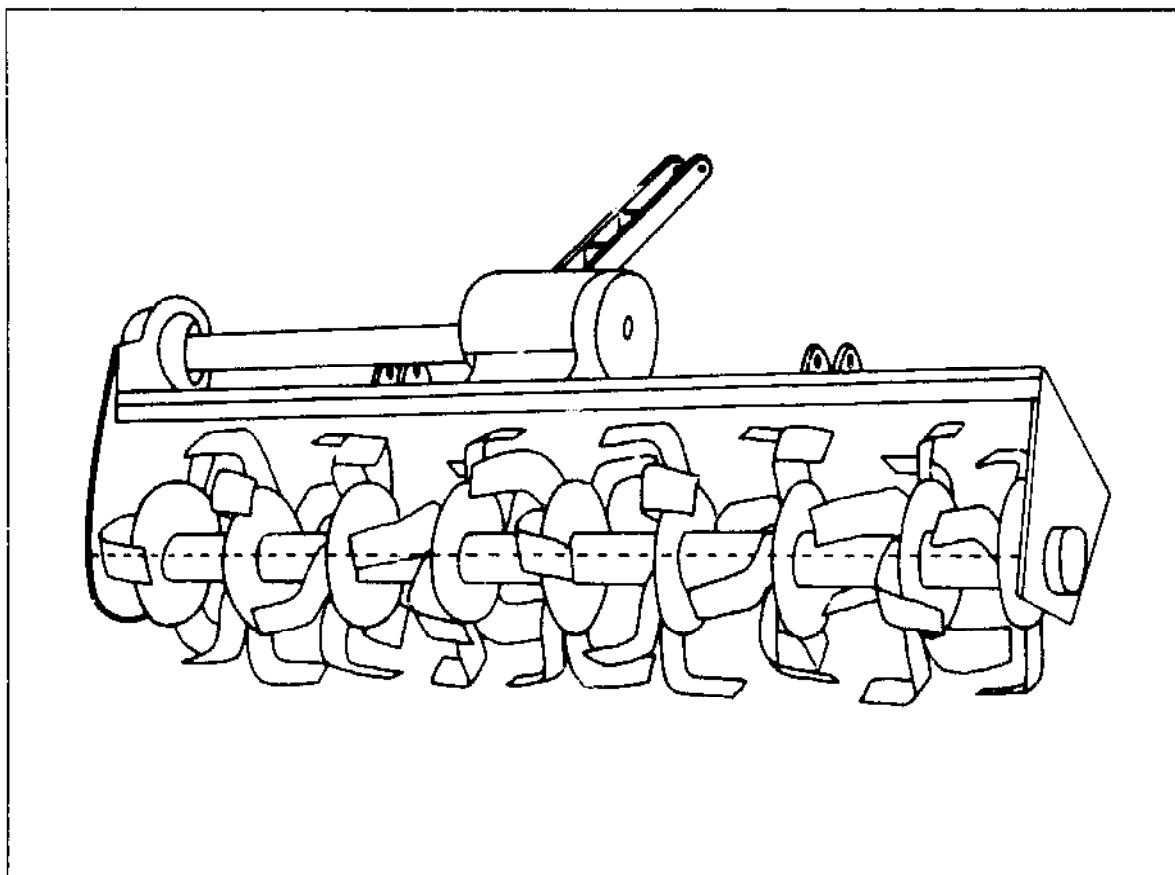

Fig. 43. Rotary tiller.

Rotary tillers have the following advantages:

- the desired crumbling and mixing can be achieved under a wide range of soil conditions by adjusting the number of revolutions and the forward speed. in many cases only one pass is necessary to produce a seedbed (time saving, sowing at the correct time, fewer wheeltracks);
- they are very suitable for working in organic material, mulching, grassland clearing (accelerating decomposition);
- stubble tillage is still possible on hard firm soils where disc or rotary harrows cannot be used. This operation does, however, impose heavy demands on the machine, tractor and driver and causes considerable wear;
- they produce hardly any tillage or compaction soles;
- the power transmission is very efficient (about 80%) because of the p.t.o. drive (a plough is only about 50%). They cause hardly any slippage of the tractor's driving wheels and so uphill working is possible;
- their short length removes less load from the front axle of the tractor;
- they can be combined with mounted sowing machines (very short sowing time);
- they are very reliable.

The disadvantages of rotary tillers are:

- the power required per volume of manipulated soil is high compared with a (chisel) plough because of the operating intensity;
- when the tillage intensity is too high (excessive rpm, low speed), the operation may cause surface slaking, crusting and soil erosion;
- accelerated decomposition of organic matter can be expected;
- the capacity is not always satisfactory, especially for deep tillage; with a working width of 2.75 m the capacity is only 1 ha/h for stubble tillage;
- a serious strain is imposed on the tractor p.t.o. and drive system on hard stony soils;
- the driveshaft must match the tractor's p.t.o. shaft (profile, length); adaptors are sometimes necessary.

#### 2.4.2 Functioning

The rotating blades on the main shaft of a rotary tiller cut the soil when moving downwards. The blade's course is cycloidal because of the forward travel and it cuts wedge-shaped slices from the soil (Fig. 44). These slices are thrown backwards against the hood and trailing screen which causes further crumbling. When the shaft is driven from the centre, a narrow untilled ridge is left (a tine is sometimes needed to break up this ridge). When the drive is mounted on one side of the machine, its protection shield determines the maximum depth (generally up to 15 cm or up to 30 cm on special machines). The preferable working depth is between 5 and 15 cm. For seedbed preparation, however, the tilling depth should not exceed 10 cm.

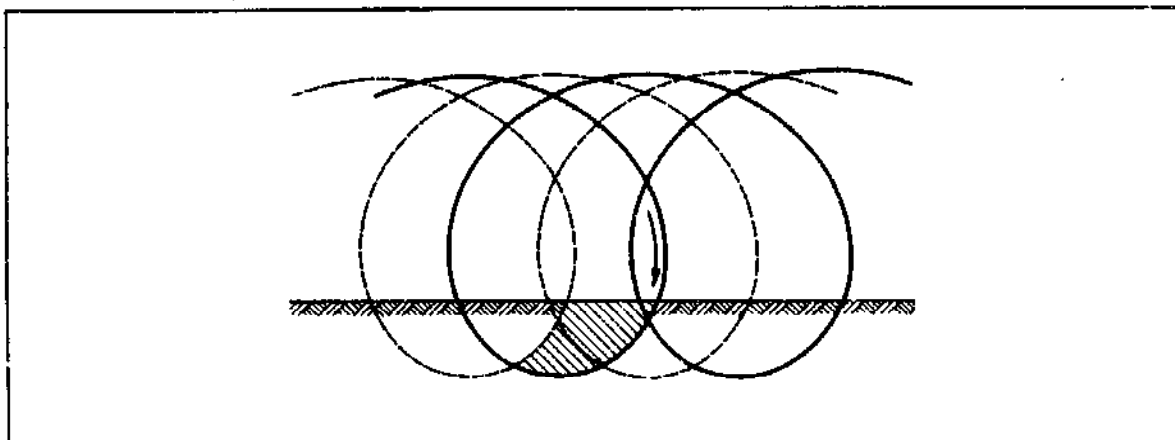
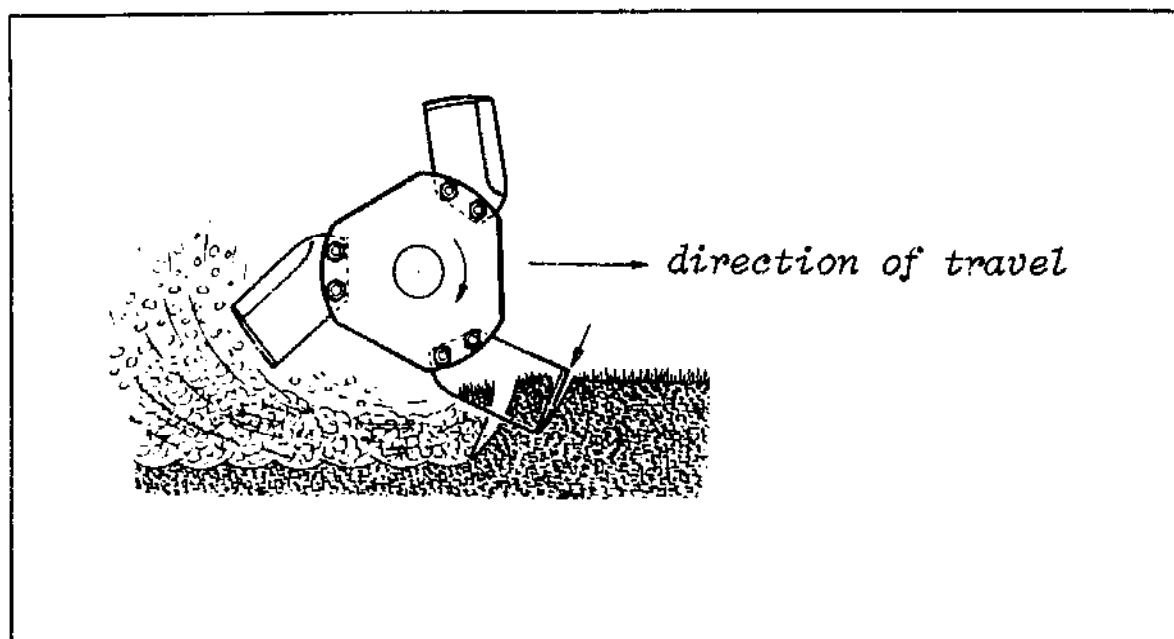

*Fig. 44. Cycloidal paths of points on the cutting edge of two consecutive knives of one working set of a rotary tiller.*

The tractor wheel-tracks can be loosened directly by off-set mounting for narrow machines or by using machines wide enough to cover both tractor-wheels. The number of revolutions of the tiller shaft (100-300 rpm) can be adapted to the travelling speed (up to approx. 6 km/h) and the soil conditions. In many cases, therefore, seedbeds can be prepared in one single pass (time-saving, fewer tracks), especially when the machine is fitted with a crumbling roller.

The axle revolutions and forward speed must be synchronized to achieve the desired crumbling rate. Depending upon the shape of the blade, a clearance angle must be left between the plane of the blade and the tangent to the cutting trajectory (Fig. 45). If this angle is too small, the cutting surface of the soil will be smeared.

As the number of blades along the periphery is increased (2-4-6), the tillage becomes more intensive.



*Fig. 45. Clearance angle of rotary tiller knives (indicated by arrow).*

The rotary tiller is very efficient for chopping and mixing (see Fig. 17), especially when it is fitted with standard (L-shaped) blades. Organic matter can be well worked in if it is evenly distributed over the surface. When there is a risk of wind or water erosion or in quick-drying conditions, the working depth should be shallow and the tilling intensity as low as possible so that the surface is left as rough as possible.

The infiltration capacity of the soil can be improved by shallow tillage but only if it is not limited by the infiltration rate of the subsoil (e.g. owing to tillage or tractor tyres). Nonetheless, a rotary tiller should never be used merely to improve infiltration. The pronounced loosening of the soil by a rotary tiller causes considerable decomposition of the organic matter and also considerable nitrification of the nitrogen bound to that material (important in a closely integrated crop rotation).

Strips can be cultivated for row crops (e.g. potatoes, cotton) by removing various units; this reduces the organic matter decomposition and the risk of erosion. The strip system can be employed for sowing (cereals, sugarbeet, cotton) and for crop protection operations (weeding, ridging, etc.).

Propagation of rooted weeds by partitioning of the rhizomes can be prevented (in dry weather) by tilling more than once with a rotor revolving at high speed.

A special model - the rotary tiller with reverse rotation - permits satisfactory inversion and crumbling in one pass for grassland clearance.

Owing to the thrust action of a rotary tiller (excluding the reverse rotation type) hardly any slippage occurs by the tractor drive wheels (no smearing of the soil). A rear-mounted packer is often used for levelling and packing the soil and for improved depth control.

Rotary tillers have recently been produced with passive soil-loosening tools (rippers, chisels) mounted either in front of or behind the rotor and operating below the (rotor's) working depth. These implements make it possible to combine shallow crumbling with deep loosening.

#### 2.4.3 Linkage And Drive System

Larger rotary tillers are generally suitable for 3-point hitch linkage (categories I - III, depending upon the power requirement) and only rarely for use as a trailer implement. The tillage operation is performed with the hydraulic system in free-floating mode since the system is not needed for depth control. Two adjustable depth wheels or skids or a rear-mounted roller control the working depth. The lifting capacity at the ends of the tractor's lower links should be more or less twice the weight of the implement. The centre of gravity is located close to the tractor.

Many rotary tillers can operate in an offset position so that they can be adapted to the track width (Fig. 46). A device is available for work in orchards which shifts the implement sideways and back when a tree is encountered.

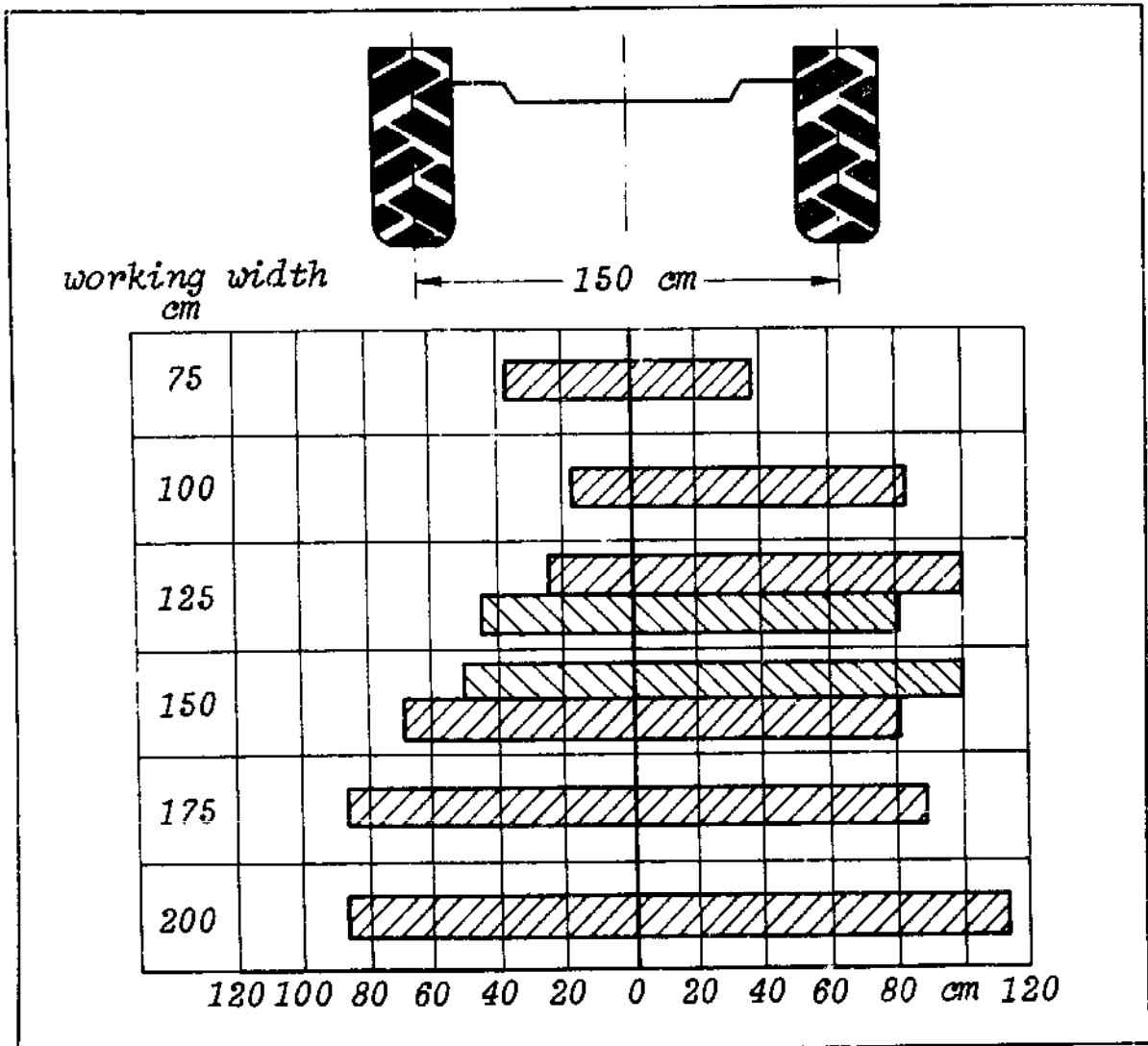

Fig. 46. Working widths related to the center of the tractor for rotary tillers of 0.75 - 2.00 m wide.

The implement is driven by the p.t.o. at 540 or 1000 rpm. The higher rpm is now commonly used for the larger rotary tillers to save the drive system and bearings. The gear-wheels in the gearbox usually have to be (inter) changed when switching from 540 to 1000 rpm.

Pto- and drive shaft should have the same spline profile and the driveshaft should be the correct length (when at working depth the telescoping joints of the shaft should overlap for at least 200 mm; when lifted, at least 20 mm clearance should be left to allow for further shortening of the shaft). At working depth the universal joints in the drive shaft should have a maximum angle of 30 deg. An overload safety device is strongly recommended, especially on hard stony soils.

Rotary tillers require power (almost entirely through the p.t.o.) of 25-35 kW (approx. 35-45 hp) per meter of working width for primary tillage at a speed of 3-4 km/h. This reduces to 18-22 kW/m (approx. 25-30 hp) on ploughed soils.

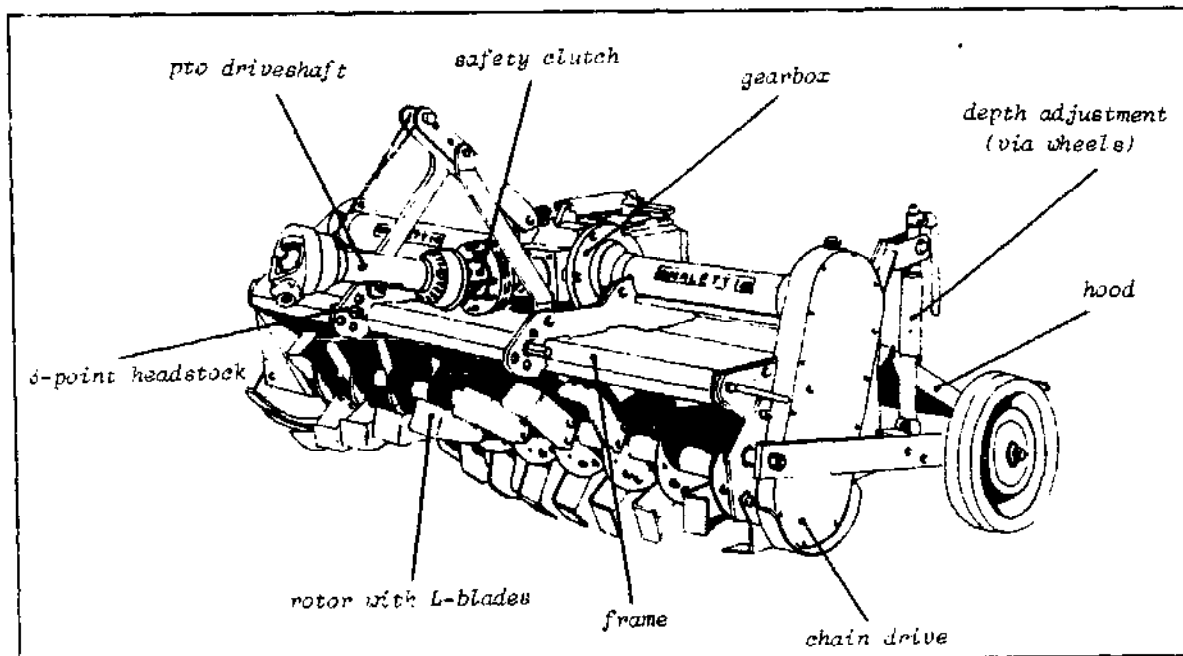

Fig. 47. Rotary tiller.

#### 2.4.4 Description Of The Implement And Tools

A frame (Fig. 47) supports the main shaft which is mounted across the direction of travel and supported by bearings, either in the centre or at both ends. The rigid soil-engaging tools (blades or knives, Fig. 48) are mounted on separate flanges (interval  $> 20$  cm) each with up to 6 tools arranged in "working sets". The blades are set to the left and right in an equal number of pairs (2-6), except for the sets on the sides. The complete unit made up of shaft and tools is called the rotor. The blades are arranged in a spiral pattern to provide smooth operation: only one blade should hit the soil at a time.

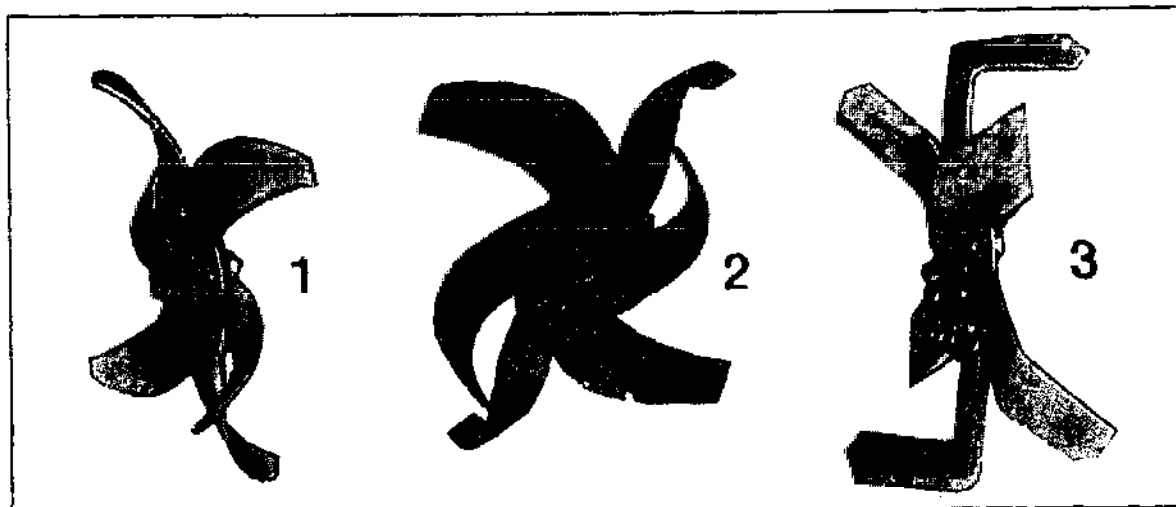

Fig. 48. Working sets with:

1. Cutting blades for light to heavy soils,
2. Crumbling blades for light to medium soils (fine tilth),
3. Mulching blades to incorporate straw, farmyard- and green manure.



The rotor is driven by chain transmission or gear-wheels from the centre or one of the sides. There is usually a gearbox and overload safety device between the tractor drive system (p.t.o. shaft and driveshaft with universal joints) and the drive system of the rotor.

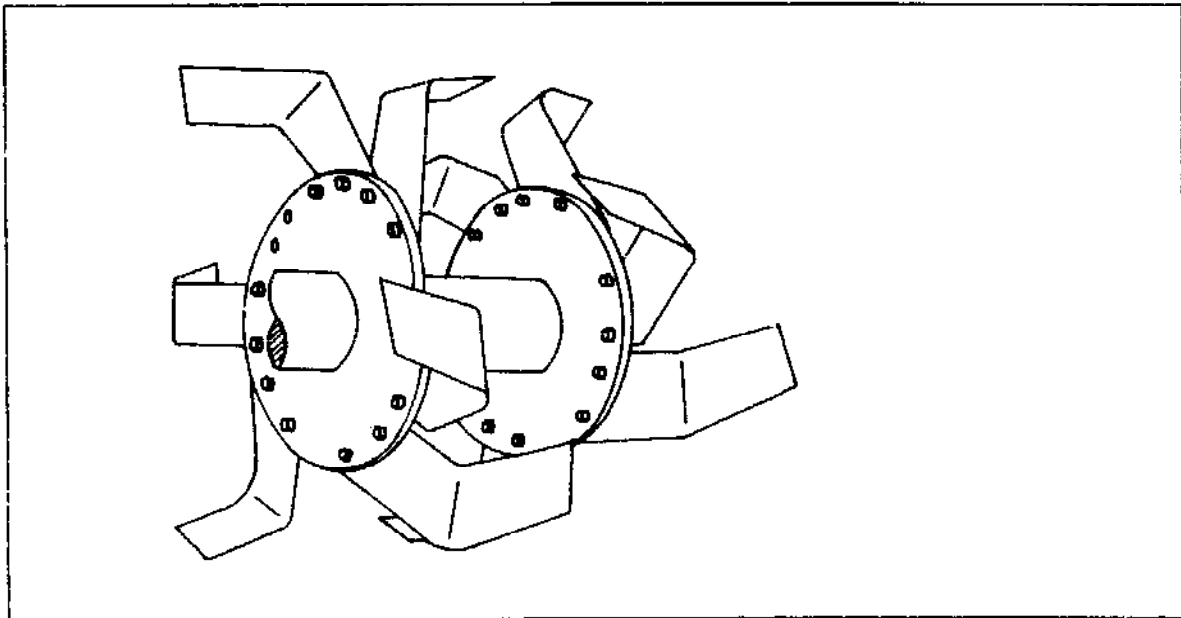

Fig. 49. Working sets.

The rotor usually rotates in the same direction as the tractor-wheels (concurrent revolutions, Fig. 50A).

Reverse-revolution rotary tillers (Fig. 50B) are also available. On both types a hood is used for additional crumbling of the soil aggregates and for guiding the flow of soil material produced by the rotor (protection against flying stones, etc.). One or more trailing screens extending over the entire working width may be used to level the soil surface.

A screen of iron bars between the rotor and hood is a special feature of the reverse-revolution type (Fig. 50B). This screen separates the coarse soil material, sods, trash, etc. and deposits them before and below the fine material which passes through the bars. This machine is frequently used for grassland renovation when a seedbed for resowing is made in one pass.

The rotary tillers' working depth can be adjusted by gauge wheels or skids or by using a packer. Because of their short length rotary tillers are very suitable for attaching tools to the rear (rollers to compact or crumble the soil) and for mounting sowing equipment (direct drilling).

The rotor can also be fitted with tines (Fig. 77) or spikes (Fig. 42) for secondary tillage on ploughed land. Rotary tillers are often combined with other implements for primary tillage, especially implements fitted with rigid tines (combination of chisel plough and rotary tiller). The tines produce deep loosening of the soil while the rotary tiller performs more intensive tillage on the surface.

The spike rotary tiller is commonly used for making ridges in one pass; special ridging units or shapers are mounted at the rear. The machine can be used later for maintenance (re-ridging, strip tillage) by removing certain working sets.

Rotary tillers are designed as mounted, trailer or self-propelling (power tillers, see chapter 6.2) implements.

#### 2.4.5 Adjustments, Operation

2.4.5.1 Working Depth - The depth may be varied from 0 to 25 cm by adjusting the gauge wheels or skids by means of spindle or bolts. The depth can also be set by transferring the load to a packer (when mounted). The shielding of the drive system will control the depth on very dry and hard soils. Sickle-shaped blades work at greater depths than universal blades. Adjustment of the tractor's lifting arms (spindle) makes it possible to level the machine in a lateral direction.

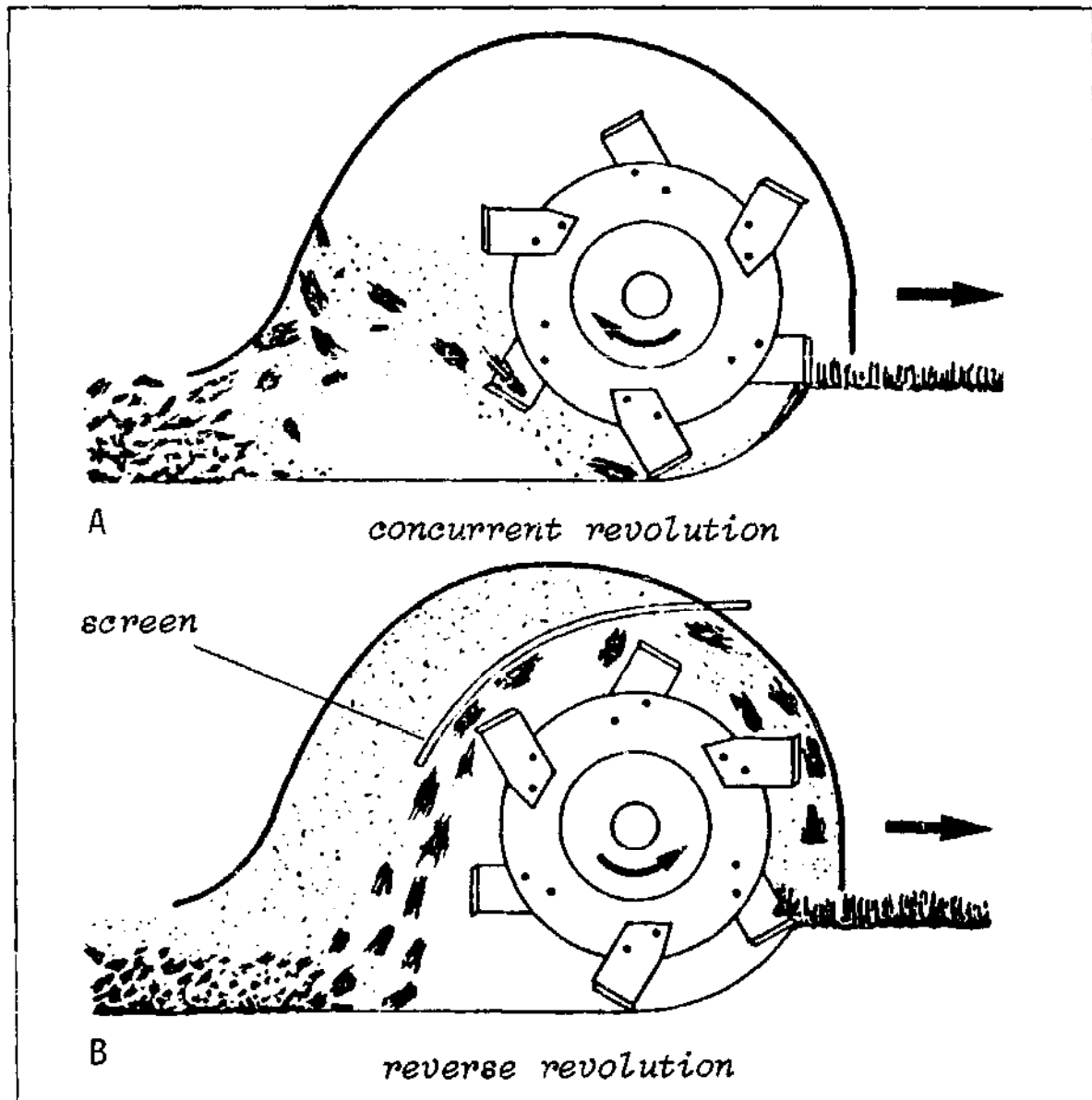

Fig. 50. Concurrent revolution (top) and reverse revolution (bottom) rotary tiller. - Source: Heege.

2.4.5.2 Tillage Intensity - The tillage intensity (bite length, number of cuts per square meter) depends upon the rotor speed (usually between 100 and 300 rpm) and the forward travel speed (Fig. 51) as follows:

- low rotor speed and high forward speed: leaves clods and preserves the soil structure;
- high rotor speed and low forward speed (1.0-1.5 km/h): intensive tillage;
- a very high rotor speed requires a great deal of power from the p.t.o. (the increase is more than proportional) and imposes a heavy strain on the drive system;
- the rotor's peripheral speed should be about three times the forward travel speed;
- the hood is used for additional crumbling;
- the trailing screen greatly influences the resulting tilth: the lowest position gives the greatest intensity;
- rear-mounted rollers are used for re-compacting the soil, controlling the depth and, sometimes, for levelling or final crushing.

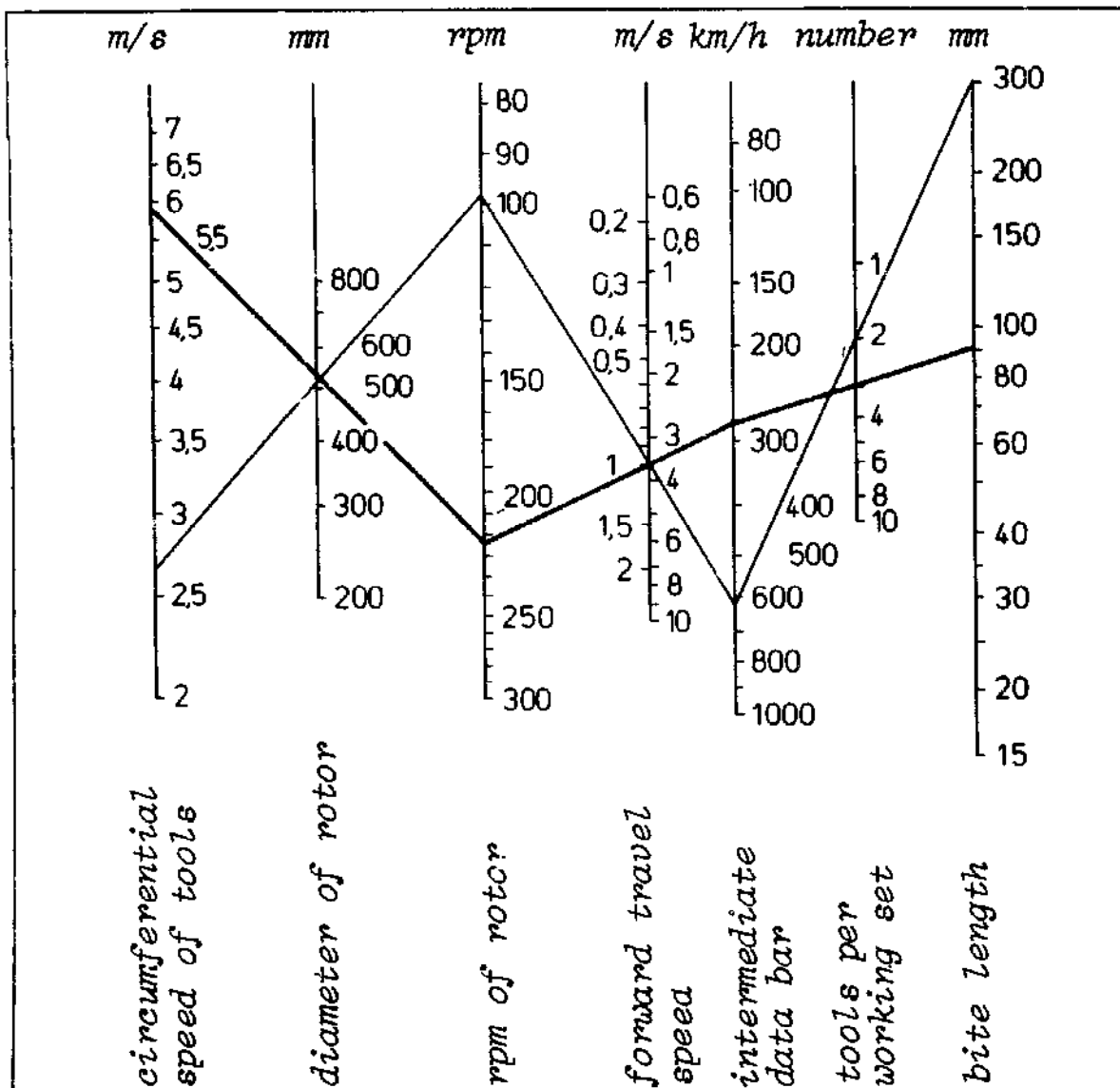

Fig. 51. Bite length as a function of design and adjustment for a rotary tiller. Based on the required bite length (extreme right axis), the possible combinations for adjustment can be found.

2.4.5.3 **Operation** - Rotary tillers can easily be mounted and adjusted by one man; a quick-coupling device can be used. A rotary tiller does not require high skills from the driver. Clean working can be achieved by allowing an overlap (about 10%).

#### 2.4.6 Technical Data

Working width	up to 4.5 m
Working depth	5-15(30) cm
Rpm of p.t.o. drive	540/1000
Travel speed	up to 6 km/h
Power required	from 20 kW (better is 30 kW) per metre of working width
Gearbox (rotor rpm)	up to 10 steps
Rotor's peripheral speed	4.0-7.5 m/s
No. of blades per set/total	2-6/up to about 132
Distance between sets	from 20 cm; up to 45 cm when used behind loosening tines
Weight	350-500 kg/m
Safety devices	friction clutch (single or multiple disc type)
Packing/crumbling roller	400 mm in diameter.

#### 2.4.7 Literature

See literature of chapters 1 and 2.0.

### 3.0 IMPLEMENTS FOR SECONDARY TILLAGE



**Implements for shallow tillage, mulching, working in surface material and weed control.**

This group of implements has a very important function in tropical and subtropical climates. The advantages of mulching to prevent erosion and increase the infiltration and water-retention capacity have been mentioned earlier. Good mechanical weed control is also vitally important; on the one hand, measures to increase production (water, nutrients, soil tillage) also encourage weed growth while, on the other hand, mechanical weed control measures reduce the use of chemical herbicides to a minimum with all the resultant ecological and economical advantages.

The types of implements shown in Table 5 are, in principle, available for the functions listed in the heading of this section. The chisel plough and rotary tiller were examined in Chapters 2.3 and 2.4 although they are used mainly for stubble tillage. The plough is also frequently used for stubble tillage and may operate satisfactorily at a depth of only 12 cm. The skim plough, a special implement for stubble tillage, will not be described here because the principles of its design are similar to those of the mouldboard plough. The only difference is that the skim plough is lighter and its bodies smaller. A roller is often mounted behind the skim plough. The investment in a special skim plough is rarely justified since a range of other implements with active, rotating or oscillating tools offers a wide choice for skim and mulch tillage.

implements with passive tools	implements with active tools		
	ground driven	others (pto; hydromotors)	
		rotating      oscillating	
skim plough cultivator	disc plough one-way tiller disc harrow rotary harrow rotary hoe	rotary tiller (tine rotor) rotating hoe recipr. rotor	reciprocating hoe

*Table 5. Implements for shallow tillage, mulching, incorporation of surface material and weed control.*

## Mechanical weed control in row crops

The following chapters will discuss equipment which is used between cropping periods.

Weed control is, however, an important tillage operation in an established crop. The weeder (Chapter 4.6) may be used to eradicate small weeds in both broadcast and drilled crops when the crop is still fairly young. In a more mature broadcast crop mechanical weed control will cause too much damage to the crop.

Weeds in row crops can be controlled by special equipment for inter-row cultivation. Basically, these implements consist of a toolbar with weeding units spaced out at intervals equivalent to the distance between the crop rows, similar to the ridgers described in Chapter 4.7 (Figs. 101 and 104). L-, T- and duckfoot-shaped weeding blades can be fitted instead of a ridging body. The working area of these blades travels horizontally and cuts off the roots just below the surface.

Other tools suitable for (parallelogram) mountings are spring tines (see Figs. 70 and 71) and rotary hoe units (Fig. 62).

Large vertical discs or fixed shields may be used to protect the crop from damage by the weeding tools. If they are to operate correctly and efficiently (by cutting as close as possible to the plants) the number of units should be the same as on the sowing machine; the sowing pattern must be followed during the weeding operations.

## Literature

- Bilbro, J.D. and Wanjura, D.F., 1980. Disks versus rotary hoes for increasing cotton emergence. ASAE paper, No. 80-1010, pp. 10.
- Bode, L.E., B.J. Butler and L.M. Wax, 1978. Herbicide incorporating capabilities of several tillage tools. 1978 Meeting Weed Science Society of America, 56.
- Hartwig, N.L. and L.D. Hoffman, 1980. Incorporation effectiveness of various tillage tools. Proceedings of the Northeastern Weed Science Society, Vol. 34: 82-86.

**3.1 The Disc Harrow**





### 3.1.1 Use And Assessment

The disc harrow (Fig. 52) is used for:

- stubble tillage,
- working in long pliable plant residue,
- seedbed preparation for intermediate crops,
- working in manure,
- seedbed preparation in a ploughed field with large clods,
- levelling,
- smoothing out holes after an intermediate crop has been cleared,
- keeping the soil surface open,
- sod cutting before grassland is cleared,
- fallow tillage,
- working in broadcast seeds.

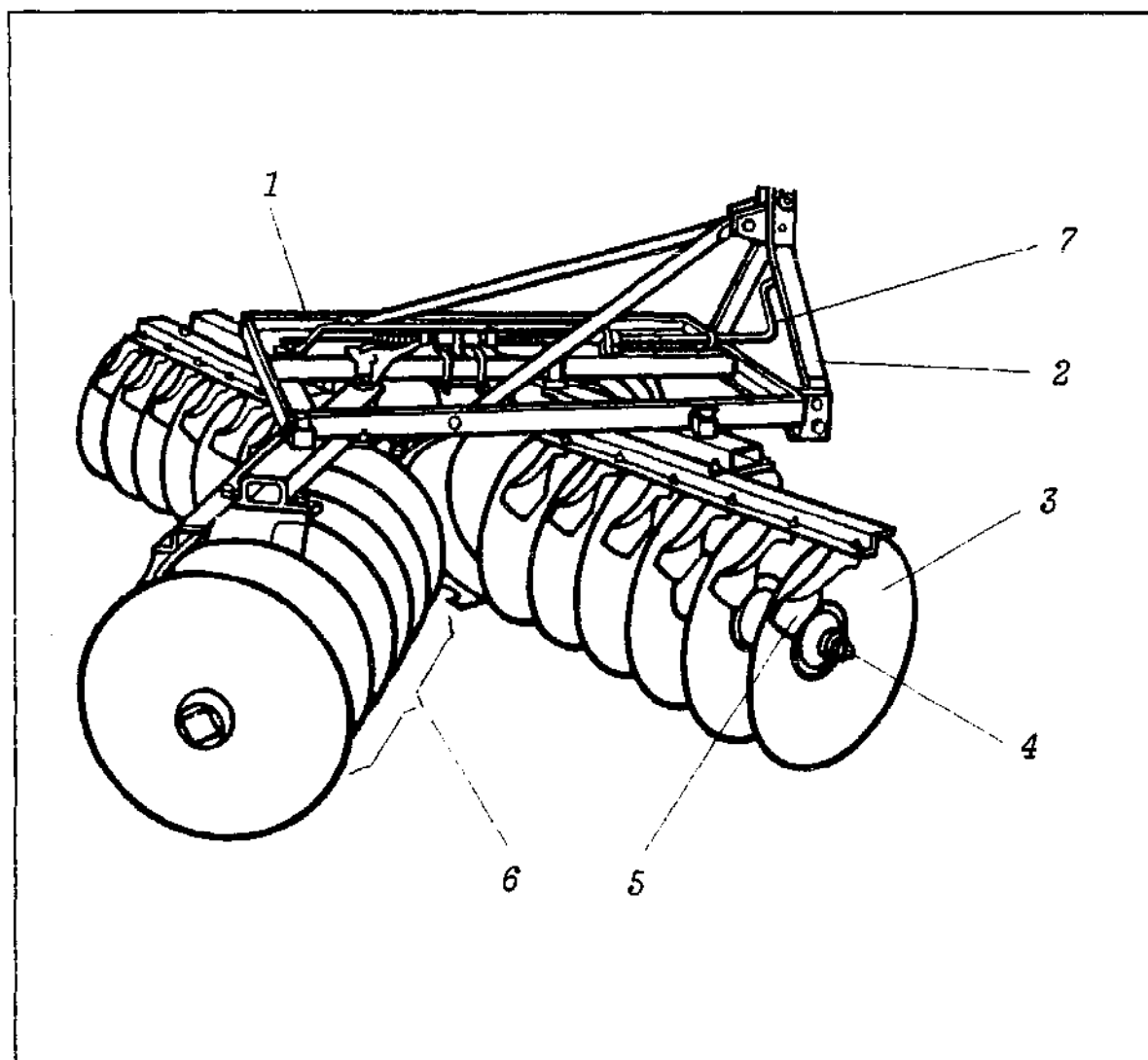

Fig. 52. Disc harrow:

- |                  |                             |
|------------------|-----------------------------|
| 1. Frame,        | 5. Scraper,                 |
| 2. Headstock,    | 6. Disc gang,               |
| 3. Disc,         | 7. Device for adjusting the |
| 4. Ball bearing, | disc angle (cutting angle). |

Because of its method of operation and range of adjustments the disc harrow can be used for both primary and secondary tillage. This implement is outstanding in its versatility and has the following advantages:

- the ability to work in organic material up to the size of maize stalks,
- reduction of erosion when plant residue can be mulched (in one pass),
- simple to operate, maintain and service,
- highly reliable,
- roll over obstacles,
- produces hardly compaction soles,
- reduces evaporation by capillary action.

These advantages must be set against the following disadvantages:

- not very effective against root-propagating weeds,
- may cause slaking, crusting and, possibly, erosion in the event of over-intensive tillage,
- usually needs more than one pass (compaction by tractorwheels!),
- high draught requirement,
- hardly any possibility of combining it with other implements.

### 3.1.2 Functioning

Like all disced implements, the disc harrow does not penetrate the soil of its own accord. Penetration is caused mainly by its own weight and, possibly, extra weights but at certain disc angles it may also be caused by the resistance of the soil.

As in the case of the disc plough, curved discs - set at an angle to the direction of travel - will rotate in the same direction as the tractor-wheels (because of the resistance of the soil). Soil and plant residue are lifted and deposited in a pouring motion. The mixing action is even more thorough as the soil is moved by the next unit (a unit consisting of a group of discs on one shaft is called a "gang"). The discs move the tilled soil layer over the width of one disc to the side facing the disc opening. The rear gang compensates for this movement of the soil by tilling the same strip in the opposite direction. Since, in relation to the front discs, the rear discs are staggered by half the distance between the discs, the ridges thrown up on the surface by the discs and those cut into the bottom of the tilled layer are levelled when working at a speed of 5-6 km/h. The larger the discs, the better they are at rolling over obstacles and coping with plant residue on the surface.

Plain (smooth) discs are generally used. Cut-out discs are preferred when more cutting action (e.g. to cut up surface material or very dry stubble) is required. Their shape gives these discs a very large cutting area. Because of the high impact velocity the corners of the disc edge cause some separation of plant material. Cut-out or notched discs may be used on peat soils since they have less friction and a smaller sticking area and are less likely to become choked. Cut-out discs with less mixing but better cutting action are often used for the front gangs while plain discs whose mixing is better than their cutting action are fitted as the rear gang. The discs' concavity also greatly influences the tillage intensity. A small radius of curvature improves the mixing action but also increases the draught traction required and reduces the lateral forces. The range of adjustments for these discs is limited. If the disc is too wide, the rear of the disc skids and smears the furrow wall.

When the tractor is pulling a trailer implement with the hitchbar sloping forward, the load on the rear gangs is lessened while an extra load is imposed on the front gangs. So extra weights should always be placed behind the centre. The operating speed is 5-6 km/h. The working depth decreases as the speed increases.

In a few cases rollers can be attached at the rear.

### 3.1.3 Linkage And Drive System

Disc harrows are designed as trailer or mounted implements. They are mounted by the 3-point hitch system (Category I - III) and trailed by a linkage or swinging drawbar.

Since mounted implements have no wheels, they are easy to manoeuvre: the implement is simply lifted for turning and transport.

Trailer implements are usually fitted with transport wheels which can be operated manually or hydraulically. It is not easy to switch the manual type to the transport position and they have to be turned in the field with the discs inserted in the soil.

Heavy disc harrows can be mounted more easily by adjusting the hitchbar hydraulically to the same height as the drawbar.

A special device (Fig. 53) makes it possible to level the implement at any working depth and for the entire weight to be supported almost completely by the discs.

The draught required is between 18 and 25 kW per metre of width depending upon the type of implement, the adjustments and weight. Special types of implements have specific requirements. The effective capacity at 5 km/h is 0.35-0.45 ha/h per metre of width.

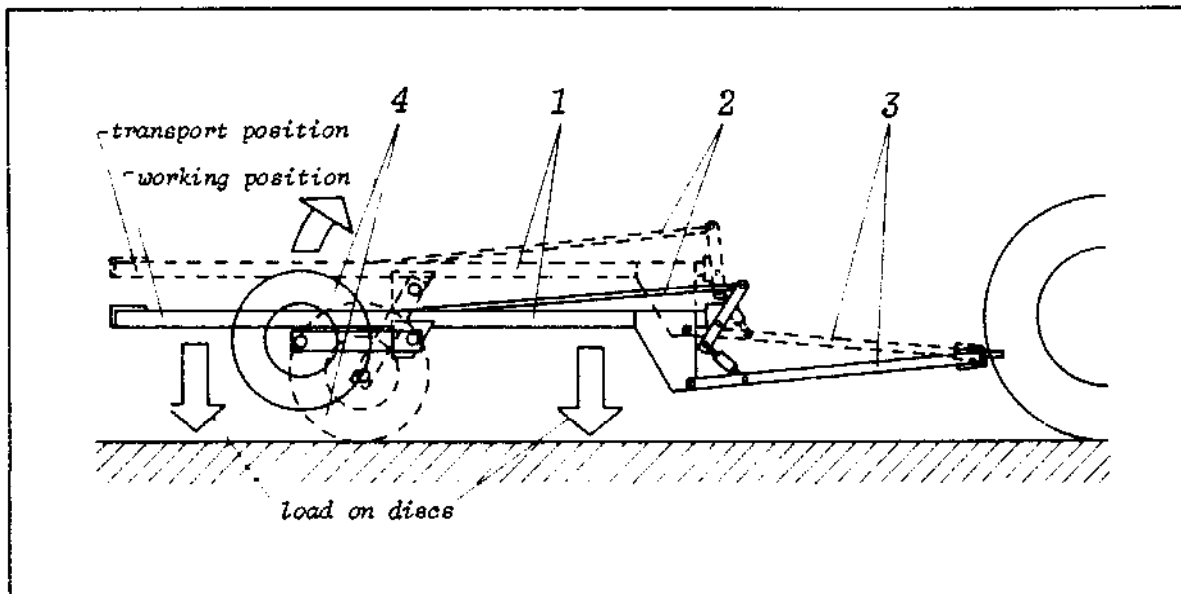

Fig. 53. Hitching device to enable both a full load transfer of the implement mass on to the discs as well as a correct levelling.

- |                     |                    |
|---------------------|--------------------|
| 1. Frame,           | 3. Drawbar,        |
| 2. Adjusting lever, | 4. Support wheels. |

### 3.1.4 Description Of The Implement And Tools

The working parts of the disc harrows (Fig. 54) consist of steel discs. The sharp blades with plain or cut-out edges are 400-650 mm in diameter and 4-6 mm thick. They are usually spherical but sometimes cone-shaped. The concavity (depth at the centre of the disc) ranges from 100 mm for small to 140 mm for large discs. The concave side of the disc faces forward.

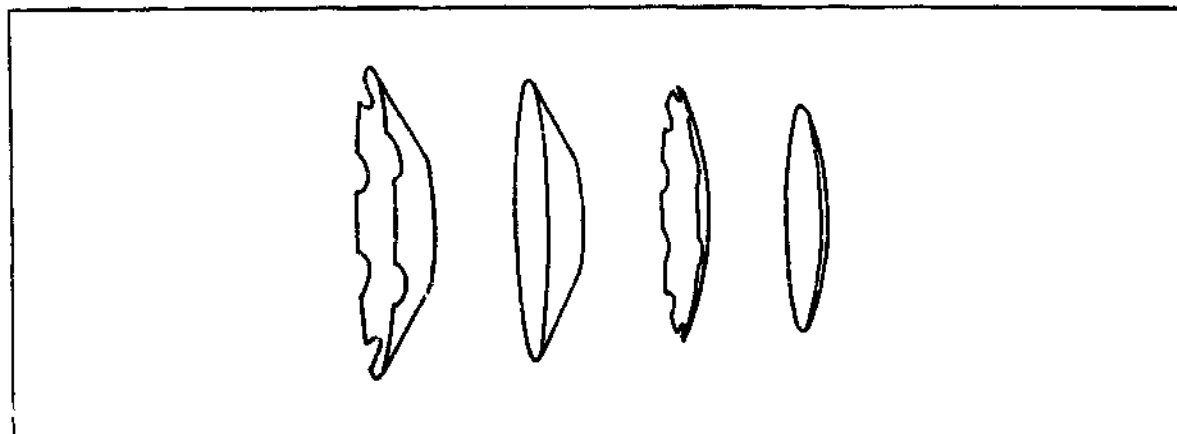

Fig. 54. Disc shapes. From left to right: cone shaped, cut-out; cone shaped, plain; spherical, cut-out; spherical, plain.

Each disc should be fitted with a scraper to remove the soil sticking to it. Discs are mounted in groups on a common shaft at intervals of 100-300 mm. The shaft is mounted on the frame with bearings at an angle to the direction of travel. Two bearings per metre are usually placed on a gang shaft. The types of bearings most commonly used at present are the ball- or tapered roller bearings with special dirt seals. Hard wood and white iron bearings are fitted on older or cheaper models.

Gangs are placed in adjoining or following pairs at adjustable angles so that the discs cut into the soil when the implement is moved forward. The lateral forces exerted on one gang by the soil are counter-balanced by those acting on the matching unit with its opposite curvature and direction of work. On larger trailer implements the remote hydraulic system which operates the transport wheels also acts as a depth control system.

Various methods are used to attach the gangs to the frame (Fig. 55).

The following general types of disc harrow can be distinguished:

Single acting: Two gangs are placed end to end so that they form an obtuse angle to the direction of travel (Fig. 55.1);

Double acting or tandem: Four gangs are arranged in the shape of an X (Fig. 55.2).

V (or A)- shaped: Two gangs are arranged behind each other (along the direction of travel) and form an open V (A) to one side (Fig. 55.3);

Offset: Here again two gangs are arranged behind each other but are staggered laterally. This makes it possible to work in an offset position so that the harrow moves to the left or right of the tractor (very suitable for orchards) (Fig. 55.4).

The V shaped and offset types are basically identical and in most cases the offset position can be fixed by adjusting the hitch.

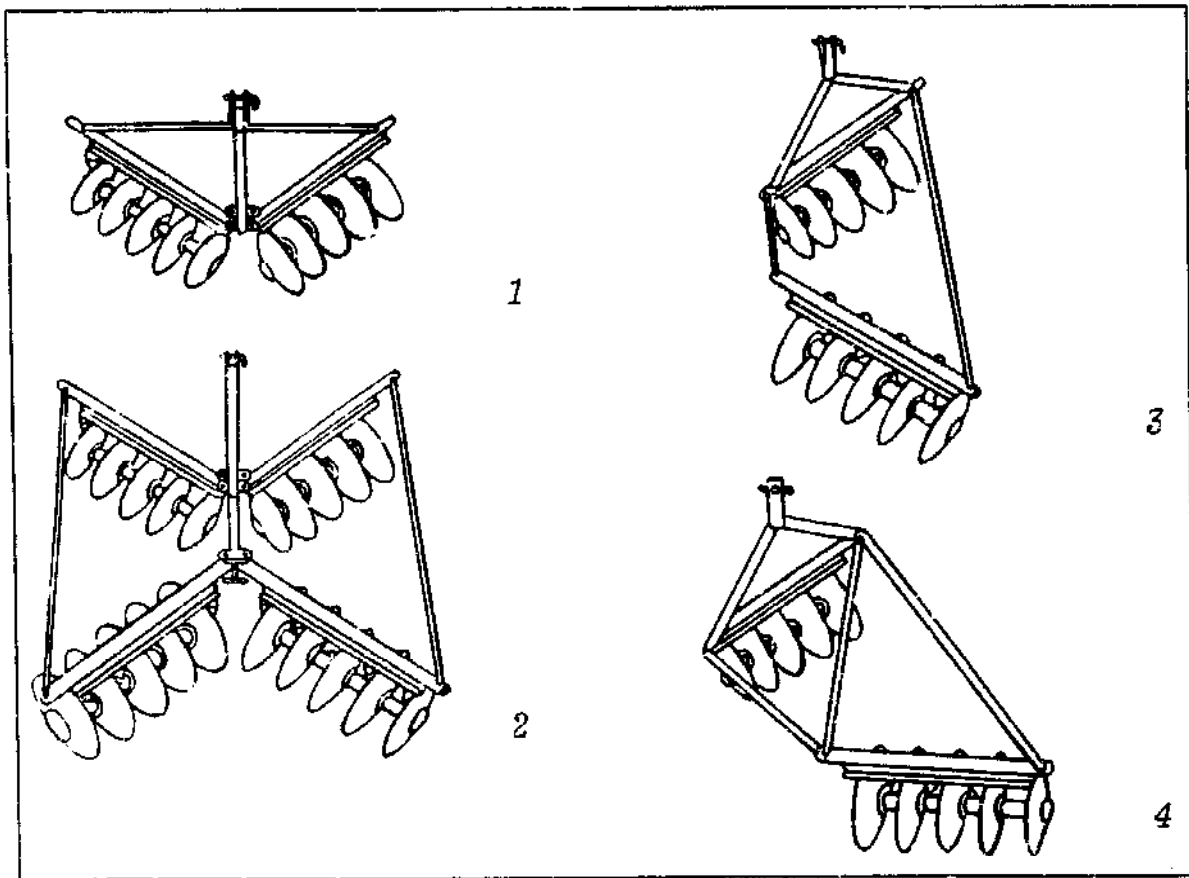

Fig. 55. Construction configurations of disc harrows:  
 1. Single acting, 3. V (A) shaped,  
 2. Double acting or tandem, 4. Offset.

Disc harrows are available for any type and size of tractor. Very large implements have a hinged folding frame, allowing the various units to follow the contours of the field (Fig. 56). Staggered disc gangs are preferred nowadays because they do not leave a strip of untilled soil in the centre (Fig. 57).

"Heavy-duty" disc harrows are manufactured for special conditions. With a disc diameter of 900 mm and a working width of 2.50 m, a 16-disc implement (weighing 5 tonnes) requires a draught of 150 kW. These types can be used for clearing scrub or on sugar-cane plantations. These heavy disc harrows are also equipped with hydraulically raised transport (depth) wheels.

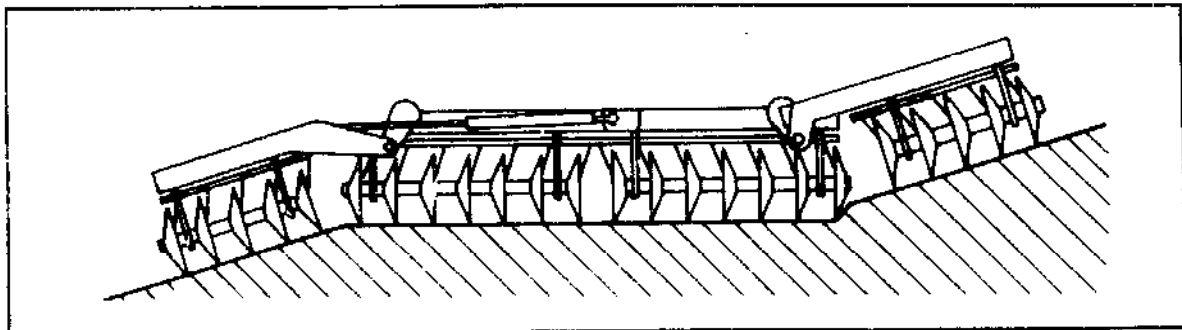

Fig. 56. Disc harrow with articulated frame for undulating surfaces.

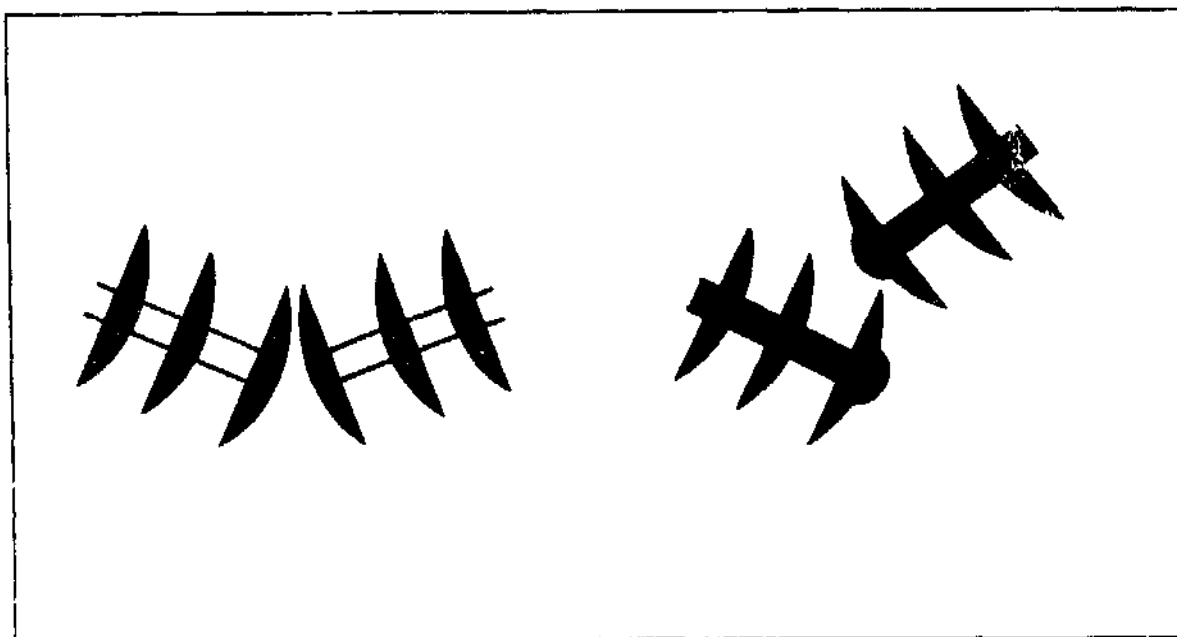

Fig. 57. Arrangement of the front disc gangs.  
 Left: overlapping action of center discs, right: center strip left untilled.

### 3.1.5 Adjustment, Operation

The external factors which influence the quality of the tillage are: the soil type and condition, soil moisture content, organic matter content, stones, roots and plant residue on the surface.

A number of fixed and adjustable parameters of the implement determine the working depth and intensity. These parameters are:

- the diameter of the discs,
- shape of the discs' circumference (plain or cut-out edge),
- weight per disc,
- curvature and shape of the disc,
- sharpness of the cutting edge,
- the units' angle to the direction of travel (disc or gang angle),
- travel speed.

The discs are fitted vertically on every disc harrow; only the disc angle can be adjusted either for each gang or for each set of related gangs. These angles can be adjusted mechanically or hydraulically to between 14 and 23 degrees to the direction of travel. So the discs' cutting plane forms an acute angle to the direction of travel (Fig. 58).

Since the adjusting devices are coupled, paired units will always be adjusted symmetrically. A small angle gives a better cutting action and greater working depth (though seldom more than 15 cm) while a wide angle produces better crumbling. The disc angle cannot be adjusted on some implements and the depth is fixed hydraulically by the transport and depth wheels. Each disc places a weight of 25-50 kg on the soil and this may be increased by extra weights (100 kg/disc) or reduced by using a transport wheel system. The cutting edges are self-sharpening so that the discs need only occasional grinding. The implement is easily operated by one man.

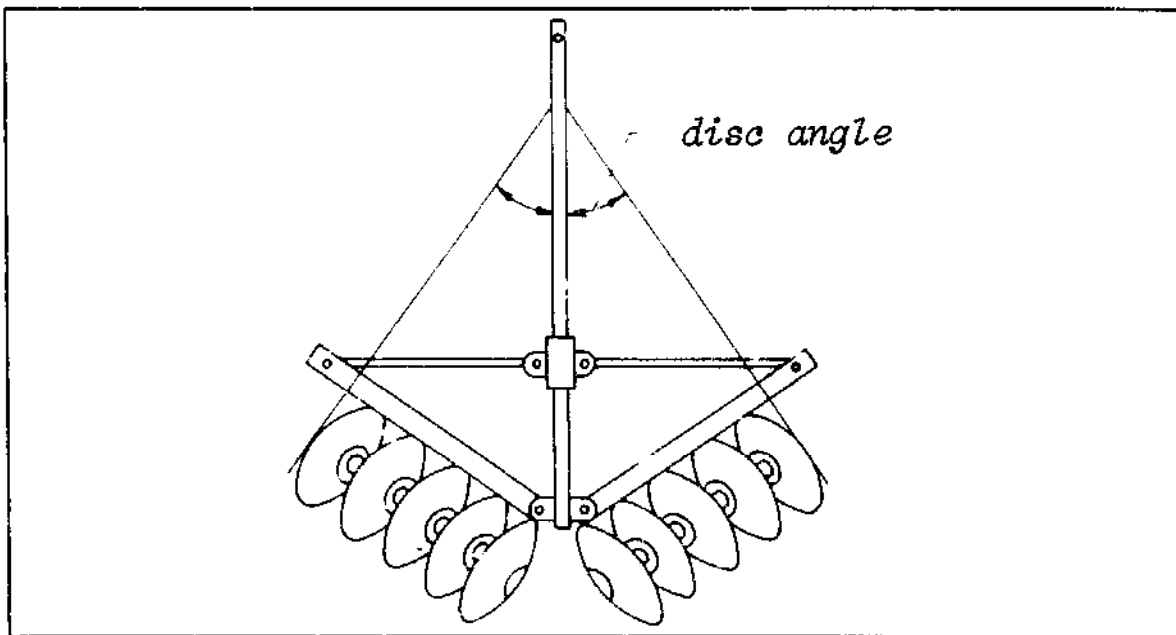

Fig. 58. Disc angle to adjust depth and intensity of tillage.

### 3.1.6 Technical Data

Length	2.00 - 8.00 m
Width	1.00 - 10.00 m
Height	1.00 - 1.50 m
	folding types 3.00 m
Number of gangs	2 - 12
Discs	plain or cut-out
Number of discs	single acting 4 - 6 per m
	double acting 8 - 12 per m
Distance between discs	160 - 300 mm
Diameter of discs	400 - 650 mm (900 mm)
Concavity (depth)	100 - 200 mm (300 mm)
Thickness	4 - 6 mm (9 mm)
Disc angle	14 - 23 degr. with direction of travel
Weight	25 - 50 kg per disc
Power requirement	1.0 - 2.5 kW per disc

### 3.1.7 Literature

See literature of chapter 3.0.

Gill, W.R., A.C. Bailey and C.A. Reaves, 1982. Harrow disk curvature - influence on soil penetration. Transactions of the ASAE, 25(5): 1173-1180.

Gill, W.R., C.A. Reaves and A.C. Bailey, 1981. The influence of harrow disk curvature on forces. Transactions of the ASAE, 24(3): 579-583.

Sheikh, G.S., J. Sial and M. Afzal, 1980. Disk harrow - an appropriate tillage implement. AMA, 11(4): 41-44.

### 3.2 The Rotary Harrow





### 3.2.1 Use And Assessment

The rotary harrow can be used on light, heavy and stony soils and on both level land and slopes.

The implement is used for:

- stubble tillage,
- working in chopped short material,
- seedbed preparation for intermediate crops,
- working in manure,
- cutting grass sods,
- weed control (fallow tillage),
- seedbed preparation after ploughing (possibly used as a rear-mounted implement),
- aerating the soil and breaking up crusts,
- reducing evaporation losses.

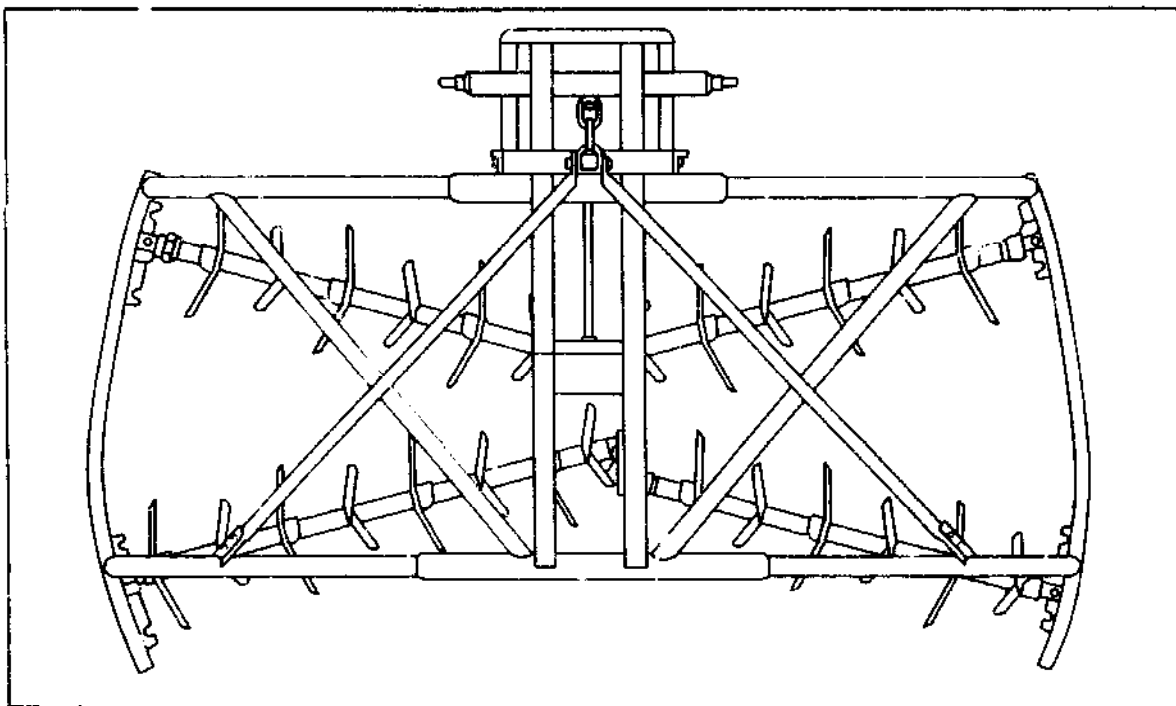

*Fig. 59. Rotary harrow.*

The rotary harrow is a simple implement (Fig. 59).

Its main advantages are:

- good mulching action on light to medium heavy soils,
- no smearing, but a tearing effect,
- increases the infiltration capacity,
- reduces evaporation by capillary action,
- reduces the risk of soil erosion because it produces a coarse surface mixed with plant residue,
- wide range of uses obtained by changing the setting, weight and speed,
- high working speed and capacity,
- versatility,
- possibilities for extra attachments or combinations with other implements,
- simple maintenance and servicing,
- good manoeuvrability and reliability,
- low price.

The following disadvantages should be mentioned:

- inability to work in long plant material satisfactorily,
- risk for wrapping, especially of moist straw on light soils,
- high working speed (8-12 km/h) required, i.e. more demands on the tractor and driver,
- two or more passes (crosswise) required,
- less effective on hard soils.

### 3.2.2 Functioning

The soil's resistance drives the active tools of the rotary harrow. The knives inserted in the soil are held by it and the implement's forward movement causes the shaft to rotate so that other knives cut into the soil. Since the cutting angle of the knives changes, the soil is not cut - as with the rotary tiller - but is torn away by a "rolling-off" movement. The soil is transported sideways by the front gang and returned by the rear gang and is crumbled and mixed in the process; the intensity of the latter operations depends upon the forward speed. The lateral forces occasioned by the tearing action are offset by the arrangement of the gangs in the frame.

When the harrow has flexible hitching it travels with a "wriggling" movement and may therefore be used for preparing a seedbed on ploughed soil. The soil must be thoroughly broken up (8-12 cm deep) when seedbeds are prepared on stubble. Stubble, straw and weeds are worked in at shallow depths so that rotting is accelerated. Volunteer grain and weed seeds may emerge. Two or more passes are required before an effect comparable with the rotating hoe can be achieved. The drier and harder the soil, the less the effect even if sharpened knives are used with multiple (crosswise) passes. Long moist plant residue may easily cause wrapping and choking. The required tillage can be achieved only at high speeds. The rotary harrow is often combined with a crumbling roller, especially for seedbed preparation. It is also used as a rear-mounted attachment for the chisel plough.

### 3.2.3 Linkage And Drive System

The rotary harrow is usually mounted with the 3-point hitch system (at least for transport). Wide harrows (more than 3 m) can be folded hydraulically while extended harrows can be carried (lengthwise) on a trailer.

When in a working position rotary harrows may be fixed in the 3-point hitch or allowed freedom of movement in relation to the tractor. A crossbar whose height and width can be adjusted is used for mounting on the lower links; the upper link is often a chain or the entire rotary harrow may be suspended from one heavy chain.

Rotary harrows follow the contours of the soil and do not have to be lifted for turns because of the flexible mounting of the hitch and the blade gangs which can move vertically. The capacity is about 1 ha/h per metre of working width at a speed of 12 km/h. The draught required depends upon:

- the working width,
- the number of blades,
- the weight,
- the soil type and condition.

Some information on the power required is given in Table 6:

blade gang arrangement	working width (m)	power requirement (kW)	mass without extra weights (kg)
2 rows	1.70	as from 25	300
3 "	1.70	" 32	400
2 "	2.00	" 35	350
3 "	2.00	" 42	450
2 "	2.50	" 45	450
3 "	2.50	" 55	650
2 "	3.00	" 55	700
3 "	3.00	" 65	1000

Up to 50% of the mass of the implement can be added by extra weights.

Table 6. Power requirement of rotary harrows.

### 3.2.4 Description Of The Implement And Tools

Two to six or sometimes even eight tool-bearing shafts (gangs) are mounted in a steel frame with adjustable slide bearings (Fig. 59). Two gangs fitted perpendicularly (angled) to the direction of travel form one row. Any two successive rows form a X or diamond shape. Other types have only one gang over the entire working width. Implements with two rows (one right and one left-handed) leave a very level surface. The gangs have some upwards and downwards movement so that they can more easily follow the surface of the soil.

Working sets of blades, curved to one side (Fig. 61), are mounted on the shaft at intervals of about 20 cm and are separated by spacers. A working set consists of two blades mounted perpendicularly to each other and 10 mm thick, slanted and easily replaceable. Each working set is staggered at 45 degrees to the next set. The mulching effect is produced specifically by the slanting blade. The working sets on successive gangs face right and left alternately. Spacers on the shaft bearings prevent wrapping.

Most implements allow weight boxes to be attached or have facilities for "pick-a-back" shaped weights. The link between the hitch frame (column) and frame is flexible to some extent so that the implement can follow the contours of the soil.

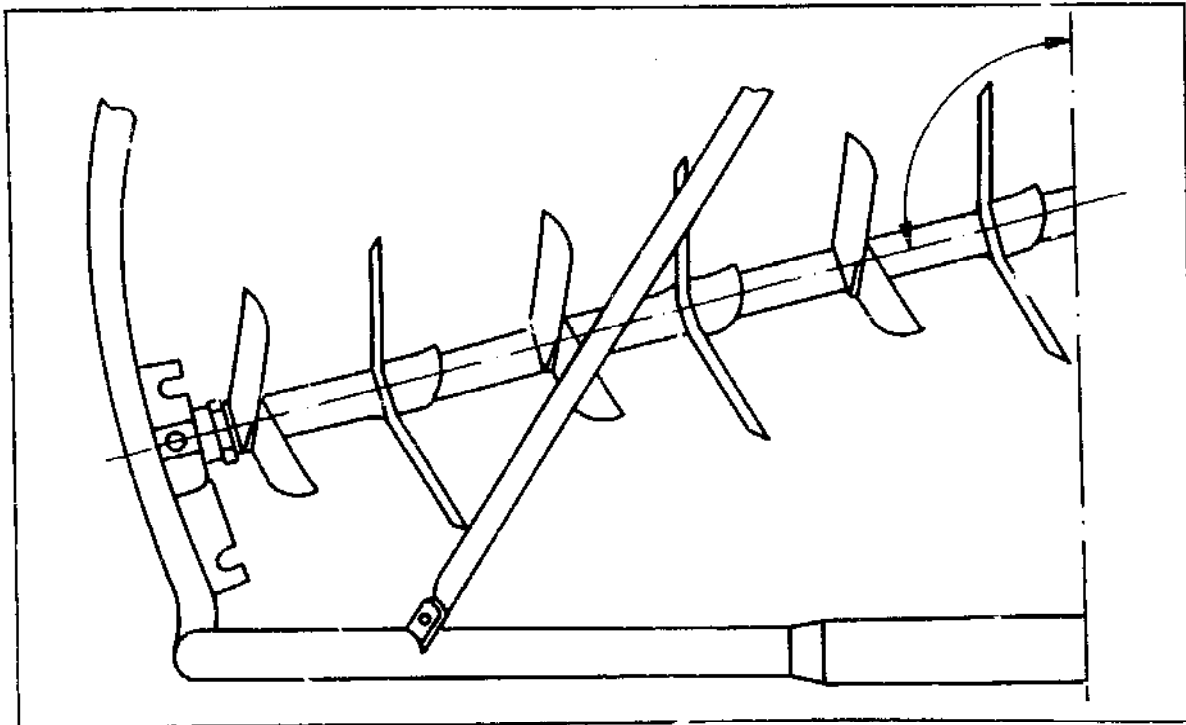

Fig. 60. Adjusting the blade angle (the rear, left-hand gang is shown).

### 3.2.5 Adjustments, Operation

On many makes the blades can be set along the direction of travel (cutting action) or across it (churning and crumbling action), as required. The angle between the gangs and the direction of travel (blade angle or grip) can be adjusted by shifting the mountings on the frame (Fig. 60, Table 7).

A narrow blade angle should be used to avoid wrapping on moist soils and with large amounts of straw.

	blade angle (in degrees)		
	strong	medium	slight
front gang	70	75	80
center gang	110	105	100
rear gang	70	75	80

Table 7. Blade grip of rotary harrows.

The working depth can be increased by extra weight. Careful adjustment of the upper link with a fixed mounting is needed to obtain the same depth for the front and rear gangs. The intensity and quality of the tillage is strongly influenced by the travel speed which should be between 8 and 15 km/h.

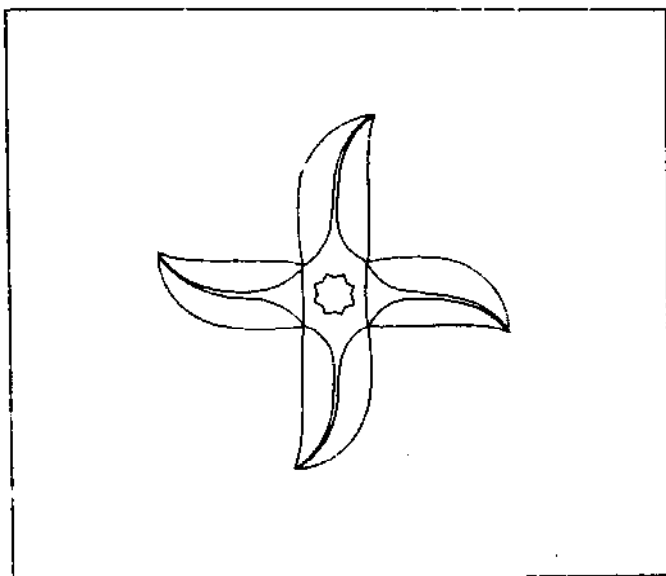

Fig. 61. Working set of a rotary harrow.

### 3.2.6 Technical Data

Length	1.50 - 3.50 m
Total width	1.60 - 5.50 m
Height	1.00 - 1.30 m
Working width	1.50 - 5.00 m
Number of gangs	2 - 8
Number of blades per metre of working width	2 row implement: approx. 10 3 row implement: approx. 15
Spacing of working sets	150 - 200 mm
External diameter	370 - 400 mm
Length of blades	370 - 400 mm
Width of blades	about 70 mm
Thickness of blades	about 10 mm
Weight per metre of working width	150 - 250 kg (without extra weights)
Weight per working set	20 - 25 kg (with extra weights)
Power requirement	15-25 kW per m

### 3.2.7 Literature

See literature of chapter 3.0.

Zumbach, W., 1975. Erfahrungen mit Spatenrolleggen. FAT Mitteilungen, Schweizer Landtechnik 37(8): 490-496.

### 3.3 The Rotary Hoe



### 3.3.1 Use And Assessment

The rotary hoe (USA: skew treader, Fig. 62) is used for:

- weed control in row crops,
- soil preparation in irrigation practices,
- breaking up crusts, loosening and aeration (also over germinating seeds),
- working in broadcast seeds, manure or fertilizers and chemicals,
- crumbling and packing of seedbeds,
- ridging for plant rows and also for forming ridges before planting,
- flattening stubble and other plant residue so that they can be worked in more satisfactorily.

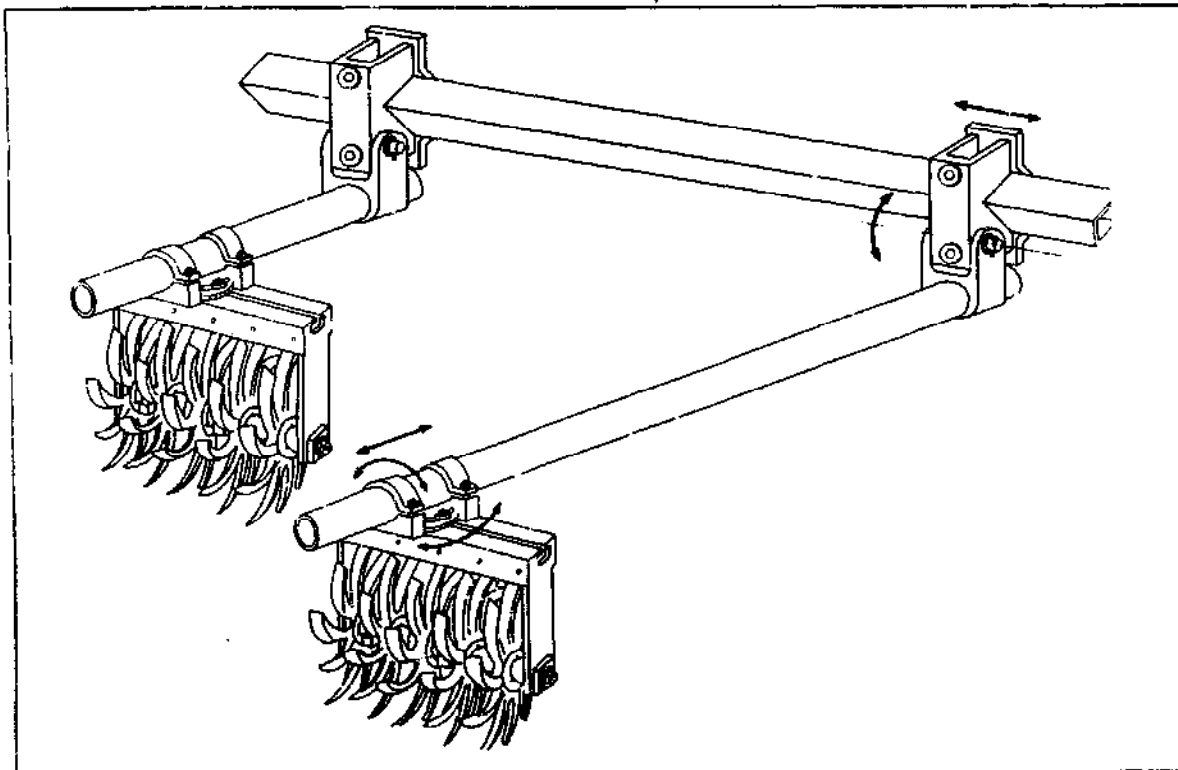

Fig. 62. Rotary hoe.

The rotary hoe is simple in design and reliable to use. So it is very suitable for developing countries. The supporting frame can also be used to attach a large number of other tools, especially ridging bodies.

The advantages which should be mentioned are:

- high capacity owing to the high speed (up to 14 km/h),
- low draught requirement,
- easy to use and maintain,
- easy to adapt to other conditions or to increase its width,
- can be combined with other implements,
- good manoeuvrability,
- can be used with a wide range of soil moisture provided that the soil can take traffic; also works well on dry soils.

The main disadvantage is the possibility that a compacted layer may be formed at a shallow depth. Moreover, this implement is not particularly effective with larger weeds and there is a serious risk of choking.

### 3.3.2 Functioning

Essentially the rotary hoe can be used for two different purposes:

A. The curved tines point forward when penetrating the soil. The tines' sharp tips meet the soil vertically and penetrate for 25-50 mm depending upon the weight and condition of the soil. The tools are rotated by the soil's resistance. When the tines emerge from the soil, it is thrown upwards. With this type of operation parts of the soil crust are loosened and the roots of weeds are destroyed or left exposed on the surface and dry out. The best results are obtained either before the emergence of the crop or when the plants are tall enough to withstand the treatment without serious damage.

B. When shallow tillage is required, the implement is drawn backwards so that the tines point backwards and do not penetrate deeply into the soil. With this method the rotary hoe can compact a seedbed, work in broadcast seeds or tread a layer of surface material into the soil. Plant residue may be spread evenly over the surface without choking.

With both types of use the best work is achieved at speeds of between 8 and 17 km/h. The crumbling action cuts off the capillary movement of water in the soil and thus reduces evaporation losses. Rotary hoes may be designed for use at full width and for strip tillage. The angle of the working sets can be adjusted both horizontally and vertically so that the rotary hoe can be used for ridging (or destroying ridges) and for increasing the intensity of the tillage. It can be guided in the direction of travel by using disc coulters (approx. 500 mm in diameter). The crop can be protected by special screens or discs. The width of the implement can easily be extended by adding more units. The hoe is also used as a rear-mounted tool behind chisel or sweep ploughs.

### 3.3.3 Linkage And Drive System

The rotary hoe is either mounted to the 3-point hitch system and used in free-floating mode or simply employed as a trailer implement. The tine sets are driven by the soil. The draught requirement is low (5-8 kW/m) but may rise to 10 kW/m at higher speeds. Very wide implements can be folded for transport.

### 3.3.4 Description Of The Implement And Tools

Rotary hoes can be built in various designs:

The first type, the rotary hoe, has working sets of 12 to 18 radial, slightly curved tines made of spring steel. These sets ("spider" wheels) with diameters of 400-500 mm, are assembled in gangs perpendicularly to the direction of travel. The gangs are often fitted with roller or ball bearings to auxiliary frame sections mounted flexibly on the main frame (Fig. 63). With this system all the tools can follow uneven surfaces.



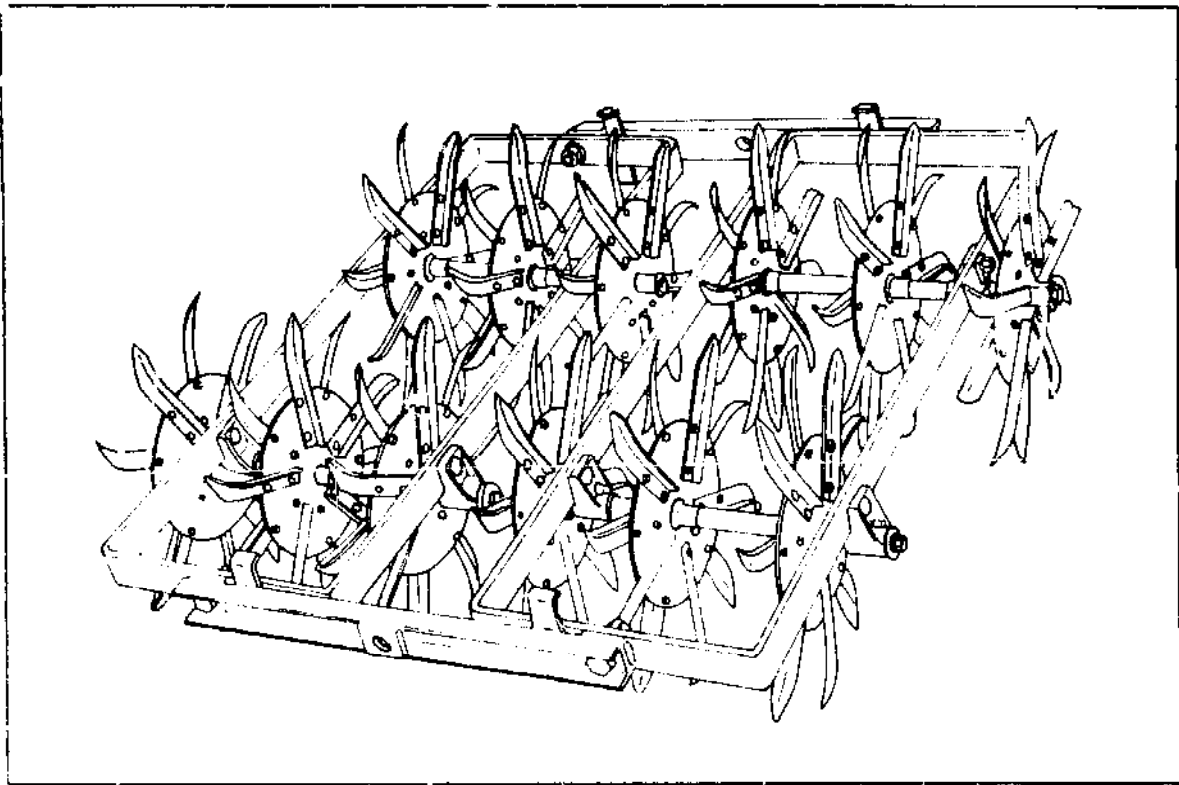

Fig. 63. Auxilliary frame sections of a rotary hoe equipped with spider wheel gangs.

A second type (similar to the Lilliston principle and usually called rotary cultivators) uses cast iron wheels or working sets (Fig. 64). Three to seven of these sets are again arranged in gangs and mounted on a light steel frame (tool carrier). These frames can be moved along the direction of travel and rotated horizontally and vertically because they are mounted on a shank positioned along the direction of travel (see Fig. 62). These shanks are attached - either rigidly or with hinges (hinged singly or in a parallelogram) - to the main toolbar so that they can be shifted laterally to adjust to the distance between the rows. Consequently, the individual gangs each adjust to the uneven surface of the field.

### 3.3.5 Adjustments, Operation

The depth is determined by the weight of the implement or it can be adjusted by adding extra weights; the weight may be offset by the tractor's hydraulic system or the support wheels. On some types the gangs are spring-loaded. The implement is drawn forwards or backwards, increasing and reducing the penetration in keeping with the required type of tillage. The individual sections can be adjusted horizontally and vertically for ridging in row crops or for shallow tillage of ridges and contours. As on the disc and rotary harrow, the gangs are set at an angle to the direction of travel (grip) so that the soil moves in the direction of travel and the rotation. New ridges may be formed or existing ones moved by means of this setting. A screen can be used to protect small plants from damage or from being buried by the soil.

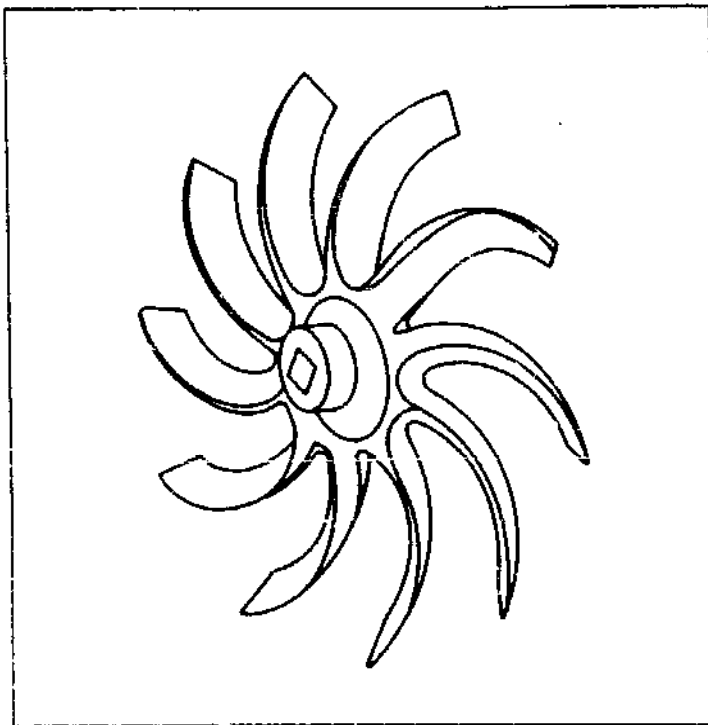

Fig. 64. Spider wheel (cast iron):

### 3.3.6 Technical Data

Width		1.00 - 8.00 m:
Height		.60 - 1.20 m
Length		1.20 - 1.80 m
Working sets	no. per metre of shaft:	4 to 5
	spacing on the shaft:	60 - 150 mm
	diameter:	450 - 550 mm
	tines per set:	12 - 18
Weight		150 - 200 kg per metre of working width
Power required		5-10 kW/m

### 3.3.7 Literature

See literature of chapter 3.0.

# 4.0 IMPLEMENTS FOR SEEDBED PREPARATION



After primary tillage operations the soil surface has to be prepared for sowing or planting. Seedbeds may be prepared in one pass in combination with primary tillage or in separate passes with longer intervals between them. This "secondary tillage" operation is intended to create optimum germination conditions with regard to the soil structure, the oxygen, water and nutrient supplies and the temperature. It may also include leveling of the soil surface and working in of manure and chemicals.

A very wide choice of implements is available ranging from the primary tillage implements (which may also be used for this purpose) and the trailer (passive) rigid and spring-tined implements to the driven (active) rotating and oscillating tools. Only the basic implements representing each group can be mentioned in the following chapters.

A warning must be given against over-intensive tillage operations on soils which are susceptible to erosion and slaking in tropical regions. On the other hand, only accurate and correct soil tillage allows precise placement of the seed and suitable soil cover (as protection against the drying-out of the seeds or damage by birds) which is essential for the satisfactory emergence of the plant.

#### 4.0 1 Literature

- Achilles, A. (Ed.), 1977. Neuzeitliche Bestelltechnik. KTBL-Schrift 212, Darmstadt, pp. 119.
- Heege, H.J., 1978. Getreidebestellung aktuell; Bodenbearbeitung, Saetechnik, Kombination von Arbeitsgaengen. DLG, Frankfurt, pp. 142.
- Heege, H.J. and K. Theissig, 1976. Mischwirkung und Oberflaechengestaltung von Geraeten zur Saatbettbereitung. Zeitschrift fur Acker- und Pflanzenbau, 142(2): 143-152.
- Henrikson, L., 1979. Implements for seedbed preparation, an approach in performance studies. Proceedings of the 8th conference of ISTR0, Hohenheim, Fed. Rep. of Germany: 137-142.
- Irla, E., 1982. Typentabellen Saatbettvorbereitungsgeraete. FAT Blaetter fuer Landtechnik, No. 202, pp. 13.
- Sieg, R., 1977. Moderne Bodenbearbeitung und Bestellung mit zapfwellengetriebenen Geraeten. Landtechnik, 32: 102-105.
- Steinkampf, H. and M. Zach, 1974. Leistungsbedarf und Kruemlungseffekt von gezogenen und zapfwellengetriebenen Geraeten zur Saatbettbereitung. Landbauforschung Voelkenrode, 24(1): 55-62.

## 4.1 The Spike Tooth Harrow



The spike tooth harrow was the typical implement used for shallow seedbed preparation in the temperate climatic zones during the era of draught animals but because of the general desire for equipment with high capacities and fewer passes (tracks) on the field, the harrow was superseded by combination implements in many western countries.

The disc harrow is predominant in tropical and subtropical regions but simple "drag harrows", such as the "malla" in Anatolia, are still widespread.

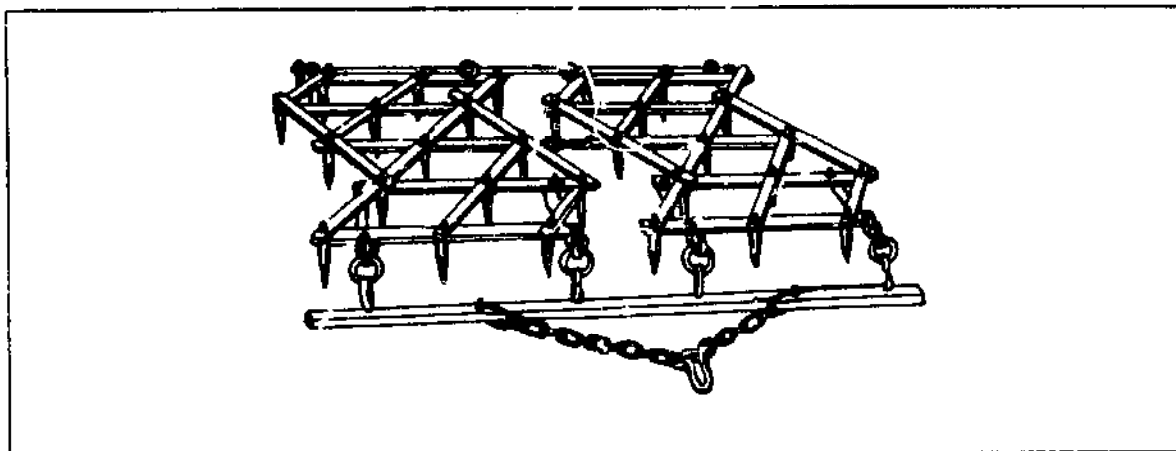

Fig. 65. Spike-tooth harrow.

#### 4.1.1 Use And Assessment

The harrow (Fig. 65) is used for:

- crumbling the soil after primary tillage,
- loosening and roughening the surface of crusted soils,
- aerating the soil,
- working in and mixing organic material,
- working in and mixing fertilizers and chemicals,
- seedbed preparation,
- levelling (ridges, wheel-tracks, undulations).

The harrow can be employed in the tropics and subtropics if correctly used with suitable tools. Particular mention should be made of the harrow and roller combination (see Chapter 8.2).

The advantages of the harrow are:

- suitable for use on all types of soil,
- simple and inexpensive design,
- suitable for motorized and, to some extent, animal traction,
- wide range of applications because of a large variety of tools,
- by combining it with other implements and adjusting the speed of travel, the required crumbling and mixing of the soil can be achieved with a wide range of soil types. One single pass with a combination implement is often sufficient for preparing a field,
- the water infiltration capacity can be increased,
- the harrow can be adjusted to suit:
  - the available power
  - the quality of previous tillage operations
  - the soil conditions
  - adaptations to soil irregularities by various individual sections.

Disadvantages are:

- the narrow starts jumping in hard dry soils; the disintegrating action of the harrow is inadequate,
- the structure of the soil may be destroyed with over-intensive operations,
- a high travel speed is necessary,
- wheeltracks are not always levelled satisfactorily,
- greater risk of erosion when the resultant soil structure is too fine,
- it is rarely possible to prepare a seedbed with one single pass of the harrow; seedbed combinations are preferable,
- harrows tend to work too deeply and to clog up with heavy weed populations, especially on light soils.

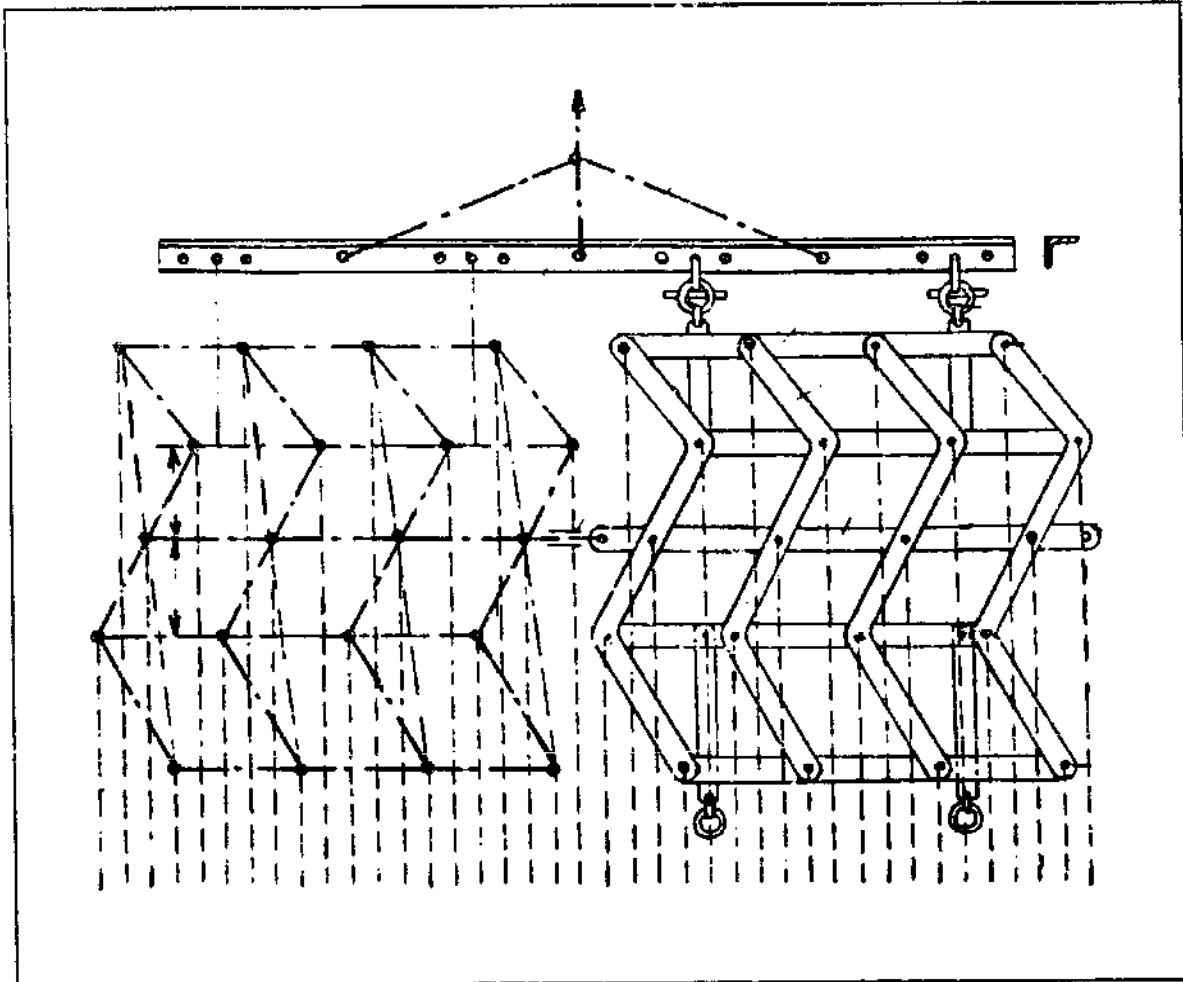

*Fig. 66. Top view of spike-tooth harrow with two sections.*

#### 4.1.2 Functioning

The harrow functions in keeping with the "scratch and blow" principle. When dragged through the soil the tools run up against soil clods and break them into smaller pieces. These pieces move sideways and are smashed again by the following tools which are staggered (Fig. 66). This process is furthered by the slight swinging (sinusoidal) movement of the harrow which makes it possible to smooth and level surface irregularities but some patches may be left untilled.

On a sling or following harrow, this sinusoidal movement develops into a type of hurling motion. This harrow is designed so that, alternately, one side is held back (by the soil) while the other moves forward at twice the travel speed; the harrow "stalks" through the soil causing more intensive crumbling and mixing and some tearing out of weeds.

Harrow teeth perform a sorting operation: fine soil moves downwards while larger aggregates are transported towards the surface. For satisfactory operation the travel speed should be at least 8 km/h.

#### 4.1.3 Linkage And Drive System

Harrowes are designed for dragging or for 3-point hitch mounting by means of a supporting frame. The dragged type is hitched to the (linkage) drawbar. If the 3-point hitch mounting is used, the operation is performed in free-floating mode. No hydraulic control system is necessary. The drag harrow's depth is controlled by the angle of the line of pull. The tractor's lifting capacity should be about twice the weight of the implement. The power required for harrowing is 2-6 kW (approx. 3-8 hp) for each metre of working width at a speed of approx. 8 km/h.

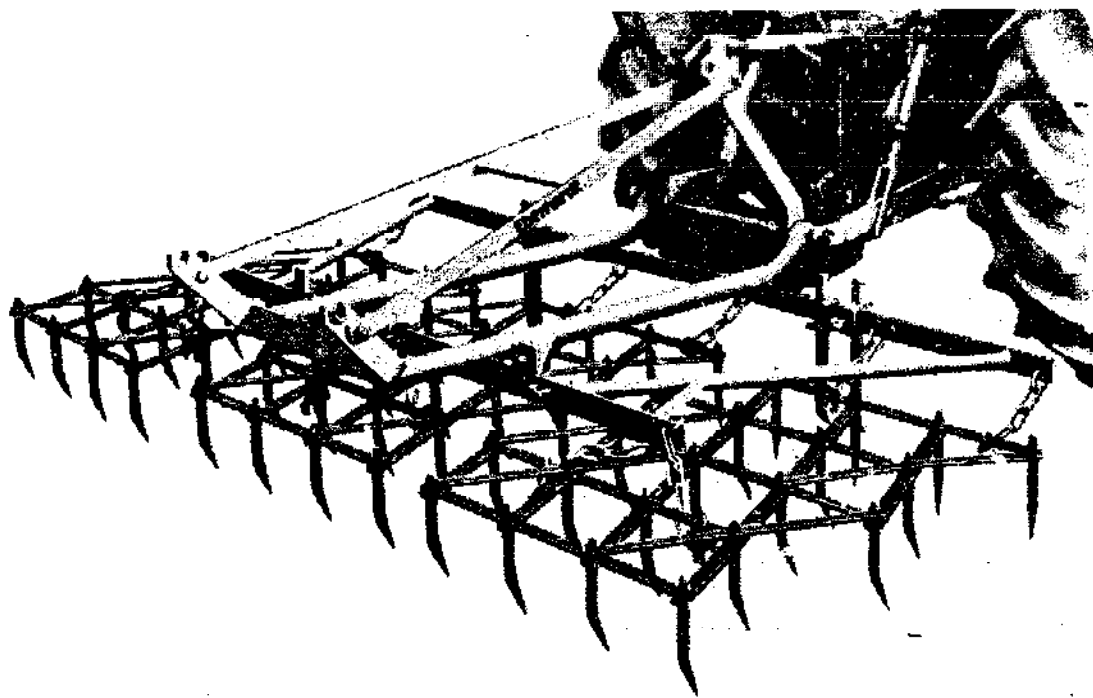

*Fig. 67. Harrow with three sections in suspending frame.*



#### 4.1.4 Description Of The Implement And Tools

Depending upon the type, harrows are equipped with a rigid or articulated frame which carries the teeth (Fig. 67).

type of harrow	light	heavy	heavy zig-zag	spiked-chain	reversible spiked-chain
nr. of teeth per section (approx.)	28	20	24	77-110	24
tooth weight (g)	250-900	1200-2000	1700-2500	115-700	about 2500
tooth length (mm)	110-130	160-220	160-200	120-175	about 120
diameter (mm)	11-13	14-22	16-20	5-10	about 30
furrow width (mm)	25-35	40-55	50-80	20-45	50
working width (m)	1.00	1.00	1.00	1.50-9.00	1.20
weight (kg)	15	26-40	50-75	30-75	60

Table 8. Harrow teeth and spring teeth.

The teeth - weighing 0.25-2.5 kg (Fig. 68 and Table 8) - are arranged in sections approximately 1 metre wide. Chains attach these sections to a supporting frame or hitch bar. The furrow distance (5-6 cm) is the lateral distance between the furrows which the teeth produce in the soil. The rigid harrow has a rigid frame with cross and longitudinal bars. The longitudinal bars may have the following shapes:

- zig-zag
- S
- straight (when these bars also face straight forward the frame is dragged in an oblique position).

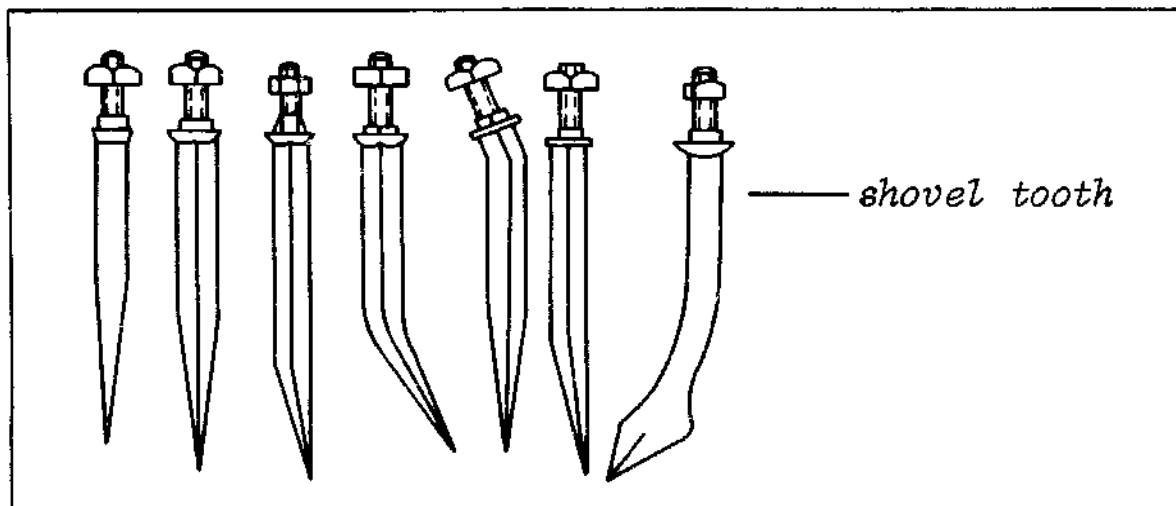

Fig. 68. Harrow teeth.

The teeth are mounted on the bar intersections. These teeth (16-20 cm long) are usually rigid but can also be made of spring steel. Teeth made of high-quality tempered steel generally have a square cross-section and various diameters, lengths and weights. Straight and curved teeth are used (the front row is generally straight and the following one curved towards the direction of travel). The teeth have a square upper section which fits into a square opening in the bar so that they do not turn.

Rigid harrows can be divided into the following categories:

- light harrows : light construction with narrow distance between furrows,
- medium harrows : medium to heavy construction,
- shovel or chisel harrows : heavy construction with shovel teeth.

In principle, the articulated harrow is designed like the rigid harrow but the frame is divided into small sections by cross and longitudinal hinges which allow those sections to follow irregular surfaces.

The spiked-chain harrow or weeder-net harrow is described separately in Chapter 4.6.

The sling harrow is a special version of the rigid harrow. It has a reinforced frame and reinforced longitudinal and cross bars so that this type of construction and linkage increase the swinging movement of a normal harrow until it becomes a hurling motion. This harrow has fixed shanks with replaceable chisels (see cultivator chisels) instead of teeth fitted to the frame by bolts. This implement is dragged by a chain connected to the (linkage) drawbar.

The grassland or spiked-chain harrow is a special chain harrow with short, knife-shaped teeth which tear out moss and lichen from the sod with only a shallow penetration. It is also used to spread straw and farmyard manure and to scatter molehills. Its design is similar to the weeder-net harrow and is either mounted (support frame) or trailed (hitchbar).

#### 4.1.5 Adjustments, Operation

4.1.5.1 Working Depth - This can be changed by alternating the weight of the harrow itself or by adding extra weights to the support frame. The line of pull or 3-point hitch is also adjustable. Angled and curved teeth will penetrate more deeply into the soil than straight teeth when pointing forward but not so deeply when pointing backwards. The working depth decreases as the travel speed increases.

4.1.5.2 Working Intensity - The working intensity can be affected by changes in the travel speed, the type of hitching and the type of tools. This means that:

- at low speeds (< 4 km/h): coarse structure-conserving tillage, hardly any crumbling or mixing but loosening and aeration of the soil;
- at high speeds (> 4 km/h): intensive tillage, pronounced crumbling and mixing; if the speed is too fast there is a risk that furrows will form (soil particles are thrown some distance) and the harrow will jump;
- close mounting of the harrow sections on the supporting frame: minimum swinging action by the harrow, coarse tillage which is uniform over the

- entire working width;
- loose mounting of the sections: lateral swinging of the harrow, intensive tillage but with untilled patches;
- sharp teeth will crumble more satisfactorily than blunt ones;
- blunt teeth will have more of a bulldozing action so that the soil will be pushed aside: more mixing effect;
- teeth which are curved forward will drag more deeply into the soil; the harrow will have a better "grip";
- as the weight of the harrow increases, the teeth penetrate more deeply into the soil;
- the front row of teeth will be raised when the line of pull is too high.

4.1.5.3 Operation - The harrows can easily be mounted by one man. On trailer or dragged harrows the hitchbar (whipple-tree) is connected to the tractor (linkage) drawbar by a chain.

Disadvantage: A trailer should be available for transporting drag harrows (the harrow is often transported by being dragged upside-down!).

When mounted, the harrow can be connected to the 3-point hitch system, possibly even by a quick-coupling system. For greater widths the supporting frames are fitted with folding outriggers so that the tractor can be driven on public roads without exceeding the permissible transport width.

Working with the harrow does not impose heavy demands on the driver. A clean tillage operation can be achieved by using zig-zag type harrows or by working with an overlap of approx. 10%.

#### 4.1.6 Technical Data

The main data for teeth and teeth sections are given in Table 8.

Total working width	up to 14 m
Working depth	up to 8 cm
Power required	approx. 3 kW per m width (at 8 km/h)

#### 4.1.7 Literature

See literature of chapter 4.0.

Starkey, P. and H. Verhaeghe, 1981. A modified triangular spike tooth harrow and swamp leveller. *Appropriate Technology*, 8(2): 8-9.

## 4.2 The Field Cultivator

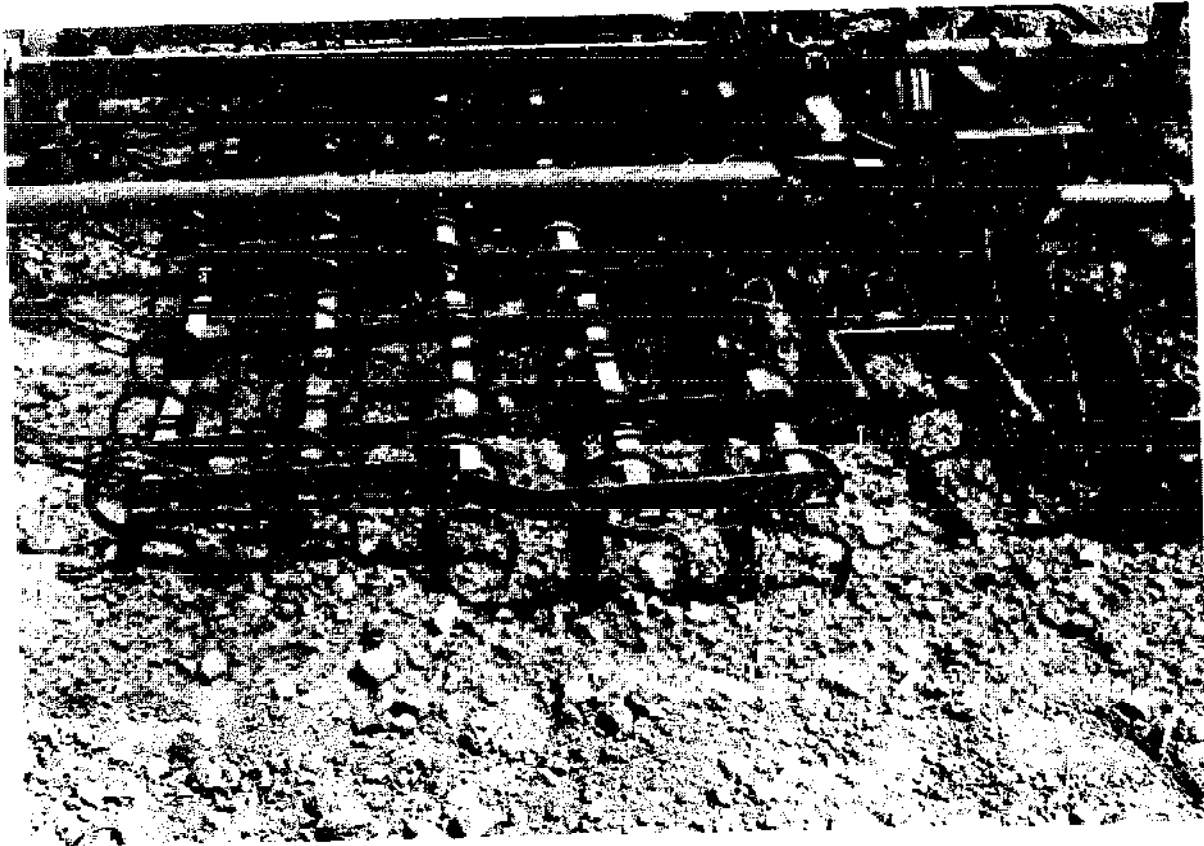

#### 4.2.1 Use And Assessment

A field cultivator can be used for the following purposes:

- seedbed preparation (especially shallow and medium deep),
- stubble tillage (only spring tine cultivator; short stubble without straw),
- weed control, also in row crops,
- working in manure,
- levelling,
- grassland maintenance and clearing,
- tillage for dust mulch fallow.

At one time the use of cultivators with various types of tines declined but, as new tines made of better materials have been developed, these implements are again extensively used, especially in seedbed combinations (Fig. 69). They are employed particularly to accelerate seedbed preparation and to reduce the number of wheel-tracks. Their "precision tillage" permits precise placement of the seed, which improves the emergence of the crop.

These major advantages will be obtained only on light to medium-heavy soils in good condition (i.e. not many stones or roots). Choking of the implement can be expected in the case of high weed populations. The work is not satisfactory on difficult soils (very dry with a large proportion of foreign materials). The implements are unsuitable for stubble mulch systems because they are liable to choke.

#### 4.2.2 Functioning

The light (Danish type) cultivator can be used on all types of soils. They are suitable only for deeper tillage because of the furrow distance of approx. 10 cm. To ensure complete coverage the working depth should be at least equal to the furrow distance.

If the tines are set at a steep angle to the soil surface, wet soil is not brought up. Hardly any choking may be expected when the implement has four crossbars with rows of tines. Special mention should be made of their pronounced levelling action, even on fields with large clods after ploughing or with wheel-tracks. Two or more passes are necessary (crosswise, if possible) on hard soils. On light soils care should be taken to avoid excessive pulverization.

The light cultivator can also be used for stubble tillage (without straw) but at least 2 or 3 passes (with increasing depth) are needed. Occasionally the cultivator can even be used for ploughless drilling of cereals after root crops on light loose soils.

If the right type of tines are correctly arranged, this cultivator can be employed for weed control in a standing row crop and in fields laid out for furrow irrigation (Fig. 70).

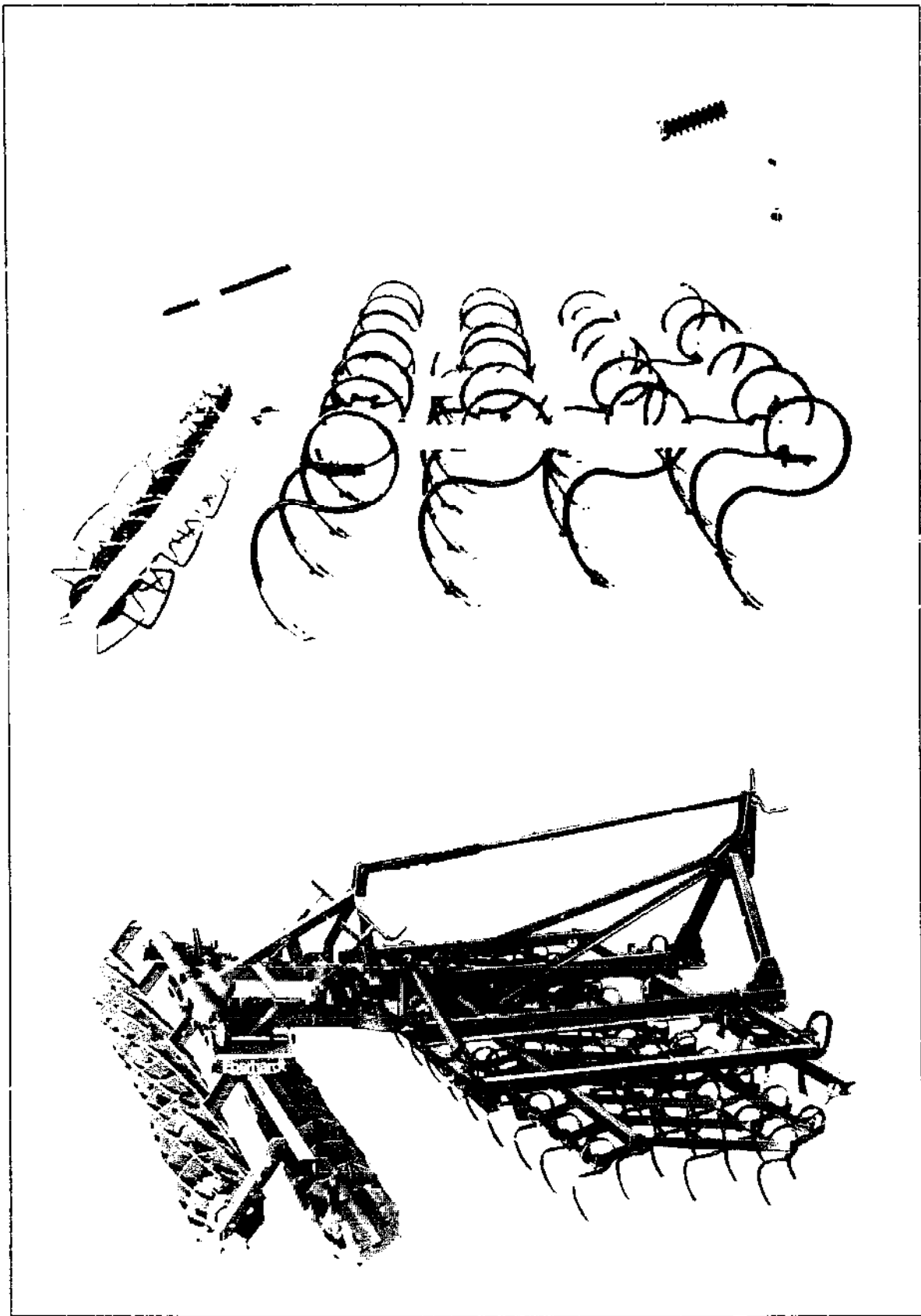

*Fig. 69. Top: light cultivator (Danish type) with rear-mounted roller,  
Bottom: flexible tine cultivator with two rear-mounted rollers.*

Flexible tine cultivators can also be used on nearly every type of soil. The strongly vibrating tines produce intensive crumbling of the soil and sufficiently shallow tillage (i.e. shallow seed deposition) is possible because of the narrow distance between the furrows (approx. 5 cm). The risk of choking is still slight with a large distance between tines (several rows). Rooted weeds are pulled upwards towards the surface and the soil is shaken off by the vibration so that the weeds will dry rapidly.

Unlike rigid harrows, flexible tine cultivators till evenly over the entire working width and depth because of the depth control (by wheels, if necessary) and the strictly-followed line of direction. Rear-mounted attachments may considerably improve the action of light cultivators and flexible tine cultivators.

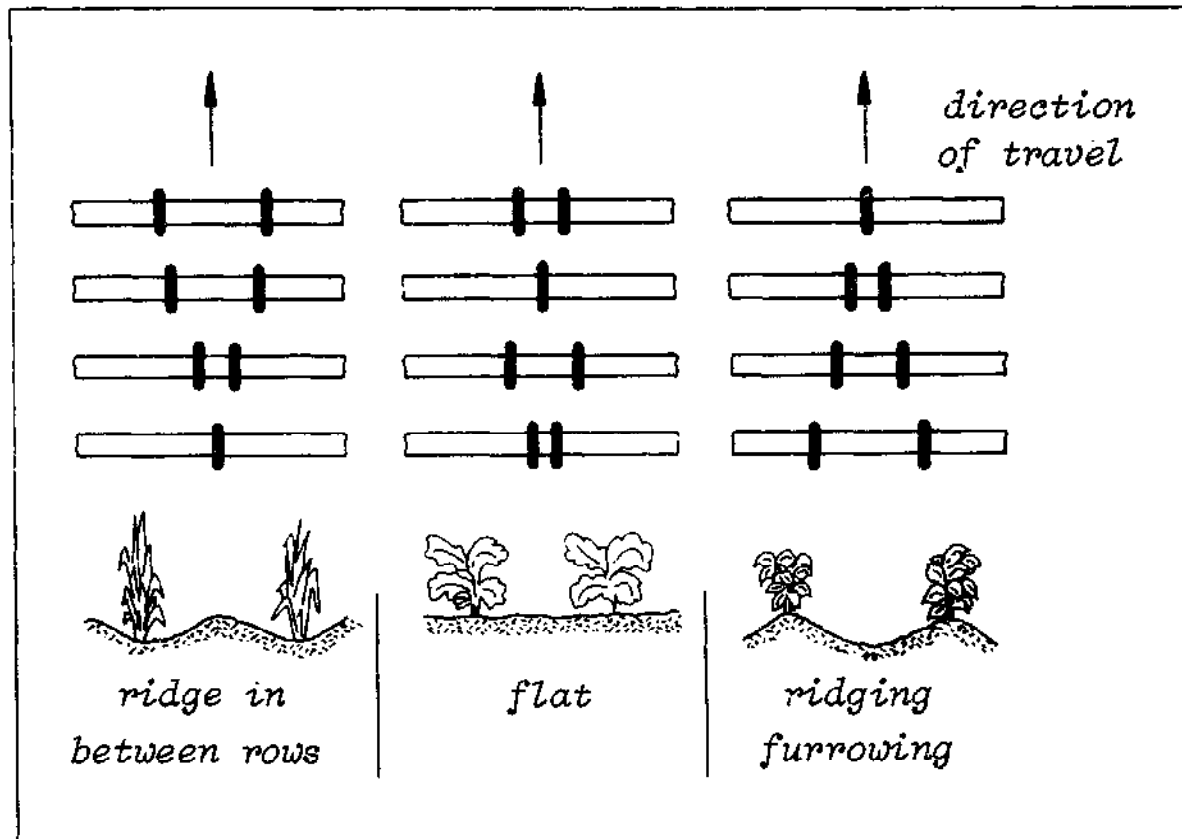

Fig. 70. Arrangement of the tines of a light cultivator with four crossbars in ridge and bed systems.

#### 4.2.3 Linkage And Drive System

(Light) cultivators and flexible tine cultivators are mounted implements suited for the 3-point hitch systems in category I-III, depending upon their working width. Quick-coupling devices may be used since mounting and dismounting the large implements may cause problems, especially on loose soil (sinking into the soil).

The implements are mainly used in combination with harrows, packers or levellers to form "seedbed combinations". Since these implements are heavy and the centre of gravity is located comparatively close to the rear of the implement, the easing of the load on the tractor's front axle must be taken into account. Outriggers can be folded mechanically (springs) or

hydraulically on very wide implements. Care should be taken to ensure that the tines of the folded sections do not protrude too far (danger to traffic). The working speed of these implements is around 5 km/h. They require 0.75 kW per tine or around 7.5-15 kW per metre of working width. The power required for seedbed combinations is between 11 and 18 kW per metre.

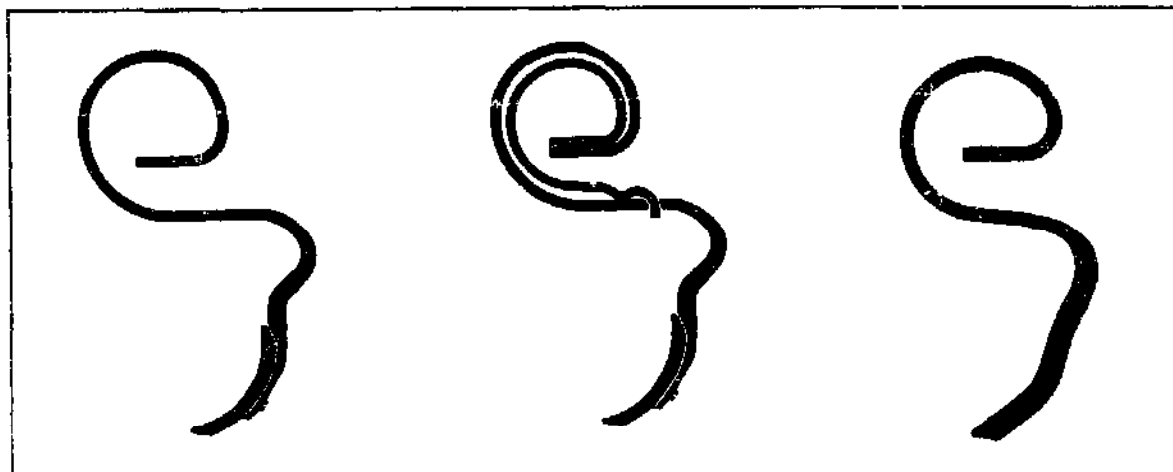
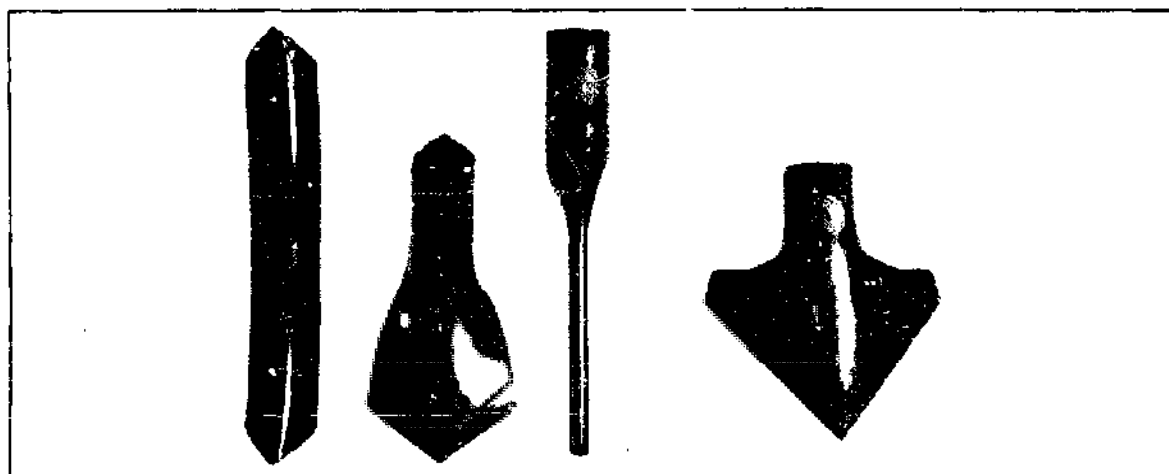

*Fig. 71. Spring tines for light cultivators.*

#### 4.2.4 Description Of The Implement And Tools

Light cultivators have relatively large C-, G- and S-shaped tines (Fig. 71), fitted with interchangeable points or chisels (Fig. 72), giving a furrow distance of approx. 100 mm. The furrow distance can be halved by using double-spring tines (Fig. 73). Like the flexible tine cultivator, the light cultivator can be employed for shallow tillage. Pointed chisels are mainly used but various chisel shapes for light (approx. 35 mm wide) and heavy soils (10 mm) can be fitted. If equipped with an extra spring, the tine may produce a uniform working depth even on heavy soils and at high speeds.

The front rows can sometimes be fitted with tines pointing backwards to avoid over-penetration of the tines in front of the implement.



*Fig. 72. Chisels for light cultivators: From left to right: standard (pointed) chisel, duckfoot chisel for stubble, grassland chisel for pasture, duckfoot chisel for tillage in row crops.*



Sufficient frame clearance (400-550 mm) allows the implement to be used in row crops. The guidance (along the direction of travel) can be improved by mounting disc coulters (this is important when working along contours). Precision work can be achieved with independent parallelogram linkage for each tine.

Flexible tine cultivators are similar to light cultivators but are fitted with a lighter rigid frame and three to six rows of spring tines with interchangeable shares of various shapes and widths which are arranged to give a furrow distance of 50-80 mm. They have narrow (30-55 mm) C- and G-shaped tines which vibrate strongly (Fig. 71). The width of some implements may be as much as 3 m but a system comprising separate sections of 0.75-1.5 m (possibly with parallelogram linkage) built into combination implements is preferred. These models have a much larger total working width but can still closely follow the field surface.

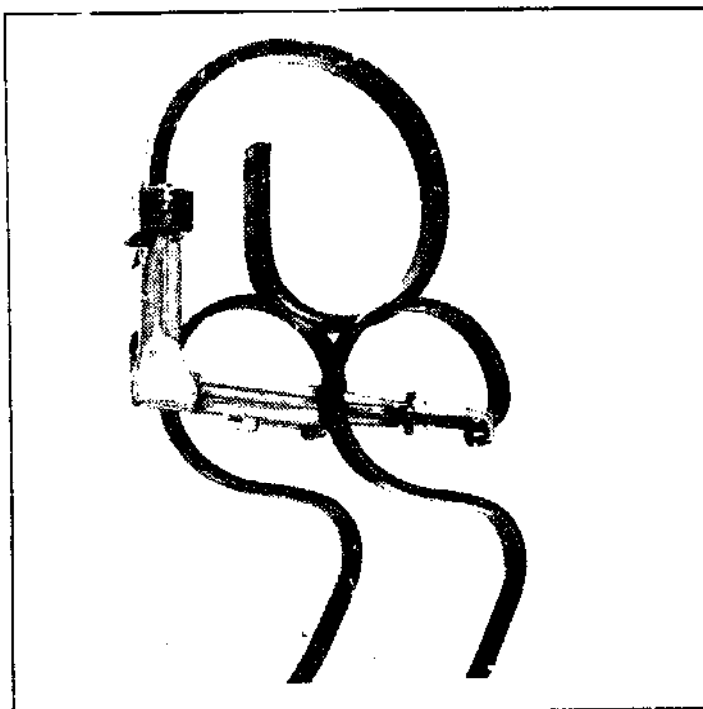

Fig. 73. Dual spring tines for flexible tine cultivators.

#### 4.7.5 Adjustments, Operation

It is essential to maintain a uniform shallow working depth during full-width preparation of a seedbed. Flexible tine cultivators work at shallow depths because of the narrow distance between tines. The depth is controlled by gauge-wheels on the supporting frame, by adjusting the upper link of the tractor and by reducing or increasing the load on the rear-mounted roller. These rear-mounted tools may be adjusted by chains (Fig. 74), a spindle or pin-and-hole system (Fig. 75) or by auxiliary springs on the parallelogram linkage (Fig. 76).

The tilling intensity of any implement can be increased only by increasing the travel speed. Speeds of 10 km/h or more are possible. When used alone, cultivators are very simple to operate but seedbed combinations require quite considerable skill by the operator if they are to be correctly adjusted.

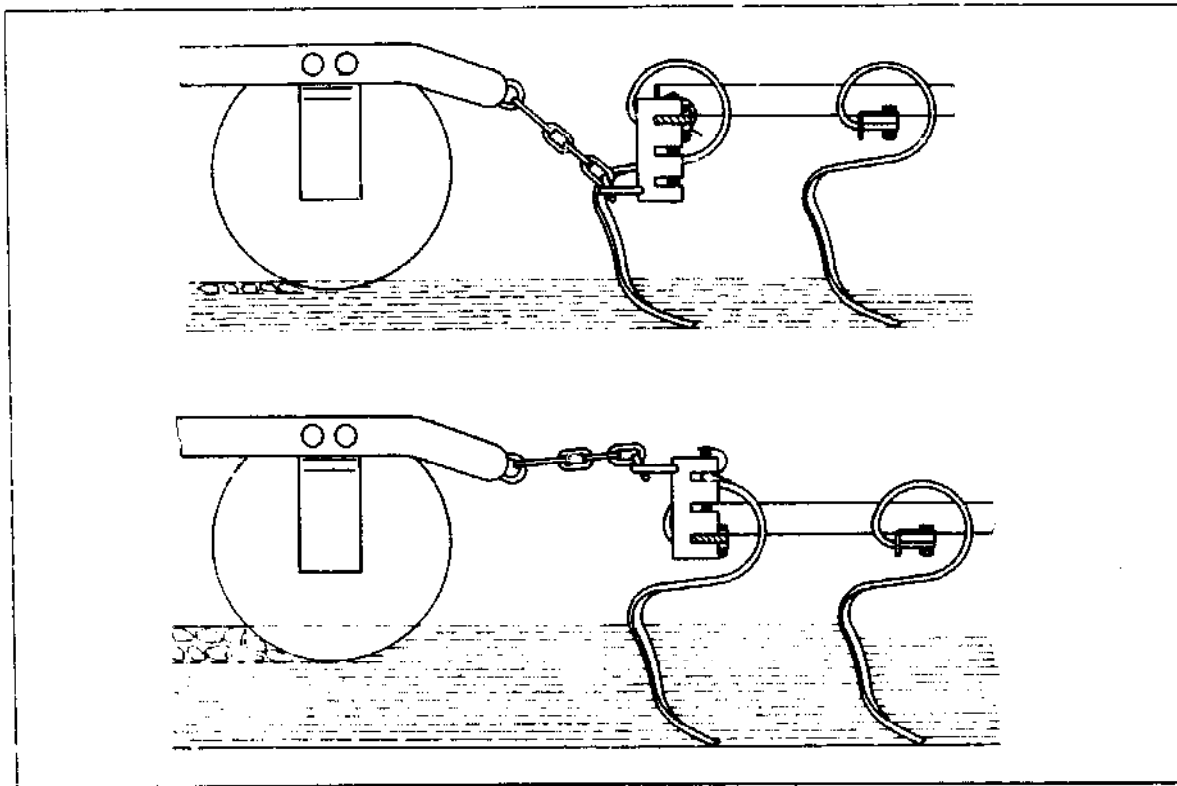

Fig. 74. Flexible tine cultivator with rear-mounted roller; adjustment of depth.

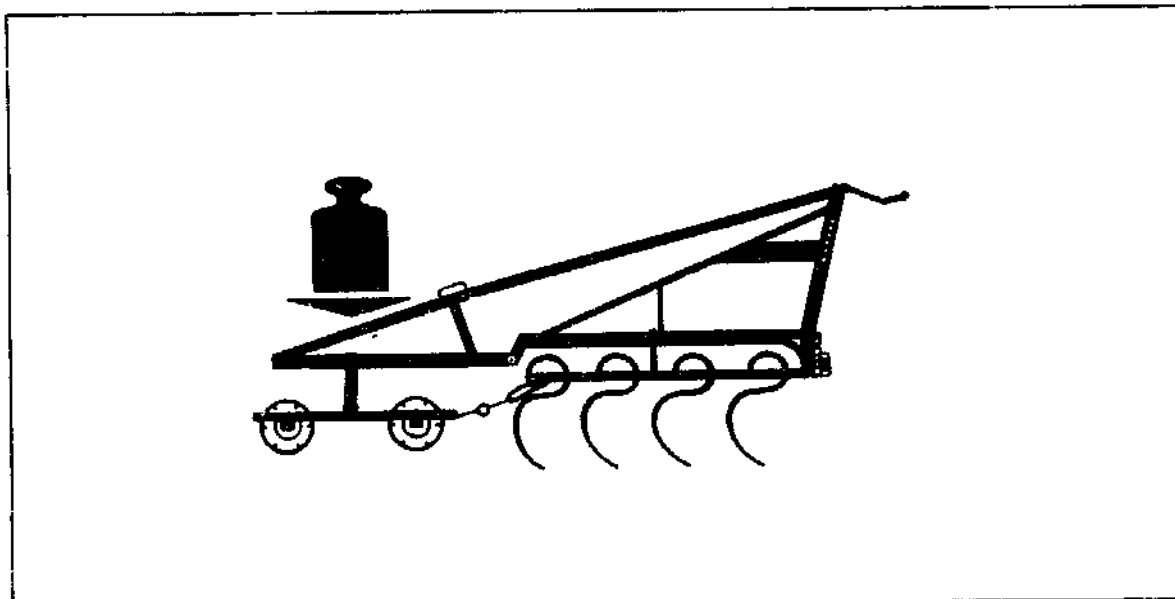

Fig. 75. Light cultivator with two rear-mounted rollers; depth adjustment by spindle system.

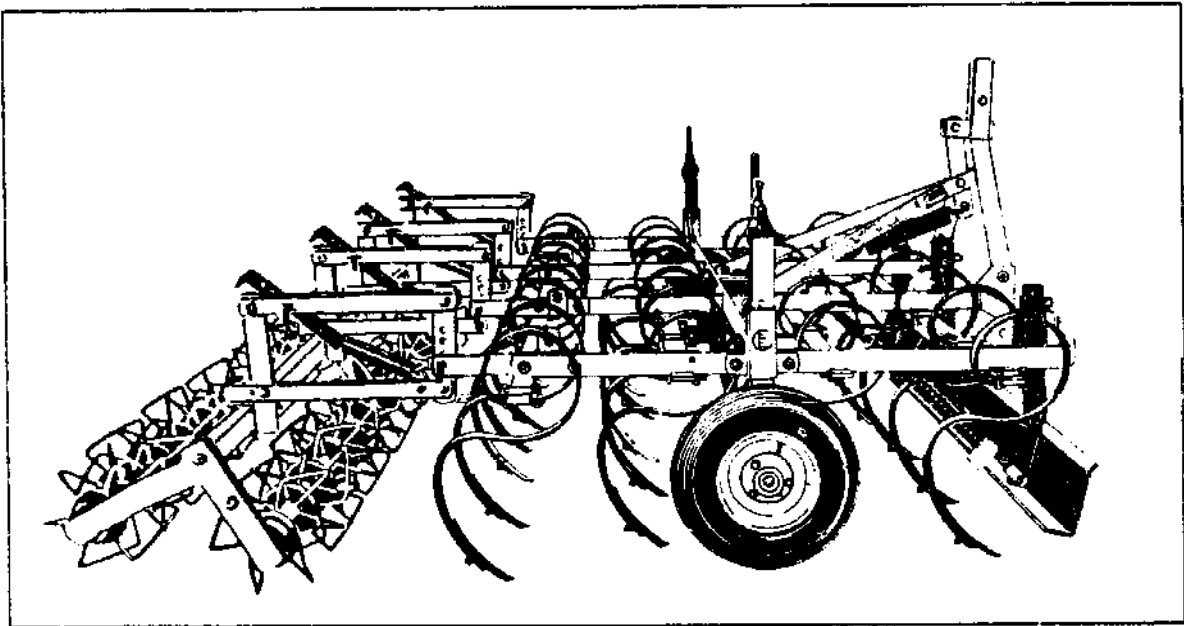

Fig. 76. Light cultivator with rear-mounted rollers in spring loaded parallelogram linkage.

#### 4.2.6 Technical Data

Working width	up to 18 m
Working depth	50-150 mm
Width of tines (chisels)	10-105 mm (the latter figure is for duckfeet)
Number of rows	1-6
Distance between tines	no. of rows x furrow distance
Furrow distance	
- flexible tine cultivator	approx. 50 mm
- light cultivator	approx. 100 mm
Travel speed	5-10 km/h
Power required	0.75 kW per tine
- seedbed combinations	
with high speeds	up to 18 kW/m
Weight (single implement up to seedbed combination with double roller harrow)	100-300 kg/m

#### 4.2.7 Literature

See literature for chapter 4.0.

### 4.3 Pto-Driven Implements for Seedbed Preparation



The essential characteristic of pto-driven implements for seedbed preparation is that tine- or knife-shaped tools, moving horizontally or vertically, are driven by the tractor pto.

The fact that, especially for heavy soils, the number of these implements is increasing more rapidly than trailer seedbed-preparation implements can be attributed to the following advantages which are essentially valid for every pto-driven tillage implement:

1. The crumbling action can be adapted more satisfactorily to the prevailing conditions by changing the tillage intensity. Consequently, a field can be prepared for sowing in one single pass - even on heavy soils - so that the number of wheel-tracks is reduced.
2. The tractor's power can be used with a high level of efficiency from the power transmission system (about 80% compared with 50% for trailer implements) because the tractor-wheels do not slip.
3. The short length of the implements makes it possible to combine them with sowing machines, permitting seedbed preparation and sowing in one operation.

Although the advantages of pto-driven implements are essentially valid for the soils of the arid and semi-arid regions and the time saved is very valuable in a closely integrated crop rotation, very careful consideration should be given to any recommendation for their use in developing tropical countries. Many of the tractors available in those countries are not equipped with a power take-off system and, even if they are, the system may have a different number of revolutions, direction of rotation, shaft profile or location. Good training is required to tune the equipment to the correct combination of forward speed and rpm and to adjust the implement so that the required effect is achieved under the given conditions. It is scarcely possible for implements to be too simple in view of the well-known problems concerning supplies of spare parts. Complicated drive systems and bearings are particularly problematic and also involve safety risks.

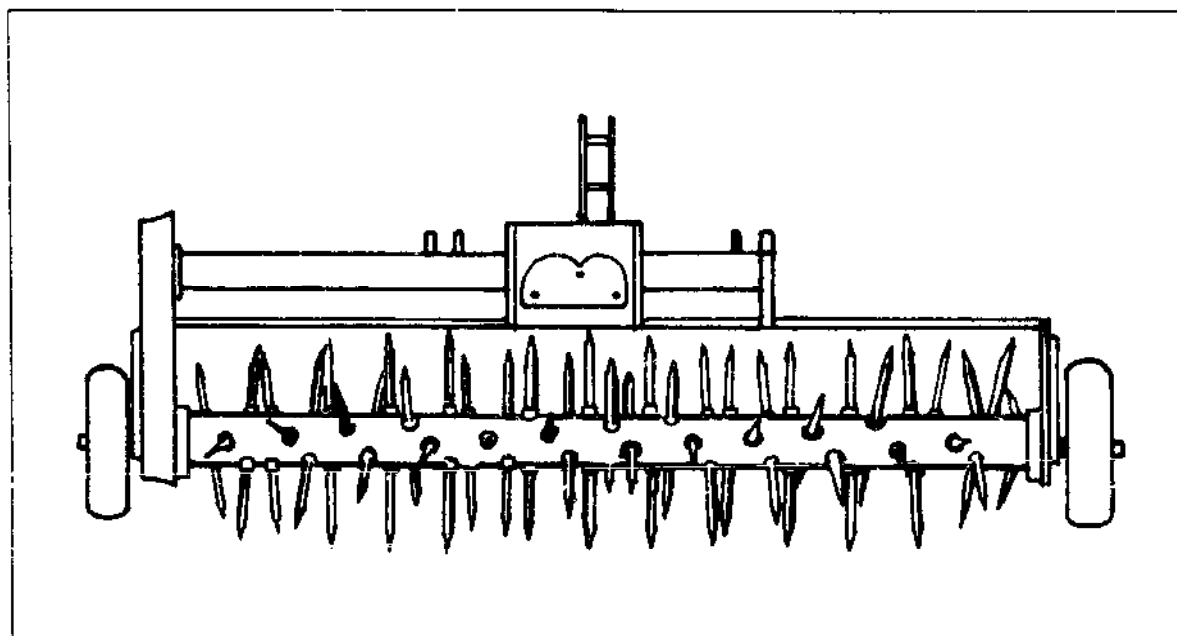

*Fig. 77. Tine rotor.*

The most widely used pto-driven implements for seedbed preparation are the rotating and the reciprocating hoe and the rotary tiller (see chapter 2.4) which for this purpose may be equipped with a tine rotor (Fig. 77) instead of a blade rotor. The large number of tines produce a better crumbling action despite the lower energy requirement while a tillage pan cannot be formed. On the other hand, the levelling and mulching action is markedly less satisfactory than with the blade rotor.

Table 9 shows the total power required and the proportions used for draught traction and for working the pto-driven implements.

implement	total energy requirement per m working width kW (hp)	share of total for draught	share of total for drive
rotary tiller (on ploughed land)	18-22 (25-30)	0	3/3
rotary tiller with tine rotor	15-18 (20-25)	0	3/3
reciprocating hoe	11-18 (15-25)	2/3	1/3
rotating hoe	15-18 (20-25)	1/3	2/3

Table 9. Power requirement per m width for pto-driven implements for seedbed preparation.

A more detailed comparison of the implements in this group is given in Table 10 which also includes the "reciprocating rotor" harrow. This implement is mentioned for completeness only: it has a very limited use in some European countries. In some ways the functioning of the tine sets is similar to that of the rotating hoe but the design is such that they require satisfactory maintenance and cannot be used on difficult soils.

For safety reasons the use of implements with rotating or oscillating tools calls for particularly careful training for drivers or operators.

implement	freq. or rpm tines	tool speed m/s 1)	depth ave. max. cm cm	opt. speed km/h	req. tractor kW/m 3)	capacity ha/h 2)
recipr. hoe	constant	0.9-1.1	4) 15	5-6	10-15	0.3-0.4
recipr. rotor	constant	ca. 1.4	4) 20	5-6	15-20	0.3-0.4
rotating hoe	variable	5-4	4) 20(40)	6-8	15-20	0.4-0.5
rotary tiller with tines	variable	3-13	4) 15	6-8	15-20	0.4-0.5

1): at standard pto rpm: 540 or 1000

2): per m working width

3): at 5-7 cm working depth

4): according to required sowing depth

Table 10. Some characteristics of pto-driven implements for seedbed preparation.

One of the most recent developments is a dual-rotor machine (Fig. 78), with a deep-working rotor in front and a shallow-working rotor immediately behind it. The rotation speed, type and size of the tools on these two rotors differ. They produce very intensive tillage.

A ground-driven version of this machine has also become available; the deep-working front rotor drives the second rotor which rotates about 3 times faster. The rotors are equipped with spoon (or shovel)-shaped tines. They work at depths of up to 10 cm.

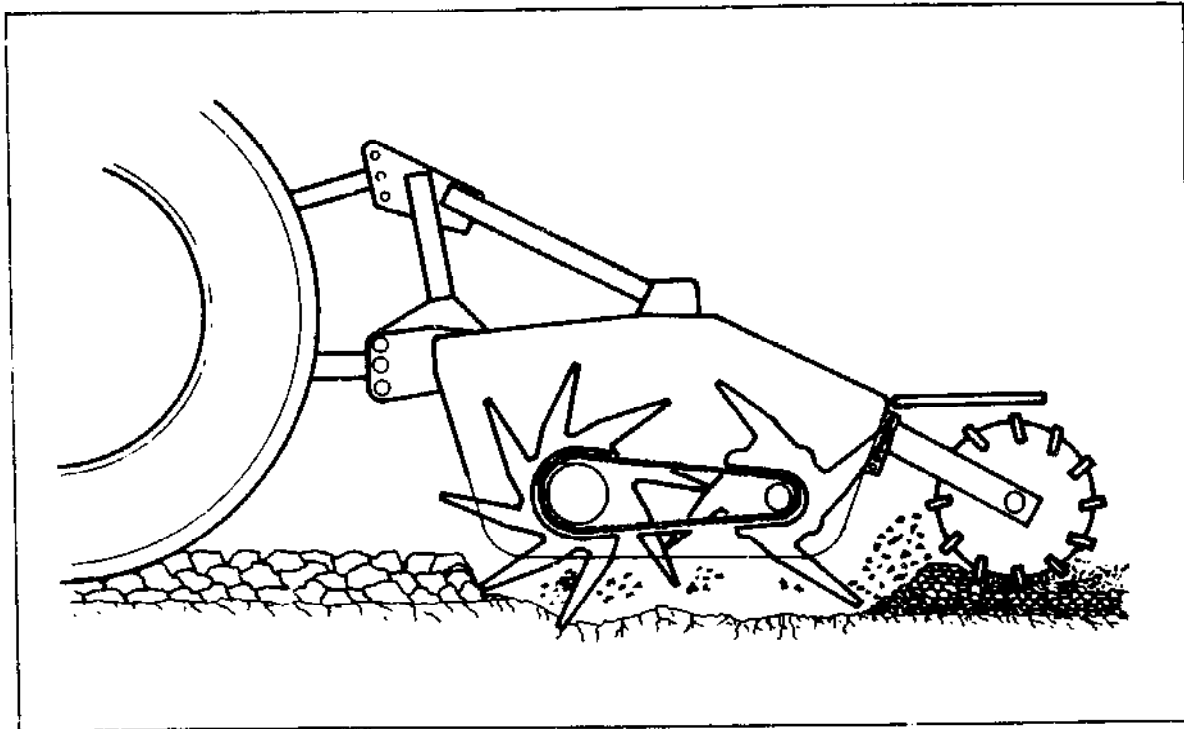

*Fig. 78. Dual-rotor combination.*

#### 4.3.0.1 Literature

See literature of chapter 4.0.

Irla, E., 1980. Ackerfraesen, Kreisel-, Ruettel- und Taumlegen. *Landtechnische Zeitschrift*, 31(7): 984-994.

Irla, E., 1980. Vergleichsuntersuchung von zapfwellengetriebenen Eggen. *FAT Blaetter fuer Landtechnik*, No. 166, pp. 12.

NN, 1975. Zapfwellengerate fuer die Saatbett bereitung. *Agrartechnik International*, 54(17): 12-13.

Stroppe, A. and R. Reich, 1982. Vergleichsuntersuchungen an Geraten zur Saatbettbereitung mit zapfwellengetriebenen rotierenden Werkzeugen. *Grundlagen der Landtechnik*, 32(3): 86-95.

### 4.3.1 The Rotating Hoe

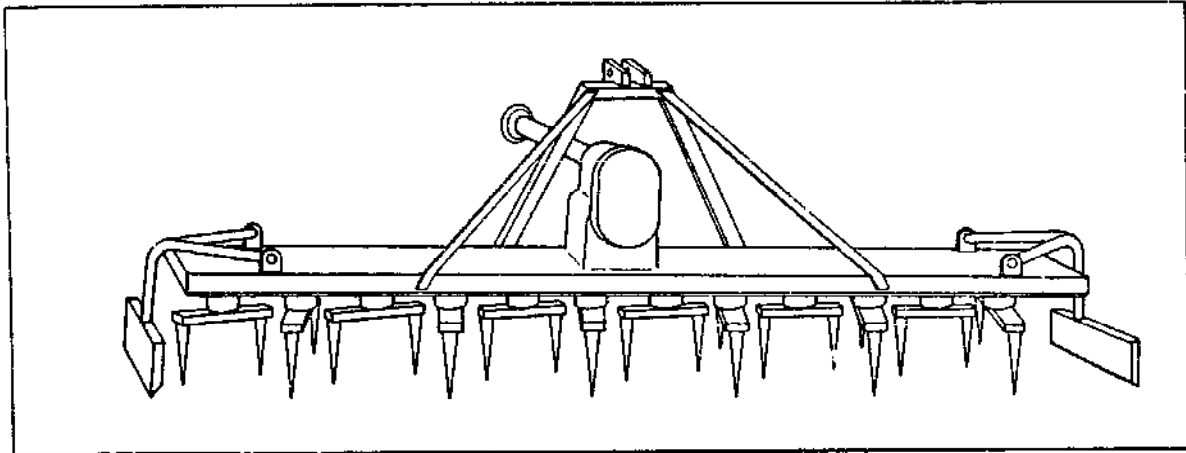

Fig. 79. Rotating hoe.

#### 4.3.1.1 Use And Assessment

The main use of the rotating hoe (Fig. 79) is for seedbed preparation. In special cases it can also be employed for stubble tillage or grassland clearance. Since it is possible to vary the tillage intensity both by changing the gears and by varying the travel speed, a well-crumbled and level seedbed can be prepared in one operation even on heavy soils. Generally speaking, the rotating hoe cannot be recommended for (primary) stubble tillage, especially when straw also has to be worked in. Even if angled special-purpose tines are fitted, satisfactory mixing may not be achieved despite the high power requirement but this implement is very suitable for secondary tillage of (chisel-)ploughed stubble fields.

The rotating hoe is rather vulnerable to damage by stones. The performance is not satisfactory on moist fields. Its ability to prepare a field for sowing in one pass and, possibly, to combine this operation with the actual sowing reduces the number of wheel-tracks on the field which in turn reduces the time and costs involved.

Strip cultivation is possible if working sets are omitted. The rotating hoe is a relatively expensive implement to purchase and operate.

#### 4.3.1.2 Functioning

Since the travel and circumferential speeds of the tine elements which mesh in the horizontal plane are aggregated, the tines move in a horizontal cycloid path (Fig. 80). Each element rotates in the opposite direction to its adjoining element. The shape of this trajectory and the intensity of the implement's operation depend upon the ratio between the tools' forward travel and circumferential speeds of the tools.



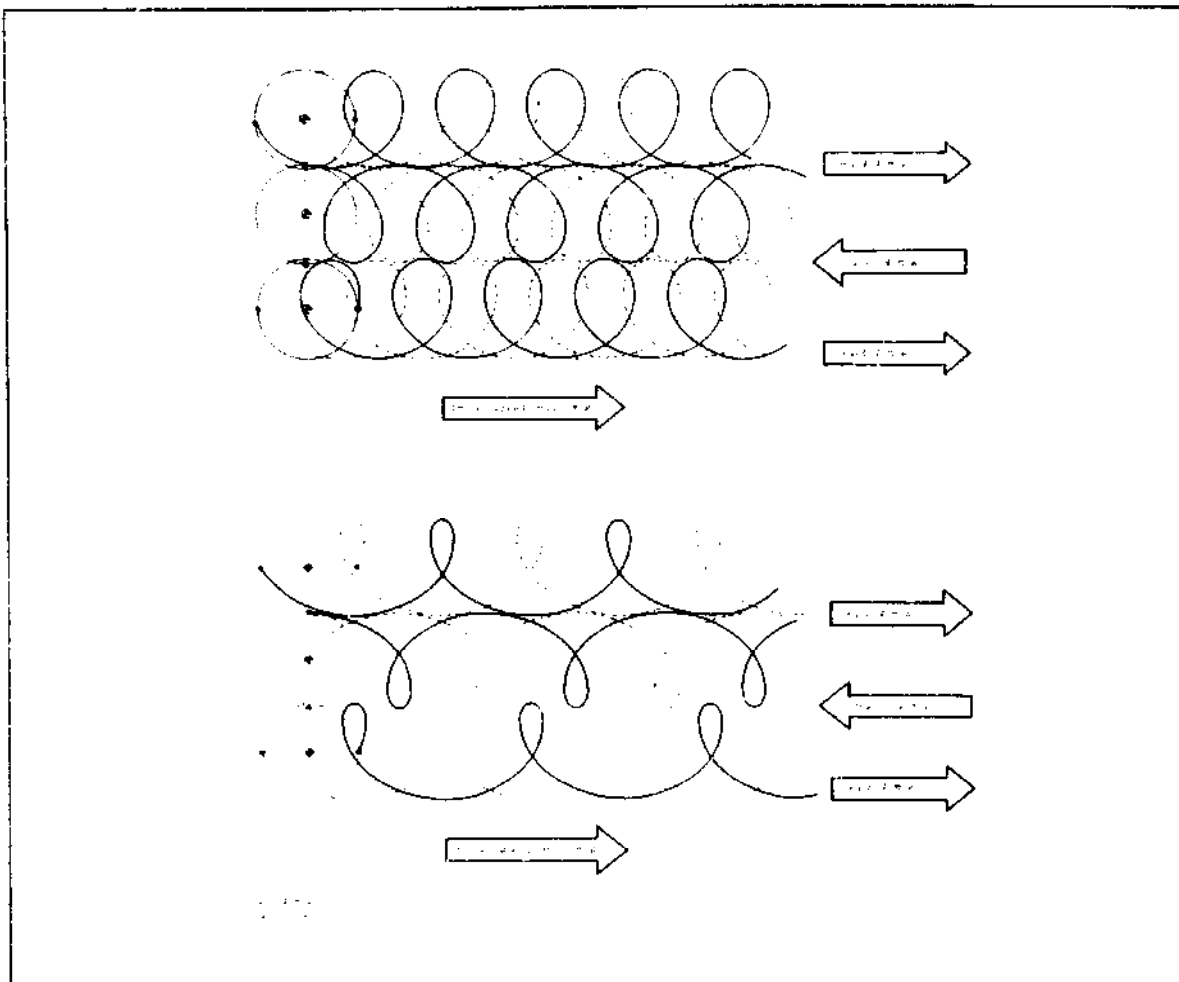

Fig. 80. Path of the tines of a rotating hoe in the soil (three adjacent elements). Forward travel speed 1.0 m/s (top) and 2.0 m/s (bottom).

Little crumbling is produced by a high forward speed and low rpm while a low forward speed and high rpm cause pronounced crumbling. The optimum effect will be achieved only with a specific ratio for the given soil type and conditions. A general rule for the rotating hoe is that the circumferential speed should be twice the forward speed but, for satisfactory operation, the latter should not exceed 6 km/h.

In addition to a good crumbling performance the rotating hoe also produces good levelling. The formation of ridges between adjacent passes is prevented by (spring-mounted) shields on both sides of the machine (see Fig. 79). The vertical mixing action is weak and so only the (dry) soil on the surface is crumbled and no moist soil is brought up (low water losses). Various jobs can be done by choosing a specific length or shape of the tines.

Tines about 25 cm long are usually employed for shallow seedbed preparation although tines up to 40 cm in length are used, for example, for preparing a field for potatoes or for cultivating in a row crop. The rotating hoe may be fitted with special angled "skim tines" for stubble tillage but this implement rarely operates satisfactorily on untilled soil after the harvest and requires a high power input. A special form of the implement with tines

pointing outwards and forwards (for better grip) produces stronger penetration (up to 25 cm) and a better mixing action.

The rotating hoe is very suitable for secondary tillage of (chisel-ploughed) stubble fields even if large amounts of straw have been left on the surface. Although it does to some extent compact and level the loose seedbed, the rear-mounted cage roller (Fig. 81) is essentially used to control the working depth of the rotating hoe.

Its ability to create a tilth in keeping with the soil type and conditions means that the easily-operated rotating hoe can be used for a variety of purposes on light to heavy soils. If the soil conditions are suitable, sowing is possible in one pass by combining the hoe with sowing machinery. When fitted with special attachments, the rotating hoe can also be used for ridging.

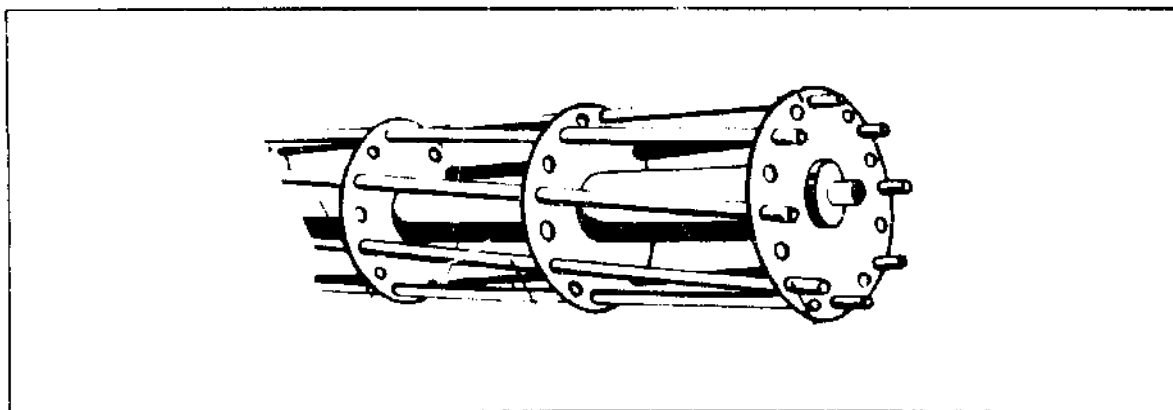

*Fig. 81. Cage roller.*

#### 4.3.1.3 Linkage And Drive System

The rotating hoe is usually designed for 3-point hitch mounting (category I-III) on the tractor and is used in free-floating mode with the depth being controlled by rear-mounted rollers or (in a few cases) support wheels. When the lift arms of the 3-point hitch system are equipped with slots allowing a movable attachment of the lower links, this setting permits completely independent levelling of the machine (i.e. by the rear-mounted roller alone). The centre of gravity is very near the tractor and so the tractor's lifting capacity will rarely be a restrictive factor. When a sowing machine is mounted (Fig. 82), however, care should be taken to ensure that the lifting capacity is sufficient (the hopper on the sowing machine also has to be filled). If a front pto is available, the rotating hoe may be mounted in front of the tractor. The rotating hoe is driven by the pto at 540 or 1000 rpm through an oil-filled gearbox (placed along the same axis as the pto shaft) to a central gear-wheel which drives the other gear-wheels to which the sets of tines are attached. On some rotating hoes the rotor sets are driven from the gearbox by lateral profiled shafts. The advantage of these implements is that the working width can easily be extended by adding extra sets. Very wide rotating hoes (up to 9 m) can be driven by an auxiliary engine.

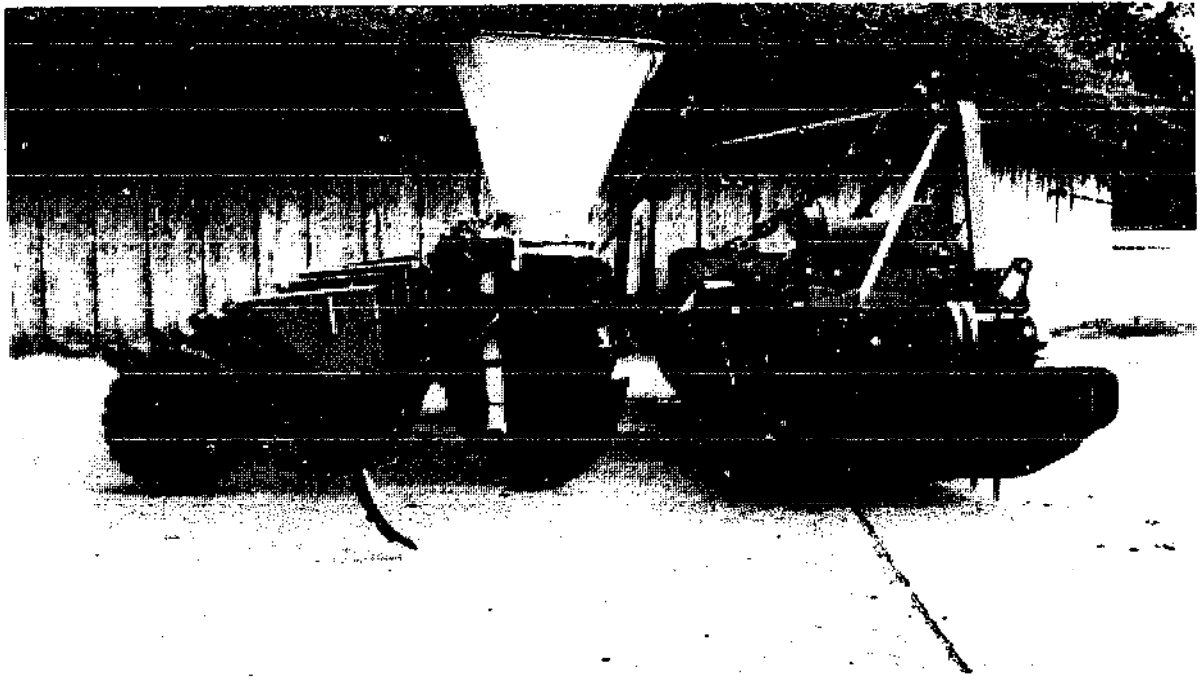

*Fig. 82. Rotating hoe with rear-mounted precision drill.*

The rpm of the rotor sets can be varied from approx. 130 to 480 by changing the gears. The hoe's gearbox can be equipped with a rear extension shaft so that pto-driven sowing machines, for example, can be mounted.

The power required by pto-driven implements can be divided into draught-energy and rotational energy, each depending upon the travel speed and the circumferential speed of the tools. An increase in the forward speed greatly increases the draught proportion and the tillage intensity will be reduced, i.e. as the travel speed increases, the advantage of the pto-drive system or its efficiency is reduced. So the travel speed when working with a rotating hoe should not exceed 6 km/h. Any increase in the rpm of the tools also raises the rotation energy requirement. The ratio between the tractor and rotative energy requirements for rotating hoes is about 1:2 and so a large proportion of the energy is transmitted by the pto. There is no danger of wheel slippage. When working at a depth of 8-10 cm at speeds of 5-6 km/h, 15-25 kW/metre of width may be taken as an indication of the total power required.

Very wide rotating hoes can be switched hydraulically from the working to the transport (endways) position.

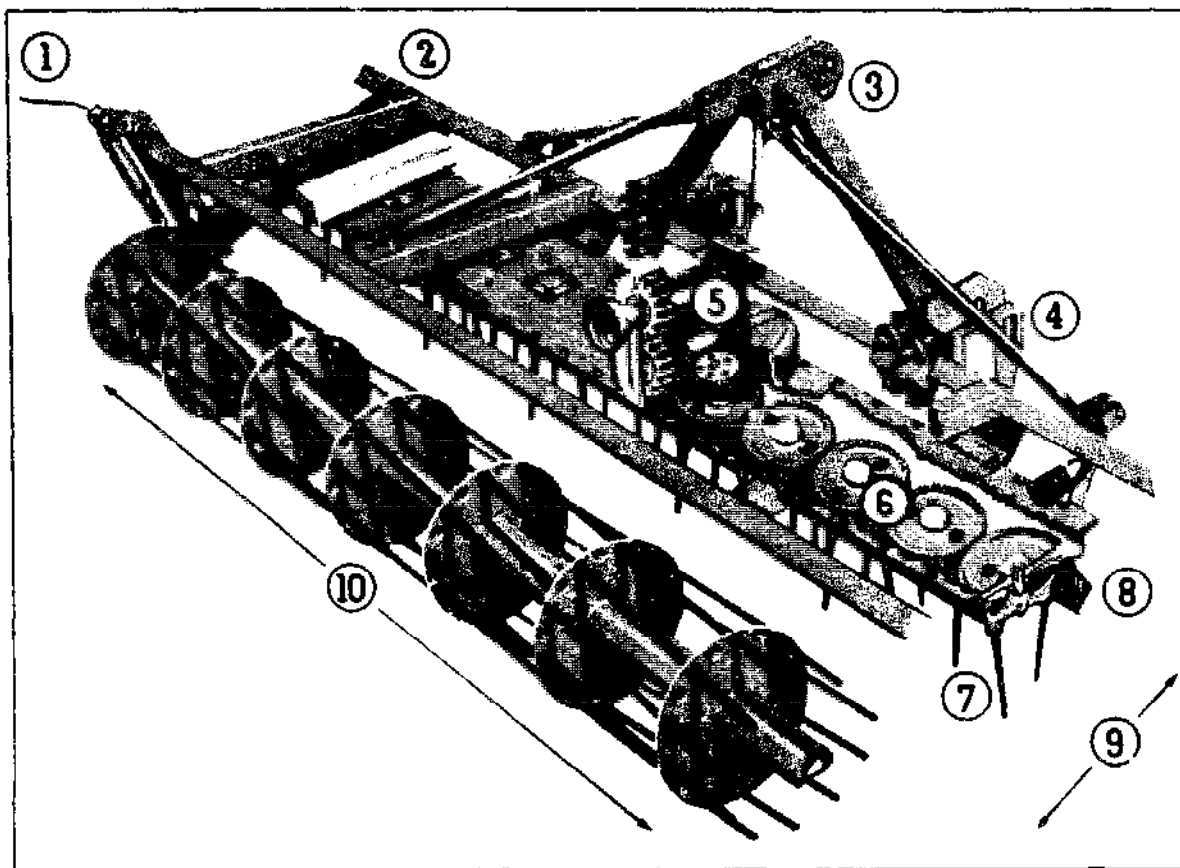

Fig. 83. Rotating hoe:

- |  |                               |
|--|-------------------------------|
| 1. Spindle for depth adjustment<br>(by cage roller), | 6. Sprocket wheel,            |
| 2. Frame,  | 7. Tine,                      |
| 3/4. Headstock,                                      | 8. Levelling board,           |
| 5. Gearbox,  | 9. Total length of implement, |
|  | 10. Packing roller.           |

#### 4.3.1.4 Description Of The Implement And Tools

The rotating hoe (Fig. 83) has a frame with a headstock for 3-point linkage. A gearbox and housing containing a specific number of gear-wheels (depending on the model and its width) are attached to the frame. Vertical rotor-shafts with horizontal tool "carriers" are mounted in the centre of each of these gear-wheels. These carriers may be fitted with two to four easily replaceable tines or knife-shaped tools. On some implements the tines are angled slightly backwards (when viewed from the direction of rotation). The shape and length of the tines can be chosen to match their intended use. The tines may protrude slightly at the bottom for better mixing. Adjoining sets are counter-rotating (Fig. 84). The system is equipped with a device to protect against overloading. Only rarely is each set of tines protected against stones (shearbolts or a hydro-pneumatic system may be mounted on heavy-duty types).

Rotating hoes are usually equipped with a cage roller and possibly (by special mounting parts) with a sowing machine. Sowing equipment may even be mounted on top of the hoe (i.e. hopper and seed metering system). A levelling bar in front of the tines serves as protection and produces a very smooth level seedbed (sugarbeet, etc.). A special ridging kit (special tines, hoods, support wheels and frame for the ridging bodies) is available.

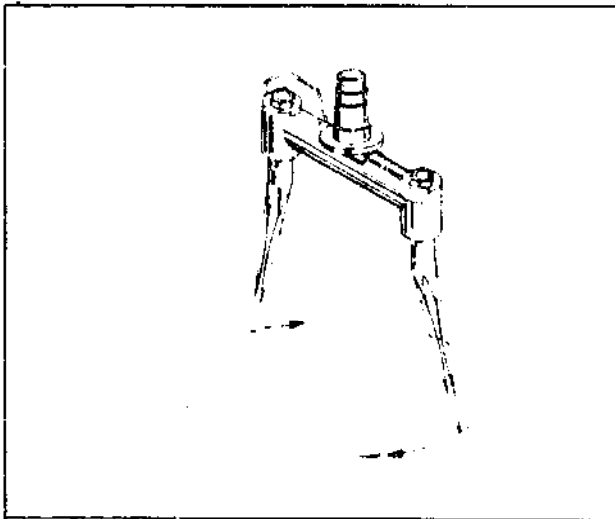

Fig. 84. Tool carrier with two tines.

#### 4.3.1.5 Adjustments, Operation

The depth is usually controlled by the cage roller (adjusted by bolt or spindle). The tillage intensity increases in line with the higher speed of the rotor sets and the number of tines per set (2 or 4) and also as the forward speed is reduced. Strip tillage is possible by removing certain sets of tines.

The machine can easily be mounted and adjusted and tools replaced by one man. The pto-driven rotating tines require special attention from the driver when in operation (looking out for stones, woods, etc. in the field). The gear-wheels operate in an oilbath and do not require special care.

#### 4.3.1.6 Technical Data

Working width	1-9 m
Working depth	up to 25 cm
Travel speed	5-7 km/h
Rpm of the rotor	(83) 120-530
Rpm of the pto	540 or 1000
Circumferential speed of the rotor sets	1.8-6.5 m/s
Number of sets	2-4 per m width
Number of tines per set	2-4
Weight	170-330 kg per metre of width
Power required	15-30 kW per metre of width

#### 4.3.1.7 Literature

See literature for chapter 4.3.

### 4.3.2 The Reciprocating Hoe

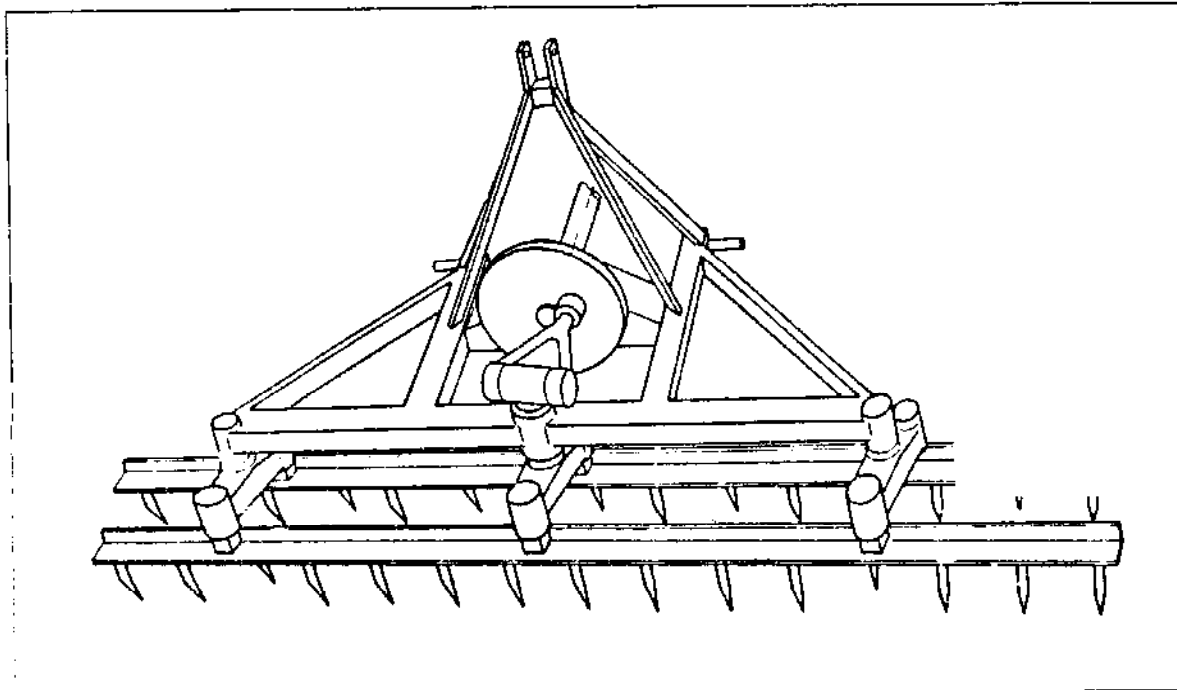

Fig. 85. Reciprocating hoe.

#### 4.3.2.1 Use And Assessment

The reciprocating hoe (Fig. 85) is used mainly for seedbed preparation but may also be employed for secondary tillage of (chisel) ploughed stubble fields. Although, in principle, the intensity of the tillage operation can be varied only by changing the travel speed, it is possible to prepare a field for sowing in one operation, even on heavy soils. The hoe is distinguished by its good crumbling effect and its levelling action but more passes are necessary on hard soils with big clods. The reciprocating hoe can be used on comparatively wet soils without the packing roller. The hoe is sturdy and requires little maintenance cost.

Owing to its short length the reciprocating hoe can be combined with a sowing machine so that the number of passes (wheel-tracks) during the sowing operations can be reduced. Mounting and adjustment can easily be performed by one man.

#### 4.3.2.2 Functioning

Since the tines' reciprocating movement and the tractor's forward movement are aggregated, the tines follow a sinusoidal path in the soil (Fig. 86). The locus followed by the tools is determined by these two speeds. When one of them is changed, the tool's trajectory in the soil and thus the tillage intensity also alter.

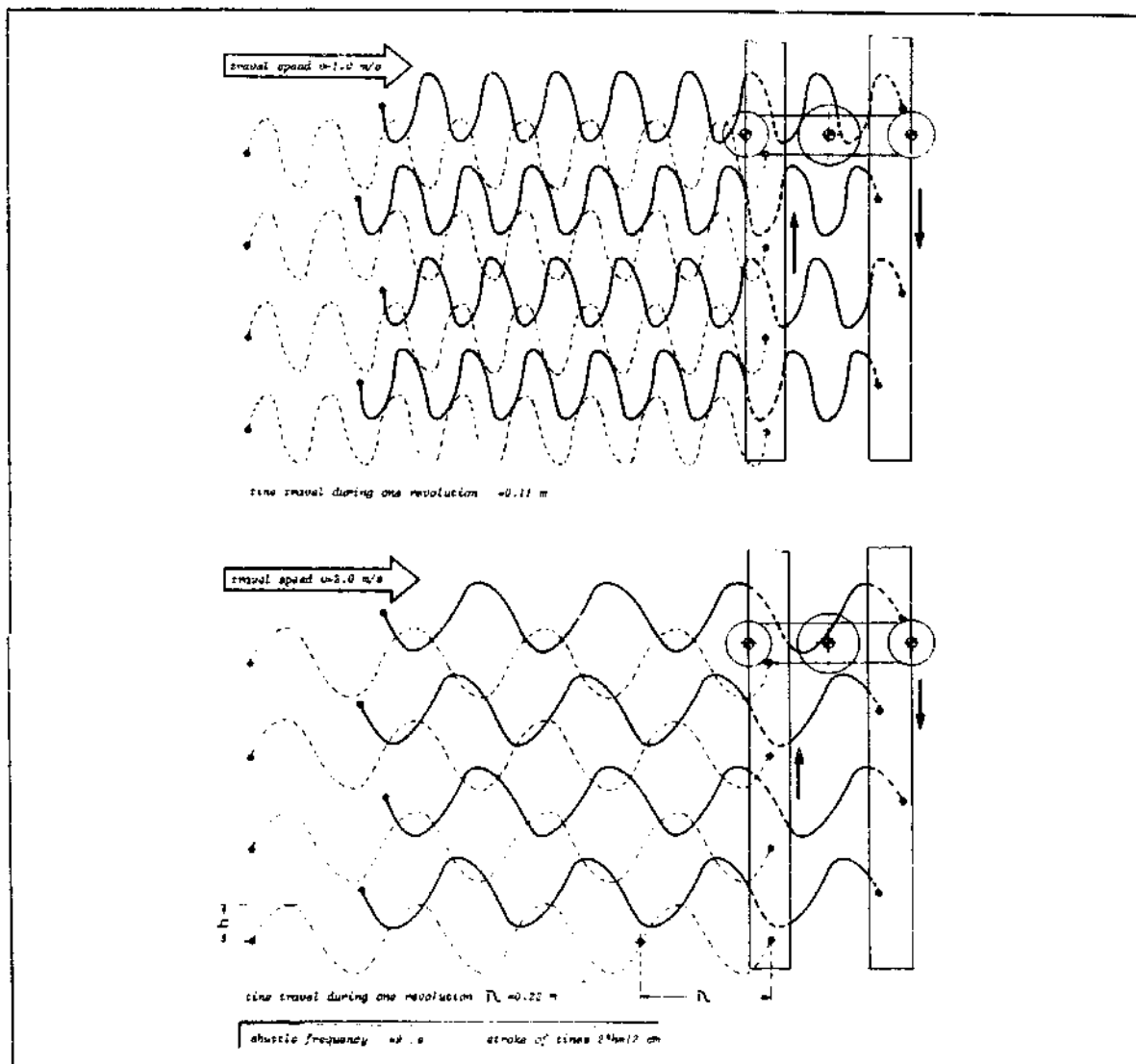

Fig. 86. Path in the soil of the tines of a reciprocating hoe with two bars. Forward travel speed 1.0 m/s (top) and 2.0 m/s (bottom).

This intensity can be influenced only by the forward speed because the shuttle frequency, the stroke of the tines, the number of tines per bar and other parameters are fixed by the manufacturer.

The stroke depends upon the length of the arms driving the bars. On some implements the stroke of each successive bar increases in stages, e.g. on a 4-bar reciprocating hoe the stroke ranges from 9 cm for the front bar to 49 cm for the rear one. With the same frequency the tool speed and thus the tillage intensity increase with the higher strokes. So 4-bar implements are recommended for heavy soils since they crumble more satisfactorily than the 2-bar types.

The soil is crumbled and levelled by the reciprocating tines. Wheel-tracks are also eliminated if the hoe operates at sufficient depths. Its functioning prevents moist (sub)soil from being raised to the surface (just like the rotating hoe). It is possible to prepare a seedbed in one operation on both light and heavy soils to maximum depths of up to 20 cm (no

more than 15 cm is recommended for efficient operation).

Large amounts of harvest residue on the field may cause clogging. That is why secondary tillage of (chisel) ploughed stubble fields using the reciprocating hoe is possible only if small amounts of straw are on the surface. The tillage intensity decreases as the speed increases; soil piled up in front of the machine is pushed forward. The speed should not exceed 6 km/h for satisfactory results.

Precise depth control can be obtained by using a rear-mounted cage roller which compacts light to medium-heavy soils. Sowing is possible in one pass by combining the reciprocating hoe and a sowing machine.

#### 4.3.2.3 Linkage And Drive System

The reciprocating hoe is designed for the 3-point hitch linkage on the tractor and is used in free-floating mode. As with the rotating hoe, the centre of gravity is located close to the tractor. Care should be taken to ensure that the tractor's lifting capacity is sufficient when a sowing machine is mounted.

The hoe is driven by the tractor pto (540 rpm) through a driveshaft to a crankwheel which converts the rotational motion in a reciprocating motion. So the bars placed in parallel one behind the other are moved in a reciprocating direction. If the moving masses are not perfectly balanced (which includes sufficiently large hinges to act as a buffer), the lateral forces are transmitted to the tractor, causing heavy strain not only on the 3-point hitch but also on the tractor and driver. In severe cases this means that a larger tractor than is really needed for the power requirement is chosen. On modern implements so much of the torque peaks generated by the oscillating movements are absorbed that they do not damage the tractor.

The ratio between the draught and rotational energy requirement is about 2:1 for the reciprocating hoe. The draught requirement increases with the speed while the rotational-energy requirement remains relatively constant. The speed should not exceed 6 km/h in view of the increasing total energy requirement and the resultant unsatisfactory work. A total power requirement of 15-20 kW/m of width can be expected at that speed and when working at depths of 8-10 cm.

#### 4.3.2.4 Description Of Implement And Tools

Up to four bars or "tool-carriers" are mounted on a frame (see Fig. 85) in parallel to each other and perpendicular to the direction of travel. The number of tines on each bar depends upon the make and model (and the intended use) of the implement. An interval of 15 cm between the tines and a length of 20-30 cm are normal. Tines are easily changed. The heart of the machine is a heavy crankwheel with an eccentric for converting the rotating movement of the driveshaft into an oscillating movement for the tine bars. The frequency is between 140 and 540 movements per minute. Most reciprocating hoes are equipped with a cage or packing roller and may have mounting parts for combination with a sowing machine (Fig. 87).



#### 4.3.2.5 Adjustments, Operation

The only possible adjustment on the reciprocating hoe is the depth control exerted by the cage roller or the tractor's hydraulic system. So the tillage intensity is determined solely by the forward speed. The operation of the reciprocating hoe is very simple.

The (pto) drive system requires no attention except for the normal care given to these types of implements (lubrication, checking the bearings).

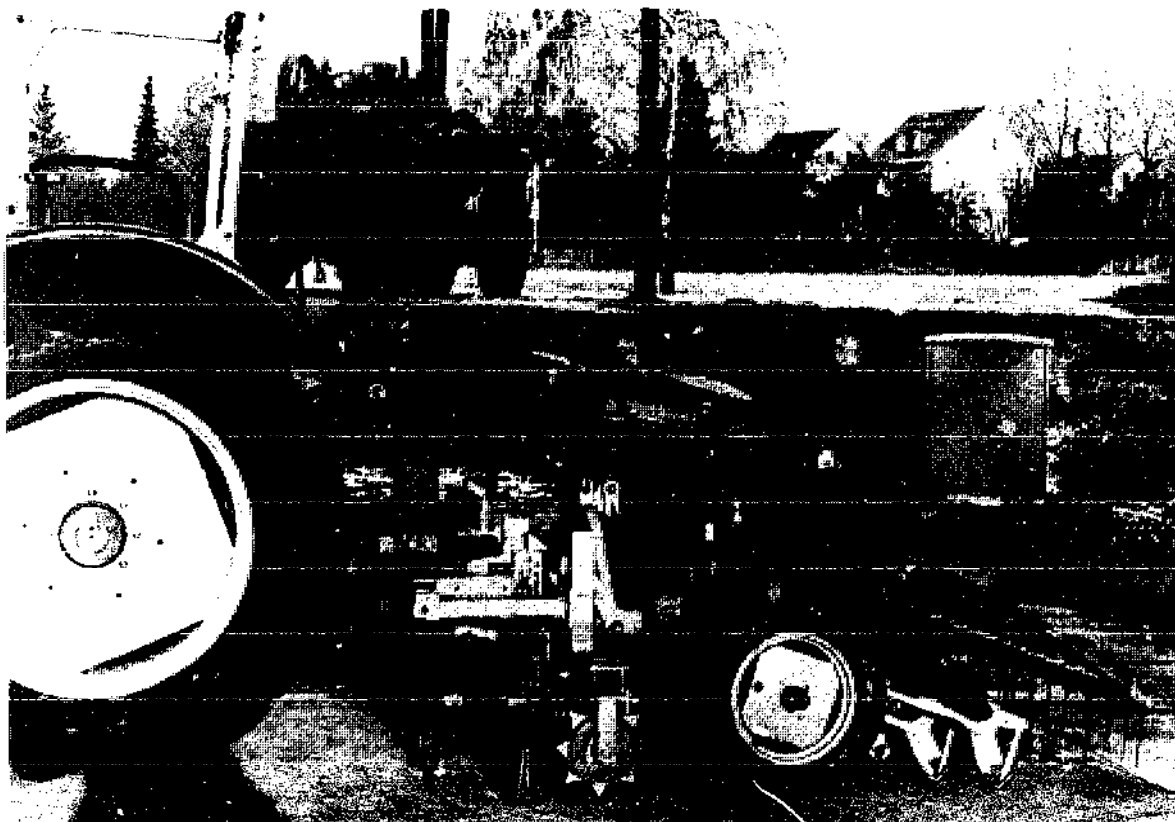

*Fig. 87. Reciprocating hoe with rear-mounted drill.*

#### 4.3.2.6 Technical Data

Number of bars	2-4
Working width	2-6 m
Working depth	up to 20 cm
Speed	5-7 km/h
Rpm of the pto	540
Frequency of the bars	140-540/min
Breadth of bars	10-50 cm
Power required	15-22 kW/m of width
Weight (including roller)	200-300 kg/m of width

#### 4.3.2.7 Literature

See literature for chapter 4.3.

## 4.4 The Leveller

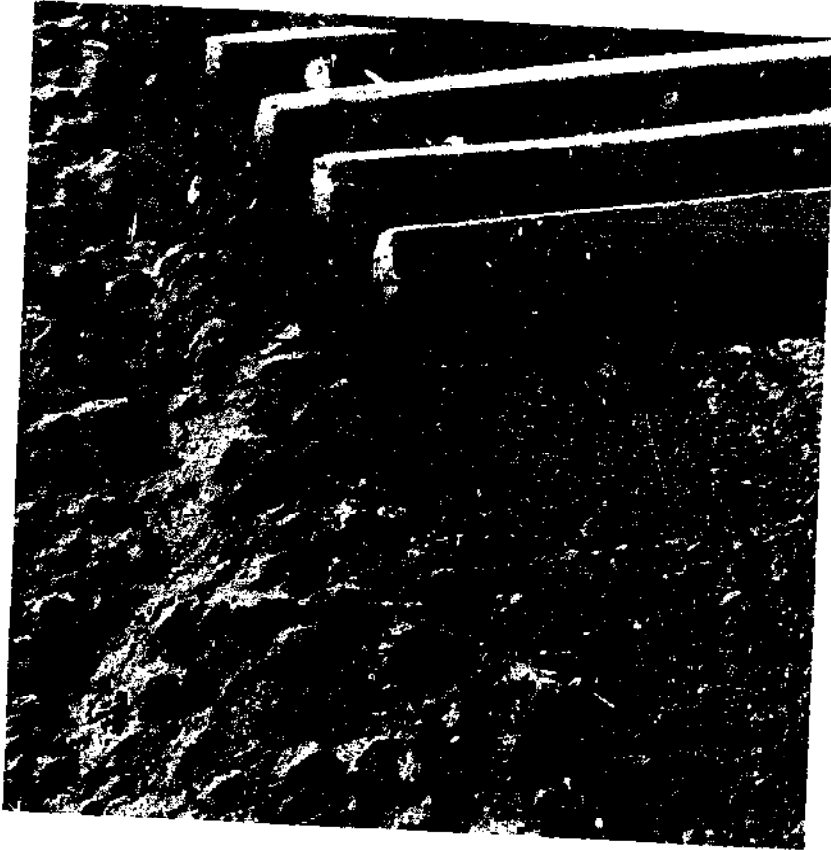

#### 4.4.1 Use And Assessment

The leveller is an ancient implement whose use is still widespread because of its simplicity (Fig. 88). It is used for:

- levelling and smoothing of the soil surface,
- crumbling the surface layer,
- improving the drying-out of the surface soil,
- control of early weeds,
- compacting the soil surface (to a certain depth),
- breaking up crusts.

The leveller is suitable for use in the tropics only under certain conditions since the risk of erosion is increased by leaving a bare smooth and finely aggregated surface.

The advantages of the leveller are:

- simple and sturdy construction,
- the user does not require a high standard of skill,
- the soil surface dries out uniformly,
- an insulating layer is created on the surface, preventing serious losses of water,
- it can be produced by local craftsmen.

Its disadvantages are:

- smearing on moist soils, thus reducing the infiltration capacity,
- some compaction of the soil,
- fine material is deposited on the surface with larger cavities below,
- the travel speed is limited,
- 3-point hitch linkage is not easy to use (transport problems).

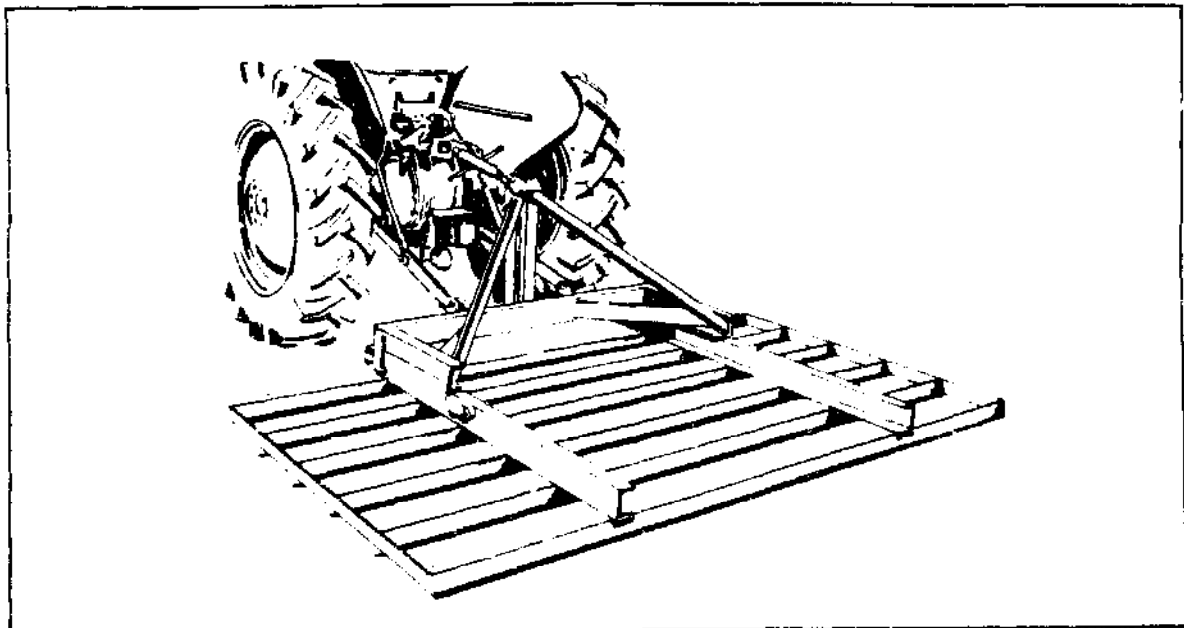

Fig. 88. Leveller (3-point hitch type).

#### 4.4.2 Functioning

The leveller pushes soil forward, pulverizing and depositing it in local depressions. Weeds are torn away and will dry out. The leveller should not push too much soil. The tillage depth and intensity on heavy soils may be influenced by extra weights, special linkage or the travel speed. In many cases the required effect can be achieved only by mounting several units behind the other and/or by more passes over the field. On moist soils a compromise must be found between sufficient levelling and the prevention of smearing.

It is important for the implement to be well adapted to the surface, and this may be achieved by suspending separate units independently on a toolbar. The best effect is obtained when the levelling is carried out at an angle to the direction of the previous (main) tillage operation.

#### 4.4.3 Linkage

The majority of levellers are designed as dragged implements. A hitch system with a toolbar is used to mount tools one behind the other. The angle of pull and thus the working depth and intensity are changed by extending or shortening the hitch device or by choosing a higher or lower linkage point. The tools may be staggered. Levellers are sometimes used in combination implements. Three-point hitch linkage is not normally employed.

#### 4.4.4 Description Of The Implement And Tools

Levellers are divided into:

- a. Levellers using beams,
- b. " " boxes,
- c. " " hoops (tyres),
- d. " " chains.

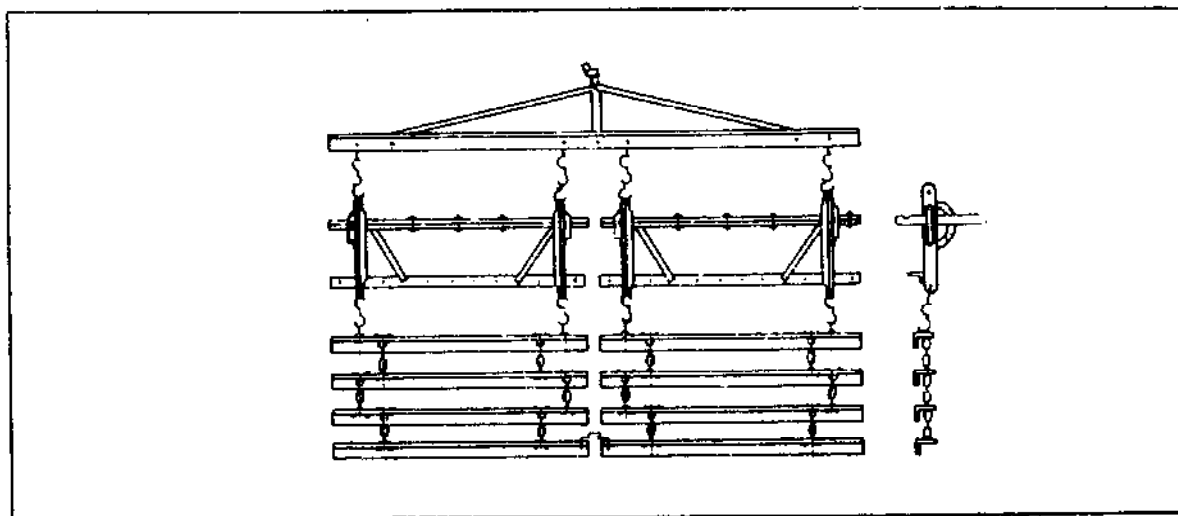

Fig. 89. Beam leveller (drag type).

a) Beam levellers.

These levellers (Fig. 89) consist of either a single beam or plank (possibly fitted with stones, short tines or other tools at their base) or a number of beams placed one behind the other. These beams are all set perpendicularly to the direction of travel and attached to a toolbar by chains or links. These levellers usually are made of wood. They may be staggered. The front (working) edge usually covered with a steel strip.

Beams (or floats) are also extensively used for surface-irrigated farming, (see Chapters 5 and 6).

b) Box levellers.

Unlike the beams the boxes permit an extra load and adjustment of the tool plane's angle of attack. This adjustment can produce planing or compacting. Other levellers have a frame consisting of a mesh of branches which can be filled with stones. These implements belong to the same group.

c). Hoop levellers.

At least three hoops set in staggered formation are attached to and pulled by a toolbar (Fig. 90). Steel hoops or rubber tyres may be used.

Steel hoops, about 50 mm in height, are attached to each other by short chains or eyes. Tyres are usually cut in half and the two rings formed in this way are attached "back to back" so that the leveller may be used either way up.

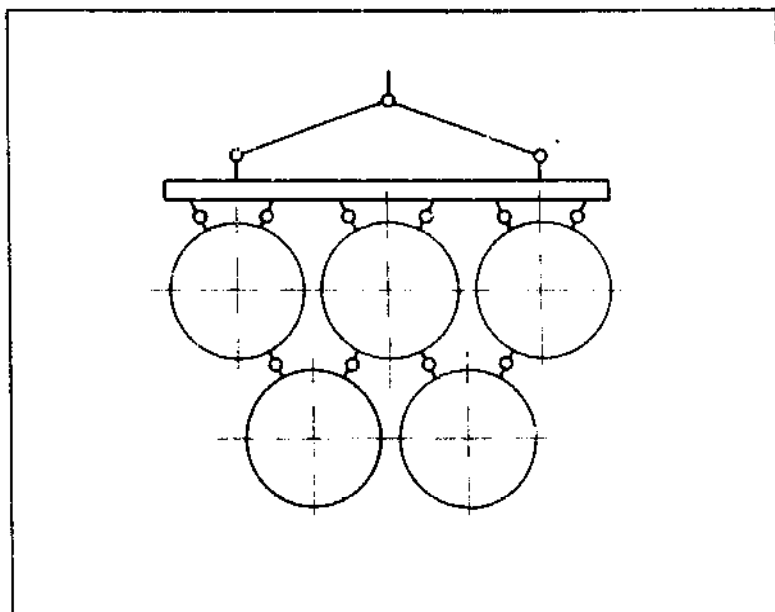

Fig. 90. Hoop-leveller (ārag type).

d) Chain levellers.

Several strong chains are attached to the hitchbar to form various patterns. Both the tyre and chain leveller are also used on pasture (dung spreading).

#### 4.4.5 Adjustments, Operation

The effect produced by a leveller depends not only upon the design but also on the following adjustable parameters:

- a. Weight of the leveller (including extra weights)
- b. Angle of pull
- c. Angle of the working plane
- d. Travel speeds

Passes with the leveller may also be repeated until the required effect has been achieved. Although a smooth surface can be obtained, the soil will be considerably compacted when a tractor is used. A beam leveller makes it possible to vary the action from strong cutting to cutting/planing or compacting in keeping with the angle of the beam.

The leveller requires no special knowledge and is very easy to use.

#### 4.4.6 Technical Data

Working width	up to 8 m
Working depth	up to 50 mm
Number of tools	up to 12
Weight	30-50 kg/m
Working speed	up to 8 km/h
Power required	approx. 5 kW per metre of width

#### 4.4.7 Literature

See literature for chapter 4.0.

## 4.5 The Roller

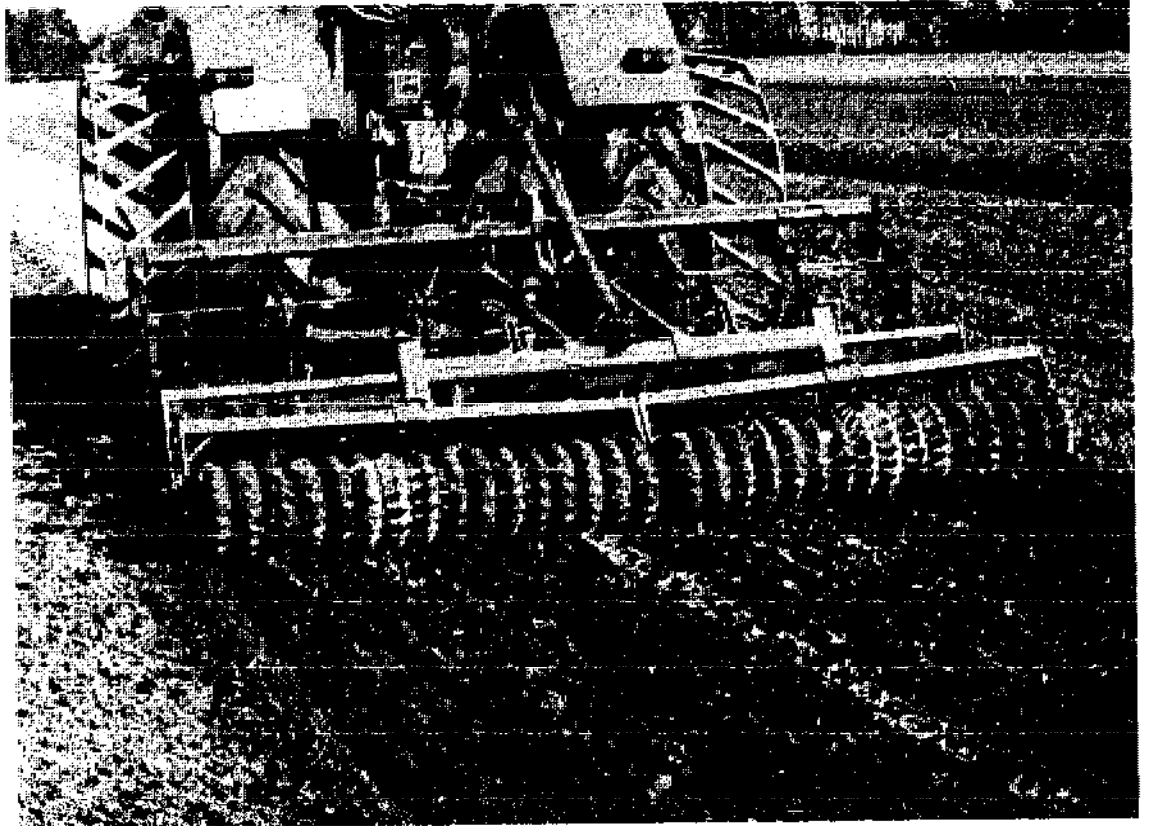

#### 4.5.1 Use And Assessment

Rollers (Fig. 91) are used for:

- compacting the soil at various sections of the arable layer,
- filling cavities,
- breaking up clods,
- breaking up surface crusts,
- controlling the water movement in the soil by compacting the soil surface, thus accelerating evaporation,
- levelling the soil (including molehills on grassland),
- compressing the soil around young plants when the topsoil is not closely integrated with the subsoil,
- maintaining grassland.

If fitted with suitable tools, rollers may be used under certain conditions in the tropics and subtropics.

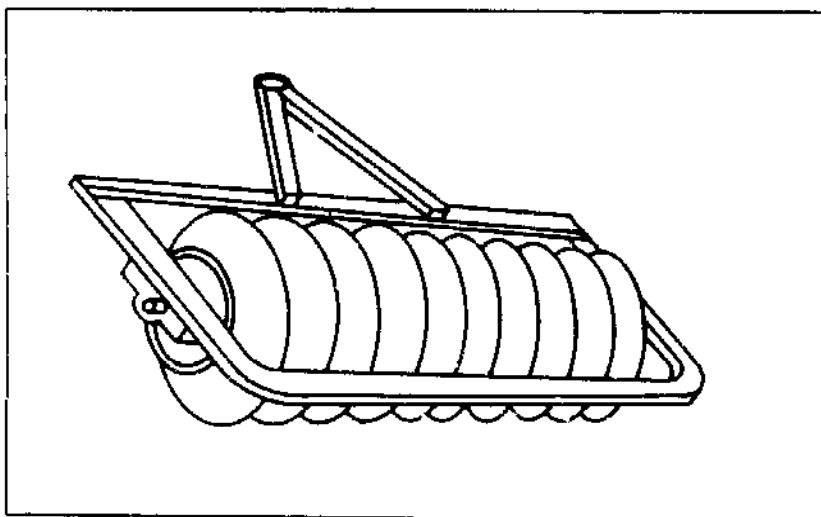

Fig. 91. Roller.

The advantages of rollers are:

- almost unlimited use,
- good crumbling of hard clods if the correct tool is fitted,
- highly efficient,
- may be used on slopes and undulating land (articulated rollers),
- high capacity,
- low draught requirement,
- suitable for the heaviest soils,
- simple sturdy construction so that hardly any wear or breakdowns occur,
- easy to build.

Their disadvantages are:

- soil compaction cannot be avoided even when only crumbling is required,
- the soil's infiltration capacity is reduced when a smooth roller is used
- the drying process is accelerated (this may be an advantage),
- a drying heavy soil may completely clog up an open roller,
- soil erosion may be increased.



#### 4.5.2 Functioning

The primary soil tillage operation often causes excessive loosening of the soil. Especially in a closely integrated crop rotation (allowing scarcely any time for the soil to consolidate naturally), it may be necessary to compact the soil mechanically, possibly in combination with the ploughing. The roller's compaction effect is produced by the pressure on the surface. The degree of pressure depends upon the roller's weight, its diameter, the shape of its surface and the manner on which it adapts to the soil surface but, in the last analysis, the essential factor is the degree and direction of the forces exerted on the soil surface which is actually in contact with the roller. The duration of the pressure (determined by the travel speed) is another important factor. The pressure causes compaction and, simultaneously, pulverization of the clods on the surface. The roller's shape is the essential parameter determining the amount of crumbling and compaction at various depths. Since the force is always transmitted downwards from the surface (especially with smooth rollers), however, the compaction obtained is always greatest near the surface and decreases with the depth. In deeper layers the effect is limited.

To achieve a uniform action over the entire area the rollers are often divided into single rings with various shapes which move independently. This system also allows better cleaning. The roller's diameter is the crucial factor. Rollers with large diameters produce less penetration and less (negative) slip; the pressure per area unit is less but the effect on the deeper layers is greater.

The degree and duration of the pressure on the surface determine the depth to which the rollers compact. With smooth and open rollers compaction is achieved down to 15 cm while with subsurface packers this increases to 20 cm.

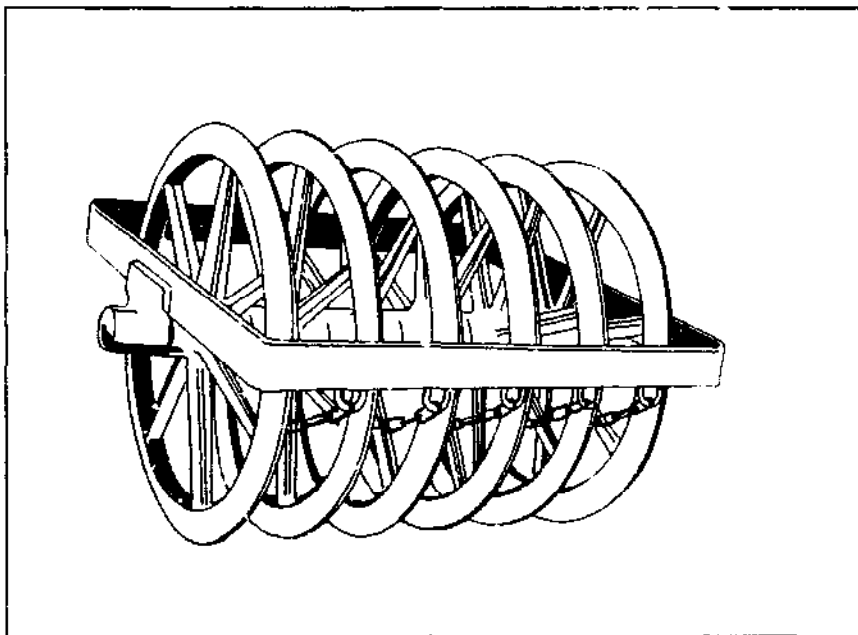

Fig. 92. Subsurface packer.

The subsurface packer (Fig. 92) is used for deeper action. The narrow spiked wheels penetrate deeply into the soil and cause compaction at penetration depth. The spikes pick up loose soil and raise it to the surface, creating a loosened layer near the surface.

#### 4.5.3 Linkage

Rollers are used mainly as trailed tillage implements. Hitching to the 3-point system is, however, becoming more widespread. The advantages are simpler mounting, troublefree operation and especially easy transportation. When equipped for use as trailer implements, the rollers are hitched to the tractor's (linkage) drawbar.

Packers in particular are being increasingly used on light soils as rear-mounted implements on the plough, drawn by a chain or catching bow in the case of two-way ploughs. They require little power which is inversely proportionate to the diameter of the roller.

#### 4.5.4 Description Of The Implement And Tools

Rollers can be divided into:

- a. Smooth rollers
- b. Corrugated rollers
- c. Subsurface packers
- d. Crust breakers

a) On smooth rollers one or more smooth steel cylinders with diameters of approx. 300-700 mm (up to 1500 mm on special purpose rollers for use on pasture or marshy land) can rotate freely on an axle mounted on a frame with bearings. The frame is suitable for either trailed or 3-point hitch mounting. Smooth rollers are usually operated as single-unit implements (Fig. 93) but more units staggered in 2 or more rows are also possible.

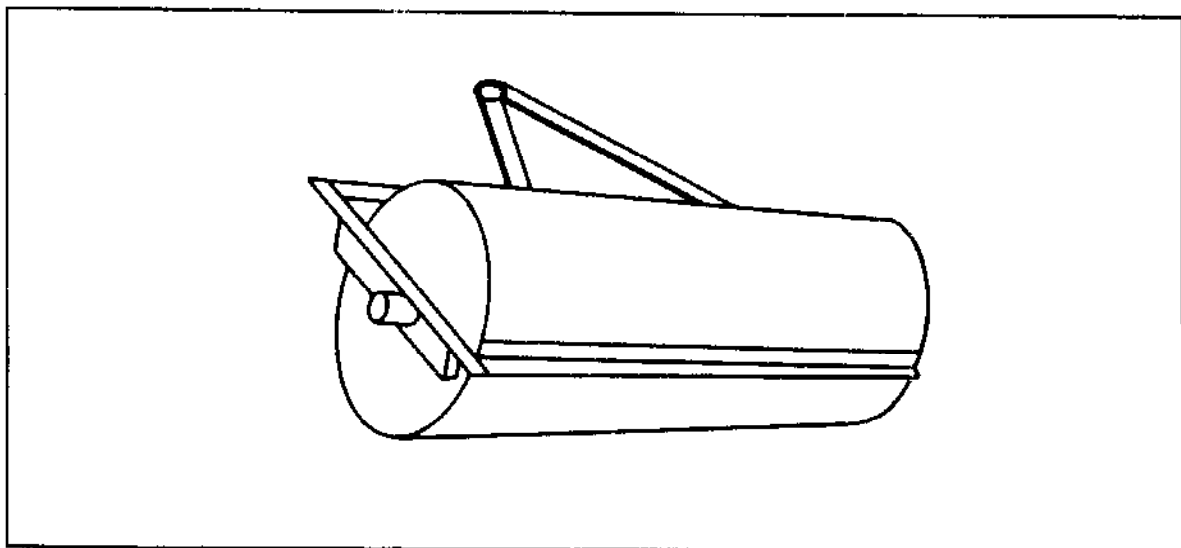
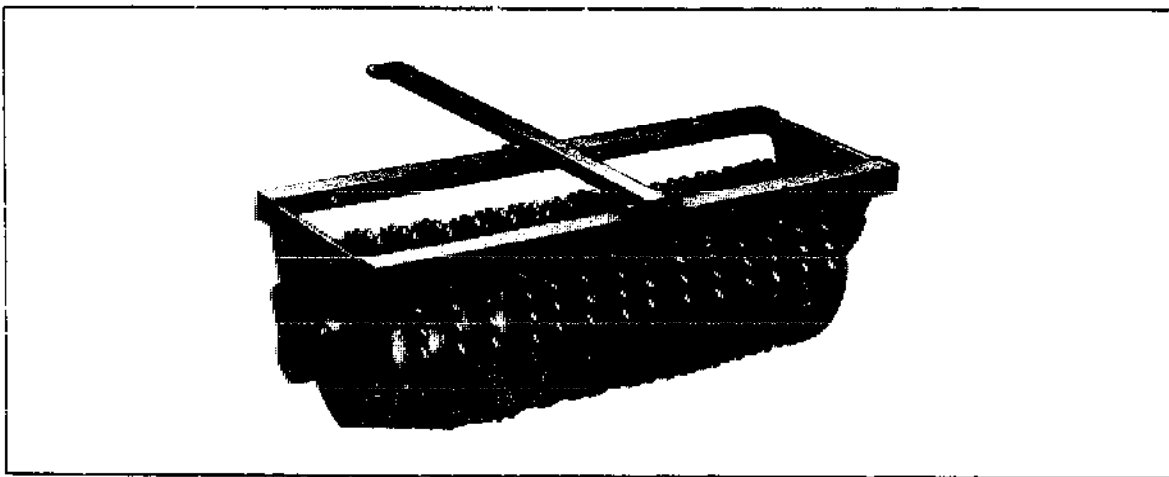

Fig. 93. Smooth roller.

- b) Corrugated rollers (Fig. 94) are available in the form of:
- ring rollers,
  - sprocket-wheel rollers,
  - Cambridge rollers,
  - Croskill rollers.

As on smooth rollers, the various elements (approx. 8-12 per metre) rotate on an axle but the diameter of the ring's central opening is larger than the axle's diameter. Corrugated rollers are generally designed as a set of narrow rollers. On the Cambridge roller plain and toothed rings with different diameters are mounted alternately, 10 of each for each metre of width. They are arranged to allow independent and eccentric movement so that the rollers follow the soil surface as closely as possible and a good self-cleaning action is obtained. On the Croskill or crowfoot roller the rings are fitted with teeth and lateral lugs alternately, producing more intensive crumbling, even on heavy soils.



*Fig. 94. Cambridge roller.*

c) Subsurface packers. The general design and construction of these packers (Fig. 92) are similar to the smooth and corrugated rollers. Narrow cast-iron spiked wheels - usually with a wedge-shaped rim and a diameter of 700-1100 mm - can rotate freely on a common axle. The distance between the wheels is 100-180 mm. Since the wheels are freely mounted on the axle, the roller can be turned easily and does not cause problems in curved fields. The packers may be mounted behind the plough and, in some cases, even in combination with sowing equipment, allowing sowing in one operation.

d) The crust breaker is a special type which enables seedlings to emerge through a crust. Tines or teeth are mounted on the circumference of a smooth steel drum and they merely penetrate and break the crust without damaging the plant.

#### 4.5.5 Adjustments, Operation

The potential adjustments are: changing the travel speed (3-10 km/h) or changing the load on the rollers by means of extra weight or by filling them with water or sand. The intensity of the operation depends upon the type of roller:

- corrugated rollers: good clod crushing action;
- packers: good compaction of the subsoil (=lower sections of the arable layer);
- smooth rollers: good levelling and compaction of seedbeds for fine seed.

The intensity may be improved by using combinations of various types of rings or by combining the rollers with other tillage implements (e.g. harrows). The trailer and mounted rollers can easily be handled by one man. Only very short preparation times are needed. The driver does not require special skills for operating the roller but choosing the correct type and the correct time to use it is very important.

#### 4.5.6 Technical Data

Working width	one-unit type	up to 4.5 m
	more units	up to 9 m
Number of elements	smooth rollers	1-2 /m
	corrugated rollers	8-20 /m
	packers	5-10 /m
Diameter	smooth rollers	300-1500 mm
	corrugated rollers	350-650 mm
	packers	700-1100 mm
Average pressure on the surface	smooth rollers	1.00-5.30 kN/m
	(grassland rollers	up to 30.00 kN/m)
	corrugated rollers	1.00-5.00 kN/m
	packers	2.50-5.00 kN/m
Travel speed		up to 10 km/h

#### 4.5.7 Literature

See literature for chapter 4.0.

Renaud, J., 1981. Rouleaux et herses roulantes. Motorisation et Technique Agricole, 30: 5-13.

Werner, K., 1982. Rotary wire cage cultivator improves weed control. American Vegetable Grower, 30(4): 85,86.

4.6 The Weeder

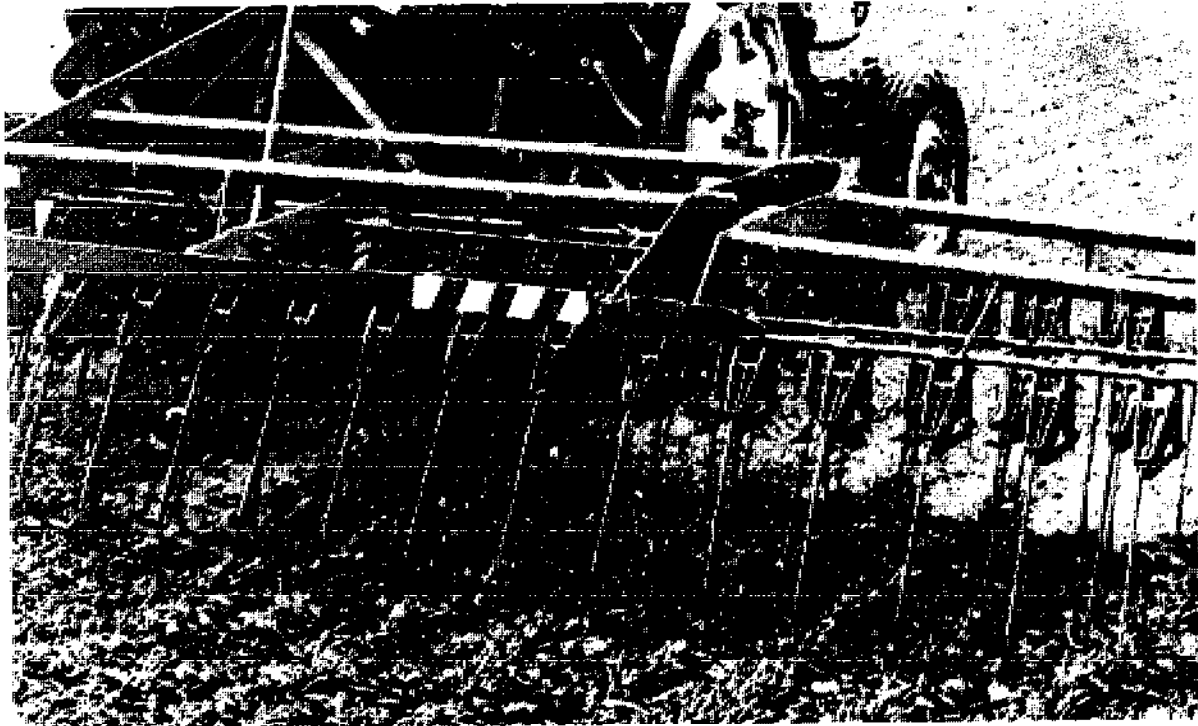

As its name indicates, this implement is used essentially for weeding. Two quite distinct types of implements can be classified as weeders: the spring-toothed weeder (Fig. 95) and the spiked-chain harrow (Fig. 96).

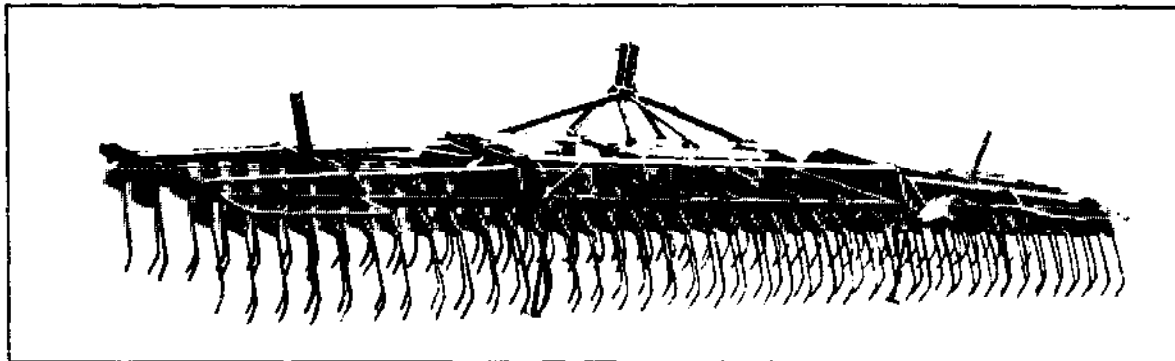

Fig. 95. Spring-toothed weeder.

#### 4.6.1 Use And Assessment

The weeder is used for:

- mechanical weed control,
- loosening and roughening the surface layer of crusted soils,
- crumbling the soil,
- aerating the soil,
- working in seeds and chemicals,
- spreading manure (fertilizer).

The weeders are suitable for use in the tropics and subtropics if correctly operated.

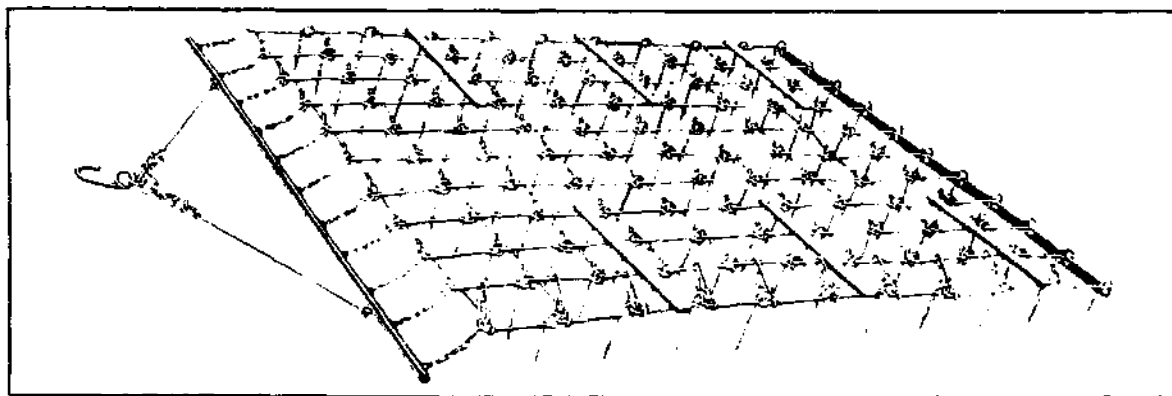

Fig. 96. Spiked-chain harrow (net).

Their advantages are:

- suitable for many types of soil,
- simple and inexpensive construction,
- they increase the soil's infiltration capacity,
- coarse crumbling of the soil,
- high travel speed,
- can be used as levellers in root-crops before the plants emerge and as harrows after emergence,
- can be used in bed and ridge systems.

Their disadvantages are:

- not suitable for heavy soils,
- after repeated use, the soil becomes too fine and risk of erosion increases.

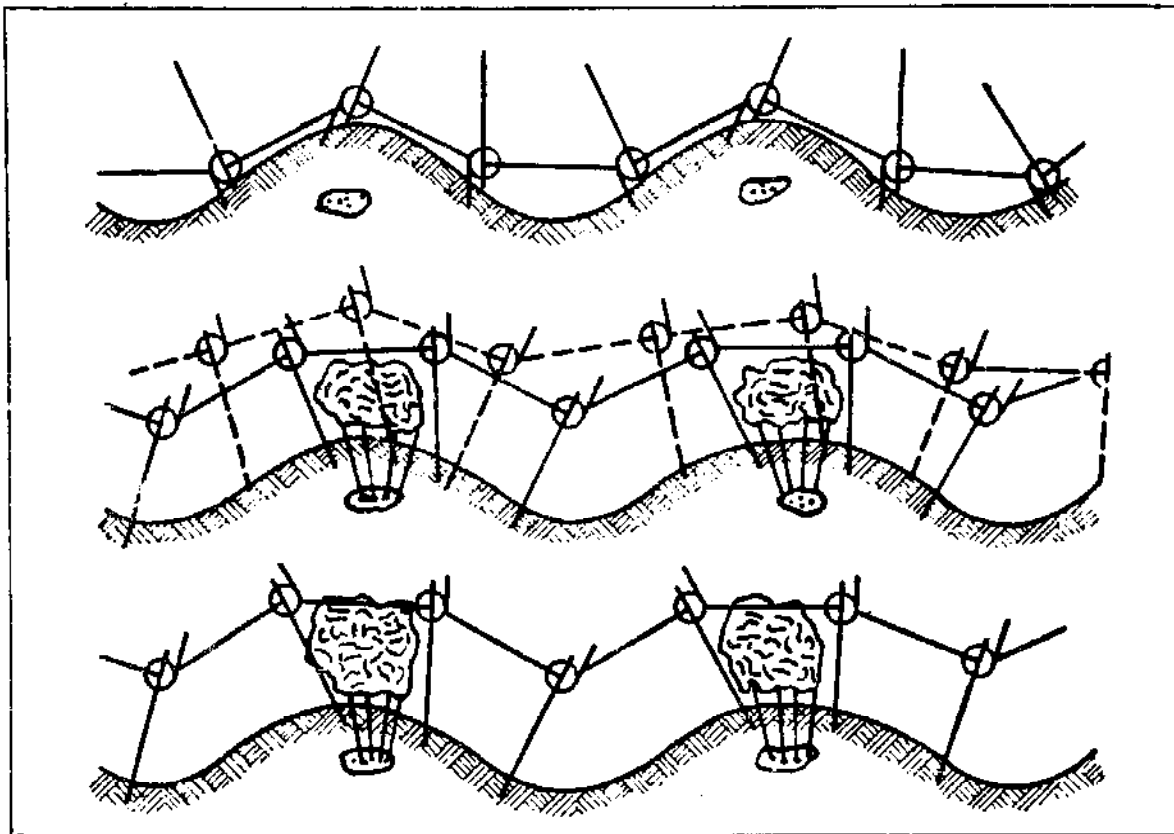

Fig. 97. Spiked-chain harrow operating on ridges.

#### 4.6.2 Functioning

The weeder functions on the "scratch-blow" principle. The tools closely follow the soil's surface relief even in ridge systems. On the spring-toothed weeder this is made possible by separately hinged spring-loaded teeth or tines while on the spiked-chain harrow tools assembled in an articulated mesh perform this function (Fig. 97). This also produces a uniform working depth.

The leaves of firmly embedded plants move sideways to allow the tools to pass and only lightly rooted plants are caught and, possibly, torn out. On the other hand, the weeder's tools can independently divert around obstacles. Weeders loosen and crumble the topsoil and may even have a slight levelling and mixing effect.

#### 4.6.3 Linkage And Drive System

The spring-toothed weeder is a mounted implement for the 3-point hitch system: the hitch system is set at a fixed height and no hydraulic control system is needed.

Essentially, the spiked-chain harrow is a trailer implement but nowadays it is usually suspended in a frame and mounted to the 3-point hitch system. It should be mounted in such a way that the spikes reach a uniform depth and follow their own individual tracks. For these implements the tractor's lifting capacity should be more or less twice their weight. Some 3-7 kW/per metre of width is required for these operations.

#### 4.6.4 Description Of The Implement And Tools

As mentioned above, two different designs can be distinguished - the spiked-chain harrow (a) and the spring-toothed weeder (b).

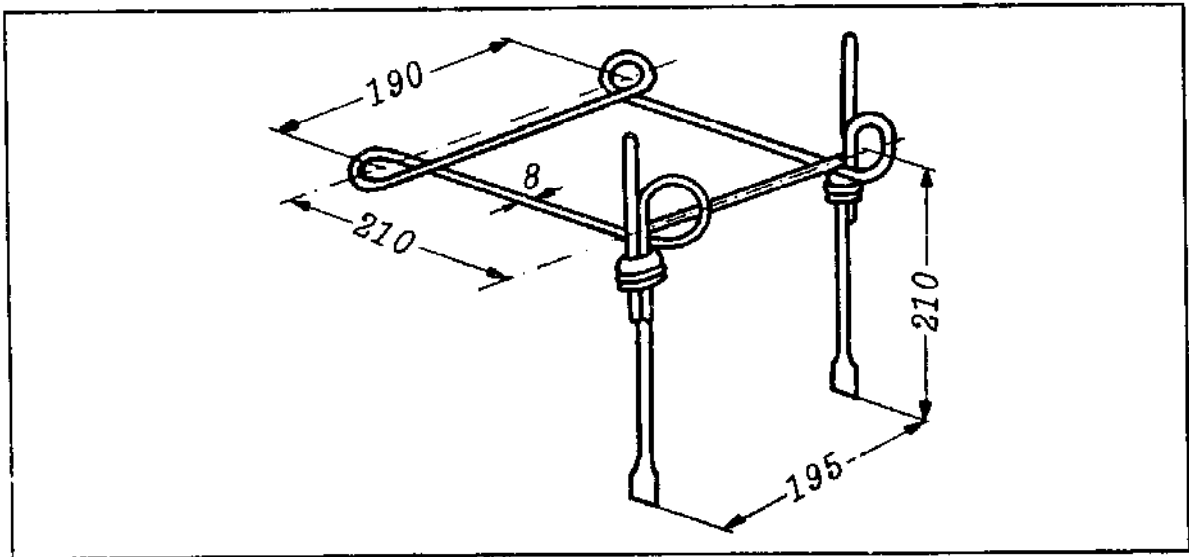

Fig. 98. Link with tines of a spiked-chain harrow.

(a) The links of the spiked-chain harrow form a mesh without a frame. Each link is made of bent steel wire in various shapes (an example is given in Fig. 98). The horizontal parts of each link determine both the forwards and sideways spacing. The links are attached to each other by the eyes in their corners. Two tines are fitted to each link perpendicularly to the surface of the mesh (and thus to the soil); short tines are placed on one side and longer ones on the other. The tines penetrate the soil under the pressure of the total weight.

The shape of the tools (tines, spikes, see Fig. 99) chosen with respect to the condition of the soil's surface rather than to the type of soil. The harrows may be used upright or on their backs with the short tines pointing towards the surface of the soil.

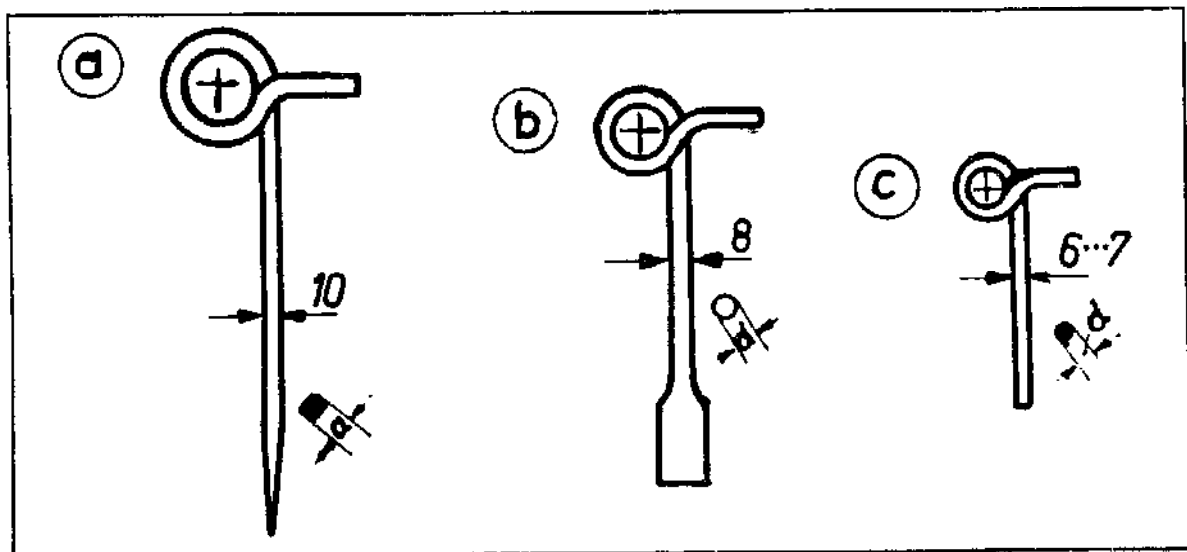

Fig. 99. Spikes of a chain harrow.



(b) The teeth (made from spring steel) of the spring-toothed weeder are mounted on the frame so that they point downwards and backwards (see Fig. 95).

The teeth have a circular or square cross-section and are straight or curved about 10 cm above the point. The tines are mounted by an adjustable tipping device so that the pressure on the teeth can be changed (Fig. 100). Individual tines or groups of tines may be folded back and not used for tillage in rows or ridges. The frame may be folded to transport width. Quick-coupling devices for the 3-point hitch may be used.

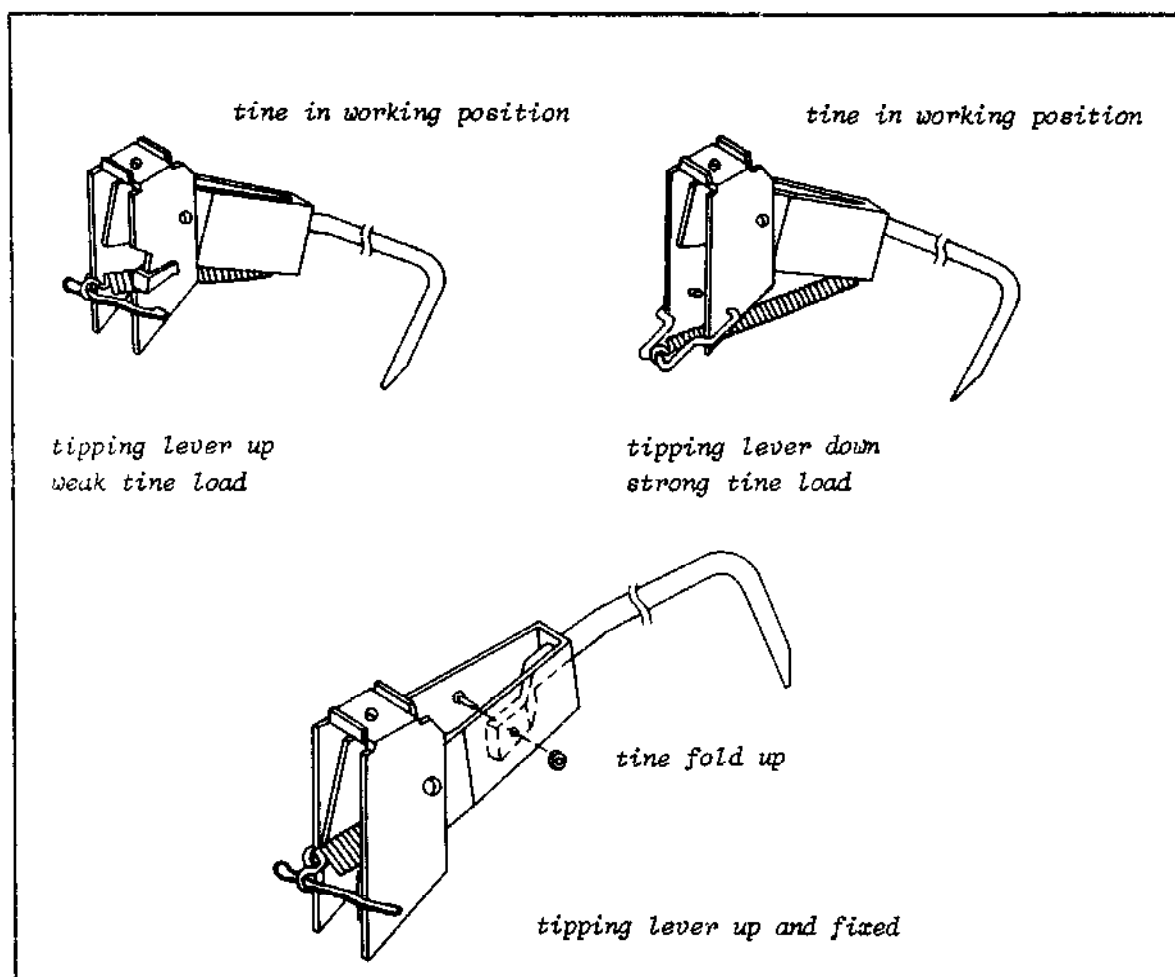

Fig. 100. Tipping device of a spring-toothed weeder in different positions.

#### 4.6.5 Adjustments, Operation

##### 4.6.5.1 Working Depth -

(a) Spiked-chain harrow: the working depth may be changed by the speed, the height of the hitch point, the load on the supporting frame or by turning the harrow on its back (short tines downwards).

(b) Spring-toothed weeder: the depth is adjusted by the speed, by changing the height of the tractor's 3-point hitch system and by altering the pressure on the tines by means of tension springs or a tipping device. The distance between the teeth clearly influences the working depth.

#### 4.6.5.2 Tillage Intensity -

The fineness of the tilth formed by the weeders can be changed by altering the speed, the number of teeth and the distance between them, as follows:

- slow speed: less weed control, coarse soil surface;
- minimum number of widely-spaced teeth: less weed control, coarse soil surface,
- high speed (up to 12 km/h) and maximum number of teeth: fine crumbling and mixing, maximum weed control.

#### 4.6.5.3 Operation -

The operator needs no special skills. The implement can be mounted and used by one person. The exception is when the spring-toothed weeder is used in row crops, in which case the driver must steer precisely between the rows.

#### 4.6.6 Technical Data

	spiked-chain harrow	spring-toothed weeder
Width	up to 4 m	up to 6.5 m
Number of tines	77-110	68-156
Length of tines	12-17.5 cm	approx. 30 cm
Furrow distance	2-4.5 cm	approx. 4 cm
Adjustable pressure on the tines	-	20-40 N
Weight	30-75 kg/m. of width	200-460 kg/m.
Capacity	up to 5 ha/h	up to 7 ha/h
Power requirement per m width	approx. 4 kW	approx. 7 kW

#### 4.6.7 Literature

See literature for chapter 4.0.

## 4.7 The Ridger

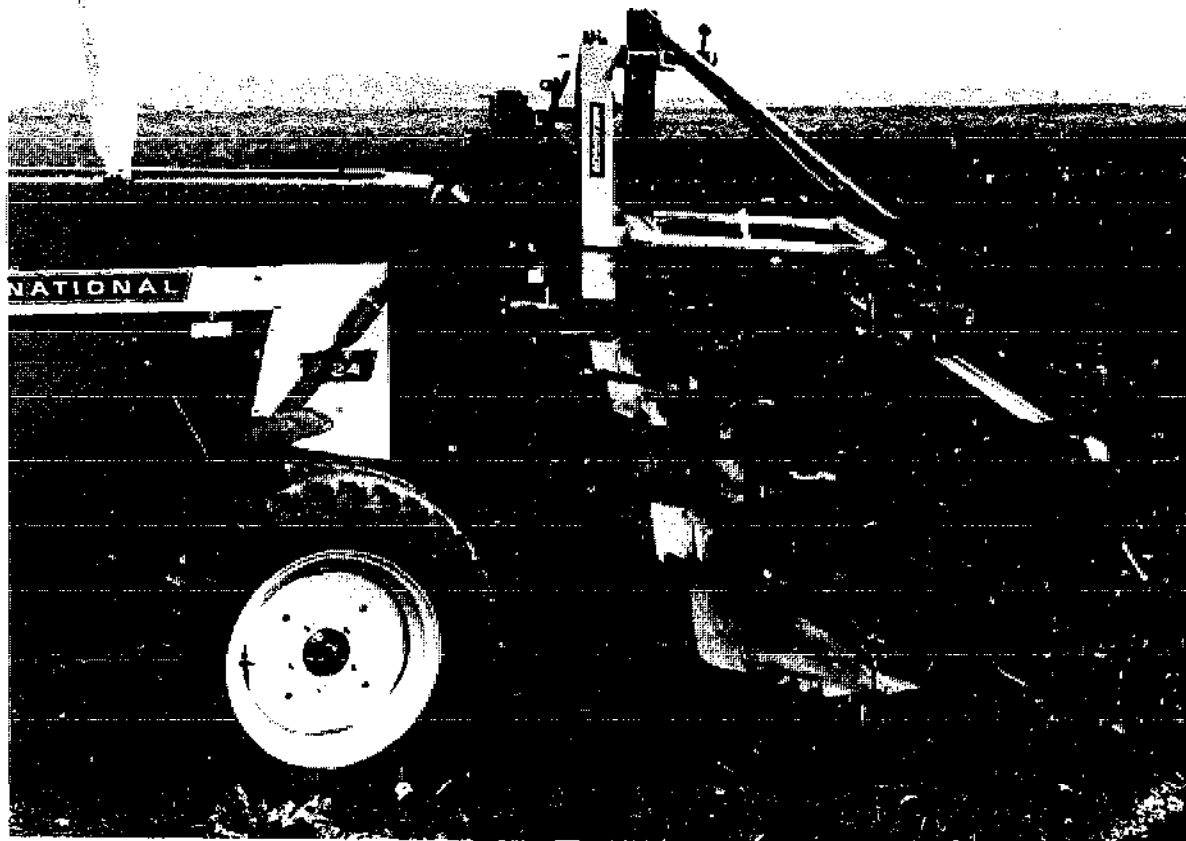

#### 4.7.1 Use And Assessment

Ridgers (Fig. 101) are used for:

- building ridges,
- covering seed, tubers,
- rebuilding ridges,
- constructing ridges and furrows for surface irrigation.

Ridgers are used extensively in the tropics and subtropics because numerous crops, such as cotton, maize, sorghum, potatoes and sugar-cane are grown mainly on ridges. A ridge system is also a logical part of a furrow irrigation system. The mouldboard and disc ridgers will be examined in detail in Chapter 5.2 in the description of special machinery for irrigated crop production. The mouldboard ridger which is widely used in the crop production systems of humid climates will be discussed in this section.

The advantages of ridgers are:

- they can be used as single or multiple-row units,
- suitable for animal and motorized traction,
- they can be used in combination with other implements,
- the toolbar for ridging bodies may be used for other tools (weed control in row crops).

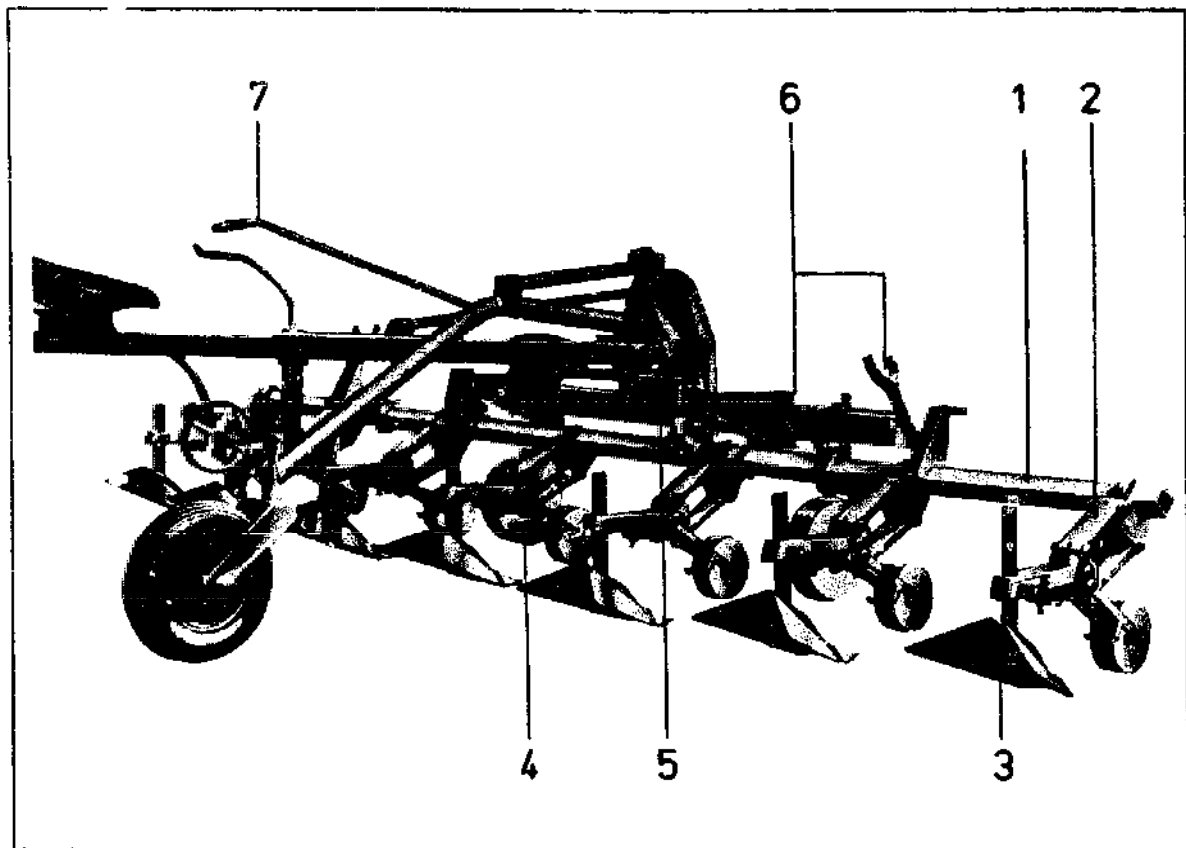

Fig. 101. Ridger:

- |                            |   |
|----------------------------|---|
| 1. Toolbar,                | 5. Hydraulic cylinder for lateral shift of toolbar,     |
| 2. Parallelogram mounting, | 6. Hinge and support for folding to transport position, |
| 3. Ridging bodies,         | 7. Auxilliary steering lever.                           |
| 4. Support wheel,          |   |

The disadvantages of ridgers are:

- compaction of the surface (smearing effect),
- a special guiding system is needed (parallelogram, single or four-hinged mountings) on undulating fields,
- additional steering to compensate for slopes is needed when working on contours,
- difficulties on stony hard soils or soils containing roots.

### Tied ridging

A special type of surface configuration is the tied-ridging system whereby the ridges are "tied" to each other at regular intervals by cross-dams, thus blocking the furrow. The system can be used when surface run-off has to be prevented. The run-off may be caused either by natural rainfall or by high intensity sprinkler irrigation systems.

Various types of implements are available:

- The basic concept is a shovel dragged over the bottom of the furrow, collecting soil; a cross-dam is formed by lifting the shovel.
- Large multiple-furrow implements using a four-blade rotor which is dragged along in a blocked position; a cross-dam is formed when it is allowed to rotate over 90 degrees by operating an hydraulic release system.
- Simpler units (also suitable for animal traction) operate a shovel attached to a frame which jumps at regular intervals as a result of the action of a triangular or off-centre support wheel.

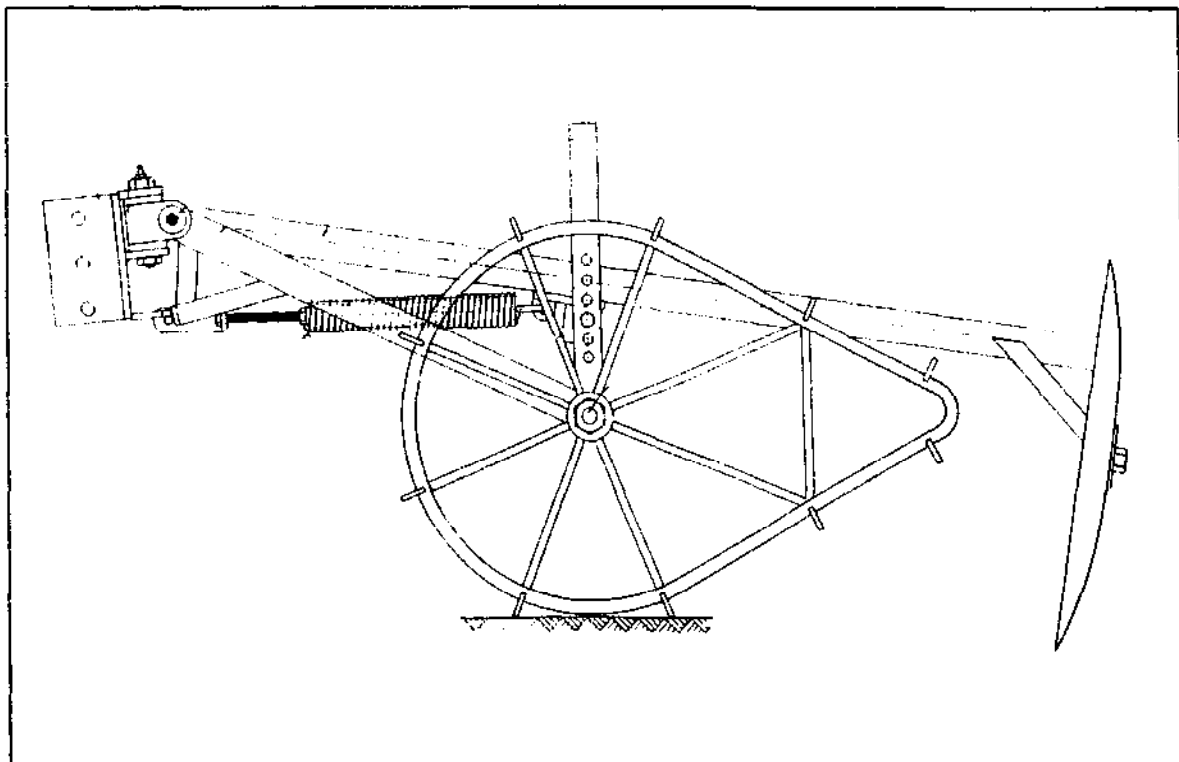

Fig. 102. Tied-ridging unit.

With these systems provision must be made for ploughing out the cross-dams in subsequent operations by using mouldboard ridging bodies mounted in front of the tractor's front wheels.

#### 4.7.2 Functioning

The share or shovel of the ridging body penetrates the soil in keeping with the angle of attack and the depth control setting. The soil is lifted and transported evenly along the breast and wings onto the shoulders or top of the ridge. The required shape of the ridging body is determined by the type and condition of the soil, the desired shape of the ridge and the potential travel speed.

#### 4.7.3 Linkage

Ridgers are usually designed for 3-point hitch linkage and consist of a frame (toolbar) bearing a number of ridging bodies. The depth is controlled by support wheels fitted to the toolbar or to each individual body. The steering system may be added for extra guidance.

Implements with more than one unit may be built with a supporting frame and wheels.

In addition to these two rear-mounting systems the toolbar with the bodies may also be mounted between the front and rear axles. This type is preferable because it provides good visibility and assists the steering (working on contours) although the available space is limited.

A system with the toolbar mounted in front of the tractor may be used for combined weeding and re-ridging operations. Front-mounted bodies are also used for tied ridging systems to smooth the furrow for the tractor-wheels.

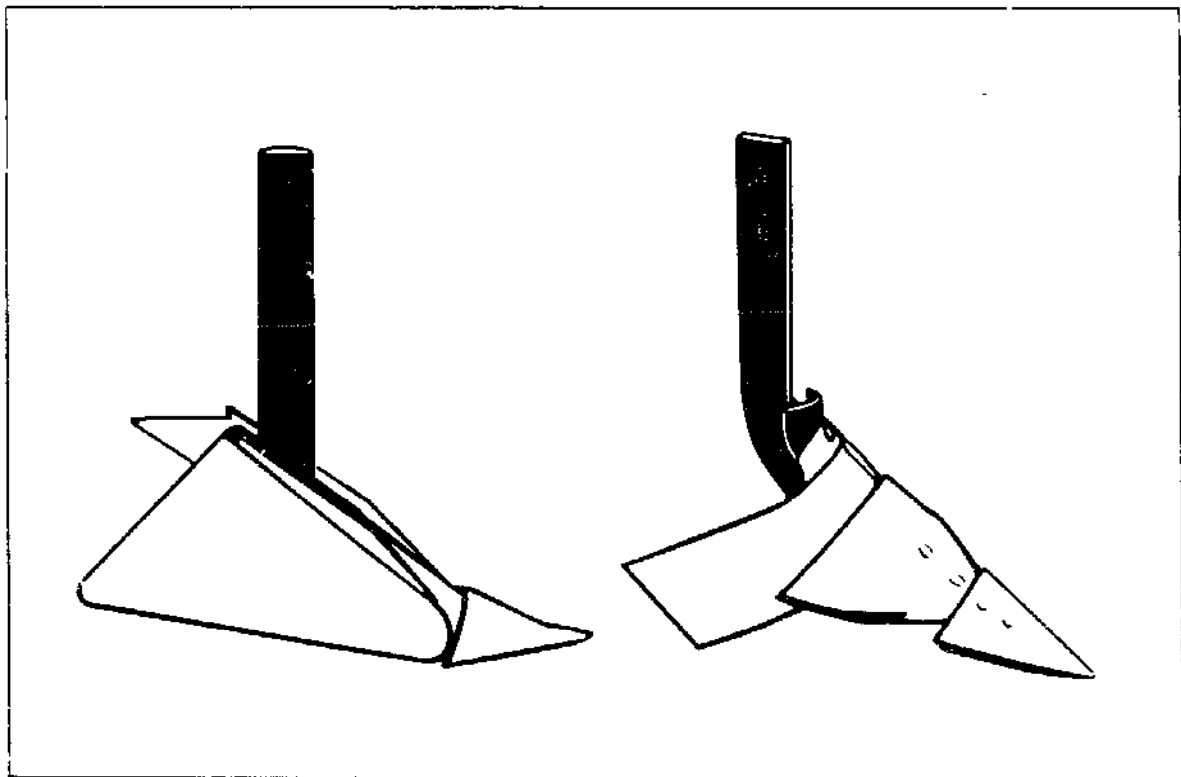

*Fig. 103. Ridging bodies: Left: standard body, right: high speed body.*

#### 4.7.4 Description Of The Implement And Tools

Two types of ridgers (Fig. 101) are available:

- a) with toolbar construction
- b) mounted between the tractor's axles

They can also be sub-divided in keeping with the shape of the ridging bodies (Fig. 103):

- a) bodies for speeds up to 6 km/h
- b) bodies for higher speeds

The implement itself consists of a toolbar (except on models with only one body) placed perpendicularly to the direction of travel. The ridging bodies whose width and height are adjustable are mounted on this toolbar. For precise steering the bodies may be guided by a lever and parallelogram system (Fig. 104).

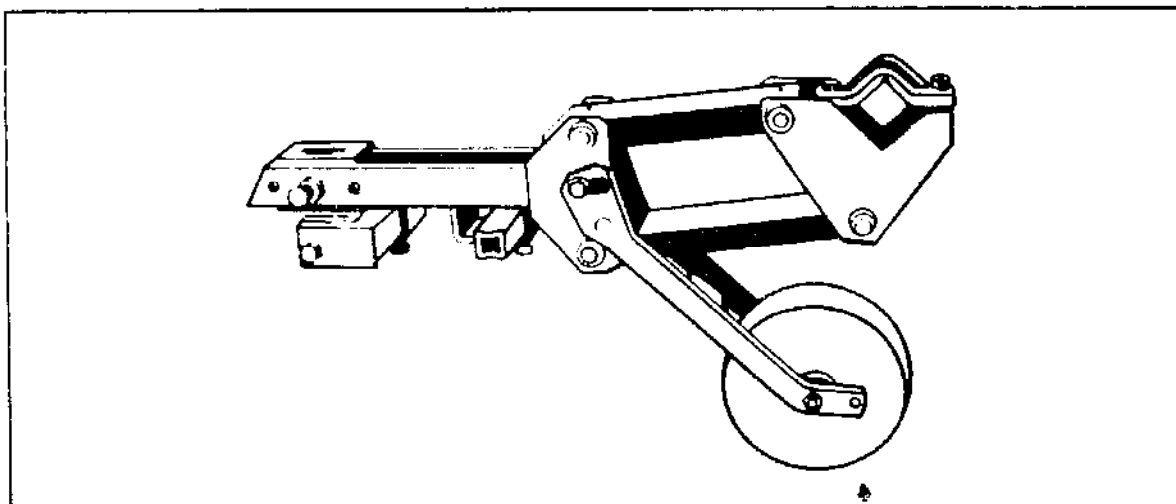

*Fig. 104. Paralellogram mounting for ridgers.*

The ridger is mounted (via the toolbar) either to the (rear) 3-point hitch or to a mounting device between the axles.

The ridging bodies consist of (see Fig. 103):

(a): a shank, (b): a breast, (c): a share or shovel, (d): wings.

Some designs allow the wings and/or shank to be adjusted (Fig. 105).

#### 4.7.5 Adjustments, Operation

**4.7.5.1 Working Depth** - The shape and size of the required ridge determine the working depth. The shape and tilt angle of the ridging share are important in this respect, as is the depth setting fixed by means of support wheels or guide wheels on each body.

4.7.5.2 Working Width - The effective width of each body depends upon the construction. Bodies are designed for a specific width (or range of widths). Some bodies have an adjustable width (Fig. 105) but this feature is not often used. The implement's total width is determined by the length of the toolbar which may be up to 9 m.

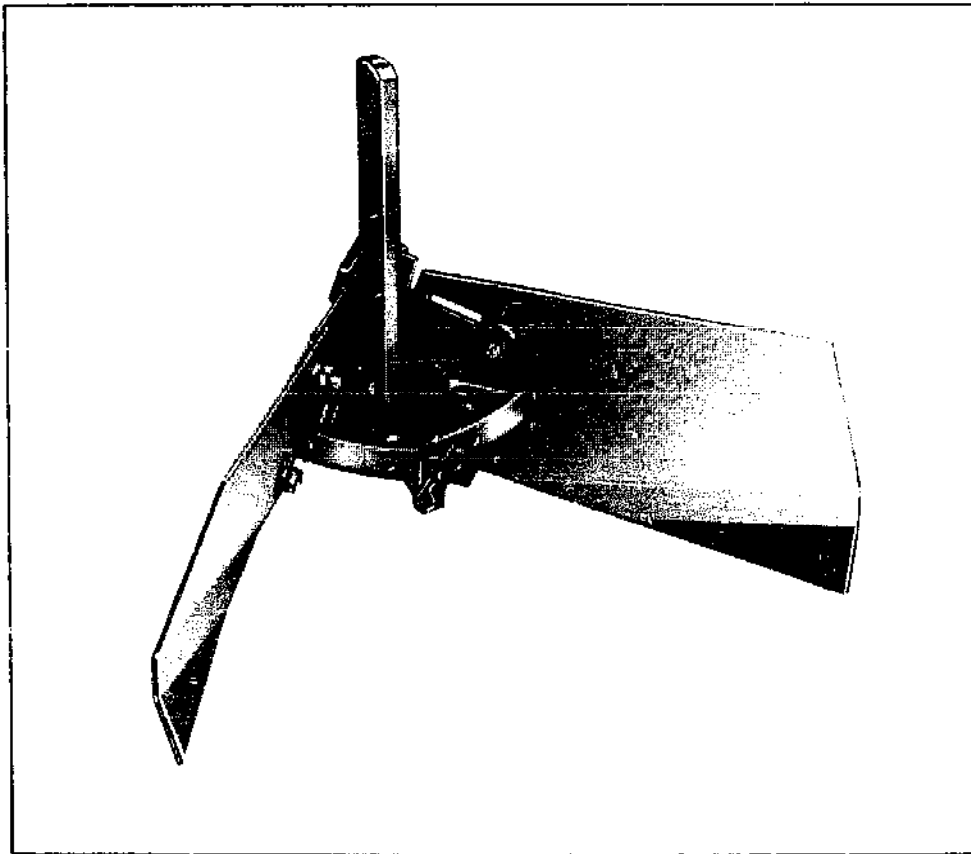

*Fig. 105. Adjustable ridging body.*

4.7.5.3 Tillage Intensity - The manner in which the soil is distributed depends upon the speed and angle of the body. The shape of the ridge is an important factor. The slope of the ridge's shoulder should not exceed 40 degrees; if it does, fine soil material may fall back into the furrow.

4.7.5.4 Operation - Mounting the implement is simple but some skill is required for adjusting and steering it.



#### 4.7.6 Technical Data

Working width	row distance per body	up to 1 m
	total width	up to 9 m
Working depth		up to 28 cm
Power required		approx. 10 kW per body
Speed	standard bodies	4-6 km/h
	high-speed bodies	6-10 km/h
Angles	of the share	30-40 degrees
	of the wings	30-50 degrees

#### 4.7.7 Literature

See literature for chapter 4.0.

FAO, 1966. Equipment and methods for tied ridging. FAO Informal Working Bulletin No. 28, pp. 40.

Kolstad, O.C., R.T. Schuler and G.W. Randall, 1981. Ridge forming tools for reduced tillage. ASAE Paper, No. 81-1018, pp. 20.

Kouwenhoven, J.K., 1979. Ridging for potatoes. Proceedings of the 8th conference of ISTR0, Hohenheim, Fed. Rep. of Germany: 277-283.

Lyle, W.M. and D.R. Dixon, 1977. Basin tillage for rainfall retention. Transactions of the ASAE, 20(6): 1013-1017,1021.

Lyons, T. and A.N. Bhattarai, 1981. The Nepal ridger. Publ. CIMMYT, Mexico, pp. 7.

NN, 1979. Furrow diking for "basin tillage". World Farming, July 1979: 48-49.

Ogborn, J.E., 1980. Straddle ridge cultivation and equipment for the heavy lands of the African Savanna. Proceedings of the Appropriate Tillage Workshop, IAR, Zaria, Nigeria. Commonwealth Secretariat, London, U.K.: 49-57.

Stokes, A.R., 1973. Ox-drawn tie-ridger / weeder implement. ITDG Group, London, pp. 3.

Terpstra, R. and J.K. Kouwenhoven, 1981. Inter-row and intra-row weed control with a hoe-ridger. Journal of Agricultural Engineering Research, 26(2): 127-134.

## 5.0 SPECIAL IMPLEMENTS FOR IRRIGATED AGRICULTURE



With the traditional method of irrigated agriculture the special surface configuration of the field regulates the manner in which the water is distributed so that the soil becomes an integral part of the irrigation system. The shape, gradient and topography of the fields are determined by that system. Careful and intensive tillage is necessary to obtain the proportionally higher yields required to justify the high financial investment in an irrigation system. The transport and distribution of water and its infiltration, storage and release to the plant demand a high standard of soil (field) preparation and tillage.

In the case of surface irrigation the soil surface should be level so that the water is uniformly distributed over the entire area, thus avoiding waterlogging on lower sites or water deficits on higher sites. Some (slight) gradient should also be maintained if the field is to be evenly wetted. To achieve efficient water distribution the size of the fields must be reduced as the standard of field preparation drops. A level field surface should be the objective even during the primary tillage activities (e.g. by using a reversible rather than a one-way plough).

The range of implements discussed in the previous chapters does not include the various items for tillage operations in irrigated agriculture. Specific implements are needed for special jobs, such as the levelling and creation of ridges and furrows. Most of the well-known implements have been developed for the large irrigation schemes in California, Australia or South Africa while traditional irrigated crop production in the tropical and subtropical developing countries still uses mainly manual and animal labour. The introduction of tractors on these traditional small holdings (usually about 1 ha) will not only cause serious difficulties but will also mean that suitable machine systems will have to be adapted or developed. The field accessibility, trafficability and workability are particular problems in irrigated agriculture.

Some special operations performed as part of the tillage in irrigated agriculture are:

- levelling the surface,
- building (border) dams along the slope (following the direction of the water movement) to direct the water flow to borders and strips,
- the construction of (cross-check) dams to improve the uniform distribution of the water,
- shaping the cross-section and surface of the ridges,
- the construction of small ridges for corrugation irrigation (again following the direction of the water movement).

Many soils in the climatic zones where irrigated agriculture is carried on tend to form crusts which must be destroyed after each water gift.

#### 5.0.1 Literature

See literature for chapters 1 and 6.

Buxton, D.R. and J.C. Zalewski, 1983. Tillage and cultural management of irrigated potatoes. *Agronomy Journal*, 75(2): 219-225.

FAO, 1977. Mechanization of irrigated crop production. *FAO Agricultural Services Bulletin No. 28*, FAO Rome, pp. 404.

NN (Various authors), 1982. Mechanization of irrigation farming in semi-arid areas. *Proceedings of an International Symposium at the 56th DLG Exhibition. Band 173*, DLG Verlag, Frankfurt, pp. 238.

## 5.1 The Landplane, Leveller

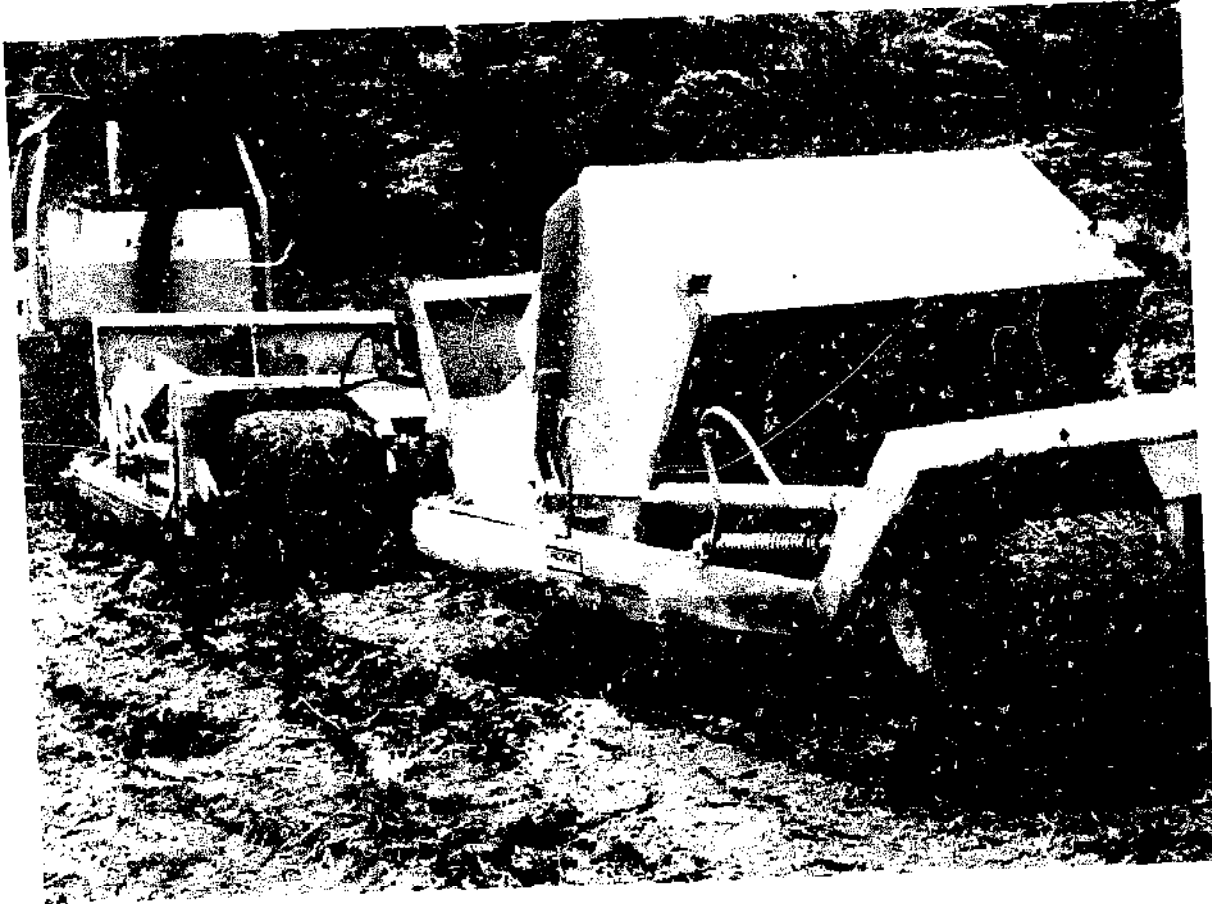

### 5.1.1 Use And Assessment

The landplane and leveller are used for:

- moving the soil, levelling the surface,
- water management and distribution,
- reducing evaporation,
- protecting against soil erosion,
- terracing,
- road building.

The landplane (Fig. 106) and leveller are essential implements for preparing fields for surface irrigation.

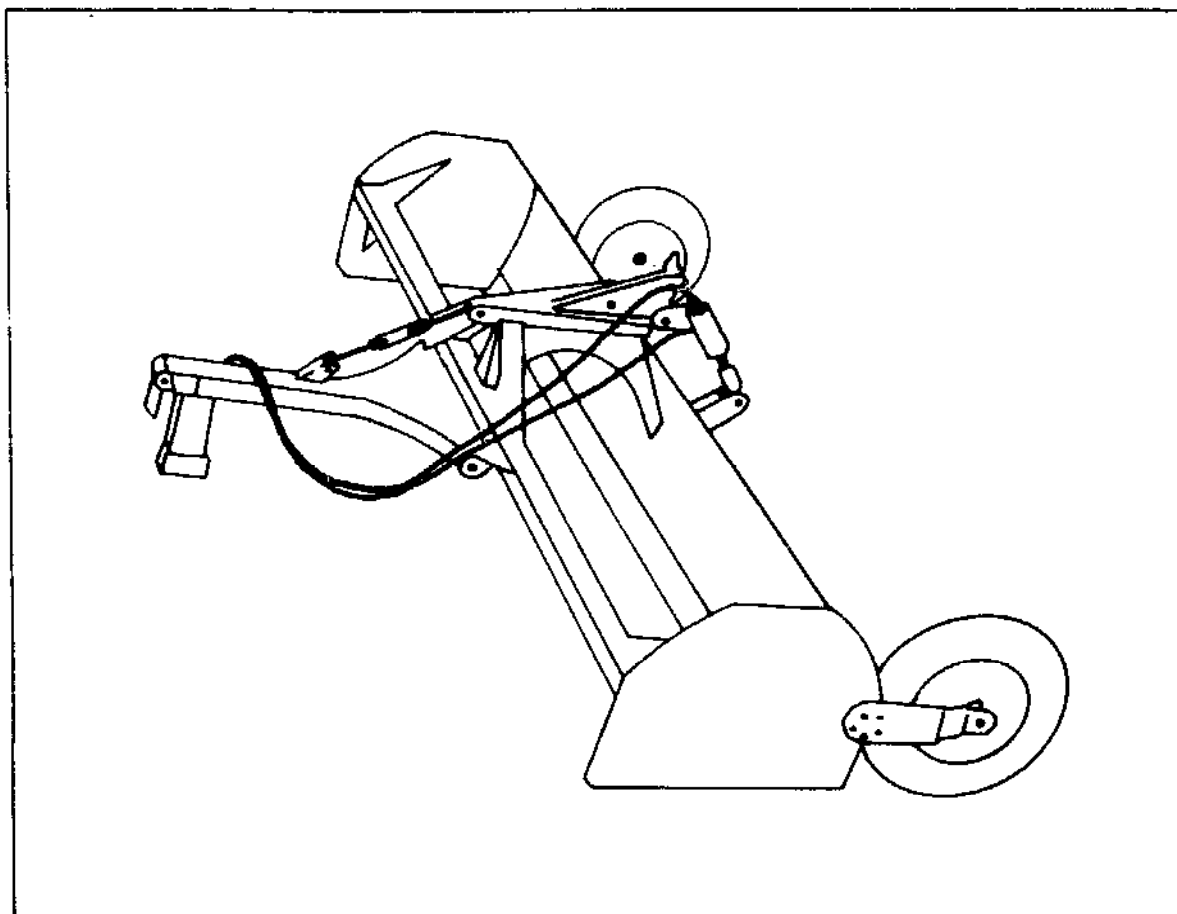

*Fig. 106. Landplane or leveller.*

### 5.1.2 Functioning

The blade of the landplane presses on field irregularities in a horizontal direction so that any soil above the blade's cutting edge is moved along the direction of travel. Depending upon the depth setting, between 5 and 40 cm of the soil is taken up and deposited in depressions. The soil should be dry enough to avoid smearing. To achieve the best levelling action the tractor hitchpoint, the blade and the plane's support wheels should be as far apart as possible. On the other hand, landplanes should be easy to manoeuvre in small irrigated fields. A float is dragged behind the plane as an auxiliary implement to smooth any remaining irregularities.

### 5.1.3 Linkage And Drive System

Smaller implements may be (semi-)mounted either in front or to the 3-point hitch system behind the tractor. Larger implements are usually trailed models. The depth is set on the implement itself. Support wheels are absolutely essential. The power required is determined by type and condition of the soil, the speed, working width, fixed working depth and the configuration of the surface. It ranges from 15 to 50 kW per metre of working width.

### 5.1.4 Description Of The Implement And Tools

A large number of different models of land planes are available. Very simple models are made of wood in the form of a float. The large implements which are used mainly on very large farms or cooperatives will not be examined here and this description will be limited to the simple smaller versions used by the farmer himself. The basic frame - constructed from steel - carries a rigid planing blade or bucket with a replaceable edge mounted perpendicularly to the direction of travel. The plane is designed as either a mounted or a trailed implement and is supported by one or more wheels. The depth can be adjusted manually or hydraulically. Landplanes are usually equipped with a smoothen attached to the rear of the plane and used for the final smoothing of the surface.

### 5.1.5 Adjustment, Operation

The working depth is adjusted manually or hydraulically by one or more guide wheels. If the tractor and guide wheels are far apart, not all the tractor's vertical movements are transmitted to the blade. The depth depends upon the volume of soil to be moved and the power available from the tractor. The landplane can easily be mounted by one man; quick-coupling devices may be used. The larger implements are steered from the tractor. Accurate working is necessary. Little maintenance is required and, on the larger implements, is limited to lubrication of the wheels.

### 5.1.6 Technical Data

Working width	1.5-3.0 m
Volume of soil moved	1-2.5 cubic metres
Speed	3-6 km/h
Power required	15-50 kW/m
Total length	up to 12 m

### 5.1.7 Literature

See literature for chapters 5 and 6.

Buras, N. and G. Manor, 1970. Field comparison of land smoothers. Trans. of the ASAE, 13(5): 639-640,643.

**5.2 The Ridger (Furrower)**



Three types of ridgers can be distinguished:

- rigid type (mainly made of wood),
- mouldboard type (lister), as described in Chapter 4.7,
- disc type (disc bedder).

### 5.2.1 Use And Assessment

The ridger (Fig. 107) is one of the most important implements for irrigated farming. It is used principally to build ridges for furrow, strip and border irrigation systems (Fig. 108) but can also carry out the following tillage activities:

- building ridges for bordering plots or for planting on their crests (ridges or beds),
- controlling weeds emerging from the ridges,
- covering manure (fertilizer), herbicides in furrows, rows and on ridges,
- producing a coarse surface in ridge systems to improve aeration and water infiltration,
- building contour (dams) for erosion control,
- digging trenches for irrigation and drainage.

Successful use of ridgers depends first and foremost upon the choice of the correct implement and its accurate adjustment. The lister is often preferred for crop maintenance operations (Figs. 103 and 105). The implement can be adapted to the required ridge shape and the prevailing conditions by using suitable configurations of the bodies (see Fig. 109). The disc ridger is used principally when harvest residue, stones or roots are likely to be encountered. The disc ridger is also preferred for cotton production.



*Fig. 107. Ridging body (mouldboard type) with coulter welded on share. Parallelogram mounting.*



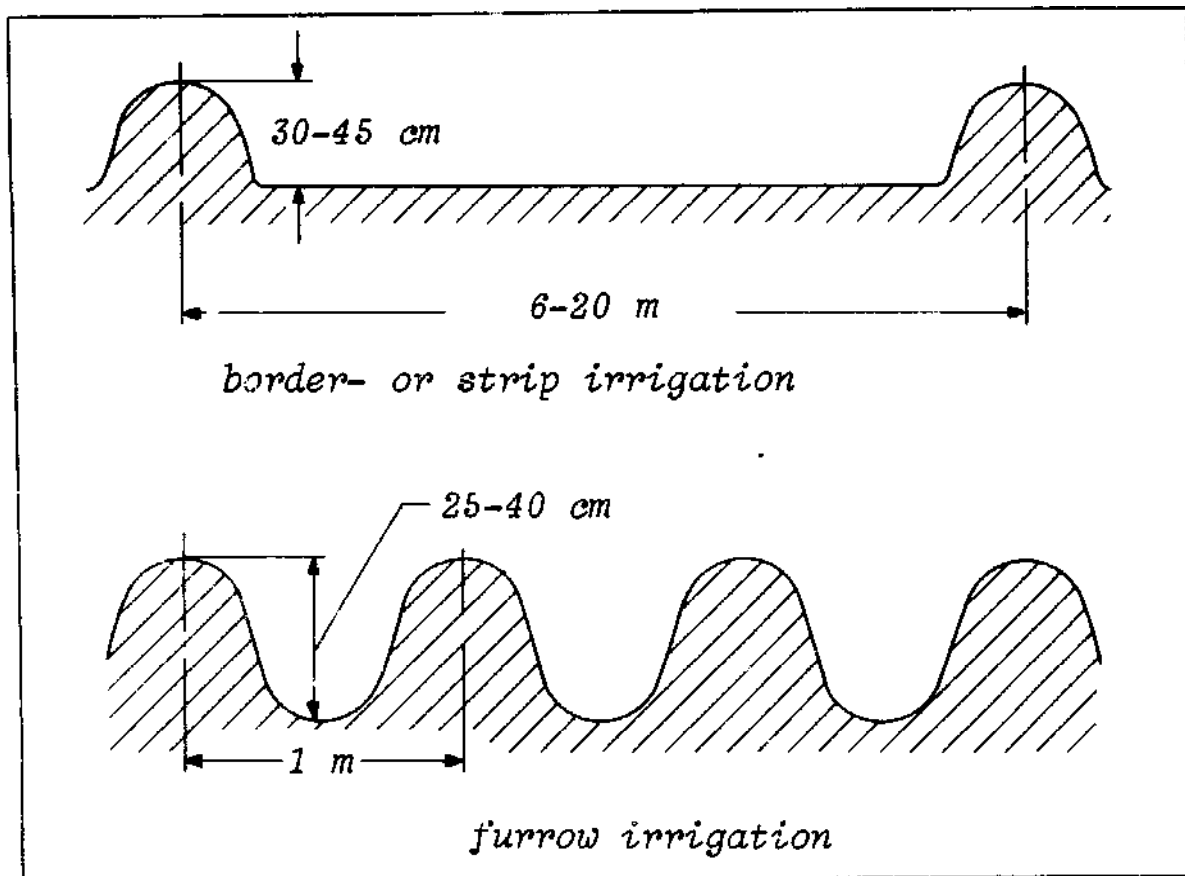

Fig. 108. Ridges (bunds) for strip- or border irrigation (top) and furrow irrigation (bottom).

The disc ridger has advantages when short furrows have to be formed on a steep slope for furrow irrigation. It creates a loose crumbly furrow which reduces the flow velocity and increases the water infiltration rate. On the other hand, listers are recommended for long, slightly sloping fields since they create a clean furrow (faster surface flow, lower infiltration rate). The disc is more effective on the edges and thus causes less damage to small plots.

The disc ridger leaves a narrow depression along the top of the ridges and this may impede harvesting operations (e.g. cotton leaves collect in it). A cut-out disc performs more satisfactorily than a mouldboard (lister) on firm moist soils while ridgers with two or more discs per gang may clog up on moist adhesive soils.

### 5.2.2 Functioning

As on all disced implements, the working parts of a disc ridger are driven by their contact with the soil (Fig. 110). They crumble the soil and so do not produce smooth shoulders on the ridges. Multiple-disc units give a finer topsoil than single disc models which leave a rough furrow. The ridge is relatively level and loose with a high infiltration capacity. Some crops and soils require subsequent compaction - particularly for moisture control - and this is usually performed in a separate pass.

If correctly adjusted, the disc units should be able to tear a heavy weed cover (such as grass) away from the ridge and deposit the sod in the centre of the furrow for subsequent chemical weed control treatment. In the case of contour farming on slopes it is advisable to fit discs with larger diameters on the downslope side of the unit so that more soil can be transported upwards. As regards listers, simple wooden designs with oblique mounted boards or planks give results comparable to the mouldboard types.

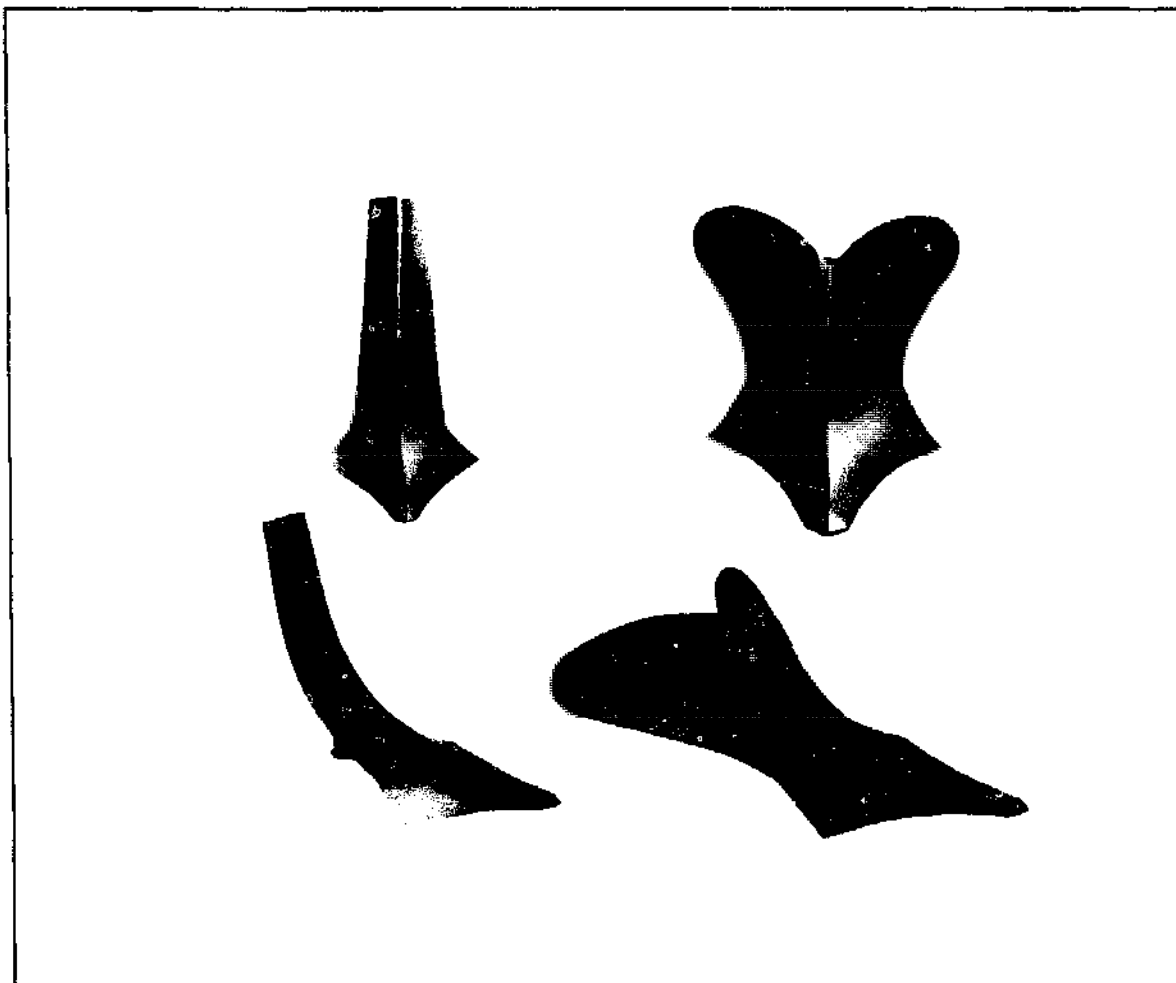
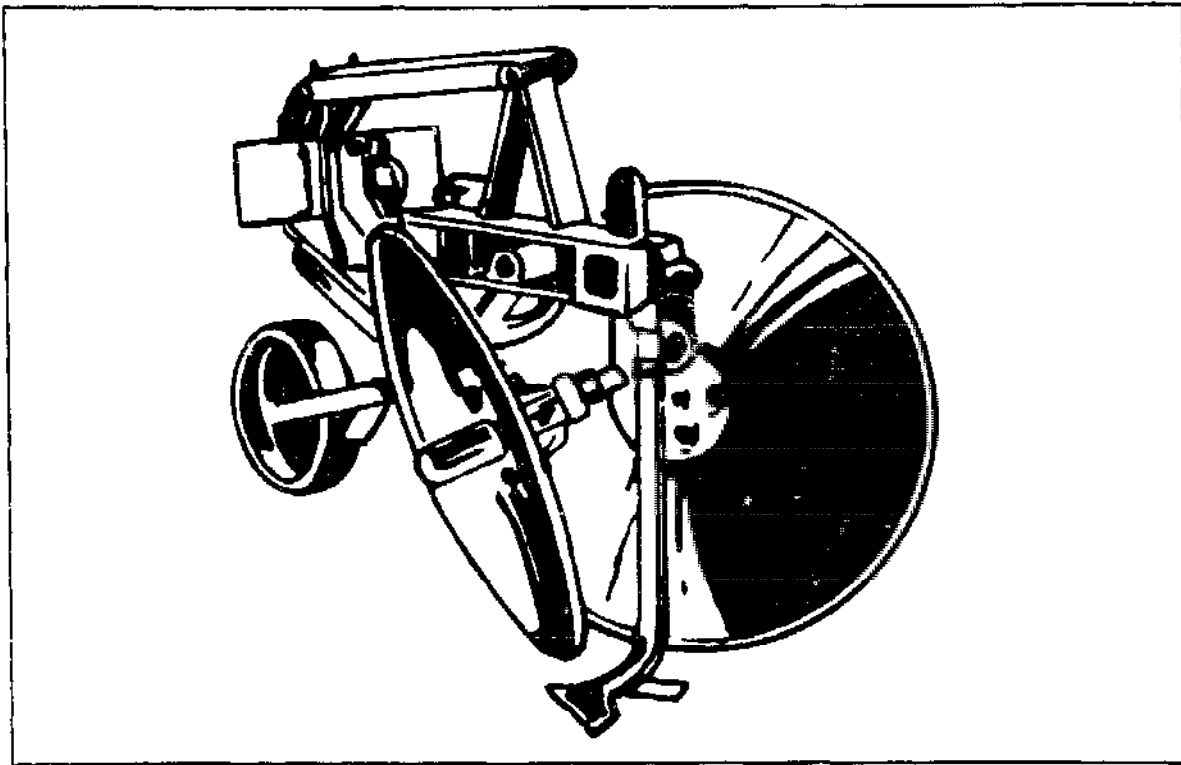

*Fig. 109. Ridging bodies: Left: body for hard, dry soils (in combination with discs), right: universal body.*

### 5.2.3 Linkage And Drive System

Listers and disc ridgers are usually mounted on a toolbar which allows them freedom of movement in a lateral direction. The toolbar is suitable for 3-point hitching. Wooden ridgers are trailed. Disc ridgers are driven by contact with the soil while listers are passive tools drawn through the soil.

The draught required for disc ridgers depends upon the number of discs, design, size, weight, tilt and disc angle, working speed and the type and condition of the soil. The draught required for listers depends upon the geometry and adjustment of the share and wings and on the soil parameters. The traction power required for each body is 5 - 15 kW.



*Fig. 110. Disc ridger with two discs.*

#### 5.2.4 Description Of The Implement And Tools

Ridger bodies and discs are usually mounted to a multi-purpose toolbar. Two opposite discs or disc gangs form a disc ridger unit. A unit may consist of between two and ten discs; a 6-disc unit (Fig. 111), for example, has a left and a right-handed gang of three discs each which are mounted to the toolbar by a support, allowing both horizontal and vertical adjustment. The shaft of each gang is mounted to the rigid unit frame with tapered or roller bearings. The discs attached to the shaft may be fitted with scrapers.

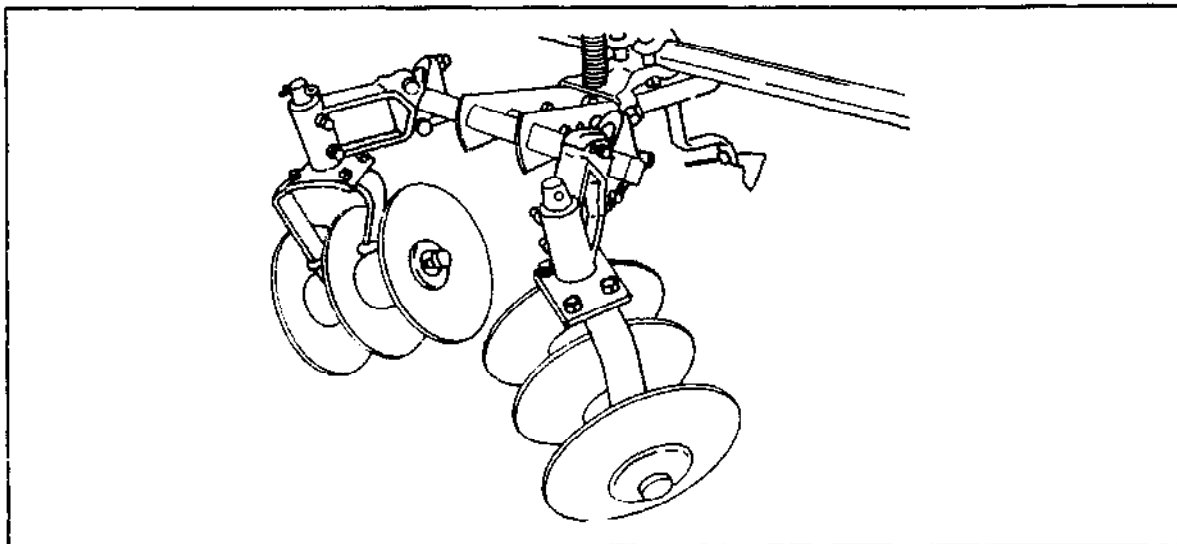

*Fig. 111. Disc ridger with two gangs of three discs each.*

Notched discs are preferred when plant material or hard soils make cutting difficult. When large ridges are to be formed, different sized discs are required with the largest disc running along the bottom of the furrow at the rear of the unit. Ridgers are often combined with other tools or implements, especially chisel tines (Fig. 112) and press wheels and also with manure spreaders and herbicide sprayers.

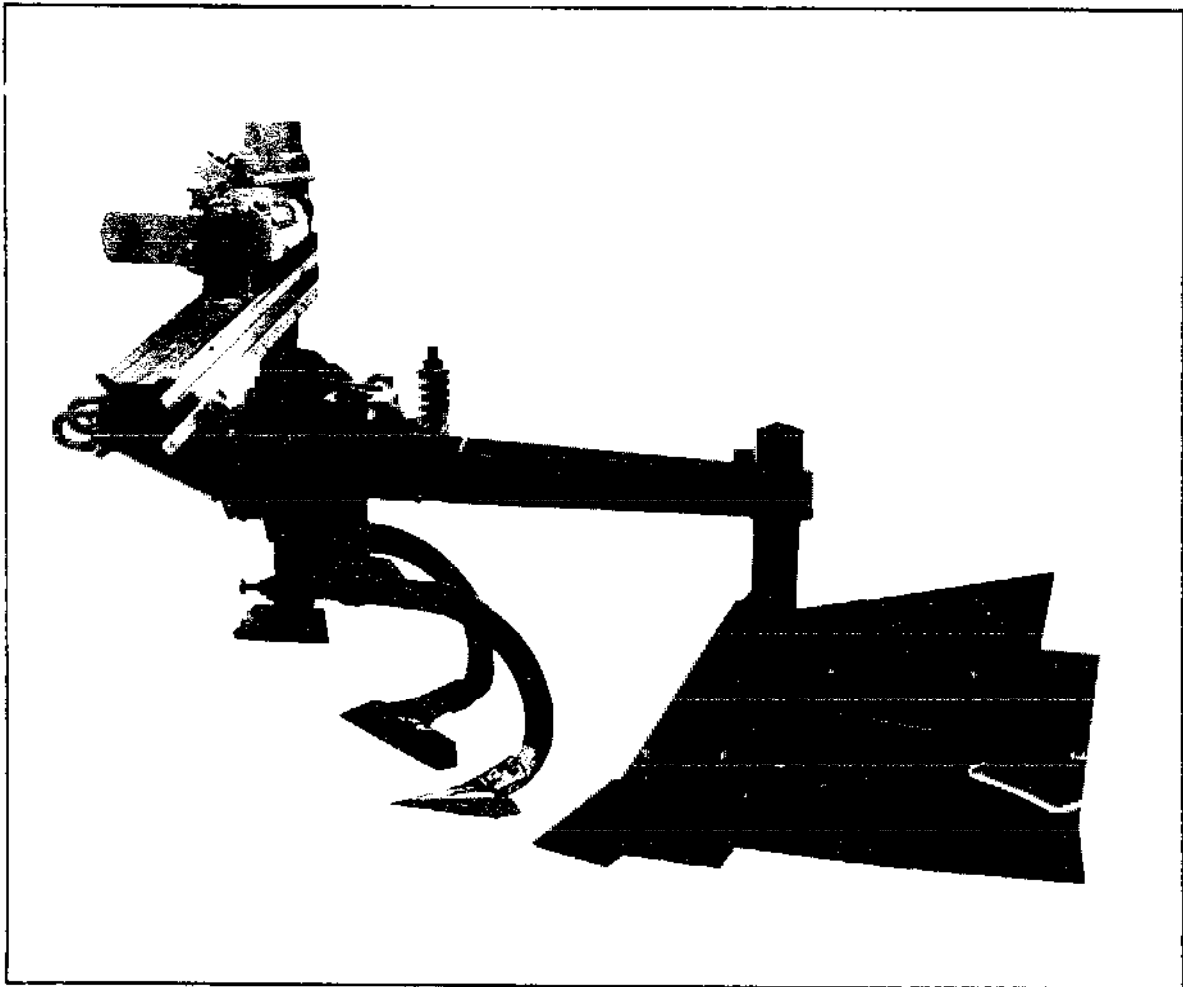

*Fig. 112. Ridging body with duckfoot chisels running ahead.*

#### 5.2.5 Adjustment, Operation

The width of the ridges and the distance between them can be controlled by shifting the tools on the toolbar in a lateral direction. In the case of listers, the height and gradient of the shoulders are determined by the shape of the share and wings and only rarely by setting the angle. The depth can be changed in various ways (e.g. altering the spring load, the height of the toolbar or the support wheels). On disc ridgers the angles can be adjusted in the same way as for disc ploughs. When the disc angle is increased, the disc "grip" is improved so that more soil is moved. The setting of the tilt angle determines the slope of the ridge shoulders. The best working speed is 5 km/h. The height of the ridge increases with the speed (sharper crests). Increased crumbling can be produced by mounting two or three discs in each gang. When the condition of the soil makes penetration difficult, extra weights can be added.

Both types of ridgers are simple to operate. The bearings of the disc ridger shafts should be lubricated. The wear is spread over the entire circumference of the discs and is relatively light.

#### 5.2.6 Technical Data

For listers see chapter 4.7.

Disc ridges:

Discs' external diameter	400-650 mm (900 mm)
Concavity ("depth")	100-200 mm (300 mm)
Thickness	4-6.5 mm (9 mm)
Discs per unit	2-10
Distance between discs	200-300 mm
Disc angle	0-50 deg
Tilt angle	0-45 deg
Weight without extra weights	25-50 kg per disc

#### 5.2.7 Literature

See literature for chapters 4.7 and 5.0.

### 5.3 The Bed Shaper

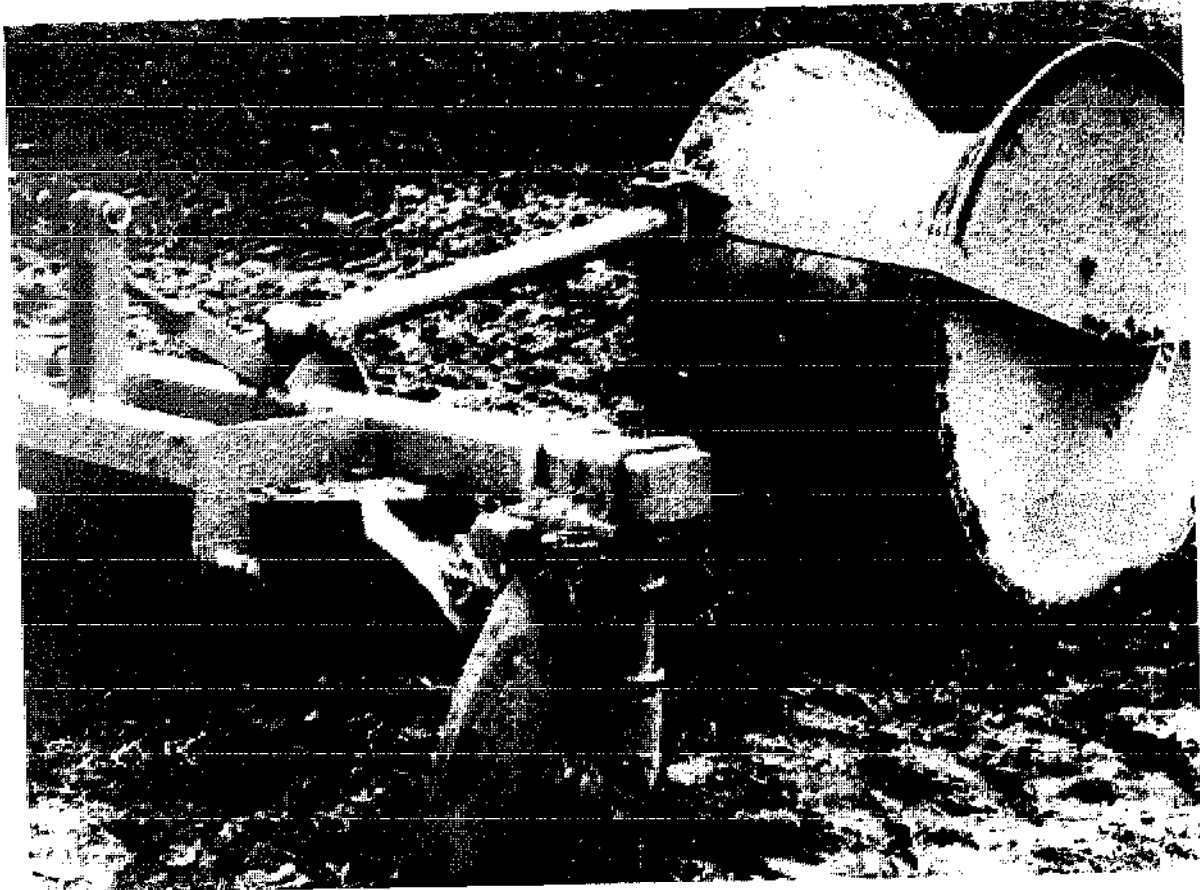

The bed shaper is used for:

- geometric shaping of ridges and beds,
- compacting the soil (surface),
- configuring the soil surface.

The bed shaper is useful for soil and water management, for distributing and conducting water and for stabilizing ridges to protect them against heavy rainfall.

The bed shaper is often used in combination with the ridger or other implements. Since it closes the macropores and the surface, it increases the velocity of the water flow and allows better distribution of the water over the length of the field, particularly after a disc or strip rotary tiller has been used on loose surface soils, when only a short consolidation time is available and on long fields with a slight gradient. Plant-beds for 1, 2, 3 or 4 rows of plants may be formed after stubble tillage or immediately before planting. Salts may accumulate at the crest of a ridge in regions with high evaporation rates. To protect them against salt damage the plants should not be planted in the zones where the highest concentrations of salt can be expected, usually on the sides of the bed (Fig. 113, centre). Another solution is to build a narrow ridge where the salt can accumulate on top of the bed and between two plant rows (Fig. 113 bottom).

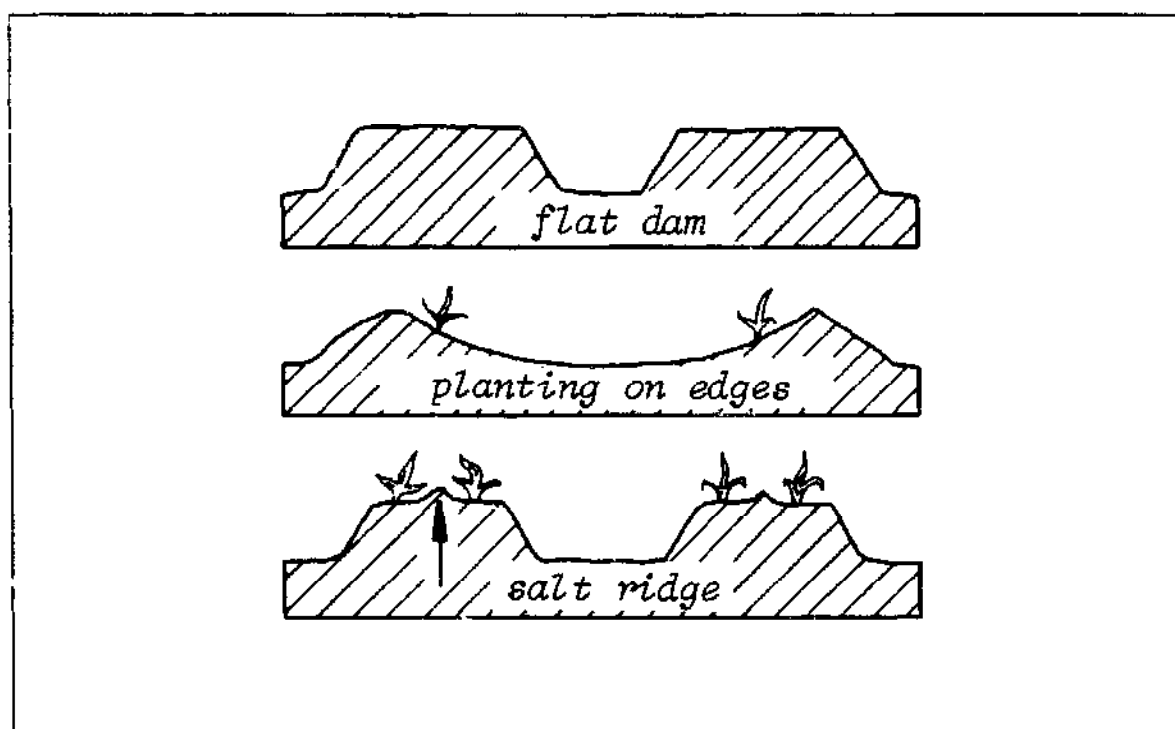

Fig. 113. Bed shapes to protect plants against salt damage.

Various designs and models of ridge and bed shapers are available, ranging from simple and press wheels running between the ridging bodies over the crest of the ridge, to profiled cone-shaped rollers (Fig. 114) and trailed profiled bodies (runners, Fig. 115).

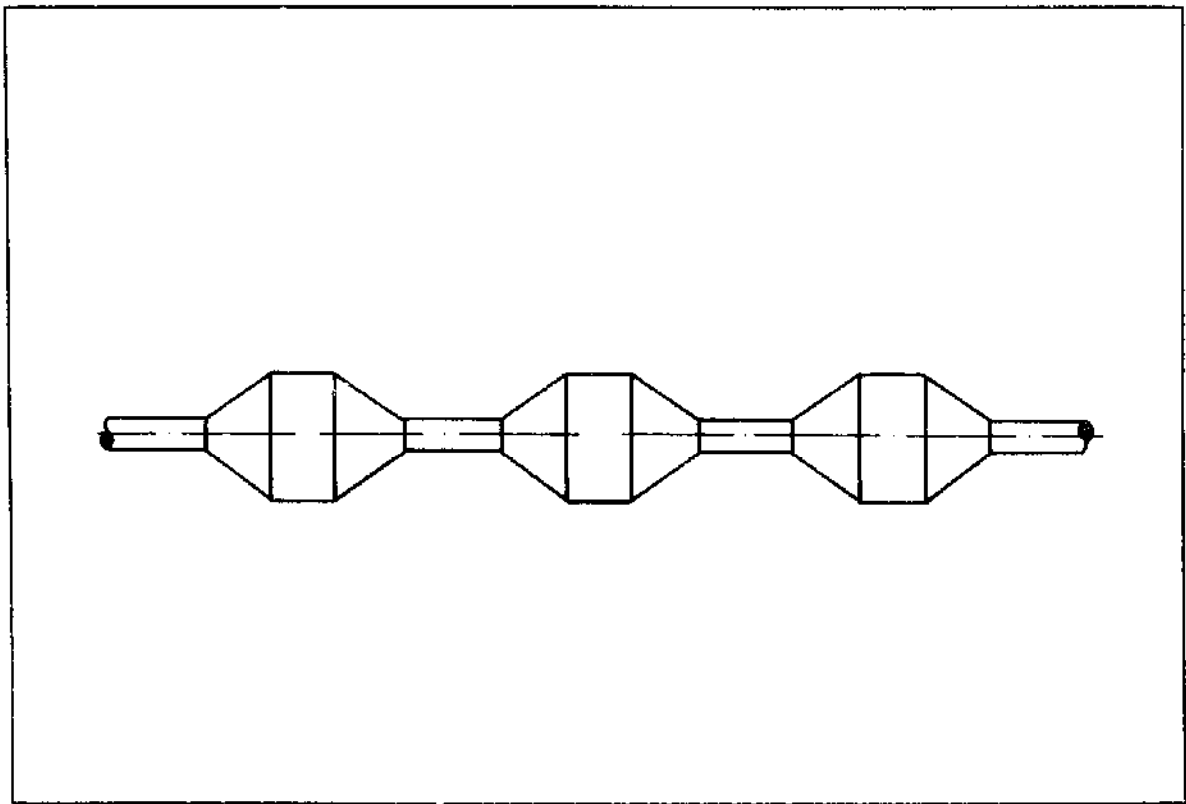

Fig. 114. Bed shaper (profiled roller).

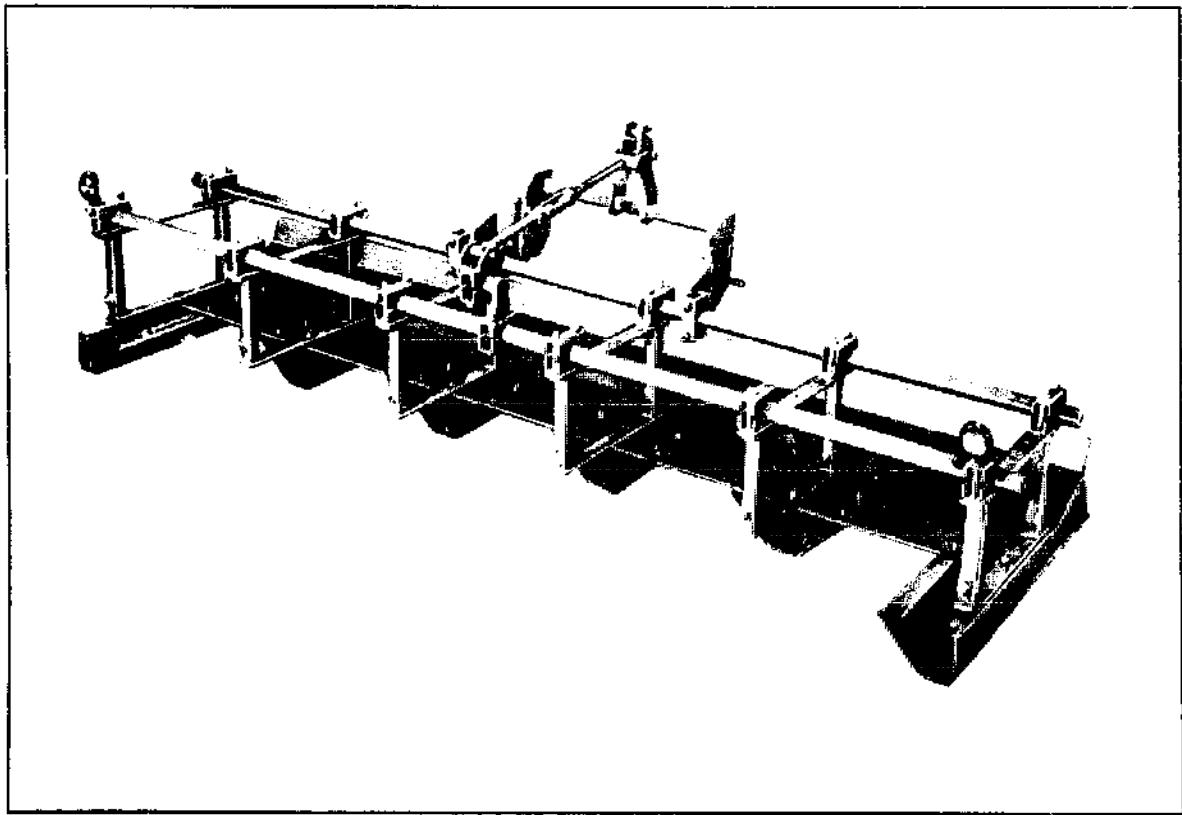

Fig. 115. Bed shaper.



## 6.0 SPECIAL IMPLEMENTS FOR PADDY RICE PRODUCTION



Rice is the most important food crop in the tropics; in 1970 it covered 94 million ha throughout the world and produced more than 170 million tonnes. This crop is given special attention here and also in the previous chapter on irrigated agriculture because rice plants can grow in flooded soils. Not all the rice crops are produced on flooded fields: five main cropping systems can be distinguished:

Rainfed lowland - irrigated lowland - upland - deep water - direct seeded, irrigated.

Some 65% of the total rice-growing areas in the tropics apply a (rainfed or irrigated) lowland system while 25% is grown as upland rice (like other crops - without flooded fields, transplanting, etc.) and approximately 9% as floating rice in river valleys and flood plains; the remaining 1% is produced by a highly mechanized system with large tractors and equipment, often including aircraft for sowing, fertilizing and spraying. Dry soil preparation techniques are mainly used in the latter three systems.

The lowland rice production system generally assumes the following pattern: (small) level fields are bordered by dikes or "bunds" to retain water on the field surface. When the fields are flooded, the soil is ploughed mainly in order to work in the stubble and weeds. Subsequent (secondary) tillage operations consist of "puddling" which is intended to destroy the aggregates of the top soil and create a layer of fine mud. In the meantime rice seedlings are being raised on nursery beds for transplanting in the puddled fields.

Even in the case of lowland rice the primary tillage operation is not always performed on flooded land; a dry primary tillage is often followed by several puddling treatments (as in Japan) but this is suitable only for irrigated systems because, under rainfed conditions, the soil is usually in a dry workable state for too short a time.

Puddling is still a subject of controversy and not everyone is convinced that the operations improve the final yields. The main objectives of puddling (as a secondary tillage operation) are:

- to create a less permeable zone at the bottom of the arable layer;
- to create suitable physical, chemical and bacteriological conditions;
- to spread and work in organic matter in the lower zone of the puddle;
- to promote germination and subsequent destruction of weeds;
- to create conditions which favour seed germination and/or plant establishment.

After various rice production systems had been compared it was found that puddling has the most beneficial effect on well-aggregated soils where large amounts of water and, more important, nutrients would otherwise be lost. Puddling is far less effective on soils with an impermeable layer or a high groundwater table.

Puddling is a tillage operation which can be performed by nearly every type of secondary tillage equipment but some are more suitable than others, depending upon the specific conditions. An intensive form of tillage is most effective since the soil is saturated and possesses a liquid consistency.

One practical problem is the trafficability of a flooded field; its load-carrying capacity is low when the soil is fully saturated. Tractors are very likely to become stuck when the bottom of the arable layer is not firm. It may be necessary to use dual wheels or extra cage wheels.

A major aspect of tillage in rice fields is the need to keep the surface as level as possible; the growth of rice is harmed when the water layer deviates too much from the average optimum depth. Consequently, two-way (reversible) ploughs (Chapter 2.1) should be used. Disc harrows (Chapter 3.1) are also employed but use of the rotary tiller (Chapter 2.4) is widespread. The forward thrust of the driven rotor is a considerable advantage under conditions producing poor trafficability. In Asia particularly the rotary tiller is frequently used in combination with two-wheeled tractors. Since these tractors are so common, some attention will be given to special tillage equipment for them.

#### 6.0.1 Literature

- Agarwal, M.C., R. Singh, M.L. Batra and R.P. Agrawal, 1978. Evaluation of different implements for puddling of rice soils. *Riso*, 27(4): 301-305.
- Bernasor, P.C. and S.K. de Datta, 1981. Long term effects of reduced tillage on weed shift in wetland rice. *WSSP Newsletter (Philippines)*, 9(1): 4.
- Dei, Y. and K. Maeda, 1973. On soil structure of plowed layer of paddy field. *Japan Agricultural Research Quarterly*, 7(2): 86-92.
- FAO, 1972. Report on the meeting of experts on the mechanization of rice production and processing, Paramaribo, Surinam, 1971. FAO, Rome, pp. 203.
- FAO, 1975. Report on the expert consultation meeting on the mechanization of rice production, IITA, Nigeria, pp. 280.
- FAO, 1976. Mechanization of Rice Production in India, Nigeria and Senegal. Report of an international coordinated research project. FAO, Rome, pp. 152.
- Herblot, G., 1974. La lutte contre les mauvaises herbes par les moyens mecaniques dans certaines cultures tropicales annuelles: cas particulier du riz. *Machinisme Agricole Tropical*, 46: 31-42.
- Japan Machinery Exporters' Association, 1980. Japan agricultural machinery and land internal combustion engines. Tokyo, Japan, pp. 119.
- Johnson, L., 1972. Mobility in rice fields. In: Report on the meeting of experts on the mechanization of rice production and processing, Paramaribo, Surinam, 1971. FAO, Rome: 61-63.
- Kisu, M., 1970. Technical problems in mechanization of soil preparation (Proceedings; symposium on farm mechanization). *Tropical Agriculture Research Series*, Tokyo, No. 4: 137-146.
- LeMoigne, M., Mechanization and small-scale farming: agricultural communities and motorized operations. In: Report on the meeting of experts on the mechanization of rice production and processing, Paramaribo, Surinam, 1971. FAO, Rome: 30-36.

- Madramootoo, H., 1972. Tillage practices and tillage equipment for rice production on small family farms. In: Report on the meeting of experts on the mechanization of rice production and processing, Paramaribo, Surinam, 1971. FAO, Rome: 64-68.
- Moomaw, J.C. and H.P. Curfs, 1972. Some general and particular aspects of rice and soil tillage. In: Report on the meeting of experts on the mechanization of rice production and processing, Paramaribo, Surinam, 1971. FAO, Rome: 55-60.
- Moormann, F. and N. van Breemen, 1978. Rice: soil, water, land. Int. Rice Res. Institute, Los Banos, Philippines, pp. 185.
- Sakai, J., 1979. Engineering characteristics of rotary tillage resistances of Japanese rotary tillers with tractors. Proceedings of the 8th. Conference of ISTRO, Hohenheim, Fed. Rep. of Germany: 415-420.
- Scheltema, W., 1974. Puddling against dry plowing for lowland rice culture in Surinam: effect on soil and plant and interactions with irrigation and nitrogen dressing. Agricultural Research Reports, Wageningen, No. 828, pp. 241.
- Zhao Cheng-zai, Zhou Zheng-du and Dong Bo-shu, 1981. A comparative study on methods of tillage of paddy soils in Taihu lake region. Proceedings of a symposium on paddy soil, China. Springer Verlag, Berlin: 780-785.

## 6.1 Special Implements for Puddling



### 6.1.1 The Comb Harrow

The comb or peg-tooth harrow is commonly used for paddy soil in the Far East. Wooden or iron teeth (20-30 cm long at intervals of about 10 cm) attached to a wooden beam are pulled through the soil as a rake. This implement is used only with draught animals. Implements for one and two animals exist (width approx. 1 metre per animal). The depth is difficult to control because of the lack of supporting units.

### 6.1.2 The Levelling Board

The levelling board is an extremely simple tool consisting of a wooden board, beam or plank (dimensions varying from 1 m for animal traction to 15 m for large tractors) equipped with a pole for (yoked) animals or eyes for attaching chains or traces. When it is used with animal traction the operator usually stands on the leveller to improve its penetration and steerability (uneven spots, etc.).

Despite its simplicity this tool is often essential for obtaining a level and fine surface. Clods and aggregates are pulverized by the leveller's rubbing action (see also Chapter 4.4).

### 6.1.3 The Rotary Harrow

The rotary harrow discussed in Chapter 3.2 may be used for puddling. Special animal-drawn rotary harrows made (partially) of wood and based on the same principle are used in the Far East. The tine rotor may be wooden (diameter 20-25 cm) to which wooden or iron tines or lugs are attached. The working widths range up to 180 cm. The rotor is mounted by simple bearings onto a rectangular frame which acts as a skid and controls the depth. All-metal types with tine rotors, similar to the ones shown in Fig. 63, are used in Japan.

### 6.1.4 The Weedcutter, Stalkcutter And Mudroller

Essentially, these three types of implements have the same construction and functioning. They are all rollers with transverse knives or lugs on the circumference of a drum or open frame. The implements were originally designed for clearing operations (shrub, forest) or, in the case of smaller models, as part of roller-harrow combinations for secondary tillage. The types used for puddling are adapted models. Typical examples of these implements as used on (large) mechanized farms, are described below:

- Mudroller: weight 600 kg, working width 350 cm, diameter of the (open) roller 100 cm. The transverse bars on the circumference of the roller (at intervals of 30 cm) are 2.5 cm in height.
- Weedcutter: a closed drum, (diameter 50 cm) with 8 transverse knives or blades about 10 cm in height. The weight of a section 150 cm wide is 140 kg, which may be increased to 220 kg by filling the drum with water. More sections (3 or 5) may be combined if sufficient power is available.
- Stalkcutter: an open frame with 5 knives or blades 13 cm in height, similar to the weedcutter, weight 450 kg, working width 180 cm.

The working depth depends upon the shape and size of the blades and the weight. The stalk-cutter is the heaviest implement and is used when large amounts of organic material are present. The weedcutter can be used under average conditions while the mudroller is more effective when the field is soft.

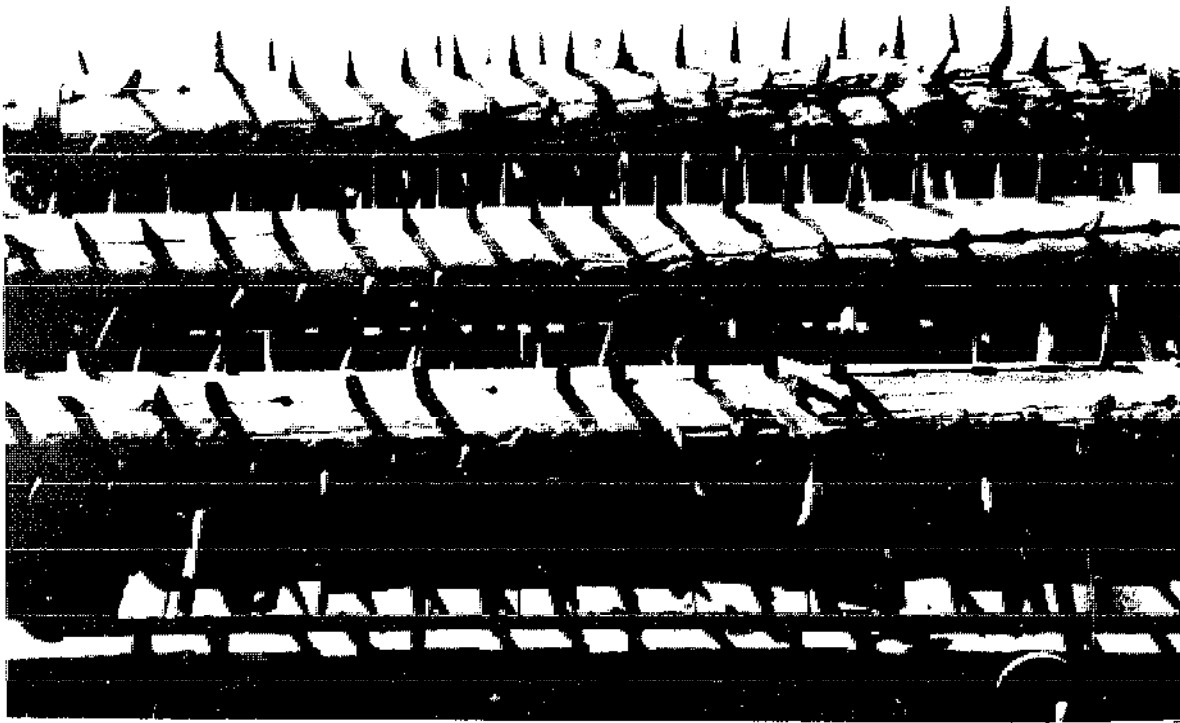

*Fig. 116. Mudroller.*

#### 6.1.5 Literature

See literature for chapter 6.0.

## 6.2 Motor Hoes and Two-Wheeled Tractors





The small two-wheeled or walking tractors are an important group of implements used primarily for tillage operations. These implements are included in this chapter because they are developed and used extensively in paddy production systems in the Far East and especially in Japan. In 1979 330,000 of these "power tiller" units were manufactured in Japan, approximately 100,000 of them for export.

Although the tractors could be regarded purely as sources of power, they are usually very closely combined with tillage tools. Essentially, three types can be distinguished:

#### 6.2.1 The Motor Hoe

This comprises a rotor with blades which are driven from the center by a small engine mounted on top of the rotor. The machine has no wheels but is propelled by the blades. The engine (1 - 3 kW, usually fuelled with gasoline) is operated by the two steering handles at the rear of the machine. This simple design frequently produces handling problems and the tillage action is not always satisfactory. The forward speed depends upon the condition of the soil: on hard soils penetration is very poor and the machine "walks away" while on soft soils the blades dig too deeply into the soil. The machine is tiring to operate and turning is difficult. The front of some models is fitted with a wheel for depth control, turning and transport. The rotor may be replaced by an axle with wheels for carting purposes.

#### 6.2.2 The Single-Wheel Tractor Or Motor Hoe

This tractor is equipped with a power-driven wheel in addition to the blade rotor. This makes the rotor much more efficient since the forward speed can be adjusted independently to the rotor rpm. The rotor's working width rarely exceeds 60 cm. The width can also be reduced for inter-row tillage (crop management, weeding).

#### 6.2.3 The Two-Wheeled Tractor Or Power Tiller

These tractors have one axle which drives two wheels. They are fitted with engines of 3 - 10 kW and the heavier ones sometimes have diesel engines. The tractor is much more of a power unit and can be used for mounting all types of agricultural machinery. The rotary tiller is still the most widely used implement for tillage but (mouldboard) ploughs, harrows, etc. are also available. In paddy fields the pneumatic tyres are often replaced by cage wheels which, with the rotary tilling, produce a dual puddling action.

A rotor hoe can be very tiring to use (especially on the soft mud of a paddy field). Ergonomically, there is much room for improvement. The more expensive models are equipped with a differential gear and a clutch to facilitate steering. A small cart is usually available for seating the driver.

The tractive power of two-wheeled tractors is generally restricted by the low ground pressure of the wheels (slippage) and not so much by the horsepower available from the engine.  
Some characteristics of the different types are given in Table 11.

engine (hp)	weight (kg)	main work	characteristics
< 3	< 100	tillage, weeding and ridging with the rotary unit, carting, pest control.	management work in row crops and orchard.
3 to 5	100 to 150	ploughing, rotary tillage, puddling, ridging, weeding, crop maintenance, carting.	wide range of work, versatile.
6 to 8	150 to 250	rotary tillage ploughing, carting.	dismountable rotary unit.
9 to 12	250 to 350	rotary work.	deep tillage possible.

*Table 11. Characteristics of motor hoes and power tillers.*

#### 6.2.4 Literature

See literature for chapter 6.0.

## 7.0 SPECIAL IMPLEMENTS FOR DRYLAND FARMING

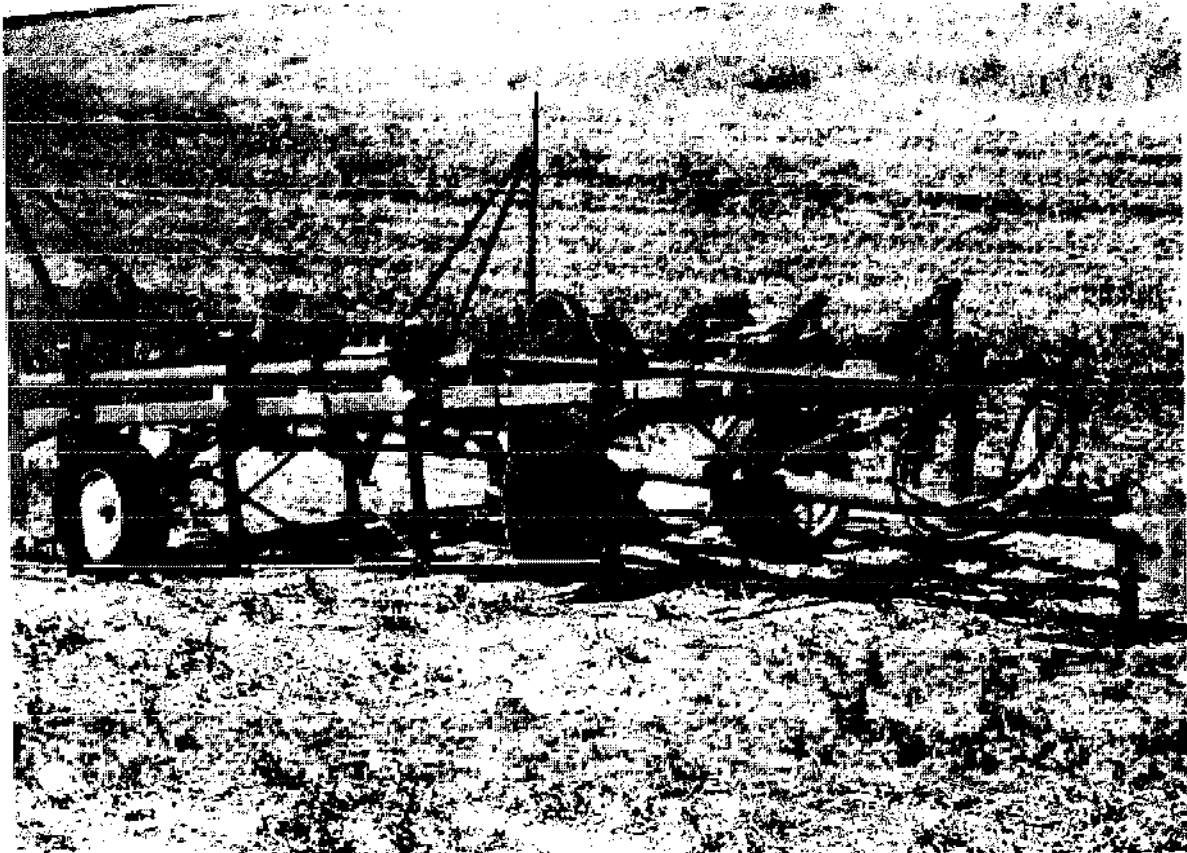

Dry(land) farming can be defined as crop production in arid or semi-arid zones using only natural precipitation without supplementary irrigation (see Chapters I.3.2 and I.5.1). Water is the restrictive factor for this crop production system.

The principal aim of every tillage operation should be to increase the infiltration and water-holding capacity of the soil and to reduce water losses (by evaporation and deep drainage). Wind erosion should also be prevented (see Chapter I.4.1).

Reduced tillage systems, such as direct drilling, stubble mulch tillage or conservation tillage, are being considered and applied as alternatives to conventional tillage practices (see Chapter 10). The wide variety of factors involved in these methods cannot be examined in detail in this book. A number of implements with special functions for dryland farming are described in the following sections.

#### 7.0.1 Literature

- Burrows, W.C., R.E. Reynolds, F.C. Stickler and G.E. van Riper (Eds.), 1970. Proceedings of an international conference on mechanized dryland farming (August 1969). John Deere & Co., Moline, Ill., pp. 343.
- Colvin, T.S., J.M. Laflen and D.C. Erbach, 1981. A review of residue reduction by individual tillage implements. ASAE: Crop production with conservation in the 80's: 102-110. ASAE, St. Joseph, USA.
- Doty, C.W. and D.C. Reicosky, 1978. Chiseling to minimize the effects of drought. Transactions of the ASAE, 21(3): 495-499.
- FAO, 1971. Tillage and seeding practices and machines for crop production in semi-arid areas. FAO Agricultural Development Paper no. 92, pp. 53.
- Hopfen, H.J., 1969. Farm implements for arid and tropical regions. FAO Agricultural Development Paper, No. 91, pp. 159.
- Marston, D. and P.J. Garland, 1978. Conservation tillage machinery. Journal of the Soil Conservation Service of New South Wales, 34(4): 220-227.

## 7.1 The One-Way or Disk Tiller

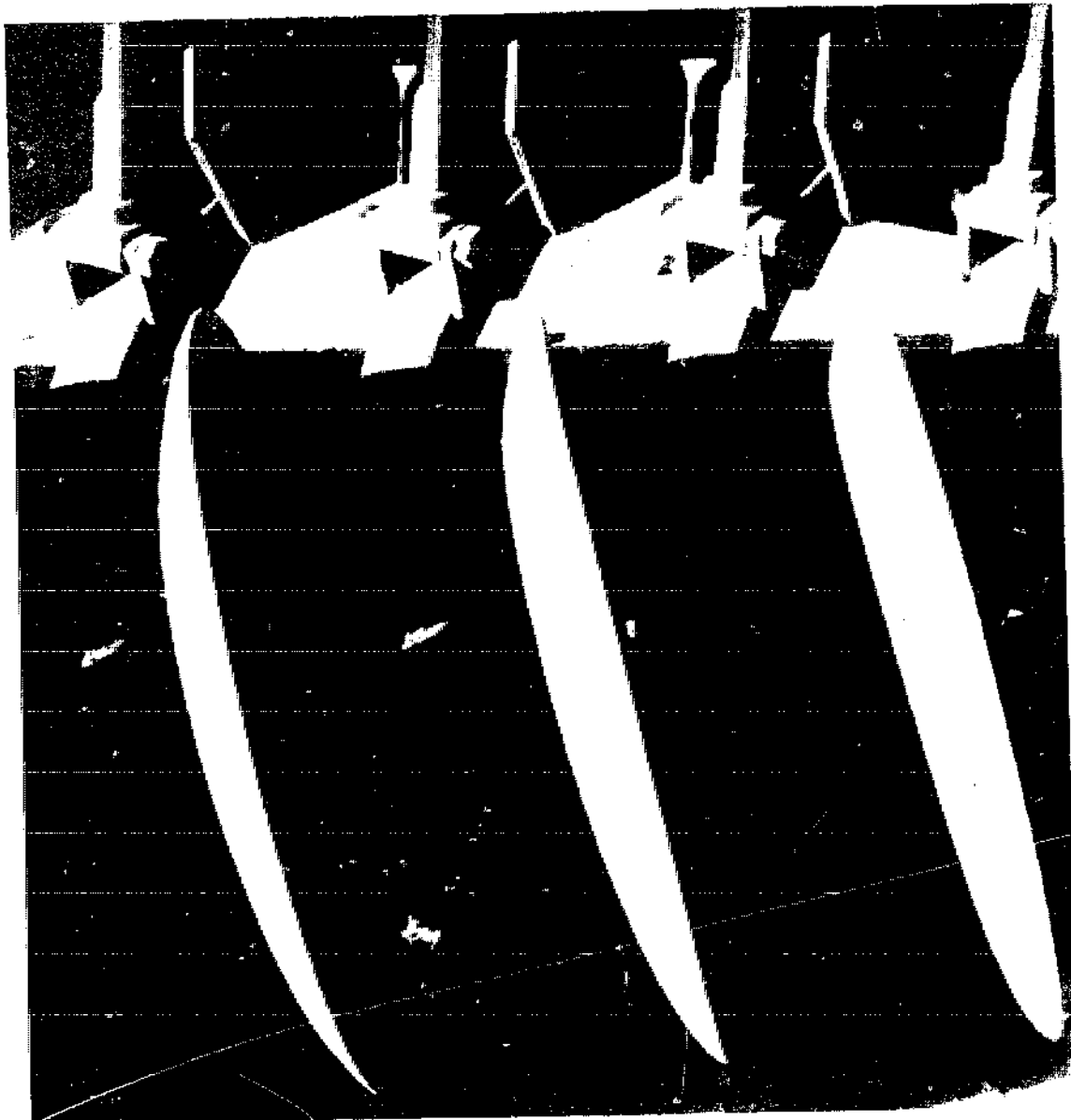

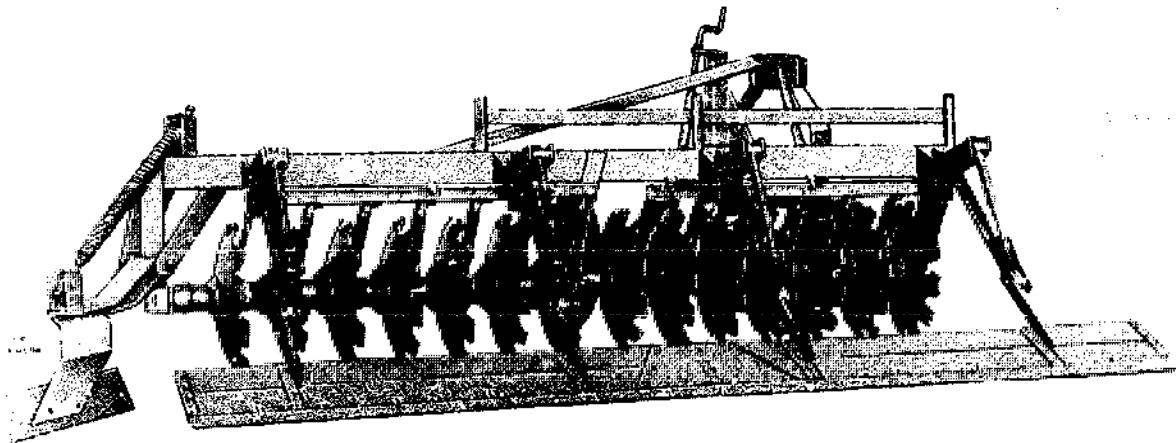

*Fig. 118. One way tiller (3-point hitch, cut-out discs).*

#### 7.1.1 Use And Assessment

Unlike the disc plough, the one-way tiller is equipped with discs fitted at short intervals vertically or at a slight angle on a common axle. On larger implements the discs may be mounted in one or more gangs. The one-way tiller is suitable only for shallow tillage. It is used mainly in dryland areas and especially for:

- primary tillage,
- seedbed preparation in one operation,
- seedbed preparation after ploughing,
- stubble tillage, often combined with the drilling of the subsequent crop,
- fallow tillage,
- working in broadcast seeds, manure, spray materials and plant residue.

The success of the one-way tiller (Fig. 118) is due to its specific advantages in dryland farming areas. These include:

- versatility, used for both primary and secondary tillage,
- good mulching action,
- possibility of producing a seedbed in one operation (reduced risk of erosion),
- adaptation to the relief of the soil surface,
- high capacity,
- relatively low energy requirement,
- long life,
- possible combination with sowing equipment.

One negative aspect is the high cost. A heavy weight is required to produce penetration in hard soils (higher costs, difficult to transport). The implement may clog up in heavy weeds or large amounts of plant residue. Large working depths (> 15 cm) cannot be reached.

### 7.1.2 Functioning

Being a disc implement, the one-way tiller does not penetrate into the soil without weight or a load on the discs by springs. Consequently, extra weights can be attached to the frame and furrow wheels. The soil is raised by the discs and deposited in a pouring movement (skim tillage). The resultant mixing of the soil and the surface material increases the infiltration rate, reduces evaporation and does much to prevent wind and water erosion. Cut-out discs can cut into plant residue more efficiently than smooth discs. If travel speed is too high (> 6.5 km/h) the tilled layer becomes too fine and plant residue is buried, increasing the erosion.

Because the discs can be suspended in groups or individually the one-way tiller can easily adapt to an uneven surface. On several implements each disc is loaded (equally and individually) by a spring or hydraulic or pneumatic system. When fitted with a rear-mounted mulcher/leveller it produces better crumbling, levelling and compaction. The one-way tiller may be used as a single implement but is also combined with sowing or fertilizing equipment.

### 7.1.3 Linkage And Drive System

The one-way tiller is usually trailed, allowing a combination of two or three units. As on the disc plough, the implement tools are driven by the soil resistance. Mounted implements are also available. Since large types of this implement are used, the draught requirement may seem high but, when related to the area covered, it is comparable to that of other implements. The power requirement rises with an increased curvature of the discs, increased disc angle and increased travel speed. It ranges between 28 and 45 kW per metre of width at 6.5 km/h. The capacity at this speed is approximately 0.6 ha/h per metre of width.

### 7.1.4 Description Of The Implement And Tools

The implement (Fig. 119) is half-way between the disc plough and the disc harrow. The curved, plain or cut-out steel discs are mounted with dust-proof bearings either in gangs on a common shaft or individually to the frame by means of strong shanks (often spring-loaded). The frame consists of a heavy, usually square welded steel tube from which the discs are suspended at intervals of 150-260 mm. When in operation, the entire implement is aligned oblique to the direction of travel and the discs cut into the soil during the forward movement. The discs are 450-600 mm in diameter and 4-6 mm thick. Their concavity (depth at centre) is between 80 and 140 mm. Each disc is generally fitted with a scraper to avoid clogging.

The implement is usually trailed (rarely mounted) and, like the disc plough, is fitted with a front and rear furrow wheel which can be set at an angle of up to 45 degrees to the surface. A disc coulter or guiding share is often mounted as well. The rear support wheel and the furrow wheel form the rear bridge on which the implements can be lifted by a remote hydraulic system. When being transported, the furrow wheels are set vertically and the frame is rotated to the direction of travel.



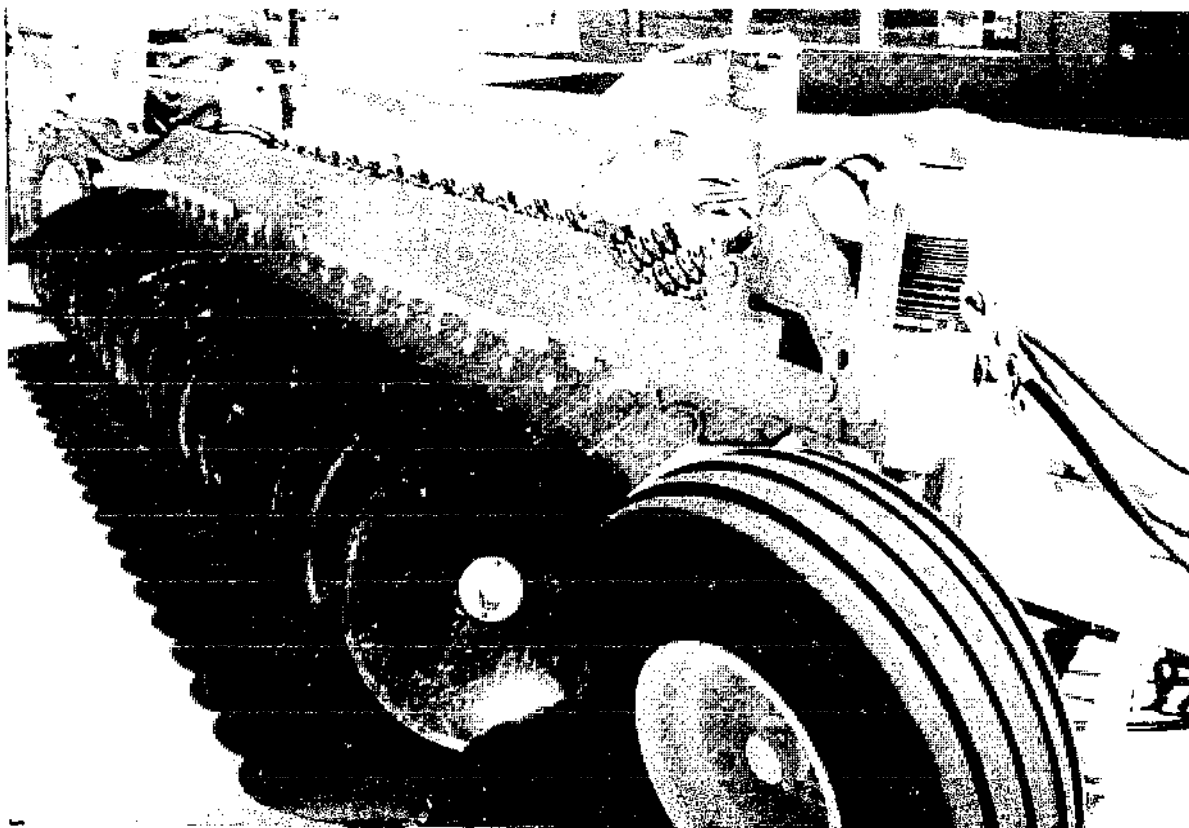

Fig. 119. One way tiller (trailed type, individually spring-loaded discs).

#### 7.1.5 Adjustments, Operation

The working width and disc angle are adjusted from one central point by a hitch brace rod. With this system every tool has the same setting. The disc angle can be set between 30 and 60 deg (usually 40-50 deg) and the working width between 70 and 100% of the maximum width which may be as much as 4.80 m for a 20-disc implement. The discs are placed vertically or at a fixed tilt angle of about 15 deg.

The depth is adjusted by cranks on the axles of the furrow and depth wheels or by a hydraulic system remotely controlled from the tractor. The front and rear of large implements are raised and lowered simultaneously. The penetrative force reduces as the disc angle is increased (requiring more weight). The hitch point can be adjusted to the line of pull in order to distribute the load uniformly over the entire length of the implement. For accurate guidance the larger implements have not only the furrow wheel but also a disc coulter or guiding share. Link bars connect the wheels to each other and to the hitch system so that the steering is guided during turns (small turning space). The support bars on some mounted implements may be moved laterally, adapting them to the track width of the tractor.

### 7.1.6 Technical Data

Length		2.00-10.00 m
Width		1.00-4.00 m
Height		0.80-1.50 m
Discs:	number	10-40
	diameter	450-600 mm
	concavity	80-140 mm
	thickness	4-6 mm
	interval	150-260 mm
Width of cut		150-260 mm per disc
Working depth		80-150 mm
Weight (without extra weights)		120-135 kg per disc
Possible load for setting by springs		150-250 kg (for each unit)
Maximum lift per disc		250-400 mm
Disc angle		30-35 deg
Tilt angle (fixed)		0 or 15 deg
Depth adjustment		manually or hydraulically
Power required		28-45 kW/m

### 7.1.7 Literature

See literature for chapter 7.0.

## 7.2 The Sweep Plough

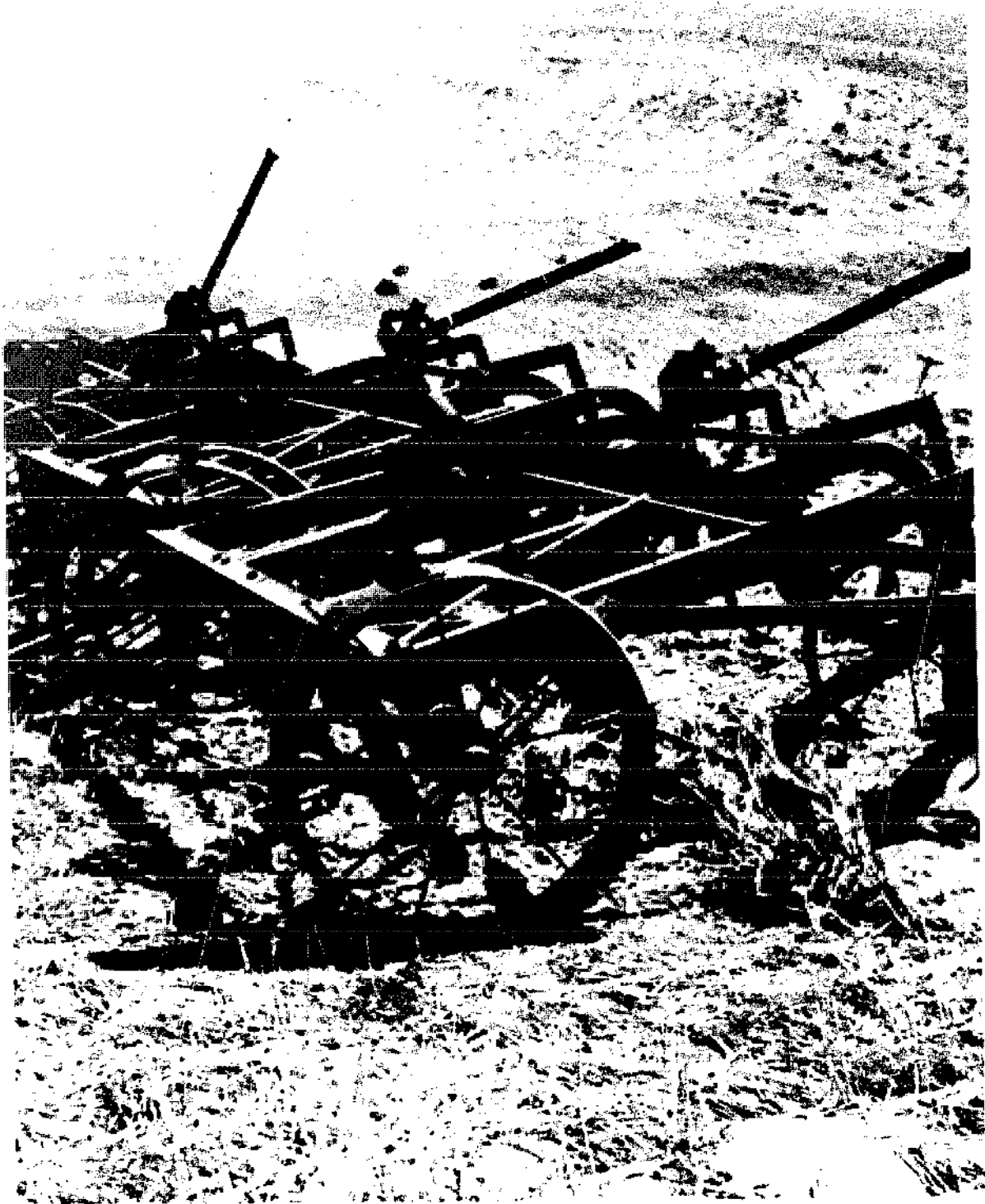

### 7.2.1 Use And Assessment

The sweep plough is used for:

- stubble tillage (mulching),
- weed control during fallow,
- primary soil tillage.

The sweep (Fig. 120) has been developed especially for dryland farming for which implements with a high efficiency and capacity are required. The sweep is particularly suitable for mulching and can to some extent replace the plough. The soil is not inverted but loosened so that precipitation is absorbed with little loss. Weeds are killed mechanically, leaving 80-90% of the plant material on the surface. This protective layer reduces wind and water erosion, increases the infiltration capacity with heavy rainfall, protects against evaporation and surface crusting and prevents pronounced rises in the soil temperature. The sowing method has to be adapted to these conditions. The implement is unsuitable for stony or recently cleared land (stumps, roots). Even on sweep-tilled fields weeds often start to grow immediately after rain and this can be prevented only by using rear-mounted tools.

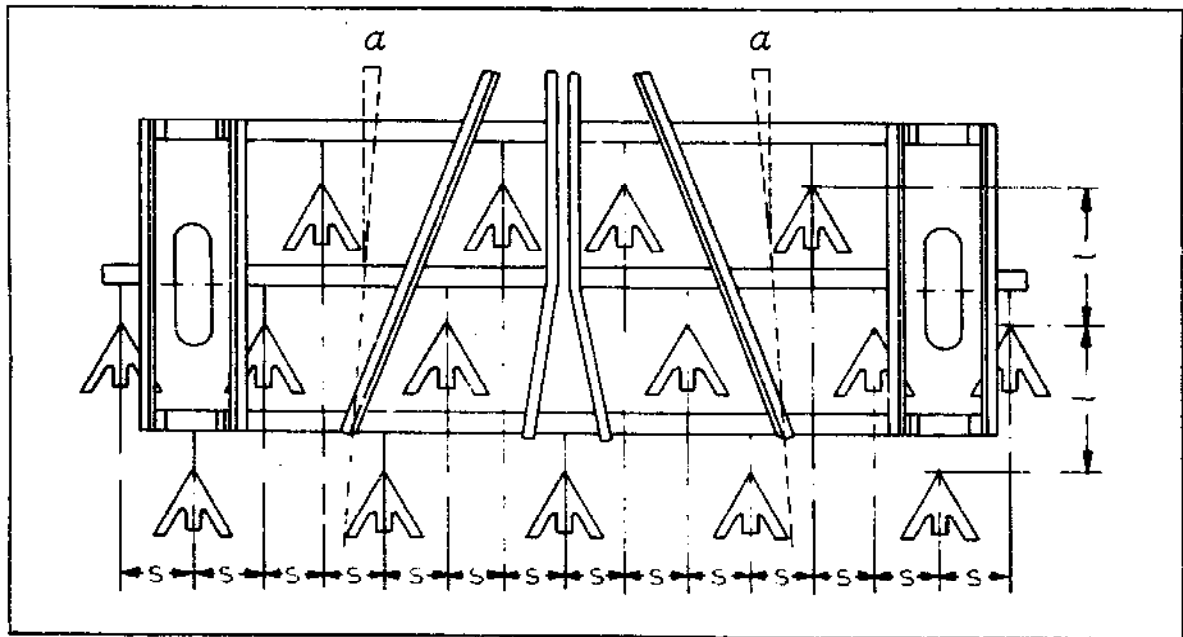

Fig. 120. Sweep plough with symmetrical arrangement of tools.

### 7.2.2 Functioning

The objectives of tilling with a sweep are:

- a. to cut off the weed roots,
- b. to disturb the soil capillary system (reducing water losses by evaporation),
- c. to loosen the soil so that the infiltration capacity is increased without too much disturbance of the surface. Plant residue must not be worked in but should remain on the surface to form a protective layer.

These objectives are best fulfilled by a sweep with a broad cutting width. A delta-winged shaped tool is drawn horizontally through the soil at a depth

of 8 - 15 cm (Fig. 121). This cuts the weed roots and disturbs the capillary system. Because of the share lift angle the soil is slightly raised (25-30 mm) and, when dry enough, loosened and crumbled. A certain amount of overlap between adjoining tools ensures effective working over the entire width even if the implement is set at a slight angle from the forward direction. Almost the entire protective mulch layer of stubble and plant residue is preserved (80-90% of the material remains on the surface). A rear-mounted rotary hoe tears out the weeds after they have been cut off and prevents them from growing again during the next rains. The tillage operation is usually repeated with the second run at a shallower depth than the first. The sweep is used after harvest and shortly before sowing or during the summer fallow period.

The greater the number of tools/shanks and the smaller the cutting widths of those tools, the more the sweep produces the same effect as a cultivator with duckfeet. A narrower shank distance and smaller tools are suitable for stubble mulch tillage while a broad shank distance and wide tools are better for weed control (preserving the surface, reducing evaporation and protecting against erosion). The quality of the tillage operation can be improved by placing cut-out disc coulters in front of the shanks and by using rear-mounted tools (e.g. rotary hoes).

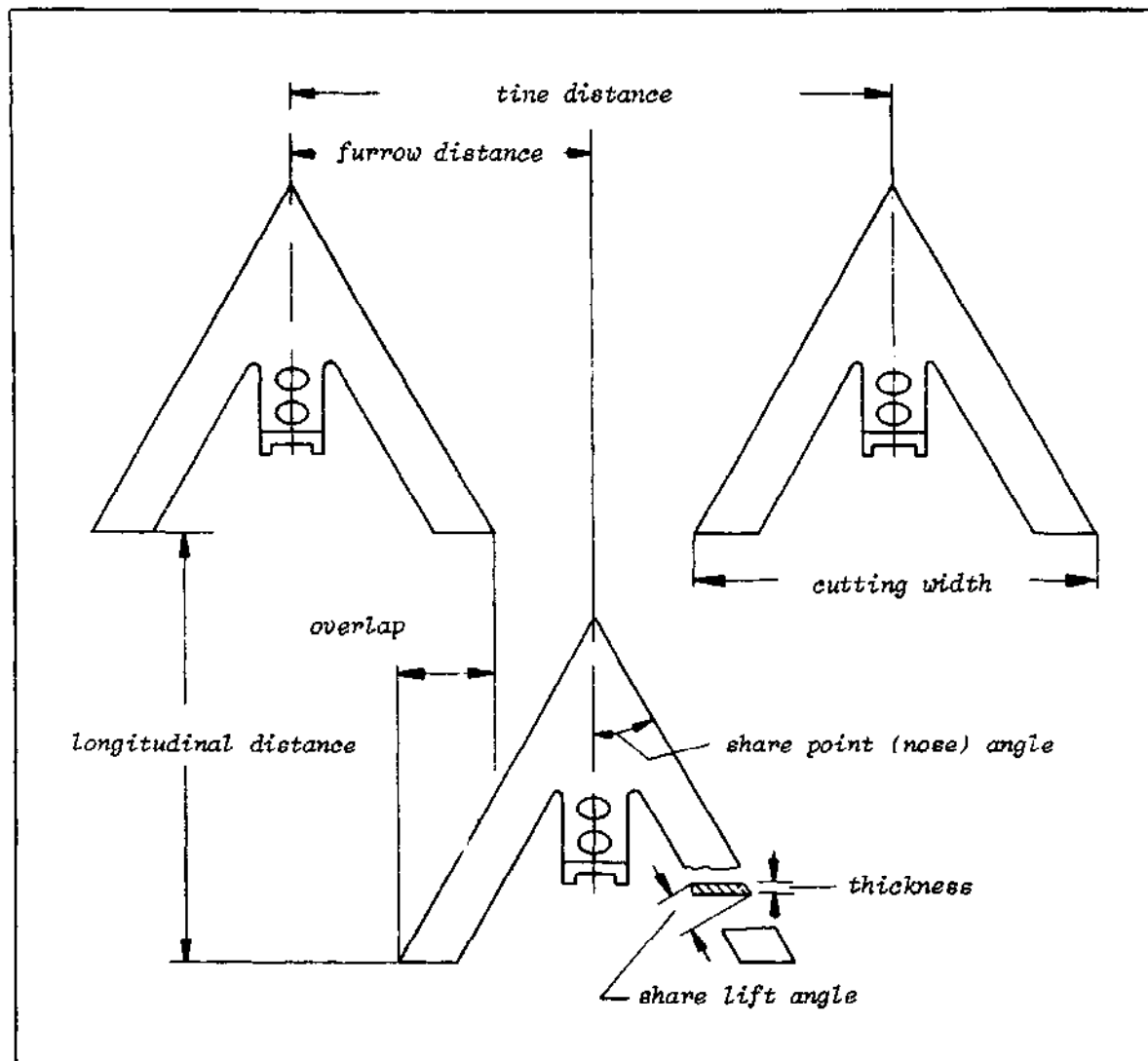

Fig. 121. Tools of a sweep plough.

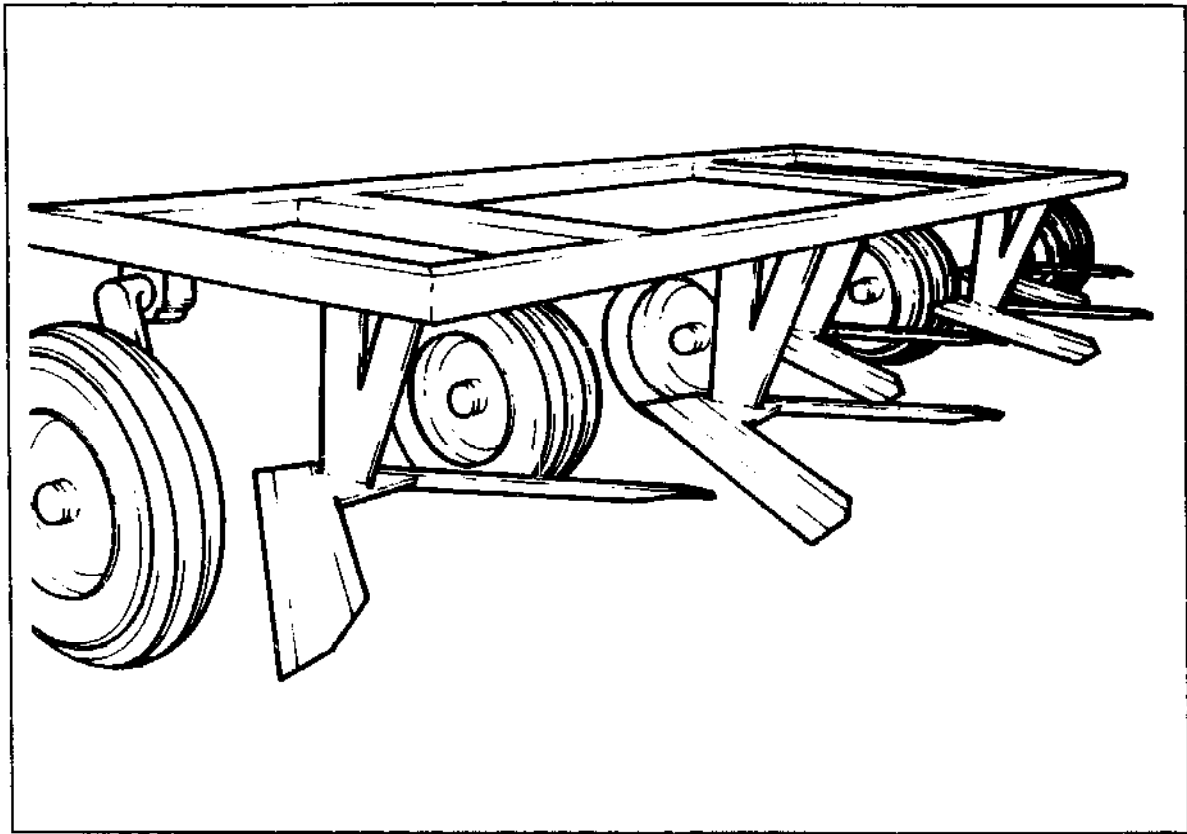

Fig. 122. *Wide sweep plough.*

As in the case of tillage with a chisel plough, the quality of the operation depends upon the soil moisture content. Penetration is difficult on hard dry soils while smearing can be expected in plastic soils. A small share lift angle and thin blades will increase the penetration. Guidance is improved by large working widths and a slight tilting of the tools towards the point and also by a reduced downwards suction.

When moving backwards, flexible tines change the depth and tilt angle, producing irregular depths. Rigid tines with large tools are very vulnerable to obstacles in the soil (stones, roots).

### 7.2.3 Linkage And Drive System

Small implements are equipped for the 3-point hitch system for which quick-coupling devices may be used. The lifting capacity required for mounted implements is more or less the same as for chisel ploughs. Large implements with working widths of up to 12 metres are trailed or semi-mounted.

The sweep is a passive drawn tool. As in the case of cultivators, the power required depends upon the number of tines, the design (rigid, spring-loaded), size of tools, depth, tilt angle, soil condition and soil type. The power obviously increases with the depth, speed and share lift angle. The power required from the tractor is comparable to that required for the cultivator. This is approximately 10 kW for a tool 400 mm wide at a speed of around 8 km/h. The sweep is often combined with other tools,

especially the rotary hoe. When moving backwards, this implement acts as a stubble treader, as it is called in the USA, destroying weeds and embedding plant residue more firmly in the soil.

#### 7.2.4 Description Of The Implement And Tools

Leaving aside its tools, the sweep plough (Fig. 120) looks very much like the chisel plough. The solid main frame is usually made of flat and tubular steel. The rigid or flexible tines are mounted either on fixed welded steel clamps or on adjustable flanges. They are placed on one to three crossbars (distance between bars: 650-700 mm) staggered one behind the other. Rigid tines have an overload protection device, shearbolts or springs. The tines (shanks) are fitted perpendicularly to the frame or slightly curved or angled towards the front. The V-shaped tools are mounted on the shanks. The shape, dimensions, nose angle and share lift angle determine the functioning of these tools (Fig. 123). The dimensions and nose angle also determine the number of tines, the distance between them, the number of (and distance between) the crossbars and the furrow distance.

The tool shares (wings) are 6-8 mm thick with a total (cutting) width of 310-2100 mm and they usually work with an overlap of approximately half the width of one wing (a quarter of the tool's width). The tines may be fixed symmetrically around the implement's central axis, giving an odd number of tines (Fig. 120) or asymmetrically, giving an even number. The latter type can be expected to deviate on hard soils. Spring tines are used only for tools with a narrow cutting width. Penetration can be improved by tilting the tool slightly forwards.

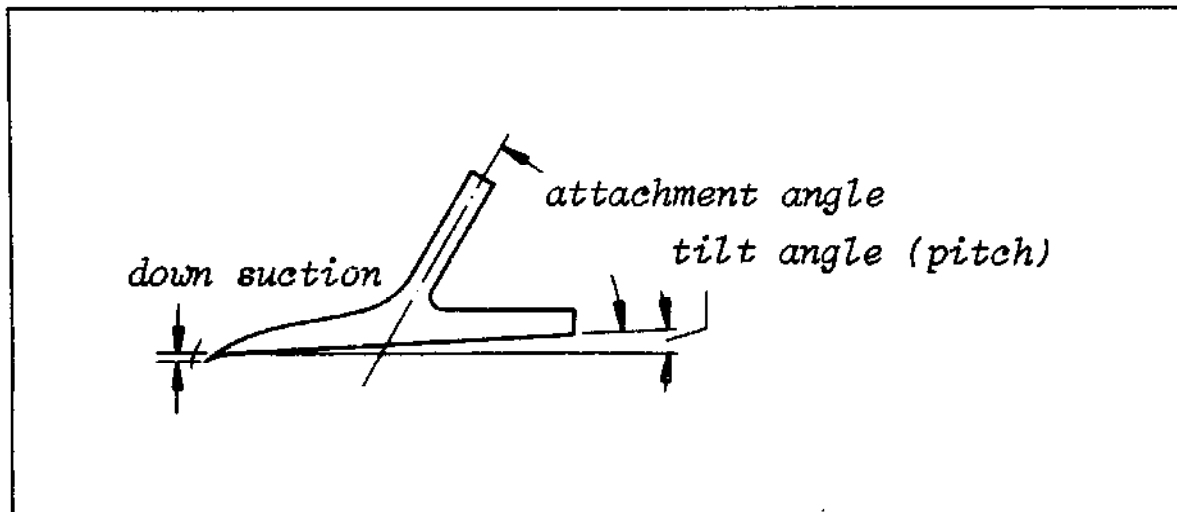

Fig. 123. Geometry of a sweep.

The frame height and the distance between the crossbars and tines must be sufficient to allow the mulch layer to flow freely. Disc coulters are often mounted in front of the tools to prevent choking and the creation of surface furrows (rills, water erosion).

The frame is carried by support wheels which also control the depth. Multiple-use tool carriers are frequently used for mounting the tools. The

frame is usually too unstable for tools with a broader cutting width. The tool's cutting widths average 400 mm with an overlap of 50-100 mm. Implements equipped with much wider tools (up to 2100 mm on the wide sweep plough, Fig. 122) require fewer shanks, thus causing less disturbance to the surface and reducing the risk of choking. A heavier and therefore a more expensive design is required for this. The implements are used particularly for deeper tillage.

The nose angle is 30-50 deg and so roots, plant residue and stones can slide off the tool. If the share lift angle is too small, the soil will not be sufficiently loosened. If it is too large, penetration is poor, the flow of soil and plant residue is uneven (leaving bare spots) and the draught requirement is high. Implements are either trailed or mounted, depending upon their size. Trailed implements can achieve widths of up to 12 m with an articulated frame. Working depths are between 6 and 12 cm.

#### 7.2.5 Adjustments, Operation

Different share sizes may be used on implements on which the distance between tines can be adjusted. The depth is controlled almost entirely by the support wheels; by a crank system on smaller implements and hydraulically on larger ones. As on the cultivator, the working depth is determined by the frame height blocking the flow of soil and plant residue. Inadequate penetration in dry soils may be improved by changing the tilt angle (pitch) or by adding extra weights. The tillage intensity depends upon the speed, the number and type of the tines (rigid, springs), the size of the tools, nose angle, overlap and the working depth. The distance between tines and the tool size can be adapted to the specific purpose of the operation.

The implement is simple to use and can be operated by one man. Mounted implements can be fitted with quick-coupling devices. The driver has to leave the tractor to make any adjustments (except in the case of hydraulic depth control). The only maintenance required is lubrication of the support wheels.

#### 7.2.6 Technical Data

Frame height	up to 900 mm
Number of crossbars	1-3
Distance between crossbars	650-700 mm
Tool's cutting width	about 400 mm (300-2100 mm)
Nose angle	30-50 degrees
Share lift angle	12-25 degrees
Distance between tools	up to 2.00 m
Working width	up to 12.00 m
Power required	up to 25 kW/shank
Overload protection	shearbolts, springs



### 7.2.7 Literature

See literature for chapter 7.0.

Kiss, G.C. and Bellow, D.G., 1981. An analysis of forces on cultivator sweeps and spikes. *Canadian Agricultural Engineering*, 23(2): 77-83.

Sial, J.K. and H.P. Harrison, 1978. Soil reacting forces from field measurements with sweeps. *Transactions of the ASAE*, 21(5): 825-829.

Speedie, T. and K. McSwain, 1977. Blade ploughs reduce erosion in the Mallee. *Journal of Agriculture, Victoria*, 75(2): 59-60.

### 7.3 The Rod Weeder



### 7.3.1 Use And Assessment

The rod weeder (Fig. 124) has been developed specifically for dryland farming systems. The implement is used, principally for:

- stubble tillage,
- weed control during the summer fallow period,
- secondary tillage before sowing.

The rod weeder was developed primarily for mechanical weed control on fallow land susceptible to wind erosion in the dry-farming areas. This implement is suitable only for soil in a proper mulch condition. Like the sweep, the rod weeder's main advantages are that the soil is loosened, the capillary system is disrupted and weeds are controlled while the surface is scarcely disturbed and soil water and organic matter are preserved. Only 10% of the plant material on the surface is worked into the topsoil. The resultant mulch layer provides protection against erosion, evaporation and excessive heating and also increases the infiltration capacity of the soil under heavy rainfall. The implement is unsuitable for recently cleared land (stumps, roots); penetration is a problem on hard and dry soils.

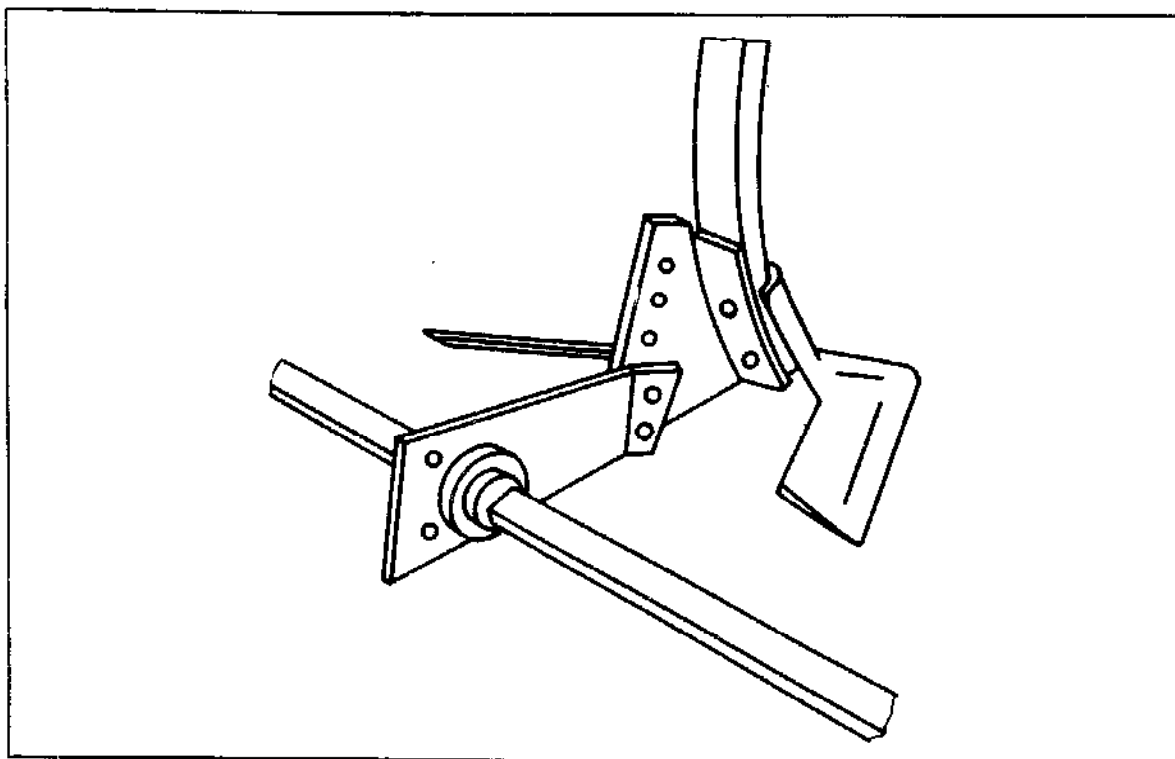

*Fig. 124. Rod weeder mounted on a sweep plough.*

### 7.3.2 Functioning

A square rod slowly rotates against the direction of travel at a depth of approximately 5-10 cm, moving parallel to the surface. The tilled layer is slightly lifted and loosened, increasing the water infiltration capacity without unnecessarily accelerating the decomposition of organic matter. The capillaries at that depth are interrupted, reducing evaporation from deeper layers. The reverse rotation of the square rod pulls up roots of weeds from deeper layers and deposits them on the surface where they will dry out. Up

to 90% of the plant material remains on the soil surface and forms an effective protective layer against erosion and evaporation. Pronounced loosening occurs only immediately around the tines. Coarse soil material is moved upwards and fine material downwards (protection against erosion).

Extra tines and chisels improve the implement's loosening action. When tilling soil which is too wet, the weed control is less effective and choking, smearing and coiling may result. Although every unit has an overload protection device, the implement is unsuitable for heavy soils and soils with many stones and roots.

### 7.3.3 Linkage And Drive System

The basic frame of small implements is usually a tool carrier so that the square rod can be driven by the pto. Little lifting capacity is required. Large implements (working widths of up to 25 m) consisting of independent units each with a width of 3 m may be driven (individually) by large profiled support wheels by means of a sprocket and chain or by hydromotors.

The power requirement is low owing to the shallow working depth and the tool's rotating movement. It depends upon the speed, working depth, soil condition and soil type. Approximately 5-10 kW per metre of width are required at a speed of 8 km/h; this figure is valid for a rod weeder but not for a chisel plough/rod weeder combination.

A remote hydraulic system is used for depth control and for lifting trailed implements. On very wide implements the support wheels must be placed along the entire width to obtain a uniform working depth.

### 7.3.4 Description Of The Implement And Tools

Angled or curved tines are mounted in one row on a steel tube frame (in the direction of travel). Replaceable shoes (which can be used on both sides) are mounted with bearings at the bottom of the tines. These bearings allow the square rod (which may be rounded near the bearing) to rotate. The rod is made of high quality steel with a diameter of 20-25 mm (see Fig. 124). Although only shallow tillage is performed with the rod weeder (5-10 cm), the frame should be high enough to avoid choking when working with thick layers of mulch.

The frame is supported by wheels which are also used for depth control and driving the square rod. Power is transmitted by gears and chains (Fig. 125). Very accurate depth control can be achieved on large implements by means of support wheels mounted in tandem behind and in front of the rod. Implements with very large widths (up to 25 m) have articulated frames. Each element about 3 m wide forms an independent unit when driven individually. These units may also have an independent hydraulic depth control system and overload protection device (shearbolts or automatic reset system). On some models the shanks are spring-loaded. The elements' working widths overlap by 10-15 cm. The frame can be loaded with extra weights to assist penetration in hard dry soils.

Special assembly kits of rod weeder components are often used (Fig. 124). These modules can be attached to the last row of tines on a chisel or sweep plough.

### 7.3.5 Adjustments, Operation

The depth is controlled hydraulically (by a crank on smaller implements) through the support and drive wheels supporting the frame. The hydraulic system is controlled from the tractor. The maximum working depth is determined by the frame height. The number of revolutions of the rod must correspond to the travel speed. Rod weeder attachments can be used which combine the rod weeder's weed-killing capacity with the better loosening action obtained by the chisel plough. The rod weeder is often fitted with a rear-mounted tool (e.g. a rotary hoe) which smoothes the furrows produced by the tines or prepares a seedbed.

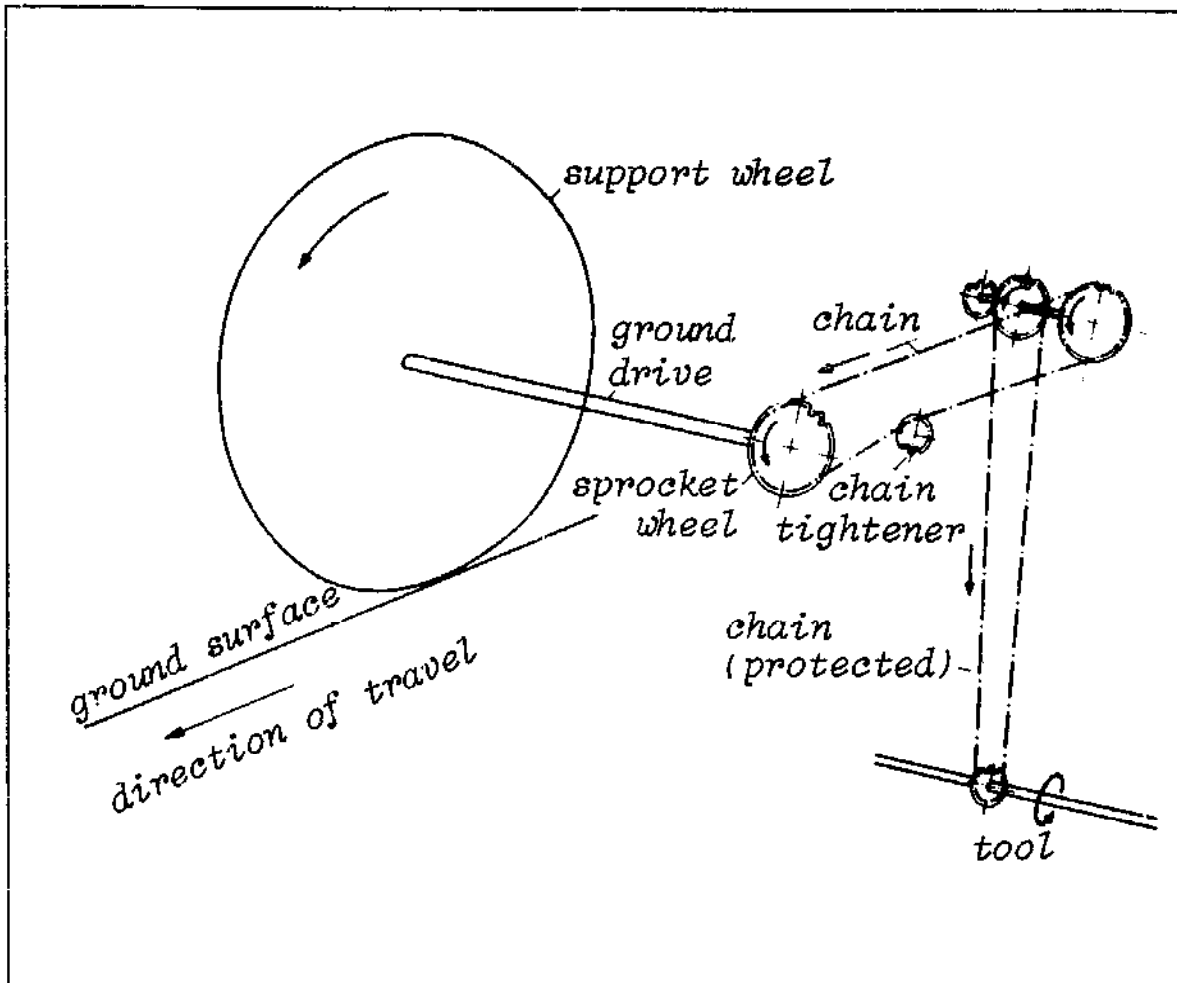

Fig. 125. Drive system of a rod weeder.

Extra units (3 m each) up to a total width of 25 m can be added to some implements. Mounted implements may have quick-coupling devices. They are simple to use and can be operated by one man. The switch from working to transport position is done more easily and faster by two men. The following maintenance operations are required: lubrication of the support wheels, drive system, depth control system and (where necessary) the adjustment system of the rear-mounted tool. Chains must be kept at the correct tension. The bearings of the rod are self-lubricating.

### 7.3.6 Technical Data

Frame height	approx. 700 mm
Working width	up to 25 m
Working depth	up to 120 mm
Power required	approx. 5-10 kW/m
Distance between tines	up to 2.00 m
Overload protection	shearbolts or hydraulic system

### 7.3.7 Literature

See literature for chapter 7.0.

Harrison, H.P. and R.P. Atkins, 1981. Rodweeder soil forces from field measurements. Transactions of the ASAE, 24(3): 590-592,597.

NN, 1978. Rod weeder - what it does, how it works. World Farming, 20(7): 58-59.

## 8.0 'MPLEMENT COMBINATIONS

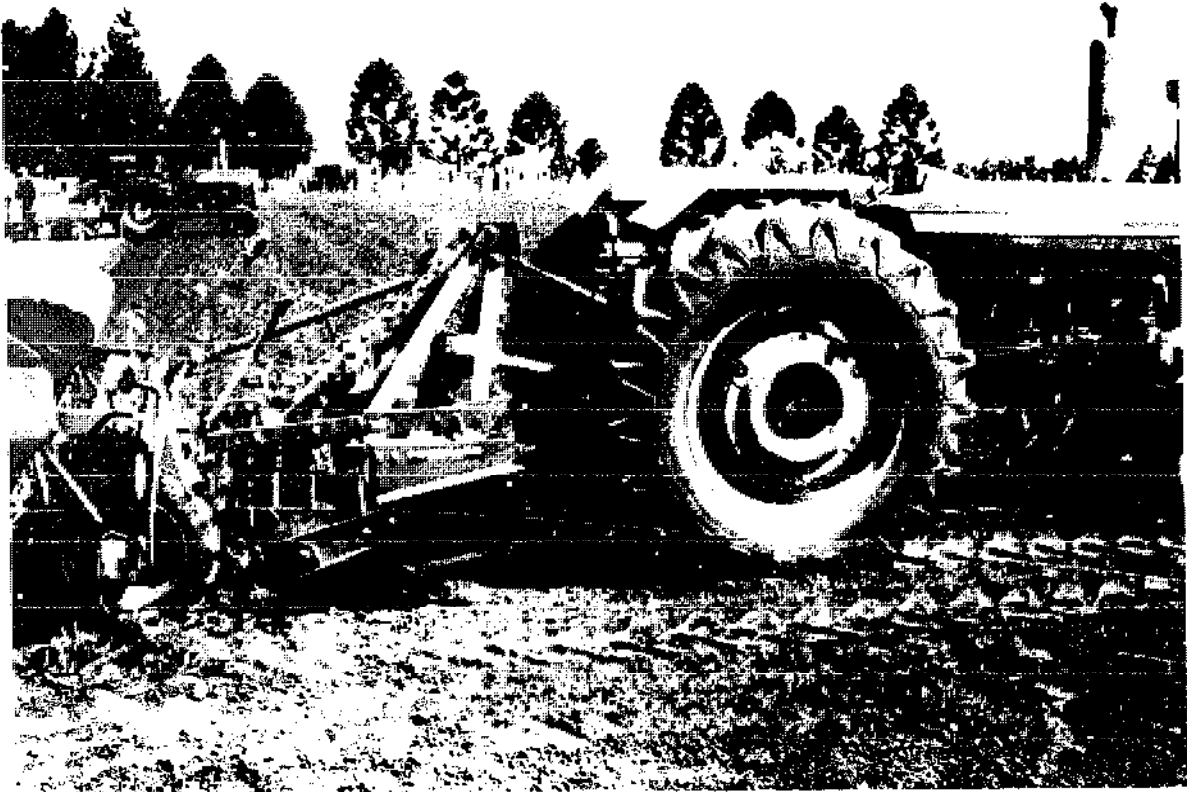

Generally speaking, individual implements have only a limited range of applications and so attempts are increasingly being made to combine separate implements with different functions for the following reasons:

- to reduce the number of passes over the fields,
- to save time,
- to obtain a specific loosening, crumbling, mixing and (re-)compaction action on the soil,
- to make the equipment more versatile.

Research is being carried out all over the world with the aim of reducing or rationalizing soil tillage under the slogan: "As little as possible, as much as necessary". These matters are usually referred to under the general heading of "Minimum Tillage".

By amalgamating different tillage operations and using combinations of highly efficient implements it becomes possible to use machinery under the optimum conditions for trafficability and workability. This causes the minimum structural damage by wheel-tracks, minimum wear on the implements and minimum energy requirements.

Some serious disadvantages of combinations of equipment should, however, be mentioned:

- The ranges of conditions under which the various elements of a combination work most satisfactorily may differ; for example, the optimum moisture range for the entire unit is narrower than for the individual tools;
  - Combination equipment is more expensive, usually requires large tractors and is complicated and thus more difficult to operate and adjust.
- These factors are even more important in less developed countries.

Combinations of implements can be assembled for various purposes but, on a general level, two essentially different groups can be distinguished:

1. Combinations for loosening the deeper layers of the soil while, at the same time, intensively tilling a surface layer.
2. Combinations for seedbed preparation. The best possible seedbed (specific for the crop, soil and climate) can be created with the minimum number of passes by arranging various shallow-working implements or tools one behind the other.

Table 12 summarizes the methods which can be applied in a temperate humid climate.

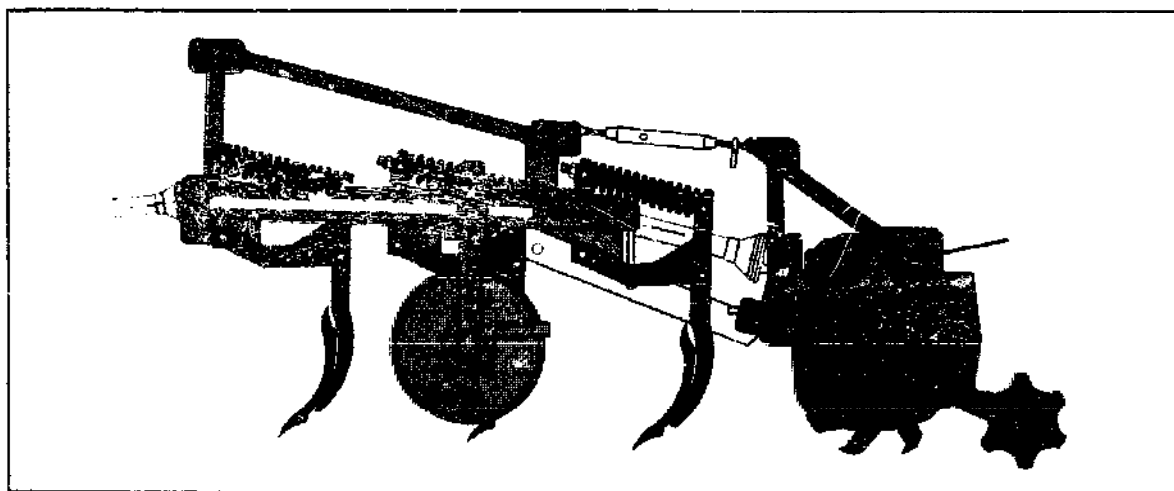

*Fig. 126. Combination of chisel plough with rear-mounted rotary tiller.*



## 8.1 Seedbed Preparation in one Operation

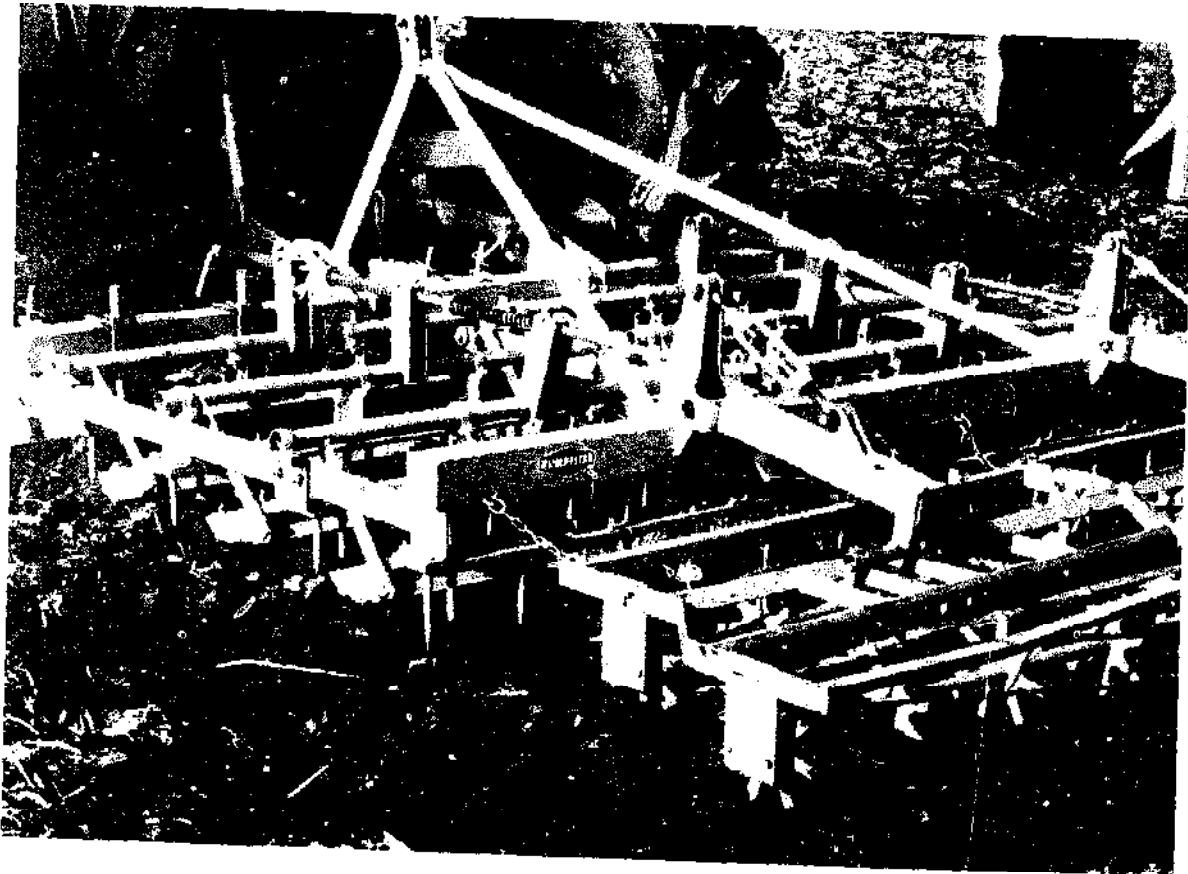

Combinations of implements for deep loosening and shallow secondary tillage in one operation are used only in specific situations, e.g. when organic material (plant residue, green manure, etc.) has to be mixed uniformly on the surface and a seedbed is required. When performed at the same time as surface tillage the deep and coarse loosening of the soil (in certain cases, to the full depth of the arable layer) should improve the soil structure for water management by increasing the rooting space and soil pore volume.

A typical combination for this purpose is a chisel plough with rear-mounted tools (Fig. 127). The type of chisel plough should be chosen in keeping with the anticipated field conditions. The follow basic correlations apply:

	medium tillage	deep
Tine clearance	large	large
Furrow distance	20-25 cm	30-35 cm
Frame height	up to 75 cm	over 75 cm
Chisel angle (angle of attack)	approx. 60 deg	approx. 35 deg
Chisel type	wide (e.g. diamond-shaped)	narrow (e.g. pointed)

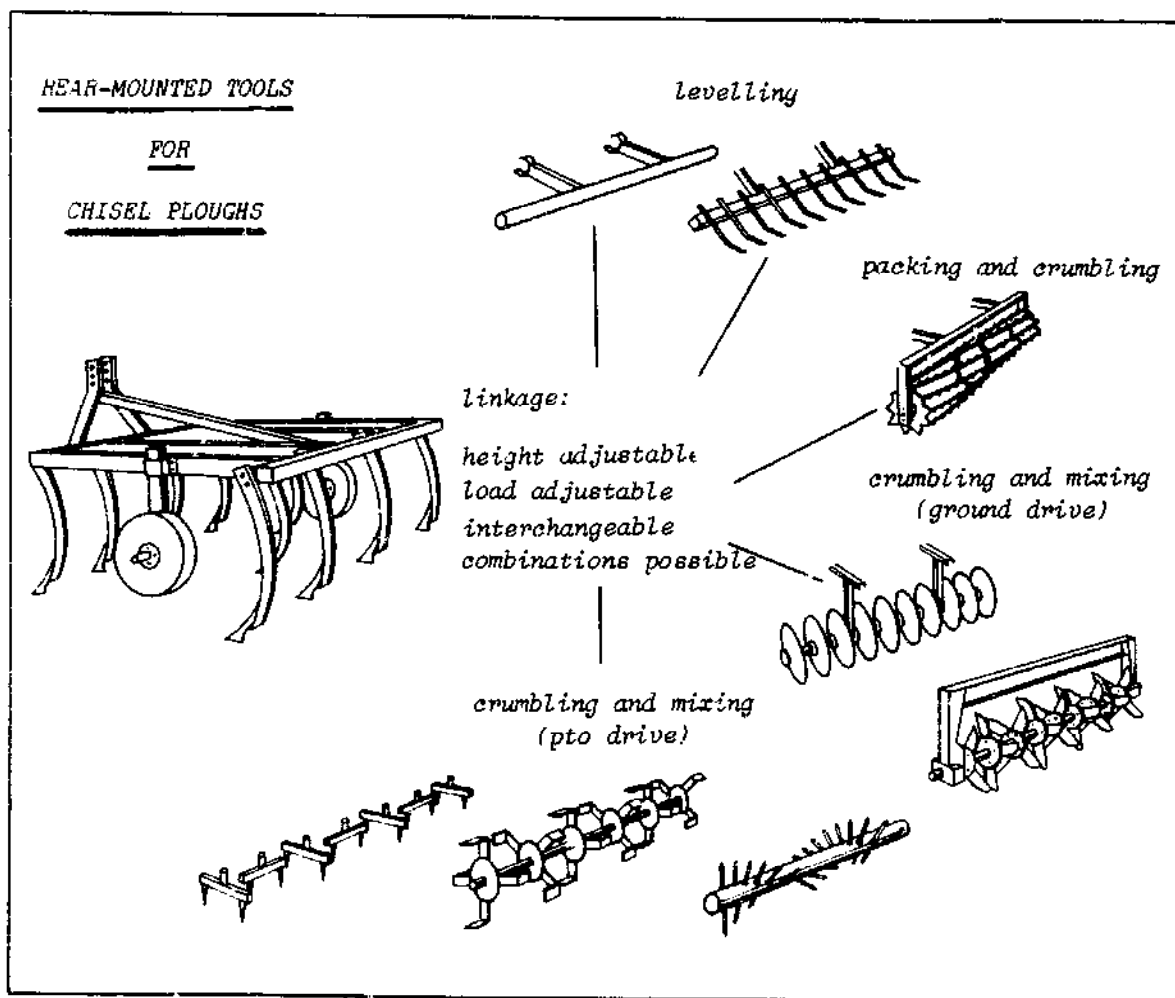

Fig. 127. A chisel plough with various rear-mounted tools. - Source: Eetler.

Tillage with the chisel plough produces a slightly corrugated surface owing to the larger furrow and tine distance. The tine and chisel shapes preferred nowadays bury organic material at a depth of only 15 cm even when the soil itself is loosened to greater depths. In addition, too much loosening on the soil often occurs.

So the chisel plough is frequently equipped with rear-mounted tools which vary in design and are used to level the soil, produce extra crumbling or packing and to mix it well with the organic material. Mention should be made of the beneficial effect of disc gangs on very heavy soils. Pto-driven tools for rear-mounting have recently become available (Fig. 126) in addition to trailing and rolling tools.

Rear-mounted implements have the advantage that their working depth is adjustable and they can carry extra weights and are interchangeable, thus allowing various combinations. With careful selection and arrangement of the tools, these implements can be adapted to a wide range of practical conditions. The rear-mounted tools should not pulverize the soil too intensively in tropical regions with a risk of erosion. If they do, rapid re-establishment of a plant cover should be ensured.

crop	sowing/seedbed preparation after plough.	comb. with pl.	sowing/rotary tillage without plough.	direct drilling without plough.
cereals	packer light cultivator recipr. hoe, rotating hoe, tine rotor, all combined with fertilizer application	complete system, combining: ploughing fertilization shallow tillage broadcasting rear-mounted drill for plough	full-width rotary tiller with mounted drill. strip tillage by rotary tiller with mounted	triple disc equipment killing of sod with herbicides
row crop	strip tillage and combined precision sowing	complete system, (as above) with precision drill	as above	special precision drill
interm. crop	as cereals	skim plough or rear-mounted tools.	as above, or combined with chisel plough or disc harrow.	

Table 12. Sowing after reduced-tillage techniques.

## 8.2 Combinations for Seedbed Preparation

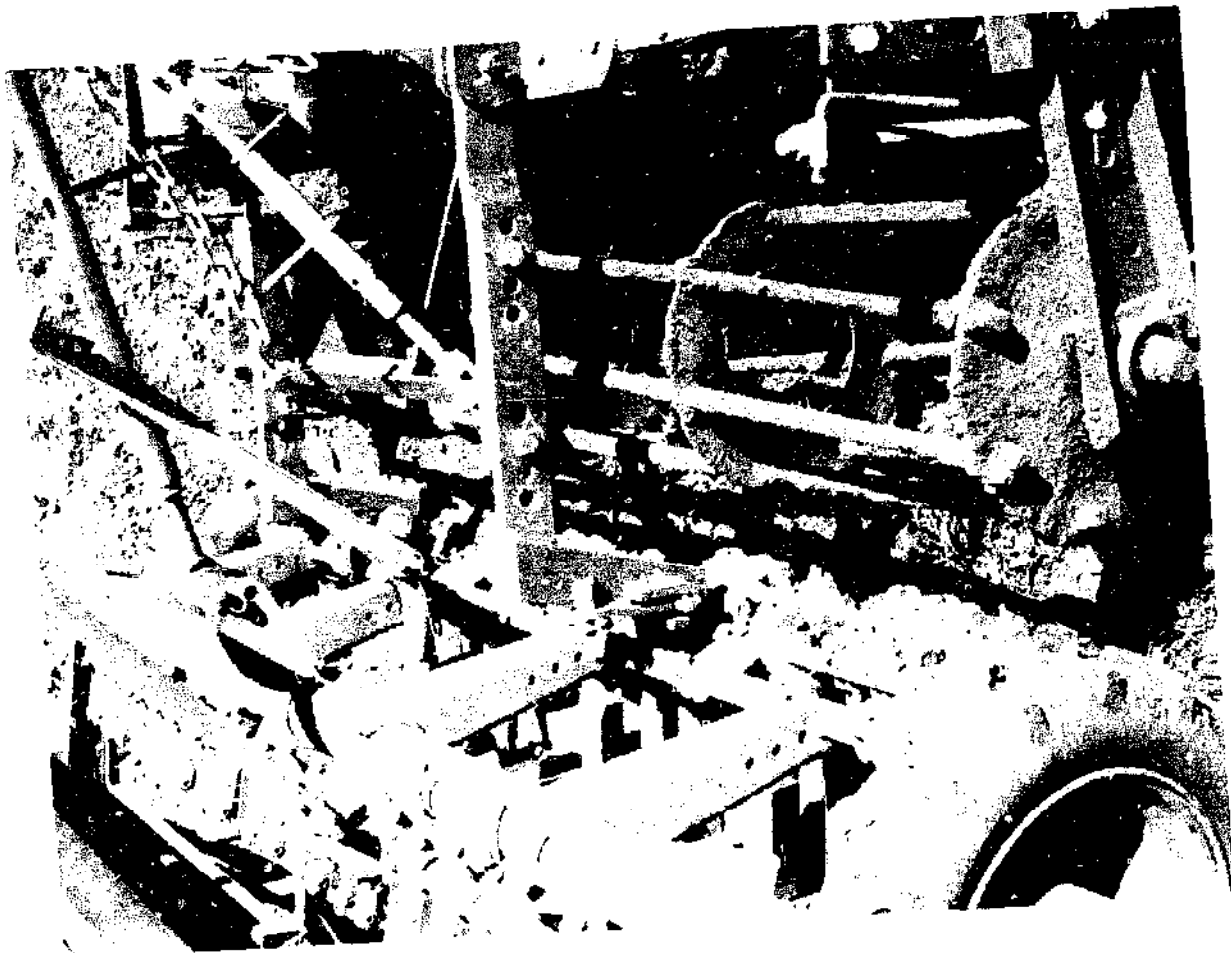

Combinations of implements for preparing seedbeds can be distinguished according to:

- the arrangement of the individual implements, and
- the number of tools set one behind the other.

With the basic arrangement the front tools loosen the surface of the soil while the rear tool(s) produce adequate pulverization and, when necessary, recompact the soil. The following implements can be combined in keeping with the objectives and prevailing conditions:

#### seedbed combination

##### front-mounted tools

##### rear-mounted tools

light cultivator	flex. tine cultivator	rigid tine harrow	rigid tine harrow	rolling harrow	packer	roller
---------------------	--------------------------	----------------------	----------------------	-------------------	--------	--------

The simplest combination consists of a light cultivator with a rolling harrow mounted directly to the frame (Fig. 128 top). The main support for the cultivator is provided by the roller. An infinitely variable adjustment system allows a precise setting of the working depth and ensures an adequate load on the roller. Support wheels are recommended on very loose soils. In a simpler form the crumbling roller can be mounted to the cultivator by a spring-loaded parallelogram system.

This combination is characterized by a simple, relatively inexpensive and sturdy construction, high reliability and versatility and can be used on almost every soil. A working depth of 10 cm is advisable because of the wide furrow distance (approx. 10 cm). Light cultivators cause problems in the case of crops requiring a very shallow seedbed (e.g. sugar-beet or rye).

Combinations of harrows with various rear-mounted tools require a special type of support frame (Fig. 128 center) to:

- provide proper guidance for front- and rear-mounted tools,
- allow precise depth control even at high speeds,
- permit the load to be adjusted separately on the individual tools.

Supporting frames with toolbars are now preferred. The rear-mounted tool is hitched to the front tools by short chains. With this arrangement the front tools are mounted between the front toolbar and the rear-mounted tools and so have little lateral movement. This permits high travel speeds and precise depth control.

When separate toolbars are used for front- and rear-mounted tools these tools can move independently but precise depth control then becomes difficult because the harrows may start jumping if the speed is too fast. When choosing the implements care must be taken to ensure that the depth of the front tools can be set at the required range of 3-8 cm which is usually done by means of spindles or hydraulic cylinders from the supporting frame.

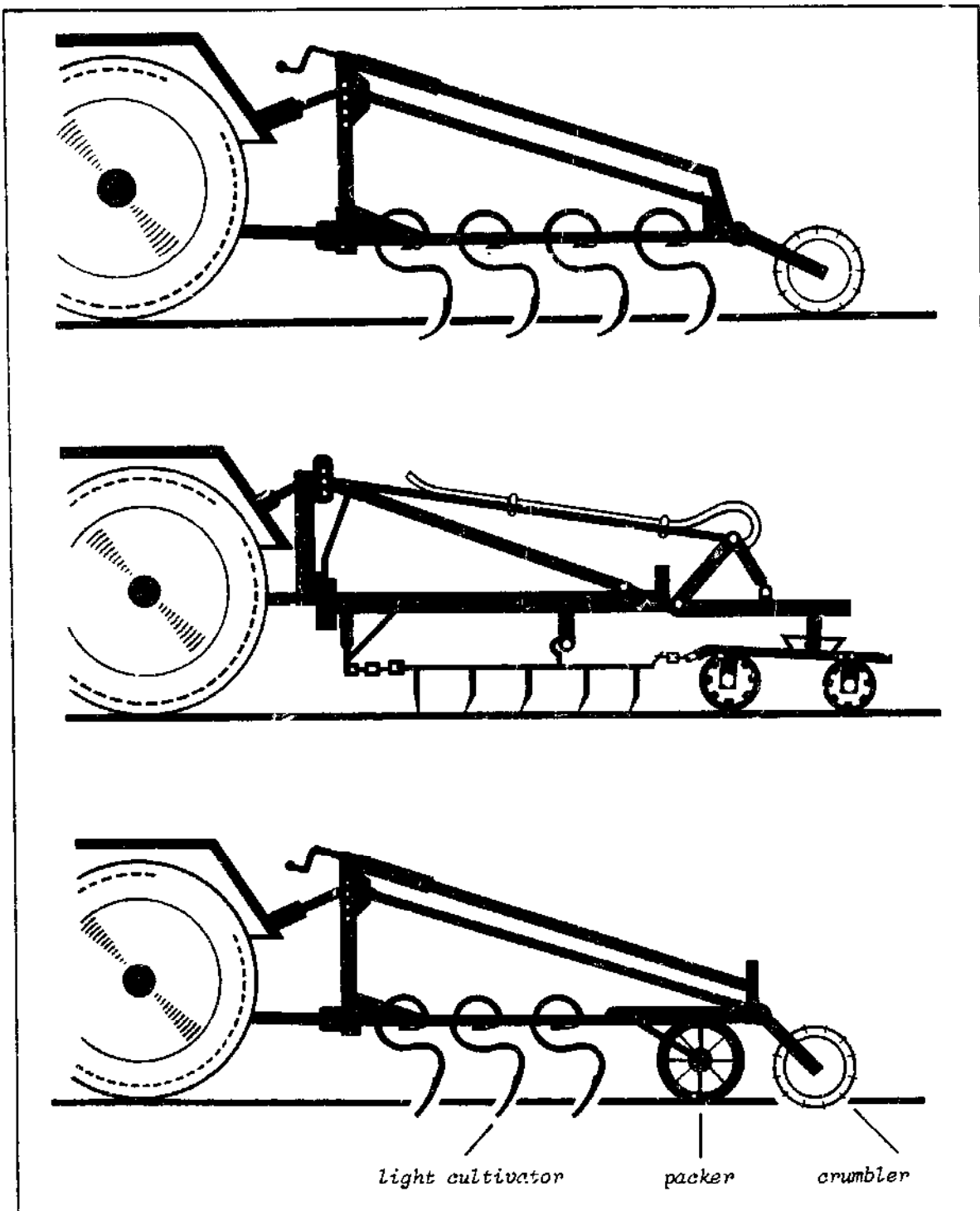
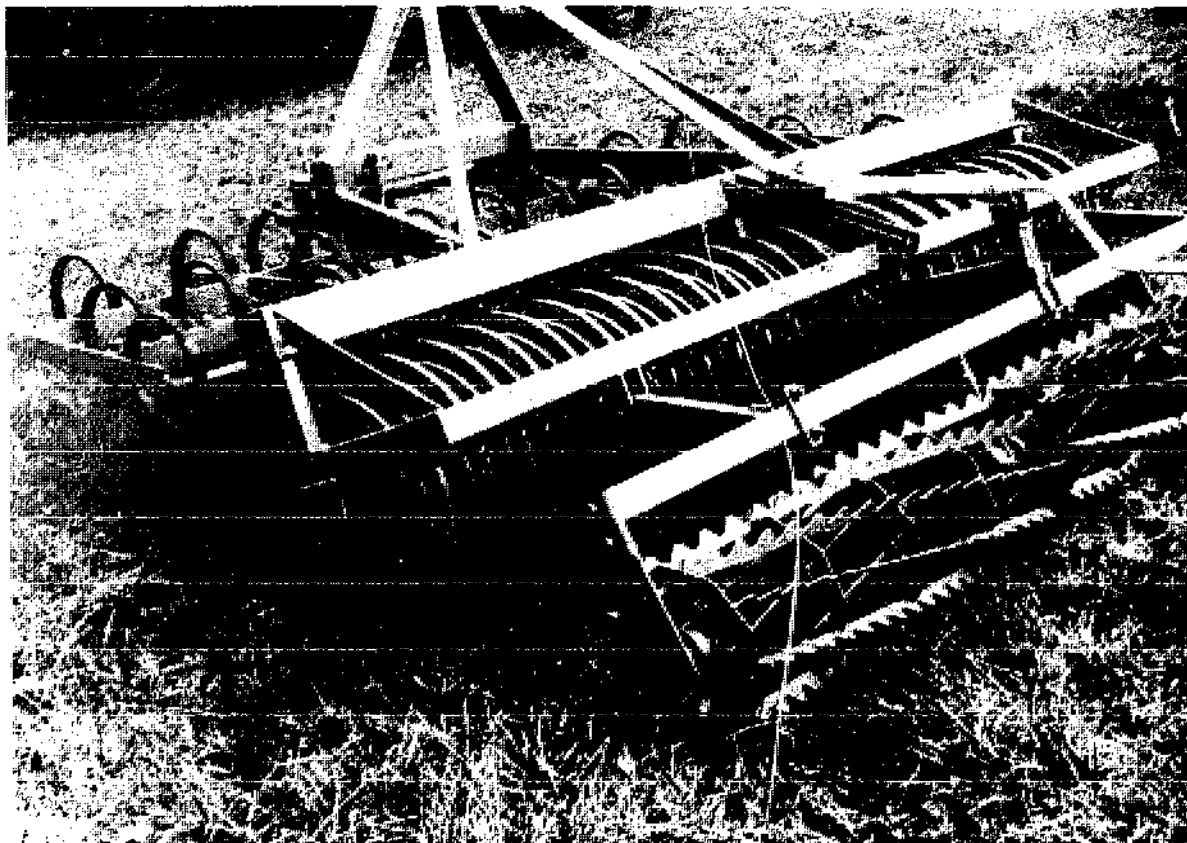

Fig. 128. Seedbed combinations with packer roller (top), suspending frame (center) and front- and rear-mounted tools (bottom).

## Multiple combinations

Dual combinations produce a satisfactory effect under normal conditions. The compaction is often inadequate on light and very loose soils but packers can be mounted between front- and rear-mounted tools ("triple combinations", see Fig. 128, bottom, and Fig. 129) for such conditions. This arrangement improves the mechanical consolidation of the soil and provides sufficient contact between the surface and deeper layers. The tools may also be arranged in the following order: tine harrow, rolling harrow and crumbling packing roller.



*Fig. 129. Triple combination of light cultivator, packer and roller.*

## Use of the combinations

The implement combinations must be carefully chosen to achieve the required efficiency when the field is being prepared and to adapt to the site and the types of soil and plants. The following aspects should be taken into account:

- A small number of operations: implement combinations are used so that the soil is tilled in as few passes as possible, thus reducing the compaction of the field by traffic to a minimum. The wide range of available combinations offers sufficient potential.
- High travel speed: the implements forming modern combinations are designed to perform well at high speeds. The speed for both groups of tools should be at least 8 km/h and the optimum effect of the tools can be ensured only at such speeds.

- Correct working width: the working width of the combination must match the power available from the tractor. In the event of uncertainty, it is better to work at the optimum speed with a slightly narrower combination rather than working with a combination which is too wide and produces an unsatisfactory effect owing to the low speed.
- Sufficient drawbar performance of the tractor: the various combinations have different power requirements. For chisel plough combinations approx. 5-8 kW per tine is required when working at medium depths while at full depth (to the bottom of the arable layer; 25-35 cm) 10-12 kW/tine should be used. Seedbed combinations require approximately 11-15 kW per metre of working width. It is advisable to use cage wheels or dual-mounted tyres, especially for seedbed preparation. This prevents damage from the load and slippage and improves the efficiency of the drawbar power.

### 8.2.1 Literature

- Bukhari, S.B., S. Pal, L. Laszio and B.T. Devrajani, 1981. Performance of tillage implement combinations. *AMA*, 12(3): 33-36.
- Heege, H.J., 1978. Getreidebestellung aktuell; Bodenbearbeitung, Saetechnik, Kombination von Arbeitsgaengen. *DLG*, Frankfurt, pp. 142.
- Neuber, E.K., K. Koeller and E. Rabius, 1975. Geraetekompositionen fuer Saatbettbereiten, Saen und Bestellen. *Landtechnik* 30(2): 52-58.
- Renaud, J., 1980. Travaux combines et semis direct. *Motorisation et Technique Agricole*, 21: 7-23.



## 9.0 SPECIAL IMPLEMENTS FOR ANIMAL TRACTION



### Introduction

As mentioned earlier, tillage equipment suitable for animal traction will not be examined in detail. This subject is given exhaustive treatment by Munzinger (1982) and FAO (1972) with reference to African conditions.

Two aspects do, however, justify a brief discussion of the subject in this book:

1. A large number of farms throughout the world use animals for farm-work the heaviest being the tillage operations. In Asia approximately 98% of the farms have only animal traction.

2. No dramatic change in this situation can be expected in the near future in view of the economic situation of the vast majority of the developing countries. The introduction of engines and tractors is very difficult in those countries due to the lack of capital, inadequate infrastructure, etc.



9.1 The Draught Animals

The animals used for draught farmwork are: oxen, buffaloes, horses, mules, cows and, less frequently donkeys, camels and elephants.

The choice of animals at any particular location does, of course, depend upon the climatological, ecological, sociological and historical factors. Oxen are the main source of power in Asia and the Middle East and in some parts of Latin America. Though used for draught in Western Europe, horses are employed only for riding and transport in many parts of the world; they are, however, used for draught in a few places in South America.

When it comes to using and keeping animals some major aspects which affect the available power and efficiency are:

- Health. In some cases no animal draught is available because of the presence or risk of disease, as in some African regions where the tsetse fly causes serious diseases (trypanosomiasis). Fertile areas with potential for agricultural production are not exploited because of this disease.
- Breed. Each animal has certain characteristics which determine how suitable it is for specific functions, such as milk or meat production, draught work or combinations of different purposes. Preference should usually be given to local breeds because they are accustomed to the prevalent conditions.
- Weight. This depends very much upon the type of animal, breed, age health and nutritional condition and greatly affects the potential draught power. As a rule of thumb, it can be assumed that an animal can exert 10-20% of its own body weight as draught power (see Chapter 9.2).
- Sex. Oxen are generally more suitable; bulls are often difficult to handle and train while cows are less strong (lower weight) but walk faster. Well-fed cows may be used and even dairy cows can work for a few hours a day without any serious effect upon their milk yield. The animals should not be used around calving time.
- Nutritional condition. The condition of the animals depends to a large extent upon their food both during and outside their working period. "Maintenance feeding" during the non-productive period (the dry season in semi-arid regions) is important. The food supply is often limited and the animals are weak at the start of the rainy season which is precisely when the demand for labour is greatest.  
The land required for fodder production may cause serious problems; up to 30% of the total land on a farm using draught animals is needed to grow fodder when no other (external) sources, such as forest, wild shrubs, or the banks of roads, canals or trenches, are available. Land is often expensive in irrigated regions and unexploited areas are rare; there is often competition between the production of human foods, cash crops and fodder (e.g. in Egypt). Generally speaking, 9-10% of the energy absorbed by cattle in the form of food is available for work (10-12% in the case of horses). Concentrated food is an advantage during periods of (hard) work.
- Training. After proper training animals will provide a maximum traction after about one year. Training includes the development of specific muscles which is achieved in the course of the work itself.
- Variations in the required draught. Animals tire much more quickly when pronounced variations occur in the required draught.
- Harnessing. The harnessing method is largely determined by local conditions and customs.
- Environmental conditions. High temperatures and air humidity impair the animals' performance. They often work early in the morning or late in the afternoon.
- Soil condition. When a soil is very loose or soft (muddy) much of the animals' energy will be required simply for walking so that less is available for draught work.

## 9.2 Tillage Equipment

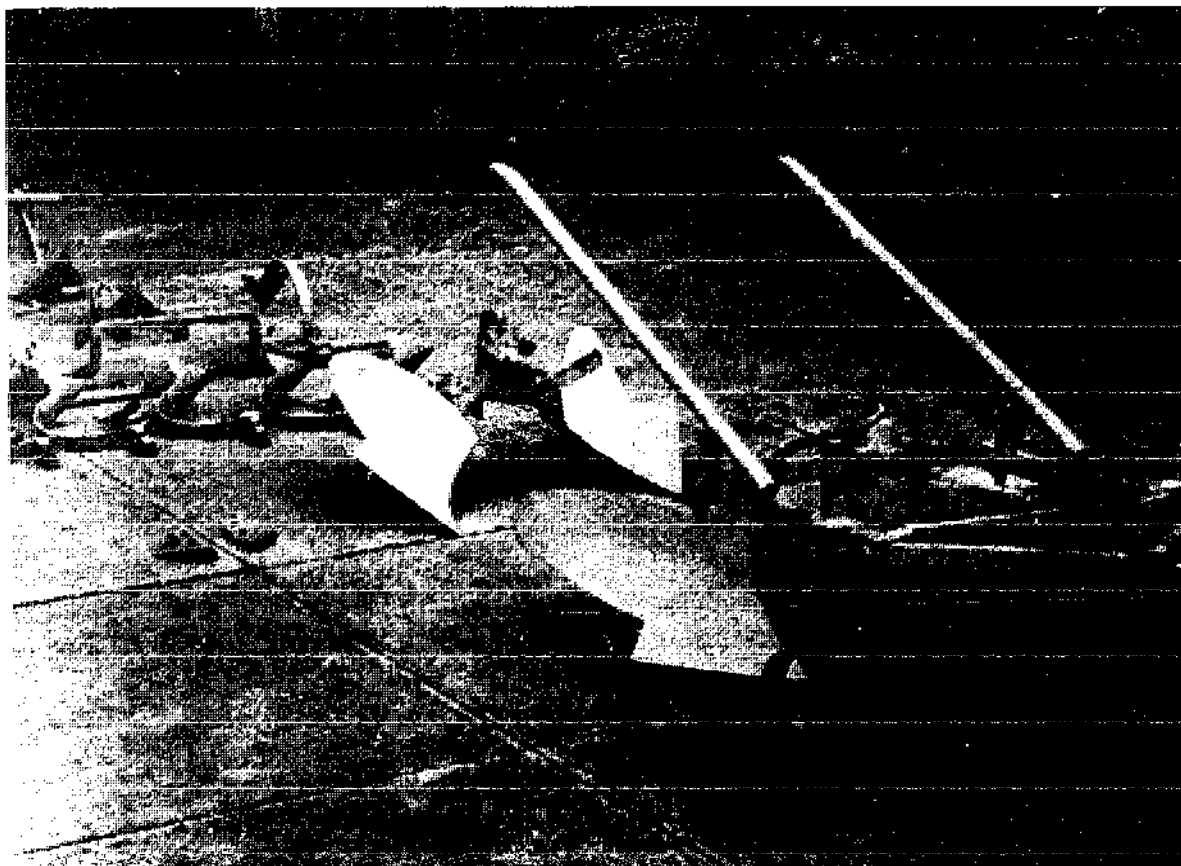

The principles of tillage implements for animal traction are similar to those for motorized traction except for the following (obvious) restrictions:

- every implement is dragged or trailed and its tools are essentially passive or, in some cases, driven by the soil resistance;
- the forward speed is low (no more than 2-3 km/h);
- their size is limited by the available draught power. Under tropical conditions a pair of oxen can provide 80-140 kgf at walking speeds of 1.6-2.5 km/h. At 2.0 km/h 80 kgf is equivalent to 0.435 kW (100 kgm/s = 0.98 kW). Well-fed and correctly harnessed animals have a much better power:weight ratio. Draught animals are capable of producing considerably more power than the above figures over short peak periods.
- implements with active tools driven by the wheels cannot be used. The travel speed is too low or, when a high transmission ratio is required, the torque on the ground-drive mechanism becomes too high.

Positive factors favouring the use of these implements are that they are usually produced by local blacksmiths, are simple to handle and repair and are not dependent upon the availability or price of fuel.

The accessibility of the fields, which may seriously restrict the use of tractors, causes scarcely any problems when animals are used.

Draught animals do not usually compact the soil to any harmful extent.

The range of implements available for animal traction will be discussed in this chapter but only limited details will be given.

### 9.2.1 Implements For Primary Tillage

Three types of implements for primary tillage can be distinguished:

1. The breaking or wedge plough, commonly known as the "ard".
2. The soil-inverting or mouldboard plough.
3. The cultivator or chisel plough.

1. As mentioned briefly in the introduction, the ard is the most basic, commonly used implement, for shallow tillage in semi-arid regions. The plough (scarcely more than a hook) does not turn the soil and therefore leaves (uprooted) vegetation on the surface to dry out.

The main parts of the plough, such as the beam, handles, and even the body, are (still) made of wood while the share or point is produced from iron or steel. Owing to its simple design the plough is easy to operate and adjust; only adjustment of the depth is possible by changing the hitch point or the angle between beam and the body. A detailed description of a large number of different ard ploughs is given by Hopfen(1969).

To achieve a satisfactory result the soil should be tilled with the ard more than once; this is usually done crossways and, where possible, with increasing depth. The depth is limited to about 10 cm and depends to a large extent upon the type and condition of the soil.

2. The characteristic features of the mouldboard plough are that it produces an open furrow and inverts the soil. The earliest types of mouldboard ploughs for animal draught were probably based on the ard. The

beam, handles and part of the body are often made of wood. Only the share and, possibly, part of the mouldboard are iron. Since the inversion and lateral movement of the soil slice results in a sideways pressure on the plough body, a landside has to be mounted, usually combined with a sole to take up the downward pressure. The hitch in front of the beam can be adjusted to find the optimum line of pull.

Ploughs made entirely of iron or steel evolved from the simple design and have become the most commonly used ploughing implements in the western (temperate) nations. Instead of a fully balanced plough (swing plough), the beam is supported in front (near the hitch) by a skid or, more often, a wheel. Further developments have been the mounting of coulters and the use of reversible bodies.

A considerable amount of research is still being carried out in many institutions to improve and adapt the design of animal-drawn ploughs, mainly with a view to reducing the energy required and partially so that one animal can be used instead of two which are often unavailable.

3. In the form used for primary tillage with tractors, cultivators and chisel ploughs are rarely animal-drawn although some modified types of the ard may be regarded as chisel ploughs. Cultivators are used for animal traction but generally for secondary or inter-row tillage (see Chapter 2.3).

(4.) It should be noted that disc ploughs are rarely used for animal traction, mainly because:

- Disc ploughs do not penetrate the soil by their own weight but need extra weights. This makes them very difficult to handle.
- The side thrust produced by the disc cannot be absorbed by a passive landside (as with the mouldboard) and so a furrow wheel would be required.
- The mounting of the rotating disc is complicated (bearing) and expensive.

### 9.2.2 Implements For Secondary Tillage

Harrows are also used with animal traction for tillage operations after the main tillage, as mentioned in Chapter 3.

Essentially, the same types of harrows are available, such as the spike-tooth and spring-tooth harrows.

A special type widely used in India is the blade harrow. This consists of a steel blade, 40-100 cm wide, whose sides are attached to a (wooden) beam and which is pulled horizontally through the soil a few centimetres beneath the surface. The roots of weeds are cut while the surface is scarcely disturbed. It is an effective tool in dry regions. Other types of harrows are the rake or comb harrow and the rotary harrow or hoe which is used for wet paddy cultivation; they have been described briefly in Chapter 6. Small V-type disc harrows and ridgers (mouldboard type) are also available for animal traction.

### 9.2.3 Multi-purpose Tool Carriers

The equipment described above includes traditional tools and implements as well as modern, improved or adapted versions. A new approach is the tool carrier (Fig. 130), a basic toolbar or frame to which various tools can be attached, such as plough bodies, cultivator tines, ridging bodies, weeders or harrows.

Extensive research into their practical applications has been carried out by a number of institutions, such as ICRISAT (India), NIAE (U.K.) and CEEMAT (France).

Quite a number of tool carriers have now been developed, ranging from very simple types consisting of a basic beam, handles and (sometimes) a support wheel, to the riding types with two wheels with pneumatic tires and quite sophisticated hitch and lift systems.

The following aspects should be considered with regard to the use of tool carriers:

- Costs. Unfortunately, the cost of many types of tool carriers still prevents their widespread use by small farmers. The carrier and a range of tools should be no more expensive than the total cost of the individual implements.
- Construction. The basic frame should be strong enough to allow the implement to be operated with the tools attached and with the maximum animal draught. This imposes heavy demands upon the materials and the design. The tool mounting system must be simple and sturdy and the tools must be arranged so that they do not produce excessive lateral forces.
- Weight. This should be kept down to a level which does not cause handling problems, especially for models with one or no wheels.

Unfortunately, these implements are still not in common use owing to their relatively high price.

A recent review of tool carriers (including a list of manufacturers) is given by Bansal and Thierstein (1982).



*Fig. 130. Multi-purpose tool carrier.*



#### 9.2.4 Literature

- Amadi, B.C., 1978. Improved hoes in Nigerian agriculture. *Agricultural Systems*, 3(2): 81-84.
- Amorim Pouce, C. de and A. Almeida de Souza, 1982. *Bibliografia de mecanizacao agricola; tracao animal*. EMBRAPA-DID, Brasilia, Brasil, pp. 309.
- Bansal, R.K and G.E. Thierstein, 1982. Animal drawn multi-purpose tool carriers. *AMA*, 13(4): 27-36.
- Beck, S., 1976. Die Mallas - zwei verbesserte landwirtschaftliche Geraete. *Entw. und landlicher Raum*, 5: 14-15.
- Berhane, T., 1979. Study on the use of ox-drawn equipment for the production of cowpea, maize, cotton and groundnut under irrigation in the Middle Awash Valley - Melka Werer. *Agricultural Engineering Bulletin*, No. 1, pp. 13.
- Boyd, J., 1976. *Tools for agriculture; a buyer's guide to low-cost agricultural implements*. Intermediate Technology Publications Ltd. London, pp. 173.
- FAO, 1972. *The employment of draught animals in agriculture*. (Translation of original French version by CEEMAT). FAO, Rome, pp. 249.
- Hopfen, H.J. and E. Biesalski, 1978. *Small farm implements*. FAO Agricultural Development Paper, No. 32, pp. 79.
- Hussain, M.D. and M.R.I. Sarker, 1978. Performance studies of country ploughs in Bangladesh. *AMA*, 9(3): 55-60.
- ICRISAT, 1981. *The animal drawn tool carrier*. ICRISAT Information Bulletin, No. 8, pp. 8.
- Inns, F.M., 1980. Animal power in agricultural production systems with special reference to Tanzania. *World Animal Review*, No. 34: 2-10.
- Madramootoo, H., 1972. Tillage practices and tillage equipment for rice production on small family farms. In: *Report on the meeting of experts on the mechanization of rice production and processing*, Paramaribo, Surinam, 1971. FAO, Rome: 64-68.
- Mazed, M.A., K.C. Roy and M.A. Satter, 1980. Performance evaluation of modern and traditional ploughs in Bangladesh. *AMA*, 11(4): 38-40.
- Muchiri, G., 1979. Development of tillage and equipment systems in Kenya. *Proceedings of the Appropriate Tillage Workshop*, IAR, Zaria, Nigeria. Commonwealth Secretariat, London, U.K.: 107-115.
- Munzinger, P. (Ed.), 1982. *Animal Traction in Africa*. Schriftenreihe der GTZ No. 120, Eschborn, Fed. Rep. of Germany, pp. 490.

#### 9.2.4 Literature

- Amadi, B.C., 1978. Improved hoes in Nigerian agriculture. *Agricultural Systems*, 3(2): 81-84.
- Amorim Pouce, C. de and A. Almeida de Souza, 1982. *Bibliografia de mecanizacao agricola; tracao animal*. EMBRAPA-DID, Brasilia, Brasil, pp. 309.
- Bansal, R.K and G.E. Thierstein, 1982. Animal drawn multi-purpose tool carriers. *AMA*, 13(4): 27-36.
- Beck, S., 1976. Die Mallas - zwei verbesserte landwirtschaftliche Geraete. *Entw. und landlicher Raum*, 5: 14-15.
- Berhane, T., 1979. Study on the use of ox-drawn equipment for the production of cowpea, maize, cotton and groundnut under irrigation in the Middle Awash Valley - Melka Werer. *Agricultural Engineering Bulletin*, No. 1, pp. 13.
- Boyd, J., 1976. *Tools for agriculture; a buyer's guide to low-cost agricultural implements*. Intermediate Technology Publications Ltd. London, pp. 173.
- FAO, 1972. *The employment of draught animals in agriculture*. (Translation of original French version by CEEMAT). FAO, Rome, pp. 249.
- Hopfen, H.J. and E. Biesalski, 1978. *Small farm implements*. FAO Agricultural Development Paper, No. 32, pp. 79.
- Hussain, M.D. and M.R.I. Sarker, 1978. Performance studies of country ploughs in Bangladesh. *AMA*, 9(3): 55-60.
- ICRISAT, 1981. *The animal drawn tool carrier*. ICRISAT Information Bulletin, No. 8, pp. 8.
- Inns, F.M., 1980. Animal power in agricultural production systems with special reference to Tanzania. *World Animal Review*, No. 34: 2-10.
- Madramootoo, H., 1972. Tillage practices and tillage equipment for rice production on small family farms. In: *Report on the meeting of experts on the mechanization of rice production and processing*, Paramaribo, Surinam, 1971. FAO, Rome: 64-68.
- Mazed, M.A., K.C. Roy and M.A. Satter, 1980. Performance evaluation of modern and traditional ploughs in Bangladesh. *AMA*, 11(4): 38-40.
- Muchiri, G., 1979. Development of tillage and equipment systems in Kenya. *Proceedings of the Appropriate Tillage Workshop*, IAR, Zaria, Nigeria. Commonwealth Secretariat, London, U.K.: 107-115.
- Munzinger, P. (Ed.), 1982. *Animal Traction in Africa*. Schriftenreihe der GTZ No. 120, Eschborn, Fed. Rep. of Germany, pp. 490.

- Musa, H.L., 1979. Traditional tillage operations and development and use of animal drawn equipment. Proceedings of the Appropriate Tillage Workshop, IAR, Ibadan, Nigeria. Commonwealth Secretariat, London, U.K.: 29-36.
- Nag, P.K. and P. Datt, 1979. Effectiveness of some simple agricultural weeders with reference to physiological responses. Journal of Human Ergology, 8(1): 13-21.
- NN, 1978. New bullock-drawn disc plough. Indian Tobacco Journal, 10(1): 7.
- Nolle, J., 1975. Le tracteur animal. Machinisme Agricole Tropical, No. 51: 46-56.
- Richard, J.F., 1982. Quinze années de diffusion de la traction bovine au Sénégal. Le cas des unités expérimentales du Sine Saloum (1966-1980). Machinisme Agricole Tropical, 77: 22-38.
- Wijewardene, R., 1978. Appropriate technology in tropical farming systems. World Crops, May/June 1978: 128-129,132,134.

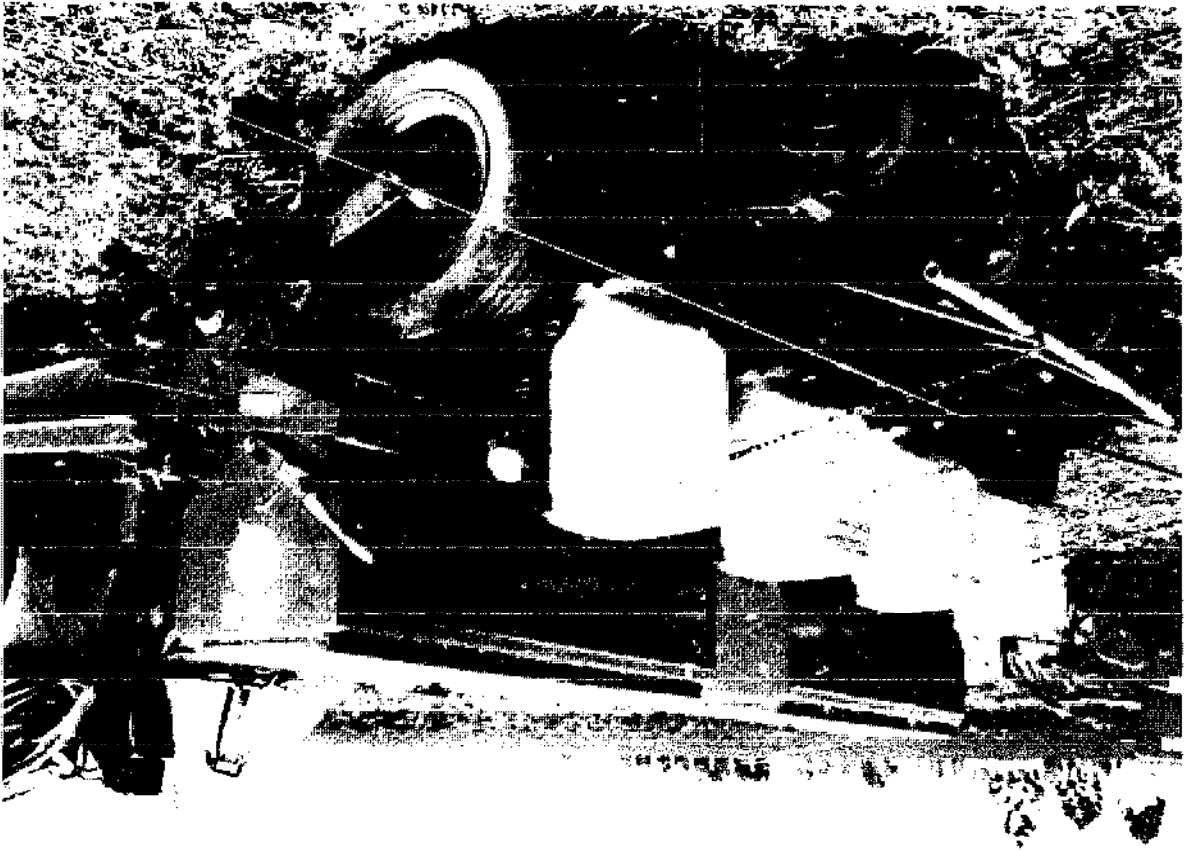

10.0 ZERO TILLAGE - DIRECT DRILLING

The development of desiccant herbicides which are deactivated in the soil (such as paraquat and diquat) and, more recently, the systemic herbicide glyphosate have made it possible to omit (under certain conditions) the soil tillage operations which are carried out basically for weed control purposes. The seed is sown directly in the unprepared soil. The first trials with this method were disappointing because of technical constraints (sowing machinery) and it was only when the triple-disc sowing machine became available that the area under zero tillage expanded rapidly in the U.K., the south of the USA, South America, Australia and other countries.

The advantages of the direct drilling system are that it:

- prevents erosion: the soil surface remains closed,
- reduces the number of operations, i.e. savings in man-hours, machine-hours and energy,
- allows correct scheduling, i.e. use of the best sowing period,
- avoids water losses by evaporation,
- conserves and, possibly, increases the amount of organic matter by reducing aeration,
- increases the water and nutrient holding capacity,
- preserves the soil structure,
- causes lower soil temperatures (less damage to seeds),
- improves the biological activities in the soil (arthropods, bacteria).

Direct drilling systems are certainly not suitable for all conditions (soil, climate) and crops. The production method has to be completely adapted to the system and, quite frequently, even the crop rotation has to be changed. The essential prerequisites for a direct drilling system are:

- sufficient water infiltration and drainage capacity in the soil;
- availability of sufficient plant residue to ensure good soil cover when erosion can be expected;
- the straw residue must be well distributed and chopped to ensure that the sowing equipment functions correctly;
- no compacted layers impede the root growth in the soil profile;
- no serious structural damage, e.g. as a result of harvest operations with heavy machinery (including transport) when the soil is wet (the soil on headlands and near the field entrance often has to be loosened);
- no perennial weeds which are hard to control;
- weed seeds and shattered grain should have had sufficient time to germinate, thus permitting successful control. This is particularly difficult in dryland areas. Cropping in monocultures is often the only solution;
- a smooth soil surface; undulating fields (e.g. with erosion rills) should first be levelled;
- careful (usually multiple) spraying for weed control, requiring accurate adjustment of the nozzles and correctly spaced series of passes (extremely difficult);
- skilful farm management and operators; more skilled personnel required than on farms using conventional systems;
- initial favourable conditions for the crops, e.g. by higher inputs of fertilizer.

The advantages and disadvantages of direct drilling in tropical and subtropical soils have not yet been sufficiently examined. Here again, it is true to say that experience acquired in cooler areas cannot be automatically applied to tropical climates. The surface cover has a detrimental effect on temperatures in cooler climates (e.g. in the northern part of the USA, causing delay in the growth of maize) but is beneficial in

tropical areas where soil temperatures of more than 50 degrees Celsius may be found in the seed zone.

Very heavy soils and soils with poor drainage do not allow direct drilling or, at least, not without previous mechanical loosening. Direct drilling appears to be an interesting alternative for soils susceptible to erosion despite the constraints mentioned above; it is essential for the yields to remain at consistently high levels over long periods.

The zero-tillage system is best suited for grain crops; when harvesting root crops, the soil has to be manipulated which wipes out most of the advantages of this system.

It is essential that suitable herbicides are available for use with direct drilling systems.

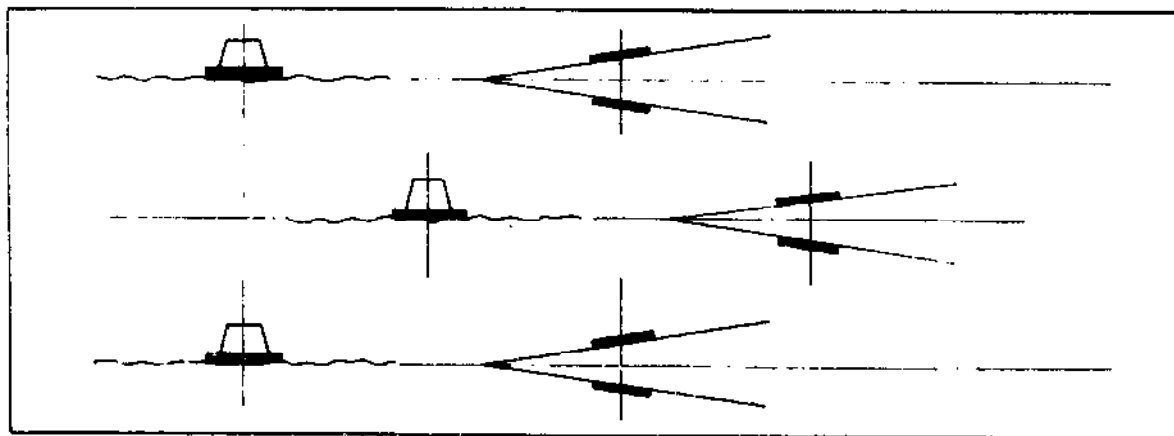

Fig. 131. Disc arrangement of a triple-disc direct drilling machine.

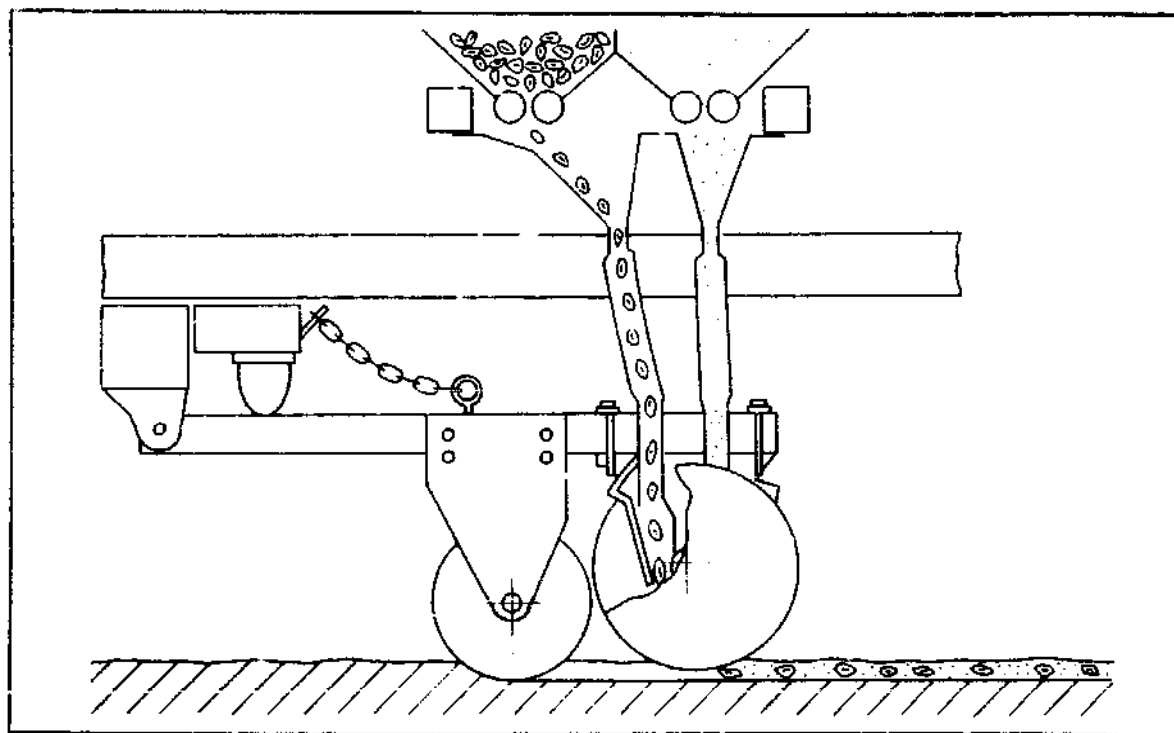

Fig. 132. Direct drilling unit (side view).

The machinery available for this system cannot be examined in detail here. The best known sowing equipment is the triple-disc machine: a front-running, usually fluted coulter cuts through plant residue and opens up the soil while a second pair of plain discs (usually spring-mounted) forming a V-shape, make the furrow (Fig. 131) in which the seeds and fertilizer are placed (Fig. 132). No special tool is used for closing the furrow. The capacity of this type of machine is about 1 ha/h with a working width of 2.5 m.

Other types of direct seeders use tined furrow openers instead of discs. On these models the tines are usually widely spaced and they may be fitted with (low pressure) press wheels to close the furrow. These machines are less expensive than the disc types but are more likely to become clogged with trash.

A rotary tiller with a tine rotor and mounted sowing equipment may also be used for direct drilling. The working sets on the rotor cut a narrow slot for each row. The machine has a lower capacity and this system cannot really be described as "no-tillage" since a (very narrow) strip is tilled.

It is vital for the direct drilling machine to perform accurately if the system is to be permanently used.

A no-tillage system may be an interesting alternative for developing countries because the shifting cultivation technique is in many respects similar to a no-tillage or reduced-tillage system. Simple equipment for planting (jab planters, sharp sticks, small hoes) and for applying herbicides has been developed but is not generally available.

A change to "manual no-tillage" may give more satisfactory results than a switch to conventional systems with large tractors and expensive equipment but, of course, only if the above conditions are fulfilled.



*Fig. 133. Direct drilling machine.*

### 10.0.1 Literature

An enormous volume of literature on zero or reduced-tillage systems is available and only a small selection of the most recent and most relevant literature is given below:

- Aubineau, M. and J.F. Billot, 1980. Le semis direct; itineraires techniques. Bulletin d'Information du CNEEMA, No. 265: 41-52.
- Elliot, J.R., 1978. Are tractors limiting the expansion of direct drilling? ARC Research Review, 4(3): 76-78.
- Gibbon, D., J. Harvey and K. Hubbard, 1974. A minimum tillage system for Botswana. World Crops, 26(5): 229-234.
- Hamblin, A.P., 1980. Changes in aggregate stability and associated organic matter properties after direct drilling and ploughing on some Australian soils. Australian Journal of Soil Research, 18(1): 27-36.
- Holway, J., 1978. Abschied vom Pflug? Entwicklung und Zusammenarbeit 4/78: 15-16.
- Hughes, K.A. and C.J. Baker, 1977. The effects of tillage and zero-tillage systems on soil aggregates in a silt loam. Journal of Agricultural Engineering Research, 22(3): 291-301.
- IAPAR, 1981. Plantio direto no estado do Parana. Fundacao Instituto Agronomico do Parana, Londrina, Parana, Brasil, pp. 244.
- ICI, 1980. Handbook of direct drilling. ICI Plant protection Division, Farnham, U.K., pp 56.
- Kahnt, G., 1976. Ackerbau ohne Pflug. Ulmer, Stuttgart, pp. 128.
- Maurya, P.R. and R. Lal, 1980. Effects of no-tillage and ploughing on roots of maize and leguminous crops. Experimental Agriculture, 16(2): 185-193.
- Moody, T., 1980. The rotary injection planter a minimum tillage tool in production. Appropriate Technology, 6(4): 4-6.
- Musick, J.T., A.F. Wiese and R. Allen, 1977. Management of bed-furrow irrigated soil with limited- and no-tillage systems. Transactions of the ASAE, 20(4): 666-672.
- NN (Various authors), 1970. Papers on zero tillage. Special issue, Netherlands Journal of Agricultural Science 18(4): 219-324.
- NN, 1980. Rice direct drilled in pasture and stubble. World Crops, 32(1): 27.
- Phillips, R.E., G.W. Thomas and R.L. Blevins (Eds.), 1981. No tillage research; research reports and reviews. Univ. of Kentucky, Col. of Agric. and Agric. Res. Station, Lexington, pp. 151.



- Phillips, R.S. and H.M. Young, 1973. No-tillage farming. Reimann Assoc., Milwaukee, Wisc., pp. 224.
- Pidgeon, J.D., 1960. A comparison of the suitability of two soils for direct drilling of spring barley. Journal of Soil Science, 31: 581-594.
- Renaud, J., 1980. Travaux combines et semis direct. Motorisation et Technique Agricole, 21: 7-23.

11.0 TRENDS AND NEW DEVELOPMENTS

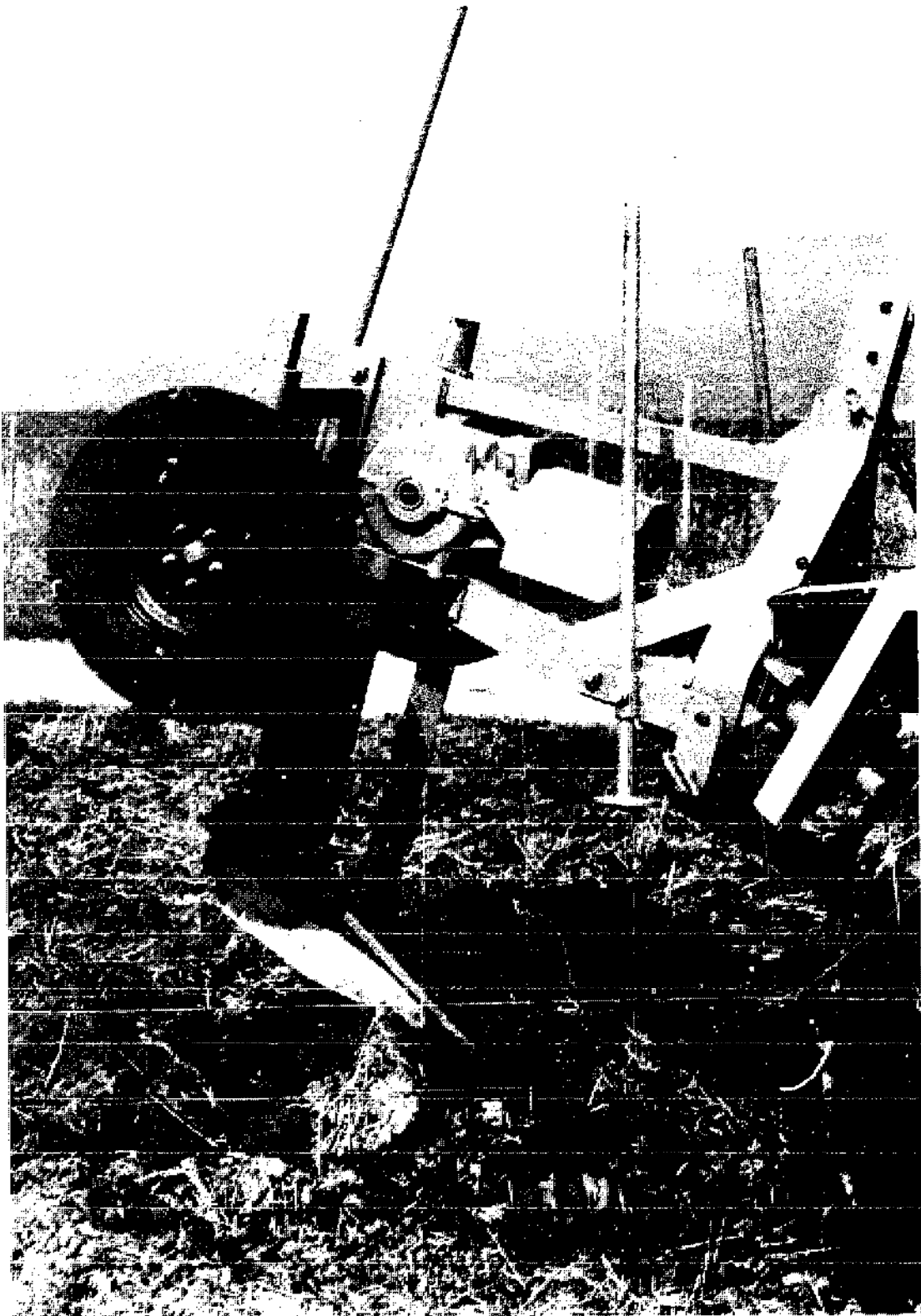

Constant adaptation, development and improvement of equipment and systems is necessary in the soil tillage sector because of a large number of factors. Some of these factors (which have either a direct or indirect influence are:

- the increasing need for food caused by the growing world population;
- progress in the biological-technical (including breeding, plant nutrition and protection), mechanical and organizational sectors;
- a change in living and eating habits;
- a change in outlook (including a different attitude towards the environment);
- the shortage and rising prices of raw materials and energy.

Any adaptation of tillage methods to these changes should include not only the improvement of machinery in terms of its performance, operation, servicing, life and ease of maintenance and repair (reducing the relative energy requirement) but also the development of entirely new systems, such as the direct drilling systems which were made viable by the use of herbicides.

### Some new implements

Compared with other implements used in modern agriculture, the plough, cultivator, harrow, drag and roller have remained unchanged for centuries without causing any problems. This is because their basic design is very simple, they suffer little wear and the maintenance and servicing requirements are very low. The number and diversity of tillage implements available on the markets all over the world are now so great that it is scarcely possible to list them all. This situation is caused not only by marketing and patents but also by the wide range of production methods and conditions, the use of agro-chemicals, the availability of energy and, last but not least, a better understanding of the processes in the soil.

Inverting tillage with the plough is no longer unrestrictedly advocated. The disadvantages (risk of erosion, water losses, loss of organic matter) have become quite obvious, particularly in the climatic regions on which this book concentrates. It is impossible to over-emphasize the importance of conserving the soil fertility in view of the constantly increased areas under monocultures and the systems with higher cropping intensities. Only very careful soil tillage can produce profits from the high input of labour, capital and materials, especially fertilizers. In the USA these activities are grouped together under the heading of "conservation tillage". A careful balance between mechanical weed control and the use of herbicides not only saves costs but also reduces pollution of the environment with agro-chemicals. The need to use energy thriftily requires a continuous assessment of the entire production system. Since of all field operations soil tillage consumes the most energy, a very critical evaluation is necessary. The greatest savings can undoubtedly be achieved by omitting or combining operations, as the term "minimum tillage" indicates. The scope of this book allowed only a brief examination of minimum tillage in Chapter 10 but mention should also be made of strip tillage (as part of the seedbed preparation) since this system offers specific advantages as regards efficient water use and weed control.

Basically, however, the aim of these activities should be to optimize (rational tillage) rather than minimize. The further development of tools and implements so that they make more efficient use of energy will probably be given more attention in the future.

The disadvantage of drawn implements as regards the transmission of power (low efficiency, structural damage to the soil because of slippage) and the desire for more specific intensive and controlled mechanical soil tillage (in one operation, if possible) are matters receiving constant attention from machine designers. This has already resulted in implements with active rotating or oscillating tools, such as the rotary plough, spading plough, oscillating subsoilers, as well as the rotary tiller and rotating and reciprocating hoe which have already proved successful.

Attempts to reduce the draught force requirement by using high-frequency vibrations have not yet achieved any lasting success. Non-metal tools, coatings for tool surfaces (Teflon), lubrication of tool surfaces (liquid polymers) and air cushions between the soil and steel surfaces have all been tried as means of reducing the friction and adhesion on tool surfaces. The experience so far gained indicates that none of these systems can be recommended for (sub-)tropical regions because of their unsatisfactory life, the high costs involved in applying surface lubrication and the limited availability of the lubricants.

A clear trend can be observed towards implements with different tools, especially combinations of passive cutting and loosening tools with active mixing and crumbling tools. The objective is to obtain deep loosening and intensive shallow mixing and crumbling in such a way that the flow of soil through the active tools is, in part, supplied by the passive tools. A typical example of this trend is the chisel plough/rotary tiller combination developed in the U.K. (NIAE) and West-Germany (Hohenheim). It must be remembered, however, that pto-driven tools require not only better construction, operation and maintenance but also high-powered tractors and suitable operating conditions. Unfortunately, all of these factors are problematic in less developed tropical countries.

Another reason for the (further) development of soil tillage implements is the harmful soil compaction resulting from the weight placed on the soil by heavy tractors, implements and trailers. Consequently, pto-driven implements for loosening the subsoil are being used more frequently. In many places experiments are being carried out with production systems in which no traffic at all passes over the production areas and permanent tracks are used for all operations ("controlled traffic").

New developments can also be observed in connection with the recompaction of loosened soils when insufficient time is available to allow natural consolidation. Mention can be made of the plough with a rear-mounted packer, the "tiltrotor" (a rear-mounted tool for the plough with a driven rubber roller) and the "vibro-packer" which uses packing discs vibrating at a frequency of approximately 60 Hz.

Very wide implements and implements operated at high travel speeds have been developed, partially because of the high wages paid to tractor drivers in the industrialized countries but also because of the need for correctly timed soil tillage operations. This trend will probably be perceptible in the developing countries too in the future. Pto-driven implements can also be adapted to higher travel speeds (by changing the number of revolutions). These implements make it possible to work heavy soils with a wider range of moisture contents.

In the past it has been possible to observe a move away from multi-purpose implements (such as the wedge plough) with a wide range of applications

towards special-purpose implements over the entire field of agricultural mechanization. The use of special-purpose implements does, however, require that a large number of implements are available with a high capacity over a comparatively short period of use. This is feasible only for large farms and/or cooperatives. This trend is less marked in relation to soil tillage. Great care must be taken when choosing this type of implement for tropical and subtropical developing countries.

The objectives set for the development of soil tillage implements which are particularly suitable for use in tropical and subtropical regions must be:

- conservation and treatment of vulnerable soils in order to maintain the level of soil fertility,
- a positive effect upon the water balance,
- careful use of the limited supplies of energy,
- high output during periods favourable to agricultural operations (short periods in close crop rotations),
- aligning the requirements for operating the implements with the skill and experience of the potential users (combined with further training),
- creating servicing and repair facilities in countries with a low level of development,
- preserving the level of employment in agriculture.

The next chapters will briefly discuss a number of implements chosen from the many recent developments. It is impossible at this stage to give a final assessment of those implements because they have only recently been put to practical use.

Unfortunately, none of these implements fulfils the particular requirements of the vast majority of small and very small farms in developing countries.

### 11.0.1 Literature

- Dalleine, E. and J.F. Billot, 1982. Evolution recente des materiels de travail du sol. Bulletin d'information du CEMAGREF, No. 290-291: 15-34.
- Koeller, K. and R. Reich, 1979. Ergebnisse aus Untersuchungen an einer neuen Bodenbearbeitungsmaschine. Grundlagen der Landtechnik, 29(4): 125-130.
- Moore, M.A., V.A. McLees and F.S. King, 1979. Hardfacing soil-engaging equipment. Agricultural Engineer, 34(1): 15-19.
- Patterson, D.E., 1982. The performance of alternative cultivation systems. The Agricultural Engineer, 37(1): 8-11.
- Petersen, C.L., E.A. Dowding, K.N. Hawley and R.W. Harder, 1981. Field evaluation of the "chisel-planter" minimum tillage system. ASAE Paper, No. 81-1017, pp. 21.
- Schafer, R.L., W.R. Gill and C.A. Reaves, 1977. Lubricated plows vs. sticky soils. Agricultural Engineering, 58(10): 34-38.
- Zumbach, W., 1982. La preparation du sol sans charrue. Technique Agricole, 44(6): 253-260.
- Zumbach, W., 1982. Hat der Pflug ausgedient? Landtechnische Zeitschrift, 33(7): 1014-1017.

### 11.1 The Diamond Plough

As regards its functioning and use the diamond plough (Fig. 134) is very similar to the mouldboard plough. This plough has been the subject of considerable discussion since its introduction in 1973. It was designed primarily to cope with the problems produced by the use of increasingly larger tractors (and tractor tyres) and implements:

- The width and clearance of the furrow achieved with the current depth:width ratio of traditional mouldboards are no longer sufficient; the wide tyres of large tractors do not fit the furrows and so some of the loosened soil is recompactd.
- Multi-body mouldboard ploughs, especially the reversible type, are very heavy and the centre of gravity is located well away from the tractor so that the load on the front axle is greatly reduced and the tractor's steering is affected.



*Fig. 134. Diamond plough.*

The diamond plough is distinguished from the ordinary mouldboard plough by the fact that the furrow slice is diamond-shaped instead of rectangular. Consequently, the furrow is wider at the top, allowing more room for broad tyres (Fig. 135). There is less risk of recompaction even though the pressure on the soil at the bottom of the furrow is not reduced. Unlike the conventional mouldboard, the working width per body (35-50 cm) can be set quite independently of the depth. Sufficient inversion is obtained over the entire range of depth:width ratios from 1:1 to 1:1.4.

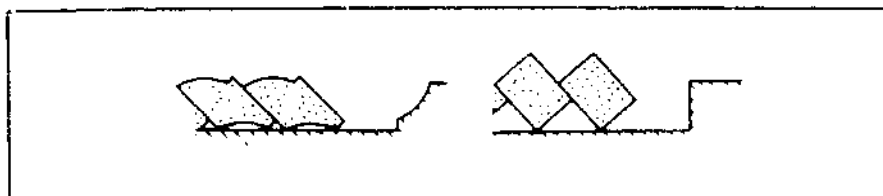
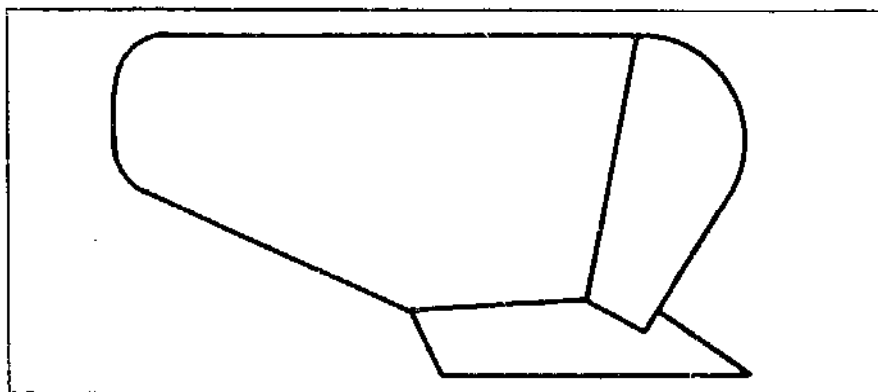

*Fig. 135. Cross sectional view of furrows made by a diamond plough (left) and a conventional plough (right).*

The clearance of the furrow is not always satisfactory since coulters cannot be used. In particular, problems may be expected to occur when large amounts of harvest residue are being ploughed in.

Owing to the different inversion process and the trajectory of the soil flow the length of the bodies can be less than the conventional bodies so that the plough's centre of gravity is closer to the tractor. The height of the frame must, however, be correspondingly greater than on conventional ploughs.

The plough bodies are cylindrical and marked by a shin which curves well out to the front (Fig. 136). The individual bodies do not have a landside and to ensure that the lateral guidance is still adequate a very large spring-loaded landside has to be fitted to the last body. Pointed shares are generally used to increase the grip of the plough.



*Fig. 136. Body of a diamond plough.*

Measurements which compare the performances of conventional mouldboards and diamond ploughs usually show that diamond ploughs require (slightly) less energy. The reasons for this difference have not yet been thoroughly investigated but it could be caused by the different soil flow, reduced soil crumbling, and by the lower rolling resistance of the tractor in the open furrow.

The diamond plough is available with 3 to 6 bodies as one-way and reversible type. The bodies are semi-mounted and mounted to the 3-point hitch.



## Literature

See literature for chapter 11.0.

Stoppel, A. and R. Reich, 1979. Vergleichende Untersuchungen an Rauten- und Normalpflugkoerpern. Grundlagen der Landtechnik, 29(3): 73-78.

Stubenbock, H.J., 1981. Untersuchungen ueber das Pflugen mit Rauterkoerpern. Grundlagen der Landtechnik, 31(1): 1-9.

## 11.2 Sweep Combined With A Pto-Driven Rotary Hoe

Attempts have recently been made to use the sweep plough, which was developed especially for dryland agriculture, for tilling heavy and moist soils. For this purpose the sweep is combined with pto-driven tools.

These implements are used for:

- stubble and primary tillage,
- working in green manure or other organic matter,
- preparing a seedbed,
- sowing, combined with tillage to form one operation,
- clearing grassland,
- weed control.

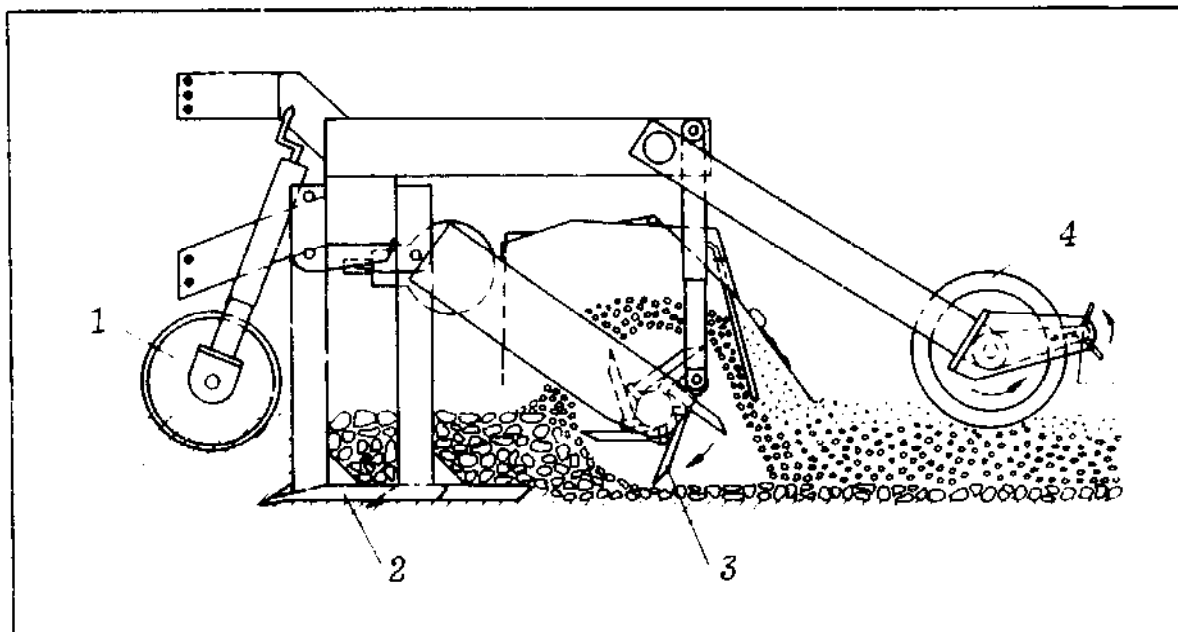

Fig. 137. The main parts of the "Justus":

- |                 |                    |
|-----------------|--------------------|
| 1. Disc roller, | 3. Tine rotor,     |
| 2. Sweeps,      | 4. Packing roller. |

Variants of this basic design are now available. Although similar designs can be obtained elsewhere (U.K. etc.), we shall describe two examples from West-Germany:

The "Justus", a complete unit comprising a sweep plough with a pto-driven rotary hoe (Fig. 137), and the "Weichel", a model which can be assembled from various parts including a sweep plough and a pto-driven rotary hoe (Figs. 138 and 139).

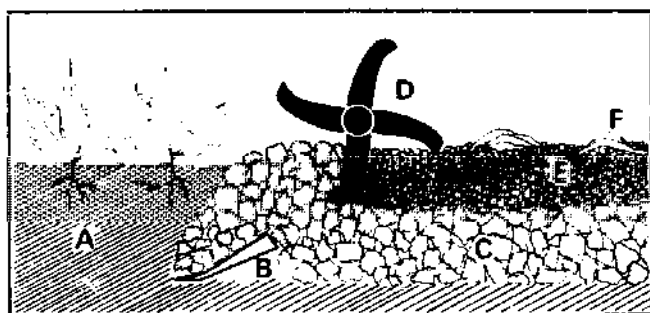
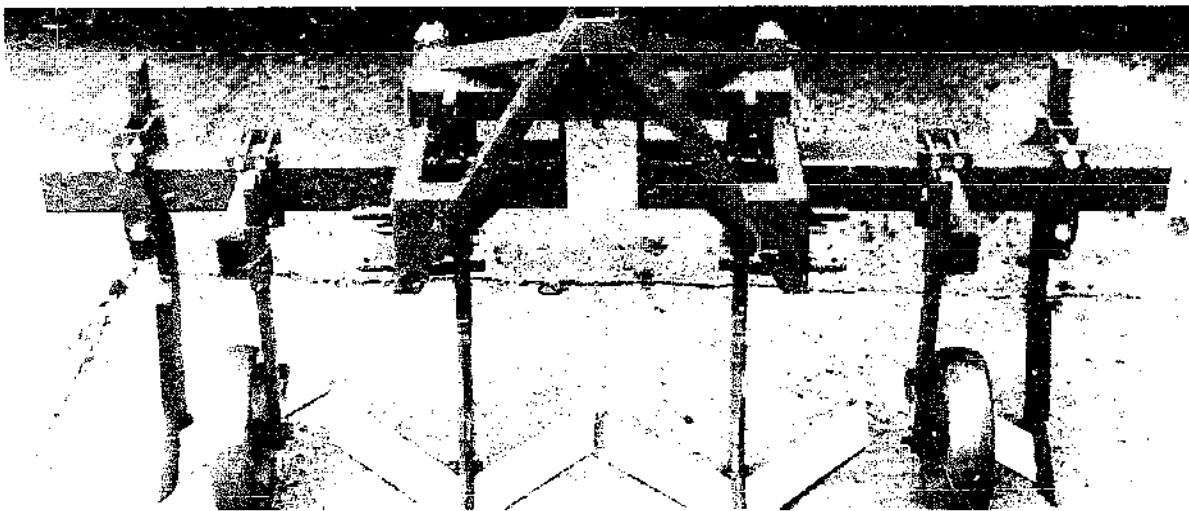

Fig. 138. Functioning of the sweep (B) with rotary hoe (D).



*Fig. 139. Sweeps of the "Weichel".*

The implements are designed for intensive soil tillage under difficult conditions. The combination of passive and active pto-driven tools and the numerous possible adjustments have produced a versatile and sophisticated machine. It must be used with higher-powered tractors and perform satisfactorily on heavy wet soils. The number of passes can, of course, be reduced but a relatively high proportion of the land is covered by wheel-tracks because of the small working width (about half the width of seedbed combinations suitable for similar tractors).

The Justus combination consists of a line of tools and elements arranged one behind the other (see Fig. 137). A disc roller placed in front controls the depth and produces a vertical separation of the soil. Behind this roller the wide sweep blades cut the soil over the entire working width at a depth of 5-40 cm. The separated soil slice is fed directly into a tine rotor fitted with pointed spoon-shaped tines (Fig. 140). This rotor can be rotated in either direction and its rpm can be adjusted.

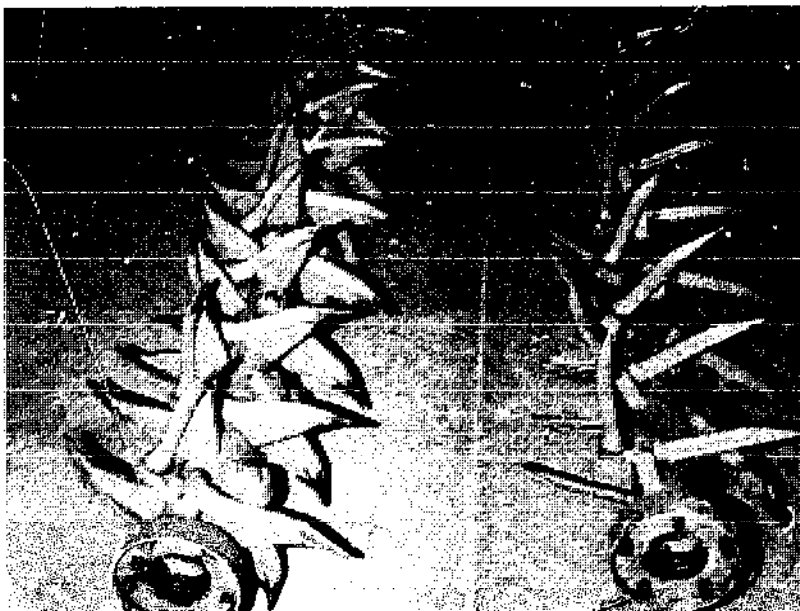

*Fig. 140. Tine rotor of the "Justus".*

A crumbling/packing roller mounted closely behind this unit helps to control the working depth (especially when the front disc roller is omitted) and recompacts the soil (Fig. 141). The roller is coated with Teflon and can be fitted with a counter-rotating scraper for use on sticky soils.

Like the Justus, the Weichel model must be mounted to the 3-point hitch but its sweeps are mounted on a compact toolbar with a 3-point coupling at the rear. So it is possible to mount the rotary hoe mentioned earlier or any other type of implement (possibly pto-driven), such as a second set of sweeps, sowing or planting equipment, etc. These machines have to be driven by heavy tractors and are therefore suitable only for large farms or cooperatives. The Weichel model may be used with lighter tractors because it can work in narrower strips, using a device which shifts the toolbar to a lateral position to obtain a close fit between successive passes.

Special care should be taken to preserve a coarse surface structure when working on soils susceptible to erosion.

The operation, adjustment and servicing of these machines are complicated and require highly-skilled personnel and supervision.

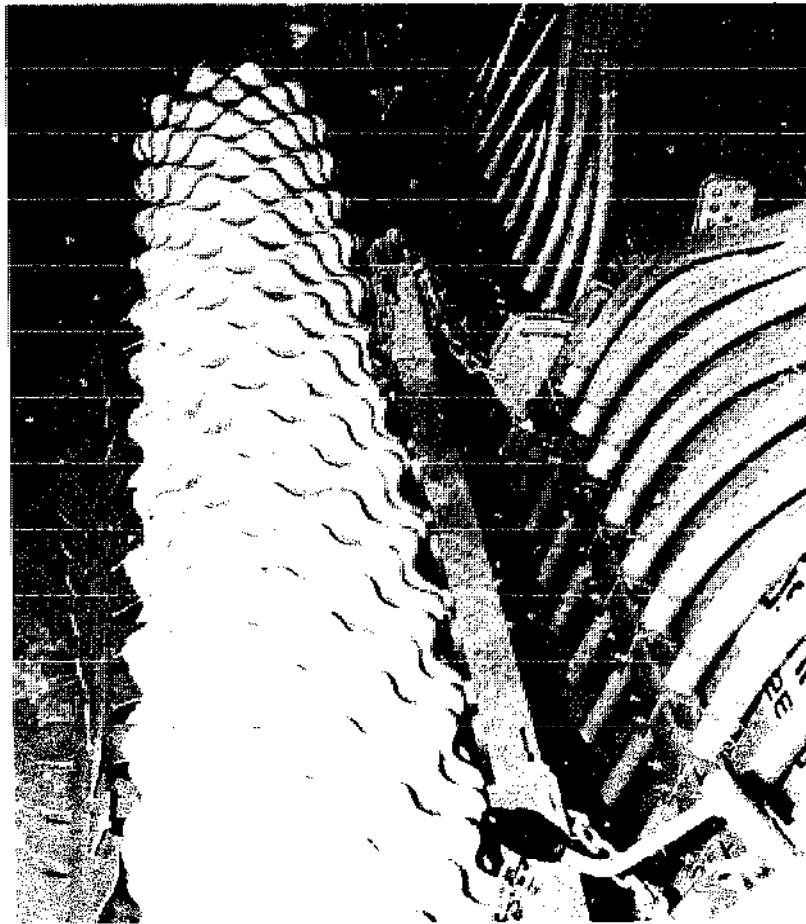

*Fig. 141. Packing-roller (Teflon coated) with rotating scrapers.*

## Technical data

	Justus	Weichel
Working width	2.10 and 2.60 m	0.80-3.00 m
Working depth: sweep	5-40 cm	5-35 cm
rotor	5-40 cm	2-15 cm
Working speed	3-9 km/h	
Nose angle	35 degrees	
Share lift angle	20 degrees	
Rpm of the rotor	200-580	adjustable
Weight	1200-1450 kg	
Rpm of pto	540 or 1000	540 or 1000
Power required	from 25 kW per m	from 30 kW
Overload protection:		
rotor	friction clutch	friction clutch
sweeps	shearbolts	shearbolts, spring loaded reset
Front disc roller, dia.	250 mm	
Rear mounted roller, dia.	450 mm	
Total length	2.20 m	varies
height	1.30 m	
width	2.50 or 2.90 m	

## Literature

See literature for chapter 11.9.

### 11.3 The Clod Breaker

Two types of implements for tilling hard dry soils will be discussed in this chapter - the "Multitiller" and the clod pulverizer.

#### The multitiller\*

Heavy implements are expedient for dry hard soils in the semi-arid and arid regions. The "Multitiller" (MT, Fig. 142) was developed for the following jobs:

- stubble tillage,
- seedbed preparation,
- levelling, mixing and packing,
- crumbling; pulverizing and breaking up clods,
- soil preparation and sowing in one operation.

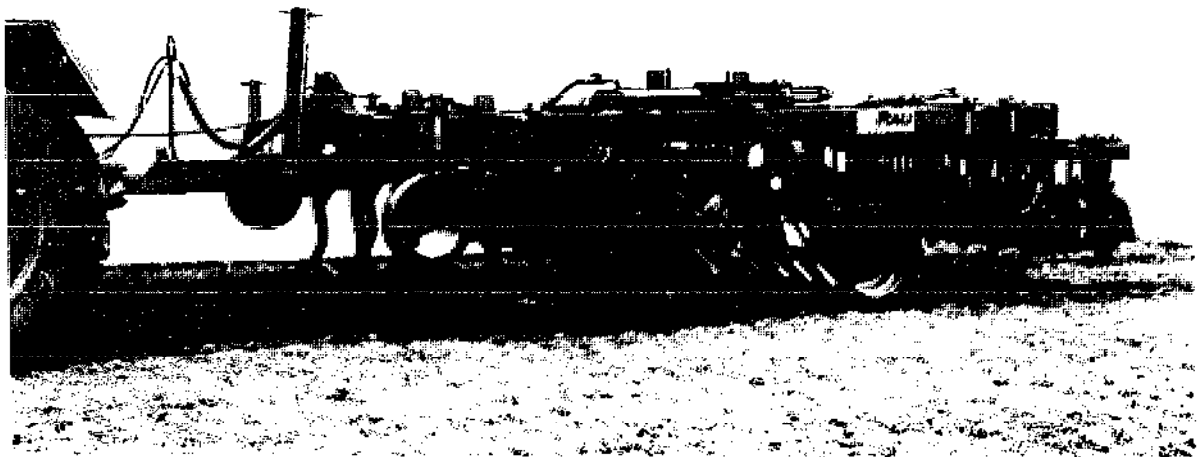

*Fig. 142. The Multitiller with 2-row chisel plough.*

The MT can be classified as one of the group of stubble tillage and seedbed preparation implements, as are the disc and rotary harrow. The machine is heavy and combines passive (rigid or spring tines) and active tools (rotating star-shaped discs). This design produces satisfactory destruction of clods and also cutting and compaction even on the dry soils of arid regions, which saves time and reduces the number of passes and wheel-tracks on dry and (under certain conditions) moist fields.

The functioning of the machine depends upon the type of tools which are mounted in rows perpendicularly to the direction of travel (Fig. 143). After the surface has been smoothed by a levelling tool (bar or rake) any coarse lumps are pulverised by two rows of "rotostars". The following rows of tines bring up clods which are fed to the two rows of "rotostars" at the rear of the unit. In the course of this operation smaller soil aggregates may fill cavities near the bottom of the furrow.

The MT is a trailer implement. Hydraulically operated (pneumatic) tyres are available for transport. The manufacturer gives the power required as 26 kW per metre of width which means that tractors in the medium and heavy class (up to 260 kW) are necessary for working widths of 2.5-6 m. Trailer implements of this size should be used only on suitably large fields.

\* "Multitiller" is the trademark of the RAU Company.

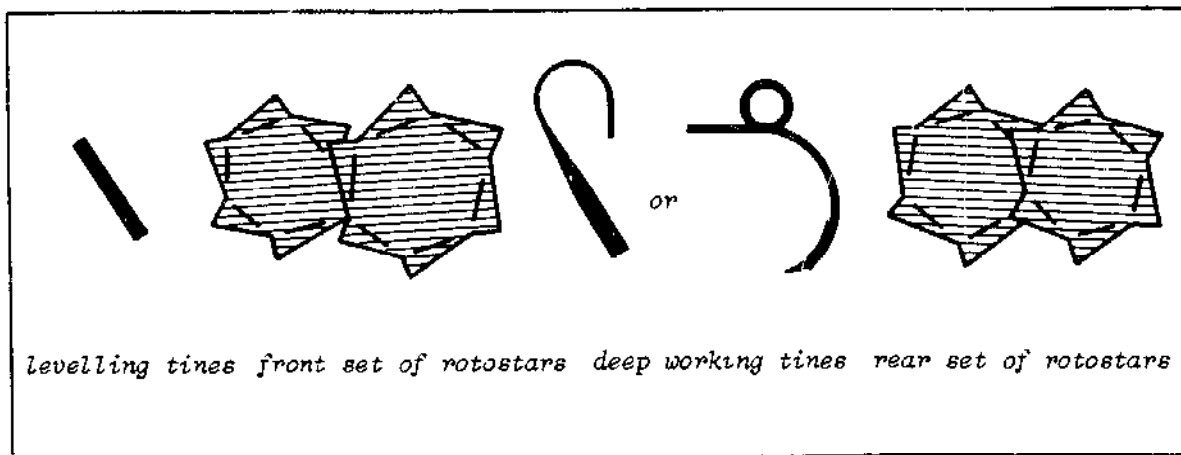

Fig. 143. Tools of the Multitiller (side view with two alternatives for the deep working tine section).

The implement operates at two depths: the tines' working depth can be set independently of the "rotostars". The working depth is reduced as the speed increases. The rotostars in the second, third and fourth gangs are identical. Each star has 6 points bent left and right alternately to produce more compaction. The rotostars in the front row are larger and have the special function of breaking up large lumps. The first and second rows are inter-meshed, as are the third and fourth rows. Hitch points for 3-point mounting of sowing equipment can be attached to the rear of the machine (Fig. 144).

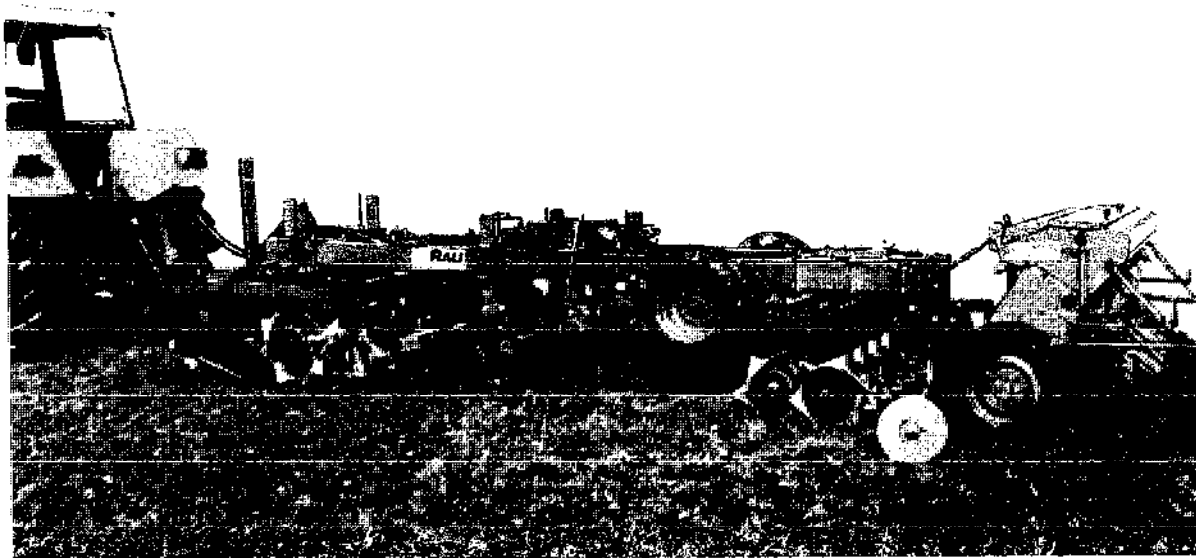

Fig. 144. Multitiller with leveller and rear-mounted drill.

#### Technical data

Working width	2.5, 3, 4, 5 and 6 m
Weight	approx. 1000 kg/m
Power required	from 26 kW/m
Speed	from 5 km/h

## The clod pulveriser

A much simpler tool for breaking up hard and large clods has been developed in Israel: a roller which functions on principles similar to the Cambridge or Crosskill roller but with much heavier and larger toothed rings (Fig. 145). The rings' central opening is much larger than the diameter of the central axis so that they can roll over the soil surface independently.

Curved teeth or chisels around the circumference of each ring are angled forward and hit the soil clods with a sudden blow so that they break up or pulverize.

The effect is satisfactory only when the clods are hard and dry enough to break up under the impact. If the soil is too moist, the result is excessive compaction and the rings clog up. If all the clods are not broken up after one pass, a second pass should not be made until a chisel plough has been used to raise the larger clods to the surface, thus preventing the creation of very fine material on the surface.

The implement is available for 3-point hitch mounting (narrow implements) and as a trailer model (wider types). It can also be used as a rear-mounted tool on a chisel plough or disc harrow.

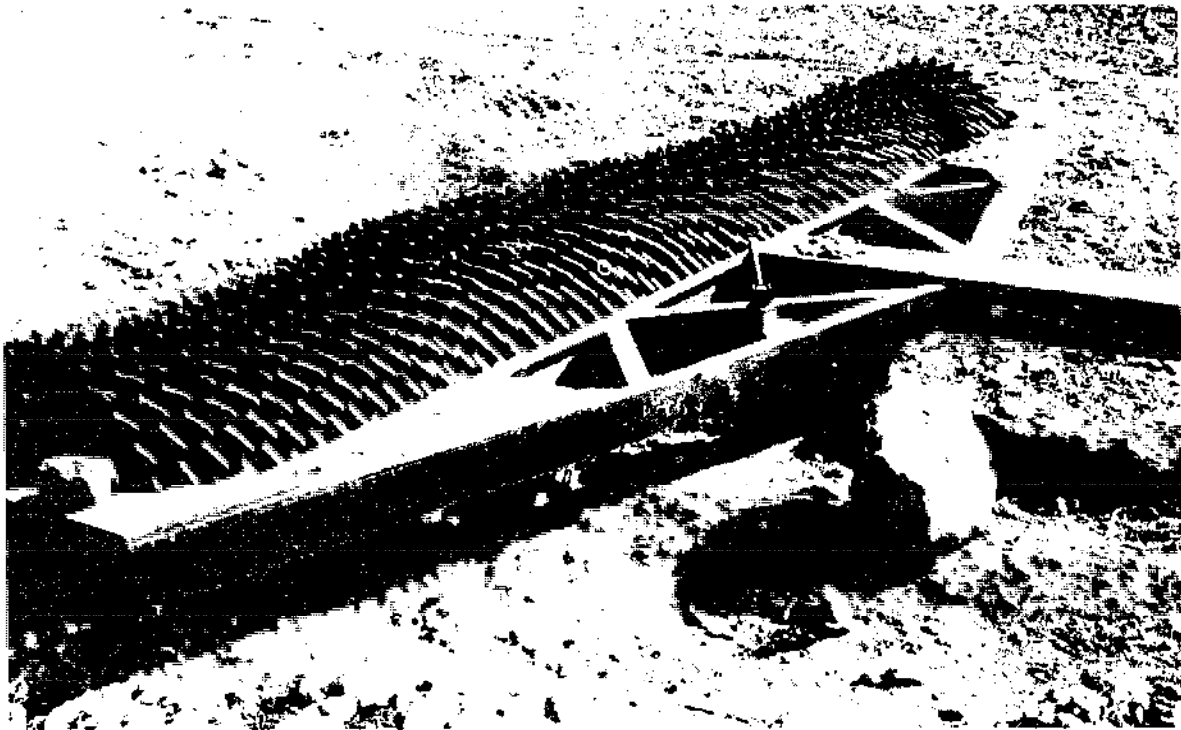

Fig. 145. "Kipnis" clod pulverizer.

### Technical data

* Working width	1.20-6.60 m
Diameter	
outside ring	420 mm
inside ring	310 mm
axle	200 mm



## Literature

See literature for chapter 11.0.

Flammer, M., 1982. Entwicklung und Erprobung von Bodenbearbeitungsverfahren (Multitiller). Report to GTZ, Eschborn, Proj. nr. 77.2071.7, pp. 100.

Flammer, M., 1982. Multitiller - soil tillage machine. Proceedings of the 9th conference of ISTR0, Osijek, Yougoslavia: 615-620.

Flammer, M., 1982. Multitiller - A soil tillage system appropriate to tropical conditions? Proceedings of the 9th conference of ISTR0, Osijek, Yougoslavia: 621-626.

Kopp, E., 1983. Entwicklung der Landwirtschaft im Unteren Mondegotal Portugal; Abschlussbericht, Proj. nr. 77.2071.7, pp. 71.

Wolf, D. and H.J. Luth, 1979. Tillage equipment for clod-forming soils. Transactions of the ASAE, 22(5): 1029-1032.

## 11.4 The Soil Loosener

The problem of soil compaction by traffic over the field has been repeatedly referred to in this book. Heavier tractors and harvesting equipment tend to exacerbate the compaction problems, especially on soils where reduced tillage or direct drilling has been applied. The "natural" regeneration of the soil structure by root growth and biological activity is often inadequate in soils which are only marginally suitable for reduced cultivation systems.

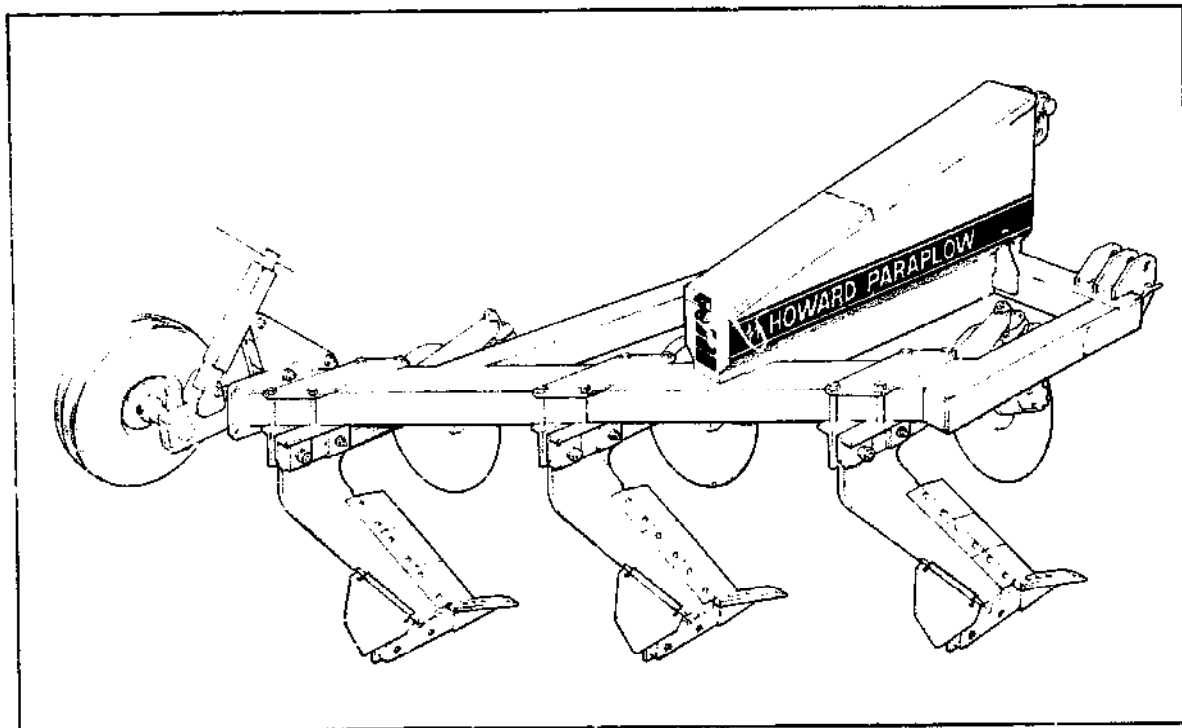

Fig. 146. The "Paraplow".

The Paraplow\* (Fig. 146) has been developed in the UK for loosening compacted layers of soil. It is a tined implement but differs considerably from the conventional chisel ploughs or subsoilers. The Paraplow's legs are slanted, producing a forward and lateral angle of about 45 degrees. Adjustable shatterplates behind the legs cause disturbance of the soil but this can be controlled. Since the soil is lifted as it flows over the legs and plates, the loosening occurs along natural cracks resulting from the tension in the soil slice rather than from compressive forces. The implement leaves the surface more or less undisturbed so that a crop can be drilled without further tillage. Disc cruetters mounted at the same angle in front of each leg allow the work to be done without interruption.

The implement is (semi-)mounted to the tractor's 3-point hitch and equipped with a depth wheel at the rear.

\* "Paraplow" is the registered trademark of Howard Rotavator Company.

The uses of this implement include the loosening of:

- compacted headlands on fields whose structure is suitable in all other respects,
- fields under reduced tillage or direct drilling which have been damaged by compaction (only when the need arises and not usually every year),
- fields whose soil types are marginally suitable for reduced cultivation systems (annually),
- soil under permanent grassland which must be loosened without seriously disturbing the sward.

#### Technical data

	mounted	semi-mounted
Number of legs	3, 4, 5	6 or 8
Total length	3.4-4.6 m	9.5-10 m
Total width	1.8-2.8 m	3.9-4.7 m
Working width (max.)	1.5-2.5 m	3.0-4.0 m
Working depth (max.)	35.5 cm	35.5 cm
Frame clearance	69 cm	71 cm
Lift capacity		
required	1,850-2,660 kg	2,500-2,800 kg
Weight	833-1,339 kg	3,200-3,600 kg
Power required	18-26 kW (25-35 hp) per leg	
Linkage	3-point hitch (cat. II or III)	
Overload protection		
legs	shearbolts	shearbolts

#### Literature

See literature for chapter 11.0.

Davies, D.B, J.D. Pidgeon, E. Lord and M. Gowan, 1982. Responses to deep loosening by "Paraplow" in continuous cereal production. Proceedings of the 9th conference of ISTRO, Osijek, Yugoslavia: 591-596.

## 11.5 The Spade Plough

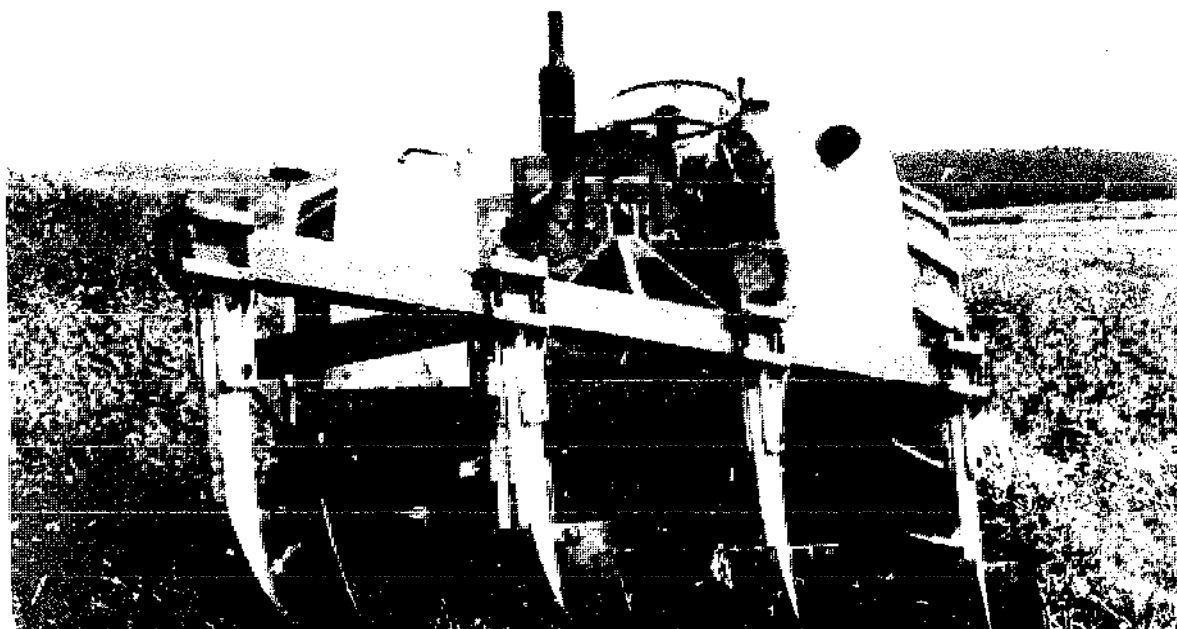

*Fig. 147. Spade plough (rear view).*

The advantages of a chisel plough as an alternative to the mouldboard or disc plough have been mentioned in Chapter 2.3 but one of its major disadvantages is the clogging problem when the tines are set too closely together. The furrow distance has to be relatively narrow for chisel ploughs because the effective ranges of each chisel should touch or overlap. An interesting development has been reported in Brazil: the "spade plough". This is a very simple sturdy implement fulfilling a function half-way between the mouldboard and chisel ploughs (see Figs. 147 and 148).



*Fig. 148. Spade plough (side view).*

Four to five "spade" shovels are attached by rigid shanks to the oblique bar of a flat triangular frame. The spades (300 mm wide with a total height of 300 mm) are set at an angle of about 70 degrees to the direction of travel. The angle of attack of the spades which are lightly curved is about 45 degrees. They produce more inversion than a chisel but markedly less than a mouldboard. The design allows the furrow distance to be varied; tillage is more intensive and a large proportion of the surface trash is covered when the distance is around 30 cm. If it is greater, the implement leaves a rough surface with more trash.

Ploughing occasions some lateral transport of the soil and so the implement should be used as a one-way plough. One major advantage is that hardly any clogging occurs because of the frame clearance (> 70 cm) and the clearance between the spades (70-90 cm depending upon the furrow distance).

The plough is mounted on the 3-point hitch and the depth is controlled by an adjustable support wheel. One problem with the current models is the side draught, caused by the spade setting and which is not absorbed by any wheel or landside so that steering is tiring.

The draught requirement is the same as for the chisel plough.

#### Technical data

Number of spades	4-5
Working width	30-50 cm per spade
Working depth (max.)	25 cm
Frame clearance	72 cm
Linkage	3-point hitch
Power required	same as for chisel ploughs

#### Literature

See literature for chapter 11.0.

Hoogmoed, W.B., 1982. Final report of a consultancy to IAPAR, Londrina (Erosionsbekaempfung Parana, Brasilien). GTZ, Eschborn, Proj. No. 76.2014.9, pp. 174.

# Publikationen in der Schriftenreihe der GTZ

## Schriftenreihe Nr. 1

Gachet, Paul und Jaritz, Günter: „Situation und Perspektiven der Futterproduktion im Trockenanbau in Nordtunesien“. 1973. 30 Seiten. Deutsch. DM 10,-.

## Schriftenreihe Nr. 2

Jahn, Hans-Christoph und König, Siegfried: „Forst in Paktia/Afghanistan“. 1972. 56 Seiten. Englisch, Farsi und Deutsch. DM 5,-.

## Schriftenreihe Nr. 3

Jaritz, Günther: „Die Weidewirtschaft im australischen Winterregenklima und ihre Bedeutung für die Entwicklung der Landwirtschaft in den nordafrikanischen Maghrebländern“. 1973. 40 Seiten. Deutsch. DM 10,-.

## Schriftenreihe Nr. 4

Wienberg, Dieter; Weiler, Norbert und Seidel, Helmut: „Der Erdbeeranbau in Südspanien“. 1972. 92 Seiten. 22 Abbildungen. Deutsch. DM 15,-.

## Schriftenreihe Nr. 5

Neumaier, Thomas (Redaktion): „Beiträge deutscher Forschungsstätten zur Agrarentwicklung in der Dritten Welt“. 1973. 568 Seiten. Deutsch. DM 15,-.

## Schriftenreihe Nr. 6

Neumaier, Thomas (Redaktion): „Deutsche Agrarhilfe – Was, wo, wie 1973?“ 1973. 572 Seiten. Deutsch. DM 15,-.

## Schriftenreihe Nr. 7

Seidel, Helmut und Wienberg, Dieter: „Gemüsesortenversuche in Südspanien“. 1973. 104 Seiten. Deutsch. DM 10,-.

## Schriftenreihe Nr. 8

„Tsetse- und Trypanosomiasisbekämpfung“. 1973. 102 Seiten. Deutsch. DM 10,-.

## Schriftenreihe Nr. 9

Schieber, Eugenio: „Informe Sobre Algunos Estudios Fitopatológicos Efectuados en la República Dominicana“ (Bericht über einige phytopathologische Studien in der Dominikanischen Republik). 1973. 68 Seiten, 35 Abbildungen. Spanisch. DM 10,-.

## Schriftenreihe Nr. 10

Bautista, Juan Elias; Hansen del Orbe, Raymundo und Jürgens, Gerhard: „Control de Malezas en la República Dominicana“ (Unkrautbekämpfung in der Dominikanischen Republik). 1973. 40 Seiten. Spanisch. DM 10,-.

## Schriftenreihe Nr. 11

Neumaier, Thomas (Redaktion): „Internationale Agrarentwicklung zwischen Theorie und Praxis“ (Bericht über die vierte landwirtschaftliche Projektleitertagung, Bonn 1973). 1974. 390 Seiten. Deutsch. ISBN 3-9800030-1-9. DM 18,-.

## Schriftenreihe Nr. 12

Adelhelm, Rainer und Steck, Karl: „Agricultural Mechanisation – Costs and Profitability“ (Mechanisierung der Landwirtschaft – Kosten und Rentabilität). 1974. 70 Seiten. Englisch. ISBN 3-9800030-2-7. DM 12,-.

## Schriftenreihe Nr. 13

Neumaier, Thomas (Redaktion): „Mokwa Cattle Ranch“ (Modell eines Rindermastbetriebes für Westafrika). 1974. 46 Seiten. Englisch, Französisch und Deutsch. 35 Abbildungen. ISBN 3-9800030-3-5. DM 10,-.

## Schriftenreihe Nr. 14

„La Lutte contre la Mouche Tse-Tse et la Trypanosomiase“ (Tse-tse- und Trypanosomiasisbekämpfung). 1973. 106 Seiten. Französisch. DM 10,-.  
Übersetzung der Nr. 8

## Schriftenreihe Nr. 15

Zeuner, Tim und H. Stiegler: „Mandi – Projekt in einer indischen Bergregion“ 1974. 76 Seiten. 1 Karte. 41 Abbildungen. Englisch und Deutsch. ISBN 3-9800030-5-1. DM 10,-.

## Schriftenreihe Nr. 16

Rüchel, Werner-Michael: „Chemoprophylaxe der bovinen Trypanosomiasis“. 1974. 252 Seiten. Deutsch. ISBN 3-9800030-6-X. DM 15,-.

## Schriftenreihe Nr. 17

Lindau, Manfred: „El Koudia/Marokko, – Futterbau und Tierhaltung – Culture fourragère et entretien du bétail“. 1974. 74 Seiten. 4 Abbildungen. Deutsch und Französisch. ISBN 3-9800030-7-8. DM 10,-.

## Schriftenreihe Nr. 18

Kopp, Erwin: „Das Produktionspotential des semiariden tunesischen Oberen Medjerdatales bei Beregnung“. Hydrotechnische und agronomische Folgerungen und die Entwicklung einer

neuen Produktionskonzeption. 1975. 332 Seiten. 28 Abbildungen. Deutsch. ISBN 3-88085-000-3. DM 15,-.

#### **Schriftenreihe Nr. 19**

Grove, Dietrich: „Ambulante andrologische Diagnostik am Rind in warmen Ländern“. 1975. 288 Seiten. 40 Abbildungen. Deutsch. ISBN 3-88085-005-4. DM 24,50.

#### **Schriftenreihe Nr. 20**

Eisenhauer, Georg (Redaktion): „Forstliche Fakultät Valdivia/Chile – Facultad de Ingeniería Forestal Valdivia/Chile“. 1975. 245 Seiten. 4 Abbildungen. Deutsch und Spanisch. ISBN 3-88085-015-1. DM 15,-.

#### **Schriftenreihe Nr. 21**

Burgemeister, Rainer: „Élevage de Chameaux en Afrique du Nord“ (Kamelzucht in Nordafrika). 1975. 85 Seiten. Französisch. ISBN 3-88085-010-0. DM 10,-.

#### **Schriftenreihe Nr. 22**

Agpaoa, A.; Endangan, D.; Festin, S.; Gumayagay, J.; Hoenninger, Th.; Seeber, G.; Unkel, K. und Weidelt, H. J. (Compiled by H. J. Weidelt): „Manual of Reforestation and Erosion Control for the Philippines“ (Handbuch der Aufforstung und Erosionskontrolle auf den Philippinen). 1975. 569 Seiten. Englisch. ISBN 3-88085-020-8. DM 18,-.

#### **Schriftenreihe Nr. 23**

Jürgens, Gerhard (Redaktion): „Curso Básico sobre Control de Malezas en la República Dominicana“ (Grundkurs zur Unkrautbekämpfung in der Dominikanischen Republik). 1975. Spanisch. ISBN 3-88085-010-0. DM 10,-.

#### **Schriftenreihe Nr. 24**

Schieber, Eugenio: „El Status Presente de la Herumbre del Café en América del Sur“ (Der aktuelle Stand der Kaffeerostbekämpfung in Südamerika). 1975. 22 Seiten. Spanisch. DM 8,-.

#### **Schriftenreihe Nr. 25**

Rohrmoser, Klaus: „Ölpflanzenzüchtung in Marokko – Selection des Oleagineux au Maroc“. 1975. 278 Seiten. 8 Colorfotos, 1 Übersichtskarte. Deutsch und Französisch. ISBN 3-88085-035-6. DM 15,-.

#### **Schriftenreihe Nr. 26**

Bonarius, Helmut: „Physical Properties of Soils in the Kilombero Valley (Tanzania)“ (Physikalische Zusammensetzung der Böden im Kilombero Tal/Tansania). 1975. 34 Seiten. Englisch. DM 8,-.

#### **Schriftenreihe Nr. 27**

Neumaier, Thomas (Redaktion): „Mandi – A Project in a Mountainous Region of India“ (Mandi – Projekt in einer indischen Bergregion). 1975. Englisch – Hindi. ISBN 3-9800030-5-1. DM 10,-.

#### **Schriftenreihe Nr. 28**

Schmidt, Gerhard und Hesse, F.-W.: „Einführung der Zuckerrübe in Marokko – Introduction de la betterave sucrière au Maroc“. 1975. 136 Seiten. 16 Tabellen. 17 Schwarzweißfotos. Mehrfarbige Standortkarte. Deutsch und Französisch. ISBN 3-88085-001-1. DM 18,-.

#### **Schriftenreihe Nr. 29**

„Landwirtschaftliche Entwicklung West-Sumatra“. 1976. 30 Seiten. 13 Schwarzweißfotos. 1 farbige Standortkarte. Deutsch. ISBN 3-88085-007-0. DM 10,-.

#### **Schriftenreihe Nr. 30**

Rüchel, Werner-Michael: „Chemoprophylaxis of Bovine Trypanosomiasis“. (Chemoprophylaxe der bovinen Trypanosomiasis). 1975. 252 Seiten. Englisch. ISBN 2-9800030-6-X. DM 10,-. Übersetzung der Nr. 16.

#### **Schriftenreihe Nr. 31**

„Bildung und Wissenschaft in Entwicklungsländern“ (Die Maßnahmen der staatlichen deutschen Bildungs- und Wissenschaftsförderung). Zusammengestellt von Wolfgang Küper. 1976. 242 Seiten. ISBN 3-88085-004-6. DM 13,50.

#### **Schriftenreihe Nr. 32**

Wagener, Wilhelm Ernst: „Baukasten für die praktisch-pädagogische Counterpartausbildung“. 1976. 156 Seiten. Deutsch. ISBN 3-88085-006-2. DM 18,50.

#### **Schriftenreihe Nr. 33**

„Journées Agrostologie – Élevage des Ruminants“ (Erfahrungsaustausch über Weideverbesserung). 1976. 188 Seiten. Französisch. ISBN 3-88085-009-7. DM 10,-.

#### **Schriftenreihe Nr. 34**

Neumaier, Thomas (Redaktion): „Internationale Zusammenarbeit im Agrarbereich – was, wo, wie 1976?“. 1976. 524 Seiten. ISBN 3-88085-012-7. DM 16,50.

#### **Schriftenreihe Nr. 35**

Lamster, Ernst; Neumaier, Thomas (Redaktion): „Colheitas melhores para Minas Gerais – Bessere Ernten für Minas Gerais“ (Fünf Jahre brasilianisch-deutsche Zusammenarbeit in Minas

Gerais). 1977. 54 Seiten. 52 Abbildungen. Portugiesisch und Deutsch. ISBN 3-88085-018-6. DM 10,-.

#### **Schriftenreihe Nr. 36**

Kassebeer, von Keyserlingk, Lange, Link, Pollehn, Zehrer und Bohlen: „La Défense des Cultures en Afrique du Nord – en considérant particulièrement la Tunisie et la Maroc“ (Pflanzenschutz in Nordafrika unter besonderer Berücksichtigung von Tunesien und Marokko). 1976. 272 Seiten. 375 Color-Abbildungen. DM 41,20.

#### **Schriftenreihe Nr. 37**

„Agricultural Development in West Sumatra“ (Landwirtschaftliche Entwicklung in Westsumatra). 1976. 30 Seiten. 13 Schwarzweißfotos. 1 farbige Standortkarte. Englisch. ISBN 3-88085-007-0. DM 10,-.  
Übersetzung der Nr. 29.

#### **Schriftenreihe Nr. 38**

Kopp, Erwin: „Le Potentiel de Production dans la Région semiaride de la Haute Vallée de la Medjerda tunisienne sous irrigation par aspersion“ (Das Produktionspotential des semiariden tunesischen Oberen Medjerdatales bei Beregnung). 1977. 360 Seiten. Französisch. ISBN 3-88085-021-6. DM 26,-.  
Übersetzung der Nr. 18.

#### **Schriftenreihe Nr. 39**

Schmutterer, Heinz: „Plagas e Enfermedades de Algodon en Centro America“ (Krankheiten und Schädlinge bei Baumwolle in Zentralamerika). 1977. 104 Seiten. 50 Colorabbildungen. Spanisch. DM 22,-.

#### **Schriftenreihe Nr. 40**

„Dritte externe Veterinärtagung“ (Berichte und Arbeitsergebnisse). 1977. 370 Seiten. Deutsch. ISBN 3-88085-022-4. DM 24,50.

#### **Schriftenreihe Nr. 41**

Becker, Günther: „Holzzerstörung durch Termiten im Zentralafrikanischen Kaiserreich – Destruction du bois par les termites dans l'Empire Centralafricain“. 1977. 96 Seiten. 16 Abbildungen. Deutsch und Französisch. DM 12,60.

#### **Schriftenreihe Nr. 42**

Furtmayr, Ludwig: „Besamungsstationen an tropischen und subtropischen Standorten“. 1977. 64 Seiten. Deutsch. ISBN 3-88085-031-3. DM 10,80.

#### **Schriftenreihe Nr. 43**

Wirth, Frigga: „Culture de plants à parfum en Tunisie – Parfumpflanzenanbau in Tunesien“.

Introductions pratiques – Anleitung für den Praktiker. 1977. 196 Seiten. Französisch und Deutsch. ISBN 3-88085-060-7. DM 18,40.

#### **Schriftenreihe Nr. 44**

Hofmann, Rudolf und Otte, Kai-Christian: „Nutzung der Vikunjas in Peru“. 1978. 48 Seiten. 39 Abbildungen. Deutsch-Englisch-Spanisch. ISBN 3-88085-048-8. DM 13,-.

#### **Schriftenreihe Nr. 45**

Grove, Dietrich: „Diagnostico Andrológico Ambulante en el Bovino en Países Cálidos“ (Ambulante andrologische Diagnostik am Rind in warmen Ländern). 1977. 280 Seiten. Spanisch. ISBN 3-88085-038-0. DM 24,50.  
Übersetzung der Nr. 19

#### **Schriftenreihe Nr. 46**

Nägel, Ludwig: „Aquakultur in der Dritten Welt“. 1977. 110 Seiten, 21 Abbildungen. Deutsch. ISBN 3-88085-029-1. DM 18,50.

#### **Schriftenreihe Nr. 47**

Wagener, Wilhelm E.: „Model for Practical-Educational Counterpart Training“. 1977. 106 Seiten. Englisch. ISBN 3-88085-006-02. DM 18,50.  
Übersetzung der Nr. 32.

#### **Schriftenreihe Nr. 48**

Metschies, Gerhard: „Technisch-wirtschaftliche Möglichkeiten und Grenzen des ländlichen Straßenbaus in Entwicklungsländern“. 1977. 219 Seiten. Deutsch. DM 25,-.

#### **Schriftenreihe Nr. 49**

Bischof, Friedrich: „Common Weeds from Iran, Turkey, the Near East and North Africa“. (Unkräuter im Iran, in der Türkei, im Nahen Osten und in Nordafrika). 1979. 234 Seiten, 204 Colorabbildungen. Englisch. ISBN 3-88085-061-5. DM 56,-.

#### **Schriftenreihe Nr. 50**

Ballestrem, C. Graf und Holler, H.-J.: „Potato Production in Kenya. Experiences and Recommendations for Improvement“. (Kartoffelerzeugung in Kenia). 1977. 88 Seiten. 69 Abbildungen. Englisch. ISBN 3-88085-026-7. DM 19,60.

#### **Schriftenreihe Nr. 51**

Neumaier, Thomas: Richter, Wolfgang. Weers, Egge: „Saver Farm – The Central Breeding-Station of Bangladesh (Saver-Farm – Die zentrale Tierzuchtstation von Bangladesch). 1977. 44 Seiten. 41 Abbildungen. Englisch und Deutsch. ISBN 3-88085-039-9. DM 7,50.



**Schriftenreihe Nr. 52**

„Progress on Lake Malawi – The Central Region Lakeshore Development Project 1967–1977“. (Fortschritt am Malawi-See). 1978. 54 Seiten. 37 Abbildungen. Englisch. ISBN 3-88085-036-4. DM 10,50.

**Schriftenreihe Nr. 53**

Kisselmann, E. (Redaktion): „Gutachten – Studien – Berichte“ (Beiträge aus 20 Jahren internationaler Zusammenarbeit im ländlichen Raum). 1977. 540 Seiten. Deutsch. ISBN 3-88085-037-2. DM 28,-.

**Schriftenreihe Nr. 54**

„Tierärztliche diagnostische Labors in Malaysia – Beispiel malayisch-deutscher Zusammenarbeit“. 1978. 32 Seiten. 17 Abbildungen. Deutsch. Englisch. ISBN 3-88085-051-8. DM 8,60.

**Schriftenreihe Nr. 55**

Neumaier, Thomas (Redaktion): „Technische Zusammenarbeit im ländlichen Raum. was – wo – wie 1978“. 1978. 690 Seiten. Deutsch. ISBN 3-88085-044-5. DM 22,50.

**Schriftenreihe Nr. 56**

Leppack, Eberhardt und Roskamp, Robert: „Almacenamiento de Papas en Panama – un ejemplo para zonas tropicales y subtropicales (Kartoffellagerung in Panama – ein Beispiel für tropische und subtropische Zonen)“. 1978. 102 Seiten. 28 farbige Abbildungen, 13 Skizzen. Spanisch. ISBN 3-88085-059-3. DM 26,50.

**Schriftenreihe Nr. 57**

Walker, J. B.; Mehlitz, D.; Jones, G. E. und Gerroth, E.: „Notes on the ticks of Botswana“. (Anmerkungen zu den Zecken in Botswana). 1978. 83 Seiten. 32 Abbildungen. Englisch. ISBN 3-88085-052-6. DM 18,40.

**Schriftenreihe Nr. 58**

Hueck, Kurt: „Los Bosques de Sudamérica – Ecología, composición e importancia económica“. (Die Wälder Südamerikas). 1978. 476 Seiten. Mit Vegetationskarte von Südamerika. Spanisch. ISBN 3-88085-053-4. DM 49,50.

**Schriftenreihe Nr. 59**

Dorow, Eberhard: „Hubschrauber in der Feldheuschreckenbekämpfung – Helicopter in Grasshopper Control – L'hélicoptère dans la lutte contre les criquets“. 1978. 66 Seiten. 13 Abbildungen. Deutsch, Englisch, Französisch. ISBN 3-88085-047-X. DM 15,20.

**Schriftenreihe Nr. 60**

Hubert, Klemens und Sander, Friedrich: „The Rehabilitation of Rural Roads in Handeni District (Tanzania) – Project description and assessment of experiences –“. 1978. 81 Seiten. 3 Karten. Englisch. ISBN 3-88085-046-1. DM 12,60.

**Schriftenreihe Nr. 61**

German Agricultural Team (GAT) in Kenya: „Passion Fruit Growing in Kenya – A Recommendation for Smallholders“. 1978. 46 Seiten. 57 Abbildungen. Englisch. ISBN 3-88085-056-9. DM 11,50.

**Schriftenreihe Nr. 62**

Lippmann, Dieter: „Cultivation of Passiflora edulis S.“. (General Information on Passion Fruit Growing in Kenya). 1978. 88 Seiten. 88 Abbildungen. Englisch. ISBN 3-88085-065-6. DM 18,-.

**Schriftenreihe Nr. 63**

Kopisch-Oburlin, Friedrich-W.; Ulsperger, Walter; Werner, Hans-J.; Wieland, Thomas: „Rückstandsprobleme im Pflanzenschutz in der Dritten Welt.“ (Ein Beitrag des GTZ-Rückstandslabors). 1978. 67 Seiten. 35 Abbildungen. Deutsch. ISBN 3-88085-057-7. DM 14,50.

**Schriftenreihe Nr. 64**

Schmutterer, Heinz: „Cotton Pests in the Philippines“. 1978. 110 Seiten. 47 Abbildungen. Englisch. ISBN 3-88085-064-X. DM 21,-.

**Schriftenreihe Nr. 65**

„Dune Stabilization – A Survey of Literature on Dune Formation and Dune Stabilization“ (Dünenstabilisierung). 1977. 407 Seiten. Englisch. ISBN 3-88085-032-1. DM 18,50.

**Schriftenreihe Nr. 66**

Maier, Hermann (Redaktion): „51 x Ausbildung – Förderung der beruflichen Bildung in Entwicklungsländern“. 1977. 324 Seiten. Deutsch. ISBN 3-88085-034-8. DM 14,50.

**Schriftenreihe Nr. 67**

Becker, Silke: „La Propagación de la Roya del Cafeto“. (Die Verbreitung des Kaffeerostes). 1979. 70 Seiten. 13 Abbildungen. Spanisch. Englisch. Deutsch. ISBN 3-88085-075-5. DM 12,50.

**Schriftenreihe Nr. 68**

Vollweiler, Berthold: „Escuela de Topografía y Catastro (ETC). Ausbildungsstätte für Vermessungswesen und Kataster – Costa Rica. College of Surveying and Cadastral Science“. 1978. 29 Seiten. 13 Abbildungen. Spanisch. Deutsch. Englisch. ISBN 3-88085-049-6. DM 10,-.

**Schriftenreihe Nr. 69**

Marouani, A.; Kouki, N.; Ghanmi, M. und Grell, P.-H.: „Gutes Saatgut – eine Voraussetzung für hohe Erträge“. 1979. 56 Seiten. 61 Abbildungen. Deutsch. Französisch. Arabisch. ISBN 3-88085-066-6. DM 15,50.

**Schriftenreihe Nr. 70**

Michels, Thomas: „Medical Laboratory Development in Tanzania.“ 1978. 30 Seiten. 22 Abbildungen. Englisch. ISBN 3-88085-061-1. DM 12,50.

**Schriftenreihe Nr. 71**

Korte, Rolf (Redaktion): „Nutrition in Developing Countries – A Seminar for German Technical Assistance Personnel“. 1978. 394 Seiten. Englisch. ISBN 3-88085-062-3. DM 22,50.

**Schriftenreihe Nr. 72**

Brüning, Dietrich C.: „Population Planning in Pakistan – A Study of the Continuous Motivation System“ (Bevölkerungsplanung in Pakistan). 1977. 300 Seiten. Englisch. ISBN 3-88085-043-7. DM 18,50.

**Schriftenreihe Nr. 73**

Seeber, G.; Weidelt, H. J. und Banaag, V. S.: „Dendrological Characters of Important Forest Trees from Eastern Mindanao“. 1979. 440 Seiten. Englisch. ISBN 3-88085-068-2. DM 22,60.

**Schriftenreihe Nr. 74**

Heidemann, C. und Ries, H. O.: „Raumordnung, Regional- und Stadtentwicklung. Ein methodisches Konzept.“ 1979. 52 Seiten. Deutsch. ISBN 3-88085-067-4. DM 11,25.

**Schriftenreihe Nr. 75**

Goedicke, P. T.; Reisch, E.; Schnuer G. und Zülle A.: „Landtechnische Ausbildungs- und Beratungszentren als Mittel zur Förderung der Landwirtschaft in Entwicklungsländern.“ 1979. 96 Seiten. Deutsch. ISBN 3-88085-069-0. DM 16,50.

**Schriftenreihe Nr. 76**

Gassert, Werner L.: „Research on Coffee Berry Disease in Ethiopia“. 1979. 64 Seiten. 17 Abbildungen. Englisch. ISBN 3-88085-070-4. DM 12,60.

**Schriftenreihe Nr. 77**

Roskamp, Robert; Leppack, Eberhardt: „Potato storage in Panama“ (Kartoffellagerung in Panama). 1979. Englisch. ISBN 3-88085-073-9. DM 26,50.  
Übersetzung der Nr. 56.

**Schriftenreihe Nr. 78**

Myntti, Cynthia: „Women and Development in Yemen Arab Republic“ (Frauen und Entwicklung

in der Arabischen Republik Jemen). 1979. 170 Seiten. 28 Abbildungen. Englisch. ISBN 3-88085-079-8. DM 24,50.

**Schriftenreihe Nr. 79**

Krause, R. und Lorenz, F.: „Bodenbearbeitung in den Tropen und Subtropen.“ 1979. 252 Seiten. Deutsch. ISBN 3-88085-079-8. DM 24,50.

**Schriftenreihe Nr. 80**

„Die Ökologie und Bekämpfung des Blutschnabelwebervogels (*Quelea quelea*) in Nordostnigeria.“ 1983. 274 Seiten. Deutsch. ISBN 3-88085-167-0. DM 76,–.

**Schriftenreihe Nr. 81**

Heim, Sepp: „Orthopädie-technisches Versorgungszentrum und Ausbildungsstätte für Orthopädie-Techniker, Lomé/Togo“ 1979. 38 Seiten. Deutsch. Englisch. Französisch. ISBN 3-88085-071-2. DM 15,60.

**Schriftenreihe Nr. 82**

„Pesticide Residue Problems in the Third World“ (Rückstandsprobleme im Pflanzenschutz in der Dritten Welt). 1979. 64 Seiten. Englisch. ISBN 3-88085-074-7. DM 14,50. Übersetzung der Nr. 63.

**Schriftenreihe Nr. 83**

Wagner, R.: „University of Dar es Salaam Faculty of Engineering.“ 48 Seiten. 26 Abbildungen. Englisch. ISBN 3-88085-072-0. DM 17,–.

**Schriftenreihe Nr. 84**

Grotthus, Otto, Frhr. von (Redaktion): „Die Bundesrepublik Deutschland und die Forstwirtschaft der Dritten Welt.“ 1980. 184 Seiten. Deutsch. ISBN 3-88085-099-2. DM 12,50.

**Schriftenreihe Nr. 85**

Beyer, Erich; Friedel, Peter (Redaktion): „Sportförderung in Ländern der Dritten Welt“. 1979. 228 Seiten. Deutsch. ISBN 3-88085-078-X. DM 29,–.

**Schriftenreihe Nr. 86**

„Agricultural Engineering, Training and Advisory Centres as a Means of Promoting Agriculture in Developing Countries“. 1980. 92 Seiten. ISBN 3-88085-069-0. DM 16,50.  
Übersetzung der Nr. 75.

**Schriftenreihe Nr. 87**

Mielke, Gerd (Redaktion): „57 × Ausbildung – Förderung der beruflichen Bildung in Entwicklungsländern“. 1979. 358 Seiten. Deutsch. ISBN 3-88085-077-1. DM 16,50.

**Schriftenreihe Nr. 88**

„Technical Cooperation in Rural Areas – Facts and Figures 1979“ (Technische Zusammenarbeit im ländlichen Raum – Fakten und Daten 1979). 1979. 580 Seiten. Englisch. ISBN 3-88085-082-8. DM 22.–.

**Schriftenreihe Nr. 89**

Küper, Wolfgang (Redaktion): „Bildung und Wissenschaft in der Technischen Zusammenarbeit mit Entwicklungsländern“. 1979. 505 Seiten. Deutsch. ISBN 3-88085-081-X. DM 29.–.

**Schriftenreihe Nr. 90**

Hayfa, Gisela und Korte, Rolf: „Gesundheit, Bevölkerungsentwicklung, Ernährung“. 1979. 228 Seiten. Deutsch. ISBN 3-88085-084-4. DM 13,50.

**Schriftenreihe Nr. 91**

„Masterplans for Electric Power Supply“ (Objectives and Methods). 1980. 277 Seiten. Englisch. ISBN 3-88085-093-3. DM 32,80.

**Schriftenreihe Nr. 92**

Rau, Norbert und Rau, Anke: „Commercial Marine Fishes of the Central Philippines.“ 1980. 608 Seiten. Englisch. ISBN 3-88085-089-5. DM 38.–.

**Schriftenreihe Nr. 93**

Shankat Ali, Chandhary – Raman, Revri: „Weeds of North Yemen (Yemen Arab Republic)“. 1983. 412 Seiten. Englisch. ISBN 3-88085-195-6. DM 45.–.

**Schriftenreihe Nr. 94**

Bandel, Klaus und Salameh, Elias: „Hydrochemical and Hydrobiological Research of the Pollution of the Waters of the Amman Zerka Area/Jordan“. 1981. 60 Seiten. 6 Fotos und zahlreiche Illustrationen. Englisch. ISBN 3-88085-115-8. DM 17,95.

**Schriftenreihe Nr. 95**

„Problemas de residuos de pesticidas en el Tercer Mundo.“ 1981. 67 Seiten. 35 Abbildungen. Spanisch. ISBN 3-88085-057-7. DM 14,50. Übersetzung der Nr. 53.

**Schriftenreihe Nr. 96**

„Problèmes de résidus résultant de la protection des végétaux dans le tiers monde.“ 1982. 67 Seiten. 35 Abbildungen. Französisch. ISBN 3-88085-127-1. DM 14,50. Übersetzung der Nr. 63.

**Schriftenreihe Nr. 97**

Wasserhyazinthen. In Vorbereitung.

**Schriftenreihe Nr. 98**

Heidemann, G. und Ries, H. O.: „Regional and Urban Development“ A methodological framework. 1980. 48 Seiten. Englisch. ISBN 3-88085-087-9. DM 11,25. Übersetzung der Nr. 74.

**Schriftenreihe Nr. 99**

Heidemann, C. und Ries, H. O.: „Ordenamiento Espacial, Desarrollo Regionals y Desarrollo Urbano“. (Raumordnung, Regional- und Stadtentwicklung). 1980. 51 Seiten. Spanisch. ISBN 3-88085-085-2. DM 11,25. Übersetzung der Nr. 74.

**Schriftenreihe Nr. 100**

Hagenbrock, T., Pohl, H., Ries, H. O., Spanger, U., Springer, W.: „Aufgaben und Chancen von Regionalentwicklungsprojekten in Entwicklungsländern.“ 1979. 256 Seiten. Deutsch. ISBN 3-88085-092-5. DM 39,50.

**Schriftenreihe Nr. 101**

„CBE – College of Business Education Dar es Salam/Dodoma, Tanzania.“ 1980. 28 Seiten. Englisch und Kiswaheli. ISBN 3-88085-088-7. DM 14,20.

**Schriftenreihe Nr. 102**

„Technical College Arusha – Training of Technicians in Tanzania.“ Eine Projektcurriculumdarstellung. 1980. 32 Seiten. Englisch. ISBN 3-88085-090-9. DM 18,70.

**Schriftenreihe Nr. 103**

„Centres de formation et de vulgarisation en génie agricole, un moyen de promotion de l'agriculture dans les pays en voie de développement.“ 1980. Französisch. ISBN 3-88085-094-1. DM 24,50. Übersetzung der Nr. 75.

**Schriftenreihe Nr. 104**

„Das Verwaltungsinstitut Sana'a, Arabische Republik Jemen.“ 1982. 32 Seiten. Englisch. ISBN 3-88085-096-8. DM 17.–.

**Schriftenreihe Nr. 105**

Doppler, Werner: „The Economics of Pasture Improvement and Beef Production in Semihumid West Africa.“ 1980. 195 Seiten. Englisch. ISBN 3-88085-101-8. DM 14.–.

**Schriftenreihe Nr. 106**

„Studien, Gutachten, Berichte – Beiträge internationaler Zusammenarbeit im ländlichen Raum. 1977–1980.“ 1981. 351 Seiten. Deutsch. ISBN 3-88085-102-6. DM 13,80.

**Schriftenreihe Nr. 107**

„Fischerei am Assad-See, Syrien“. 1981. 32 Seiten. Deutsch. Englisch. Französisch. ISBN 3-88085-100-X. DM 16,25.

**Schriftenreihe Nr. 108**

Schmidl, Gerhard, Hesse, Friedrich-Wilhelm und Trost, Karl: „Die Zuckerrohrkultur in Marokko“. 1981. 88 Seiten. 26 farbige Abbildungen, 13 Skizzen. Deutsch. ISBN 3-88085-105-0. DM 34,50.

**Schriftenreihe Nr. 109**

Nienhaus, Franz: „Virus- and similar diseases in tropical and subtropical areas“. 1981. 216 Seiten. 155 farbige Abbildungen. Englisch. ISBN 3-88085-106-9. DM 34,50.

**Schriftenreihe Nr. 110**

Reiholec, Christel (Gesamtedaktion): „Technische Zusammenarbeit im ländlichen Raum – was, wo, wie 1981“. 1981. 962 Seiten. Deutsch. ISBN 3-88085-107-7. DM 30,-.

**Schriftenreihe Nr. 111**

Munzinger, Peter: „Handbuch der Zugtiernutzung in Afrika“. 1981. 496 Seiten. Über 100 Abbildungen. Deutsch. ISBN 3-88085-103-4. DM 60,-.

**Schriftenreihe Nr. 112**

Schmidt, G.; Hesse, F.-W.; Trost, K.: „La Culture de la Canne à Sucre au Maroc“. 1981. 88 Seiten. Französisch. ISBN 3-88085-105-0. DM 34,50.  
Übersetzung der Nr. 108

**Schriftenreihe Nr. 113**

„Problèmes de post-récolte. Documentation sur un Séminaire OUA/GTZ“. 1980. 247 Seiten und 31 Seiten Anhang. Französisch. DM 15,40.

**Schriftenreihe Nr. 114**

Drescher, Wilhelm und Crane, Eva: „Technical Cooperation Activities: Beekeeping A Directory and Guide“. 1982. 166 Seiten. Englisch. ISBN 3-88085-111-5. DM 39,50.

**Schriftenreihe Nr. 115**

„Post Harvest Problems. Documentation of a OUA/GTZ Seminar“. 1981. 258 Seiten und 33 Seiten Anhang. Englisch. DM 15,40.  
Übersetzung der Nr. 113.

**Schriftenreihe Nr. 116**

Karbe, Eberhard und Komlanui Freitas, Edem: „Trypanotolerance – Recherche et Application/ Research and Implementation“. 1982. 314 Seiten. Französisch und Englisch. ISBN 3-88085-158-1. DM 19,50.

**Schriftenreihe Nr. 117**

Jahn, Samia Al Azharia: „Traditional Water Purification in Tropical Developing Countries. – Existing Methods and Potential Application“. 1982. 284 Seiten. 15 Farb- und 3 Schwarzweiß-Abbildungen, 31 Zeichnungen. Englisch. ISBN 3-88085-116-6. DM 35,-.

**Schriftenreihe Nr. 118**

Kopp, E.: „Stickstoffproblematik in einem semiariden Raum“. 1981. 276 Seiten. 25 farbige Abbildungen, 26 Grafiken, 38 Tabellen. Deutsch. Englische und französische Zusammenfassung im Anhang. ISBN 3-88085-117-4. DM 51,60.

**Schriftenreihe Nr. 119**

Jaritz, Günther: „Grünlandnutzung in Tunesien“. 1982. 340 Seiten. Französisch. ISBN 3-88085-118-2. DM 52,50.

**Schriftenreihe Nr. 120**

Munzinger, Peter: „Animal Traction in Africa“. (Handbuch der Zugtiernutzung in Afrika). 1982. 490 Seiten. Englisch. ISBN 3-88085-133-6. DM 60,-.  
Übersetzung der Nr. 111.

**Schriftenreihe Nr. 121**

Munzinger, Peter: „La Traction Animale en Afrique“. (Handbuch der Zugtiernutzung in Afrika). 1982. 496 Seiten. Französisch. ISBN 3-88085-184-4. DM. 60,-.  
Übersetzung der Nr. 111.

**Schriftenreihe Nr. 122**

Philipp, Ottmar; Koch, Werner und Köser, Heinz: „Utilization and Control of Water Hyacinth in Sudan.“ (Die Nutzung und Kontrolle der Wasserschilfpflanze im Sudan). 1983. 224 Seiten. Englisch. ISBN 3-88085-184-0. DM 32,-.

**Schriftenreihe Nr. 123**

„Fleisch aus Ferké. Ein Feedlot am tropischen Standort.“ 1983. 112 Seiten. Deutsch. ISBN 3-88085-180-8. DM 14,60.

**Schriftenreihe Nr. 124**

Becker, E. W.: „Mikrologen. Ergebnisse aus drei Versuchsvorhaben.“ 1982. 118 Seiten. Deutsch. ISBN 3-88085-149-2. DM 24,50.

**Schriftenreihe Nr. 125**

Gross, Rainer und Bunting, E. S.: „Agricultural and Nutritional Aspects of Lupines.“ (Land- und ernährungswirtschaftliche Aspekte von Lupinen). Proceedings of the First International Lupine Workshop. 1982. 884 Seiten. Englisch. ISBN 3-88085-134-4. DM 39,-.

**Schriftenreihe Nr. 126**

Diehl, Lothar: „Smallholder Farming Systems with Yam in the Southern Guinea Savannah of Nigeria.“ 1982. 340 Seiten. Englisch. ISBN 3-88085-135-2. DM 36,-.

**Schriftenreihe Nr. 127**

„Mas Granos Basicos para Honduras.“ (Mehr Getreide für Honduras). 1982. 44 Seiten. 55 Farbabbildungen. Spanisch. DM 12,50.

**Schriftenreihe Nr. 128**

Kropp, E.: „Ländliche Regionalentwicklung – ein Orientierungsrahmen.“ 1983. ■ Seiten. Deutsch. ISBN 3-88085-221-9. DM ■.

**Schriftenreihe Nr. 130**

„Maschinengemeinschaften in Rio Grande do Sul“.  
In Vorbereitung.

**Schriftenreihe Nr. 131**

Thal, J. M. Taoidi: „Bedeutung, Biologie und Bekämpfung der Kartoffelmotte in Marokko. Importance, Biology and Control of the Potato Moth in Morocco. Importance et biologie de la tergue de la pomme de terre, la lutte contre ce ravageur au Maroc.“ 1982. 144 Seiten. 19 Abbildungen. Deutsch-Englisch-Französisch. ISBN 3-88085-139-5. DM 23,-.

**Schriftenreihe Nr. 132**

Weidelt, Hans Joachim und Banaag S.: „Aspects of Management and Silviculture of Philippine Dipterocarp Forests.“ 1982. 308 Seiten. Englisch. ISBN 3-88085-157-3. DM 18,-.

**Schriftenreihe Nr. 133**

Finck, Horst und Oelert, Gerhard: „Investitionen im Energiebereich.“ Ein Leitfaden zur Berechnung der Wirtschaftlichkeit. 1983. 106 Seiten. Deutsch. ISBN 3-88085-210-3. DM 37,00.

**Schriftenreihe Nr. 134**

Schlöglaut, W.: „Kompendium der Kaninchenproduktion unter Berücksichtigung der Verhältnisse in der Dritten Welt.“ 1984. ■ Seiten. Deutsch. ISBN 3-88085-215-4. DM ■.

**Schriftenreihe Nr. 135**

Rüdenauer, Michael: „Production de viande de bovins trypanotolerants en savane guinée d'Afrique occidentale.“ Organisation, rentabilité et possibilités de développement compte tenu notamment des possibilités d'intégration en petites exploitations, à l'exemple du Togo. 1982. 344 Seiten. Französisch. ISBN 3-88085-144-1. DM 29,-.

**Schriftenreihe Nr. 136**

Merkle, Alfred: „The Cost of Health for All.“ A feasibility study from Upper Volta. (Der Preis für „Gesundheit für alle“ – eine Durchführbarkeitsstudie aus Obervolta). 1982. 101 Seiten. Tabeleinteil im Anhang. Englisch. ISBN 3-88085-145-X. DM 20,-.

**Schriftenreihe Nr. 137**

Steiner, Kurt, G.: „Inter Cropping in Tropical Smallholder Agriculture with Special Reference to West Africa.“ (Mischkulturen in der tropischen Kleinlandwirtschaft unter besonderer Berücksichtigung Westafrikas). 1982. 312 Seiten. Englisch. ISBN 3-88085-176-X. DM 41,50.

**Schriftenreihe Nr. 138**

Hayfa, Gisela: „Aufbau von Frauengruppen in Bangladesh. Familienplanung, Gesundheitserziehung, Einkommensverbesserung.“ 1982. 92 Seiten. 12 Schwarzweiß-Abbildungen. 1 Standortkarte. Deutsch. ISBN 3-88085-155-7. DM 24,50.

**Schriftenreihe Nr. 139**

Küper, Wolfgang; Birkert, Andreas: „Bildung und Wissenschaft in der Technischen Zusammenarbeit mit Entwicklungsländern.“ 1982. 636 Seiten. Deutsch. ISBN 3-88085-182-4. DM 32,-.

**Schriftenreihe Nr. 140**

„La pequeña minería en la región de los Andes. Experiencia de un decenio.“ 1983. 256 Seiten. Spanisch. ISBN 3-88085-208-1. DM 32,-.

**Schriftenreihe Nr. 141**

In Vorbereitung.

**Schriftenreihe Nr. 142**

Frey, Franz und Yabar, Erik: „Enfermedades y plagas de Lupinos en el Peru.“ 1983. 88 Seiten. 32 Abbildungen. Spanisch. ISBN 3-88085-188-3. DM 14,-.

**Schriftenreihe Nr. 143**

Becker, E. W.: „Microalgae. Findings of three Experimentation Projects.“ Englisch. 1983. 94 Seiten. ISBN 3-88085-189-1. DM 30,50.  
Übersetzung der Nr. 124.

**Schriftenreihe Nr. 144**

„Technische Zusammenarbeit im ländlichen Raum – was, wo, wie. 1984.“ 1984. 1048 Seiten. Deutsch. ISBN 3-88085-191-3. DM 32,50.

**Schriftenreihe Nr. 145**

Neumaier, Thomas (Redaktion); Wörner, Beate (Texte): „Landtechnische Ausbildung in der Türkei.“ 1983. 72 Seiten. Deutsch. ISBN 3-88085-192-1. DM 21,-.

**Schriftenreihe Nr. 146**

*Link, Rolf; Mouch, Moustapha: „Contributions à la biologie, à la propagation et à la lutte contre les adventices au Maroc.“ 1984. ■ Seiten. Französisch. ISBN 3-88085-193-X. DM ■.*

**Schriftenreihe Nr. 147**

*Maydell, H.-J. von: „Arbres et arbustes du Sahel – Leurs caractéristiques et leurs utilisations.“ 1983. 538 Seiten. Zahlreiche farbige Abbildungen. Französisch. ISBN 3-88085-195-6. DM 97,50.*

**Schriftenreihe Nr. 148**

*Heim, Sepp; Kaphingst, Wieland: „Tanzania Training Centre for Orthopaedic Technologists (TAT-COT). Moshi/Tanzania.“ 1984. ■ Seiten. Deutsch. Englisch. ISBN 3-88085-198-0. DM ■.*

**Schriftenreihe Nr. 149**

*Weinberger, Peter; Park, Geun-Je; Kwan, Du-Jung: „Korean Woodlands (Im-Ya) as Resources for Grassland Development.“ 1983. 228 Seiten. Englisch. ISBN 3-88085-199-9. DM 29,50.*



*Deutsche Gesellschaft für Technische Zusammenarbeit (GTZ) GmbH*

*Dag-Hammarskjöld-Weg 1 · 2 · D 6236 Eschborn 1 · Telefon (06196) 79-0 · Telex 41523-0gtz.d*

The government-owned GTZ operates in the field of Technical Cooperation. 2,200 German experts are working together with partners from about 100 countries of Africa, Asia and Latin America in projects covering practically every sector of agriculture, forestry, economic development, social services and institutional and material infrastructure. – The GTZ is commissioned to do this work both by the Government of the Federal Republic of Germany and by other government or semi-government authorities.

The GTZ activities encompass:

- appraisal, technical planning, control and supervision of technical cooperation projects commissioned by the Government of the Federal Republic or by other authorities
- providing an advisory service to other agencies also working on development projects
- the recruitment, selection, briefing, assignment, administration of expert personnel and their welfare and technical backstopping during their period of assignment
- provision of materials and equipment for projects, planning work, selection, purchasing and shipment to the developing countries
- management of all financial obligations to the partner-country.