

**AT** MICROFICHE  
REFERENCE  
LIBRARY

A project of Volunteers in Asia

Evaluation of the Bissa--An Indigenous Storage Bin

by: K. Palipane

Published by:

Food and Agriculture Organization, Sri Lanka  
202, Bauddhaloka Mawatha  
Colombo 7  
Sri Lanka

Available from:

Food and Agriculture Organization, Sri Lanka  
202, Bauddhaloka Mawatha  
Colombo 7  
Sri Lanka

Reproduced by permission of the Food and  
Agriculture Organization, Sri Lanka.

Reproduction of this microfiche document in any  
form is subject to the same restrictions as those  
of the original document.

RPDC Report N° 5/78  
May - 1978



**EVALUATION OF THE BISSA - AN INDIGENOUS  
STORAGE BIN**

by

**K. B. Pallipane**

**RICE PROCESSING DEVELOPMENT CENTRE  
(FAO - UN Assisted Project)  
ANURADHAPURA - SRI LANKA**

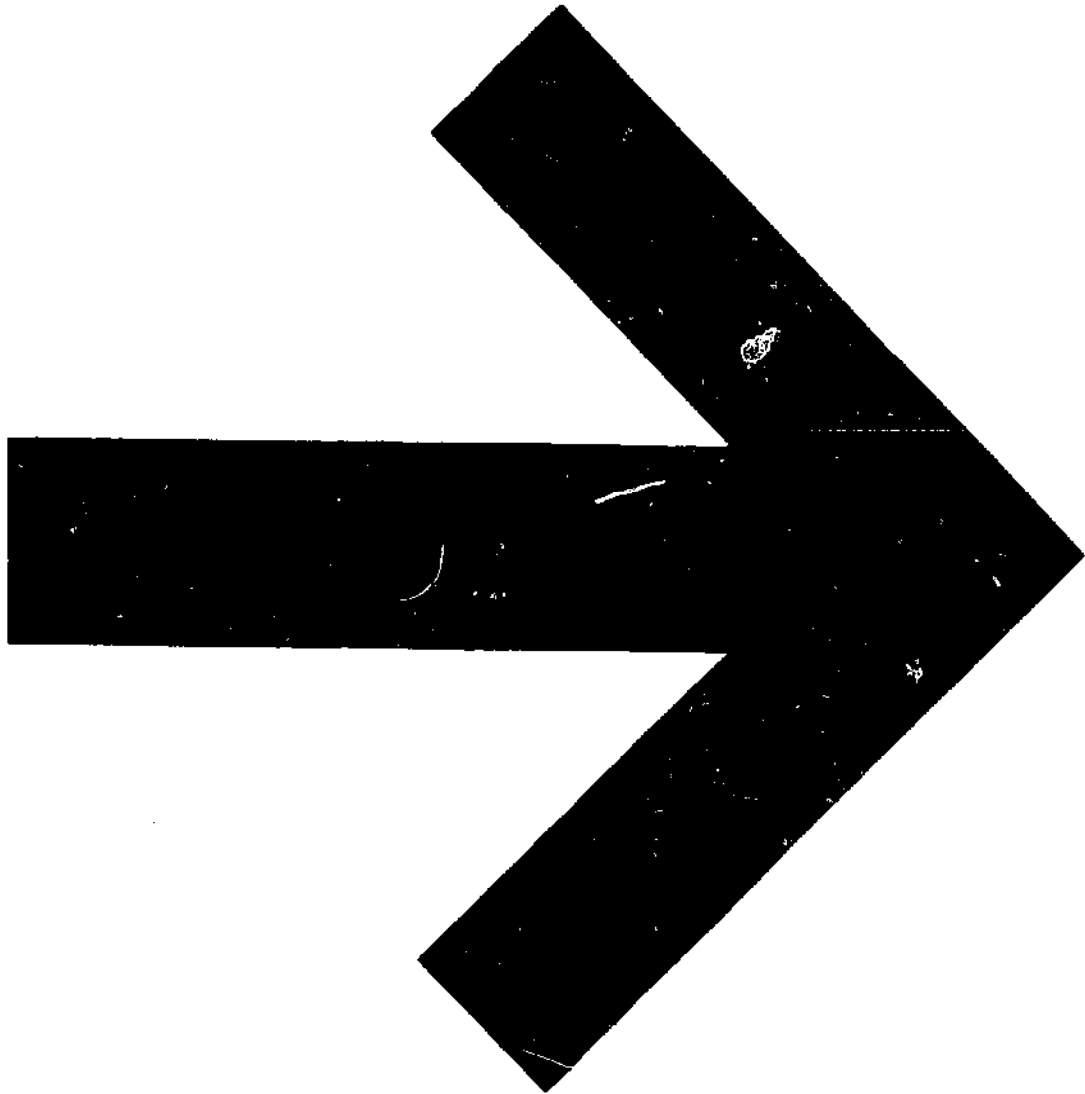

## C O N T E N T S

	Page
FOREWORD           ...   ...   ...   ...	1
ACKNOWLEDGMENTS   ...   ...   ...   ...	2
INTRODUCTION       ...   ...   ...   ...	3
METHODOLOGY       ...   ...   ...   ...	4
RESULTS OF STUDY   ...   ...   ...   ...	7
1. Construction   ...   ...   ...   ...	7
2. Loading and Unloading   ...   ...   ...	10
3. Performance     ...   ...   ...   ...	11
4. Strength and durability   ...   ...   ...	14
5. Cost of Storage ...   ...   ...   ...	16
6. Storage of other grains   ...   ...   ...	17
7. Variations of the Structure   ...   ...	17
IMPROVEMENTS SUGGESTED   ...   ...   ...	19
CONCLUSION           ...   ...   ...   ...	21
REFERENCES CITED     ...   ...   ...   ...	22

FOREWORD

The problem of storage of Paddy and other grains has assumed serious proportions in Sri Lanka as in many other Asian countries, as a result of the prodigious increases in production over the past few years. Traditional systems of grain storage have been gradually phased out with increasing Government intervention in the grain business. One very important method of significantly alleviating the storage problem is to have farmers store their grain for as long as possible. This is automatic in a free market since the cost of storage and compensation for any losses is more than balanced by the increase in prices obtained a few months after harvest. At the present time, with a guaranteed price and a guarantee of purchase by Government, no farmer will consider it worth his while to invest in, and operate storage for grain except for his own use or for seed purposes. The policies declared by the present Government tend to indicate a gradual movement of Paddy industry into a growing free market, and it is timely that farm level storage development should be undertaken so that the technology is ready when needed. The "Bissa" is a proven and age-old method of storage and this study is the first step towards developing a technology that would suit the farmers' needs. It is a structure of wattle and daub with straw roof and is found in one form or another in many Asian countries and in Africa. The structure costs practically nothing to the farmer besides his own labour, and future work on the application of modern technology to this basic structure will involve mainly operational aspects. Further work on this and other indigenous structures is continuing and will be reported in due course.

V.E.A. Wikramanayake

Manager

Rice Processing Development Centre.

28th April 1978.

ACKNOWLEDGMENTS

This work was suggested and initiated by Mr. V.E.A. Wikramanayake Manager - EPDC. I gratefully acknowledge the encouragement and invaluable guidance given to me by him throughout the study.

I wish to acknowledge with thanks Mr. J. Ramalingam, Senior Advisor, FAO and Dr. Rama Rao V. Vellanki, Rice Processing Specialist - FAO for their advice on the engineering aspects, valuable comments on the original draft and encouragement given to complete this study speedily.

Special thanks to Laboratory Assistants Mr. W. Smil for sketching the pictures of the Bissa, Mr. R. Palipane and Mr. J. Coonekardene for assisting me in the laboratory analysis. The services of Miss. Anula de Silva for typing right through the study; and - Mr. J. L. David for mimeographing and binding of this report is gratefully acknowledged.

EVALUATION OF THE "BISSA"-AN INDIGENOUS STORAGE BIN

by

K.B. Palipane\*

INTRODUCTION

The need for storage arises because harvests are seasonal and the consumers want their food at a fairly constant rate through-out the year. A regular supply of food for daily consumption can only be assured and maintained through storage.

In Sri Lanka, only 40% of the total production of paddy is available as marketable surplus and the remaining 60% is held by the farmers for seed, wages and consumption. Surveys conducted by international organisations like F.A.O have revealed that the major loss in the post harvest operation occurs only in storage, particularly at the farm level due to improper and inadequate storage facilities. Improving and popularising farm level storage may not only help in reducing these losses but also help in overcoming the storage problem now the country is facing at commercial level. In this context, the significance of a complete evaluation of the already existing farm level permanent storage structures which are constructed by from locally available material and the technical know-how of it is known by our farmers, hardly needs emphasis.

"The Bissa" is a traditional storage structure used by farmers mainly in the districts of Anuradhapura, Polonnaruwa, Kurunegala and to a lesser extent in all the other districts of Sri Lanka. It is a permanent storage structure, build in the open air normally close to the farmer's residence. It is constructed in various sizes and the capacities varie from  $\frac{1}{2}$  ton (25 bushels) to 10 tons (500 bushels). The material required for its construction could be easily obtained in the village and the design and operation of it is traditionally known by farmers. Various types of the structure are constructed in different areas which differ slightly in the shape, material used for construction, but the basic structural features from point of view of storage remains the same in all types.

---

\* Research Officer - Rice Processing Development Centre, Anuradhapura.

**METHODOLOGY**  
\*\*\*\*\*

The evaluation was based on :

- a) A complete study of a "Bissa" constructed in the RPDC premises at Anuradhapura in which paddy was stored for a period of 6 months.
- b) Information obtained from farmers who use "the Bissa" for paddy storage.

A most common type of "Bissa" of capacity 5 tons was constructed in the open air, away from buildings, by a villager who had previous experience in construction. Detailed sketches were drawn of every stage of construction and the total labour input, material input for construction and their costs were recorded.

After completion of construction, the structure was allowed to dry for 3 months before loading with paddy. Freshly harvested paddy belonging to the variety BG 11-11 was given the following treatments before storing in the structure.

- i Sent through a scalper cleaner to remove sand, stones, chaff and dust.
- ii Sundryed for 6 hours to bring down the moisture content from 16% to 12.5%

Before loading into the structure the paddy was weight accurately using a platform balance. Photographs were taken during the loading operation and the labour input for loading, any problems encountered during the operation were recorded. The structure was filled to  $\frac{2}{3}$  rd its capacity only in order to have enough space at the top for drawing out samples and for temperature measurements.

The paddy was kept in storage for a period of six months. During this period representative samples were drawn out every fortnight using a double tube grain probe of length 5 ft. The initial and the final samples were taken before loading and after unloading the paddy. The samples were analysed in the laboratory to determine the following :

- a. Moisture content :- This was determined as soon as the sample was drawn out using a Satake moisture meter.
- b. Test weight with & without impurities:- was determined in the Toledo grain balance which has a scale on which the bushel weight in pounds can be directly read off by weighing one pint of paddy.



- c. Mechanically damaged grains (percent by weight):-  
A representative sample of 50 grams was examined visually, broken grains and grains with the husk layer partially or completely removed were separated by hand and weighed using a gram balance.
- d. Immature, empty & partly filled grains (percent by weight):-  
This was determined on a 50 g. sample of paddy, and on a 50 g. sample of head rice. Sample was examined visually, immature empty & partly filled grains were separated by hand & weighed using a gram balance.
- e. Fungal damaged grains (percent by weight):-  
A representative sample of 50 g. of paddy & 50 g. of head rice was examined visually, grains showing fungal growth on the surface & dark spots accompanied with large extents of chalkiness were separated by hand & weighed using a gram balance.
- f. Chalky & brittle grains (percent by weight):-  
These grains were examined visually in 50 g. of head rice separated by hand & weighed using a gram balance.
- g. Nadi Grains :-  
These are grains which appear dark in colour due to wetting & subsequent temperature built up. These grains were separated visually in 50 g. of head rice, separated by hand and weighed using a gram balance.
- h. Stress cracked grains (percent by count) :-  
Grains that show fractures in the bran coats and endosperm were separated by examining through a crack detector in a representative sample of 500 grains, and counted.
- i. Insect Damaged grains :-  
In a small representative sample the insect damaged grains were separated from good grains. The number and the weight of damaged grains and good grains were found separately in order to determine the following.
  - i. Percentage insect damaged grains by number
  - ii. The percentage weight loss due to insect damage
- j. Sprouted grains :-  
Grains that are sprouted were separated in a 50 g. representative sample and the percentage calculated.

k. Milling Quality :-

Sample milling was done using 175 g. of paddy. The paddy was dehusked using a laboratory Satake rubber roll huller. The brown rice was weighed and given a  $4.5\% \pm 0.5$  polish using a Ho-gill miller No.1. Milled rice was weighed. (Total milling yield). This was next separated into head grain and broken grain using laboratory grader and weighed separately. The total milling yield and the head rice yield was calculated as a percentage of the Paddy while the amount of broken grains was calculated as a percentage of the total milled rice.

During the storage period of 6 months, temperature of the grain mass was measured every fortnight using an Electronic thermometer having a temperature probe, at the top center, middle center, bottom center and sides (6" away from the wall).

Throughout the storage period close observations were made on Termite activity, Rodent activity, and bird activity. Records were kept on the condition, any repairs done, on the structure.

At the end of 6 months in storage the paddy was unloaded from the structure and weighed using a platform balance. Labour, time requirement for unloading and any problems encountered during this operation were recorded.

The date of loading with paddy was 14 September 1977. The date of unloading was 17 March 1978. These dates were selected so that the period of experimentation coincided with north east monsoonal rains- (Naha Season).

Apart from the above study the evaluation was also based on information obtained from farmers in the districts of Anuradhapura and Kurunegalle, who use the Bissa for storage of paddy. For this purpose a field information sheet was prepared (annexure 1) and the farmers were interviewed by visiting their homes.

**RESULTS OF STUDY**  
\*\*\*\*\*

The study findings are presented under the following headings :-

- 1 Construction
- 2 Loading and Unloading
- 3 Performance of the structure
- 4 Strength and Durability of the structure
- 5 Cost of storage
- 6 Storage of other grains
- 7 Variations of the structure

**1. Construction :**

Figs : 2,3, show the external appearance of the completed structure of capacity 5 tons. The main stages of construction were as follows:

- A Construction of the wooden floor, which is raised above ground by four wooden pillars
- B Construction of the wooden framework of the circular wall
- C Erecting the 4 vertical supporting posts of the circular wall
- D Construction of the wooden framework of the roof
- E Plastering the upper surface of the floor, the inside and outside of the wall framework with mud
- F Placing the roof on the structure and covering with straws.

Fig. 4 gives the dimensions of the wooden framework of the floor and the wall and also the dimensions and the kind of timber used for its construction. Fig. 5 shows the wooden framework of the roof, the kind of timber used and dimensions, Fig. 6 shows the cross section of the completed wall and Fig. 7 is the elevation of the completed structure showing its dimensions.

**Floor :-**

A hard wood called "Ehela", which has a high resistance to decay and termite attack, was used for the 4 posts which elevate the floor above ground level by one foot (Fig. 4). The floor was made of timber posts of D.5 inches placed horizontally, close to each other, on the 4 legs. The upper surface of which was plastered with mud to a thickness of 3 inches,

**Wall :-**

The vertical wooden posts (diameter 2 inches) of the circular wall were bent slightly outwards in the middle and held in this position by three jungle creepers (called "Eraminiya Wal") tied firmly to the posts by coir rope at the middle, bottom and top (Fig.4). Due to this the diameter of the wall was more by 22 inches at the middle than at the top and bottom giving a spherical appearance to the structure. The advantages of a structure of this shape are :-

- a. Since the vertical reinforcements are already deflected there will be no further deflection of them to cause cracks in the clay layers, when a load is imparted on the wall.
- b. Since the lower part of the wall is of a smaller diameter, this area will be less exposed to direct rains by the roof than in a structure having a larger diameter in the lower parts.

The advantages of making the structure cylindrical and not square is that for the same cross sectional area the perimeter of a circular bin is very much less than the perimeter of a square bin. Therefore a cylindrical structure is always cheaper to construct. Also since the lateral pressure exerted by the grain mass is uniformly distributed on the wall, the strength of the wall at all points of the perimeter can be the same unlike in a square bin where at certain parts of the wall a greater pressure is exerted by the grain mass and more reinforcement is required, which means, a circular bin is easier to fabricate.

Mud plastering of the wall and top surface of the floor was done twice that is after the 1st plastering it was allowed to dry and then plastered again to fill all cracks which have appeared. Finally the inside and outside of wall and the floor were coated with dissolved cow dung and allowed to dry (Fig.6)

**Roof :-**

The diameter of the Jungle creeper in the roof framework (Fig.5) is slightly less than the diameter of the upper edge of the wall so that it fits into the wall and prevent displacement of the roof. In covering the roof, bundles of straw were placed overlapping one another, starting from the outer diameter and going up to the center.

**Supporting pillars :-**

The function of the 4 supporting posts (diameter 6") of the cylindrical wall (Fig.2) is to prevent the structure from displacement due to loads imposed by the grain mass and loads imposed by rain and wind.

The labour, material inputs and the cost of construction of the 5 ton Bissa is given below :-

(a) Material inputs :

<u>Material</u>	<u>Qty</u>	<u>*Cost Rs.cts</u>
Coir rope	10 lbs	20.00
Wooden posts L10' D6" (Satin wood)	6	210.00
Wooden posts L4' D7" (Satin wood or Ehela)	4	60.00
Wooden posts L8' D5" (Weera)	20	120.00
Wooden posts L8' D2" (Weera)	48	72.00
Wooden sticks L6' D $\frac{1}{2}$ "-1" (Jungle sticks)		30.00
Jungle Creepers L100' (Eraminiya)		<u>10.00</u>
		535.00

\* Cost of material was calculated on the current market prices.

(b) Labour inputs:-

<u>Operation</u>	<u>Labour input man hours</u>	<u>Cost @ 1.09/hr</u>
a. Slicing timber, cutting posts, drilling holes on the ground	32	34.88
b. Erecting posts and construction of the floor of the Bissa	16	17.44
c. Cutting sticks and constructing the frame of the wall	48	52.32
d. 1st clay plastering of the wall	32	34.88
e. 2nd clay plastering of the wall	16	17.44
f. Coating the wall with cow dung	8	8.72
g. Constructing the frame of the roof	8	8.72
h. Covering the roof with straw	4	<u>4.36</u>
		178.76

● The total cost of construction = 713.00

From the information obtained from farmers it was found that almost all of them have obtained the material required for construction from the jungles, free of charge, and also family labour had been utilized for construction, which means, the above cost analysis is subjected to wide variation from place to place with the availability and price paid for labour and material inputs for fabrication.

## 2. Loading and Unloading :-

Both loading and unloading was done by lifting the roof from one side (Fig. 8) so that a space of about 2 ft. was created between the wall and the roof, through which paddy was filled in or taken out in baskets. The loading operation was performed by two men, while for unloading three men were required, where one had to get inside the structure and give out the paddy.

A serious problem encountered in these operations was that, when lifting the roof it tend to shift from the original position due to which damage can be caused to the roof structure.

The labour requirement and the cost of loading and unloading of paddy in the 5 ton capacity Bissa is given below.

### Loading operation :-

Labour requirement to load 1 ton	= 2.94 man hours
Cost of loading/ton (@ Rs.1.09/man hour)	= Rs. 3.20

### Unloading operation:-

Labour requirement to unload 1 ton from upper half of the grain mass	= 6.65 man hours
Cost (@ Rs.1.09/man hour)	= Rs.7.25
Labour requirement to unload 1 ton from lower half of the grain mass	= 7.37 man hours
Cost (@ Rs.1.09/Man hour)	= Rs.8.03
The average cost of unloading per ton	= Rs.7.64

Following additional information was obtained from the farmers, with regard to loading and unloading operations.

- a. These operations are performed by utilizing family labour, therefore no cost is incurred.
- b. Loading is done once or twice a year after the harvesting seasons, While unloading is done every week or fortnight because most of the paddy stored in, is used for consumption. The quantity taken out at a time varies from 1-2 bushels.
- c. Since farmers own much smaller structures, mostly of capacities below 2 tons, the problem of the difficulty in lifting the roof and also the shifting of the roof while lifting is not encountered.

3. Performance of the structure :-

Table 1 gives quality changes of paddy during the storage period of six months:

- a. Moisture migration :- The moisture content of the grain has increased from 12.7% to the equilibrium moisture content of 14.2% during the 1st two weeks of storage and there after remained almost uniform except for slight changes, which may be due to the change in the relative humidity of the atmosphere. This shows that the structure was completely weather tight even during heavy N.E. monsoonal rains in Anuradhapura. Also since the floor is raised above ground, there was no possibility of ground water to come in contact with the paddy. But still the moisture content of the grain throughout the storage period was above the "Critical Moisture Content" of paddy (14.2%)<sup>1</sup> when microorganism and insects are fully activated to bring about deterioration.
- b. Temperature changes :- Table 2 gives the temperature of the grain mass at various places during the storage period of 6-months. The temperature of the grain mass never went more than 1-2°C above the ambient temperature up to 4 months of storage, showing that no hot spots to indicate rapid deterioration of grain were developed. Except during the last 2 months, when the temperature changes of the grain close to the wall rose by about 4°C. The reason was later found out to be due to wetting, followed by fungal invasion of grain close to the wall (about 2"- from the wall ) because of termite activity and nesting in the wall. From the readings of table 2, graphs were drawn to show the changes in the temperature of the grain mass with the ambient temperature. (Fig1). During the first fifteen days the temperature rose rapidly. This was expected because when freshly harvested grain is stored there is a initial rise in temperature which can go up to even 7°C above the ambient temperature<sup>2</sup>. - After the 45th day the temperature remained almost constant throughout even though the ambient temperature fluctuated very much showing that the wall and roof material resist heat flow in and out of the structure. Still, a favourable average temperature of about 32°C existed in the grain throughout the storage to active the chemical (respiration), biological (microorganisms and insects) variables of deterioration.

A main defect of this structure is that it has no facilities for aeration to bring down temperature rises.

- c. Purity of the Grain:- The percentage impurities in the grain has remained constant at 0.5% during storage (table 1) until the paddy was taken out of the structure, when the percentage was increased by 0.2%. This was due to the scraping of the wall when collecting paddy and minute clay particles getting contaminated with paddy.
- d. Stress cracks in the grains :- After 105 days of storage there had been a marked increase in the % stress cracked grains (table 1) this may indicate that with changes in the diurnal humidity, there had been unequal moisture gradients produced within the grains creating a stress within the endosperm for grains to crack<sup>3</sup>.
- e. Mechanically damaged grains :- There was no change in the % mechanically damaged grains showing that, during the loading and unloading operation and also during storage, no mechanical damage was caused to the grains,
- f. Sprouting :- No sprouting of the grain occurred during the storage period (table 1). Showing that the grains never got wet; in other words the moisture content never exceeded the maximum possible equilibrium moisture content of 30-36% to cause sprouting.<sup>4</sup>
- g. Insect Activity :- There was a continuous increase in the percentage of insect damaged grains with storage (table 1) reaching 0.6% at the end of 6 months. The weight loss due to insect damage was 1% after 6 months. The extent of damage was more marked after the 3rd month. At the rate of 89 cents a pound of paddy, a 1% loss cannot be considered as an economic damage, and adopting any chemical pest controlling practices may be uneconomical.

If a serious insect infestation is encountered, fumigation of the grain could be done easily. Because by keeping a polythene sheet in between the roof and the upper edge of the wall on which the roof rests, the structure can be made air tight.

The insects observed were :- *Sitotroga Cerealla* (Paddy Store moth), *Sitophilus oryzae* (Rice Weevil) and *Rhizopertha dominica* (Paddy store Beetle).

It was found that some farmers adopt chemical insect controlling practices like spraying malathion on the grain mass or adding B.H.C. dust once a month. According to them, the cost incurred-



per application was one rupee (average) per 1 ton of paddy. But the majority of the farmers do not adapt any pest controlling practices because according to them, the damage due to insect attack is negligible, if clean dry paddy is stored in the structure.

- h. **Mold activity :-** There was only a slight increase in fungal damaged grains (0.3%) during the 1st 4 months of storage but during the last 1½ months a marked increase was observed. (table 1). At the end of six months the increase was 1.5%. This was due to active mold growth in the grain close to the wall (1½ inches from the wall), at certain places, whose moisture content went upto 20% due to termite activity.
- i. **Rodent activity :-** No rodent activity or damage was observed during the storage period of six months. Still the structure cannot be considered as rodent proof because rats can climb along the four vertical support posts of the wall, also along the legs of the structure and reach the grain through the straw covered roof. Some farmers who were interviewed, complained about rodent damage. They overcome this problem to some extent by keeping traps inside the structure.
- j. **Termite Activity:-** This was a serious problem encountered during the experiment. Termites damaged the wall by building nests on the inner surface. The source of infestation was traced to the ground, from where they have climbed along the wooden legs of the structure and tunneled into the wall. The moisture content of the grain in the vicinity of the nests (1-1½ inches from the wall) was 20% and the grains were brittle and chalky with white mold growth of the surfaces. The extent of damage to the grains due to this was about 1% (table 1). All the farmers who were interviewed were aware that the structure is prone to termite attack. They overcome this problem as follows :-
- a) A layer of common salt is sprinkled round the posts in contact with the soil so that termites can't reach them.
  - b) Keeping the ground close to the structure clean and observing constantly for termite activity in order to destroy any termite paths built.
- k. **Bird activity :-** No bird activity or damage was observed in the grain during the storage period of six months. The structure therefore can be called as "completely bird proof".

During the first two months after completion of construction when the straw covering of the roof was still new, birds started picking the straw causing very slight damage to the roof. Later as the straw got old and settled, this problem was not encountered. There was no way to overcome this problem except to rearrange or replace the straw to cover the thinned out areas.

- l. Milling quality :- After 56 months in storage, there was a reduction in the total milling yield by 1%. The head rice yield was reduced by 11.5% (table 1). This can be expected because of the increase in the number of stress cracked grains<sup>5</sup>.
- m. Test weight :- From the readings of table 1, the weight per bushel at 14% moisture was computed (table 3). At the end of 6 months in storage there was a loss of 1.8 lbs. in the Bushel weight.
- n. Weight changes :- Table 4 gives the initial weight of the paddy, the weight after 6 months in storage and the respective moisture contents of the grain. There was a apparent increase in weight of 102.50 lbs. The increase in weight due to the change in moisture content from 12.7% to 15% is 2.71%, that is 183.33 lbs. Therefore there had been a dry matter loss of 80.83 lbs. or 1.2% after 6- months in storage. At the rate of 89 cts/lb of paddy, the loss incurred by storing 1 ton of paddy for 6 months will be about Rs.24/- which is quite negligible compared to the value of a ton of paddy, which come to Rs.1993.60

Summarising the above findings with respect to performance, it is clear if precautions are taken to prevent termite damage and Rodent damage, the structure can store paddy without any significant deteriorative losses upto a period of six months. (which is the normal storage period required by our farmers). But since no aeration facilities are provided, storage of high moisture paddy will not be possible.

From the information obtained from farmers it was found that some keep paddy even upto 1 year without many noticeable damage.

#### 4. Strength and Durability of the structure :-

From the date of completion of construction until the paddy was taken out (9 months) no repairs were done on the structure.

After the paddy was unloaded following repairs had to be done to make the structure suitable for loading with paddy once again.

Nature of Repair	Material inputs	Labour inputs man hours	Material cost (Rs.)	Labour cost (@ 1.09/m.h)	Total cost
Covering the roof with new straw	50 bundles of straw	4	4.00	4.36	8.36
Breaking termite nests in the wall & replastering with mud	clay soil	8	nil	8.72	8.72
Coating the inner & outer surfaces of the wall with a thin layer of mud	clay soil	16	nil	17.44	17.44
TOTAL COST					34.52

The above cost would have reduced by Rs.8.72 if precautions were taken to prevent termites from reaching the structure.

Information obtained from farmers revealed that, once a year the roof has to be covered with new straw and replastering with a thin layer of mud to cover any cracks, which have appeared should be done to keep the structure in sound shape. They incur no cost for these repairs because material is obtained free of charge at village level and family labour is utilized. According to them a "Bissa" if maintained properly will last for over fifty years.

The loads imposed by paddy on the wall and floor of a 5 ton capacity Bissa is as follows.

A) Lateral pressure imposed on the wall

Assumptions

- a. Angle of Repose of Paddy =  $\phi = 36^\circ$
- b. Specific weight of paddy = (w) = 36°
- c. Structure is loaded to full capacity

Applying Rankine's Equation

$$L = Wh \left( \frac{1 - \sin \phi}{1 + \sin \phi} \right)$$

Where

- L = Lateral pressure (Force/unit area)
- W = Grain specific weight (Weight/unit volume)
- $\phi$  = Angle of Repose of paddy
- h = Depth of grain (ft.)

The pressure at anypoint on the center perimeter

$$= 35.96 \text{ lbs/sq.ft.}$$

The pressure at any point on the bottom perimeter

$$= 71.93 \text{ lbs/sq.ft.}$$

B) The vertical load imposed on the wall due to frictional force of Paddy.

- Assumptions
- a. Grain to bin wall erection coefficient =  $50^\circ$
  - b. The structure is filled to full capacity

Applying equation

$$E_v = L \tan \phi$$

Where

$$F_v = \text{Vertical wall load/unit of perimeter}$$

$$L = \text{Lateral pressure on the wall (Force/unit area)}$$

$$\phi = \text{Grain to bin wall friction coefficient}$$

The vertical load at any point on the center peri-meter:

$$= \underline{42.79} \text{ lbs/sq.ft}$$

The vertical load at any point on the bottom perimeter:

$$= \underline{84.49} \text{ lbs/sq.ft.}$$

C) Load imposed on the floor.

- Assumption
- a. Structure filled to full capacity
  - b. Specific weight of paddy = 36 lbs/cu.ft

Applying Equation

$$V = Wh$$

Where

$$V = \text{Floor load (force/unit area)}$$

$$W = \text{Specific weight of paddy}$$

$$h = \text{depth of grain}$$

The load per unit area on the floor :

$$= \underline{266.4} \text{ lb /sq.ft}$$

### 5. Cost of Storage :

Given below is the cost analysis for storage of 1 ton of paddy for one year in a "Bissa".

a) Fixed costs :-

(i) Construction (page 9)

$$\text{Material cost} = 535/5 = \text{Rs. } 107/-$$

$$\text{Labour cost} = 178.76/5 = \text{Rs. } 35.75$$

(ii) Depreciation (life span of the structure-

$$20 \text{ years}) = 107.00/20 = \text{Rs. } 5.35$$

(iii) Total fixed cost/ton/annum = Rs. 148.10

b) Variable costs:

(i) Maintenance cost (page 15)	= 25.80/5	= Rs. 5.16
(ii) Cost of loading (page 10)		= Rs. 3.20
(iii) Unloading cost (page 10)		= Rs. 7.64
(iv) Total variable cost/ton/annum		= <u>Rs. 16.00</u>
Cost of storage/ton of paddy/annum		= Rs. 164.00
		=====
		(OR Rs. 3.28 per bushel).

As mentioned earlier (page 9) above cost analysis is subjected to wide variations with the availability and price paid for labour and material inputs

6. Storage of other grains :

Apart from storage of paddy, some farmers use this structure for storage of the cereal, "Kurakkan". According to them this grain stores equally well as paddy.

7. Variations of the structure :

Given below are some variations of the structure, from the common type, found in Sri Lanka.

(i) Stone posts are used instead of wooden posts to raise the structure. These may be more durable than timber which is susceptible to decay and termite damage. But in some areas, it may be difficult to obtain stone posts of the required dimensions.

(ii) The wall is constructed by weaving closely a kind of jungle creeper called "Alukada Wal" of diameter  $\frac{1}{2}$ " and plastering the inside of the wall only with a thin layer of cowdung, or inside with cowdung and outside upto half the height of the wall with clay.

With the clearing of the old jungles it is now difficult to obtain these creepers. Therefore this type of structure is not built anymore. According to farmers these creepers resist termite attack, decay and last for over 50 years.

(iii) Roof is covered with cajan instead of straw. In areas where cajan is freely available (e.g. coconut triangle of Sri Lanka) this could be adapted because cajan is equally good as straw, if not better, against weather factors.

(iv) Instead of making the roof circular, it is constructed as shown in Fig. 9. Advantages of a roof of this shape may be :

- a. Loading and unloading is done through the space between roof and the wall, which is easier than having to lift the roof.
- b. To a certain extent there is aeration of the grain because fresh air circulates on the surface of the grain mass.
- c. Frequent inspection of the grain becomes easy.

The disadvantages which may arise are :

- a. The grain is more exposed to rats, birds, insects, which bring about damage to the grain.
- b. The grain is more exposed to the environmental temperature and humidity changes.
- c. Small droplets of water carried by wind during heavy rains may wet the grain.
- d. Stealing of paddy from the structure becomes easy.

(v) Instead of lifting the whole roof for loading and unloading operations, a section of the roof which is on hinges is lifted, creating a space enough for a man to get in easily through which paddy is put in or taken out. Fig. 10 gives the wooden frame work of this kind of roof. Comparing with the common type this has the following advantages :

- a. Loading and unloading operations could be performed easily and conveniently.
- b. No displacement of the roof causing damage to the roof structure will occur during this operation.
- c. Time consumed for loading and unloading operations will be reduced.

(vi) Fig. 11 shows a Bissa in Africa. No information could be obtained regarding its construction, operation and performance. Probably loading is done through the opening found on upper part of the wall. One disadvantage of having an opening of this nature is that, unless strict security measures are taken paddy could be pilfered.

IMPROVEMENTS SUGGESTED

- 1) Construction :- If timber is costly and difficult to obtain, it may be possible to construct a solid brick floor rising from the ground instead of the wooden platform. If so, cement will have to be used as the binding material for bricks in order to resist damage by direct rains hitting the floor area. Drains may have to be cut around the structure to prevent run off water coming in contact with the floor and there by damaging it. Also a sheet of polythene will have to be sandwiched in the floor structure in order to prevent the floor getting moist due to seepage water from the ground. But with a floor of this nature, following problems may arise a) making the structure rodent proof and termite proof will be more difficult than in a structure which is raised on pillars, b) obtaining polythene sheet, cement etc., will be difficult at farm level. Further studies will have to be carried out to overcome these problems.

There is also a possibility of making a cylindrical wall using bricks instead of the wooden frame structure, if timber is a scarce and expensive item. For this a solid brick floor will be needed. Further studies will have to be carried out in order to determine the strength of the structure and cost benefits.

- 2) Loading and Unloading :- Lifting the roof, to perform these operations is one of the major defects of the structure. This could be overcome by constructing a roof, where a section of it only could be lifted and unloading could be done Fig. 10. The design and operation is very easy and material for construction is available at farm level. This has been discussed in detail, earlier (Page 18). Another possibility is to have a small opening (diameter 1 ft) and a chute with a sliding door made out of metal constructed in the lower part of the wall, through which paddy could be taken out. But to construct this, obtaining metal sheet and welding material will be difficult, at farm level and also the technical know how is not available at farm level. Further more, unless it is built strong incurring a high expenditure, any person can break open the door and steal the paddy.

3) Performance :-

- a) A major limitation of the structure is that, it has no aeration facilities. Therefore the paddy stored in have to be well dried if deterioration has to be prevented. Further studies have to be carried out to design a cheap aeration device using locally available material.
- b) The structure is prone to termite attack. This could be avoided by painting the posts rising from the ground with "LINTOX 8" or any other chemical used to control termites. In addition, by adding common salt round the posts and by regular observation to break any termite paths, this problem could be completely overcome.
- c) The paths which rodents can take, to enter the structure from the top, are along the 4 vertical supporting posts of the wall and the 4 legs of the structure. By raising the structure 2 - 2½ ft. off the ground and fixing rat baffles (rat guards) Figs:12,13,14 on the 4 legs and the 4 vertical posts 2 ft. above ground will make the structure completely rodent proof.



CONCLUSION

In improving farm level storage, it is always better to improve and popularise the already existing permanent storage structures, which can be fabricated from material easily available at farm level at a low cost and also whose design and operation is known by our farmers, than introducing a new structure. In this context, the Bissa, with slight modifications, is an ideal structure for farm level storage because of the following reasons.

1. Easy to fabricate, material for fabrication available at farm level.
2. Design and operational know how is available at farm level.
3. With precautions taken against termite and rodent damage, it stores properly dried paddy without any significant quality deterioration for a period of over six months (which is the normal period required by our farmers to store paddy from one season of cultivation to the other).
4. Strong and durable. If properly maintained lasts for over 25 years.
5. Workable under all conditions.
6. With slight modification loading and unloading become easy.
7. Low cost of storage.

REFERENCES CITED

1. Panasenko V.T, 1967 Ecology of Microfungi. Botan. Rev. 33, 189-215
2. Williamson W.F 1964. Temperature changes in grain dried and stored on farms. J. Agri. Eng. Res 9, 32-47.
3. Grosh, Gordon M. and Max Milner. 1959. Water penetration and internal cracking in tempered wheat grain. Cereal Chem. 26:260-273
4. Trisvyatskii L.A. 1966 Khraneniye Zerna. KOLOS. Moscow. 407 p (Russian) (Storage of Grain. English translation by D.M. Keane. Vol. 1-3, 1969. Natl. Lending Library Sci. Technol., Boston Spa, England. 845 p.)
5. Chandra Brekenridge 1973. A study of criteria for the establishment of grades and standards for paddy and rice in Sri Lanka. P. M. B. Res. Bull. 1/73 p.15.

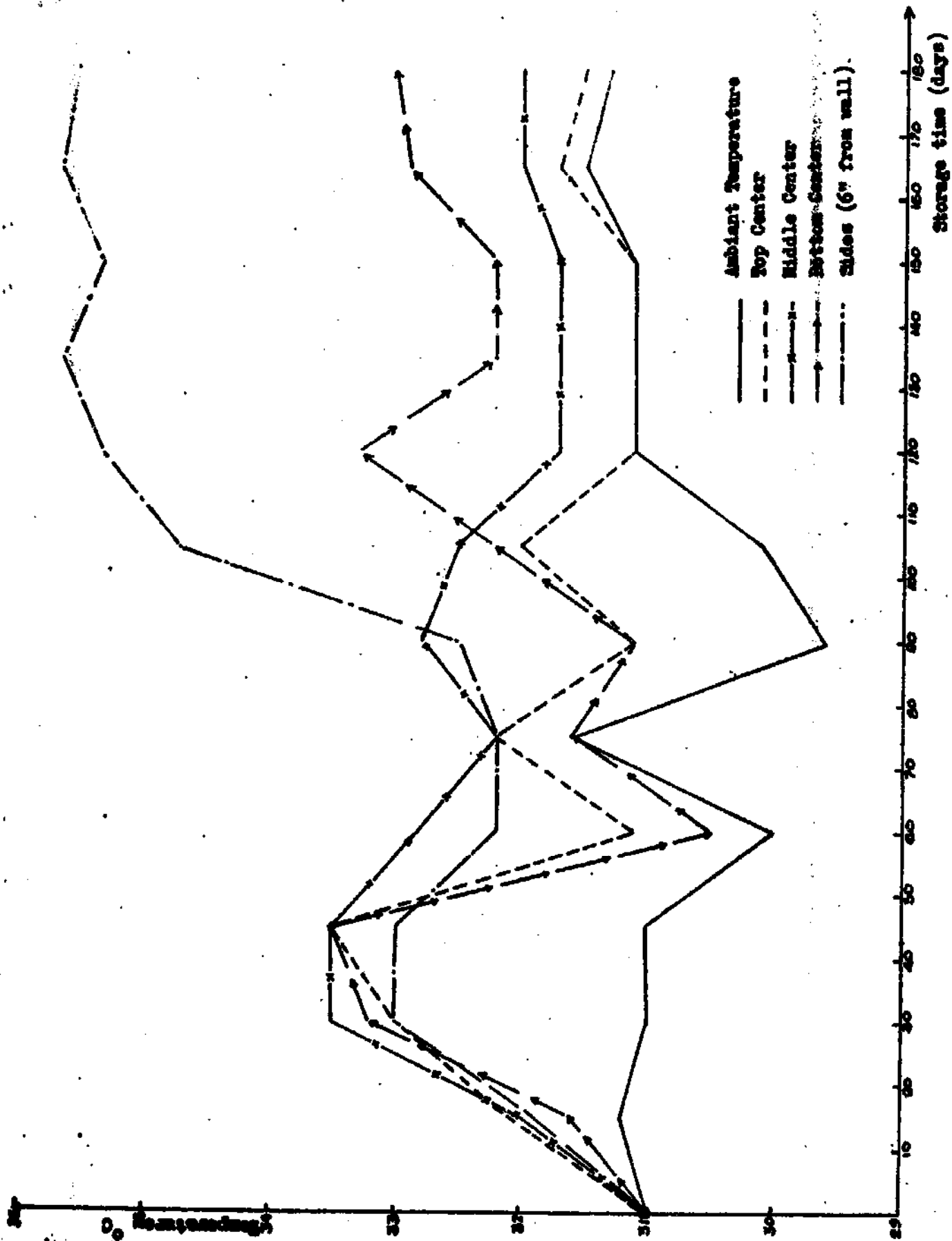

Fig. 1 - Temperature changes in cavity with storage time



Fig. 2 - External view of a Bism

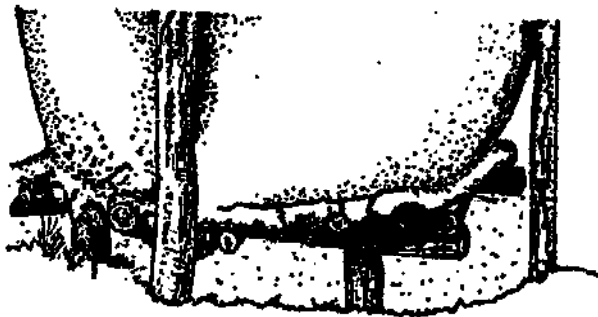

Fig. 3 - Lower part of a Bism

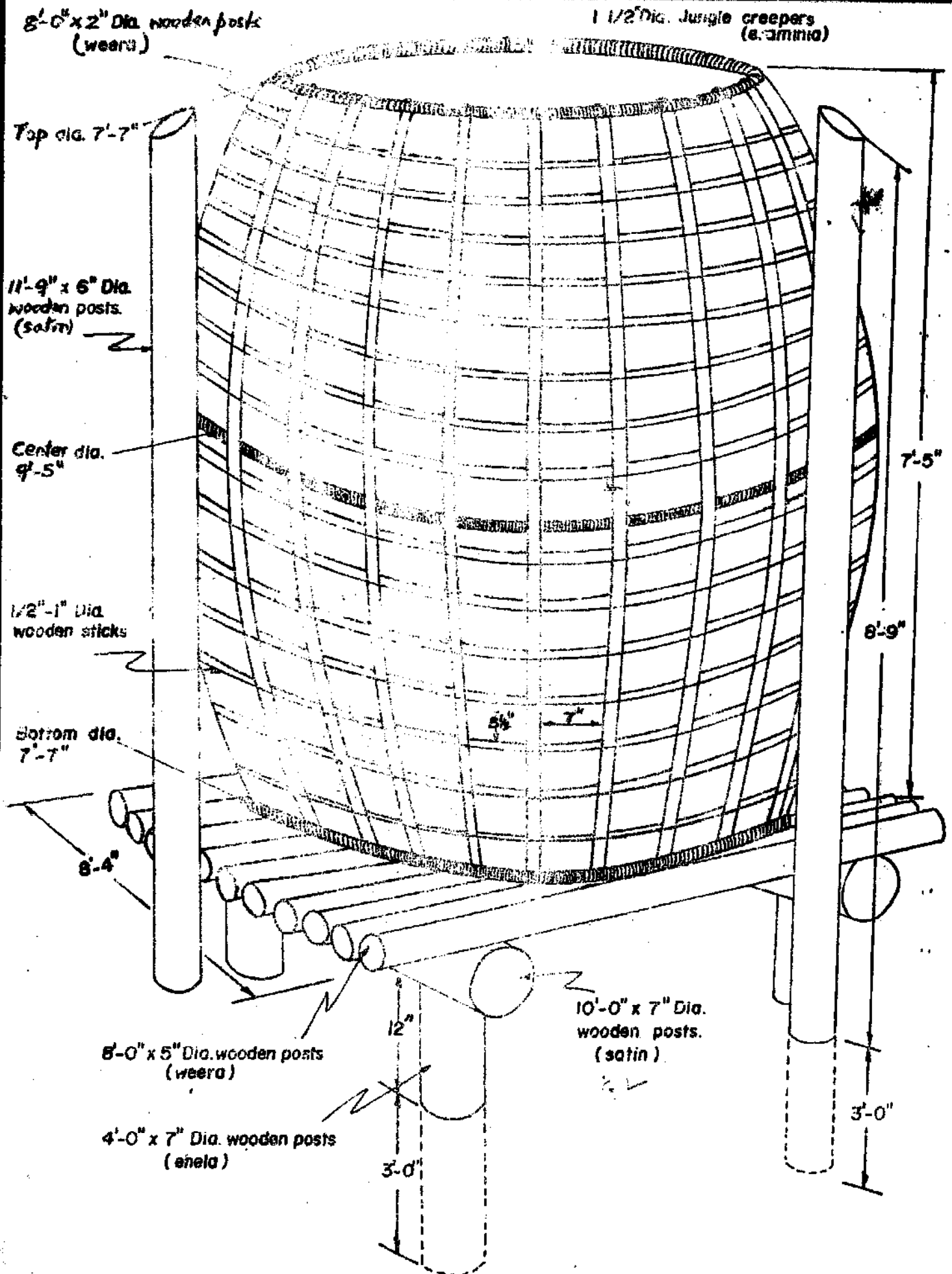

Fig. 4 BASE AND WALL FRAMEWORK OF A BISSA (Capacity 5 tons)

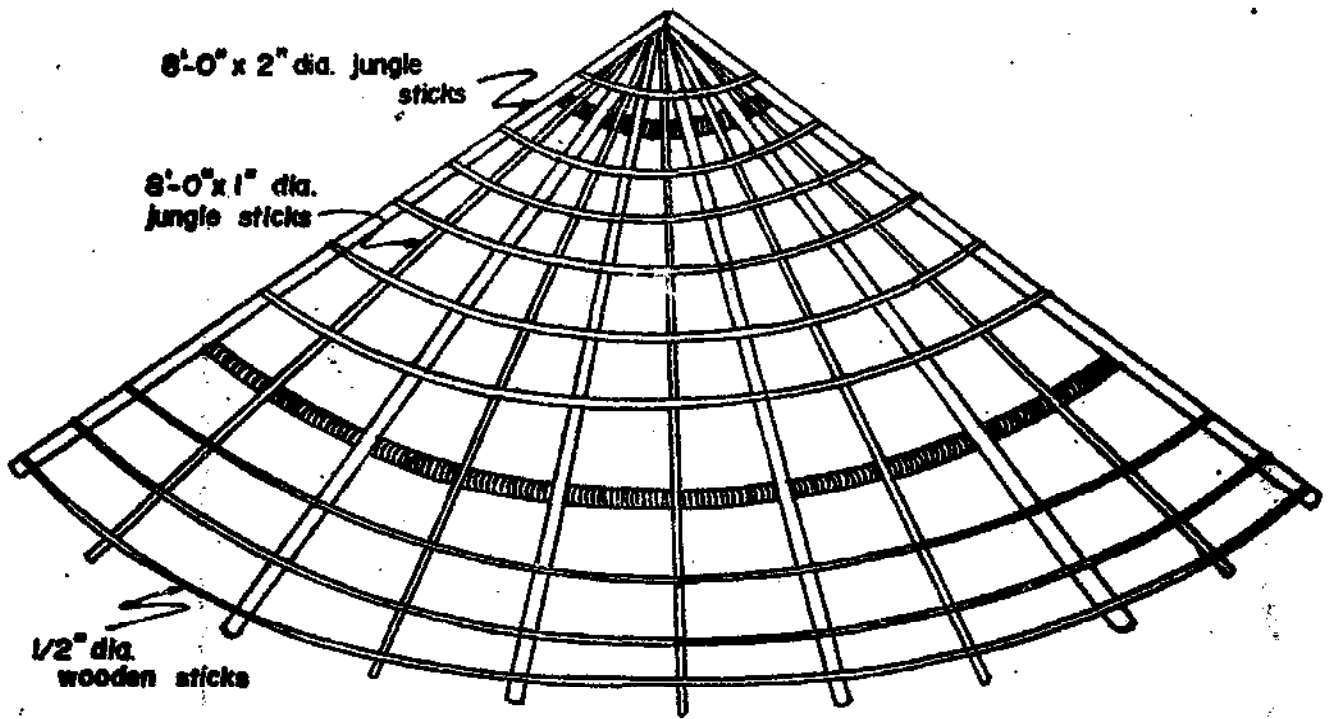

FIG. 5. ROOF FRAMEWORK OF A BISSA ( 5 ton capacity )

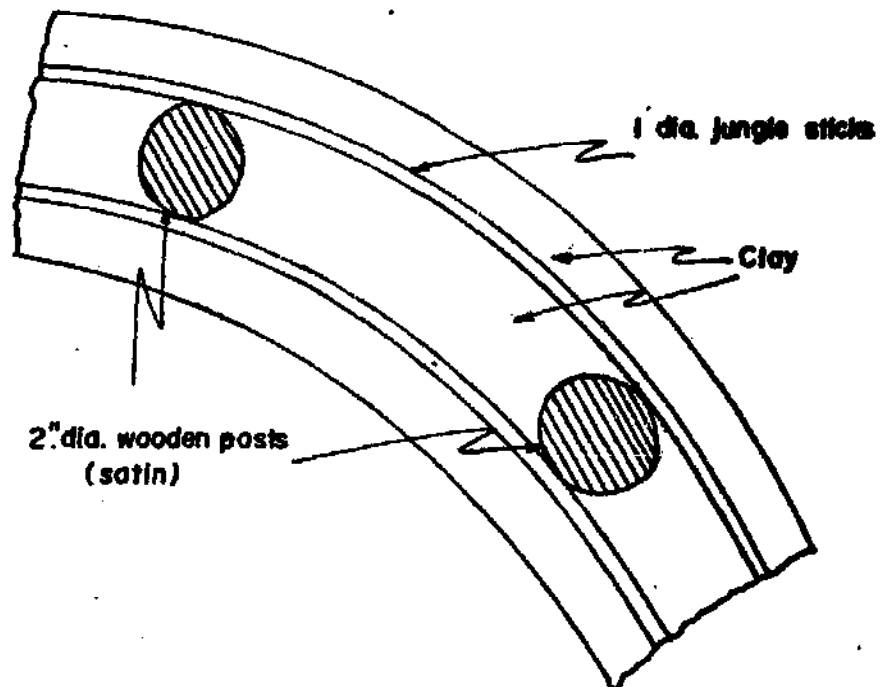
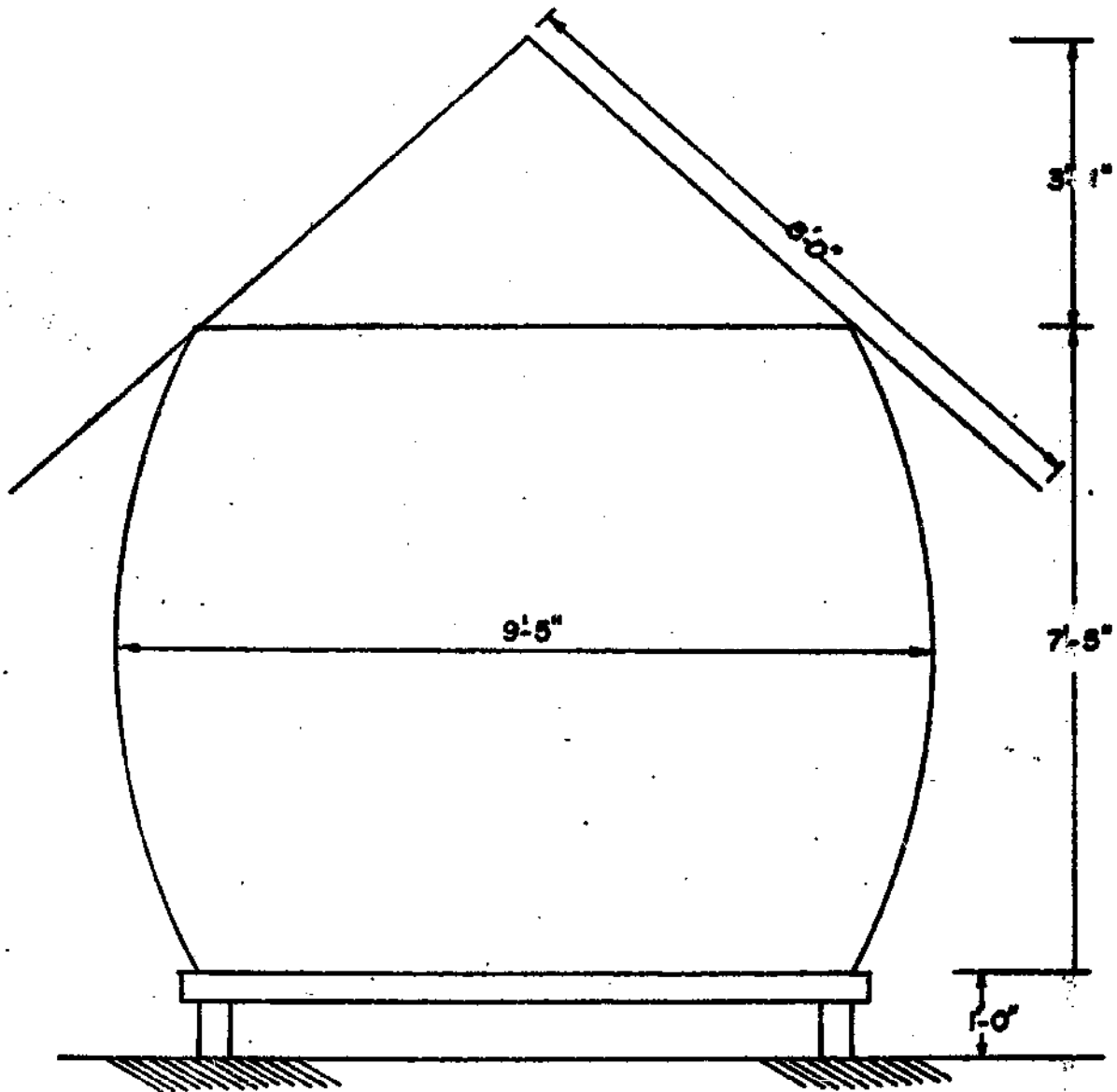

FIG. 6. CROSS SECTION OF THE WALL



**FIG. 7 ELEVATION OF A BISSA (5 ton capacity)**



(A)



(B)



(C)

**Fig. 8 - Loading & Unloading operation**



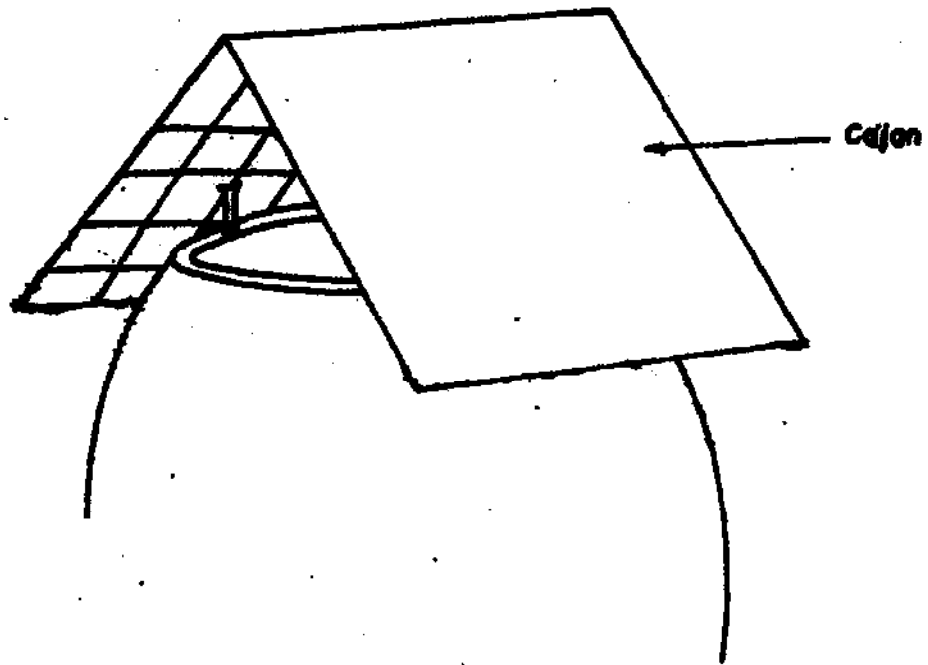

**FIG. 9 A VARIATION OF THE ROOF STRUCTURE**

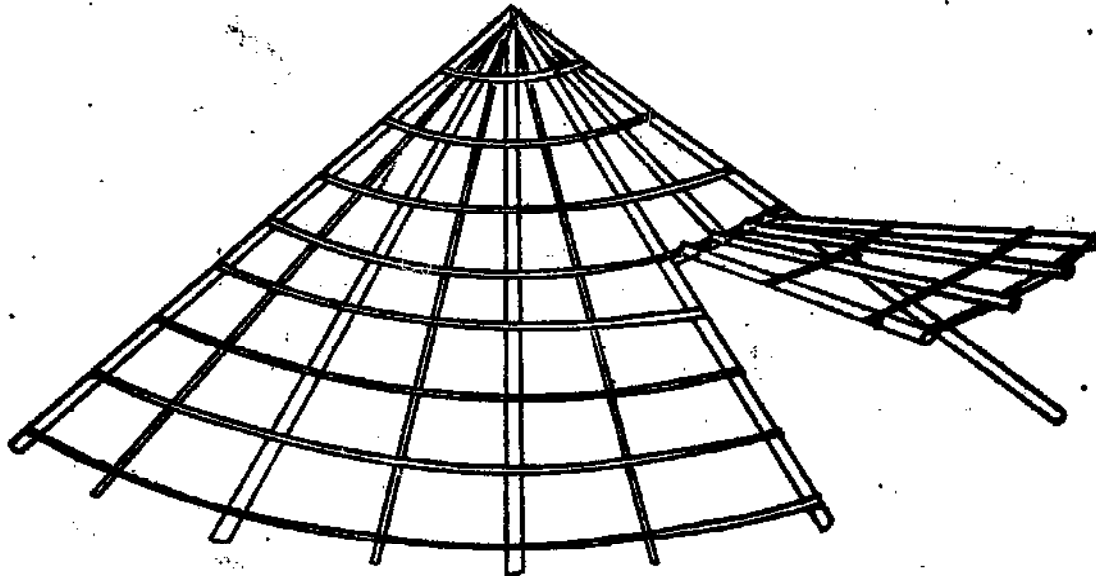

**FIG 10 ROOF FRAMEWORK SHOWING HINGED PORTION  
FOR LOADING AND UNLOADING**



Fig. 11 - A Bissa in Africa

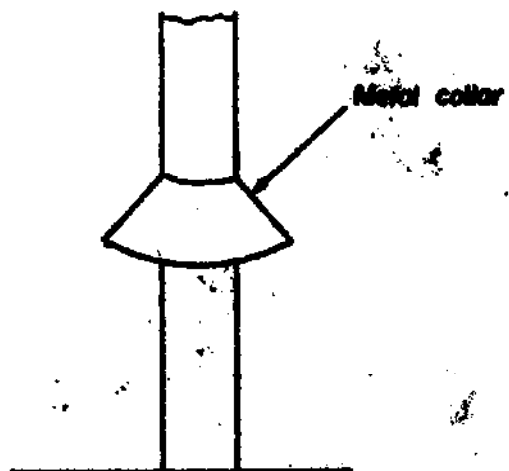

**FIG. 12 RAT GUARD**

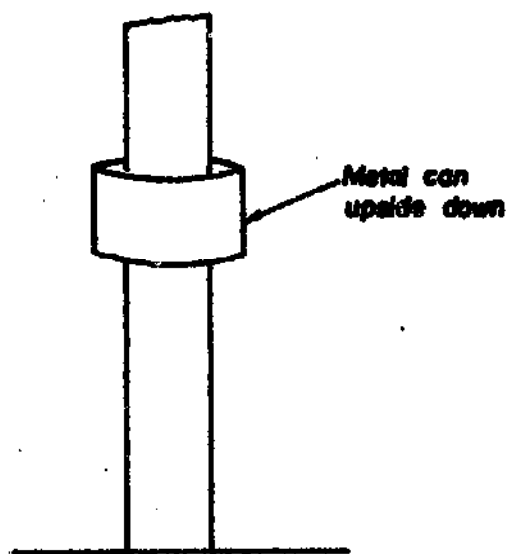

**FIG. 13 RAT GUARD**

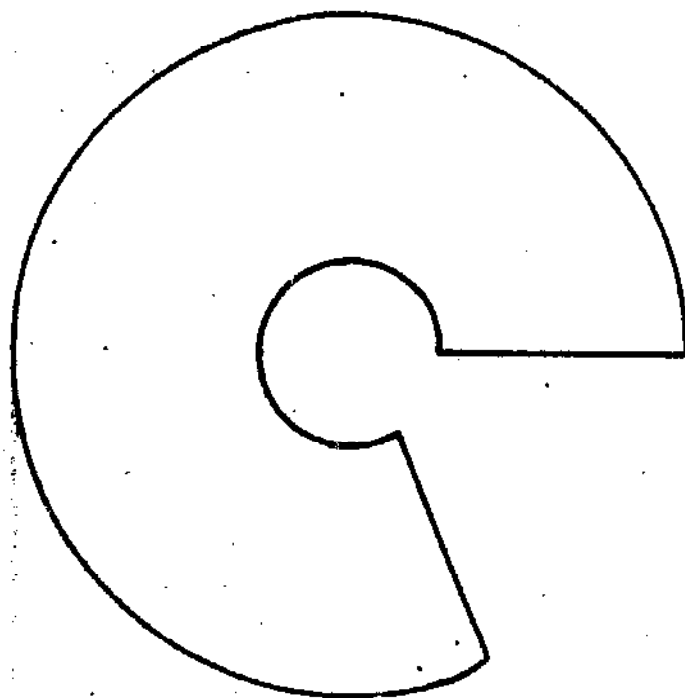

**FIG. 14 PATTERN FOR A RAT GUARD TO BE CUT FROM A  
PIECE OF TIN**

Table 1 - Changes in the quality of Paddy with storage time in a 5 ton capacity "Bison".

Period of storage (days)	Moisture content %	Impurities % by wt.	Bushel weight without impurities lbs.	Mechanically damaged grains % by wt.	Immature empty & partly filled grains % by wt.	Fungal damaged grains %	Sprouted grains % number	Stress cracked grains % by Number	Insect damaged grains % by Number	Total milling yield % wt loss	Total milling yield % by wt.	Head rice yield % by wt.	Broken grains % by wt.
0	12.7	0.5	45.4	0.1	4.0	0.1	0	40	0.0	0.0	74.3	50.3	31.4
15	14.2	0.5	45.9	0.1	4.0	0.2	0	40	0.3	0.1	74.3	50.1	32.7
30	15.4	0.5	45.7	0.1	3.8	0.5	0	40	0.3	0.1	-	50.4	30.1
45	14.5	0.5	45.3	0.1	3.9	0.5	0	40	0.3	0.1	74.3	49.2	32.7
60	14.5	0.5	45.3	0.1	3.9	0.5	0	40	0.4	0.2	74.4	49.2	32.7
75	14.8	0.5	45.4	0.1	3.9	0.5	0	43	0.5	0.2	73.5	49.2	32.7
90	14.7	0.5	45.4	0.1	3.9	0.5	0	43	0.6	0.2	73.6	48.4	34.2
105	14.7	0.5	45.4	0.1	3.9	0.6	0	43	0.8	0.5	73.5	48.4	34.2
120	15.0	0.5	45.4	0.1	3.9	0.5	0	53	1.0	0.7	-	45.2	36.9
135	15.2	0.5	45.7	0.1	4.0	0.6	0	55	1.5	1.0	73.3	45.4	37.2
150	14.1	0.5	42.2	0.1	3.9	0.9	0	55	1.6	1.0	73.3	46.4	36.7
165	14.4	0.5	42.1	0.1	3.9	0.9	0	55	1.7	1.1	73.3	43.7	40.6
180	14.3	0.7	44.1	0.1	3.6	1.7	0	55	1.8	1.1	73.3	41.0	44.6

Table 2 -- Temperature changes in the grain during storage.

Period of Storage (days)	Ambiant temperature (°C)	Temperature of the Grain (°C)			
		Top Center	Bottom Center	Middle Center	Sides 6" from wall
0	31.0	31.0	31.0	31.0	31.0
15	31.2	32.1	31.6	32.0	31.9
30	31.0	33.0	33.2	33.5	33.0
45	31.0	33.5	33.5	33.5	33.0
60	30.0	31.1	30.5	32.8	32.2
75	31.6	32.2	31.6	32.8	32.2
90	29.6	31.1	31.1	32.8	32.2
105	30.1	32.0	32.2	32.5	34.7
120	31.1	31.1	33.3	31.7	35.3
135	31.1	31.1	32.2	31.7	35.6
150	31.1	31.1	32.2	31.7	35.3
165	31.5	31.7	32.9	32.0	35.6
180	31.3	31.5	33.0	32.0	35.5

Table 3 - Change in Bushel weight with time of storage

Period of storage (days)	0	15	30	60	75	90	105	120	135	150	165	180	19
Bushel wt. without impurities at 14% moisture (lbs)	46.0	45.7	45.1	45.1	45.1	45.0	45.1	45.1	45.0	45.2	44.2	43.9	43.4

Table 4 - Change in weight of paddy with the period of storage

Storage period (days)	Weight (lbs)	Moisture content
0	6765.25	12.7
180	6867.75*	15.0

\* Weight of the samples drawn out were added to the final wt.

Annexure 1.

FIELD INFORMATION SHEET

- 1. NAME OF FARMER : . . . . .
- 2. NAME OF VILLAGE : . . . . .
- 3. NAME OF DISTRICT : . . . . .
- 4. TYPE OF STORAGE STRUCTURE : . . . . .
- 5. CAPACITY : . . . . .
- 6. CONSTRUCTION
  - a. Shape of the Structure (Draw sketches) : . . . . .
  - b. Date constructed : . . . . .
  - c. Material used for construction of the
    - Floor : . . . . .
    - Wall : . . . . .
    - Roof : . . . . .
  - d. From where were the material obtained : . . . . .
  - e. Cost of construction : . . . . .
- 7. LOADING & UNLOADING
  - a. Method of loading : . . . . .  
. . . . .
  - b. How many persons are required for the loading operation : . . . . .
  - c. How often is the paddy loaded : . . . . .
  - d. What are the problems encountered in the loading operation: . . . . .  
. . . . .  
. . . . .
  - e. Method of unloading : . . . . .  
. . . . .
  - f. How many persons are required for the unloading operation : . . . . .



- g. How often is the paddy unloaded : . . . . .
- h. Problems encountered in the unloading operation : . . . . .  
. . . . .  
. . . . .

8. STORAGE OF PADDY

- a. What are the treatments given to paddy before loading } : . . . . .  
} . . . . .  
} . . . . .
- b. For how long paddy is sundried before loading : . . . . .
- c. Can you store high moisture paddy in the structure : . . . . .  
. . . . .
- d. Are there any aeration facilities : . . . . .  
. . . . .  
. . . . .
- e. What is the period of storage : . . . . .
- f. What is the condition of the paddy at the end of the above storage period } : . . . . .  
} . . . . .  
} . . . . .
- g. Do you notice any loss in the grain at the end of the storage period ? : . . . . .

If so how do you account for the loss : . . . . .  
. . . . .

In your opinion is the loss due to the following :

- a. Rodents : . . . . .
- b. Dryage : . . . . .
- c. Insects : . . . . .
- d. Birds : . . . . .
- e. Termites : . . . . .
- f. Handling : . . . . .

Do you take any precautions to prevent this loss

: . . . . .  
. . . . .

h. Do you observe insect activity and damage ?

If so how do you overcome this problem

i. Do you observe rodent activity and damage ?

If so how do you overcome this problem

j. Do you observe termite activity & damage ?

If so do you overcome this problem

k. Do you observe bird activity and damage ?

If so, how do you overcome this problem

l. Is the structure moisture proof during heavy rains ?

9. STORAGE OF OTHER GRAINS

a. Is the structure used to store other grains?

b. If so what are the grains stored

10. STRENGTH & DURABILITY OF THE STRUCTURE

a. What is the life span of a Bissa ?

b. How often do you have to repair the structure

c. Nature of the repair

d. Cost

-0-0-0-0-0-0-