

AT MICROFICHE REFERENCE LIBRARY

A project of Volunteers in Asia

Manual on Improved Farm and Village Level Grain
Storage Methods

by: David Dichter

Published by:

Deutsche Gesellschaft für Technische
Zusammenarbeit (GTZ)
D-6236 Eschborn 1
Federal Republic of Germany

Paper copies are \$ 9.00.

Available from:

Deutsche Gesellschaft für Technische
Zusammenarbeit (GTZ)
D-6236 Eschborn 1
Federal Republic of Germany

Reproduced by permission of Deutsche
Gesellschaft für Technische Zusammenarbeit (GTZ).

Reproduction of this microfiche document in any
form is subject to the same restrictions as those
of the original document.

MANUAL ON
IMPROVED FARM & VILLAGE-LEVEL GRAIN
STORAGE METHODS

Published by:

Deutsche Gesellschaft für Technische Zusammenarbeit (GTZ) GmbH

German Agency for Technical Cooperation, Ltd. (GTZ)

Dag-Hammarskjöld-Weg 1

D-6236 Eschborn 1

Federal Republic of Germany

Print: Hoehl-Druck Bad Hersfeld

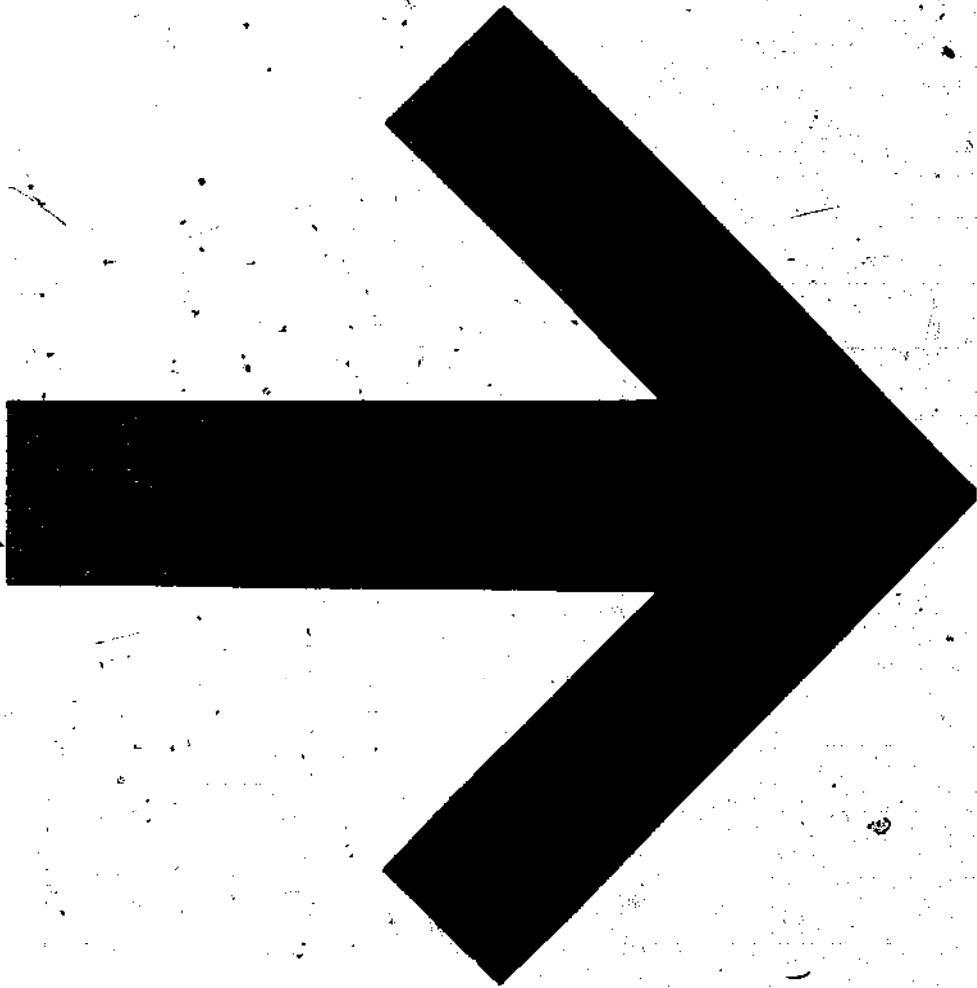

CONTENTS

	Page
Foreword	5
Acknowledgements	8
Introduction	9
CHAPTER I: WHY STORE GRAIN	13
More food for the family	17
More stable prices	18
Better seeds for better crops	19
Conclusion	20
CHAPTER II: THE GRAIN YOU STORE	27
CHAPTER III: DRY GRAIN = SAFE STORAGE	37
How air, moisture and grain interact	40
Safe moisture levels in grain	45
Insects, molds, and grain heating	48
CHAPTER IV: CHOOSING YOUR STORAGE SYSTEM	55
The considerations for choice of farm and village-level grain storage methods	56
Storing grain in sacks	61
CHAPTER V: CONSTRUCTION AND UTILIZATION OF A VARIOUS IMPROVED FARM AND VILLAGE- LEVEL GRAIN STORAGE FACILITIES	69
Model 1 – improved maize crib	70
Model 2 – improved mud brick silo	94
Model 3 – the 4.5 ton cement stave silo	114
Model 4 – cement block (square) silo	145
CHAPTER VI: CONSTRUCTING AND USING YOUR DRYER	157
A. General description of Partially-enclosed dryers	159

	Page
B. Advantages of partially-enclosed dryers ..	160
C. General remarks on construction of dryers	161
D. Construction of the model 1 dryer	161
E. Construction of cover for models 1 and 2 dryers	169
F. Construction of drying trays	176
G. Construction of model 2 dryer	176
 CHAPTER VII: GRAIN-INSECTS, RODENTS AND INSECTICIDES	 206
1. Know your enemies	207
2. Care in drying, cleaning and storing of grain	207
3. Measures that can be taken without insecticides	209
4. Insecticides	210
 CHAPTER VIII: POPULARIZING IMPROVED METHODS OF FARM AND VILLAGE-LEVEL GRAIN STORAGE TECHNOLOGY	 224
Step 1 - Assessment	225
Step 2 - Formulation	226
Step 3 - Organization and administration	227
Step 4 - Evaluation	228
 CHAPTER IX: DEVELOPING A NATIONAL STRATEGY FOR FARM AND VILLAGE-LEVEL GRAIN STORAGE	 233
 CHAPTER X: FIELD QUESTIONNAIRE	 235
I: The grain cycle and seasonal work kalender	237
II: The local farm economy	239
III: The use of grain	240
IV: The current storage practices	241
Conclusions	242

FOREWORD

This is the third* in a series of training manuals developed by David Dichter & Associates, in cooperation with the Government of the Federal Republic of Germany, devoted to improved grain storage practices at the farm and village-level in the developing countries of Asia, Africa, and Latin America. This Manual is largely based on material developed for the EAST AFRICAN WORKSHOP/TRAINING COURSE ON IMPROVED FARM & VILLAGE-LEVEL GRAIN STORAGE METHODS held at the East African Community Management Institute in Arusha, Tanzania from 28 February to 12 March 1977. The course was sponsored by the Ministry of Agriculture of the Government of Tanzania (Kilimo) and by the German Foundation for International Development (DSE). David Dichter & Associates of Geneva, Switzerland served as the Workshop Secretariat.

Whereas much of the information contained in this Manual was prepared for use in the East African Regional Workshop, it was also designed to serve the needs of many other regions in the developing world, particularly as a general training guide for technical and extension personnel engaged in reducing post harvest grain storage losses. Accordingly, every effort has been made to produce a book which can be used not only as a practical teaching device, but also as a comprehensive field training manual. The fact that more than half of the participants' time at the Arusha Workshop was devoted to on-the-job training in silo/dryer construction, maintenance, and appropriate utilization, serves to emphasize the "self-help" approach of this Manual. Many of the dryer and storage units featured in this Manual have been successfully used for a number of years in various parts of West Africa and the Sahel, regions which have comparable temperature and humidity.

*"WEST AFRICAN SEMINAR ON THE VOLUNTEER ROLE IN FARM & VILLAGE-LEVEL GRAIN STORAGE", Cotonou, Dahomey, December 13-21, 1974. Published by the German Agency for Technical Cooperation (GTZ), Postfach 5180, Eschborn 6236, F. R. Germany, 1975.

"WORKBOOK FOR EAST AFRICAN WORKSHOP/TRAINING COURSE ON IMPROVED FARM & VILLAGE-LEVEL GRAIN STORAGE METHODS", Arusha, Tanzania, February 28-March 12, 1977, German Foundation for International Development, 8123 Feldafing, F. R. Germany.

dity conditions to many parts of East Africa. Thus, the organizers of the Course felt that it was reasonable to introduce these models to the trainees attending the Arusha course. In addition to applying the successful experiences gained in West Africa, an effort was made during the Workshop to analyse, discuss – and in some cases actually construct – those types of grain storage and drying systems which have been found to produce the best results for subsistence farmers in East Africa.

To make best use of this training guide, it is recommended that the reader first learn as much as possible about the area in which he or she is working. To assist him in this effort, a "Field Questionnaire" is included as the last chapter. Besides providing simple data-gathering techniques on local social and economic conditions, the "Questionnaire" enables the user to make a systematic analysis of the information collected about local grain storage practices.

The Manual itself is divided into ten chapters. If used in conjunction with a training course, each chapter provides information for approximately a half-day's study. Two of the chapters – "Storage Systems" and "Dryer Systems" – contain detailed building plans of improved grain storage/dryer units for use in an on-the-job training programme.

Although the manual contains data about various types of improved farm and village-level grain storage and dryer systems, it is not meant to be a complete reference work in itself. It does offer, however, information on selected models which have proved successful in a wide variety of operational and climatic conditions. The user is encouraged to make any necessary improvements or modifications based on local conditions.

We recommend, especially if the Manual is being used in a training course, that the reader first look over the book quickly in order to see how the subject matter has been presented. He should then read carefully each chapter before it is discussed in class.

As part of the systematic approach used in this Manual, there is a series of questions at the end of each chapter. The user is advised to try and answer the questions after becoming familiar with the subject matter, thus fixing the most important features in his mind. Experience has

shown that the most effective way for a person to make use of this part of the Manual is first to answer the questions in pencil, and later jot down comments and questions which he may have in order to discuss them with his colleagues in the classroom, at his place of work, or in the field. After the classroom period, or after he has consulted his supervisors, it is suggested that he recopy the answers and additional notes in ink as a permanent record.

There is a bibliography of books and other works at the end of the Manual that may be useful if more detailed information on the subject is required.

May 1978
Geneva, Switzerland

David Dichter
Senior Associate
DAVID DICHTER & ASSOCIATES
9 rue de Vermont
1202 Geneva, Switzerland

ACKNOWLEDGEMENTS

The author would like to express his sincere appreciation to the government and the people of the United Republic of Tanzania and the People's Republic of Benin for their cooperation in the preparation of this Training Manual. Sincere thanks are also extended to the officials of the German Foundation for International Development (DSE), in particular to Dr. Herman von Mylius, for their splendid support. To members of the Nordic Project for Cooperative Assistance to Tanzania, especially Mr. Robert Tamm, Ms. G. N. Pedersen, and Mr. Erik Bentzen, who did so much to assist us in the organization of the Arusha Workshop and who are responsible for some of the excellent illustrations in the Manual. A special note of thanks is also extended to the officials of the Agricultural Engineering Service of the Food & Agriculture Organization for their advice and kind assistance, and also to UNICEF/East Africa Regional Office for making the services of Oscar Mann available in Arusha.

To Harald Thorshaug of Norway, Samuel Adesuyi from Nigeria, Felix Kaijage, A. J. Hauli, A. Mushi, and Alec Mosha from Tanzania, Kotewang Metuge from Cameroon, Steven Graham, Jay Gould, and Robert Hellyer from the United States, and to my colleagues René Wadlow and William Sorsby, my sincere thanks and appreciation for their wonderful assistance and also for the significant contributions they have made and advice given in the final preparation of this Manual. And to all those other individuals, organizations and groups who have counseled and helped me in advancing the cause of improved farm and village-level grain storage methods in developing countries, I should like to express my gratitude.

Finally, I should like to offer my sincere thanks and appreciation to the Government of the Federal Republic of Germany and in particular Dr. Peter Müller and Mr. Thomas Neumaier of the German Agency for Technical Cooperation, Ltd. (GTZ) who did so much to make the printing of this manual possible.

D. D.

INTRODUCTION

Feeding the world's population has always been one of mankind's greatest problems, and yet it has taken on even greater importance in recent years. Widespread famine is now a reality. The year 1972 represented a turning point downwards; for the first time in over twenty years, worldwide production of cereal grains decreased, while the world's population continued to increase at an alarming rate.

Reactions to this crisis were many and diverse. International organizations mobilized their resources, new agencies were created and massive relief shipments were begun, and in some particularly hard-hit areas airlifts were instituted. The affected countries in the West African and Sahelian regions for example, banded together to work on both short and long-term solutions to their food problems. The United Nations, through its Food and Agricultural Organization, held a World Food Conference in Rome in 1974.

The statistics, however, continue to be disheartening, with deaths reported in units of 10,000 or even 100,000 accompanied by predictions of possibly even greater catastrophes in the future. The long-term damage to agriculture and herds in the affected regions is virtually incalculable to human society in terms of brain damage (through malnutrition) and other horrifying afflictions. Plans for making just one of these regions – the African Sahel – famine-proof, call for the expenditure of billions of dollars.

In an assessment prepared by FAO for the World Food Conference in 1974, it was estimated that the demand for cereals in the developing countries would reach 929 million tons by 1985, yet the report predicted that production would not rise over 853 million tons. The deficit of 76 million tons would be about 100 million tons if the cereal exporting countries among them were excluded. Assuming that losses in the post-harvest period are not more than 10%, which FAO believes is a rather conservative estimate, this means 86 million tons lost per year by 1985 **if no action is taken to prevent it.** Furthermore, if one considers that these statistics include bulk storage facilities where losses can be much better controlled, then the on-farm and village-level grain storage losses in developing countries are obviously going to be higher than

10%: in fact, perhaps as high as 20–30 % for grain stored six months to a year, and most likely substantially higher for carry-over stocks of more than a year. The FAO report concludes that with the recent weighted export price of US \$ 176 per ton, this would represent a loss in foreign exchange to developing countries of the order of approximately US \$ 7.5 billion per year.

International aid programmes and many extension services have traditionally concentrated their attention either on increasing the volume and means of production or on introducing new systems of marketing and distribution. Actually, it is in the middle – between harvest and sale (or harvest and consumption) – that the greatest losses occur, especially to the individual farmer's grain. The effects of these losses are staggering when applied to overall grain production of the less developed countries of Asia, Africa, and Latin America. They are tragic when measured against the circumstances of the individual subsistence farmer, who is still the mainstay of agriculture in most developing countries. Add to this fact that 80% of the average subsistence farmer's grain crop is kept on the farm or in his village for seed and consumption, and the effect of these storage losses becomes readily apparent. The problem of maintaining adequate food security stocks at the farm and village-level is of vital concern to government officials in the developing countries. Because of inadequate storage facilities at the local level, however, there is little if any effective carry-over stocks of cereal grains from one year to the next. Under serious drought conditions, or in the event of other natural or man-made disasters, this often causes severe hardships for subsistence farmers and their families in the affected regions:

Because subsistence farmers in most developing countries are unable to store their excess grain adequately for more than a few months before it begins to deteriorate, the practice at harvest time in most developing countries is for farmers to try to sell off their surplus amount immediately. This represents virtually their only cash income from cereal production for the season. Since thousands of other farmers in the region are also selling their surplus at the same time, the inevitable result is either plummeting grain prices (in a free market situation), or where there is a single purchasing authority, bottlenecks and delays

brought on by overtaxed centralized storage facilities and inadequate inland transport. However, just before the next harvest season, when their cash reserves are likely to be at their lowest level and their personal grain stocks hardly sufficient to maintain their families on a subsistence basis, local farmers invariably find themselves in very difficult circumstances. It is a common practice for subsistence farmers to go into serious debt because they were forced to buy grain stocks – often at inflated prices – from private dealers in order to replenish their household supplies.

Whereas efforts to combat the problem through the introduction of cooperatives, price supports and the like are very useful and do in some cases help subsistence farmers to pull themselves out of this vicious economic cycle, there is another solution that is perhaps often overlooked because of its inherent simplicity. If the farmer had access to inexpensive, efficient farm and village-level storage/dryer systems for his grain (and where necessary some form of agricultural credit), he could not only hold back his grain until later in the agricultural year when he was most in need of cash and likely to get a better price for it, but most important of all, guarantee himself and his family a much more secure as well as nutritious food supply during the coming year.

As urbanization has advanced in varying degrees in the developing countries, with the resultant growth of population in cities and towns, the aggregate demand by non-producers for food grains has grown steadily. This growing demand has been met during the good crop years by surplus production on farms which could be offered for sale. The more recent years of drought and reduced production, have seen commercial sales from the nations' farms significantly reduced, leaving governments in Asia, Africa, and Latin America little choice but to import large amounts of grain, often utilizing badly needed foreign exchange reserves.

It is well known by this time that local storage losses are widespread among subsistence farmers in developing countries. Many traditional storage methods, however, are not wholly appropriate or technically efficient and also require modifications or improvements to their basic designs or the introduction of new techniques. Consequently, many experts agree that much larger quantities of grain could be made avail-

able for commercial sale if improvements were made, thus providing subsistence farmers with additional cash income.

Our experience has shown that the technology is now available for constructing effective, relatively inexpensive farm and village-level grain storage/dryer facilities using locally available material and employing labour-intensive methods. Furthermore, we believe that the question of significantly reducing local grain storage losses is essentially a management problem – not a technical one – and one which can be resolved through the establishment of clearly defined national policies. What is urgently needed at this time is to bring this knowledge to the appropriate “change agents” in the developing countries and to assist these personnel in devising the most effective procedures for assuring its rapid and widespread application at the farm and village-level.

David Dichter, Ph. D.
Geneva, Switzerland
September 1977

CHAPTER I: WHY STORE GRAIN

During the past ten years, technological advances in agriculture have been responsible in large part for a worldwide increase in total food production. But the disappointing fact remains that the population growth of the globe has canceled out most of these gains. As a result, there is actually lower per capita food production today than there was in 1970, and global food reserves in 1974 were approximately 25 per cent of what they were in 1961.

It is now widely recognized that the struggle to feed the world is intensifying. The United Nations Food and Agriculture Organization has recently estimated that nearly 500 million people throughout the world suffer from some form of malnourishment. But FAO has also estimated that over 200 million tons of grain are destroyed each year by insects, molds, rodents, birds, and other pests. This 200 million tons of grain is enough to feed 500 million people for one year and essentially eliminate the present food gap.

These statistics illustrate why world food shortages must be solved not only by increased food production, but also by reducing food losses. This need was recognized at the World Food Conference, held in Rome in November 1974, when its official conference report recognized the fact that "in many developing countries large quantities of food are lost between the farm field and the consumer, and that deterioration in the nutritional value of food before it reaches the consumer is a serious problem". And later in the same Resolution, the Conference "requests all countries to reduce to a minimum the waste of food and of agriculture resources".

As you are already aware, great efforts are being made in all countries to improve agricultural production and to raise the level of well-being of rural families. Such efforts are everywhere more necessary than ever. In many parts of the world there is acute hunger, even to the point of starvation. Many of you are aware of the vast loss of life due to lack of food that took place in the Sahel countries of West Africa. The same drought situation which began in 1972 had serious effects in Ethiopia and in parts of East Africa. The scars left from the drought are still plainly visi-

ble, and it will take a long time before the animal herds can be built up again.

Although actual starvation is a dramatic and extreme situation, malnutrition is much more common in developing countries, and especially among children. According to the World Health Organization, 10 million children in the Third World under the age of five are chronically and severely malnourished, and some 90 million more are moderately affected. These United Nations figures show that of all the deaths in the poor countries, more than half occur among children under five, and perhaps as many as 75 per cent of the deaths are due to malnutrition complicated by infection – that is, the child does not die of malnutrition, but because malnutrition has already weakened him, he is more susceptible to disease. Malnutrition must thus be overcome, because an inadequate diet makes all people, but especially children, less able to combat diseases. Children who are malnourished have less energy and do less well in school, too. Men and Women who are malnourished are less productive, more easily tired and less able to do a real day's work. A wife who is pregnant must eat well if the new child is to be healthy. For all these reasons, the farm family is interested in having more and better food.

From the point of view of the nation as a whole, food is as vital to the life of the country as it is to the life of a man.

Self-reliance is increasingly recognized as a fundamental goal of all developing nations and as the precondition for proper development. As long as a nation is dependent upon other nations for its very livelihood, it leaves them in a weakened position. Many countries fear that food – because it can be sold or held back – depending on another nation's policies – puts them at a serious disadvantage. Furthermore, when a country is not self sufficient in its basic food needs, then money – often involving hard currencies – has to be spent to import food. This money has to be earned by exporting goods, and the world's terms of trade are usually unfavorable to the exports of poor countries. It is far better for a developing country to be self-sufficient in its food needs and to use its money to import goods and machines so as to be able to increase production in a variety of sectors.

Thus, self-sufficiency in food is the policy of most Asian, African, and Latin American states, but real efforts will have to be made to bring the policy to reality.

From a national point of view, increased food production and better storage of food is important so that life may be made more rewarding for rural people. If such improvements can be made, it is likely that it will help slow down the flow of young people to the cities, where there is often no productive work for them.

For a more rewarding life in the rural areas, farm families must get the most from their efforts. They must be helped to produce more, but also to lose less. It is to help overcome the great losses that occur between the time grain is harvested and consumed that this Manual has been produced.

Considerably more attention is now being given to the problem of reducing post-harvest grain storage losses at the farm and village-level. Of course, a great amount of work has been done to improve storage facilities in countries that export much of their grain, and in the same way, a good deal of agricultural experimentation and extension work in a number of Third World countries has gone into work on "export crops".

Now, however, the need to improve methods at the farm and village-level is being recognized. Effective improved storage at the farm and village-level is of crucial importance, for it is on the farm or in the village that the great bulk of grain is stored, both for use of the farm family, and until it can be sold at the market.

It is also at the farm and village-level that great losses occur, losses due to molds and other forms of bacteriological deterioration, to insects and rats. Mold spores are similar to seeds, for molds are really a large number of very, very small plants. With moisture, these mold spores start to grow, as is the case with any plant, and they need food to keep on growing. Thus the molds enter into the kernels of the grain and use up the nutritive value of the kernel. It is at the farm and village-level, therefore, that the first determined efforts must be made to improve grain storage techniques for the benefit of farm families and for the nation as a whole.

By concentrating at the farm and village-level, we do not mean to overlook problems at central collection points of larger-scale storage facilities. It is simply that the managers of larger storage facilities can get help from storage specialists more easily than can the local farmer. The drying and preservation of food at the farm and village-level is important. Food preservation and storage will enable one region to supply food to others, and such preservation may serve as the base for local industries. Thus, proper preservation of food is not limited to the storage of grain. The proper drying of fish, of meat, of vegetables and of fruit can all be part of a program for better nutrition and for sale on the local market.

This workbook, however, is designed to help improve the storage of grain at the farm and village-level, for grain is of great importance both in local diets and as a cash crop.

Most people throughout the world depend on food grains to live. Maize, millets and sorghums, and rice are the basic foods for most people in the world. In some areas, root crops such as yams and manioc also play a large part, but there seems to be a trend for food grains to increase in importance as grain is easier to transport. Thus grains play an important role in feeding the increasingly large populations in cities. The need to feed people living in the urban centers means that farmers can sell their crops for cash to buy goods necessary for their welfare.

Grains have other uses also. In some parts of the world, grain is fed to livestock such as cattle, pigs and chickens. Although relatively little grain is used in developing countries for livestock production, it is likely that more may be used in the future as techniques of animal production are modified.

Thus, more grain is needed both for the individual farm family and for the nation as a whole. The quality of the grain must also be improved. There are many efforts being made to increase production — better seeds, new tools, the use of compost (green manuring) or chemical fertilizers. But some of these techniques are often costly or require people to farm in very different ways. Farmers are often reluctant to change their ways of doing things, and so it might be more useful to try, if possible, to improve what is already being done locally.

This is why improvements in storage methods are a real possibility. We know that farmers already store a large part of their grain. The aim of this Manual is to help the farmer to improve what he is already doing and to have him understand better some of the results he is getting. We will look briefly at the three major reasons farmers already store grain:

- More food for the family.
- More stable prices.
- Better seeds for better crops.

More Food for the Family

Food for the family has always been the concern of every farmer. It is his first thought when he is planting or hunting or fishing. When there is a food shortage, the farmer sees it reflected directly in the faces of his wife and children.

Whenever possible, the farmer likes to vary his meals and to have extra food in order to be able to invite family and friends to eat with him. There are special feast days throughout the year when many people are invited to eat.

Today we also know from scientific studies that there is a close link between health and proper nutrition. We have already mentioned some of the profound and sad consequences of malnutrition. Malnutrition can be of two sorts: chronic and seasonal. Chronic malnutrition is the case when a person never gets enough to eat or when his diet is permanently unbalanced through a poor choice of food. Seasonal malnutrition is the type experienced in the Sahel for some five to seven years. It usually occurs when food from one harvest has been largely used up and the new harvest has not yet come in.

If larger and improved storage facilities can be built and losses cut down, then there is real hope of eliminating seasonal hunger and malnutrition.

The farm family should be the first to benefit from more food for the family.

More Stable Prices

More and more farmers in the Third World are selling their surplus grain on the local market. There are very few farmers left totally outside a money economy. Cash is needed for household and farm improvements, for taxes or school fees, and for an increasing number of things that cannot be had without buying them with money.

Those of you who read about the Nairobi meetings of the United Nations Conference on Trade and Development, held in May 1976, will remember that the group of developing countries has been working hard to try to stabilize the prices of their agricultural export commodities. In the past, the price paid for coffee or tea or jute on the world market changed from year to year, sometimes going up, more often going down. It is very difficult for a nation to plan its investments – the building of industry, of schools, etc. – if it does not know how much money will be coming in during the year.

What is true for the nation is also true for the individual farmer. It is difficult for a farm family or for a rural cooperative to plan if prices change too much.

In many countries of the region, market prices follow what has been called a "law" of supply and demand. Basically, this means that the more of the same product there is on the market at the same time, the lower the price will be. If there is a great deal of fruit on the market, the price will be lower than if there were only a little bit. So it is with the cereal grain market. At harvest time, when all the farmers have just brought in the grain and there is too much to store, the price paid the farmer will be at the lowest point of the year. In some countries, the farmer has no choice. Either he must sell his grain at the low price, or it will go to waste, for he cannot eat it all at one time; he cannot store it properly; and he cannot trade it with his neighbors, most of whom have grain also. In such cases, before the next harvest, when his cash funds are likely to be exhausted and the family's personal grain stocks are hardly sufficient to maintain life on a subsistence basis, the farmer is forced to borrow money in order to sustain himself and his family. As a result, there are many farmers in developing countries who become trapped in a perpetual debt cycle.

One of the benefits of the cooperative system which is spreading throughout the Third World is that if farmers can store and sell in common, it is easier to control the supply and thus the price. Moreover, if a farmer does not have enough grain for his own family needs, he can buy from the cooperative at a fairer price than if he had to buy it from the merchant.

Today many governments are trying to make grain prices more stable by fixing a basic price throughout the year. However, for the government such efforts are difficult because the government cannot store all the grain itself. In the longer run, proper storage at the farm and village-level will help stabilize year-round prices.

Thus it is very important from the standpoint of both the farm family and the state that grain be properly stored, to be available when and where needed, at a price that is just, so that the farmer will be rewarded for his work, yet low enough so that the workers in the cities will also be able to feed their families properly.

Thus, you must know some things about the economic situation in the local area where you are working, such as the average prices for grain at harvest time and the yearly high, as well as the government's policy with regard to grain prices. You must know something of the habits of the farmer, so that you can point out the economic advantages of proper grain storage.

Because social and economic conditions can influence the acceptance or rejection of new techniques, the replies to the social and economic questionnaire will help you to determine the economic problems of the local farmer. But it is likely that more stable prices are in the interest both of the local farmer and of the nation as a whole.

Better Seeds for Better Crops

Generally farmers do not buy new seeds to plant, but use seeds stored from the past harvest. This, of course, is natural and good, especially if the seeds selected are the best from the past harvest and have been well stored so that the largest number of them will take root.

As we shall see later, the grain must be kept alive during storage. Otherwise it will not take root.

It has been estimated that in Africa about 3 per cent of the average maize harvest should be set aside for seed grain for the next planting. The ears of maize should be well chosen, as large and even as possible, for the quality of the grain will determine the quality of the plant.

Grain for seed should be stored separately from grain that is to be used for family food or for later sale. The farmer should never use grain that is merely left over from the family food supply.

Since the quantities needed for seed are much smaller than those needed for food or for sale, grain for seed can be stored in different ways than grain to be used for family food or for sale. Grain for seed can be placed in plastic bags or closed mud jars – both methods that would be too expensive or take up too much space if a great deal of grain had to be stored in this way.

Conclusion

We have seen that from the point of view of the local farm family, there are three basic needs that can be met through improved techniques of storage at the farm and village-level: more food for the family, stable prices for the sale of grain, and better seeds for better crops.

We have also seen that from the standpoint of the government and the national interest, there are three additional reasons for a program of improved storage of grain at the farm and village-level:

Improved health and higher productivity due to improved nutrition and the reduction of seasonal malnutrition:

Self-sufficiency by making more locally-grown food available at the farm and village-level, and better year-round supplies for urban centers:

Self-reliance through an increased availability of locally-grown food. The increased supply of good locally-stored grain will help reduce the importation of food, thus saving badly needed foreign exchange otherwise required for industrial development.

Workbook Exercises

1. What are some of the basic consequences of malnutrition?

Notes:

2. What are some of the signs of malnutrition?

Notes:

3. Why is malnutrition so dangerous for children?

Notes:

4 From the point of view of the farm family, proper and effective storage of grain at the farm and village-level is important for the following reasons:

Notes:

5. What are the consequences to the farmer of the loss of stored grains?

Notes:

6. What are some of the ways that grain is lost or destroyed during storage?

Notes:

7. Why do farmers today not store larger amounts than they do at the farm and village-level? (Give examples that you know.)

Notes:

8. From the point of view of the over-all well-being of the country, what are some of the reasons for the importance of improved grain storage at the farm and village-level?

Notes:

9. What government regulations and practices exist in your area for the sale of cereal grains?

Concerning prices?

Concerning quality?

Notes:

10. Why should grain for planting the new crop be specially selected and separately stored?

Notes:



CHAPTER II: THE GRAIN YOU STORE

If it were necessary to name any one category of food as the most important in the world, the answer would go to cereals. Cereals come closer than any others to being complete foods.

Actually, no entirely complete food – meaning one which can sustain adult health with no complement from other sources – exists, but cereals lack little (chiefly vitamin A and calcium). Despite these few missing elements, cereals constitute today the indispensable basic food for all the people of the world, providing the energy for physical and mental effort with a minimum intake in volume – 100 grams of grain will generate 350 calories. Thus, cereals have been called the “staff of life”.

Cereals are defined as those members of the grass family cultivated primarily for their edible seeds – chiefly wheat, maize, sorghum, rice, millet and oats. All these cereal grains belong to the same family, and although they may look rather different, they are quite similar in nature. On a world-wide basis, wheat is the most widely grown cereal – some 31 per cent of all cereals grown; then maize, some 23 per cent; and then rice. These are the “big three” on a world basis, followed by barley, oats and rye, then millet and sorghum.

Rice, maize, and other food and feed (cereal) grains are actually seeds being grown by the plant for the purpose of reproduction. Consequently, each seed is a living organism that breathes, requires nourishment, grows and dies. As you might expect an optimum environment is therefore required for the living organism to remain alive and in good condition. The seed embryo is particularly sensitive to moisture and the surrounding temperature and humidity.

Under the circumstances the original high quality of harvested cereal grains must be preserved over a period of months in order to be economically marketable and also consumable as a human food. Primarily the seeds must be reduced in moisture content to a range of 12 to 13 per cent wet basis. Storage conditions must then be provided to maintain the grain seeds at the low moisture content in order to keep them viable but inactive.

In order for the farmer to get the greatest benefit from his production of grain, the grains must be well stored so as to keep their nutritive value

until used. Unfortunately, storage conditions usually result in the deterioration of the grain. This deterioration should be minimized by using proper storage management, techniques and facilities. The deterioration which occurs results in two major categories of change: quantity and quality.

The most easily seen changes are the loss of quantity. Insects and rodents, for example, can consume large quantities of cereal grains. The farmer can see the maize cobs eaten by the rats or the holes in grain made by insects.

Loss due to a deterioration in the quality of the grain is less easily seen. That is why it is necessary for the farmer to know some basic facts about the physical structure of the grain that he is storing.

The farmer, of course, already knows a great deal about cereals from his long experience, but usually his knowledge is of a very practical nature and not always systematic. The local farmer is probably not going to become a scientist doing research on grains, but he should be aware of the following points which are essential for understanding the reasons behind the improved storage methods.

It will be your task to present him with basic information about the nature of grains when necessary for understanding the improved storage techniques and facilities. In order to be better able to take care of the grain that has been stored after harvesting, it is useful to have the following knowledge of the physical structure of cereal grains:

First, it is important to know that all grain kernels are really **living organisms**. If you wish to use them for planting the next season, the grains must be kept alive through proper storage practices.

Secondly, living seeds **resist deterioration** better than dead seeds. Thus, seeds kept alive are better for food use also.

Each kernel of grain is actually a fruit of the grass plant and consists basically of three parts:

- First, a protective coating: the seed coat.
- Second, the endosperm.
- Third, the embryo - the germ of new life.

The protective coating protects the seed from moisture, from some molds and some insects. In many of the older varieties of cereal grains and especially in maize, this outer coat was thick and afforded a good

deal of protection (see Figure 1). There is very little food content in the coat, however, and so improved varieties of maize have thinner coats, with more room for the nutritional content. But a farmer must be more careful in using improved varieties of maize because the coat breaks open fairly easily. It is very important that the protective coating not be broken open. This can happen during harvesting or thrashing. It is one reason why you should take a look at harvesting practices, too. For the way grain is harvested and thrashed will influence the quality of the grain to be stored.

You should store only unbroken, whole grain. If you have too many broken kernels, insects and molds will surely invade your grain.

Even with good, whole grain, there is a small "tip cap" by which the kernel is attached to the growing plant, and through this very small hold, mold and moisture can reach the heart of the seed.

The endosperm – the second part – consists primarily of carbohydrates (starches) and protein. It forms the greatest part of the seed – about 80 per cent in most grains. This is the "food storage area" of the seed itself and will provide food for the seed when the seed starts to grow. Thus the endosperm is also largely what we eat when we eat grain (see Figure 2).

The third section, the embryo, is the germ of life, that part of the seed which will produce the new crop when planted. One part of the embryo will grow above ground and be the shoot of the new crop; the other part of the embryo will grow underground and be the roots.

The embryo is a highly nutritious part of the seed, containing proteins, fats and vitamins. It is also the part of the seed which is most readily destroyed by molds. When the embryo is hurt, it will not grow, and once dead, is even more likely to be attacked by molds. A seed can grow into a new plant just like the one it came from. Although there are sometimes accidents when a good seed grows into a real plant, it is essentially true that it is best to use the best seeds for planting the new crop. You should be careful not to overheat seeds that you will use for planting, especially if you use fire to dry the seeds, for overly great heat will kill the embryo. Since the farmer should select only the best seeds to plant, it is a good idea to store grains to be used as seed separately from the rest, lest they be confused with the grain to be eaten or sold.

THE KERNEL OF DENT CORN

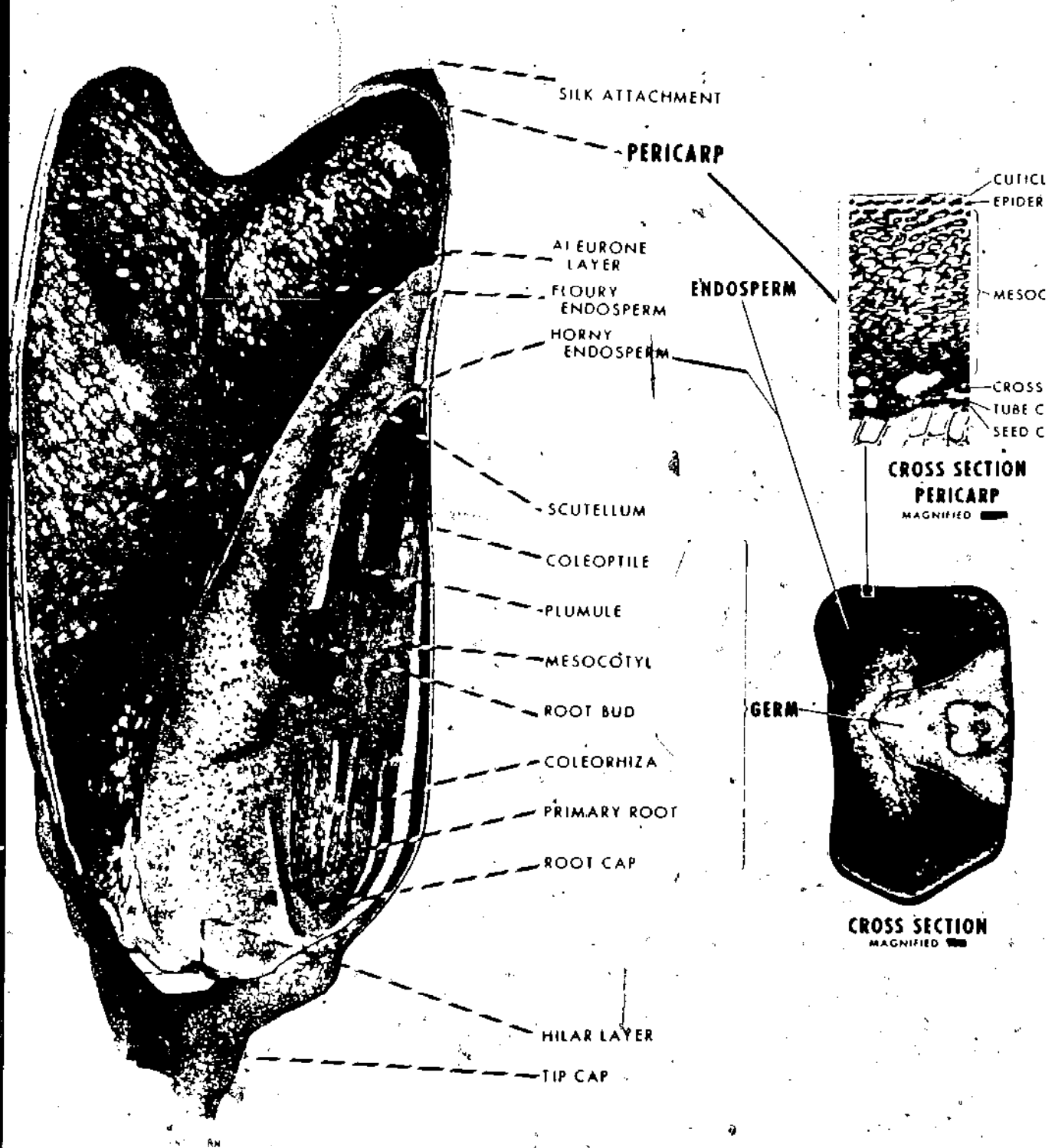

LONGISECTION
MAGNIFIED

Fig. 1

THE RICE KERNEL

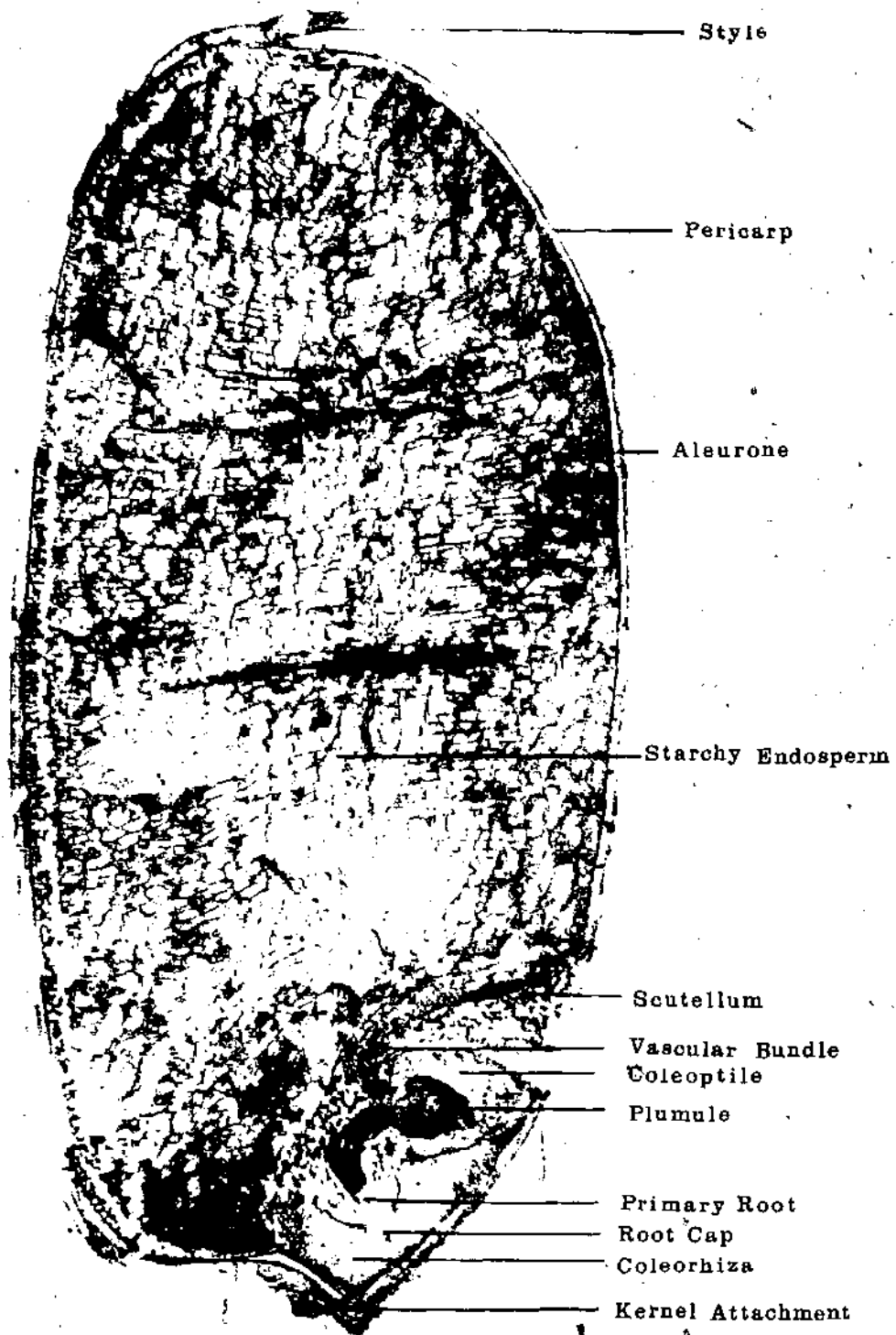

RICE KERNEL (DELETED) ZEPHYR VARIETY
MONTANA COLLEGE, BOZEMAN, MONTANA 1941
A. P. STEINER, JR., ILLINOIS STATE UNIVERSITY
MONTICELLO, ILLINOIS

Fig. 2

Properly stored grain will keep its nutritive qualities for the period of normal storage – most often up to a year at the farm and village-level. Thus, healthy grain can be kept in storage longer than grain which is broken or damaged. Careful handling of the grain protects it from dangers.

Because grain is a living thing, it breathes like all other living things. Each kernel gets a little bit of oxygen from the air and burns off a bit of food from its storehouse – the endosperm. This process gives off heat and carbon dioxide. This process in grain is called **respiration**.

Respiration is slower when grain is cool and dry. Then there is only enough respiration to keep the embryo alive, and growth (germination) does not take place.

However, if the stored grain has too much moisture in it, the grain begins to breathe faster. When seed grain is planted and the farmer wants it to grow, it does germinate because respiration has been speeded up by water in the ground and the warmth of the soil.

Grain produces heat during respiration. If the grain is cool and dry, very little heat is produced. If respiration speeds up, however, more heat is produced, and you can get "hot spots" in the stored grain.

One of the reasons you should check stored grain, perhaps every two weeks to a month is to see if the grain is getting too hot. "Hot spots" are a sign that the grain has too high of a humidity content and must be dried some more.

Thus temperature also plays an important role in the proper care and storage of grain, but it is difficult to control or change the temperature. There are two kinds of temperature which interest us in the proper storage of grain: temperature in the air outside the storage container; and temperature of the grain within the storage container.

The basic principle here is that the lower the temperature, the easier it is to store grain. It is easier to store grain in the cooler, higher plateau areas than in the hot, humid plains.

At the farm and village-level, care should be taken to provide some insulation to prevent the stored from getting too hot.

Workbook Exercise Questions

1. Why are cereal grains so important in the diet?

Notes:

2. Of what botanical family are all cereal grains?

3. What are the cereals most commonly grown in the area in which you work?

Notes:

4. Why should efforts be made to keep cereal grains alive?

Notes:

5. What are the consequences of overheating cereal grains?

Notes:

6. Why should only clean, unbroken grain be stored?

Notes:

7. What are the names and uses of the three sections of an individual seed?

a.

b.

c.

Notes:

8. What is respiration?

Notes:

9. Is respiration faster or slower when grain is moist?

Notes:

10. Is respiration faster or slower when grain is hot?

Notes:

CHAPTER III: DRY GRAIN = SAFE STORAGE

One of the first considerations in connection with the drying of grain for safe storage is to be familiar with the crops, the climatic conditions under which they are grown and harvested, and the climatic conditions under which they are being stored.

This involves determining what particular cereal grains are being produced (maize, sorghum, millet, rice, etc.), and in what quantities they are being produced. Practical solutions to grain-storage problems vary considerably from country to country and even from area to area within a single country. Farm and village-level storage problems are made a good deal more complex by local economic, social and geographic considerations. The **Questionnaire** will help you recognize a number of social and economic factors, but remember, this is often a long and delicate task. Also, the economic possibilities available to one farmer might be impossible to match in the case of a less well-off neighbor. In some villages, farmers fear to build storage facilities outside their habitations because of theft, but they may be reluctant to discuss this fact at the start of your inquiry.

Geographic information is very important and is easier to gather because it is more neutral information. You might perhaps make inquiries from the local meteorological official or government department directly concerned with collecting geographical data.

The first step is to gather information on monthly rainfall – which are the wet months, which the dry months? When can you expect the heaviest rains? In what month is each type of crop planted? What is its growing season? In which month is it harvested? Conditions of harvest play an important role in determining whether the grain will need to be dried before safe storage is possible. If grains are harvested during warm, humid or wet weather, it will be necessary to dry the grain in some manner before it can be stored safely. Rain and high humidity during the harvest season will not allow grains to dry naturally to a safe storage moisture content.

One needs to be aware of the climatic conditions under which the cereal grains are to be stored, also. As will be pointed out later, the conditions of temperature and humidity under which a grain is to be stored can and

will affect the storability of the grain. Not only will temperature and humidity affect the condition of the grain, but they can also be a consideration in the type of storage facility and materials from which the facilities are constructed. For instance, if there are wide day-night temperature fluctuations, one would attempt to minimize these fluctuations within the storage facility by "shading", "insulation", or some other method. If humidities are high, attempts at reducing exchange of the atmosphere within a grain mass with that of the outside might be attempted through near air-tight storage or other methods.

Elevation (or altitude) can provide more favorable storage conditions through lower temperatures which are generally encountered at higher elevations. As a general rule, one can expect approximately 2 degrees F reduction in temperature for every 1,000 ft. of altitude (about 1°C for each 300 meters). Cool temperatures can be an important factor in the storage of grains.

You should also gather information on the prevailing winds, which can play a role in the techniques of drying, especially where crib storage is concerned.

Information on the slope of the land and the directions in which rain runs off is also important, in order not to build storage facilities in an area that retains moisture.

This type of information is vital in working out the most appropriate measures for drying the grain, the desired capacity of the storage facilities, and whether storage of grain unthreshed or threshed may be more desirable.

Moisture

Moisture is the most important factor bringing about harmful changes during storage. In many ways, moisture is the most dangerous enemy, because – unlike rats or birds – you cannot see moisture.

Moisture is water of wetness. But moisture is a better word to use when talking about grain storage. When farmers use the word "water", they are likely to think of lakes, rivers, wells. They think of water as a liquid which is easy to see and to measure.

A farmer is not as familiar with the word "moisture". Moisture is a good word because it can describe something which is wet or contains water.

without looking wet. For example, the earth can have moisture and not look wet. A plant does not look wet, but when you crush it, you will feel moisture (wetness).

Each kernel of grain has moisture inside. But the grain kernel does not look wet when you look at it. The farmer can tell if it is wet by cracking it between his teeth. Wet grain is not hard because the water inside is wetting the seed and keeping it soft. When the moisture leaves the grain during drying, the grain becomes harder. The dryer the grain, the harder it becomes.

Grains hold different amounts of water at different times: the amount of moisture in harvested grain depends mostly on the time of the harvest. For example, grain harvested in the rainy season will have more moisture than grain harvested in dry, sunny weather.

Moisture in the Air

Air contains moisture also. Of course, the farmer cannot see this kind of wetness when he looks at the air, because the moisture in the air is in the form of vapor.

Just as grains hold different amounts of water, air holds different amounts of water. Warm air can hold more moisture than cool air.

On a very hot day, there can be a lot of moisture in the air. When evening comes and the temperature goes down, the air, now cooler, cannot hold all the moisture it held when it was warmer. So the extra moisture falls out of the air and lands on the earth. This moisture from the air is the dew seen in the cool early morning.

As the sun rises higher during the day, the air temperature goes up. The air, now warmer, can hold more moisture. So the dew on the land is taken up by the air.

Relative Humidity

Most farmers will not be familiar with the words "relative humidity". Nor do they really have to be. It is not important to most farmers to understand that relative humidity is a percentage measurement of the amount of moisture actually in the air as compared to the maximum amount of moisture that air at that temperature could hold. Nor do most farmers need to understand that if the moisture content in the air remains the same and the air temperature goes up, the relative humidity goes down.

Relative humidity is a meaningful phrase only to those who can measure it and apply the knowledge to drying times.

Most farmers do not have instruments with which to measure relative humidity. But they have good information if they understand two facts about air and moisture:

1. Warm air can hold more moisture than cold air can.
2. Air at any temperature does not always hold as much moisture as it possibly can. The amount it actually holds changes. When air holds as much water as it possibly can (100 per cent relative humidity), rain is likely. (See Table 1 for relationship between temperature and relative humidity as it affects different crops.)

How Air, Moisture and Grain Interact

Scientists say that grain is hygroscopic because it loses or gains moisture from the air around it. Thus, since all things containing moisture have pressure, grain and air have pressure. Grain dries in the sun because moisture vapor is moving from higher pressure in the wet grain to lower pressure in the air, until the grain and the air reach equilibrium vapor pressure.

The more moisture there is, the harder the moisture can push. If there is comparatively more moisture in the grain than there is in the air around the grain, the moisture in the grain will push out into the air.

The key to the drying process, then, is placing grain in the sun or in a drying machine so that the kernels of grain can be touched by warm moving air which has less moisture in it than the grain has. The heat in the moving air will make the moisture in the grain evaporate. The moisture will become water vapor and be absorbed and carried away by the moving air.

It is useful for a farmer to know that drying continues only as long as the air around the grain is able to absorb more moisture from the grain. If the air contains a lot of moisture, the grain is likely to take in that moisture from the air. The farmer should understand this fact because it explains the need to keep dry grain away from moisture as much as possible. Grain that is not sealed in a closed container will continue to exchange moisture with the air. During the rainy season, for example, grain will take on moisture if left in an open container. In the hot, dry season, grain will lose the moisture again.

Table 1: Grain Equilibrium moisture content (% wet basis)

Material	Temp. °F	Relative Humidity (%)									Ref.	
		10	20	30	40	50	60	70	80	90		100
Barley	77	4.4	7.0	8.5	9.7	10.8	12.1	13.5	15.8	19.5	26.8	(1)
Buckwheat	77	5.0	7.6	9.1	10.2	11.4	12.7	14.2	16.1	19.1	24.5	(1)
Cottonseed	77				6.9	7.8	9.1	10.1	12.9	19.6		(2)
Dry beans, Michelle	40						12.8	14.4	17.0			(3)
	50						13.8	15.3	18.0			(3)
	77	5.6	7.4	8.6	9.8	11.2	12.9	14.9	17.5			(4)
	100						12.0	14.2	17.1			(3)
	130						12.4	14.3	18.5			(3)
Dry beans, red Mexican	77	6.0	7.5	8.6	9.8	11.0	12.8	15.2	18.6			(4)
Dry beans, great Northern	77	5.9	7.4	8.5	9.6	10.9	12.6	15.0	18.0			(4)
Dry beans, light red kidney	77	6.1	7.5	8.7	9.9	11.1	12.9	15.1	18.5			(4)
Dry beans, dark red kidney	77	5.4	7.2	8.4	9.9	10.7	12.5	15.0	18.6			(4)
Dry beans, flat, small white pinto	77	6.0	7.1	8.3	9.6	11.0	12.6	15.0	18.1			(4)
Dry beans, pinto	77	6.1	7.4	8.5	9.8	11.0	12.6	15.2	18.2			(4)
Flaxseed	77	3.3	4.9	5.6	6.1	6.8	7.9	9.3	11.4	15.2	21.4	(1)
	77				6.1	6.8	7.9	9.3	11.4	15.7		(5)
Oats	77	4.1	6.6	8.1	9.1	10.3	11.8	13.0	14.9	18.5	24.1	(1)
Peanuts, pod	50			5.5	6.1	7.1	8.6	9.8	11.9			(6)

Material	Temp. °F.	Relative Humidity (%)										Ref.		
		10	20	30	40	50	60	70	80	90	100			
Peanuts, kernels	50			4.8	5.5	6.0	6.6	7.3	9.0					(6)
Rice, whole grain	77	5.9	8.0	9.5	10.9	12.2	13.3	14.1	15.2	19.1				(7)
Rice, whole grain	100	4.9	7.0	8.4	9.8	11.1	12.3	13.3	14.8	19.1				(7)
Rice, milled	77	5.1	7.6	9.0	10.3	11.5	12.6	12.8	15.4	18.1	23.6			(1)
Rice, rough	80				9.2	10.4	11.7	13.2	15.0	17.1				(8)
	111						10.3	12.3	14.3	16.5				(8)
	32		8.2	9.9	11.1	12.3	13.3	14.5	16.6	19.2				(9)
	68		7.5	9.1	10.4	11.1	12.5	13.7	15.2	17.6				(9)
	86		7.1	8.5	10.0	10.9	11.9	13.1	14.7	17.1				(9)
	77	4.6	6.5	7.9	9.4	10.8	12.2	13.4	14.8	16.7				(10)
	73	4.9	7.3	8.7	9.8	10.9	12.4	13.5	15.9	19.0				(11)
	77	5.2	7.6	8.7	9.9	10.9	12.2	13.5	15.7	20.6				(11)
Rye, Shelled corn YD	20				10.4	11.8	13.3	15.0	16.6					(12)
	32	6.6	8.0	9.3	11.0	12.5	14.0	15.8	18.0	21.8				(13)
	50				10.8	12.2	13.8	15.2	17.5	21.8				(14)
	70				8.3	9.8	11.4	13.2	15.6	19.6	23.8			(12)
	77	5.1	7.0	8.3	9.8	11.2	12.9	14.0	16.2	19.3				(12)
	90	4.9	6.6	7.7	9.3	10.8	12.4	14.0	16.2	19.3				(14)
	120				8.6	10.0	11.2	13.1	14.9					(14)
	30	6.7	9.2	10.7	12.7	14.1	17.7							(15)
	86	4.4	7.4	8.2	9.0	10.2	11.4	12.9	14.8	17.4				(16)
	60	7.5	7.8	9.0	10.3	11.3	12.4	13.9	16.3	19.8				(16)
	50				9.2	10.7	12.1	13.6	15.5					(12)
	32				10.1	11.8	13.3	15.0	16.6					(12)
	155				7.4	8.4	10.0	11.5	12.2					(14)
	160				9.1	10.4	11.9	13.9	15.2	17.9				(15)
	40	6.3	8.6	9.8	11.0	12.4	13.8	15.7	17.6	21.5				(16)
	60		4.8	6.8	8.6	10.7	12.1	13.9	17.6	21.5				(15)
	86				11.0	12.5	14.0	15.8	18.0	21.8				(13)

Material	Temp. °F	Relative Humidity (%)										Ref.
		10	20	30	40	50	60	70	80	90	100	
	100	4.0	6.0	7.3	8.7	9.0	11.0	12.5	14.2	16.7		(16)
	122	3.6	5.5	6.7	8.0	9.2	10.4	12.0	13.6	16.1		(16)
	140	3.0	5.0	6.0	7.0	7.9	8.8	10.3	12.1	14.6		(16)
	120				5.3	6.5	7.8	9.3	10.7			(15)
	90			5.3	6.6	8.3	10.2	12.1	13.9			(15)
Shelled corn	77	5.1	7.2	8.5	9.8	11.2	12.9	13.9	15.5	18.9	24.6	(1)
WD												
Shelled popcorn	77	5.6	7.4	8.5	9.8	11.0	12.2	13.1	14.2	18.4	23.0	(1)
Sorghum	30		8.2	10.1	11.2	12.3	13.3	14.5	15.8			(15)
	60		7.5	9.5	10.7	11.8	12.9	14.0	15.5			(15)
	77	4.4	7.3	8.6	9.8	11.0	12.0	13.8	15.8	18.8	21.9	(1)
	90		7.0	8.7	10.2	11.8	12.2	13.1	14.8			(15)
	120		6.6	8.0	9.4	10.7	11.6	12.7	14.3			(15)
Sorghum,	40	6.8	8.5	9.7	11.0	12.3	13.7	15.3	17.3			(17)
kafir	70	6.0	7.7	9.1	11.3	11.5	12.8	14.2	16.0	19.0 ¹		(17)
	90	5.0	7.0	8.4	9.6	10.8	12.0	13.2	14.7	17.0 ¹		(17)
* Soybeans	77		5.5	6.5	7.1	8.0	9.3	11.5	14.8	18.8		(18)
	77				7.0	8.0	10.1	12.2	16.0	20.7		(5)
Sugar beet	40			10.0	11.5	12.7	13.9	15.3	17.6	22.6		(19)
seeds	60			9.0	10.0	11.5	12.5	14.1	16.2	19.9		(19)
	80			8.0	9.1	10.4	11.6	12.9	14.7	18.0		(19)
	100			7.0	8.3	9.2	10.4	11.5	13.2	15.8		(19)
Wheat, soft	20				11.3	12.8	14.1	15.3	17.0			(12)
red winter	32				11.0	12.2	13.5	14.7	16.2			(12)
	50				10.2	11.7	13.1	14.4	16.0			(12)
	70				9.7	11.0	12.4	14.0				(12)
	77	4.3	7.2	8.6	9.7	10.9	11.9	13.6	15.7	19.7	25.6	(1)

Material	Temp.		Relative Humidity (%)										Ref.
	F		10	20	30	40	50	60	70	80	90	100	
Wheat, hard red winter	77		4.4	7.2	8.5	9.7	10.9	12.5	13.9	15.8	19.7	25.0	(1)
Wheat, hard red spring	77		4.4	7.2	8.5	9.8	11.1	12.5	13.9	15.9	19.7	25.0	(1)
Wheat, white	77		5.2	7.5	8.6	9.4	10.5	11.8	13.7	16.0	19.7	26.3	(1)
Wheat, durum	77		5.1	7.4	8.5	9.4	10.5	11.5	13.1	15.4	19.3	26.7	(1)
Wheat	30		6.9	9.2	10.4	11.8	13.2	14.5	16.3	19.3	26.7		(15)
	60		6.1	7.8	9.6	10.7	12.7	13.8	15.3	18.8	20.6		(15)
	77		5.8	7.6	9.1	10.7	11.6	13.0	14.5	16.8	20.6		(20)
	90			5.3	7.0	8.6	10.3	11.5	12.9	14.3			(15)
	120			6.2	7.4	8.1	9.6	10.4	11.9	13.6			(15)
	122		4.0	5.8	6.7	8.1	10.0	10.8	12.6	15.1	19.4		(20)
	32						13.0	14.2	16.0	18.0	21.1		(13)
	68						12.2	13.2	15.1	17.1	20.3		(13)
	104						12.6	14.1	16.3	19.8			(13)
	50			7.9	9.2	10.6	12.7	14.2	15.0	17.3			(21)
	68		5.6	7.1	8.3	9.6	10.9	12.2	13.5	15.0			(22)
	104		4.6	6.2	7.4	8.6	10.0	11.3	12.3	14.2			(22)
	176		2.5	3.7	4.8	5.7	6.7	8.0	9.8	11.5			(22)

Unreliable because of mold growth

(1) Coleman and Fellows (1955), (2) Karon (1947), (3) Dexter et al. (1955), (4) Weston and Morris (1954), (5) Larnmour et al. (1944), (6) Beasley (1962), (7) Houston and Kester (1954), (8) Hogan and Karn (1955), (9) Bakharev (1960), (10) Breese (1957), (11) Henderson (1970), (12) Thompson and Shedd (1954), (13) Pixton and Warburton (1971), (14) Gustafson (1972), (15) Haynes (1961), (16) Rodriguez-Arias (1956), (17) Fenton (1947), (18) Ramstad and Geddes (1942), (19) Hall (1956), (20) Becker and Sallans (1956), (21) Young and Nelson (1967), (22) Pichler (1957).

Safe Moisture Levels in Grain

Grain put into storage should not have more than a certain amount of moisture inside its kernels. Although the amount of moisture grain can hold in storage safely can change, depending upon storage conditions, some general moisture-safety percentages have been established (see Tables 2 and 3).

The chart which follows shows that maize can be stored safely at 13.5 per cent moisture (that is, 13.5 per cent of the total weight of the kernel can be moisture), in air which is 25–30°C and has 70 per cent relative humidity (that is, the air at this temperature can hold 30 per cent more water than it is holding). At this point, the kernel of maize and the air are not going to exchange moisture back and forth. This is an equilibrium point. This equilibrium is the condition good grain storage tries to set up, but it is very hard to keep grain stored at conditions which keep equilibrium.

MAXIMUM MOISTURE CONTENT FOR ONE YEAR (OR LESS) STORAGE AT 70 PER CENT RELATIVE HUMIDITY, AND 27°C (Table 2)

GRAIN TYPE	RELATIVE HUMIDITY, AND 27°C
Wheat	13.5%
Maize	13.5%
Paddy Rice	15.0%
Milled Rice	13.0%
Sorghum	13.5%
Millet	16.0%

The table below shows grain moisture contents normally recommended for safe storage of grain. The portion of grain with the highest moisture content in the lot should be used as an index as to whether or not the grain is safe for storage.

Grain	Required for safe storage	
	for 1 Yr.	for 5 Yrs.
	% (w.b.)	% (w.b.)
Barley	13	11
Corn	13	10–11
Oats	14	11
Rice	12–14	10–12
Rye	13	11
Sorghum	12–13	10–11
Wheat	13–14	11–12

(Table 3)

The table below shows a relationship between corn moistures, temperatures and allowable storage time. Safe storage periods increase markedly as grain temperatures are lowered and moisture contents are decreased.

(Table 4)

Storage Temperature °F	Corn moisture content (% w.b.)			
	15	20	25	30
	(Safe Storage Period In Days)			
75	116	12	4	2
70	155	16	5	3
65	207	21	7	4
60	259	27	9	5
55	337	35	12	7
50	466	48	17	10
45	726	75	27	16
40	906	94	34	20
35	1,140	118	42	25

Remember, the figures above are maximum recommended moisture levels. Generally, farmers should dry their grain as thoroughly as possible.

It is not easy to know the percentage of moisture without having some testing instruments – instruments which are not often available in rural areas.

Farmers have always had their own methods for assessing the amount of moisture in grain. These methods include pressing the grain with the thumbnail; crushing grains between the fingers or the teeth; rattling the grain in a tin can; or getting a feel of the grain by smelling a handful and shaking it. But such techniques depend on the experience and the skill of the farmer who uses them. In many cases, such techniques can be a good guide, but in other cases, if a farmer is inexperienced or not feeling well, his senses may betray him.

Commercial moisture meters have been developed that should be available to regional agricultural extension workers (they are too expensive for the individual local farmer). The types of commercial meters available will depend on the persons responsible for the purchase of material for the Ministry of Agriculture. There are two main types of meters in common field service: a hair hygrometer probe, and an electric moisture meter.

More important than the type of meter is getting the agricultural extension worker to use it on as many farms as possible in a short time, for most farmers will be harvesting, drying and storing grain at the same time.

Movement of Moisture in Stored Grain

Grain which is dry and cool will keep for a long time if it is stored correctly (see Tables 2 and 3). However, there are a number of bad things which can happen to grain while it is in storage. And moisture is a key part of most of the processes of deterioration that can occur in stored grain.

To discuss the role of moisture in the storage container, it is necessary to know something about:

- grain condition
- temperature
- insects, molds, and grain heating.

Grain Condition

The farmer must store only clean, healthy grain which has been dried to safe storage levels. Broken grains and pieces of straw or dirt increase the chances of storage trouble. And, if the storage container does not keep out moisture or insects, even healthy, clean, dry grain can deteriorate. Trouble is less likely to happen if the grain starts in good condition.

Temperature

There are two kinds of temperature: temperature in the air outside the storage container, and temperature of the grain inside the storage container.

There are some things to remember about temperature:

- Low temperature is better than high temperature for grain storage. Insects and molds do not grow as well at low temperatures.
- Grain breathes very slowly at low temperatures.
- At low temperatures, little heat builds up inside the grain from the living and breathing of insects and molds - and the grain.
- Rising temperatures outside the containers can increase the temperature inside the container, - particularly if the container is not shaded.

- Rising temperatures can lead to insect and mold growth. Even in grain that looks clean, insects are almost always there to some degree; mold spores are present everywhere. As the temperature of the grain goes up, these insects and molds will start to grow.
- As the temperature goes up, molds and insects grow faster. The grain respire more quickly. If the grain contains much moisture, this process goes even faster.
- Hot spots can form in areas of the grain where the most mold and insect activity is occurring. These hot spots spread and cause great damage and loss of the stored grain.

Therefore, grain placed into storage should be as dry and cool as possible (see Table 3). Even then, there can be a moisture problem during storage.

This problem often is the result of a difference in temperature between the inside and outside of the storage container. When cool air and warm air mix in the stored grain, the warm air cools and may be forced to lose moisture. This lost moisture becomes water which can be seen at the top and bottom of the storage container.

These changes caused by temperature can be seasonal, or they may be daily. This depends upon where the farmer lives. Obviously, it is best to keep stored grain at a relatively constant temperature.

Insects, Molds, and Grain Heating

Remember the dew and how it forms because cold air and warm air cannot hold the same amount of moisture? This same thing is what happens in stored grain when cold air and warm air meet each other because of changing temperatures. The farmer who understands dew will be able to understand how his grain got caked and moldy even if it was dry when he put it inside the storage tin or container.

The pools of water formed by the moisture forced out of the air make the stored grain wet. This wet grain begins to respire at a faster and faster rate. If there are insect larvae and mold spores present, they begin to grow and reproduce. Soon the insects, molds, and grain all are giving off heat. This produces hot spots. When the temperature gets too high, insects will leave the heated spot and go out into the grain mass to find better living conditions. Other trouble spots can then develop.

Molds also make the grains bad-tasting, as well as less nutritious, so that you do not like to eat moldy grain. In fact, some molds create a sort of poison which can make you very ill.

You will have to be on the look-out for the growth of molds all during the period the grain is stored.

Thus, proper drying of grain is vital to safe storage of cereals.

Workbook Exercises

1. In order to determine proper drying and storage facilities, what sort of basic information is needed?

Notes:

2. Why are climatic considerations so important, especially at harvest time?

Notes:

3. Why is it better to store grain in a cool place?

Notes:

4. How does moisture get into the grains?

Notes:

5. Why is moving air important in the drying process?

Notes:

6. Why must the farmer store only clean, healthy grains?

Notes:

7. Why are molds harmful?

Notes:

8. What are "hot spots" and why are they danger signs?

Notes:

9. What are the ways a farmer tests for moisture in your area?

Notes:

10. What types of moisture-testing equipment are available in your area?

Notes:

CHAPTER IV: CHOOSING YOUR STORAGE SYSTEM

Since most farmers are already storing part of their grain harvest, storage is not so much introducing a new idea as it is trying to improve on what is being done.

The successful implementation of a national programme aimed at reducing post-harvest farm and village-level grain storage losses should involve a flexible, practical field work approach. Thus, the initial planning for adopting a national strategy analyses the problem as seen from the point of view of the farmer in the particular locality to be served. He is the key figure! Any successful programme must be based upon the realities of the situation as seen by the individual farmer storing his grain.

Accordingly, before any consideration, choice, and planning is given to an improved grain storage (dryer) system, it is essential to first study local traditional methods in order to:

1. Understand their shortcomings (if any), and therefore the need for improved techniques, and
2. Determine possible simple, yet effective needed improvements.

It is well understood here that minor and effective changes of existing methods of grain storage are easier to popularize than the introduction of complex and costly new alternatives. Furthermore, in the search for finding efficient methods for drying and storing grain at the farm and village-level, it is also important to keep in mind who is going to use the stores, i.e., is it the subsistence farmer or a group of farmers, the climatic conditions (especially relative humidity) involved, and also the amount of grain to be stored.

It is true that there are some types of food storage that may be totally new to an area, such as making pit silos to store grass for cattle or the techniques of preservation of fruits. With the introduction of such new concepts, you will have to take more social and economic items into consideration than with grain storage. Any improvement in his storage method must, however, be made in accordance with steps the farmer sees as the right ones for his particular situation or need.

With grain storage, great care must be taken in helping farmers to choose the appropriate improved grain storage system. Nevertheless,

there are certain basic principles that can be carried out in all storage systems, and these are reviewed at the end of the chapter.

Thus, in helping the farmers to make the appropriate choices, you must take a number of considerations into account.

These considerations have been grouped into a convenient, easy-to-use chart. In your area, you should be able to use this table when discussing possible storage systems with local farmers.

The Considerations for Choice of Farm and Village-Level Grain Storage Methods

1. The Geography of the Area

Temperature, average rainfall during the period of harvest and of storage, winds, type of soil on which storage facilities are to be built (rocky, sandy, clay).

2. Type of Grain to be Stored and the Use to be Made of It

Grain that is to be used for food by the farm family is often being opened constantly, and thus the ease of use is of first importance. Grain held for longer periods, till sold on the market, may be stored differently

3. Quantity of Grain Currently being Produced and the Amount to be Stored

If productivity per individual farmer is low, collective storage facilities may be necessary. The possibility of collective storage through the creation of cooperatives will vary from place to place. Acceptance will depend on past experiences, on government policy, on the degree of cooperative work already being done. In many cases, a group of farmers working together will be able to get more done than working individually, and thus store larger quantities of grain. However, storage facilities should be no larger than needed. Half-filled storage facilities are wasteful. It is better to add new storage facilities as production and storage needs grow.

4. Length of Time Grain is to be Stored

This factor depends on the number of harvests per year – usually either one or two.

5. Construction Costs

Costs are usually calculated for comparative reasons by cost per ton to be stored. Appropriate storage technologies must be inexpensive. Most farmers have little cash revenue and thus costs must not seem to be greater than benefits, especially as some benefits – such as better health through better nutrition – are not easily translated into cash terms. Thus, the practical benefits of a new method must be thought through from the farmer's standpoint if it is not to be rejected because of simple economic realities.

6. Efficiency

Has the method been tested in the field in the local area or not?
What has been the previous result of its use?

7. Availability of Materials

What materials are needed (cement, plastic sheets, insecticides, wood, water, screening)? Are special tools required?

8. Skills Necessary

How much training time and supervision are necessary to assure proper construction and use? Can the farmer maintain the new technique or structure by himself? Once the storage facility is built, can the farmer build others without external help? Can the farmer's neighbors build the storage facility with just his help?

9. Marketing Considerations

As it is likely that part of the stored grain will be sold on the market, marketing considerations can play a role in the selection of the most appropriate technology. What sort of cereals are most in demand? What quality is demanded? Is grain sold to a government marketing board or to private buyers?

10. The Influence of Tradition and Current Practices

As has been mentioned before, current social and cultural practices influence what can be done. If all work on grain storage must be done by women, then the type and size of storage facilities may

be different from what would be the case if men did the building. If farmers are used to building with mud brick, it will be easier to introduce a mud silo than if people only use wood. If work is already done collectively, it may be easier to store collectively than if it is done individually.

There are a wide variety of techniques of storage already in use; the techniques chosen usually depend upon the amount of grain produced and traditional techniques in use. Thus farmers with a small grain production usually store grain in their dwellings, very often above the cooking area. Similarly, groups of people who are good at making clay pots will store grain in large clay pots, while those who are good at making baskets will store grain in closely woven baskets.

Many of these traditional methods are useful and are a base on which to build improved storage techniques. Many of these techniques can continue to be used, especially for the storage of grain that is to be used as seed for planting. Only a limited amount of grain needs to be kept for replanting.

However, the basic problem with many of the adequate traditional techniques – such as storage in clay pots – is that they are not adapted to the storage of larger amounts of grain. Many of the traditional techniques were of use when a farmer grew grain only for his own family. However, as the scale of production changes in order to sell grain on the market, so storage techniques also have to change in scale.

A chart has been made of the aforementioned ten points. If you expect to use it in a Workshop/Training session, you can try filling in each section for the different types of storage being discussed. Once you are back in your local area, you can use the table in discussions with local farmers in trying to find the most appropriate methods.

Even with this Table of Considerations to assist you, the choice of appropriate storage methods can be difficult. One problem is whether you should select comparatively complicated techniques which can bring great advantages to a fairly small number of better-off farmers (on the assumption that the number of these farmers will increase over the years) or whether you should introduce simpler techniques which can be adopted easily by the average farmer. This is a question and will have to be discussed openly with the local leaders.

However, whatever kind of storage system a farmer uses, there are certain basic principles on which every method is based. Most have been mentioned before, but it is useful to review them here.

Every storage container – to the maximum extent possible – no matter how large or how small, no matter of what material it is made, should:

- Keep grain cool and dry;
- Protect grain from insects;
- Protect grain from rodents.

All storage methods should try to accomplish these three objectives and particularly where "closed" systems are involved.

But no storage container is adequate without good storage techniques and management. The following seven points represent a suggested **Code of Good Storage Practices**, and thus offer a set of guidelines in the adoption of an appropriate storage system.

1. Drying grain well before putting it into storage. The grain must be kept **dry**.
2. Putting only clean grain into **containers** which themselves have had all old grain, dust, straw and insects removed. All dust, old pieces of grain, dirt, straw should be burned, for they are likely to contain insects.
3. Keeping the grain **cool** and protected from large changes in outside temperatures. This can be done in a number of ways – by using building materials which do not easily pass on changes in outside temperatures to the stored grain, by keeping or building storage containers away from direct sunlight, by applying a coat of white plaster to the outside of the containers.
4. Protecting the grain from insects by following rules for **cleanliness** and drying, by applying **insecticide**, and/or by putting the grain into airtight storage.
5. **Waterproofing** the buildings and containers as much as possible. This is done by the way the building is constructed and by applying materials which keep water from soaking into the building material. Storage buildings should be built on well-drained locations. They should not be placed where they will be flooded by ground water run-off during heavy rains.
6. Making sure containers are **rodent-proofed** in all possible ways.

7. **Checking** the grain regularly while it is in storage to make sure it is not infested, and following re-cleaning instructions to destroy insects, if they are found when the grain is checked. Check the grain every two weeks and suggest to the farmer that he make checking his grain part of a weekly or bi-weekly routine. Put his hand into a sack of grain to check for heating. He can smell the grain and look for dark kernels: signs of mold. If these signs are found, he should dump out the grain and dry it again.

A farmer who has these **seven points** firmly in mind will know why a particular silo or storage method has been built or changed in a certain way. He can then do much to improve his own storage facility by applying the knowledge to his own problems.

Storing Grain in Sacks

A very common method at both the farm and village-level and in the storage centers of merchants, is the storage of grains in sacks.

Putting grain in sacks or bags is a very old method of storing. Storage sacks are made of woven jute, hemp, sisal, local grasses, cotton – whatever material is available in the area. Sacks are relatively expensive as they do not often last for more than two seasons, and they do not give much natural protection against insects, rodents, and moisture. But sack storage has some advantages for the small farmer, and there are things farmers can do to protect their sacked grain.

Sacks are easy to label. Farmers can label old grain sacks and new grain sacks to keep them separate. Seed grain can be marked and kept separately from the other grains.

Sacks are easy to move around, and can be used as they are needed. Farmers in one village may decide to build a shed to hold the grain belonging to all the village's farmers. It is easy to mark sacks so that each farmer's grain can be found simply.

However, grain stored in fiber sacks is easily attacked by insects, rodents, and molds. Often these attacks are worse because a farmer has not done all he can to protect his grain sacks.

There are a few measures that the farmer can take, such as to waterproof the walls and roof of the building where the grain is stored.

The farmer should also **stack the sacks on platforms raised off the floor**. This keeps sacked grain from taking moisture from the floor. Farmers can make these platforms out of whatever materials they have. If no wood or bricks are available to make a platform, the ground can be covered with plastic sheets. The raised platform is better than the plastic because it also allows air to flow under the sacked grain.

Finally, as we have said before, whatever choice of improved storage system is decided on, that decision will have to be made by the farmer himself. However, you can help introduce the material from this training manual to him because you know the area where you work.

Although there are a number of different types of improved farm and village-level storage units for farmers to choose from, in the following chapters this Manual will concentrate on four selected models which years of usage in West Africa have confirmed their operational effectiveness under a wide variety of geographical and climatic conditions, and also, from an economic point of view, are within the means of most subsistence farmers on an individual as well as collective basis. These include:

– IMPROVED MAIZE CRIB

adapted by FAO from a model originally developed by the Nigerian Stored Products Research Institute; combines drying and storage.

– "Northern Ghana" IMPROVED MUD BRICK SILO

which has proven to be an ideal container for home storage needs, not only in the dryer areas but also has been recently improved to meet the requirements of humid zones as well; basic model holds 1.5 tons.

– 4.5 ton CEMENT STAVE SILO

has been found to be one of the most versatile yet inexpensive storage units in use; particularly popular with cooperatives and village-level groups.

– CEMENT BLOCK (Square) SILO

this silo can be made with storage capacities ranging from 1 to 7 tons; either as a single unit or joined together in a series of compartments.

Workbook Exercises

1. What are the current ways in which grain is stored in your area?

Notes:

2. What quantities of grain are being stored in your area, by the individual farmer, on a cooperative basis?

Notes:

3. What are the advantages that the farmers see in the methods they are now using?

Notes:

4. What are the disadvantages that the farmers have mentioned of the methods they are now using?

Notes:

5. What are the construction costs in money and time of the methods of storage in current use?

Notes:

6. What are the three basic aims of all grain-storage systems?

Notes:

7. What are some of the measures that are currently being taken to waterproof buildings or containers for grain storage?

Notes:

8. What are some of the measures currently being taken to make storage facilities as rodent-proof as possible?

Notes:

9. What are some of the advantages of putting grain in sacks?

Notes:

10. What are some of the disadvantages of putting grain in sacks?

Notes:

11. How can some of these disadvantages be overcome?

Notes:

12. What plan of action will you follow, in discussing the different types of improved storage containers with local village leaders?

Notes:

CHAPTER V. CONSTRUCTION & UTILIZATION OF VARIOUS IMPROVED FARM & VILLAGE-LEVEL GRAIN STORAGE FACILITIES

INTRODUCTION

In most developing countries it is estimated that upwards of 75% of foodgrains are stored and consumed on the farm. This is especially true where farming is carried out predominantly at the subsistence level. Losses in farm storage caused by insects, rodents, birds, and moulds occur in nearly all grains and in all climatic zones, but are particularly severe on maize in the humid tropics and on pulses in both dry and humid zones. The importance of improved farm and village-level grain storage methods to developing countries cannot be overestimated, and in view of the large quantities of grain stored at this level, it is rather ironic that greater emphasis has not been given in the past to this activity.

Traditional methods of storage used by subsistence farmers in developing countries have achieved varying degrees of success. These variations are mainly a result of climate, local natural resources and social customs. The majority of the traditional storage bins constructed of indigenous materials (largely of an organic nature), suffer from the same problem of not being air tight, insect resistant or rodent proof. Many of them do protect the stored grain from exposure to liquid water but not from the vapor form, especially in high humidity climatic areas where microorganisms and insects flourish particularly during tropical rainy seasons.

Modern storage methods are basically improvements over traditional practices. Although these units are essentially based on sound engineering principles involving the best available appropriate technology, the real test of their usefulness depends on whether they meet the criteria dictated by local economic and social conditions. It is not enough to have an expert engineer put some modern building materials together in order to make a structurally sound and air tight bin; what is of prime importance is whether subsistence farmers can afford to own, operate, and maintain such a unit.

Thus, in the search to find efficient and safe methods for drying and storing grain at the farm and village-level, it is important to keep in mind the specific needs and requirements of the subsistence farmers who are going to use them. Experience has shown that the following general conditions have to be met in order to successfully promote any new storage/dryer technology at the local level:

- a) Cheap and simple to construct and operate,
- b) the materials used for construction should be easy to find locally, and
- c) Safe to operate. If the method introduced involves a certain amount of risk for the farmer, he is not likely to accept it.

With these rules in mind carefully study the following improved farm and village-level grain storage systems. Remember, the typical subsistence farmer is by nature a cautious person and often suspicious of all that is new and unknown to him. Adopting a new method normally means an extra outlay of money and also a risk of losing his crop; something he is not prepared to do unless he is sufficiently convinced of the advantages offered by the new storage methods.

CONSTRUCTING AND USING YOUR STORAGE SYSTEM (OPEN) MODEL 1 - IMPROVED MAIZE CRIB

The storage of husked and unhusked maize is a common practice among subsistence farmers in many developing nations. A number of variations are used but the two essential requirements for successful open storage are:

1. that drying take place while the crop is being stored, and
2. that you are able to control insect attack at the same time.

In many parts of Africa for example one finds farmers hanging bunches of unhusked maize (or corn) on poles set in the ground, in the branches of trees, and in the roofs of cooking or living shelters. Sometimes farmers remove the husks and pile the cobs loosely in open-weave basket granaries or in covered crib granaries. The latter containers partly protect the grain from rain and also allow air to pass over the grain, and help dry it better.

In humid wetter areas, it is more advisable to put the crop in a crib-type storage container. In many countries of sub-Saharan Africa, the traditional storage crib is either round or rectangular, and is built approximately 1/2 meter off the ground, with walls made out of mud and/or palm leaves. This type of storage unit is easy and cheap to make, but the storage losses due to insects and rodents are often as high as 40 per cent. Insects are the main problem, because they are able to attack maize drying in these traditional cribs very easily, especially in the case of Maize, when farmers choose to leave the husk on the maize cob. This method provides some protection from insect attack, but it also means that drying takes longer because the air cannot pass freely over the cob. Also, the husks are full of moisture which increases the risk of molding. During the last several years, experts at the FAO African Rural Storage Centre in Ibadan, Nigeria, have designed a crib (based on a model originally developed by the Nigerian Stored Products Research Institute) which offers subsistence farmers a number of advantages over traditional open storage systems. The following plan is for a 2 m long crib which holds approximately 800 kg of cob maize (or some 540 kg of shelled maize). Another variation of the same crib, which is 1 m long, 1.50 m high and 0.60 m wide, will store 400 kg of cob maize or 270 kg of shelled corn.

Insect Control in Cribs

To reduce losses due to insects, a number of insecticides have been tested for open crib storage. The maize put into the cribs must have the husks removed so that the insecticide can cover the whole surface of the kernels on the cob.

Apply the insecticide to the maize cobs in layers. Put down a layer of cobs 20–25 cm deep. Dust the layer with insecticide. Put down another layer of cobs, and then more insecticide. Continue until the crib is full. When the crib is full, put insecticide on the outside walls of the crib to prevent insects from entering.

The wind, rain, and sun all can affect how long the insecticide lasts. You can put more insecticide on the outside of the crib every three to four weeks. Look at the maize in the crib every few weeks to see if the insecticide is still working. The insecticide put inside the crib will last only

Figure 5 Improved Crib

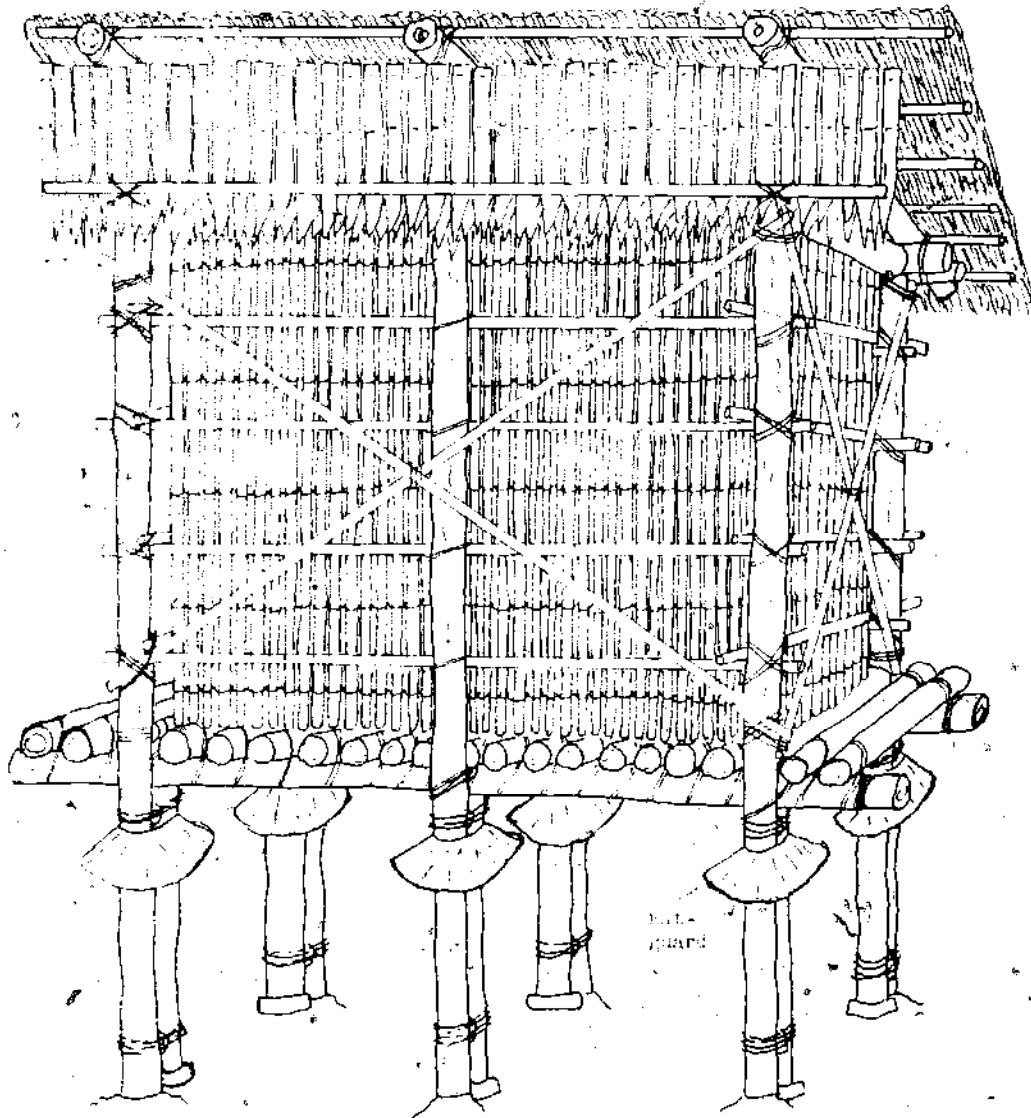

Source: African Rural Storage Centre
Drawing by - Harald Thorshaug

four or five months. But while it is working, it can reduce the amount of maize damaged by insect attack.

After four months, check the grain moisture level. The maize may be dry enough to shell and store in sacks or bins. The maize is dry when the kernels crack sharply between your teeth and are not soft. If the grain is not dry enough, remove all the maize and put it back into the crib again, layer by layer, dusting with insecticide as you go.

Faster Drying

Keep the crib no wider than 1 m. Between 60 and 100 cm are good widths for dryer storage cribs. The narrow width helps maize to dry more quickly. Air cannot move through wider cribs to cool the grain in the middle. The grain in a wider crib will heat, and be attacked by mold and insects.

Rain which wets the grain through open crib walls is not generally a problem. Only the surface of the maize on the sides gets wet, and this dries quickly after the rain stops. The rain causes no increase in moisture content of the grain, if there is sunny weather afterwards.

Some General Remarks About the Improved Maize Drying and Storage Crib

- Use materials that are easy to find in your local area.
- The crib will work best if it is no wider than 60–70 cm.
- A good height for the crib is 2.00–2.25 m from the ground to the roof. There is at least 50–75 cm between the bottom of the crib and the ground. Most rats cannot jump this high.
- If bamboo in your area is attacked by insect borers, use another local wood for the legs. Make sure the wood is termite-proof. These legs must have rat guards put on them.
- The long sides of the crib must face the sun. That is, they should face the east and west. The short sides will then face north and south.
- Make the crib larger by adding more sections. Make it longer. Do not make it wider.

Following is a detailed description of how to construct the Maize Crib.

THE MAIZE CRIB

Tools and Materials

This is a guide. You can use what you have available. The frame is bamboo. If bamboo is not available in your area, or if the bamboo in your area is attacked by insect pests, use wood that is resistant to termites or any other pests. Lash it together the same way you would lash bamboo.

For the building frame (all bamboo or substitute):

- (a) 3 vertical supports, 3 $\frac{1}{2}$ m long, with V-notches and lashing slots in one end of each one
- (b) 3 vertical supports, 3 m long, with V-notches and lashing slots in one end of each one
- (c) 2 horizontal roof supports, 2 $\frac{1}{2}$ m long
- (d) 2 horizontal platform (floor) supports, 2 $\frac{1}{2}$ m long
- (e) 6 vertical platform supports (with V-notches in one end of each), 1 $\frac{1}{2}$ m long
- (f) 6 notched horizontal width spacers, 70 cm long
- (g) 25 poles, 95 cm long, for the platform surface

For the wall bracing and covering (raffia, small bamboo or other wood):

- (h) 8 cross braces (optional if frame is very strong):
 - 4 must be about 2 $\frac{1}{2}$ m long
 - 4 must be about 1.70 m long
- (i) 8 wall supports, 2 $\frac{1}{4}$ m long
- (j) 8 wall supports, 1 m long
- (k) raffia or other strong slats for the wall covering. Tie these together into a mat. The finished mat should be about 6 m long and 1 $\frac{1}{2}$ m high.

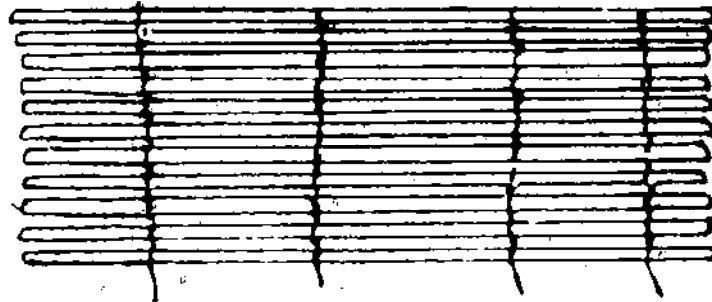

For the roof (all bamboo or substitute, except for purlins, and roof covering and loading cover):

- (l) 2 horizontal pieces, 3 1/4 m long
- (m) 3 cross pieces, 1 m long
- (n) 2 angle braces, 1 m long
- (o) 7 purlins, 3 1/4 m long. Six of these will be lashed across the cross pieces to support the roof covering; one may be attached to the front loading cover.



- (p) raffia mat or grass for thatch to cover the roof, and also for the front loading cover. You will need a horizontal piece at least 2 1/4 m long to weave the loading cover material onto – it need not be bamboo or of a large diameter.

For rat guards (if you need them):

See Section 6. Part 2 of this manual for directions on making rat guards (baffles).

For the lashing material:

- (q) You will need plenty of rattan, rope or tie vine for lashing all the wood pieces together.

1. Select a site.

- Find a good site for your storage crib. Keep the crib away from the fields. This stops insects from flying to the drying grain from the fields.

2. Prepare your materials.

- Collect all the materials you will need.
- Make V-shaped notches in one end of each of the three 3 1/2 m vertical supports (a), and cut some grooves on each side just beneath the notches to provide a hold for the lashing there. Do the same on one end of each of the three 3 m vertical supports (b).

(a) & (b)



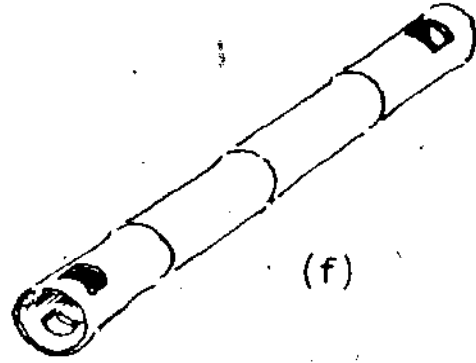
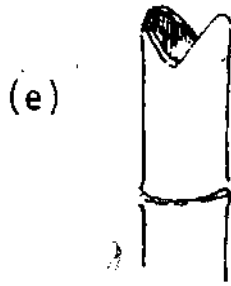

- Make V-shaped notches in one end of each of the six 1½ m vertical support posts (e).
- Make holes all the way through each end of all six 70 cm horizontal spacers (f).
- Organize all the pieces, or mark them with the appropriate letters, so you can find them quickly during construction.

3 Make holes in the ground for the legs.

- Mark spots for holes for the vertical supports (legs) (a) and (b) on the ground. Make a mark for the first hole; measure 1 m and make another mark. Measure 1 m from that mark in the same direction and make a third mark. You should now have 3 marks in a straight line. Each mark will be the center of a hole.
- Make three more marks, each 1 m apart, in a line parallel to the first line and 75 cm away. Each of the three new marks should be directly opposite one of the first marks and 75 cm away.
- Dig six holes, each centered on one of the marks. Make the holes 50 cm deep and wide enough so that **two** vertical supports will fit down into each one.

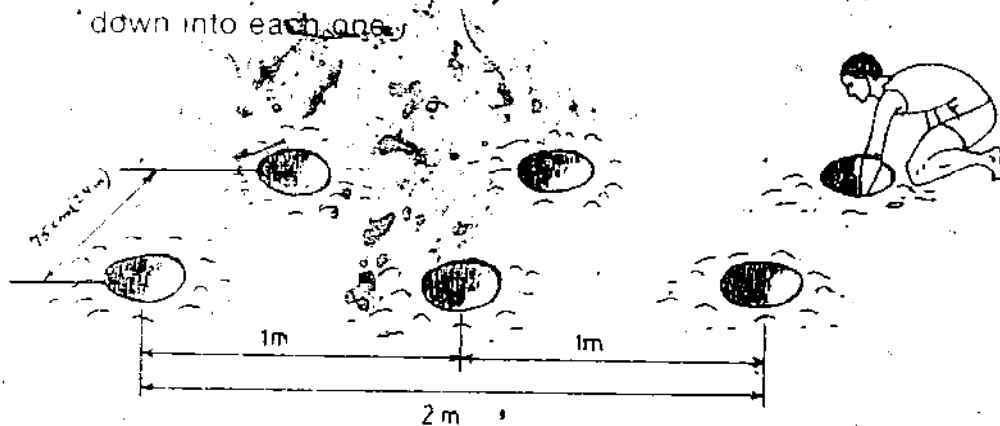

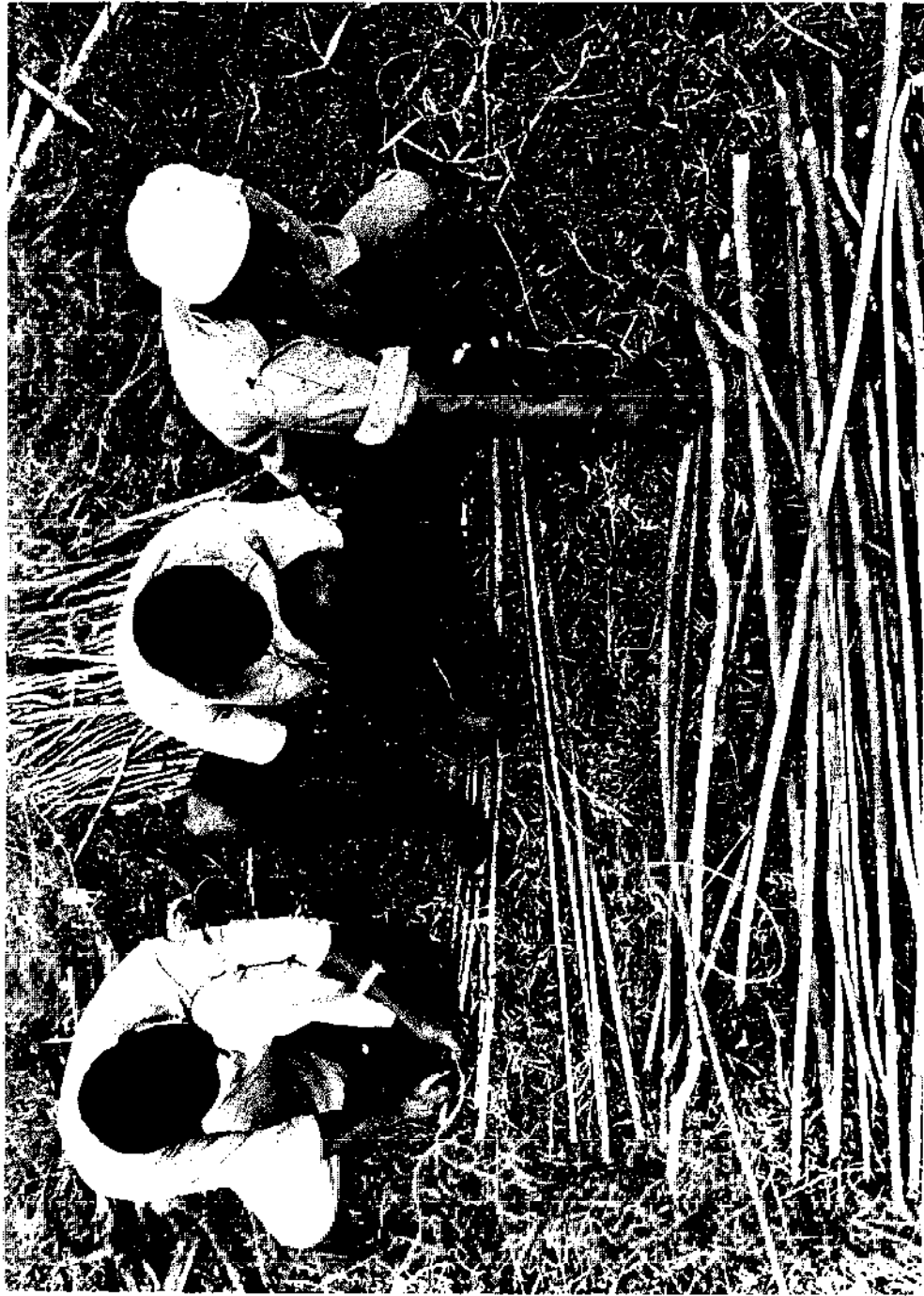

Assembling materials to make wall bracings. Photo: Erik Bentzen

4. Erect the vertical supports.

- Lay the three 3½ m vertical supports (a) on the ground 1 m apart, with their ends lined up. Lash one of the 2½ m horizontal roof supports (c) to the notched ends.
- Lay the three 3 m vertical supports (b) on the ground in the same way and lash the other horizontal roof support (c) to the notched ends.
- Place the two assemblies into the holes.

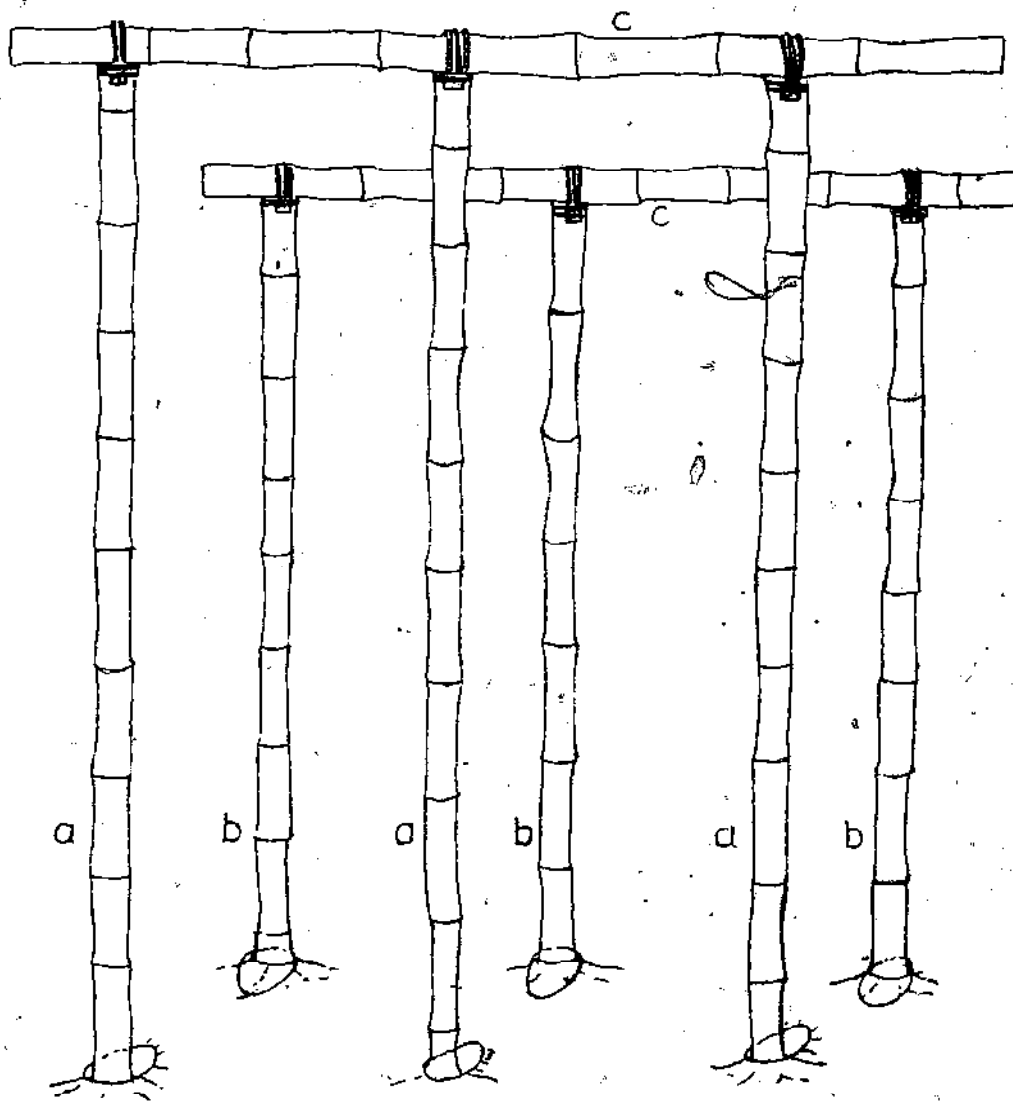

5. Erect the vertical platform supports.

- Place the vertical platform supports (e) into the holes on the insides of the vertical supports you have placed in the holes. Make sure the V-notches are facing upwards.

Tie the platform supports to the longer supports temporarily until the next step is completed.

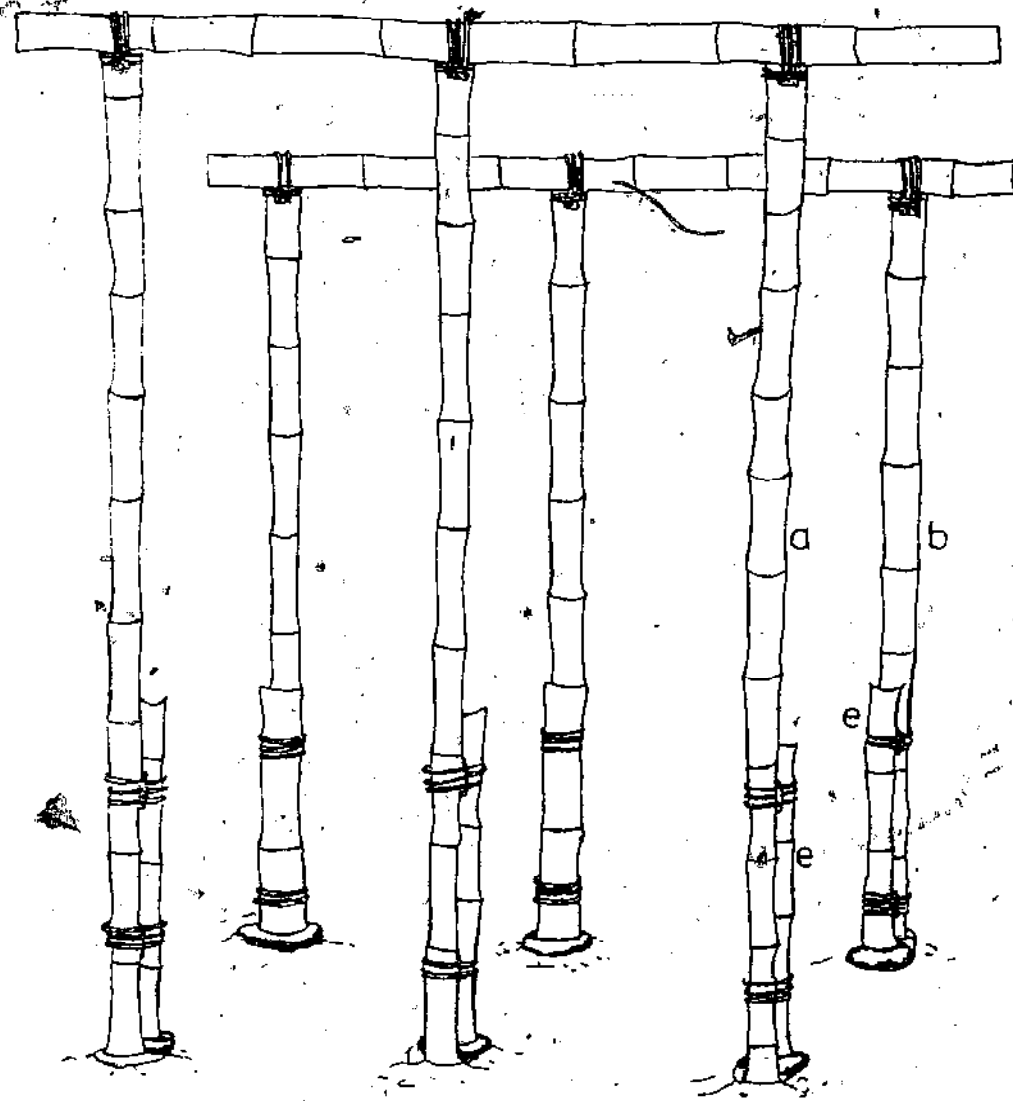

6. Install the platform support framework and make the structure rigid.

- Place the two horizontal platform supports (d) in the V-notches of the platform supports.
- Lash three of the notched horizontal spacers (f) to the vertical supports (a) and (b), across the width of the crib.
- Level and square the framework.
- Fill the holes around the vertical supports with small stones and soil. Tamp down firmly.
- Lash all joints tightly.

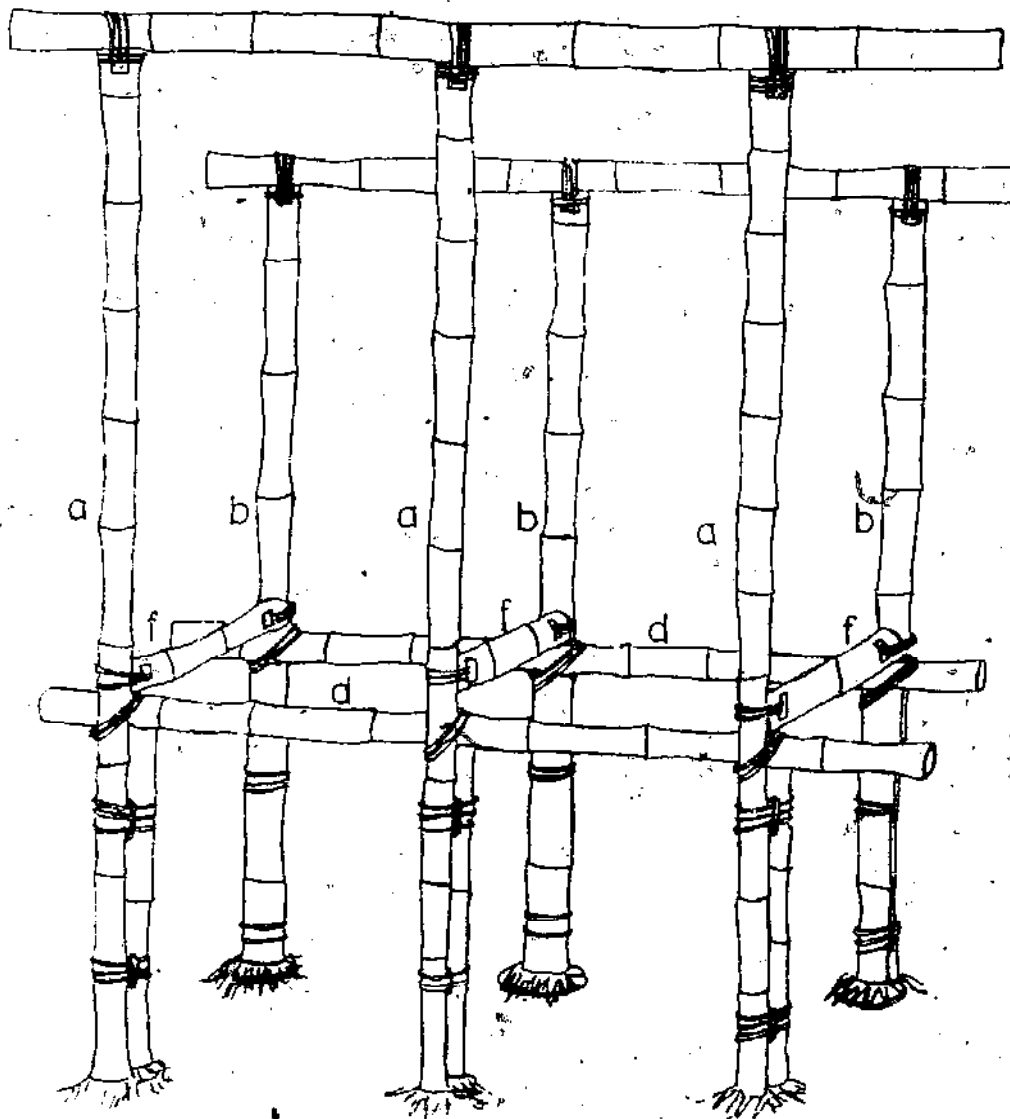

7 Finish the platform.

- Lash the twenty-five 95 cm poles (g) next to each other on the horizontal platform supports. This forms the platform.

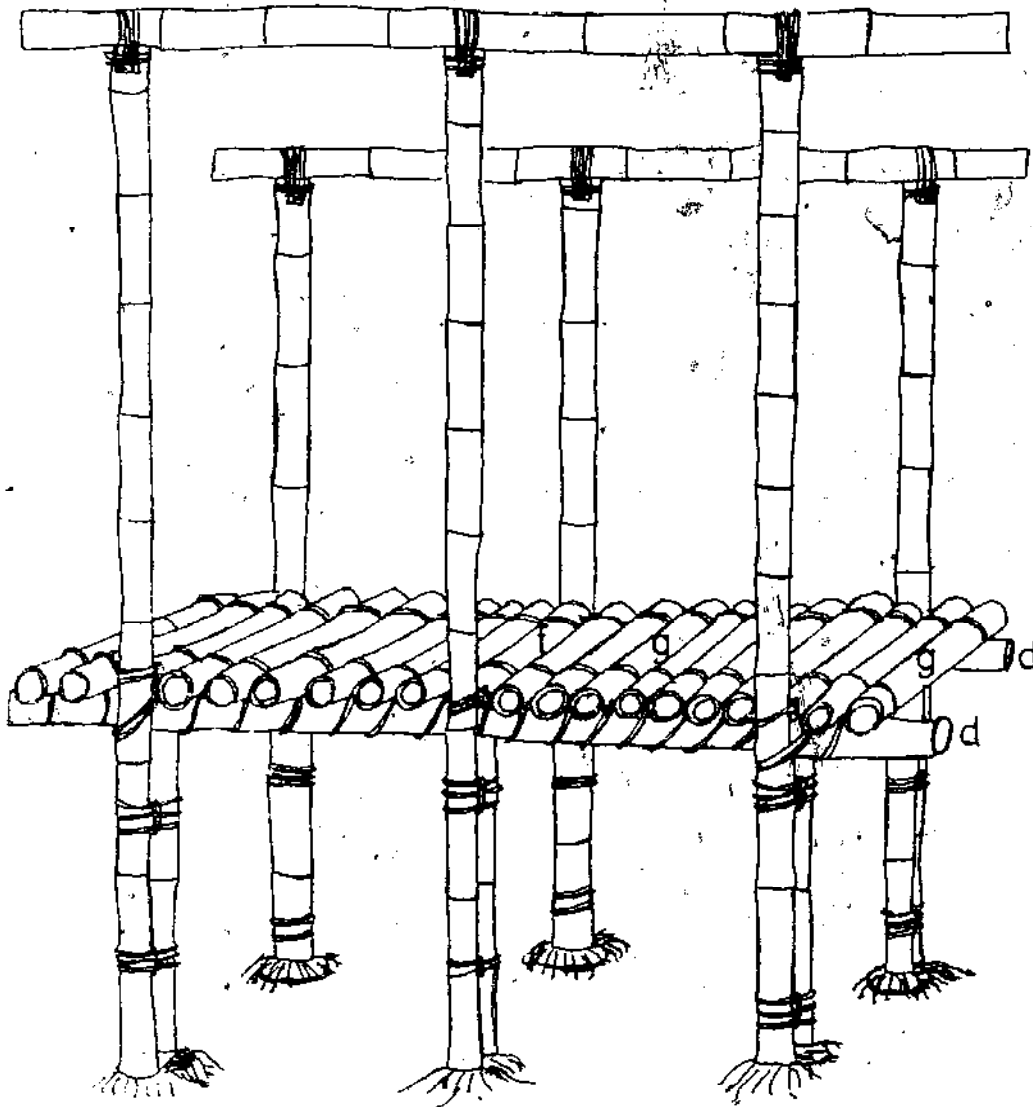

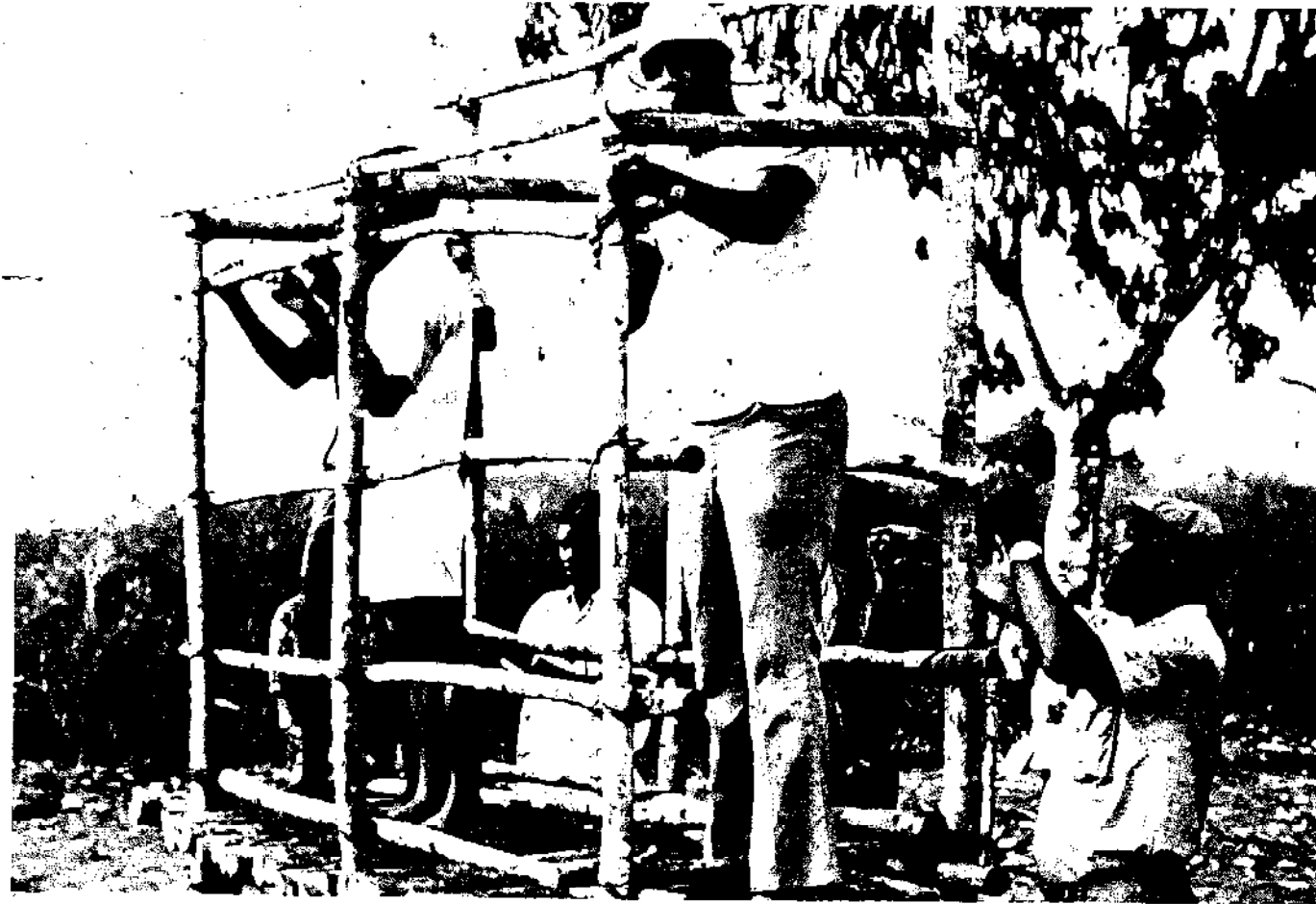

Using local materials found in the bush nearby, participants at a West African Workshop on Improved Farm and Village-Level Grain Storage Methods are shown here lashing the wall supports to the legs of the Field Maize Crib, using step-by-step construction procedures. The completed crib can be used for drying and also short-term storage of husks and cobs of maize.

8. Install the cross braces.

- If you think the frame is not sturdy enough by itself, lash the cross braces (h) loosely to the vertical supports on the outside of the crib.
- The 2 1/2 m cross braces are paired on the long sides of the crib, and the 1.70 m cross braces are paired on the ends of the crib.
- Each brace should extend from somewhere near a top corner to somewhere near the opposite bottom corner. Leave room for a loading cover on the higher side of the crib.
- Make sure the frame is straight and even. Lash the braces securely.

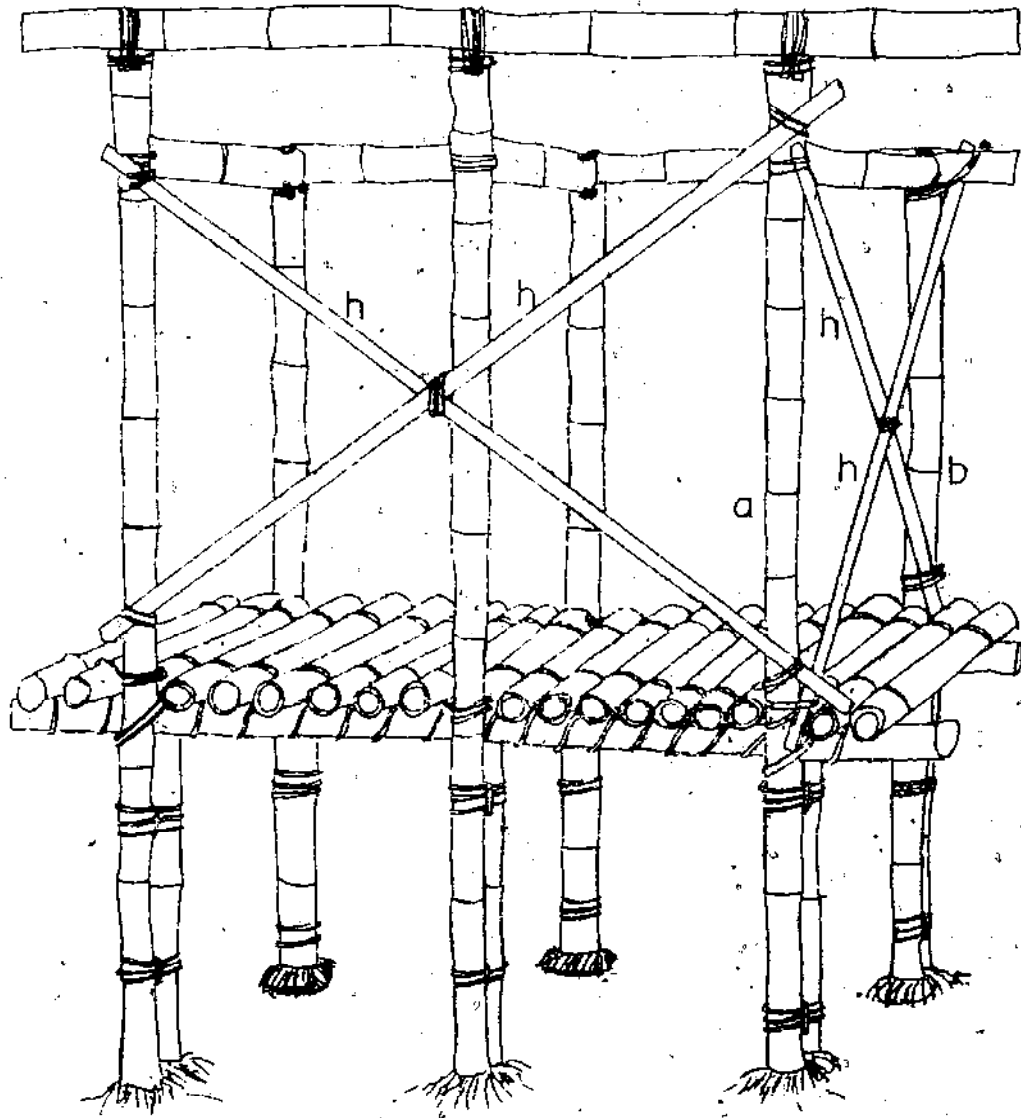

9. Install the wall supports and wall covering.

- Lash four of the 2 1/4 m wall supports (i) to the vertical supports along the inside of one of the long sides of the crib. Lash the remaining four supports to the inside of the other long side of the crib.
- Lash four of the 1 m wall supports (j) to the vertical supports along the inside of one end of the crib, and four of them along the inside of the other end.
- Lash the already-prepared wall covering, 6 m x 1 1/2 m (k), to all the wall supports on the inside of the frame.

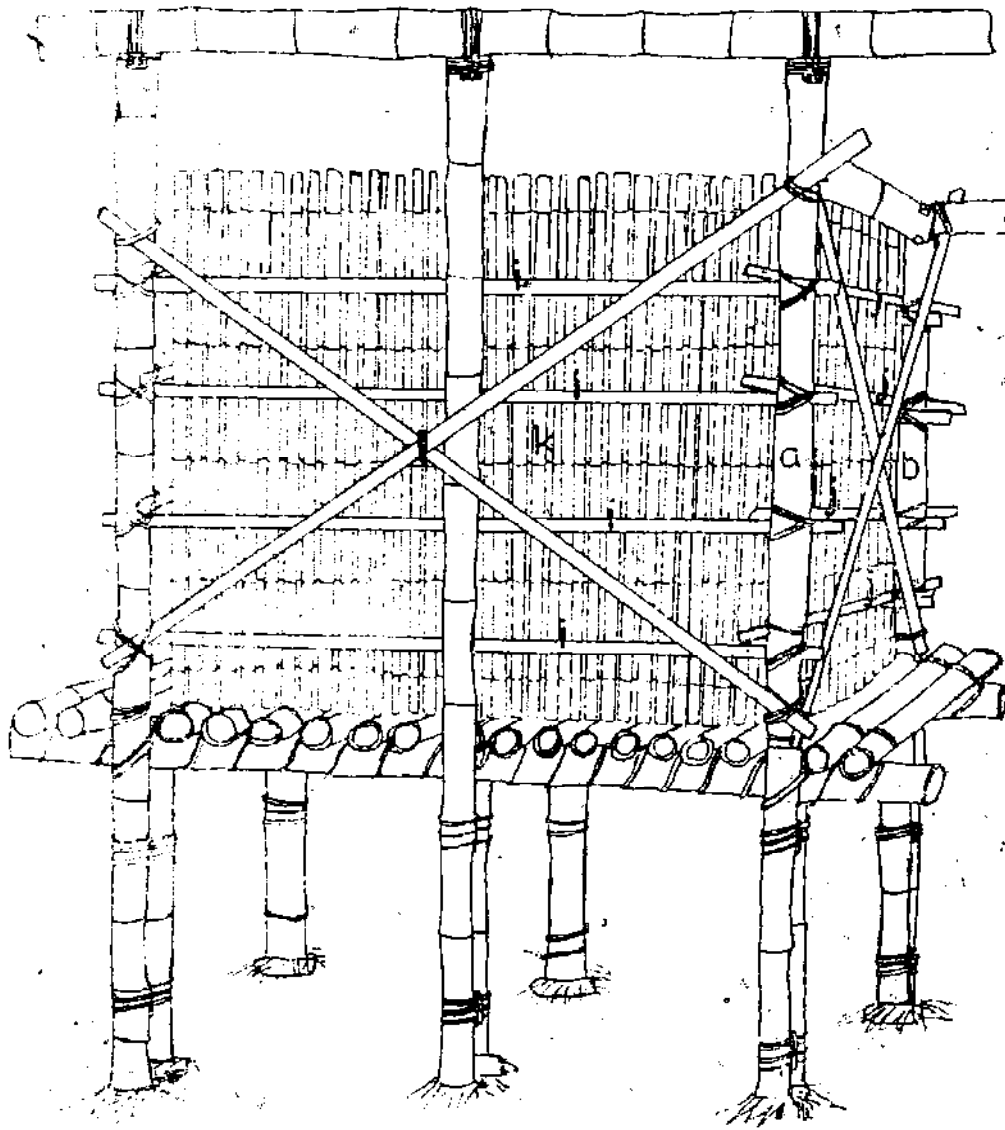

10. Build the roof.

- Call the high side of the crib the front and the lower side the back.
- Measure the distance between the centerlines of the front and the back horizontal roof supports (c) which are lashed to the tops of the vertical supports (a) and (b).
- Lay out the two $3\frac{1}{4}$ m horizontal roof pieces (l) on the ground so their centerlines are the same distance apart as the measurement you have just made.

Lash the three 1 m cross pieces (m) on top of the horizontal roof pieces. When the roof is placed on top of the frame, the cross pieces should cross over the ends of the vertical supports of the frame.

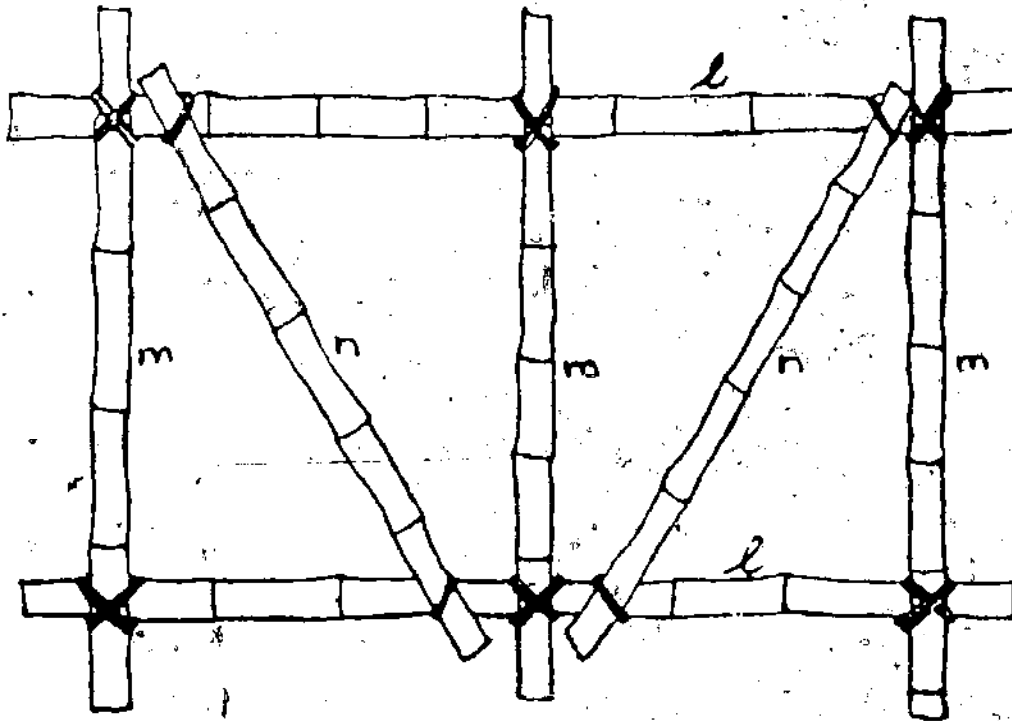

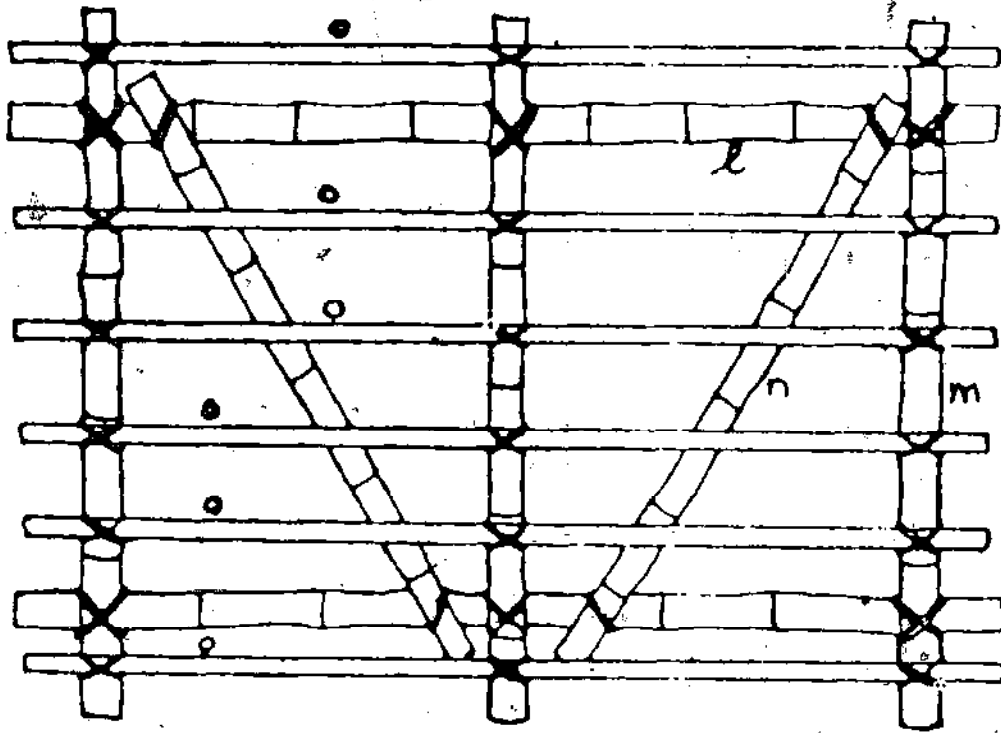

- Lash the two 1 m angle braces (n) to the horizontal roof members so that they extend diagonally across the two spaces in the roof frame.
- Lash six 3 1/4 m purlins (o) on top of the three cross braces so that they extend longways along the roof frame. Lash the first and last purlins near the ends of the roof cross braces.
- Lash raffia mat in overlapping layers to the roof frame.

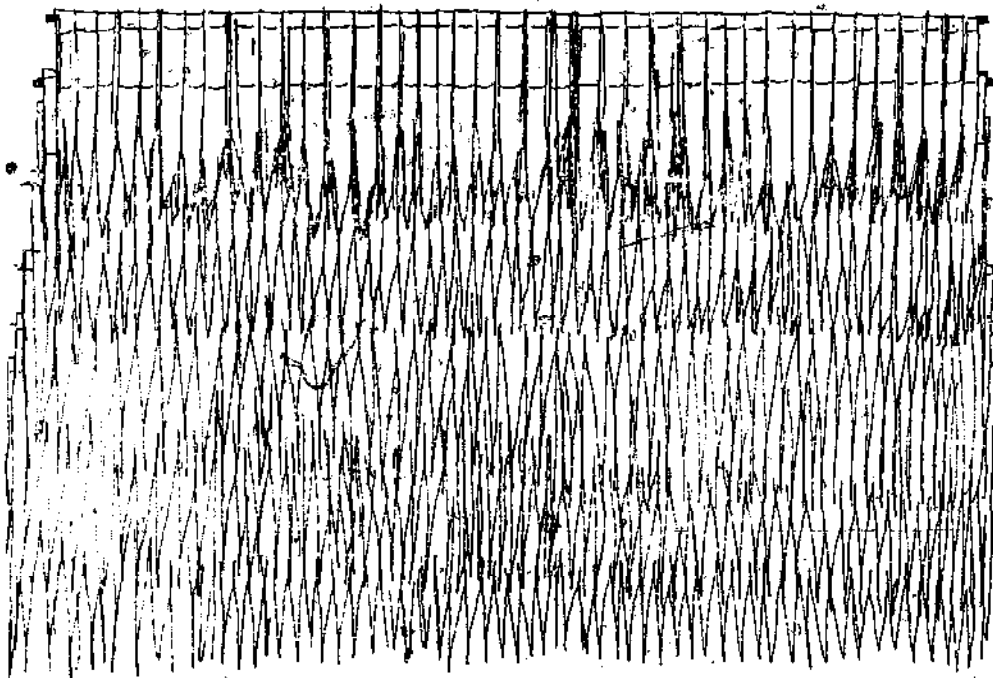

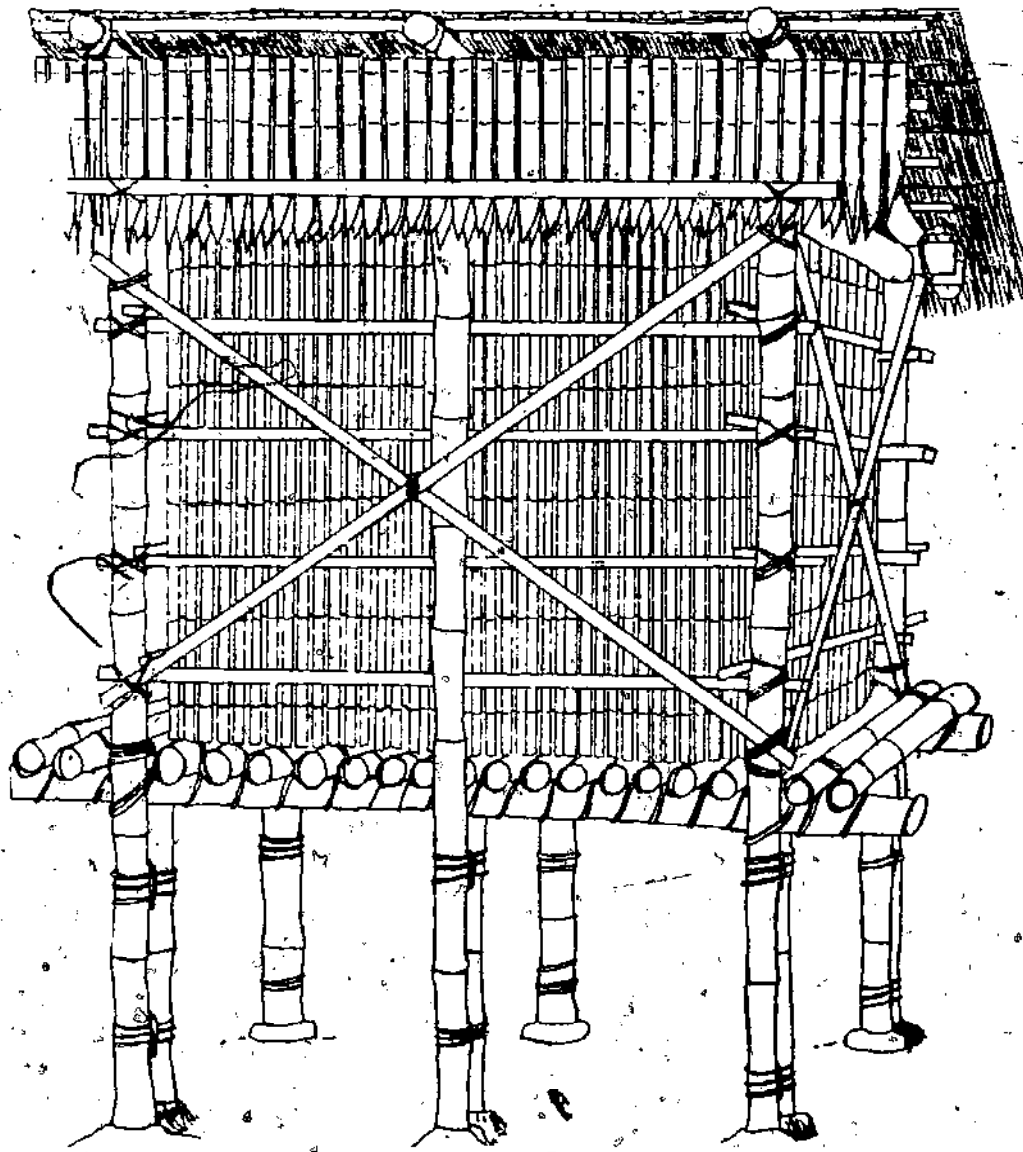

13. The crib is ready for use.

- Load the crib. Lash down the bottom corners of the loading cover to the frame during drying and storage.

WORKBOOK EXERCISES

1. What are the two main requirements for a successful open storage system?

Notes:

2. Describe what steps should be taken to limit insect attack in open crib storage?

Notes:

3. Describe how farmers in your area use open storage system methods?

Notes:

4. What are the advantages and disadvantages between "open" and "closed" storage systems?

Notes:

5. Are local building materials available in your area for constructing the Maize Crib described in this chapter?

Notes:

6. How would you prevent rodents from attacking maize stored in the FAO Maize Crib?

Notes:

7. Can you suggest any other type of open storage system which offers satisfactory results?

Notes:

8. What influence does the prevailing wind have in choosing a location for your Maize Crib?

Notes:

CONSTRUCTING & USING YOUR STORAGE SYSTEMS (CLOSED) MODEL 2 – IMPROVED MUD BRICK SILO

INTRODUCTION

The "Northern Ghana Mud Silo" as it was originally called, was initially developed at the Garu Agricultural Station in the Upper Region of Ghana. The project was a joint Ghanaian-West German agricultural development undertaking aimed at improving the traditional mud silo common to the area. Their principal objective was to try and make the traditional mud silo more airtight and durable and at the same time still incorporating low construction and operating costs. This silo as first introduced in northern Ghana was built on a layer of large rocks, had mud brick walls, a wooden unloading chute, and a cement slab serving as the top cover. It was soon found, however, that with certain modifications, this model could be effectively utilized in other regions as well, especially where humidity was a factor and where rocks were not available as a building material.

MODIFICATIONS

Accordingly, the following changes were made on the silo to render it more adaptable to other geographical and climatic regions:

1. Constructing the silo on pillars and insulating the silo from ground moisture by putting tar paper between the pillars and the bottom slab
2. Making the bottom and top slabs out of reinforced concrete to give added strength to the structure.
3. Replacing the wooden unloading chute with a plastic pipe cap which is airtight.
4. Eliminating the sloping floor inside the silo to increase capacity.
5. Topping the silo with an inverted thatch cone to protect it against the sun and rain, and
6. Painting the Silo with a coat of coal tar to inhibit moisture absorption.

Although these changes increased the cost a little in comparison to the original "Northern Ghana Mud Silo", the improved model is in terms of increased efficiency still much cheaper than a one ton cement silo or one ton's worth of metal barrel storage.

RESULTS OF TESTING (Peoples Republic of Benin, West-Africa)

Several interesting facts were learned about these silos. One important thing is that after construction they must be allowed to dry completely before they can be filled. This was learned in a previous test in 1975. When grain is put into a silo, the grain should not be tamped with a stick. Since the silo has no reinforcing around the sides, tamping can cause cracking of the silo walls, especially if the silo walls are not completely dry.

Improved Mud Brick Silos

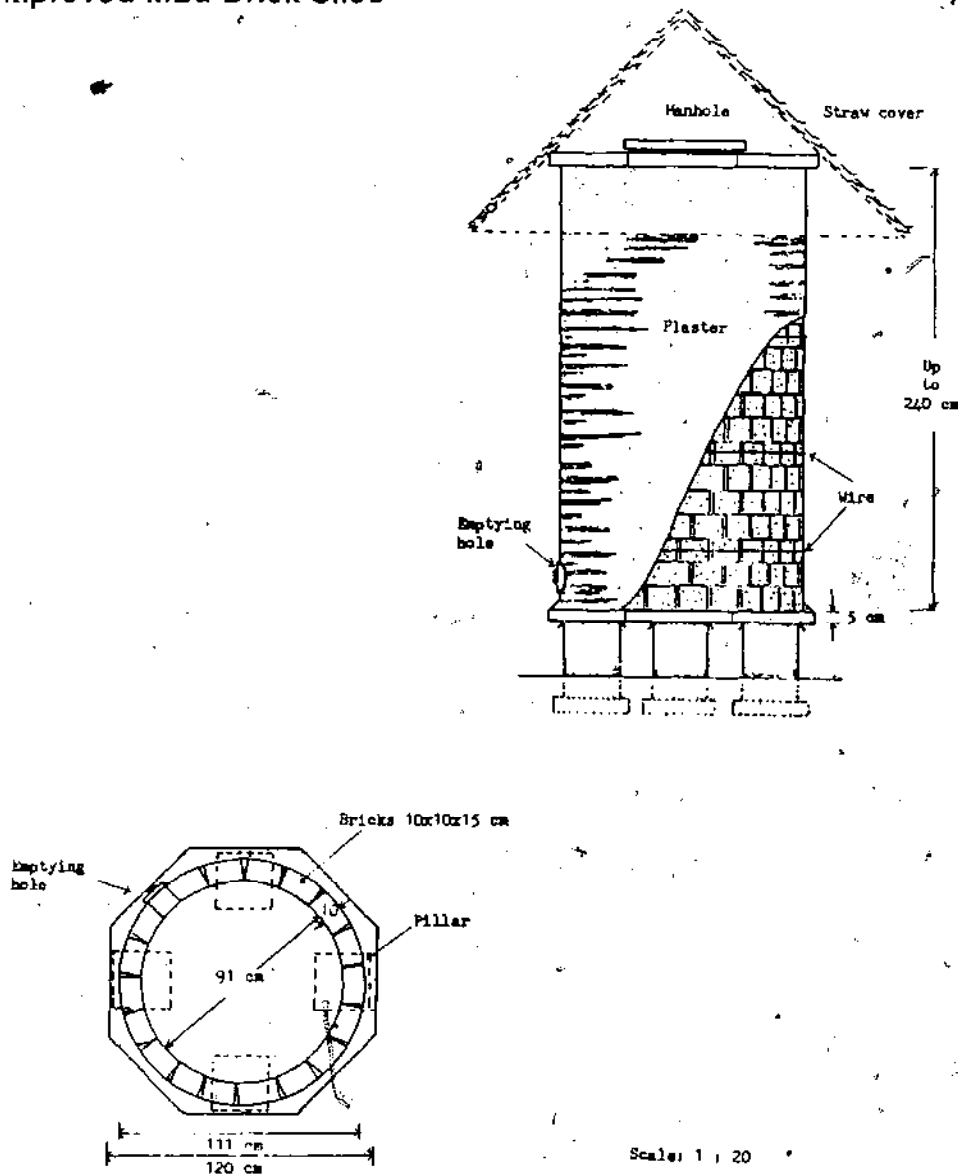

As there are no big rocks in the south of Benin to use as a silo foundation, it was decided to adapt a system of pillar bricks and a reinforced bottom slab (such as is used on the cement stave silos developed in Benin). Between the pillars and the bottom slab, pieces of tar paper were placed. When the ground is really wet, cement tends to transmit humidity from the ground up into whatever structure is above the ground. In the case of a silo, a humid bottom slab will mean wet, mouldy corn. The tar paper has proved to be an effective method of stopping the humidity transmission.

With the addition of the plastic pipe cap for the emptying hole and the sealing of the entry hole in the top slab, the silos have been found to be nearly airtight. If the silo is full and has not many insects, carbon dioxide will build up in the silo and control the insects. However, if many insects are present, the silo can be treated with a fumigant such as Phostoxin to assure the complete and immediate control of the insects.

In northern Ghana a roof on the silo is not really needed during the time of storage. However, in the southern humid of Africa regions, storage many time takes place during at least part of a rainy season. With the addition of the thatch cone roof, a cheap and effective method of protecting the silo was found. The roof is light enough to be lifted into place by two men.

Questions as to whether the whitewashing of the silos, as is done in Ghana, would protect the silos against the rain and humidity of the south were raised. Thus, one of the two silos tested at Niaouli* was whitewashed while the other was painted with coaltar. (The silo in Cotonou was whitewashed. The idea behind painting the silos with whitewash is to minimize the change of temperature inside the silo. This change in temperature is caused by the sun heating the silo in the daytime and the cooler night air cooling the silo at night. The heating and cooling causes air currents in the silo which may form pockets of humidity, leading to rotting of the grain. Whitewashing a silo causes the sun's rays to be reflected, resulting in a cooler silo.) However, it was wondered if whitewash would provide enough protection against rain and humidity. Coaltar is impermeable to water so one silo was painted with it. Coaltar is black and the color black absorbs light rays, so the

* Agricultural Research Station near Cotonou

part of the silo hit by the sun's rays was protected with a reed mat. In this way, it was hoped to minimize the effects of heating and cooling of the silo. Results showed the corn stored in the whitewashed silos had a slightly higher level of humidity at the end of testing as compared to the corn stored in the coaltarred silo. However, corn in the whitewashed silos was still in the safe humidity range for storage in silos or closed containers.

Construction Summary

Due to a lack of large rocks in the south of Benin, it was decided to place the silo on a cement foundation and pillar bricks. Three holes are dug in the ground and a foundation of cement 10 cm deep is poured. On the foundation three pillars of two bricks each are mounted. Between the pillars and the bottom slab of the silo, pieces of tar paper must be placed in order to insulate the slab from moisture coming up through the pillars.

The bottom slab can be made on the ground in a circular formwork. Diameter of the slab is 1.20 m and the thickness is 8 cm. The cement in the slab is reinforced with 6 mm rerod. The slab should be watered three times a day for seven days to insure proper curing of the cement. Once cured the slab may be lifted by several men and placed in position on top of the pillars, provided the tar paper has already been placed.

The wall of the silo is made of 325 mud bricks. These bricks can be rectangular or have beveled ends which fit more nicely the circular form and demand less mortar. The beveled bricks are 10 cm high, 10 cm wide, and 15 cm long on one side and 18 cm long on the other side. To mount the wall, a circle one meter in diameter is traced on the bottom slab. A layer of mortar is placed between the circle and the outside of the slab. The first layer of bricks may then be placed on the mortar. Space must be left for the plastic pipe cap that serves as the emptying hole. Once the bricks and the pipe cap have been mortared in place, the second layer of bricks may be placed. The silo wall ends up 17 bricks high with 19 bricks per layer. The mortar used to mount the wall and plaster over the bricks may be a mixture of cement and sand; cement, sand, and clay mud; or clay mud only if it has good bonding properties.

The top slab for the silo can be made on the ground in a circular form-

work just as the bottom slab is made. The top slab has a hole 50 cm in diameter in the center which serves as the filling hole. It is large enough to permit a man to enter into the silo in order to completely empty and clean the silo. This slab is 6 cm thick and 1.20 m in diameter and is reinforced with 6 mm rerod. Once the slab has cured for one week, several men can place the slab on a layer of mortar on top of the wall. Since the top slab has the filling hole in it, a method of sealing the hole is needed. Thus, a small cement cover slab is made. The cover slab is made 5 cm thick and 10 cm larger than the filling hole or 60 cm in diameter. There is a simple rerod handle embedded in the slab to aid the removal of the cover slab from the filling hole. A small mortar lip is placed around the filling hole. Once the mortar is dry and the silo filled, the cover slab can be placed on the lip and the crack between the two can be sealed with clay mud or a light mortar mixture. If the emptying hole and filling hole are both well sealed, the silo will be insect and rat-proof plus airtight.

Options and possible modifications in the silo construction

If stealing is a problem in the area where the silo is to be built, rerod can be imbedded in the wall on either side of the emptying hole and in the slab on either side of the filling hole. Bars can then either hinge on or slide through the rerod pieces and be locked with a padlock. This is a simple and effective way of eliminating most thefts.

The foundation and floor slab of the silo could possibly be done in another way, although it is still experimental. A hole with an outside diameter of 1.30 m would be dug to a depth of 30–50 cm or more until hard-packed earth or rock was reached. A circular foundation of bricks would be built around the edge of the hole, leaving the center empty. The foundation should extend 15–20 cm above the ground. Once the foundation bricks had been laid, the hole could be filled up with sand which was hard-packed and level with the top of the foundation. To waterproof the base, plastic sheets, coaltar, or tar felt (tar paper) would be used. The plastic sheets can be layed directly on the sand and foundation bricks. If one is using the coaltar or tar felt, a 3 cm layer of mortar must be placed on top of the hard-packed sand. One would overlap joints of tar felt 20 cm and spread coaltar on the seams. With the coaltar

only, one would paint the mortar and foundation bricks' top four times. Over the plastic sheets, tar felt, or coaltar another layer of mortar 4-5 cm thick would be placed. This mortar layer would serve as the floor of the silo and the base for the walls.

The top slab could be built using only cement, sand, and gravel - no re-rod. Four or more boards could be placed across the top wall to form a square which would serve to support the slab's weight. Thus, one could conceivably do away with the need for re-rod in both the top and bottom slabs. As mentioned in the paragraph above, these ideas are still experimental. Time and money have not yet been found to prove or disprove them. The ideas are presented to show a certain design should not always be thought of as perfect. Reasonable design changes should be sought after and looked into.

The improved Mud Brick Silo provides a reasonably cheap and effective method of storing one ton of grain. The silo works in dry regions and has now been adapted to work in humid regions. The silo can even be built on a lightly larger bottom slab, have the wall bricks turned so their short side faces outside, and have a larger top slab to increase capacity to one and a half tons. The silo works and is so adaptable because it is something basically uncomplicated in an increasingly complicated age.

Construction Materials

Mud bricks	325
Cement	4-5 sacks
Re-rod	3 six meters bars (6 mm diameter)
Tar felt	1 square meter m ²
Plastic pipe cap	1 (10-12 cm diameter)
Gravel	.25 m ³ cubic meter
Sand	.75 m ³ cubic meter
Coal Tar	3-4 liters
Whitewash	
Thatch and wood for cone roof	

Mixture Proportions

Foundation, pillars,

top and bottom:

1 part cement – 2 parts sand

slabs, and manhole cover

3 Parts gravel

Mortar joints and plaster Job

1 part cement – 4 parts sand/or a mixture of cement, sand and mud.

Wall bricks all mud/or mud and cement depending on quality of mud.

MOLD SIZES

L X W X H

Pillar bricks

30 cm x 30 cm x 20 cm

Mud Wall bricks

15 cm x 10 cm x 10 cm or bricks with one long side 18 cm long and the other long side 15 cm long x 10 cm x 10 cm. These bricks conform better to the circle and need less mortar between their joints.

CONSTRUCTION OF THE SILO

MUD BRICKS

The number of mud wall bricks will depend on the height and diameter of the silo. A silo with a 200 m interior height and a 100 m interior diameter will need 325 bricks.

Good quality mud should be at least $\frac{1}{3}$ sand and 5–30% clay. In Benin a distinct red colour indicates a good clay content and makes solid bricks. A brown to yellow colour means a high sand content. Clay could be added to make this soil better for brick making. Soil dark brown or black has a high humus content and is not recommended for brick making.

To prepare the soil, clean the soil of all organic debris and break up clods. Adjust the composition if necessary by adding sand or clay-rich soil, which is unavailable, broken-up termite hills may be used. Add just enough water to be workable. Excess water causes clay to swell and then shrink when drying causing cracking of the bricks.

In some regions plain sun-dried mud bricks are very strong. Other regions have mud that makes strong bricks if mixed with a little (1:15–20)

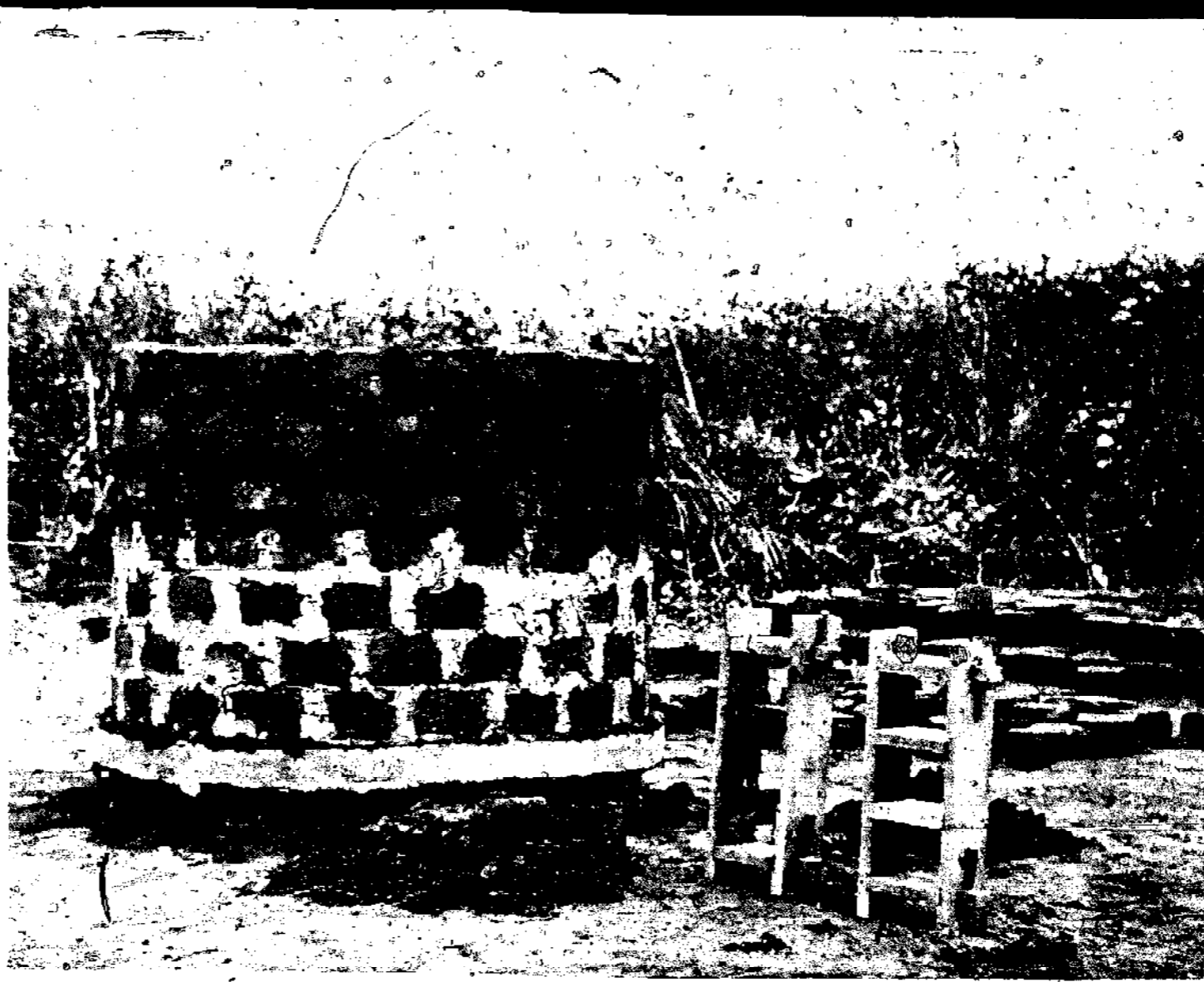

101

cement. Some types of soil become less strong when mixed with cement. Thus, a few bricks should be made to try the different possible combinations. When the bricks have dried, break them and see which mixture produced the strongest bricks.

Once the type of mixture has been selected, bricks can be made. Select a good, flat, sheltered area on which to build the bricks. Mix the mud and water taking care not to add too much water. To be strong, the bricks should be well tamped and then well dried. Be sure and protect the bricks from rain or else you might have to start over again.

PILLAR BRICKS

Six bricks 30 x 30 x 20 cm are needed to form three pillars of two bricks each. The bricks can either be done with a mixture of concrete with the proportions 1:2:3 or with a mixture of mortar with the proportion 1:4-6 (according to the quality of sand and cement employed).

One could also use cement blocks that are used for housebuilding if their size and strength are similar to the regular pillar bricks. **The pillar bricks must be watered 3 times a day for seven days** in order to be well cured and strong.

PILLAR CONSTRUCTION

Trace a circle with a radius of 60 cm on the ground. This gives the circumference of the silo's inferior slab. Next, from the same point, trace a circle with a radius of 45 cm and divide the circle into three equal parts. To divide the circle into three parts, pick a point on the circle and with the radius of 45 cm mark two more points on the circle, one on each side of the chosen point. From each one of these two points, mark two more new points, again with the 45 cm radius. These last two points and the first point chosen divide the circle in three equal parts. The three points on the circle will be the centers of the pillars. From one center to another should be approximately 79 cm. Around each point, trace a circle with a radius of 25 cm and dig a hole 50 cm deep. In each hole pour a foundation of concrete (1:2:3) 10 cm deep. Tamp the concrete well and level entirely. After this, construct the pillars using two pillar bricks, one on top the other, in each hole. Put the first bricks on their sides so their 30 cm long sides are perpendicular to the axis running through the

center point in between the three pillars (see diagram). The 20 cm sides are parallel with the axis. Next, place a layer of mortar 1–2 cm thick on the first bricks and set the second bricks in place. The three pillars must be level to permit an equal distribution of the slab's weight and to insure the slab will not crack under load.

INFERIOR SLAB

The diameter of the slab is 1.20 m with a thickness of 8 cm. It is reinforced with 7.5 m (ϕ 6 mm) of reinforcing rod and poured with a mixture of concrete (1:2:3).

To facilitate construction of the silo, the bottom and top slabs can be poured on the ground and later lifted into place. A form work should be made, either dug into the ground or sitting on the ground. Diameter of the formwork is 1.20 m. Line the formwork with paper to prevent the cement from sticking and wet the paper before pouring the concrete. To make the slab smoother on the sides, a piece of masonite can be used to form the circle of the formwork. The original Ghana mud silo had a top slab in the shape of an octagon. A circle was used for this changed model because it is easier to form.

REINFORCING RODS

To fabricate the reinforcing pattern, two 6 m rods (ϕ 6 mm) are needed. Trace a circle on the ground with a 55 cm radius to obtain the model of the pattern. Divide this circle into six equal parts, marking six points on the circle. Bend one bar around the circle and cut to fit. Next, fit three straight bars to the circle so they correspond to the six points on the circle and cross each other in the center of the circle (see diagram). Each bar or rod should have at least 5–10 cm extra at each end that can be bent over the circle in order to hold the bar in place. These bent ends can then be attached with little pieces of wire to secure them firmly. Before pouring the cement for the slab, it is important to place the pattern in the slab formwork to make sure it is round and flat and not too big. Once the formwork and the rebar pattern have been completed, the concrete mixture can be prepared. The bottom slab will use approximately 1 1/4 sacks of cement. Mix the concrete thoroughly and add the right amount of water 20–25 liters per 50 kg sack of cement. Once the



Photo—Erik Bentzen.

Bottom slab for the Improved Mud Brick Silo is made essentially the same way as floor slab for cement stave silo.

water has been added to the mixture, pour the concrete with as little delay as is possible, preferably in less than one hour. When the mixture is ready to pour, wet the paper or sand in the formwork. Pour and tamp a layer 3-4 cm thick before placing the rerod pattern. Be sure and mark on the formwork the position of the three straight rerods in the slab. Once the slab is to be placed on the pillars, the rerod positions will be important. Cover the rerod pattern with a 4-5 cm layer of concrete (to obtain a total of 8 cm) and tamp well. If the slab is not well tamped, it risks cracking under the maize's weight. Smooth and level the surface of the slab. It is very important to **water the slab three times a day for seven days** and to let the slab cure in the shade.

PLACING THE SLAB

Once the slab has been watered and cured for one week, it may be placed on the pillars. First, one must remove the formwork around the slab. Make sure that the slab has been marked with the position of the rerod first. Next, **place tar paper pieces 25 x 35 cm on top of the three pillars.** The tar paper serves as a moisture barrier between the pillars and the slab. On the tar paper place a little mortar (1:6-8) with the same shape as the pillar and 1-2 cm thickness. Now the slab can be placed on the pillars. It is important that three of the rerod position marks be placed in the center of each pillar so that the future weight of the maize will be evenly distributed among the pillars. Level the slab on the pillars by adding a little mortar on one or two pillars if it is necessary.

MOUNTING THE WALLS

After the slab is in place and the mortar has dried some, the walls can be mounted. Trace a circle of one meter in diameter on the slab. Place a small layer of mortar between the circle and the outside of the slab. The mortar may be either cement and sand (1:4) or cement, sand, and mud (1:3:3, 1:4:4, etc. depending on conditions). The exact mixture depends on the mixture in your bricks and the interaction of the cement, sand, and mud in that particular region.

Commence placing the bricks on the mortar. Their inside face should fall on the one meter diameter line traced on the slab. Leave space bet-

ween the bricks for mortar to be placed. In the first layer of 19 bricks, the plastic emptying hole should be placed in between two bricks. BE sure and leave enough space to allow the cap to easily screw on and off. The bricks for the second layer should be placed on a small layer of mortar applied to the top of the first layer. Stagger the bricks so the center of the second layer bricks falls over the joint between two first layer bricks. This will give strenght to the wall and avoid cracks in the joints from going all the way up the wall. To place the bricks of the second layer over the plastic emptying hole demands putting three little pieces of rerod over the hole. The rerod acts as a support for the bricks and helps keep them level and even. After the second layer the wall is mounted in the same fashion up to two meters from the bottom slab. This will give approximately one metric ton of storage. The wall needs 17 layers of bricks which, when combined with the mortar joints, makes approximately two meters of wall. If it is deemed necessary, a rerod apparatus could be placed in the wall when it is constructed so that the emptying hole could be locked afterwards to protect the silo against theft. There are several different ways to make a locking device. Two rerod hooks might be displaced in the mortar joints on either side of the plastic emptying hole plug. A third bar can be attached to one of the hooks so it hinges over the plastic plug and can be locked to the second hook. A plate that hinges and covers the entire plastic plug could also be used. More elaborate devices could be made, depending upon imagination and possibifities of materials.

PLASTERING

The plastering of the silo can be done before or after placing the top slab but it is much easier if it is done before. The inside and the outside walls are plastered with a mixture of cement and sand (1:4) or with cement, sand, and mud (1:3:3, 1:4:4, etc. according to conditions). The inside wall may be completely plastered or just the joints, according to conditions of humidity in the region.

TOP SLAB

The top slab can be made in a formwork on the ground as is the bottom slab. The slab has a hole 50 cm in diameter in the center which serves as

The watering and curing of the top slab and cover slab are the same as for the bottom slab and pillar bricks. **One should water the slab 3 times a day for at least 7 days if not for 10 days.** This is because the top slab must be lifted to the top of the silo and also must support the weight of a man when he wants to enter into the silo. No one wants the slab to break and hurt some one.

When the slab is cured, it may be put on the silo wall. Place a small layer of mortar on the top of the wall and lift the slab into place. Center it well on the wall and then mortar in the remaining space inside and outside between the wall and the slab. One might also bet a layer of mortar five to seven centimeters wide around the filling hole. This will put the little cover slab up off the top slab and help prevent any chance water from running into the silo. The lifting of the slab into place will take at least six strong men and some caution.

PAINTING THE SILO

After the silo has dried for two weeks, it may be painted. This painting will render the silo more air and water tight. Three systems are possible. The silo may be painted with whitewash on the exterior. If there is much rain in the area during a storage period, it might be painted externally with coal tar. This might possibly, though not for sure, cause problems of heating and cooling of the inside silo air. One possible option is to paint the inside of the silo with coal tar and paint the outside with whitewash. The coal tar will protect against the entry of humidity while the whitewash makes the silo cooler and prettier.

SILO ROOF

The mud silo needs protection against rain. A simple and inexpensive method of protection is to construct a thatch cone in the shape of an inverted "V" and put it on the silo. If the cone hangs over and down a ways, it will also help protect against the sun's rays. Of course, a big roof to protect the entire silo could always be built but is not a necessity.

FILLING AND TREATING THE SILO

Once the silo is painted, dry, and has a roof, corn can be put in the silo by way of the filling hole in the top slab. Fill the silo but **do not tamp the**

The watering and curing of the top slab and cover slab are the same as for the bottom slab and pillar bricks. **One should water the slab 3 times a day for at least 7 days if not for 10 days.** This is because the top slab must be lifted to the top of the silo and also must support the weight of a man when he wants to enter into the silo. No one wants the slab to break and hurt some one.

When the slab is cured, it may be put on the silo wall. Place a small layer of mortar on the top of the wall and lift the slab into place. Center it well on the wall and then mortar in the remaining space inside and outside between the wall and the slab. One might also bet a layer of mortar five to seven centimeters wide around the filling hole. This will put the little cover slab up off the top slab and help prevent any chance water from running into the silo. The lifting of the slab into place will take at least six strong men and some caution.

PAINTING THE SILO

After the silo has dried for two weeks, it may be painted. This painting will render the silo more air and water tight. Three systems are possible. The silo may be painted with whitewash on the exterior. If there is much rain in the area during a storage period, it might be painted externally with coal tar. This might possibly, though not for sure, cause problems of heating and cooling of the inside silo air. One possible option is to paint the inside of the silo with coal tar and paint the outside with whitewash. The coal tar will protect against the entry of humidity while the whitewash makes the silo cooler and prettier.

SILO ROOF

The mud silo needs protection against rain. A simple and inexpensive method of protection is to construct a thatch cone in the shape of an inverted "V" and put it off the silo. If the cone hangs over and down a ways, it will also help protect against the sun's rays. Of course, a big roof to protect the entire silo could always be built but is not a necessity.

FILLING AND TREATING THE SILO

Once the silo is painted, dry, and has a roof, corn can be put in the silo by way of the filling hole in the top slab. Fill the silo but **do not tamp the**

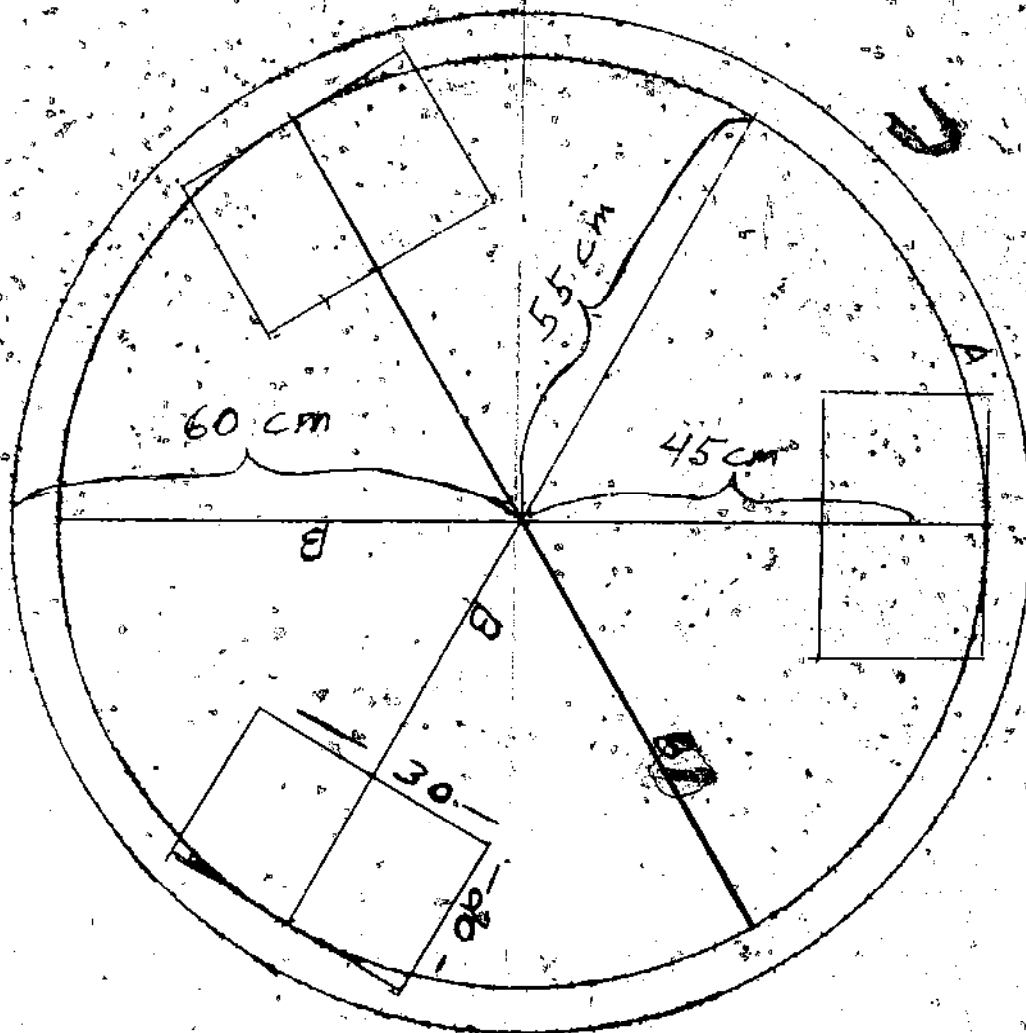

**IMPROVED MUD BRICK SILO
REROD PATTERN - BOTTOM SLAB**

Pillars: Holes - 50 cm ø
 Depth: 50 cm
 Foundation: 10 cm thickness

2 bricks per pillar

A = 3 M 60
 B = 1M 30 x 3 = 3 M 90
 TOTAL = 7 M 50 rerod

grain as excess pressure could cause the wall to crack. The silo is tight enough to be treated with fumigants. Put the fumigant in, seal the cover slab with mortar or mud and place the roof. If there were insects at the time of treatment, control the silo in one and a half to two months' time to see if a retreatment is warranted. Make sure the emptying hole is locked so no one steals your grain!



Photo – Erik Bentzen

Inside and outside walls of Improved Mud Brick Silo are plastered with a mixture of cement and sand.

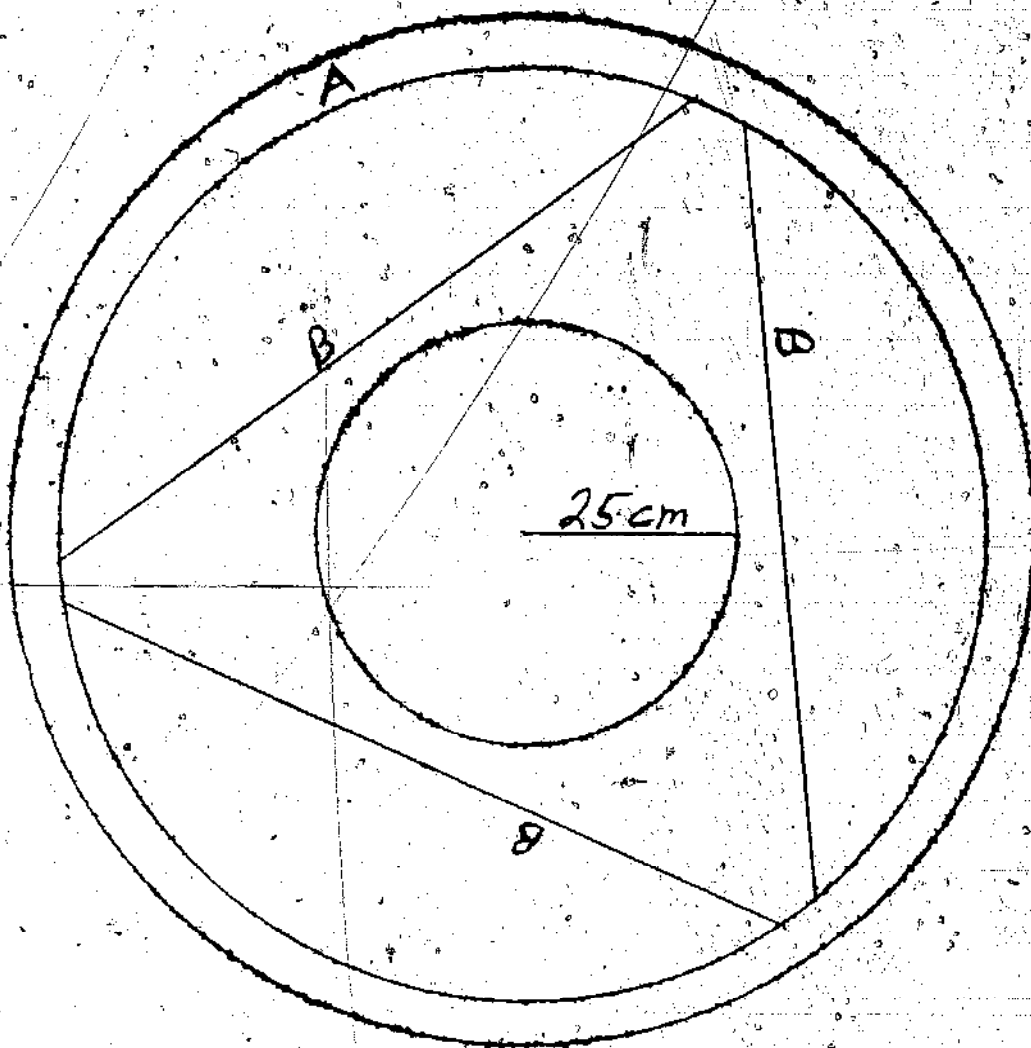

**IMPROVED MUD BRICK SILO
REROD PATTERN TOP SLAB**

A = 3M 60
 B = 1M 20 x 3 = 3M 60
 TOTAL = 7M 20 rerod
 Grand Total = 14M 70 rerod
 needed for
 14.70 m Rerod for both slabs

HOW TO USE YOUR IMPROVED MUD BRICK SILO

- Put only clean, dry grain into your silo.
- Wet grain will rot in the closed silo. It will get moldy.
- Wet grain will make the silo wet. The silo walls will crack if they get wet. Your grain will be no good.



1. Coal-tarred Modified Ghana Mudbrick Silo with Mat to Protect Against the Sun's Rays.
2. White-washed Modified Ghana Mud Silo with Mat to Protect Against the Sun's Rays.
3. Experimental Mud and Screen Wire Silo Resembling Original Ghana Mud Silo.

- Dry your grain in the sun.
- Keep the grain in the sun or in the dryer until it is dry.
- Test the grain when you think it is dry. Put one grain between your teeth. Dry grain is very hard to break with your teeth.
- Remember, if storing maize – put kernels into the silo right after you remove them from the cobs. Do not let maize stay on the cobs after you remove the cobs from the drying place.
- When the grain is dry, take the cover off the manhole. Put the grain into the silo right away. Fill the silo to the top.
- Stir the grain in the silo with a large stick. This helps the grains settle.
- It is good to add an insect poison to the grain before you close the silo. Insects are always present in grain. Insect larvae live inside the kernels where they can not be seen. Talk to your extension worker about what poison to use and how to use it.
- Remember, poisons can kill animals and people. Do not use them before you talk to an extension worker.
- Put the cover on the manhole as soon as possible. Flying insects can enter the grain if the cover is not on the manhole.
- Put mud all around the cover so nothing can get into any cracks between the cover and the manhole.
- Make sure the Plastic pipe cap closes tightly.
- Make sure there are no cracks around the plastic pipe cap.
- Keep the area around the silo clean. Rats do not like to live where it is clean.
- Check your silo often. Put new plaster on any cracks you find. It is important to find the cracks and put plaster on them right away.
- Keep the silo white. The white color keeps the silo cool. Put on new whitewash when the silo needs it.
- You may have to use the plastic pipe to take out small amounts of grain to sell or eat. Make sure you close the cap carefully. Do not leave it open. If theft is a problem, the cap can be locked and grain removed from the top of the silo.
- Do not leave grains scattered on the ground. These grains will attract insects and rats.
- When you empty the silo, make sure all the grain is out. Grain left in an empty silo will attract insects and rodents.

- Clean the silo well before you fill it again. You can burn a small fire made of grass inside the silo. This kind of fire makes a lot of smoke. The smoke and heat from the fire kill insects and insect eggs.
- Sweep out the ashes, and old grain.
- When your silo is clean and repaired, you are ready to put the next crop of grain into the silo.

CLOSED STORAGE - (Continued) SYSTEMS

(with Supplementary information on construction of 2.5 T. Cement Stave Silo)

MODEL 3 - THE 4.5 TON CEMENT STAVE SILO

The construction of farm and village-level cement silos on pillars with capacities currently ranging from 2 to 4.5 tons provides a means of storing maize and other grains for up to two years with minimal losses. It should be recognized, however, that these units require more care in drying and insecticide treatment than traditional methods. The 4.5 ton model is considered the optimum size because units of smaller capacity are less economical to build. Experience has shown that the Cement Stave Silo will work just as well in drier areas as in humid ones. The only limiting factor is one of economic feasibility.

The silo was developed and field tested over the past seven years in Benin, West Africa, by Government Agricultural Extension Agents in cooperation with U.S. Peace Corps Volunteers. Since the program first began, over 350 of these silos have been built and successfully used.

ADVANTAGES

- Stores large amounts of grain.
- Gives good insect control when insecticide is added to the grain to kill insects already in the grain.
- Offers good protection for the grain from rodents.
- Is less expensive than a metal silo of similar capacity and is more durable.

DISADVANTAGES

- Has to be protected from rain or it does not provide good moisture control.
- Uses materials and equipment which make it more expensive to build than the mudblock silo.

THE SITE

- Build the silo on high, well-drained ground. Do not build the silo where it will be in the path of water from flooding or heavy rains.
- Test the ground to see if it will support the silo. You should build this silo on hard-pan, rock, or stable soil.
- Dig a small hole, about 65 cm deep. If you do not reach hard-packed earth or rock, try another location, if possible. If there is no other location available, and you are in doubt about whether the earth is hard enough, special precautions should be taken.
- Locate the silo so that it is level. If a dryer, for example, the Pit Oil Barrel Dryer, is being built on the same site, the location must be chosen so that the front of the dryer is facing the oncoming winds during the time of year you will be drying.

THE SHELTER: (see Figure)

Before construction of the silo and dryer is begun, a straw or tin roofed shelter should be built. This provides protection from rain and sunlight for the silo and dryer as well as better working conditions during construction. Completion of the shelter assures that the units will be ready for use as soon as the corn is ready, and can also give an idea of the interest of the owner in the project.

For a 4.5 T silo, the shelter dimensions are 8.00–10.00 meters by 4.00 meters, height to cross pieces, 2.50 meters. The height from the cross pieces to the roof beam is 1.50 m for the 4.5 T and 2.5 T hangar. For a 2.5 T silo, a length of 8.00 meters with the same width and height as the hangar for the 4.5 T silo is necessary.

Placement of support posts for the roof beam in the center of the shelter is determined by the location of the silo and dryer hole.

The type of roof for the shelter will depend on the economic capabilities of the owner. A thatch roof can always be replaced by a tin one after the unit has had several years to pay for itself.

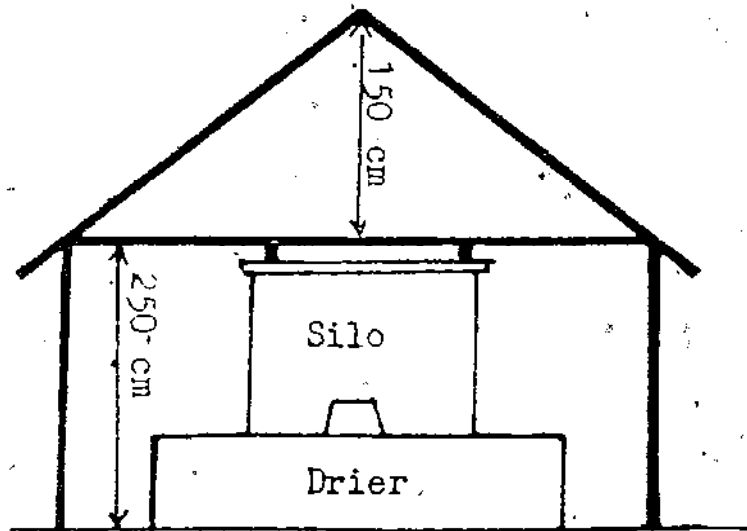

MATERIALS: (see table 1)

Cement should be stored on log supports or plastic, since it will harden if placed directly on the ground. If lumps are present and cannot be broken easily, they should be discarded and the quantity of cement increased by $\frac{1}{4}$ to $\frac{1}{3}$.

Road sand can be used if it is clean and does not have too much clay content.

Gravel should be smaller than $\frac{1}{3}$ the thickness of the slab it is used in. It should be washed if mixed with dirt or other impurities.

Water should be free of dirt, oil, and chemicals, which weaken cement. If stored in barrels, they should be washed thoroughly beforehand.

MIXING: should be done on cement or swept, packed earth. Care should be taken not to scrape dirt into the mixture. On dirt, all mixtures should be made on the same spot since the spot will harden after the first mixing.

Excess water causes separation of cement from the mixture when it is **tamped**, and thus weakens it. 20–25 liters of water for each 50 kg sack of cement is about right for all mixes.

After making bricks and slabs, the strength of cement is increased by watering it 3 times a day for 7 days and drying in the shade. If this is not done the silo will not support the pressure of the stored corn.

MIXTURE PROPORTIONS:

- mortar for staves 1 part cement - 4 parts sand (1:4)
- mortar for plastering, pillar bricks and joints 1 part cement - 6-8 parts sand (1:6-8)
- concrete for slabs, lintels 1 part cement - 2 parts sand - 3 parts gravel (1:2:3)

TABLE I. CONSTRUCTION MATERIALS

A) TOTAL MATERIALS NECESSARY

Materials	Silo 4.5 tons	Silo 2.5 tons
Cement	12 sacks (50 kg)	9 sacks
Re-rod (\varnothing 6 mm)	8 bars (6 m long)	4 bars
Galvanized wire (\varnothing 3 mm)	1 roll (4 kg)	0.5 roll
Wire tighteners	10	10
Coal tar	15 l	12 l
Tar paper	1 m ²	1 m ²
Gravel	0.6 m ³ (3 barrellfuls)*	0.4 m ³ (2 barrellfuls)*
Sand	2 m ³	1.5 m ³
Emptying Hole Plug	1	1
Wire screening		
Barrels (200 l)		

* 200 l barrels (5 barrellfuls = 1 m³)

CONSTRUCTION OF 4.5 T CAPACITY CEMENT STAVE SILO ON PILLARS (see fig. 2)

The 4.5 T. silo is the basic unit used in grain storage in southern Benin because units of smaller capacity are considered less economical. The

interior diameter is 2.0 meters. The interior height is 2.0 meters, giving a volume of 6.3 cubic meters. Total height from ground level is 2.5 meters and diameter of the floor slab is 2.2 meters.

CEMENT STAVE SILO – PERSPECTIVE VIEW – (Fig. 2)

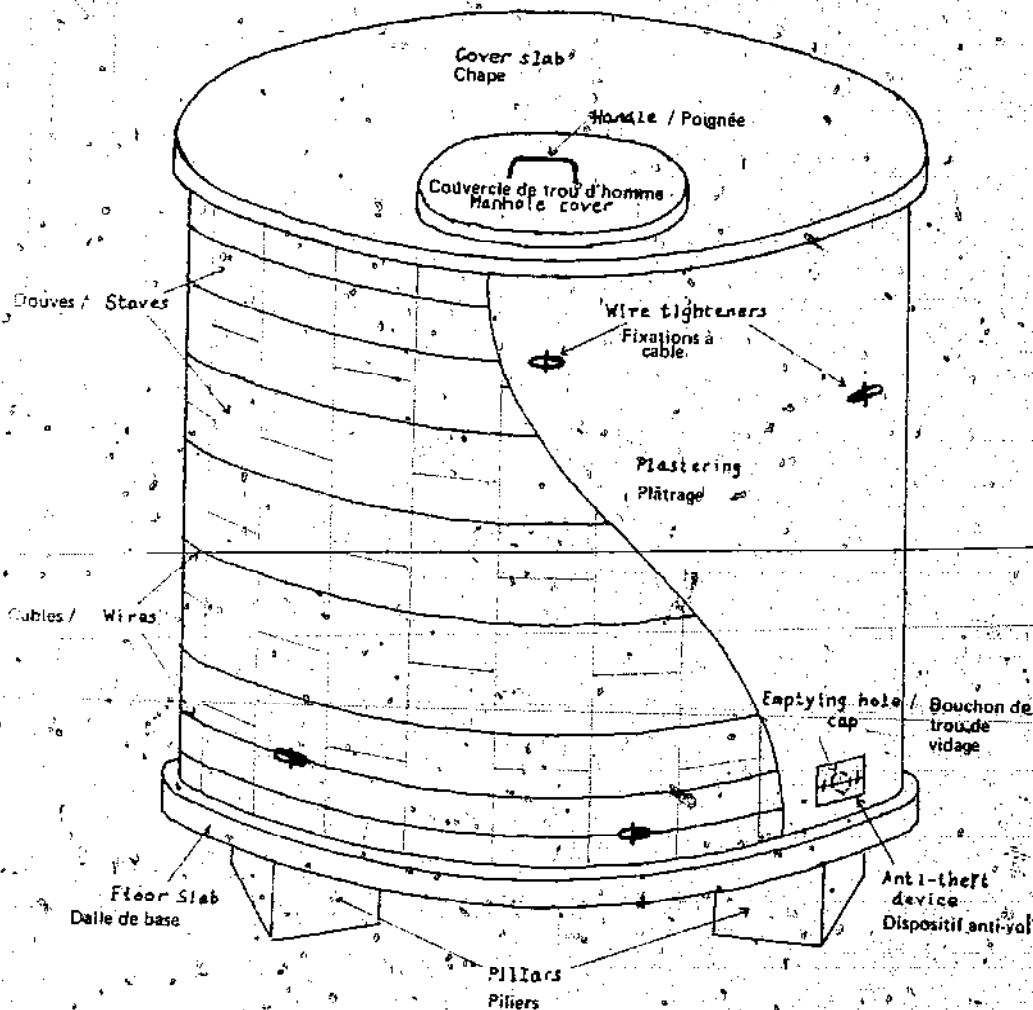

TABLE I: CONSTRUCTION Materials
B) USE OF MATERIALS

Operation	Material	Silo 4.5 T	Silo 2.5 T
Staves	Cement	5 sacks	4 sacks
	Re-rod 6 mm Ø	50 cm	50 cm
Pillar Bricks	Cement	1 sack	0.75 sack
Mounting pillars	Cement	1 sack	0.75 sack
	Gravel	0.1 m ³	0.1 m ³
		(0.5 barrelful)	(0.5 barrelful)
Floor slab	Cement	2 sacks	1.5 sack
	Gravel	0.2 m ³	0.2 m ³
		(1 barrelful)	(0.75 barrelful)
Silo wall	Re-rod 6 mm Ø)	4 bars 6 m	2 bars
	Galvanized-wire	1 roll	0.5 roll
Mounting- plastering, painting	Wire tighteners	10	10
	Cement	1 sack	1 sack
	Coal tar	13 l	10 l
Anti-theft device	Re-rod 6 mm Ø	120 cm	120 cm
	Emptying hole plug	1	1
	Barrel end	1	1
Cover slab (with filling hole cover)	Cement	2 sacks	1.5 sack
	Gravel	0.2 m ³	0.2 m ³
		(1 barrelful)	(1 barrelful)
Dryer lintels	Re-rod 6 mm Ø	4 bars 6 m	2 bars
	Cement	0.3 sack	
	Gravel	0.1 m ³	
		(0.5 barrelful)	
	Re-rod	1 bar 6 mm Ø	
		6 m	

STAVES

For the silo wall, 91 large staves and 26 small ones are necessary. Five extra large staves should be made in case of breakage. They are made with a 1:4 mixture of cement to sand. 4.5 to 5 packages of cement will be required. The staves are made using special molds shown in figure 3 which produce staves 5 cm thick with bevelled edges.



Photo – Erik Bentzen

Cement staves are made using special wooden molds; normally 5 cm. thick with bevelled edges.

The staves should be tamped well, with a bottle, for example, and care should be taken so that the cement is not so wet that water runs out of the mold or the staves slump.

One large staff should be made with a hole (1.2 cm in diameter) in it for insertion of the emptying plug, centered 10 cm from the end of the staff. This hole should be reinforced with a ring of 6 mm re-rod (50 cm long) in the staff around the hole and by tamping well. The staves will require 5 packs of cement. **Water the staves 3 times per day for 7 days and dry in the shade.**

Figure 3 - Forms for the Staves

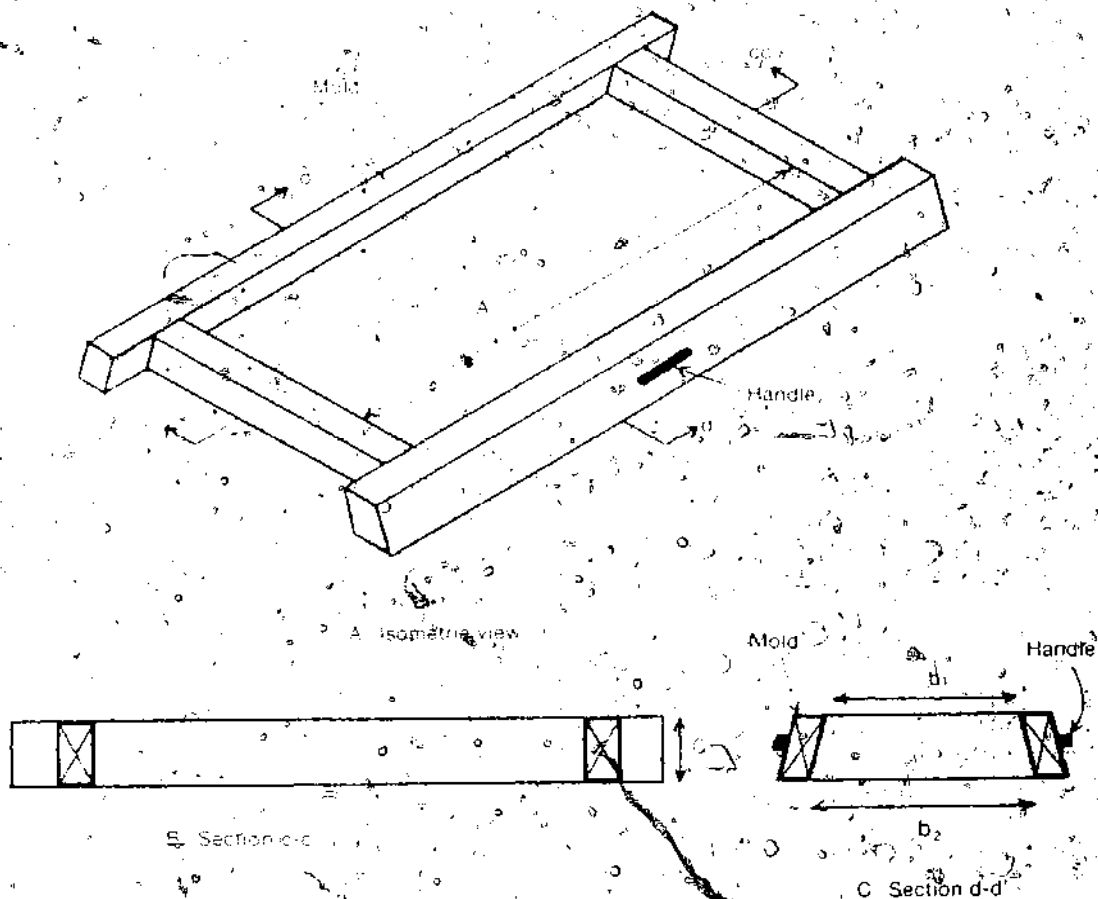

Table 3. Interior Dimensions of the Molds

Slab Diameter	1,50 meters		2,00 meters	
	Large	Small	Large	Small
Length A	50,0 cm	25,0 cm	50,0 cm	25,0 cm
Widths b ₁	21,4 cm	21,4 cm	24,0 cm	24,0 cm
	b ₂	22,8 cm	22,8 cm	25,2 cm
Thickness C	5,0 cm	5,0 cm	5,0 cm	5,0 cm

PILLAR BRICKS

24 bricks are needed to build 4 pillars of six bricks each. The bricks can be made from a 1:2:3 concrete mix or a 1:4-6 mortar mix, according to the quality of the sand and cement. Molds of 14 x 20 x 30 cm will give bricks which will provide 30 x 30 cm pillars. Also, regular cement blocks used in houses can be used if they are the right size or if they can be cut to fit and if they are strong. Dry and water the pillar bricks the same as the staves.

BUILDING THE PILLARS (see fig. 4)

Trace a circle of 110 cm radius on the ground. This will be the circumference of the bottom slab of the stove. Next, using the same center, trace a circle of 85 cm radius and divide it in thirds. These three points and the center point of the circle will be the centers of the pillars. Around each of the four points trace a circle of 30 cm radius, and dig a hole 50 cm deep. (To know how to divide the circle in third, see "re-rod armature" p. 11).

Pour a concrete foundation (1:2:3) 12 cm thick in each hole. It should be tamped and levelled. Next the pillars should be built using three layers of two bricks each. The vertical mortar joint between the two bricks forming each layer of the pillars should be criss-crossed perpendicular to the preceding layer. The 4 pillars should be levelled carefully to provide even weight distribution for the slab. One half barrelful of gravel and 1 sack of cement are required for making the pillar foundations and mounting the pillars.



123

Fixing location of pillar positions under floor slab.

Photo - Erik Bentzen

FLOOR SLAB

The floor slab has a diameter of 2.20 m and is 10 cm thick. It is reinforced with 24 m of re-rod (ϕ 6 mm). The 1:2:3 concrete mixture requires 2 sacks of cement and about 1 barrelful of gravel.

FIGURE 4. The Pillar

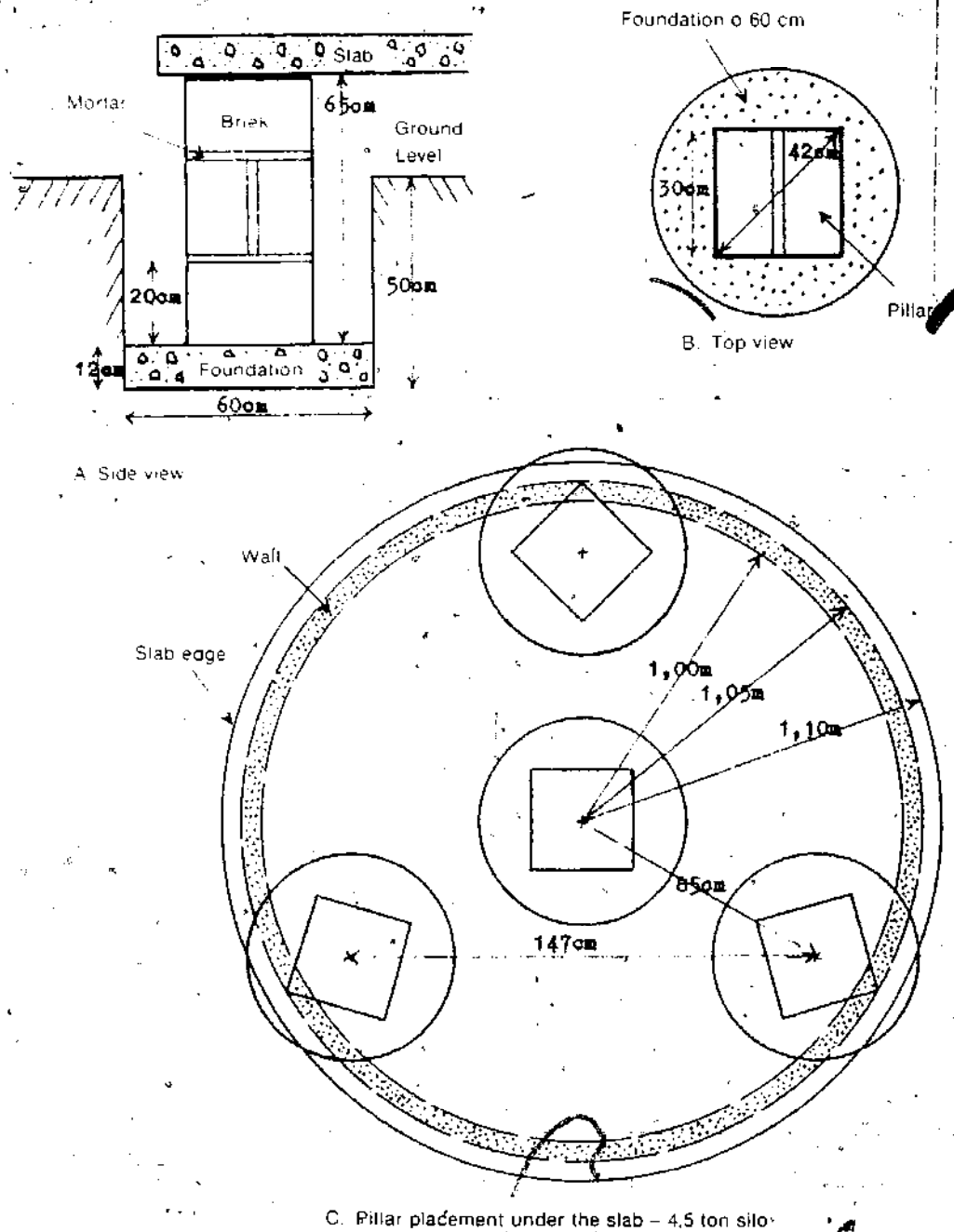

Table I: **CONSTRUCTION Materials**

C) **LABOR REQUIREMENTS**

SILO	- Staves	3 man-days
	- Pillar bricks	1 man-day
	- Mounting pillars	1 man-day
	- Floor Slab	1 man-day
	- Mounting silo wall	0.5 man-day
	- Plastering	1 man-day
	- cover slab	1 man-day

For the form work, 29 large staves (3 more than for the silo wall) are placed temporarily around the outside of the pillars in a circle of 111 cm radius. The staves are held in place with two wires with tighteners which later will be used for the walls. The round formwork is filled with dirt or sand to the level of the pillars, dampened and tamped. The location of the outside corner of the pillars should be marked on the formwork to aid in later placement of the re-rod armature. The inner face of the staves is lined with paper, plastic or masonite to prevent sticking when the staves are later removed. The thickness of the slab can be marked on the formwork also. Tar paper or plastic must be placed over the pillars as a permanent moisture barrier.

RE-ROD ARMATURE (see fig. 5)

The re-rod armature requires four bars 6 m long – 6 mm ϕ . To make the armature pattern, first draw a circle on the ground with a radius of 1.05 m. Divide the circumference into three equal parts by choosing a point on the circumference and with the radius (1.05 m) mark off two points on the circumference, one on each side of the chosen point. From each of these two points once again mark off another point with the radius (1.05 m). These last two points, with the initial chosen point divide the circumference into three equal sections. From each of the 3 tri-section points draw an arc crossing through the circumference with a radius 150 cm.

The bar which forms the circumference is 6.60 m long requiring one 6 m bar and a one meter piece which will be attached with 10 cm hooks bent

at the ends of each of the two bars. The 3 arcs require pieces 2.80 m long. The three straight bars which intersect at the center of the slab are 230 cm long. To cut the bars without unnecessary wastage of materials, carefully cut the bars into the following sized pieces:

- 1st bar 6 m not cut (for outer circle)
- 2nd bar 6 m $230 + 230 + 100 + 40$
- 3rd bar 6 m $280 + 280 + 40$
- 4th bar 6 m $280 + 230 + 40 + (50 \text{ cm for bouchon circle})$

Bend the three 280 pieces to follow the 3 arcs. Band 10 cm hooks at the ends of each piece. Also, bend 10 cm hooks at the ends of the three 230 cm pieces and place them straight across the diameter of the circle each passing through the center and one of the three intersection points of the three arcs. With fine wire, attach all hooks and intersecting points of the re-rod armature. Before pouring the cement for the slab, it is important to place the armature in the formwork to assure that it fits and that the arc intersection points cross over the pillars.

The concrete should be mixed so that it can be worked easily but does not flow. The inside of the formwork should be wetted thoroughly before pouring the cement. 4 cm of concrete should be poured and tamped before placing the armature, making sure to align it with the marks indicating the pillars. Cover the armature with 6 cm layer of concrete for total of 10 cm and tamp well. **If the concrete is not well tamped it will not support the weight of the silo and stored corn.** Finally, smooth the surface and level. If the surface is not well levelled it will cause problems later in mounting the wall. **It is extremely important to water the dalle 3 times per day for 7 days and dry in the shade.**

MOUNTING THE WALL

The bottom slab should be allowed to dry at least a week before mounting the wall. In addition to the 91 large staves and 26 small ones, 1 roll of 3 mm galvanized wire (4 kg) and 10 wire tighteners are needed.

Trace a circle of 100 cm radius from the center on the slab. The first layer consists of 13 large and 13 small staves alternately placed around the circle with the smaller faces inside. A thin layer of 1:6 mortar may be placed under the staves for proper seating. The large stave with the emptying hole must be placed in the bottom layer with the hole towards



127

Form for floor slab consists of 29 large staves placed temporarily around outside foundation pillars in 111 cm radius. .

Photo - Erik Bentzen

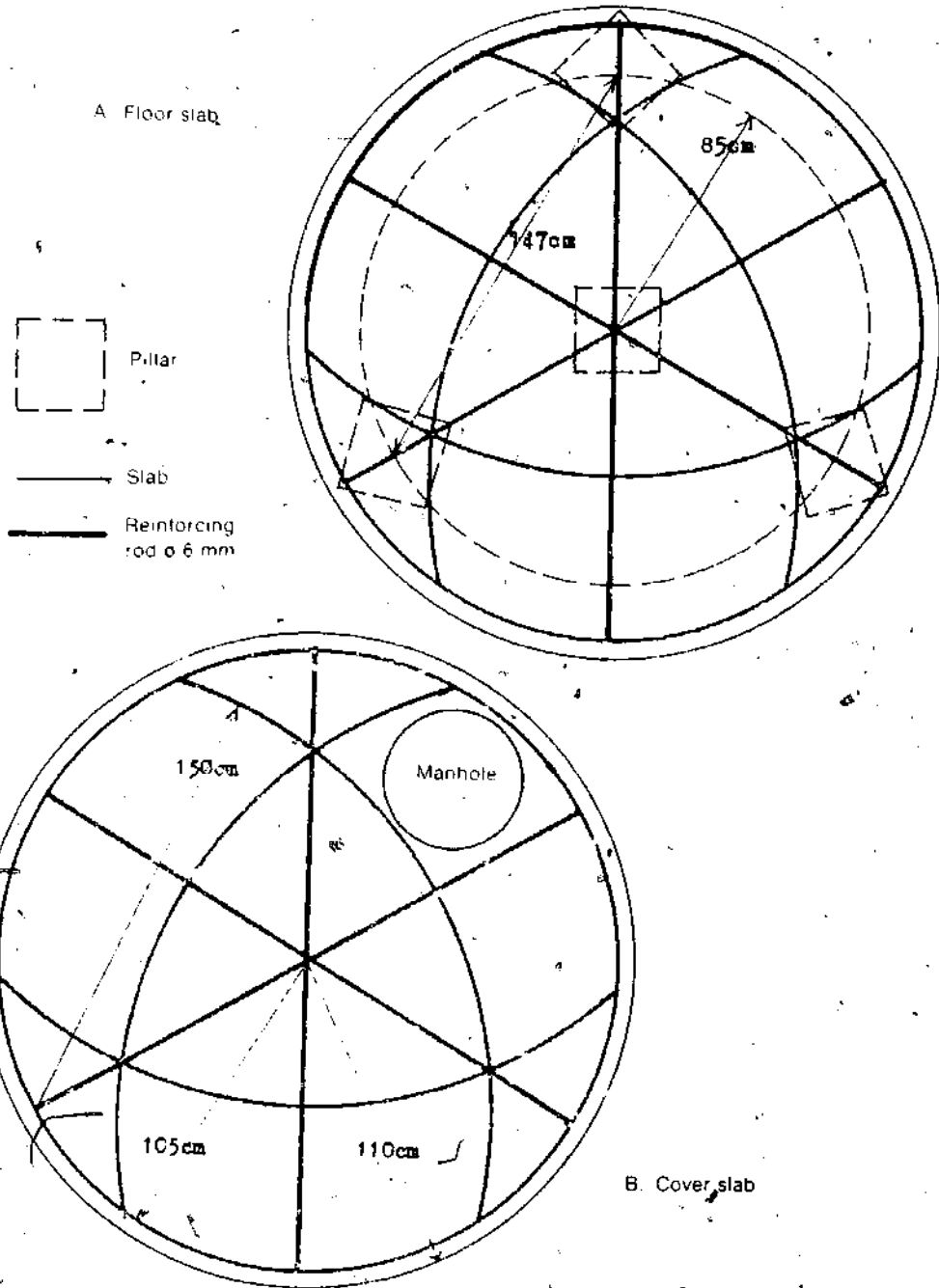

Photo – Erik Bentzen

Staves held in place with two wires; round formwork filled in with dirt or sand to level of pillars, dampened and tamped and lined with paper or plastic to prevent sticking when staves are later removed.



FIGURE 5 Reinforcing rod pattern - 4.5 ton silo



the bottom of the silo. This stave should be placed to facilitate emptying of the silo (i.e. not next to the dryer chimney). No mortar is placed between the staves. At each 25 cm of height a retaining wire is placed and tightened. For the bottom 25 cm, 2 wires should be placed 8 cm from the top and the bottom of the small staves, (one above and one below the emptying hole). The tighteners should be placed only on the bottom of the large staves and when tightened should be centered on them. Each successive layer is made by placing 13 large bricks in the gaps until a height of 2.00 m (4 large staves vertically) is reached. The final layer is completed by placing 13 small staves in the remaining gaps, held in place by 2 wires 8 cm from the top and the bottom of the small staves.

COVER SLAB (see fig. 6)

The cover slab is like the floor slab except that it must have a filling hole. It should be 8 cm thick and 2.20 m in diameter. The 1:2:3 concrete mixture uses 2 sacks of cement, 1 barrelful of gravel, 4 bars of re-rod (\varnothing 6 mm) are necessary.

The formwork is made by covering the top of the wall completely with boards and placing an upright collar of masonite held in place with nails 3 cm outside of the limits of the walls. If the boards are not strong enough to support the weight of a man without sagging, they should be braced from the inside. Paper or plastic should be placed completely covering the boards inside the masonite circle to prevent the concrete from sticking to the boards.

The man hole (for entry and filling) formwork should be 20 cm inside the masonite circle. It should be a 50 cm diameter circle made with masonite held in place with nails or an inverted basket.

The reinforcing armature is the same as for the floor slab except that space must be left for the man hole. Test the re-rod armature for fit in the formwork before pouring concrete. A 4 cm layer of concrete should be poured and tamped before placing the armature. After completing the pouring, the slab should be tamped and smoothed out with a slight slope away from the entry hole.

A cover 6 cm thick and 10 cm larger than the man hole can be made with the concrete which is left over. The formwork can be a masonite strip or a hole lined with paper. A small re-rod armature should be placed in the



Photo – Erik Bentzen
Mounting the wall. In addition to 91 large staves and 26 small ones, one roll of 3 mm galvanized wire (4 kg) and 10 wire tighteners are needed.

middle to anchor a handle (see diagram). Curing and drying of the top slab are the same as for the bottom slab except that extra care should be taken to assure that the slab is dry before removing the formwork (at least 10 days). It is easiest to remove the boards through the use of levers. Care must be taken not to exert pressure on the strip between the entry hole and outer wall as this is the weakest point of the slab.

After taking out the boards for the formwork, the space between the cover slab and the upper walls should be closed with a rich mortar. Finally, a ring of mortar should be placed around the man hole, covered with paper, and the cover sealed on it. This will provide a raised horizontal joint to prevent the entrance of water around the hole.

EMPTYING HOLE PLUG AND ANTI-THEFT SYSTEM:

The plastic plug can be mortared into place, taking care that it is not placed so far into the wall to prevent unscrewing it. Anti-theft device (see fig. 7) with three 40 cm pieces of re-rod remaining from the bottom and top slab armatures, two hinges and one clasp will be made for the anti theft device. Bend each piece into a "U", the hinges with 5 cm between the legs of the "U" and the clasp with 3 cm. With the 5 cm hinges bend the legs perpendicular to the "U" 5 cm from the bottom of the "U". With the 3 cm clasp, bend each of the two legs in opposite directions, parallel to the "U", 5 cm from the bottom of the "U". With the 3 cm clasp, bend each of the two legs in opposite directions, parallel to the "U", 5 cm from the bottom of the "U". Next, with the bottom removed from one of the dryer barrels, cut a piece 20 cm wide and 25 cm long. Pierce two holes on one of the 20 cm sides 2 cm in from the edge and 4 cm from each end. One hinge will pass through each of these holes. Next cut a slot 5 cm long and 1.5 cm wide, centered on the other 20 cm side of the metal plate, 3 cm in from the edge. Slip the ends of the bottom hinge under the first wire on one side of the emptying hole and the top hinge under the second wire on the same side. Next hook the two legs of the clasp under the first and second wire on the other side of the emptying hole. Adjust the placement of the hinges and clasp so that the plate will swing easily and close over the clasp.



Photo – Erik Bentzen
4 cm of concrete poured and tamped before placing re-rod armature; then covered with another 6 cm layer of concrete.



Photo – Erik Bentzen

To make cover slab (with filling hole) two concentric masonite forms are held in place with nails atop wooden planks and filled with 8 cm concrete including reinforcing armature.

The mortar applied to the exterior of the silo walls will secure the anti-theft assembly in place. To assure tight sealing of the emptying hole plug the plastering should be done carefully around it.

PLASTERING

Can be done before or after the placement of the cover slab. The outside walls should be plastered 2 cm thick with a 1:6-8 mortar mixture. The inside joints should be closed with a cement wash or plaster to keep grain from lodging in the joints and to decrease the permeability. One sack of cement is required for plastering and closing the interior joints.

PAINTING

Before the silo can be used it should be allowed to dry for at least one month. The permeability of the silo can be further decreased by the application of coaltar. The painting should be done so that it covers the outside surfaces of the silo wall and the cover slab. The interior floor should be painted also. If painted, it should be allowed to dry for at least two weeks before storing corn to prevent sticking. The plastering should be allowed to dry at least 2 weeks before painting with coaltar.

CONSTRUCTION OF THE 2.5 T SILO (see fig. 8)

Silos can be built with the same basic design as the 4.5 T silo by varying the height of the walls, by varying the diameter of the bottom slab (see table 2).

The 2.5 T silo is of the same basic construction as the 4.5 T silo with certain modifications due to its smaller size. Due to its smaller capacity, the 2.5 T silo is primarily useful for farmers with smaller production capabilities especially where a cooperative dryer is available. Silos smaller than 2.5 T become less economical. This 2.5 T silo has an interior diameter of 1.50 m and an interior height of 2 m giving a volume of 3.5 cubic meters.



Photo – Erik Bentzen

Outside walls should be plastered with 2 cm thick mortar mixture.

TABLE II: SILO SIZES AND CAPACITIES

Diameter	Height	Volume	Capacity (Corn)	Number of Large	staves Small
1.50 m	1.00 m	1.77 m ³	1325 kg	33	22
1.50 m	1.25 m	2.21 m ³	1650 kg	44	22
1.50 m	1.50 m	2.65 m ³	2000 kg	55	22
1.50 m	1.75 m	3.09 m ³	2325 kg	66	22
1.50 m	2.00 m	3.53 m ³	2650 kg	77	22
2.00 m	1.00 m	3.14 m ³	2350 kg	39	26
2.00 m	1.25 m	3.93 m ³	2950 kg	52	26
2.00 m	1.50 m	4.71 m ³	3625 kg	65	26
2.00 m	1.75 m	5.50 m ³	4125 kg	78	26
2.00 m	2.00 m	6.28 m ³	4600 kg	91	26

The total height of the silo from ground level is 2.50 m (same as 4.5 T) and the total diameter of the bottom slab is 1.70 m.

The material requirements for this silo are given in Table 1.

PILLARS

The 2.5 T silo requires 3 pillars (18 pillar bricks 14 x 30 x 20). The holes for these pillars are centered on the trisection points of a circle of radius 60 cm from the slab center. The pillars are mounted with the outside corners 81 cm from the slab center.

The formwork for the floor slab of the 2.5 T silo is built in the same way as for the 4.5 T silo, placing the large staves upright, on a circle of radius 86 cm, around the outside of the pillars. Twenty five large staves are required to complete this circle.

RE-ROD ARMATURE

The patterns for the slab reinforcing armatures are shown in **figure 8**. The armature requires 2 bars of re-rod used as follows: trace a circle on the ground with radius 80 cm. Concentric with this circle trace a circle of radius 45 cm. Tri-sect the 45 cm circle and place stakes at the trisection points. One bar of re-rod is bent and cut to fit along the 80 cm outer circle and the other bar is cut into 3 pieces (each 2 m long). These 3 pieces are bent in smooth curves so that each piece touches two of the stakes, and each end hooks around the outer circle. The armature for



Photo - D. Dichter

Moisture transfer through walls of stave silo can be prevented by applying outside layer of coal tar. Shown here are two completed 4.5 ton cement stave silos, part of a cluster of five such units belonging to a farmer's co-operative association in Benin, West Africa.

Figure 8: Reinforcing Rod Pattern - 2,5 ton silo

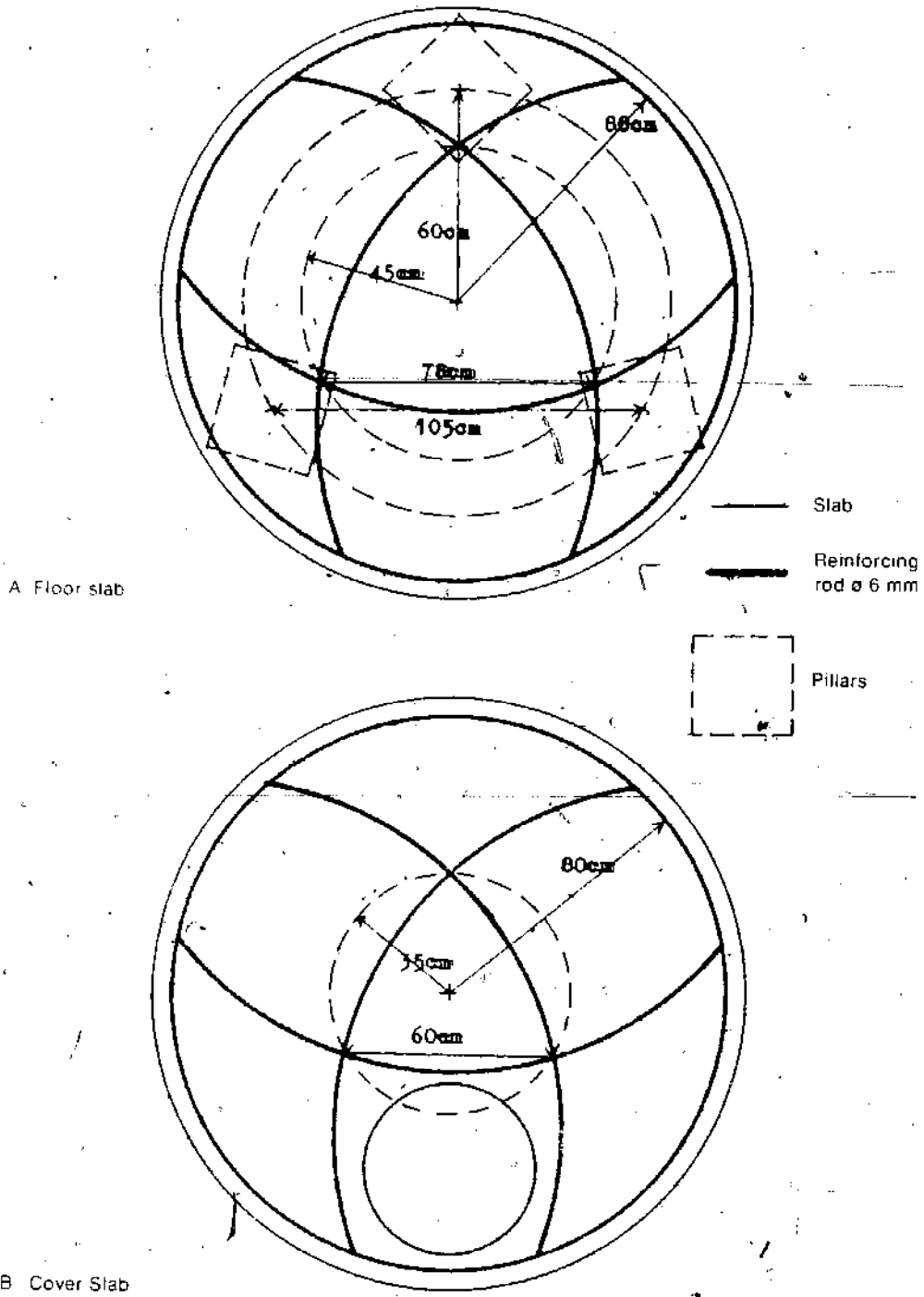

the cover slab is the same except the inner circle has a radius of 35 cm to allow space for the man hole. The 2.5 T silo slab is poured in the same manner as the 4.5 T silo slab with a thickness of 10 cm, requiring 1.5 sack of cement.

The silo wall requires 77 large and 22 small staves which are made with smaller width molds whose dimensions are given in **table 3**. Four sacks of cement are needed for the staff fabrication. The wall is formed by placing 11 large and 11 small staves alternately on a circle of diameter 1.50 m centered on the slab.

INSTRUCTIONS FOR THE USE OF YOUR SILO

If you want to be sure to have good quality storage of your harvest, it is important to understand the proper way to use your silo and dryer. To use them correctly isn't difficult or complicated. It simply needs care and attention at the right times.

I. The Shelter

The silo and dryer must have a good roof over them to protect them from the rain. Before you start construction, you must build a good, solid shelter. It is very important to frequently check the roof covering the silo and dryer to make sure that there are no holes in it which will let rain water fall on the silo or dryer. Any holes should be repaired immediately since rainwater will weaken the dryer wall, and can seep through the silo causing the grain to rot.

II. The Silo

1. After completion of the silo, it should be allowed to dry for at least one month before beginning storage. If the silo is painted with coal tar, this should be done after letting the wall mortar dry for two weeks. In this case, you should wait at least two more weeks, for a total drying time of one month, to allow the coal tar to dry on the silo floor to prevent grain from sticking to it.
2. During the entire time of storage, the silo filling and emptying holes should be well sealed. Each time you add grain to the silo, it should be carefully re-sealed. This can be done with cement mortar or banco. Banco is less expensive and easier to use. If the emptying hole

does not seal tightly, it can be well sealed with melted candle wax or banco.

3. Shortly before the beginning of storage each year, someone should get inside the silo to clean it and check for cracks in the walls. These can be easily seen because light will pass through even the smallest cracks. If any cracks are found, they should be carefully covered with a mixture of cement and water.
4. The proper use of insecticide is essential for grain storage in your silo. Even though the silo is completely closed and insects cannot enter to attack the stored grain, there will always be some insects in the grain at the time of filling. The insects not only destroy the grain by eating it but can cause conditions leading to rotting. This makes it necessary to properly employ insecticides to assure that all insects in the silo are dead.

The two basic kinds of insecticides are

- 1) those in powder form (contact insecticides) which are mixed evenly with the grain and
- 2) the fumigant or gas form which is used only in closed containers like a well-sealed silo.

(Liquid contact insecticides are not very practical for smallscale grain storage. They are difficult to apply evenly and since they are mixed with water, this increases the moisture content of the stored grain and can cause rotting if done improperly.)

Powdered (contact) insecticides must be mixed very evenly with every sack or basket of grain emptied into the silo. This means that if powdered insecticides are used, each load of corn removed from the dryer must be treated individually. It is impossible to treat the grain with this type of insecticides once the silo has been filled, without emptying it completely and treating during the refilling.

It is very important to understand that there are insecticides which are safe to use on food which will be eaten by men or animals and that there are others which are to be used ONLY on plants like cotton which are NOT TO BE EATEN. Insecticides commonly used on cotton like 45-12, Endrine and HCH are very strong and can cause people or animals to become sick or die if used on their foods like maize or beans. For this reason, it is very important to ask your agri-

cultural agent to help you select and apply insecticides whenever you use them.

It is very important to **READ AND FOLLOW THE DIRECTIONS** for any insecticides used. The **exact** recommended dosage should be applied. Less than the recommended dosage will be ineffective and too much will not only be wasteful and expensive, **BUT COULD BE DANGEROUS. NEVER** use an insecticide you don't know or that you haven't asked your agricultural agent about.

The easiest and recommended insecticides to use in your silo is the fumigant or gaseous kind. Testing done by agricultural experts in Benin has found PHOSTOXIN to be one of the most convenient and effective forms of fumigant insecticides to use in your silo. This can be purchased only through your agricultural extension agent or a approved sales agent. PHOSTOXIN is a very poisonous gas which kills the insects in the silo when they breathe it. It is in a small tablet which turns into a poisonous gas when it is taken out of its specially sealed can and exposed to the air. However, the gas can kill people or animals too if they breathe enough of it. Therefore, it must be used carefully.

When the silo is filled and ready to be treated, the tablet is taken from the can and wrapped in paper or leaves, dropped into the silo on top of the grain and the silo cover is **IMMEDIATELY** sealed with banco. In seven (7) days the gas will become harmless and only powder will remain wrapped up in the paper or leaves. Three to six (3-6) tablets are used for each ton of grain stored, depending on the level of insect attack. Each month, the emptying hole should be opened to check to be sure that the corn is storing well and that no insects are alive inside. Every two months, a new treatment should be made. When emptying the silo, the paper or leaf packages of insecticide dust should be taken out and buried where children or animals will not dig them up.

When you open your silo, if it seems very warm inside or if there is the smell of rotting corn, the silo should be immediately emptied and the corn should be re-dried. This can happen if the corn is not well dried so care should be taken to dry the corn correctly the first time before putting it in the silo.

CLOSED STORAGE SYSTEMS (Continued)

MODEL 4 – CEMENT BLOCK (Square) SILO

The "Tori-Cada" Square Cement Silo was also developed in the West African State of Benin. Originally it was built as an alternative to the more costly metal bins. Although this model has not been as extensively built, tested, or used as the other Closed Storage Systems discussed in this Manual, it is thought to have considerable potential. The Square type Cement Silo has the advantage, in comparison to the round silo, that it is easier to build, and the method is already well known to local craftsmen from the construction of houses. On the other hand the round silo requires less building materials than the square one. Each bin or silo can be made with a storage capacity ranging from 1 to 7 ton. Standard height is 2 m. To make the silo air-tight each bin is covered by planks of reinforced concrete.

Figure 9 shows the details of the wall construction. Besides the foundation there are 2 layers of reinforced concrete in the walls, one in the middle and one on the top. The concrete floor has a layer of tar paper to prevent water from penetrating into the silo. The walls are plastered on both the inside and the outside and painted with coal tar on the outside to make it airtight and moisture proof. The posts that support the roof of the hangar are made of reinforced concrete and placed in the corners between the silos.

The standard height is 200 cm as mentioned before, the other interior dimensions are as follows:

- Capacity 1 ton : 80 x 80 cm
- Capacity 2 ton : 115 x 115 cm
- Capacity 3 ton : 135 x 135 cm
- Capacity 4 ton : 160 x 160 cm
- Capacity 5 ton : 180 x 180 cm
- Capacity 6 ton : 195 x 195 cm
- Capacity 7 ton : 210 x 210 cm

Naturally the construction price is lowest per ton for the largest silo (7 ton) but it is also cheaper per ton to build 4 silos (bins) together instead of only one.

FIGURE 9 – Cement Block (square) Silo

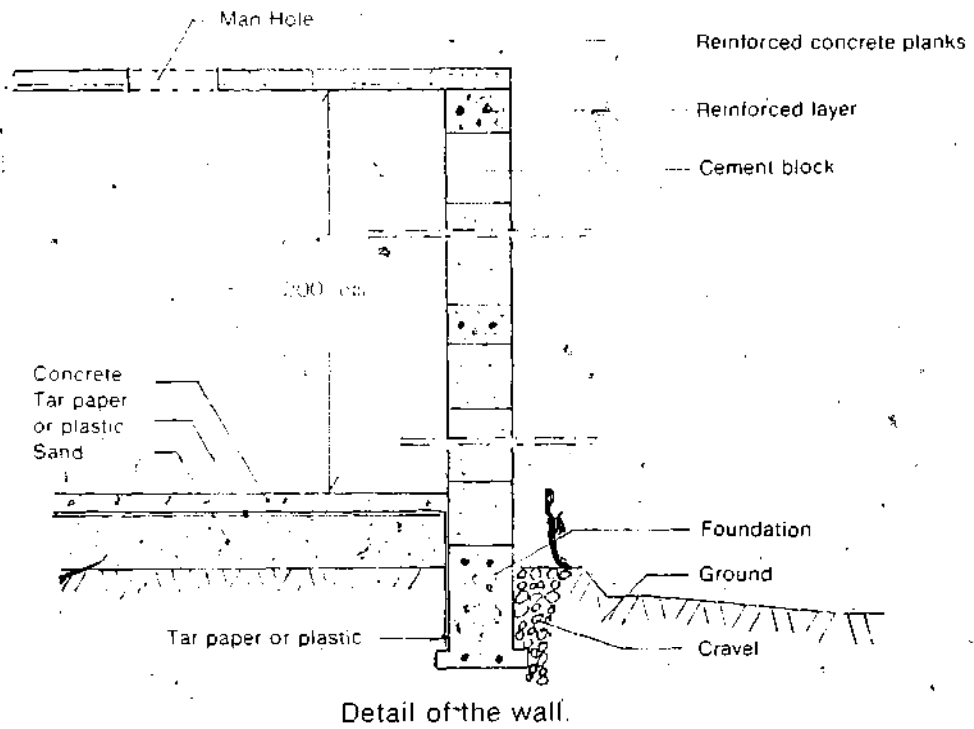
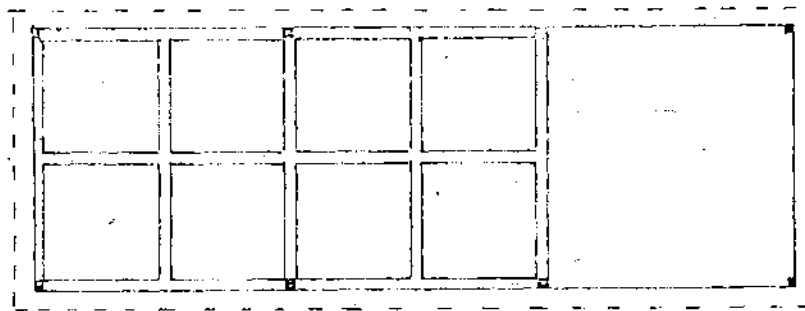
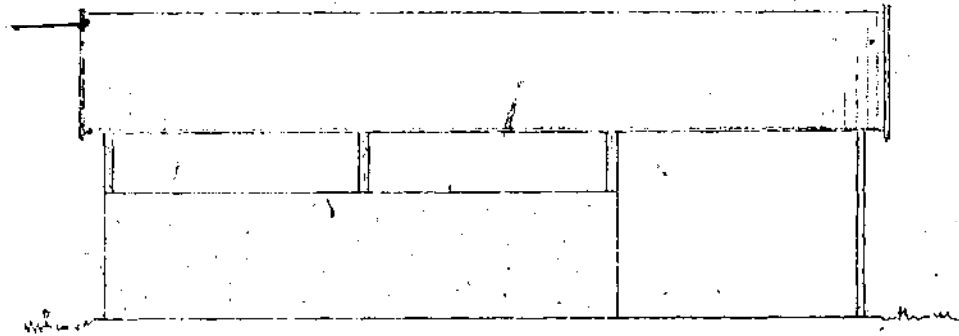

Given below is a detailed description for constructing a single unit Cement Block (Square) Silo with a 5 ton capacity:

This silo when constructed has interior dimensions of 1.80 x 1.80 x 2.70 m, which gives a said capacity of 5 tons. The silo is built primarily out of regular construction bricks 40 x 20 x 10 cm. The design uses building techniques that nearly any local mason already knows.

Once the materials are at the site, building can commence. The first thing to do is dig a hole for the foundation. Select a spot that is level, well-drained, and on solid ground. Trace out a square 2.20 x 2.20 m on the ground, then trace another square with dimensions 1.60 x 1.60 m inside the first square. Between the two squares will be a space 30 cm wide. Dig this space out to a depth of 40 cm. Once this is done, pour a layer of concrete (1 part cement: 2 parts sand: 3 parts gravel) in the hole to a thickness of 30 cm. Water and cure this layer for a few days or a week if possible.

Once the foundation has cured, put a little layer of mortar down. Upon this bricks will be placed until they mount 20–40 cm from ground level. The bricks are placed on their 20 cm wide sides so as to form a wide base for the wall to come later. Depending on soil and humidity conditions, there will be 3–5 layers of bricks. When the appropriate level has been reached and the mortar has cured some, the space formed by the square of bricks can be filled with dirt to a level 8 cm less than the top of the bricks. The dirt should be well tamped and leveled. This hole is then filled with 8 cm of concrete (1:2:3) til it is exactly level with the top of the bricks. Be sure and water the concrete three times a day for seven days so it will cure well.

When the concrete has cured, cover the entire area of bricks and concrete with tar paper. Over the tar paper a smooth and level layer of mortar (1 part cement: 3–4 parts sand) is laid down. This will be the floor of the silo. The tar paper's function is to keep ground moisture from coming up into the walls and floor of the silo. Any such moisture would rot the corn.

After the mortar has cured, mounting of the walls may start. The bricks are now placed as they normally are in a wall- with the 20 cm side vertical. Leave 5 cm between the outside of the floor and the bricks. This will give the desired interior dimensions of 1.80 x 1.80 m. The brick layers

should be mounted with the joints between brick layers staggered so as to avoid cracks. At each corner the bricks may be staggered or, if the roof is to be supported at each corner of the silo, a space may be left for the eventual peuring of a concrete corner pillar which would also hold the bricks in place.

The bricks are mounted to a level of one meter or five bricks high. At this time a layer of concrete 10 cm wide and 20 cm high is poured. Rerod reinforcement is used. Four 8 mm rerods go the length of the wall and are held in place by bands of 6 mm rerod. The four 8 mm rerods form a rectangle 15 cm high and 5 cm wide. This layer of rerod helps to reinforce the wall against the grain's weight.

Once the concrete layer has cured enough, the wall of bricks may be continued. Five or six additional layers may be put on the concrete middle layer. At the desired level another concrete layer 10 x 20 cm is poured. The rerod pattern and concrete mixture are the same as in the other layer. The only difference between the two layers is the addition of a concrete piece crossing the middle of the silo. This piece will be the support for the top slabs that cover the silo. The middle cross piece is 1.80 m x 20 cm x 20 cm and is reinforced with rerod.

While the concrete layer is drying, the silo may be plastered. The inside and outside should be entirely plastered. A 10-12 cm plastic pipe cap is fitted into one of the lower outside walls in order to empty the silo. A brick may be made with a hole already in it or a hole may be dug into a brick afterwards.

At the time the concrete flooring was poured, the two top slabs for the silo could have been poured. These consist of two 2.00 x 1.00 x 0.60 m slabs. One of the slabs must have an entry hole either 50 x 50 cm square or 50 cm in diameter. Formwork is made on the ground in which the two slabs are poured. A grid of rerod is made with the 2 m length using 8 mm bars and the 1 m width using 6 mm bars. Spaces of 15-20 cm are left between the bars.

As mentioned, one slab must have an entry hole. Thus, one grid must leave space to accommodate the hole. A mixture of concrete (1:2:3) is poured first to a 2-3 cm depth. The rerod grid is placed, then the rest of the concrete is poured to a depth no greater than 6 cm. The proper depth must be maintained if the slabs are to be lifted in place by men. A

small cover slab for the entry hole should also be poured at the same time as the two top slabs. A rero handle should be placed to facilitate handling of the cover slab. **All three of these slabs should be cured by watering three times a day for seven days.** When the slabs have cured, they may be lifted in place and mortared to the wall and each other. Once the entire silo has dried for two or three weeks, it may be painted. This could be done in a couple ways. The outside of the silo and the inside floor might be painted with coal tar. If sun shining on the silo will be a problem, the outside might be painted with whitewash and the inside with coal tar. If sun and rain are no problem, the outside could be whitewashed. The interior also might be whitewashed to make the silo interior brighter when the silo is opened.

As mentioned earlier, the corners of the silo might be made out of reinforced concrete that projects beyond the top of the silo. These corners could then support the roof. Otherwise, a separate roof could be built in order to protect the silo against sun and rain.

To protect against people stealing grain out of the silo, rero or flat pieces of metal could be put in the bricks around the emptying hole. One piece could hinge across the hole and lock to the other piece. The not too serious robber of grain would thus be deterred.



Shown here is a large capacity Cement Block (Square) Storage Bin used by a farmer's co-operative organization in Benin, West Africa

Photo – D. Dichter

WORKBOOK EXERCISES

1. What are the principal advantages to using a closed grain storage system?

Notes

2. Are there any closed storage containers currently in use in your area?
If so, what types are they and how much grain can be stored in them?

.....

.....

.....

.....

.....

.....

.....

.....

.....

.....

Notes:

3. What are the advantages and disadvantages in using the 1.5 ton Improved Mudblock Silo?

Notes:

4. List some of the ways the traditional mud silo has been improved upon.

Notes:

5. Up till now, why have closed-system mud silos been seldom used in humid areas?

Notes:

6. What are the principal advantages in using a cover over the 4.5 ton Cement Stave Silo?

Notes:

7. What are the principal advantages of airtight storage? How can insects be controlled with such methods?

Notes:

8. What are the proper methods to use in storing cement?

Notes:

9. Will closed storage systems work in your area? If so, which of the two suggested models offers the best possibilities and why?

Notes:

10. While concrete is drying, what steps should be taken to prevent it from cracking?

Notes:

CHAPTER VI: CONSTRUCTING AND USING YOUR DRYER

Farmers throughout the world have long recognized the need to dry their cereal grains. Try to put yourself in the farmer's place and take a look at the methods currently used by him.

- Do his present drying methods produce satisfactory results? If they do, why change them? If they do not work, why not?
- By using improved drying methods can he harvest earlier and get his land ready sooner for a new crop?
- Would he be able to maintain a new drying machine? Could he fix it if it broke down? Does he have enough time to operate it?
- Would the initial cost of the dryer be easy for the farmer to recover because with better, more controlled drying it means he will eventually make more money from the sale of his grain?
- Would it be more advisable for him to join a group of farmers and pay for the cost of a dryer with a group? Or does the farmer dry enough grain to make use of a dryer by himself?

In this section, four different drying methods are presented. Three employ the principles of solar drying and one involves the use of oil barrels which are heated with a fire.

1. Traditional Sun-Drying

The oldest and most widespread method of drying grain is **sun-drying**. You should look first at the local techniques of sun-drying in your area. How much work is required of the farm family? What are the losses and inconveniences? In drying maize, for example, the simplest method is often to leave the maize in the field until the moisture content has dropped sufficiently for storage. The principal advantage of this method is that the grain is subject to direct attack by grain-eating insects, birds or rodents.

Another traditional way of sun-drying maize is to leave the cobs or shelled corn on a flat piece of ground in the sun. Experience has shown that this method also doesn't achieve the best results because there is too little movement of air close to the ground, and consequently the drying takes longer. Besides, dust or stones may

be taken up with the crop and contaminate it. It is always worth remembering that clean grain is essential for proper storage!

However, improvements can be made involving even the simplest traditional methods. Rather than dry grain directly on the ground, where the grain can pick up moisture from the earth, you can introduce the farmer to using a plastic sheet. You will probably need a sheet about 10 m x 3 m. It is recommended that the plastic be at least .004 gauge thick.

- Build a mound of hard-packed earth on which to place the plastic. If you use level ground, build a dike of earth around the area on which the plastic will be placed to protect the drying grain from water.
- Make sure there are no rocks, wood and sharp things on the ground where the plastic will go. Plastic tears easily.
- Place the plastic in the prepared place.
- Attach the narrow end of the plastic to straight poles made from bamboo or other smooth material.
- Put clean grain on the plastic. Do not make the grain more than 5 cm deep.
- Stir often so the grain will dry faster. Turning and stirring make sure all parts of the grain are touched by air and sun.
- The rake or other tool used to stir the grain must have smooth, rounded edges. This tool then will not damage the plastic or the grain.
- As the grain dries, moisture from the grain collects on the plastic. After the grain has been drying for two hours, push all the grain to one half of the plastic.
- Let this plastic dry for five minutes or so.
- Push all the grain to the other half of the plastic that is now dry and let this half dry for five minutes.
- The plastic sheet should be aired in this way every two hours while drying is going on.
- Cover the grain at night. Push all the grain to one end and fold the plastic over as a cover.

2. Solar Drying

Increasing attention is being given to improved methods of solar (sun) drying. Although there are several distinct advantages in using solar dryers, i.e., you do not require any fuel (which in many developing countries is becoming increasingly scarce, especially fire wood), the drying time is reduced, and they can be used to dry other crops such as cassava, fruits and vegetables; they also have certain drawbacks – the most important being the extremely high temperatures which build up (65–80°C) inside the box under the plastic sheet. Such high temperatures damage grain like rice (which tends to crack at temperatures above 50°C) and also seed grains.

From the information provided in Chapter II concerning basic principles of drying, it is possible to arrive at a set of requirements for effective solar drying of grain in humid climates. These are:

- 1) Both the material to be dried and the surrounding air should be heated.
- 2) There should be maximum possible movement of air over the surface of the material.
- 3) The surface area of material exposed to the air should be as large as possible.

It is not possible to attain requirements 1) and 2) with traditional methods in which material is directly exposed to the sun. Some form of enclosed drying system, in which the material to be dried and the air surrounding it can be heated significantly is needed.

It is nevertheless possible to fulfil these requirements using simple equipment which traps the heat of the sun, but which, at the same time, encourages air movement by convection of heated air. Equipment of this type can be made simply and cheaply using materials which are generally readily available in developing countries.

A. General Description of Partially-enclosed Dryers

The partially-enclosed sun-dryer is a structure which acts as a heat trap, but which is also provided with ventilation openings to allow air to move through the dryer by convection.

Two of the models described in this WORKBOOK (Nos. 1 and 2) are simple, box-like structures, provided with upper and lower ventilation

openings, and closed with a cover of transparent polyethylene film. The cover is "double glazed", i.e., it is made of two layers of film with an insulating air space in between. The box itself is constructed of material which will provide adequate insulation to prevent the escape of heat. All interior surfaces are painted matt-black to achieve maximum absorption and retention of heat. Material to be dried is supported inside the dryer on perforated trays which can be of wire netting or woven from local material such as papyrus reed.

Air movement through the dryer is achieved by convection. As the material to be dried and the air surrounding it becomes heated, the hot air rises and escapes through the upper ventilation openings, resulting in cooler air being drawn in through the lower openings. There is thus a constant movement of heated air over and through the material being dried. Air temperature inside the drier in bright tropical sunlight will usually be twice that of the outside air. Drying temperature can be controlled by opening or closing the upper ventilation outlets.

B Advantages of Partially-enclosed Dryers

The major advantage of the partially-enclosed sun dryer is, of course, in its ability to generate the high temperature and air movement essential for effective drying in humid climates. However, as mentioned earlier, it also possesses a number of distinct advantages over traditional "open" drying methods, even in areas where high humidity is not a serious problem. Some of these advantages are:

- 1) The dryer is rainproof and can be left in continuous operation without attention, and without the necessity for covering up drying material or removing it into shelter during showers.
- 2) The higher temperatures possible with this type of dryer greatly speed up the drying process, not only giving a much greater output than open methods, but also eliminating the possibility of mold or microbial spoilage which is common with open drying methods.
- 3) As well as protecting the drying material from re-wetting by rain, the covered dryer also gives protection from dust and dirt, from attack by birds and rodents, and from insect infestation.
- 4) The high temperature to which the material is subjected will effec-

tively kill or drive off any insect infestation which may be present in the material as it comes from the fields.

The partially-enclosed dryer will, therefore, produce a well-dried, clean and pest-free product which will be in excellent condition for prolonged storage or for immediate use.

C. General Remarks on Construction of Dryers

Instructions and sketches showing constructional details of two models are given in the following pages. However, since it is intended that these dryers should be made from whatever materials are most readily available locally, it should be noted that such details as to dimensions which are given are meant for general guidance only, and local adaptation in terms of changes in length, width or depth will not affect the efficiency of these dryer. The sketches for Models 1 and 2 are based on a useful practical working size of 8 ft. in length, 4 ft. in width, and 9 to 12 inches overall depth. While there is a limit to which internal depth can be reduced, changes in area can be made to suit local conditions, and dimensions of materials available.

The dimension which is of importance, and which should be adhered to as closely as possible, is the thickness of insulation on the Model 1 box-type dryer. Where wood shavings, wood wool, dried grass, leaves, or similar material is being used, a minimum thickness of 2 inches should be used. Also, for practical reasons, the internal depth of Models 1 and 2 should not be less than 6 inches.

D. Construction of the Model 1 Dryer

Details of the construction of this model are given in Figures 1 to 5. As will be seen, it consists of an outer box and an inner box. The dimensions of the inner box are at least 4 inches less in length and width, and at least 2 inches less in depth than the outer box. The space between the boxes is packed with suitable insulating material. Lower ventilation holes are drilled through the bottom of the boxes (and through battens fitted in the insulation space for this purpose), and slots are cut in the upper edges of the sides of the box to provide upper ventilation openings. The dryer is supported about 6 inches above the ground on four legs (which also form the main corner members for the box).

FIGURE 1

MODEL 1 SOLAR DRYER
SKETCH SHOWING DRYING BOX (WITHOUT COVER OR DRYING TRAYS)

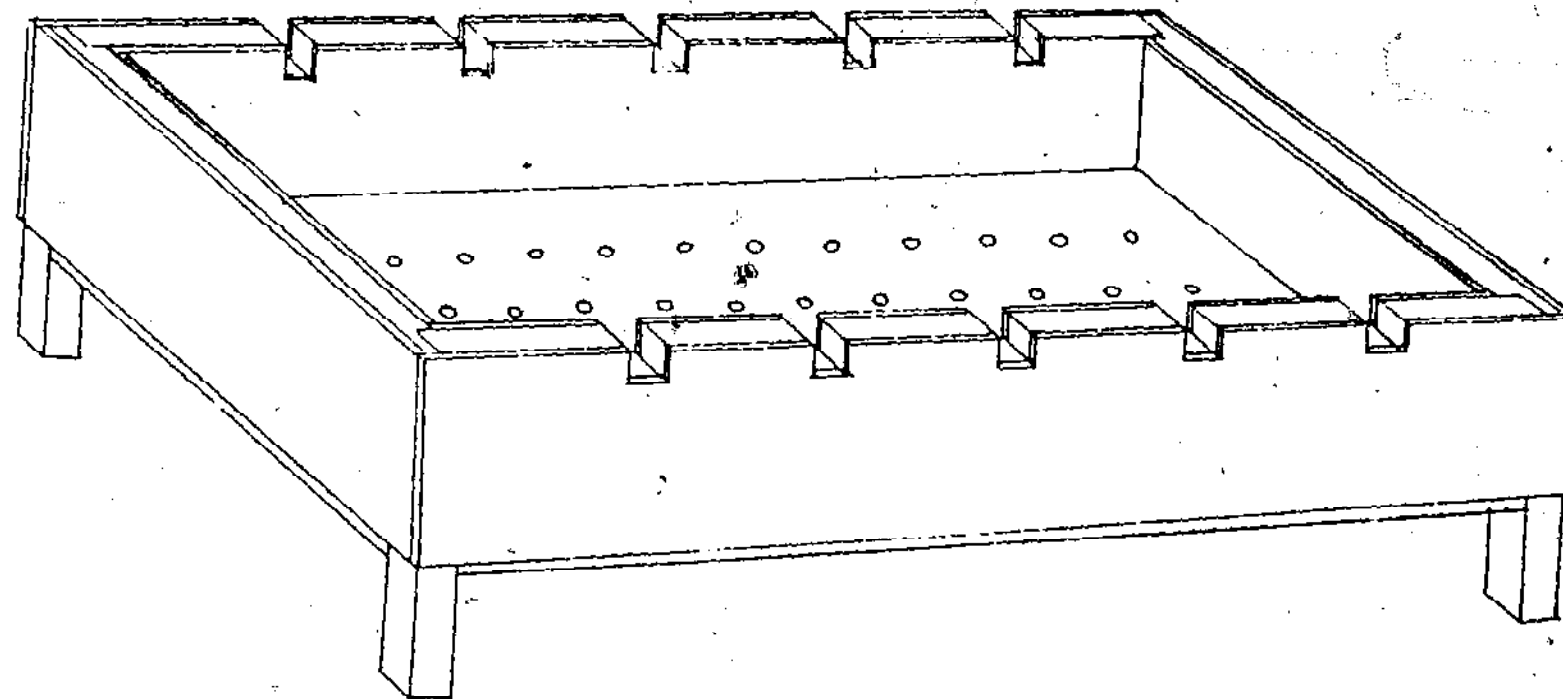

FIGURE 2

**MODEL 1 DRYER
PLAN AND ELEVATION DRAWINGS.**

Scale 1 cm = 6 inches

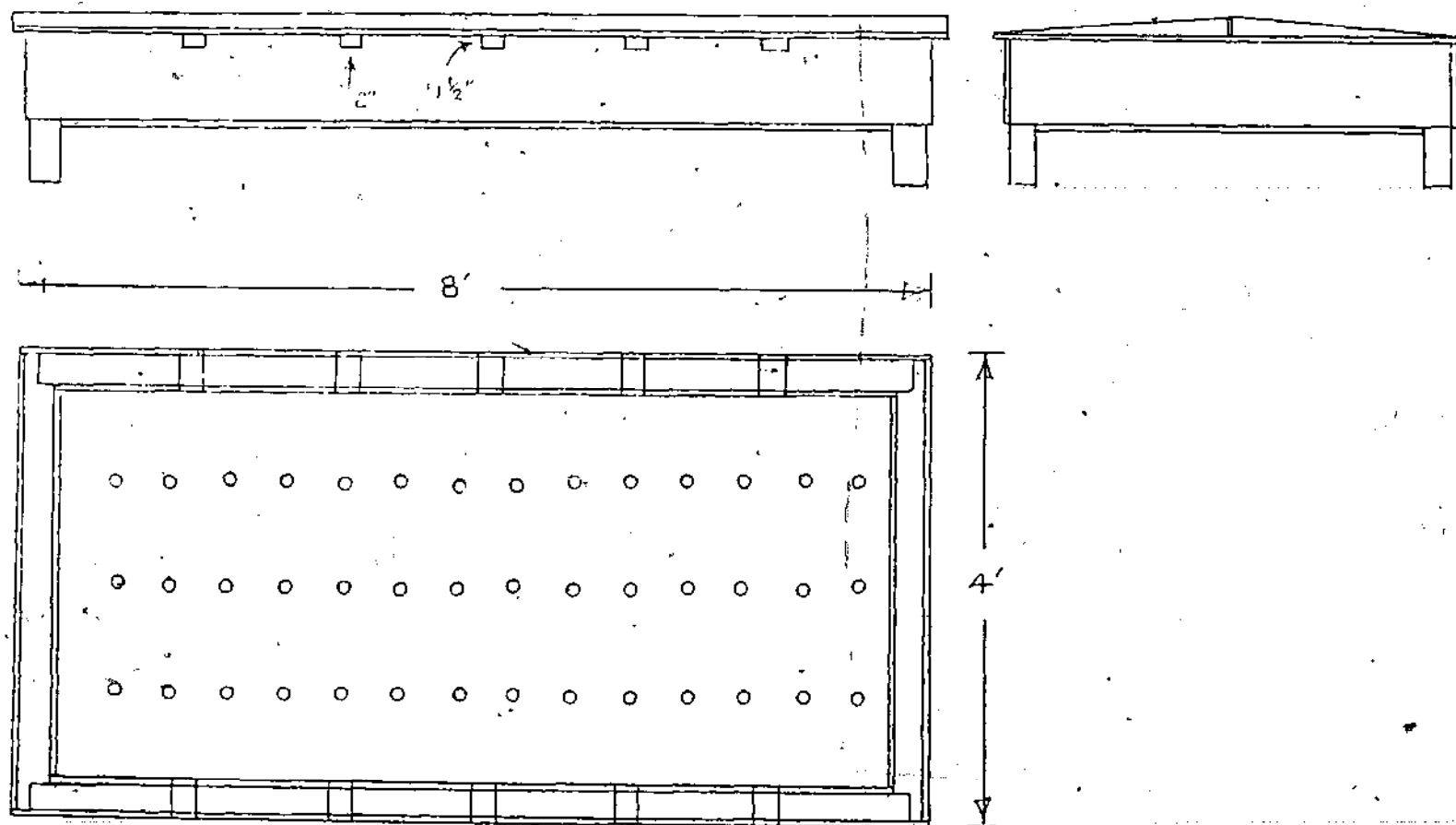

FIGURE 3a

CONSTRUCTION OF MODEL 1 DRYER
DETAIL OF ONE POSSIBLE TYPE OF CORNER JOINT

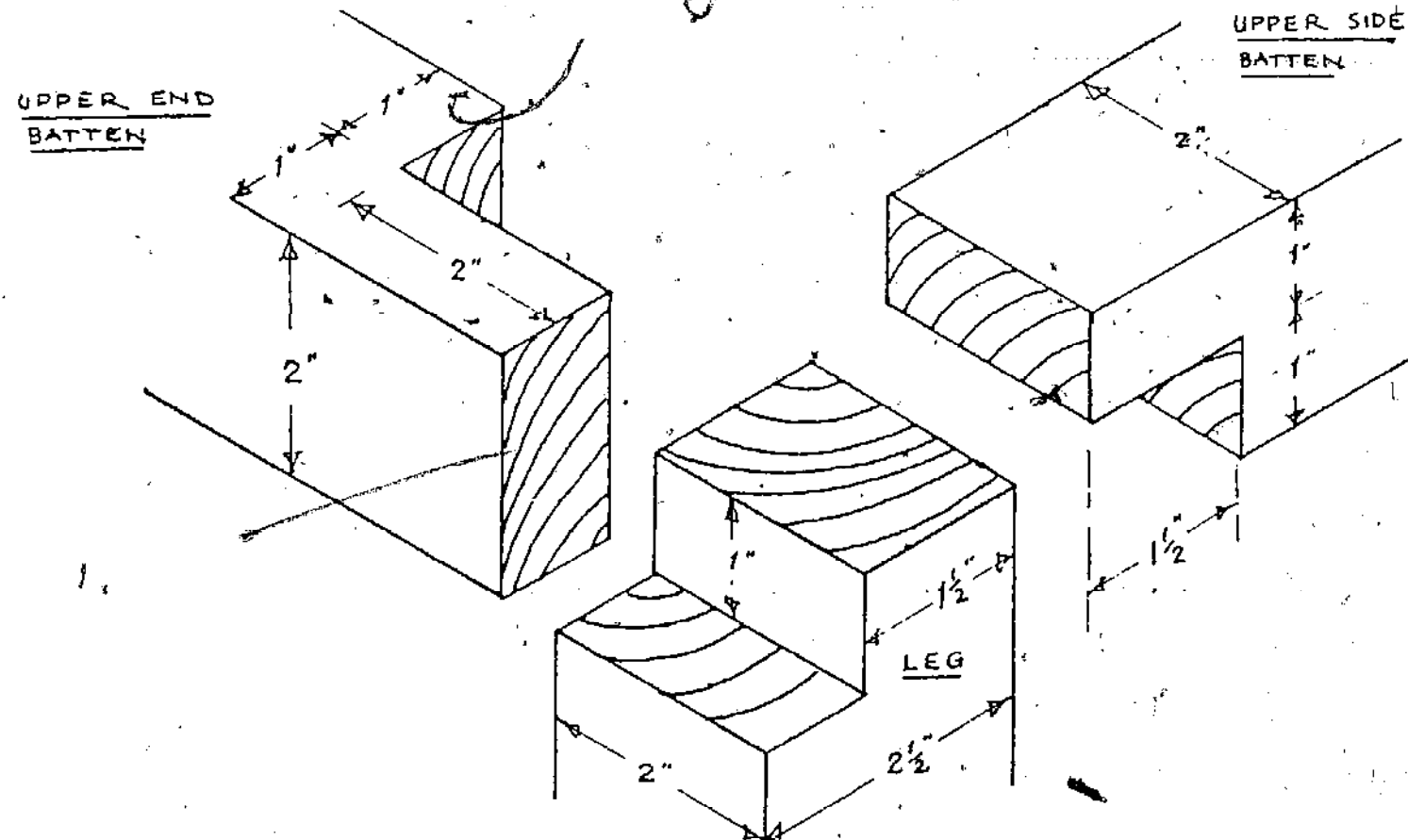

FIGURE 3b

**CONSTRUCTION OF MODEL 1 DRYER.
DETAIL OF WEATHERBOARDING**

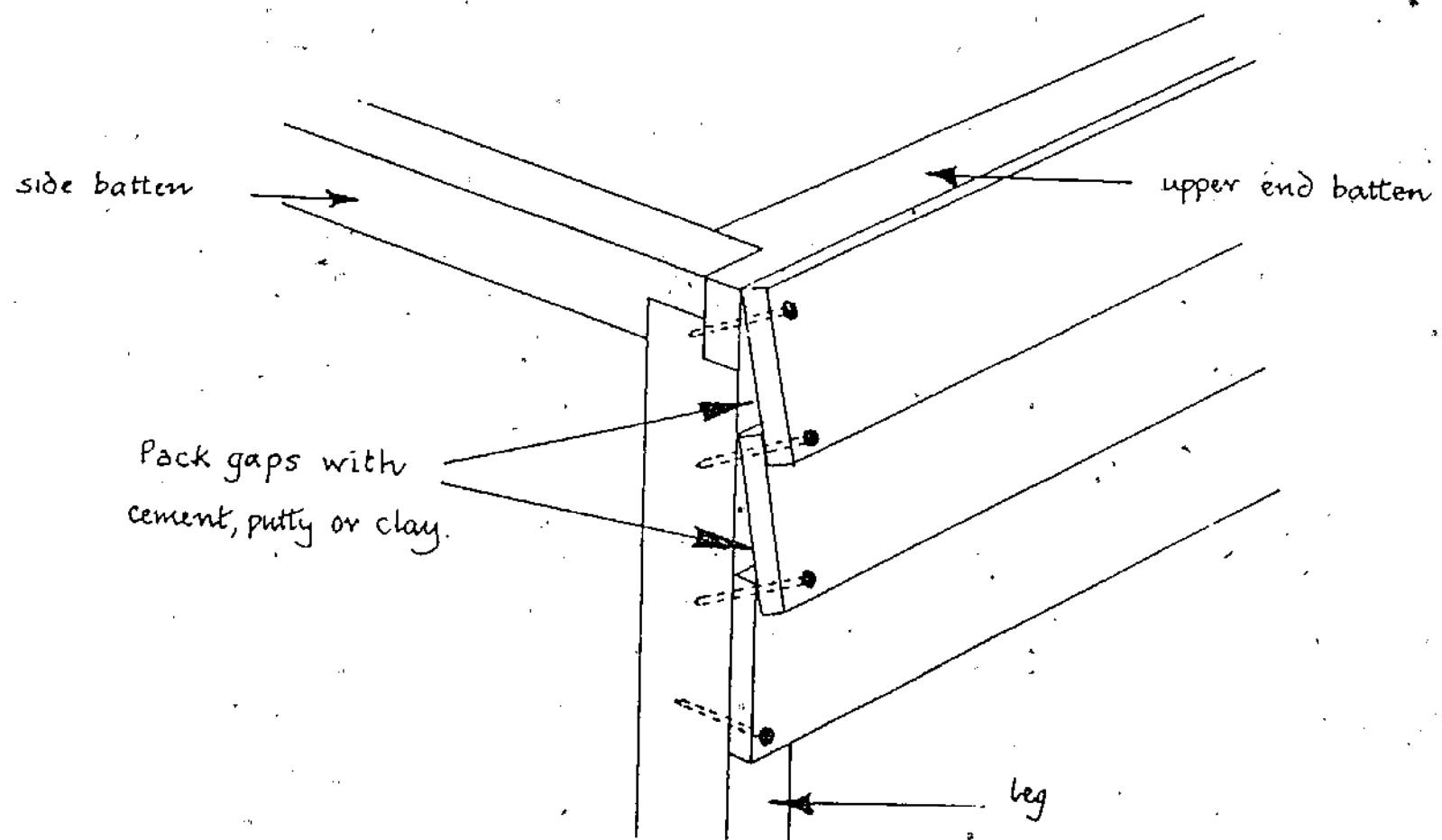

FIGURE 4

CONSTRUCTION OF MODEL 1 DRYER
"CUT-AWAY" SKETCH OF ONE CORNER SHOWING DETAIL OF INTERNAL FRAMING

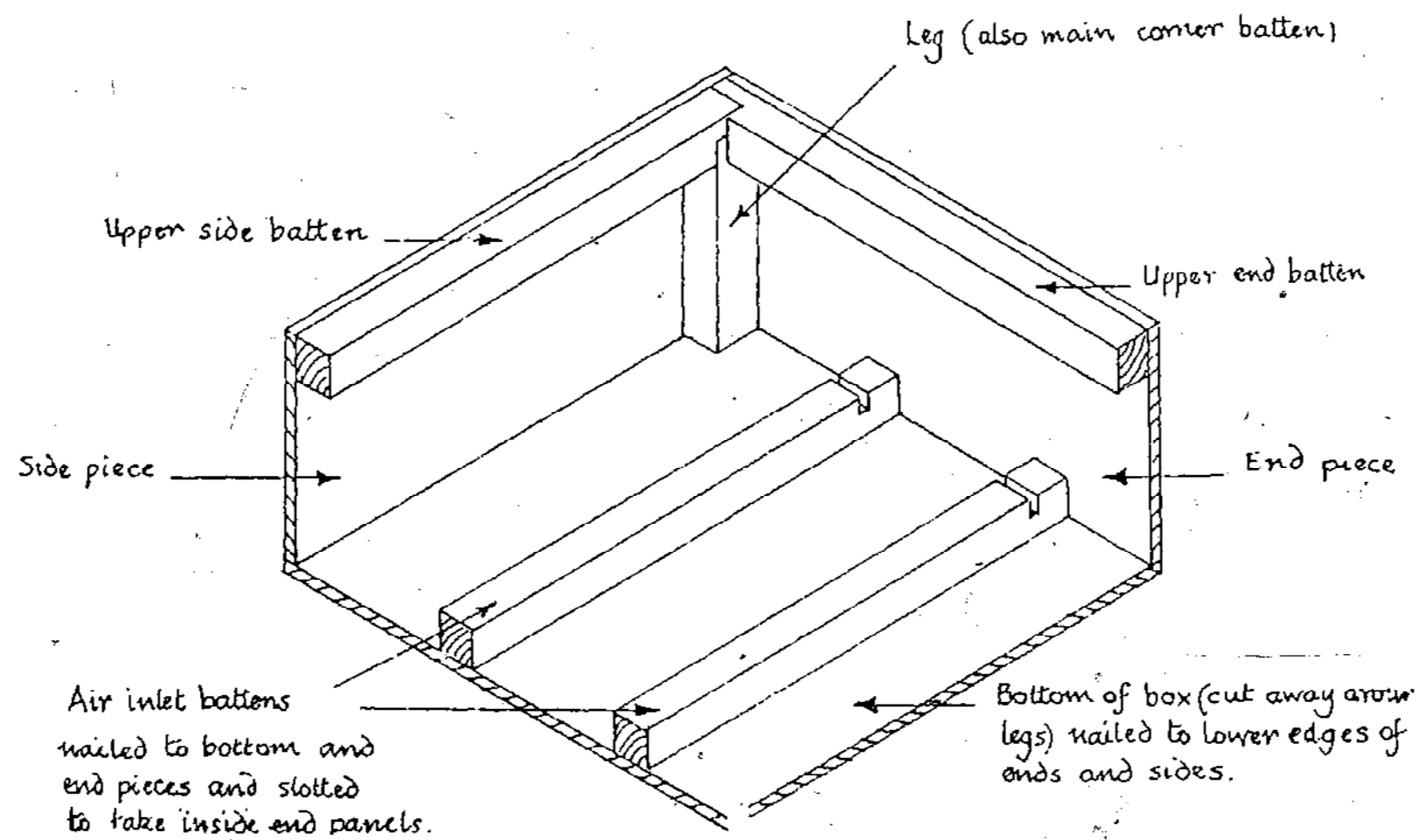
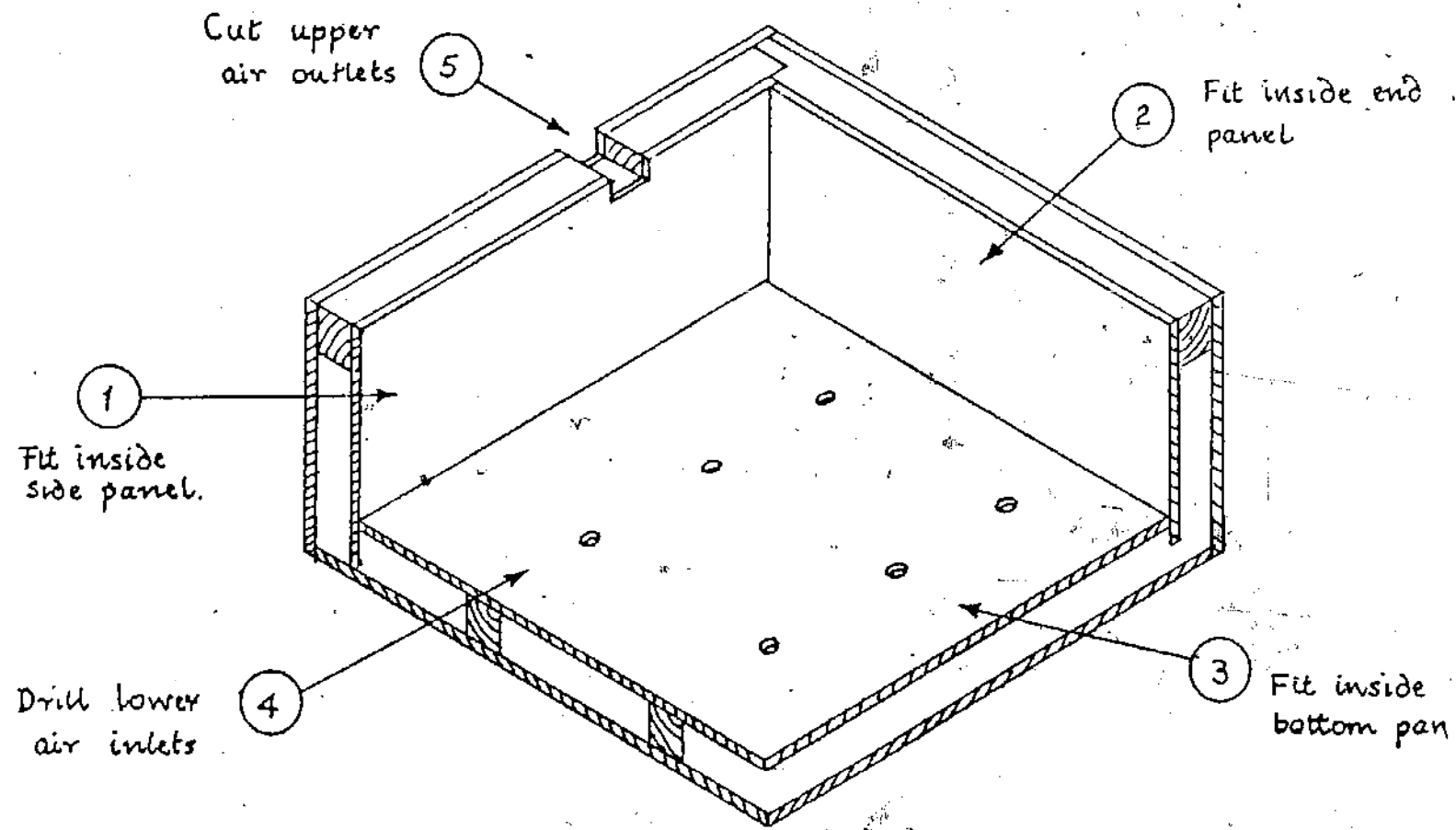

FIGURE 5

CONSTRUCTION OF MODEL 1 DRYER
"CUT-AWAY" SKETCH SHOWING STAGES IN COMPLETION OF INNER BOX



Steps in Construction:

Remember that it is a very useful practice to re-check all measurements and markings on timber before cutting. Follow the maxim "measure twice and cut once".

First build the outer box as follows:

1. Cut leg pieces, side, and end battens to size, and join together to make the basic frame. The type of joint illustrated in Figure 3a can be used if basic carpentering skills are available. Otherwise the pieces may simply be butted together and joined by driving long nails or screw nails. All nails should be driven home so that heads are flush with the surface of the wood.
2. Cut side and end pieces (these can each be one single piece or plank, or a number of narrower pieces). If a number of narrow planks are being used to cover the outer sides and ends, these should not be simply butted together edge to edge, but should be "weather-boarded" as shown in Figure 3b, so as to deflect rain and avoid wetting of insulation. When this form of construction is used, the gaps between planks and frame members should be filled with plaster, mud, or putty. If tongued and grooved planks are used, these should be fitted tongue uppermost to prevent rain getting into the joint.
3. See Figure 4. Nail end pieces to legs and end batten and then nail side pieces in position. Cut bottom pieces (to full length and width of box). Cut out corners so as to fit around legs and nail in place to lower edges of side and end pieces.
4. Cut and fit air inlet battens, nailing through from the ends and bottom of the box. When nailing, take care to avoid sites of the holes which will later be drilled through these battens.

Next, put insulating material in place and complete the inner box in the following manner:

- a) See Figure 5. Cut inner panels to size. The length of the inner side panels will be the internal length of the box between the end battens. The depth of side panels will be the internal depth from bottom of box to upper edge of side batten. The length of the side panels will be the width of the box between the leg pieces **less** the combined thickness of the two side panels. The depth of end panels will be the distance from the upper edge of the side batten to the bottom of the

slots cut in the air-inlet battens. The length of the bottom panels will be the length of the box between the end of the battens **less** the combined thickness of the two end pieces. Its width will be the width of the internal end panels.

- b) Turn the box on to one side and pack in the insulation on that side so that it is slightly above the level of the legs and side batten. Nail the inner side panel in place to the side batten and legs and through the bottom of the box. Repeat this process for the other side and two ends.
- c) Mark the center lines on the air-inlet battens on to the end pieces so that the marks will be visible once the internal bottom panel has been fitted. Pack insulation in place on the bottom of the box up to the level of the air-inlet battens, and nail the bottom panel(s) in place to the air-inlet battens (again avoiding the sites of holes to be drilled later).
- d) Mark the center lines of air-inlet battens on the bottom panel(s) and mark off position of holes. Drill through from the inside to the bottom of the box.
- e) Mark the position of the air-outlet slots on the upper sides, cut the sides of each slot with a saw and chisel, out the slots.
- f) Paint or stain the internal surfaces of the box with a dark color, preferably matt-black (black-board paint is useful for this purpose). Treat the exterior of the box with wood preservative (if available) and paint with gloss paint or marine varnish (if available).

E. Construction of Cover for Models 1 and 2 Dryers

The same type of cover is used for both these dryers. It consists of a simple rectangular wooden frame with a central ridge piece, which is covered with a double layer of polyethylene film. Details of construction of the cover are shown in Figures 6 and 7.



170

FIGURE 6

COVER FRAME FOR MODELS 1 AND 2 DRYERS

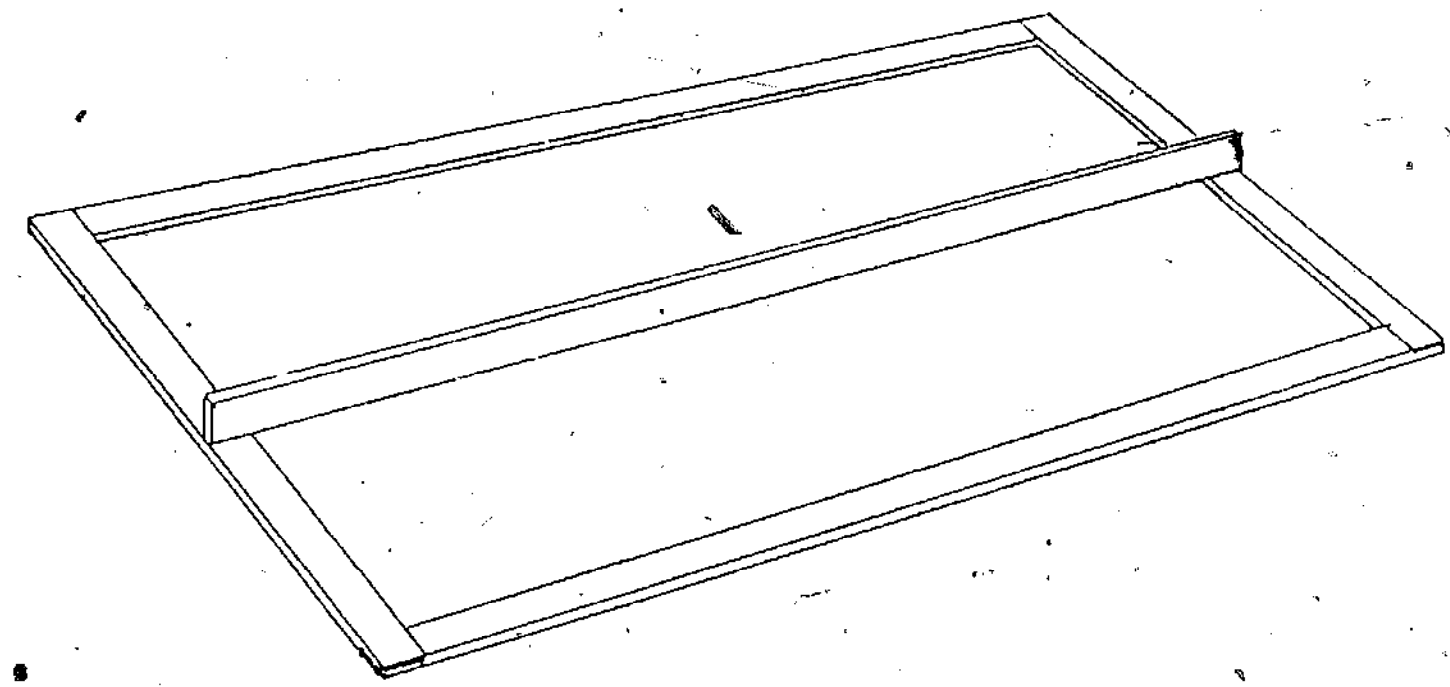

Tools and Materials:

Tools needed: Saw (preferably tenon saw), screwdriver, sharp knife or scissors, try square, marking gauge.

Materials: Lengths of timber 2" x 3/4" or nearest. Transparent polyethylene film (preferably 0.005 in. or heavier). Screwnails, (5/8" x 8s C.S.). Blued tacks (1/2"), or large office stapler.

TOOLS AND MATERIALS

Tools needed: Hammer, screwdriver, try square, saw, brace and 1" wood drill, 3/4" wood chisel.

Materials: Wooden planking or plywood for sides, ends and bottom of boxes.

Lengths of timber 2" x 2 1/2" for legs, and 2" x 2" for side, end and air-inlet battens.

Insulating material, e.g., wood wool, dried grass or leaves, coir fibre, etc.

Nails and screwnails of appropriate size.

Matt-black paint or other suitable black staining material, e.g., charcoal.

Wood from old packing cases is very useful for this purpose.

Steps in Construction

The frame should be made so that its overall length and width are each 3 inches greater than the box to be covered, i.e., so that it can overlap the box by 1-1/2" in each direction.

1. Cut the frame members to length and assemble as indicated in Figures 6 and 7. **N.B.** After construction is completed, the frame should be allowed to dry out in the hot sun before the cover is applied. The cover should be applied while the wood is still warm and at a time of day when humidity is low. These precautions are necessary to prevent condensation occurring between the layers of polyethylene, thus "fogging" the cover. If, despite this precaution, some fogging does occur during use, withdraw tacks or staples from a short length at each end of the cover, open up the polyethylene to allow moisture to

- escape while the dryer is in operation, and then refasten the polyethylene in place.
2. Cut a piece of polyethylene sheet for covering the lower side of the frame so that it is 3 inches wider and 3 inches longer than the frame.
 3. Turn the frame upside down and lay the polyethylene sheet in place. Fold one side of the polyethylene back on itself to form a triple layer seam $\frac{3}{4}$ " as shown in Figure 7b (i).
 4. Starting at the middle of the frame and working progressively towards both ends, stretching the polyethylene lightly but firmly lengthwise, tack or staple through the seam at 3" intervals to fasten this edge of the polyethylene to the frame. **N.B. Do not overstretch the polyethylene. Polyethylene will "give" and distort if fingertips are dug into it, and such distorted areas are likely to perish during use. It is preferable that polyethylene should be slightly loose rather than overstretched.**
 5. Repeat this process at the other side of the frame, stretching the polyethylene across the frame as tacking or stapling proceeds.
 6. Fold similar seams at each end, and tack the ends of the sheet to the frame, tucking the polyethylene neatly at each corner and fastening firmly in place.
 7. Cut a piece of polyethylene sheet for covering the upper side, so that when draped over the frame it is 4 inches wider and 4 inches longer than the frame. Turn the frame upside down and, making a triple-fold seam as before, tack or staple one edge to one side of the frame so that the seam is inside that of the lower sheet (Figure 7b (ii)).
 8. Stretch the polyethylene over the ridge and around to the lower edge of the other side member. Make a folded seam and tack or staple in place as before.
 9. Stretch the polyethylene over one end of the frame, fold and tack as before, cutting away any excess material resulting from the slope from ridge to side member. Tuck the corners of the sheet in neatly, and tack firmly in place. Repeat for the other end of the frame.

Attachment of Covers to Dryers

The covers, being very light in weight, are liable to be blown off the dryers by even a moderate gust of wind. Arrangements should therefore

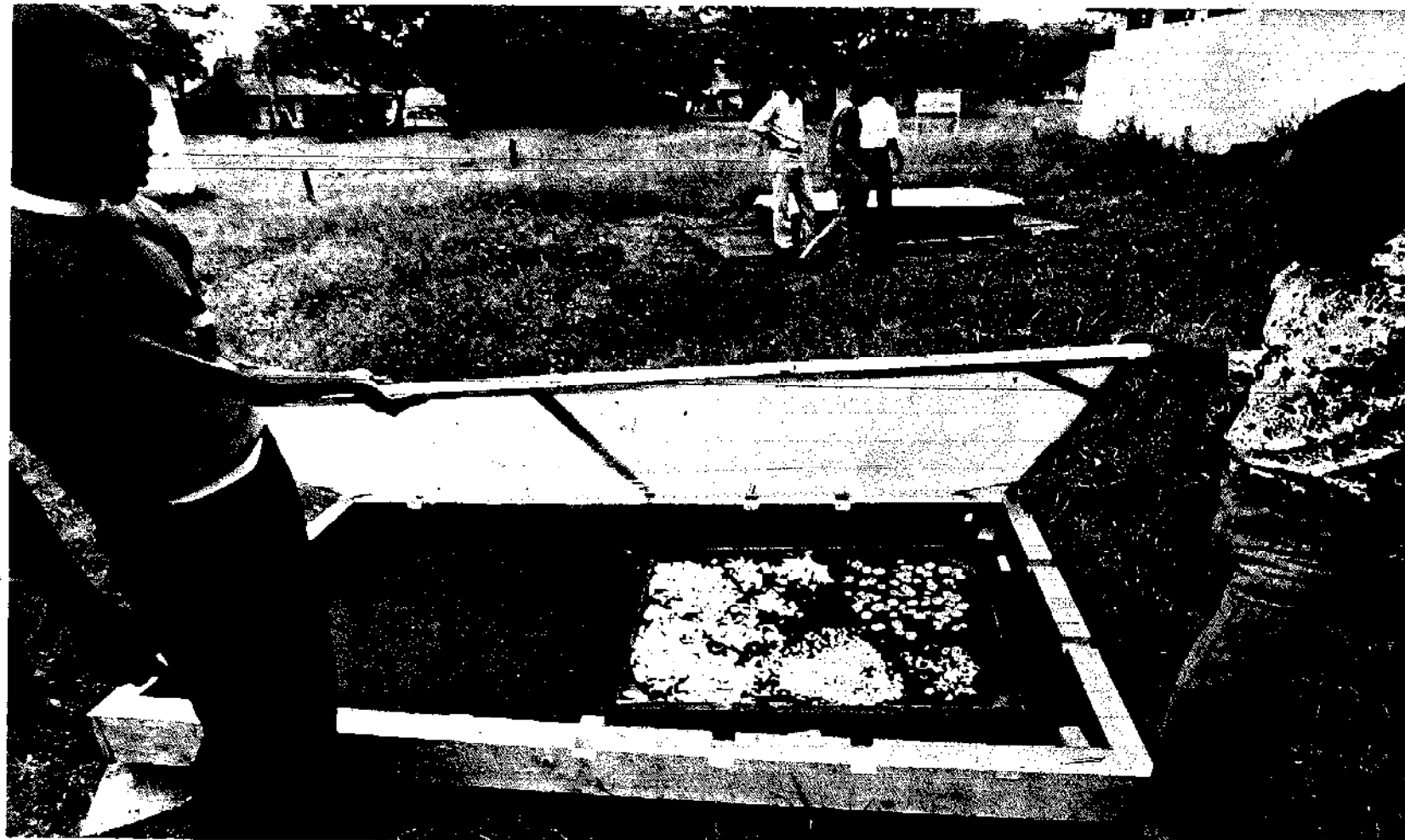

173

Completed - Model 1 Solar Dryer

Photo - Erik Bentzen

FIGURE 7

CONSTRUCTION OF COVER FOR MODEL 1 AND MODEL 2 DRYERS.

A. CONSTRUCTION OF FRAME.

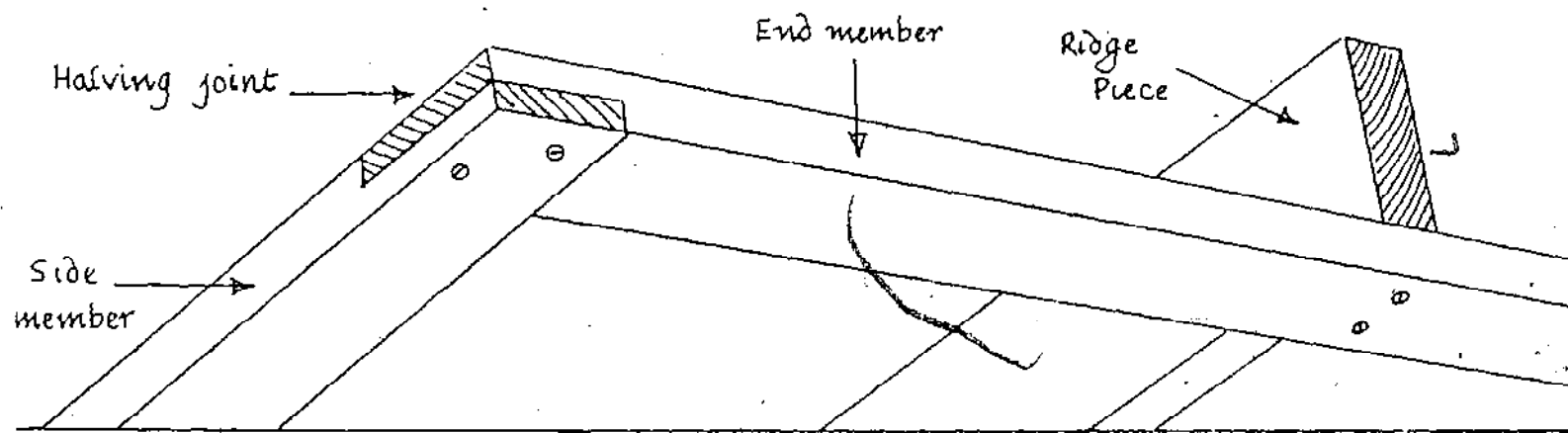

B. ATTACHMENT OF POLYTHENE FILM TO FRAME

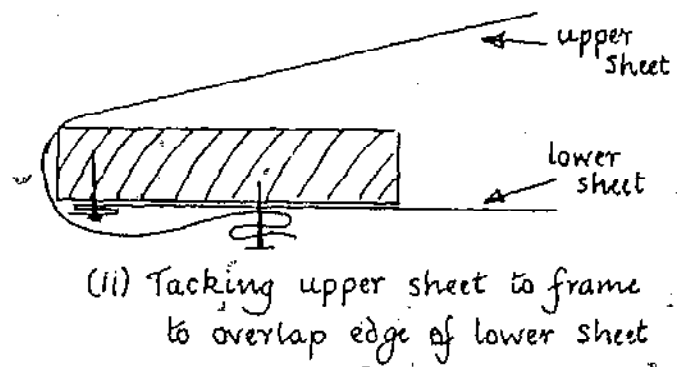
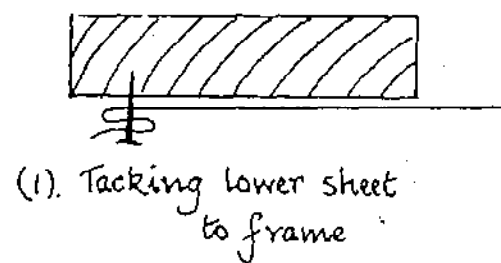
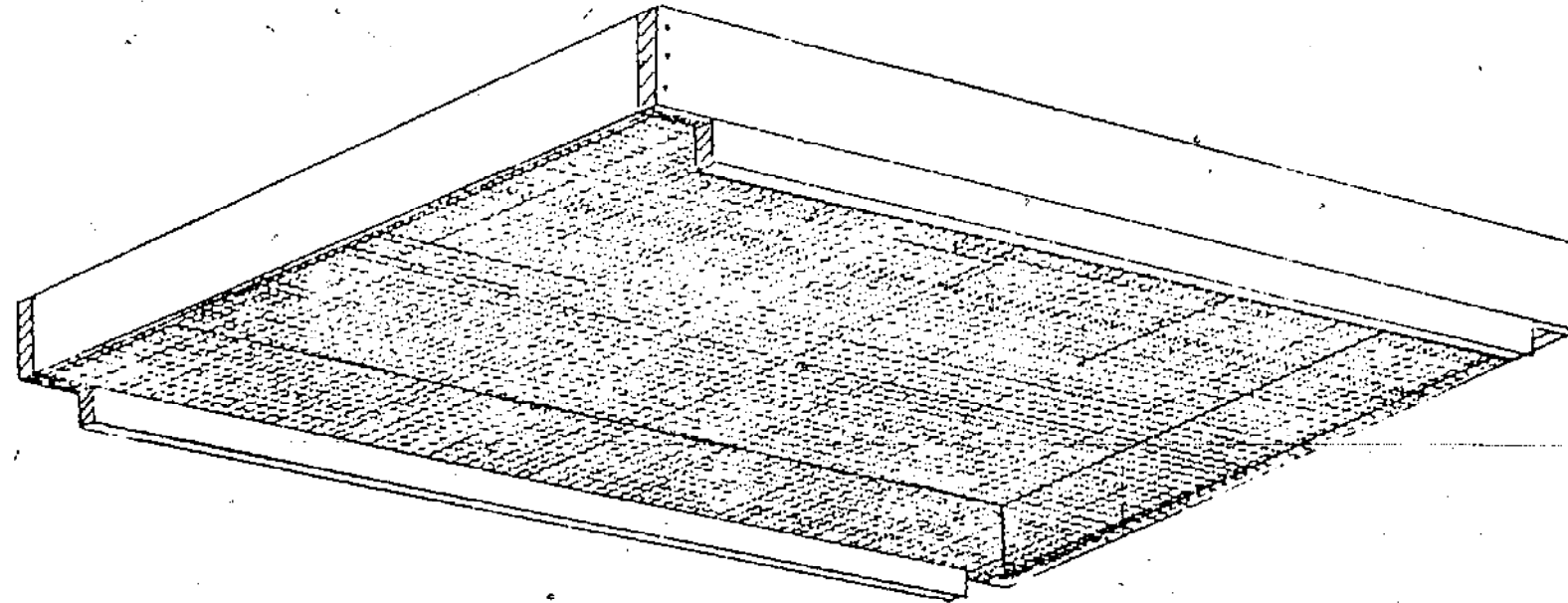

FIGURE 8

SKETCH SHOWING ONE POSSIBLE TYPE OF DRYING TRAY

175



be made to keep them firmly in place. This can conveniently be done by fastening hooks of stiff wire to each corner of the cover and swingin these hooks into place around nails or pegs fixed in the sides of the dryer. Alternatively, lengths of stout twine or cord fastened to one side of the dryer may be drawn tightly across the cover and tied to nails or pegs on the other side.

F. Construction of Drying Trays

An example of one possible type of drying tray is illustrated in Figure 8. This is a simple wooden frame with fine wire mesh stapled to its underside. Two support runners are nailed to the underside (over the edge of the wire mesh). If necessary, two laths may be tacked over the edges of the wire mesh to hold it in place at the ends. However, folding the edges of the mesh over upon itself before stapling maybe all that is needed. A suitable size of tray for use with 8' x 4' dryers illustrated in the sketches is 3' 6" x 3' 6", overall, two trays of this size being used in the dryer.

Simpler trays made of course be made from local materials. Papyrus reed matting, or a frame with slats of reed or split bamboo, for example, makes an excellent support on which material can be dried. Coarse hessian sacking material or open weave grass or fibre matting stretched on a frame can also be used.

G. Construction of Model 2 Dryer

This dryer, illustrated in Figures 9 and 10, is not portable like Model 1. It is meant to be permanently sited and to be constructed of clay bricks, mud and wattle, or similar materials. Compressed bricks made by the Cinva-Ram using local earth mixed with cement are ideal for the purpose. If hollow bricks are available, this would be an advantage. Hollows in such bricks should be packed with dried grass, coir fiber or other insulating material before the bricks are laid.

Siting

Because of its permanent nature, care should be taken in the choice of a site, which must be flat and level, and which should not be shaded by trees or buildings. The dryer may be built on a floor of solid hard-beaten

earth, or, if it is felt to be necessary, a base of concrete may be used. A drainage trench about 9 to 12 inches in width and depth should be dug all around the dryer to protect it from floods resulting from heavy rain. The dryer should preferably be sited so that it is end-on to the prevailing wind. In tropical latitudes, its siting in relation to the sun is relatively unimportant, but there may be a slight advantage in having its length in an east-west direction, but only provided this does not expose the sides rather than the ends to the wind.

Materials

Clay or similar bricks as described above, mortar or clay. Thick bamboo (2 1/2 to 3 inches in diameter).

Steps in Construction

- 1) Prepare the site and lay the first course of bricks.
- 2) Prepare the bamboo pipes as follows: Choose bamboo of even thickness and with as few joints as possible. Cut to the overall width of the dryer. Split the bamboo into halves lengthwise and cut away the partition at each joint. Put the two halves together again and bind together with string, wire, or other suitable binding material. Cut or drill holes in each pipe as indicated in the sketch. The holes should be about 1 1/2 inches in diameter.
- 3) Lay the second layer of bricks, placing the bamboo pipes in position as shown in the sketches, cutting appropriate bricks, short as needed. Lay the third layer of bricks, packing the gaps around the bamboo with mortar or clay.
- 4) Lay the top layer of bricks, cutting away as necessary to form air-outlet slots. Alternatively, lay the top layer of bricks leaving one-inch gaps appropriately spaced along the two sides.
- 5) Paint the inside of the dryer a dark color. Charcoal mixed with clay may provide a suitable means of doing this.
- 6) Construct a cover and drying trays as described in 6 and 7 above.

Alternatively, bamboo inlet pipes of only 12" in length may be used instead of the full-width pipes. Length of these pipes is shown by the thick lines in Figure 9.



Early construction of Model 2 Solar Dryer

Photo – Erik Bentzen

FIGURE 9

MODEL 2. DRYER CONSTRUCTED OF CLAY BRICKS PLAN AND ELEVATION DRAWINGS

Scale 1 cm = 6 inches

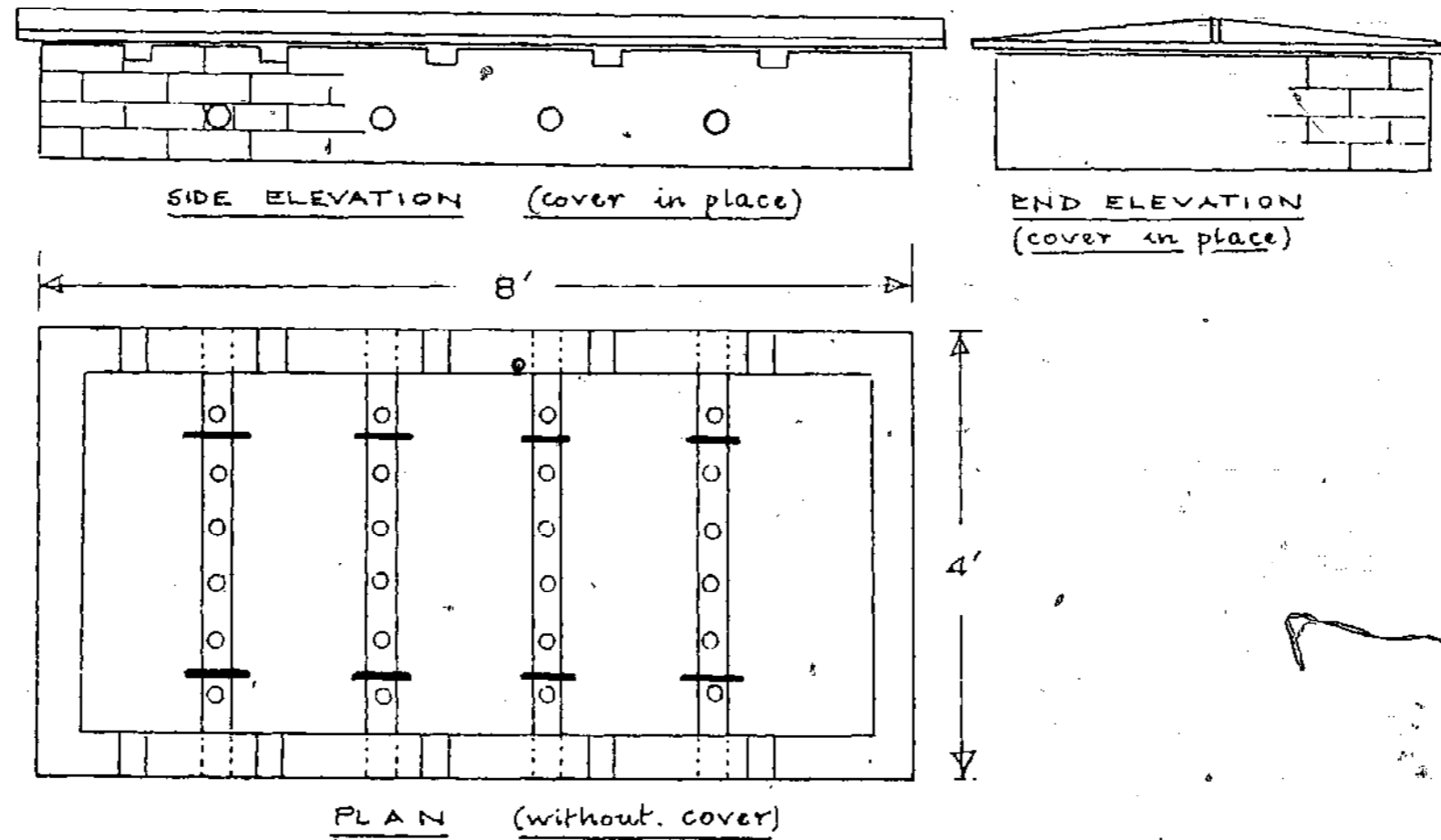
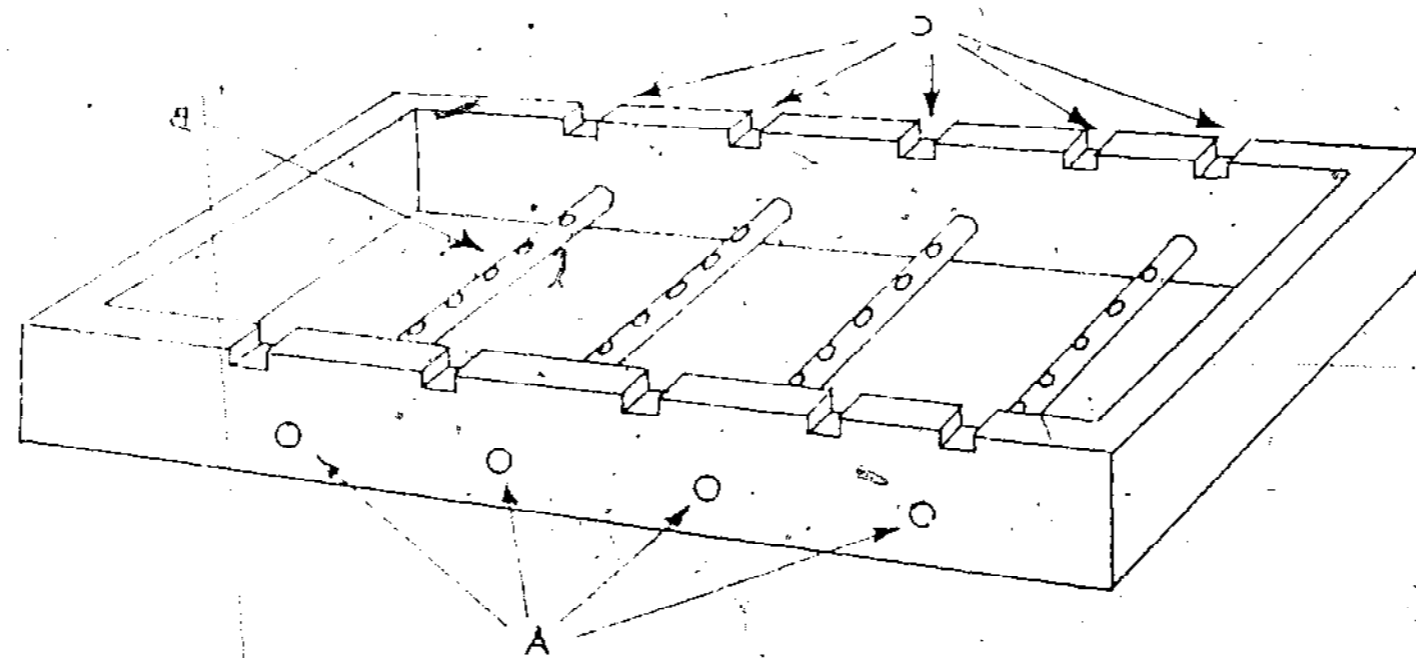

FIGURE 10

MODEL 2 DRYER - SKETCH SHOWING VENTILATION ARRANGEMENTS

A & B - BAMBOO "PIPES" WITH HOLES FOR AIR INLETS

C - SLOTS FOR AIR OUTLET.



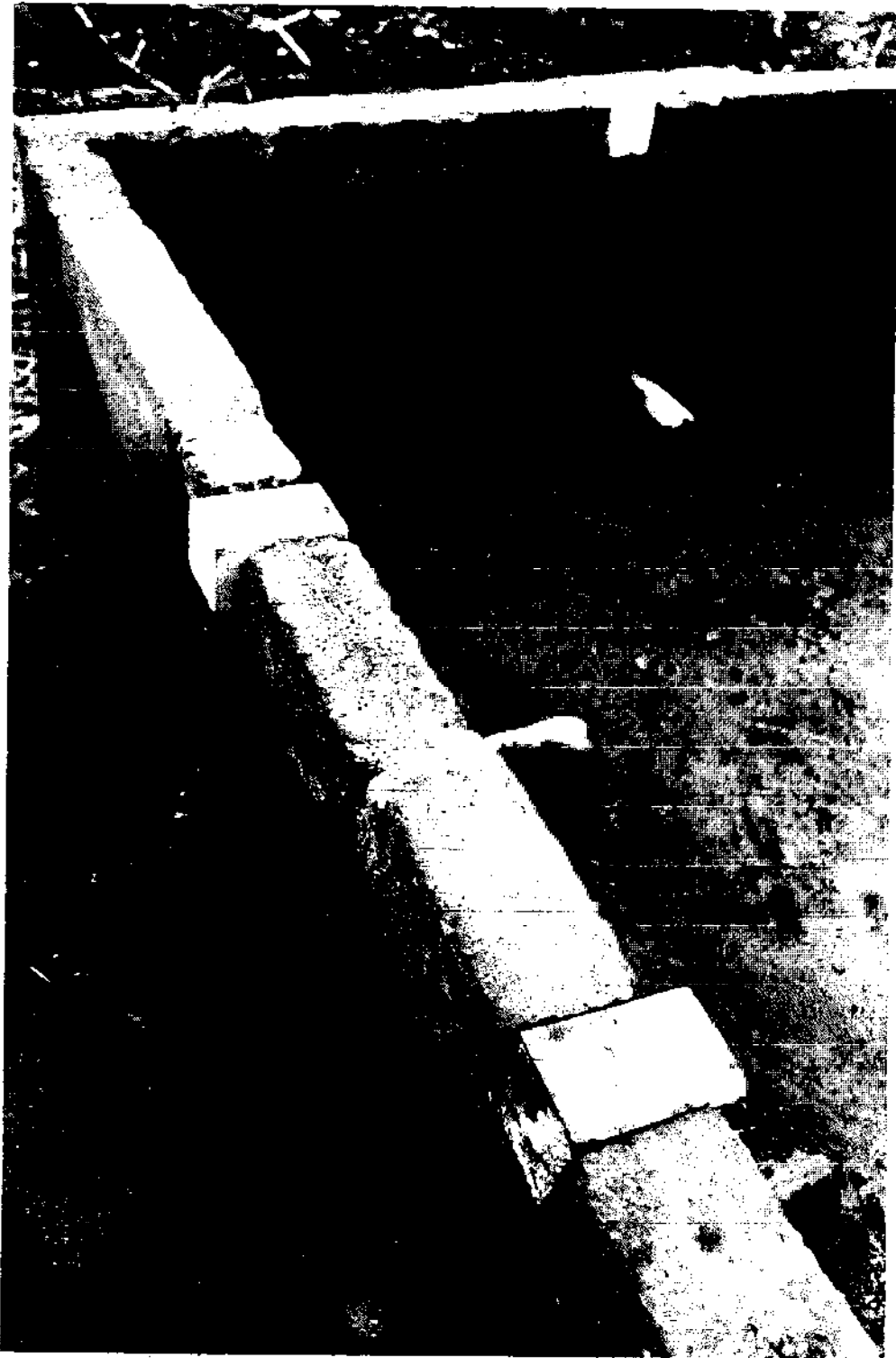

Photo – Erik Bentzen
Model 2 Solar Dryer – showing ventilation arrangements.

A Simple Cover Frame for Sun Dryers

The attached sketches illustrate the construction of a simple "double glazed" polythene cover for sun dryers. This can be made in the village situation, using only the tools and materials normally available: The only external input needed is polythene sheet in the form of a tubular sheath.

The frame (Sketch 1) consists of two "coat-hanger" shaped end pieces joined by three pieces of bamboo or other straight poles such as wattle or eucalyptus.

The end pieces (Sketch 2) can be chopped out to shape with a "panga", cutlass, or machete-type knife, and the nesting sockets for the joining poles can be carved out with a smaller knife or burnt out with a hot iron. Poles are selected for straightness and uniformity of diameter. Perfectly straight and uniform poles are rare. It is important that the two side poles are straight in the horizontal plane, and the frame should be put together on a perfectly flat piece of ground and the two side poles arranged to achieve a frame which is not warped and which does not twist upwards at one or more corners. Slight irregularities in the poles do not matter since, although these may prevent the frame seating accurately on the top edges of the dryer, this does not matter, since air vents are in any case required between the cover frame and the top edges of the dryer.

Fastening bamboo or thin poles with nails can be a problem because of the risk of splitting. For this reason, holes for the nails should first be drilled in the ends of the poles (Sketch 3). This is done using a nail heated to redness. The nails are then inserted in these holes and driven firmly into the wooden end piece.

The joint can be strengthened (Sketch 4) by nailing a strip of hammered-out tin (cut from an old tin can) over the joint. This tin strip would be likely to abrade the polythene so, to avoid this, the joint should be wrapped in a piece of cloth, banana fiber, soft barkcloth or similar soft material before covering the frame with polythene.

The cover frame must be made to that it fits snugly into the polythene sheath and so that the sheath is stretched taut. The key dimensions in this respect are those of the end piece, and it is necessary to make the first end piece by trial and error. The end piece should be cut to shape

Making A Simple Cover For A Solar Dryer

(When Only Plain Polythene Sheet Is Available)

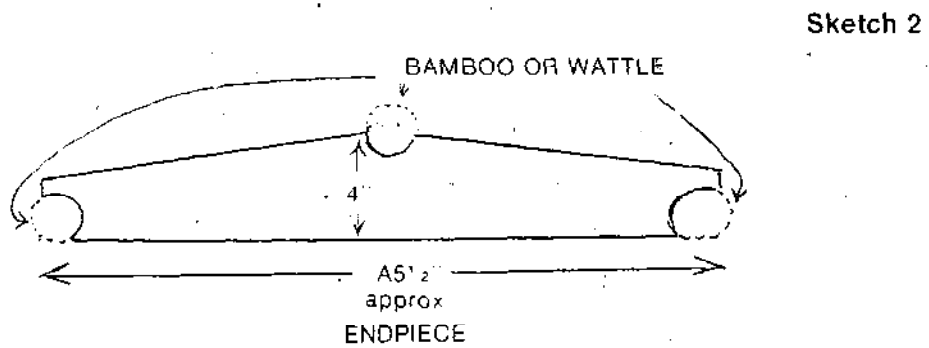
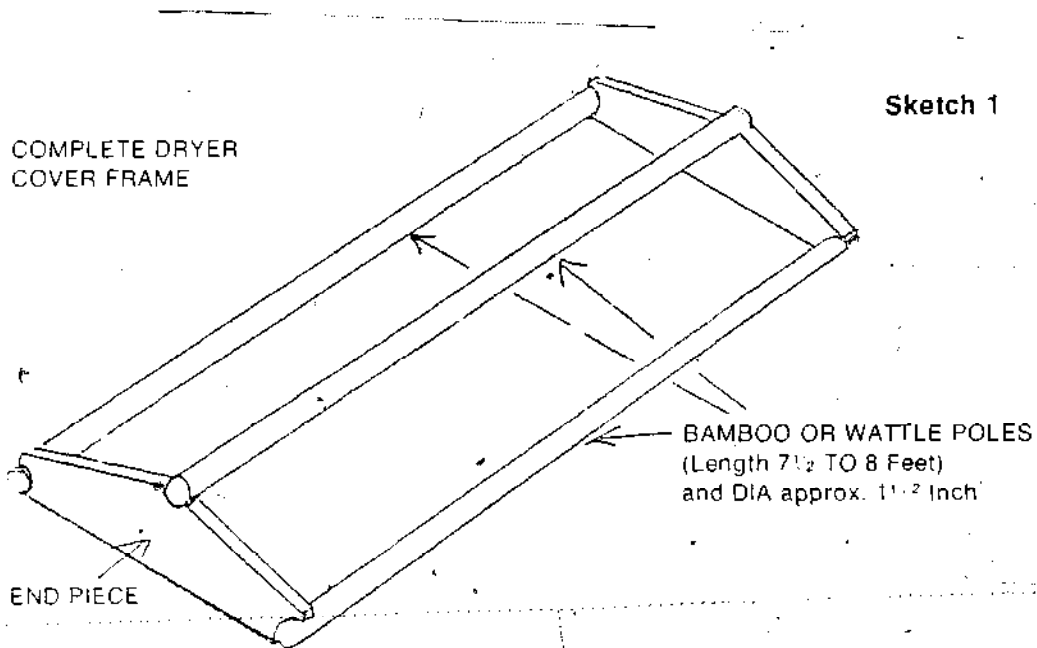

(Made from A Piece of 4"x1" plank.)



Making simple cover frame for Solar Dryer.

Photo – Erik Bentzen

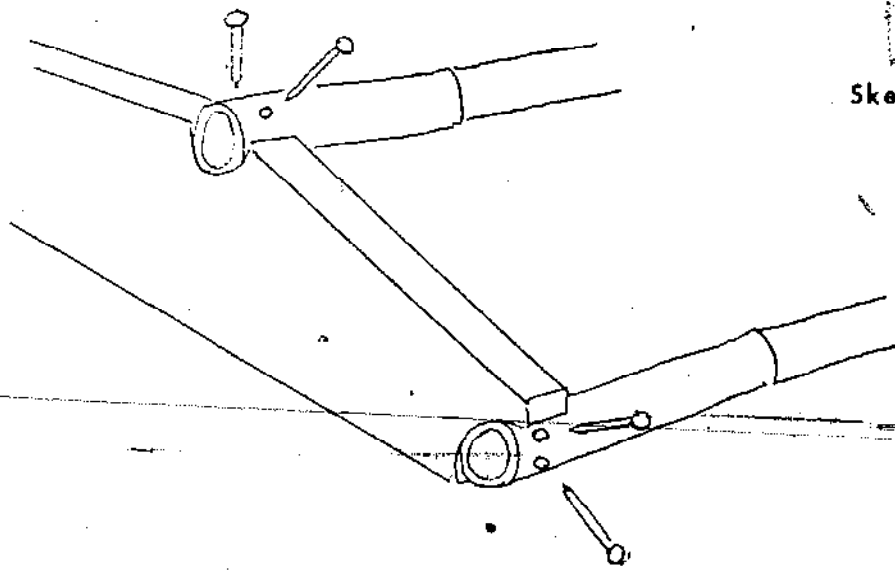

Sketch 3

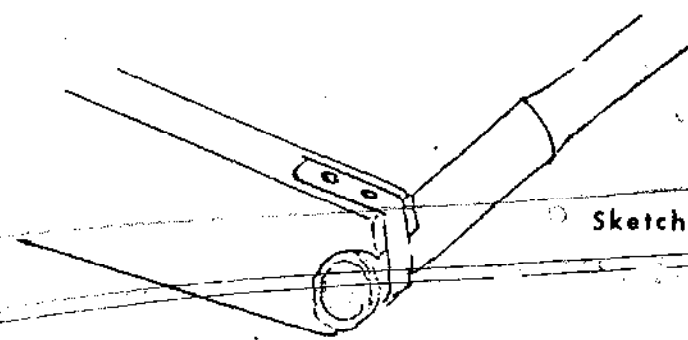

Sketch 4

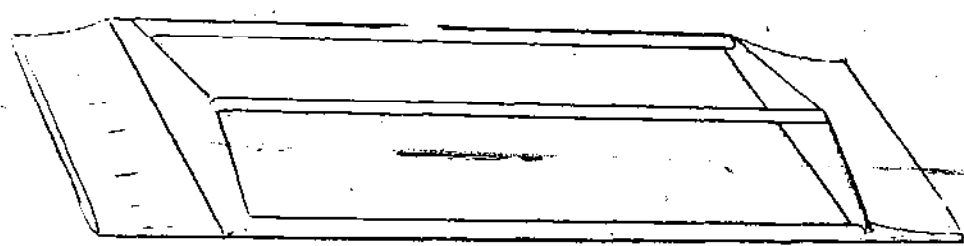

Sketch 5

Fit the sleeve over the frame so that
approx 12" of the sleeve overlaps at each end

SKETCH 6

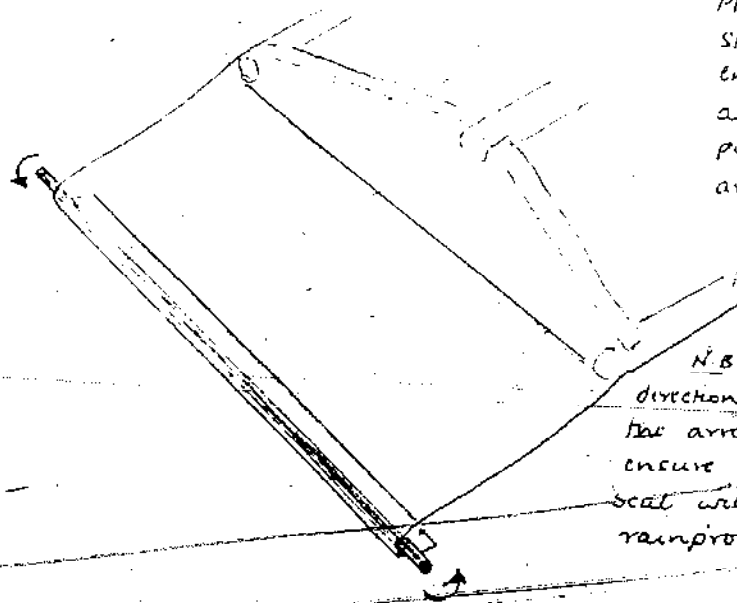

Place a thin stick under the end of the sleeve and roll up the plythene tightly around the stick

N.B Roll in the direction shown by the arrows to ensure that the seal will be rainproof.

SKETCH 7

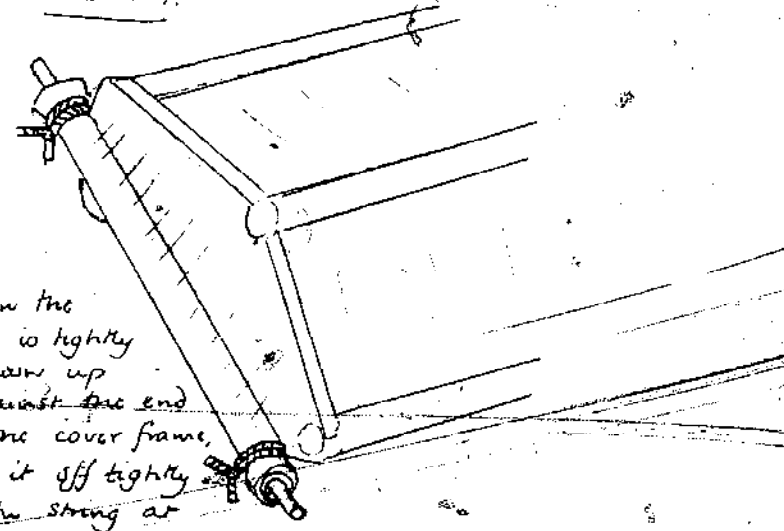

When the roll is tightly drawn up against the end of the cover frame, tie it off tightly with string at both ends

Do the same at the other end of the cover.

Judwell 27/1/75

COVERING A SOLAR DRYER DOVER FRAME WHEN POLYTHENE SLEEVES ARE NOT AVAILABLE

1. Lay cover frame on top of polythene sheet which is 24" longer and 18" wider than cover frame.

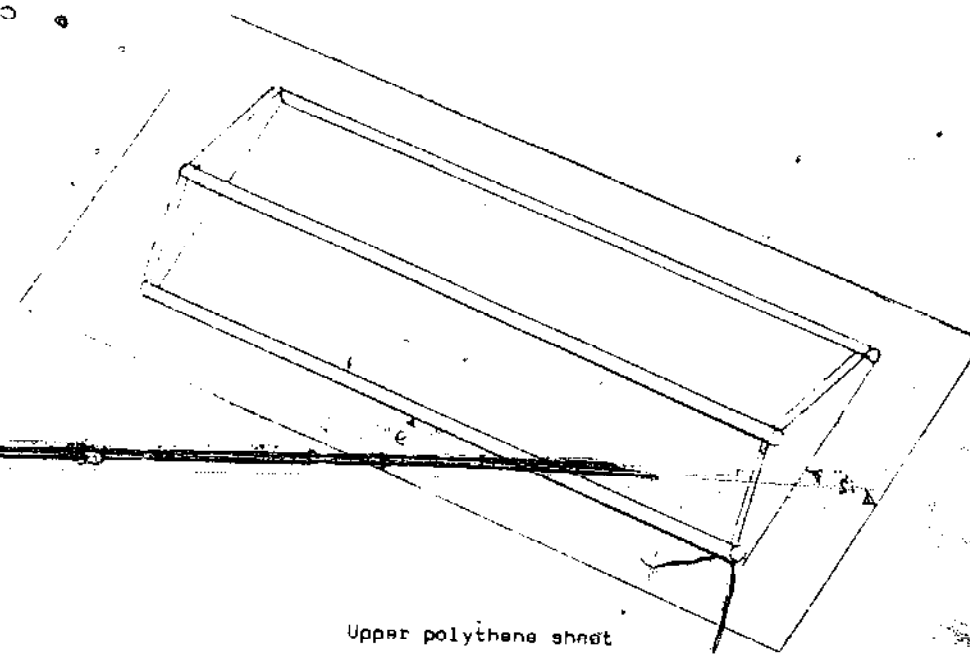

Upper polythene sheet

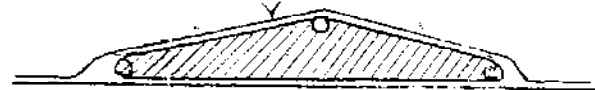

Lower polythene sheet

2. End views

- a) Lay second sheet of polythene over top of frame.

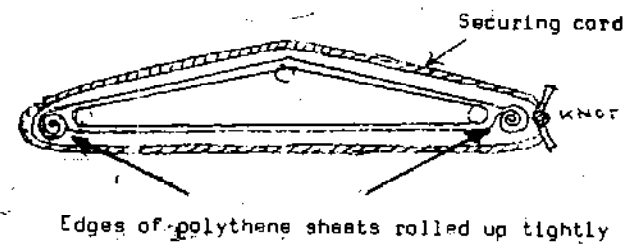

- b) Roll up edges of sheets tightly against frame and secure in place with cord tied around width of frame at both ends.

3. Frame with edges of polythene sheets rolled up and tied (as in 2 (b)).

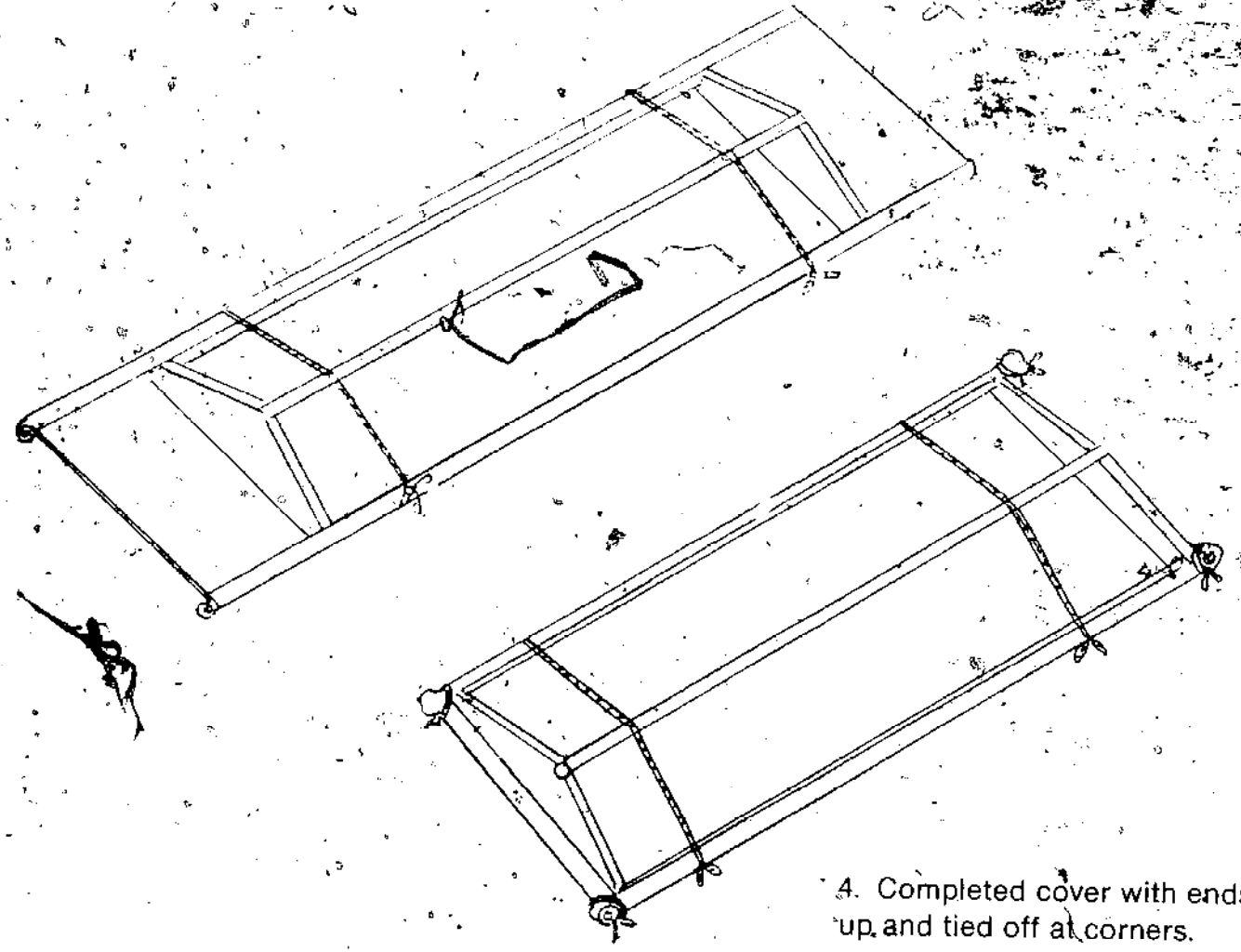

4. Completed cover with ends of sheets also rolled up and tied off at corners.

but finished off the same width as the sheath. Its width should then be reduced by paring slivers from each end until it will just fit into the sheath. It will be found that the width of an end piece which is 4 inches high at its highest (middle) point will need to be about $\frac{1}{2}$ to $\frac{3}{4}$ shorter than the width of the sheath.

The following is a practical example:

A polythene sheath was made by folding 8' wide polythene film and seaming along the open edges. The effective internal width of this sheath was 46" (two inches used up in seaming). The size of end piece needed for this sheath is illustrated in Sketch 2, i.e., 45 $\frac{1}{2}$ inches long and 4 inches high. A cover frame made from two end pieces of this size fitted neatly into the sheath without undue stretching of the polythene. The polythene sheath is fitted to the frame as described in Sketches 5, 6 and 7.

3. Drying with Fire

There may be times, however, when climatic conditions will not permit the effective use of even an improved solar dryer. This may be the case where there are long periods of rainfall or very cloudy weather. Also, when the amount of grain to be dried is too large, another method will have to be found.

Here we present a model called the **Pit Oil Barrel Dryer** or **Brooks Field Dryer** that can be used quite effectively at the farm and village level, either by an individual farmer if he has a fairly large amount of grain to dry, or by a group of farmers working together as in a cooperative. Storage of grain in a closed container requires that the grain be sufficiently dry to prevent rotting. For maize this is optimally 12% moisture content. The traditional method of sun drying is neither assured nor very efficient, especially for large quantities of grain. It requires much labor to spread and gather the grain each morning and evening and this is especially difficult in times of inclement weather.

Artificial drying permits drying large quantities of grain in a relatively short period of time. The higher drying temperature drives insects from the grain and allows the grain to be harvested sooner with less drying time in the field, thus decreasing insect and rodent damage, which occurs before harvest.

Figure 1. Le Hangar

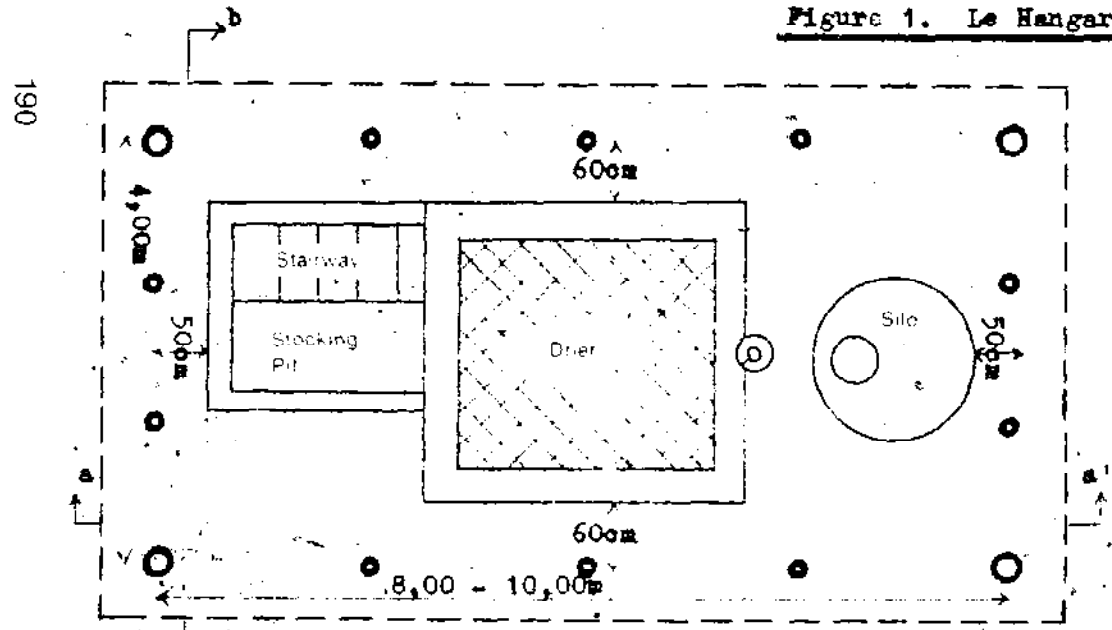

A Top view

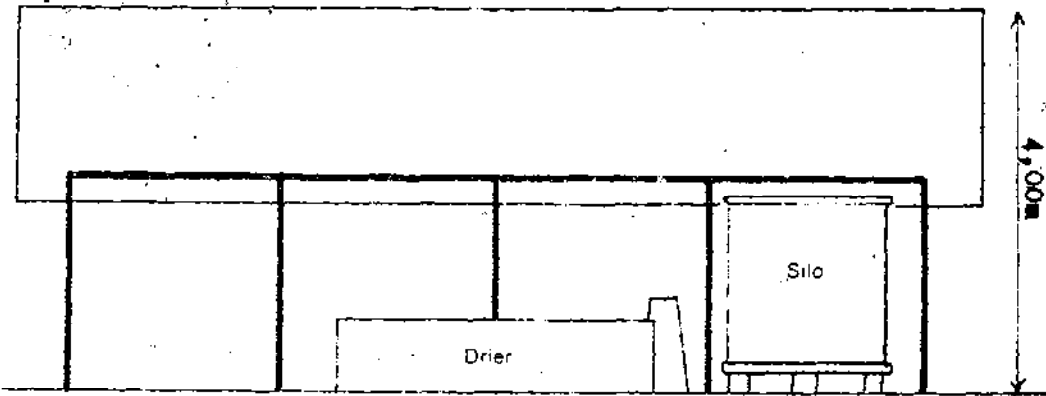
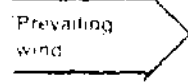

B Section a-a

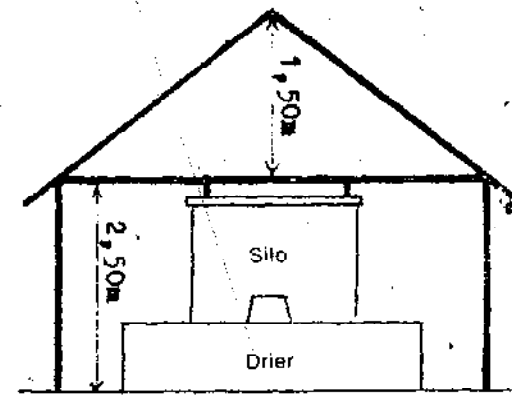

C Section b-b

Shelter with Brooks' Fire Drier
and Cement Stave Silo.

Drawing by - Harald Thorshaug

The dryer consists of banco walls with a screened false floor for drying the corn with heat from a fire box consisting of three 220 liter drums joined end to end below the drying floor.

CONSTRUCTION (see figures 9 - A - B - C - D)

The drying chamber has interior dimensions of 2.40 x 2.20 m and a height of 40 cm from the screen floor. The walls should be 30 cm thick giving exterior dimensions of 3.00 x 2.80 m. The stoking pit will be built on the upwind end of the dryer. It should have interior dimensions of 1.80 m long and 1.70 m wide, including the stairway.

LINTELS

The end walls will be supported by 2 concrete lintels (1.20 x 0.30 x 0.08 m), requiring $\frac{1}{3}$ sack of cement and one 6 m bar of re-rod (\varnothing 6 mm). The lintels can be made any time a 1:2:3 concrete mixture is made, though the sooner they are made, the sooner they can be placed. The formwork can be made from boards or bricks lined with paper. Three pieces of re-rod 100 cm long should be evenly spaced horizontally 4 cm from the bottom edge of the lintel.

THE DRYER

First stake out the drying chamber 2.80 m wide x 3.00 m long. This should be centered between the two sides of the hangar. Extending upwind on 1 side of the drying chamber, stake out the stoking pit, 2 m long x 2.10 m wide. This will leave an unused area on one side of the stoking pit 2 m long x 0.70 m wide on the opposite side of the drying chamber. Dig all of this staked out area 30 cm deep and pile all of this removed top soil to one side so that it will not be later mixed with the banco.

Next, dig a trench centered in the length of the drying chamber 70 cm wide and 140 cm deep. This will extend 480 cm from the chimney end of the drying chamber (leaving a 20 cm ledge for the retaining wall of the stoking pit.). Remove all of this dirt taking care not to mix it with the top soil which was earlier removed.

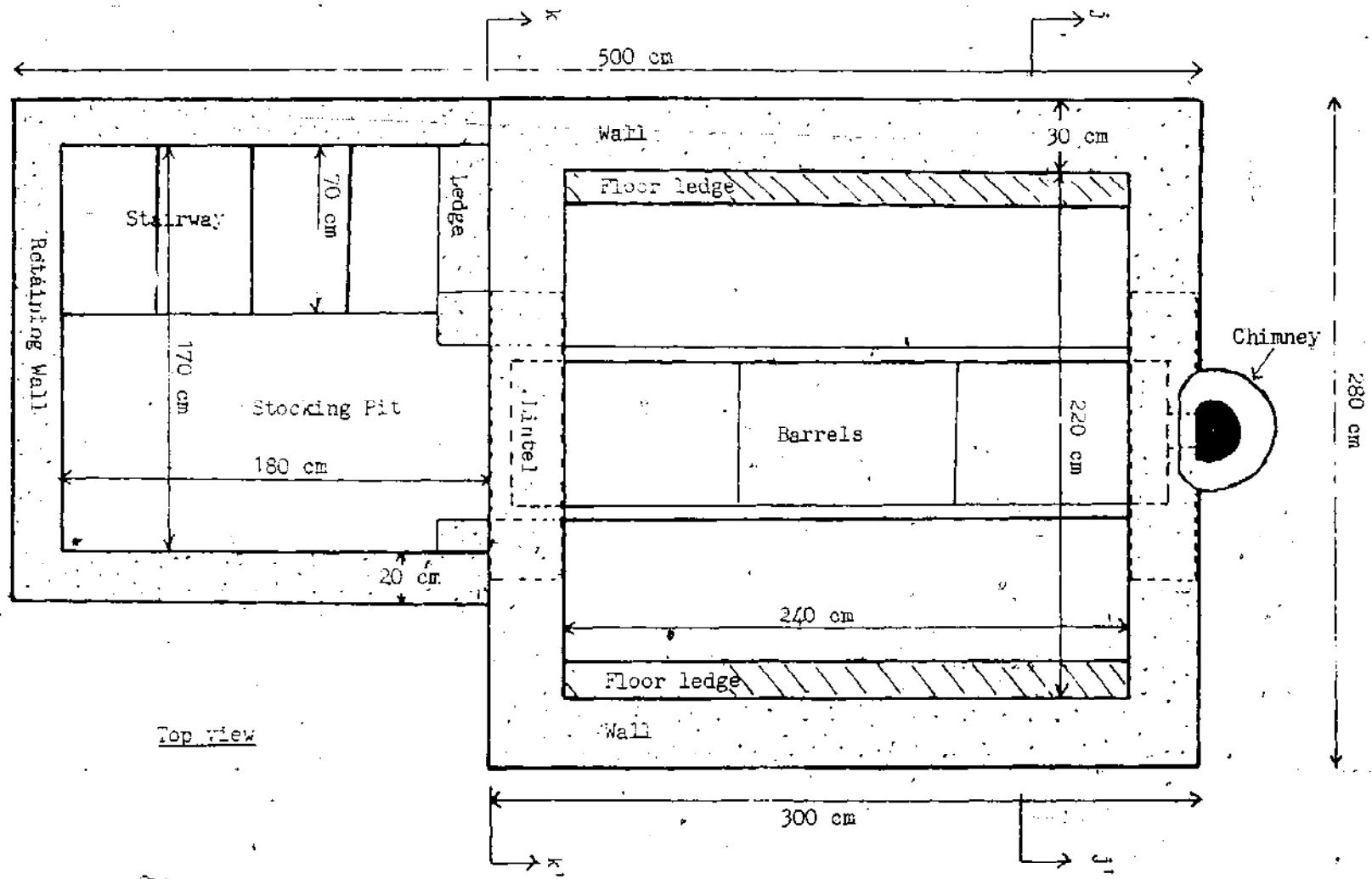
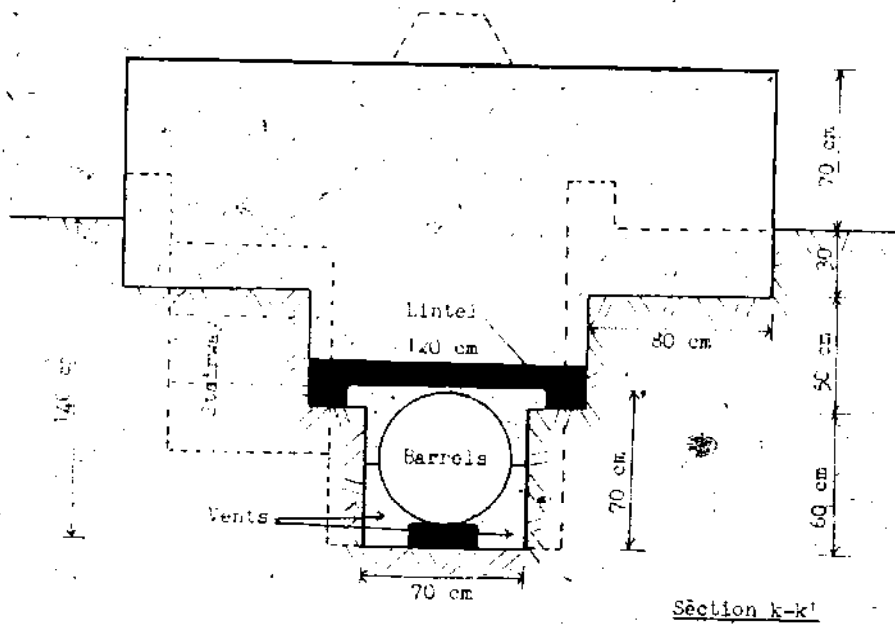
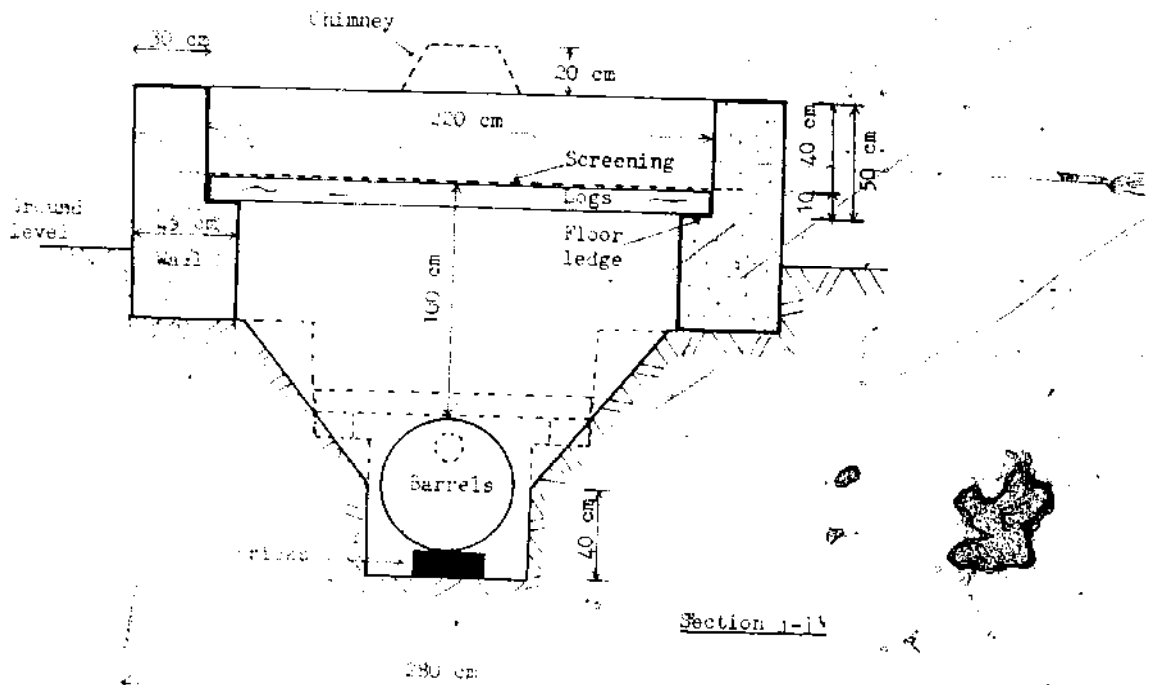

FIGURE 3 Brooks's Fire Drier

Drawing by - Harald Thorshaug

Brook's Fire Drier



Scale 1 : 10

Drawing by - Harald Thorshaug

Labour	- Digging hole	5 man-days
Requirements	- Prepare Banco	6 man-days
	- Mount walls	6 man-days
	- Place barrels	1 man-day
	- Place floor	1 man-day



PLACING LINTELS

Carefully measure and mark points 3 m and 2.70 m from the chimney end of the trench and cut slots on both sides of the trench, where the lintel will rest. These will descend to 70 cm from the trench floor, 30 cm wide and 30 cm long. Cut similar slots up against the chimney end of the drying chamber - 75 cm from the trench floor. The 5 cm difference is to give a slope to the barrels and thereby facilitate smoke escape through the chimney. Next cut the chimney hole 30 cm wide x 30 cm long x 30 cm deep centered at the end of the trench. A channel 15 cm x 15 cm is then extended from the center of the chimney hole to 50 cm from the bottom the trench. A 5 cm layer of mortar or banco is laid in each of the 4 lintel slots and the lintels are lowered into place taking care that they are level and square with the dryer side walls. If banco has been prepared in advance the construction of the walls can now begin.

MOUNTING THE DRYER WALLS

Mount the walls 30 cm wide over the lintels and 45 cm on the sides, extending the stoking pit retaining wall along its ledge 20 m thick to a height 20 cm ground level around the extremities of the stoking pit (2 m x 210 cm). This retaining wall protects against erosion of the pit walls and keeps dirt and trash from falling into the pit.

The height of the wall over the lintels which can be mounted in one day without danger of collapse depends on the quality and water content of the banco. When the drying chamber walls reach 90 cm from the lower edge of the lintel, the side walls thickness is reduced to 30 cm, leaving a 15 cm ledge on the inside of each side wall which will support the drying floor logs. Before the walls are mounted much above the ground level the rest of the digging and dirt removal should be done in the drying chamber to avoid unnecessary difficulty in removing the dirt. From the base of interior side walls to a point 40 cm from the bottom of the barrel

trench remove the dirt on both sides of the trench leaving a slope of about 45°. When the retaining wall is mounted to 20 cm above ground level, it should be level with the drying chamber walls at the point where they are diminished to a thickness of 30 cm. At a height of 10 cm higher than the 15 cm side wall ledge, a strip of chicken wire 20 cm wide should be embedded 10 cm in the wall all the way around leaving 10 cm extending out into the drying chamber to which will later be attached the drying floor screen. This embedded screening should be 1.00 m from the bottom edge of the front lintel. The walls are mounted to a height 40 cm above the embedded screening. At the same time that the drying chamber walls are being mounted, the chimney can be done. Its height should be extended 20 cm higher than the top of the dryer wall. The opening can be reduced to 10 cm in diameter to prevent undue heat loss.

The stoking pit is finished at any convenient time during the dryer construction. The stairs are cut out in four equal steps 30 cm high and 40 cm wide, leaving a 30 cm wide ledge against the dryer wall and the lowest step. This will lend solidity to the dryer wall and lintel. The stoking pit can be enlarged by cutting away 15 cm on each side of the stoking pit.

The walls can be polished as they are built. A layer of 1:8 mortar on top of the wall all around will keep the walls from being worn away during use. Cracks in the dryer wall should be filled with banco to improve both its solidity and appearance. Extra care should be taken in filling cracks in the chimney end wall to avoid smoke entering into the drying chamber.

PLACING THE FIRE BOX BARRELS:

The sloping sides of the pit must be dug away before placing the barrels. First, cut both ends from two barrels, and one end from the third. A small hole 20–30 cm wide should be cut in the other end for the chimney hole. One side of the chimney hole is formed by the barrel rim. This hole will be on the top side of the barrel when it is placed in the dryer.

The barrels are joined with four heavy wires spaced evenly around the circumference. The barrels should be supported with bricks or broken staves 10 cm thick.

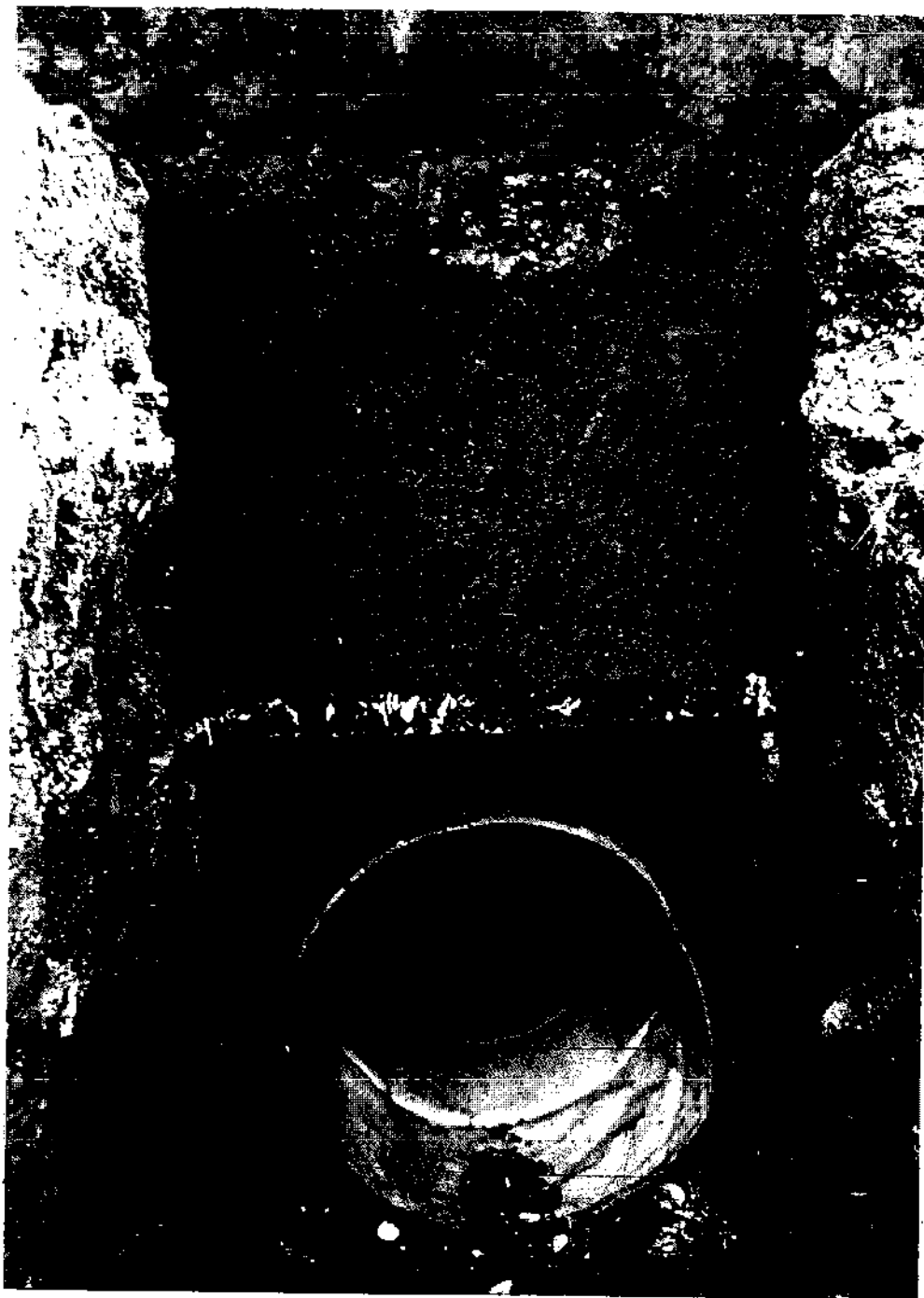

Photo – Erik Bentzen

Shown here is one of the two concrete lintels which support the end walls.



Photo – Erik Bentzen
Mounting the dryer walls. (In the background is a nearly completed 4.5 ton cement stave silo.)

The joints should be sealed by placing a strip of screening around them and plastering with a 1:8 mortar. If the screen holes are too big to hold the cement, place paper under the screening. From inside the barrels, the bottoms can be sealed as well as any spaces showing in the top joint seal.

The trench must now be closed around the barrel ends with banco. At the chimney end the seal must go completely around the barrel to keep smoke from coming into the drying chamber. The opposite end is closed only around the top of the barrel to let cool air enter the drying chamber.

The joint seals can be tested by lighting a smoky fire in the barrels and watching to see if smoke escapes into the drying chamber. Do not let it burn too long or it will dry the sealing mortar too quickly causing it to be brittle.

FLOOR SUPPORTS

Use 10 logs of solid wood 8–10 cm in diameter and 2.15 m long to support the drying floor. A very straight log should be placed directly against each end wall to keep the screen from pulling out under pressure.

WIRE SCREENING

can now be stretched across the logs and attached to the anchoring strips. Small hole screening is often very expensive, so chicken wire is usually used. In this case, straw mats must be placed on top of the screening to prevent the grain falling through.

The strips of screening should be longer than the 2.40 m length of the drying chamber because the weight of the corn will pull it down between the floor supports. The strips should be overlapped 5–10 cm and attached by weaving thin wire up and down through the holes. For all of the wire screening used in the dryer, 9 m² are required.

Instructions for the use of the Brooks Field Dryer.

1. Before using the dryer each time, you should clean out the stoking pit-hole to make sure that the air vents underneath the barrels are open and not blocked by ashes or dirt. This should be done during drying also.
2. Check the barrels to make sure there are no holes rusted in them or cracks in the joints which will allow smoke to enter the grain in the

Table 3. Interior Dimensions of the Molds

Slab Diameter	1.50 meters		2.00 meters	
	Large	Small	Large	Small
Length A	50,0 cm	25,0 cm	50,0 cm	25,0 cm
Widths b ₁ b ₂	21,4 cm	21,4 cm	24,0 cm	24,0 cm
	22,8 cm	22,8 cm	25,2 cm	25,2 cm
Thickness C	5,0 cm	5,0 cm	5,0 cm	5,0 cm

PILLAR BRICKS

24 bricks are needed to build 4 pillars of six bricks each. The bricks can be made from a 1 : 2 : 3 concrete mix or a 1 : 4 : 6 mortar mix, according to the quality of the sand and cement. Molds of 14 x 20 x 30 cm will give bricks which will provide 30 x 30 cm pillars. Also, regular cement blocks, used in houses can be used if they are the right size or if they can be cut to fit and if they are strong. **Dry and water the pillar bricks the same as the staves.**

BUILDING THE PILLARS (see fig. 4)

Trace a circle of 110 cm radius on the ground. This will be the circumference of the bottom slab of the silo. Next, using the same center, trace a circle of 85 cm radius and divide it in thirds. These three points and the center point of the circle will be the centers of the pillars. Around each of the four points trace a circle of 30 cm radius, and dig a hole 50 cm deep. (To know how to divide the circle in third, see "re-rod armature" p. 1)

Pour a concrete foundation (1 : 2 : 3) 12 cm thick in each hole. It should be tamped and levelled. Next the pillars should be built using three layers of two bricks each. The vertical mortar joint between the two bricks forming each layer of the pillars should be criss-crossed perpendicular to the preceding layer. The 4 pillars should be levelled carefully to provide even weight distribution for the slab. One half barrelful of gravel and 1 sack of cement are required for making the pillar foundations and mounting the pillars.

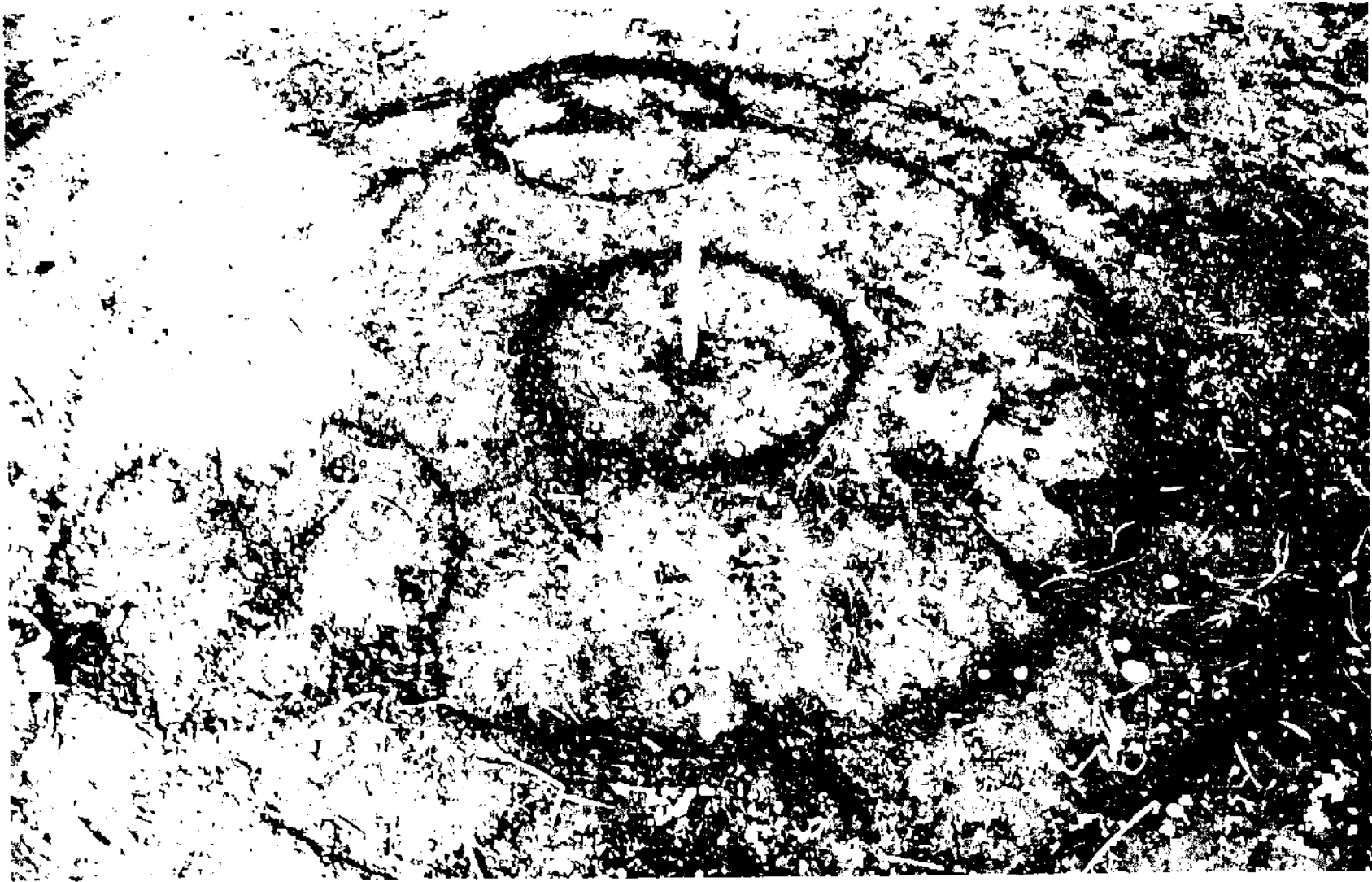

FLOOR SLAB

The floor slab has a diameter of 2.20 m and is 10 cm thick. It is reinforced with 24 m of re-rod (ϕ 6 mm). The 1:2:3 concrete mixture requires 2 sacks of cement and about 1 barrelful of gravel.

FIGURE 4. The Pillar

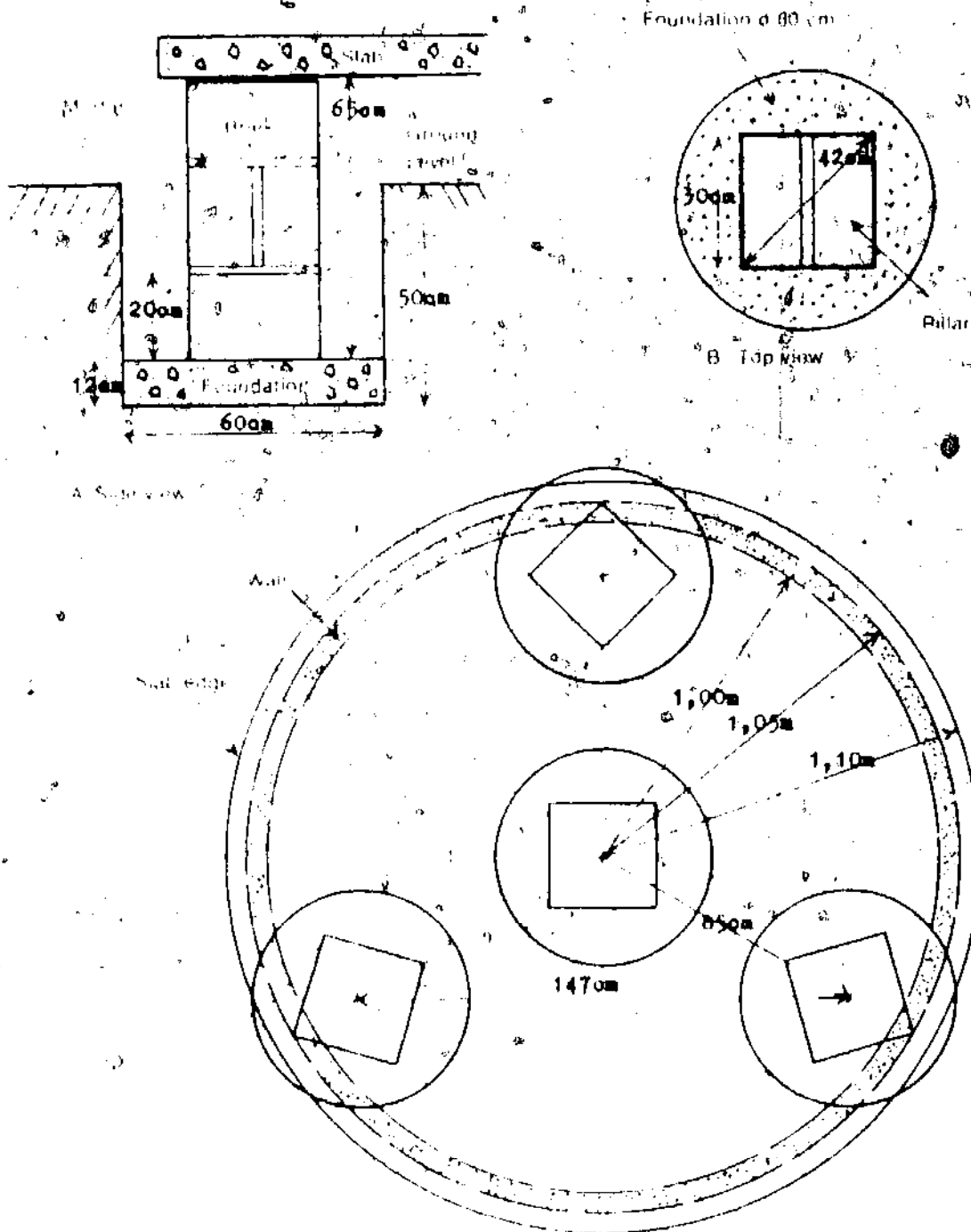

Pillar placement under the slab - 4.5 ton site

FLOOR SLAB

The floor slab has a diameter of 2.20 m and is 10 cm thick. It is reinforced with 24 m of re-rod (ϕ 6 mm). The 1:2:3 concrete mixture requires 2 sacks of cement and about 1 barrelful of gravel.

FIGURE 4. The Pillar

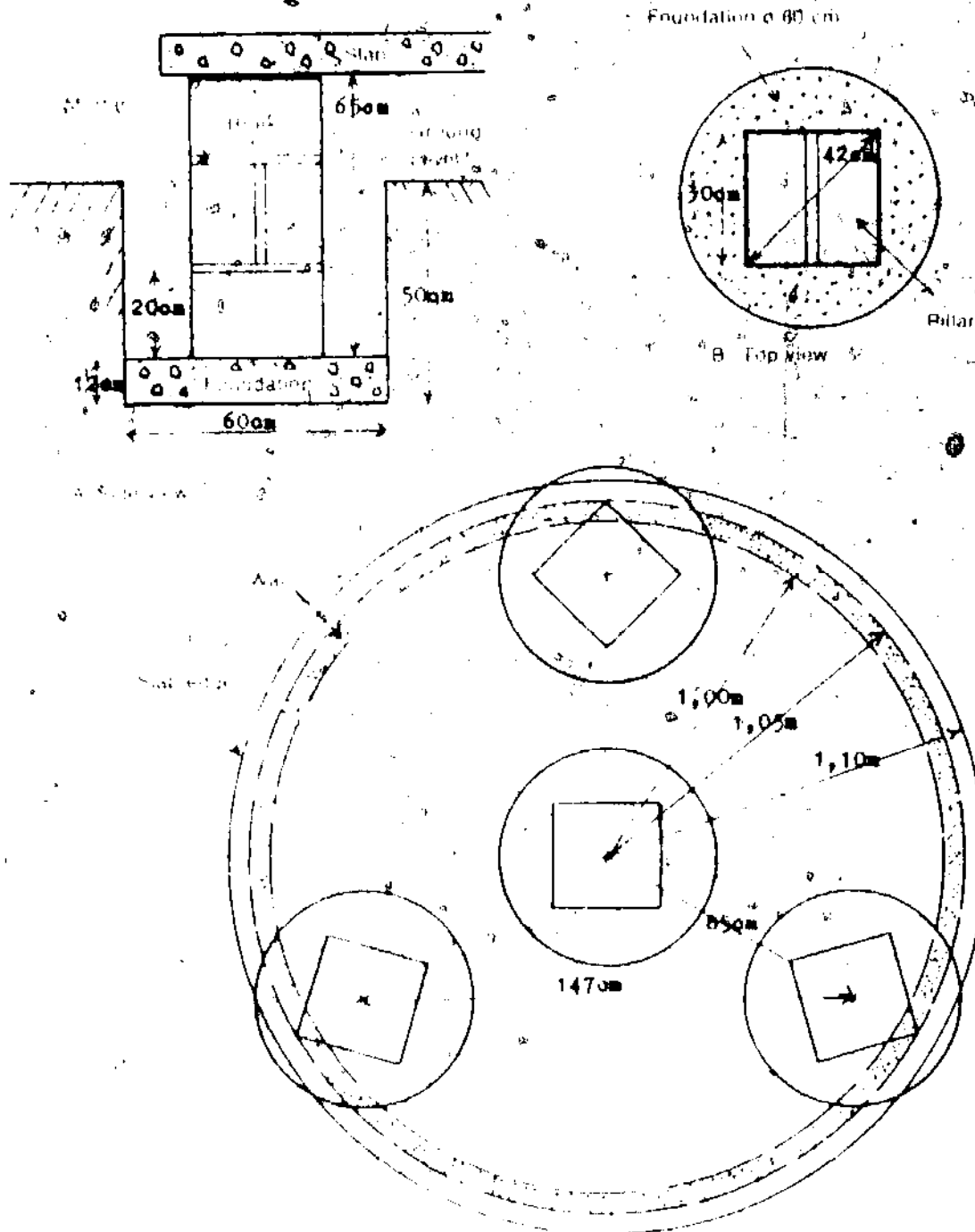

Reinforcing steel under the slab - 4.5 ton pile

Table-1 CONSTRUCTION Materials

C) LABOR REQUIREMENTS

SILO	- Staves	3	man-days
	- Pillar bricks	1	man-day
	- Mounting pillars	1	man-day
	- Floor Slab	1	man-day
	- Mounting silo wall	0.5	man-day
	- Plastering	1	man-day
	- cover slab	1	man-day

For the form work, 29 large staves (3 more than for the silo wall) are placed temporarily around the outside of the pillars in a circle of 111 cm radius. The staves are held in place with two wires with tighteners which later will be used for the walls. The round formwork is filled with dirt or sand to the level of the pillars, dampened and tamped. The location of the outside corner of the pillars should be marked on the formwork to aid in later placement of the re-rod armature. The inner face of the staves is lined with paper, plastic or masonite to prevent sticking when the staves are later removed. The thickness of the slab can be marked on the formwork also. Tar paper or plastic must be placed over the pillars as a permanent moisture barrier.

RE-ROD ARMATURE (see fig 5)

The re-rod armature requires four bars 6 m long - 6 mm ϕ . To make the armature pattern, first draw a circle on the ground with a radius of 1.05 m. Divide the circumference into three equal parts by choosing a point on the circumference and with the radius (1.05 m) mark off two points on the circumference, one on each side of the chosen point. From each of these two points once again mark off another point with the radius (1.05 m). These last two points, with the initial chosen point divide the circumference into three equal sections. From each of the 3 tri-section points draw an arc crossing through the circumference with a radius 150 cm.

The bar which forms the circumference is 6.60 m long requiring one 6 m bar and a one meter piece which will be attached with 10 cm hooks bent

Table-I CONSTRUCTION Materials

C) LABOR REQUIREMENTS

SILO	- Staves	3	man-days
	- Pillar bricks	1	man-day
	- Mounting pillars	1	man-day
	- Floor Slab	1	man-day
	- Mounting silo wall	0.5	man-day
	- Plastering	1	man-day
	- cover slab	1	man-day

For the form work, 29 large staves (3 more than for the silo wall) are placed temporarily around the outside of the pillars in a circle of 111 cm radius. The staves are held in place with two wires with tighteners which later will be used for the walls. The round formwork is filled with dirt or sand to the level of the pillars, dampened and tamped. The location of the outside corner of the pillars should be marked on the formwork to aid in later placement of the re-rod armature. The inner face of the staves is lined with paper, plastic or masonite to prevent sticking when the staves are later removed. The thickness of the slab can be marked on the formwork also. Tar paper or plastic must be placed over the pillars as a permanent moisture barrier.

RE-ROD ARMATURE (see fig 5)

The re-rod armature requires four bars 6 m long – 6 mm ϕ . To make the armature pattern, first draw a circle on the ground with a radius of 1.05 m. Divide the circumference into three equal parts by choosing a point on the circumference and with the radius (1.05 m) mark off two points on the circumference, one on each side of the chosen point. From each of these two points once again mark off another point with the radius (1.05 m). These last two points, with the initial chosen point divide the circumference into three equal sections. From each of the 3 tri-section points draw an arc crossing through the circumference with a radius 150 cm.

The bar which forms the circumference is 6.60 m long requiring one 6 m bar and a one meter piece which will be attached with 10 cm hooks bent

at the ends of each of the two bars. The 3 arcs require pieces 2.80 m long. The three straight bars which intersect at the center of the slab are 230 cm long. To cut the bars without unnecessary wastage of materials, carefully cut the bars into the following sized pieces

1st bar 6 m not cut (for outer circle)

2nd bar 6 m $230 + 230 + 100 + 40$

3rd bar 6 m $280 + 280 + 40$

4th bar 6 m $280 + 230 + 40 + (50 \text{ cm for bouchon circle})$

Bend the three 280 pieces to follow the 3 arcs. Bend 10 cm hooks at the ends of each piece. Also bend 10 cm hooks at the ends of the three 230 cm pieces and place them straight across the diameter of the circle each, passing through the center and one of the three intersection points of the three arcs. With fine wire, attach all hooks and intersecting points of the re-rod armature. Before pouring the cement for the slab, it is important to place the armature in the formwork to assure that it fits and that the arc intersection points cross over the pillars.

The concrete should be mixed so that it can be worked easily but does not flow. The inside of the formwork should be wetted thoroughly before pouring the cement. 4 cm of concrete should be poured and tamped before placing the armature, making sure to align it with the marks indicating the pillars. Cover the armature with 6 cm layer of concrete for total of 10 cm and tamp well. **If the dalle is not well tamped it will not support the weight of the silo and stored corn.** Finally, smooth the surface and level. **If the surface is not well levelled it will cause problems later in mounting the wall. It is extremely important to water the dalle 3 times per day for 7 days and dry in the shade.**

MOUNTING THE WALL

The bottom slab should be allowed to dry at least a week before mounting the wall. In addition to the 91 large staves and 26 small ones, 1 roll of 3 mm galvanized wire (4 kg) and 10 wire tighteners are needed.

Trace a circle of 100 cm radius from the center on the slab. The first layer consists of 13 large and 13 small staves alternately placed around the circle with the smaller faces inside. A thin layer of 1.6 mortar may be placed under the staves for proper seating. The large stave with the emptying hole must be placed in the bottom layer with the hole towards

at the ends of each of the two bars. The 3 arcs require pieces 2.80 m long. The three straight bars which intersect at the center of the slab are 230 cm long. To cut the bars without unnecessary wastage of materials, carefully cut the bars into the following sized pieces.

1st bar 6 m not cut (for outer circle)

2nd bar 6 m $230 + 230 + 100 + 40$

3rd bar 6 m $280 + 280 + 40$

4th bar 6 m $280 + 230 + 40 + (50 \text{ cm for bouchon circle})$

Bend the three 280 pieces to follow the 3 arcs. Bend 10 cm hooks at the ends of each piece. Also bend 10 cm hooks at the ends of the three 230 cm pieces and place them straight across the diameter of the circle each, passing through the center and one of the three intersection points of the three arcs. With line wire, attach all hooks and intersecting points of the rebar armature. Before pouring the cement for the slab, it is important to place the armature in the formwork to assure that it fits and that the arc intersection points cross over the pillars.

The concrete should be mixed so that it can be worked easily but does not flow. The inside of the formwork should be wetted thoroughly before pouring the cement. 4 cm of concrete should be poured and tamped before placing the armature, making sure to align it with the marks indicating the pillars. Cover the armature with 6 cm layer of concrete for total of 10 cm and tamp well. **If the dalle is not well tamped it will not support the weight of the silo and stored corn.** Finally, smooth the surface and level. If the surface is not well levelled it will cause problems later in mounting the wall. **It is extremely important to water the dalle 3 times per day for 7 days and dry in the shade.**

MOUNTING THE WALL

The bottom slab should be allowed to dry at least a week before mounting the wall. In addition to the 91 large staves and 26 small ones, 1 roll of 2 mm galvanized wire (4 kg) and 10 wire tighteners are needed.

Trace a circle of 100 cm radius from the center on the slab. The first layer consists of 13 large and 13 small staves alternately placed around the circle with the smaller faces inside. A thin layer of 1.6 mortar may be placed under the staves for proper seating. The large stave with the emptying hole must be placed in the bottom layer with the hole towards



Photo - Erik Bentzen
Photo - Erik Bentzen

Photo - Erik Bentzen
Photo - Erik Bentzen



Photo - Erik Bentzen

Staves held in place with two wires; round formwork filled in with dirt or sand to level of pillars. dampened and tamped and lined with paper or plastic to prevent sticking when staves are later removed.

FIGURE 5 Reinforcing rod pattern – 4.5 ton silo

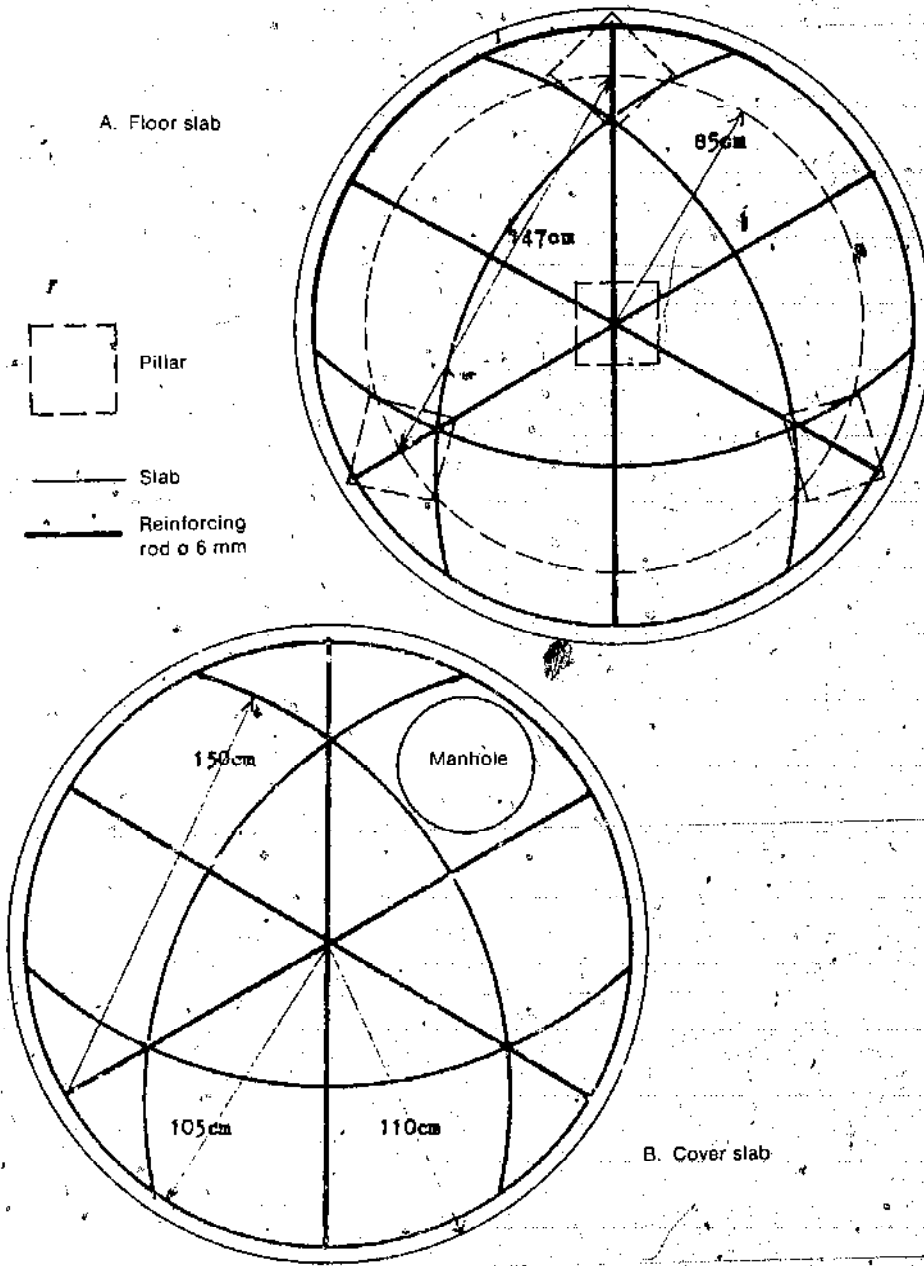

the bottom of the silo: This stave should be placed to facilitate emptying of the silo (i.e. not next to the dryer chimney). No mortar is placed between the staves. At each 25 cm of height a retaining wire is placed and tightened. For the bottom 25 cm, 2 wires should be placed 8 cm from the top and the bottom of the small staves, (one above and one below the emptying hole). The tighteners should be placed only on the bottom of the large staves, and when tightened should be centered on them. Each successive layer is made by placing 13 large bricks in the gaps until a height of 2.00 m (4 large staves vertically) is reached. The final layer is completed by placing 13 small staves in the remaining gaps, held in place by 2 wires 8 cm from the top and the bottom of the small staves.

COVER SLAB (see fig. 6)

The cover slab is like the floor slab except that it must have a filling hole. It should be 8 cm thick and 2.20 m in diameter. The 1:2:3 concrete mixture uses 2 sacks of cement, 1 barrelful of gravel. 4 bars of re-rod (\varnothing 6 mm) are necessary.

The formwork is made by covering the top of the wall completely with boards and placing an upright collar of masonite held in place with nails 3 cm outside of the limits of the walls. If the boards are not strong enough to support the weight of a man without sagging, they should be braced from the inside. Paper or plastic should be placed completely covering the boards inside the masonite circle to prevent the concrete from sticking to the boards.

The man hole (for entry and filling) formwork should be 20 cm inside the masonite circle. It should be a 50 cm diameter circle made with masonite held in place with nails or an inverted basket.

The reinforcing armature is the same as for the floor slab except that space must be left for the man hole. Test the re-rod armature for fit in the formwork before pouring concrete. A 4 cm layer of concrete should be poured and tamped before placing the armature. After completing the pouring, the slab should be tamped and smoothed out with a slight slope away from the entry hole.

A cover 6 cm thick and 10 cm larger than the man hole can be made with the concrete which is left over. The formwork can be a masonite strip or a hole lined with paper. A small re-rod armature should be placed in the



Photo— Erik Bentzen

Mounting the wall: In addition to 91 large staves and 26 small ones, one roll of 3 mm galvanized wire (4 kg) and 10 wire tighteners are needed.

middle to anchor a handle (see diagram). Curing and drying of the top slab are the same as for the bottom slab except that extra care should be taken to assure that the slab is dry before removing the formwork (at least 10 days). It is easiest to remove the boards through the use of levers. Care must be taken not to exert pressure on the strip between the entry hole and outer wall as this is the weakest point of the slab. After taking out the boards for the formwork, the space between the cover slab and the upper walls should be closed with a rich mortar. Finally, a ring of mortar should be placed around the man hole, covered with paper, and the cover seated on it. This will provide a raised horizontal joint to prevent the entrance of water around the hole.

EMPTYING HOLE PLUG AND ANTI-THEFT SYSTEM:

The plastic plug can be mortared into place, taking care that it is not placed so far into the wall to prevent unscrewing it. Anti-theft device (see fig. 7): with three 40 cm pieces of re-rod remaining from the bottom and top slab armatures, two hinges and one clasp will be made for the anti theft device. Bend each piece into a "U", the hinges with 5 cm between the legs of the "U" and the clasp with 3 cm. With the 5 cm hinges bend the legs perpendicular to the "U" 5 cm from the bottom of the "U". With the 3 cm clasp, bend each of the two legs in opposite directions, parallel to the "U", 5 cm from the bottom of the "U". With the 3 cm clasp, bend each of the two legs in opposite directions, parallel to the "U", 5 cm from the bottom of the "U". Next, with the bottom removed from one of the dryer barrels, cut a piece 20 cm wide and 25 cm long. Pierce two holes on one of the 20 cm sides 2 cm in from the side and 4 cm from each end. One hinge will pass through each of these holes. Next cut a slot 5 cm long and 1.5 cm wide, centered on the other 20 cm side of the metal plate, 3 cm in from the edge. Slip the ends of the bottom hinge under the first wire on one side of the emptying hole and the top hinge under the second wire on the same side. Next hook the two legs of the clasp under the first and second wire on the other side of the emptying hole. Adjust the placement of the hinges and clasp so that the plate will swing easily and close over the clasp.



Photo – Erik Bentzen
4 cm of concrete poured and tamped before placing re-rod armature; then covered with another 6 cm layer of concrete.

FIGURE 6 The Manhole Cover

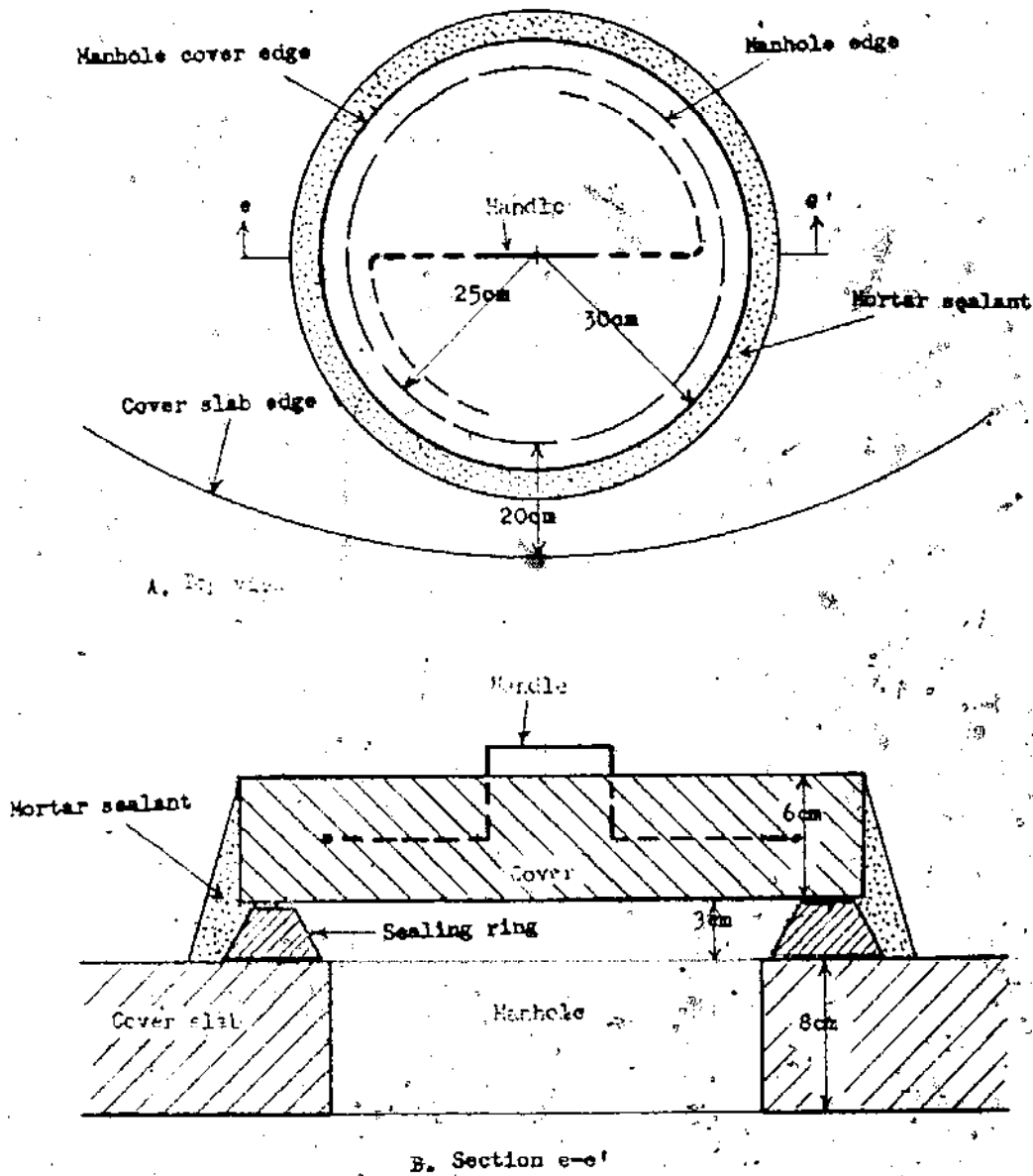
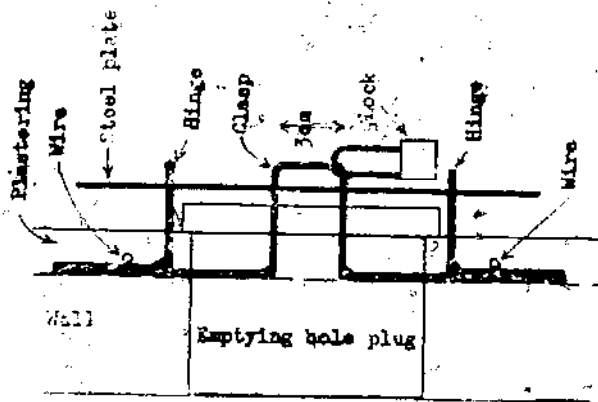
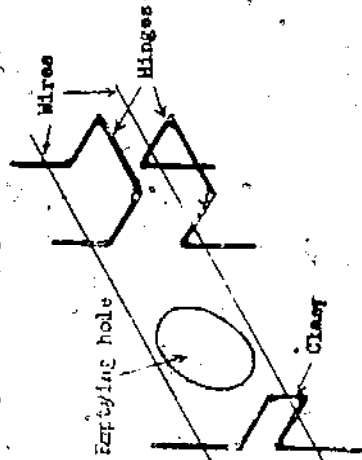

FIGURE 7. The Anti-theft System



B. Section f-f'



D. Isometric View

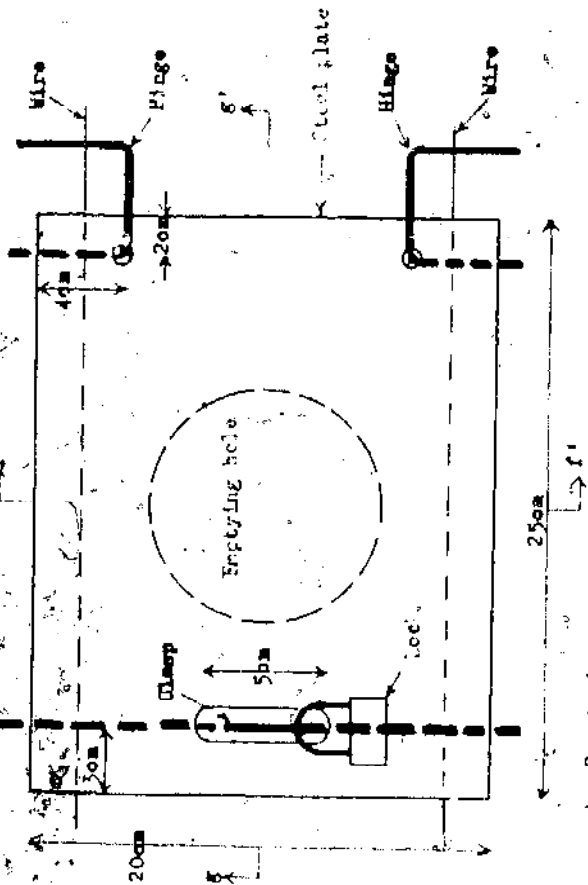

A. Front view

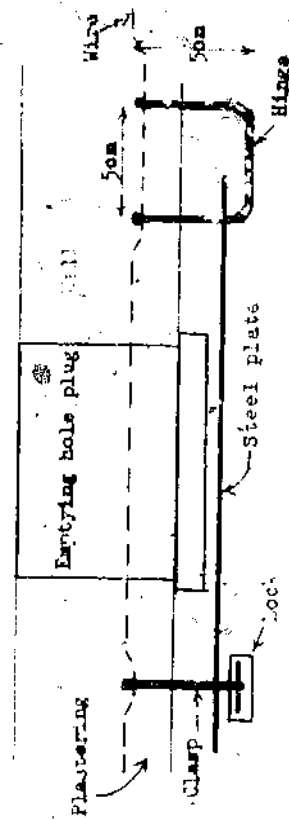

C. Section g-g'



Photo – Erik Bentzen
To make cover slab (with filling hole) two concentric masonite forms are held in place with nails atop wooden planks and filled with 8 cm concrete including reinforcing armature.

The mortar applied to the exterior of the silo walls will secure the arched assembly in place. To assure tight sealing of the emptying hole plug the plastering should be done carefully around it.

PLASTERING

Can be done before or after the placement of the cover slab. The outside walls should be plastered 2 cm thick with a 1:6-8 mortar mixture. The inside joints should be closed with a cement wash or plaster to keep grain from lodging in the joints and to decrease the permeability. One sack of cement is required for plastering and closing the interior joints.

PAINTING

Before the silo can be used it should be allowed to dry for at least one month. The permeability of the silo can be further decreased by the application of coaltar. The painting should be done so that it covers the outside surfaces of the silo wall and the cover slab. The interior floor should be painted also. If painted, it should be allowed to dry for at least two weeks before storing corn to prevent sticking. The plastering should be allowed to dry at least 2 weeks before painting with coaltar.

CONSTRUCTION OF THE 2.5 T SILO (see fig. 8)

Silos can be built with the same basic design as the 4.5 T silo by varying the height of the walls, by varying the diameter of the bottom slab (see table 2).

The 2.5 T silo is of the same basic construction as the 4.5 T silo with certain modifications due to its smaller size. Due to its smaller capacity, the 2.5 T silo is primarily useful for farmers with smaller production capabilities especially where a cooperative dryer is available. Silos smaller than 2.5 T become less economical. This 2.5 T silo has an interior diameter of 1.50 m and an interior height of 2 m giving a volume of 3.5 cubic meters.



Photo – Erik Bentzer

Outside walls should be plastered with 2 cm thick mortar mixture.

TABLE II: SILO SIZES AND CAPACITIES

Diameter	Height	Volume	Capacity (Corn)	Number of Large	staves Small
1.50 m	1.00 m	1.77 m ³	1325 kg	33	22
1.50 m	1.25 m	2.21 m ³	1650 kg	44	22
1.50 m	1.50 m	2.65 m ³	2000 kg	55	22
1.50 m	1.75 m	3.09 m ³	2325 kg	66	22
1.50 m	2.00 m	3.53 m ³	2650 kg	77	22
2.00 m	1.00 m	3.14 m ³	2350 kg	39	26
2.00 m	1.25 m	3.93 m ³	2950 kg	52	26
2.00 m	1.50 m	4.71 m ³	3625 kg	65	26
2.00 m	1.75 m	5.50 m ³	4125 kg	78	26
2.00 m	2.00 m	6.28 m ³	4600 kg	91	26

The total height of the silo from ground level is 2.50 m (same as 4.5 T) and the total diameter of the bottom slab is 1.70 m.

The material requirements for this silo are given in Table 1.

PILLARS

The 2.5 T silo requires 3 pillars (18 pillar bricks 14 x 30 x 20). The holes for these pillars are centered on the trisection points of a circle of radius 60 cm from the slab center. The pillars are mounted with the outside corners 81 cm from the slab center.

The formwork for the floor slab of the 2.5 T silo is built in the same way as for the 4.5 T silo, placing the large staves upright, on a circle of radius 86 cm, around the outside of the pillars. Twenty five large staves are required to complete this circle.

RE-ROD ARMATURE

The patterns for the slab reinforcing armatures are shown in **figure 8**. The armature requires 2 bars of re-rod used as follows: trace a circle on the ground with radius 80 cm. Concentric with this circle trace a circle of radius 45 cm. Tri-spet the 45 cm circle and place stakes at the trisection points. One bar of re-rod is bent and cut to fit along the 80 cm outer circle and the other bar is cut into 3 pieces (each 2 m long). These 3 pieces are bent in smooth curves so that each piece touches two of the stakes, and each end hooks around the outer circle. The armature for



Photo - D. Dichter

Moisture transfer through walls of stave silo can be prevented by applying outside layer of coaltar. Shown here are two completed 4.5 ton cement stave silos; part of a cluster of five such units belonging to a farmer's co-operative association in Benin, West Africa.

Figure 8: Reinforcing Rod Pattern – 2.5 ton silo

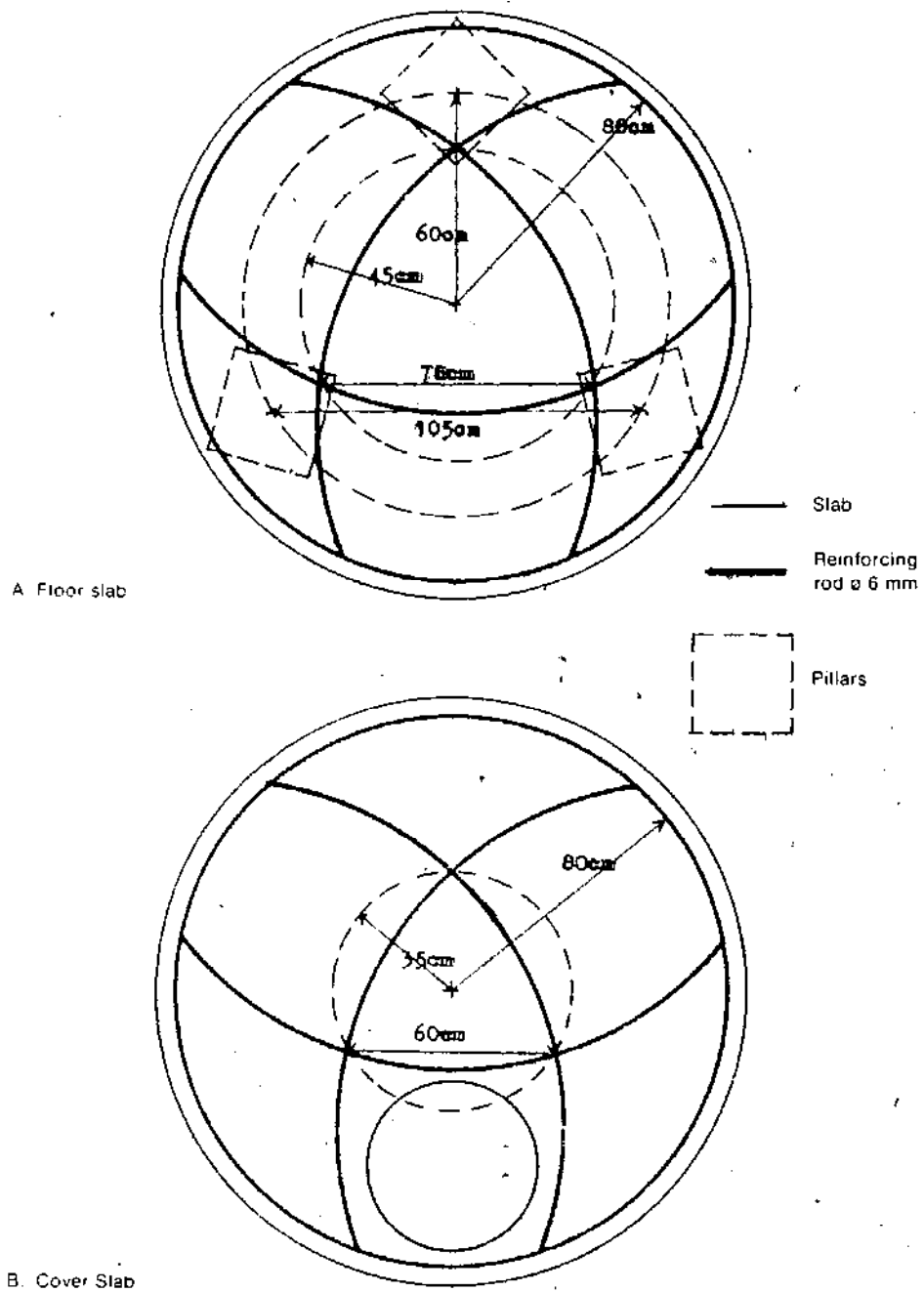

the cover slab is the same except the inner circle has a radius of 35 cm to allow space for the man hole. The 2.5 T silo slab is poured in the same manner as the 4.5 T silo slab with a thickness of 10 cm, requiring 1.5 sack of cement.

The silo wall requires 77 large and 22 small staves which are made with smaller width molds whose dimensions are given in **table 3**. Four sacks of cement are needed for the staff fabrication. The wall is formed by placing 11 large and 11 small staves alternately on a circle of diameter 1.50 m centered on the slab.

INSTRUCTIONS FOR THE USE OF YOUR SILO

If you want to be sure to have good quality storage of your harvest, it is important to understand the proper way to use your silo and dryer. To use them correctly isn't difficult or complicated. It simply needs care and attention at the right times.

I. The Shelter

The silo and dryer must have a good roof over them to protect them from the rain. Before you start construction, you must build a good, solid shelter. It is very important to frequently check the roof covering the silo and dryer to make sure that there are no holes in it which will let rain water fall on the silo or dryer. Any holes should be repaired immediately since rainwater will weaken the dryer wall, and can seep through the silo causing the grain to rot.

II. The Silo

1. After completion of the silo, it should be allowed to dry for at least one month before beginning storage. If the silo is painted with coal tar, this should be done after letting the wall mortar dry for two weeks. In this case, you should wait at least two more weeks, for a total drying time of one month, to allow the coal tar to dry on the silo floor to prevent grain from sticking to it.
2. During the entire time of storage, the silo filling and emptying holes should be well sealed. Each time you add grain to the silo, it should be carefully re-sealed. This can be done with cement mortar or banco. Banco is less expensive and easier to use. If the emptying hole

does not seal tightly, it can be well sealed with melted candle wax or banco.

3. Shortly before the beginning of storage each year, someone should get inside the silo to clean it and check for cracks in the walls. These can be easily seen because light will pass through even the smallest cracks. If any cracks are found, they should be carefully covered with a mixture of cement and water.
4. The proper use of insecticide is essential for grain storage in your silo. Even though the silo is completely closed and insects cannot enter to attack the stored grain, there will always be some insects in the grain at the time of filling. The insects not only destroy the grain by eating it but can cause conditions leading to rotting. This makes it necessary to properly employ insecticides to assure that all insects in the silo are dead.

The two basic kinds of insecticides are

- 1) those in powder form (contact insecticides) which are mixed evenly with the grain and
- 2) the fumigant or gas form which is used only in closed containers like a well-sealed silo.

(Liquid contact insecticides are not very practical for smallscale grain storage. They are difficult to apply evenly and since they are mixed with water, this increases the moisture content of the stored grain and can cause rotting if done improperly.)

Powdered (contact) insecticides must be mixed very evenly with every sack or basket of grain emptied into the silo. This means that if powdered insecticides are used, each load of corn removed from the dryer must be treated individually. It is impossible to treat the grain with this type of insecticides once the silo has been filled, without emptying it completely and treating during the refilling.

It is very important to understand that there are insecticides which are safe to use on food which will be eaten by men or animals and that there are others which are to be used ONLY on plants like cotton which are NOT TO BE EATEN. Insecticides commonly used on cotton like 45-12, Endrine and HCH are very strong and can cause people or animals to become sick or die if used on their foods like maize or beans. For this reason, it is very important to ask your agri-

cultural agent to help you select and apply insecticides whenever you use them.

It is very important to **READ AND FOLLOW THE DIRECTIONS** for any insecticides used. The **exact** recommended dosage should be applied. Less than the recommended dosage will be ineffective and too much will not only be wasteful and expensive, **BUT COULD BE DANGEROUS. NEVER** use an insecticide you don't know or that you haven't asked your agricultural agent about.

The easiest and recommended insecticides to use in your silo is the fumigant or gaseous kind. Testing done by agricultural experts in Benin has found PHOSTOXIN to be one of the most convenient and effective forms of fumigant insecticides to use in your silo. This can be purchased only through your agricultural extension agent or a approved sales agent. PHOSTOXIN is a very poisonous gas which kills the insects in the silo when they breathe it. It is in a small tablet which turns into a poisonous gas when it is taken out of its specially sealed can and exposed to the air. However, the gas can kill people or animals too if they breathe enough of it. Therefore, it must be used carefully.

When the silo is filled and ready to be treated, the tablet is taken from the can and wrapped in paper or leaves, dropped into the silo on top of the grain and the silo cover is **IMMEDIATELY** sealed with banco. In seven (7) days the gas will become harmless and only powder will remain wrapped up in the paper or leaves. Three to six (3-6) tablets are used for each ton of grain stored, depending on the level of insect attack. Each month, the emptying hole should be opened to check to be sure that the corn is storing well and that no insects are alive inside. Every two months, a new treatment should be made. When emptying the silo, the paper or leaf packages of insecticide dust should be taken out and buried where children or animals will not dig them up.

When you open your silo, if it seems very warm inside or if there is the smell of rotting corn, the silo should be immediately emptied and the corn should be re-dried. This can happen if the corn is not well dried so care should be taken to dry the corn correctly the first time before putting it in the silo.

CLOSED STORAGE SYSTEMS (Continued)

MODEL 4 - CEMENT BLOCK (Square) SILO

The "Tori-Cada" Square Cement Silo was also developed in the West African State of Benin. Originally it was built as an alternative to the more costly metal bins. Although this model has not been as extensively built, tested, or used as the other Closed Storage Systems discussed in this Manual, it is thought to have considerable potential. The Square type Cement Silo has the advantage, in comparison to the round silo, that it is easier to build, and the method is already well known to local craftsmen from the construction of houses. On the other hand the round silo requires less building materials than the square one.

Each bin or silo can be made with a storage capacity ranging from 1 to 7 ton. Standard height is 2 m. To make the silo air-tight each bin is covered by planks of reinforced concrete.

Figure 9 shows the details of the wall construction. Besides the foundation there are 2 layers of reinforced concrete in the walls, one in the middle and one on the top. The concrete floor has a layer of tar paper to prevent water from penetrating into the silo. The walls are plastered on both the inside and the outside and painted with coal tar on the outside to make it airtight and moisture proof. The posts that support the roof of the hangar are made of reinforced concrete and placed in the corners between the silos.

The standard height is 200 cm as mentioned before, the other interior dimensions are as follows:

- Capacity 1 ton : 80 x 80 cm
- Capacity 2 ton : 115 x 115 cm
- Capacity 3 ton : 135 x 135 cm
- Capacity 4 ton : 160 x 160 cm
- Capacity 5 ton : 180 x 180 cm
- Capacity 6 ton : 195 x 195 cm
- Capacity 7 ton : 210 x 210 cm

Naturally the construction price is lowest per ton for the largest silo (7 ton) but it is also cheaper per ton to build 4 silos (bins) together instead of only one.

FIGURE 9 – Cement Block (square) Silo

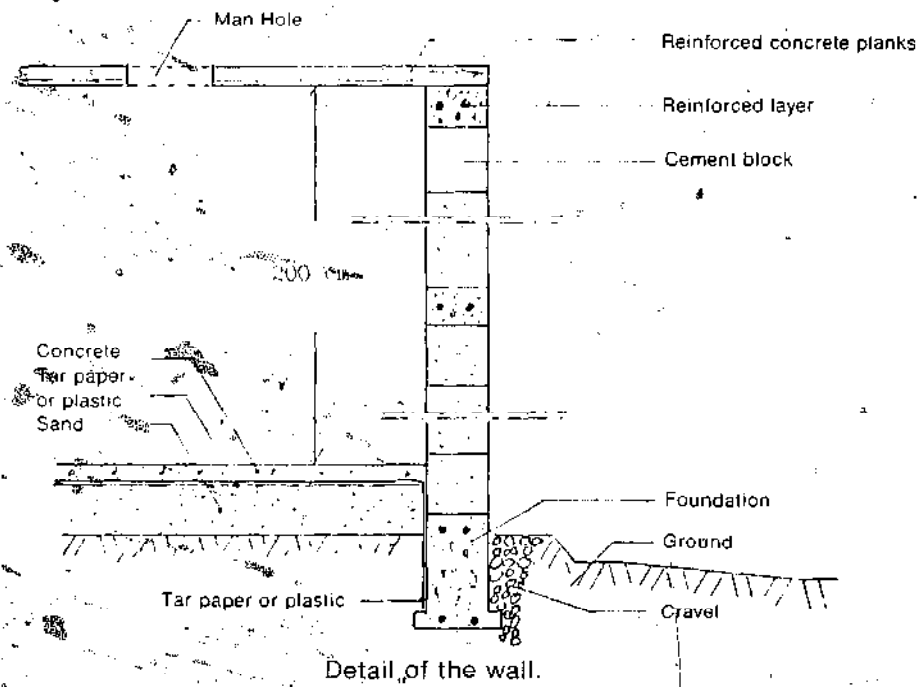
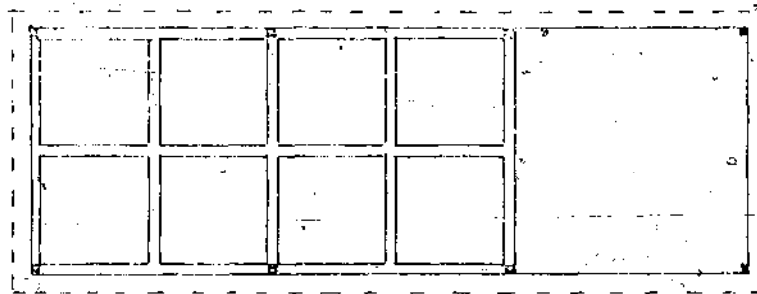
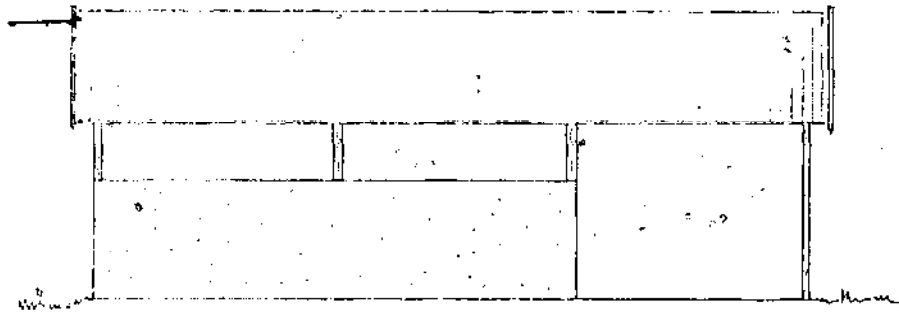

Given below is a detailed description for constructing a single unit Cement Block (Square) Silo with a 5 ton capacity;

This silo when constructed has interior dimensions of 1.80 x 1.80 x 2.70 m, which gives a said capacity of 5 tons. The silo is built primarily out of regular construction bricks 40 x 20 x 10 cm. The design uses building techniques that nearly any local mason already knows.

Once the materials are at the site, building can commence. The first thing to do is dig a hole for the foundation. Select a spot that is level, well-drained, and on solid ground. Trace out a square 2.20 x 2.20 m on the ground, then trace another square with dimensions 1.60 x 1.60 m inside the first square. Between the two squares will be a space 30 cm wide. Dig this space out to a depth of 40 cm. Once this is done, pour a layer of concrete (1 part cement: 2 parts sand: 3 parts gravel) in the hole to a thickness of 30 cm. Water and cure this layer for a few days or a week if possible.

Once the foundation has cured, put a little layer of mortar down. Upon this bricks will be placed until they mount 20–40 cm from ground level. The bricks are placed on their 20 cm wide sides so as to form a wide base for the wall to come later. Depending on soil and humidity conditions, there will be 3–5 layers of bricks. When the appropriate level has been reached and the mortar has cured some, the space formed by the square of bricks can be filled with dirt to a level 8 cm less than the top of the bricks. The dirt should be well tamped and leveled. This hole is then filled with 8 cm of concrete (1 : 2 : 3) til it is exactly level with the top of the bricks. Be sure and water the concrete three times a day for seven days so it will cure well.

When the concrete has cured, cover the entire area of bricks and concrete with tar paper. Over the tar paper a smooth and level layer of mortar (1 part cement: 3–4 parts sand) is laid down. This will be the floor of the silo. The tar paper's function is to keep ground moisture from coming up into the walls and floor of the silo. Any such moisture would rot the corn.

After the mortar has cured, mounting of the walls may start. The bricks are now placed as they normally are in a wall- with the 20 cm side vertical. Leave 5 cm between the outside of the floor and the bricks. This will give the desired interior dimensions of 1.80 x 1.80 m. The brick layers

should be mounted with the joints between brick layers staggered so as to avoid cracks. At each corner the bricks may be staggered or, if the roof is to be supported at each corner of the silo, a space may be left for the eventual peuring of a concrete corner pillar which would also hold the bricks in place.

The bricks are mounted to a level of one meter or five bricks high. At this time a layer of concrete 10 cm wide and 20 cm high is poured. Rerod reinforcement is used. Four 8 mm rerods go the length of the wall and are held in place by bands of 6 mm rerod. The four 8 mm rerods form a rectangle 15 cm high and 5 cm wide. This layer of rerod helps to reinforce the wall against the grain's weight.

Once the concrete layer has cured enough, the wall of bricks may be continued. Five or six additional layers may be put on the concrete middle layer. At the desired level another concrete layer 10 x 20 cm is poured. The rerod pattern and concrete mixture are the same as in the other layer. The only difference between the two layers is the addition of a concrete piece crossing the middle of the silo. This piece will be the support for the top slabs that cover the silo. The middle cross piece is 1.80 m x 20 cm x 20 cm and is reinforced with rerod.

While the concrete layer is drying, the silo may be plastered. The inside and outside should be entirely plastered. A 10-12 cm plastic pipe cap is fitted into one of the lower outside walls in order to empty the silo. A brick may be made with a hole already in it or a hole may be dug into a brick afterwards.

At the time the concrete flooring was poured, the two top slabs for the silo could have been poured. These consist of two 2.00 x 1.00 x 0.60 m slabs. One of the slabs must have an entry hole either 50 x 50 cm square or 50 cm in diameter. Formwork is made on the ground in which the two slabs are poured. A grid of rerod is made with the 2 m length using 8 mm bars and the 1 m width using 6 mm bars. Spaces of 15-20 cm are left between the bars.

As mentioned, one slab must have an entry hole. Thus, one grid must leave space to accommodate the hole. A mixture of concrete (1:2:3) is poured first to a 2-3 cm depth. The rerod grid is placed, then the rest of the concrete is poured to a depth no greater than 6 cm. The proper depth must be maintained if the slabs are to be lifted in place by men. A

small cover slab for the entry hole should also be poured at the same time as the two top slabs. A rero handle should be placed to facilitate handling of the cover slab. **All three of these slabs should be cured by watering three times a day for seven days.** When the slabs have cured, they may be lifted in place and mortared to the wall and each other. Once the entire silo has dried for two or three weeks, it may be painted. This could be done in a couple ways. The outside of the silo and the inside floor might be painted with coal tar. If sun shining on the silo will be a problem, the outside might be painted with whitewash and the inside with coal tar. If sun and rain are no problem, the outside could be whitewashed. The interior also might be whitewashed to make the silo interior brighter when the silo is opened.

As mentioned earlier, the corners of the silo might be made out of reinforced concrete that projects beyond the top of the silo. These corners could then support the roof. Otherwise, a separate roof could be built in order to protect the silo against sun and rain.

To protect against people stealing grain out of the silo, rero or flat pieces of metal could be put in the bricks around the emptying hole. One piece could hinge across the hole and lock to the other piece. The not too serious robber of grain would thus be deterred.



Photo - D. Dichter
Shown here is a large capacity Cement Block (Square) Storage Bin used by a farmer's co-operative organization in Benin,
West Africa.

WORKBOOK EXERCISES

1. What are the principal advantages to using a closed grain storage system?

Notes:

2. Are there any closed storage containers currently in use in your area?

If so, what types are they and how much grain can be stored in them?

Notes:

3. What are the advantages and disadvantages in using the 1.5 ton Improved Mudblock Silo?

Notes:

4. List some of the ways the traditional mud silo has been improved upon.

Notes:

5. Up till now, why have closed-system mud silos been seldom used in humid areas?

Notes:

6. What are the principal advantages in using a cover over the 4.5 ton Cement Stave Silo?

Notes:

7. What are the principal advantages of airtight storage? How can insects be controlled with such methods?

Notes:

8. What are the proper methods to use in storing cement?

Notes:

9. Will closed storage systems work in your area? If so, which of the two suggested models offers the best possibilities and why?

Notes:

10. While concrete is drying, what steps should be taken to prevent it from cracking?

Notes:

CHAPTER VI: CONSTRUCTING AND USING YOUR DRYER

Farmers throughout the world have long recognized the need to dry their cereal grains. Try to put yourself in the farmer's place and take a look at the methods currently used by him.

- Do his present drying methods produce satisfactory results? If they do, why change them? If they do not work, why not?
- By using improved drying methods can he harvest earlier and get his land ready sooner for a new crop?
- Would he be able to maintain a new drying machine? Could he fix it if it broke down? Does he have enough time to operate it?
- Would the initial cost of the dryer be easy for the farmer to recover because with better, more controlled drying it means he will eventually make more money from the sale of his grain?
- Would it be more advisable for him to join a group of farmers and pay for the cost of a dryer with a group? Or does the farmer dry enough grain to make use of a dryer by himself?

In this section, four different drying methods are presented. Three employ the principles of solar drying and one involves the use of oil barrels which are heated with a fire.

1. Traditional Sun-Drying

The oldest and most widespread method of drying grain is **sun-drying**. You should look first at the local techniques of sun-drying in your area. How much work is required of the farm family? What are the losses and inconveniences? In drying maize, for example, the simplest method is often to leave the maize in the field until the moisture content has dropped sufficiently for storage. The principal advantage of this method is that the grain is subject to direct attack by grain-eating insects, birds or rodents.

Another traditional way of sun-drying maize is to leave the cobs or shelled corn on a flat piece of ground in the sun. Experience has shown that this method also doesn't achieve the best results because there is too little movement of air close to the ground, and consequently the drying takes longer. Besides, dust or stones may

be taken up with the crop and contaminate it. It is always worth remembering that clean grain is essential for proper storage!

However, improvements can be made involving even the simplest traditional methods. Rather than dry grain directly on the ground, where the grain can pick up moisture from the earth, you can introduce the farmer to using a plastic sheet. You will probably need a sheet about 10 m x 3 m. It is recommended that the plastic be at least .004 gauge thick.

- Build a mound of hard-packed earth on which to place the plastic. If you use level ground, build a dike of earth around the area on which the plastic will be placed to protect the drying grain from water.
- Make sure there are no rocks, wood and sharp things on the ground where the plastic will go. Plastic tears easily.
- Place the plastic in the prepared place.
- Attach the narrow end of the plastic to straight poles made from bamboo or other smooth material.
- Put clean grain on the plastic. Do not make the grain more than 5 cm deep.
- Stir often so the grain will dry faster. Turning and stirring make sure all parts of the grain are touched by air and sun.
- The rake or other tool used to stir the grain must have smooth, rounded edges. This tool then will not damage the plastic or the grain.
- As the grain dries, moisture from the grain collects on the plastic. After the grain has been drying for two hours, push all the grain to one half of the plastic.
- Let this plastic dry for five minutes or so.
- Push all the grain to the other half of the plastic that is now dry and let this half dry for five minutes.
- The plastic sheet should be aired in this way every two hours while drying is going on.
- Cover the grain at night. Push all the grain to one end and fold the plastic over as a cover.

2. Solar Drying

Increasing attention is being given to improved methods of solar (sun) drying. Although there are several distinct advantages in using solar dryers, i.e., you do not require any fuel (which in many developing countries is becoming increasingly scarce, especially fire wood), the drying time is reduced, and they can be used to dry other crops such as cassava, fruits and vegetables; they also have certain drawbacks – the most important being the extremely high temperatures which build up (65–80°C) inside the box under the plastic sheet. Such high temperatures damage grain like rice (which tends to crack at temperatures above 50°C) and also seed grains.

From the information provided in Chapter II concerning basic principles of drying, it is possible to arrive at a set of requirements for effective **solar drying** of grain in humid climates. These are:

- 1) Both the material to be dried and the surrounding air should be heated.
- 2) There should be maximum possible movement of air over the surface of the material.
- 3) The surface area of material exposed to the air should be as large as possible.

It is not possible to attain requirements 1) and 2) with traditional methods in which material is directly exposed to the sun. Some form of enclosed drying system, in which the material to be dried and the air surrounding it can be heated significantly is needed.

It is nevertheless possible to fulfil these requirements using simple equipment which traps the heat of the sun, but which, at the same time, encourages air movement by convection of heated air. Equipment of this type can be made simply and cheaply using materials which are generally readily available in developing countries.

A. General Description of Partially-enclosed Dryers

The partially-enclosed sun-dryer is a structure which acts as a heat trap, but which is also provided with ventilation openings to allow air to move through the dryer by convection.

Two of the models described in this WORKBOOK (Nos. 1 and 2) are simple, box-like structures, provided with upper and lower ventilation

openings, and closed with a cover of transparent polyethylene film. The cover is "double glazed", i.e., it is made of two layers of film with an insulating air space in between. The box itself is constructed of material which will provide adequate insulation to prevent the escape of heat. All interior surfaces are painted matt-black to achieve maximum absorption and retention of heat. Material to be dried is supported inside the dryer on perforated trays which can be of wire netting or woven from local material such as papyrus reed.

Air movement through the dryer is achieved by convection. As the material to be dried and the air surrounding it becomes heated, the hot air rises and escapes through the upper ventilation openings, resulting in cooler air being drawn in through the lower openings. There is thus a constant movement of heated air over and through the material being dried. Air temperature inside the drier in bright tropical sunlight will usually be twice that of the outside air. Drying temperature can be controlled by opening or closing the upper ventilation outlets.

B. Advantages of Partially-enclosed Dryers

The major advantage of the partially-enclosed sun dryer is, of course, in its ability to generate the high temperature and air movement essential for effective drying in humid climates. However, as mentioned earlier, it also possesses a number of distinct advantages over traditional "open" drying methods, even in areas where high humidity is not a serious problem. Some of these advantages are:

- 1) The dryer is rainproof and can be left in continuous operation without attention, and without the necessity for covering up drying material or removing it into shelter during showers.
- 2) The higher temperatures possible with this type of dryer greatly speed up the drying process, not only giving a much greater output than open methods, but also eliminating the possibility of mold or microbial spoilage which is common with open drying methods.
- 3) As well as protecting the drying material from re-wetting by rain, the covered dryer also gives protection from dust and dirt, from attack by birds and rodents, and from insect infestation.
- 4) The high temperature to which the material is subjected will effec-

tively kill or drive off any insect infestation which may be present in the material as it comes from the fields.

The partially-enclosed dryer will, therefore, produce a well-dried, clean and pest-free product which will be in excellent condition for prolonged storage or for immediate use.

C. General Remarks on Construction of Dryers

Instructions and sketches showing constructional details of two models are given in the following pages. However, since it is intended that these dryers should be made from whatever materials are most readily available locally, it should be noted that such details as to dimensions which are given are meant for general guidance only, and local adaptation in terms of changes in length, width or depth will not affect the efficiency of these dryer. The sketches for Models 1 and 2 are based on a useful practical working size of 8 ft. in length, 4 ft. in width, and 9 to 12 inches overall depth. While there is a limit to which internal depth can be reduced, changes in area can be made to suit local conditions, and dimensions of materials available.

The dimension which is of importance, and which should be adhered to as closely as possible, is the thickness of insulation on the Model 1 box-type dryer. Where wood shavings, wood wool, dried grass, leaves, or similar material is being used, a minimum thickness of 2 inches should be used. Also, for practical reasons, the internal depth of Models 1 and 2 should not be less than 6 inches.

D. Construction of the Model 1 Dryer

Details of the construction of this model are given in Figures 1 to 5. As will be seen, it consists of an outer box and an inner box. The dimensions of the inner box are at least 4 inches less in length and width, and at least 2 inches less in depth than the outer box. The space between the boxes is packed with suitable insulating material. Lower ventilation holes are drilled through the bottom of the boxes (and through battens fitted in the insulation space for this purpose), and slots are cut in the upper edges of the sides of the box to provide upper ventilation openings. The dryer is supported about 6 inches above the ground on four legs (which also form the main corner members for the box).

FIGURE 1
MODEL 1 SOLAR DRYER
SKETCH SHOWING DRYING BOX (WITHOUT COVER OR DRYING TRAYS)

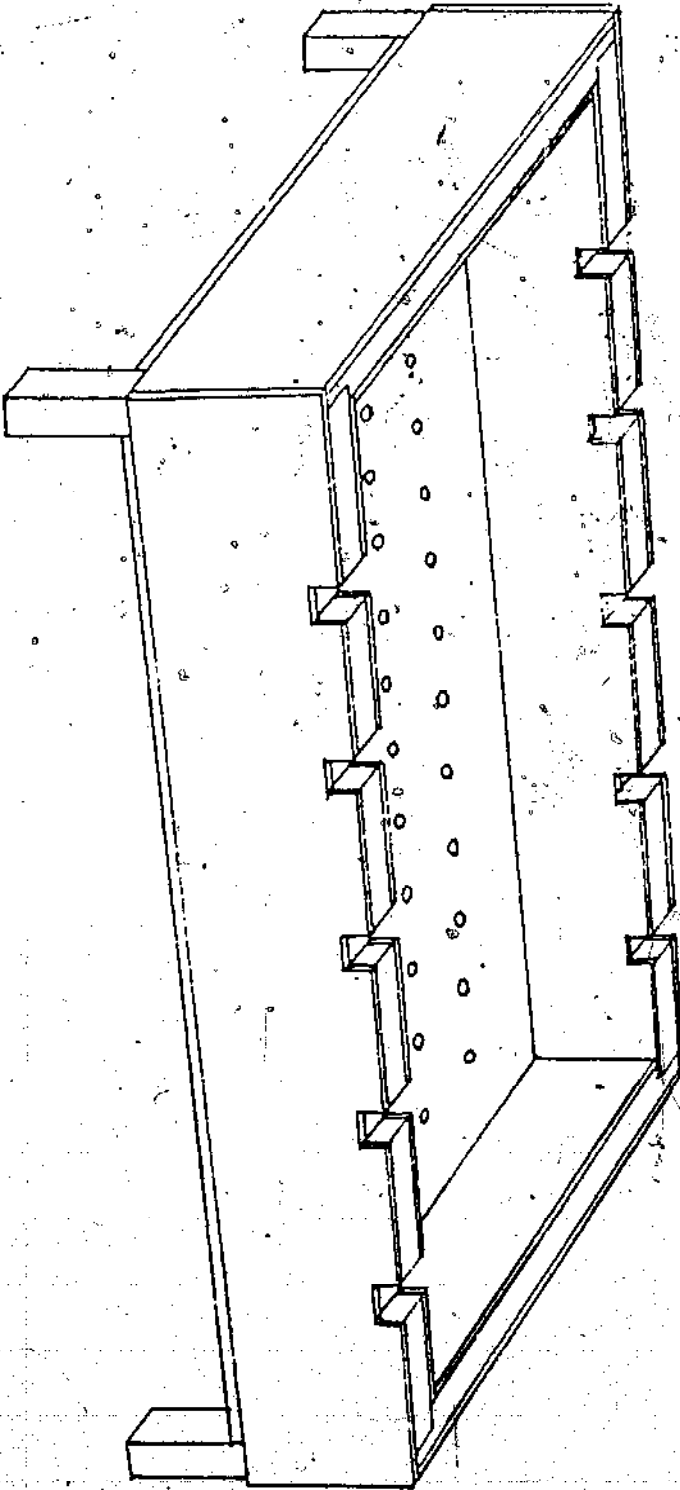

FIGURE 2

MODEL 1 DRYER

PLAN AND ELEVATION DRAWINGS

Scale 1 cm = 6 inches

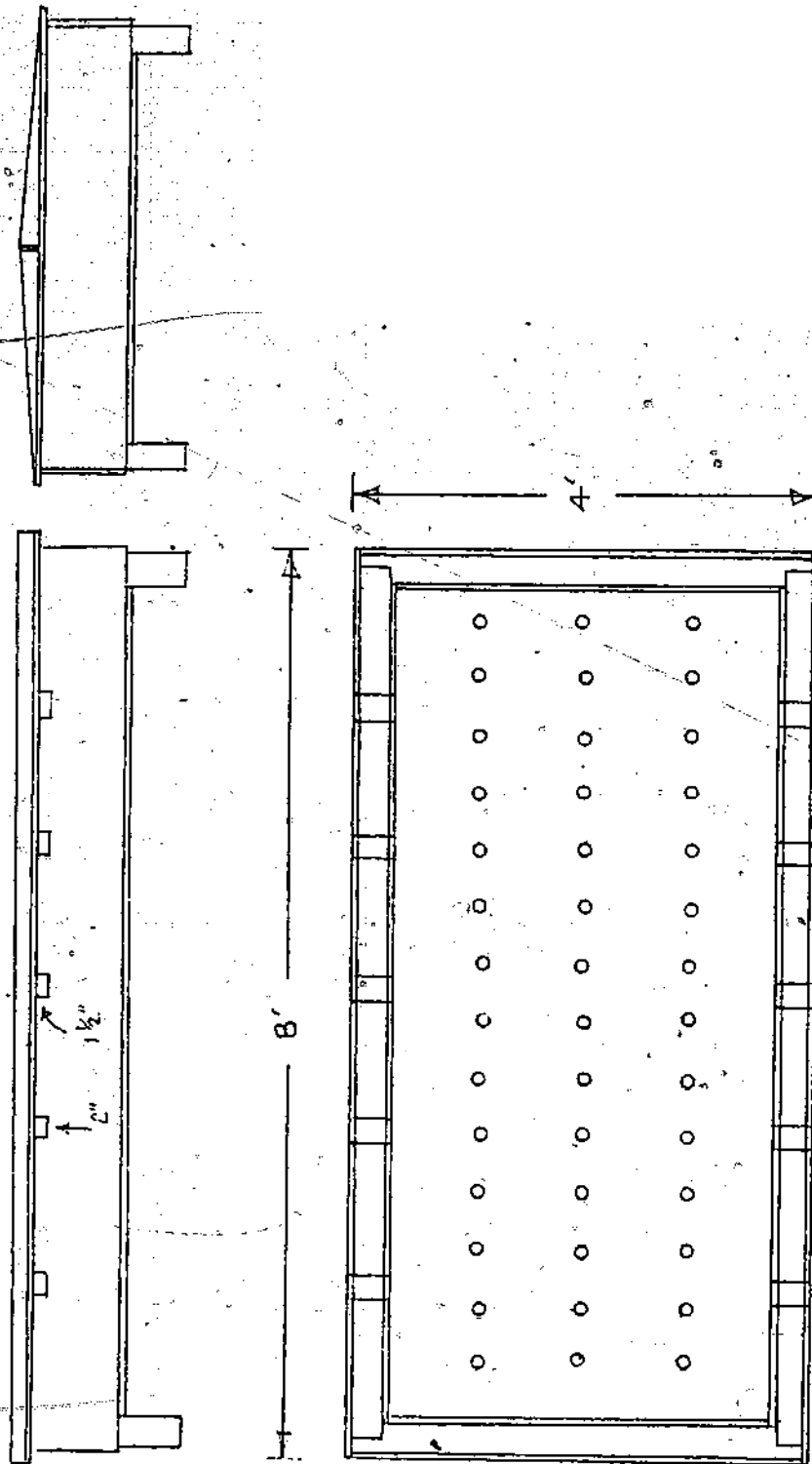

FIGURE 3a

**CONSTRUCTION OF MODEL 1 DRYER
DETAIL OF ONE POSSIBLE TYPE OF CORNER JOINT**

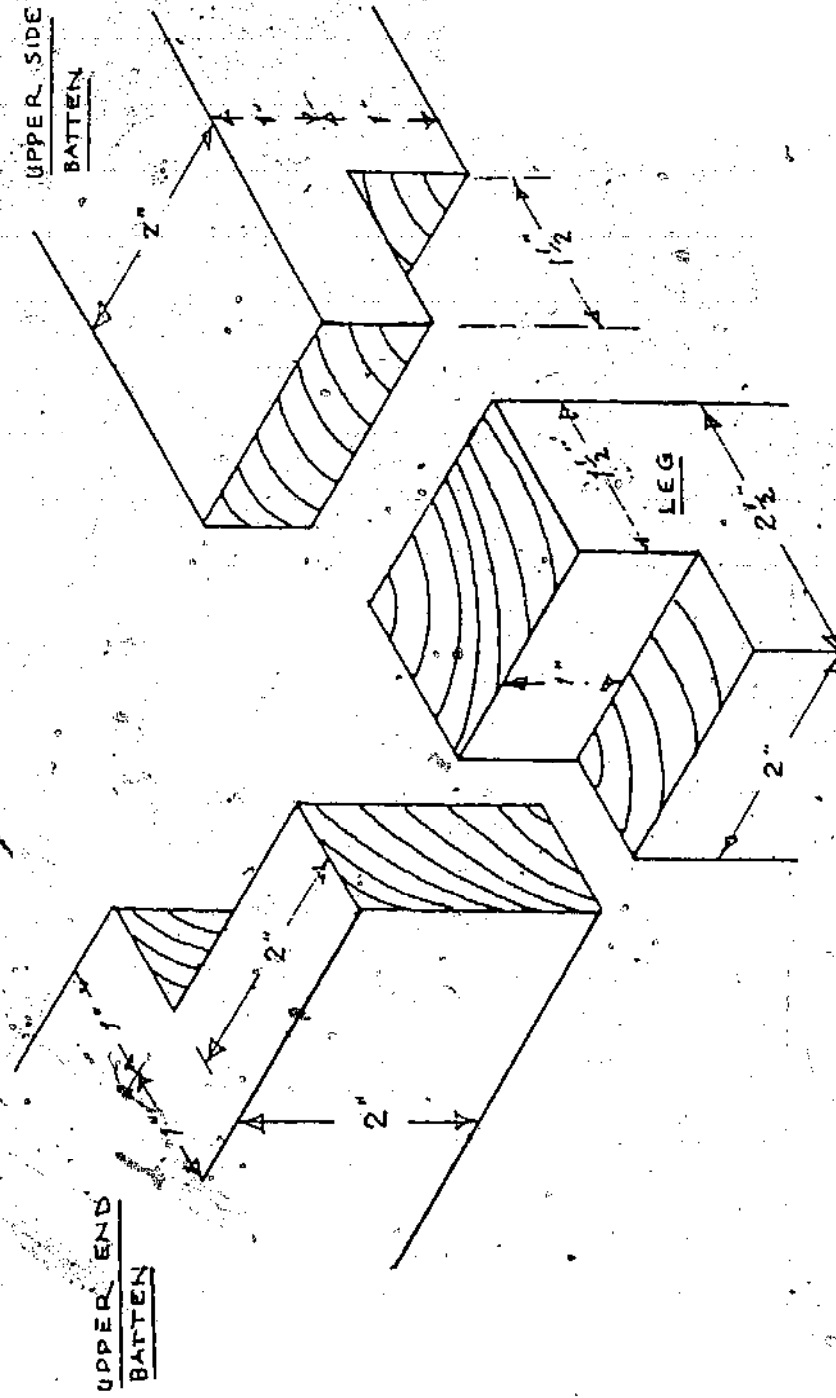

FIGURE 3b
CONSTRUCTION OF MODEL 1 DRYER,
DETAIL OF WEATHERBOARDING

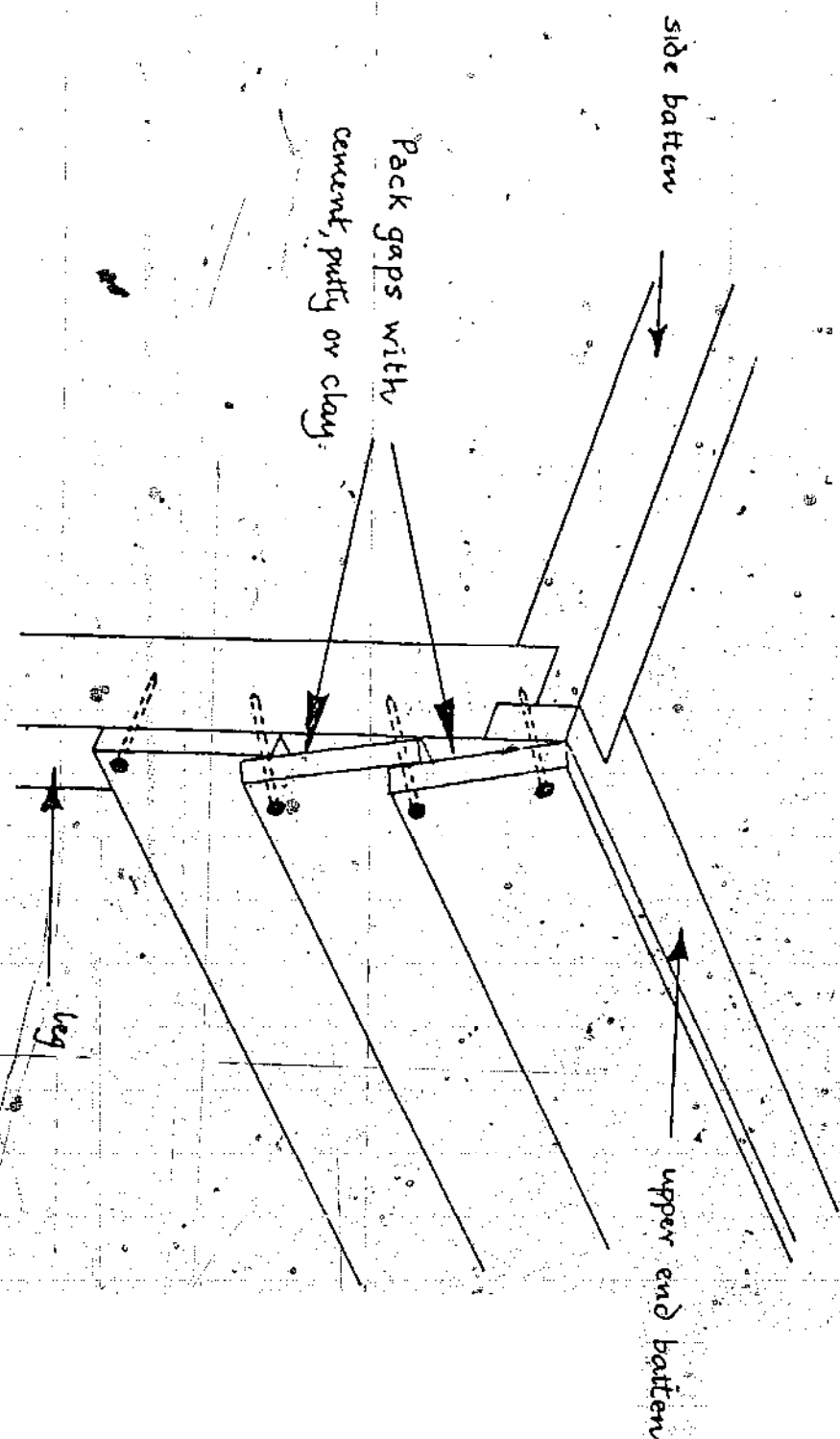

FIGURE 3b

CONSTRUCTION OF MODEL 1 DRYER.
DETAIL OF WEATHERBOARDING

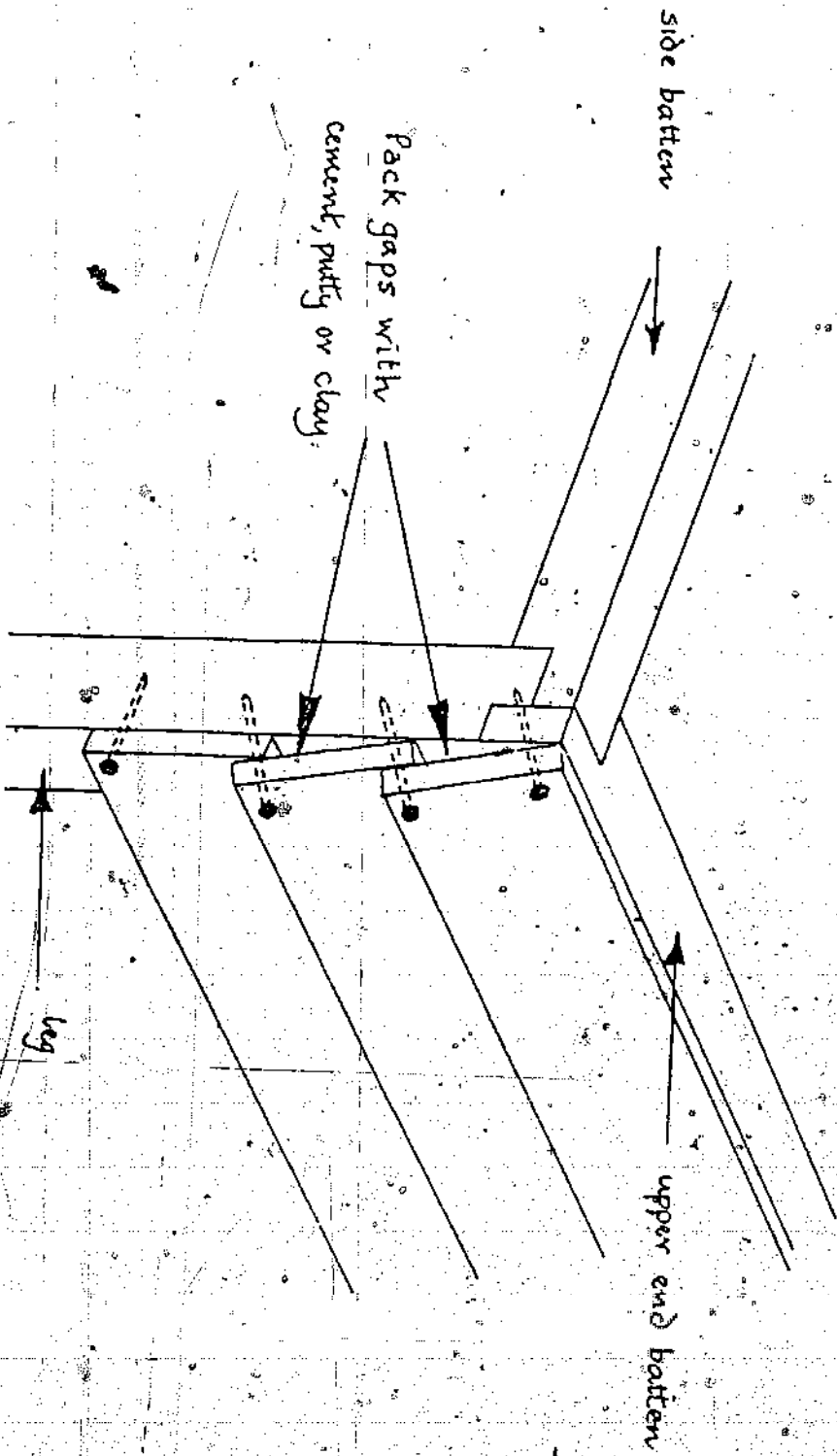

FIGURE 4

CONSTRUCTION OF MODEL 1 DRYER
"CUT-AWAY" SKETCH OF ONE CORNER SHOWING DETAIL OF INTERNAL FRAMING

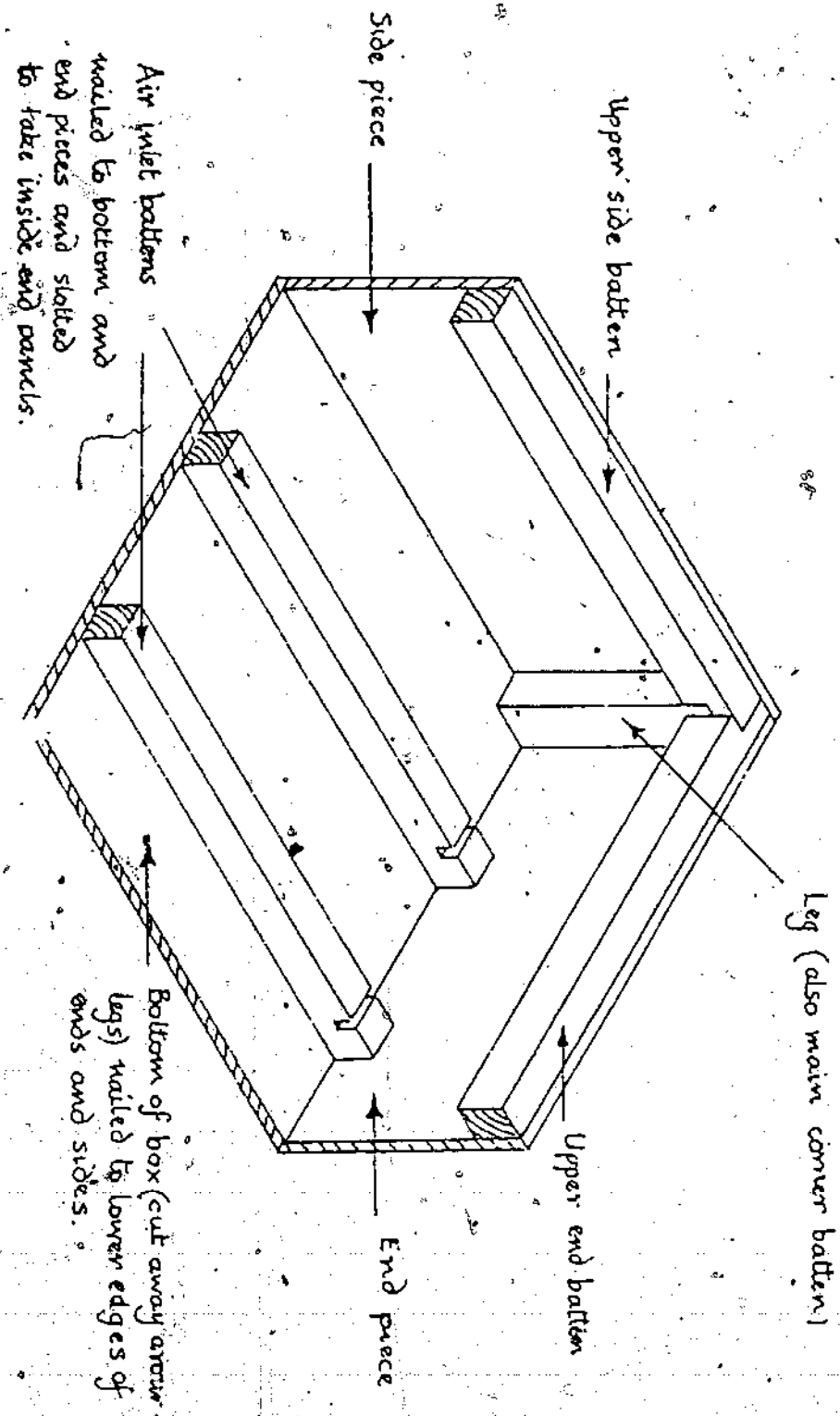
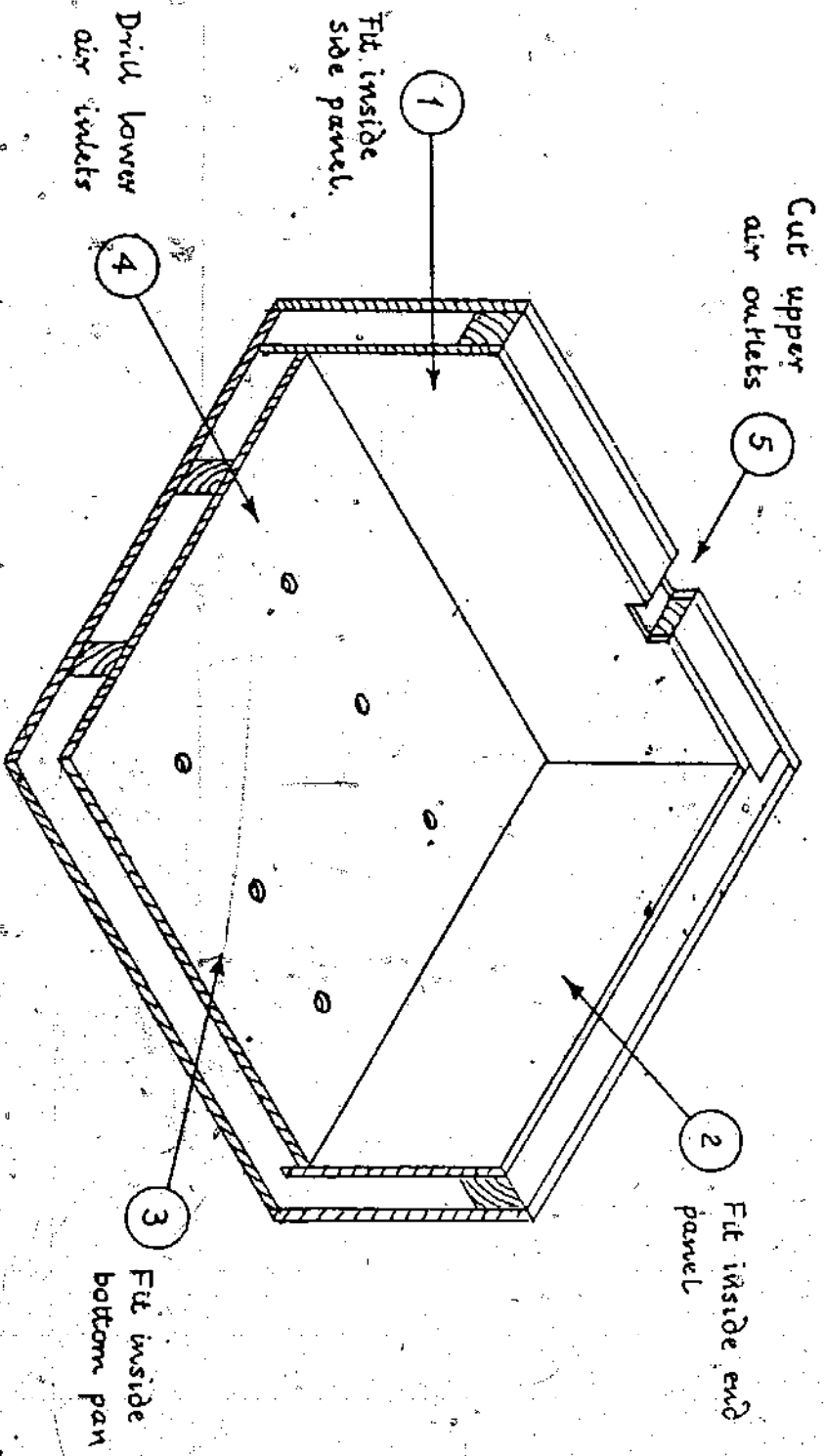

FIGURE 5

CONSTRUCTION OF MODEL 1 DRYER
"CUT-AWAY" SKETCH SHOWING STAGES IN COMPLETION OF INNER BOX



Steps in Construction:

Remember that it is a very useful practice to re-check all measurements and markings on timber before cutting. Follow the maxim "measure twice and cut once".

First build the outer box as follows:

1. Cut leg pieces, side, and end battens to size, and join together to make the basic frame. The type of joint illustrated in Figure 3a can be used if basic carpentering skills are available. Otherwise the pieces may simply be butted together and joined by driving long nails or screw nails. All nails should be driven home so that heads are flush with the surface of the wood.
2. Cut side and end pieces (these can each be one single piece or plank, or a number of narrower pieces). If a number of narrow planks are being used to cover the outer sides and ends, these should not be simply butted together edge to edge, but should be "weather-boarded" as shown in Figure 3b, so as to deflect rain and avoid wetting of insulation. When this form of construction is used, the gaps between planks and frame members should be filled with plaster, mud, or putty. If tongued and grooved planks are used, these should be fitted tongue uppermost to prevent rain getting into the joint.
3. See Figure 4. Nail end pieces to legs and end batten and then nail side pieces in position. Cut bottom pieces (to full length and width of box). Cut out corners so as to fit around legs and nail in place to lower edges of side and end pieces.
4. Cut and fit air inlet battens, nailing through from the ends and bottom of the box. When nailing, take care to avoid sites of the holes which will later be drilled through these battens.

Next, put insulating material in place and complete the inner box in the following manner:

- a) See Figure 5. Cut inner panels to size. The length of the inner side panels will be the internal length of the box between the end battens. The depth of side panels will be the internal depth from bottom of box to upper edge of side batten. The length of the side panels will be the width of the box between the leg pieces less the combined thickness of the two side panels. The depth of end panels will be the distance from the upper edge of the side batten to the bottom of the

slots cut in the air-inlet battens. The length of the bottom panels will be the length of the box between the end of the battens less the combined thickness of the two end pieces. Its width will be the width of the internal end panels.

- b) Turn the box on to one side and pack in the insulation on that side so that it is slightly above the level of the legs and side batten. Nail the inner side panel in place to the side batten and legs and through the bottom of the box. Repeat this process for the other side and two ends.
- c) Mark the center lines on the air-inlet battens on to the end pieces so that the marks will be visible. Do this since the internal bottom panel has been fitted. Pack insulation in place on the bottom of the box up to the level of the air-inlet battens, and nail the bottom panel(s) in place to the air-inlet battens (again avoiding the sites of holes to be drilled later).
- d) Mark the center lines of air-inlet battens on the bottom panel(s) and mark off position of holes. Drill through from the inside to the bottom of the box.
- e) Mark the position of the air-outlet slots on the upper sides, cut the sides of each slot with a saw and chisel out the slots.
- f) Paint or stain the internal surfaces of the box with a dark color, preferably matt-black (black-board paint is useful for this purpose). Treat the exterior of the box with wood preservative (if available) and paint with gloss paint or marine varnish (if available).

E. Construction of Cover for Models 1 and 2 Dryers

The same type of cover is used for both these dryers. It consists of a simple rectangular wooden frame with a central ridge piece, which is covered with a double layer of polyethylene film. Details of construction of the cover are shown in Figures 6 and 7.

FIGURE 6

COVER FRAME FOR MODELS 1 AND 2 DRYERS

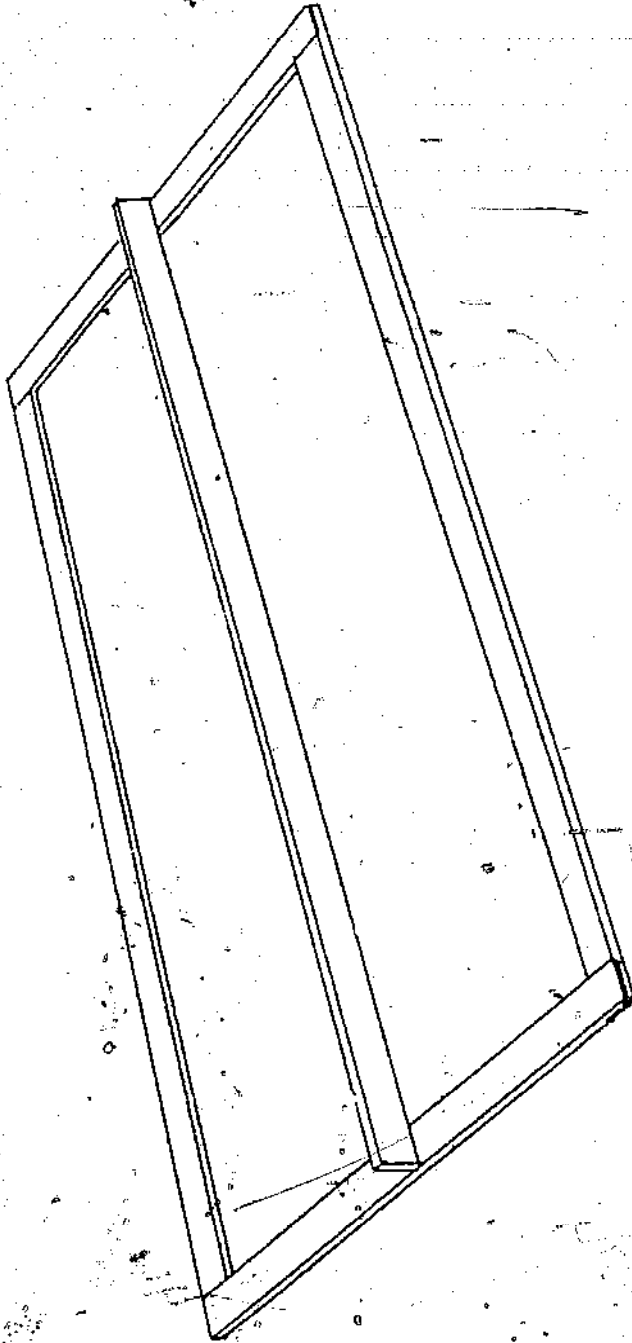

Tools and Materials

Tools needed: Saw (preferably tenon saw), screwdriver, sharp knife or scissors, try square, marking gauge.

Materials: Lengths of timber 2" x 3/4" or nearest. Transparent polyethylene film (preferably 0.005 in. or heavier). Screwnails, (5/8" x 8s C.S.). Blued tacks (1/2"), or large office stapler.

TOOLS AND MATERIALS

Tools needed: Hammer, screwdriver, try square, saw, brace and 1" wood drill, 3/4" wood chisel.

Materials: Wooden planking or plywood for sides, ends and bottom of boxes.*

Lengths of timber 2" x 2 1/2" for legs, and 2" x 2" for side, end and air-inlet battens.

Insulating material, e.g., wood wool, dried grass or leaves, coir fibre, etc.

Nails and screwnails of appropriate size.

Matt-black paint or other suitable black staining material, e.g., charcoal.

* Wood from old packing cases is very useful for this purpose.

Steps in Construction

The frame should be made so that its overall length and width are each 3 inches greater than the box to be covered, i.e., so that it can overlap the box by 1-1/2" in each direction.

1. Cut the frame members to length and assemble as indicated in Figures 6 and 7. **N.B.** After construction is completed, the frame should be allowed to dry out in the hot sun before the cover is applied. The cover should be applied while the wood is still warm and at a time of day when humidity is low. These precautions are necessary to prevent condensation occurring between the layers of polyethylene, thus "fogging" the cover. If, despite this precaution, some fogging does occur during use, withdraw tacks or staples from a short length at each end of the cover, open up the polyethylene to allow moisture to

- escape while the dryer is in operation, and then refasten the polyethylene in place.
2. Cut a piece of polyethylene sheet for covering the lower side of the frame so that it is 3 inches wider and 3 inches longer than the frame.
 3. Turn the frame upside down and lay the polyethylene sheet in place. Fold one side of the polyethylene back on itself to form a triple-layer seam 3" as shown in Figure 7 b (i).
 4. Starting at the middle of the frame and working progressively towards both ends, stretching the polyethylene lightly but firmly lengthwise, tack or staple through the seam at 3" intervals to fasten this edge of the polyethylene to the frame. **N.B. Do not overstretch the polyethylene. Polyethylene will "give" and distort if fingertips are dug into it, and such distorted areas are likely to perish during use. It is preferable that polyethylene should be slightly loose rather than overstretched.**
 5. Repeat this process at the other side of the frame, stretching the polyethylene across the frame as tacking or stapling proceeds.
 6. Fold similar seams at each end, and tack the ends of the sheet to the frame, tucking the polyethylene neatly at each corner and fastening firmly in place.
 7. Cut a piece of polyethylene sheet for covering the upper side, so that when draped over the frame it is 4 inches wider and 4 inches longer than the frame. Turn the frame upside down and, making a triple-fold seam as before, tack or staple one edge to one side of the frame so that the seam is inside that of the lower sheet (Figure 7 b (ii)).
 8. Stretch the polyethylene over the ridge and around to the lower edge of the other side member. Make a folded seam and tack or staple in place as before.
 9. Stretch the polyethylene over one end of the frame, fold and tack as before, cutting away any excess material resulting from the slope from ridge to side member. Tuck the corners of the sheet in neatly, and tack firmly in place. Repeat for the other end of the frame.

Attachment of Covers to Dryers

The covers, being very light in weight, are liable to be blown off the dryers by even a moderate gust of wind. Arrangements should therefore

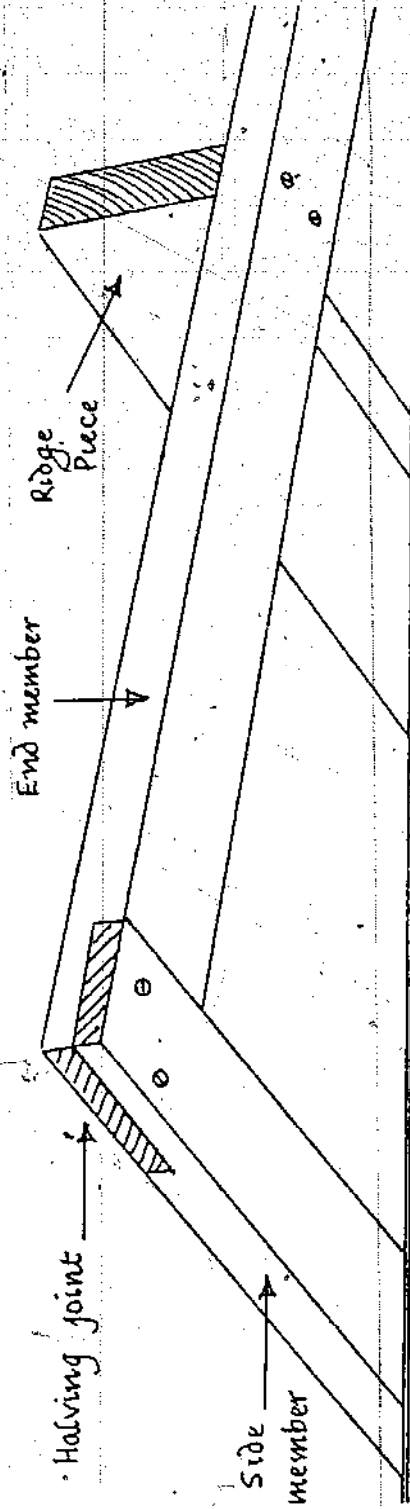

Photo — Erik Benizen

Completed — Model 1 Solar Dryer

FIGURE 7

CONSTRUCTION OF COVER FOR MODEL 1 AND MODEL 2 DRYERS. A. CONSTRUCTION OF FRAME.



B. ATTACHMENT OF POLYTHENE FILM TO FRAME

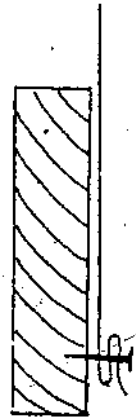

(1). Tacking lower sheet to frame



(ii) Tacking upper sheet to frame to overlap edge of lower sheet

FIGURE 8

SKETCH SHOWING ONE POSSIBLE TYPE OF DRYING TRAY

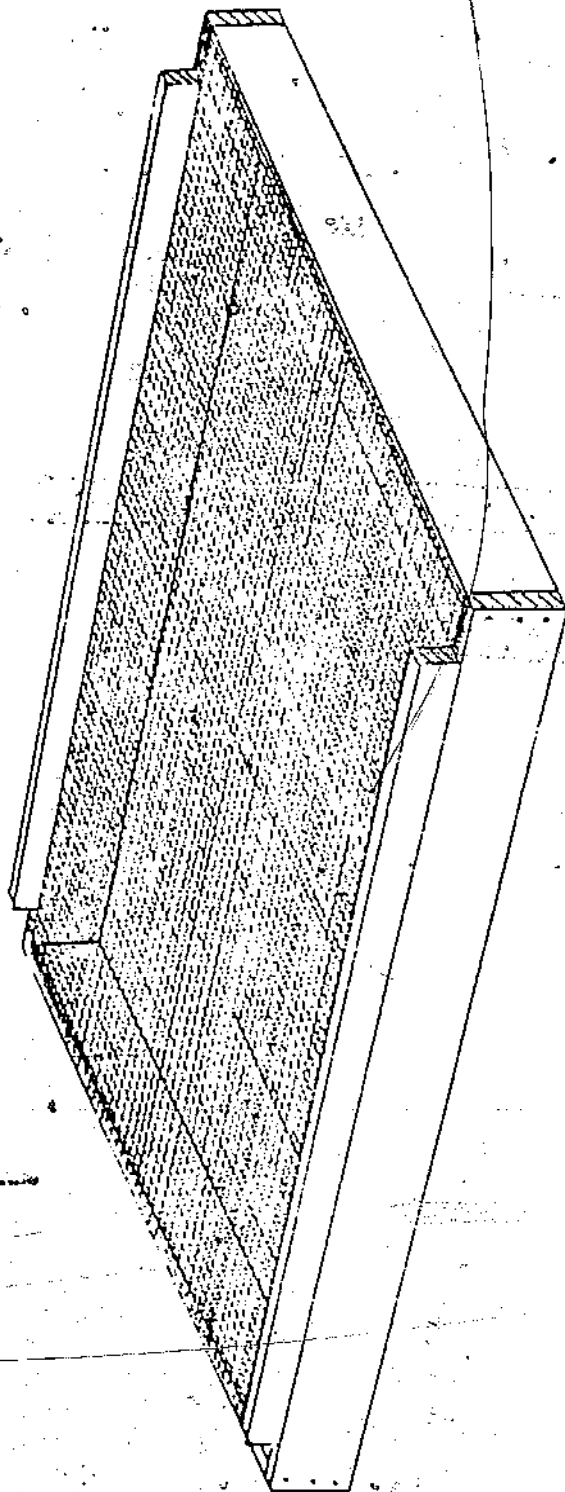

be made to keep them firmly in place. This can conveniently be done by fastening hooks of stiff wire to each corner of the cover and swinging these hooks into place around nails or pegs fixed in the sides of the dryer. Alternatively, lengths of stout twine or cord fastened to one side of the dryer may be drawn tightly across the cover and tied to nails or pegs on the other side.

F. Construction of Drying Trays

An example of one possible type of drying tray is illustrated in Figure 8. This is a simple wooden frame with fine wire mesh stapled to its underside. Two support runners are nailed to the underside (over the edge of the wire mesh). If necessary, two laths may be tacked over the edges of the wire mesh to hold it in place at the ends. However, folding the edges of the mesh over upon itself before stapling may be all that is needed. A suitable size of tray for use with 8' x 4' dryers illustrated in the sketches is 3' 6" x 3' 6", overall, two trays of this size being used in the dryer.

Simpler trays made of course be made from local materials. Papyrus reed matting, or a frame with slats of reed or split bamboo, for example, makes an excellent support on which material can be dried. Coarse hessian sacking material or open weave grass or fibre matting stretched on a frame can also be used.

G. Construction of Model 2 Dryer

This dryer, illustrated in Figures 9 and 10, is not portable like Model 1. It is meant to be permanently sited and to be constructed of clay bricks, mud and wattle, or similar materials. Compressed bricks made by the Cinva-Ram using local earth mixed with cement are ideal for the purpose. If hollow bricks are available, this would be an advantage. Hollows in such bricks should be packed with dried grass, coir fiber or other insulating material before the bricks are laid.

Siting

Because of its permanent nature, care should be taken in the choice of a site, which must be flat and level, and which should not be shaded by trees or buildings. The dryer may be built on a floor of solid hard-beaten

earth, or, if it is felt to be necessary, a base of concrete may be used. A drainage trench about 9 to 12 inches in width and depth should be dug all around the dryer to protect it from floods resulting from heavy rain. The dryer should preferably be sited so that it is end-on to the prevailing wind. In tropical latitudes, its siting in relation to the sun is relatively unimportant, but there may be a slight advantage in having its length in an east-west direction, but only provided this does not expose the sides rather than the ends to the wind.

Materials

Clay or similar bricks as described above, mortar or clay. Thick bamboo (2 1/2 to 3 inches in diameter).

Steps in Construction

- 1) Prepare the site and lay the first course of bricks.
- 2) Prepare the bamboo pipes as follows*: Choose bamboo of even thickness and with as few joints as possible. Cut to the overall width of the dryer. Split the bamboo into halves lengthwise and cut away the partition at each joint. Put the two halves together again and bind together with string, wire, or other suitable binding material. Cut or drill holes in each pipe as indicated in the sketch. The holes should be about 1 1/2 inches in diameter.
- 3) Lay the second layer of bricks, placing the bamboo pipes in position as shown in the sketches, cutting appropriate bricks, short as needed. Lay the third layer of bricks, packing the gaps around the bamboo with mortar or clay.
- 4) Lay the top layer of bricks, cutting away as necessary to form air-outlet slots. Alternatively, lay the top layer of bricks leaving one-inch gaps appropriately spaced along the two sides.
- 5) Paint the inside of the dryer a dark color. Charcoal mixed with clay may provide a suitable means of doing this.
- 6) Construct a cover and drying trays as described in 6 and 7 above.

* Alternatively, bamboo inlet pipes of only 12' in length may be used instead of the full-width pipes. Length of these pipes is shown by the thick lines in Figure 9.



Early construction of Model 2 Solar Dryer

Photo - Erik Bentzen

FIGURE 9

MODEL 2. DRYER CONSTRUCTED OF CLAY BRICKS PLAN AND ELEVATION DRAWINGS

Scale 1 cm = 6 inches

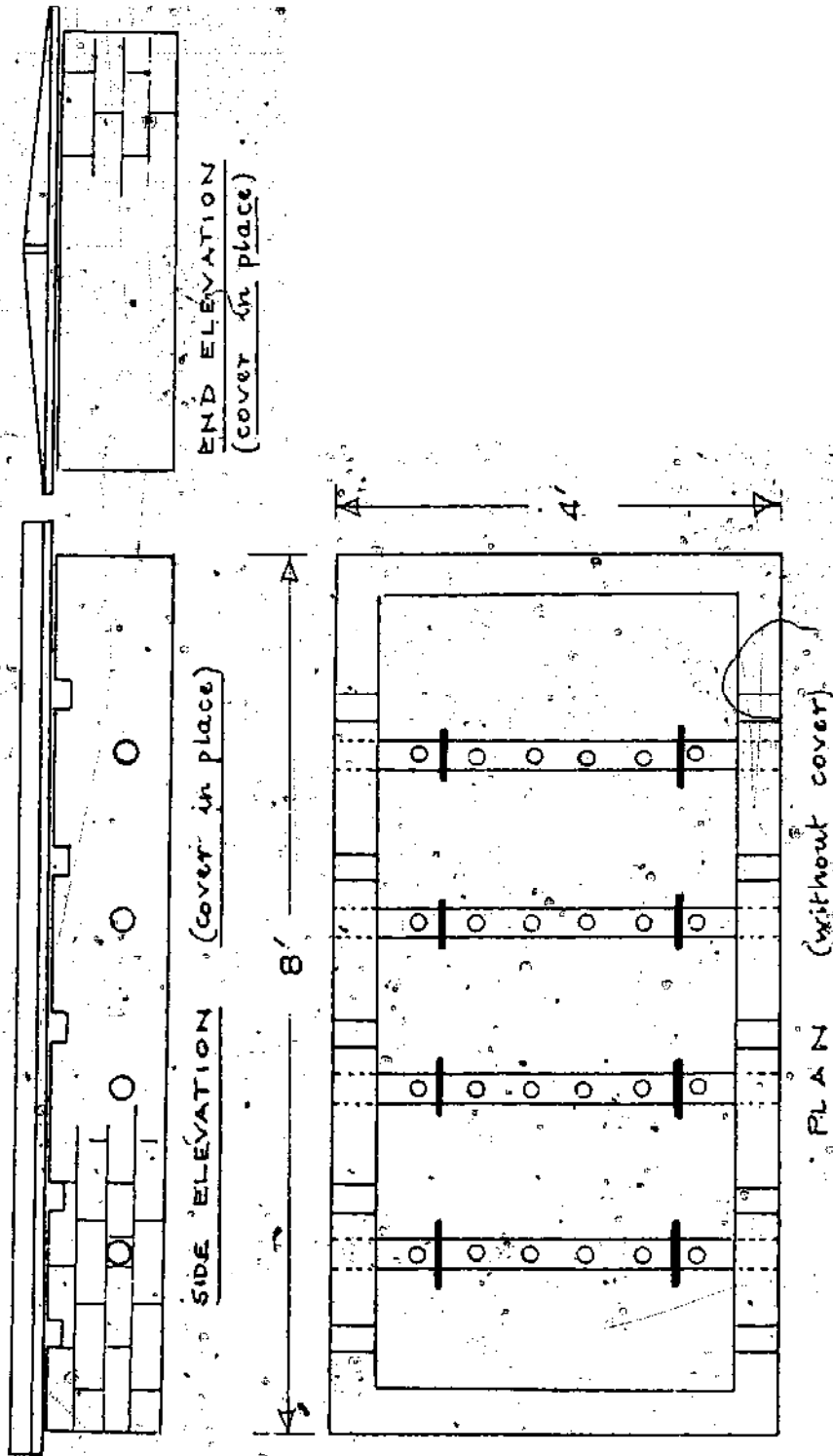
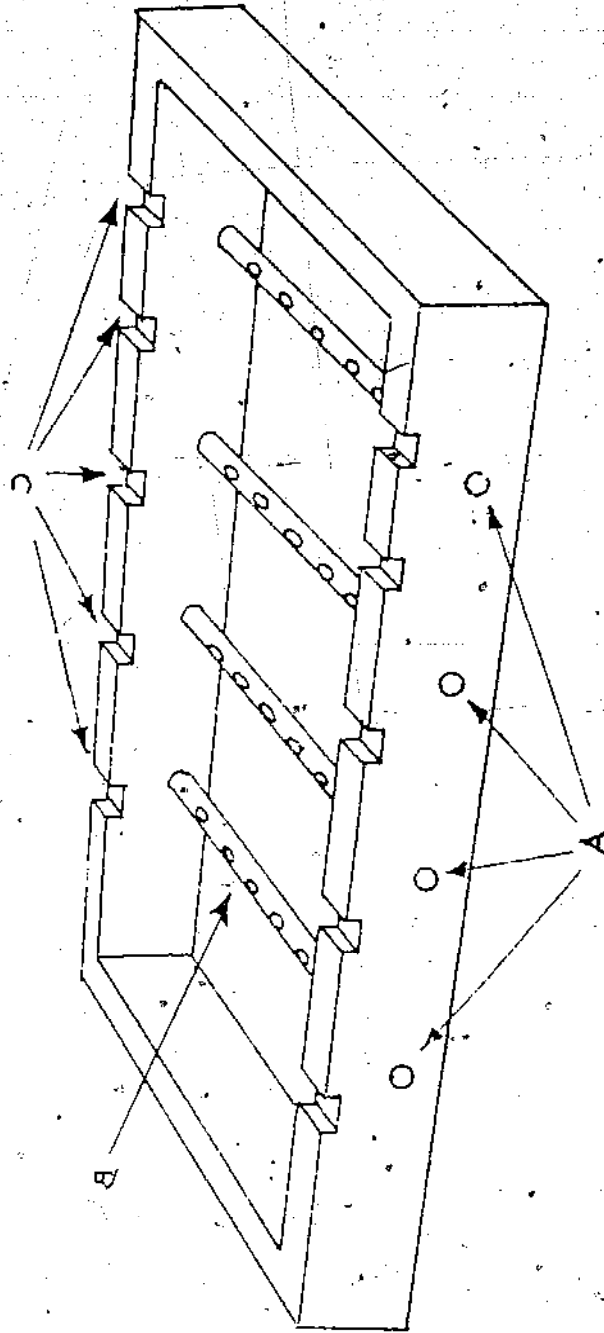

FIGURE 10

MODEL 2 DRYER - SKETCH SHOWING VENTILATION ARRANGEMENTS

A & B - BAMBOO "PIPES" WITH HOLES FOR AIR INLETS

C - SLOTS FOR AIR OUTLET.



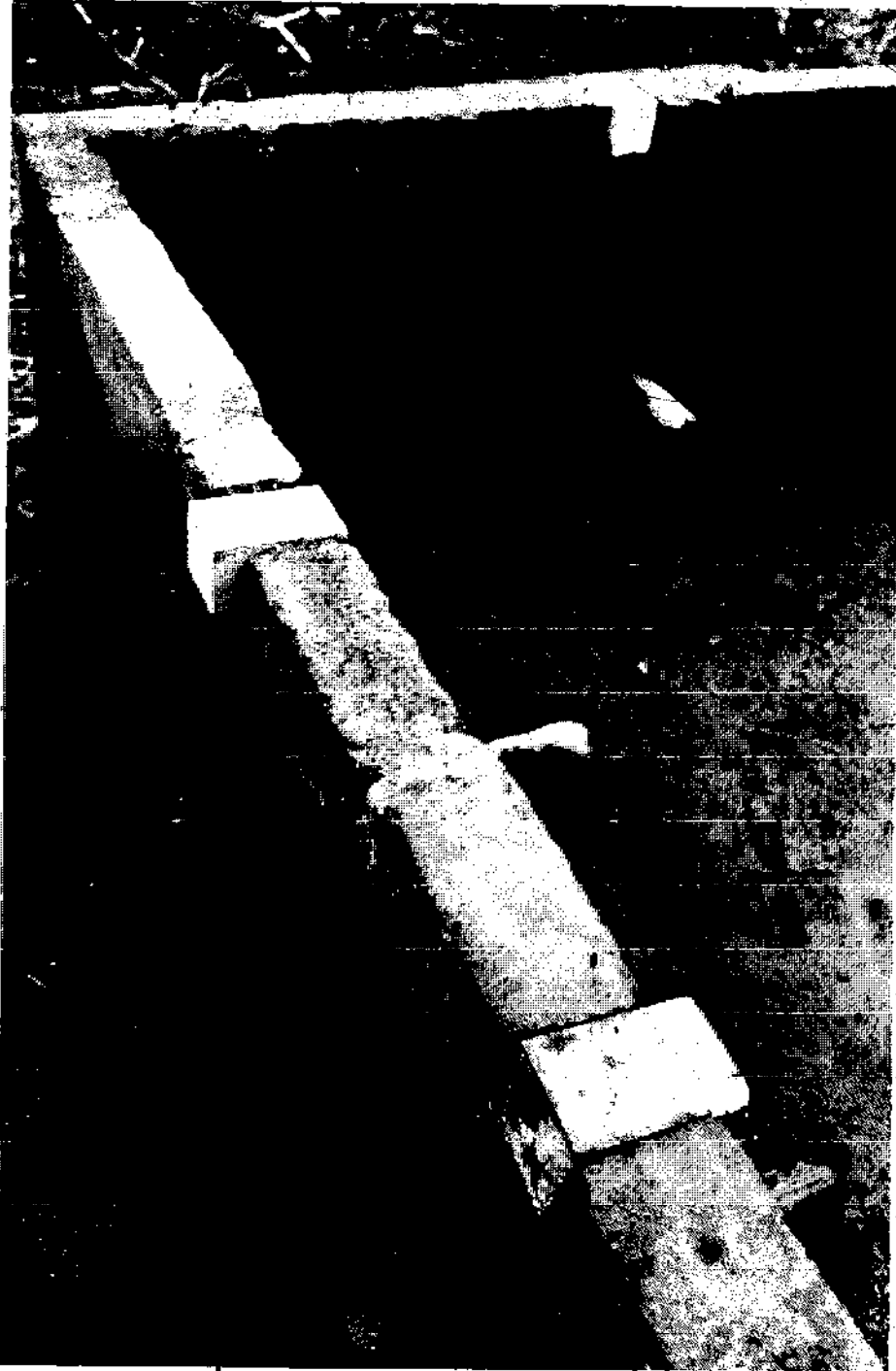

Photo – Erik Bentzen

Model 2 Solar Dryer – showing ventilation arrangements.

A Simple Cover Frame for Sun Dryers

The attached sketches illustrate the construction of a simple "double glazed" polythene cover for sun dryers. This can be made in the village situation, using only the tools and materials normally available. The only external input needed is polythene sheet in the form of a tubular sheath.

The frame (Sketch 1) consists of two "coat-hanger" shaped end pieces joined by three pieces of bamboo or other straight poles such as wattle or eucalyptus.

The end pieces (Sketch 2) can be chopped out to shape with a "panga", cutlass, or machete-type knife, and the nesting sockets for the joining poles can be carved out with a smaller knife or burnt out with a hot iron. Poles are selected for straightness and uniformity of diameter. Perfectly straight and uniform poles are rare. It is important that the two side poles are straight in the horizontal plane, and the frame should be put together on a perfectly flat piece of ground and the two side poles arranged to achieve a frame which is not warped and which does not twist upwards at one or more corners. Slight irregularities in the poles do not matter since, although these may prevent the frame seating accurately on the top edges of the dryer, this does not matter, since air vents are in any case required between the cover frame and the top edges of the dryer.

Fastening bamboo or thin poles with nails can be a problem because of the risk of splitting. For this reason, holes for the nails should first be drilled in the ends of the poles (Sketch 3). This is done using a nail heated to redness. The nails are then inserted in these holes and driven firmly into the wooden end piece.

The joint can be strengthened (Sketch 4) by nailing a strip of hammered-out tin (cut from an old tin can) over the joint. This tin strip would be likely to abrade the polythene so, to avoid this, the joint should be wrapped in a piece of cloth, banana fiber, soft barkcloth or similar soft material before covering the frame with polythene.

The cover frame must be made to that it fits snugly into the polythene sheath and so that the sheath is stretched taut. The key dimensions in this respect are those of the end piece, and it is necessary to make the first end piece by trial and error. The end piece should be cut to shape

Making A Simple Cover For A Solar Dryer

(When Only Plain Polythene Sheet Is Available)

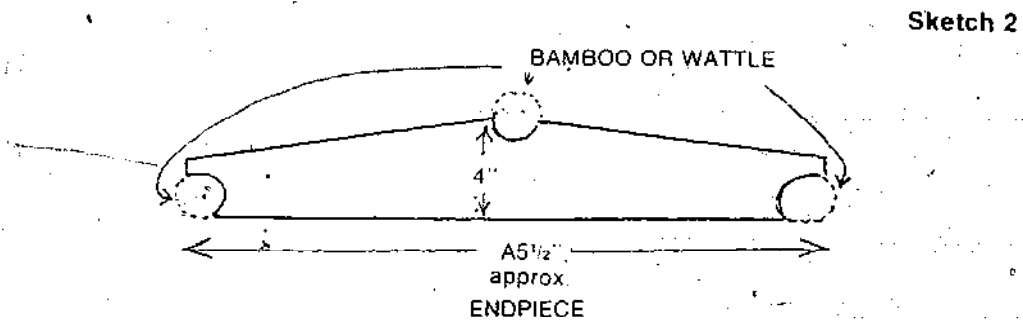
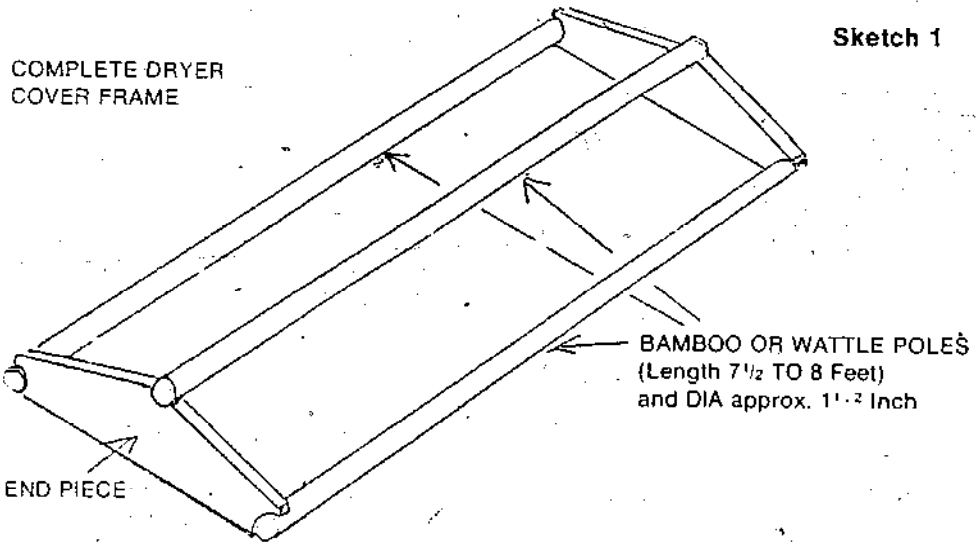

(Made from A Piece of 4"x1" plank.



Making simple cover frame for Solar Dryer.

Photo – Erik Bentzen

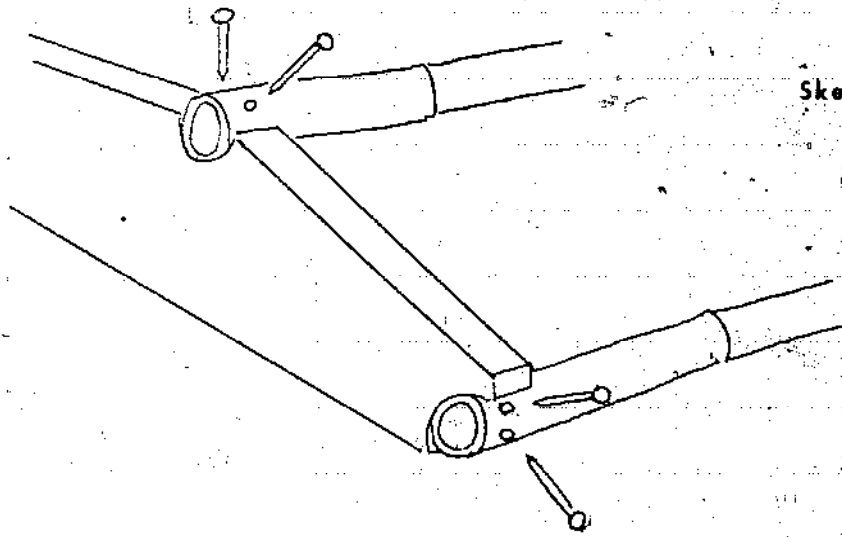

Sketch 3

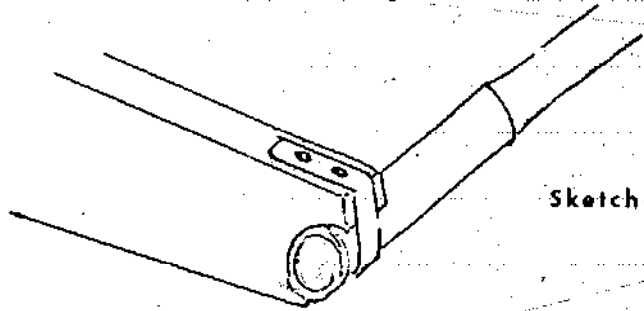

Sketch 4

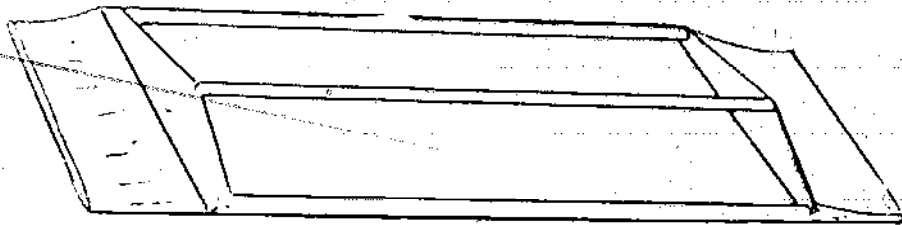

Sketch 5

Fit the sleeve over the frame so that
approx 12" of the sleeve overlaps at each end

SKETCH 6

Place a thin stick under the end of the sleeve and roll up the polythene tightly around the stick

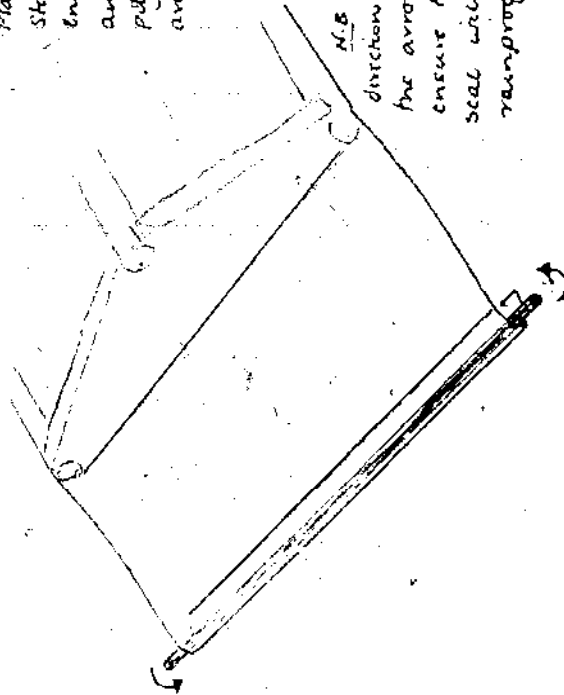

N.B. Roll in the direction shown by the arrows to ensure that the seal will be rainproof.

SKETCH 7

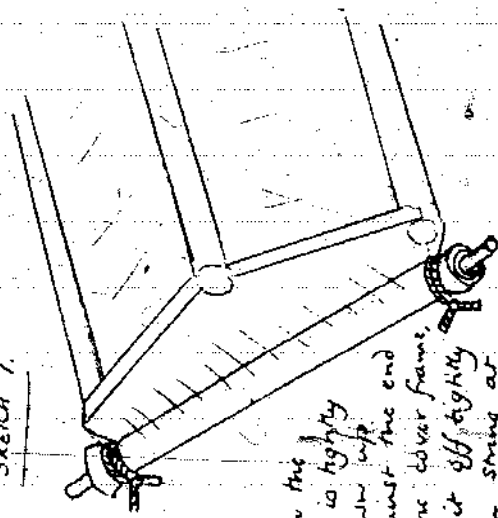

When the roll is tightly drawn up against the end of the cover frame, as it is off tightly with string at both ends

Do the same at the other end of the cover.

Di-2-11 20/5/75

COVERING A SOLAR DRYER COVER FRAME WHEN POLYTHENE SLEEVES ARE NOT AVAILABLE

1. Lay cover frame on top of polythene sheet which is 24" longer and 18" wider than cover frame.

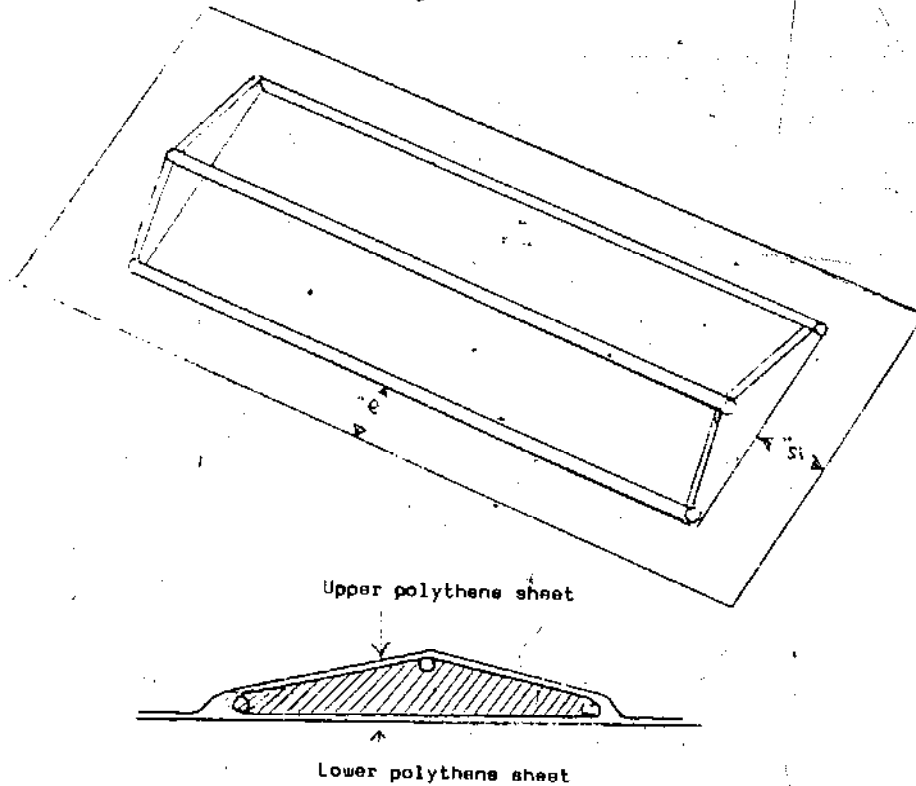

2. End views

- a) Lay second sheet of polythene over top of frame.

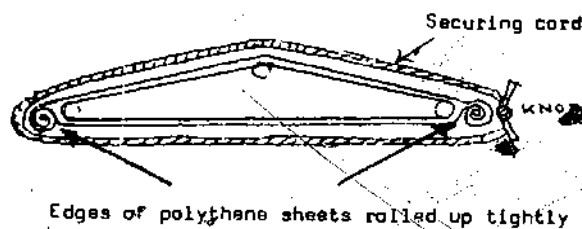

- b) Roll up edges of sheets tightly against frame and secure in place with cord tied around width of frame at both ends.

3. Frame with edges of polythene sheets rolled up and tied (as in 2 (b))

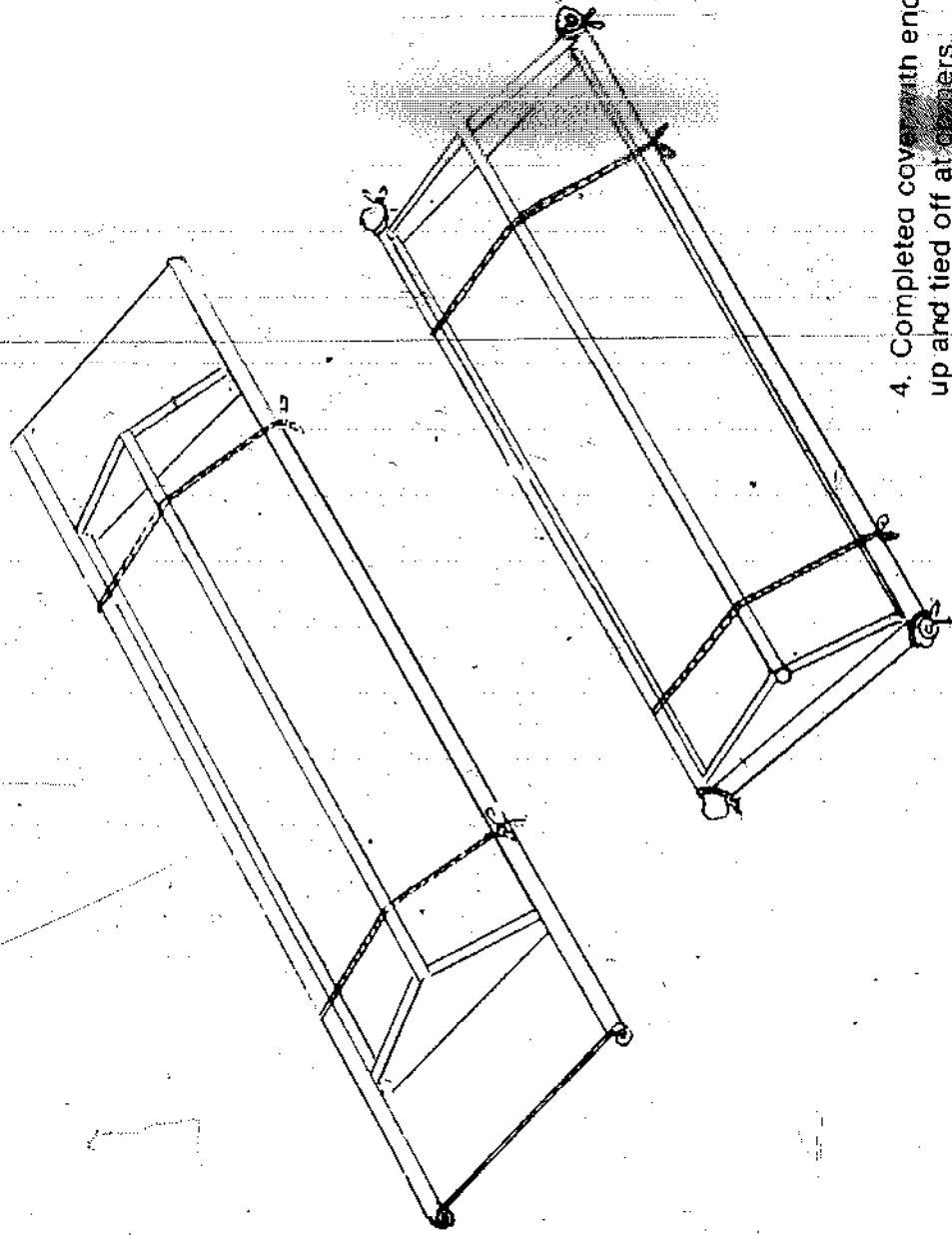

4. Completed cover with ends of sheets also rolled up and tied off at corners.

but finished off the same width as the sheath. Its width should then be reduced by paring slivers from each end until it will just fit into the sheath. It will be found that the width of an end piece which is 4 inches high at its highest (middle) point will need to be about $\frac{1}{2}$ to $\frac{3}{4}$ shorter than the width of the sheath.

The following is a practical example:

A polythene sheath was made by folding 8' wide polythene film and seaming along the open edges. The effective internal width of this sheath was 46" (two inches used up in seaming). The size of end piece needed for this sheath is illustrated in Sketch 2, i.e., 45 $\frac{1}{2}$ inches long and 4 inches high. A cover frame made from two end pieces of this size fitted neatly into the sheath without undue stretching of the polythene. The polythene sheath is fitted to the frame as described in Sketches 5, 6 and 7.

3. Drying with Fire

There may be times, however, when climatic conditions will not permit the effective use of even an improved solar dryer. This may be the case where there are long periods of rainfall or very cloudy weather. Also, when the amount of grain to be dried is too large, another method will have to be found.

Here we present a model called the **Pit Oil Barrel Dryer** or **Brooks Field Dryer** that can be used quite effectively at the farm and village level, either by an individual farmer if he has a fairly large amount of grain to dry, or by a group of farmers working together as in a cooperative. Storage of grain in a closed container requires that the grain be sufficiently dry to prevent rotting. For maize this is optimally 12% moisture content. The traditional method of sun drying is neither assured nor very efficient, especially for large quantities of grain. It requires much labor to spread and gather the grain each morning and evening and this is especially difficult in times of inclement weather.

Artificial drying permits drying large quantities of grain in a relatively short period of time. The higher drying temperature drives insects from the grain and allows the grain to be harvested sooner with less drying time in the field, thus decreasing insect and rodent damage, which occurs before harvest.

Figure 1. Le Hanger

Shelter with Brooks Fire Drier
and Cement Stave Silo.
Drawing by - Harald Thorshaug

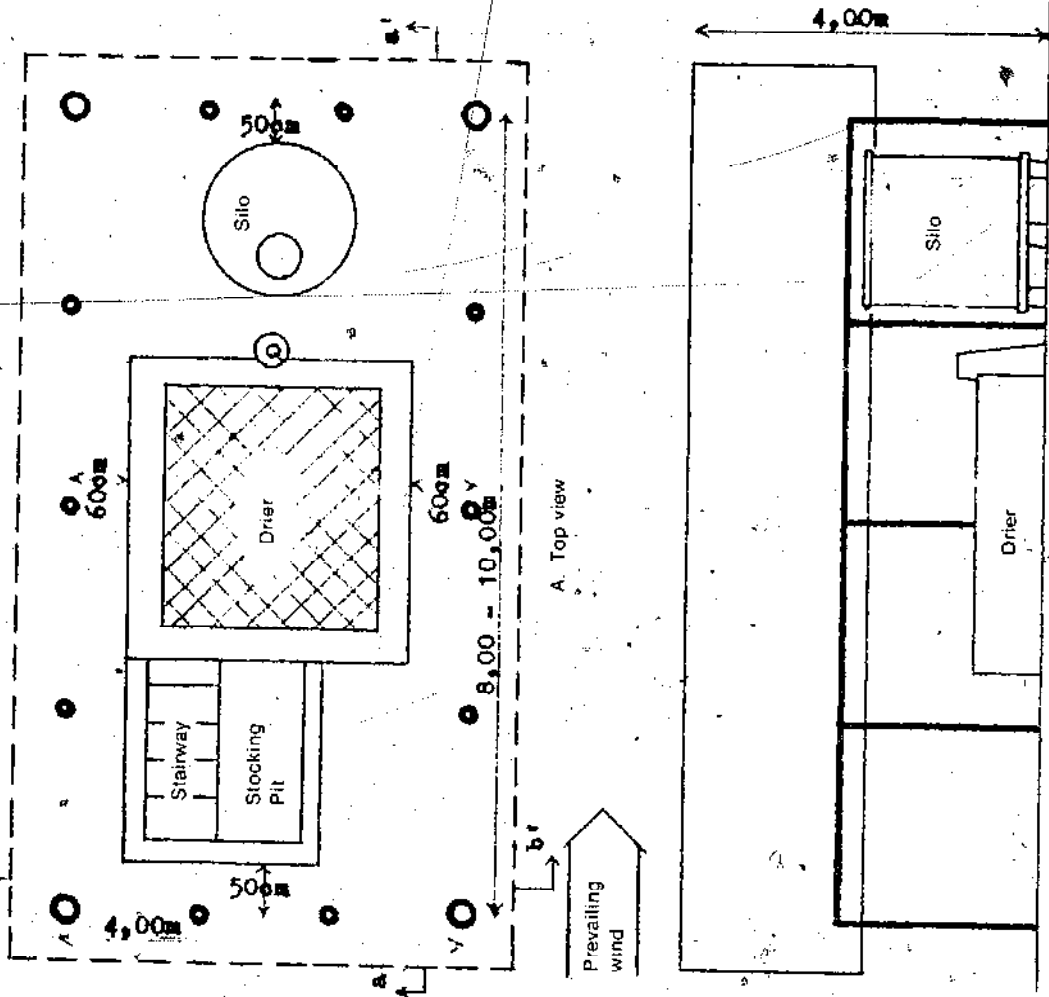

The dryer consists of banco walls with a screened false floor for drying the corn with heat from a fire box consisting of three 220 liter drums joined end to end below the drying floor.

CONSTRUCTION (see figures 9 - A - B - C - D)

The drying chamber has interior dimensions of 2.40 x 2.20 m and a height of 40 cm from the screen floor. The walls should be 30 cm thick giving exterior dimensions of 3.00 x 2.80 m. The stoking pit will be built on the upwind end of the dryer. It should have interior dimensions of 1.80 m long and 1.70 m wide, including the stairway.

LINTELS

The end walls will be supported by 2 concrete lintels (1.20 x 0.30 x 0.08 m), requiring $\frac{1}{3}$ sack of cement and one 6 m bar of re-rod (\varnothing 6 mm). The lintels can be made any time a 1:2:3 concrete mixture is made, though the sooner they are made, the sooner they can be placed. The formwork can be made from boards or bricks lined with paper. Three pieces of re-rod 100 cm long should be evenly spaced horizontally 4 cm from the bottom edge of the lintel.

THE DRYER

First stake out the drying chamber 2.80 m wide x 3.00 m long. This should be centered between the two sides of the hangar. Extending upwind on 1 side of the drying chamber, stake out the stoking pit, 2 m long x 2.10 m wide. This will leave an unused area on one side of the stoking pit 2 m long x 0.70 m wide on the opposite side of the drying chamber. Dig all of this staked out area 30 cm deep and pile all of this removed top soil to one side so that it will not be later mixed with the banco.

Next, dig a trench centered in the length of the drying chamber 70 cm wide and 140 cm deep. This will extend 480 cm from the chimney end of the drying chamber (leaving a 20 cm ledge for the retaining wall of the stoking pit.). Remove all of this dirt taking care not to mix it with the top soil which was earlier removed.

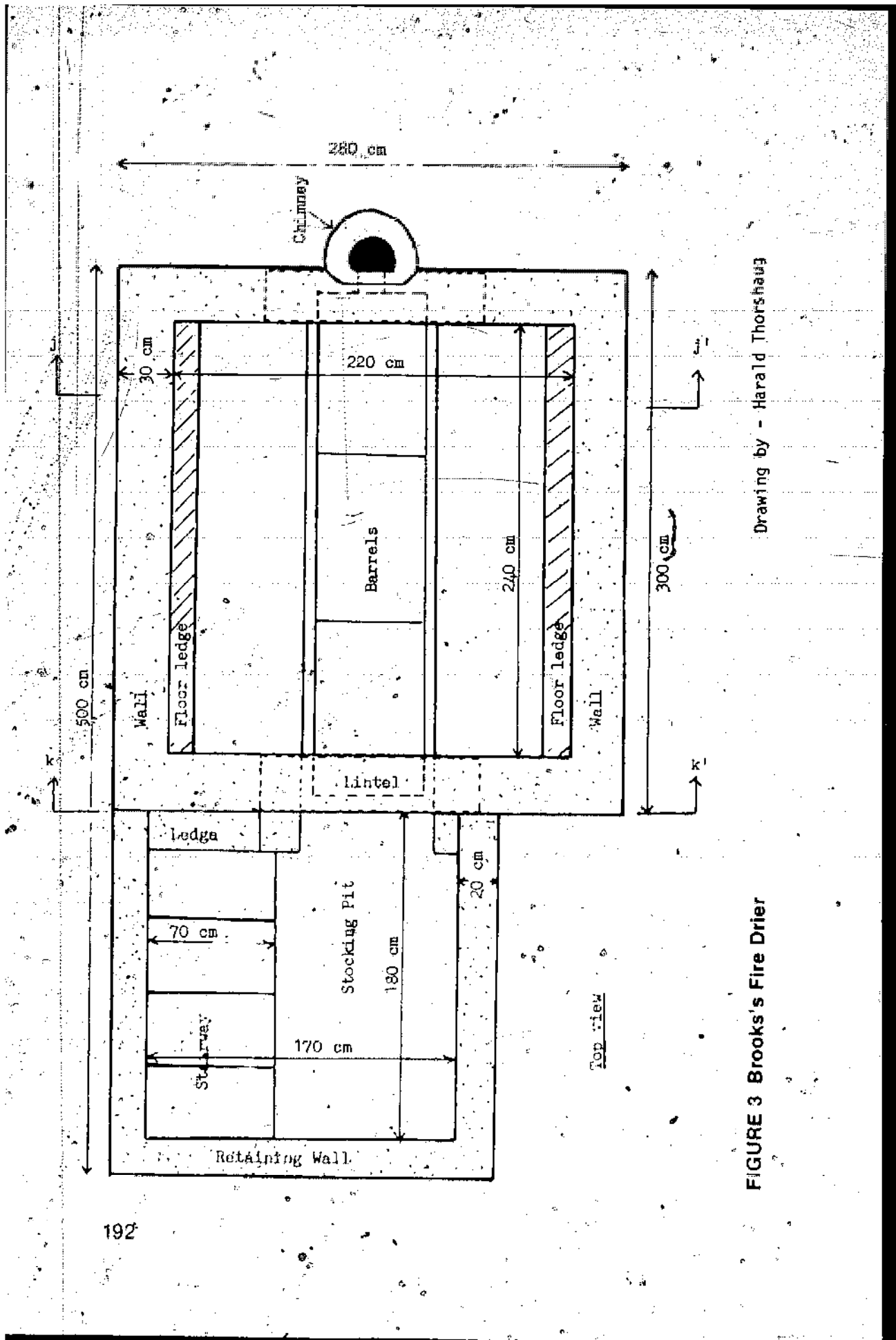

Drawing by - Harald Thorshaug

FIGURE 3 Brooks's Fire Drier

Brook's Fire Drier

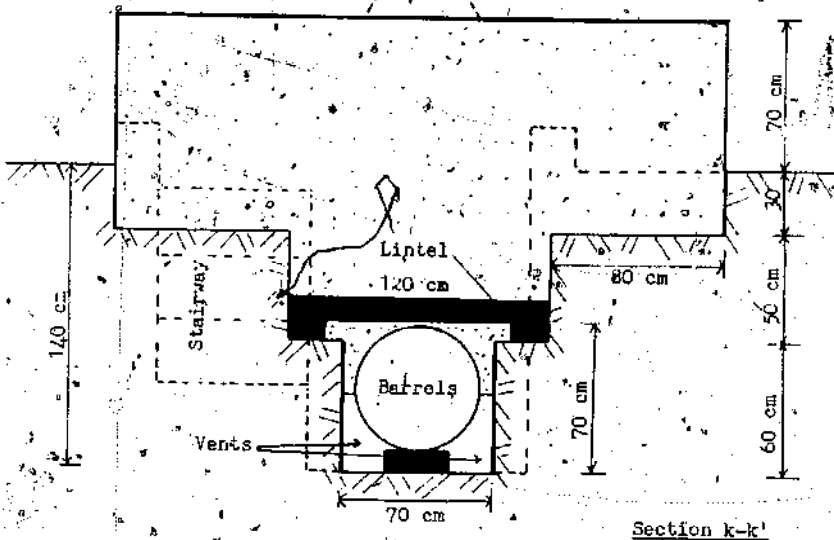
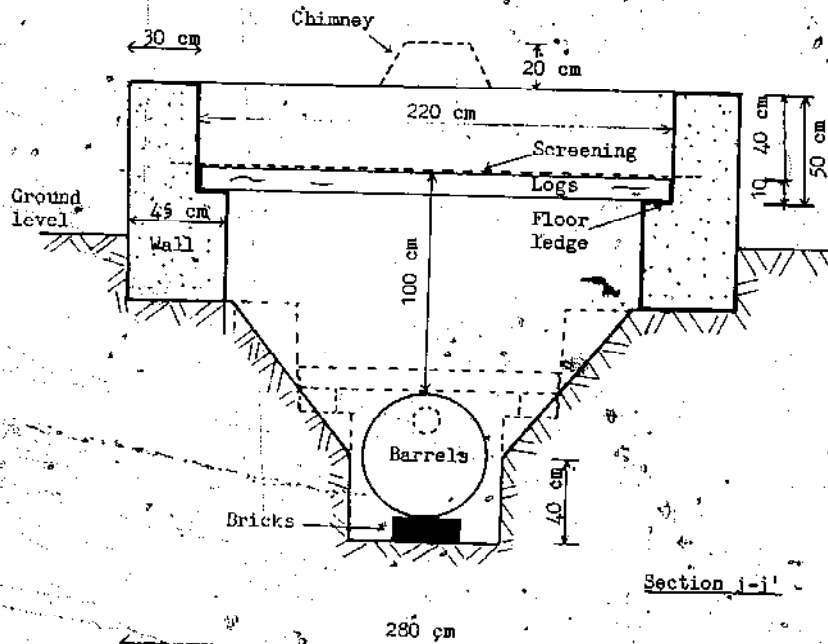

Scale 1 : 25

Drawing by - Harald Thorshaug

Labour	- Digging hole	5 man-days
Requirements	- Prepare Banco	6 man-days
	- Mount walls	6 man-days
	- Place barrels	1 man-day
	- Place floor	1 man-day

PLACING LINTELS

Carefully measure and mark points 3 m and 2.70 m from the chimney end of the trench and cut slots on both sides of the trench, where the lintel will rest. These will descend to 70 cm from the trench floor, 30 cm wide and 30 cm long. Cut similar slots up against the chimney end of the drying chamber - 75 cm from the trench floor. The 5 cm difference is to give a slope to the barrels and thereby facilitate smoke escape through the chimney. Next cut the chimney hole 30 cm wide x 30 cm long x 30 cm deep centered at the end of the trench. A channel 15 cm x 15 cm is then extended from the center of the chimney hole to 50 cm from the bottom the trench. A 5 cm layer of mortar or banco is laid in each of the 4 lintel slots and the lintels are lowered into place taking care that they are level and square with the dryer side walls. If banco has been prepared in advance the construction of the walls can now begin.

MOUNTING THE DRYER WALLS

Mount the walls 30 cm wide over the lintels and 45 cm on the sides, extending the stoking pit retaining wall along its ledge 20 m thick to a height 20 cm ground level around the extremities of the stoking pit (2 m x 210 cm). This retaining wall protects against erosion of the pit walls and keeps dirt and trash from falling into the pit.

The height of the wall over the lintels which can be mounted in one day without danger of collapse depends on the quality and water content of the banco. When the drying chamber walls reach 90 cm from the lower edge of the lintel, the side walls thickness is reduced to 30 cm, leaving a 15 cm ledge on the inside of each side wall which will support the drying floor logs. Before the walls are mounted much above the ground level the rest of the digging and dirt removal should be done in the drying chamber to avoid unnecessary difficulty in removing the dirt. From the base of interior side walls to a point 40 cm from the bottom of the barrel

trench remove the dirt on both sides of the trench leaving a slope of about 45°. When the retaining wall is mounted to 20 cm above ground level, it should be level with the drying chamber walls at the point where they are diminished to a thickness of 30 cm. At a height of 10 cm higher than the 15 cm side wall ledge, a strip of chicken wire 20 cm wide should be embedded 10 cm in the wall all the way around leaving 10 cm extending out into the drying chamber to which will later be attached the drying floor screen. This embedded screening should be 1:00 m from the bottom edge of the front lintel. The walls are mounted to a height 40 cm above the embedded screening. At the same time that the drying chamber walls are being mounted, the chimney can be done. Its height should be extended 20 cm higher than the top of the dryer wall. The opening can be reduced to 10 cm in diameter to prevent undue heat loss.

The stoking pit is finished at any convenient time during the dryer construction. The stairs are cut out in four equal steps 30 cm high and 40 cm wide, leaving a 30 cm wide ledge against the dryer wall and the lowest step. This will lend solidity to the dryer wall and lintel. The stoking pit can be enlarged by cutting away 15 cm on each side of the stoking pit.

The walls can be polished as they are built. A layer of 1:8 mortar on top of the wall all around will keep the walls from being worn away during use. Cracks in the dryer wall should be filled with banco to improve both its solidity and appearance. Extra care should be taken in filling cracks in the chimney end wall to avoid smoke entering into the drying chamber.

PLACING THE FIRE BOX BARRELS:

The sloping sides of the pit must be dug away before placing the barrels. First, cut both ends from two barrels, and one end from the third. A small hole 20–30 cm wide should be cut in the other end for the chimney hole. One side of the chimney hole is formed by the barrel rim. This hole will be on the top side of the barrel when it is placed in the dryer.

The barrels are joined with four heavy wires spaced evenly around the circumference. The barrels should be supported with bricks or broken staves 10 cm thick.



Photo – Erik Bentzen

Shown here is one of the two concrete lintels which support the end walls.



Mounting the dryer walls. (In the background is a nearly completed 4.5 ton cement stave silo.)

Photo – Erik Bentzen

The joints should be sealed by placing a strip of screening around them and plastering with a 1:8 mortar. If the screen holes are too big to hold the cement, place paper under the screening. From inside the barrels, the bottoms can be sealed as well as any spaces showing in the top joint seal.

The trench must now be closed around the barrel ends with banco. At the chimney end the seal must go completely around the barrel to keep smoke from coming into the drying chamber. The opposite end is closed only around the top of the barrel to let cool air enter the drying chamber.

The joint seals can be tested by lighting a smoky fire in the barrels and watching to see if smoke escapes into the drying chamber. Do not let it burn too long or it will dry the sealing mortar too quickly causing it to be brittle.

FLOOR SUPPORTS

Use 10 logs of solid wood 8–10 cm in diameter and 2.15 m long to support the drying floor. A very straight log should be placed directly against each end wall to keep the screen from pulling out under pressure.

WIRE SCREENING

can now be stretched across the logs and attached to the anchoring strips. Small holed screening is often very expensive, so chicken wire is usually used. In this case, straw mats must be placed on top of the screening to prevent the grain falling through.

The strips of screening should be longer than the 2.40 m length of the drying chamber because the weight of the corn will pull it down between the floor supports. The strips should be overlapped 5–10 cm and attached by weaving thin wire up and down through the holes. For all of the wire screening used in the dryer, 9 m² are required.

Instructions for the use of the Brooks Field Dryer.

1. Before using the dryer each time, you should clean out the stoking pit-hole to make sure that the air vents underneath the barrels are open and not blocked by ashes or dirt. This should be done during drying also.
2. Check the barrels to make sure there are no holes rusted in them or cracks in the joints which will allow smoke to enter the grain in the



Placing the fire box barrels.

Photo – Erik Bentzen



Photo – Erik Bentzen

Completed Brooks Field Dryer (without wire screening).

- drying chamber. Do this by building a small smoky fire in the barrels before putting grain in the dryer. Badly rusted barrels should be replaced and cracked joints can be re-sealed with mortar.
3. Remember that to dry a large quantity of grain, a lot of firewood will be necessary so it is a good idea to start gathering wood before you start drying.
 4. The quality of your drying depends upon the person who watches over it. He should be responsible and understand how to use the dryer. He should be present at all times during the drying to control the fire.
 5. If the drying fire is too large, the grain on the bottom layer of the dryer may begin to char. This will change the color and the taste of the grain, and it will be hard to sell afterwards. The best temperature for drying maize is 50–55 degrees Centigrade. This means that the grain from the bottom layer must not be too hot to hold in your bare hands.
 6. About one day is needed to dry 0.5 T (500 kg) of maize. During all of the drying time a responsible person should watch over the dryer. It is best to begin the drying early in the morning and continue all day long. **Never** leave a fire in the dryer if there is no one to watch over it.
 7. If you dry maize on the cob, remove the husks and dry a layer not more than 30 cm deep. If you dry shelled maize, you can dry 500 kgs. at a time or four large sacks. This will be a layer about 10 cm deep. Continue drying until the maize has moisture content of 12–13 percent. The first time you dry, be sure to have someone help you who has had experience in drying. When you have dried once or twice, you will easily be able to tell when the grain is dry enough by cracking it between your teeth. When the grain is dry, it is hard and breaks with a sharp crack. If you are in doubt, be sure to ask someone who has had experience in drying.
 8. Grain which is to be planted for the next season should not be dried in the dryer since the heat will kill many of the seeds and they will not grow. Thus, more seeds will be needed for a good stand in the field. For this reason, grain to be used for seed should be dried thoroughly in the sun. It should be stored separately in a closed container and checked monthly for rotting or mildew.
 9. Don't forget that the secret of good storage is good drying.

WORKBOOK EXERCISES

1. What drying techniques are currently in use in your area?

Notes:

2. What are the advantages and disadvantages of these techniques?

Notes:

3. What improvements in these techniques can you suggest?

Notes:

4. Why is it better to dry grain on a plastic sheet than directly on the ground?

Notes:

5. What are the advantages of an improved solar dryer?

Notes:

6. When should an oil barrel dryer be used:

Notes:

7. Could such a dryer be used in a cooperative way in your area?

Notes:

8. Discuss the advantages as well-as disadvantages of drying grain with fire.

Notes:

CHAPTER VII: GRAIN- INSECTS, RODENTS AND INSECTICIDES

If a farmer were told that more than one-third of his grain harvest would be stolen, he would most likely react with sufficient anger to take the necessary steps to protect his hard-earned food. Yet every year farmers in developing countries are estimated to lose between 10 and 30 per cent of their harvested grain, not to human enemies, but to the thieves of mold, insects and rodents.

A sustained battle must be waged against these thieves if the farmer is to receive greater benefit from his labor.

It is difficult to store grain in the tropical (and even the temperate) parts of the world without an insect problem developing. Long periods of storage increase the potential spoilage caused by insects. Multiple handling of the commodities, inadequate storage facilities both contribute to the problem.

We have already seen the dangers of molds when we discussed the need to dry grain sufficiently for safe storage. Molds are in some ways the most dangerous of enemies, for you cannot see them as easily as the two other major thieves: insects and rats.

Insects are everywhere, but they are particularly dangerous around grain. Adult insects are easy to see in grain. They live outside the kernel. A farmer often waits until he sees adult insects before taking any steps to combat them, but when you see the insects, it is already too late, for inside the kernels there are no doubt many more young ones growing.

Insect control should begin well before the grain is put into storage. There are several steps a farmer can take to help protect his grain from insects. Some of these steps may include insecticides, but all depend on thorough cleaning of storage containers.

A farmer needs to make a regular "battle plan" against insects, for they breed at an accelerated rate under tropical conditions, and are also very adaptable to new surroundings.

There are four steps in such a battle plan:

1. **"Know your enemy"**. Find out which insects are damaging the grain, how the insects grow (their life-cycle), and how they get into the grain.

2. ~~Take care in drying, cleaning, storing of grain.~~
3. Measures that can be taken **without insecticides.**
4. Ask advice about **insecticides** and decide if the farmer(s) has enough money to buy insecticides, and whether it is possible to develop a **sound, safe extension-program.**

1. Know your Enemies

There is a habit of calling any small bug, fly, moth or mosquito an "insect", but for our grain-storage interests, we need to be more precise. Insects are creatures with six legs and hard outer skeletons. Their bodies are divided into three distinct sections: the head, the thorax (with three pairs of legs and two pairs of wings), and the abdomen. They grow in stages – eggs, larvae, pupae and adults. Insect eggs and larvae are so small that they are difficult to see, and so may already be living in what looks like good, clean grain.

There are many insects that will attack grain. In any given area, however, there is a tendency for only a few types to be dominant. For this reason, it is best to check with an agricultural specialist as to which types of insects are most prevalent in the area – especially if an insecticides is used.

2. Care in Drying, Cleaning and Storing of Grain

The drying and storage areas must be kept clean. This includes tools for harvesting and threshing, and carts that may be used for carrying the grain.

Cleaning means sweeping out old grain, grain dust and dirt from storage bins or areas in the home where grain is kept; removing pieces of grain and dust from between cracks, ledges or other parts of the storage area. Repairs must be made in the floors, walls and ceilings where insects might live, and patching any holes in the building to make sure it is watertight.

Remember: No hole is so small that insects can't hide there. One important precaution is to store new grain away from the old grain that may still be on hand. By the end of a storage period, even with proper care, there will be insects in old grain. If the old and the new are stored too closely together, insects will quickly spread to the new grain.

Farmers have always tried to fight off insects. Through techniques of trial and error, certain effective methods have been developed, although the farmer probably does not know the scientific principle behind the techniques he has learned.

Among the techniques used are the following:

Sunning: Farmers have seen that insects leave grain which is placed in hot sunlight. Insects do not like heat that is much over 40–44°C. Sunning, however, does not kill the eggs and larvae which may be in the grain.

Mixing certain plants with the grain: In many areas, farmers mix certain plants with the grain. As with herbal medicines for humans, it is not always easy to know what herbs are used. The information is usually given by father to son or mother to daughter. Such natural control methods, which provide active control without insecticide, need to be looked at more carefully.

Mixing sand or wood-ash with grain. This is another traditional control method. It is based on two correct observations. The first is that sand and ash fill in the space between the grains and thus lessen the amount of oxygen available for the insects to breathe. Also, sand scratches the covering of the insect's body, and the insect loses moisture through the scratches. If the grain is dry, insects will not be able to get enough moisture to replace that lost through the scratches, and the insects will die.

Smoking: Some farmers store unthreshed grain on raised wooden platforms. They build small smokey fires under the platforms. Other farmers store grain in the roof of the building used for cooking. Both of these methods use the smoke and heat of fires to kill and drive away insects from the grain. The heat from the fires also helps to keep the grain dry and thus protects the grain from new insect attacks.

There are ways of building upon the principles of the traditional methods and improving the techniques.

One way to kill insects is to **deprive them of oxygen**. As with all living things, insects cannot live without oxygen. Cutting out oxygen can be done by making storage as air-tight as possible, by using oil drums with lids, for instance, although relatively little grain can be stored in this way; or using polythene bags. All improved grain storage methods aim

at being as air-tight as possible, for the carbon dioxide given off by the respiration of the grain itself will kill off many of the insects.

3: Measures that Can be Taken without Insecticides

A traditional way of excluding oxygen is to fill up all the spaces between the grains so that less air is mixed with the crop. This principle can be maintained, and is especially effective when activated clay or charcoal is mixed with the grain. Activated clay or charcoal is made by washing small pieces of charcoal or clay in diluted hydrochloric acid, rinsing it with clean water, and heat-drying it. You should use 1/2 to 1 per cent of the volume of the crop.

Grain in storage should always be checked for insects, flying beetles, or moths. It is best to put the grain through a sieve. If a large number of insects are present, dump all the grain out on a tray or plastic sheet under a hot sun, but do not put the grain directly on the ground. Then put all the grain through a sieve and remove and burn the insects so that they cannot return to the grain.

As insecticides are costly and also dangerous to use, it is recommended that as much as possible be done to fight against insects without the use of insecticides. We offer a checklist, a list of reminders in your discussions with farmers. You can stress those points that will be most helpful in your area:

- Store grain away from wet areas.
- Protect the stored grain from falling rain.
- Keep stored grain or grain containers out of strong sunlight. This will keep the grain cooler. Warm grain will breed more insects.
- Place stored grain containers or buildings where winds can help cool the containers.
- Keep the stored grain as far away from the fields as possible. This helps keep flying insects pests from flying to the stored grain from the fields.
- Make sure the storage area is clean. Sweep the walls, ceilings, and floors and get out all dirt + old grain, and dust before you put new grain in.
- Make sure the containers for the grain are very clean.
- Clean the grain well.

- Dry the grain well.
- Put only whole, healthy grains into storage. Do not store broken grains.
- Place grain into special containers which you can seal tightly – if possible.
- Watch for flying beetles in the early morning or late afternoon.
- Watch for moths any time of day.
- Shake a sack on the floor. Then let it rest out of direct sunlight for a while. Then check to see if there are any weevils on the outside of the sack.
- Dump part of the grain out or take some out from the middle of the storage container.
- Put the grain through a sieve.
- If a large number of insects is present, dump all the grain out on a tray or plastic sheet under a hot sun. Do not put the grain directly on the ground.
- Or put all the grain through a sieve and remove the insects. Burn the insects so they cannot return to the grain.
- Mix grain with sand and ash when you put it into the storage containers. Sand and ash damage the insects' bodies, and they die.
- Store unthreshed grain on raised wooden platforms and build small smokey fires underneath. The heat and smoke from the fire help drive the insects away.
- Plan for storing the next crop. If you continue to have trouble with insects, see if there is a storage method which might be better. Also, find someone who knows how to use insecticide and get advice on your problem.

4. Insecticides

Insecticides are poisons for killing insects. But insecticides also can kill or injure humans and animals if they are not used properly. Insecticides must always be used with care and with the advice of local agricultural agents. The farmer must always weigh the cost of the insecticides against the potential benefits. Most farmers already know something about insecticides, but often they are not aware of exactly which insecticides should be used. Farmers may use insecticides without knowing

how to apply the insecticide properly or on what materials the insecticides can be used. Some insecticides are safer than others. Some insecticides can be used on grain for seed but cannot be used on grain for food, but others can be used for treating both types of grain.

Types of Insecticides

Many different poisons kill insects, but there is a much smaller number of insecticides which are useful in grain storage work. The insecticides available to farmers to use for grain storage are of two major types: contact chemicals and fumigant gases. These insecticides can be bought in a number of forms. They are applied differently, depending upon the type of grain and the type of storage facility.

Contact Chemicals: These are the contact poisons. The insect must get these insecticides onto its body. The contact chemicals are available in the following forms:

- **Dusts:** These contain a low concentration of insecticides mixed with powder. This makes them safer to handle than some of the other forms. Dusts are ready to use but must be kept very dry until used or they will not mix evenly nor last as long. Dusts can be used on floors, flat surfaces and around the bottom of storage containers. Dusts are often mixed with grain at the time of storage.
- **Malithion dust** is one of the insecticides most widely used in the storage grains. In using this particular type, the grain must be well-dried, for malithion dust does not work well with wet or moldy grain. Usually one packet of 110 grams should be mixed with each sack (or 90 kilos) of shelled maize. The mixing is done by shoveling the grain into a heap for ten minutes or so, until each seed has been covered with the malithion dust. The cereal which has been so treated may be used in twelve to thirteen weeks, for the chemical breaks down completely and does not leave a harmful residue.

Wettable Powders: These contain a high concentration of insecticides. Wettable powders must be mixed with water before they can be used and require careful mixing. They are used to spray outside surfaces of sacked grain, storage containers or buildings. They can be applied with simple sprayers which can be made or purchased. Wettable powders must never be used directly on grain.

Emulsion Concentrates: These are liquid concentrates which must be mixed with water before they can be used. They contain a high amount of insecticide mixed with other ingredients. However, they need special equipment to apply and thus are more expensive and more difficult for the farmer to use.

DDT: One of the most common of the contact chemical insecticides is DDT. In fact, in some places, DDT has become the general name of insecticides. DDT must be used with care. DDT can protect storage buildings against insect attack. It can be applied either by spraying or painting it on with a brush. The treatment should be repeated every six to eight weeks. However, DDT must not be used near food nor on the grain itself. It should not be used to dust inside grain storage containers.

With all the contact chemical insecticides, great care must be taken for even a small dose of insecticide can make a person sick. Do not eat, drink or smoke while using insecticides. Wash the clothes you are wearing separately from your other clothes. Keep the insecticide containers away from children and animals. Bury or burn all the empty containers.

Fumigants: The second major category of insecticides is the fumigants. Fumigants are gases and have several advantages as an insect-control method. Gases can enter all the cracks in storage facilities and kill insects hiding there. Fumigants can get between the grains in storage and, in many cases, can kill the larvae within the kernels. Gas does not leave marks on the grain as some insecticides do.

However, there are also very real dangers in using fumigants. They are poison gases and some are extremely dangerous to man. Fumigations must only be carried out by properly trained personnel who have received training not only in the techniques required but also in the safety aspects necessary. At least two operators must be employed in fumigation in infested produce for safety reasons. The operator in charge should have proper training or experience in the type of fumigation he is likely to undertake.

In any type of fumigation work the approved procedures must be carried out to ensure

1. The safety of the operators and the other persons involved;
2. The avoidance of damage to produce and hazards to consumers;
3. The effectiveness of the treatment.

Fumigants kill only insects which are already in the grain. They do not protect grain from new attacks. Fumigants must be used in airtight containers. Thus, if the farmer is storing his grain in jute sacks, he will have to find some other container which he can make airtight before he can fumigate his grain. He may also be able to cover his grain sacks with heavy plastic and fumigate in this way.

However, fumigation may hurt the ability of seeds to germinate and thus should not be used on seeds kept for planting.

The most widely used fumigants at the farm or village level come in solid form as pellets, tablets or packets. The active chemical is Aluminum Phosphide. The tablets release phosphine gas when moisture touches them. One of the most common of these fumigants is Phostoxin, also sold under the names of Celphos, Phosphine. This insecticide must be used only in airtight containers. Fumigation must continue for at least 72 hours.

Fumigation must be done with very great care by persons with the required training and experience. Its value is especially great for larger amounts of stored grain and should be of interest to cooperatives and other forms of joint storage.

Informing farmers about the use of insecticides is an important yet delicate task. The world is now becoming conscious of an over-use of insecticides, and the dangers of their constant or habitual use. It is difficult to know where to draw the line in the debates among experts as to what is harmful to the environment and what is not.

Since in most areas some insecticides will already have been in use, it is necessary to know what is the local opinion concerning them. Will insecticide-treated grain have a changed taste or odor? Is grain so treated acceptable by the farmer for his own consumption? Have there been any bad experiences in the locality as a result of the misuse of insecticides?

Rodents

Along with insects, rodents are the major enemy of stored grain. Relatively less effort has been devoted to research on rodents as agricultural pests as compared with research on insects. Of course, some work has been done in the past, but this has been confined mainly to emergency situations, such as sudden rodent population explosions. There have

been real rat "invasions" recently in the Sahel states of West Africa, for example.

Thus, a great deal remains unknown about the best methods of prevention and control, or about the environmental factors favoring rodent increase and the amount of damage done.

There is ample evidence, however, that rodents do a great deal of damage, and hence it is essential to know something about rodents and some of the ways to combat them.

Rats are very numerous and very intelligent. In university laboratories, rats are used to study how people think, because rats are among the most clever of animals. You must thus take strong measures against rats, for they can find ways of getting into the most unexpected places. Rats always live near people. It is estimated that in large cities there is at least one rat for each human being.

In some areas, rats are eaten for meat, but this is often because they feed so well on the farmer's grain. Rats can carry diseases, and they should thus be kept as far away as possible.

The first thing to know is what rodents are most common in a particular area, for this can vary. Sometimes when a new crop is grown, a new type of rodent will come to eat it.

There are three main families of rodents that are the principal enemies of stored grain.

The largest is **Rattus Norvegicus**, so common that he is often called the "common rat", or the sewer rat, or again the brown rat. The adult weighs about 330 grams and he eats a great deal of grain. He digs in the ground and can burrow under a wall.

The second rat family is **Rattus Rattus**, also called "roof rat" because he likes to climb. He is also sometimes called a ship rat or an Alexandrine rat. He is somewhat smaller than **Rattus Norvegicus** and weighs about 250 grams when full-grown. He, too, can eat a great deal of grain, and is especially dangerous because of his ability to jump and climb.

Mus Musculus is the scientific name for the well-known mouse. He weighs only some 16 grams, has a long tail and a pointed nose. Since mice are so small, many farmers do not realize how much grain they can eat. Moreover, since a mouse does not eat the whole grain, he ruins more grain than he eats.

Rats and mice have large families and reproduce often. Fortunately, many die young; but those that survive can cause great damage, and steps must be taken against them.

These steps must be coordinated into a regular "battle plan":

1. The first step is to keep the farm and the storage area as clean as possible. The area around the storage facilities must be free from long grasses or brush where rats and mice can hide. There should not be any trees or poles around which a rat can climb onto the storage facility. There should not be any split grain on the ground which can serve to tempt the rats.

Food should be stored carefully, and if any trash or wasted food is to be thrown away, it should be buried well away from the house and storage areas.

2. The second step is more on the order of an offensive tactic. Rats and mice can be actively hunted and trapped. Cats and certain dogs will hunt or frighten away rodents.

There are also a variety of traps, many of them traditional, such as a covered pit or a petrol tin filled with water. There are, as well, commercially-made steel traps which are useful, but can be expensive. The number and type of traps will depend on whether the farmer is seeking to control rodents in his grain fields, in the storage facility, in his home, or in all of these.

3. The third step is to make the storage facilities as "rodentproof" as possible.

If the farmer is using an improved storage crib, rat guards should be fitted onto each of the crib's legs. These rat guards should be placed about 2½ feet above the ground, so that rats cannot jump over them.

This means that maize cribs and grain stores should be raised on platforms some three feet high.

If grain is stored in bags within a building, the bags should also be raised so that rodents cannot hide. Watchfulness is very important.

Keep looking for rat droppings, and for spilt grain that may have come from rodents having broken open a bag or plastic sack.

4. The fourth step is the use of rat poisons. As with insecticides, great care must be taken with rat poison. All the more so as rat poisons are mixed with food and left on the ground, where they may be eaten by

children and animals. Thus, poisons should be used only when other means have been employed, and then only on the advice of someone who is familiar with their use.

The poisons easily available will vary from area to area, and are sold under different trade names. Basically, rat poisons are of two types: acute poisons and anticoagulant poisons.

Acute poisons, such as zinc phosphide or arsenious oxide, are single-dose poisons. Rodents need eat only a mouthful of poison and can die in a half an hour. However, such poisons are extremely dangerous. The bait food which is mixed with the poisons can be picked up and eaten by children or by farm animals. Such poisons can also be eaten by wild animals who are good hunters of rodents. In fact, rats have increased partly because many of their natural enemies have been killed off.

Anticoagulant poisons are used in lower dosages and must be eaten for a number of days before death occurs. Only a little poison is mixed in with the bait food each day. These poisons cause rodents to bleed inside their bodies and die.

Anticoagulant poisons are probably the best to recommend. They must be used with care.

It is important to keep enough bait out for a long enough period of time—around two weeks. Each pile of bait should be about 200 cm and should be laid in places where signs of rodents have been found. Rodents tend to use the same paths or entry places over and over, so once the path is discovered, place the bait there. If the bait is not being eaten, however, this probably means that the path is no longer being used, and the farmer should look for a new place to set the bait.

Poisons are expensive. They should be used along with other less expensive methods. They should **always** be used with care.

WORKBOOK EXERCISES

1. Why is an effort against insects so necessary?

Notes:

2. How do insects attack grain?

When standing in the field?

When stored?

Notes:

3. What are the traditional methods of protection against insects in storage in your area?

Notes:

4. What is the effect of filling the space between grains with either smaller grains or with clay or sand?

Notes:

F.
24

5. What types of insecticides are used in your area? How expensive are they?

Notes:

6. Are any fumigants used to protect stored grain in your area?

By whom are they used?

Notes:

7. What dangers do rodents present –

to people? _____

to stored grain? _____

Notes:

8. What rodents are most common in your area?

Notes:



9. Are they used for food? _____
Are they left alone, or are they actively fought against? _____

Notes:

10. Why should garbage and trash be buried away from the house? _____

Notes:

11. What types of rat poisons are available in your area?

Notes:

12. What are the dangers in the use of certain poisons?

Notes:

13. What methods other than poisons can be used for fighting rodents?

Are they used in your area?

Notes:

CHAPTER VIII: POPULARIZING IMPROVED METHODS OF FARM AND VILLAGE-LEVEL GRAIN STORAGE TECHNOLOGY

It is in the interest of the nation as a whole that improved grain storage methods be accepted as widely as possible at the farm and village level, for the cost of cereals plays a vital part in the cost of living and in the living standards of the majority of the population. It is therefore crucial to take measures so that the producer receives a fair price for his products, that they are made available to the consumer at a reasonable price, and that the processing and distribution costs are not excessive. Efficient storage at the farm and village level and good marketing are key activities in safeguarding both the consumer and producer interests.

Therefore it is essential that improved grain storage methods be popularized as widely as possible. If improved storage is limited to a few farmers or a few villages, such improved grain storage methods would not be playing the great national role that they can.

However, effective storage must often be part of a broader program of improvements, beginning with better selection of seeds, protection and betterment of the soil, improvements in growing care, in harvesting, storage and marketing. Each step is important. It is useful to have an overall vision, even if you are concentrating only on a particular aspect of the problem.

Improved grain storage techniques at the farm and village level will expand only if they are part of an overall program of improving rural life. In order to help carry out an expanded program of grain storage technology, you should consider the following four related steps in the extension of an improved grain storage program in your own rural areas.

1. **Assessment of the problem;** establishing the potential costs and benefits of the program to the farmer; including compatibility of recommendations with existing skills and social values.
2. **Formulation of a possible range or "package" of approved practices.**
3. **Setting up an organizational and administrative structure for the adoption of recommended practices.**

4. Evaluation and modification of the program in the light of the experiences.

Step 1 – Assessment:

The initial phase in the planning and expanding of improved storage techniques is an analysis of the problem from the point of view of the farmer in the particular locality to be served. All the programs must be based on realities as seen by the farmer who is storing his grain.

Each village has slightly different problems, even within a small region. For various reasons, one village will be more open to change than another. In one, the farmers will be ready to make a mud silo; in another, the farmers may want to store grain in plastic sacks or in oil barrels. You must remain flexible, with a clear vision of your overall aims and objectives: a better life through better preservation of the crops grown. The techniques are the means, and they must never be forced upon a village. You will have to decide with the local farmers and village leaders what is possible immediately. You must also have in the back of your mind a variety of possible techniques to reach the same ends.

For assessment of the problems and possibilities, you should approach the village-level authorities. They should be made aware of the importance of storage, even if they are not grain cultivators themselves. The support of such local persons of importance is always of value. Such local leaders will be able to indicate to you some of the farmers who have been innovators in the village, who have started to use improved tools or who are active in the social betterment of the village. You should also ask local leaders about the historical background of past efforts in rural extension projects.

The Historical Background

It is likely that there have been other extension programs in the area. The success or failure of past programs influences the ways a farmer will look at new programs.

What were the past experiences in your area? Ask the older members of the community. They usually have memories reaching far into the past. They are often able to tell you what has been tried and has failed. You will have to learn from past experiences.

A knowledge of the past will also help you to identify the families who have played an active role in village life in the past.

How are the Local Farmers Organized?

In every society – developing a industrialized – there are a wide variety of organizations, both traditional and modern. It is helpful to know how the farmers are organized and who plays a leadership role. It is also useful to know how village leaders exercise their responsibilities.

Once you know who are the local leaders, go and speak with them, even if they are not grain farmers themselves. They will give you advice on how to implement the next steps in your development program. In some areas, it is possible to hold a special meeting for all the farmers. In other cases, there will already exist a cooperative, or an agricultural improvement committee with which you can work.

Step 2 – Formulation:

The second step is to formulate as wide a range of approved practices as possible.

If you have only one thing to offer, you place the farmer in an "accept or reject" situation. If, however, you have a wide range of useful techniques, the farmer will be better able to choose some, modify others, and reject still others.

It is during this second stage that the different improved techniques must be field-tested. Field trials can help to verify the adaptability of local materials as substitutes for more costly materials. Field tests uncover hidden problems and unanticipated social impediments. The field tests can indicate the level of farmer interest in the proposed new technique.

The farmers with whom you set up the field test must understand that there are risks. Even with the best faith in the world, there are experiments that do not work out. The farm family must not have to suffer from the failures of field tests.

However, properly executed field tests often produce successful results, and thus can have a positive influence on the opinions of local farmers about adopting improved storage practices.

Demonstration of improved storage methods can be very effective in convincing farmers to adopt the new methods for themselves. Demon-

stration models should be highly visible and built to attract attention. Possible locations for demonstration sites are near the home of a well-respected farmer, at the farmers' cooperative, at agricultural youth clubs, at agricultural expositions or on publicly-owned land.

Step 3 – Organization and Administration:

The third step, setting up an organizational and administrative structure for the adoption of improved methods, will depend in large measure on what has been found during steps 1 and 2. It will also depend on the existing agricultural extension structures, the presence or not of cooperatives, and the possible methods of financing the introduction of new storage techniques.

Integration into the Local Infrastructure

A grain-storage program can have a more lasting and broader impact if it is closely integrated with agricultural extension services, farmers' organizations, local craftsmen and the local marketing structure. Additionally, such integration can reduce the program's organizational and logistical responsibilities. For example, the management of insecticide supplies might be turned over to merchants' or farmers' organizations. Craftsmen, once trained in storage construction skills, can take over further training through apprenticeship of younger craftsmen. Agricultural agents can supervise drying, treatment and storage. Involvement at all levels of the agricultural, economic and social sectors will help bring about an integration which hopefully results in adaptation of improved storage practices.

Coordination with other related projects can also extend the longrange effect of a grain-storage project. For example, a broader, more effective base might be gained by joining forces with grain commercialization programs or improved production projects which encourage the use of fertilizers, improved seeds and/or animal traction. This type of coordination can provide complementary benefits for other sectors of activity as well. For example, a local committee for improved grain storage or an organization to provide credit on a cooperative basis can be an occasion for people who do not always work together to come and discuss their common problems. From such meetings may come cooperation

on other issues, such as bettering the road leading to the market or a better water supply.

In those areas where existing local institutions are strong, you can see if they can be used as a system of support for improved methods of grain storage. Where they are not strong, a program for better grain storage may be helpful in setting up local committees that will continue to work together for better rural life.

Step 4 – Evaluation:

The fourth and final step – evaluation – is in many ways the most difficult. What is success? Usually precise quantifiable goals are not set out in a program – such as, for example, precisely 25 per cent of all grain farmers should be using improved techniques exactly two years after the first demonstration has been made. It is likely that such quantifiable goals should not be set out at all, for the process of development and bettering rural life has many dimensions.

Too often, however, programs are not adequately evaluated, and as a result are either continued beyond their usefulness, or dropped before effective modifications might have been made.

There must be set a certain number of criteria for evaluating an extension program:

1. Is the program helping the farmers to meet their basic needs?
2. Is the program helping the farmers to be more self-reliant?
3. Is the program helping to meet basic national needs such as a sure food supply?

Conclusions

Thus, each of the four steps is equally important. It is up to you, who know your local situation well, to help organize an efficient, viable farm and village-level grain storage program suitable to the needs of the farmers in your area.

WORKBOOK EXERCISES

1. What past extension projects have been carried out in your area over the last ten years?

Notes:

2. Were you involved in any of these programs?

Notes:

3. What do local leaders feel about these programs?

Notes:

4. How would you go about estimating the cost and benefits to the local farmer of improved grain-storage techniques?

Notes:

5. What is the organizational structure of the agricultural extension work at the level of the region in which you work (To whom are you responsible? To whom is he responsible, and so on all the way u.)

Notes:

6. What other structures or organizations are active in rural improvement in your area?

Notes:

7. Have you participated in an evaluation of a project? If you had to do so, what sorts of things would you look for?

Notes:

8. It is possible for you to take advantage of the mass media (i.e., press, radio, etc.) in popularizing improved farm and village-level storage methods? If so, how? If not, what steps should be taken to take advantage of mass media in your area?

Notes:

CHAPTER IX: DEVELOPING A NATIONAL STRATEGY FOR FARM AND VILLAGE-LEVEL GRAIN STORAGE

It is clear from your own experience and from the information given in the WORKBOOK that there can be considerable reduction of post-harvest losses of grain at the farm and village-level through improved grain storage techniques. Such reductions on a wide scale are necessary both for the good of the farm family and for the good of the nation. National self-sufficiency in food grains is a national priority that can be reached with a combination of better information, better technology and better organization. There is growing international concern for the need to reduce post-harvest food losses. At the Seventh Special Session of the United Nations General Assembly on September 18, 1975, there was a resolution stating that "the further reduction of post-harvest food losses in developing countries should be undertaken as a matter of priority with a view to reaching at least 50% reduction by 1985."

The aim of this WORKBOOK has been to encourage you to adopt grain storage techniques that can be effectively implemented at the farm and village level. The techniques offered here were chosen in view of their practicality, simplicity and also on the basis of the meagre financial resources available to most subsistence farmers in developing countries. These improved techniques can significantly reduce farm and village-level post-harvest grain losses. The technology has been adapted so that the farmer does not have to acquire a wide range of new and complicated technical skills. Thus, improved storage facilities can become a reality for many subsistence farmers. Furthermore, the technology involved here can no longer be considered "experimental". The ability to construct effective low-cost and simple on-farm and village-level silos and drying units, which are able to considerably reduce post-harvest grain storage losses, has been conclusively proven.

The major question now is how to translate this information concerning improved farm and village-level grain storage into a nation-wide strategy. The development of a national strategy is never easy and requires the realization on the part of many people, at all levels of society,

both of the problem and of the technical possibilities available to cope with it. However, there are four suggested basic steps that can be used as guidelines in helping to develop such a nation-wide program.

The First Step is the presentation of the problem and the technical solutions possible in policy-oriented discussions and workshops at both the regional and national levels. Such discussions and practical workshops (in which various storage and drying units are actually constructed for the benefit of local farmers) should have as their aim encouraging national, regional and local leaders to adopt a strategy to implement improved grain storage procedures at the farm and village-level. These discussions must make specific references to technical information, availability of necessary supplies, marketing services and credit availability. The information gathered at the local level with the help of the **Field Questionnaire** can be organized in a comprehensive, systematic way and presented at such national, policy-oriented meetings.

The Second Step is field testing with a view to analyzing the relative advantages and disadvantages of alternative storage systems. Testing of facilities should be viewed in terms of the following considerations:

1. Cost and efficiency,
2. Geographic and climatic adaptability,
3. Construction material availability,
4. Skills necessary for construction, proper use and maintenance,
5. Current field experiences and practical considerations related to encouraging changes.

The Third Step is the choice of model grain-storage facilities that will be used on a nation-wide basis. There is never any perfect storage system, and there is always a danger of continuing to put off the final choice. Some technicians always want "another experiment", but this keeps putting off the necessity of adopting a national program in which proven standardized models can be constructed on a massive scale throughout the country. At some point, a firm choice must be made of those grain-storage facilities that seem best adapted to the overall needs and requirements of the country. Of course, any national model must be modified and upgraded in light of the geographic, economic and market considerations of a particular region, but this should pose

no great problem once the commitment for certain standardized models has been made.

The Fourth Step is the nation-wide training of extension workers and technicians to carry out such a nation-wide grain storage program. One of the most effective ways is by "on-the-job training" workshops, such as you are now experiencing at Artsha – combining essential information with practical training skills. This type of "learn-by-doing" training can be done relatively inexpensively. It also readily allows for improvements to be built into a training program, on an "as-needed" basis. It might be added that such training programs are increasingly of interest to international aid agencies.

On-the-job training programs also give greater opportunities for periodic and meaningful discussions with farmers and thus can improve on what the farmer is already doing, thereby enhancing his own efforts for a better life.

CHAPTER X: FIELD QUESTIONNAIRE

This questionnaire is organized in outline form to help you collect economic and social information as well as agricultural data that will be useful to you when trying to determine what, if any, improvements in grain-storage methods should be suggested to local farmers.

Thus the questionnaire is used for the systematic collection of data about the ways a family lives, the way it grows and especially the way it stores its food. Experience has shown that if you know something about the interests of the families in your area, it is easier to suggest improvements to them – either in adapting new agricultural techniques or improving their grain-storage practices. You do not have to know everything about the way people live, but you have to know enough to be able to help them with their most pressing needs. In the past, technicians were inclined to tell farmers what they thought they needed rather than talking things over with them in order to learn what their real requirements were.

The questions posed here are meant to serve as a guide to enable you systematically to collect the type of information available to you. When you go out to a village or farm, we suggest the first thing you should do is to look, to try and see the way people are doing things as if you were seeing it for the first time, even if it is the region in which you have grown up. We all take many things for granted, as if it were the only way of doing things. Thus, we do not really look at what people we know are doing. You must try to see with "new eyes" as though you had just landed in the country, so that everything, the way people eat or plant their crops, or live in their houses was being seen for the first time. If you can look with "new eyes", you then ask yourself why people are doing things in this particular way.

At that point, you are now ready to write down your observations using the questionnaire approach as a tool for gathering your data.

The next step we suggest you follow is to talk over with the local farmer and his wife the things you have already observed. They may think the questions strange, especially as they may feel you already know the answers. But ask the question anyway. You may be surprised by their answers, and they may lead you into more detailed conversation. You should also try and note on your questionnaire the answer of the farmer next to what you have seen.

Then compare your observations and answers with others working on the same type of problems. What are the differences?

It is by such patient, systematic methods that you can discover what is truly in the best interests of the farmer and not what you suppose. From that point on, you are in an excellent position to bring about the necessary changes. Of course, we all realize that we live in a rapidly changing world, and it is necessary to modify certain modes of thinking and ways of doing things. But above all, we must try to be creative without ignoring past accomplishments.

A questionnaire is set out in a certain logical order – usually a chronological order – that is, one thing follows another in time. The questions about planting a crop come before those about harvesting, for example, and those about harvesting before questions about selling grain.

However, you may not always be able to get the answers to your questions in that precise order. You may arrive in a region at the time when grain is being sold at the market, so that your first observations and questions will be about who buys the grain, how it is weighed, at what price it is bought. It will be only later that you will be able to get answers to such other questions as who plants the grain, what work there is to do during the growing season, how it is harvested.

But with patience, you will find answers to every question, for each question is important in giving you a picture of the way the farmer cultivates his grain, how he uses it, and the ways that you may help him improve his storage techniques.

This questionnaire will allow you to note down in a fairly systematic way observations that you make in the course of your work, answers to questions you ask of farm families, and ideas received from fellow agricultural development workers.

The questionnaire is divided into four sections:

- I. The Grain Cycle and Seasonal Work Calendar.
- II. The Local Farm Economy.
- III. The Uses of Grain.
- IV. The Current Storage Practices.

I. The Grain Cycle and Seasonal Work Calendar

The work of a farmer is largely determined by the seasons and the alternating wet and dry periods. Climate, of course, is something that man can do very little to change, and through long experience he has learned to work within its proscribed limits to his maximum benefit.

In the past, certain agricultural improvement projects have failed, because seasonal changes were not as seriously considered as they might have been. For example, improvements at home were made at times when everyone was needed for work in the fields.

Thus, although you are concerned with improving the storage of grain at the farm and village level, you must know something about the whole cycle of grain – planting, caring for it, harvesting and storage – in order to know if the improved techniques for storage can be put into practice. You must also know something about the place of grain in the economy

of the local farmer. In some areas, grain is the main crop and takes up most of the farmer's time. In other areas, less so.

1. What is the place of grain crops in the local economy?
What amount of time does the farm family spend on grain crops in comparison to time spent on root crops, vegetables, caring for animals, handicrafts?
2. What grain crops are grown locally? (Names in both local languages and in translation: maize, millet, sorghum, etc.)
3. Does the farmer make a distinction as to their use – that is, is one type of grain destined for sale, another for food consumption, yet another for feeding of animals?
4. How large are the fields under cultivation?
Are they single-crop fields, or are crops mixed – one row of maize, the next of groundnuts, for instance?
5. What is the grain production cycle?
 - a) In which month is the grain planted and by whom (wife, children, husband, collective labor)?
 - b) How long does the crop take to mature?
 - c) What work is required during the growing period? (weeding, protection from birds, etc. By whom is it done: wife, children, husband, collective labor?)
 - d) When is the grain crop harvested?
By whom?
 - e) Who does what work at each step – preparing the fields, planting, weeding, harvesting, etc.? (husband, husband and sons, wife, wife and which children, cooperative work with other relatives and neighbors?)
6. How is the grain cycle linked to the climate cycle?
 - a) Which are the rainy months?
The average rainfall?
 - b) Which are the dry months?
Is there any danger of rain during the drying period following harvest?
 - c) Which are the months of maximum temperature?
 - d) Which are the months of minimum temperature?

e) What sort of climatic fluctuations or cycles does your area normally experience?

- 1) over 5 years' time
- 2) over 10 years' time
- 3) over 20 years' time

7. Can short and long-term communal storage needs be synchronized with anticipated drought periods?
8. Are there times when winds are constant or frequent?
9. Are there periods of the year when there is less pressing agricultural work to do, when new buildings could be built, etc.?

II. The Local Farm Economy

Basically, farmers will undertake improvements in their agricultural techniques and storage facilities if they are convinced that the results will be worth the effort. The benefit must be worth the cost.

More and more often, benefit is measured in cash terms. Cash benefits are not the only kind to be taken into consideration, however. A better diet is a benefit, too. Nevertheless, cash plays an important role for the farmer. Thus, an important factor in motivating the farmer to use improved storage facilities is that he will have more grain to sell.

You should be able to discuss with the farmer the economic benefits of improved storage, and so you should know as much as possible about the local farm economy. What does the farmer sell, to whom, for how much money, what does he do with his earnings?

1. What percentage of farmers sell any of their grain produce on the local market? (A number of studies indicate that only some 20% of the farmers sell to the local markets, and that for the remaining 80% all grain is consumed by the family.)

2. Of the farmers who do sell on the market, what percentage of their grain do they sell (one-quarter, one-half, three-quarters)?

What are the difficulties of transportation?

Would the farmer sell more of his grain if he had easier access to the market?

Are there more lucrative markets that could be reached if transportation were improved?

3. How does the farmer organize his year in terms of his needs for

cash? (In many instances, the farmer sells at harvest time because debts usually fall due at that time, school fees and taxes must be paid, etc.)

Are there any local savings facilities – postal savings or banks? Does the farmer use them? The times when farmers need cash must be studied locally, and possibilities of modifying the pattern discussed.

4. When does the farmer sell his grain?
 - Most of it immediately after harvest?
 - When grain crops have been dried but not stored for any length of time?
 - Later in the year?

5. How is the grain bought at the market? (In some areas, grain is sold by volume – number of bags – rather than by weight. In such cases, a farmer can mix a larger proportion of his damaged corn, made lighter because insects have eaten part of the kernel, with good grain. He can then sell his grain at the same price as well-stored grain.)

In this respect, what types of quality control are there on the local market? Are there ways that a farmer could be rewarded for selling better quality grain?

III. The Use of Grain

People will make changes in their ways of doing things only if it is really important to them to make these changes.

If grain does not play an important role in the lives of people – as is the case for many cattle-herding peoples – it is not much use to talk to them about improved grain storage.

It is therefore important to know what place grain has in the lives of people. If there are some months between harvests, when people feel hungry, then it is easy to point out the need for better storage so that they will have more food all year round.

It is also important to know who decides how grain that has been stored will be used. If the husband decides, then it is important to talk with him, even if it is his wife who does most of the work; or, if it is the wife who decides how much grain is to be used, it is important to talk with her about

the benefits of improved storage, even if it is the husband who does most of the work.

Much grain is normally used by the family as food. Although a detailed study of nutrition habits is impossible to make in a short time, it is useful to inquire into and discuss the use of grains in the regular diet:

1. How often are food dishes with grain eaten? (Twice a day, once a day, several times a week but not daily?)
2. Does the frequency of eating dishes made with grain vary at different times of the year?
3. If so, what is the yearly food pattern?
4. Are there inter-harvest food scarcities?
5. If yes, in which months is scarcity the greatest?
6. What are the other principal elements in a rural family's diet? (Meat, fish, eggs, yams, etc.)
7. How are grains prepared for food? (Hand-pounded in a mortar, ground between stones, small grinding machine, commercial mills) Is grain prepared daily for immediate use, or prepared in larger quantities and stored?
8. By whom are grains prepared? (Wives, younger girls, boys, men?)
9. Who decides how much grain is to be used daily? (Wife, husband?)
10. Are there local programs for improved nutrition?

IV. The Current Storage Practices

It is important to try to get as complete a picture as possible of current grain-storage practices. Farmers who live in a particular area may have very good reasons for doing things in the way they are doing them.

There is a long record of "improvements" that turned out not to be improvements at all. On the other hand, just because people have been doing something for a long period of time is no reason to believe that this is the best way. The only way to tell is

first, to study what is being done currently;

second, to test in the field the new methods being proposed;

third, to compare the two and to make necessary modifications.

It is also useful to gather some quantitative information – that is, how many farmers store how much grain in what ways?

Quantitative information is useful because in an area not everyone does things in the same way. If you ask a farmer, "How do you store maize in this village?", he will give you one answer. It will probably be the way he stores maize. If you go and see, family by family, you are likely to find a good deal of variety. Such a survey family-by-family will help you to see which are the better farmers and so to know with which farmers to start to work most closely.

1. How are cereals dried? How long are they left in the fields after cutting?
2. How is grain thrashed? (By hand; by a hand mill, at a commercial mill?)
3. Is maize removed from the cob, left to dry with the covering, left to dry on the cob but without covering?
4. Of what are made local storage containers of grain? (Banana or sisal fiber, bark, reeds, bamboo splits, mud, jars, oil drums, corrugated metal-sheet granaries?)
5. Where are grains stored? (In the habitation, in a pit, in a building directly on the ground, on a raised platform?)

Knowing the types of traditional storage methods tells you something about the type of technology already in use. It is easier to teach people to use an improved mud silo if they already use mud for building than if they merely tie maize cobs on the branch of a tree.

6. Are there farmers in the area already using improved storage techniques?

What techniques are being used?

7. How did these farmers learn?

Are there indications that these techniques are spreading?

CONCLUSIONS

Once you have gathered the information asked for by the questionnaire, you will be ready to take up some of the methods for popularizing improved grain storage methods that are outlined in Chapter 9: "Popularizing Improved Methods of Farm and Village-Level Grain Storage Technology".

The questionnaire will help you to discover the way people really live, even if they are people you have known all your life. It is only by under-

BIBLIOGRAPHIC GUIDE

There is a good deal written about grain storage, however relatively little deals with storage at the farm and village level.

Among the studies that will be of most practical use to you are the following:

1. Carl Lindblat and Laurel Durben. **Small Farmer Grain Storage**. (Volunteers in Technical Assistance, Via Publications No. 35 E)
2. D. W. Hall. **Handling and Storage of Food Grains in Tropical and Sub-Tropical Areas** (Food and Agriculture Organization of the United Nations, Via delle Terme di Caracallo, 00100 Roma, Italy)
3. David Dichter (ed.) **West African Seminar on the Volunteer Role in Farm and Village-Level Grain Storage** (D. Dichter & Associates, 9 rue de Vermont, 1202 Geneva, Switzerland)
4. David Dichter (ed.) **Workbook for East African Workshop/Training Course on Improved Farm and Village-Level Grain Storage Methods (1977, DSE 227 pp)**

Probably one of the best sources for recent publications on grain storage is:

Tropical Stored Products Center
Tropical Products Institute
London Road
Slough SL3 7HL, Bucks.
England, U.K.

The Center publishes twice a year a journal, **Tropical Stored Products Information**.

Also active in grain-storage problems is:

The Tropical Products Institute
Overseas Development Administration
56-62 Gray's Inn Road
London WC1 8LU
England, U.K.

The United States Department of Agriculture has long been active in research and publications on grain storage. Some of the research publications can be of value in tropical areas. Write for current lists to:

Foreign Agriculture Division
United States Department of Agriculture
Washington, D.C. 20402, U.S.A.

The United States Agency for International Development has also been active on grain storage. Of particular use is the **Report of the Maize Food Storage Seminar**, April 1975. For this and other publications available, write to:

Technical Assistance Bureau
Agency for International Development
Washington, D.C. 20523, U.S.A.

Research on grain storage at the farm and village level is important in India, a land of many villages. Indian research is available from:

Central Food Technological Research Institute
Mysore 2, India

and is reported in:

The Bulletin of Grain Technology
Foodgrain Technologists' Research Association of India
Hapur, India.

Of particular interest are the publications of:

The Nigerian Stored Products Research Institute
Federal Ministry of Trade
Ibadan, Nigeria

Although there are different problems in tropical and temperate climates, some of the research publications of the European and Mediterranean Plant Protection Organization, 1 rue le Notre, Paris, France, can also be of use to you.

standing what motivates people that you can get them to try out some of the improved methods outlines in this WORKBOOK.

You will understand better how the farmer uses his grain and how he is storing it. It is only if you build on the foundations of what is being done currently that you can get farmers to use improved grain storage techniques.