

**OWNER-BUILT - WOOD-FIRED - KITCHEN HEATER -
COOKING RANGE - WATER HEATER
OVEN - FOOD DRYER**

DESIGNED
BY AUTHOR
1974

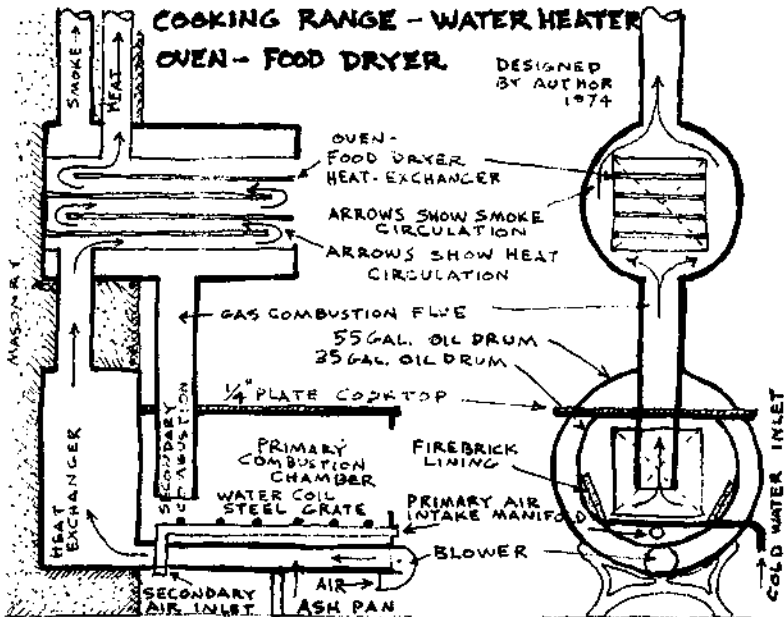

6.2 OWNER-BUILT WOOD-FIRED COOKING RANGE, HEATER, OVEN, WATER HEATER, FOOD DRYER

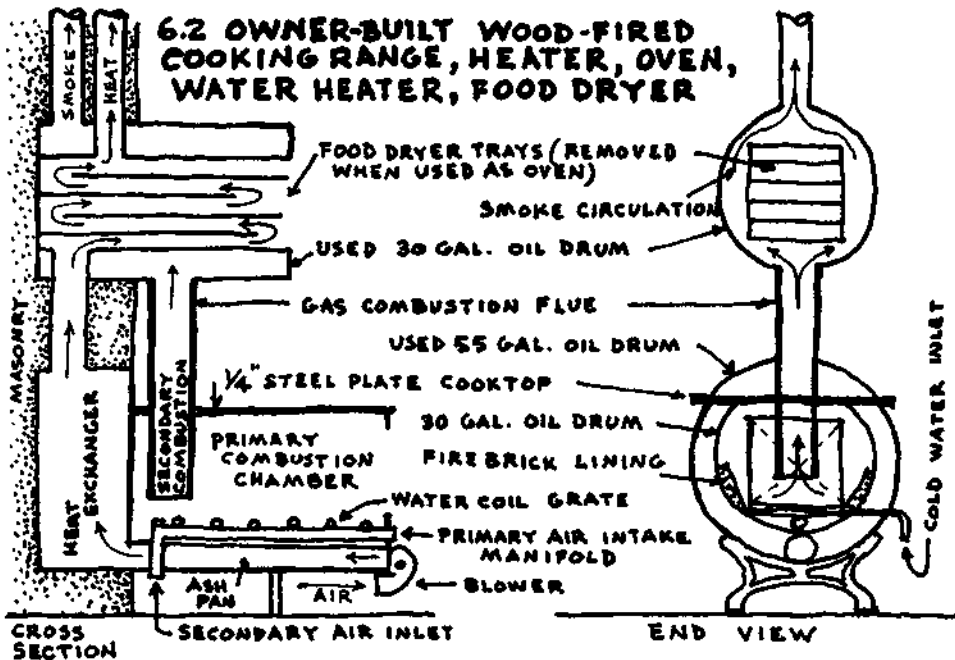

This general background introduction to efficient wood heater design demonstrates how utterly wasteful the usual installation is. But it says more: by understanding the basic fundamentals of complete combustion we can design and build our own superior unit. I would wager the opinion that, in recent years, more wood heaters have been put together in small blacksmith and backyard welding shops than in all stove foundries combined. Cast-iron stoves were popular in Emerson's time because people liked the evenly distributed heat which they radiated. But cast-iron stoves cannot be made airtight, and, of course, they require factory techniques for their mass production. Cutting and welding metal is no longer the specialized craft it once was in our grandfather's time; simple arc and oxy-acetylene equipment have replaced blacksmithing skills.

The traditional home-fabricated stove is made from a 55-gallon oil drum, laid horizontally. A pair of cradle legs made from bent angle iron is welded to the bottom side, and a fuel access door is cut out of the front end. The outlet flue is customarily located at the rear top of this lower-level barrel and connects to a second, upper-level 55-gallon oil barrel which functions as both a heat chamber and an oven. The final flue

outlet flows chimneyward at the upper back end of this heat chamber oven, although on more sophisticated barrel stoves the flue for this upper-level chamber is located above the front oven door and, thence, flows into the chimney.

These stoves were so common in the Northwest territories at one time that they were known as Yukon stoves. To meet the popular demand for the Yukon barrel stove (also called the "belly stove"), manufacturers can supply conversion kits consisting of a cast-iron fuel door, legs and a grate designed to fit the 55-gallon oil drum.

This kind of heater installation is, at best, crude and inefficient, fuel-wise. But it does speak to one of the major shortcomings of American stoves; that is, to the lack of fuel capacity. Quite a number of 3-foot-long logs can be packed into the Yukon stove. The old-fashioned school stoves had this faculty, too. They were made from half a ton of cast-iron and could burn 24 hours with one loading. Logs 2 feet in diameter and 3 feet long could be packed into these stoves, which are now collectors' items. The epitome of limited fuel capacity is the traditional cast-iron (and modern steel!) wood-burning stove.

There is good reason to combine cooking and heating functions in one unit, especially for a compact, open-planned house such as my proposed Concord design. We already imagined how Emerson (or more likely his wife) must have trotted to keep half a dozen separate fires stoked on chilly days. And, remember, each fire required a separate flue, each hot metal flue contacting potentially flammable roofing material in the attic, compounding the risk of destructive fire.

Wood-to-flue joining substantially decreases the risk of fire danger if done properly, but the build-up of creosote and tar in the flue as a result of using an inefficient

stove (or green wood) is another matter. Wood is one of the hottest burning fuels. Unburned gases condense in an uninsulated metal flue, forming caked layers of combustible creosote and tar. A spark will ignite this shaft of concentrated fuel, blasting flames out of a cherry-red chimney. This is why houses burn down in the middle of a cold winter.

For fire safety, as well as for economy, I recommend combining the cooking and stove heating functions into one facility. The flue from this dual-purpose unit should be clay tile, wrapped with fiberglass insulation and encased in the centrally located fireplace masonry.

Some of the salient features of my proposed cooking-heating unit are illustrated below. The combustion chamber consists of a 35-gallon oil drum set inside and welded to an outer shell which is a 55-gallon oil drum. I chose oil drums because of their availability, their low cost, and their strong curvilinear construction. To provide a heat-absorbing cooking surface, a sheet of 1/4-inch steel plate is welded to the top of the intersecting drums. Spaced bars of 1-inch reinforcing steel form the grate. Below the grate is welded a continuous length of 2-inch diameter steel pipe, perforated at the bottom with drilled holes which, when open, emit a continuous draft of air the full length of the fuel bed. Draft inlets are provided at the front of the stove for quick starting and at the rear of the stove for the complete combustion of gases accumulating there. Both draft inlets are equipped with positive, fine-adjustment controls for opening and closing. The rear draft is supplied from under-the-floor air space, thereby creating a full-circle, no-draft convection current. During seasons of colder temperatures a front-mounted squirrel cage fan (virtually silent) is ac-

tivated to help circulate jacketed hot air into the room. A second 55 gallon drum encases the oven at a convenient level above the cooking surface of the lower-level drum. Hot air flows from the central chamber of this upper-level drum, through a metal-boxed heat exchanger, and from there into the room.

One of the most unique--and valuable--features of the Riteway or Fuel-Master stove is its gas combustion flue. The use of such a flue should be included in our homemade version. Due to the high temperatures incurred at the point of gas combustion, a heat-resistant material, such as heavy steel pipe, should be used. It is connected directly to the heat exchanger.

Our total winter-time hot water needs are met because a thoughtful Riteway engineer provided space in the firebrick lining of the combustion chamber for a metal, water-heating collector. This one simple installation has, doubtless, saved enough electricity or gas to repay many times over the original cost of the heater itself through its uncomplicated, trouble-free, 15-year performance for our family. At one time Superior Fireplace Company, makers of the Heatform fireplace liner, offered a water-heating coil that fastened onto the metal fireback. Drawing hot water from heater and fireplace is an excellent idea and should certainly be included in the new Concord dwelling. Heated water naturally thermosiphons into an upper-level storage tank. In summer months a solar collector provides hot water. Solar, fireplace, and stove units are all tied into the same storage tank.

Heating water in a stove is best accomplished by circulating the water through a 1-inch iron pipe grate. One possible grate design is illustrated in Figure 6. Note that the iron pipe must be welded to 24-inch lengths of angle iron. The angle iron, in turn, rests on the inner drum combustion chamber.

With intensive use, ashes need to be removed from the stove periodically. To facilitate their removal, the grate can be swung upward against the bottom of the cook plate and secured with a wire hook. Iron pins are welded to the rear of the angle iron grate, providing this hinge action. When a water-circulating pipe grate is used, some form of swivel connection must be provided. A simple coupling should work, providing the connection is threaded an extra amount.

Water heating is only one of a half-dozen functions of this stove design. As illustrated in the drawing below, Figure 4, by simply

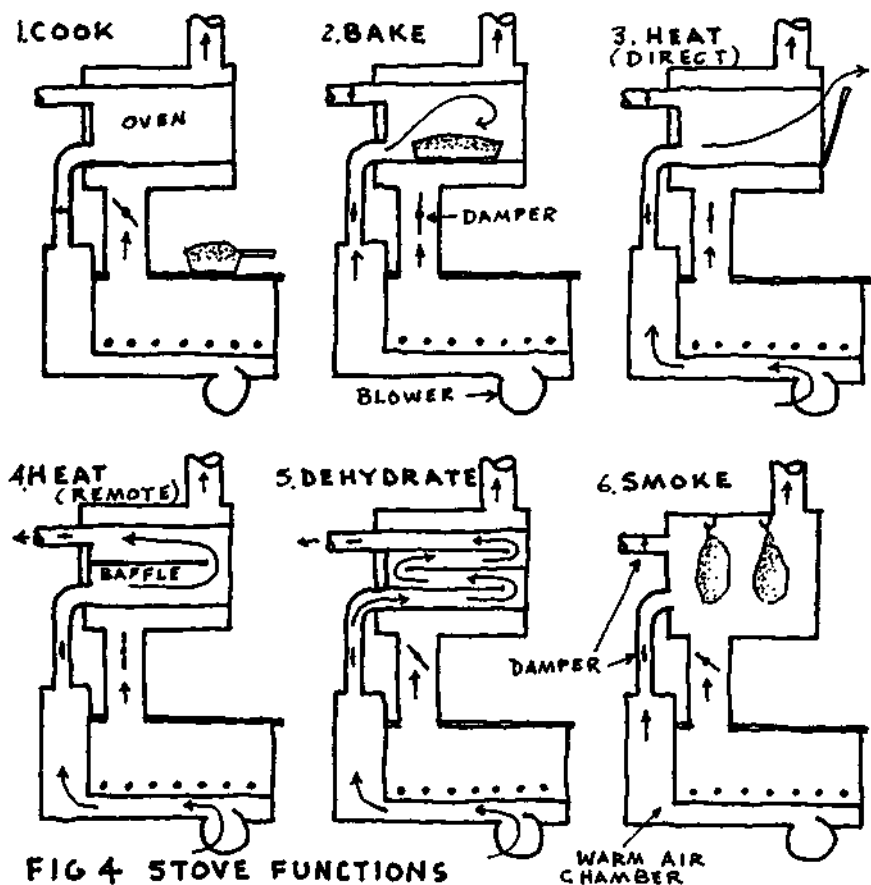
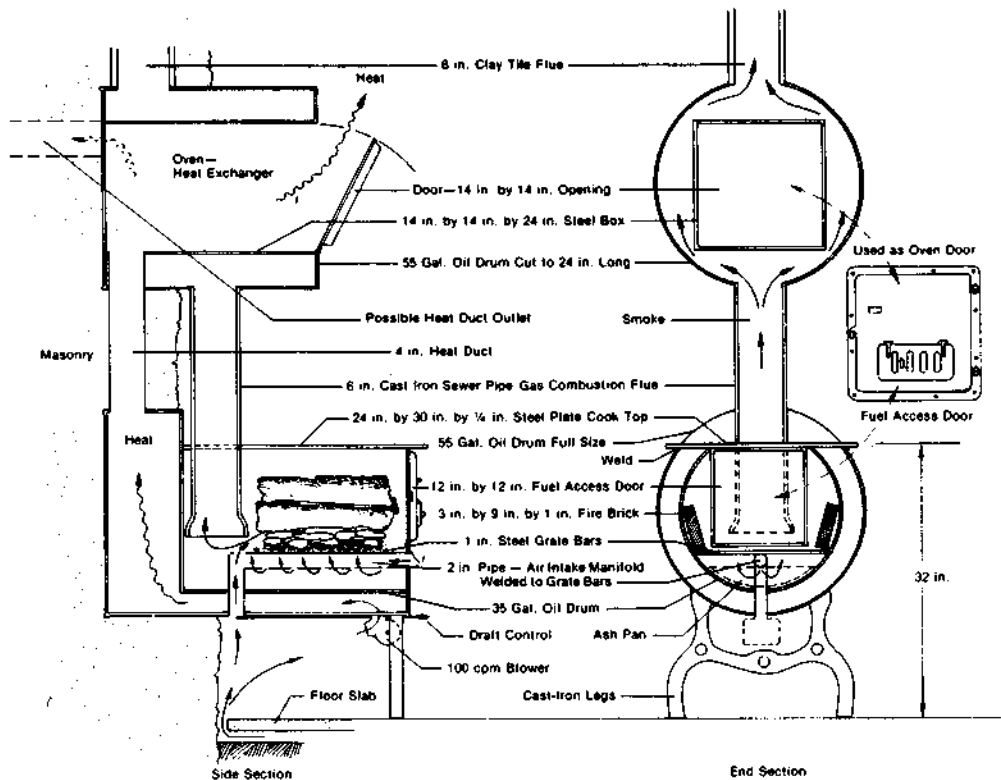

FIG 4 STOVE FUNCTIONS

WARM AIR CHAMBER



Kitchen heater-cooking range-oven.

adjusting a damper, a blower switch or a baffle plate one can use the stove for direct or remote room heating--or one can cook, bake, dehydrate or smoke food with it. The multi-functional aspects of this stove design make it especially well-suited for the average, wood-fueled productive homestead.

In the discussion that follows, I have disassembled each component of the stove and described its separate fabrication. Although I may specify a particular size or gauge of metal for various parts, the owner-builder should realize that his range of choice may vary widely. Many times my choice was influenced by the fact that a particular metal happened to be in stock on our homestead.

For instance, the gas combustion flue is specified to be 10-gauge, 7-inch round steel well casing. Theoretically, this flue should be heavier gauge, larger diameter cast iron and able to withstand the intense heat of combustion encountered in this section of the stove. But, while steel is easier to cut and to weld than is cast iron, well casing is cheaper and more readily available. Furthermore, on my prototype stove, the well casing combustion flue proved to be entirely satisfactory.

I designed the stove unit so that any semi-skilled, metal-working homesteader could fabricate the entire unit in his home workshop. This happened only partly by choice for my own metal-working faculty is limited by inexperience and lack of sophisticated tooling. A basic understanding of arc and gas welding techniques is, of course, essential. But even here, an expertly applied bead of weld is not essential when liberal quantities of furnace cement are available. Furnace cement made the whole project possible! It took a \$2 pint-size can of this amazing material to cover the multitude of welding sins on the prototype stove alone.



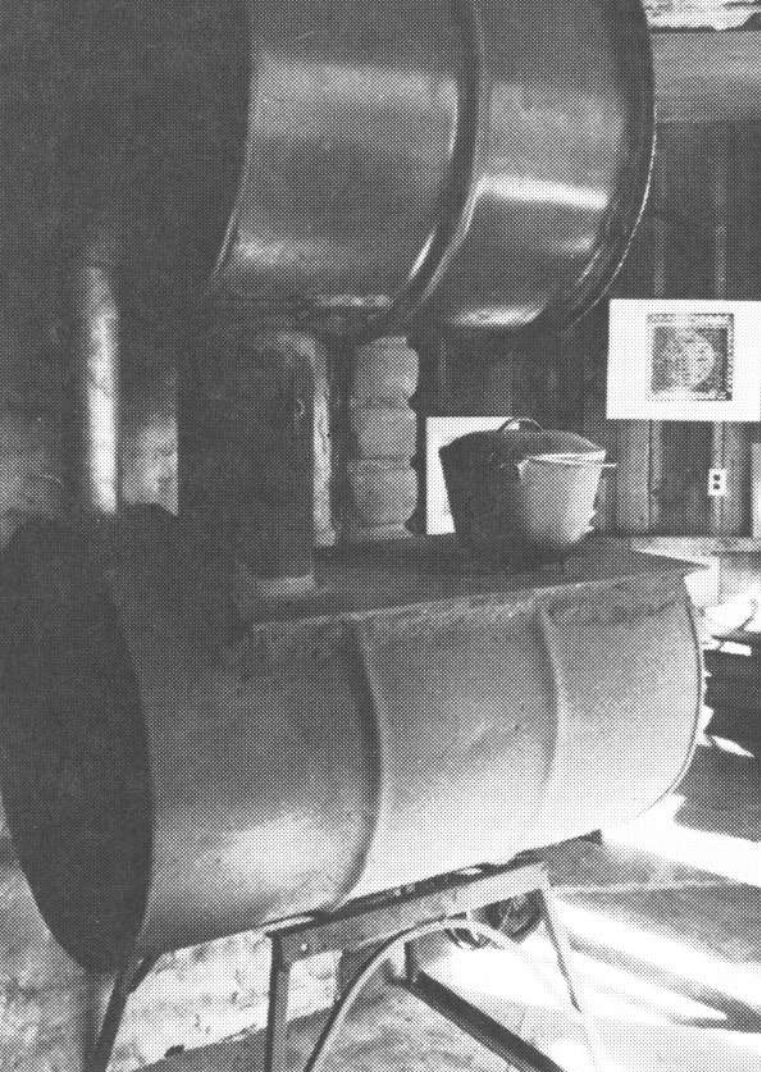

Stand

Construction of the metal base support is self-explanatory in Figure 5. The stand is anchored to the 55 gallon oil drum by 4-3/8" bolts which fasten the angle iron frame directly to the two ribs found on most oil drums. Note: oil drums, having these two mid-section ribs, are much preferred for their additional rigidity over plain metal drums. Drill and tap the ribs to receive the 3/8" bolts--two on each side.

Combustion Drum

A 4-inch segment is first cut longitudinally out of a 35 gallon oil drum. This cut represents a chord length of 15 inches. When the plate steel cook top is welded to the cut surface there should be a net distance of 14 inches from the bottom of the barrel to the cooktop.

After the grate assembly is installed in the combustion drum and is anchored by a hinge pin on each end of the grate, the cooktop can then be welded to the combustion drum. Now cut out the front face of the combustion drum. With the grate swung up and anchored against the bottom of the cooktop, one can proceed to install the air-intake manifold. Details for assembling the manifold are illustrated in Figure 6. Now it becomes possible to weld the gas combustion flue into place. A connector flange is provided for attaching the oven assembly. Construction of this flange is also illustrated in Figure 6.

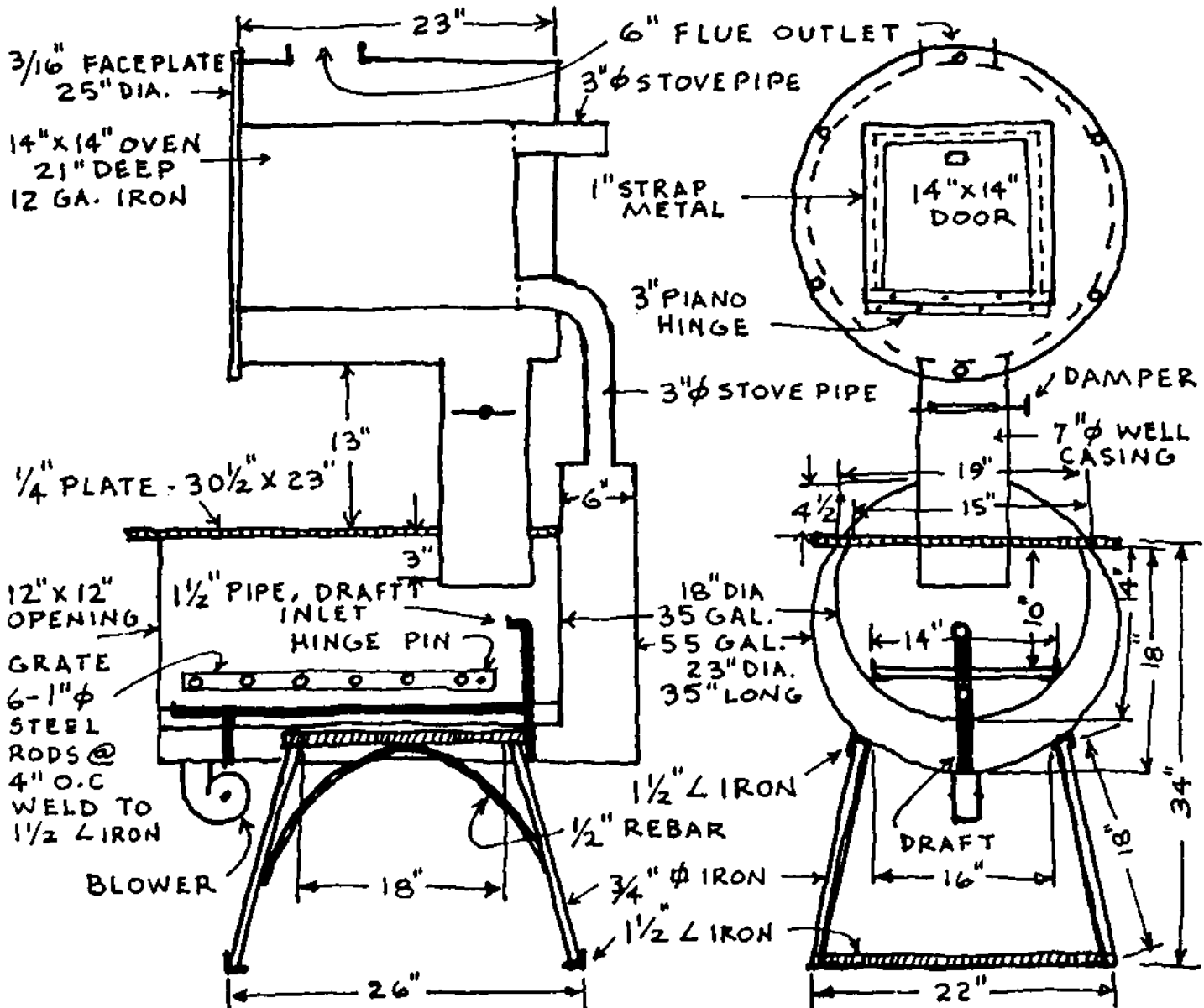

FIG 5 STOVE CONSTRUCTION

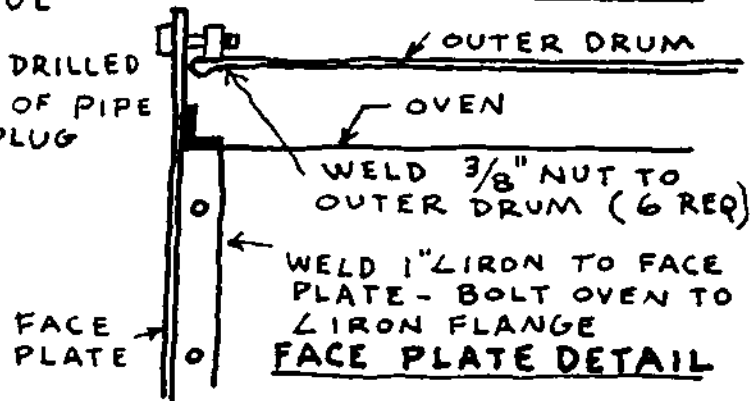
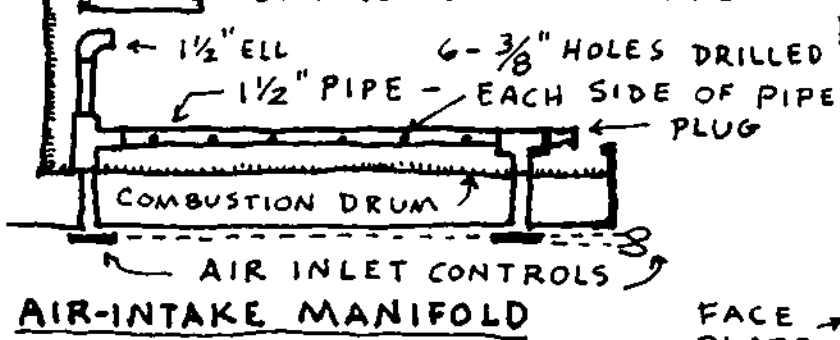
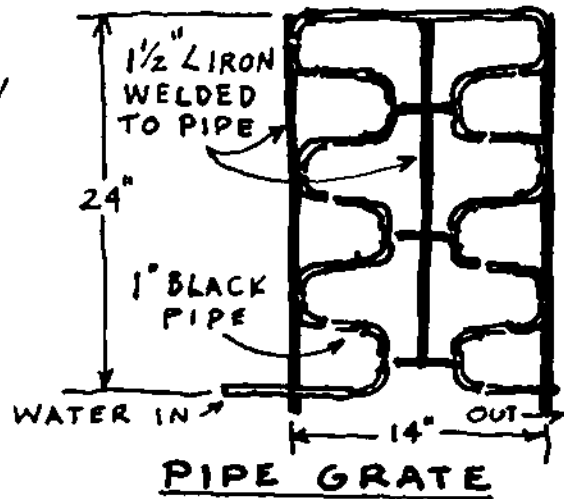
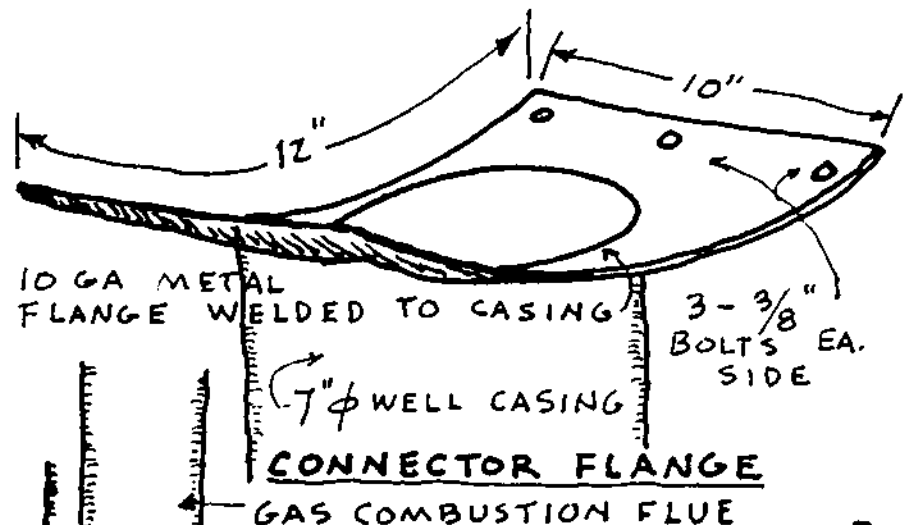

FIG. 6 DETAILS

Warm Air Chamber

The warm air chamber consists of a 55 gallon oil drum. A 5-inch segment is cut out of the drum, establishing a chord length of 19 inches and an 18-inch distance between the bottom of the drum and cooktop. Now weld the drum to the cooktop, install the fore and aft dampers and the blowers. The stand can now be bolted to the drums, and the fuel access door may be bolted in place. On the prototype model the fuel access door was salvaged from an old wood heater. One can also be made from 3/16" steel plate, using a 3-inch piano hinge.

Oven

Smoke circulates between the outer shell and the actual oven chamber. To form the outer shell, cut a 1/3 section off of a 55 gallon drum. Remove the lip from the discarded section and weld it to the drum edge. This provides a finished edge onto which the oven face plate can be bolted. The 3/16" steel face plate is anchored to the outer oven shell with 6-3/8" bolts. An illustration, Figure 6, shows how this is done. The oven chamber is welded directly to the face plate. When the outer chamber is used for smoking meat, the inner chamber must be removed. One method for making this attachment is illustrated in Figure 6.

Outlets

All that remains to complete the stove is the provision for smoke flue, dampers and warm air outlets. A metal ring needs to be welded on the top of the outer oven shell to receive a 6-inch stove pipe. For this, I re-curved a 2-inch section of well casing. All warm air outlet pipes were made from 3-inch galvanized iron flue pipe. A system of dampers is necessary if heat is to be supplied to other room areas.

Over a period of a winter season a number of adjustments and changes in the stove design were made, increasing its basic efficiency. This is not to say that further changes are not in order. As individual owner-builders fabricate their own stoves I am certain that improvements will be forthcoming. Hopefully, feedback from the experience of others will enable us to update this material regularly.

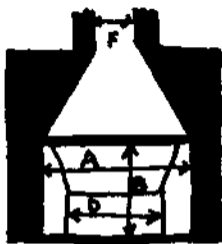
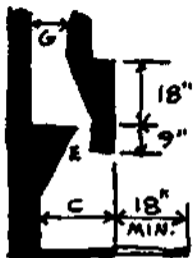

8.3 FIREPLACE PROPORTIONS

FLUE SIZE FOR
STACK HEIGHTS

No.	A	B	C	D	E	TO 13'		TO 26'		TO 39'		ROOM SIZE	
						F	G	F	G	F	G	SQ. FT.	CU. FT.
1	24	20	13	14	4	10 x 10	8 x 8	8 x 8	70-240	1400-2100			
2	30	24	15	19	4	10 x 10	8 x 8	8 x 8	240-320	2100-3200			
3	36	27	16	24	5	15 x 10	10 x 10	10 x 8	320-430	3200-4200			
4	42	30	17	29	5	15 x 15	15 x 10	10 x 10	430-540	4200-6400			
5	48	33	19	33	6	15 x 15	15 x 10	10 x 10	540-750	6400-8800			
6	52	35	20	36	6	15 x 15	15 x 15	15 x 10	750-	8800-			

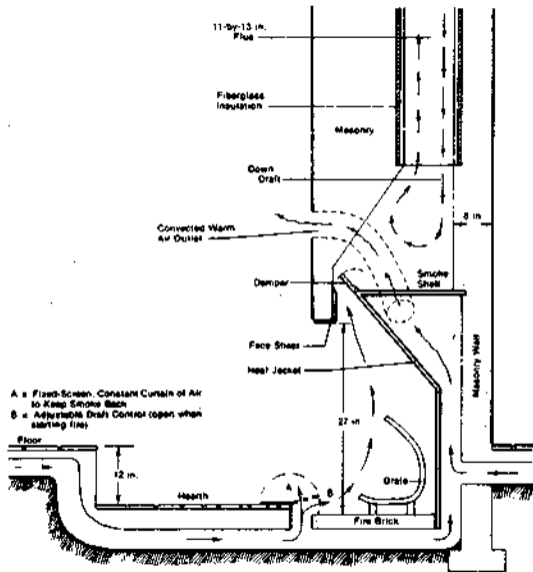

Cross-section of Kern's fireplace.

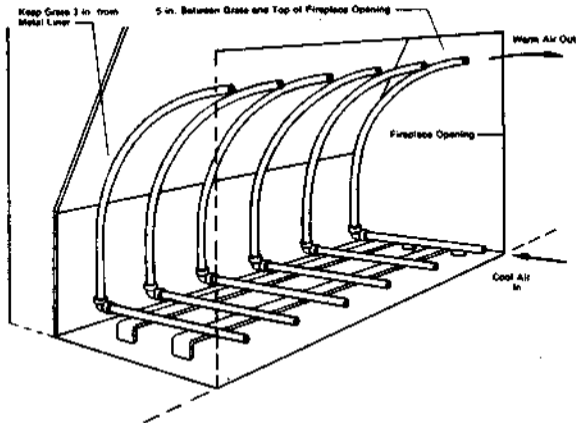

Fuel grate constructed from short pieces of iron pipe.

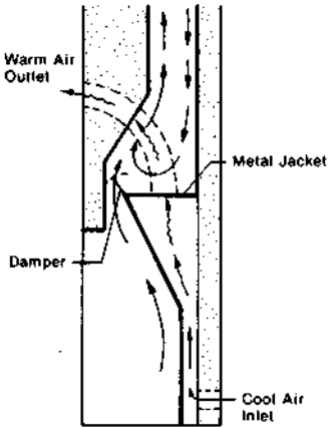

Kern

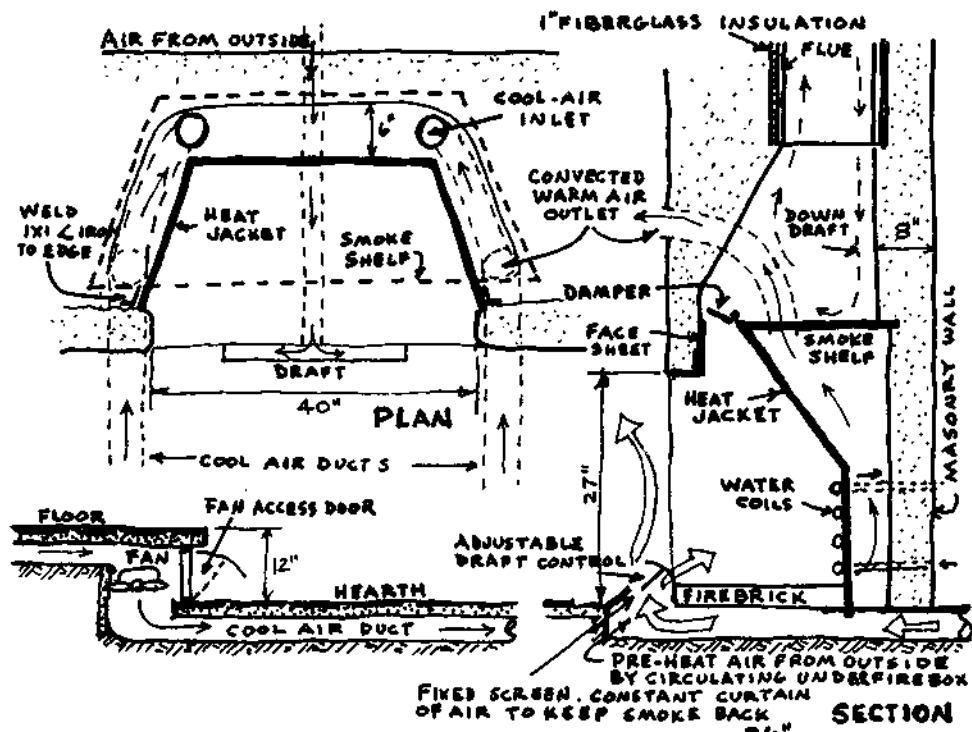

ELEVATION

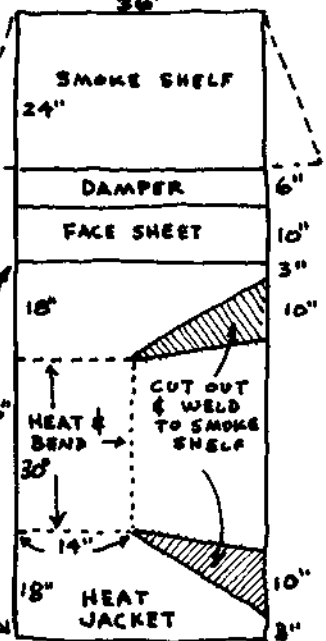
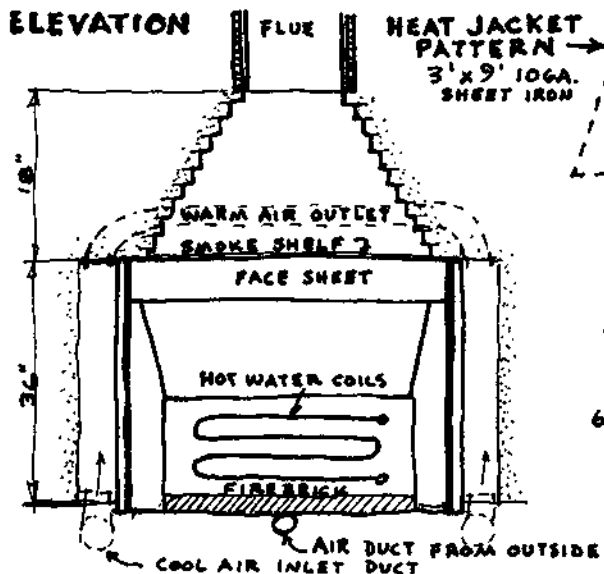

8.5 OWNER-BUILT FIREPLACE

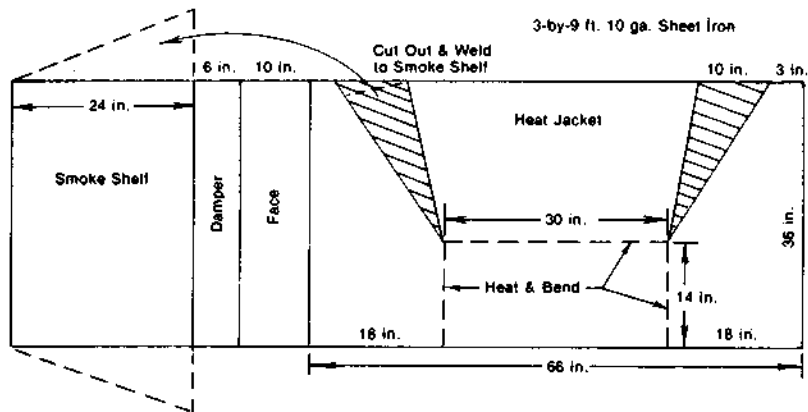
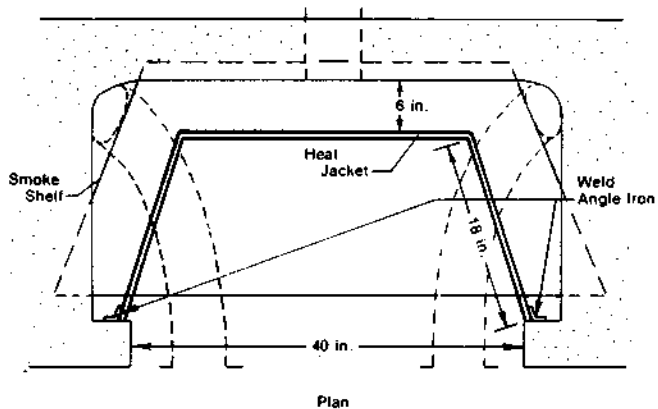

FIGURE 44. Heat jacket pattern.

The metal chamber may be cut, bent, and welded out of a single 3- by 9-foot piece of sheet iron. A damper, welded to a pair of hinges, is, in turn, welded to the smoke shelf. A cool-air-supply duct should be provided at the front lower sides or at the rear of the lower back of the unit. The warm-air outlet is best placed at the upper front of the fireplace. Outlet ducts, built into the floor slab or into the attic space, can be positioned in an adjacent room when a forced-air circulation fan is employed to distribute the hot air through controlled outlet grilles.