

AT MICROFICHE
REFERENCE
LIBRARY

A project of Volunteers in Asia

Design of Cross-flow Turbine BYS/T1

by: Ueli Meier

Published by:
Swiss Center for Appropriate Technology
Varnbuelstrasse 14
CH-9000 St. Gallen
Switzerland

Paper copies are \$10.00.

Available from:
Swiss Center for Appropriate Technology
Varnbuelstrasse 14
CH-9000 St. Gallen
Switzerland

Reproduced by permission of the Swiss Center for
Appropriate Technology.

Reproduction of this microfiche document in any
form is subject to the same restrictions as those
of the original document.

CROSSFLOW TURBINE

type: BVS/T1

- with manually operated flow regulator
- Rotor diameter: 400 mm
- Nozzle width: 50 to 400 mm

Flow: $Q \approx Q_s \cdot x \cdot \sqrt{H_n}$

where: Q_s = specific discharge = 0.30 l/s

x = nozzle width (mm)

H_n = net head (m)

Rated speed: $N = n_s \cdot \sqrt{H_n}$

$n_s =$ 98.5 RPM

Calculation of nozzle width:

$$x \text{ [mm]} = \frac{Q \text{ [l/s]}}{Q_s \cdot \sqrt{H_n} \text{ [m]}}$$

$$P \text{ [kW]} = \frac{Q \cdot H_n}{102} \cdot \eta \quad (\eta = 0.7 \text{ at full opening})$$

SKAT

SKAT
Schweizerische Kontaktstelle für Angewandte Technik am ILL
Institut für Lateinamerikaforschung und Entwicklungs-
zusammenarbeit an der Hochschule St.Gallen

SKAT
Swiss Center for Appropriate Technology at ILL
Institute for Latin-American Research and for Development
Co-operation, University of Saint-Gall

Varnbühlstraße 14, CH-9000 St.Gallen,
Switzerland, Tel. 071 23 34 81

SKAT
Centre Suisse pour la Technologie Appropriée à l'I.L.L.
Institut de Recherche sur l'Amérique Latine et de
Coopération au Développement, Université de Saint-Gall

SKAT
Centro Suizo de Tecnología Apropriadada en el I.L.L.
Instituto de Investigación sobre América Latina y
de Cooperación al Desarrollo, Universidad de Saint-Gallen

CF Turbine BYS/T1

Hints for the use of the drawing set:

- Drawing are divided into sub-assembly and assembly groups. Parts-lists and (sub)-assembly drawings bear an identical number code, followed by drawings of individual parts with the same code and serial number.
- Assembly groups T1-10.0 and T1-11.0 refer to the gate operation by hydraulic cylinder only.
- Drawings 01.1/1-3, 01.2, 01.3, 01.4 are required only for execution with draft-tube.
- Reinforcing disk (drwg. 04.4) and inlet rib (drwg. 08.9) are optional depending on head and turbine width. This must be determined by a separate stress calculation (on request done by SKAT).
- Permissible shaft loading requires to be checked for $P > 10$ kW and $H < 7$ m and also $P > 20$ kW and $H < 14$ m.
- Assembly groups 05.0 and 07.0 (bearing housings) may be replaced by commercially available standard bearing housings. However, height of shaft axis has to be taken into account.
- Code "x" refers to the variable nozzle width. All drawings with x-related measurements have to be completed by adding the chosen x. Example: $x=400$ as calculated. For drawing 01.5 : $x + 412 = 400 + 412 = \underline{812 \text{ mm}}$.
- On some drawings not all standard sizes could be included on a single drawing. Example: For $x = 400$, drawing 01.1/3 is required where measurements for y, z and k are found. Drawings 01.1/1 and 01.1/2 are not required for this turbine size.

SKAT

SKAT
Schweizerische Kontaktstelle für Angewandte Technik am ILL.
Institut für Lateinamerikaforschung und Entwicklungs-
zusammenarbeit an der Hochschule St.Gallen

SKAT
Swiss Center for Appropriate Technology at ILL.
Institute for Latin-American Research and for Development
Co-operation, University of Saint-Gall

Varnbühlstraße 14, CH-9000 St.Gallen,
Switzerland, Tel. 071 23 34 81

SKAT
Centre Suisse pour la Technologie Appropriée à l'ILL,
Institut de Recherche sur l'Amérique Latine et de
Coopération au Développement, Université de Saint-Gall

SKAT
Centro Suizo de Tecnología Apropriada en el ILL,
Instituto de Investigación sobre América Latina y
de Cooperación al Desarrollo, Universidad de Sankt-Gallen

POS	NO.OF ITEM	ITEMS	DRAWING NUMBER	SPECIFICATION	REMARKS
1	1	FOUNDATION FRAME	T1-01.0		SUB. ASSEMBLY
2	1	SUPPORT ASSEMBLY	T1-02.0		" "
3	1	BAFFLE HOUSING	T1-03.0		" "
4	1	ROTOR ASSEMBLY	T1-04.0		" "
* 5	2	MAIN BEARING ASSEMBLY	T1-05.0		" "
6	1	REGULATOR WING ASSEMBLY	T1-06.0		" "
* 7	2	R.W BEARING HOUSING ASSEMBLY	T1-07.0		" "
8	1	INLET ASSEMBLY	T1-08.0		" "
9	1	REGULATOR MECHANISM ASSEMBLY	T1-09.0		" "
12	2	STUFFING BOX	T1-12.1		
13	2	STUFFING BOX LID	T1-12.2		
14	2	STUFFING BOX GASKET	T1-12.3		
15	2	OIL SEAL			
16	2	OIL SEAL HOUSING	T1-12.4		
17	2	LOCK SPRING	T1-12.5		
18	2	OIL SEAL HOUSING GASKET	T1-12.6		
19	2	COVER SHEET	T1-12.7		
20	1	COVER SHEET GASKET	T1-12.8		
21	2	SEALING PLATE 'A'	T1-12.9		
22	2	SEALING PLATE 'B'	T1-12.10		
23	1	SEALING FLAP GASKET	T1-12.11		
24	1	BAFFLE PLATE GASKET	T1-12.12		
25	1	SUPPORTING STRIP	T1-01.5		
26	1	FOUNDATION FRAME GASKET	T1-12.13		
27	2	GLAND PACKING			
28	18	TAPER PIN			
29	2	GREASE CUP			
30	X	NUT/BOLT .HEX W 1/2" X 1 1/2"			
31	X	" " " W 3/8" X 3/4"			
32	12-2	—/ " " W 1/4" X 5/8"			
33	2	" " " W 3/4" X 1 1/2"			
34	4	" " " W 3/4" X 2"			
35	4	" " " W 1/2" X 2"			
37	4	" " " W 1/4" X 5/8"			
36	1	ADAPTER	T1-14.0		SUB. ASSEMBLY

SEE
PART LIST
T1-13.0

* STANDARD BEARING HOUSING
MAY BE USED INSTEAD.

Revised 10.8.82. A

PART LIST

TURBINE ASSEMBLY
WITH HAND REGULATOR

00.1-1/00.2/00.3

Alt Revised 29.7.92

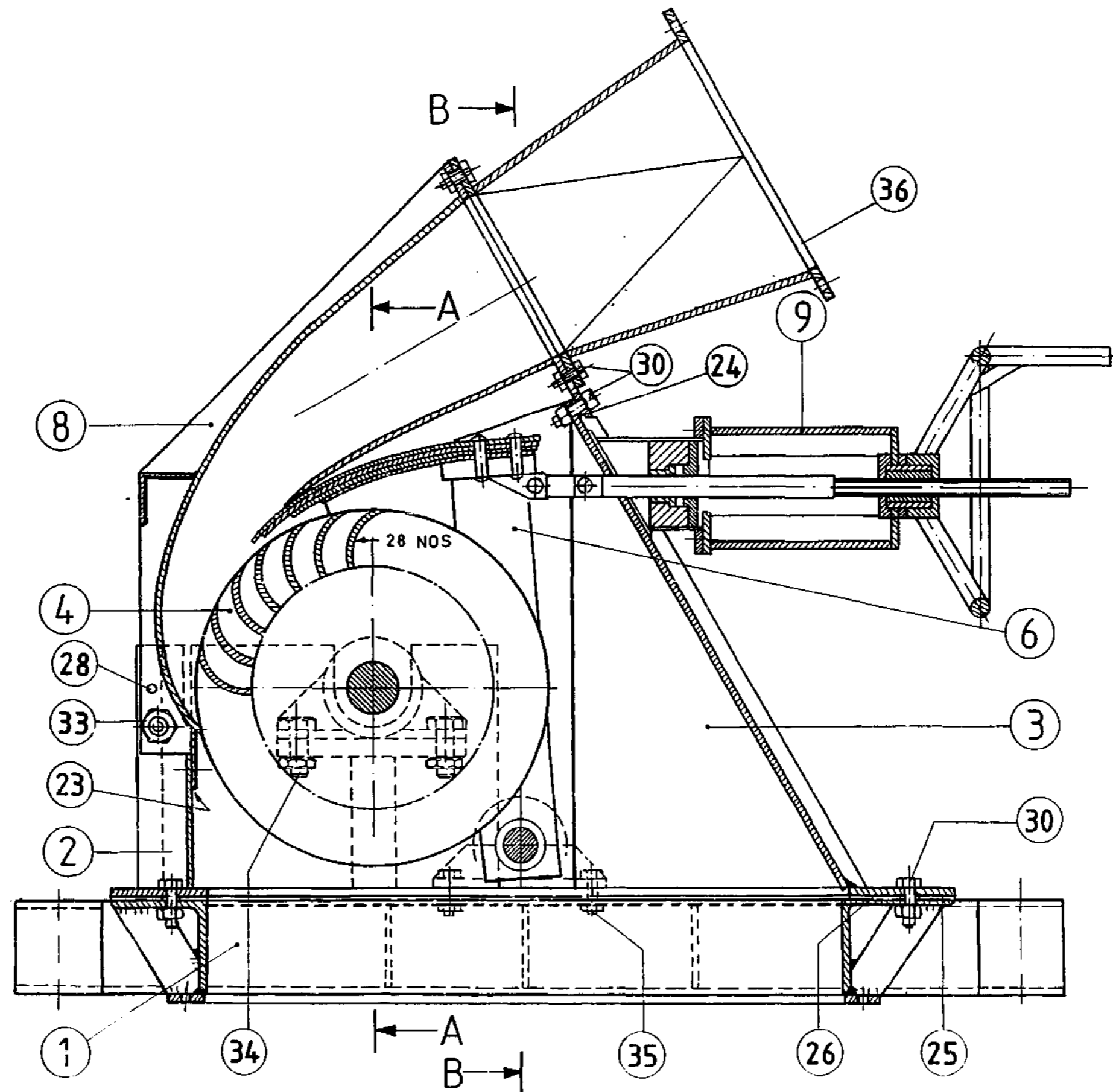

CF TURBINE ASSEMBLY 1:5
WITH HAND REGULATOR

T1-00.1-1

Revised 29.7.81

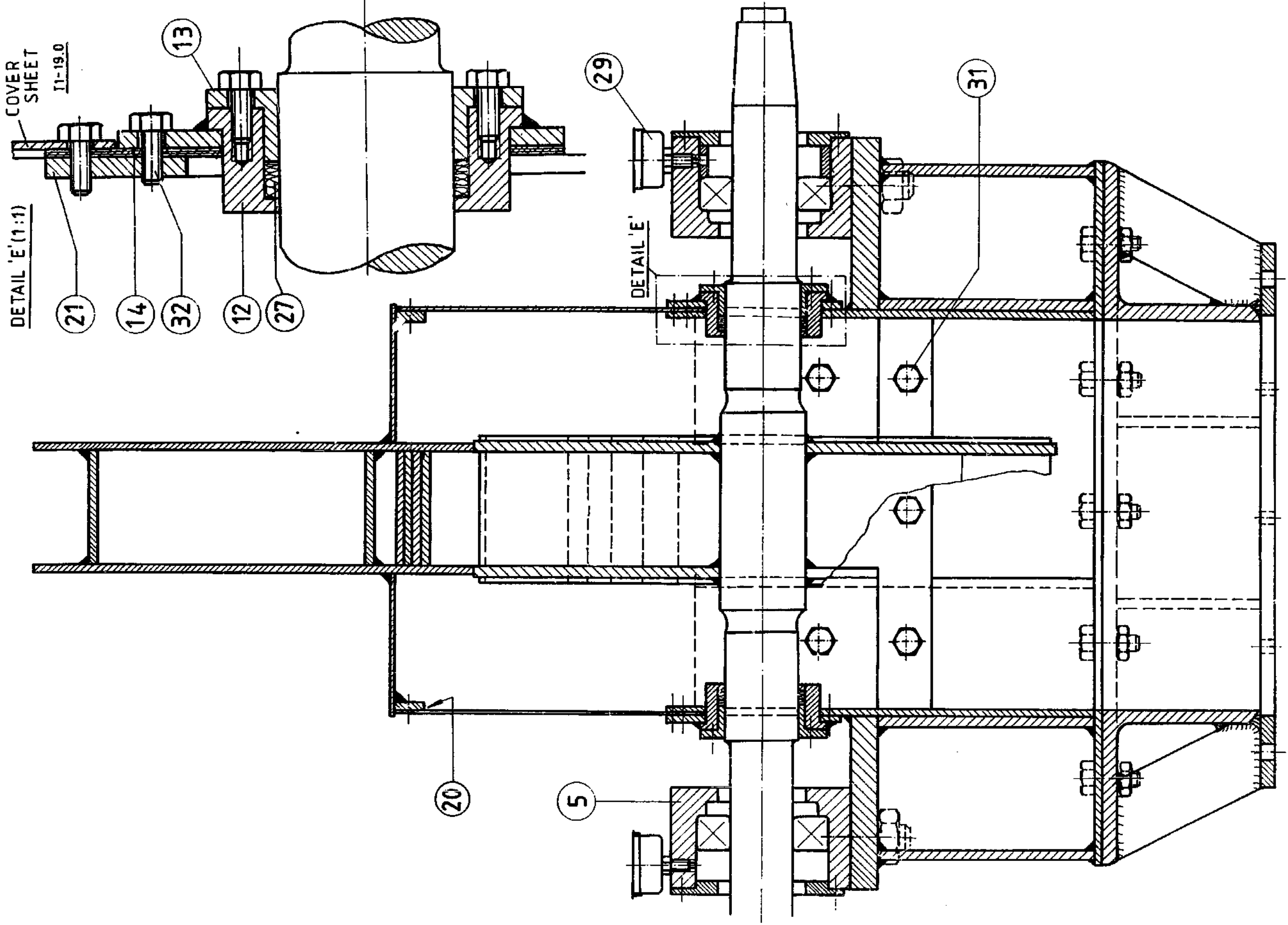

SECTION A-A 1:2.5 (1:1)

T1-00.2

Revised 29.7.81

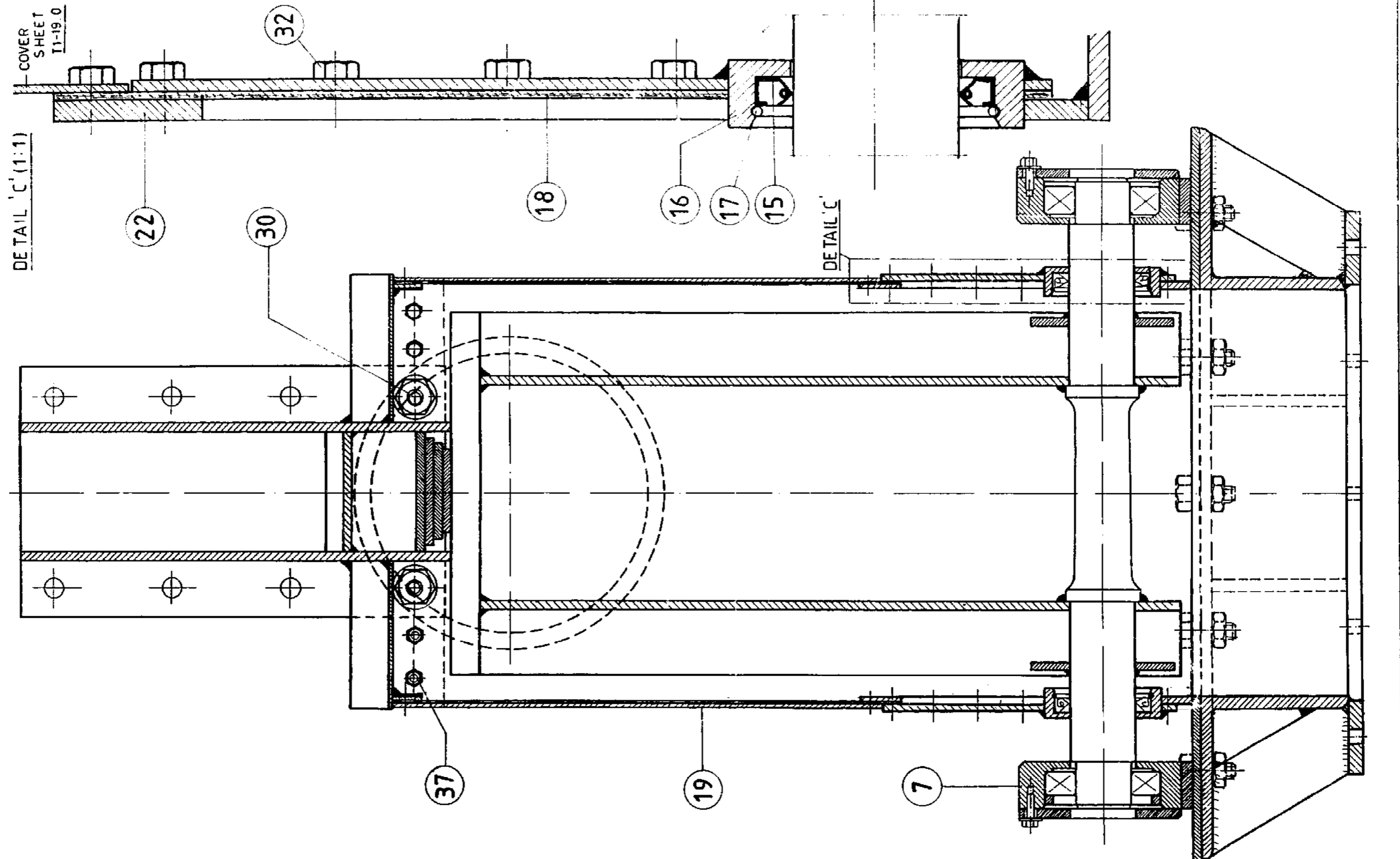

POS	NO. OF ITEMS	ITEM	DRAWING NO.	SPECIFICATIONS	REMARKS
1	2	M.S. ANGLE 110 X 110 X 10 LENGTH: X +	T1-01.0		
2	2	M.S. ANGLE 110 X 110 X 10 LENGTH:	T1-01.0		
3	14	RIB OUT OF M.S. FLAT 8 X 50	T1-01.2		
4	2	DRAFT TUBE FLANGE	T1-01.1/1-4		
5	1	DRAFT TUBE	T1-01.3		
	2	DRAFT TUBE SUPPORT	T1-01.4		USED IN INST -ALLATION ONLY.
—	4	SUPPORTING STRIPS	T1-01.5		USED IN FINAL ASSEMBLY ONLY. DRG. NO. T1-00.1-1

Revised 2.7.81

↑
CONSISTING OF

FOUNDATION FRAME

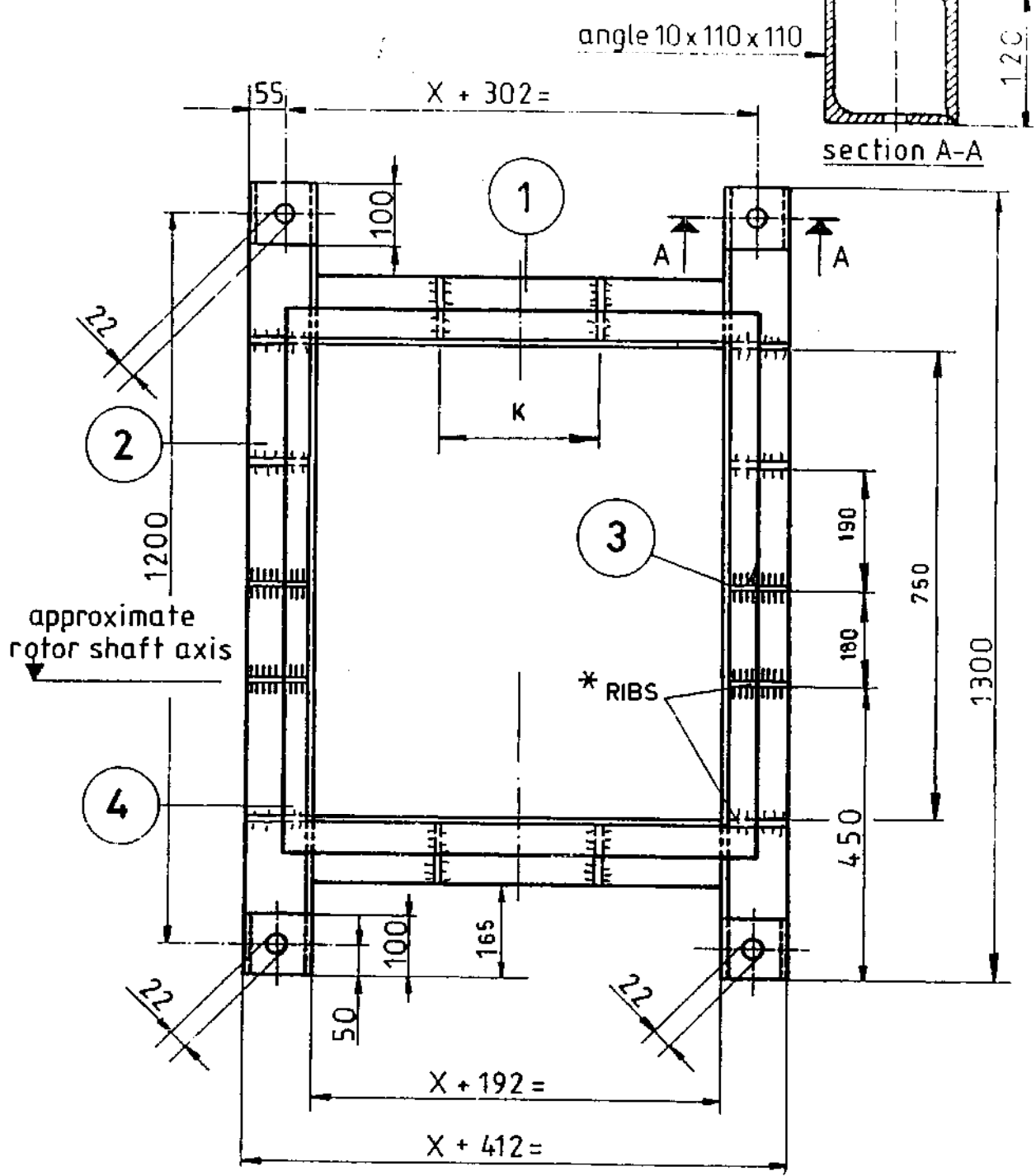

* weld after joining draft tube flange

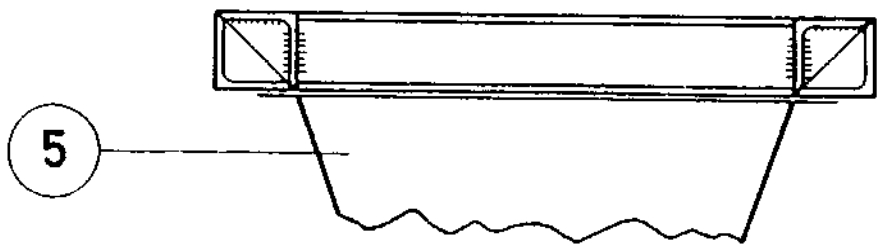

SEE DRAWING NO. T1-01.1/1 TO T1-01.1/3 FOR THE VALUE OF 'K'

scale 1:10

FOUNDATION FRAME

T1-01.0

Revision 27.2.92

SECTION A-A (2:1)

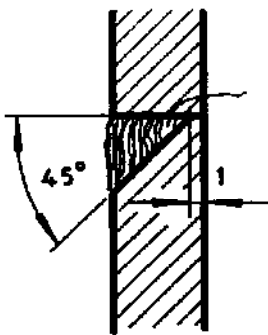

TACK WELD ONLY. FULL WELDING TO BE DONE IN ASSEMBLY WITH T1-01.0

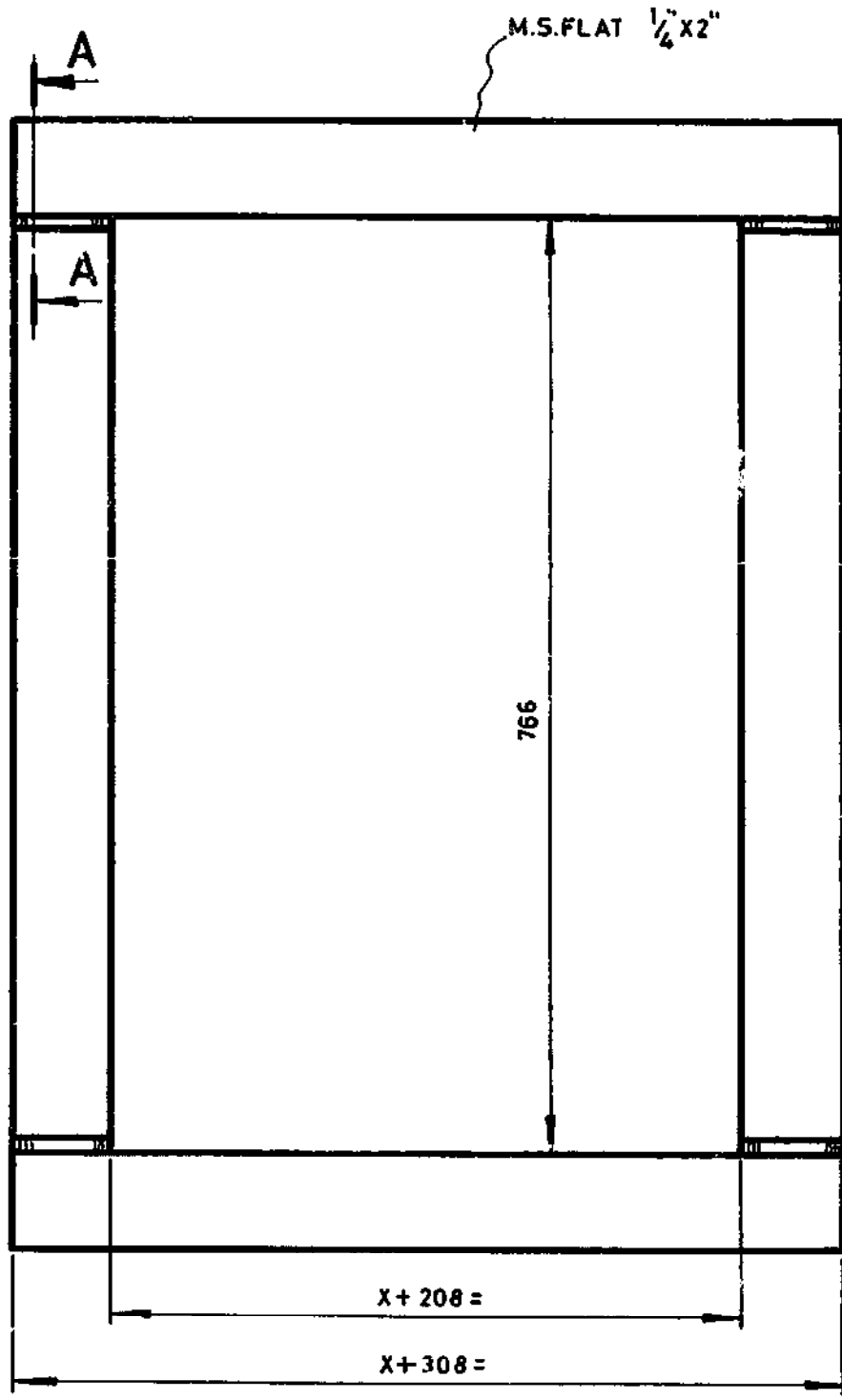

DRILLING ACCORDING TO DRAWING T1-01.1/1-1/4

Revised 27.7.82 of

DRAFTTUBE FLANGE

T1-01,1

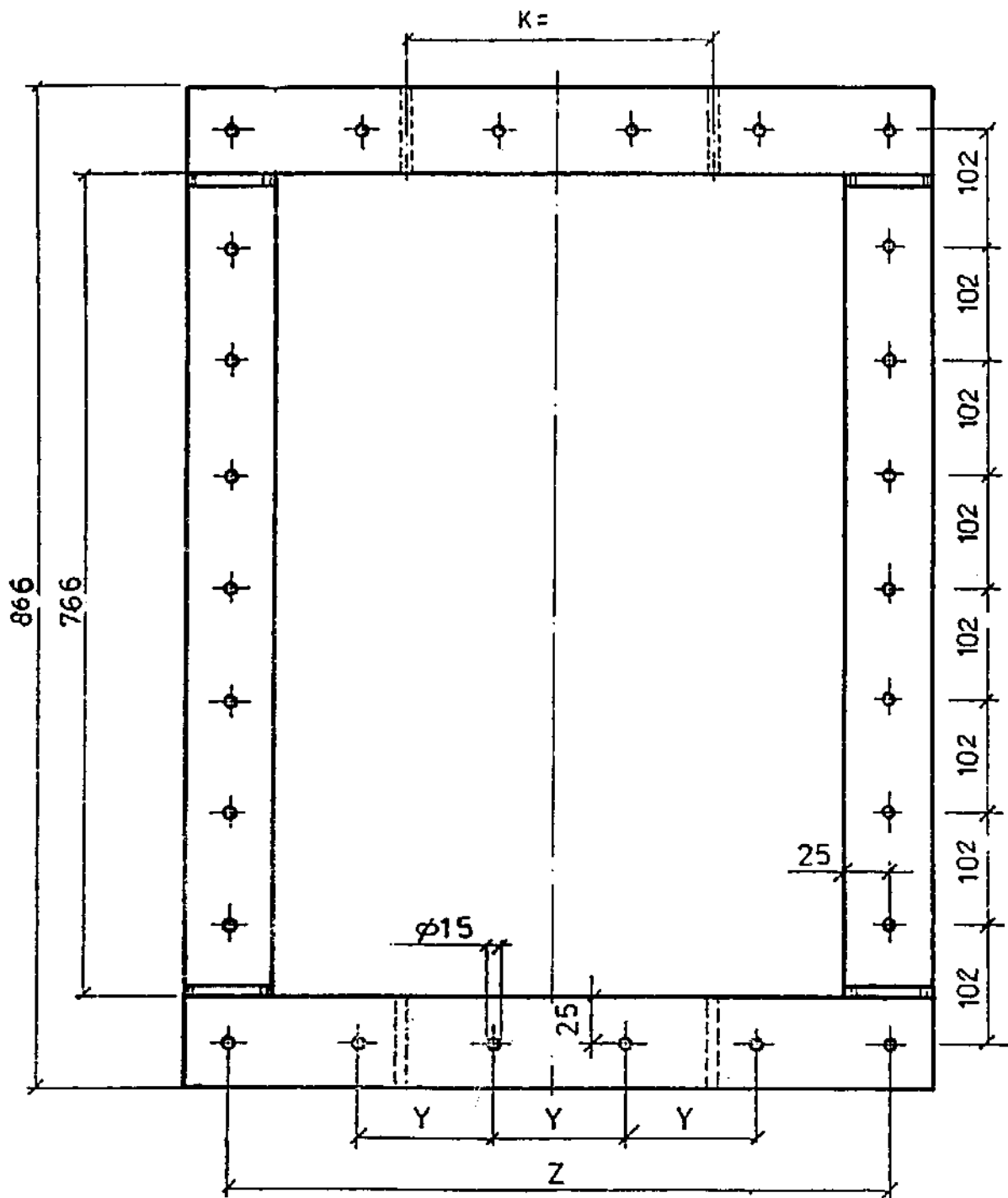

	X180	X200	X220
Y	90	94	98
Z	438	458	478
K	186	196	206

Revised 21.2.84

DRAFTTUBE FLANGE (X180, X200, X220)

T1-01.1/2

Y

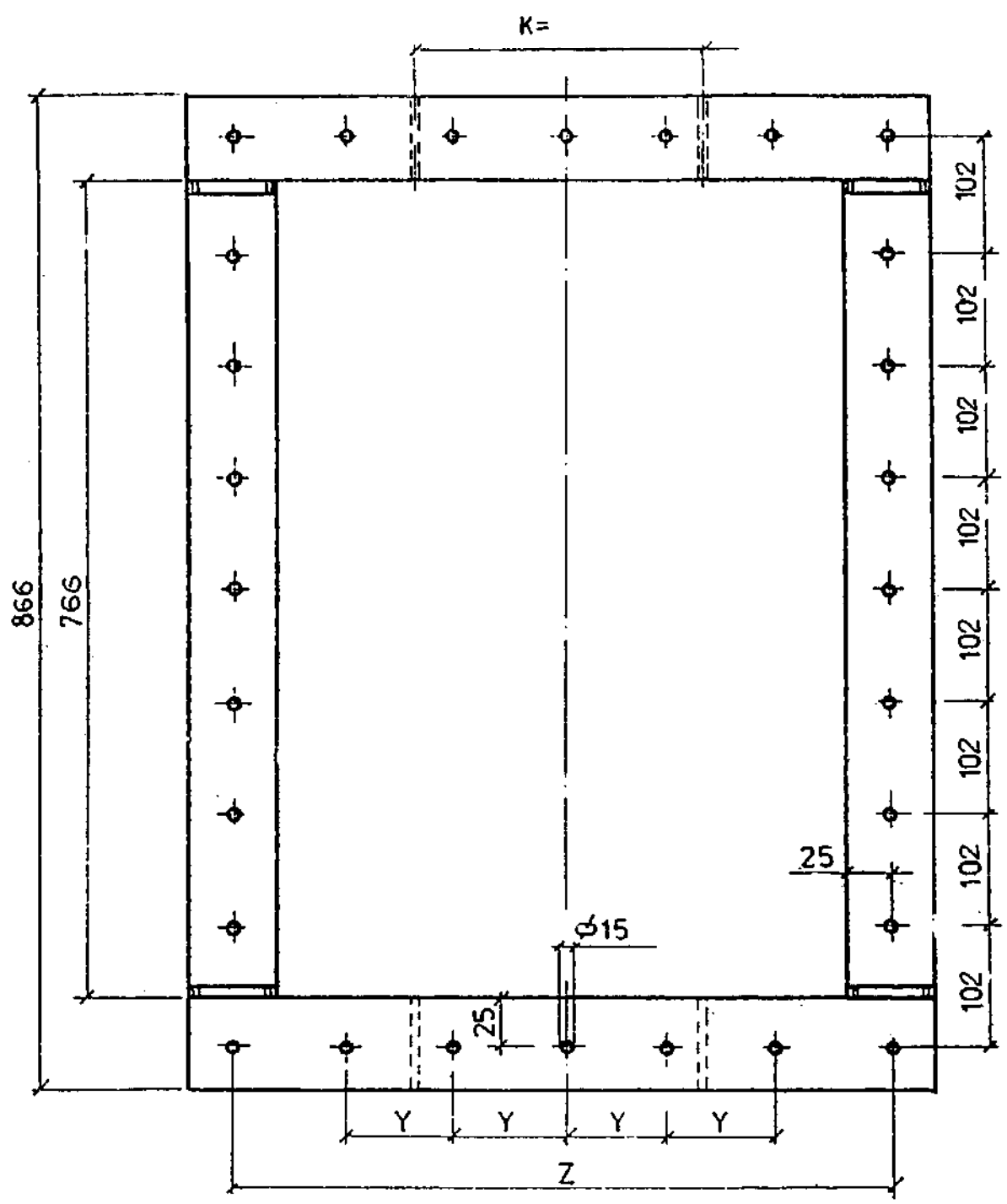

Revised 27.7.82-84

	X 300	X 360	X 400
Y	95	105	112
Z	558	618	658
K	250	284	296

DRAFTTUBE FLANGE (X300,X360,X400)

T1-01.1/3

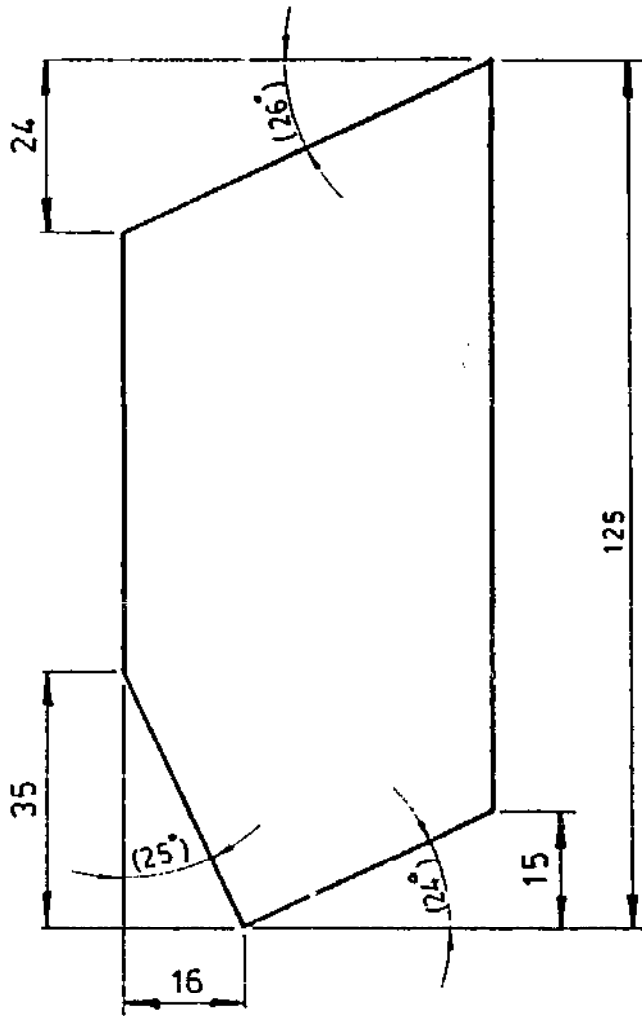

M.S. FLAT 6 X 50

14 NOS

Revised 27.1.01 A

RIB

1:1

T1-01.2

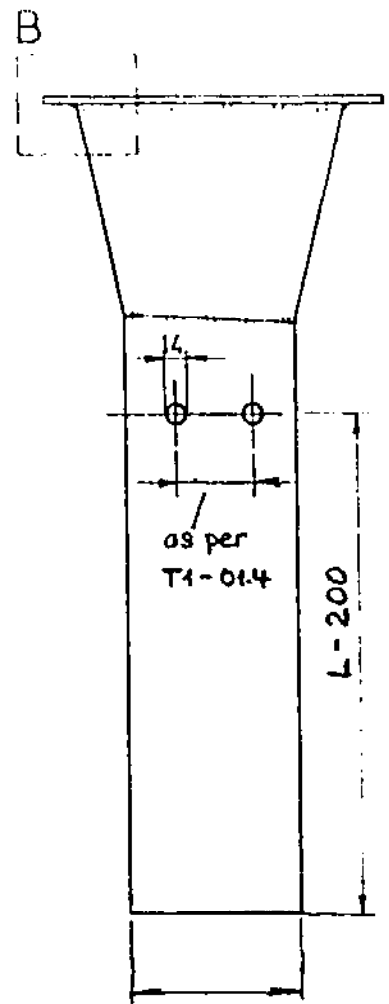
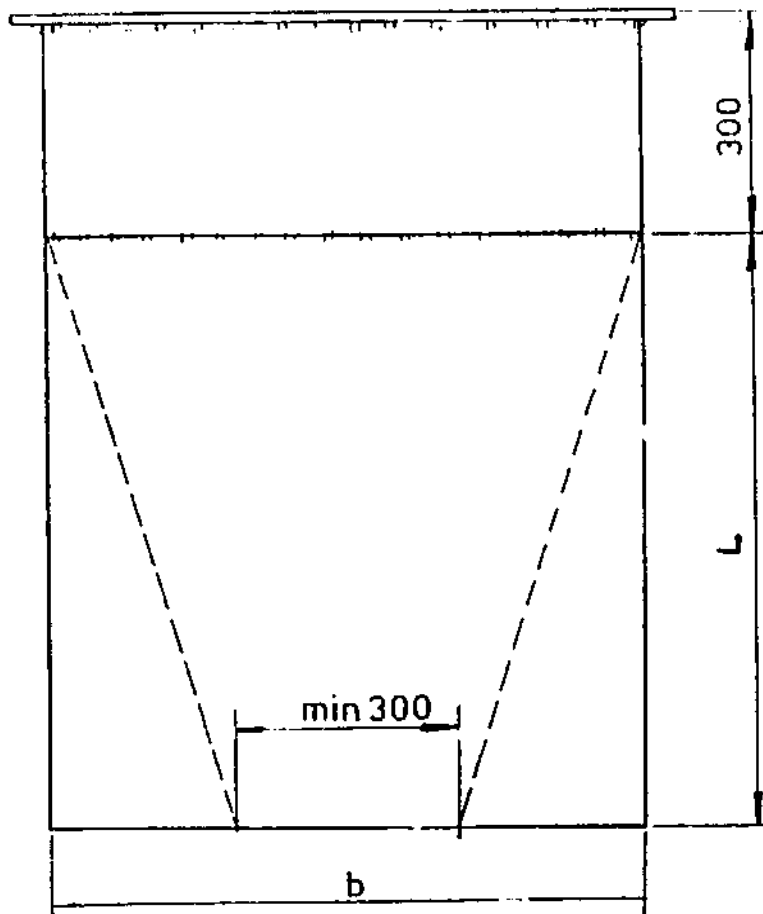

$$\text{width (dm)} = \frac{Q (l/s)}{10 \cdot b (dm)}$$

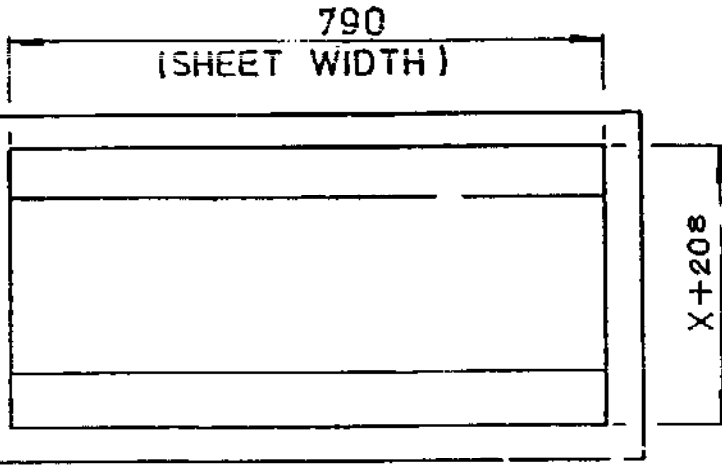

MS. SHEET 2.5 mm
NOS

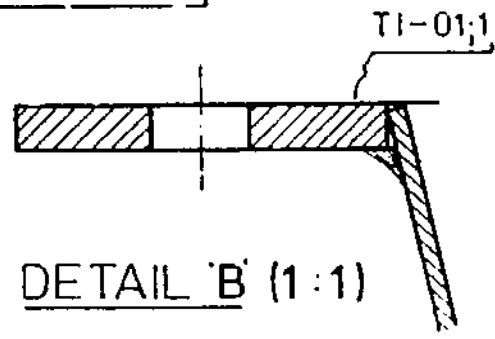

DETAIL 'B' (1:1)

Rev 02 23.7.82

DRAFT TUBE

T1-01.3

Revised 12.1.82

DRAFT TUBE SUPPORT

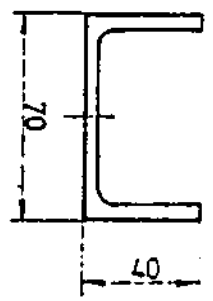
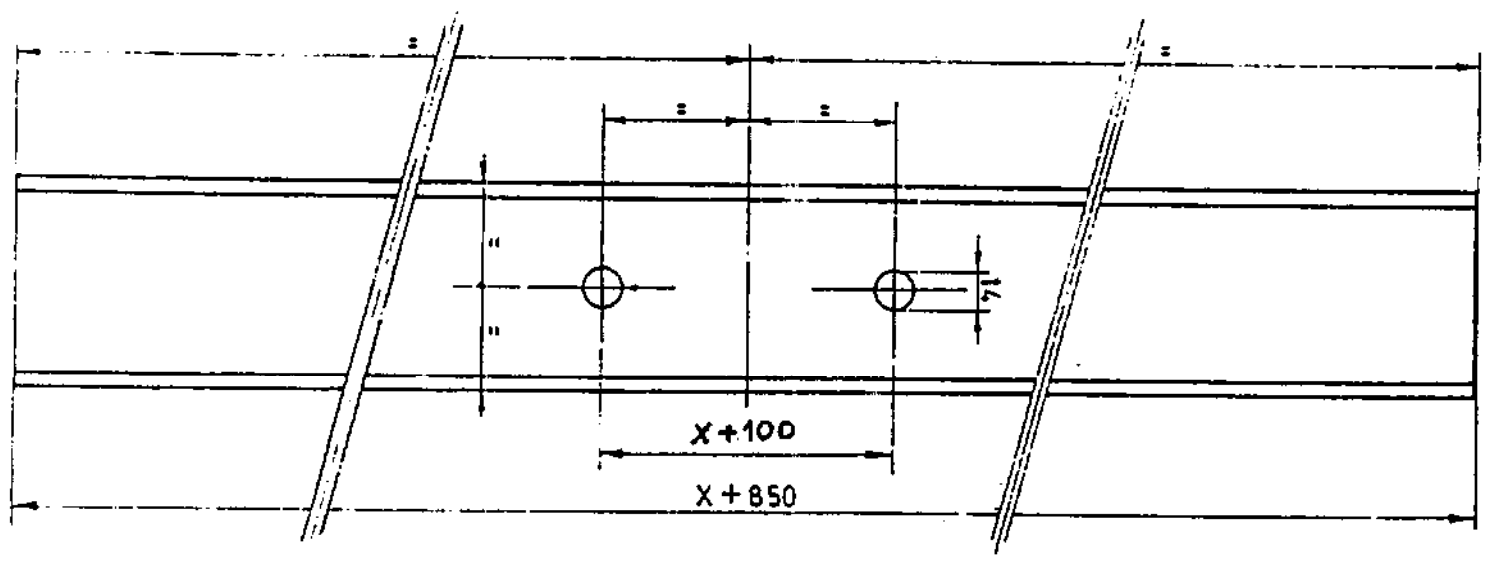

U CHANNEL 75 X 40
2. NOS.

SCALE 1:25

T1-01.4

MOUNT FLUSH WITH OUTSIDE EDGES OF
SUPPORT ASSEMBLY AND BAFFLE HOUSING
ASSEMBLY ON BASE FRAME DURING FINAL
ASSEMBLY. SPOT WELD AFTER ASSEMBLY.

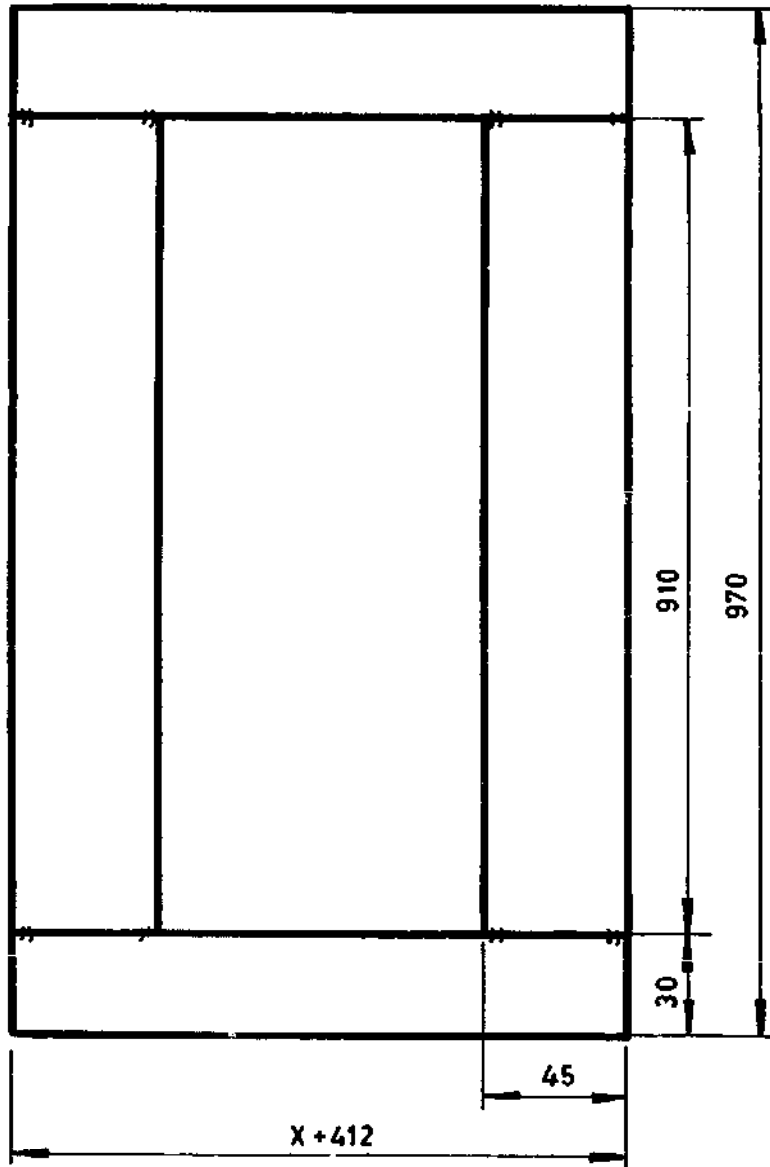

3.15 MM SHEET : 2 STRIPS 45 x 910
2 STRIPS 30 x $X+412$

Revised 28.9.2014

SUPPORTING STRIPS

T1- 01,5

POS	NO.OF ITEMS	ITEM	DRAWING NO.	SPECIFICATIONS	REMARKS
1	1	SUPPORT BASE	T1-02.1	M.S.Plate 6mm	—
2	1	SUPPORT FRONT	T1-02.2		Sub assay
3	2	SUPPORT MEMBER	T1-02.3	M.S.Plate 25mm U.Chan.100 X 50	—
4	2	SUPPORT PANEL	T1-02.4	M.S.Plate 6mm	—
5	2	SEALING PLATE	T1-02.5	M.S.Plate 6mm	—

↑
CONSISTING OF

SUPPORT ASSEMBLY

PARTS LIST

T1-02.0

revised 2-7-82

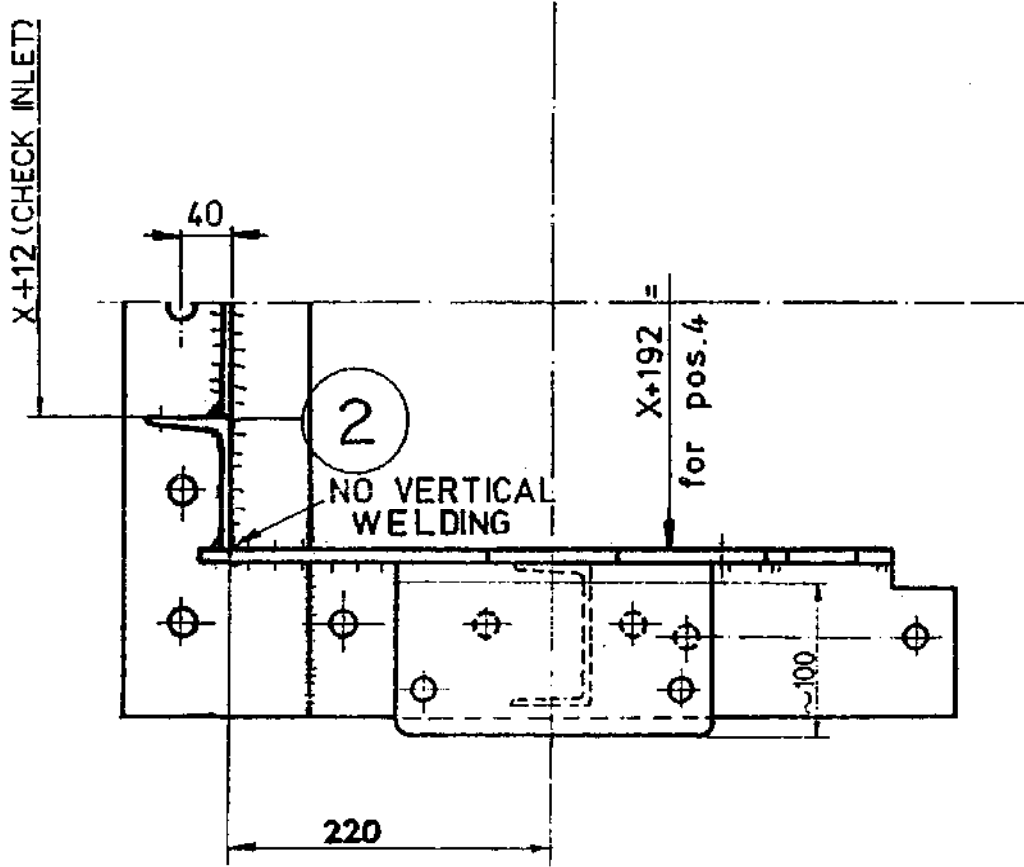
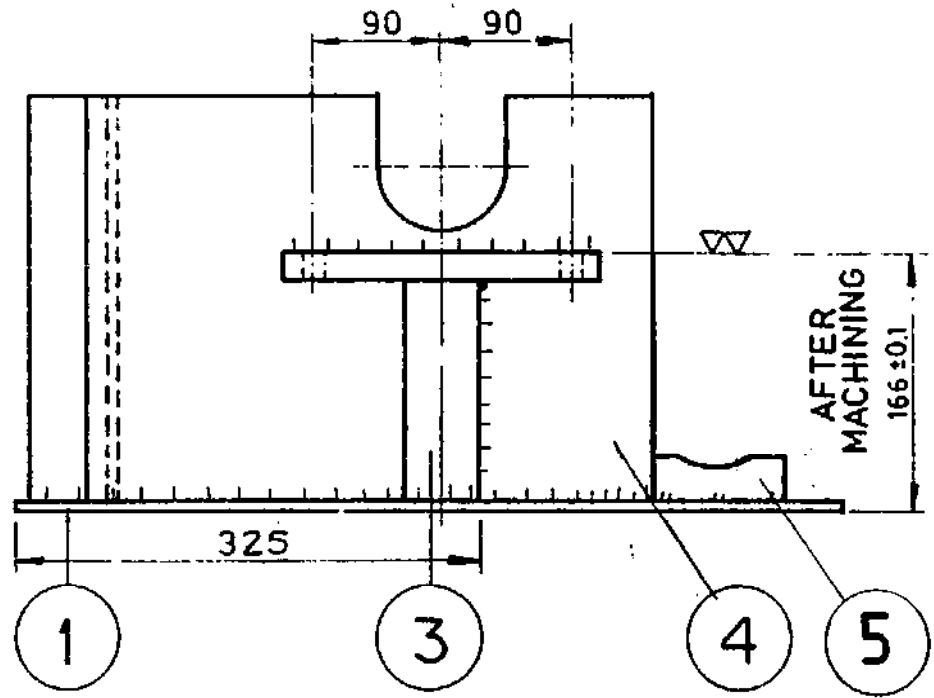

Revised 29.7.82 *dyf*

SUPPORT ASSEMBLY

T1-02.0

SCALE 1:5

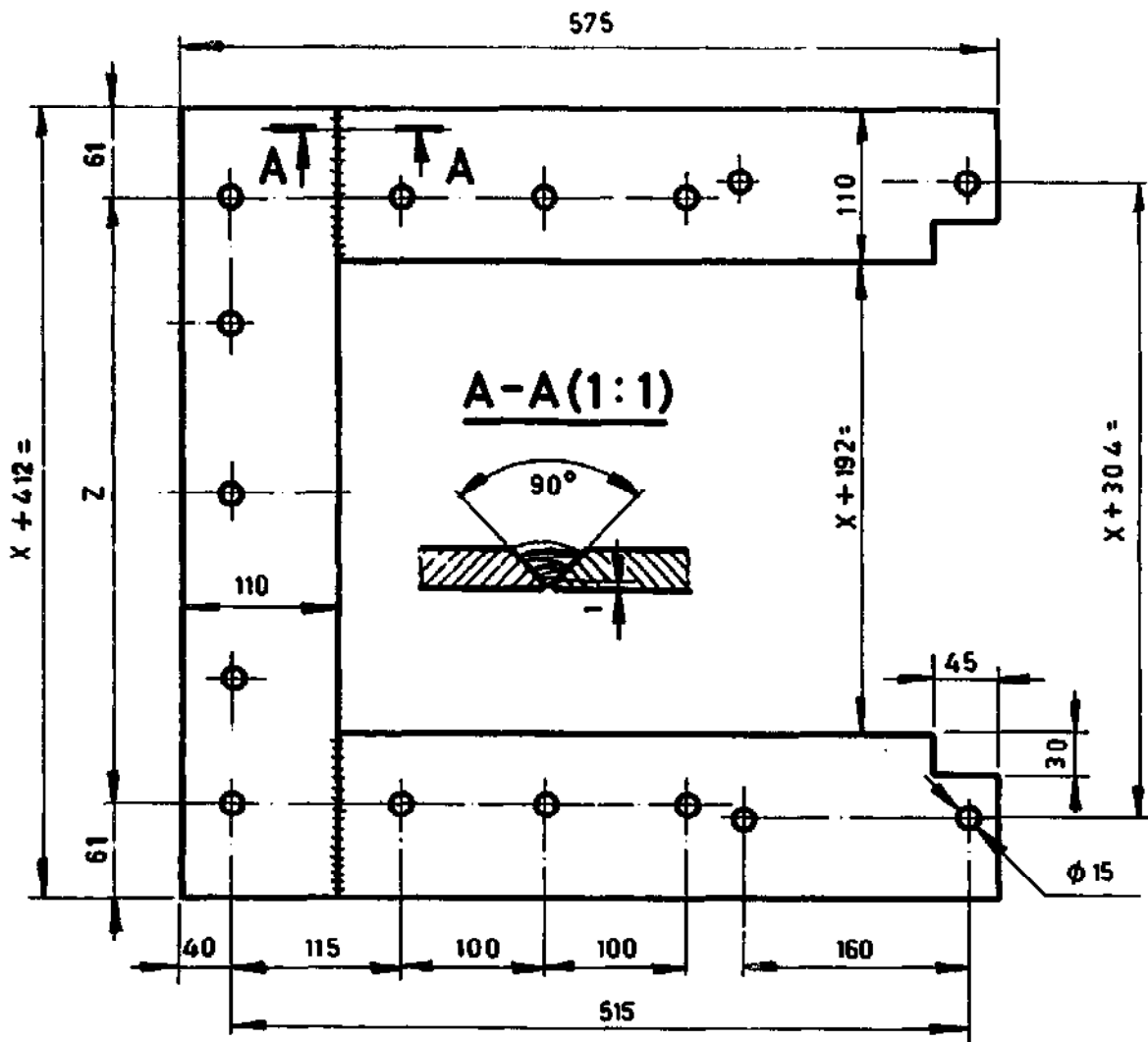

HOLE CENTERS

	Z												
X 70	+	90	+	90	+	90	+	90	+				
X 100	+	98	+	97	+	97	+	98	+				
X 150	+	88	+	88	+	88	+	88	+				
X 180	+	94	+	94	+	94	+	94	+				
X 200	+	98	+	98	+	98	+	98	+				
X 220	+	102	+	102	+	102	+	102	+				
X 300	+	100	+	100	+	95	+	96	+	100	+	100	+
X 360	+	109	+	108	+	108	+	108	+	108	+	109	+
X 400	+	105	+	125	+	115	+	115	+	125	+	105	+

6 MM SHEET
1PC

Revised 29.7.82 H.

SUPPORT BASE

T1-02,1

1:5

POS	NO. OF ITEMS	ITEM	DRAWING NO.	SPECIFICATIONS	REMARKS
1	1	M.S. PLATE 6 X 150 LENGTH: X + 12	T1-02.2		
2	2	M.S. ANGLE 60 X 90 X 6 LENGTH: 280	T1-02.2		

Revised 29.7.82. adf



↑ CONSISTING OF

SUPPORT FRONT

PARTS LIST

T1-02.2

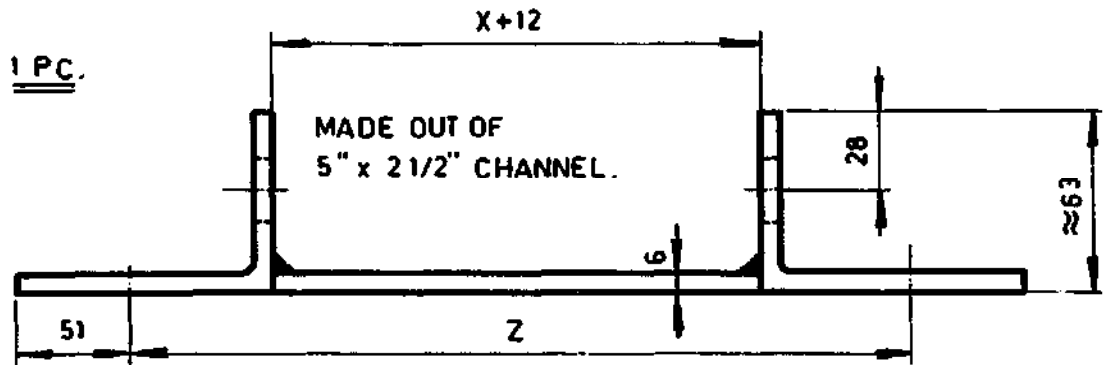
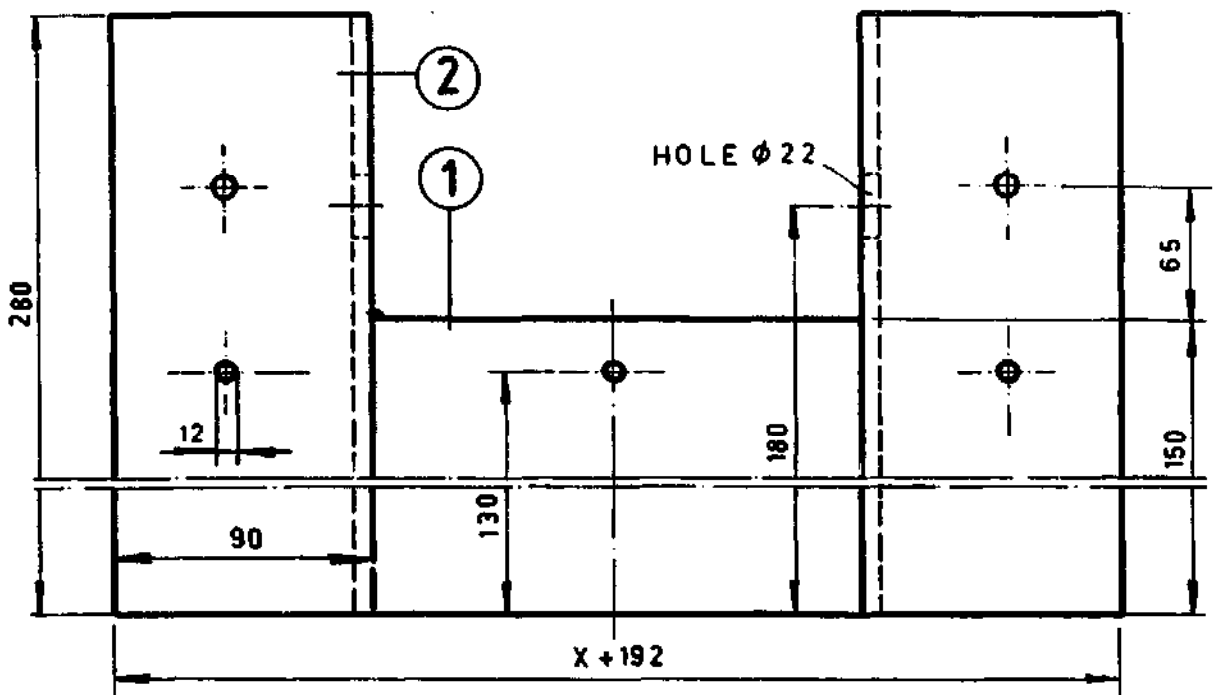

1 PC.

HOLE CENTERS

	Z		HOLE CENTERS								
X 70	+	80	+	80	+						
X 100	+	95	+	95	+						
X 150	+	80	+	80	+						
X 180	+	90	+	90	+						
X 200	+	97	+	97	+						
X 220	+	78	+	77	+	77	+	78	+		
X 300	+	98	+	97	+	97	+	98	+		
X 360	+	90	+	90	+	90	+	90	+	90	+
X 400	+	98	+	98	+	98	+	98	+	98	+

1 PC

- HOLE ($\phi 22$) SHOULD BE DRILLED BEFORE WELDING.

- DRILL HOLES ($\phi 12$) AFTER WELDING.

Revised 29.7.21. 44

SUPPORT FRONT

T1-02.2

1 : 2.5

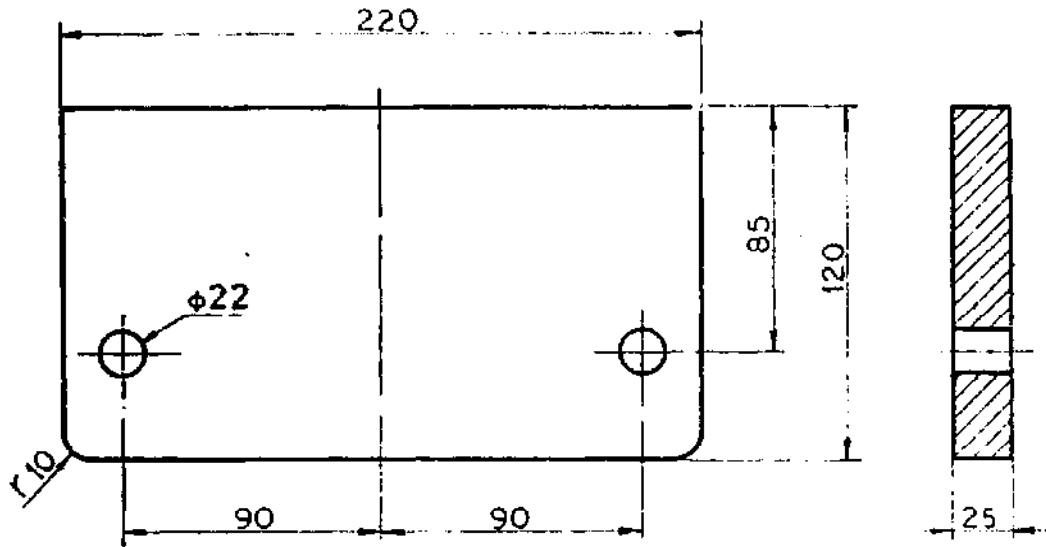

2 PIECES
M.S. PLATE 25mm

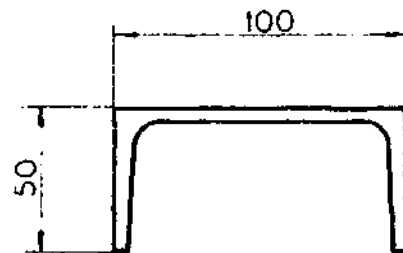
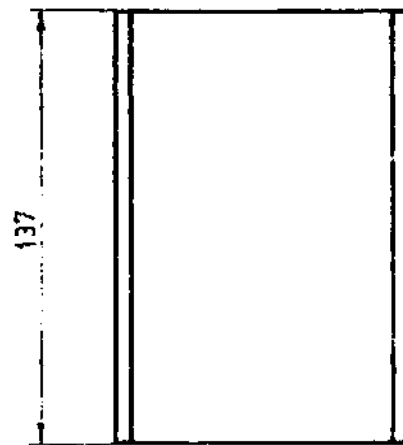

2 PIECES
U CHANNEL 4" X 2"

Revised 29.9.82 AL

SUPPORT MEMBER

T1-02.3

SCALE 1:2.5

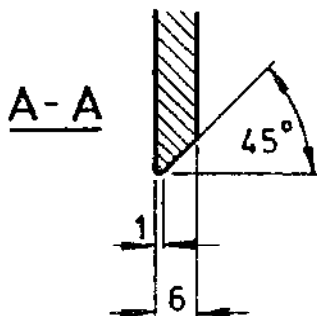
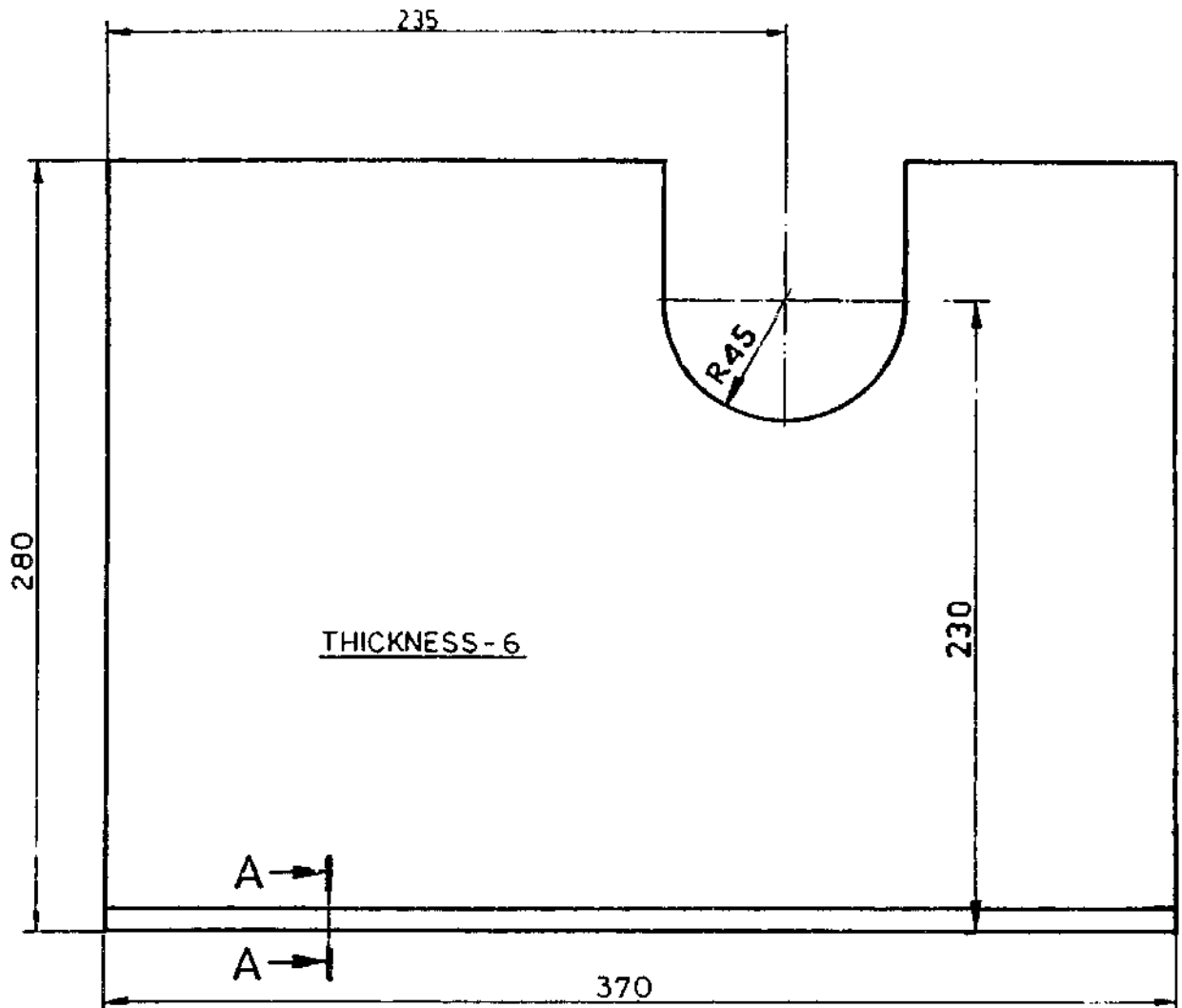

2 PIECES

NB: MAKE CHAMFER ON THE OTHER SIDE OF NEXT SHEET.

Revised 29.7.81. M

SUPPORT PANEL

T1-02.4

SCALE 1:2,5

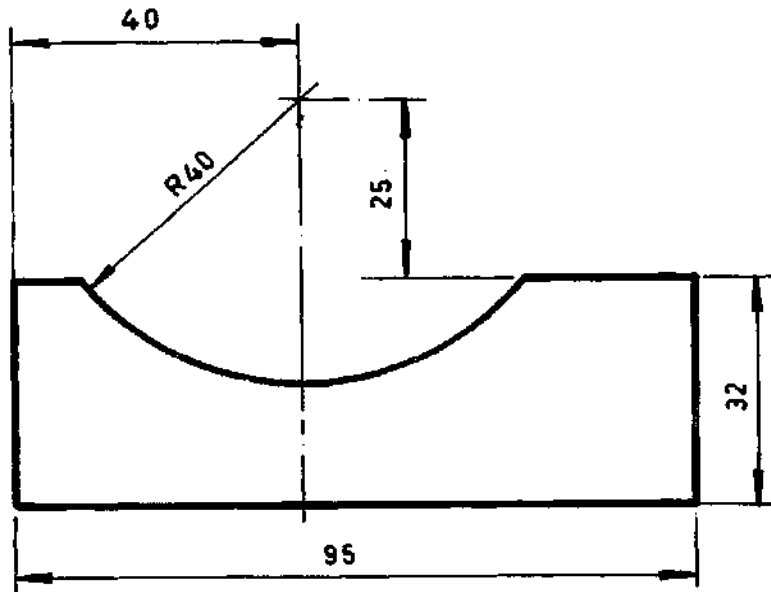

6. MM FLAT
2. NOS

Revised 29.7.82

SEALING PLATE

T1-02,5

POS.	NO OF ITEMS	ITEM	DRAWING NO	SPECIFICATIONS	REMARKS
1	1	BAFFLE HOUSING BASE	T1-03.1	M.S.Plate 6mm	
2	2	BAFFLE HOUSING PANEL	T1-03.2	M.S.Plate 6mm	
3	1	BAFFLE HOUSING TOP	T1-03.3	M.S.Plate 6mm	

Revised. 29.7.92 M

↑
CONSISTING OF

BAFFLE HOUSING ASSEMBLY

PARTS LIST

T1-03.0

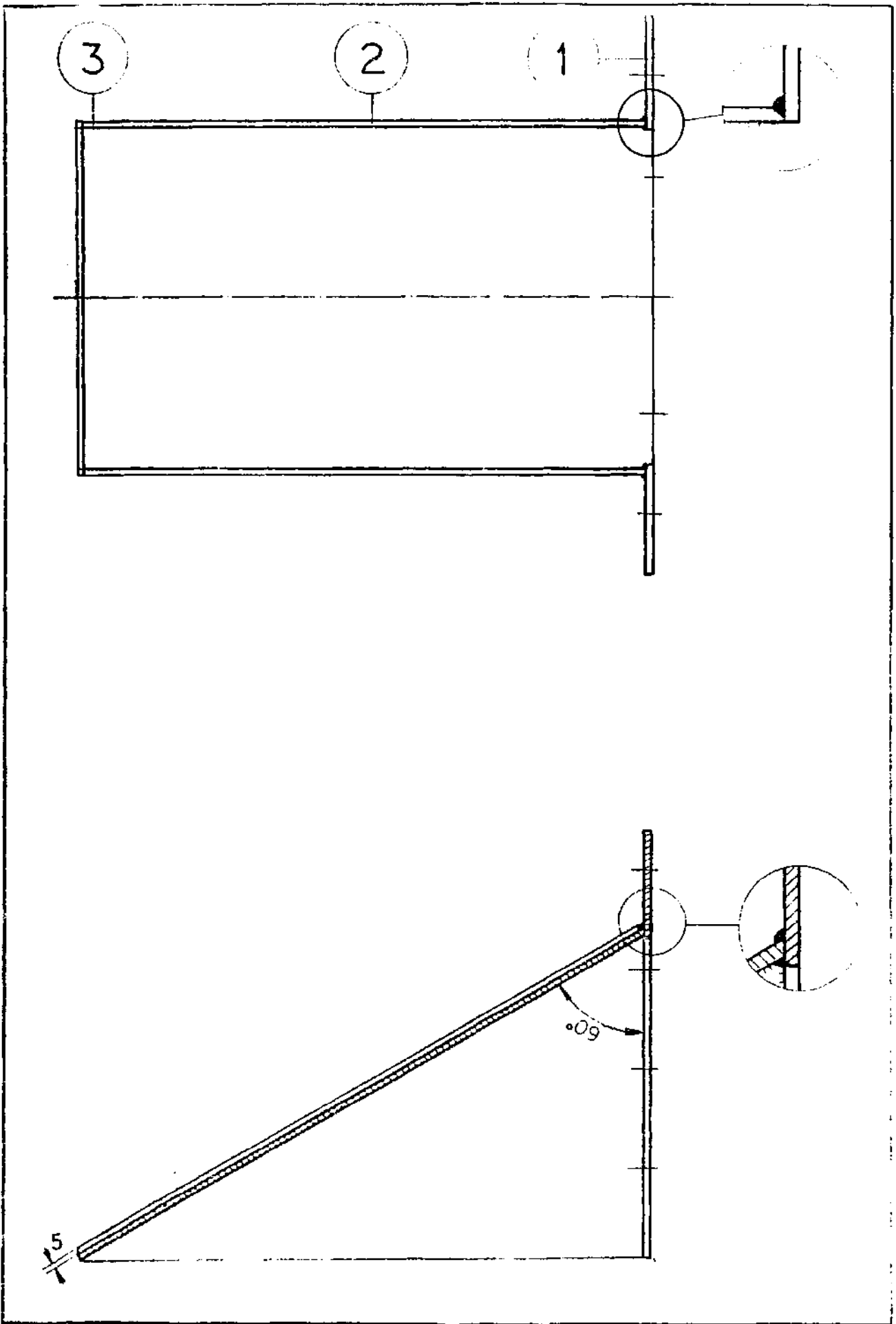

Revised 297.9L *ML*

BAFFLE HOUSING ASS.

T1-030

SCALE 1:5

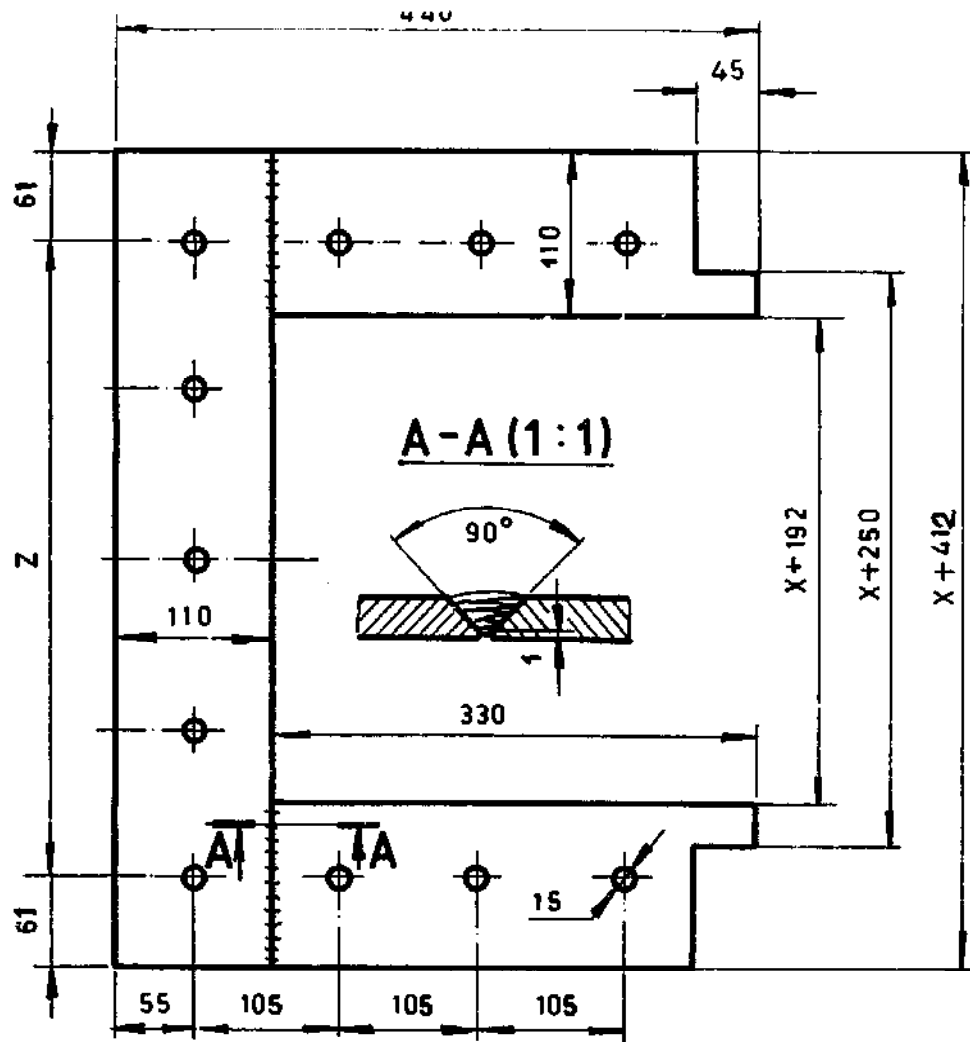

HOLE CENTERS

	Z												
X 70	+	90	+	90	+	90	+	90	+				
X 100	+	98	+	97	+	97	+	98	+				
X 150	-	88	+	88	+	88	+	88	+				
X 180	+	94	+	94	+	94	+	94	+				
X 200	+	98	+	98	+	98	+	98	+				
X 220	+	102	+	102	+	102	+	102	+				
X 300	+	100	+	100	+	95	+	95	+	100	+	100	+
X 360	+	109	+	108	+	108	+	108	+	108	+	109	+
X 400	+	105	+	125	+	115	+	115	+	125	+	105	+

6 MM SHEET
1PC

Revised 29.7.82 ad.

BAFFLE HOUSING BASE

T1-03.1

1:5

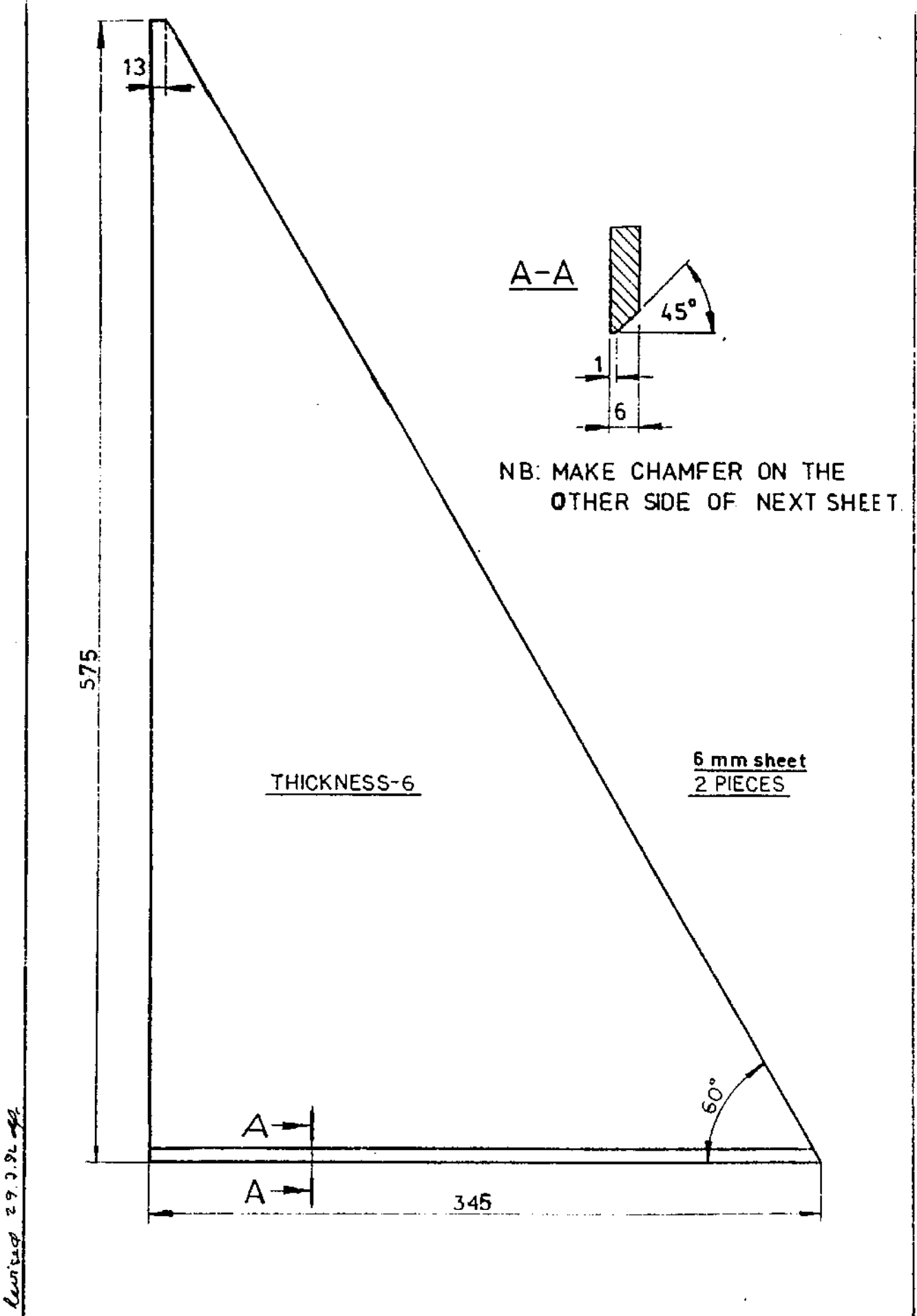

BAFFLE HOUSING PANEL

T1-03.2

SCALE 1:2.5

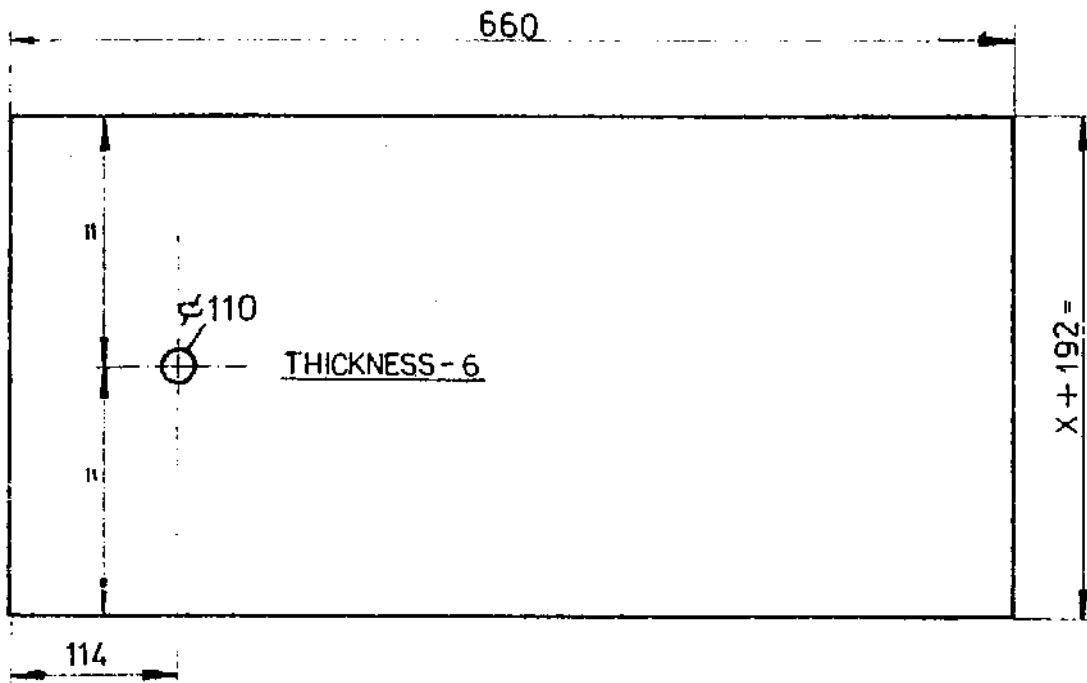

6 mm sheet

1 PC

Revised 29.7.92 ay

BAFFLE HOUSING TOP

T1-033

SCALE 1:5

POS	NO. OF ITEMS	ITEM	DRAWING NO.	SPECIFICATIONS	REMARKS
1	1	ROTOR SHAFT	T1-04.1	M.S. Rod ϕ 84	
2	2	ROTOR DISK	T1-04.2	M.S. Plate 8mm	
3	28	ROTOR BLADE	T1-04.3	2.5 MM SHEET	
4*	1	ROTOR INTERMEDIATE DISK	T1-04.4	M.S. Plate 6mm	
<p>*ONLY REQUIRED FOR TYPES 220, 300, 360 AND 400 FOR TYPE 200 WITH HEAD ABOVE 8mm AND FOR TYPE 180 WITH HEAD ABOVE 11m</p>					

Revised 29.7.82 M.H.

↑
CONSISTING OF

ROTOR SHAFT ASSEMBLY

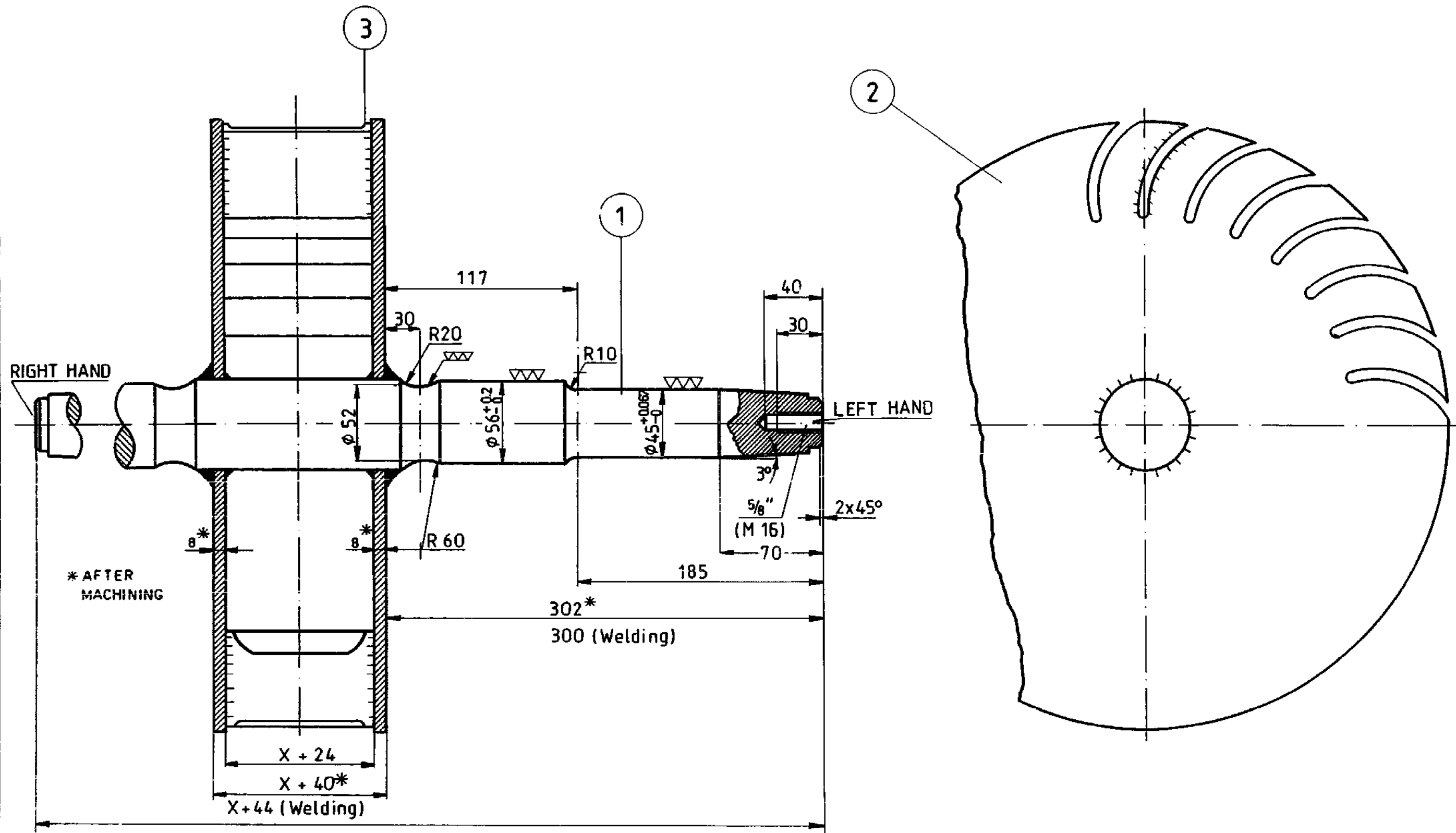

ROTOR SHAFT MACHINED AFTER
FULL WELDING OF ALL PARTS

ROTOR ASSEMBLY

T1-040

SCALE 1 : 25

Revised 24.7.02

Revised 9.8.82 HJ

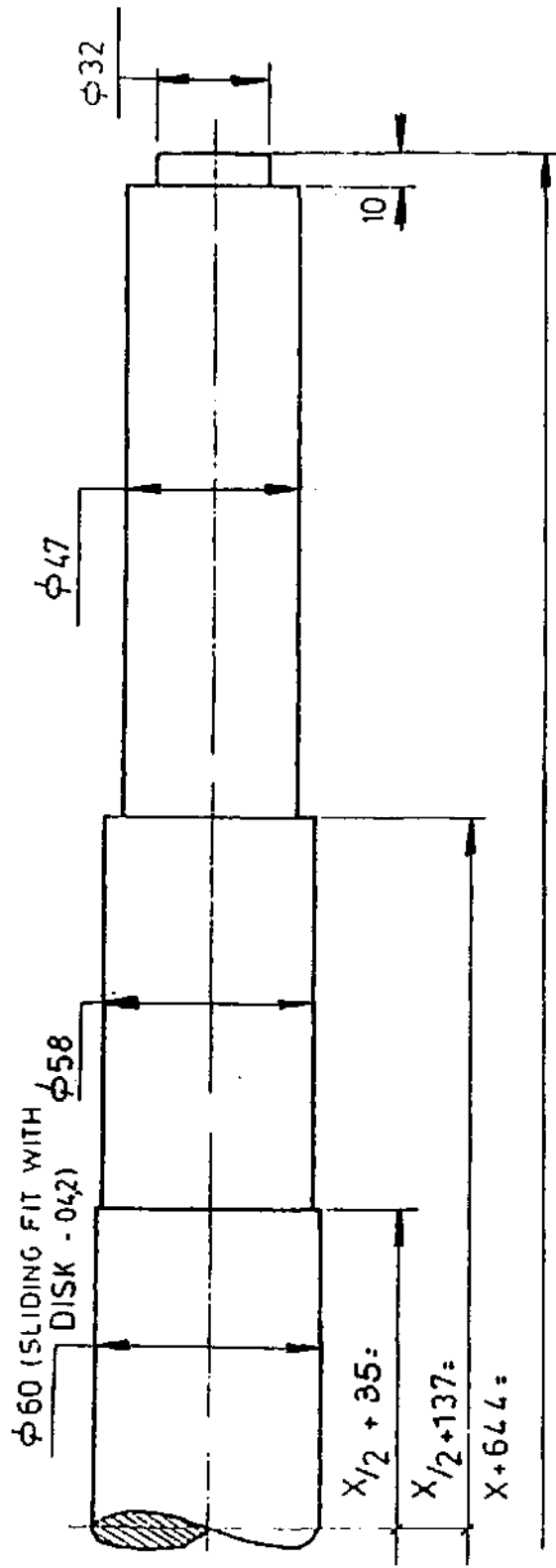

(PREMACHINED)

ROTOR SHAFT

SCALE 1:2

T1-04.1

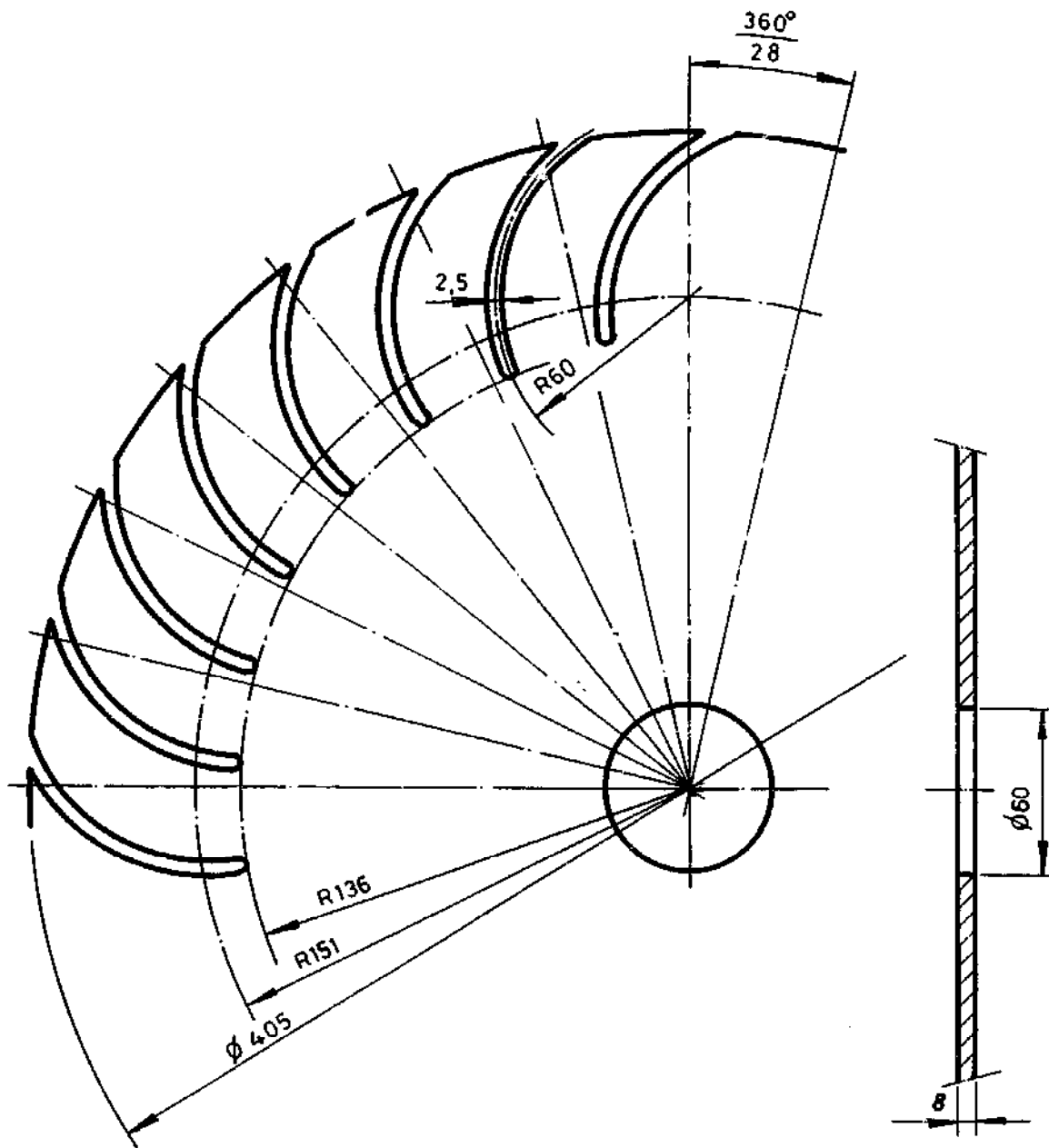

2.PCS

NOTE: $\frac{360^\circ}{28}$ ANGLE SHOULD BE MEASURED BY MILLING MACHINE.

Revised 29.7.92

ROTOR DISK

T1-04.2

SCALE 1:2

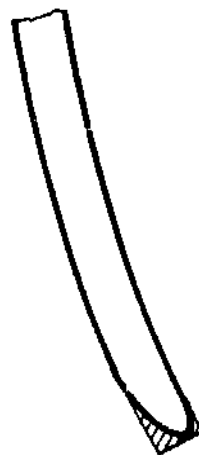
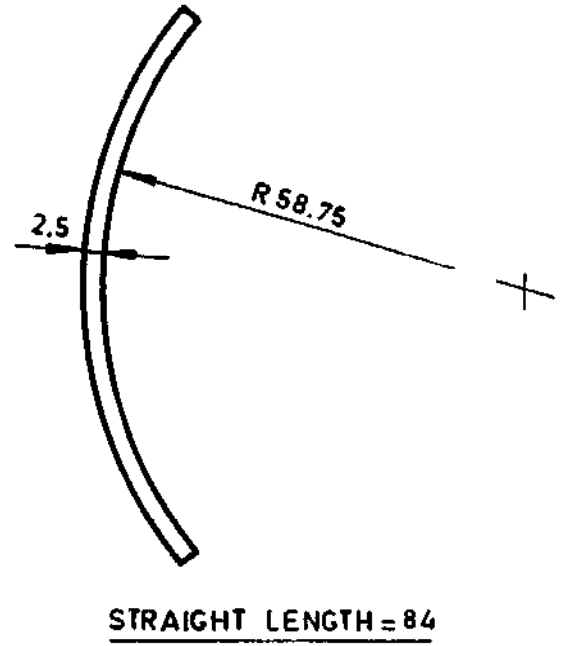
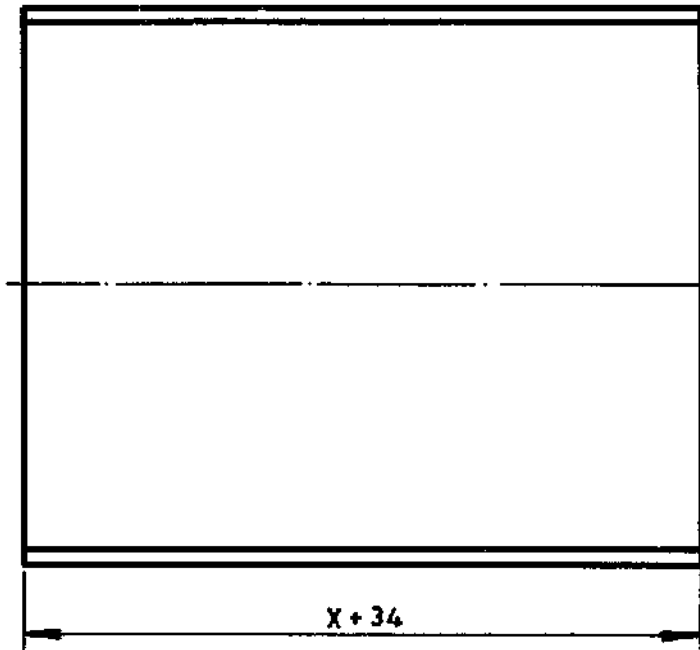

M.S SHEET
28 PCS

EDGE PROFILE (2.5:1)
MAKE ON ONLY ONE EDGE
OF THE BLADE.

Revised 9.9.82

ROTOR BLADE

T1-04,3

1:1 (2.5:1)

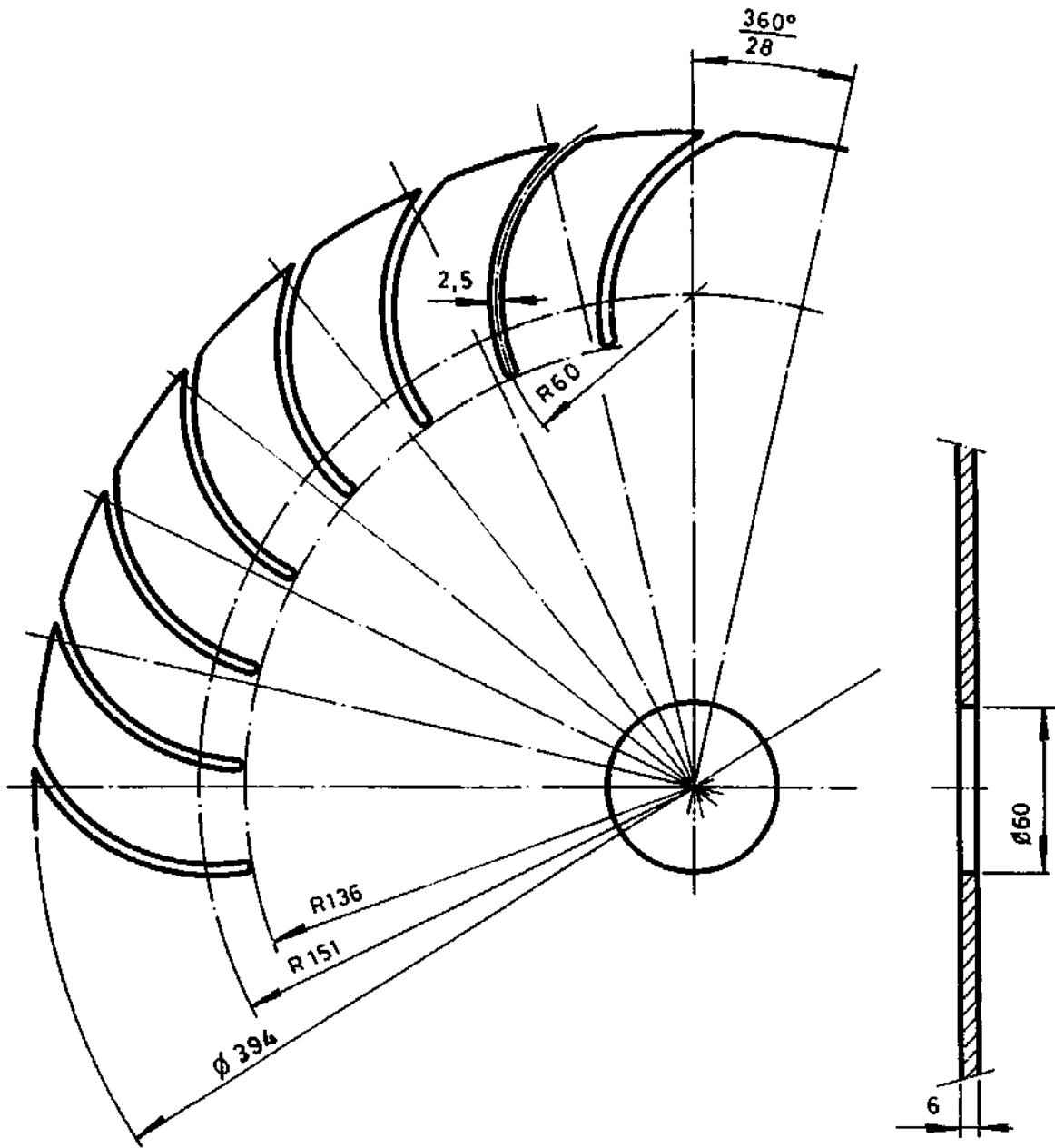

NOTE: $\frac{360^\circ}{28}$ ANGLE SHOULD BE MEASURED BY MILLING MACHINE.

-USE ACCORDING TO STRENGTH REQUIREMENTS
AS PER DIAGRAM.

Drawing 29.7.82.44.

ROTOR INTERMEDIATE DISK

T1-04.4

SCALE 1:2

POS	NO OF ITEMS	ITEM	DRAWING NO	SPECIFICATIONS	REMARKS
1	2	BEARING HOUSING LID	T1 05.1	M.S. ROD ϕ 1.27	
2	1	SPACER RING	T1 05.2	BLACK PIPE 30	
3	2	SELF ALIGNING ROLL BEARING		FAG 22210	
4	2	MOUNTING SLEEVE		FAG KM10	
5	8	HEXAGON HEAD BOLT		W $1/4$ X $5/8$ "	
6	2	BEARING HOUSING ASSEMBLY	T1 05.6		



CONSISTING OF

MAIN BEARING ASSEMBLY

PARTS LIST

T1-05.0

As per drawing 2022.05.01

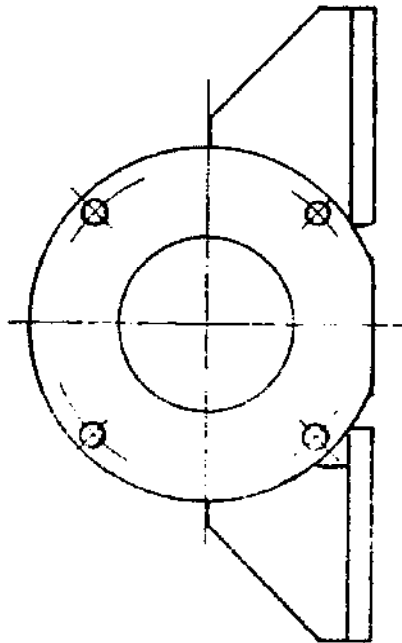
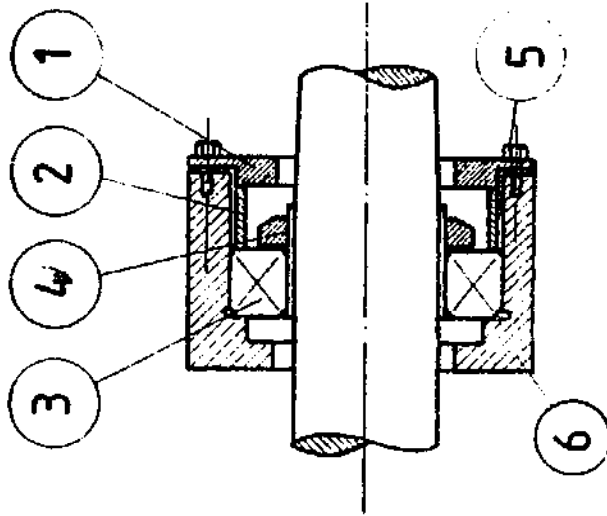

Revised 12-7-52 A

MAIN BEARING ASSEMBLY

SCALE 1:2.5

T1-05.0

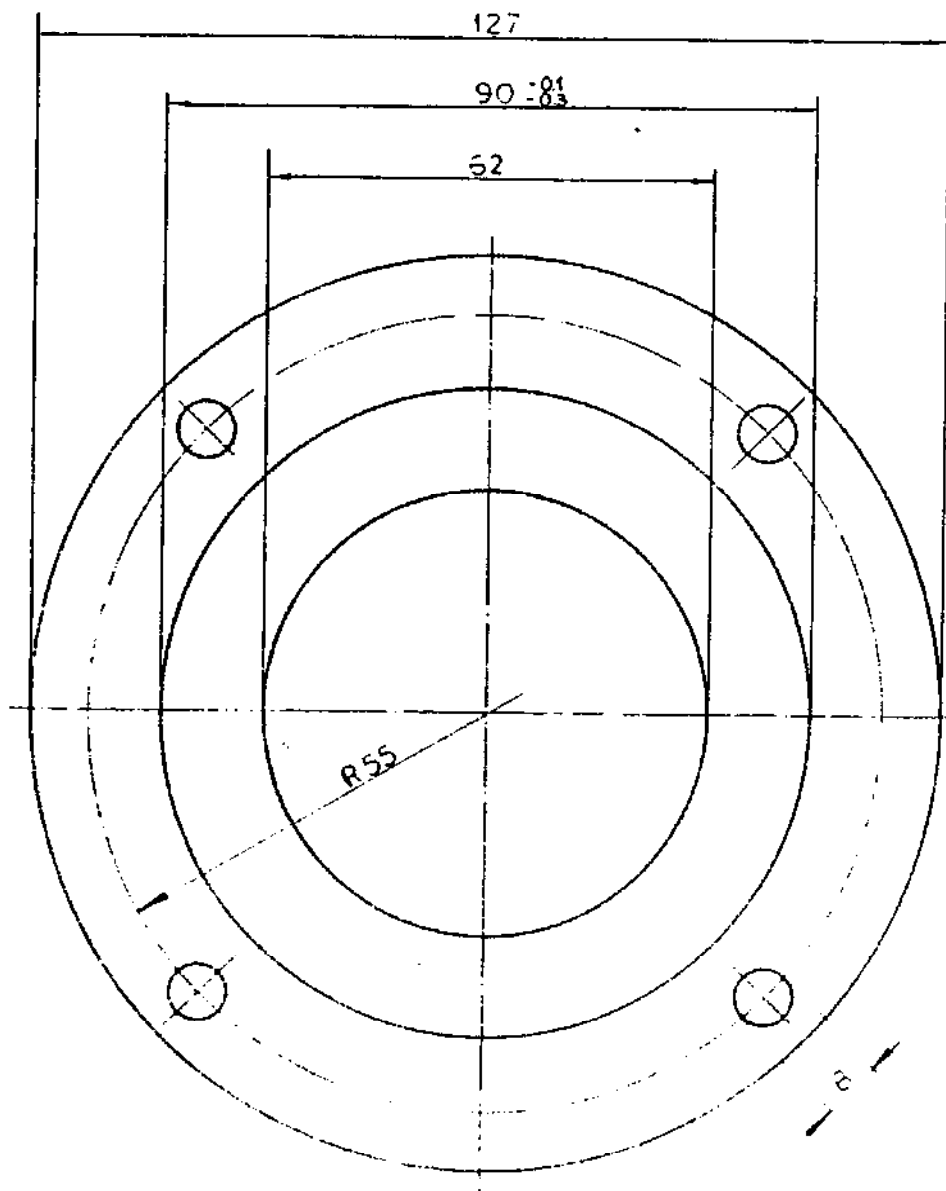
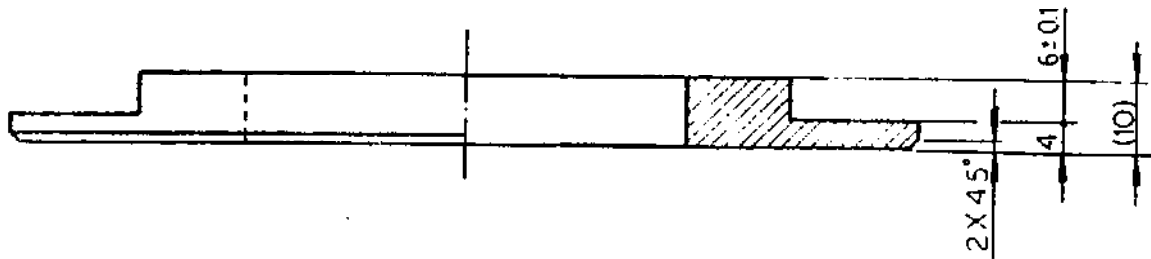

REVISED 02.27.90

BEARING HOUSING LID

T1-05.1

SCALE 1:1

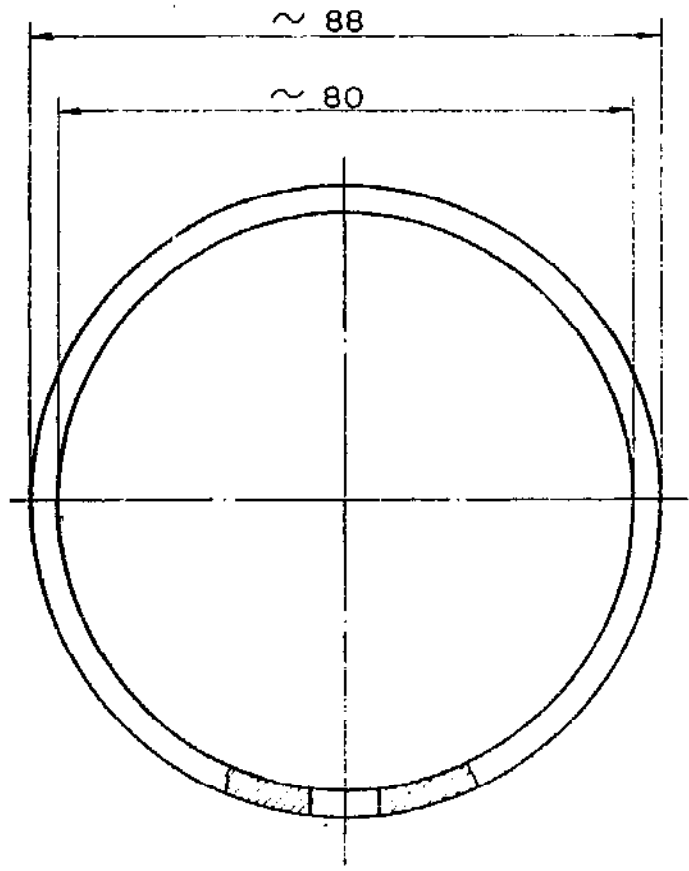
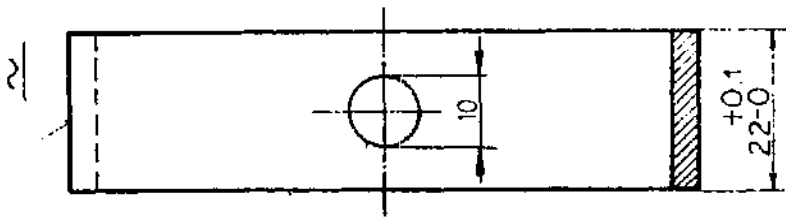

Amw 02.10.02

1-No.
BLACK PIPE

SPACER RING

T1-05.2

SCALE 1:1

POS	NO. OF ITEMS	ITEM	DRAWING NO.	SPECIFICATIONS	REMARKS
1	2	BEARING BODY	T1 - 05.6	MS.Rod ϕ 127	
2	8	BEARING BRACE	T1 - 05.2	MS.Flat 6 X 50	
3	4	BEARING BASE	T1 - 05.3	MS. Plate 12X75	



↑ CONSISTING OF

MAIN BEARING HOUSING ASSEMBLY

PARTS LIST

T1-05.6

Revised 12.2.72

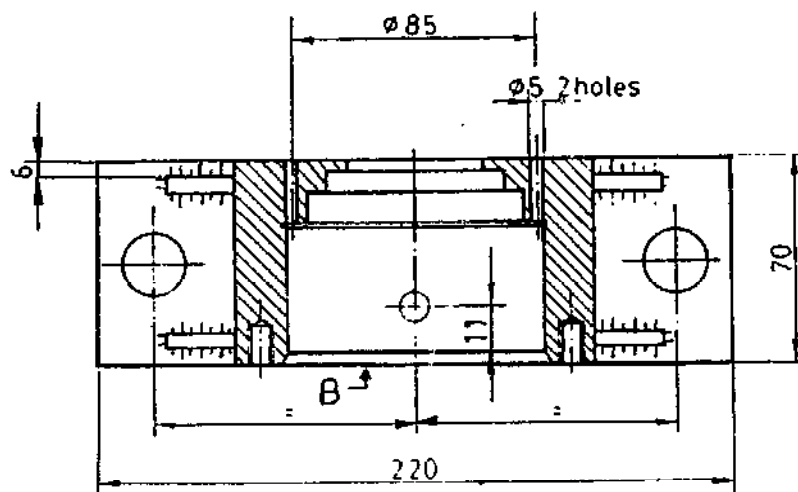
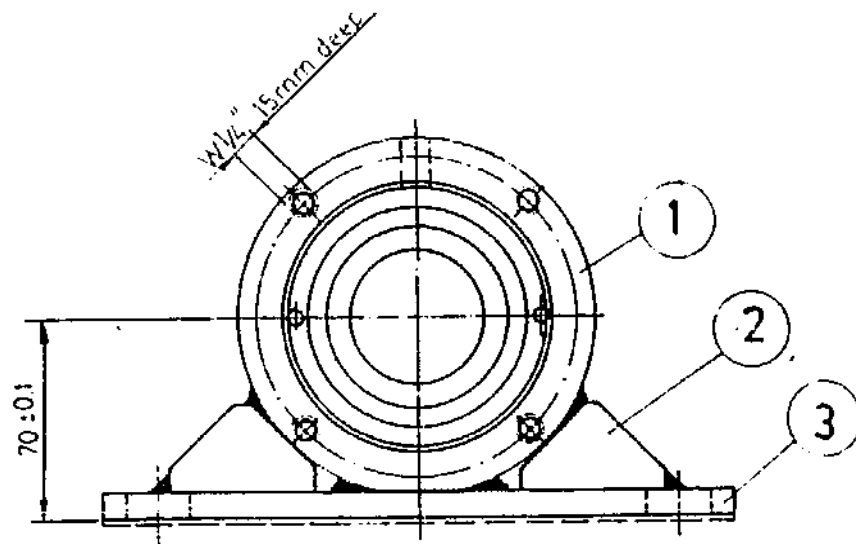

- 1 WELD THE BASE PLATE AND BRACES TO PART 05 6
- 2 MILL SUPPORTING SURFACE RECTANGULAR TO SIDE "B" TO A CENTRE HEIGHT OF 70±0.1
- 3 DRILL HOLES OF $\phi 5$ MAKE THREADS $1/4"$ USE JIG1 AND MAKE THREAD FOR GREASE CUP

BEARING HOUSING ASSEMBLY

T1-05.6

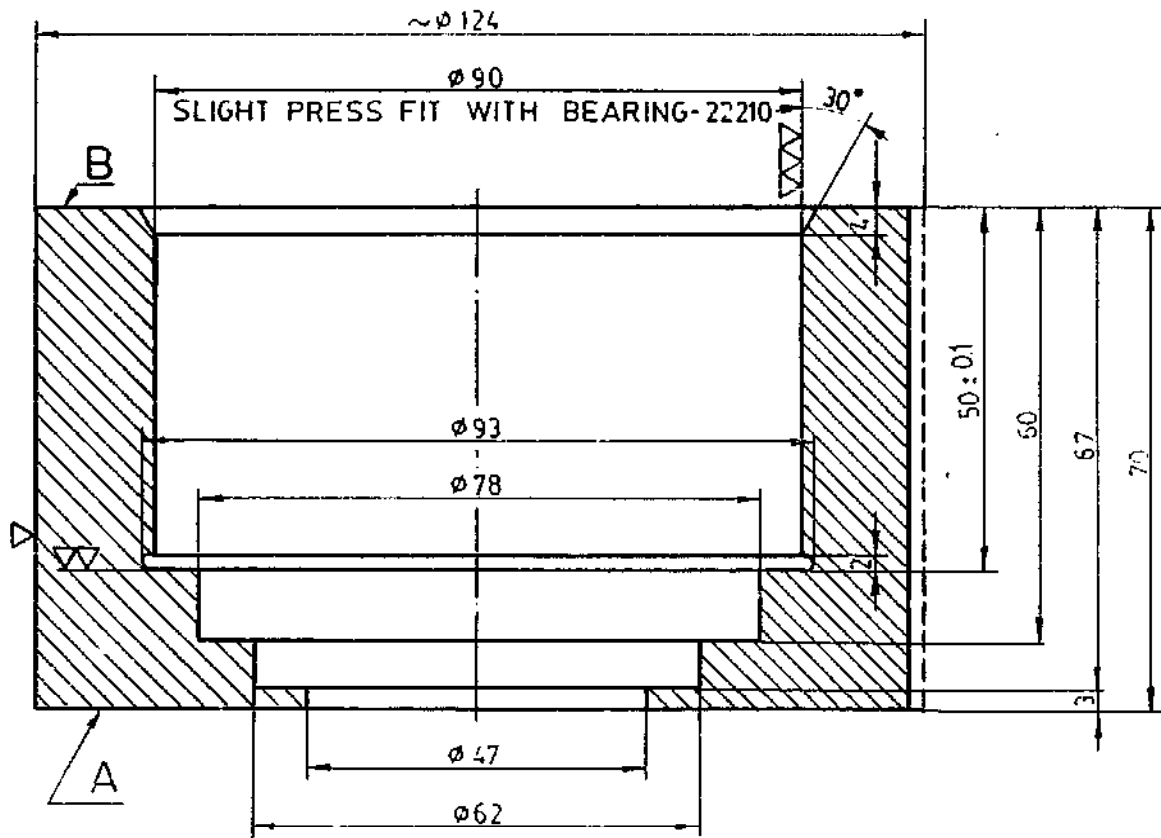
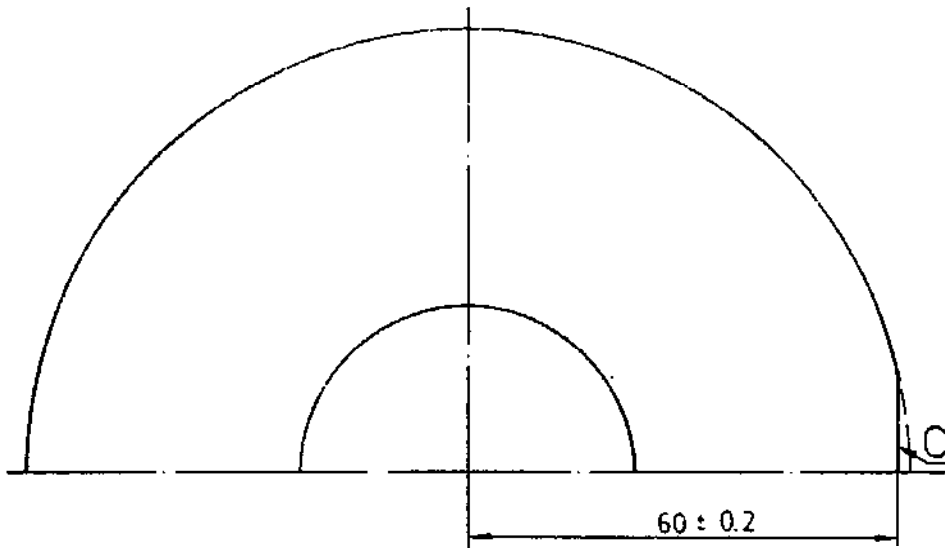

2-NOS.

SEQUENCE

- 1 MACHINE OUTSIDE DIA AND SIDE "A"
- 2 RECLAMP PART TO MACHINE FROM SIDE "A"
- 3 FACE SIDE "B" TO 70mm CENTRE BORE
- 4 BORE $\phi 47$ AND $\phi 52 \times 78$ TO CORRECT DEPTH
- 5 CUT RECESS $\phi 93$ MACHINE $\phi 90$ TO FINAL DEPTH
- 6 MACHINE TO RECTANGULAR TO SIDE "B"

BEARING BODY

T1-05.6/1

SCALE 1:1

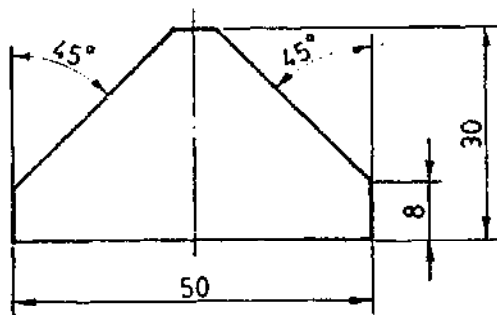

8-NOS.
M.S.FLAT 1/4"X2"

Revised 2-7-82

BEARING BRACE

T1-05.6/2

SCALE 1:1

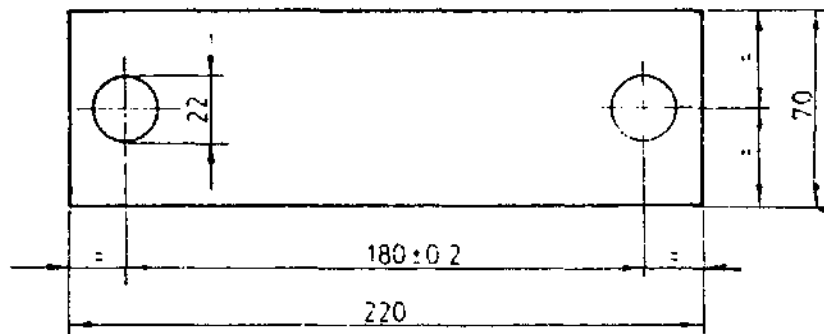
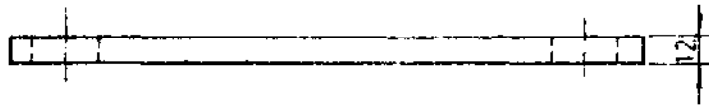

2-105

Rev. 22.4.2.2.2

BEARING BASE

T1-05.6/3

SCALE 1:2.5

POS	NO. OF ITEMS	ITEM	DRAWING NO.	SPECIFICATIONS	REMARKS
1	1	REGULATOR WING SHAFT	T1 - 06.1	M.S.Rod ϕ 50	SUB.ASSEMBLY
2	1	REGULATOR WING CROSS BAR	T1 - 06.2	M.S.Plate 20mm	
3	2	REGULATOR WING ARM	T1 - 06.3	_____	
4	1	REGULATOR WING BLADE	T1 - 06.4	_____	
5	X	ROUND HEAD RIVET	T1 - 06.5	ϕ 12 X 60	
*6	1	REINFORCING PLATE	T1 - 06.6	M.S.Plate 10mm	
		* ONLY REQUIRED FOR HEADS ABOVE 10m.			



CONSISTING OF

REGULATOR WING ASSEMBLY

PARTS LIST

T1-06.0

Rev. no. 29.7.82. Hf.

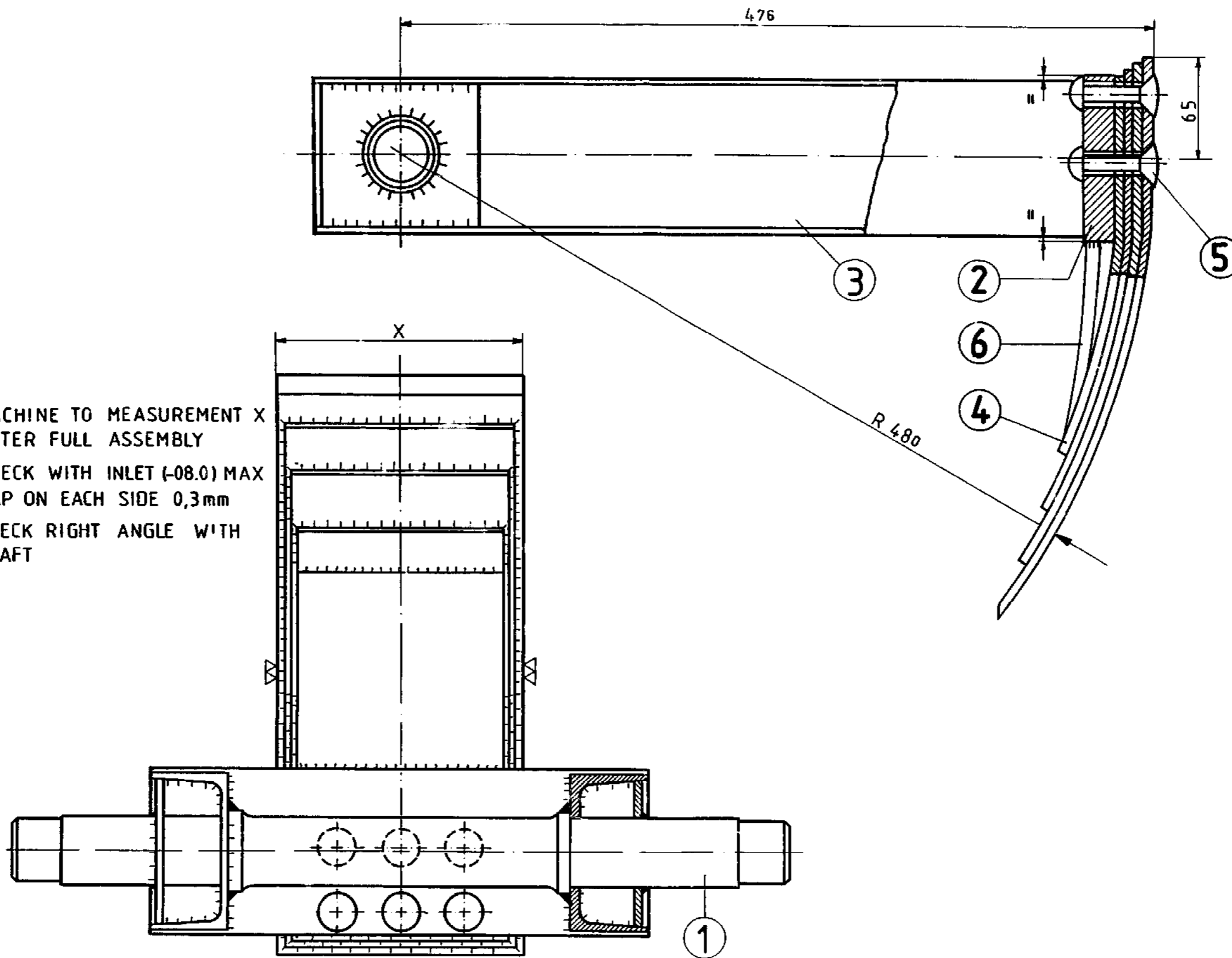

MACHINE TO MEASUREMENT X
 AFTER FULL ASSEMBLY
 -CHECK WITH INLET (-08.0) MAX
 GAP ON EACH SIDE 0,3mm
 -CHECK RIGHT ANGLE WITH
 SHAFT

29.7.82

REGULATOR WING ASSEMBLY

T1-06.0

SCALE 1 : 25

	X 70	X 100
Y	32	56

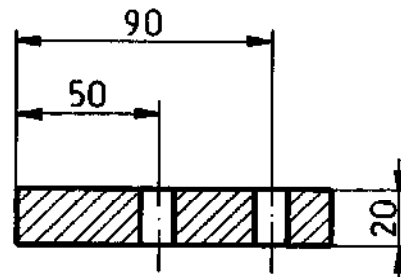
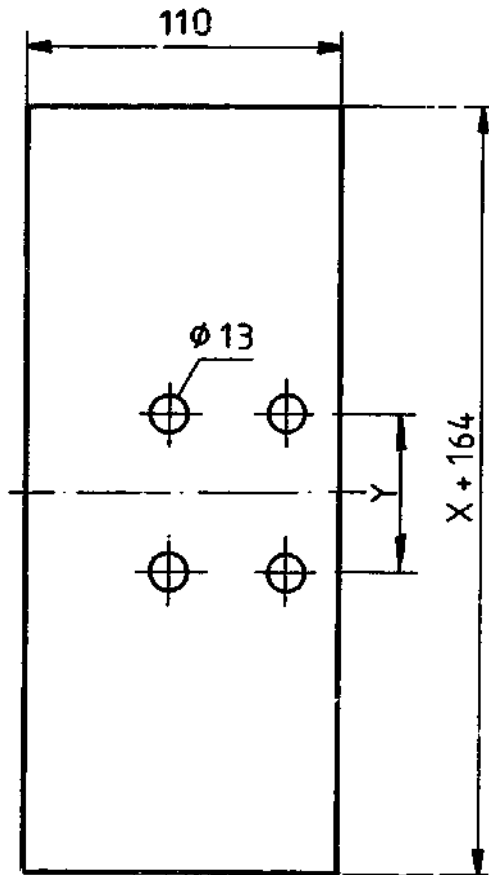

Series 29.7.2. Af

REGULATOR WING CROSS BAR
X 70, X 100

T1-06.2/1

	150	X 180	X 200	X 220
Y	35	40	51	57

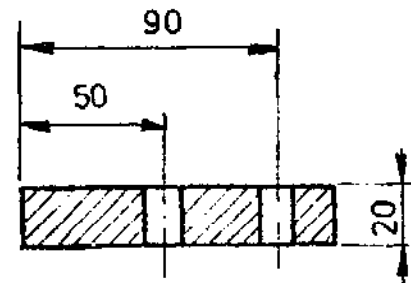
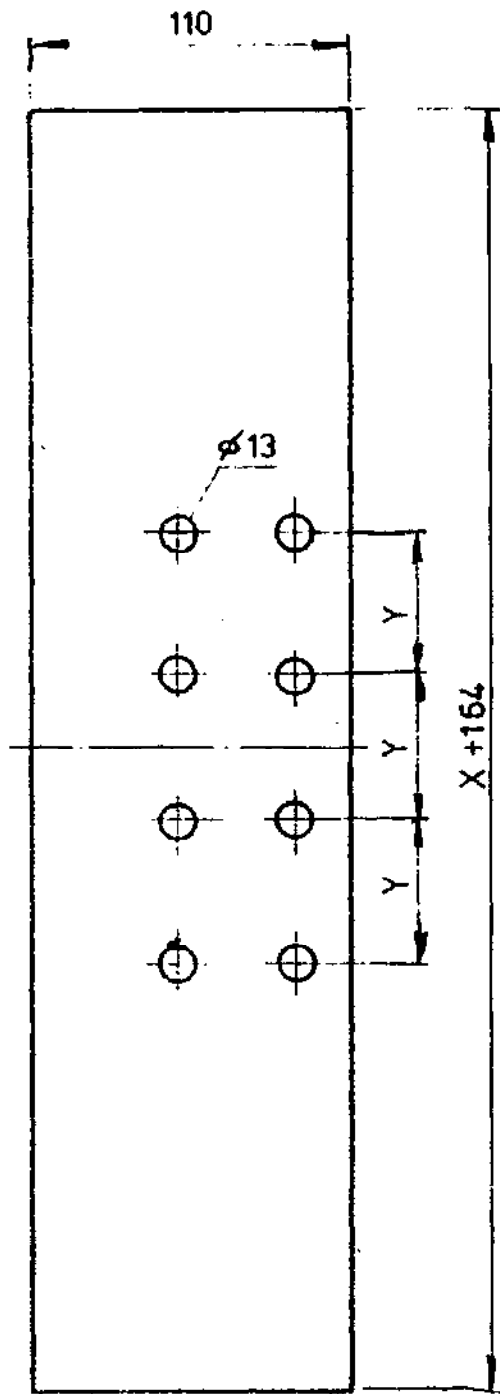

Revised 1977.9.21 H.

REGULATOR WING CROSS BAR
X 150, X 180, X 200 X 220

T1-06.2/2

	X 300	X 360	X 400
X	48	62	70

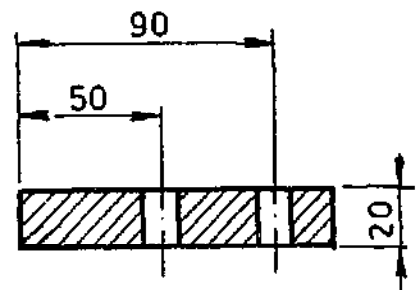
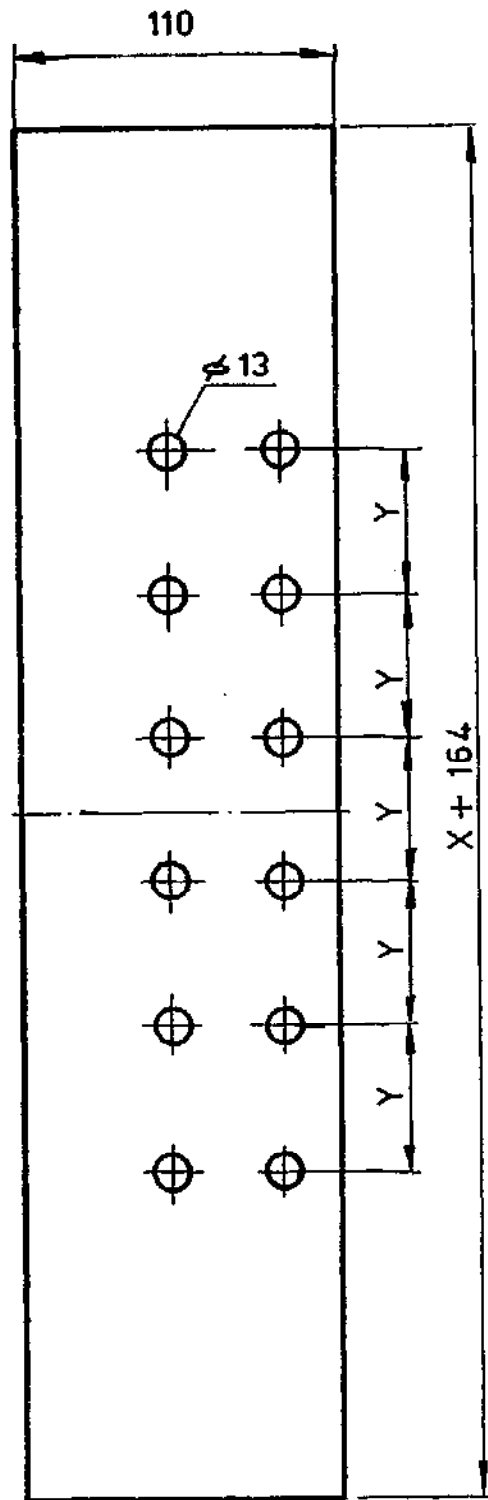

Revised 29.9.86 af.

REGULATOR WING CROSS BAR
X 300, X360, X 400

T1-06.2/3

POS	NO. OF ITEMS	ITEM	DRAWING NO.	SPECIFICATIONS	REMARKS
1	2	M.S.U. CHANNEL LENGTH 485	T1-06.3	100X50 X 6	A4
2	2	M.S. PLATE	T1-06.3	100 X 85	A4

Approved 29.2.12



CONSISTING OF

REGULATOR WING ARM

PARTS LIST

T1-06.3

REVISED 29.7.82.44.

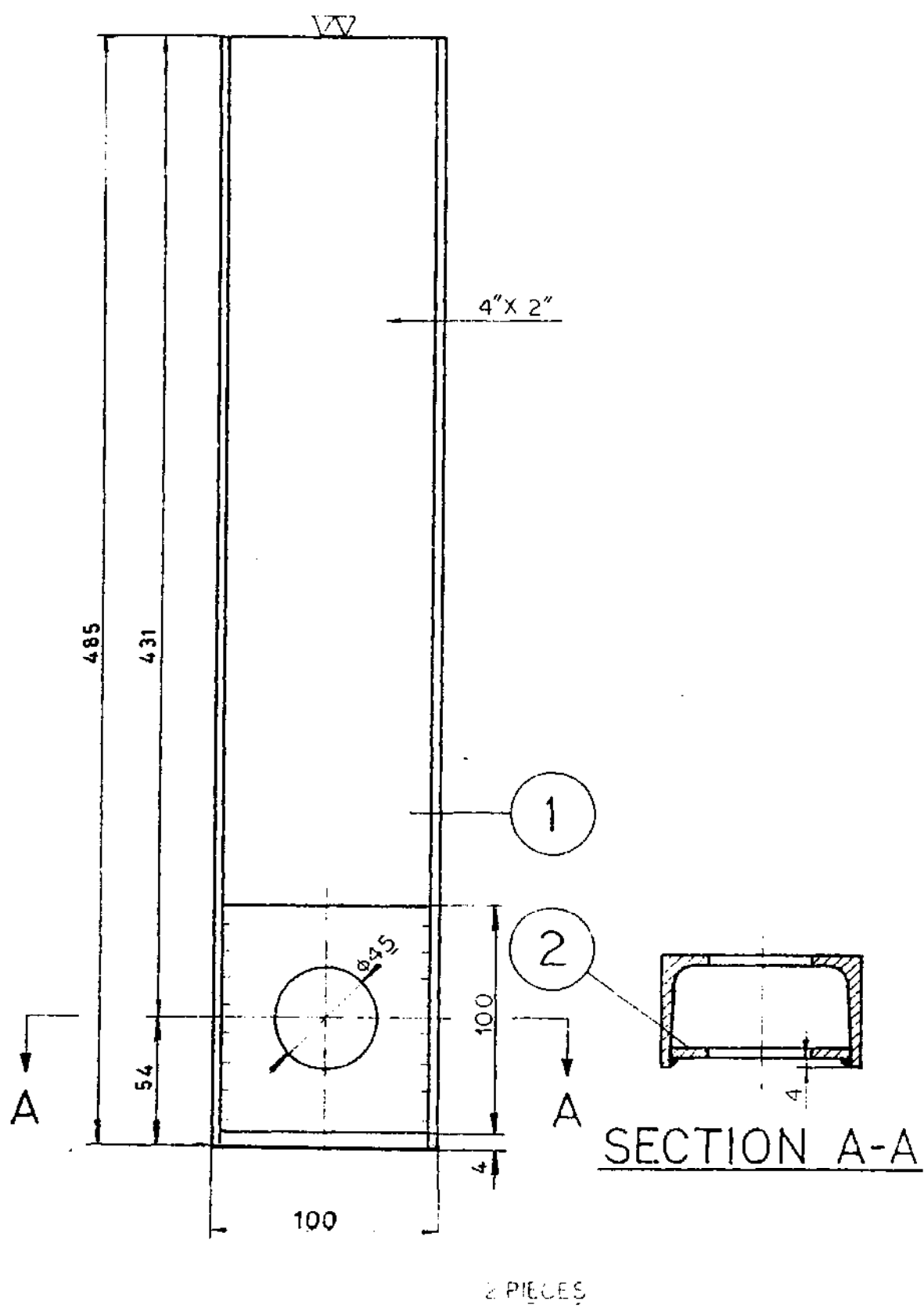

REGULATOR WING ARM

T1-063

SCALE 1:2.5

POS	NO. OF ITEMS	ITEM	DRAWING	SPECIFICATIONS	REMARKS
1	1	M.S PLATE 6mm	T1-06 4	(X-5)X 394	A4
2	1	" " "	"	(X-8)X 346	"
3	1	" " "	"	(X-16)X 298	"
4	1	" " "	"	(X-24)X 243	"

As Revised 29.7.82



CONSISTING OF

REGULATOR WING

PARTS LIST

T1-06.4

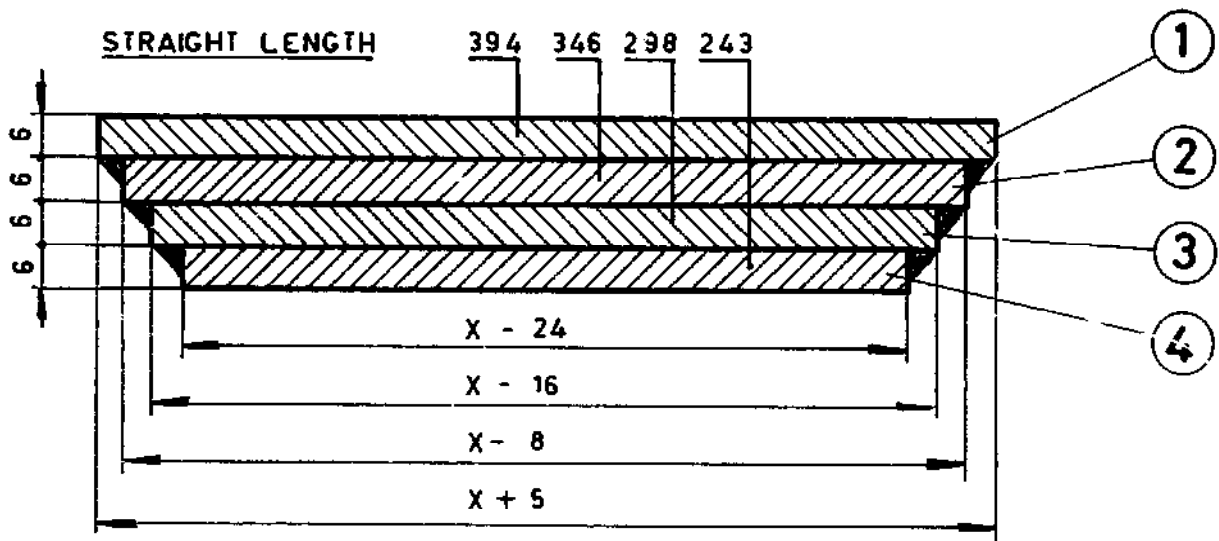
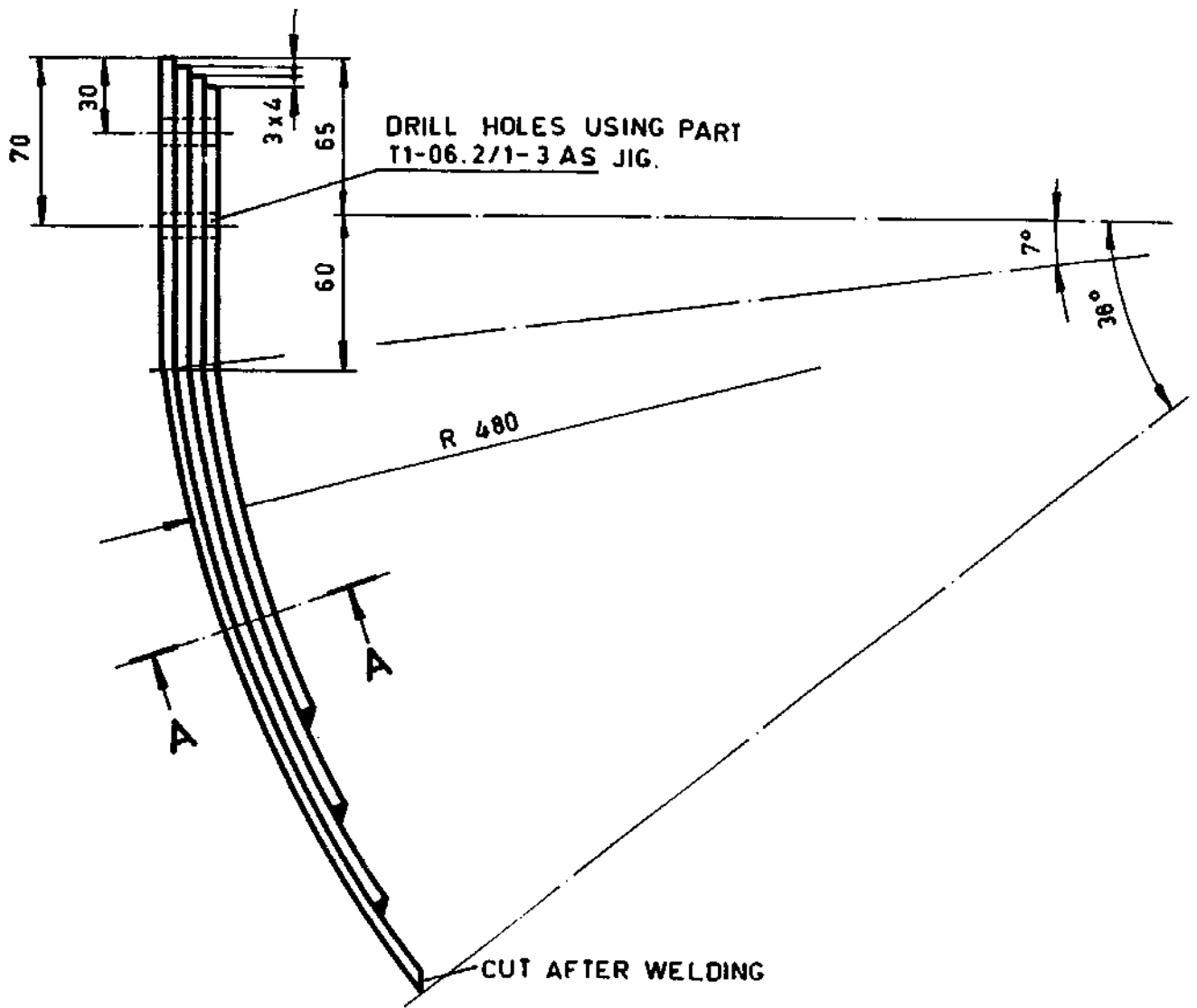

SECTION A-A (1:1)

1.PC

Revised 29.7.82

REGULATOR WING

T1-06.4

1:2.5 (1:1)

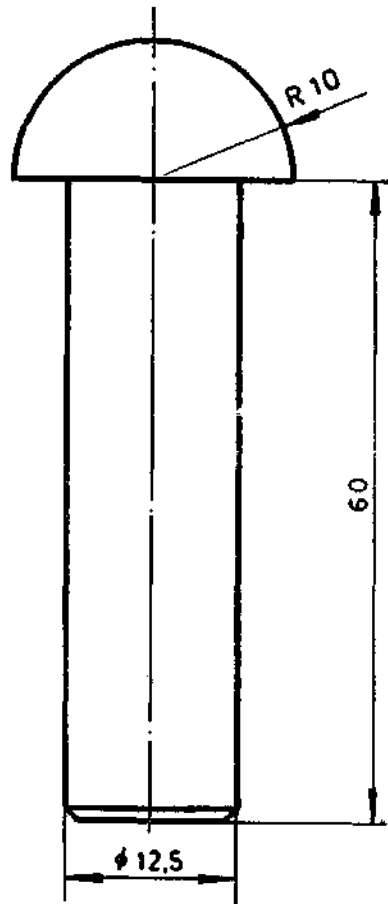

X 70	X 100	X 150	X 180	X 200	X 220	X 300	X 360	X 400
4	4	8	8	8	8	12	12	12

HALF ROUND HEAD RIVET

T1-06,5

2:1

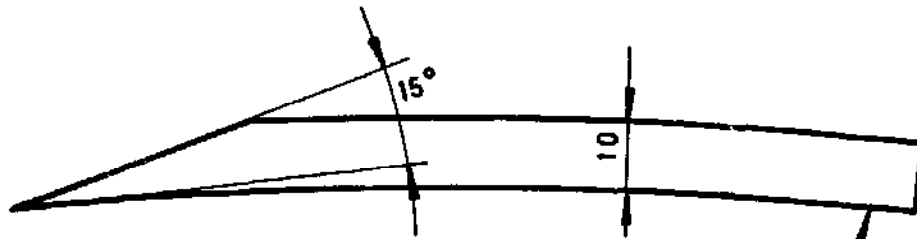

STRAIGHT LENGTH = 127

WIDTH = X

1.PC.

WELD THIS PART DURING
ASSEMBLY WITH ROTOR.

REINFORCING PLATE

T1-06,6

1:1

POS	NO. OF ITEMS	ITEM	DRAWING NO.	SPECIFICATIONS	REMARKS
1	2	HOUSING BASE PLATE	T1-07.1	M.S. Flat 8 X 35	
2	2	BEARING HOUSING	T1-07.2	M.S. Rod ϕ 115	
3	2	HOUSING LID	T1-07.3	M.S. Rod ϕ 115	
4	1	SPACER RING	T1-07.4	Black pipe 75	
5	2	BALL BEARING		SKF 6280	
6	6	HEXAGONAL BOLT		$W\frac{1}{4} \times 5/8$	

Revised 2.2.2.2-



CONSISTING OF

R.W. BEARING HOUSING ASSEMBLY

PARTS LIST

T1-07.0

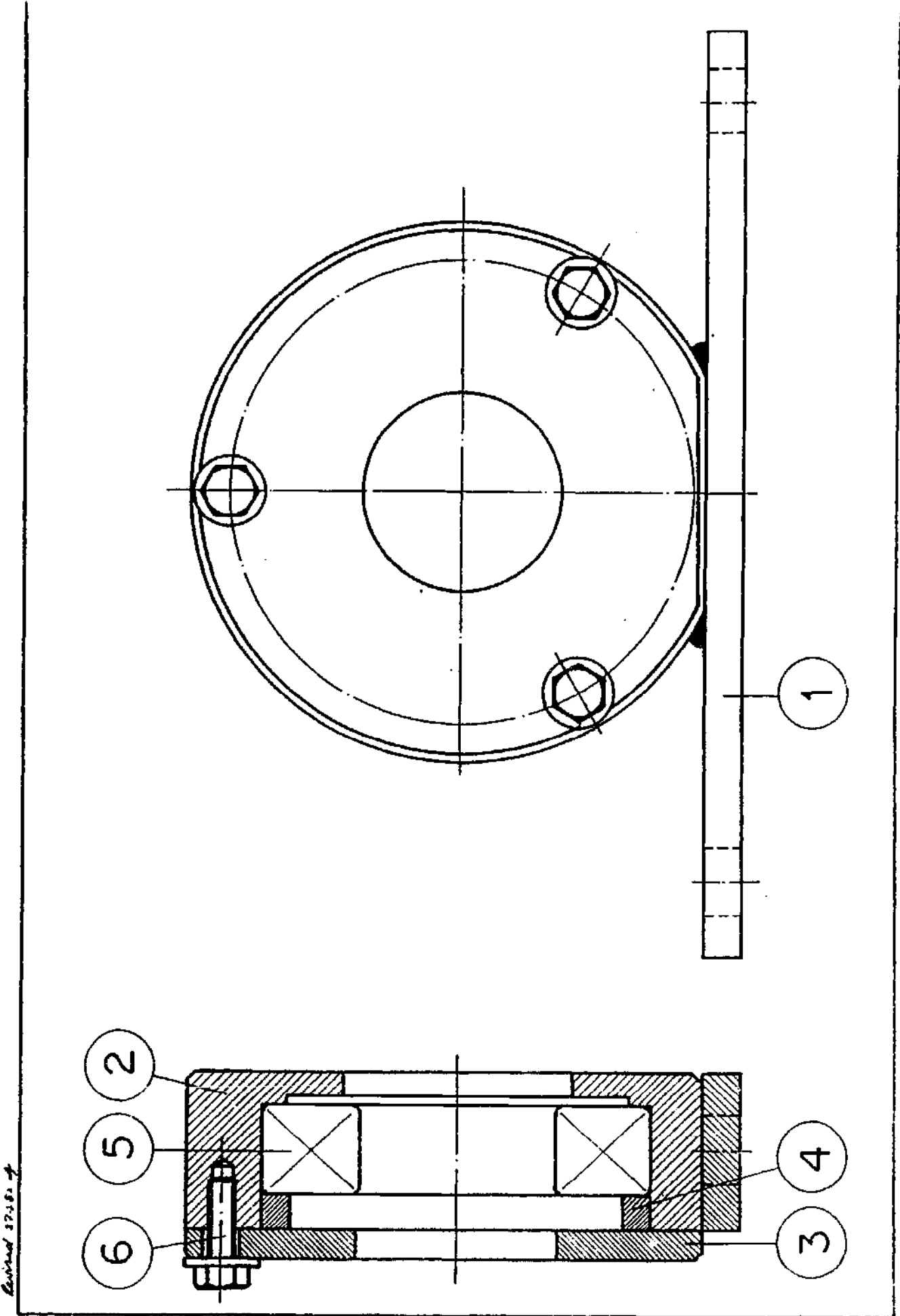

R.W. BEARING HOUSING ASSEMBLY T1-07.0

SCALE 1:1

Revised 12/18/54

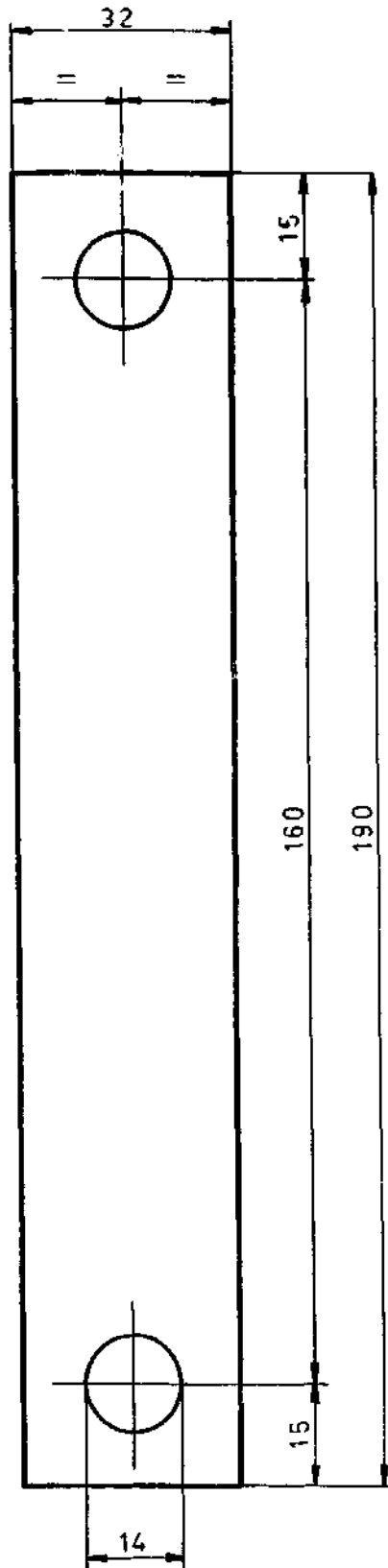

THICKNESS 8 MM

2 PIECES

Revised 8/7/84

HOUSING BASE PLATE

T1-07.1

SCALE 1:1

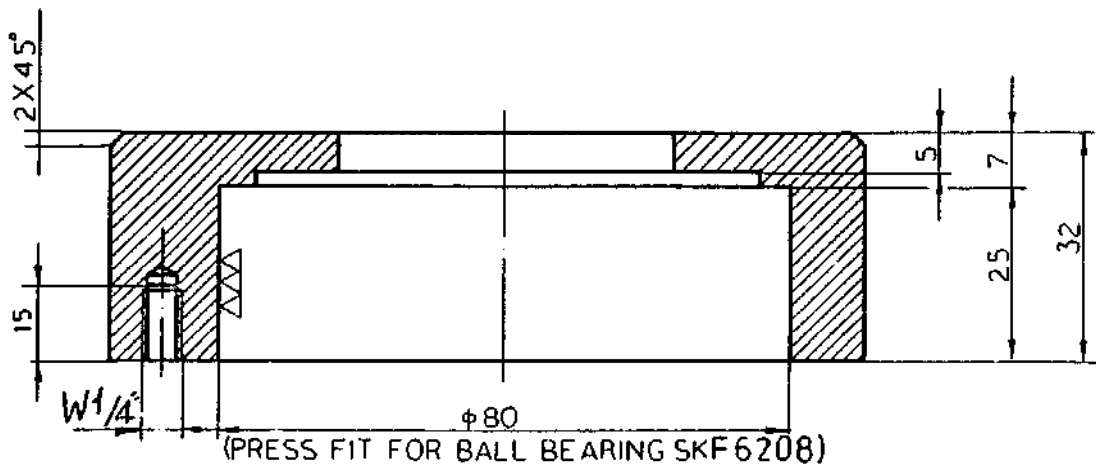
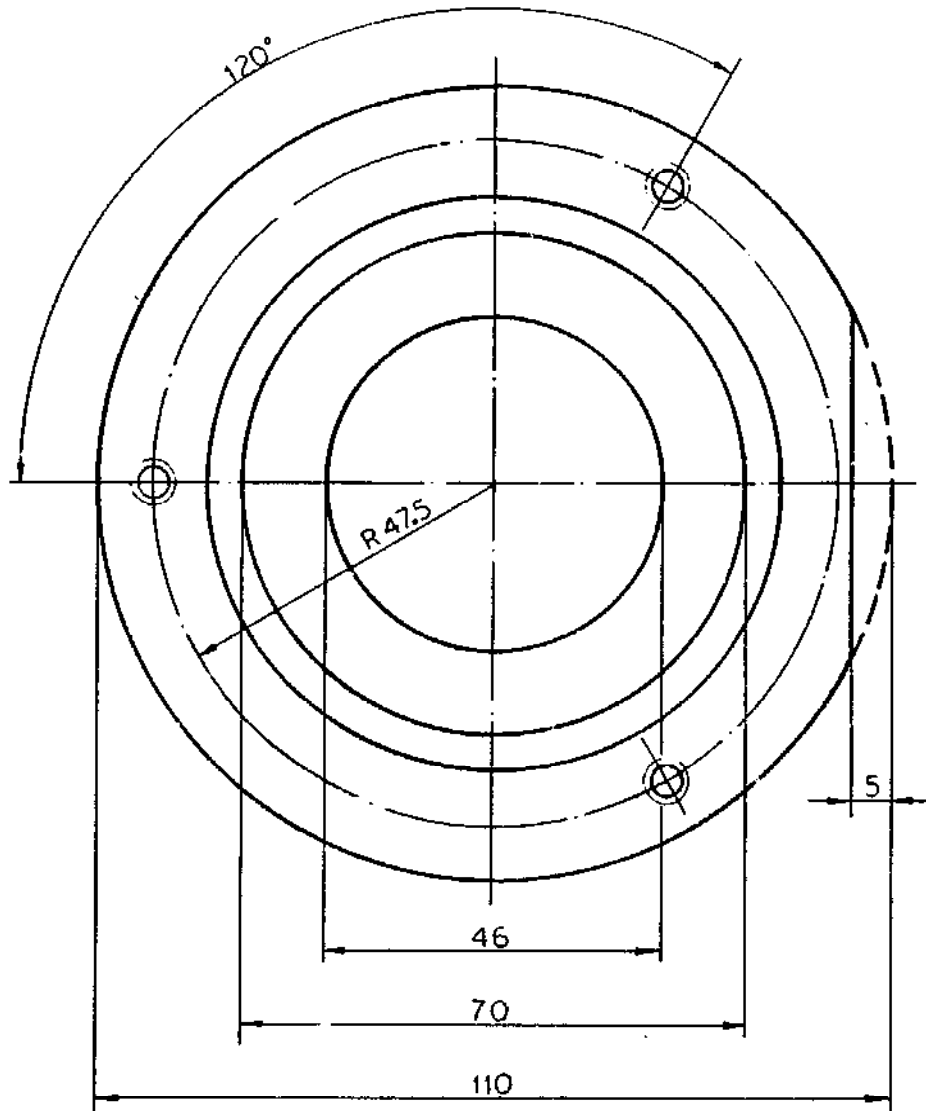

2 PIECES

Revised 20.7.81 A1

BEARING HOUSING

T1-07.2

SCALE 1:1

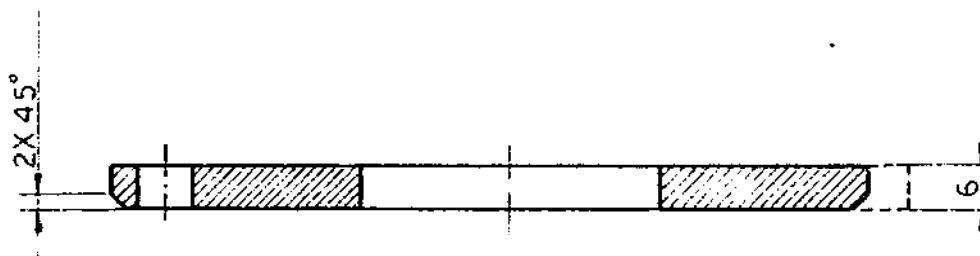
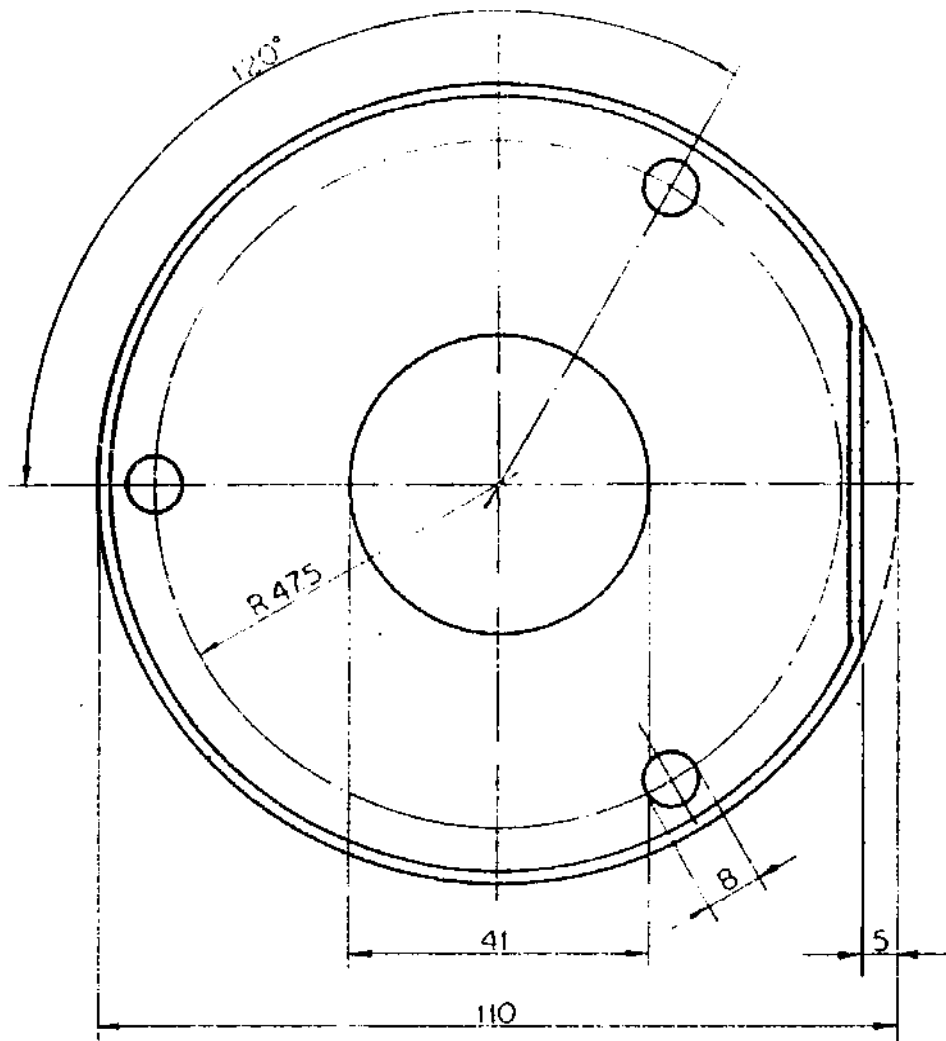

2 PIECES

Revised 27.2.81 m/c

HOUSING LID

T1-073

SCALE 1:1

Revised 29.3.71. X

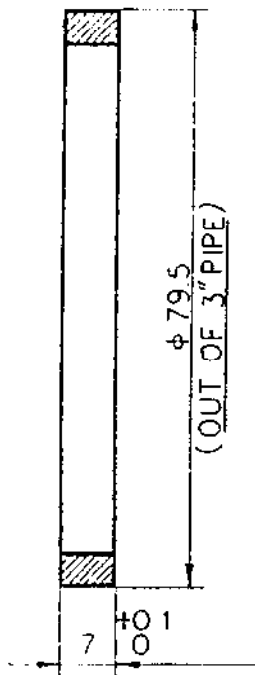

SPACER RING

T1-074

SCALE: (1)

POS	NOOF ITEMS	ITEM	DRAWING NO.	SPECIFICATIONS	REMARKS
1	1	INLET BOTTOM GUIDE	T1-08.1	MS.PLATE 6 MM	
2	1	INLET TOP GUIDE	T1-08.2	MS.PLATE 6MM	
3	2	INLET SIDE PANEL	T1-08.3	MS.PLATE 6MM	
4	2	COVER SHEET FRAME 'A'	T1-08.4	MS.SHEET/STRIP	
5	2	COVER SHEET FRAME 'B'	T1-08.5	MS.SHEET/STRIP	
6	1	STRENGTHENING ANGLE	T1-08,6	MS.ANGLE (64x64) <u>2 1/2" x 2 1/2"</u>	
7	1	SEALING FLAP	T1-08,7	MS.SHEET 3MM	
8	2	SEALING STRIP	T1-08,8	MS.SHEET 3MM	
9	X	INLET CENTRE RIB	T1-08.9	M.S.SHEET 6MM	
10	1	INLET SQUARE FLANGE	T1-08.10	MS.FLAT 40 x 10	SUB.ASSEMBLY
11		HEX. NUT	T1-08.11	W3/8"	SEE PART LIST T1-13.0 FOR NOS OF NUTS REQUIRED.
		* ONLY REQUIRED FOR TYPES X220.300.360.400 FOR TYPE 200 WITH HEAD ABOVE 8M AND FOR TYPE 180 WITH HEAD ABOVE 11M.			



CONSISTING OF

PARTS LIST

INLET ASSEMBLY

T1-08,0

Revised 3.8.78. N. H.

VIEW FROM 'D'

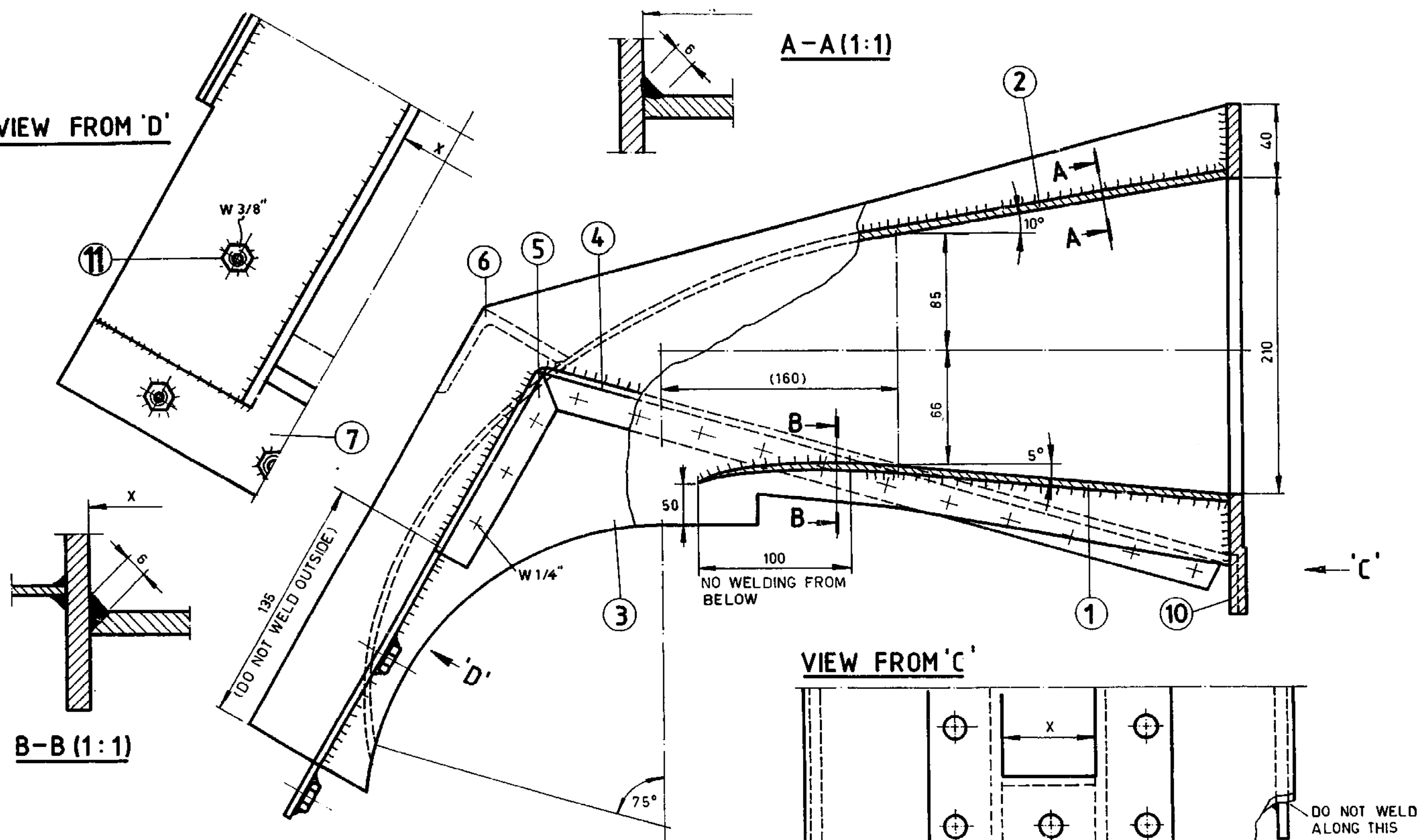

B-B (1:1)

A-A (1:1)

VIEW FROM 'C'

TO WELD W 3/8" NUT (POS. 11)

ASSEMBLE INLET ASSEMBLY IN POSITION WITH SUPPORT ASSEMBLY T1-02.0. USE HOLES IN SUPPORT FRONT T1-02.2 AS GUIDE. DRILL HOLE THROUGH RESPECTIVE SHEET. INSERT BOLTS OR A PIECE OF ROD. MOUNT NUT. SELECT POSITION. WELD NUTS.

WELD POS. 7, 5, 4, 1 DURING FINAL ASSEMBLY.

NO WELDING FROM BELOW

DO NOT WELD ALONG THIS CORNER

USE HOLES IN THIS ROW AS GUIDE TO DRILL HOLES ON BAFFLE HOUSING TOP T1-03.3.

INLET ASSEMBLY

T1-08,0

1:2.5

Revised 12.7.82

Revised 28.7.82 M

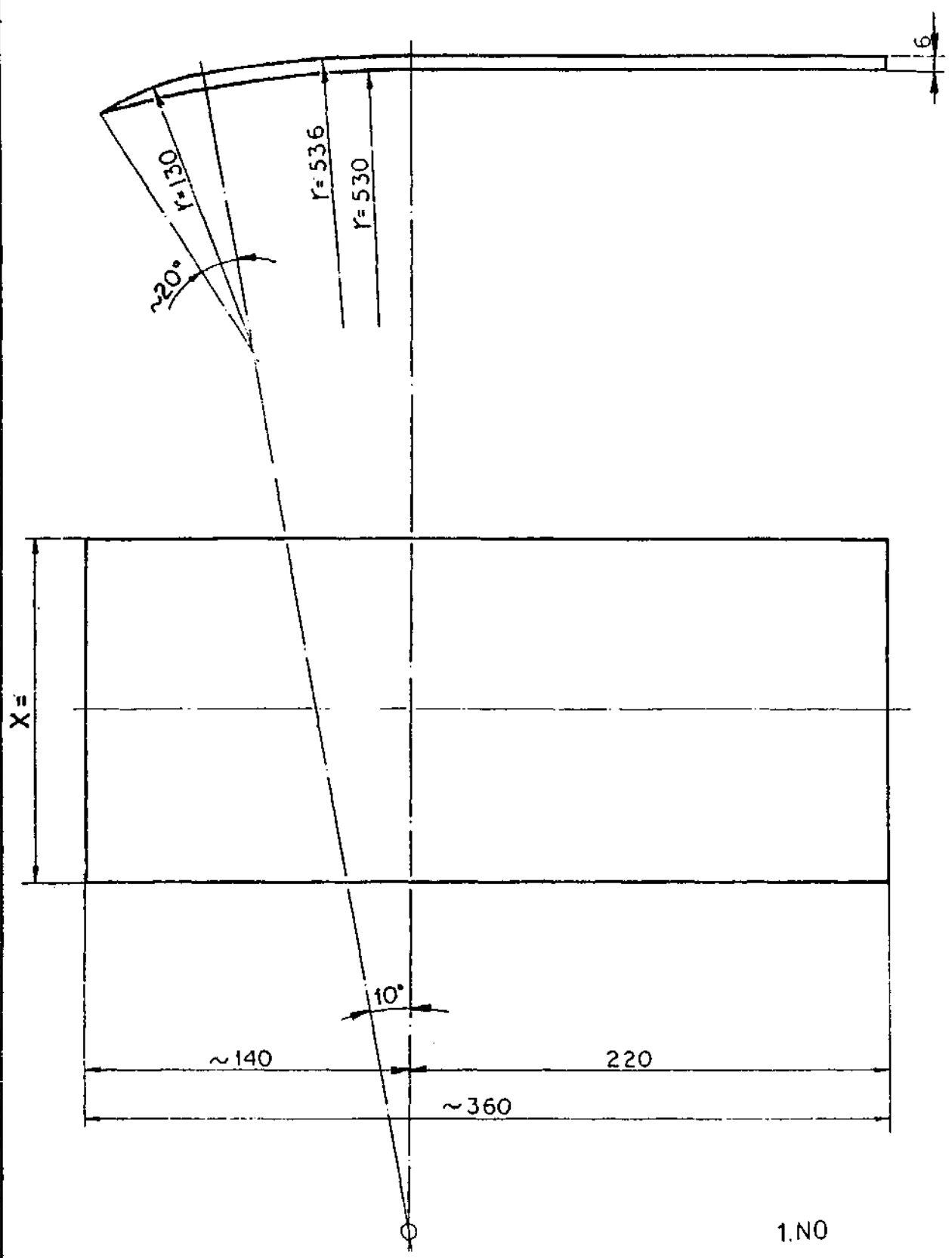

INLET BOTTOM GUIDE

T1-08,1

SCALE 1:2.5

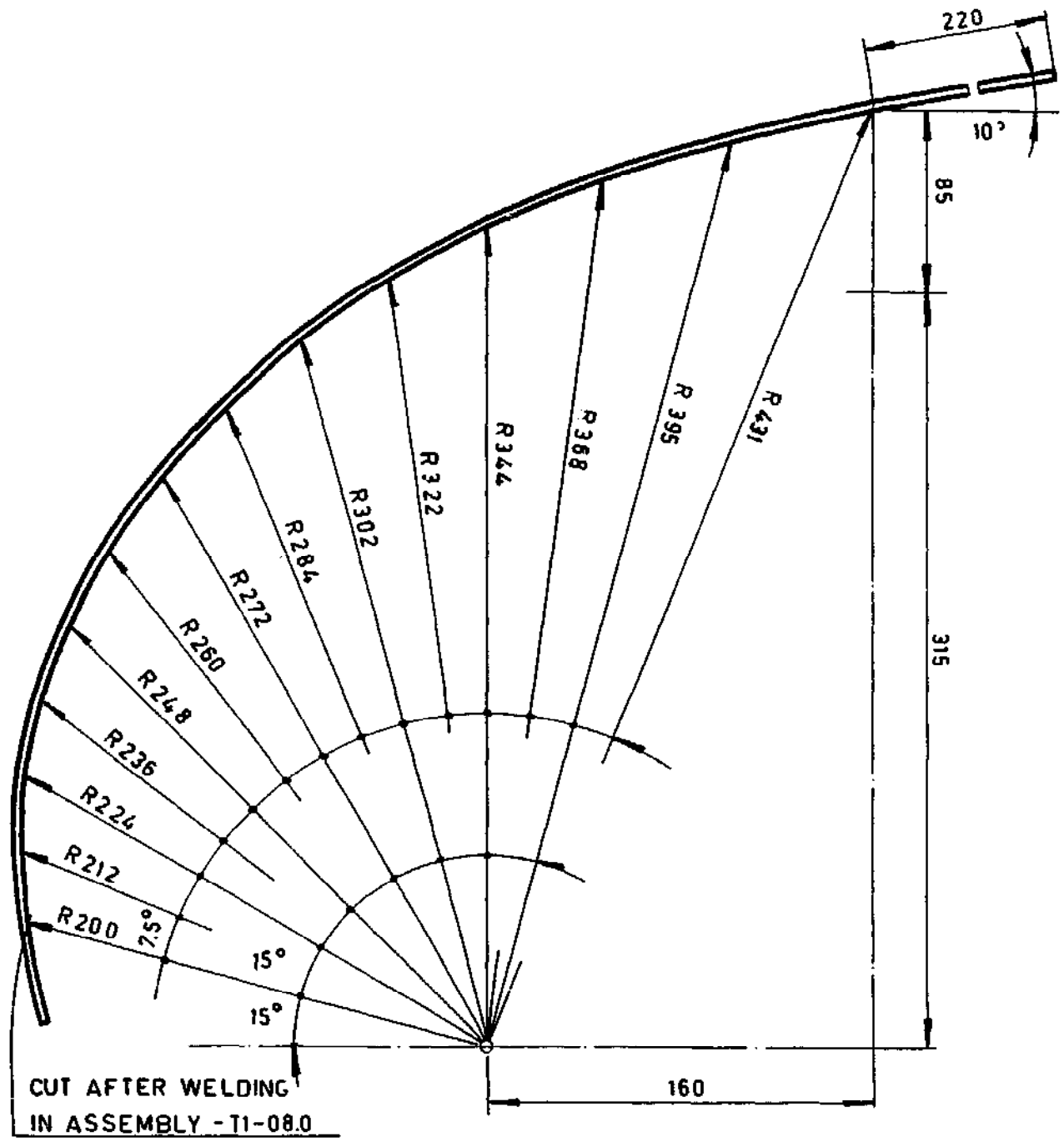

6MM MS. PLATE
 WIDTH = X
 STRAIGHT LENGTH = 870
 1.PC

Revised 28.7.81 AY

INLET TOP GUIDE

T1-08,2

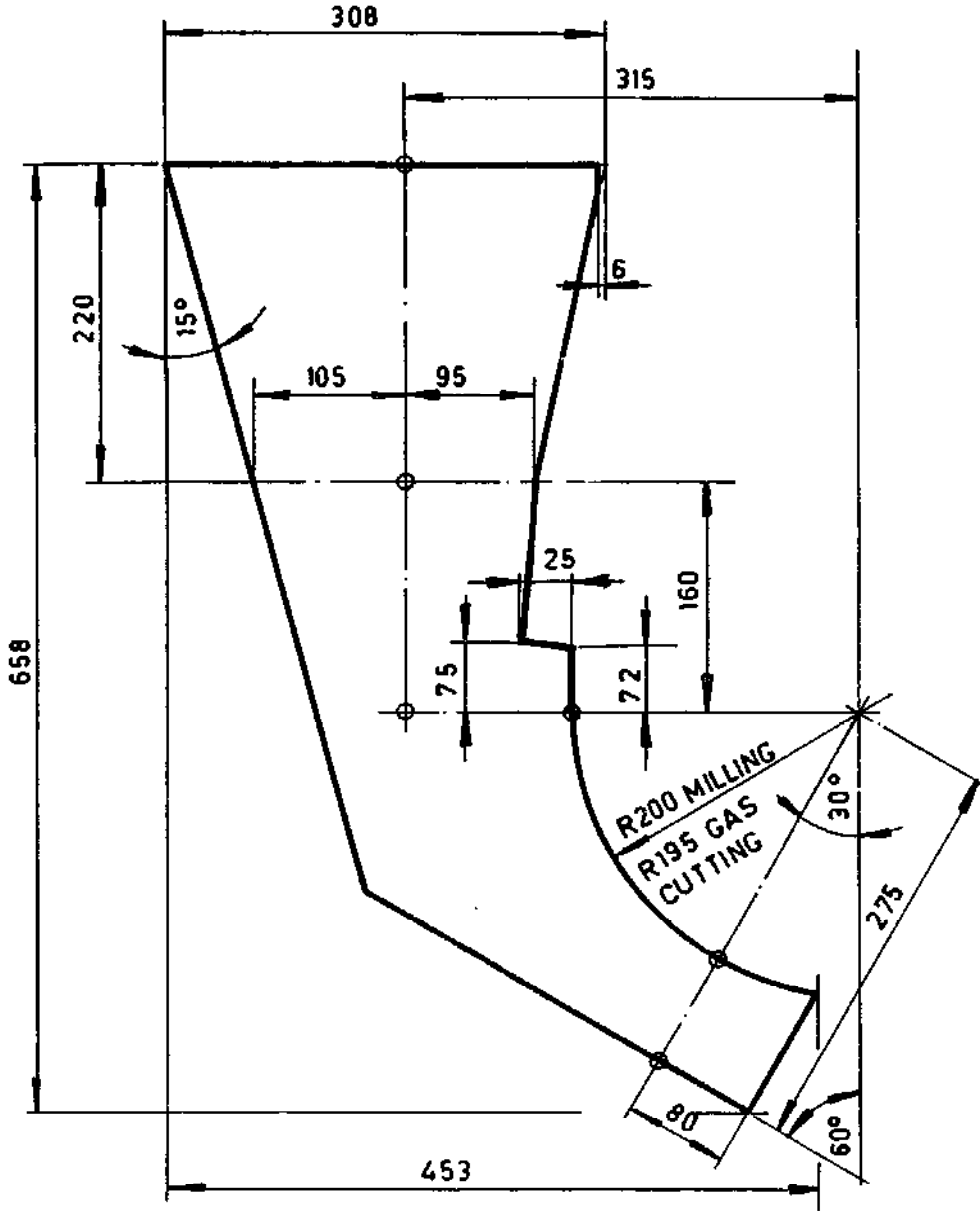

POINTS AND SYM-LINE
MUST BE VISIBLE ON THE PLATE.

6MM MS PLATE
2.PCS

Revised 28.7.82 AL

INLET SIDE PANEL

T1-08.3

1:5

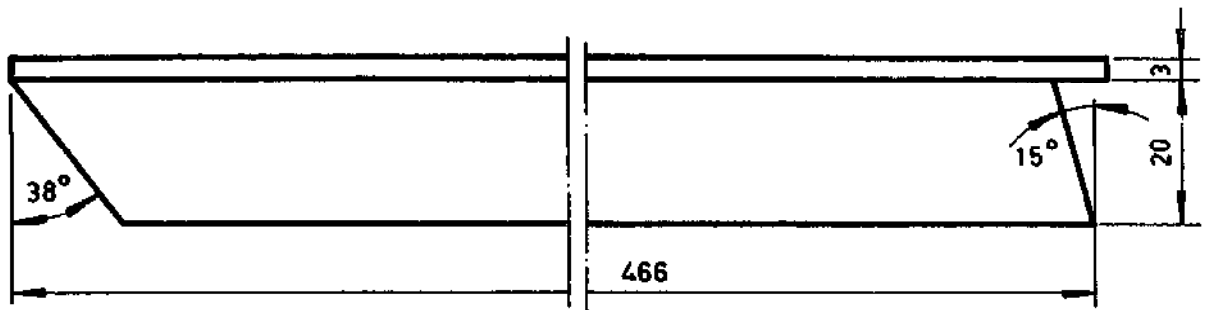

2.PCS

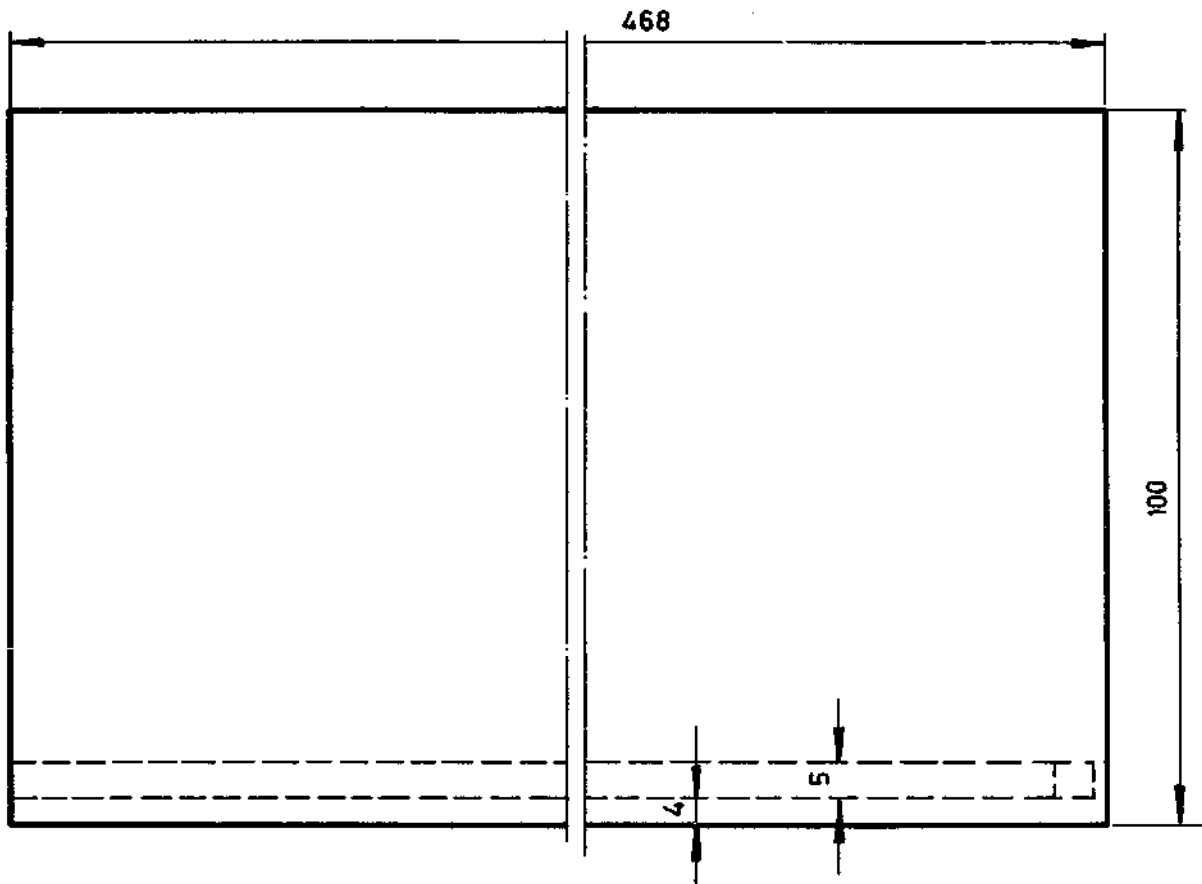

-MAKE ONE SET AS PER DRAWING

-ON THE NEXT SET, WELD 466x20x5 FLAT ON THE SAME SURFACE BUT NEAR OTHER EDGE. LEAVE MARGIN OF 4MM AS SHOWN.

Revised 20.7.2014

COVER SHEET FRAME 'A'

T1-08,4

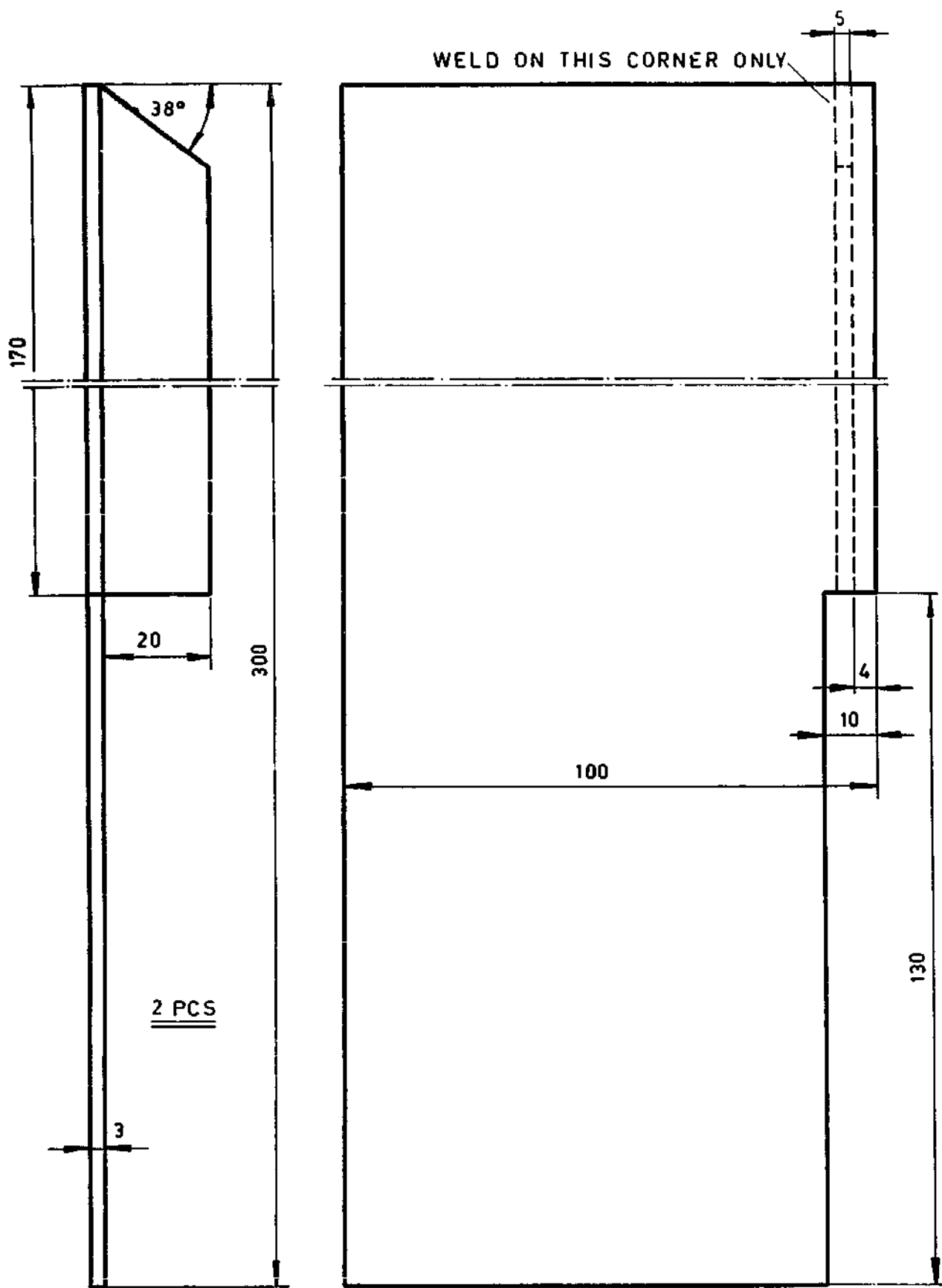

- MAKE ONE SET AS PER DRAWING AND SECOND SET MIRROR INVERTED.

Revised 18.7.02 AL

COVER SHEET FRAME 'B'

T1-08,5

1:1

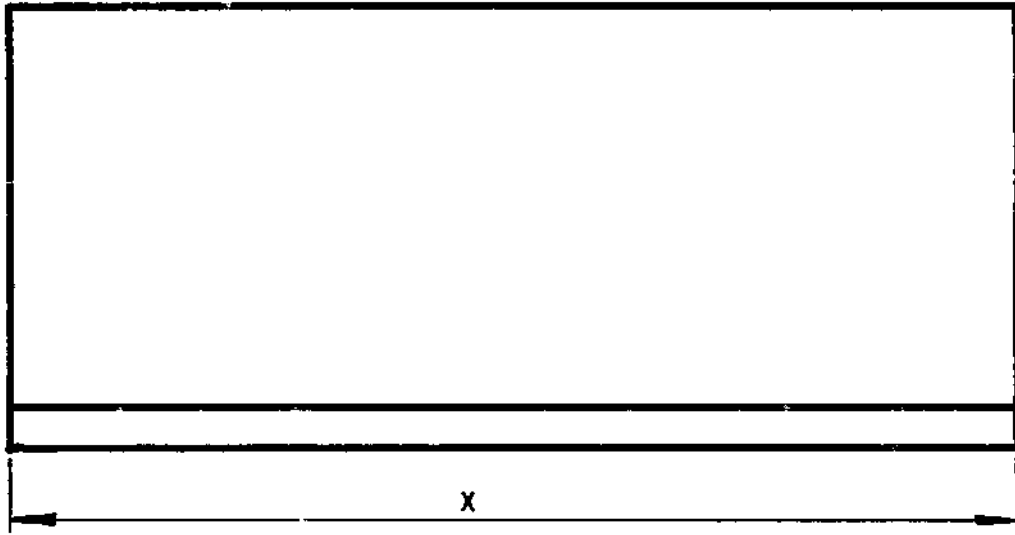

M.S. ANGLE 2 1/2" x 2 1/2" (64 x 64).

1.P.C.

Revised 20.7.81

STRENGTHENING ANGLE

T1-08,6

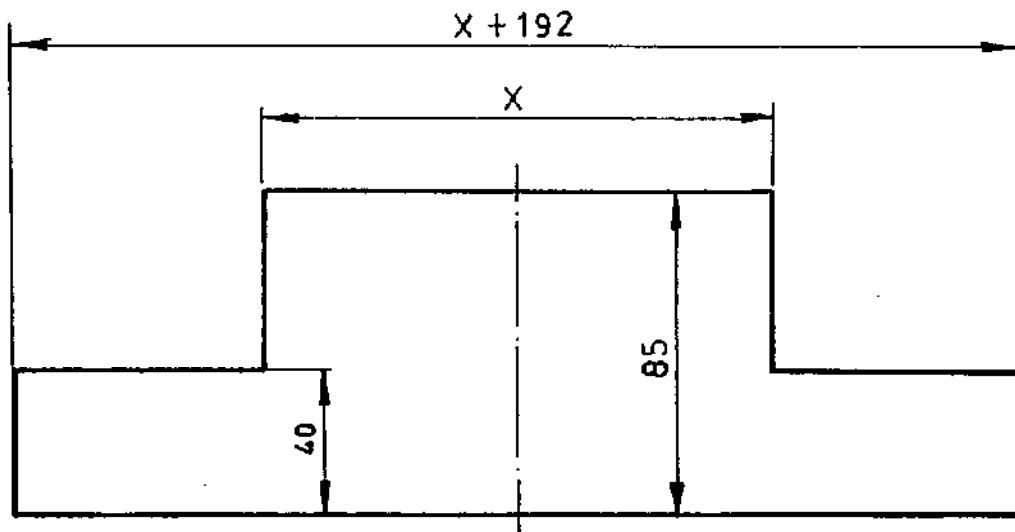

3 MM. SHEET

1. NO

WELD TO INLET AFTER COMPLETE ASSEMBLY (-00.1)

Revised 20.7.72 A/-

SEALING FLAP

T1-08,7

WELD THESE STRIPS TO INLET ASSEMBLY T1-08.0.
USE $\phi 8$ HOLES AS GUIDE TO DRILL HOLES REQUIRED
ON BAFFLE HOUSING ASSEMBLY.

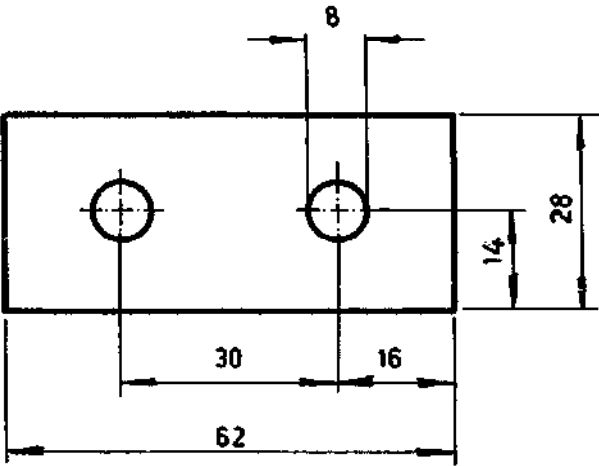

3MM MS.SHEET
2.PCS

Revised 28.7.82 AL

SEALING STRIP

T1-08,8

1:1

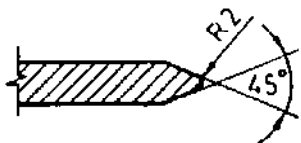

SECTION A-A

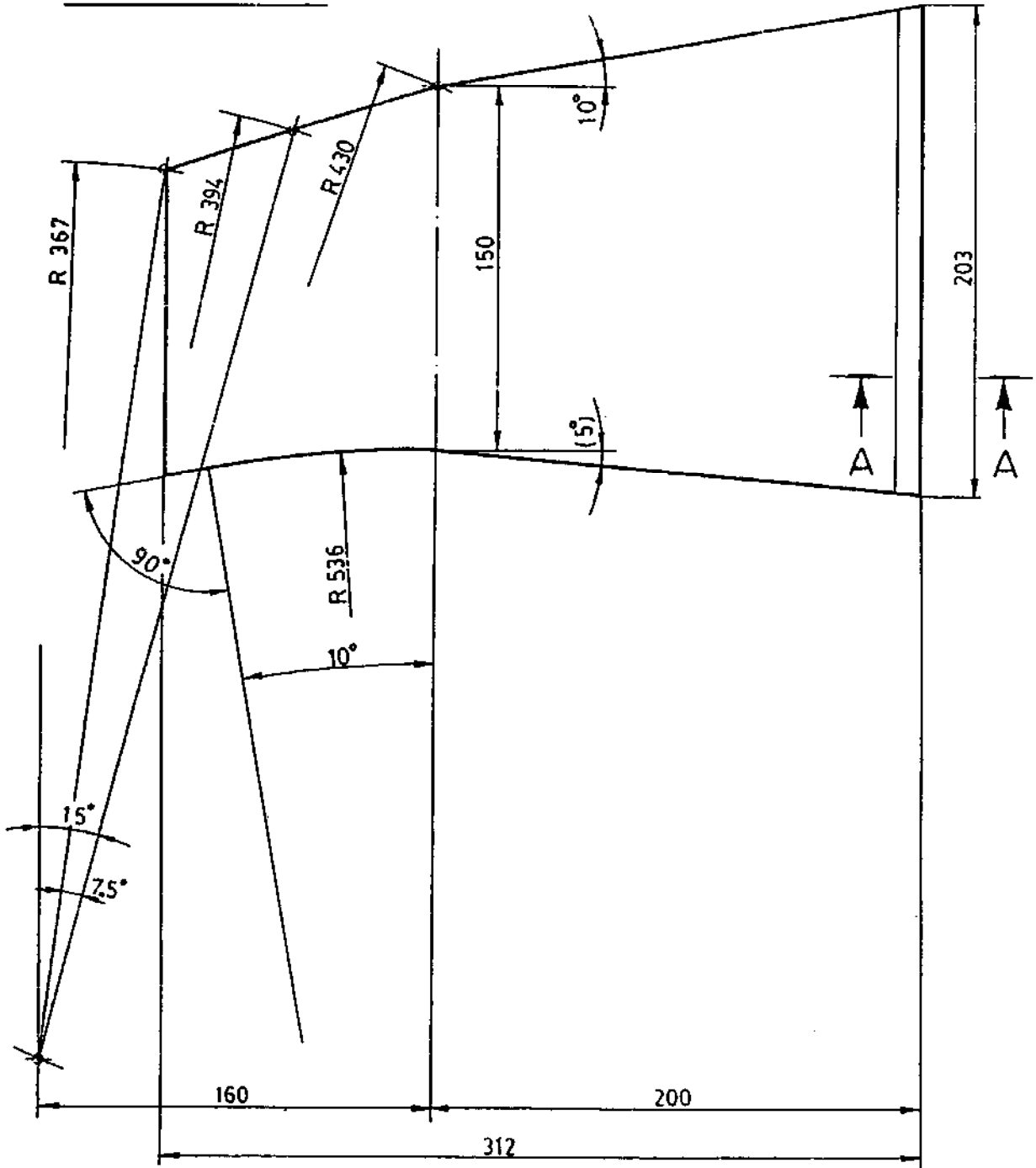

REVISED 29.7.82. P. A.P.

MEASUREMENTS VERY APPROXIMATE ONLY.
ADJUST TO FIT IN INLET

1 PIECE
6mm M.S. Plate

INLET CENTRE RIB

T1-08.9

SCALE 1:25 1:1

POS	NO. OF ITEMS	ITEM	DRAWING NO.	SPECIFICATIONS	REMARKS
1	1	M.S. FLAT LENGTH: X + 80	T1 - 08.10	10 X 40	
2	2	M.S. FLAT LENGTH: X	T1 - 08.10	10 X 40	
3	2	M.S. FLAT LENGTH: 290	T1 - 08.10	10 X 40	
		FLANGE FOR X 70	T1 - 08.10/1		
		FLANGE FOR X 100, X 150, X 180	T1 - 08.10/2		
		FLANGE FOR X 200, X 220	T1 - 08.10/3		
		X 300, X 360, X 400	T1 - 08.10/4		

Revised 23.7.92

↑ CONSISTING OF

INLET SQUARE FLANGE

PARTS LIST

T1-08.10

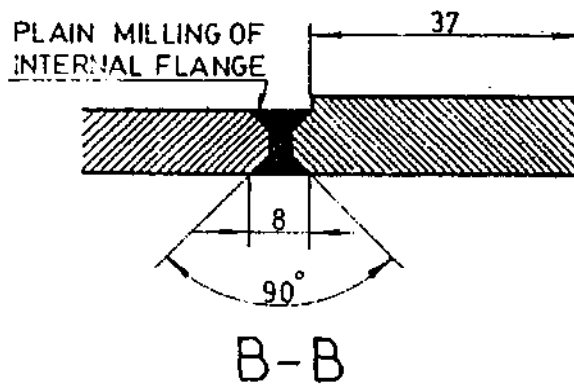
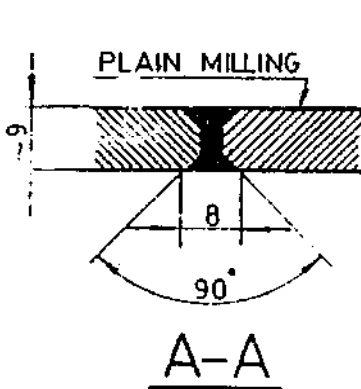
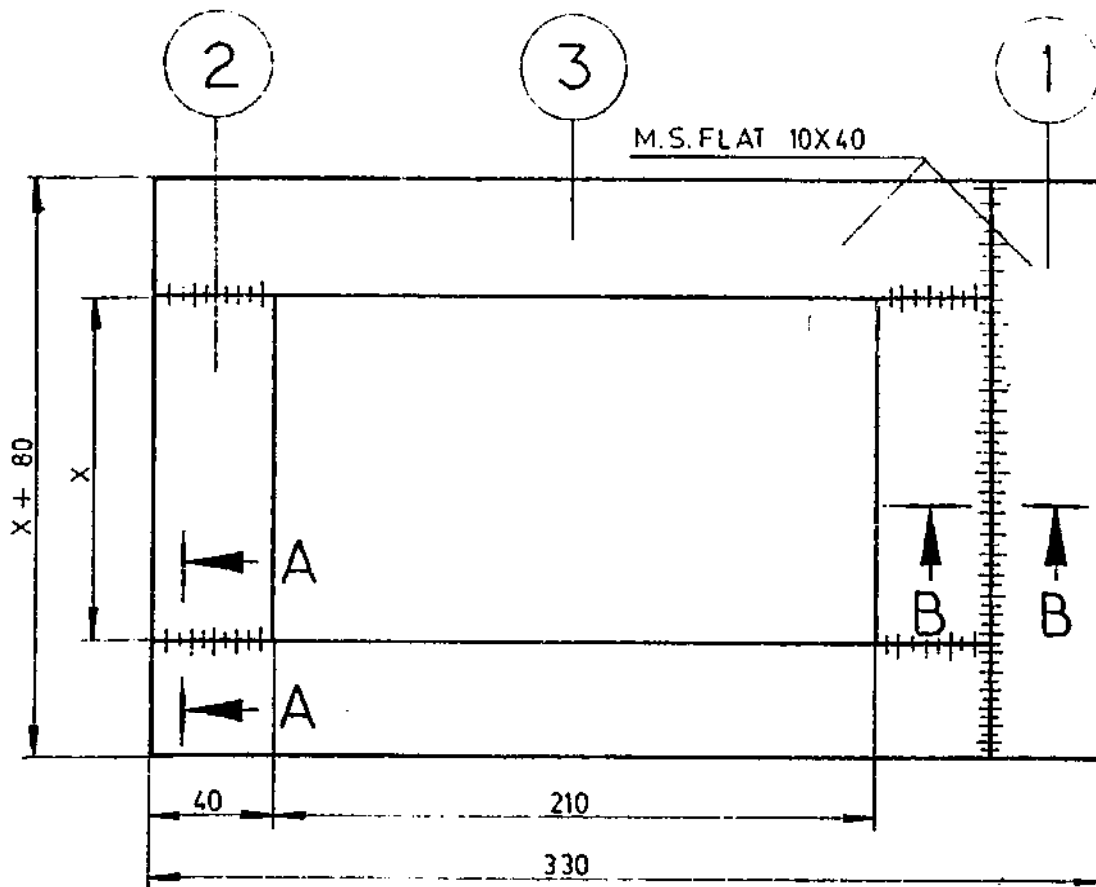

NOTE . FOR DRILLING HOLES REFER TO DRG T1-08.5/1-3

Revised 20.7.82

INLET SQUARE FLANGE

T1-08.10

SCALE 1:25

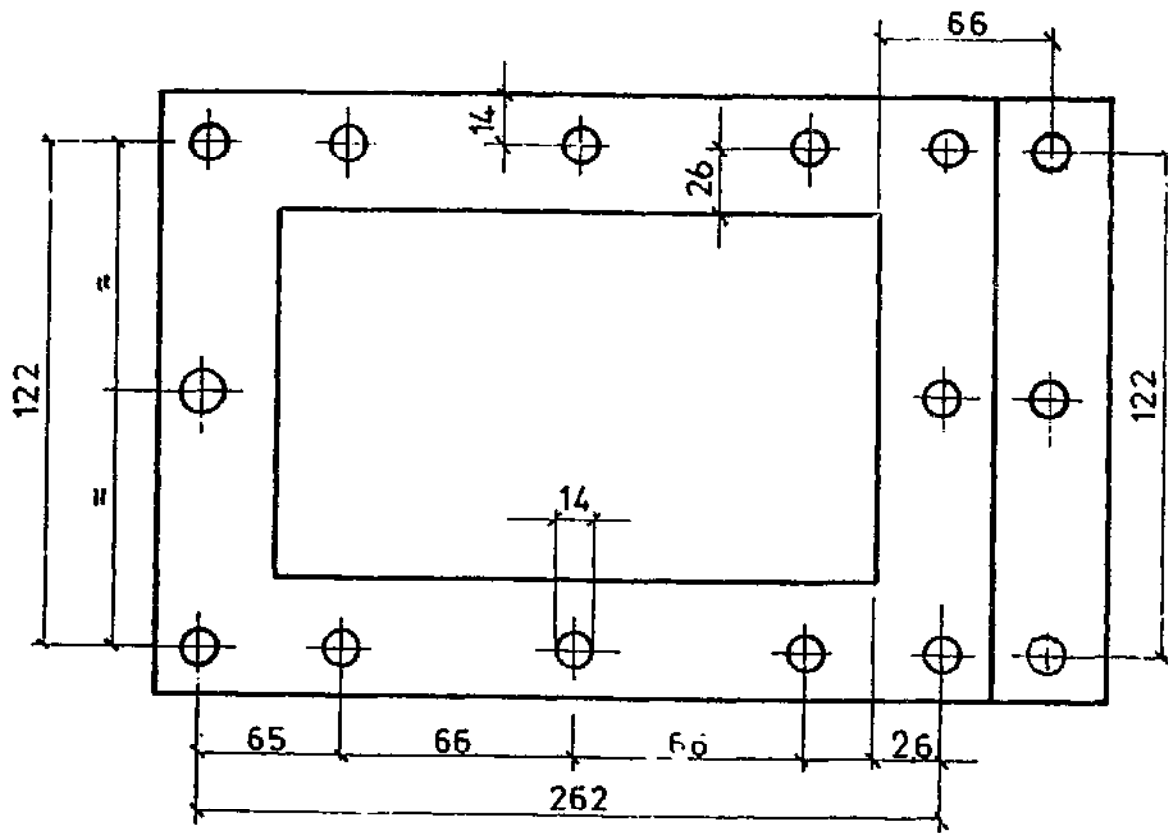

287.22 Revins A

INLETSQARE FLANGE X 70

T1-08,10/1

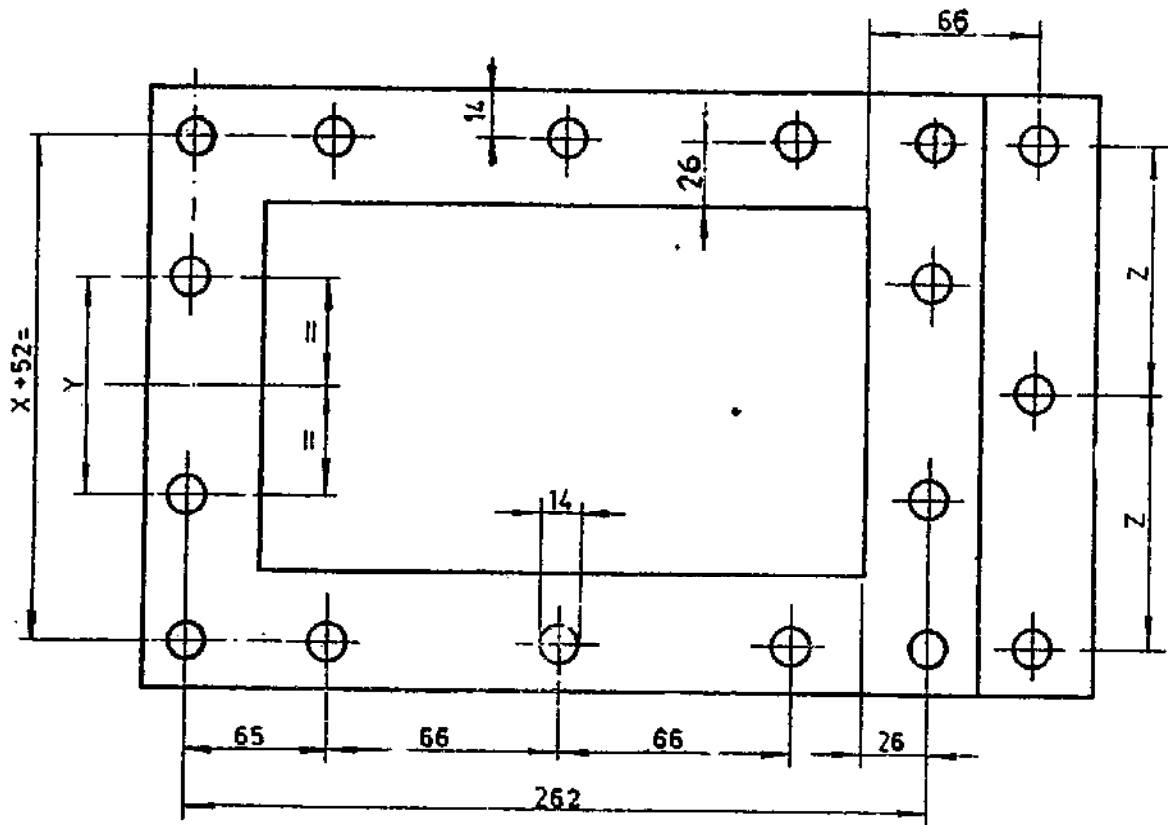

	X 100	X 150	X 180
Y	50	68	80
Z	76	101	116

Revised 28.7.92

INLET SQUARE FLANGE (X100, X150, X180) T1 08.10/2

SCALE 1:2.5

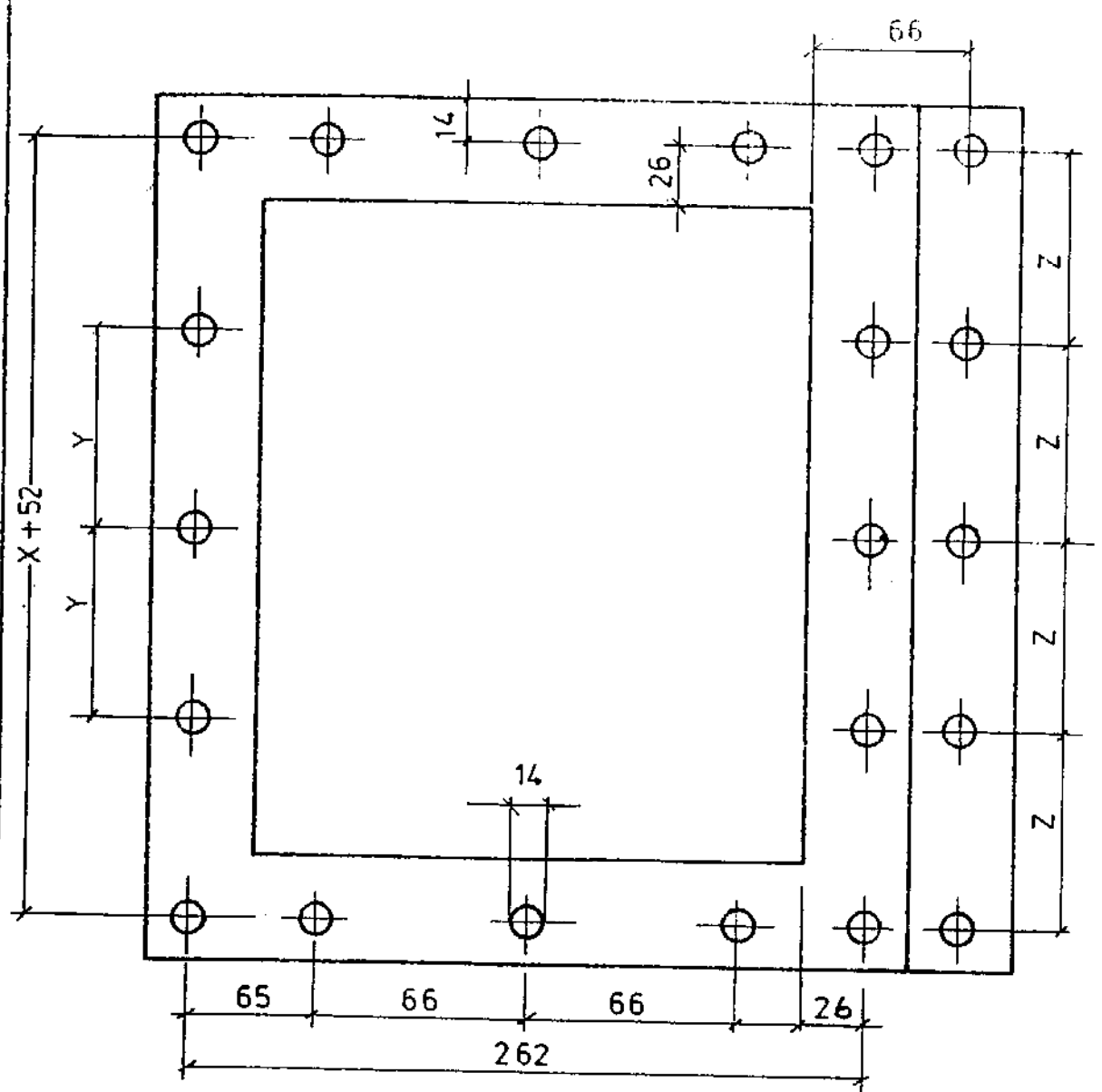

	X 300	X 360	X 400
Y	88	103	113
Z	88	103	113

Revised 28.7.82

INLET SQUARE FLANGE X 300, X 360, X 400.

T1-08, 10/4

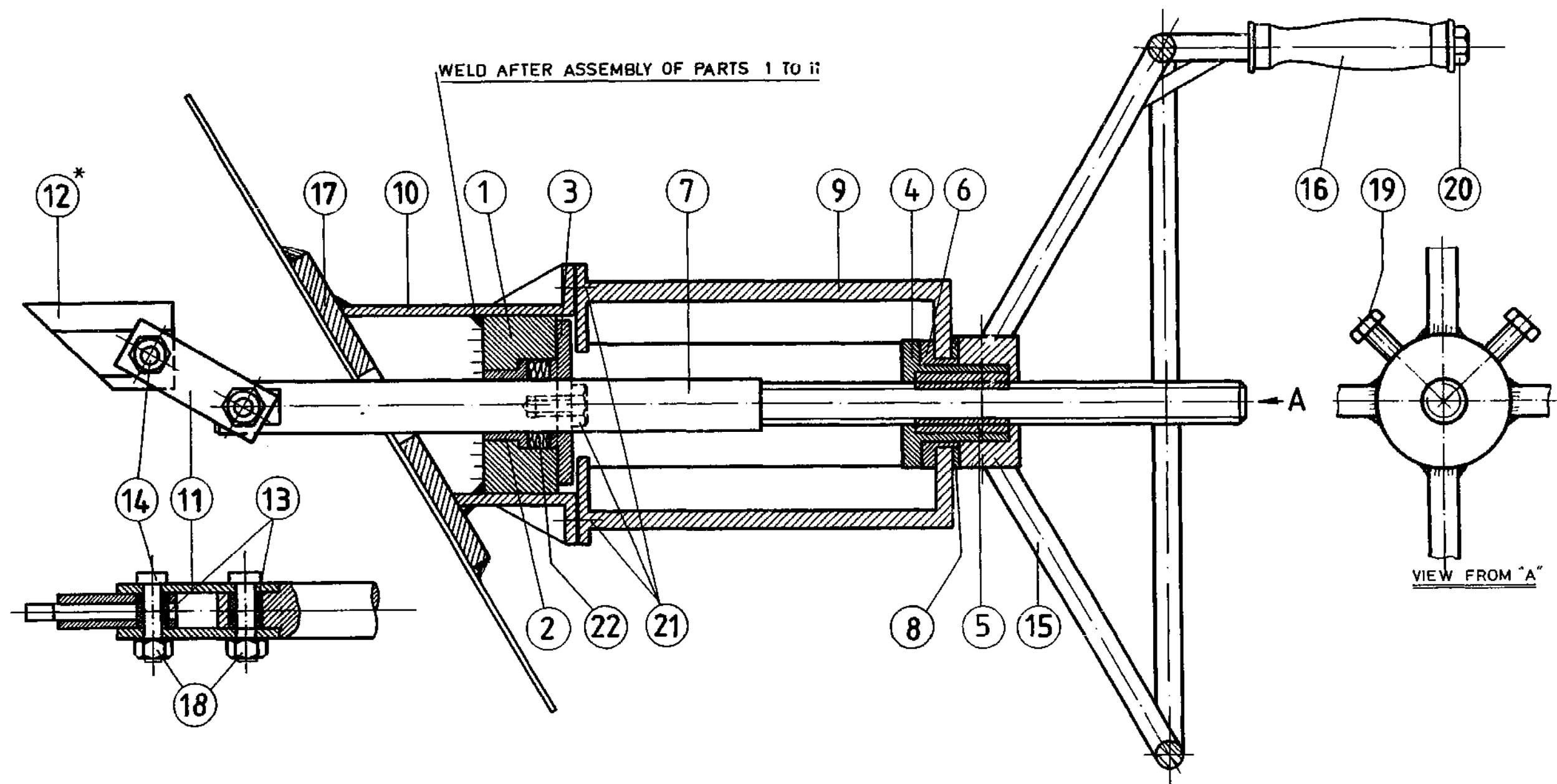

* WELD TO REGULATOR WING ASSEMBLY (T1-06.0)
 DURING ASSEMBLY IN OPEN POSITION OF GATE.
 MAKE SURE THAT FULL CLOSING OF GATE IS
 POSSIBLE BEFORE FULL WELDING.

REGULATOR MECHANISM

T1-09.0

SCALE 1:25

Revised 59.7.52

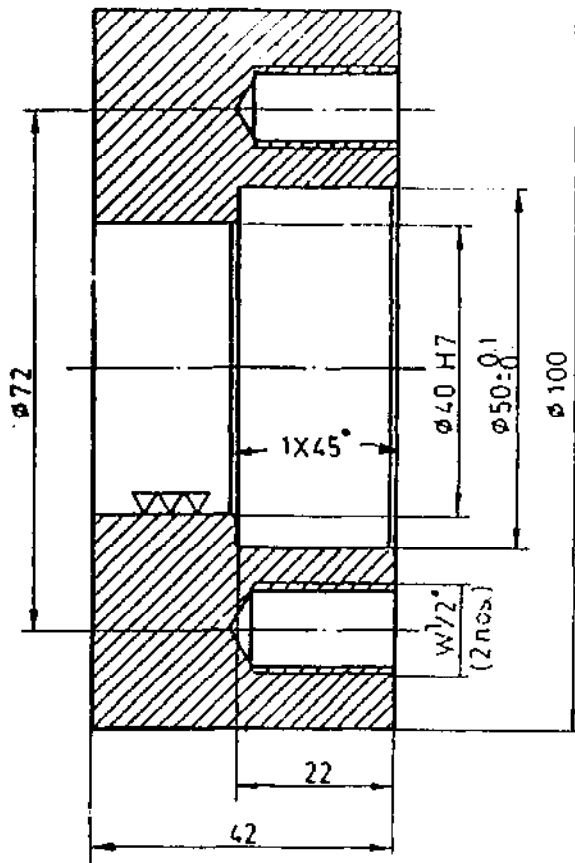

POS. - 1 M.S. ROD. 1 Pc.

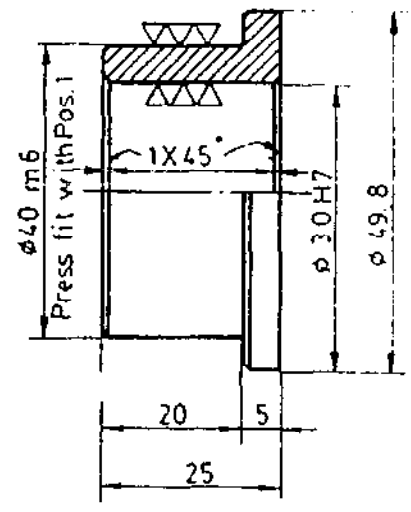

POS. - 2 BRASS ROD. 1 Pc.

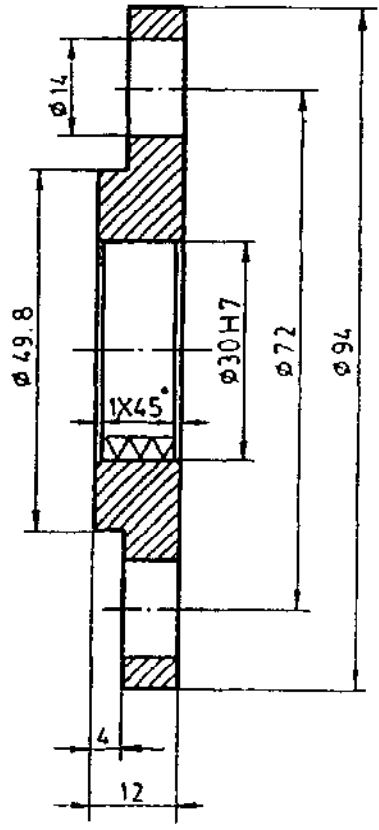

POS. - 3 M.S. ROD. 1 Pc.

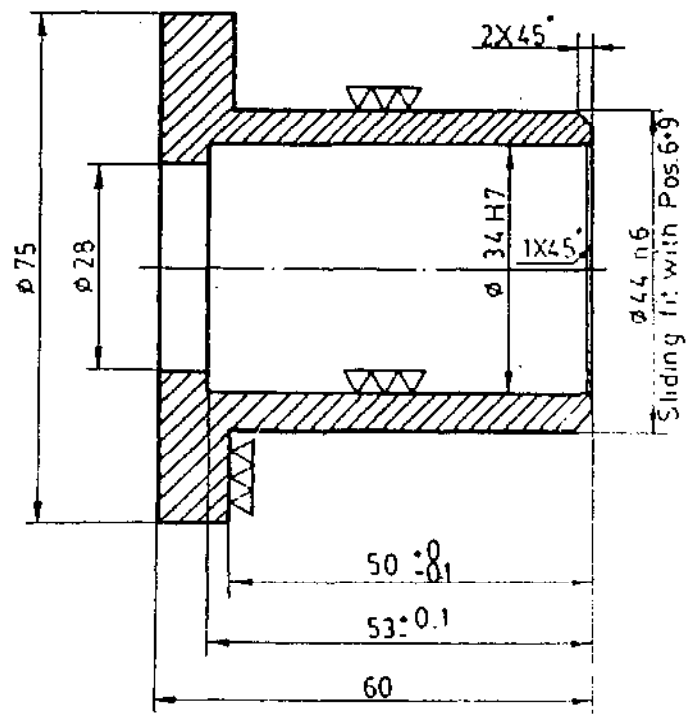

POS. - 4 M.S. ROD. 1 Pc.

Revised 29.7.81 by

REGULATOR MECHANISM PARTS

T1-09.1-4

SCALE 1:1

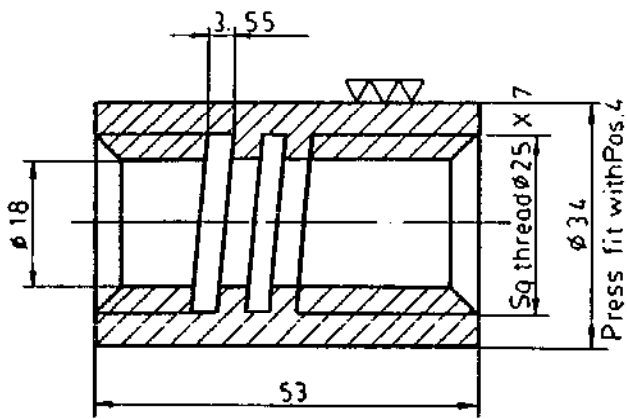

Pos. - 5 BRASS 1Pc.
 CUT THREAD AFTER ASSEMBLY
 WITH POS. 4

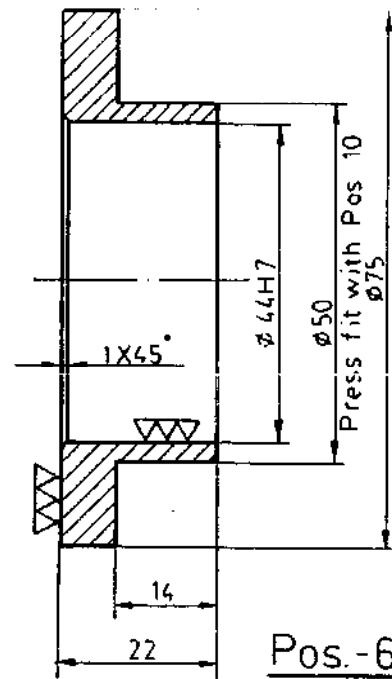

Pos. - 6
 BRASS 1Pc.

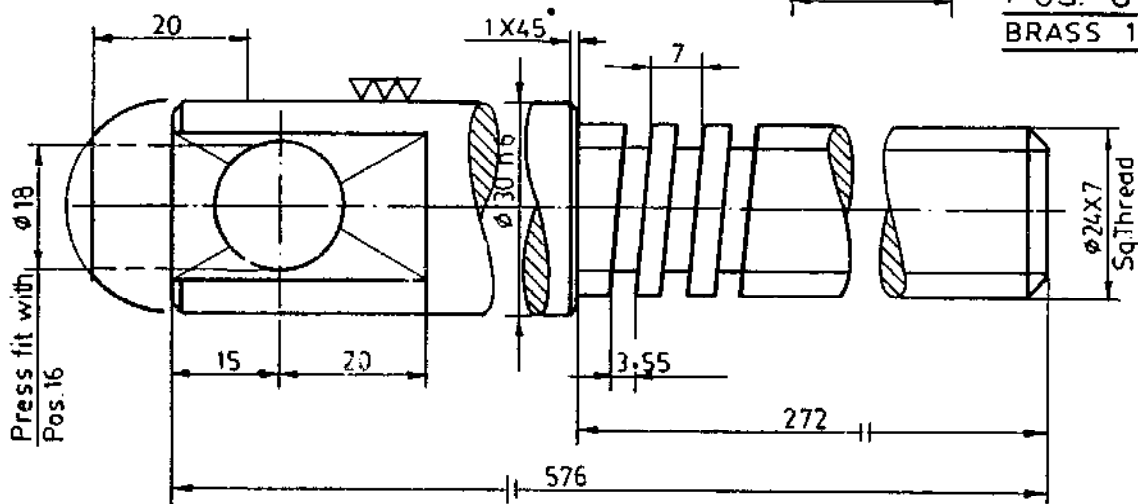

Pos - 7 M.S. ROD $\phi 1\frac{1}{2}$ 1Pc.

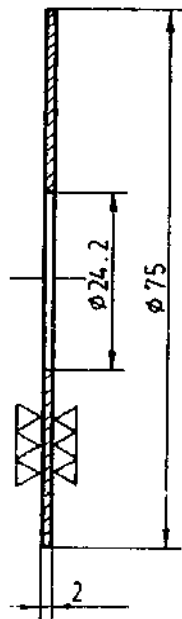

Pos - 8 BRASS 1Pc.

Revised 1977 82 def.

REGULATOR MECHANISM PARTS

T1-0.9.5-8

SCALE 1:1

POS	NO.OF ITEM	ITEM	DRAWING NUMBER	SPECIFICATION	REMARKS
1	1	BEARING PLATE	T1- 09.9	M.S.PLATE 6 MM X ϕ 75	
2	1	SUPPORT PLATE	T1- 09.9	M.S.PLATE 10 MM 100 X 140.	
3	2	ANGLE	T1-09.9	50 X50X196	
4	2	FLANGE	T1-09.9	M.S.PLATE 6MM 50 X75	

PART LIST

ANGLE FRAME

T1-09.9

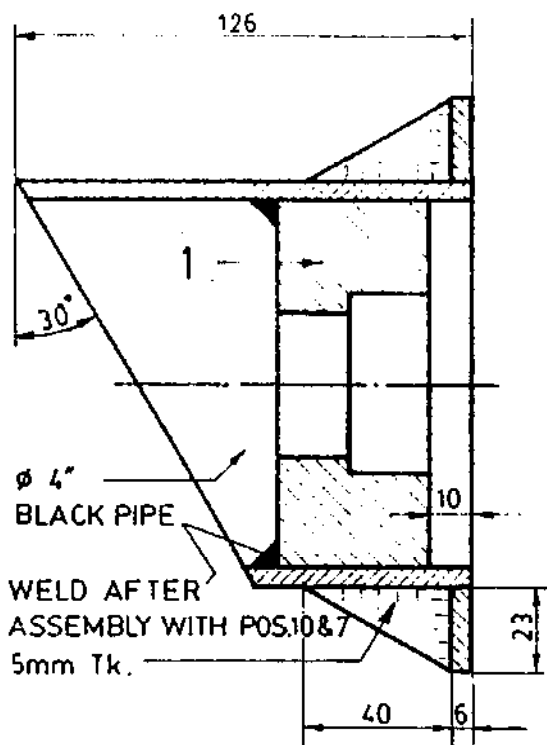
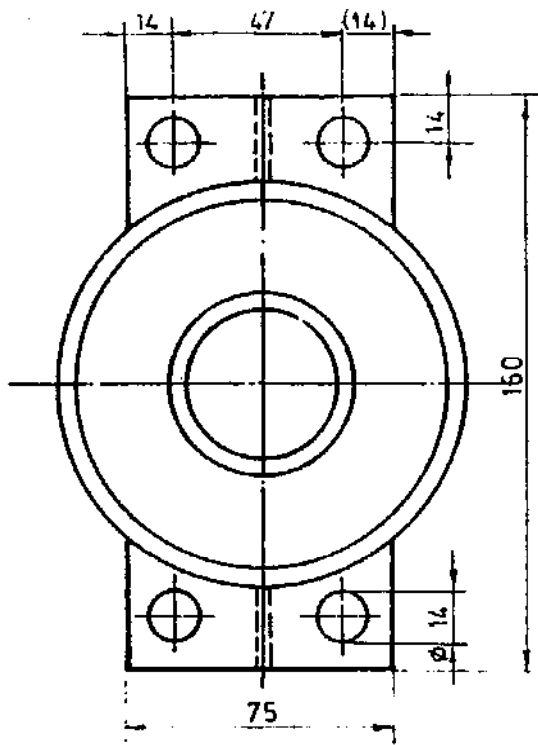

Pos -10 INO. ASSEMBLY

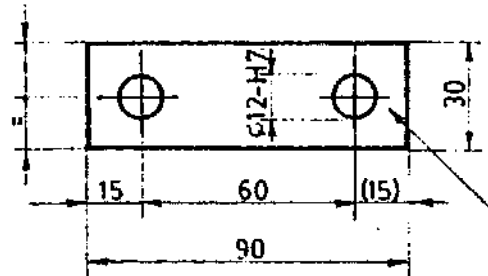

M.S. FLAT 6X30
 (DRILL BOTH PARTS TOGETHER)

Pos.11 2Pcs.

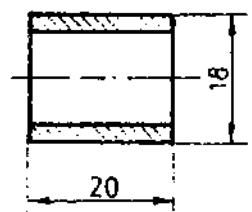
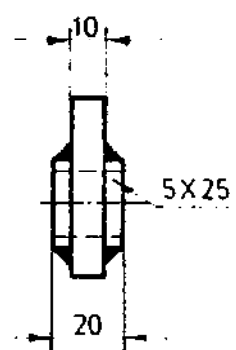
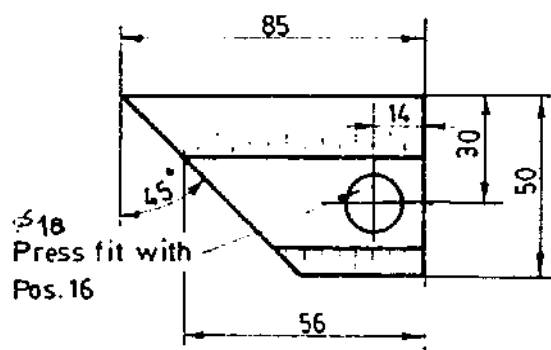

Pos. -12 1Pc.
 (1:1)

PVC PIPE ϕ 12
Pos. -13 2 Pcs.
 SCALE 1:1

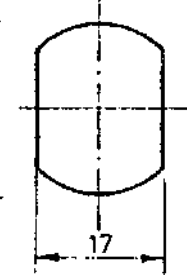
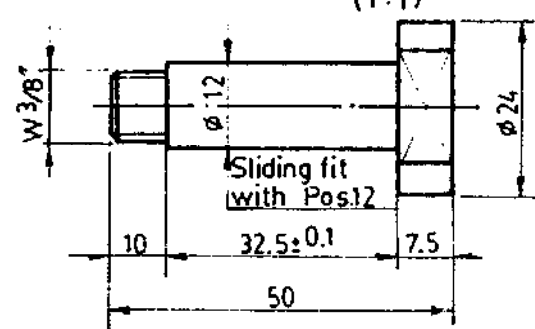

M.S. ROD ϕ 1" Pos. -14 2Pcs.

Revised 29.7.82

POS	NO.OF ITEM	ITEM	DRAWING NUMBER	SPECIFICATION	REMARK
1	1	HUB	T1-09.15	M.S.ROD ϕ 3" X 32	
2	4	SPOKE	T1-09.15	M.S.ROD ϕ 5/8" X 130	
3	1	RIM	T1-09.15	M.S.ROD ϕ 5/8" X 940	
4	1	HANDLE	T1-09.15	M.S.ROD ϕ 5/8" X 180	
5	1	RIB	T1-09.15	M.S.FLAT 6 X 12 X 62	

PART LIST

HAND WHEEL

T1-09,15

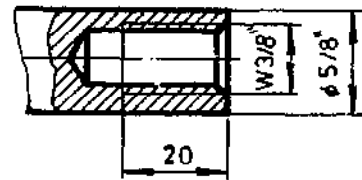
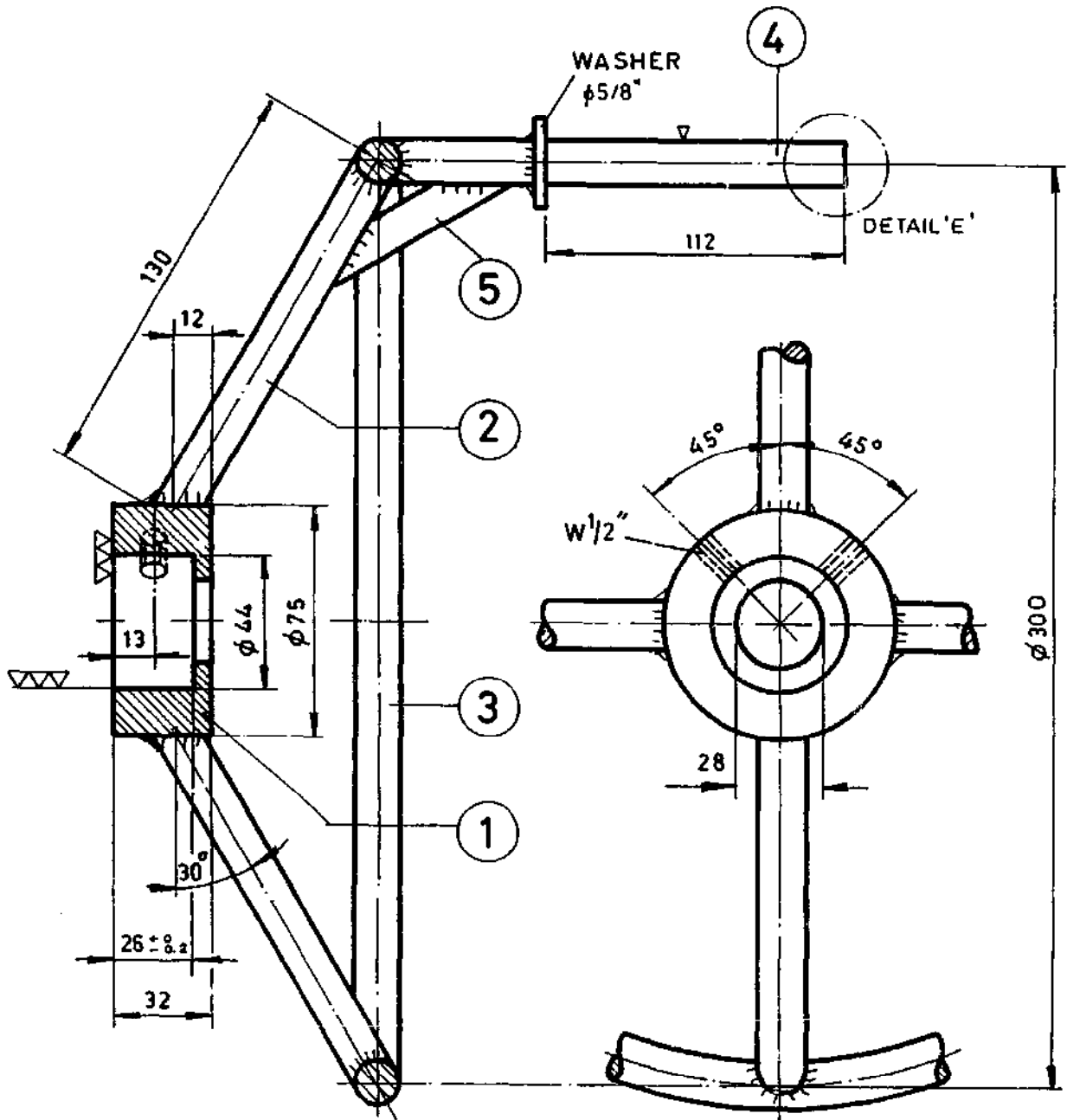

DETAIL E (1:1)

1. PC

Revised 29.7.82 dff

HAND WHEEL

1:2 (1:1)

T1-09,15

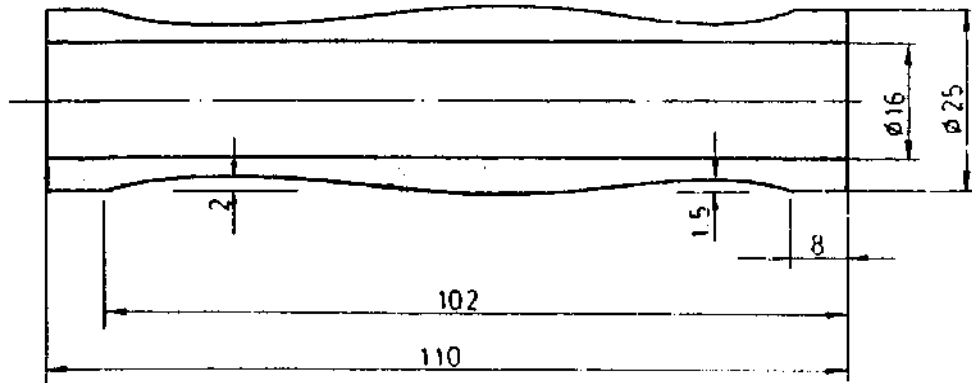

POS.16 (1:1)
SEASONED WOOD
 1. NO

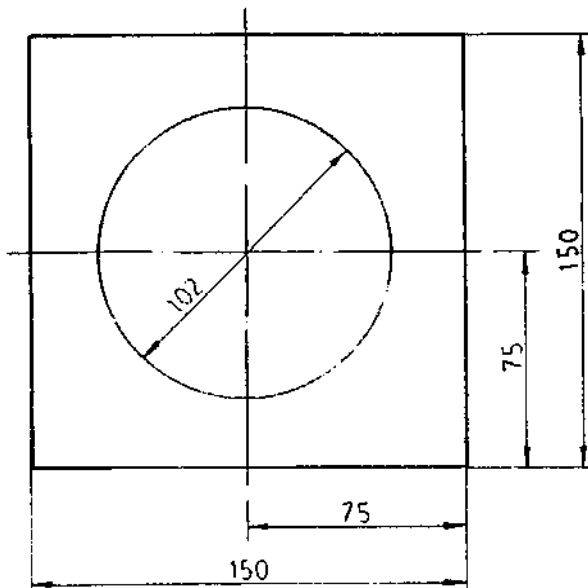

POS.17 (1:2.5)
M.S. PLATE 6 MM
 1. NO

Revised 24.7.8.02

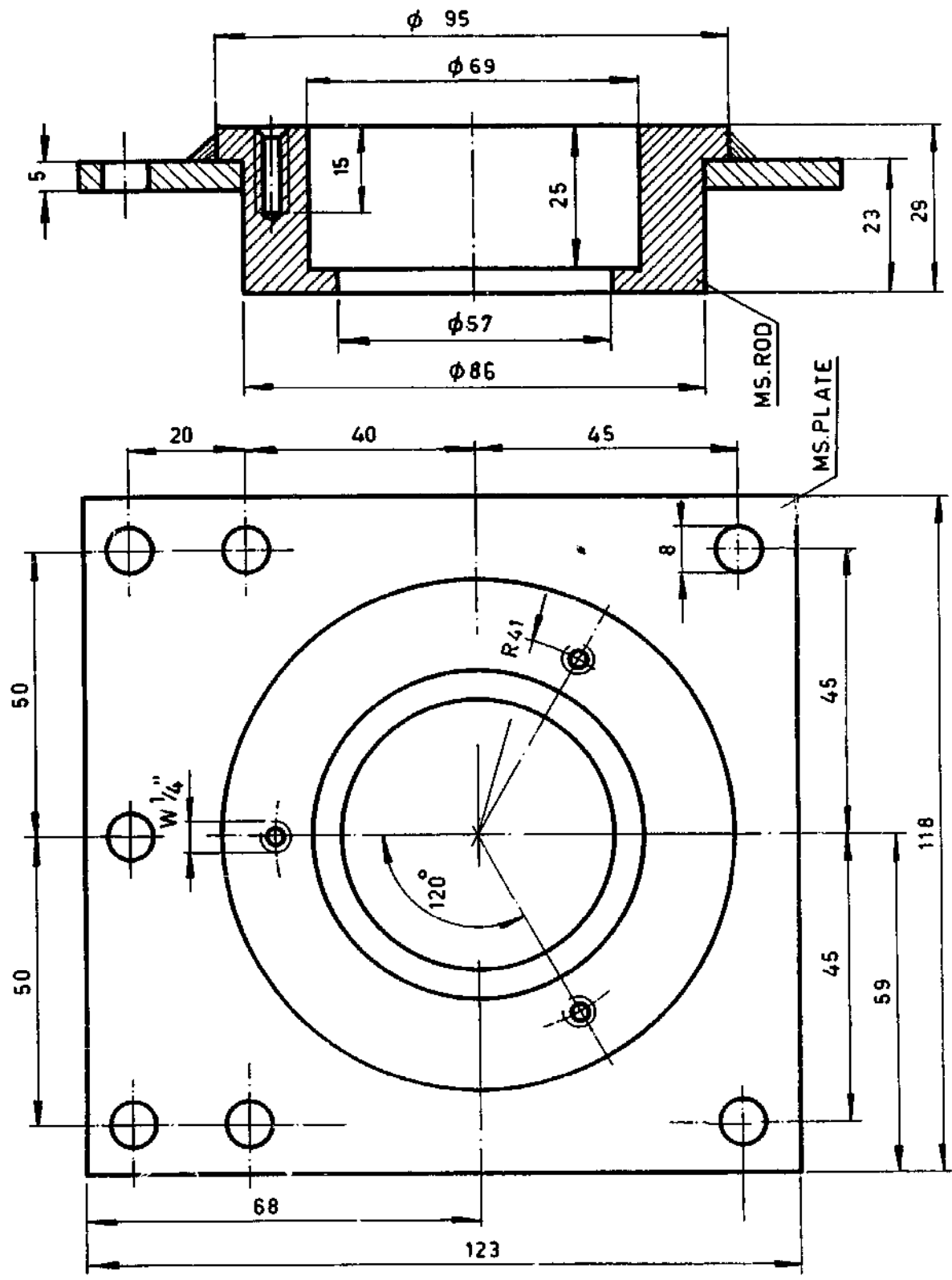

USE STUFFING BOX AS JIG TO DRILL HOLES FOR $W \frac{1}{4}$ " THREADS ON SUPPORT BASE ASSEMBLY (T1-02.0) AND SEALING PLATE 'A' (T1-12.9).

2.PCS

Revised 28.8.12.04

STUFFING BOX

T1-12.1

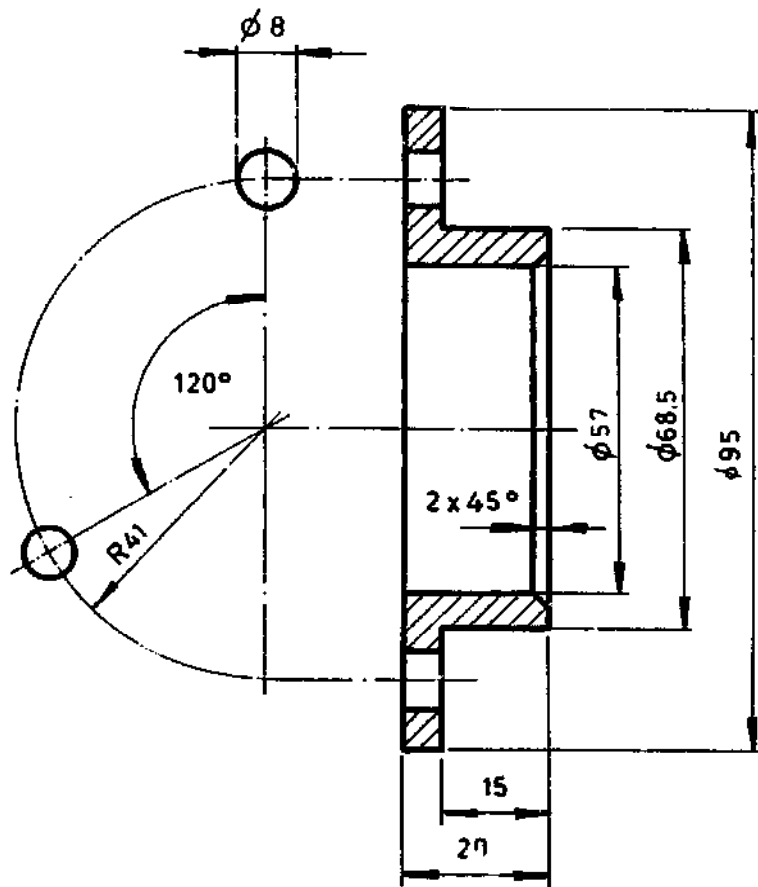

M.S.ROD

2.PCS

REVISED 20.7.82

STUFFING BOX LID

T1-12.2

1:1

USE THIS PART AS JIG TO DRILL HOLES
 FOR W 1/4" THREAD REQUIRED ON. T1-2.4, T1-03.2, T1-02.5
T1-12.9

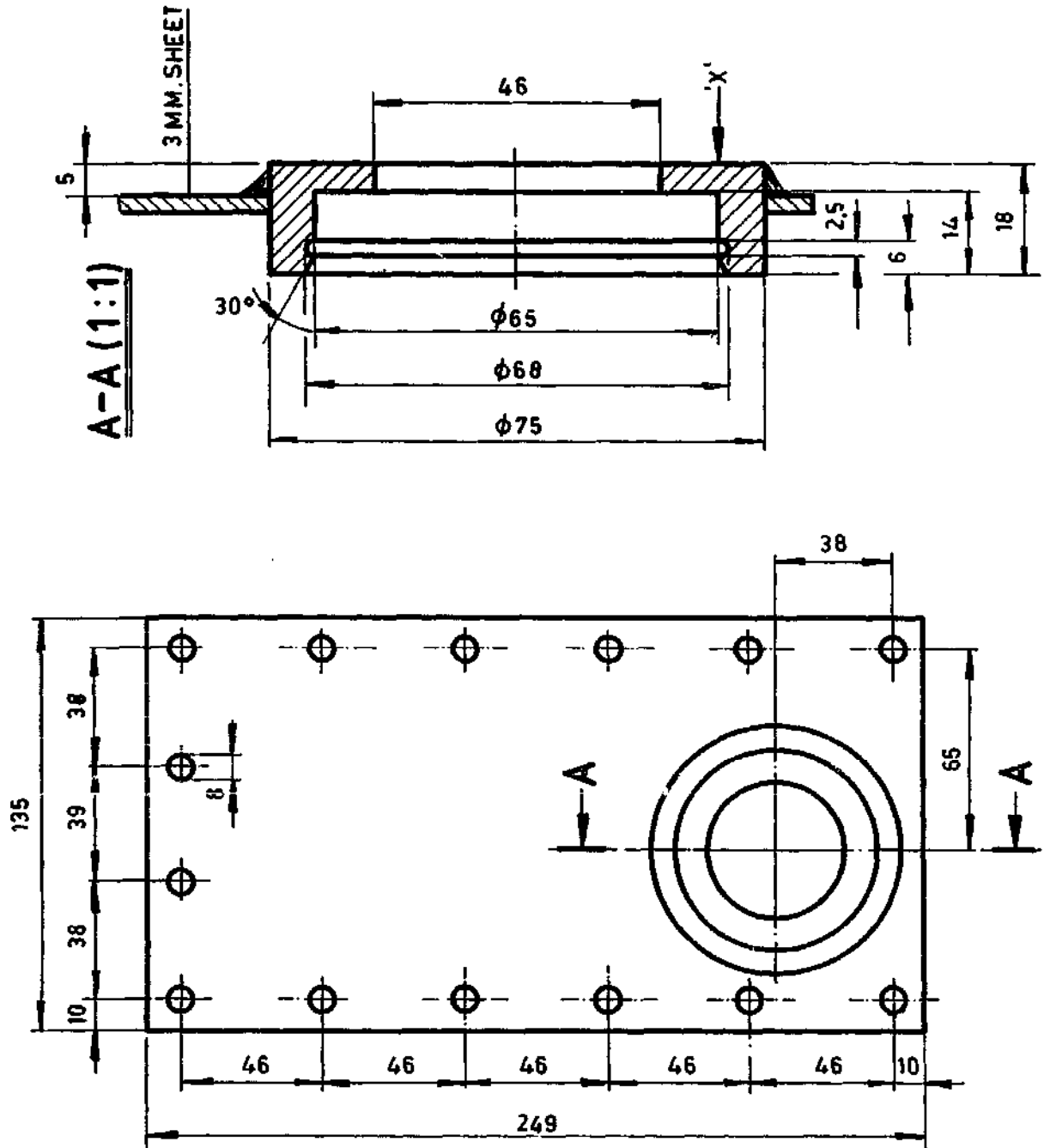

- MAKE ONE SET AS PER DRAWING.
- TURN THE FACE 'X' OF THE DISH ONLY ON THE NEXT SET AND WELD

2.PCS

Revised 20.7.02

OIL SEAL HOUSING

T1-12.4

1:2 (1:1)

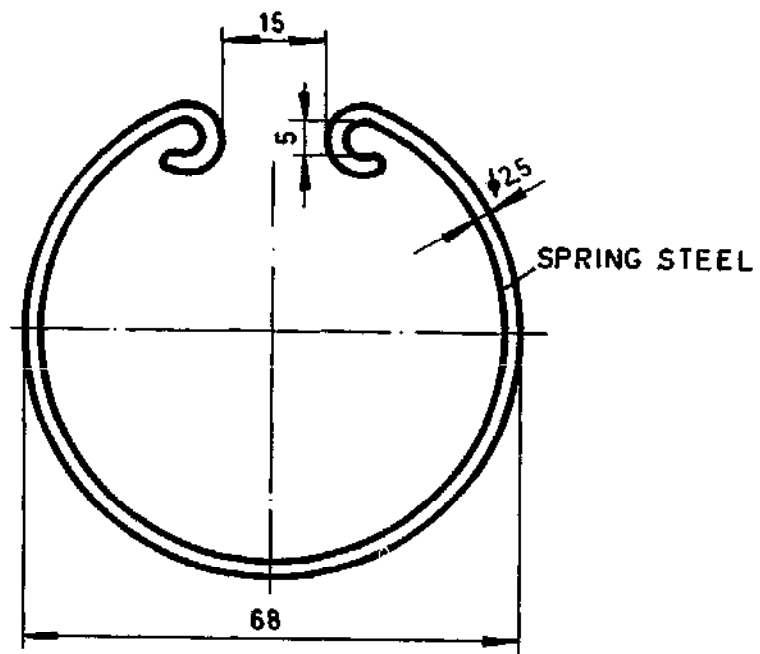

2.PC

Revised 28.7.92 JH

LOCK SPRING

1:1

T1-12,5

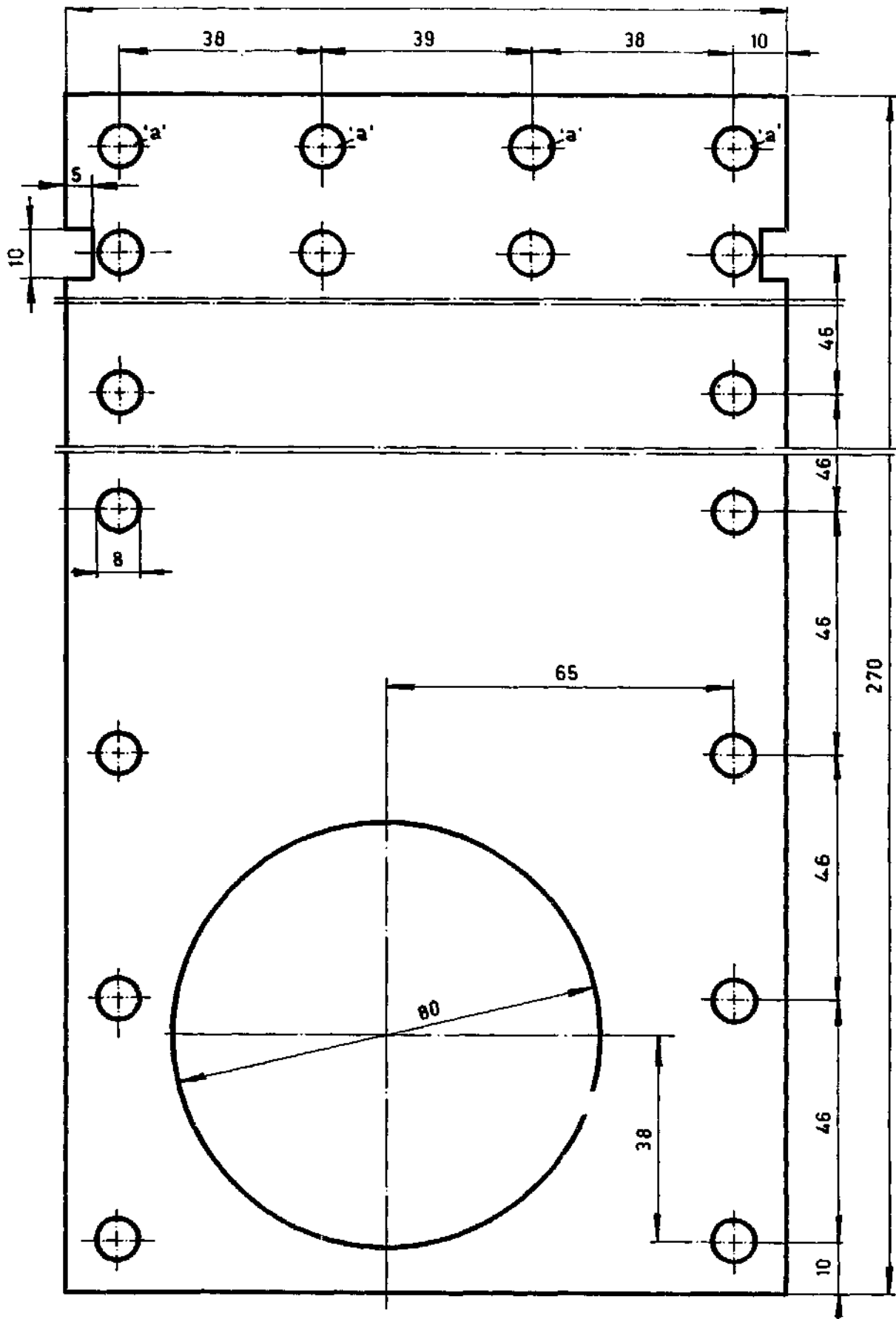

3 MM. RUBBER
2. PCS

USE COVER SHEET (T1-10,3) AS JIG TO MARK CENTRES OF THE HOLES INDICATED BY 'a'.

Revised 28.7.82 H

OIL SEAL HOUSING GASKET

T1-12.6

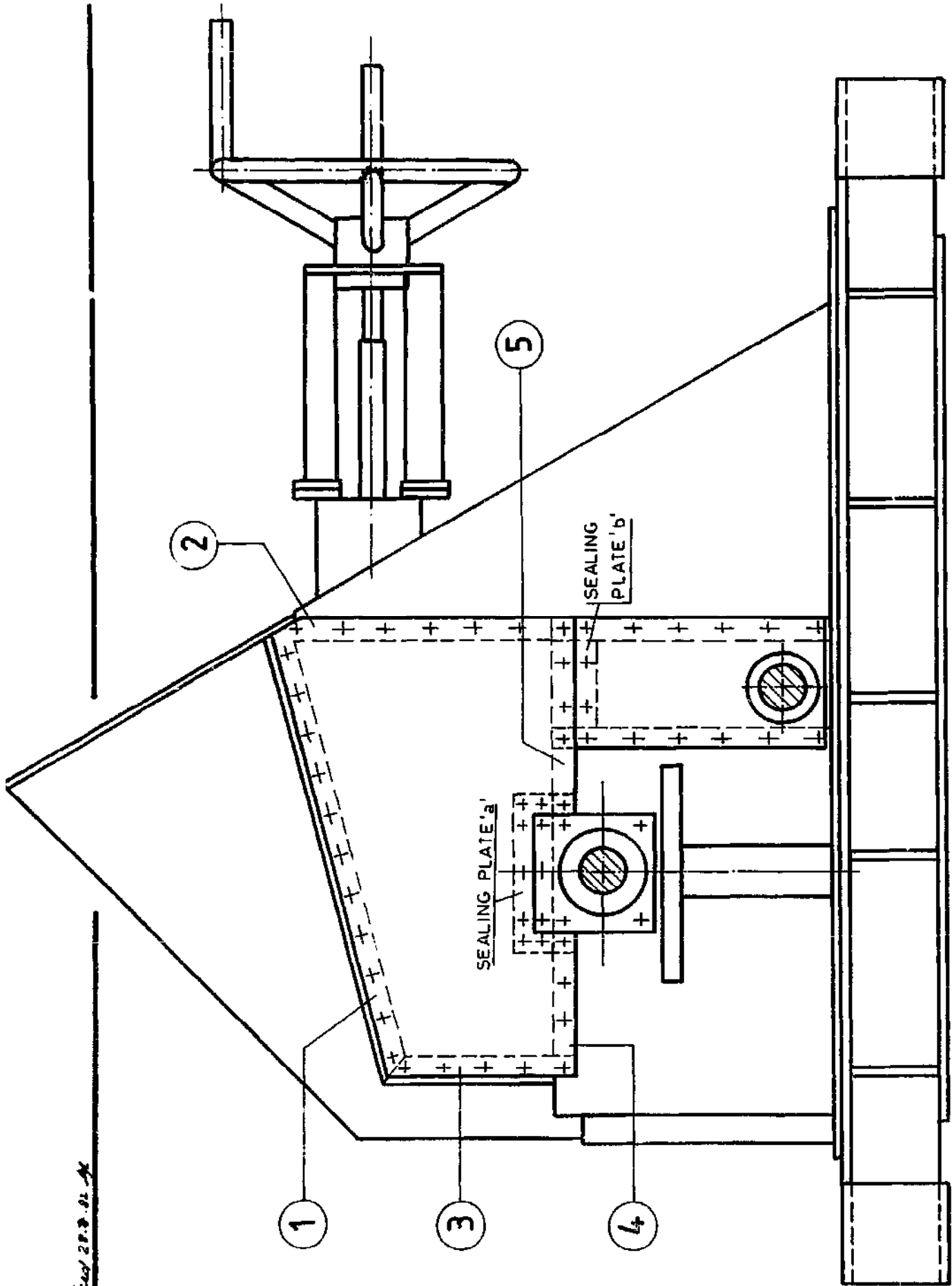

Revised 28.8.81 M

SHEET COVER GASKETS

T1-12.8

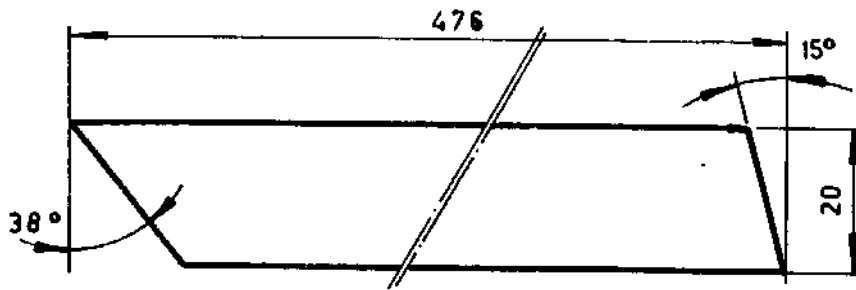

POS 1

2.PCS

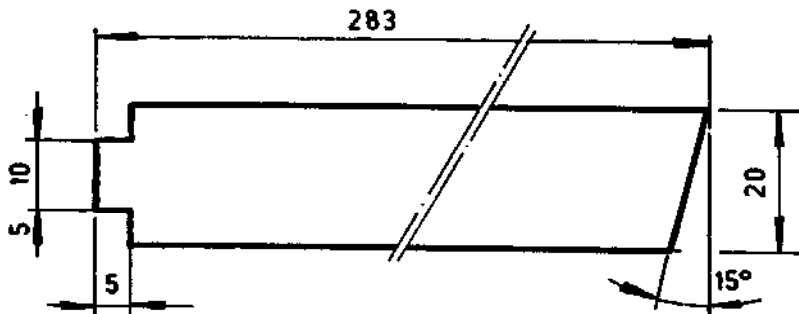

POS 2

2.PCS

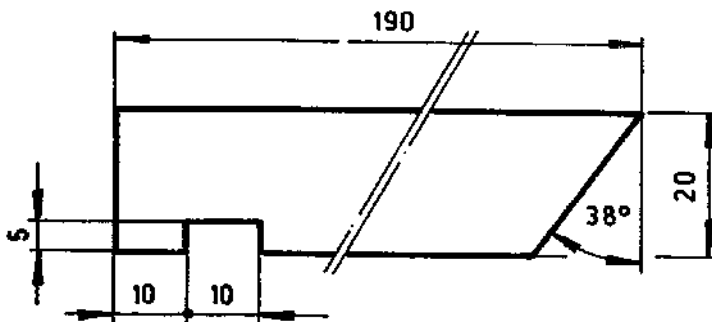

POS 3

2.PCS

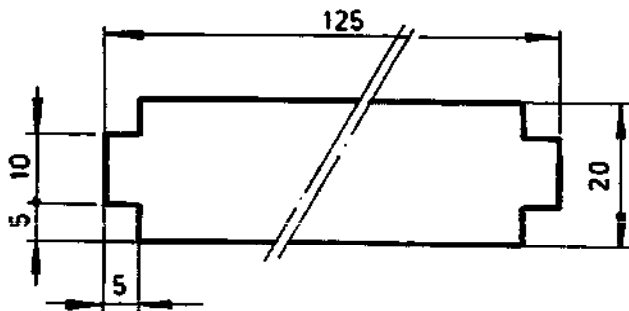

POS 4

2.PCS

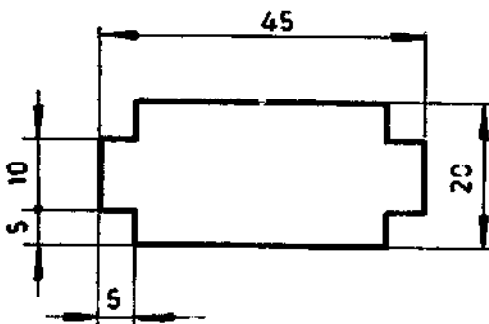

POS 5

2.PCS

USE 3MM THICK RUBBER FOR ALL POSITIONS

Revised 20.2.21

COVER SHEET GASKET

T1-12.8/1-5

1:1

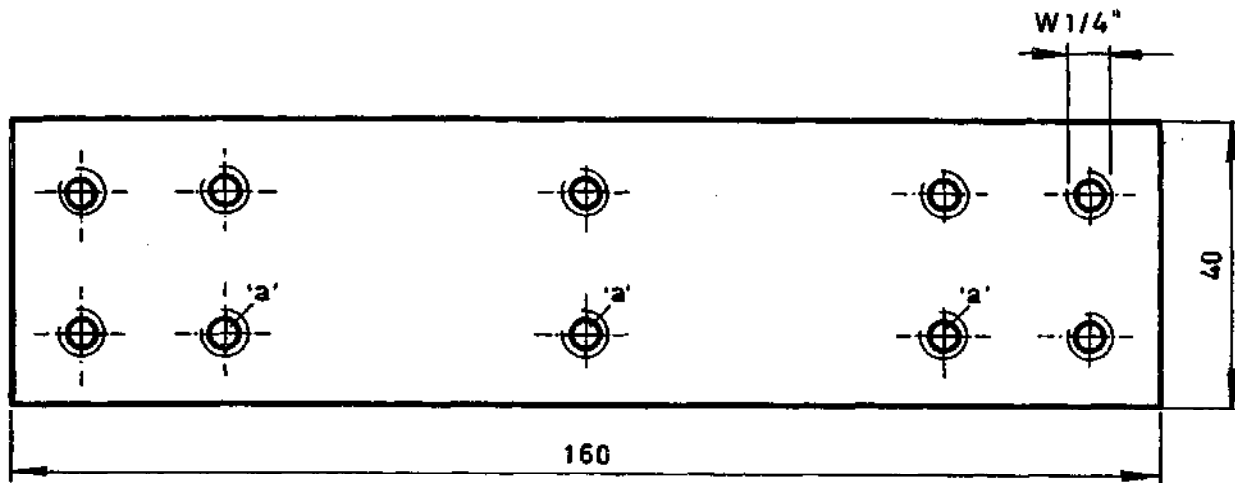

- A. USE STUFFING BOX (T1-12.1) AS JIG TO DRILL HOLES FOR THE THREADS INDICATED BY 'a'.
- B. USE COVER SHEET (T1-12.7) AS JIG TO DRILL HOLES REQUIRED FOR REST OF THE THREADS
- C. ABOVE MENTIONED OPERATIONS SHOULD BE CARRIED OUT DURING ASSEMBLY WORK.

6.MM PLATE

2.PCS

28.7.72 Revised

SEALING PLATE 'A'

T1-12-9

1:1

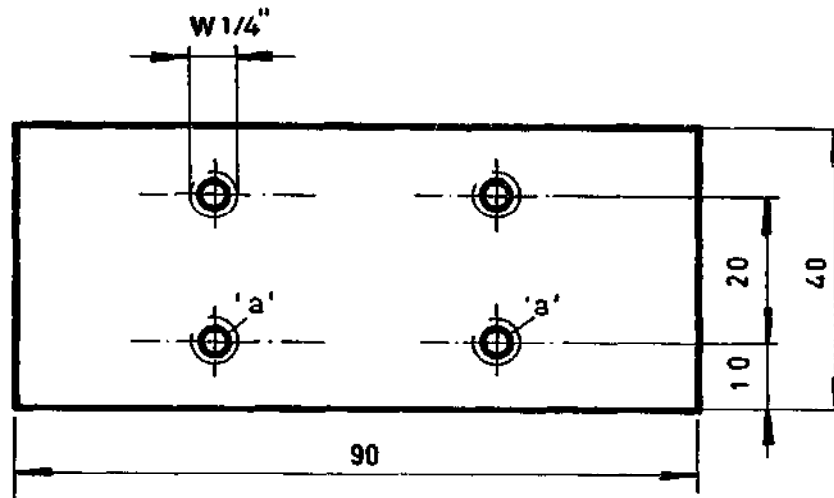

6. MM PLATE

2. PCS

- THREADS INDICATED BY 'a' SHOULD BE MADE FIRST.
USE OIL SEAL HOUSING (T1-12.4) AS JIG TO MARK HOLE CENTER FOR THREADS.
- USE COVER SHEET (T1-12.7) AS JIG TO MARK HOLE CENTERS FOR REST OF THE TREADS.

REVISED 28.7.82 AF

SEALING PLATE 'B'

T1-12.10

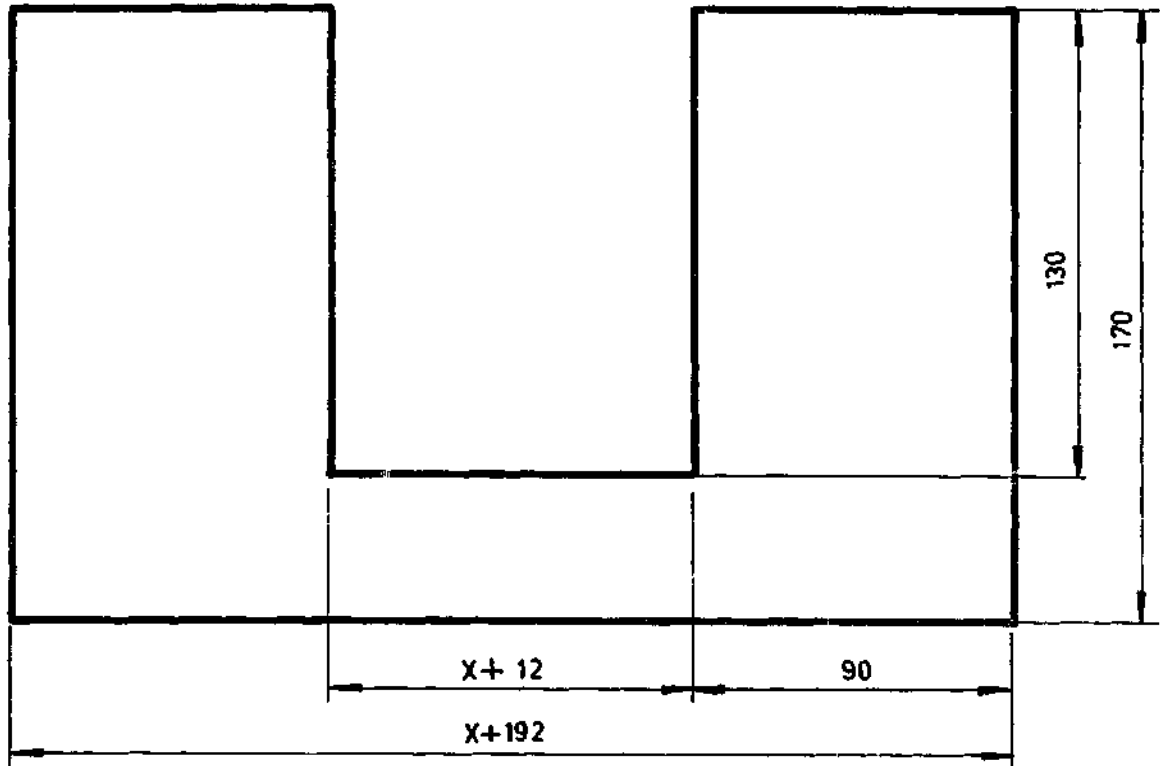

3 MM RUBBER

1.PC

PUT THIS RUBBER IN BETWEEN INLET ASSEMBLY (T1-08.0) AND SUPPORT FRONT (T1-02.20) OF SUPPORT ASSEMBLY. MARK HOLE CENTER. PUNCH HOLES.

Revised 12.7.82 AK

SEALING FLAP GASKET

T1-12.11

1:2

3.MM RUBBER

1 PC

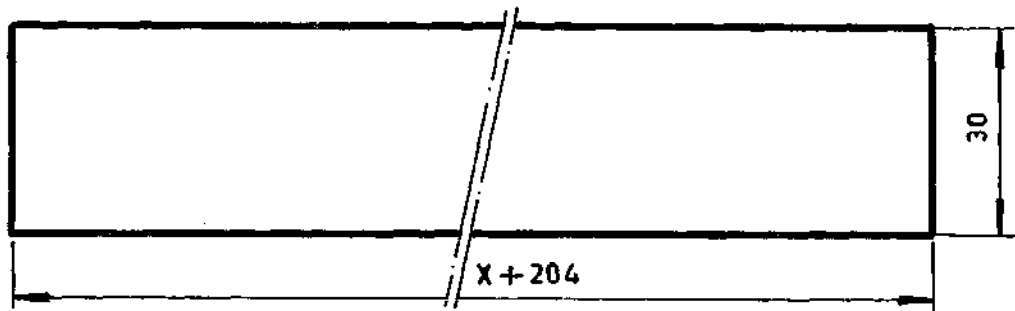

PUT THIS RUBBER INBETWEEN IN FLANGE (T1-08.5)+
SEALING STRIP (T1-08-8) AND BAFFLE HOUSING TOP (T1-03.3),
DURING ASSEMBLY WORK, MARK HOLE CENTRES. PUNCH HOLES.

Revised 10.7.2004

BAFFLE PLATE GASKET

T1-12.12

1:1

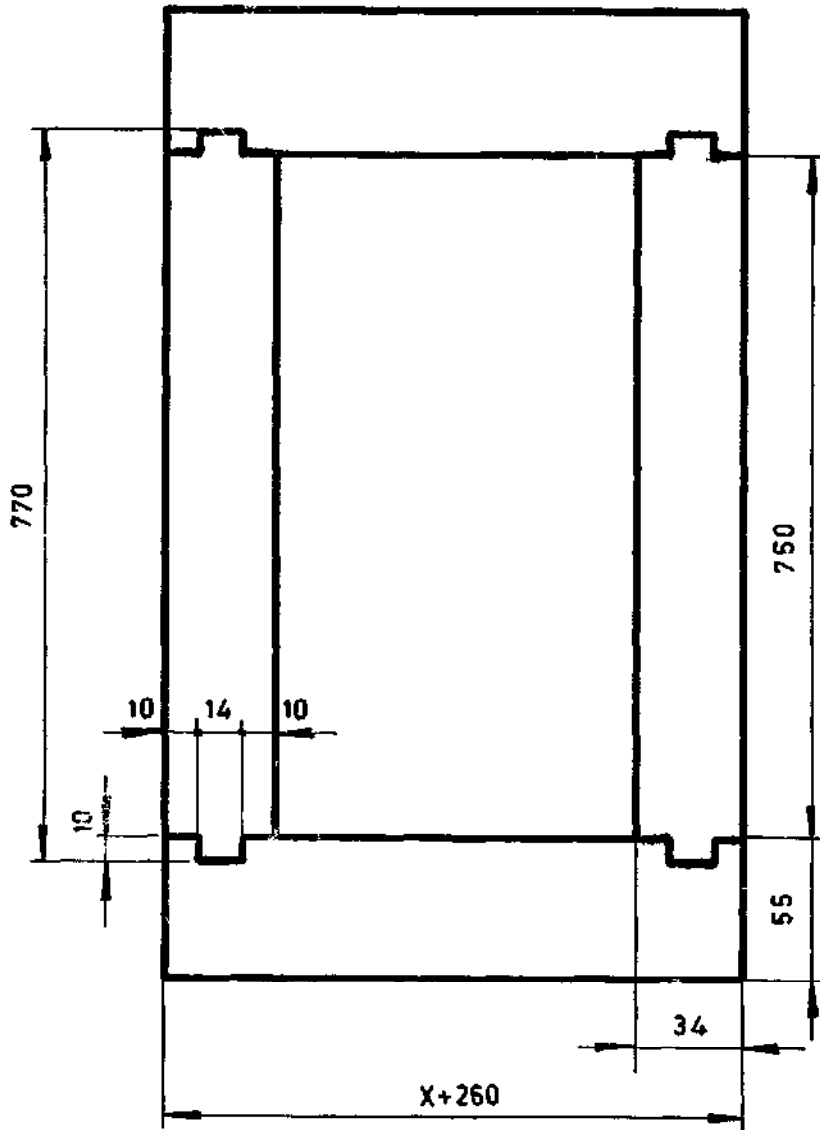

6. MM RUBBER
1 NOS

Revised 28.7.82 H

FOUNDATION FRAME GASKET

T1-12-13

HEX. HEAD BOLT

SR.NO	POS	SIZE	PCS									DRAWING NUMBER
			X70	X100	X150	X180	X200	X220	X300	X360	X400	
1	34	W 3/4" X 2"	4	4	4	4	4	4	4	4	4	T1-00.1-1
2	33	W 3/4" X 1/2"	2	2	2	2	2	2	2	2	2	T1-00.1-1
3	35	W 1/2" X 2"	4	4	4	4	4	4	4	4	4	T1-00.1-1
4	30	W 1/2" X 1 1/2"	37	39	41	41	44	44	47	47	47	T1-00.1-1
5	19	W 1/2" X 1 1/2"	2	2	2	2	2	2	2	2	2	T1-09.0
6	21	W 1/2" X 1"	6	6	6	6	6	6	6	6	6	T1-09.0
7	31	W 3/8" X 3/4"	5	5	6	6	6	7	7	8	8	T1-00.2
8	20	W 3/8" X 3/4"	1	1	1	1	1	1	1	1	1	T1-09.0
9	32	W 1/4" X 5/8"	122	122	122	122	122	122	122	122	122	T1-00.2
10	5	W 1/4" X 5/8"	8	8	8	8	8	8	8	8	8	T1-05.0
11	6	W 1/4" X 5/8"	6	6	6	6	6	6	6	6	6	T1-07.0
12	37	W 1/4" X 5/8"	4	4	4	4	4	4	4	4	4	T1-00.3

HEX. NUT

SR.NO	POS	SIZE	PCS									DRAWING NUMBER
			X70	X100	X150	X180	X200	X220	X300	X360	X400	
1	34	W 3/4"	4	4	4	4	4	4	4	4	4	T1-00.1
2	33	W 3/4"	2	2	2	2	2	2	2	2	2	T1-00.1
3	35	W 1/2"	4	4	4	4	4	4	4	4	4	T1-00.1
4	30	W 1/2"	37	39	41	41	44	44	47	47	47	T1-00.1
5	21	W 1/2"	4	4	4	4	4	4	4	4	4	T1-09.0
6	31	W 3/8"	5	5	6	6	6	7	7	8	8	T1-00.2/T1-08.0
7	18	W 3/8"	2	2	2	2	2	2	2	2	2	T1-09.0
8	37	W 1/4"	4	4	4	4	4	4	4	4	4	T1-00.3
HEX. NUT/BOLT W 1/2" X 1 1/2"*			24	24	24	26	26	26	28	28	28	

* REQUIRED ONLY IF DRAFT TUBE IS USED.

PART LIST

FASTENERS

T1-13.0

Revised 12.1.82

POS	NO OF ITEMS	ITEM	DRAWING NO.	SPECIFICATIONS	REMARKS
1	1	ADAPTER	T1-14.1		
2	1	SQUARE FLANGE	T1-14.2		
3	1	PIPE FLANGE	T1-14.3		

Revised 28.7.81 M.

▲
CONSISTING OF

ADAPTER ASSEMBLY

PARTS LIST

T1-14.0

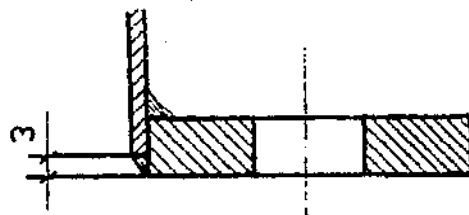
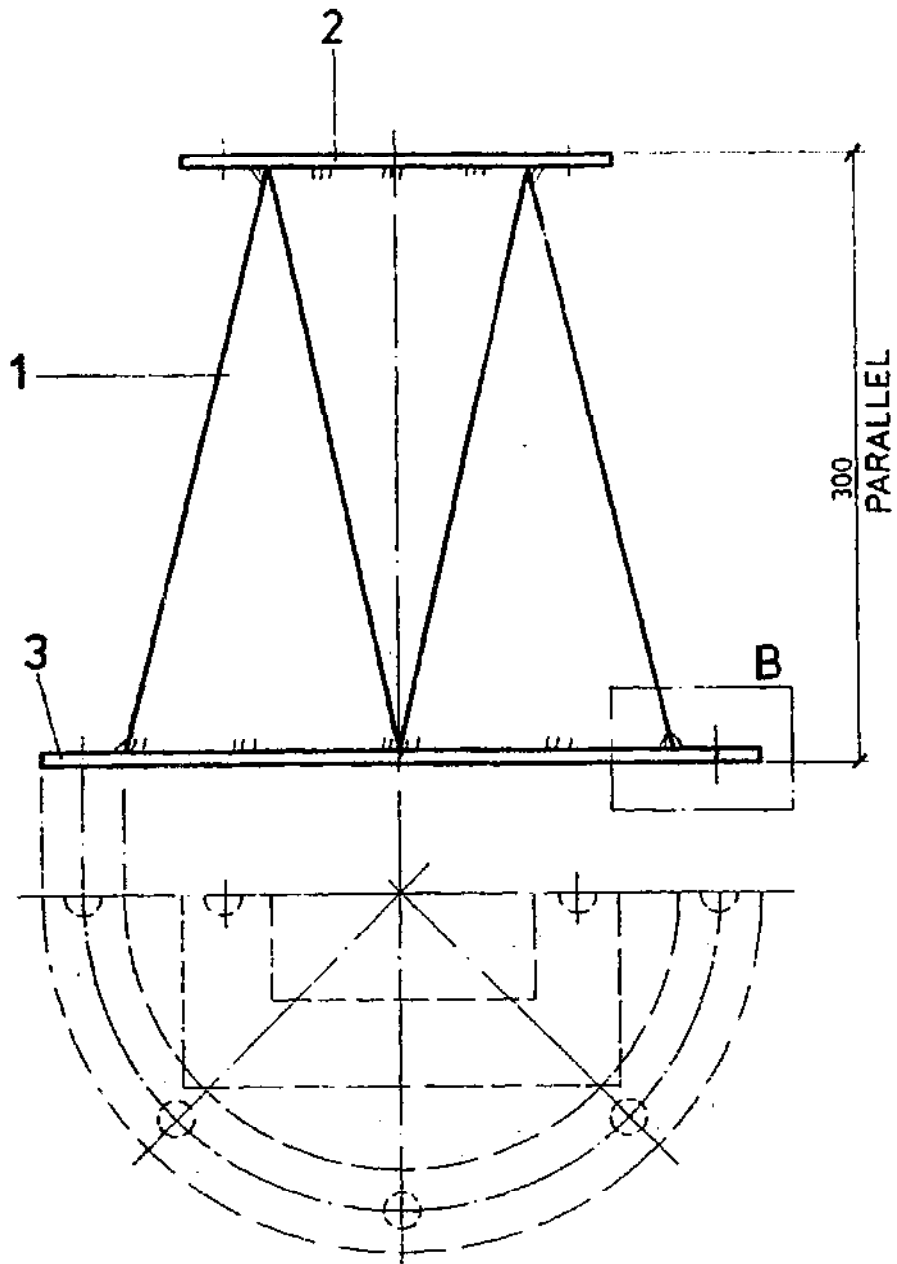

DETAIL 'B'

Revised 88792 H

ADAPTER

T1-14.0

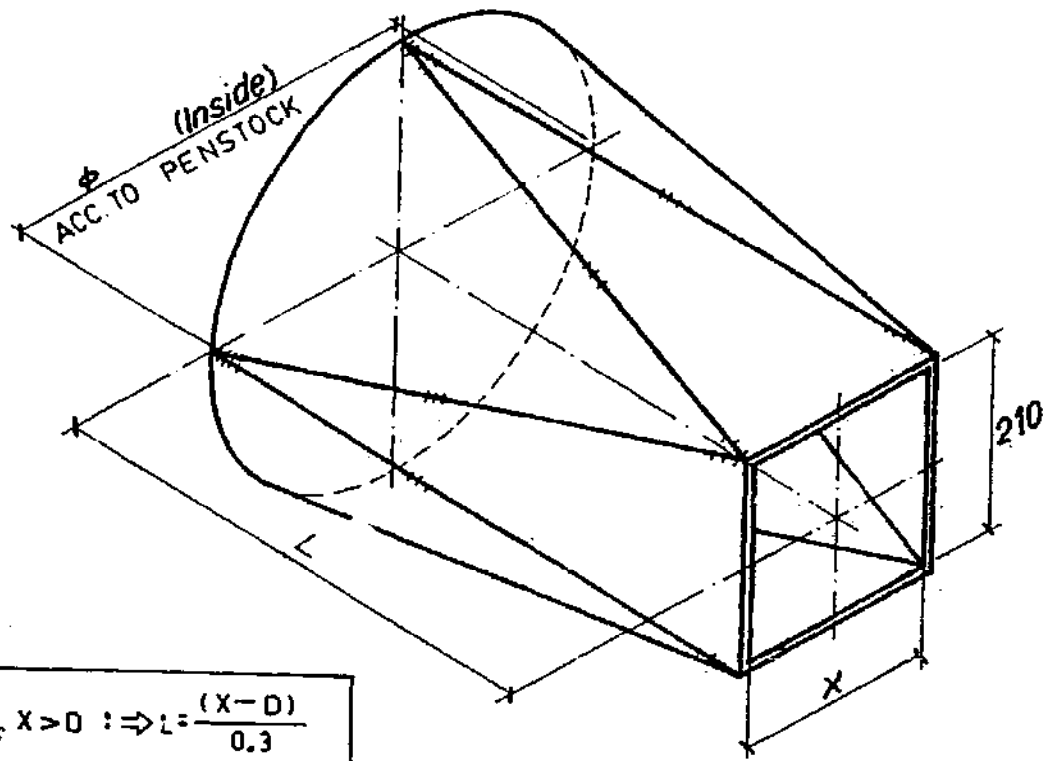

$$\begin{aligned}
 x > D & \Rightarrow L = \frac{(x - D)}{0.3} \\
 x \leq D & \Rightarrow L = 300 \text{ mm}
 \end{aligned}$$

M.S SHEET 2.5 mm

1.Pc

Revised 28.7.84

ADAPTER

T1-14.1

MS FLAT 10 X 40

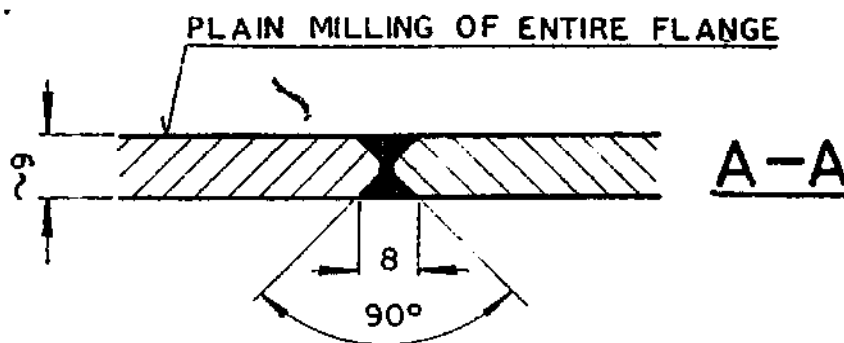
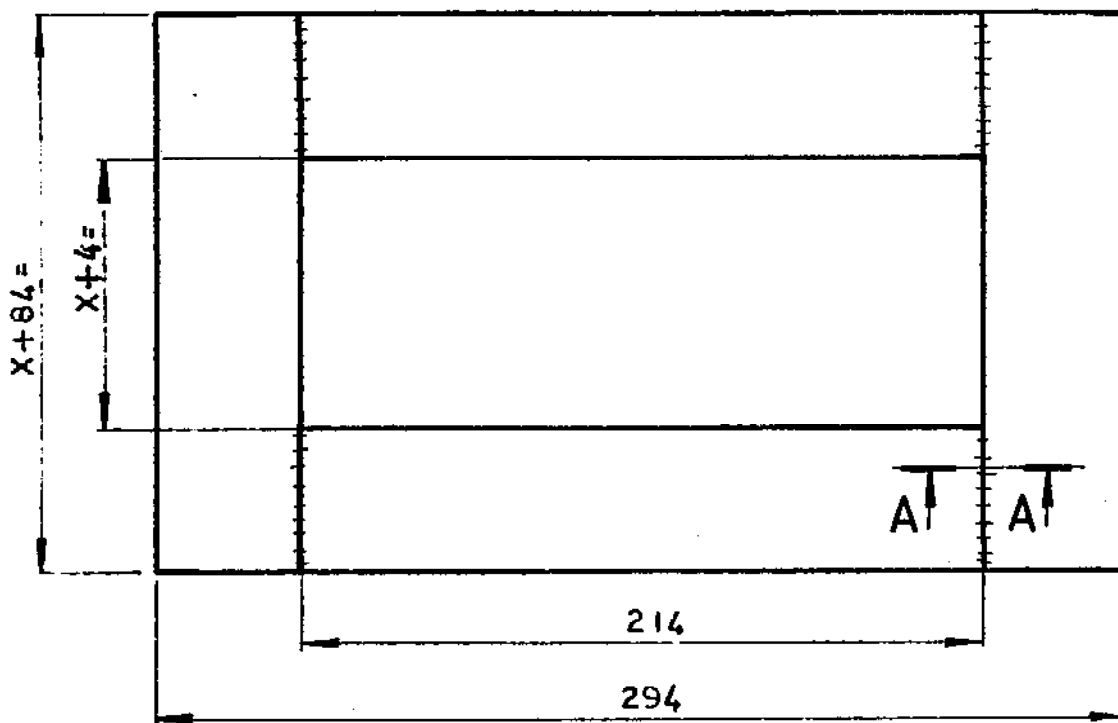

FOR DRILLING HOLES REFER TO T1-14.2/1 - 2/4

Revised 20.7.21 by

ADAPTER SQUARE FLANGE

T1-14.2

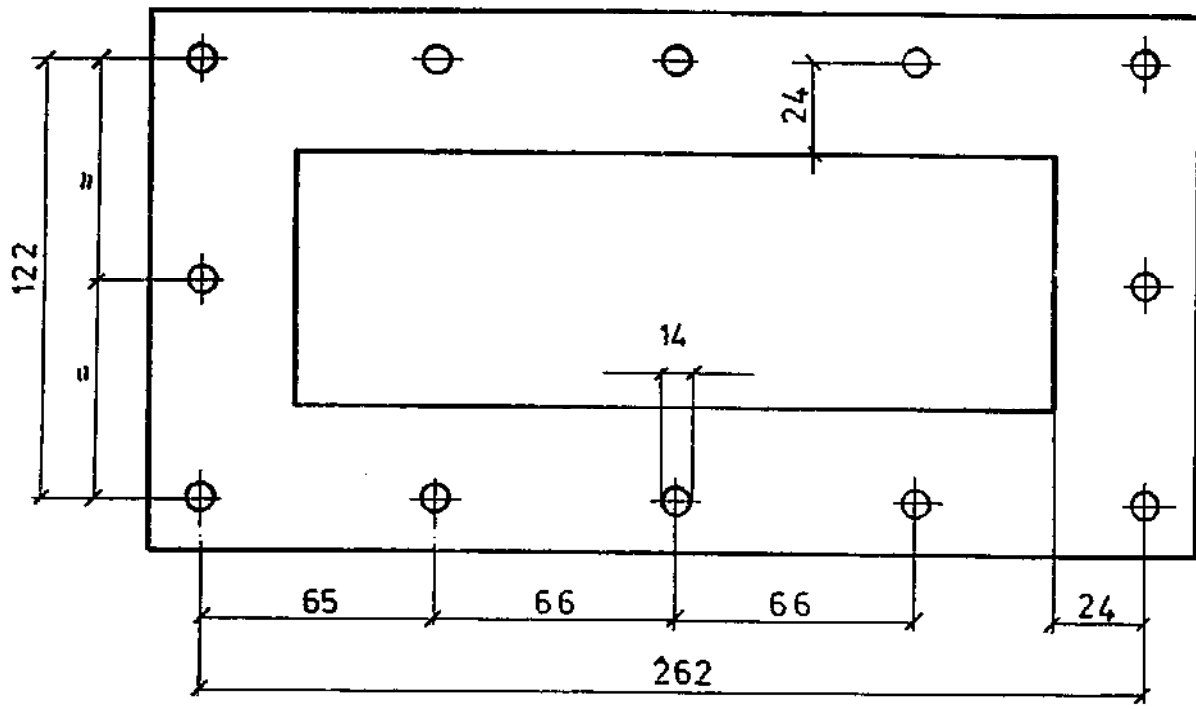

REVISED 28.7.11.04X

ADAPTER FLANGE (X70)

T1-14.2/1

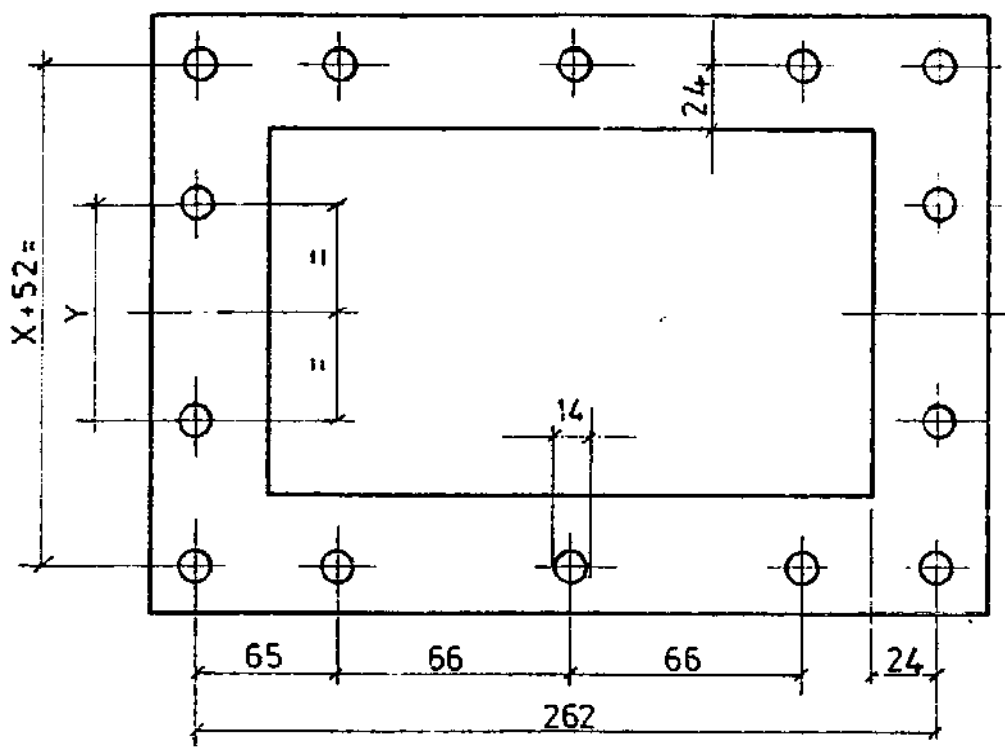

	X 100	X 150	X 180
Y	50	68	80

Leaving 207.914

ADAPTER FLANGE (X100, X150, X180)

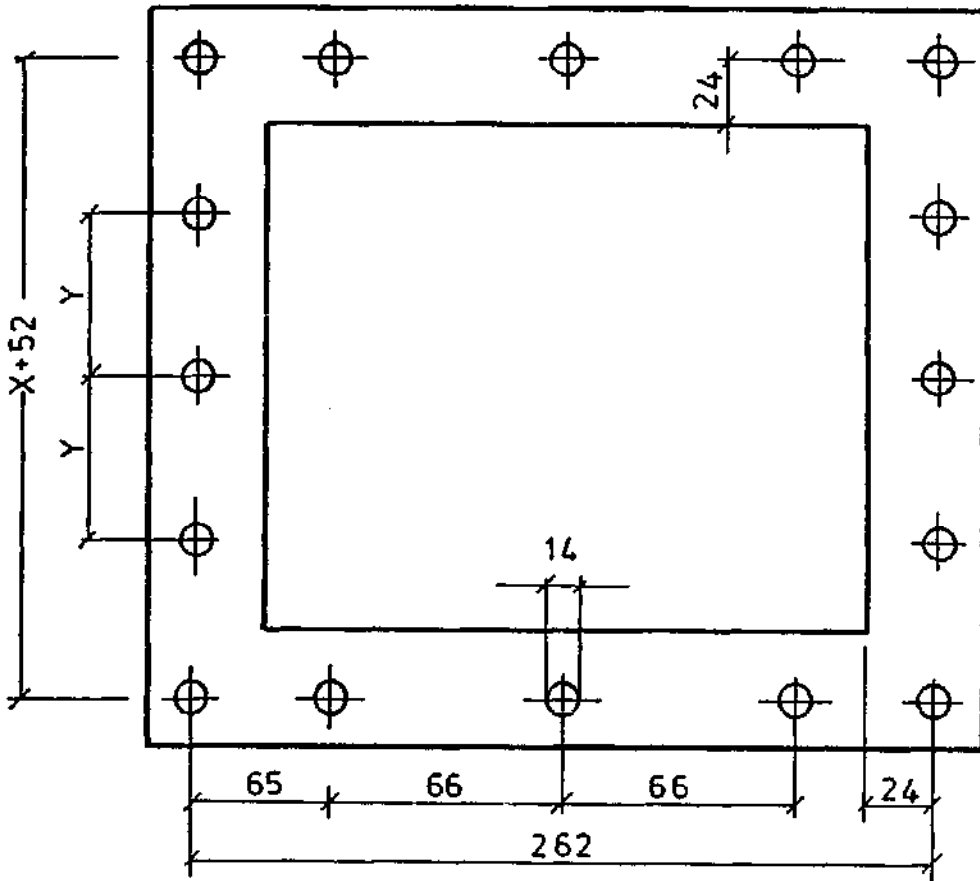

	X 200	X 220
Y	63	68

Revised 28.7.81. *af*

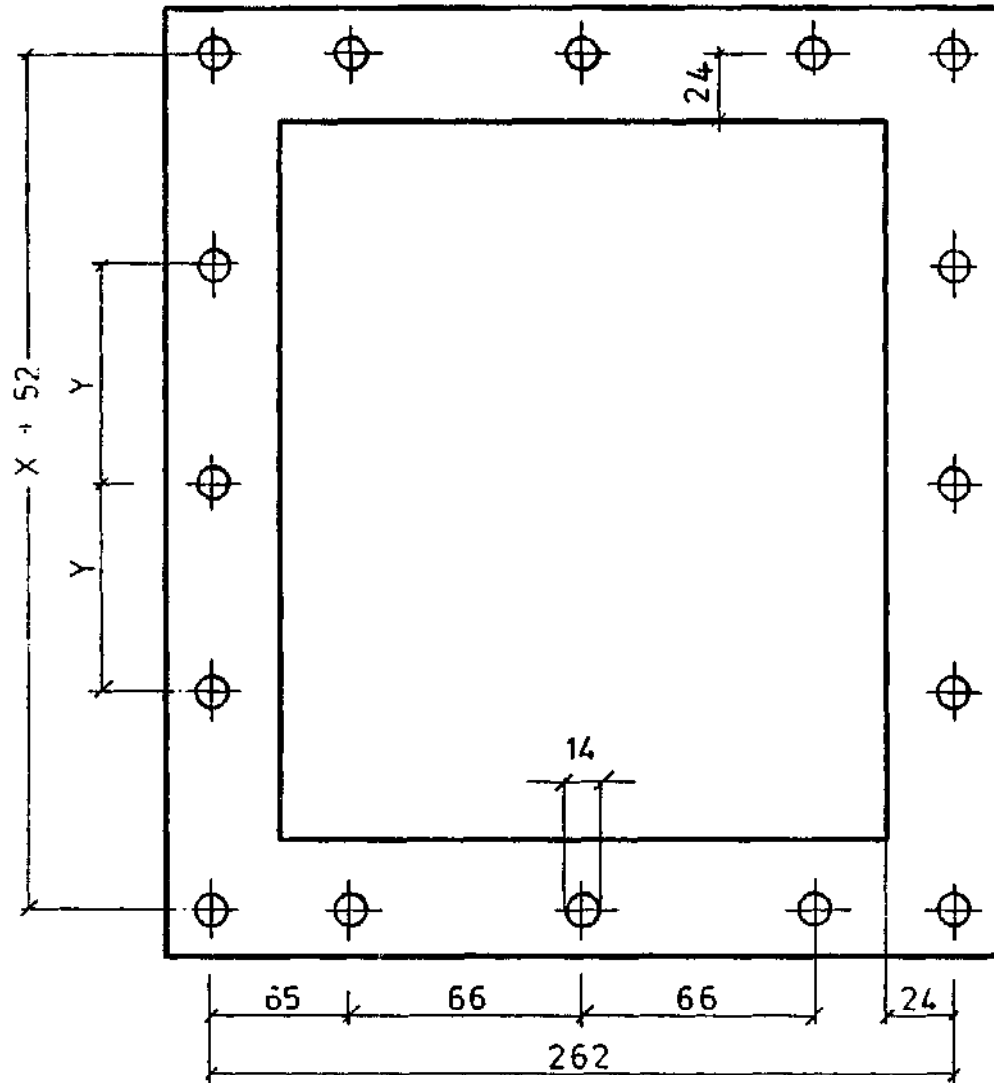

	X 300	X 360	X 400
Y	88	103	113

Revised 2/17/81

ADAPTER FLANGE (X300, X360, X400)

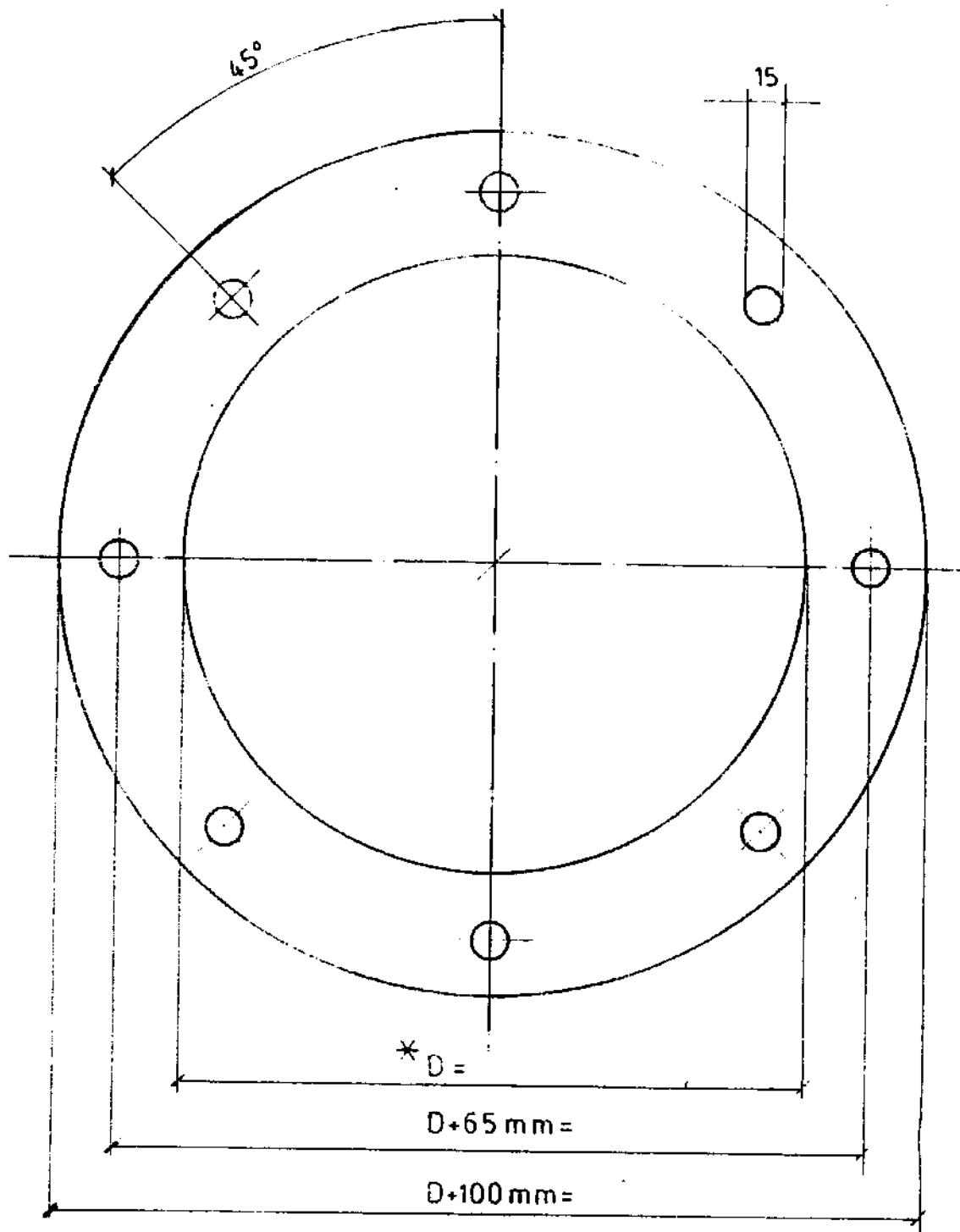

USE 8 MM PLATE

NOS

* ACCORDING TO PENSTOCK USED.

Revised 25.7.81 dfl.

PIPE FLANGE

T1-14.3