

AT MICROFICHE
REFERENCE
LIBRARY
A project of Volunteers in Asia

Micro Pelton Turbines
MHPG Series Volume 9
By: Markus Eisenring

Published by: SKAT, Swiss Center for Appropriate Technology
Tigerbergstrasse 2
CH-9000 St. Gallen, Switzerland

Available from: SKAT, Swiss Center for Appropriate Technology
Tigerbergstrasse 2
CH-9000 St. Gallen, Switzerland

Reproduced with permission.

Reproduction of this microfiche document in any form is subject to the same restrictions as those of the original document.

**MHPG Series
Harnessing Water Power on a Small Scale**

Volume 9

Micro Pelton Turbines

Markus Eisenring



Micro Pelton Turbines

**Volume 1: Local Experience with
Micro-Hydro Technology**

Volume 2: Hydraulics Engineering Manual

**Volume 3: Cross Flow Turbine Design and
Equipment Engineering**

Volume 4: Cross Flow Turbine Fabrication

Volume 5: Village Electrification

Volume 6: The Heat Generator

Volume 7: MHP Information Package

Volume 8: Governor Product Information

Volume 9: Micro Pelton Turbines

First edition: 1991 by
SKAT, Swiss Center for Appropriate Technology

Author: Markus Eisenring, Niederuzwil, Switzerland

Published by: SKAT, Swiss Center for Appropriate Technology,
St.Gallen, Switzerland
and
GATE, German Appropriate Technology Exchange,
Eschborn, Germany

Layout: Werner Fuchs, SKAT

Cover: F. Hartmann, ASG, St. Gallen, Switzerland

Copyright: GATE and SKAT within MHPG

Comments: Please send any comments concerning this publication to:
SKAT
Tigerbergstrasse 2
CH-9000 St. Gallen, Switzerland

Printed by: Niedermann AG, St.Gallen, Switzerland

ISBN: 3-908001-34-X



MHPG, the Mini Hydro Power Group is an international network constituted by GTZ-GATE, Germany, FAKT, Germany, IT, U.K., PPL, Germany, Projekt-Consult, Germany, and SKAT, Switzerland.

The MHPG is one of the most expert and experienced group concerned with hydro work. It can give advice in the field of both small and large projects. The member organisations have a long term experience in fruitful collaboration in the field of micro and mini-hydro projects.

Further information is available at SKAT or one of the other members of the group.

Preface

This publication has its origin in a workshop on "Micro hydropower energy", organized by GATE, which was held in Eschborn, Germany. The aim of the workshop was to discuss relevant experience in planning and implementation of very small hydropower plants in developing countries, to determine problems and deficits in the technical and socioeconomic fields and to discuss matters on direct utilization of mechanical power. One of the deficits stated at this workshop concerned micro Pelton turbine installations.

The author was commissioned by GTZ/GATE for the writing of this manual on the layout, design, manufacture and installation of very small, locally built Pelton turbine plants. It is part of a program on micro hydropower.

This publication is directed to those who intend to design, dimension, build, install and to run Pelton turbines. It provides all the necessary theoretical background, designs and hints on manufacturing and on procedures of installation. The technical information provided is an aid for the successful installation of Pelton turbines, while at some time, shortening the way for beginners. Thus unnecessary delay and expenses can be avoided.

It is with purpose that no descriptions are given of very simple designs, but achievement of the highest standards of Pelton turbine manufacturing is not aimed at either. It provides an average of such information on what can be reproduced in many developing countries.

Niederuzwil, September 1991

Markus Eisenring

Acknowledgment

This publication was made possible by Mr. Klaus Rudolphi of GATE and was financed by GTZ/GATE, in the project "Kleinstwasserkraft". It is part of this project, which has been implemented by the company Project-Consult. Wolf Boje and Michael Priester, from this company, attended to this project.

Many valuable hints came from my fellow colleagues on various occasions, such as the coordination meetings on the project. I am also grateful to Andy Brown and Rod Edwards of ITDG, Rugby, England, who are active in the promotion of Pelton turbines and who contributed many good ideas and hints from their practical work. Many thanks also to Roland Hugentobler of the company HUGAL, for the designing work and the permission to take photos in their workshop, to Arthur Wellinger of the Agricultural Research Centre of Tänikon, Switzerland, for the permission to use the examples of application of Pelton turbines in appendix 8, to Matthias Viertler for the contribution of comments, as well as to Rob Schönberg and Alex Arter for proof reading.

Units

In this publication only units of the international system of units (SI-units) are used. Conversions of the other important units are given below.

Basic units:

physical quantity	designation	symbol
length	meter	m
mass	kilogram	kg
time	second	s
temperature	Kelvin	K

Derived units:

force	Newton	$N = \text{kgms}^{-2}$
energy	Joule	$J = \text{Nm} = \text{Ws}$
power	Watt	$W = \text{Js}^{-1}$
pressure	Pascal	$\text{Pa} = \text{Nm}^{-2}$
discharge	cubic meter/second	m^3s^{-1}
velocity	meter/second	ms^{-1}
acceleration	meter/square second	ms^{-2}

Conversions:

1 m	=	1000 mm
1 inch	=	0.0254 m
1 foot (ft)	=	0.3048 m
1 m	=	3.281 ft
1 foot per second (ft/sec)	=	0.3048 ms^{-1}
1 square foot (sq.ft. or ft^2)	=	0.0929 m^2
1 m^2	=	10.764 ft^2
1 pound-mass (lb)	=	0.4536 kg
1 kg	=	2.205 lb
1 pound weight (lbf)	=	4.45 N
1 bar	=	10^5 Pa or Nm^{-2}
pressure of 1 m water column (WC)	=	0.0981 bar
(10 m WC)	=	1 bar
1 pound/square inch (psi)	=	6.8948103 Nm^{-2}
1 pound/square inch (psi)	=	0.7031 m WC
1 m water column (WC)	=	1.4222 lbf/sq.in (psi)
1 kW	=	1000 W
1 hp (UK)	=	745.70 W
1 m^3s^{-1}	=	1000 lt/s
1 cubic foot per second (cf/s)	=	0.0283 m^3s^{-1}
1 m^3s^{-1}	=	35.315 cf/s or ft^3/s
1.55 Fr (or SFr) (1991)	=	1 US\$

Nomenclature

a	width of bucket opening	[m]
b	bucket width	[m]
c_1	absolute velocity of water jet	[ms^{-1}]
d	optimal jet diameter	[m]
D	pitch circle diameter (PCD)	[m]
D_u	runner outside diameter	[m]
F	force	[N]
g	gravitational constant = 9.81	[ms^{-2}]
h	bucket height	[m]
H_u	net head	[m]
k_c	nozzle coefficient ($k_c = 0.96...0.98$)	[-]
k_u	coefficient ($k_u = 0.45...0.49$)	[-]
n	rotational speed (RPM)	[min^{-1}]
P	power output	[kW]
Q	water discharge	[m^3s^{-1}]
t	bucket depth	[m]
u_1	optimal peripheral velocity (at the PCD)	[ms^{-1}]
z	approximate number of buckets	[-]
η	efficiency	[-]
ψ_D	jet contraction coefficient	[-]

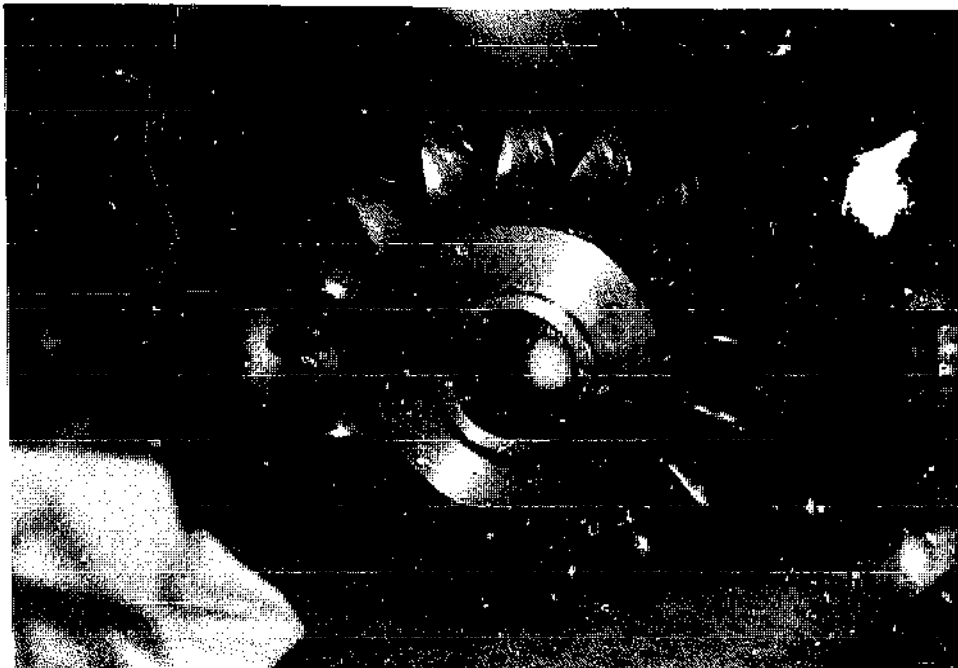

Photograph 1.: Pelton turbine runner

***Micro Pelton Turbines* is a manual on the layout, design, manufacture and installation of very small, locally built Pelton turbine plants.**

This publication is directed to those who intend to design, dimension, build, install and to run small Pelton turbines. It provides all the necessary theoretical background, designs and hints on manufacturing and on procedures of installation. The technical information provided is an aid for the successful installation of micro Pelton turbines.

ISBN 33-908001-34-X

Contents

Preface

Acknowledgment

Units

Nomenclature

1.	Introduction	1
1. 1.	Classification of the Turbines	1
1. 2.	Introduction to Pelton Turbines	2
1. 3.	Range of Application for Micro Pelton Turbines	3
2.	Dimensioning of Pelton Turbines	5
2. 1.	Theory	5
2. 2.	Turbine Layout	6
2. 3.	Efficiency	7
2. 4.	Speed and Pitch Circle Diameter	8
3.	Components and Design Principles	9
3. 1.	Intake	9
3. 2.	Forebay	10
3. 3.	Penstock	10
3. 4.	Nozzle	12
3. 5.	Jet Deflector	18
3. 6.	Bucket	19
3. 7.	Rotor	23
3. 8.	Housing	25
3. 9.	Shaft	29
3.10.	Bearings	30
3.11.	Transmission	30
3.12.	Turbine Control	31
4.	General Notes	33
4. 1.	Fabrication, Checks, Installation and Maintenance	33
4. 2.	Balancing	34
4. 3.	Cost	35
4. 4.	Safety	36
5.	Further Hints	37
5. 1.	Application of Pelton Turbines	37
5. 2.	Noise	37
5. 3.	Training Courses	37
Appendix 1.:	List of relevant publications	39
Appendix 2.:	Addresses of institutions...	40
Appendix 3.:	Addresses of manufacturers...	41
Appendix 4.:	Cost of Pelton buckets	43
Appendix 5.:	Cost of Pelton turbine wheels	44
Appendix 6.:	Cost of Pelton turbines	45
Appendix 7.:	Flow nomogram for MDPE pipes	48
Appendix 8.:	Examples of application of Pelton turbines	49
Appendix 9.:	Exploded view of Pelton turbine	60
Appendix 10.:	Drawing set of Pelton turbine	63
Appendix 11.:	Double jet Pelton turbine	85

1 Introduction

In developing countries the necessity and the possibilities to manufacture machines locally are increasing. Often the necessary equipment, machines, material and the skilled labour as well as technical staff are available, but what is missing is the information and the know-how.

One category of machines used to harness water power and which can be produced locally, are water turbines. In some countries there is an established tradition in the production, installing and running of small water mills. Often these are units with simple vertical axis wheels or are large water wheels. For example, one country with experience on vertical axis water wheels - ghattas - is Nepal. In this country there is also know-how available on the building of canals. These canals are generally used for irrigation and to run the ghattas .

In Nepal, the first few cross flow turbines were built and installed in the early seventies. Then it took some time, until the end of the seventies, that water mills, equipped with crossflow turbines, started to spread. By 1990 more than 600 water mills had been installed, distributed all over the country. These installations run with different types of turbines and were locally built by more than ten different manufacturers.

For local manufacturing, the crossflow turbine is the simplest model. The head range often fits in well with the local conditions. Information on this type of

turbine can be obtained from various agencies, such as SKAT and GATE.

Sometimes, for crossflow turbines, the head is too big while the discharge is too small. In this case the Pelton turbine is more suitable. It is the second easiest turbine to be manufactured locally. This publication provides the necessary information for the local manufacturing of Pelton turbines and for installing and running them successfully. The range of application of Pelton turbines described here, does not exceed 50 kW of power output and therefore lies in the mini-micro-range.

This manual is based upon specialized literature, on documentation by suppliers and on the practical and theoretical experience of the author, of other engineering offices and of manufacturers. It has been written mainly to facilitate the design, manufacture and installation of Pelton turbines. All information has intentionally been kept simple, so as to facilitate reproduction with simple means. The formulas in the theoretical section are reduced to the necessary minimum and are partly approximate calculations, which are purposed for the practical use.

The utilization of the produced power is not dealt with. However, all options are kept open, whereas local conditions are to be considered when an installation is planned. In case the statements made should not suffice, detailed information will be found in the literature listed at the end, or can be obtained from the suppliers of turbine components.

1.1 Classification of the Turbines

Water turbines may be classified in different ways. One way of classification is according to the method of functioning (impulse or reaction turbine); another way is according to the design (shaft arrangement and feed of water). Water turbines may operate as turbines, as pump turbines or as a combination of

both. They may be of the single regulated or double regulated type. Turbines may also be classified according to their specific speed.

Illustration 1 demonstrates how the right turbine can be determined for a certain discharge and head.

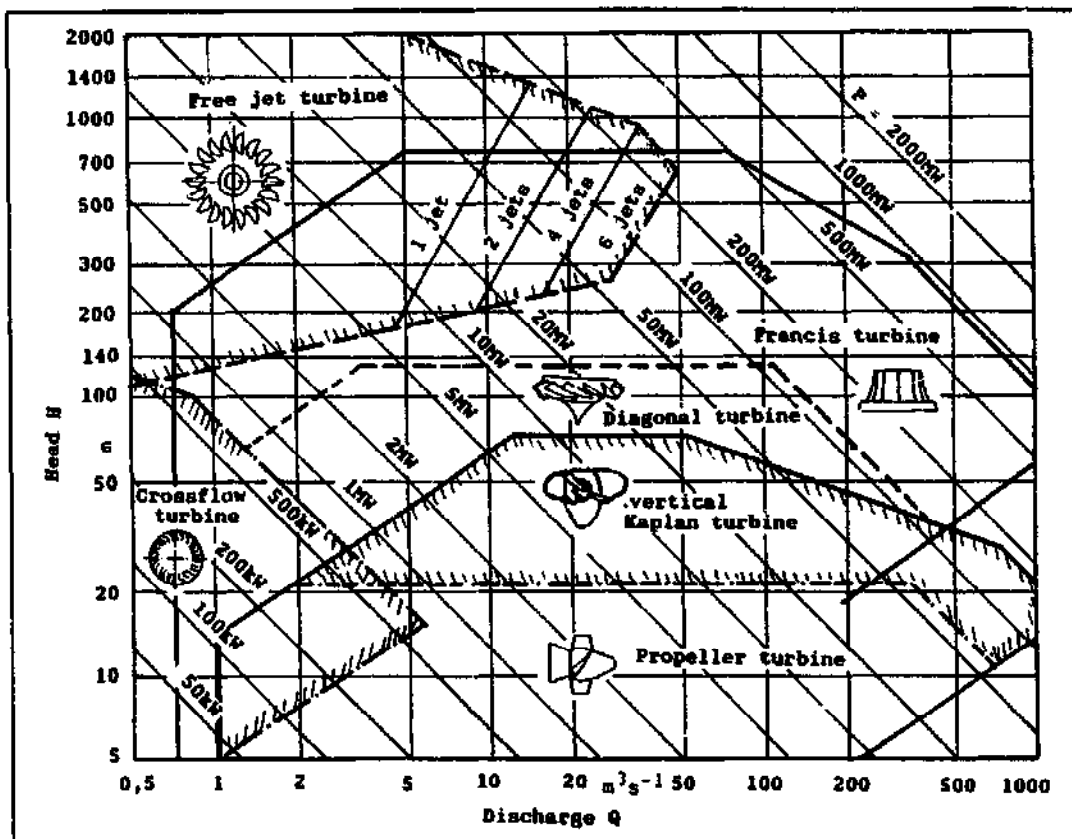

Illustration 1: Functional range of different water turbines (source Escher-Wyss)

1.2 Introduction to Pelton Turbines

This chapter deals with the history and the latest developments of Pelton turbines. Together with Turgo and crossflow turbines, Pelton turbines belong to the impulse type. The common characteristic is the pressureless and partial admission of flow into the runner.

On the Pelton turbine the torque is generated by deflection of the free jet in the double buckets of the

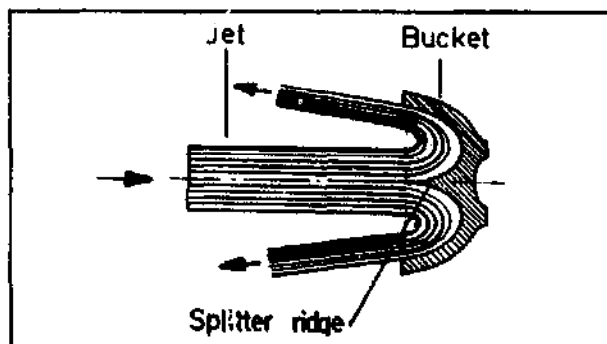

Illustration 2: Reversal of the Jet

runner. That is why the Pelton turbine is also called free jet turbine.

The free jet turbine was invented around 1880 by the American Pelton, after whom it got its name. The greatest improvement that Pelton made was to introduce symmetrical double buckets. This shape is basically still valid today. The splitter ridge separates the jet into two equal halves, which are diverted sideways. Since then the turbine has been considerably improved in all respects and the output of power has increased.

The free jet turbine is used for heads up to 2000 m. Below 250 m, mostly the Francis turbines are given preference. Today the maximum output lies at around 200 MW.

Depending on the discharge, head and quality of the water, Pelton turbines are installed with a horizontal shaft, with 1 or 2 jets per runner, as single or twin

turbine, or with a vertical shaft with up to 6 jets. Generally the electrical generator is coupled directly to the shaft. The speed of small turbines may be adjusted by belt drives or gear boxes.

Basically the turbine consists of the following parts: nozzle, runner and housing. The runner (photograph 1) is mostly a one piece steel casting, containing 13% chrome. The largest Pelton wheels have a diameter of more than 5 m and weigh more than 40'000 kg.

In the nozzle (illustration 8) the pressure of the water is converted into velocity. The nozzle consists of a nose-piece which is fixed to a pipe bend, and a needle which can be moved inside the pipe bend. The nose cone and nose piece, which are subject to wear, are made out of high quality material and are easy to exchange.

The buckets are shaped in such a way that the ridge in the middle divides the free jet into two equal parts which are reversed by almost 180° (illustration 2).

By the reversal almost all the kinetic energy is transferred into force of impulse at the outer diameter of the wheel. Because of the symmetry of the flow almost no axial force is created at the runner.

The wheel must be placed above the tailrace water level, which means a loss of static head, but avoids watering of the runner. In order to avoid an unacceptable raise of pressure in the penstock, caused by the regulating of the turbine, jet deflectors are sometimes installed (illustration 12). The deflector diverts the jet, or part of it, from the runner.

1.3 Range of Application for Micro Pelton Turbines

The Pelton turbine installations described in this treatise are substantially smaller than the ones described above. These turbines can be manufactured locally with good results. Different methods and

various materials are described for the manufacturing of the buckets or of the runner as well as for different nozzle arrangements and the regulating mechanism.

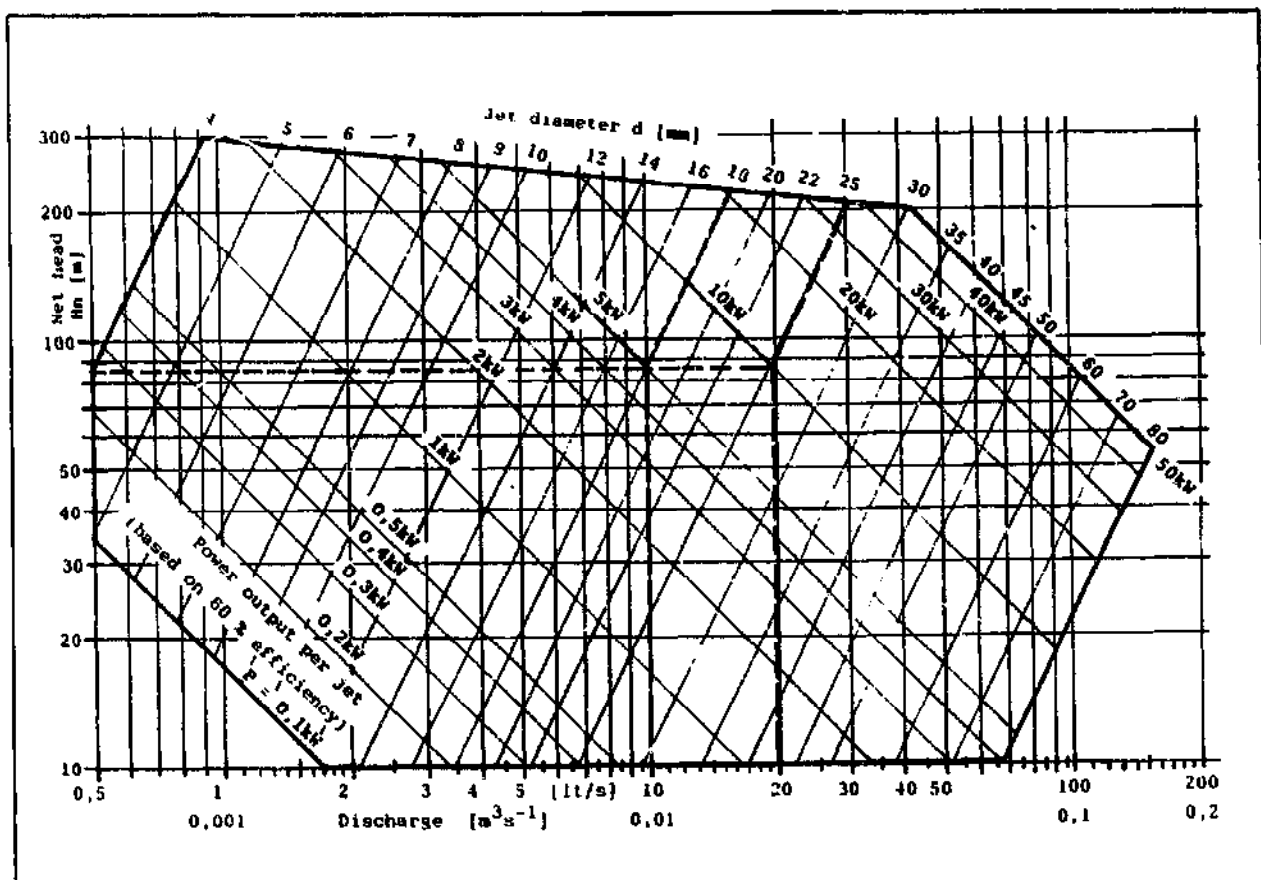

Illustration 3: Range of application of micro Pelton turbines

Various constraints limit the application range for locally manufactured Pelton turbines. For instance with higher heads problems may arise with the penstock. Here not only the static pressure is relevant, but pressure waves may occur when the conduit is filled, or when the turbine is started or regulated. This can have disastrous consequences. High heads also imply high rotational speed which may cause problems with the rotor due to centrifugal forces in connection with dynamic forces. Larger wheels are generally built for higher discharge rates, which implies larger nozzles and buckets. In the context of this publication only very small, locally manufactured Pelton turbines are dealt with. The application range of these should be within the following, reduced limits (see illustration 3):

maximum head:

300-200 m, limit set by dynamic and hydraulic forces on the buckets, torque on the shaft

minimum head:

10 m, limit set by small discharge and power output, large dimensions of wheel and low RPM

minimum discharge:

0.5 lt/s, limit set by the small size of bucket

minimum power output:

0.1 kW, limited power application

maximum power output:

50 kW, limited by size of turbine and design limits

minimum jet diameter:

4 mm, limit set by small size of buckets and by difficulty to concentrate the jet

maximum jet diameter:

80 mm, limit set by large size of buckets

These limits are not compulsory, but can be taken as guidelines, taking into consideration the local conditions for manufacturing, such as availability of materials, casting facilities, testing equipment and others.

In comparison to what is said in chapter 1.2 on the latest developments of Pelton turbines, these limits considerably restrict the application range of micro Pelton turbines. But they still open a new, interesting field for the local fabrication of turbines.

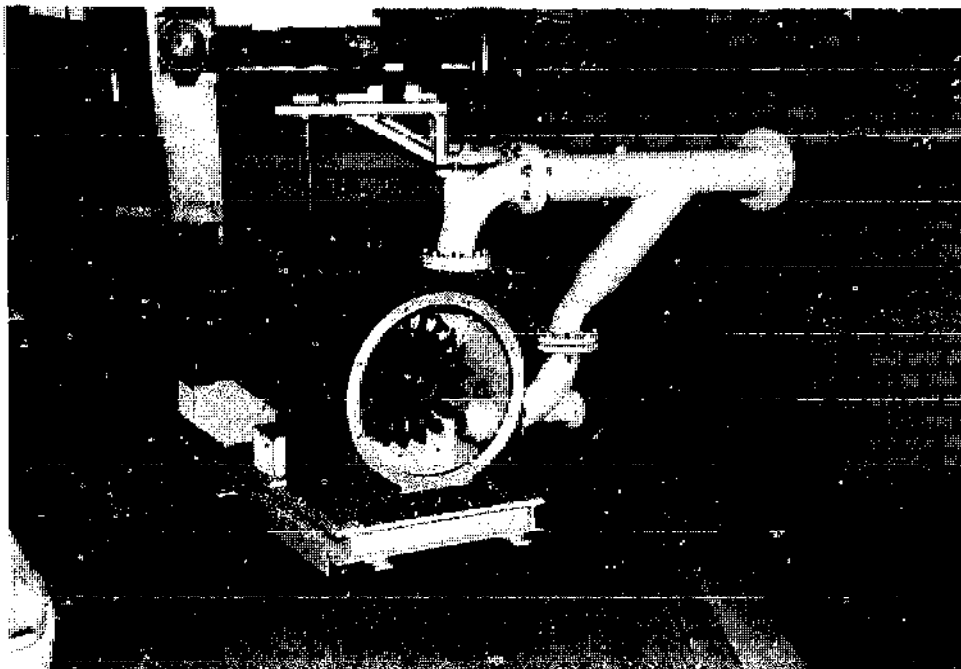

Photograph 2: Double jet Pelton turbine, designed power output up to 100 kW, head up to 400 m, in stainless steel for up to 410 kW and 1000 m

2 Dimensioning of Pelton Turbines

2.1 Theory

Following are the necessary formulas for the design and the layout of micro Pelton turbines:

F1	$c_1 = k_c \sqrt{2gH_n}$	c_1 = absolute velocity of water jet [ms^{-1}] k_c = nozzle coefficient ($k_c = 0.96 \dots 0.98$) g = gravitational constant = $9.81 \text{ [ms}^{-2}\text{]}$ H_n = net head [m]
F2	$d = \sqrt{\frac{4Q}{\pi c_1}}$	d = optimal jet diameter [m] Q = water discharge [m^3s^{-1}]
F3	$u_1 = k_u \sqrt{2gH_n}$	u_1 = optimal peripheral velocity [ms^{-1}] (at the pitch circle diameter) k_u = coefficient ($k_u = 0.45 \dots 0.49$)
F4	$b = (2.5 \dots 3.2) d$	b = bucket width [m]
F5	$h = (2.1 \dots 2.7) d$	h = bucket height [m]
F6	$h_1 = (0 \dots 0.35) d$	h_1 = see illustration 14.
F7	$h_2 = (0.85 \dots 1.5) d$	h_2 = see illustration 14.
F8	$t = 0.9 d$	t = bucket depth [m]
F9	$D = \frac{60 u_1 i}{\pi n_o}$	D = pitch circle diameter (PCD) [m]
F10	$n_o = \frac{60 u_1 i}{\pi D}$	n_o = rotational speed of driven machine (RPM) [min^{-1}] i = transmission ratio (RPM of driven machine / RPM of turbine) ($i=1$ if a generator is coupled directly)
F11	$a = 1.2 d$	a = width of bucket opening [m]
F12	$k = (0.1 \dots 0.17) D$	k = offset of bucket
F13	$z = \frac{D \pi}{2 d}$	z = approximate number of buckets
F14	$D_a = D + 1.2 h$	D_a = outside diameter of runner [m]
F15	$P = Q H_n g \rho \eta \frac{1}{1000}$	P = power output [kW] η = efficiency ρ = density of water = $1000 \text{ [kg m}^{-3}\text{]}$

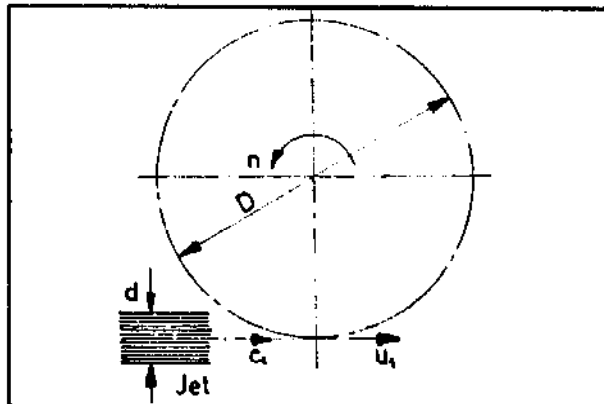

The parameters are explained in illustration 4, on the left side, and in illustration 14 (on page 21).

Illustration 4:
Fundamentals of the Free Jet Turbine

2.2 Turbine Layout

The principle dimensions of a Pelton turbine are determined by the jet diameter. Once the jet diameter is given most other dimensions of the rotor can be derived with the aid of the formulas in chapter 2.1. The size of the jet diameter determines the minimum size of the buckets, which gives the size of the rotor and of the whole turbine.

In certain cases it is possible to install a turbine with larger buckets than required. This does not necessarily reduce the overall efficiency of the installation in an unacceptable way if the overdimensioning is kept within certain limits. This may be the case if a second-hand turbine is used, if only the design of a larger turbine is available or if modifying the manufacturing facilities would involve too large expenses.

To determine the size of a turbine two of the three parameters power (P), discharge (Q) and net head (H_n) must be known. The third parameter can be calculated (F15). When all of these parameters are within the limits described in chapter 1.3, installation of a Pelton turbine is feasible. When one of the three parameters is above these limits it is sometimes still possible to install a Pelton turbine, but it is recommended to study the different possibilities carefully. Maybe a turbine with more than one jet can be installed, or the other extreme would be the importing of the whole turbine.

The most difficult task in Pelton turbine manufacturing is the making of the buckets, because when these would break while rotating at high speed, this could be quite dangerous. That is the reason why it is often preferable to purchase the buckets from a reputed manufacturer. In this case, or when the buckets are made by an experienced, local manufacturer, the limits of locally manufactured Pelton turbines, as described in chapter 1.3, may be raised.

In case that the discharge is above, or the head is below the described limits it is recommended to look for an alternative type of turbine design.

The jet diameter can be determined by approximation according to illustration 3, when two of the parameters head (H_n), discharge (Q) and power output (P) are given. The diagram is based on an overall plant efficiency of 60 %.

When the main dimensions of a Pelton turbine plant have to be determined the various parameters interact with each other. It is a process of iteration to reach the most suitable layout. This process is illustrated by the following example:

The survey at a planned site proves that a gross head of 96 m is available. For the same example a description is given in chapter 3.3 on how to design the penstock and how to determine the net head of 86 m, while the testing of the buckets is described in chapter 4.1. The owner in this case intends to install a generator with 10 kW power output, turning at a speed of 1500 RPM and designed to withstand the runaway speed of 2700 RPM. The owner further plans to install an electronic load controller. An overall efficiency of 60 % of the machinery is assumed. The manufacturer with whom he intends to order the machinery has buckets available with a width of 60 mm.

With the aid of illustration 3 the necessary discharge is determined to be 20 l/s and the jet diameter is 25,5 mm. These parameters and the other main dimensions of the turbine will be calculated in the following with the aid of the formulas in chapter 2.1. First the discharge is calculated with formula F15, which is rearranged as follows:

$$\begin{aligned}
 Q &= \frac{P \cdot 1000}{H_n g \rho \eta} \\
 &= \frac{10 \cdot 1000}{86 \cdot 9,81 \cdot 1000 \cdot 0,6} = 0,01975 \text{ m}^3/\text{s} = 19,75 \text{ l/s} \\
 &(\approx 20 \text{ l/s})
 \end{aligned}$$

After that the absolute velocity of the water jet c_1 , the jet diameter d , the optimal peripheral velocity u_1 , the pitch circle diameter D , the width of the buckets b and the number of buckets z are calculated with the following formulas:

$$\begin{aligned}
 \text{F1: } c_1 &= k_c \sqrt{2 g H_n} \\
 &= 0,97 \cdot \sqrt{2 \cdot 9,81 \cdot 86} = 39,84 \text{ m/s}
 \end{aligned}$$

$$\begin{aligned}
 \text{F2: } d &= \sqrt{\frac{4Q}{\pi c_1}} \\
 &= \sqrt{\frac{4 \cdot 0,02}{\pi \cdot 39,84}} = 0,0253 \text{ m} = 25,3 \text{ mm}
 \end{aligned}$$

$$\begin{aligned} \text{F3: } u_1 &= k_u \sqrt{2gH_n} \\ &= 0,46 \sqrt{2 \cdot 9,81 \cdot 86} = 18,9 \text{ m/s} \end{aligned}$$

$$\begin{aligned} \text{F9: } D &= \frac{60 u_1}{\pi n} \\ &= \frac{60 \cdot 18,9}{\pi \cdot 1500} = 0,2406 \text{ m} = 240,6 \text{ mm} \end{aligned}$$

$$\begin{aligned} \text{F4: } b &= 2,85 d \\ &= 2,85 \cdot 25,3 = 72,1 \text{ mm} \end{aligned}$$

$$\begin{aligned} \text{F13: } z &= \frac{D \pi}{2 d} \\ &= \frac{240,6 \cdot \pi}{2 \cdot 25,3} = 14,94 \end{aligned}$$

Since the minimum number of buckets should be at least 16 (see chapter 2.4) and the calculated width of the required bucket is more than the ones available by the manufacturer it is decided to build a turbine with two jets. Therefore each jet will have a discharge of 10 l/s. The procedure of calculation continues as follows:

c_1 , u_1 and D remain the same because the net head has not changed.

$$\begin{aligned} \text{F2: } d &= \sqrt{\frac{4Q}{\pi c_1}} \\ &= \sqrt{\frac{4 \cdot 0,01}{\pi \cdot 39,84}} = 0,0179 \text{ m} = 17,9 \text{ mm} \end{aligned}$$

$$\begin{aligned} \text{F4: } b &= 2,85 d \\ &= 2,85 \cdot 17,9 = 51,0 \text{ mm} \end{aligned}$$

$$\begin{aligned} \text{F13: } z &= \frac{D \pi}{2 d} \\ &= \frac{240,6 \cdot \pi}{2 \cdot 17,9} = 21,1 \end{aligned}$$

According to table 3 in chapter 3.6 a bucket width of 60 mm is suitable for jet diameters of 15 to 20 mm. That is why the available buckets can be used although F4 gives an optimal bucket width of 51,0 mm. By dividing the jet diameter by the nozzle coefficient ($17,9 \cdot 1,25 = 22,5$ mm) the 22,5 mm diameter of the bore of the orifice insert (see chapter 3.4 and illustration 8) was calculated.

The pitch circle diameter of the wheel of 240 mm and the number of buckets (21) are reasonable, so that the nominal speed can be reached without step up or step down transmission. Thus the generator can be coupled directly.

Since an electronic load controller will be installed, it is not necessary to install a complicated governor. No jet deflectors need to be installed, either, because the generator can withstand the runaway speed. A simple valve is installed before one of the nozzles and the other nozzle has a needle and a spear.

The flow rate of 20 lt/s is available in the river most of the time. Only at some days in the dry season the discharge must be adjusted by closing the spear of the nozzle, which is manually regulated, or by closing the other nozzle completely to guarantee a residue of flow in the river bed and to guarantee the head in the penstock pipe. Because all dimensions fit the requirements, the main dimensions of the rotor are now determined.

2.3 Efficiency

The efficiency (η) of small, locally manufactured Pelton turbines is normally not as high as with larger turbines. It is therefore recommended to calculate the turbine parameters with an efficiency of 0.70 to 0.85. This may result in an efficiency of 0.5 to 0.6 for an installation with an electrical generator. It has proved reasonable in various installations to calculate with such efficiencies. Considering the low efficiencies, the head and the discharge must be available to reach the required power output.

There are many factors which may influence the efficiency of Pelton turbines, such as geometrical arrangement of the buckets, shape of buckets,

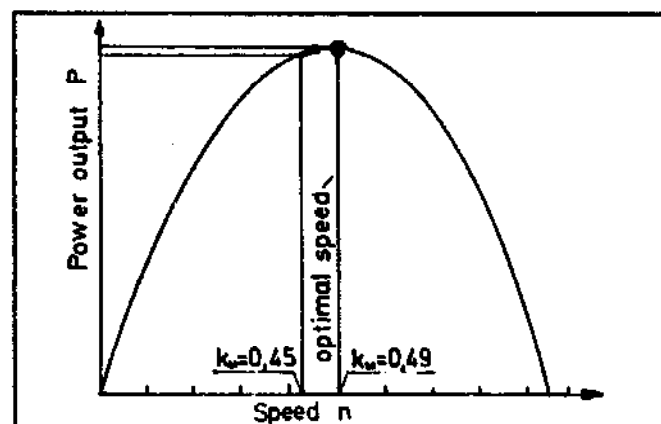

Illustration 5: Power versus speed curve of a Pelton turbine.

mistakes in manufacturing, misalignment of the jet, friction of the water stripper and gaskets. The losses by windage may also have a considerable influence on the efficiency of micro turbines. It is therefore recommended to lay out the nominal point in the power versus speed chart rather on the lower speed side of the maximum power point, towards a smaller k_u value.

2.4 Speed and Pitch Circle Diameter

The product of the speed (RPM) and the pitch circle diameter (PCD) of a Pelton turbine is constant (F9 and F10) for a given head. Thus, with a given head and PCD this results in a certain number of revolutions of the turbine. Often the speed of the turbine is given by the required RPM of the driven machine, be it a generator or any other end-use equipment. With a given net head the RPM can be adjusted by changing the diameter of the wheel.

Another possibility is not to run the turbine at the optimal speed. Illustration 5 shows that for a given PCD the speed of the runner may be considerably different from the optimal speed, without having a too large influence on the efficiency of the turbine and thus allowing the manufacturer to have a series of standardised sizes of PCDs. In the case of illustration 5 a speed which is 16 % lower than the optimal speed means only a loss of efficiency of 3 % (see also explanation on page 63).

A jet diameter which is smaller than the optimal jet diameter or a partly closed nozzle does not have too big an influence on the efficiency, provided that the actual jet diameter is not smaller than one third of the optimal jet diameter or one sixth of water discharge is still possible at good part-load efficiency.

For a certain bucket size, the PCD has to be within certain limits. The minimum wheel diameter results from the fact that a minimum of at least 16 buckets should be installed and from the permissible centrifugal force on the buckets. The maximum wheel diameter is not so much of a problem, because normally a high RPM is required. Mostly economical considerations limit the size of the rotor, because a large wheel also means a large number of buckets and a large housing.

The runaway speed of a Pelton turbine is about 1.8 to 1.9 times the nominal speed. At runaway speed the runner turns at almost the speed of the water jet, the water is no more able to transfer energy to the rotor. This is the case when no load is taken from the turbine.

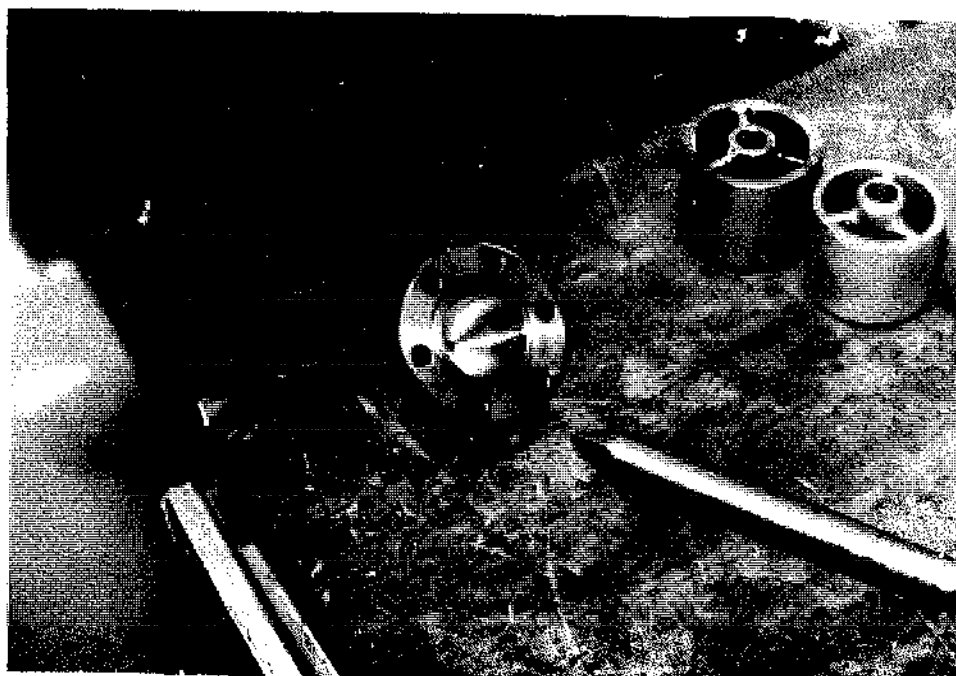

Photograph 3: Needle, orifice and star guide of a nozzle

3 Components and Design Principles

3.1 Intake

The arrangement of the intake poses no special problem for Pelton turbines. Basically any kind of intake may be constructed. This chapter deals with the relevant peculiarities of Pelton turbine plants. The building of a safe structure must be recommended. Other points to be considered are erosion and flooding. In the dry season it must be guaranteed that the necessary amount of water is tapped, whereas for ecological reasons a residue of water must be left in the river bed.

An often used, cost effective intake is the Tirolian weir as shown in illustration 6. It has proved to be reliable for tapping water from small rivers with steep gradients in mountainous regions. The water is diverted from the riverbed by a kind of channel across the riverbed, which is covered by a trash rack. At times of a small flow rate in the riverbed, all the water can be diverted. In case of surplus water or flood the intake is overflowed by the river. Due to its flat structure it is unobtrusive. The larger portion of the debris load slides over the trash rack. An important point to be considered is the risk of icing up of the weir.

1. River bed
2. Weir structure, may be constructed of concrete or stone masonry, with a slope at the bottom towards the outlet.
3. A frame, made of angle iron (e.g. 40/40 mm), is anchored in structure 2.
4. The trash rack can be made of flat iron (e.g. 30/6 mm) and is removable. The bars can be welded vertically by the ends to another flat iron, or to two rods in between. The spacing between the flat bars should be 6 to 12 mm. The slope of the trash rack must be at least 15°.
5. The water leaves the weir and the riverbed in a pipe placed at the bottom of the weir.

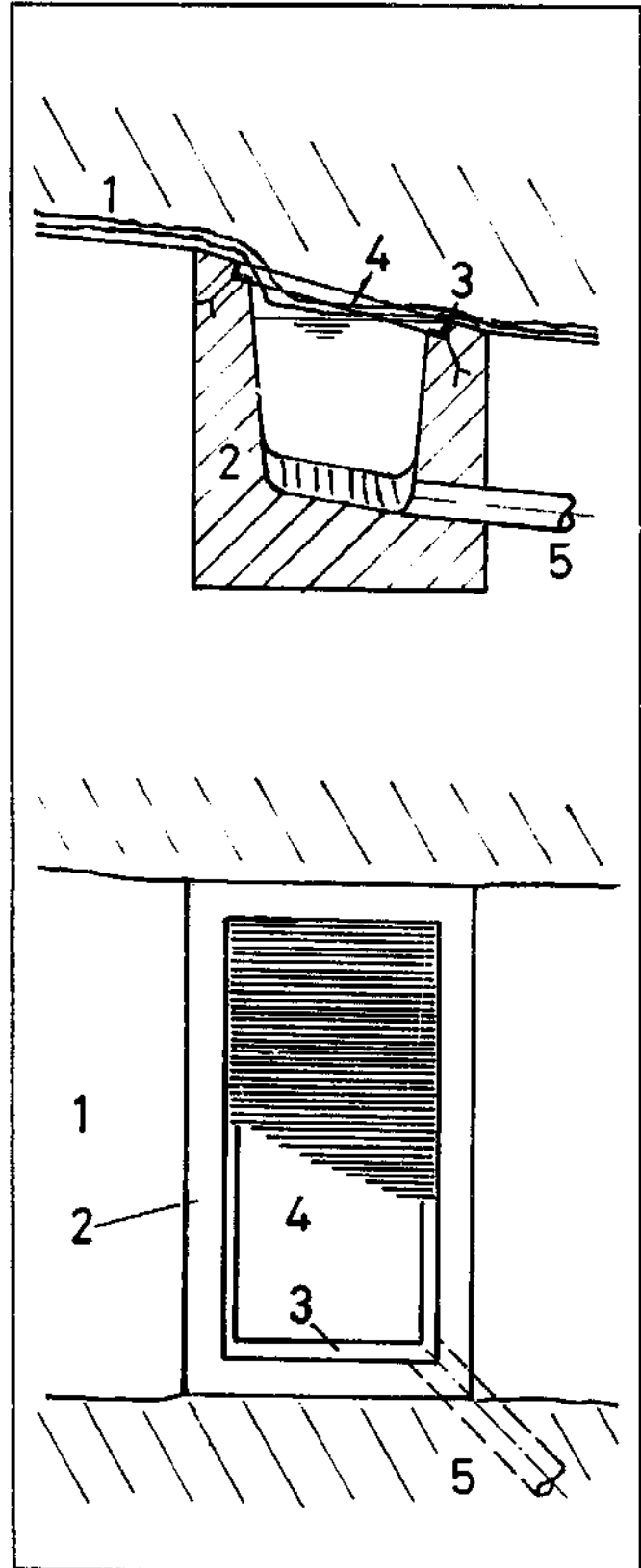

Illustration 6: Tirolian weir type intake structure

3.2 Forebay

A forebay is normally combined with a desilting chamber. As the discharge at Pelton turbine installations is relatively small, the size of the forebay may be small. Often it is enough to have just a vat, where the velocity of the water is low enough for the suspended particles to settle. The accumulated debris has to be flushed out from time to time. This can be done by opening the flushing gate or valve. In this manner the material is allowed to return to the river bed. If there is a sufficient amount of surplus water available, this can be done without stopping the plant. In some cases also floating material, such as leaves and branches, may cause problems. This can be encountered by a dip wall or by a dip beam.

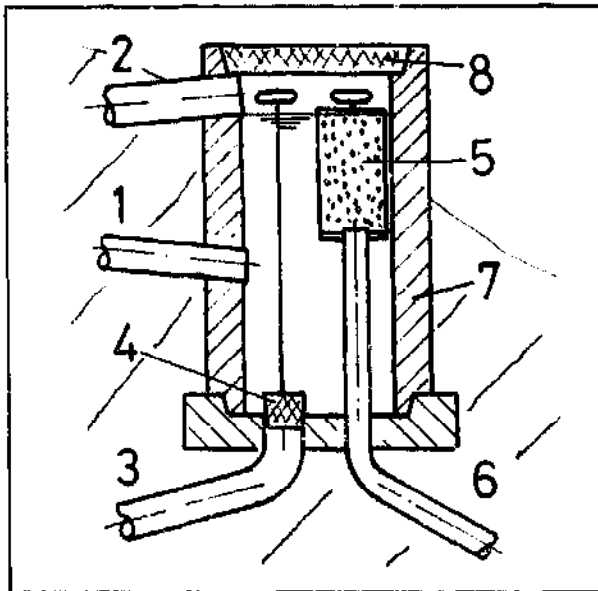

Illustration 7: Forebay tank

The floating parts are washed away by the excess water along the overflow in a suitable arrangement.

If the source of water for the Pelton turbine is a spring, the water may be diverted directly from the source to the turbine without complicated intake, desilting and forebay constructions, because such water is clean.

Concrete pipes are often suitable for the forebay basin, as shown in illustration 7.

1. Supply pipe from intake.
2. Overflow pipe, leads the excess water back to the river, may also be an overflow channel.
3. Flushing pipe, may be opened and closed by a plug, a valve or a gate. It is opened and closed manually as and when required. The cross-sectional area of 2 and 3 must be bigger than that of the supply pipe.
4. Plug with handle.
5. Penstock sieve, should be as large as possible, may be made of perforated sheet metal with holes of 3 to 5 mm diameter, the top can be of the same material, with a handle, at the bottom it can be fixed to a wooden flange, which fits to the upper end of the penstock pipe.
6. Top end of the penstock pipe, must be submerged in the water, to avoid the intake of air.
7. Forebay tank, can be made of a concrete pipe as shown in the drawing, or of a barrel, stone masonry or other material.
8. It is useful to cover the forebay basin to prevent leaves, branches or other items and playing children from falling into it.

3.3 Penstock

The most important aspects of the layout and design of the penstock are the correct choice of the pipe diameter, the permissible pressure and the material. There is an extensive choice of special literature (see also references 1, 2, 3 and 8) on these items, therefore only some basic ideas are given here.

Penstock pipes constitute a relatively large portion of the costs of Pelton turbine installations. This is due to the high pressure involved and because of the length of the pipe. The wall thickness and the cost of a penstock are almost linear to the permissible

pressure of the penstock. For this reason the closing time of the turbine regulating mechanism may not be too short, because pressure waves and water hammer effects could occur. This can be achieved by a slow closing device on installations where the runaway speed of the turbine plays a minor role, or which have a large enough flywheel. This problem may also be solved by a jet deflector as described under 3.5.

The kind of penstock and the material used are selected in accordance with the pressure, the terrain conditions and the local circumstances. For the power

Table 1: Flow characteristics of polyethylene pipes (nominal pressure 10 bar)

Pipe diameter		Velocity of water v [m/s]	Discharge Q [lt/s]	Power output with Q and nethead 100m [kW]
outside [mm]	inside [mm]			
32	26,2	0,6	0,3	0,2
40	32,6	0,7	0,6	0,4
50	40,8	0,8	1,0	0,7
63	51,4	0,9	1,8	1,3
75	61,4	1,0	3,0	2,1
90	73,6	1,2	5,1	3,6
110	90,0	1,4	8,9	6,2
125	102,2	1,5	12,3	8,6
140	114,6	1,6	16,5	12
160	130,8	1,8	24	17
180	147,2	2,0	34	24
200	163,6	2,1	44	31
225	184,0	2,3	61	43
250	204,6	2,4	79	55

plants described in this publication mainly high-density polyethylene pipes (HDPE) are used. They are available in most countries, can be entrenched or embedded in concrete or can be laid on the surface. The pipes have to be protected against pasturing cattle, landslides, avalanches, vandalism and solar radiation. With respect to ecological aspects it is also recommended to cover them.

Table 1 shows the recommended speed and discharge for a pressure drop of 2 m WC for a pipe length of 100 m for commercial HDPE pipes. It also shows the available power with a net head of 100 m and a turbine efficiency of 70 %.

The surface roughness of the inner wall of the penstock and the speed of the water are relevant for the pressure losses. With respect to pipe diameter, nominal pressure and cost of pipes, 1% to 5% head loss in the penstock pipe are reasonably obtained, whereas it is recommended to keep the losses under 10 %.

Pipes are available for different nominal pressures. When a long penstock with a high head must be installed, to reduce costs, it may be advisable to use pipes for a lower nominal pressure at the upper end where the static pressure is lower. Another possibility is to install a pipe with a smaller diameter at the lower part of the penstock. A smaller pipe diameter means a higher velocity of water and higher pressure losses.

An example of a flow nomogram for MDPE pipes is shown in appendix 7. The friction losses can be read out for given internal diameters and flow rates.

In the following for the same example as in chapter 2.2, the penstock diameter is determined, and the pipe losses and net head are calculated. The gross head is 96 m and the length of the penstock is 300 m. The owner plans to use polyethylene pipes, which are readily available in the country.

Table 1 shows that if the friction losses in the penstock must not exceed 2 m/100 m pipe length the inside diameter should be bigger than 114,6 mm. But, though he takes into account that the losses are higher, the owner prefers to install pipes with this diameter in order to save costs, because the next bigger diameter would be considerably more expensive. Hints for the pre-selection of the economically optimal penstock diameter are given under reference (2) and (3).

According to the table of appendix 7 an inside diameter of 114 mm and a flow rate of 20 lt/s result in a flow velocity of 1.9 m/s and a hydraulic gradient of 3 m/100 m pipe length. This gives losses in the penstock of 9 m water column for a penstock length of 300 m. This is just a little below 10 % of the gross head and may be tolerated with respect to the considerations mentioned above. The nozzle of the turbine is located 0,6 m above the tailrace water level and the losses in the bends, joints and the valve are assumed to be 0,4 m. This results in a total loss of 10 m, thus the net head is 86 m.

3.4 Nozzle

The manifold with its needles and spear valves is a costly component of the Pelton turbines. Such devices are used to regulate the speed or the discharge of the turbine. Generally the valve is regulated by a governor.

The manifold should have as few bends as possible, with a radius as large as possible to avoid losses and turbulence of the jet.

Pelton turbines may have more than one jet. Turbines with a horizontal axis are built with one or two jets, turbines with a vertical axis are built with up to six jets. To reach a certain number of revolutions the wheel diameter is selected accordingly. To get the minimum number of buckets, the diameter of the rotor must not be smaller than a certain minimum, because it is either physically not possible or part of the water does not hit a bucket. For this reason it is sometimes preferable to use smaller buckets with the possibility of making a smaller pitch circle diameter. With smaller buckets the maximum jet diameter is limited and so is consequently the water flow rate. To overcome this handicap more than one jet may be installed. The water from the penstock is distributed to the different nozzles by the manifold. Towards the last jet the diameters of the distribution pipes are gradually reduced.

When more than one jet is installed, it is often possible to regulate only the flow of one jet with a governor, whereas the other jets are controlled by a simple hand valve.

The nozzle must be designed in such a way that the pressure loss is as small as possible and that thus the nozzle coefficient is increased. When calculating the diameter of the nozzle it must be considered that the cross-sectional area of the jet will be smaller than the area of the orifice opening by the factor ψ_D . ψ_D is the ratio of the diameter of the nozzle opening and the jet diameter. The jet contraction factor ψ_D is in the range of 1,6 for holes with sharp edges, to 1,05 for nicely rounded edges. ψ_D is in the range of 1,25 for properly shaped nozzle openings, such as in illustration 8. An increased velocity of the water means higher losses. That is why the part of the nozzle, in which the water has a high speed, has to be as short as possible.

In order to avoid friction losses and turbulence of the jet, the bend of the nozzle should have the largest possible radius. The spear is guided at two points, at the place where it emerges from the bend and with a star guide in front of the nozzle tip. The star guide also streamlines the water flow (item 4 in illustration 8 on page 14).



Photograph 4: Needle of Pelton turbine nozzle



Photograph 5: Needle and spear at different stages of fabrication (parts 3 & 6 in illustration 8 on page 14)



Photograph 6: Star guide before and after machining (part 4 in illustration 8 on page 14)

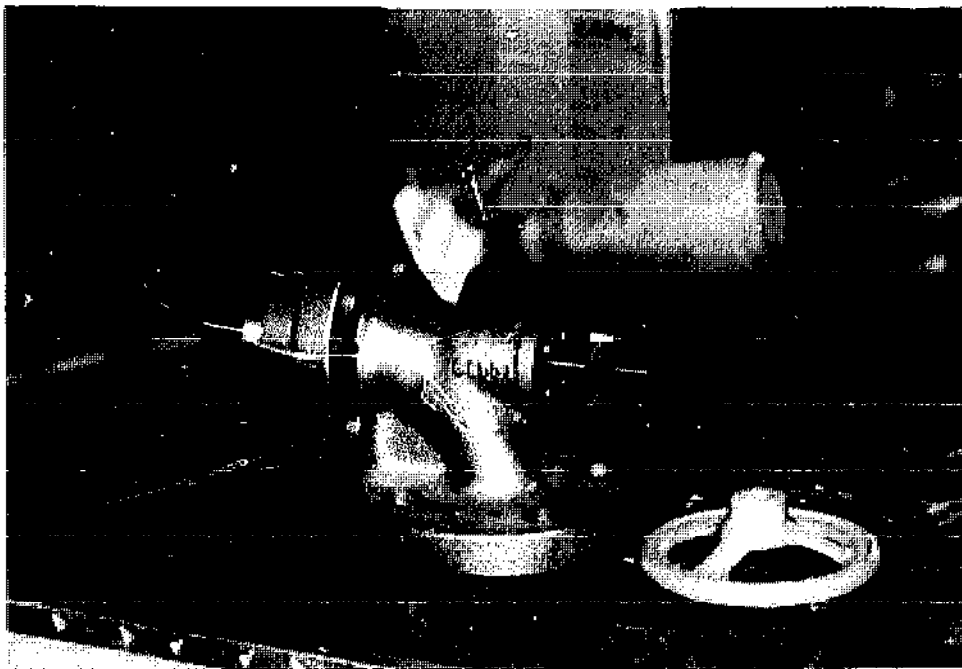

Photograph 7: Nozzle with all parts put together

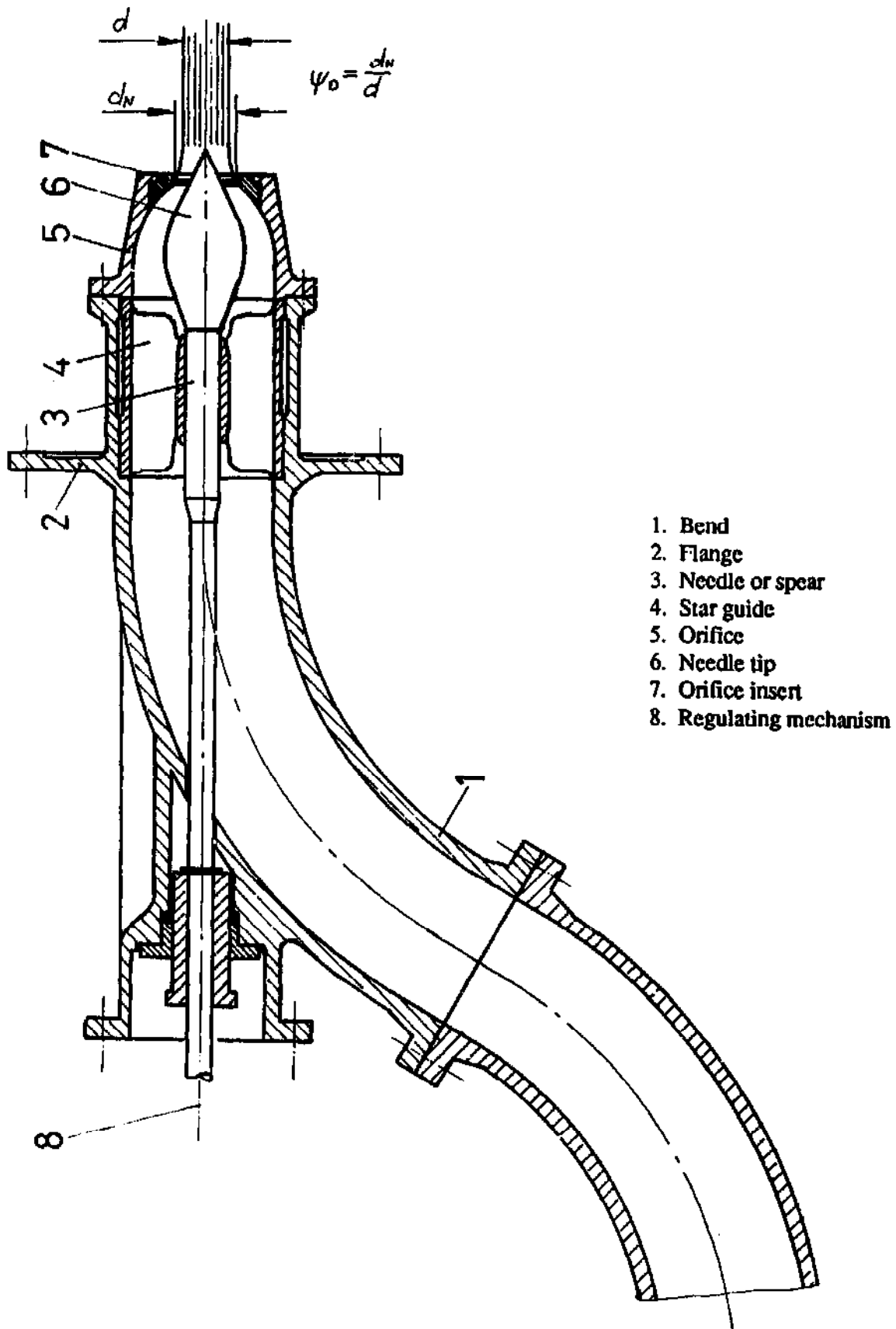

Illustration 8: Example of Nozzle

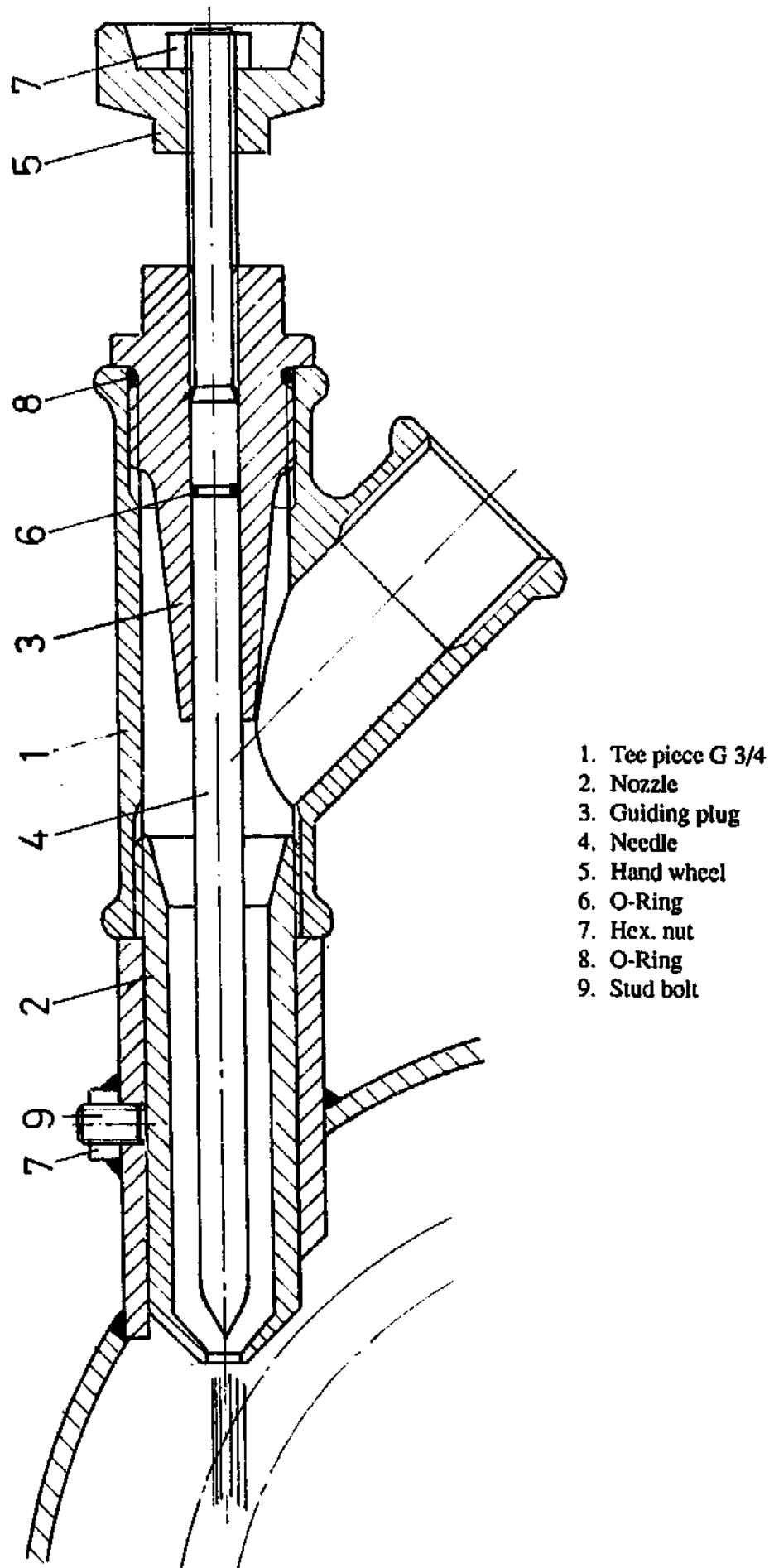

Illustration 9: Example of a simple, hand regulated nozzle (source Aebi)

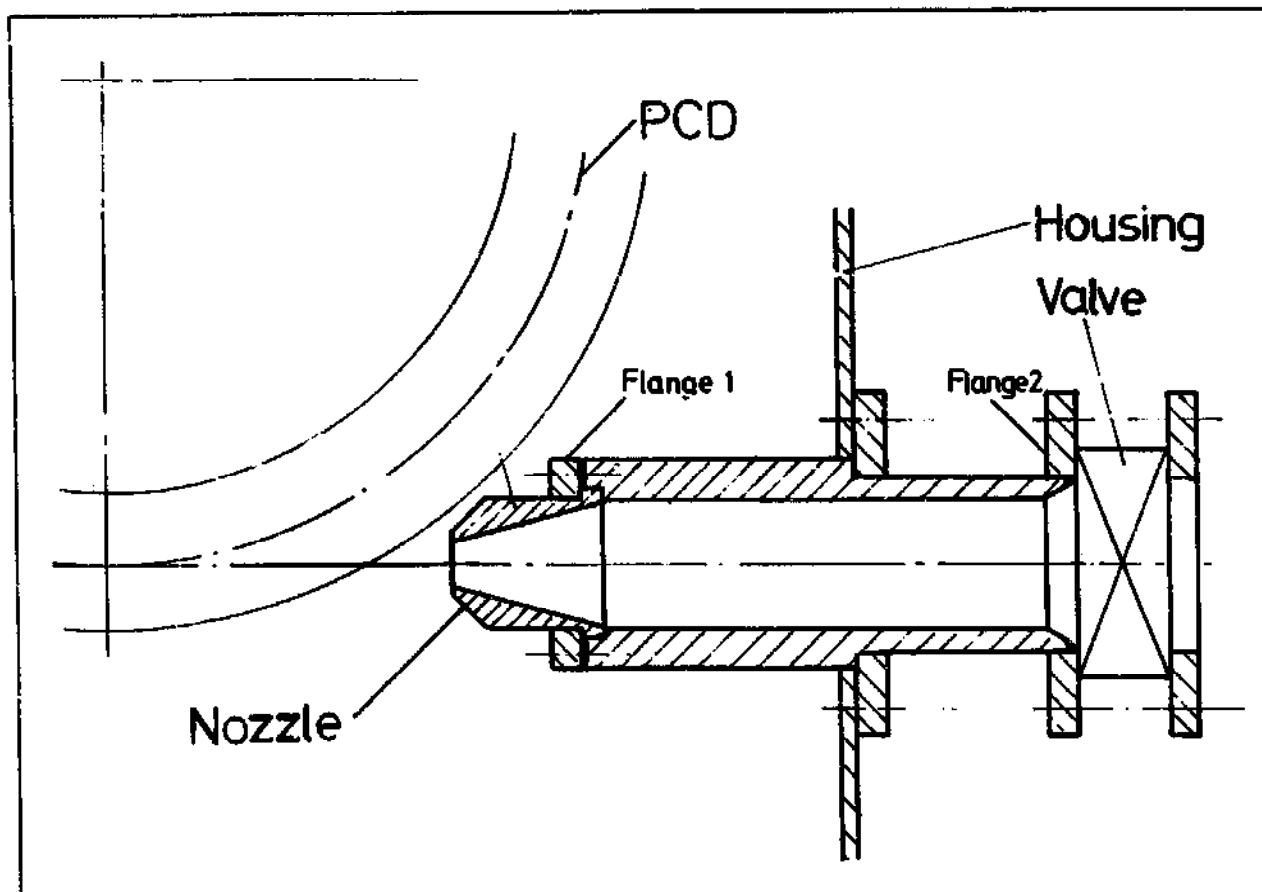

Illustration 10: Example of nozzle without regulating device

Irregularities on the surface of the spear tip and the orifice cause disturbances in the flow of the jet. Cavitation or erosion with increased wear could cause fast destruction of these parts. Damage caused by erosion can also strongly affect the efficiency of the turbine. This is because part of the water jet may no longer be hitting the buckets or is hitting them with reduced velocity. For this reason the orifice insert and the needle tip of the nozzle must be easily exchangeable (illustration 8).

In the design of illustration 10, a valve is installed before the nozzle. Its sole purpose being the closing off of the water flow, it is not possible to control the speed of the rotor with this valve. If this valve is at a position between open and closed, it basically reduces the pressure and thus reduces the speed of the outflowing water. The discharge is also adjusted in this manner.

Some alternative designs for the orifice of the nozzle (illustration 11) are proposed by Allen Inversin in his brochure "A Pelton micro-hydro prototype design" (9). Such low cost alternatives may be envisaged with regard to the requirements and the available material.

A design of the orifice, which is very easy to manufacture, is by using just a piece of sheet metal with a hole drilled in the required diameter. When determining this diameter the jet contraction coefficient must be taken into consideration. ITDG suggested a design in which this metal plate is introduced and fixed into the nozzle from outside without having to dismantle the nozzle assembly (illustration 11d). The orifice plate of the nozzle in illustration 11d, can be inserted from outside through the longish hole in the front plate and it is fixed from outside by means of bolts. Seasonal variations of the flow rate may be adjusted by inserting plates with different holes.

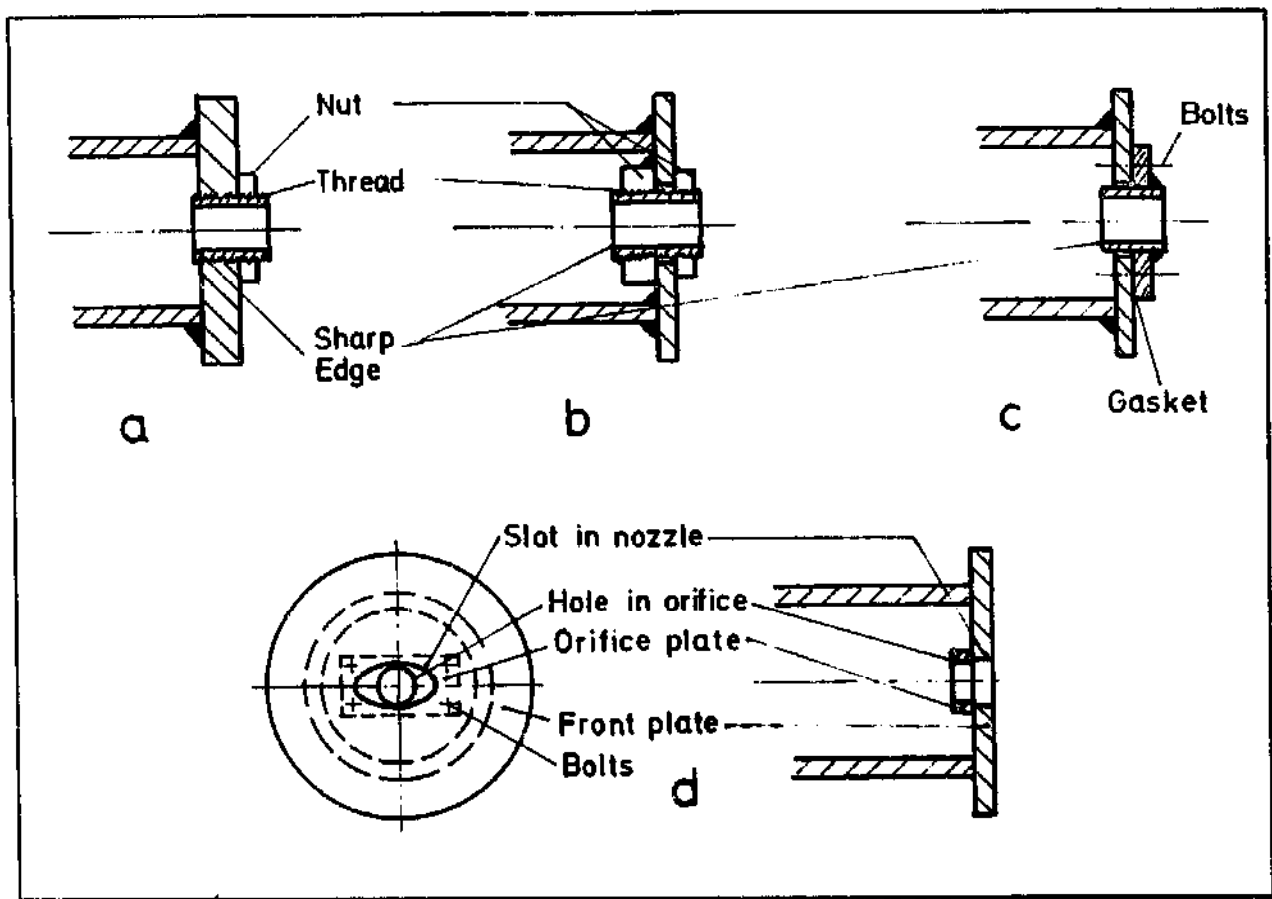

Illustration 11: Alternative nozzle designs without possibility of flow regulation (source Inverstrn)

These nozzles are used for non-regulated flow conditions with a constant flow rate and load. They may be installed with an electronic load controller or when fluctuation of the speed does not play a role. To obtain the best efficiency of such nozzles the inner edge of the orifice should be sharp and the threaded piece of pipe should be as short as possible so as to avoid the contracted water jet touching again.

The diameter of the jet can be smaller than the optimal design diameter without having a great influence upon the efficiency.

When the penstock and the nozzle are filled with water, forces act upon the nozzle with the tendency to move it out of position. Load changes can have the

same effect. While the turbine is in operation vibrations occur, with an effect of moving the turbine from its position. These are reasons why the nozzles and the turbine must be fixed together and why the turbine must be rigidly fastened on its place. This is mostly done with a flange on the nozzle, which is bolted to the turbine housing. With some designs it is possible to adjust the position of the nozzle in such a way that the same housing and nozzle can be used for different pitch circle diameters. On some installations the connection of the nozzle to the housing was omitted, which resulted in enormous problems with alignment of the nozzle and consequent power loss, splashing water and the high costs for overhauling.

3.6 Bucket

In case that the buckets of the Pelton turbine are also to be manufactured locally, casting facilities will be required. Either single buckets, two buckets together, or the complete rotor have to be cast. The casting of buckets for Pelton turbines can be done by copying from other existing buckets. It is advisable to cast the single buckets and, after machining, to fix them to the rotor disk. In this manner complicated casting moulds can be avoided.

If a suitable size is not available, the buckets can be manufactured as shown in illustrations 14 and 15 or they can be manufactured by reducing or enlarging existing buckets on a copy milling machine if such a machine is available. It is not recommended to manufacture the buckets of halved pipe sections or other "ingenious" welding constructions of sheet metal sections, because of lacking strength and poor efficiency. After an enthusiastic start and a lot of work such projects more than once ended quietly as one more developing business ruin.

The optimal number of buckets in a Pelton wheel can be calculated with the aid of formula F13 in chapter 2.1. Various authors give different formulas, which can vary considerably. Generally each cutting of the water jet by the buckets means a disturbance of the jet. Part of the water gets an abrupt and unwanted diversion. This explains why the number of buckets should not be chosen too large. On the other hand not all the water of the jet may hit a bucket if the number of buckets is too small. The number of buckets influences the efficiency of the turbine, but has no influence on the optimal speed of the runner.

Besides faults in manufacturing, such as casting, alignment, surface finish, the main problem with free jet turbines is erosion of the buckets, particularly where the water impinges on the buckets and due to sandy water or chemically aggressive substances in the water.

An often occurring problem is erosion of the buckets, caused by particles of sand suspended in the water. This can be avoided by letting the particles settle in a desilting basin. Sometimes the life time of the runner can be improved by using a better material for the buckets, e.g. stainless steel. In some cases good results have been obtained by the application of a plastic coat to the buckets. This could be a coat based on epoxy or polyurethane resins. Compared with

epoxies, polyurethanes show higher water resistance, but slightly lower chemical and solvent resistance. In southern Switzerland the lifetime of the buckets could be tripled by this method in cases where the water contained small particles of quartz sand.

The buckets can be made of different materials. This is also the case if the rotor is cast in one piece. On modern Pelton turbines the buckets are mostly of cast steel with 13% chrome. But other materials and methods are also used, including cast iron, or alloys such as bronze or aluminium, or injection moulding with fiber glass reinforced plastic.

Each material has its own properties, one of these being the allowable stress. The limits for application must be calculated carefully for each material. When calculating the allowable head for a certain turbine configuration not only the static forces must be calculated, but the fatigue stress and the centrifugal forces are also to be considered. Quick changing of the load on the buckets has an unfavourable effect on the admissible forces, especially when the stress is higher than normal. This could be caused by unequal distribution of the material, cracks at critical places, due to corrosion or due to welding. Roughly spoken, the maximum applicable stress on Pelton buckets is about three to four times smaller than the allowable static stress. Heat treatment can essentially improve the properties of the material.



Photograph 8: Pelton turbine bucket

Table 2: Mechanical properties of different casting materials.

Material	Tensile strength N/mm ²	Modulus of elasticity kN/mm ²	Fatigue/ tensile ratio	Brinell hardness (HB)
Grey cast iron	150-400	75-145	0,45-0,38	135-300
Malleable cast iron	300-600	169-176	0,6-0,4	120-240
Carbon, low alloy and medium alloy steel casting	580-900	200-215	0,4-0,5	160-310
Stainless steel	750-850	195-205	0,4-0,5	250-290
Aluminium and alloys	90-250	50-90	0,3-0,4	30-80
Bronze alloys	220-540	100-120	0,3-0,4	45-160

If the properties of the material are not sure, the smaller values must be taken for calculation (see also reference (11)).

It is essential that a safety factor of about three is taken into account when manufacturing the buckets. Strict quality control must be assured. Generally there is a risk of poor material quality of castings, due to possible shrinkage cavities, blow holes and inclusions.

The formulas for the determination of the main dimensions of Pelton buckets in illustration 14 are given in chapter 2.1 Illustration 15 shows different sections through a bucket. The size can be reduced or enlarged as required with the aid of a photocopier. Patterns are made from these copies and the buckets are modelled according to these patterns.

If different sizes of Pelton turbines have to be manufactured frequently, it is recommended to use a series of standardized bucket sizes which work with the following jet diameters:

Table 3: Jet diameter and bucket width

Jet diameter d:	Bucket width b:
3 to 6 mm	19 mm
6 to 10 mm	30 mm
10 to 15 mm	45 mm
15 to 20 mm	60 mm
20 to 25 mm	75 mm
25 to 30 mm	90 mm

Errata

The illustration 14. on page 21 and illustration 15. on page 22 of the MHPG-publication "Micro Pelton Turbines" have some drawing mistakes. As this drawings are vital parts of the publication, please use the revisions on this page.

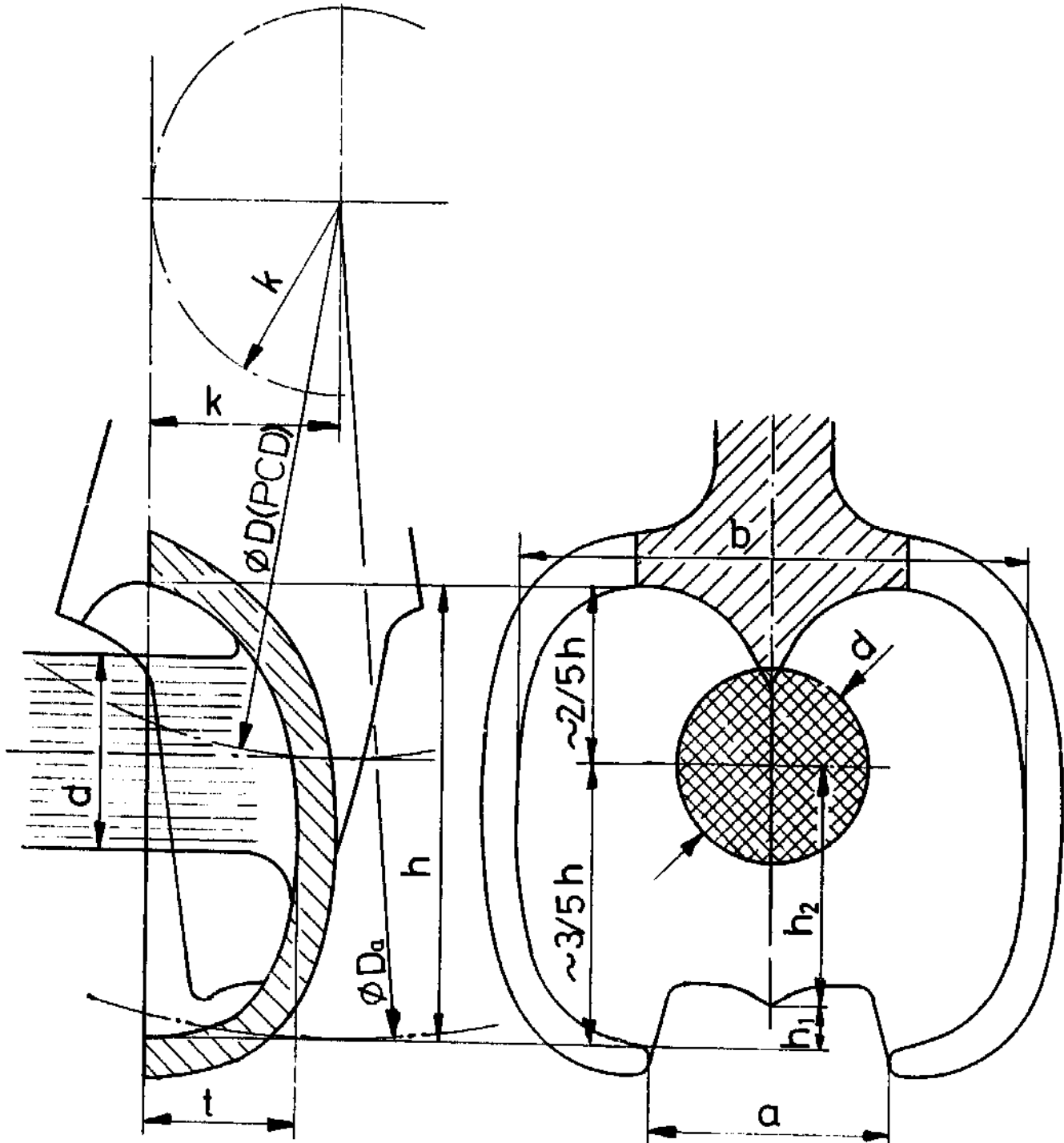

Illustration 14: Cross sections of Pelton buckets

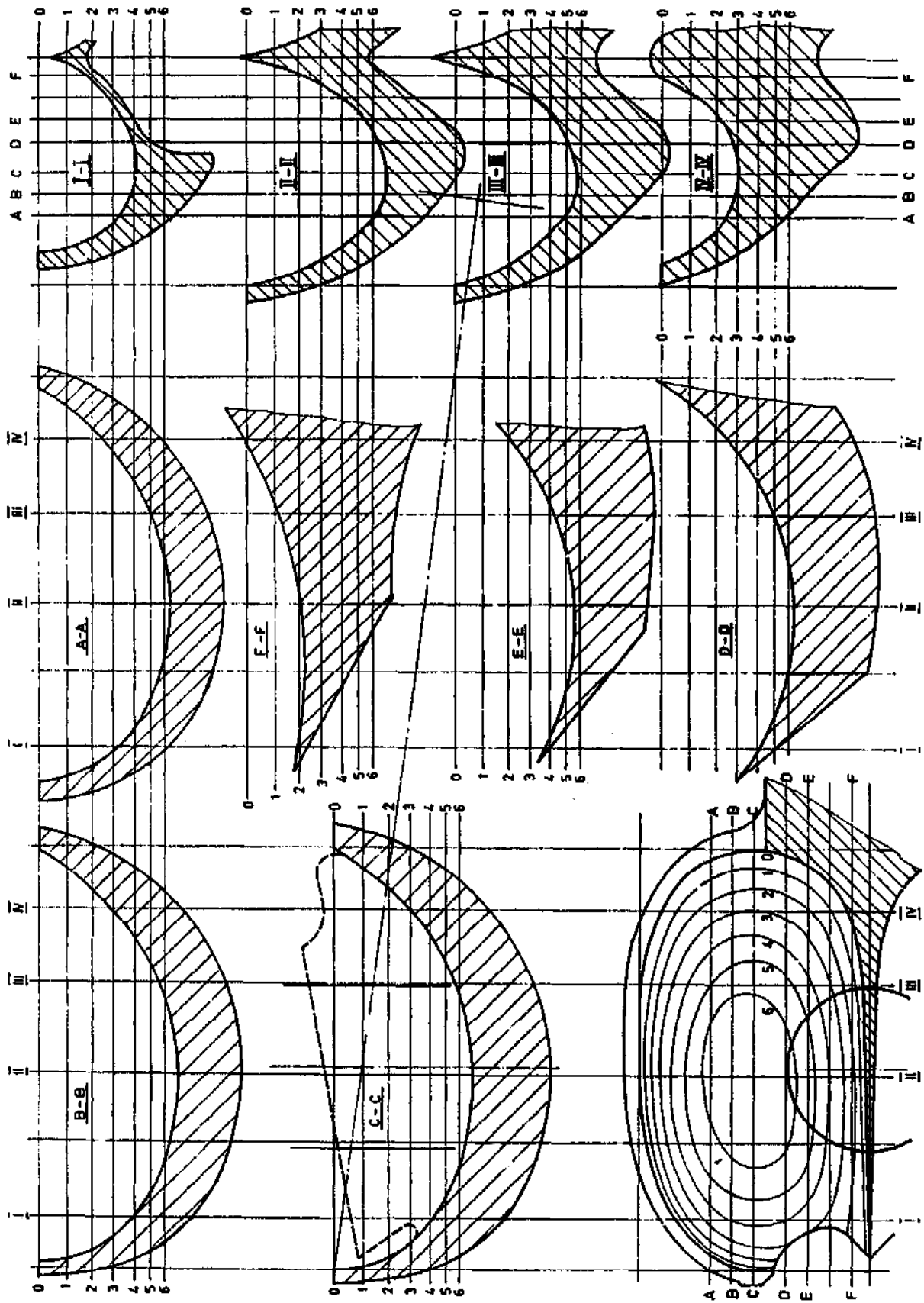

Illustration 15: Main dimensions of Pelton buckets

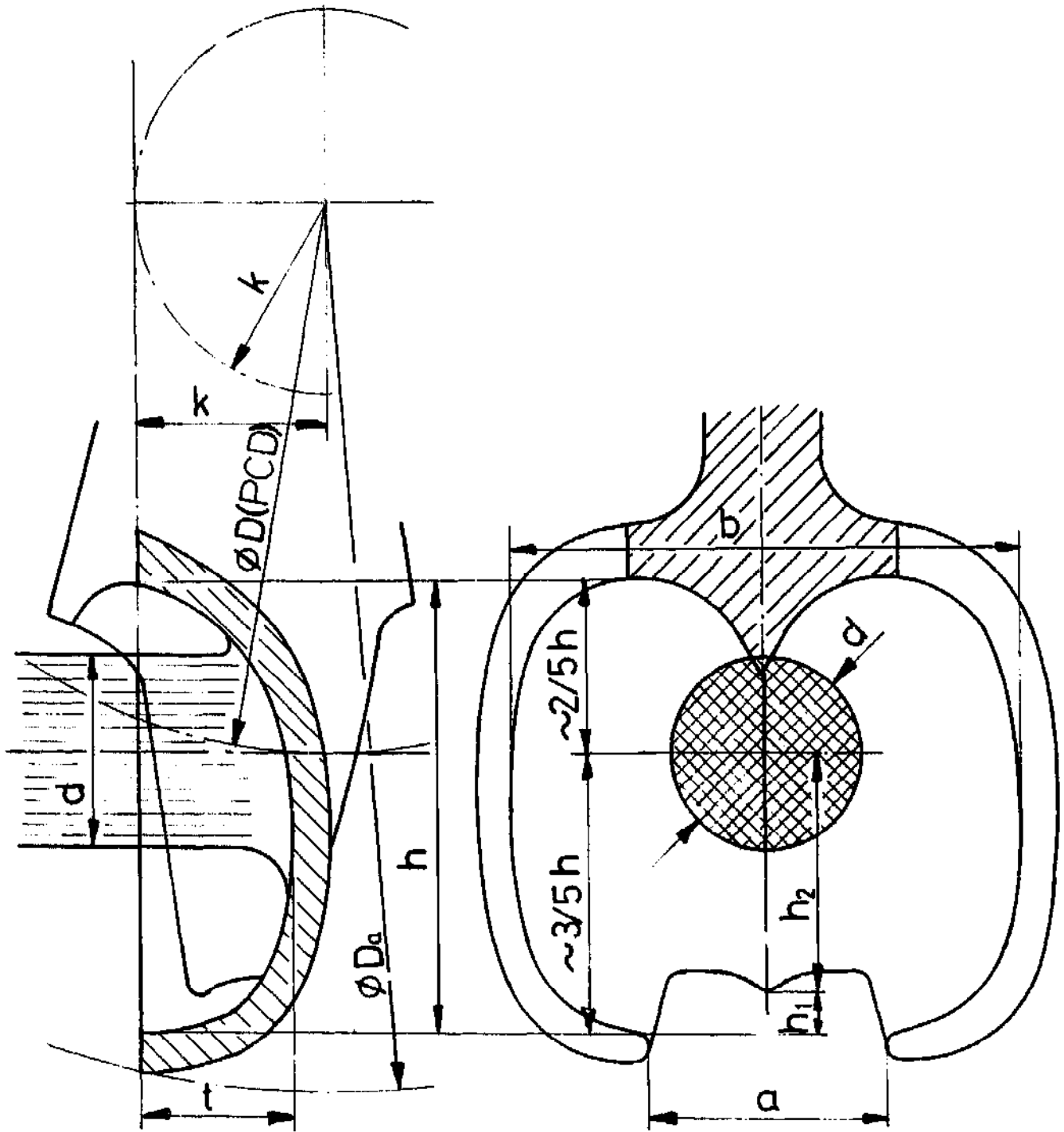

Illustration 14: Main dimensions of Pelton buckets

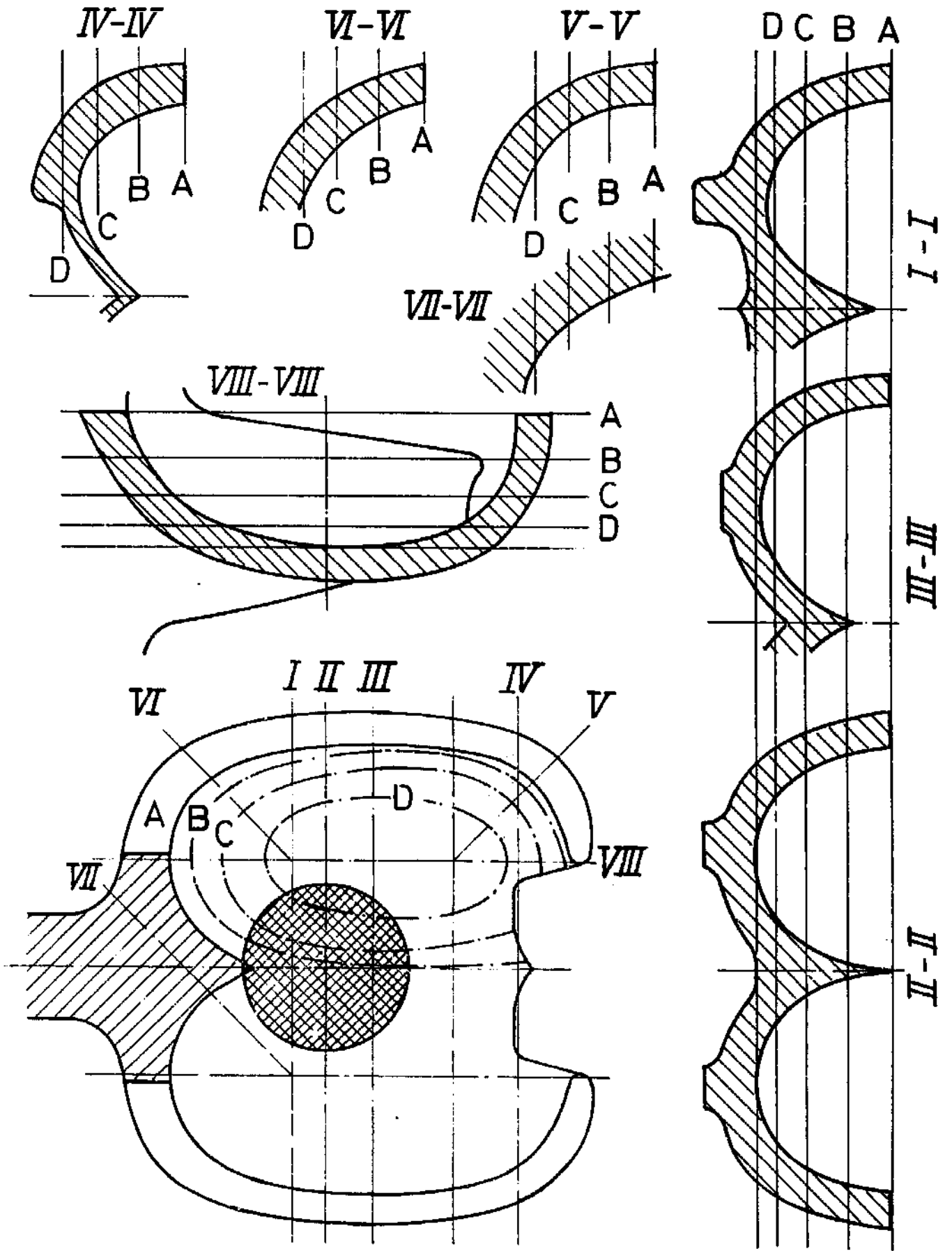

Illustration 15: Cross sections of Pelton buckets

The different parts of the water jet pass the buckets along distinct paths. This is most obvious with the parts which hit the bucket at the beginning and at the end of the path through the wheel. They leave the wheel in different directions, according to the position of the buckets related to the water jet. Therefore the shape of the buckets is laid out for the most significant flow conditions. That is also the reason

why the shape of the buckets is a key factor for the efficiency of the turbine.

The surface finish of the buckets has a great influence on the efficiency and on wearing. That is why often not only the inner surface of the buckets is polished, but also the edges of the rear surface.

3.7 Rotor

The rotor, wheel or runner of a Pelton turbine basically consists of a disk with a number of buckets fixed at its circumference. The disk is mounted on a shaft by means of a hub.

The net head determines the velocity of the water jet c_1 (F1) and the peripheral velocity of the rotor u_1 (F3). The pitch circle diameter (PCD) of the rotor can be calculated (F9) with the speed of the driven machine and the ratio of the transmission. The formulas are given in chapter 2.1.

There are different methods of fixing the buckets to the rotor disk (illustration 16). If the buckets are bolted to the disk, each bucket must be connected to the disk with two bolts or with a bolt and a pin. The holes in the buckets and the disk should be drilled together and fit bolts or positioning pins should be used. To avoid loosening of the single buckets in circumferential direction, under the hammer-blow

like force when the water hits the buckets, attempts were made to prestress the buckets in peripheral direction by means of conical pins between the buckets (illustration 16a). In combination with the internal stress of the casting, this resulted in uncontrolled pretension with local stress peaks in the area of the pins leading to "explosion" of the rotor.

On modern Pelton turbines very often the single buckets are fixed to the disk of the rotor by positive connection. This may be done with a type of dovetail on the buckets. The buckets are held by two disks (illustration 16c), by one disk and two rings (illustration 16d) or by one disk and one ring, which are bolted together. This kind of fixation of the buckets to the rotor disk is expensive, but has a number of advantages. It can be used for high head application, because the foot of the buckets is not weakened by holes. The intention of giving these examples is to avoid similar mistakes in future.

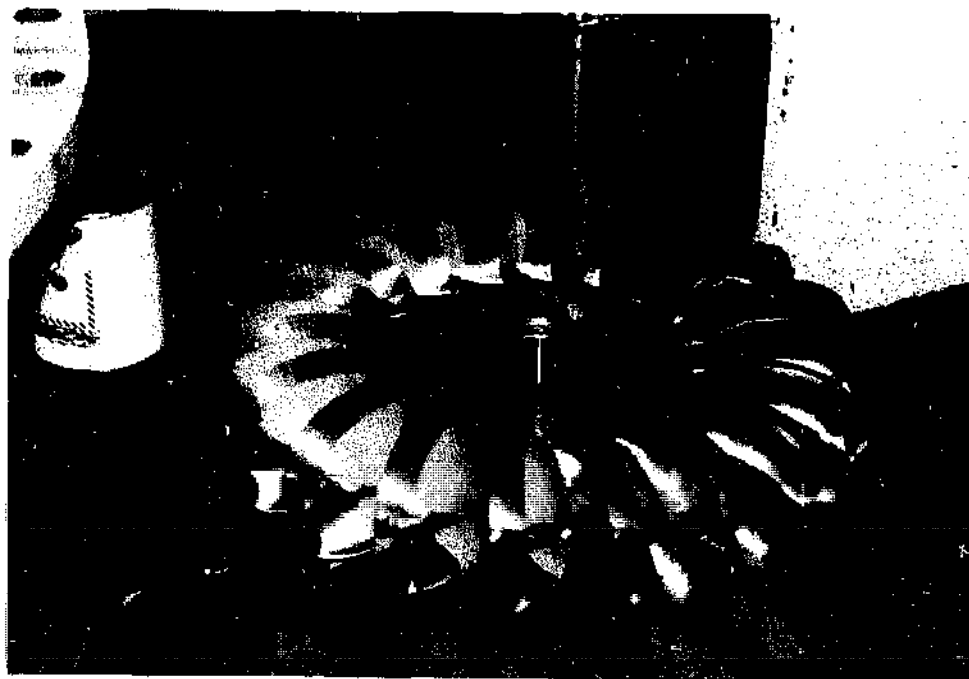

Photograph 9: Pelton turbine runner

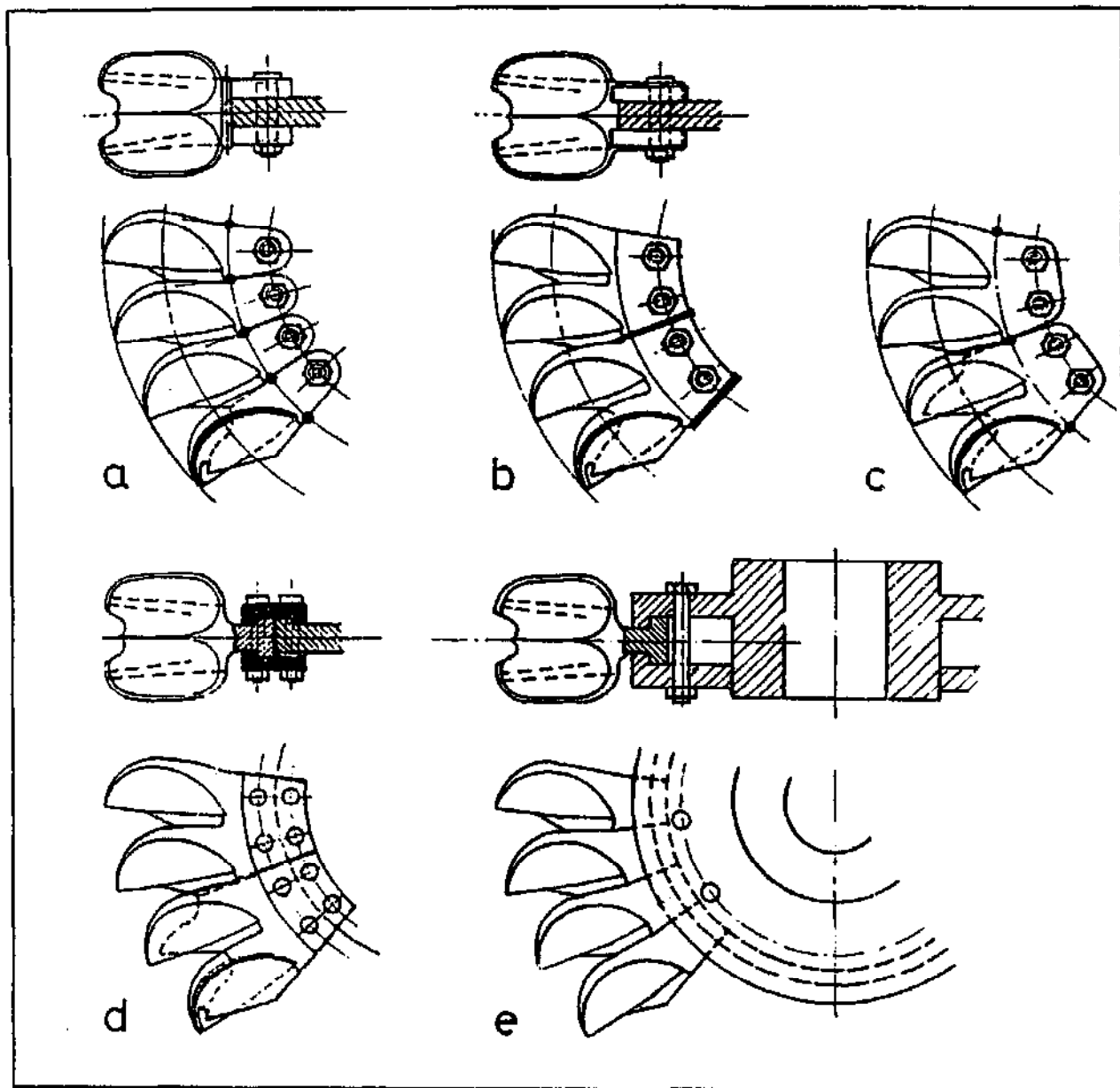

Illustration 16: Different possibilities for fixing the buckets to the rotor disk
(source Escher-Wyss and Aebi)

Casting single buckets is easier than casting the whole rotor. The buckets can be very well machined on CNC machines. The safety is higher and in case a bucket is broken not the whole rotor has to be replaced.

Solutions a), b) and c) in illustration 16 for the fixation of the buckets on the rotor disk are outdated methods, which have sometimes proved to be unreliable.

The rotor is usually connected to the shaft by means of a key. With this design notch sensitivity must be considered. On modern small and medium size turbines the rotor is often fixed to the shaft by shrinking-

on. This requires very close tolerances on the shaft and on the wheel in the range of 1/100 of a millimeter. It also requires cooling facilities for the shaft and the possibility to heat up the wheel. When the rotor has to be dismantled, separation of the wheel and the shaft can be a problem due to fretting rust when these designs are used. A very good solution, though probably not everywhere available, is to use a taper-lock connection between the shaft and the wheel.

Sometimes labyrinth seals are mounted between the turbine shaft and the housing at the point where the shaft protrudes the casing. Often a ring is fixed on the shaft, which turns in a ring-shaped chamber of the housing with an outlet at the bottom (illustration 19).

One of the courses offered by ITDG deals with investment casting of Pelton turbine rotors. Investment casting, also called the lost-wax process, was already used in ancient Egypt and China, but, with the need to produce precision parts in high-temperature materials for jet engines, has found widespread

industrial application only since the Second World War. With this method it is possible to produce the most complex shapes, because the positive models are made out of wax. This method is therefore suited for the fabrication of Pelton buckets and runners. Detailed information is given under reference (10).

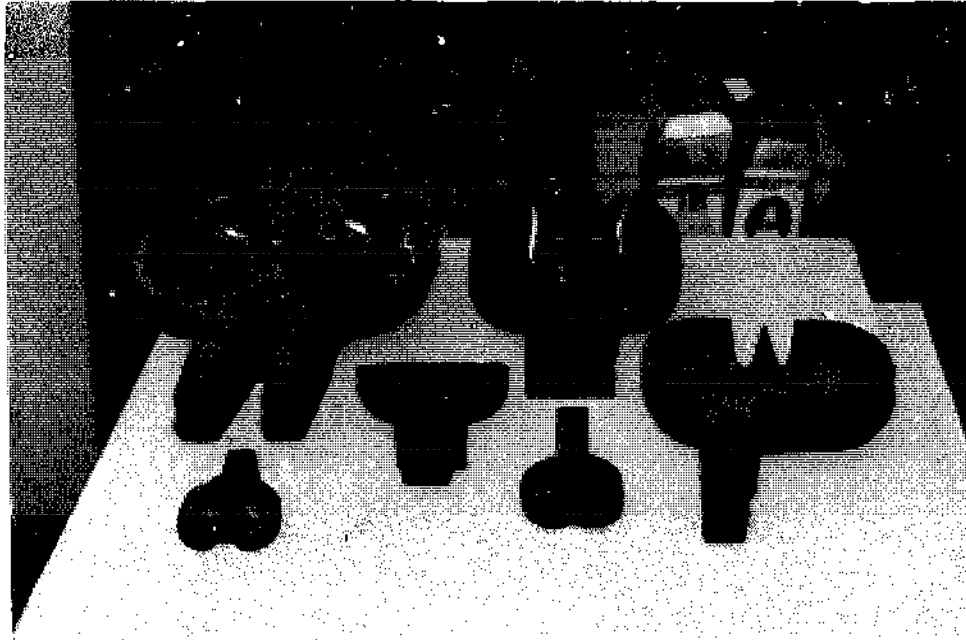

Photograph 10: Pelton buckets showing different ways of fixation

3.8 Housing

The housing of the Pelton turbine has the function of catching the splashed water and diverting it in such a way that neither the rotor nor the jet are disturbed. It also serves to fix and hold the nozzles in place. The housing should be installed high enough above the tailrace water level so that the rotor does not plunge into the water. It must be manufactured strong enough to protect the surroundings in case of damage of a bucket or of the runner.

The housing of a Pelton turbine can be arranged either with a horizontal or with a vertical shaft. A vertical shaft (illustration 17) has the advantage that an optimal draining-off of the water is guaranteed and up to four jets can be installed (on large turbines up to six). In this arrangement optimal results are obtained when the side walls taper upwards by about 10° . In this manner the water flows down helically.

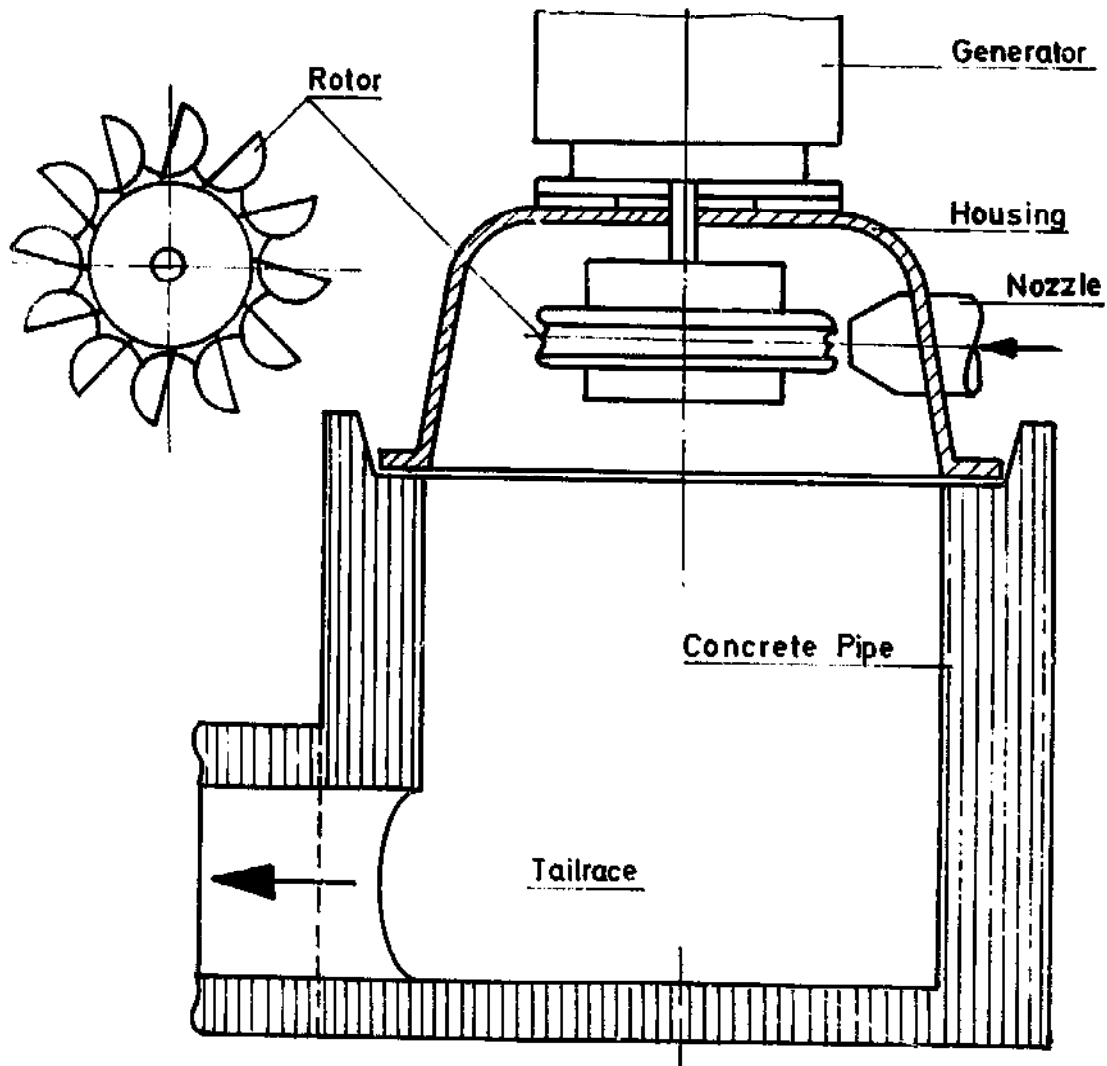

Illustration 17: Vertical arrangement of turbo-generating unit (source Aebi)

In order to avoid the necessity of casting a foundation, the turbo generating unit may be fixed on a customary commercially available concrete pipe. The drain-off pipe, which serves as the tailrace device, is inserted at the bottom of it.

The nozzle can be designed so that it is adjustable. This enables using the same housing design for different pitch circle diameters.

The most economical solution is when the generator is fixed directly on the housing and the rotor is mounted on the generator shaft. Two bearings, one shaft, one seal and a coupling can be eliminated with this design.

The disadvantage of this design is that it is not suitable for installations in which loads of more than a quarter of the design power can be switched at a time, because there is no possibility to install a flywheel.

The housing of a Pelton turbine with a horizontal shaft (illustration 18) normally consists of at least two parts.

Usually the housing can be split horizontally at the level of the shaft. Another possibility is a large flange on one side by which the rotor can be mounted (see photograph 12). The design of the housing must be so that it will enable the water to flow away from the rotor without disturbances. The width of the housing is generally three to four times the width of the buckets.

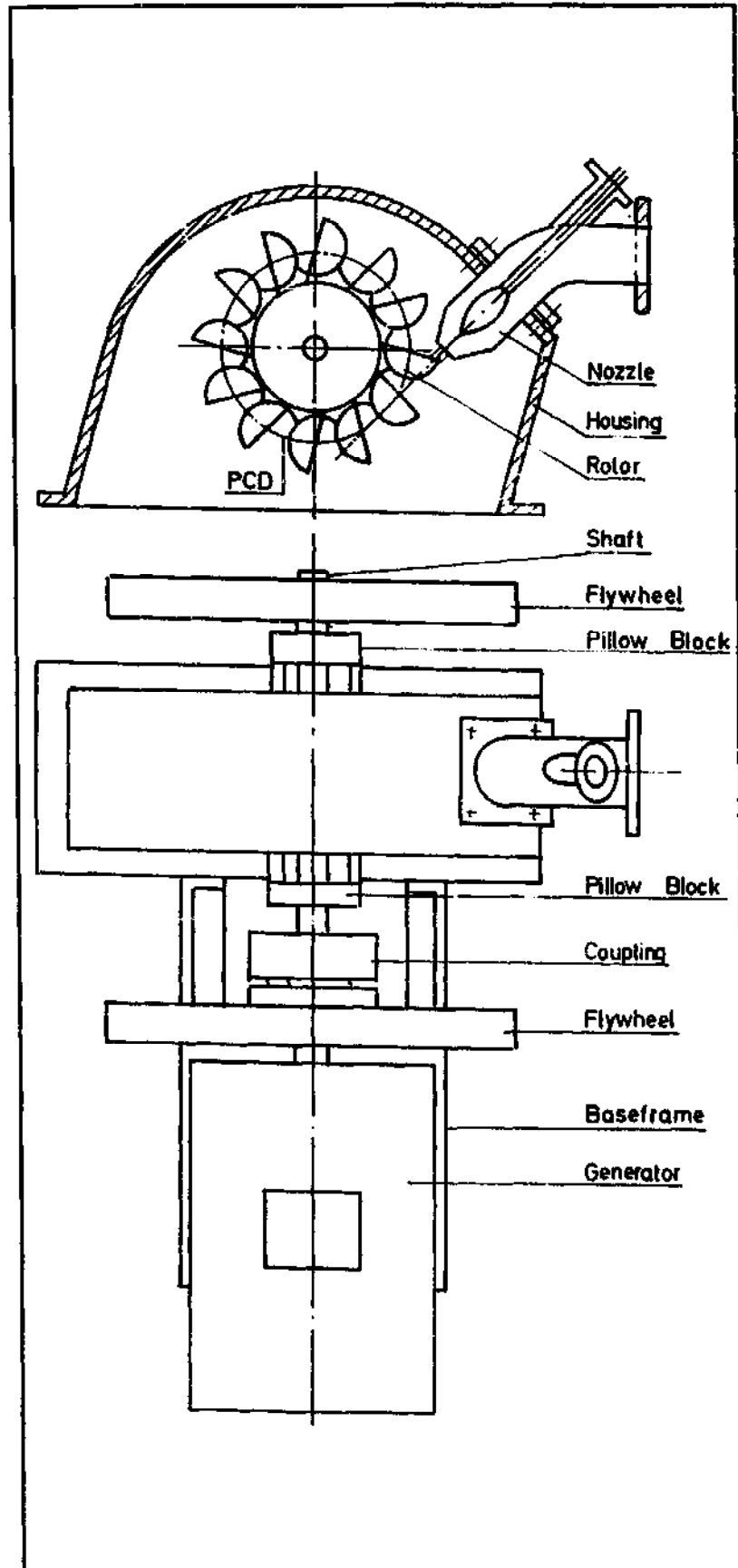
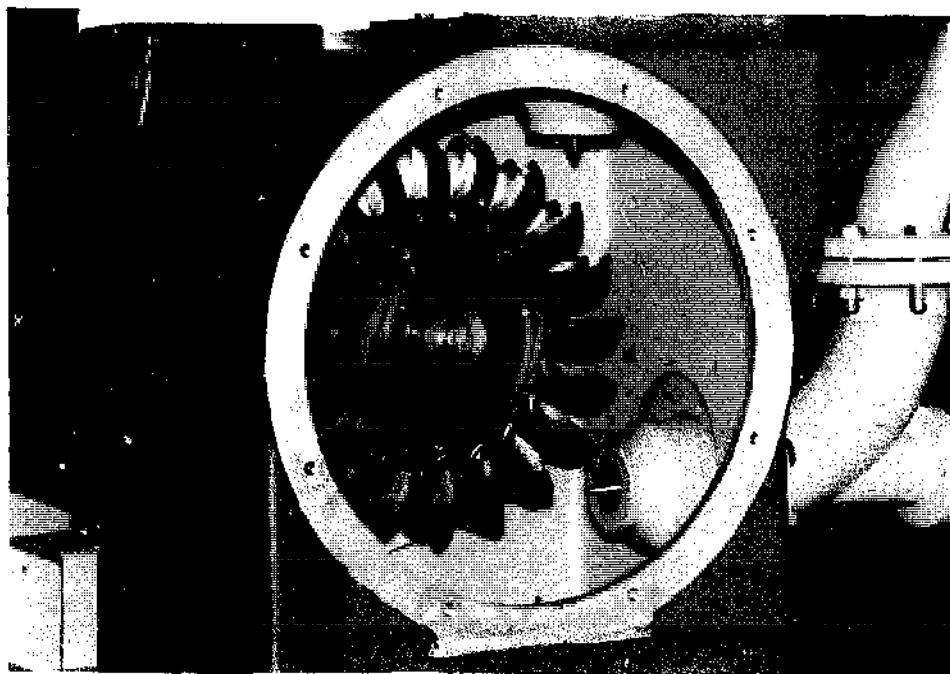

Illustration 18: Horizontal arrangement of turbo-generating unit (source Aebi)



Photograph 11: Standardized Pelton turbine housing, the application limits of this design are 400 m head, 180 l/s discharge and 400 kW power output. It is possible to install one or two jets. Note the ribs for the strengthening of the housing and for the reduction of noise.



Photograph 12: Double jet Pelton turbine with the rotor fixed on the generator shaft

Turbines with a horizontal shaft can be equipped with a maximum of two jets and are well suited for the installation of one or two flywheels. With a flywheel fluctuation of the speed can be reduced. Excessive torque on the coupling can be avoided if the flywheel is mounted directly on the second shaft end of the generator.

If serial production of Pelton turbines is not planned, generally the housings will be made as a welding construction of sheet metal. The need for costly moulds will be avoided in this manner. However, for

the fabrication of Pelton buckets casting facilities are required, so it is often also a very good solution to cast the housing of Pelton turbines.

The sealing of the shaft proves to be a further problem in designing. Some hints have already been given in 3.7. Stuffing boxes generally cause relatively high power losses and are connected with maintenance problems, such as wearing of the shaft and leakage. These are reasons why there is a tendency to design contactless seals with a drain at the bottom leading to the inside of the housing as shown in illustration 19.

3.9 Shaft

When a Pelton turbine drives a generator, the rotor is mostly coupled directly to the shaft of the generator. To provide for the necessary distance for the housing between the generator and the rotor, a long hub is required on the rotor (see appendix 10, drawing NP 2244 - E). This requires special care for balancing of the rotor.

A type of labyrinth seals between the shaft and the housing, which may be used on horizontally split casings, is shown in illustration 19. At the bottom of

the casing (8) there is a hole, which allows the water to flow off via the drain pipe (6). A disk (2) is fixed on the shaft (1). It throws off the water by centrifugal force while it is turning. Another type of seal is shown in appendix 10.

For the calculation of the shaft diameter of the turbine rotor, bending moments and torsion moments must be considered. The shaft mostly has a larger diameter in the middle than at the ends.

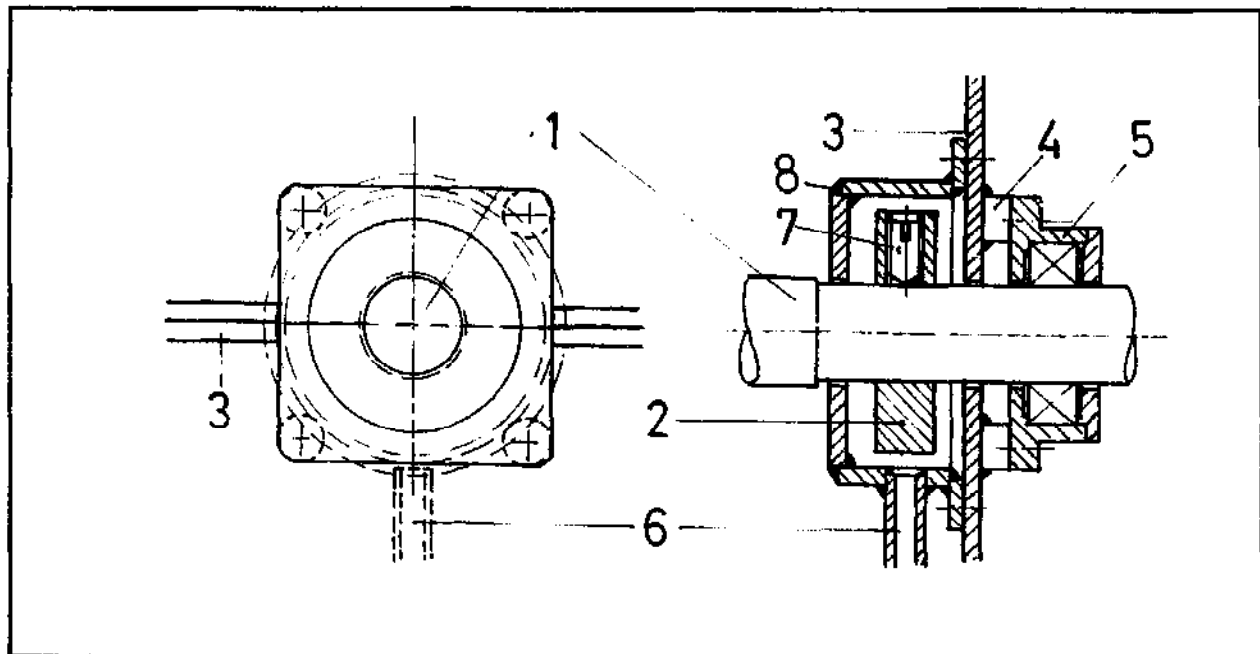

Illustration 19: Labyrinth seal of Pelton shaft

1 Turbine shaft, 2 Throw ring (fixed on the shaft by stud bolts), 3 Separated housing, 4 Spacers, 5 Flange type bearing block, 6 Drain off pipe, 7 Stud bolts, 8 Casing

3.10 Bearings

The bearings are always mounted on the outside of the housing. If two bearings are mounted, one of them is a fixed bearing, with the purpose of fixing the rotor in axial direction.

Generally there is a space between the housing and the pillow block, so as to allow leakage water to flow off and to stop it from entering the bearing housing. This can be achieved by placing spacers between the flange type bearing units and the housing (part 4 in illustration 19). Generally self-aligning double-race ball bearings are installed. When the jet is correctly centered on the buckets, almost no axial forces occur.

3.11 Transmission

Outside the housing a pulley is keyed on the shaft end. In some cases the rotor is mounted directly on the generator shaft.

Power transmissions may serve different purposes, for example to transfer power to another physical location. In former times often rope transmissions were used when the power had to be transferred over a long distance, for instance from a power station in a gorge to a factory on a flat, easily accessible place.

Generally power transmissions have the function of adapting the speed of the turbine to the requirements of the driven machines. Step up or step down transmissions can be achieved by a couple of pulleys or by a gear drive.

A very efficient way to distribute power to different machines mechanically is by means of flat belt or V-belt transmissions. For short distances also chain drives are used. For V-belt drives several belts can be installed in parallel. V-belts require a smaller center distance of the two shafts compared with flat belts, they have smaller axial forces and related to the space required, more power can be transmitted. Modern flat belts however, make up for some of the handicaps mentioned above and have a higher efficiency. They can also be installed in the so-called half-crossed manner to transfer the power from vertical axis turbines to horizontal axis machines.

The bearing housing must be fixed rigidly. This is important to allow trouble free operation. Flange type bearings can be fixed to the housing, plumb-blocks are fixed on supports on a common base frame carrying the turbine and possibly also the generator. It is recommended to dimension the bearings for a lifetime of 100'000 running hours.

If the rotor is fixed to the shaft of the driven machine the bearing at this end of the shaft must be designed strong enough to take up all the forces which may occur. Mostly the bearing at the shaft end of the generator must be replaced by a stronger one, because it is usually not designed for such loads.

Gear boxes are a complicated and costly solution in comparison with belt drives, because in most cases they have to be custom made.

Gear boxes and belt transmissions should be avoided if possible. The cheapest, best and most efficient way is to fix the wheel directly to the shaft of the generator or of other machines, e.g. pumps.

There are various different types of couplings available to connect the shaft of the turbine to the shaft of the driven machine. Mostly one of the following three types is used: flange type coupling, flexible coupling or toothed coupling.

Flange type couplings are rigid connections between the two shafts. The torque is generally transmitted by friction between the two disks. The shafts must be accurately aligned. When cast iron couplings are installed the maximum admissible speed must be considered.

Flexible couplings reduce and dampen torque peaks, dampen vibration and compensate axial, radial and angular misalignment of the shafts, which may be a result of inaccuracy of fabrication or installation, of temperature differences or of other reasons.

Toothed couplings can take up axial displacement and some types allow a certain degree of radial and angular misalignment. They can transfer a high torque with a small physical size and moment of inertia.

3.12 Turbine Control

An isolated power station has to fulfill a much more difficult task than a power station which is connected to a grid. It has to adjust the RPM by itself. The power production has to comply with the power demand. If the load is not constant, the turbine has to be regulated. Governing of the discharge has the advantage that always only as much water is used as required to meet the momentary power demand.

To compensate quick, small load changes a flywheel can be installed. To guarantee undisturbed operation, the maximum power which can be switched at the time should not be more than 10 % to 30 % of the installed capacity. This is not only a question of the regulating mechanism, but also of water hammer effects in the penstock, which may occur when the regulating device is opened or closed too fast.

To avoid overspeed, runaway speed or overvoltage, governors are necessary. A simple way of governing is by hand regulation. This, however, is only recommended for constant conditions or if the speed of the turbine plays a minor role. On a Pelton turbine hand regulation can be easily achieved by regulating the needle with a hand wheel (illustration 9).

In cases where there is a constant flow rate which is always available, nozzles with a fixed opening and without regulating mechanism can be installed on the turbine. In other cases, where the flow rate is not always constant, for instance during the dry season, more than one jet may be installed with different jet diameters. Another possibility is to install a manifold with exchangeable nozzle diameters. In such cases the size of the nozzle must be chosen small enough to maintain the head in the penstock. The penstock must always be filled with water. Otherwise the power output of the turbine will drop drastically.

In cases where the supply of water, and thus the valve setting is constant, the speed of the turbine may also be regulated by an electronic load controller (ELC). It diverts all excess electric power of a plant to a ballast load, which could be an immersion heater. A jet deflector should be installed as an emergency shutdown.

If electrical DC power is produced, the RPM does not have to be kept constant. For the regulation of the voltage, the resistance of the excitation is changed. Excess energy is stored in batteries. If the energy is only used for lighting, a DC distribution system can be installed. But there is also the possibility to produce 220 V AC power by means of a DC-AC inverter.

If the load is not subject to quick changes, simple methods of regulation may be applied. If a multi-jet turbine is used, the jets could have different diameters. If a single jet turbine is used, it could be fitted with exchangeable mouth pieces of the nozzle, having different diameters of the opening of the orifice (illustrations 10 & 11).

Information on governing systems is given under reference (4). On Pelton turbines, it must be noted that the pressure of the water mostly has the tendency to close the needle in the nozzle at all its positions. The closing force is the highest when the needle is at its closed position. With oil hydraulic governors the needle is closed by the force of a spring. Pressure is applied on a hydraulic cylinder to open it. The required opening and closing times are achieved by orifices in the control flow. When the turbine has a jet deflector, the governor first changes the position of the deflector quickly and subsequently adjusts the needle slowly. These double regulated systems are expensive.

4 General Notes

4.1 Fabrication, Checks, Installation and Maintenance

Fabrication

Pelton turbines can be built locally where steel working, welding, machining and possibly casting facilities are available.

The fabrication of the turbine should be fairly straightforward, providing that the fabrication stages have been carefully marked out. The really important point is the alignment of the runner, so that the splitter ridges of the buckets are centered to the axis of the jets. This can be done by sight, with the aid of cross wires over the two stub flanges (see illustration 10, flanges 1 and 2) of the turbine.

When looking along the cross wires towards the splitter ridges, the runner and shaft assembly are moved so that all three are in one line. The bearings are then locked at the correct lateral and angular position. It is best to fix the position of the nozzle between the flange and the housing, as well as the position of the bearings with locating pins. This is done at the workshop when the whole turbine is pre-assembled.

The nozzle can also be aligned by inserting a pointed shaft through the nozzle bore. The shaft is centered by the orifice and the bore for the regulating spindle. Eventually the position of the runner is adjusted until the tip of the shaft is pointing at the splitter ridge of the buckets. If necessary the direction of the jet is adjusted by heating the manifold with a welding torch and then bending it into the correct position.

Other hints on the fabrication of the different turbine parts are given in the relevant chapters.

Checks

Since an "explosion" of a Pelton turbine could cause serious damage, not only material, but also to persons, it is very important to build and check the rotor of the Pelton turbine with utmost care. Special attention must be given to the root of the buckets, the place where they are connected to the rotor disc, and also to the outer ends of the spoon of the buckets.

The surface of the buckets must be carefully checked for cracks and irregularities. This can first be done visually. Other methods can also be applied, such as the Magna-Flux, acid pickling or liquid penetrant method. It is also very important that the buckets are checked for their perfect shape.

The strength of the root of a bucket can be tested statically by applying weight at the place where the water hits the bucket. To do this the buckets must be fixed in the same way as they are fixed to the rotor disc. The direction of the force of the weight must be the same as that of the water jet. It is essential that the force of the applied weight is at least three times higher than the force of the water jet. This is because this method only allows static testing. Dynamic and centrifugal forces will be much higher and instead of the tensile stress the fatigue stress is relevant. The force of the water jet F on the buckets is calculated with the following formula:

$$F = 2 \cdot 1000 \cdot Q \cdot c_1 \text{ [N]} \quad Q \text{ in [m}^3\text{/s]; } c_1 \text{ in [m/s]}$$

This formula considers that the force is the highest when the runner is beginning to rotate. For the buckets of the example in chapter 2.2. the force resulting from the discharge of $0,01 \text{ m}^3\text{/s}$ and the jet velocity of $39,84 \text{ m/s}$ is

$$F = 2 \cdot 1000 \cdot Q \cdot c_1 = 2 \cdot 1000 \cdot 0,01 \cdot 39,84 = 796,8 \text{ N}$$

This force is equivalent to about 81 kg weight. Because the applied load must be at least 3 times higher, these buckets must be tested statically by the application of at least 250 kg weight.

Before the plant is put into operation the penstock is to be filled with water and checked for leaks with the valve at the bottom closed. It is also advisable to clean the penstock entirely from stones and other items which may have entered the pipe during construction. This is very important, because often buckets are broken due to stones hitting them. The nozzle can also get obstructed, with the result that the power is reduced or causing the turbine to run irregularly.

Installation

The recommended procedure is to install the turbine first, to align it correctly and fix it in place to the base frame or to the foundation with anchor bolts. Afterwards the penstock can be mounted, starting from the bottom. When this is done the other way round it is difficult to align the penstock and the turbine. Mostly a piece of the penstock has to be fitted in, which may then be a very difficult task, considering the possible misalignment in lateral and angular direction.

The penstock must be well anchored, because the weight of the pipe and the pressure of the water have the tendency of moving their position. If the penstock is not well fixed it is difficult to install the turbine again, once it has had to be removed, for instance for overhauling.

Once the nozzle and the bearings have been positioned and located with pins in the workshop, as described above, only the lateral position of the rotor will have to be adjusted on site during installation.

On power transmissions where belts are used, the pulleys must be aligned properly. For this the pulley on the runner shaft is secured first. The second pulley is then aligned in all directions. To do this a straight-edge is placed across the face of the first pulley and matched with the second. The lining out is repeated with the second pulley, when the belt is tightened and the position of the second pulley is secured. Afterwards the alignment is checked once again.

4.2 Balancing

Balancing, also called equilibration, means removal of unequally distributed masses on moving parts. Due to the high speed of rotation of the runner it is necessary to balance out forces occurring from the unequal distribution of the material, which may be caused by casting or by the grinding of the buckets.

For the Pelton turbine rotors described in this publication, static balancing is sufficient, because the whole rotor is almost a disk. If the rotor is carefully manufactured, balancing is generally not a problem. But especially on turbine installations where the rotor is fixed on the free shaft end of the driven machine, it should be balanced to avoid excessive

Maintenance and Operation

To facilitate operation and maintenance of the plant it is advisable to set up easy-to-follow user instructions, a set of drawings and a spare parts list and to keep a log-book.

Pelton turbines require only very little maintenance. If the bearings do not have lifetime lubrication, these have to be greased regularly. From time to time the wear and tear of the buckets, of the orifice and the spear of the nozzle and of the housing at the places where the water hits it, should be checked. Periodical routine maintenance comprises checking for leaks, optical checking of all components, checking whether all bolts are properly secured. The paint coat should be touched up sometimes on all such parts which could rust, so as to prolong the lifetime of the material.

If stuffing boxes are installed, the gland must be tightened. And the belts will probably have to be replaced from time to time.

The intake, trash rack and forebay must be regularly checked and cleaned from leaves, branches and debris.

forces on the shaft end and on the bearings. Illustration 20 shows a simple device for static balancing.

It is best to assemble the wheel and the shaft for balancing. The support can be made of angle iron (e.g. 40/40 mm), which is welded together in an arrangement as shown in illustration 20. The balancing edges are made of flat iron strips (e.g. 80/10 mm). The strips are machined on one side to form a sharp, straight edge. There are two slots at the position where they are fixed to the support. It is now very important to align the two edges exactly and to tighten the bolts properly. The whole support with the balancing edges must also be positioned in such a way that the edges are exactly leveled out.

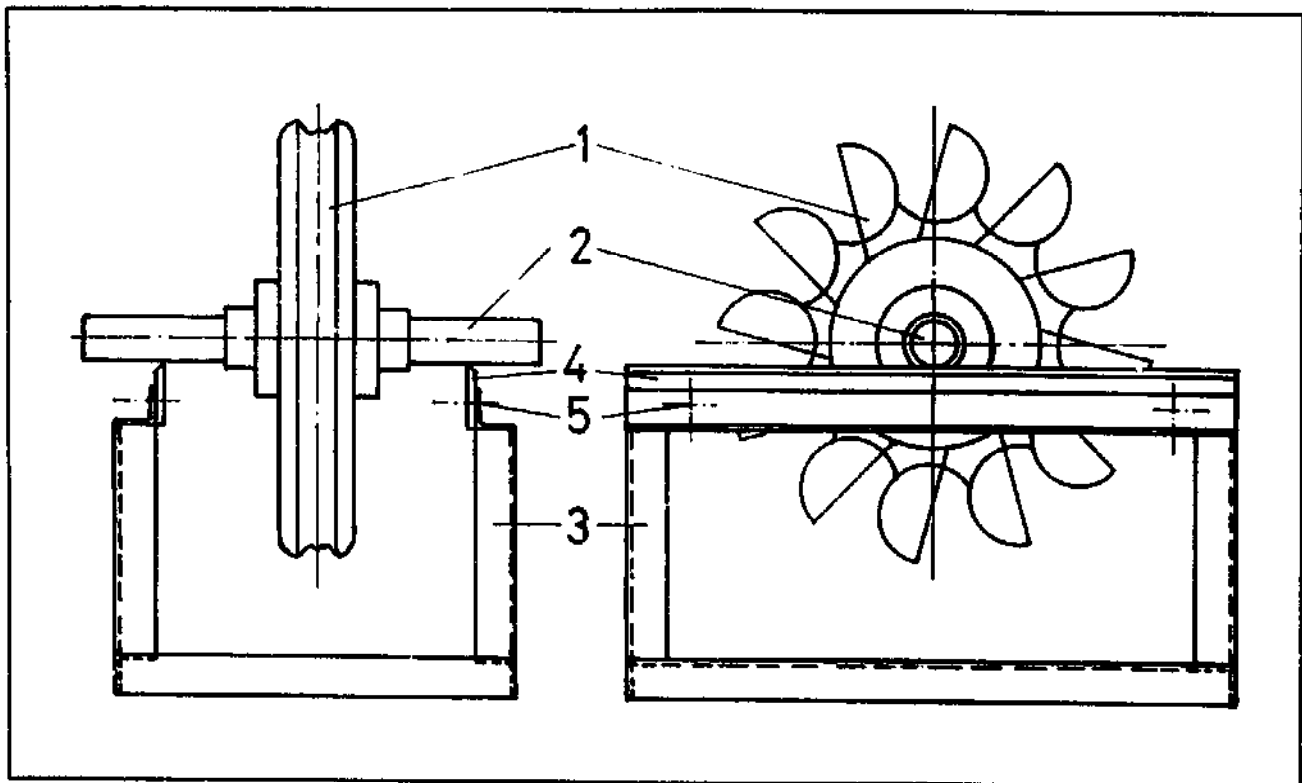

Illustration 20: Device for static balancing

1 Turbine rotor, 2 Rotor shaft, 3 Support, 4 Balancing edges, 5 Nuts and bolts

To balance the rotor it is now placed on the edges. After gently putting it into motion, the heavier part of the rotor will tend to come at the bottom. For equalizing either material can be removed at the heavier side, e.g. by drilling holes into the disks, or by adding material to the other side, e.g. by bolting or welding on. When the rotor no more turns by itself, it is statically balanced.

Another simple method of balancing is by using two ball bearings, placed offset and slightly overlapping, on each side of the shaft, so as to cradle the ends of the shaft in them. The inner rings of the bearings are fixed to a support by a spigot or a bolt. They must be cleaned properly and must not have seals. The procedure of balancing is the same as described above. With this method even better results may be achieved. After use the bearings should be greased before storage.

4.3 Costs

Power stations - also very small ones - always have to be built to match the local conditions. Statements on the costs that are generally applicable cannot be made. Only when a project is studied, a reliable cost estimate can be made. The costs can be considerably reduced if part of the civil works is done by the owners or by community labour and by using locally available materials.

Often the water of a spring is used to drive Pelton turbines. Such installations are generally less costly than intakes on river beds, because no forebay and no desilting tank are necessary.

Generally the penstock pipe is the most costly part of the installation, because high heads require long and strong pipes and because access is sometimes difficult. The terrain conditions can have an essential influence on the cost. Some approaches towards cost reduction are described under 3.3.

The costs for the machine house are a question of the size and of the way it is constructed.

The costs of the turbine, the governor, the generator and the other equipment make up only part of the total costs. Of the turbine itself the governor, the

nozzle and the buckets make up a substantial part of the expenses. The costs for these parts will be reduced considerably if made in serial production. If parts have to be imported this can make things very much more expensive. Some manufacturers offer just the Pelton buckets. An example of the costs of various bucket sizes and material is given in appendix 4 and 5.

Off-the-shelf items should be used wherever possible. Approaches towards cost reduction are given in the relevant chapters.

The cost for survey, planning and installation, as well as for transportation, if the access to the plant is difficult, and to be on the safe side, the unforeseen, must also be taken into the account of the total costs for an installation.

4.4 Safety

There are many safety aspects which must be considered. Most of them have been treated under the corresponding chapters. As serious problems may occur if not respected, they are recapitulated here.

The penstock must be designed not only for static pressure, but also to withstand water hammer effects. It is possible to circumvent this by making provisions to avoid the water hammer effects, such as slowly closing valves or jet deflectors for emergency shutdown.

The nozzle must be fixed to the housing and the housing to the foundation while all bolts must be

The yearly operating costs are composed of depreciation, interest, costs for water rights, insurance. The depreciation time may be taken at 10 to 20 years. The costs for personnel, maintenance and repair must also be included. The yearly operating costs may account for 10 to 20 % of the total investment.

According to calculations by ITDG, unit generating costs have found to be of the order of 0.025 to 0.05 US\$ per kWh (assuming capital cost charged at 10 % discount rate over 20 years) and unit costs of power usefully consumed 0,06 to 0,125 US\$ per kWh with a 40% load factor (1986). This will however be valid only for very simple selfmade installations.

properly tightened up. Regular checks ensure the proper functioning of all the parts.

Buckets must be carefully fabricated and checked. They must be designed to withstand fatigue stress and centrifugal forces.

The housing must be thick enough to protect the surroundings from a possible explosion of the rotor.

If a belt drive is installed, the belt should have a guard. All moving parts, including the flywheel, must be safeguarded in such a manner that any physical contact by persons is inhibited.

5 Further Hints

5.1 Application of Pelton Turbines

Though the number of types of standardized turbines offered is increasing, the correct choice requires expert knowledge and experience. For equal heads and discharges different solutions are possible. The conditions of operation have to be considered, such as fluctuation of the discharge, the amount and duration of load peaks and the RPM of the driven machine.

For the range of power output of the turbines described in this publication, mainly the Pelton turbine and the crossflow turbine are suitable for local production. The application range of the crossflow turbine is for lower heads and larger flow rates. It has a lower efficiency than the Pelton turbine. Another possibility is to install centrifugal pumps, which run in the reverse direction while functioning as a turbine. Though they are not suitable for variable flow rates, their employment may be interesting for constant loads when sufficient water is available. Pumps are considerably cheaper than turbines and often readily available.

5.2 Noise

A severe problem may be the noise of the running turbine. It is advisable to make the layout of a plant already in the planning stage in a such way that the turbine will disturb as little as possible. This can be achieved by having no windows in the machine

Pelton turbines are also suited for semi-permanent application. During construction works, on seasonal business, such as cheese factories, mountain lodges or others, transportable units can provide electrical power. They can be removed again when they are no longer needed.

Due to its pollution-free operation the Pelton turbines can be installed in drinking water supply schemes.

A further application of direct drive is to connect a water pump to the turbine. If water is required at a location above the intake, this is a simple and efficient way to pump the water up. The part of the water which has to be pumped up is branched off from the penstock to the suction side of the pump before the turbine. In this manner the head at the intake to the turbine can be utilized and only the difference in height from the intake to the consumer and the friction losses have to be produced.

house at the side of inhabited houses, or by placing the turbine in a separate small building. Active noise protection measures can be the covering of the turbine with a wooden casing or with sound-proofing material.

5.3 Training Courses

Training courses are offered by the MHPG members SKAT, GATE, FAKT and ITDG. These courses cover different aspects on micro hydropower, which are not mentioned in this publication. One of the courses offered by ITDG focuses on Pelton turbine

design and manufacture. Local manufacturers are trained to design and fabricate Pelton turbines which are particularly suited for remote mountainous regions.

Appendix 1: List of Relevant Publications

- (1) Local Experience with Micro-Hydro Technology, Ueli Meier, SKAT, St.Gallen, 1991: local turbine technology, developed in Nepal, serves as the basis for comparison with conventional hydro technology and other small scale sources.
- (2) Micro Hydropower Sourcebook, Allen R. Inversin, NRECA, Washington, 1986: a practical guide to design and implementation in developing countries, an excellent description of all relevant aspects.
- (3) Hydraulics Engineering Manual, Alex Arter/Ueli Meier, SKAT, St.Gallen, 1990: covers theory required by hydropower engineers, is based on practical experience.
- (4) Governor Product Information, Gerhard Fischer et al., SKAT, St.Gallen, 1990: reflects the conclusions of adequate governing, gives the various types of governors and specifications.
- (5) Water Power Development, Emil Mosonyi, Hungarian Acad. of Sciences, Budapest, 1960: describes all relevant aspects of water power development.
- (6) Strömungsmaschinen, Berechnung und Konstruktion, Willi Bohl, Vogel Verlag, Würzburg, 1980: describes the structure and function of fluid machines.
- (7) Strömungsmaschinen, Aufbau und Wirkungsweise, Willi Bohl, Vogel Verlag, Würzburg, 1977: describes the calculation and design of fluid machines.
- (8) Technische Strömungslehre, Willi Bohl, Vogel Verlag, Würzburg, 1982: deals with the flow characteristics of fluids and gases; textbook with practical examples.
- (9) A Pelton Micro-Hydro Prototype Design, Allen R. Inversin, Appropriate Technology Development Institute, Lae, 1980: describes a Pelton turbine design for local manufacturing.
- (10) Pelton turbine training course, a manual of ITDG, document of a course held in Nepal in July/August 1989: describes relevant elements of Pelton turbine manufacturing, fabrication process, design details and investment casting process.
- (11) Kempes Engineering Year Book 1990, Morgan-Grampion Book Publishing Co. Ltd., London, 2 volumes: General engineering book, deals also in various sections with useful aspects on micro Pelton turbine engineering.

Appendix 2: Addresses of institutions engaged in micro hydropower development and active in publishing literature on small hydropower

**FAKT, Association for Context-Appropriate Technology, Gänsheidestrasse 43,
D-7000 Stuttgart 1, Germany**

**GATE, German Appropriate Technology Exchange, Postfach 5180,
Dag-Hammarskjöld-Weg 1-2, D-6236 Eschborn 1, Germany**

**ITDG, Intermediate Technology Development Group, Myson House, Railway Terrace,
Rugby CV21 3HT, UK**

**NRECA, National Rural Electric Cooperative Association, 1800 Massachusetts Avenue N.W.,
Washington D.C. 20036, USA**

**SKAT, Swiss Center for Appropriate Technology, Tigerbergstrasse 2,
CH-9000 St. Gallen, Switzerland**

**HYDRONET, R. Metzler, Stephan Blatmannstrasse 11,
D-7743 Furtwangen, Germany**

**PPL, Projekt-Planung-Lauterjung, Grauhofstrasse 16,
D-3340 Wolfenbüttel, Germany**

Appendix 3: Reference addresses of manufacturers of components and of Pelton turbines

Bell Engineering Works Ltd.
CH-6010 Kriens/Luzern, Switzerland
Phone (041) 49 51 11, Telex 78167

Biwater Hydropower, Millers Road
Warwick, CV34 5AN, UK
Phone (0926) 411740, Telex 317473 BWaterG,
Fax (0926) 410740

Canyon Industries Inc, 5346 Mosquito Lake Road,
Deming
Washington 98244, USA
Phone (206) 592 5552

Chapallaz Jean-Marc, Ingenieur EPFL/SIA,
Dryade 2
CH-1450 Ste-Croix, Switzerland
Phone (024) 61 10 42

China National Machinery & Equipment, 6 Tian Mu
Shan Rd.
Hangzhou, China
Phone 72164 25072, Telex 35015 CMEC2 CN

Dependable Turbines Ltd, 7-3005 Murray Street,
Port Moody, B.C.
Canada V3H1X3, Phone (604) 461 3121, Telex 04-
54262

DISAG, CH-7320 Sargans, Switzerland
Phone (085) 2 21 81, Telex 855 597,
Fax (085) 2 78 34

Dravske Elektrarne Maribor, Tozd, Elektrovinar
Lasko
Dero 13, Lasko, Slovenija, Yugoslavia
Phone 063-730041, Telex 33121 DEM YU

Drees & Co. GmbH, Abt. Wasserturbinen,
Schützengasse 36 -38
D-4760 Werl, Germany

EFG, Turbinen- und Kraftwerksanlagenbau,
Untere Tiebelgasse 16
A-9560 Feldkirchen, Austria
Phone 04276/4670, Fax 04276 / 46703

Elektro GmbH, St. Gallerstrasse 27
CH-8400 Winterthur, Switzerland
Phone (052) 22 22 53

Elsa, Enterprise électrique S.A., Electromécanique
Av. de France 13, CH-1950 Sion, Switzerland
Phone (027) 22 57 21

Enzfelder Franz, A-2551 Enzesfeld, Austria
Phone (02256) 81287, Telex 14258

Evans Engineering & Power Company, Priory Lane,
St. Thomas
Launceston, Cornwall, UK
Phone (0566) 3982, Telex 45639 COMPUTG

GEC Energy Systems, Cambridge Road, Whetstone,
Leicester LE8 3LH, UK
Phone (0533) 863 434

Geppert, Breitweg 8-10, A-6060 Hall i. Tirol, Austria
Phone (05223) 7788-0

Gilbert Gilkes & Gordon Ltd., Kendal
Cumbria LA9 7BZ, UK
Phone (0539) 20028, Telex 65125

Gugler, A-4085 Niederranna 41, Austria
Phone 07285/514, Telex 116540 box a

HUGAL, Hugentobler, Turbinen & Maschinenbau,
Stockenstrasse
CH-9249 Algetshausen, Switzerland
Phone (073) 51 66 22, Fax (073) 51 75 78

Hydro-Watt Systems, 146 Siglun Road
Coos Bay, Oregon 97420, USA
Phone (053) 247 3559

IREM S.p.A. Via Vaie 42
I-10050 S. Antonino (Torino), Italy
Phone (011) 9649133/4/5, Telex 212134
IREMTO-I

J. Justo SA, Apartado 43
Bilbao, Spain
Phone (94)4675061, Telex 31558 JJSA E

Jyoti Ltd., Bombay Shopping Center,
R.C. Dutt Road
Vadodara 390 005, India

Koessler GmbH, Engineering Works
A-3151 St. Georgen, Austria
Phone (02746) 8272, Telex 015652,
Fax (02746) 2626

Newmills Hydro, Mill Lane, Island Road, Ballycarry
Carrickfergus, Co. Antrim, N. Ireland
Phone 78433/78610, Telex 74448 HYDRO G

Obermeyer Hydraulic Turbines Ltd, 10 Front Street
Collinsville, CT 06022, USA
Phone (203)6930295

Paget Resources Ltd., 1230 - 800 West Pender Street
Vancouver B.C. V6C 2V6, Canada
Phone (604) 669-8800, Fax (604) 683-2173

Small Hydro East, Star Route 240,
Bethel, Maine, USA
Phone (207) 824 3244

Tamar Design PTY. LTD
Deviot, Tasmania 7251, Australia
Phone (003) 94 73 57 or (003) 31 20 47, Telex AA
58772

Turbosun AB, Box 71
S-66900 Deje, Sweden
Phone 0552 21085, Telex 66176

Tz Litostroj, Djakoviceva 36
61000 Ljubljana, Yugoslavia
Phone 061 556 021

Voest Alpin AG, Postfach 2
A-4010 Linz, Austria
Phone (585)8118, Telex 2208603 VA A

Voith GmbH, Postfach 1940
D-7920 Heidenheim, Germany
Phone (07321) 376, Telex 71479920 VH D

Wasserkraft Volk, Gefäll 45
D-7809 Simonswald, Germany

Water Power Machinery Company
P.O. Box 9723,
Midland 08. Texas, USA
Phone (915) 697-6955

ZOBO AG, Werkzeuge und Apparatebau,
Seestrasse 9
CH-3855 Erienz, Switzerland
Phone (036) 51 17 15

**The following manufacturers offer electronic load
controllers.**

Dulas Engineering, Llwyngwern Quarry,
Machynlleth
Powys, Wales SY20 9AZ, UK
Phone 0654 2782

GP Electronics, Pottery Road, Bovey Tracy,
Devon UK
Phone 0626 832670

Kobel Hans, Elektromechanische Werkstätte
CH-3416 Affoltern im E., Switzerland
Phone (034) 75 14 13

THES, Thompson and Howe Energy Systems Inc.,
Site 17, Box 2
S.S. 1, Kimberly, British Columbia,
Canada V1A 2Y3
Phone (604) 427-4326

Appendix 4: Cost of Pelton Buckets

ZOBO AG BRIENZ
WERKZEUGE UND APPARATEBAU

SEESTRASSE 9 CH-3855 BRIENZ TELEFON 036 51 17 15



1.4.90

Dimensions of Pelton Buckets and Price-List

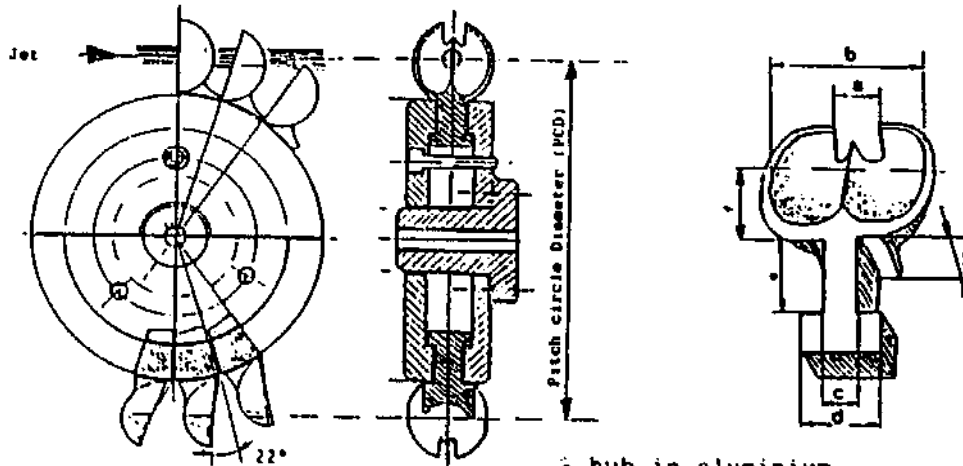

Ny = reinforced plastic GG = grey cast iron Nir = stainless steel * hub in aluminium

Bucket size	Jet diameter a (mm)	Width of bucket b (mm)	Width of shaft c (mm)	Width of foot d (mm)	Width of ring e (mm)	Cost of rotor SPR x buckets	PCD f (mm)	Pitch g (mm)	Material of buckets	Cost of Buckets machined	
										yes	no
B	4.6	19	8	14	10	*16.50	11.0	14.9	Ny	5.-	-
C	11.0	30	10	18	11	*18.50	15.0	19.8	Ny	7.-	-
D	18.0	47	15	22	14	*20.-	25.0	22.0	Ny	11.-	-
									GG	39.-	19.-
									Nir	91.-	51.-
E	21.0	67	20	36	22	*20.-	35.0	38.0	GG	68.-	28.-
									Nir	96.-	56.-
F	26.0	80	25	40	25	*20.-	40.0	42.0	GG	78.-	38.-
									Nir	120.-	80.-
G	32.0	92	28	43	28	*20.-	46.0	46.0	GG	89.-	49.-
									Nir	145.-	105.-
H	44.0	125	40	60	40	*20.-	47.0	47.0	GG	100.-	60.-
									Nir	180.-	130.-
J	55.0	160	42	67	55	*20.-	49.0	49.0	GG	105.-	65.-
									Nir	198.-	152.-
K	70	190	55	90	65	*20.-	51.0	51.0	GG	120.-	78.-
									Nir	256.-	200.-

according to offer

Appendix 5: Cost of Pelton Turbine Wheels

HUGAL
Turbinen- und Maschinenbau



CH-9249 Algershausen
Switzerland

Ref.: Prices for Peltonrunners

28.12.90

Pelton turbine runners

Material	Pitch diameter	Bucket width	Price (ex Work) sFr.
stainless steel	290	35	4'800.-
stainless steel	310	35	7'800.-
stainless steel	310	50	8'800.-
stainless steel	350	70	14'600.-
Alu-Bronce	240	50	5'800.-
Alu-Bronce	240	70	6'400.-
Alu-Bronce	290	50	6'200.-
Alu-Bronce	290	70	6'800.-
Alu-Bronce	350	70	11'300.-
Alu-Bronce	370	100	17'600.-
Alu-Bronce	410	70	13'800.-
Alu-Bronce	410	110	18'500.-
Alu-Bronce	410	130	19'800.-
Alu-Bronce	430	120	19'500.-
Alu-Bronce	490	110	21'400.-

For the above mentioned runners the molds are on stock and the runners can be cast at any time.

The runners are cast in one piece, without a shaft, are equilibrated and are ready for fixing.

Appendix 6: Cost of Pelton Turbines

ZOBO AG BRIENZ
WERKZEUGE UND APPARATEBAU

SEESTRASSE 9 CH-3855 BRIENZ TELEFON 036 51 17 15



Pricelist Pelton Turbines

1.4.90

- Our Pelton turbines PT 150 - 600 are manufactured with a vertical shaft
- Simple installation on customary in trade concrete pipes
- Installation of 1-3 nozzles and jets, with fixed or adjustable position is possible
- The rotor is generally fixed directly on the shaft of the generator
- Execution of the nozzle:
 - without closing device
 - with closing valve
 - manual flow regulation
 - flow controlled by positioning motor
- Output voltage according to requirement:
 - 12 V=
 - 24 V=
 - 220 V
 - 380 V
- Governors according to requirement

- Prices are guiding prices

			including installation	excluding installation
PT 150/200	0,05- 1KW		from Fr 2500.-	from Fr 2200.-
PT 250	0,5 - 2KW		from Fr 3800.-	from Fr 3500.-
PT 350	1,5 - 5KW		accord. expenses	from Fr10800.-
PT 500	3.0 - 15KW		accord. expenses	from Fr21600.-
PT 600	10,0- 30KW		accord. expenses	from Fr32400.-

- Larger turbines or turbines for special applications upon request

ZOBO AG BRIENZ

WERKZEUGE UND APPARATEBAU

SEESTRASSE 9 CH-3855 BRIENZ TELEFON 036 51 17 15



ZOBO

1.4.90

Pricelist: Housings Jets

PT 150: with fixed nozzle	Fr 187.-
nozzle with hole	Fr 62.-
gasket	Fr 7.-
tailrace casing	Fr 105.-

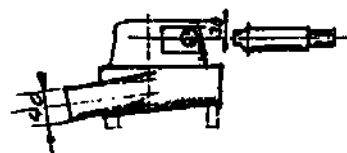

PT 250: with fixed nozzle	Fr 262.-
nozzle with hole	Fr 83.-
with adjustable nozzle	Fr 312.-
gasket	Fr 9.-
tailrace casing	Fr 203.-

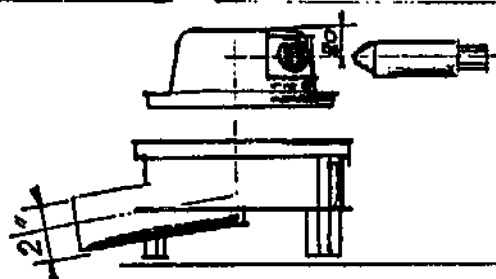

Pt 350 : with fixed nozzle	Fr 331.-
with adjustable nozzle	Fr 527.-
nozzle	Fr 107.-
gasket	Fr 11.-

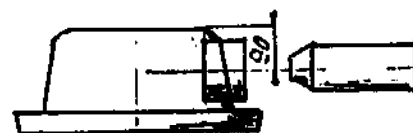

PT 500 : with fixed nozzle	Fr 456.-
with adjustable nozzle	Fr 637.-
nozzle	Fr 137.-
manually adjustable no.	Fr 842.-
electr. adjustable noz.	Fr 2052.-
gasket	Fr 13.-

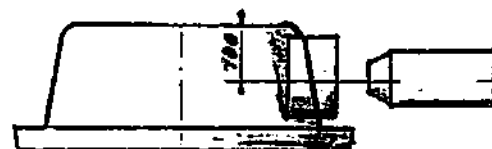

PT 600 : upon request

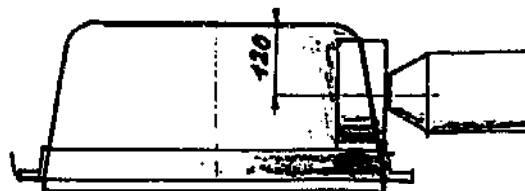

ZOBO AG BRIENZ

WERKZEUGE UND APPARATEBAU

SEESTRASSE 9 CH-3055 BRIENZ TELEFON 036 51 17 15



ZOBO

24.8.89

Dimensions: Housing and Nozzle

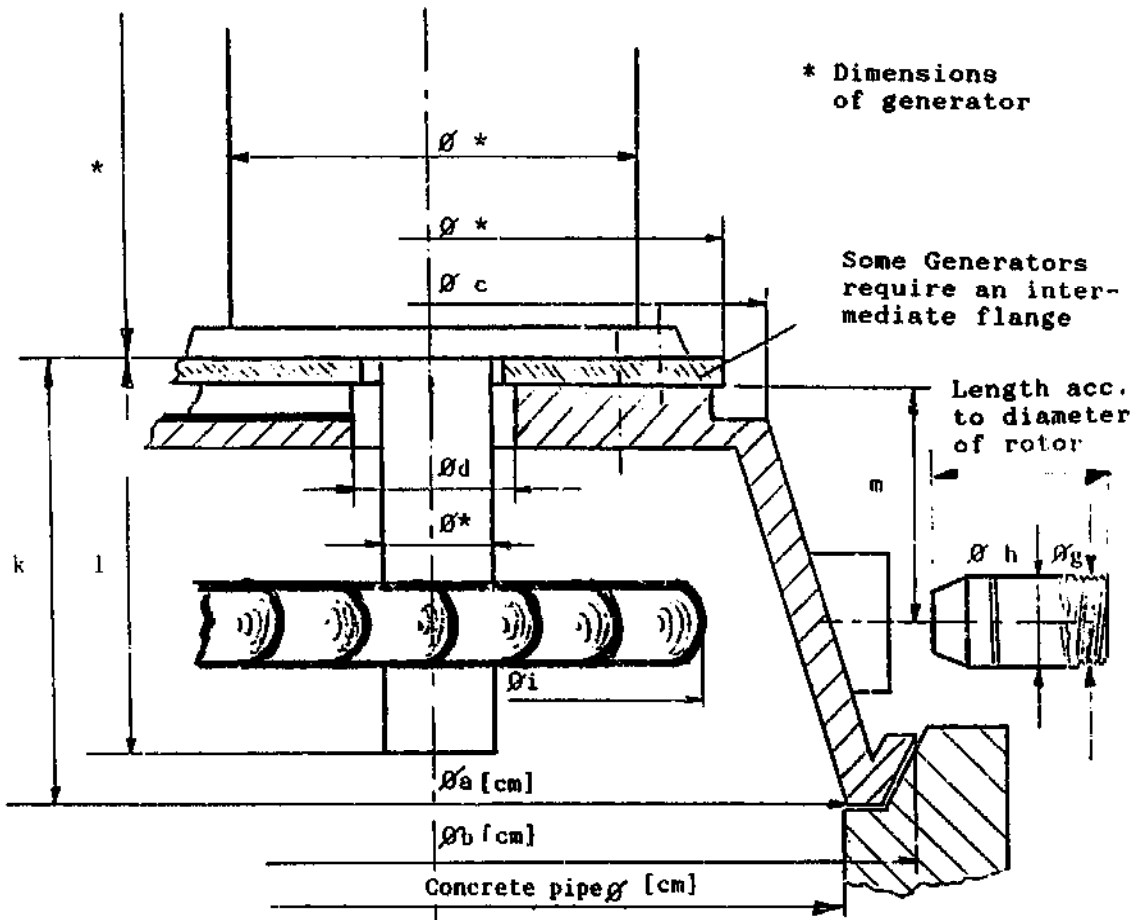

Type a	b	c	d	concr. pipe Ø	hous- ing	thread g	h ØA/ØI	i max	k	l	m
150	180	100	16	150	A1-B1	1/2"	20/14	100	65	60	30
250	290	200	30	250	A1-G	3/4"	28/19	160	150	90	80
350	390	260	35	350	A1-G	1 1/2"	50/40	270	170	150	90
500	550	360	60	500	A1-G	2 1/2"	80/60	400	260	200	100
600	Auf	Anfrage		upon	request						

Appendix 7: Flow Nomogram for MDPE Pipes

Flow Nomogram (for MDPE pipes)

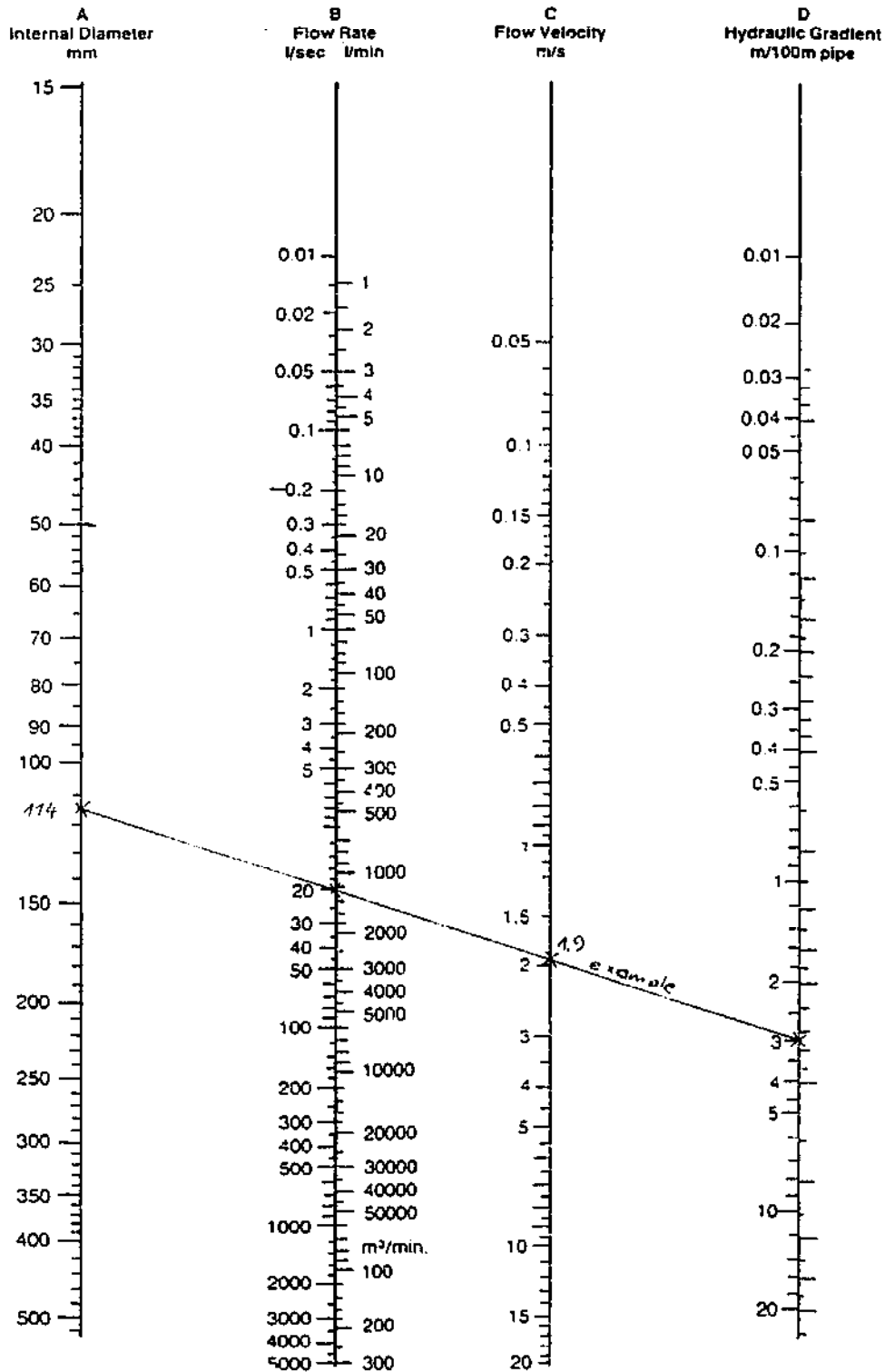

Appendix 8: Examples of application of Pelton turbines

Source FAT, CH-8356 Tänikon TG, Switzerland

A description of a number of installations in various regions of Switzerland shows the diversity of local conditions and also that of requirements on electricity supply.

The table on page 59 gives an overview of the principle data on the small power stations which are described hereafter.

A8.1 Blackenalp (0.15 kW)

Blackenalp is residence for 760 heads of cattle of which 10 are milk-producing cows that supply the small cheese dairy. When the water supply had to be renewed this was an opportunity to make the 400 m supply line for drinking water with a slightly larger diameter (90 mm nominal width) in order to operate a small water power station (see fig. 1 and 2).

With the small head of 18.5 m the Pelton turbine requires a water quantity of approximately 1.5 l/s to generate an output of 150 W. The water is not contaminated by the turbine, so that it remains fit for drinking. The generated energy is stored in accumulators with a capacity of 600 Ah. When the batteries are charged the water supply to the turbine is automatically shut off.



Fig. 1: Micro-Pelton turbine with built-on DC-Generator. (The turbine at Blackenalp has about the same dimensions, but is equipped with three nozzles.)

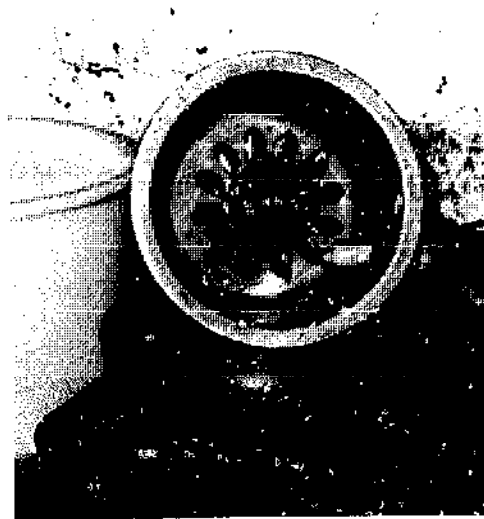

Fig. 2: Also on the smallest Pelton turbines there is a runner with the typical double spoon-shaped buckets.

The 24 volt batteries supply a 220 Volt system via a D.C.- A.C. inverter, which allows connecting units with a capacity of up to 1 kW. This is sufficient for lighting, to run the stirrer for cheese making, a butter churn and a small centrifuge, whereas the milking machine is run by a water jet pump.

A8.2 Beuertweid (2 kW)

Beuertweid is an Alp with the rights for holding 55 heads of cattle of which at the moment, 12 cows supply milk and 10 are calves. The excessive milk is made to cheese in a wood-heated cauldron.

For supplying the household and cow shed with electricity two springs in a marsh are kerbed (fig. 3), from where the water is led into a wooden case with a capacity of approximately 200 liters. From this "surge tank" the necessary water for generating electricity (4 l/s) flows through a sieve into the penstock, while the excess water runs over the case into the marshland and the successive stream.



Fig. 3: Simple water intake in a marshland below the spring (no floods, no debris load).



Fig. 4: An old wooden box serves as surge tank.

The penstock - which is an embedded PE-pipe with a nominal width of 75 mm - follows the course of the stream, through alp meadows, 350 m downwards towards the valley (fig. 5). The head is 90 m; the average slope 27%. The pipes could be dug in with the aid of a machine for laying cables, which can be attached to the rear end of a tractor.

The machine house consists of a masonry box with a front made out of an old electrical distribution housing, entrenched in the slope alongside the brook (fig. 6). Inside, the Pelton turbine, with top mounted generator and a constant output of 2 kW single-phase alternating current of 220 V and 50 Hz, is installed on top of a concrete pipe with 25 cm inner diameter (fig. 7).

This installation supplies two buildings which are normally not inhabited at the same time, the secondary dwelling some 400 m towards the valley and the main dwelling, about 50 m higher up (see fig. 5). The electricity supply to both buildings is via buried electrical cables. The machines and appliances used in the household and cow shed of the main dwelling have a total connected load of about 5 kW.

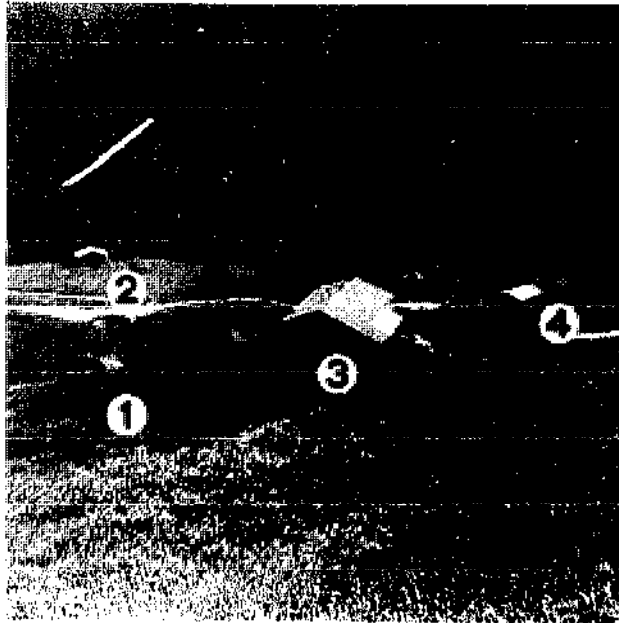

Fig. 5: Beuertweid: The penstock leads through meadows at an average slope of 27%.

- 1 Penstock (buried)**
- 2 Machine house**
- 3 Main dwelling**
- 4 Secondary dwelling**



Fig. 6: Machine house: By covering it with earth and planting the appearance could be improved.

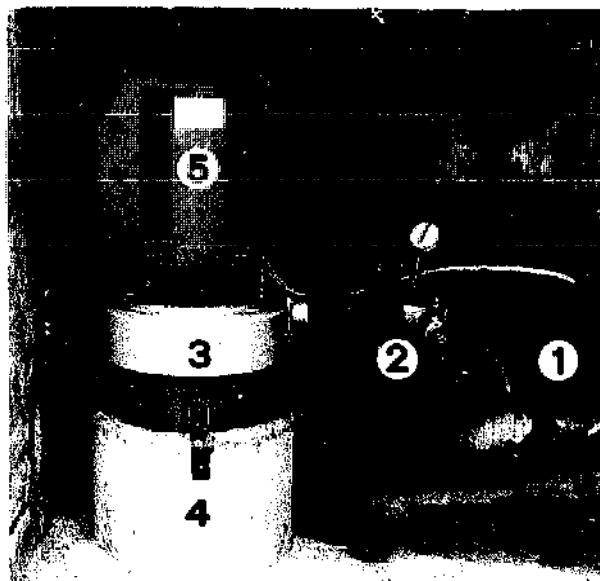

Fig. 7: Turbine-generator unit.

- 1 Penstock (PE-pipe 75 mm outer dia.), 2 Shut-off valve with pressure gauge, 3 Pelton turbine**
- 4 Turbine base (concrete pipe 32 cm outer dia.), 5 Synchronous generator (nominal output power 3 kW, 220 V, 50 Hz).**



Fig. 8: Spring kerb: Immediately after emerging, the water is collected in a concrete basin and is led into a PVC-pipe (inner diameter 100 mm).

A8.3 Hinterchirel (2.4 kW)

The alpine pasture of Hinterchirel - with 29 heads of cattle of which about 15 are milk-cows and 14 are calves - is a summer dwelling. Also cheese and butter are produced at this family enterprise.

In order to supply this pasture with electricity for the milking machine, lighting, hot water, the cheese stirrer as well as the hot plate, two refrigerators and other kitchen utensils a spring was kerbed, which after dry seasons, in autumn, supplies at least 3 l/s water, and in spring and summer more than double that. Immediately after it emerges, the water is collected in a concrete basin and led into a PVC pipe with 100 mm nominal width (fig. 8). The pipe leads to a well which is made of a concrete pipe of 35 cm inner diameter, which acts as a surge tank.

From the surge tank a nearly 300 m long PE-pipe with a nominal width of 63 mm leads to the bottom of the valley below the pasture house (fig. 9). The head is 130 m; the average slope is 50%. The penstock was dug in together with a new drinking water supply line. The upper quarter of the penstock leads through steep terrain (about 70% slope) interspersed with loose stones and rock and had to be dug in by hand. The remaining part of the line could be dug in with the aid of an off-road earth mover.

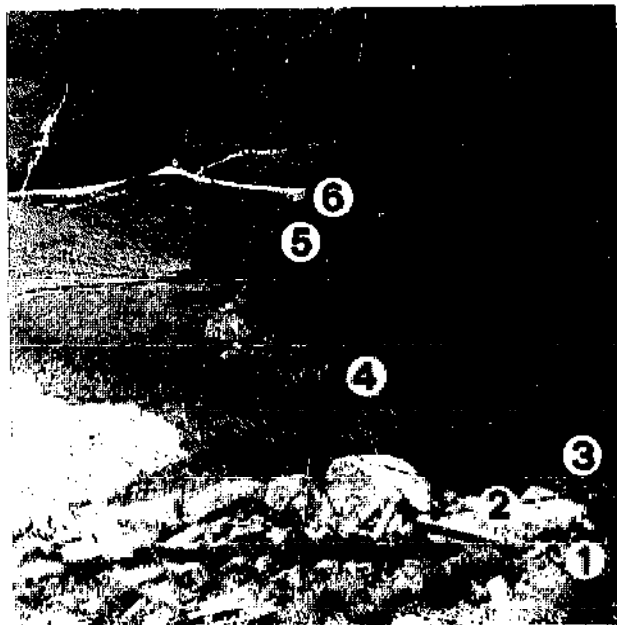

Fig. 9: Hinterchirel: The penstock leads through steep terrain (up to 70 % slope) with rocks and boulders.

1 Spring kerb, 2 Lead-over to surge tank, 3 Surge tank, 4 Penstock (buried), 5 Machine house, 6 Cow shed



Fig. 10: Machine house (well integrated into its surroundings)

A wooden hut with about 4 m² area was built to house the turbine and generator assembly (fig. 10). The generator supplies single-phase alternating current at 220 V and with a frequency of 50 Hz. The electricity is transferred to the houses over a distance of about 50 m via buried cables.

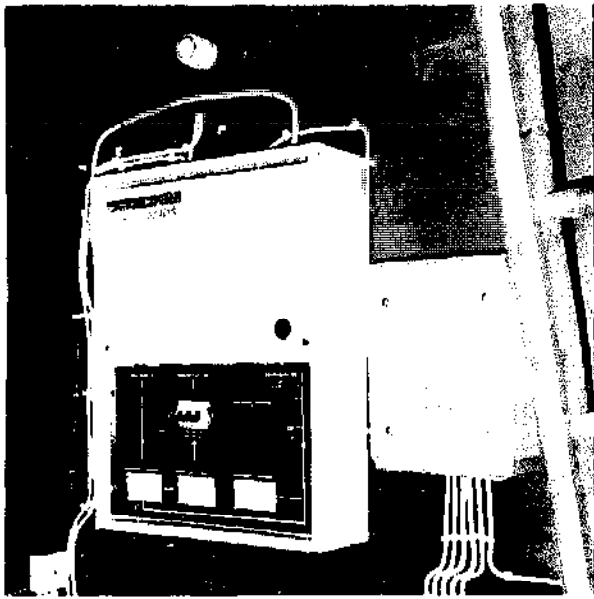

Fig. 11: Electrical control cabinet in the alpine hut with electronic governor and indicating instruments for current, voltage and frequency.

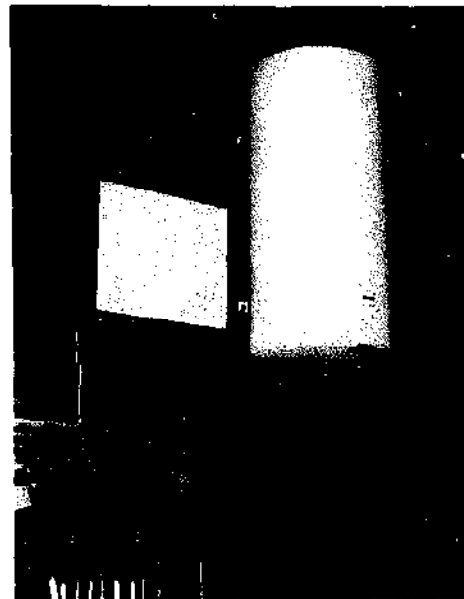

Fig. 12: For load compensation at the consumer side the excessive power is led to a 200 l immersion heater (right) or to an air-cooled load resistor (left).

The electrical cabinet with the control and monitoring instrument is fitted inside the farm house (fig. 11). The electronic governor always leads so much power to a 200 l immersion heater that the generator is constantly loaded with 2.4 kW. When the immersion heater is fully charged the excessive energy is led off via an air cooled load resistor (fig. 12).

Electrical appliances and lamps with a total connected load of about 7 kW are installed in the alpine pasture buildings.

A8.4 Bachläger (8.6 kW)

Four enterprises with in total 264 heads of cattle and a hill restaurant belong to the alpine community of Bachläger. The small power station in the first place provides the enterprises with electricity for the milking machines and for lighting and hot water. The excessive energy is used to supply the immersion heater of the restaurant.

The water is taken from the run-off of a mountain lake by means of a simple trash rack intake - a concrete pipe of 1 m inner diameter dug into the bed of the stream. The concrete pipe is covered with a simple grid of concrete-reinforcing steel (fig. 13). In order to avoid suspended particles (moss, parts of plants) which are carried by the brook, from entering the intake, a finely perforated plate is placed over the grid.

The upper part of the penstock, which begins directly at the intake, passes through rock terrain (fig. 14) and then about 50 cm under the surface, further to the machine house. The length of the PE-pipe line with a nominal diameter of 160 mm and 6 bar nominal pressure, is 160 m, the head is 50 m. This results in an average slope of 33%.

The generator on the three-nozzle Pelton turbine with vertical axis supplies a constant 8.6 kW electrical power. The transmission lines to the four enterprises are short; the one to the restaurant is about 1 km. All electrical lines are buried.



Fig. 13: A simple intake consisting of a trash rack made of concrete reinforcing steel, placed on a concrete pipe (inside dia. 100 cm) which is dug into the bed of the stream.

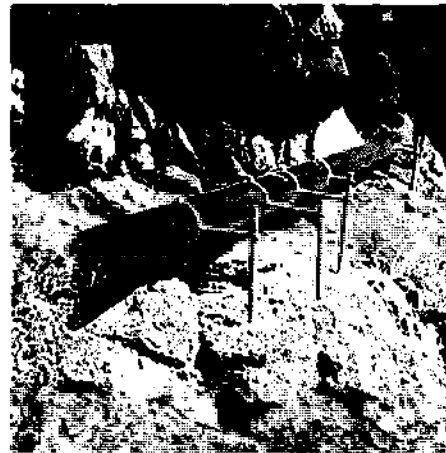

Fig. 14: The upper section of the penstock (PE-pipe, outside dia. 160 mm) leads open through rock terrain.

A8.5. Cavel (15.4 kW)

At the occasion of the redevelopment of the alp pasture with rights for 333 heads of cattle an electrical cheese making plant for 100 milk cows was installed and a small hydro-electric power plant was built.

In a flat section of a brook above a waterfall, water is taken by a Tirolian weir which covers approximately one quarter of the bed of the stream, and is led to a desilting chamber (fig. 15 to 17). From the desilting chamber a PE-pipe line with a nominal diameter of 200 mm leads first along the flatter section of the stream and then sideways along the slope of the valley, with an average gradient of less than 1%, to a pit made of glass-fibre reinforced plastic, with a diameter of 1.5 m and 1.8 m deep - the surge tank with a volume of 3 m³ (fig. 18). Since this flat low-pressure penstock of 350 m length has also a slight opposite slope, further small intersection and venting pits are required.

From the surge tank a penstock with a length of 295 m leads first at an angle and then following the line of the hill slope to the machine house. The head is 84 m, the average slope 30%. The diameter of the penstock is stepped. The upper part has a nominal diameter of 200 mm and a nominal pressure of 6.3 bar; the lower section is 160 mm and 10 bar.



Fig. 15: Water intake and desilting basin in the flat section of the stream.
1 Tirollian type intake (flooded)
2 Desilting chamber

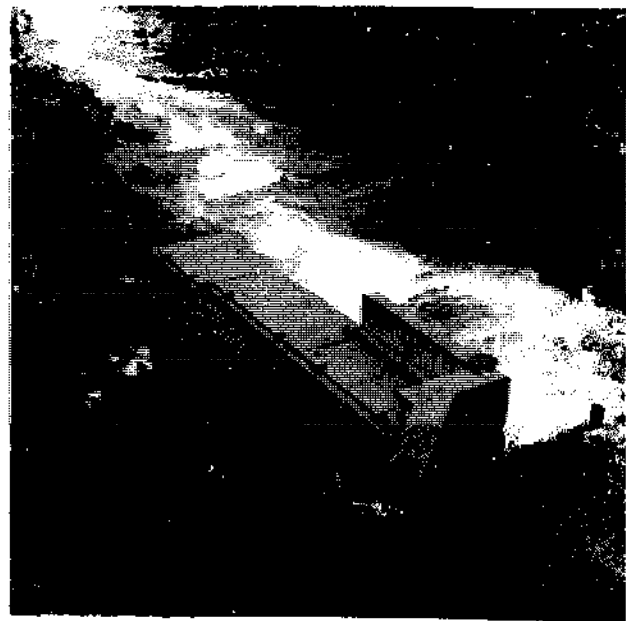

Fig. 16: Desilting system with protection wall against high water (looking downstream).

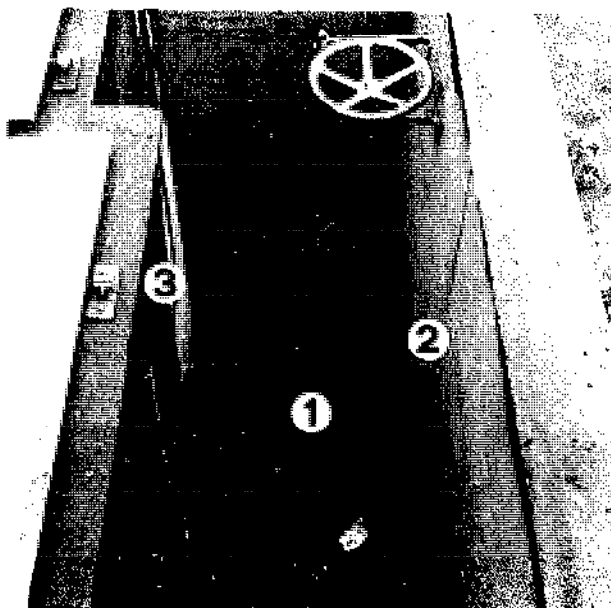

Fig. 17: View into the desilting chamber while flushing (water has been partially let off). 1 Baffle plate, 2 Flushing slide, 3 Intake sieve on the low-pressure penstock drain.

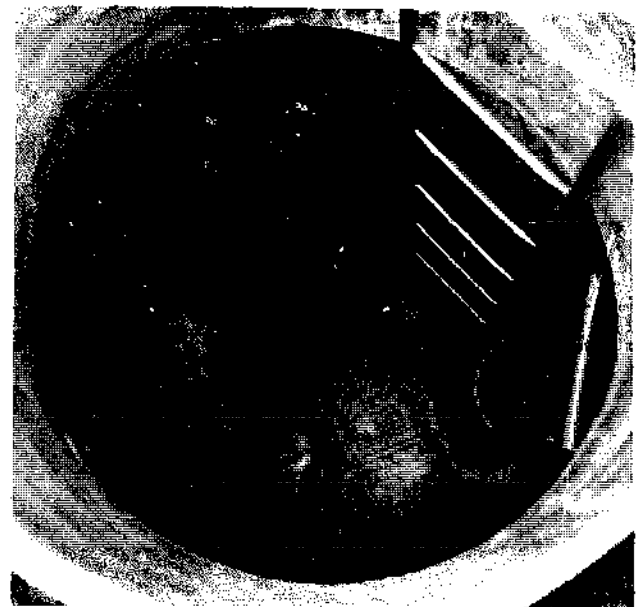

Fig. 18: Surge tank of glass-fibre reinforced plastic (1.5 m dia.) with intake sieve on penstock and overflow via the plugging pipe in the bottom .

The machine house was built 30 m above the bottom of the valley in the slope of the hill, because the snow masses of the opposite avalanche-prone slope often have not melted by the beginning of the summer. A solid, avalanche proof concrete construction was made. The twin nozzle Pelton turbine with horizontal shaft is coupled directly to the generator. The power plant supplies three-phase alternating 220/380 V, 50 Hz current. The output is adjusted at a constant 15.4 kW. The hot water accumulator of the cheese-making plant takes up the largest amount of power and acts as a load compensator for regulating.

The power transfer to the alpine pastures over a distance of 400 m is by means of buried cables which are led inside a PE-pipe with 60 mm diameter.

A8.6 Aebnet (16 kW)

When the communal dairy for six alpine pastures with a total of 150 heads of cattle was planned a possibility was sought to electrify the dairy as well as each of the farms.

The nearby stream proved to supply a rather sparse amount of water during autumn, so in order to provide the electrical dairy with sufficient power a large head would be required. Therefore the location of the machine house was decided on at a place below the pasture buildings, where the stream flattens out. The optimal place for the water intake was a point underneath the water chamber for the drinking water supply, which granted also a reliable flow during dry periods (fig. 19). This arrangement provided an effective head of 220 m. Placing the intake higher would have meant doing without the surplus water of the drinking water chamber. However, the overflow of the water chamber to the intake of the power plant (fig. 20) is a substantial contribution towards power supply during autumn.

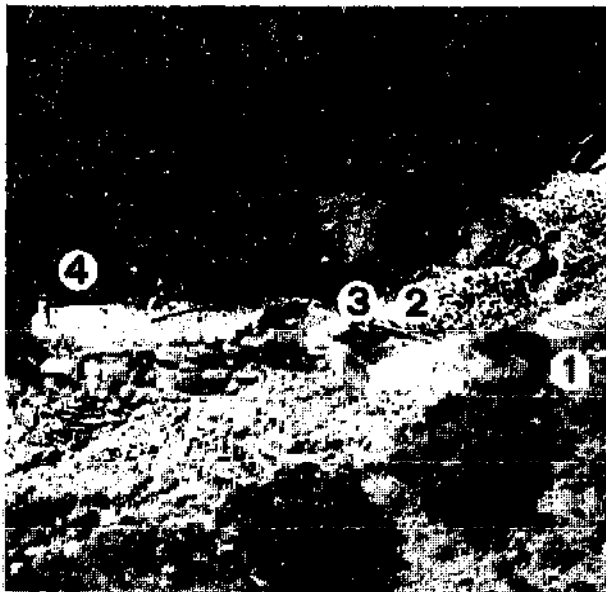

Fig. 19: Water intake with desilter in steep section of stream (approx. 60% slope).
 1 Water chamber for drinking water supply, 2 Overflow from water chamber to intake, 3 Tirolian weir type intake, 4 Desilting system and surge tank



Fig. 20: Tirolian weir type intake .
 1 Trash rack
 2 Perforated plate cover over trash rack
 3 Overflow from drinking water supply (PVC pipe, outside dia. 90 mm)

At the area of water intake the terrain has a slope of nearly 60%. Conditions for an extended desilting system are not ideal. Therefore, a concrete pipe, with an inner diameter of 120 cm, which is separated into two compartments by means of a steel plate with overflow edge, was used as surge tank and desilting chamber (fig. 21). A dip wall before the overflow edge keeps back floating debris, while sand settles at the bottom of the first compartment and can be flushed away by pulling out the overflow pipe. The second compartment serves as a surge tank.

The upper section of the 650 m long penstock leads through a steeply sloping area with many rocks and boulders. Burying the pipe line was elaborate and required blasting. For the lower section with a length of 140 m, steel pipes with 121 mm outer diameter and a wall thickness of 4 mm were used. The other parts of the penstock consist of PE-pipes with corresponding diameter and nominal pressures of 16, 10 and 6.5 bar - accordingly adapted to the height.

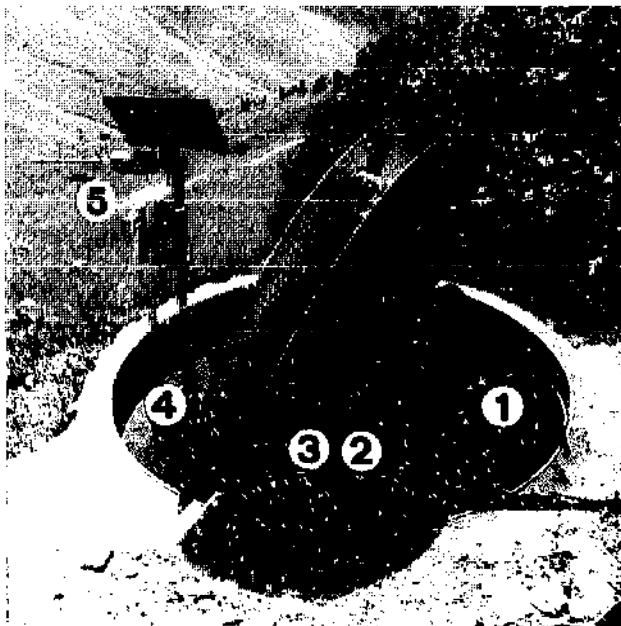

Fig. 21: Desilting system and surge tank (inside dia. 1.2 m).

- 1 Desilting system with overflow via plug pipe in bottom drain**
- 2 Baffle**
- 3 Overflow edge (separating wall between desilter and surge tank)**
- 4 Surge tank**
- 5 Wireless system for monitoring of the water level**



Fig. 22: The machine house stands in an avalanche prone area, protected by a rock.

The machine house which stands in an avalanche prone area and is built of concrete, is protected by a large rock (fig. 22).

With a total water supply of 11 l/s the installed turbine-generator group (fig. 23), in spring, has an electrical output of 16 kW, which is quite sufficient, though the water supply of 6 l/s towards autumn allows merely for the generation of 8 kW. Despite the smaller quantity of milk to be processed, this compels an extremely sparing use of electricity at each of the enterprises in order to secure supply to the dairy.

The decreasing supply of water requires a level control in the surge tank and adaptation of the flow rate at the turbine. Whereas the level control is automatic and the persons in charge are alerted via wireless, adjustment of the needle in the nozzle of the Pelton turbine is done by hand.

On the consumers side the load is governed by an electronic load controller. Electricity supply to the alpine pasture and adjacent buildings is via a 630 m buried cable. A building which stands in the opposite direction from the machine house, requires a separate cable of 360 m length. An efficient method could be found for burying the cables.

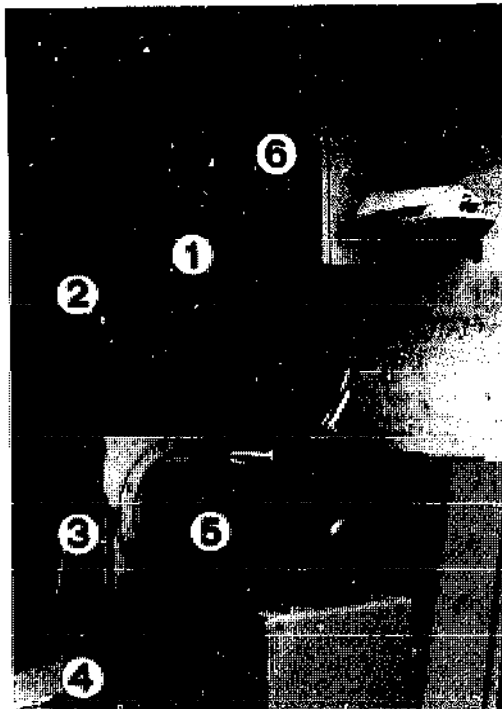

Fig. 23: View into the machine house.

1 Shut-off slide with pressure gauge

2 Handwheel for nozzle control

3 Pelton turbine

4 Turbine tail race with built-in water cooled load resistors for excess current

5 Three-phase synchronous generator (nominal output 20 kW, 220/380 V, 50 Hz)

6 Electrical control cabinet with instruments for current, tension and frequency.

Table: Technical data of the described power plants

(Source: FAT, CH-8356 Tänikon TG, Switzerland)

Power plant	Blackenalp	Beuertweid	Hinterchirel	Bachläger	Cavel	Aebnet
Electrical output[kW]	0,15	2	2,4	8,6	15,4	16
Head [m]	18,5	90	130	50	84	220
Water flow rate [lt/s]	1,6	4	3	26	27	11
Water intake:						
height above sea level [m]	1795	1785	1590	2005	2040	1865
used water supply	3)	spring/brook	spring	brook	brook	spring/brook
Penstock:length m]	-	350	280	160	295(645)4)	640
outside dia. 1)[mm]	-	75	63	150	160	121
inside dia. 1) [mm]	-	66	51,4	141	130,8	113
nominal pressure 1) [bar]	-	6	10	6	10	>30
material 1)	-	PE	PE	PE	PE	Steel
average slope[%]	-	27	52	33	30	37
speed of water at nominal output 1) [m/s]	-	1,2	1,4	1,7	2,0	1,1
Turbine: type,						
position of axis 2)	Pelton, v	Pelton, v	Pelton, v	Pelton, v	Pelton, h	Pelton, h
regulation	(battery)		←----- electronic load controller ----->			
cooling of ballast load with:	-	air	air	water	water	water
Electrical transmission lines:						
length [m]	-	460	50	1500	415	1000
voltage [V]	24	220	220	220/380	220/380	220/380

1)lower section
2)h=horizontal; v=vertical

3)supply line for drinking water
4)total with low-pressure penstock of 350 m length

Appendix 9: Exploded view of Pelton Turbine

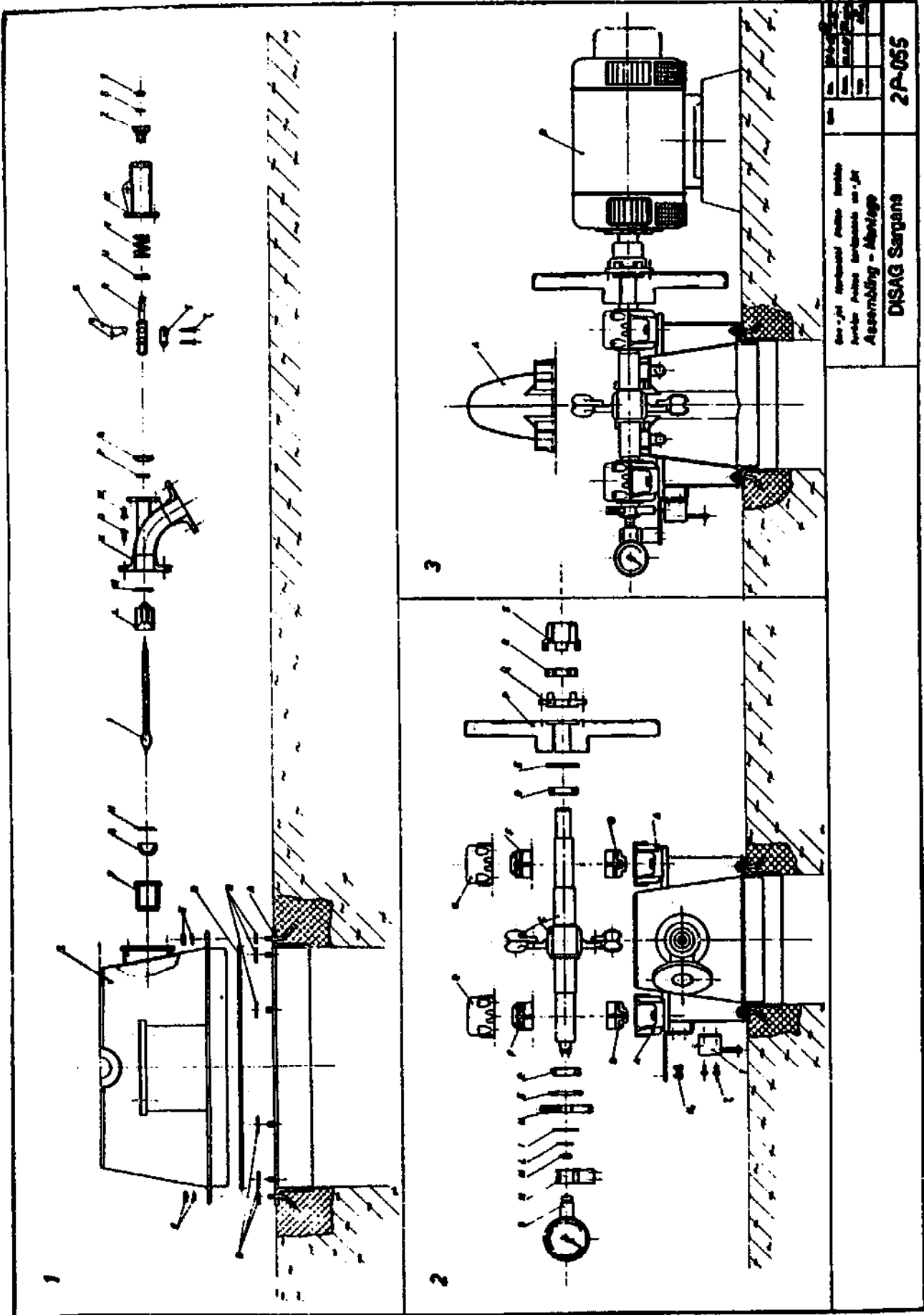

Part list of exploded view of Pelton turbine drawing 2P-055
(Source Disag)

View 1

- A. Base frame with anchor bolt
- B. Washer
- C. Bottom of housing
- D. Gasket
- E. Washer and nut
- F. - H. Nozzle orifice parts
- I. Needle and spear
- L. Star guide
- M. - Q. Manifold parts
- R. - Z. Regulating mechanisms

View 2

- A., B., F., G. Bearing parts
- C. Runner and shaft
- D., E. Bush and washer
- H. - O. Speed measuring parts
- P. - S. Flywheel and coupling parts

View 3

- A. Top of housing
- B. Generator

Appendix 10: Drawing set of Pelton Turbine

Appendix 10 shows the design of a Pelton turbine. The diagram below gives the application range of the turbine. The turbine may be installed with 1 or 2 jets. It was important to the manufacturer to be able to offer a standard turbine at a reasonable price.

With a pitch circle diameter of 160mm the turbine can be used with a head of 15 to 25 m at a speed of 1000 RPM and with a head of 25 to 40 m at a speed of 1500 RPM. Within these limits the k_u value varies between 0.38 and 0.56. But the efficiency is only affected by a maximum decrease of 5%.

HUGAL

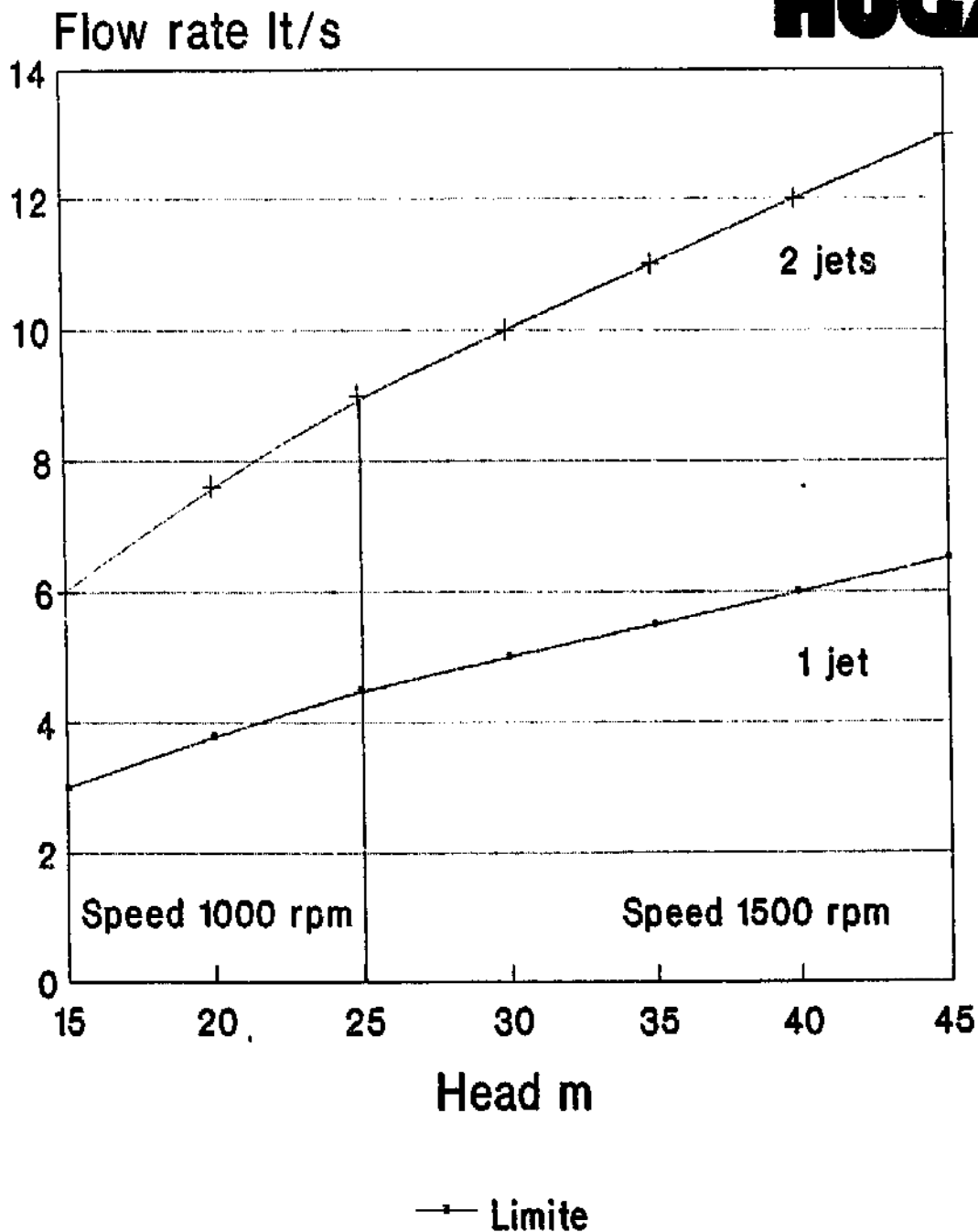

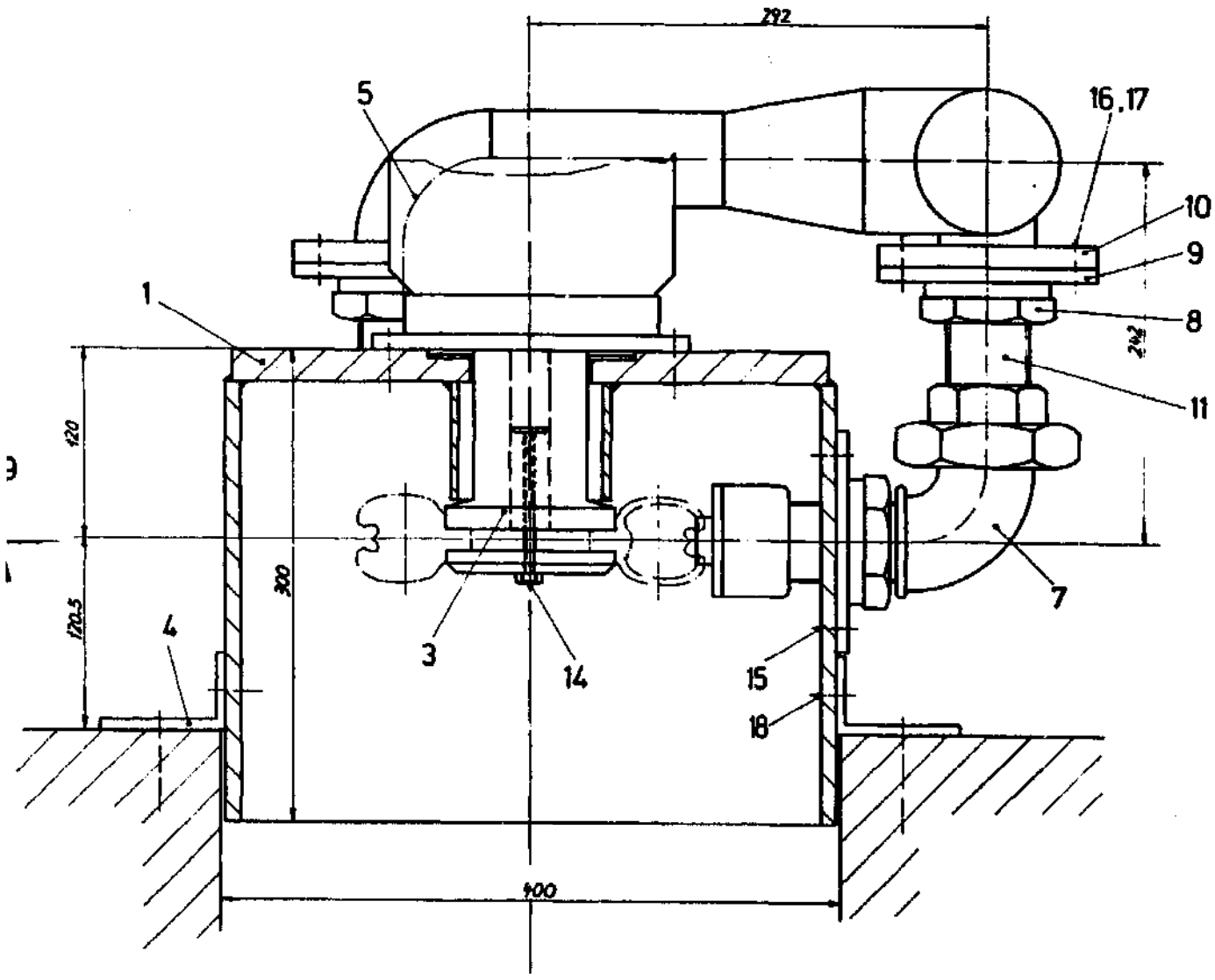

№	1	Assembly drawing	1:2	NP-1016
PEJON - TURBINE		NP-1016		

Method 1

single buckets fixed to the rotor disk (not recommended)

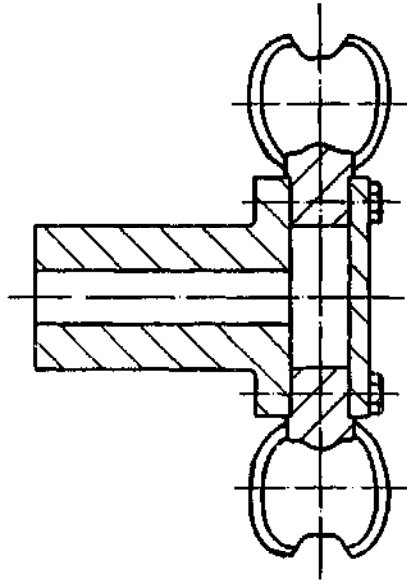

Method 2

wheel cased in one piece

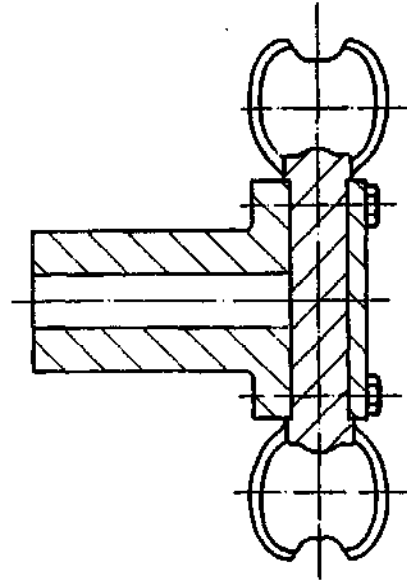

Sheet Number of sheets	Approved Specification	Part No.	Material Notes	Notes Models	Manufacture Observations
B 1	Approved Modifications:				
Different methods of fixation		Exact each Particular per Order for Reference		Material Schedule 8.1.94	Quantity 1
PELTON TURBINE		HUGOL		NP-2263	

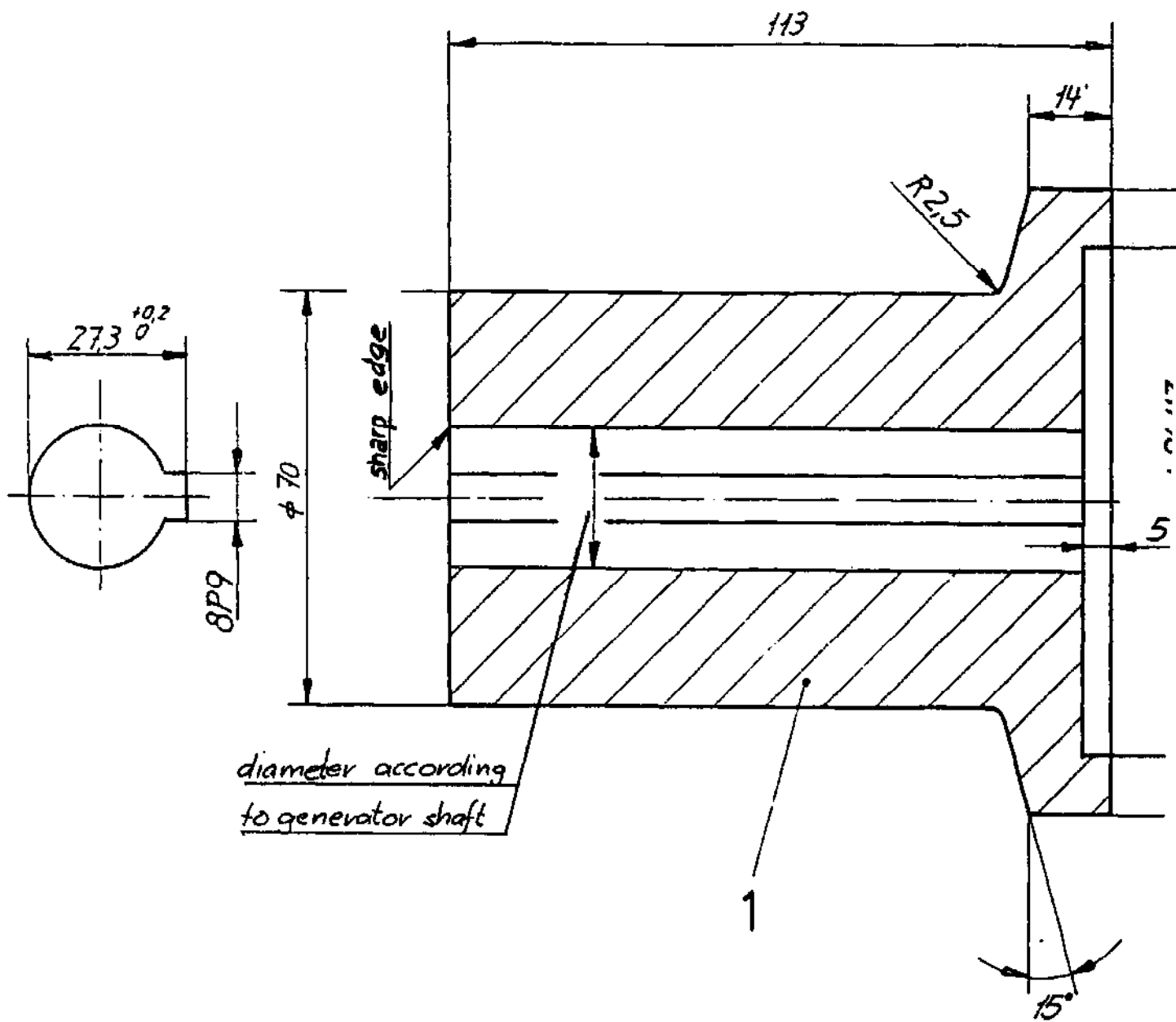

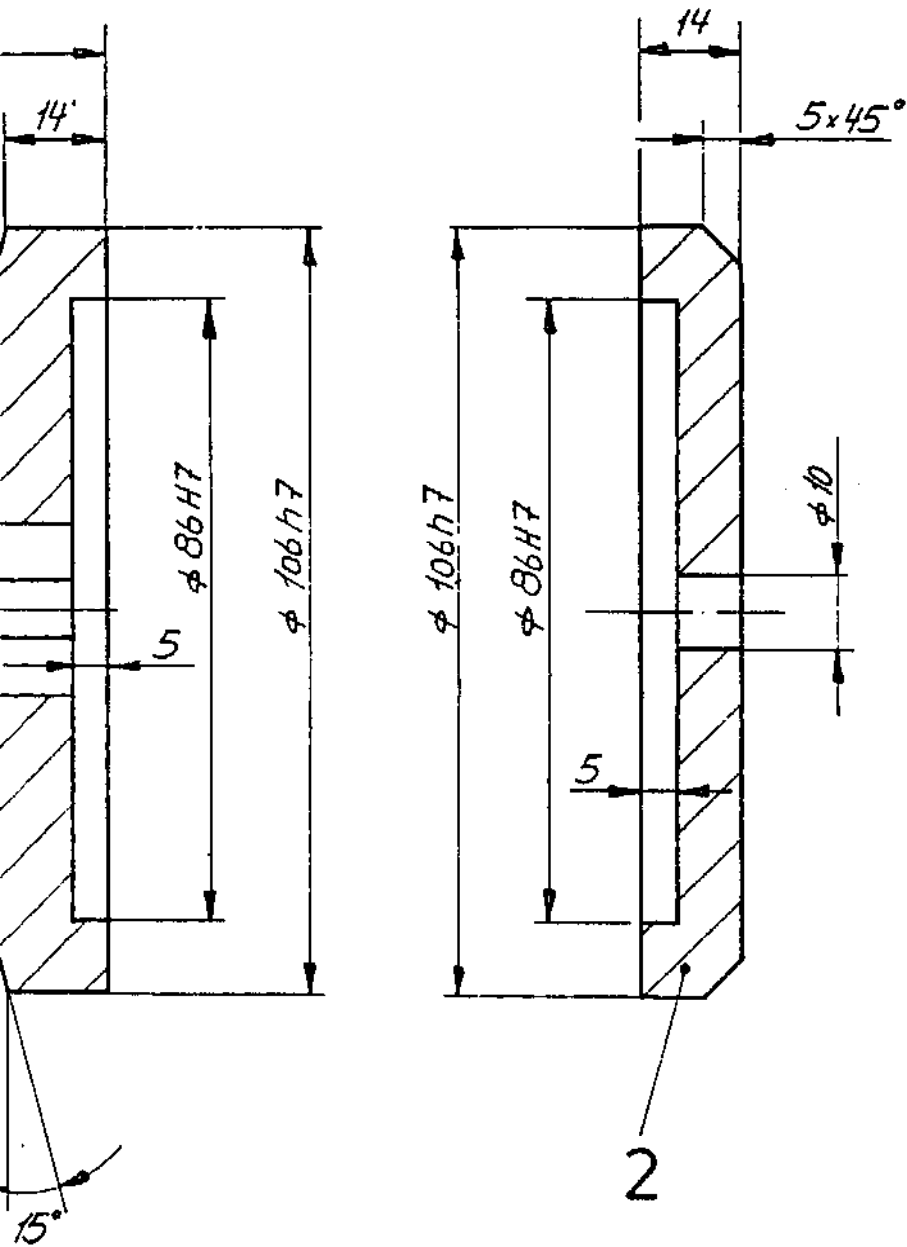

1	Cover	2	St. 37				
1	Rotor hub	1	St. 37				
Stück Nombre de pièces	Gegenstand Spécification	Pos. Rep.	Material Matière		Modell Modèle	Bemerkungen Observations	
II	1	Änderungen: <i>E: Engl. Übersetzung mit gleicher Nr. 13.12 90 Jany</i>				Ersetzt durch Remplacé par	
		Modifications:				Ersetzt für Remplace	
	Hub of Rotor			Maßstab Echelle 1:1	Gezeichnet Dessiné 25.8.89 Geprüft Contrôlé Jany		
	HUGAL PELTON-TURBINE			NP-2244-E			

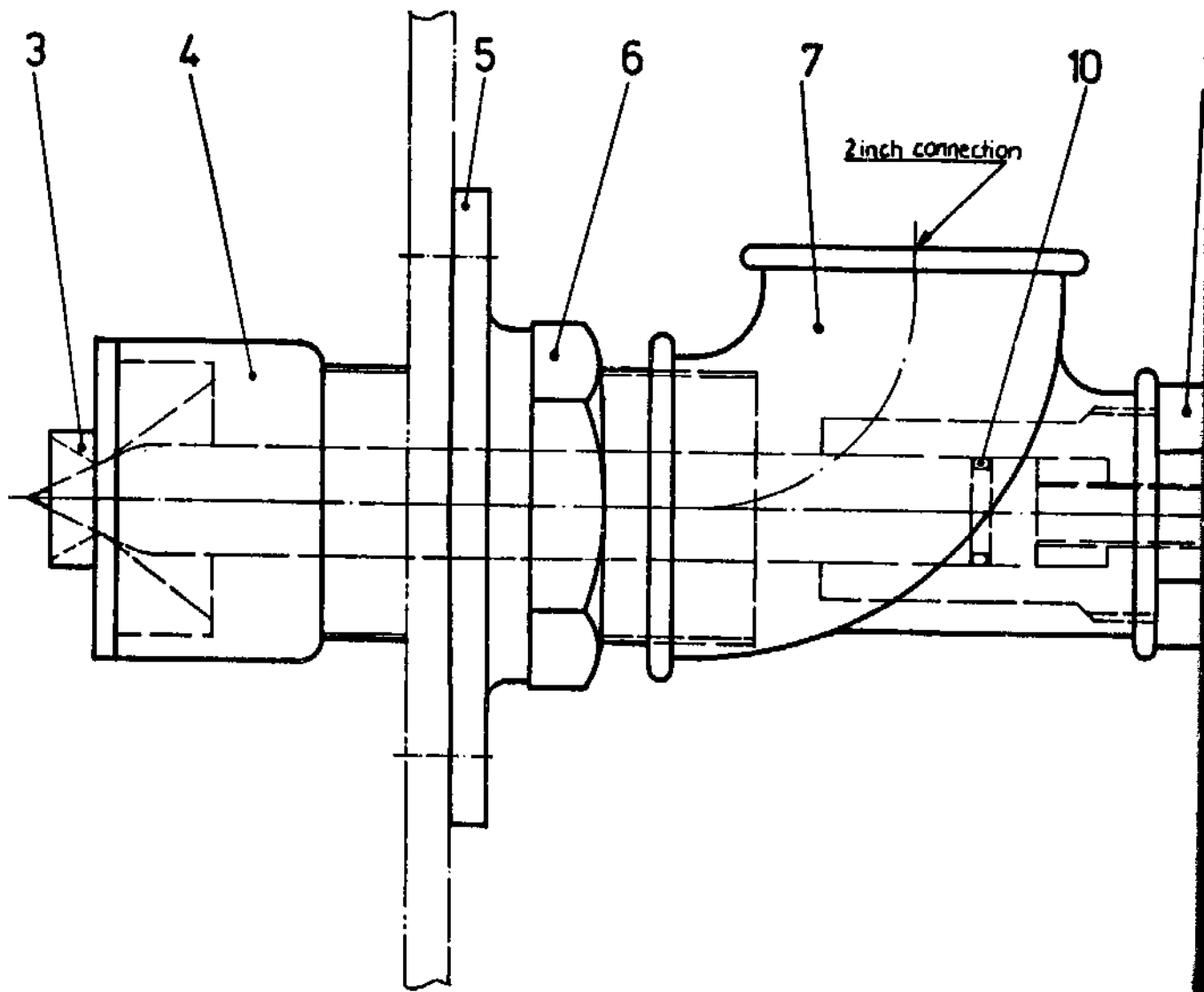

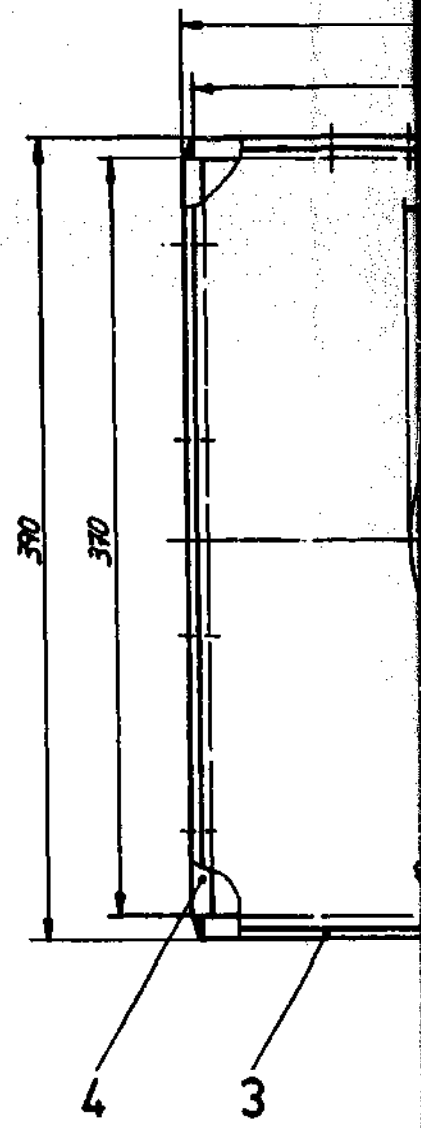
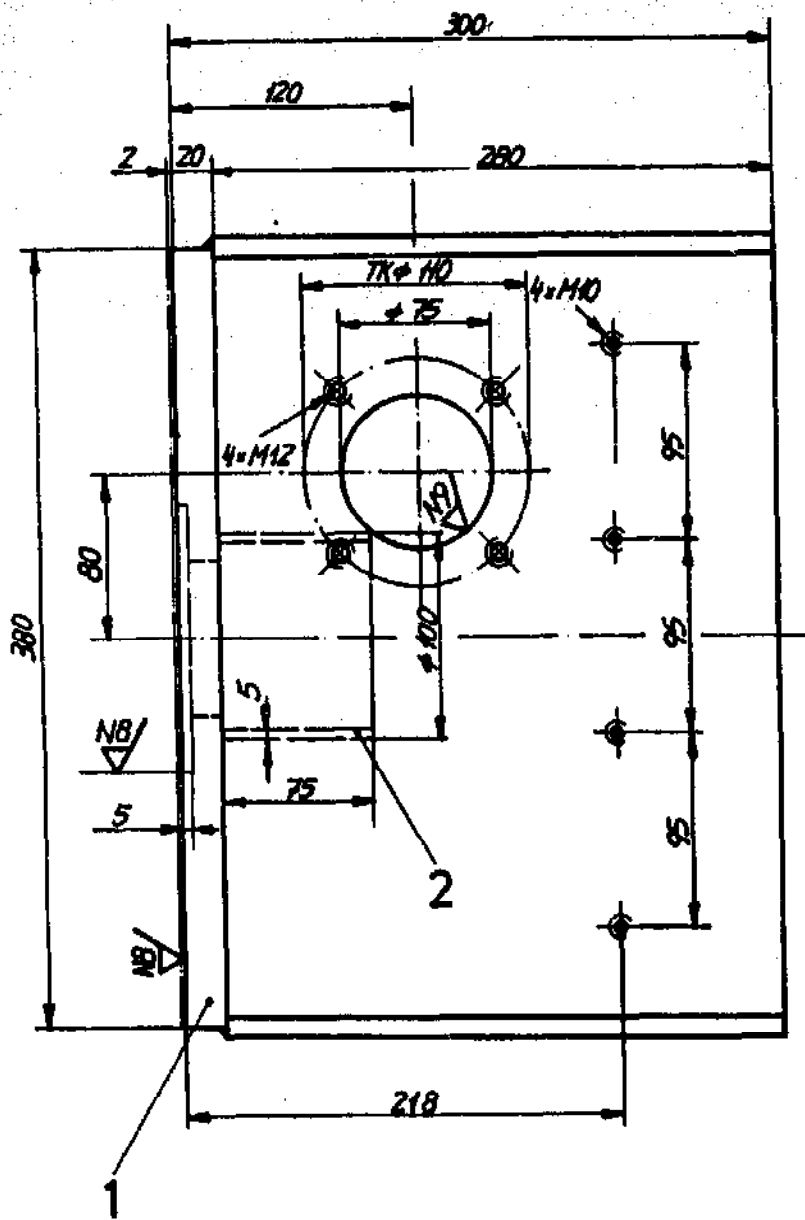

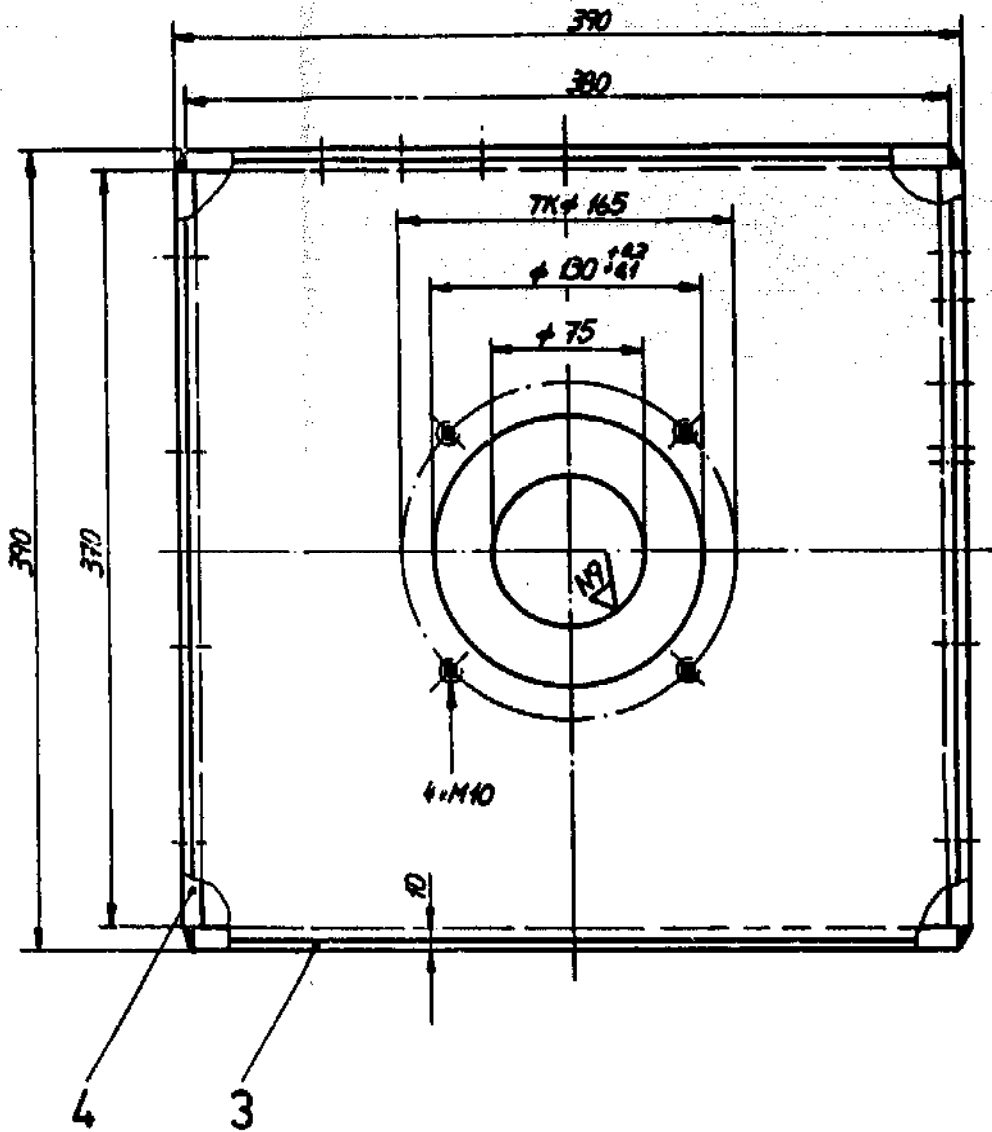

2	Flat	280 x 10 x 370	4	St. 37		
2	Flat	280 x 10 x 300	3	St. 37		
1	Pipe	∅100 x ∅90 x 75	2	St. 37		
1	Flat	300 x 22 x 300	1	St. 37		
	Item number de pièce	Description	Qty.	Material Matière	Model Modèle	Remarques Observations
		2-Orifice Housing				Gravé par Stampé par Craie for Sample
						13.12.90 <i>Guany</i>
		HUGAL PELTON-TURBINE				NP-3548

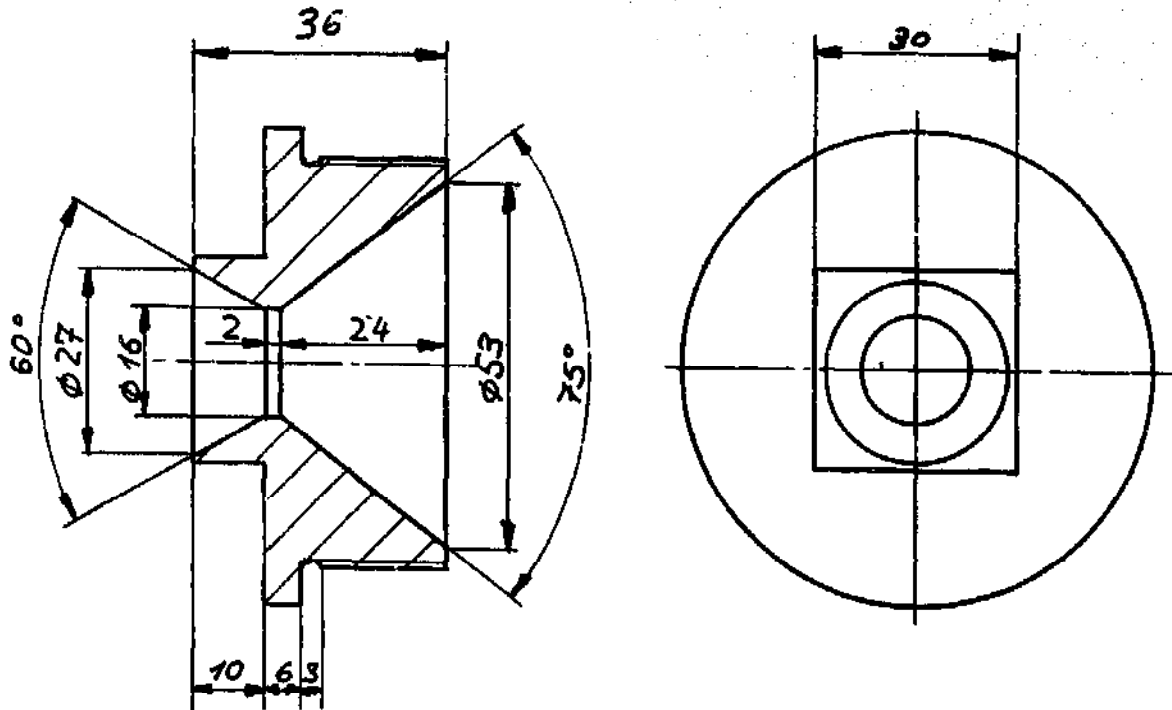

Stück Nombre de pièces	Gegenstand Spécification	Pos. Rep.	Material Matière	Modell Modèle	Bemerkungen Observations
1	Orifice	1	stainless- steel	Kohler Nr. 237-2"	
II	Änderungen: E: Englische Übersetzung mit gleicher Nr. 13.12.90 Modifications:		Ersetzt durch Remplacé par Ersatz für Remplace		
	Orifice		Meßmaß Echelle 1:1	Gezeichnet Dessiné 24.8.89 Geprüft Contrôlé Gezeichnet Vr	Garof.
HUGAL PELTON-TURBINE				NP-4131-E	

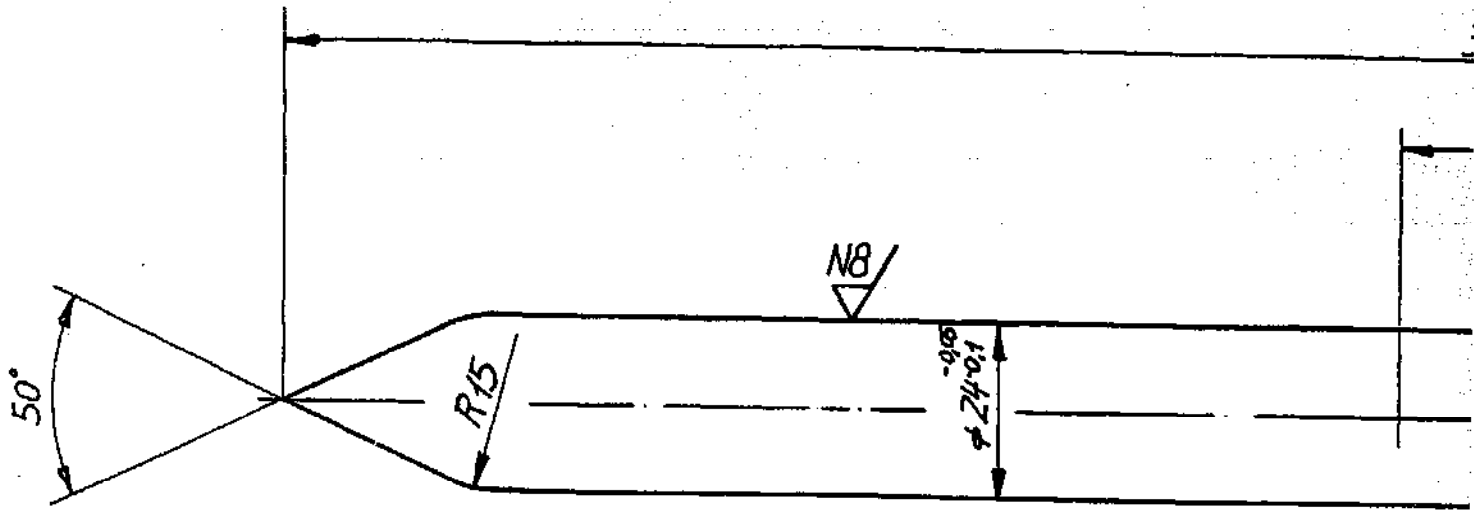

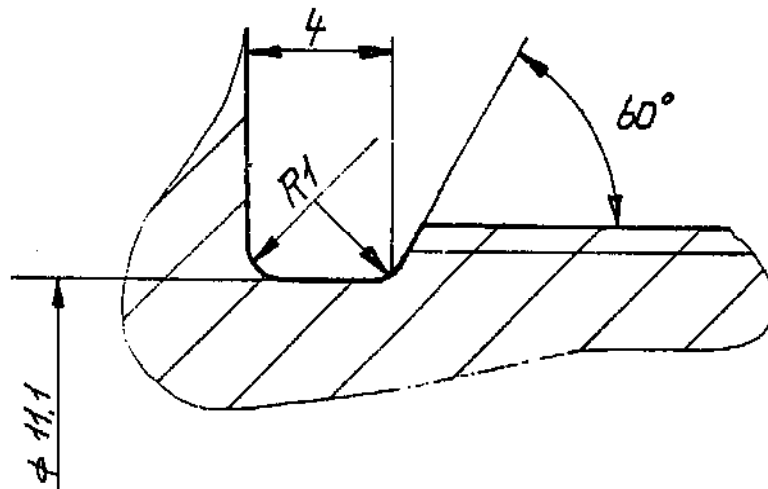
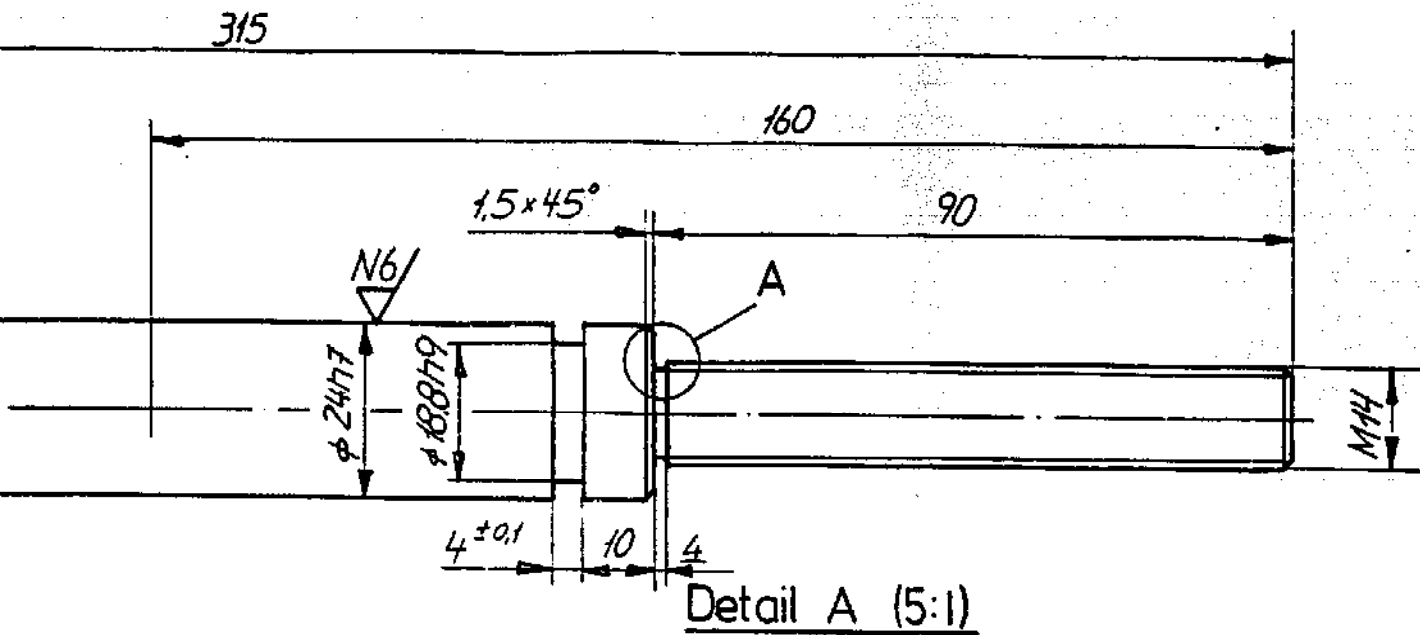

1	Needle	1	stainless-steel			
Stück Nombre de pièces	Gegenstand Spécification	Pos. Rep.	Material Matière		Modell Modèle	Bemerkungen Observations
II	I	Änderungen: E: Engl. Übersetzung mit gleicher Nr. 13.12.90 Modifications: <i>Jenung</i>			Ersetzt durch Remplacé par Ersatz für Remplace	
	Needle			Maßstab Echelle 1:1 5:1	Gezeichnet Dessiné 24.8.89 Geprüft Contrôlé <i>Jenung</i>	
HUGAL PELTON-TURBINE				NP-4133-E		

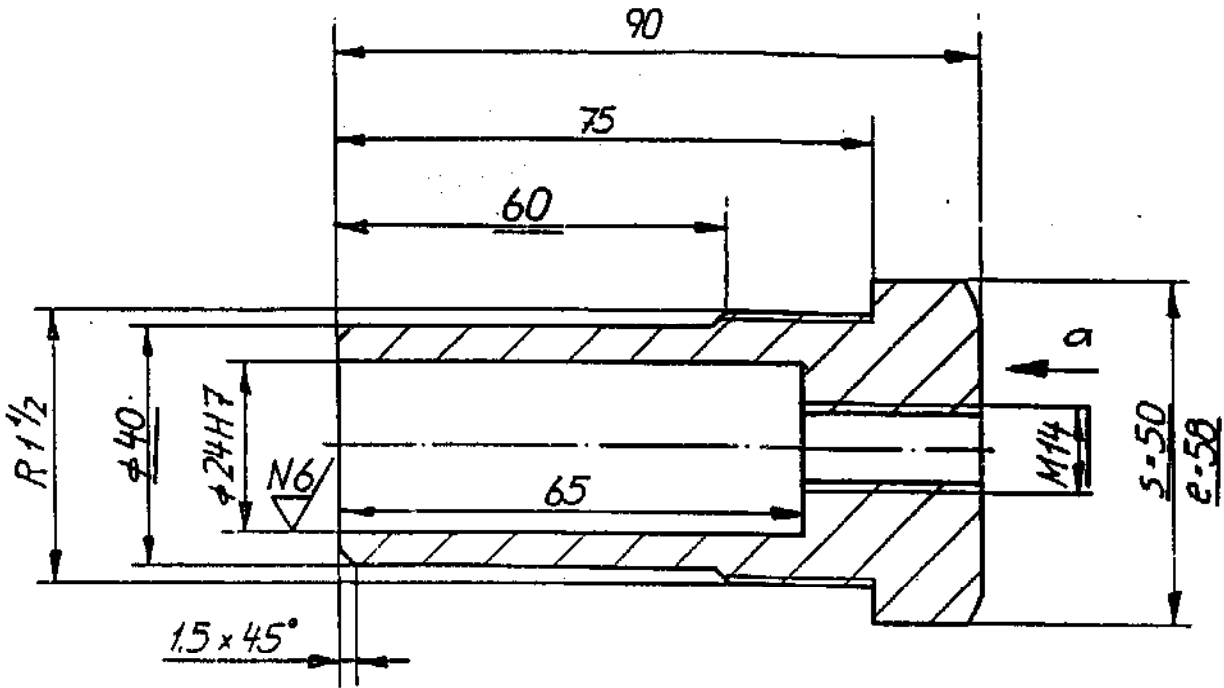

view a

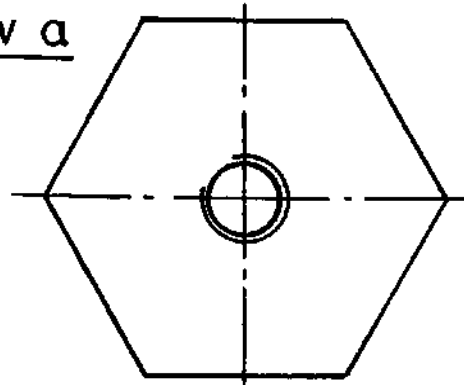

Pos.1 ∇ $\frac{N8}{\nabla}$ (✓)

1	Guide of Needle	1	Alu- Bronze			
Stück Nombre de pièces	Gegenstand Spécification	Pos. Rep.	Material Matière		Modell Modèle	Bemerkungen Observations
1	Anderungen: <i>E: Engl. Übersetzung mit gleicher Nr.</i> 13.12.90 Modifications:					Ersetzt durch Remplacé par Ersetz für Remplace
	Guide of Needle			Maßstab Echelle 1:1	Gerechnet Dessiné 23889 Geprüft Contrôle Gesehen Vu	<i>Geuzoff</i>
HUGAL PELTON - TURBINE				NP-4132-E		

Tee, B1 reducing NP 4134 - Pos - 7

Size of Connection	l ₁	l ₂	l ₃	z ₁	z ₂	z ₃
1 2 3						
1 - 1/4 - 3/4	42	40	41	25	21	26
• 1/4 - 1/2 - 1	34	38	32	15	25	15
• 1/4 - 3/4 - 3/4	36	41	33	17	26	18
• 1/4 - 3/4 - 1	36	41	35	17	26	18
1/4 - 1 - 1/2	40	42	34	21	25	21
• 1/4 - 1 - 3/4	40	42	36	21	25	21
• 1/4 - 1 - 1	40	42	38	21	25	21
• 1/4 - 1/4 - 1/2	45	45	38	26	26	25
• 1/4 - 1/4 - 3/4	45	45	41	26	26	26
• 1/4 - 1/4 - 1	45	45	42	26	26	25
1/4 - 1/2 - 1	48	46	46	29	27	29
• 1/2 - 1/2 - 1/4	36	42	34	17	29	15
• 1/2 - 3/4 - 1/4	38	44	36	19	29	17
• 1/2 - 1 - 1	42	46	38	23	29	21
• 1/2 - 1 - 1/4	42	46	40	23	29	21
• 1/2 - 1/4 - 1	46	48	42	27	29	25
• 1/2 - 1/4 - 1/4	46	48	45	27	29	26
• 1/2 - 1/2 - 1/2	50	50	42	31	31	29
• 1/2 - 1/2 - 3/4	50	50	44	31	31	29
• 1/2 - 1/2 - 1	50	50	46	31	31	29
• 1/2 - 1/2 - 1/4	50	50	48	31	31	29
1/2 - 2 - 1/4	56	54	56	37	30	37
2 - 1/2 - 1/2	38	48	38	14	35	19
• 2 - 3/4 - 1/2	40	50	38	16	35	19
• 2 - 1 - 1/2	44	52	42	20	35	23
• 2 - 1/4 - 1/4	48	54	45	24	35	26
• 2 - 1/4 - 1/2	48	54	46	24	35	27
2 - 1/2 - 1	55	57	54	31	38	37
• 2 - 1/2 - 1/2	52	55	50	28	36	31
2 - 2 - 1/2	57	57	48	33	33	35
• 2 - 2 - 3/4	58	58	50	34	34	35
• 2 - 2 - 1	58	58	52	34	34	35
• 2 - 2 - 1/4	58	58	54	34	34	35
• 2 - 2 - 1/2	58	58	55	34	34	36
2 1/2 - 1/2 - 2	60	64	60	33	45	36
2 1/2 - 2 - 2	62	68	62	35	44	38
2 1/2 - 2 1/2 - 1	71	71	71	44	44	54
2 1/2 - 2 1/2 - 1/2	69	69	64	42	42	45
2 1/2 - 2 1/2 - 2	69	69	66	42	42	42
• 3 - 2 - 2	65	76	65	35	52	41
3 - 3 - 2	85	85	85	55	55	61



Long Screw Sockets NP 4134 - Pos - 4

536

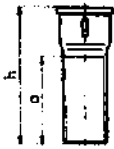

Size of Connection	h	a
3/8	74	48
1/2	79	50
3/4	90	57
1	102	65
1 1/4	116	75
1 1/2	125	84
2	143	98

Screwed Flanges PN1, NP 4134 - Pos - 5 round with boss, with or without bolt holes

321

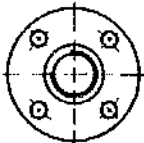
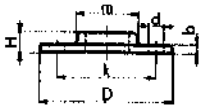

Size of Connection		D	b	k	H*	m	Bolts		d
Inch	DN								
1/2	15	80	5	55	12	32	M10	-	11,5
3/4	20	90	5	65	13	38	M10	-	11,5
1	25	100	6	75	14	46	M10	-	11,5
1 1/4	32	120	6	90	15	56	M12	1/2	14
1 1/2	40	130	7	100	16	63	M12	1/2	14
2	50	140	8	110	18	77	M12	1/2	14
2 1/2	65	160	9	130	20	92	M12	1/2	14
3	80	190	10	150	22	106	M16	3/8	18
4	100	210	11	170	24	132	M16	3/8	18

Backnuts P4 NP 41 34 - Pos - 6

310

Size of Connection	b	s
• 1/8 □	7	19
• 1/4 □	7,5	22
• 3/8 □	8	27
• 1/2	9	32
• 3/4	10	36
• 1	11,5	46
• 1 1/4	13	55
• 1 1/2	14	60
• 2	16,5	75
• 2 1/2	19	95
• 3	22	105

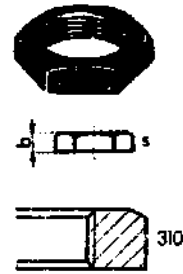

Union Elbows, taper sent UA 11 NP 1016 - Pos - 7

Size of Connection	G	l ₁	l ₂	z ₁	z ₂	z ₃	s	s ₁
• 1/4	5/8	21	48	11	38	9	28	rund
• 3/8	3/4	25	52	15	42	10	32	rund
• 1/2	1	28	58	15	45	8	39	rund
• 3/4	1 1/4	33	62	18	47	7	48	31
• 1	1 1/2	38	72	21	55	8	54	38
• 1 1/4	2	45	82	26	63	11	67	48
• 1 1/2	2 1/4	50	90	31	71	13	73	54
• 2	2 3/4	58	100	34	76	10	90	66
• 2 1/2	3 1/2	70	112	43	85	10	110	64
• 3	4	78	125	48	95	11	123	97

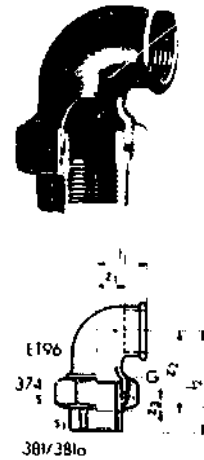

Plug with square head and collar NP 4131 - E - Pos - 1

R-237

Einsteckstopfen mit Kopf und Ansatz
Bouchon à vis avec tête et épaulement

G	L ₁	L ₂	SW	D	Preis/pos. (1000/4438)
Zoll/pouce	mm	mm	mm	mm	
1	27	14	20	39,5	14,55
1 1/4	33	19	22	49,5	20,80
1 1/2	35	20	25	59	24,45
2	36	21	30	70	34,55
2 1/2	42	25	40	88	57,50
3	42	25	45	100	80,20

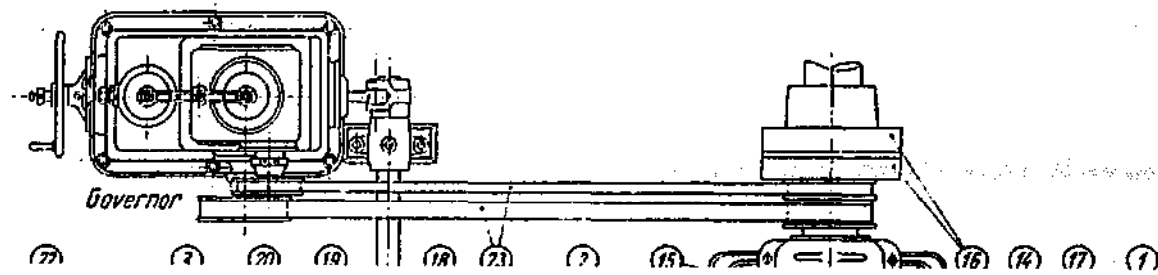
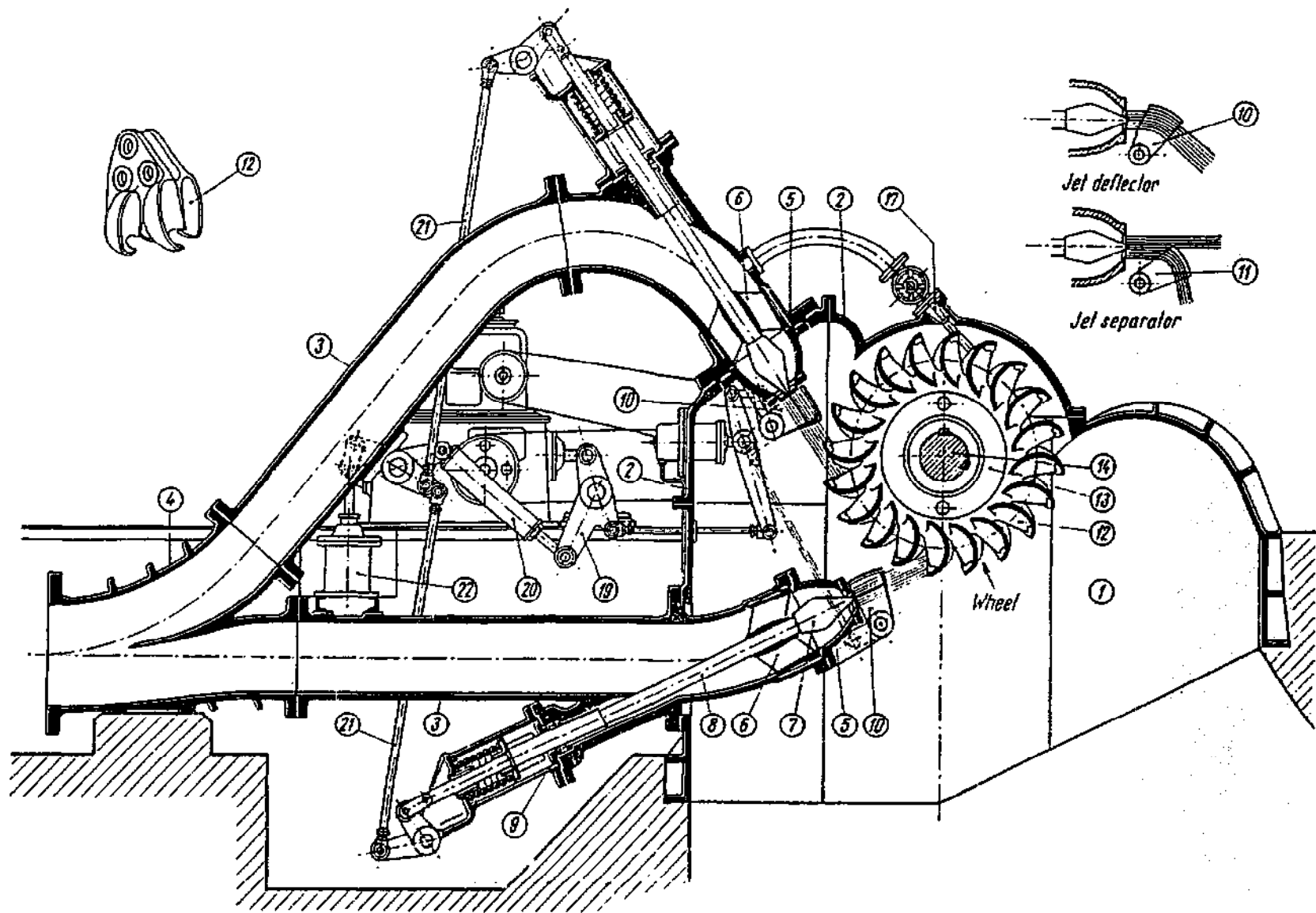

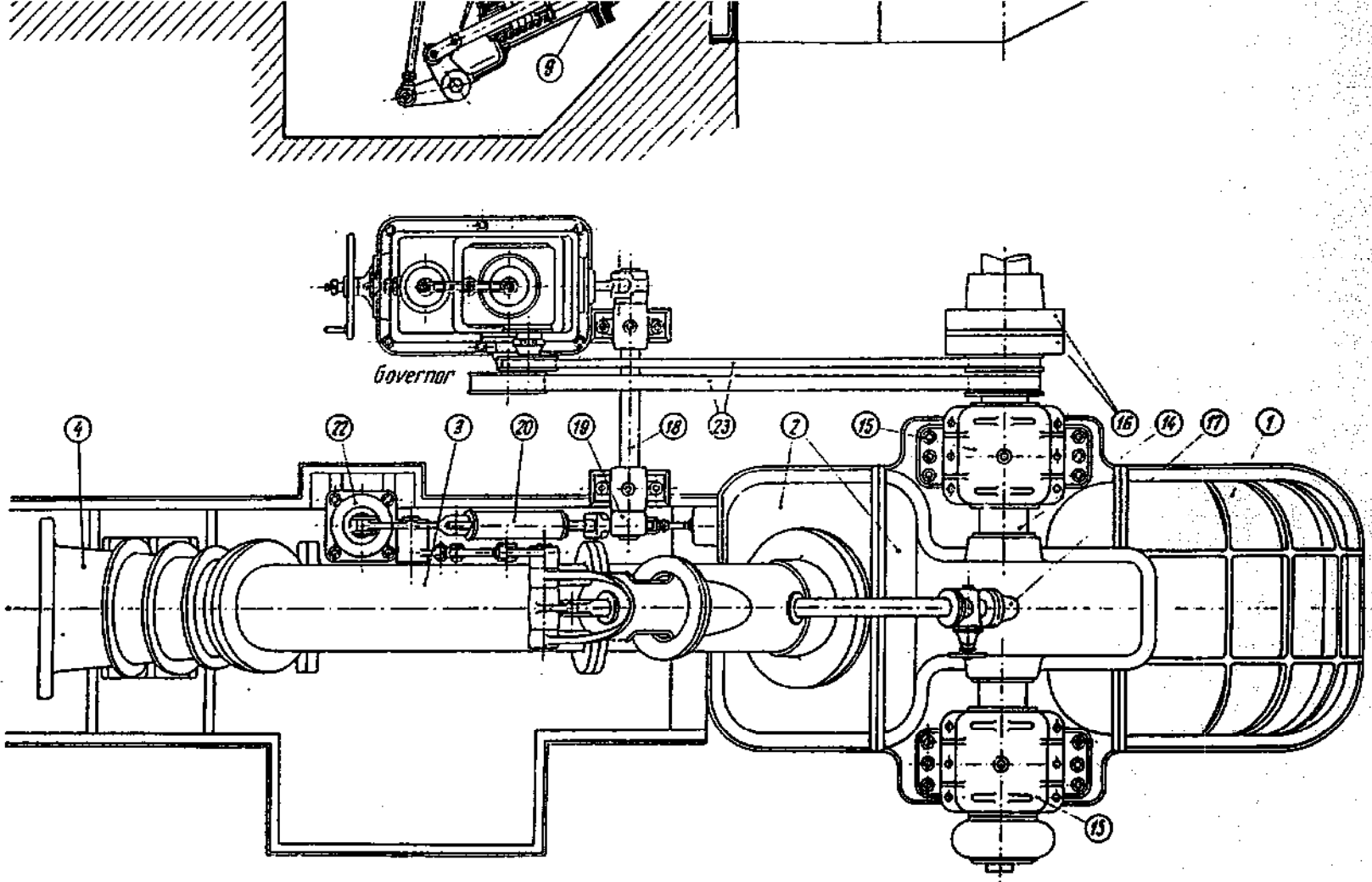

- 1. Casing
- 2. Cover
- 3. Nozzle pipe
- 4. Wye branch
- 5. Nozzle tip
- 6. Stac guide

- 7. Needle tip
- 8. Needle stem
- 9. Stem packing
- 10. Jet deflector
- 11. Jet separator (in detail only)
- 12. Bucket

- 13. Runner disc
- 14. Shaft
- 15. Bearing
- 16. Shaft coupling
- 17. Braking jet
- 18. Regulating shaft

- 19. Regulating lever
- 20. Spring drawbar
- 21. Needle control rod
- 22. Dashpot
- 23. Belt drive

Mechanical Water Power Development, Vol. II

Appendix 11: Double jet Pelton Turbine