

AT MICROFICHE
REFERENCE
LIBRARY

A project of Volunteers in Asia

Mill Drawings

by: W. Foreman

Published by:

Society for the Protection of Ancient
Buildings
55 Great Ormond Street
London WC1
England

Available from:

Society for the Protection of Ancient
Buildings
55 Great Ormond Street
London WC1
England

Reproduced by permission of the Society for the
Protection of Ancient Buildings.

Reproduction of this microfiche document in any
form is subject to the same restrictions as those
of the original document.

MILL DRAWINGS

Measured Drawings and Details

by

W. FOREMAN



CHURCH ENSTONE MILL . OXON.

0 1 2 3 4 5 6 7 8 9 10 11 12 FEET

0 1 2 3 4 METRES

BY KIND PERMISSION OF MR IVINGS, OWNER.

SECTIONS DRAWN AT SCALE OF 1/4" TO 1'0"
BLOCK PLANE - - - 1/32" TO 1'0"

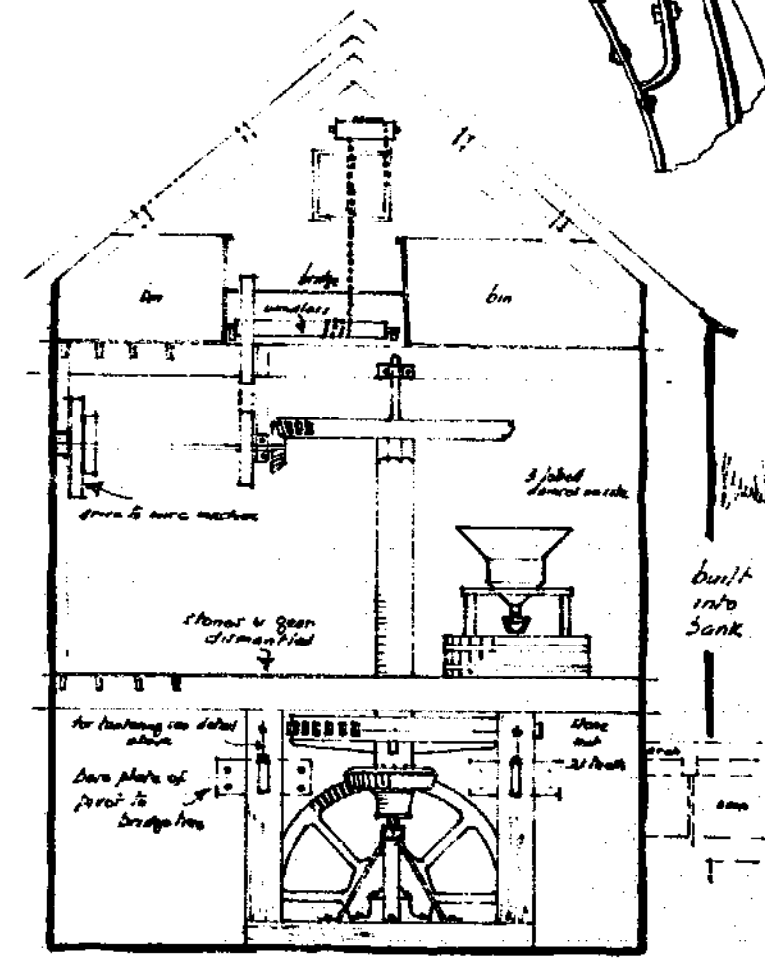
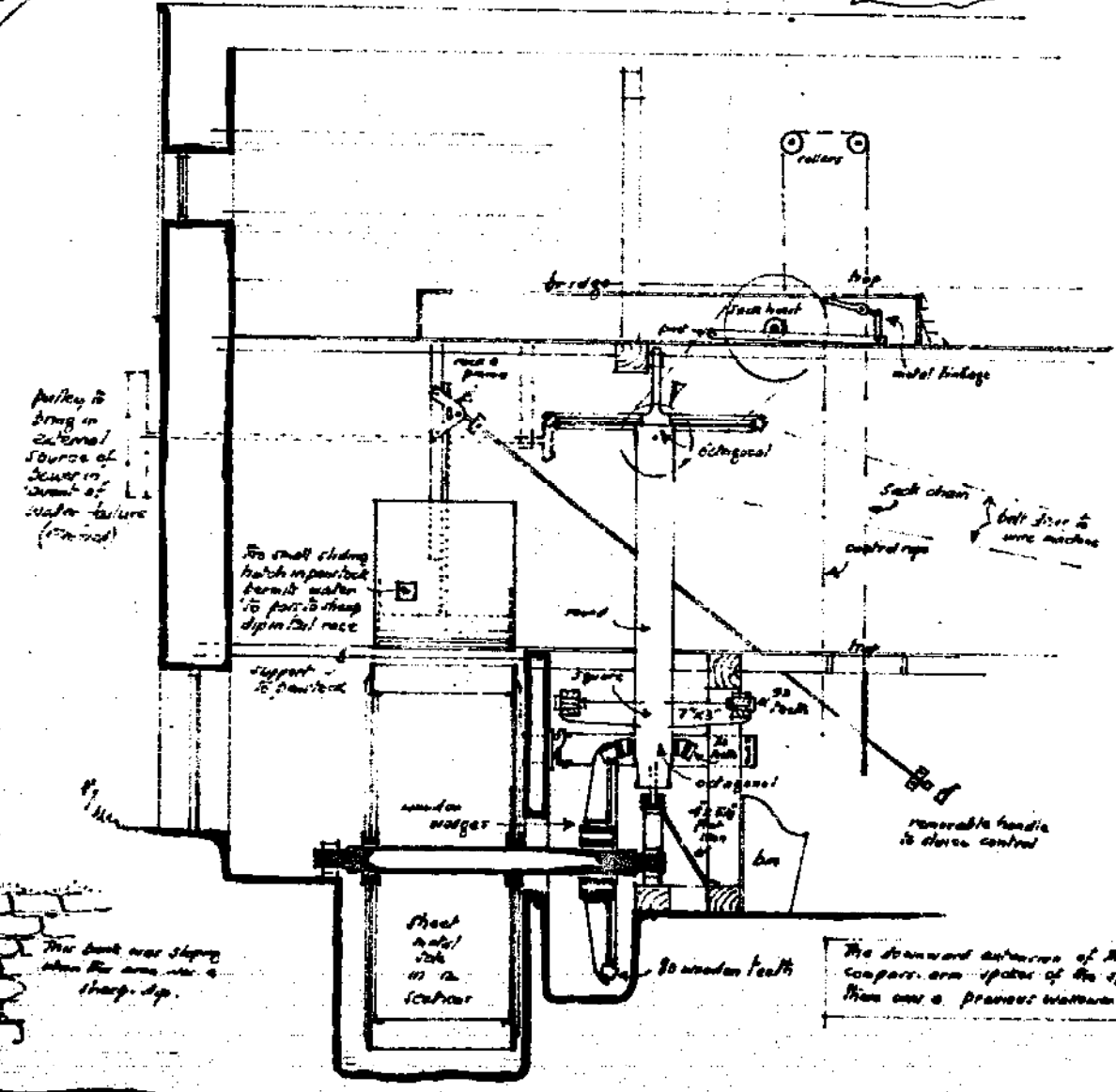
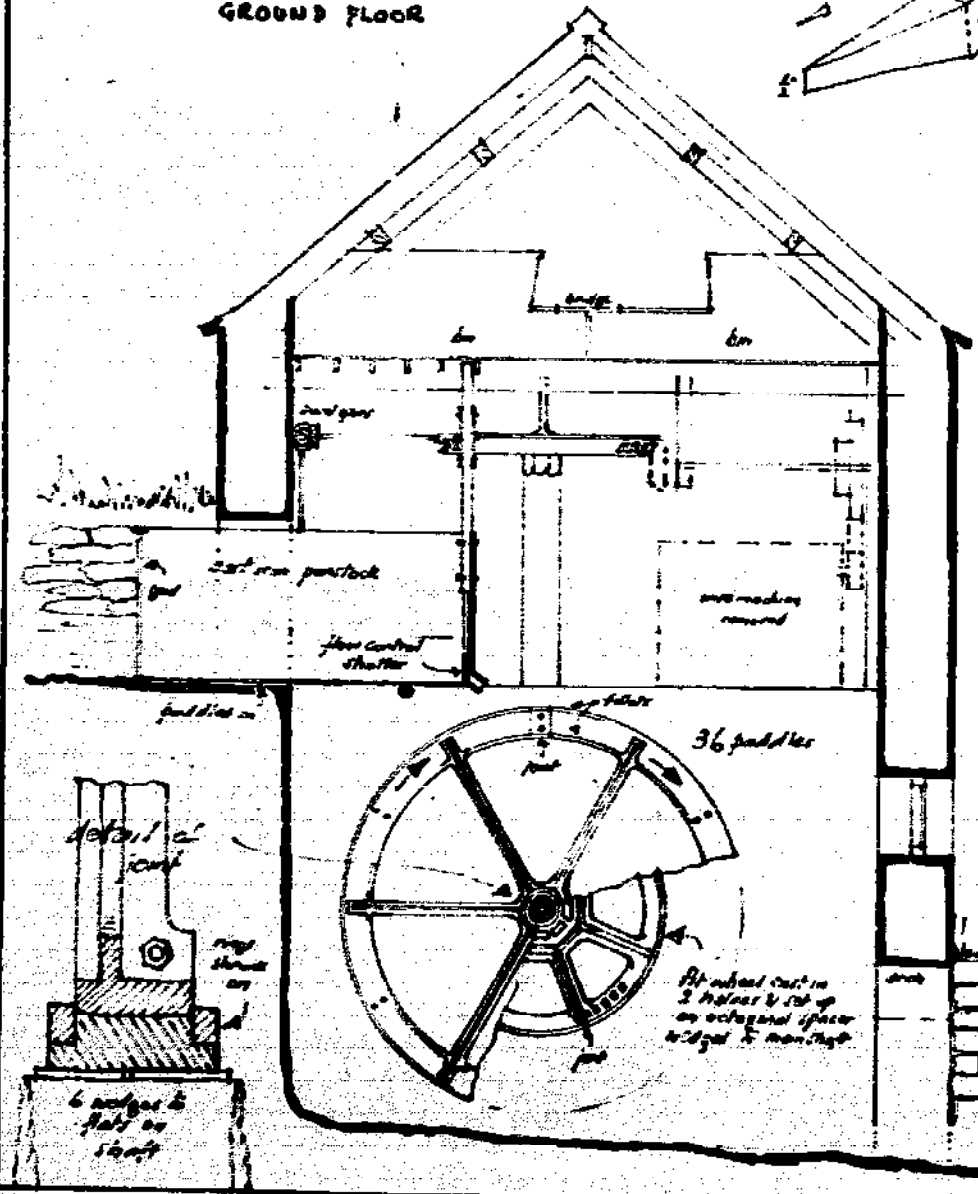
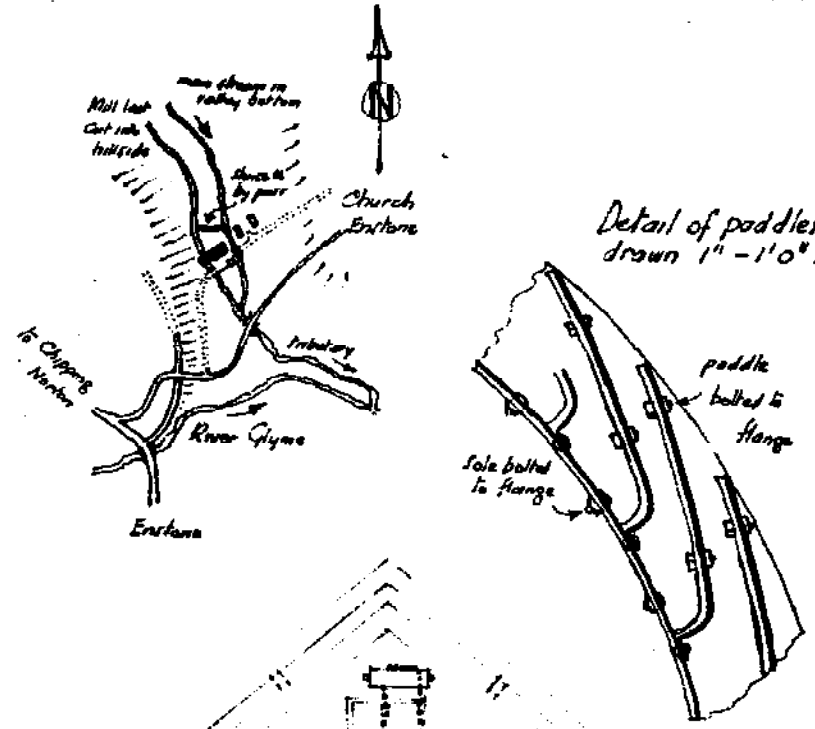
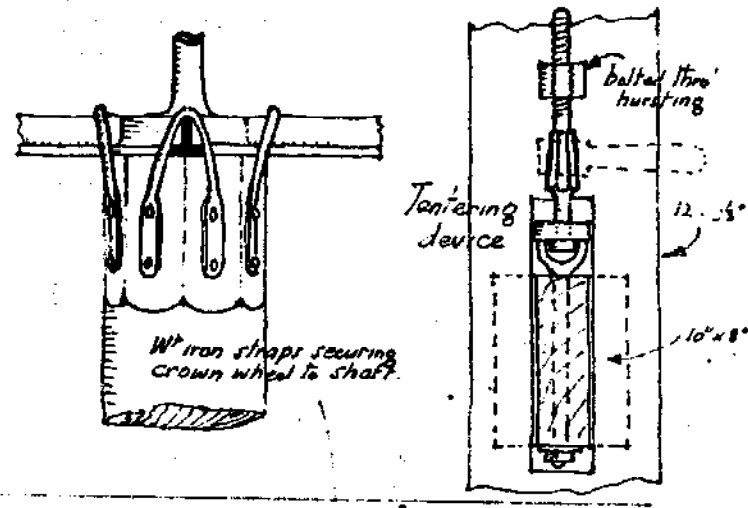
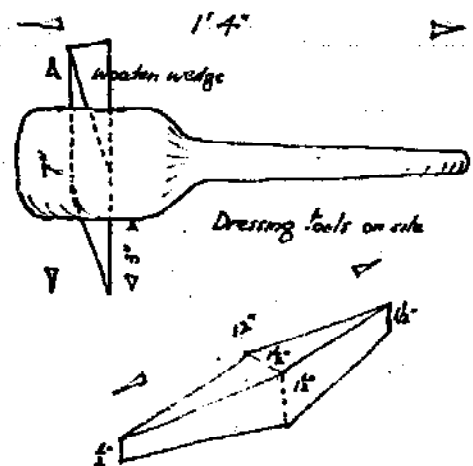
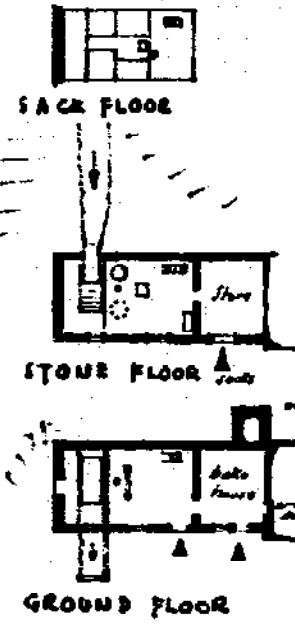

The downward advance of the housing for the scupper, arm & spool of the overhead support from over a previous waterway with timber spool

OLD CHALFORD. OXON. WATER WHEEL & SHAFT DRIVE.
 O.S. REF. SHEET 145 S.P. 345 259

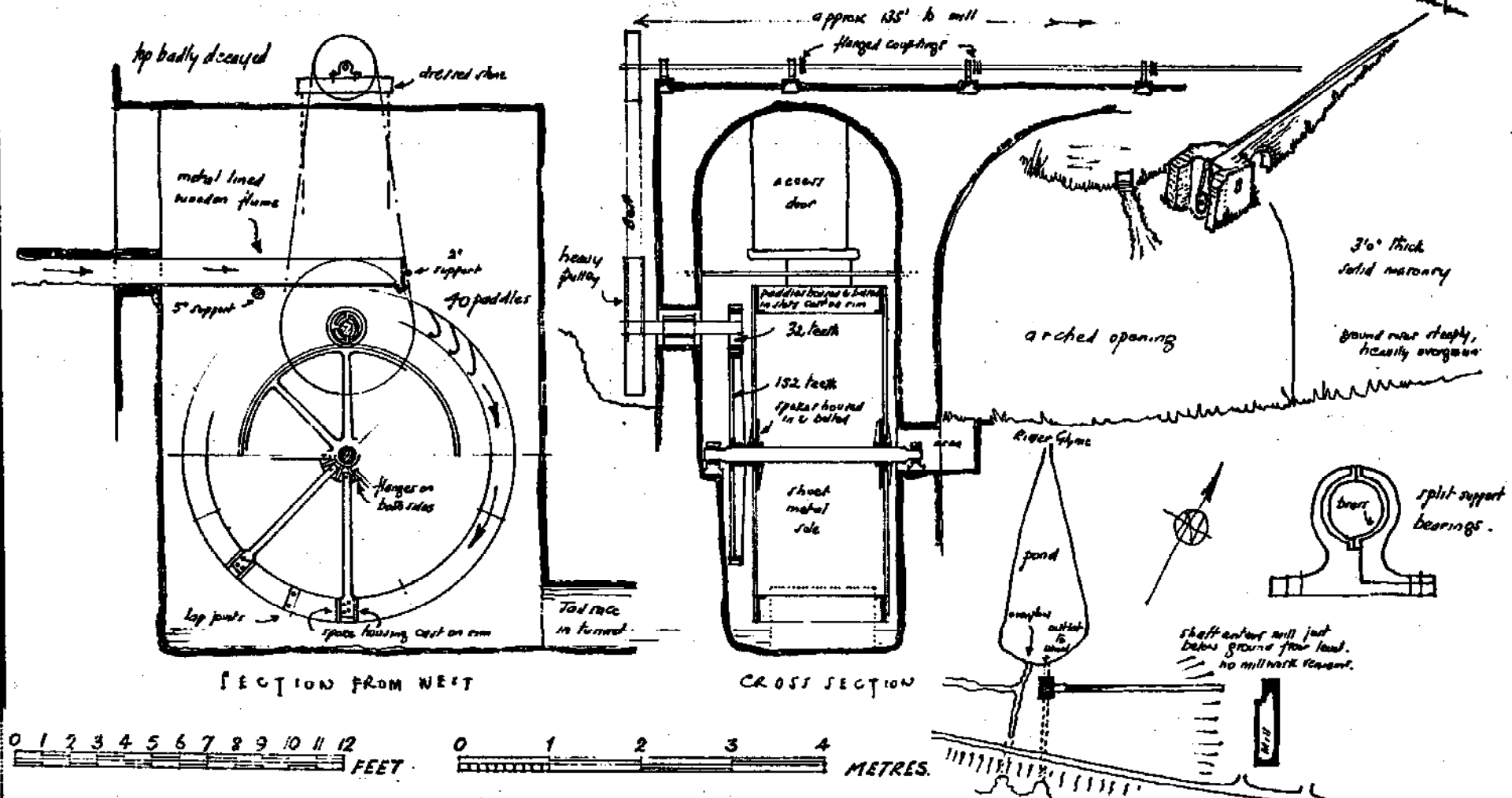

RADFORD MILL. OXON.
 SCALE 1/2" TO ONE FOOT.
 O.S. REF. SHEET 145 S.P. 109 237

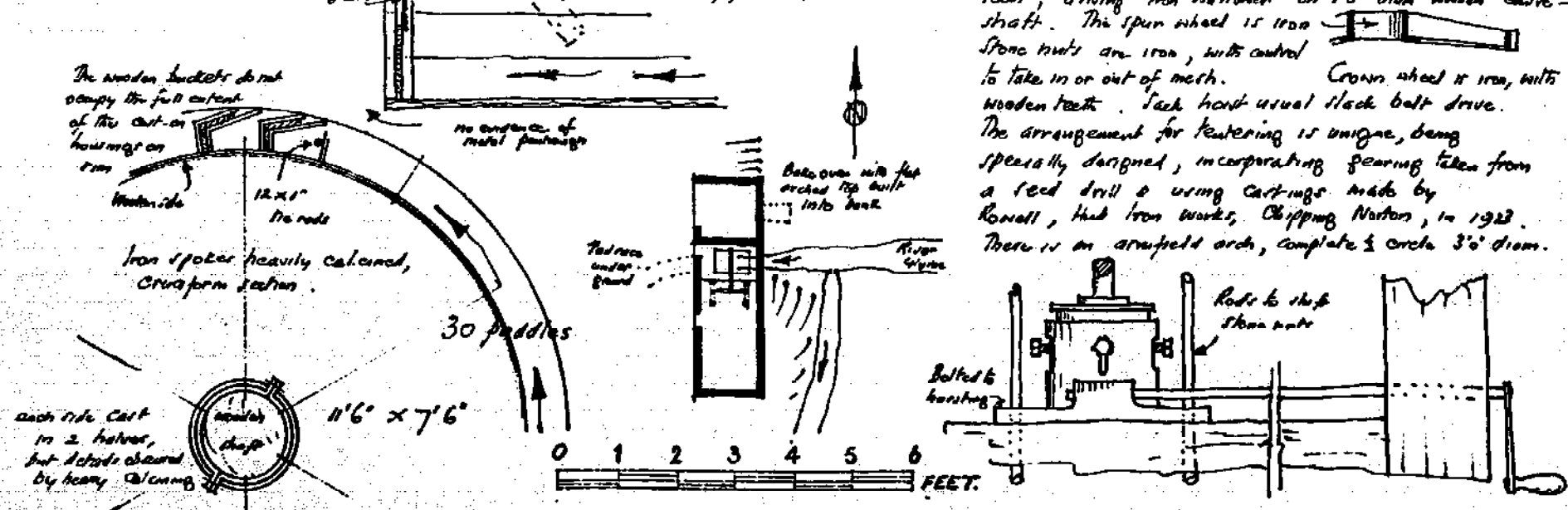

The millwork, which is assembled within a very heavy wooden housing, consists of iron pit wheel with wooden teeth, driving iron waterwheel on 1'3" diam wooden centre shaft. The spur wheel is iron. Stone nuts are iron, with control to take in or out of mesh. Crown wheel is iron, with wooden teeth. Each has usual slack belt drive. The arrangement for feathering is unique, being specially designed, incorporating gearing taken from a feed drill & using castings made by Rowell, the iron works, Chipping Norton, in 1923. There is an arched arch, complete 1/2 circle 3'0" diam.

STADHAMPTON MILL, OXON.

O.S. REF. SHEET 158. SU 604 986

BY KIND PERMISSION OF MR & MRS PEET.

0 1 2 3 4 5 6 7 8 9 10 11 12
FEET

Because of the flat countryside the mill stream was taken off the main stream some distance away, & the mill pond area was considerable.

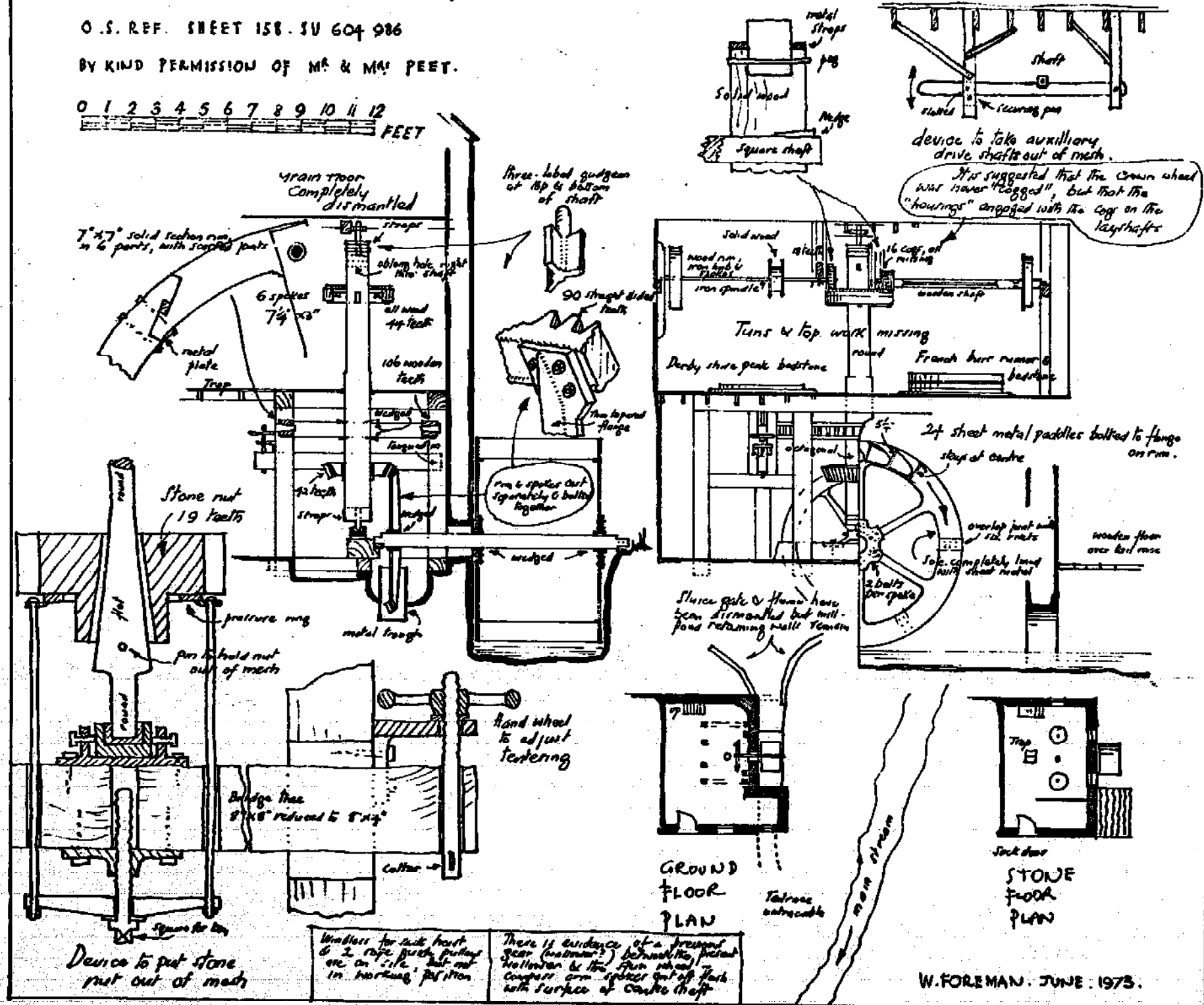

Device to put stone nut out of mesh

Windows for oak heart & 2 rope pulley pulley are on site, but not in working position

There is evidence of a freewheel gear (not shown?) behind the present hollow in the spur wheel. Copper arm spoker cut off flush with surface of crown shaft

W. FOREMAN. JUNE. 1973.

BURFORD TOWN MILL OXON.

O.S. REF. SHEET 144. 252 126

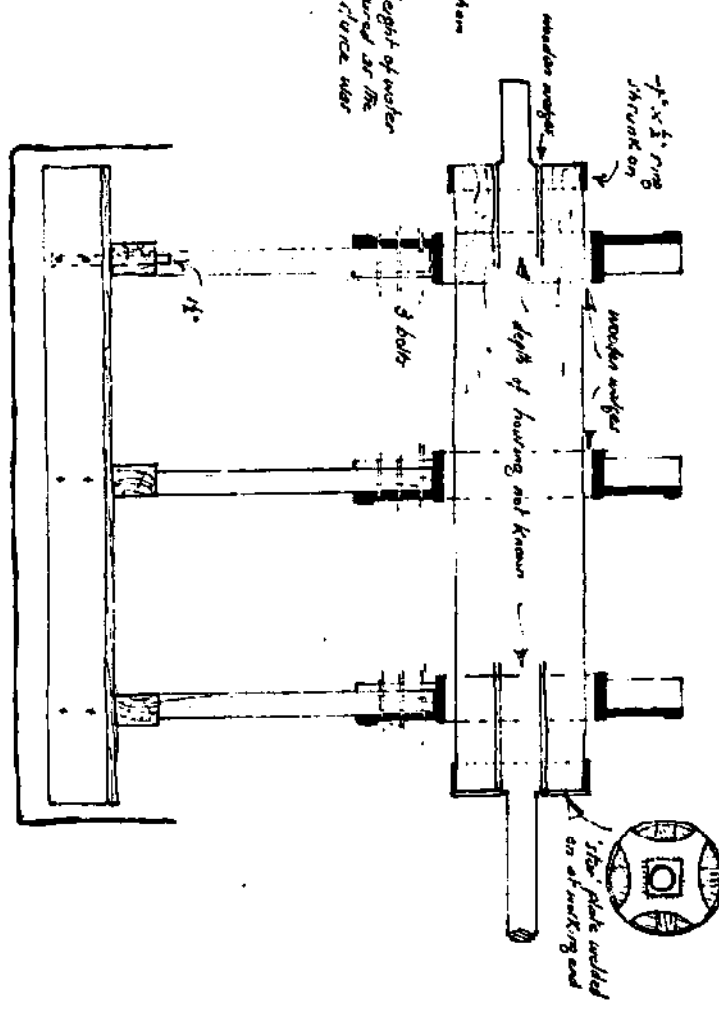
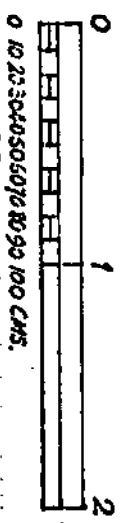
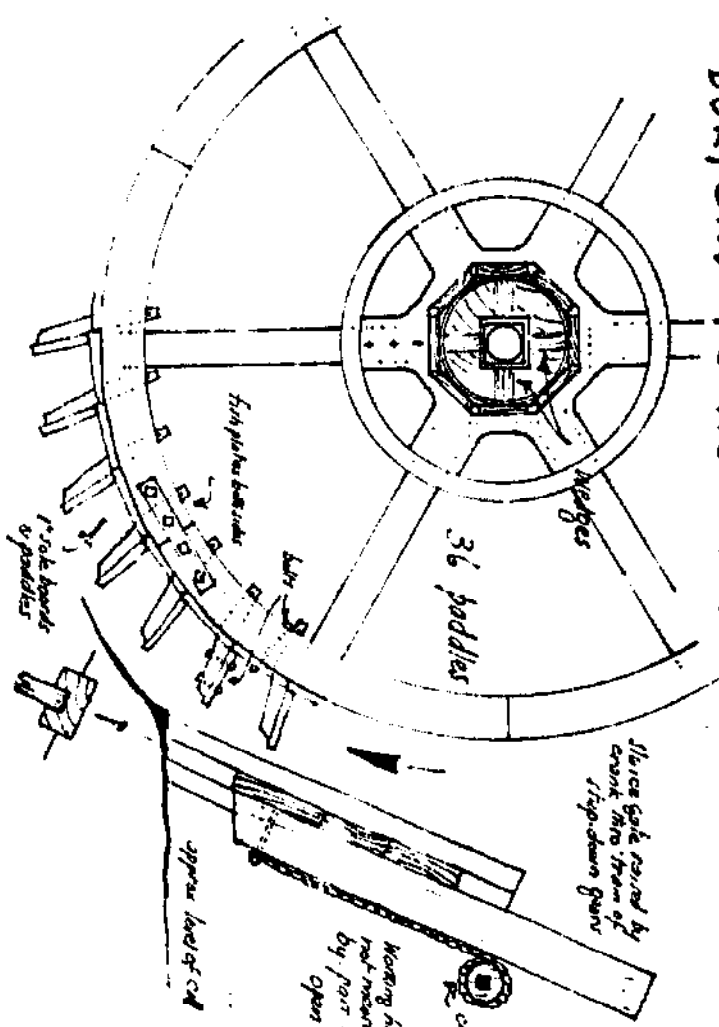

FRINGFORD MILL. OXON.

O.S. REF. SHEET 145 SP 614 287

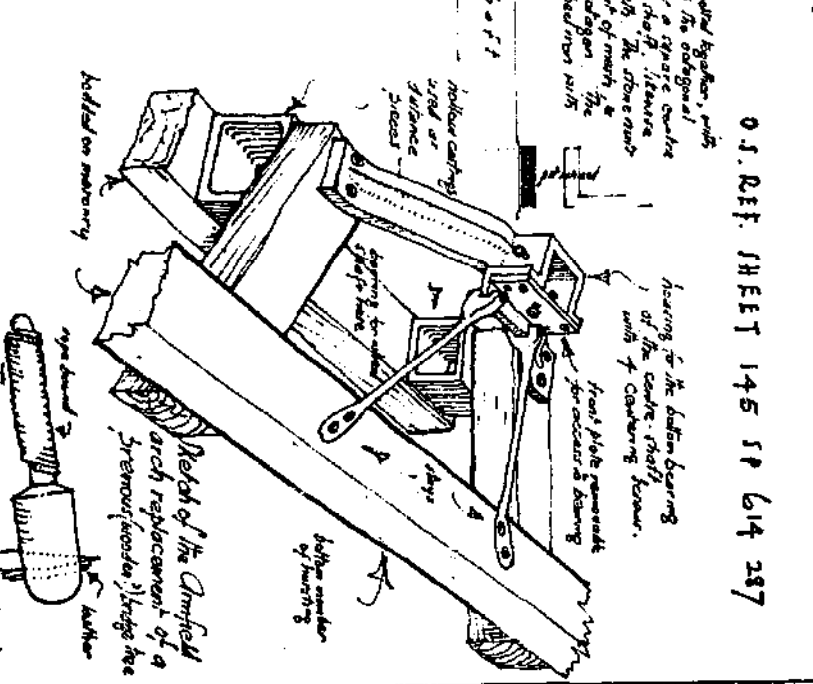
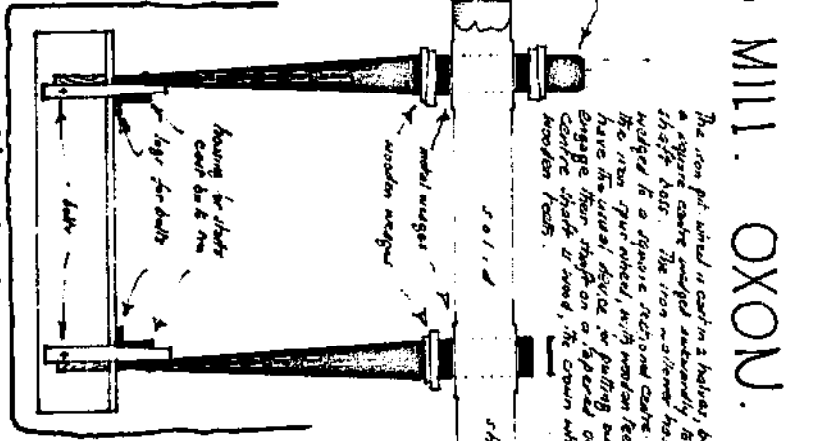
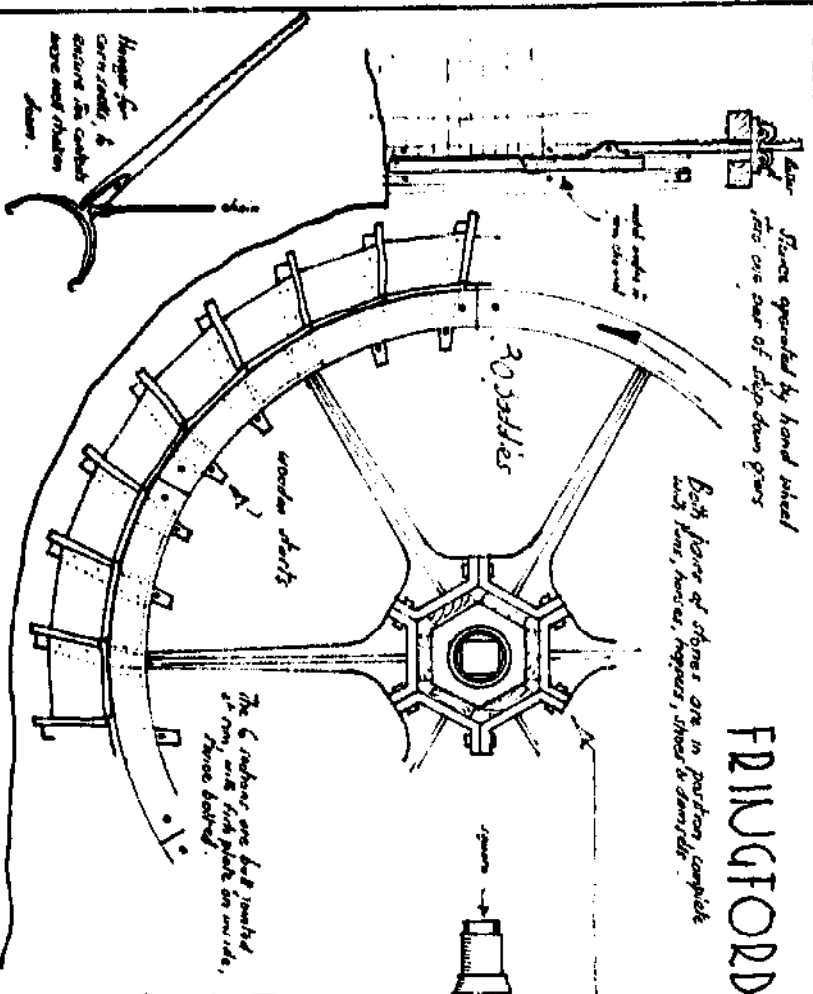

BOTH WHEELS DRAWN TO SCALE OF 1/4" TO 1'0"

by kind permission of the owner, Mark Waghorn.

BROADWELL MILL. OXON.

SHEET 157 270.015

LITTLE CLANFIELD MILL.

SHEET 157 256 025

SCALE 1/2" TO ONE FOOT

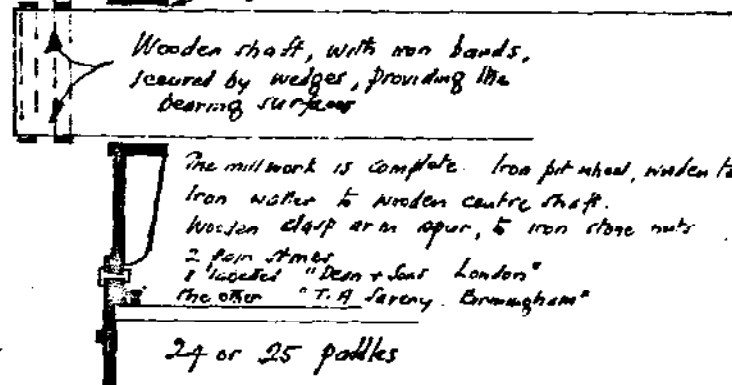
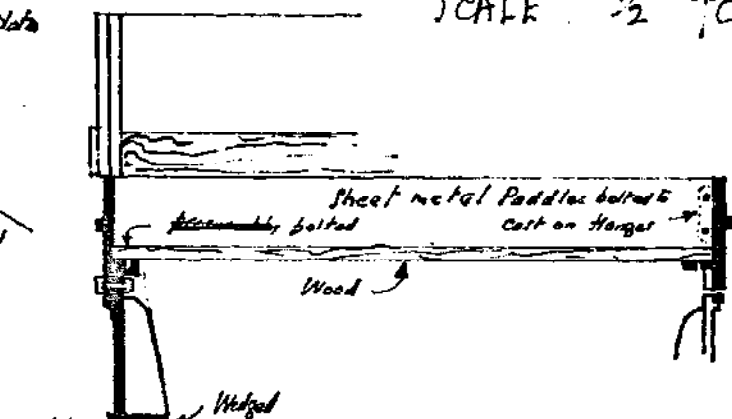
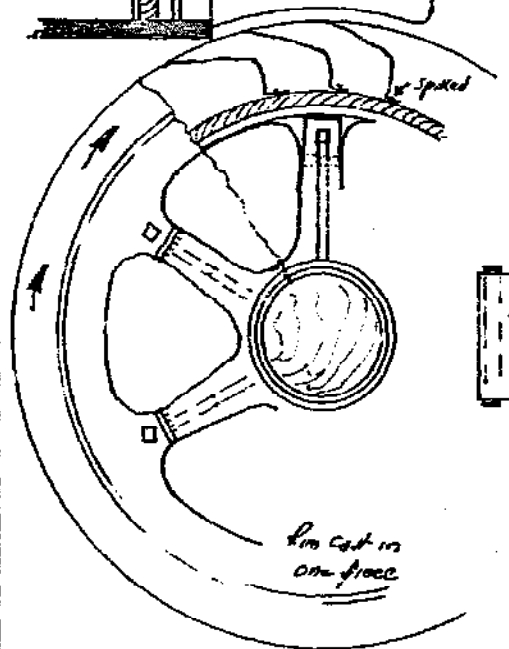
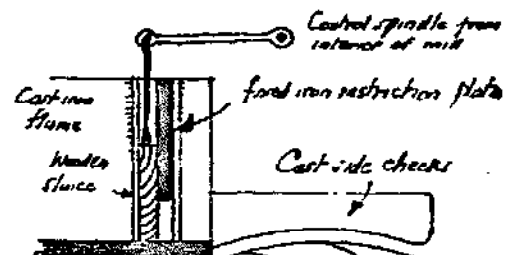

The millwork is complete. Iron pit wheel, wooden teeth iron water to wooden centre shaft. Wooden clasp arm in spur, to iron stone nuts. 2 pair stones. 1 "washed" "Dean & Son London" the other "T. A. Savory, Birmingham"

24 or 25 paddles

This is a fairly accurate representation, but the interior is impossible to reach - there may be eight spokes. Correction - 6.

THIS MILL RETAINS COMPLETE MILLWORK - USUAL 2 PAIR STONES ARRANGEMENT

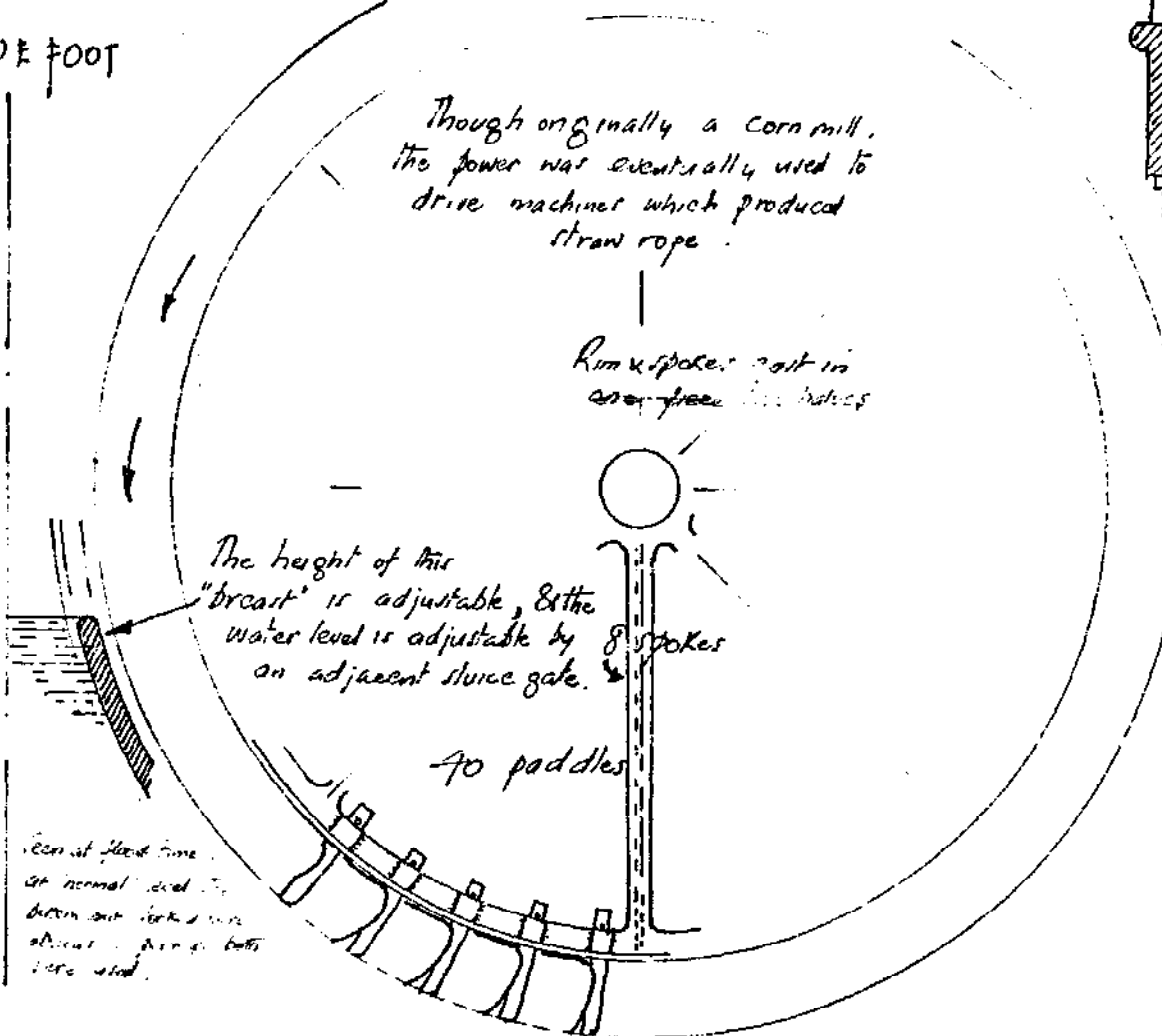

Though originally a corn mill, the power was eventually used to drive machines which produced straw rope.

Rim & spokes cast in one piece in cast iron

The height of this "breast" is adjustable, & the water level is adjustable by 8 spokes on adjacent sluice gate.

40 paddles

Can at flood time. At normal level the beam and links are adjusted. All parts here used.

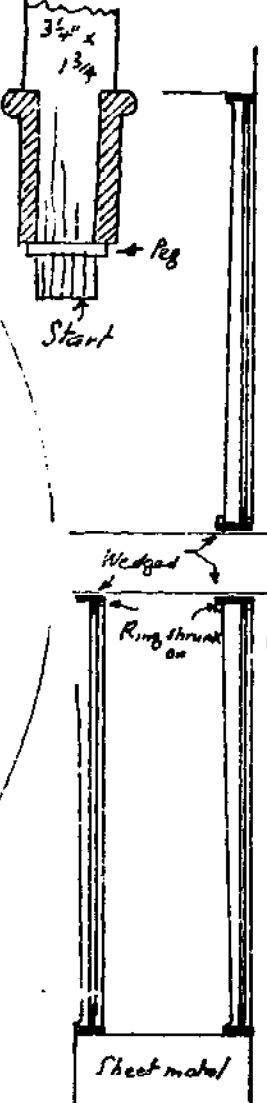

W. FOREMAN MARCH 1973

OVERY MILL . DORCHESTER . OXON .

SCALE $\frac{1}{2}$ " TO ONE FOOT .

ORIGINAL WOODEN MILLWORK .

fit wheel rim & wallower .

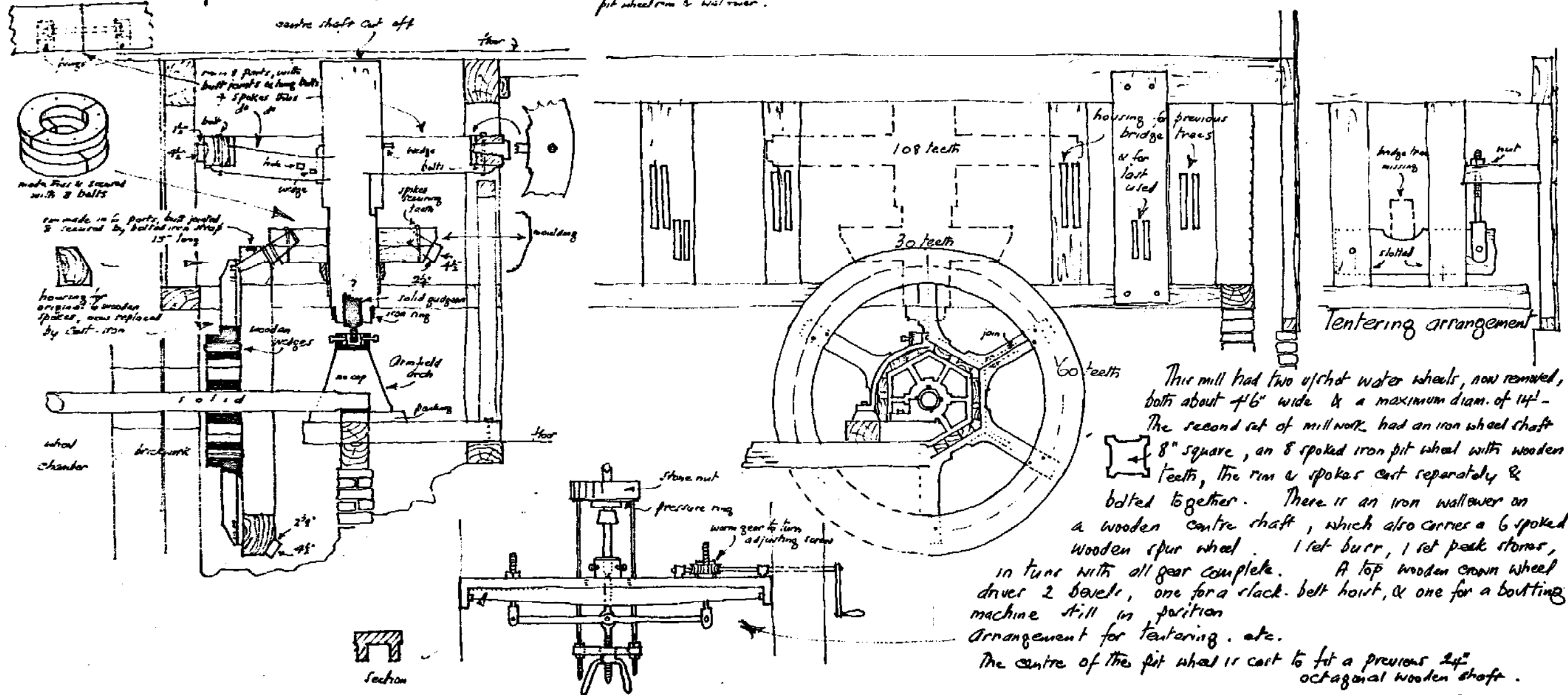

This mill had two upshot water wheels, now removed, both about 4'6" wide & a maximum diam. of 14' - The second set of millwork had an iron wheel shaft 8" square, an 8 spoked iron pit wheel with wooden teeth, the rim & spokes cast separately & bolted together. There is an iron wallower on a wooden centre shaft, which also carries a 6 spoked wooden spur wheel. 1 set burr, 1 set peak stones, in tune with all gear complete. A top wooden crown wheel drives 2 bevels, one for a slack belt hoist, & one for a botting machine still in position. Arrangement for tentering, etc. The centre of the pit wheel is cast to fit a previous 2 1/2" octagonal wooden shaft.

W. FOREMAN. JUNE. 1974.

WATER WHEEL .

MORRELL'S BREWERY .

OXFORD

SCALE . HALF INCH TO ONE FOOT.

Cast iron frame with wooden starts and paddles

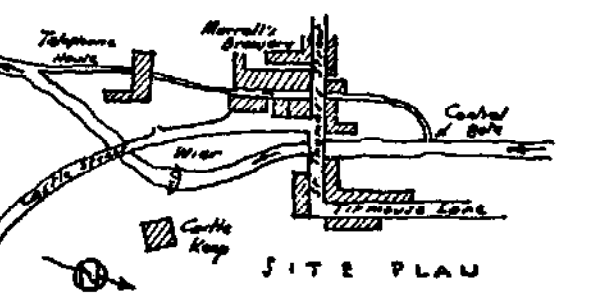
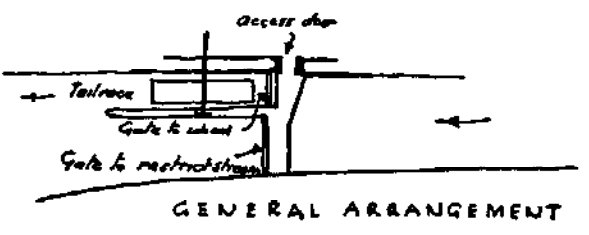
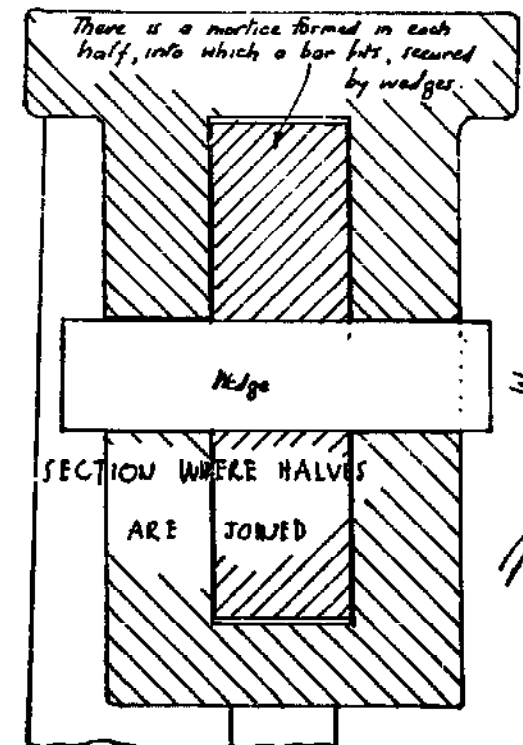
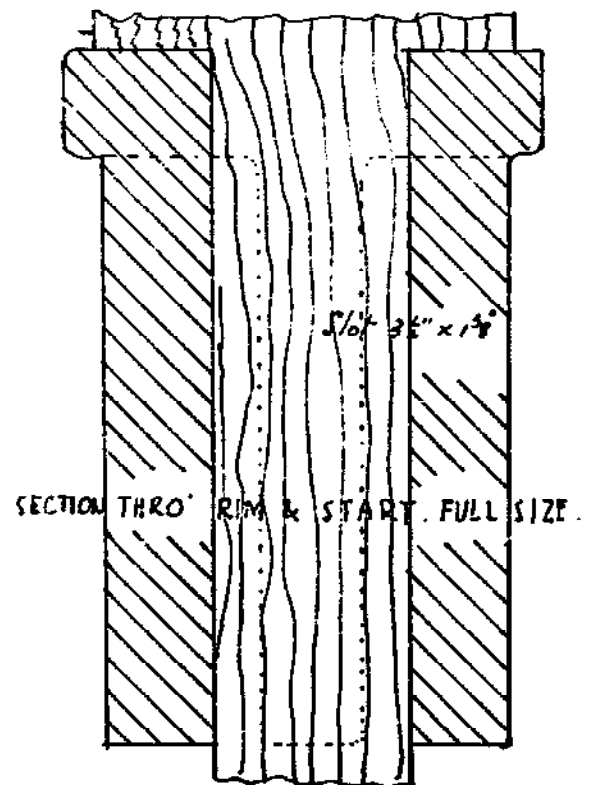
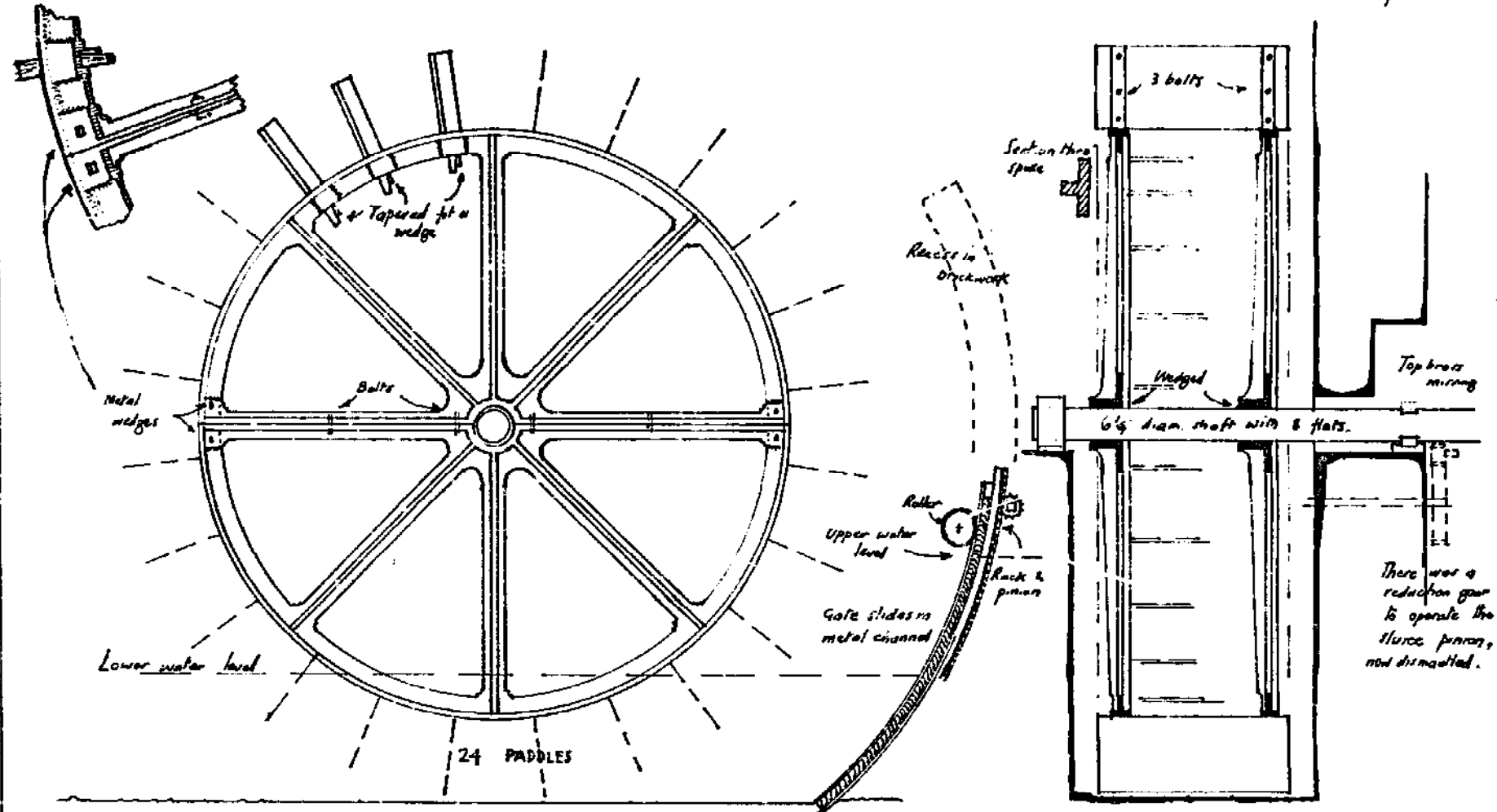

W. FOREMAN. 10.7.72

CHURCH MILL. STANDLAKE.

BY KIND PERMISSION OF MR. H. F. COLLINS

SCALE 1/2" TO ONE FOOT.

ORD. REF. SHEET 158.
397.038.

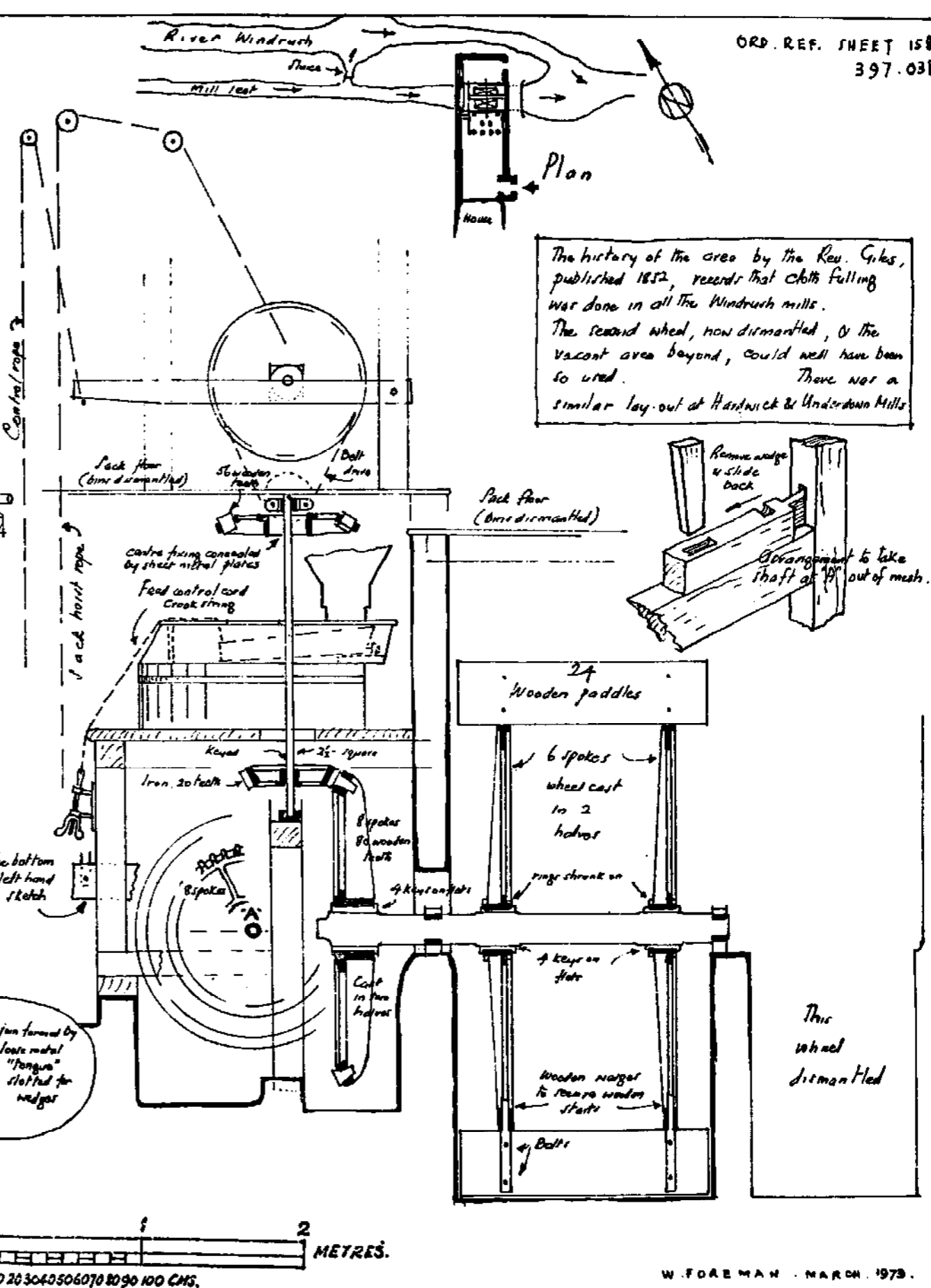
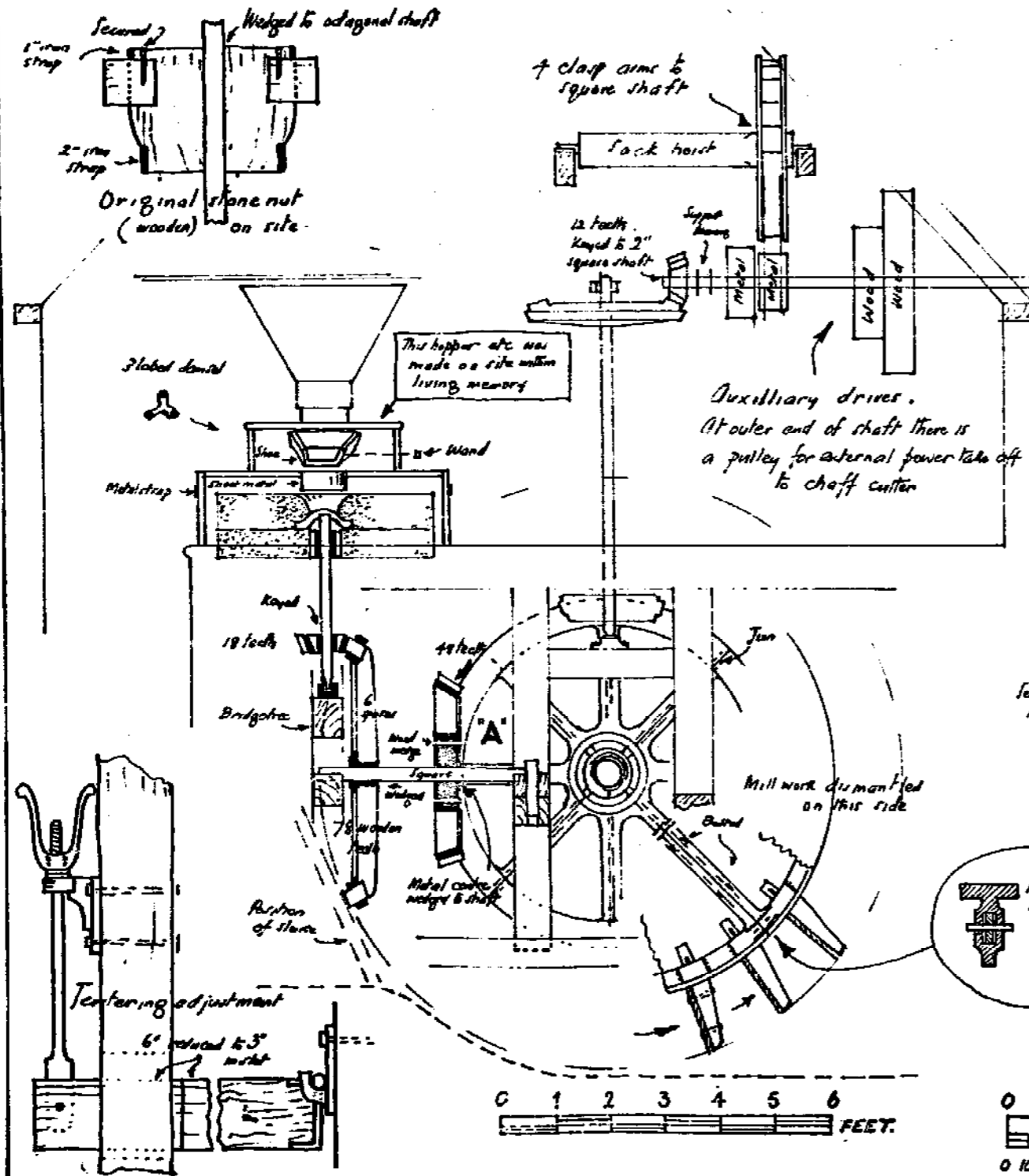

THE FISH HOUSE . N^r. DUCKLINGTON . OXON .

ORDS. REF. S.P. 373 066

SCALE . HALF INCH TO ONE FOOT.

2" iron plates on both sides of rim at butt joints, with 4 bolts

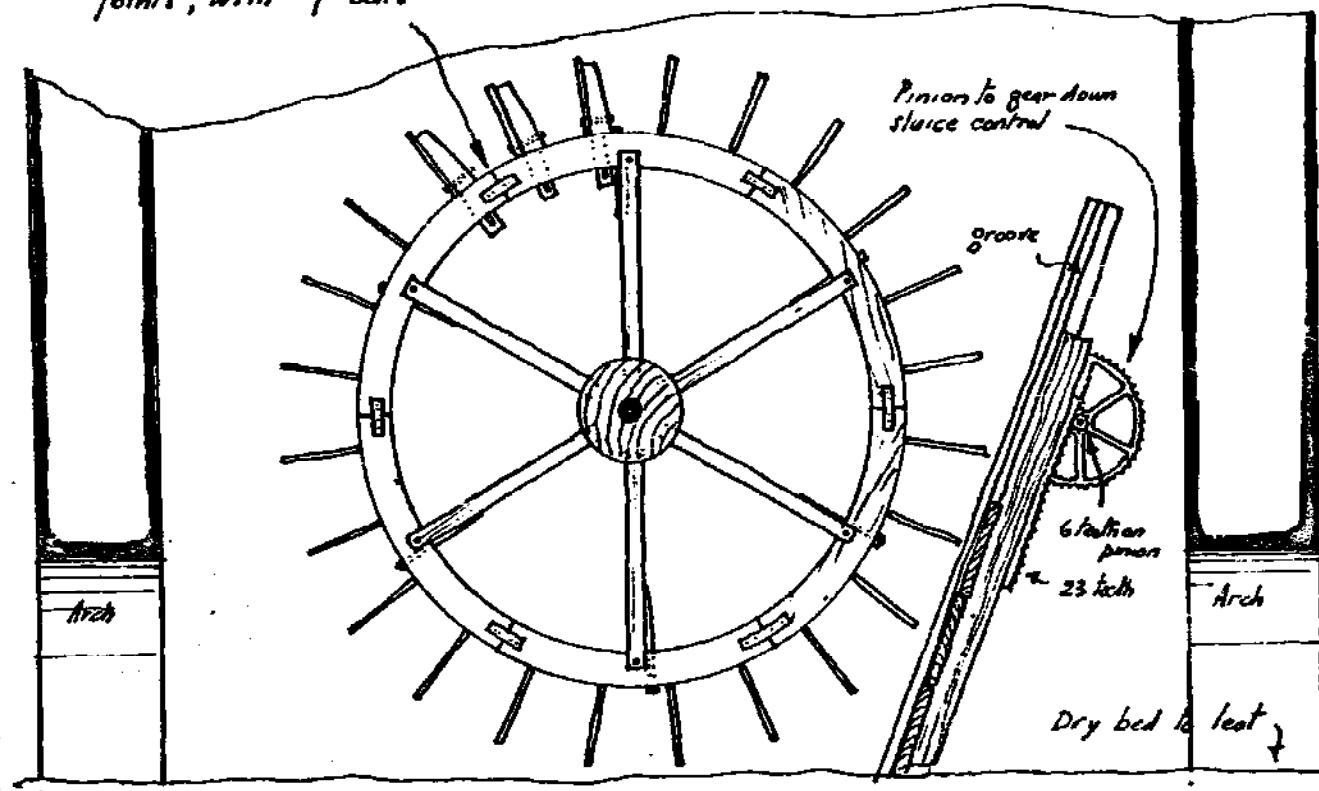
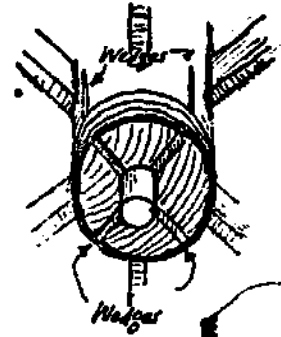

L O N G S E C T I O N

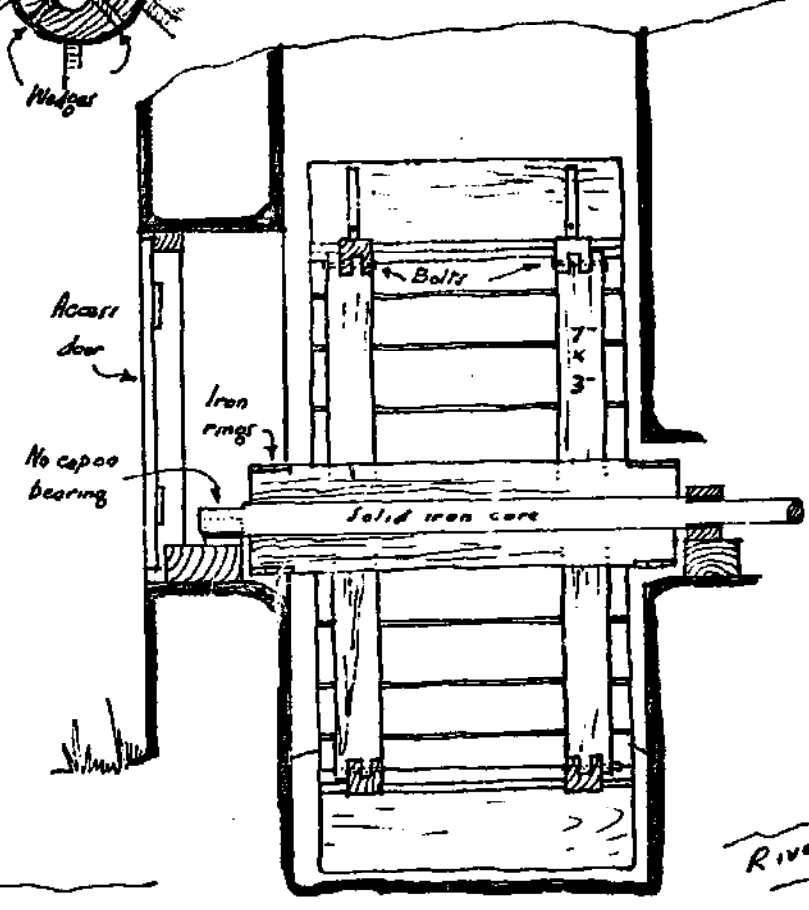

S E C T I O N

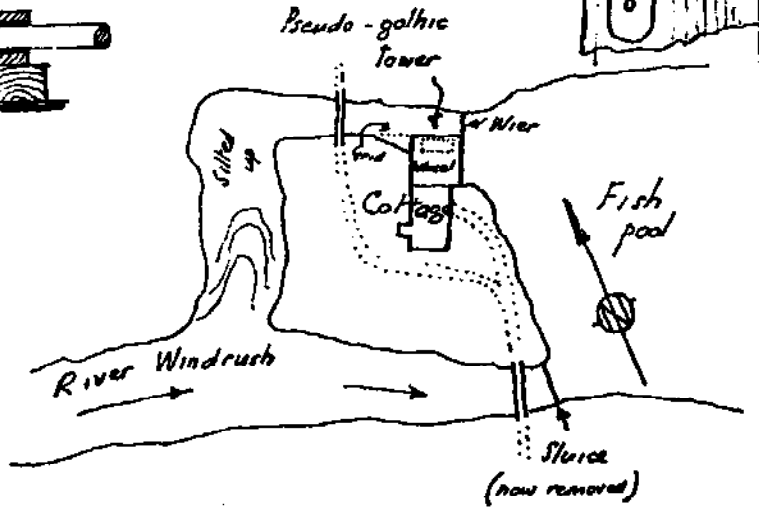
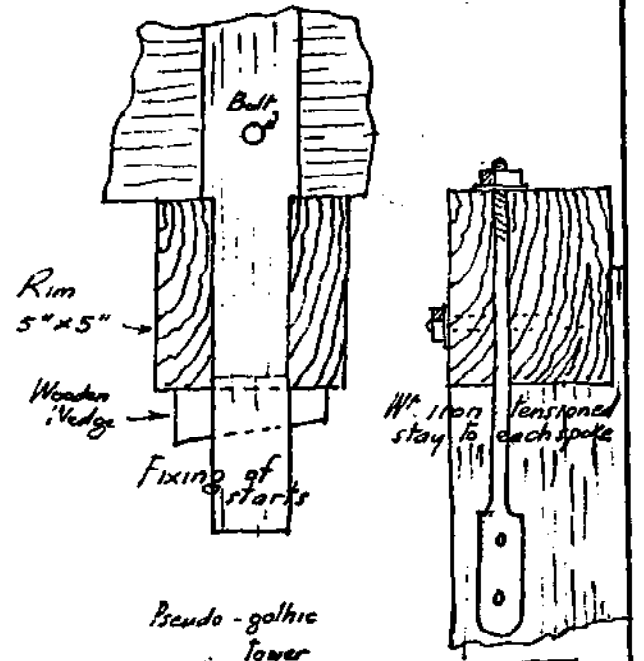

BUILDING ERECTED 1710. WHEEL PRESUMABLY BUILT IN THEN,

& PUMPED WATER FOR COKETHORPE HOUSE TILL 1950.

W. FOREMAN . JAN. 1973

HOLTON MILL, WHEATLEY, OXON.

BY KIND PERMISSION OF MR L.A. RING.
O.S. REF. SHEET 158. S.P. 614 058.

SCALE . HALF INCH TO ONE FOOT

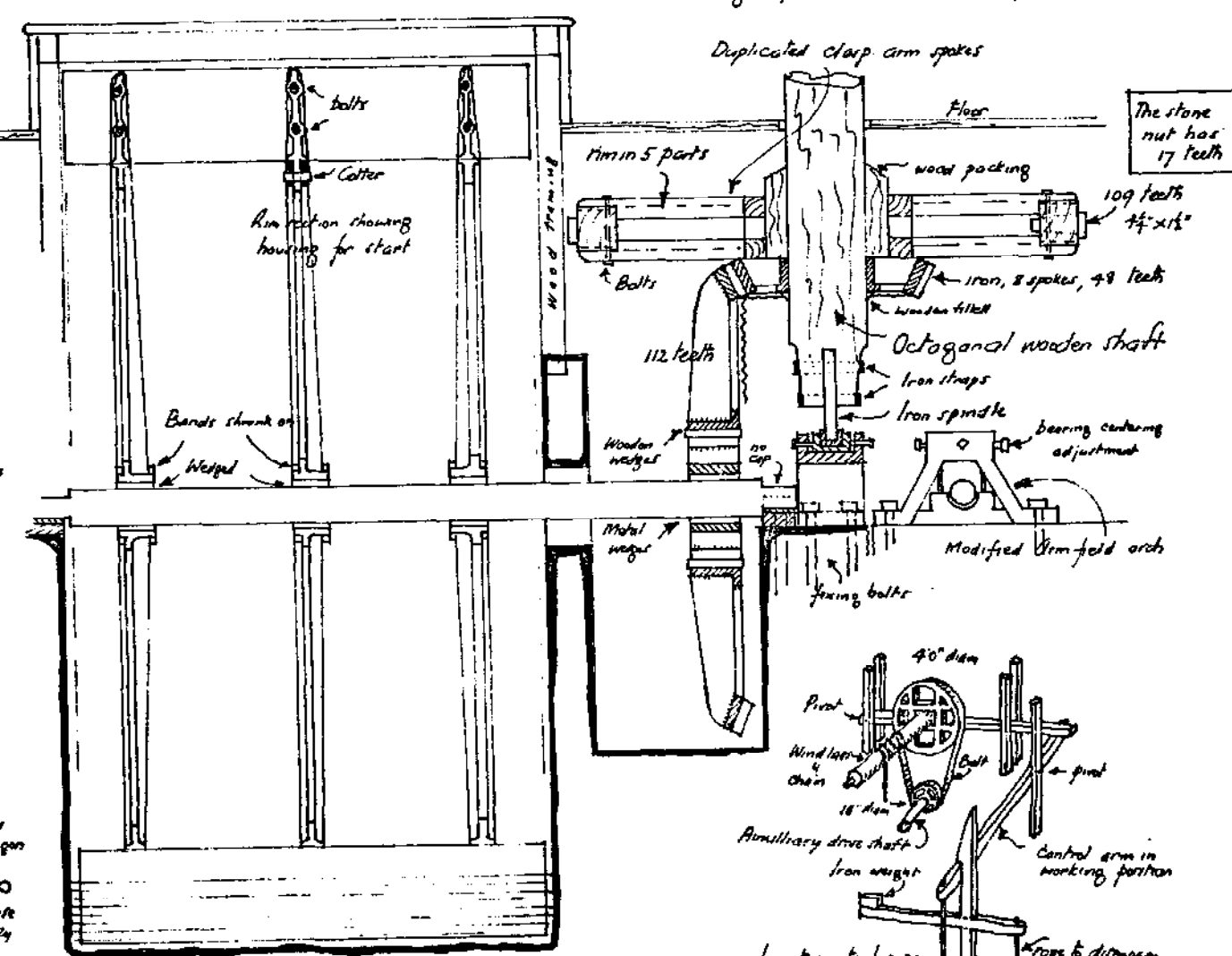
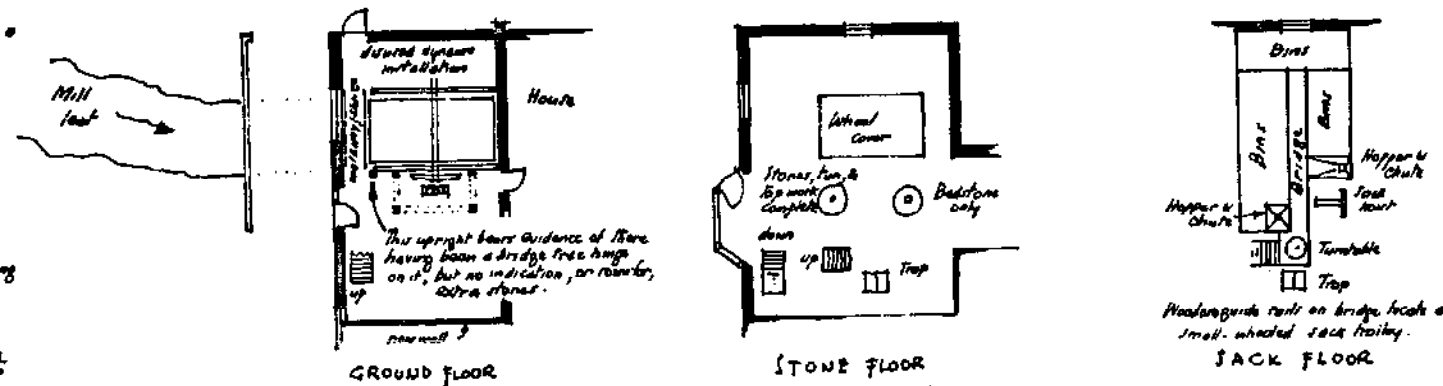
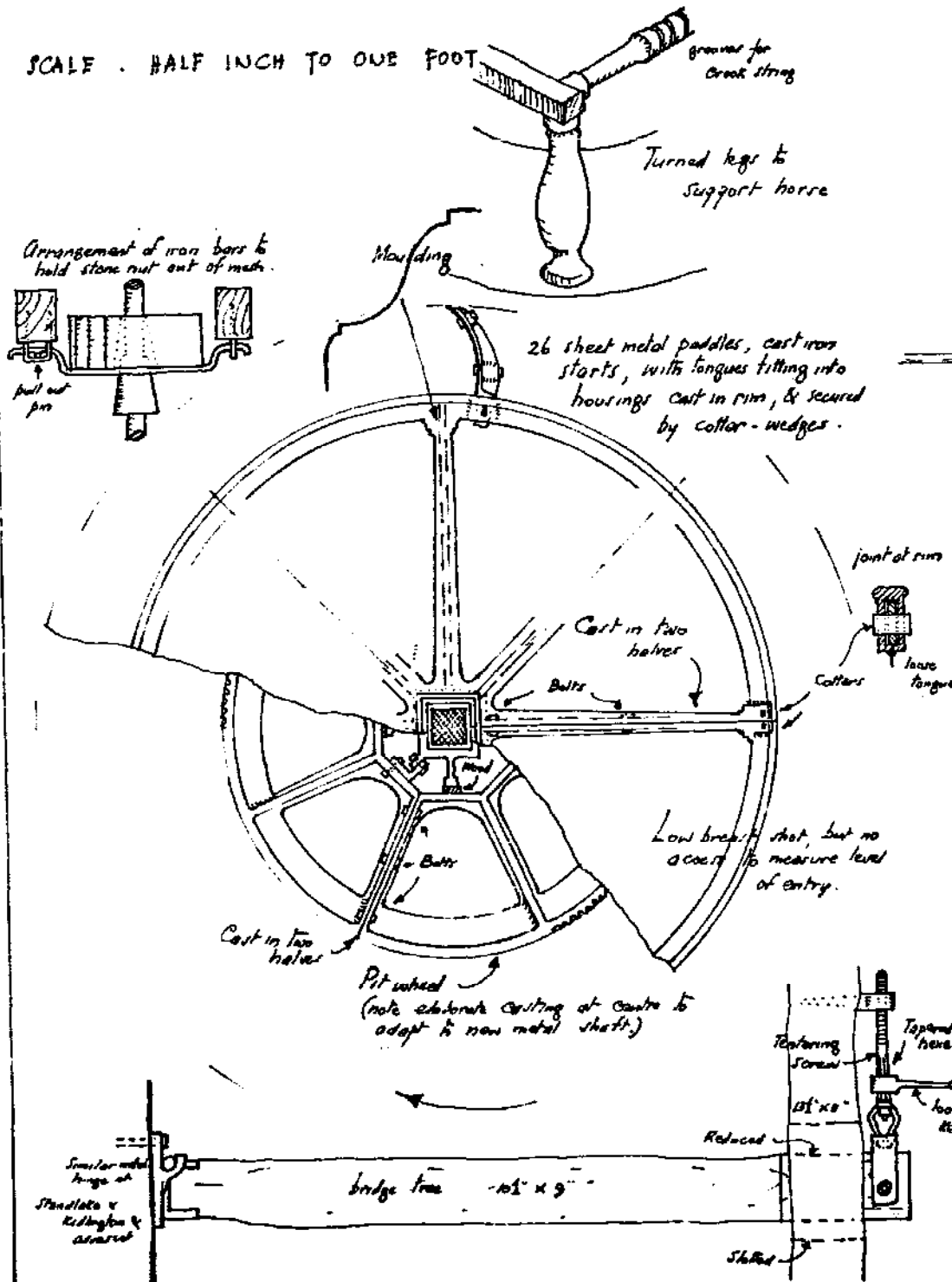

W. FOREMAN . APRIL 1973.

HARDWICK MILL . OXON.

ORD. MAP REF. EP 380 061

BY COURTESY OF THE OWNERS - M^{rs} M^{rs} IRONS

DETAILS AT HALF INCH TO ONE FOOT

MOST OF THE IRONWORK WAS SOLD FOR SCRAP IN 1940.

(ONE FIRST MOTION SHAFT REMAINS), & THIS IS A RE-CONSTRUCTION, BASED ON EVIDENCE ON SITE.

THE RIVER NOW RUNS THRU THE MILL LEAT A WHEEL CHAMBER, & THE ORIGINAL COURSE IS SILTED UP.

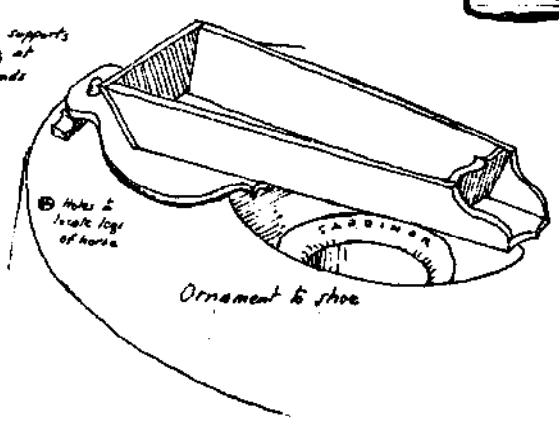
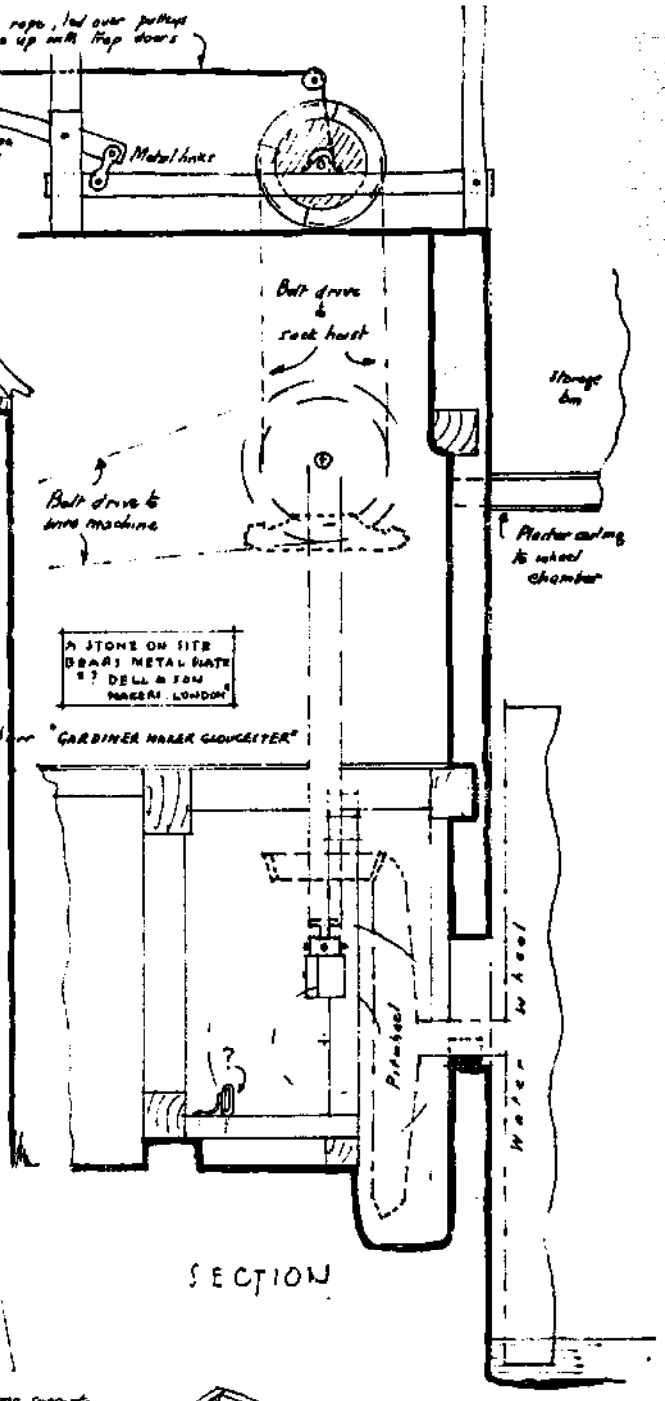
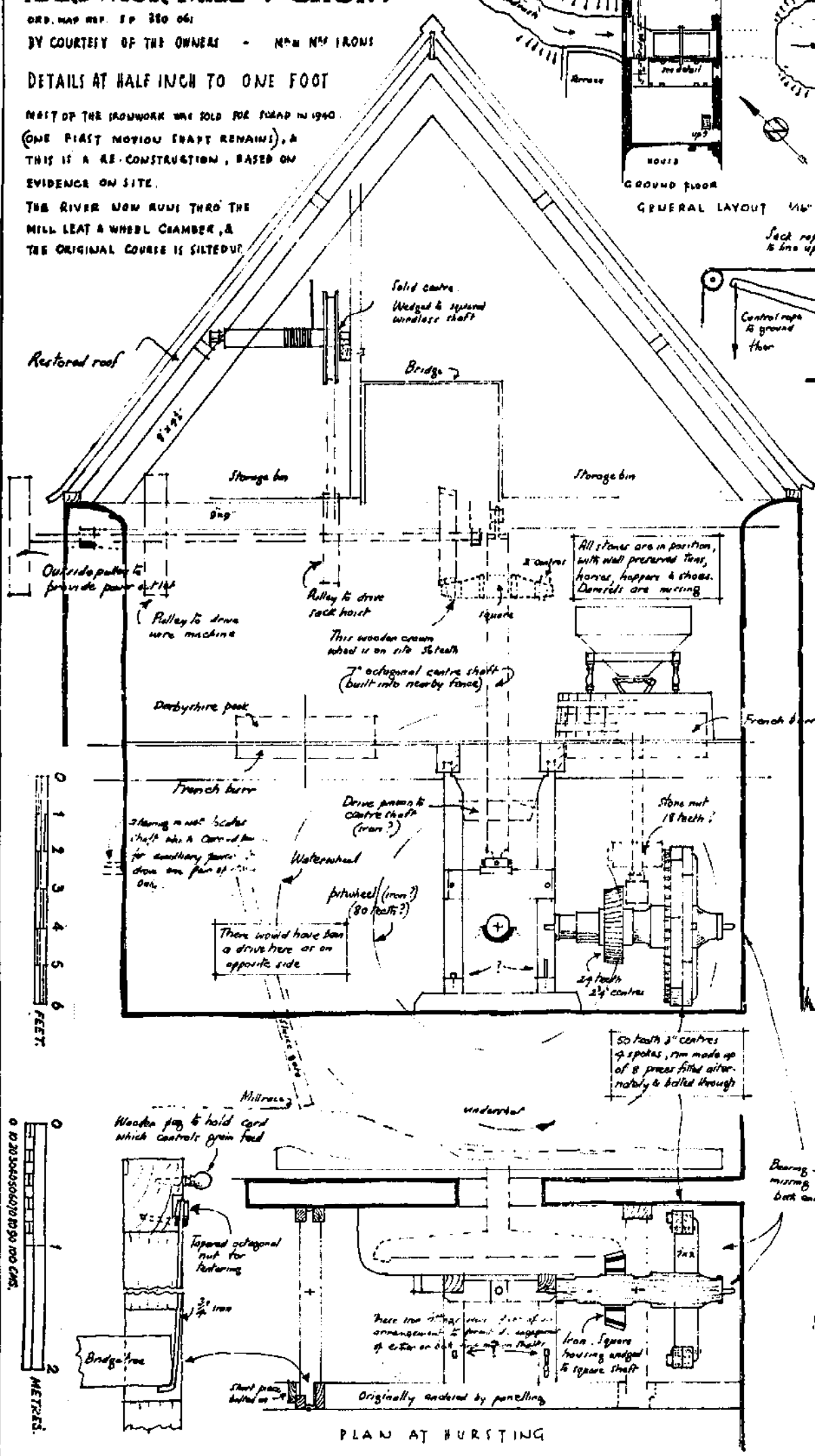
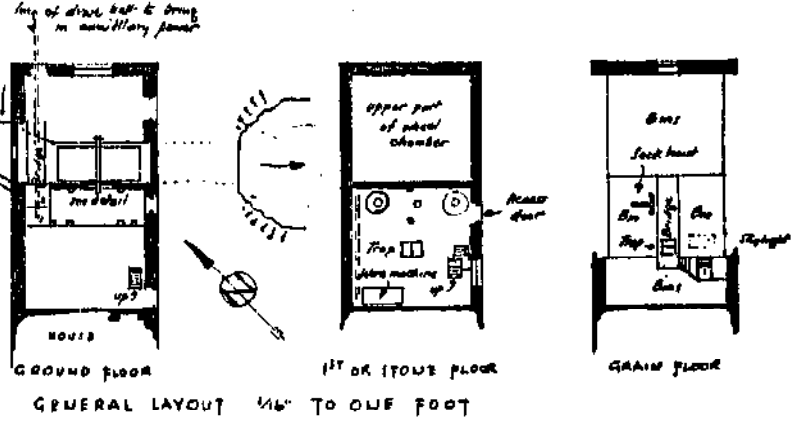

CLIFTON MILL . OXON.

THESE SECTIONS DRAWN TO SCALE OF 1/4" TO ONE FOOT.

BY KIND PERMISSION OF MR A. R. WELFORD
ORD. REF. 145 S.F. 491 318

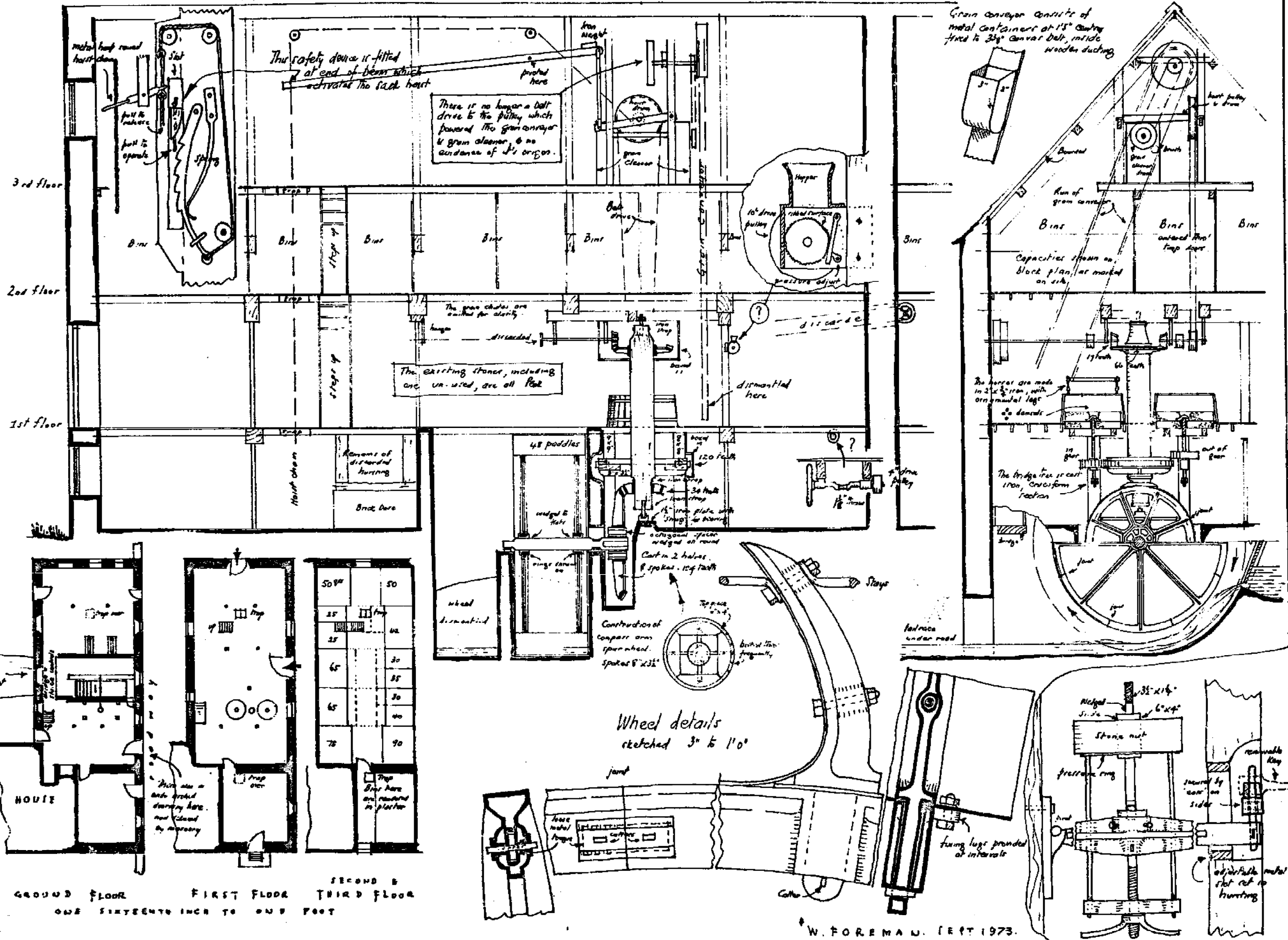

NORTH NEWINGTON MILL. OXON.
SCALE HALF INCH TO ONE FOOT.

WATER WHEEL & PIT WHEEL.

O.S. REF. SHEET 145 S.P. 424 394

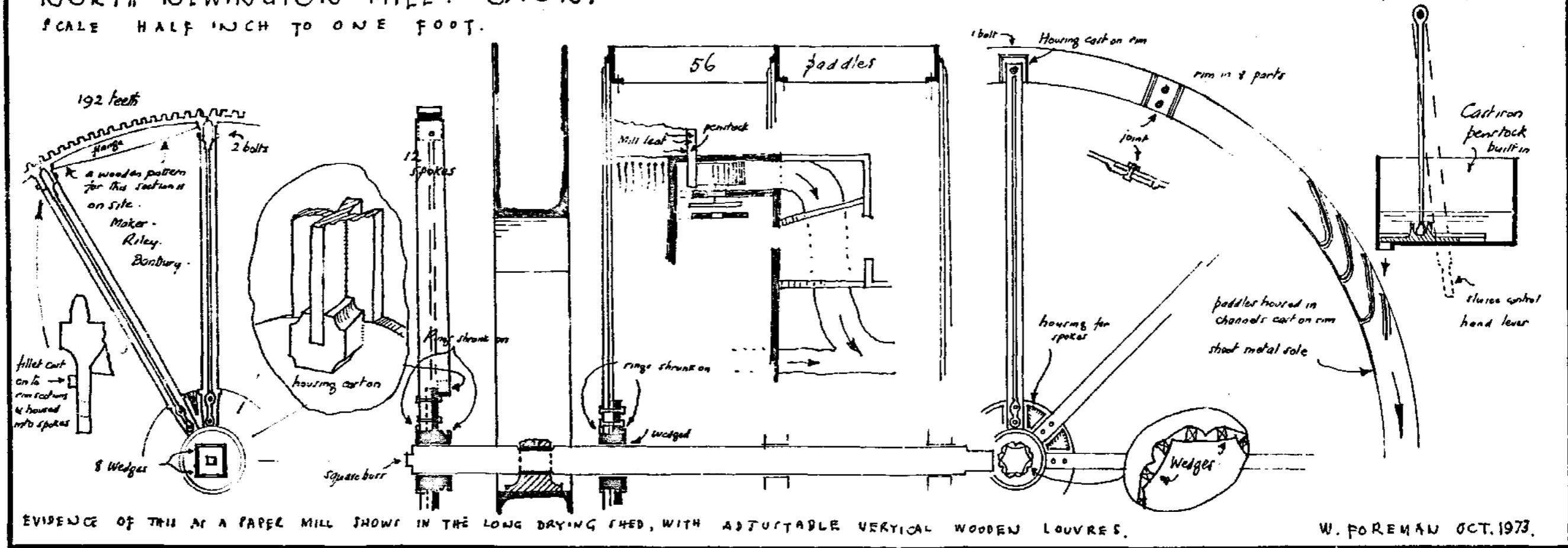

EVIDENCE OF THIS AT A PAPER MILL SHOWS IN THE LONG DRYING SHED, WITH ADJUSTABLE VERTICAL WOODEN LOUVRES.

W. FOREMAN OCT. 1973.

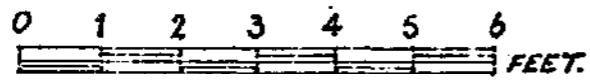

OVERY MILL. DORCHESTER. OXON.
ISOMETRIC SKETCH.

W. FOREMAN

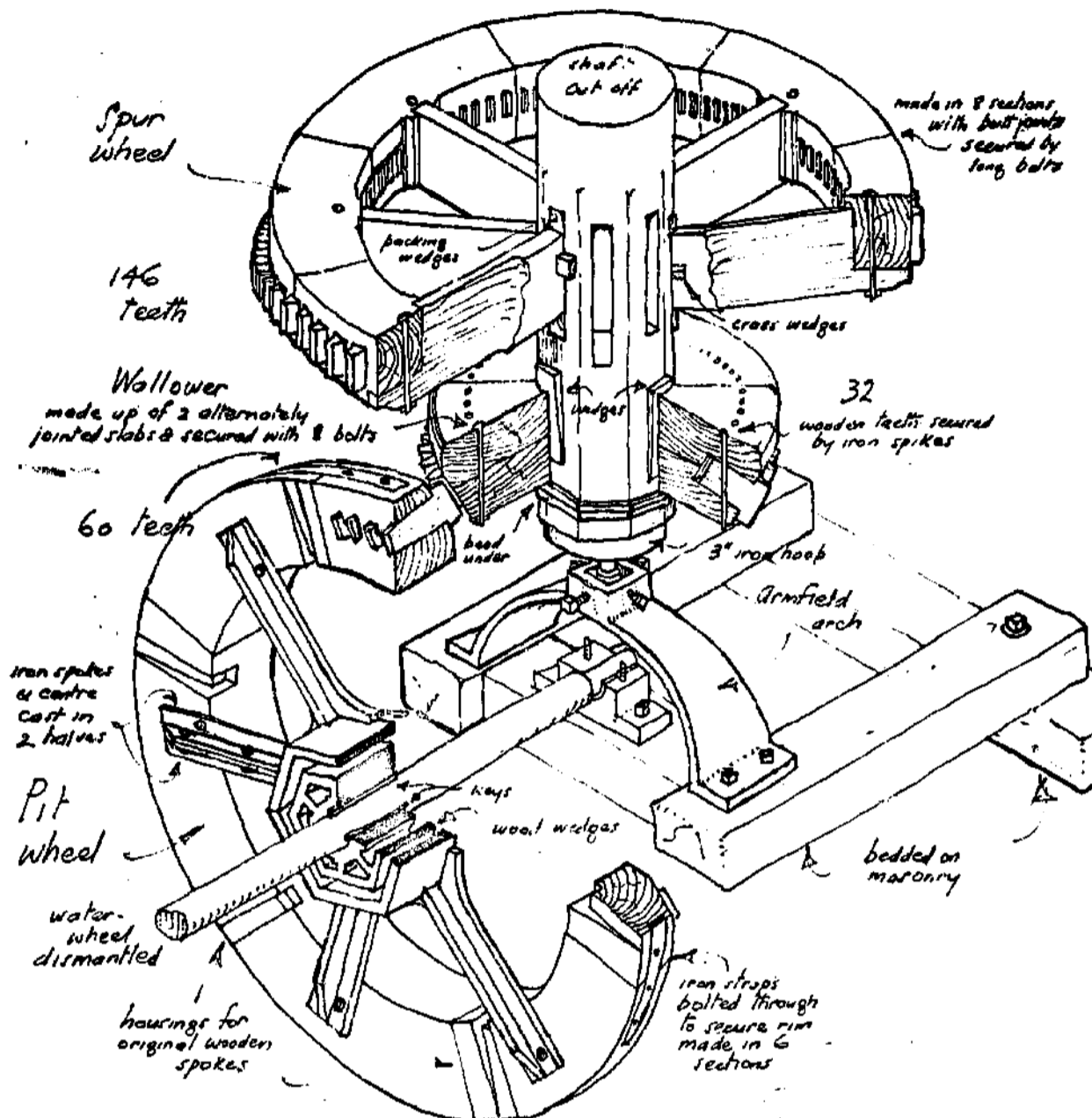

WOODEN PIT WHEELS WERE ALWAYS AT RISK & IN LOCAL MILLS WERE THE FIRST PART TO BE REPLACED BY IRON. IN THIS CASE THE SPOKES ONLY HAVE BEEN REPLACED. NOTICE HOW THE CENTRE WAS CAST TO FIT AN OCTAGONAL WOODEN WHEEL-SHAFT, & WHEN THAT SHAFT WAS REPLACED BY A SMALLER IRON ONE, A SPACER HAD TO BE SPECIALLY CAST TO MAKE UP BETWEEN THE OLD CENTRE & THE NEW SHAFT. IN SOME 200 MILLS I HAVE NEVER BEFORE FOUND A WOODEN WALLOWER.

CHALGROVE MILL . OXON.

OS. REF. S.U. 631 970

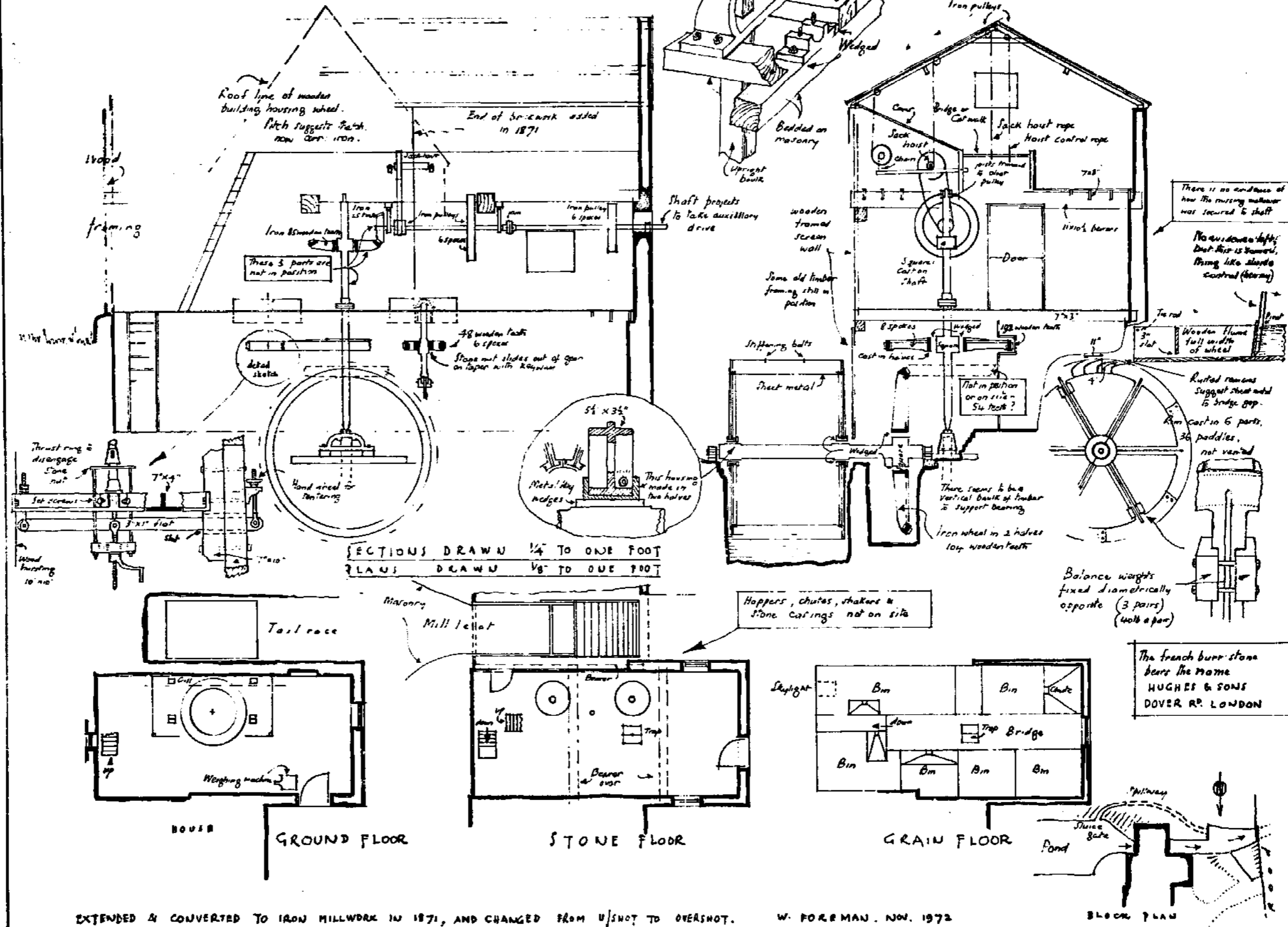

EXTENDED & CONVERTED TO IRON MILLWORK IN 1871, AND CHANGED FROM U/SNOT TO OVERSHOT.

W. FORSMAN. NOV. 1872

SALFORD MILL. N^o. CHIPPING NORTON. OXON.

O.S. REF 175 S.P. 292 276

BY KIND PERMISSION OF MR. FAWCETT.

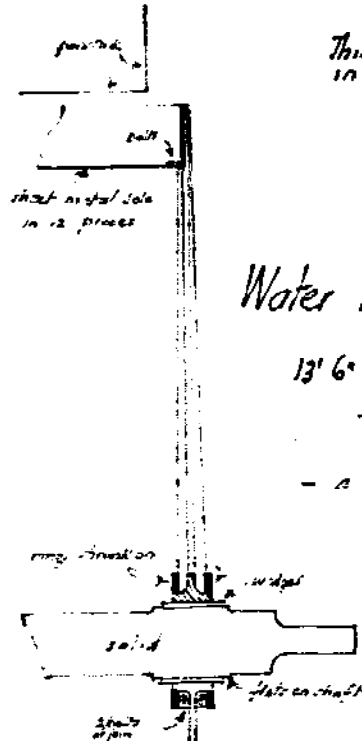

This is the only mill-work in the country bearing a maker's name

Water wheel

13' 6" diam 5' 0" wide
48 paddles
- a very clean casting -

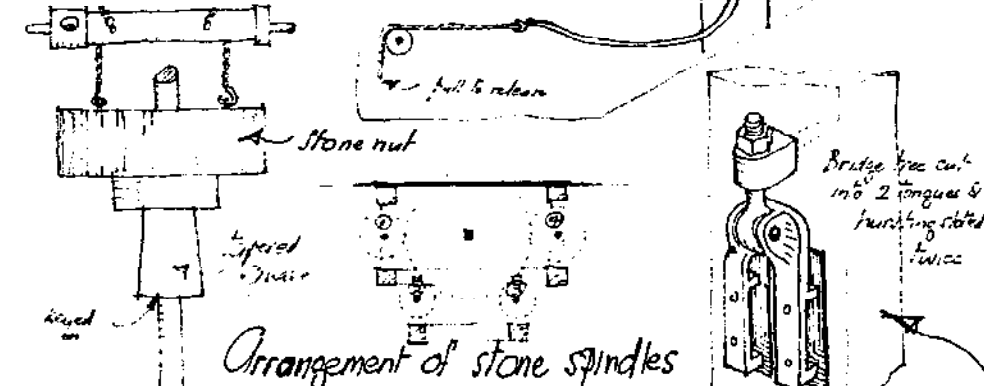
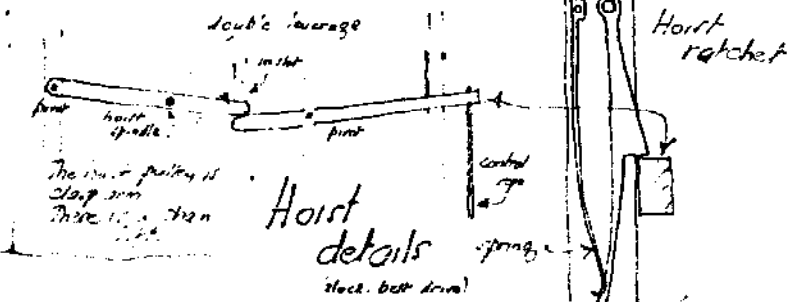
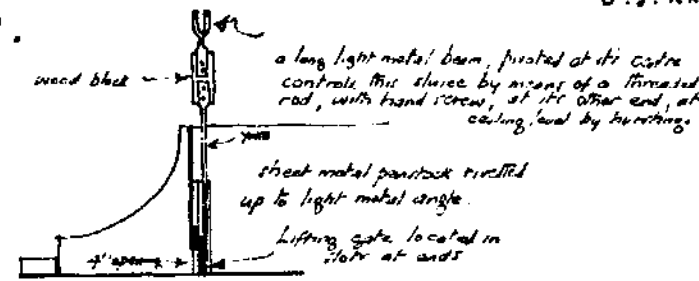
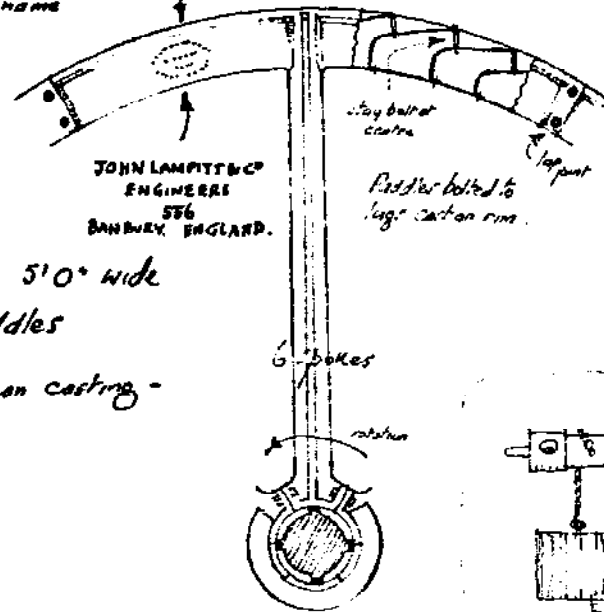

Arrangement of stone spindles

Drive ① with stones etc. over, has been dis-
mantled completely, tho' a bevel driven feathering screw remains.
Drive ② is carried on a wooden bridge-tree, with feathering
as shown, & the usual jack screw & pressure ring
arrangement to dis-engage the drive.
Drives ② & ③ were presumably acquired from another
mill, in fact these bevel gears have no matching
bevel drive, & the dis-engaging arrangement is not
necessary.
Note the chains & hooks to raise the stone nut out
of mesh, by means of a small Tommy-bar operated
without.

Pit wheel is heavily cast in 2 halves, fitted to a square bar cast on shaft.
Iron Wallower, fitted to pass cast on 5" dia centre shaft, which bar also
carries 8 spokes cast in one piece, bolted to a rim cast in 2 halves, to make
up the spur wheel. The stone nuts are iron

The crown wheel is an unusually heavy (8 1/2" x 7 1/2" wooden rim) with 4 compass
arm spokes which are housed into a cast iron hub. It is 6' 8" diam.

There are 2 tons & hoppers complete, one ② with peak stones, the other ①
with pair of french burrs from GARDNER & SONS, GLOUCESTER. There
is another pair of peak stones in situ ④ & 2 runner french burrs of dark
colour stored on site. Two 7 lobed saws in working position ③ & ⑤.

Barn thresher by GOOD, HARLESTON, NORTHAMPTONSHIRE.

Dust & chaff separator by S. HANSE, SILVER CREEK, NEW YORK.

Un-named wire machine & bolting machine.

There is a larger
than usual
storage on
sack floor.

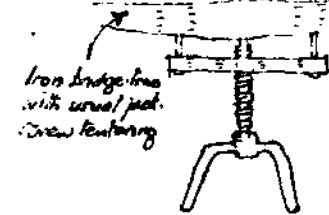
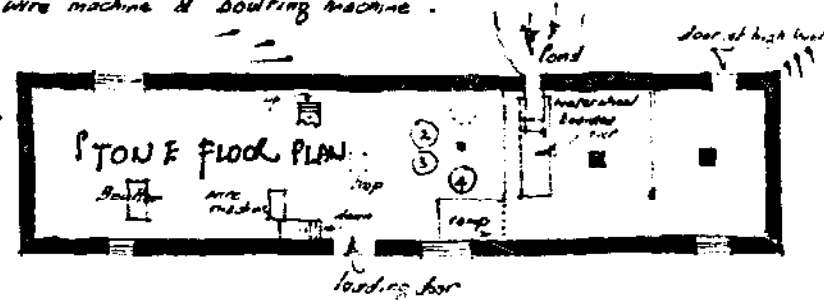

MILL BUILDINGS . BARFORD ST JOHN . OXON .

O.S. S.P. 445 330

SCALE ~ 1/8" & 1/4" TO ONE FOOT.

BY KIND PERMISSION OF MAGDALEN COLLEGE, OXFORD. OWNERS & M^{rs} P.E. LOVELL, TENANT

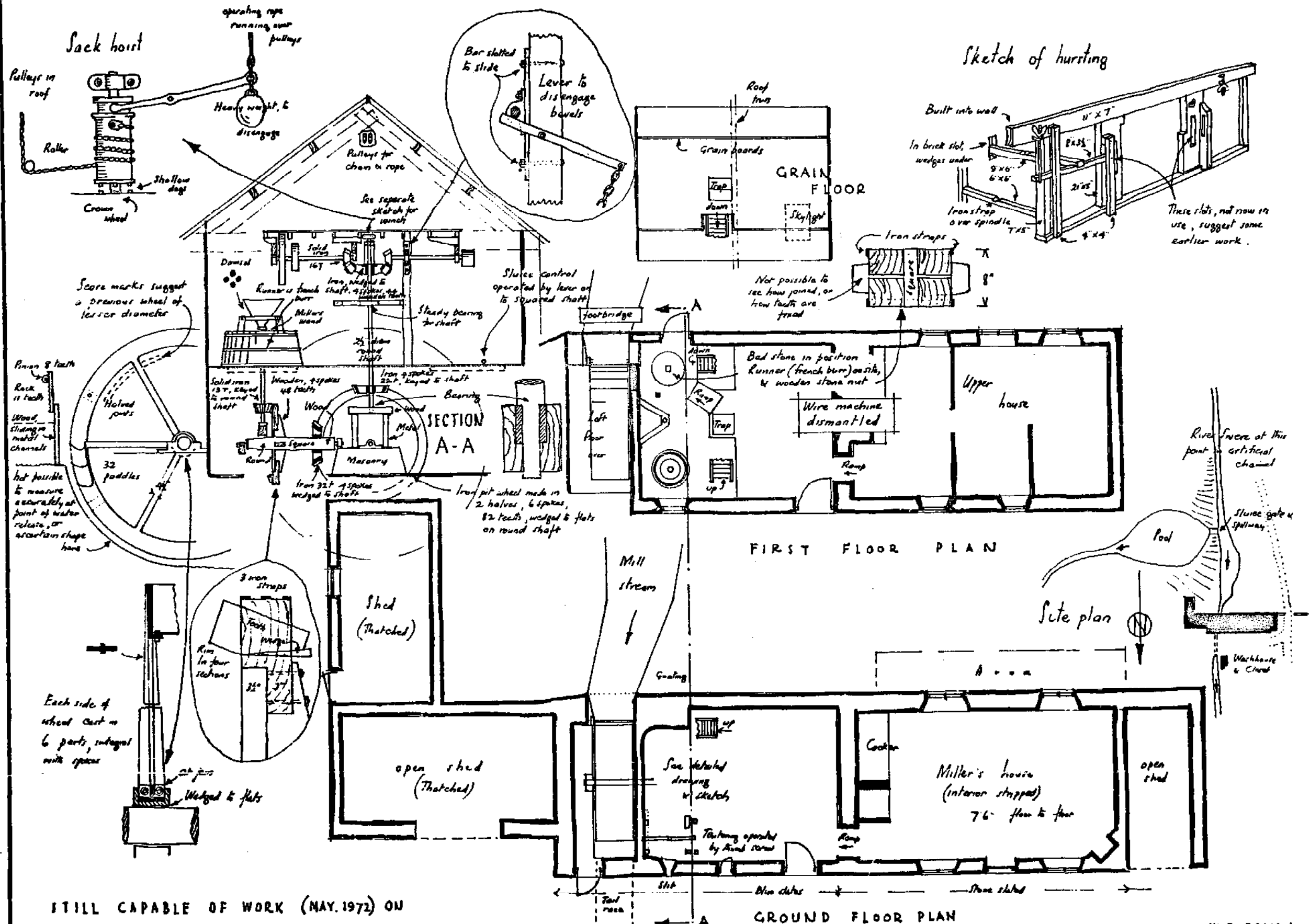

STILL CAPABLE OF WORK (MAY. 1972) ON THE REMAINING PAIR OF STONES.

W. FOREMAN. MAY. 1972

THE WATER WHEEL. BROUGHTON POGGES MILL.
ISOMETRIC VIEW 8 O'CLOCK BREAST SHOT.

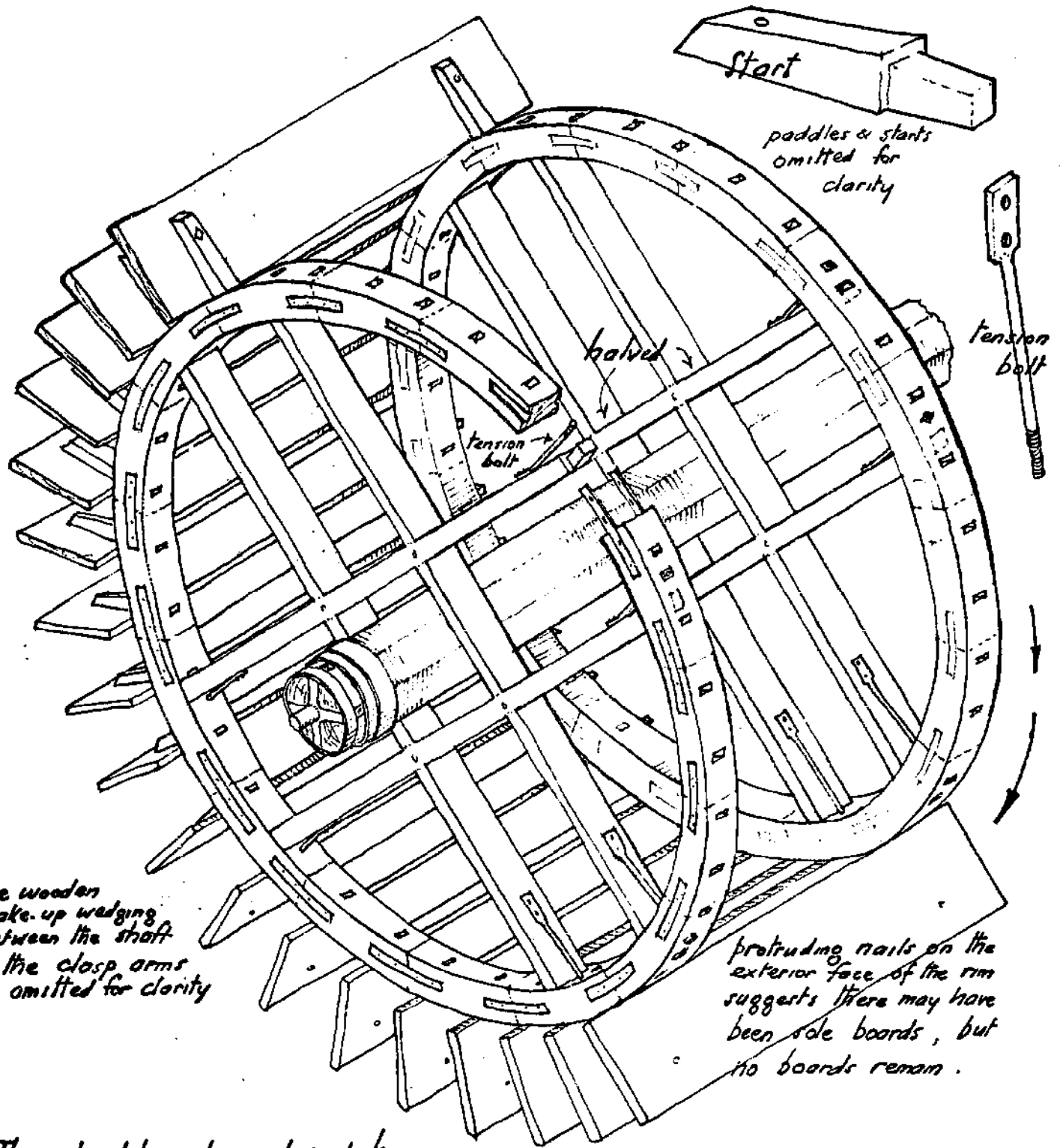

The wooden make-up wedging between the shaft & the clasp arms is omitted for clarity

protruding nails on the exterior face of the rim suggests there may have been side boards, but no boards remain.

This wheel has decayed and has collapsed into the wheel chamber.

W. FOREMAN . 74 .

SOUTH WESTON MILL. LEWKWOD. OXON.

BY KIND PERMISSION OF MR R. C. KEEB.

O.S. REF. SHEET 159 S.U. 702, 913.

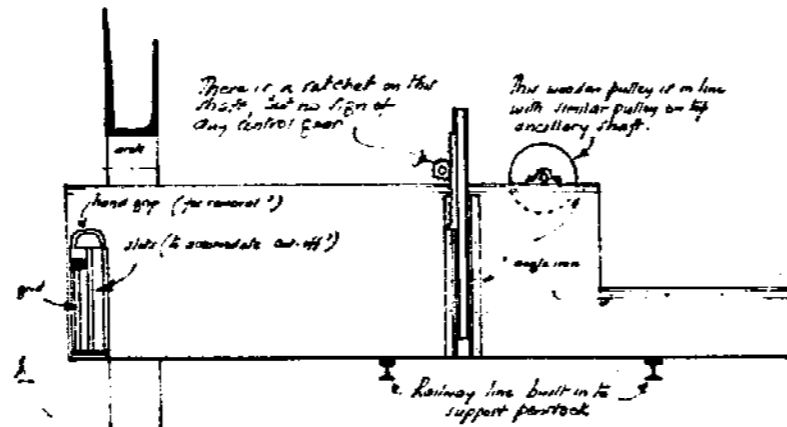

There is a void here, no support from the counter, not ed. from the cord.

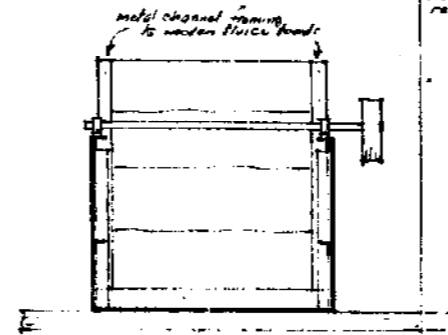

open area at start of far race hand

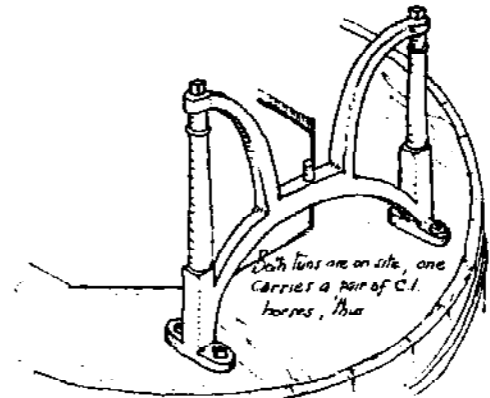
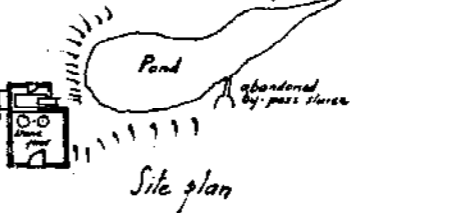

The pit wheel is heavily cast, with wooden cogs. It has a large square open centre, with a cast boss to accommodate to twisting metal water wheel shaft.

The water wheel is iron, wedged to a 6" square section metal centre shaft, which carries adjacent iron spur wheels, both with wooden cogs. First iron drive was brought in to drive the lower spur, which had steel cogs, while the upper one drove the stone mill. These would be taken out of gear by the wheel pressure ring.

The upper part of the centre shaft is 2 1/2" square, & the main wheel iron with wooden teeth. It drives 2 shafts with various pulleys. The wheel itself has no finger cogs.

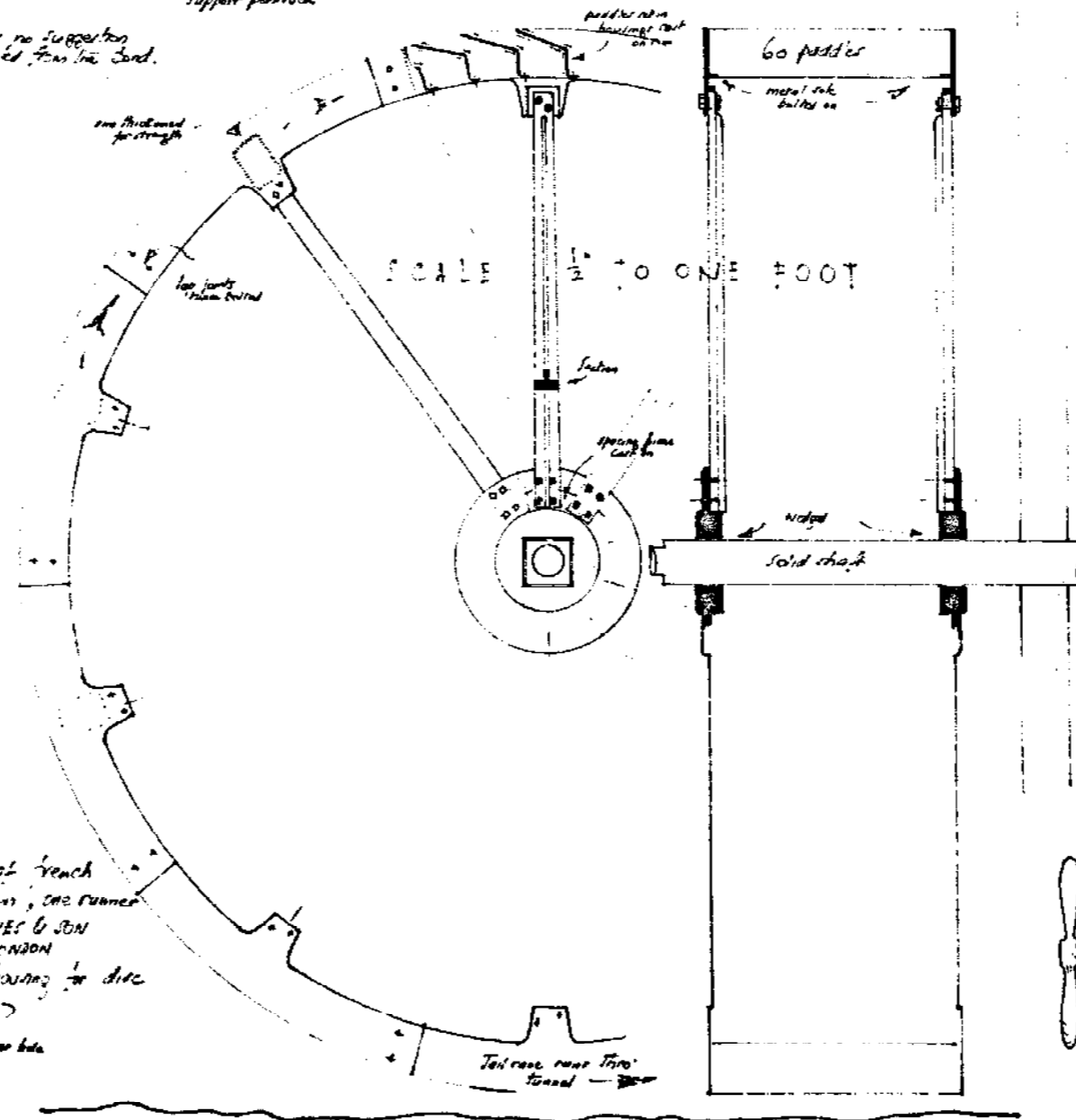

There are 2 sets of bench part stones in position, one runner bearing name HUGHES & SON LONDON

This stone has a housing for disc balance weights

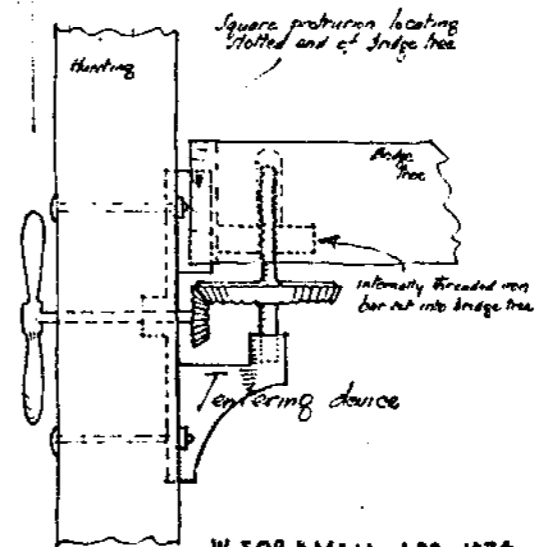

WATER MILL & BAKEHOUSE AT LIDSTONE, OXON.

O.S. REF. SHEET 145. S.P. 346 148

SCALE 1/4" TO ONE FOOT. AS EXISTING 7.9.71. PRIOR TO DEMOLITION.

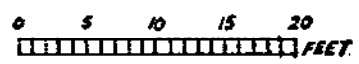
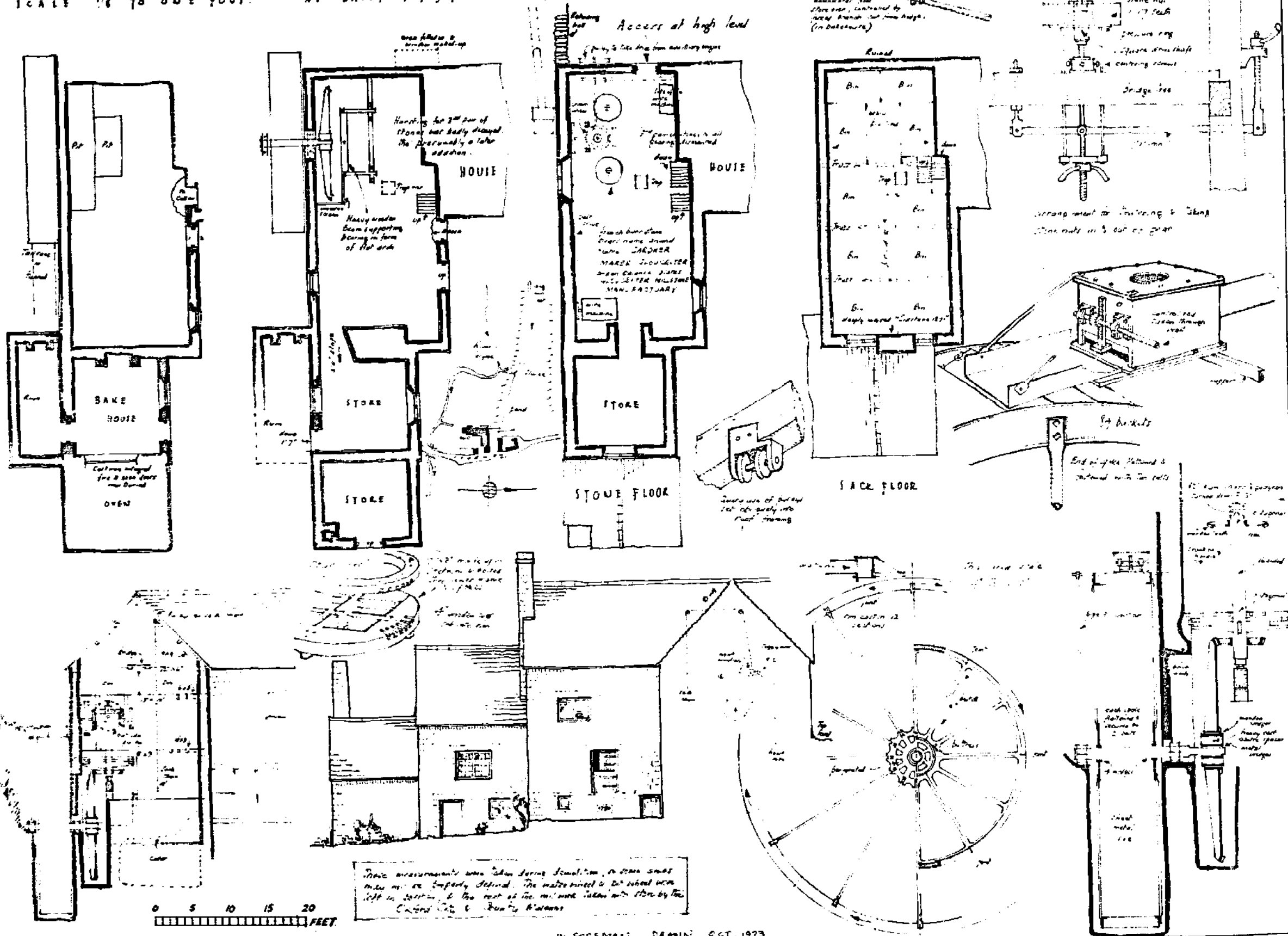

Some measurements were taken during demolition in some cases this may be slightly different. The millstone is 10' 6" long and 11' 6" wide. The rest of the millstone is shown by the dotted line & the rest of the millstone is shown by the dotted line & the rest of the millstone is shown by the dotted line.

ALVESCOT MILL . OXON .

SCALE 1/4" TO ONE FOOT.

O.S. REF. SHEET 157 4276 2049.

Some shows of 2 rollers
only found on site. Rest of
100' but not to accommodate
ed a new stone suggest that the
same are being used
for the 60 in number

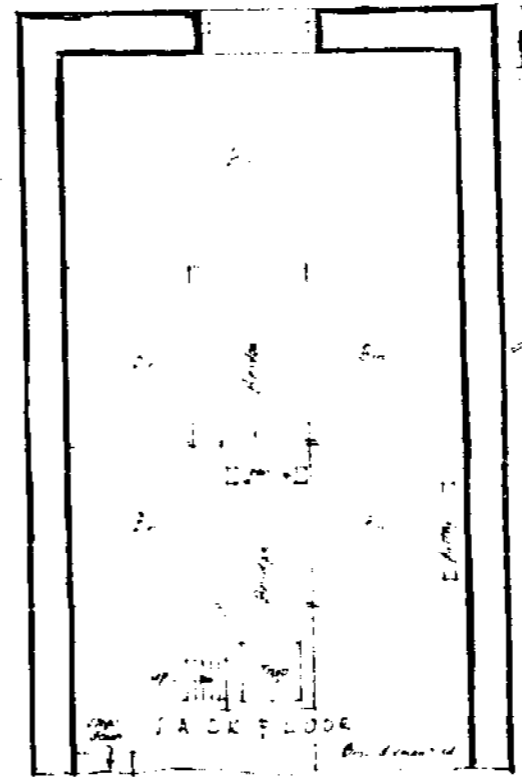
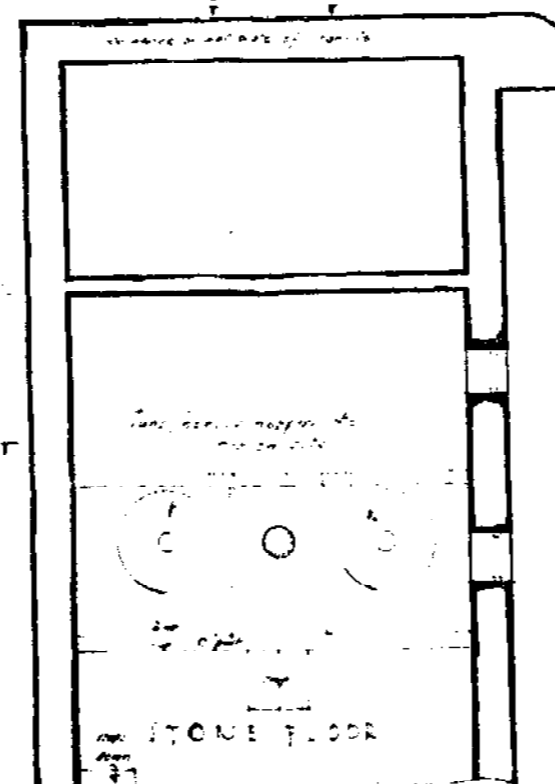
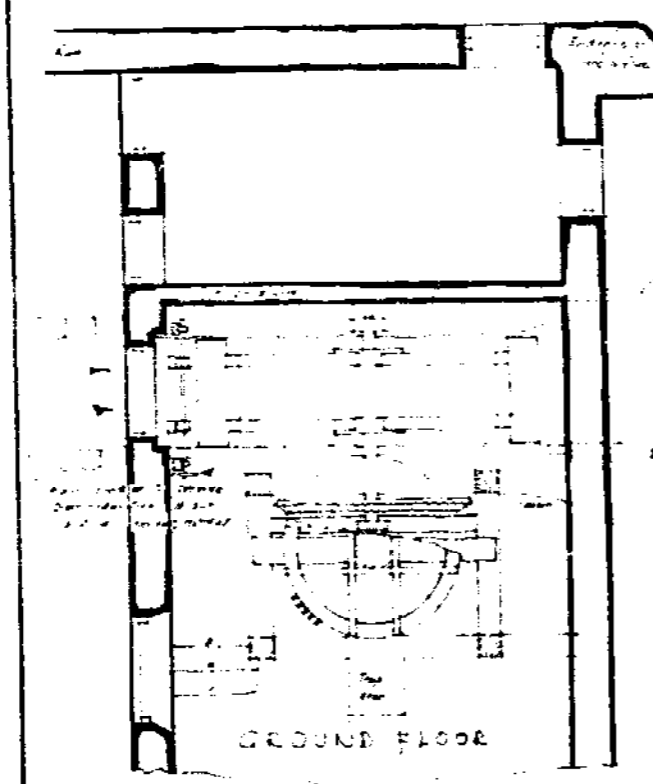
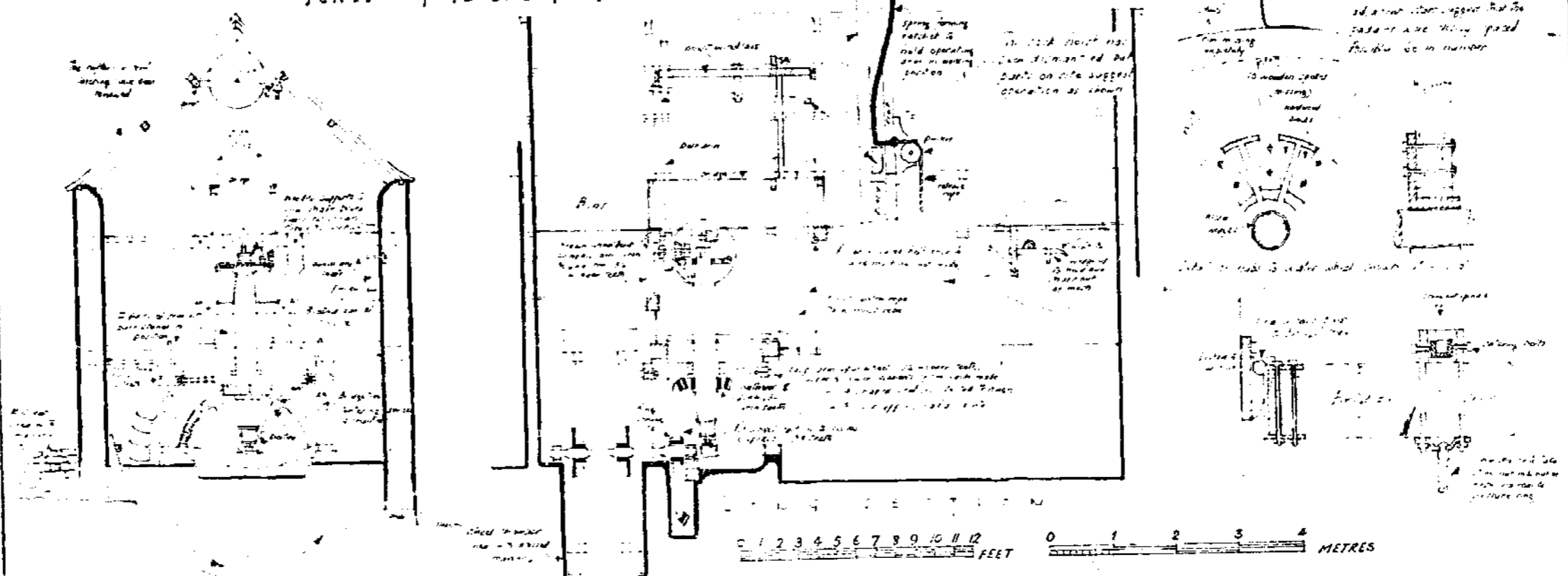

W. FOREMAN. DEC. 1973.

DEAN MILL . OXFORDSHIRE .

O.F. REF. S.P. 343 232

SCALE 1/4 INCH TO ONE FOOT

BY KIND PERMISSION OF THE OWNERS . M^r & M^{rs} GERRARD.

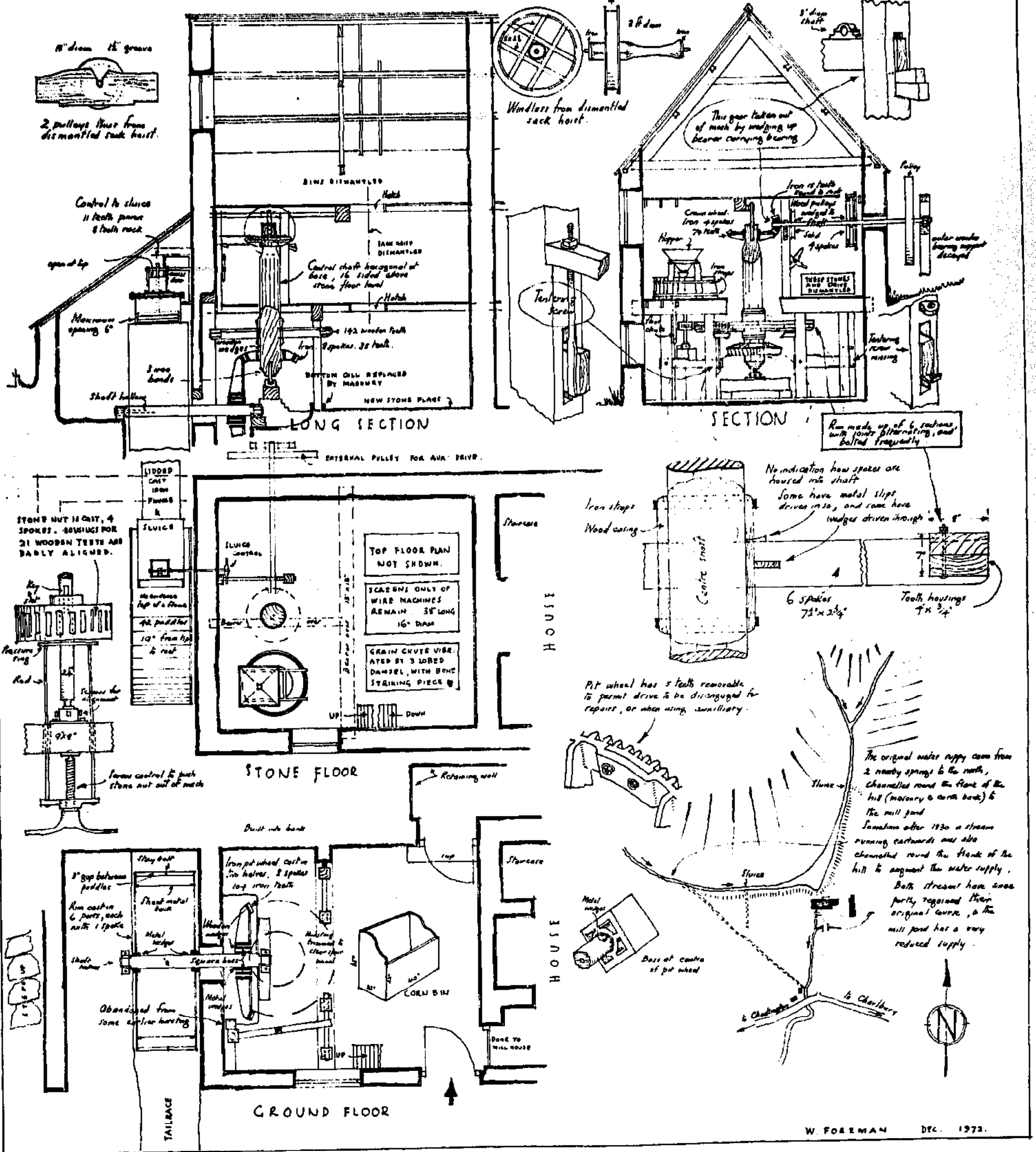

COMBE MILL. OXON.

WATER WHEEL POWERING WORKSHOP SHAFTING & SAW MILL.

SCALE 1/4" TO ONE FOOT.

O.S. REF. GREAT 145 S.P. 414 151

WHEN WATER WHEEL TURNED ONCE, ITS MOTION WOULD TURN $1\frac{3}{4}$ TIMES, WORKSHOP SHAFTING 91 TIMES, & FORGE BLOWER 180 TIMES.
THE DATE 1852 ON THE BEAM ENGINE BUILT INTO THIS COMPLEX SUGGESTS AN APPROXIMATE DATE OF ERECTION.

There is a workshop on the first floor.

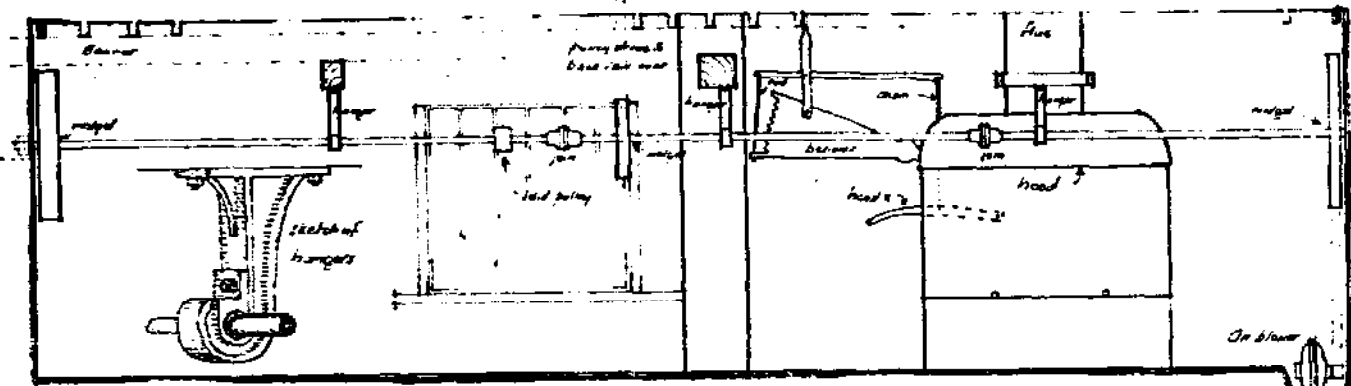

LONG SECTION.

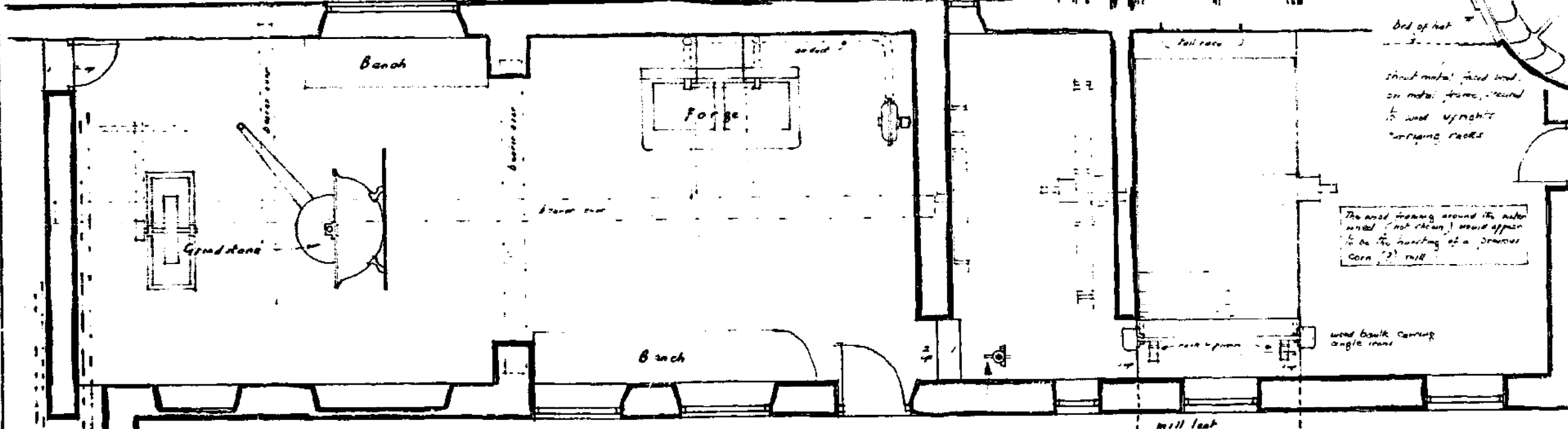
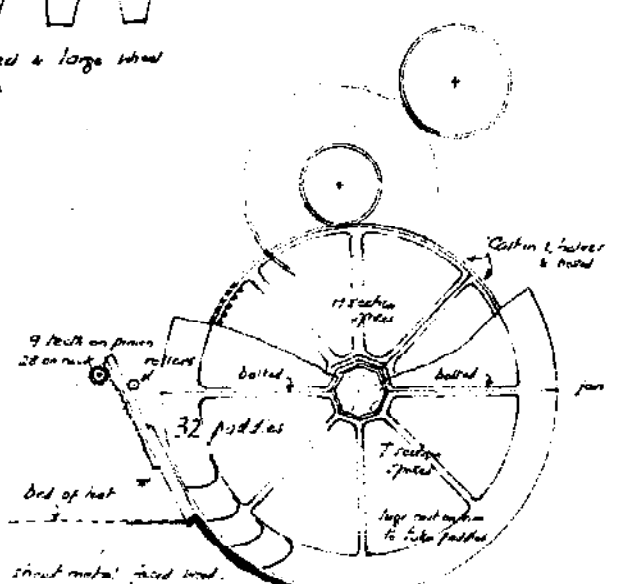
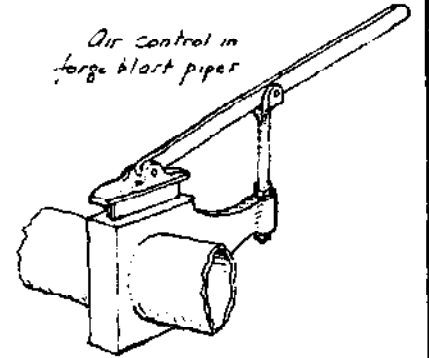
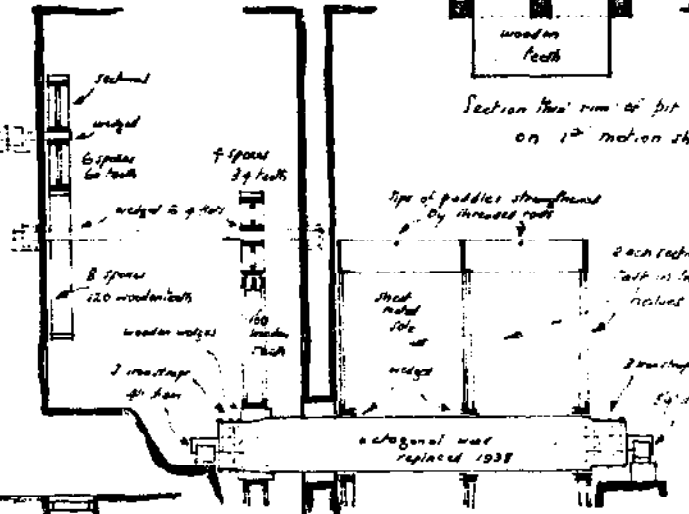

GROUND FLOOR PLAN

Alternative belt drive to saving floor could be dropped in for either the steam engine or water wheel.

Hand wheel in timber shop controlled this race & belts to rock & power controlling these.

Also direct hand wheel control of

W. FOREMAN. 1978.



THE MILL . CHARNEY BASSETT .

SCALE 1/4 INCH TO ONE FOOT .

ONE RUNNER PEAR STONE ON SITE
50 FRENCH BURE BEARING MAKER'S
NAME - GARDNER . GLOUCESTER .
ONE BED STONE FRENCH BURE ON SITE

ALSO ON SITE . ONE RHYND , ONE
BROKEN GUDGROW SPINDLE & TWO
STONE LIFTING WEDGES, LEV HAUNES,
TWO MEAL BINS .

SECTION ON B-B

SECTION ON A-A

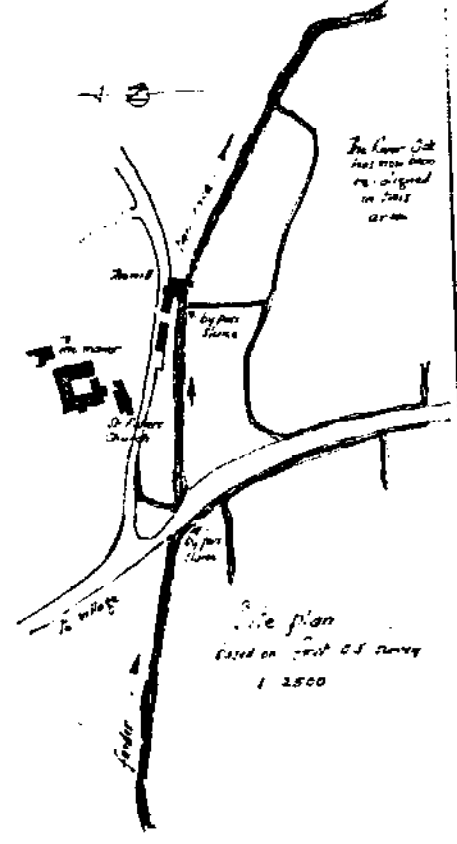
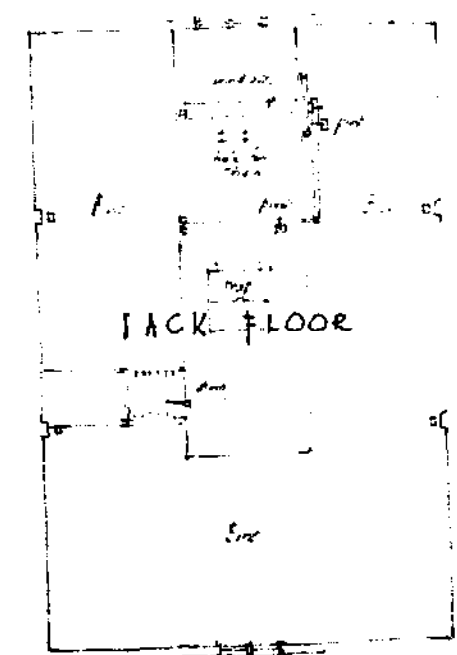
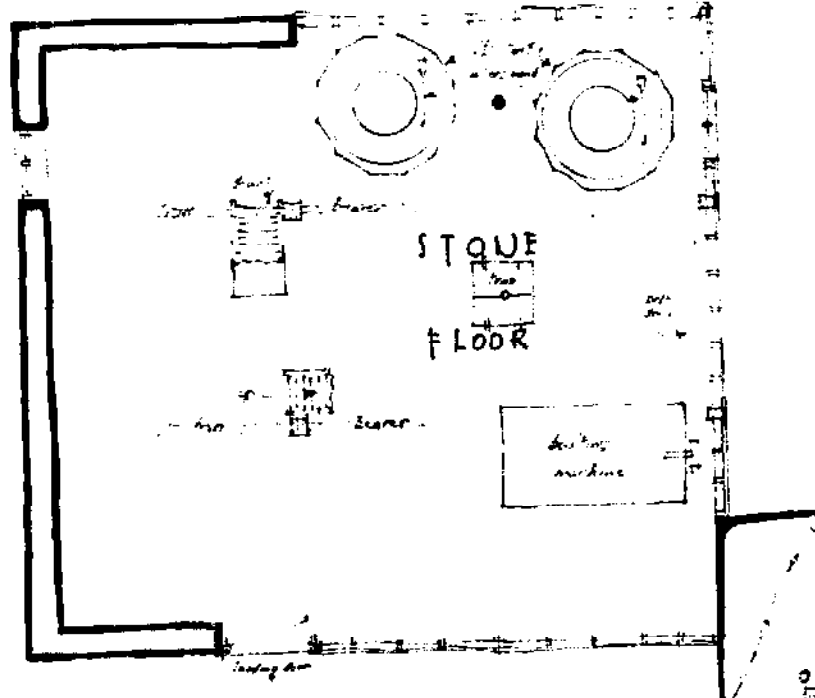
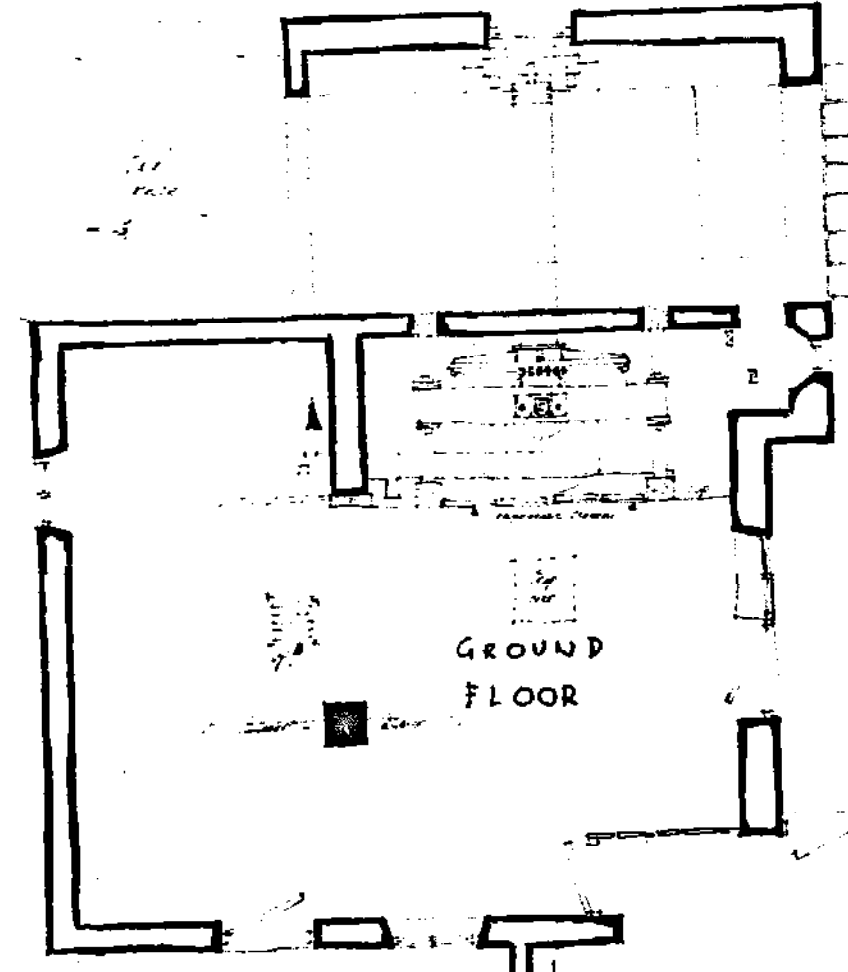
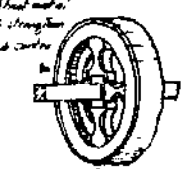
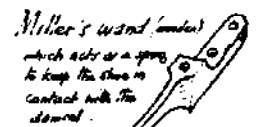

0 1 2 3 4 5 6 7 8 9 10 11 12 FEET 0 1 2 3 4 METRES