



Comparison of White LEDs

Lightfair

June 1, 2006

Dr. John W. Curran, CTO
Dr. John P. Peck, Optics Group Manager
Dialight Corporation



White Through History

Limelight - the first solid-state lighting device (introduced by Thomas Drummond in 1826)

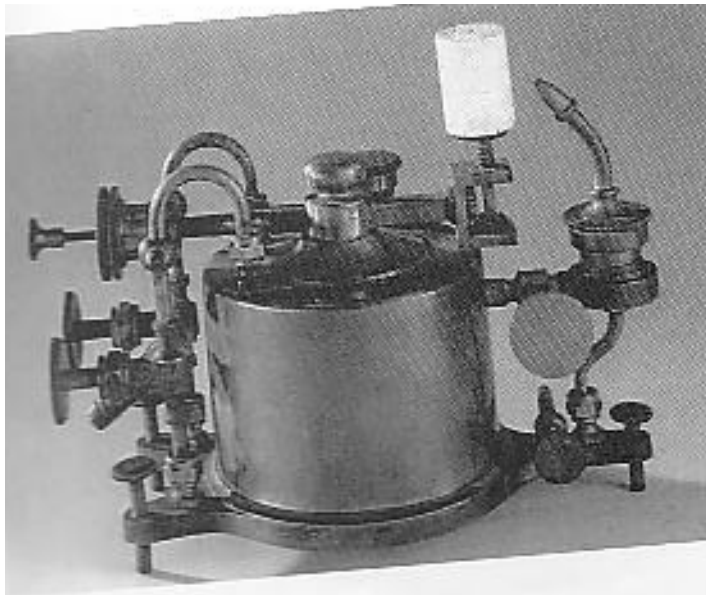

Cylinder of lime (calcium oxide)
which is heated to a state of dazzling brilliancy by
the flame of the oxy-hydrogen blowpipe

Introduction

Background Terminology

Flux

Color

- Measuring Color

- White

Forward Voltage, Vf

LED construction

General

White

Lifetime Discussion

Design Guidelines

Thermal Issues

Differences in data sheet vs actual flux values

Manufacturer's Data

Specifications [Cool White]

Specifications [Warm White]

Binning

Test Results

Spectral Data

Chromaticity Data

CCT

Luminous Flux Data

Trends

Conclusions

Questions

- White LED Technology
 - Types of white LEDs
 - How do they work
- Design Advantages of the Technology
 - Life
 - Efficiency
- Design Considerations
 - Color matching
 - Heat dissipation
 - Cost
- Range of Products Available Today

Progress in lighting

Luminous Efficiency (lm/W)				
Candle 1400's	Incandescent 1800's	Flourescent 1920's	HID 1950's	LED 2000's
				
1	10-15	70-100	80-120	80-100

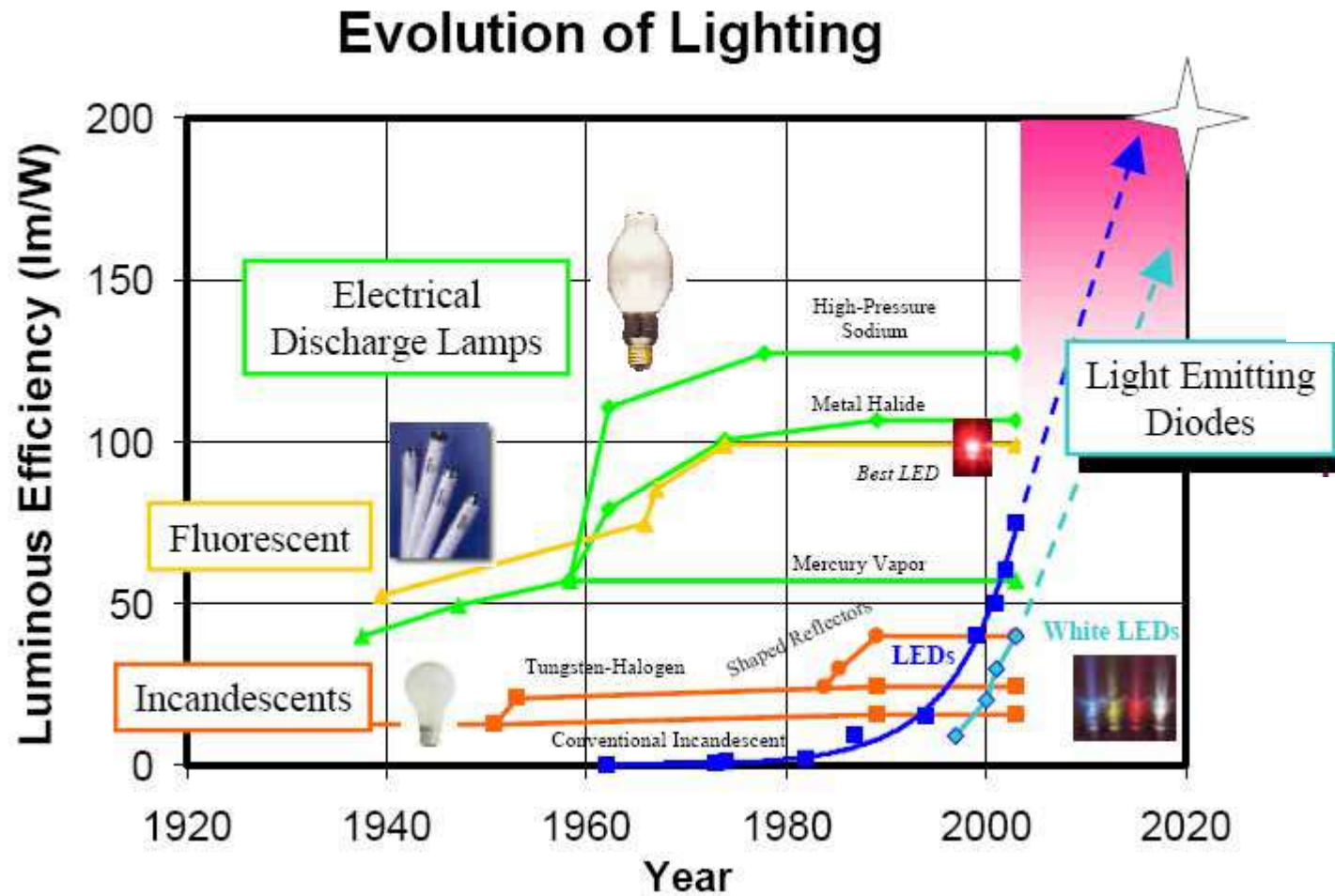

- Type (3mm, 5mm, High Flux, etc.)
- Flux
- Color
- Forward Voltage

Photometric (Lighting) Terms

- Standard Candle—a candle which emits uniform luminous intensity in all directions of one candlepower
- Lumen—rate at which luminous flux falls on a one foot square surface of a unit sphere from a uniform source of one candela located at the center of the sphere. The standard candle emits 4π lumens
- Luminous Energy (Q)—term used to describe luminous power
$$Q \quad \text{(in lumen-seconds, lm-sec)}$$
- Luminous Flux (ϕ)—rate of flow of luminous energy given by
$$\phi = dQ / dt \quad \text{(in lumens, lm)}$$
- Luminous Intensity (I)—is the luminous flux divided by the solid angle in a specific direction given by
$$I = d\phi / d\omega \quad \text{(in candelas, cd)}$$
- Solid Angle (ω)—is the ratio of the area A of a sphere to the square of the radius r
$$\omega = A / r^2 \quad \text{(in steradians, sr)}$$
- Illumination (E)—is the incident luminous flux (ϕ) per unit area of the receiving surface
$$E = d\phi / dA \quad \text{(in footcandles, fc)}$$

Radiometric (Physics) Terms

- Radiant Energy (U)—term used to describe energy emitted by a light source
 U (in joules)
- Radiant Flux (Φ_e)—rate of flow of radiant energy given by
 $\Phi_e = dU / dt$ (in watts)
- Radiant Intensity (I_e)—is the radiant flux divided by the solid angle in a specific direction given by
 $I_e = d\Phi_e / d\omega$ (in watts/steradian)
- Spectral Power Distribution or SPD ($\Phi_{e\lambda}$)—is the spectral density of the radiant flux given by
 $\Phi_{e\lambda} = d\Phi_e / d\lambda$ (in watts/meter)
- Solid Angle (ω)—is the ratio of the area A of a sphere to the square of the radius r
 $\omega = A / r^2$ (in steradians, sr)
- Illumination (E)—is the incident luminous flux (ϕ) per unit area of the receiving surface
 $E = d\phi / dA$ (in footcandles, fc)

How the two worlds relate

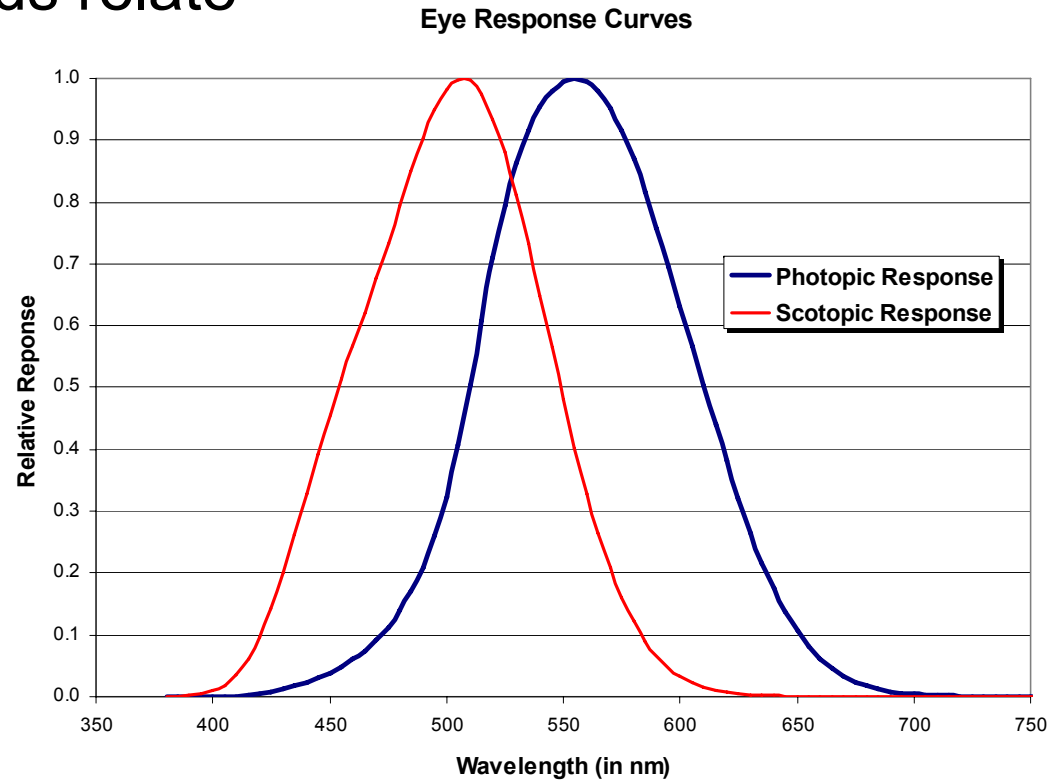

$$\phi_{e\lambda} = 683 \text{ lm/watt} \int \Phi_{e\lambda} V(\lambda) d\lambda$$

Definitions—Flux

Radiometric Flux to Luminous Flux

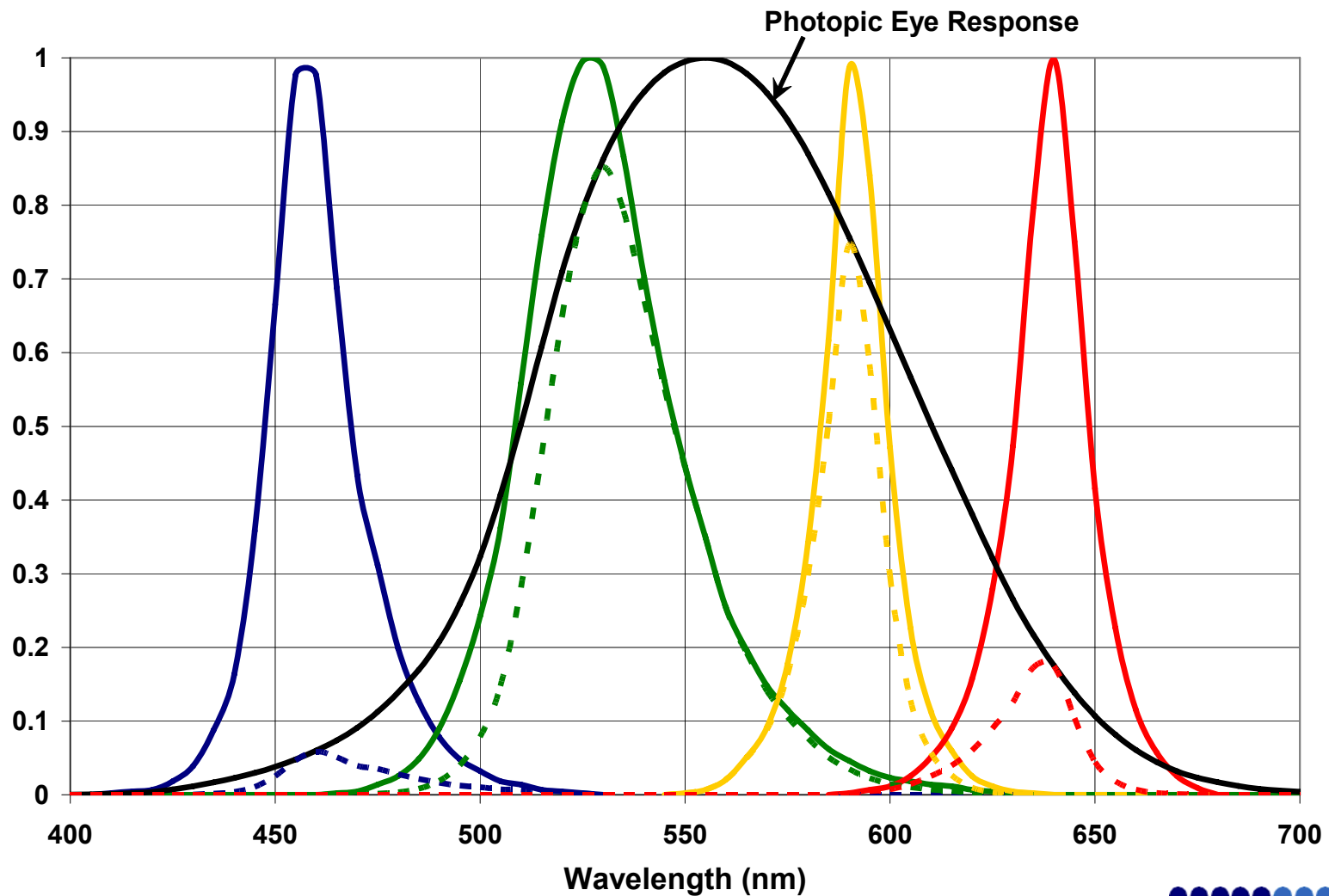

\bar{X} , \bar{Y} and \bar{Z} are the spectral response curves for the three different cone receptors in the eye. If the eye response to a color stimulus is given by X , Y and Z , we can define a color coordinate system as the relative stimulus given by the following equations:

$$X = \frac{X}{X + Y + Z}$$

$$y = \frac{Y}{X + Y + Z}$$

$$Z = \frac{Z}{X + Y + Z}$$

With $X + Y + Z = 1$ by definition only two coordinates are necessary to define a color.

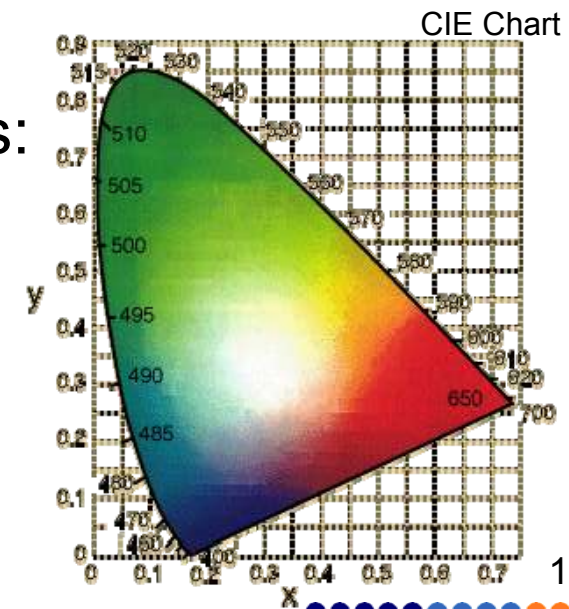
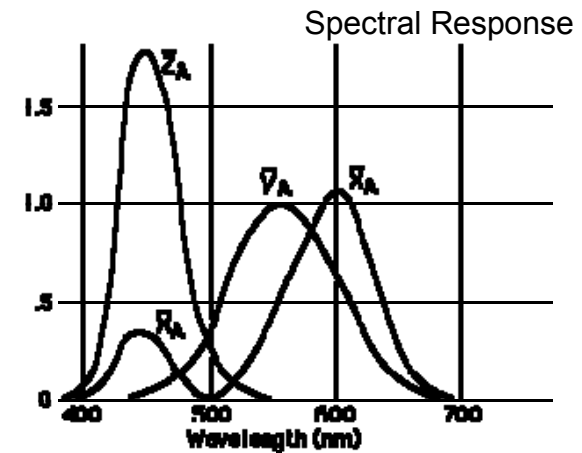

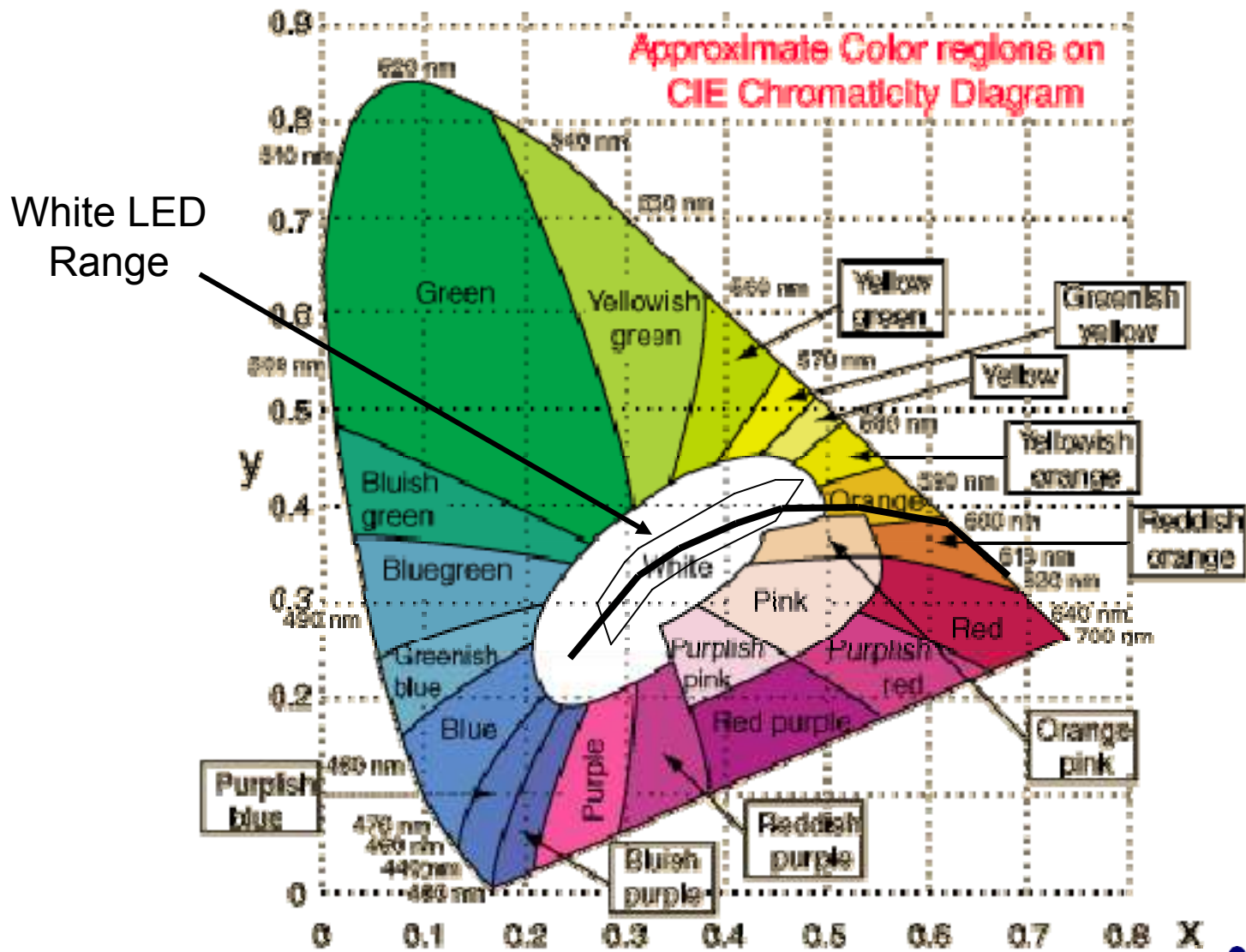

Definitions—Color Chromaticity Comparison

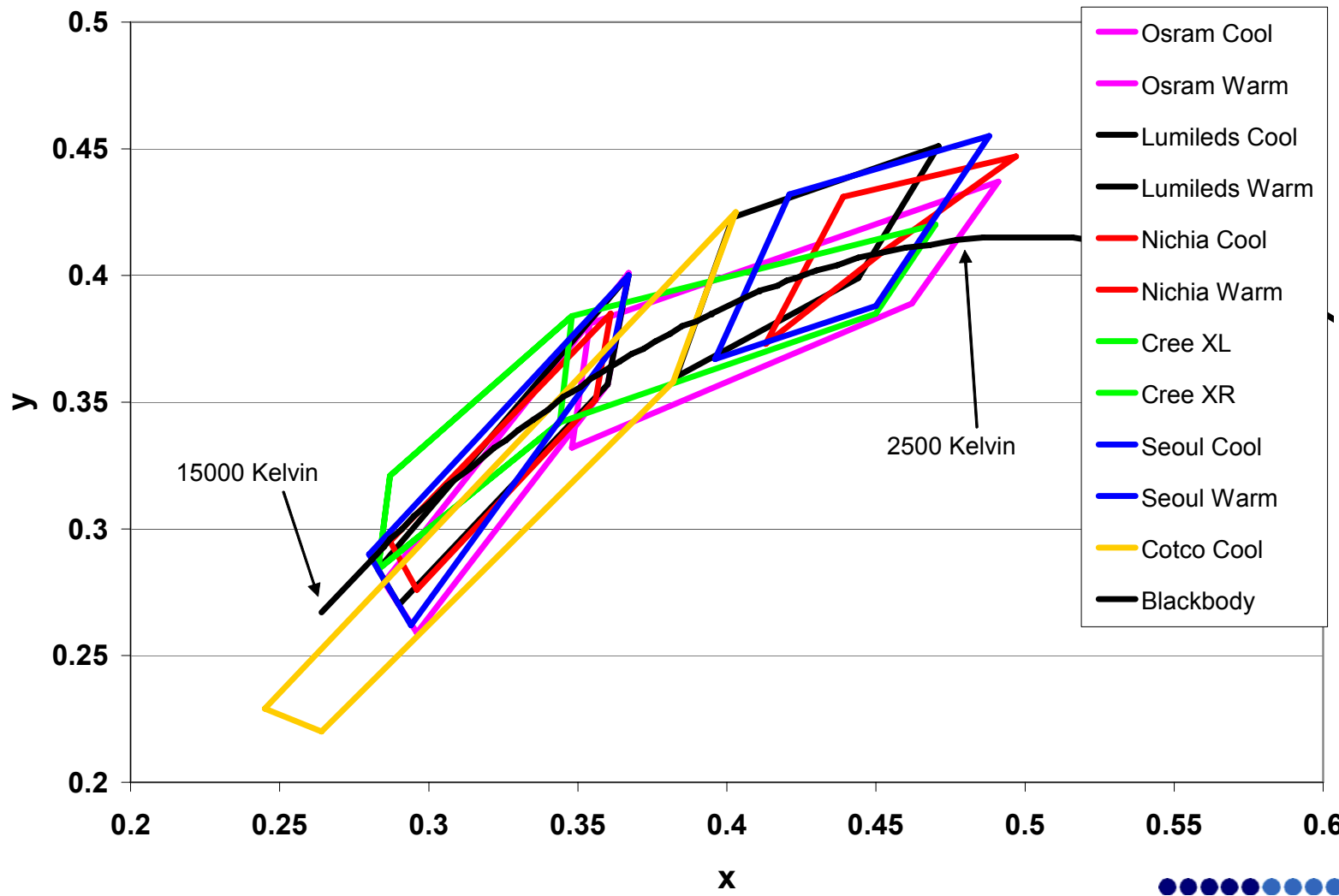

Measuring Color Color Rendering Index (CRI)

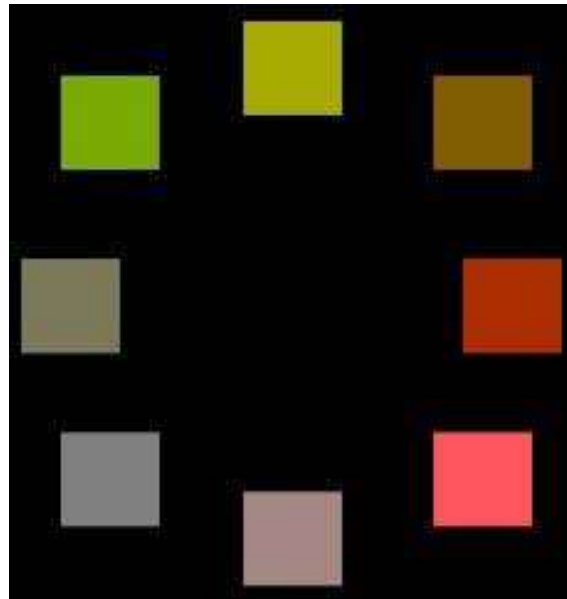

CRI is a calculated value based on the difference in chromaticity of a series of 8 different colors (CIE Color Space) when illuminated with a reference light source versus a test subject light source.

It is a measure of a light source's ability to show colors realistically as compared to familiar sources (e.g. an incandescent bulb or the sun)

Measuring Color Color Rendering Index (CRI)

$$\Delta E_i = \sqrt{\Delta U_i^2 + \Delta V_i^2 + \Delta W_i^2}$$

where U, V and W are the 1964 Uniform Color Coordinates

$$R_i = 100 - 4.6 \Delta E_i$$

where R_i is the Color Rendering Index for the specific color sample i

$$\text{CRI} = (1/8) \times \sum_{i=1}^{i=8} R_i$$

Full Spectrum Index (FSI)

- Mathematical measure of how much a light source deviates from an equal energy spectrum {Useful for evaluating color rendering properties of light sources}

Gamut Area

- The area of the polygon defined by the chromaticities of the 8 CIE standard color samples in CIE 1976 color space {Useful for evaluating color saturation}

No single index provides all the answers

It depends on the application

Blackbody Radiator is a device that absorbs all electromagnetic radiation that falls on it. Its emissivity is equal to 1.

Planck's Radiation Law describes the radiation emitted from a blackbody radiator.

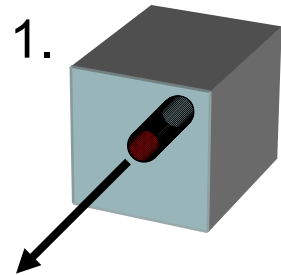

$$U(\lambda, T) = 8\pi hc \lambda^{-5} / [e^{hc/\lambda kT} - 1]$$

where

$U(\lambda, t)$ = Spectral Energy Density

λ = wavelength (in meters)

T = temperature (in degrees Kelvin)

$c = 3.0 \times 10^8$ m/sec (Speed of Light)

$h = 6.63 \times 10^{-34}$ Joule sec (Planck's Constant)

$k = 1.38 \times 10^{-23}$ Joule/K (Boltzmann's Constant)

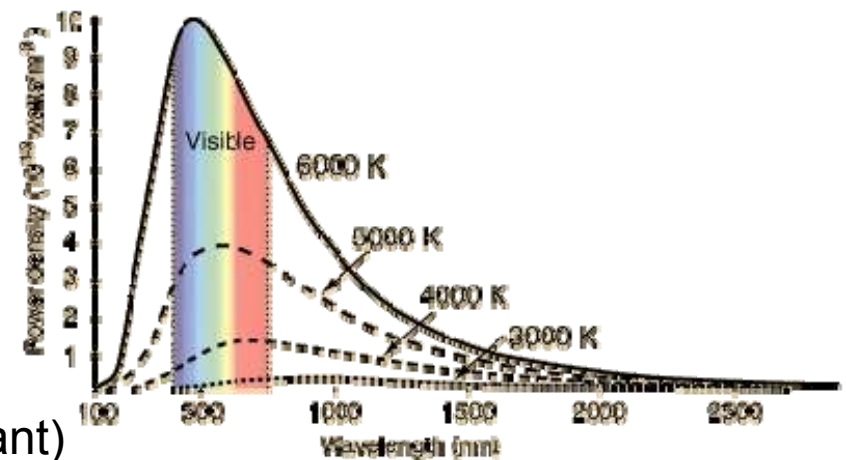

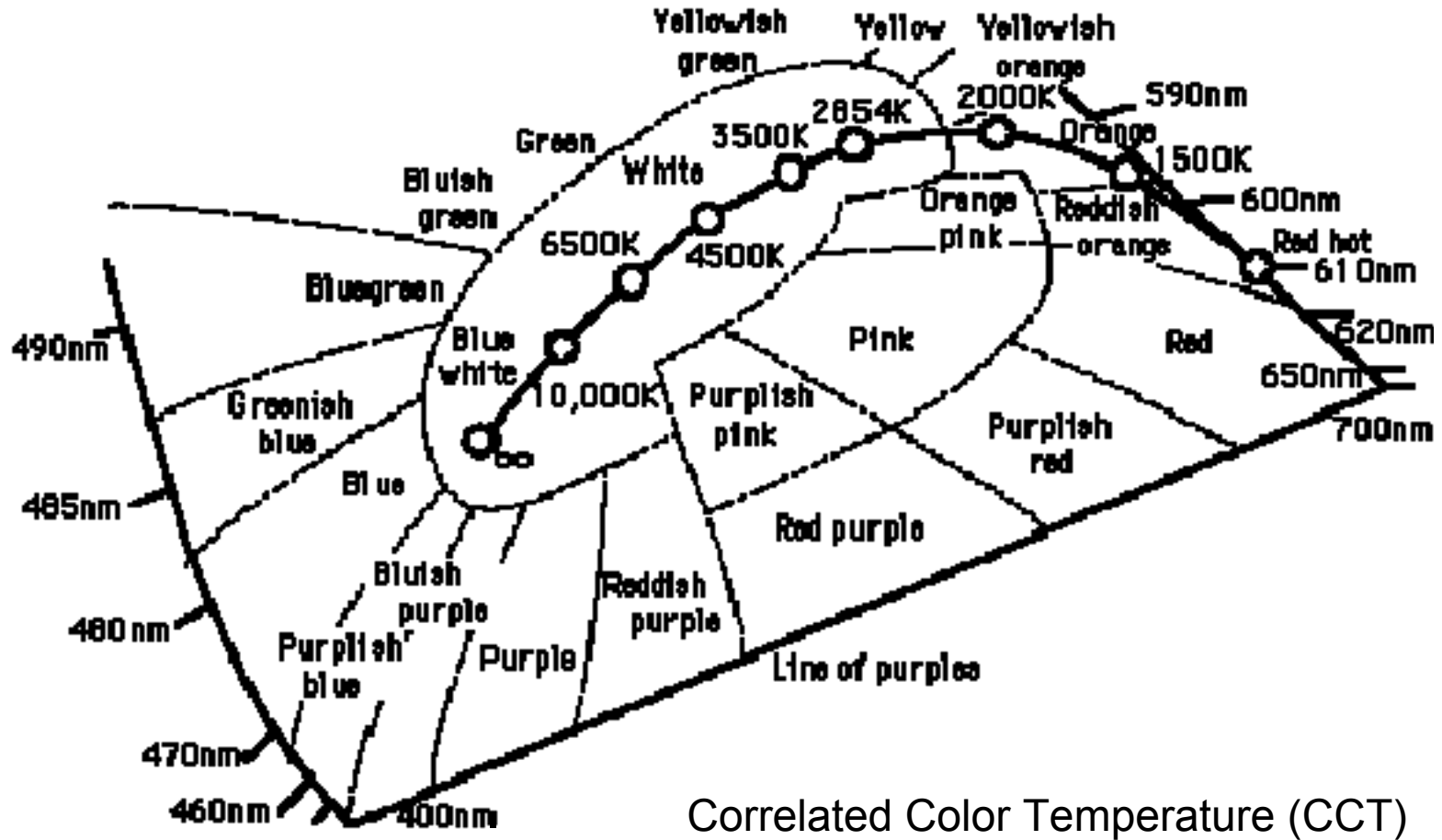

Irradiance of the Sun/Blackbody

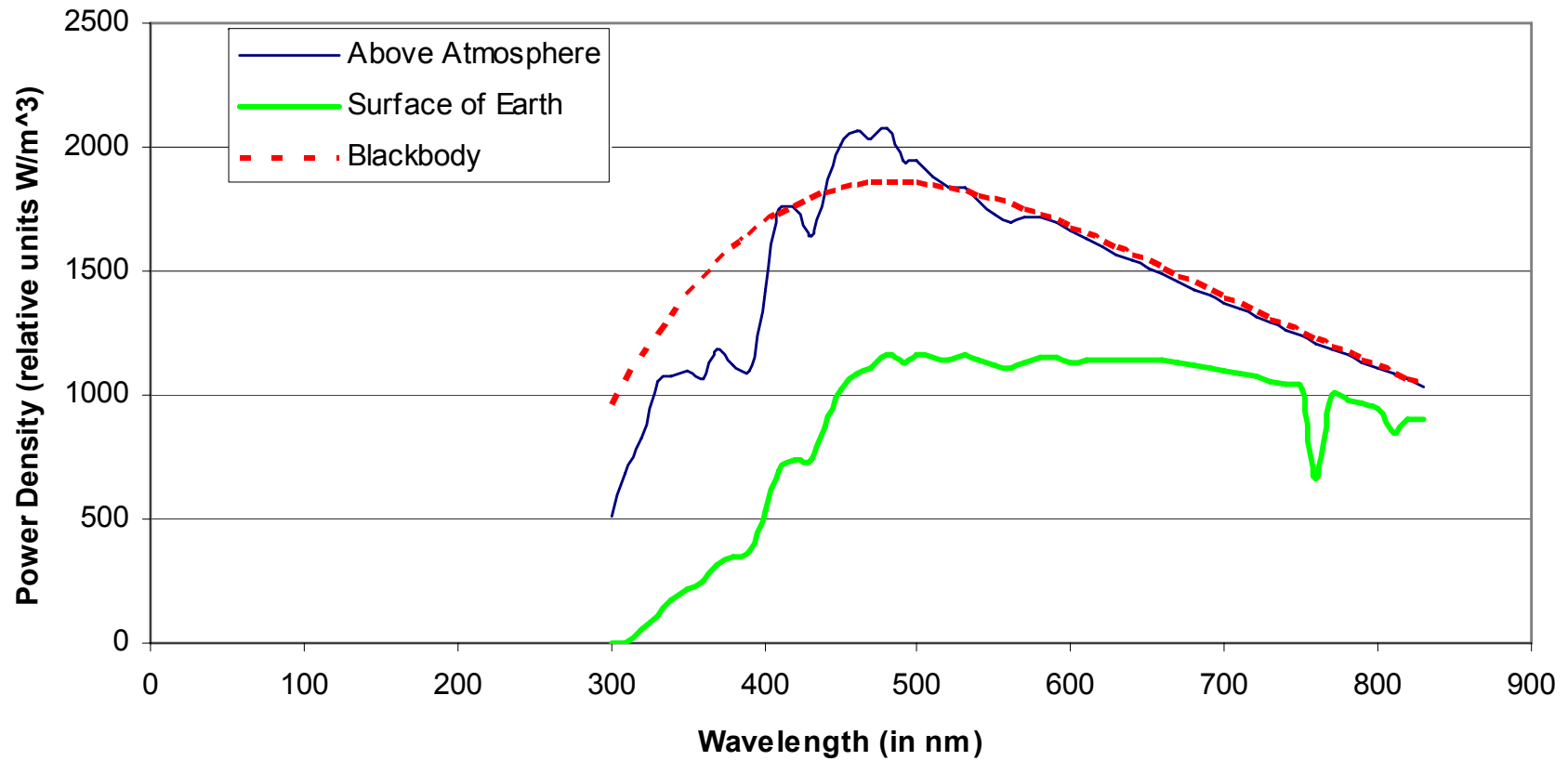

Definitions – Forward Voltage

- Forward Voltage V_f is roughly equal to the bandgap energy of the LED semiconductor divided by the elementary charge

$$V_f = E_g / q$$

where $q = 1.6 \times 10^{-19}$ coulombs

- Output Intensity of typical high brightness LEDs is dependent on the Forward Current I_f

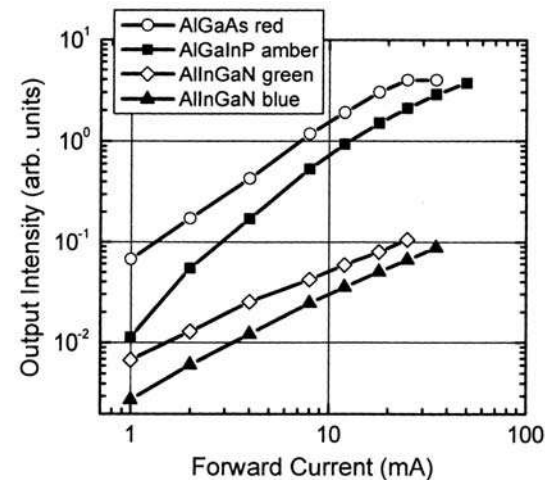
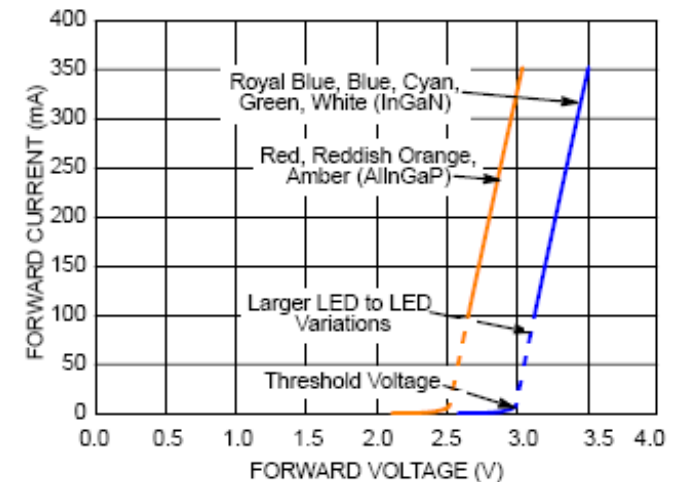

Construction Difference (5mm versus High Flux LEDs)

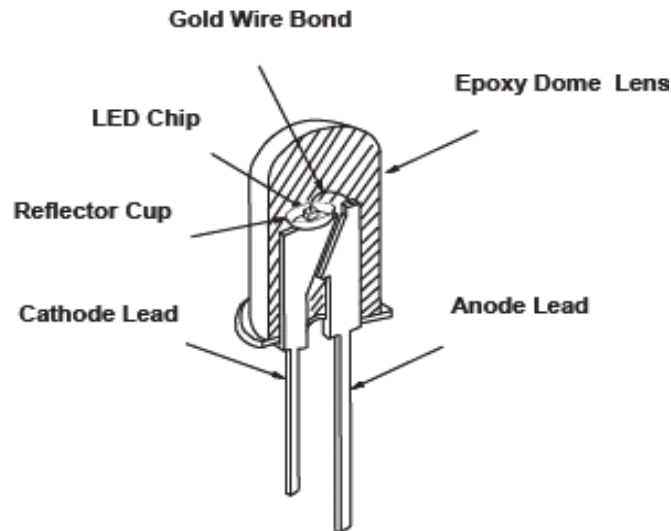

**Typical construction
for a 5mm LED**

Typical Flux = 3 lm

Number of LEDs to equal the
output of a 60W incandescent
light bulb = 200

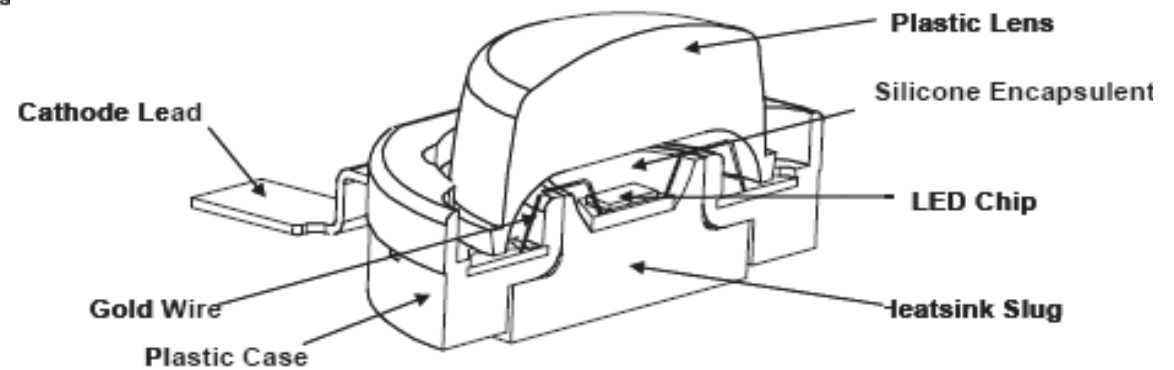

**Typical
construction for a
High Flux LED**

Typical Flux > 30 lm

Number of LEDs to equal the
output of a 60W incandescent
light bulb < 20

How do you make LEDs?

AlInGaP
Red, Red-Orange
Yellow

AlInGaN
Green, Blue,
White

Group XIII	Group XIV	Group XV
5 B Boron 10.811	6 C Carbon 12.0107	7 N Nitrogen 14.006
13 Al Aluminum 126.981	14 Si Silicon 28.0955	15 P Phosphorus 30.973
31 Ga Gallium 69.723	32 Ge Germanium 72.61	33 As Arsenic 74.921
49 In Indium 114.818	50 Sn Tin 118.710	51 Sb Antimony 121.760

Substrates
Silicon Carbide (SiC)
Sapphire (Al₂O₃)



Base Elements
P-Type Dopants
N-Type Dopants

How do you make LEDs?

Lens Materials

3 mm and 5 mm

- Epoxy lens
 - Bad expansion coefficient (stresses bond wire)
 - Yellows
 - Degradation blue/UV

HIGH FLUX

- COC, other hard plastic lens with silicone gel
 - Plastic with silicone gel
 - Not reflow solderable
- Silicone polymer lens with silicone gel
 - Robust for reflow, lead free temperature 260C
 - Better moisture handling
 - Susceptible to dirt and scratches
- Glass lens with silicone gel
 - More robust
 - Higher cost

How do you make LEDs?

Substrate Materials

- Sapphire (Al_2O_3)
 - Lower cost (estimated at \$3/cm²)
 - More transparent (more light output)
 - Low thermal conductivity (40 W/m/K)
- Silicon Carbide (SiC)
 - Higher cost (estimated at \$12/cm²)
 - Better ESD protection
 - High thermal conductivity (350-490 W/m/K)

How do you make a White LED?

RGB Method

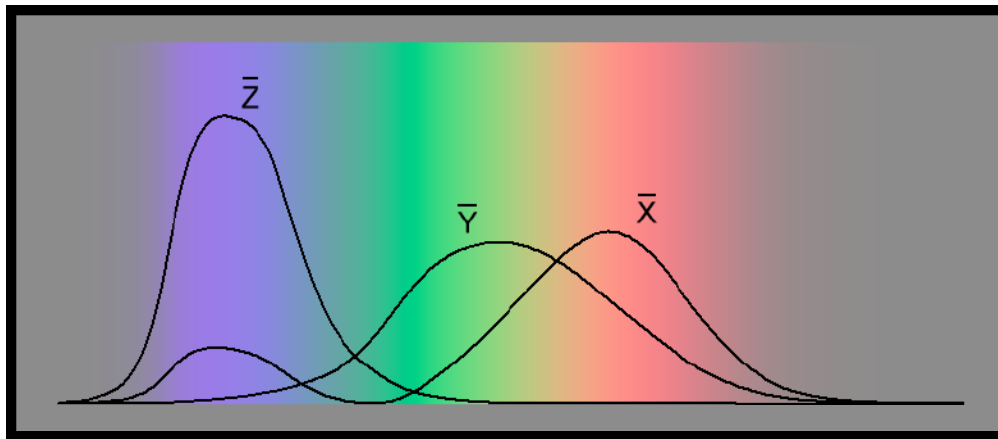

Mixing light from red, green and blue LEDs (either discrete or combined in one package) can produce white light

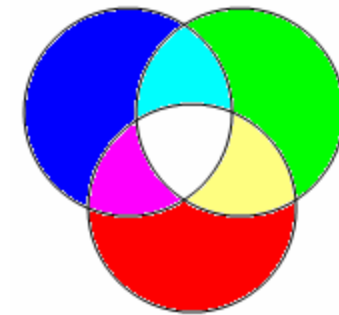

How do you make a White LED?

Visible LED Pump + Phosphor Method

Blue LED + YAG **Cool White**

Blue LED + YAG + Other phosphor (red, green, etc.) **Warm White**

UV LED Pump + Phosphor Method

UV LED + Red phosphor + Green phosphor + Blue phosphor

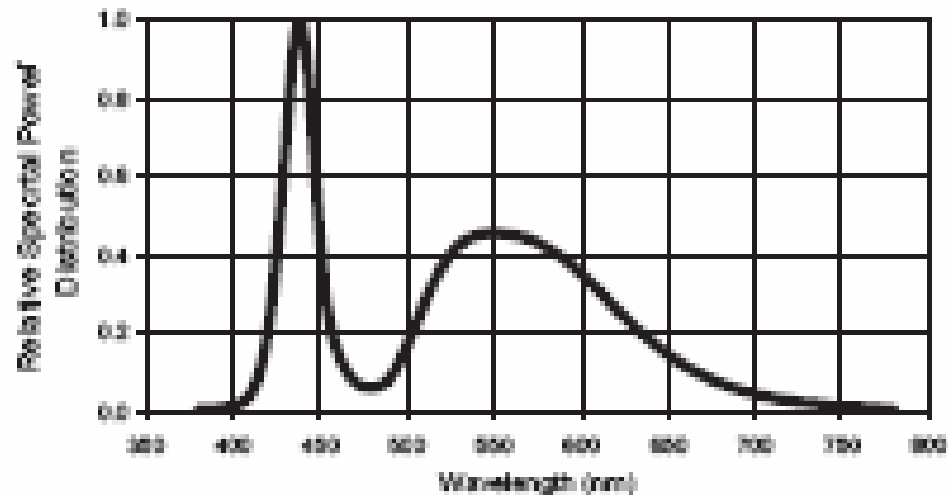

Luxeon K2

How do you make a White LED? (Blue + Phosphor) VS (Red + Green + Blue)

Warm White (3500K)

Blue + Phosphor

100	lumens
34	lumens/watt
2.92	watts

Blue	Green	Red	Total	
2.3	66.7	30.7	100	lumens
13.4	38.9	29.9	n/a	lumens/watt
0.17	1.71	1.03	2.91	watts

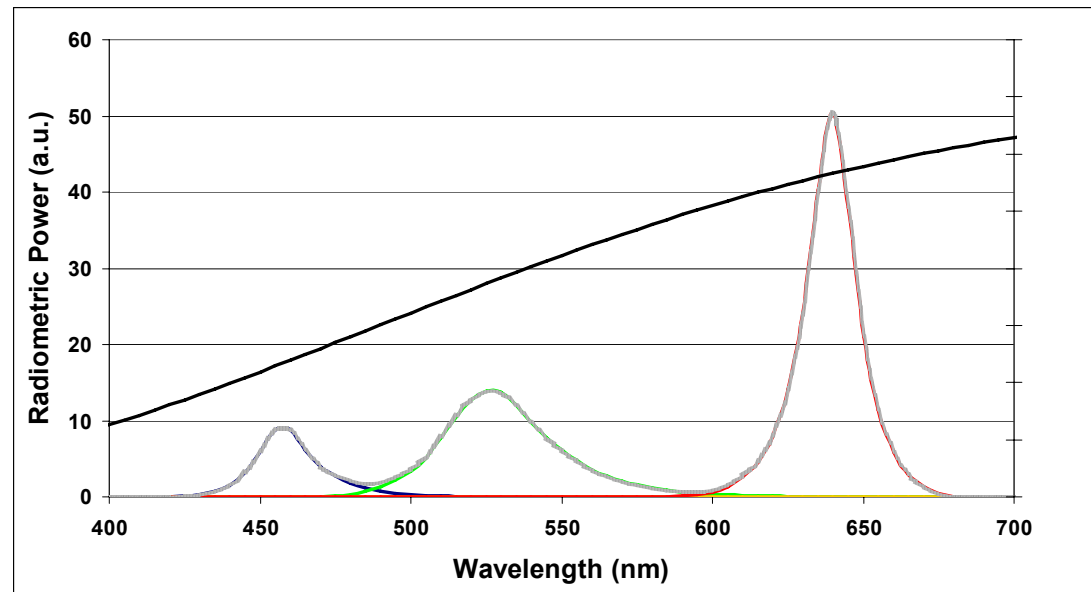

How do you make a White LED? Phosphor Deposition

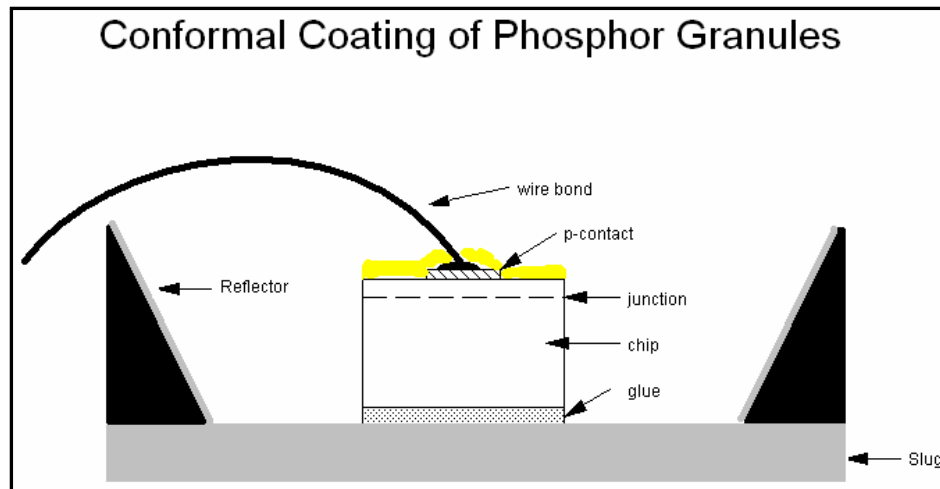
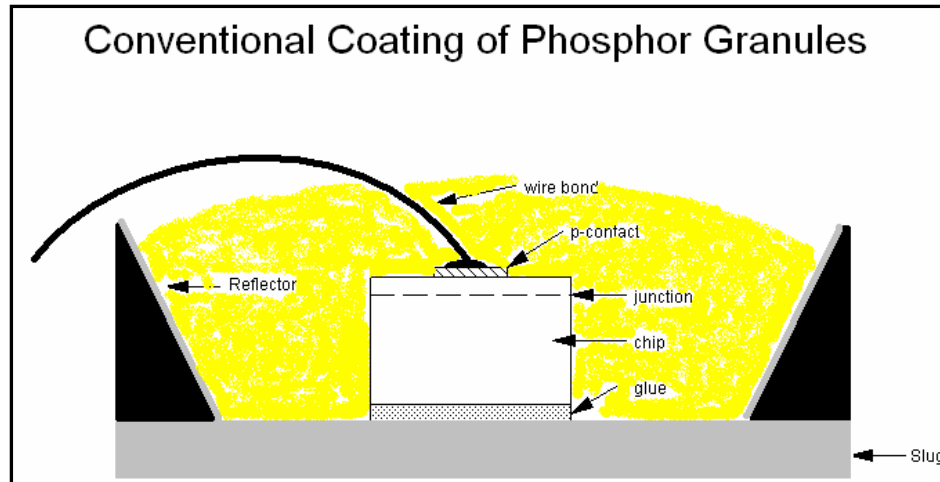

Light source is smaller and often allows for a smaller secondary optic

How do you make a White LED? Phosphor Deposition Examples

Lumileds

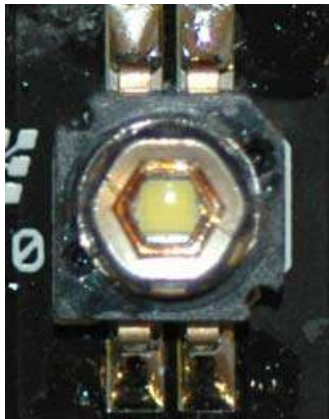

Lumileds

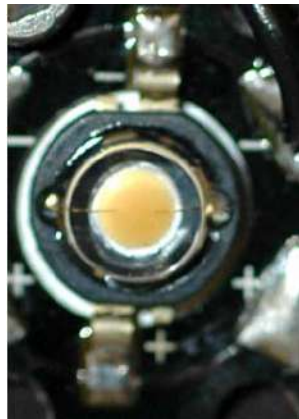

Seoul Semiconductor



Cree



Nichia

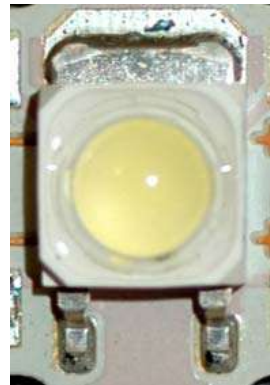

Osram



How do you make a White LED?

Which method is better for making white?

RGB

Blue + Phosphor

UV + Phosphor

	RGB	Blue + Phosphor	UV + Phosphor
Advantages	<ul style="list-style-type: none"> • Color can be changed dynamically • As a luminance source, millions of colors can be produced • Highest theoretical luminous efficiency of all three methods • No UV output 	<ul style="list-style-type: none"> • High theoretical luminous efficiency • Can provide color temperatures between 3200 K (warm white) and 10,000 K (cool white) • No UV output 	<ul style="list-style-type: none"> • Good color uniformity • Simple driver electronics • Potential for limited tint variation • Eliminates the pump color variation; only phosphor variation
Disadvantages	<ul style="list-style-type: none"> • Color can shift due to aging and temperature • Requires more sophisticated electronics • Poor color rendition • Fixture efficiency drop caused by color mixing 	<ul style="list-style-type: none"> • Potential to create variations in tint • Must be controlled using optics and binning 	<ul style="list-style-type: none"> • Lowest luminous efficiency • Shorter life • Clouding of the epoxy (UV packaging problems) • New phosphors necessary



How long do light sources last?

Time to change the lightbulb!

- The sun >4.5 billion years (so far)
- Candle <12 hours
- Oil Lamp <24 hours
- Incandescent 1k-1.5k hours
- Fluorescent 5k-24k hours
- Mercury Vapor 10k-20k hours
- Sodium Vapor 24k hours
- Metal Halide 20k-30k hours
- 5mm LEDs <10k hours
- High Flux LEDs >20k hours

What is End of Life
for some
illumination
sources?



How long do light sources last? LED Lifetime

How long do they last?

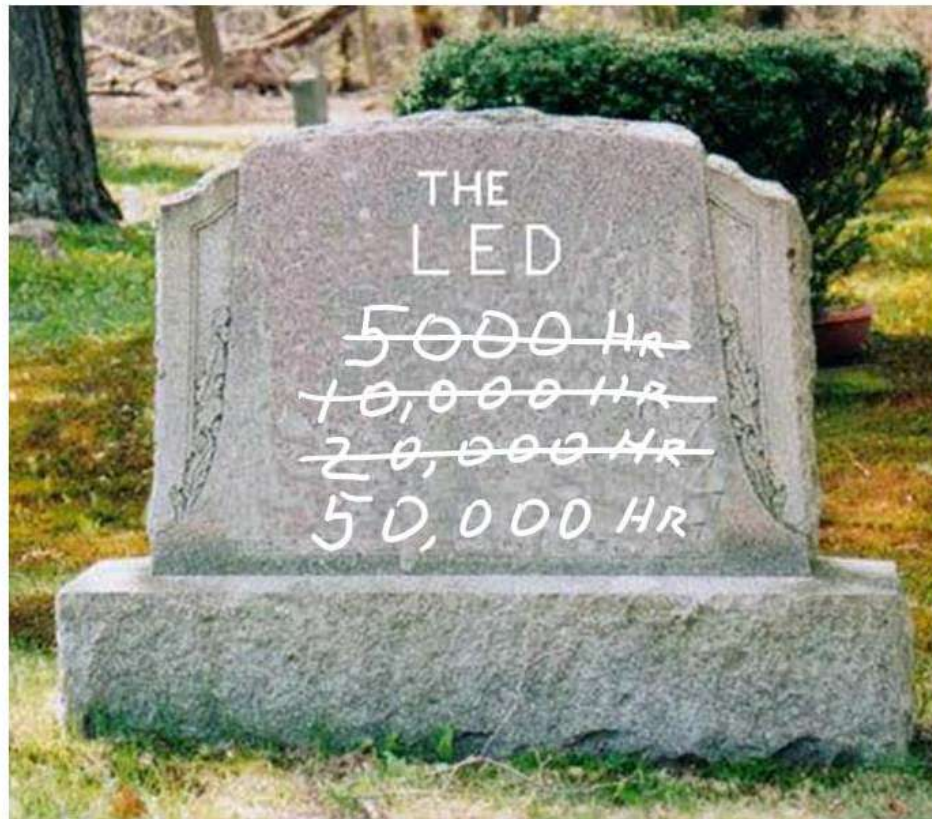

How long do light sources last? What do we mean by Lifetime?

Traditionally Lifetime was the time it took for 50% of the population of incandescent bulbs to fail

Many light sources don't fail catastrophically—Define EOL by reduction in light output from initial values for example 70% or 50% of initial value

Under what conditions do we measure lifetime?

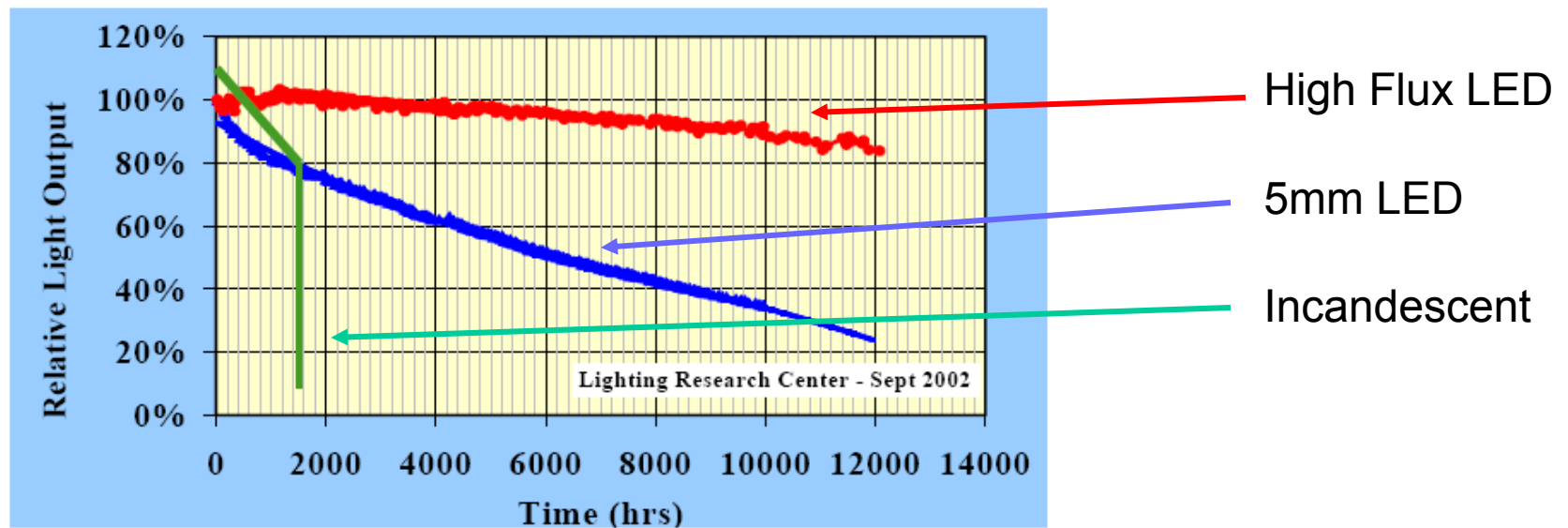

“Statistics are like a drunk with a lamppost; used more for support than illumination”
Sir Winston Churchill

How long to light sources last? Lab Data on 5mm LED Lifetimes

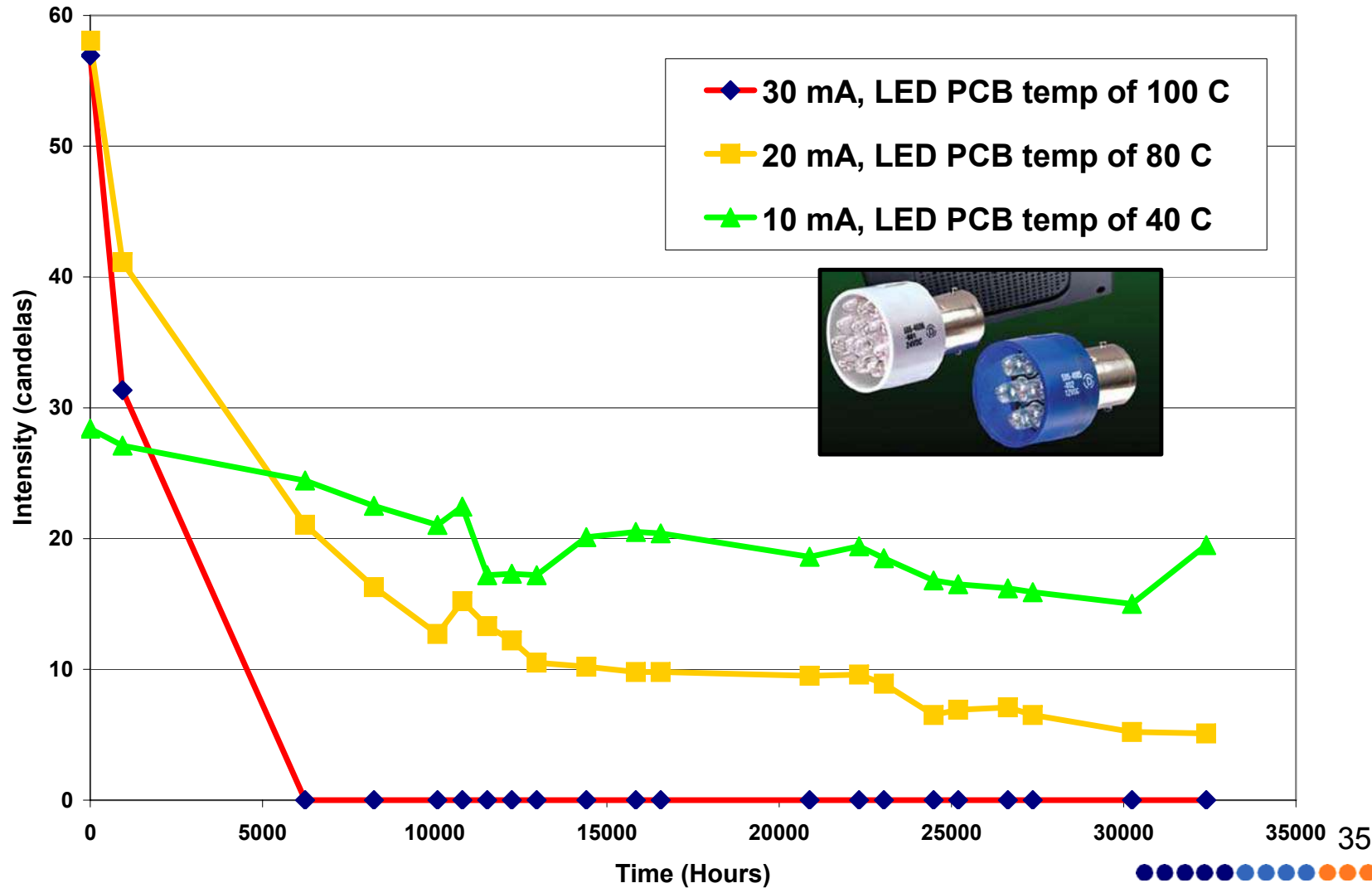

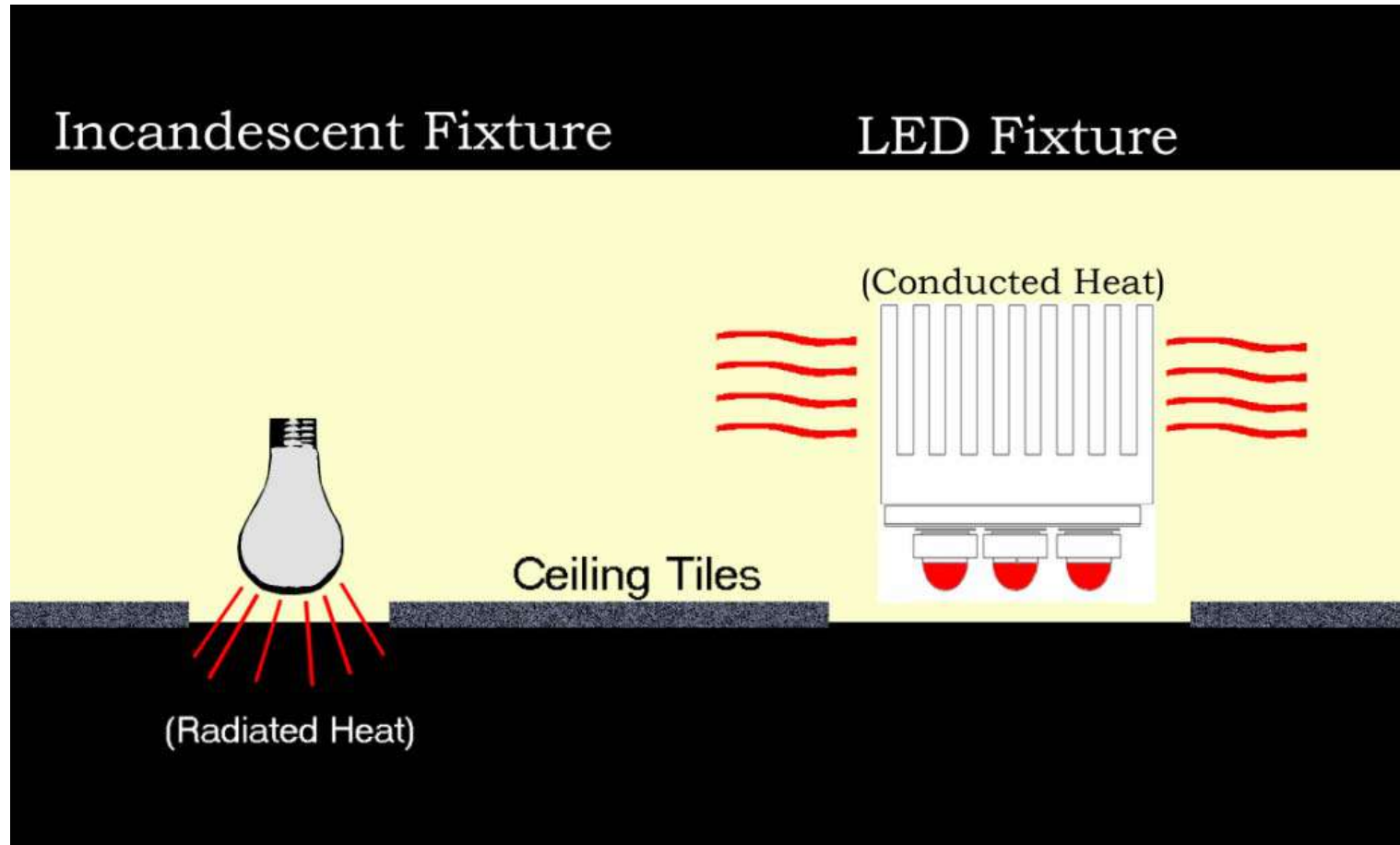

Which heat sink do I need?



40 °C/W

or

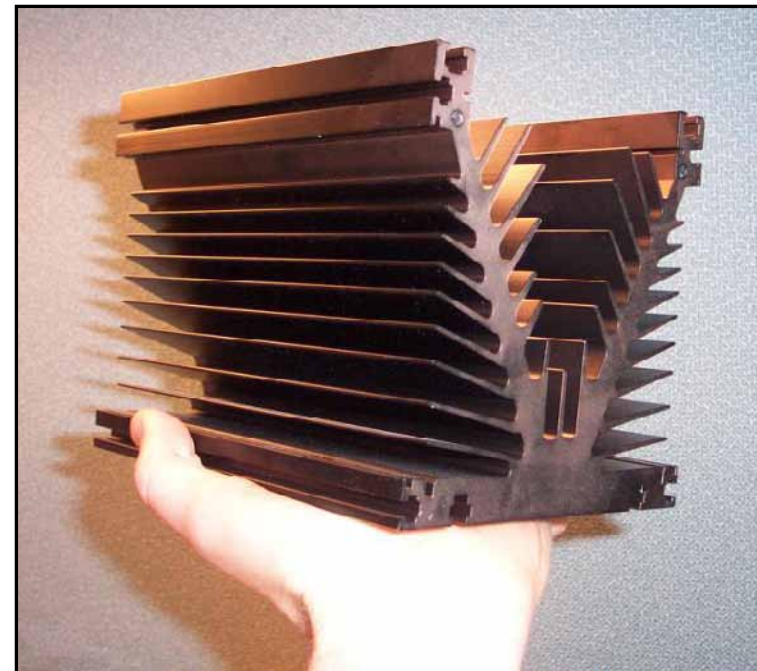

0.4 °C/W

Thermal Management Issues

Calculating Safe Junction Temperatures

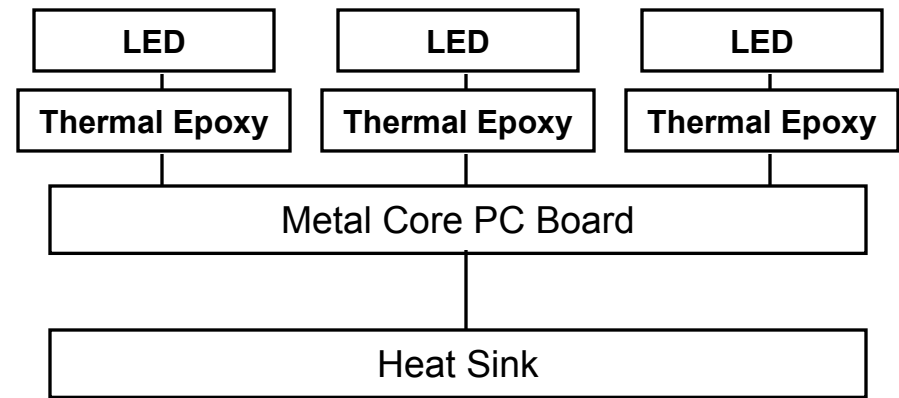
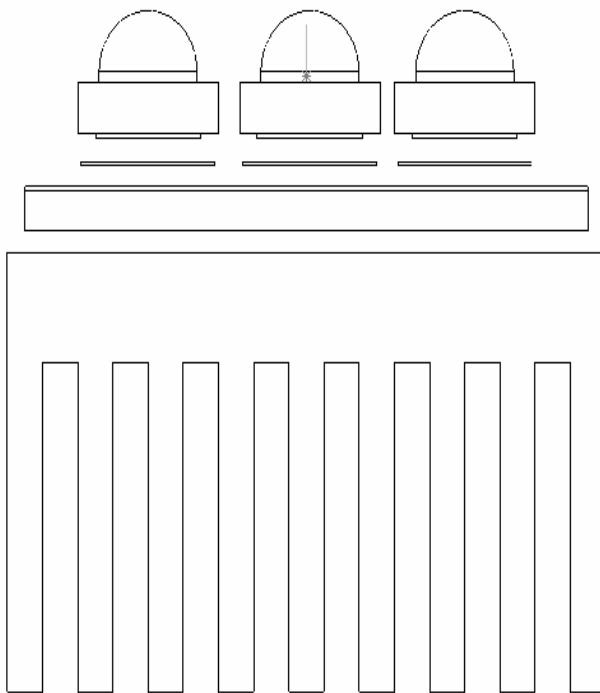

$$T_{Junction} = T_A + (P_{LED}) \cdot (R\Theta_{LED}) + (P_{LEDs}) \cdot (R\Theta_{Heatsink})$$

Thermal Management Issues

Increasing from 1W to 3W LEDs

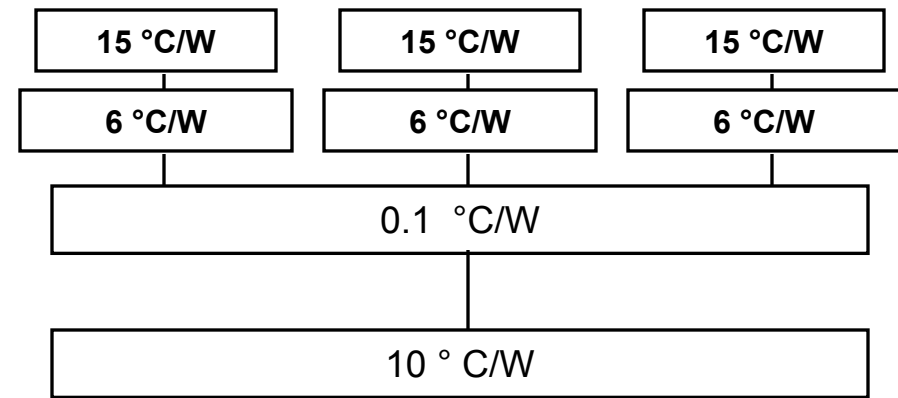
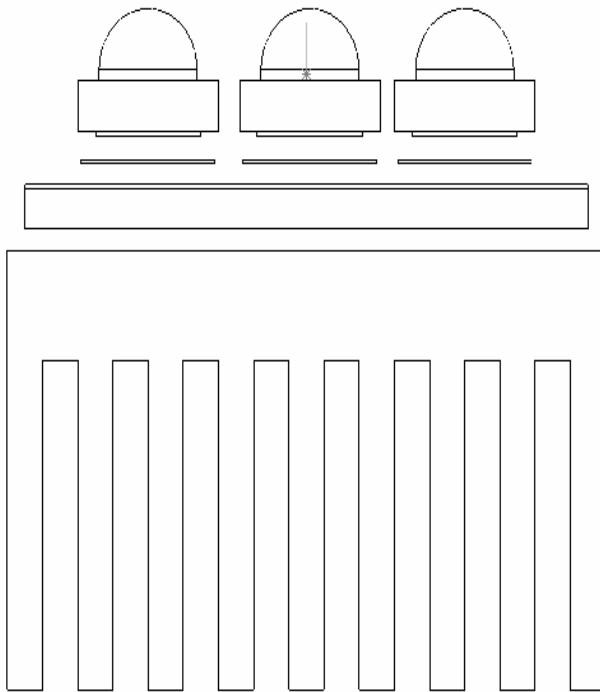

$$T_{Junction} = 25^{\circ}C + (1W) \cdot (21^{\circ}C/W) + (3W) \cdot (10.1^{\circ}C/W)$$

$$T_{Junction} = 76.3^{\circ}C$$

$$T_{Junction} = 25^{\circ}C + (3W) \cdot (19^{\circ}C/W) + (9W) \cdot (10.1^{\circ}C/W)$$

$$T_{Junction} = 172.9^{\circ}C!!!$$

Thermal Management Issues 20W MR16 Example



BULBAB/US \$39.99
Quantity:

OSRAM SYLVANIA

- **Brand:** Sylvania
- **Bulb:** MR 16
- **Watts:** 20
- **Volts:** 12 Volts

- **Beam Type:** Flood
- **Beam Spread:** 40°
- **Life Hours:** 4,000
- **Base:** GU 5.3 Base
- **Candlepower:** 700

A 40° beam spread with a 700 cd peak requires about 350 lumens
Ten 1-watt LEDs (35 lumens/LED) or Five 3-watt LEDs (70 lumens/LED)
Needs power supply (creates additional heat)
Lights are often recessed (restricts air flow)
Small housing makes it difficult to get thermal resistance below 10 C/W
CONCLUSION: Too much heat!

Datasheet Lumens vs Actual Lumens

1-watt LEDs, 25 °C ambient temperature

Datasheet: 45 Lumens at a 25 °C die temperature

Dynamic resistance: 1 Ω

Temperature coefficient of Vf: -2.0 mV/ °C

15 °C/W thermal resistance for the LED

6 °C/W thermal resistance for the thermal epoxy and PCB dielectric

10 °C/W for the heatsink, board interface, etc.

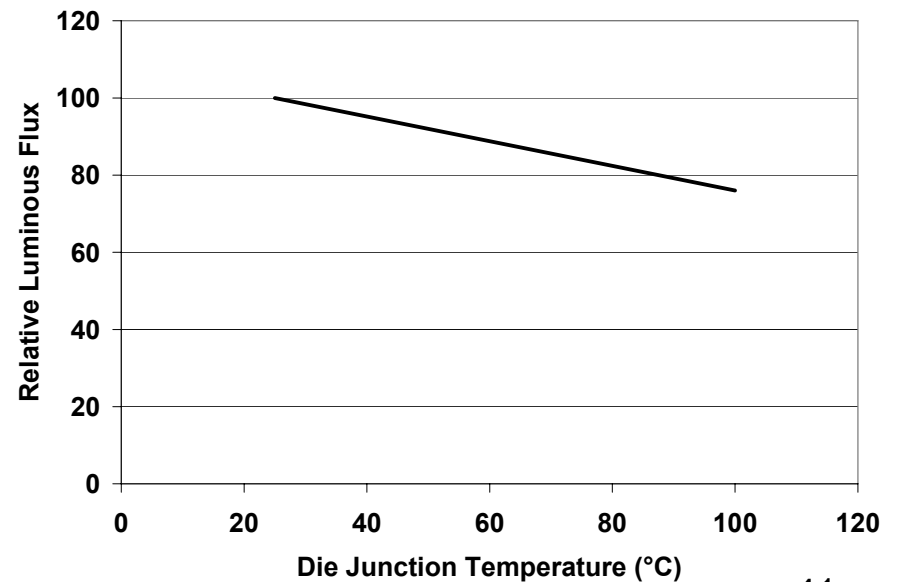
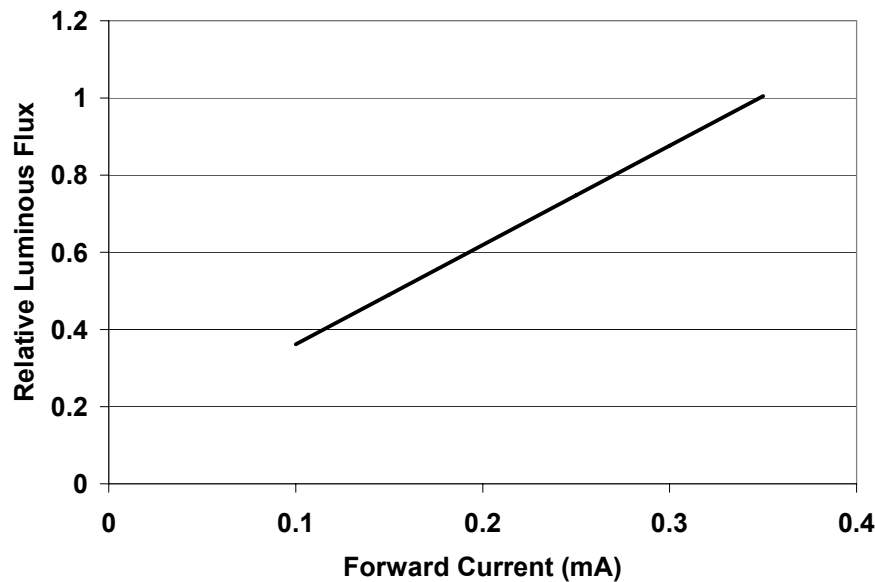

Datasheet Lumens vs Actually Lumens

3 LEDs

I	V	W	Lumens	Lumens/Watt	Die Temp
0.1	3.14	0.31	15.5	49.4	41
0.15	3.17	0.48	20.4	42.9	49
0.2	3.2	0.60	24.9	41.5	58
0.25	3.24	0.81	29.2	36.0	66
0.3	3.27	0.98	33.1	33.7	75
0.35	3.3	1.16	36.7	31.8	84
0.4	3.33	1.33	39.9	30.0	93
0.45	3.37	1.52	42.8	28.2	102
0.5	3.4	1.70	45.2	26.6	112

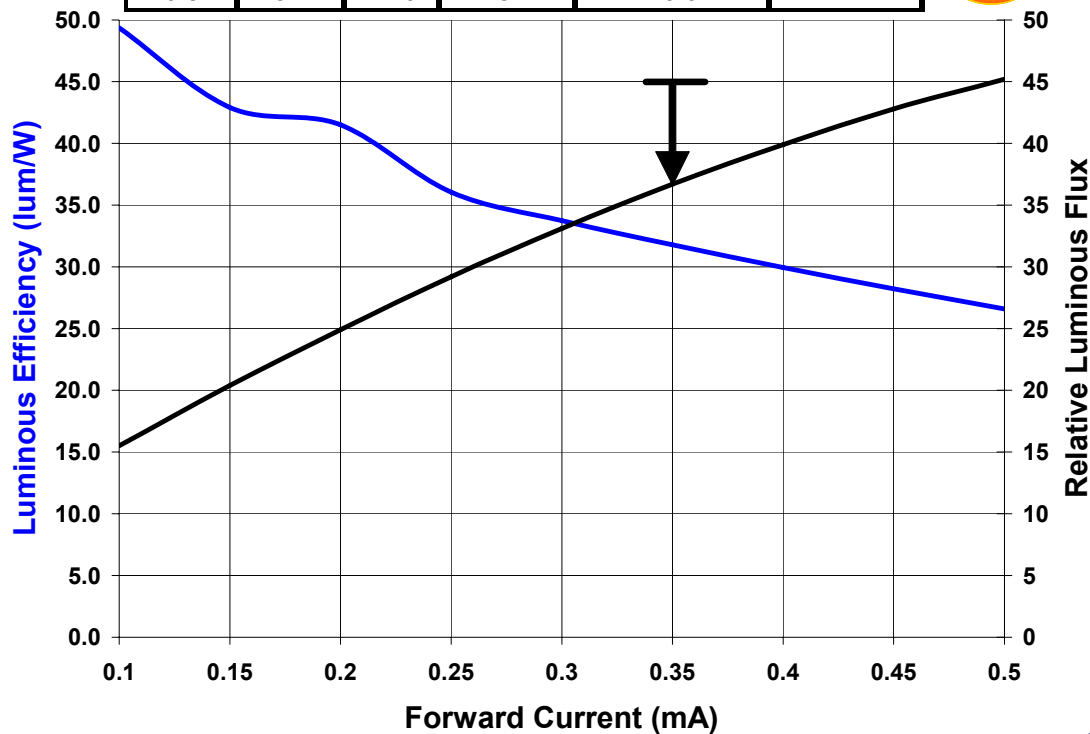

Datasheet Lumens vs Actually Lumens

6 LEDs

I	V	W	Lumens	Lumens/Watt	Die Temp
0.1	3.12	0.31	15	48.1	50
0.15	3.14	0.47	19.4	41.2	63
0.2	3.17	0.60	23.3	38.8	76
0.25	3.19	0.80	26.7	33.5	90
0.3	3.21	0.96	29.6	30.7	103
0.35	3.24	1.13	31.9	28.1	117
0.4	3.26	1.30	33.8	25.9	131
0.45	3.28	1.48	35.1	23.8	145
0.5	3.3	1.65	35.8	21.7	159

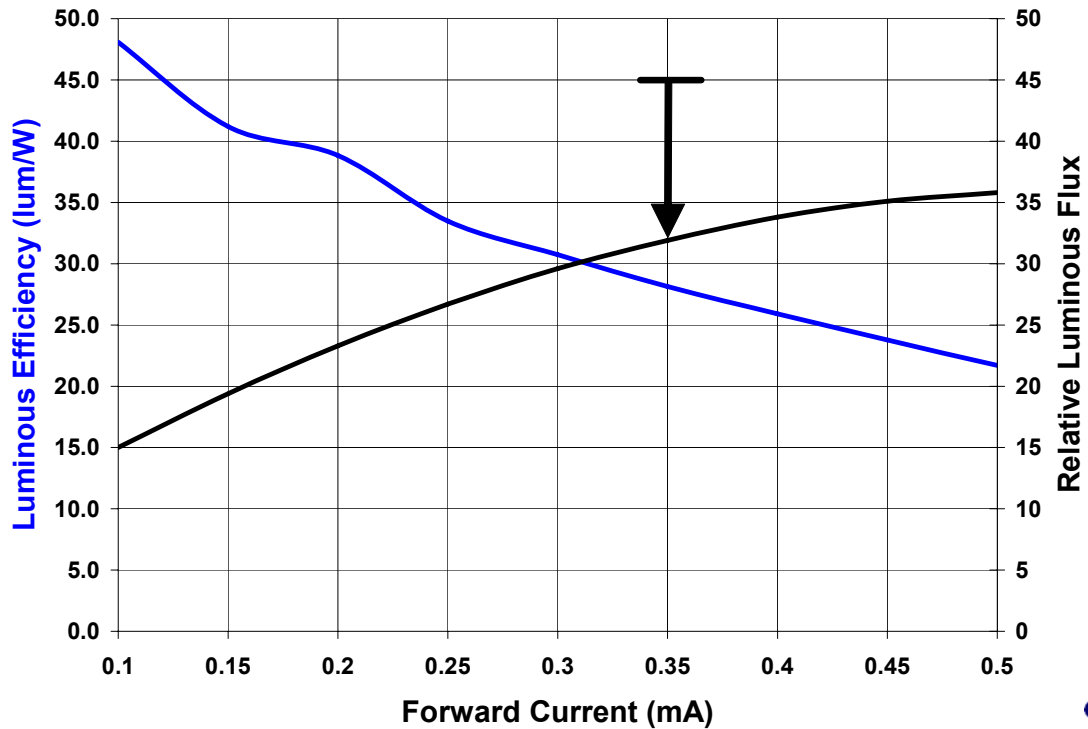

De-rating Forward Current for Ambient Temperature

15. Ambient Temperature vs Allowable Forward Current for 1 chip White,Blue,Green,Cyan

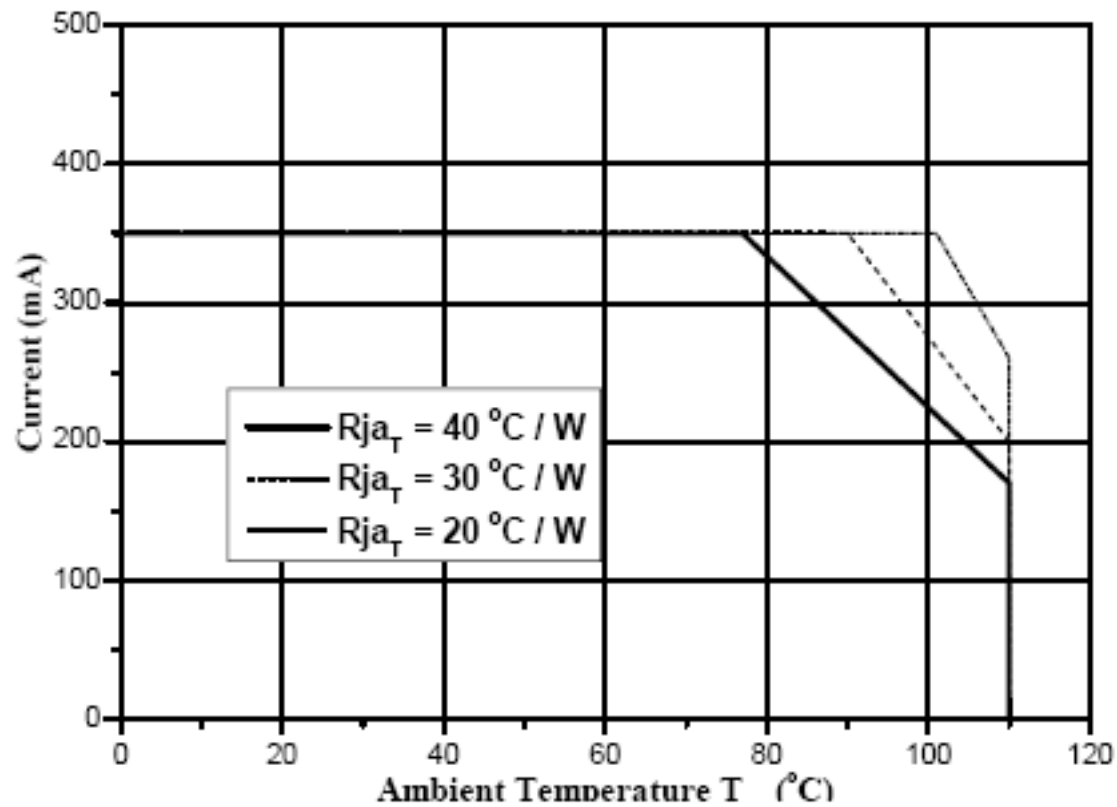

- Cree
 - XLamp Series
- LumiLeds
 - Luxeon Series
 - K2 Series
- Nichia
 - Jupiter Series
- Osram
 - Golden Dragon Series
- Seoul Semiconductor
 - Z-Power Series

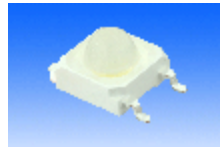

Cool White LED Comparison

	Dice #	Viewing Angle Degees	Typical Lumens					Typical Current mA	Typical Voltage Vf	Typical Power W	Thermal Resistance °C/W	Rise LED Only °C	Max Junction °C	CRI	
			350 mA	500 mA	700 mA	1000 mA	1400 mA	1500 mA							
Osram LW W5SG Cool	1	120	21-39	41					350	3.8	1.3	9	12	125	80
Osram ZW W5SG Cool	1	120	33-71	60					350	3.2	1.1	15	17	125	80
Osram LW W5SN Cool	1	120			52-97				700	3.8	2.7	8	21	135	80
Osram LW W5SM Cool	1	120		64					350	3.2	1.1	15	17	125	80
Osram LEW E3A Cool	6	120			300				700	22.5	15.8	3.6	57	150	80
Osram LEW E3B Cool	6	120			420				700	22.5	15.8	3.6	57	125	80
Osram LEW E2A Cool	4	120			200				700	15	10.5	5	53	150	80
Osram LEW E2B Cool	4	120			280				700	15	10.5	5	53	125	80
Lumileds LXHL-PW01 Cool	1	120	45						350	3.42	1.2	15	18	135	70
Lumileds LXHL-DW01 Cool	1	Side-emit	40.5						350	3.42	1.2	15	18	135	70
Lumileds LXHL-BW02 Cool	1	Batwing	45						350	3.42	1.2	15	18	135	70
Lumileds LXHL-PW09 Cool	1	120			65	80			700	3.7	2.6	13	34	135	70
Lumileds LXHL-DW09 Cool	1	Side-emit			58	70			700	3.7	2.6	13	34	135	70
Lumileds LXHL-PW03 Cool	4	150			87.4				700	6.84	4.8	8	38	135	70
Lumileds L XK2-PW etc Cool	1	150	52.5		87.5	110	135		1000	3.72	3.7	9	33	150	70
Nichia NCCW002, etc Cool	1	35,70,120	42	?					350	3.7	1.3	17	22	105	80
Nichia NS6W083 Cool	4	120	60	?					350	3.6	1.3	10	13	120	80
Cree XL7090 Cool	1	100	52		?				350	3.5	1.2	17	21	125	75
Cree 3XL7090 Cool	1	100			76				700	4	2.8	17	48	145	75
Cree XL7090XR Cool	1	100	53.5		?				350	3.5	1.2	8	10	145	75
Seoul Semi W10190 Cool	1	70,110	52						350	3.5	1.2	8	10	125	70
Seoul Semi W10290 Cool	2	70,110			103				700	3.5	2.5	6	15	125	70
Seoul Semi W10490 Cool	4	70,110				178			1400	3.5	4.9	4	20	125	70
Cotco LD-700AWN1-70 Cool	1	70	27						350	3.6	1.3	15	19	125	



Warm White LED Comparison

	Dice #	Viewing Angle Degees	350 mA	500 mA	700 mA	1000 mA	1400 mA	1500 mA	Typical Current mA	Typical Voltage Vf	Typical Power W	Thermal Resist- ance °C/W	Temp Rise LED Only °C	Max Junction °C	CRI
Osram LCW W5SG Warm	1	120	15-33	31.7					350	3.8	1.3	9	12	125	85
Lumileds LXHL-BW03 Warm	1	Batwing	20						350	3.42	1.2	15	18	120	90
Nichia NCCL002, etc Warm	1	35,70,120	32	?					350	3.7	1.3	17	22	105	75
Nichia NS6W083 Warm	4	120	52	?					350	3.6	1.3	10	13	120	75
Cree XL7090XR Warm	1	100	41	?					350	3.5	1.2	8	10	145	75
Seoul Semi W10190 Warm	1	70 or 110	35						350	3.5	1.2	8	10	125	80
Seoul Semi W10290 Warm	2	70 or 110	60					700	3.5	2.5	6	15	125	80	
Seoul Semi W10490 Warm	4	70 or 110	120					1400	3.5	4.9	4	20	125	80	



White is White is White

Binning Issues



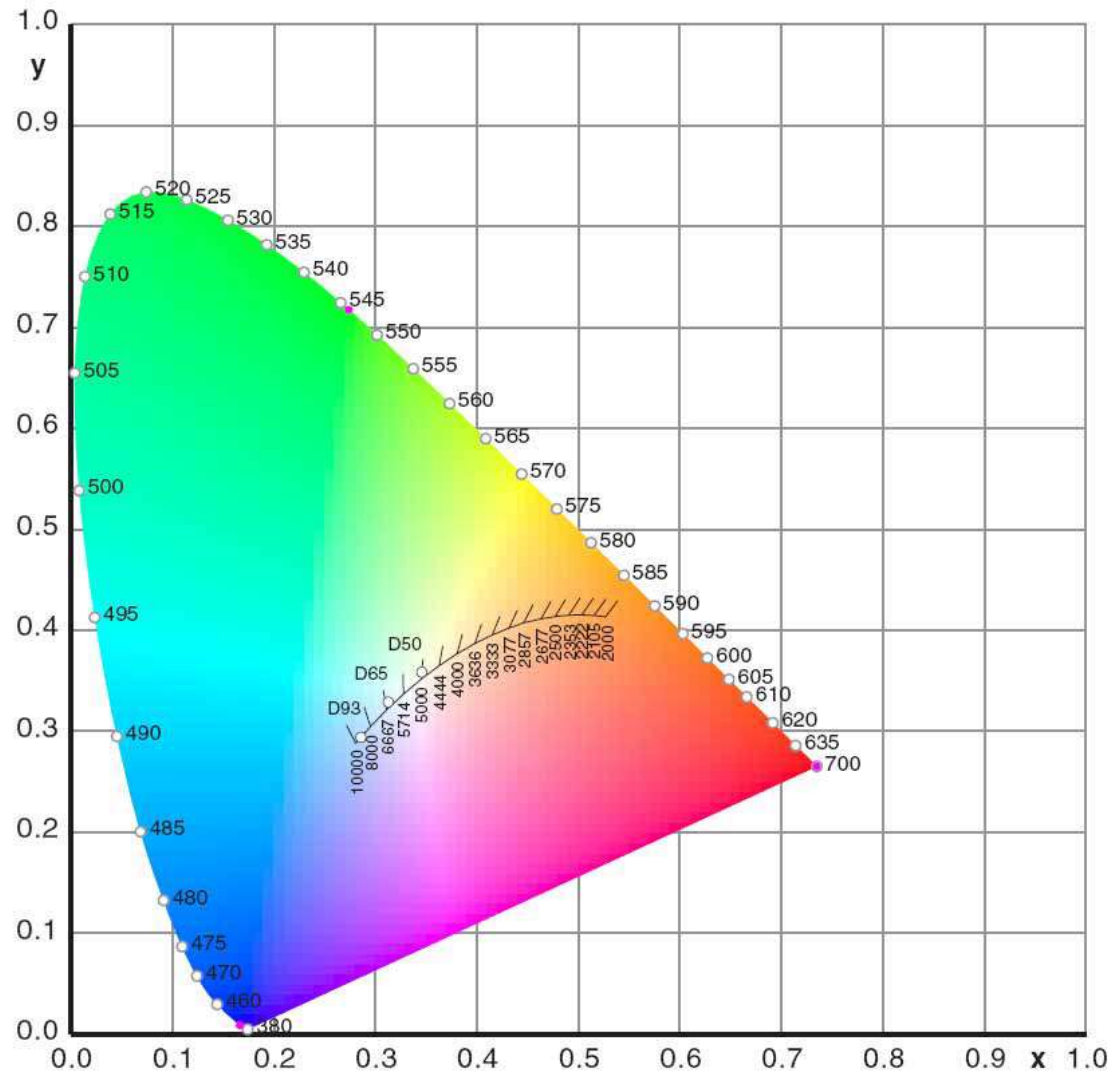

White is White is White

Binning Issues

Lumileds 1st White Binning

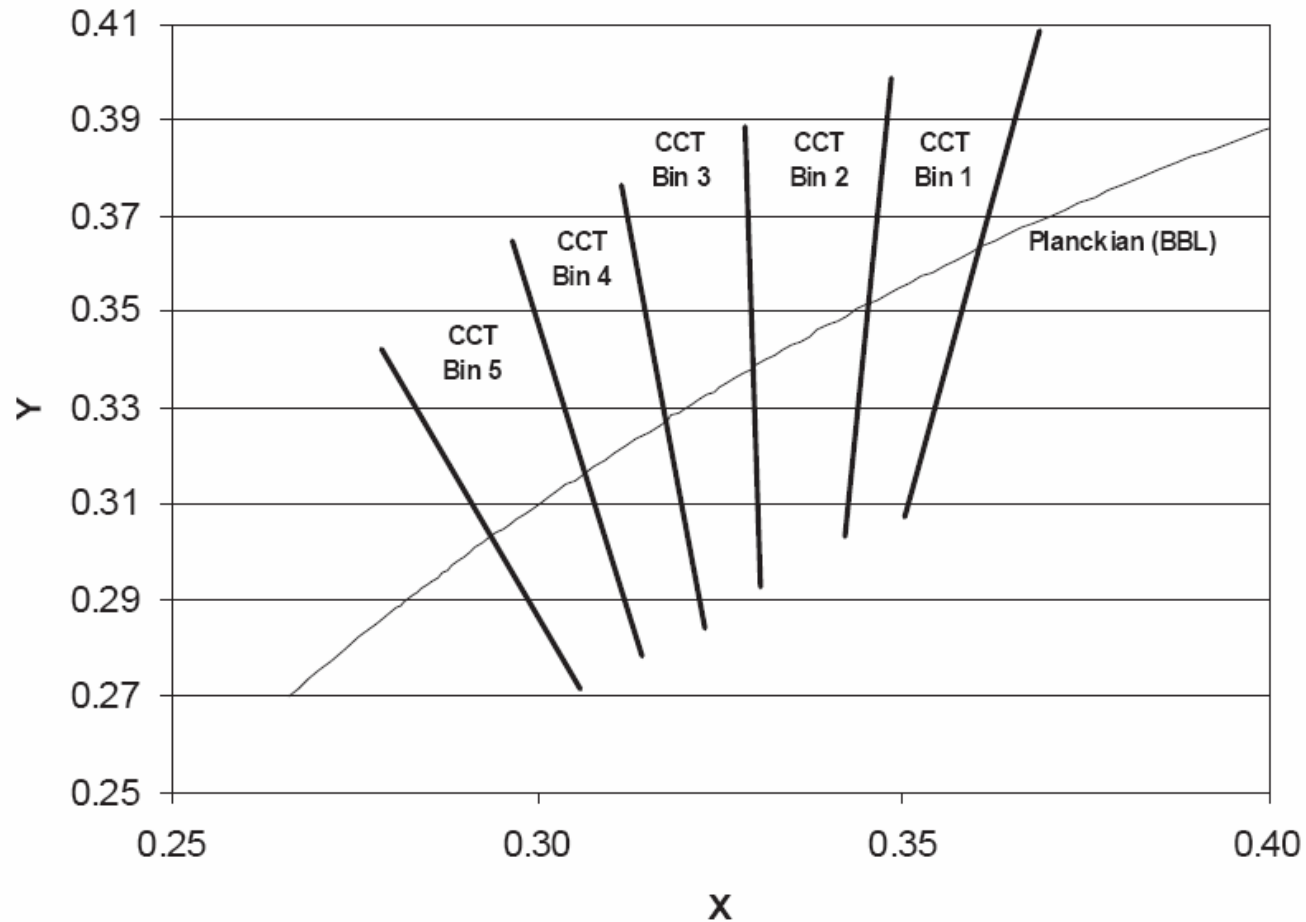

White is White is White

Binning Issues

Lumileds 2nd White Binning

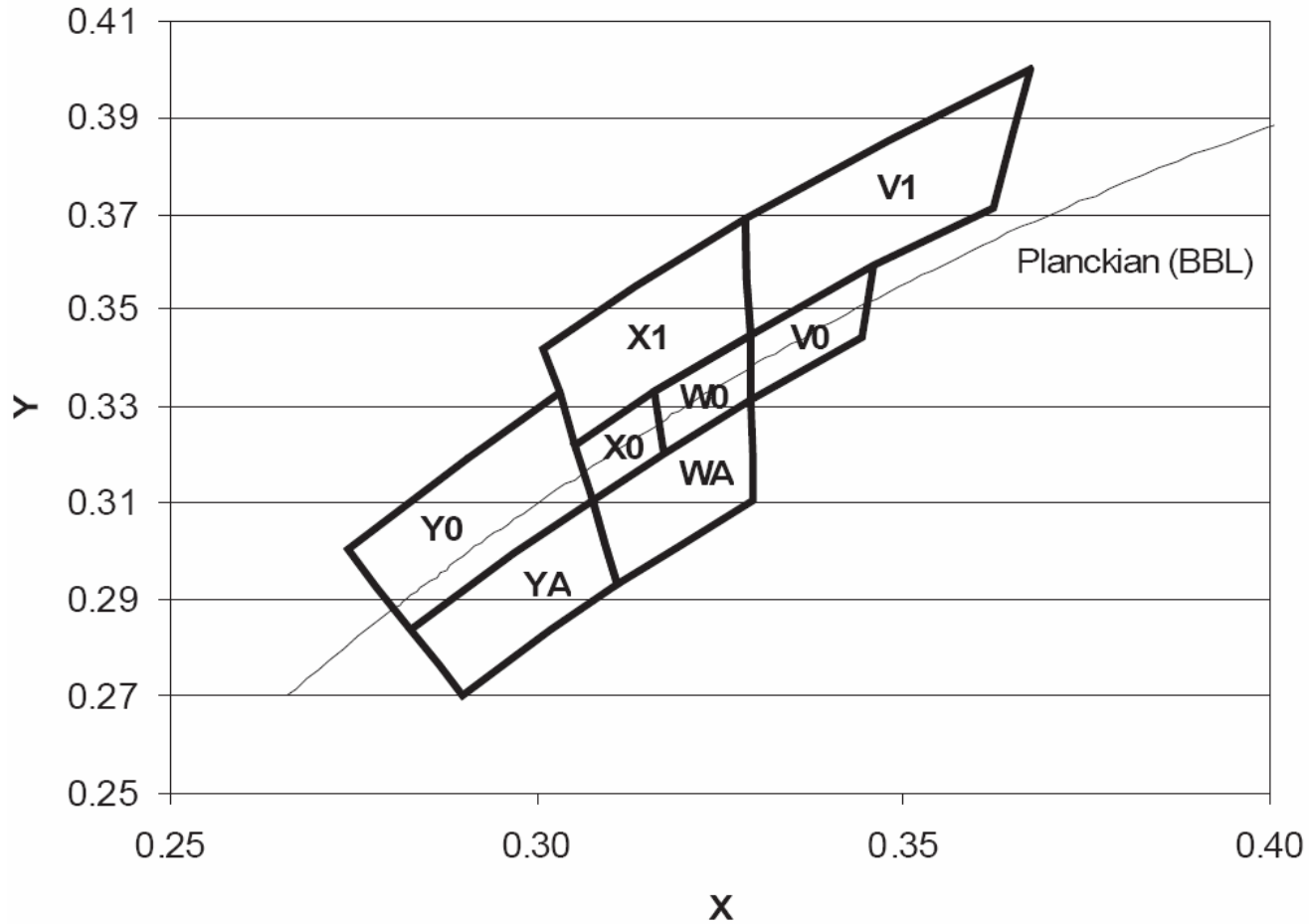

White is White is White

Binning Issues

Lumileds 3rd White Binning

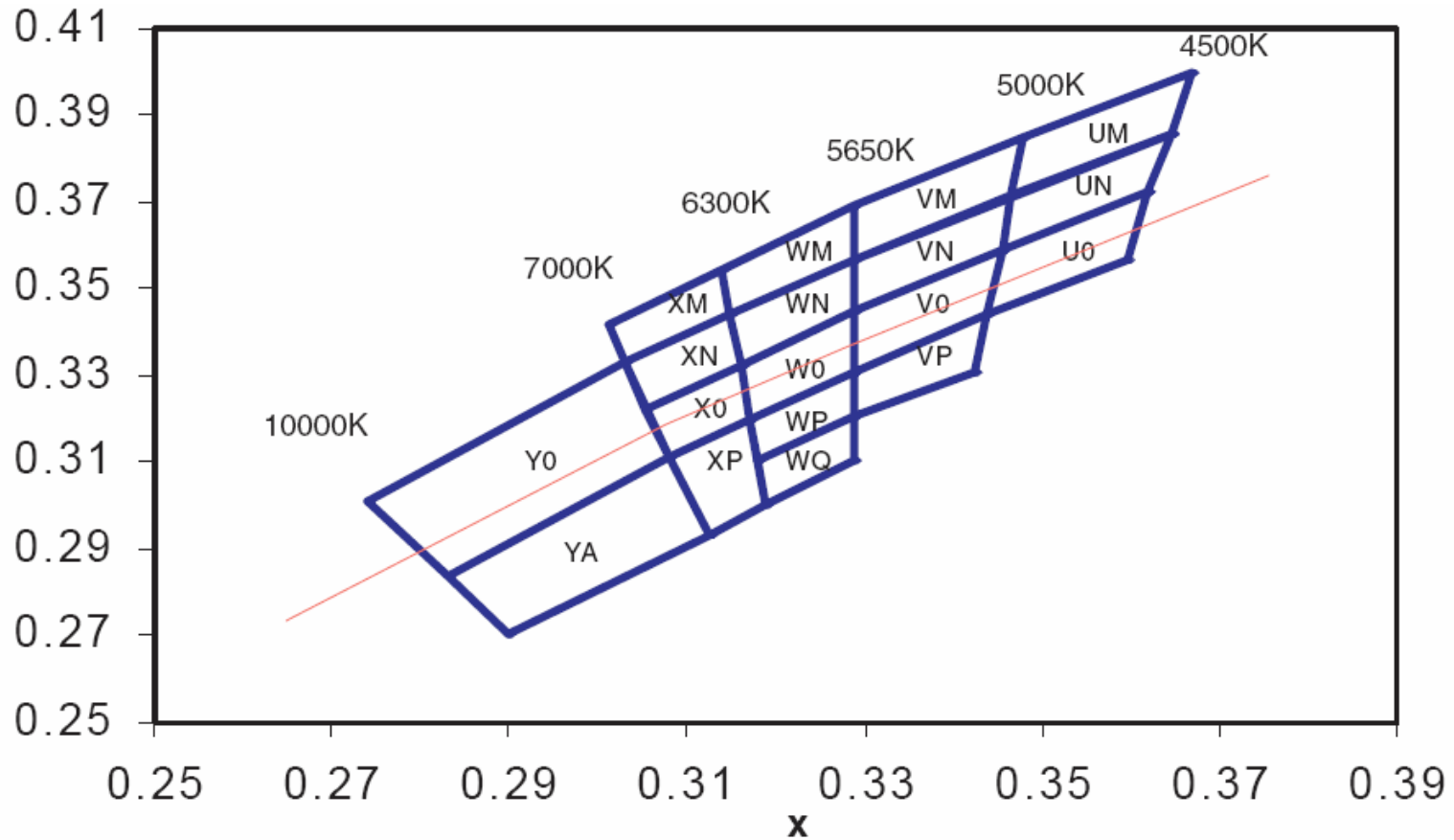

White is White is White

Binning Issues

Cree XL7090 White Binning

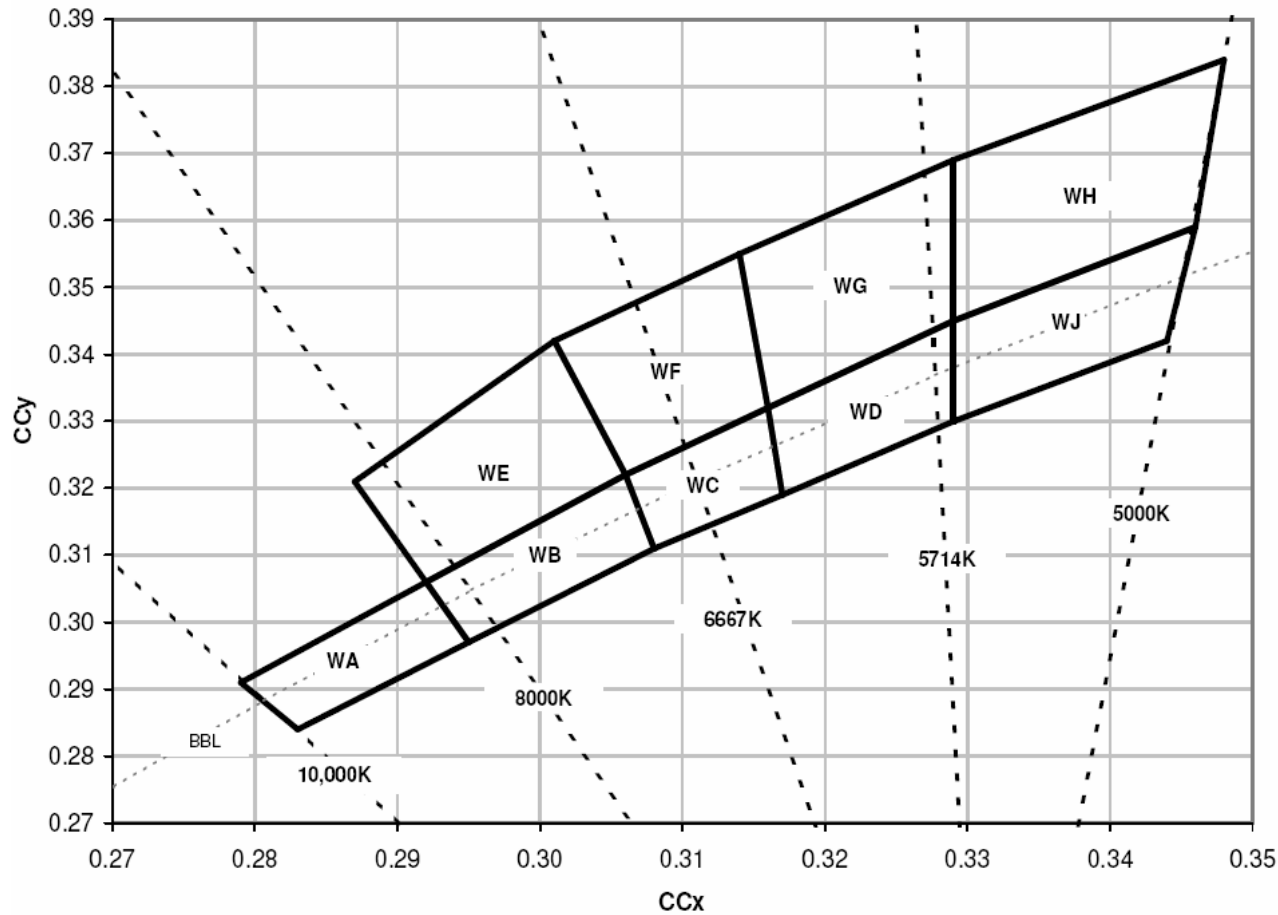

White is White is White

Binning Issues

Cree Cool & Warm White Binning

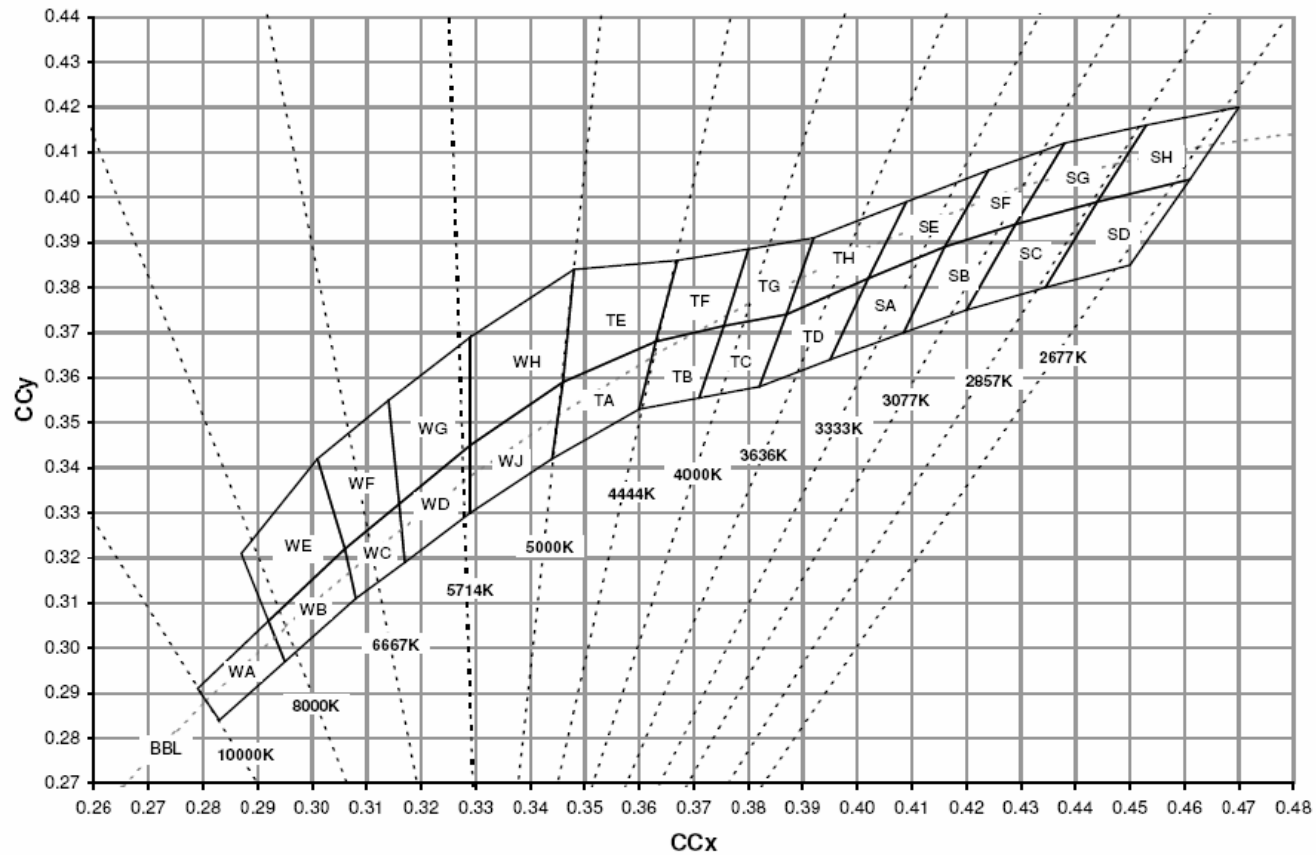

White is White is White

Binning Issues

Nichia White Binning

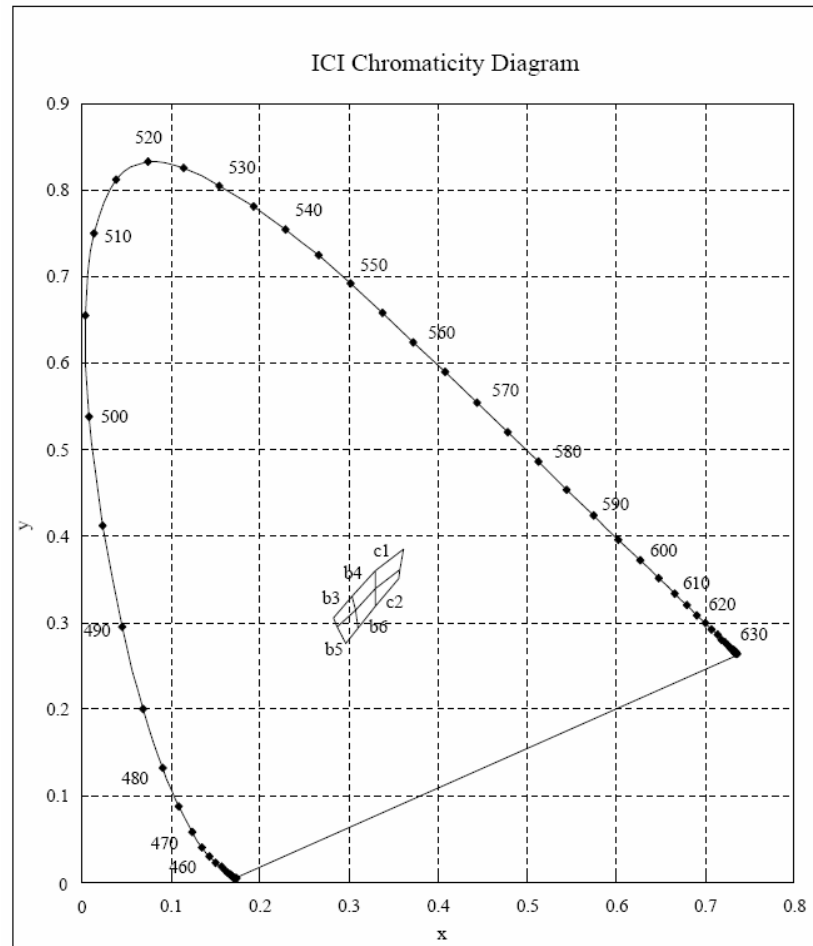

White is White is White

Binning Issues

Osram White Binning

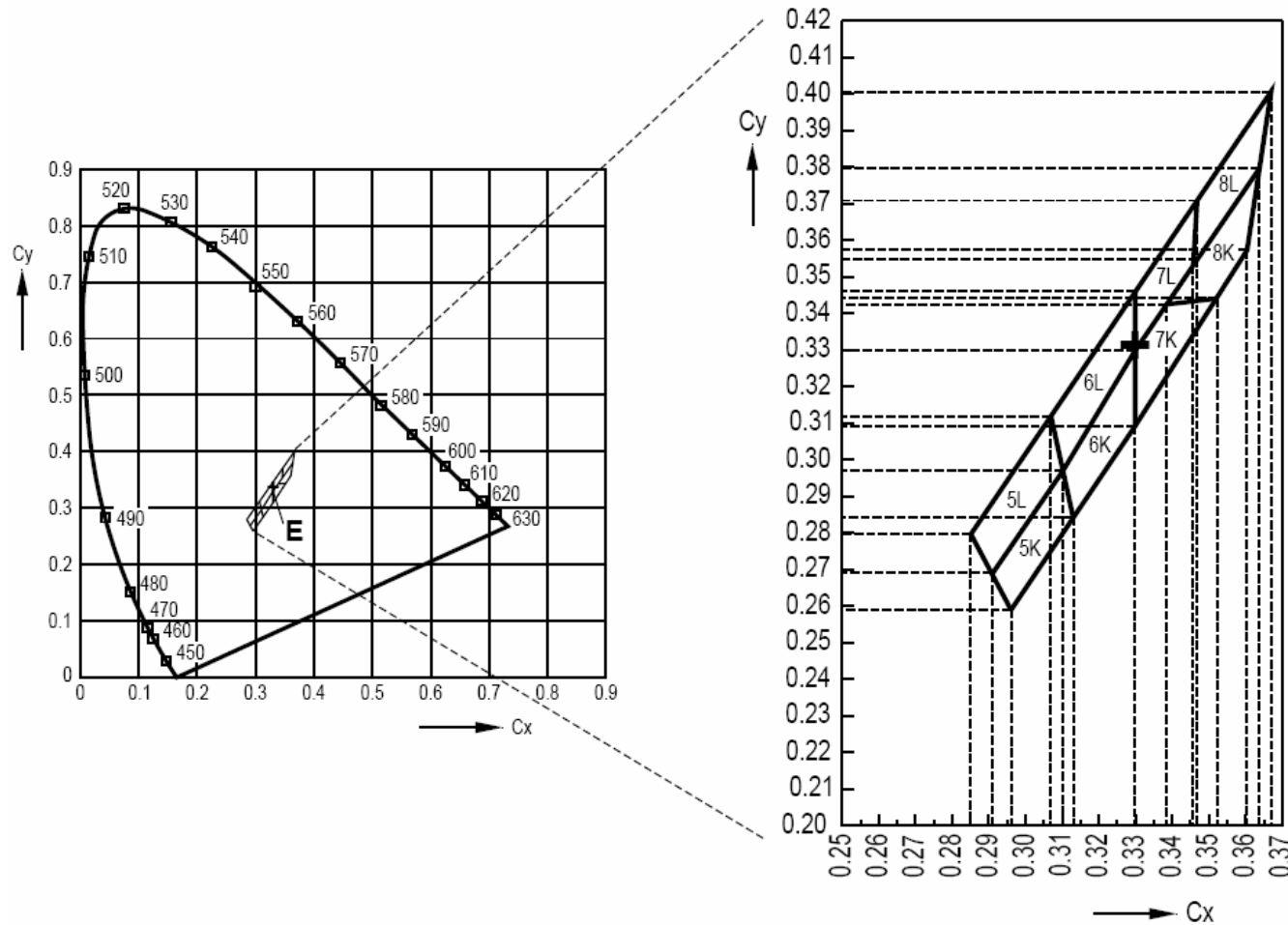

White is White is White

Binning Issues

Seoul White Binning

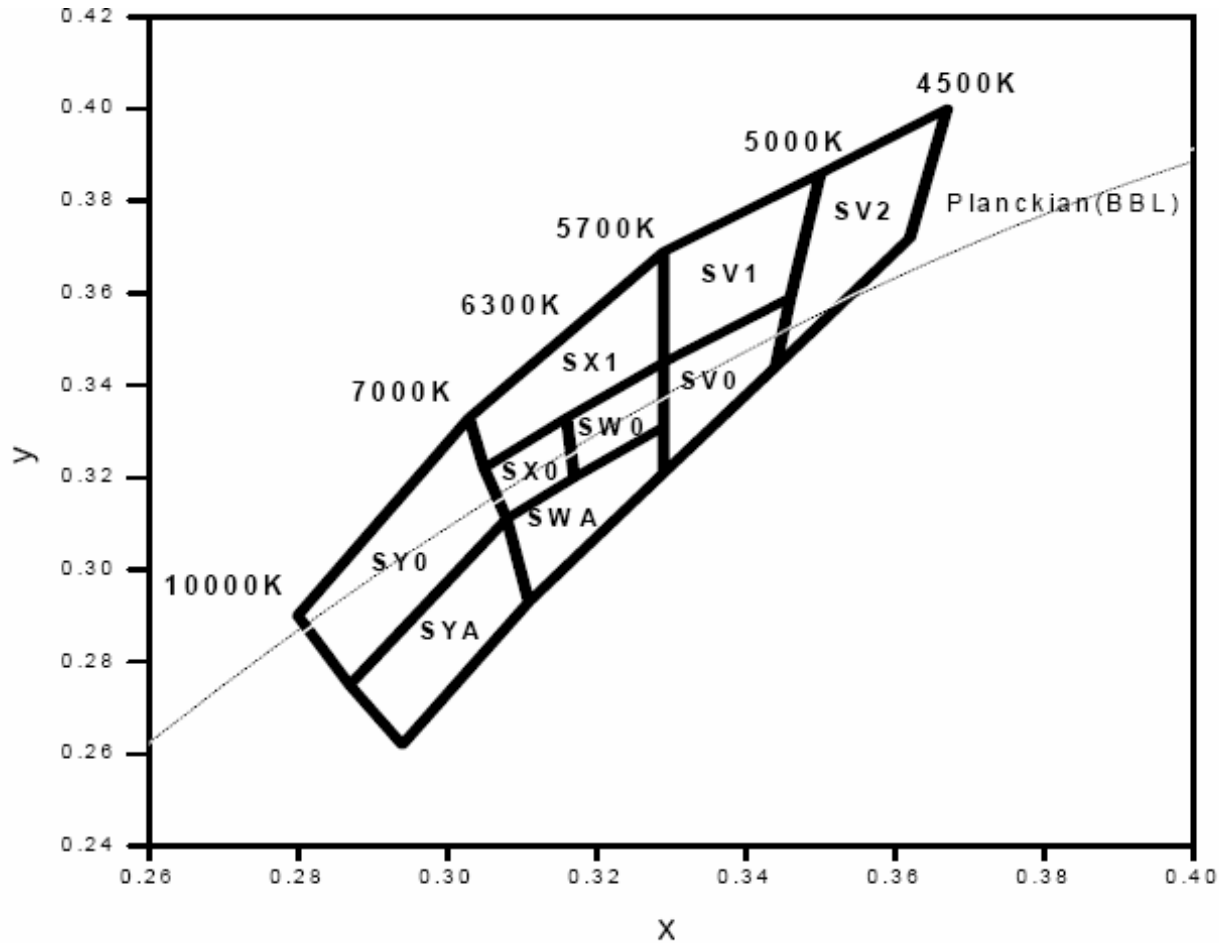

Chromaticity Binning Comparison

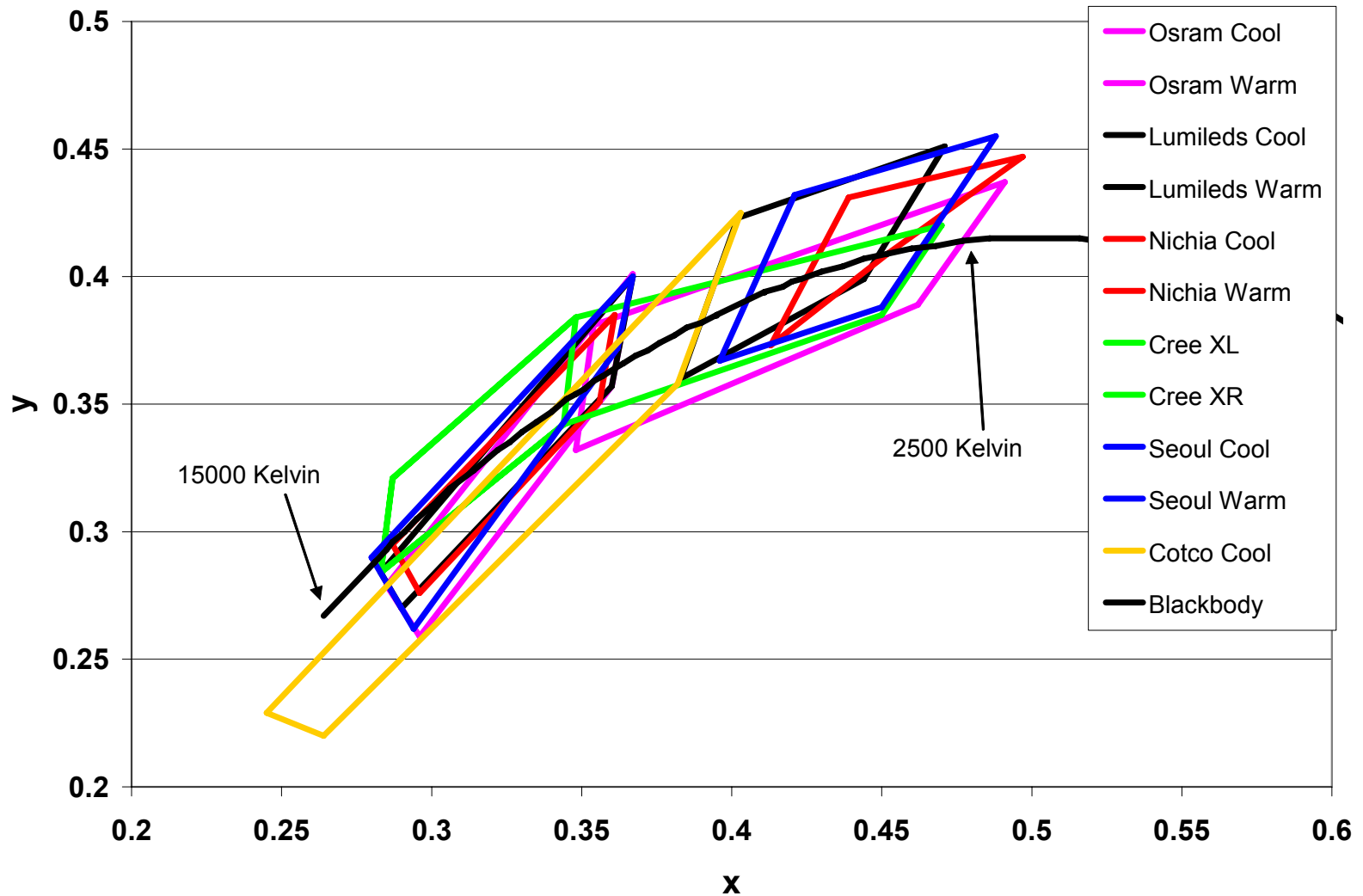

Spectral and Chromaticity Measurements

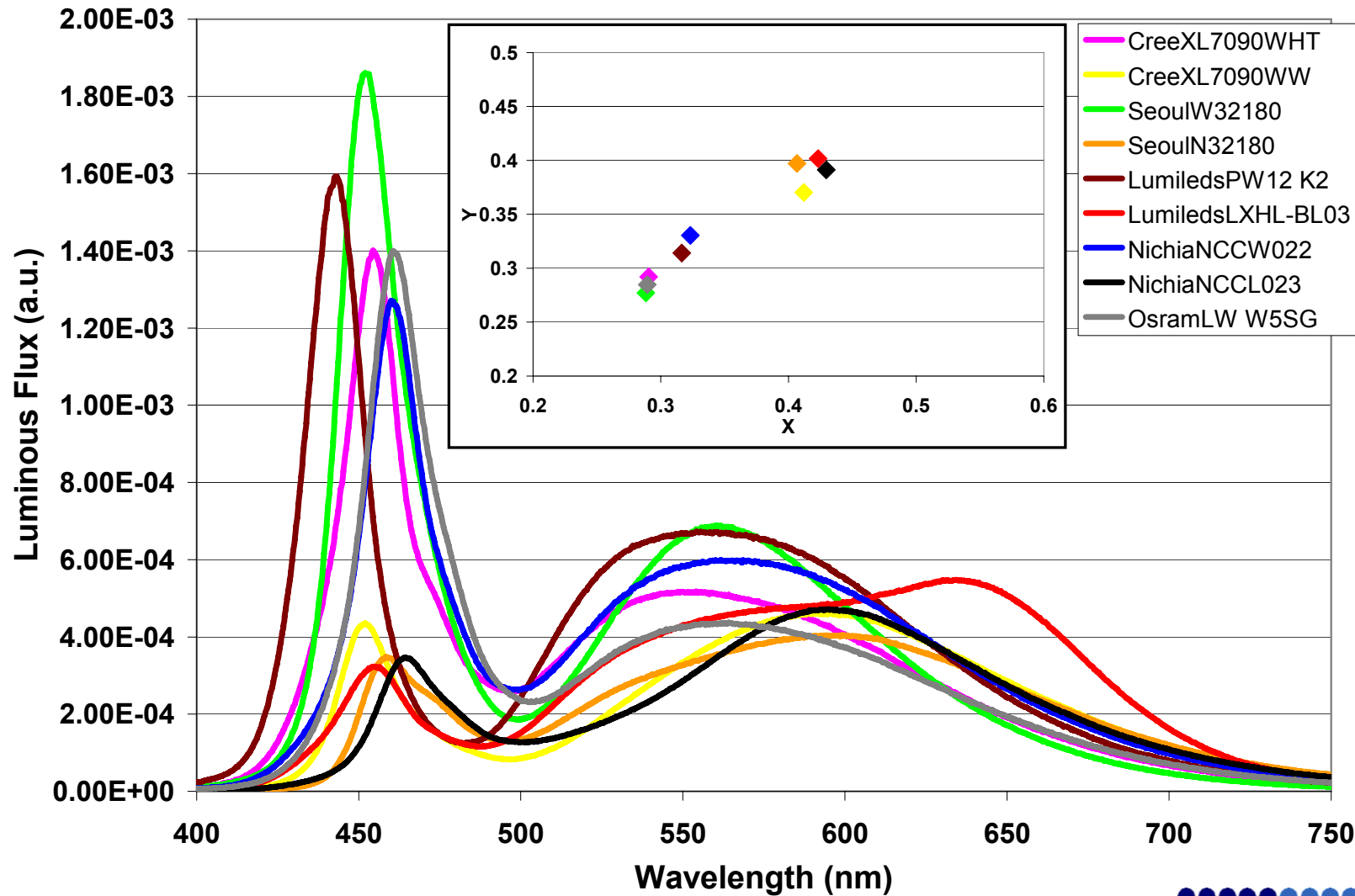

Spectral and Chromaticity Measurements

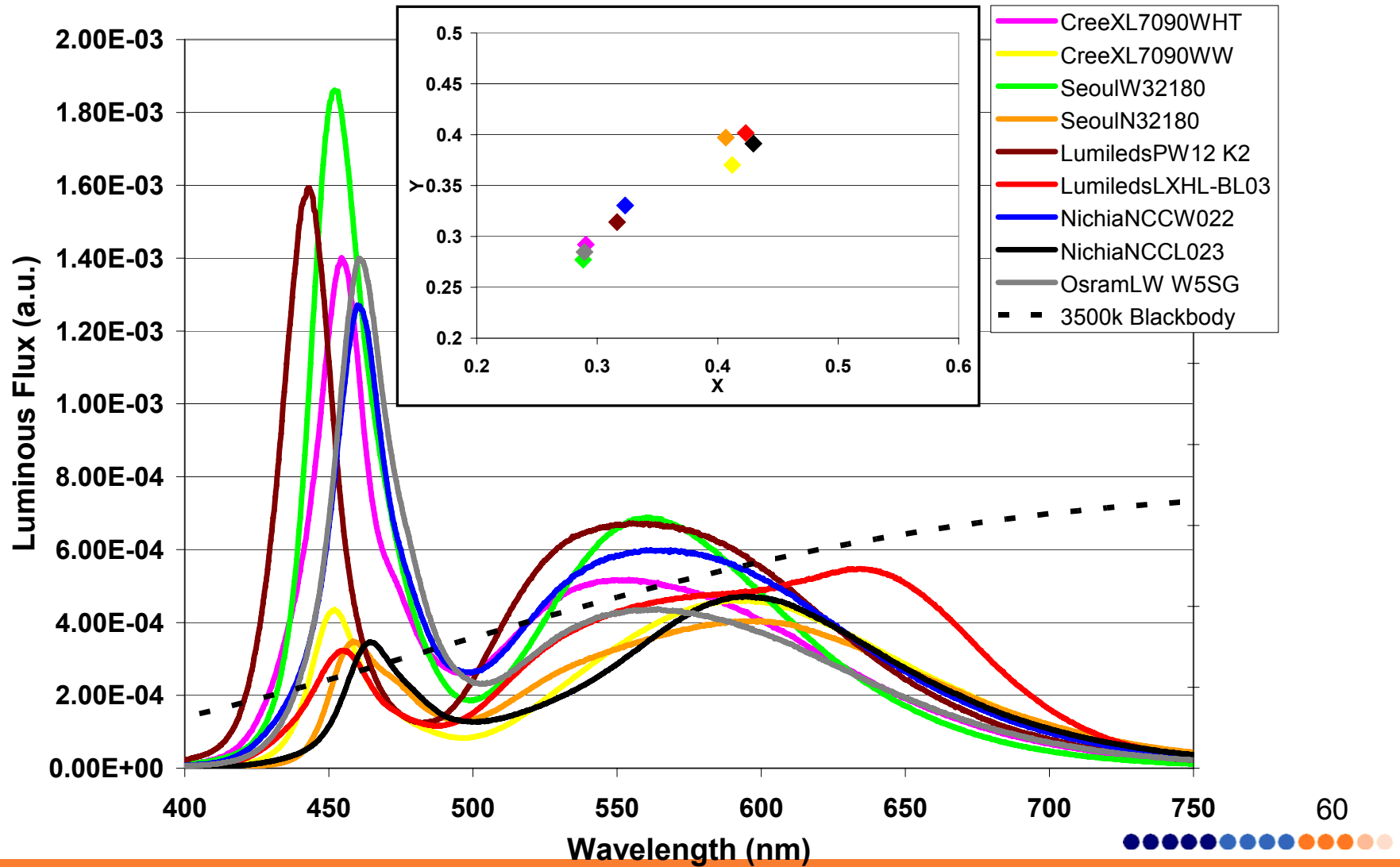

CCT Change with Time

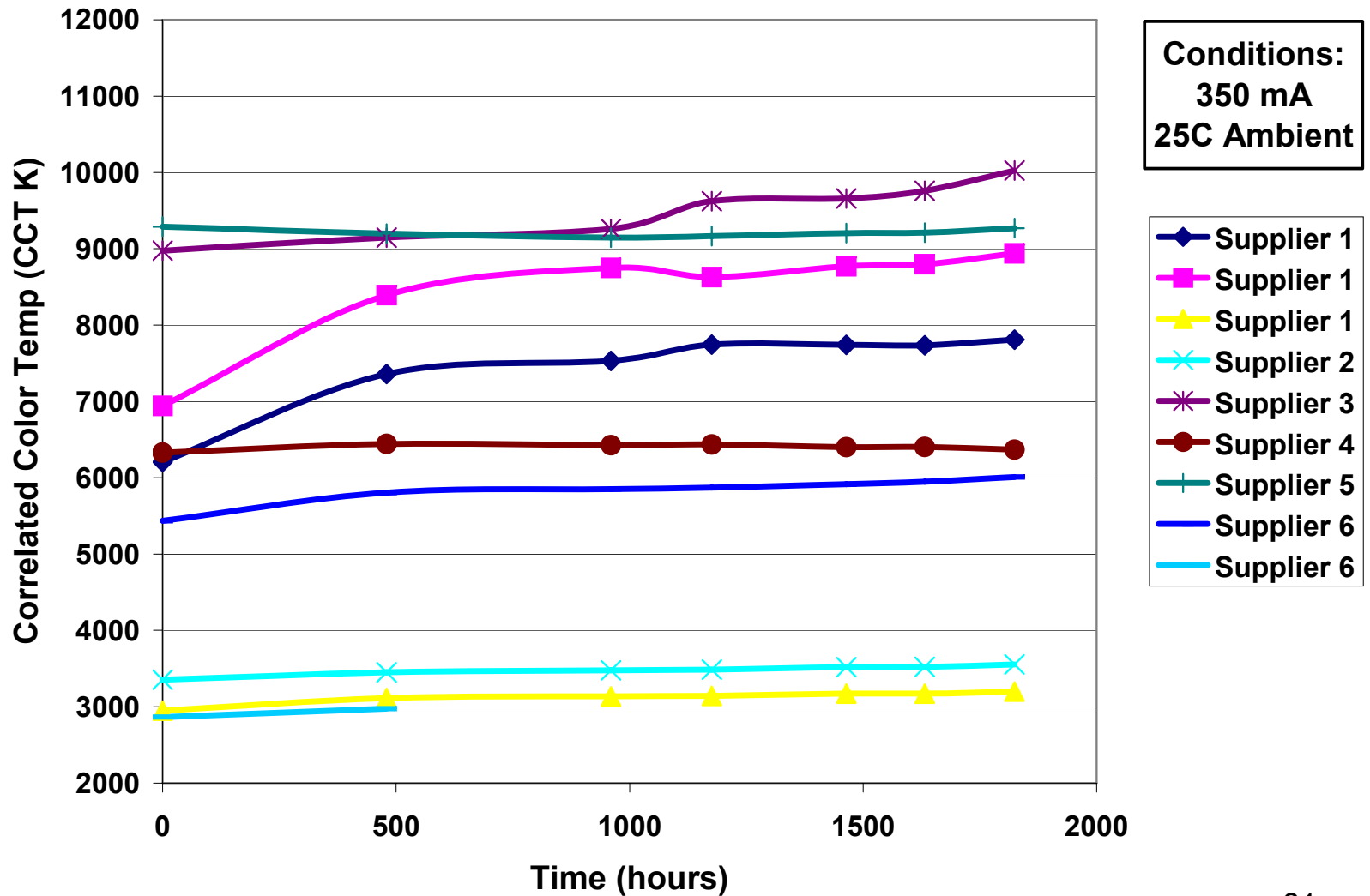

CCT Change with Time

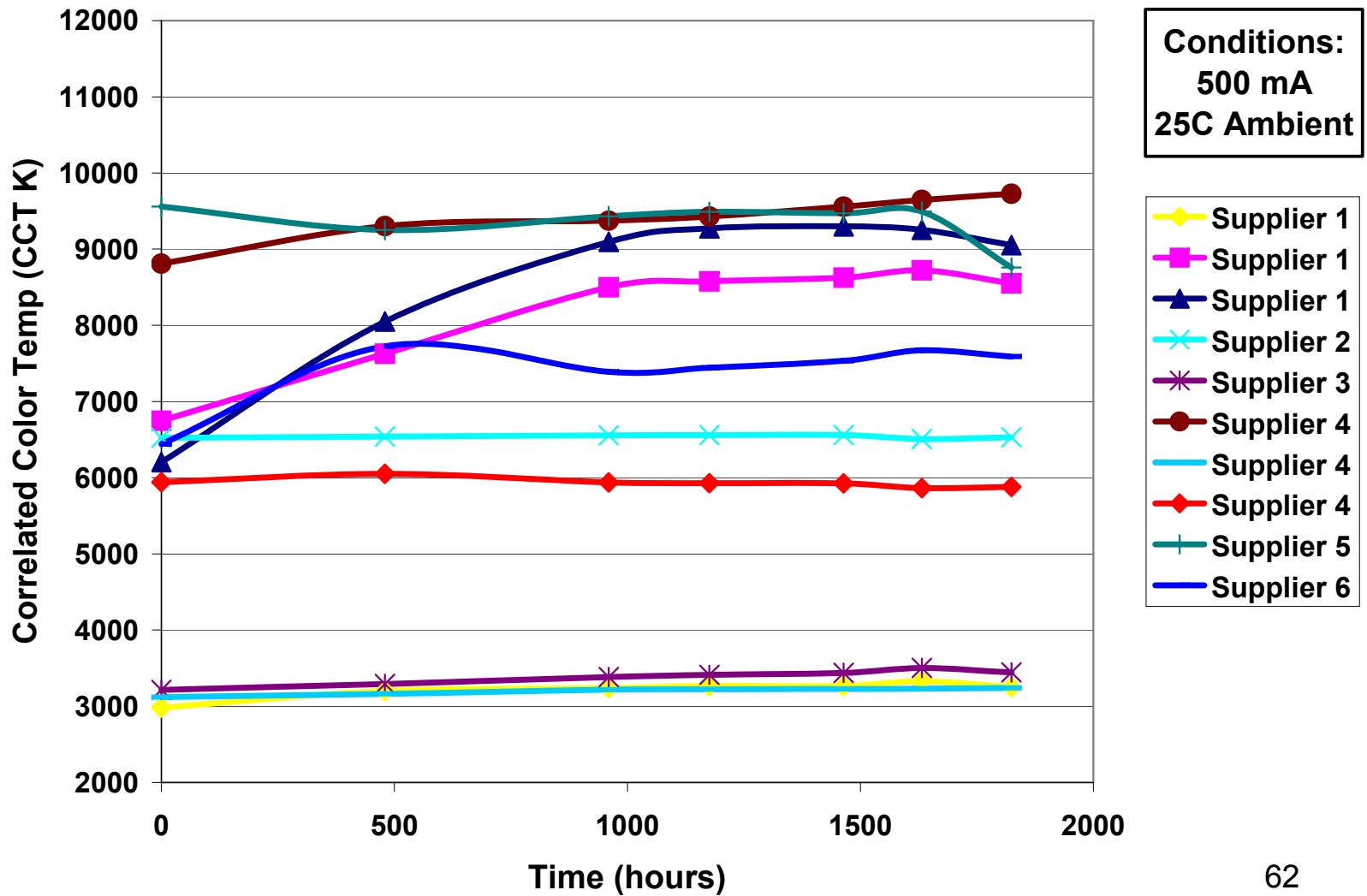

CCT Change with Time

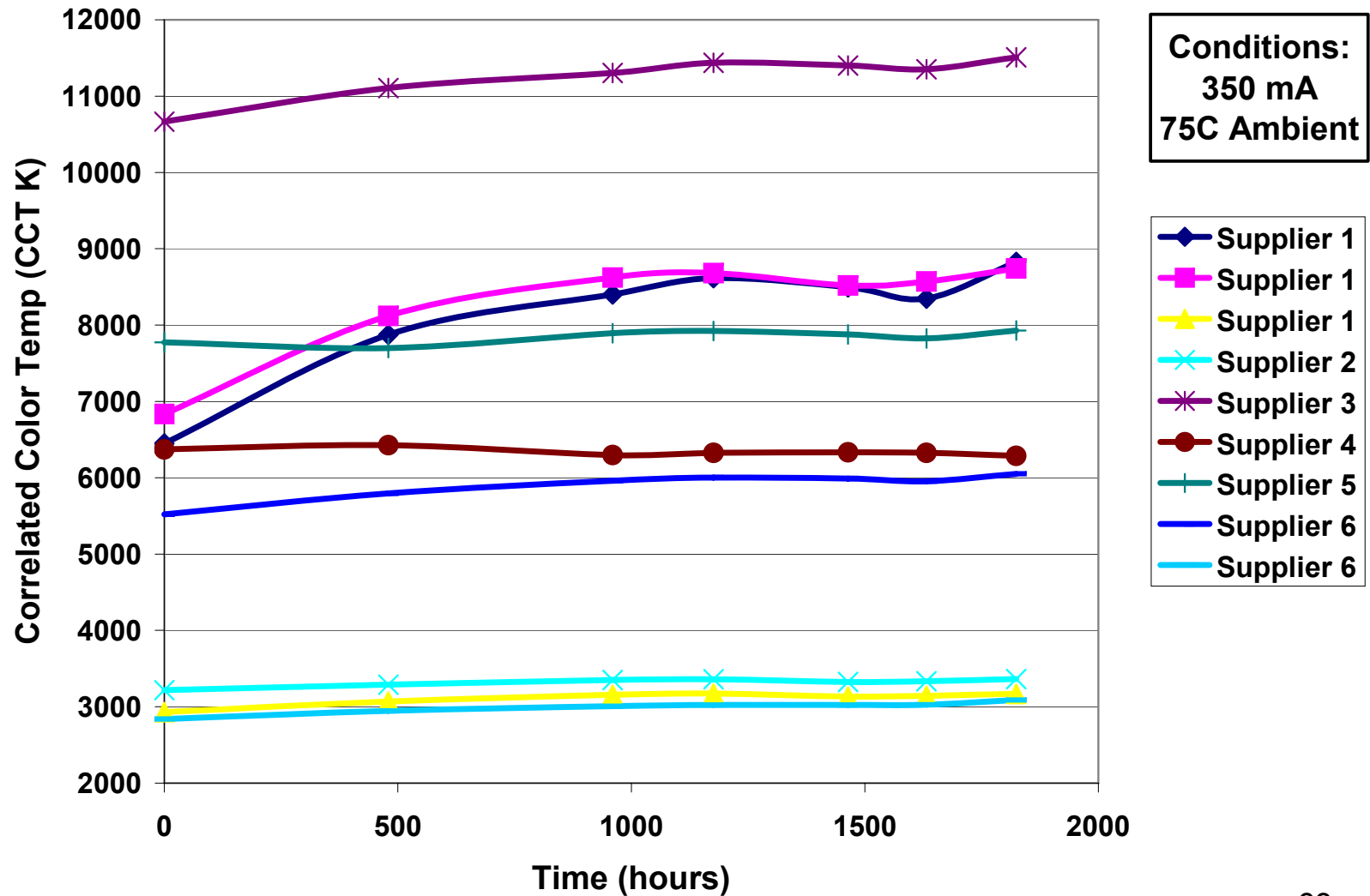

CCT Change with Time

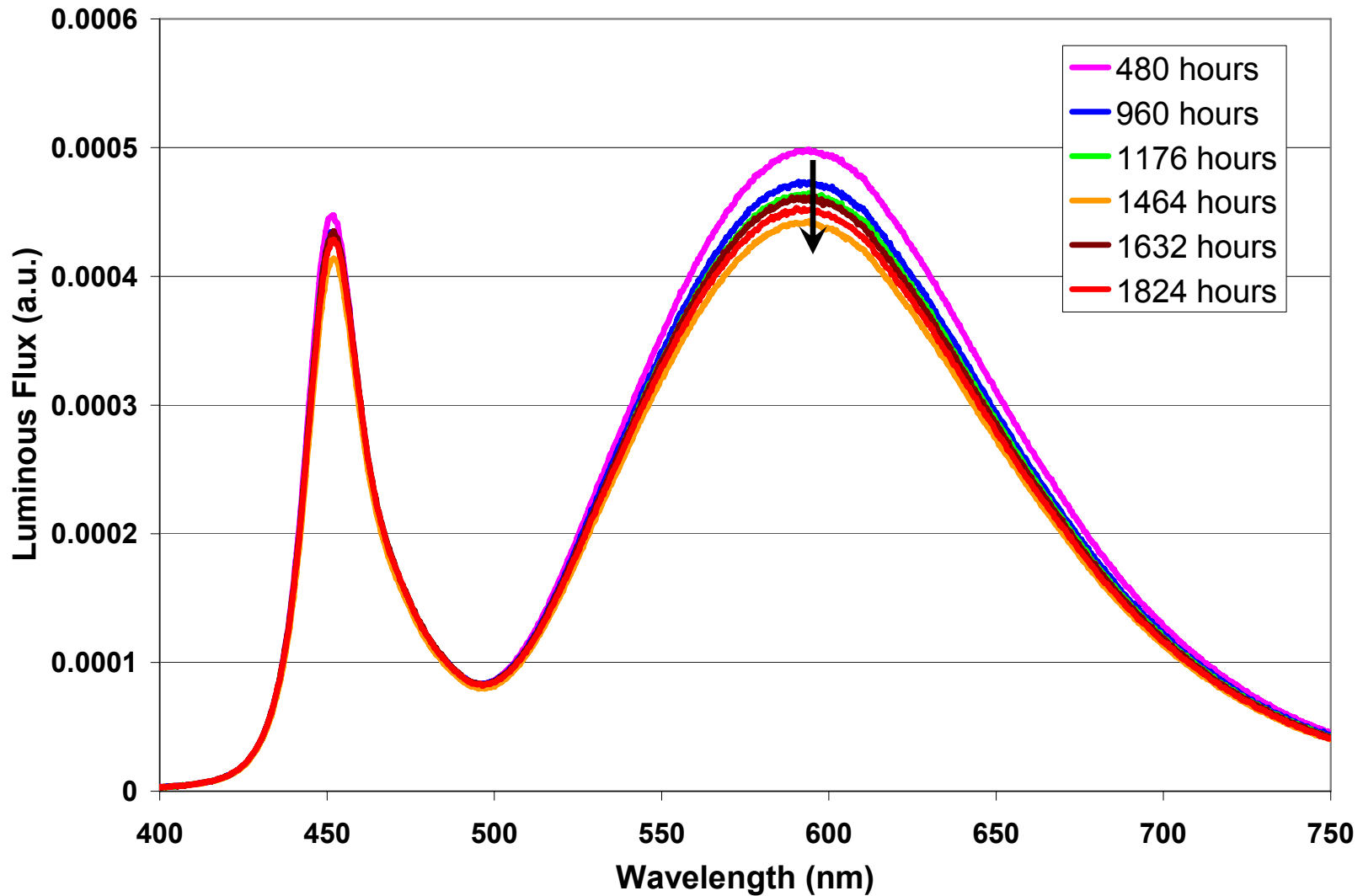

Luminous Flux Change with Time

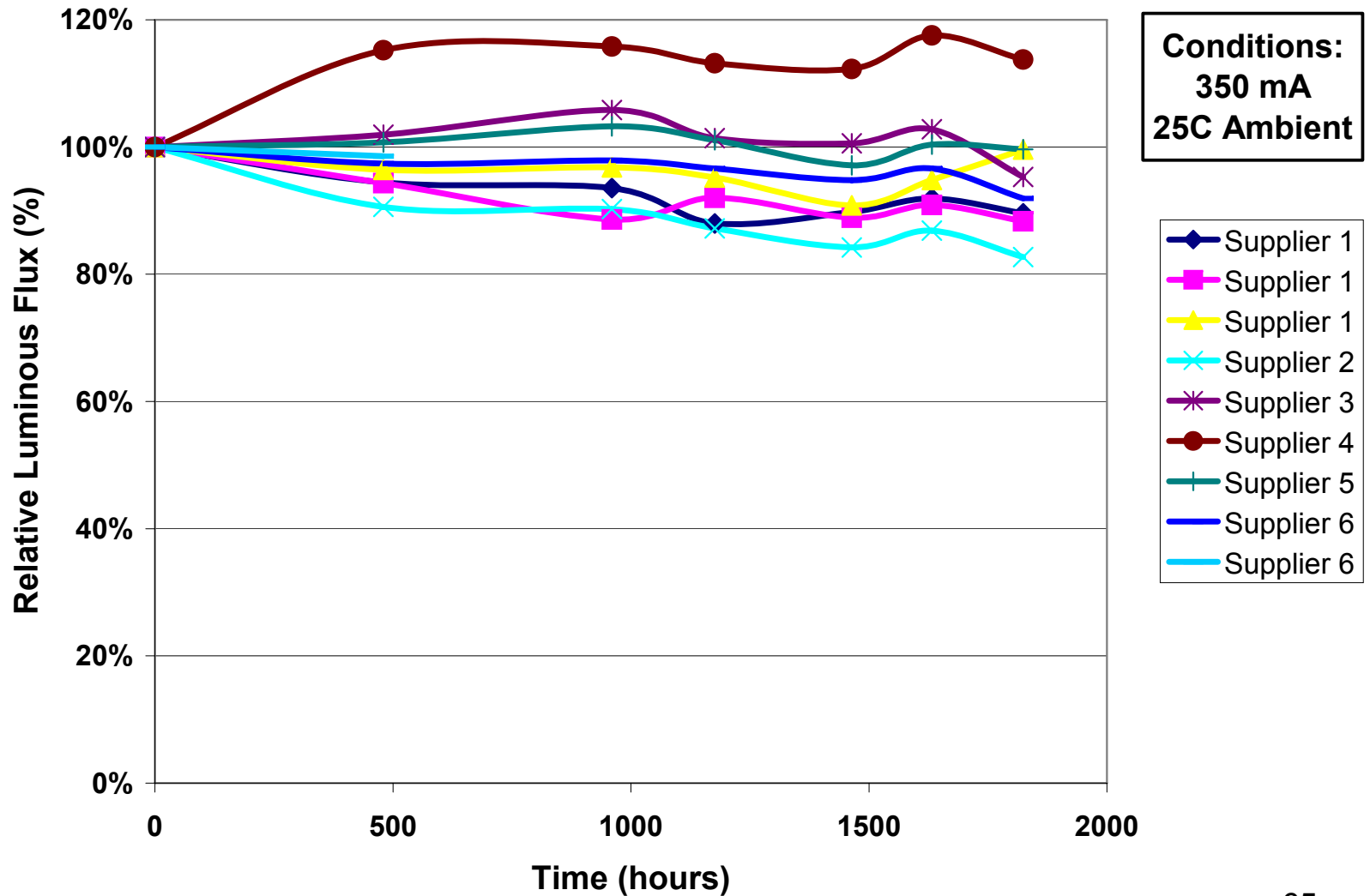

Luminous Flux Change with Time

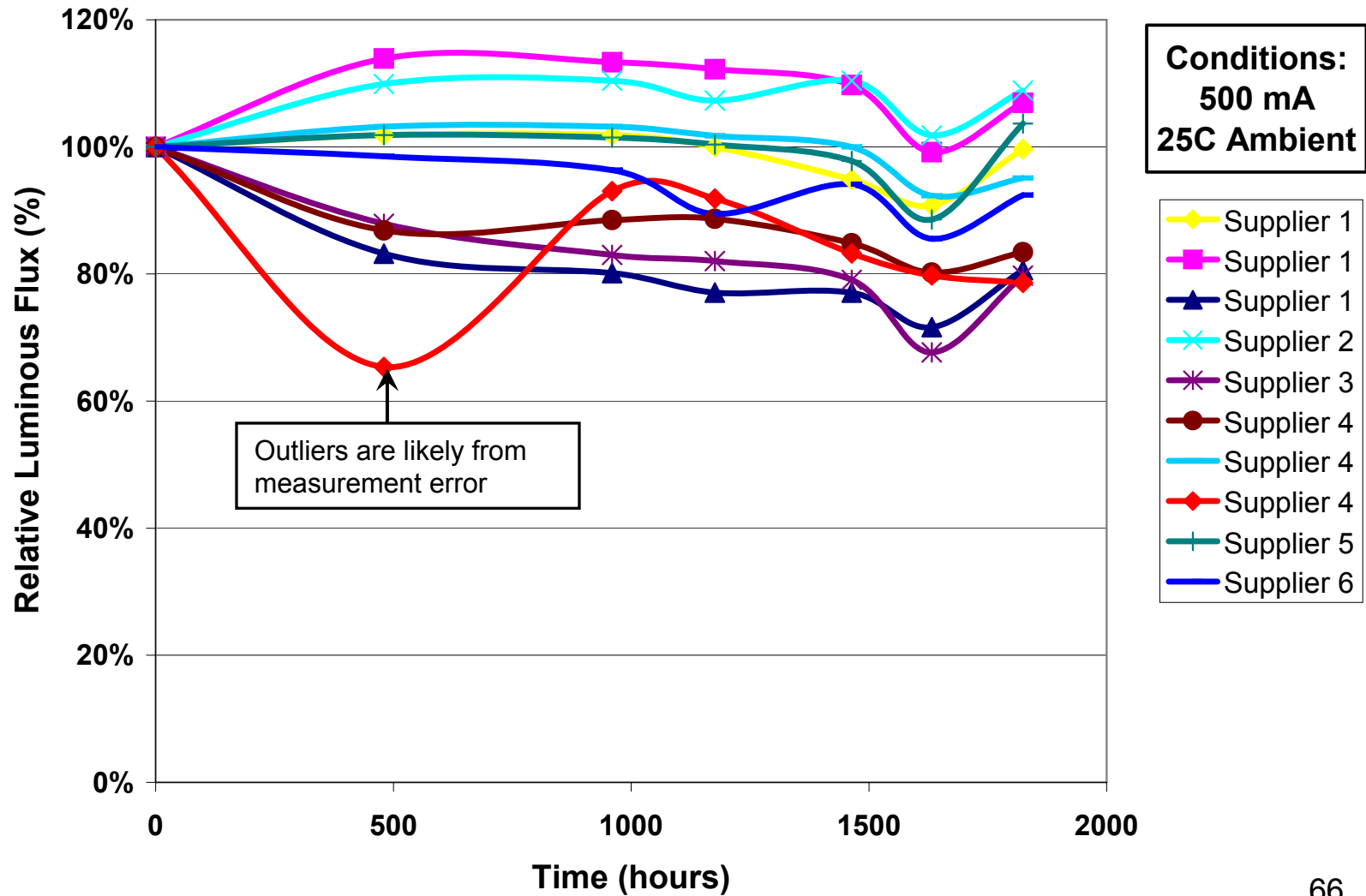

Luminous Flux Change with Time

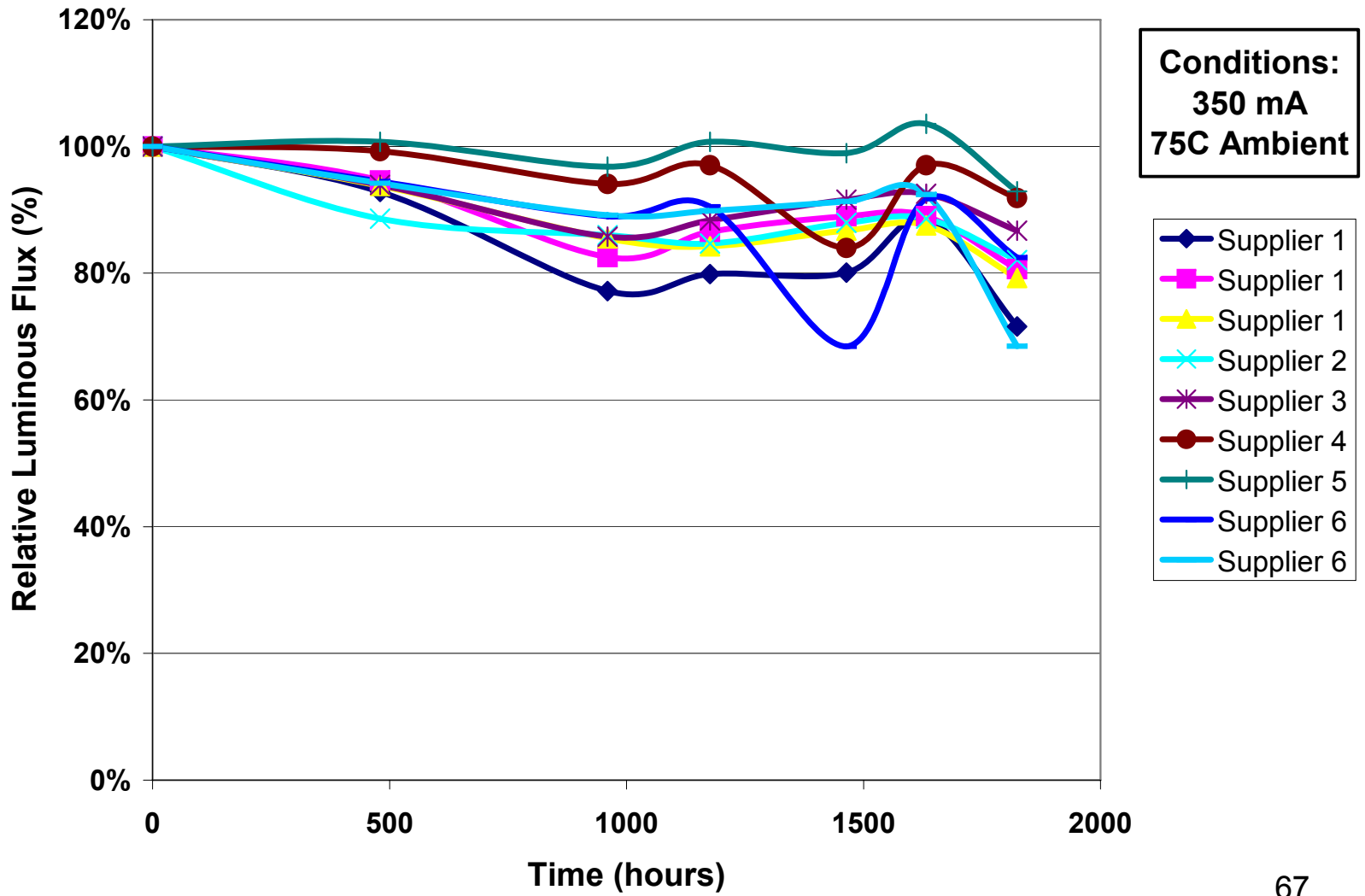

Lamp Type	Watts	Life	Initial Lumens	Maintained Lumens	Price	Luminous Efficiency	klm/\$	\$/Mlmh
Incandescent	60	1,000	850	850	\$0.90	14	0.94	\$12.82
Flourescent	32	24,000	3,000	2,900	\$1.50	91	2.00	\$1.18
High Pressure Mercury	250	24,000	11,000	8,500	\$21.00	34	0.52	\$3.06
High Pressure Sodium	250	24,000	28,000	27,000	\$27.00	108	1.04	\$0.97
Metal Halide	400	20,000	36,000	24,000	\$70.00	60	0.51	\$1.82
White LED (Luxeon K2)	5	50,000	100	75	\$3.50	15	0.03	\$8.67

$$\text{Cost of Light} = \frac{[p + h] / L + [W \times R]}{F} \quad (\text{in } \$ / \text{Mlm-hr})$$

Where

- p is the lamp price (in cents)
- h is the labor cost to replace lamp (in cents) assumed to be 400¢
- L is the lamp life (in hours)
- F is the lamp flux output (in lumens)
- W is the lamp input power (in watts)
- R is the energy cost (in cents/kW-hr) assumed to be 10¢



- Higher luminous efficiency (lumens/watt)
- Higher lumens per package
- Lower thermal resistance
- Lower cost per lumen
- Lower cost per LED
- Tighter color bins
- Specific color and flux bin availability
- Higher CRI values

Luminous Efficiency Improvement Trends

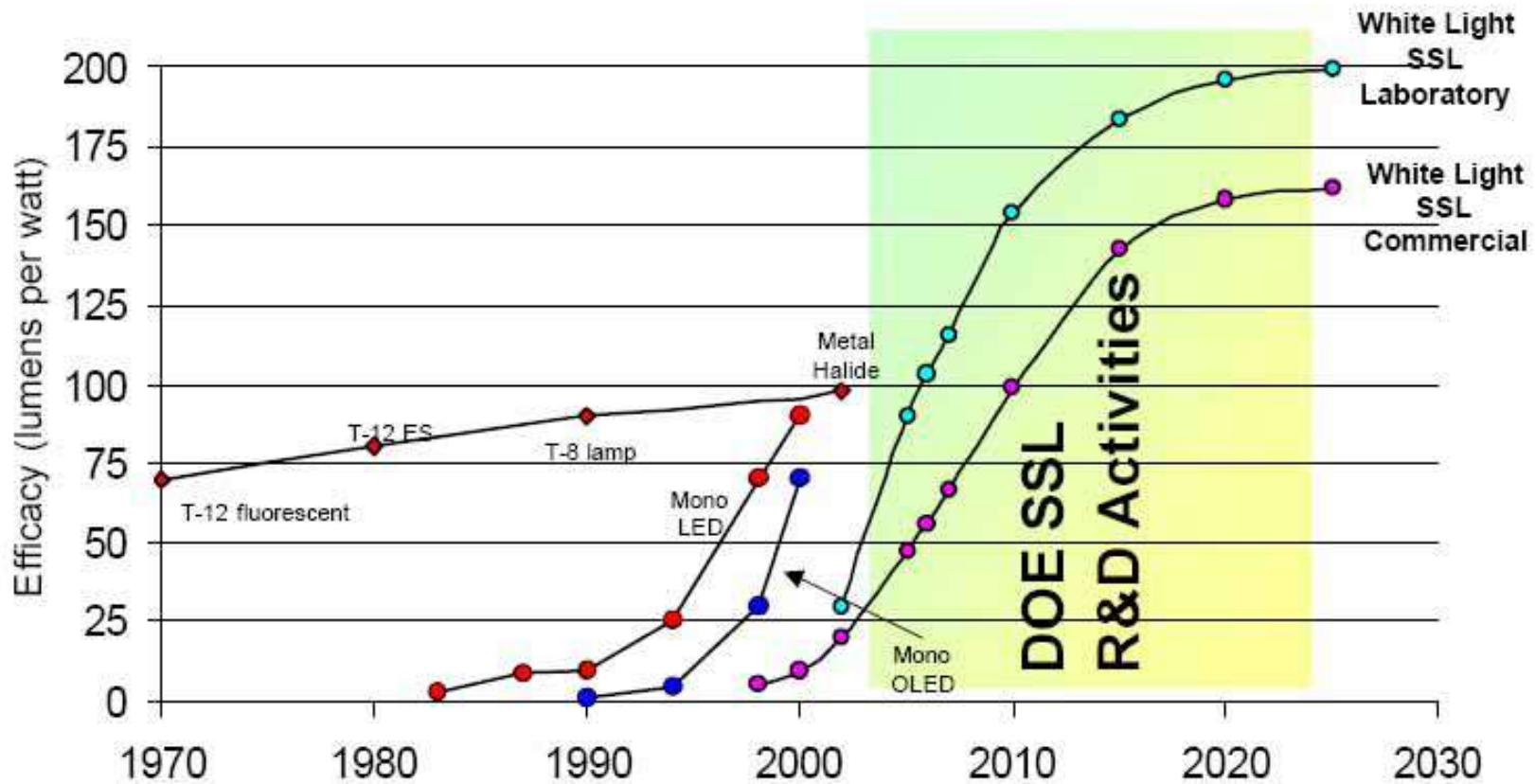

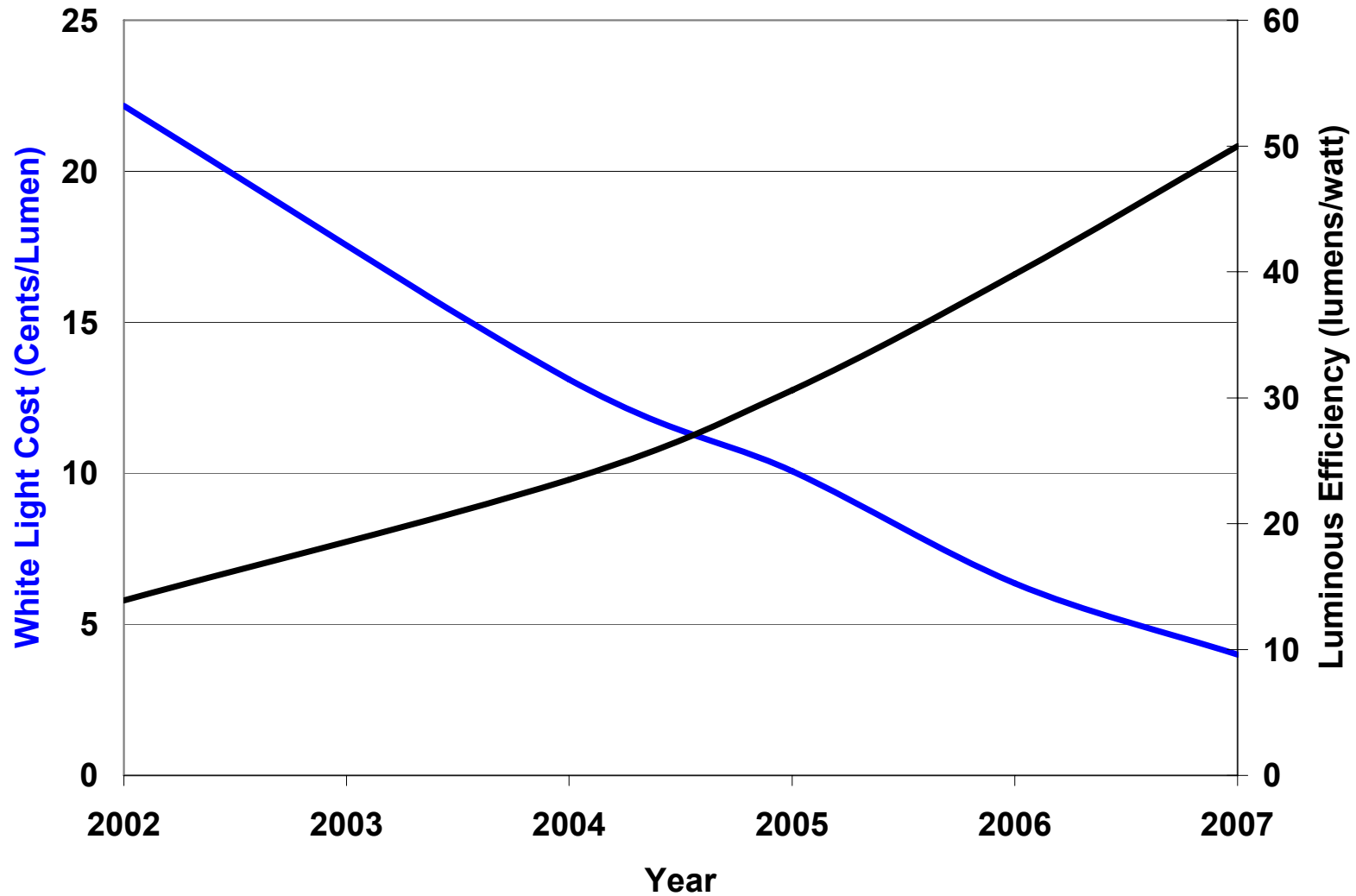

- Dialight Staff
 - Rich Huegi
 - Dave Weimer
- LED Manufacturers:
 - Cree
 - Lumileds
 - Nichia
 - Osram
 - Seoul Semiconductor



Comparison of White LEDs

Lightfair

June 1, 2006

JCURRAN@DIALIGHT.COM

732-751-5898

JPECK@DIALIGHT.COM

732-751-5849

Presentation located at:

WWW.DIALIGHT.COM/INDEXP.CFM

Link located at lower left corner of page

