

1. THE WOOD-WORK LATHE

Since the piston-pump needs circular parts (valve and piston body) we decided to build a lathe for wood-work. The lathe is made from rough wood left over from previous projects, mainly, Connections are made with screws, nails, lengths of threaded bars and bicycle parts. The lathe is easy to use and is turned by foot treadle.

1.1. Assembly

Figure 1.1. shows the assembly of the lathe. The frame consists of two parallel beams which form the support for the tool rest and the tailstock, both of which can be fixed to the horizontal beams with wooden clamps.

The headstock consists of two upright pieces of timber, one of which acts as a post.

A ball-head, sawn from a bicycle frame, is clamped into a groove in the ends of the headstock, using a loop of wire or a bracket of metal strip, thus forming a revolving headstock spindle.

As the legs of the fork have been sawn off the ball-head, a large circular disc can be screwed onto the top of the fork (fig. 1.2.).

This disc is centred on the centre point; this is a piece of pipe that fits into the centre tube of the fork and can be fastened there.

Teeth are filed in the projecting end.

The wooden disc should preferably consist of plywood or a similar type of layered wood. This can be made by laying several planks across each other, nailing or glueing them together and then sawing out the disc.

Aim of the disc is twofold: to fix the object to be turned, if this is not turned between the centres (disc shaped objects), and to act as a fly-wheel.

Since the lathe is driven by a pedal-crank mechanism, the disc is essential and should be as large as possible.

The assembly of the tool rest and the tailstock with their locking devices may be seen from the drawings.

1.2. Transmission

A bicycle wheel fixed to a crank is driven by means of a bicycle foot pedal placed on the long axis of the frame. The drive is transmitted by a flat belt (cut from the profiled surface of a bicycle tire) to a wooden disc that is coupled to the spindle. A transmission ratio of 1:4 has proved to be the most satisfactory.

It is advisable that the wooden pulley has a spherical shape to prevent the belt from slipping off it.

There are several ways of attaching a crank to the bicycle wheel. In fig. 1.1. this has been done by clamping two pieces of timber in one line between the rim and on either side of the hub. These two pieces of wood balance each other.

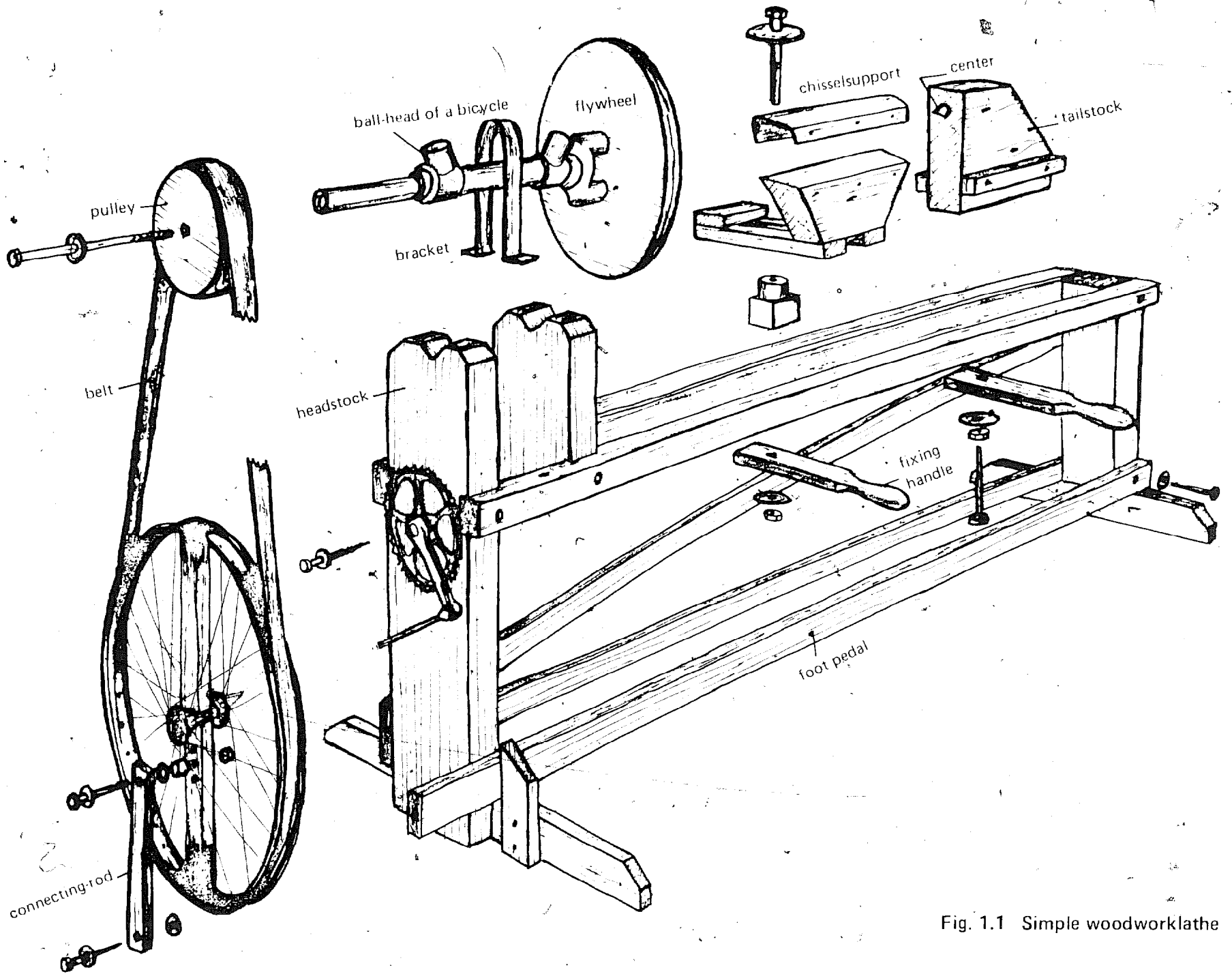

Fig. 1.1 Simple woodworklathe

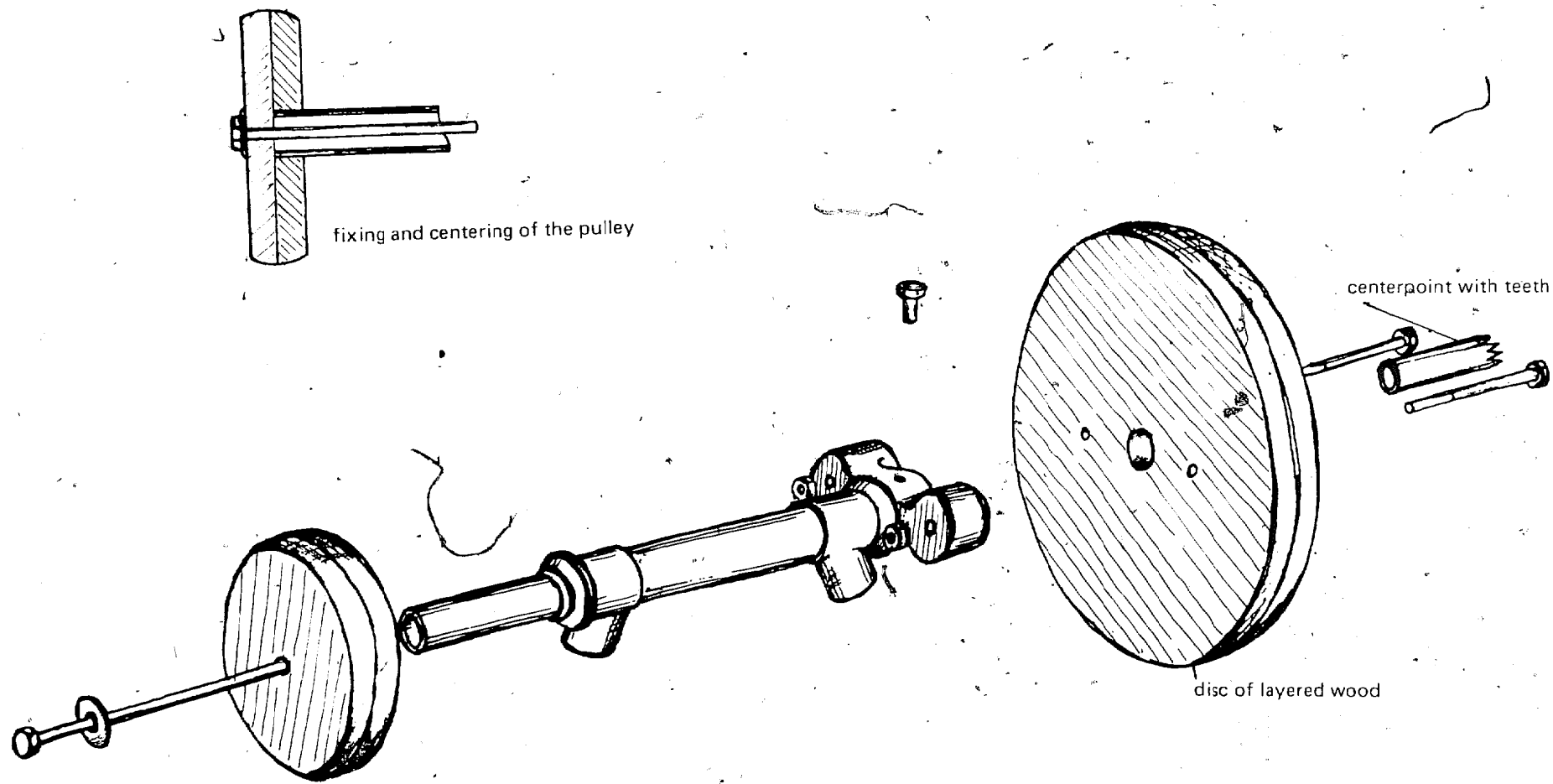

Fig. 1.2

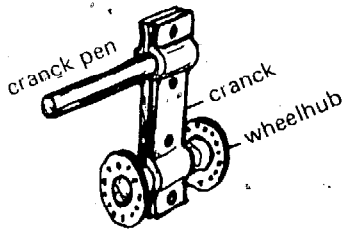

Fig. 1.3

The handle should be about 6 cm long, but experiments can be carried out using one's own judgment.

1.3. Operating the lathe

We distinguish between two kinds of pieces to be turned: long thin ones and disc-shaped ones. The former are fixed between the fly-wheel and the tailstock. It is advisable to make a centre point, in the form of a small conical hole of a few millimetres deep, at the end of the workpiece before fixing it.

This may be done using a nail punch or similar instrument. The pointed handle of a file is another alternative.

Then the front of the workpiece is placed against the serrated driven centre point and hammered into it with several firm hammer-blows against the rear end.

The tailstock is then screwed on and fixed with slight pressure against the workpiece. A disc-shaped workpiece is centred as accurately as possible on the large wooden fly-wheel and then firmly screwed to it.

The tool rest is placed as near as possible to the surface to be turned so that the cutter bears as far as possible on the tool rest and not on the hands.

Since the lathe operator stands on one leg to operate the lathe, he must also be able to lean on the tool rest and still be able to handle the cutter correctly (fig. 1.4.)

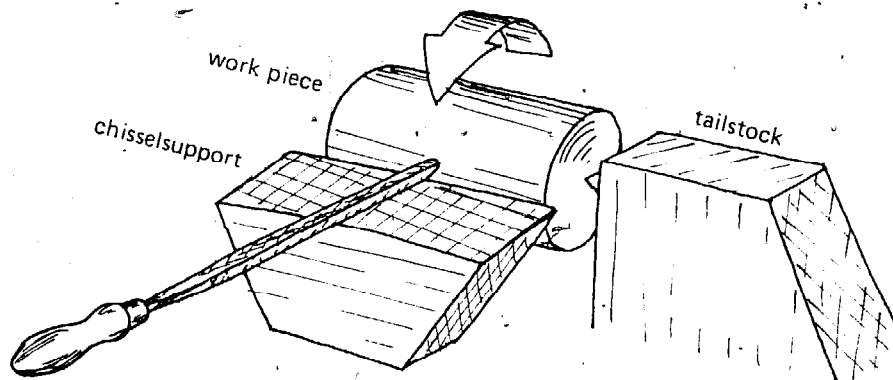

Fig. 1.4

It is clear that the operator needs a steady hand; it is also a question of "practice makes perfect".

It is possible that none of the more professional cutting tools will be available. A simple and adequate tool can be made from an (old, blunt) file; preferably one with a square cross section.

The file is sharpened with the aid of a grinding stone, as shown in fig. 1.5.

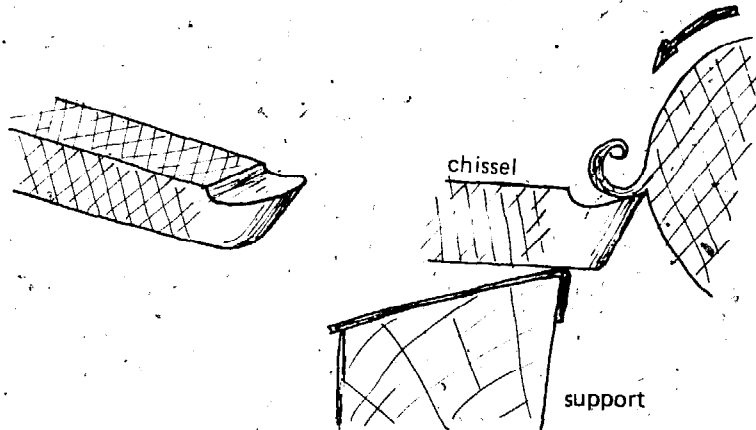

Fig. 1.5

If the cutter starts to "bite" or jump during turning, it must be held at a slant, that is with the handle raised. The cutting process then has a scraping character.

In this way very smooth workpieces can be obtained which can be finished or smoothed to size with sandpaper, if necessary.

In general, smoother surfaces are obtained on harder and short grained timber.

However, the final result is largely dependent on the skill and experience of the lathe operator.

9

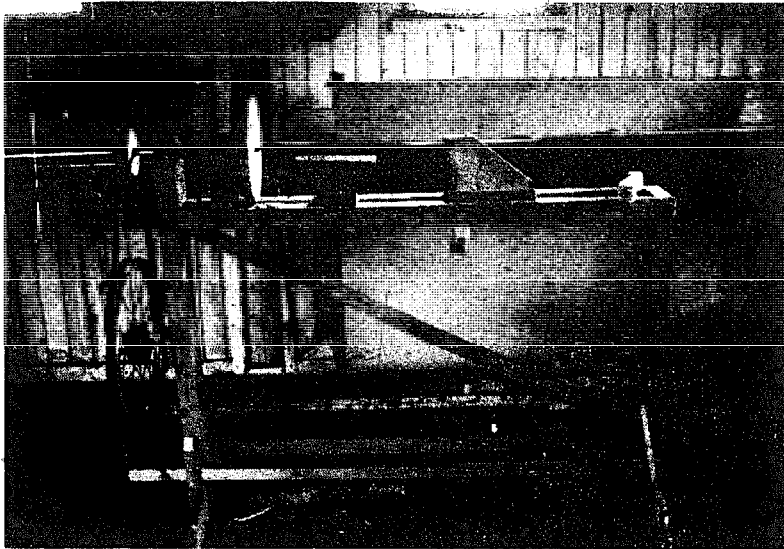

de houtdraaibank
the lathe

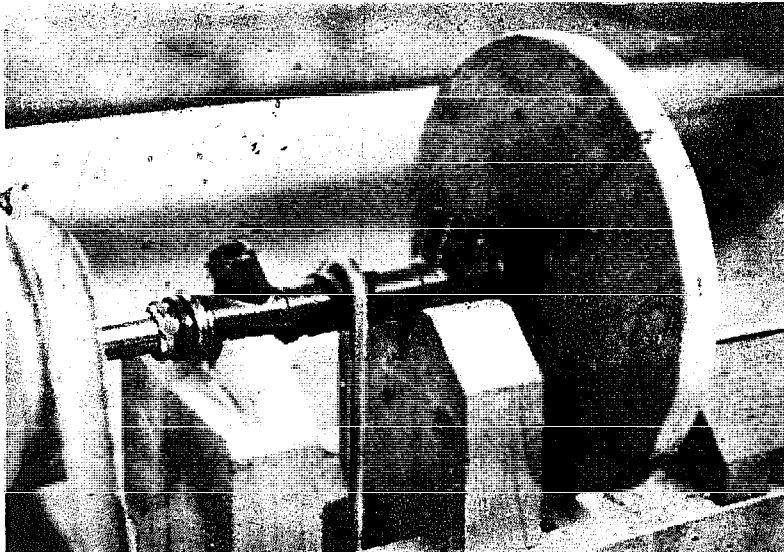

de hoofdspil en het vliegwiël
the spindle and flywheel

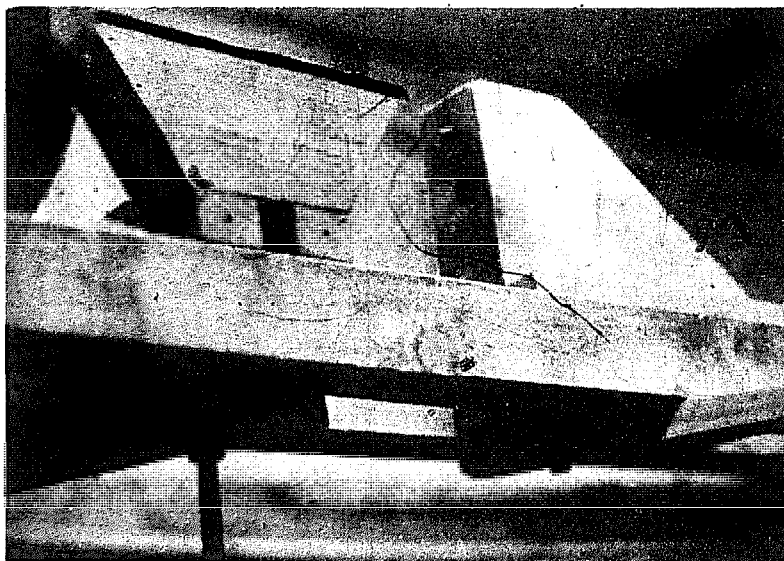

de leunspaan en de losse kop
support, bed and centerhead