

AT MICROFICHE
REFERENCE
LIBRARY

A project of Volunteers in Asia

The Low-Cost Wooden Duplicator

by David Elcock

Published by:

Intermediate Technology Development Group (ITDG)

Available from:

Intermediate Technology Publications
9 King Street
London WC2E 8HN
ENGLAND

Reproduced by permission.

Reproduction of this microfiche document in any form is subject to the same restrictions as those of the original document.

The Low-cost Wooden Duplicator

How to make it; how to use it

David Elcock

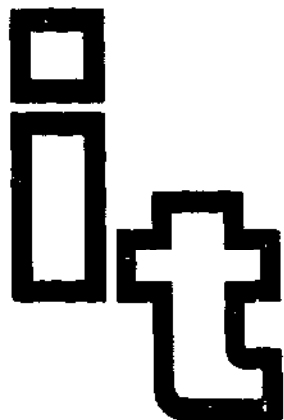
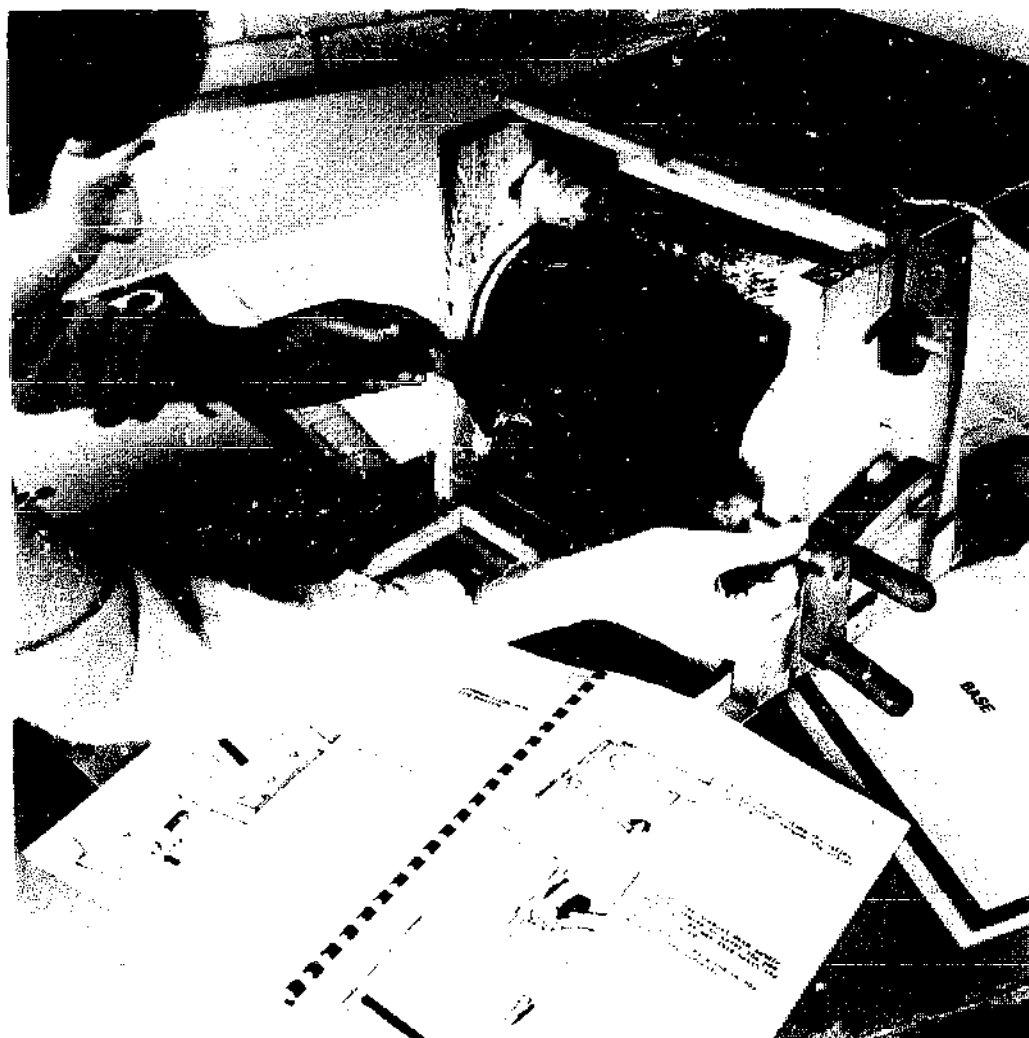

The Low-cost Wooden Duplicator

How to make it; how to use it

by David Elcock

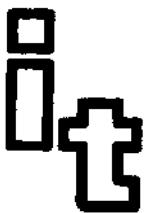

Intermediate Technology Publications 1984

**Published by Intermediate Technology Publications Ltd.,
9 King Street, London WC2E 8HW, U.K.**

© Intermediate Technology Publications 1984

ISBN 0 946688 41 9

Printed by Imediaprint Ltd., London

INTRODUCTION

The low cost wooden stencil duplicator is a printing machine which can be made for use in schools, colleges and small organizations. From one inking you can, with practice, produce over 200 copies of good quality print. The quality of the print is nearly as good as that from much more expensive machines. The duplicator is made mostly from wood and you need only simple woodwork tools to build it. However, some knowledge of basic carpentry is necessary to follow the instructions. It is very easy to use and maintain. Broken or damaged parts are simple to replace. The machine is small, made from wood and is very easy to carry around.

ACKNOWLEDGEMENTS

The original idea for a low cost, alternative technology duplicator came from Dr Salahuddin, of Lipikar Industries in Bangladesh. The Industrial Services section of ITDG has also instigated further developments with the help of David Elcock, Senior Lecturer in the Combined Engineering Department at Coventry (Lanchester) Polytechnic. These improvements have been incorporated in this manual. The content was designed by Linda Robinson, Anthea Logan, Magda Lohman and Sue Hyne, students in the Department of Graphic Design at Coventry Lanchester Polytechnic, under the guidance of Ian McLaren, Principal Lecturer at the Polytechnic.

The illustrations in this manual were drawn by Mirjam Southwell.

Before starting to build the duplicator please read the following notes:

1. This instruction manual should be read fully before the duplicator is built.

You will notice that specific quantities of materials have not been stated.

You can use the templates as guides to the basic size, but the

*You should check the sizes of the locally available stencils before making the stencil drum.

width of the stencil drum will depend on the width of the stencils you will be using.*

2. It should be noted that the illustrations are not an accurate guide to the sizes of the finished parts.

3. It is suggested that hardwood be used wherever mentioned to avoid parts of the duplicator warping in damp conditions. Using seasoned wood where possible is also advisable.

GENERAL DESCRIPTION

- A single drum is covered with an ink absorbent material over which the stencil is placed (item 1 on Parts and Materials list)
- The pressure roller (item 8) is turned by a handle, this rolls the paper over the stencil and ink is squeezed on to the paper.
- The pressure roller and stencil drum are squeezed together by rubber bands. These can be made by cutting bands from a bicycle tyre inner tube. Extra bands may be required to give greater pressure.
- The hinged covers (items 11, 12 and 13) which give protection for carrying and storage are also the serving and collecting trays for the paper.
- The deflector plate (item 4) guides the paper to the front of the machine.

When closed, the unit stores the handles, clamp, inking roller and duplicating ink.

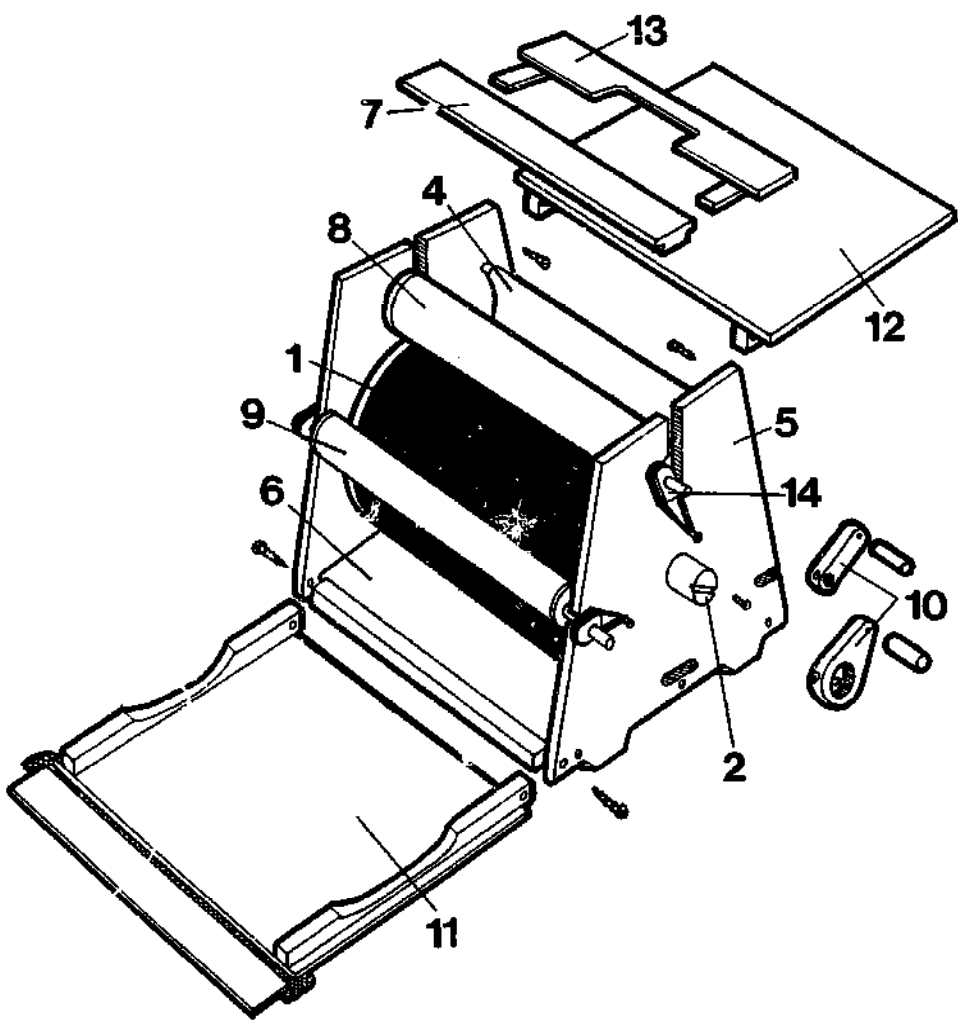

With a little innovation the measurements and materials may be changed to suit locally available materials.

Parts and Materials List

Item No	Description	Material
1	Stencil drum	$\frac{3}{4}$ " thick wood 1mm thick plywood or tin plate; felt or other absorbent material, 1" diameter washers. It is important to note that the width of the stencil drum will depend upon the width of the stencils you will use on the duplicator
2	Shaft	1" diameter dowel
3	Fabric grip (not visible on drawing: see page 7)	$\frac{7}{8}$ " square hardwood flat headed screws scraps of tin plate
4	Deflector plate	Tin plate $\frac{3}{8}$ " diameter dowel
5	Side panels	$\frac{3}{4}$ " thick planed wood round head woodscrews
6	Base	$\frac{3}{4}$ " thick planed wood flat headed woodscrews
7	Case handle	$\frac{3}{4}$ " thick planed wood
8	Pressure roller	1 $\frac{1}{2}$ " diameter hardwood
9	Ink roller	1" diameter dowel
10	Pressure roller and stencil drum handles	Various pieces of wood
11	Front cover panel	(
12	Back cover panel	((3mm thick plywood (tacks
13	Top cover panel	(
14	Bearings	Hardwood

NB: It is suggested that the wood should be seasoned or given some kind of protective varnish to protect it.

HOW TO BUILD IT

Equipment

These are the tools needed to make the stencil duplicator.

1 A hand drill

2 A wood chisel

3 A plane to smooth the wood

4 A hammer and a screw driver

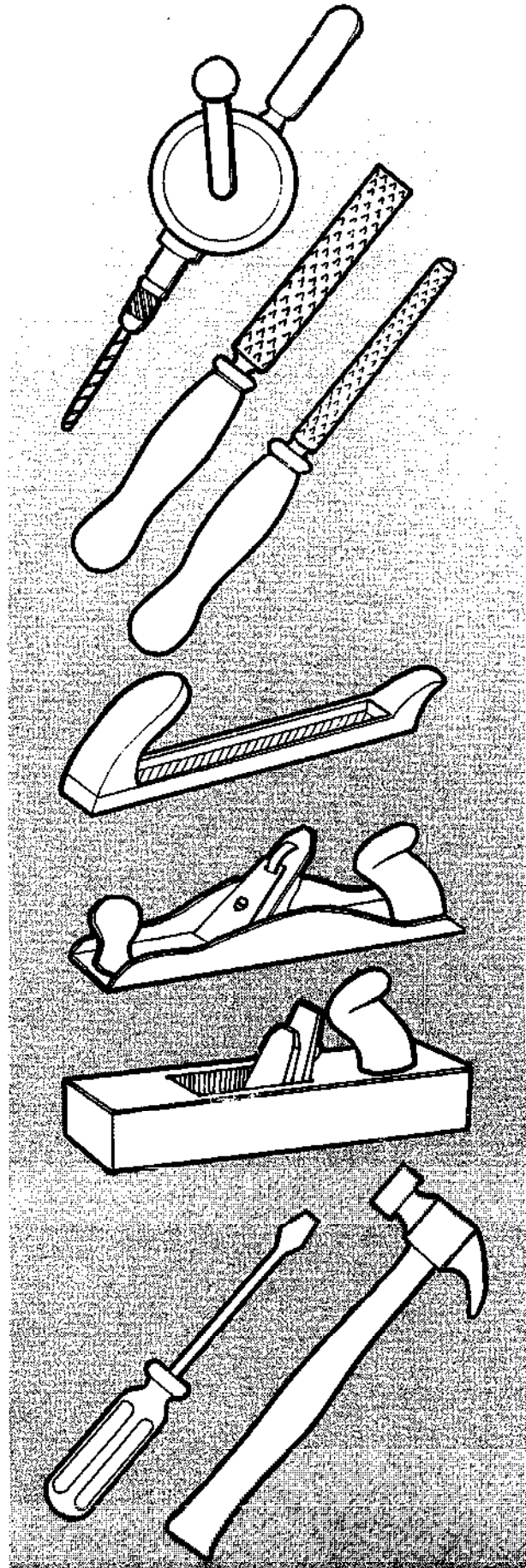

5 A hand saw

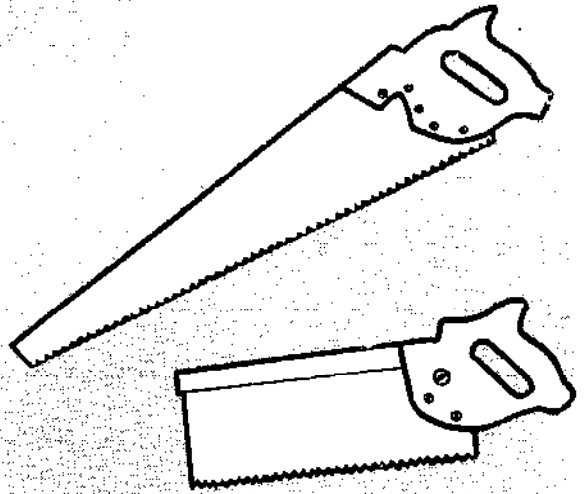

6 Several round headed and countersunk headed screws and a selection of nails

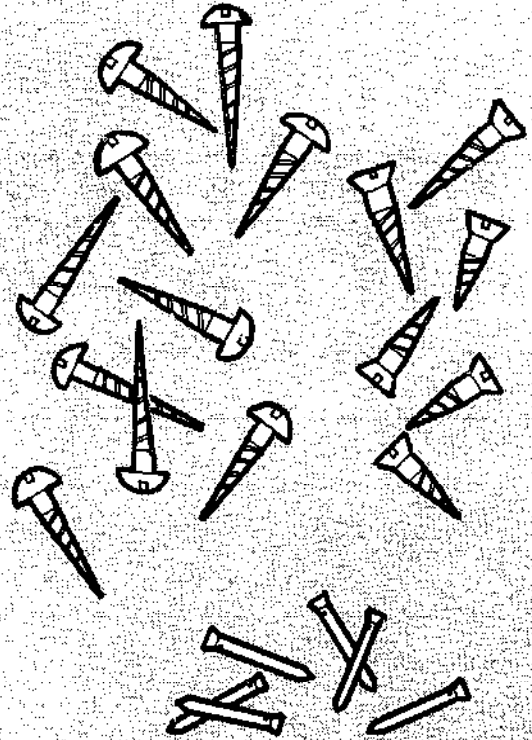

7 A pencil to use with the templates and various pieces of wood

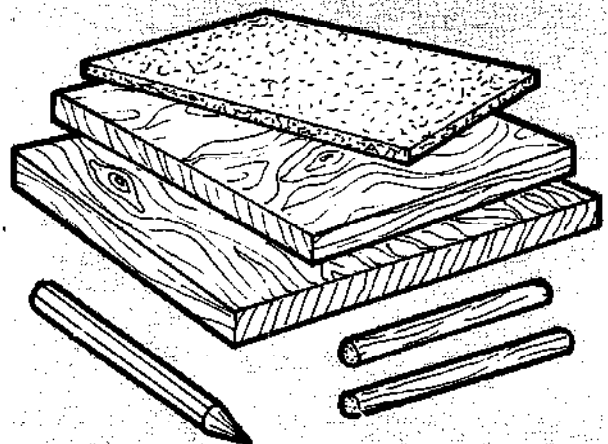

How to use the templates
(pull out middle pages)

- 1 Plane both sides of the wood smooth

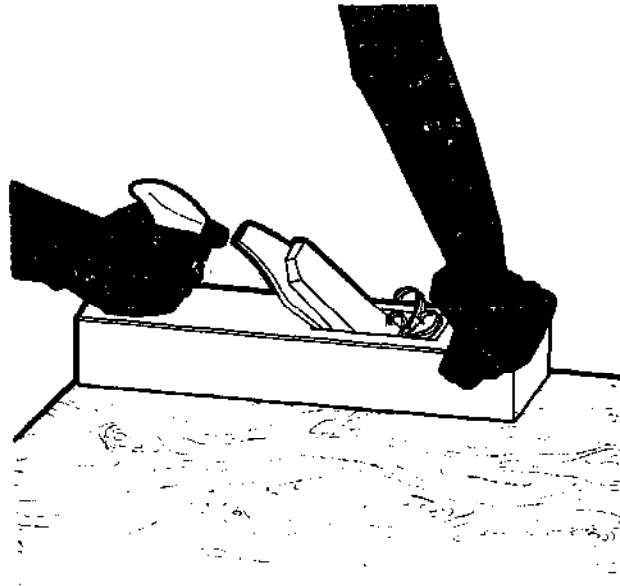

- 2 Cut out the template and place it on the wood. Draw around the template and mark on the wood the various screw positions and holes

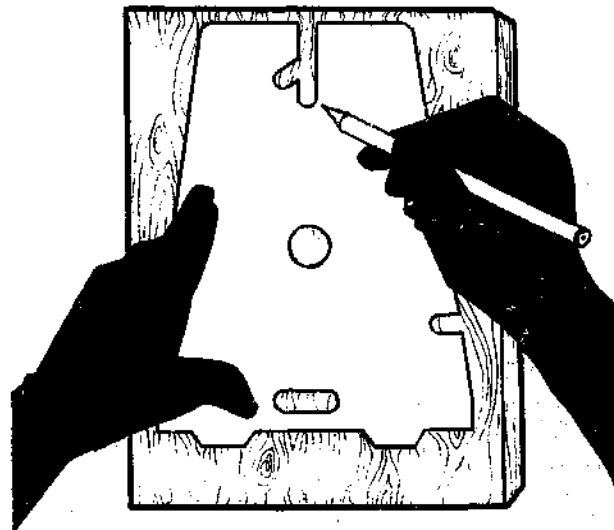

- 3 Cut out along the lines and sand all surfaces before assembling the duplicator

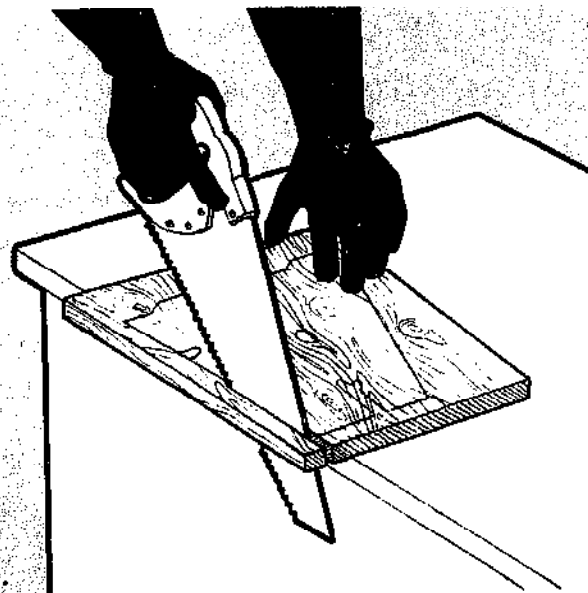

Making the stencil drum

- 1 Using template 1 cut out together three wooden discs (diameter of 6" and central hole 1" diameter)

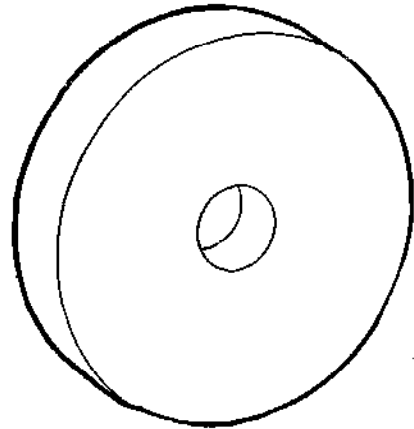

- 2 Cut from each disc a channel for putting in the fabric grip (item 3), $\frac{1}{2}$ " deep and 1" wide, drill a 1" diameter hole in the middle to take the shaft

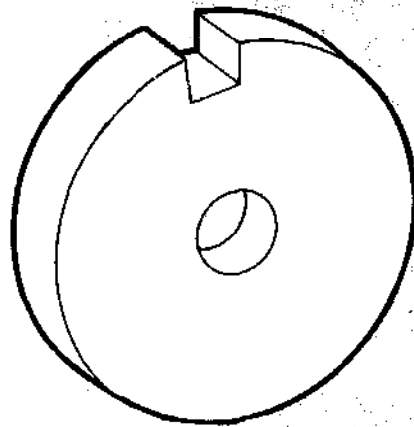

- 3 The shaft is made from 1" diameter dowel cut to a length of 15". To locate the handle cut a groove into each end of the shaft

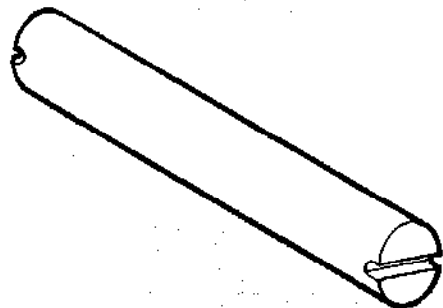

- 4 One disc should be glued centrally on the shaft and the other two discs should be glued approximately $2\frac{1}{4}$ " from the ends of the shaft such that their other surfaces are $10\frac{1}{2}$ " apart. This should leave approximately $2\frac{1}{4}$ " of shaft at each end

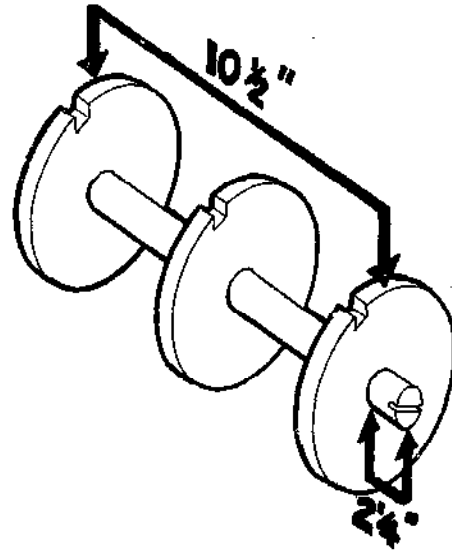

- 5 Make a U shaped piece of hardwood, like that shown in the drawing, $10\frac{1}{2}$ " long and $\frac{1}{4}$ " thick. This should fit in the wooden discs as shown. Join to the discs with screws

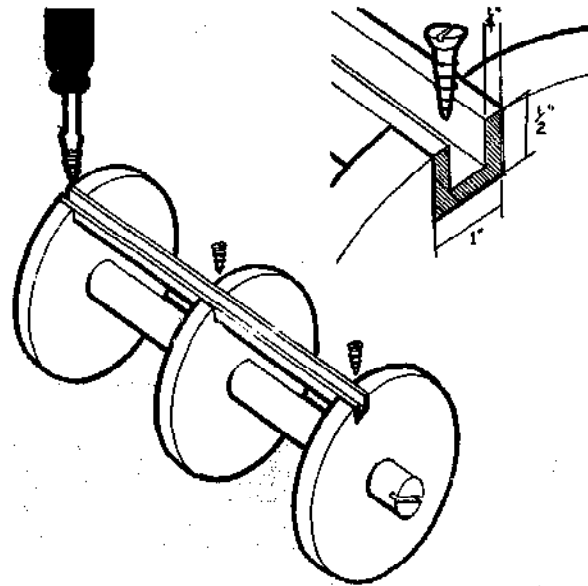

- 6 Use a piece of tin plate or 1mm plywood to cover the wooden discs. Join the tin plate to the wooden channel section with tacks. Leave a gap to put in the fabric grip

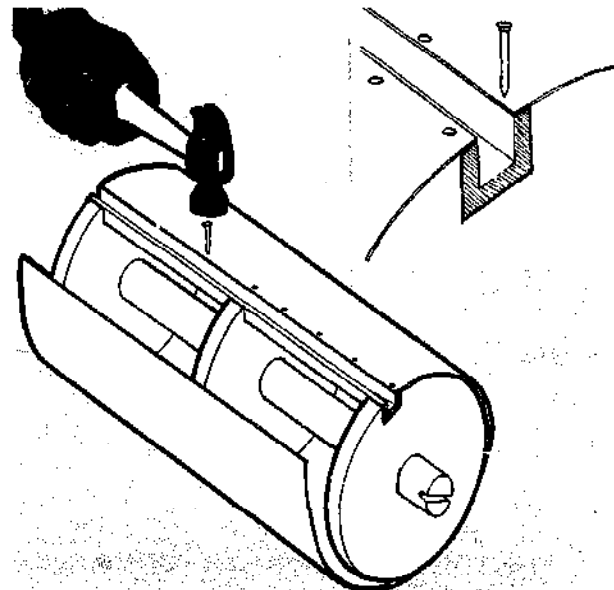

- 7 Cover the stencil drum with felt or absorbent material, allowing the material to overlap. Cut out the fabric grip from a strip of hardwood $\frac{7}{16}$ " square and $10\frac{1}{2}$ " long. Put the fabric grip into the channel on the stencil drum. This will tighten the fabric around the drum. Trim as required then secure the fabric grip to the stencil drum with screws

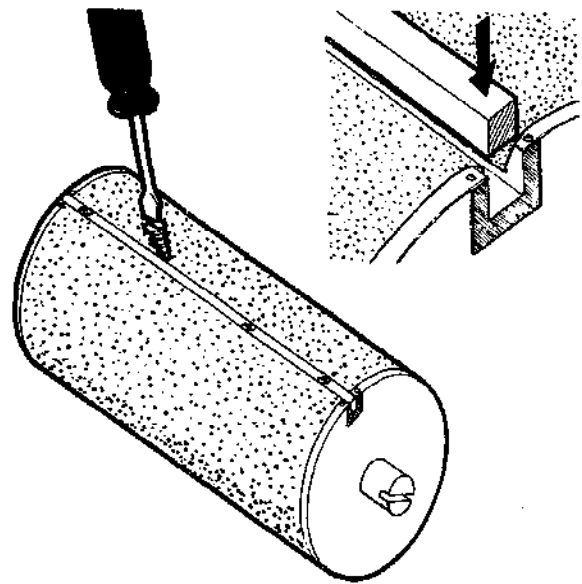

- 8 Attach three metal grips to hold the stencil. These grips should be positioned in such a way that the head of the stencil you use will be held in position (different stencils have different head fittings).

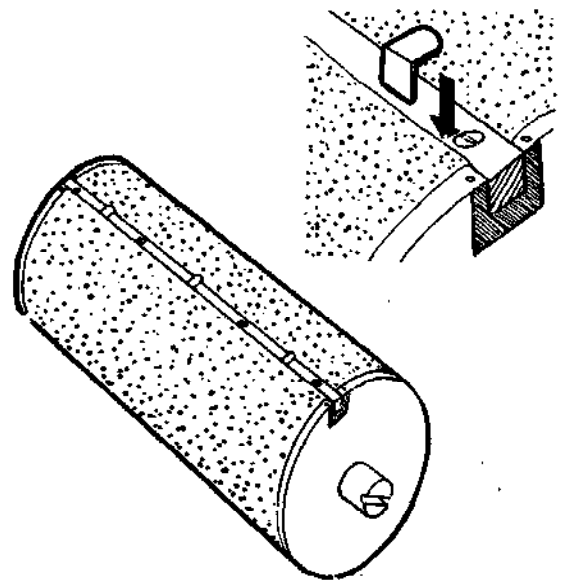

- 9 Cut out two washers from a plastic bottle or something similar. Put one on each end of the drum shaft to allow the stencil drum to turn freely

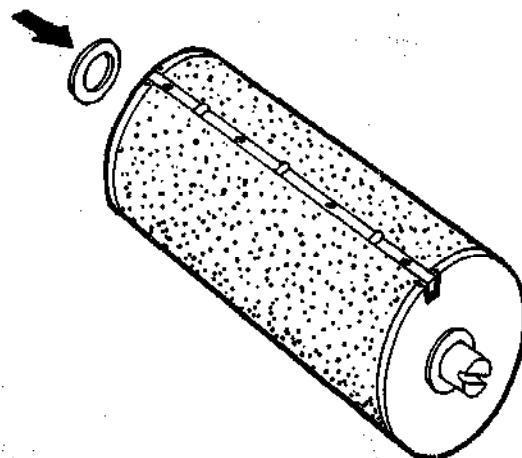

Making the side panels and base

- 1 Using template 2 cut out together two side panels from $\frac{3}{4}$ " thick planed wood. Cut out the various holes and mark on the positions for the screws

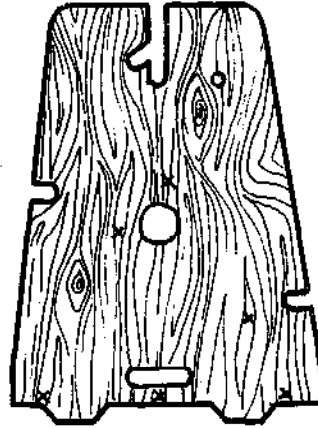

- 2 Using template 3 cut out the base from $\frac{3}{4}$ " thick planed wood and make a groove $\frac{1}{4}$ " deep for inserting the deflector plate (item 4)

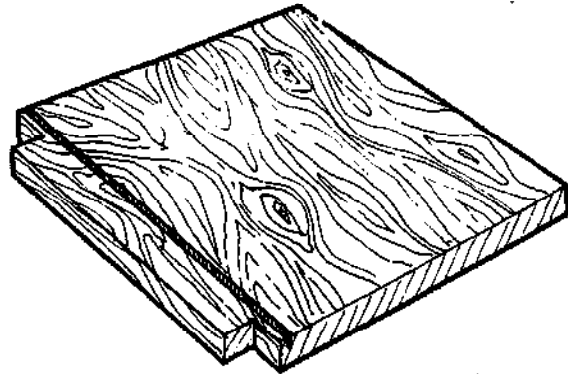

- 3 Join one of the side panels to the base using three screws. Put the stencil drum shaft into one of the side panels

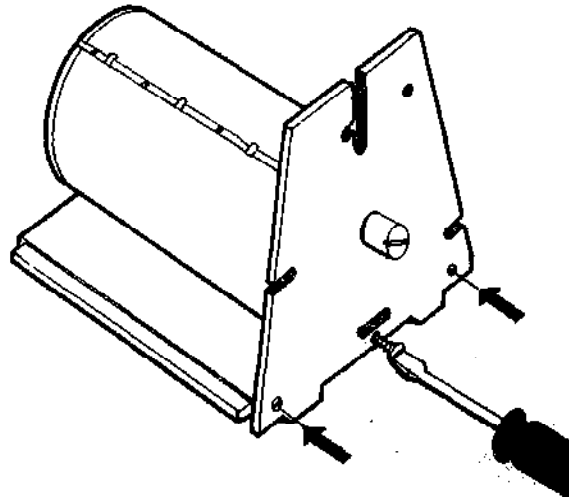

- 4 Join the second side panel to the base using three screws

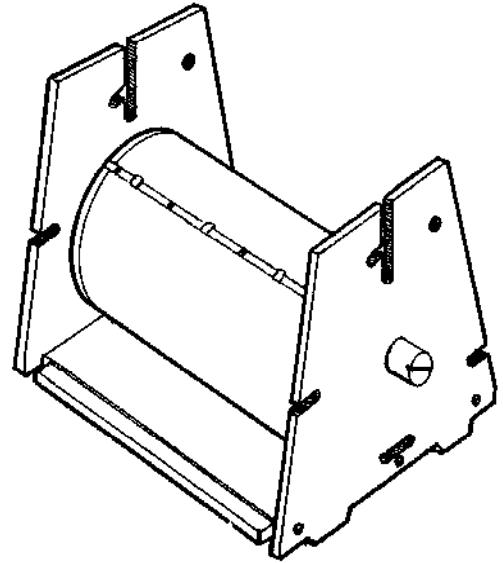

Deflector plate

Cut out a piece of tin plate approximately 10" wide. Bend the tin plate around the drum to get a rough curve. Fit one end of the tin plate into the slot in the base and curve the tin plate around the back of the drum. Glue a piece of $\frac{3}{8}$ " diameter dowel into the holes at the top of the side panels and bend the tin plate around the dowel.

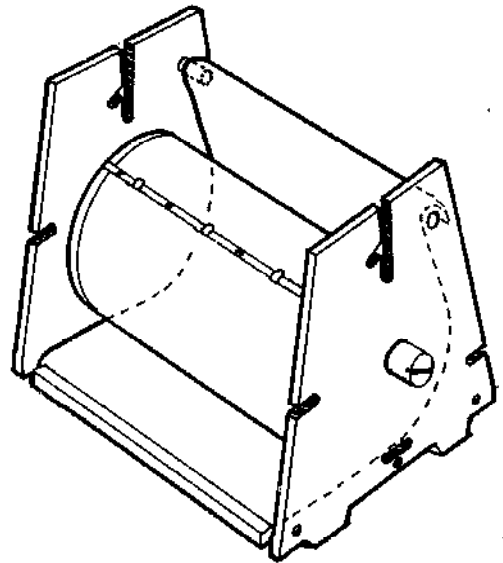

Making the pressure and inking rollers

1 Make the pressure roller from a $1\frac{1}{2}$ " diameter piece of dowel which is $10\frac{1}{2}$ " long. Similarly with the inking roller, but this time with 1" diameter dowel. In each roller make a $\frac{3}{8}$ " diameter hole at each end to a depth of 2"

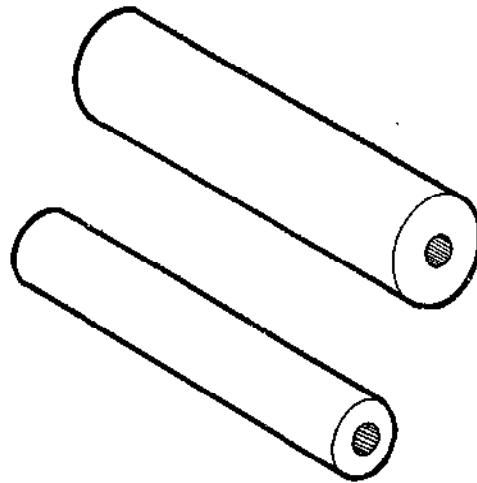

2 Glue the holes and insert shafts made from four $2\frac{1}{2}$ " lengths of dowel

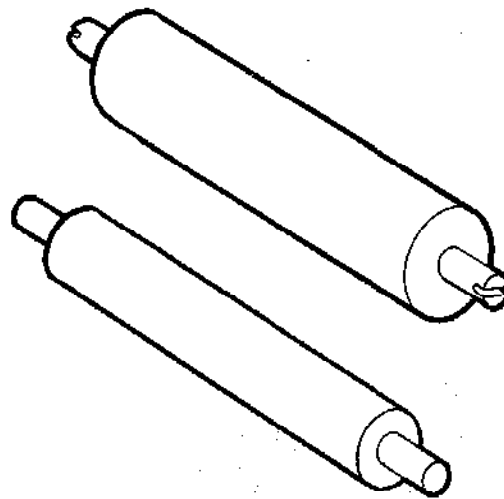

3 Cover both rollers with material, preferably felt

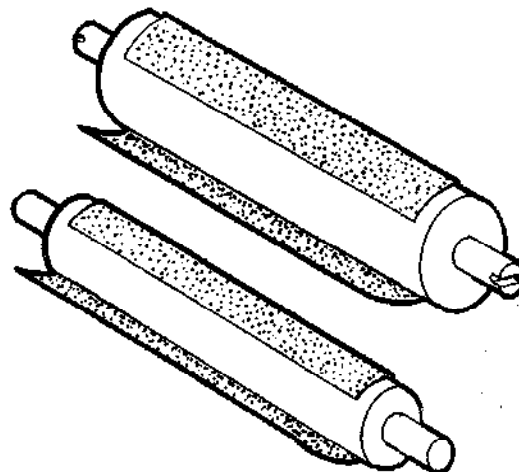

Bearings

Cut out four bearings using template 4 from hardwood to a width of approximately $\frac{3}{8}$ ". Slot two of the bearings onto the pressure roller shaft. Put screws in position shown in the drawing and then hook rubber bands around the bearings and screws. When using the inking roller attach the bearings as above

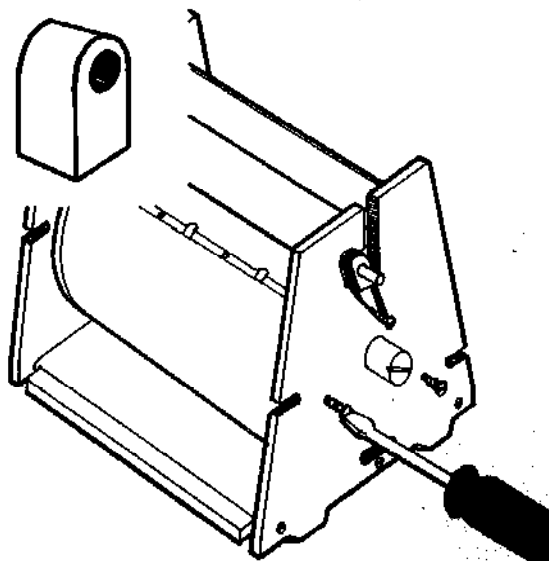

Pressure roller and stencil drum handles

- 1 Cut out the handles using the templates 5 and 6. Mark on the screw position and cut out the holes

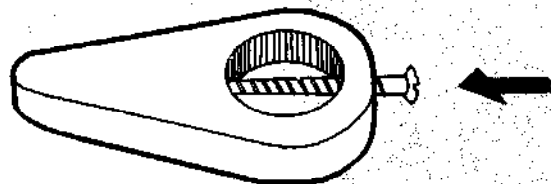

- 2 To attach the handles to the shafts put a screw of minimum length $1\frac{3}{8}$ " through the end of the handle

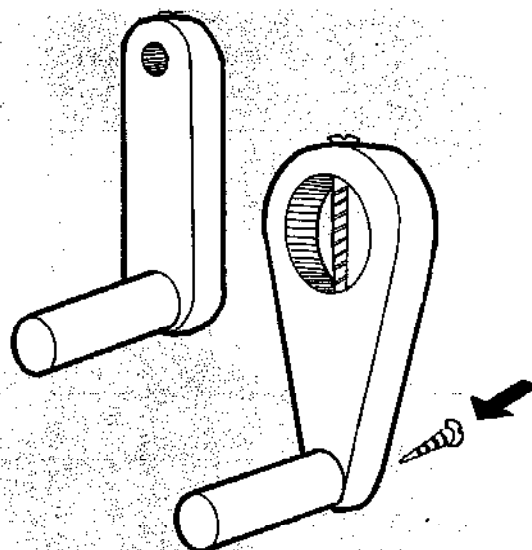

- 3 Join a length of dowel to the handle and attach it using a countersunk headed screw

Making the cover panels

(This is an option and is not needed for the duplicator to work. A brief description is given below, also refer to general description drawing on page 2)

- 1 Using template 7 cut out the cover panels from 5mm plywood. Glue and tack the supports to the main pieces. For the front cover panel (item 11) make a hinge from a piece of material or something similar and fix it with glue. Join the panel to the base using two long screws which pass through the holes in the cover panel supports
- 2 Join the back cover panel (item 12) to the side panels using round headed screws. Put the screws through the slots to allow the panel to move up and down
- 3 The top cover panel (item 13) should fit underneath the case handle (item 7)

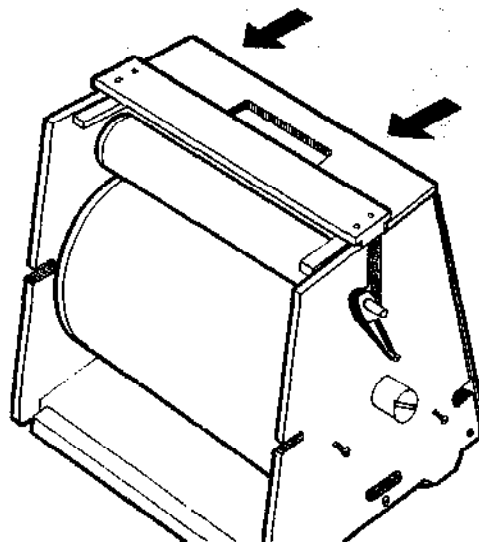
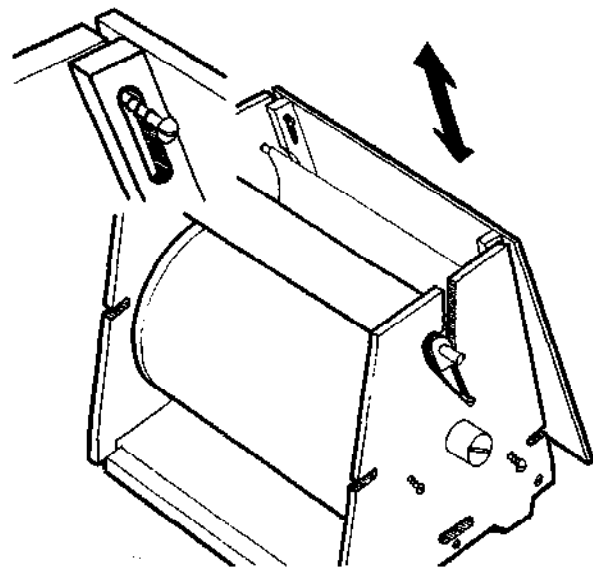
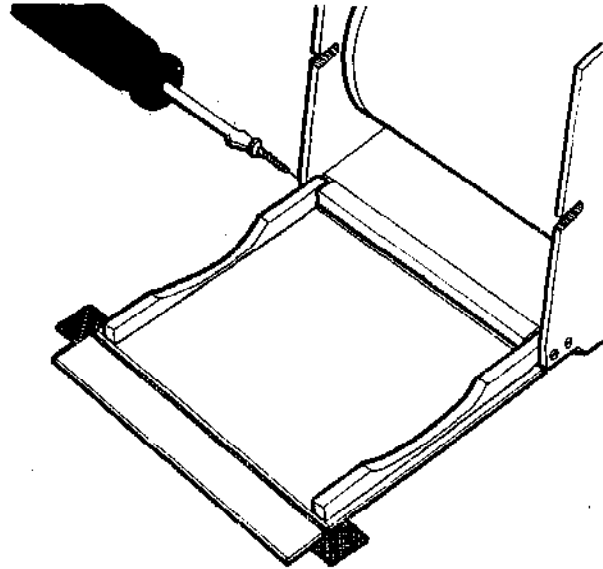

HOW TO USE THE DUPLICATOR

Inking

- 1 Lift the pressure roller into the non-printing position
- 2 Remove the inking roller from its store position at the back of the duplicator and attach as shown
- 3 Attach the handle to the stencil drum

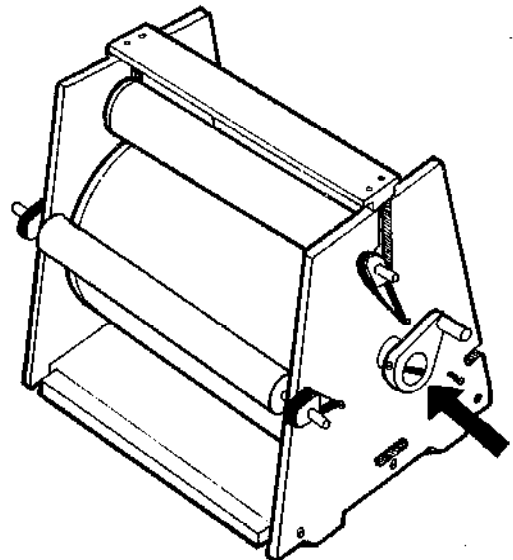
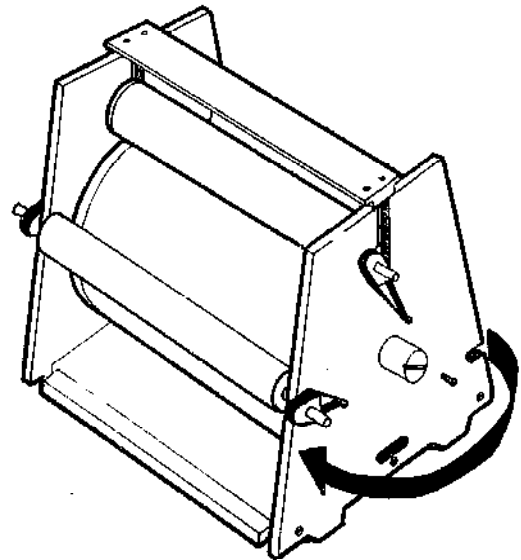
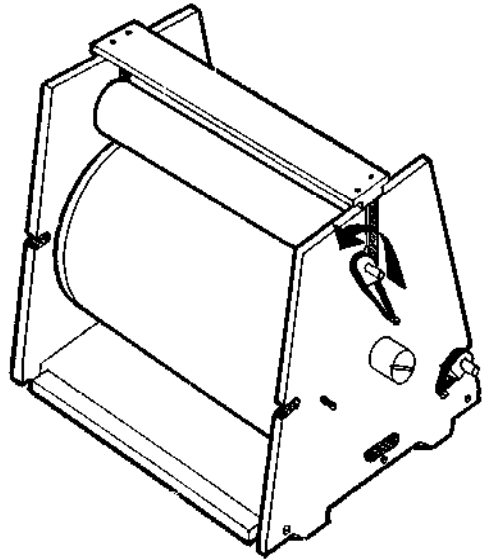

- 4 Put the ink along the roller in the trough between the roller and drum.

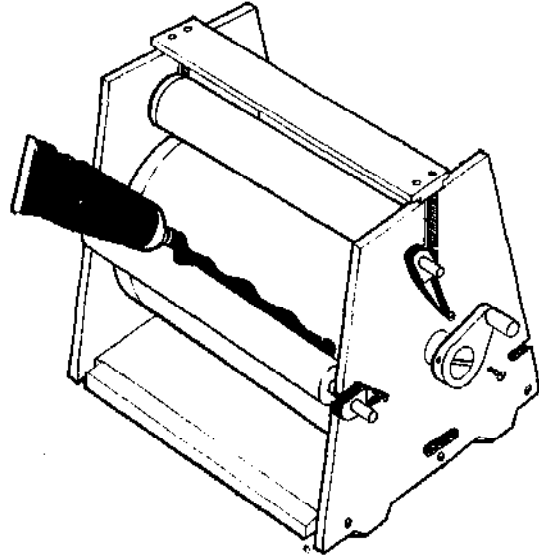

- 5 Turn the stencil drum handle back and forth to spread the ink over the roller. Make sure you only ink the area which will be covered by the stencil (you do not even need to ink the outer edges of the roller as you will not type to the very edge of the stencil). Do not use too much ink and do not cover the complete stencil drum or you will ruin the stencil and rollers.

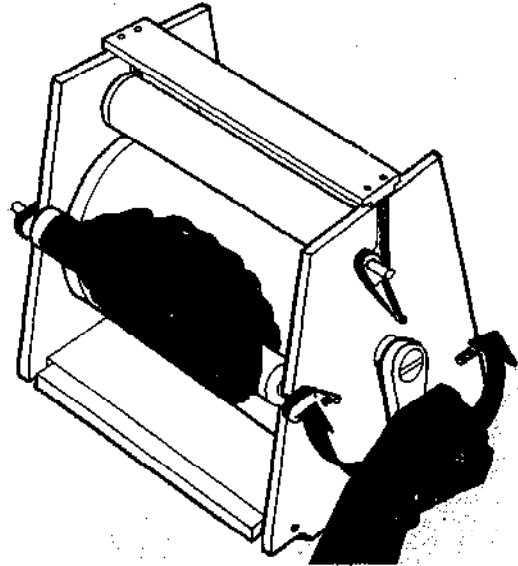

- 6 Remove the inking roller and store it in the back of the duplicator.

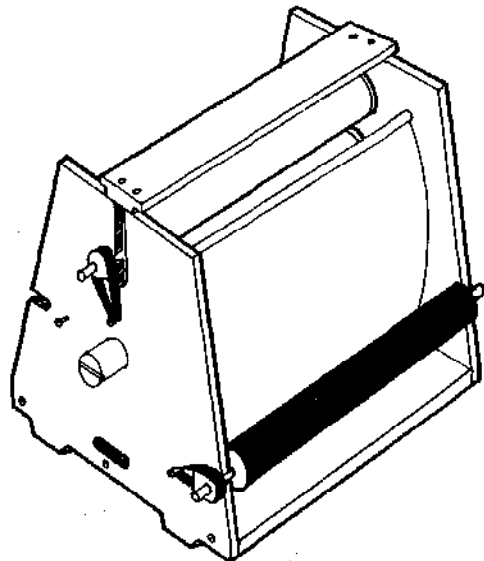

The stencil

- 7 Remove the carbon from between the stencil and the backing paper

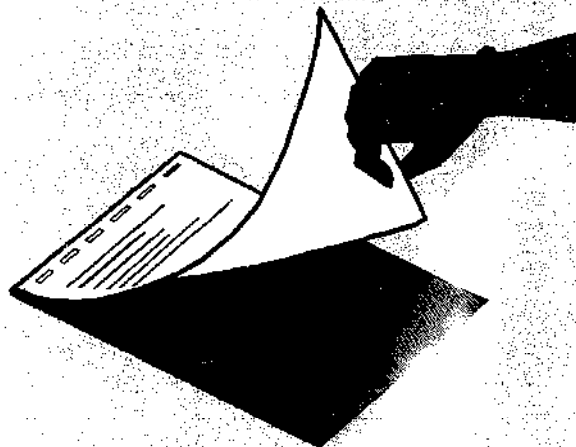

- 8 Hook the stencil with the backing paper attached on to the metal clips on the stencil drum

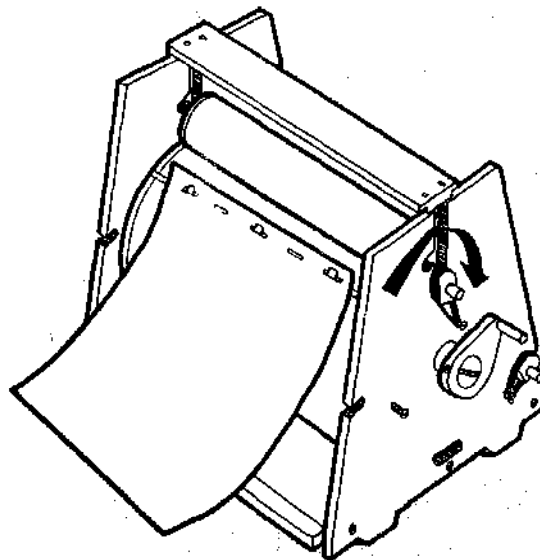

- 9 Put the pressure roller into the working position

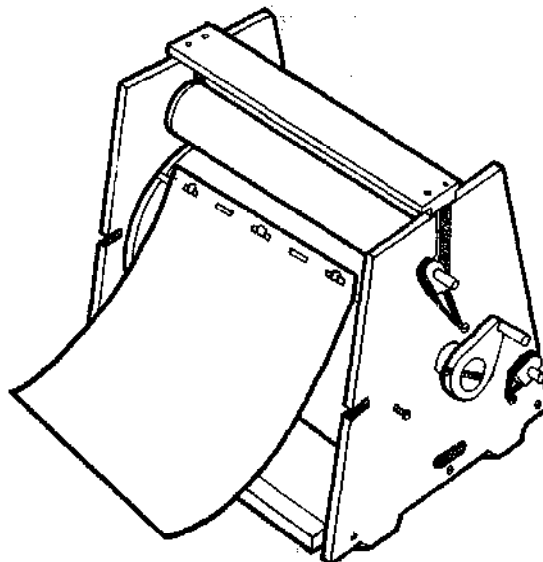

- 10 Remove the handle from the stencil drum and attach the pressure roller handle to the pressure roller

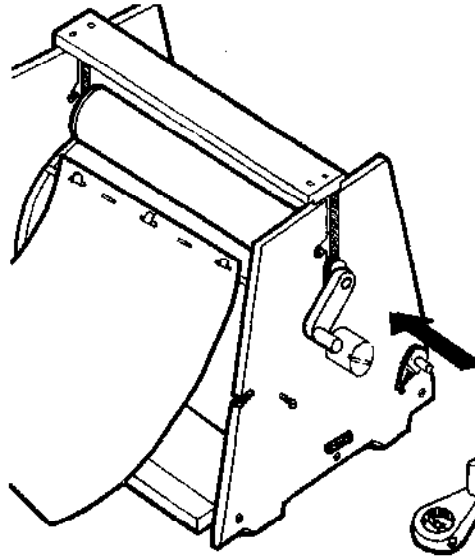

- 11 To test if the ink is passing through the stencil turn the pressure roller anti-clockwise. If not enough ink is passing through the stencil add extra rubber bands or rub your fingers over the backing paper to squeeze the ink through. Once this is done the ink will flow continuously

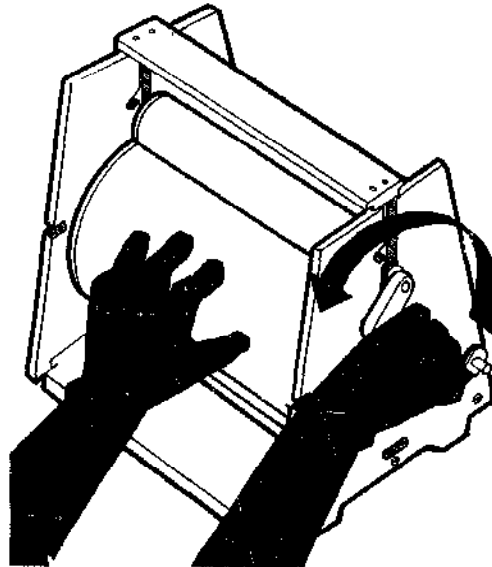

Taking the copies

- 12 Remove the backing sheet and then put a piece of blank paper between the pressure roller and the stencil drum. Turn the pressure roller anti-clockwise

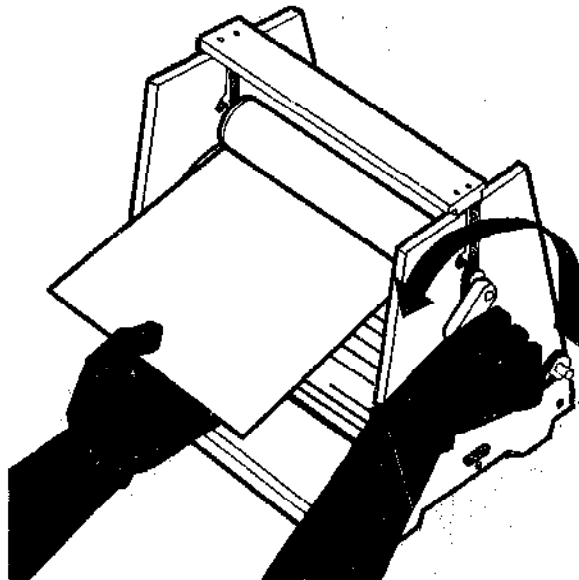

- 13 The printed copy will be deposited in the tray

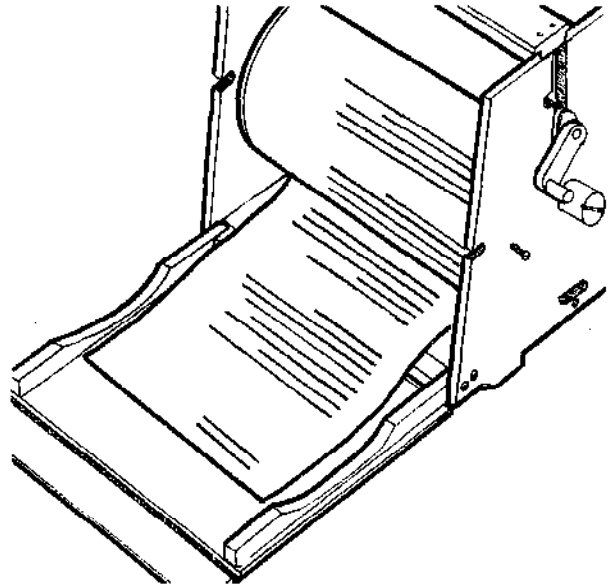

CAUTION

Do not turn the pressure roller without paper over the stencil because it will put ink on to the pressure roller and on to the back of further copies

If this happens clean the ink off the pressure roller

After use

- 14 Remove the stencil from the machine using top edge under clips
- 15 Take the handle off the pressure roller and fold the covers down, put the handle inside before closing

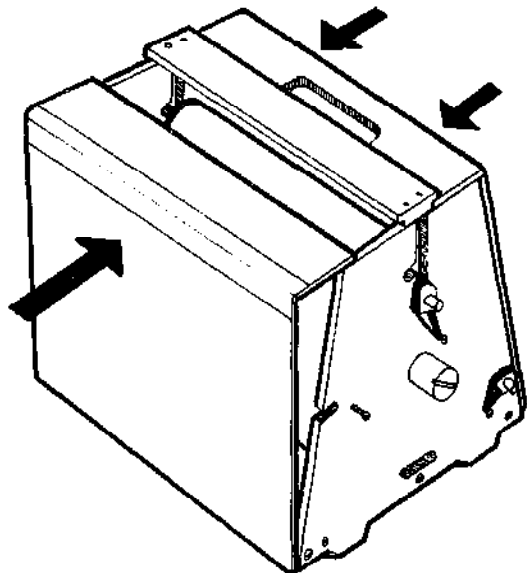

Now that you have read the manual, we would be interested in hearing from you about your experiences of building and using the Low Cost Duplicator.

Please cut out this page and send it, with your comments, to the address below. We will also arrange for you to receive information about further improvements and developments concerning this machine and information about similar projects.

NAME.....

ADDRESS.....

.....

.....

.....

I would like to receive a
catalogue of Intermediate
Technology Publications

Please send this form to: Intermediate Technology
Development Group, 3rd Floor, Myson House, Railway
Terrace, Rugby CV21 3HT., U.K.